

# Essential Radiobiology for Radiation Epidemiologists



# Do epidemiologists need radiobiology?

- The exposure situations that we are interested in are generally **not** those that are amenable to quantitative epidemiology
- Extrapolations:
  - ⇒ *Dose*
  - ⇒ *Dose rate*
  - ⇒ *Radiation quality*

# Low dose radiation risk estimation

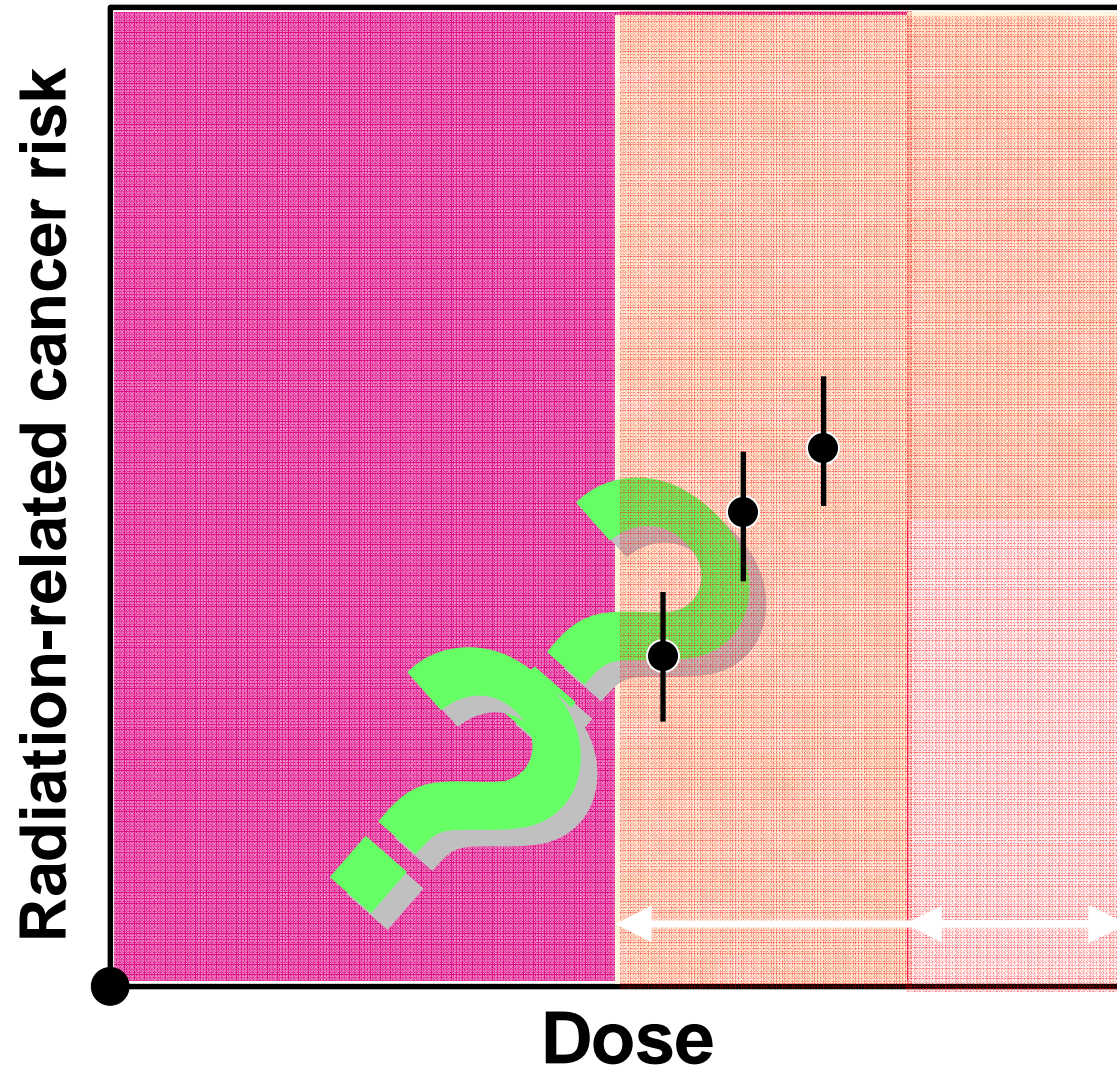

# Different possible low-dose extrapolations

What is the  
“anchor point” for  
extrapolation to lower doses?

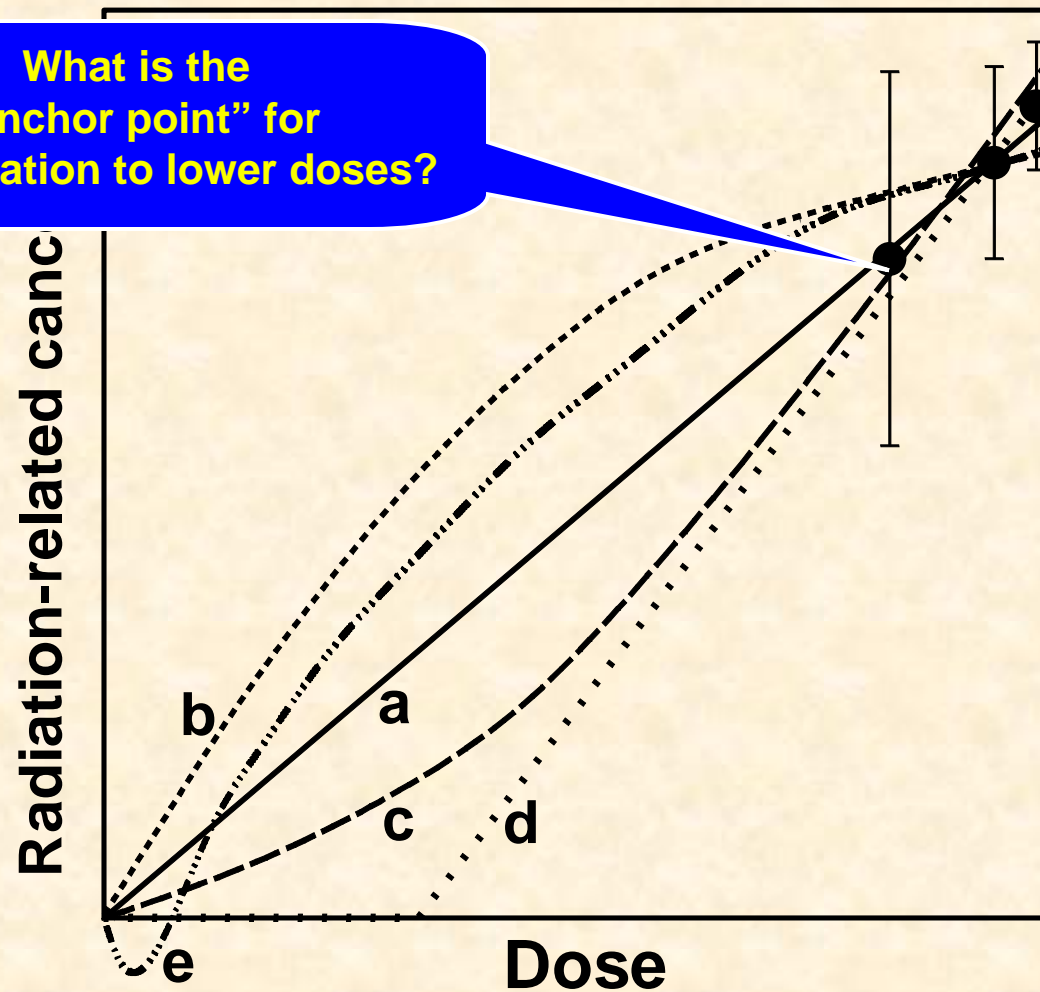

***In-Utero* x-ray exposure:  
Pelvimetry, obstetric abdominal exam**

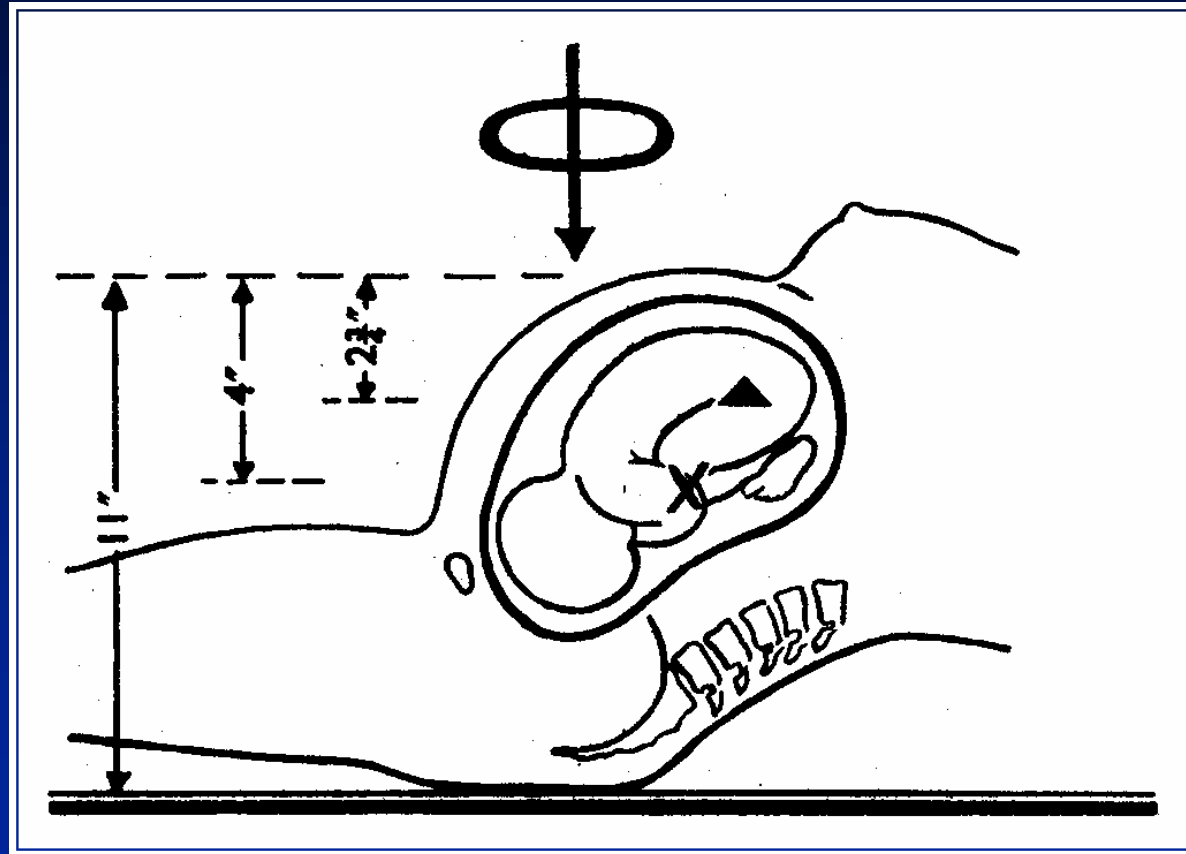

**Mean dose 5-10 mGy, 80 kVp x rays**

# Why are we particularly interested in childhood cancer after in-utero x-ray exposure?

1. Low doses  
(~1 photon / cell nucleus)
2. Lower background  
“noise” expected  
(childhood cancer is rare)
3. High “signal” expected  
(younger people are more radiosensitive)

## The Oxford Survey of Childhood Cancers



Alice Stewart

## Arguments supporting a causal assumption between low-dose in-utero exposure and cancer risk

- There is a dose-response
- Coherence: higher risks in those years when the dose/film was higher
- Recall bias unlikely
- Selection bias unlikely (twins study)
- Similar risk estimates from many studies
- Biophysically plausible
- Confounding variables have been sought but not found

## Arguments questioning a causal assumption between low-dose in-utero exposure and cancer risk

- Consistency with A-bomb data:
  - Childhood cancer data after exposure *in utero*
  - Childhood cancer data after exposure *in childhood*
- Recall bias
- Selection bias

(Modified from Boice & Miller, 1999)

# In-utero x-ray exposure at 6-10 mGy

## Conclusion

- Scrutiny of the objections to causality suggests that they are not, or may not be, valid. A causal explanation is supported by evidence indicating an appropriate dose-response relationship and by animal experiments.
- It is concluded that radiation doses of the order of 10 mGy received by the fetus *in utero* produce a consequent increase in the risk of childhood cancer”.



Doll & Wakeford 1997



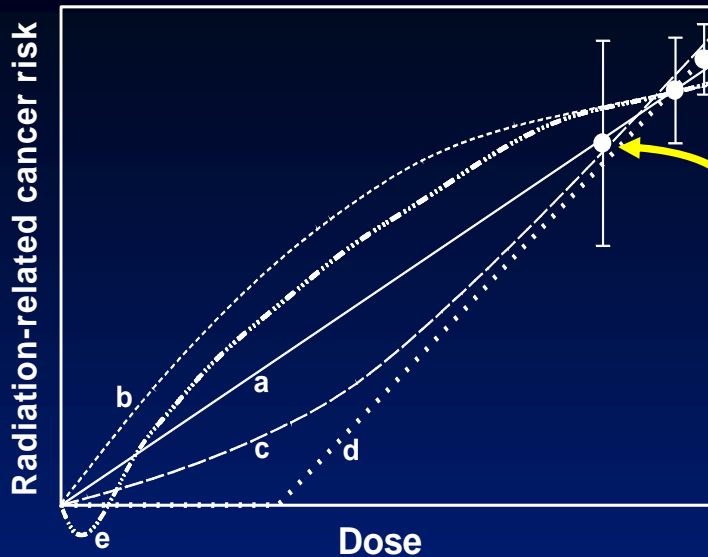

So our “anchor point”  
is about 5-10 mGy

- **We know there are cancer risks at this dose**
- **It is unlikely that we will be able to directly estimate risks at much lower doses**
- **What can we do?**

# Different possible low-dose extrapolations

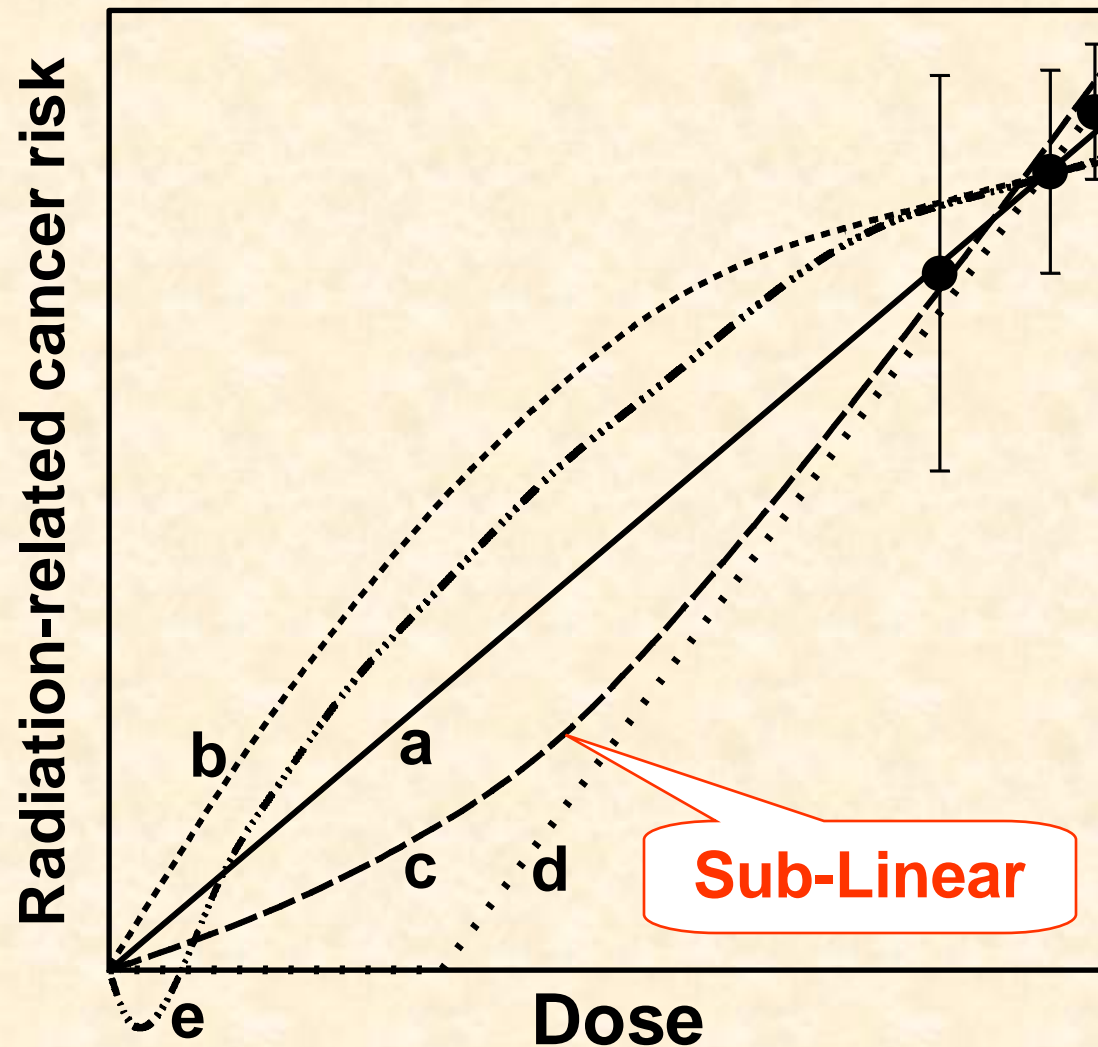

# "Two break" stable aberrations: inter-arm (translocation)

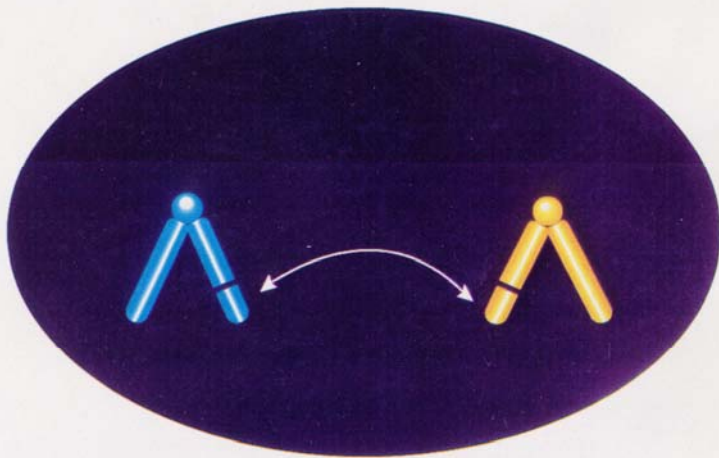

Incorrect ↓ Rejoining

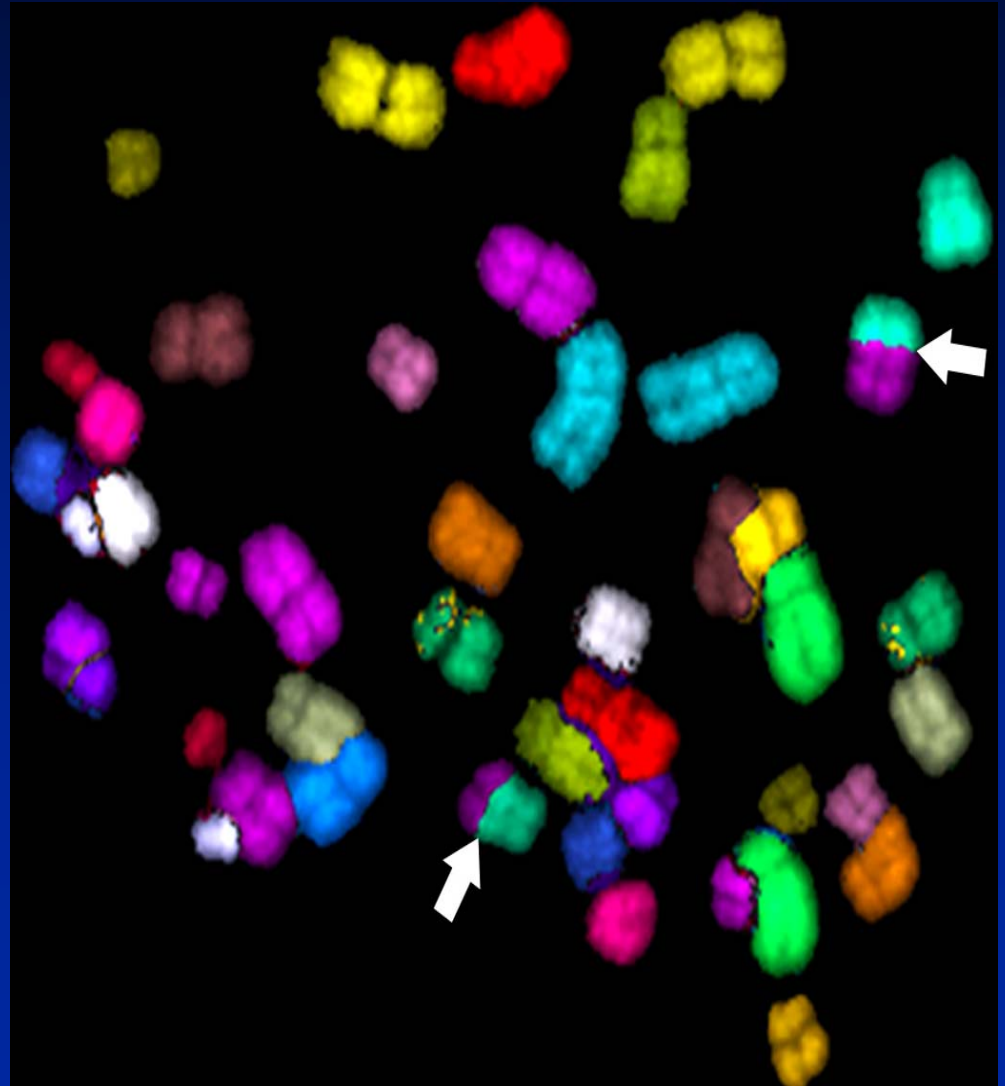
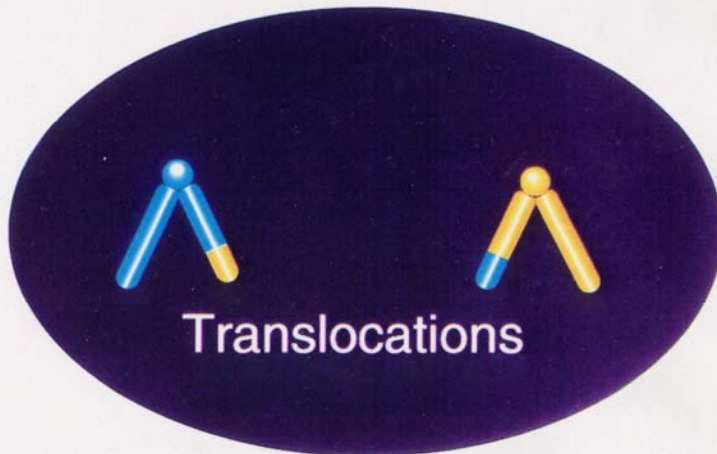

# "Two break" stable aberrations: inter-arm: pericentric inversion

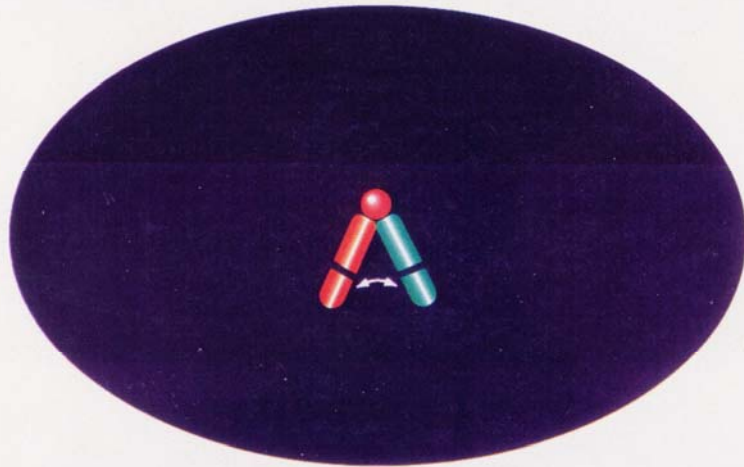

Incorrect ↓ Rejoining

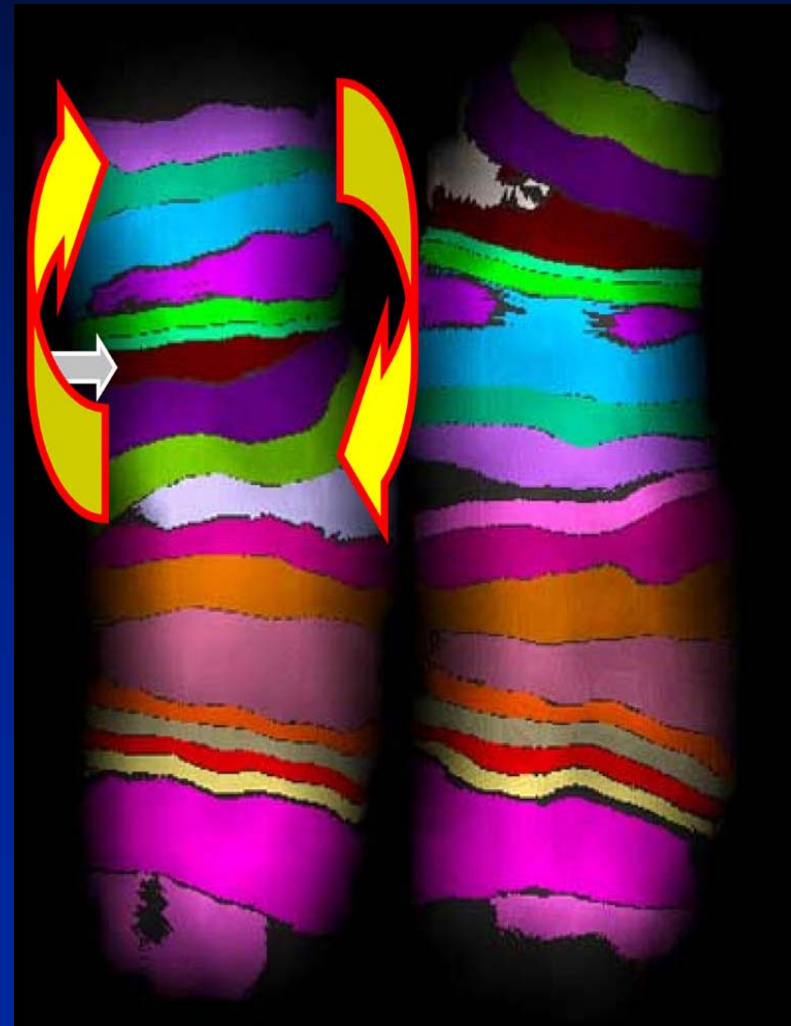
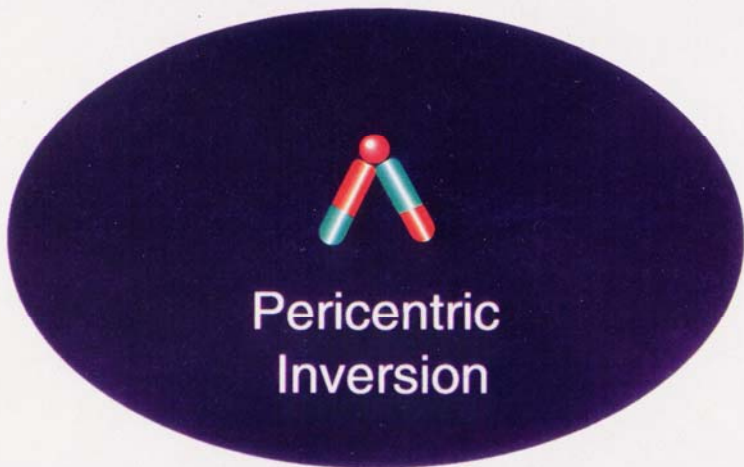

# "Two break" stable aberrations: intra-arm: Paracentric Inversion

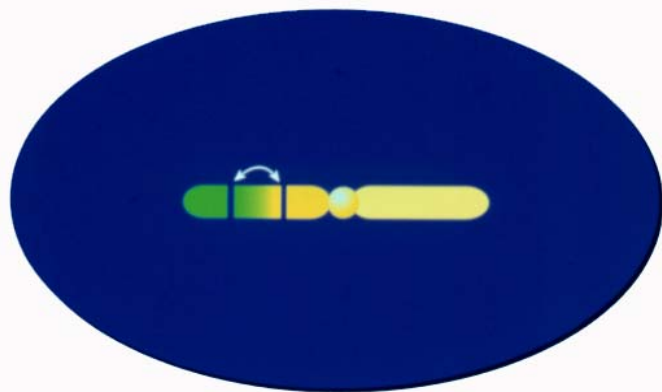

Incorrect Rejoining

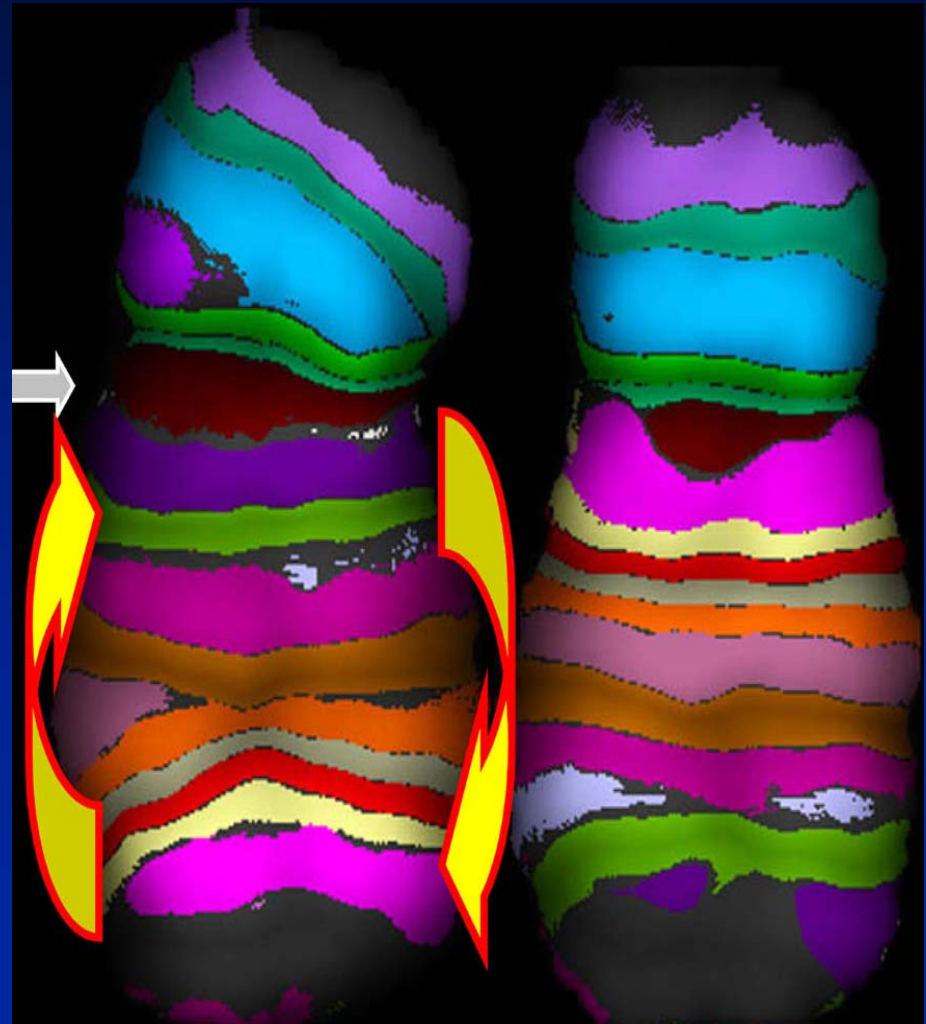

1 DSB  $\rightarrow$  linear

2 independent DSB  $\rightarrow$  quadratic

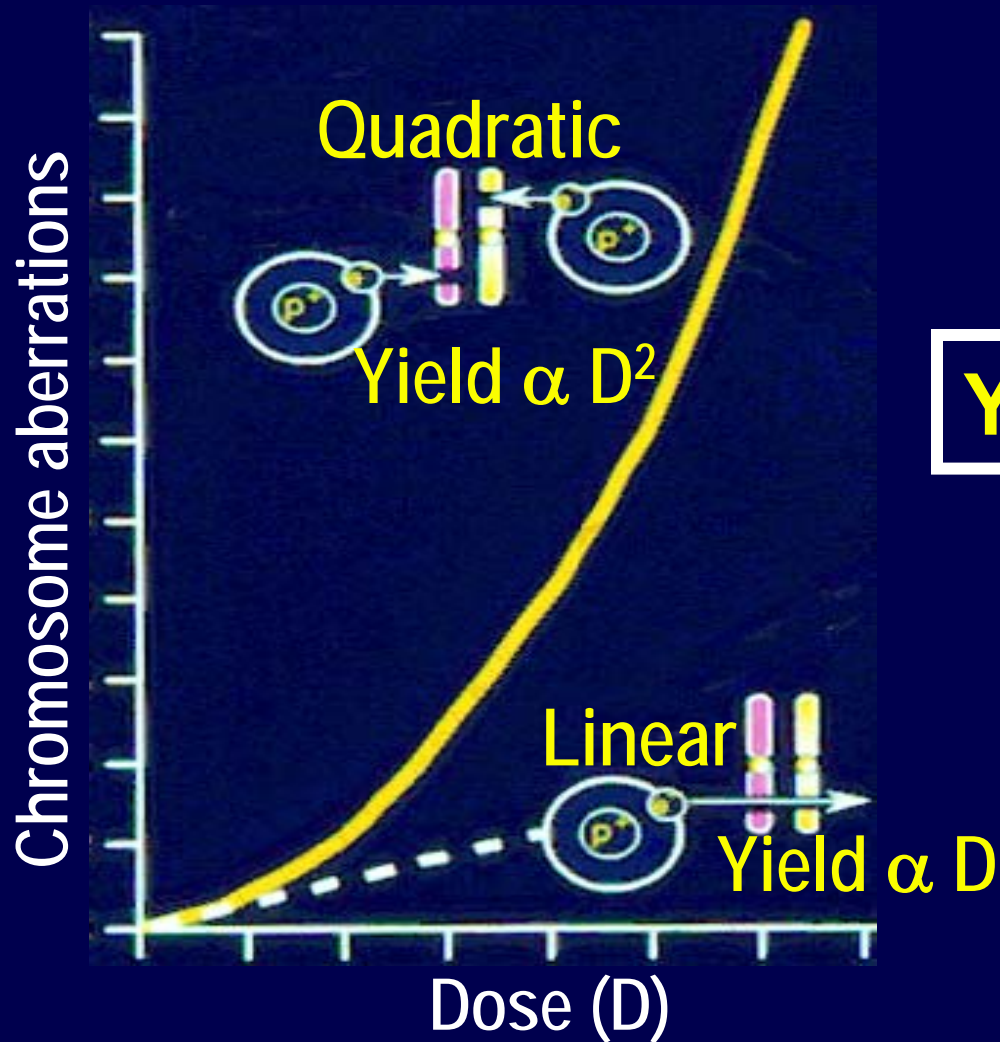

$$\text{Yield} = \alpha D + \beta D^2$$

# Aberration induction in human lymphocytes

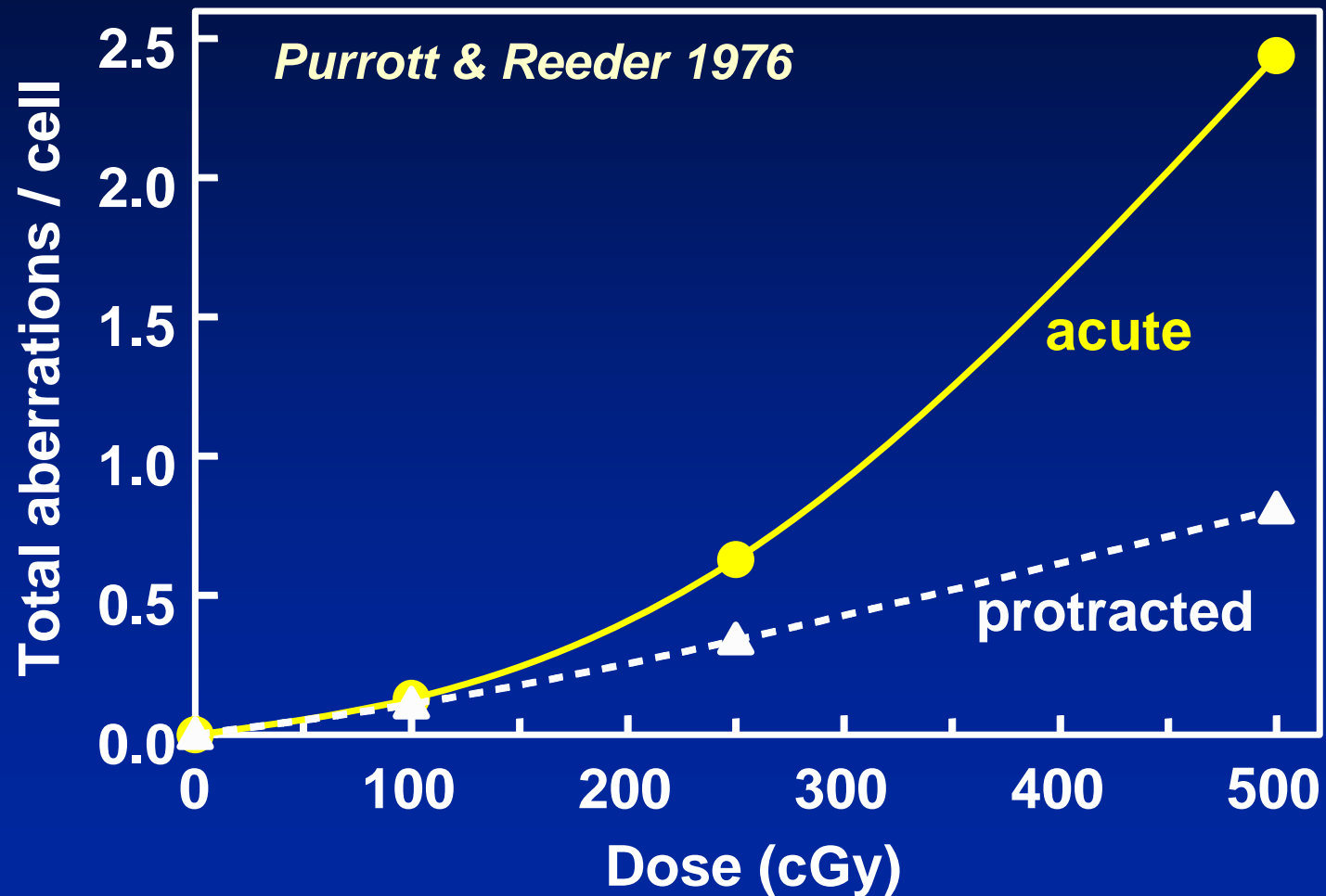

# X-ray induction of myeloid leukemia in CBA/H mice

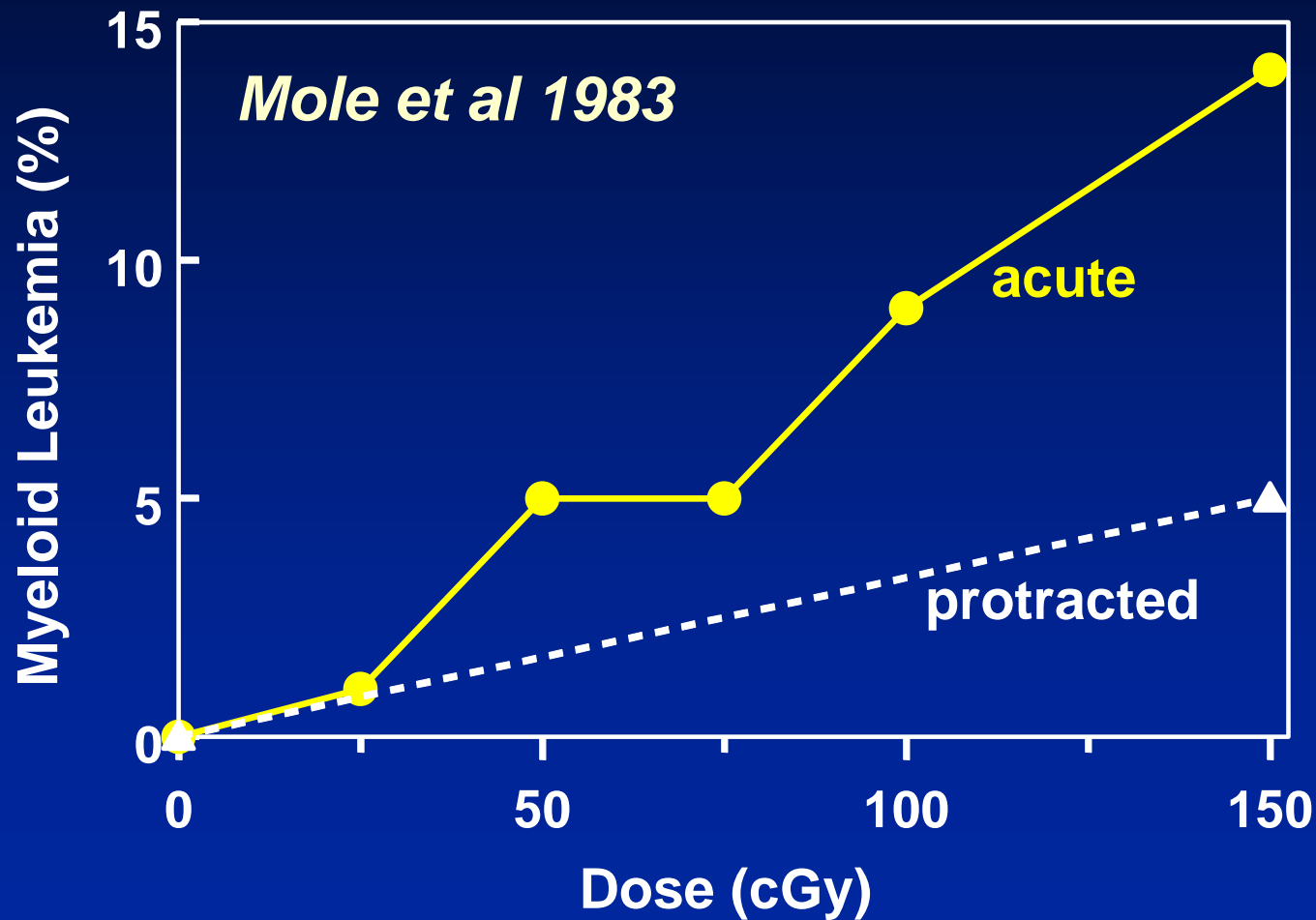



# Excess leukemia in A-bomb survivors (Pierce *et al* 1996)

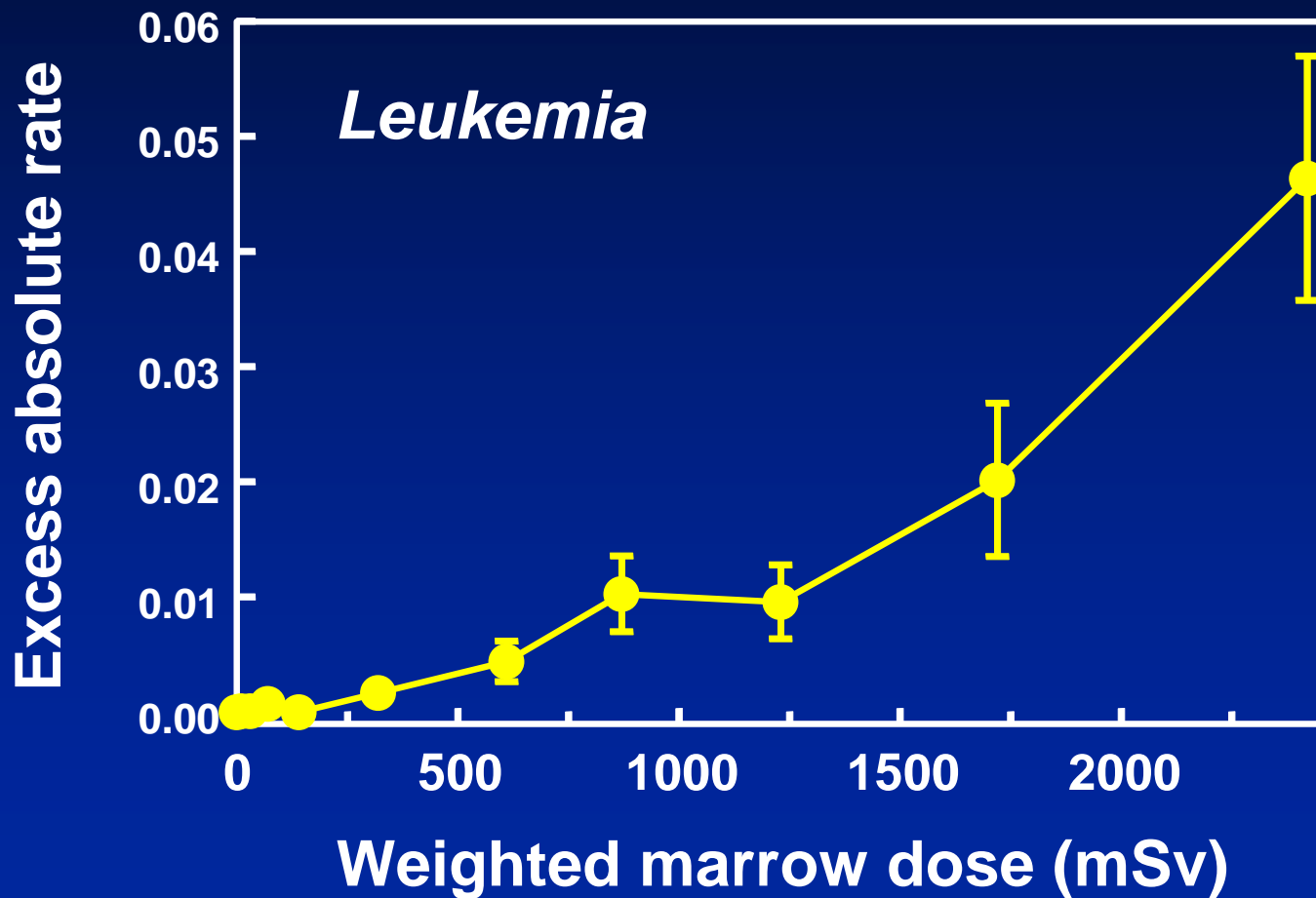



# In-vitro oncogenic transformation (Miller et al 1979)

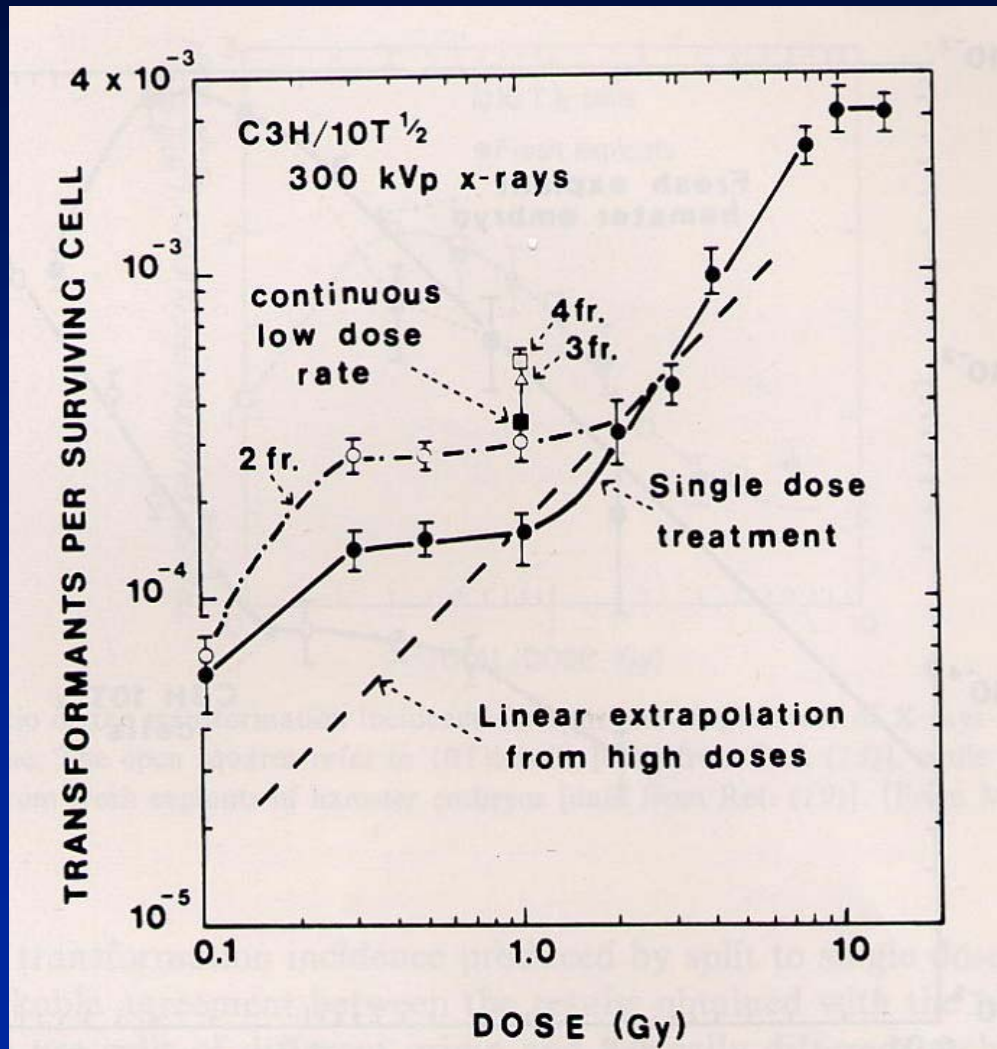

# "Evidence" for downwardly-curving dose-effect relations - Solid cancer incidence at low doses in A-bomb survivors

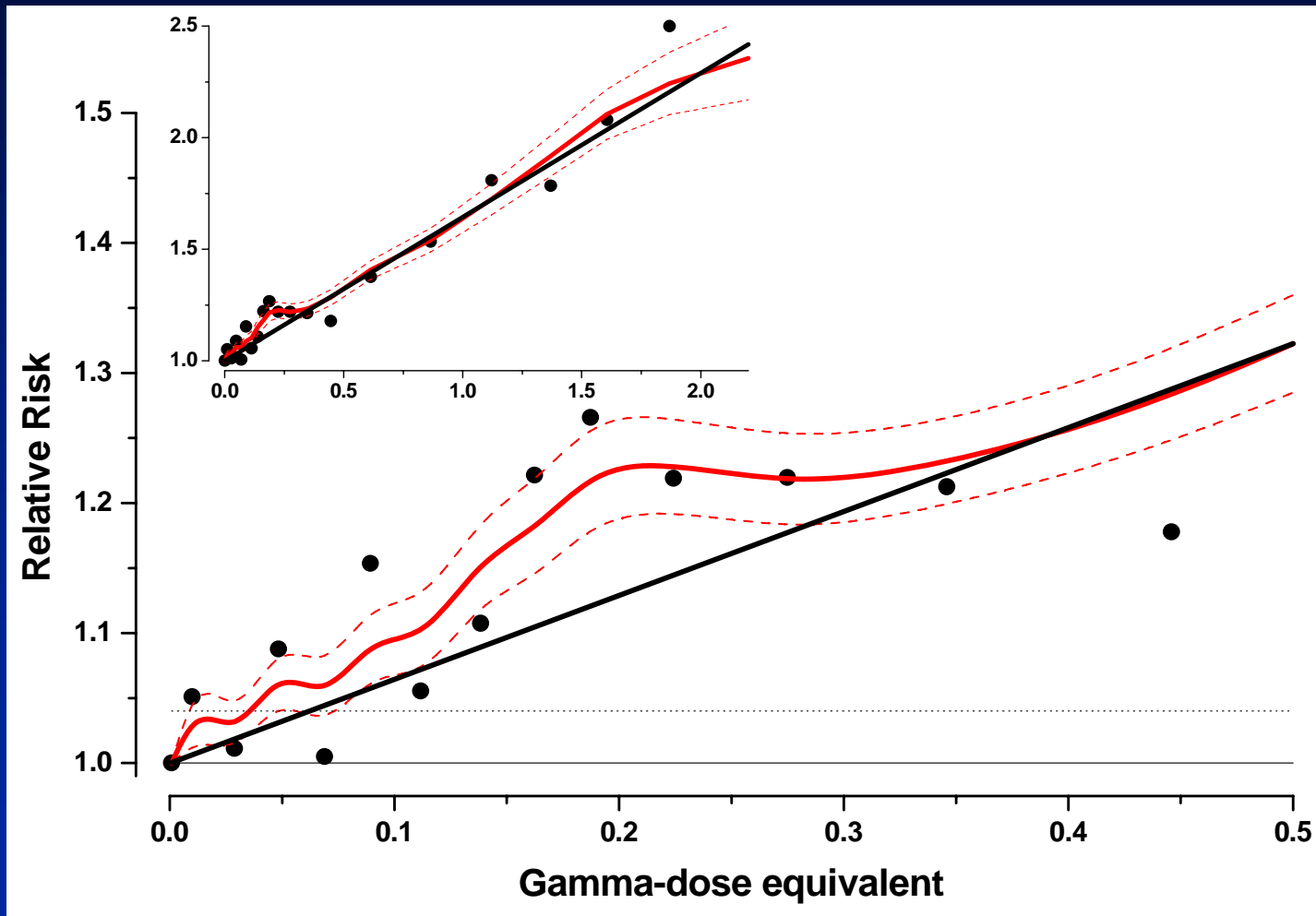

# A scenario for downwardly curving dose responses - a highly radiosensitive subpopulation

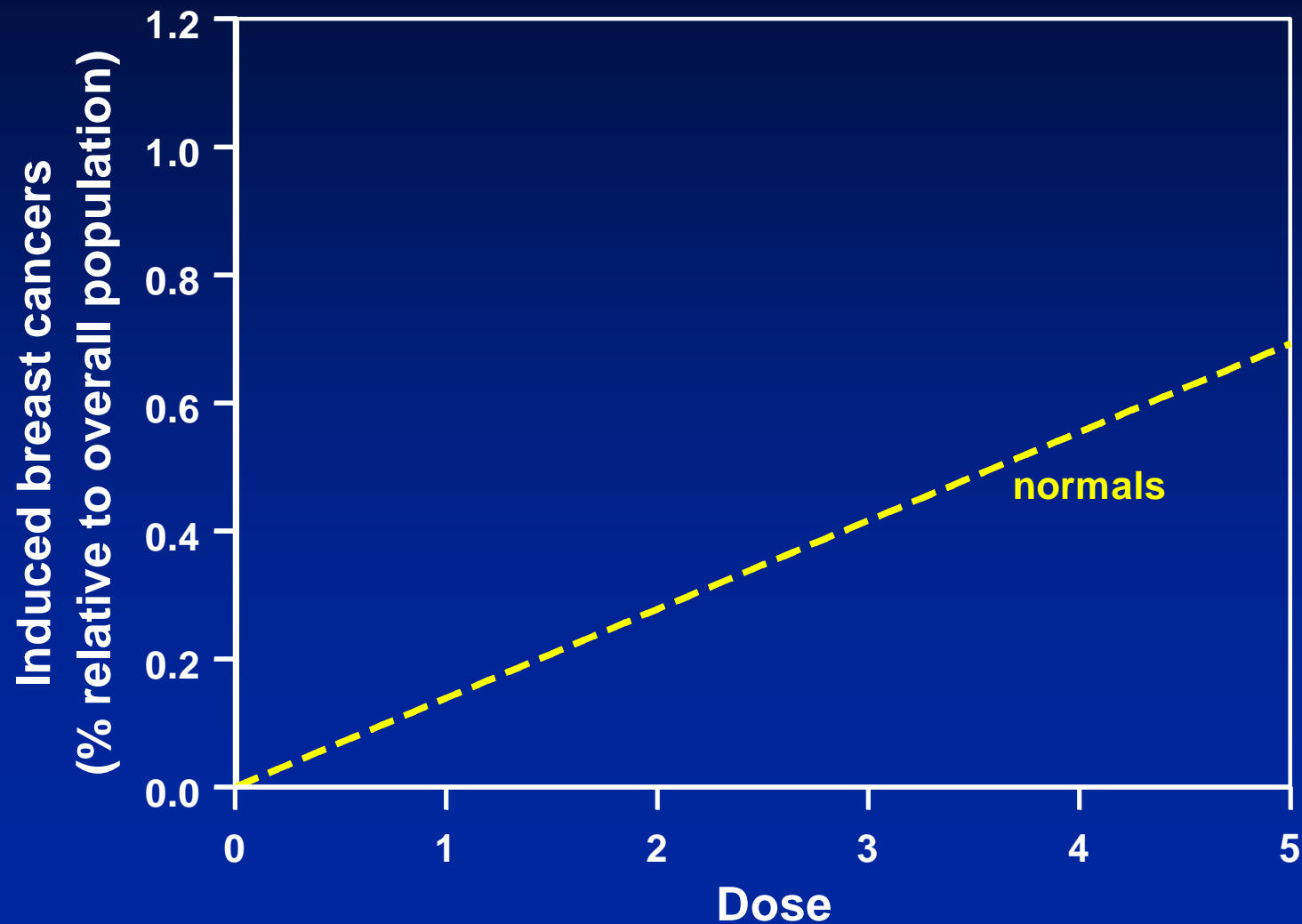

# A scenario for downwardly-curving dose responses - a highly radiosensitive subpopulation

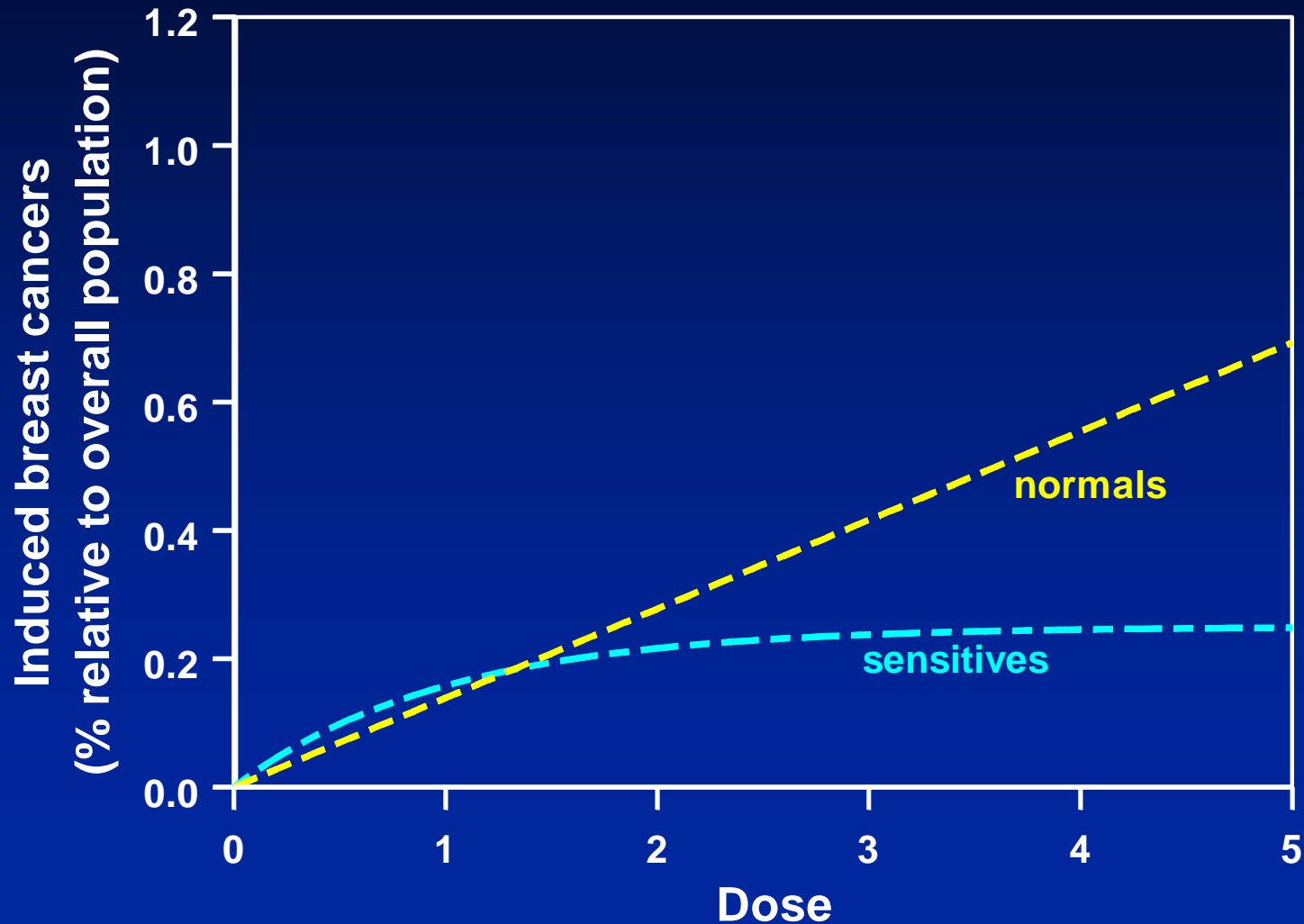

# A scenario for downwardly-curving dose responses - a highly radiosensitive subpopulation

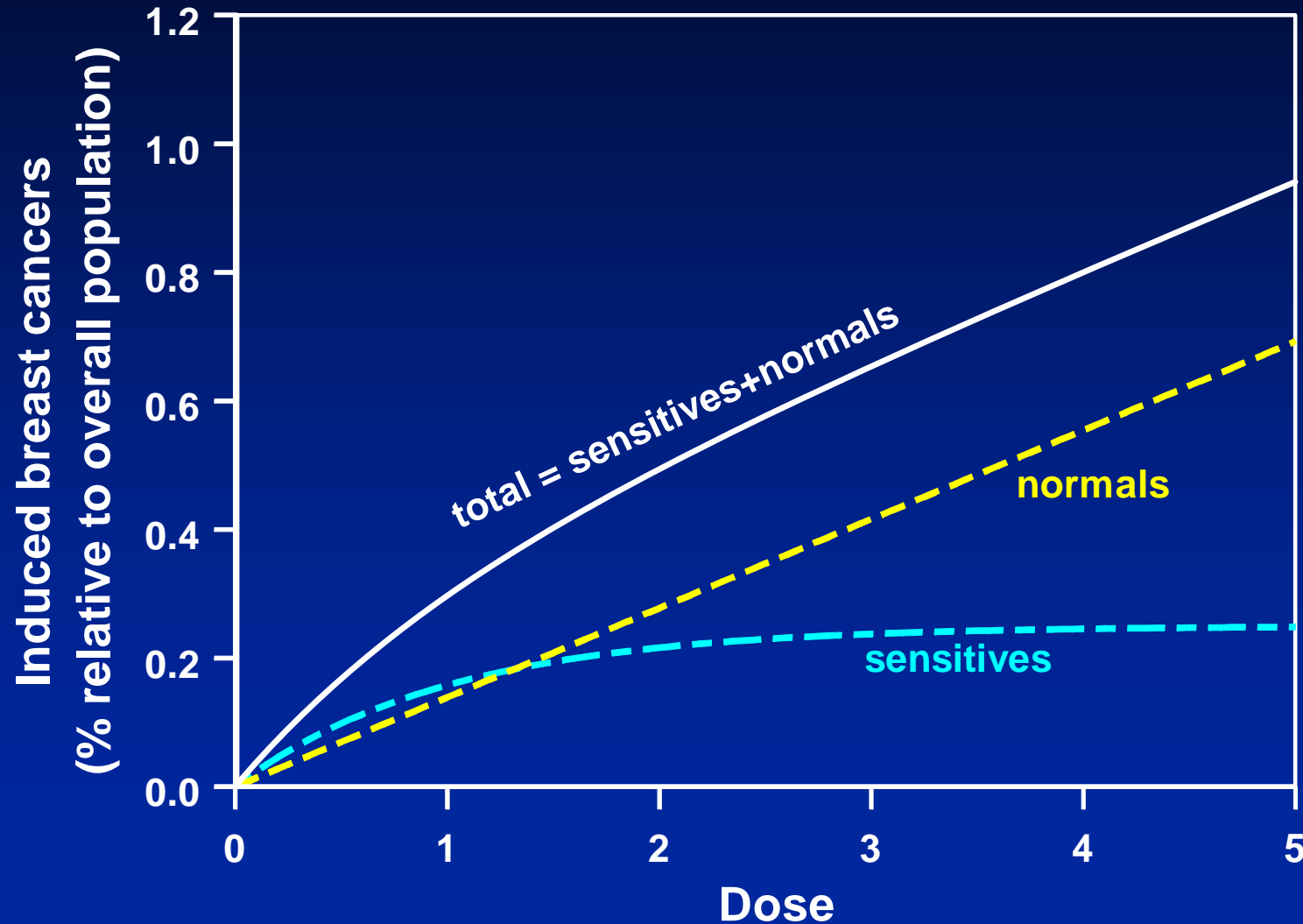

# A scenario for downwardly-curving dose responses - a highly radiosensitive subpopulation

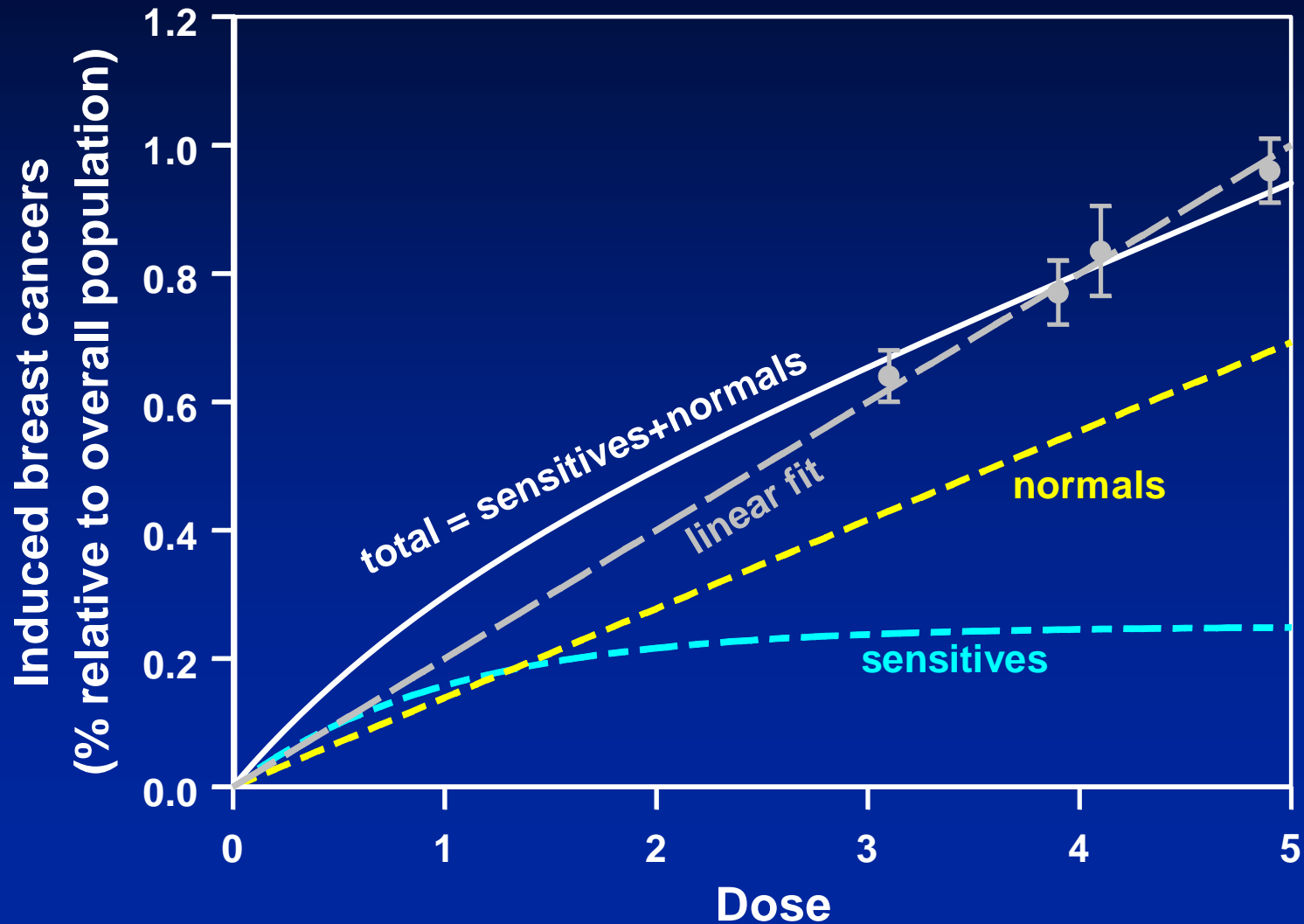



# A scenario for downwardly-curving dose responses – An adaptive response

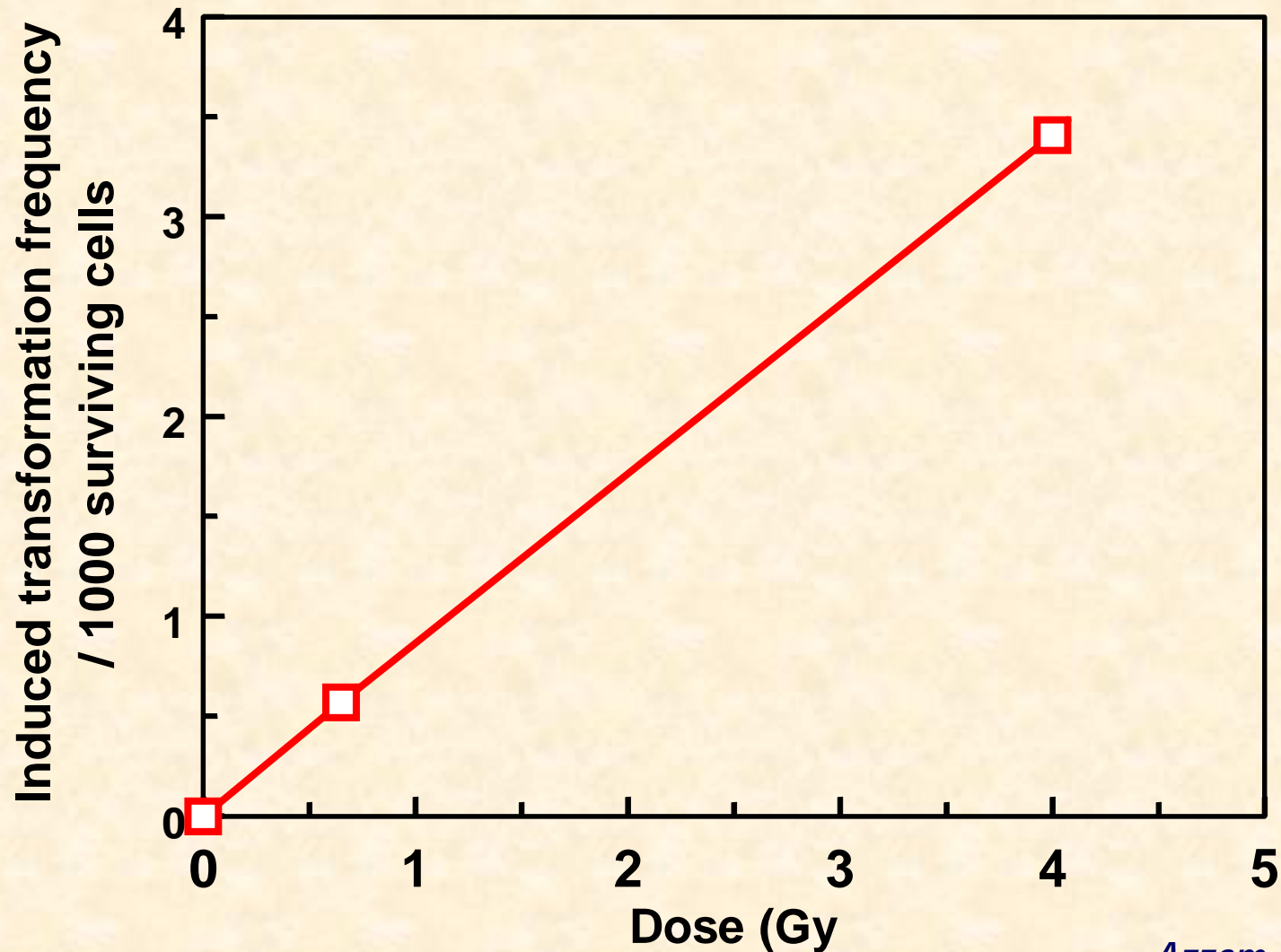

*Azzam et al. 1994*

# A scenario for downwardly-curving dose responses – An adaptive response

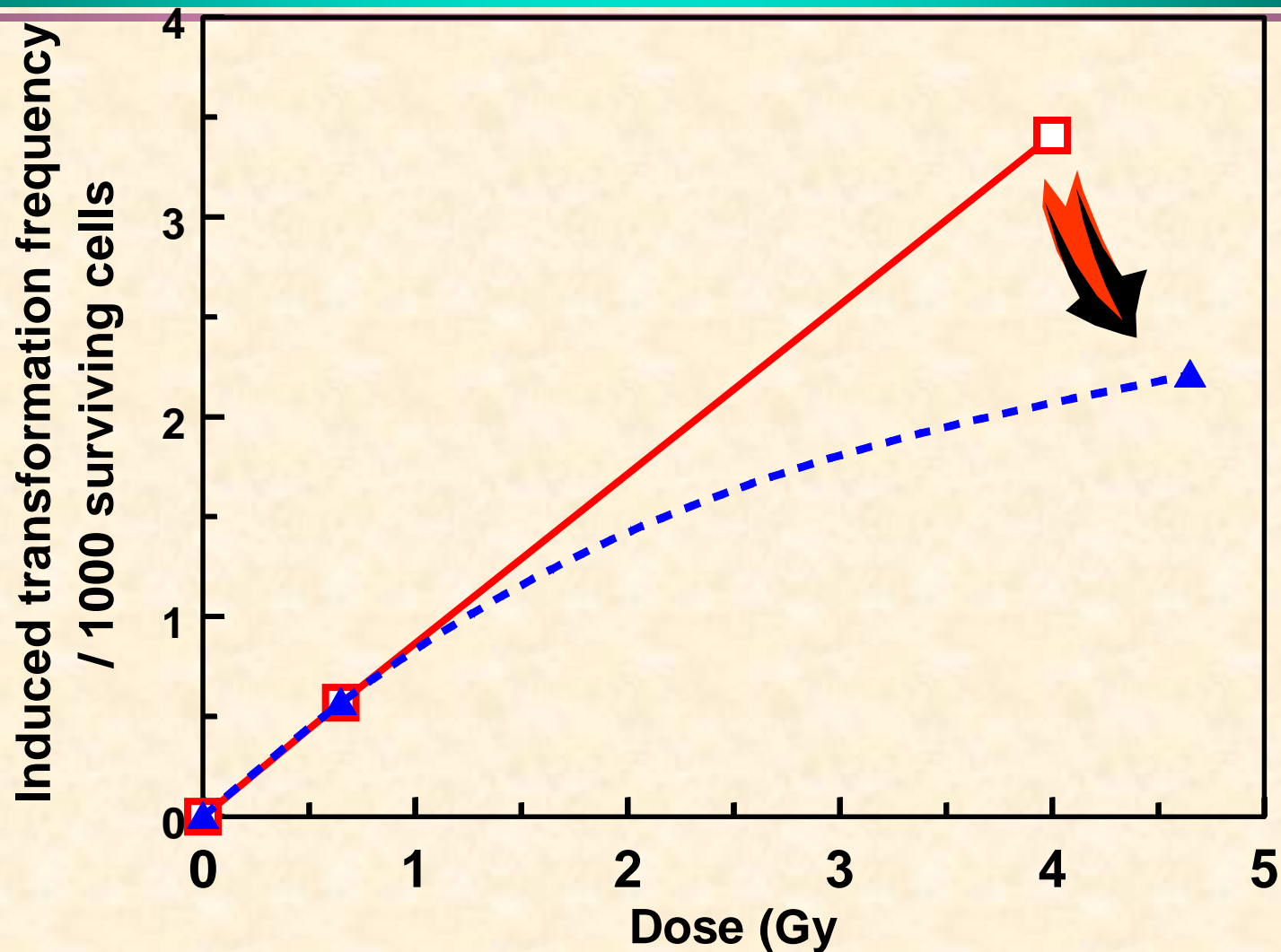

*Azzam et al. 1994*

# A scenario for downwardly-curving dose responses - Bystander Effects

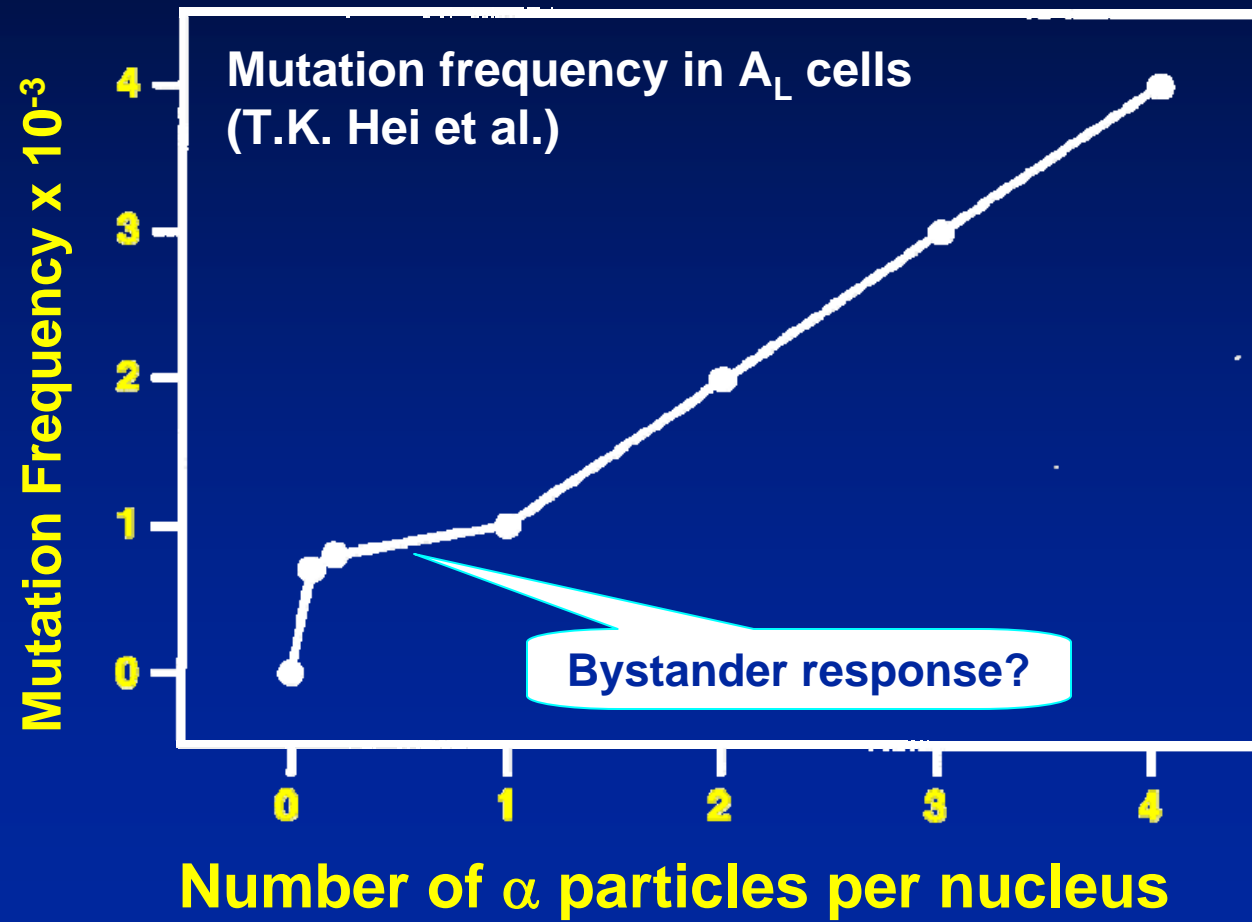

# Different possible low-dose extrapolations

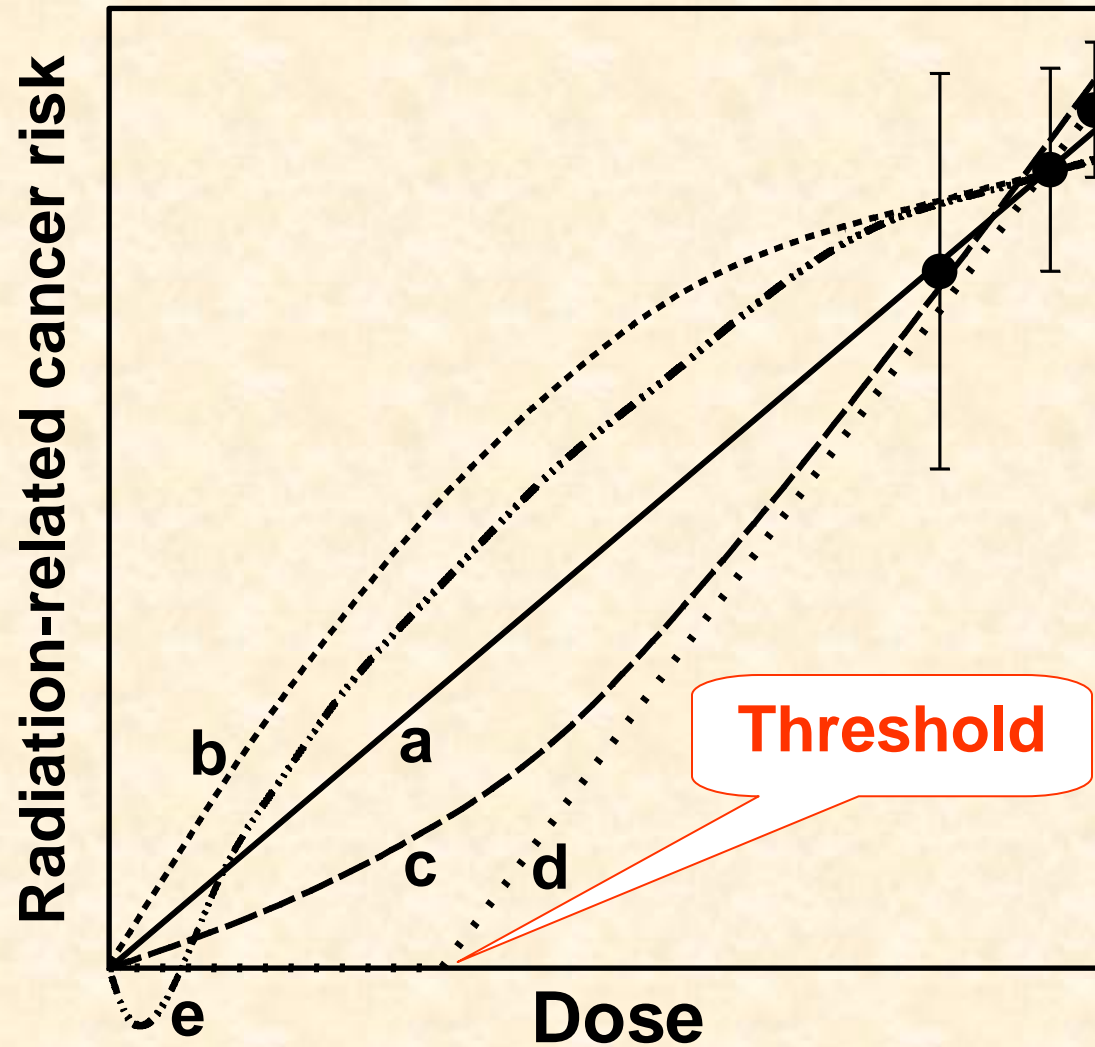

# Thresholds for radiation-induced sarcomas

- **Non-cycling cells need a large dose to stimulate then to cycle**
- **Evidence in animal studies**

# A threshold response - bone sarcomas in beagles

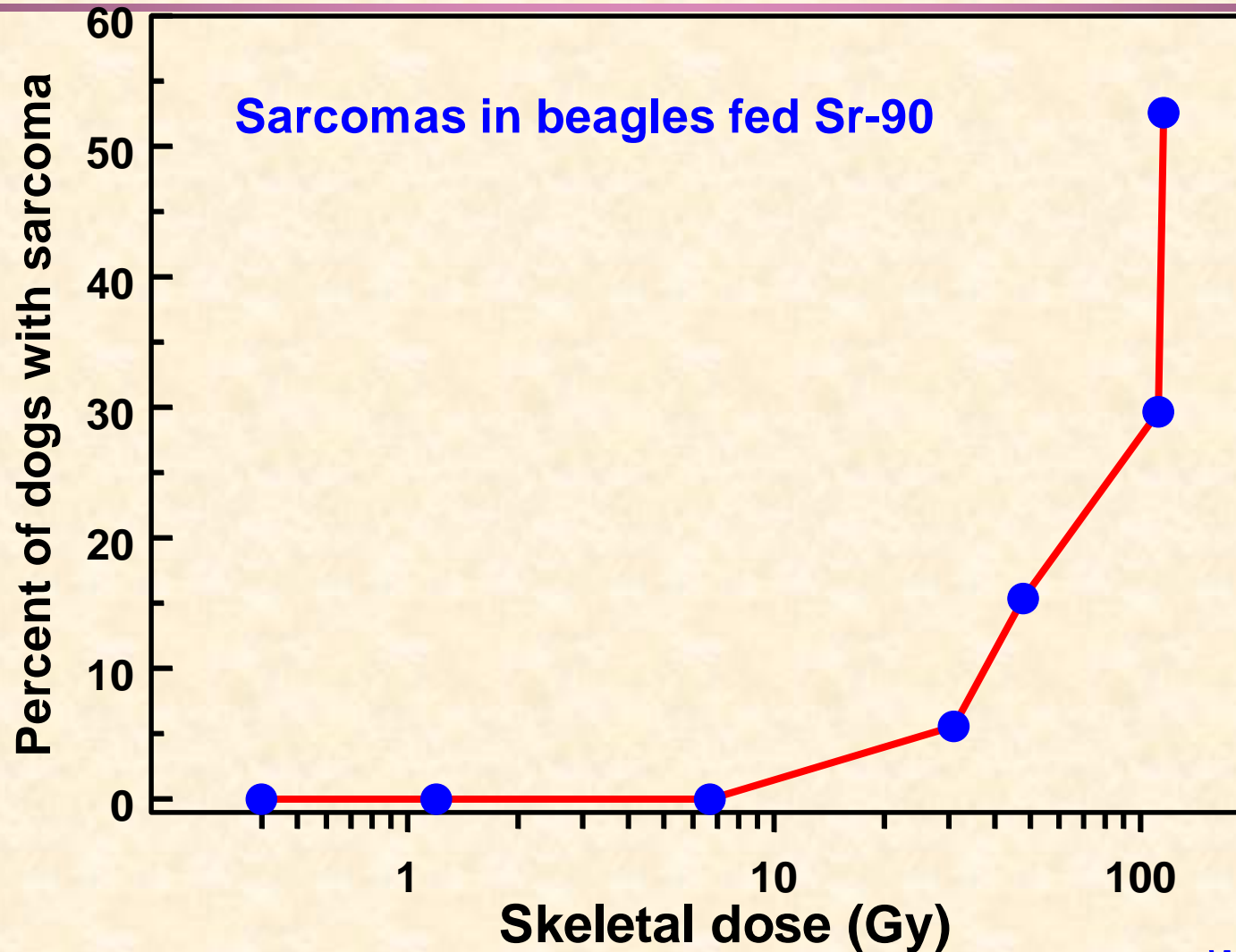

White *et al* 1993

# Thresholds for radiation-induced sarcomas

- **Non-cycling cells need a large dose to stimulate them to cycle**
- Evidence in animal studies
- **Evidence for thresholds in induced sarcomas after RT**
- Evidence in A-bomb survivors
  - » Mean dose 200 mSv
  - » No significance increase in bone cancers
  - » Significant increase in **carcinomas**

# Different possible low-dose extrapolations

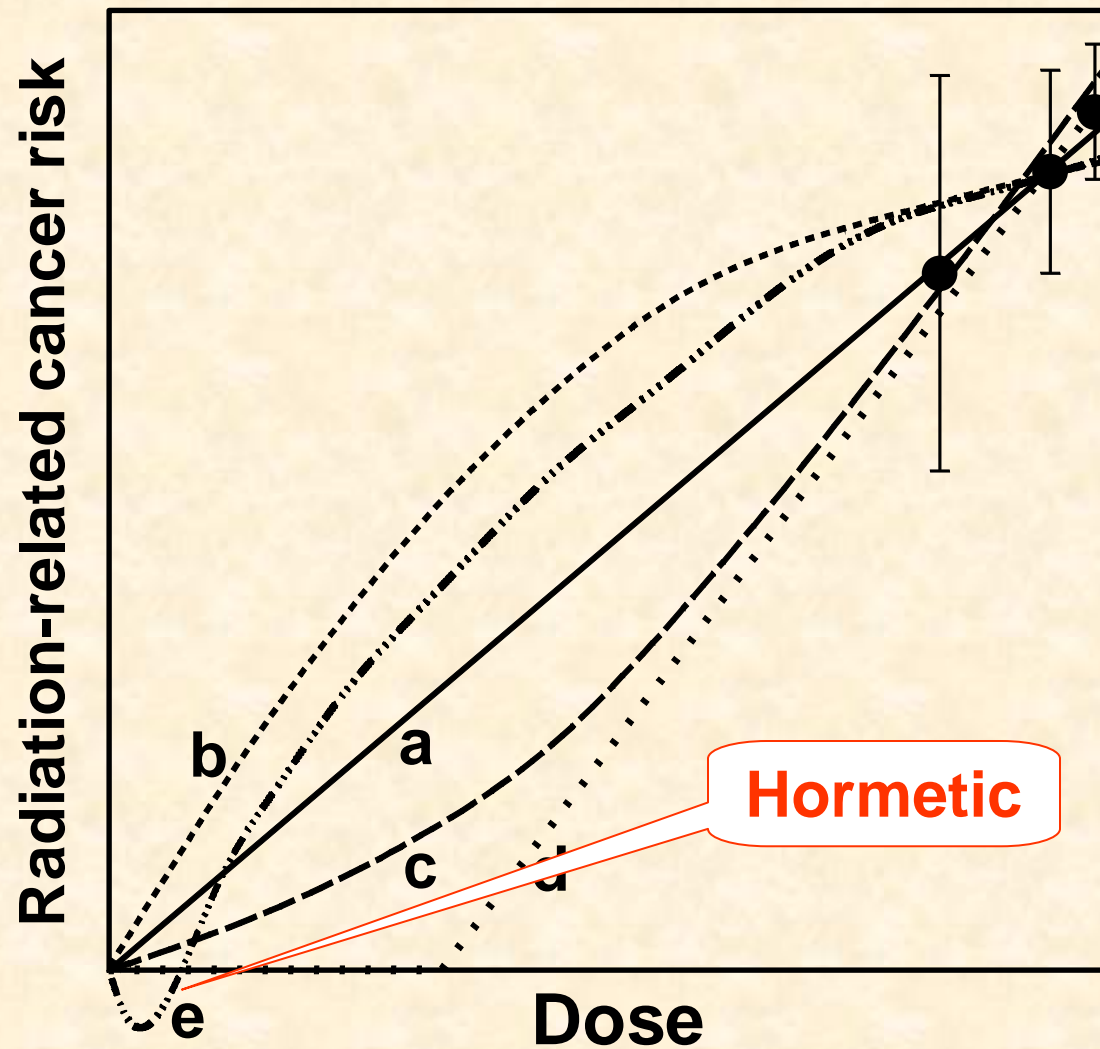



# Hormesis:

## DNA repair vs. immune response

- In those animal experiments in which an increase in lifespan has been observed, the gain has generally **not reflected a reduction in malignant disease**, but rather an **early reduction in mortality from infections** and other non-malignant diseases.
- This suggests that a lifespan increase, if real, is less likely to be associated with a radiation-related stimulation of DNA repair mechanisms, and more likely to be associated with a **radiation-induced enhancement in the immune system**.

# Different possible low-dose extrapolations

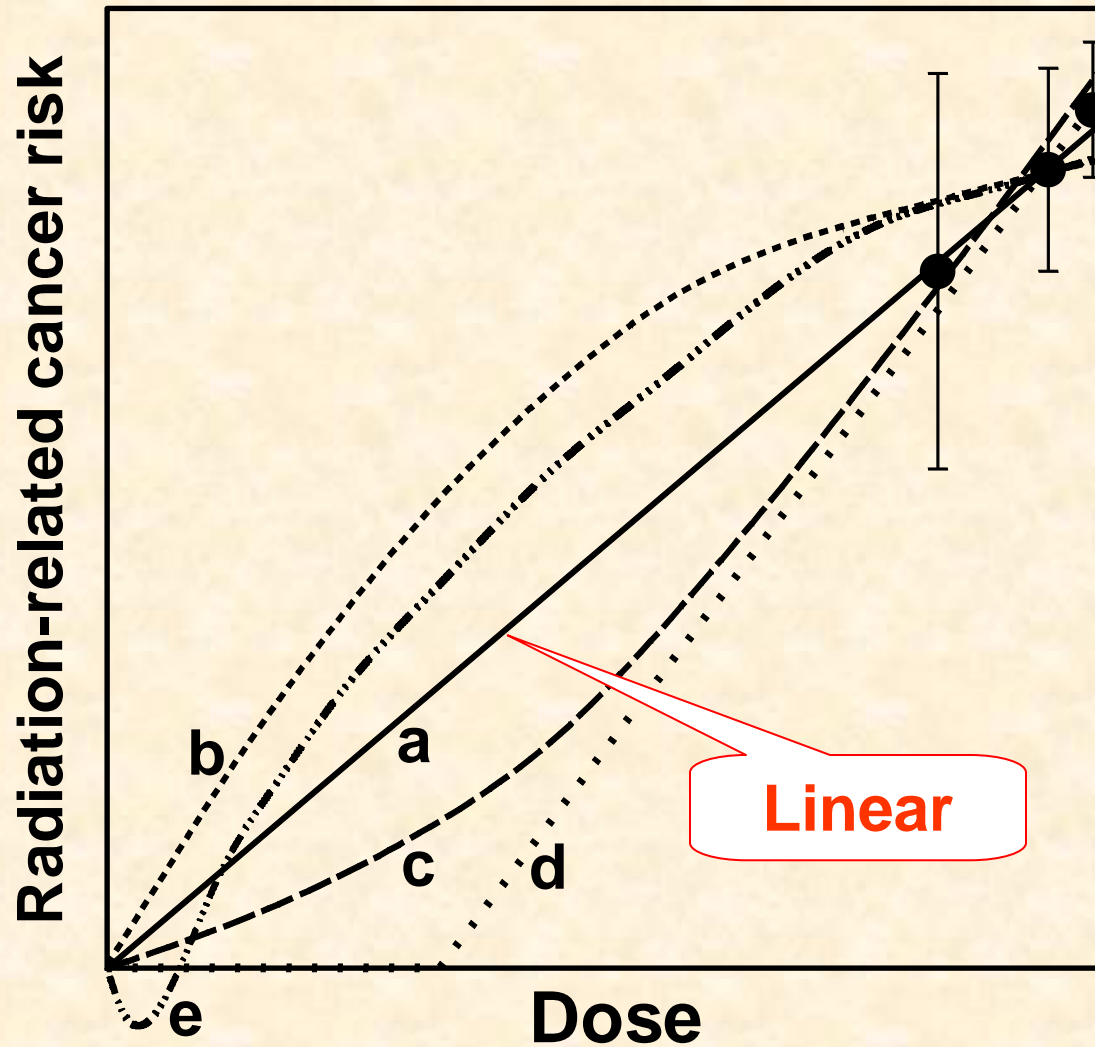

Once we are down to doses corresponding to about 1 electron track per cell, extrapolation to still lower doses becomes a potentially easier task

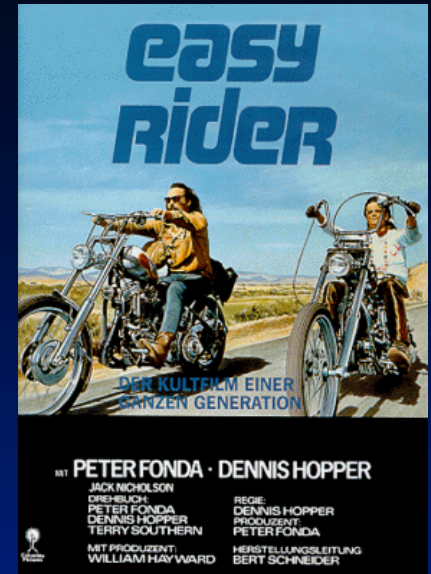

All that happens at still lower doses is that fewer cells feel exactly the same type of damage....

# The Biophysical Argument for Linearity

1. There is direct evidence that a dose of about 6 mGy of diagnostic x rays causes DNA damage and has been convincingly shown to be associated with an increase in human cancer risk.
2. At this dose of diagnostic x rays, most irradiated cell nuclei will be traversed by 1 or at most a few physically-distant electron tracks.

# The Biophysical Argument

(continued)

3. At low doses, decreasing the dose by (say) a factor of 10 will decrease the number of damaged cells by a factor of 10, all hit by essentially a single photon.
4. Given that the energy deposition is the same, one could not expect qualitatively different biological processes to be active at (say) 0.6 mGy that were not active at 6 mGy.
5. The argument suggests that the risk of most radiation-induced endpoints will decrease linearly, without threshold, from ~6 mGy down to arbitrarily low doses.

# The effect of cellular communication on the biophysical argument

The biophysical argument refers to the development of monoclonal tumors by autonomous (independently developing) cells

Perhaps the carcinogenic process is counteracted by effective defense mechanisms in the cell, tissue, and the organism?

# The effect of inter-cellular communication on the biophysical argument

- If the interactions are between unirradiated tissue and radiation-damaged cells, the argument for linearity remains valid.
- The argument would potentially not hold if other irradiated cells could significantly change the probability that a radiation-damaged cell develops into a cancer, in a way which is non-linear with dose.
- But it would still then remain to be quantitated whether linearity was underestimating or overestimating low-dose cancer risks

# Quantitation of inter-cellular communication effects: Bystander Responses

- Where inter-cellular communication effects have been quantitated, “bystander” effects have shown saturation at low doses.

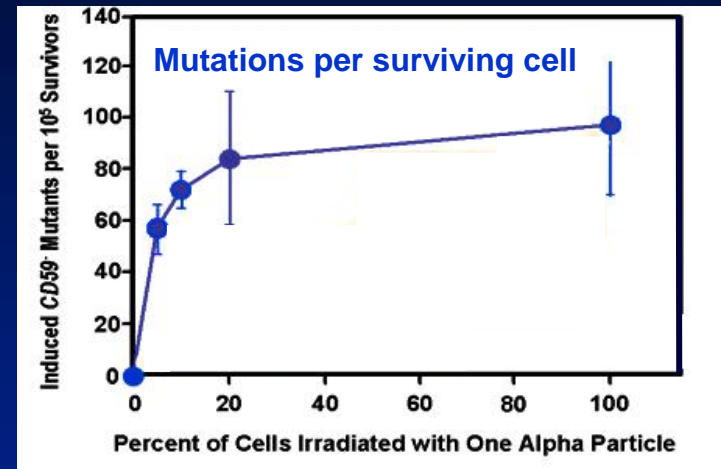

- One interpretation is that the first hit to any cell in an interacting community of cells could be more damaging than subsequent hits to other cells in the community.
- In such a case, extrapolating linearly from low to very low doses could underestimate the risk at very low doses.



What we know of the effect inter-cellular communication suggests that it might modify the dose-response upwards at low doses

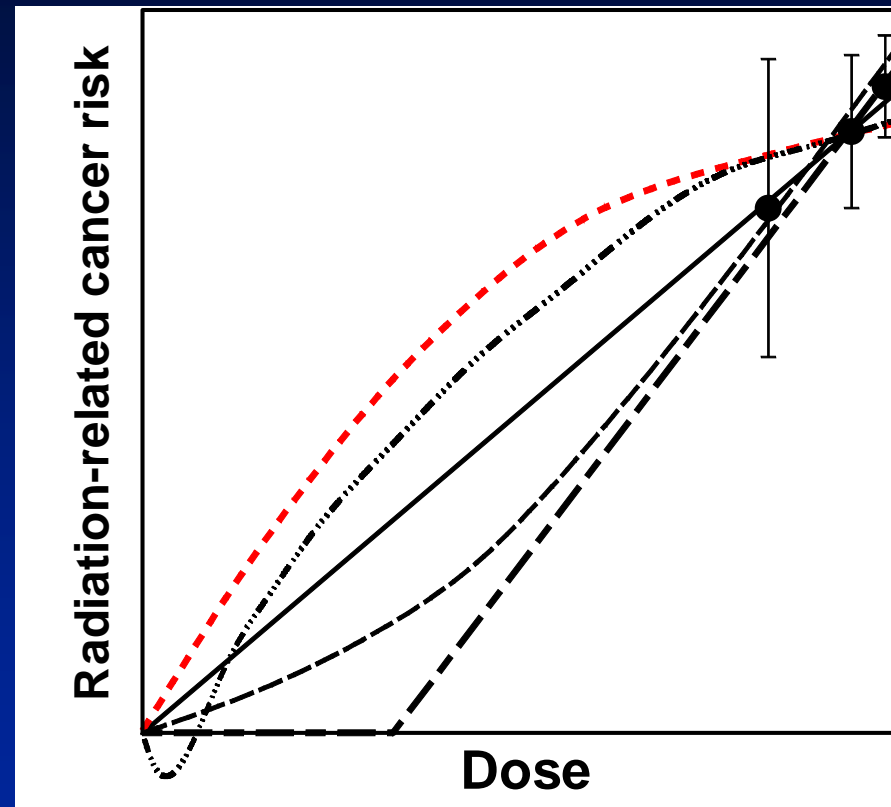

....but we don't know a lot, quantitatively

# Dose Rate Effects

Shape of the  
acute dose-response curve  
at low doses

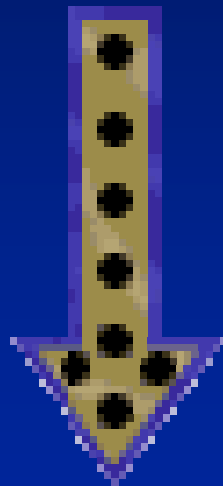

Dose rate effects

# Splitting the Dose into Fractions

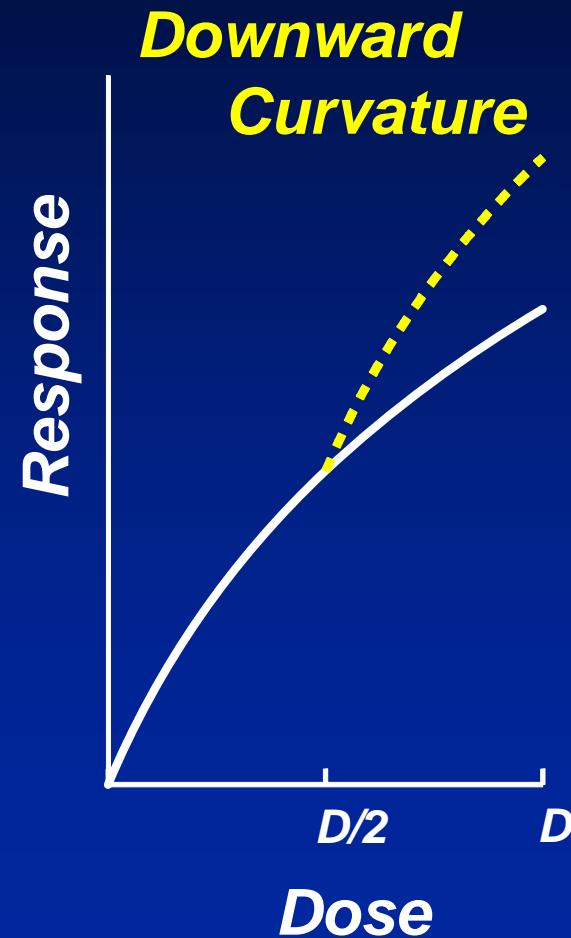
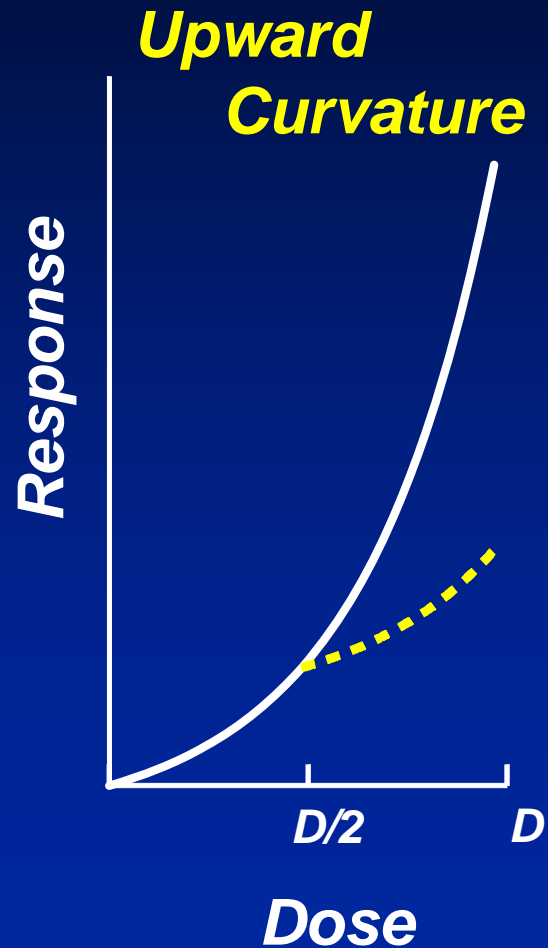

1 DSB  $\rightarrow$  linear

2 independent DSB  $\rightarrow$  quadratic

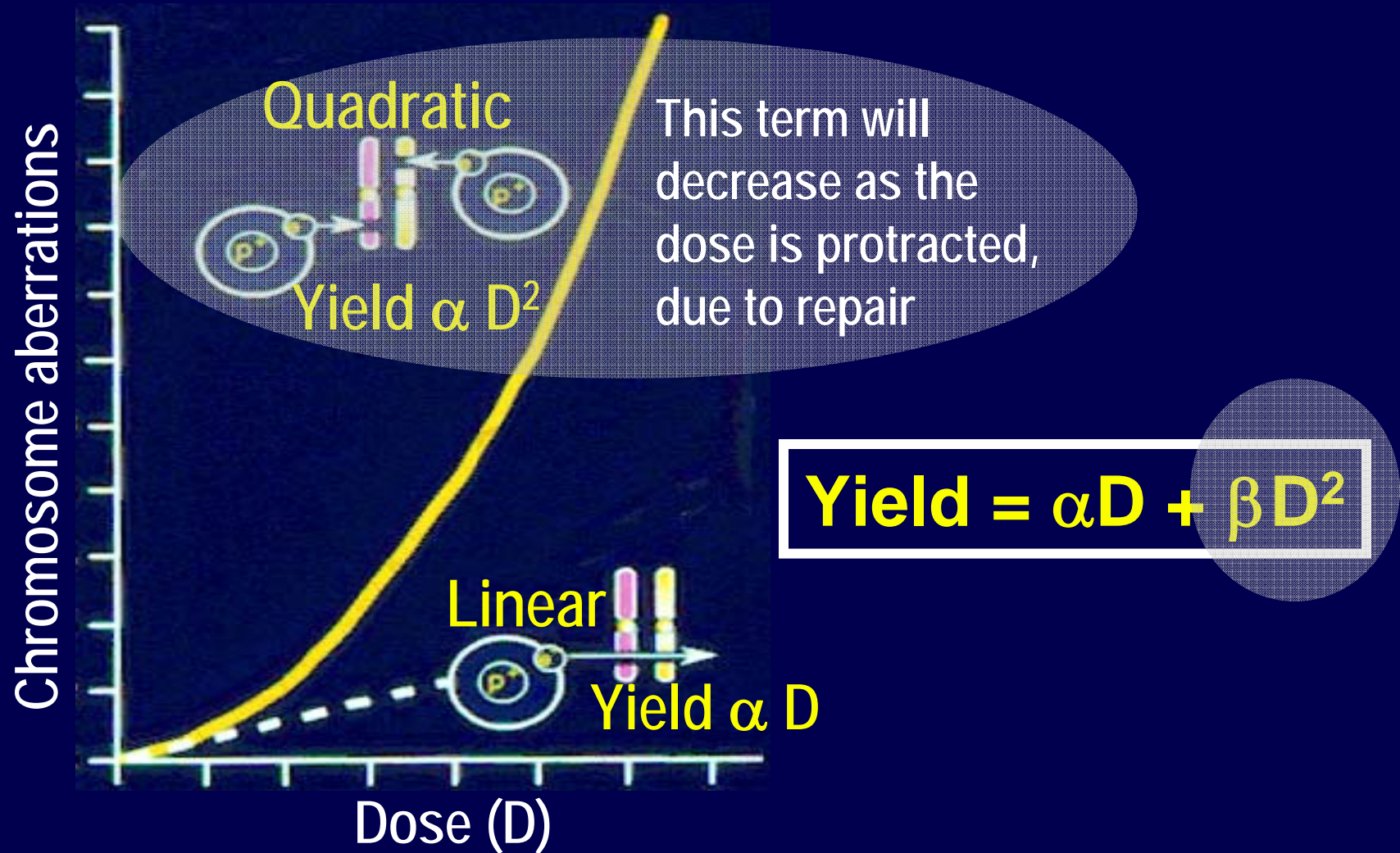

# The standard linear-quadratic model (LQ)

$$\text{Yield} = \alpha D + G \beta D^2$$

*for continuous exposure...*

$$G = 2(\tau/T)^2 [(T/\tau) - 1 + \exp(-T/\tau)]$$

T: time of exposure,

$\tau$ , characteristic repair time

- For very short exposures,  $G=1$
- For very long exposures,  $G=0$

# Aberration induction in human lymphocytes 10 cGy/h vs 400 cGy/h

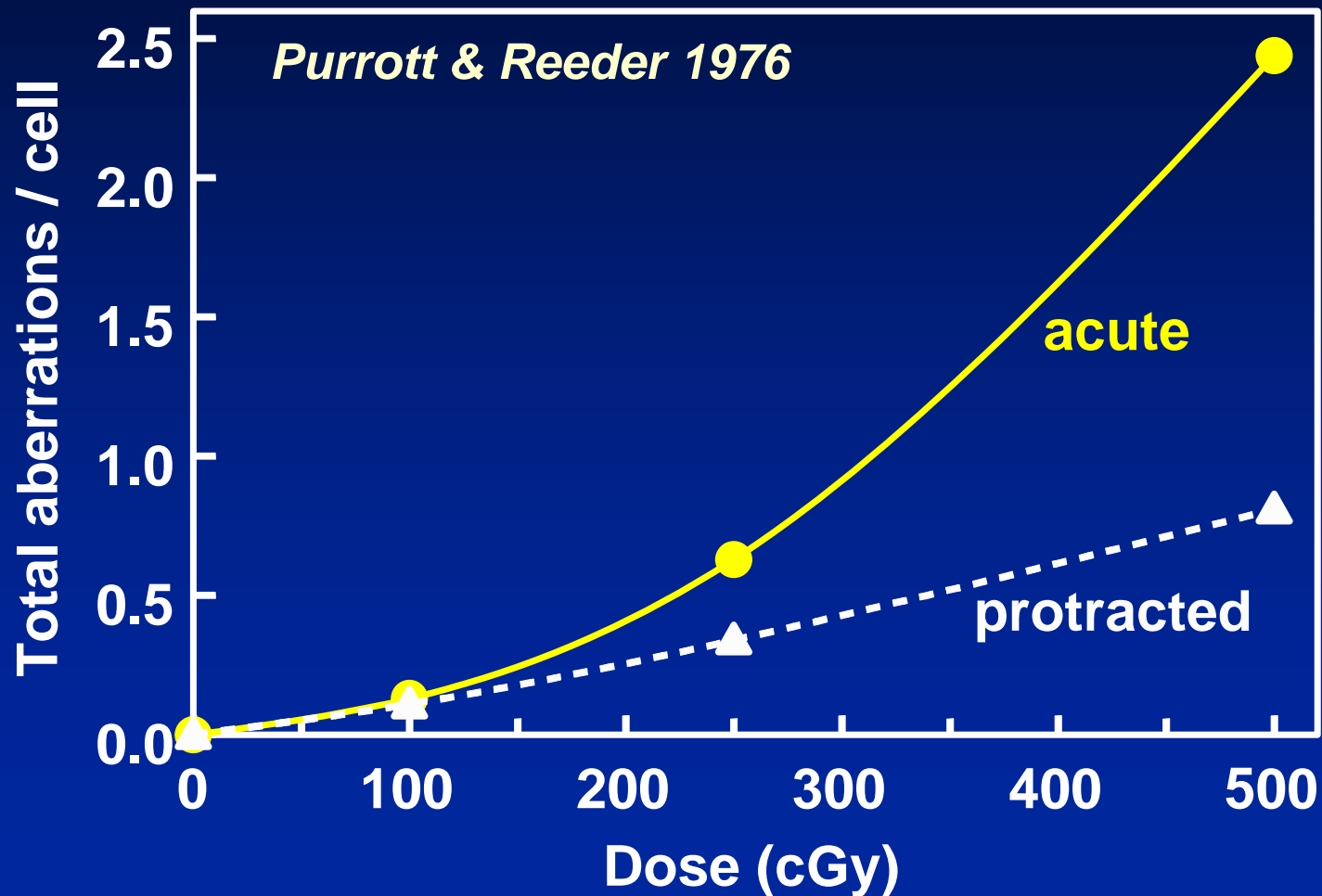

# X-ray induction of myeloid leukemia in CBA/H mice

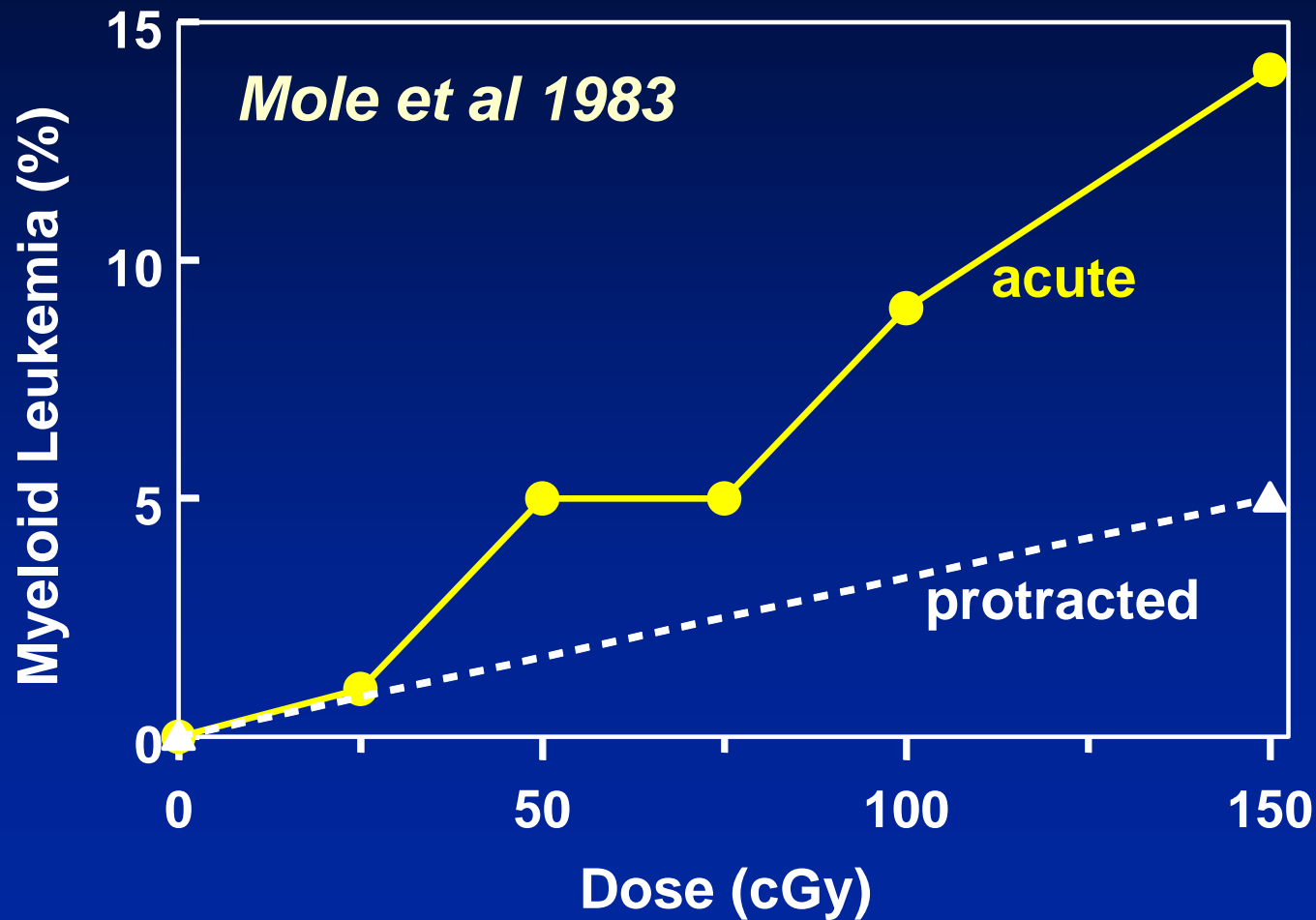

# Dose rate effects for cell killing in normal human cells

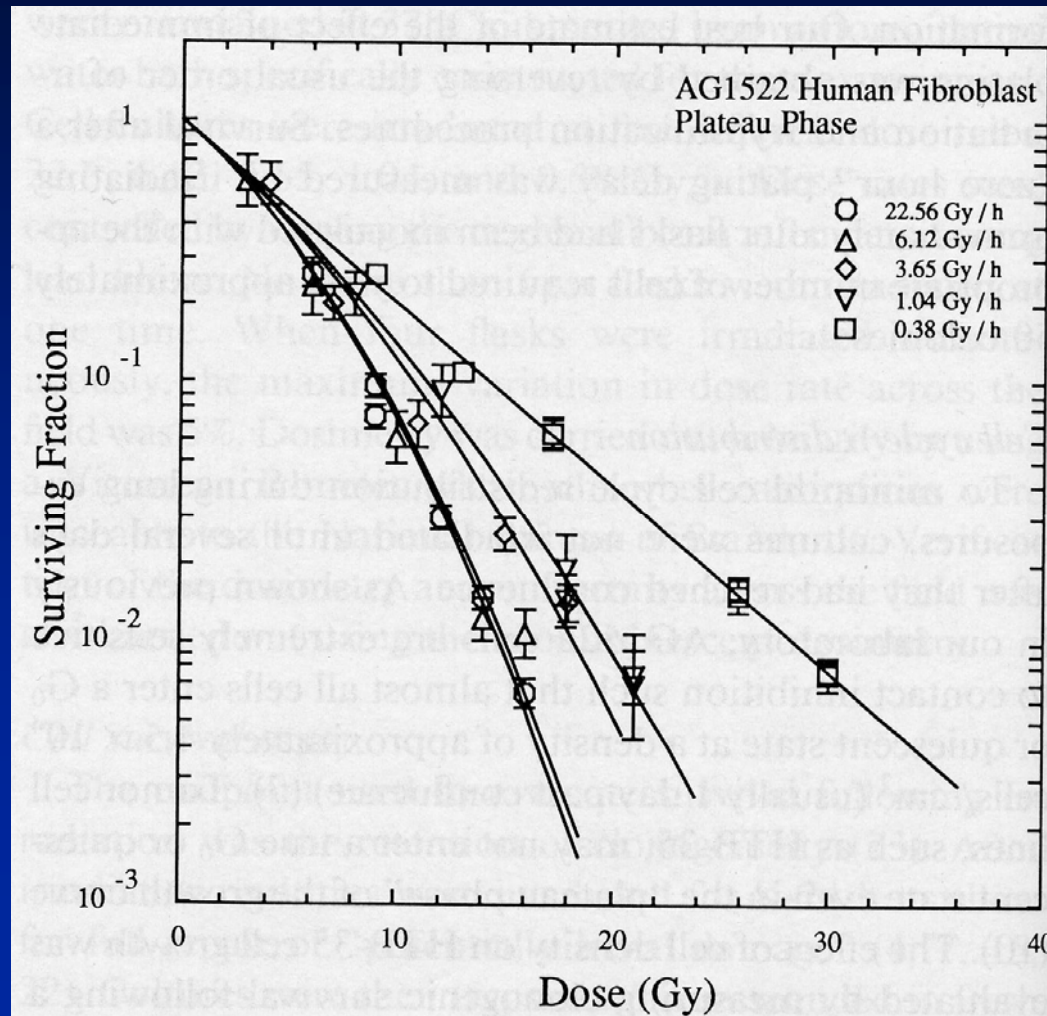

**Amdur &  
Bedford 1994**



# Excess leukemia in A-bomb survivors (Pierce *et al* 1996)

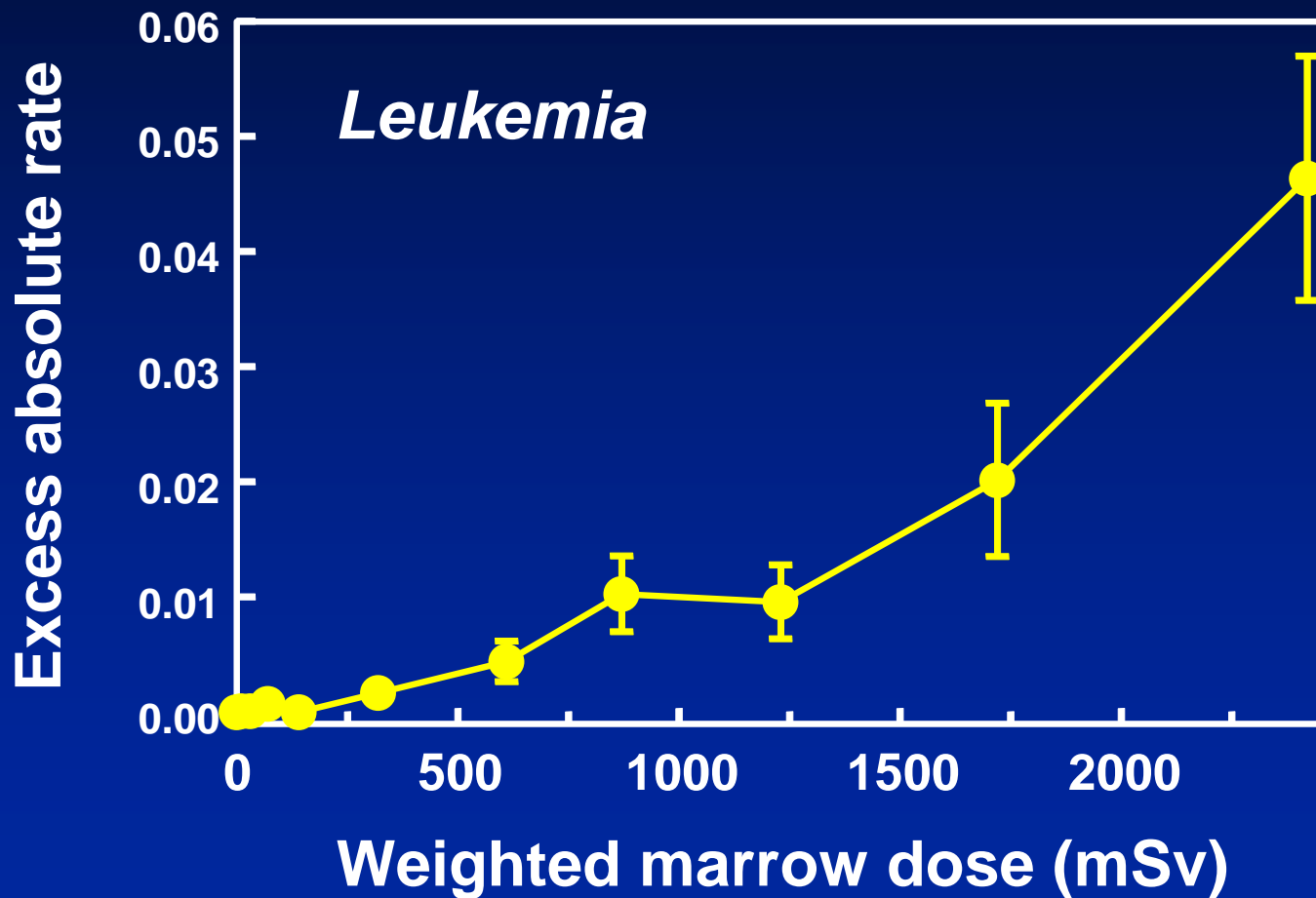

# Mammary tumors induced in BALB/c mice by low doses of $\gamma$ rays and neutrons at high and low dose rates

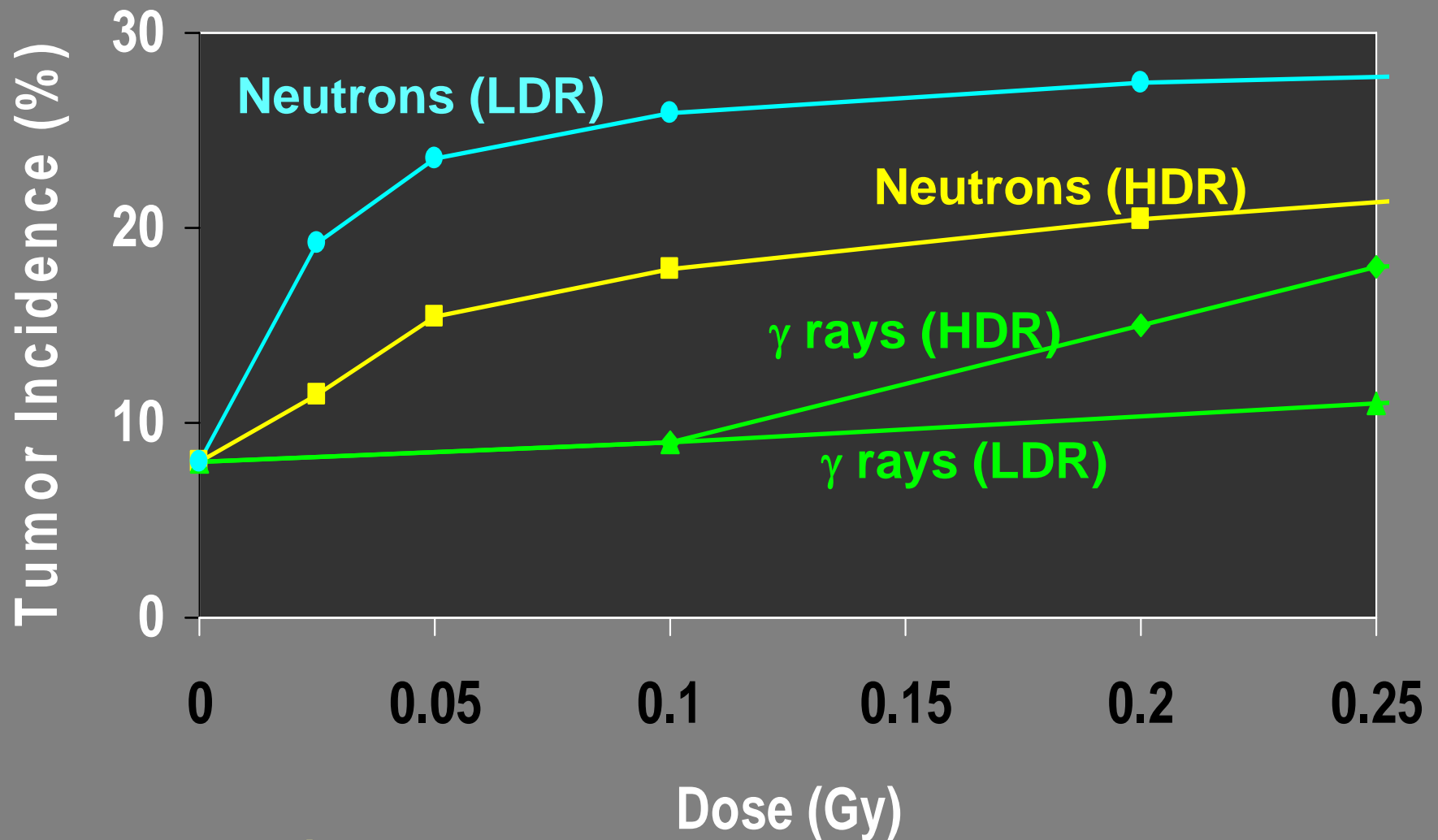

Courtesy R.L. Ullrich

# The inverse dose-rate effect

For a given dose of **densely-ionizing** radiation, lowering the dose rate increases the cancer risk

# Inverse Dose Rate Effect

- If target cell(s) are hit by one or zero alpha particles, there will not be any dose-rate effect of any kind
- So the inverse dose rate effect must decrease as the exposure decreases

# Excess relative risk in uranium miners as a function of *exposure time* and *exposure*.

Red lines: Fit with extended 4 parameter BaD model

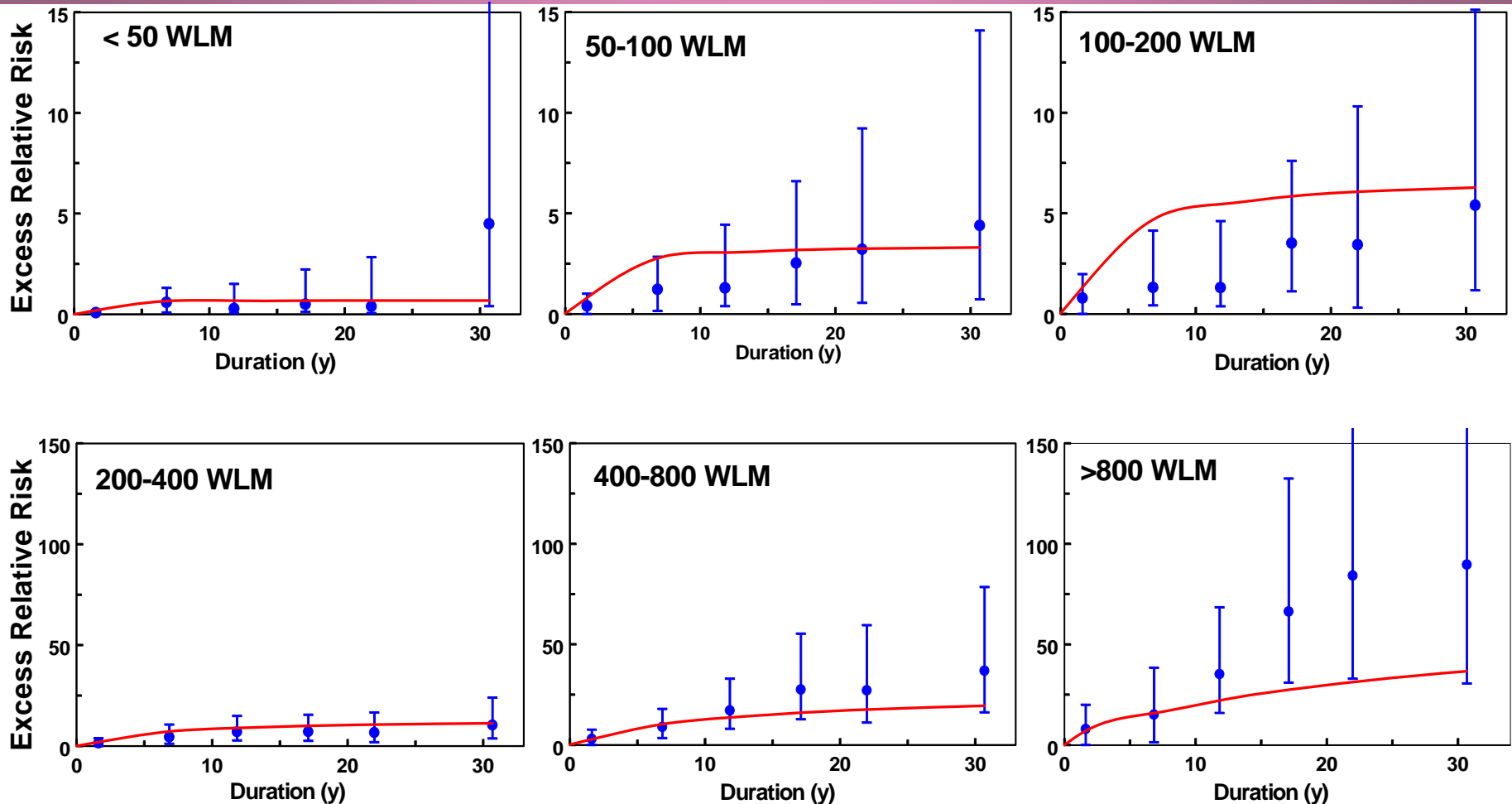

Data: Lubin et al 1995  
Model: Brenner and Sachs 2003

# Relative Biological Effectiveness

**RBE =**

**Dose for given probability of effect  
by reference radiation**

---

**Dose for given probability of effect  
by test radiation**

# Relevance of RBE

- Radon
- Mammography
- Neutrons
- I-131

# RBE is typically dose dependent

Photons have curved dose-response relations, while those for more densely-ionizing radiations are straighter

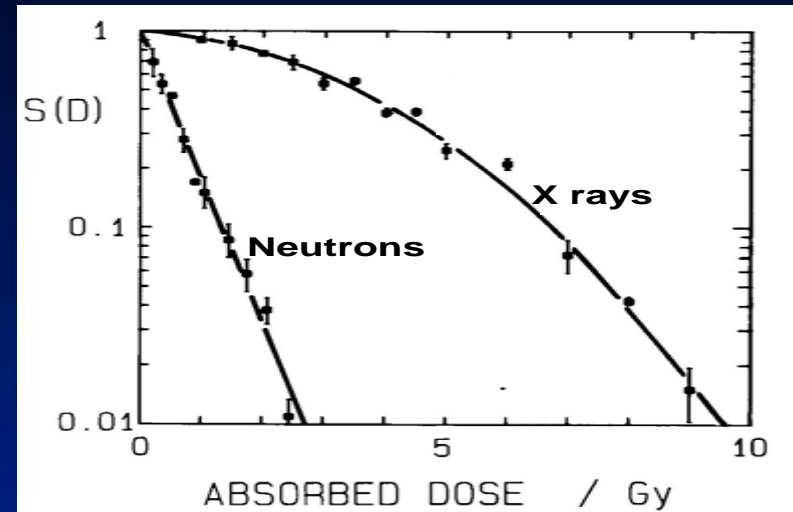

It follows that high-LET RBEs are generally dose dependent, with a constant maximal value ( $RBE_M$ ) at low doses

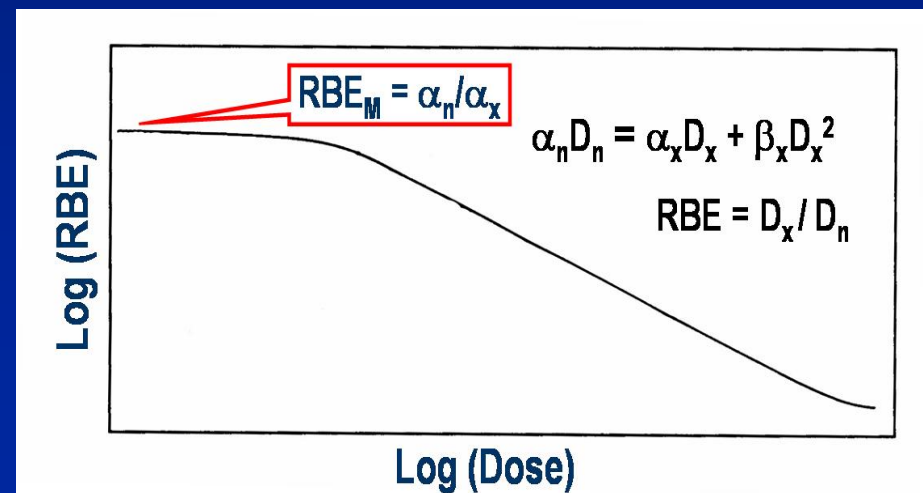



# Rat mammary carcinogenesis, neutrons vs photons

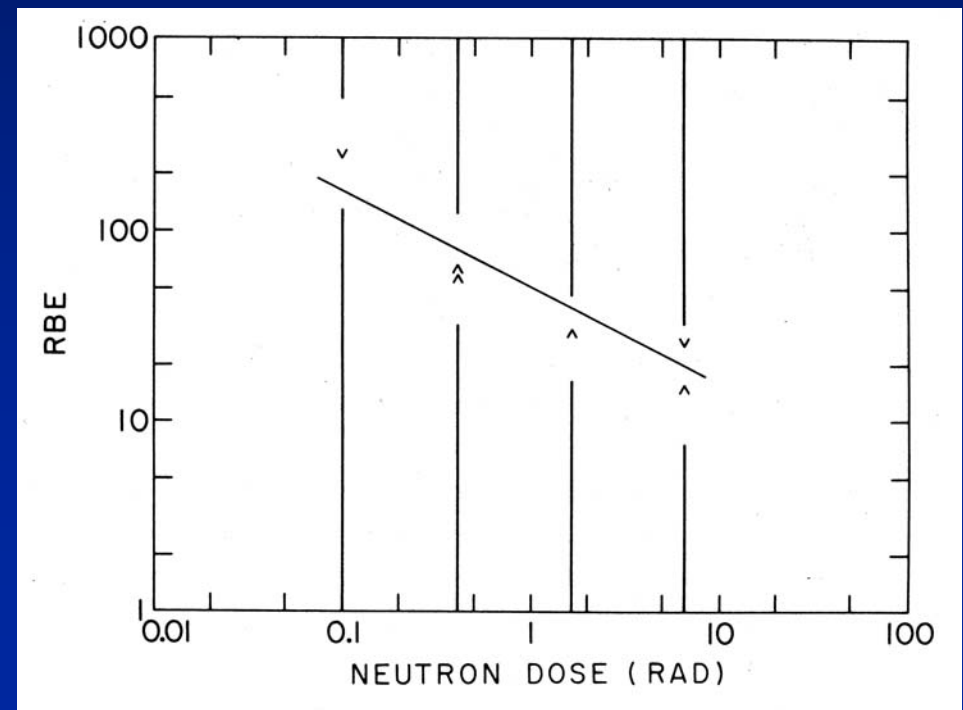
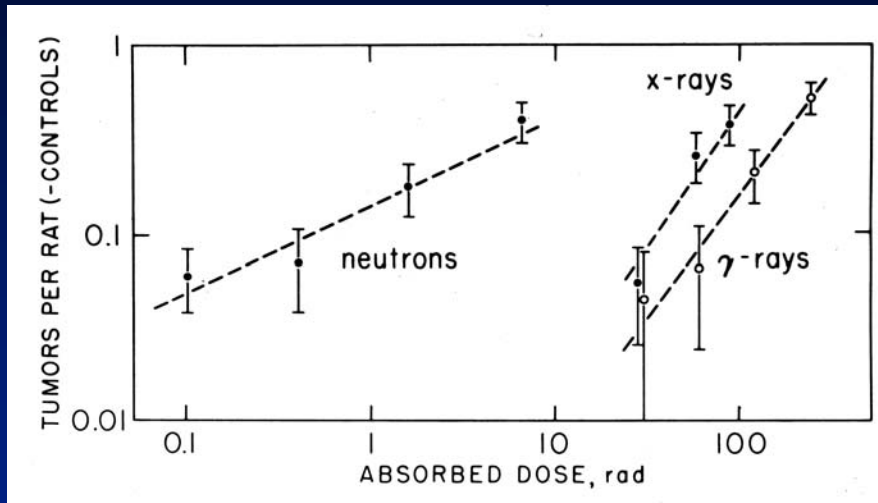

Data from Shellabarger et al 1973

# A neutron walks into a bar...

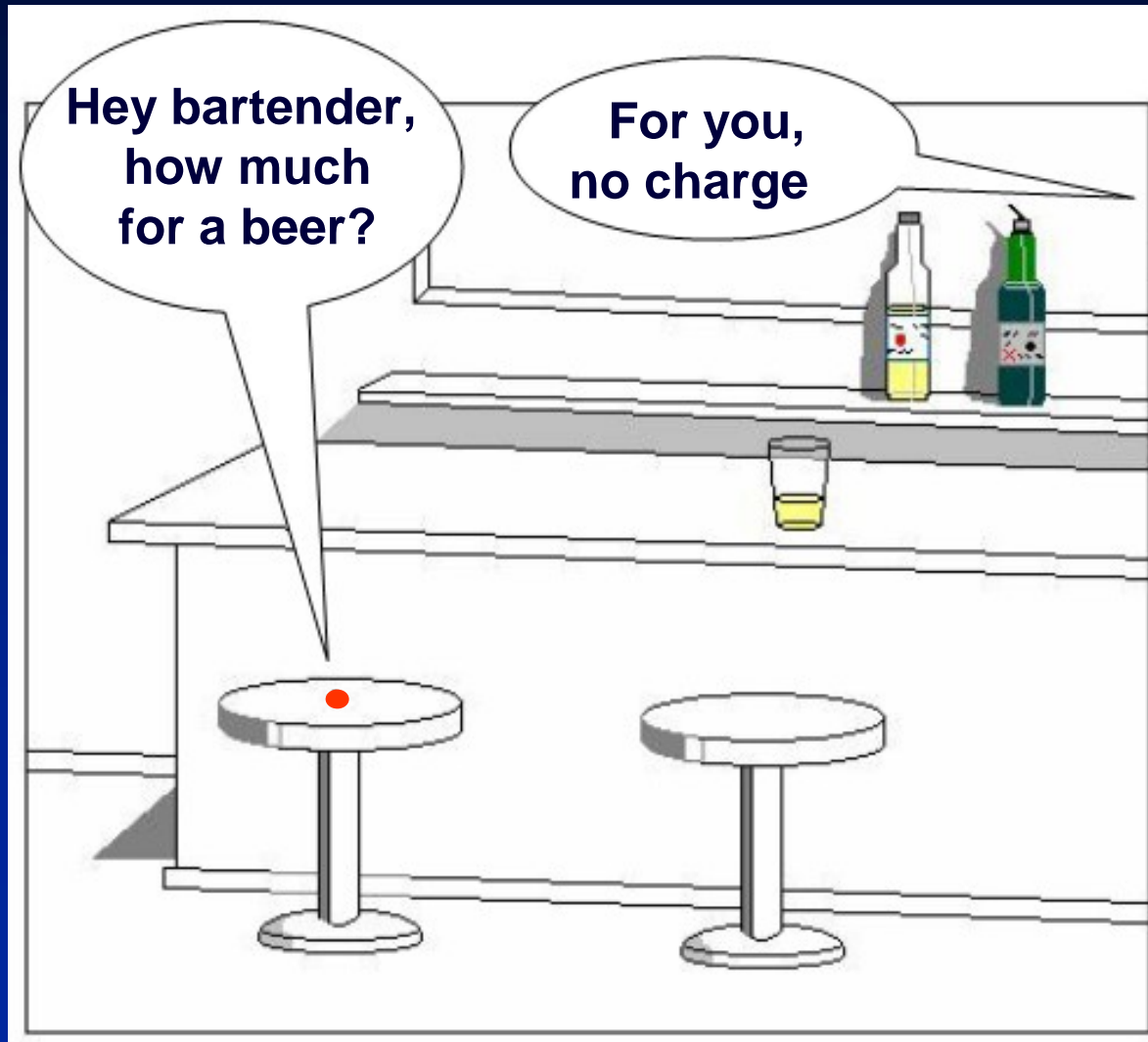

Meanwhile,  
the neutron starts chatting with a proton...

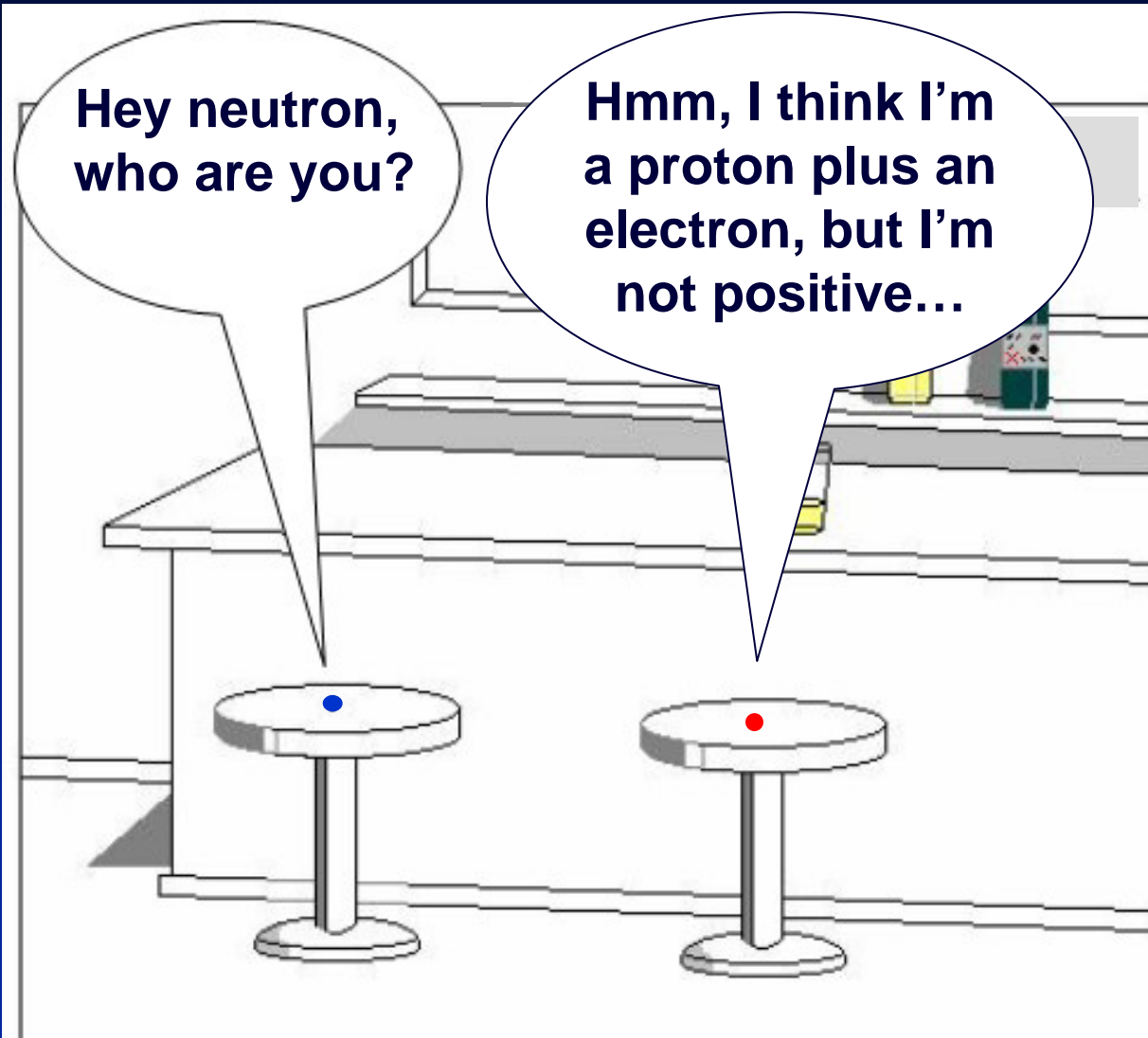

# RBE must be due to the initial track structure

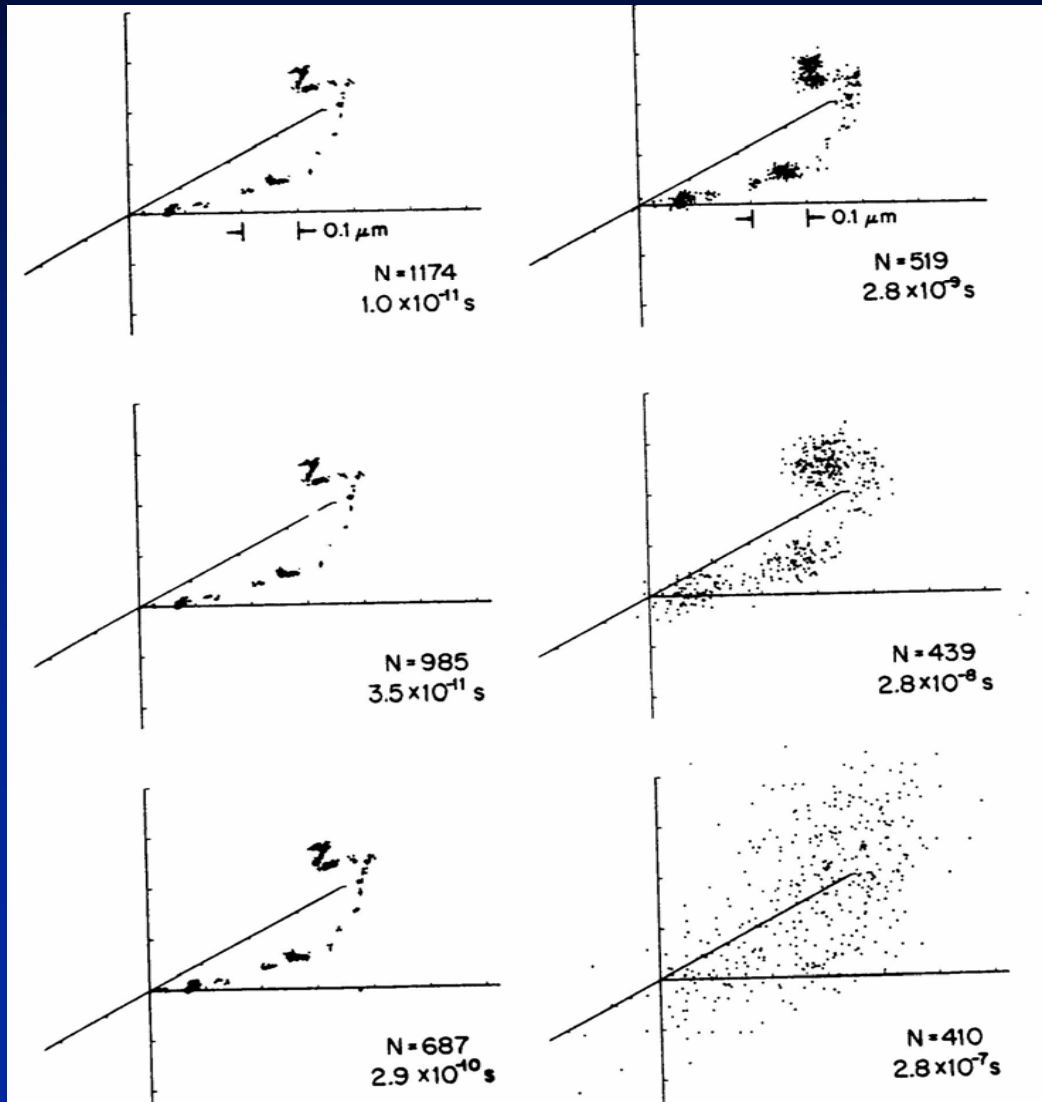

*Wright et al*  
*1982*

# Microdosimetry - The Study of Track Structure

- Ionizing radiations deposit energy in a fundamentally different way from that of other mutagens or carcinogens
- The energy imparted, and the subsequent radiation products are not distributed in simple uniform patterns.
- The radiation track is structured, with energy depositions occurring in clusters along the trajectories of charged particles.
- The characterization of energy depositions on micrometer (and smaller) scales is the field of *microdosimetry*

# Simulated track of 1 keV electron

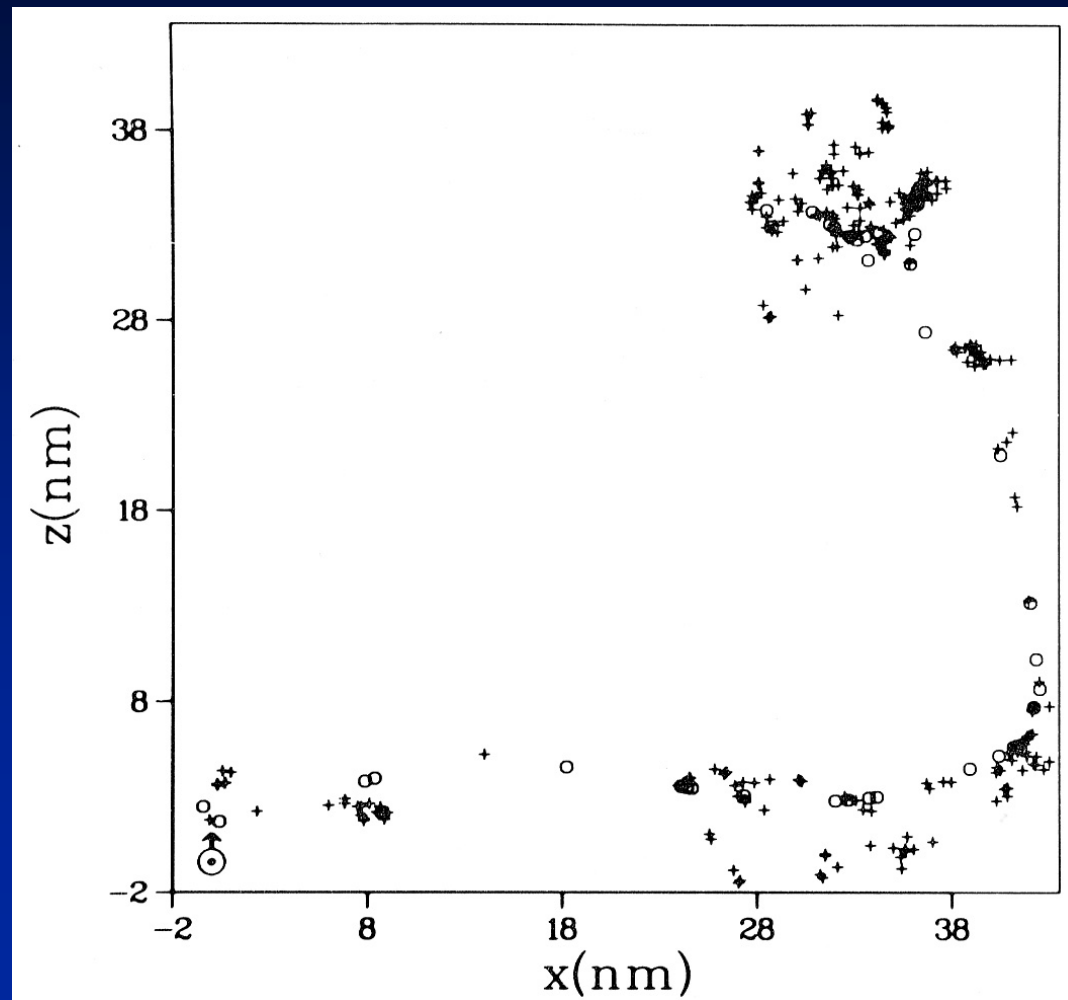

(Zaider & Brenner 1983)

# Simulated charged-particle tracks

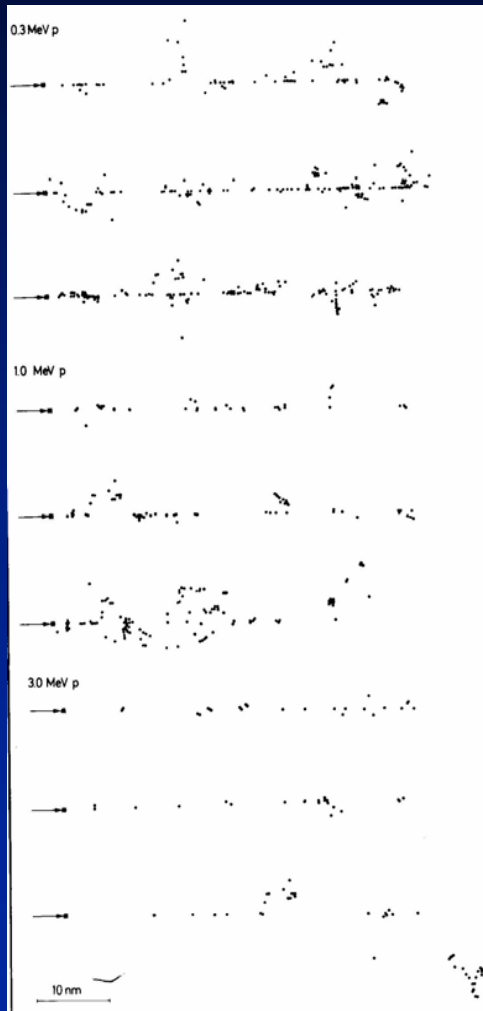

protons

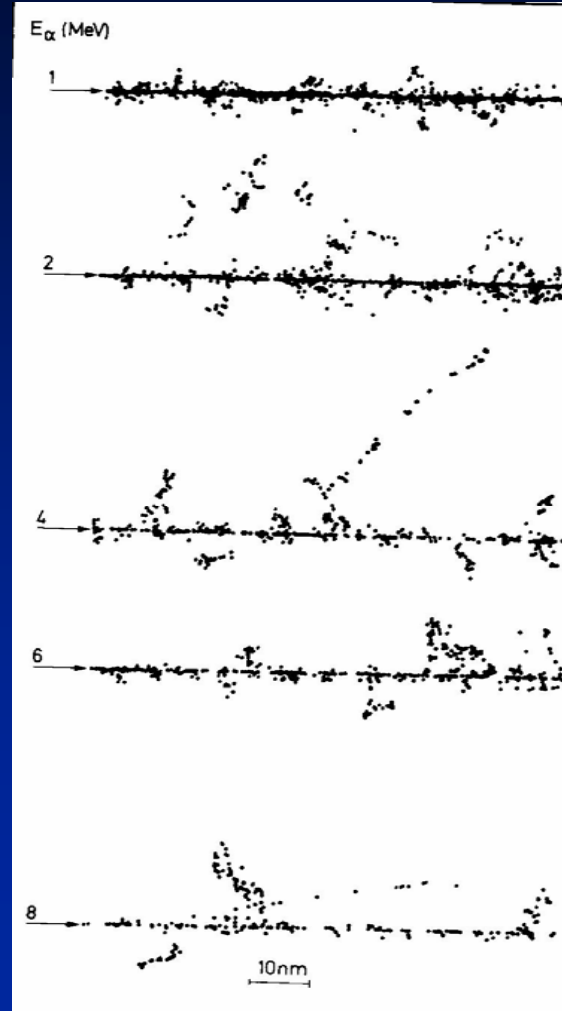

alpha particles

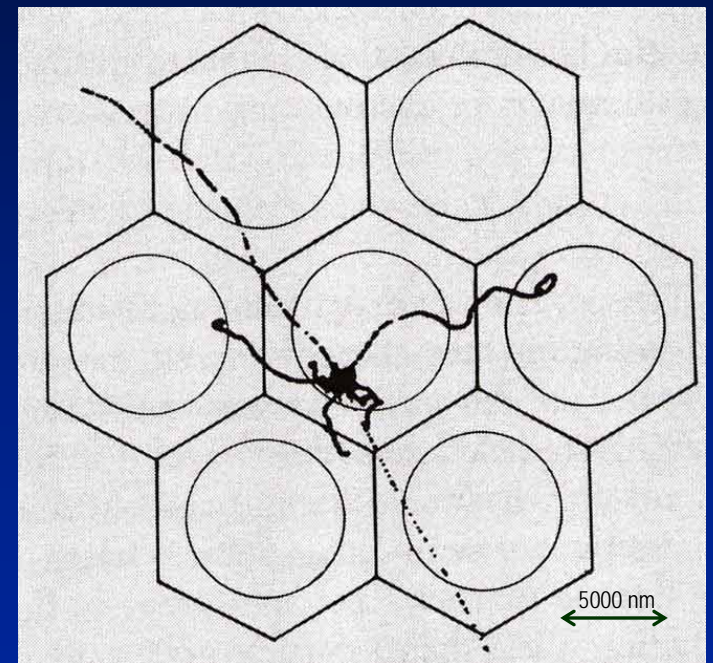

Cosmic-ray iron ion  
passing through  
lens of eye

# Microdosimetry: Lineal Energy ( $y$ )

**Energy deposited in a target  
by a single radiation track, divided by  
the mean chord length of the target**

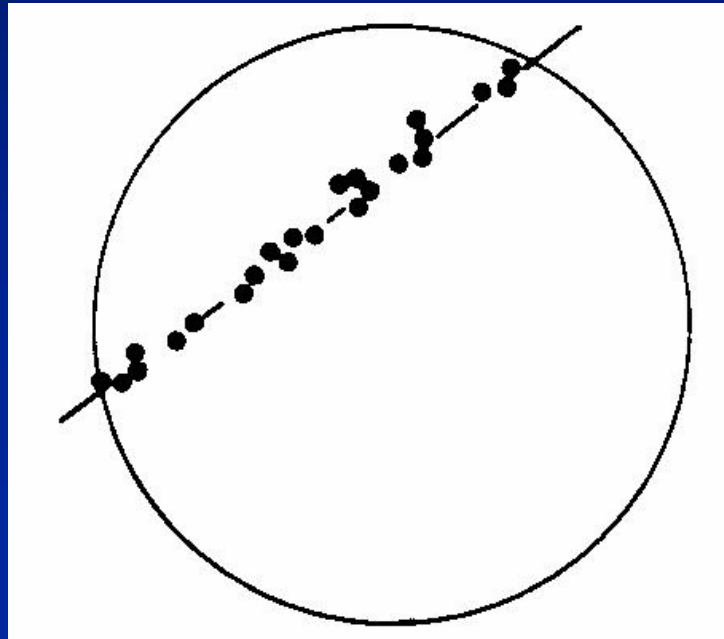



# Microdosimetry:

## Stochastics of ionizing radiation energy deposition

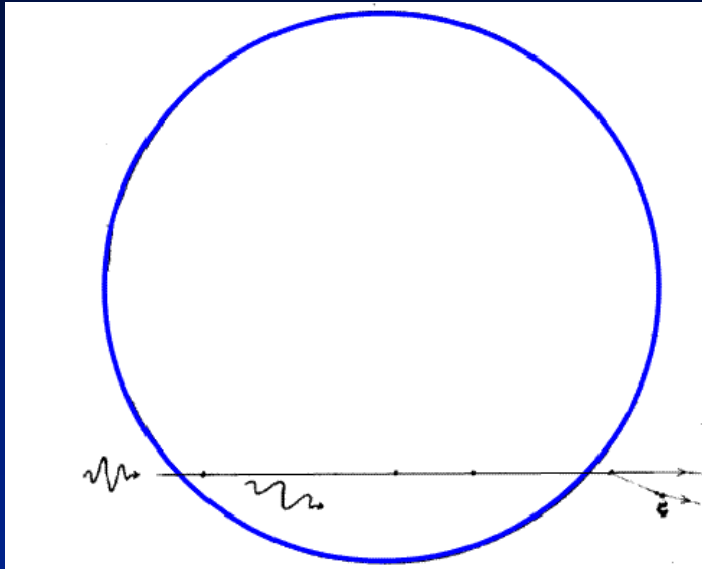

Simulation of single gamma ray  
passing through cell nucleus

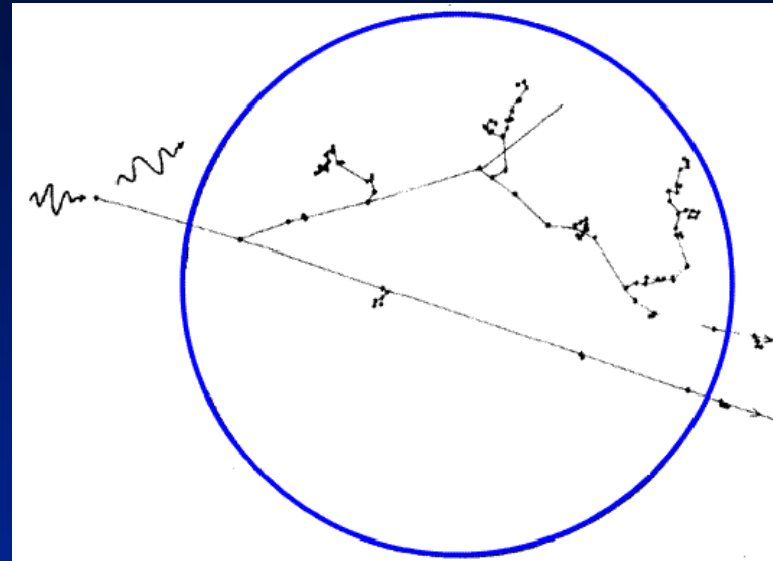

Simulation of single gamma ray  
passing through cell nucleus

# The distribution of energy depositions in a cell nucleus by a single photon

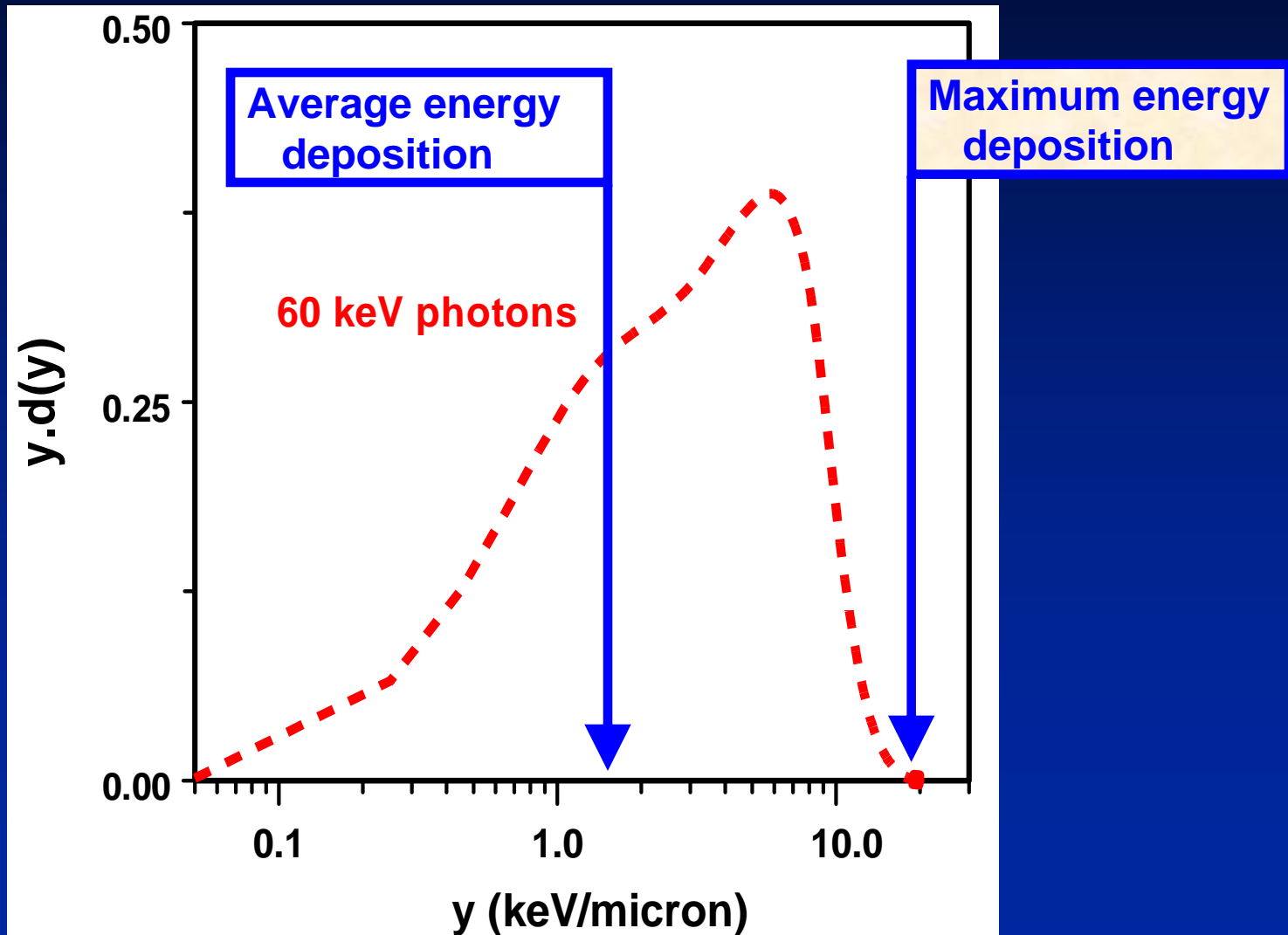

# Microdosimetric Distributions:

Distributions of energy deposition in micron site sizes

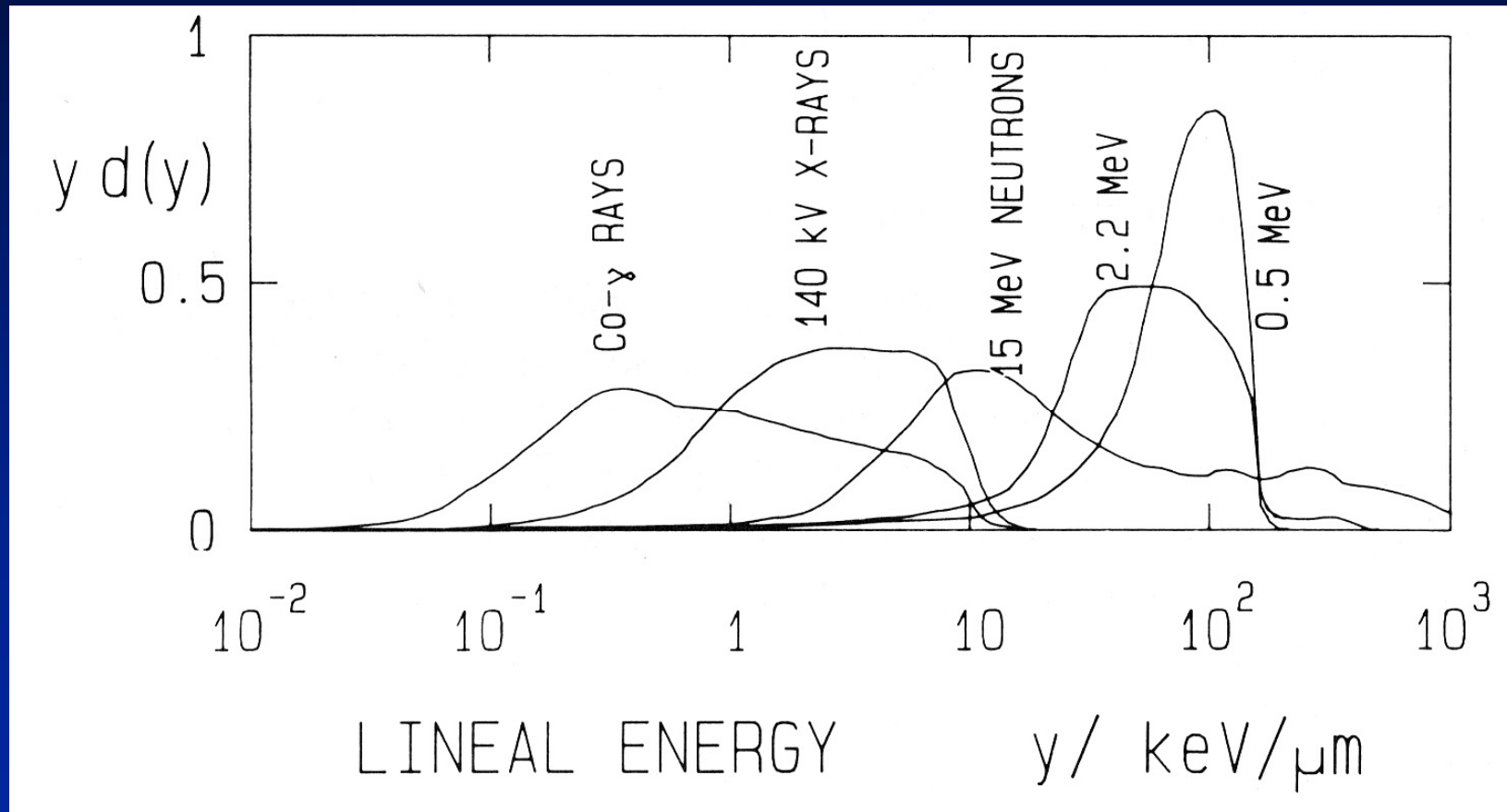

# Microdosimetric spectra can be calculated or measured

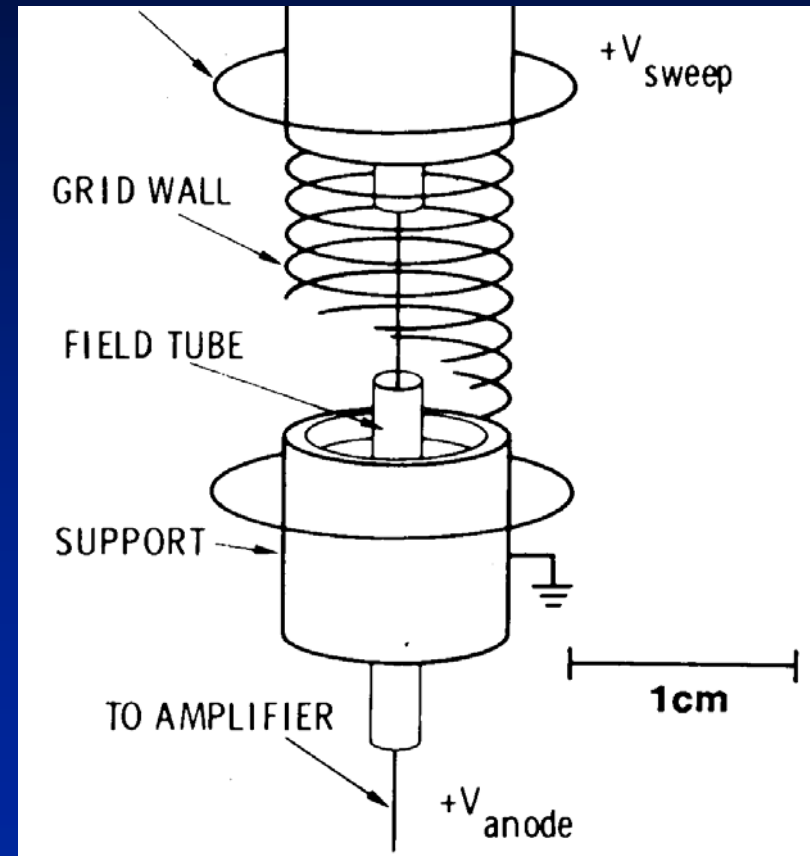

# From track structure to $RBE_M$

## 1. Site model (empirical)

$$RBE_M = \int d(y) r(y) dy$$

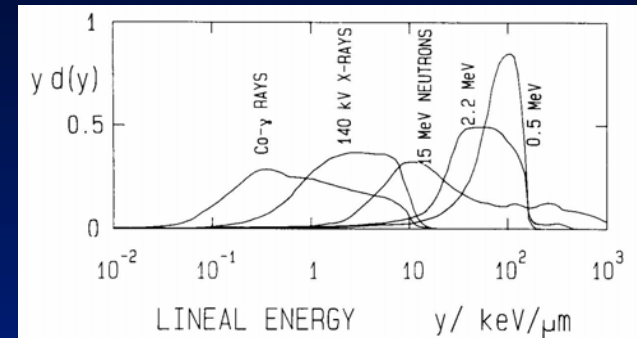

## 2. Distance model (mechanistic)

$$RBE_M = \int t(x) \gamma(x) dx$$



# Low dose and high-dose track structures are different

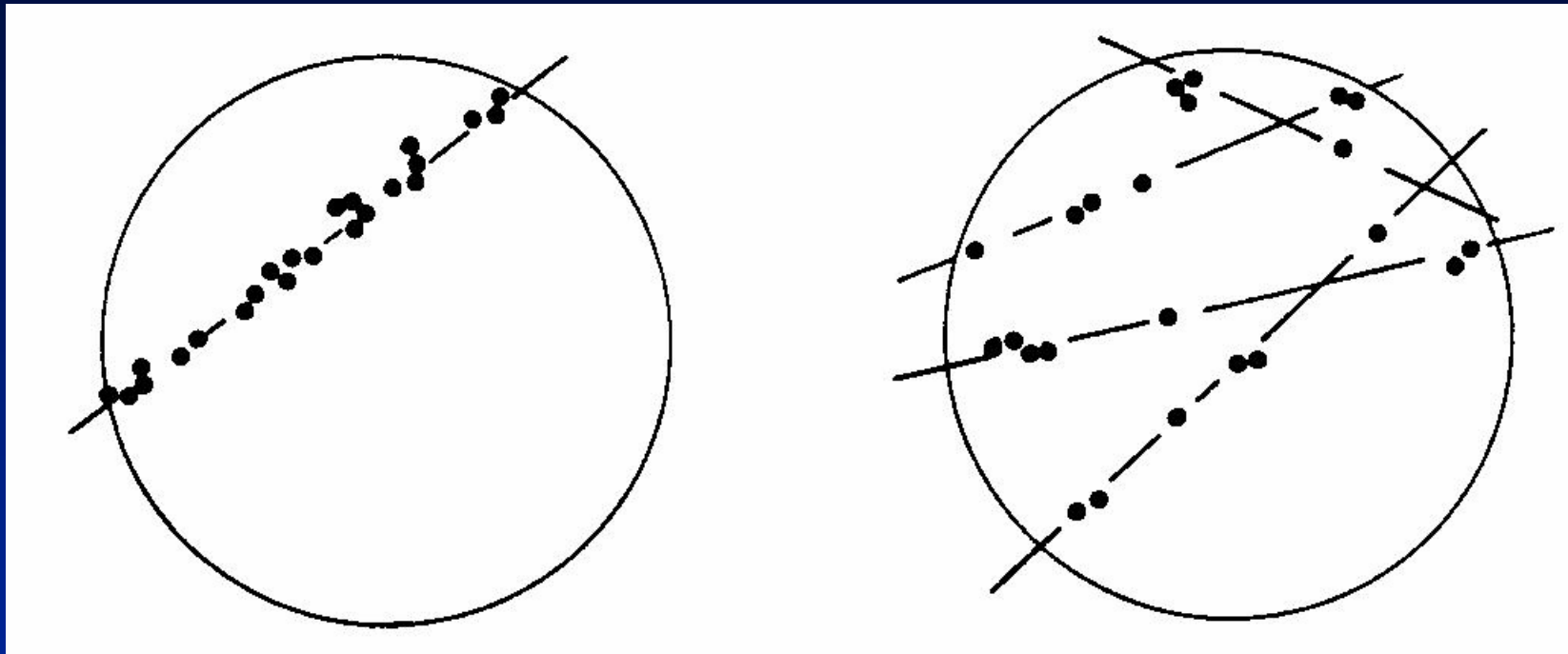

but you can calculate high dose track structure from low dose track structure

# Different photon energies produce quite different microdosimetric spectra

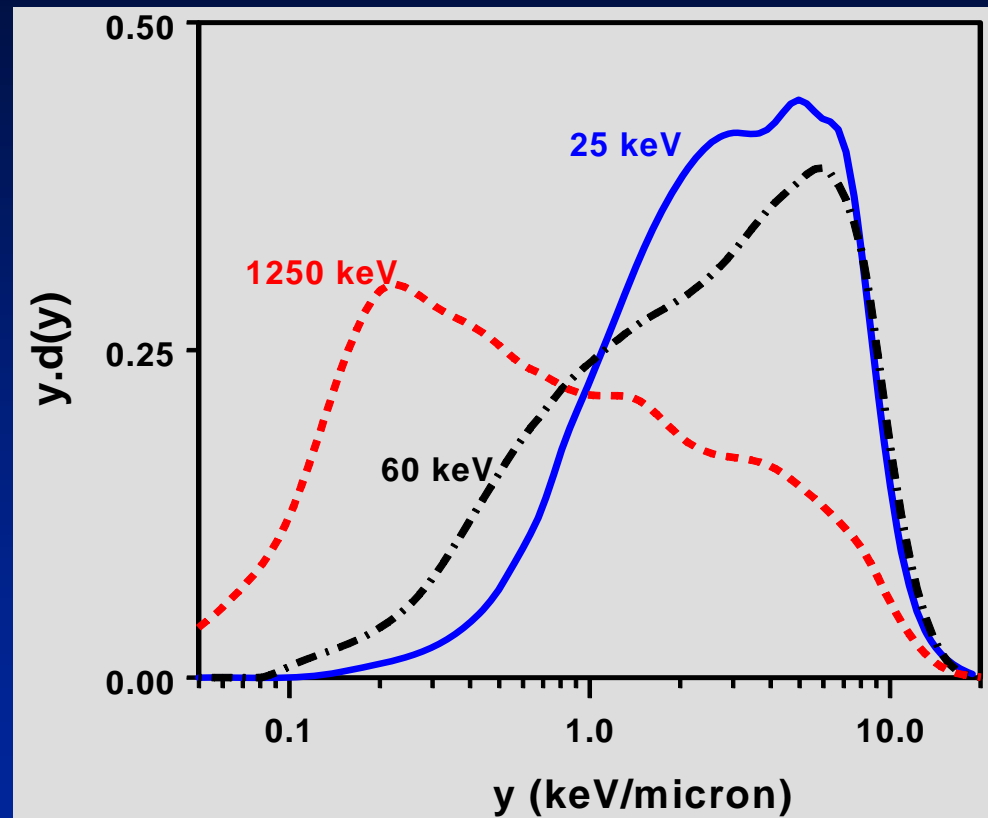

So, for example, mammographic x rays have an RBE of 2-3, compared to high energy photons

# Low dose RBE of $^{131}\text{I}$ vs. 250 kVp x rays

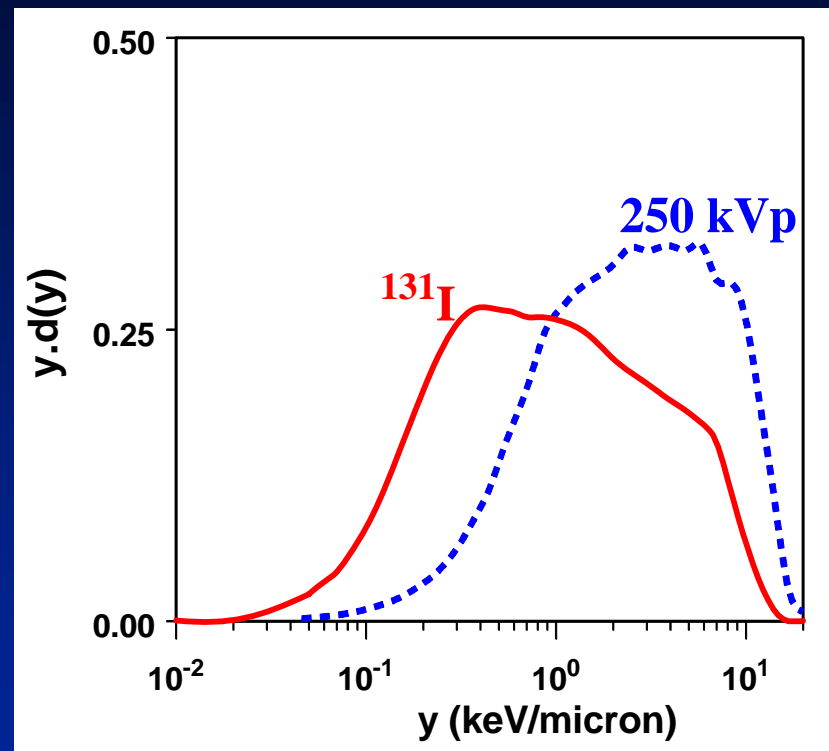

- Based on microdosimetric spectra,  $\text{RBE}_M \sim 0.6$



# Bystander Effects

*Unirradiated "bystander" cells respond to signals emitted by nearby irradiated cells*



# A paradigm shift in interpreting radiation effects

Generations of students were taught that heritable and carcinogenic effects require direct damage to DNA .....



# Bystander Dose Response

- Where bystander responses have been quantitated, they have shown saturation

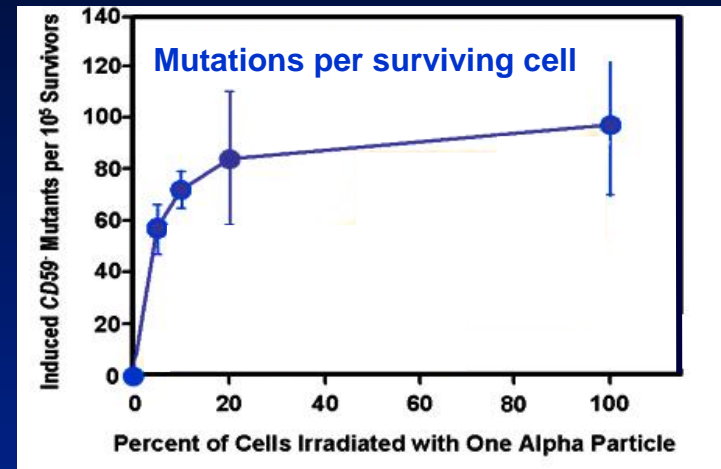

- In such a case, extrapolating linearly from low to very low doses could underestimate the risk at very low doses.

# Various experimental approaches to bystander studies

- Irradiate with a broad beam of high-LET radiation at a very low dose, such that most cells not hit
- Intra-media signal transfer
  - » Irradiate cells/medium, then transfer irradiated medium/cells onto fresh cells
  - » Co-culturing dishes
- Microbeam studies:
  - Hit only specified cells in the field

# Early microbeam-based bystander studies

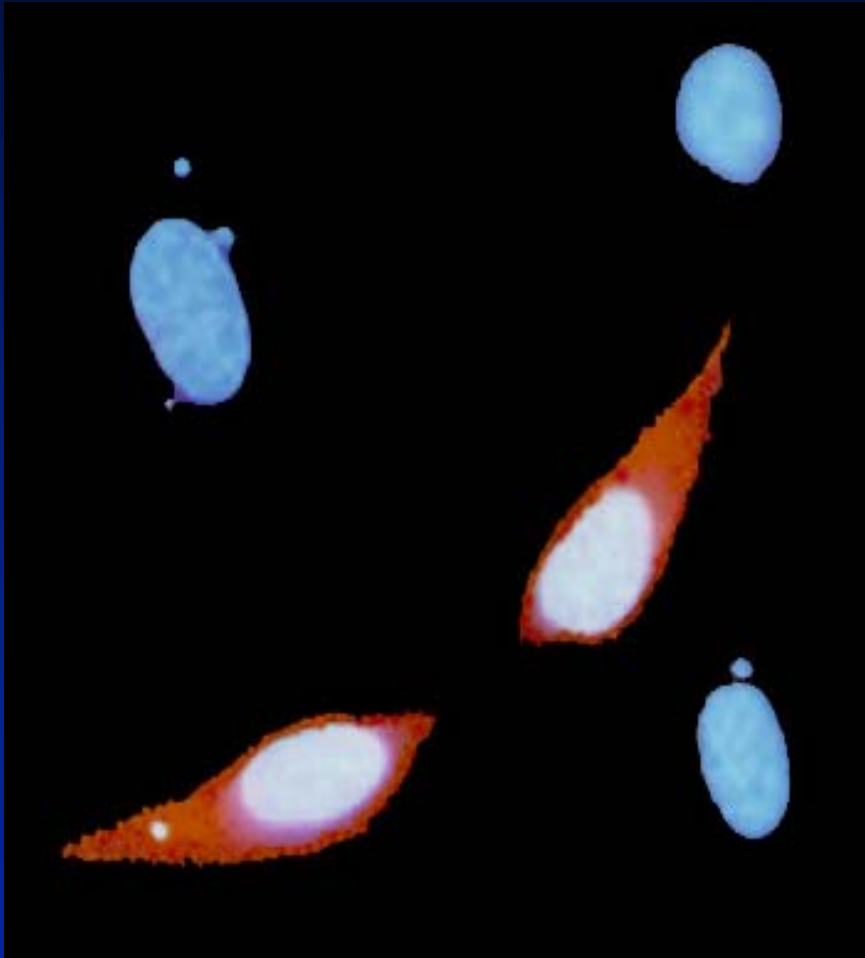

Shoot  $\alpha$  particles at the fibroblasts with blue-stained nuclei, but not at those with red-stained cytoplasm, then score micronuclei

Frequency of micronuclei:

- Controls  $0.8 \pm 0.6\%$
- Hit cells  $30 \pm 4\%$
- Non-hit cells  $5 \pm 1\%$

# We can hit a predetermined fraction of cells....

One  $\alpha$  particle hitting 20% of cells

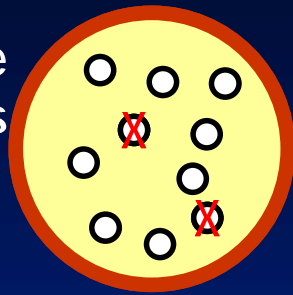

One  $\alpha$  particle hitting every cell

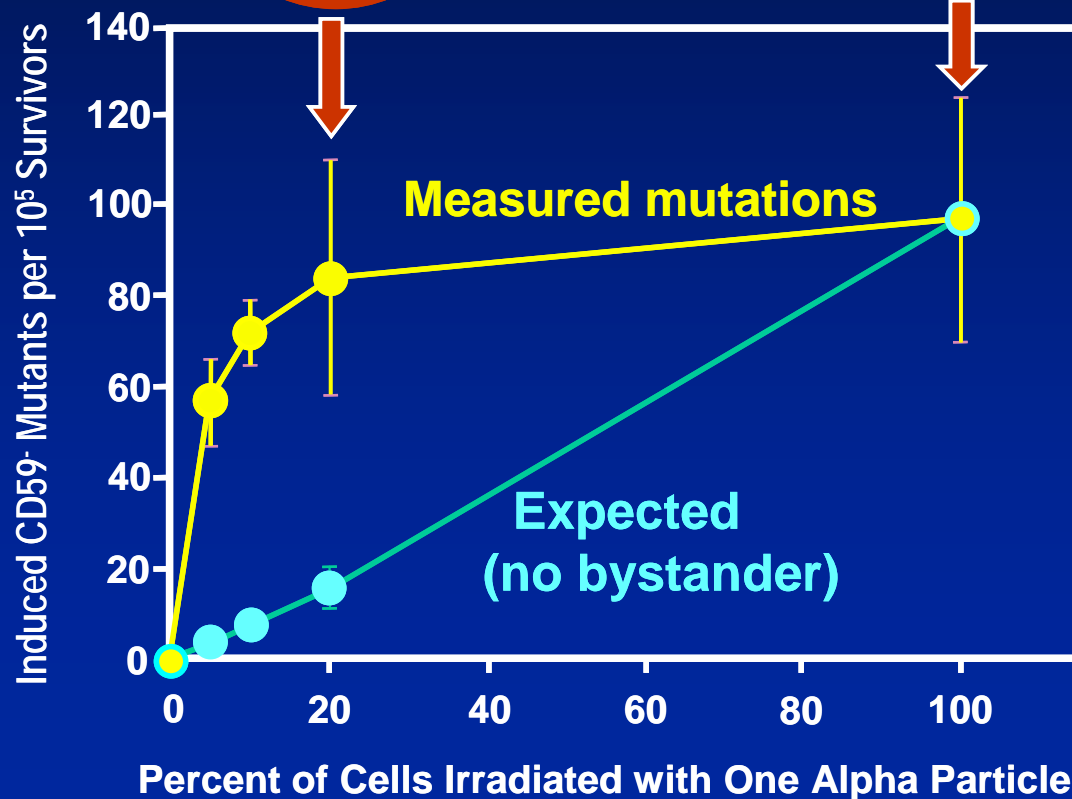
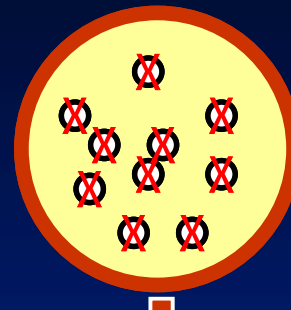

# *In-vitro oncogenic transformation with microbeam*

**White:** All cells hit by  $\alpha$  particles;  
**Yellow:** Only 1 in 10 cells hit

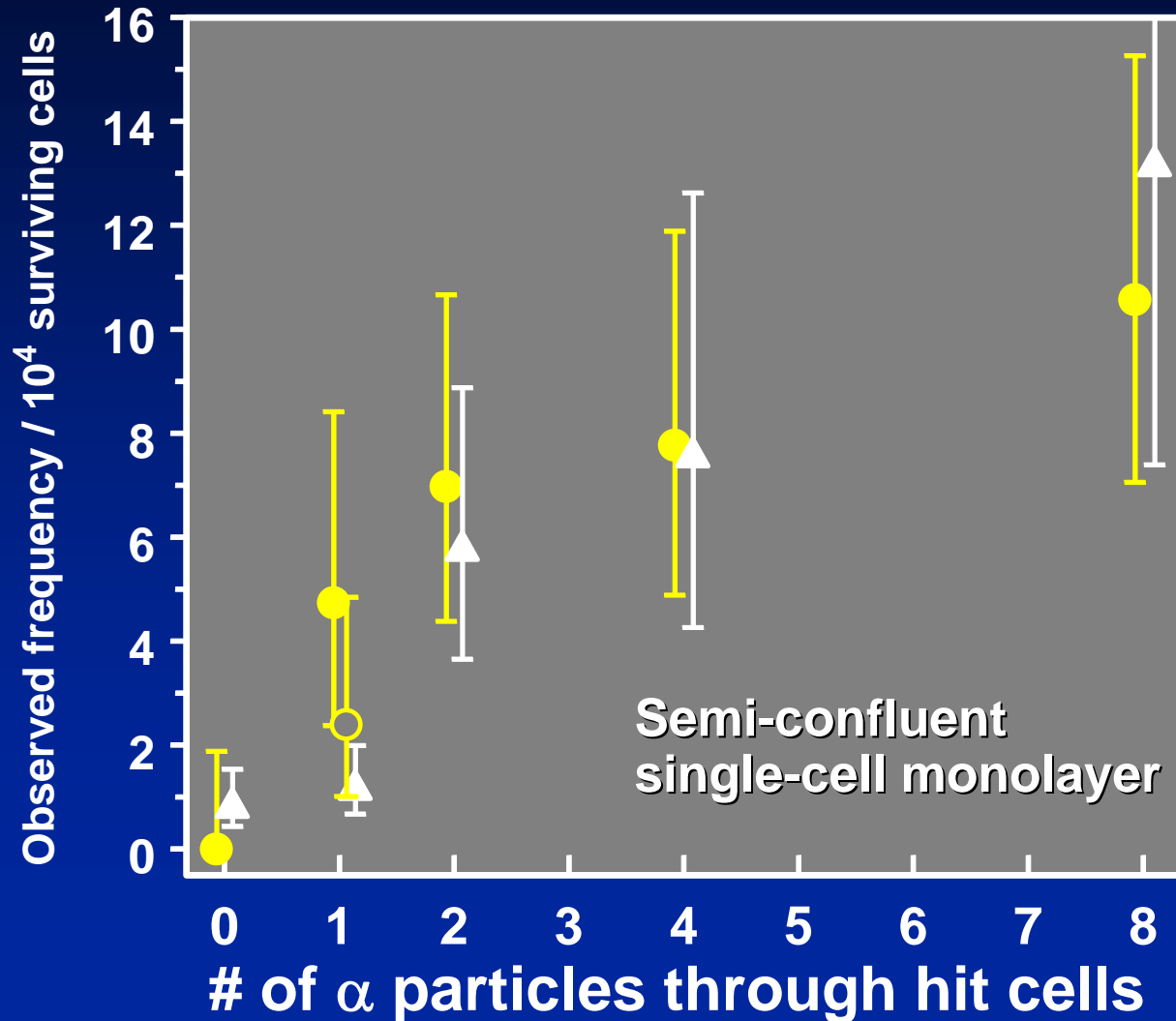

# The Two Bystander Effects:

The effect of cell-to-cell contact on oncogenic transformation

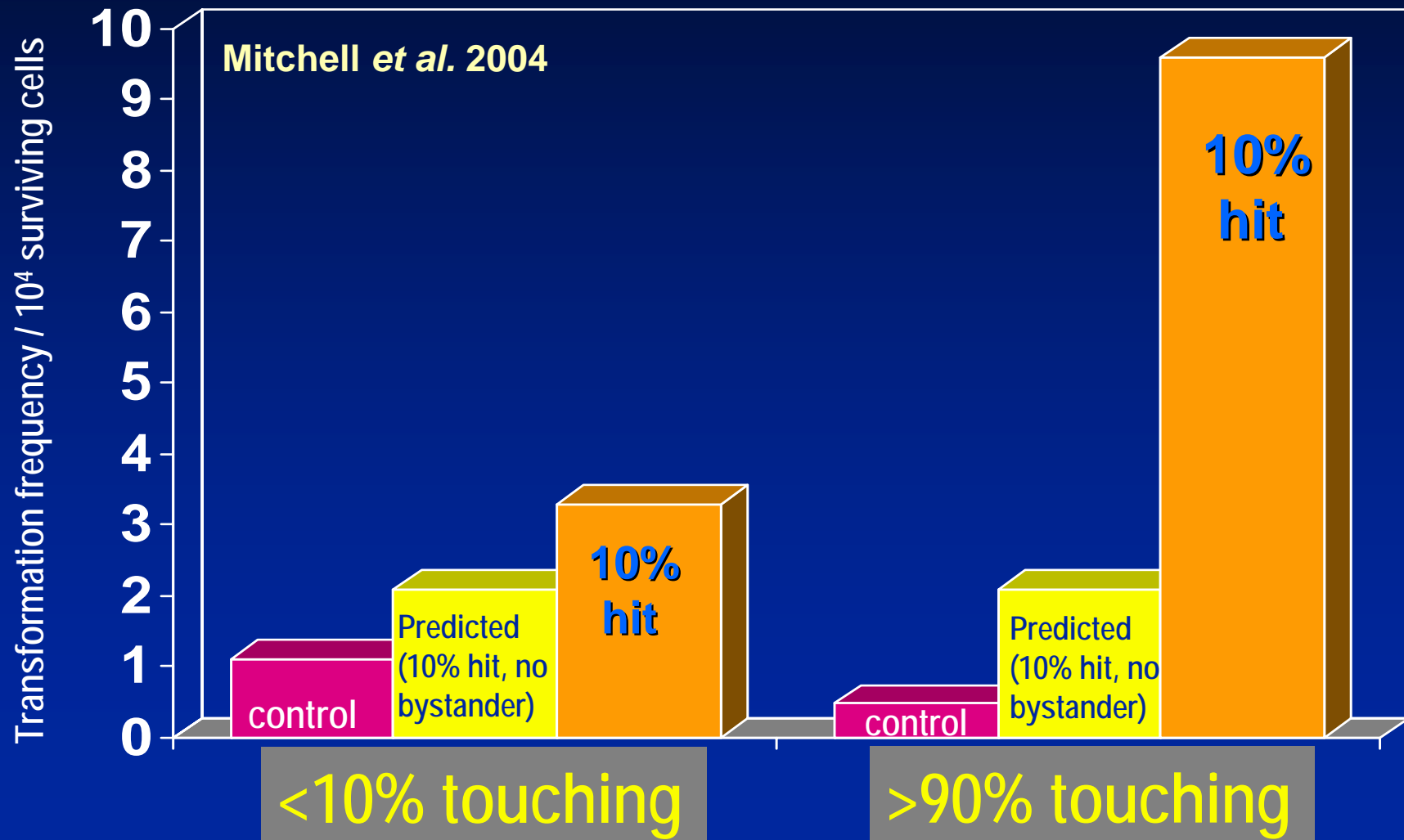





**Most bystander studies  
have been performed with  
single-cell systems**

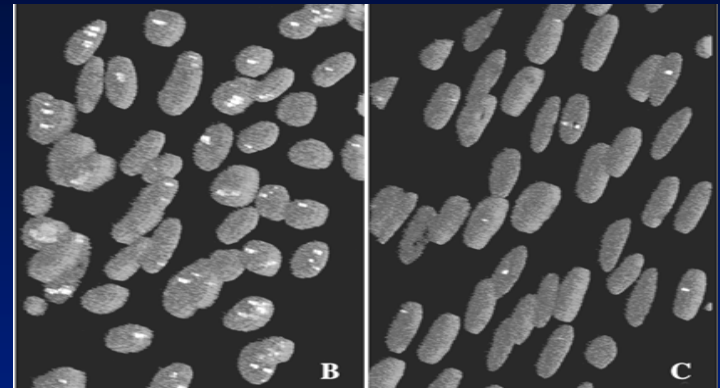

**In that bystander effects involve  
cell-to-cell communication,  
it is important to study these effects  
in normal three-dimensional human  
tissue**

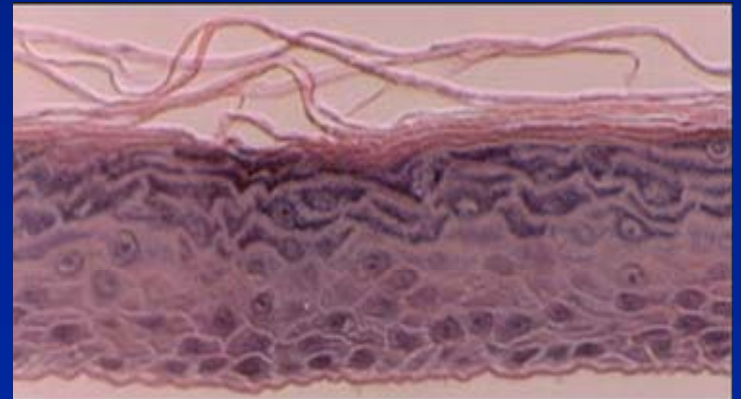

# Microbeam-based bystander studies in human artificial 3-D skin

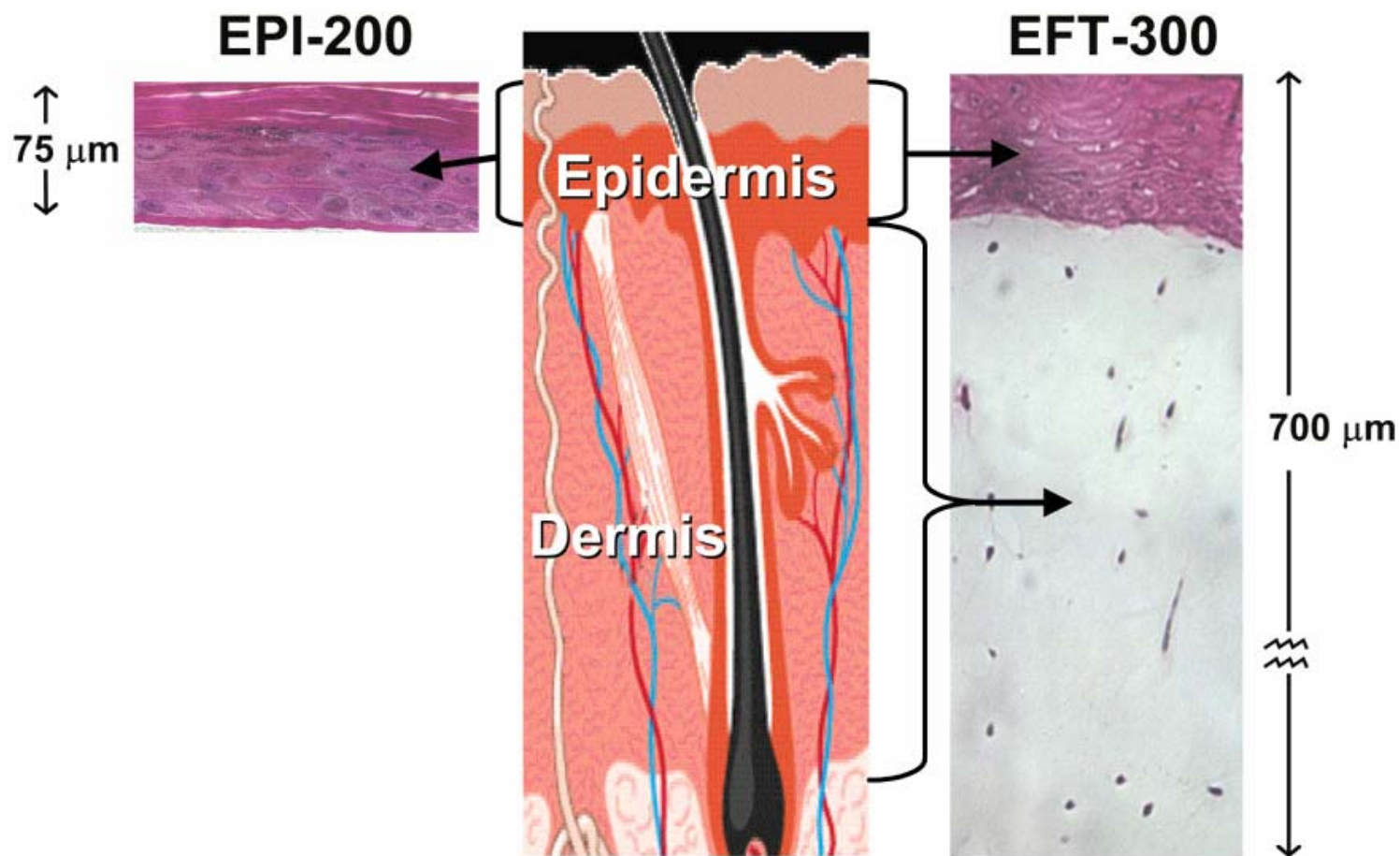

# Microbeam-based bystander experiments in human 3-D tissue systems

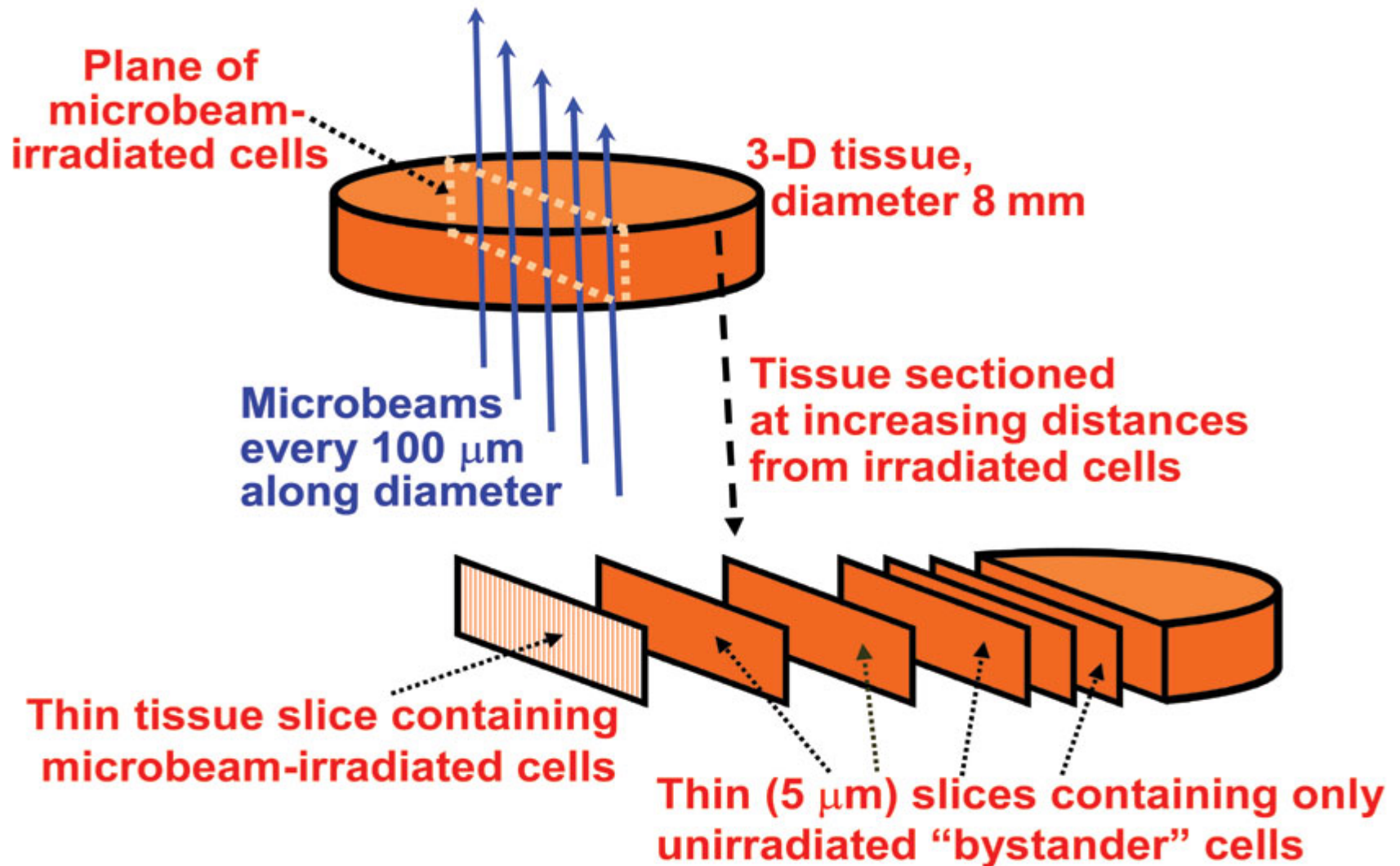

## Apoptosis

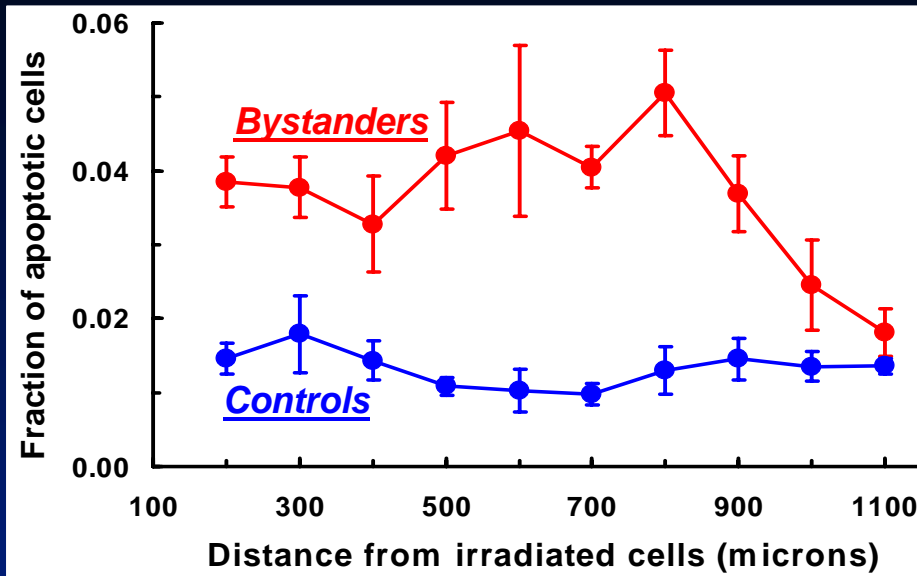

## Micronuclei

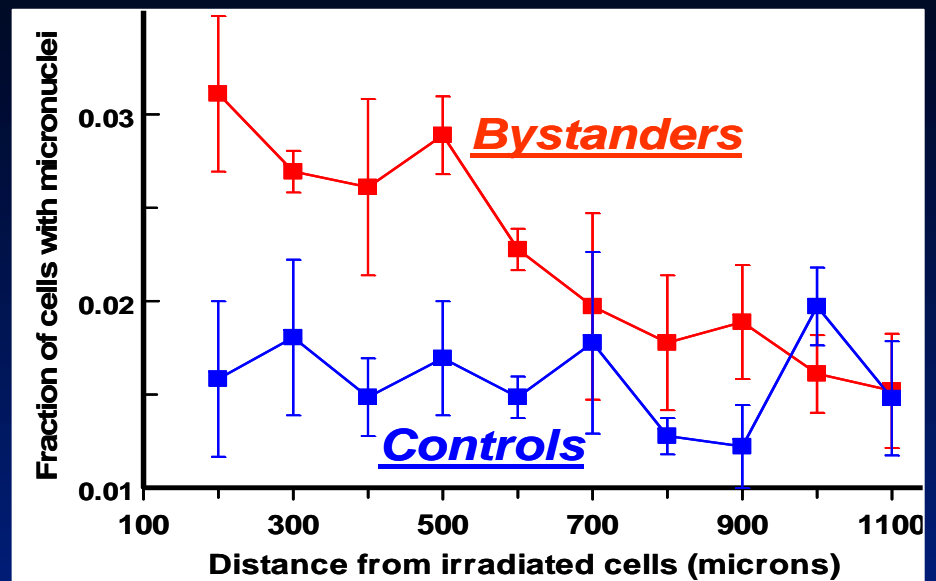

Belyakov et al PNAS 102, 14203-8 (2005)

- For both apoptosis and micronucleus induction, the range of the bystander effect in tissue is about 1 mm, or 50 to 100 cells
- The average enhancement in effect, over this range of distances, is about 1.6 for micronuclei and 2.8 for apoptosis.

# JNK phosphorylation in 3-D tissue, measured in individual cells

Proton microbeam: 1 h post irradiation

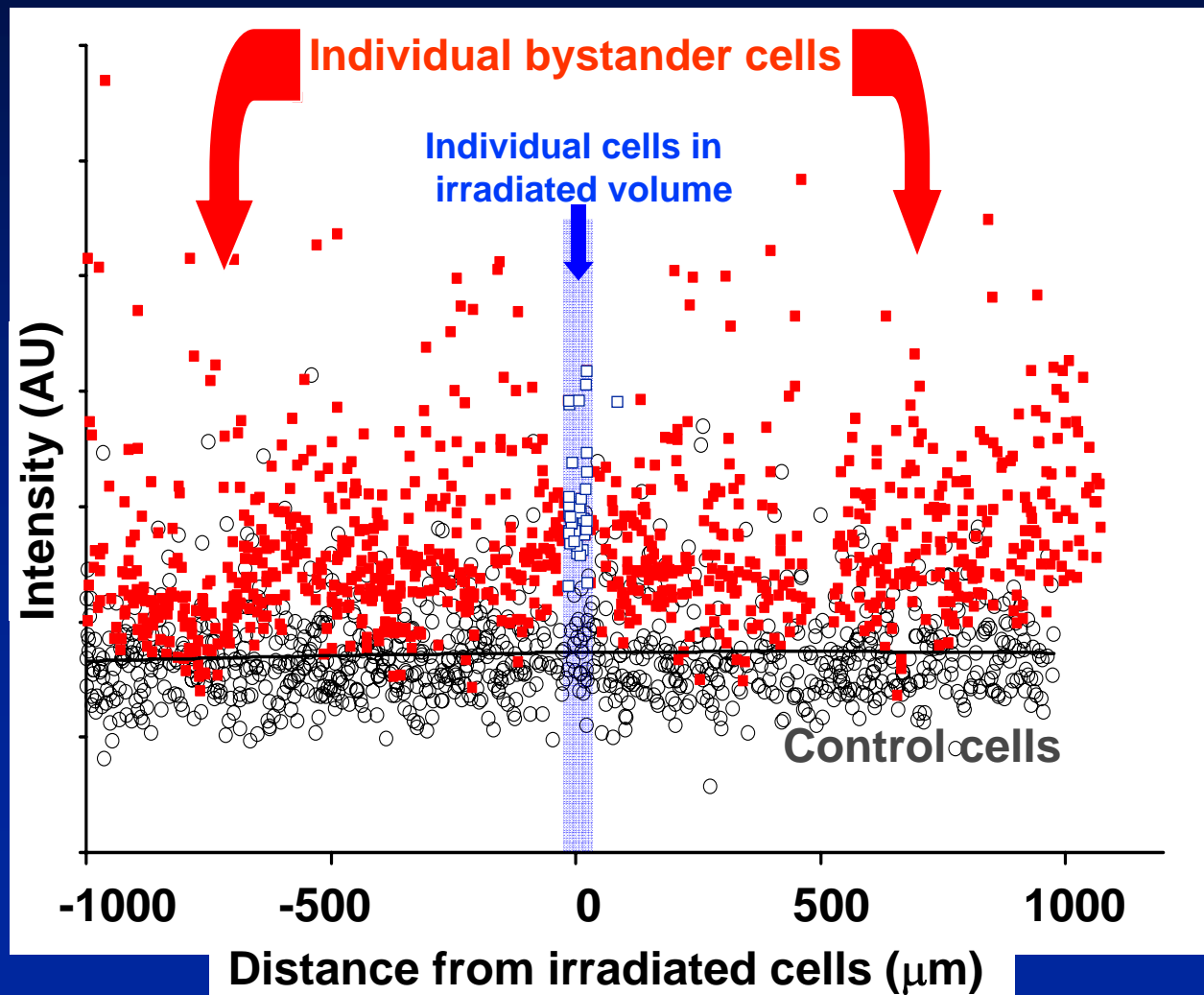

# Spatial Modeling of Bystander Effects

- ➡ **The spatial aspects of the bystander effect are a key to understanding its low-dose significance**
- ➡ **We don't know all the molecules involved, but we do have a reasonable understanding of how the effect propagates**
- ➡ **So we are in a position to build quantitative spatial models**

# The basics of the bystander effect

- Bystander effects result from signaling molecules ( $S$ ) that rapidly propagate from hit cells
- The signals can, depending on their concentration, change the state of a recipient cell from normal to one of an epigenetic hypermutable phenotype ( $M$ ), for example to a state of oxidative stress
- In this  $M$  state, which can be long lived, cells are more genomically unstable, more prone to DNA damage, thus leading to an increased response ( $R$ ) for a wide range of endpoints

# What do we know about the signal ( $S$ )?

- 1)  $S$  can travel hundreds (thousands) of microns
- 2)  $S$  is *fast*

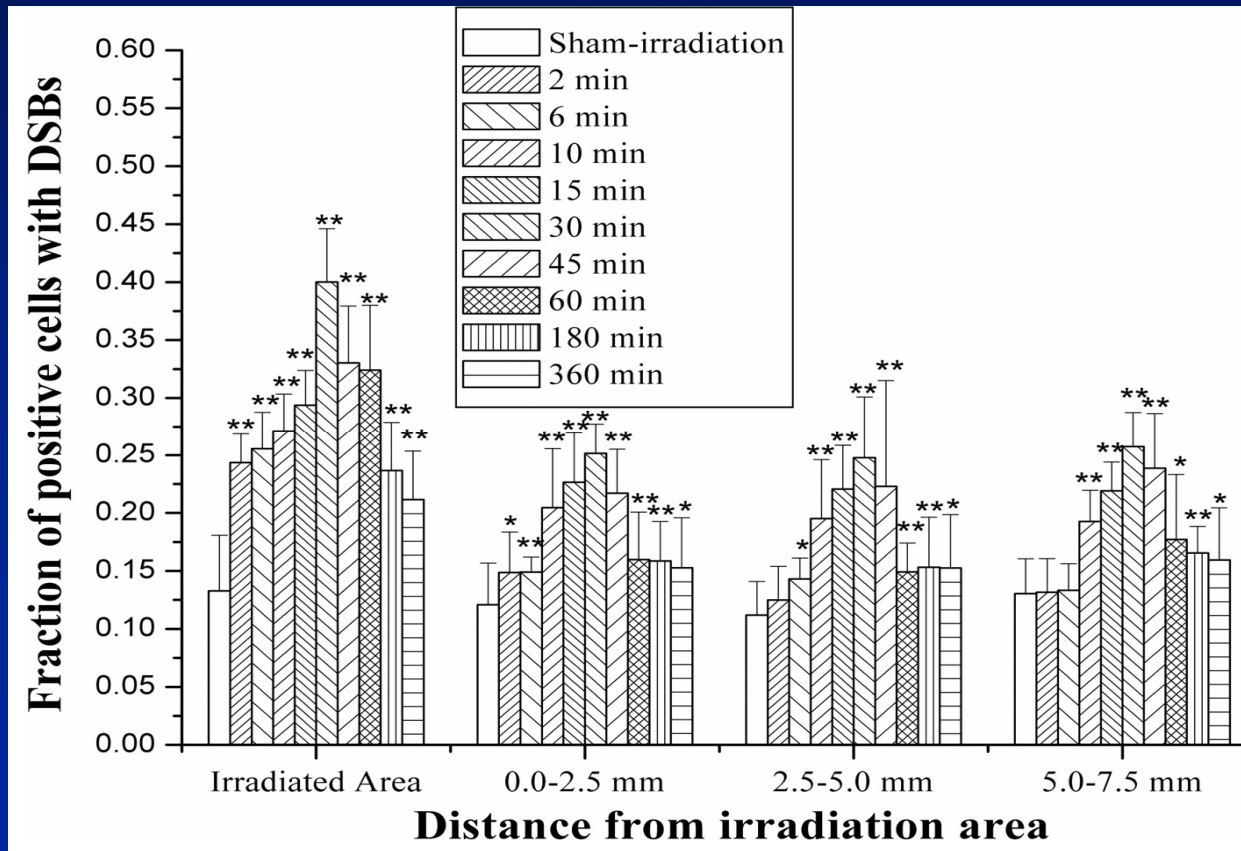

$\gamma$ -H2AX yield in bystander cells, as a function of distance from irradiated cells



# How can we explain the very rapid and long range signaling ( $>5 \mu\text{m}/\text{sec}$ )?

- Diffusion of the signal, inter- and intra-cellular, is too slow.
  - » Even the fastest diffusing molecules (e.g. NO) cannot diffuse this fast
- Clue from calcium signaling waves, which spread very rapidly over long ranges: “*Fire-Diffuse-Fire*”:
  - » Stimulated cells “fires” and releases signal
  - » Signal diffuses locally to adjacent cell
  - » Adjacent cell “fires” and releases (reduced amplitude) signal
  - » etc., etc.

# FIRE-DIFFUSE-FIRE

---

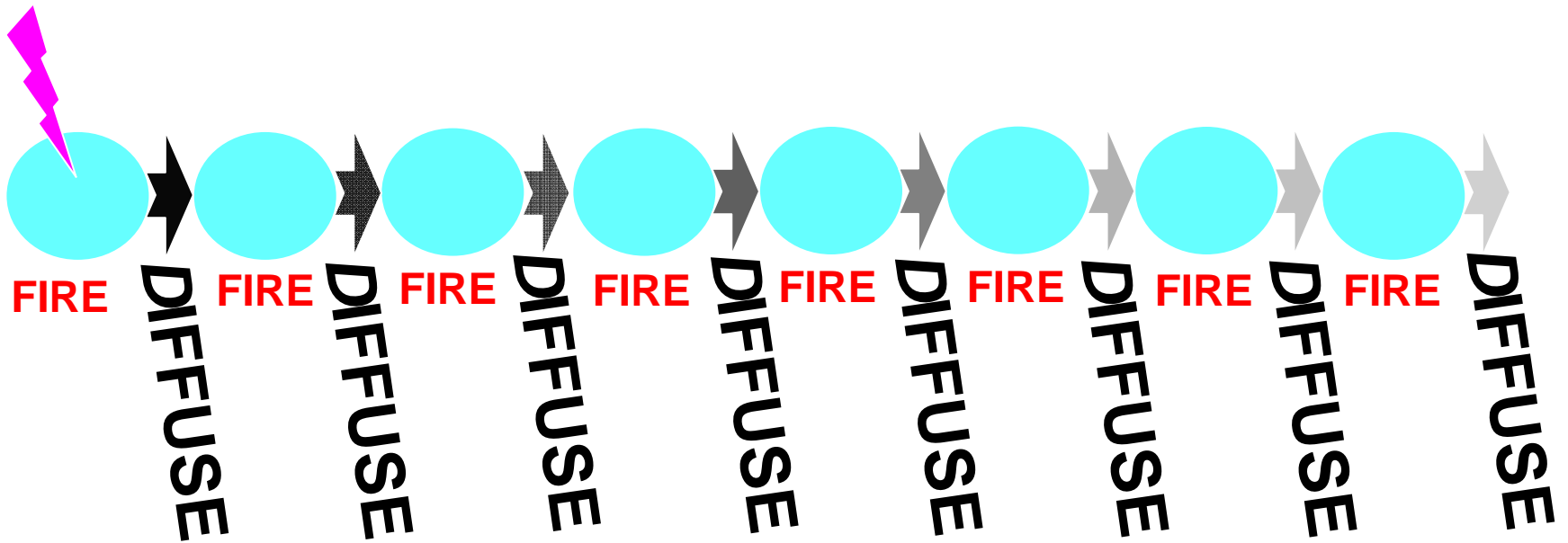

## Apoptosis

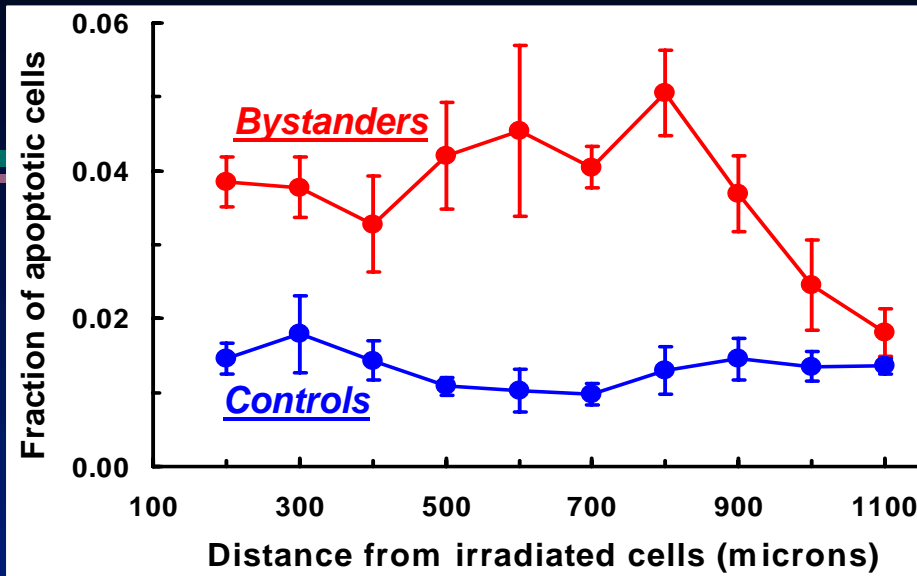

## Micronuclei

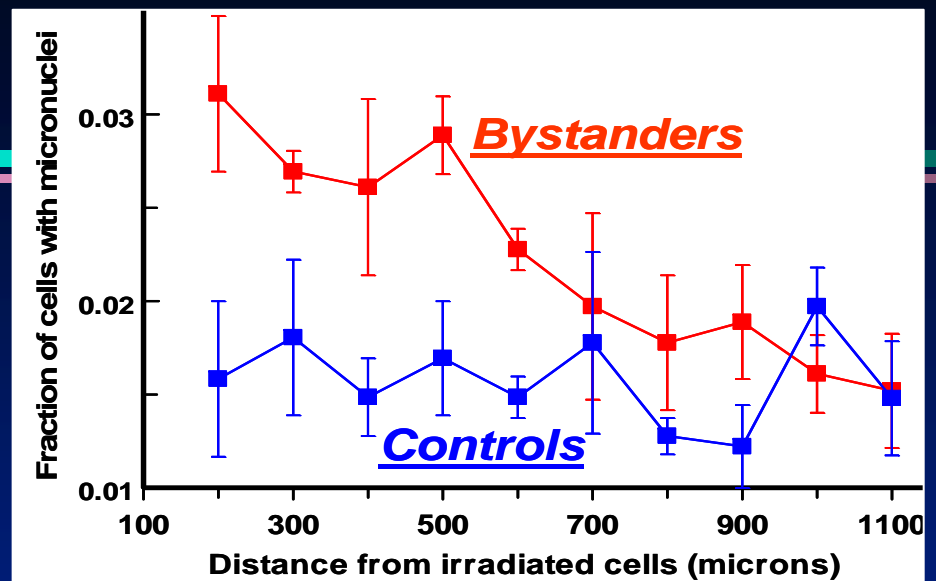

Belyakov et al PNAS 102, 14203-8 (2005)

- For both apoptosis and micronucleus induction, the range of the bystander effect in tissue is about 1 mm, or 50 to 100 cells
- The average enhancement in effect, over this range of distances, is about 1.6 for micronuclei and 2.8 for apoptosis.

Signal large enough to induce oxidative stress condition in **all** sensitive cells

Signal large enough to induce oxidative stress condition in **a fraction** of sensitive cells

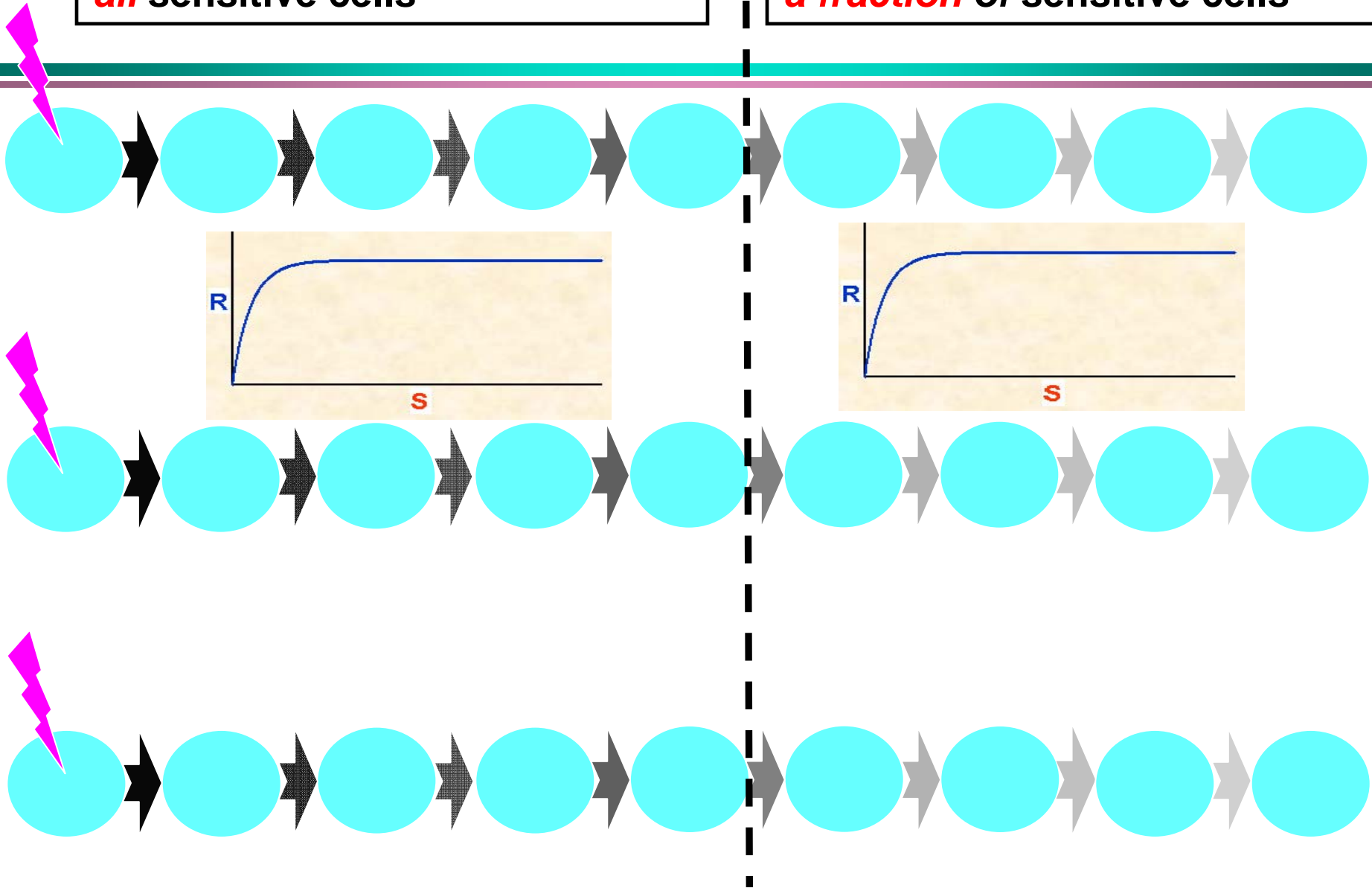

# Where might bystander effects be important?

- **RADON!**
- **Neutrons**
- **A Mars mission**
  
- **Low doses of photons??**

# Bystander effects with photons...

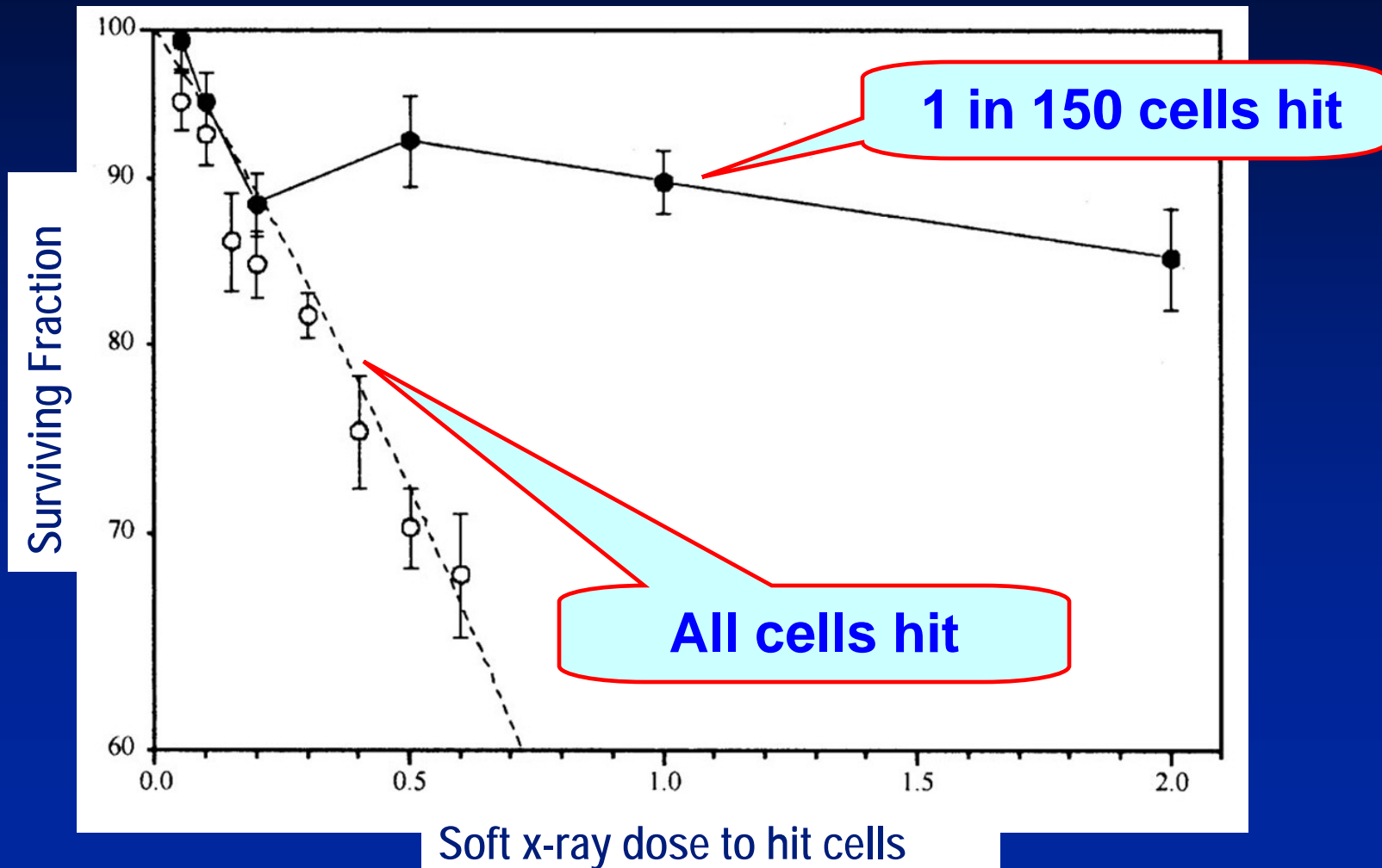

# Why might bystander effects be relevant for domestic vs miner exposure?

- **Cells are directly hit less frequently at low doses compared to high doses**
- **So the proportion of the overall risk due to bystander effects may be larger at lower doses**
- **Variations in the proportion of the response due to bystander effects can lead to non-linear dose-effect relations**

# Are bystander effects important for radon risk estimation?

- The patterns of radon risks as a function of dose and time are highly suggestive that bystander effects are important at low doses
- Significant bystander effects would lead to **non-linear** dose-response relations
- In such situations, naïve linear extrapolation of risk from high to low doses could produce misleading results - typically under-predicting the true risk

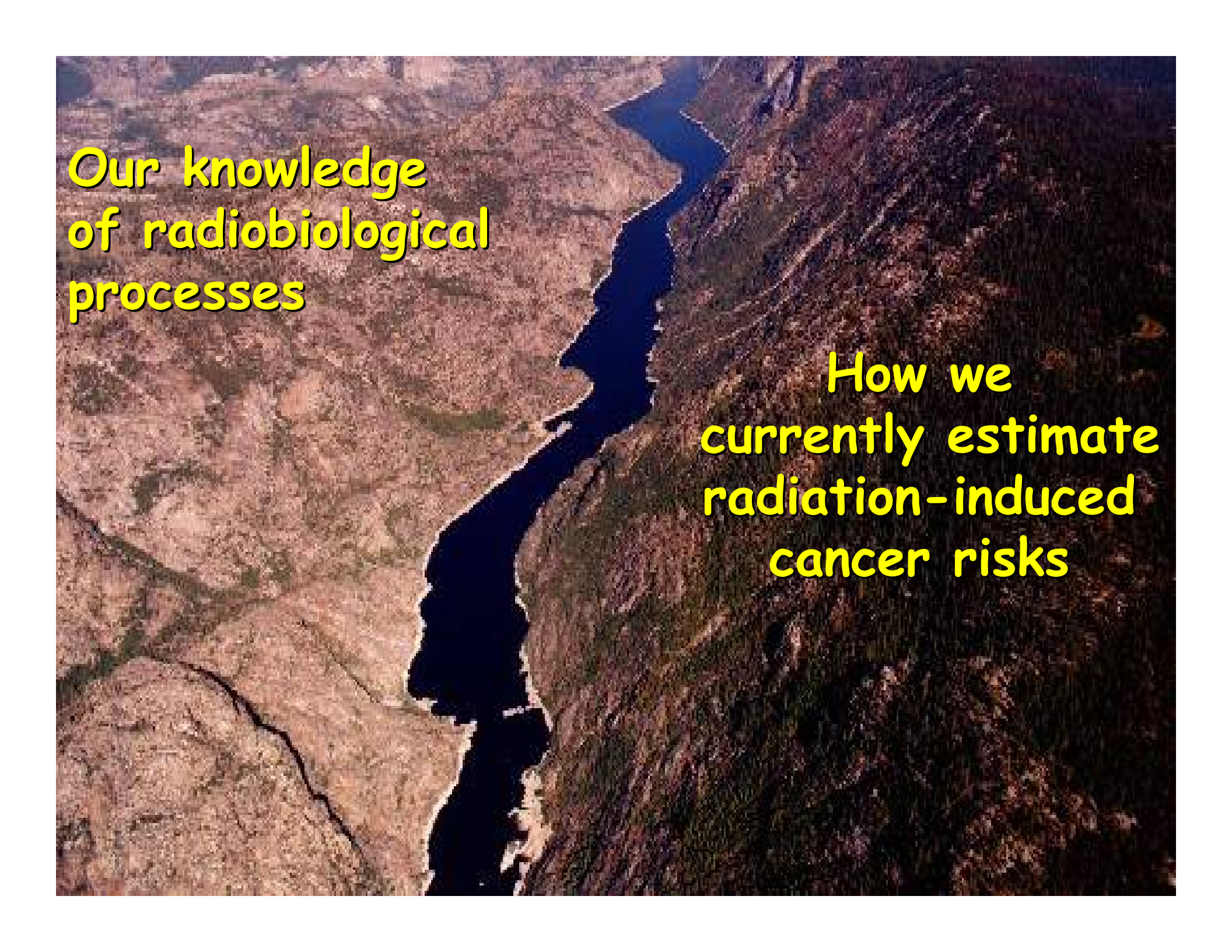

An aerial photograph of a winding river flowing through a rugged, hilly landscape. The river is dark blue and meanders through the terrain, which is covered in brownish, rocky soil and sparse vegetation. The hills are steep and eroded, with visible gullies and ridges. The overall scene is one of a natural, somewhat desolate environment.

**Our knowledge  
of radiobiological  
processes**

**How we  
currently estimate  
radiation-induced  
cancer risks**

# BEIR VII (2006)

**“State of the art” evaluation of the human health consequences of low levels of radon**

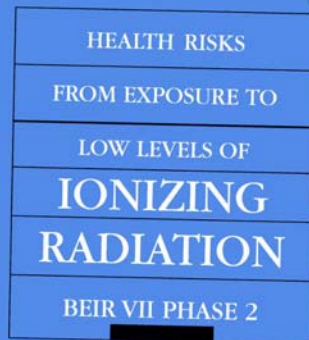

- *406 pages long*
- *Molecular genetics discussed on pp 32-42*
- *Molecular genetics not used in risk estimation*

# Molecular genetics & risk estimation

One day, molecular techniques will help us to directly quantify the risks to human health of low levels of radiation.



That day is probably a fair way in the future.

# Radiobiology

can guide

**empirical epidemiological  
analyses**

*in specific areas where there  
is uncertainty*

## Radiobiology has the potential to provide **relative** information concerning cancer risks, such as

- high dose vs. low dose,
- wild-type vs. heterozygote,
- acute vs. fractionated
- low-LET vs. high LET

This **relative** information can be applied to modify radiation risk estimates that are originally based, for example, on A-bomb survivor data.

***This “relative” approach minimizes our dependence on the details of the particular models we use.***

Our knowledge  
of radiobiological  
processes

How we  
currently estimate  
radiation-induced  
cancer risks



# NCI 2007

Interactions between  
radiation epidemiologists and radiation biologists  
are going to become increasingly important as  
the field focuses more and more on the effects of  
low radiation doses

# NCI 2007

**Radiation  
epidemiology**

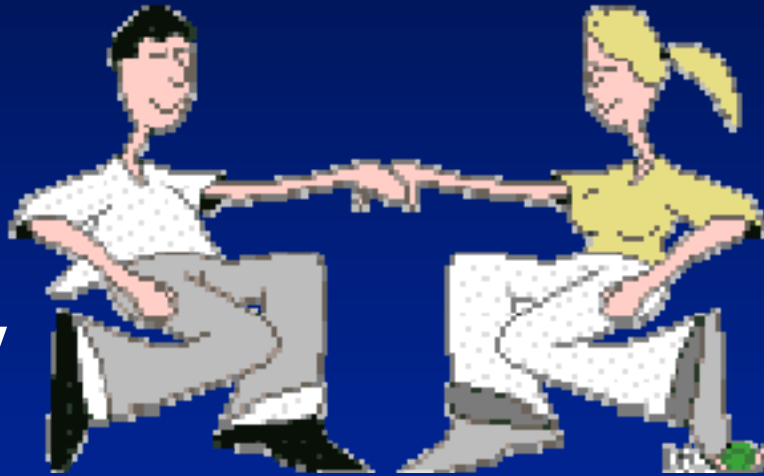

**Radiation  
biology**