

NIH Guide for Grants and Contracts

U.S. DEPARTMENT OF HEALTH
AND HUMAN SERVICES

Vol. 13, No. 1, January 6, 1984

IN THIS ISSUE:

Notice

Early Release of Summary Statements Page 1
Index - SUMMARY STATEMENTS

Notice

National Research Service Award
Guidelines Revised Page 2
Index - NATIONAL RESEARCH SERVICE
AWARDS (NRSA)

Notice

New Application Form Available for National
Research Service Award Institutional
Training Grants Page 3
Index - NATIONAL RESEARCH SERVICE
AWARDS (NRSA)

Notice

Availability of Human Cell Lines Established
from Patients with Genetic Diseases Page 4
National Institute of General Medical Sciences
Index - GENERAL MEDICAL SCIENCES

Announcement

Availability for Request for Applications: RFA
84-AM-02 - Data Coordinating Center for a
Cooperative Clinical Study of Dietary Modifi-
cation of the Course of Progressive Renal
Disease Page 5
National Institute of Arthritis, Diabetes,
and Digestive and Kidney Diseases
Index - ARTHRITIS, DIABETES, AND
DIGESTIVE AND KIDNEY DISEASES

Continued

The NIH Guide is published at irregular intervals to announce scientific initiatives and to provide policy and administrative information to individuals and organizations who need to be kept informed of opportunities, requirements, and changes in grants and contracts activities administered by the National Institutes of Health.

Two types of supplements are published by the respective awarding units. Those printed on yellow paper concern contracts: solicitations of sources and announcement of availability of requests for proposals. Those printed on blue paper concern invitations for grant applications well-defined scientific areas to accomplish specific program purposes.

Have You Moved?

If your present address differs from that shown on the address label, please send your new address to: Grants and Contract Guide Distribution Center, National Institutes of Health, Room B3BN10, Building 31, Bethesda, Maryland 20205, and attach your address label to your letter. Prompt notice of your change of address will prevent your name from being removed from our mailing list.

Announcement

Availability of Request for Applications: RFA
National Research and Demonstration Centers
in Adult Respiratory Failure Page 6
Division of Lung Diseases
National Heart, Lung, and Blood Institute
Index - HEART, LUNG, AND BLOOD INSTITUTE

Announcement

Availability for Requests for Applications: RFA
Clinical Studies of Effects of
Orphan Products Page 7
Food and Drug Administration'
Index - FOOD AND DRUG ADMINISTRATION

Announcement

Request for Applications: RFA
84-ES-01 - Immunological Hypersensitivity
Resulting from Exposure to Environmental
Chemicals Page 8
National Institute for Environmental Health Sciences
Index - NATIONAL INSTITUTE FOR
ENVIRONMENTAL HEALTH SCIENCES

Announcement

Request for Applications: RFA
84-ES-02 - Mechanisms of Dioxin Toxicity Page 12
National Institute of Environmental Health Sciences
Index - NATIONAL INSTITUTE OF
ENVIRONMENTAL HEALTH SCIENCES

Announcement

Liver Transplantation Research Page 15
National Institute of Arthritis, Diabetes,
and Digestive and Kidney Diseases
National Institute of Allergy and Infectious Diseases
National Cancer Institute
National Institute of Child Health and
Human Development
National Institute of General Medical Sciences
Index - TRANS-NIH

Announcement

Availability of Senior International
Fellowships for 1985-86 Page 23
John E. Fogarty International Center for
Advanced Study in the Health Sciences
Index - FOGARTY INTERNATIONAL CENTER

Continued

Announcement

Small Grant Program Page 25
National Institute of dental research
Index - DENTAL RESEARCH

Announcement

Cerebrovascular Disease Related to Stroke Page 28
National Institute of Neurological
and Communicative Disorders and Stroke
Index - NATIONAL INSTITUTE OF NEUROLOGICAL
AND COMMUNICATIVE DISORDERS AND STROKE

Announcement

Antidepressant Drugs in the Treatment
of Anxiety Disorders..... Page 31
National Institute of Mental Health
Index - NATIONAL INSTITUTE OF MENTAL HEALTH

NOTICE

EARLY RELEASE OF SUMMARY STATEMENTS

The National Institutes of Health (NIH) awarding components are currently preparing to implement procedures by which program offices will send grant and cooperative agreement application summary statements, with priority scores, to the principal investigators (PIs) and program directors (PDs) for those applications, promptly following Initial Review Group (IRG) meetings and before the subsequent National Advisory Council/Board meetings.

PIs and PDs have been receiving summary statements through two procedures. Statements have been available through Privacy Act requests, under which they have been provided without priority scores when requested prior to Council/Board meetings. They have also been sent automatically following the Council/Board meetings, at which time the priority scores are displayed.

The new procedures for early release of summary statements will be effective with applications for the May 1984 round of National Advisory Council/Board meetings. Awarding components will thereupon discontinue the routine practice of sending IRG summary statements to PIs and PDs after Council/Board meetings, although additional communications will be sent regarding the actions at the latter, including any recommendations differing from those of the IRGs. Applicant investigators should continue to address all inquiries concerning summary statements to the appropriate program office.

NOTICE

NATIONAL RESEARCH SERVICE AWARD GUIDELINES REVISED

The Special Edition of the National Research Service Award Guidelines for Individual Awards - Institutional grants has been revised to reflect changes in policy and procedures affecting recipients of these awards. The revision is published as a Special Edition of this volume (Vol. 13, No. 1, January 6, 1984) of the NIH Guide for Grants and Contracts. Copies will be distributed to institutional offices of sponsored programs and training grant program directors. A limited number of additional copies may be available upon request from the following:

Office of Grant Inquiries
Division of Research Grants
National Institutes of Health
Bethesda, Maryland 20205

Telephone: (301) 496-7441

NOTICE

NEW APPLICATION FORM AVAILABLE FOR
NATIONAL RESEARCH SERVICE AWARD INSTITUTIONAL TRAINING GRANTS

A new competing National Research Service Award (NRSA) Institutional Training Grant application is available. The form, PHS 6025-1, Rev. 1/83, replaces form PHS 6025, Rev. 2/80 and any earlier revisions. The new application, which has undergone extensive changes, should be used for the June 1, 1984, and subsequent deadlines. (The old form will be accepted for the February 1, 1984, deadline.)

Individual requests for National Institutes of Health (NIH) NRSA application kits should be sent to:

Office of Grants Inquiries
Westwood Building - Room 449
Division of Research Grants
National Institutes of Health
Bethesda, Maryland 20205

Individual requests for Alcohol, Drug Abuse, and Mental Health Administration (ADAMHA) NRSA application kits should be sent to:

Grants Management Office
5600 Fishers Lane
Rockville, Maryland 20857

A self-addressed gummed label will expedite handling. Bulk supplies of the NRSA institutional grant application are available by writing the following:

Administrative Branch
Westwood Building - Room 438
Division of Research Grants
National Institutes of Health
Bethesda, Maryland 20205

Telephone: (301) 496-9797

The application kit covered by this announcement is the National Research Service Award Institutional Training Grant. The instructions for completing the application are specific to the NRSA program. Non-NRSA institutional training grant programs have their own application packets. Requests for such program kits should be made directly to the appropriate PHS agency or program office.

NOTICE

AVAILABILITY OF HUMAN CELL LINES ESTABLISHED FROM PATIENTS WITH
GENETIC DISEASES

NATIONAL INSTITUTE OF GENERAL MEDICAL SCIENCES

The National Institute of General Medical Sciences (NIGMS) sponsors a bank of human cell lines representing a wide variety of genetic disorders. The bank, known as the Human Genetic Mutant Cell Repository, is maintained at the Institute for Medical Research in Camden, New Jersey (Contract No. N01-GM-4-2100). The purpose of this cell bank is to promote and facilitate research on human genetic disease by providing to qualified investigators cell cultures that are of high quality, viable, well characterized, and free of contamination.

The cell bank contains fibroblast and lymphoblast lines from a range of inherited metabolic diseases or from disorders characterized by chromosomal abnormalities. There are approximately 3000 cell lines representing over 300 genetic diagnoses. These include disorders of amino acid, carbohydrate, lipid, protein, and nucleic acid metabolism. In addition to cell lines exhibiting well-characterized metabolic or chromosomal abnormalities, the cell bank includes a number of special collections of cell lines representing diseases where the defect cannot, as yet, be demonstrated in culture. These include cells from patients with psychiatric disorders, neurodegenerative disorders such as Huntington's disease, diabetes, cystic fibrosis and ophthalmologic diseases. Each special collection varies in size from a limited number of cell lines from unrelated individuals to sets of cells from large kindreds with numerous affected probands.

A modest fee is charged for these cell lines. A catalog summarizing information on cell lines stored in the cell bank is available from:

Dr. Arthur E. Greene
Institute for Medical Research
Copewood and Davis Streets
Camden, New Jersey 08103

Telephone: (609) 966-7377

ANNOUNCEMENT

AVAILABILITY FOR REQUEST FOR APPLICATIONS: RFA

84-AM-02

DATA COORDINATING CENTER FOR A COOPERATIVE CLINICAL STUDY OF
DIETARY MODIFICATION ON THE COURSE OF PROGRESSIVE RENAL DISEASE

NATIONAL INSTITUTE OF ARTHRITIS, DIABETES, AND
DIGESTIVE AND KIDNEY DISEASES

Application Receipt Date: March 15, 1984

The National Institute of Arthritis, Diabetes, and Digestive and Kidney Diseases (NIADDK) invites applications from organizations to serve as the Data Coordinating Center (DCC) in a multicenter cooperative clinical study, to ascertain the influence of controlled nutritional intervention on progression of chronic renal disease/renal insufficiency. The Data Coordinating Center shall participate with the NIADDK, and approximately ten (!0) Clinical Centers in all phases of this trial. A separate Request for Cooperative Agreement Applications (RFA-NIADDK-83-1) was published (NIH Guide for Grants and Contracts, Vol. 12, No. 9), inviting applications for Clinical Centers to participate with the NIADDK in this multicenter cooperative clinical study.

The Cooperative Agreement is similar in many respects to the traditional NIH research grant, but differs from a research grant principally in the extent and nature of the involvement of NIADDK staff. The staff of the NIADDK will be involved as an active partner in all aspects of the scientific and technical management of this study above and beyond the levels required for administration of traditional research grants.

The deadline for receipt of applications by the NIH Division of Research Grants (DRG) is March 15, 1984. Applications received after this date will not be considered. Logistics and managerial practicality necessitate that only applicant institutions in the United States will be eligible. Additional information and copies of a more detailed RFA, which outlines the DCC requirements for participation in the proposed study and the method of applying can be obtained from:

Gladys H. Hirschman, M.D.
Chronic Renal Disease Program Director
National Institute of Arthritis, Diabetes,
and Digestive and Kidney Diseases
National Institutes of Health
Westwood Building - Room 621
Bethesda, Maryland 20205

Telephone: (301) 496-7571

ANNOUNCEMENT

AVAILABILITY OF REQUEST FOR APPLICATIONS: RFA
NATIONAL RESEARCH AND DEMONSTRATION CENTERS
IN ADULT RESPIRATORY FAILURE

DIVISION OF LUNG DISEASES

NATIONAL HEART, LUNG, AND BLOOD INSTITUTE

Application Receipt Date: May 1, 1984

The National Heart, Lung, and Blood Institute (NHLBI) announces its intent to allow current Specialized Centers of Research (SCOR) in Adult Respiratory Failure to compete for designation as National Research and Demonstration Centers (NRDC). To attain this status, current SCOR grantees will have to submit a competing supplemental application that details plans for demonstration and education research activities that are thematically related to adult respiratory failure and for core activities that will serve to coordinate and integrate the various components of the NRDC.

A Request for Applications (RFA) will be sent to the current SCOR grantees in Adult Respiratory Failure. The application receipt date is May 1, 1984. After initial technical merit review these competing applications will be reviewed by the National Heart, Lung, and Blood Advisory Council in October 1984. The award date for successful applicants will be December 1, 1984 and the duration of these supplemental grants will be 4 years.

The issuance of the RFA for NRDC on Adult Respiratory Failure does not imply any intent to discontinue support for a separate and distinct Adult Respiratory Failure SCOR program. The NHLBI will continue to employ a variety of support mechanisms, including NRDCs, SCORs, investigator-initiated projects, training grants, and contracts, to promote its comprehensive research program.

Although this competition is limited to current SCOR grantees in Adult Respiratory Failure, other interested parties may receive an informational copy of the RFA by writing to:

Alfred Small, Ph.D.
Interstitial Lung Diseases Branch
Division of Lung Diseases
National Heart, Lung, and Blood Institute
National Institutes of Health
Westwood Building - Room 6A05
Bethesda, Maryland 20205

Telephone: (301) 496-7034

ANNOUNCEMENT

AVAILABILITY FOR REQUESTS FOR APPLICATIONS: RFA

CLINICAL STUDIES OF EFFECTS OF ORPHAN PRODUCTS

FOOD AND DRUG ADMINISTRATION

The Food and Drug Administration (FDA) announces the availability of funds for fiscal year 1984, for awarding grants to support clinical trials on safety and effectiveness of orphan products. FDA has funds to award approximately 10-20 grants ranging from \$20,000 to \$70,000. The Agency will consider grants greater than \$70,000 if they extend over a two or three year period. The awards will be made in June and July 1984.

Orphan products are drugs, biologics, medical devices (including in vitro diagnostics), food for medical purposes, and veterinary products that may be useful in an uncommon or common disease but lack committed commercial sponsorship because they are not considered commercially attractive for marketing. A subcategory of orphan products are those marketed products with suggestive evidence of usefulness in an uncommon, serious disease but which are not labeled for that disease because definitive evidence is lacking.

One way to make orphan products more easily available is to support research to determine whether the products are safe and effective. FDA has allocated funds to support such research.

INQUIRIES

In order to receive a copy of the Request for Application (RFA) or to receive further information, inquiries should be directed to:

Mr. Benjamin P. Lewis
Health Scientist Administrator
Office of Orphan Products Development/HF-35
Parklawn Building - Room 12-11
5600 Fishers Lane
Rockville, Maryland 20857

Telephone: (301) 443-4903

ANNOUNCEMENT

REQUEST FOR APPLICATIONS: RFA

84-ES-01

IMMUNOLOGICAL HYPERSENSITIVITY RESULTING FROM EXPOSURE TO ENVIRONMENTAL CHEMICALS

NATIONAL INSTITUTE FOR ENVIRONMENTAL HEALTH SCIENCES

Application Receipt Date: April 2, 1984

I. BACKGROUND INFORMATION

Acute hypersensitivity diseases refer to pathological states resulting from repeated sensitization to a specific compound or structurally related compounds. An increasing number of industrial chemicals or their metabolites which can be considered environmental pollutants induce lung and skin hypersensitivity reactions in humans. These compounds are sometimes directly antigenic but more often haptenate proteins or cellular constituents of the host.

The problem of occupational immunological illness is well recognized in industry resulting in both lung ailments and contact hypersensitivity. Although a variety of sensitive procedures have been identified in laboratory animals to determine the potential of a particular chemical to cause hypersensitivity, a large number of false positives and negatives have prevented accurate extrapolation to humans. Obviously, human testing with relatively unknown and potentially toxic chemicals is not possible.

II. GOALS AND SCOPE

The objective of this announcement is to indicate that the NIEHS has an interest in supporting high quality research in the area of chemical-induced hypersensitivity which will elucidate the role of environmental agents in producing adverse effects on the immune system.

Although all areas of research which will contribute to an understanding of the mechanism of action of these agents will be considered, emphasis will be placed on the development and validation of immunological methods, particularly short-term

This program is described in the Catalog of Federal Domestic Assistance, No. 13.112, Characterization of Environmental Health Hazards; 13.113, Biological Response to Environmental Health Hazards; 13.114, Applied Toxicological Research and Testing; 13.115, Biometry and Risk Estimation. Awards will be made under the authority of the Public Health Service Act, Title III, Section 301 (Public Law 78-410, as amended; 42 USC 241) and administered under PHS grant policies and Federal Regulations 42 CFR Part 52 and 45 CFR Part 74. This program is not subject to Health Systems Agency review.

in vitro tests to determine the potential of chemicals of environmental concern to induce lung and skin hypersensitivity reactions in humans.

In order to accomplish the goals of the program, the following areas of research have been identified for priority considerations.

- A. The development and refinement of short-term in vitro models for predicting chemicals that have allergic potential in humans.
- B. The application of hypersensitivity tests to evaluate changes in the immune response following exposure to chemicals of environmental concern.
- C. The validation of hypersensitivity tests in humans in order to determine accuracy of future extrapolation.
- D. Testing scheme(s) that provide a highly systematic and comprehensive approach to identify agents or chemical structure that might be potential sensitizers.

III. MECHANISM OF SUPPORT

The support mechanism for this program will be the NIH research project grant. This type of announcement (the RFA) is used when an Institute--with the concurrence of its National Advisory Council or another appropriate advisory group--wishes to stimulate investigator interest in a particular research problem that is important to its program. The RFA solicitation represents a single competition with usually one specific deadline for receipt of applications. All applications in response to an RFA are reviewed by the same initial review group in competition with each other, usually for a designated amount of funds or number of awards.

The RFA identifies the scope of the Institute's interest but does not require that the proposal conform to a specific research protocol. Thus it is expected that each successful applicant will plan, direct, and carry out the research program. As with any research grant, the recipient must obtain prior approval for any major change in the scope or objectives of the approved project. Applicants should be aware that this general requirement is particularly pertinent when, as in the case of RFA solicitations, the awarding Institute has committed funds in response to a specific program need.

It is anticipated that \$500,000 will be allocated for this program during the first year; however, award of grants is contingent upon the availability of funds. The project period should adequately reflect the time required to accomplish the stated goals and be consistent with the NIH policy for grant support.

IV. REVIEW PROCEDURES AND CRITERIA

A. Review Procedure

Proposals in response to this solicitation will be reviewed in competition with each other on a nationwide basis. The initial review will be for scientific merit and will be carried out by an appropriate peer review group. The secondary review for relevance and responsiveness to the announcement will be made by the National Advisory Environmental Health Sciences Council.

Applicants will be informed of the results of the competition as soon as possible after the September meeting of the Council.

B. Review Criteria

Applications must be responsive to the RFA and, therefore, relevant to the program goals of the sponsoring institute. Those factors considered to be important for review include a demonstrated knowledge of the applicable science, adequacy of facilities and commitment, availability of subject population when applicable and in-depth knowledge of the state-of-the-art to which the RFA is directed. The application will be judged upon the overall scientific merit, adequacy of methodology, facilities and proposal. The sponsoring institution should indicate a commitment of facilities and resources to the program.

Applications not responsive to this RFA but with a major objective to study the induction or progression of hypersensitivity lung diseases will receive primary assignment to the National Heart, Lung, and Blood Institute (NHLBI). Applications whose major emphasis is the immune mechanism will be referred to the National Institute of Allergy and Infectious Diseases (NIAID).

V. METHOD OF APPLYING

Applications should be submitted on form PHS 398, the application form for the traditional research grant. Applications kits containing this form and the necessary instructions are available in most institutional business offices or from the Division of Research Grants (DRG) NIH. The original and six copies of the application must be received by April 2. Applications must be sent to:

Division of Research Grants
National Institutes of Health
Westwood Building - Room 240
5333 Westbard Avenue
Bethesda, Maryland 20205

The face page of the application should be labeled **"In response to RFA-ES-84-01."**

VI. STAFF CONTACT

Questions relating to this announcement may be directed to Dr. Edward Gardner, Jr. (address above) or 919-541-7724.

Questions on research related to the interests of NIAID or NHLBI as indicated above should be address to one of the following as appropriate:

Robert A. Goldstein, M.D., Ph.D.
Chief, Allergy and Clinical Immunology Research
National Institute of Allergy and
Infectious Diseases
Westwood Building - Room 755
Bethesda, Maryland 20205
Telephone: (301) 496-7104

or

Suzanne S. Hurd, Ph.D.
Acting Director, Division of Lung Diseases
National Heart, Lung, and Blood Institute
Westwood Building - Room 6A16
Bethesda, Maryland 20205

Telephone: (301) 496-7104

ANNOUNCEMENT

REQUEST FOR APPLICATIONS: RFA

84-ES-02

MECHANISMS OF DIOXIN TOXICITY

NATIONAL INSTITUTE OF ENVIRONMENTAL HEALTH SCIENCES

Application receipt date: April 2, 1984

I. BACKGROUND INFORMATION

The range of potency of dioxins in producing biological damage in the species studied extends over a thousand-fold or more. In approaching the problem of estimating the risk of dioxin exposure to man, it appears that increased knowledge of the cellular and molecular systems affected will have unusual importance as a basis for reasoned decisions.

II. GOALS AND SCOPE

NIEHS is seeking research proposals which are directed toward a definition of the basic mechanisms that determine the toxicity of dioxins in different species of animals.

Several areas of research in the mechanisms of toxicity of dioxin have provided fundamental knowledge that may be further advanced at both the molecular and integrated systems levels. These include but are not limited to:

- A. The molecular genetics and regulation of enzymatic systems that are related to dioxin toxicity and the role of the dioxin receptor.
- B. The actions of dioxins in the molecular mechanisms which are entrained in the sequence of promotion of neoplastic transformation.
- C. The genetic sites and mechanism of regulation of epithelial cell differentiation which are involved in dioxin toxicity.
- D. The cellular immunology and immunogenetics that underlie the depressed immunity produced by dioxin.

This program is described in the Catalog of Federal Domestic Assistance, No. 13.112, Characterization of Environmental Health Hazards; 13.113, Biological Response to Environmental Health Hazards; 13.114, Applied Toxicological Research and Testing; 13.115, Biometry and Risk Estimation. Awards will be made under the authority of the Public Health Service Act, Title III, Section 301 (Public Law 78-410, as amended; 42 USC 241) and administered under PHS grant policies and Federal Regulations 42 CFR Part 52 and 45 CFR Part 74. This program is not subject to Health Systems Agency review.

- E. Abnormalities in the process of arachadonic acid metabolism, prostalandin and leurotriene synthesis that may be related to dioxin toxicity.

III. MECHANISM OF SUPPORT

The support mechanism for this program will be the NIH research project grant. This type of announcement (the RFA) is used when an Institute--with the concurrence of its National Advisory Council or another appropriate advisory group--wishes to stimulate investigator interest in a particular research problem that is important to its program. The RFA solicitation represents a single competition with usually one specific deadline for receipt of applications. All applications in response to an RFA are reviewed by the same initial review group in competition with each other, usually for a designated amount of funds or number of awards.

The RFA identifies the scope of the Institute's interest but does not require that the proposal conform to a specific research protocol. Thus it is expected that each successful applicant will plan, direct, and carry out the research program. As with any research grant, the recipient must obtain prior approval for any major change in the scope or objectives of the approved project. Applicants should be aware that this general requirement is particularly pertinent when, as in the case of RFA solicitations, the awarding Institute has committed funds in response to a specific program need.

It is anticipated that \$800,000 will be allocated for this program during the first year; however, award of grants is contingent upon the availability of funds. The project period should adequately reflect the time required to accomplish the stated goals and be consistent with the NIH policy for grant support.

IV. REVIEW PROCEDURES AND CRITERIA

A. Review Procedure

Proposals in response to this solicitation will be reviewed in competition with each other on a nationwide basis. The initial review will be for scientific merit and will be carried out by an appropriate peer review group. The secondary review for relevance and responsiveness to the announcement will be made by the National Advisory Environmental Health Sciences Council. Applicants will be informed of the results of the competition as soon as possible after the September meeting of the Council.

B. Review Criteria

Applications must be responsive to the RFA and, therefore, relevant to the program goals of the sponsoring institute. Those factors considered to be important for review include a demonstrated knowledge of the applicable science, adequacy of facilities and commitment, availability of subject population when applicable and in-depth knowledge of the state-of-the-art to which the RFA is directed. The application will be judged upon the overall scientific merit, adequacy of methodology, facilities and resources, commitment of time, and cost effectiveness of the proposal. The sponsoring institution should indicate a commitment of facilities and resources to the program.

Applications whose major thrust is on the primary immune mechanism will be referred to the National Institute of Allergy and Infectious Diseases (NIAID). If the application is determined to be unresponsive, the applicant will be given the option to withdraw the application or have it considered in the traditional grants program of NIH.

V. METHOD OF APPLYING

Applications should be submitted on form PHS 398, the application form for the traditional research grant. Application kits containing this form and the necessary instructions are available in most institutional business offices or from the Division of Research Grants, NIH. The original and six copies of the application must be received by April 2. Applications must be sent to:

Division of Research Grants
National Institutes of Health
Westwood Building - Room 240
5333 Westbard Avenue
Bethesda, Maryland 20205

The face page of the application should be labeled **"In response to RFA 84-ES-02."**

VI. STAFF CONTACT

Questions relating to this announcement should be directed to:

Dr. Edward Gardner, Jr.
Program Director
Regular Research Grants Program, SPB, EP
National Institute of Environmental
Health Sciences
P.O. Box 12233
Research Triangle Park, North Carolina 27709

Telephone: (919) 541-7724

Questions on research directly related to the immune mechanism should be addressed to:

Robert A. Goldstein, M.D., Ph.D.
Chief, Allergy and Clinical Immunology Research
National Institute of Allergy
and Infectious Diseases
Westwood Building - Room 755
Bethesda, Maryland 20205

Telephone: (301) 496-7104

ANNOUNCEMENT

LIVER TRANSPLANTATION RESEARCH

NATIONAL INSTITUTE OF ARTHRITIS, DIABETES, AND

DIGESTIVE AND KIDNEY DISEASES

NATIONAL INSTITUTE OF ALLERGY AND INFECTIOUS DISEASES

NATIONAL CANCER INSTITUTE

NATIONAL INSTITUTE OF CHILD HEALTH AND HUMAN DEVELOPMENT

NATIONAL INSTITUTE OF GENERAL MEDICAL SCIENCES

Application Receipt Dates: March 1, July 1, November 1

I. BACKGROUND INFORMATION

The above Institutes desire to expand their support of liver transplantation research. This announcement invites applications for individual research projects (R01 and R23) and supplements to existing Program Project grants (P01). In making this announcement, the intent is to encourage investigator-initiated research in the broad area of liver transplantation research. The research topics listed in Section II below are to provide examples but are not to be considered limiting.

The number of institutions now performing liver transplantation and the number of liver transplants being performed is increasing. A Consensus Conference on Liver Transplantation held at the National Institutes of Health (NIH) on June 20-23, 1983, concluded that "liver transplantation is a therapeutic modality for end-stage liver disease that deserves broader application". The availability of patients receiving transplants offers an important new resource for research into a variety of important questions concerning the pathogenesis of various liver diseases.*

*Digestive Diseases Advisory Board Report of 1983 - copies available from National Digestive Diseases Advisory Board, NIH
Liver Consensus Conference of June 20-23, 1983 - copies available from Office of Medical Applications of Research, NIH

These programs are described in the Catalog of Federal Domestic Assistance No. 13.848, Digestive Diseases and Nutrition, NIADDK; No. 13.855, Immunology, Allergic and Immunologic Diseases Program, NIAID; No. 13.399 Cancer Control NCI; No. 13.865 Center for Research for Mothers and Children, NICHD; and No. 13.859 Pharmacological Sciences Program NIGMS. Grants are awarded under the authority of Public Health Service Act, Section 301 (42 USC 241) and Section 402 (Public Law 78-410, as amended; 42 USC 241; 42 USC 282) and administered under PHS grant policies and Federal Regulations, most specifically 42 CFR Part 52 and 45 CFR Part 74. This program is not subject to review by a Health Systems Agency.

Various investigators currently involved with liver transplantation, having access to liver transplantation patients or material, as well as groups working on problems in general transplant immunology and pharmacology who could apply their expertise to problems of the liver, are encouraged to consider the areas listed, as well as many other unexplored areas of research that may improve the understanding of the pathogenesis of liver disease, the early identification and understanding of liver rejection, technical improvements in liver transplant procedure, pharmacology of immunosuppressant drugs and the use of monoclonal antibodies, liver regeneration and growth. The areas listed below are neither all inclusive nor directive but are meant to convey the wide array of disciplines and the excellent and diverse opportunities that exist. New applications, renewal applications with an expanded scope, and supplemental applications which incorporate liver research into ongoing programs such as transplant immunology of other organs, are all acceptable. The appropriate staff contact is indicated for each area or group of research topics.

II. RESEARCH GOALS AND SCOPE

A. Pathogenesis of Disease

- o Study of the recurrence or non-recurrence of disease in the donor liver may provide much information about the cause of the disease. The new liver will not carry the gene defect, and metabolic diseases which do recur must be due to extra-hepatic factors. Some conditions that can be examined are Wilson's disease, hemochromatosis, protoporphyria and storage diseases.
- o The ability of a liver transplant to reverse certain processes that result from end-stage liver disease can be studied, such as the bone disease of primary biliary cirrhosis, the neurological deficits in Wilson's disease, the chronic hepatic encephalopathy of cirrhosis.
- o In the hepatorenal syndrome, liver transplantation may correct the abnormality, implicating the liver in its pathogenesis. Substances such as vasoconstrictors may be looked for in the diseased liver.
- o In alpha-1-antitrypsin deficiency, both liver and lungs may be involved, yet liver transplantation may ameliorate the lung disorder and cure the liver problem. Is the new liver synthesizing and exporting alpha-1-antitrypsin to the lungs?
- o Can the study of liver transplant patients provide insights into metabolic diseases in which the liver performs a major functional role, such as the hyperlipoproteinemias?

B. Technical Aspects of Liver Transplantation

- o In some cases, host hepatectomy is extremely difficult and hazardous. For example, patients who have had previous surgery of the biliary tract, who have abnormal vessels or who have severe portal hypertension which usually results in massive operative blood loss. Can the procedure of auxiliary liver transplants be improved for these individuals? Currently, the success rate of the procedure is poor, but these procedures have not been tried with improved immunosuppressive therapy.

- o Crucial to successful auxiliary liver transplantation are studies into the importance, nature and mechanism of action of hepatrophic substances that help maintain liver growth and structure. The blood supply to auxiliary transplants would receive less of these substances than the blood supply of replacement transplants which receive virtually all of the blood drainage from the intestine.
- o Because of the limited number of donor organs, particularly for pediatric recipients, there has been some consideration of the use of a single lobe of liver for transplantation. From anatomical considerations, only the left lobe would appear suitable. Although this technique has been used in animal models, there have been no long-term human survivors. A far reaching clinical application of such research may be the use of living related donors.

C. Use of Resected Liver

- o Liver transplantation can provide investigators with a unique opportunity to study the liver in specific disease states. For example, the "autoimmune" nature of primary biliary cirrhosis and certain forms of chronic active hepatitis may be examined by eluting autoantibodies from the resected liver.
- o Immunologically active cells may be removed and tested in vitro for cytolytic and antibody producing potential.
- o The resected liver may serve to study the anatomy of the diseased liver; for example, the vascular supply of the biliary tree could be studied to define its relevance in biliary atresia.
- o The diseased liver may have accumulated abnormal metabolites which can be analyzed and may give a clue to the pathogenesis of the disease. This may be a unique opportunity for studying enzyme defects.
- o The cirrhotic liver might be harvested for mRNA for collagen to determine the molecular cause of the fibrous tissue deposition. Many other uses of the resected liver can be envisaged although any such use will require careful orchestration with the surgical team to obtain proper tissue. Various growth factors, enzymes, amines, etc., may be extracted from the resected liver.

Sarah C. Kalser, Ph.D.
Liver and Biliary Diseases Program
National Institute of Arthritis, Diabetes
and Digestive and Kidney Diseases
National Institutes of Health
Bethesda, Maryland 20205

Telephone: (301) 496-7858

D. Immunology of Liver Rejection

- o Early rejections are usually reversible, but are much harder to detect in an organ such as the liver than they are in the heart. Therefore there is

a need to develop quantitative blood tests that are indicative of rejection. For instance, there may be different types of T-cells in the circulation under immunosuppression in the presence or absence of rejection.

- o What is the nature of the rejection reaction in transplanted livers? Given the liver's place in the reticuloendothelial system, there may be a much greater degree of delayed hypersensitivity type reaction with infiltration of macrophages rather than cytotoxic lymphocytes in the rejecting liver. Monoclonal antibodies could be used to characterize the inflammatory cells infiltrating the hepatic allograft.
- o What is the histopathologic picture of acute rejection; of chronic rejection?
- o What is the distribution of HLA antigens in human liver? Are they on the parenchymal cells, the bile ducts, Kupffer cells? If hepatocytes display few HLA antigenic receptors in comparison with bile duct cells, does this account for the patterns of injury that are observed in rejection?
- o Will matching of HLA tissue types of the donor and the recipient reduce rejection of donor organs and increase patient survival? Such matching is not now carried out prior to liver transplantation because of the limited availability of donor organs and because of time constraints between identification of donor organs and the need for their transplantation.

E. Monoclonal Antibody and Liver Transplant Survival

The advent of cell cloning and hybridoma technologies has made possible the systematic preparation of monoclonal antibodies specific for cell-surface antigens. These antibodies can be used to:

- o Monitor lymphocyte populations in candidate patients for liver transplants; monitor lymphocyte and non-lymphocyte populations that are introduced into the patient via the liver transplant.
- o Evaluate the use of monoclonal antibodies as therapeutic agents for preventing and/or abrogating rejection episodes.

Jane S. Schultz, Ph.D.
 Genetics and Transplantation Biology Branch
 Immunology, Allergic and Immunologic
 Diseases Program
 National Institute of Allergy
 and Infectious Diseases
 National Institutes of Health
 Bethesda, Maryland 20205

Telephone: (301) 496-5598

F. Immunology of Liver Rejection in Cancer Patients

In addition to basic studies of the immunology of liver rejection, studies aimed at facilitating engraftment of a transplanted liver in cancer patients are of interest. For example:

- o What is the role of passenger leukocytes present in the donor liver in the establishment of engraftment/rejection?
- o What is the relationship of the patient's general immune status and of any antitumor immunity in the establishment of engraftment/rejection?

G. Effect of Immunosuppression in the Cancer Patient

The role of the immune system in the control of metastatic tumor growth is an active area of basic research. For studies of liver transplantation:

- o It is important to evaluate the effect of immunosuppression on the exacerbation of any potential metastatic disease developing after transplantation.
- o The use of cyclosporin A appears to be beneficial for survival of the transplant patient. Studies of its effects on the various components of the immune system and on the subsequent course of disease in the cancer patient would be useful.

H. Immune Response to Hepatic Tumors

Primary hepatic malignancy confined to the liver but not amenable to resection may be an indication for transplantation. Results to date indicate strong likelihood of recurrence of the malignancy.

- o The availability of large quantities of involved liver may allow for studies of the profile (phenotype, immunologic reactivity) of immune cells infiltrating the various involved areas of the resected liver.
- o Does the nature of the immune cell infiltrate in the resected liver correlate with subsequent emergence of metastatic disease following transplantation?
- o What role, if any, does antitumor immunity play in effectiveness of liver transplantation as treatment for primary hepatic tumors?

Faye C. Austin, Ph.D.
Immunology Program
Division of Cancer Biology and Diagnosis
National Cancer Institute
National Institutes of Health
Bethesda, Maryland 20205

Telephone: (301) 496-7815

I. Development, Regeneration and Nutrition

- o There is great potential for new knowledge on development of liver function by studying development of function in recipients of liver transplants.
- o Studies are needed on the regenerative properties of liver in infants and children. Experimental studies in animals directed toward the utilization of a single lobe of liver instead of the entire liver may allow the opportunity for studying the regenerative process. Should this experimental approach become feasible, it will be especially important to liver transplants in infants and children where the size of the transplant is a limiting factor.
- o The nutritional management of infants and children with disfunctional livers or who have received a liver transplant poses many problems. Assessment of nutritional status and matching of nutrients to the metabolic needs of these individuals are of great importance to clinical management.

Thorsten A. Fjellstedt, Ph.D.
Clinical Nutrition and Early Development Branch
National Institute Child Health
and Human Development
National Institutes of Health
Bethesda, Maryland 20205

Telephone: (301) 496-5575

J. Pharmacology of Immunosuppressant Drugs

The liver is a major site of metabolism of many drugs and xenobiotics. Transformation by various enzyme systems within the liver, including the cytochrome P450 system, results in compounds which are more water soluble and thus more easily excreted. While many compounds are rendered inactive by this procedure, others are made more toxic. In patients undergoing immunosuppressant therapy following liver transplantation, it is important to know the metabolic status of the immunosuppressant drugs as well as any other drugs to which the patient may be exposed. Aspects of this study include, but are not limited to:

- o Effects of pre-existing disease state on the pharmacokinetics and metabolism of immunosuppressant drugs.
- o Effect of immunosuppressant drugs on the hepatic cytochrome P450 system.
- o Interaction of immunosuppressant drugs with other drugs, especially those affecting the cytochrome P450 system.

- o Genetic determinants of immunosuppressant drug metabolism.

Christine K. Carrico, Ph.D.
Pharmacological Sciences Program
National Institute of General Medical Sciences
National Institutes of Health
Bethesda, Maryland 20205

Telephone: (301) 496-7181

In making this program announcement, it is not the intent of the above Institutes to make or imply any delimitation of investigator-initiated research in this field.

III. MECHANISM OF SUPPORT

The mechanism of support for this program will be the grant-in-aid. Research Project Grants (R01), New Investigator Research Grants (R23) and supplements to the preceding grants as well as to Program Project Grants (P01) will be accepted. The award of grants pursuant to this Program Announcement is contingent upon receipt of appropriated funds for this purpose. The specific amount to be funded will depend upon the cost of the research and the merit of the application. The earliest funding would be December 1984. All policies and requirements that normally govern the grant programs of the PHS apply. All applicants, both non-profit and for-profit institutions are eligible. This is not a one time invitation.

IV. REVIEW PROCEDURES AND CRITERIA

A. Review Procedure

Applications received in response to this announcement will be considered along with other non-solicited applications and will be assigned in accordance with the NIH Referral Guidelines. The initial review will be for scientific merit and will be carried out by an appropriate peer review group. The secondary review for relevance and responsiveness to the announcement will be made by the appropriate National Advisory Council or National Advisory Board.

B. Review Criteria

The factors considered to be important for review include a demonstrated knowledge of the applicable science, adequacy of facilities and commitment, availability of subject population, and in-depth knowledge of the state-of-the-art to which the announcement is directed. The application will be judged upon the overall scientific merit, adequacy of methodology, facilities and resources, commitment of time and cost effectiveness of the proposal.

V. METHOD OF APPLYING

Applications should be submitted on form PHS 398, the application for the traditional research grant. Application kits containing this form and the necessary instructions are available in most institutional business offices or from the Division

of Research Grants (DRG), NIH. The title **"LIVER TRANSPLANTATION RESEARCH"** should be typed in Section 2 of the first page of the application. The original and six copies of the application must be sent to the following:

Division of Research Grants
National Institutes of Health
Westwood Building - Room 240
5333 Westbard Avenue
Bethesda, Maryland 20205

ANNUAL RECEIPT AND REVIEW SCHEDULE

<u>Receipt Dates</u>		<u>Initial Review Group</u>	<u>Council Meeting</u>	<u>Earliest Possible Start Date</u>
<u>Renewal, Supplements</u>	<u>New</u>			
Feb 1	Mar 1	June	Sept/Oct	December 1
June 1	July 1	October	Jan/Feb	April 1
Oct 1	Nov 1	February	May	July 1

ANNOUNCEMENT

AVAILABILITY OF SENIOR INTERNATIONAL FELLOWSHIPS FOR 1985-86

**JOHN E. FOGARTY INTERNATIONAL CENTER FOR ADVANCED STUDY IN THE
HEALTH SCIENCES**

Application Receipt Date: June 1, 1984

The John E. Fogarty International Center for Advanced Study in the Health Sciences (FIC) announces the availability of senior postdoctoral fellowships to outstanding U.S. health scientists who wish to conduct collaborative research abroad. The purpose of these fellowships is to enhance the exchange of ideas and information in the biomedical, behavioral and health sciences. The types of activity that are supported by this program include collaboration in health studies, basic or clinical research, and the familiarization with or utilization of special techniques and equipment not otherwise available to the applicant. This program does not provide support for brief observational visits, attendance at scientific meetings, attendance in formal training courses, independent research projects, or full-time clinical, technical or teaching services.

I. ELIGIBILITY REQUIREMENTS

Applicants must meet the following requirements:

- o Be a U.S. citizen or permanent U.S. resident.
- o Hold a doctoral degree in one of the biomedical, behavioral or health sciences.
- o Have five years or more postdoctoral experience.
- o Have professional experience in one of the health, biomedical or behavioral sciences for at least two of the last four years.
- o Hold a full-time appointment on the staff of a U.S. not-for-profit institution.
- o Be nominated by the dean or appropriate U.S. institutional official.
- o Be invited by a not-for-profit foreign institution.
- o Not be a previous recipient of a Senior International Fellowship.

II. APPLICATION AND SELECTION

The next receipt date for Senior International Fellowship applications is June 1, 1984. All applications are reviewed for scientific merit by the National Institutes of Health (NIH). Fellowship awards are made for periods of three to twelve months. A fellowship must be activated within one year after receiving the Notice of Award and the starting date of the fellowship is set by mutual agreement

between the fellow and the collaborator at the foreign host institution. Prospective applicants for the Senior International Fellowship Program may obtain information brochures from FIC. Fellowship applications will be available from the FIC between January 15, 1984 and May 15, 1984 and may be requested only by the dean or equivalent institutional official. Information and fellowship applications are available from:

Senior International Fellowship Program
International Research and Awards Branch
Fogarty International Center
Building 38A - Room 615
National Institutes of Health
Bethesda, Maryland 20205

For an expeditious reply, please send a self-addressed label with your request to the above address.

ANNOUNCEMENT

SMALL GRANT PROGRAM

NATIONAL INSTITUTE OF DENTAL RESEARCH

I. PURPOSE

The National Institute of Dental Research (NIDR) Small Grants Program is intended to provide limited support for meritorious dental research projects in all program areas which include, but are not limited to, the following purposes:

- To conduct research which determines the feasibility of a research project. This may be described as the conduct of pilot studies or venture research.
- To develop and test new techniques and procedures for solving a particular research problem.
- To carry out a small clinical research project.
- To analyze existing data.

II. ELIGIBILITY

Investigators from any scientific discipline and at any stage of their career may apply for a Small Grant. These awards are appropriate for new investigators, and those changing areas of research or resuming research careers. Participation in this program by minority and women investigators and those located at institutions not traditionally associated with oral health research is encouraged.

III. TERMS AND CONDITIONS OF THE AWARD

The proposed project may be related to, but the aims must be distinctly different from those of, pending grant applications or funded research projects. The request may not be used to supplement projects currently supported by Federal or non-Federal funds or to provide interim support for projects under review by the Public Health Service.

Awards will be made under the authority of the Public Health Service Act, Title III, Section 301 (Public Law 78-410, as amended; 42 USC 241) and administered under PHS grant policies and Federal Regulation 42 CFR Part 52 and 45 CFR Part 74. This program is not subject to Health Systems Agency review. Research programs of the NIDR are described in the Catalog of Federal Domestic Assistance, Numbers 13.840, 13.841, 13.842, 13.843, 13.844, 13.845, and 13.878.

- Applicants may request up to \$15,000 (direct costs) for a one-year grant period. Successful applicants who require additional time to perform the proposed research may request extensions of the grant period without additional funds. This grant is not renewable; however, grantees under this program are encouraged to apply for a regular Research Project Grant to maintain continuity in their studies.

IV. APPLICATION PROCEDURE

Applications are to be submitted for February 1, June 1 and October 1 deadlines on form PHS 398. Forms are available at most institutional business offices or from the following:

Office of Grants Inquiries
Division of Research Grants
National Institutes of Health
Bethesda, Maryland 20205.

Specific supplementary instructions required for use by applicants to the NIDR Small Grant Program should be obtained from the following:

National Institute of Dental Research
Grants Management Office
Westwood Building - Room 518
Bethesda, Maryland 20205

Telephone: (301) 496-7658.

V. ALLOWABLE EXPENSES

Support may be requested for the following categories:

- Supplies
- Travel to attend a domestic meeting or to visit another laboratory for the purpose of gathering more information or to learn a new technique or procedure relevant to the application.
- Small items of equipment. The purchase of large pieces of equipment will be discouraged.
- Salary for technical personnel. Salary of the principal investigator will be allowed only with strong justification.

VI. REVIEW AND AWARD

A special NIDR review committee will determine the overall quality and scientific merit of each Small Grant application. Applications will be evaluated with respect to the following criteria: the significance and scientific merit of the proposed project, its characterization as an innovative and/or pilot project which provides a basis for more extended research. Additional consideration will be given to the investigator's potential for carrying out the project, the time commitment of the investigator, the adequacy of the facilities and the adequacy of the justifications presented for budget requests.

The application will be recommended for approval and assigned a priority score or recommended for disapproval. All applications will be forwarded to the National Advisory Dental Research Council (NADRC) for final review and recommendation on an accelerated schedule as follows:

<u>Receipt Date</u> <u>Annually</u>	<u>Institute Committee</u> <u>Review</u>	<u>Council</u> <u>Review</u>	<u>Earliest Possible</u> <u>Beginning Date</u>
February 1	March	May-June	July
June 1	July	Oct.-Nov.	December
October 1	November	Jan.-Feb.	March

Awards for application judged to have high scientific merit will be made as soon after the final review as possible.

For additional information, contact:

Deputy Associate Director for Extramural Programs
 National Institute of Dental Research
 Westwood Building - Room 504
 Bethesda, Maryland 20205

Telephone: (301) 496-7748

ANNOUNCEMENT

CEREBROVASCULAR DISEASE RELATED TO STROKE

NATIONAL INSTITUTE OF NEUROLOGICAL AND COMMUNICATIVE DISORDERS AND STROKE

The Stroke and Trauma Program of the National Institute of Neurological and Communicative Disorders and Stroke (NINCDS) invites applications for support of research that will increase our knowledge and understanding of cerebrovascular disease, especially in relation to stroke.

I. BACKGROUND

Stroke is a major cause of disability and death, particularly in the aged; it ranks as the third leading cause of death in the United States. At least a half-million Americans each year suffer a new, acute cerebrovascular event. The overall problem is even more imposing than annual incidence and mortality figures would indicate, since recurrent vascular accidents are common in nearly all forms of cerebrovascular disease. For survivors, disability and dependency are the usual result. The need for medical care and hospital facilities for these patients is enormous, and meeting that need remains a major challenge to medical and social service agencies alike.

II. GOALS AND SCOPE

The program is seeking investigator-initiated research grant applications for basic and applied studies related to the etiology, prevention, early (presymptomatic) diagnosis, and treatment of stroke, as well as for rehabilitation of stroke victims.

Examples of approaches related to cerebrovascular disease and stroke considered appropriate for support by the NINCDS include studies directed toward effects on the nervous system:

Basic research in cerebrovascular disease and the changes in metabolism and physiology of neurological tissue during and after anoxia and ischemia;

Stroke prevention, including epidemiology of risk factors;

This program is described in the Catalogue of Federal Domestic Assistance, number 13.853, Stroke, Nervous System Trauma. Grants will be awarded under the authority of the Public Health Service Act, Title IV, Section 301 (Public Law 78-410, as amended; 42 USC 241) and administered under PHS grant policies and Federal Regulations 42 CFR Part 52 and 45 CFR Part 74. This program is not subject to Health Services Agency review.

Function of central nervous system in controlling cerebral blood flow, vascular resistance, perfusion pressure, and related events as they pertain to stroke;

Conduct of clinical trials, when need can be justified, to evaluate new or previously unproven techniques in stroke prevention, diagnosis, treatment, or rehabilitation;

Application and evaluation of emerging techniques for the diagnosis and treatment of cerebrovascular disease;

Improved methods for measuring relation between cerebral blood flow and cerebral metabolism; and

Improvement of noninvasive diagnostic tests for differentiating clearly the several varieties of stroke and for detecting potential stroke patients.

Applicants are encouraged to address any specific aspects of the several examples listed above. This program announcement does not preclude investigator-initiated research proposals in other areas related to stroke.

Applications appropriate to the programs of other Institutes will be assigned accordingly. For example, applications that focus primarily on the vascular system without a neurological component, including cardiovascular risk factors, diagnostic techniques, or treatment, will be assigned to the National Heart, Lung, and Blood Institute (NHLBI).

III. APPLICATION AND REVIEW PROCEDURES

Although it is anticipated that most applications received in response to this announcement will be in the form of individual (traditional) research grants (R01), certain multidisciplinary research approaches may be better suited to the program project (P01) mechanism or appropriate as a stroke center. The published Guidelines for NINCDS Program Projects and Centers (NIH Guide for Grants and Contracts, Volume 10, Number 9, July 1981) will apply in these circumstances. A letter succinctly outlining the intended approach and contact with the Stroke and Trauma Program before submission of a program project grant or center application is recommended. "Guidelines for the New Investigator Research Award (NIRA)" can be found in the NIH Guide for Grants and Contracts, Volume 9, Number 1, January 3, 1980.

Applications should be prepared on form PHS 398 according to the instructions contained in the application kit. Applications are available from most institutional business offices, or may be obtained from:

Division of Research Grants
National Institutes of Health
Westwood Building - Room 240
Bethesda, Maryland 20205

Type the phrase **CEREBROVASCULAR DISEASE RELATED TO STROKE** in item 2 of the first (face) page of the application. The original and six (6) exact photocopies of the signed application should be mailed to the address above. The applications will be reviewed for scientific merit either by an appropriate study section of the DRG or by a review committee of the NINCDS.

Additional information may be obtained from:

Ms. Jean D. Benedict
National Institute Neurological and
Communicative Disorders and Stroke
Federal Building - Room 8A13
Bethesda, Maryland 20205

Telephone: (301) 496-4226

ANNOUNCEMENT

ANTIDEPRESSANT DRUGS IN THE TREATMENT OF ANXIETY DISORDERS

NATIONAL INSTITUTE OF MENTAL HEALTH

I. PROGRAM OBJECTIVES

The objective of this announcement is to encourage and stimulate research on the use of antidepressants in the treatment of anxiety disorders. Antidepressants are broadly defined to include the standard tricyclic antidepressants and MAO inhibitors such as imipramine and phenelzine, as well as the newer antidepressants such as the tetracyclic, maprotiline, and the triazolopyridine, trazodone. This announcement also encourages research on antidepressant drug use in a broad spectrum of anxiety disorders, including the following DSM-III diagnostic categories: agoraphobia with panic attacks, agoraphobia without panic attacks, social phobia, panic disorder, generalized anxiety disorder, obsessive compulsive disorder, and post-traumatic stress disorder. This announcement is restricted to the evaluation of psychopharmacologic agents either alone or in combination with behavior therapy.

II. RESEARCH ISSUES

Applications should focus on clinical and theoretical issues related to the use of antidepressants in the treatment of anxiety disorders, e.g., which antidepressants are best for which anxiety disorders, as well as the possible mechanisms of action of the antidepressants in these disorders. It is conceivable that more than one research issue described in this announcement will be incorporated in the grant application. Issues of research interest are listed below; other issues may occur to the applicant.

A. The Right Drug for the Right Patient

Specific research questions that might be addressed under this heading include:

- Are antidepressants only effective in patients with panic attacks? Because current thinking suggests the antidepressants have a direct biological effect in blocking panic attacks and have limited value as therapeutic agents in anxiety disorder patients who do not experience panic attacks, it would be of interest to test the comparative efficacy of antidepressants in agoraphobic patients with and without panic attacks.
- Are antidepressants effective in the treatment of patients with a DMS-III diagnosis of panic disorder? Reports of beneficial effects of antidepressants on panic attacks have been limited to agoraphobic patients with panic attacks and have not been replicated in panic disorder patients, i.e., patients who are not agoraphobic but who do experience panic attacks.

The effects of antidepressants on post-traumatic stress disorder patients are also an area for investigation.

- How effective are the antidepressants for the treatment of generalized anxiety disorder? A recent study showed imipramine to be more efficacious than the benzodiazepine chlordiazepoxide in the treatment of an outpatient sample of primarily anxious patients. This finding needs to be replicated along with a comparison of the efficacy of an antidepressant, such as imipramine, and one of the new benzodiazepines, such as alprazolam, in this patient population.
- Are any of the new benzodiazepines as effective as the antidepressants in the treatment of anxiety disorder patients with panic attacks? This question has taken on new meaning with the recent finding that a new benzodiazepine, alprazolam, was as successful as imipramine in the treatment of agoraphobics with panic attacks. Standard benzodiazepines such as diazepam have known benefits as anxiolytics in the treatment of generalized anxiety disorder patients and were felt to have some value in reducing anticipatory anxiety in agoraphobic patients with panic attacks. Prior to the recent alprazolam study, benzodiazepines had not proven effective in reducing or eliminating panic attacks. Comparative studies comparing the antiphobic and antipanic effects of the newer benzodiazepines with the antidepressants are a target area for research.

B. The Mechanism(s) of Action of the Antidepressants in the Treatment of Anxiety Disorders

Some of the antidepressants possess antipanic and antiphobic properties but it is unclear whether they have a direct biological effect on the physiological mechanisms that trigger panic attacks, or work only in depressed agoraphobic and panic disorder patients by reducing the depression in these patients. Not only an understanding of the psychophysiological effects of the drugs themselves is required but also an understanding of the pathophysiological mechanisms underlying the induction of panic attacks and of other forms of anxiety. For example, for spontaneous panic attacks a variety of pathophysiological mechanisms, including beta adrenergic overactivity and locus ceruleus instability, have been proposed.

Specific research questions that might be addressed under this heading include:

- Are antidepressants only effective in anxiety disorder patients who have significant depression in addition to their anxiety? Despite the importance of this issue, there are no systematic studies with sufficient numbers of anxiety disorder patients with both high and low initial levels of depression. This issue is of particular importance for patients with panic attacks where it has been proposed that the antidepressants have a direct biological effect on the panic attacks.
- What can we learn from attempts at a pharmacological dissection of anxiety? There are studies in this area underway which use psychopharmacologic agents as probes to further our understanding of the biologic bases for the anxiety disorders. For example, infusion of

sodium d-l lactate precipitates a panic attack in approximately 70 percent of patients with prior histories of panic attacks.

Further, if it can be shown that antidepressants that are ineffective in blocking panic attacks have different effects on neurotransmitter systems than antidepressants that are effective in blocking panic attacks, this would suggest that tricyclic antipanic and antidepressant mechanisms are distinct.

III. ELIGIBILITY

Private, nonprofit or for-profit and public institutions (such as units of State or local government and authorized units of the Federal Government) are eligible to apply for grants under this announcement.

IV. FUNDING AND TERMS AND CONDITIONS OF SUPPORT

It is estimated that approximately \$750,000 is available in Fiscal Year 1984 for awards under this announcement. It is anticipated that three to four grant projects can be supported from these funds. Applicants are urged to limit direct and indirect costs to under \$200,000. Applications may request a maximum period of support of five years. Support beyond that period must be requested by a competing extension application which will undergo the dual review described below and, if recommended for approval, compete for available funds. Grants are awarded directly to the applicant institution. Grant funds may be used only for those expenses clearly related to and necessary to carry out research projects, and must be expended in conformance with the Public Health Service Grants Policy Statement.*

In general, grant funds may be used for: (1) direct costs which are necessary to carry out the project, including salaries, consultant fees, supplies and equipment, and essential travel; (2) actual indirect costs to cover related overhead.

V. CONSULTATION AND INFORMATION

Potential applicants may contact Dr. Allen Raskin, Project Officer, for consultation concerning submission of applications in response to this announcement.

Allen Raskin, Ph.D.
Parklawn Building - Room 10C-14
5600 Fishers Lane
Rockville, Maryland 20857

Telephone: (301) 443-3527

*Public Health Service Grants Policy Statement, DHHS Publication No. (OASH) 82-50-000 GPO-017-020-00 90-1 (rev.) December 1, 1982, available for \$5.00 from the Superintendent of Documents, U.S. Government Printing.

VI. APPLICATION PROCEDURES

State and local government agencies should use form PHS 5161. All other applicants should use form PHS 398 (Rev. 5/82). Applications kits are available from the following:

Grants Operations Section
National Institutes of Mental Health
Parklawn Building - Room 7C-05
5600 Fishers Lane
Rockville, Maryland 20857

Telephone: (301) 443-4414

These kits may also be obtained from the grants office of a university. Instructions for applicants are included in the kit. The phrase, **Antidepressant Drugs in the Treatment of Anxiety Disorders**, should be entered in item #2 of the face page of the application.

The signed original and six copies (two copies if form PHS 5161 is used) of the application should be sent directly to:

Division of Research Grants
National Institutes of Health
Bethesda, Maryland 20205

VII. APPLICATION REVIEW AND AWARD PROCEDURE

A dual review system is used by PHS to assure that the highest standards of quality are applied to assessment of applications before funding decisions are made by authorized Federal officials. This system involves review of grant applications by initial review groups (IRGs), composed of non-Federal experts, for scientific or technical merit.

Each application receives a second review by the National Advisory Mental Health Council. Only those applications recommended for approval by Council may be considered for funding.

VIII. REVIEW AND AWARD CRITERIA

A. Review Criteria

Criteria in evaluating applications include:

- o potential contributions to the field in areas covered by the objectives and scope of this announcement
- o adequacy of the conceptual and theoretical framework for the research
- o evidence of familiarity with relevant research literature
- o scientific merit of the research design, approaches, and methodology
- o adequacy of the data analysis plan

- o qualifications and experience of the investigative team
- o adequacy of the existing and proposed facilities and resources
- o appropriateness of the budget, staffing plan, and time-frame to complete the project
- o adequacy of proposed procedures for protecting human subjects

B. Award Criteria

- o quality of the proposed project as determined during the review process
- o programmatic relevance of the proposed project
- o availability of funds
- o balance among objectives of the announcement.

IX. RECEIPT, REVIEW, AND AWARD SCHEDULE

<u>Receipt of Application</u>	<u>Initial Review</u>	<u>Advisory Council Review</u>	<u>Earliest Award Date</u>
March 1, 1984	June 1984	September 1984	September 1984

While this announcement invites applications for a specific receipt, review, and funding cycle, applications addressing the research issues described in this announcement may be submitted at any time after March 1, 1984, for consideration in the Institute's research grants program, the schedule for which is:

<u>Receipt of Application</u>	<u>Initial Review</u>	<u>Advisory Council Review</u>	<u>Earliest Award Date</u>
July 1	Oct.-Nov.	Jan.-Feb.	April 1
November 1	Feb.-Nov.	May	July 1
March 1	June	September	December 1

NIH Guide for Grants and Contracts

U.S. DEPARTMENT OF HEALTH
AND HUMAN SERVICES

SPECIAL EDITION

Vol. 13, No. 1. January 6, 1984

NATIONAL RESEARCH SERVICE AWARDS

Guidelines

for

Individual Awards - Institutional Grants

Public Health Service

National Institutes of Health

Alcohol, Drug Abuse, and Mental Health Administration

and

Division of Nursing, Health Resources Administration

The NIH Guide is published at irregular intervals to announce scientific initiatives and to provide policy and administrative information to individuals and organizations who need to be kept informed of opportunities, requirements, and changes in grants and contracts activities administered by the National Institutes of Health.

Two types of supplements are published by the respective awarding units. Those printed on yellow paper concern contracts: solicitations of sources and announcement of availability of requests for proposals. Those printed on blue paper concern invitations for grant applications in well-defined scientific areas to accomplish specific program purposes.

Have You Moved?

If your present address differs from that shown on the address label, please send your new address to: Grants and Contract Guide Distribution Center, National Institutes of Health, Room B3BN10, Building 31, Bethesda, Maryland 20205, and attach your address label to your letter. Prompt notice of your change of address will prevent your name from being removed from our mailing list.

NATIONAL RESEARCH SERVICE AWARDS

Guidelines

for

Individual Awards - Institutional Grants

January 6, 1984

Public Health Service

National Institutes of Health

Alcohol, Drug Abuse, and Mental Health Administration

and

Division of Nursing, Health Resources Administration

For Administrative Use Only

TABLE OF CONTENTS

E	Payback and Reporting Requirements for Recipients	20
1	Background	20
2	Amount of Payback Service	20
3	Criteria for Acceptable Payback	20
4	Alternative Service	21
5	Timing of Service Obligation	22
6	Financial Payback	22
7	Extension or Waiver of Payback	22
8	Annual Payback Activities Certification (Form PHS 6031-1, See Illustration VI.).....	24

Illustrations

1. General Steps in the NRSA Program
2. Research Fellowship Activation Notice
3. Statement of Appointment of Trainee
4. National Research Service Award
Payback Agreement
5. National Research Service Award
Termination Notice
6. National Research Service Award
Annual Payback Activities Certification

GUIDELINES FOR NATIONAL RESEARCH SERVICE AWARDS

A. BACKGROUND

Under authority of Section 472 of the Public Health Service Act (42 USC 2891-1) as amended, the National Institutes of Health (NIH), the Alcohol, Drug Abuse and Mental Health Administration (ADAMHA), and the Division of Nursing, Health Resources Administration (DN) provide National Research Service Awards to individuals for training in specified areas of biomedical and behavioral research at public and non-profit private institutions including Federal laboratories. NIH, ADAMHA, and DN also make NRSA grants to domestic public and non-profit institutions for the research training of individuals selected by the institutions. The National Research Service Award legislation requires recipients of support to payback the Federal Government by engaging in health related biomedical or behavioral research, teaching, or any combination of these activities. (See Section E. for details.) Title 42 of the Code of Federal Regulations, Part 66, is applicable to these awards.

1. Individual National Research Service Awards (Fellowships)

National Research Service Awards (NRSA) are made to individual fellowship applicants selected for award as a result of national competition for research training in specified health-related areas. NIH makes individual awards only at the postdoctoral and senior levels. NIH does not support individual predoctoral fellows except through the Minority Access to Research Careers program, which is announced separately. ADAMHA and DN make individual awards at both the predoctoral and postdoctoral level.

The application must clearly indicate the applicant's arrangements for sponsorship by a public or non-profit institution or a Federal laboratory that has the staff and facilities suitable to provide the proposed training. Under exceptional circumstances an individual may request support for training abroad. In such cases, the applicant is required to provide detailed justification based on the nature of the facilities, the training opportunity, and the particular suitability of the foreign situation, rather than the domestic, to the proposed research. The justification is evaluated in terms of the scientific advantages of the foreign training as compared to training available domestically. Only in cases where there are clear scientific advantages will the foreign training be approved.

Each applicant must (a) submit an application using forms provided by the appropriate agency (see Section B.2) and (b) arrange for submission of references on his or her behalf. The major emphasis of the application should be the research training experience and broadening of scientific competence. Postdoctoral applicants requesting training at their doctoral degree granting or current

training institution should explain in the application why further training at that institution would be valuable. The application must include the sponsor's Facilities and Commitment Statement and the applicant's signed statement that he or she has read the payback information and will meet the payback provisions required under the law as a condition for accepting the National Research Service Award. An individual may not have two competing NRSA applications pending review concurrently in the National Research Service Award program.

2. Institutional National Research Service Awards (Training Grants)

A domestic public or non-profit private institution may apply for a grant to support a research training program in a specified area(s) of research. Support for predoctoral, postdoctoral, or a combination of trainees may be requested. Each applicant institution must submit an application according to instructions, using forms provided by the appropriate agency (see Section B.2).

The applicant institution must have the staff and facilities required for the proposed program. The training program director at the institution will be responsible for the selection and appointment of trainees and the overall direction of the training program. In selecting trainees, the program director must make certain that individuals receiving support meet the eligibility requirements set forth in these guidelines.

B. GENERAL PROVISIONS

1. Eligibility

- a. Research Areas National Research Service Awards may be made for research training in areas which fall within the mission of NIH, ADAMHA, or HRA/DN as indicated in their program announcements. Applications which do not fit these guidelines will be returned.

An increased emphasis has been placed on the research training of physicians. The Secretary is required by law, in taking into account the Nation's overall needs for biomedical research personnel, to give special consideration to physicians who agree to undertake a minimum of two years of biomedical research.

- b. Research Training Program The National Research Service Award must be used to support a program of research training. The NRSA may not support studies leading to the M.D., D.O., D.D.S., D.V.M., or other similar professional degrees; nor to support residencies, the primary purpose of which is the attainment of a medical or nursing specialty. Research trainees in clinical areas are expected to devote their time to the proposed research training and to confine clinical duties to those which are a part of the research training.

c. Degree Requirements

- (1) Predoctoral Individuals, trainees or fellows, must have received, as of the beginning date of their NRSA appointment, a baccalaureate degree and must be training at the postbaccalaureate level in a program leading to the award of a doctor of philosophy of science or equivalent degree. NIH training grant program directors may appoint individuals at the predoctoral level who wish to interrupt their medical, veterinary, dental, or other professional school studies for a year or more to engage in full-time research training before completing their professional degrees. Program directors are advised to consult with NIH staff in the awarding unit before appointing such trainees unless such training was part of the approved training grant. Predoctoral fellows supported by ADAMHA must also have completed two or more years of graduate work and be enrolled in a doctoral degree program as of the proposed activation date. A predoctoral applicant to the Division of Nursing must be a registered professional with a baccalaureate or master's degree in nursing.
 - (2) Postdoctoral Individuals must have received, as of the beginning date of the NRSA appointment, a Ph.D., M.D., D.O., D.D.S., D.V.M., O.D., D.P.M., Sc.D., D. Eng., D.N.S., or equivalent domestic or foreign degree. Certification by an authorized official of the degree granting institution that all degree requirements have been met is also acceptable.
 - (3) Senior Fellows As of the beginning date of their award, senior fellows must have received a doctoral degree (as in B.l.c.(2) above) and must have had at least seven subsequent years of relevant research and professional experience. The senior fellowship is awarded by NIH to provide opportunities for experienced scientists to make major changes in the direction of their research careers, to broaden their scientific background, to acquire new research capabilities, or to enlarge their command of an allied research field. In addition, these awards will enable individuals beyond the new investigator stage to take time from regular professional responsibilities for the purpose of increasing their capabilities to engage in health-related research.
- d. Citizenship The individual to be trained must be a citizen or a non-citizen national of the United States or have been lawfully admitted for permanent residence at the time of application for individual applicants or at the time of appointment in the case of an institutional award. A non-citizen national is a person who, although not a citizen of the United States, owes permanent allegiance to the U.S. They are generally persons born in lands which are not States, but are under U.S. sovereignty, jurisdiction, or administration, for example, American Samoa. An individual

lawfully admitted for permanent residence must submit a notarized statement, upon activation of the award, indicating possession of the alien registration receipt card (I-151 or I-551). Individuals on temporary or student visas are not eligible for support from the NRSA.

2. Applications and Receipt Dates NIH application kits containing forms, instructions, and related information may be obtained from Office of Grants Inquiries, Division of Research Grants, National Institutes of Health, Bethesda, Maryland 20205, 301-496-7441. National Institute of Mental Health, National Institute on Alcohol Abuse and Alcoholism, or National Institute on Drug Abuse application kits are available from the appropriate ADAMHA component Grants Management Branch, 5600 Fishers Lane, Rockville, Maryland 20857. Division of Nursing information and applications are available from the Division of Nursing, Health Resources Administration, 5600 Fishers Lane, Rockville, Maryland 20857. The application for the institutional training grant is Form PHS 6025. The application for the individual fellowship is Form PHS 416-1. These application forms are also usually available at institutional Offices of Sponsored Research, Grants and Contracts Offices, or their equivalent.

Applicants are encouraged to submit applications well in advance of the published application receipt dates to allow sufficient time to provide any supplemental information which may be required. Application receipt dates are widely publicized in NIH, ADAMHA, and HRA/DN announcements. Applications received too late for one review will be considered at the next published review cycle.

3. Review Each initial application will be evaluated for scientific merit by a PHS peer review group. Institutional applications will also be reviewed by the appropriate Council, Board, or other advisory group to the PHS awarding unit whose activities relate to the proposed research training. Institutional applications will be evaluated on the basis of qualifications of participating faculty, the proposed research training objectives and program design, and the previous training record of the research program and its ability to attract high-caliber trainees. The extent of the institutional commitment, the available facilities, the quality of the training environment, and the relationship of the proposed program goals to the needs for research training in specified NIH, ADAMHA, and HRA/DN program areas will be considered. Applications for individual fellowship awards will be evaluated on the basis of the applicant's past academic and research record, the research training proposal, the sponsor's general qualifications, the training environment, publications, references, other relevant information, and the applicant's research goals in terms of the research training priorities specified by the awarding unit. Individual fellowship applications receive the normal initial review and a secondary staff review and are not reviewed by National Advisory Councils or Boards.

4. Notification of Action The applicant will be notified by letter concerning the final review recommendation. Approximately six to nine months transpire between the initial application and final notification. A Notice of Grant Award will be issued to applicants selected for funding.
5. Period of Support Institutional grants may be made for competitive segments of up to five years and are renewable. Awards within an approved competitive segment are normally made in 12-month increments with support for additional years dependent upon satisfactory progress and availability of funds. Trainees are customarily appointed for full-time 12-month periods. No trainee may be appointed under an institutional grant for less than nine months except with the prior approval of the awarding unit; and then usually only to complete a planned program of training. An appointment or a reappointment may not exceed 12 months without prior approval by PHS. The amount of the stipend and tuition for each full period of appointment must be obligated from funds available at the time the individual begins training, unless other instructions are furnished by PHS.

HRA/DN awards predoctoral individual fellowships for periods up to five years. ADAMFA limits predoctoral fellowships to three years. NIH, ADAMFA, and HRA/DN limit postdoctoral support to three years. The awards are made in 12-month increments.

All trainees and fellows are required to pursue their research training on a full-time basis devoting no less than 40 hours per week as specified by the sponsoring institution in accordance with its own policies.

No individual trainee or fellow may receive more than five years of aggregate NRSA support at the predoctoral level and three years of aggregate NRSA support at the postdoctoral level, including any combination of support from institutional and individual awards. Any exception to this requires a waiver from PHS based on review of justification from the individual and the sponsoring institution. The grounds for approving extensions of support are as follows:

- a. Physicians Individuals requiring additional time to complete training, either as a participant in a combined M.D.-Ph.D. program or physicians, dentists, and veterinarians who are completing postdoctoral research training, may anticipate favorable consideration of a reasonable request for waiver of the time limitation. This action is contingent upon certification of the recipient's good academic standing.

- b. Interruptions Requests for additional time will also be considered if an event unavoidably has altered the planned course of the research training; the interruption has significantly detracted from the nature or quality of the planned research training; and if a short extension would permit completion of the training as planned. Such events include sudden loss of the preceptor's services or an accident, illness, or other personal situation, which prevents a trainee or fellow from pursuing research training in an effective manner for a significant period of time. Requests for extension of support will also be considered if a short additional period would provide the trainee or fellow an opportunity to use an exceptional training resource.
- c. Other Exceptions Requests that do not arise from circumstances considered in 5.a. or 5.b. will be considered if they are accompanied by an exceptionally strong justification.

Requests for extension must be made in writing by the trainee or fellow and addressed to the awarding unit. The trainee's program director, or in the case of fellowship, the sponsor, must endorse the request certifying the need for additional time. The request must include a sound justification and specify the amount of additional time for which approval is sought.

6. Initiation of Support

a. Individual Fellowship

- (1) The awarding unit will notify the individual of the intention to make an award and confirm the actual plans for the start of the fellowship support. The Notice of Research Fellowship Award will be issued so that the individual may begin the fellowship immediately, or to permit a period of up to 6 months for the individual to finalize arrangements, such as the completion of degree requirements, final coordination with the sponsor, and, if necessary, a move to the sponsoring institution. The fellow must start the period of training under the award by the latest effective date or activation date as shown on the Notice of Research Fellowship Award. Extensions of the activation period may be granted for good reason.

The day the fellow begins training, the Activation Notice and the Payback Agreement must be completed and submitted to the awarding unit (see Sections D.1.(a)(1) and (2)). A stipend may not be paid until these forms are submitted and the fellow begins training. If necessary for payroll

purposes, the Activation Notice and Payback Agreement may be submitted up to 30 days in advance of the begin date. However, any change in this planned begin date must be reported immediately to the business office and the awarding unit. If an award is conditioned upon the completion of degree requirements, certification of completion by the degree granting institution must be submitted with the Activation Notice.

Subsequent periods of approved fellowship training are consecutive with the first year of support and are usually in 12-month increments. An Activation Notice and Payback Agreement are required at the beginning of each new year of support. If a fellow decides not to activate the award, or to terminate early, he or she should notify the institutional business office and the awarding unit immediately.

- (2) Domestic sponsoring institutions receive an award for the stipend and the institutional allowance. The fellow is then paid directly by the domestic institution, which also disburses the institutional allowance.

Fellows training at Federal laboratories are paid directly by the awarding unit, which also reimburses the fellow for appropriate expenditures from the institutional allowance. Fellows training at foreign sites receive direct payment for their stipend from the awarding unit, however, the institutional allowance is awarded to and disbursed by the sponsoring institution. See Illustration I for a summary of the general steps in the NRSA program (Fellow).

- b. Institutional Trainee A Notice of Grant Award is issued to the grantee institution normally with a start date of July 1 and with a budget period of 12 months.

A predoctoral or postdoctoral trainee may be appointed at anytime during the course of the budget period for an appointment period of 12 months.

At the time of each appointment, the training program director must submit a Statement of Appointment and a Payback Agreement to the awarding unit (see Sections D.1.(b)(1) and (2)). The Statement of Appointment includes biographical data on the trainee and the stipend level for the period of training. The stipend is paid by the institution directly to the trainee.

Subsequent appointments are consecutive with the first year of support. A Statement of Appointment and Payback Agreement must be submitted with each reappointment. See Illustration I for a summary of the general steps in the NRSA program (Trainee).

C. FINANCIAL PROVISIONS

1. Stipends A stipend is provided as a subsistence allowance for trainees and fellows to help defray living expenses during the research training experience. It is not provided as a condition of employment with either the Federal Government or the institution. Changes in stipend levels are published in the NIH Guide for Grants and Contracts. Stipends must be in accordance with the stipend levels set by this policy. No departure from the standard stipend schedule, as provided from the grant, may be negotiated by the institution with the trainee. Institutions may supplement stipends as necessary from institutional resources; however, no supplementation may be provided from Federal funds unless explicitly authorized under terms of the specific program from which the supplemental funds are derived. (See Sections D.2. and D.3. on Concurrent Benefits, Supplementation and Compensation).

a. Predoctoral The current stipend level for predoctoral individuals at all levels of experience is \$5,292 per annum.

b. Postdoctoral The stipend level for the entire first year of support is determined by the number of years of relevant postdoctoral experience at the time of appointment or in the case of an individual fellow, at the time the award is issued. Relevant experience may include research experience (including industrial), teaching assistantship, internship, residency, or other time spent in full-time studies in a health related field beyond that of the qualifying doctoral degree. The stipend for each additional year of NRSA support is the next level in the stipend structure and does not change mid-year. Current stipends effective July 1, 1983 for post-doctoral trainees and fellows are as follows:

<u>Years of Relevant Experience</u>	<u>Stipends</u>
0	\$14,040
1	14,736
2	15,468
3	16,236
4	17,040
5	17,892
6	18,780
7 or more	19,716

c. Senior Fellows (NIH only) The amount of the stipend to be paid shall be commensurate with the salary or remuneration which the individual receiving the award would have been paid by the institution with which he or she has a permanent affiliation on the date of the fellowship award, but in no

case shall the NIH stipend award exceed \$30,000. Fringe benefits are not provided with this award. The level of NRSA support will take into account concurrent salary support provided by the institution, other supplementation, and the policy of the sponsoring institution. Senior fellowships are made for full-time research training. Health professionals may utilize some of their time in clinical duties only if it is an integral part of the research training experience.

2. Other Costs

a. Individual Awards

- (1) Institutional Allowance An institutional allowance to support the costs of training may be requested and awarded. Interested applicants should consult the application guidelines from the respective awarding agencies regarding specific levels of the allowance for pre-doctoral and post-doctoral support, including those individuals training at Federal laboratories. Allowance levels are published in the NIH Guide for Grants and Contracts.

The allowance is intended to defray such expenses for the individual fellow as tuition and fees, research supplies, equipment, travel to scientific meetings, medical insurance, and to otherwise offset, insofar as possible, appropriate administrative costs of graduate training. The allowance for individuals training at Federal laboratories, which is administered by the PHS awarding unit, is intended to cover the costs of scientific meeting travel, medical insurance, and tuition and fees for specific courses. The following are specific guidelines for the use of the institutional allowance:

- (a) A fellow's tuition and fees, and medical insurance are allowable costs only if required of all persons in a similar training status regardless of the source of support. Family medical insurance is not an appropriate charge; however, the individual may elect personally to pay the differential between Self and Family options. Tuition and fees for postdoctoral fellows are limited to those for specific courses required by the training program.
- (b) Payment for travel to scientific meetings is appropriate when it is necessary to the individual's training. For fellows at Federal laboratories, reimbursement for travel cost is in accordance with the current government travel regulations prevailing at the Federal laboratory to which the fellow is assigned.

- (c) Funds may not be expended to cover the costs of travel between the trainee's place of residence and the domestic training institution, except that the grantee institution may authorize the cost of a one-way travel allowance in an individual case of extreme hardship.
- (d) The sponsoring institution authorizes the expenditure of the allowance in behalf of the fellow according to the institutional policy. The institution is entitled to expend up to the full institutional allowance upon official activation of the award. However, if an individual fellow is not in a training status for more than six months of the award year, only one-half of that year's allowance may be charged to the grant, the other half must be refunded to the PHS.

- (2) Travel to Foreign Training Site The awarding unit may authorize the cost of a single round trip economy or coach ticket to an approved foreign training site. As in the case of all foreign travel, U.S. carriers must be used when available.
- (3) Field Research Travel ADAMHA may also provide an additional allowance for field research where a fellow is undertaking a field research project as part of the research training and the annual allowance is not sufficient to cover the costs of such research.

b. Institutional Awards

- (1) Training Related Expenses Funds are provided to defray the costs of training such as staff salaries, consultant costs, equipment, research supplies, staff travel, and other expenses. Funds are requested and awarded as a lump sum on the basis of the predetermined amount per pre-doctoral and post-doctoral trainee approved for support. The current levels are published in the NIH Guide for Grants and Contracts. Interested applicants should also consult the application guidelines from the respective awarding agencies regarding specific levels for programs, such as the institutional training grant, short-term training program, and the MARC program.

- (2) Trainee Tuition and Fees Tuition, fees, and medical insurance are allowable trainee costs only if such charges are required of all persons in a similar training status at the institution, without regard to their source of support. Tuition at the postdoctoral level is limited to that required for specific courses in support of the approved training program. The trainee's medical insurance is an allowable cost only if required of all persons in a similar training status regardless of the source of support. Family medical insurance is not an appropriate charge. However, the trainee may elect personally to pay the differential between Self and Family options.
- (3) Trainee Travel Costs If requested by the institution, the awarding unit may award grant funds to cover the costs of trainee travel including attendance at scientific meetings which the institution determines to be necessary to the individual's training. Funds may not be expended to cover the costs of travel between the trainee's place of residence and the training institution, except the grantee institution may authorize a one-way travel allowance in an individual case of extreme hardship.
- (4) Rebudgeting of Funds Expenditure and rebudgeting of funds awarded in lump sum for training related expenses do not require awarding unit prior approval. When awarding unit prior approval is normally required for expenditures by the PHS Grants Policy Statement, the prior approval authority is delegated to the institution except that funds awarded for trainee costs (stipends and tuition and fees including medical insurance) may not be used for other purposes except under unusual circumstances and then only with the prior written approval of the awarding unit. Rebudgeting into or within the category of trainee costs is allowable without awarding unit prior approval. Trainee travel is not considered a trainee cost for the purpose of rebudgeting.
- (5) Expenditure of Funds Expenditure of all training grant funds are those permitted under the Public Health Service Grants Policy Statement and applicable cost principles, unless otherwise indicated in the Notice of Grant Award. A reasonable amount up to that awarded for training related expenses is considered available for expenditure even if the full complement of approved trainee positions is not filled.
- (6) Indirect Costs On institutional training grants, the institution will receive indirect costs based on their actual indirect cost rate, or 8% of total direct costs (exclusive of tuition and fees) whichever is less. Applications from State and local government agencies, except State universities or hospitals, may receive full indirect cost reimbursement.

D. OTHER TERMS AND CONDITIONS

1. Reporting Procedures for Individuals and Institutional Award Recipients

The following documents are critical to the process of establishing the payment of stipends and other costs, as well as the determination of possible payback service.

a. Individual Awards

- (1) Activation Notice (Form PHS 416-5, See Illustration II)
Immediately upon the initiation of training the individual completes and signs the Activation Notice, obtains the signature of the designated sponsoring institution officials, and forwards the notice along with the payback agreement to the NIH, ADAMHA, or DN awarding unit. An Activation Notice is enclosed with each Notice of Grant Award.

For fellows whose stipend is paid through the institution, the Activation Notice may be submitted up to 30 days before the individual goes on duty if such is necessary for payroll purposes. However, the institution should not release any money until the individual has actually begun training. Furthermore, if the individual does not begin research training on the day indicated, the institution must notify the PHS awarding unit immediately.

For fellows paid directly by PHS, the forms should not be submitted before he or she actually goes on duty. Stipend checks are issued when both the Activation Notice and the Payback Agreement are received by the awarding unit.

Approved continuation awards must be activated on the day following termination of the previous award period.

- (2) Payback Agreement (Form PHS 6031, See Illustration IV)
A National Research Service Award Payback Agreement must be signed by each individual who is to receive an individual fellowship and be submitted to the awarding unit annually with the Activation Notice. This form will be completed beginning with the initial period of support even though the first 12 months may be excluded from the cumulative payback requirement.
- (3) Progress Reports Interim progress reports must be submitted with all applications for continuation or renewal support in accordance with the instructions accompanying the application forms. For individual awards the terminal progress report is required as part of the Termination Notices.

- (4) Termination Notice (Form PHS 416-7, See Illustration V) Under an individual award, a Termination Notice is sent to the fellow by the awarding unit about one month prior to the scheduled termination date; for early terminations the form will be issued immediately upon receipt of information from the awardee or an authorized institution official. This form must be completed and returned to the awarding unit immediately. The lack of timely and accurate information on this form could adversely affect the payback determination.
- (5) Financial Status Report An annual or final Financial Status Report is not required on individual awards. In the event of early termination, the stipend must be prorated according to the amount of time spent in training. As mentioned in Section C.2.a.(1).(d), one-half of the allowance must be refunded if the training has been for six months or less.
- (6) Changes in the Project Individual awards are made for training at a specific institution under the guidance of a particular sponsor. A transfer to another institution, or a change in sponsor, requires the prior approval of the awarding unit. As a part of that approval process, if a fellow sponsored by a domestic non-Federal institution requests a transfer to another domestic non-Federal institution before the end of the current award year, the initial institution will continue to pay the stipend until the end of the current award year. Disposition of the institutional allowance is negotiable between the two sponsoring institutions.

Any proposed change in the individual's specified area of research training will be reviewed by the awarding unit to assure that the training continues, as required by law, to be in an area of need as specified by the awarding unit.

An interim sponsor must be named by the institution and approved by PHS when the sponsor is going to be absent for a period of more than three months.

b. Institutional Awards

- (1) Statement of Appointment (Form PHS 2271, See Illustration III) The institution must submit this form to the awarding unit at the start of each trainee's appointment or reappointment. No stipend or other allowance may be paid until the appointment form has been submitted along with a signed Payback Agreement. It is important to note that the information on the Statement of Appointment and the Termination Notice is the basis for determination of the length or amount of an individual's payback requirement. The

program director and the institutional financial officials should coordinate the information reported on the Statement of Appointment. It should be treated as a financial document for obligating costs (stipends) which later are reflected as part of the total costs in the Financial Status Report (see Section D.1.b.(6)). A supply of Statement of Appointment forms (PHS 2271) is provided to the program director by the awarding unit.

- (2) Payback Agreement (Form PHS 6031, See Illustration IV)
A National Research Service Award Payback Agreement must be signed by each individual who is to receive a stipend through an institutional award. This form and the Statement of Appointment is submitted annually at the time of each appointment. This form will be completed beginning with the initial period of support even though the first 12 months may be excluded from the cumulative payback requirement.
- (3) Verification Reports (for NIH only) A computer list identifying trainees for whom a Statement of Appointment of trainee form has been received by NIH will be mailed to program directors 60 days after the budget end date of each institutional grant. The list must be verified by the program director and an appropriate business official and returned to the Trainee Control Unit of the Division of Research Grants within 30 days after receipt.
- (4) Progress Reports Interim progress reports must be submitted with all applications for continuation support in accordance with the instructions accompanying the application forms. In addition, a terminal progress report must be submitted to the awarding unit within 90 days after the end of each competing segment of a project period.
- (5) Termination Notice (Form PHS 416-7, See Illustration V)
The institution must submit a Termination Notice immediately upon a trainee's termination of support under the grant. The lack of timely and accurate information on this form could adversely affect the payback determination. A supply of Termination Notices will be sent to program directors annually by the awarding unit.
- (6) Financial Status Report A Financial Status Report is required for all institutional grants no later than 90 days after the close of each budget period. This report will document the financial status of the grant according to the official accounting records of the grantee institution. Stipends and tuition are obligated for the full 12-month appointment from the budget

period in which the appointment is initiated. Portions of stipends and tuition that extend beyond the budget period are carried as unliquidated obligations. However, the report for the final budget period must have no unliquidated obligations and must indicate the exact balance of unobligated funds.

- (7) Changes in the Project Changes in the program objectives as they relate to the area of research training for which the grant was approved require prior approval by the awarding unit. Where absence of the program director is expected to exceed a continuous period of more than three months, plans for the conduct of the program during his or her absence must be approved by the awarding unit. Any proposed change of program director must be requested by the grantee institution and be approved by the awarding unit following review of the nominee's qualifications and re-evaluation of the project in the light of the proposed change. Institutional grants may be transferred from one institution to another only under most unusual circumstances. Such a change will generally be approved only if all of the major benefits attributable to the original grant can be transferred.

c. Interim Revisions

- (1) Any changes or corrections involving an appointment under an institutional grant, i.e., name, permanent mailing address, period of training, stipend support, must be reported by the training program director to the awarding unit on an amended PHS-2271 at the time of the change.
- (2) Any such changes related to an individual NRSA should be reported immediately by the fellow to the awarding unit by letter.
2. Concurrent Benefits A National Research Service Award may not be held concurrently with another Federally-sponsored fellowship or similar Federal award which provides a stipend or otherwise duplicates provisions of the NRSA. An individual may accept concurrent educational remuneration from the Veterans Administration (G.I. Bill) and Federal loan funds.
3. Stipend Supplementation - Student Compensation Trainees and fellows are supported for 12-month full-time training appointments for which they receive stipends to defray their expenses. Stipends may be supplemented by an institution from non-Federal funds without obligation by the fellow or trainee. Institutions can determine what amount of stipend supplementation, if any, will

be provided according to their own formally established policies governing stipend support. These policies must be consistently applied regardless of the source of funds. No Federal funds may be used for stipend supplementation unless specifically authorized under the terms of the program from which the funds are derived. An individual may make use of Federal educational loan funds or V.A. benefits when permitted by those programs as described above in Section D.2.

It is recognized that trainees and fellows as students may seek part-time employment coincidental to their training program in order to further offset their expenses. In circumstances of actual employment, the funds provided as compensation (salary or tuition remission) for services rendered, such as, teaching or laboratory assistance are not considered stipend supplementation. Funds characterized as compensation may be paid to fellows and trainees when there is an employer-employee relationship, the payments are for services rendered, and the situation otherwise meets the conditions of the compensation of students as detailed in the PHS Grants Policy Statement. Under these conditions trainees and fellows may be compensated for actual employment on Federal grants, including PHS research grants. However, it is expected that compensation from research grants will occur on a limited part-time basis for employment apart from the normal training activities which require a minimum of 40 hours per week (see Section B.5).

Under no circumstances may the conditions of stipend supplementation or coincidental employment detract from or prolong the approved training program.

Compensation may not be paid from a research grant which supports the same research that is part of the trainee's planned training experience as approved in the training grant application. Institutional training grant program directors or fellowship sponsors must approve all instances of employment on research grants in order to verify that the circumstances will not detract from or prolong the approved training program.

4. Leave

- a. Vacations and holidays Trainees in academic institutions are not entitled to vacations as such. They are entitled to the normal short student holidays observed by their training institution. The time between semesters or academic quarters is to be utilized as an active part of the training period. Trainees in non-academic institutions are entitled to the holiday and vacation schedule applicable to all trainees at the institution. A period of terminal leave (vacation) is not permitted and payment may not be made from grant funds for leave not taken.

- b. Other leave Up to 15 days per year of sick leave with pay may be taken without requesting permission from the awarding unit. Additional sick leave or other leaves of absence must have the prior approval of the sponsor or program director and the awarding unit and must be without pay. Maternity leave may be granted without pay, for a length of time that is in accordance with normal institutional guidelines and with the prior approval of the awarding unit. The fellowship or training support period may be extended upon return to full-time training.
5. Termination The Director of the awarding agency may terminate an Individual award or training grant prior to its normal expiration date (1) at the written request of the recipient, or (2) if the Director finds that the recipient has materially failed to comply with the terms and conditions of the award or to carry out the purpose for which it was made. In the event an award is terminated, the Director shall notify the awardee in writing of this determination, the reasons therefore, the effective date, and the right to appeal the decision.
6. Publications Trainees and fellows are encouraged to submit reports of their findings for publication to the journals of their choice. Responsibility for direction of the project should not be ascribed to NIH, ADAMHA, or HRA/DN. However, awarding unit support must be acknowledged by a footnote in language similar to the following: "This investigation was supported by (Name of Agency) , National Research Service Award (number) _____ from the (awarding unit) _____."
7. Copyright Except as otherwise provided in the conditions of the award, when publications or similar materials are developed from work supported by the awarding unit the author is free to arrange for copyright without awarding unit approval. Any such copyrighted material shall be subject to a royalty-free, nonexclusive, and irrevocable license to the Government to reproduce them, translate them, publish them, use and dispose of them, and to authorize others to do so.
8. Disposition of Professional Fees Fees resulting from clinical practice, professional consultation or other comparable activities performed pursuant to the purpose of the award may not be retained by the awardee. Such fees will be assigned to the sponsoring or grantee institution for disposition in accordance with PHS policy on grant related income. The term professional fees does not apply to honoraria, and fees for scholarly writing, delivery of occasional outside lectures, and service in an advisory capacity to public or private nonprofit organizations. These fees, if within institutional policy, may be retained by the awardee.

9. Taxability of Stipends Section 117 is that part of the Internal Revenue Code which applies to the tax treatment of all scholarships and fellowships. In general, it provides that, subject to certain limitations, degree candidates may exclude the full amount of their scholarships or fellowships from their gross income for purposes of taxation, and non-degree candidates may exclude up to \$300 a month of such awards for up to 36 months.

It must be emphasized that the interpretation and implementation of the tax laws are the domain of the Internal Revenue Service and the courts. PHS takes no position on what the status may be for a particular taxpayer, and it does not have the authority to dispense tax advice. Individuals should consult their local IRS office about the applicability of the law to their situations and for information on the proper steps to be taken regarding their tax obligations. The business office of the sponsoring institution will be responsible for the annual preparation and issuance of the IRS Form 1099 for fellows and trainees paid through the institution. PHS agencies will issue the subject form for all fellows paid directly by them (fellows training at federal or foreign laboratories).

10. Nondiscrimination Institutions administering National Research Service Awards are subject to (a) the prohibition against discrimination on the basis of race, color, or national origin imposed by Title VI of the Civil Rights Act of 1964 and the implementing DHHS regulations (45 CFR Part 80); (b) the prohibition against discrimination on the basis of sex imposed by Title IX of the Education Amendments of 1972, and in particular, section 901 of such Act and the implementing DHHS regulations (45 CFR 84); (c) the prohibition against discrimination against the handicapped imposed by section 504 of the Rehabilitation Act of 1973, as amended, and the implementing DHHS regulations (45 CFR 86); and (d) the prohibition against age discrimination imposed by the Age Discrimination Act of 1975 (45 CFR 90). Applicant organizations are required to have appropriate Assurance of Compliance forms, for example, HEW 441, HEW 641, HEW 639, or any other required assurances on file with the Office for Civil Rights, Office of the Secretary, DHHS, before a grant may be made to that institution.

11. Human Subjects - Animal Welfare - Recombinant DNA No award may be made unless the sponsoring or grantee institution has complied with the following:

(a) HHS Regulations for the Protection of Human Subjects (45 CFR 46), which require written Assurance of Compliance with the regulations and Certification to HHS of review and approval by an institutional review board for all nonexempt research involving human subjects.

On occasion, applications for training grants are submitted to the Department with the knowledge that subjects may be involved within the period of funding, but definite plans can not be set

forth in the application or proposal. These applications need not be reviewed by an IRB before an award may be made. However, except for research described in 46.101(b) (exempted research) no human subjects may be involved in any project supported by these grants until the project has been reviewed and approved by the IRB, as provided in these regulations, and certification submitted to the Department.

In activities such as the above, even though an IRB review need not take place at the time of submission of the application, DHHS requires the attachment to the application of the Form HHS-596, "Protection of Human Subjects Assurance/Certification/Declaration." This form may serve either as a certification that IRB review and approval has taken place for the research proposed in the application, or as a pledge that review and approval and submission of a certification will occur before human subjects are involved in the research.

In many instances trainees supported by institutional training grants will be participating in research supported by research project grants for which the IRB review of human subjects is already complete. This review is sufficient providing that the research would not be substantially modified by the participation of a trainee.

For proposed projects in which the research has received IRB review and approval, block 5 of the Form HHS-596, "Certification of IRB Review and Declaration of Exemption," should indicate the date of review. For research in which definite plans are not set forth in the application, instead of checking a box in block 5 of the Form HHS-596, the applicant should write "See Note," and on the reverse of the form indicate the following: "This is an institutional research training grant for which plans are not definite. A certification of IRB review and approval of research involving human subjects will be provided before the activity begins if certification has not already been filed. This is in accord with 45 CFR 46.11.8";

(b) Chapter 1-43 of the HHS Grants Administration Manual (Chapter 1-43 of the PHS Grants Administration Manual) which requires written assurance of compliance with PHS animal welfare policy. (The Office for Protection from Research Risks, NIH, 3A18 Westwood Building, Bethesda, MD, 20205, can be contacted for information and instructions on the requirements for protection of human subjects and animal welfare.)

(c) The current NIH Guidelines for Research Involving Recombinant DNA Molecules. (The Office of Recombinant DNA Activities, NIH, Building 31 Room 4A52, Bethesda, MD 20205, can be contacted for further information.)

E. PAYBACK AND REPORTING REQUIREMENTS FOR RECIPIENTS

1. Background The National Research Service Award legislation requires recipients of support to pay back the Federal Government by engaging in health related biomedical or behavioral research, teaching, or combination of these activities. The NRSA payback obligation may be satisfied by either serving in a position in which a combination of biomedical or behavioral research or teaching constitutes more than 20 hours per week or by financially recompensating the Government in an amount of money determined in accordance with a recovery formula specified in the legislation. Payback is required in an amount equal to the total period of support in excess of the initial 12 months of support. This section outlines the payback provisions and procedural requirements necessary for institutions and individuals to comply with the payback obligation.
2. Amount of Payback Service The amount of required payback service is equal to the total period of support in excess of the initial 12 months of postbaccalaureate support. Once an individual has had 12 months of postbaccalaureate NRSA support, all subsequent NRSA support is subject to payback.
3. Criteria for Acceptable Payback The NRSA payback obligation may be satisfied by either serving in a full-time position in which health-related research or teaching constitutes the primary activity or, if not serving in a full-time position of this kind, engaging in such research or teaching in a position(s) for periods that average more than 20 hours per week of a full work year. It is generally expected that any full-time academic appointment in a biomedical or behavioral field would meet the payback requirement. Teaching and research duties include not only time spent in the classroom, laboratory, or research clinic, but also time spent in preparation for those activities. Total employment averaging 20 hours or less a week cannot be counted toward fulfilling the payback obligation.

Payback service must be performed following completion of NRSA training. No amount or type of activity prior to or during the tenure of NRSA support will satisfy the NRSA payback obligation.

- a. Research For the purposes of NRSA, research is defined as activity which involves the design of experiments, development of protocols, and collection and interpretation of data. Research support functions, such as routine laboratory analyses, managerial and administrative activities, and a technical advisory role on development or marketing of products are not considered to be research.
- b. Teaching The range of activities acceptable as teaching will take into account the certifying institution's policy on the definition of teaching responsibilities. Teaching activities will be accepted only if they take place in an organized educational or other instructional environment.

- c. Research Setting The research setting may be in the academic, governmental, or commercial sector—domestic or foreign. The academic sector includes universities, professional schools, research institutes, teaching hospitals, colleges, and universities. The source of funds supporting the payback activity is not generally restricted. An individual could be supported by a PHS grant or by a grant or fellowship from another organization. The only restriction on the sources of funds is that a payback activity may not be supported by another NRSA award.
- d. Payback Limitations Credit for research and teaching activities undertaken by the recipient after terminating NRSA support, but while still in training status for example, activities as graduate student, resident, or clinical fellow, is subject to the following limitations:
- (1) Credit for service will be given only in instances where the proposed teaching or research activities include responsibilities that distinguish them from activities required of trainees and which require more than 20 hours per week. For graduate students the distinguishing feature may be assignment of responsibility as teaching assistant or laboratory instructor or responsibility for conduct of research; for residents and clinical fellows the distinguishing feature may be teaching responsibility other than clinical supervision or responsibility for conduct of research that is not a requirement of residency training.
 - (2) Without such distinguishing responsibilities, the dissertation research of graduate students or the clinical supervision characteristic of residency or clinical fellowship training are unacceptable as payback service. However, some advanced resident positions in which research or teaching is either the primary activity or involves more than 20 hours a week may count toward fulfilling the payback obligation.
4. Alternative Service Alternative service in lieu of research and teaching was deleted by the Omnibus Budget Reconciliation Act of 1981. Individuals who entered the NRSA program on or after August 13, 1981, the date the Act was signed, are not eligible for alternative service. Individuals who entered the NRSA program before August 13, 1981 are governed by the alternative service provisions in effect when their appointment started. The Secretary, DHHS, must authorize alternative service and make a determination that no suitable research or teaching positions are available to the individual. More information on alternative service is available from the awarding unit.

5. Timing of Service Obligation An individual must begin to undertake the payback service requirement within two years after the termination date of the individual's NRSA support.
6. Financial Payback If any individual to whom the requirement for service is applicable fails to undertake or perform such service as required in E.5. above, the United States shall be entitled to recover from the individual the amount determined in accordance with the following formula plus interest:

$$A = \phi \frac{t-s}{t}$$

Where "A" is the amount the United States is entitled to recover. " ϕ " is the sum of the total amount paid to the individual under the National Research Service Award support less the amount paid for the initial twelve months. "t" is the total number of months in the individual's service obligation. "s" is the number of months of the obligation served by the individual. The total paid to the individual (ϕ) under institutional grants and individual awards at domestic, non-federal sponsoring institutions is considered to be the stipend only. The total paid an individual under a fellowship award at a foreign sponsoring institution includes the payment for the round trip travel costs. The total paid an individual under a fellowship award at a federal sponsoring institution includes any money expended from the institutional allowance provided for such purposes as medical insurance, travel, tuition, and fees.

Interest on the amount begins and is at a rate fixed by the Secretary of the Treasury considering private consumer rates which prevail on the date the determination is made that the NRSA payback requirements will not be fulfilled through service. The amount to be recovered financially shall be paid to the United States within the three-year period following such date.

7. Extension or Waiver of Payback

- a. Extension The Secretary, DHRS, may extend the period for undertaking payback service, permit breaks in continuous service, or extend the period for repayment if the Secretary determines:
- (1) such an extension or break in service is necessary so the individual may complete his or her research training;
 - (2) the individual is unable to complete the requirements within the required period because of a temporary disability; or
 - (3) completion by the individual of the requirement within the required period would involve substantial hardship to the individual and that failure to extend the period would be against equity and good conscience.

Reasons for an extension or break in service include such things as physicians completing residency training and graduate students completing degree requirements. Requests must be made in writing to the awarding unit, specifying the need for additional time and the length of the required extension.

- b. Waiver Where an individual fails to undertake or perform such service requirement the Secretary, DHHS, may waive in whole or in part the obligation of the individual to repay upon determination that compliance by the individual is impossible, or would involve substantial hardship, and enforcement of the obligation to that individual would be against equity and good conscience. Requests for waivers should be made in writing to the awarding unit and explain the need for waiver according to the following criteria:
- (1) Compliance by an individual will be deemed impossible if the individual is permanently and totally disabled;
 - (2) In determining whether compliance would involve substantial hardship to the individual and would be against equity, the Secretary shall take into consideration:
 - (a) the individual's present financial resources and obligations;
 - (b) the individual's estimated future financial resources and obligations;
 - (c) the reasons for the individual's failure to complete the requirements within the prescribed period, such as problems of a personal nature;
 - (d) the extent to which the individual has engaged in payback activities;
 - (e) whether the individual has received sufficient training to be qualified to perform such activities; and
 - (f) the unavailability of employment opportunities appropriate to the individual's education and training; or
 - (3) Any obligation of any individual toward payback will be cancelled upon the death of the individual.

8. Annual Payback Activities Certification (Form PHS 6031-1,
See Illustration VI)

- a. Annual Certification Approximately one year after the completion of NRSA support, if an individual has incurred a payback obligation, he or she will receive an Annual Payback Activities Certification (APAC) form. On this form, the individual will report the activity in which he or she was engaged for the preceding 12 months. These forms are to be returned within 30 days of the reporting period end date to:

Trainee and NRSA Control Office
Division of Research Grants
National Institutes of Health
Westwood Building
5333 Westbard Avenue
Bethesda, Maryland 20205

The PHS awarding unit will review the activity and make a decision on its acceptability and inform the former awardee of the decision. This process will continue annually until the individual's total payback obligation is satisfied. Individuals who do not submit an APAC or cannot be located will have their file forwarded to the appropriate agency for financial payback.

- b. Change of Address Any change in the mailing address of a NRSA recipient must be reported promptly to the Trainee and NRSA Control Office (see above). This should continue for a minimum period of five years following the completion of support or for such additional time as is required to ensure satisfaction of the payback obligation and to participate in occasional program evaluation.

Request for policy clarification in individual cases should be addressed to the appropriate PHS awarding unit.

GENERAL STEPS IN THE NRSA PROGRAM
INSTITUTIONAL (TRAINEE)

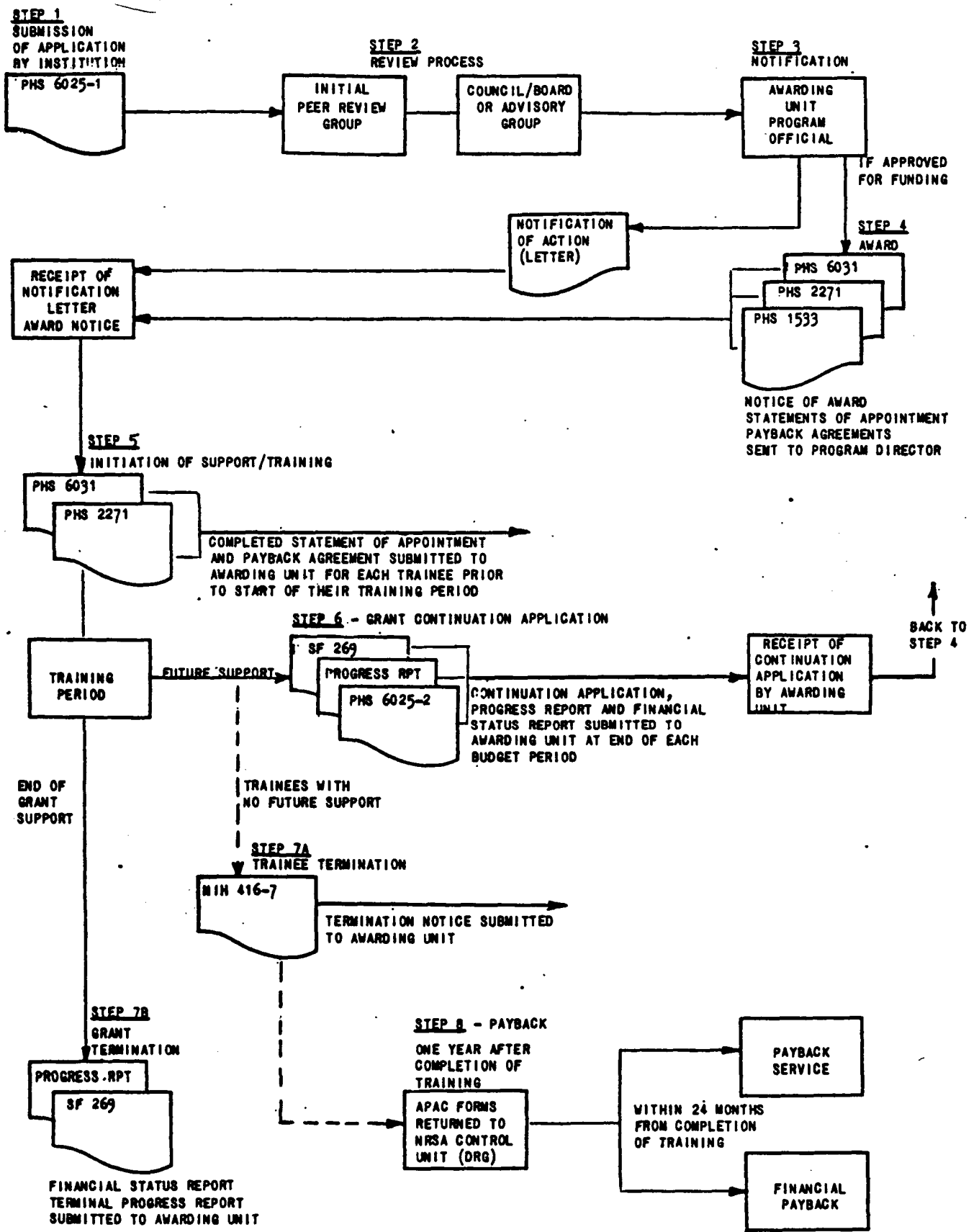

GENERAL STEPS IN THE NRSA PROGRAM
INDIVIDUAL (FELLOW)

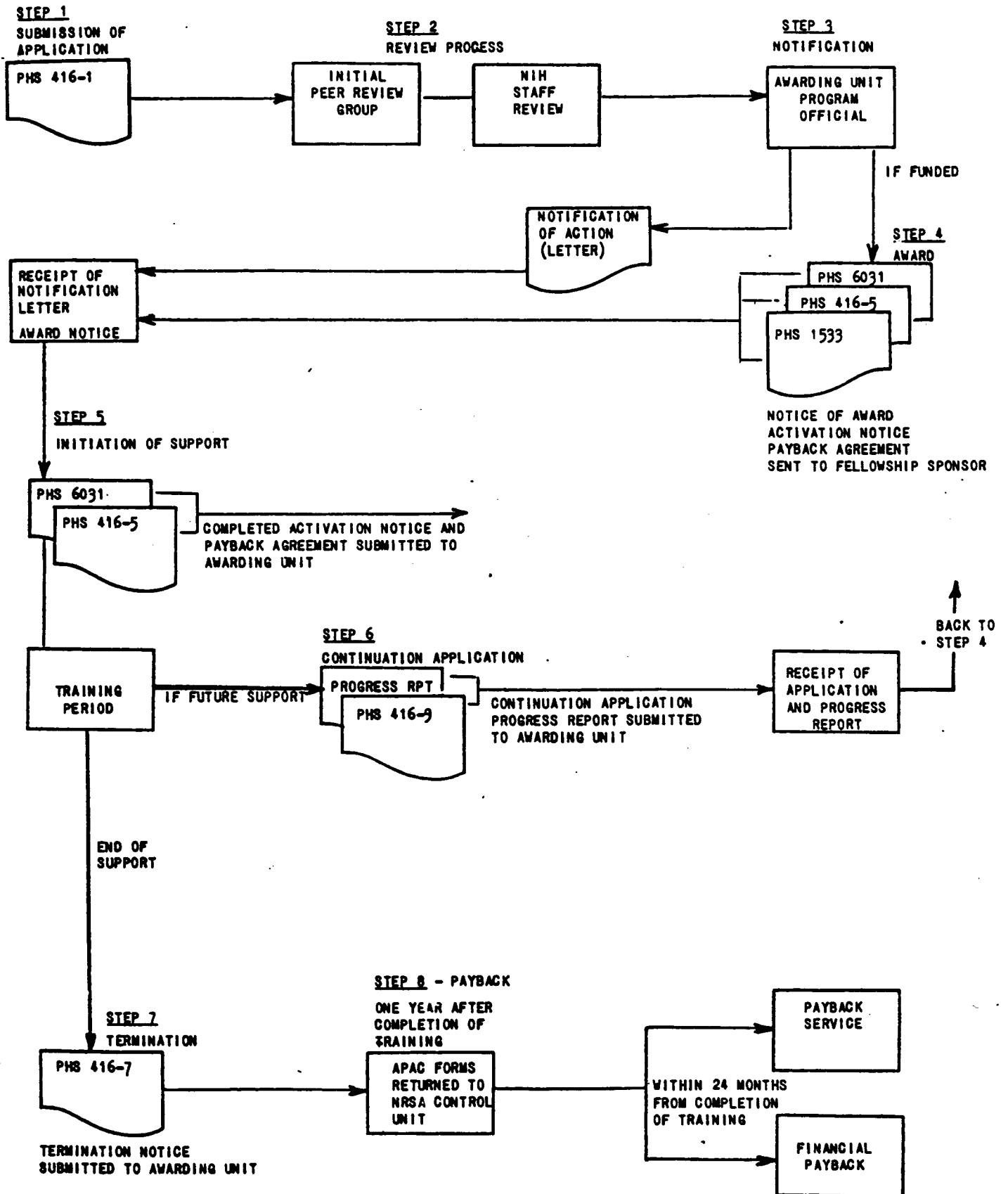

Please use typewriter. Return original and first three copies.

DEPARTMENT OF
HEALTH AND HUMAN SERVICES
PUBLIC HEALTH SERVICE

FELLOWSHIP NUMBER

DATE FELLOW ENTERED ON DUTY (Month, day, year)

RESEARCH FELLOWSHIP ACTIVATION NOTICE

1. Send the original and first three copies of the completed form to the address in the "RETURN TO" box immediately after the fellow enters on duty. Keep the last copy.
2. An appropriate statement regarding degrees (certified by degree granting institution) must be attached if such contingency appears on the award notice.
3. For National Research Service Awardees, a signed payback agreement must accompany this form.
4. No funds may be disbursed until the fellow enters on duty, and the proper forms are submitted to PHS.

NAME OF FELLOW (Last, first, middle initial)	NAME OF SPONSORING INSTITUTION
RETURN TO:	FULL ADDRESS WHERE CHECKS SHOULD BE MAILED <i>Fellows sponsored by Federal or foreign institutions should see * below before completing.</i>

* Foreign sponsored fellows are encouraged to have monthly stipend checks deposited in a financial institution located in the United States because of past delays encountered in foreign mail deliveries. Fellows are responsible for making the financial arrangements of their choosing, include account number, name, and mailing address of the financial institution above.

REQUIRED SIGNATURES

FELLOW	TELEPHONE (Code, no., and extension)	DATE
SPONSOR	TELEPHONE (Code, no., and extension)	DATE
INSTITUTIONAL BUSINESS OFFICIAL	TELEPHONE (Code, no., and extension)	DATE

DO NOT WRITE IN THIS BLOCK (FOR PHS USE ONLY)

AWARD PERIOD		COMMON ACCOUNTING NUMBER	LIST NUMBER
From:	Through:		
(FOR DIRECT PAY FELLOWS)		SPECIAL INSTRUCTIONS	
STIPEND (Monthly) \$ _____	Total \$ _____	PREPARED BY: _____ DATE: _____	
TRAVEL	\$ _____		
OTHER	\$ _____		
TOTAL PAYMENT	\$ _____		

N See instruction sheet and follow carefully. Complete and submit this form at the time trainee enters training, is reappointed, or the
O reported appointment is amended. Return Institute/Division copy, green copy, and DRG Statistical copy to the PHS Awarding
T component. For National Research Service Award (T32) trainees, a signed payback agreement must accompany this form on new
E and reappointments. PLEASE USE TYPEWRITER.

DEPARTMENT OF HEALTH AND HUMAN SERVICES Public Health Service STATEMENT OF APPOINTMENT OF TRAINEE		1. Type _____ Activity _____ I/D Serial No _____																								
3. NAME OF TRAINEE (Last, first, initial) _____		2. TYPE OF ACTION (Check one type) <input type="checkbox"/> New Appointment (NOT previously supported by this grant) <input type="checkbox"/> REAPPOINTMENT (Previously supported by this grant) <input type="checkbox"/> AMENDMENT OF ITEMS CHECKED <input type="checkbox"/> 3 <input type="checkbox"/> 4 <input type="checkbox"/> 16 <input type="checkbox"/> 18																								
5. SOCIAL SECURITY NO. _____	6. SEX <input type="checkbox"/> F <input type="checkbox"/> M	4. PERMANENT MAILING ADDRESS _____ 7. Birthdate (Mo., day, yr.) _____																								
8. U.S. Citizen or U.S. Noncitizen National OR Permanent Resident of U.S. <input type="checkbox"/> Yes <input type="checkbox"/> No (See instructions)		9. PRIOR NRSA SUPPORT (Individual or Institutional) <input type="checkbox"/> Yes <input type="checkbox"/> No (If YES, See instructions)																								
10. EDUCATION - AFTER HIGH SCHOOL (Include all academic and professional education. For foreign degrees, give U.S. equivalent.)																										
NAME OF INSTITUTION, DEPARTMENT & LOCATION	Month and Year Attended From: _____ To: _____	Degree(s) Received Degree: _____ Mo. & Yr. _____	MAJOR FIELD	MINOR FIELD																						
11. EMPLOYMENT - AFTER COLLEGE (Include military service, internships and residencies)																										
NAME AND LOCATION OF EMPLOYER	OCCUPATION OR POSITION TITLE	FROM Mo. & Yr. _____	TO Mo. & Yr. _____																							
12A. Name of Specialty Board: _____		12B. Seeking Certification For _____		12C. Certified by (include date of certification) _____																						
13A. Is Trainee Seeking a Degree? <input type="checkbox"/> Yes <input type="checkbox"/> No		13B. Degree(s) Sought _____		13C. Month and Year Expected _____																						
14A. Discipline, Specialty or Field of Proposed Training _____			14B. Subdiscipline or Subspecialty of Proposed Training _____																							
15. Will this Training be taken in an Institution, School, Department other than that entered in item 10? <input type="checkbox"/> Yes <input type="checkbox"/> No If "Yes," give complete name and address _____																										
16. Period of this Appointment (Month, day, year) From _____ Thru _____		17. Approximate percent of trainee's time on this appointment <input type="checkbox"/> 100% <input type="checkbox"/> 75% <input type="checkbox"/> 50% <input type="checkbox"/> 25%																								
19. This trainee is qualified for the proposed training and is eligible to receive financial support from this grant for the period specified above. A copy of this appointment form will be given to trainee. Signature of Program Director _____ Date _____ Typed Name of Program Director _____		18. TRAINING SUPPORT FOR PERIOD OF APPOINTMENT <table border="1" style="width:100%; border-collapse: collapse;"> <tr> <th rowspan="2">TYPE</th> <th colspan="2">This Grant (omit cents)</th> <th rowspan="2">Other Sources</th> </tr> <tr> <th>TOTAL</th> <th>MONTHLY</th> </tr> <tr> <td>Stipend</td> <td>\$ _____</td> <td>\$ _____</td> <td>\$ _____</td> </tr> <tr> <td>Tuition & fees (est.)</td> <td>XXXXXXXXXXXX</td> <td>XXXXXXXXXXXX</td> <td></td> </tr> <tr> <td>Travel (est.)</td> <td>XXXXXXXXXXXX</td> <td>XXXXXXXXXXXX</td> <td></td> </tr> <tr> <td>TOTAL</td> <td>\$ _____</td> <td>XXXXXXXXXXXX</td> <td>\$ _____</td> </tr> </table>			TYPE	This Grant (omit cents)		Other Sources	TOTAL	MONTHLY	Stipend	\$ _____	\$ _____	\$ _____	Tuition & fees (est.)	XXXXXXXXXXXX	XXXXXXXXXXXX		Travel (est.)	XXXXXXXXXXXX	XXXXXXXXXXXX		TOTAL	\$ _____	XXXXXXXXXXXX	\$ _____
TYPE	This Grant (omit cents)		Other Sources																							
	TOTAL	MONTHLY																								
Stipend	\$ _____	\$ _____	\$ _____																							
Tuition & fees (est.)	XXXXXXXXXXXX	XXXXXXXXXXXX																								
Travel (est.)	XXXXXXXXXXXX	XXXXXXXXXXXX																								
TOTAL	\$ _____	XXXXXXXXXXXX	\$ _____																							
School _____	Department _____	20. I certify that the statements herein are true and complete to the best of my knowledge, and that I will comply with all applicable Public Health Service terms and conditions governing my appointment. (A willfully false certification is a criminal offense. U.S. Code, Title 18, Section 1001.) Signature of Trainee _____ Date _____																								
Name and Address of Institution (Street, city, state, zip code) _____																										

NATIONAL RESEARCH SERVICE AWARD
PAYBACK AGREEMENT

This agreement is required under Section 472 of the Public Health Service Act, as amended (42 USC 289L-1), for all individuals who receive a National Research Service Award directly or through an institutional grant.

- I. SERVICE REQUIREMENT - In accepting a National Research Service Award, I hereby agree to engage in biomedical or behavioral research and/or teaching within two years after termination of my National Research Service Award. This service shall be on a continuous basis, and shall be for a period equal to my total National Research Service Award support in excess of 12 months.
- II. PAYBACK PROVISIONS - I understand that if I fail to undertake or perform such service in accordance with Section I above, the United States will be entitled to recover from me an amount determined in accordance with the following formula:

$$A = \phi \left(\frac{t-s}{t} \right)$$

where "A" is the amount the United States is entitled to recover;
"φ" is the sum of the total amount paid to me under my National Research Service Award support less the amount paid for the initial 12 months; "t" is the total number of months in my service obligation; and "s" is the number of months of such obligation served.

Except as provided in Section III below, any amount the United States is entitled to recover shall be paid within the three-year period beginning on the date the United States becomes entitled to recover such amount. Interest on the amount begins on the date the United States becomes entitled to recover such amount and is at the rate fixed by the Secretary of the Treasury after taking into consideration private consumer rates prevailing on that date.

- III. CONDITIONS FOR BREAK IN SERVICE, WAIVER AND CANCELLATION - I hereby understand that the Secretary of Health and Human Services:

A. May extend the period for undertaking service, permit breaks in service, or extend the period for repayment, if it is determined that:

1. Such an extension or break in service is necessary to complete my research training;
2. Completion would be impossible because of temporary disability; or
3. Completion would involve a substantial hardship and failure to extend such period would be against equity and good conscience;

(over)

- B. May waive my obligation if it is determined that:
1. Fulfillment would be impossible because I have been permanently or totally disabled; or
 2. Fulfillment would involve a substantial hardship and the enforcement of such obligation would be against equity and good conscience;
- C. Will, in the event of my death, cancel any obligation incurred under this payback agreement.

IV. TERMINATION NOTICE - ANNUAL REPORT OF EMPLOYMENT - CHANGE OF ADDRESS AND/OR NAME - I agree to complete and submit a termination notice immediately upon completion of support. I agree to complete and submit an annual post-award report concerning pertinent employment, and agree to keep the Public Health Service advised of any change of address and/or name until such time as my total obligation is fulfilled.

V. PROGRAM EVALUATION - I understand that I may also be contacted from time to time, but no more frequently than once every two years, after the termination of this award to determine how the training obtained has influenced my career. Any information thus obtained would be used only for statistical purposes and would not identify me individually.

VI. CERTIFICATION - In accepting my National Research Service Award, I certify that I will comply with the terms and conditions of this payback agreement.

Signature: _____ Date: _____

Support received under PHS Award/Grant No. _____

Name (Last, First, Middle):

(TYPE OR PRINT)

Mailing Address: _____

(TYPE OR PRINT)

Illustration V

Form Approved Through 12/31/84
OMB No. 0925-0002

DEPARTMENT OF HEALTH AND HUMAN SERVICES PUBLIC HEALTH SERVICE NATIONAL RESEARCH SERVICE AWARD TERMINATION NOTICE			Type and submit original and two copies to PHS awarding component. Items 1 through 10 (except 7b) should be completed by fellow or trainee; items 7b and 11 by appropriate institution official. One copy will be returned to the fellow or trainee following validation by PHS official. SEE REVERSE FOR ADDITIONAL INFORMATION		
1. NAME OF FELLOW OR TRAINEE (Last, first, middle initial)			2. FELLOWSHIP OR TRAINING GRANT NUMBER		
3. NAME OF SPONSORING INSTITUTION			4. DEGREE SOUGHT	5. DATE DEGREE RECEIVED OR EXPECTED	
6. DATES OF NRSA SUPPORT UNDER THIS AWARD (Month, day, year): FROM: _____ TO: _____					
7a. TOTAL NRSA STIPEND RECEIVED AND NUMBER OF MONTHS SUPPORTED UNDER THIS AWARD.			7b. VERIFICATION OF ITEMS 6 AND 7a: Institutions that pay stipends to fellows and trainees shall certify the information provided in items 6 and 7a is correct according to institutional records. Not applicable to individual fellows sponsored by Federal or foreign institutions.		
			SIGNATURE OF BUSINESS OFFICIAL		DATE
YEAR OF SUPPORT	AMOUNT OF STIPEND*	NUMBER OF MONTHS	TYPED NAME OF BUSINESS OFFICIAL		TELEPHONE NUMBER
1st Year					
2nd Year					
3rd Year					
TOTAL					
* See reverse of form					
8a. Provide a short summary of research undertaken during fellowship or traineeship tenure and list publications, if any, resulting from the research during this period. Do not exceed space below. If fellowship or training appointment is being terminated early, state reason.					
8b. DESCRIBE THE ACTIVITY IN WHICH YOU WILL ENGAGE UPON COMPLETION OF THIS AWARD AND GIVE POSITION TITLE					
9. MAILING ADDRESS AFTER TERMINATION OF NRSA SUPPORT (Street, city, state, zip code and telephone number)			11. Certification of Sponsor or Program Director: This is to certify that to the best of my knowledge all the information in items 1 through 6, 8a & 9 is correct.		
			SIGNATURE OF SPONSOR OR PROGRAM DIRECTOR		DATE
10. SIGNATURE OF FELLOW OR TRAINEE		DATE	TYPED NAME OF SPONSOR OR PROGRAM DIRECTOR		
12. THE INFORMATION PROVIDED IN ITEMS 6 and 7a IS IN AGREEMENT WITH PHS RECORDS.					
SIGNATURE OF PHS OFFICIAL		DATE	TYPED NAME AND AWARDCING COMPONENT OF PHS OFFICIAL		

Illustration VI

Form approved through 12/31/81
OMB No. 0925-0002

DEPARTMENT OF HEALTH AND HUMAN SERVICES — PUBLIC HEALTH SERVICE NATIONAL RESEARCH SERVICE AWARD ANNUAL PAYBACK ACTIVITIES CERTIFICATION	PLEASE TYPE. See instructions in transmittal letter. Note Privacy Act information on back of Part 4.
---	--

NAME (last, first, middle initial)	PHS FELLOWSHIP OR GRANT NUMBER (S)
------------------------------------	------------------------------------

ADDRESS (Correct if address has changed)	REPORTING PERIOD				
	From: _____ To: _____				
	RECORD OF PAYBACK OBLIGATION				
	<table border="1" style="width:100%; border-collapse: collapse;"> <tr> <td style="width: 50%;">TOTAL MONTHS OF NRSA SUPPORT</td> <td style="width: 50%;">TOTAL MONTHS OF PAYBACK SERVICE PREVIOUSLY CREDITED</td> </tr> <tr> <td style="height: 40px;"></td> <td style="text-align: center;"> 1 1 </td> </tr> </table>	TOTAL MONTHS OF NRSA SUPPORT	TOTAL MONTHS OF PAYBACK SERVICE PREVIOUSLY CREDITED		1 1
TOTAL MONTHS OF NRSA SUPPORT	TOTAL MONTHS OF PAYBACK SERVICE PREVIOUSLY CREDITED				
	1 1				

SECTION I. PAYBACK STATUS (Check applicable block(s))

1. Have not engaged in payback service during reporting period (Complete Section IV)
2. Have elected to engage in financial payback (Complete Section IV)
3. Have been engaged in continuous regular payback service during reporting period (Complete Section II [1, 2, 3, 5], Section III, and Section IV)
4. Have been engaged in continuous alternative payback service previously authorized by DHHS (Complete Section II [1, 2, 4, 5], Section III and Section IV)

SECTION II. PAYBACK SERVICE DESCRIPTION

1. Number of months engaged in payback during reporting period: _____ Dates: _____
2. Position Title: _____
3. Regular Payback
 - a. Full-time position with health-related biomedical or behavioral research and/or teaching as primary activity.
 - b. Other position(s) where health-related biomedical or behavioral research and/or teaching averages more than 20 hours per week of a full work year.
4. Alternative Payback. Date authorized by DHHS: _____
 - a. National Health Service Corps.
 - b. Specialty practice in designated shortage area.
 - c. Practice in HMO as meeting National Research Service requirements.
 - d. Health-related service.
5. Description of duties, source of salary support, and average number of hours per week. Use continuation pages as necessary.

SECTION III. EMPLOYMENT INFORMATION

NAME OF EMPLOYING ORGANIZATION	VERIFICATION OF SUPERVISOR. If self-employed, provide notarized statement that employment information reported is accurate.
ADDRESS OF EMPLOYING ORGANIZATION	NAME OF SUPERVISOR
	TITLE
	SIGNATURE _____ DATE _____

SECTION IV. CERTIFICATION OF NRSA RECIPIENT

I certify that all of the above statements are true, complete, and correct to the best of my knowledge. (A willfully false certification is a criminal offense. U.S. Code, Title 18, Section 1001.)	SIGNATURE _____ DATE _____
---	----------------------------

SECTION IV. ACCEPTANCE BY PHS OFFICIAL (LEAVE BLANK)

NAME AND TITLE OF PHS OFFICIAL	SIGNATURE	DATE	NUMBER OF MONTHS OF ACCEPTABLE PAYBACK SERVICE THIS REPORTING PERIOD