



U.S. Department
Of Transportation

**Federal Railroad
Administration**

Research Results

RR08-03
July 2008

Slab Track Test and Demonstration for Shared Freight and High-Speed Passenger Service

SUMMARY

As part of the Next Generation High Speed Rail Program, two types of concrete slab track were tested to determine their ability to retain the exacting track geometry tolerances required for high speed rail operations while also withstanding the high axle loads of main line freight service. These two designs were proposed options for locations where future high speed passenger service may need to share track with heavy freight service, particularly in urban areas where available rights-of-way are limited and where access for maintenance may be difficult.

The test and demonstration was conducted at the Transportation Technology Center (TTC) near Pueblo, CO, from July 2003 to July 2006, as a cooperative effort between the Federal Railroad Administration (FRA) and the Portland Cement Association (PCA). The demonstration section was 500 feet long, with 250 feet of direct fixation slab track (DFST) and 250 feet of independent dual block track (IDBT), shown in Figure 1. During the test and demonstration, a train with 39-ton axle loads was run repeatedly over the two concrete slab track sections. Over 3 years, a total of 170 million gross tons (MGT) of traffic was accumulated.

Various measurements taken during and at the end of the demonstration indicated that FRA Class-9 track geometry tolerances (the highest track class, for speeds up to 200 mph) were successfully retained. In addition, no signs of structural distress appeared.



Figure 1. Independent Dual-Block Track (IDBT) at the demonstration site.



Introduction

The mission of the Next Generation High Speed Rail Program was to look to the future in anticipation of the implementation of more high speed rail (HSR) service and to explore technologies which could assist with HSR operations. Recognizing that limited right-of-way availability in urban areas may require HSR passenger trains to share the same track with freight trains, a track structure would be needed to retain the tight geometry requirements for higher speed passenger trains while sustaining the heavier loads imposed by freight service. In addition, a highly durable track design may be needed for locations with difficult or limited maintenance access. To address these needs, FRA and PCA proposed a demonstration of two types of concrete slab track to provide the required performance. A successful demonstration would also help in validating the slab track design process.

Concrete slab track is constructed somewhat like a concrete highway with rails fastened on top, with the concrete slab and its sub-base and subgrade support designed to withstand railroad loading. While there are several types of slab track, the main difference among them is the manner in which the rails are supported by and fastened to the concrete slab. Slab track is used to some extent in Europe and in Japan, but it is not designed for axle loads nearly as high as those which operate in freight service in the United States.

The Two Slab Track Designs

The two proposed slab track designs for this demonstration were chosen and refined through extensive testing at the Construction Technologies Laboratory (CTL). One choice was a DFST, as shown in Figure 2. With this design, the concrete slab is 1 foot thick, using 5,000 pounds/square inch (psi) strength concrete. The rail fasteners are spaced at 2-foot intervals, with four anchor bolts in each fastener plate used to anchor the rails to the slab. For the DFST, track resilience and damping are provided primarily through rubber pads installed between the fastener plates and the slab surface.

The other choice was independent dual block track (IDBT), as shown in Figure 3. With this design, the rails are supported by concrete blocks, each approximately 11.65" wide and 26.5" long, set into the slab 24" apart. A layer of rubber surrounds the blocks to reduce vibration and sound, as well as add resilience to the track. The total slab thickness here is 15" using 5,000 psi concrete - 7.75" below the

blocks and 7.25" above the bottom of the blocks. The part of the slab above the block bottoms has no reinforcing. As with DFST, the rails are fastened with a pad under the rail base.

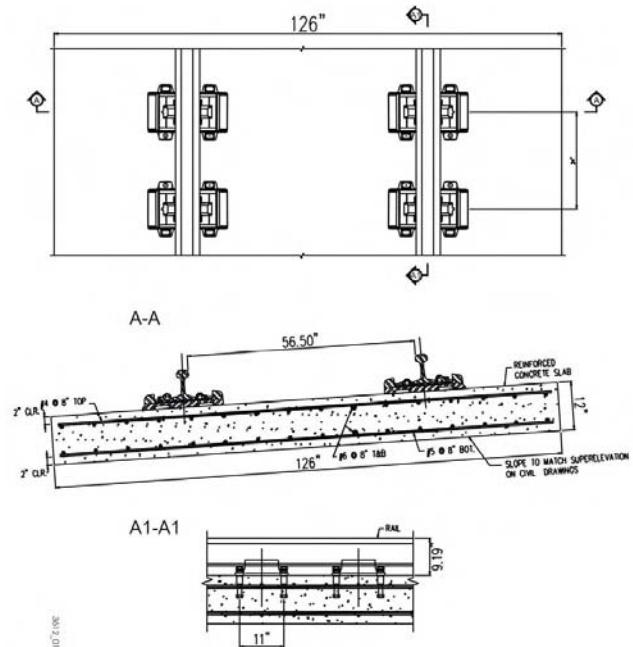

Figure 2. DFST slab track: plan and details

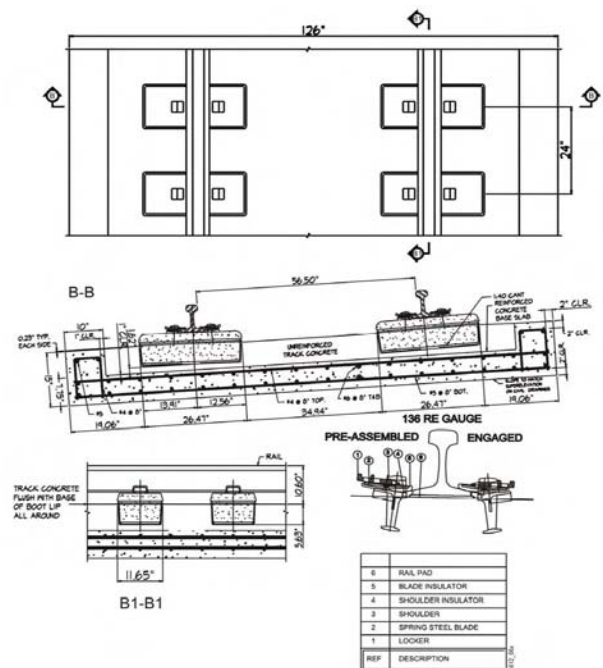

Figure 3. IDBT slab track: plan and details



For both designs, pads were chosen to provide a track with a relatively low stiffness, with the track modulus for the DFST at 2,100 pounds/inch/inch and 3,100 for the IDBT. (Conventional concrete tie track commonly has a stiffness in the range of 4,000 to 6,000.)

Construction and Testing

The tests were conducted at TTC near Pueblo, CO. A 10'6" wide by 500 foot length of slab track was constructed on the FAST track, where a train with 39-ton axle loads runs around a 2.7-mile loop. The slab had 250' of each design. The test section was in a 5-degree curve with 4" of superelevation (and thus the reason for the design cross sections shown at an angle in Figures 2 and 3).

To provide proper support for the concrete slab, the subgrade was first compacted at its optimum water content (the moisture level which allows maximum compaction density). Over the subgrade, a 6 inch soil-cement layer of sandy silt with 5 percent (by weight) added cement was placed and compacted at its optimum moisture content to produce a support layer with a minimum of 700 psi compressive strength. (Tests showed actual strength achieved in the range of 780 to 840 psi).

Figures 4 and 5 show later stages of construction for each design. Considerable care and precision were required to produce a finished track alignment and surface that would meet the required FRA track Class-9 geometry specifications.



Figure 4. Construction of DFST Using Topdown Method

Construction was completed by August 2003, with testing conducted from September 2003 to July 2006.

During this period, the test section accumulated 170 MGT of traffic from the test train.



Figure 5. Construction of IDBT

PCA and CTL personnel mapped cracking in the concrete slab twice during the test period. Ground-penetrating radar was used to inspect for voids in the concrete and between the slab base and the soil-cement layer.

Test Results

Ground-penetrating radar testing conducted in September 2003 showed no voids or loss of support between the base of the slab and the soil cement layer. Inspection of the slab at the end of the test period showed the normal cracking distribution and growth expected for a slab of this size, with no signs of structural distress.

During construction, four elevation benchmarks were set into the slab surface, two in each section. At the end of testing, the maximum settlement at these benchmarks was 0.07". This stability is reflected in the minimal change in track surface during the test period, as shown in Figure 6.

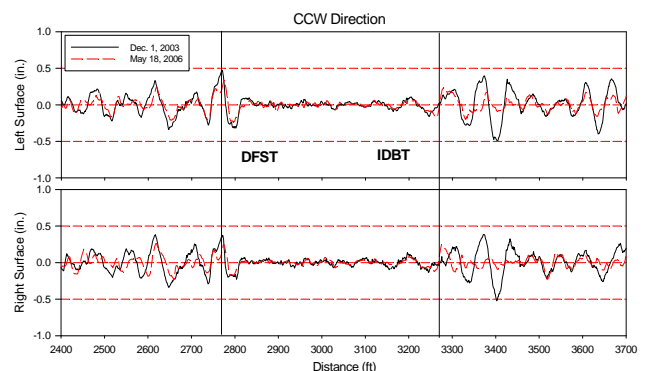

Figure 6. Change in track surface



Track gage-holding strength was tested using 33,000 lb vertical and 18,000 lb lateral wheel loads. The summary data is shown in Figure 7. The lower graph shows delta gage (change in gage), which is the gage measurement without load subtracted from the gage measurement with the applied loads. Loaded gage, in particular, can be affected by the resilience of the railseat pads. For these tests, pad stiffness was lower than would typically be chosen in regular service.

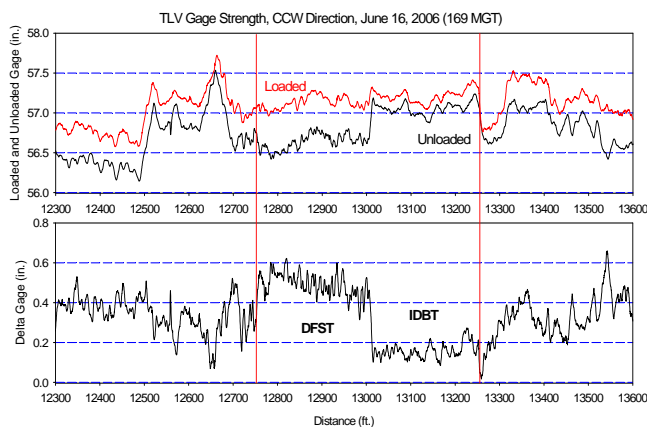

Figure 7. Track gage strength at 169 MGT.

The higher unloaded gage within the IDBT section (as seen in Figure 7) was attributed to some untypical conditions at the test site, along with characteristics of the particular fastening arrangement. During the tests, stiffness of the IDBT track changed as well, and also attributed to the same conditions as affected the unloaded gage. This aspect is covered in greater detail in the full report. While observations of fastening system performance were made, comprehensive testing of the rail fastening system was beyond the scope of these tests.

Conclusions

The slab track test section demonstrated the capability to support heavy freight train loads while

maintaining the geometry requirements for FRA Class-9 track. Little track geometry degradation was measured after 3 years of testing and 170 MGT of accumulated traffic. No track maintenance was required due to surface, alignment, gage, or cross-level deterioration. There was minimal cumulative settlement and little lateral movement of the slab, and track surface within the slab track remained superior to that in the adjacent ballasted track.

Slab track performance can be affected by the rail fastening system. Many choices are possible, and specific testing would be required for each system.

For More Information

Slab Track Test and Demonstration for Shared Freight and High-Speed Passenger Service Scheduled to be published by FRA in 2008.

Contact

Donald Plotkin
Federal Railroad Administration
Office of Research and Development
1200 New Jersey Avenue SE - Mail Stop 20
Washington, DC 20590
TEL: (202) 493-6334
FAX: (202) 493-6333
Donald.Plotkin@fra.dot.gov

Ted Sussmann
Tel: (617) 494-3663
Fax: (617) 494-3616
Ted.Sussmann@volpe.dot.gov

Volpe National Transportation Systems Center
55 Broadway, Kendall Square
Cambridge, MA 02142

KEYWORDS: slab track, concrete slab track, high-speed track, track performance

Notice and Disclaimer: This document is disseminated under the sponsorship of the United States Department of Transportation in the interest of information exchange. Any opinions, findings and conclusions, or recommendations expressed in this material do not necessarily reflect the views or policies of the United States Government, nor does mention of trade names, commercial products, or organizations imply endorsement by the United States Government. The United States Government assumes no liability for the content or use of the material contained in this document.