CMS Manual System

Pub. 100-18 Medicare Prescription Drug Benefit Manual

Department of Health & Human Services (DHHS)
Centers for Medicare & Medicaid Services (CMS)

Transmittal 4

Date: SEPTEMBER 26, 2008

SUBJECT: Initial release of Chapter 14-Coordination of Benefits

I. SUMMARY OF CHANGES: The initial publication of Chapter 14 of the Medicare Prescription Drug Benefit Manual includes information on Coordination of Benefits.

NEW/REVISED MATERIAL - EFFECTIVE DATE*: September 26, 2008
IMPLEMENTATION DATE: September 26, 2008

Disclaimer for manual changes only: The revision date and transmittal number apply to the red italicized material only. Any other material was previously posted to http://www.cms.hhs.gov/PrescriptionDrugCovContra/12_PartDManuals.asp#TopOfPage or <http://www.cms.hhs.gov/manuals/> and disseminated via the Health Plan Management System (HPMS). However, if this revision contains a table of contents, you will receive the new/revised information only, and not the entire table of contents.

NOTE: The Medicare Prescription Drug Benefit Manual can be accessed at http://www.cms.hhs.gov/PrescriptionDrugCovContra/12_PartDManuals.asp#TopOfPage or <http://www.cms.hhs.gov/manuals/>. All revisions to Pub. 100-18 will be issued via HPMS.

II. CHANGES IN MANUAL INSTRUCTIONS: (N/A if manual not updated.)
(R = REVISED, N = NEW, D = DELETED)

R/N/D	CHAPTER/SECTION/SUBSECTION/TITLE
N	14/Entire Chapter/Coordination of Benefits

III. FUNDING: No additional funding will be provided by CMS; contractor activities are to be carried out within their operating budgets.

IV. ATTACHMENTS:

	Business Requirements
X	Manual Instruction
	Confidential Requirements
	One-Time Notification
	Recurring Update Notification

*Unless otherwise specified, the effective date is the date of service.

Medicare Prescription Drug Benefit Manual

Chapter 14 — Coordination of Benefits

Table of Contents
(Rev. 4, 09-26-08)

- 10 – Introduction
- 20 – Overview
- 30 – CMS Requirements
 - 30.1 – Enrollment File Sharing
 - 30.2 – Validation of Information About Other Payers
 - 30.3 – Establishing the Order of Payment for Part D Coordination of Benefits (COB)
 - 30.4 – Contracting with a TrOOP Facilitation Contractor
 - 30.4.1 –TrOOP Facilitation Process
 - 30.4.2 –Enhancements to E1 Transactions
 - 30.4.3 –Real-time versus Batch Processing
 - 30.4.4 –Enhancements to N1 Transactions
 - 30.4.5 –TrOOP Accounting
 - 30.5 –Assessment of COB User Fees
- 40 – Beneficiary Requirements
 - 40.1 – Providing Information to *Sponsors* on Other Coverage
 - 40.2 – Using On-line Processing
 - 40.3 – Submitting Documentation for Off-line Processing on a Timely Basis
- 50 – Part D *Sponsor* Requirements
 - 50.1 – Providing 4Rx Data on Primary Coverage
 - 50.2 – Surveying Beneficiaries Regarding Other Prescription Drug Coverage and Transmitting Such Information to CMS
 - 50.3 – Connecting to Systems Supporting COB
 - 50.4 – Processing Claims and Tracking TrOOP
 - 50.4.1 –Receiving an N1, Without Supplemental Payer on File
 - 50.4.2 – Beneficiary Cash Purchases
 - 50.5 – Standardized Claims Messaging
 - 50.5.1 – Primary Payer Use of Optional Fields to Support COB
 - 50.6 – Accepting Payment of Premiums From Other Payers
 - 50.7 – Coordinating Payment of a Lump Sum for Supplemental Coverage

- 50.7.1 – The Risk-Based Combined Uniform Benefit/Lump Sum Contribution Approach
- 50.7.2 – The Non-Risk-Based Lump Sum Payment with Claims Reconciliation Approach
- 50.8 – Claims Reconciliation Reports
- 50.9 – Transferring TrOOP Balance When a Beneficiary Changes Part D
 - Sponsors*
 - 50.9.1 – *Manual TrOOP Balance Transfer Process*
 - 50.9.2 – *Automated TrOOP Balance Transfer Process*
- 50.10 – Special Transition Period for Retroactive Enrollment Situations
- 50.11 – Sharing Formulary Information with Other Payers
- 50.12 – Sharing Claims Data
- 50.13 – Applying Medicare Secondary Payer (MSP) Requirements
 - 50.13.1 – Workers’ Compensation
 - 50.13.2 – Flexible Savings Accounts (FSAs), Health Savings Accounts (HSAs), Archer Medicare Savings Accounts (MSAs), and Health Reimbursement Accounts (HRAs)
- 50.14 – Executing Business Associate Agreement with TrOOP Contractor
- 50.15 – Payment Reconciliation
 - 50.15.1 – Plan-to-Plan Reconciliation during Transition Periods
 - 50.15.2 – Other CMS-Defined Reconciliation Processes
 - 50.15.3 – Retrospective Resolution Directly with Other Payers
 - 50.15.4 – Re-adjudication versus Pharmacy Reprocessing
 - 50.15.5 – Claims Filing Timeframes
- 60 – Coordination of Benefit Activities of Non-Part D Payers
 - 60.1 – Reporting the Existence of Prescription Drug Coverage Provided to Enrollees
 - 60.2 – Obtaining and Reporting Rx Identifiers
 - 60.3 – Supplying Claims Information When a Supplemental Payment Is Made
 - 60.4 – Coordinating with Part D *Sponsors* for Payment of Premiums
 - 60.5 – Following MSP Laws and Order of Payment Standards
 - 60.5.1 – Internal Revenue Service (IRS)/Social Security Administration (SSA)/CMS Data Match
 - 60.5.2 – FSAs, HSAs, MSAs, and HRAs
- [Appendix A - TrOOP Facilitation Process](#)
- [Appendix B - COB-related Web Sites](#)
- [Appendix C - COB Survey](#)
- [Appendix D - Part D Sponsor Implementation Guide Automated TrOOP Balance Transfer](#)
- [Appendix E - Issues for Other Entities Providing Prescription Drug Coverage](#)
- [Appendix F - Part D Requirements Waived for PACE Organizations](#)

10 – Introduction

(Rev. 4; Issued: 09-26-08; Effective/Implementation Date: 09-26-08)

This chapter provides guidance to Part D sponsors regarding our requirements and procedures for coordination of benefits (COB) with other providers of prescription drug coverage. The chapter is divided into five main areas:

- Section 20 – Overview
- Section 30 – CMS Requirements
- Section 40 – Beneficiary Requirements
- Section 50 – Part D *Sponsor* Requirements
- Section 60 – Coordination of Benefit Activities of Non-Part D Payers

20 – Overview

(Rev. 4; Issued: 09-26-08; Effective/Implementation Date: 09-26-08)

Part D sponsors are required to coordinate with State Pharmaceutical Assistance Programs (SPAPs) and other providers of prescription drug coverage with respect to the payment of premiums and coverage, as well as coverage supplementing the benefits available under Part D. * The Medicare Modernization Act (MMA) specified that these coordination requirements must relate to the following elements: (1) enrollment file sharing; (2) claims processing and payment; (3) claims reconciliation reports; (4) application of the protection against high out-of-pocket expenditures by tracking true out-of-pocket (TrOOP) expenditures; and (5) other processes that CMS determines.

When a Medicare Part D enrollee has other prescription drug coverage, COB allows the plans that provide coverage for this same beneficiary to determine each of their payment responsibilities. This process is necessary in order to avoid duplication of payment and to prevent Medicare from paying primary when it is the secondary payer. While this is the principal purpose of COB within the contexts of Medicare Parts A and B, COB also serves an additional function within the Part D context: it provides the mechanism for support of the tracking and calculating of beneficiaries’ “true out-of-pocket” (TrOOP) expenditures, or “incurred costs” as defined in the MMA and CMS’ implementing regulations. Costs for covered Part D drugs are treated as “incurred” only if they were paid by the individual (or by another person, such as a family member, on behalf of the individual), paid by CMS on behalf of a low-income subsidy-eligible individual, or paid under a qualified SPAP as defined in our regulations. Costs do not count as “incurred”

* Under 42 CFR 423.458(d), Part D requirements may be waived for Programs of All-Inclusive Care for the Elderly (PACE) organizations if the requirements are determined to be duplicative of, or in conflict with, provisions that would otherwise be applicable to these organizations. Appendix F provides additional guidance on the applicability of the COB requirements to PACE organizations.

when: 1) no benefits are provided because of the application of either a formulary or the Medicare Secondary Payer (MSP) laws, or 2) when costs are reimbursed through insurance or otherwise, a group health plan, or similar third party arrangement. Therefore, only certain costs not paid for by the Part D *sponsor* count toward TrOOP. In *2008*, under the defined standard Part D benefit, catastrophic coverage is triggered only after *\$4,050* of TrOOP expenditures; *in 2009, this amount increases to \$4,350*.

The MMA provided CMS with authority to impose user fees to defray the costs of Part D COB activities, as well as to retain a portion of those user fees to offset costs associated with the TrOOP facilitation process. The MMA prohibits CMS from levying user fees on SPAPs, however. In CMS' regulations, CMS clarifies that only Part D *sponsors* – not SPAPs or other payers – will be assessed user fees beginning in 2006. However, CMS also notes that, while Part D sponsors may charge user fees to other payers for COB activities, these user fees must be reasonable and related to the Part D sponsors' actual costs of COB with these entities. In addition, any user fees Part D *sponsors* charge other entities must specifically exclude those activities which are covered by the user fees CMS is collecting for COB. Thus, for example, Part D *sponsors* may not charge user fees for activities such as the costs of the claims transaction by supplemental payers (since Part D user fees funded by CMS are used in part for that purpose), but *sponsors may* charge for activities such as the exchange of claims data.

Although this chapter provides guidance primarily for Part D *sponsors*, the various processes associated with COB involve interaction between multiple parties. For that reason, CMS provides detailed guidance regarding the COB requirements applicable to *the* various parties including beneficiaries, Part D *sponsors*, and other payers.

In Appendix A of this guidance, CMS provides an illustration of how the TrOOP facilitation process works. Appendix B *contains a list of Web sites relevant to COB and referenced in this chapter*. In Appendix C, *CMS offers a sample format for the beneficiary COB survey, and in Appendix D includes the automated TrOOP balance transfer guidance issued March 18, 2008*. Appendix E provides detail on specific issues that may relate to (or be of particular interest to) other payers and entities with which Part D *sponsors*, per the requirements of 42 CFR 423.464(f), are required to coordinate, including SPAPs, Medicaid, VA, TRICARE, Indian Health Service and tribal health coverage, safety-net providers, patient assistance programs (PAPs), personal health savings vehicles, AIDS drug assistance programs (ADAPs), PACE plans, and Medicare Part B. Further guidance on systems requirements and technical details involved in the COB process has been issued in other communications and is included here by reference. In Appendix F, CMS addresses the applicability of COB to PACE requirements.

30 – CMS Requirements

(Rev. 4; Issued: 09-26-08; Effective/Implementation Date: 09-26-08)

CMS leveraged its existing Medicare COB processes to facilitate COB under Part D. In addition, through the use of a TrOOP facilitation process that uses an existing industry

claims transactions set (described in further detail in section 30.4 of this chapter), CMS supports the tracking and calculation of enrollees' TrOOP balances by Part D sponsors.

30.1 – Enrollment File Sharing

(Rev. 4; Issued: 09-26-08; Effective/Implementation Date: 09-26-08)

Prior to the enactment of the mandatory insurer reporting provision of the Medicare, Medicaid, and SCHIP Extension Act of 2007 (Section 111 of P.L. 110-173), except for employers/union plans that are required by MSP-related law to report enrollment information on certain active employees, there was no requirement for other payers of health benefits to report their enrollment to CMS or the plans. The COB enrollment file sharing programs provides inherent incentives for other payers to coordinate drug benefits. Many other payers voluntarily provide information regarding prescription drug coverage they offer that is either primary or supplemental to Part D.

Beginning in 2009, the new mandatory insurer reporting of MSP group health coverage will become operationally effective. The provisions will be implemented January 1, 2009 for information about group health plan arrangements, and July 1, 2009, for information about liability insurance, no-fault insurance, and workers' compensation. Although these requirements are not specific to Part D, CMS will encourage insurers providing prescription drug coverage to include this information in their mandatory reporting.

Currently, CMS coordinates benefits with other payers with respect to Part A and B coverage to reduce mistaken payments and administrative expenses that would otherwise be incurred by the Medicare program. The CMS COB contractor collects information on beneficiaries' other coverage primarily through the use of data sharing agreements. The Voluntary Data Sharing Agreements (VDSAs) and Coordination of Benefits Agreements (COBAs) that already existed were modified to include Part D information. CMS also created new types of agreements, such as those with SPAPs, specifically for the exchange of Part D information.

After *the data sharing* agreement is executed, the other payer sends the COB contractor a file of its enrollees. For Part D purposes, the COB contractor: 1) compares the list of the other payer's enrollees to the current population of Medicare Part D enrollees; 2) captures and maintains the resulting matches and any information updates; and 3) transmits the matches/updates to the CMS Medicare Beneficiary Database (MBD). CMS sends this information *as often as daily* to the TrOOP facilitator and the *sponsor*. *The data* consist of a detail record for each enrollee whose other payer information is reported in the attachments to the detail record. Attachments to the detail record may include up to 20 primary records containing information on other payers that are primary to Part D, and up to 20 supplemental records containing information on payers that pay after Part D. The data elements that are included, if applicable, in the detail, primary and supplemental records are reflected in tables below.

Table 30.1-1 COB File—Data Elements in Detail Record

Record Type
HICN/RRB Number
SSN
Date of Birth
Gender Code
Contract Number
Plan Benefit Package
Action Type

Table 30.1-2 COB File—Data Elements in Primary Record

Record Type	Employee Information Code
HICN/RRB Number	Employer's Name
SSN	Employer's Address 1
Date of Birth	Employer's Address 2
Gender Code	Employer's City
RxID Number	Employer's State
RxGroup Number	Employer's ZIP Code
RxBIN Number	Filler
RxPCN Number	Employer TIN
Rx Plan Toll Free Number	Filler
Sequence Number	Claim Diagnosis Code 1
COB Source Code	Claim Diagnosis Code 2
MSP Reason (Entitlement Reason from COB)	Claim Diagnosis Code 3
Coverage Code	Claim Diagnosis Code 4
Insurer's Name	Claim Diagnosis Code 5
Insurer's Address-1	Attorney's Name
Insurer's Address-2	Attorney's Address 1
Insurer's City	Attorney's Address 2
Insurer's State	Attorney's City
Insurer's ZIP Code	Attorney's State
Insurer TIN	Attorney's ZIP
Individual Policy Number	Lead Contractor
Group Policy Number	Class Action Type
Effective Date	Administrator Name
Termination Date	Administrator Address 1
Relationship Code	Administrator Address 2
Payor ID	Administrator City
Person Code	Administrator State
Payer Order	Administrator ZIP
Policy Holder's First Name	WCSA Amount
Policy Holder's Last Name	WCSA Indicator
Policy Holder's SSN	

Table 30.1-3 COB File—Data Elements in Supplemental Record

Record Type
HICN/RRB Number
SSN
Date of Birth
Gender Code
RxID Number
RxGroup Number
RxBIN Number
RxPCN Number
Rx Plan Toll Free Number
Sequence Number
COB Source Code
Supplemental Type Code
Coverage Code
Insurer's Name
Insurer's Address-1
Insurer's Address-2
Insurer's City
Insurer's State
Insurer's ZIP Code
Individual Policy Number
Group Policy Number
Effective Date
Termination Date
Relationship Code
Payor ID
Person Code
Payer Order

Further information about the format and business rules of the COB file to *sponsors* is contained in Section 10 of the Plan Communications User's Guide (PCUG); the guide is available on the CMS Web site. For *further* information about current Medicare COB processes, see the Medicare Part D COB Web site. *(See Appendix B for the specific Web addresses for these sites.)*

The COB Contractor will send as much information as is available. In some cases, CMS through the COB contractor may determine there is other prescription drug coverage, but may be unable to identify the Rx identifiers. In such cases, CMS will supply the information so that the *sponsors* are at least aware of the other coverage.

30.2 – Validation of Information About Other Payers

(Rev. 4; Issued: 09-26-08; Effective/Implementation Date: 09-26-08)

When a Part D *sponsor* or a beneficiary provides information to the COB contractor about other coverage, the COB contractor validates the completeness of this information,

then applies and maintains it in MBD. MBD transmits this information to both the TrOOP facilitator and Part D *sponsors* from the Medicare Advantage-Prescription Drug (MARx) system via the COB file.

The COB contractor’s role in Part D COB is to assist sponsors in identifying other coverage and in determining whether other payments count toward the beneficiary’s TrOOP by specifying the supplemental payer type.

The table below crosswalks the TrOOP eligibility of payments by other payers with the MSP reason codes and insurance or coverage type codes on the COB file.

Table 30.2-1-Other Payer Codes and TrOOP Eligibility

Other Payer	MSP Reason Code	Insurance or Coverage Type Code	Relationship of Coverage to Medicare	TrOOP Eligibility
Employer Group Health Plan	A (Working Aged) B (ESRD) G (Disabled)		Primary	N
Non-Employer Group Health Plan	D (Auto insurance; no fault) E (Workers’ Compensation (WC)) L (Liability) H (Black Lung (BL))		Primary	N
Secondary Insurance		L (Supplemental insurance) M (Medigap) O (Other)	Secondary	N
Federal Government Programs		T (Federal Employees Health Benefit Program [FEHBP], Veterans Administration (VA) coverage ¹ , Indian Health Service (IHS)/Tribal coverage ²) 2 (TRICARE)	Secondary	N
Other Payer	MSP Reason Code	Insurance or Coverage Type Code	Relationship of Coverage to Medicare	TrOOP Eligibility

Qualified State Pharmaceutical Assistance Program (SPAP) ³		Q	Secondary	Y
Non-qualified SPAP		N	Secondary	N
Medicaid		I	Secondary	N
<i>Manufacturer</i> Patient Assistance Program (PAP) ¹		P	Secondary	N
AIDS Drug Assistance Programs (ADAPs)		S	Secondary	N
Charities		R	Secondary	Y
Health Reimbursement Accounts (HRAS) ⁴		Z	Secondary	N

¹ Coverage is separate and distinct from Part D; see Appendix E for further discussion.

² Tribes using Tribal-only money qualify as TrOOP-eligible, but manual processing will be necessary to handle these cases.

³ State-only funded SPAPs

⁴ For non-working, aged beneficiaries, payments are secondary to Medicare and non-TrOOP-eligible

30.3 – Establishing the Order of Payment for Part D Coordination of Benefits (COB)

(Rev. 4; Issued: 09-26-08; Effective/Implementation Date: 09-26-08)

In order to provide a consistent set of rules for the order of payment on Part D claims and establish a basis for the accurate calculation of the TrOOP balance, CMS establishes that Part D *sponsors* and all secondary payers on Part D claims should adhere to the following order of payment standards. All payers are legally required to adhere to MSP laws and any other federal and state laws establishing payers of last resort (e.g., TRICARE). In all other situations, the Rules for Coordination of Benefits adopted in the most current National Association of Insurance Commissioners Coordination of Benefits Model Regulation should be followed.

The COB contractor includes payment order indicators on other payer records it sends to MBD. *Sponsors* use this data element to sort COB records for display in reply transactions to the pharmacy. The COB contractor calculates payer order based on MSP

rules, relationship to policyholder, and type of supplemental insurance. Rules for using the payment order indicator are contained in the PCUG.

30.4 – Contracting with a TrOOP Facilitation Contractor

(Rev. 4; Issued: 09-26-08; Effective/Implementation Date: 09-26-08)

All Part D *sponsors* must correctly calculate the TrOOP amount in order to properly adjudicate beneficiary claims, as well as to communicate this information to plan enrollees. This process is logistically complex because there may be multiple payers (for example, SPAPs or employer or union plans). True COB, in which the order of payment among multiple payers with responsibility for paying prescription drug claims on behalf of an individual is established and programmed into the systems of the secondary payers, did not generally take place in pharmacy benefit management prior to Part D implementation. In lieu of Part D sponsors separately setting up procedures to coordinate benefits with every other payer with responsibility for drug coverage for one of their Part D enrollees, CMS published a request for comment on the feasibility of an online real-time process. In response to this CMS request, representatives from pharmacies, pharmacy benefit managers (PBM) companies and pharmacy data processing and standard-setting organizations provided extensive input and comments to design an automated solution for COB and the facilitation of the TrOOP accounting process. The industry, working in collaboration with the National Council of Prescription Drug Programs (NCPDP), developed a TrOOP facilitation process that allows the majority of pharmacy claims processing to take place “real time” at the pharmacy at point of sale (POS). To this end, supplemental payers are required to utilize the Health Insurance Portability and Accountability Act (HIPAA) coordination of benefits transaction standard, which requires the use of the NCPDP Telecommunication Standard Implementation Guide to communicate secondary payer transactions back to the primary Part D *sponsor* for purposes of tracking TrOOP in real time. Version C.1 of the NCPDP Implementation Guide first detailed the processing requirements involved in the TrOOP facilitation process.

In 2005, CMS awarded a contract to NDC Health (*currently RelayHealth*) to act as the TrOOP facilitation contractor (also referred to as the TrOOP facilitator) for Part D claims processing. The TrOOP facilitation contractor, in conjunction with CMS, is responsible for establishing procedures for facilitating eligibility queries (E1 transactions) at POS, identifying costs that are being reimbursed by other payers, and for alerting Part D sponsors about such transactions.

30.4.1 –TrOOP Facilitation Process

(Rev. 4; Issued: 09-26-08; Effective/Implementation Date: 09-26-08)

With the implementation of Medicare Part D, new electronic transaction capabilities became available to pharmacies. These offer pharmacies the ability to submit *eligibility*

inquiries without the need to fill a prescription and to bill payers supplemental to Medicare.

A pharmacy uses the eligibility inquiry process, known as an E1 transaction, to submit real-time transactions to the TrOOP Facilitator. Eligibility transactions are used to determine a Medicare beneficiary's Part D coverage information. Pharmacies use this service when the beneficiary does not have their Medicare Part D Plan Card information to retrieve information needed to bill a claim to a patient's insurance plan, or to determine billing order if the beneficiary has multiple insurance coverage.

Part D *sponsors*, supplemental payers, switches (claims routers), and the TrOOP Facilitator must interact to accurately track a patient's true out of pocket expenses. Claims to supplemental payers, known as B transactions, are submitted by the pharmacy to their switch. The switch will forward to the TrOOP facilitator the B transactions that are not rejected by the supplemental payer and that contain an RxBIN/Processor Control Number (PCN) combination for a plan that covers Medicare Part D beneficiaries. This RxBIN/PCN combination is the flag that switches use to route the data to the facilitator.

The TrOOP facilitator uses the B transaction to trigger the creation of a reporting transaction (N) and delivers the *N transaction* to the Part D sponsor in real-time. All supplemental billing claims must be processed through a switch so that the switch can deliver the transactions to the TrOOP facilitator to enable accurate TrOOP reporting at the Part D *sponsor*.

30.4.2 –Enhancements to E1 Transactions

(Rev. 4; Issued: 09-26-08; Effective/Implementation Date: 09-26-08)

Prior to the implementation of Part D in 2006, additional functionality for eligibility inquiries was made available through an enhanced E1 transaction. This enhanced E1 capability enables pharmacies to separately request verification of a beneficiary's Medicare Part A/B eligibility—an essential step in the POS facilitated enrollment process (described in section 50.15 of this chapter).

As of December 1, 2006, further enhancements to the E1 inquiry added data elements to the E1 response. Expanding the E1 response to include, for example, the Part D *sponsor's* contract number, benefit ID, benefit effective date and benefit termination date, better informs pharmacies of beneficiaries' enrollment in Part D. *For more information about the E1 transactions, see the RelayHealth Web site. See Appendix B for the specific Web address.*

30.4.3 –Real-time Versus Batch Processing

(Rev. 4; Issued: 09-26-08; Effective/Implementation Date: 09-26-08)

For instances in which Part D plan enrollees' secondary coverage is identified in advance by CMS systems (as described in section 30.1 of this chapter), multiple-payer claims are automatically adjudicated at the POS. The TrOOP facilitation contractor captures secondary payer claims transactions based on unique routing information collected previously at enrollment or through the COB contractor's system. The TrOOP facilitation contractor also has a batch process available for claims that it receives in a manner other than real time (for example, claims from programs such as the Indian Health Service (IHS) or those presented by the beneficiary to a secondary payer in hard copy). Other payers can then send their paid claims data directly to the TrOOP facilitation contractor in batch form. Once the contractor receives the batched paid claims data, it will follow the same online process, creating an NCPDP N1 transaction and sending it to the beneficiary's Part D *sponsor* for accurate TrOOP recalculation.

30.4.4 –Enhancements to N1 Transactions

(Rev. 4; Issued: 09-26-08; Effective/Implementation Date: 09-26-08)

CMS, through the TrOOP facilitation contractor, continues to seek to enhance N_x transactions. One *such* enhancement would involve *the creation* by the TrOOP facilitator *of a unique Transaction Reference ID for each N1 transaction created and the inclusion of this ID in subsequent N transactions routed to the Part D sponsor. In handling adjustments and reversals, the TrOOP facilitator would use certain designated fields to match the B transactions to prior N1 transactions. When a B2 transaction is received without a Cardholder ID, the facilitator would use the fields to match the B2 transaction to the prior N1 transaction in order to retrieve the Cardholder ID for inclusion in the N2 transaction to the Part D sponsor. If an adjustment/reversal matches a prior B1 transaction on all the designated fields, the facilitator would include the Transaction Reference ID from the N1 transaction for the matched claim on the N2 and N3 transactions routed to the Part D sponsor. So, when the facilitator sends an N2, N3 and/or a final N1 transaction to a Part D sponsor, the transaction reference number would be consistent among all transactions for the same prescription/service claim.* CMS and the TrOOP facilitation contractor will provide guidance on this enhancement as soon as it is available.

30.4.5 –TrOOP Accounting

(Rev. 4; Issued: 09-26-08; Effective/Implementation Date: 09-26-08)

Part D *sponsors* should note information about a payer's TrOOP eligibility status based on the information in the COB file in order to determine whether *or not* a payment should count toward TrOOP. CMS recognizes that pharmacies play an integral role in claims processing and TrOOP accounting, and CMS has engaged pharmacists in extensive outreach efforts so that they fully understand how they can interact with these systems. For more detail about the TrOOP facilitation process, see Appendix A.

30.5 –Assessment of COB User Fees

(Rev. 4; Issued: 09-26-08; Effective/Implementation Date: 09-26-08)

The MMA provided CMS with the authority to impose user fees to facilitate the transfer of information necessary for benefit coordination. In conjunction with this authority, CMS is using the fees for activities such as, covering the cost of N1 transactions, funding the COB Contractor, and supporting CMS systems upgrades for transferring COB data to *sponsors*.

Sufficient time has elapsed since the implementation of Medicare Part D for CMS to refine its budgetary needs related to the information transfer necessary for COB in Part D. Over these past months, CMS has made a number of systems improvements, such as enhancing the eligibility query (E1) response, and has increased systems security for the COB-associated data exchanges.

Further systems upgrades are planned or are under discussion for next year. In addition to automating the transfer of TrOOP balances between sponsors when beneficiaries transfer between plans during the coverage year, CMS is exploring an expanded role for the TrOOP facilitator to further support Part D sponsor activities related to COB. Examples of these enhancements include:

- Replaying N transactions when a claim initially rejects;
- Development and production of reports to Part D sponsors on N1s; and
- Analysis and creation of a test environment to improve the E1 match rate.

As a result, the user fee increased for 2007 to \$1.36 per enrollee *and continued at that rate for 2008*. It *is* collected at the rate of \$0.15 per enrollee per month from January through August, and \$0.16 per enrollee for the month of September. *Upon review of the anticipated costs of COB activities in 2009, the COB user fee will increase to \$2.52 per enrollee for contract year 2009. The 2009 user fee will be collected at a monthly rate of \$0.28 for the first 9 months of the coverage year (for an annual rate of \$0.21 per enrollee per month.)*

40 – Beneficiary Requirements

(Rev. 4; Issued: 09-26-08; Effective/Implementation Date: 09-26-08)

40.1 – Providing Information to *Sponsors* on Other Coverage

(Rev. 4; Issued: 09-26-08; Effective/Implementation Date: 09-26-08)

Beneficiaries must supply Part D sponsors with information about other prescription drug coverage *the beneficiaries* have. As provided in the MMA, beneficiaries are legally obligated to report this information, and any material misrepresentation of such

information by a beneficiary may constitute grounds for termination of coverage from Part D. *CMS guidance on material misrepresentation regarding third party reimbursement and disenrollments for this reason is provided in section 40.2.5 of the Prescription Drug Plan (PDP) Eligibility, Enrollment and Disenrollment Guidance available on the CMS Web site. See Appendix B for the specific Web address.* Part D *sponsors* must regularly survey their enrollees regarding any other coverage they may have (as described in section 50.2 of this chapter) and report that information to the COB Contractor for validation.

40.2 – Using On-line Processing

(Rev. 4; Issued: 09-26-08; Effective/Implementation Date: 09-26-08)

CMS expects beneficiaries to take advantage of automated real-time prescription drug claim processing whenever it is available so that the supplemental payer information can be utilized to coordinate benefits seamlessly at the point of sale. Paper claim (receipt) submission should be limited to those situations (such as out-of-network pharmacies) in which on-line claims processing is not available at the pharmacy in order to promote accurate TrOOP accounting, and to minimize both administrative costs to the Part D *sponsors* and the Medicare program as well as opportunities for fraudulent duplicative claim reimbursements.

40.3 – Submitting Documentation for Off-line Processing on a Timely Basis

(Rev.)

(Rev. 4; Issued: 09-26-08; Effective/Implementation Date: 09-26-08)

Beneficiaries are responsible for submitting documentation for purchases that are made off-line (i.e., when on-line claims processing is not available at the pharmacy). These would include out-of-network claims, claims resulting from the use of drug discount cards other than that of the beneficiary's Part D *sponsor*, as well as other occasions on which the beneficiary had to pay and submit a paper claim to the plan. It is the beneficiary's responsibility to submit documentation *to the Part D sponsor* so that beneficiary TrOOP balance and other accumulators can be updated timely.

50 – Part D Sponsor Requirements

(Rev. 4; Issued: 09-26-08; Effective/Implementation Date: 09-26-08)

50.1 – Providing 4Rx Data on Primary Coverage

(Rev. 4; Issued: 09-26-08; Effective/Implementation Date: 09-26-08)

Effective August 2007, all plan-submitted enrollment transactions to the MARx system must include 4Rx data. The 4 Rx data, including the RxBIN, Processor Control Number (PCN), Group ID (*RxGRP*) and Cardholder ID (*RxID*), are

identifying data required for claims routing. If *CMS* accepts *the enrollment transaction, the enrollment information with the 4Rx data* are sent by the *MBD* to the TrOOP facilitation contractor to support eligibility (E1) transactions from pharmacies, which are needed anytime a beneficiary *presents* for the first time at a pharmacy and does not have a plan-issued card for drug benefits. *For CMS-generated enrollment transactions, including auto-enrollments, facilitated enrollments, plan rollovers, reassignments, and user interface transactions, Part D sponsors are required to submit the 4Rx data via a 72 transaction to CMS within 72 hours following the date of the Transaction Reply Report (TRR) reporting the enrollment to the sponsor.*

Two important benefits *accrue as a result of this change in the enrollment process*. *CMS* and the TrOOP facilitation contractor have a set of 4Rx data for all enrollees whose transactions have been processed successfully in *CMS* systems. *In addition*, most of the time lag between *CMS* accepting an enrollment and the TrOOP facilitation contractor having 4Rx data *has been* eliminated.

50.2 – Surveying Beneficiaries Regarding Other Prescription Drug Coverage and Transmitting Such Information to CMS

(Rev. 4; Issued: 09-26-08; Effective/Implementation Date: 09-26-08)

As provided in the MMA, beneficiaries are legally obligated to report information about other prescription drug coverage or reimbursement for prescription drug costs that *the beneficiaries* have or expect to receive; any material misrepresentation of such information by a beneficiary may constitute grounds for termination of coverage from a Part D plan. Part D *sponsors* must, therefore, regularly survey their enrollees regarding any other prescription drug coverage they may have and report that information – including, if known, any Rx *data* (RxBIN, PCN, RxGRP, and RxID) – to the COB contractor so that it can be validated, captured, and maintained in MBD for COB purposes. Anytime a Part D *sponsor* receives information concerning a change, this information should be sent electronically to the COB contractor within 30 days of receipt. *Sponsors* shall not transmit information about other coverage that the COB contractor has already applied to MBD and that the *sponsor* has already received in the COB file, but rather only change transactions.

Except as noted, this survey should be performed within 30 days of the date the sponsor processes a beneficiary's enrollment and annually thereafter. Beneficiaries who may be exempted from the survey at the time of plan enrollment include auto-enrolled beneficiaries, those who are deemed to have elected an MA-PD, and those individuals who are passively enrolled in a MA-PD Special Needs Plan. *Sponsors*, however, must survey these individuals, along with all other plan enrollees, as part of their annual survey process. In addition to the exempted beneficiaries, if an enrollee indicates on his or her enrollment form that there is no other prescription drug coverage, no sponsor follow-up is required until the annual survey is performed. However, if the enrollee indicates on the

enrollment form that he or she in fact has other prescription drug coverage or does not provide any response to those questions, the sponsor must perform the 30-day survey.

The survey should collect from the enrollee the same information on other payers that Part D *sponsors* must submit electronically to the COB contractor. *Sponsors* have the flexibility to design their survey process according to their own needs. CMS has developed an electronic survey form (see Appendix C) that *sponsors* are free to use or adapt for this purpose. Note that use of this form is optional and *sponsors* are not required to submit their surveys for marketing material review. *Sponsors* may conduct their survey by telephone, mail, *email if available*, or in-person. *The survey should not require that the beneficiary provide his or her SSN; instead, sponsors should use other identifiers, such as the Member ID. Also, in addition to providing a self-addressed return envelope for mail surveys, sponsors should include on the survey form itself the mailing address to be used for completed surveys in case the envelope is lost or damaged.*

Further, if *an MA-PD* sponsor wishes to do so, this survey may be combined with the working aged survey for Medicare Advantage (MA) plans, *now known as the MSP Survey*. If the *sponsor* elects this approach, the timing of the combined survey must be such that the *sponsor meets the timing requirement of the MSP Survey to permit* appropriate payment adjustments to be made based on the *MSP information* provided by the beneficiaries.

A non-response to the survey regarding other prescription drug coverage cannot be interpreted as a negative answer, since effective coordination of benefits with other prescription drug coverage requires that *sponsors* be aware of any other prescription drug coverage a beneficiary may have. Therefore, sponsors are required to follow up with enrollees who fail to respond. Follow-up with non-responding enrollees may be conducted by telephone, mail, *email if available*, or in person. After unsuccessful attempts to gain a response using one mode, *sponsors* may find a change to another mode is more productive. Also, if the beneficiary has had drug claims, *sponsors* may contact the pharmacy to determine if COB information was captured while the beneficiary was in the pharmacy. *Sponsors* are expected to make a *minimum of three* attempts to follow up with non-responding enrollees. *At least one of the follow-up efforts must involve the use of a different method of contact. For example, if the initial survey was mailed, at least one of the follow-up attempts must be other than a mailed survey; i.e., must be conducted by telephone, email if available, or in-person.*

Part D *sponsors* also are responsible for sending electronic updates about their enrollees' other sources of prescription drug coverage to the COB contractor. Since supplemental payer information is essential for coordination of benefits, *sponsors* should submit this information to the COB contractor at least monthly.

50.3 – Connecting to Systems Supporting COB

(Rev. 4; Issued: 09-26-08; Effective/Implementation Date: 09-26-08)

Data from CMS to sponsors

The COB contractor performs a daily update of information on other coverage to MBD. *Sponsors* must establish connectivity with CMS systems, which, among other things, allows Part D *sponsors* to have direct access to other payer status information as often as their business requirements indicate. Every Federal business day, the COB contractor pushes out updated information to MBD and then CMS sends the COB file to the Part D *sponsors*. For more information on receiving COB files, see the Plan Communications User's Guide (PCUG) available on the CMS Web site. (*Refer to Appendix B for the Web address.*) It is incumbent upon Part D sponsors to note any changes to other payer status included in CMS systems and to send that information to the COB contractor.

Data from sponsors to the COB system

There is an electronic interface between Part D *sponsors* and the COB contractor known as the Electronic Correspondence Referral System (ECRS). ECRS allows Part D *sponsors* to submit post-enrollment transactions that change or add to currently known COB information. Part D *sponsors* may send ECRS transactions in any of three possible ways: 1) by using Network Data Mover (NDM) (a secure file transfer process) to connect to the ECRS Online Application; 2) by using NDM to send an ECRS flat file; or 3) by using a current SFTP connection to send an ECRS flat file. Part D *sponsors* are updated on the status of these transactions as they move through the COB systems and informed on the determination made by the COB contractor on the transactions via a COB data report/file. Further information on ECRS is contained in the ECRS User Guide available on the CMS Web site; *see Appendix B for the specific Web address.*

The data provided by the COB contractor on supplemental payers and order of payment is generally the best available information for Part D *sponsors* and pharmacies to act upon. However, it is important to note that Part D *sponsors* must coordinate benefits with all other payers providing coverage for covered Part D drugs, even if the COB contractor is unaware of some payers who have submitted batched claims after the point-of-sale transaction at a network pharmacy. Although the COB contractor may be unaware of them, these other payers may submit claims directly to the Part D sponsor or through the TrOOP facilitation contractor, thereby enabling benefit coordination by the Part D sponsor. Once a *sponsor* becomes aware of these other payers, *sponsors* must submit this information via ECRS to the COB contractor.

Sponsors should utilize the electronic interface established with CMS (via the MARx system) to handle plan enrollments, to transmit certain other payer data elements upon enrollment, and to receive daily transmissions of validated COB information. As new information about other prescription drug coverage is discovered, *sponsors* should use ECRS to send the information to CMS. *Sponsors* should not use the enrollment update transaction to communicate this subsequent information.

Beyond the electronic data transfers requirements described above, Part D *sponsors* must establish procedures for at least weekly file processing. *Sponsors* are required to not only receive information, but also apply it to their systems.

50.4 – Processing Claims and Tracking TrOOP

(Rev. 4; Issued: 09-26-08; Effective/Implementation Date: 09-26-08)

Part D *sponsors* must correctly calculate the TrOOP amount in order to properly adjudicate beneficiary claims, as well as to communicate this information to plan enrollees. In order to calculate TrOOP, Part D *sponsors* will have to determine if other entities have made payments on covered drugs, and whether such payments fall under the legal definition of incurred costs (as described in 42 CFR §423.100). CMS assists in this process by providing a TrOOP facilitation contractor (described in section 30.4 of this chapter) that requires that supplemental payers utilize the HIPAA coordination of benefits transaction standard, which requires the use of the NCPDP Standard Implementation Guide to communicate other payer transactions back to the primary Part D *sponsor* for purposes of tracking TrOOP in real time. Part D *sponsors* are required to process claims and track TrOOP in real time including providing known supplemental payer information to the pharmacy and by accepting and processing N transactions. CMS expects Part D *sponsors* to establish policies and procedures appropriately restricting the use of paper claims to those situations in which on-line claims processing is not available to the beneficiary at the point of sale in order to promote accurate TrOOP accounting, as well as to minimize administrative costs to the Part D sponsors and the Medicare program and opportunities for fraudulent duplicative claim reimbursements.

When secondary payer information is not captured upfront in CMS systems, however, Part D *sponsors* are required to retroactively adjust claims and TrOOP balances. CMS also establishes an order of payment (see section 30.3) to the validated payer-identifying data that is transmitted to both the TrOOP facilitator and the Part D *sponsors* from MARx via the COB file. This order of payment assists *sponsors* in processing claims when there are multiple other payers on a beneficiary's record. This is important, particularly for payers – such as SPAPs – considered payers of last resort. Because Part D *sponsors* are ultimately responsible for accurately tracking TrOOP, they are required to retroactively adjust claims and TrOOP balances when errors are made in terms of order of payment.

Regardless of whether a retroactive change to TrOOP is the result of a sponsor's receipt of retroactive secondary payer information or an error in payer order, the sponsor has two choices. The sponsor may adjust each claim that was affected by the retroactive change or may process the adjustment as they administer the benefit, provided that:

- TrOOP accumulators are updated immediately;*
- Monies owed beneficiaries are refunded promptly;*
- Claims are restacked and adjustments are processed at least quarterly; and*
- An exceptions process exists for more frequent processing to meet beneficiary needs, such as at disenrollment during the coverage year.*

The methodologies for handling retroactive changes in TrOOP are described in Section 9 of the Prescription Drug Event (PDE) guidance available on the CMS Web site. See Appendix B for the specific Web address. For further detail on reconciling payments, see section 50.15 of this chapter.

Part D *sponsors* must make timely retroactive adjustments of claims and TrOOP balances. CMS reserves the right to establish required timeframes for these adjustments based on acquired experience.

While this document is not meant to capture the TrOOP facilitation process in exhaustive detail, other sources are available in:

- Appendix A of this chapter which contains more information, in flow chart format, about what the TrOOP facilitation process entails.
- The TrOOP facilitation contractor Web site; *see Appendix B for the specific Web address.*
- The NCPDP Implementation Guide which is the official vehicle for establishing electronic processing rules.
- The Prescription Drug Event (PDE) Data Guidance on the CMS Web site which explains TrOOP and PDE data reporting; *see Appendix B for the Web address.*
- Chapter 5 of this manual which will **address benefits, beneficiary protections and benefit design** and will contain information on incurred costs counting toward TrOOP.

50.4.1 –Receiving an N1, Without Supplemental Payer on File

(Rev. 4; Issued: 09-26-08; Effective/Implementation Date: 09-26-08)

Part D *sponsors* should accept N1 transactions even in those instances where they have no supplemental payer information on file to identify the payer. CMS encourages *sponsors* to then follow up by contacting the beneficiary (which may be accomplished in conjunction with the annual COB survey of plan enrollees if that survey will be conducted within the next 2 months) to identify the supplemental payer. Once the *sponsor* receives this information, it should be transmitted to the COB contractor for verification of the secondary coverage.

Note that in the event that a Part D *sponsor* is a secondary payer in accordance with the application of Medicare Secondary Payer (MSP) rules, the Part D *sponsor* is required to process claims in real time to support the TrOOP facilitation process.

Explanations of benefits (EOBs) provide enrollees with their year-to-date TrOOP balances and gross covered drug costs and information on the enrollees' position in the Part D benefit. To ensure enrollees are appropriately informed, CMS requires that *sponsors* develop EOBs that provide information in a form understandable to all enrollees. EOB formats are included in the Medicare marketing guidelines available on the Web site; *see Appendix B for the specific Web address.*

50.4.2 – Beneficiary Cash Purchases

(Rev. 4; Issued: 09-26-08; Effective/Implementation Date: 09-26-08)

Although CMS expects it to happen rarely, an individual may be able to obtain a lower price at a network pharmacy than that which his or her plan charges (the plan's negotiated price) in any applicable coverage gap or deductible. This may be possible if the pharmacy is offering a "special" price or other discount for all customers, or if the beneficiary is using a discount card, and the beneficiary is in any applicable coverage gap or deductible phase of his or her Part D benefit and is able to receive a better cash price for a covered Part D drug at a network pharmacy than the *sponsor* offers via its negotiated price. In this situation, he or she may purchase that covered Part D drug without using his or her Part D benefit or a supplemental card. The enrollee's purchase price for the discounted drug will count toward total drug spend under his or her Part D benefit and TrOOP balance provided the Part D sponsor becomes aware of it.

The enrollee must take responsibility for submitting the appropriate documentation to his or her plan in order to have the amount count toward his or her total drug spend and TrOOP balances.¹ *Sponsors* must accommodate the receipt of such information directly from enrollees and adjust total drug spend and TrOOP balances accordingly consistent with their established processes and clear instructions for *these* enrollee paper claim submissions.

Note that this lower cash purchase policy does not apply in any phase of an enrollee's Part D benefit in which he or she is liable for any less than 100 percent cost-sharing. In other words, it does not apply outside of any applicable coverage gap or deductible phase of his or her benefit. CMS has limited the policy's applicability in order to ensure that

¹ Note that in cases where a pharmacy offers a lower price to its customers throughout a benefit year, this would not constitute a "lower cash price" situation that is the subject of this guidance. For example, Wal-Mart and other retailers recently introduced programs offering a reduced price for certain generics to its customers. The low Wal-Mart price on these specific generic drugs is considered Wal-Mart's "usual and customary" price, and is not considered a one-time "lower cash" price. Part D sponsors consider this lower amount to be "usual and customary" and will reimburse Wal-Mart on the basis of this price. To illustrate, suppose a Plan's usual negotiated price for a specific drug is \$10 with a beneficiary copay of 25% for a generic drug. Suppose Wal-Mart offers the same generic drug throughout the benefit for \$4. The Plan considers the \$4 to take the place of the \$10 negotiated price. The \$4 is not considered a lower cash price, because it is not a one-time special price. The Plan will adjudicate Wal-Mart's claim for \$4 and the beneficiary will pay only a \$1 copay, rather than a \$2.50 copay. This means that both the Plan and the beneficiary are benefiting from the Wal-Mart "usual and customary" price, and the discounted Wal-Mart price of the drug is actually offered within the Plan's Part D benefit design. Therefore, the beneficiary can access this discount at any point in the benefit year, the claim will be adjudicated through the Plan's systems, and the beneficiary will not need to send documentation to the plan to have the lower cash price count toward TrOOP.

enrollees: (1) do not unwittingly forego sponsor-funded coverage, which in most cases will be the lowest price available given the price concessions built into the plan's negotiated prices; (2) have the benefit of plan drug utilization review and other safety edits that can only be provided if the plan adjudicates the claim; and (3) proceed through the benefit as quickly as possible in order to reach catastrophic coverage. It is unlikely that the use of discount cards or other special discounts will be a significant source of savings for most enrollees. It is possible, however, depending on the cost of the drug that if an enrollee fails to submit even one claim for a purchase made under the circumstances explained above, the enrollee will ultimately spend more than he or she would have under his or her plan's negotiated prices.

CMS also notes that organizations or entities offering discount card or other discounted price arrangements must comply with all relevant fraud and abuse laws, including, when applicable, the Federal anti-kickback statute and the civil monetary penalty law prohibiting inducements to beneficiaries. The HHS Office of the Inspector General (OIG) enforces Federal fraud and abuse statutes, and all questions regarding the compliance of specific arrangements with these statutes should be referred to the OIG.

This section reflects CMS' current beneficiary cash purchase policy. However, if significant issues arise, CMS will revisit the policy.

50.5 – Standardized Claims Messaging

(Rev. 4; Issued: 09-26-08; Effective/Implementation Date: 09-26-08)

CMS requires the rapid adoption and use of new standardized messaging procedures approved by NCPDP in order for Part D *sponsors* to more effectively communicate with pharmacies and coordinate with other payers in real time. The adoption of new messaging will address issues that have arisen at point of sale needing clarification of certain claims adjudication responses that are specific to Part D, such as claims rejections for drugs excluded from Part D coverage and for drugs that are covered under Medicare Part B for the particular beneficiary. Further, by sending this additional information to the pharmacy, payers can expedite resolution of questions concerning how to fill the prescription and minimize staff time in answering phone calls and prior authorization processes.

Therefore, Part D *sponsors* must promptly implement appropriate systems changes to achieve the goals of any additional new messaging approved by the industry through NCPDP to address clarifying information needed to adjudicate a Part D claim and appropriately coordinate benefits in real time. While CMS strongly encourages sponsor adoption and use of the standardized approach in the NCPDP guidance as issued in the 5.1 Editorial Document, until such time as alternative transactional coding is implemented in a new version of the HIPAA standard, sponsors may adopt alternative approaches that achieve the goals intended in the messaging guidance.

In order to promote the use of best practices and assist beneficiaries, pharmacies and payers, CMS requires Part D *sponsors* implement an appropriate strategy that achieves

the goal of the industry consensus on messaging as expeditiously as practicable after a consensus has been reached and documented by NCPDP.

50.5.1 – Primary Payer Use of Optional Fields to Support COB

(Rev. 4; Issued: 09-26-08; Effective/Implementation Date: 09-26-08)

While CMS recognizes the version C.1 (and any future version) of the NCPDP Implementation Guide as the official vehicle for establishing the special electronic processing rules to be used in coordinating benefits and generating the N1 transaction, version C.1 does not require that primary payers provide certain optional fields. The optional fields are “Amount Applied to Periodic Deductible” [517-FH] and “Amount of Copay” [518-FI] in the response pricing segment of the NCPDP telecommunication standard. However, CMS encourages payers to use these fields to assist secondary payers in administering their benefit whenever possible. When these fields are provided by the primary payer, they can be passed from the pharmacy to the secondary payer.

50.6 – Accepting Payment of Premiums From Other Payers

(Rev. 4; Issued: 09-26-08; Effective/Implementation Date: 09-26-08)

As provided by the MMA, supplemental payers may wish to pay premiums on behalf of Part D enrollees instead of (or in addition to) providing wrap-around coverage. Part D sponsors are required to facilitate the billing and collection of such premiums. While Part D *sponsors* must accept premium payments by supplemental payers on behalf of their Part D enrollees, the details of such arrangements are strictly between Part D sponsors and such payers. Part D sponsors should ensure that in accordance with the uniform premium requirement the total premium payment for a beneficiary does not vary among plan enrollees, except in the case of employer group plans for which this requirement has been waived in part.

A beneficiary must not be disenrolled from a Part D *sponsor* if it has been notified that the premiums are being paid by a SPAP or other payer and the sponsor has not yet coordinated receipt of the premium payments with the SPAP or other payer. In these cases, Part D *sponsors* are required to work directly with the SPAPs or the other payers to systematically coordinate and accept premium payments in accordance with the Federal regulations at 42 CFR 423.464(a)(1). That is, sponsors must bill the SPAP or other payers directly for the beneficiary’s premium and not bill the beneficiary. Until the *sponsor* can bill the SPAP or other payers directly, *sponsors* will not be in compliance with the coordination of benefit requirements. *Sponsors* must not take any action, including sending disenrollment notices directly to the beneficiary, to disenroll the beneficiary for failure to pay premiums when the *sponsor* has failed to coordinate the collection of premiums from other payers.

Sponsors currently receive data from CMS in the COB file indicating which beneficiaries are covered under SPAPs. *The Supplemental Type Code data field of the COB file (see*

the PCUG, Appendix E.6.4) indicates the type of supplemental coverage a beneficiary may have. An indicator of 'Q' identifies when a beneficiary has qualified SPAP coverage. (Refer to Appendix B for the PCUG Web site.) Sponsors could use this data to withhold systematic release of disenrollment notices to these beneficiaries when an SPAP is paying on behalf of the beneficiary.

In addition to accepting payment of premiums from other payers, Part D sponsors may wish to consider providing advance notice to such payers when an enrollee is at risk of losing coverage due to failure to pay their portion of a premium.

50.7 – Coordinating Payment of a Lump Sum for Supplemental Coverage

(Rev. 4; Issued: 09-26-08; Effective/Implementation Date: 09-26-08)

The MMA specifies that CMS' COB requirements must include a method for the application by a Part D *sponsor* of specified funding amounts (a lump sum per capita method) from an SPAP for supplemental prescription drug benefits. Given that all COB requirements established with respect to SPAPs must also be applied to other entities providing prescription drug coverage, CMS requirements regarding the payment of a lump sum for supplemental coverage (of cost sharing) are also applicable to other payers mentioned in this *chapter*. Consequently, Part D *sponsors* are required to coordinate the receipt and management of lump sum arrangements with other payers. It is important to note, however, that the cost sharing funded by lump sum amounts will generally only apply toward TrOOP if made by a qualified SPAP or a charity for Part D benefits, and if made for expenditures on covered Part D drugs before a beneficiary reaches the annual out-of-pocket limit.

SPAPs (and other payers) may choose to provide their wrap-around benefits to Part D beneficiaries using four basic approaches:

1. Pay premiums for basic and/or supplemental benefits offered by Part D sponsors.
2. Wrap-around benefits at the point-of-sale: Pharmacy files a secondary claim to the SPAP (or its processor) for payment.
3. Contract with Part D sponsors on a risk or non-risk-based lump sum per capita method, i.e., solicit lump sum per capita bids from Part D *sponsors* in exchange for the provision of wrap-around benefits.
4. Provide some combination of these approaches.

CMS is establishing standards for option 3 in order to provide clear guidance on the approaches that will be deemed to be non-discriminatory among Part D *sponsors* in accordance with §1860D-23(b)(2) of the Social Security Act. These include a risk-based and a non-risk-based approach.

50.7.1 – The Risk-Based Combined Uniform Benefit/Lump Sum Contribution Approach

(Rev. 4; Issued: 09-26-08; Effective/Implementation Date: 09-26-08)

CMS believes this market-based approach is equitable to both the SPAP and the Part D *sponsor*, since it establishes a benchmark payment amount derived from the submission of competitive Part D sponsor quotes and balances the interests of both parties. This approach does not involve CMS in the bidding process. The following steps outline the approach SPAPs may adopt when paying lump sum per capita payments to Part D *sponsors* for wrap-around benefits in order to be deemed non-discriminatory with respect to providing such benefits without regard to the Part D *sponsor* in which the SPAP beneficiary enrolls. Note that this approach does not address or substitute for non-discriminatory standards with respect to education and enrollment of beneficiaries by any SPAP, or co-branding with Part D *sponsors*.

1. States that wish to adopt a lump sum per capita approach would define a uniform “benefit package” that would be available to eligible beneficiaries who enroll in Part D basic (not enhanced alternative) prescription drug coverage plans. (These wrap-around benefit packages would be subsidized by the State and would reduce cost-sharing from that included in the basic benefit to a uniform cost-sharing level. No changes would be made in plan formularies, plan pharmacy networks, or other coverage rules.) The State would be free to include risk-sharing arrangements in their defined benefit solicitation as long as identical arrangements were included in every plan contract, and as long as such arrangements would be fully reconciled prior to CMS allowable cost reconciliations with Part D *sponsors*.
2. All Part D *sponsors* in the region would be invited by the State to submit a quote (note – the quote is for the increment above basic benefits) for providing the uniform wrap-around benefit for a full-risk, lump sum per capita amount. States must use normal channels for publishing procurement notices to publicize these requests for proposals.
3. Part D sponsors that did not want to participate in this market would not be required to submit quotes, and States would not be obligated to provide wrap-around benefits to any beneficiaries choosing to enroll in such plans, or to promote such plans. (This does not preclude a State from providing wrap-around coverage on behalf of SPAP beneficiaries choosing to enroll in such plans, if it so chooses. In fact, if the SPAP also elects to pay the premium for all basic benefits, this approach does not permit the SPAP to exclude payment of premium for any Part D sponsors that do not participate in the lump sum approach.) CMS recognizes that there will be some Part D *sponsors* that will not be interested in the individual market (and will, in fact, not be available to individuals) and will not want to be required to submit their quotes to the SPAPs. Likewise, some Part D *sponsors* may not want to assume the additional

(unsubsidized) risk of the lump sum per capita approach, and would not be required to enter into the bidding process.

4. Based upon the per capita quotes submitted by the *sponsors*, each State would determine what it would pay using one of the two following approaches. CMS believes that both approaches encourage *sponsor* participation in the lump sum approach while balancing the interests of both parties.
 - A. States pay the actual quote proposed by each Part D *sponsor*. Under this approach, all Part D *sponsors* that wanted to participate in the lump sum per capita approach would submit their quotes. States would pay amounts based upon each Part D *sponsor's* quote, and the *sponsors* would accept full risk for the supplemental costs of the SPAP beneficiaries as specified in the defined benefit. This approach is equitable for the SPAP since it provides the option to choose this approach over the 75th percentile approach if the results of paying each *sponsor's* quote would result in lower costs to the State. It is equitable to Part D *sponsors* because SPAPs would be required to accept all quotes and no willing *sponsor* may be excluded. CMS plays no role in this process other than standard setting, and the terms of the bidding and contracting process are defined in the State's request for proposal (RFP) and contract. **OR**
 - B. States pay each Part D *sponsor* an amount equal to the 75th percentile quote. This approach requires the State to pay a uniform amount to all *sponsors* based upon the Part D *sponsor* quote amount submitted at the 75th percentile. Paying all Part D *sponsors* the same amount is necessary under this approach in order to provide protection against excessively low bids, given the competitive downward pressure on bids and the lack of risk sharing. It also gives the State the opportunity to cap its payments. Those sponsors with quotes above the 75th percentile would need to collect the difference between the *sponsor* bid and the State's uniform contribution amount from the beneficiary in the form of an additional premium. This approach is equitable to both the SPAP and the Part D *sponsor* since it establishes a payment amount derived from the submission of competitive Part D *sponsor* quotes, protects Part D *sponsors* from excessively low bids and States from excessively high ones, and excludes no willing *sponsors*. Again, CMS plays no role in this process other than to set the non-discriminatory rules and threshold, and the terms of the bidding and contracting process are defined in the State's RFP and contract.

CMS notes that any additional premium collected from the beneficiary attributable to the difference between the *sponsor* quote and the State's uniform contribution amount would not be a Part D premium. Therefore, it would not be consolidated with the Part D premium for purposes of withholding by SSA or plan payment determination. Any such premium must be collected directly from the beneficiary by the *sponsor*.

As part of the State's RFP and contract, any Part D *sponsor* that submits a quote would be required to accept the lump sum per capita payments made by the State under its chosen approach. Part D *sponsors* with lump sum quotes at or below the State's uniform contribution limit would have to accept the uniform contribution limit as payment in full for the provision of SPAP wrap-around benefits. (Note that some *sponsors* may be paid more than their quotes under this approach.) Under the 75th percentile option, Part D *sponsors* with quotes higher than the uniform contribution limit would have to accept the uniform payment from the State and charge the balance of the quote to the beneficiary in the form of an additional premium. Part D *sponsors* with quotes higher than the uniform contribution limit would not have the option to accept the uniform contribution and waive the additional beneficiary premium.

A Part D *sponsor* with a quote above the uniform contribution limit would be allowed to withdraw its quote if it did not wish to participate with an additional enrollee premium. However, in turn, the SPAPs would not be obliged to promote or provide wrap-around benefits to beneficiaries that join these withdrawing *sponsors*. CMS notes that if the SPAP also elects to pay the premium for all basic benefits, this approach does not permit the SPAP to exclude payment of premium for any Part D sponsors that do not participate in the lump sum approach. To do otherwise would be violating the non discrimination requirements that an SPAP must provide assistance to individuals in ALL part D *sponsors* without regard to the plan in which the individual is enrolled.

5. In return, the State would have to ensure that its beneficiaries received **equal access** to enrollment in and comparable information on all the Part D *sponsors* participating in the chosen approach, without any steering to individual plans. In addition, even if a *sponsor* is not accepting lump sum payments, the State should still explain that beneficiaries can still enroll in that *sponsor*, but they will get only basic coverage – without the SPAP additional defined benefit – if they do so. If the State has also elected to pay the premium for all Part D basic benefits, this approach does not permit the SPAP to exclude payment of premium for any Part D sponsors that do not participate in the lump sum approach.

Note that this guidance is not intended to address all requirements on SPAPs with respect to non-discriminatory beneficiary education, enrollment and co-branding activities. Other guidance exists on CMS' Web site; for example, guidance on co-branding with SPAPs is included in the Medicare marketing guidelines available on the CMS Web site; see *Appendix B for the specific Web address.*

CMS recognizes that under option A there is a strong financial incentive for SPAPs to steer to *sponsors* with the lowest quotes in violation of CMS guidance. Therefore, CMS forewarns States that CMS will be evaluating enrollment patterns among Part D *sponsors*. If CMS determines that the distribution of SPAP beneficiaries in participating Part D *sponsors* differs substantively and without good cause from the

distribution of similar non-SPAP Medicare beneficiaries enrolled in those *sponsors*, CMS may conclude that the State has steered their SPAP beneficiaries towards particular sponsors. In this case, CMS may no longer count that State's SPAP payments towards the beneficiary's TrOOP threshold.

6. States would be required to report the results of the bidding process to CMS for oversight purposes.
7. Part D *sponsors* participating in the lump sum approach would be required to provide clear and prominently displayed information, which may include co-branding on the sponsor's ID card, identifying the SPAP as a co-provider of benefits under the combined approach. (This requirement is limited to coordination of benefits with SPAPs, and need not be extended to other payers unless desired by the Part D sponsor.)
8. Part D *sponsors* would be required to provide claims data on the State's enrollees to the SPAPs periodically in order for the State to understand the utilization underlying its costs.

CMS believes that this approach allows for a simplified method for SPAPs to provide supplemental (cost sharing) benefits to their beneficiaries, as well as the following additional benefits:

- Provides a seamless process from the point-of-view of beneficiaries and pharmacies.
- Does not require the pharmacist to route a secondary claim.
- Eliminates the need for multiple wrap-around methods on the part of the State.
- Relieves SPAPs of obligation to provide wrap-around benefits for *sponsors* that do not accept the lump sum payment.
- Establishes a fair and equitable lump sum amount based on competitive market forces.
- Makes additional risk bearing optional for Part D sponsors.
- Although not required for other payers, this approach could work just as well for other payers, if desired.

50.7.2 – The Non-Risk-Based Lump Sum Payment with Claims Reconciliation Approach

(Rev. 4; Issued: 09-26-08; Effective/Implementation Date: 09-26-08)

States that wish to fully subsidize a fixed portion of beneficiary cost sharing through their SPAPs may do so as long as an equal subsidy amount is offered to each beneficiary in each Part D *sponsor*. (This uniform payment requirement would not preclude reimbursement of subsidy amounts in the event a given beneficiary did not incur the entire amount of cost sharing.) These subsidy amounts would need to be applicable to any enrollee cost sharing and not be tied to any particular benefit design, such as the deductible or coverage gap, so that they would be applicable to every Part D *sponsor* basic benefit design. Part D *sponsors* would enter into arrangements to receive such subsidies and to apply the subsidy amounts to first dollar coverage of cost sharing for each applicable beneficiary. Part D *sponsors* would be required to provide claims data on the State's enrollees to the SPAPs in order for the State to understand the utilization underlying its costs, and for reconciliation of paid to incurred amounts.

The regulation at 42 CFR 423.464(a) requires that Part D *sponsors* must coordinate with SPAPs and other entities providing other prescription drug coverage. This includes if the SPAP or other payer is adopting a lump sum per capita approach when supplementing Part D benefits in accordance with section 42 CFR 423.464(a)(2). Therefore, CMS requires all Part D *sponsors* to have the capacity to participate in non-risk based arrangements, if offered by the State, SPAPs or other payers so that their beneficiaries can receive coordinated, wrap-around coverage at the point-of-sale. If a *sponsor* is out of compliance with this regulatory requirement, CMS will not disqualify a state program from its qualified SPAP status. CMS will not view SPAPs as discriminating, in violation of section 1860D-23(b)(2) of the Act, due to a Part D sponsor's failure to adhere to this COB requirement.

50.8 – Claims Reconciliation Reports

(Rev. 4; Issued: 09-26-08; Effective/Implementation Date: 09-26-08)

Except for the non-risk-based lump sum with reconciliation approach described in section 50.7.2, above, CMS does not believe there is any need for claims reconciliation reports. In general, States (and other payers) will either receive secondary claims through their own processors, or they will coordinate using approaches that do not require claim reconciliations.

50.9 – Transferring TrOOP Balance When a Beneficiary Changes Part D *Sponsors*

(Rev. 4; Issued: 09-26-08; Effective/Implementation Date: 09-26-08)

Part D rules require *sponsors* to track the beneficiary's TrOOP and correctly apply these costs to the TrOOP limit in order to provide the catastrophic level of coverage at the appropriate time. The TrOOP threshold is calculated on an annual basis and must be transferred between Part D *sponsors* if a beneficiary disenrolls and re-enrolls at any time before the end of a coverage year. *Sponsor* collection, and transfer if appropriate, of the

TrOOP and gross covered drug spending balances are essential for *sponsors* to correctly manage the Part D benefit.

50.9.1 – Manual TrOOP Balance Transfer Process

(Rev. 4; Issued: 09-26-08; Effective/Implementation Date: 09-26-08)

In 2006, the TrOOP balance transfer or explanation of benefits (EOB) transfer process was first implemented to facilitate the required coordination of benefits between *sponsors*, and the plan-to-plan transfer of TrOOP and total drug spend balances for beneficiaries affected by the Enrollment Reconciliation process. CMS continues to require its use to transfer TrOOP-related data whenever beneficiaries transfer from one *sponsor* to another during the coverage year. *Once the automated process is implemented in 2009, further routine need for the manual data transfer process will be eliminated.*

Part D *sponsors* are requested as a first step to populate the “EOB Transfer Contact” field in the Health Plan Management System (HPMS). To enter this information, *sponsors* need to follow this navigation path: HPMS Homepage > Contract Management > Contract Management > Select Contract Number > Contact Data > EOB Transfer Contact. CMS maintains a periodically updated posting of these contacts that is available *on the CMS Medicare Prescription Drug Coverage Contracting Web page; see Appendix B for the specific Web address.*

When a *sponsor* receives a disenrollment transaction with a transaction reply code of [014] or [015] indicating that a member has disenrolled, the disenrolling *sponsor* must create a special transfer EOB. This EOB must be created regardless of whether or not the disenrolled beneficiary had claims activity. The transfer EOB must contain information concerning the beneficiary’s TrOOP balance and gross covered drug costs and must be sent to the new *sponsor* of record. The Source File ID field on the TRR identifies the contract number of the *sponsor* of record that will receive the EOB which can be used to locate the contact information posted as described above. The transfer EOB must be sent to the new sponsor of record within 7 days of the date of the disenrollment TRR.

Because these data are essential to the accurate positioning of the beneficiary in the benefit by the new *sponsor* of record, should the TrOOP balance or gross covered drug costs change after an EOB has been sent, the disenrolling *sponsor* must send both the beneficiary and the new *sponsor* of record an updated EOB reflecting the new total TrOOP and gross covered drug spend balances. Any updated *transfer* EOBs must be *sent to the new sponsor of record* by the 15th of the month following the change.

If the total number of beneficiary records to be transmitted to any one *sponsor* of record is less than 100, this information may be in the form of a paper copy EOB. Note that only the two relevant fields need be filled in, and there is no need to send a complete EOB that includes proprietary pricing detail. If 100 or more records must be transmitted to a new *sponsor* of record, the disenrolling *sponsor* must create an Excel file in the format shown below.

Transfer EOB Format

A	B	C	D	E	F
HICN	Transfer Out Plan Contract Number	Effective Date	TrOOP Balance	Gross Covered Drug Costs	Coverage Year

The effective date to be *reported* in Column C is the date through which the Column D and E balances were calculated *or updated*. *This date is critical to ensure that the subsequent sponsor of record recalculates their TrOOP accumulators for the beneficiary using the most recent information from the prior plan.*

For example, a disenrolling sponsor sends the initial transfer EOB on February 4, 2007 (i.e., within 7 days of the date of the disenrollment TRR as required). The data reported in this EOB reflect balances calculated through February 1, 2007. The EOB would look as follows:

A	B	C	D	E	F
HICN	Transfer Out Plan Contract Number	Effective Date	TrOOP Balance	Gross Covered Drug Costs	Coverage Year
xxx-xx-xxxxA	Sxxxx	2/1/2007	\$ 42.00	\$ 280.00	2007

In March, the sponsor receives and adjudicates a paper claim from January 2007 and on 03/29/07 recalculates the beneficiary's TrOOP balances. By April 15, the sponsor must send an updated transfer EOB. In this example, the updated EOB will contain the following:

A	B	C	D	E	F
HICN	Transfer Out Plan Contract Number	Effective Date	TrOOP Balance	Gross Covered Drug Costs	Coverage Year
xxx-xx-xxxxA	Sxxxx	3/29/2007	\$ 52.00	\$ 350.00	2007

Regardless of the transmission method used, a cover sheet should accompany the EOB transfer data and include a contact should the receiving sponsor have questions or require follow-up. Paper copy EOBs may be faxed to the EOB Transfer Contact specified in HPMS for the sponsor of record or shipped through a common carrier to the contact either as paper copy EOBs or scanned copies on a CD-ROM. When creating transfer EOBs for fax transmission, *sponsors* should use a font that is large enough for the EOB data to be legible even after multiple faxes.

Excel files must be shipped on a CD-ROM through a common carrier or encrypted using a Federal Information Processing Standards (FIPS) approved encryption method and attached to a transmittal email. The password for the encrypted file must be sent in a separate email. (FIPS compliant encryption modules are listed on the National Institute of Standards and Technology Web site; see Appendix B for the specific Web address.)

In the process of EOB transfer, should a *sponsor* receive EOB information for a beneficiary who is not in their plan, contact should be made with the EOB Transfer Contact at the *sponsor* that sent the EOB information to resolve the problem. The *sponsor* sending the EOB is responsible for promptly querying CMS systems or contacting CMS to identify the *sponsor* of record and for reissuing the transfer EOB data.

50.9.2 – Automated TrOOP Balance Transfer Process

(Rev. 4; Issued: 09-26-08; Effective/Implementation Date: 09-26-08)

Effective January 1, 2009, use of the new NCPDP Financial Information Reporting (FIR) standard will be required to transfer TrOOP balances and gross covered drug costs whenever a beneficiary makes an enrollment change at the contract-level during the coverage year. The transfer process will begin with TrOOP facilitator's identification of a change in enrollment at the contract-level. Upon identification of the change, the facilitator will generate a FIR transaction to each prior sponsor with which the beneficiary was enrolled or which paid covered part D drug claims for the beneficiary during the coverage year. Transactions will begin with a FIR Inquiry to the earliest sponsor on record in the coverage year; that sponsor's Inquiry response will be returned to the facilitator. Each sponsor will respond with their monthly gross covered drug costs and TrOOP amounts. If there are multiple plans prior to the current plan of record, the accumulator values from the response just received are placed in a FIR Exchange transaction and forwarded to the next sponsor. The facilitator will receive that next sponsor's transaction response and will continue the process of receiving and forwarding the prior accumulators until each subsequent sponsor in consecutive order has received and responded to a FIR Exchange transaction. The final Exchange transaction response will contain the year-to-date monthly TrOOP-related data for all plans prior to the current plan of record; these accumulated monthly amounts will then be forwarded by the facilitator via a FIR Update transaction to the current plan of record.

A copy of the automated TrOOP balance transfer implementation guidance issued by CMS on March 18, 2008, is included in Appendix D. Detail on the FIR transaction standard is provided in the NCPDP Financial Information Reporting Standard Implementation Guide v1.0 is available to NCPDP members on their Web site; see Appendix B for the specific Web address.

50.10 – Special Transition Period for Retroactive Enrollment Situations

(Rev. 4; Issued: 09-26-08; Effective/Implementation Date: 09-26-08)

In 2007, CMS implemented a special transition period with important COB implications that requires Part D *sponsors* provide limited reimbursement for covered Part D drugs for a time immediately preceding the minimum 30- or 90-day transition period. This requirement applies to those situations involving claims incurred by, or on behalf of, a beneficiary who has subsequently been retroactively enrolled in a Part D *sponsor* by CMS. These situations almost exclusively involve beneficiaries who are full-benefit dual eligibles. The special transition period will be available to all beneficiaries.

Although CMS is working with the States to identify as many individuals as possible in advance of the date they will become dually eligible in order to minimize issues involving retroactivity, there will be some situations CMS will not be able to identify in advance. Because eligibility for Medicaid may be retroactive for up to 3 months prior to the month in which the Medicaid application was filed and Medicaid applications frequently require significant time for the State to process, periods of retroactivity will continue to be several months in duration. CMS expects that this problem will usually be mitigated by the fact that, as a Medicare beneficiary, the individual will have had an opportunity to enroll in a Part D sponsor and apply for the low-income subsidy. For those who do enroll in a Part D plan, and then are retroactively eligible for Medicaid, the effective date of their Part D plan enrollment is the later of the first of the month the beneficiary is dually eligible, or January 2006.

For 2006, with respect to claims incurred during a period covered under actual Part D enrollment, Part D *sponsors* were responsible for paying or reimbursing the costs of a beneficiary's Part D covered drugs to the extent that the *sponsor* would have paid as a primary payer. If the beneficiary's existing drug regimen required prior authorization or included non-formulary drugs and the retroactive period preceded the *sponsor's* transition period, this may have resulted in gaps in coverage. Coverage gaps may also have resulted from out-of-network pharmacy status or pricing in excess of the *sponsor's* negotiated rates that have been paid by the beneficiary or another payer on the beneficiary's behalf.

Beginning in 2007, CMS requires *sponsors* to provide a special transition period to accommodate claims incurred during a no greater than 7 month period of retroactive eligibility. The special transition period will be available to all beneficiaries. During this special transition period, normal transition rules will apply, but *sponsors* will be responsible for the allowable charges paid by other third party payers for all Part D drugs, including non-formulary drugs provided outside the transition period and formulary drugs with prior authorization requirements. The beneficiary, or CMS in the case of low-income subsidy individuals, will be responsible for any out-of-network or pricing differentials.

Sponsors need to accommodate and facilitate requests for reimbursement of claims incurred during these periods. CMS prefers that *sponsors*, to the extent they are able, do

this electronically rather than by processing paper claims. *To ensure that beneficiaries and other third party payers have opportunity to request reimbursement for claims incurred during the retroactive period, sponsors must use the date of the Medicaid notification to establish a new timely claims filing period. Likewise, best available evidence (BAE) documenting a reduced cost-sharing level of a low income subsidy eligible beneficiary may be used to establish a new timely claims filing period for the recovery of excess cost-sharing amounts; however, State notification of Medicaid eligibility with an earlier effective date would supersede the BAE and open an additional timely claims filing period for claims incurred during the retroactive period.*

For example, a sponsor receives BAE dated April 2, 2008, for a beneficiary who has been enrolled in their plan since December 2007, the BAE documents SSI eligibility effective January 1, 2008. The sponsor uses the BAE to reduce the beneficiary's cost-sharing effective January 2008 and permits network pharmacies holding a receivable on behalf of the beneficiary to recover the excess cost-sharing amounts for claims that normally would be outside the sponsor's timely claims filing window. In May, the sponsor receives a copy of a State notice dated May 26 reporting Medicaid eligibility effective June 2007 and a TRR on June 7, 2008, reporting a retroactive Part D effective date of June 2007. The sponsor uses the May notification from the State to create a new timely filing window for claims incurred during the period June- November 2007.

Further, in order to give effective meaning to our special transition guidance, a March 31st deadline cannot be used as a barrier to payer requests for reimbursement of claims incurred during periods covered by the retroactive enrollment. Rather, Part D plan sponsors must accommodate and facilitate requests for reimbursement of claims associated with retroactive enrollment coverage.

Thus, for example, if a sponsor receives a TRR on April 5, 2008, with a new enrollee effective January 2008, the retroactive period is January 1, 2008 to April 4, 2008. Since the sponsor must provide a special transition period to accommodate claims incurred during the no greater than 7 month period of retroactive eligibility, the sponsor is responsible for all claims during the retroactive period.

Similarly, if a sponsor receives a TRR on April 5, 2008, with a new enrollment effective June 2007 for a beneficiary who was not previously enrolled in a Part D plan, the retroactive period is June 1, 2007 to April 4, 2008, and the special transition period applies for September 5, 2007 through April 4, 2008. For the retroactive period prior to September 5, 2007, the sponsor can apply their formulary and pay negotiated rates.

Further, if a sponsor has a member enrolled effective January 1, 2008, and receives a TRR on April 5, 2008, reporting a retroactive effective date to November 1, 2007, the retroactive enrollment period is November 1 through December 31, 2007, and the special transition provision applies for the 2-month period.

It is important to note also that plans are liable for claims received after March 31st even in those instances when retroactive enrollment is not an issue. While in these instances

contractual provisions regarding timely claims filing may limit claims from network pharmacies, non-network pharmacies and beneficiaries must still have the opportunity to submit claims for reimbursement.

The table below describes several frequently occurring scenarios to further clarify when timely claims filing limits may, or may not, be applied in situations involving special transition periods for retroactive enrollments.

Special Transition Period for Retroactive Enrollment and Timely Claims Filing Scenarios

<i>Scenario</i>	<i>Required Action by the Part D Plan Sponsor</i>
<i>A beneficiary first enrolled in Part D in 2007 is retroactively determined to be dual eligible effective in 2006 and another payer paid for covered drugs in the retroactive period.</i>	<i>Sponsors must coordinate benefits with other payers as required by the regulations at 42 CFR 423.464(f) without imposing time limits.</i>
<i>A beneficiary first enrolled in Part D in 2007 is retroactively determined to be dual eligible effective in 2006 and a network pharmacy is holding receivables for claims in the retroactive period.</i>	<i>For claims incurred during the period of retroactive enrollment in Part D, sponsors must use the date of the Medicaid eligibility notification to establish a new timely claims filing period.</i>
<i>A beneficiary first enrolled in Part D in 2007 is retroactively determined to be dual eligible effective in 2006 and a non-network pharmacy (includes state-operated, facility-based pharmacies) is holding receivables for claims in the retroactive period.</i>	<i>Sponsors must consider the non-network pharmacy as an “other” payer and coordinate benefits without imposing time limits.</i>
<i>A beneficiary first enrolled in Part D in 2007 is retroactively determined to be dual eligible effective in 2006 and receives notice of Medicaid eligibility close to or after March 31, 2007.</i>	<i>Sponsors must accept claims from the beneficiary without imposing time limits.</i>
<i>A beneficiary not previously enrolled in Part D is retroactively (auto- or)</i>	<i>Sponsors must accommodate claims for non-formulary Part D drugs during a no-</i>

facilitated enrolled in 2007 with a coverage effective date in 2006.

greater-than-7 month period of retroactive eligibility, and claims for formulary drugs during the entire period of retroactive coverage.

50.11 – Sharing Formulary Information with Other Payers

(Rev. 4; Issued: 09-26-08; Effective/Implementation Date: 09-26-08)

Although Part D *sponsors* may share detailed information about their formularies (in electronic format) with other payers upon request, there is no specific requirement that they do so. CMS has made the Medicare Prescription Drug plan information available for purchase in Public Use Files (PUFs). These files contain all of the plan and formulary data for all of the plans with the exception of the pricing data which is considered proprietary. This is the only data set that is publicly available. Further information is available on the CMS Web site; *see Appendix B for the specific Web address.*

In addition, as required by 42 CFR 423.120(b)(5)(i), *sponsors* will be required to inform other payers of formulary changes (whether formulary deletions or changes in the tiering status of a drug) at least 60 days in advance of such a change. This may be accomplished by means of posting this information on Part D *sponsor* Web sites.

50.12 – Sharing Claims Data

(Rev. 4; Issued: 09-26-08; Effective/Implementation Date: 09-26-08)

CMS does not have the authority to require data exchanges between Part D *sponsors* and the States except as required for COB purposes. While the MMA requires Part D *sponsors* to allow SPAPs and other entities providing prescription drug coverage to “coordinate” with them, this language does not support requiring coordination of anything but payment. However, CMS strongly encourages Part D *sponsors* to independently share historical and ongoing data on these shared enrollees with other payers – particularly with States – provided such disclosure is consistent with the requirements of the HIPAA Privacy Rule. CMS encourages Part D *sponsors* to discuss reciprocal arrangements with State Medicaid Plans under which Part D *sponsors* would provide Part D drug claims data in exchange for both historical prescription drug claims data and ongoing medical claims (particularly diagnoses) on the dual eligible population to assist with medication therapy management and other quality assurance programs. CMS also encourages *sponsors* to provide for this reciprocal data exchange without the charging of user fees.

Part D *sponsors* and States may negotiate the details regarding the development of a Standard File Format for Patient Drug History and Standard Data Sharing Agreement. NCPDP, which is the national standards organization for pharmacy claims, has adopted the “Post Adjudication Standard”. Section 10 of the “Post Adjudication Standard

Implementation Guide, Version 1.0” contains the “Post Adjudication Utilization Record” which is the recommended standard record States and Medicare Part D *sponsors* could use to exchange drug history information. In order to access the NCPDP documentation and use the Post Adjudication Utilization Record, the States and/or their contractors must be members of NCPDP.

If the States and Medicare Part D *sponsors* agree to exchange enrollees’ drug history information, states and sponsors are new business associates. It is therefore necessary that the exchange of data complies with the requirements of HIPAA. To accomplish this, a Patient Drug History Data Sharing Agreement signed by the Medicare Part D *sponsor* and the State must be in place prior to executing file transfers between these entities.

CMS believes States have the authority under 42 USC §1396a(a)(25) to request information to coordinate benefits States may have paid under the State Medicaid program. CMS will be issuing guidance to States regarding the implementation of these statutory requirements. CMS encourages Part D *sponsors* to review 42 USC §1396a(a)(25) as well as the related CMS guidance.

50.13 – Applying Medicare Secondary Payer (MSP) Requirements

(Rev. 4; Issued: 09-26-08; Effective/Implementation Date: 09-26-08)

The MMA (§1860D-2(a)(4)) extended MSP laws applicable to MA organizations to Part D sponsors. Accordingly, Part D sponsors will have the same responsibilities under MSP laws as do MA plans, including collection of mistaken primary payment from insurers, group health plans, employer sponsors, enrollees, and other entities; and the interaction of MSP rules with State laws. Part D *sponsors* must properly apply MSP laws and regulations to their payments (e.g., working aged, WC).

Part D sponsors are responsible for adjudicating enrollees’ claims in accordance with the following MSP rules. Also, sponsors are responsible for identifying and recovering any MSP-related mistaken payments and submitting associated adjustments to CMS.

According to law, Medicare is the secondary payer in the following situations:

1. Employer group health plans (EGHP) MSP

a. Working Aged GHP – The beneficiary is actively working and is covered under the employer's GHP or the beneficiary's spouse is actively working and the beneficiary is covered under the spouse's employer GHP (≥20 employees; or another employer in GHP ≥ 20 employees.) (42 U.S.C. §1395(y)(b)).

b. Disability with GHP – The beneficiary is actively working for a large employer and is covered under the employer's GHP, or a beneficiary's family member is actively working for a large employer and the beneficiary is covered under the family member's employer GHP (LGHP, ≥100 employees).

c. End Stage Renal Disease (ESRD) GHP – GHP (any size) is primary for the first 30 months when an individual also becomes eligible for Medicare Part A due to ESRD status. After 30 months of Part A eligibility, Medicare becomes primary.

2. Non-GHP MSP

a. WC – Beneficiary covered under WC due to job-related illness or injury.

b. Black Lung (BL) – The beneficiary has black lung disease and is covered under the Federal Black Lung Program.

c. No-Fault/Liability – The beneficiary is covered by no-fault or liability insurance due to an accident.

However, Part D sponsors should not immediately pay only as secondary. The action required of the Part D sponsor is dependent on the type of other primary payer as follows:

1. For the types of Employer Group Health Plans (EGHP) listed above, the Part D sponsor will always deny primary claims that fall within the EGHP's applicable coverage dates and default to MSP. The types as listed above include: working aged GHP, disability GHP, and ESRD GHP for first 30 months of Medicare Part A eligibility.

2. For WC, BL, and No-Fault or Liability coverage, the sponsor will always make conditional primary payment unless the sponsor is aware that the enrollee has WC/BL/No-Fault/Liability coverage and has previously established that a certain drug is being used exclusively to treat a related injury. For example, when a beneficiary refills a prescription previously paid for by WC, the Part D sponsor may deny primary payment and default to MSP.

In all other instances, the Part D sponsor is required to make conditional primary payment then recover any mistaken payments where it should have only paid secondary to WC/BL/No-Fault/Liability coverage. For example, if a sponsor does not know whether a given drug for which it is billed is related to the covered injury, the sponsor must pay for the drug (if it is a covered Part D drug) and later retrieve any amounts that the other insurance was supposed to cover.

This section provides clarification regarding a limited number of MSP situations; however, Part D *sponsors* are required to apply all MSP laws whether or not they are specifically mentioned here.

50.13.1 – Workers' Compensation

(Rev. 4; Issued: 09-26-08; Effective/Implementation Date: 09-26-08)

Payment under Medicare may not be made for any item or service when payment has been made, or can reasonably be expected to be made, for such item or service under a WC law or plan of the United States or any state. CMS recognizes that diagnostic information is not collected at the point of sale, however, CMS expects Part D *sponsors* to make good faith efforts to identify claims associated with WC.

It is, therefore, imperative that Medicare's interests be protected when parties enter into WC settlements. One method of protecting Medicare's interest in a WC situation is a Workers' Compensation Medicare Set-aside Arrangement (WCMSA), which allocates a portion of the WC settlement for future medicals and future prescription drug expenses. "Future medicals and future prescription drugs" are those services and items provided after the final WC settlement. *CMS urges Medicare beneficiaries (and individuals who expect to become entitled to Medicare within 30 months of receiving a WC settlement) who are parties to WC settlements, judgments or awards to submit settlement documentation to CMS for review prior to settlement to ensure the terms protect Medicare interests.* CMS reviews WCMSA proposals for Medicare beneficiaries with WC settlements greater than \$25,000 and for individuals who are within 30 months of Medicare entitlement and possess a WC settlement greater than \$250,000. *Based on this review, CMS will either concur with the proposal or counter with a different amount.* Additional information with regard to CMS' WCMSA policy and procedures *is available on the CMS Web site, refer to Appendix B for the specific Web address.*

WCMSA funds are administered by the claimant or a professional administrator employed by the workers' compensation employer, carrier or the claimant. CMS keeps a record of the WCMSA amount determined by CMS to be adequate to protect Medicare's interests with regard to the claimant's future medical treatment and/or prescription drug expenses. The claimant/professional administrator is responsible for submitting an annual attestation form or professional accounting to the Medicare contractor. This document attests that the claimant has appropriately expended the WCMSA funds for that year.

In order to assist the Part D *sponsors* in making proper payments with regard to WCMSAs, CMS will provide the Part D *sponsors* with the WCMSA amount. The WCMSA amount is the combined amount for future medical and future prescription drug costs related to the WC injury. Exhaustion of the combined WCMSA amount includes both services (i.e., future prescription drug treatment and future medicals). For example, if the total WCMSA amount provided to the Part D *sponsors* is \$10,000, this amount can include \$7,000 for future prescription drug treatment and \$3,000 for future medical expenses. However, it is important that the Part D *sponsors* understand that even though the total WCMSA amount is \$10,000, the final actual expenditures could be \$6,000 for future prescription drug treatment and \$4,000 for the future medical expenses, which will still appropriately exhaust the WCMSA.

When the funds in a WCMSA are exhausted, the Part D *sponsors* must notify CMS so that the MSP occurrence may be terminated. This is currently accomplished by reporting

the exhaustion of the WCMSA to the COB contractor. *Once the entire CMS-approved WCMSA has been properly exhausted, the Medicare Part D plan sponsor will resume responsibility for paying claims for covered Part D drugs as though there were no WC settlement.*

50.13.2 – Flexible Savings Accounts (FSAs), Health Savings Accounts (HSAs), Archer Medicare Savings Accounts (MSAs), and Health Reimbursement Accounts (HRAs)

(Rev. 4; Issued: 09-26-08; Effective/Implementation Date: 09-26-08)

Part D *sponsors* should not require beneficiaries to use the funds in their FSAs, HSAs, or MSAs before making payments when the group health plans attached to such accounts are primary under the MSP laws. However, under the MSP group health plan laws (e.g., when a beneficiary with current employment status has an HRA through his employer), sponsors should make secondary payments after HRA funds are used.

When a beneficiary is non-working, an HRA is secondary to Medicare, but drug costs paid or reimbursed from the HRA are not TrOOP-eligible.

50.14 – Executing Business Associate Agreement with TrOOP Contractor

(Rev. 4; Issued: 09-26-08; Effective/Implementation Date: 09-26-08)

Consistent with the HIPAA Privacy Rule (45 CFR Parts 160 and 164), the TrOOP facilitation contractor will be a business associate of Part D *sponsors* for the purpose of performing TrOOP and COB functions. Accordingly, each Part D *sponsor* will be required to execute a business associate agreement with the TrOOP facilitation contractor covering TrOOP and COB functions. Note, however, that PBM subcontractors to Part D *sponsors* will not be required to enter into separate business associate contracts with the TrOOP facilitation contractor, since data at the PBM will be protected through business associate agreements between the Part D *sponsor* and the PBM. To facilitate the execution of these agreements between the TrOOP facilitation contractor and the Part D sponsors, a standard language business associate agreement has been developed by CMS and sponsors are strongly encouraged to sign this agreement without modification.

50.15 – Payment Reconciliation

(Rev. 4; Issued: 09-26-08; Effective/Implementation Date: 09-26-08)

Because of program start-up issues in 2006, lags in the information available to pharmacies at the point-of-sale regarding which Part D *sponsor* to bill may have resulted in the pharmacies' having access to outdated or incomplete information. Because pharmacies generally relied in good faith on this information, in some cases the wrong payer paid for a prescription. Given the volume of drug claims that pharmacies would

need to re-adjudicate as a result of incorrect Part D enrollment information available at the point-of-sale, re-adjudication would have imposed a significant administrative and financial burden on pharmacies. Therefore, payer-to-payer reconciliation procedures were developed to mitigate the administrative and financial burden involved with re-adjudication of claims.

Although this payer-to-payer process was designed initially to be a temporary measure during Part D's start-up phase, CMS requires that *sponsors* continue to use the payer-to-payer process. In addition, unforeseeable future events may create further need for processes to reconcile payments when a payer other than the correct Part D *sponsor* of record pays as primary for a covered Part D drug for an enrolled beneficiary. These other reconciliation processes may be developed by CMS to accomplish payment reconciliation without involving pharmacy reversal and re-adjudication of claims or the public release of a payer's proprietary information, such as negotiated rates.

50.15.1 – Plan-to-Plan Reconciliation During Transition Periods

(Rev. 4; Issued: 09-26-08; Effective/Implementation Date: 09-26-08)

The opportunity for beneficiaries to change their Part D plan enrollment during the coverage year creates situations in which, due to lags associated with the enrollment process and information systems updates, the *sponsor* from which a beneficiary has transferred makes payment for covered prescription drug costs incurred after the effective date of the beneficiary's enrollment in the new *sponsor* of record. In 2006, CMS developed a plan-to-plan (*P2P*) reconciliation process with *sponsor* participation. *This process, implemented in three phases, enabled CMS to process prescription drug event (PDE) data in these P2P transition situations and allow for financial reconciliation between the affected Part D sponsors.* The process's design reflects the consensus of sponsor participants to prevent disclosure of proprietary pricing information by masking the NDC coding. *Furthermore, to protect sponsors from exposure to costs outside the initial formulary transition period, CMS established a 30-day P2P transition period. The P2P transition period ends on the later of:*

- 1. 30 days after the effective date of the new plan enrollment, or*
- 2. 30 days after the date the new contract of record submits the enrollment to CMS.*

To address *the* payment reconciliations that are *needed* to resolve these enrollment transition issues, CMS *requires the on-going use of the P2P* reconciliation and reimbursement process. *Therefore, throughout each coverage year, Part D sponsors will continue to receive monthly P2P reports showing the payables and receivables for which financial settlement is required. PDE guidance describing the process is available on the CMS Web site; see Appendix B for the specific Web address.*

50.15.2 – Other CMS-Defined Reconciliation Processes

(Rev. 4; Issued: 09-26-08; Effective/Implementation Date: 09-26-08)

Unforeseeable events in the future may create the need for processes that would require Part D sponsors to coordinate benefits on a timely basis with other third parties and use CMS-developed reconciliation processes, when established, in situations in which a payer other than the correct Part D *sponsor* of record pays for covered Part D drug costs as a primary payer. For example, this was the case in 2006 with respect to the State-to-Plan Reconciliation Project in which some States made drug payments for dual eligible beneficiaries and low-income subsidy entitled beneficiaries enrolled in Part D and were subsequently reimbursed by CMS through a special demonstration authority. Processes, similar to the State -to-Plan Reconciliation process employed in 2006, may need to be developed by CMS in lieu of requesting pharmacy claims reversals and re-adjudications or the public release of a payer's proprietary information (such as negotiated prices).

50.15.3 – Retrospective Resolution Directly with Other Payers

(Rev. 4; Issued: 09-26-08; Effective/Implementation Date: 09-26-08)

The plan-to-plan reconciliation process resolves those situations in which a Part D *sponsor* other than the *sponsor* of record paid claims for a beneficiary during the initial transition period. However, situations will continue to arise outside the plan-to-plan process in which other payers that are not Part D *sponsors* either pay, but should not have paid at all, or pay more than they should have because they paid out of the correct payer order. In these situations, Part D *sponsors* are required to work with these providers of other prescription drug coverage to resolve these payment issues. Other payers, *as well as beneficiaries*, are entitled to seek compensation from the Part D *sponsor* once the Part D enrollment is confirmed. The *sponsor* should have a process in place to handle the payment resolution and this process should not be restricted by the implementation of timely filing requirements.

Further, Part D *sponsors* must determine whether or not any amount paid by these other payers was TrOOP-eligible and must adjust, as necessary, the affected beneficiaries' TrOOP balances. For example, the IHS, Tribes and Urban pharmacies are non-TrOOP eligible payers when Federal funds are utilized.

As noted in the discussion of IHS/Tribal health coverage in Appendix *E*, some Tribes may use exclusively non-Federal funding to pay Part D coverage on behalf of American Indian and Alaska Native (AI/AN) Medicare beneficiaries when receiving services through I/T/Us and other Part D providers. To the extent that a Tribe uses only non-Federal funding for all its medical services, payments made on behalf of AI/AN beneficiaries for Part D cost-sharing may count toward TrOOP (provided no other sources of funding otherwise render it a government-funded health program). Therefore, Part D *sponsors* must ensure that they have a process in place to distinguish among Tribes whose Part D cost-sharing payments count toward TrOOP (those that are exclusively non-Federally funded) versus those whose Part D cost-sharing payments do

not count toward TROOP (those that, for example, receive any Federal or other government funding for medical services). Many Tribal payments may not be made on an on-line real-time basis and it may be difficult for *sponsors* to recognize those that are TrOOP-eligible. In light of the difficulty, *sponsors* when approached by beneficiaries, or by Tribes on their behalf, must have a process to make retroactive adjustments of TrOOP balances.

50.15.4 –Re-adjudication Versus Pharmacy Reprocessing

(Rev. 4; Issued: 09-26-08; Effective/Implementation Date: 09-26-08)

If the total payment to the pharmacy for a claim was correct, however the *sponsor* subsequently determines that an adjustment is required that does not affect the total payment, but does alter the *sponsor*-beneficiary liability split, the *sponsor* must re-adjudicate the claim within its own system without involving the pharmacy. This is most likely to occur when the *sponsor* corrects low-income beneficiary cost-sharing subsidy levels.

Part D *sponsors* are encouraged to avoid pharmacy reprocessing, but CMS recognizes that reversals may be appropriate under certain circumstances. *Sponsor* requests for pharmacy reprocessing should in general be limited to those situations where the total payment to the pharmacy changes, for example, in situations involving a pricing error. *Sponsors* are responsible for reimbursing or collecting amounts from beneficiaries that result from the reprocessing of these claims and should not transfer this responsibility to pharmacies.

50.15.5 – Claims Filing Timeframes

(Rev. 4; Issued: 09-26-08; Effective/Implementation Date: 09-26-08)

A number of issues associated with Part D, such as multiple payers, payer order, and retroactive eligibility, create challenges for coordinating benefits among Part D *sponsors* and other providers of prescription drug coverage. When all payer information is available at the point-of-sale, pharmacies typically serve as the intermediary facilitating coordination between Part D *sponsors* and other payers. However, when the information necessary to identify the correct primary payer for Part D drugs provided to Medicare beneficiaries enrolled in Part D *sponsors* is lacking, pharmacies may, through no fault of their own, bill the State and other payers instead of a beneficiary's Part D *sponsor*.

CMS addressed a major portion of these situations occurring during the first quarter of 2006 through special one-time reconciliation processes. The balance of these situations, as well as those occurring subsequently, may some times require resolution through claims reversal and rebilling. In their role of facilitating coordination between Part D *sponsors* and payers, some pharmacies are agreeing to reverse incorrect claims and bill the proper Part D *sponsor*. CMS believes that in those circumstances in which the pharmacy is not at fault it would inappropriate for Part D *sponsors* to impose the

conventional 30-90 day timely filing limits rather than a less restrictive timeframe, as this industry standard generally applies only when the pharmacy is in a position to correctly bill, but fails to do so. CMS also believes that this process is appropriate for use in the Point of Sale Facilitated Enrollment process when incorrect health insurance claim numbers (HICNs) were used.

To ensure effective coordination between Part D sponsors, SPAPs and other entities providing prescription drug coverage, CMS required Part D *sponsors* to implement a 180-day timely claims filing limit for claims incurred January 1 through June 30, 2006. This afforded pharmacies when not at fault for the original billing error adequate opportunity to reverse and rebill such claims. This claims filing window was necessary to accommodate the identification and resolution of coordination of benefits issues requiring claims reversal and rebilling to appropriate payers.

Beginning in 2007, in lieu of a requirement for a 180-day timeframe, CMS requires *sponsors* to establish at least a 90-day claims filing timeframe and to make appropriate allowances for COB claims on a case-by-case basis. Once the next HIPAA coordination of benefits transaction standard for retail pharmacy drug claims is effective, Part D *sponsors* could consider using certain delay reason codes in the external code list, specifically those that specify the reason for the delay in claims submission, in field number 357-NV to differentiate COB-related delays from other types of delays.

60 – Coordination of Benefit Activities of Non-Part D Payers

(Rev. 4; Issued: 09-26-08; Effective/Implementation Date: 09-26-08)

60.1 – Reporting the Existence of Prescription Drug Coverage Provided to Enrollees

(Rev. 4; Issued: 09-26-08; Effective/Implementation Date: 09-26-08)

As discussed in section 30.1 of this chapter, CMS expects that other payers will provide information regarding any other prescription drug coverage that their Medicare enrollees may have. As noted in section 40.1, Medicare beneficiaries are required to disclose this information to Part D *sponsors*; consequently, other payers responsible for payment or reimbursement of Part D claim cost sharing should assist their enrollees in discharging this obligation. There are certain legal requirements to inform CMS when another payer provides coverage that is primary to Medicare under the MSP laws (e.g., employers sent the Data Match questionnaire described later in this chapter, the 42 CFR 411.25 notice requirement). For this required MSP reporting, affected entities should use the MSP-specific reporting methods CMS requires (e.g., Data Match forms) or provides (e.g., VDSA in lieu of Data Match forms). However, for seamless benefit coordination and accurate TrOOP accounting, CMS strongly encourages payers to report their coverage information even when it is not legally required.

To do this, CMS makes available a direct and easy data exchange process through a vendor, the COB contractor. A data exchange with CMS allows other payers:

1. To assist beneficiaries in fulfilling their statutory obligation to disclose third party reimbursement for Part D drug costs.
2. To avoid the cost of paying as primary when the payment should be secondary to Part D.
3. As a *sponsor* of record, to be notified if a paid claim is reversed or adjusted outside an on-line adjudication process.
4. If TrOOP-eligible, to cease payments for beneficiaries receiving the full low-income subsidy who reach the catastrophic phase of the benefit, since at that point, Medicare fully subsidizes the beneficiary's incurred costs for covered Part D drugs.

The data exchange agreements require payers to periodically submit an input file containing certain enrollee populations. In return, the payer will receive a response file from the COB contractor indicating which of its enrollees are Medicare Part D beneficiaries. More information about the COB process offered by CMS *is available on the Medicare COB Web site. See Appendix B for the specific Web address.*

60.2 – Obtaining and Reporting Rx Identifiers

(Rev. 4; Issued: 09-26-08; Effective/Implementation Date: 09-26-08)

Payers supplemental to Medicare should obtain a unique RxBIN and/or PCN combination that will identify their paid claim responses for TrOOP tracking purposes for those situations in which Part D is the primary payer. CMS recommends that payers obtain an RxBIN and/or PCN combination unique to each separate plan they offer in order to distinguish among all of their plans. This allows each benefit plan to fulfill its obligation as a supplemental payer if it is identified on the COB file as secondary coverage.

In order for Rx identifier information to be available at point-of-sale through the TrOOP facilitation contractor and Part D *sponsors*, payers must report these unique identifiers to CMS through the COB reporting process described in section 30 of this chapter. Payers primary to Medicare will continue to use their existing BIN and/or PCN.

NOTE: Not all other prescription drug coverage will have Rx identifiers. For instance, incident-driven coverage, such as Worker's Compensation, does not normally provide electronic, point-of-sale benefits and thus does not need such identifiers; also SPAPs that only offer premium assistance will not have them.

60.3 – Supplying Claims Information When a Supplemental Payment Is Made

(Rev. 4; Issued: 09-26-08; Effective/Implementation Date: 09-26-08)

In order for the COB and TrOOP tracking processes to function as effectively as possible, other payers should supply paid claims information to the Part D *sponsor* after making a payment that is supplemental to a Medicare payment. This will happen automatically if the other payer reports their coverage information to CMS in accordance with the processes described in section 60.1 of this chapter with the appropriate Rx BIN and/or PCN combination to enable the TrOOP facilitator to identify the supplemental payer's status.

However, if the other payer is aware that the TrOOP facilitation process was not used for some reason, or if the other payer does not have electronic claims capability, the payer may alternatively submit paper claims or make arrangements to submit information in another format in order for the data to be available for TrOOP calculations by Part D *sponsors*. Further information on the batched claims process is available on the TrOOP facilitator's Web site; *see Appendix B for the facilitator's Web address*.

60.4 – Coordinating with Part D *Sponsors* for Payment of Premiums

(Rev. 4; Issued: 09-26-08; Effective/Implementation Date: 09-26-08)

If one of the "other payers" listed in 42 CFR 423.464 chooses to pay Part D premiums on behalf of its members who are enrolled in Part D *sponsors*, that payer should coordinate directly with the Part D *sponsors* in question. Part D *sponsors* are required to allow and facilitate premium payment coordination with other payers. If the *sponsor* fails to comply with this requirement, it cannot disenroll a beneficiary for failure to pay premiums. Further discussion on coordination of premiums is contained in section 50.6 of this chapter.

60.5 – Following MSP Laws and Order of Payment Standards

(Rev. 4; Issued: 09-26-08; Effective/Implementation Date: 09-26-08)

MSP laws apply to all payers, including those providing prescription drug coverage, and all payers are legally required to make themselves aware of and follow such laws. This chapter provides clarification regarding the limited number of MSP situations described below; however, payers are required to know and apply all MSP laws whether or not they are mentioned in this chapter.

60.5.1 – Internal Revenue Service (IRS)/Social Security Administration (SSA)/CMS Data Match

(Rev. 4; Issued: 09-26-08; Effective/Implementation Date: 09-26-08)

IRS/SSA/CMS Data Match requirements pursuant to the Consolidated Omnibus Budget Resolution Act of 1989 apply to prescription drug coverage. Employers required to complete Data Match forms must include prescription drug information – including their ordinary RxBINs, PCNs, RxGRPs, and RxIDs – on their Data Match forms. Data Match requirements may be fulfilled by obtaining a VDSA, (see section 30.1 of this chapter for a brief description), and providing coverage information through that process. Note that for Data Match and other MSP purposes, payers primary to Medicare do not need to report the unique RxBIN and PCN combination they acquired for TrOOP purposes because MSP claims do not go through the TrOOP facilitation process. (However, beneficiary cost sharing on Part D *sponsor* claim payments as a secondary payer will count toward TrOOP.)

60.5.2 –FSAs, HSAs, MSAs, and HRAs

(Rev. 4; Issued: 09-26-08; Effective/Implementation Date: 09-26-08)

Payers that are required to report group health plan coverage to CMS under the MSP laws do not have to report the FSAs, HSAs, or MSAs that may be attached to such coverage. However, HRAs are group health plans, and payers should report HRAs to CMS in the same manner as group health plan information is reported. Note that all of these accounts must be structured to comply with Federal laws, including laws that may restrict their use by Medicare beneficiaries.

Appendix A: TrOOP Facilitation Process

NCPDP v5.1 B1 Transaction Flow

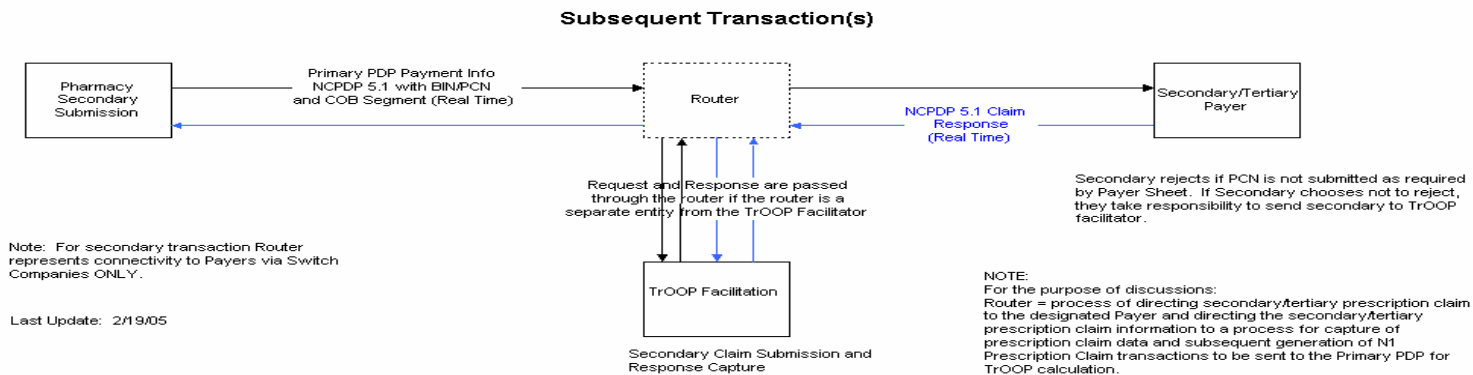
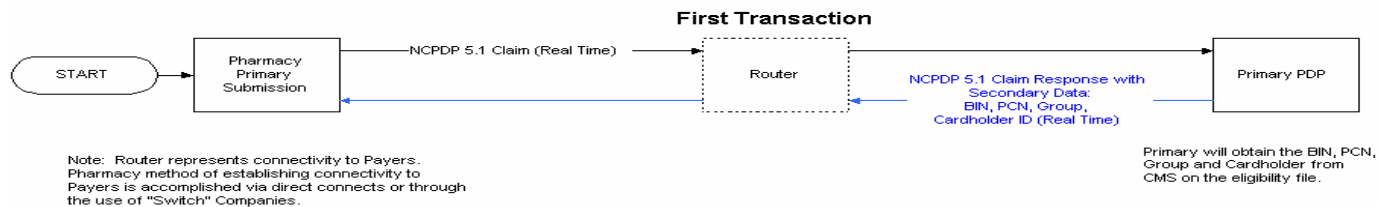

TrOOP Facilitation

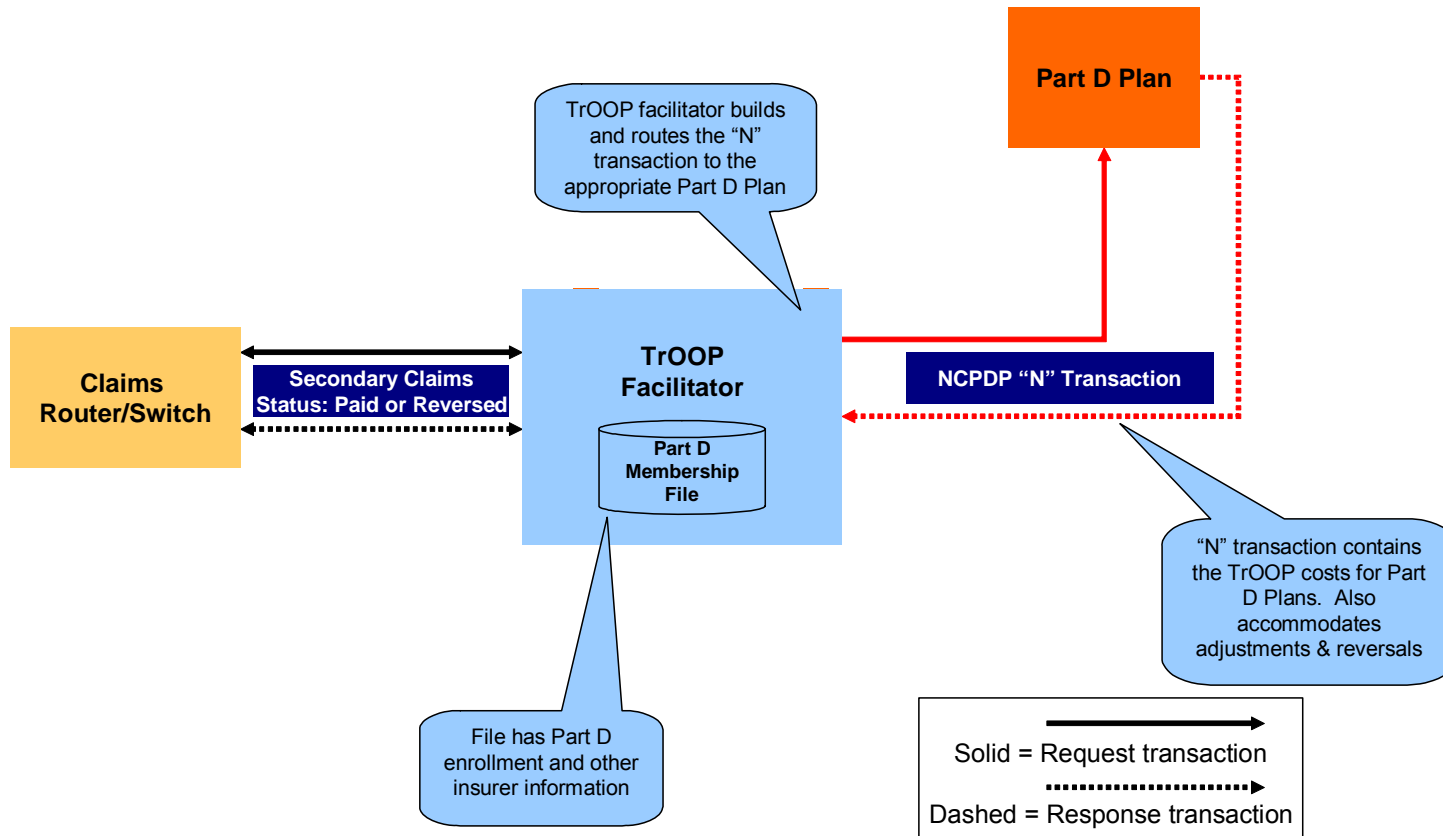

Eligibility Transaction

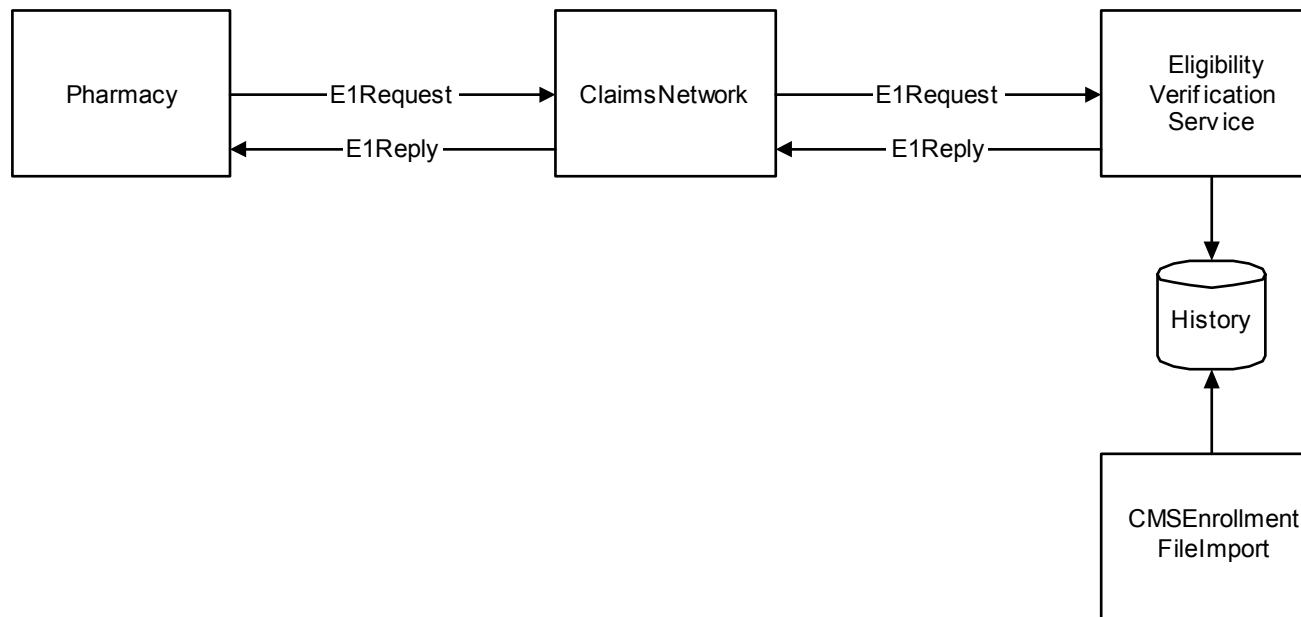

Appendix B – COB-related Web Sites

(Rev. 4; Issued: 09-26-08; Effective/Implementation Date: 09-26-08)

CMS Medicare Prescription Drug Coverage Contracting
<http://www.cms.hhs.gov/PrescriptionDrugCovContra/>

CMS WCMSA Policy
<http://www.cms.hhs.gov/WorkersCompAgencyServices>

Dual Eligible PACE Plan Beneficiary Accumulated True Out-of-Pocket Cost Calculator
<http://www.cms.hhs.gov/apps/troopcalculator/>

ECRS User Guide
http://www.cms.hhs.gov/manuals/downloads/msp105c05_att1.pdf

Medicare COB
<http://www.cms.hhs.gov/COBGeneralInformation/>

Medicare Marketing Guidelines
<http://www.cms.hhs.gov/PrescriptionDrugCovContra/Downloads/FinalMarketingGuidelines.pdf>

National Council for Prescription Drug Programs
www.ncpdp.org

National Institute of Standards and Technology
<http://csrc.nist.gov/groups/STM/cmvp/documents/140-1/1401vend.htm>

OIG Guidance on Part D and PAP
<http://www.oig.hhs.gov/fraud/docs/advisoryopinions/2006/AdvOpn06-03F.pdf>

PAP Data Sharing Agreements
http://www.cms.hhs.gov/PrescriptionDrugCovGenIn/07_PAPData.asp#TopOfPage

PDE Guidance
<http://www.cms.hhs.gov/DrugCoverageClaimsData/Downloads/PDEGuidance.pdf>

PDP Eligibility, Enrollment and Disenrollment Guidance
<http://www.cms.hhs.gov/MedicarePresDrugEligEnrol/Downloads/CurrentPDPEnrollmentGuidance.pdf>

Plan Communications User's Guide (PCUG)
http://www.cms.hhs.gov/mmahelp/downloads/PCUG_Main_Guide_v3_Final_Combined_121007.pdf

Public Use Files (PUFs)

http://www.cms.hhs.gov/NonIdentifiableDataFiles/09_PrescriptionDrugPlanFormularyandPharmacyNetworkFiles.asp#TopOfPage

RelayHealth

http://medifacd.relayhealth.com/home/MediFacd_home.htm

TrOOP Facilitation Contractor

http://medifacd.relayhealth.com/home/MediFacd_home.htm

Appendix C – COB Survey

(Rev. 4; Issued: 09-26-08; Effective/Implementation Date: 09-26-08)

CITY _____ STATE _____
 ZIP CODE _____

GROUP IDENTIFICATION NUMBER _____
 DATE OF INSURANCE COVERAGE BEGAN _____ POLICY NUMBER _____
 M M - D D - Y Y Y Y

SECTION C – INFORMATION ABOUT YOUR SUPPLEMENTAL COVERAGE

1) Do you have any supplemental prescription drug coverage under your policy or another family member?

YES **NO** (If **NO**, go to **SECTION D**)
 If **YES**, what is your relationship to the policy holder? Self Family Member
 Both

2) What type of policy is your supplemental drug coverage?
 TRICARE MEDIGAP State Pharmaceutical Assistance
 Program (SPAP) Other

Please print below the name, and address of the insurance company providing your prescription drug coverage:

NAME _____
 ADDRESS _____
 ADDRESS _____
 CITY _____ STATE _____
 ZIP CODE _____

POLICY NUMBER _____ DATE COVERAGE _____
 BEGAN _____
 M M - D D - Y Y Y Y

Please use your insurance card to provide the following information if available:

Rx Group _____ Rx PCN _____
 MEMBER ID _____
 Rx BIN _____

(CONTINUED ON NEXT PAGE)

SECTION D – MORE INFORMATION ABOUT YOU

1) Are **YOU** receiving **Black Lung** Benefits? **YES** **NO**
 2) Are **YOU** receiving **Worker's Compensation** benefits? **YES** **NO**
 3) Are **YOU** receiving treatment for an injury or illness which another party could be held liable or could be covered under no-fault or auto insurance? **YES**
NO



If **YOU** answered **YES** to any questions in this section, go to **SECTION E**
If **YOU** answered **NO** to all of these questions, sign below and return this

form.

YOUR SIGNATURE

AREA CODE PHONE NUMBER

Grid for area code and phone number

SECTION E – MORE INFORMATION ABOUT YOUR BENEFITS

1) If **YOU** are getting **Black Lung** (Coal Miner's) Medical Benefits, print the date the benefits began.

Grid for date: MM-DD-YYYY

2) If **YOU** are now receiving any medical services related to an illness or injury which occurred on the job, for which **YOU** have or will file a **Worker's Compensation** claim, print the date the illness or injury began.

Grid for date: MM-DD-YYYY

Please provide information about the employer, insurance carrier, and attorney in the spaces below:

Grids for EMPLOYER NAME, ADDRESS, CITY, STATE, ZIP CODE, NAME OF INSURANCE CARRIER, ADDRESS, CITY, STATE, ZIP CODE, POLICY OR CLAIM NUMBER, NAME OF ATTORNEY (If Applicable), ADDRESS, ADDRESS

CITY

STATE

ZIP CODE

BRIEF DESCRIPTION OF ILLNESS OR INJURY

(TURN PAGE OVER)

SECTION E – MORE INFORMATION ABOUT YOUR BENEFITS, CONTINUED

3) If **YOU** are now getting any treatment for an illness or injury for which another party could be held liable, please print the date of illness or injury:

MM DD YYYY

NAME OF INSURANCE CARRIER

ADDRESS

ADDRESS

CITY

STATE

ZIP CODE

POLICY OR CLAIM NUMBER

NAME OF ATTORNEY (If Applicable)

ADDRESS

ADDRESS

CITY

STATE

ZIP CODE

BRIEF DESCRIPTION OF ILLNESS OR INJURY

4) If **YOU** are now getting any treatment for an illness or injury which could be covered under **no-fault** or **automobile insurance**, print the date of the illness or injury:

MM DD YYYY

NAME OF INSURANCE CARRIER

ADDRESS

ADDRESS

CITY

STATE

ZIP CODE

POLICY OR CLAIM NUMBER

Appendix D

(Rev. 4; Issued: 09-26-08; Effective/Implementation Date: 09-26-08)

Part D Sponsor Implementation Guidance—

Automated TrOOP Balance Transfer

Part D Plan Sponsor Guidance on the Financial Information Reporting (FIR) Transactions for Transferring True Out-of-Pocket Balances

Table of Contents

- Background on TrOOP Balance Transfers
- Implementation Timing and Issues
 - Pre-Implementation Testing and Certification
- Plan Enrollment Types
- Procedures for TrOOP Balance Transfer using FIR Transactions
 - Role of the TrOOP Facilitator
 - Inclusion of non-plans of record
 - Evaluation of transaction responses
 - Part D Sponsors' Requirements
 - Multiple enrollments within a contract
 - Multiple Enrollment Types
 - Receipt of Inquiry when a prior plan is known
 - Sponsor requested FIR transactions
 - Correction of unacceptable responses
 - FIR transaction rejects
 - Timing of the FIR Inquiry and Update Transactions
 - FIR Transaction Response Time
 - Exceptions from Automated Processing
- Scenarios

Background on TrOOP Balance Transfers

Part D rules require sponsors to track the beneficiary's true out-of-pocket (TrOOP) costs and gross covered drug spending and correctly apply these costs to the TrOOP and benefit limits in order to correctly place the beneficiary in the benefit and provide the catastrophic level of coverage at the appropriate time. The TrOOP threshold and gross covered drug spending are calculated on an annual basis and must be transferred between Part D plans if a beneficiary disenrolls and re-enrolls at any time before the end of the coverage year.

The TrOOP-related data must also be transferred between Part D plans in those circumstances in which a Part D plan other than the plan of record paid for covered Part D drug costs as a primary payer and subsequently becomes aware; for example, through a CMS enrollment reconciliation process, that the beneficiary is enrolled in another Part D plan.

Currently, CMS requires the use of a manual process to transfer the TrOOP-related data between plans; however, the National Council for Prescription Drug Programs (NCPDP) has approved a Financial Information Reporting (FIR) transaction standard that will support the automated plan-to-plan transfer of these data. The "TrOOP facilitation process," established by CMS to capture TrOOP-relevant data from Part D sponsors online and send these data to the appropriate Part D Plan for TrOOP calculation, will use the FIR to electronically transfer the TrOOP-related data between plans.

Implementation Timing and Issues

Part D sponsors must be prepared to initiate systems testing in the new transactions by September 1, 2008, complete systems certification by November 1, 2008, and be fully prepared to respond to transactions for 2009 enrollees on January 1, 2009. Previously, CMS had announced a July 1, 2008 implementation. However, this new implementation timeline will obviate the need for a mid-year conversion from the current manual TrOOP data transfer process to the automated FIR process and the development of associated coding unique to the implementation year. With the January 1, 2009, implementation of the new FIR transactions to electronically transfer TrOOP and gross covered drug costs, further routine need for the manual data transfer process will be eliminated.

Pre-Implementation Testing and Certification

The TrOOP facilitator in collaboration with CMS, NCPDP and industry representatives will be developing a set of testing scenarios and a FIR testing certification process. Guidance describing this process will be released when available. Part D sponsors must ensure that their pharmacy benefit managers (PBM) or other processors are certified by November 1, 2008. Therefore, CMS needs Part D sponsors to require their PBM/processor to cooperate fully with and respond timely to all contacts from the TrOOP facilitator, to participate in the testing process and achieve certification.

CMS reminds sponsors that under the regulations at 42 CFR 423.464, Part D sponsors are required to coordinate benefits with other Part D plans to transfer TrOOP and gross covered drug costs when a beneficiary changes enrollment during the coverage year to enable the new plan of record to properly position the beneficiary in the benefit. According to this regulation, sponsors must also comply with CMS established processes to ensure coordination between plans. If the procedures and timelines outlined in the FIR testing and certification guidance are not adhered to by Part D sponsors and any applicable plan contractors, CMS has the authority to consider the sponsor out of compliance with the Part D requirements and to take appropriate action.

CMS believes the extended timeframe for implementation of the automated TrOOP balance transfer process will allow adequate time for all sponsors to program and test. However, if any sponsors are not prepared to respond to the FIR transactions at the time of implementation, the other Part D sponsors will be required to operate dual systems for TrOOP balance transfer data, responding to electronic transactions and transferring data received manually from non-compliant sponsors to systems for electronic retrieval.

Plan Enrollment Types

For purposes of the automated TrOOP balance transfer process,

1. A “plan of record” - is a Part D sponsor with a valid, effective enrollment in the CMS system for a Medicare beneficiary for whom the sponsor receives final monthly payment. A sponsor may be the beneficiary’s initial plan of record for the coverage year, a subsequent plan of record with a closed period of enrollment, and/or the current plan of record.
2. A “non-plan of record” is a Part D sponsor that paid covered Part D drug claims for a Medicare beneficiary for whom the sponsor did not have a valid and effective enrollment in the CMS system and for whom the sponsor did not receive final monthly payment. This may occur in situations in which the sponsor submitted an enrollment transaction that was processed, but then audited off due to CMS’ receipt of a subsequent valid enrollment transaction for the same effective date, or if the sponsor’s enrollment transaction was not accepted by CMS and, therefore, is not in the CMS system. There might be multiple non-plans of record for a beneficiary during a coverage year, even for the same month.

Procedures for TrOOP Balance Transfer Using FIR Transactions

Role of the TrOOP Facilitator

Using the information the CMS TrOOP facilitation contractor receives nightly from the CMS Medicare Beneficiary Database (MBD), the facilitator will identify when a change in enrollment at the contract-level has occurred and will generate a FIR transaction to each prior sponsor with which the beneficiary was enrolled or which paid covered part D drug claims for the beneficiary during the coverage year. Transactions will begin with a FIR Inquiry to the earliest sponsor on record in the coverage year; that sponsor's Inquiry response will be returned to the facilitator. Each sponsor will respond with their monthly gross covered drug costs and TrOOP amounts. If there are multiple plans prior to the current plan of record, the accumulator values from the response just received are placed in a FIR Exchange transaction and forwarded to the next sponsor. The facilitator will receive that next sponsor's transaction response and will continue the process of receiving and forwarding the prior accumulators until each subsequent sponsor in consecutive order has received and responded to a FIR Exchange transaction. The final Exchange transaction response will contain the year-to-date monthly TrOOP-related data for all plans prior to the current plan of record; these accumulated monthly amounts will then be forwarded by the facilitator via a FIR Update transaction to the current plan of record. The FIR transaction process flows, involving a single prior plan and multiple prior plans, are detailed in section 4 of the NCPDP Financial Information Reporting Standard Implementation Guide v1.0.

Inclusion of non-plans of record

As noted previously, TrOOP-related data must also be transferred between Part D plans when a Part D plan other than the plan of record (i.e., a non-plan of record) paid for covered Part D drug costs as a primary payer and subsequently becomes aware that the beneficiary is enrolled in another Part D plan. This may occur if this other plan's enrollment was processed and then audited off due to CMS' receipt of a subsequent valid enrollment transaction for the same effective date, or if the enrollment in this other plan was not accepted by CMS and, therefore, is not in the CMS system. Most audited enrollments will be identifiable by the facilitator, unless more than one record was audited off on the same day; in this case, only the latest audited record will be reflected on the TrOOP file.

In situations in which the facilitator is unable to identify the existence of a non-plan of record, in order for the TrOOP data to be transferred, the non-plan of record sponsor must contact the facilitator and request inclusion in the FIR reporting. To include these non-plan-of-record sponsors in the FIR process, the facilitator must create a "proxy" enrollment record identifying the sponsor, rather than CMS, as the source of the information, the contact person providing the information and the date of contact. The facilitator will include the non-plan of record in the FIR transaction stream preceding the actual plan of record for the month(s) the non-plan of record paid Part D claims.

Evaluation of transaction responses

CMS will work with the facilitator to define a set of business rules for evaluating the acceptability of sponsor FIR responses; these will be limited to edits to verify that there are no missing/invalid data elements in the response that are required by the facilitator to generate the next FIR transaction in the stream. If any of these business rules are violated, the facilitator will suspend the transaction flow and contact the sponsor to correct their transaction response. After the sponsor has completed correction, the facilitator will re-initiate the FIR transaction stream.

Part D Sponsors' Requirements

Part D sponsors must track TrOOP-related data for their months of coverage for beneficiaries who disenroll during the coverage year and report these data, even if the accumulator values are zeros, to the facilitator in response to FIR transaction requests. Sponsors must also receive FIR transactions reporting TrOOP-related data reported by prior plan sponsors through the facilitator, update their systems to incorporate these data, examine their claims history and any previously reported amounts from prior plan sponsors to determine the impact of any changes in reported data on the beneficiary's position in the benefit and re-calculate, as necessary, any prior claims affected by changes in the TrOOP accumulators.

A change at the contract level will trigger the FIR transaction process. If the beneficiary changes plan benefit packages (PBPs) within a contract, the sponsor is responsible for ensuring that the TrOOP balance and gross covered drug costs for all months of the first PBP's coverage are available to the subsequent PBP regardless of whether the PBPs within the contract use the same or different processors.

Further, some sponsors use different contractors for eligibility/enrollment functions and claims processing. It is the sponsor's responsibility to ensure that the contractor responsible for TrOOP balance transfer has all eligibility and enrollment information to properly administer the TrOOP balance transfer process consistent with this guidance and the NCPDP Financial Information Reporting Standard Implementation Guide. This would include having information to identify the beneficiary (e.g., the CMS date of birth) and his or her eligibility and enrollment periods consistent with CMS requirements.

Multiple enrollments within a contract

When a beneficiary has multiple enrollments within a contract prior to a contract-level enrollment change, the determination of which FIR transaction(s) is (are) sent and what data are reported back on the transactions is dependent upon whether the BIN/PCN for the multiple enrollments within the contract are the same or different. If there is a single BIN/PCN for the multiple enrollments, the facilitator will send a single transaction to the processor and the processor will report all months of coverage for the multiple enrollments. If there are different BIN/PCNs for the multiple enrollments within the contract, the facilitator will send separate transactions to each different BIN/PCN combination and each processor will report for their months of coverage for that specific BIN/PCN only.

The following scenarios describe the FIR reporting requirements in situations in which a beneficiary has multiple plan enrollments within a contract during the coverage year, involving the same and different BIN/PCN combinations.

Scenario 1

Beneficiary Enrollment History

Months of Coverage	Contract/PBP Number	Plan	BIN/PCN	FIR Transaction	Processor Response
Jan. – Mar.	S0001-001	A	611220/ 1234567890	FIR Inquiry	Reports Jan. – May data
Apr.- May	S0001-002	B	611220/ 1234567890		
Effective June	S0002-001	C	121212/ 23232323bb	FIR Update	

When the facilitator identifies the contract-level enrollment change to Plan C, a FIR Inquiry transaction will be sent to the BIN/PCN for Contract S0001. Since the BIN/PCN combination is the same for both contract S0001 PBPs, the processor will respond with the January through May accumulators, reporting all months of enrollment in Plans A and B. The monthly accumulators for January through May will be forwarded by the facilitator to the Plan C sponsor in a FIR Update transaction.

Scenario 2

Beneficiary Enrollment History

Months of Coverage	Contract/PBP Number	Plan	BIN/PCN	FIR Transaction	Processor Response
Jan. – Mar.	S0001-001	A	611220/ 1234567890	FIR Inquiry	Reports Jan. – Mar. & June – Aug. data
Apr.- May	S0002-001	B	121212/ 23232323bb	FIR Exchange	Reports Apr. – May data
June – Aug.	S0001-001	C	611220/ 1234567890	FIR Exchange	Reports Jan.- Mar data & any changes to June - Aug. data resulting from Apr.- May data
Effective Sept.	S0003-001	D	999991/ 1552bbbbbb	FIR Update	

When the facilitator identifies the contract-level enrollment change to Plan D, a FIR Inquiry transaction will be sent to the BIN/PCN for Contract S0001. Since the BIN/PCN is the same for both Plans A and C, the processor will respond with the January through March and June through August accumulators, reporting all months of enrollment in Plans A and C. The Plan B sponsor will then receive a FIR Exchange transaction and must respond by adding the April through May accumulators. Next, although Plan C has already reported the June through August accumulators, the processor will receive a FIR Exchange transaction from the facilitator to provide Plan B data from April to May. Plan C will then be required to make any necessary adjustments resulting from reprocessing based on their receipt and review of the April through May data from Plan B. The adjusted amounts may be reported in the current or next/later response to the facilitator. The accumulators for all months January through August will be forwarded by the facilitator to the Plan D sponsor in a FIR Update transaction.

Scenario 3

Beneficiary Enrollment History

Months of Coverage	Contract/PBP Number	Plan	BIN/PCN	FIR Transaction	Processor Response
Jan. – Mar.	S0001-001	A	611220/ 1234567890	FIR Inquiry	Reports Jan. – Mar. data
Apr.- May	S0002-001	B	121212/ 23232323bb	FIR Exchange	Reports Apr. – May data
June – Aug.	S0002-002	C	166666/ 88Abbbbbb	FIR Exchange	Reports June – Aug. data
Effective Sept.	S0003-001	D	999991/ 152bbbbb	FIR Update	

When the facilitator identifies the contract-level enrollment change to Plan D, a FIR Inquiry transaction will be sent to the BIN/PCN for Contract S0001. The processor will respond with the January through March accumulators. Although Plan B and C are within the same contract, the PBPs have different BIN/PCNs. Therefore, the facilitator will send a FIR Exchange transaction to the Plan B BIN/PCN and the processor will respond by providing the April through May accumulators. A subsequent FIR Exchange transaction will be sent to the Plan C BIN/PCN for that processor to report the data for the months of Plan C enrollment; this is the June through August accumulator data. The accumulators for all months January through August will be forwarded to the Plan D sponsor in a FIR Update transaction.

While these scenarios do not depict every possible situation involving multiple plan enrollments within a contract, they are illustrative of the application of the NCPDP FIR transaction flow to these situations and the potential need for sponsors to respond to sequential FIR transaction requests.

At any time a plan sponsor has paid Part D drug claims for a beneficiary who is later determined to be enrolled in another plan and the sponsor has not received a FIR transaction to report the beneficiary's TrOOP-related data, the sponsor must contact the TrOOP facilitator to initiate the FIR process and include the additional sponsor in the transaction stream.

Multiple Enrollment Types

Regardless of whether a sponsor is a plan of record or a non-plan of record, the sponsor must receive FIR transactions with TrOOP-related data reported by prior plans (both prior plans of record and non-plans of record), update their systems to incorporate these data, examine their claims history and previously reported amounts from the prior plans to determine the impact of these data on the beneficiary's position in the benefit, and recalculate, as necessary, any prior claims affected by the new TrOOP accumulator data. The recalculation of prior claims by both non-plans of record and plans of record based

on the receipt of new TrOOP-related data reported to them is necessary to ensure that beneficiary adjustments resulting from the recalculation are appropriately handled by the sponsor that adjudicated the affected claim(s).

In addition, for any month in which a plan other than the actual plan of record for the month (whether a prior plan of record or non-plan of record) has paid claims, the other plan will precede the actual plan of record for the month in the FIR transaction stream. The other plan's accumulator data also will precede the actual plan of record's claims data for that month.

The following scenario describes FIR reporting in situations involving multiple enrollment types.

Beneficiary Enrollment History

Months of Coverage	Contract/PBP Number	Plan	BIN/PCN	FIR Transaction	Processor Response
Jan. – Feb., but paid claims for Mar.	S0001-001	A (plan of record)	611220/ 1234567890	FIR Inquiry	Reports Jan. – Mar. data
Mar. - June	S0002-001	B (plan of record)	121212/ 23232323bb	FIR Exchange	Reports Mar.(including Plan A data) – June data
July – Aug.	S0003-001	C (non-plan of record)	999991/ 1552bbbbbb	FIR Exchange	Reports July – Aug. data
Effective July	S0004-001	D (plan of record)	166666/ 88Abbbbbbb	FIR Update	

In August, the facilitator identifies a contract-level enrollment change involving the auditing off of the Plan C enrollment and the new enrollment in Plan D effective July. A FIR Inquiry will be sent to the BIN/PCN for Contract S0001. The processor will respond with the accumulator data for their months of enrollment, January and February. In addition, because the Plan A paid claims in early March prior to receiving the TRR from CMS reporting the beneficiary's change in enrollment, the processor will include their accumulator data for March as well.

The facilitator will send a FIR Exchange transaction to the BIN/PNC for Contract S0002. The processor will incorporate the Plan A data into their system, including applying the March data from Plan A prior to the Plan B claims for March. After examining the amounts previously reported and their own claims history and recalculating any prior claims, as necessary, the sponsor will respond with their March through June accumulators either as a response to that, or a future transaction, from the facilitator.

A subsequent FIR Exchange *transaction* will be sent to the BIN/PCN for the non-plan of record Plan C. This sponsor will incorporate the Plan A and B data into their system. After examining the amounts previously reported and their own claims history and recalculating any prior claims, as necessary, the sponsor will respond with their July through August accumulators either as a response to that, or a future transaction, from the facilitator.

The monthly accumulators for January through August will be forwarded to the Plan D sponsor in a FIR Update transaction. With the retroactive enrollment of the beneficiary in Plan D back to July, the Plan D sponsor must apply the July and August accumulators reported by Plan C to each of those months prior to any claims Plan D adjudicated in July and August.

Receipt of Inquiry when a prior plan is known

If a plan receives an Inquiry transaction from the facilitator, but is aware there was a prior plan, the plan should process the FIR Inquiry transaction. The identity of the prior sponsor must be known and may be determined by the sponsor's previous receipt of a P2P Plan Payable Report (Report 43) from CMS requiring payment to another Part D sponsor or the beneficiary's presentation of a paper EOB from a prior Part D payer.

In the Inquiry response, the sponsor will report the financial accumulators for their months of enrollment only and will retrospectively contact the facilitator to identify the prior payer. The existence in the sponsor's system of financial accumulators that were not added as a result of a FIR transaction could be used in these instances to trigger an alert that would identify the need for follow-up with the facilitator.

If the facilitator can verify that the identified other sponsor had a terminated or cancelled/audited enrollment for the beneficiary, that sponsor will be added, as appropriate, to the FIR transaction process flow. Absent confirmation of a prior enrollment transaction on the TrOOP file, the facilitator will contact the other sponsor and secure the information necessary to create a proxy enrollment record, add the sponsor to the FIR process flow, and initiate a new round of transactions. Although this process currently requires manual follow-up, CMS will work to develop an automated process to handle these situations.

Sponsor requested FIR transactions

If a change in a beneficiary's TrOOP-related data occurs outside the scheduled timing cycle or is of such a magnitude that the sponsor believes it is important to transfer the updated data without waiting for the next scheduled transaction, the sponsor should call the TrOOP facilitator's help desk call center and request that a FIR transaction be initiated. CMS will monitor the frequency of these requests and arrange for a secure Web site to receive the requests if the volume warrants.

Correction of unacceptable responses

When the facilitator suspends a FIR response transaction as unacceptable, for example, if the accumulated TrOOP reported for a month is negative number, the sponsor must make the necessary changes and, once made, the facilitator will re-initiate the transaction stream. Each sponsor must identify in the Health Plan Management System (HPMS) a TrOOP Balance Transfer (TBT) Contact at the entity responsible for responding to the sponsor's FIR transactions. The facilitator will contact this person to determine the estimated timeframe for correction and resumption of the transaction flow.

In the interim, if the suspended transaction was part of the initial stream following a contract-level change in enrollment, the facilitator will continue the transaction flow with the next payer. This will permit the new plan of record to receive all other accumulators to position the beneficiary in the benefit. If the suspended transaction was part of a subsequent flow, so accumulator data was reported previously to the new plan of record, the facilitator will not re-initiate the transaction flow until the problem is corrected and the suspended transaction can be processed.

Sponsors should not routinely question balances reported on the FIR transactions, including accumulated TrOOP reported in excess of the maximum. A sponsor may initially report accumulated TrOOP amounts that exceed the maximum for the coverage year, but must reduce reported TrOOP to the maximum in a subsequent transaction flow. The resolution of an amount reported in excess of the TrOOP limit will require that the sponsor examine claims-level data to determine which claims will require reprocessing.

FIR transaction rejects

Part D sponsors may reject FIR transactions for missing or invalid data; e.g., a missing/invalid BIN number. However, under current CMS rules, X2 (Accumulated Gross Covered Drug Cost exceeds maximum) will not be used.

The FIR transaction standard requires a patient date of birth, if known, in the patient segment. If the date of birth is reported, the date reported in this field must match the CMS date of birth to avoid rejects for a missing/invalid date of birth.

Timing of the FIR Inquiry and Update Transactions

For enrollment changes with prospective enrollment dates, the Inquiry transaction will be sent 2 days prior to the new enrollment effective date. For enrollment changes with retroactive effective dates, the Inquiry transaction will be sent the day following the day the enrollment change is made in MBD and passed to the TrOOP facilitator.

Subsequent Inquiry transactions will be sent weekly for a 4-week period, then monthly for an additional 6 months or until March 31st of the following year, whichever is sooner. This pattern of Inquiry transactions will be followed for each subsequent enrollment change occurring during the coverage year. The series of transactions will always begin with the beneficiary's first plan for the coverage year; this plan may be the actual first

plan of record or another plan that paid claims believing the beneficiary was enrolled in their plan.

FIR Transaction Response Time

The facilitator will time out transactions without a response in 15 seconds. If a transaction is timed-out, the facilitator will retry the transaction every 15 minutes for 48 hours. If after the 48-hour period the plan never responds, the facilitator will report the occurrence to CMS for compliance action for sponsor failure to implement the FIR transaction process as required. The facilitator will also contact the sponsor’s TBT Contact for an estimated timeframe for correction and, as indicated previously in the discussion of the handling of unacceptable transaction responses, will continue the transaction flow if it is the first one following an enrollment change or suspend the flow pending correction if the transaction is part of a subsequent transaction stream.

Exceptions from Automated Processing

Part D sponsors should accept FIR data as reported unless a problem is identified. Problems may be identified through conflicting information, such as paper EOBs presented by, or on behalf of, the beneficiary, that suggests reported data are wrong. Also, there will be rare situations in which a discrepancy exists between the CMS and sponsor’s enrollment information for a beneficiary and the discrepancy affects the FIR-reported data. These situations, or those in which the beneficiary complains that his/her TrOOP accumulators are materially incorrect, must be removed from automated processing. In these instances, the sponsor should contact the facilitator’s help desk call center to request the facilitator suspend the FIR transactions until the discrepancy is resolved or, if necessary, for the remainder of the coverage year. Once the error is resolved, the facilitator will remove the suspension and re-initiate the FIR process. A manual process will be developed for the facilitator and CMS to work with the sponsors to resolve the discrepancy and to report any updates to the financial accumulators that occur while the discrepancy is being resolved.

Scenarios

Scenario One: The beneficiary was enrolled in Plan A in January 2008, in Plan B in February, 2008 and in Plan C for the remainder of the year. Both Plan A and B had claim activity as reflected below.

Month	Plan A		Plan B	
	Accumulated TrOOP	Accumulated Gross Covered Drug Cost	Accumulated TrOOP	Accumulated Gross Covered Drug Cost
January	200.00	275.00		
February			50.00	200.00
March	New plan C begins coverage			

Plan C began adjudicating claims with the \$475 drug spend and \$250 TrOOP amounts received from Plan B. In April, Plan A received a reversal on a \$100 claim and in response to the next FIR Inquiry reported the following updated information to Plan B.

Month	Plan A	
	Accumulated TrOOP	Accumulated Gross Covered Drug Cost
January	150.00	175.00

Plan B compared the previous transaction from Plan A and determined that the drug spend accumulator decreased by \$100. Plan B administers the defined standard benefit. The plan reviewed its claims history and determined that the \$100 decrease moved Plan B's first \$100 claim from the ICP back to the Deductible. Because Plan B needed to recalculate this claim to change it from \$75 plan pay, \$25 patient pay to \$100 patient pay, the plan passed on the new Plan A accumulators and its existing February amounts to Plan C. In order to "pay back the benefit" Plan B was responsible for recouping the \$75 differential from the beneficiary. In response to the next FIR Exchange transaction received, Plan B reported its updated amounts to Plan C as shown below.

Month	Plan A		Plan B	
	Accumulated TrOOP	Accumulated Gross Covered Drug Cost	Accumulated TrOOP	Accumulated Gross Covered Drug Cost
January	150.00	175.00		
February			125.00	200.00
March	New plan C begins coverage			

Scenario Two: Same circumstances as described in Scenario One except Plan B administers a Basic Alternative benefit with no deductible; for the first \$2500 the plan pays 75% and the beneficiary pays 25%. Plan B reviewed its claims history and determined that the \$100 decrease in Plan A gross covered drug cost had no claims impact, because no claims were repositioned in different benefit phases. Plan B forwarded to Plan C the updated Plan A amounts for January and the existing Plan B accumulators for February.

Scenario Three: The beneficiary was enrolled in Plan A in January 2008, in Plan B in February, 2008 and in Plan C for the remainder of the year. Both Plan A and B had claim activity as reflected below.

Month	Plan A		Plan B	
	Accumulated TrOOP	Accumulated Gross Covered Drug Cost	Accumulated TrOOP	Accumulated Gross Covered Drug Cost
January	175.00	175.00		
February			125.00	200.00
March	New plan C begins coverage			

Plan C began adjudicating claims with the \$375 drug spend and \$300 TrOOP amounts received from Plan B. In April, Plan A received documentation from the beneficiary showing a \$100 out-of-network prescription drug purchase. Plan A adjudicated the paper claim and in response to the next FIR Inquiry reported the following updated information to Plan B.

Month	Plan A	
	Accumulated TrOOP	Accumulated Gross Covered Drug Cost
January	275.00	275.00

Plan B compared the previous transaction from Plan A and determined that the drug spend accumulator increased by \$100. The plan reviewed its claims history and determined that the \$100 increase moved Plan B's first \$100 claim from the Deductible into the ICP. Because Plan B needed to recalculate this claim to change it from \$100 patient pay to \$75 plan pay, \$25 patient pay, the plan responded to the next FIR Exchange transaction by passing on to Plan C the updated Plan A amounts for January and Plan B's existing February amounts. Plan B was responsible for reimbursing \$75 to the beneficiary.

In response to the next FIR Exchange transaction received, Plan B forwarded its updated TrOOP accumulator to Plan C.

Month	Plan A		Plan B	
	Accumulated TrOOP	Accumulated Gross Covered Drug Cost	Accumulated TrOOP	Accumulated Gross Covered Drug Cost
January	275.00	275.00		
February			50.00	200.00
March	New plan C begins coverage			

Scenario Four: The beneficiary was enrolled in Plan A in January 2008, in Plan B in February, 2008 and in Plan C for the remainder of the year. Both Plan A and B had claim activity as reflected below.

Month	Plan A		Plan B	
	Accumulated TrOOP	Accumulated Gross Covered Drug Cost	Accumulated TrOOP	Accumulated Gross Covered Drug Cost
January	275.00	275.00		
February			50.00	200.00
March	Plan C begins			

Plan C began adjudicating claims with the \$475 drug spend accumulator it received from Plan B. In April, Plan A received documentation from the beneficiary showing a \$100

out-of-network prescription drug purchase. Plan A adjudicated the paper claim and in response to the next FIR Inquiry reported the following updated information to Plan B.

Month	Plan A	
	Accumulated TrOOP	Accumulated Gross Covered Drug Cost
January	300.00	375.00

Plan B compared the previously reported amounts from Plan A and determined that the gross covered drug cost had increased. Plan B administers the defined standard benefit. Based on a review of its claims history, Plan B determined that the \$100 increase had no claims impact, because no claims were repositioned in different benefit phases.

Therefore, Plan B responded to the FIR Exchange transaction by reporting the following amounts to Plan C.

Month	Plan A		Plan B	
	Accumulated TrOOP	Accumulated Gross Covered Drug Cost	Accumulated TrOOP	Accumulated Gross Covered Drug Cost
January	300.00	375.00		
February			50.00	200.00
March	New plan C begins coverage			

Scenario Five: The beneficiary was enrolled in Plan A in January and February, 2008 and in Plan B for March, 2008 and forward. Plan B administers the defined standard benefit. Because Plan A had no claim activity, it reported zero accumulators to Plan B on the initial Inquiry transaction and Plan B adjudicated a \$100 claim in the Deductible on March 1.

Later on March 1, Plan B received a FIR Update transaction reporting the following amounts from Plan A.

Month	Plan A	
	Accumulated TrOOP	Accumulated Gross Covered Drug Cost
January	200.00	225.00
February	100.00	250.00

Upon receipt of this transaction, Plan B reviewed its claims history and determined that the \$475 increase moved Plan B's first \$100 claim from the Deductible into the ICP. Plan B recalculated this claim to change it from \$100 patient pay to \$75 plan pay, \$25 patient pay. Plan B was also responsible for reimbursing \$75 to the beneficiary.

Scenario Six: The beneficiary initially enrolled in Plan A during the AEP in December 2007. On December 31, 2007, the beneficiary sends an application to Plan B for

enrollment effective January 2008. Both plans administer the defined standard benefit, and both issue a member ID card to the beneficiary. In February, the beneficiary changed enrollment to Plan C.

During the month of January, the beneficiary used the ID cards from both Plan A and B. Prior to receiving the TRR reflecting the enrollment change, Plan A paid claims in January totaling \$100 all patient pay in the Deductible. Plan B then paid a \$50 claim in January, also all patient pay in the Deductible. Because the Plan A enrollment was processed for January, the TrOOP facilitator was able to identify the change of enrollment to Plan B and sent a FIR Inquiry to Plan A. Upon the subsequent enrollment change to Plan C, the Plan A and B amounts are reported as follows:

Month	Plan A		Plan B	
	Accumulated TrOOP	Accumulated Gross Covered Drug Cost	Accumulated TrOOP	Accumulated Gross Covered Drug Cost
January	100.00	100.00	50.00 Plan B 100.00 (Plan A) + 50.00 (Plan B) = 150.00(to new plan)	50.00 Plan B 100.00 (Plan A) + 50.00 (Plan B) = 150.00(to new plan)
February	New plan C begins coverage			

In March, one of Plan A's paid claims from January was reversed by the pharmacy decreasing the beneficiary's gross covered drug cost and TrOOP amounts to \$50. Plan A reported the new accumulators to Plan B on the next FIR Inquiry transaction and submitted a deletion PDE for the reversed claim.

Plan B reviewed its claims history and determined that the \$50 decrease had no claims impact, because no claims were repositioned in different benefit phases. Plan B sent the updated amounts to Plan C as follows:

Month	Plan A		Plan B	
	Accumulated TrOOP	Accumulated Gross Covered Drug Cost	Accumulated TrOOP	Accumulated Gross Covered Drug Cost
January	50.00	50.00	50.00 Plan B 50.00 (Plan A) + 50.00 (Plan B) = 100.00(to new plan)	50.00 Plan B 50.00 (Plan A) + 50.00 (Plan B) = 100.00(to new plan)
February	Plan C begins			

Scenario Seven: The beneficiary was in Plan A January-March 2008, in Plan B in April and May 2008, and in Plan C for the remainder of the year. Both Plan A and B had claim activity as reflected below.

Month	Plan A		Plan B	
	Accumulated TrOOP	Accumulated Gross Covered Drug Cost	Accumulated TrOOP	Accumulated Gross Covered Drug Cost
January	150.00	150.00		
February	125.00	125.00		
March	31.25	125.00		
April			187.50	750.00
May			62.50	250.00
June	New plan C begins coverage			

Plan C began adjudicating claims with the \$1400 in gross covered drug cost it received from Plan B.

Plan A responded to the next FIR Inquiry transaction by reporting its existing accumulators of \$400 in gross covered drug costs and \$306.25 in TrOOP to Plan B, but Plan B was unable to respond before the Exchange transaction was timed out. The TrOOP facilitator retried Plan B as specified in their FIR protocol. Once Plan B responded, a FIR Inquiry was again sent to Plan A, and on their Exchange transaction, Plan B responded with their current balances. The TrOOP facilitator then sent a FIR Update transaction to Plan C reporting Plan A and B balances.

Scenario Eight: The beneficiary was in Plan A January-March 2008. During these months, Plan A had claims activity. On March 12, the beneficiary elected enrollment in Plan B for April, but subsequently, on March 29, elected enrollment for April in Plan C. Because the Plan B enrollment was processed prior to the April cut-off, Plan B received a TRR reporting the enrollment and issued a member ID card to the beneficiary. During April, the Plan C enrollment was processed and Plan B enrollment was audited. The beneficiary remained in Plan C through May and enrolled in Plan D effective June 2008. With the TrOOP facilitator's identification of the Plan B enrollment, Plan A received a FIR Inquiry transaction on March 31st and reported accumulators to Plan B.

Month	Plan A	
	Accumulated TrOOP	Accumulated Gross Covered Drug Cost
January	100.00	100.00
February	175.00	175.00
March	31.25	125.00

Plan B began adjudicating claims in April with the \$400 drug spend accumulator. The Plan C enrollment was processed in April with a retroactive enrollment date of April 1. Both Plan B and Plan C received TRRs reporting the Plan C enrollment, however prior to receipt of this TRR, Plan B paid \$100 in claims.

With the TrOOP facilitator's notification of the Plan C enrollment, Plan A again received a FIR Inquiry transaction and reported their accumulators to Plan B. Plan B compared

this with the previous FIR transaction from Plan A, determined there had been no change, and forwarded the following accumulators to Plan C.

Month	Plan A		Plan B	
	Accumulated TrOOP	Accumulated Gross Covered Drug Cost	Accumulated TrOOP	Accumulated Gross Covered Drug Cost
January	100.00	100.00		
February	175.00	175.00		
March	31.25	125.00		
April			25.00	100.00

Plan C began adjudicating claims with the \$500 drug spend accumulator it received from Plan B, and had claims activity. With the TrOOP facilitator's identification of the Plan D enrollment, Plan A again received a FIR Inquiry transaction and reported their accumulators to Plan B. Plan B again compared this with the previously reported amounts from Plan A, determined there had been no change, and forwarded the balances to Plan C. Plan C compared this with the previous FIR Exchange transaction from Plan B, determined there had been no change, and forwarded the balances to Plan D.

Month	Plan A		Plan B		Plan C	
	Accumulated TrOOP	Accumulated Gross Covered Drug Cost	Accumulated TrOOP	Accumulated Gross Covered Drug Cost	Accumulated TrOOP	Accumulated Gross Covered Drug Cost
January	100.00	100.00				
February	175.00	175.00				
March	31.25	125.00				
April			25.00	100.00	37.50 Plan C 25.00 (Plan B) + 37.50 (Plan C) = 62.50(to new plan)	150.00 Plan C 100.00 (Plan B) + 150.00 (Plan C) = 250.00(to new plan)
May					125.00	500.00
June	New Plan D					

Plan D began adjudicating claims with the \$1150 drug spend accumulator it received from Plan C.

Scenario Nine: The beneficiary was enrolled in Plan A effective January 1, 2008, and the plan had claims activity. On January 30, the beneficiary elected enrollment in Plan B effective February 1. Because the Plan B enrollment was processed after the February cut-off, Plan A continued processing claims until mid-February when the Plan B enrollment was processed and Plan A received a TRR reporting the audited enrollment. On March 10, the beneficiary's enrollment request for Plan C was processed with an effective date of April 1.

In February, when the TrOOP facilitator identified the Plan B enrollment, Plan A received a FIR Inquiry transaction and reported the beneficiary's accumulators to Plan B.

Month	Plan A	
	Accumulated TrOOP	Accumulated Gross Covered Drug Cost
January	175.00	175.00
February	112.50	150.00

Plan B began adjudicating claims with the \$325 drug spend accumulator. In March, the pharmacy reversed a \$75 February claim to Plan A changing the plan's accumulators for February. When the Plan C enrollment was processed in March, the TrOOP facilitator identified the enrollment change and sent a FIR Inquiry transaction to Plan A which reported the following updated accumulators to Plan B.

Month	Plan A	
	Accumulated TrOOP	Accumulated Gross Covered Drug Cost
January	175.00	175.00
February	75.00	75.00

Plan B reviewed its claims history and determined that the \$75 decrease moved Plan B's first February claim from wholly in the ICP to straddling the Deductible and ICP. Because Plan B needed to recalculate this claim, the plan reported to Plan C the updated Plan A January accumulators, the combined Plan A and B February drug costs, and the total of the updated Plan A February TrOOP amount with the previous Plan B February TrOOP balance.

Month	Plan A		Plan B	
	Accumulated TrOOP	Accumulated Gross Covered Drug Cost	Accumulated TrOOP	Accumulated Gross Covered Drug Cost
January	175.00	175.00		
February	75.00	75.00	25.00 Plan B 75.00 (Plan A) + 25.00 (Plan B) = 100.00(to new plan)	100.00 Plan B 75.00 (Plan A) + 100.00 (Plan B) = 175.00(to new plan)

With the next FIR Inquiry transaction, Plan A reported unchanged accumulators for January and February to Plan B. Plan B reported the accumulators as previously sent to Plan C, except the plan was also able to send an updated TrOOP balance for February reflecting the re-adjudication of the straddle claim.

	Accumulated TrOOP	Accumulated Gross Covered Drug Cost	Accumulated TrOOP	Accumulated Gross Covered Drug Cost
January	175.00	175.00		
February	75.00	75.00	43.75 Plan B 75.00 (Plan A) + 43.75 (Plan B) = 118.75` (to new plan)	100.00 Plan B 75.00 (Plan A) + 100.00 (Plan B) = 175.00(to new plan)

After re-adjudicating the first February claim that had previously been processed in the ICP as \$75 plan pay and \$25 patient pay, Plan B was responsible for recovering the additional amount owed by the beneficiary.

Scenario Ten: The beneficiary was in Plan A January-February 2008, then Plan B during March through June. Both plans had claims activity during the months of the beneficiary's enrollment in their plan. Effective July, the beneficiary chooses to re-enroll in Plan A.

With the TrOOP facilitator's identification of the Plan B enrollment, Plan A received a FIR Inquiry transaction and reported accumulators to Plan B as follows:

Month	Plan A	
	Accumulated TrOOP	Accumulated Gross Covered Drug Cost
January	75.00	75.00
February	75.00	75.00

Subsequent FIR Inquiry transactions were sent to Plan A according to the established schedule and the accumulators reported to Plan B. Then, with the TrOOP facilitator's identification in late June of prospective Plan A re-enrollment effective July 1st, Plan A received a FIR Inquiry transaction and reported the accumulators to Plan B. Plan B received and responded to a FIR Exchange transaction with the combined accumulators. The following data were sent to Plan A in a FIR Update transaction and Plan A began to adjudicate claims in July using \$450 in gross covered drug costs.

Month	Plan A		Plan B	
	Accumulated TrOOP	Accumulated Gross Covered Drug Cost	Accumulated TrOOP	Accumulated Gross Covered Drug Cost
January	75.00	75.00		
February	75.00	75.00		
March			25.00	25.00
April			100.00	100.00
May			14.25	75.00
June			25.00	100.00
July	Re-enrollment Plan A			

Subsequently in early July, Plan A and B received TRRs indicating that the Plan A re-enrollment was audited due to the beneficiary's election to remain enrolled in Plan B. However, because the Plan A re-enrollment was processed, Plan A paid claims in July prior to receipt of the TRR. With the TrOOP facilitator's identification of the audited Plan A re-enrollment and the continuation of Plan B enrollment, Plan A received a FIR Inquiry transaction and reported their January, February and July accumulators to Plan B.

Month	Plan A		Plan B	
	Accumulated TrOOP	Accumulated Gross Covered Drug Cost	Accumulated TrOOP	Accumulated Gross Covered Drug Cost
January	75.00	75.00		
February	75.00	75.00		
March			25.00	25.00
April			100.00	100.00
May			14.25	75.00
June			25.00	100.00
July	23.75	95.00		

Plan B compared these data with the January and February accumulators previously reported by Plan A to determine if there had been a change that would affect Plan B's adjudication of the claims processed during the period March through June. Plan B then began processing claims in July with \$545 in gross covered drug costs.

Appendix E – Issues for Other Entities Providing Prescription Drug Coverage

(Rev. 4; Issued: 09-26-08; Effective/Implementation Date: 09-26-08)

As provided in 42 CFR 423.464(f), Part D plans must permit SPAPs and entities providing other prescription drug coverage to coordinate benefits with them. Examples of entities providing other prescription drug coverage include SPAPs, Medicaid programs, group health plans, FEHBP plans, military coverage, IHS coverage, *charities, manufacturer PAPs*, Federally qualified health centers (FQHCs), and rural health centers (RHCs). In this appendix, CMS discusses COB issues applicable to some of these entities.

State Pharmaceutical Assistance Programs

Qualified SPAPs are unique among other payers because any payments supplementing the benefits available under Part D coverage before a beneficiary reaches the annual out-of-pocket limit made on their enrollees' behalf count toward TrOOP. CMS expects that qualified SPAPs will share enrollment files with CMS through the data sharing arrangements outlined in section 30.1. Although SPAP wrap-around coverage automatically counts toward TrOOP – and some programs have questioned the need for SPAPs to participate in CMS' COB and TrOOP facilitation processes – there are benefits to participation in the COB process as other payers. For example, as part of the enrollment file sharing with SPAPs, CMS provides SPAPs with certain information fields (for example, low-income subsidy status and details) that they will need to effectively wrap-around Part D coverage on behalf of their Part D enrollees. In addition, as noted above, by making their claim payments a matter of record with the Part D plans, SPAPs provide the means for Part D sponsors to execute reimbursement of erroneous payments, such as those that may occur in reimbursing cost sharing incurred by low-income subsidy eligible enrollees between the date of their eligibility and the time the subsidy has been programmed by the Part D sponsor. Most importantly, participation in the TrOOP facilitation process allows the beneficiary's multiple benefits to process seamlessly at the point of sale, even if they do not present all of their ID cards.

Exchanging Historical and Ongoing Claims Data

As mentioned in section 50.12 of this *chapter regarding the sharing of claims data*, CMS cannot require data exchanges between Part D *sponsors* and the States, except as required for COB purposes. However, CMS strongly encourages *sponsors* to independently share historical and ongoing data on these shared enrollees with SPAPs, provided such disclosure is consistent with the requirements of the HIPAA Privacy Rule. Drug history exchanges between States and *sponsors* are discussed further in the section 50.12.

Coordinating Payment

As provided in these guidelines, SPAPs may choose to coordinate their benefits with Part D *sponsors* using a variety of approaches. With the exception of the risk-based approach, all Part D *sponsors* are required to coordinate with the SPAP. As indicated in the prior

section discussing the non-risk approach, CMS will take compliance action against all *sponsors* that do not comply with the non-risk requirement. If a *sponsor* is out of compliance with this requirement, CMS will not disqualify a state program from its qualified SPAP status. SPAPs will not be viewed as discriminating based on Part D *sponsor's* non-compliance because CMS believes the *sponsor*, by failing to adhere to this COB requirement, has effectuated the discrimination. CMS will require states to collect an attestation from the *sponsor* that it does not want to participate in the non-risk approach. States will submit this attestation to CMS so that CMS may work with the *sponsors* to comply with this COB requirement. *Sponsors* will also be required to provide information to its beneficiaries that it is not participating in the state's program.

In addition to the lump sum scenarios mentioned in section 50.7 of this chapter, SPAPs may provide their own wrap-around benefit at the point-of-sale, or solicit a *sponsor* or processor who agrees to administer their wrap-around benefit for them. The *sponsor* or processor (who may or may not be a Part D sponsor) will administer their SPAP wrap-around benefit. This organization will agree to administer the SPAP benefit to all Part D beneficiaries that qualify for the SPAP benefit regardless of what Part D *sponsor* in which the beneficiary is enrolled. As the administrator of the benefit, SPAPs will most likely require these organizations to:

- Process secondary claims using the NCPDP V. 5.1 electronic claims format.
- Require COB segment on the secondary claim.
- Provide coverage of drugs on the State's formulary.
- Provide coverage of drugs at SPAP network pharmacies.
- Administer rebates applicable to the SPAP wrap benefit.

Enrollment

Certain SPAPs may have the authority to enroll their members directly into Part D *sponsors* if using an enrollment methodology expressly approved by CMS, and have expressed a desire to be allowed to use a standard electronic file format to complete the enrollment process. While Part D *sponsors* will not be required to accept a standard electronic file directly from an SPAP, CMS encourages *Part D sponsors* to negotiate with SPAPs on this point so as to facilitate a streamlined enrollment process.

Medicaid

Beginning January 1, 2006, Medicaid can no longer receive Federal Financial Participation (FFP) for drugs covered under Part D that are provided to full benefit dual eligibles. State Medicaid programs continue to have the option of providing Medicaid coverage of drugs listed under section 1927(d)(2) of the Social Security Act, which the MMA excludes from the definition of coverage under Part D drugs. To the extent that Medicaid covers those excluded drugs, the state can receive FFP for that coverage.

However, coverage of non-Part D drugs by State Medicaid programs will not count toward a beneficiary's TrOOP balance.

Drug coverage— CMS understands that many Medicaid programs may wish to provide coverage for non-Part D drugs to provide continuity of coverage to dual eligible Part D enrollees. To that end, Part D *sponsors* may wish to develop a process whereby the pharmacy is informed that Medicaid is a payer only if a claim is denied as a non-Part D drug and there are no other secondary/tertiary payers that may pay the claim. As of August 2006, Part D *sponsors* are required to implement reject messaging that will allow pharmacies to identify claims for excluded Part D drugs that can be billed to the State.

Data exchange— As discussed previously in section 50.12 of this chapter, CMS does not have the authority to require data exchanges between Part D *sponsors* and the States, except as required for COB purposes. However, CMS strongly encourages Part D *sponsors* to independently share historical and ongoing data on these shared enrollees with State Medicaid agencies, provided such disclosure is consistent with the requirements of the HIPAA Privacy Rule. CMS believes claims data exchanges will be mutually beneficial to States and Part D *sponsors* as they structure their benefits.

Veterans Administration Coverage

VA benefits – including prescription drug coverage – are separate and distinct from benefits provided under Part D. By law, VA cannot bill Medicare. In other words, coordination of benefits between Part D and VA benefits is not possible. While a beneficiary may be eligible to receive VA prescription drug benefits and enroll in a Part D *sponsor*, he or she cannot use both benefits for a single prescription. VA prescriptions generally must be written by a VA physician and can only be filled in a VA facility or through VA's Consolidated Mail Outpatient Pharmacy (CMOP) operations. VA does not fill prescriptions for Part D *sponsors*. Since VA and Part D benefits are separate and distinct, a veteran's payment of a VA medication copayment does not count toward his or her gross covered drug costs or TrOOP expenditures under his or her Part D benefit.

Given the fact that VA prescription drug coverage is creditable coverage, beneficiaries will not face a penalty if they delay enrollment in a Part D plan. However, some beneficiaries who receive less than full VA prescription drug benefits may benefit from enrollment in a Part D plan – particularly if they are eligible for the low-income subsidy.

TRICARE

TRICARE for Life pays secondary to Medicare to the extent that a benefit is payable by both Medicare and TRICARE. TRICARE for Life's pharmacy benefit wraps around Medicare Part D and will pay any beneficiary cost-sharing remaining – up through the cost-sharing that beneficiary would have had otherwise paid under TRICARE – but only if a beneficiary is enrolled in a Part D plan, the drug is a covered Part D drug, the covered Part D drug is also covered by TRICARE, and the drug is obtained at a pharmacy participating in both the Part D plan's and TRICARE's network.

Given the fact that TRICARE for Life is creditable coverage, beneficiaries will not face a penalty if they delay enrollment in a Part D plan. However, some beneficiaries who receive TRICARE for Life benefits may benefit from enrollment in a Part D plan – particularly if they are eligible for the low-income subsidy. To the extent that a beneficiary is enrolled in both TRICARE for Life and a Part D plan, information about that beneficiary’s TRICARE coverage should be captured and maintained by the COB contractor, and available to Part D *sponsors* as part of the COB process, through the MARx system. Any wrap-around payments made by TRICARE for covered Part D drugs will count toward a Part D enrollee’s gross covered drug costs but not toward TrOOP because TRICARE is a government-funded health program and, as such, a TrOOP-excluded payer.

Indian Health Service (IHS)/Tribal Health Coverage

The Indian health care system, consisting of tribal, urban, and federally operated IHS programs, delivers a spectrum of clinical and preventive health services to its beneficiaries, via a network of hospitals, clinics, and other entities. Section 42 CFR 423.464(f) implementing the Part D COB requirements requires *sponsors* to coordinate benefits with the IHS and providers of other prescription drug coverage. Tribal health coverage is recognized by CMS as a provider of other prescription drug coverage.

In most cases, supplemental coverage by *IHS, Indian tribes and organization, and urban Indian organizations* (collectively I/T/U) facilities will not be considered TrOOP eligible because these entities will fall under CMS’ definition of “government-funded health program,” in 42 CFR 423.100. However, *sponsors* should be aware that some tribes, when providing other prescription drug coverage, may be independent entities that use only non-*government* funding to pay secondary coverage for all medical services, including Part D drugs. This being the case, the secondary coverage may be TrOOP-eligible.

Although assistance with Part D cost-sharing by *I/T/U* pharmacies may not count as incurred costs toward meeting the out-of-pocket threshold at which catastrophic coverage under the Part D benefit begins, neither the MMA nor its implementing regulations prohibit I/T/U facilities from assisting with cost-sharing or subsidizing of premiums. In fact, by custom and regulation, AI/AN beneficiaries cannot be charged any cost-sharing, meaning that I/T/U facilities must waive any co-payments or deductibles that would have been applied by a Part D *sponsor*. CMS regulations require all Part D sponsors to offer network contracts to all I/T/U pharmacies operating in their service area and, in addition, will have to demonstrate to CMS that they provide convenient access to I/T/U pharmacies for AI/ANs. Thus, COB with the IHS and tribes is inextricably tied to pharmacy network contracting with I/T/U pharmacies. I/T/U pharmacies may submit claims to Part D *sponsors* electronically (or via paper claims, to the extent that some of the more remote I/T/U sites lack electronic capability). There does not exist any capability under the current NCPDP Telecommunication Standard Implementation Guide for I/T/U pharmacies that are not TrOOP-eligible to indicate the subsidization by IHS or tribes of any applicable beneficiary cost-sharing so that such subsidies are not applied to the beneficiary’s TrOOP balance. CMS recommends that *sponsors* set up logic in their systems so that all claims from network I/T/U pharmacies are flagged and any applicable

beneficiary cost-sharing is not added to the beneficiary's TrOOP amount. For cases in which tribal organizations using tribal-only money qualify as TrOOP-eligible payers, Part D *sponsors* must set up manual processes to receive this information and to adjust TrOOP calculations accordingly.

If a tribal member *new to the Part D benefit is* initially unable to receive Part D benefits through his/her Part D plan, the tribe may have stepped in to pay for the AI/AN Medicare eligible's Part D prescription drugs, utilizing a non-*government* source of funds, in lieu of a Part D plan's primary coverage. In such cases, tribes are entitled to seek compensation from the Part D plan once enrollment is confirmed. Consistent with CMS COB requirements, plans will be required to reimburse tribes when the tribe has paid primary, just like any other provider of prescription drug coverage.

Safety-Net Providers

A majority of Medicare beneficiaries served by safety-net provider organizations have limited incomes. These safety-net provider typically include Federal, State, and locally supported community health centers (CHCs) or clinics, many of which are deemed FQHCs, public hospital systems, and local health departments. In some communities they also include mission-driven teaching hospitals, community hospitals and ambulatory care clinics (which are often located in central city areas or serve as the sole provider of health care in the community). RHCs, small rural hospitals, critical access hospitals, clinics that receive Ryan White HIV/AIDS grant funding, and nurse managed clinics also constitute key components of the safety net.

An estimated 12,000 safety-net providers participate in the Health Resources and Services Administration's (HRSA) 340B Drug Pricing Program, which allows them to buy their prescription drugs at significantly discounted prices. Participation in the 340B Program can enable pharmacies to provide prescriptions to their patients at lower-than-market price. Because many safety-net providers acquire their prescription drugs through Federal purchasing programs such as the 340B Drug Pricing Program, access to prescription drugs and pharmacy services may be limited to their own patients and not to the public at large. Such "closed pharmacies" may therefore not be open to the general public. For this reason, safety-net pharmacies are typically smaller and less visible to the public than retail pharmacies.

Part D sponsors are not required to contract with safety-net providers. However, CMS created an incentive for Part D *sponsors* to contract with certain safety-net providers – FQHCs and RHCs – by allowing them to count these pharmacies toward their retail pharmacy networks.

COB between Part D *sponsors* and safety-net providers is inextricably tied to pharmacy network contracting with safety net pharmacies *because the assistance with cost-sharing provided by safety-net pharmacies consists of waived or reduced Part D cost-sharing amounts for beneficiaries enrolled in plans with which the pharmacies contract.* The MMA added a new exception to the anti-kickback statute under which pharmacies are permitted to waive or reduce *Part D cost-sharing amounts under certain circumstances.* *For more information about this exception to the anti-kickback statute and the potential*

impact on TrOOP of Part D cost-sharing waived or reduced by safety-net pharmacies, refer to Chapter 5, section 30.4.

Charities

Regardless of whether a charity is a bona fide charity – and unless the charity is a group health plan, insurance or otherwise, or other third party payment arrangement – any assistance with Part D cost-sharing a charity provides on behalf of a Part D enrollee will count toward a beneficiary's TrOOP balance. However, to the extent that a charity provides assistance in the form of in-kind donations, CMS generally considers that entity to be a manufacturer patient assistance program (PAP) operating outside Part D, and the value of that assistance does not count toward a beneficiary's TrOOP balance (refer to the section below on manufacturer PAPs for more detail).

Manufacturer Patient Assistance Programs

Pharmaceutical manufacturers sponsor a number of PAPs *that provide* free product (through in kind product donations) to low income patients – particularly those with incomes below 200 percent of the federal poverty level (FPL) – with no or insufficient prescription drug coverage. *Part D sponsors are required to coordinate with manufacturer PAPs (hereinafter referred to simply as “PAPs”), as detailed below.*

Although sponsors are required to coordinate with PAPs, because PAPs operate entirely outside the Part D benefit (unlike charities offering cost-sharing assistance), this coordination is different in nature than coordination of benefits with supplemental payers operating within the benefit. This is because any assistance a PAP provides to a Part D enrollee for drugs that would have been covered under his/her Part D plan cannot count as an incurred cost that would be applied toward the enrollee's TrOOP balance or total drug spend. In other words, beginning when a beneficiary's assistance under a PAP is effective (and for as long as the beneficiary remains eligible for PAP assistance), a claim for a drug for which a PAP has provided assistance will never be submitted to a beneficiary's Part D plan.

The most effective – and, ultimately, for the beneficiary, the safest – way for PAPs to operate outside the Part D benefit involves front-end data exchanges with CMS through the use of PAP data sharing agreements (DSAs). General information about eligibility file exchange with supplemental payers and other entities is provided in section 30.1 of this chapter. Specific information about PAP DSAs is available on the CMS Web site; see Appendix B for the Web address.

To address safety concerns associated with prescription drugs provided outside the Part D benefits, the front-end data exchange process will enable sponsors to follow-up with PAPs to identify those Part D drugs an enrollee is receiving outside the Part D benefit. This will facilitate sponsors' provision of required drug utilization review and, if applicable, medication therapy management program activities. Alternatively, a PAP that does not participate in CMS's DSA process may provide its enrollees with a notice indicating that they are receiving one or more drug products from that PAP. Sponsors

should follow up with PAPs regardless of how they receive information about the possibility of PAP-provided assistance for any of their enrollees.

When a PAP exchanges eligibility file with CMS, it is identified on the COB data file as Coverage Type “P,” which is not TrOOP-eligible. When a sponsor receives a COB data file for an individual indicating a Coverage Type of “P,” it must follow up with the PAP to obtain the drug-specific information it needs in order to: (1) set its systems to recognize that drug as part of a patient’s profile for purposes of drug utilization review; and (2) set its systems edits to prevent any payment for that prescription. This will be a manual follow-up process because the COB file does not provide sponsors with information about the specific drugs being provided to enrollees by the PAP. Although CMS provides PAP sponsors with a list of COB contacts for each sponsor on the CMS Web site to facilitate this communication, it remains a sponsor requirement to coordinate the exchange of information with PAPs operating outside the Part D benefit.

Contact information for PAPs will be available in the COB data file, and sponsors should use this number to initiate this manual follow-up and data exchange process. The PAP’s phone number will appear in the PDP COB data file, Appendix E.6.4 Supplemental Record: Subordinate to DTL (Unlimited Occurrences), which can be found in the PCUG. The phone number will be located in the data field labeled “Rx Plan Toll Free Number” when the “Supplemental Code Type” is “P=Patient Assistance Program.”

CMS has encouraged PAPs operating outside the Part D benefit to enter into DSAs with CMS similar to those entered into by supplemental payers coordinating benefit administration with Medicare. Manufacturers sponsoring PAPs continue to express interest in entering into DSAs with CMS, and CMS expects that sponsors will see an increase in “P” (PAP) coverage type indicators on their COB data files as more PAPs enter into DSAs and enroll Part D enrollees.

Sponsors may provide information on or even facilitate enrollment in PAPs for financially needy enrollees, particularly as they reach the coverage gap. To the extent that they do so, however, they will need to account for the potential decrease in utilization resulting from enrollees’ receipt of free assistance in their bids.

Operating outside the Part D benefit does not preclude a PAP from requiring its enrollees – including those enrolled in a Part D plan – from paying a nominal copayment when they fill a prescription for a covered Part D drug for which they provide assistance. CMS believes that any copayments assessed by PAPs operating outside the Part D benefit should be nominal, since only nominal beneficiary cost-sharing is consistent with the concept of operating outside Part D. Moreover, given that copayments are typically assessed for purposes of minimizing drug overutilization, the assessment of anything but nominal cost-sharing by PAPs is seemingly inconsistent with the mission of a charitable organization structured to provide assistance with prescription drug costs to low-income patients.

Although PAP payments made for those covered Part D drugs outside the benefit may never count toward enrollees’ TrOOP or total drug spend balances, CMS clarifies that any nominal PAP copayment amounts paid by Part D enrollees will be aggregated to their

TrOOP and total drug spend balances, provided the enrollees take responsibility for submitting the appropriate documentation to their plan. It will not be permissible, however, for beneficiary payments structured as administrative fees or premiums to be aggregated to Part D TrOOP and total drug spend balances, as these types of beneficiary out-of-pocket expenditures do not meet the definition of “incurred costs” at 42 CFR 423.100 *and in chapter 5, section 30*.

Enrollee submission of this documentation is necessary because a PAP operating outside the Part D benefit should never submit a claim for assistance provided for a covered Part D drug to a Part D enrollee’s Part D plan. Consistent with CMS guidance on claims processing, plans should process these enrollee-submitted claims in the order in which they are received, not based on date of service.

Organizations or entities offering PAPs must comply with all relevant fraud and abuse laws, including, when applicable, the Federal anti-kickback statute and the civil monetary penalty prohibiting inducements to beneficiaries. *Liability under the anti-kickback statute requires a case-by-case analysis of the particular facts and circumstances, including the intent of the parties.* The HHS Office of the Inspector General (OIG) enforces Federal fraud and abuse statutes, and all questions regarding the compliance of specific arrangements with these statutes should be referred to the OIG. *General OIG guidance regarding Part D and PAPs is available on the OIG Web site; see Appendix B for the specific Web address.*

Personal Health Savings Vehicles

In the final Part D regulations, CMS indicated that HSAs, FSAs, and MSAs are not group health plans for TrOOP purposes, and that distributions from these personal health savings vehicles will count as incurred costs for the purposes of TrOOP accounting. Thus, information about these accounts need not be reported to CMS. However, if any of these accounts is set up to pay benefits at the point-of-sale, and wishes to be included in the automated payer data exchange provided by the TrOOP facilitation contractor, the administrators of such accounts would need to exchange eligibility files with CMS and be included in the COB files provided by CMS. Alternatively, account administrators may require beneficiaries to submit paper claims after the POS transaction and can then submit those claims to the TrOOP facilitation contractor in batch form. The TrOOP facilitation contractor will create an NCPDP N1 transaction based on that batched claims data and will send it back to the beneficiary’s Part D *sponsor* for accurate TrOOP recalculation.

HRAs, however, generally are considered group health plans for purposes of Part D, and distributions from these accounts will not count toward TrOOP. HRAs are therefore group health plans subject to all the requirements that apply to other payers providing prescription drug coverage. HRA administrators will have the option of entering into data sharing agreements offered by CMS, or they can submit batched claims data to the TrOOP facilitation contractor after the POS transaction. This will help supplement the information about other payers that beneficiaries must relay to their Part D *sponsors* and aid in the accurate calculation of TrOOP.

AIDS Drug Assistance Programs (ADAP)

AIDS Drug Assistance Programs (ADAPs), which are funded under the Ryan White CARE Act, are an integral component of the safety-net for HIV/AIDS patients because they fill coverage gaps in public and private insurance for critical HIV/AIDS drug treatments. Although assistance with Part D cost-sharing by ADAPs may not count as incurred costs toward meeting the out-of-pocket threshold at which catastrophic coverage under the Part D benefit begins, neither the MMA nor its implementing regulations prohibit ADAPs from assisting with cost-sharing or subsidizing of premiums.

To the extent that ADAPs want to be set up to pay benefits at the point-of-sale and wish to be included in the automated payer data exchange provided by the COB contractor, they will need to exchange eligibility files with CMS and be included in the COB files provided by CMS. The advantage to this approach is that claims will be automatically adjudicated at point-of-sale (POS). Alternatively, ADAPs may require beneficiaries to submit paper claims after the POS transaction and can then submit those claims to the TrOOP facilitation contractor in batch form. The TrOOP facilitation contractor will create an NCPDP N1 transaction based on that batched claims data and will send it back to the beneficiary's Part D *sponsor* for accurate TrOOP recalculation.

Appendix F – Part D Requirements Waived for PACE Organizations

(Rev. 4; Issued: 09-26-08; Effective/Implementation Date: 09-26-08)

PACE is a comprehensive, coordinated model of care designed to meet the needs of frail elders. There are several key differences between the way in which PACE organizations (POs) provide the Part D benefit and how it is provided by other Part D *sponsors*.

Tracking of TrOOP

- Dual Eligible Beneficiaries:

CMS fully subsidizes dual eligible individuals' Part D coverage in PACE organizations. Therefore, consistent with PACE rules, there is no beneficiary out-of-pocket expense, which eliminates the applicability of TrOOP for these beneficiaries.

- Beneficiaries Eligible for Only Medicare:

PACE beneficiaries who are only Medicare eligible pay a supplemental premium based on the anticipated cost-sharing covered by the PACE plan. As a result, for these beneficiaries TrOOP does not apply.

Accessing Covered Part D Drugs

For the most part, POs fully coordinate their participants' access to covered Part D drugs, providing prescriptions directly to the participant. As a result, most POs are not set up for real-time, on-line prescription drug claims processing and neither have nor report 4Rx data to CMS.

Transferring Data When a Beneficiary Changes *Sponsors*

When a beneficiary disenrolls from a PO and re-enrolls in another Part D *sponsor* at any time during the coverage year, the PO is required to transfer the TrOOP balance (if any) and the gross covered drug *costs* to the new *sponsor* of record to permit the correct placement of the beneficiary in the benefit.

Prior to the January 1, 2009, implementation of the automated TrOOP balance transfer (TBT) process, POs must send the beneficiary's year-to-date TrOOP and gross covered drug costs, including amounts accumulated during the beneficiary's period of enrollment in the PO plus amounts previously reported to the PO by a prior plan sponsor for months of enrollment during the same coverage year. For beneficiaries who are Medicare and Medicaid dual eligibles, POs should use the Dual Eligible PACE Plan Beneficiary Accumulated True Out-of-Pocket Cost Calculator to calculate the amount of TrOOP to be reported to the new plan sponsor. The calculator is available on the CMS Web site; see Appendix B for the specific Web address.

After the January 2009 implementation of the automated TBT process, POs will no longer be required to forward amounts from any prior plans of enrollment. These amounts will be reported to the new sponsor via the FIR transactions. POs will be exempt from the automated TBT process; therefore, POs must continue to use the current manual process to report TrOOP balances and gross covered drug costs for beneficiaries transferring enrollment to the new plan sponsor as reflected on the TRR reporting the disenrollment from the PO.

CMS will continue to develop guidance to further clarify the applicability of the COB requirements to the POs.