

EQUIPMENT REDESIGN TREATMENTS (see Techniques Requiring Equipment Redesign)

Case History 47: Wood Planer

Case History 48: Textile Braiding Machine

Case History 49: Steam Line Regulator

Case History 50: Speed Control Device

CASE HISTORY 47: WOOD PLANER\*  
(OSHA Noise Problem)

Problem Description

Wood planers use a high-speed rotating cutter head to produce lumber with a finished surface. Sound levels near the operator are high.

There are apparently many noise sources for investigation:

- (1) The board, excited by cutter knife impacts;
- (2) The heavy structure under the cutter head, excited by vibration transmitted through the board;
- (3) Modulation of air flow by cutter knife chopping at the chip collector air stream;
- (4) Motor windage, hum;
- (5) Dust collector blower, vibration noise;
- (6) Machine surfaces excited by impacts.

Problem Analysis

Analysis resulted in the following possibilities for control of planer noise:

- (1) Restrain the board from vibrating. Feed belts on both sides can be used with considerable backup mass and pressure. This would require a radical machine design change.
- (2) Contact the board by means that add damping, to reduce resonant vibration. If this is done as an add-on, it must occur beyond the feed and delivery ports of the planer. Thus it would be helpful only for long lengths of board.
- (3) Use a helical knife cutter head, which will also reduce idling noise. A helix angle larger than is commonly available would be desirable.
- (4) Enclose the planer and board. This is a brute force method that depends for its success on controlling the amount of sound that escapes from the feed and delivery areas; most of the acoustic energy contributing to the sound level is between 500 and 5000 Hz.

---

\*Steward, J.S. and Hart, F.D. 1972. Analysis and control of wood planer noise. Sound and Vibration 6 (3): 24.

## Results

The result achieved by the helical knife cutter head is shown in Figure 6.47.1: reduction from 106 dBA to 93 dBA. Figure 6.47.2 shows the operator sound level related to length of board planed, comparing the helical knife cutter with the straight knife cutter. The helical knife is by far the quieter.

## Comments

To meet OSHA operator sound levels for full-day operation, the plant would need a further sound level reduction, perhaps by the design of a total enclosure with an acoustic lined tunnel for the infeed and outfeed. This should not be tried until it has indeed been determined that the openings are the chief sources. In many mills, however, the planer is not operated on a full-time basis, thus allowing a higher sound level for the shorter time period that an operator is present. At 93 dBA, 5.3 hr are permitted.

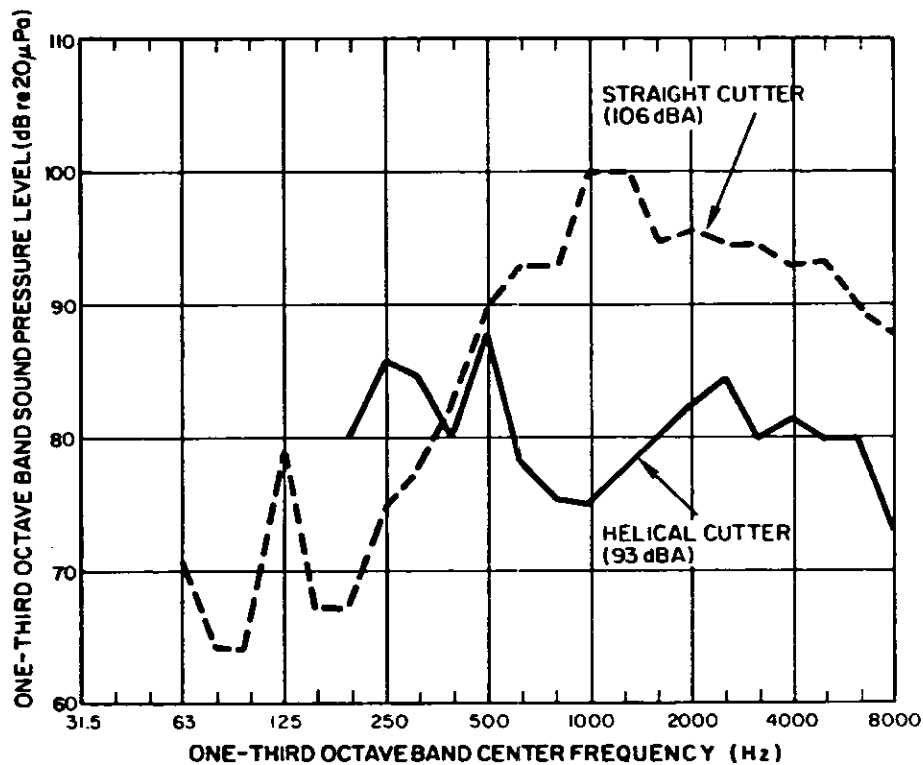

Figure 6.47.1. Before-and-after third-octave-band sound pressure levels for wood planer.

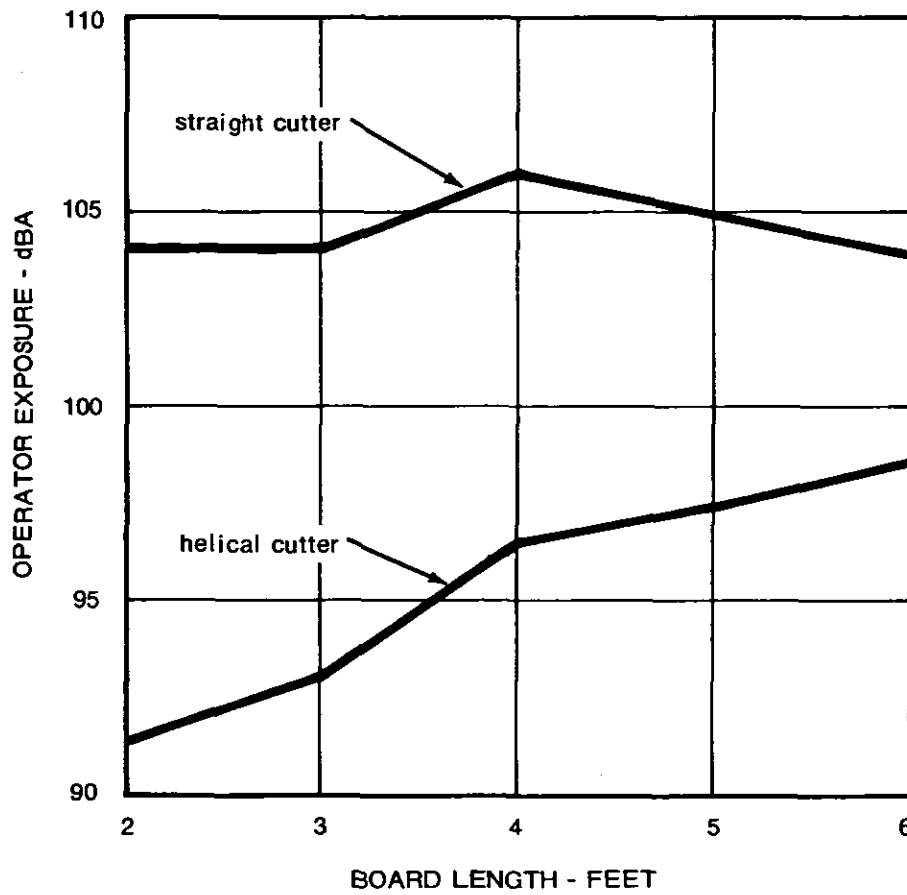

Figure 6.47.2. Effect of board length on noise from wood planer.

CASE HISTORY 48: TEXTILE BRAIDING MACHINES\*  
(OSHA Noise Problem)

Problem Description

In braiding operations, a bobbin of thread is rotated on a carrier base in a special slotted cam. This cam revolves as it is rotated around the machine, with several other carriers and cams. The carriers are thrown from one cam to another. With steel carriers, the major source of the intense noise present is the resulting metal-to-metal impact. The manufacturer was willing to consider machine modifications to reduce noise in the case history reported here.

Problem Analysis and Control Description

In a laboratory study, the metal-to-metal contact was easily identified as the chief noise source. It was recognized that a carrier with inherent damping properties should reduce the noise. Replacement of the carrier by a nonmetallic one was thus considered. Of the several materials tried, the material that provided the best combination of strength, light weight, and damping was an injection moldable polyurethane.

Result

The carriers were installed in a 13-carrier braider operating at a handle speed of 340 rpm. With the microphone 10 in. above the top plate of the braider and 18 in. out, the sound pressure levels were as shown in Figure 6.48.1. A reduction of 11 dB was obtained.

The above results were obtained in the laboratory. For an in-plant test, a row of 84 braiders was converted to plastic carriers. The adjacent row was left with steel carriers; other rows of braiders were operating. The microphone was 3 ft from the centerline between the test rows, and 3 ft above the floor. The sound levels for various combinations of machines are shown below (an x indicates on).

Sound Level, dBA	97	97	90	85
Steel test row	x	x		
Plastic test row	x		x	
All other	x	x	x	x

Residual noise from the motor cooling system remained and limited the noise reduction to the 7 dB achieved in this production test.

\*Cudworth, A.L. and Stahl, J.E. 1972. Noise control in the textile industry. Proc. Inter-Noise. 72:177.

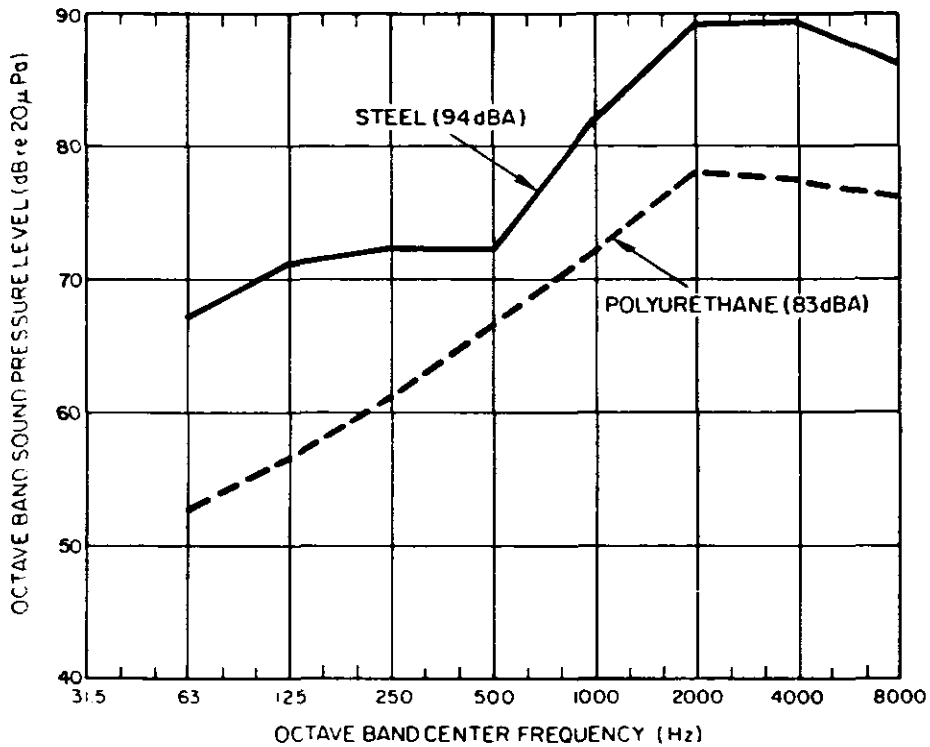

Figure 6.48.1. Textile braiding machine: comparison of sound pressure levels from steel carriers and from polyurethane carriers.

Comments

Since this study, it has been found that the plastic carriers are not strong enough for some operations requiring heavy yarn (or wire). This finding suggests consideration of a composite carrier with a steel core for strength and a cladding of heavy polyurethane for damping. To our knowledge, this concept has not yet been tried. This case emphasizes the need for considering nonacoustical parameters along with the acoustical.

CASE HISTORY 49: STEAM LINE REGULATORS\*  
(OSHA Noise Problem)

Problem Description

Steam lines with regulators are used in many industries and can be a problem noise source if they are in an area occupied by employees.

Control Description

The method used here, which can also be used to regulate other gas flows, was to modify the design of the main valve plug. The redesigned valve plug has throttling vanes, as shown in Figure 6.49.1, to reduce the noise source - the turbulence of the steam flowing through the space between the regulator's main valve and its valve seat.

Results

For a 2-1/2-in. steam line handling 50,000 lb/hr through a reduction of 555 to 100 psig, the redesigned valve reduced pipe line noise from 97 dBA to 85 dBA.

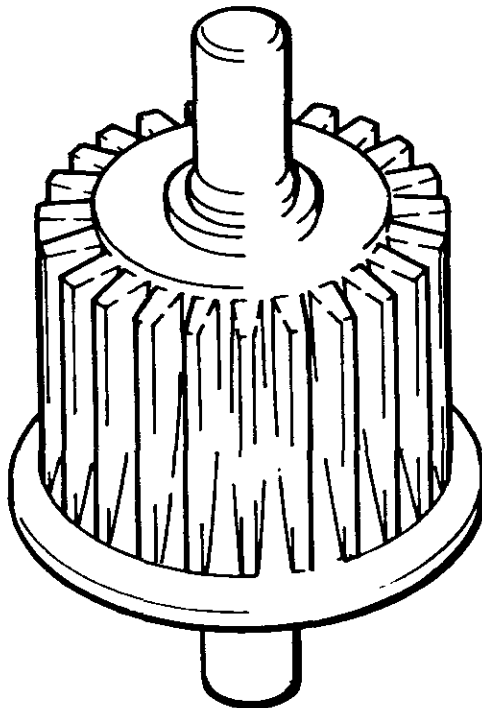

Figure 6.49.1. Main valve plug with throttling vanes to reduce noise in steam line regulator.

---

\*From Electrical World. January 1973.

## CASE HISTORY 50: SPEED CONTROL DEVICE

J.B. Moreland  
Westinghouse Electric Corp.  
Research and Development Center  
1310 Beulah Road  
Pittsburgh, Pennsylvania 15235

### Problem Description

The speed control for a rapid transit system controls the train speed by electronically varying the voltage delivered to the traction motor. Basically, the speed control (illustrated in Figure 6.50.1) consists of a main box that houses the electronic components: a scrubber blower that is used as part of the air cleaning system, and a fan-cooled motor that is used to drive the main blower.

### Problem Analysis

In general, the operational noise of the speed control is predominantly the aerodynamic noise caused by the fans, determined by measuring the noise with the fans inoperative. Noise control considerations included source redesign, since the noise-making equipment was made by the investigators on this project. The major noise reduction was accomplished by (1) using a smaller main blower impeller since, for a given speed, smaller impellers are quieter than larger ones, (2) removing the scrubber blower and using a static air cleaning device, and (3) installing a specially designed muffler at the main blower inlet. Figure 6.50.2 shows the essential features of the treatments.

### Results

The cumulative effect on the noise is shown in the polar plot of Figure 6.50.3. An average sound level reduction of 7 dB was achieved.



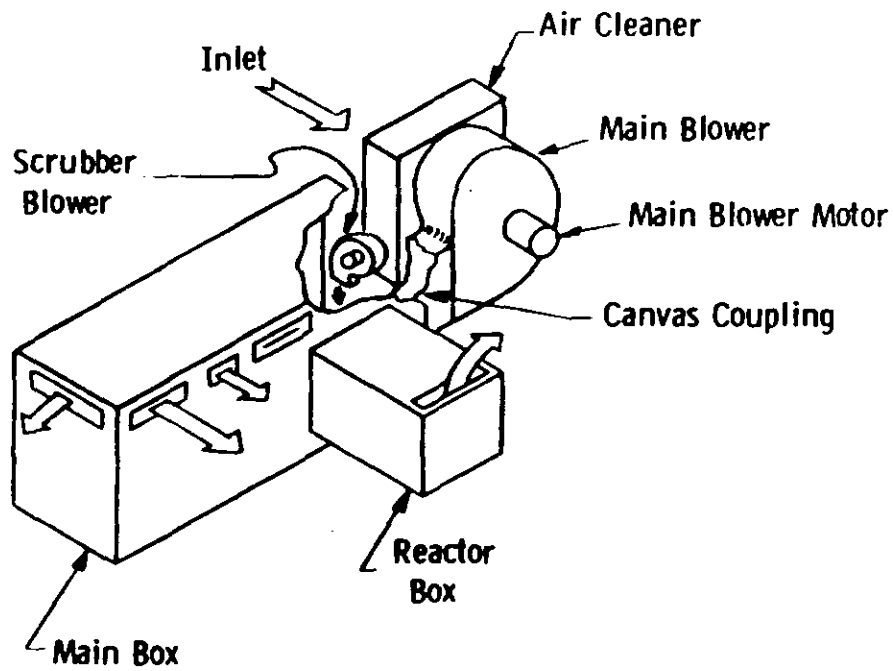

Figure 6.50.1. Essential features of the speed control system.

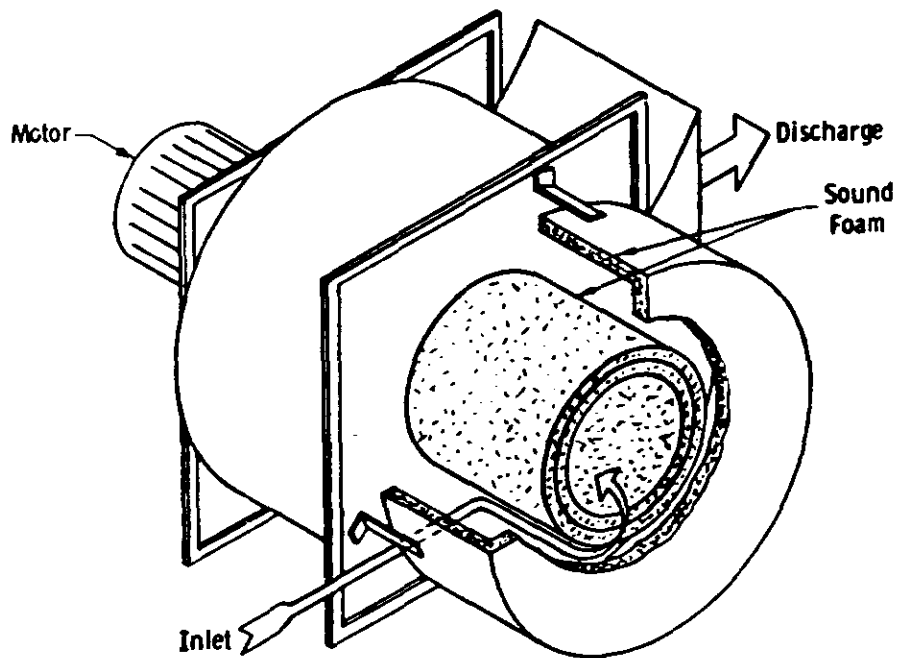

Figure 6.50.2. Essential features of the muffler.

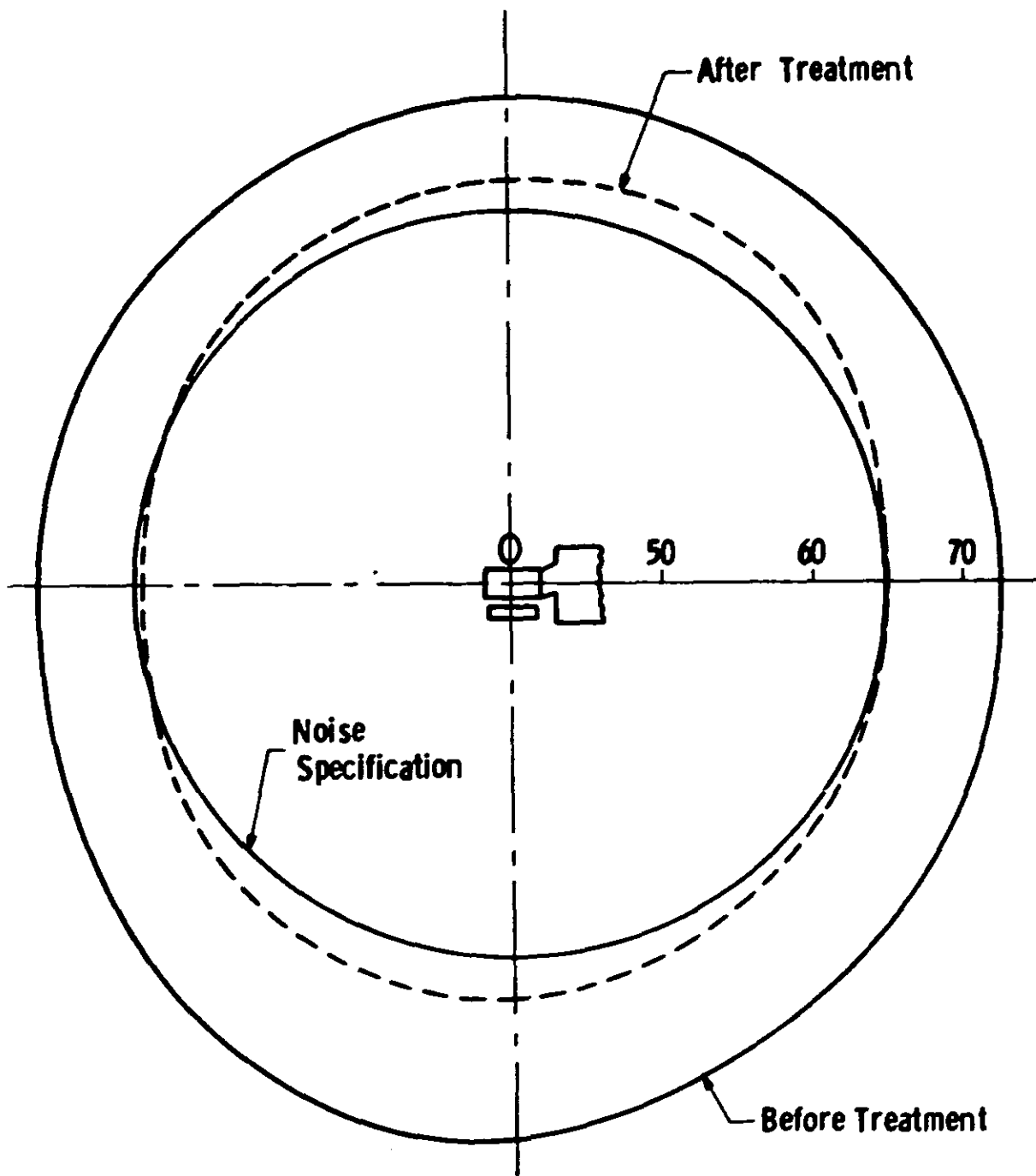

Figure 6.50.3. Constant A-weighted sound level contours for the speed control cooling system before and after acoustical treatment as measured 15 ft from the blower housing center.

## COMBINATIONS OF TREATMENTS

- Case History 51: Steel Wire Fabric Machine
- Case History 52: Barley Mill
- Case History 53: Punch Press
- Case History 54: Cut-Punch Press
- Case History 55: Punch Press
- Case History 56: Newspaper Printing Press
- Case History 57: Letterpress Rotary Printing Machines
- Case History 58: Chemical Process Plants
- Case History 59: Vibration Table
- Case History 60: Teletype Machine .
- Case History 61: Process Plant Noise Control at the  
Plant Design Stage

CASE HISTORY 51: STEEL WIRE FABRIC MACHINE  
(OSHA Noise Problem)

Problem Description

This 8-ft fabric machine manufactures wire netting spaced at 6-in. spacings, starting with individual wires from large spools that run through the length of the machine. A perpendicular wire, known as staywire, is fed across at 6-in. intervals and spot-welded at each intersection. This staywire is then cut off at the left-hand side of the machine. The long wires are then moved through the machine another 6 in., and the staywire operation is repeated. This machine produces 6 x 6 in. No. 8 or No. 10 wire netting, which is used as concrete reinforcement in the home building industry. The machine is made by Keystone Steel and Wire Company.

Problem Analysis

At the operator position, the sound level was found to be 99 dBA and 102 dBC, indicating low-frequency components. This kind of noise ( $L_C - L_A = 3$ ) is very unpleasant.

The daily noise dose was found to be 2.5; the acceptable level is 1.0.

Criteria were established to reduce the noise exposure to 1.0 or less, a level equivalent to 90 dBA or less.

The octave-band sound pressure level measurements made at the main drive gear, at the operator station, and at the wire spool area (Figure 6.51.1) showed that noise sources included (1) general mechanical noise because of needed maintenance, (2) the wire wrapper, a ratchet-action machine operated from main drive gears and found to cause 1000-Hz peak noise, and (3) mechanical sources within the machines, which could lend themselves to isolation.

Control Description

In addition to the direct noise corrections implied above, another solution could have been to construct a noise shelter for the operator. This solution was dropped in favor of working on specific noise sources. A program was established to:

(1) Overhaul the machine: replace bearings, reduce metal-to-metal banging, replace worn gears, and so on.

(2) Replace ratchet-type drive on wire wrapper with chain drive. (This device pulled the long wires through the fabric machine.)

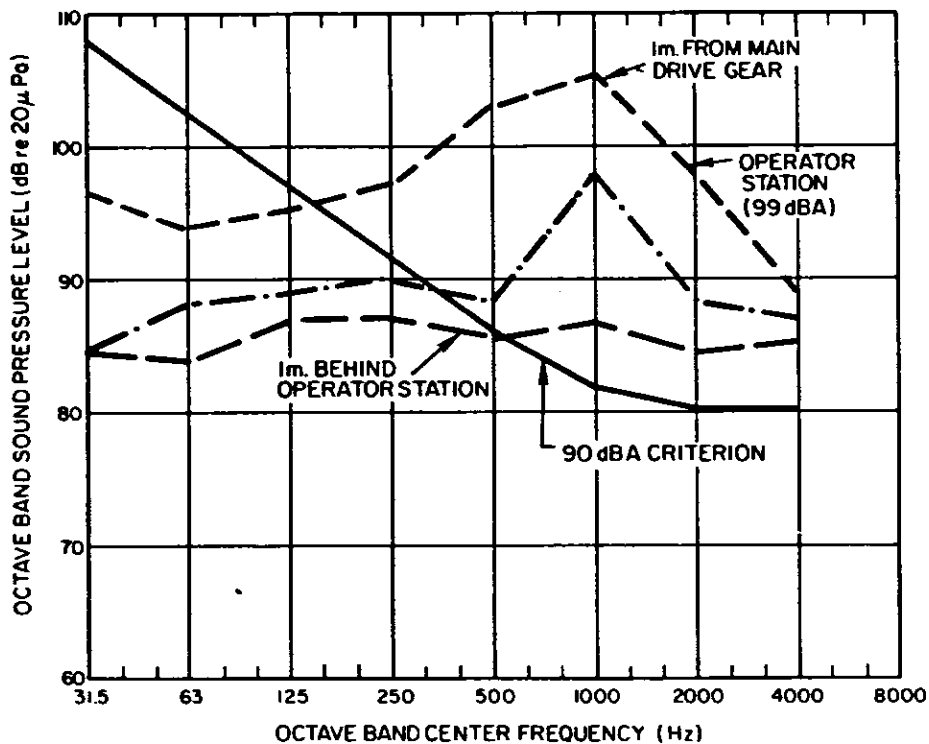

Figure 6.51.1. Sound pressure levels at 8-ft fabric machine.

(3) Add steel plates (10 lb/ft<sup>2</sup>) to the frame of the machine. These plates were welded to the frame to block direct air path noise to the operator. The machine frame casting had many openings, which were covered by these steel plates, as shown in Figure 6.51.2.

### Results

The sound level at the operator station was reduced from 99 dBA to 93 dBA (93 dBC). With this reduction, an additional source was noted and determined to be the staywire lifter arms. These were covered with a 3/8-in.-thick piece of Lexan (see Figure 6.51.3) for the full length of the operator position, hinged so that it could be easily removed for maintenance.

The sound level was reduced to 89 dBA at the operator station and OSHA compliance was achieved.

Costs were mainly internal plant labor for machine overhaul, plus the cost of the steel barrier plates welded to the frame (estimated at less than \$100), plus the cost of the piece of Lexan at \$5.00/ft<sup>2</sup>, or about \$50 plus installation labor.

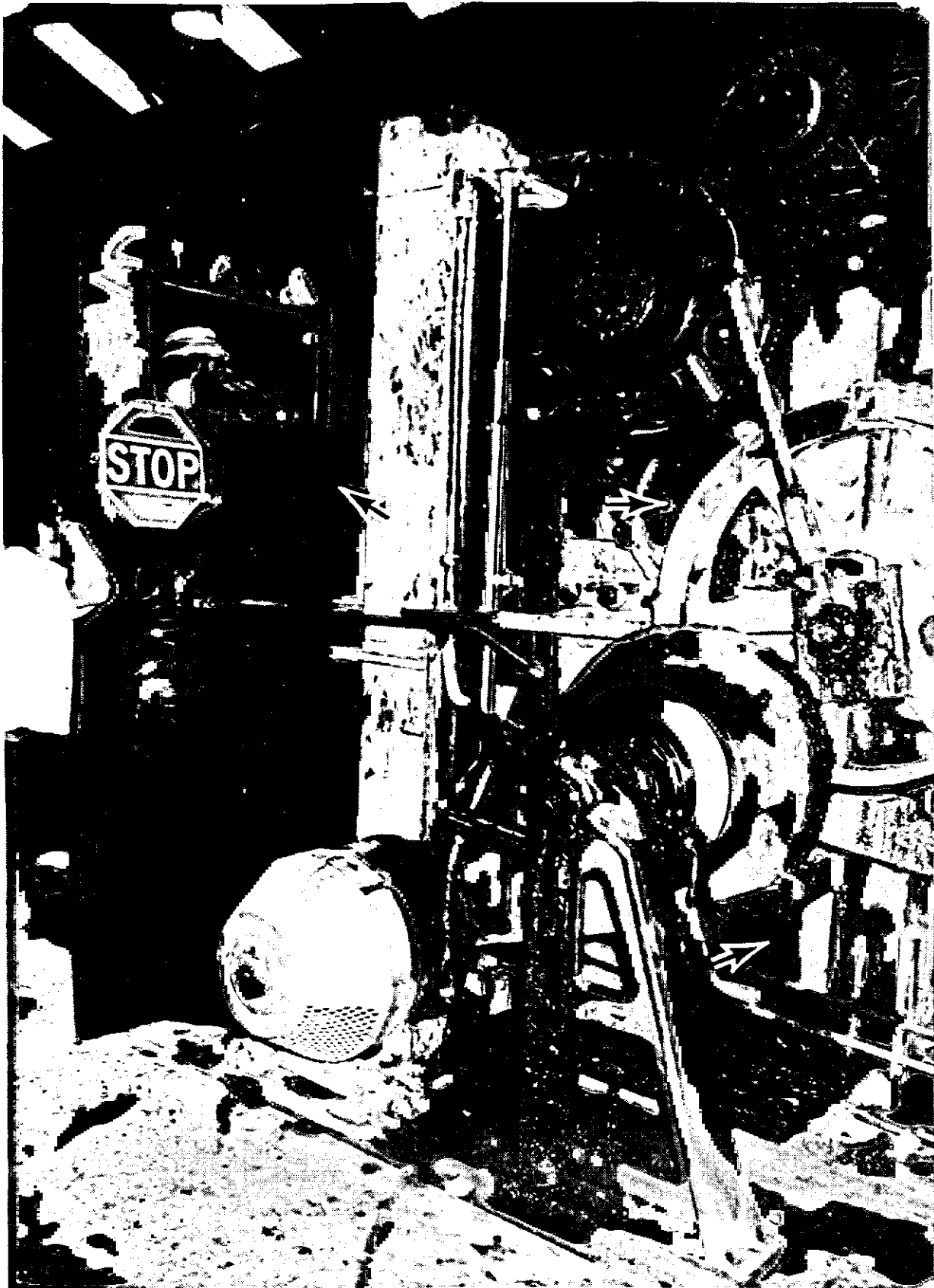

Figure 6.51.2. Steel plate barrier with window (stop sign hung on it).

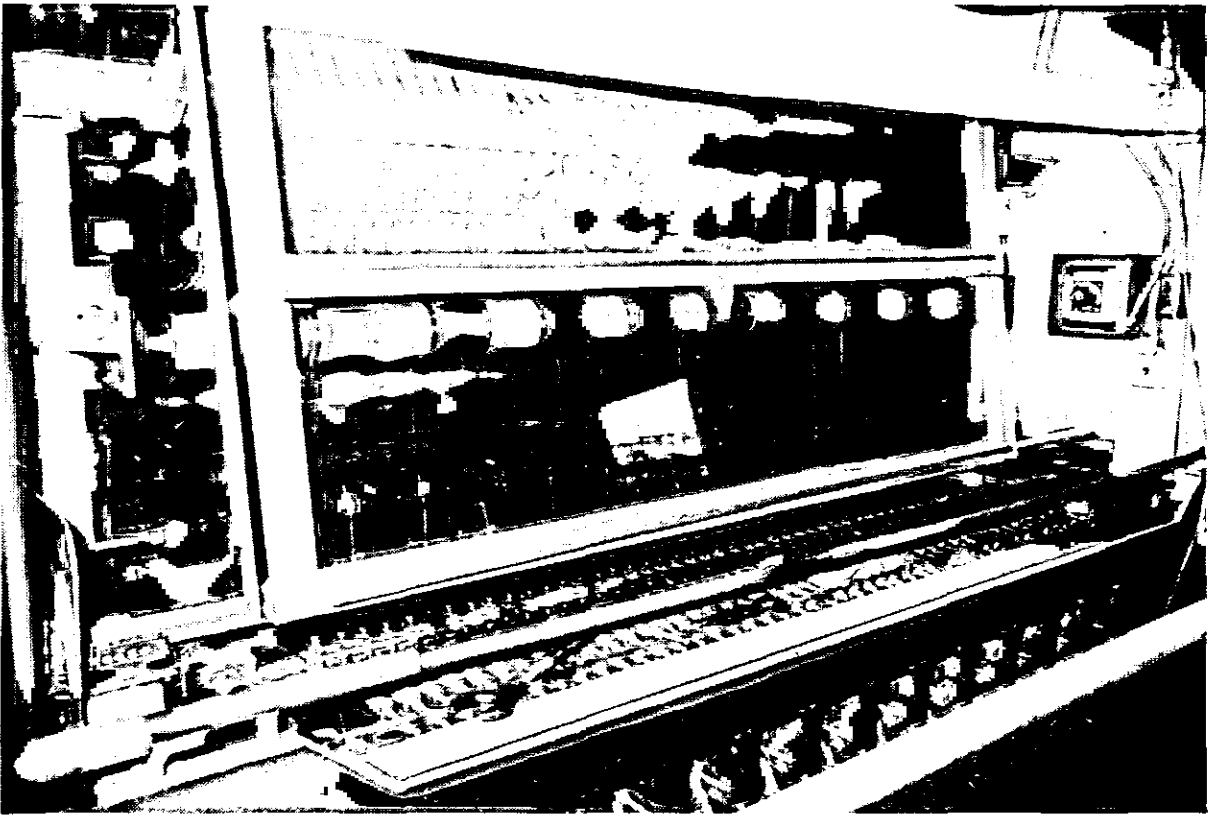

Figure 6.51.3. Lexan barrier in two sections; slides up for access.

#### Comments

A shelter could have solved the problem, but, where possible, attack on direct noise is recommended. When major noise sources are reduced, the contribution of other noise sources can be better determined and corrected. By replacing the ratchet-type drive on the wrapper with a chain drive, the production rate was increased by 50%.

A major pitfall in this kind of approach is moving too fast. Testing each technique under actual conditions is far better than moving rapidly into failure. From beginning to end, this solution took two years to develop.

CASE HISTORY 52: BARLEY MILL  
(OSHA Noise Problem)

Problem Description

Excessive sound levels existed around the Moorspeed and Ross barley mills (rolls 8-in.-diameter, 15-in.-long), a hay shredder, and a control operator's chair in a cattle feed grinding mill. The objective was to reduce the sound level at the operator's position for OSHA compliance.

Problem Analysis

A- and C-weighted sound levels and octave-band sound pressure level measurements were made between the Moorspeed and the Ross mills and at the hay shredder with both mills in normal continuous operation. With  $L_C - L_A = 9$  dB, excessive low-frequency sound levels were predicted. These were confirmed by octave-band sound pressure level measurements. Octave-band sound pressure level measurements at the control operator's chair, the mills, and at the hay shredder are shown in Figure 6.52.1. Figure 6.52.2 is a sketch of the room, showing the relative location of the equipment.

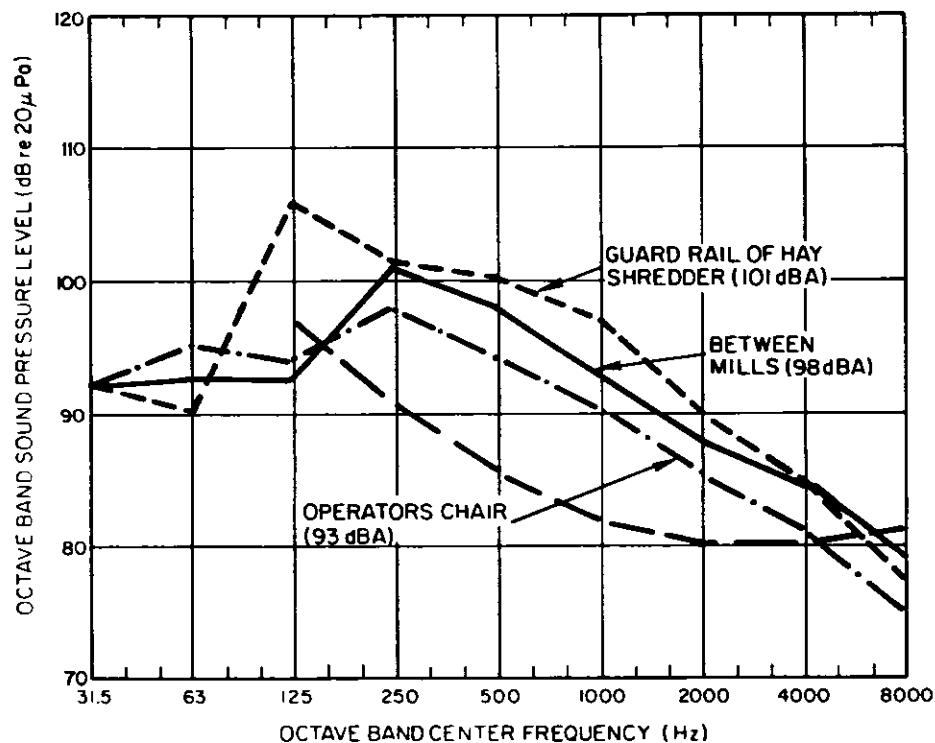

Figure 6.52.1. Sound pressure levels at mills, hay shredder, and operator's chair.



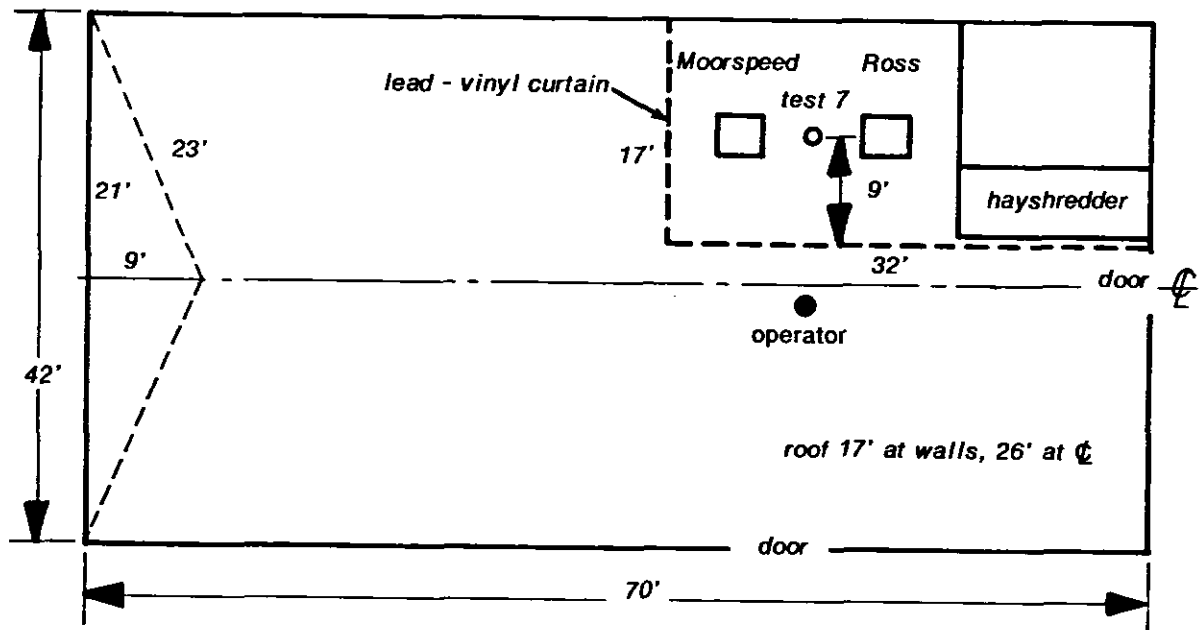

Figure 6.52.2. Floor plan of barley mill.

Roller crushing actions produced high sound levels, and correction by machine redesign was believed to be too costly a method for solving this problem. When the source is too difficult or uneconomical to attempt to correct, working on the noise path will often result in a more economical solution. Therefore, a partial enclosure, open at the top, was chosen.

#### Control Description and Design

Although walls can be of solid construction with a minimum of access doors, in this case access was needed for adjustment, maintenance, repair, and roll replacement. For roll replacement, a forklift truck entry was required. For ease of quick access, a fixed barrier wall was discarded in favor of a lead-vinyl curtain wall extending, if required, up to the 17-ft height of the roof support beams. All three noise sources could be enclosed by two curtain walls at the corner of the building, as shown in Figure 6.52.2. The curtains run on rails for easy sliding back and are held together by Velcro closures.

Figure 6.52.1 shows that, if the sound pressure levels from 250 Hz up are reduced by at least 14 dB, the resulting A-weighted sound level readings would be less than 90 dBA for compliance outside the curtain walls.

Barrier wall attenuation is limited in three ways: (1) direct transmission loss in each octave band, (2) noise over the wall, and (3) room absorption, noise-source side.

(1) Direct transmission loss (TL): The manufacturer of lead-vinyl fiberglass curtains, 0.75 lb/ft<sup>2</sup>, was chosen. Manufacturer's literature gave the transmission loss in each octave band as follows:

	<u>125 Hz</u>	<u>250 Hz</u>	<u>500 Hz</u>	<u>1000 Hz</u>	<u>2000 Hz</u>
TL =	11 dB	16 dB	20 dB	26 dB	31 dB

It is seen that the transmission loss is not a limiting factor.

(2) Noise over wall: Barrier wall attenuation can be estimated from data in Beranek (1971\*) using the dimensions from Figure 6.52.2 and from the sectional view in Figure 6.52.3.

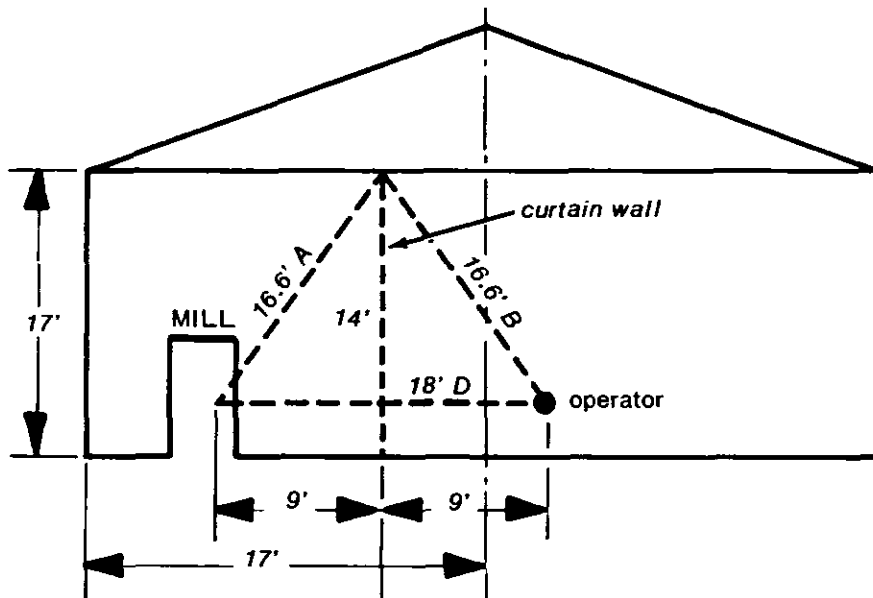

Figure 6.52.3. Sectional view of barley mill.

$$N = \frac{2}{\lambda} (A + B - D) = \frac{2}{\lambda} (16.6 + 16.6 - 18)$$

$$N = \frac{30.4}{\lambda} \text{ (Fresnel number)}$$

\*Beranek, L.L. 1971. Noise and Vibration Control, McGraw-Hill, New York, N.Y. p. 178.

	<u>125 Hz</u>	<u>250 Hz</u>	<u>500 Hz</u>	<u>1000 Hz</u>	<u>2000 Hz</u>
$\lambda =$	9.6 ft	4.8	2.4	1.2	0.6
$N =$	3.2	6.3	12.6	25.2	50.4
Attenuation (dB)	14	16	18	20	20

(Beranek, 1971, graph on page 178). In practical situations, the attenuation is limited to about 20 dB.

By a rough first approximation procedure, we can obtain an estimate of the reduction afforded by the curtain walls. In the listing below, we start with the worst-case octave-band sound pressure levels of Figure 6.52.1 and then list the transmission loss and barrier effects just calculated. Subtracting the minimum of these two reduction mechanisms yields a tentative spectrum of the resulting sound in the room. After A-weighting and combining of sound pressure levels, the predicted reduced room sound level is 85 dBA.

<u>Octave bands</u>	<u>125</u>	<u>250</u>	<u>500</u>	<u>1000</u>	<u>2000</u>
Noise source	106	101	98	97	90
Direct TL	11	16	10	26	31
Over wall	14	15	18	20	20
Reduced sound pressure levels	95	85	80	79	70
A-weighting	-16	-9	-3	0	1
A-weighted	79	76	77	77	71
A-weighted sound level	84 dBA				

For visual access, the enclosure can have 10- × 20-in. plastic windows placed to order; use only the minimal number. To reduce leaks, the curtains should be long enough to drag a bit on the floor. Some rerouting of power, steam, and air lines may be required.

The approximate 1973 costs were: \$4.00/ft<sup>2</sup> for curtains made to order with grommets; Velcro fasteners, \$3.00/ft; track, \$1.50/ft; rollers (one per grommet), about \$2.50 each; windows, \$25.00 each; total cost about \$4,000.

The preceding simplified treatment neglects an important fact: We have not gotten rid of the noise, but have merely redistributed it. Thus, the total sound power from the machines escapes from the topless enclosure and spreads throughout the room. Close to the curtains, there should be some reduction, but very little farther away. Absorption is required for actual reduction of the sound power. This was considered next.

(3) Absorption, noise-source side of wall: When noise sources are confined to a space with less absorption than before, they may build up higher sound levels because of reverberation. The sound barrier curtain material can be obtained with sections of sound absorbent on the inside, to counteract this effect. In the barley mill, however, this choice was not recommended as the porous open material could easily become dust-clogged. Shortly after this noise control job was completed, absorbents covered with a plastic film became available. At the time, the recommendation was for an easily installed and maintained material, Owens-Corning Fiberglas Noise Stop Baffles.\* These are 23 x 48 x 1.5-in. baffles, which comprise an absorbent board wrapped in a washable, noncombustible plastic film; each baffle is supplied with two wires through the 23-in. dimension. These wires terminate in hooks; to install, stretch wires, 3 ft on center, parallel to the line joining the two mills and about flush with the top of the enclosure rails.

The enclosure developed by the curtain walls is, in effect, a separate small room, and the noise reduction can be estimated from the relationship of total absorption before and after adding the sound absorption panels. This relationship is

$$\text{dB Attenuation} = 10 \log A_2/A_1,$$

where:  $A_2$  is new total absorption

$A_1$  is original absorption

(from Bibliography: Harris, Handbook of Noise Control, pages 18-19<sup>†</sup>).

---

\*These are no longer sold by OCF, but can be readily fabricated from acoustical insulation board.

<sup>†</sup>Harris, C.M., ed. 1951. Handbook of Noise Control, McGraw-Hill, New York, N.Y.

Original absorption,  $A_1$ :

	Area	Coefficient = Absorption (Sabins)
Long wall	$32 \text{ ft} \times 17 \text{ ft} \times 2 \times 0.02$	22
End wall	$17 \text{ ft} \times 17 \text{ ft} \times 2 \times 0.02$	11
Roof	$17 \text{ ft} \times 20 \text{ ft} \times 1 \times 0.02$	$\frac{7}{40} \text{ ft}^2\text{-Sabin}$

Absorption by adding 100 panels  $2 \times 4 \text{ ft}$

$100 \times 2 \text{ ft} \times 4 \text{ ft} \times 2 \text{ sides} \times 0.8$  (average A-weighted absorption coefficient of panel) = 1280

Original absorption 40

New total absorption 1320  $\text{ft}^2\text{-Sabin}$

$$\text{dB attenuation} - 10 \log \frac{A_2}{A_1} = 10 \log \frac{1320}{40} = 15.2 \text{ dB}$$

Resultant level = measured level - reduction = 86 dBA.

#### Result

The measured final sound level was 87 dBA, a reduction of 7 dB. This level was 3 dB lower than the maximum desired sound level, and was the result of paying careful attention to elimination of leaks. The room formed by the curtain did not realize such a reduction, but since these machines required no attention while running, the noise exposure of personnel was significantly reduced below unity. The major remaining path is reflection from the ceiling.

#### Comments

Barrier walls of various heights can often be used between a noise source and a machine operator. A major pitfall is that, in a room with a high level of reverberant noise, the partial barrier will be short-circuited by the reflected noises from walls, ceilings, and other surfaces. In such cases, attenuation based on the partial wall theory will not be obtained, and the result may often be no attenuation at all in highly reverberant rooms. Curtain walls must be kept closed to get attenuation. Sound-absorbing units must be kept clean to be efficient.

Even in a semireverberant room, a reduced barrier height can be used. In this case, a 7-ft barrier should ideally reduce the level to 89 dBA at the receiving location. However, since the semireverberant conditions will introduce more reflected sound with the lower barrier, the high wall used in this case history is recommended because the added absorption within the barrier area has, in effect, made a separate small room and created the condition on which the barrier wall theory was based.

CASE HISTORY 53: PUNCH PRESS  
(OSHA Noise Problem)

Problem Description

Punch presses in use in this shop were Summit, Bliss Diamond, and Benchmaster. Within the room were four large presses and four small punches. One of the Summit presses was chosen as representative of the large press group, and the Benchmaster was chosen as representative of the small press group. The general room layout is shown in Figure 6.53.1.

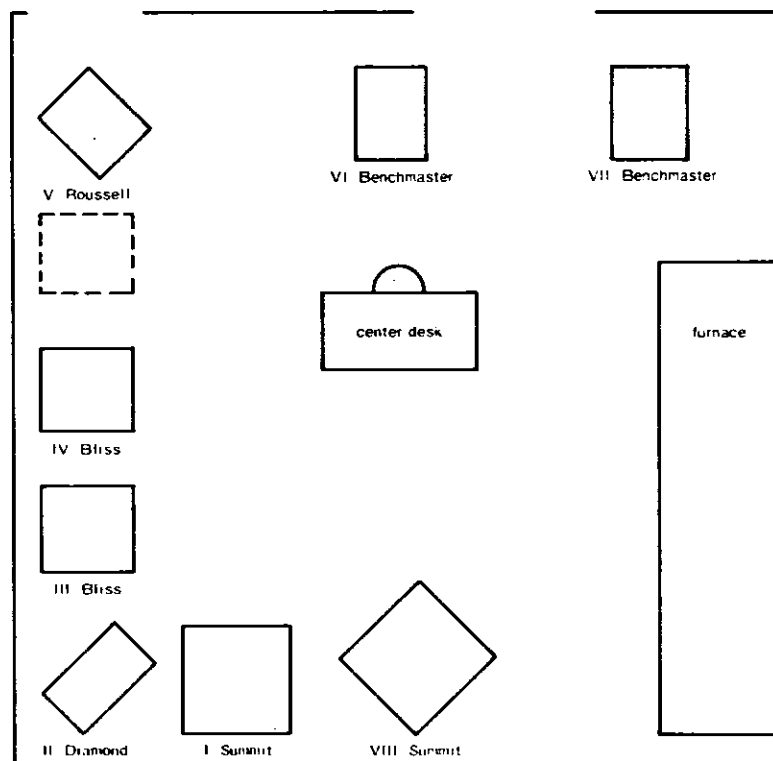

Figure 6.53.1. Layout of punch press room.

Problem Analysis

Octave-band sound pressure level measurements were made of the ambient when all the presses and nearby furnaces were shut down. Readings were taken near the central supervisor's desk. The A-weighted sound level was a very low 58 dBA, indicating that there were no other serious noise sources. Also noted was the difference in sound level with and without the furnaces. With the furnace on, the sound level increased to 69 dBA, still quite low for most industrial situations. Thus, the furnace was also eliminated as an irritant noise source.

Figure 6.53.2 is an octave-band analysis taken from the center desk with two Summit presses, two Bliss punches, and one Benchmaster in operation. The sound level at the desk is 97 dBA, a definite overexposure condition.

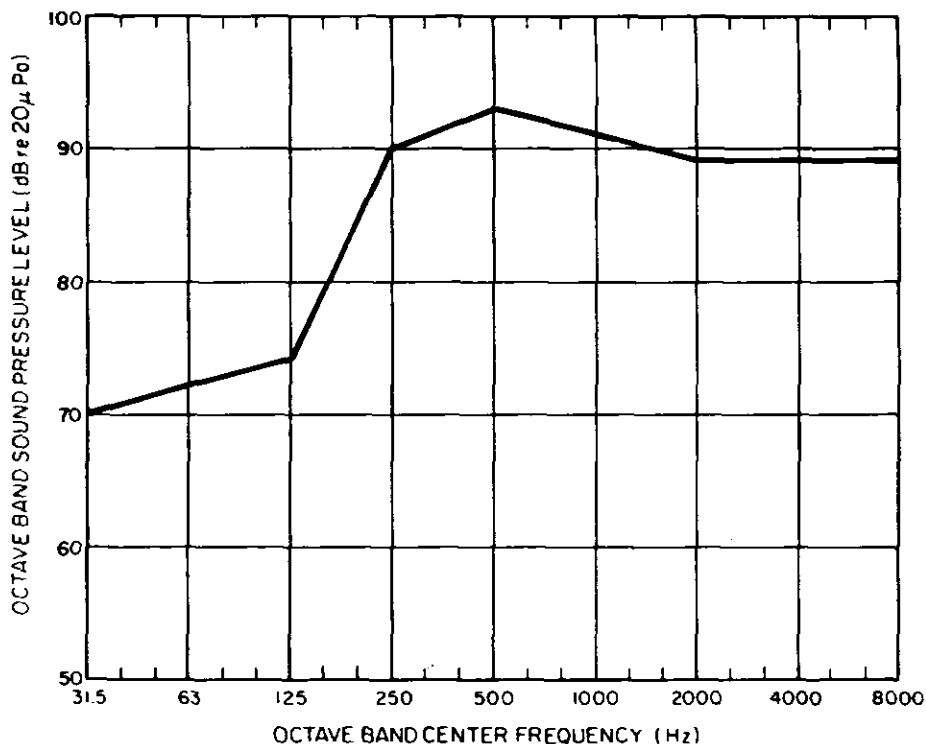

Figure 6.53.2. Ambient sound pressure levels with furnace on, two Summit, two Bliss, and one Benchmaster presses in operation (microphone 1.5 m above floor, directly above desk chair).

The Summit punch, Location I in Figure 6.53.1, was chosen as a typical large press. Operator sound levels, shown in Figure 6.53.3, were 106 dBA during the operating cycle and 90 dBA during preparation with Punch I off. At 106 dBA, the permitted exposure time is 0.87 hr. The octave-band analysis showed that important noise contributions came from the 500-Hz and higher bands.

Figure 6.53.3 also shows the spectrum of noise from operation with nothing in the die. Although a reduction was noted in the 500-Hz band and a small reduction in the 250-Hz and 1000-Hz bands, the 2000- to 8000-Hz bands, which were main contributors to the A-weighted sound level, remained the same as with the full operation. The 2000- to 8000-Hz bands were apparently due to the effect of air exhaust noise from jets for removing parts and pushing them into the collection chute. For these higher frequencies and short wavelengths, barriers are efficient. Close-in diagnostic measurements were made behind the press, but no new noise sources were noted except the directionality of some of the air ejection noise.



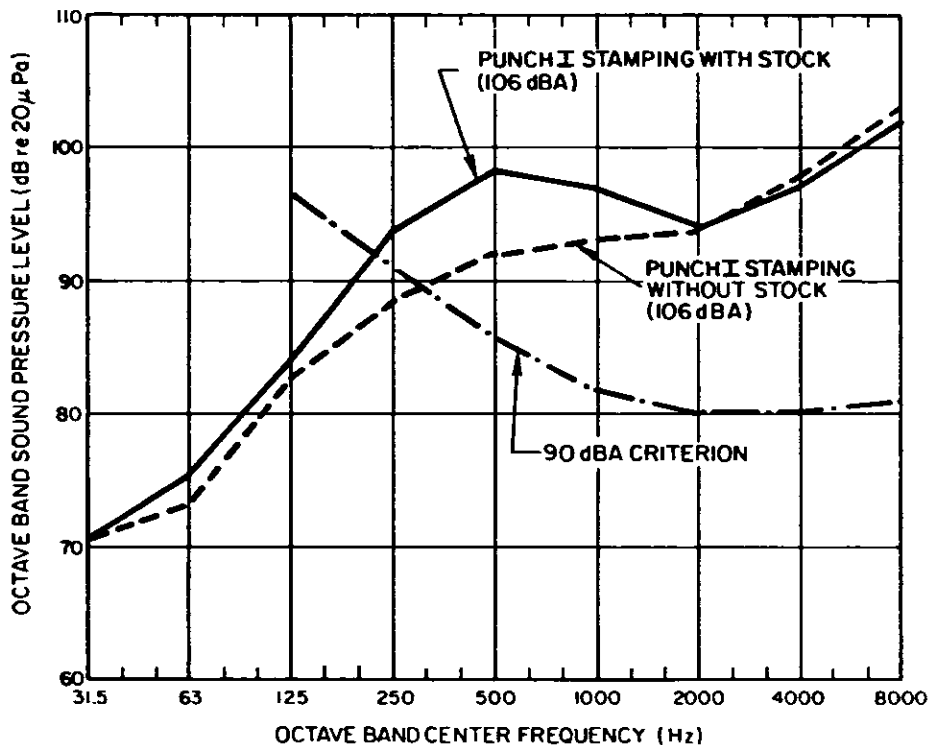

Figure 6.53.3. Sound pressure levels at Punch I.

The reduction sought was from 106 dBA to 86 dBA, with 90 dBA acceptable. This level required reductions of about:

- 13 dB in 500-Hz band
- 20 dB in 1000-Hz band
- 26 dB in 2000-Hz band
- 28 dB in 4000-Hz band
- 31 dB in 8000-Hz band.

For a separate study of a typical small press, the Benchmaster (Punch VII) was chosen. The operator's position octave-band analysis in Figure 6.53.4 shows somewhat less noise than the large press; it has the same general configuration and air jet noise source. Figure 6.53.4 also shows the sound levels with no stock in the press, and with the press in punching operation with no stock and no air ejection. Again, data were very similar to those for the larger press.

The recommendations were: Reduce air noise along path by installing a barrier between noise source and operator, and reduce noise from air ejection at the source. The latter was considered first.

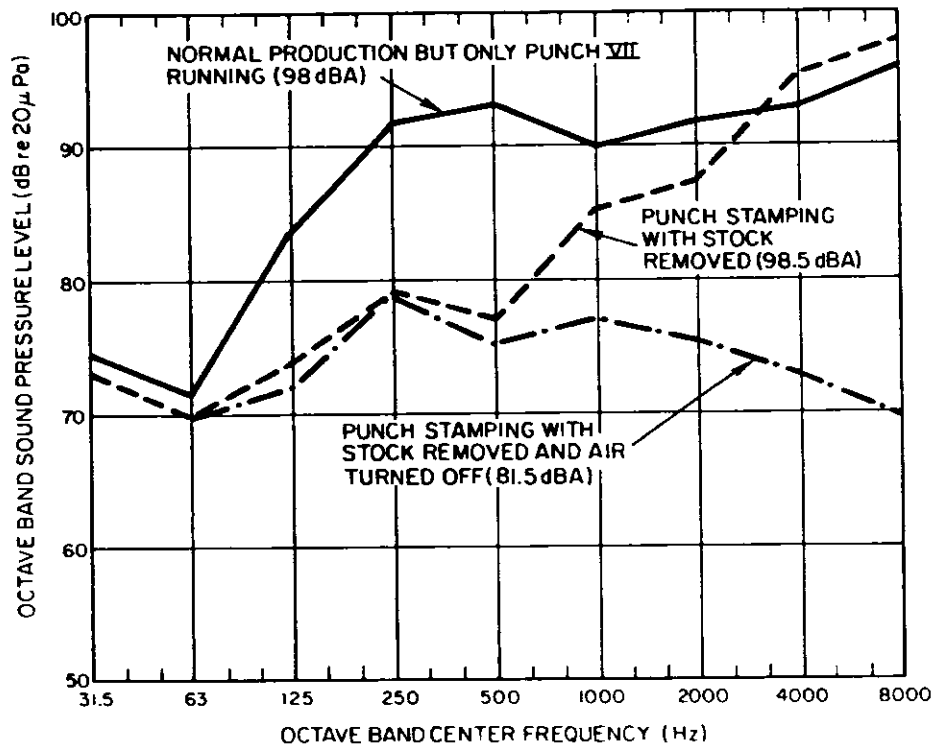

Figure 6.53.4. Sound pressure levels at the operator position of Punch VII.

Noise caused by high air velocity can be reduced by decreasing the linear flow velocity by increasing the nozzle opening, for same air mass flow. If the diameter of the nozzle is doubled, in a constant volume velocity system, flow velocity is reduced to one-fourth, and noise level is reduced nearly 30 dB (noise of air jet varies approximately as fifth power of velocity). However, thrust would also be reduced to one-fourth of original value. For proper ejection, the nozzle should be aimed more accurately and more efficiently toward the target. Experiments should be conducted to determine the maximum thrust required for minimum noise.

A barrier between source and operator can add to the attenuation obtained. The barrier could be box-shaped around the die (with far side and bottom missing). This barrier replaces the present guard, and handles both mechanical and acoustical guard functions. Materials suggested include 1/4-in. plywood, 1/4-in. Plexiglas or Lexan, made with airtight corner joints. Noise-absorbent material, Mylar-faced for dirt and oil protection, was added inside the box; it must be kept clean during normal operations.

#### Control Description

Based on suggested possible methods of nozzle construction, a quiet nozzle cover was made. The design of this nozzle is shown in Figure 6.53.5. Air pressure, controlled by a reducing valve,

was reduced to the minimum to do the ejection job. (Low-noise air jets are also available commercially.)

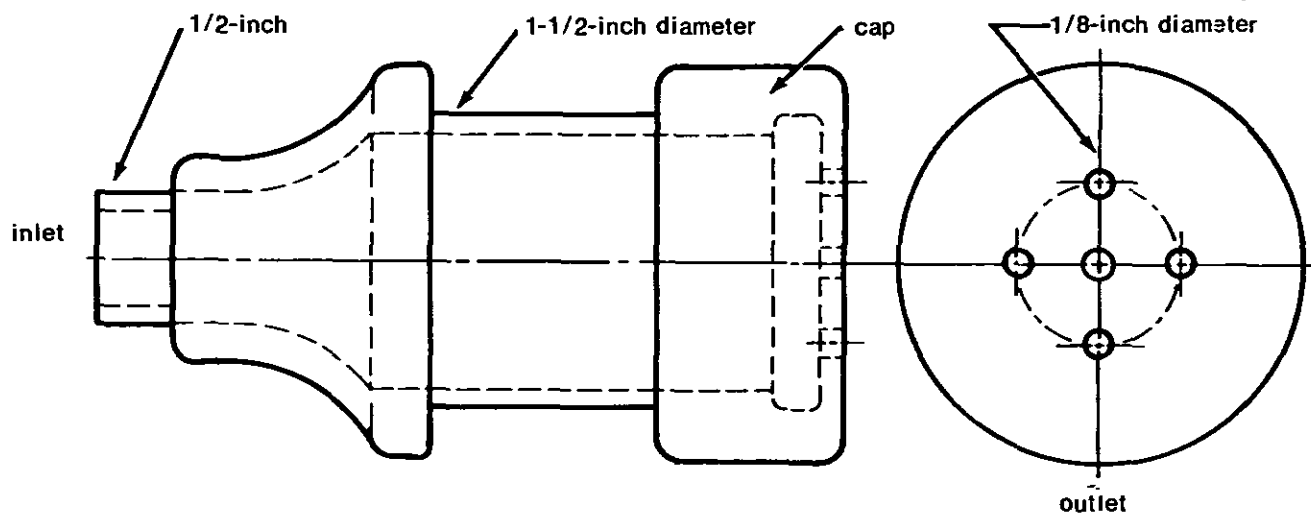

Figure 6.53.5. Design of nozzle.

A sketch of the barrier is shown in Figure 6.53.6. To afford visual access, the material chosen for the barrier was 1/4-in. Plexiglas. The three-sided barrier was locally designed, aiming to have minimum leakage at bottom of barrier (toward the operator).

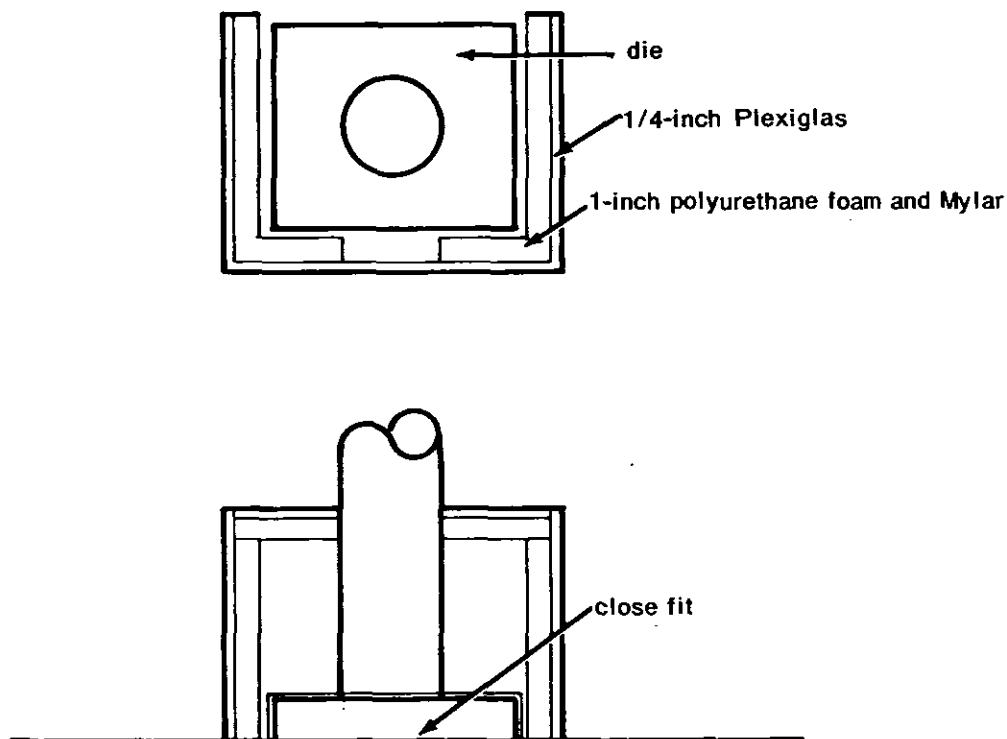

Figure 6.53.6. Sketch of Plexiglas barrier.

For absorption, 1-in. acoustical (fully reticulated) polyurethane, with Mylar film covering for ease of cleaning, was glued to the inside surface, leaving a minimum uncovered portion for operator viewing of punch action.

Accurate costs were not available for this in-plant effort; however, the materials were less than \$100 and labor was estimated at \$250.

## Results

After experiments with reduced jet velocity and with the barriers described, the following sound levels were attained:

Large punch press reduced from 106 dBA to 85 dBA;

Small punch press reduced from 99.5 dBA to 82.5 dBA.

## Comments

The major pitfall for barriers will be to see that they are used. Also, when used, the bottom opening or noise leak toward the operator should be kept at a minimum. Another pitfall to continued efficiency will be allowing the Mylar-covered noise absorbent to become dirt- and grease-laden; periodic cleaning is needed.

A pitfall associated with air volume reduction is the tendency of operators to increase pressure or remove the nozzle.

Attenuation will depend on the success of air velocity reduction in maintaining the needed thrust for ejection in conjunction with noise reduction of barrier. Unless these experiments involved the operators, they may not accept the alterations.

If a mechanical method could be developed to replace air jet part ejection, this would be the best alternative.

CASE HISTORY 54: CUT-PUNCH PRESS  
(OSHA Noise Problem)

Problem Description

This punch press had been modified to produce metal stampings out to a predetermined size. This machine was the first stage of a stamping operation in which the metal was sized and roughly shaped. In two following stages, each part was finished.

Problem Analysis

Figure 6.54.1 gives the octave-band analysis of the operator exposure, which is 102 dBA while punching and 88 dBA during idling. Figure 6.54.2 shows close-in octave-band data for gear noise, illustrating the continuous nonpunching noise source in the gear mechanism. Figure 6.54.3 shows close-in measurements of the dog and flywheel noise and similar close-in measurements of noise from piston-collar impact on the air cylinder.

Clearly, punching noise is the critical part of this noise problem, yet it requires a large amount of noise reduction if one desires to bring maximum operator position sound levels down to no more than 90 dBA. The idling noise aggravates the problem.

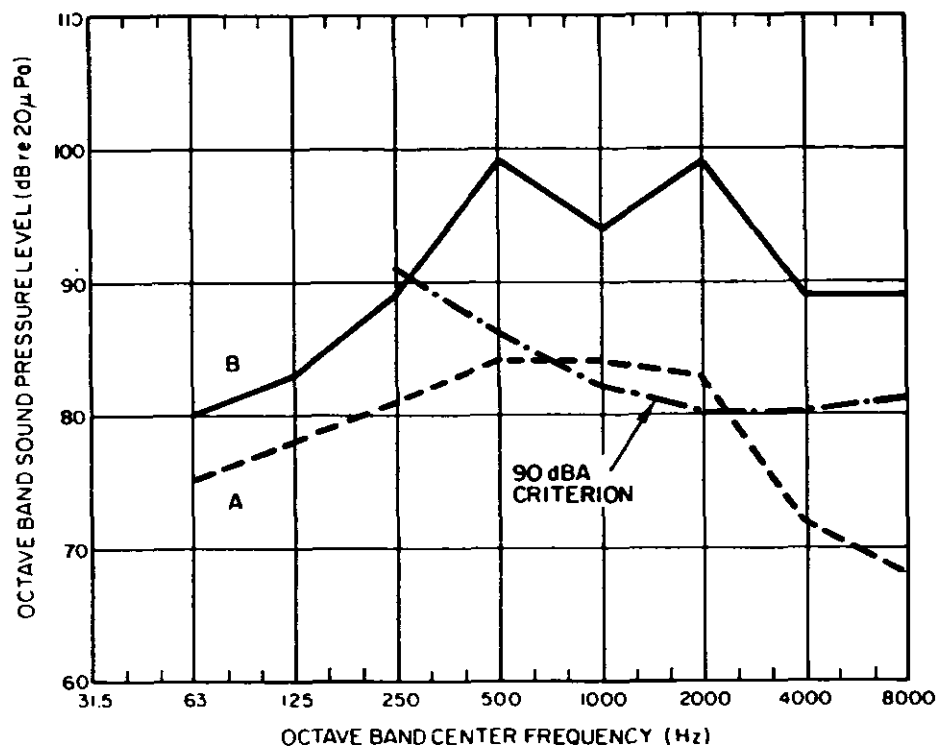

Figure 6.54.1. Cut-punch press operator position sound pressure levels. A, idling; B, punching.

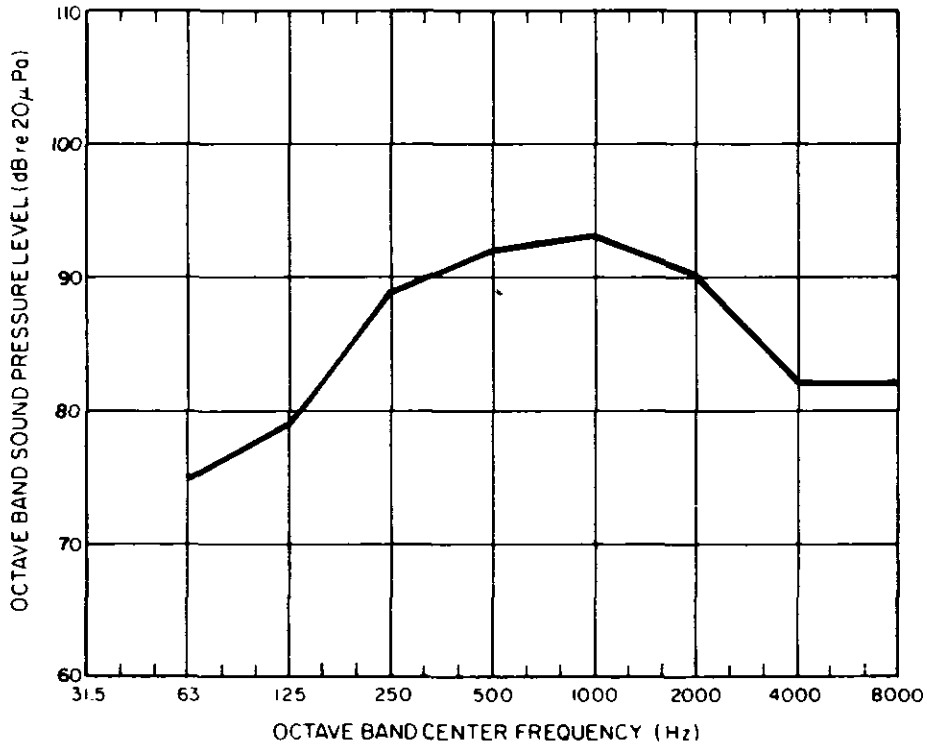

Figure 6.54.2. Cut-punch press, close-in diagnostic data, 14 cm from gears.

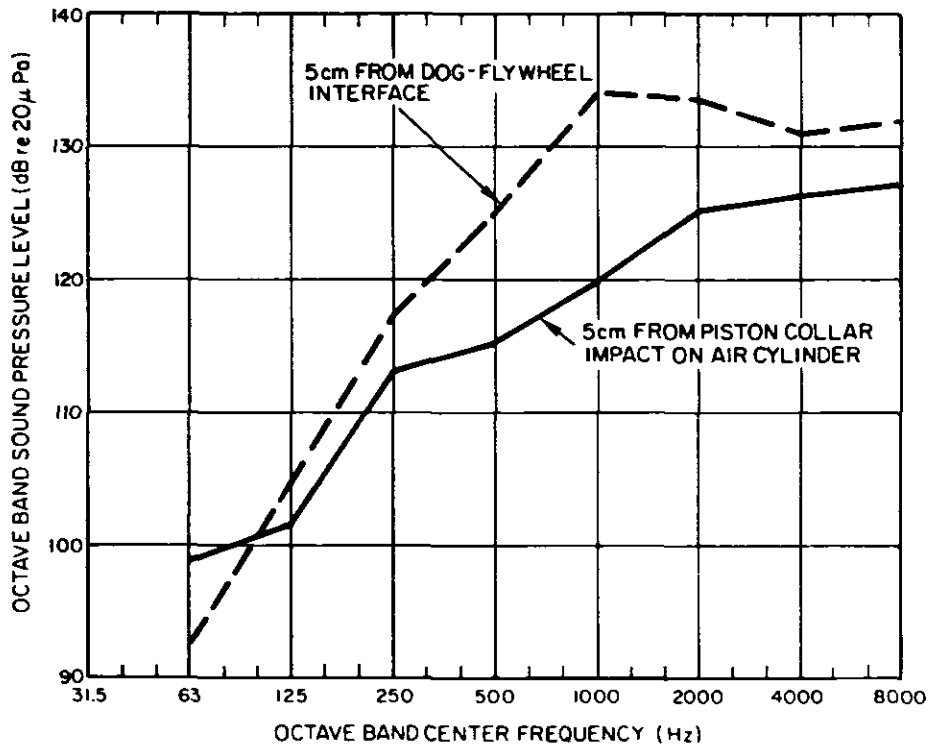

Figure 6.54.3. Cut-punch close-in data.

Recalling the principles of decibel addition, if we were to reduce punching noise to 90 dBA, idling noise would have to contribute no more than 81 dBA to enable the sound level to remain at 90 dBA. In this case, it was decided to aim for a 12-dB reduction in sound level in punching noise, together with a 7-dB reduction in sound level in idling noise, rather than for the 16-dB reduction in sound level in punching noise that would be required if the idling noise were left unchanged.

As machine change was not practical, changes had to be made in the noise transmission path to the operator on two of these noise sources. The other source, piston-collar impact on the air cylinder, was modified at the source by adding washers made from Unisorb Type D pad between the piston stop and the collar to reduce metal-to-metal impact noise.

### Control Description

The gear noise and dog-flywheel impact noises were attenuated by constructing an extended barrier about these noise sources. To obtain the attenuation required, 1-in. plywood was used. The enclosure was attached to the right side of the press (as the operator looks at press) and extended upward to the top of the press, downward to operator chest level, and outward several inches past the flywheel guard. The top, bottom, and right-hand edges had a small 6-in. extension at the barrier extending 90° away from the operator, as shown in Figure 6.54.4.

An absorbent was added to both sides of enclosure, of Mylar covered with 1-in. acoustical foam absorbent, available from several suppliers. The joint between the enclosure and the right-hand side of the press was sealed to prevent noise leakage; a 2-in.-wide strip of closed cell foam weatherstripping was specified.

Normally, absorbing material is used only on the noise source side of a barrier wall; however, if other noise sources might reflect from the barrier wall to the operator, absorbing materials on the operator side will reduce this noise component.

### Results

Sound levels during idling were reduced from 88 dBA to 81 dBA. Punch operational sound levels were reduced from 102 dBA to 88 dBA, thus bringing the entire operation into compliance.

Though not recorded, costs are estimated at less than \$200 for plywood, polyurethane foam, and the labor for attachment.

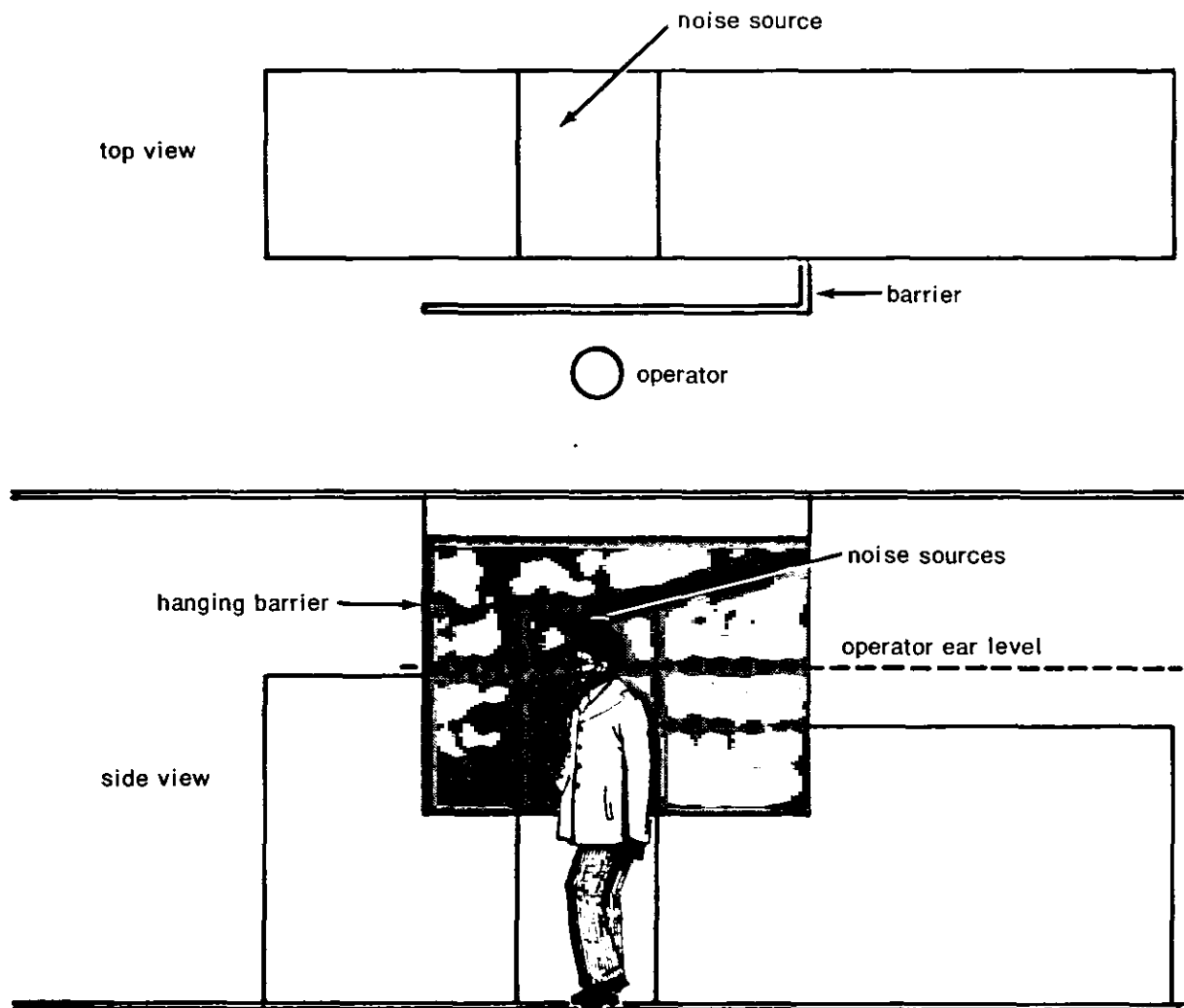

Figure 6.54.4. Sketch of hanging barrier for cut-punch press.