

# **Cable Response to Live Fire (CAROLFIRE) Volume 2: Cable Fire Response Data for Fire Model Improvement**



United States Nuclear Regulatory Commission

*Protecting People and the Environment*

NUREG/CR-6931, Vol. 2  
SAND2007-600/V2

# **Cable Response to Live Fire (CAROLFIRE) Volume 2: Cable Fire Response Data for Fire Model Improvement**

Manuscript Completed: January 2008

Date Published: April 2008

Prepared by  
S.P. Nowlen, F.J. Wyant

Sandia National Laboratories  
Risk and Reliability Analysis Department 6761  
P.O. Box 5800  
Albuquerque, NM 87185

H. Woods, NRC Project Manager

NRC Job Code N6125

Office of Nuclear Regulatory Research

## AVAILABILITY OF REFERENCE MATERIALS IN NRC PUBLICATIONS

### NRC Reference Material

As of November 1999, you may electronically access NUREG-series publications and other NRC records at NRC's Public Electronic Reading Room at <http://www.nrc.gov/reading-rm.html>. Publicly released records include, to name a few, NUREG-series publications; *Federal Register* notices; applicant, licensee, and vendor documents and correspondence; NRC correspondence and internal memoranda; bulletins and information notices; inspection and investigative reports; licensee event reports; and Commission papers and their attachments.

NRC publications in the NUREG series, NRC regulations, and *Title 10, Energy*, in the Code of *Federal Regulations* may also be purchased from one of these two sources.

1. The Superintendent of Documents  
U.S. Government Printing Office  
Mail Stop SSOP  
Washington, DC 20402-0001  
Internet: [bookstore.gpo.gov](http://bookstore.gpo.gov)  
Telephone: 202-512-1800  
Fax: 202-512-2250
2. The National Technical Information Service  
Springfield, VA 22161-0002  
[www.ntis.gov](http://www.ntis.gov)  
1-800-553-6847 or, locally, 703-605-6000

A single copy of each NRC draft report for comment is available free, to the extent of supply, upon written request as follows:

Address: Office of Administration, Reproduction and  
Distribution Services Section  
U.S. Nuclear Regulatory Commission  
Washington, DC 20555-0001

E-mail: [DISTRIBUTION@nrc.gov](mailto:DISTRIBUTION@nrc.gov)  
Facsimile: 301-415-2289

Some publications in the NUREG series that are posted at NRC's Web site address <http://www.nrc.gov/reading-rm/doc-collections/nuregs> are updated periodically and may differ from the last printed version. Although references to material found on a Web site bear the date the material was accessed, the material available on the date cited may subsequently be removed from the site.

### Non-NRC Reference Material

Documents available from public and special technical libraries include all open literature items, such as books, journal articles, and transactions, *Federal Register* notices, Federal and State legislation, and congressional reports. Such documents as theses, dissertations, foreign reports and translations, and non-NRC conference proceedings may be purchased from their sponsoring organization.

Copies of industry codes and standards used in a substantive manner in the NRC regulatory process are maintained at—

The NRC Technical Library  
Two White Flint North  
11545 Rockville Pike  
Rockville, MD 20852-2738

These standards are available in the library for reference use by the public. Codes and standards are usually copyrighted and may be purchased from the originating organization or, if they are American National Standards, from—

American National Standards Institute  
11 West 42<sup>nd</sup> Street  
New York, NY 10036-8002  
[www.ansi.org](http://www.ansi.org)  
212-642-4900

Legally binding regulatory requirements are stated only in laws; NRC regulations; licenses, including technical specifications; or orders, not in NUREG-series publications. The views expressed in contractor-prepared publications in this series are not necessarily those of the NRC.

The NUREG series comprises (1) technical and administrative reports and books prepared by the staff (NUREG-XXXX) or agency contractors (NUREG/CR-XXXX), (2) proceedings of conferences (NUREG/CP-XXXX), (3) reports resulting from international agreements (NUREG/IA-XXXX), (4) brochures (NUREG/BR-XXXX), and (5) compilations of legal decisions and orders of the Commission and Atomic and Safety Licensing Boards and of Directors' decisions under Section 2.206 of NRC's regulations (NUREG-0750).

**DISCLAIMER:** This report was prepared as an account of work sponsored by an agency of the U.S. Government. Neither the U.S. Government nor any agency thereof, nor any employee, makes any warranty, expressed or implied, or assumes any legal liability or responsibility for any third party's use, or the results of such use, of any information, apparatus, product, or process disclosed in this publication, or represents that its use by such third party would not infringe privately owned rights.

## ABSTRACT

This report documents the cable electrical performance and fire-induced failure test results from the Cable Response to Live Fire Project (CAROLFIRE). CAROLFIRE testing included a series of 78 small-scale tests, and a second series of 18 intermediate-scale open burn tests. The tests were designed to complement previous testing and to address two needs; namely, to provide data supporting (1) resolution of the 'Bin 2' issues as identified in Regulatory Issue Summary 2004-03 Revision 1 - Risk informed Approach for Post Fire Safe Shutdown Circuit Inspections and (2) improvements to fire modeling in the area of cable response to fires. The small-scale tests involved exposure of from one to six lengths of cable to grey-body radiant heating in a cylindrical exposure chamber called Penlight. The intermediate-scale tests involved exposure of cables in various routing conditions to open fires created by a propene (propylene) gas diffusion burner. In both test series cables were tested as individual lengths of cable, in bundles of from 3 to 12 cables, and in a limited number of tests, fully loaded electrical raceways. Cables were tested in cable trays, in conduits, and in air drop configurations. The intermediate-scale tests included exposure of cables both in the fire plume and under hot gas layer exposure conditions. A broad range of representative cable products were tested including both thermoset and thermoplastic insulated cables that are typical of the cable types and configurations currently used in U.S. nuclear power plants. All tests measured the cable thermal response using TCs placed both on the surface and embedded within the target cables, and cable electrical performance based on two different electrical monitoring systems. This volume of the three volume project report focuses on the second need area, namely, the fire modeling improvement. The test data gathered are presented and discussed in this context. The discussions focus in particular on data documenting the exposure conditions, the thermal response of the cables, and correlation of thermal response to the onset of electrical failure. A more detailed discussion of the cable electrical performance and failure data and the 'Bin 2' items is provided in Volume 1. Volume 3 was prepared by the National Institute of Standards and Technology (NIST) and documents the thermally-induced electrical failure (THIEF) model whose development was based on the CAROLFIRE test data. THIEF takes, as input, an estimate of the air temperature time history near a cable during a fire and predicts, as output, the temperature response of the cable. The time to electrical failure is then based on an assumed failure threshold temperature characteristic of the cable of interest.

## FOREWORD

The 1975 Browns Ferry Nuclear Power Plant cable spreading room fire demonstrated that instrument, control and power cables are susceptible to fire damage. At Browns Ferry, over 1600 cables were damaged by the fire and caused short circuits between energized conductors. These short circuits (i.e., “hot shorts”) caused certain systems to operate in an unexpected manner. In general, hot shorts can fail equipment important to safety and instrumentation relied on for human actions, and can initiate accidents such as LOCAs that challenge the nuclear power plant’s response.

Under certain circumstances, such events can contribute significantly to overall nuclear power plant risk and should be taken into account by plant risk analyses.

In order to better understand the issue of cable hot shorts, the nuclear industry (Nuclear Energy Institute/Electric Power Research Institute) conducted a series of cable fire tests that were witnessed by the NRC staff in 2001. Based on the results of those tests, and data from previous tests available in the literature, the NRC facilitated a workshop on February 19, 2003. The workshop led the NRC to issue Regulatory Issue Summary (RIS) 2004-03, Revision 1, “Risk-Informed Approach for Post-Fire Safe Shutdown Circuit Inspections,” dated December 29, 2004 (ADAMS Accession No. ML042440791), which describes the guidance NRC inspectors currently follow in deciding which causes of fire-induced hot shorts are important to safety and should be considered during inspections. The RIS also describes “Bin 2” items, which are scenarios where the importance to safety of cable hot shorts was unknown at the time of the workshop.

This report describes the CAROLFIRE (CAble Response tO Live FIRE) testing program. The primary objective of this program was to determine the safety importance of these Bin 2 items. A secondary objective of CAROLFIRE was to foster the development of cable thermal response and electrical failure fire modeling algorithms. To achieve these objectives, Sandia National Laboratories conducted a variety of fire experiments designed to examine the “Bin 2” items, and designed to capture cable thermal response and failure data. The cable thermal response data has been provided to the National Institute of Standards and Technology and the University of Maryland for use as the basis of development and initial validation of cable target response models.

The results presented in this report were from a series of both small- and intermediate-scale cable fire tests. The combined test matrices comprised 96 individual experiments of varying complexity. The tests involved a variety of common cable constructions and variations in test conditions like thermal exposure, raceway type, and bundling of similar and dissimilar cable types. The results provide the most extensive set of cable thermal response and failure data to date. This research provides valuable information and insights that may be used to evaluate the risk of fire-induced cable hot shorts.

Christiana H. Lui, Director  
Division of Risk Analysis  
Office of Nuclear Regulatory Research  
U.S. Nuclear Regulatory Commission

# CONTENTS

Abstract.....	iii
Foreword.....	v
List of Figures.....	ix
List of Tables.....	xv
Executive Summary.....	xvii
Acknowledgments.....	xix
List of Acronyms.....	xx
1 Background.....	1
1.1 Overview of the CAROLFIRE Project.....	1
1.2 Overview of the Fire Modeling Improvement Need Area.....	2
2 Approach.....	5
2.1 Overview of Experimental Approach.....	5
2.2 Small-Scale Radiant Heating Tests.....	6
2.3 Intermediate-Scale Cable Burn Tests.....	12
2.4 Cable Selection Results.....	21
3 Primary Measurements Performance Diagnostics and Experimental Setups.....	29
3.1 Thermal Exposure Conditions.....	29
3.2 Temperature Measurements.....	34
3.3 Other Measures of Fire Behavior.....	43
3.4 Cable Electrical Performance.....	45
4 Test Matrices.....	47
4.1 Overview of Test Matrices.....	47
4.2 The <i>Penlight</i> Small-Scale Test Matrix.....	48
4.3 The Intermediate-Scale Test Matrix.....	49
5 Analysis of the <i>Penlight</i> Small-Scale Test Series.....	61
5.1 Introduction and Organization.....	61
5.2 XLPE/CSPE Cables and Fundamental Behaviors Observed in Testing.....	63
5.3 Penlight Tests with Individual Lengths of the Other Cable Types.....	73
5.4 Penlight Tests with Cable Bundles.....	84
5.5 Correlating Thermal Response and Electrical Performance for the Penlight Single Cable Tests.....	87
6 The Intermediate-Scale Test Series.....	95
6.1 Introduction and Organization.....	95
6.2 Tests IP-1 and IP-2.....	96
6.3 Test IP-3.....	101
6.4 Test IP-4.....	104
6.5 Test IT-1.....	105
6.6 Test IT-2.....	110
6.7 Test IT-3.....	114
6.8 Test IT-4.....	117
6.9 Test IT-5.....	121
6.10 Test IT-6.....	125
6.11 Test IT-7.....	129
6.12 Test IT-8.....	133

6.13	Test IT-9 .....	137
6.14	Test IT-10 .....	141
6.15	Tests IT-11 & IT-12.....	145
6.16	Test IT-13 .....	150
6.17	Test IT-14 .....	154
7	Summary .....	159
8	References.....	161

## LIST OF FIGURES

<u>Figure number and title:</u>	<u>Page:</u>
Figure 2.1: General view of the Penlight Facility with the cable tray in place and a test in progress. Note that this view shows Penlight in an ‘open-ends’ configuration used in many of the Penlight Preliminary Tests. ....	6
Figure 2.2: View of Penlight with a cable tray in place and in the ‘closed-ends’ configuration. ....	7
Figure 2.3: Average absorbance (or absorbtivity) as a function of surface temperature for the Penlight shroud. ....	8
Figure 2.4: Illustration of Penlight configured for cable tray testing. ....	8
Figure 2.5: Illustration of Penlight configured for Conduit Testing. ....	9
Figure 2.6: Illustration of Penlight configured for air drop testing (no raceway). ....	9
Figure 2.7: Placement of the TCs on the inner surface of the Penlight shroud with TC numbers as referred to in Figures 2.8 and 2.9. The figure on the left is an end view of the shroud illustrating the designation of positions around the shroud (0, 90, 180, and 270 degree positions). The figure to the right is a view of the shroud as if it were cut along the 180-degree (bottom) location and then unrolled. ....	10
Figure 2.8: Example of the penlight shroud temperature measured along the length of one side of the exposure shroud during a typical penlight test. TC-11 is the primary control point. ....	10
Figure 2.9: Example of shroud temperatures measured at the bottom, top and two side locations centrally along the length of the shroud during a typical Penlight test. ....	11
Figure 2.10: Schematic representation of the CAROLFIRE Intermediate-Scale Test Structure. ....	14-15
Figure 2.11: Schematic representation of the CAROLIFRE Intermediate-Scale Test Structure (or ‘rig’) located within the outer test facility. ....	16
Figure 2.12: Photograph of a cable tray penetration of the test structure at Location E. ...	18
Figure 2.13: Illustration of the sand box burner. ....	18
Figure 2.14: Photograph illustrating the relative size of all fifteen of the CAROLFIRE cables. ....	25
Figure 3.1: Dimensions of the B-Line Series 2 cable trays overall (left illustration), the side rails (center illustration shows the left side rail), and a cross-section of an individual tray rung (right illustration). All figures are taken from the manufacturer’s sales literature. Note that the “chart on page A-5” referenced in the left-hand illustration <i>is</i> the center illustration. ....	31
Figure 3.2: Approximate dimensions for Penlight with the conduit (left-hand illustration) and cable tray (right-hand illustration) in place. (All dimensions are mm.) ....	33
Figure 3.3: Illustration of a sheathed TC inserted under a cable’s jacket. ....	37
Figure 3.4: Illustration of cable identification code for the ‘3+1-Cable bundle in conduit.’ ...	38



## LIST OF FIGURES

<u>Figure number and title:</u>	<u>Page:</u>
Figure 3.5: Cable identification code and placement of the standard complement of TCs for the 6-cable bundles in cable tray. ....	39
Figure 3.6: Standard complement of TCs for the 12-cable thermal response bundles in cable tray. ....	40
Figure 3.7: TC complement for the random fill tray in IT-1. ....	41
Figure 3.8: TC complement for the random fill tray in IT-13 & IT-14. ....	41
Figure 3.9: Photograph of the conduit used in Penlight showing three installed surface TCs. Note the three small bright spots along the length of the conduit with the sheathed TC leads running above each secured measurement tip and then out of the picture to the right. Each TC tip is secured to the conduit surface under a small length of stainless steel which is spot-welded to the conduit. ....	43
Figure 3.10: Picture of the two brass slug calorimeters in place in the test structure during intermediate-scale tests IT-8 through IT-14. ....	44
Figure 3.11: Photograph of the IRMS (left) and SCUDU racks. ....	46
Figure 5.1: Photograph that compares the four XLPE/CSPE cables used in CAROLFIRE	63
Figure 5.2: Placement of the TCs in a typical fully instrumented 7/C thermal response cable such as those tested in PT-11, PT-12, and PT-13. The upper illustration shows a cross-section of the cable and indicates where each TC was placed. The lower illustration shows how the TCs were distributed along the length of the cable.....	65
Figure 5.3: Cable thermal response during PT-11 .....	66
Figure 5.4: Overlay of the electrical performance and thermal response for the cables in PT-11.....	66
Figure 5.5: Illustration of the repeatability of the Penlight exposure conditions. ....	67
Figure 5.6: Illustration of the repeatability of the cable thermal response results.....	68
Figure 5.7: Illustration in the repeatability of the cable’s electrical performance and the onset of electrical failure.....	68
Figure 5.8: Placement of the TCs for the 3/C cable in PT-9 (left illustration) and for the 12/C cable in PT-62 (right illustration). ....	69
Figure 5.9: Comparison of the thermal response for cables with varying relative copper versus plastics content. ....	70
Figure 5.10: Comparison of the electrical performance for cables with varying relative copper versus plastics content. ....	70
Figure 5.11: Illustration of the uniformity of temperatures within the 3/C cable during the PT-9. ....	71
Figure 5.12: Thermal response comparison for cables in tray, conduit and air drop routing configurations. ....	72

## LIST OF FIGURES

<u>Figure number and title:</u>	<u>Page:</u>
Figure 5.13: Electrical performance comparison for cables in tray, conduit and air drop routing configurations. ....	72
Figure 5.14: Condition of the XLPE-insulated cables after a typical Penlight test. ....	73
Figure 5.15: End-view photograph of the four PVC/PVC cable items. ....	74
Figure 5.16: Illustration of two example PVC/PVC cable tests. ....	75
Figure 5.17: Typical condition of the PVC-insulated cables following a Penlight test. ....	75
Figure 5.18: End-view photograph of the PE/PVC cable item #15. ....	77
Figure 5.19: Illustration of two cable tray tests, PT-15 and PT-16, for the PE-insulated cables. ....	77
Figure 5.20: End view photograph of the Tefzel/Tefzel cable. ....	78
Figure 5.21: Shroud temperature, cable temperature and electrical failures for test PP-18.	79
Figure 5.22: End view photograph of the EPR/CSP cable Item #2. ....	79
Figure 5.23: Typical test data for the EPR/CPE cable taken from PT-17. ....	80
Figure 5.24: End view photograph of the XLPO/XLPO cable Item #8. ....	81
Figure 5.25: XLPO/XLPO cable thermal response and electrical performance from PT-19. Note that both of the sub-jacket cable TCs are shown (Cable 1 and Cable 4). ....	81
Figure 5.26: End view photograph of the SR/Aramid cable Item #9. ....	82
Figure 5.27: Post test photo of the SR cables following a Penlight test. Note that the cable did not fail in this test (PP-10). ....	83
Figure 5.28: End view photograph of the Vita-Link® cable Item #11. ....	83
Figure 5.29: Temperature data from the ‘special thermal test’ Spec. 1. ....	86
Figure 5.30: An illustration of a test case where ignition occurred prior to electrical failure and yet the data were used included in the analysis results tables (test PT-17). “Cable 1” and “Cable 4” were the names given to the two sub-jacket TCs installed on the thermal response cable. ....	88
Figure 5.31: Compilation of test results for the XLPE-insulated cables. ....	92
Figure 5.32: Compilation of the test results for the TP cable types. ....	94
Figure 5.33: Compilation of the test results for the EPR- and XLPO-insulated cable types and for the one TS/TP cable. ....	94
Figure 6.1: Illustration of the test conditions for tests IP-1 and IP-2. ....	97
Figure 6.2: Fuel gas measured flow rate and nominal heat release rate for IP-1. ....	98
Figure 6.3: Hood temperatures during IP-1. ....	98
Figure 6.4: Cable thermal response and first electrical failures for the 3/C cable in IP-1. .	99
Figure 6.5: Cable thermal response and first electrical failures for the 7/C cable in IP-1. .	99

## LIST OF FIGURES

<u>Figure number and title:</u>	<u>Page:</u>
Figure 6.6: Fuel gas measured flow rate and nominal heat release rate for IP-2. ....	100
Figure 6.7: Hood temperatures during IP-2. ....	100
Figure 6.8: Cable thermal response and first electrical failures for the 3/C cable in IP-2...	101
Figure 6.9: Cable thermal response and first electrical failures for the 7/C cable in IP-2...	101
Figure 6.10: Test setup for IP-3. ....	102
Figure 6.11: Fuel flow rate and nominal HRR (eff=0.85) for burner in IP-3. ....	102
Figure 6.12: General temperatures within the test structure hood during IP-3. ....	103
Figure 6.13: Cable thermal response and first IRMS electrical failures for the 3/C PVC/PVC cable in IP-3. ....	103
Figure 6.14: Cable thermal response and first SCDU failures for 7/C PVC/PVC cable in IP-3. ....	104
Figure 6.15: Test setup for IP-4. ....	104
Figure 6.16: Fuel flow rate and nominal HRR for IP-4. ....	105
Figure 6.17: General air temperatures for IP-4 ....	105
Figure 6.19: Test setup for IT-1. ....	106
Figure 6.18: Photograph of the random fill cable tray at Location A in IT-1. ....	107
Figure 6.20: Fuel flow rate and nominal HRR for IP-4. ....	108
Figure 6.21: Hood temperatures measured during IT-1. ....	108
Figure 6.22: Temperatures measured within and near the random fill cable tray in IT-1. .	109
Figure 6.23: Test setup for IT-2. ....	109
Figure 6.24: Photograph of the air drop cable in IT-2. ....	111
Figure 6.25: Fuel flow rate and nominal HRR for IT-2. ....	112
Figure 6.26: Hood temperatures measured during IT-2. ....	112
Figure 6.27: Thermal response and electrical performance data for the paired single lengths of the PVC/PVC cable at Location G in IT-2. ....	113
Figure 6.28: Thermal response and electrical performance results for the paired 12-cable thermal response bundle and SCDU cable bundle at Location A during IT-2. ....	113
Figure 6.29: Test setup for IT-3. ....	114
Figure 6.30: Fuel flow rate and nominal HRR for IT-3. ....	116
Figure 6.31: Hood temperatures measured during IT-3. ....	116
Figure 6.32: Illustration of the responses for the paired thermal and IRMS bundles at Location C during IT-3. ....	117

## LIST OF FIGURES

<u>Figure number and title:</u>	<u>Page:</u>
Figure 6.33: Thermal response and electrical performance for the single 3/C PVC/PVC cables at Location G during IT-3. ....	117
Figure 6.34: Test setup for IT-4. ....	118
Figure 6.35: Fuel flow rate and nominal HRR for IT-4. ....	120
Figure 6.36: Hood temperatures measured during IT-4. ....	120
Figure 6.37: Temperature data for the 3/C XLPE-insulated cable at Location G. ....	121
Figure 6.38: Test setup for IT-5. ....	122
Figure 6.39: Fuel flow rate and nominal HRR for IT-5. ....	124
Figure 6.40: Hood temperatures measured during IT-5. ....	124
Figure 6.41: Data recorded for the EPR-insulated cables at Location G during IT-5. ....	125
Figure 6.42: Test setup for IT-6. ....	125
Figure 6.43: Fuel flow rate and nominal HRR for IT-6. ....	128
Figure 6.44: Hood temperatures measured during IT-6. ....	128
Figure 6.45: Temperature response data for the cables and conduit at Location G in IT-6. ....	129
Figure 6.46: Test setup for IT-7. ....	129
Figure 6.47: Fuel flow rate and nominal HRR for IT-7. ....	132
Figure 6.48: Hood temperatures measured during IT-7. ....	132
Figure 6.49: Thermal response and electrical performance results for the cable bundle in conduit at Location E. ....	133
Figure 6.50: Test setup for IT-8. ....	134
Figure 6.51: Fuel flow rate and nominal HRR for IT-8. ....	136
Figure 6.52: Hood temperatures measured during IT-8. ....	136
Figure 6.53: Temperature response data for the cable bundle in conduit at Location E during IT-8. ....	137
Figure 6.54: Temperature response for the slug calorimeters and the cable bundle at Location G during IT-8. ....	137
Figure 6.55: Test setup for IT-9. ....	138
Figure 6.56: Fuel flow rate and nominal HRR for IT-9. ....	140
Figure 6.57: Hood temperatures measured during IT-9. ....	140
Figure 6.58: Temperature response data for the cable bundles at Locations A, C and G during IT-9. ....	141
Figure 6.59: Test setup for IT-10. ....	141
Figure 6.60: Fuel flow rate and nominal HRR for IT-10. ....	144

## LIST OF FIGURES

<u>Figure number and title:</u>	<u>Page:</u>
Figure 6.61: Hood temperatures measured during IT-10. ....	144
Figure 6.62: Temperature response data for the configuration 10-4 cable bundle in cable tray at Location G during IT-10 and the corresponding electrical performance data for the PE-insulated cable 'A' (C1V4) and the EPR-insulated cable 'C' (C4V1) in the pair-matched electrical response bundle. ....	145
Figure 6.63: Test setup for IT-11 and IT-12. ....	145
Figure 6.64: Photograph of the horizontal air-drop cable bundle from IT-11. ....	147
Figure 6.65: Fuel flow rate and nominal HRR for IT-11. ....	148
Figure 6.66: Fuel flow rate and nominal HRR for IT-12. ....	148
Figure 6.67: Hood temperatures measured during IT-11. ....	149
Figure 6.68: Hood temperatures measured during IT-12. ....	149
Figure 6.69: Test setup for IT-13. ....	150
Figure 6.70: Fuel flow rate and nominal HRR for IT-13. ....	153
Figure 6.71: Hood temperatures measured during IT-13. ....	153
Figure 6.72: Thermal response and electrical failure data for the cable bundles at Locations F&G during IT-13. ....	154
Figure 6.73: Test setup for IT-14. ....	155
Figure 6.74: Fuel flow rate and nominal HRR for IT-14. ....	157
Figure 6.75: Hood temperatures measured during IT-14. ....	157
Figure 6.76: Temperatures measured in and around the random fill cable tray at Location C. ....	158

## LIST OF TABLES

<u>Table number and title:</u>	<u>Page:</u>
Table 2.1: Short description and cable markings for the CAROLFIRE cables.....	24
Table 2.2: Physical characteristics of the CAROLFIRE cables. ....	26-27
Table 3.1: Relationship between shroud temperature and shroud heat flux assuming an emissivity of 0.815.....	30
Table 4.1: Matrix of Preliminary Penlight Tests (PP-1 through PP-26).....	50
Table 4.2: Primary Matrix of CAROLFIRE Penlight Tests (PP-1 through PP-68 and Spec. 1). ....	51-54
Table 4.3: Matrix of Intermediate-scale Tests (IP-1 through IT-14).....	56-60
Table 5.1: Penlight tests involving single lengths of XLPE/CSPE cables. ....	64
Table 5.2: Matrix of PVC/PVC cable tests in Penlight involving individual lengths of cable.....	74
Table 5.3: Matrix of PE/PVC cable tests in Penlight involving individual lengths of cable. ....	76
Table 5.4: Matrix of Penlight Tests involving the Tefzel-insulated cables.....	78
Table 5.5: Matrix of Penlight tests involving individual lengths of the EPR/CPE cable Item #2.....	80
Table 5.6: Matrix of Penlight tests involving individual lengths of XLPO/XLPO cables. ....	81
Table 5.7: Matrix of Penlight tests involving individual lengths of SR cables. ....	82
Table 5.8: Matrix of Penlight tests involving individual lengths of Vita-Link® cables. ....	84
Table 5.9: Summary of test results for the PP series tests (PP1 through PP26) which all involved single lengths of cable.....	89
Table 5.10: Summary of test results for the Group 1 PT series tests (PT1 through PT 31) which all involved single lengths of cable. ....	90
Table 5.11: Summary of test results for the Group 6 and Group 7 PT series tests (PT62 through PT 64) which all involved single lengths of cable. ....	91

## EXECUTIVE SUMMARY

This report documents the cable thermal exposure, thermal response, and general electrical failure data gathered during the Cable Response to Live Fire (CAROLFIRE) project. The cable fire tests conducted were designed to complement previous industry testing by the Nuclear Energy Institute (NEI) and the Electric Power Research Institute (EPRI)<sup>1</sup> in order to address two need areas; namely, to provide data supporting (1) resolution of the ‘Bin 2’ items as identified in Regulatory Issue Summary 2004-03 Revision 1 – *Risk-informed Approach for Post-Fire Safe-Shutdown Circuit Inspections*, and (2) improvements to fire modeling to reduce prediction uncertainty in the area of cable response to fires. Volume 1 of this report focuses on the first need area; namely, resolution of the Bin 2 items. Volume 2 (this volume) focuses on the second need area, fire modeling improvement.

CAROLFIRE testing included a series of 78 small-scale radiant heating tests and 18 intermediate-scale open burn tests. The small-scale tests were performed in an SNL facility called *Penlight* and involved exposure of from two to seven lengths of cable to grey-body radiant heating. These tests were aimed in large part at the fire model improvement need area, but also provided data pertinent to the resolution of two of the five Bin 2 items being addressed in this project; namely, Bin 2 items A and B which both deal with inter-cable shorting configurations.

The intermediate-scale tests involved exposure of cables, generally in bundles of 6 to 12 cables each, under various routing configurations and at various locations within a relatively open test structure. The fires were initiated by a propene (also known as propylene) gas diffusion burner. The fire typically spread, at a minimum, to those cables located directly above the fire source. The intermediate-scale tests exposure included cables just above the upper extent of the gas burner’s flame zone, in the fire plume above the flame zone, and outside the plume but within a hot gas layer. The intermediate-scale tests contribute to both need areas.

Testing included a broad range of both thermoset (TS) and thermoplastic (TP) insulated cables as well as one mixed TS-insulated and TP-jacketed cable. The tested cables are representative of those currently in use at U.S. commercial nuclear power plants (NPPs). The tested cables also span a range from those cables that are most vulnerable to fire-induced electrical failure to those that are most resistant to fire-induced electrical failure.

Cable electrical functionality (electrical failure) was measured using two different electrical monitoring systems. One system, the Sandia National Laboratories (SNL) Insulation Resistance Measurement System (IRMS), measured the insulation resistance of individual cable conductors (or groups of conductors) providing a direct measure of cable electrical integrity. The IRMS was able to detect the onset of cable degradation and determine the specific pattern and timing of shorts occurring among the conductors of one or more cables. The second system, the Surrogate Circuit Diagnostic Units (SCDUs), involved control circuit simulators where a hot short (i.e., a short circuit between an energized ‘source’ conductor and a normally non-energized ‘target’ conductor) could

---

<sup>1</sup> Specific references to the NEI/EPRI tests are provided in the main text.

lead to spurious actuation of a motor contactor. The SCDUs were typically configured to simulate a common Motor Operated Valve (MOV) control circuit in the exact same manner as was employed in the NEI/EPRI test program.

The exposure conditions used in testing represent a range of credible fire conditions. The exposure heat fluxes used in the small-scale radiant heating tests were set so as to induce cable failure times of on the order of several minutes consistent with cable damage times typically predicted in risk-relevant fire scenarios (e.g., in fire risk analyses). The intermediate-scale tests used gas burner fire intensities between 200 and 350 kW (190-332 BTU/s), a range that was representative of the fire intensities expected from many credible fire ignition sources (e.g., moderate size oil spills and electrical control panel fires). The intermediate-scale test structure allowed for the creation of hot gas layer conditions sufficient to induce cable failure. At the same time, the test structure was quite open allowing for open burning conditions (i.e., no oxygen starvation) consistent with expectations for cable fires in the relatively large spaces common in a typical nuclear power plant (NPP). The gas burner fuel, propene (also known as propylene), was chosen because it produced a luminous yellow flame and generates considerable visible smoke, again consistent with the anticipated behavior of actual NPP fires. The test structure was housed in a larger test facility so that the smoke layer development and other general fire conditions were also typical of those expected in actual nuclear power plant applications.

The data gathered during CAROLFIRE have filled a unique need with respect to fire modeling improvement. The ability to analytically predict the timing of cable failure under fire conditions plays a key role in Fire Probabilistic Risk Assessment (FPRA) applications including risk-informed regulation. CAROLFIRE has directly explored the cable thermal response and failure behavior in a manner that allows for the development and calibration of improved fire modeling tools to fill this analytical need. The development and ultimately the validation of improved cable response models will improve the accuracy and reliability of the associated FPRA calculations thereby reducing the uncertainty associated with these key calculations.



## ACKNOWLEDGMENTS

The authors acknowledge and appreciate the many people who contributed to the success of this project. First, we acknowledge the contributions of our collaborative partners at NIST and at UMD. In particular, the assistance of Dr. Kevin McGrattan (NIST) during the planning stages of this project, and throughout the testing process was most helpful. We also acknowledge the contributions of Elie Avidor and Genebelin Valbuena from UMD to planning and execution of the tests. We also acknowledge the contributions of Pat Brady (Technadyne Engineering Consultants) and Bob Nichols (KTech Corporation) who provided technical support during the actual testing efforts. We also offer particular thanks to Mr. Kent Brown of Tennessee Valley Authority for his patience in our many discussions and for the many insights he provided relative to the cable manufacturing industry and the use of cables by the U.S. nuclear industry. Kent's insights were clearly one key to our success. We also acknowledge H.W. 'Roy' Woods and Mark Henry Salley who were the sponsors of this program at the NRC Office of Nuclear Regulatory Research (RES) and who provided valuable guidance throughout the project. We also offer thanks to those who supported the NRC's peer review process including Nathan Siu of RES, Anthony Hamins of NIST, Vern Nicolette of SNL, and Mohammad Modarres of UMD. We also gratefully acknowledge the peer review contributions made by Dan Funk of Edan Engineering as well as his patience in dealing with our many queries made over the course of the project. We also acknowledge the comments provided throughout the project by the NRR staff including in particular Ray Gallucci. Appendix F of this document presents an introductory discussion of polymer chemistry that was prepared in its entirety by Felix Gonzalez of the RES Fire Research Branch staff. Finally, the authors acknowledge the support provided by Gabriel Taylor and Felix Gonzalez of the RES Fire Research Branch staff who completed a rather tedious update of the test data files that added substantive value to the data presentations.

## LIST OF ACRONYMS

AC	Alternating Current	NPP	Nuclear Power Plant
AOV	Air Operated Valve	NRC	Nuclear Regulatory Commission
ASTM	American Society for Testing and Materials	NRR	NRC Office of Nuclear Reactor Regulation
AWG	American Wire Gauge	PE	Polyethylene
BNL	Brookhaven National Laboratory	PLC	Programmable Logic Controller
CAROLFIRE	Cable Response to Live Fire	PORV	Power Operated Relief Valve
CFAST	Consolidated Model of Fire and Smoke Transport	PVC	Poly-vinyl Chloride
CPT	Control Power Transformer	RES	NRC Office of Nuclear Regulatory Research
CPE	Chlorinated Polyethylene	RIS	Regulatory Issue Summary
DAQ	Data Acquisition	RTI	Response Time Index
DC	Direct Current	SA	Spurious Actuation
DOE	Department of Energy	SCDU	Surrogate Circuit Diagnostic Unit
EPR	Ethylene-Propylene Rubber	SCETCh	Severe Combined Environmental Test Chamber
EPRI	Electric Power Research Institute	SNL	Sandia National Laboratories
FB	Fuse Blow	SOV	Solenoid Operated Valve
FPRA	Fire Probabilistic Risk Assessment	SR	Silicone-Rubber
HRR	Heat Release Rate	TC	Thermocouple
HS	Hot Short	THIEF	Thermally-induced Electrical Failure (model)
IEEE	Institute of Electrical and Electronics Engineers	TP	Thermoplastic
IR	Insulation Resistance	TS	Thermoset
IRMS	Insulation Resistance Measurement System	TVA	Tennessee Valley Authority
MOV	Motor Operated Valve	UMd	University of Maryland
NEI	Nuclear Energy Institute	VA	Volt-Amperes
NFPA	National Fire Protection Association	VL	Vita-Link®
NIST	National Institute of Standards and Technology	XLPE	Cross-Linked Polyethylene
		XLPO	Cross-Linked Polyolefin

# 1 BACKGROUND

## 1.1 Overview of the CAROLFIRE Project

This report describes a series of cable fire tests performed by Sandia National Laboratories (SNL) under the sponsorship of the U.S. Nuclear Regulatory Commission (NRC) Office of Nuclear Regulatory Research (RES). This program was known as the Cable Response to Live Fire (CAROLFIRE) project and was designed to address two specific need areas; namely, (1) to provide an experimental basis for resolving five of the six items identified as “Bin 2” circuit configurations in *Risk-informed Approach for Post Fire Safe Shutdown Circuit Inspections*, Regulatory Issue Summary (RIS) 2004-03, Rev. 1, 12/29/04 (hereafter referred to as the ‘Bin 2 Items’) [1], and (2) to improve fire modeling tools for the prediction of cable damage under fire conditions.

The project plan for CAROLFIRE was developed over the course of several months beginning in August 2005. The test plan was treated as a “living document” and underwent several revisions up to and including the final Revision C.2, August 1, 2006. The project planning efforts were conducted as a collaborative process involving representatives of RES, SNL, the NRC Office of Nuclear Reactor Regulation (NRR), the National Institute for Standards and Technology (NIST), and the University of Maryland (UMd). All testing was performed during the summer and fall of 2006 using SNL facilities in Albuquerque, New Mexico.

This volume of the CAROLFIRE project report focuses on the data specifically relevant to the fire model improvement need area. The companion Volume 1 report provides a much more complete description of the general background material associated with the program. This background material was not repeated in full in this volume. However, information that was considered key to the fire modeling need area and the interpretation of the data presented here was repeated (e.g., descriptions of the test facilities, instrumentation, and the complete test matrices). The reader should refer to Volume 1 of this report for details on the following aspects of the CAROLFIRE project:

- General discussions relative to project planning,
- The roles and responsibilities of our collaborative partners at the University of Maryland (UMd) and the National Institute for Standards and Technology (NIST),
- A detailed discussion of the process by which cables to be used in CAROLFIRE were selected and procured,
- Detailed descriptions of the two electrical performance monitoring systems used in CAROLFIRE; namely, the Surrogate Circuit Diagnostic Units (SCDUs) and the Insulation Resistance Measurement System (IRMS), and
- All information specific to the need area associated with resolution of the Bin 2 items and the data and results of those aspects of the data analysis.

Volume 3 was prepared by the National Institute of Standards and Technology (NIST) and documents the thermally-induced electrical failure (THIEF) model whose development was based on

the CAROLFIRE test data. THIEF takes, as input, an estimate of the air temperature time history near a cable during a fire and predicts, as output, the temperature response of the cable. The time to electrical failure is then based on an assumed failure threshold temperature characteristic of the cable of interest.

Volumes 1 and 2 were subject to public comment. “Draft for Public Comment” versions were issued June 1, 2007 for a 45 day public comment period (see Federal Register notice 72 FR 30645). The public comment period was subsequently extended to 60 days (see Federal Register notice 72 FR 34488). Public comments from the U.S. nuclear power industry were collected and provided by the Nuclear Energy Institute (NEI). The final versions of Volumes 1 and 2 include the resolution of these public comments.

## **1.2 Overview of the Fire Modeling Improvement Need Area**

As noted above, CAROLFIRE was designed to address two primary need areas; namely, resolution of Bin 2 Items and fire modeling improvement to reduce uncertainty. These need areas have distinct but complementary needs. Volume 1 of this report discusses both need areas in detail. The following represents a summary discussion of the fire modeling improvement need area which is the primary focus of this volume.

Under the fire modeling improvement need area, the CAROLFIRE project sought, to the extent feasible, to provide cable thermal response data that was correlated to the failure modes and effects data in order to support improvements in cable fire response modeling and damage time predictions. The overall goal of the fire modeling improvements is to reduce uncertainties in fire model outputs for Nuclear Power Plant (NPP) applications. A key NPP application is Fire Probabilistic Risk Assessment (FPRA) which often relies on fire models to predict cable failure times for a pre-defined set of fire conditions. These failure times are weighed against the likelihood that fire suppression succeeds within the available time to assess the conditional probability of cable damage given the fire. The ability of current compartment fire models to predict cable damage is limited. For example, in the NIST fire model CFAST, a general thermal target response sub-model is available, but this model was not specifically developed for, nor has it been calibrated for, cables as the thermal target.

Hence, one primary need with respect to fire model improvement is the development, calibration and validation of predictive thermal/damage target response models specific to cables as the target. CAROLFIRE was designed to provide data upon which the initial development of the response models might be based (i.e., model calibration data). This model calibration data involves fundamental target exposure and response under relatively simple and very well characterized exposure conditions. In CAROLFIRE, these data were generated primarily through the small-scale tests. Data are also needed to support model validation; that is, separate tests under more realistic and representative testing configurations against which model predictions can be compared. CAROLFIRE also provided data for this purpose through the intermediate-scale tests. The intermediate-scale tests provide cable thermal response and damage data for a range of credible exposure conditions (e.g., direct flame impingement, plume exposure, ceiling jet, and hot gas layers).

It should be noted that the actual model development work was not a part of the SNL project efforts. The actual development activities fall under the purview of collaborative partners NIST and UMd. The efforts performed by each of these two organizations will be documented in separate publications. The nature and goals of their planned efforts have been described in general terms in Volume 1 of this report.

## 2 APPROACH

Note that Volume 1 of the report provides an extended discussion of the process of project planning and the experimental approach undertaken for CAROLFIRE. The following represents a summary of these discussions with a focus on the fire modeling improvement need area. For additional detail on project planning and on the need area associated with resolution of the Bin 2 items, refer to Chapter 3 in Volume 1 of this report.

### 2.1 Overview of Experimental Approach

In general, testing followed a progression of increasingly more complex test conditions and configurations. Two scales of testing were pursued for CAROLFIRE. The intent was to take maximum advantage of low-cost, smaller scale and less complex testing configurations and to then move up in complexity and in scale toward more representative fire configurations. The two test scales pursued are:

- Small-scale radiant heating tests in an existing SNL facility called *Penlight*, and
- Intermediate-scale open burn tests in a larger test facility.

The testing encompasses a wide range in terms of cable types, cable bundling arrangements, heating/exposure conditions, and cable routing/raceway configurations. Testing included 26 ‘preliminary’ *Penlight* tests designed to explore the general failure behavior for each of the different cable insulation types under varying heat flux levels and an additional 51 tests in the primary *Penlight* matrix. Once the *Penlight* tests were completed, operations shifted to the intermediate-scale tests. The intermediate-scale tests included four preliminary tests and 14 intermediate-scale tests in the primary test matrix. In all there were 96 individual tests.

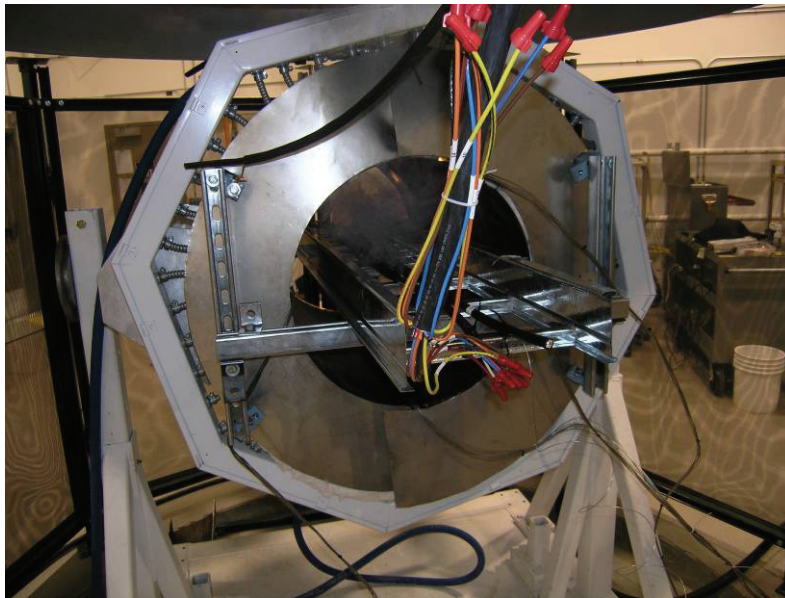
Tests included a minimum of two individual lengths of a given cable. However, most tests involved more than two cables with cables arranged in various bundling configurations since the first two Bin 2 issues were directly related to inter-cable shorting behaviors. Again, as the testing progressed, the number and arrangement of cables became more complex.

Test design intentionally allowed for flexibility as the testing proceeded. In particular, both the small- and intermediate-test facilities were configured such that changes to the cable and instrumentation configurations could be made with little effort and little or no impact on schedule should insights gained as the tests proceed suggest that changes were in order. Certain tests were also repeated with virtually identical test conditions in order to provide some understanding of the inherent (or aleatory) uncertainty, particularly in the context of the fire modeling improvement need area. Additional detail on the test facilities and configurations used for each test scale are provided in Sections 2.2 and 2.3. The cables that were tested are described in Section 2.4. Instrumentation details are provided in Section 3. The actual test matrices are presented in Chapter 4.

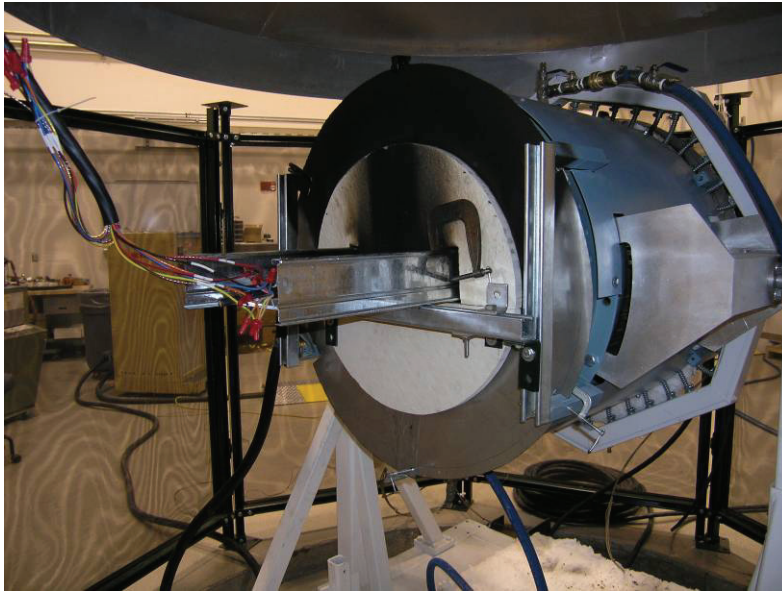
## 2.2 Small-Scale Radiant Heating Tests

The small-scale tests utilized the SNL facility *Penlight*. *Penlight* was originally designed and constructed to support the RES Fire Protection Research Program in the late 1980's and was known at that time as SCETCH (the Severe Combined Environments Test Chamber). The facility was used in a range of component exposure tests including testing of cables, pressure transmitters, and relays (e.g., ref. [2]). After a period of idleness, the facility was turned over to the SNL Fire Safety Science Group who reconfigured the facility and renamed it *Penlight*.

Figures 2.1 and 2.2 provide general views of *Penlight* with a cable tray installed for testing in what will be referred to below as the “open-ends” and “closed-ends” configurations respectively. *Penlight* consists of a cylindrical ring of rod-shaped 0.61 m (24") long quartz heating lamps each held in a water-cooled aluminum fixture with a reflector to direct the heat toward the center of the lamp array (these lamps are not easily visible in the photos because they were located under protective metal covers). A stainless steel (Inconel) cylindrical shroud (or shell) 0.51 m (20.25") in diameter and 0.81 m (32") long was installed within the array of heating lamps.



**Figure 2.1: General view of the Penlight Facility with the cable tray in place and a test in progress. Note that this view shows Penlight in an ‘open-ends’ configuration used in many of the Penlight Preliminary Tests.**



**Figure 2.2: View of Penlight with a cable tray in place and in the ‘closed-ends’ configuration.**

The quartz lamps heat the metal shroud to a desired (and controlled) temperature. The shroud in turn acts as a grey-body radiator heating any target object located within it. The radiant heat flux leaving the shroud surface was both known and controlled based on the shroud temperature (which was measured at several points). The heat flux ( $\dot{q}''$ ) is correlated to the shroud temperature with the common expression:

$$\dot{q}'' = \sigma \varepsilon T^4 \quad (1)$$

where ( $\sigma$ ) is the Stefan-Boltzmann constant ( $5.67\text{E-}8 \text{ W/m}^2\cdot\text{K}^4$  or  $1.714\times 10^{-9} \text{ Btu/h}\cdot\text{ft}^2\cdot\text{R}^4$ ) and ( $\varepsilon$ ) is the emissivity of the shroud surface. The Penlight shroud was painted with high-temperature flat black paint, Pyromark 2500®, which was cured by baking at  $1000^\circ\text{C}$  ( $1832^\circ\text{F}$ ).

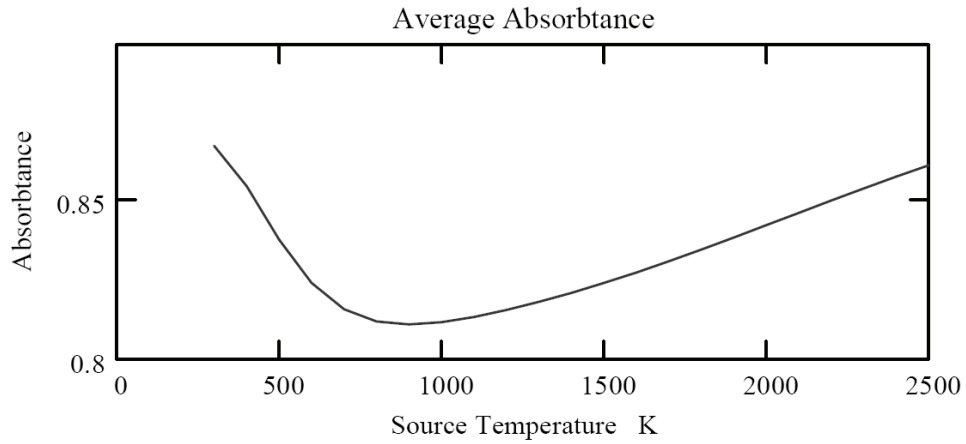
The properties of the shroud surface were measured prior to CAROLFIRE’s use of the test facility. The plot shown in Figure 2.3 illustrates the surface absorptance as a function of the surface temperature. Note that absorptance (or absorptivity) is nominally equal to the surface emissivity. For the range of temperatures applicable to the CAROLFIRE tests,  $260\text{-}900^\circ\text{C}$  ( $500\text{-}1652^\circ\text{F}$ ) or  $533\text{-}1173^\circ\text{K}$ , the emissivity was approximately  $0.81\text{-}0.82$ .

*Penlight* testing involved the exposure of individual cable lengths, bundles of three cables, and bundles of six cables. The quantity of cables that could be tested in one test was limited because the facility was not designed to endure large-scale burning. For CAROLFIRE, all of the tests were conducted with the cables passing horizontally through the *Penlight* shroud (with or without a supporting raceway). The cables were heated using a predefined shroud temperature (hence, nominal exposure heat flux) and then monitored for temperature response and for electrical failure. Note that no single cable sample was monitored for both temperature and electrical performance because

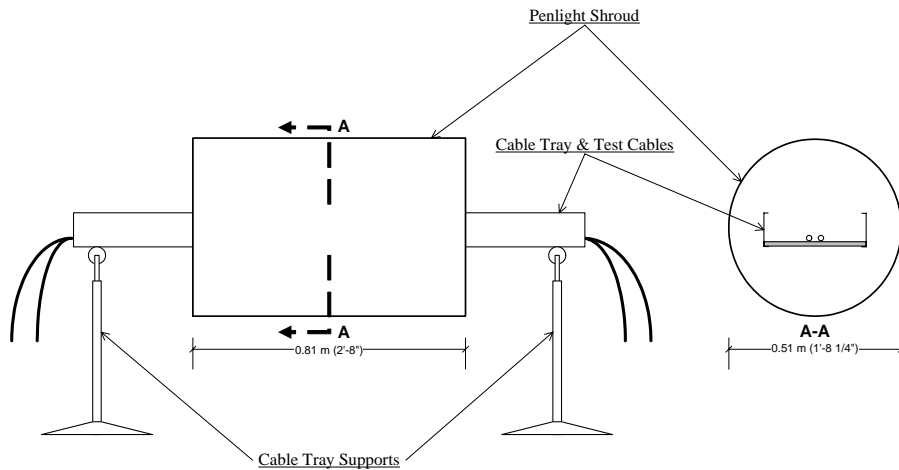


attachment of a thermocouple (TC) might impact electrical performance. Rather, two identical samples (individual cables or cable bundles) were run concurrently and in symmetric exposure locations, one with TCs, and one electrically monitored.

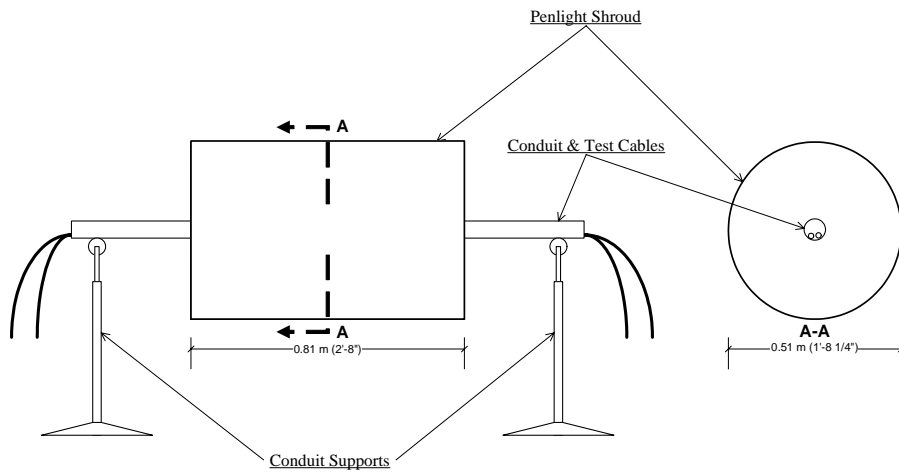
Figures 2.4–2.6 illustrate typical *Penlight* test setups with cable tray, conduit and air drop configurations, respectively. Section 3.3.3 provides more complete descriptions of the raceways used in CAROLFIRE and dimensional drawings of the experimental set-ups.



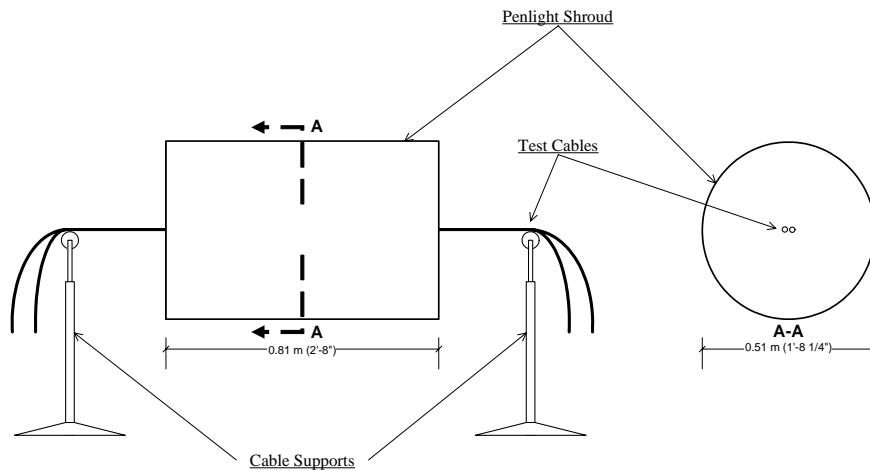
**Figure 2.3: Average absorbance (or absorbtivity) as a function of surface temperature for the Penlight shroud.**



**Figure 2.4: Illustration of Penlight configured for cable tray testing.**



**Figure 2.5: Illustration of Penlight configured for Conduit Testing.**

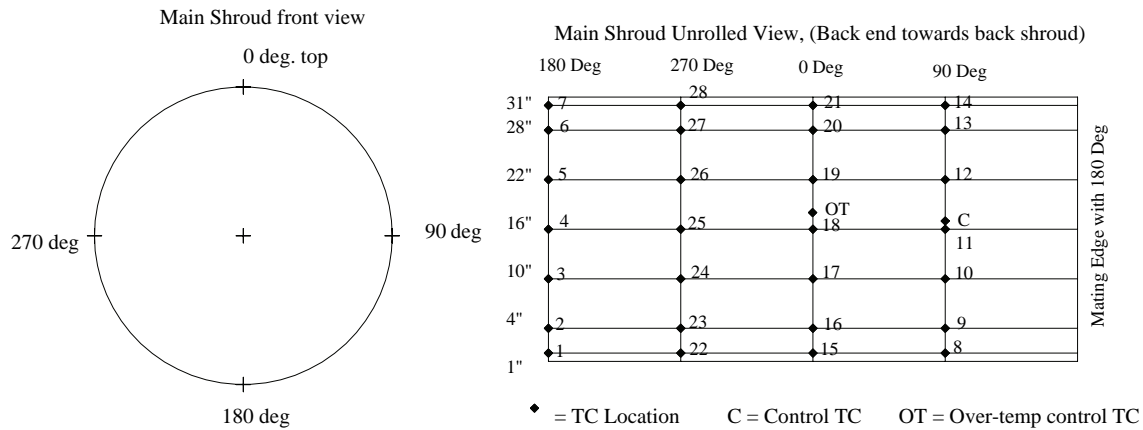


**Figure 2.6: Illustration of Penlight configured for air drop testing (no raceway).**

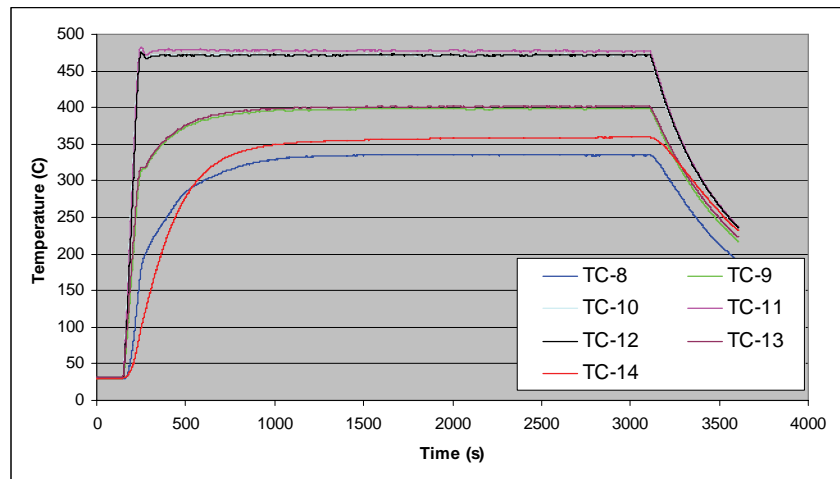
The temperature, and hence heat flux, emitted from the shroud was nominally uniform over the central 0.61 m (24") of the shroud surface. Temperature fell off sharply outside the heated portion of the shroud. The uniformity of the shroud over its heated surface was re-confirmed as a part of CAROLFIRE. Penlight was equipped with a total of 28 inner-surface TCs that can be routinely logged. The placement of these TCs is illustrated in Figure 2.7.

A line of seven TCs was placed at each of four radial locations (top, bottom, and each side). Each line consists of TCs placed at distances of 25.4 mm (1"), 102 mm (4"), 254 mm (10") and 405 mm (16", the center) from each end of the shroud. Primary control of the Penlight heating lamps was based on a separate non-logged TC that was immediately adjacent to the logged TC-11 located at the center point and at the 90 degree location (one side of the shroud). During several of the preliminary tests, all 28 TCs were monitored. In later tests, only the primary control point TC-11 was routinely

monitored. Examples to illustrate the variation in temperature over the shroud surface are provided in Figures 2.8 and 2.9.



**Figure 2.7: Placement of the TCs on the inner surface of the Penlight shroud with TC numbers as referred to in Figures 2.8 and 2.9. The figure on the left is an end view of the shroud illustrating the designation of positions around the shroud (0, 90, 180, and 270 degree positions). The figure to the right is a view of the shroud as if it were cut along the 180-degree (bottom) location and then unrolled.**



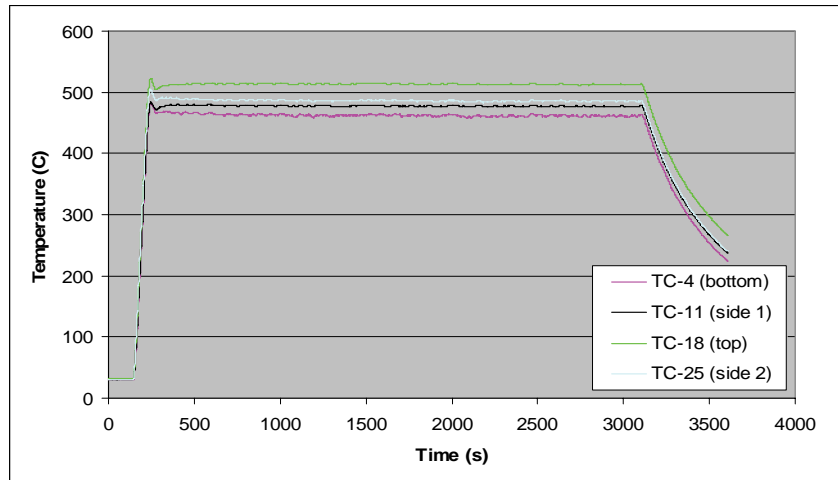
**Figure 2.8: Example of the penlight shroud temperature measured along the length of one side of the exposure shroud during a typical penlight test. TC-11 is the primary control point.**

Figure 2.8 illustrates temperatures measured along the length of the shroud by TCs 8-14.<sup>2</sup> Note that the three TCs located nearest the center (TCs 10, 11 & 12) register very uniform and consistent values. TCs 8 and 14 were actually well outside the heated portion of the shroud and TCs 9 and 13 were just at the edge of the heated zone. Also note that the TCs that were located in symmetric

<sup>2</sup> Note that in Figures 2.8 and 2.9 the plotted time is indexed to the “DAQ time” rather than the “Penlight time” in order to illustrate the temperature response behavior at the start of heating more clearly. Section 5.1 discusses these two time indices. Other plots in this report are all indexed to the “Penlight time” where time=0 corresponds to when the heating was initiated.

positions and within the heated region of the shroud (e.g., TCs 10&12 and TCs 9&13) also show very consistent temperatures, to the point where the overlaid plots are virtually indistinguishable.

Figure 2.9 provides a comparison of the four TCs at the center along the length of the shroud, but at the four locations around the shroud (top, bottom, and each side). Note here that the temperatures were again quite uniform for the majority of the exposure period. The top TC was slightly higher than the others, and the bottom TC was slightly lower than the others. This was due to the effects of natural convection within the chamber.



**Figure 2.9: Example of shroud temperatures measured at the bottom, top and two side locations centrally along the length of the shroud during a typical Penlight test.**

In analyzing the exposure conditions experienced by the cables, it is important to realize that the heat flux delivered to the target surface was not necessarily equal to the heat flux leaving the shroud surface. Also, the heat flux *does* vary over the length of the cable based mainly on the geometry of the exposure. The most intense exposure was at the center of the shroud’s axial dimension (i.e., half way through the horizontal cylinder). Three primary factors influence the net heat flux actually delivered to the cable surface.

The first factor was the condition of the shroud ends during testing. As described, the shroud was a cylindrical shell with open ends. For CAROLFIRE, these open ends were generally closed off using a 24 mm (1 in) thick, low-density, solid refractory insulating board material. Figure 2.2 illustrates this “closed-end” configuration. Note that the end covers were not heated and were not well sealed. The boards were cut to fit around the raceways, but there were gaps especially for the cable tray tests. The primary purpose of the end covers was simply to minimize air circulation into and out of the exposure chamber. However, in estimating heat flux to the cable surface, note that the unheated end covers were part of the radiant environment that the cables ‘see’.

It should also be noted that in several of the later *Penlight* tests, those that involved bundles of six cables per test, the ends of the *Penlight* chamber were actually left open. During the first tests of these larger bundles we observed that the restricted air flow conditions were inhibiting the normal

cable burning behavior. It appeared that the cables were quickly becoming oxygen starved. For the subsequent tests with the six-cable bundles the ends of the shroud were left open (the “open-ends” configuration as illustrated in Figure 2.1). Hence, the ambient environment also became part of the radiant environment that the cables could ‘see’.

The second factor impacting the heat flux delivered to a target cable was the effect of the shadowing effect of the raceways used to support the cables during most tests. A small number of tests were conducted with no raceway support (i.e., a simulated air-drop) and these tests were not impacted by shadowing. However, most tests involved cables in either a cable tray or a conduit. The cable trays cause a degree of shadowing of the primary target (the cable) mainly due to the cable tray side rails. The raceways used for this program were B-Line® brand Series 286, ladder back, 305 mm (12") wide, galvanized steel trays. The actual geometry and dimensions of these cable trays is detailed in Section 3.1.3 below. Given the geometry, the net heat flux at the cable surface was reduced substantially. For conduits, the shroud heats the conduit which in turn heats the cables. The cables naturally lay against the inner bottom of the conduit.

The third factor impacts only the cable tray tests, and that was the actual placement of the cables in the cable tray. In general, the tests in Penlight would use ‘mirror’ cables in order to gather both thermal and electrical performance data in a single test. For example, for the single cable tests, there were actually two cables present that were located off-center in symmetric locations either side of the cable tray centerline with about 2-3" of separation between the two cables. This, too, should be considered in estimating heat flux to the cable surface. For the conduits and air drop tests, the cables were located as close to the axial centerline as possible, and the effect of an off-center placement was not applicable.

### **2.3 Intermediate-Scale Cable Burn Tests**

The second test set was conducted at a more representative scale and involving the open burning of larger arrays of cable under more varied and representative exposure conditions. These are referred to as the intermediate-scale tests.

One key goal of CAROLFIRE was to assess different exposure conditions including cables exposed in the fire’s flame zone, in the fire plume above the flame zone, and under hot gas layer exposure conditions. A second key consideration was a strong preference to use, or adapt, a test protocol from a recognized testing standard. In this case, no standard test protocol directly met CAROLFIRE needs. The standard test method that came closest to meeting our needs was the ASTM E603 room fire facility standard [3]. The CAROLFIRE test structure was, in fact, adapted from the test room specified in this standard.

The decision to modify the ASTM E603 test structure was based on several factors. First, CAROLFIRE was not explicitly seeking room response data; hence, use of an enclosed room such as the ASTM E603 test structure offered few if any technical advantages beyond being tied to the standard test protocol. Second, the ASTM E603 room is considerably smaller than any compartment typically found in a nuclear power plant (NPP); hence, the exposure conditions would not be

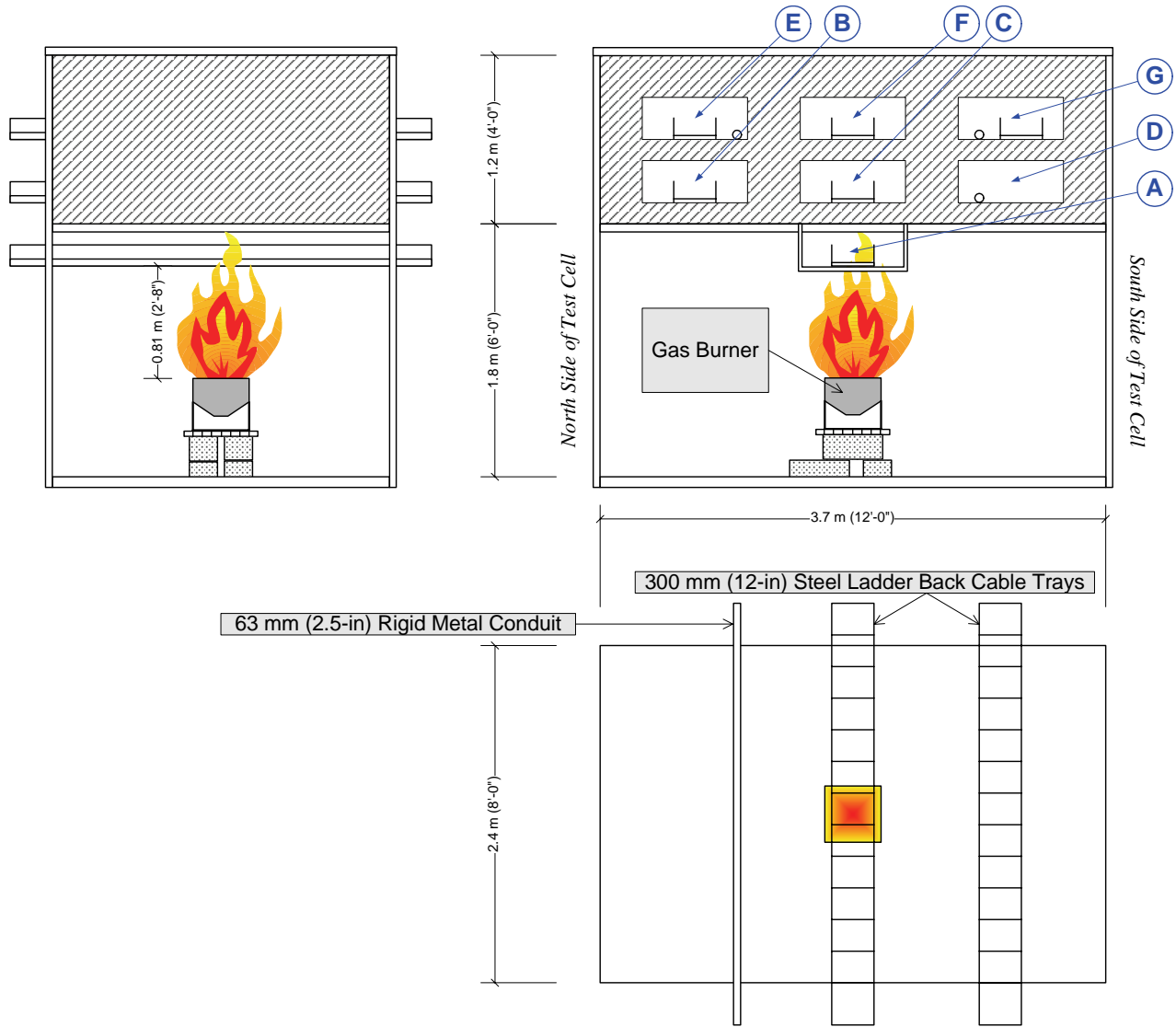
representative of in-plant configurations in any case. Third, the ASTM E603 test structure has only a single small doorway opening. Previous testing by NEI and EPRI [4] used a test structure based on a similarly sized standard room. (The NEI/EPRI tests were conducted in a room made of plate steel which was actually based on a test standard intended to represent ship-board fire conditions.) The NEI/EPRI tests saw significant cases of oxygen-limited burning. CAROLFIRE sought to create more representative open burning conditions in order to more realistically represent the type of burning that would be expected in a very large and open room such as would be typical of a nuclear power plant. Given these factors, the CAROLFIRE test structure was scaled based on ASTM E603, but was built in a much more open configuration that would allow for more open access and would not restrict air flow to the fire.

The CAROLFIRE test structure (described further below) was arguably a good analog for a very common in-plant configuration; namely, a beam pocket within a larger room (i.e., a typical in-plant situation where the floor above is supported by massive steel and/or concrete beams creating isolated ceiling level beam pockets).

The CAROLFIRE intermediate-scale test structure is illustrated in Figure 2.10. Figure 2.10(a) provides a general schematic of the test structure, and Figure 2.10(b) provides a more detailed view highlighting the dimensions of the test structure and the typical location of the various raceways (conduits and cable trays) within the structure. The test structure consisted of a steel framework of which only the upper 40% was enclosed. That is, the framework had an overall height of about 3 m (10 ft) but remained open on all sides up to a height of about 1.8 meters (6 ft). Each of the four sides from a height of 1.8 m (6 ft) up and the top of the structure were covered (enclosed) with a non-metallic material. This test structure acted to focus the fire's heat output initially to this confined volume creating the desired hot gas layer exposure conditions. As the fire progressed the hot gas layer depth increased and ultimately smoke and hot gasses spilled out naturally from under the sides of the enclosed area. This again would be quite typical of the hot gas layer development behavior for a beam pocket configuration.

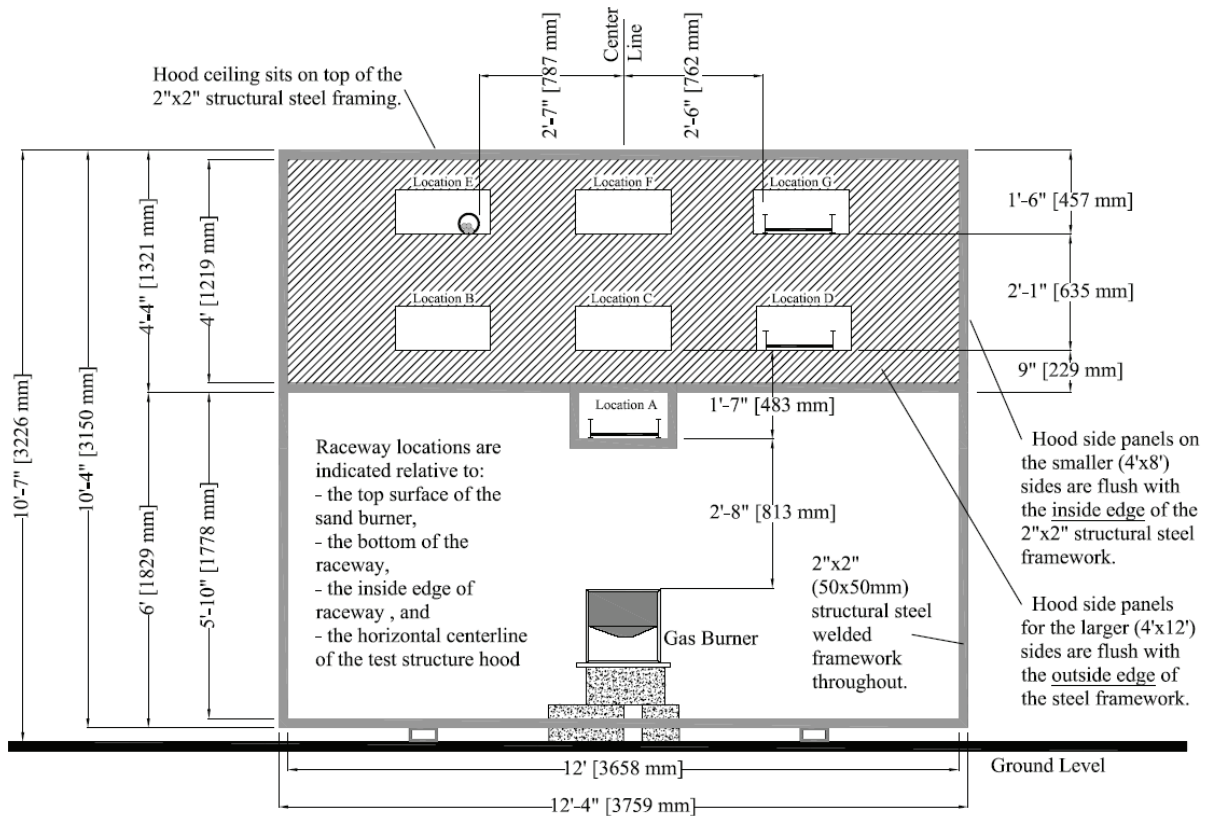
Overall, the framework was similar in size to the recommended dimensions of an ASTM E603 fire test room [3] which is typically 2.4 m x 3.7 m x 2.4 m (8'x12'x 8' - WxLxH). The CAROLFIRE test structure was the same dimension in the horizontal plane, but was slightly taller at 2.4m x 3.7m x 3.0m (8'x12'x10') allowing for some additional capacity for the upper region while maintaining accessibility. As an added bonus, the test structure's open configuration allowed for much less restrictive access and thereby optimized test turnaround times.

In the first few tests (tests IP-1 through IP-4 and IT-1 through IT-7) the enclosed sides and top the test structure were covered with a single layer of standard 13 mm (½") thick gypsum wall board. The intent was to treat the gypsum wall-board as a "sacrificial material" and to replace it as needed through the program. However, it was found that the wallboard required replacement more often than desired (three sets of the wallboard were used over the course of the first 11 tests).



(a): General schematic

Figure 2.10: Schematic representation of the CAROLFIRE Intermediate-Scale Test Structure.



(b): Dimensional drawing

Figure 2.10: Schematic representation of the CAROLFIRE Intermediate-Scale Test Structure.



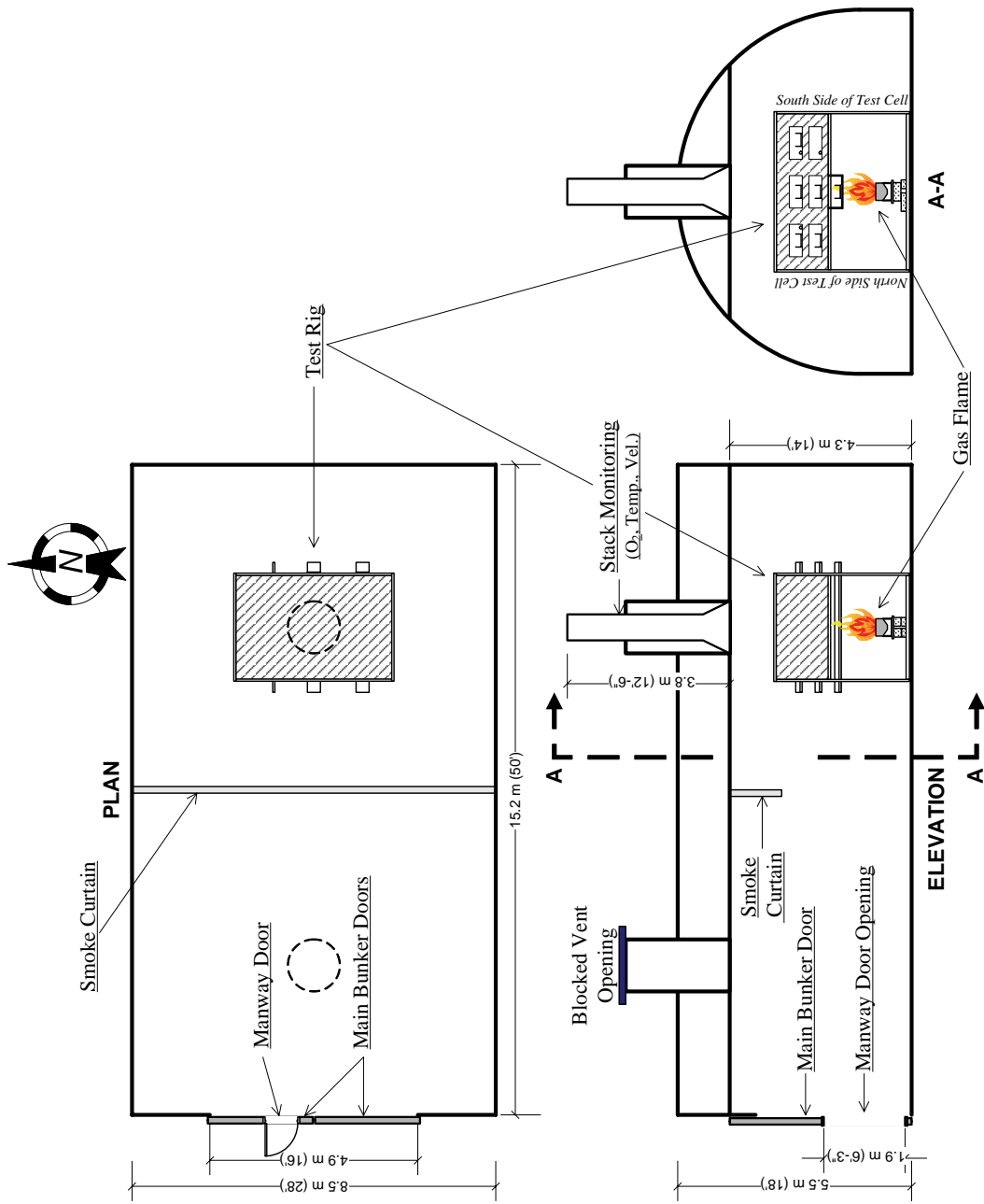


Figure 2.11: Schematic representation of the CAROLIFRE Intermediate-Scale Test Structure (or 'rig') located within the outer test facility.

A more robust treatment was provided for tests IT7 through IT14. An inner layer of 13 mm (½") thick ‘fireproof’ wall board (trade name Durarock®)<sup>3</sup> plus an outer layer of the 13 mm (½") standard gypsum wall board was used. Durarock is a panel material made of fiber-reinforced concrete. The material appeared identical to the type of concrete “backer-board” often used in the installation of tile in wet locations (e.g., in a bathroom). A single installation of this type lasted for the duration of the test series without need for replacement. The approximate properties of the gypsum wallboard and the Durarock are summarized as follows:

<u>Property</u>	<u>Wall Board</u>		<u>Durarock</u>	
	<u>Metric</u>	<u>English</u>	<u>Metric</u>	<u>English</u>
Thickness	12.7 mm	0.5"	12.7 mm	0.5"
Density	0.69 g/cm <sup>3</sup>	43 lb/ft <sup>3</sup>	1.2 g/cm <sup>3</sup>	74 lb/ft <sup>3</sup>

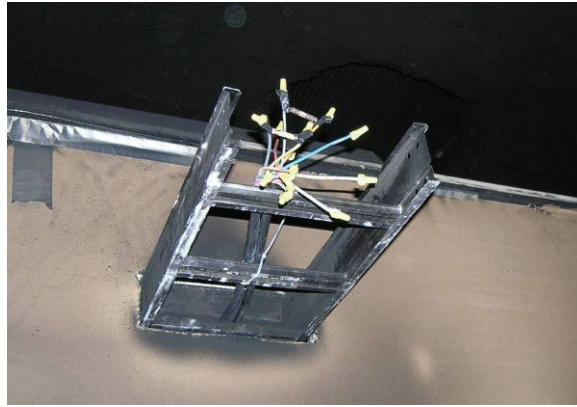
The test structure allowed for conduits and trays to be routed in any manner desired. For CAROLFIRE all raceways were routed as a single straight section passing through the full width of the test structure (i.e., across the 2.4 m (8 ft) dimension). Three meter (10 ft) long raceway sections were used, so the raceways extended about 305 mm (12 in) beyond the sides of the test structure. The test matrix included cables located near the fire source (in or just above the continuous flame zone of the fire), in the upper portion of the fire plume, and in various locations subject to hot gas layer exposure. In practice, cables were placed in seven locations. These locations are illustrated as locations A-G in Figure 2.6. The data files identify test cable locations consistent with these location labels. Through-wall penetration holes were cut in the side panels to accommodate raceway routing.

It should be noted that the various penetrations were only cut into the side panels as needed for testing. If a particular location was not being used in a test, then there was no empty hole in that location. Rather, the opening was either not cut, or was covered with a small cut panel of the wallboard material. For openings that had already been cut, the seal was not perfect, but the intent was to minimize air leakage through unused locations.

Note also that the openings as shown in the drawings above were not drawn to scale, but rather, were shown as illustrative only. In practice, the openings were cut so as to just accommodate the raceways being tested. Furthermore, cut sections of the wallboard material were used to close off unobstructed gaps in the openings as much as practical. As a result, a typical opening that was in use would have unobstructed gaps equivalent to no more than a 25x200 mm (1"x8") opening. A typical opening is illustrated in Figure 2.12. This is a photo of a cable tray installed in location E just after completion of a test with two individual lengths of cable present. Note that the fit was rather tight and that a panel (now blackened by smoke) was installed between the tray side rails to close off the opening as completely as practical.

---

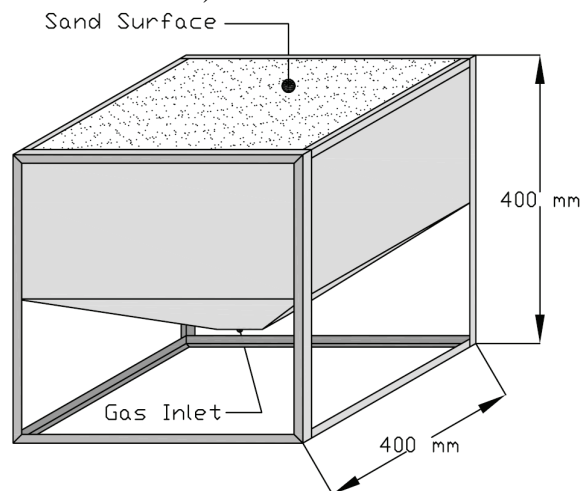
<sup>3</sup> The ‘fireproof’ wallboard was essentially low-density concrete with a fiber-mesh reinforcement and was similar in weight and appearance to concrete-based ‘backer board’ materials commonly used for bathroom tile installations.



**Figure 2.12: Photograph of a cable tray penetration of the test structure at Location E.**

The CAROLFIRE test structure was then positioned within a larger fire test facility. An existing SNL facility (Building 9830) served as the outer test structure. This isolated the test structure from the ambient environment (e.g., wind effects), allowed us to control bulk air flow conditions through the facility to some extent, and made it possible to gather outlet stack data (temperature, velocity, and Oxygen concentration). Figure 2.11 illustrates the placement of the Test Structure within the larger facility, and provides overall dimensions for the larger facility.

Fires were initiated using a gas burner. The fuel in all cases was propene (also called propylene). The burner used was a square sand box burner based on the Nordic standard burner [5] but scaled in size to suit the needs of CAROLFIRE. The top surface of the burner measured 400 mm (15.75") on a side (outside dimensions). A metal lip around the upper edge of the burner was turned to the inside of the burner on all sides and measures 12 mm (1/2") wide (a piece of standard mild steel angle iron was used to form the top rail of the burner). The sand box burner is illustrated in Figure 2.13.



**Figure 2.13: Illustration of the sand box burner.**

By itself, the burner stood a total of 400 mm (15.75") high (it's a cube). The lower half of the burner was an open support framework, while the upper half was an enclosed box section. That is, the upper

200 mm of each side of the support framework was enclosed with thin steel sheet panels welded and sealed with high-temperature caulk. Below this upper section a four-sided funnel shaped section was welded below the side panels. The lower funnel section acted as a plenum for gas entering the burner. A coarse copper screen was placed at the top of the funnel section and was supported by an X-shaped metal framework at the interface between the funnel section and the upper section side panels. A layer of 6-9 mm (1/4-3/8") gravel was placed on top of the first screen filling the lower 2/3 of the upper box section. A second (finer) screen was placed on top of the gravel and a layer of coarse sand filled the upper 1/3 of the upper box section flush to the top lip of the burner. Gas flowed into the bottom of the sand box, percolated up through the gravel, through the sand, and then burned as a diffusion flame above the sand surface.

For testing, the burner was elevated above the floor of the test enclosure. The top surface of the burner was about 840 mm (33") above the floor of the enclosure. The burner was always placed in the center of the test structure and directly below cable raceway Location A (see Figure 3.6). The flow of gas to the burner was measured and controlled by an electronic flow control valve.<sup>4</sup>

The single largest source of uncertainty associated with the intermediate-scale test conditions was that associated with conversion of the gas burner measure flow rate into an effective HRR. That is, while the gas flow rate was monitored in all tests, the HRR must be calculated. The HRR (MW) can be estimated based on the measure fuel flow rate as follows:

$$HRR = \eta \cdot V_g \cdot \rho \cdot H_c, \quad (2)$$

where  $\eta$  is the combustion efficiency,  $H_c$  is the heat of complete combustion (45.79 MJ/kg),  $\rho$  is the fuel gas density as standard conditions (1.802 kg/m<sup>3</sup>), and  $V_g$  is the measured fuel gas volume flow rate (m<sup>3</sup>/s). All but one of these parameters was either well known or directly measured, the exception being the combustion efficiency. The intent had been to estimate the burner efficiency based on cross-calculation of the HRR based on both the fuel flow rate and oxygen consumption calorimetry based on stack measurements. This proved to be impractical given the extremely long residence times for combustion products in the outer test cell which led to an untenably long delay between gas burner changes and the achievement of steady-state conditions at the stack.

Typical values for this parameter for a sand burner and a fuel such as propene will generally range from 0.8 to 0.9. For purposes of illustration, burner characterization plots are provided for each intermediate-scale test. These plots include both the fuel flow rate (in standard liters per minute (SLM)) and an estimated nominal HRR. *Note that throughout this report, whenever a value or plot of the nominal gas burner HRR has been cited, the calculation has assumed a combustion efficiency of 0.85 (85%).* The relatively low combustion efficiency reflects two factors. First, the sand burner creates a diffusion flame which is less efficient than a pre-mixed gas-air flame. Second, propene was chosen as the fuel gas specifically because under diffusion flame burning conditions propene burns with a luminous, sooty flame. However, such burning behavior is also indicative of a less complete, hence less efficient, combustion process than would be obtained with a cleaner burning fuel gas such

---

<sup>4</sup> The flow controller used was from Omega Controls and is electronic flow controller model FMA5545.

as propane. Based on these conditions, 0.85 is considered a reasonable estimate of the overall combustion efficiency of the propane sand burner. Given the range of typically measured sand burner efficiencies, the resulting HRR calculations are estimated to have a nominal uncertainty of  $\pm 5\%$ .

Gas flow to the gas burner was provided through a set-point flow control valve. The flow rate was recorded in standard liters per minute of gas. In practical application, the volume flow rate of the gas as reported by the mass flow meter must be multiplied by a constant “correction factor.” The correction factor was specified by the flow controller’s manufacturer and corrects for the flow of propane gas as compared to the flow of nitrogen gas against which the valve was calibrated. Hence, equation 2 is modified in application as follows:

$$HRR = \eta \cdot 0.4 \cdot V_{g\text{-reported}} \cdot \rho \cdot H_c \quad (3)$$

where 0.4 is the calibration correction factor and  $V_{g\text{-reported}}$  is the measured fuel gas volume flow rate as reported by the flow meter and recorded to the data files.

During the four preliminary tests (IP-1 through IP-4), the gas flow rate was varied in order to assess the relationship between gas flow rate (hence fire intensity) and the resulting temperatures within the test structure. For the balance of tests, the nominal starting point for fire intensity was at roughly 170 kW (161 BTU/s). For some tests (especially those involving hot gas layer exposures), the fire output would be increased following failure of those cables directly above the fire in order to create the desired damaging hot gas layer conditions. The maximum fire intensity used in any test was approximately 300 kW (332 BTU/s).

One final aspect of the intermediate-scale fire tests was the use of a water spray system during some tests (the test matrices in Chapter 4 indicate which tests used the water spray). The water spray system was comprised of an open head pendant sprinkler mounted on a  $\frac{3}{4}$ " galvanized piping system that was in turn mounted to one corner of the test cell such that the sprinkler head could be rotated into position just below the top-center of the capture hood. The piping was connected to a drum of water via a small electric pump. The intent of the water spray system was to allow for post-fire wetting of the cables nominally consistent with incidental wetting of the cables as the result of general fire fighting activities. It should be clearly noted that the intent *was not* to reproduce or represent an actual fire sprinkler system, to provide for fire suppression, or to simulate water sprays from a fire hose. The water flow rate to the sprinkler head was, in fact, well below typical flow rates to be expected for an actual sprinkler system. The actual flow rate was approximately 4 liters (one gallon) per minute. This produced a droplet spray pattern covering an area approximately 0.5 meter (18") in diameter at the floor.

The intent of the water spray system was only to explore the potential effects of cable wetting on any cables that had not experienced electrical failure during the course of the fire. In particular, anecdotal information gathered during the cable selection process suggested that the silicon-based cables were not likely to experience electrical failure during the fire exposure portions of the testing, but that these cables would likely fail if subsequently wetted. This did, in fact, prove to be the case

for both the silicon-rubber insulated cables and for the Vita-Link® cables (see Volume 1, Section 7.2.4 for further discussion of this aspect of the test results).

## 2.4 Cable Selection Results

A key expansion of the existing data that resulted from CAROLFIRE was the testing of a much broader range of cables and in more varied configurations than has been explored in prior testing programs such as the NEI/EPRI tests, and even in early U.S. NRC sponsored fire research programs (e.g., ref. [6]). Volume 1 of this report provides a detailed discussion of the cable selection process, criteria and results. The following discussion summarizes the characteristics of the cables tested in CAROLFIRE.

Cables are typically specified based on many factors. NUREG-1805 (Appendix A) provides an extended discussion of various factors associated with cable selection and specification [7]. For CAROLFIRE four primary factors were considered in the cable selection process. These factors are summarized as follows:

1. The conductor size and composition: In the U.S., conductor size is based on the American Wire Gage (AWG) system. A specific AWG value corresponds to the nominal conductor diameter, although the specific stranding pattern of the conductor will impact the final conductor diameter. The two most common cable conductor materials are copper and aluminum. (All of the CAROLFIRE cables were copper conductor.)
2. The conductor count: Electric cables come in a range of conductor configurations ranging from single conductor cables to cable that may have 100 or more individual conductors (e.g. communication system cables). For more typical applications certain discrete conductor count configurations are most common. These include single conductor (or 1/C) cable, 2/C, 3/C, 7/C, 12/C and 39/C. These particular configurations are popular because, with the exception of the 2/C configuration, the conductors can be arranged in concentric rings yielding a roughly round finished cable.
3. The insulation material: The insulation is the material (typically a polymer of some type) that is applied to each of the individual electrical conductors and which provides the electrical isolation of the conductor from the other conductors and from external grounds. The insulation material is often specified based on the environmental conditions that a cable must withstand during normal operation in its end application.
4. The cable jacket material: The jacket of a cable is a final layer (typically either a polymeric material or a fiber braid) that is applied of the collective group of individually insulated conductors. The jacket binds the individual conductors into a single cable unit, and provides a measure of physical protection to the insulated conductors. While most jacket materials are electrical insulators, the jacket itself is not designed to explicitly perform an electrical function.

Note that the tested cables include both Thermoset (TS) and Thermoplastic (TP) materials, and one 'mixed' cable type with a TS insulation and TP jacket. CAROLFIRE has tested 15 different cable products. This included nine different cable insulation and jacket material configurations as listed below.

- **Cross-linked polyethylene (XLPE) insulated with a Chlorosulfonated Polyethylene (CSPE, also known by the trade name Hypalon) jacket** (both TS materials) procured from the Rockbestos-Surprenant Firewall III® line of products which are fully qualified for NPP applications (e.g., IEEE-383 full qualification).
- **XLPE insulated, polyvinyl chloride (PVC) jacketed** “mixed type” cable (TS insulated, TP jacketed) procured from the BICC-Brand® line of industrial grade products (now marketed under the General Cable umbrella).
- **Ethylene propylene rubber (EPR) insulated, Chlorinated Polyethylene (CPE) jacketed** (both TS materials) procured from the BICC-Brand® line of products (now marketed under the General Cable umbrella).
- **Polyethylene (PE) (not cross-linked) insulated, PVC-jacketed** cables procured from general industrial product lines at General Cable.
- **PVC-insulated, PVC-jacketed** cables procured as industrial grade cables from the BICC-Brand® line of products (now marketed under the General Cable umbrella).
- **Silicone-Rubber (SR) insulated** with a fiberglass braid sheath over each insulated conductor and an overall Amarid braid jacket procured from First Capitol.
- **Vitalink ®**, a relatively new trade name product of Rockbestos-Surprenant Corporation.<sup>5</sup>
- **Tefzel 280 Insulated, Tefzel 200 jacketed** cable procured from Cable USA.
- **Cross-Linked Polyolefin (XLPO) insulated, XLPE jacketed, Low Halogen Zero Smoke** cable procured from the general industrial product line at Rockbestos-Surprenant.

Note that these insulation/jacket configurations represent a rather broad range of materials from essentially the least robust (thermally) to most robust cable types available and in use at current U.S. NPPs.

In order to focus the applicability of these tests on generic utilization, the emphasis for testing relative to resolution of the Bin 2 Items was on 7-conductor cables. A limited number of tests on 3-conductor 8 AWG light power cables, 12-conductor 18 AWG instrument cables, and 2-conductor 16AWG instrument cables were also performed. These secondary cable configurations were included primarily to support the fire model improvement need area (see discussion in Section 3.4.1 above). However, in those cases where a secondary configuration cable was monitored for electrical performance, the data do provide information on the duration of intra-cable conductor-to-conductor shorting prior to shorts to an external ground.

Table 2.1 lists the specific cables used in the CAROLFIRE project. The Table identifies the insulation and jacket material type (the standard nomenclature used is *insulation/jacket*), the manufacturer, the conductor count, and conductor size. Also note that the first column in Table 2.1

---

<sup>5</sup> As cited on the corporation web site, Vita-Link® "is a unique silicone rubber insulation material that ceramifies and maintains physical & electrical integrity when exposed to flame conditions."

provides an item number for each of the 15 cables tested. These item numbers were used throughout both volumes of this report, and in the accompanying data files, to identify the specific cables used in any given test. The cables were also identified throughout both volumes using the “short description” which is provided in column 2 of the table. Table 2.2 provides the physical characteristics of each cable procured. Included are insulation and jacket thickness, overall cable diameter, and conductor diameter as well as the cable mass expressed as the kg weight per linear meter (or pounds per linear foot) of cable. Also included are the volume and weight fractions for the copper. That is, these represent the fraction of the overall cable volume and cable weight that were attributable to the copper conductors rather than to the plastic insulation, jacket and filler materials. Figure 2.14 provides an end-view photograph illustrating the relative size and construction of each of the 15 cable items.



**Table 2.1: Short descriptions and cable markings for the CAROLFIRE cables.**

Item #	Short Description	Source	Cable Markings
1	PVC/PVC, 12 AWG, 7/C	General Cable	GENERAL CABLE® BICC® BRAND (WC) VNTC 7/C 12AWG (UL) TYPE TC-ER THHN/THWN CDRS DIR BUR SUN RES 600V 03 FEB 2006
2	EPR/CPE, 12 AWG, 7/C	General Cable	GENERAL CABLE® BICC® BRAND (WC) FREP 7/C 12AWG EPR/CPE (UL) TYPE TC-ER XHHW-2 CDRS 90C WET OR DRY 600V DIR BUR SUN RES 12 SEP 2005
3	XLPE/PVC, 12 AWG, 7/C	General Cable	GENERAL CABLE® BICC® BRAND (WC) CVTC 7/C 12AWG FR-XLP/PVC (UL) TYPE TC-ER XHHW-2 CDRS DIR BUR SUN RES 90C WET OR DRY 600V 08 MAR 2006
4	PVC/PVC, 16 AWG, 2/C SH	General Cable	GENERAL CABLE® BICC® BRAND (WC) VN-TC 16 AWG SHIELDED (UL) TYPE TC-TFN CDRS SUN RES DIR BUR 600V 03 NOV 2005
5	PVC/PVC, 8 AWG, 3/C	General Cable	GENERAL CABLE® BICC® BRAND (WC) VNTC 3/C 8AWG WITH GRND (UL) TYPE TC-ER THHN/THWN CDRS DIR BUR SUN RES 600V 15 MAR 2006
6	PVC/PVC, 18 AWG, 12/C	General Cable	GENERAL CABLE® BICC® BRAND (WC) VNTC 12/C 18AWG (UL) TYPE TC-ER TFN CDRS SUN RES DIR BUR 600V 09 MAR 2006
7	XLPE/CSPE, 16 AWG, 2/C(Sh)	Rockbestos-Surprenant	2/C 16 AWG COPPER ROCKBESTOS-SURPRENANT (G) 600V 90 DEG C WET OR DRY FIREWALL @ III SUN RES DIR BUR OIL RES II NEC TYPE TC (UL) FRXLPE SHIELDED CSPE I46-0021 2006
8	XLPO/XLPO, 12 AWG, 7/C	Rockbestos-Surprenant	7/C 12 AWG COPPER ROCKBESTOS-SURPRENANT (G) X-LINK® TC 600V 90 DEG C WET OR DRY SUN RES DIR BUR NEC TYPE TC (UL) FMRC GP-1 K2 COLOR CODE FRXLPE LSZH-XLPO C12-0070 2005
9	SR/Aramid Braid, 12 AWG, 7/C	First Capitol	SRGK-12(19)TPC 600V 200DEG.C 7/C
10	XLPE/CSPE, 12 AWG, 7/C	Rockbestos-Surprenant	7/C 12 AWG COPPER ROCKBESTOS-SURPRENANT (G) 600V 90 DEG C FIREWALL® III XHHW-2 SUN RES DIR BUR OIL RES II NEC TYPE TC (UL) XLPE CSPE FT4 C52-0070 2006
11	VITA-LINK, 14 AWG, 7/C	Rockbestos-Surprenant	7/C 14 AWG ROCKBESTOS-SURPRENANT (G) VITALINK® TC NCC 600V 90 DEG C (UL) TYPE TC SUN RES FT-4 FIRE RESISTANT SILICONE LSZH C65-0070 2005
12	TEF/TEF, 12 AWG, 7/C	Cable USA	7/C 12 19/TPC TEF/TEF CONTROL CABLE BLACK (SPEC. NO.: 381207U0)
13	XLPE/CSPE, 18 AWG, 12/C	Rockbestos-Surprenant	12/C 18 AWG COPPER ROCKBESTOS-SURPRENANT (G) 600V 90 DEG C WET OR DRY FIREWALL® III SUN RES DIR BUR OIL RES II NEC TYPE TC (UL) FRXLPE CSPE I57-0120 2006
14	XLPE/CSPE, 8 AWG, 3/C	Rockbestos-Surprenant	3/C 8 AWG COPPER ROCKBESTOS-SURPRENANT (G) 600V FIREWALL® III XHHW-2 90 DEG C SUN RES DIR BUR OIL RES II NEC TYPE TC (UL) FRXLPE CSPE FT4 P62-0084 2006
15	PE/PVC, 12 AWG, 7/C	General Cable	GENERAL CABLE® BICC® SUBSTATION CONTROL CABLE 7/C 12 AWG AWG 600V 30 MAY 2006



Figure 2.14: Photograph illustrating the relative size of all fifteen of the CAROLFIRE cables.

Table 2.2: Physical characteristics of the CAROLFIRE cables.

Control Cables												
Item #	Short Description	Manufacturer	Part Number	Cond. Count	Cond. Size AWG	Cond. Diameter <sup>1</sup> mm (in)	Insulation Thickness mm (in)	Jacket Thickness mm (in)	Cable Diameter mm (in)	Net Weight kg/m (lb/ft)	Copper Volume Fraction <sup>5</sup>	Copper Weight Fraction <sup>5</sup>
1	PVC/PVC, 12 AWG, 7/C	General Cable	234620	7	12	2.3 (0.092)	0.51 (0.02)	1.14 (0.045)	12.4 (0.49)	0.310 (0.217)	0.24	0.80
2	EPR/CPE, 12 AWG, 7/C	General Cable	279890	7	12	2.3 (0.092)	0.76 (0.03)	1.52 (0.06)	15.1 (0.595)	0.383 (0.268)	0.16	0.65
3	XLPE/PVC, 12 AWG, 7/C	General Cable	770950	7	12	2.3 (0.092)	0.76 (0.03)	1.52 (0.06)	15.1 (0.595)	0.372 (0.260)	0.16	0.67
8	XLPO/XLPO, 12 AWG, 7/C	Rockbestos - Surprenant	C12-0070	7	12	2.3 (0.092)	0.51 (0.02)	0.89 (0.035)	12.2 (0.48)	0.307 (0.215)	0.25	0.81
9	SR/Aramid Braid, 12 AWG, 7/C	First Capital	SRG-K	7	12	2.3 (0.092)	1.27 (0.05)	1.02 (0.04)	14.5 (0.57)	0.343 (0.240)	0.18	0.73
10	XLPE/CSPE, 12 AWG, 7/C	Rockbestos - Surprenant	C52-0070	7	12	2.3 (0.092)	0.76 (0.03)	1.52 (0.06)	15.0 (0.59)	0.393 (0.275)	0.16	0.63
11	VITA-LINK, 14 AWG, 7/C	Rockbestos - Surprenant	Special Order	7	14	1.85 (0.073)	1.54 (0.060)	1.91 (0.075)	19.6 (0.77)	0.479 (0.335)	0.06	0.34
12	TEF/TEF, 12 AWG, 7/C	Cable USA	Special Order	7	12	2.3 (0.092)	0.41 (0.016)	0.51 (0.020)	10.2 (0.40)	0.279 (0.196)	0.36	0.89
15	PE/PVC, 12 AWG, 7/C	General Cable	256750	7	12	2.3 (0.092)	0.76 (0.03)	1.14 (0.045)	15.0 (0.59)	0.522 (0.255)	0.16	0.68

**Table 2.2: Physical characteristics of the CAROLFIRE Cables (continued).**

Power Cables												
Item #	Short Description	Manufacturer	Part Number	Cond. Count	Cond. Size AWG	Cond. Diameter <sup>1</sup> mm (in)	Insulation Thickness mm (in)	Jacket Thickness mm (in)	Cable Diameter mm (in)	Net Weight kg/m (lb/ft)	Copper Volume Fraction <sup>5</sup>	Copper Weight Fraction <sup>5</sup>
5	PVC/PVC, 8 AWG, 3/C	General Cable	236370	3	8	3.71 (0.146)	0.91 (0.036)	1.52 (0.06)	15.2 (0.6)	0.440 (0.308)	0.18	0.63
14	XLPE/CSPE, 8 AWG, 3/C	Rockbestos – Surprenant	P62-0084	3	8	3.71 (0.146)	1.14 (0.045)	1.52 (0.06)	16.3 (0.64)	0.508 (0.355)	0.16	0.55

Instrument Cables												
Item #	Short Description	Manufacturer	Part Number	Cond. Count	Cond. Size AWG	Cond. Diameter <sup>1</sup> mm (in)	Insulation Thickness mm (in)	Jacket Thickness mm (in)	Cable Diameter mm (in)	Net Weight kg/m (lb/ft)	Copper Volume Fraction <sup>5</sup>	Copper Weight Fraction <sup>5</sup>
4	PVC/PVC, 16 AWG, 2/C SH <sup>4</sup>	General Cable	230830	2	16	1.47 (0.058)	0.71 (0.028)	1.52 (0.060)	7.62 (0.30)	0.073 (0.051)	0.07	0.40
6	PVC/PVC, 18 AWG, 12/C	General Cable	236120	12	18	1.17 (0.046)	0.51 (0.02)	1.14 (0.045)	11.3 (0.445)	0.187 (0.131)	0.13	0.59
7	XLPE/CSPE, 16 AWG, 2/C SH <sup>4</sup>	Rockbestos - Surprenant	I46-0021	2	16	1.47 (0.058)	0.635 (0.025)	1.14 (0.045)	7.87 (0.31)	0.093 (0.065)	0.07	0.31
13	XLPE/CSPE, 18 AWG, 12/C	Rockbestos - Surprenant	I57-0120	12	18	1.17 (0.046)	0.635 (0.025)	1.14 (0.045)	12.7 (0.5)	0.222 (0.155)	0.10	0.50

**Notes for Table 2.2:**

- 1 – These values were based on NFPA 70 National Electric Code 2002, Table 8 Conductor Properties, pages 70-625.
- 2 – These values were based on information provided by the manufacturer.
- 3 – These values were based on measured cable samples.
- 4 – The drain wire for item #7 was an 18 AWG 16-strand uninsulated wire.
- 5 – These values were measured and provided by collaborative partners at NIST.

## 3 PRIMARY MEASUREMENTS PERFORMANCE DIAGNOSTICS AND EXPERIMENTAL SETUPS

The discussion presented below focuses primarily on the measurements taken that are specifically relevant to the fire modeling improvement need area. Volume 1 of this report provides a complete description of the two electrical performance diagnostic systems, the SCDUs and the IRMS. Only summary discussions for these aspects of the program are provided here and the reader is referred to Volume 1 for additional details.

### 3.1 Thermal Exposure Conditions

#### 3.1.1 *Penlight* Exposure Conditions

The variable characterizing the exposure conditions in any given *Penlight* test was the shroud temperature which establishes the radiant heat flux leaving the shroud's inner surface (based on equation 1). Note that for the tests run with cables in conduit or cable tray, the shadowing effect of the raceway reduced the heat flux actually delivered to the cable surface. This is discussed in Section 2.2 above, and specific dimensions for the cable trays are provided in Section 3.1.3 below.

*Penlight* allowed for a maximum shroud temperature of about 900°C (1652°F). This corresponds to a maximum heat flux of 87 kW/m<sup>2</sup> (7.7 BTU/ft<sup>2</sup>s) based on equation 1 above and assuming an average emissivity of 0.815. One of the CAROLFIRE tests (PP-10) actually included an exposure at this heat flux. However, all other tests were performed at lower intensities. The matrices presented in Section 4 below specify the shroud temperature and nominal heat flux for each test.

Given the nature of typical NPP fires, it was deemed to be desirable to adjust the heat flux to yield cable failure times nominally on the order of 10-30 minutes. This was considered typical of the types of fire scenarios found to be important to fire risk analyses. The heating intensity used in the CAROLFIRE tests was 'tuned' to each cable tested because the cables used did display a wide range of thermal robustness.

The appropriate flux levels were determined during a series of 26 Preliminary *Penlight* tests (PP-1 through PP-26). Excluding Test PP-10 which used a shroud temperature of 900°C (1652°F), the rest of the Preliminary *Penlight* tests used shroud temperatures ranging from 260-675°C (500-1247°F). The Preliminary *Penlight* tests provide two unique types of information. First, they explore the general relationship between shroud temperature and time to failure for the various CAROLFIRE cables. Second, they provide correlated thermal and electrical cable response data for a range of heat flux conditions under the most simplistic of routing configurations; namely, single lengths of cable exposed to well characterized radiant heating.

For the primary matrix *Penlight* Tests (PT-1 through PT-68), the shroud temperature was set at one of a six discrete values ranging from 300-700°C (572-1292°F). For tests involving individual or bundled thermoplastic cables, the shroud temperature was generally set at either 300°C (572°F) or

325°C (617°F). Single lengths of the thermoset cables were generally run with a shroud temperature of 470°C (878°F) with the exception of test PT-1 where the shroud was at 475°C (887°F). Tests with bundles of cables were typically run at slightly higher temperatures, either 525°C (977°F) or 700°C (1292°F).

Table 3.1 shows the radiant heat flux *emitted from the shroud surface* for each of the discrete shroud temperature values used in the CAROLFIRE tests. These values were calculated based on equation 1 assuming that the shroud surface emissivity was 0.815 consistent with the average measured emissivity as discussed in Section 2 above. Recall that Section 2 discussed factors that will reduce the heat flux actually delivered to the cable surface (e.g., geometric factors).

**Table 3.1: Relationship between shroud temperature and shroud heat flux assuming an emissivity of 0.815.**

Metric Units			Equivalent values in English Units	
Temperature (°C)	Temperature (°K)	Heat Flux (kW/m <sup>2</sup> )	Temperature (°F)	Heat Flux (BTU/ft <sup>2</sup> s)
260	533	3.7	500	0.33
295	568	4.8	563	0.42
300	573	5.0	572	0.44
325	598	5.9	617	0.52
330	603	6.1	626	0.54
350	623	7.0	662	0.62
400	673	9.5	752	0.84
425	698	11.0	797	1.0
460	733	13.4	860	1.2
470	743	14.1	878	1.2
475	748	14.5	887	1.3
500	773	16.5	932	1.5
525	798	18.8	977	1.7
600	873	26.9	1112	2.4
650	923	33.6	1202	3.0
665	938	35.8	1229	3.2
675	948	37.3	1247	3.3
700	973	41.4	1292	3.6
900	1173	87.5	1652	7.7

### 3.1.2 Intermediate-scale Tests

The intermediate-scale tests involved open burning. The initial fire was created by a propene (or propylene) gas burner running at a nominal HRR of 200-350 kW (190-332 BTU/s) depending on the specific test conditions. In general, tests were initiated with the gas burner at about 200kW (190 BTU/s). However, in some tests the burner intensity was increased to as much as 350 kW (332 BTU/s) once the electrically monitored cables located directly above the fire had failed. In some cases this was necessary in order to create hot gas layer conditions severe enough to induce failure

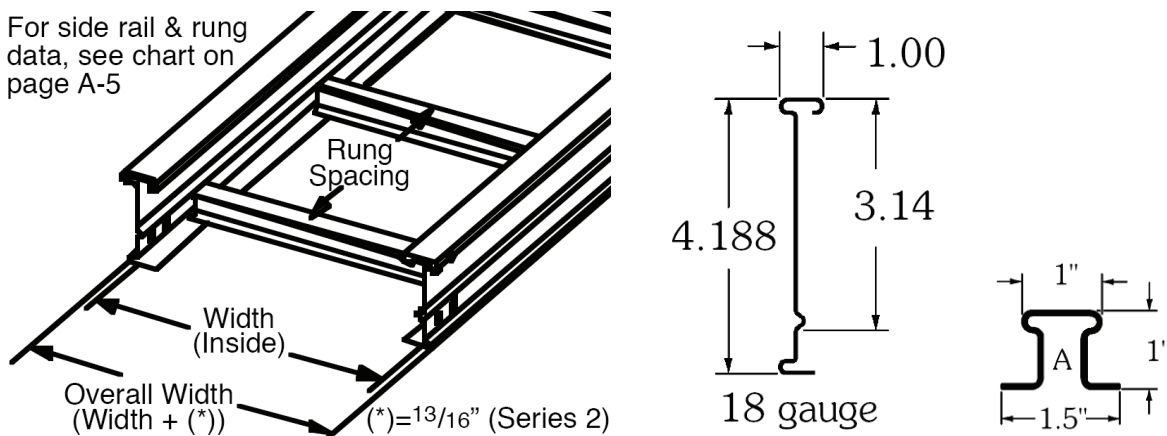
of cables located outside the fire plume. Calculations of the HRR associated with the gas burner have been discussed in Section 2.3 above.

In addition, the exhaust stack from the outer test facility was monitored for temperature, velocity, and oxygen concentration. Hence, a nominal measure of the total heat release rate was possible. Note, however, that given the test configuration there was a considerable lag (minutes) between changes in the fire and detection of those changes at the stack. In general, it was desirable that the conditions within the outer test facility be relatively calm. A pusher-type forced air ventilation system was used to ventilate the outer test facility, but was run at a relatively low flow rate in order to maintain quiescent conditions within the enclosure. Smoke venting after a typical test would take upwards of one hour, again indicating that a significant time lag was present.

### 3.1.3 Raceway Descriptions

Two types of raceways were employed for CAROLFIRE during both the *Penlight* and intermediate-scale tests. First were 300 mm (12") wide standard ladder-back cable trays and second were 63 mm (2-1/2") diameter standard rigid metal conduit. A limited number of tests were also conducted on unsupported cables ("air drops").

The cable trays procured for CAROLFIRE were B-Line® Series 2 style pre-galvanized (rather than hot-dip galvanized) steel trays with (per manufacturer specifications) "a nominal 3" NEMA VE 1 loading depth, 4" side rail, and 9" rung spacing." The specific part number was 248P09-12-144. Dimensional drawings of the cable tray and side rail as provided on the manufacturer's website, 'www.b-line.com', are shown in Figure 3.1.



**Figure 3.1: Dimensions of the B-Line Series 2 cable trays overall (left illustration), the side rails (center illustration shows the left side rail), and a cross-section of an individual tray rung (right illustration). All figures were taken from the manufacturer's sales literature. Note that the "chart on page A-5" referenced in the left-hand illustration is the center illustration.**

All dimensions shown in Figure 3.1 were given in inches per the original illustrations and have not been converted to metric units here. Note also that from the top of the side rail to the top of the tray

rung is shown as 3.14" or 80 mm (as-advertised the trays have a nominal 3" tray fill depth). Other pertinent data specific to the cable tray mass was as follows:

- Side rail weight: *Each* side rail weighs approximately 1.74 kg/m (1.17 lbs/ft). There were two side rails per tray section.
- Individual rung weight: Each rung individually weighs about 0.43 kg (0.29 lb). The CAROLFIRE trays had 9" center-to-center rung spacing.

The conduits used in testing were standard grade galvanized rigid metal conduit procured from a local electrical supply house. Standard dimensions for such conduits are summarized as follows:

<u>Characteristic:</u>	<u>Metric Units</u>	<u>English Units</u>
Size Designation	63 mm	2½"
Inside Diameter	63.2 mm	2.489"
Outside Diameter	73.0 mm	2.875"
Wall Thickness	4.9 mm	0.193"
Nominal Weight	7.94 kg/m	5.27 lb/ft

For the air drops, the cable has no support structure within the exposure environment. For Penlight, this was accomplished by simply supporting the cable outside the ends of the exposure shroud. For the intermediate-scale tests, cables were placed in the test structure using a section of cable tray with all but the last two rungs at each end removed. This created a horizontal exposure with no support rungs, but the cable tray side rails were present. Note that due to the natural sag in the cable, the center portion of such cables was below the bottom of the side rail. In some tests, a cable was allowed to drop from one tray into a second lower tray. Specific configuration details are provided for each test.

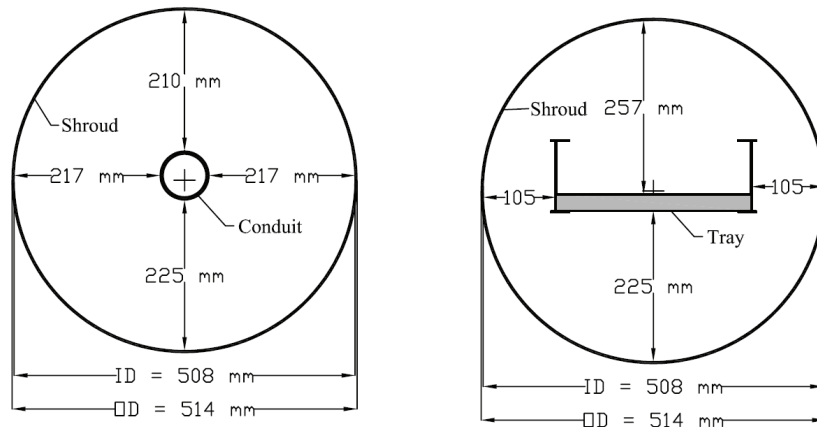
### **3.1.4 Placement of the Raceways in Penlight**

For *Penlight*, a single raceway (either a tray or conduit) was routed horizontally through the exposure shroud such that the cables would be located as near to the centerline of the shroud cylinder as was possible. The raceways were supported on stands outside the end of the shroud. Both the conduit and the cable tray were supported on the same external support stands, so the bottom of the conduit and the bottom of the cable tray side rails were actually at the same vertical height relative to the shroud. Again, the intent was to place the *cables* at the approximate center of the shroud, not to center the raceway. Figures 2.1 and 2.2 above have provided photographs illustrating the general cable tray set-up. As a compliment, Figure 3.2 illustrates the approximate dimensions for Penlight with the conduit and cable tray in place.

Once the final installations were completed for the cable tray, the top of the cable tray rungs was actually located (approximately) 3 mm (1/8") below the horizontal centerline of the Penlight shroud. In the tests of individual lengths of cable, two cables would actually be routed in symmetric locations either side of the tray center. One cable was monitored for thermal response and the second



for electrical performance.<sup>6</sup> The spacing between cables was about 50-75 mm (2-3"), although this spacing varied somewhat along the length of the cables because the cables themselves do not lie perfectly flat. No attempts were made to force a perfectly straight run of the cables. The cables were laid into the cable tray and secured with nylon cable ties only at their outer ends (outside the shroud).



**Figure 3.2: Approximate dimensions for Penlight with the conduit (left-hand illustration) and cable tray (right-hand illustration) in place. (All dimensions are mm.)**

Once the final installations were completed for the conduit, the center of the conduit was approximately 7 mm (1/4") *above* vertical centerline of the Penlight shroud. This placed the inside-bottom of the conduit, on which the cables rested, about 25 mm (1") *below* the shroud centerline. As a result, the center of a typical 3-cable bundle (the configuration most commonly used for the conduit tests) was very near the shroud center. Also note that for the conduit tests, the cables were simply pulled through the conduit and no attempts were made to maintain any separation between thermal response and electrical performance cables.

In all tests, the raceways and cables extended all the way through the shroud and to a length of about 71 mm (18") beyond the shroud ends. To simulate an air drop, cables were secured to external support stands with nylon cable ties and run horizontally through the approximate center of the chamber. All electrical connections were made outside the exposure chamber.

### 3.1.5 Placement of the Raceways in the Intermediate-scale Tests

For the intermediate-scale tests, the exact same raceways types were used as those described above for the Penlight tests. The raceways and cables were extended across the entire 2.4 m (8') width of the test structure. Various locations were used for the routing of cables as discussed (and illustrated) in Section 2.3 above. All but one of the raceway locations was above the lower edge of the enclosed portion of the test structure (i.e., 1.8m (6') or more above the floor).

<sup>6</sup> Volume 1 provides details as to why two lengths of cables were used. In summary, inserting TCs into a cable, or even attaching TCs to the cable surface can adversely impact electrical performance so no single cable was ever monitored for both thermal and electrical performance.

All electrical connections were made outside the test structure, but within the outer test chamber. In practice, the raceways would simply be placed on top of the test structure's supporting framework cross-members at the desired location. Hence, the height of the raceway was based on the height of the cross-members. Note also that the metal frame of the test structure (upon which the raceways were placed) and the installed raceways were grounded to a common earth ground along with all test instrumentation.

## **3.2 Temperature Measurements**

As will be described in Section 3.2.2 through 3.2.4, CAROLFIRE committed substantial effort to the gathering of cable thermal response data. Indeed, the bulk of the temperature measurements made for CAROLFIRE were directly related to monitoring the environment near the test cables (e.g., air temperatures above and below a cable or cable bundle, cable tray temperatures, conduit temperatures, etc.) and the thermal response of the sample cables themselves. A considerable focus was placed on the inclusion and monitoring of what were referred to in this report as "thermal response cables." All of the thermal response cables were included explicitly to provide direct data characterizing the thermal response of the sample cables to the fire environments. These samples and the associated data were specifically aimed at the fire model improvement need area.

Literally hundreds of TCs focused on the thermal response cable samples were used in the CAROLFIRE tests. TC placement included the monitoring of cable surface temperatures, but also included the thermal response within the cables themselves. Cable internal response was generally measured with TCs embedded just below the outer jacket; however, in several tests TCs were also embedded more deeply into the center of the cables. Cable thermal response monitoring included both individual cables and cable bundles.

It should also be noted that each of the thermal response cables used in the CAROLFIRE tests represents, in effect, a cable-specific slug calorimeter. Slug calorimeters are passive devices used to measure net heat flux over time to a target object and are common in fire tests. Slug calorimeters are commonly made of metals such as copper, steel or brass. In fact, as described in Section 2.3, two brass slug calorimeters were also used during the CAROLFIRE intermediate-scale tests. However, there is no reason that the same methods of analysis cannot be applied to the thermal response cables. As indicated in Table 2.2, the cables used in CAROLFIRE are, in fact, comprised primarily of copper in any case. The cable mass per unit length is also provided in 2.2 so that calculating the net heat flux delivered to a cable as a function of time is a straight-forward prospect. The only difference to be considered is that, because the cables are not entirely metal, there will be a greater degree of non-uniformity with the cable samples than with a typical slug calorimeter. To address this issue, data were also gathered to characterize the internal cable heat profiles. These data also allow for the verification of calculations of heat transfer within the cables.

This particular report has not performed these heat transfer calculations simply because extensive analysis of the test data was outside the scope of SNL's role and responsibility in the CAROLFIRE project. This report reflects SNL's role in the project which was primarily to plan and execute the tests, and to gather and report the test data. However, all of the data are publicly available so other analysts may conduct of the necessary calculations.

### **3.2.1 General Provisions for Temperature Measurement**

All of the TCs used for CAROLFIRE were Type K (Chromel-Alumel). Testing included the use of both bare-bead Teflon insulated TCs and stainless steel sheathed TCs.

Sheathed TCs were typically used in applications where we anticipated the ability to reuse the TCs in more than one test. Typically, no TC was used in more than four tests. These applications included sub-jacket cable thermal response measurements (see Section 3.2.2) with the thermoset cables because the sheathed TCs were easier to insert than the bare-bead and they could be easily recovered for reuse in another test. Sheathed TCs were also used to monitor raceway temperatures (see Section 3.2.4) and to monitor air temperatures during the intermediate-scale tests (see Section 3.2.3).

Bare-bead TCs were used where the TC would not be reusable after a test or where recovery of a used TC, while possible, would be time-prohibitive. Bare-bead TCs were not reused. All cable surface temperatures were measured using the bare-bead TCs. Bare-bead TCs were also used to measure sub-surface cable temperatures in most of the tests involving TP thermal response cables because melting of the TP materials onto the TCs generally rendered them unusable in subsequent tests.

All of the TCs procured were certified by the manufacturer to standard calibration tolerances. The nominal calibration tolerance stated by the manufacturer is accuracy equal to the greater of 2.2°C (4°F) or 0.75% of the measured value over the range from -200°C to 1250°C (-328°F to 2282°F). SNL verified TC calibration based on several randomly selected samples from each batch of TCs procured. The verification TCs were tested over a range from room temperature up to 1000°C (1832°F). All verification TCs performed well within the specified manufacturer accuracy limits. (Note that the TCs used to verify calibration were not then re-used during testing because the calibration process itself can adversely affect subsequent TC performance.)

The TC data was recorded using available SNL data recording systems. These systems were designed to sample the TCs at a rate of 100 Hz, and to then provide a time-averaged reading at any desired interval. For CAROLFIRE, temperature data was typically recorded to the data files at 1 second intervals. Hence, each measured data point actually represents an average of 100 individual measurements.

All of the TC data recorders are maintained as calibrated measurement devices through the SNL instrument calibration services. SNL is a certified calibration laboratory using practices directly traceable to NIST Standards. All instruments in the calibration services system are subject to routine

periodic calibration recall and recertification. The availability of current calibration certificates were confirmed for the TC monitoring systems used for CAROLFIRE.

### **3.2.2 Cable Thermal Response – Individual Cable Lengths**

Based on past testing experience, SNL generally prefers the use of TCs placed just below the jacket of a cable to measure cable thermal response. If a measure of cable surface temperature was desired, the TC must be installed such that the measurement bead remains in contact with the cable surface because the temperature reported by the TC is the temperature of its measurement bead (the tip of the TC). If the measurement bead was not in firm contact with, or lifts from, the cable surface during testing then the TC will measure the air temperature near the cable rather than the cable surface temperature. This was, for example, a factor in the NEI/EPRI tests where the TC beads were not secured directly to the cable, but rather, TCs were secured to the cable with tape placed some distance (about 25 mm or 1") back from the bead.<sup>7</sup> This makes it impossible to tell what the cable TCs were actually measuring at any point in the tests and also makes it virtually impossible to correlate observations of cable electrical failure to the cable thermal response for those tests.

For CAROLFIRE, when a cable surface temperature was desired, the TC bead was secured directly to the cable using 1-½ wraps of 25 mm (1") wide fiberglass tape such that there was one layer of tape over the bead itself. Fiberglass tape was used because past experience has shown that the tape will hold up through a typical fire test. The undesirable aspect of this practice was that the tape wrap itself impacted the thermal response behavior to some extent for two reasons. First, the tape created another layer of material over the cable surface that would not normally be there. Second, as cables were heated the jacket material would swell and blister and the tape wrapping restricted this behavior. For these reasons, the use of taped surface TCs was not considered the most desirable practice with respect to cable thermal response monitoring.

SNL's prior experience in this regard was confirmed based on the results of preliminary modeling efforts by our collaborative partners at NIST. They found that the damage predictions correlated most closely to the sub-jacket TCs and did not correlate nearly as well to either the surface TCs or to the more deeply embedded TCs. Hence, the sub-jacket TC was confirmed as the preferred location. Indeed, as testing progressed, the use of cable surface and more deeply embedded TCs was stopped, and sub-jacket TCs became the primary thermal response measurement method.

Note with the sub-jacket TCs, there was no artificially introduced additional layer of material as with the taped surface TCs. However, the TCs can still lead to misleading readings depending on how the cable actually behaves. In the case of the TS jacket materials in particular, if swelling and blistering occurred at the location of the TC bead, then the TC might be measuring the temperature of the vapors within the blister and may not accurately represent the cable material temperatures. In the case of the TP materials, if the jacket melted the TC could become exposed to the air and, again, the measurement may not be representative of the cable materials. These effects cannot be observed during testing, but are noted as factors to be considered in the interpretation of the test data. For

---

<sup>7</sup> This statement is based on observations made by the authors of this report who together were present during almost all of the NEI/EPRI tests.

example, sudden jumps in temperature for a TC that was measuring cable temperature might indicate ignition of the cable or it might reflect detachment of the TC bead from the cable materials. Despite these potential issues, the sub-jacket TCs are considered the most representative measurement of cable thermal response that can practically be achieved.

In order to insert a sheathed TC below a cable jacket, a razor-knife was used to cut a slit in the jacket no more than 25 mm (1") long. The TC bead was then slipped into the cable just below the jacket surface and pushed as far into the cable and away from the cut slit as was possible, and in practice, the minimum distance that could be achieved was at least 75mm (3"), and more typically was at least 100 mm (4"). A layer of fiberglass tape was then placed over the slit (but not over the TC bead) to close the slit and to protect the point of TC penetration. This process is illustrated in Figure 3.3.



**Figure 3.3: Illustration of a sheathed TC inserted under a cable's jacket.**

The upper photograph shows a shielded TC that has been inserted into the cable. Note that a tape 'flag' was attached to the TC about 305 mm (12") back from the measurement tip. This helps illustrate how far into the cable the TC tip can actually be placed, in this case about 150 mm (6"). The lower photograph shows the same cable with its final over-wrap of tape used to cover the hole cut into the jacket and to help secure the TC in place so that it does not inadvertently pull out during handling. Note again that the tape does not cover the measurement tip, but rather, only the point where the TC lead enters the cable.

Note that for most of the TP cable tests bare bead TCs (rather than the more expensive sheathed TCs) were used for sub-jacket thermal response measurements because melting of the TP materials rendered the TCs unusable in subsequent tests. The same basic process for insertion of the TC was followed. For these cases, the TC bead was typically installed on the order of 74-100 mm (3-4") from the point of insertion.

For the penlight tests, there was no measurement of the air temperature within the exposure cylinder because the environment was dominated by radiant heating. However, for each of the thermal

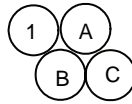
response cables tested in the intermediate-scale tests, bare bead thermocouples were also provided measuring the air temperature directly above and directly below the cable itself.

### 3.2.3 Cable Thermal Response – Cable Bundles

Most of the intermediate-scale tests involved the testing of cable bundles including complementary pairs of thermal response bundles and electrical response bundles. That is, two cable bundles of identical configuration (cable types and arrangement) would be tested side by side in a cable tray with one monitored for thermal response and the other for electrical performance. In these cases, a consistent approach to installation of TCs in the thermal response bundles was employed.

The bundles were again configured in a consistent manner, and the individual cables were identified based on a letter code. In the illustrations below, the cables at the bottom of the arrangement were in contact with the raceway.

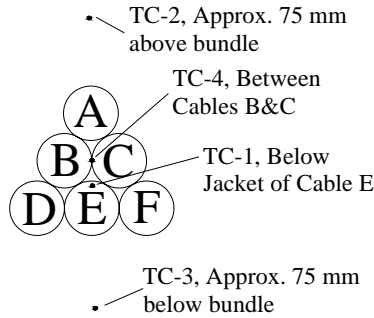
The smallest bundles tested involved three electrical response cables plus one thermal response cable in a common bundle installed in conduit. The bundling arrangement and letter code for this type of bundle is illustrated in Figure 3.4.



**Figure 3.4: Illustration of cable identification code for the ‘3+1-Cable bundle in conduit.’**

For this bundling arrangement the three cables identified as A, B, and C were monitored for electrical performance. The fourth cable, ‘Cable 1,’ was monitored for thermal response. For Cable 1, a single TC was inserted below the cable jacket. During installation, the cable was oriented so that the TC tip was facing towards the adjacent cables. Cable 1 would be placed in the bundle to the left of Cable A and in contact with Cable B as well. In addition, a second bare-bead TC was routed along the outside of Cable 1 and during installation of the cables into the conduit, the measurement bead for this TC would be installed such that it was measuring air temperature within the conduit and about 25 mm (1") above the top of cable A. In the individual test condition diagrams that are discussed in Section 6 below, this arrangement was referred to as the “3+1-Cable bundle in conduit.” This was the only cable bundle that actually included both thermal response and electrical performance cables. Note that in some of the tests with this bundle, the TC data for the bundle was compromised by interactions with the electrical performance monitoring systems.

The bundling and letter code for the six-cable bundles is illustrated in Figure 3.5 Bundles of this type were installed in cable trays only. 6-cable bundles were tested as both thermal response bundles and as electrical performance bundles. This figure also illustrates the typical placement of TCs in the 6-cable thermal response bundles.



**Figure 3.5: Cable identification code and placement of the standard complement of TCs for the 6-cable bundles in cable tray.**

As illustrated, the standard configuration involved four TCs placed as follows:

- A TC (TC1) was inserted under the jacket of Cable E as illustrated immediately above. Cable E was placed in the bundle so that the TC tip would be on the upper side of the cable (i.e., towards the center of the bundle).
- A second TC (TC4) was placed near the center of the bundle and was sandwiched between cables B and C.
- A third TC (TC2) was attached to Cable A but was adjusted so that its measurement tip was located in the air about 75 mm (3") above the top of the cable bundle.
- A fourth TC (TC3) was attached to Cable E and was adjusted so that its measurement tip was located in the air about 75 mm (3") below the bottom of the cable bundle.

All of these TCs were located in the approximate center (lengthwise) of the cable bundle. The electrical response bundles were connected either to the IRMS or to the SCDUs.

The bundling and letter code for the 12-cable bundles plus the TC placement is illustrated in Figure 3.6. In the case of the 12-cable bundle, the electrical performance monitoring focused on the cables in the core of the bundle (cables A, B, C, E, H & L). The left-hand illustration in this figure illustrates the minimum complement of four TCs installed in such bundles.

For the minimal four TC configurations the following TCs were installed:

- One TC (TC1) was installed under the jacket of Cable A with the cable oriented so that the TC tip was facing upwards towards cables J-K.
- One TC (TC2) was installed in the center of the bundle between cables A-B-C.
- One TC (TC3) measures the air temperature about 75 mm (3") above the cable bundle.
- One TC (TC4) measures the air temperature about 75 mm (3") below the cable bundle.

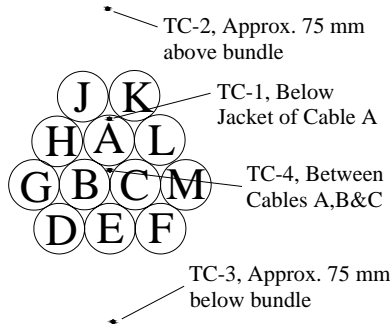


Figure 3.6: Standard complement of TCs for the 12-cable thermal response bundles in cable tray.

### 3.2.4 Cable Thermal Response – Random Fill Trays

In certain tests, random fill cable trays were included. This included IT-1 where there was one random fill tray at Location A. In IT-13 and IT-14 there were two random fill cable trays, one at Location A and one at Location B. Each random fill tray had nominally three layers of cables of various types installed. The specific combinations of cables that made up each random fill are provided in Section 6 for each of these tests.

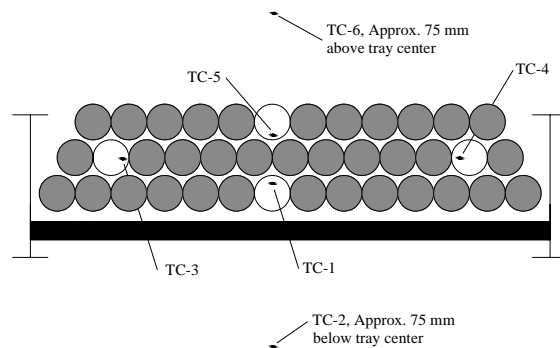
It should be noted that the cable loading for the CAROLFIRE random fill cable trays was lighter than that used by NEI/EPRI. During the NEI/EPRI tests, the cables were tightly packed into the cable trays in well-ordered rows with each row extending from one side rail to the other. This packing arrangement leaves no air passages whatsoever through the cable mass although small air gaps do remain within the cable mass. This type of packing arrangement is common in other types of cable testing, and in particular, in the testing to determine cable ampacity<sup>8</sup> and ampacity derating factors for raceway fire barrier systems. However, it is not common practice for cables to be tightly packed into a cable tray in this manner in actual installations. A more or less random placement of the cables in a tray is rather common for control and instrument circuits in particular. Medium voltage power cables will commonly be installed in a well-ordered “maintained spacing” configuration with each cable individually secured to the cable tray rungs, but even in such applications air gaps are left between adjacent cables to minimize the heating effects for energized cables. In the CAROLFIRE tests, the random fill cable trays used a less ordered arrangement with no attempt made to pack the cables into a minimal space. There was no particular attempt made to create air passages either, rather, the cables were simply laid into the tray 2-4 cables at a time, and then not re-packed. This provides an important compliment to the NEI/EPRI data set with respect to the burning behavior of the cables during the fire tests. In effect, the cables in the NEI/EPRI tests had little chance to burn because the tightly packed arrangement made the cables appear as a single solid mass with little exposed surface area. As will be noted in Section 6 below, for all of the CAROLFIRE tests, all of the cables located directly above the fire source ultimately burned with the fire spreading along the length of the trays to the limits of the test structure, including the random fill cable trays.

<sup>8</sup> “Cable ampacity” refers to the current-carrying capacity of a cable in a given routing configuration, which must be limited in order to ensure that a cable does not exceed its rated maximum operating temperatures when energized.



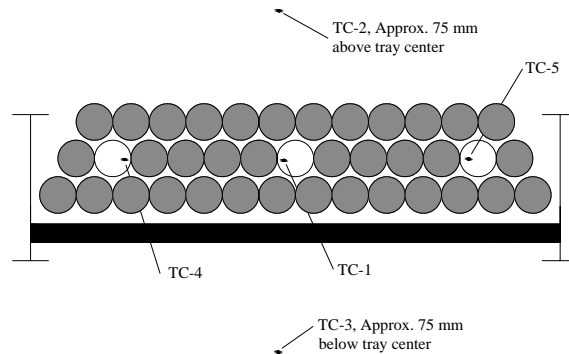
The random fill trays were included in the test program to serve two purposes. First, the random fill trays were located directly above the fire and therefore contributed to the overall burning behavior. Second, our collaborative partners had requested that we include some testing of random fill trays where a small sample of the cables were monitored for thermal response as a complement to the single cable and small bundle tests. Hence, the random fill trays were monitored for thermal response but not for electrical performance.

There were two TC complements used for such trays. The TC complement used in IT-1 included four TCs within the cable mass, a TC that measured the air temperature about 75 mm (3") above the top of the cables, and a TC that measured the air temperature about 75 mm (3") below the bottom of the cables. The placement of the four TCs within the cable mass is illustrated in Figure 3.7.



**Figure 3.7: TC complement for the random fill tray in IT-1.**

IT-13 and IT-14 used a similar arrangement, but had three rather than four TCs embedded within the cable mass. This is illustrated in Figure 3.8.



**Figure 3.8: TC complement for the random fill tray in IT-13 & IT-14.**

Note that for all of these cases, all of the TCs within the cable mass were actually inserted below the jacket of a 7/C cable in the normal manner for such TCs (see 3.2.2 above). In all cases, the

XLPE/CSPE 12 AWG, 7/C (Item #10) cables were used for this purpose. The instrumented cables were then placed in the tray as a part of the cable filling process.

Also note that the tray fills used did not reach the full fill capacity of the trays. Photographs of the random fill trays are provided in Section 6 that illustrates this. As a result, the placement of the instrumented cables was not as precise as these general layout figures might imply. For each test using the random fill trays, the cables were cut to length (1.8 m or 6') and then loaded one by one into the tray. The cables were not purposely routed in any particular manner, but there were also no attempts made to neatly arrange the cables. As the fill process progressed, the instrumented cables were simply placed in the tray in the approximate desired location, again with no particular attempt made to neatly arrange the cables.

### **3.2.5 Air Temperatures in the Intermediate-scale Tests**

During the intermediate-scale tests, certain TCs were used to monitor the air temperature in various locations consistently for all of the tests. These were as follows:

- One TC was installed to monitor the general air temperatures in the outer test enclosure. The main purpose of this TC was to provide a general indication as to whether the test facility experienced general heating.
- Air temperatures were measured at five key locations under the test structure itself; that is, within the enclosed upper portion of the test structure. These five TCs were all of the shielded type, and were inserted through the side walls and the ceiling of the test structure. A small hole was drilled through each panel at the geometric center of the panel. A TC was then inserted through the hole. The measurement tip of the TC was extended to 50 mm (2") beyond the inner surface of the panel. The TC lead wires were secured to the outer framework of the test structure. These TCs were replaced each time the side and/or top panels were replaced. In the data files these were referred to as TCs "Hood North," "Hood East," "Hood South," "Hood West" and "Hood Top."

Note that no attempts were made to measure air temperatures within Penlight because the environment in Penlight was so strongly dominated by radiant heating. A TC placed within Penlight will quickly come to equilibrium at a temperature much closer to that of the shroud than to that of the air. Extensive effort would have been needed to install aspirated and shielded TCs. After consulting with our collaborative partners (NIST and UMd), it was decided not to pursue such measurements.

### **3.2.6 Raceway temperatures**

TCs were also installed to monitor the temperature of the cable trays and conduits. This applies to both the Penlight and intermediate-scale tests.

Sheathed TCs were secured to the outer surface of the conduits by welding a thin band of stainless steel material over the tip of the TC trapping it tightly between the steel band and the outer surface

of the conduit. For the cable trays, the tip of the TCs were attached in a similar manner to side rails and in some cases to the underside of the center-most rung of the tray. Figure 3.9 is a photograph of the conduit used in Penlight testing with three surface TCs installed.



**Figure 3.9: Photograph of the conduit used in Penlight showing three installed surface TCs. Note the three small bright spots along the length of the conduit with the sheathed TC leads running above each secured measurement tip and then out of the picture to the right. Each TC tip was secured to the conduit surface under a small length of stainless steel which was spot-welded to the conduit.**

### **3.3 Other Measures of Fire Behavior**

The CAROLFIRE tests were not designed explicitly as fire characterization tests; that is, the focus of this project was not on fire behavior. The intent was, however, to take an “opportunistic” view of fire behavior data gathering. As opportunities and budgets allowed, fire characterization data was gathered, but not as a project priority. The following subsections describe measurements made using slug calorimeters during the intermediate-scale tests and measurements made of the ventilation conditions and at the outer test facility’s outlet stack.

#### **3.3.1 Intermediate-scale Slug Calorimeters**

As noted in Section 2.2, the thermal response cables used in CAROLFIRE represent, in effect, cable-specific slug calorimeters. However, in addition to the monitoring of these thermal response cables, two more conventional metal slug calorimeters were also used in seven of the intermediate-scale tests; namely, IT-8 through IT-14. Each slug calorimeter was constructed from a 49.3 mm (1.94") length of 19 mm (0.75") diameter brass rod (Alloy 360). The rod diameter was chosen to roughly match the general size of the control cables being tested.

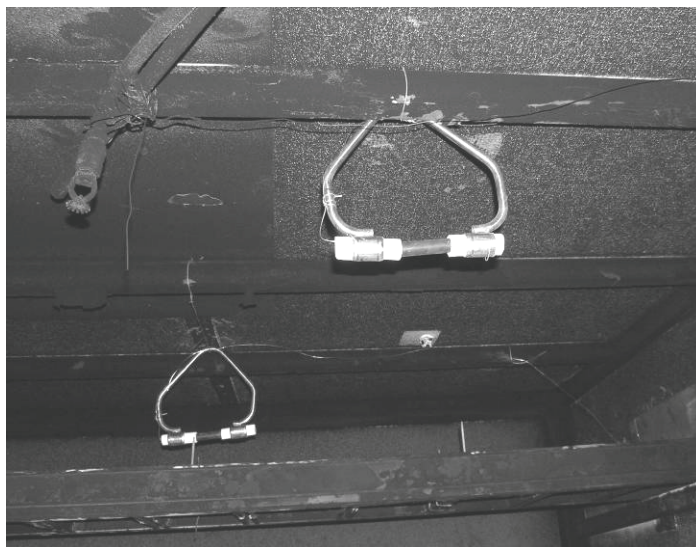
Each cut rod section was drilled down its central axis from one end to the center of the rod using a 1 mm (0.04") drill.<sup>9</sup> The sections were then painted flat-black using high temperature enamel paint. One of the sheathed type-K TCs (1 mm or 0.04" diameter, stainless steel sheathed), was inserted down this hole to the center of the slug.

The two ends of each brass slug were insulated using cylindrical sections of refractory board material slightly larger in diameter than brass slugs themselves (about 25.4 mm or 1"). Note that in order to provide support for the metal slugs, the ends of the brass cylinders were embedded into

---

<sup>9</sup> Note that the final cut length of the brass rod sections was based on twice the distance that technicians were able to drill straight down the center of the rod sections without off-center drift using 1 mm (40 mil) drill bits. The final cut length ensured that the tip of the TC would be at the center of the rod section in both the radial and axial dimensions.

the insulation to a depth of about 4 mm (0.18"). As a result, the central 1.86 mm section of each slug was exposed representing about 96% of the total slug length. The slugs were hung from the top of the test structure support frame using a bent steel rod secured to the insulating material at each end of the slug. One calorimeter was placed near the ceiling (about 152 mm (6") below the ceiling surface) directly above Location F and over the center of the gas burner. The second was placed the same distance below the ceiling and directly above location 'G'. Figure 3.10 provides a photograph of the two calorimeters in place in the test structure. The photograph was taken from the north side of the test structure looking south so the calorimeter in the foreground is the one above Location F.



**Figure 3.10: Picture of the two brass slug calorimeters in place in the test structure during intermediate-scale tests IT-8 through IT-14.**

### **3.3.2 Ventilation and Outlet Stack Data for the Intermediate-Scale Tests**

As noted in Section 2 above, air flow in the general outer test facility was nominally provided by a forced air inlet fan and nature outlet flow through a ventilation stack at the east end of the facility and directly above the test structure (see description of IT-8 for the only exception to this configuration). Data measurement included monitoring of conditions in the outlet stack; namely, the oxygen concentration, temperature, and flow velocity via a bi-directional pressure probe were recorded.

The measurements do allow for nominal oxygen consumption calorimetry calculations, a technique that can estimate a fire's HRR based on a distinct correlation between the rate of oxygen consumption and the heat released by the fire [8]. However, in practice there was a substantial delay between changes in fire intensity and the detection of those changes at the stack. This type of delay is an inevitable aspect of room fire tests, but the effect was particularly severe for the CAROLFIRE tests. The test conditions in the outer test facility were intended to be relatively quiescent. Hence, the net air flow rate through the facility was relatively low. A smoke curtain extending about 4 feet down from the ceiling of the outer test facility was installed halfway back into the facility. This smoke curtain did help to direct the fire products towards the stack. Even with the smoke curtain, the

test structure and the outer test facility both acted as capacitive elements in this process leading to the delay at the stack.

The stack delays were pronounced enough that the HRR calculations based on the stack data proved to be of relatively little use. The stack data were recorded in the data files and is also reported in raw form in the discussion of test results below. However, oxygen consumption calorimetry calculations were only attempted for two of the intermediate-scale preliminary tests, primarily as a cross-check on the gas burner flow rate versus HRR relationship and in an attempt to estimate the burner's combustion efficiency. Given the poor quality of the results, these calculations have not been reported here.

### **3.4 Cable Electrical Performance**

Two principal methods of the electrical monitoring were used to assess cable performance and to determine when electrical failure occurred. Both systems have been described in detail in Volume 1 of this report. The following two sub-sections provide summary descriptions of these systems. The SNL Insulation Resistance Measurement System (IRMS) is described in Section 3.4.1. The Surrogate Circuit Diagnostic Units (SCDUs) are described in Section 3.4.2.

#### **3.4.1 The IRMS**

The SNL IRMS, pictured in Figure 3.11, can monitor the insulation resistance (IR) between any pair of individual conductors, between any conductor and ground, between groups of conductors (e.g., between two separate cables), and between a group of conductors and ground. For CAROLFIRE all these modes of operation were used. The IRMS is described in detail in Appendix B.

In general, when complimentary sets of thermal response and electrical performance cables were deployed in testing, the electrical performance cables were monitored via the IRMS. Hence, it is the IRMS results which will be of primary interest to the fire modeling need area as it is these results that can be most directly correlated to the thermal response measurements.

The IRMS provides a continuous stream of cable IR data. Hence, the progressive degradation of the cable's insulating power was determined. As discussed in Volume 1, in the analysis of the IRMS data a control cable was considered to have failed when any one of the monitored conductors shorts to ground (e.g., the cable tray or conduit) or to another conductor with an insulation resistance less than or equal to 1000 ohms. The data plots presented in this report do include cable electrical failure plots overlaid onto the complementary thermal response plots. In these cases, only the initial failures were illustrated. That is, while the IRMS detected cascading cable faults, in the context of fire modeling the initial onset of electrical failure is the behavior of primary interest.

#### **3.4.2 The SCDUs**

In addition to the IRMS, cable failures were also monitored using surrogate control/instrument circuits referred to as the Surrogate Circuit Diagnostic Units (SCDUs). A total for four SCDUs were constructed for use in CAROLFIRE. The various modes of operation used with the SCDUs are

described in detail in Volume 1 of this report. Figure 3.11 provides a photograph of the four SCDUs in their electrical rack. Each of the four white panels visible in the lower part of the rack represents one SCDU.

In general, the SCDUs were not deployed in direct conjunction with thermal response cables. Therefore the SCDU results are less relevant to the fire modeling improvement need area as compared to the IRMS results.



**Figure 3.11: Photograph of the IRMS (left) and SCDU racks.**

## 4 TEST MATRICES

### 4.1 Overview of Test Matrices

Tables are presented below for both the *Penlight* and intermediate-scale tests. The tables are deferred to the end of the chapter given their length. A goal of the program was to maintain the option to adjust the test matrices based on insights gained as the program progressed. Adjustments were in fact made at various points in the program, and always in consultation with both the NRC staff and collaborative partners NIST and UMD. The test matrices described here document the tests as performed. Some of the tests originally planned for *Penlight* were ultimately deleted and not performed. In order to maintain continuity relative to the naming of the tests, these deleted tests were still shown in the matrix, although they were indicated as “did not run.” The test numbers as used in these matrices correspond directly to the test designations used in the naming of data files as well.

For each test, a number of relevant factors were defined. At both testing scales a certain number of ‘preliminary’ tests were conducted prior to entering the primary test matrix, and these were numbered separately from the primary tests. Each test has been given a unique test prefix and number. The prefix “PP” indicates Preliminary *Penlight* tests, PT indicates *Penlight* Tests in the primary *Penlight* matrix, IP indicates Intermediate-scale Preliminary tests, and IT indicates Intermediate-scale Tests in the primary matrix. Note that all tests provided some insights relevant to one or both need areas, and have been analyzed and reported accordingly.

For the other cited test parameters, an “X” in any given column indicates the active choice for each experimental variable. In some cases, multiple choices have been indicated (e.g., more than one cable type was often involved and, in the intermediate-scale tests, more than one raceway type was often tested). The primary test variables were:

Cable Insulation and Jacket Material - specifies the cable insulation and jacket materials for the cables being tested, the type of cable,  
Number of Conductors - specifies the number of conductors contained within the cable,  
Conductor Size - identifies the AWG size of the copper conductors within the cable,  
Cable Bundle Size - indicates the number of cables in each bundle of cables to be included in the test (note that some intermediate-scale tests involve more than one cable bundle),  
Thermal Exposure - specifies the thermal exposure conditions which vary somewhat depending on the test facility. For *Penlight*, the thermal exposure was defined by the incident heat flux (or equivalently the shroud temperature). For the Intermediate-Scale open burn tests, the thermal exposure was defined by the nominal intensity of the gas burner, and  
Raceway Type - indicates how the cable or cable bundles were routed. Raceway types were no raceway (air drop), cable tray, and conduit (for *Penlight*, only one raceway type is indicated but for the intermediate-scale tests multiple raceway types may be indicated).

The intermediate-scale test matrix has one additional column (third from left):

Location - indicates the raceway locations in the Intermediate-Scale Test Structure. Note that these tests all involve cables located in more than one of the available locations. These locations were identified by letter (A-G) and are shown schematically in Figure 3.6.

## 4.2 The *Penlight* Small-Scale Test Matrix

Table 4.1 provides a test matrix for the Preliminary *Penlight* tests (PP-1 through PP-26). These tests were performed primarily in order to assess the general relationship between shroud temperature and the cables' electrical failure times.

Table 4.2 provides the primary matrix of *Penlight* Tests (PT-1 through PT-68 and Special Test S1). These tests have been organized into several groups. Each test group represented a set of tests designed to explore a particular aspect of the overall cable failure behavior. The general nature of each test group is described in the following paragraphs.

The tests identified as Group 1 were primarily fire model calibration tests. That is, these tests were primarily aimed at the fire modeling improvement need area. The primary objective of the Group 1 tests was to provide temperature response data to support the development of the cable thermal response models. The Group 1 tests represented the most simplistic of all possible cable exposure configurations. Each test in Group 1 involved two single lengths of cable either in open air, in a cable tray, or in a conduit. One cable was monitored for thermal response, and the second (in a symmetric location) was monitored for electrical failure using the IRMS. For the tray test, the two lengths of cables were located in symmetric locations to either side of the cable tray's horizontal centerline. For the conduit and air-drop tests, the two cables were routed side-by-side. The main purpose of the Group 1 tests was to correlate the cable's thermal response and electrical performance under simplistic exposure conditions. The Group 1 tests were not relevant to resolution of the Bin 2 items because the Bin 2 Items are not generally associated with the failure of individual cables.

The remaining test groups were designed to progressively address the Bin 2 items with increasing degrees of complexity and through variations in test parameters. In general, Group 2 represented the Bin 2 baseline test runs. These tests represented a core set of failure mode tests providing initial results relevant to the Bin 2 items with small and simple bundles of like cables. The remaining *Penlight* tests represented variations on the Group 2 tests. Each subsequent test varied one or more of the testing parameters (e.g., exposure heat flux, cable type, mixing of cable types, bundle size, etc.). These *Penlight* tests were particularly designed to address Bin 2 Items A and B, those items associated with inter-cable shorting.

Note that some of the tests listed in the matrix include the notation "did not run." These tests were, in fact, not conducted, but were maintained in the test matrix in the interest of continuity of the test numbering scheme used during the test planning process and during initial distributions of preliminary test data to the CAROLFIRE collaborative partners. The reasons why specific tests or groups of tests were not conducted have been explained in Chapter 6 in conjunction with the discussion of test results.



### **4.3 The Intermediate-Scale Test Matrix**

Table 4.3 provides a test matrix for the intermediate-scale tests. There were four Intermediate Preliminary Tests (IP-1 through IP-4) and 14 primary matrix Intermediate Tests (IT-1 through IT-14). All of the intermediate-scale tests provided data directly relevant to resolution of the Bin 2 Items and, as has been noted above, involved increasing levels of configuration complexity and the variation of test parameters.

Note that just one IRMS was used in intermediate-scale tests IP-1 through IT-5. Beginning with IT-6, two IRMS units were used in each test. The SCDUs were used starting with Test IP-3 and throughout the remainder of the intermediate-scale test series. Test IP-3 used one SCUDU and the remaining tests all used all four SCDUs. The exact configurations of these systems are detailed in the accompanying data files, and are summarized in Section 6 below with additional detail available in Volume 1 of this report.

**Table 4.1: Matrix of Preliminary Penlight Tests (PP-1 through PP-26).**

Test PP #	Cable Insulation Material						Cable Item number	Number of Conductors				Conductor Size (AWG)					Cable Bundle Size			Thermal Exposure °C	Raceway Type		
	TS		TS/TP	Vita-Link	TP			3	2	7	12	8	12	14	16	18	1	3	6		Tray	Conduit	Air Drop
	XLPE	EPR			SR	XLPO																	
1	X							X								X			X				
2																							
All data lost																							
3	X							X								X			X				
4								X								X			X				
5								X								X			X				
6	X							X								X			X				
7								X								X			X				
8								X								X			X				
9	X							X								X			X				
10								X								X			X				
11								X								X			X				
12								X								X			X				
13								X								X			X				
14								X								X			X				
15								X								X			X				
16	X							X								X			X				
17								X								X			X				
18								X								X			X				
19								X								X			X				
20								X								X			X				
21								X								X			X				
22								X								X			X				
23								X								X			X				
24								X								X			X				
25	X							X								X			X				
26	X							X								X			X				

**Table 4.2: Primary Matrix of CAROLFIRE Penlight Tests (PT-1 through PT-68 and Spec. 1)**

Test PT-#	Primary Application	Cable Insulation and Jacket Material								Cable Item numbers	Number of Conductors				Conductor Size (AWG)	Cable Bundle Size			Thermal Exposure °C (°F) (note 1)	Raceway Type			Group #									
		TS/TS				TP/TP					3	2	7	12		8	12	14		16	18	1		3	6	Tray	Conduit	Air Drop				
		XLPE/CSPF	EPR/CPE	SR/Aramid	XLPO/XLPO	Vita-Link	XLPE/PVC	TS/TP	PE/PVC	PVC/PVC	Tefzel/Tefzel																					
1	FMI	X											14	X	X											X					1	
2	FMI	X											14	X	X												X					
3	FMI	X											14	X													X					
4	FMI									X			5	X													X					
5	FMI									X			5	X													X					
6	FMI									X			5	X													X					
7	FMI	X											14	X													X					
8	FMI									X			5	X													X					
9	FMI	X											14	X													X					
10	FMI									X			5	X													X					
11	FMI	X											10													X						
12	FMI	X											10												X		X					
13	FMI	X											10												X		X					
14	FMI												15		X										X		X					
15	FMI												15		X										X		X					
16	FMI												15		X										X		X					
17	FMI		X										2												X		X					
18	FMI							X					9												X		X					
19	FMI												8												X		X					

**Table 4.2: Primary Matrix of CAROLFIRE Penlight Tests (PT-1 through PT-68 and Spec. 1)**

Test PT-#	Primary Application	Cable Insulation and Jacket Material							Cable Item numbers	Number of Conductors				Conductor Size (AWG)					Cable Bundle Size			Thermal Exposure °C (°F) (note 1)	Raceway Type			Group #
		XLPE/CSP	EPR/CPE	SR/Aramid	XLPO/XLPO	Vita-Link	TS/TP	TP/TP		3	7	12	8	12	14	16	18	1	3	6	Tray		Conduit	Air Drop		
20	FMI						X		3	X						X			470 (878)	X						
21	FMI							X	1	X						X			300 (572)	X						
22	FMI							X	12	X						X			470 (878)	X						
23	FMI	X							10	X						X			470 (878)		X					
24	FMI	X							10	X						X			470 (878)		X					
25	FMI							X	15	X						X			325 (617)		X					
26	FMI							X	15	X						X			325 (617)		X					
27	FMI	X							10	X						X			470 (878)			X				
28	FMI	X							10	X						X			470 (878)			X				
29	FMI							X	15	X						X			325 (617)			X				
30	FMI							X	15	X						X			325 (617)			X				
31	FMI							X	11	X						X			700 (1292)			X				
32	Note 2							X	11	X						X			NOT RUN			X				
33	Note 2							X	11	X						X			NOT RUN				X			
34	2-A, C	X							10	X						X			525 (977)	X						
35	2-B, C	X						X	10&15	X						X			525 (977)	X						
36	2-A, C	X							10	X						X			525 (977)		X					
37	2-B, C	X						X	10&15	X						X			525 (977)		X					
38	Note 3	X							10	X						X			NOT RUN	X						
39	Note 3	X						X	10&15	X						X			NOT RUN	X						

**Table 4.2: Primary Matrix of CAROLFIRE Penlight Tests (PT-1 through PT-68 and Spec. 1)**

Test PT-#	Primary Application	Cable Insulation and Jacket Material						Cable Item numbers	Number of Conductors				Conductor Size (AWG)					Cable Bundle Size			Thermal Exposure °C (°F) (note 1)	Raceway Type			Group #														
		XLPE/CSP/EPR/CPE	SR/Aramid	XLPO/XLPO	Vita-Link	TS/TP			TP/TP		3	7	12	8	12	14	16	18	1	3		6	Tray	Conduit		Air Drop													
40	Note 3					X																														X			X
41	Note 3	X																	X			X																	
42	2-A, C	X																																					
43	2-B, C																																						
44	2-A, B, C	X	X	X															X	X	X	X																	
45	2-A, B, C	X	X	X															X	X	X	X																	
46	2-A, B, C	X																	X																				
47	2-A, C	X																	X																				
48	2-B, C																		X	X	X	X																	
49	2-A, B, C	X	X	X															X	X	X	X																	
50	2-A, B, C	X	X	X															X	X	X	X																	
51	Note 3	X																	10&2																				
52	Note 3																		2&15																				
53	Note 3	X	X	X															10,2,9,8,15 &12																				
54	Note 3	X	X	X															10,2,9,8,15 &12																				
55	Note 3	X	X	X															10,2,3,15,1 &12																				

**Table 4.2: Primary Matrix of CAROLFIRE Penlight Tests (PT-1 through PT-68 and Spec. 1)**

Test PT-#	Primary Application	Cable Insulation and Jacket Material						Cable Item numbers	Number of Conductors						Conductor Size (AWG)					Cable Bundle Size			Thermal Exposure °C (°F) (note 1)	Raceway Type			Group #																							
		TS/TS		TS/TP		TP/TP			3	2	7	12	8	12	14	16	18	1	3	6	Tray	Conduit		Air Drop																										
		XLPE/CSP	EPR/CPE	SR/Aramid	XLPO/XLPO	Vita-Link	XLPE/PVC																		PE/PVC	PVC/PVC		Tefzel/Tefzel																						
56	Note 3	X	X							X								X			X																													
57	Note 3		X							X								X			X																													
58	Note 3	X	X							X								X			X																													
59	Note 3	X	X							X								X			X																													
60	2-A, C										X							X			X																													
61	2-A, C										X							X			X																													
62	2-A, C	X																			X																													
63	2-B, C																				X																													
64	2-A, C	X																			X																													
65	2-B, C																				X																													
66	Note 2	X																			X																													
67	Note 2																				X																													
68	2-A, B, C	X	X							X											X																													
Spec1	Note 5																				X																													

---

## Notes for Table 4.2:

General notes on field entries:

‘Not Run’ in the exposure conditions column means the test was not conducted. These tests were dropped from testing per the additional notes below (see Notes 2 and 3).

‘FMI’ = Test is primarily aimed at the Fire Modeling Improvement need area.

‘2-A, B, C’ = Test is primarily aimed as resolution of Bin 2, Items A, B, and/or C.

1. Thermal Exposure conditions (Column 25) are shown based on shroud temperature but actual exposure was radiant heating. These were not oven tests.
  2. Based on the results of preliminary testing and Test 31, those subsequent tests involving the Vitalink cable in *Penlight* were not conducted. As a result, Tests 32, 33, 66 and 67 were not performed
  3. Initial plans had called for the conduct of testing at two flux levels (one high flux condition and one low flux condition). Based on peer review feedback, it was decided to run all tests at the same heat flux (an intermediate flux value appropriate to each cable configuration). As a result, those tests originally planned as repeated test configurations performed under low flux conditions (Groups 3 and 5, Tests - and 51-59) were not conducted.
  4. At the request of the fire modeling teams, the tests in groups 7 and 8 were revised to provide additional thermal response data for single cables of varying plastic to copper content.
  5. Special Test 1 (Spec1) was added to the matrix at the request of the fire modeling teams. This was a thermal-monitoring test only involving more extensive temperature response measurements for a cable bundle in conjunction with a single cable. This test involved no electrical functionality monitoring. The exposure conditions for this test were varied. The exposure began at 350°C, was increased to 360°C and then increased again to 375°C. See data file for details.
-

**Table 4.3: Matrix of Intermediate-scale Tests (IP-1 through IT-14).**

Test #	Location	Cable Insulation Material								Number of Conductors				Cable Bundle Size				Raceway Type				
		TS				Vita-Link	TP			3	2	7	12	1	3	6	12	Load Tray	Water Spray	Tray	Conduit	Air Drop
		XLPE	EPR	Silicone	XLPO		TS/TP	PE	PVC													
IP1	A	X								X				X					X			
	A	X									X			X					X			
IP2	A	X								X				X					X			
	A	X									X			X					X			
IP3	A									X				X					X			
	A									X				X					X			
IP4	A									X				X					X			
	A	X									X			X					X			
IT1	B	X												X					X			
	D	X												X					X			
	E	X												X					X			
	G	X												X					X			
	A	X												X					X			
	C	X												X					X			
	A	X								X				X					X			
IT2	C	X								X				X					X			
	C-A													X					X		X	
	E									X				X					X			
	G									X				X					X			
											X			X					X			



**Table 4.3: Matrix of Intermediate-scale Tests (IP-1 through IT-14).**

Test #	Location	Cable Insulation Material								Number of Conductors				Cable Bundle Size					Raceway Type			
		TS				Vita-Link	TP			3	2	7	12	1	3	6	12	Load Tray	Water Spray	Tray	Conduit	Air Drop
		XLPE	EPR	Silicone	XLPO		TS/TP	PE	PVC													
IT3	A	X	X												X				X			
	C	X	X									X			X				X			
	A		X				X					X			X				X			
	C		X				X					X			X				X			
	E											X			X				X			
	G											X			X				X			
												X			X				X			
IT4	A	X	X		X	X	X				X				X				X			
	C	X	X		X	X	X				X				X				X			
	A	X	X			X	X				X				X				X			
	C	X	X			X	X				X				X				X			
	C-A	X	X			X	X				X				X				X		X	
	E	X													X				X			
	G	X													X				X			
IT5	A	X	X		X		X			X					X			X	X			
	C	X	X		X		X			X					X			X	X			
	A	X	X		X		X			X					X			X	X			
	C	X	X		X		X			X					X			X	X			
	C-A	X								X					X			X	X		X	
	E		X												X			X	X		X	
	G		X												X			X	X		X	

**Table 4.3: Matrix of Intermediate-scale Tests (IP-1 through IT-14).**

Test #	Location	Cable Insulation Material								Number of Conductors				Cable Bundle Size					Raceway Type				
		TS				TP				3	2	7	12	1	3	6	12	Load Tray	Water Spray	Tray	Conduit	Air Drop	
XLPE	EPR	Silicone	XLPO	TS/TP	Vita-Link	PE	PVC	Tetzel	1														3
IT6	A	X	X	X	X		X	X	X							X		X	X				
	C	X	X	X	X		X	X	X							X		X	X	X			
	E	X					X	X	X							X						X	
	C-A	X					X	X	X							X			X	X			X
IT7	A		X	X	X	X	X	X	X							X		X	X	X			
	C		X	X	X	X	X	X	X							X		X	X	X			
	G		X	X	X	X	X	X	X							X		X	X	X			
	A	X	X		X	X	X	X	X							X		X	X	X			
	A	X	X		X	X	X	X	X							X		X	X	X			
	C	X	X		X	X	X	X	X							X		X	X	X			
	E	X			X	X	X	X	X							X		X	X	X			
	G	X	X		X	X	X	X	X							X		X	X	X			
IT8	A	X					X	X	X														
	A	X					X	X	X														
	C	X					X	X	X														
	E	X					X	X	X														
	G	X					X	X	X														
	A	X	X				X	X	X														
	E	X					X	X	X														
IT9	A	X	X	X		X		X	X									X	X	X			
	A	X	X	X		X		X	X									X	X	X			
	C	X	X	X		X		X	X									X	X	X			
	E	X						X	X									X	X	X			
	A	X	X	X		X		X	X									X	X	X			
	G	X	X	X		X		X	X									X	X	X			

**Table 4.3: Matrix of Intermediate-scale Tests (IP-1 through IT-14).**

Test #	Location	Cable Insulation Material								Number of Conductors				Cable Bundle Size					Raceway Type									
		TS				Vita-Link				TP				3	2	7	12	1	3	6	12	Load Tray	Water Spray	Tray	Conduit	Air Drop		
		XLPE	EPR	Silicone	XLPO	TS/TP	TS/TP	PE	PVC	Tetzel																		
IT10	A	X	X	X	X	X	X	X	X	X	X	X	X	X	X	X	X	X	X	X	X	X	X	X	X			
	A	X	X	X	X	X	X	X	X	X	X	X	X	X	X	X	X	X	X	X	X	X	X	X	X	X		
	C	X	X	X	X	X	X	X	X	X	X	X	X	X	X	X	X	X	X	X	X	X	X	X	X	X		
	E	X	X	X	X	X	X	X	X	X	X	X	X	X	X	X	X	X	X	X	X	X	X	X	X	X		
	G	X	X	X	X	X	X	X	X	X	X	X	X	X	X	X	X	X	X	X	X	X	X	X	X	X		
IT11	A	X	X	X	X	X	X	X	X	X	X	X	X	X	X	X	X	X	X	X	X	X	X	X	X	X		
	A	X	X	X	X	X	X	X	X	X	X	X	X	X	X	X	X	X	X	X	X	X	X	X	X	X		
	C	X	X	X	X	X	X	X	X	X	X	X	X	X	X	X	X	X	X	X	X	X	X	X	X	X		
	E	X	X	X	X	X	X	X	X	X	X	X	X	X	X	X	X	X	X	X	X	X	X	X	X	X		
	G	X	X	X	X	X	X	X	X	X	X	X	X	X	X	X	X	X	X	X	X	X	X	X	X	X		
IT12	A	X	X	X	X	X	X	X	X	X	X	X	X	X	X	X	X	X	X	X	X	X	X	X	X	X		
	A	X	X	X	X	X	X	X	X	X	X	X	X	X	X	X	X	X	X	X	X	X	X	X	X	X		
	C	X	X	X	X	X	X	X	X	X	X	X	X	X	X	X	X	X	X	X	X	X	X	X	X	X		
	E	X	X	X	X	X	X	X	X	X	X	X	X	X	X	X	X	X	X	X	X	X	X	X	X	X		
	G	X	X	X	X	X	X	X	X	X	X	X	X	X	X	X	X	X	X	X	X	X	X	X	X	X		
IT13	A	X	X	X	X	X	X	X	X	X	X	X	X	X	X	X	X	X	X	X	X	X	X	X	X	X		
	C	X	X	X	X	X	X	X	X	X	X	X	X	X	X	X	X	X	X	X	X	X	X	X	X	X		
	E	X	X	X	X	X	X	X	X	X	X	X	X	X	X	X	X	X	X	X	X	X	X	X	X	X		
	F	X	X	X	X	X	X	X	X	X	X	X	X	X	X	X	X	X	X	X	X	X	X	X	X	X		
	F	X	X	X	X	X	X	X	X	X	X	X	X	X	X	X	X	X	X	X	X	X	X	X	X	X		

**Table 4.3: Matrix of Intermediate-scale Tests (IP-1 through IT-14).**

Test #	Location	Cable Insulation Material								Number of Conductors				Cable Bundle Size				Water Spray		Raceway Type			
		TS				TP				3	2	7	12	1	3	6	12	Load Tray	Water Spray	Tray	Conduit	Air Drop	
		XLPE	EPR	Silicone	XLPO	TS/TP	Vita-Link	PE	PVC														Tetzel
IT14	A	X	X		X	X			X									X					
	C	X	X		X	X			X			X						X					
	E					X			X			X									X		
	F	X	X			X			X			X									X		
	F	X	X			X			X			X									X		
	G	X	X			X			X			X									X		
	G	X	X			X			X			X									X		
	G	X	X			X			X			X									X		

## 5 ANALYSIS OF THE *PENLIGHT* SMALL-SCALE TEST SERIES

### 5.1 Introduction and Organization

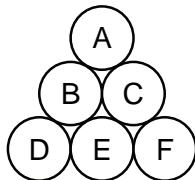
This Section summarizes the results of the Penlight tests in the context of the fire modeling improvement need area. Section 5.1 covers those tests involving individual cable lengths. Within this section, the discussions were organized by grouping the results based on the cable insulation/jacket material configuration. For example, Section 5.1.1 discusses those tests involving XLPE/CSPE cables.

Section 5.2 describes the results for the Penlight tests with cable bundles, including in particular the ‘special thermal test’ performed explicitly to support the fire modeling improvement need area. In this case, the results were organized based on grouping the results for tests involving bundles of like cables (e.g. all XLPE/CSPE cables), tests involving mixed bundles of different TS cables, and tests involving mixed bundles of both TS and TP cables.

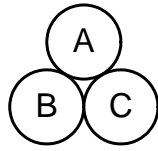
Note that the data presented here represent only a sampling of the data available from the tests. Data plots have been prepared to illustrate key behaviors. However, due to the sheer volume of data it was not practical to provide a complete presentation of all of the data gathered during the 98 CAROLFIRE tests. The reader is referred to the accompanying data files for the full data sets.

All of the Penlight tests were conducted in a very similar manner. The tests involved one of three cable arrangements; namely, (1) single lengths of cable in trays, conduits or air drops (the preliminary tests and Groups 1, 7 & 8 from the primary matrix), (2) a six-cable bundle monitored for electrical performance plus a single length of cable for thermal response monitoring in a cable tray, and (3) bundles of three cables in a conduit. Note that in addition one ‘special thermal test’ was also conducted with a 6-cable bundle monitored only for thermal response.

For the 6-bundle cable tray tests, the cables were identified using a consistent lettering scheme with cables A-F arranged per the following illustration:



In this case, the rungs of the tray were below cables D-E-F. Similarly, the three cable bundle conduits tests used a bundle configuration and lettering scheme per the following illustration:



Note that cables B and C rest on the bottom of the conduit. For each of the Penlight tests involving more than one cable the test configuration summary will identify the cables present using these two lettering schemes.

For the Penlight tests, all electrical performance monitoring was based on use of the IRMS. The configurations that were used in these tests are described in detail in Volume 1 of this report. The presentation of results here will focus on the first fault modes detected for any given test cable. Volume 1 included extensive description of the fault modes and fault progressions.

The Penlight Preliminary tests and several of the tests in the primary matrix involved the testing of two single lengths of cable of the same cable type. In each of these tests, one cable was monitored for electrical performance, and the second for thermal response. These tests involved all of the various CAROLFIRE cables and were run under a wide variety of conditions with respect to both the exposure heat flux and routing configuration.

The tests on individual lengths of cable were designed to serve two purposes. First, they provided data upon which to base the initial development and calibration of the cable thermal response and failure models under well controlled, well characterized simplistic exposure conditions. Second, they provided a general assessment of the relationship between exposure heat flux and time to electrical failure for each of the cable types.

All of tests with individual cable lengths were aimed directly at the fire modeling improvement need area; hence, they will be used to illustrate a number of fundamental behaviors explored by CAROLFIRE. In particular, those tests involving individual lengths of the XLPE/CSPE cables have been used to illustrate a number of points relative to various behaviors observed in testing. This is covered in Section 5.2. Section 5.3 then provides data samples taken from the tests involving individual cable lengths for the other cable types. Section 5.4 discusses the Penlight tests involving cable bundles. Finally, Section 5.5 analyzes the test data from the Penlight single cable tests focusing on correlating the thermal response and electrical performance results for the various cable types.

As a final note, the time index used in the plots presented in this Chapter were all based on the “Penlight time” as reported in the corresponding data files. Also provided in the data files is a second set of time records referred to as the “DAQ time.” DAQ time reflects the raw data acquisition time as originally recorded in the data files and was indexed to the time when the data acquisition systems were started. Every test included a period of pre-heating baseline data, and the duration of the baseline data period varied from test to test. The “Penlight time” has been indexed such that time=0 corresponds to when Penlight heating was initiated. The difference between the two time

record sets was simply the duration of the baseline data logging period (this value was recorded on the “Test Facts” sheet in each data file).

## 5.2 XLPE/CSPE Cables and Fundamental Behaviors Observed in Testing

This section illustrates a number of fundamental test behaviors observed during the Penlight tests. The tests involving individual lengths of the XLPE/CSPE cables have been used to illustrate these behaviors. Again, given the extensive nature of the test data, the illustrations shown represent only a sampling of the available data. However, the samples have been chosen to illustrate the behaviors of potential interest to the developers of fire modeling tools focusing in particular on the testing protocol, behavior of the *Penlight* shroud, and general aspects of the experimental data gathered. Note that Section 5.5 provides additional information that correlates the electrical performance and thermal response of the various cables tested in CAROLFIRE, including the XLPE/CSPE cables.

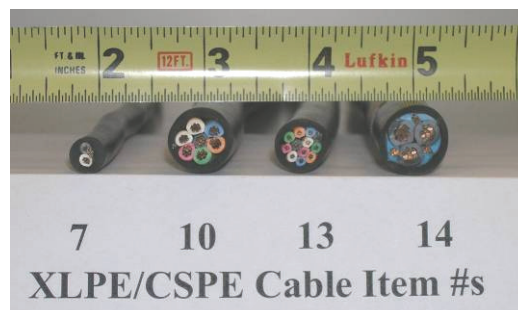
Behaviors that were explored include:

- Thermal response as a function of location within the cable (5.2.1)
- Repeatability of the Penlight exposure conditions (5.2.2)
- Repeatability in the cable thermal and electrical performance (5.2.3)
- The effects of copper-to-plastic content on cable response (5.2.4)
- The effects of cable routing configuration on cable response (5.2.5)

The XLPE-insulated, CSPE-jacketed (XLPE/CSPE) cables were the ‘core’ TS cable for the project. As such, it was tested repeatedly, and in four conductor configurations as follows:

- Cable Item #7: 16 AWG, 2/C(Sh), instrument cable
- Cable Item #10: 12 AWG, 7/C, control cable
- Cable Item #13: 18 AWG, 12/C, instrument/indication cable
- Cable Item #14: 8 AWG, 3/C, light power cable

Figure 5.1 is an end-view photograph taken with these four cables sitting side by side. Note that the 2/C 16 AWG cable (Item #7 to the left) was much smaller than the other cables. The other three cables had a similar outside diameter.



**Figure 5.1: Photograph that compares the four XLPE/CSPE cables used in CAROLFIRE.**

There were a total of 21 Penlight tests involving single lengths of XLPE/CSPE cables. The conditions for these tests are summarized in Table 5.1. Note that testing included all four conductor configurations, and the testing of cable trays, conduits and air drop routing configurations.

Note that there were several test groups that essentially represent repeats of a given test configuration. Certain tests were repeated in order to assess the general repeatability of the experiments, and this did include repeats on various XLPE/CSPE cable tests. To illustrate various points, Tests PT-11, PT-12, and PT-13 as direct repeat tests will be examined in some detail. All three tests involved cable item #10 in a cable tray at a shroud temperature of 470°C (878°F). In addition, tests PT-9, PT-11 and PT-62 will be examined to illustrate how the cable type impacted the test results.

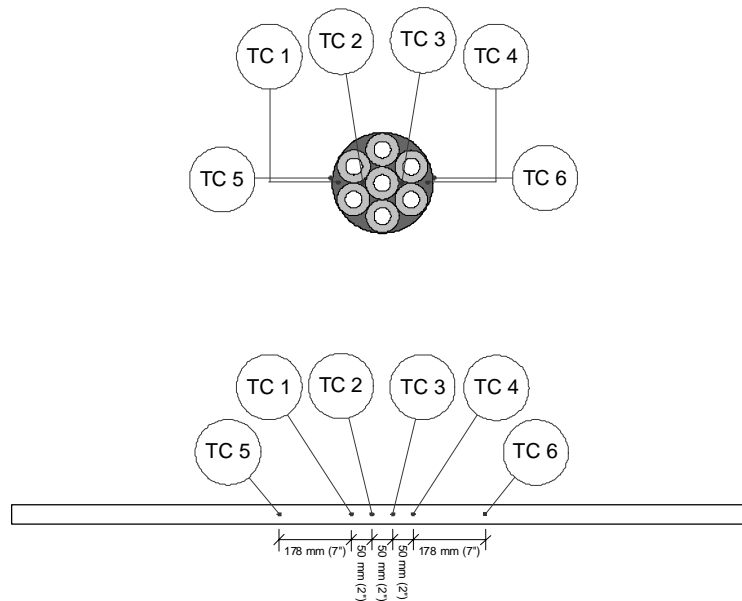
**Table 5.1: Penlight tests involving single lengths of XLPE/CSPE cables.**

Test #	Cable Item number	Number of Conductors				Conductor Size (AWG)				Shroud Temp. (°C)	Raceway Type		
		3	2	7	12	8	12	16	18		Tray	Conduit	Air Drop
PP-1	10			X			X			665	X		
PP-3	10			X			X			600	X		
PP-6	10			X			X			665	X		
PP-9	10			X			X			500	X		
PP-16	10			X			X			475	X		
PP-25	10			X			X			665		X	
PP-26	10			X			X			665	X		
PT-1	14	X				X				475	X		
PT-2	14	X				X				470	X		
PT-3	14	X				X				470	X		
PT-7	14	X				X				470		X	
PT-9	14	X				X				470			X
PT-11	10			X			X			470	X		
PT-12	10			X			X			470	X		
PT-13	10			X			X			470	X		
PT-23	10			X			X			470		X	
PT-24	10			X			X			470		X	
PT-27	10			X			X			470			X
PT-28	10			X			X			470			X
PT-62	13				X				X	470	X		
PT-64	7		X					X		470	X		



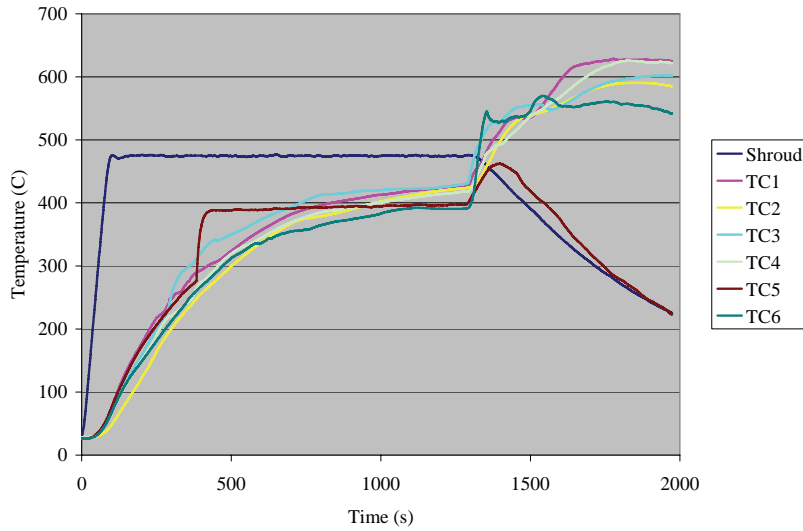
### 5.2.1 Thermal Response as a Function of Location within the Cable and General Electrical Performance Behavior

One aspect of the CAROLFIRE tests was an assessment of the thermal response of the cables as a function of the location within the cable. For example, in PT-11 there were six TCs installed on and within the thermal response cable. These locations are illustrated in Figure 5.2. Note that TC1 and TC4 were located just below the jacket, TC5 and TC6 were attached to the cable surface (with tape as described above), and TC2 and TC3 were embedded deeper within the cable below the outer layer of conductors on either side of the central conductor. The measured thermal response is illustrated in Figure 5.3.



**Figure 5.2: Placement of the TCs in a typical fully instrumented 7/C thermal response cable such as those tested in PT-11, PT-12, and PT-13. The upper illustration shows a cross-section of the cable and indicates where each TC was placed. The lower illustration shows how the TCs were distributed along the length of the cable.**

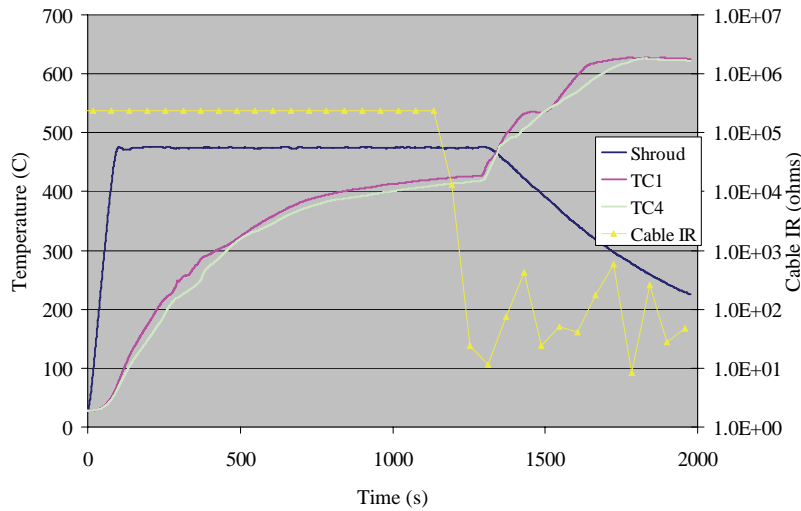
There are a number of interesting behaviors illustrated in this plot. First note the behavior of TC5 and TC6. While both were attached to the cable surface, they showed markedly different behavior. It was likely that TC5 separated from the cable surface and began to register direct radiant heating from the shroud. TC6 in contrast lags the other TCs present, likely due to the fiberglass tape overwrap. The other TCs were all embedded within the cable and showed relatively consistent behavior. The behavior of the surface TCs in this test was typical of the surface-mounted TCs in general. These surface TCs generally yielded conflicting and unreliable data. This illustrates why SNL's preferred practice has been to embed TCs below the cable jacket rather than attach them to the surface (as discussed in Section 2 above).



**Figure 5.3: Cable thermal response during PT-11**

Also note that electrical failure of the electrical performance cable was observed at about 1225 s. Concurrent with failure, the electrical performance cable did ignite, and shortly thereafter the thermal response cable also ignited. Cable ignition led to the jump in measured temperatures after this time.

Figure 5.4 illustrates the corresponding electrical failure data for the electrical performance cable. Shown in this plot are the shroud temperature, the two TCs just below the cable jacket, and a representative plot of cable IR for the electrical performance cable. In this particular test, the electrical fault detected was intra-cable shorting beginning at about 1225s (about 20 minutes). (The cable IR as shown was based on the behavior between conductor 6 and 7.)



**Figure 5.4: Overlay of the electrical performance and thermal response for the cables in PT-11.**

Note that the electrical performance cable failed when the thermal response cable experienced sub-jacket temperatures of 413-423°C (775-793°F).

### 5.2.2 Repeatability of the Penlight Exposure Conditions

As noted above, one purpose of the repeated tests was to assess the experimental repeatability. Figure 5.5 illustrates the repeatability of the Penlight shroud heating response for Tests PT-11, PT-12, and PT-13. Once all plots were indexed against the same reference time (when Penlight heating started) the shroud temperatures once heating was initiated were virtually indistinguishable. This demonstrates a high degree of repeatability in the exposure condition.

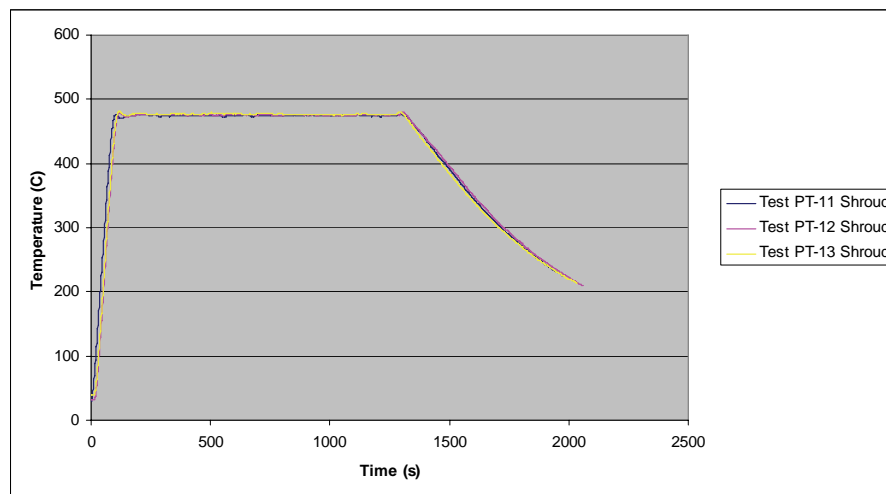
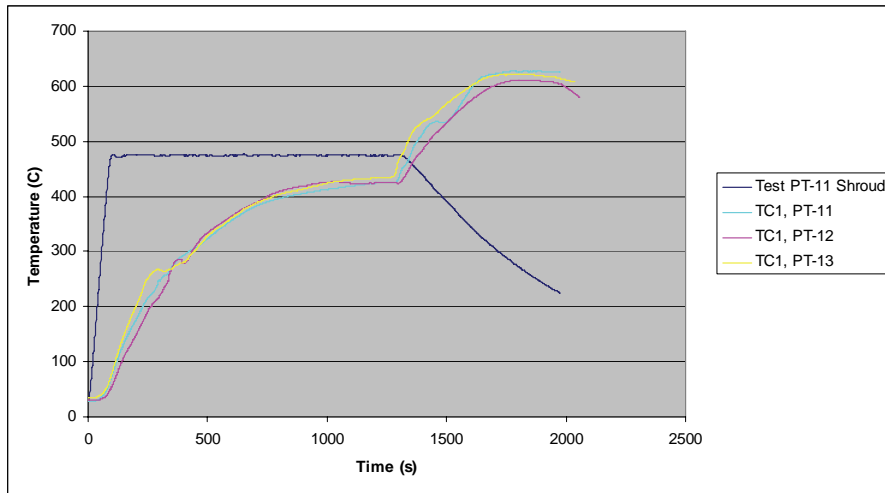


Figure 5.5: Illustration of the repeatability of the Penlight exposure conditions.

### 5.2.3 Repeatability of the Cable Thermal and Electrical performance Behavior

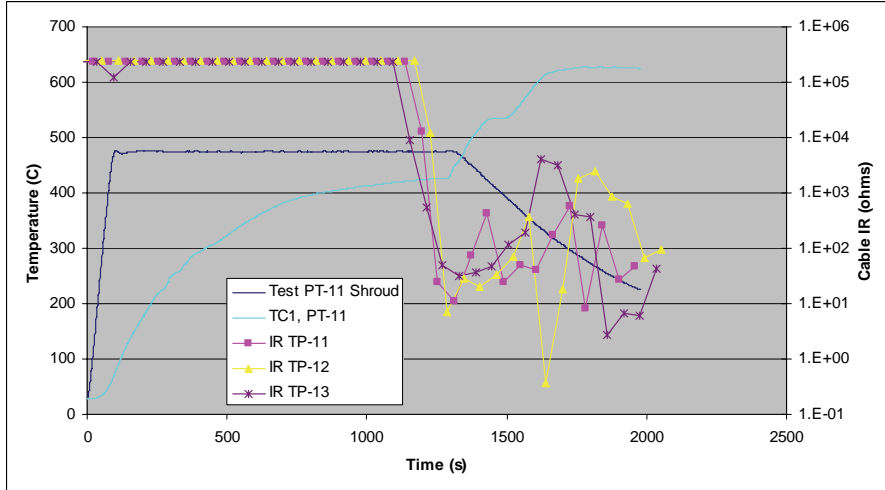
The next aspect considered was the repeatability of the temperature response behavior. The temperature plots shown are for TC1 in each of the same three tests. The shroud temperature from PT-11 is also shown for reference.

Note again that the temperature response plots were quite consistent and showed a high degree of repeatability. Somewhat remarkably, the repeatability even extended to the ignition and post-ignition behaviors. Note that all three tests experienced a sharp departure from the pre-ignition temperature response at roughly the same time relative to the start of *Penlight* heating. As noted above, this departure is indicative of the ignition point. Even the post-ignition temperature response was quite consistent for the three tests, even through the point where each cable passed a peak and temperatures began to fall off.



**Figure 5.6: Illustration of the repeatability of the cable thermal response results.**

The final aspect of repeatability considered was that associated with the cable’s electrical performance and the onset of electrical failure. This behavior is illustrated again for the same three tests in Figure 5.7. As in the earlier plots, the times have been offset, and the shroud temperature for PT-11 is shown for reference. Also shown is TC1 from PT-11 for general reference relative to the cable thermal response. Even here the degree of repeatability was quite strong. All three tests saw electrical failures at roughly the same time.



**Figure 5.7: Illustration in the repeatability of the cable’s electrical performance and the onset of electrical failure.**

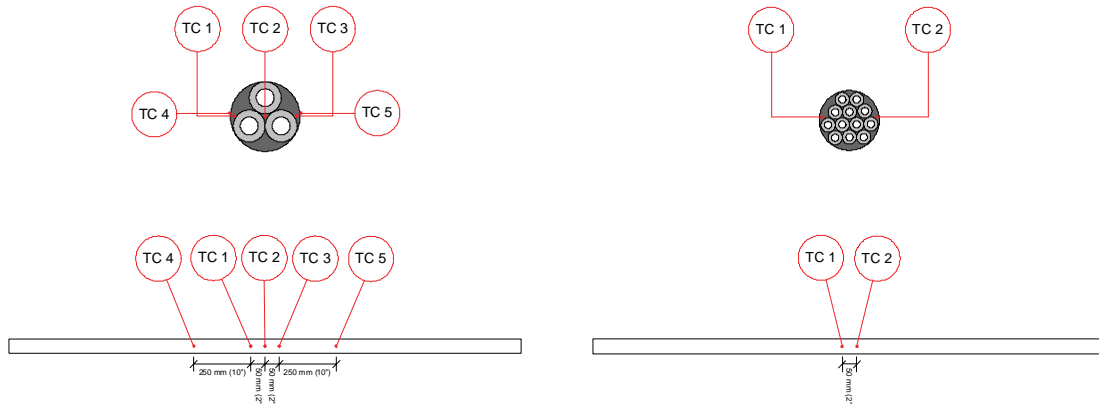
### 5.2.4 Effects of the Relative Copper-to-Plastic Cable Content

Another behavior to be noted for the XLPE/CSPE cable tests was the differences in the thermal response for the 3/C 8 AWG cable, the 7/C 12 AWG cable, and the 12/C 18 AWG cable. Note that the 3/C, 7/C and 12/C conductor configurations (Cable Items #14, #10 and #13 respectively) were selected to yield roughly the same overall cable diameter while varying the relative content of

copper versus plastics. That is, the 3/C 8 AWG cable with its relatively large copper conductor has a very high relative content of copper (16% by volume and 55% by weight). In contrast, the 12/C 18 AWG cable has relatively small copper conductors and because each conductor was individually insulated, the cable has a lower relative copper content (10% by volume and 50% by weight). (Table 2.2 provides specific values characterizing the copper content of each cable.)

An example is provided by the comparison of tests PT-9 (3/C 8 AWG), PT-11 (7/C 12 AWG), and PT-62 (12/C 18 AWG) cable. Each of these tests involved single cable lengths in a cable tray with a shroud temperature of 470 °C.

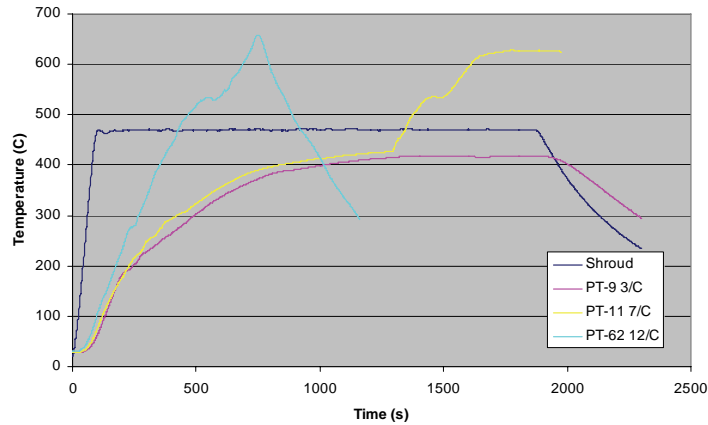
All of these tests had TCs placed on and within the cables. The placement for the 7/C cable in Test PT-11 has been illustrated above. The placement of TCs on and within the 3/C cable in PT-9, and the 12/C cable in PT-62 is illustrated in Figure 5.8. (Note that by the time PT-62 was run, testing had focused on only the TCs located below the cable jacket as most representative of the correlation between electrical performance and thermal response.)



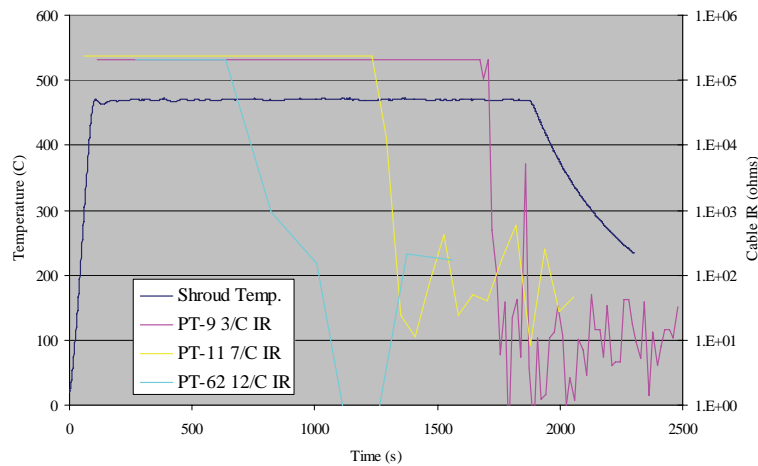
**Figure 5.8: Placement of the TCs for the 3/C cable in PT-9 (left illustration) and for the 12/C cable in PT-62 (right illustration).**

As noted above, these three cables were similar in overall diameter, but have markedly different relative copper versus plastics content. Figure 5.9 compares the temperature response as measured by TC 1 in tests PT-9, PT-11, and PT-62. Similarly, Figure 5.10 compares the electrical performance behavior for the same three tests. The shroud temperature as measured in PT-9 is also shown for reference. Note that in PT-11 and PT-62 the shroud power was actually shut off much earlier indicated by the plot for PT-62 because in both cases the cable ignited on failure.

These plots show a marked difference in behavior. The 3/C cable heated much more slowly than either the 7/C or 12/C cable. The 12/C cable actually experienced spontaneous ignition rather early in the test and failed shortly thereafter. The 7/C cable experienced electrical failure later in the exposure, and ignited on failure. The 3/C cable failed far later than either of the other two cables and did not ignite on failure. These behavioral differences can be attributed to two factors; namely, differences in the total thermal mass per length of cable and the internal cable thermal conductivity.



**Figure 5.9: Comparison of the thermal response for cables with varying relative copper versus plastics content.**



**Figure 5.10: Comparison of the electrical performance for cables with varying relative copper versus plastics content.**

Copper is both more massive and more thermally conductive than the plastic materials that make up the rest of a cable. Hence, a higher copper content implies both a greater thermal mass and higher internal thermal conductivity. The former implies that the cable could absorb more heat with a lower temperature rise and the latter implies that absorbed heat would be distributed more quickly and evenly within the cable. Given these factors, the observed behaviors were well explained.

That is, given the high copper content, the 3/C cable had both a very high per unit length thermal mass and high internal thermal conductivity. As a result, this cable absorbed more heat with less temperature rise and at the same time was able to more evenly distribute heat within the cable. As a result the surface temperature of the cable likely remained somewhat lower and ignition became more difficult to achieve. In contrast, the 12/C cable with its comparatively low copper content saw a greater temperature rise for a given amount of absorbed heat and was less able to distribute that

heat internally. The inability to readily distribute the absorbed heat likely led to higher cable surface temperatures leading to spontaneous ignition of the cable surface relatively early in the test.

The uniformity in the internal cable temperature for the 3/C cable was confirmed by the test data as shown in Figure 5.11. Note that the core temperature (TC2) was virtually indistinguishable from the two TCs just under the cable jacket (TC1 & TC3). This can be compared to Figure 5.3 which illustrates a higher degree of variability in temperature for the 7/C XLPE/CSPE cable.

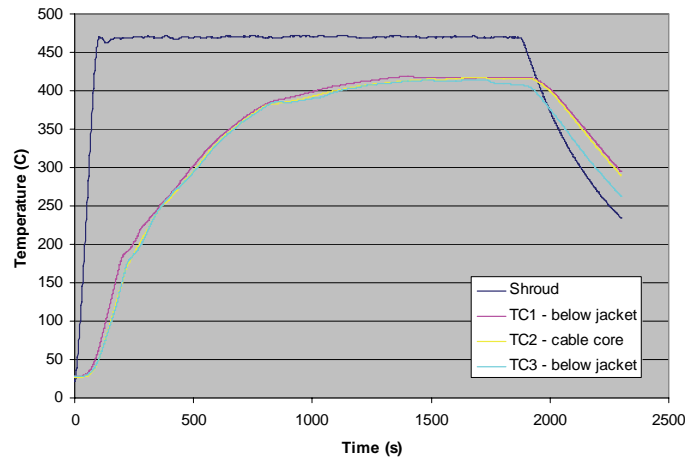
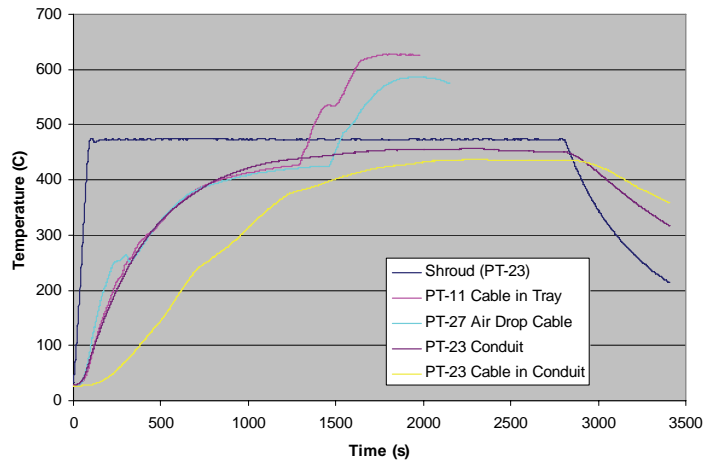


Figure 5.11: Illustration of the uniformity of temperatures within the 3/C cable during the PT-9.

### 5.2.5 The Effects of Cable Routing Configuration

One additional comparison made based on the XLPE/CSPE cable tests was to compare the response for a cable in cable tray, conduit and the air drop configurations. This is illustrated in Figure 5.12 which compares the thermal response results for PT-11 (cable tray), PT-23 (conduit) and PT-27 (air drop). All three tests used the 7/C XLPE/CSPE cable (Item #10) and a shroud temperature of 470°C. The temperatures shown are for sub-jacket TCs. The shroud temperature shown is for PT-23, the conduit tests which lasted considerably longer than either of the other two tests shown. Also shown is the measured temperature response for the conduit itself in PT-23.

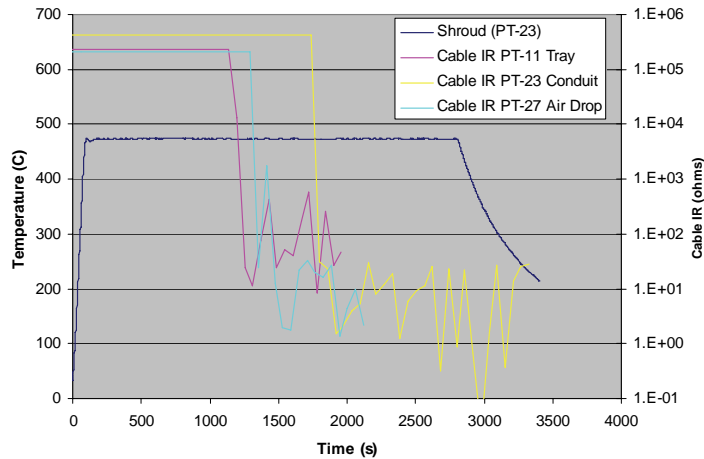
Recall that as discussed above, the air drop configuration results in no shadowing of the cable at all whereas the rails of the cable tray shade the cable to some extent and the conduit shades the cable entirely leading to secondary heating of the cable (i.e., Penlight heats the conduit which in turn heats the cable). As a result, one would expect the air drop cable to heat most quickly, the cable tray somewhat slower, and the conduit case the slowest of all. The conduit cable clearly responds more slowly during the early stages of the test. However, note that the air drop and cable tray cases show relatively little difference. This would tend to indicate that the shadowing effect of the cable tray was not as pronounced as might nominally be expected. Recall that the cables were all located roughly in the center of the tray. Cables located closer to a side rail would like see a stronger effect.



**Figure 5.12: Thermal response comparison for cables in tray, conduit and air drop routing configurations.**

It was also interesting to note that the thermal response of the conduit was remarkably similar to that of the cables in tray or in an air drop configuration. While the conduit had a much higher thermal mass than an individual cable, it also had a much larger surface area. The larger thermal mass would tend to result in slower heating whereas the larger surface area would increase total heat absorbed. It would appear that the two effects were actually rather balanced leading to similar thermal responses for the two targets.

Figure 5.13 illustrates the corresponding electrical performance behaviors. Note that the conduit cable again showed the last failures as expected given the slower temperature response.



**Figure 5.13: Electrical performance comparison for cables in tray, conduit and air drop routing configurations.**

Note that in this case, the cable in the cable tray actually experiences the earliest failure, the air drop cable second, and the conduit cable third. This was a bit unexpected as one would nominally expect the air drop cable to fail first because the air drop was fully exposed to the shroud with no blockage whatsoever whereas the cable tray and conduit both block a portion or all of the incoming radiation



from the shroud. The earlier failure of the cable in the tray may have been in part due to the effect of the cable tray rungs. That is, the cable in cable tray rests on the rungs of the tray and this may lead to localized heating of the cable by the rung. It also introduces minor stresses on the cable due to the cable's own weight being supported on the tray rung. Both effects may influence the fault behavior to some extent.

### 5.2.6 Cable Condition after Testing

Figure 5.14 illustrates the condition of the XLPE cables after a typical test. Note that the cables ignited and burned during this test approximately concurrent with the onset of electrical failure. This was typical of the Penlight tests. Also typical was the fact that there was only char remaining from the original insulation and jacket materials over the central portion of the cable in particular.

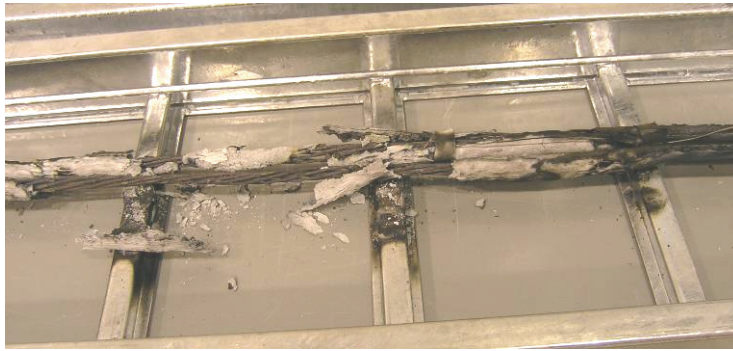


Figure 5.14: Condition of the XLPE-insulated cables after a typical Penlight test.

## 5.3 Penlight Tests with Individual Lengths of the Other Cable Types

### 5.3.1 PVC/PVC Cables

PVC-insulated and PVC-jacketed cables were tested in four conductor configurations. The cable item numbers and short descriptions were as follows:

- Cable Item #1: PVC/PVC, 12 AWG, 7/C
- Cable Item #4: PVC/PVC, 16 AWG, 2/C SH
- Cable Item #5: PVC/PVC, 8 AWG, 3/C
- Cable Item #6: PVC/PVC, 18 AWG, 12/C

Figure 5.15 provides an end-view photograph of each of these four cables side-by-side. Note again that the 2/C cable (item #4) was much smaller, but that the other three cable items have a similar outside diameter.

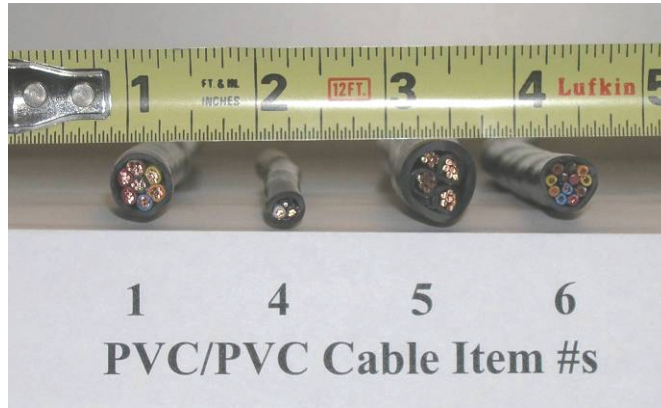


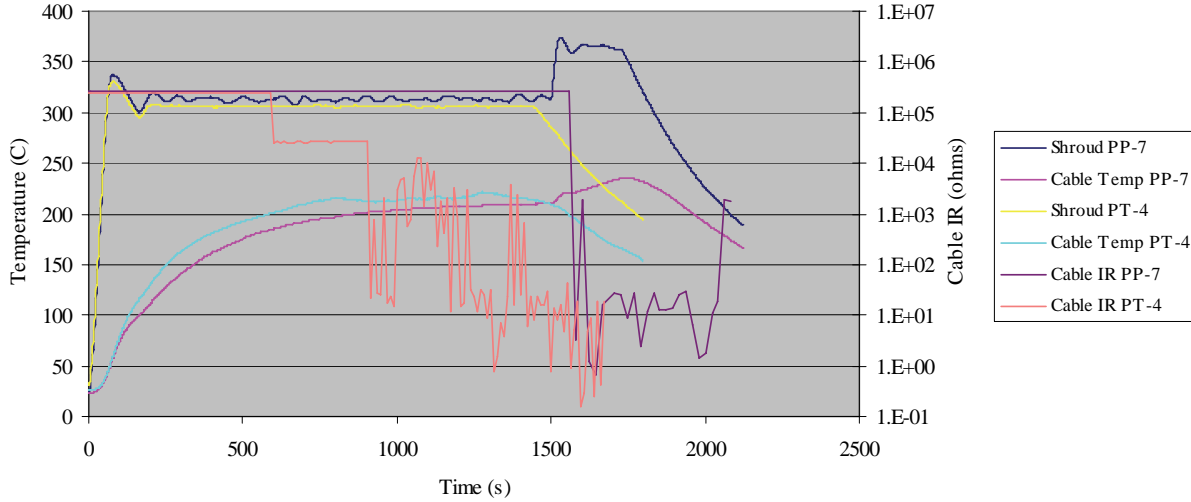
Figure 5.15: End-view photograph of the four PVC/PVC cable items.

Table 5.2: Matrix of PVC/PVC cable tests in Penlight involving individual lengths of cable.

Test #	Cable Item number	Number of Conductors				Conductor Size (AWG)					Thermal Exposure (°C)	Raceway Type		
		3	2	7	12	8	12	14	16	18		Tray	Conduit	Air Drop
PP-4	1			X			X				450	X		
PP-7	1			X			X				300	X		
PP-8	1			X			X				330	X		
PP-14	1			X			X				325	X		
PP-15	1			X			X				260	X		
PT-4	5	X				X					300	X		
PT-5	5	X				X					300	X		
PT-6	5	X				X					300	X		
PT-8	5	X				X					300		X	
PT-10	5	X				X					300			X
PT-21	1			X			X				300	X		
PT-63	6				X					X	325	X		
PT-65	6		X						X		325	X		

There were a total of 13 Penlight tests involving the testing of individual lengths of these four different cable types. The test conditions are summarized in Table 5.2. Note that as with other cable types, the preliminary tests varied the thermal exposure conditions, while the tests in the primary matrix were generally conducted at a shroud temperature of either 300°C or 325°C (572°F or 617°F).

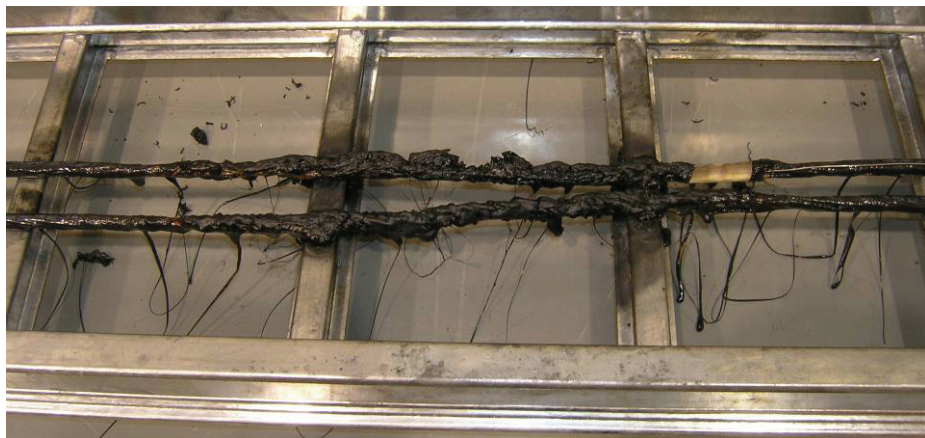
Figure 5.16 illustrates the thermal and electrical performances measured in Tests PP-7 and PT-4. These tests were both conducted at an initial shroud temperature of 300°C (572°F) and with the cable routed in a cable tray. PP-7 involved a 7/C 12 AWG cable while PT-4 involved the 3/C 8 AWG cable.



**Figure 5.16: Illustration of two example PVC/PVC cable tests.**

One difference illustrated by these two tests was the effects of the end covers on the shroud temperature. Test PP-7 was conducted with the open-ends configuration and PT-4 was conducted in the closed-ends configuration (see Section 2 for a description of these configurations). Note that the shroud temperature in PP-7 showed a more pronounced fluctuation than it did in PT-4. With the ends open, there was a higher rate of heat loss from the shroud than with the ends closed. This resulted in a bit more ‘hunting’ by the controller that maintains shroud temperature.

Also note that the temperature of the 7/C cable rose quicker than the 3/C cable. This was consistent with the higher thermal mass of the 3/C cable with its much larger copper content. Note that in Test PP-7, the shroud temperature was actually increased at about 1600 s, and that the cable failed very shortly after this time.



**Figure 5.17: Typical condition of the PVC-insulated cables following a Penlight test.**

Figure 5.17 illustrates the condition of the PVC-insulated cables after a typical penlight test. Note that, being TP materials, the PVC insulation and jacket melted during the tests with a substantial amount of material remaining after the tests. Dripping material also deposited on the bottom of the shroud where it would typically burn to ash.

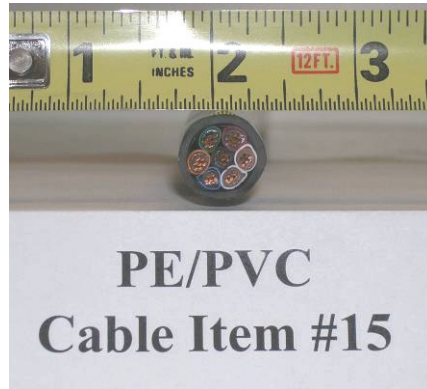
### 5.3.2 PE/PVC Cables

Only one PE-insulated and PVC-jacketed cable was used in CAROLIFRE and this was cable Item #15, a 7/C, 12 AWG control cable. Figure 5.18 provides an end-view photograph of this cable. There were a total of 9 tests conducted in Penlight with single lengths of the PE/PVC cable as shown in Table 5.3. (Also note that the ‘special thermal test’ involved a bundle of PE/PVC cables and is described in Section 5.4 below.

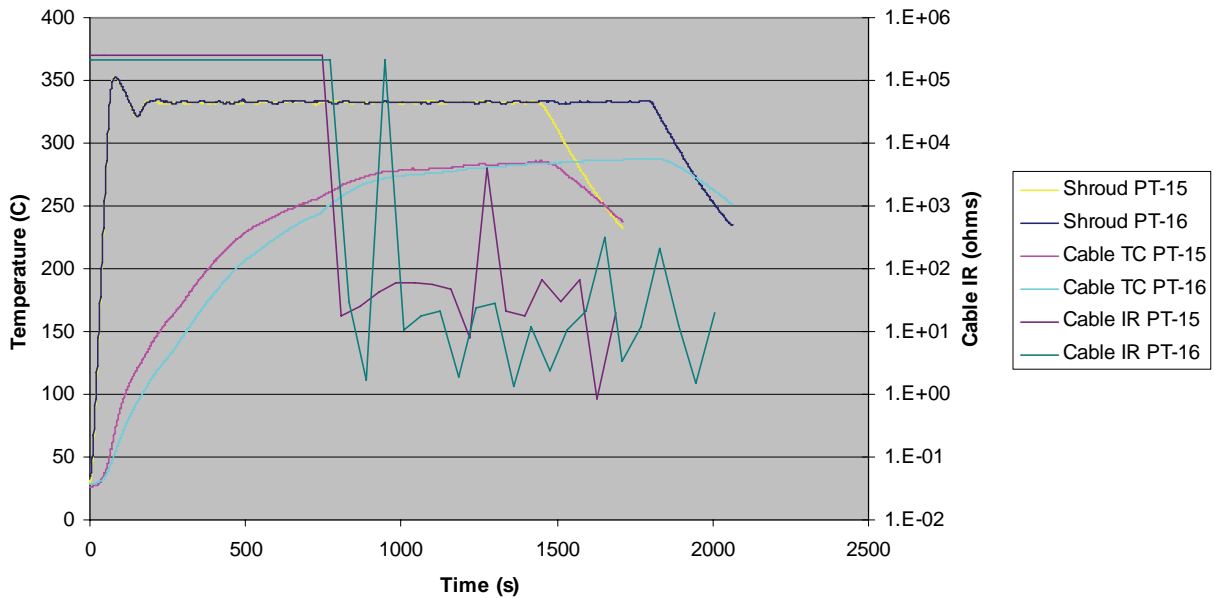
**Table 5.3: Matrix of PE/PVC cable tests in Penlight involving individual lengths of cable.**

Test #	Cable Item number	Number of Conductors				Conductor Size (AWG)					Thermal Exposure (°C)	Routing Configuration		
		3	2	7	12	8	12	14	16	18		Tray	Conduit	Air Drop
PP-19	15			X			X				300	X		
PP-20	15			X			X				325	X		
PT-14	15			X			X				300	X		
PT-15	15			X			X				325	X		
PT-16	15			X			X				325	X		
PT-25	15			X			X				325		X	
PT-26	15			X			X				325		X	
PT-29	15			X			X				325			X
PT-30	15			X			X				325			X

A typical set of test results is illustrated in Figure 5.19. This figure shows an overlay of tests PT-15 and PT-16. Both tests were run with a shroud temperature of 325°C (617°F) and with the cables in a cable tray routing configuration. All temperatures shown are for TCs placed below the cable jacket. Note that again the failure behavior was quite similar. In both cases the cable failed when the temperature below the cable jacket had reached about 260-265°C (500-509°F).



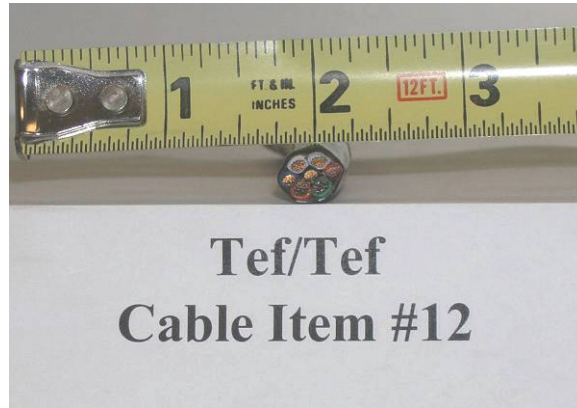
**Figure 5.18: End-view photograph of the PE/PVC cable item #15.**



**Figure 5.19: Illustration of two cable tray tests, PT-15 and PT-16, for the PE-insulated cables.**

### 5.3.3 Tefzel/Tefzel Cables

The Tefzel/Tefzel cable was also tested in just one configuration, namely a 7/C 12 AWG control cable. Note that Tefzel has a very high electrical insulating capacity for a given material thickness. As a result, the insulation and jacket layers were actually much thinner with Tefzel than they were for the other material types. Also as a result, the Tefzel/Tefzel cable was smaller in overall diameter than were the other 7/C 12 AWG cables. Figure 5.20 is an end-view photograph of the Tefzel/Tefzel cable Item #12. There were a total of just three tests of individual lengths of the Tefzel/Tefzel cable as shown in Table 5.4. All three tests were conducted in a cable tray routing configuration, but with differing shroud temperatures.



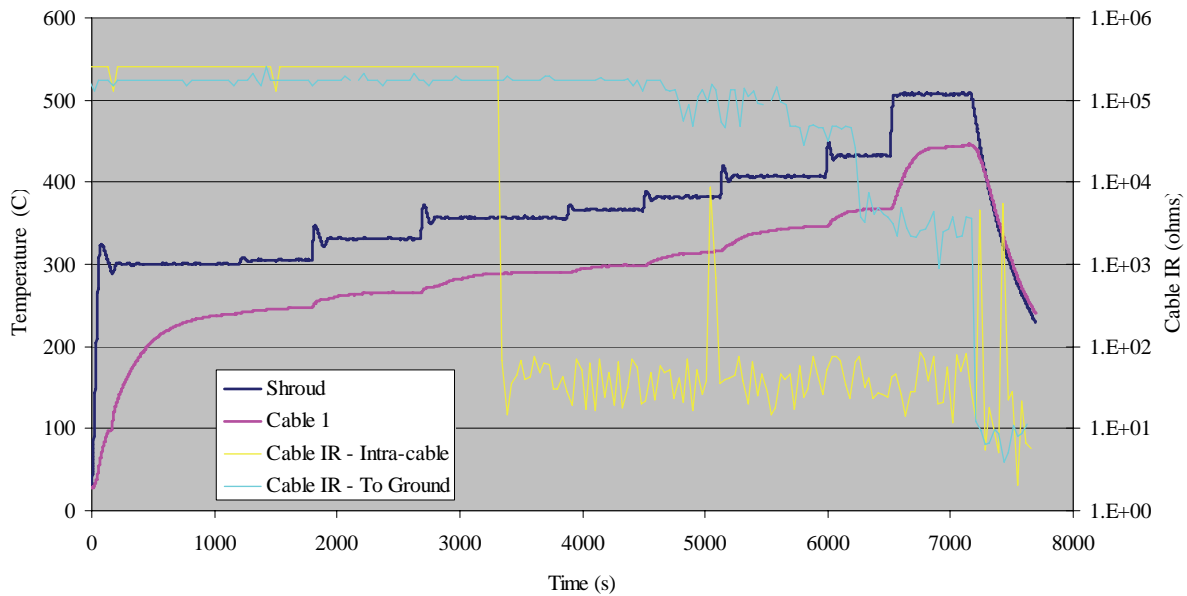
**Figure 5.20: End view photograph of the Tefzel/Tefzel cable.**

**Table 5.4: Matrix of Penlight Tests involving the Tefzel-insulated cables.**

Test #	Cable Item number	Number of Conductors					Conductor Size (AWG)					Thermal Exposure (°C)	Raceway Type		
		3	2	7	12	8	12	14	16	18	Tray		Conduit	Air Drop	
PP-18	12			X			X				295-500	X			
PP-23	12			X			X				350	X			
PT-22	12			X			X				470	X			

Test PP-18 actually involved an initial shroud temperature of 295°C (563°F), but the shroud was increased in temperature in several steps over the course of the experiment. The first failure noted was a conductor-to-conductor short just after the shroud temperature was raised to 350°C (617°F). At this point, the cable sub-jacket temperature was about 290°C (554°F). This is illustrated in Figure 5.21. Note that the test was continued beyond the point of the first electrical failure because it had not yet shorted to the external ground.

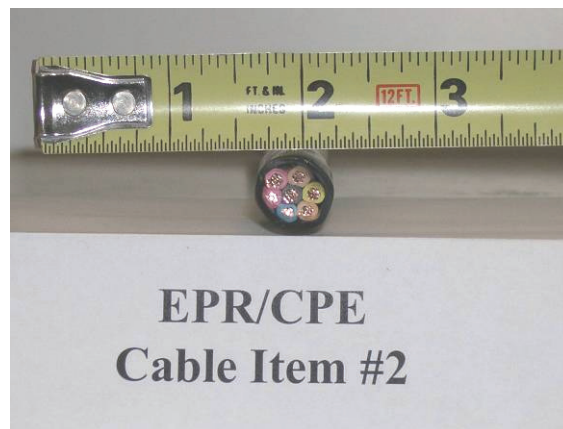
Similar behavior was noted in test PP-23 as well. In this case the shroud was maintained at a steady temperature throughout, and the cable experienced intra-cable shorting when the sub-jacket temperature reached about 290-295°C (554-563°F). In this particular test, the cable never did experience shorts to the external ground. The behavior in PT-22 was markedly different. In this case, the cable experienced both intra-cable shorting and shorts to the external ground concurrently. With the higher shroud temperature, the cable heated much more quickly and this apparently led to some changes in the electrical shorting behavior. Prior efforts (e.g., ref. [9]) have identified the exposure intensity as a potential influence factor that could impact the shorting behavior of cables. This appears to be the first direct evidence that this factor might, indeed, play a role in the shorting behavior. In this case the behavior was only observed for the Tefzel cable, but it would be premature to conclude that the effect was limited to either Tefzel or to TP-insulated cables.



**Figure 5.21: Shroud temperature, cable temperature and electrical failures for test PP-18.**

### 5.3.4 EPR/CPE Cables

The EPR/CPE cable was also tested in just one configuration, namely a 7/C 12 AWG control cable. Figure 5.22 is an end-view photograph of the EPR/CPE cable Item #2. There were a total of five tests of individual lengths of the EPR/CPE cable as shown in Table 5.5. All tests were conducted in a cable tray routing configuration, but with differing shroud temperatures.

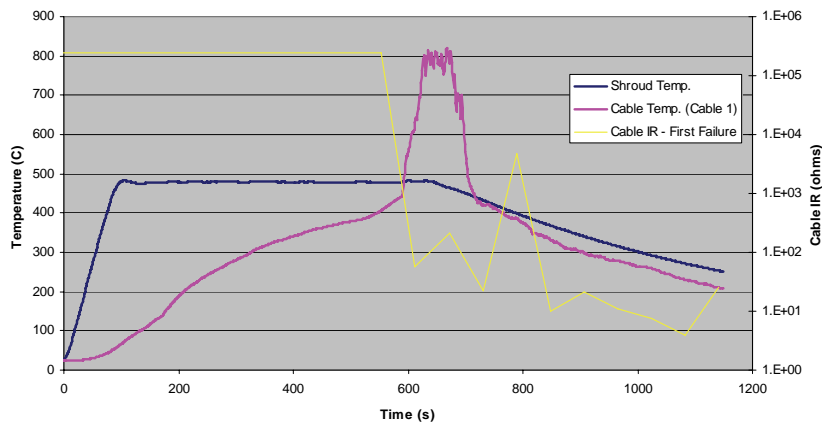


**Figure 5.22: End view photograph of the EPR/CSP cable Item #2.**

**Table 5.5: Matrix of Penlight tests involving individual lengths of the EPR/CPE cable Item #2.**

Test #	Cable Item number	Number of Conductors					Conductor Size (AWG)					Thermal Exposure (oC)	Raceway Type		
		3	2	7	12	8	12	14	16	18	Tray		Conduit	Air Drop	
PP-11	2			X			X				650	X			
PP-12	2			X			X				500	X			
PP-13	2			X			X				400	X			
PP-17	2			X			X				460	X			
PT-17	2			X			X				470	X			

Figure 5.23 illustrates typical results for this cable. The data shown were taken from PT-17 and include the shroud temperature, cable temperature below the jacket, and the first electrical failure (in this case, intra-cable shorting).



**Figure 5.23: Typical test data for the EPR/CPE cable taken from PT-17.**

Note that the cable samples did ignite and burn roughly concurrent with electrical failure (as evidenced by the sharp jump in temperatures concurrent with first failure). The temperature at the time of cable failure as measured by a TC below the cable jacket was about 400-425°C (752-797°F).

### 5.3.5 XLPO Cables

The XLPO/XLPO cable was also tested in just one configuration, namely a 7/C 12 AWG control cable. Figure 5.24 is an end-view photograph of the XLPO/XLPO cable Item #8. There were a total of five tests of individual lengths of the XLPO/XLPO cable as shown in Table 5.6. All tests were conducted in a cable tray routing configuration, but with differing shroud temperatures.



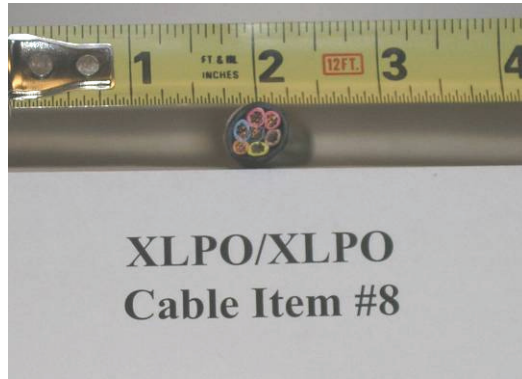


Figure 5.24: End view photograph of the XLPO/XLPO cable Item #8.

Table 5.6: Matrix of Penlight tests involving individual lengths of XLPO/XLPO cables.

Test #	Cable Item number	Number of Conductors				Conductor Size (AWG)				Shroud Temp. (C)	Raceway Type		
		3	2	7	12	8	12	16	18		Tray	Conduit	Air Drop
PP-21	8			X			X			475	X		
PP-22	8			X			X			470	X		
PT-19	8			X			X			470	X		

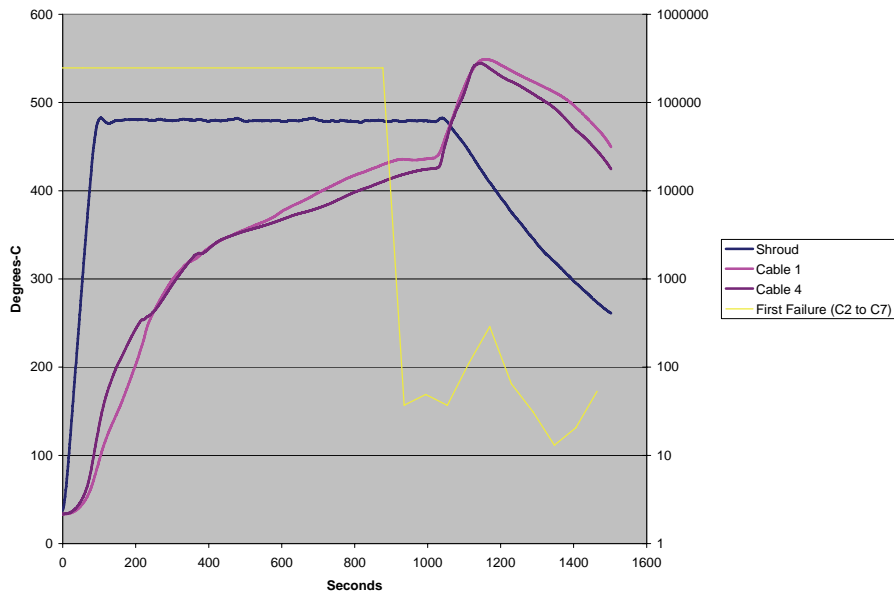


Figure 5.25: XLPO/XLPO cable thermal response and electrical performance from PT-19. Note that both of the sub-jacket cable TCs are shown (Cable 1 and Cable 4).

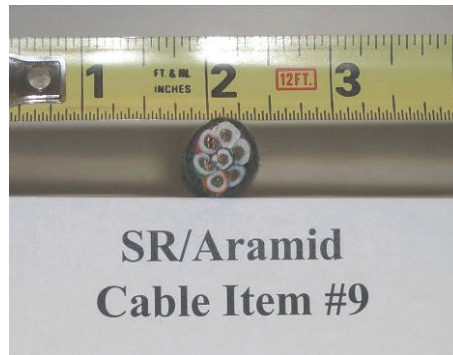
Figure 5.25 provides a typical example for the XLPO/XLPO cables taken from PT-19. Note that electrical failure occurs when the temperature below the cable jacket was approximately 415-435°C (779-815°F). Also note that the cable did ignite and burn, but not until approximately 2 minutes after initial electrical failures were detected.

### 5.3.6 Silicone-Rubber Cables

The SR cable was also tested in just one configuration, namely a 7/C 12 AWG control cable. Figure 5.26 is an end-view photograph of the SR cable Item #9. There were a total of three tests of individual lengths of the SR cable as shown in Table 5.7. All tests were conducted in a cable tray routing configuration, but with differing shroud temperatures.

**Table 5.7: Matrix of Penlight tests involving individual lengths of SR cables.**

Test #	Cable Item number	Number of Conductors				Conductor Size (AWG)				Shroud Temp. (C)	Raceway Type		
		3	2	7	12	8	12	16	18		Tray	Conduit	Air Drop
PP-5	8			X			X			665	X		
PP-10	8			X			X			900	X		
PT-18	8			X			X			700	X		



**Figure 5.26: End view photograph of the SR/Aramid cable Item #9.**

The SR cables were resistant to fire damage under the Penlight exposure conditions. While the cables did typically ignite and burn during the exposure, there were no electrical failures observed during any of the Penlight tests despite prolonged and high temperature exposures.

In test PT-18, the cables were subjected to a brief exposure at a shroud temperature of 700°C (1292°F) lasting about 4 minutes during which the cables were observed to ignite and burn. Following this exposure and after an additional 5 minutes when the cables had stopped burning and cooled off somewhat, they were subjected to ‘rough handling.’ This involved grasping and shaking one end of the cable with insulated pliers and striking the cable tray (but not the cable itself) with a

mallet. The cable still did not experience electrical failure. (Failures of the SR cables were noted during the intermediate-scale tests as discussed in Section 6.)

Figure 5.27 shows a photo of the SR cables after a prolonged Penlight exposure. Note that the cables showed a white powdery residue on the outside of the Aramid braid following testing as compared to the very dark braided jacket visible prior to testing. This powder was of a low density and was easily dislodged. Dissection of a cable revealed that the ash remaining from the original insulation was of similar appearance and consistency, although the braided over-wrap on each conductor appeared to provide a degree of integrity to the cables.



**Figure 5.27: Post test photo of the SR cables following a Penlight test. Note that the cable did not fail in this test (PP-10).**

### **5.3.7 Vita-Link Cables**

The Vita-Link® cable was also tested in just one configuration, namely a 7/C 14 AWG control cable. Figure 5.28 is an end-view photograph of the Vita-Link® cable Item #11. There were only two tests of individual lengths of the Vita-Link® cable as shown in Table 5.8. Both tests were conducted in a cable tray routing configuration, but with differing shroud temperatures.



**Figure 5.28: End view photograph of the Vita-Link® cable Item #11.**

**Table 5.8: Matrix of Penlight tests involving individual lengths of Vita-Link® cables.**

Test #	Cable Item number	Number of Conductors				Conductor Size (AWG)				Shroud Temp. (C)	Raceway Type		
		3	2	7	12	8	* 14 *	16	18		Tray	Conduit	Air Drop
PP-24	8			X			X			675	X		
PT-31	8			X			X			700	X		

Similar to the SR-insulated cables, the Vita-Link® cable were observed to ignite and burn during the exposures, but did not fail in either of these two tests during the fire exposure. The only failure observed involved one conductor which shorted to ground when the cable was subjected to rough handling following an exposure at 700°C for about 4.5 minutes. After the cables had cooled for an additional 10 minutes after the exposure, it was grasped at its end with insulated pliers and shaken. The cable tray (not the cable itself) was also struck with a hammer. After this handling, a short to ground on one conductor was detected. (Additional failures were observed in the intermediate-scale tests as discussed in Section 6 below.)

## 5.4 Penlight Tests with Cable Bundles

Tests PT-34 through PT-68 and the test designated ‘Spec. 1’ all involved cable bundles rather than individual lengths of cable. The bundles used were 6-cable bundles in the cable tray tests, and 3-cable bundles in the conduit tests. In addition, during each test there was a single length of cable instrumented for thermal response.

There was, however, a limit to the number of cables that could be tested in Penlight in any given test. As a result, it was not possible to test side-by-side thermal response and electrical performance cable bundles in the same way that the tests with individual lengths of cable had been conducted. Rather, electrical performance was monitored for a bundle of cables but thermal response was monitored for a single cable length. Hence, for tests involving a six-cable bundle there were actually seven cables present with the seventh cable representing the thermal response cable. Given this configuration it is not possible to directly correlate the thermal response and electrical performance results for these tests because the two thermal response and electrical performance samples were not identical. The conduit tests were somewhat better in this regard because the cable instrumented for thermal response was simply routed in the same conduit as the bundle of three electrical performance cables. Hence, in these cases the correspondence between the thermal response and the electrical performance was better, but not absolute. The general cable bundle tests are described in brief in Section 5.4.1 but are not described in detail here. Full data files are provided for all tests. Section 5.5 also provides additional data analysis focusing on the correlation between thermal response and electrical performance for the single cable tests.

The final Penlight test was designated ‘Spec. 1’ and was referred to as the ‘special thermal test.’ This test was run at the request of our collaborative partners in order to provide one set of thermal response data for a six-cable bundle. This test is described in detail in Section 5.4.2.

#### **5.4.1 General Cable Bundle Tests**

As noted above, tests PT-34 through PT-68 each involved a bundle of either three (conduit tests) or six (cable tray tests) cables monitored for electrical performance. This represents a total of 20 actual tests since several tests in the original matrix were not performed.

For example, the tests originally designated as Groups 3 and 5 (tests PT-38 through PT-41 and PT-51 through PT-59) were not conducted. The tests in Group 4 and Group 5 were originally intended as complementary tests where the configuration of the cables would be repeated with the Group 4 tests run at a ‘low’ heat flux and Group 5 at a ‘high’ heat flux. Based on peer review feedback the target heat flux levels were revised and all tests were run at a ‘moderate’ heat flux. As a result, the Group 4 tests were run at the new moderate heat flux and the tests in Group 5 were not performed. (The same applies to the Group 2 tests which were performed at the moderate heat flux and the Group 3 tests that were not performed.) The tests have been maintained in the test matrices in order to maintain consistency between the final test matrices and the matrices described in various planning documents associated with the project.

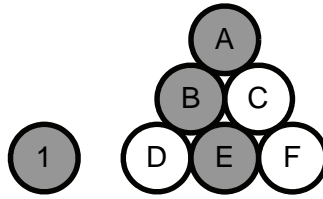
Also note that a single length of cable instrumented for thermal response was also included. These tests were aimed primarily at Bin 2 Items A and B, both of which relate to the plausibility of inter-cable shorting.

The matrix of these tests has been presented in Section 4 above, and will not be repeated here due to the number of tests involved. Note that, as illustrated in the matrix, the bundle tests involved both bundles of the same cable type, and bundles of different cable types. The bundles specifically included both all TS bundles and mixed TS&TP bundles. Again, this was specifically designed to address the two Bin 2 items associated with inter-cable shorting.

Also note that in some of the conduit tests, the TC data was compromised by interactions with the electrical power used to energize the electrical performance cables. (This was also seen in some of the tests involving individual lengths of cable.)

#### **5.4.2 The Special Thermal Test of a Cable Bundle**

The last Penlight test involved a six-cable bundle plus one individual length of cable. All of the cables were of the PE/PVC type (cable Item #15). The cables were arranged per the following illustration:



Each of the cables shown as shade was equipped with a single TC placed just below the cable jacket. The TCs were all placed at the same location along the cable length. The bundle was then installed so that the TCs were at the center of the tray along the length of the shroud. None of the cables were monitored for electrical performance.

The exposure conditions began with the shroud at 350°C (663°F). The shroud temperature was increased to 375° C at approximately 1950 s and was increased again to 400°C (752°F) at approximately 2875 s. The results for this test are illustrated in Figure 5.29. Note that the TC response for each cable is shown. The cable designators are as shown in the illustration immediately above. Also shown is the shroud temperature and the temperature measured on the cable tray rung at the center of the tray.

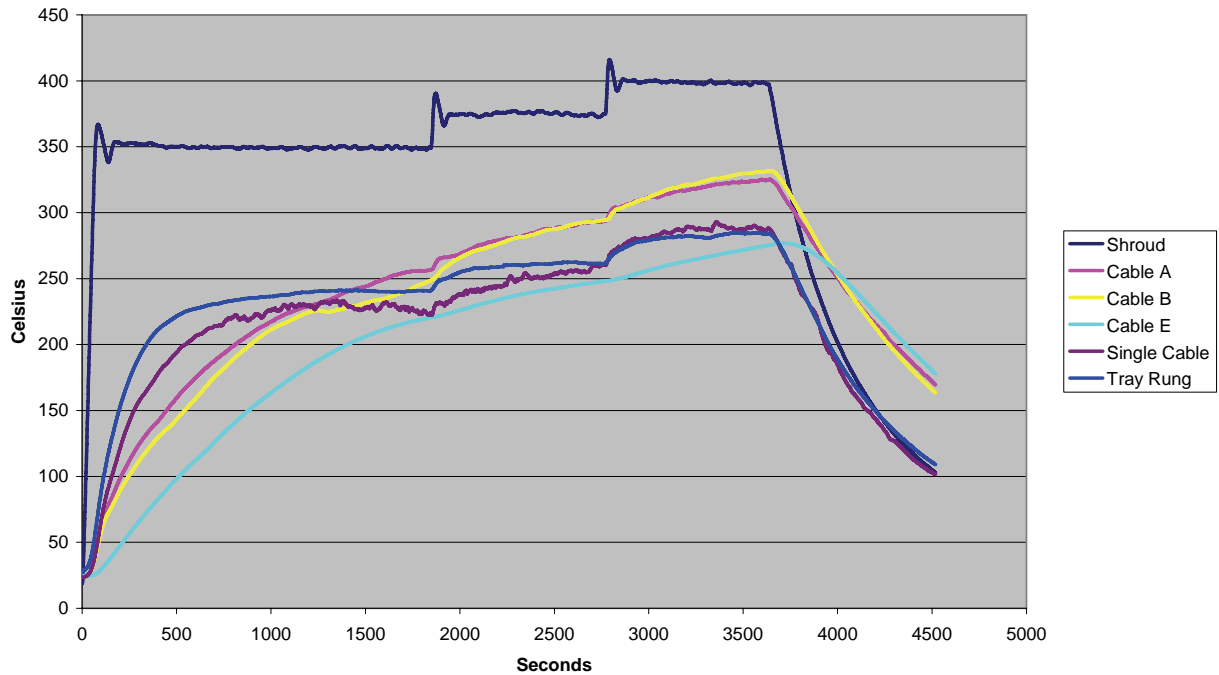


Figure 5.29: Temperature data from the ‘special thermal test’ Spec. 1.

## 5.5 Correlating Thermal Response and Electrical Performance for the Penlight Single Cable Tests

This section provides a limited analysis of the Penlight single cable tests focusing on correlating the thermal response data to the electrical failure data. In conducting this analysis the time to failure for the electrical performance cable was based on the first short circuit failure observed without regard for the specific failure mode (e.g., conductor-to-conductor versus conductor-to-ground). Also note that in all cases the temperatures reported for the thermal response cable were based on those TCs installed just below the cable jacket (the sub-jacket temperatures). The analysis has focused on the single cable Penlight tests because it is these tests that provided the most direct correlation between thermal response and electrical performance. Other similar comparisons are possible, but as noted elsewhere, it was not the objective of this report to exhaustively explore the test data. Rather, the intent was to provide examples of the types of analysis possible and to sample key data.

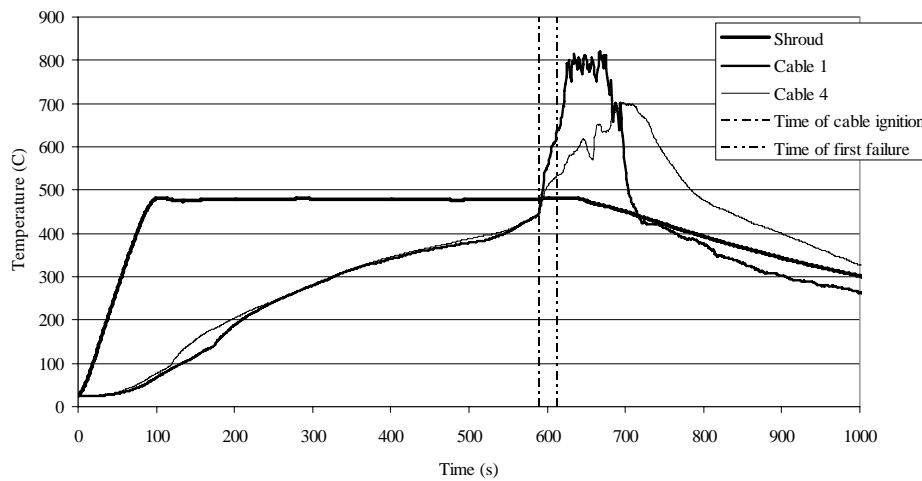
Table 5.9 provides a summary of the test results for the Preliminary Penlight test series (PP-1 through PP-26). Table 5.10 provides a similar summary for the Group 1 single cable tests from the primary series of Penlight Tests (PT1 through PT31). Table 5.11 provides similar summary for the Group 5 and 6 tests from the PT test series (PT62 through PT65). The “applicable notes” are provided for all three tables at the end of Table 5.11.

In each of these three tables, the experimental conditions are summarized including cable type, cable conductor configuration, the shroud temperature used in testing, and the routing configuration. Also provided is a summary of the test results for each test including the time to the first observed electrical failure for the electrical performance cable (in seconds), and the cable sub-jacket temperature for the thermal response cable at, nominally, that same time. As discussed in Section 3.2, for the PP-series tests there was just one sub-jacket TC present so only a single temperature value is reported for Table 5.9. For the PT-series tests there were two sub-jacket TCs present for each test (one on each side of the cable); hence, two temperature values (i.e., “Temp1-Temp2”) are reported for tables 5.9 and 5.10 (unless one of the two TCs failed during testing).

During a total of 12 of the tests covered by these three tables the thermal response cable actually ignited prior to electrical failures in the electrical performance cables (these cases are identified in the tables via “applicable notes” (2) and (3) in the right-most column). There was no pilot flame present so these cases must have involved spontaneous ignition, likely of the cable jacket. The time between ignition and subsequent failure varied from test to test, and ranged from about 20 seconds to 3 minutes. The thermocouples used were quite small (1 mm or 0.04" diameter) and therefore responded very quickly to changes in temperature as compared to the cable itself. As a result, once the thermal response cable ignited, the TCs no longer provided reliable indications of the cable temperature. Whether or not these 12 cases were included in the assessment of cable temperatures at failure depended on two factors as discussed immediately below.

First, if the time interval between ignition and failure was greater than 90s, then no temperatures were extracted and the case is considered indeterminate in this context (it is excluded). If the time interval was less than 90s, a further review was performed in which the temperature response

behavior just prior to ignition was examined. If the cable temperatures had reached a relatively stable plateau prior to ignition, the temperatures recorded just prior to ignition are taken as indicative of the cable condition at the time of electrical failure (the case is included). If, on the other hand, the cable temperatures were still climbing rapidly, no temperature is reported and the case is, again, considered indeterminate in this context (the case is excluded). In total, five of the 12 test cases met the inclusion criteria despite ignition prior to failure. A typical example of a test case that was included in the table is Test PT-17 which is illustrated in Figure 5.30. In this particular case the test cable ignited and then experienced electrical failure about 25 seconds later. Note that the temperature response measured by the sub-jacket TCs shows a sharp rise concurrent with ignition. The temperature reported in Table 5.9 for this case is the value just prior to the ignition point. Note that just prior to ignition, the measured temperature was rising slowly (2-4 degrees per minute). This example is quite typical of the other four cases where similar extrapolations were made. The other seven test cases involving ignition prior to failure were excluded.



**Figure 5.30: An illustration of a test case where ignition occurred prior to electrical failure and yet the data were used included in the analysis results tables (test PT-17). “Cable 1” and “Cable 4” were the names given to the two sub-jacket TCs installed on the thermal response cable.**



**Table 5.9: Summary of test results for the PP series tests (PP1 through PP26) which all involved single lengths of cable.**

Test Number (PP-#)	Cable Insulation and Jacket Material								Cable Item Number	Number of Conductors					Shroud Temperature °C (°F)	Raceway Type			Summary of Test Results			Applicable Notes
	XLPE/CSPE	EPR/CPE	SR/Aramid	XLPO	Vita-Link	XLPE/PVC	PE/PVC	PVC/PVC		Tefzel/Tefzel	3	7	8	12		14	Tray	Conduit	Air Drop	Time of First Failure (s)	Cable Temperature at Failure (°C)	
1	X								10	X	X				665 (1229)	X			439	n/a	n/a	(1)
3	X								10	X	X				600 (1112)	X			447	460	860	
4							X		1	X	X				450 (842)	X			297	273	523	
5			X						9	X	X				665 (1229)	X			DNF	n/a	n/a	
6	X								10	X	X				665 (1229)	X			406	436	817	
7								X	1	X	X				300-350 (572-662)	X			1584	222	432	
8							X		1	X	X				330 (626)	X			826	191	386	
9	X								10	X	X				500 (932)	X			1552	438	820	
10			X						9	X	X				900 (1652)	X			DNF	n/a	n/a	
11		X							2	X	X				650 (1202)	X			211	n/a	n/a	(3)
12		X							2	X	X				500 (932)	X			484	n/a	n/a	(3)
13		X							2	X	X				400-475 (752-887))	X			3695	409	768	
14							X		1	X	X				325 (617)	X			461	221	430	
15							X		1	X	X				260-300 (500-572)	X			7121	220	428	
16	X								10	X	X				475 (887)	X			1267	n/a	n/a	(3)
17		X							2	X	X				460 (860)	X			677	422	791	(2)
18								X	12	X	X				295-500 (563-932)	X			3347	288	550	
19						X			15	X	X				300 (572)	X			1289	209	408	
20						X			15	X	X				325 (617)	X			907	270	518	
21			X						8	X	X				475 (887)	X			811	432	810	
22			X						8	X	X				470 (878)	X			895	462	864	
23							X		12	X	X				350 (662)	X			1382	295	563	
24					X				11	X	X				675 (1247)	X			DNF	n/a	n/a	
25	X								10	X	X				665 (1229)		X		2349	456	853	
26	X								10	X	X				665 (1229)	X			495	n/a	n/a	(3)

**Table 5.10: Summary of test results for the Group 1 PT series tests (PT1 through PT 31) which all involved single lengths of cable.**

Test PT-#	Cable Insulation and Jacket Material								Cable Item number	Number of Conductors					Conductor Size (AWG)	Shroud Temperature °C (°F)	Raceway Type			Summary of Test Results			Applicable Notes
	XLPE/CSPE	EPR/CPE	SR/Aramid	XLPO	Vita-Link	XLPE/PVC	PE/PVC	PVC/PVC		Tefzel/Tefzel	3	7	8	12			14	Tray	Conduit	Air Drop	Time of First Failure (s)	Cable Temperature at Failure (°C)	
1	X								14	X		X			475 (887)	X			771	393-396	739-745		
2	X								14	X		X			470 (878)	X			864	393-410	739-770	(2)	
3	X								14	X		X			470 (878)	X			790	n/a	n/a	(3)	
4							X		5	X		X			300 (572)	X			590	195-200	383-392		
5							X		5	X		X			300 (572)	X			766	211-213	412-415		
6							X		5	X		X			300 (572)	X			776	206-216	403-421		
7	X								14	X		X			470 (878)		X		2334	403-424	757-795		
8							X		5	X		X			300 (572)		X		1245	164-174	327-345		
9	X								14	X		X			470 (878)			X	1531	413-418	775-784		
10							X		5	X		X			300 (572)			X	1173	228	442	(4)	
11	X								10		X		X		470 (878)	X			1225	415-425	779-797		
12	X								10		X		X		470 (878)	X			1273	420-425	788-797		
13	X								10		X		X		470 (878)	X			1198	419-434	786-813		
14						X			15		X		X		300 (572)	X			1464	237-238	459-460		
15						X			15		X		X		325 (617)	X			806	246-266	474-510		
16						X			15		X		X		325 (617)	X			824	236-244	457-471		
17		X							2		X		X		470 (878)	X			613	447-448	837-838	(2)	
18			X						9		X		X		700 (1292)	X			DNF	n/a	n/a	(5)	
19				X					8		X		X		470 (878)	X			935	419-436	786-817		
20					X				3		X		X		470 (878)	X			612	413-421	775-790	(2)	
21						X			1		X		X		300 (572)	X			560	196-229	385-444		
22							X		12		X		X		470 (878)	X			445	382-384	720-723		
23	X								10		X		X		470 (878)		X		1803	425-429	797-804		
24	X								10		X		X		470 (878)		X		2006	422-431	792-808		
25						X			15		X		X		325 (617)		X		2924	n/a	n/a	(6)	
26						X			15		X		X		325 (617)		X		DNF	n/a	n/a	(5)	
27	X								10		X		X		470 (878)			X	1356	423-426	793-799		
28	X								10		X		X		470 (878)			X	1314	421-430	790-806		
29						X			15		X		X		325 (617)			X	845	232-239	450-462		
30						X			15		X		X		325 (617)			X	599	243-256	469-493		
31				X					11		X		X		700 (1292)	X			DNF	n/a	n/a	(5)	

**Table 5.11: Summary of test results for the Group 6 and Group 7 PT series tests (PT62 through PT 64) which all involved single lengths of cable.**

Test PT-#	Cable Insulation and Jacket Material								Cable Item number	Number of Conductors				Conductor Size (AWG)	Shroud Temperature °C (°F)	Raceway Type			Summary of Test Results			Applicable Notes		
	XLPE/CSPE	EPR/CPE	SR/Aramid	XLPO	Vita-Link	XLPE/PVC	PE/PVC	PVC/PVC		Tefzel/Tefzel	2	12	16			18	Tray	Conduit	Air Drop	Time of First Failure (s)	Cable Temperature at Failure (°C)		Cable Temperature at Failure (°F)	
62	X								13	X		X					475 (887)	X			502	n/a	n/a	(3)
63							X		6	X		X					325 (617)	X			333	205-208	401-406	
64	X								13	X		X					470 (878)	X			348	n/a	n/a	(3) (7)
65							X		6	X		X					325 (617)	X			258	225	437	(2) (7)

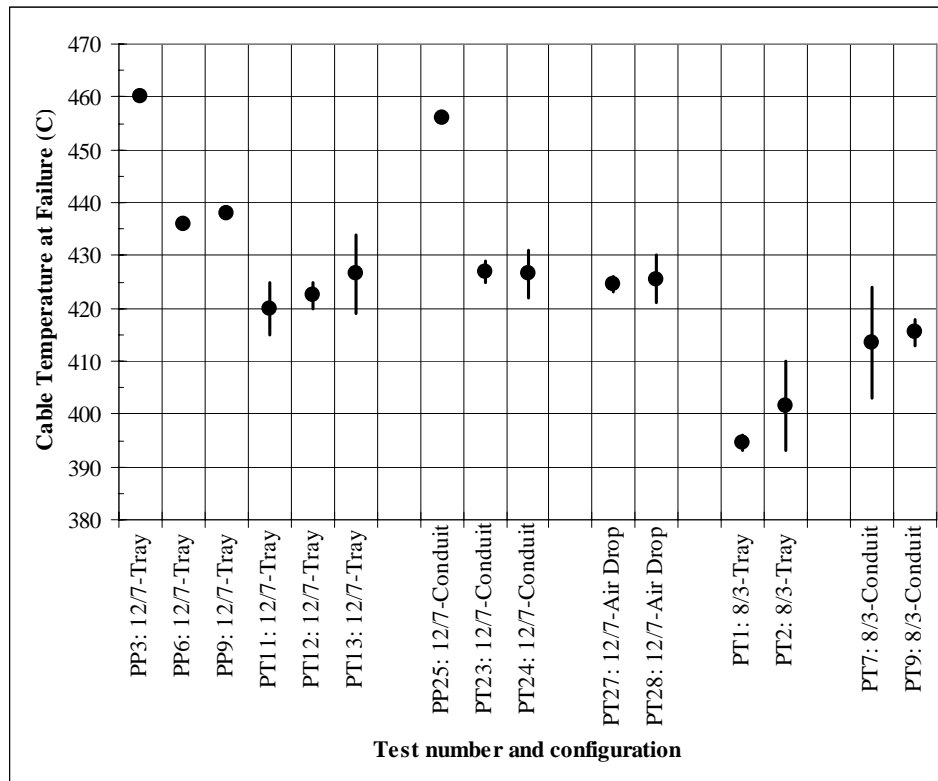
**Notes for Tables 5.8 through 5.10:**

- (1) Thermal data for Test PP1 was lost due to a logger error.
- (2) In these cases the thermal response cable ignited prior to electrical failure but the case met the criteria for inclusion in this analysis as described in the text.
- (3) In these cases, the thermal response cable ignited prior to electrical failure and the case did not meet the criteria for including in the analysis. No temperature at failure was reported for these cases and the case was considered indeterminate in this context.
- (4) One of the two sub-jacket thermocouples failed during the course of PT10 and the data from this TC has been disregarded. The single temperature value reported was based on the second TC which did not fail.
- (5) For these cases the electrical performance cable did not fail (DNF).
- (6) For test PT25 the sub-jacket TCs failed during the test so the cable temperature at the time of failure cannot be determined.
- (7) Due to the small cable diameter, these tests PT64 and PT65 used only one sub-jacket TC per test.

As a further illustration of the potential utility of the CAROLFIRE data, Figures 5.31, 5.32 and 5.33 consolidate the test results as reported in Tables 5.8, 5.9 and 5.10, although the results have been reordered based on the testing of like cable types. Figure 5.31 consolidates the results obtained for the various XLPE-insulated cable tests. The test results have been grouped by the cable configuration (abbreviated using the wire gage and conductor count; e.g., “12/7” indicates the 12AWG, 7-conductor cable configuration and “8/3” the 8AWG, 3-conductor configuration) and routing configuration (tray, conduit, and air-drop).

In all three figures, some of the tests are plotted as individual data point values while others are shown with a central data point and a high/low range bar. The cases with a single data point are those tests where there was only one sub-jacket TC. Those that include a high/low range bar are cases where there were two sub-jacket TCs, one each on opposite sides of the cable. For these latter

cases, the central point represents the average of the two individual measurements, and the high/low bar indicates the range obtained for the two individual TCs.



**Figure 5.31: Compilation of test results for the XLPE-insulated cables.**

Note that the results are quite consistent within each grouping. The most significant inconsistencies are associated with the PP-series tests which tended to indicate higher sub-jacket temperatures at the time of failure than did the corresponding PT-series tests. The difference is likely due to the fact that higher shroud temperatures were generally used in the PP-series tests as compared to the PT-series tests. The higher shroud temperature caused a higher rate of cable heating and, in turn, a higher temperature gradient across the cable cross-section. As a result, the sub-jacket temperature was likely a poorer reflection of the overall cable insulation temperature and may be a poorer indication of the failure threshold for the cables. For this reason, the PT series tests are considered a more accurate representation of the cable temperature that should be associated with the onset of electrical failure (the failure threshold).

Overall, these results provided further evidence that Penlight provided both consistency and experimental repeatability. The various tests for the XLPE-insulated cables in the PT-series all indicate failure temperatures for the 12AWG, 7-conductor cable (cable item #10) that lie between 415°C and 435°C (779-815°F) with very little scatter based on the readings from the various individual thermocouples. Recall that each cable in the PT-series tests was equipped with two sub-jacket thermocouples. Considering the average for the two thermocouples used in any given test, (as

indicated by the circles on the plot), the variation between tests drops considerably. The indicated failure threshold ranges from 420°C to 427°C (788-801°F).

Given the test configurations it would seem reasonable to presume that the measured sub-jacket cable temperatures at the time of failure, especially for the PT-series tests, can be taken as indicative of the damage threshold for the cables. It should be noted that the values indicated for the CAROLFIRE XLPE-insulated cables are somewhat higher than has been previously reported for a nominally identical cable. In particular, an earlier series of tests is presented in NUREG/CR-5546 [2] that involved a Rockbestos Firewall III, XLPE insulated, neoprene jacketed cable. This earlier study estimated the failure threshold for that particular cable at 325-330°C (617-626°F). The cable used in these earlier tests was from the same manufacturer and the same product line as the CAROLFIRE XLPE/CSPE cables, although the jacket material was different (neoprene versus CSPE).

There is no reason to doubt the accuracy of the previous test results. One potentially significant difference between the earlier study and CAROLFIRE is that the cables used in the earlier tests were manufactured in the mid-1980's whereas the CAROLFIRE cables were manufactured in 2006. During the intervening 20 years, it would not be unexpected that the cable construction and formulations would be updated to reflect more modern manufacturing methods and materials. The apparent differences in the nominal failure threshold are likely due, at least in part, to manufacturing and/or material differences. Also, the earlier tests explicitly explored the electrical failure thresholds for the cables with tests lasting up to 80 minutes before electrical failure whereas CAROLFIRE sought to create conditions leading to damage within 10-20 minutes. This second factor may also explain, in part, the apparent differences between the two experimental studies but likely would not account for more than a fraction of the observed difference.

Figure 5.32 provides a similar consolidation of the test results for the various TP cable types; namely, the PVC-, PE-, and Tefzel-insulated cable types. Note that, as expected, the TP cable types experienced failures at much lower temperatures. With the exception of one outlier (PT22) all tests indicated cable failures at less than 300°C (572°F). The lowest temperatures at failure were associated with the PVC/PVC cable types which experienced failures at temperatures no higher than 230°C (446°F) excluding one outlier case (PP4). The PE-insulated cables performed slightly better with temperatures at failure in the range of 209-270°C (408-518°F). The Tefzel cables performed the best of the group with temperatures at failure in the range of 288-295°C (550-563°F), excluding the one outlier case (PT22).

Finally, Figure 5.33 provides a similar consolidation of results for the other TS-insulated cable types; namely, the EPR- and XLPO-insulated cables and the one mixed type XLPE-insulated, PVC-jacketed TS/TP cable. Here again, the results were quite consistent within each cable type. One point of particular note here was that the one case involving the mixed type TS-insulated (XLPE), TP-jacketed (PVC) cable displayed temperatures at failure that were more consistent with the other TS-insulated cables (e.g., with the XLPE-insulated cables) than the TP-insulated cables (e.g., the PVC insulated cables). This would tend to indicate that, with respect to electrical performance at

least, the mixed type cable performance was dominated by the insulation properties rather than those of the jacket.

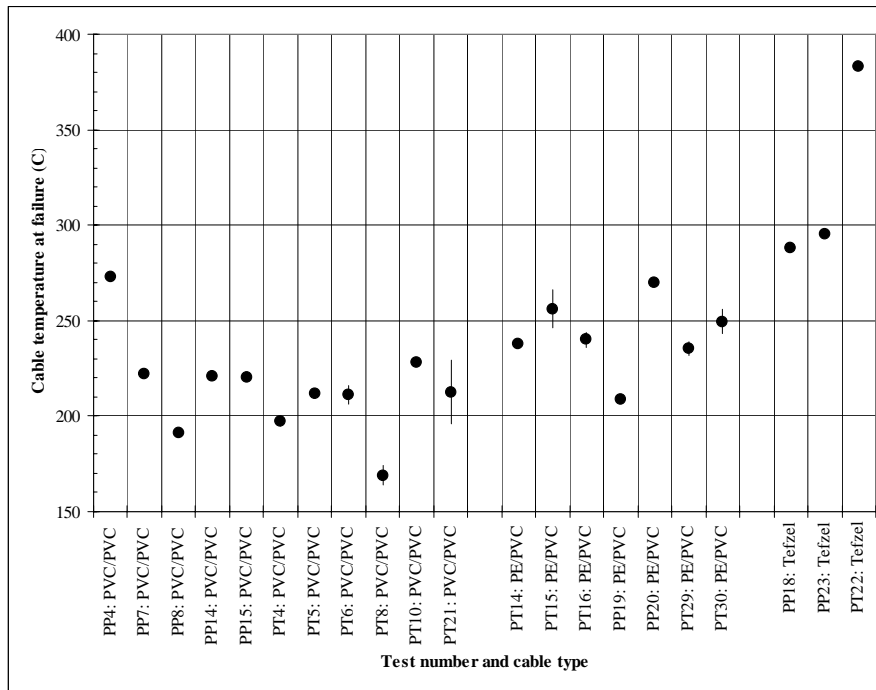


Figure 5.32: Compilation of the test results for the TP cable types.

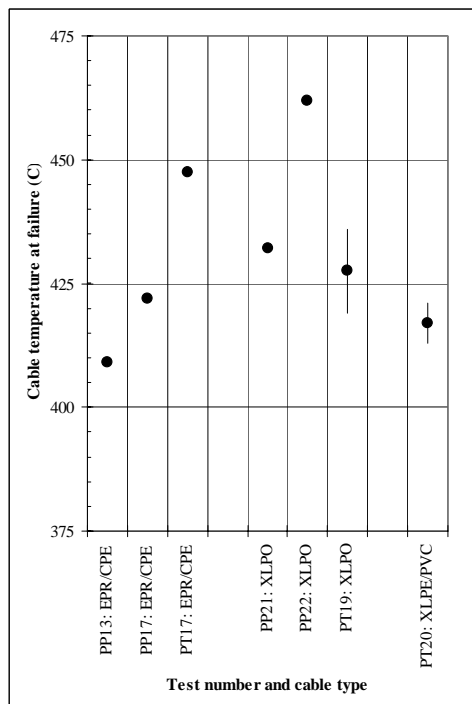


Figure 5.33: Compilation of the test results for the EPR- and XLPO-insulated cable types and for the one TS/TP cable.

## 6 THE INTERMEDIATE-SCALE TEST SERIES

### 6.1 Introduction and Organization

This Section provides a summary description of the results obtained during the intermediate-scale tests. In all, there were four preliminary tests (IP-1 through IP-4), and 14 full tests (IT-1 through IT-14). Each test involved a combination of individual lengths of cable and/or various cable bundles. Each test may also have involved cables in more than one location, and in more than one routing configuration. The intent here was not to present an exhaustive presentation of the gathered data because this was simply impractical given the sheer volume of data. Rather, the intent was to provide detailed descriptions of the tests conditions for each test performed. Data examples were provided, but primarily these were presented only in order to illustrate key aspects of the intermediate-scale test data and unique or newly introduced aspects of any given test in the series. Again, the full data sets are publicly available and are provided on a companion CD-ROM issued with this report.

Unlike the Penlight tests, there was effectively no limit to the number of cables that could be burned during the intermediate-scale tests. In practice, most of the cable trays were more lightly loaded than were the trays used in the previous tests conducted by NEI/EPRI.

As with the Penlight tests, the testing involved single lengths of cable, bundles of six cables in a cable tray, and bundles of four cables (three electrical performance cables plus one thermal response cable) in a conduit. In addition, two tests included bundles of twelve cables in a cable tray (IT-1 and IT-2) and three tests included random fill raceways, as described in Section 3.2.4 above (IT-1, IT-13 and IT-14). The most common configuration for the CAROLFIRE intermediate-scale tests was two-to-three 6-cable bundles per cable tray.

As in the Penlight tests, no single cable or cable bundle was monitored for both thermal response and electrical performance. However, unlike the Penlight tests, the intermediate-scale facility allowed for the testing of complimentary or pair-matched *bundles* of thermal response and electrical performance cables side-by-side. As a result, a direct correlation between the electrical failure and thermal response data is possible for the cable bundles as well as individual cables. Indeed, tests IT-1 through IT-14 all involved cable bundles, and in each of these tests there were at least two pair-matched sets of complementary thermal response and electrical performance bundles present.

Electrical performance monitoring involved both the SCDUs and the IRMS. For purposes of presentation here, the examples shown illustrate first failures for a given cable or cable bundle only. Volume 1 of this report provides additional data on the electrical performance monitoring and results for these tests.

Note also that the letter identification schemes used to identify specific cables in each bundle, and the typical arrangement of TCs in the various thermal response bundles has been described in Section 3 above.

In the sections that follow, each of the intermediate-scale tests is described and example results are presented. Each test description includes a detailed description of the test conditions. For those tests that involved cables placed in multiple locations, the specific conditions for each relevant location are presented in separate subsections. These are presented for each test in the form of a text description of the cable and bundle arrangements and an accompanying schematic representation of the test structure upper hood section illustrating the placement of raceways and cables. The cable raceway locations in these figures are consistent with the locations as identified in Figure 2.10 above.

The discussion of each test also includes the presentation of general data associated with factors such as the gas burner flow rate, outlet stack measurements, general air temperature responses, and the response of the slug calorimeters in tests where those were used. In addition, examples of the data relative to cable thermal response and electrical performance are presented. Electrical performance data as presented here is generally limited to the first observed failure for specific cables. The details of the electrical performance monitoring configurations and results are provided in Volume 1 of this report.

For the purposes of data reporting, all times as presented in this report were indexed such that time=0 corresponds to the gas burner ignition time. In the corresponding data files two time record sets are provided. One was labeled “DAQ time” and reflects the time relative to when the data acquisition systems were started. Each test includes a period of baseline data gathering prior to burner ignition. This baseline data serves two purposes; namely, it establishes test initial conditions and verifies proper operation of the data acquisition systems. The second set of time records was labeled “Burner time” and has been indexed such that time=0 corresponds to the time the burner was ignited. The “burner time” has been used in the data reporting as presented here. The difference between the two records was simply the duration of the baseline data gathering period which was unique to each test.

With the exception of IP-2, the time offset for the electrical performance and thermal data were the same for any given test (although the offset varies from test to test). This was because for each test all data systems were started essentially simultaneously (within, at most, a few seconds of each other). In the case of IP-2, a “file creation error” forced a re-start of the IRMS data logging system creating a significant time delay between initiation of the thermal data monitoring systems and the IRMS. This error was noted and the system was restarted prior to fire ignition, but the thermal data system was not reset. As a result, the time offset for the IRMS data was 1700s whereas that for the thermal data was 5600s. All other tests involve self-consistent burner ignition/offset times.

## **6.2 Tests IP-1 and IP-2**

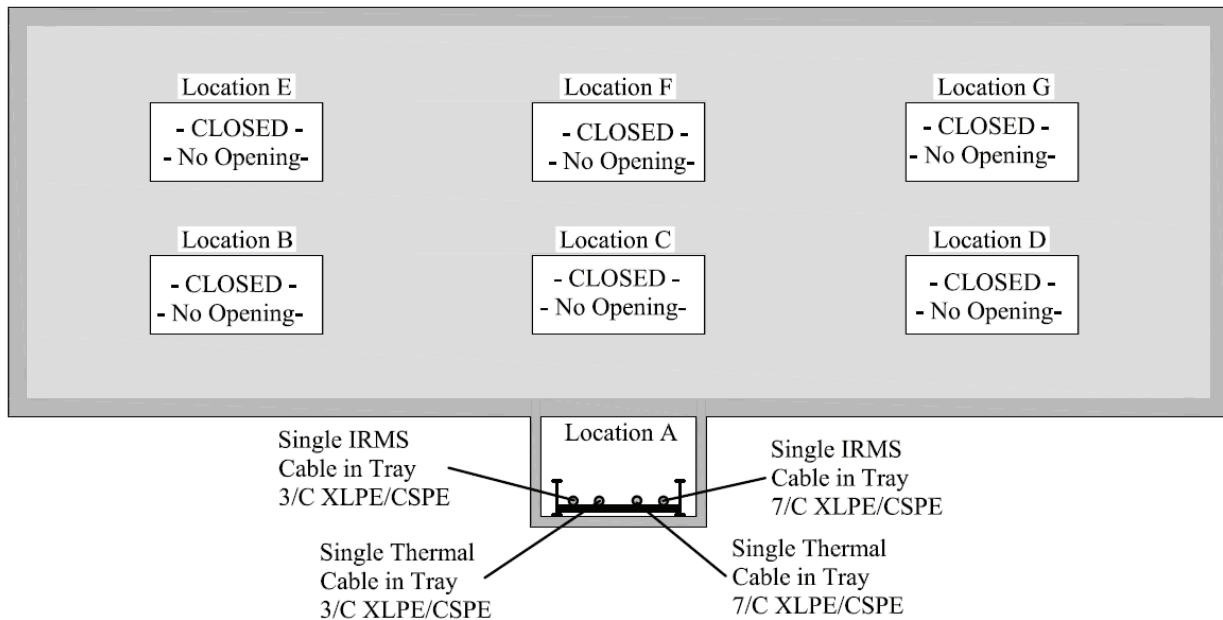
### **6.2.1 Test Conditions**

Tests IP-1 and IP-2 were the first tests run in the intermediate-scale test facility. As such their primary purpose was to ensure the proper operation of the gas burner, the various TCs, and stack



information. The tests were nominally identical in setup, but differed in the fire intensity profile. IP-1 was conducted with the burner running at progressively higher fire intensity beginning at low fuel flow rate (HRR) and working up to the maximum fuel flow rate (hence, HRR) possible given the fuel gas supply system. IP-2 was run at a constant fuel flow rate.

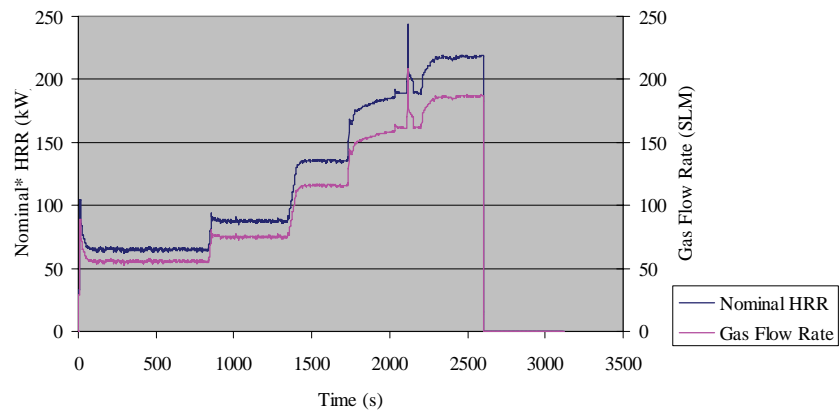
Each test was run with four individual lengths of cable in a cable tray at Location A. There were two lengths of the XLPE/CSPE, 12 AWG, 7/C (Item #10) and two lengths of the XLPE/CSPE, 8 AWG, 3/C (Item #14). One of each cable type was monitored for thermal response, and the other was monitored for electrical performance using the IRMS. All of the other cable locations were closed (i.e., the holes to allow for installation of other raceways had not yet been cut) so the entire upper area of the test cell was intact with no openings. This arrangement is illustrated in Figure 6.1.



**Figure 6.1: Illustration of the test conditions for tests IP-1 and IP-2.**

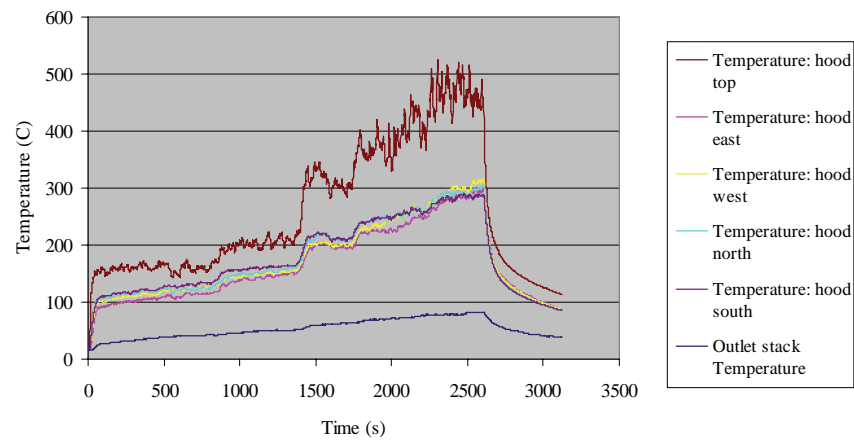
### 6.2.2 Test Results IP-1

The fuel flow rate and nominal HRR for the burner during test IP-1 are illustrated in Figure 6.2. The nominal HRR for this test assuming an efficiency of 0.85 ranged from about 60 to 220 kW (57 to 209 BTU/s). The corresponding hood temperatures measured during the test are illustrated in Figure 6.3. As noted above, IP-1 involved individual lengths of two cable types, a 3/C cable and a 7/C cable (see Section 6.2.1 for details). Figures 6.4 and 6.5 illustrate the thermal response and corresponding data for first electrical failures for these two cables respectively.



\*Nominal HRR based on an assumed 0.85% combustion efficiency

**Figure 6.2: Fuel gas measured flow rate and nominal heat release rate for IP-1.**



**Figure 6.3: Hood temperatures during IP-1.**

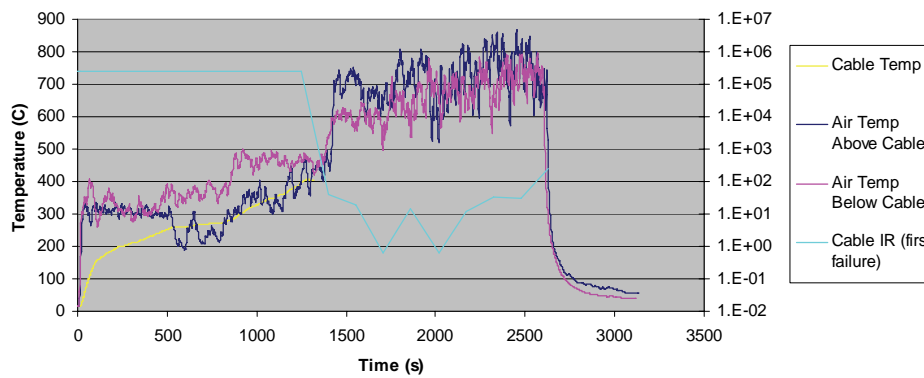
Note that these Figures 6.2 and 6.3 illustrate a distinct correlation between the hood temperatures and the fire intensity in that each step in burner flow rate (or fire HRR) was mirrored by a step in measured hood temperatures. It was also apparent that as fire intensity increased, the degree of fluctuation in the measured temperature also increased. This likely reflects the increasing levels of general turbulence induced as the fire intensity increased. This likely reflects the increasing levels of general turbulence induced as the fire intensity increased. The burner also produced the typical cyclical large-scale eddy generation behavior in the flame zone observed during large-scale fires. That is, the gas burner did not create a continuous uniform flame zone (such as might be observed with a smaller pre-mixed flame), but rather, produced a flame zone that was periodic with large eddies and was clearly in the turbulent flow regime. This behavior is expected for larger fires, and in fact, is taken as indicating that the desired large-scale burning behaviors and characteristics were achieved in the CAROLFIRE tests. The measured temperatures do reflect this behavior and, again, were typical of the behaviors commonly observed in large-scale fire tests.

Also note that the hood temperatures at the ceiling of the test structure directly above the fire source ('hood top') reached 500°C (932°F) while those at the mid-point of the side walls (i.e., 610 mm or 2' below the ceiling; 'hood east,' 'hood west,' 'hood north,' and 'hood south') reached about 300°C

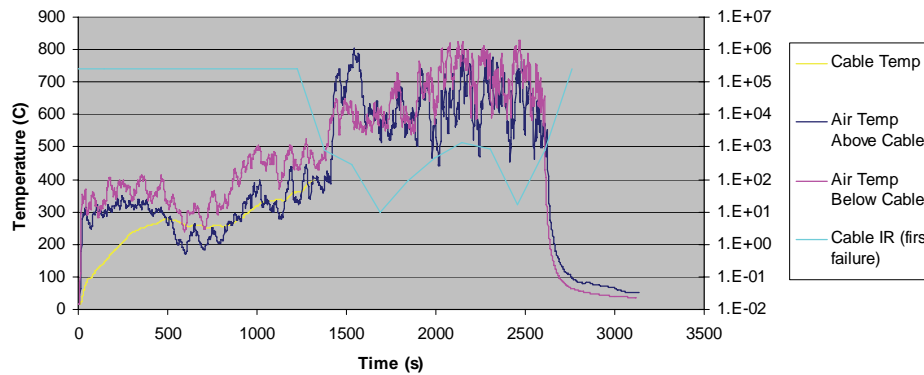
(572°F). This was a clear indication that the thermal conditions under the hood could be made severe enough to cause cable electrical failures under hot gas layer conditions, at the very least, at the upper raceway Locations E, F & G as shown in Figure 2.10 even with a fire intensity of about 180 kW (171 BTU/s).

Finally, note that temperatures under the hood fell off quite quickly once the fire was extinguished. This reflects the fact that the outer test facility was not heated significantly during the test. This is further illustrated by the “outlet stack” temperature, as shown in Figure 6.3, which never reached 200°C (392°F). The outlet stack was the vent for the outer test chamber and ultimately all fire products were exhausted through this outlet stack.

Figures 6.4 and 6.5 illustrate the thermal response and corresponding data for first electrical failures for these two cables respectively. One point to note in both of these figures is the rapid increase in the measured cable and nearby air temperatures essentially concurrent with the onset of electrical failure. This was likely an indication of cable ignition concurrent with electrical failure. This behavior has been observed in previous cable damageability studies, and was also observed in many of the Penlight tests for CAROLFIRE as well.



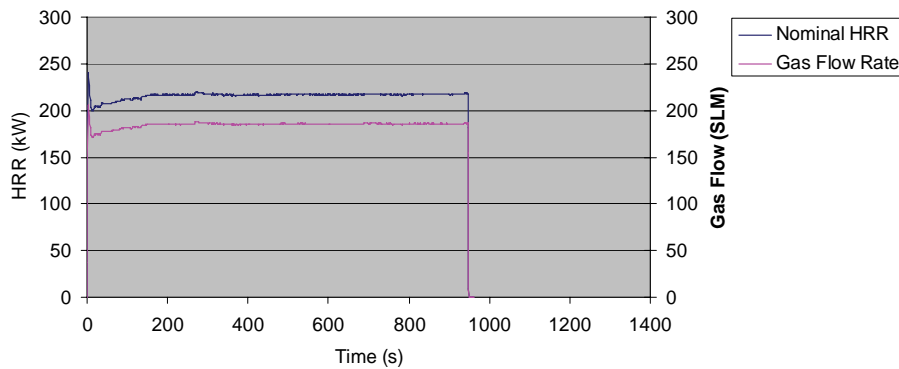
**Figure 6.4: Cable thermal response and first electrical failures for the 3/C cable in IP-1.**



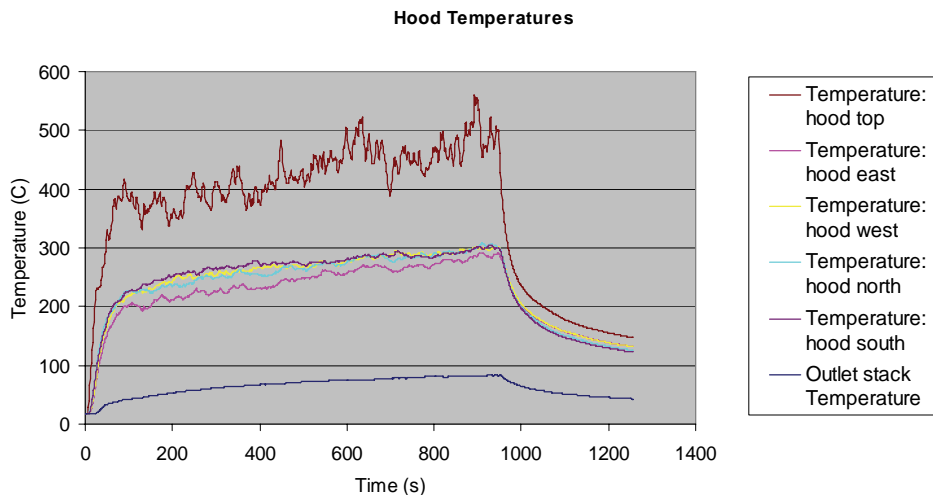
**Figure 6.5: Cable thermal response and first electrical failures for the 7/C cable in IP-1.**

### 6.2.3 Test Results IP-2

The fuel flow rate and nominal HRR for the burner during test IP-2 is illustrated in Figure 6.6. The nominal HRR for this test assuming an efficiency of 0.85 was about 220 kW (209 BTU/s). The corresponding hood temperatures measured during the test are illustrated in Figure 6.7. As noted above, as in IP-1, IP-2 involved individual lengths of two cable types, a 3/C cable and a 7/C cable (see Section 6.2.1 for details).



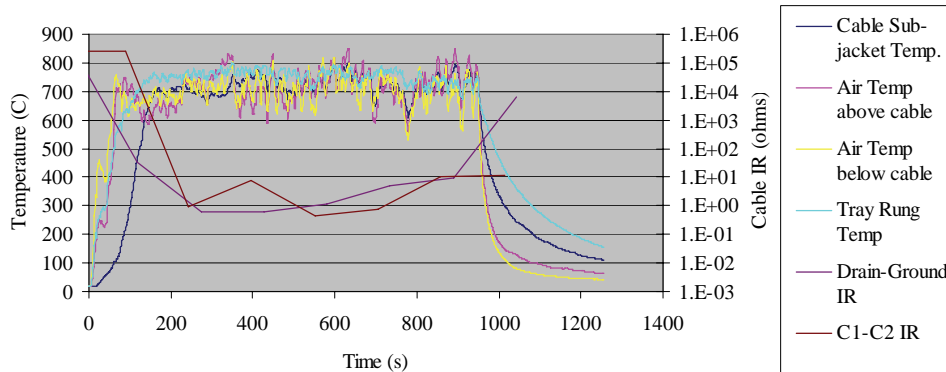
**Figure 6.6: Fuel gas measured flow rate and nominal heat release rate for IP-2.**



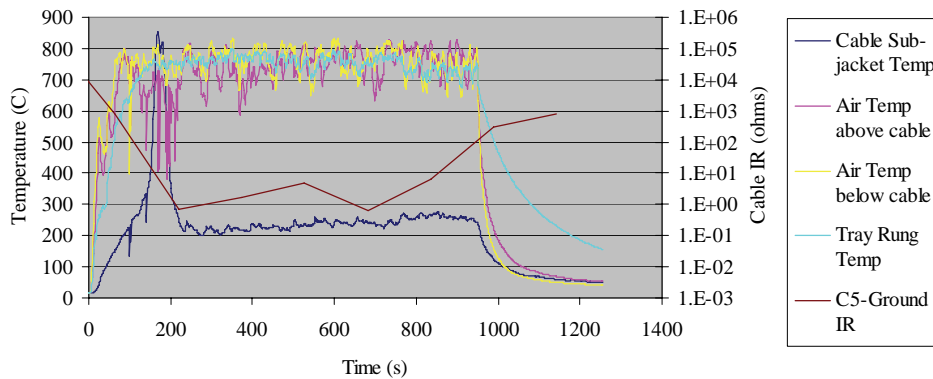
**Figure 6.7: Hood temperatures during IP-2.**

Figures 6.8 and 6.9 illustrate the thermal response and corresponding data for first electrical failures for these two cables respectively. Note that for the 3/C cable the first electrical failure noted was a short between the un-insulated drain wire and the external ground (“Drain-Ground”). This type of short would not generally imply functional failure of the cable since the drain is usually grounded during installation. The second mode of failure was intra-cable conductor-to-conductor shorting as illustrated by the IR between conductors 1 and 2 (C1-C2). Both of these failures are illustrated in Figure 6.8. Also note that the cables failed very quickly in this test, generally within 2 minutes of

fire ignition. This was likely because of their low thermal mass as individual cable lengths and because of their exposure directly above the fire source.



**Figure 6.8: Cable thermal response and first electrical failures for the 3/C cable in IP-2.**



**Figure 6.9: Cable thermal response and first electrical failures for the 7/C cable in IP-2.**

Note that in Figure 6.9 it is evident that the thermocouple embedded below the cable jacket failed at a time approximately concurrent with electrical failure of the cable. The failure appears to have resulted in formation of a ‘false bead’ somewhere back along the cable lead wires because the rather sudden drop in measured temperature was not consistent with other observed behaviors and temperatures.

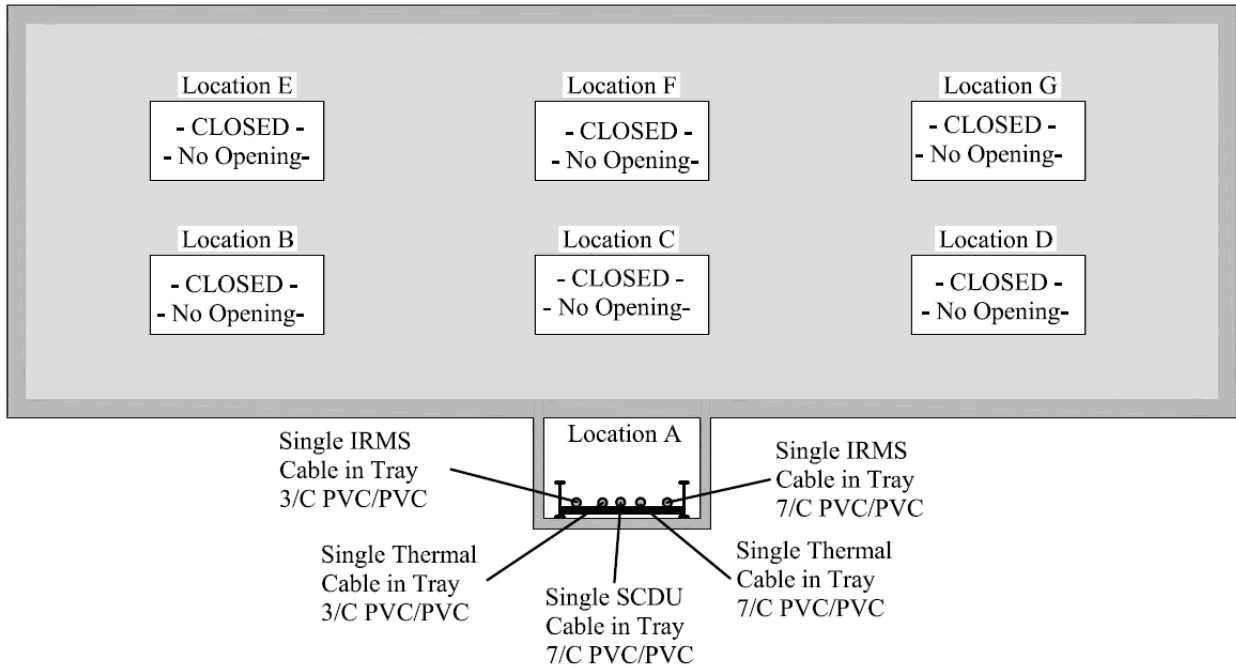
## 6.3 Test IP-3

### 6.3.1 Test Conditions

The test conditions for IP-3 were quite similar to that for IP-1 and IP-2 except that PVC/PVC cables were used instead of the XLPE/CSPE cables used in the previous tests. In addition, this was the first test to utilize the SCDUs, one unit in this case, and a fifth length of cable was added to the tray to accommodate the SCDU.

As in IP-1 and IP2, there was a cable tray at Location A. The tray contained two individual lengths of PVC/PVC, 12 AWG, 7/C (Item #1), and two individual lengths of PVC/PVC, 8 AWG, 3/C (Item

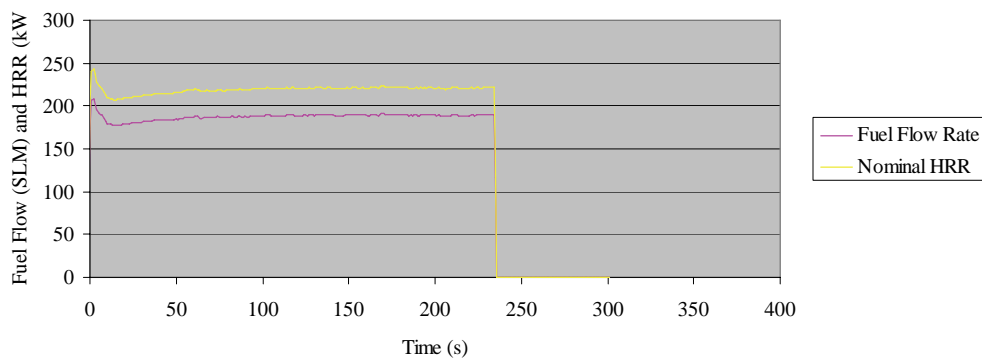
#5). One of each cable type was monitored for thermal response and one each for electrical performance (via the IRMS). In addition, a fifth length of the PVC/PVC, 12 AWG, 7/C (Item #1) cable was added to the tray at location A and connected to one of the four SCDUs in the MOV-1 wiring configuration. This arrangement is illustrated in Figure 6.10.



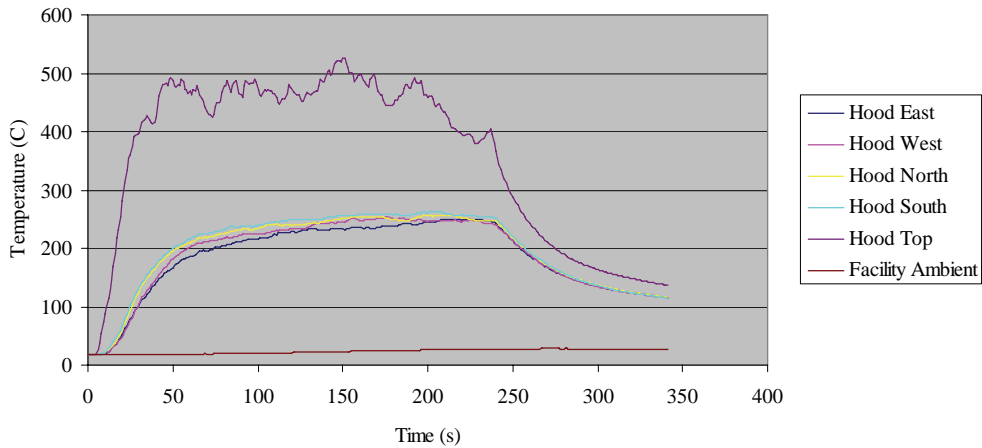
**Figure 6.10: Test setup for IP-3.**

### 6.3.2 Test Results

The gas burner fuel flow rate and nominal fire HRR are shown in Figure 6.11. The nominal HRR for this test assuming an efficiency of 0.85 was about 220 kW (209 BTU/s). Figure 6.12 illustrates the corresponding hood temperatures within the test structure.

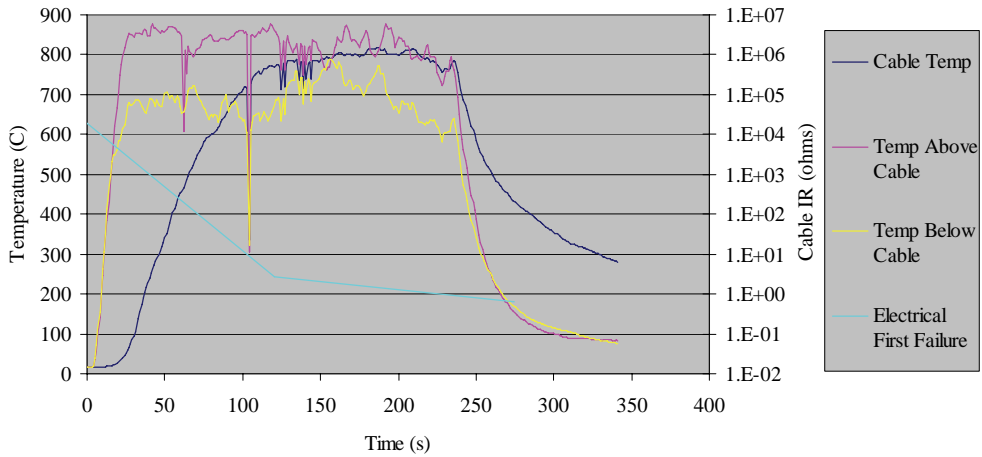


**Figure 6.11: Fuel flow rate and nominal HRR (eff=0.85) for burner in IP-3.**

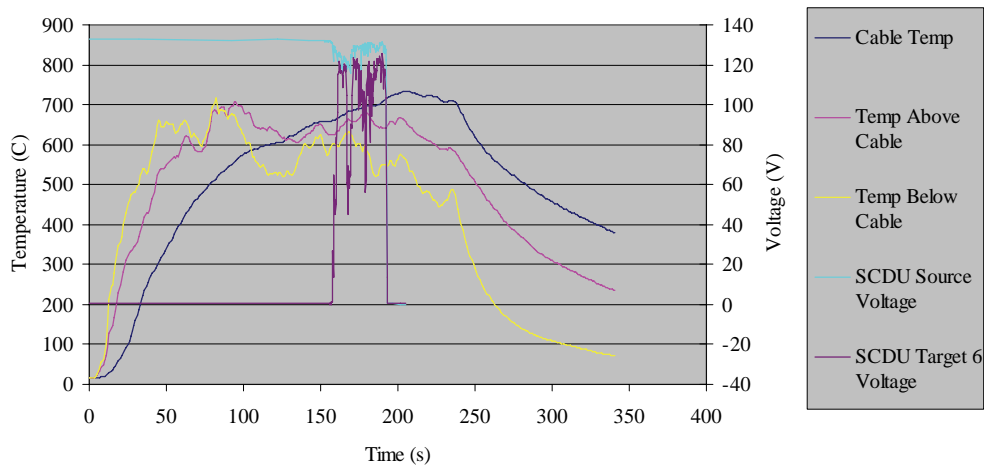


**Figure 6.12: General temperatures within the test structure hood during IP-3.**

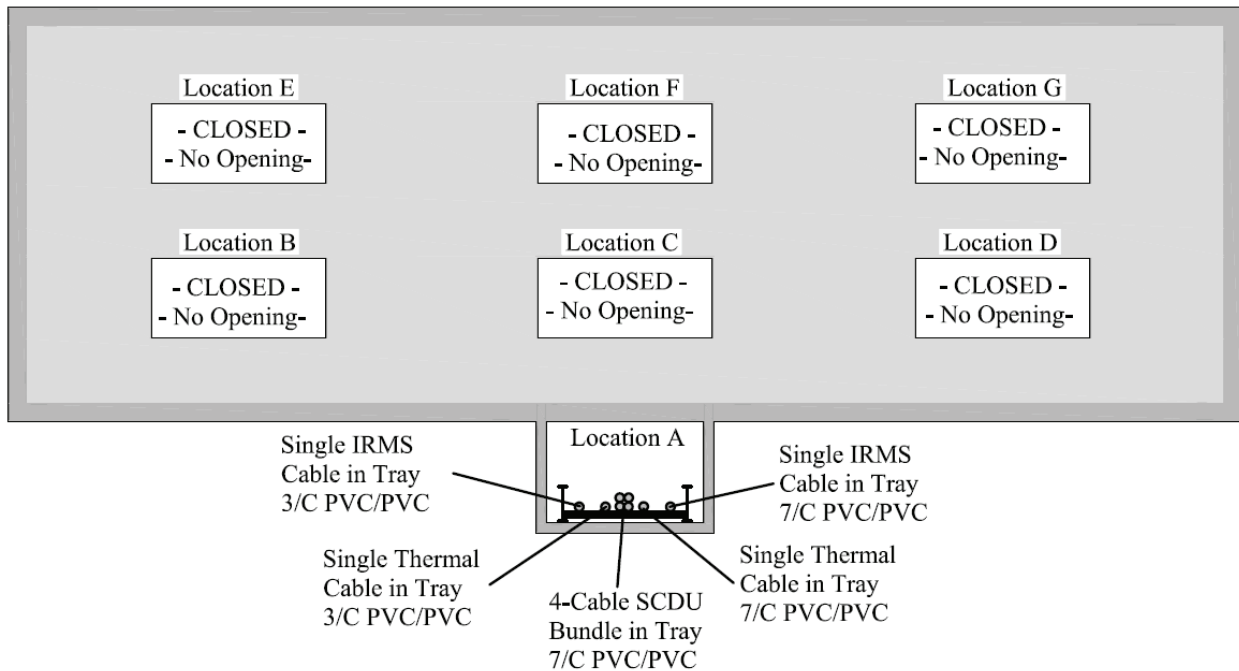
Figures 6.13 and 6.14 illustrate the cable thermal response and cable electrical failure response for the 3/C and 7/C cables for test IP-3. Note that in the case of the 7/C cable, the SCDU results are shown. In this particular test, a spurious actuation of the motor contactor on Target Path 6 occurred as indicated by the sharp rise in the voltage on ‘SCDU Target 6.’ This was followed approximately 30 seconds later by a fuse blow failure and loss of the energizing source power as indicated by the sharp drop in voltage for both of the SCDU voltage traces.



**Figure 6.13: Cable thermal response and first IRMS electrical failures for the 3/C PVC/PVC cable in IP-3.**



**Figure 6.14: Cable thermal response and first SCDU failures for 7/C PVC/PVC cable in IP-3.**



**Figure 6.15: Test setup for IP-4.**

## 6.4 Test IP-4

### 6.4.1 Test Conditions

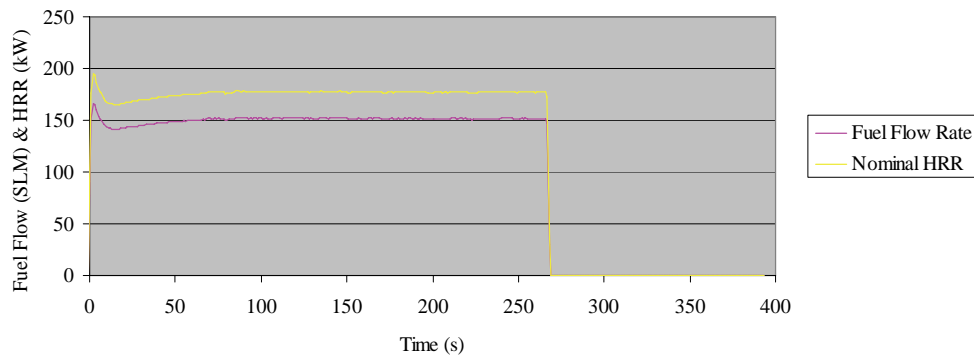
The test setup for IP-4 is illustrated in Figure 6.15. The test conditions for IP-4 were identical to those of IP-3 with one exception. In IP-3 only one of the SCDU units was used, and a single length of PVC/PVC, 12 AWG, 7/C (Item #1) was placed in the middle of the tray for this purpose. In IP-4 all four SCDUs were used, and the single length of cable was replaced by a 4-cable bundle with one cable connected to each SCDU. The same cables were used (7/C 12 AWG PVC/PVC Item #1). Each



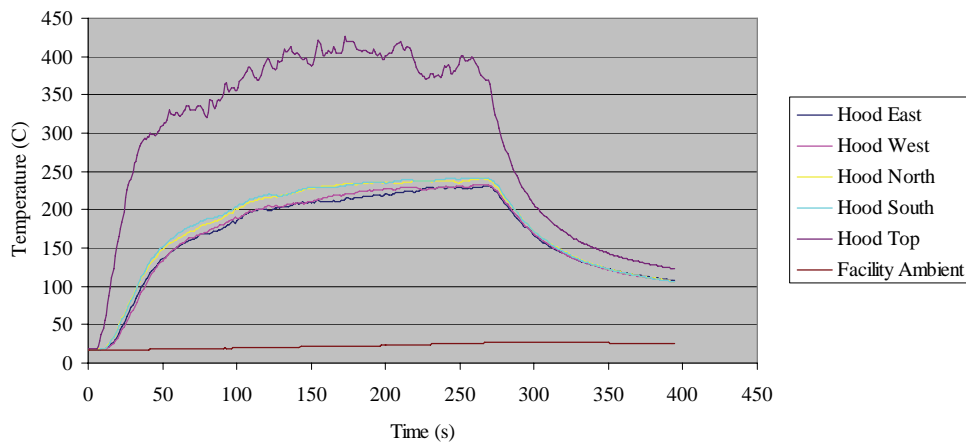
of the four cables was connected to one of the SCDUs in the wiring configuration referred to as 'MOV-1a' (see Volume 1 for a description of this wiring configuration).

## 6.4.2 Test Results

Figure 6.16 illustrates the burner flow rate and nominal HRR for test IP-4. The nominal HRR for this test assuming an efficiency of 0.85 was about 175 kW (166 BTU/s). Figure 6.17 illustrates the air temperatures measured under the hood section during IP-4.



**Figure 6.16: Fuel flow rate and nominal HRR for IP-4.**

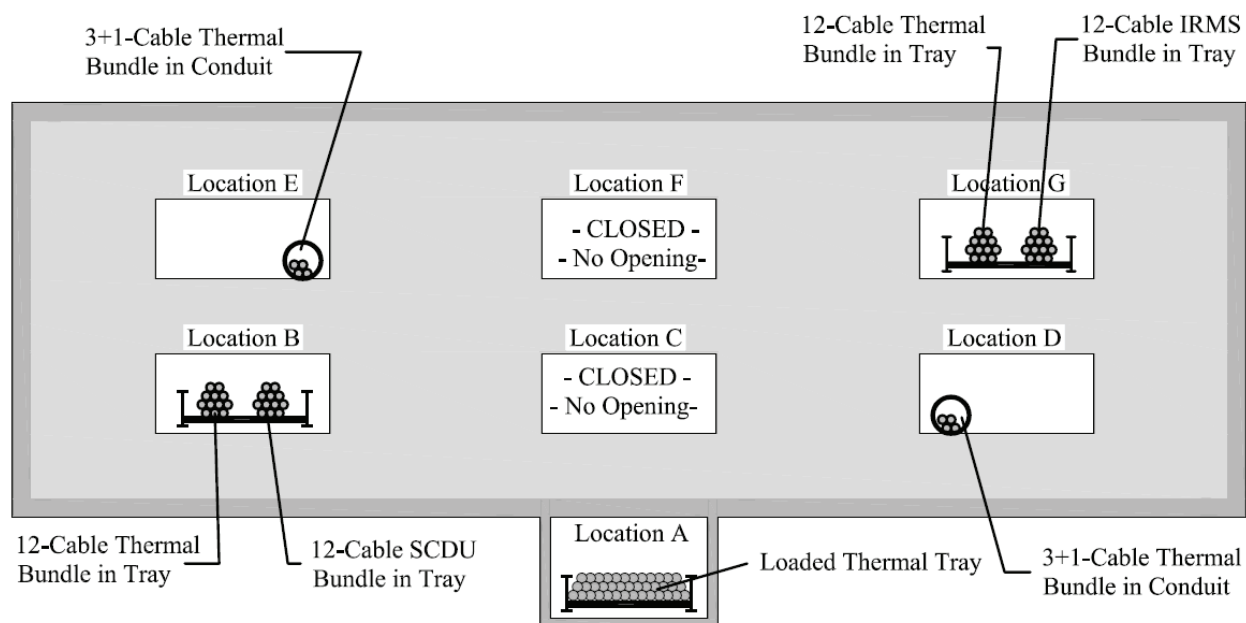


**Figure 6.17: General air temperatures for IP-4**

## 6.5 Test IT-1

### 6.5.1 Test Conditions

Test IT-1 was the first test to use a random fill cable tray which is pictured in Figure 6.18 below. The overall test conditions for IT-1 are illustrated in Figure 6.19 below. All of the cables in this test were XLPE/CSPE cables (Items #7, #10 & #13).



**Figure 6.19: Test setup for IT-1.**

### **Location A:**

IT-1 included a random-fill loaded cable tray at Location A monitored for thermal response. There were 4 TCs embedded in the cable mass (with each TC placed below the jacket of a cable in the tray), plus one TC monitoring air temperature about 75 mm (3") above and one TC a similar distance below the center of the cable tray. The cables were arranged in the tray in a random arrangement as discussed in Section 3.2.3 above. The tray load was comprised of the following combination of XLPE/CSPE cables:

- 15 lengths of the XLPE/CSPE, 16 AWG, 2/C(Sh) (Item #7),
- 15 lengths of the XLPE/CSPE, 18 AWG, 12/C (Item #13) and
- 26 lengths of the XLPE/CSPE, 12 AWG, 7/C (Item #10).

All of the cables were cut to a length of 1.8 m (6') so that only the center section of the cable tray was actually filled. Figure 6.18 provides a photograph of the random fill cable tray used in this test prior to testing. Note that the location of the TC measuring air temperature above the cable mass is also evident.



**Figure 6.18: Photograph of the random fill cable tray at Location A in IT-1.**

### **Locations B&G:**

There were four 12-cable bundles present, two each in cable trays at Locations B and G. Each 12-cable bundle was comprised entirely of XLPE/CSPE, 12 AWG, 7/C (Item #10). Each location had a matching pair of bundles, one in each pair monitored for thermal response bundle and the second monitored for electrical performance. The thermal response bundles each included the standard complement of TCs for a 12-cable bundle as described in Chapter 3 above.

The electrical performance bundle at location G was connected to the IRMS. The electrical performance bundle at Location B was connected to the four SCUDU Units, each SCUDU connected to a different cable in the standard MOV-1 wiring configuration. Details of the electrical performance configuration and results are provided in Volume 1 of this report.

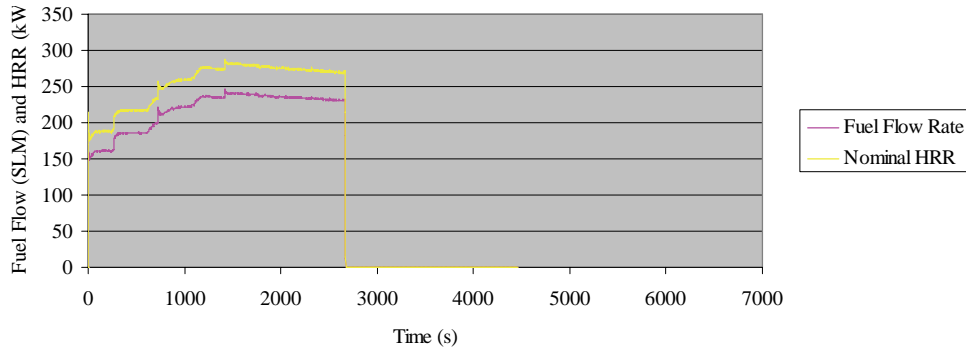
### **Locations D&E:**

There were also two conduits included at Locations D&E that were monitored for thermal response using the standard '3+1-cable bundle' as described previously. The cables were all XLPE/CSPE, 12 AWG, 7/C (Item #10). In this case, the cables were only monitored for thermal response, and not for electrical performance. Each conduit was also monitored for thermal response.

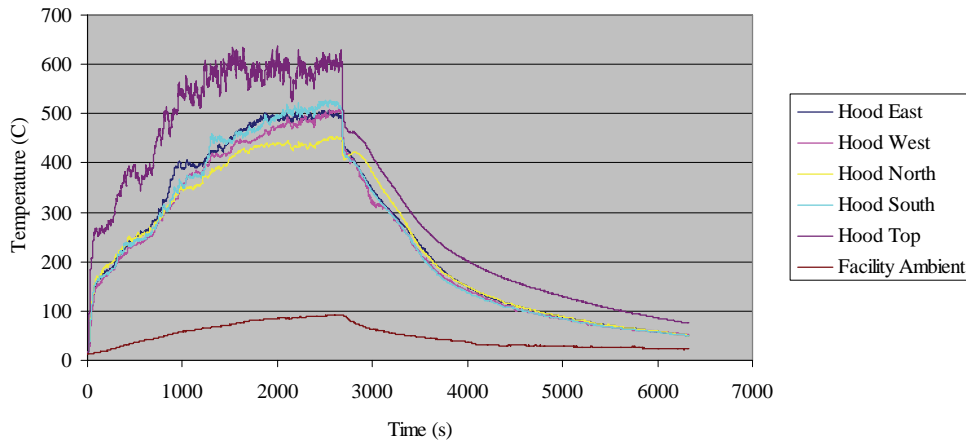
## **6.5.2 Test Results**

The gas burner in IT-1 was run through a series of step increases and the nominal HRR ranged from about 190 to 275 kW (180 to 260 BTU/s). The intent of these step changes was to ensure the failure

of all cables in the test. The fuel flow rate and nominal HRR are shown in Figure 6.20. The corresponding hood temperatures are shown in Figure 6.21.

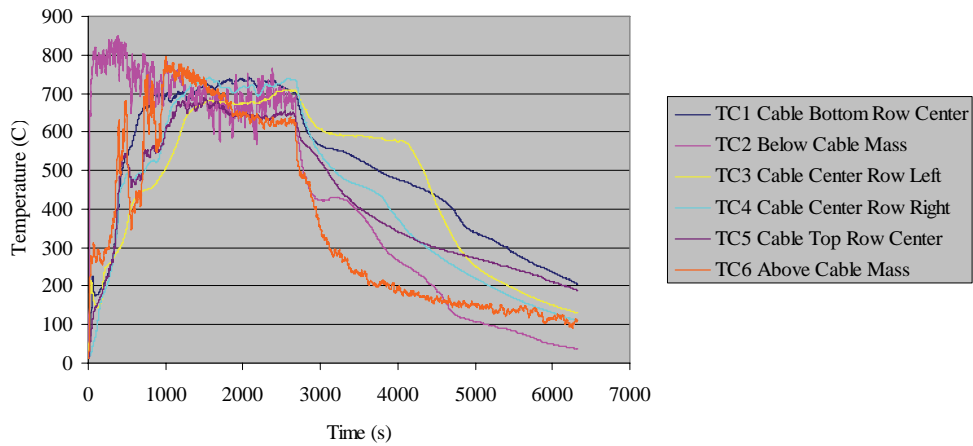


**Figure 6.20: Fuel flow rate and nominal HRR for IP-4.**

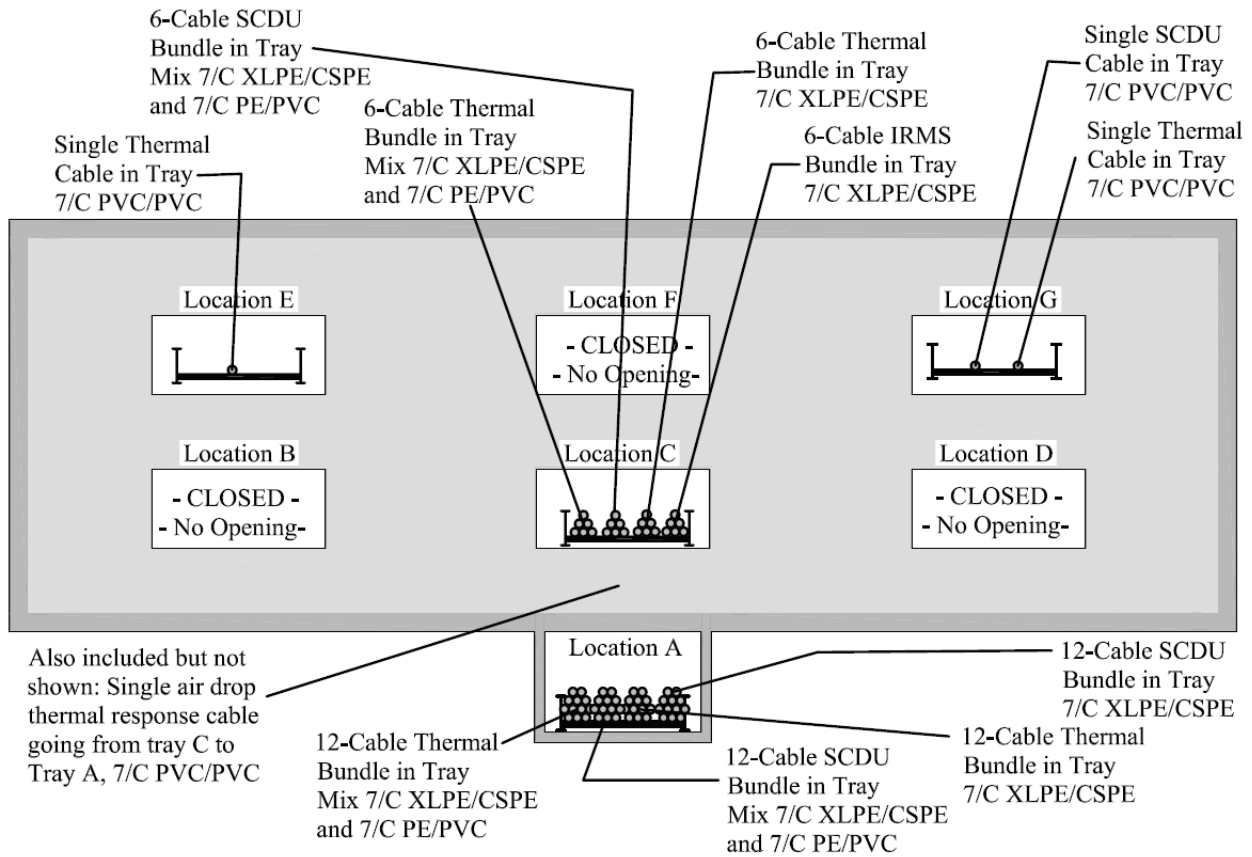


**Figure 6.21: Hood temperatures measured during IT-1.**

Again, one unique aspect of IT-1 was the use of a random fill cable tray equipped with several TCs. Figure 6.22 illustrates the temperatures measured for this cable tray. Note that there were clear indications of some degree of continued burning well after the burner itself was extinguished. This was noted in particular by TC3, the cable TC in the second row of cables towards one side of the tray. This TC continues to measure temperature well in excess of the general air temperatures. Other cable mass TCs appear to fall off more quickly and the TC above the cable mass was one of these. However the very steady behavior of TC3 between 3000s and 4000s was a clear indication of continued burning, and likely smoldering combustion.



**Figure 6.22: Temperatures measured within and near the random fill cable tray in IT-1.**



**Figure 6.23: Test setup for IT-2.**

## 6.6 Test IT-2

### 6.6.1 Test Conditions

The overall test conditions for IT-2 are illustrated in Figure 6.23. One unique aspect of IT-2 was the use of an air-drop cable between two trays as shown in Figure 6.24 below. A number of different cables were used in this test including XLPE/CSPE, 12 AWG, 7/C (Items #10), the PE/PVC, 12 AWG, 7/C (Item #15) and the PVC/PVC, 12 AWG, 7/C (Item #1).

#### Location A:

For IT-2 there were four 12-cable bundles present at Location A. The four bundles represent two matched cable bundle pairs, one bundle in each pair monitored for thermal response bundle and the second bundle monitored for electrical performance. One pair of bundles was comprised entirely of the XLPE/CSPE, 12 AWG, 7/C (Item #10). The second pair was comprised of a mixed grouping of two cable types as follows:

- Cables A, C, E, G, J, L: XLPE/CSPE, 12 AWG, 7/C cables (Item #10)
- Cables B, D, F, H, K, M: PE/PVC, 12 AWG, 7/C (Item #15).

The thermal response bundles each included the standard complement of TCs for a 12-cable bundle as described in Chapter 3 above. The two electrical performance bundles at location A were connected to the SCDUs as follows:

- SCDU-1 was connected to cables A, B and C in the XLPE/CSPE bundle in an inter-cable wiring configuration, and
- SCDU-2 was connected to cables A, B, and C in the mixed-types cable bundle in an inter-cable wiring configuration.

#### Location C:

There were four 6-cable bundles located in a cable tray at Location C. Again, this involved two matched cable bundle pairs, one bundle in each pair monitored for thermal response and the second for electrical performance.

The cable bundles were similar to those used at location A except in that there were just six cables rather than 12 per bundle. Two of the bundles were comprised of XLPE/CSPE, 12 AWG, 7/C (Item #10) only. The other two bundles were comprised of three lengths of the XLPE/CSPE, 12 AWG, 7/C (Item #10) and three lengths of the PE/PVC, 12 AWG, 7/C (Item #15).

The electrical performance monitoring of the XLPE/CSPE cable bundle at Location C was based on the IRMS. For the mixed bundle of XLPE/CSPE and PE/PVC cables, Cable A, an XLPE/CSPE cable, was connected to SCDU-4 in the standard MOV-1 wiring configuration.

### **Air-Drop A-C:**

A single length of PVC/PVC, 12 AWG, 7/C (Item #1) monitored for thermal response was installed as an air-drop from the cable tray at Location C to the cable tray at Location A. This cable had three installed TCs, all placed below the cable jacket. One TC was located near where the cable exited the upper tray, the second was in the center of the cable between the two trays, and the third was near where the cable entered the lower tray. Figure 6.24 provides a photograph of the air drop cable for this test. Note that the location of the mid-point TC is evident (just below the wrap of white tape). Also note the proximity of the air temperature TC extending below the tray at Location C (just to the left of the cable and below the upper tray) and that extending above the tray at Location A (just to the right of the cable and above the lower tray).



**Figure 6.24: Photograph of the air drop cable in IT-2.**

### **Locations E&G:**

There were cable trays located at both locations E&G each provided with single lengths of the PVC/PVC, 12 AWG, 7/C (Item #1). At location E, a single length of cable was monitored for thermal response. At location G, two individual lengths of the same cable type (Item #1) were present, one monitored for thermal response and the second for electrical performance via SCDU Unit #3 which was connected in the standard MOV-1 wiring configuration.

## 6.6.2 Test Results

The fuel gas volume flow rate and the corresponding nominal HRR for IT-2 are illustrated in Figure 6.25. The corresponding temperatures measured under the test structure hood are illustrated in Figure 6.26.

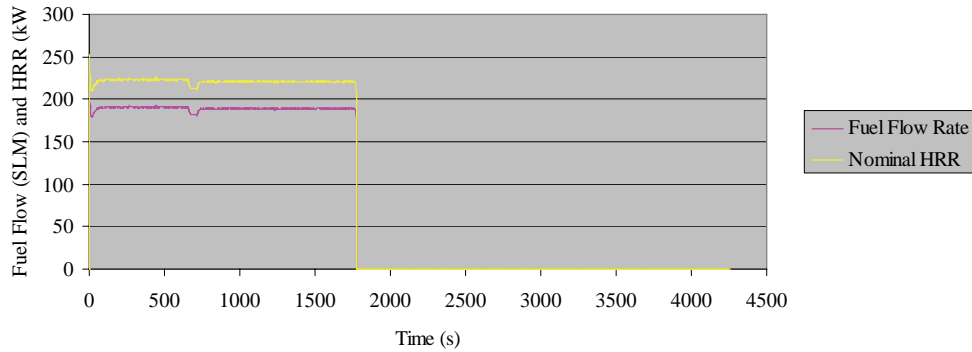


Figure 6.25: Fuel flow rate and nominal HRR for IT-2.

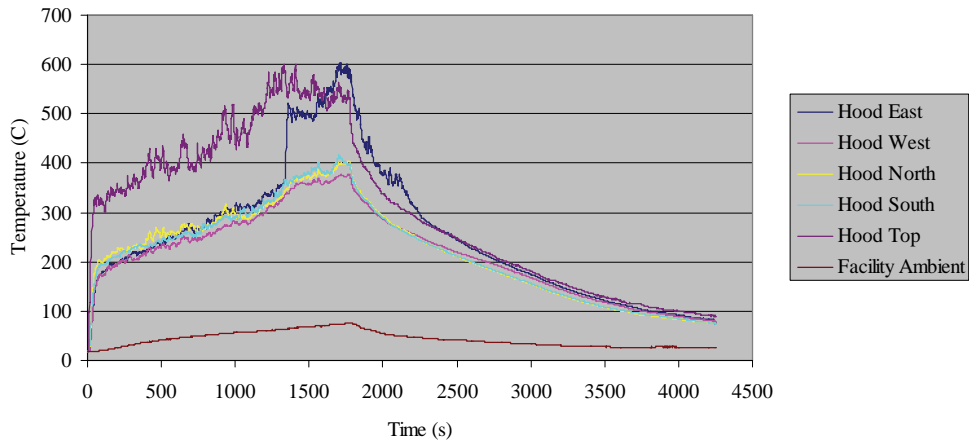
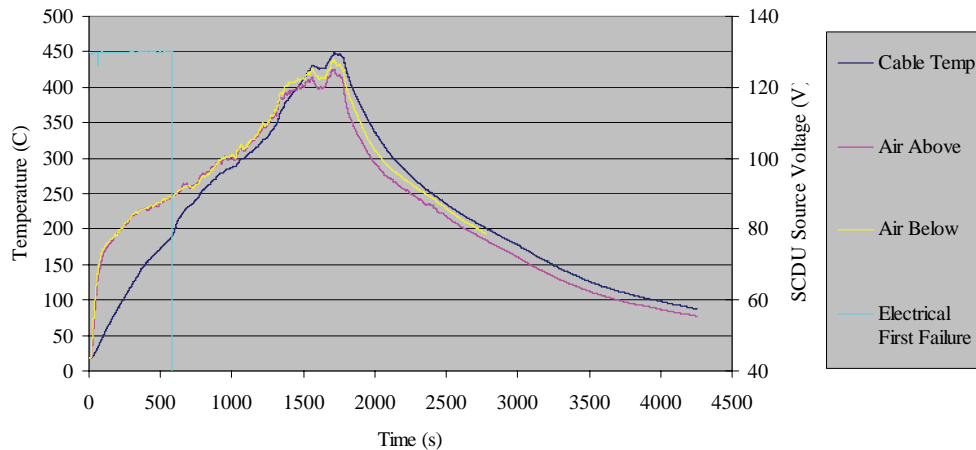


Figure 6.26: Hood temperatures measured during IT-2.

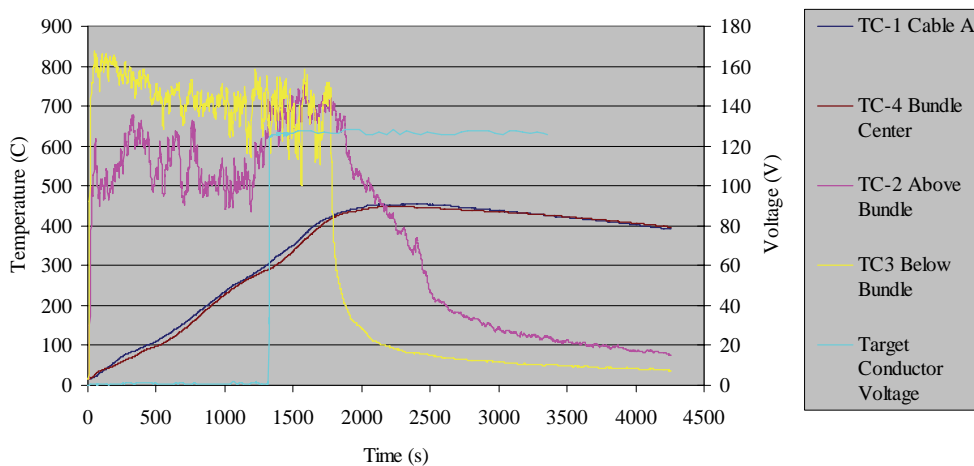
Figure 6.27 illustrates the cable thermal response and electrical response data for paired thermal response and electrical performance PVC/PVC cables at Location G. In this case, the electrical performance was based on SCDU-4 in the MOV-1 configuration. A fuse-blow failure was observed for this case, so the electrical performance and failure is illustrated based on the SCDU source voltage which drops to zero at the time of failure.





**Figure 6.27: Thermal response and electrical performance data for the paired single lengths of the PVC/PVC cable at Location G in IT-2.**

Similar data for the 12-cable XLPE/CSPE cable at Location A are shown in Figure 6.28. In this case, electrical performance was based on SCDU-1 which was wired in an inter-cable configuration. The first observed electrical failure is illustrated based on the voltage signal for Target Path 6 which increases to the source voltage (about 130 VAC) at the time of shorting. Note that in this case, the illustrated “first failure” was an inter-cable short and that it was likely that intra-cable shorting would have occurred prior to this inter-cable short. However, the SCDU was not wired to detect intra-cable shorting in this test. It was also interesting to note that for the 12-cable bundle, the temperature of TC-4, which was between the cables at the bundle center, closely mirrors that of TC-1, which was just under the jacket of ‘Cable A’ in the bundle.



**Figure 6.28: Thermal response and electrical performance results for the paired 12-cable thermal response bundle and SCDU cable bundle at Location A during IT-2.**

## 6.7 Test IT-3

### 6.7.1 Test Conditions

The general test conditions for IT-3 are illustrated in Figure 6.29. There were cable trays present at four locations, A, C, E & G and the tests involved four different cable types.

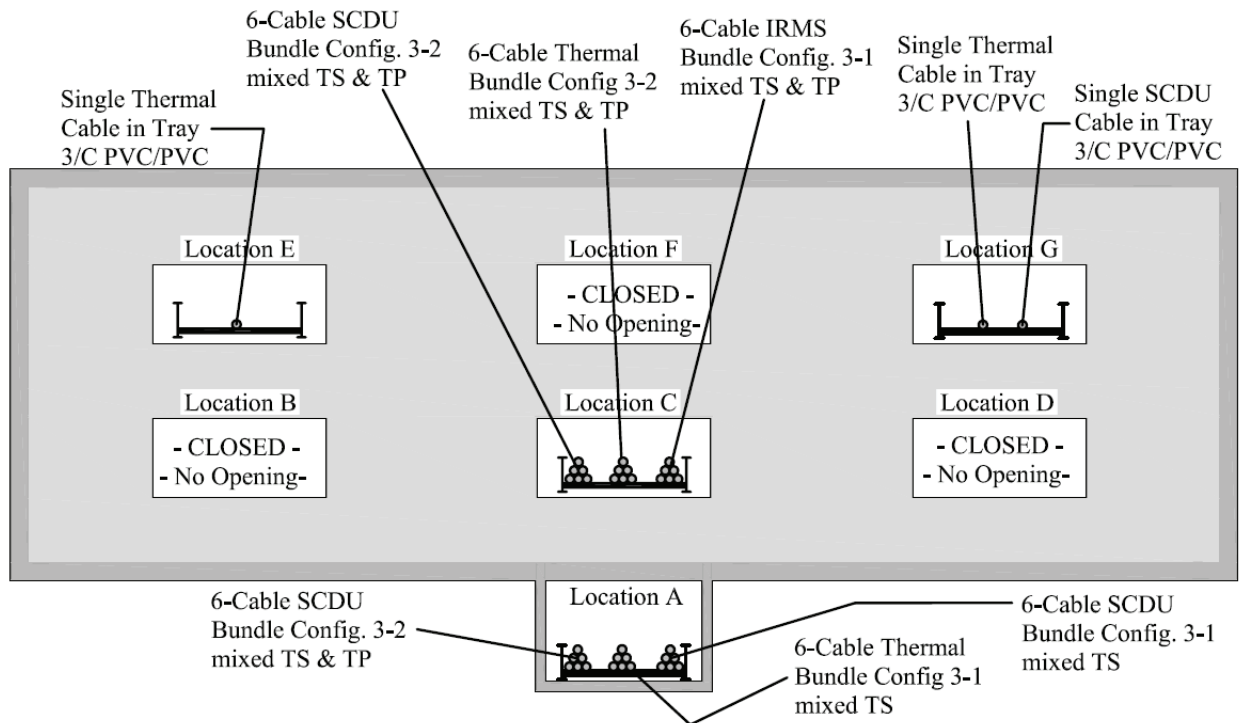


Figure 6.29: Test setup for IT-3.

#### Locations A&C:

Cable trays were again located at both locations A & C and the cable loading arrangements for these two trays were again similar. Each tray contained three 6-cable bundles, one bundle monitored for thermal response and the other two for electrical performance. In each case, the thermal response bundle was a pair-match to one of the two electrical performance bundles. The two different bundling arrangements used were as follows:

- Bundle Configuration 3-1:
  - Cables A, D & F: XLPE/CSPE, 12 AWG, 7/C (Item #10)
  - Cables B, C & E: EPR/CPE, 12 AWG, 7/C (Item #2)
- Bundle Configuration 3-2:
  - Cables A, D & F: EPR/CPE, 12 AWG, 7/C (Item #2)

- Cables B, C & E: PE/PVC, 12 AWG, 7/C (Item #15)

For Location A, there were two Configuration 3-1 bundles, one monitored for thermal response and the second for electrical performance. There was also one Configuration 3-2 bundle, monitored for electrical performance.

For Location C, there was one Configuration 3-1 bundle monitored for electrical performance. Location C also had two Configuration 3-2 bundles, one monitored for thermal response and the second for electrical performance.

Electrical performance monitoring for these locations was as follows:

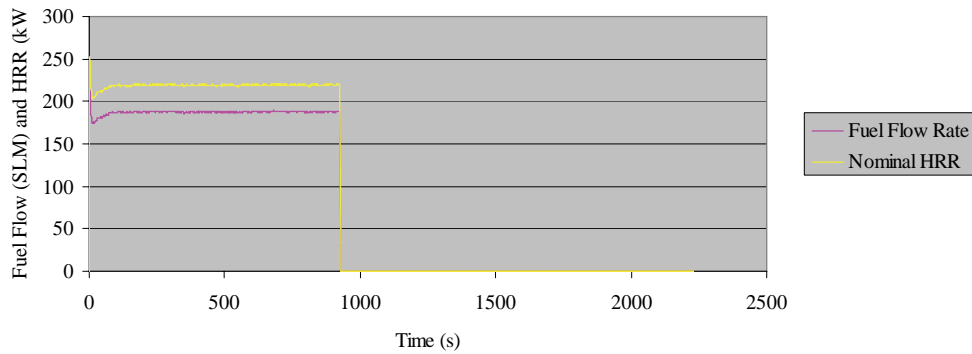
- SCDU-1 was connected to the mixed Configuration 3-1 (XLPE & EPR) electrical performance bundle at Location A in an inter-cable configuration.
- SCDU-2 was connected to the Configuration 3-2 (mixed EPR & PE) electrical performance bundle at Location A in an inter-cable configuration.
- The IRMS was connected to the Configuration 3-2 (XLPE & EPR) electrical performance bundle at location C.
- SCDU-3 was connected to the Configuration 3-2 (mixed EPR & PE) electrical performance bundle at Location C in an inter-cable configuration.

#### **Locations E&G:**

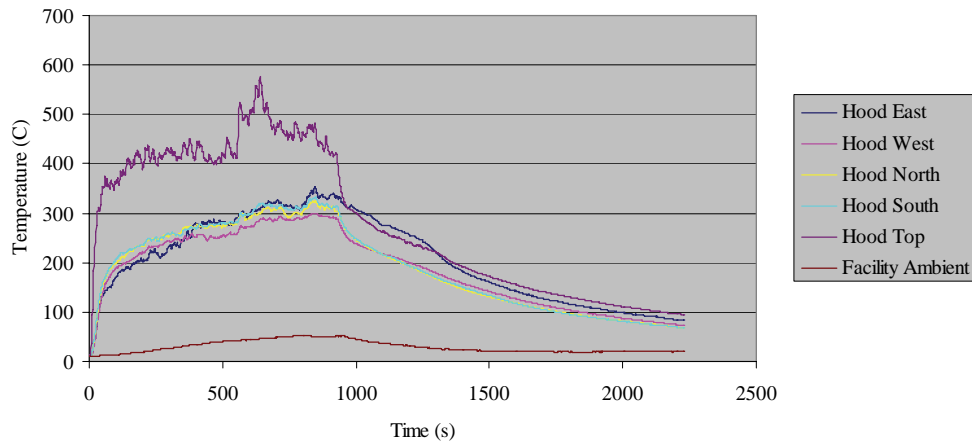
There were cable trays at both locations E&G. These were intended to replicate the conditions for these locations as during IT-2 except in that the 7/C cables used in IT-2 were replaced by the corresponding 3/C cables in IT-3. Each tray was provided with single lengths of the PVC/PVC, 8 AWG, 3/C (Item #5). At location E, a single length of cable was monitored for thermal response. At locations G, two individual lengths of cable were present, one monitored for thermal response and the second for electrical performance in this case using SCDU Unit #4 in the AC-1 wiring configuration (see Volume 1 Appendix C for descriptions of the SCDU wiring configurations).

#### **6.7.2 Test Results**

The fuel gas volume flow rate and the corresponding nominal HRR for IT-3 are illustrated in Figure 6.30. The corresponding temperatures measured under the test structure hood are illustrated in Figure 6.31.

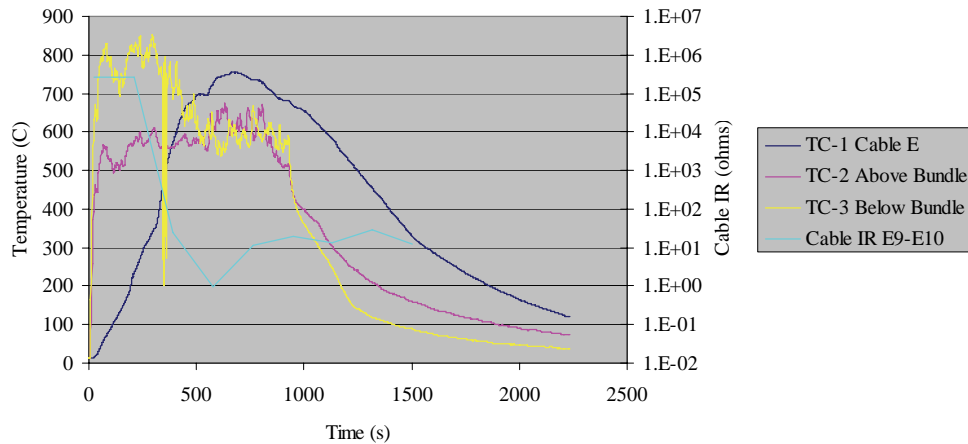


**Figure 6.30: Fuel flow rate and nominal HRR for IT-3.**



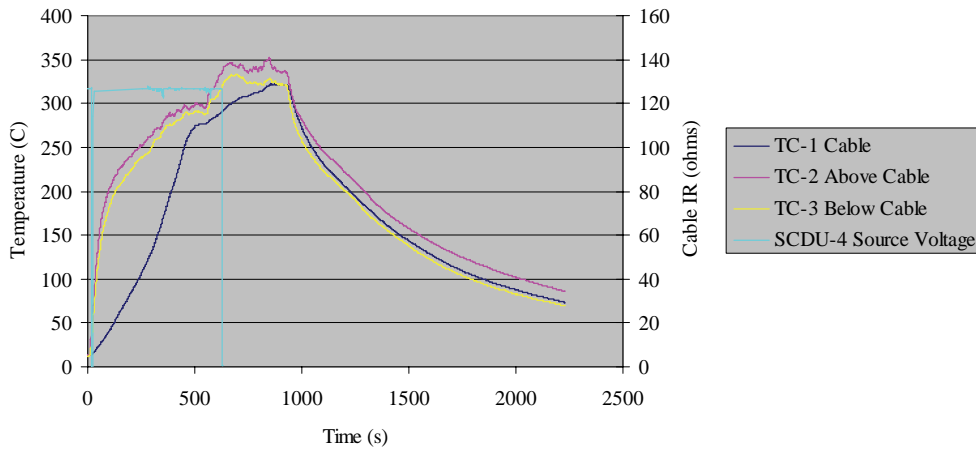
**Figure 6.31: Hood temperatures measured during IT-3.**

Figure 6.32 illustrates the thermal response and electrical performance data for the paired IRMS and thermal cable bundles at Location C. In this case, the failure data shown is that for Cable E because Cable E in the thermal bundle was the cable equipped with an under-jacket TC. Cable E was not, however, the first cable in the electrical performance bundle to experience electrical failure. Cable D actually failed just prior to Cable E. In this case, Cable E experienced intra-cable conductor-to-conductor shorting as the first mode of failure. This is shown in Figure 6.32 as the ‘Cable IR E9-E10’ data trace.



**Figure 6.32: Illustration of the responses for the paired thermal and IRMS bundles at Location C during IT-3.**

Figure 6.33 illustrates the results for the paired single lengths of 3/C PVC/PVC cables at Location G. Electrical performance was based on SCDU-1 wired in an intra-cable configuration. In this test, the circuit experienced a fuse blow failure. (Note that a momentary loss of power to the circuit was experienced early in the test (at about 16-27s), but this was not related to any cable electrical failure.

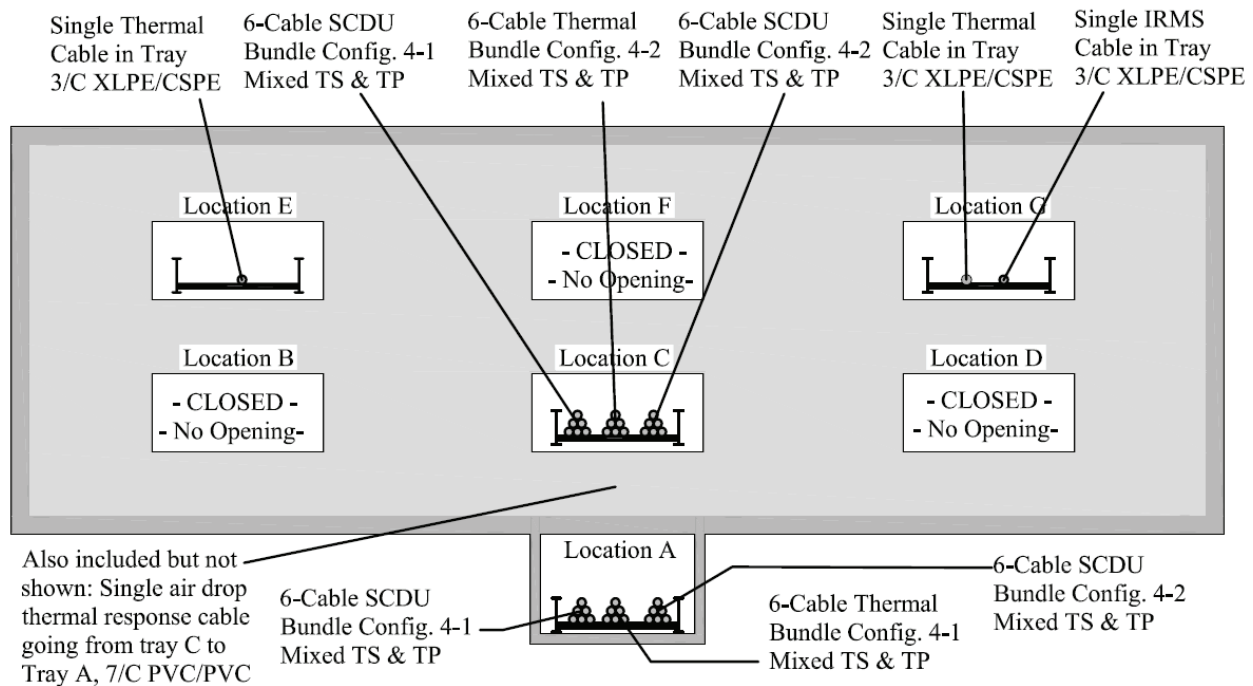


**Figure 6.33: Thermal response and electrical performance for the single 3/C PVC/PVC cables at Location G during IT-3.**

## 6.8 Test IT-4

### 6.8.1 Test Conditions

The general test conditions for IT-4 are illustrated in Figure 6.34. There were cable trays present at four locations, A, C, E & G and the tests involved seven different cable types.



**Figure 6.34: Test setup for IT-4.**

### Locations A & C:

Cable trays were again located at both locations A & C and the cable loading arrangement for these two trays were again similar. Each tray contained three 6-cable bundles, one bundle monitored for thermal response and the other two for electrical performance. In each case, the thermal response bundle was a pair-match to one of the two electrical performance bundles.

All of the cable bundles involved a mixture of various cable types including both TS and TP insulated cables. There were two specific bundle configurations for this test as follows:

- Bundle configuration 4-1:
  - Cable A: XLPE/CSPE, 12 AWG, 7/C (Item #10)
  - Cable B: PE/PVC, 12 AWG, 7/C (Item #15)
  - Cable C: TEF/TEF, 12 AWG, 7/C (Item #12)
  - Cable D: EPR/CPE, 12 AWG, 7/C (Item #2)
  - Cable E: XLPO/XLPO, 12 AWG, 7/C (Item #8)
  - Cable F: XLPE/PVC, 12 AWG, 7/C (Item #3)
- Bundle configuration 4-2:
  - Cable A: XLPE/CSPE, 12 AWG, 7/C (Item #10)
  - Cable B: TEF/TEF, 12 AWG, 7/C (Item #12)
  - Cable C: PE/PVC, 12 AWG, 7/C (Item #15)
  - Cable D: PVC/PVC, 12 AWG, 7/C (Item #1)

- Cable E: EPR/CPE, 12 AWG, 7/C (Item #2)
- Cable F: PE/PVC, 12 AWG, 7/C (Item #15)

For the cable tray at Location A, the thermal response bundle was configuration 4-1. For the cable tray at Location C, the thermal response bundle was configuration 4-2.

Each of these two trays had one each of bundle configuration 4-1 and bundle configuration 4-2 present. Three of these four bundles were monitored for electrical performance bundles as follows:

- For Location A, cables A, B & C in the configuration 4-1 bundle were connected to SCUDU-3 in an inter-cable configuration.
- For Location A, cables A, B & C in the configuration 4-2 bundle were connected to SCUDU-4 in an inter-cable configuration.
- For Location C, cables A, B & C in the configuration 4-2 bundle were connected to SCUDU-1 in an inter-cable configuration.
- For Location C, cables A, B & C in the configuration 4-1 bundle were connected to SCUDU-2 in an inter-cable configuration.

#### **Air Drop A–C:**

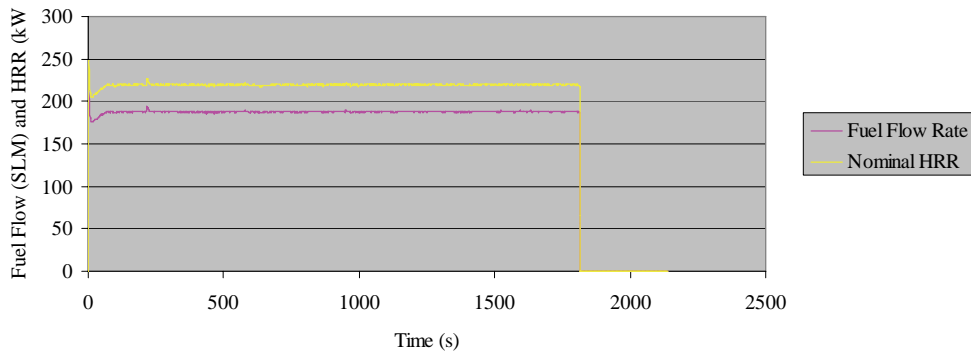
One length of the PVC/PVC, 12 AWG, 7/C (Item #1) was configured as an air drop from the tray at Location C to the tray at Location A. This cable was instrumented for thermal response.

#### **Locations E&G:**

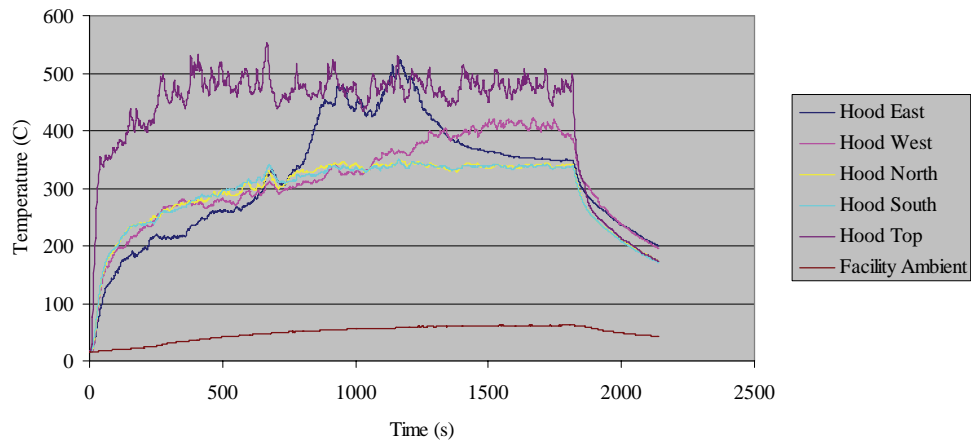
The conditions at locations E&G parallel those of previous tests involving individual lengths of cable in cable trays at these two locations. In this case, the cables were of the XLPE/CSPE types rather than PVC/PVC. One length of the XLPE/CSPE, 8 AWG, 3/C (Item #14) was placed in each of these two locations and monitored for thermal response. A third length of the same cable item was also placed in Location G and monitored for electrical performance using the IRMS. Note that this particular cable did not experience electrical failure during the test.

### **6.8.2 Test Results**

The fuel gas volume flow rate and the corresponding nominal HRR for IT-4 are illustrated in Figure 6.35. The corresponding temperatures measured under the test structure hood are illustrated in Figure 6.36.



**Figure 6.35: Fuel flow rate and nominal HRR for IT-4.**

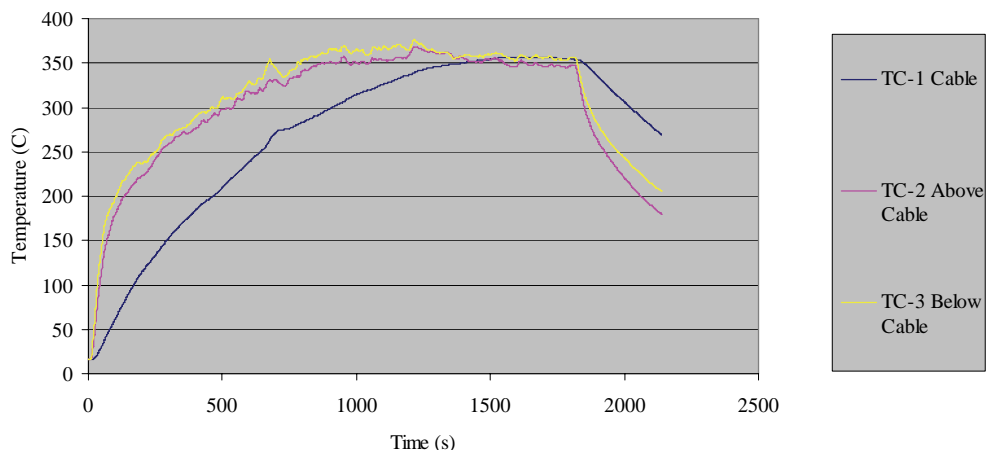


**Figure 6.36: Hood temperatures measured during IT-4.**

Note that Figure 6.36 shows that a sharp increase occurred on the “hood east” TC at about 800s into the test. There were no corresponding changes in the gas burner output, so this was taken as an indication that the fire in the cables at Locations A and/or C likely had spread to the eastern end of the cable trays adjacent to the eastern wall of the test structure. A similar though less pronounced temperature increase was seen somewhat later for the “hood west” TC. This effect was also seen in various other tests, and indicates that the cable fires had a tendency to spread more quickly to the east (i.e. towards the back of the outer test facility) than to the west. This was consistent with the fact that fresh air was introduced into the west end of the outer test facility and that fire products exhausted from the east end of the facility through a stack directly above the test structure creating a general west-to-east air flow pattern in the larger facility. Flames spreading along the cables likely traveled somewhat more quickly to the east than to the west as a result of these general air flow patterns. That is, fire spread would tend to be faster in the general direction of bulk air flow. As noted elsewhere, all of the cables in the trays at locations A and C generally burned completely during all intermediate-scale tests so the effect, while evident, was not an overriding factor in the overall fire spread behavior.



Test IT-4 was one of the few tests where a cable monitored for electrical performance did not experience electrical failures. In this case the XLPE-insulated 3/C cable at Location G did not experience electrical failure, and in fact, the IR remained above the upper detection threshold of the IRMS for the duration of the test.<sup>10</sup> The data for the pair-matched thermal response cable at Location G are illustrated in Figure 6.37. The cable temperature reached a maximum of about 355°C (635°F) over the course of the experiment as measured just below the cable’s outer jacket. The data also show that the cable did reach equilibrium with its surrounding environment.



**Figure 6.37: Temperature data for the 3/C XLPE-insulated cable at Location G.**

## 6.9 Test IT-5

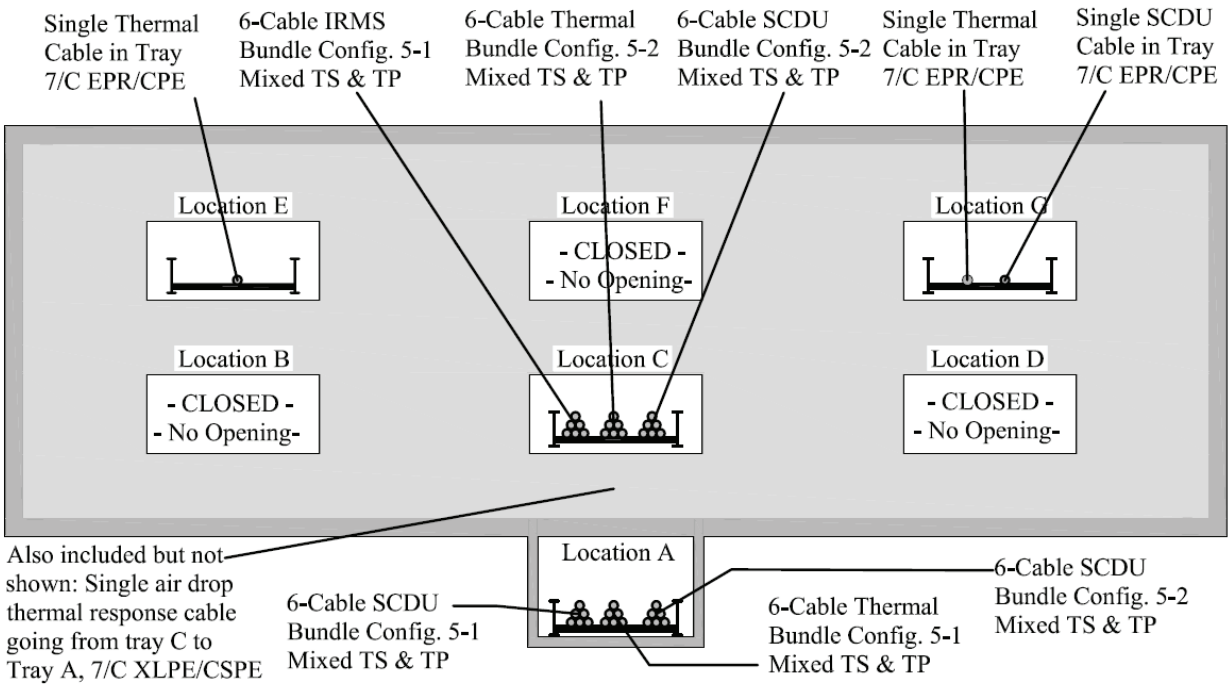
### 6.9.1 Test Conditions

The setup for IT-5 was generally the same as that of IT-4 except that the specific types of cables tested in each location differed. The specific combination of cable types and the arrangement of those cables within the various bundles were also somewhat different. Figure 6.38 illustrates the test setup for IT-5.

#### Locations A & C:

Cable trays were again located at both locations A&C and the cable loading arrangement for these two trays were again similar. Each tray contained three 6-cable bundles, one bundle monitored for thermal response and the other two for electrical performance. In each case, the thermal response bundle was a pair-match to one of the two electrical performance bundles.

<sup>10</sup> As noted in Appendix B of Volume 1 of this report, the IRMS is not designed to detect very high values of insulation resistance, but rather, is optimized for measuring low IR values. Hence, the cable in this case very likely experienced some degree of IR degradation, although the IR remained above the upper threshold of sensitivity of the IRMS for the duration of the test.



**Figure 6.38: Test setup for IT-5.**

All of the cable bundles involved a mixture of various cable types including both TS and TP insulated cables. There were two specific bundle configurations in this test as follows:

- Bundle configuration 5-1:
  - Cable A: XLPE/CSPE, 12 AWG, 7/C (Item #10)
  - Cable B: PE/PVC, 12 AWG, 7/C (Item #15)
  - Cable C: TEF/TEF, 12 AWG, 7/C (Item #12)
  - Cable D: EPR/CPE, 12 AWG, 7/C (Item #2)
  - Cable E: XLPO/XLPO, 12 AWG, 7/C (Item #8)
  - Cable F: SR/Aramid Braid, 12 AWG, 7/C (Item #9)
- Bundle configuration 5-2:
  - Cable A: XLPE/CSPE, 12 AWG, 7/C (Item #10)
  - Cable B: PE/PVC, 12 AWG, 7/C (Item #15)
  - Cable C: TEF/TEF, 12 AWG, 7/C (Item #12)
  - Cable D: EPR/CPE, 12 AWG, 7/C (Item #2)
  - Cable E: VITA-LINK, 14 AWG, 7/C (Item #11)
  - Cable F: XLPO/XLPO, 12 AWG, 7/C (Item #8)

For the cable tray at Location A the thermal response bundle was configuration 5-1. For the cable tray at Location C the thermal response bundle was configuration 5-2.

Each of these two trays had one each of bundle configuration 5-1 and bundle configuration 5-2 present as electrical performance bundles. Monitoring of these bundles was as follows:

- For Location A, cables A, B & C in the configuration 5-1 bundle were connected to SCDU-4 in an inter-cable configuration.
- For Location A, cable E (VL-insulated) in the configuration 5-2 bundle was connected to SCDU-1 in the MOV-1 wiring configuration.
- For Location C, the configuration 5-1 bundle was connected to the IRMS.
- For Location C, cables A, B & C in the configuration 5-2 bundle were connected to SCDU-2 in an inter-cable configuration.

#### **Air Drop A–C:**

One length of the XLPE/CSPE, 12 AWG, 7/C (Item #10) was configured as an air drop from the tray at Location C to the tray at Location A. This cable was instrumented for thermal response.

#### **Locations E&G:**

The two individual thermal response cables at locations E&G, and the individual electrical response cable at Location G were all changed to EPR/CPE, 12 AWG, 7/C (Item #2). The electrical response cable at Location G was connected to SCDU-3 in the MOV-1 wiring configuration.

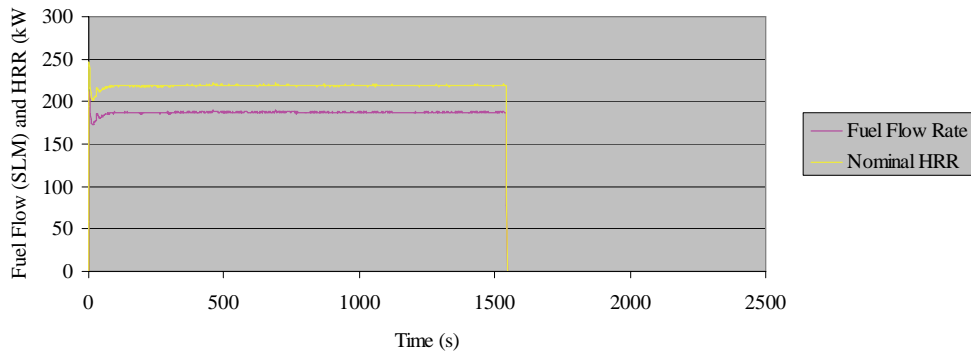
#### **Water Spray:**

Water spray was activated during IT-5 after a 1545 s (about 25 minutes) burn period because neither the SR cable in the configuration 5-1 IRMS bundle at Location A nor the VL-insulated cable connected to SCDU-1 in the configuration 5-2 bundle at Location C had experienced electrical failure. Both of these cables did experience electrical failure after the water spray was initiated.

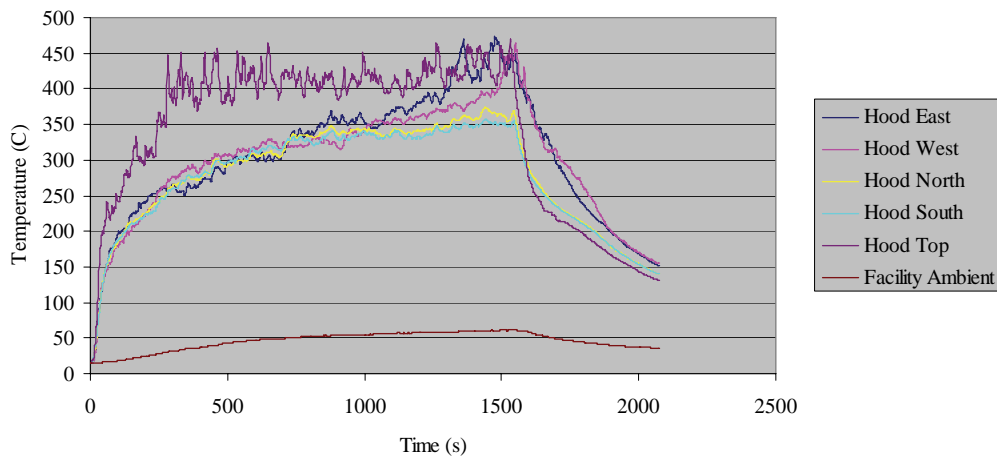
### **6.9.2 Test Results**

The fuel gas volume flow rate and the corresponding nominal HRR for IT-5 are illustrated in Figure 6.39. The corresponding temperatures measured under the test structure hood are illustrated in Figure 6.40.

As in IT-4, the single length of EPR/CPE 7/C 12 AWG cable at Location G that was being monitored for electrical performance did not experience gross failure. However, the cable, which was connected to SCDU-3, showed distinct signs of substantive degradation. The observed electrical performance behavior is illustrated in Figure 6.41 which includes an overlay of the temperature data recorded for the pair-matched thermal response cable. The general electrical performance is illustrated based on the current flow for the conductor on SCDU-3 energized source Path 1 (see Volume 1 for a complete description of the SCDUs) although other circuit traces show similar signs of cable degradation.

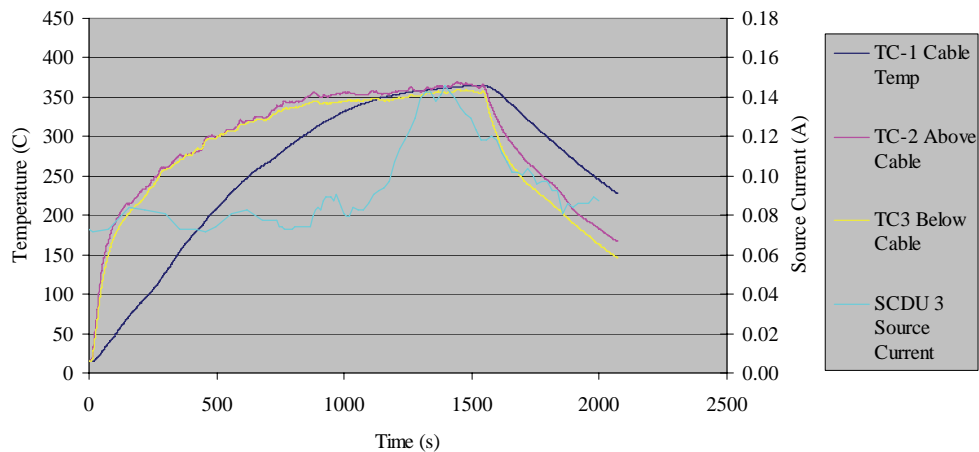


**Figure 6.39: Fuel flow rate and nominal HRR for IT-5.**

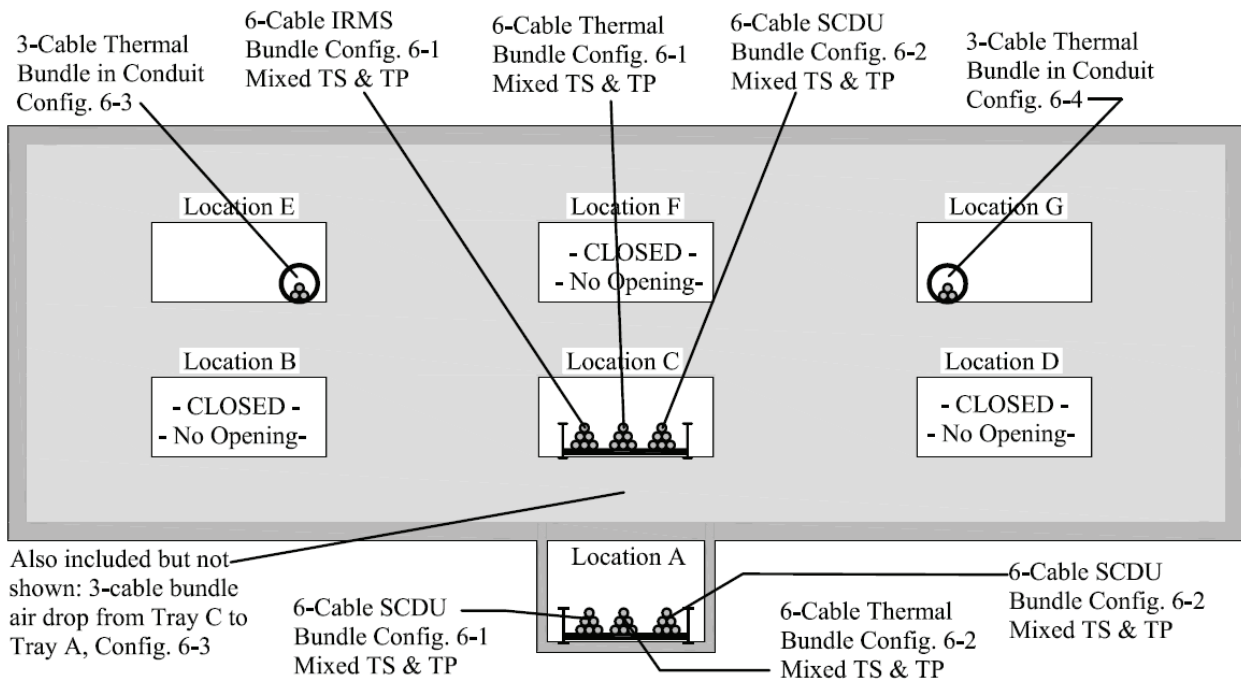


**Figure 6.40: Hood temperatures measured during IT-5.**

As configured in the ‘MOV-1’ wiring configuration, a base current load of about 80mA was imposed on conductor Path 1 simulating the load imposed by the normally illuminated position indicating light for a Motor Operated Valve (MOV) control circuit. Beginning at about 1200s after ignition, the current flow on Path 1 experiences a progressive increase reaching a peak of about 140mA, nearly twice the nominal baseline load. This current flow was not sufficient to cause a fuse blow failure for the simulated control circuit. The peak temperature experienced by the pair-matched thermal cable was about 360°C (680°F). This behavior indicates that this cable was very near its ultimate electrical performance limits.



**Figure 6.41: Data recorded for the EPR-insulated cables at Location G during IT-5.**



**Figure 6.42: Test setup for IT-6.**

## 6.10 Test IT-6

### 6.10.1 Test Conditions

The most significant change associated with the setup for IT-6 was the replacement of the cable trays previously tested at locations E&G with conduits. In this case, the conduits included 3-cable bundles monitored for thermal response. A second significant change was the replacement of the

single cable air drop from Tray A to Tray C with a 3-cable bundle air drop. The test conditions for the trays at Locations A&C were similar to IT-4 and IT-5 except that the specific types of cables tested in each location differed. IT-6 was also the first test to utilize the second IRMS unit. The two IRMS units were identical, but were typically wired to separate cables or cable bundles. For the rest of this report, they were referred to as IRMS-1 and IRMS-2. These names were consistent with the identification of the IRMS units in Volume 1 as well (i.e., references to IRMS-1 and IRMS-2 were consistent between the two volumes). Figure 6.42 illustrates the test setup for IT-6.

### **Locations A & C:**

Cable trays were again located at both locations A&C and the cable loading arrangement for these two trays were again similar. Each tray contained three 6-cable bundles, one bundle monitored for thermal response and the other two for electrical performance. In each case, the thermal response bundle was a pair-match to one of the two electrical performance bundles.

All of the cable bundles involved a mixture of various cable types including both TS and TP insulated cables. There were two specific bundle configurations for Locations A&C as follows:

- Bundle configuration 6-1:
  - Cable A: XLPE/CSPE, 12 AWG, 7/C (Item #10)
  - Cable B: SR/Aramid Braid, 12 AWG, 7/C (Item #9)
  - Cable C: EPR/CPE, 12 AWG, 7/C (Item #2)
  - Cable D: XLPO/XLPO, 12 AWG, 7/C (Item #8)
  - Cable E: PE/PVC, 12 AWG, 7/C (Item #15)
  - Cable F: TEF/TEF, 12 AWG, 7/C (Item #12)
  
- Bundle configuration 6-2:
  - Cable A: SR/Aramid Braid, 12 AWG, 7/C (Item #9)
  - Cable B: PE/PVC, 12 AWG, 7/C (Item #15)
  - Cable C: XLPO/XLPO, 12 AWG, 7/C (Item #8)
  - Cable D: TEF/TEF, 12 AWG, 7/C (Item #12)
  - Cable E: XLPE/PVC, 12 AWG, 7/C (Item #3)
  - Cable F: EPR/CPE, 12 AWG, 7/C (Item #2)

For the cable tray at Location A the thermal response bundle was configuration 6-2. For the cable tray at Location C the thermal response bundle was configuration 6-1.

Each of these two trays had one each of bundle configuration 6-1 and bundle configuration 6-2 present as electrical performance bundles. Monitoring of these bundles was as follows:

- For Location A, the configuration 6-1 bundle was connected to IRMS-1
- For Location A, the configuration 6-2 bundle was connected as follows: Cable B (PE-insulated) was connected to SCUDU-2; cable C (XLPO-insulated) was connected to SCUDU-4. Both SCUDUs were in the MOV-1 wiring configuration.

- For Location C, the configuration 6-1 bundle was connected as follows: Cable B (SR-insulated) was connected to SCUDU-1; cable C (EPR-insulated) was connected to SCUDU-3. Both SCUDUs were in the MOV-1 wiring configuration.
- For Location C, the configuration 6-2 bundle was connected to the IRMS-2

### **Air Drop A–C:**

One 3-cable bundle was configured as an air drop from the tray at Location C to the tray at Location A. This cable bundle was instrumented for thermal response. The cable arrangement is referred to as configuration 6-3 and was as follows:

- Cable A: XLPE/CSPE, 12 AWG, 7/C (Item #10)
- Cable B: PE/PVC, 12 AWG, 7/C (Item #15)
- Cable C: TEF/TEF, 12 AWG, 7/C (Item #12)

### **Locations E&G:**

For IT-6, conduits were placed at Locations E&G. A 3-cable thermal bundle was placed in each conduit. The 3-cable bundle for the conduit at Location E was the same as configuration 6-3 as described immediately above. The 3-cable bundle for the conduit at Location G is referred to as configuration 6-4 and was comprised of the following cables:

- Cable A: XLPE/PVC, 12 AWG, 7/C (Item #3)
- Cable B: PE/PVC, 12 AWG, 7/C (Item #15)
- Cable C: TEF/TEF, 12 AWG, 7/C (Item #12)

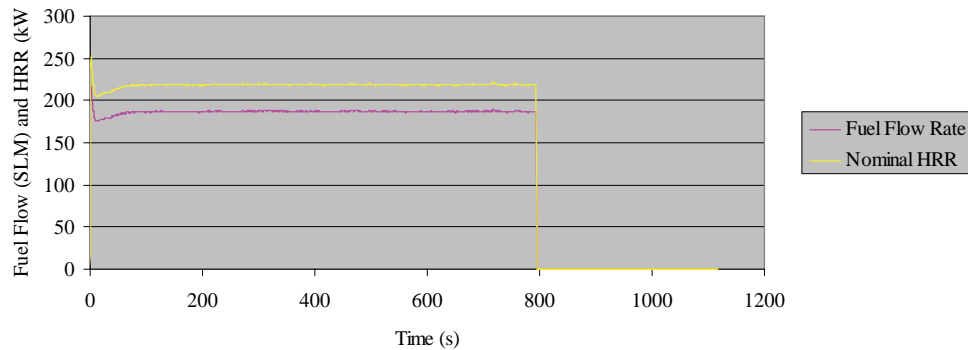
For each bundle, a TC was placed under the jacket of Cable B. As with the 3+1-cable bundle (see section 3.2.3) there was also a TC measuring the air temperature above the cables but inside the conduit as well as TCs on the outer surface of the conduit. There were no electrical response measurements made for these two locations.

### **Water Spray:**

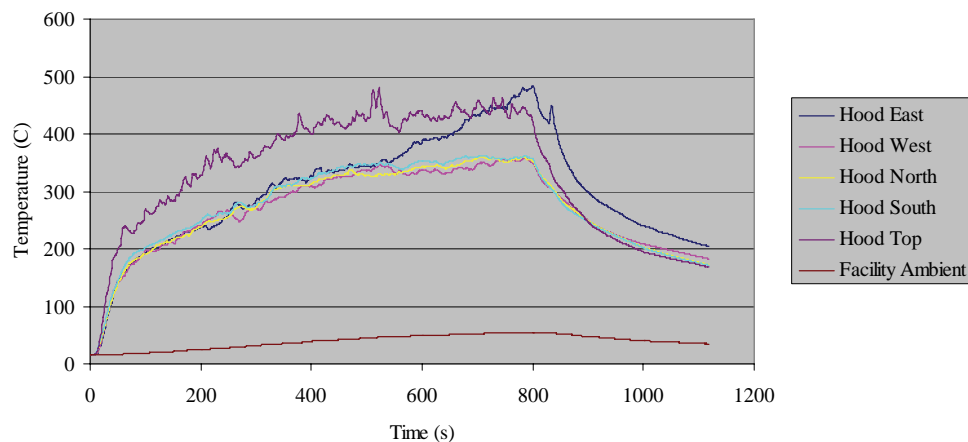
Water spray was activated during IT-6. The gas burner was shut off after a 698 s (over 11 minute) burn period. At this time, neither of the SR-insulated cables had experienced electrical failure. (One SR-insulated cable was in the configuration 6-1 IRMS bundle at Location A and the second was in the configuration 6-2 IRMS bundle at Location C.) After the burner was shut down, but before the water spray was activated, the SR-insulated cable at Location A experienced electrical failure. The SR-insulated cable at Location C failed about 118 s (approximately 2 minutes) after the water spray was initiated.

## 6.10.2 Test Results

The fuel gas volume flow rate and the corresponding nominal HRR for IT-6 are illustrated in Figure 6.43. The corresponding temperatures measured under the test structure hood are illustrated in Figure 6.44.



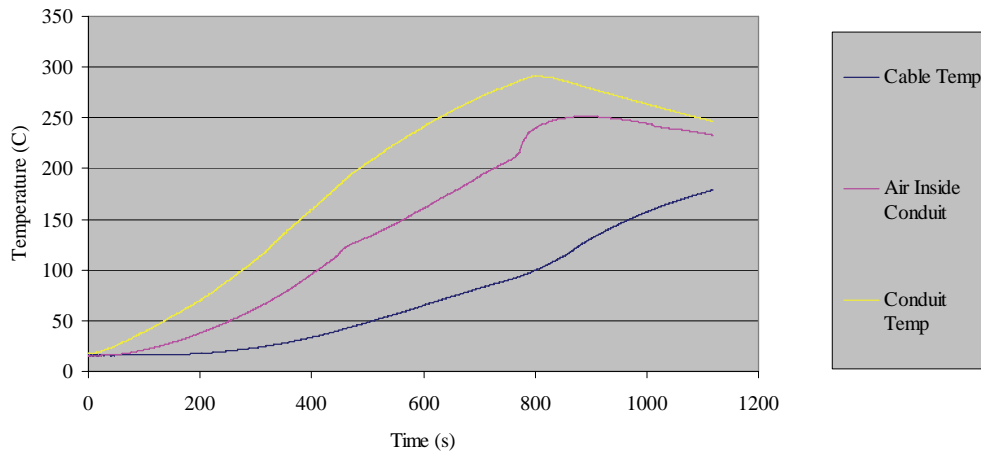
**Figure 6.43: Fuel flow rate and nominal HRR for IT-6.**



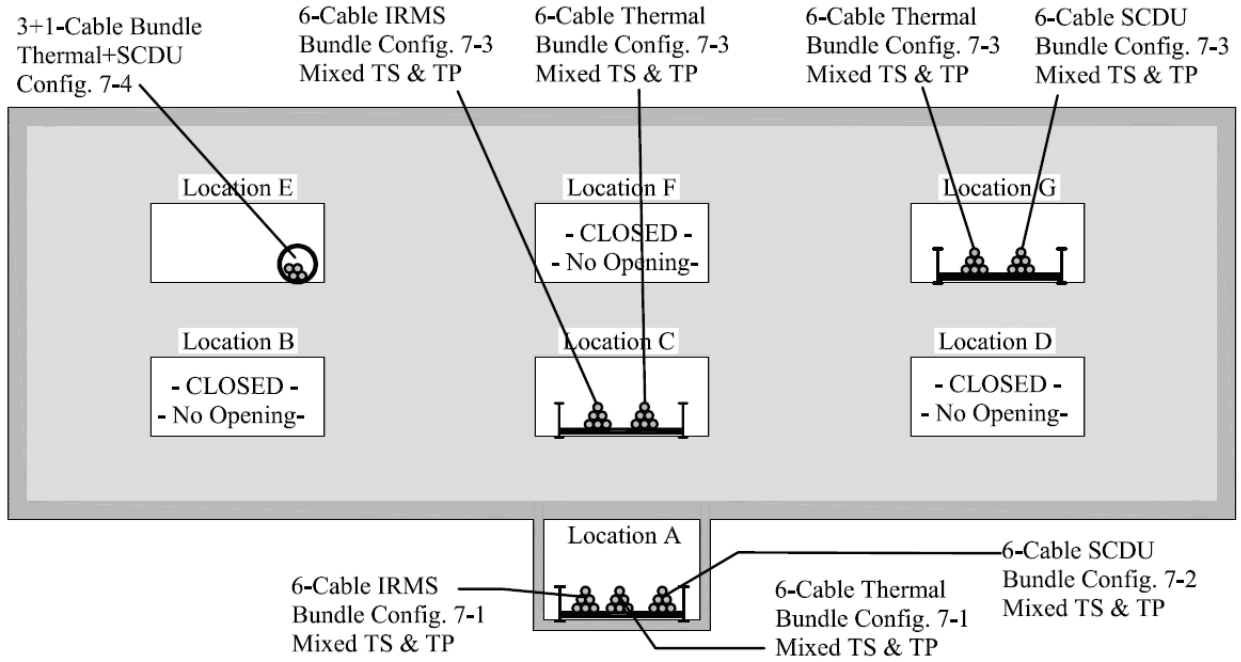
**Figure 6.44: Hood temperatures measured during IT-6.**

As noted above, one unique aspect of IT-6 was the introduction of conduits at Locations E and G. Figure 6.45 illustrates the temperature response data for the cables and conduit at Location G. Note that the conduit has a significant effect on the rate of temperature rise for the cables as compared to the cases with cables in open cable trays. The cable temperature lags that of the conduit surface substantially. The air inside the conduit also heats more quickly than the cables as expected given that the air has little thermal mass in comparison to the 3-cable bundle. In this particular case there was no pair-matched electrical performance data for comparison, although later tests do provide such comparisons. (For example, see IT-7 immediately below).





**Figure 6.45: Temperature response data for the cables and conduit at Location G in IT-6.**



**Figure 6.46: Test setup for IT-7.**

## 6.11 Test IT-7

### 6.11.1 Test Conditions

Figure 6.46 illustrates the test setup for IT-7. The most significant change associated with the setup for IT-7 was the return to use of a cable tray at Location G, although in IT-7 cable bundles were used at Location G rather than the single lengths of cable used in prior tests. A conduit was again used at Location E. Electrical performance monitoring was included for cables at both locations with

Location E using a “3+1” cable bundling arrangement (see Section 3.2.3). A second significant change was deletion of the air drop from tray A to Tray C.

Cable trays were again located at both Locations A&C although the cable loading arrangement for these two trays were somewhat more distinct than in prior tests, and are described separately in the subsections that follow. The tray at Location A again contained three 6-cable bundles, one bundle monitored for thermal response and the other two for electrical performance. The tray at Location C only had just two 6-cable bundles, one each for thermal response and electrical performance. The removal of one electrical performance bundle from Location C allowed for the electrical performance monitoring of cables at both Locations E and G.

#### **Location A:**

The cable tray at Location A again had three 6-cable bundles made up of a mixture of cable types including both TS and TP insulated cables. There were two specific bundle configurations for Location A as follows:

- Bundle configuration 7-1:
  - Cable A: XLPE/CSPE, 12 AWG, 7/C (Item #10)
  - Cable B: PVC/PVC, 12 AWG, 7/C (Item #1)
  - Cable C: PE/PVC, 12 AWG, 7/C (Item #15)
  - Cable D: EPR/CPE, 12 AWG, 7/C (Item #2)
  - Cable E: XLPE/PVC, 12 AWG, 7/C (Item #3)
  - Cable F: XLPO/XLPO, 12 AWG, 7/C (Item #8)
  
- Bundle configuration 7-2:
  - Cable A: XLPE/CSPE, 12 AWG, 7/C (Item #10)
  - Cable B: EPR/CPE, 12 AWG, 7/C (Item #2)
  - Cable C: PVC/PVC, 12 AWG, 7/C (Item #1)
  - Cable D: XLPO/XLPO, 12 AWG, 7/C (Item #8)
  - Cable E: TEF/TEF, 12 AWG, 7/C (Item #12)
  - Cable F: XLPE/PVC, 12 AWG, 7/C (Item #3)

For the cable tray at Location A the thermal response bundle was configuration 7-1. The other two bundles were monitored for electrical monitoring as follows:

- For Location A, a configuration 7-1 bundle was connected to IRMS-1
- For Location A, a configuration 7-2 bundle was connected to the SCDUs as follows: Cable A (XLPE-insulated) was connected to SCDU-3; and cable B (EPR-insulated) was connected to SCDU-2. Both SCDUs were in the MOV-1 wiring configuration.

### **Location C:**

For IT-7 just two (rather than the previous 3) 6-cable bundles were placed in the cable tray at Location C. The two bundles were identical, and the arrangement is referred to as configuration 7-3. The cable arrangement for this configuration was as follows:

- Cable A: PVC/PVC, 12 AWG, 7/C (Item #1)
- Cable B: EPR/CPE, 12 AWG, 7/C (Item #2)
- Cable C: XLPO/XLPO, 12 AWG, 7/C (Item #8)
- Cable D: PE/PVC, 12 AWG, 7/C (Item #15)
- Cable E: XLPE/PVC, 12 AWG, 7/C (Item #3)
- Cable F: TEF/TEF, 12 AWG, 7/C (Item #12)

One of the two bundles was monitored for thermal response. The second bundle was monitored for electrical performance using IRMS-2.

### **Location E:**

For IT-7, a conduit was again placed at Location E. A 3+1-cable bundle was placed in the conduit. This bundle is referred to as configuration 7-4 and was comprised of the following cables:

- Cable A: PVC/PVC, 12 AWG, 7/C (Item #1)
- Cable B: PE/PVC, 12 AWG, 7/C (Item #15)
- Cable C: XLPE/PVC, 12 AWG, 7/C (Item #3)
- Cable 1 (TC cable): PVC/PVC, 12 AWG, 7/C (Item #1)

Cable A was connected to SCDU-4 which was wired in the MOV-1 wiring configuration

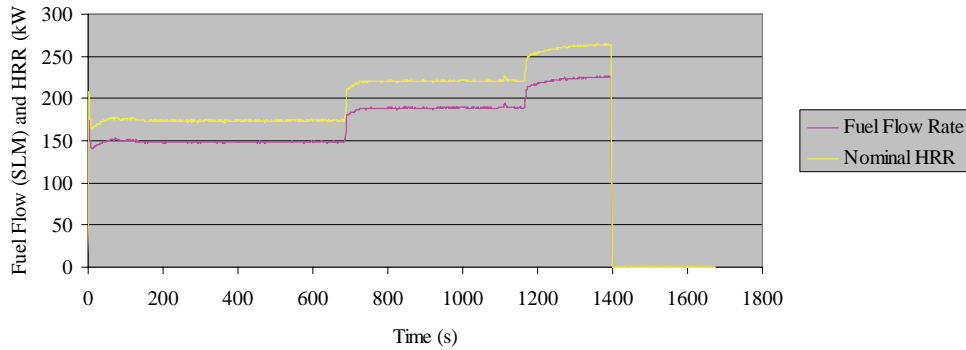
### **Location G:**

For IT-7, a cable tray was again used at location G. In this case, there were two 6-cable bundles present. These bundles were identical, and the arrangement was the same as configuration 7-3 as described immediately above. One bundle was monitored for thermal response. Cable A (PVC-insulated) in the second bundle was connected to SCDU-1 in the MOV-1 wiring configuration.

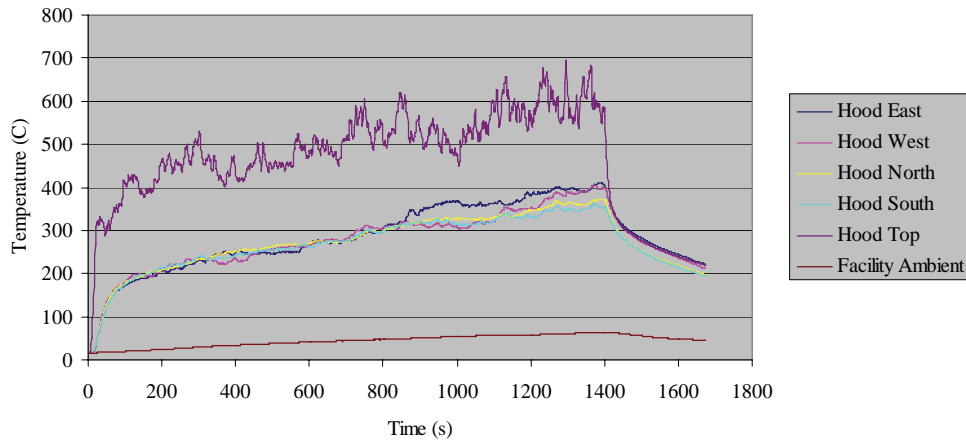
## **6.11.2 Test Results**

The fuel gas volume flow rate and the corresponding nominal HRR for IT-7 are illustrated in Figure 6.47. Note that the fuel flow rate to the gas burner was increased twice during the course of IT-7; once 688s after ignition and again 1167s after ignition. The step increases were intended to increase the severity of the thermal conditions so as to induce cable electrical failures for the cables at Locations E and G. Recall that in tests IT-5 and IT-6 electrical performance cables installed at Location G had not experienced electrical failures. Those cases where electrical performance cables did not fail provide no insights into the Bin 2 items. All of the cables monitored for electrical

performance did in fact experience electrical failure during the course of IT-7 as desired. The corresponding temperatures measured under the test structure hood are illustrated in Figure 6.48.

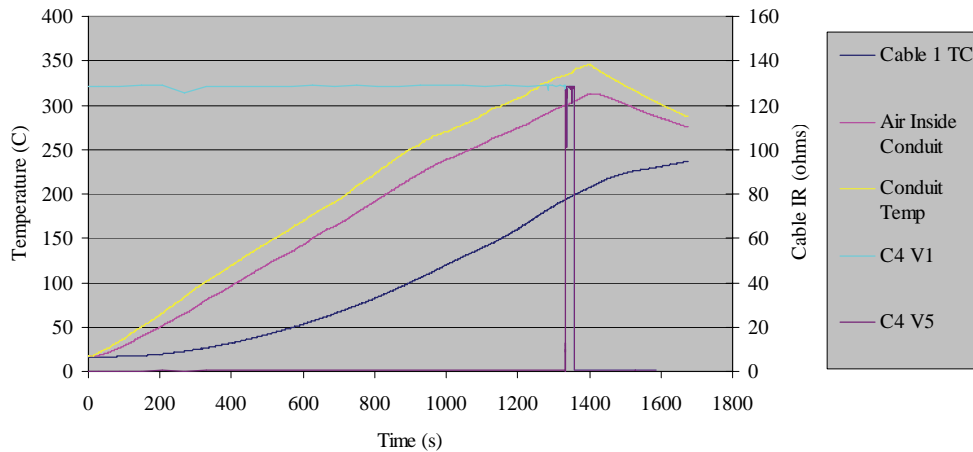


**Figure 6.47: Fuel flow rate and nominal HRR for IT-7.**



**Figure 6.48: Hood temperatures measured during IT-7.**

Figure 6.49 illustrates the thermal response and electrical performance data gathered for the 3+1-cable bundle in conduit at Location E. As noted above, the electrical performance cable in this case was a PVC/PVC 7/C 12AWG (Item #1) and electrical performance was based on SCDU-4 in an MOV-1 wiring configuration. Failure involved a spurious actuation signal to target path 5 followed 24 s later by a fuse blow failure. Both fault modes are illustrated in Figure 6.49 based on the voltage of the active target on Path 5 (C4V5) and the energizing source voltage (C4V1). When the spurious actuation occurs, the voltage on C4V5 jumps up to the source voltage (1334 s after ignition). When the fuse blow occurs, both the target and source voltages drop to zero (1358 s after ignition).



**Figure 6.49: Thermal response and electrical performance results for the cable bundle in conduit at Location E.**

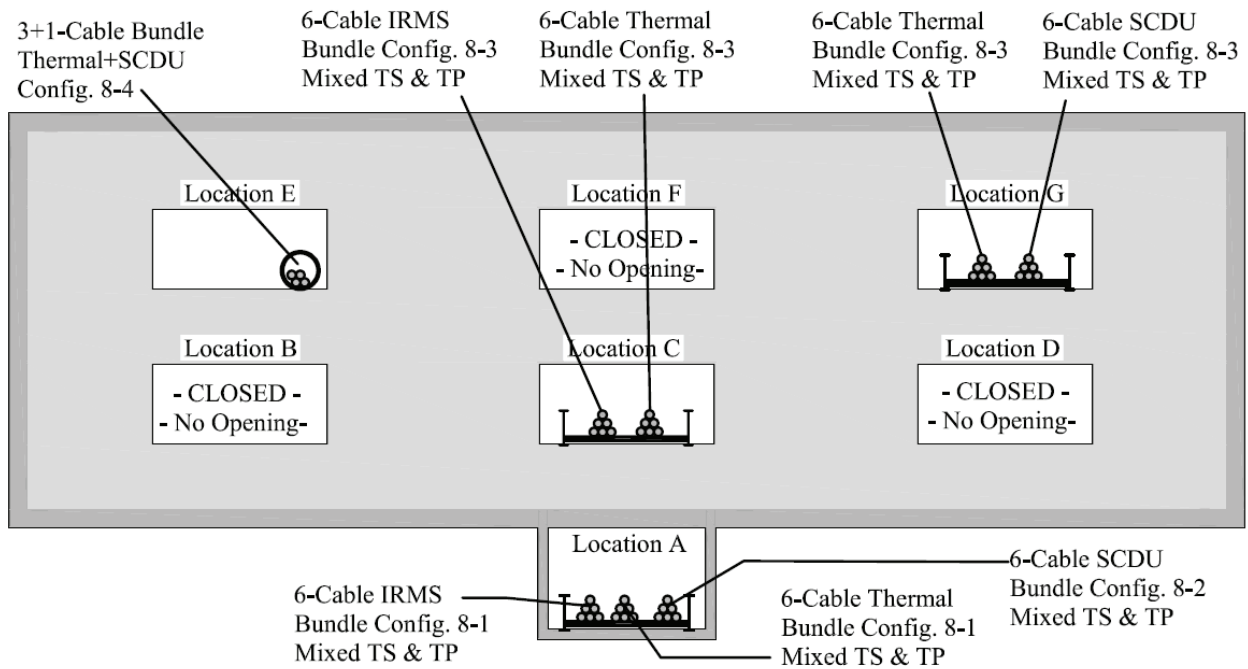
## 6.12 Test IT-8

### 6.12.1 Test Conditions

The test conditions for IT-8 are illustrated in Figure 6.50 and were very similar to those of IT-7 although the specific cable types and bundling arrangements were changed. In particular, the bundles included various conductor size/count configurations (e.g., the 18 AWG, 7/C and 16AWG, 2/C configurations) in addition to the 12 AWG, 7/C configurations that were predominant in prior tests.

Another factor that was unique to IT-8 was the use of an alternate ventilation scheme for the test enclosure. This configuration change had a clear impact on the conditions in the general test chamber and should be noted in any comparisons made between tests or in the analysis of this particular test. In all other tests, fresh air was introduced into the outer test facility via forced-inlet, natural flow outlet stack configuration. In IT-8 the ventilation configuration was altered to a natural in-flow (through an opened doorway) and a forced (suction) outlet flow. This was achieved by placing a large electric motor driven fan on top of the outlet stack exiting the roof of the outer facility directly above the CAROLFIRE test structure. All subsequent tests reverted to the original ventilation configuration.

The final change for IT-8 was the introduction of two slug calorimeters to the test. The calorimeters are described in Section 3.3.1 above. One calorimeter was located near the ceiling just above Location F, and the second above Location G.



**Figure 6.50: Test setup for IT-8.**

### **Location A:**

The cable tray at Location A again had three 6-cable bundles made up of a mixture of cable types including both TS and TP insulated cables. There were two specific bundle configurations for Location A as follows:

- Bundle configuration 8-1:
  - Cable A: XLPE/CSPE, 12 AWG, 7/C (Item #10)
  - Cable B: PE/PVC, 12 AWG, 7/C (Item #15)
  - Cable C: XLPE/CSPE, 18 AWG, 12/C (Item #13)
  - Cable D: XLPE/CSPE, 16 AWG, 2/C(Sh) (Item #7)
  - Cable E: PVC/PVC, 18 AWG, 12/C (Item #6)
  - Cable F: PVC/PVC, 16 AWG, 2/C SH (Item #4)
- Bundle configuration 8-2:
  - Cable A: XLPE/CSPE, 12 AWG, 7/C (Item #10)
  - Cable B: PE/PVC, 12 AWG, 7/C (Item #15)
  - Cable C: XLPE/CSPE, 16 AWG, 2/C(Sh) (Item #7)
  - Cable D: PVC/PVC, 16 AWG, 2/C SH (Item #4)
  - Cable E: XLPE/CSPE, 18 AWG, 12/C (Item #13)
  - Cable F: PVC/PVC, 18 AWG, 12/C (Item #6)

For the cable tray at Location A the thermal response bundle was configuration 8-1. The other two bundles were monitored for electrical monitoring similar to the monitoring for IT-7 as follows:

- For Location A, a configuration 8-1 bundle was connected to IRMS-1
- For Location A, a configuration 8-2 bundle was connected to the SCDUs as follows: Cable A (XLPE-insulated) was connected to SCDU-3; and cable B (PE-insulated) was connected to SCDU-2. Both SCDUs were in the MOV-1 wiring configuration.

### **Location C:**

For IT-8 two 6-cable bundles were placed in the cable tray at Location C. The two bundles were identical, and the arrangement is referred to as configuration 8-3. The cable arrangement for this configuration was as follows:

- Cable A, D &F: XLPE/CSPE, 12 AWG, 7/C (Item #10)
- Cable B, C &E: PE/PVC, 12 AWG, 7/C (Item #15)

One of the two bundles was monitored for thermal response. The second bundle was monitored for electrical performance using IRMS-2.

### **Location E:**

For IT-8, a conduit was again placed at Location E. A 3+1-cable bundle was placed in the conduit. This bundle is referred to as configuration 8-4 and was comprised of the following cables:

- Cable A: XLPE/CSPE, 12 AWG, 7/C (Item #10)
- Cable B: PE/PVC, 12 AWG, 7/C (Item #15)
- Cable C: PE/PVC, 12 AWG, 7/C (Item #15)
- Cable 1 (TC cable): XLPE/CSPE, 12 AWG, 7/C (Item #10)

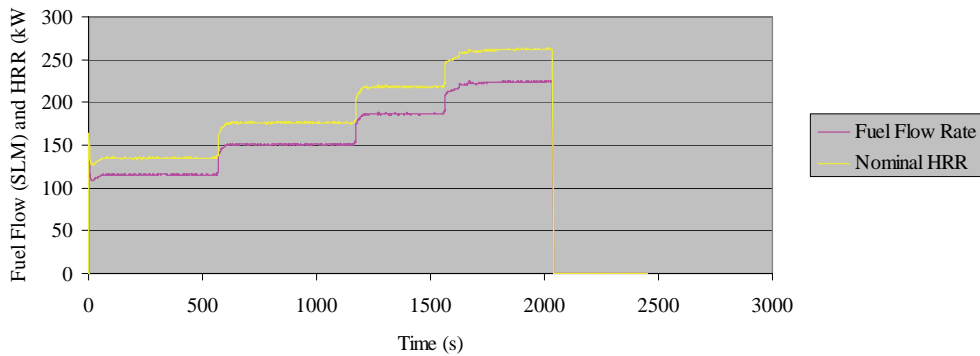
Cable A (XLPE-insulated) was connected to SCDU-4 which was wired in the MOV-1 wiring configuration.

### **Location G:**

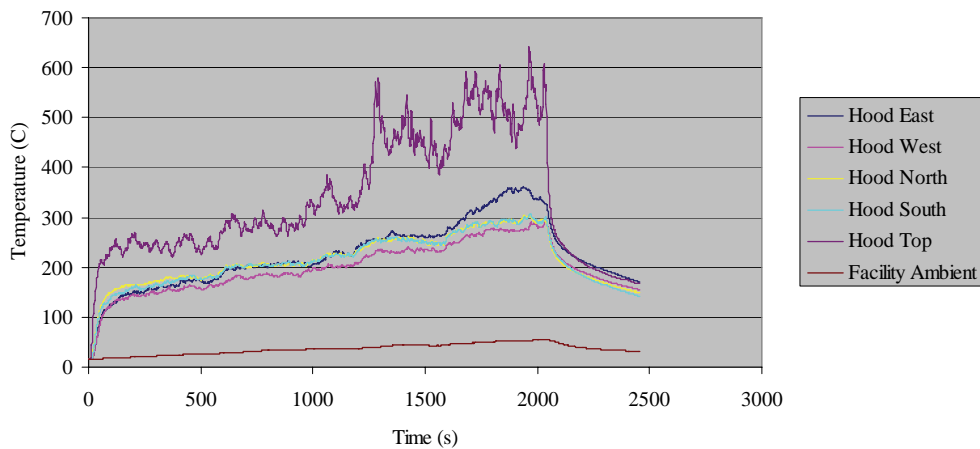
For IT-8, a cable tray was again used at location G. In this case, there were two 6-cable bundles present. These bundles were identical, and the arrangement was the same as configuration 8-3 described immediately above. One bundle was monitored for thermal response. Cable A (XLPE-insulated) in the second bundle was connected to SCDU-1 in the MOV-1 wiring configuration.

## **6.12.2 Test Results**

The fuel gas volume flow rate and the corresponding nominal HRR for IT-8 are illustrated in Figure 6.51. Note that the fuel flow rate to the gas burner was increased three times during the course of IT-8. The corresponding temperatures measured under the test structure hood are illustrated in Figure 6.52.



**Figure 6.51: Fuel flow rate and nominal HRR for IT-8.**



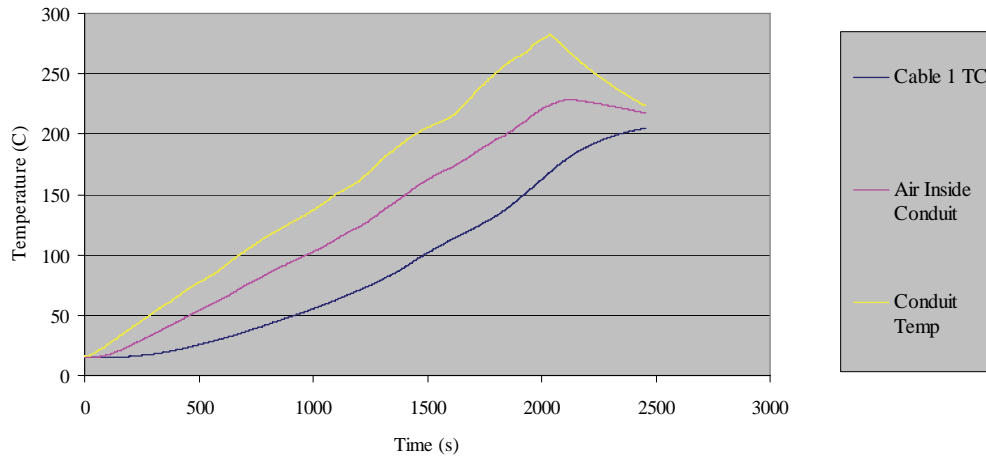
**Figure 6.52: Hood temperatures measured during IT-8.**

The ventilation configuration change (described above) substantially increased the total air flow through the test facility. Very little smoke build-up was observed in the test facility during IT-8 and the CAROLFIRE test structure remained clearly visible throughout the test. In other tests smoke buildup in the outer test facility obscured the view, typically within a few minutes of ignition. However, the change also had substantive undesired effects on the test conditions because the bulk air flow was so substantially increased. The area under the hood of the test structure also experienced increased flow of fresh air and, as a result, temperatures under the test hood were clearly lower in this test than were observed during other tests of a similar nature (e.g., IT-6 and IT-7). Note that the trace for the “hood top” TC directly above the fire source showed temperature readings very similar to those observed at the same location in IT-7 (see Figure 6.48) with a peak near 600°C (1112°F). However, for the side locations (“hood north,” “hood east,” etc.) the temperatures measured during IT-8 were nearly 100 °C (180°F) lower than the corresponding temperatures for IT-7.

Figure 6.53 illustrates the temperature response data for the configuration 8-4 cable bundle in conduit at Location E. Note that no electrical failures were noted for the XLPE-insulated electrical performance cable in this cable bundle. This was not surprising given the relatively low peak

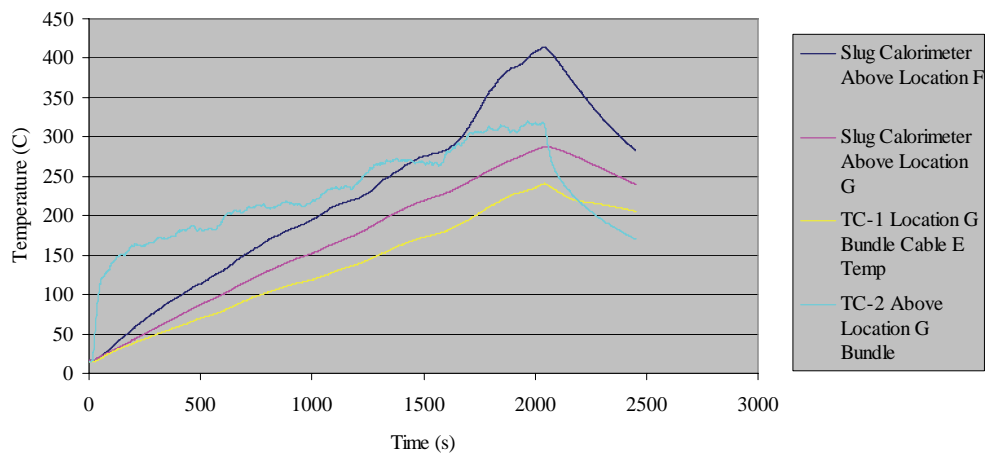


temperature reached by the cable in this test (about 200°C (392°F)) which is, again, attributed to the change in the general ventilation configuration.



**Figure 6.53: Temperature response data for the cable bundle in conduit at Location E during IT-8.**

As noted, IT-8 was the first test to utilize the brass slug calorimeters described in Section 3.3.1 above. Figure 6.54 illustrates the raw temperature data recorded by both calorimeters. For comparison, the data for the cable bundle at Location G is also shown. In particular, the sub-jacket temperature of Cable E in the bundle and the air temperature just above the cable bundle (and hence relatively close to the slug calorimeter above Location G) are shown.



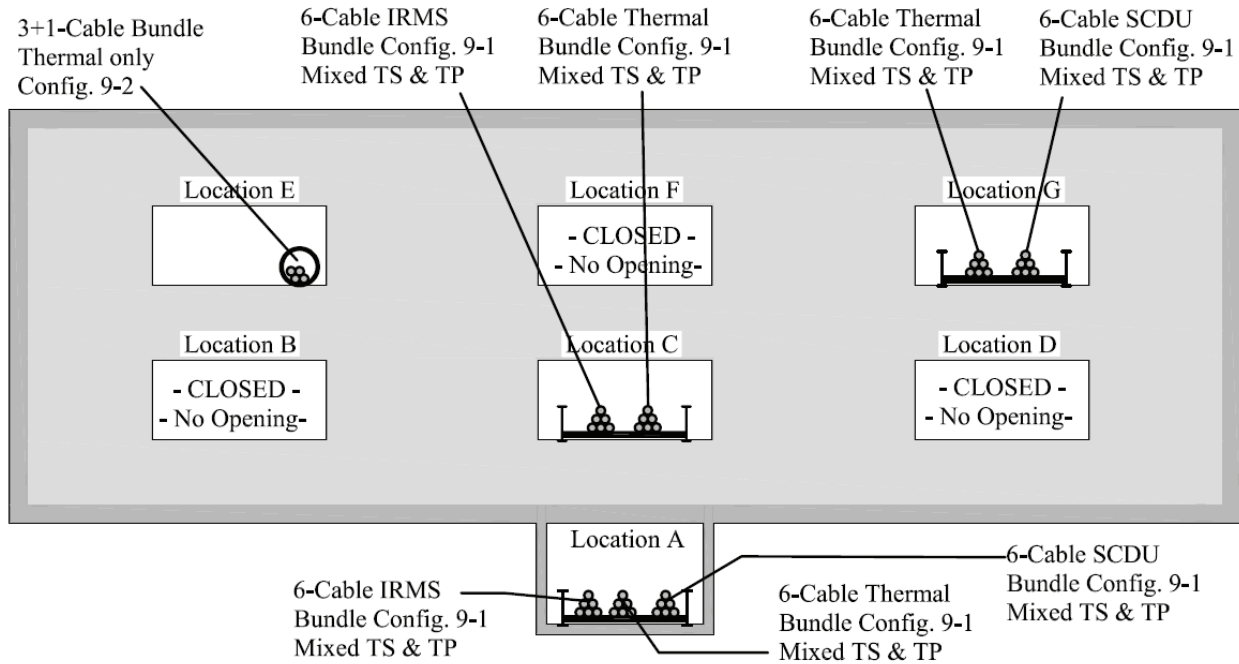
**Figure 6.54: Temperature response for the slug calorimeters and the cable bundle at Location G during IT-8.**

## 6.13 Test IT-9

### 6.13.1 Test Conditions

The test conditions for IT-9 are illustrated in Figure 6.55 and were very similar to those of IT-7 and IT-8. The most unique aspect of IT-9 was that all of the 6-cable bundles in locations A, C & G (a

total of four electrical performance bundles and three thermal response bundles) were identical. This allows for a direct comparison of the bundle thermal response and electrical performance between locations.



**Figure 6.55: Test setup for IT-9.**

### Location A:

The cable tray at Location A again had three 6-cable bundles made up of a mixture of cable types including both TS and TP insulated cables. All of the bundles were of the same configuration, and actually matched those used in Locations C&G as well. The specific bundle configuration is referred to as configuration 9-1 and was as follows:

- Bundle configuration 9-1:
  - Cable A: EPR/CPE, 12 AWG, 7/C (Item #2)
  - Cable B: PE/PVC, 12 AWG, 7/C (Item #15)
  - Cable C: TEF/TEF, 12 AWG, 7/C (Item #12)
  - Cable D: SR/Aramid Braid, 12 AWG, 7/C (Item #9)
  - Cable E: PE/PVC, 12 AWG, 7/C (Item #15)
  - Cable F: XLPE/CSPE, 12 AWG, 7/C (Item #10)

For the cable tray at Location A there was one thermal response bundle and the other two bundles were monitored for electrical monitoring similar to the monitoring for IT-7 as follows:

- For Location A, a configuration 9-1 bundle was connected to IRMS-1

- For Location A, a configuration 9-1 bundle was connected to the SCDUs as follows: Cable A (EPR-insulated) was connected to SCDU-2; and cable B (PE-insulated) was connected to SCDU-3. Both SCDUs were in the MOV-1 wiring configuration.

### **Location C:**

For IT-9 two 6-cable bundles were placed in the cable tray at Location C. The two bundles were identical to that used for the bundles at Locations A&G (i.e., configuration 9-1). One of the two bundles was monitored for thermal response. The second bundle was monitored for electrical performance using IRMS-2.

### **Location E:**

For IT-9, a conduit was again placed at Location E. A 3+1-cable bundle was placed in the conduit. This bundle is referred to as configuration 9-2 and was comprised of the following cables:

- Cable A: XLPE/CSPE, 12 AWG, 7/C (Item #10)
- Cable B: PE/PVC, 12 AWG, 7/C (Item #15)
- Cable C: TEF/TEF, 12 AWG, 7/C (Item #12)
- Cable 1 (TC cable): XLPE/CSPE, 12 AWG, 7/C (Item #10)

There was no electrical performance monitoring for this cable bundle in IT-9.

### **Location G:**

For IT-9, a cable tray was again used at location G. In this case, there were two 6-cable bundles present using the same bundle configuration as used at Locations A&C (i.e., configuration 9-1). One bundle was monitored for thermal response. Cable A (EPR-insulated) in the second bundle was connected to SCDU-1 in the MOV-1 wiring configuration. Cable B (PE-insulated) was connected to SCDU-4 in the MOV-1 wiring configuration.

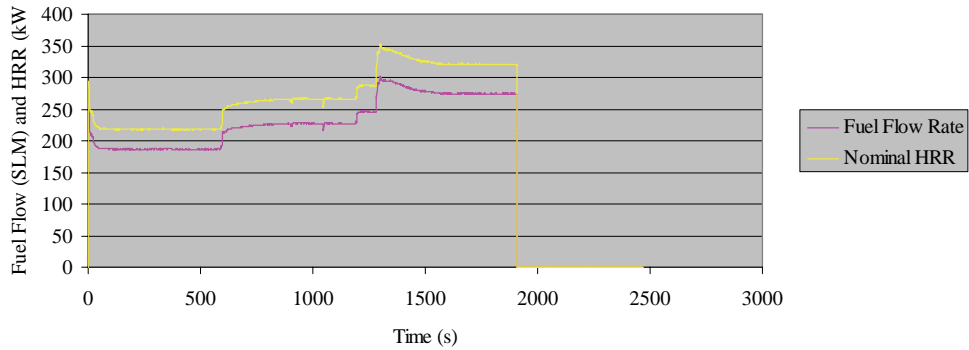
### **Water Spray:**

Water spray was activated during IT-9. The gas burner was shut off after a 1910 s (nearly 32 minute) burn period. At this time, neither of the SR-insulated cables had experienced electrical failure. (One SR-insulated cable was in the configuration 9-1 IRMS bundle at Location A and the second was in the configuration 9-1 IRMS bundle at Location C.) After the burner was shut down and water spray was initiated, both SR-insulated cables experienced electrical failure.

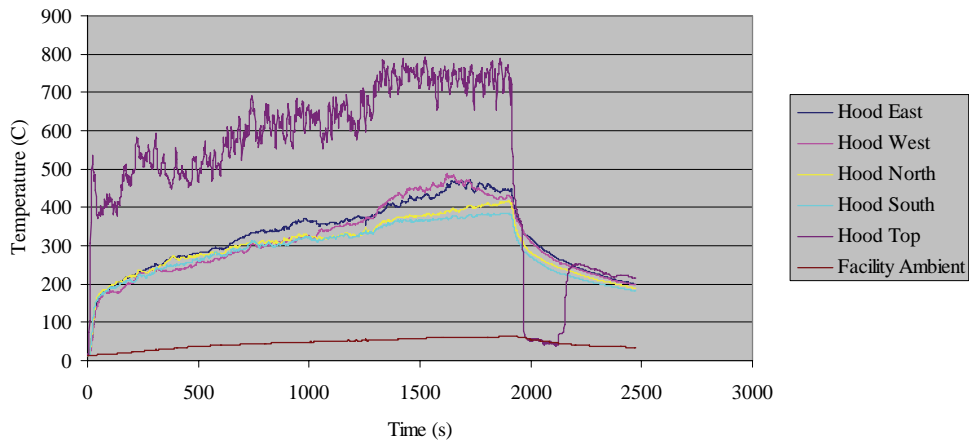
### **6.13.2 Test Results**

The fuel gas volume flow rate and the corresponding nominal HRR for IT-9 are illustrated in Figure 6.56. The corresponding temperatures measured under the test structure hood are illustrated in Figure 6.57. Note that activation of the water spray had a pronounced effect on the “hood top” TC.

Concurrent with the time of spray activation, this TC experiences a sharp drop in temperature. After the spray was stopped the temperature for this TC recovers to general under-hood levels.



**Figure 6.56: Fuel flow rate and nominal HRR for IT-9.**



**Figure 6.57: Hood temperatures measured during IT-9.**

As noted above, all of the cable bundles at Locations A, C, and G were identical. Figure 6.58 compares the thermal responses for these locations. The sub-jacket temperature for Cable E in each bundle is illustrated. Also shown for reference are the corresponding air temperatures measured directly below each bundle.

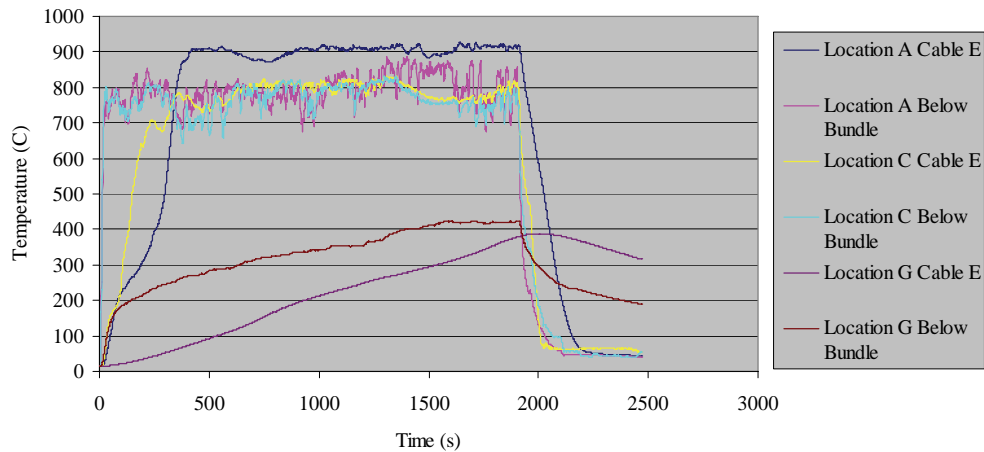


Figure 6.58: Temperature response data for the cable bundles at Locations A, C and G during IT-9.

## 6.14 Test IT-10

### 6.14.1 Test Conditions

The test conditions for IT-10 are illustrated in Figure 6.59 and were very similar to those of IT-8 although the specific cable types and bundling arrangements were changed.

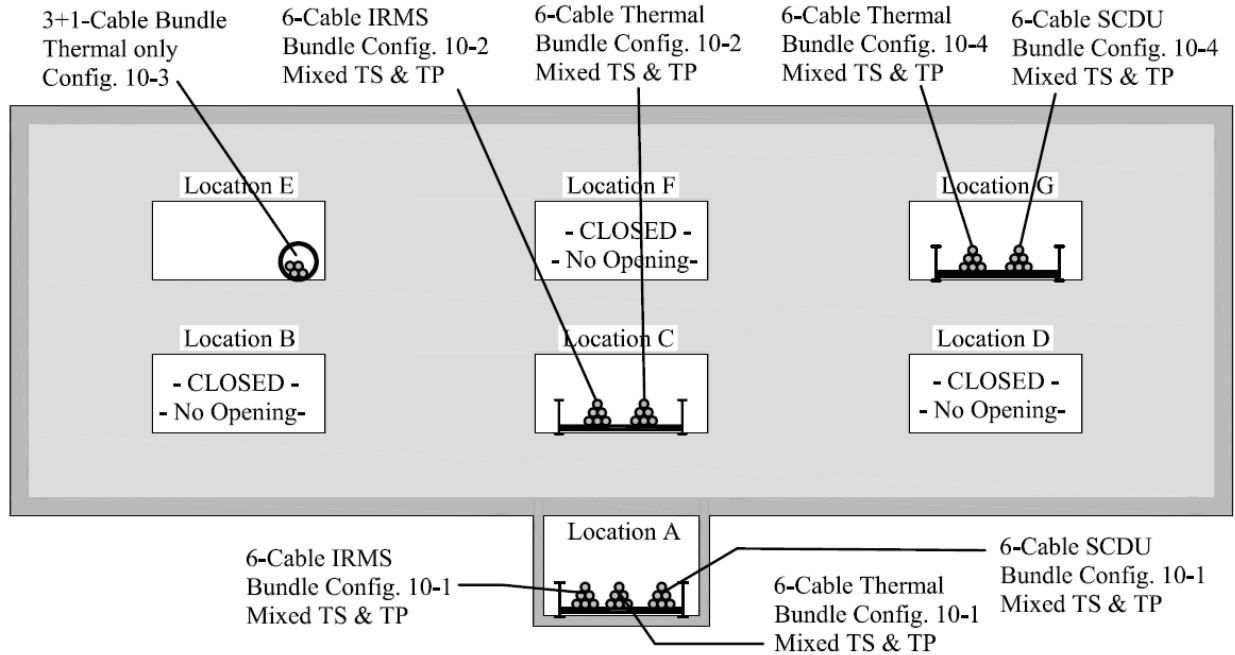


Figure 6.59: Test setup for IT-10.

## **Location A:**

The cable tray at Location A again had three 6-cable bundles made up of a mixture of cable types including both TS and TP insulated cables. All three bundles were of the same configuration as follows:

- Bundle configuration 10-1:
  - Cable A: XLPE/CSPE, 12 AWG, 7/C (Item #10)
  - Cable B: EPR/CPE, 12 AWG, 7/C (Item #2)
  - Cable C: TEF/TEF, 12 AWG, 7/C (Item #12)
  - Cable D: XLPE/PVC, 12 AWG, 7/C (Item #3)
  - Cable E: SR/Aramid Braid, 12 AWG, 7/C (Item #9)
  - Cable F: XLPO/XLPO, 12 AWG, 7/C (Item #8)

For the cable tray at Location A there was one thermal response bundle and the other two bundles were monitored for electrical monitoring similar to the monitoring for IT-7 as follows:

- For Location A, a configuration 10-1 bundle was connected to IRMS-1
- For Location A, a configuration 10-1 bundle was connected to the SCDUs as follows: Cable E (SR-insulated) was connected to SCDU-2; and cable C (Tefzel-insulated) was connected to SCDU-3. Both SCDUs were in the MOV-1 wiring configuration.

## **Location C:**

For IT-10 two 6-cable bundles were placed in the cable tray at Location C. The two bundles were identical, and the arrangement is referred to as configuration 10-2. The arrangement was similar to Configuration 10-1, except that cables A&C were of the 12/C type. The cable arrangement for this configuration was as follows:

- Bundle configuration 10-2:
  - Cable A: XLPE/CSPE, 18 AWG, 12/C (Item #13)
  - Cable B: EPR/CPE, 12 AWG, 7/C (Item #2)
  - Cable C: PVC/PVC, 18 AWG, 12/C (Item #6)
  - Cable D: XLPE/PVC, 12 AWG, 7/C (Item #3)
  - Cable E: SR/Aramid Braid, 12 AWG, 7/C (Item #9)
  - Cable F: XLPO/XLPO, 12 AWG, 7/C (Item #8)

One of the two bundles was monitored for thermal response. The second bundle was monitored for electrical performance using IRMS-2.

### **Location E:**

For IT-10, a conduit was again placed at Location E. A 3+1-cable bundle (thermal response only) was placed in the conduit. This bundle is referred to as configuration 10-3 and was comprised of the following cables:

- Bundle configuration 10-3:
  - Cable A: XLPE/PVC, 12 AWG, 7/C (Item #3)
  - Cable B: PE/PVC, 12 AWG, 7/C (Item #15)
  - Cable C: TEF/TEF, 12 AWG, 7/C (Item #12)
  - Cable 1 (TC cable): PE/PVC, 12 AWG, 7/C (Item #15)

### **Location G:**

For IT-10, a cable tray was again used at location G. In this case, there were two 6-cable bundles present. These bundles were identical, and the arrangement is referred to as configuration 10-4 and was as follows:

- Bundle configuration 10-4:
  - Cable A: PE/PVC, 12 AWG, 7/C (Item #15)
  - Cable B: XLPE/CSPE, 16 AWG, 2/C(Sh) (Item #7)
  - Cable C: EPR/CPE, 12 AWG, 7/C (Item #2)
  - Cable D: PVC/PVC, 16 AWG, 2/C SH (Item #4)
  - Cable E: XLPE/PVC, 12 AWG, 7/C (Item #3)
  - Cable F: TEF/TEF, 12 AWG, 7/C (Item #12)

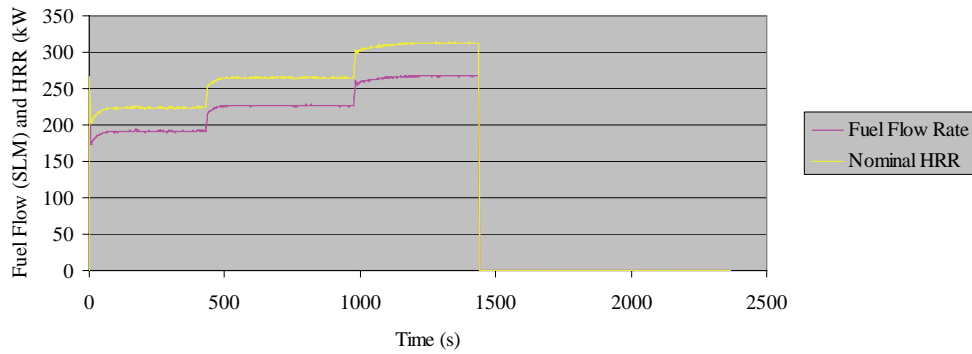
One bundle was monitored for thermal response. Cable A (PE-insulated) in the second bundle was connected to SCUDU-1 in the MOV-1 wiring configuration. Cable C (EPR-insulated) in the second bundle was connected to SCUDU-4 in the MOV-1 wiring configuration.

### **Water Spray:**

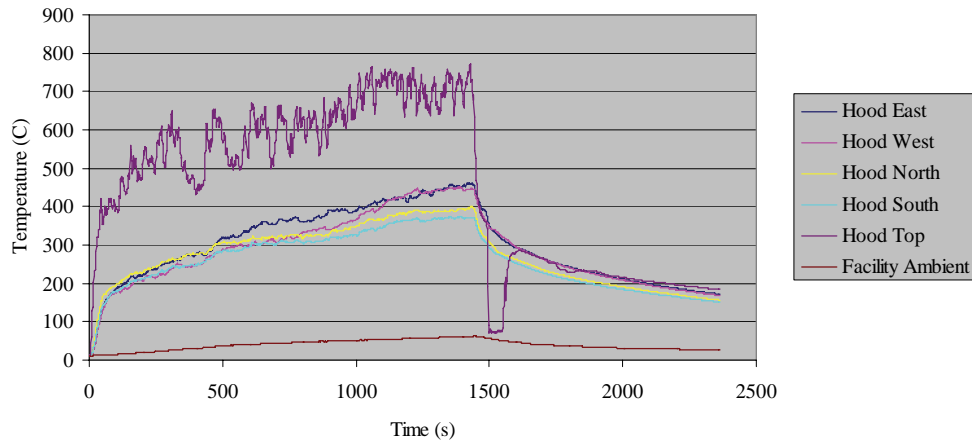
Water spray was activated during IT-10. The gas burner was shut off after a 1440 s (24 minute) burn period. At this time, neither of the SR-insulated cables had experienced electrical failure. (One SR-insulated cable was in the IRMS bundle at Location A and the second was in the IRMS bundle at Location C.) Both of the SR-insulated cables experienced electrical failures shortly after the water spray was initiated.

### **6.14.2 Test Results**

The fuel gas volume flow rate and the corresponding nominal HRR for IT-10 are illustrated in Figure 6.60. The corresponding temperatures measured under the test structure hood are illustrated in Figure 6.61. Again, activation of the water spray was mirrored in the temperature response for the “hood top” TC.



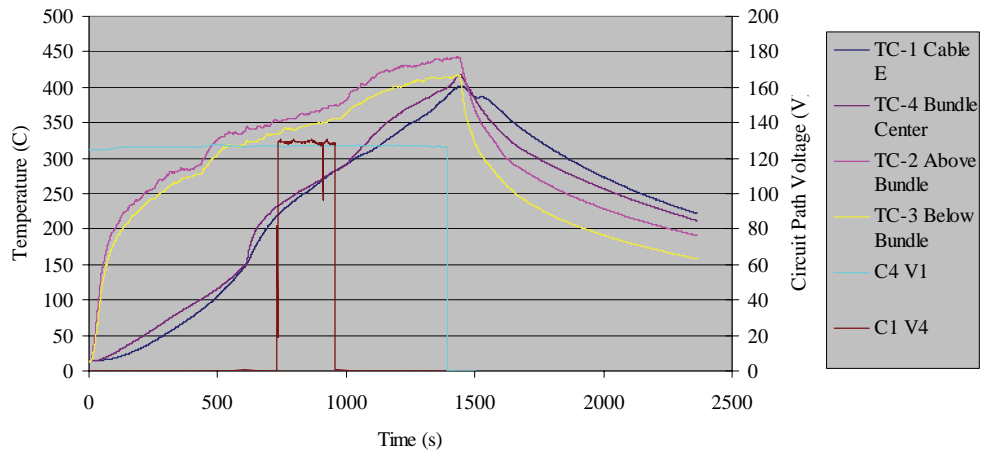
**Figure 6.60: Fuel flow rate and nominal HRR for IT-10.**



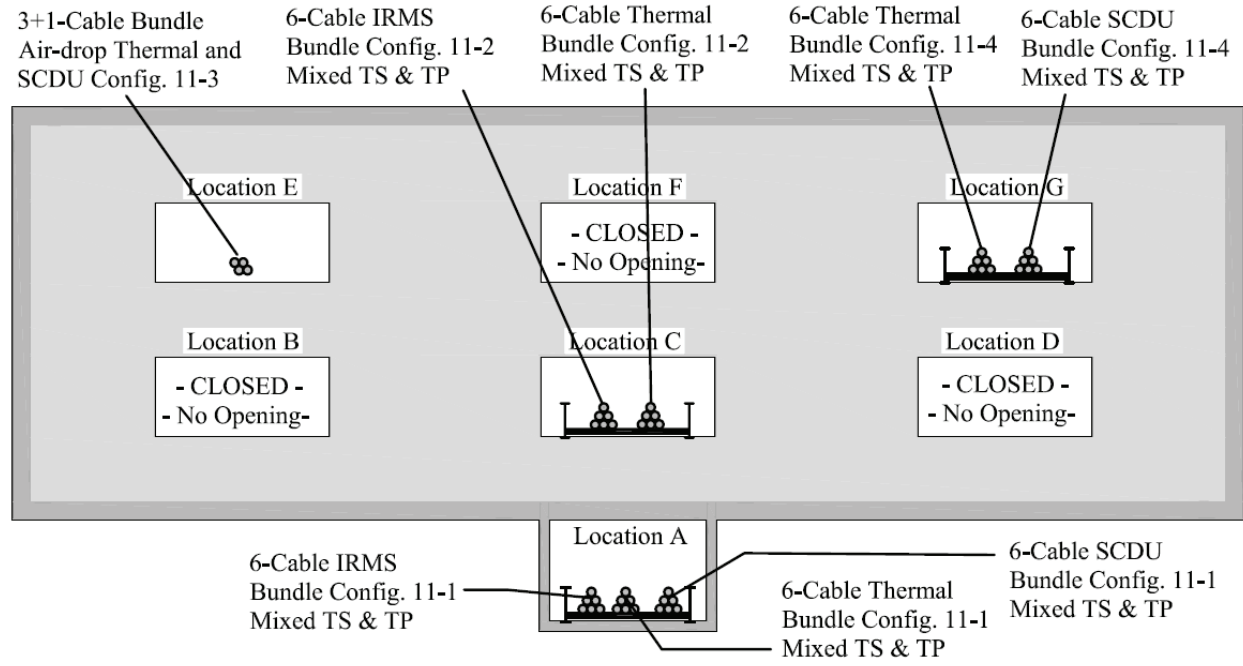
**Figure 6.61: Hood temperatures measured during IT-10.**

Figure 6.62 illustrates the thermal response and electrical performance data for the two bundles at Location G. Note that as expected, the PE-insulated cable A (on SCDU-1, C1V4) fails well before the EPR-insulated cable 'C' (on SCDU-4, C4V1). The PE-insulated cable in this case experience hot shorts prior to the fuse blow failure as illustrated in the figure by the voltage on the passive target conductor on Path 4 (C1V4). The EPR-insulated cable experienced a fuse blow failure as illustrated by the source voltage (C4V1).





**Figure 6.62: Temperature response data for the configuration 10-4 cable bundle in cable tray at Location G during IT-10 and the corresponding electrical performance data for the PE-insulated cable ‘A’ (C1V4) and the EPR-insulated cable ‘C’ (C4V1) in the pair-matched electrical response bundle.**



**Figure 6.63: Test setup for IT-11 and IT-12.**

## 6.15 Tests IT-11 & IT-12

### 6.15.1 Test Conditions

The test setup for IT-11 and IT-12 were identical in all respects and are illustrated in Figure 6.63. The intent in conducting these two tests was in large part to provide an assessment of the general repeatability of the tests under conditions of reasonable complexity. To achieve this, an attempt was

made to reproduce the conditions of the two tests as exactly as possible including the placement of all cables and cable TCs, the flow rate for the gas burner, and even the time of day that the test was run.

The general test conditions were very similar to those of IT-10. The most significant change was the use of a horizontal air-drop configuration at Location E (a cable tray with no rungs) in place of the conduit that had been present in a number of the previous tests. The air-drop bundle was, however, a 3+1-cable bundle similar to those used in the prior conduit tests so that direct comparisons were possible. Other conditions were quite similar with the exception of the specific bundling arrangement used.

### **Location A:**

The cable tray at Location A again had three 6-cable bundles made up of a mixture of cable types including both TS and TP insulated cables. All three bundles were of the same configuration as follows:

- Bundle configuration 11-1:
  - Cable A: XLPE/CSPE, 12 AWG, 7/C (Item #10)
  - Cable B: EPR/CPE, 12 AWG, 7/C (Item #2)
  - Cable C: PE/PVC, 12 AWG, 7/C (Item #15)
  - Cable D: PVC/PVC, 12 AWG, 7/C (Item #1)
  - Cable E: XLPE/PVC, 12 AWG, 7/C (Item #3)
  - Cable F: XLPO/XLPO, 12 AWG, 7/C (Item #8)

For the cable tray at Location A there was one thermal response bundle and the other two bundles were monitored for electrical monitoring as follows:

- For Location A, a configuration 11-1 bundle was connected to IRMS-1
- For Location A, a configuration 11-1 bundle was connected to the SCDUs as follows: Cable D (PVC-insulated) was connected to SCDU-1; and cable A (XLPE-insulated) was connected to SCDU-4. Both SCDUs were in the MOV-1 wiring configuration.

### **Location C:**

For IT-11 and IT-12 two 6-cable bundles were placed in the cable tray at Location C. The two bundles were identical, and the arrangement is referred to as configuration 11-2. The cable arrangement for this configuration was as follows:

- Bundle configuration 11-2:
  - Cable A: TEF/TEF, 12 AWG, 7/C (Item #12)
  - Cable B: XLPO/XLPO, 12 AWG, 7/C (Item #8)
  - Cable C: EPR/CPE, 12 AWG, 7/C (Item #2)
  - Cable D: XLPE/CSPE, 12 AWG, 7/C (Item #10)

- Cable E: PVC/PVC, 12 AWG, 7/C (Item #1)
- Cable F: XLPE/PVC, 12 AWG, 7/C (Item #3)

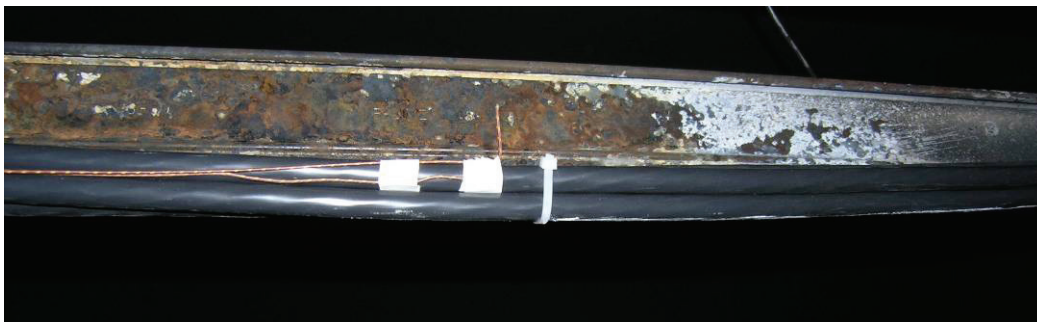
One of the two bundles was monitored for thermal response. The second bundle was monitored for electrical performance using IRMS-2.

**Location E:**

For IT-11 and IT-12, the conduit at Location E was replaced with an air-drop configuration. For this test, a section of cable tray was used but with all of the rungs removed except for those at the ends that would be outside the boundaries of the test structure. (For the entire length of the tray within the test structure, the side rails were present but there were no rungs.) A 3+1-cable bundle was routed through the test structure by securing it to each of the two end rungs, and then allowing the balance of the cable to run unsupported through the test structure. This bundle is referred to as configuration 11-3 and was comprised of the following cables:

- Bundle configuration 11-3:
  - Cable A: PE/PVC, 12 AWG, 7/C (Item #15)
  - Cable B: XLPE/PVC, 12 AWG, 7/C (Item #3)
  - Cable C: PVC/PVC, 12 AWG, 7/C (Item #1)
  - Cable 1 (TC cable): PE/PVC, 12 AWG, 7/C (Item #15)

In addition to the standard complement of TCs, Cable A in this bundle (PE-insulated) was connected to SCDU-2 and wired in the MOV-1 wiring configuration. This air-drop is illustrated in Figure 6.64. Note the presence of the cable tray side rail (visible behind the cables) but the lack of tray rungs. The TC measuring air temperature just above the bundle is also visible near the center of the photo just above the white tape wrapping the upper cable. The lead wires for both the air and sub-jacket TCs are also visible.



**Figure 6.64: Photograph of the horizontal air-drop cable bundle from IT-11.**

**Location G:**

For IT-11 and IT-12, a cable tray was again used at location G. In this case, there were two 6-cable bundles present. The bundles were similar to the 11-1 configuration, but the positions for two of the

cables (B&D) were reversed. These bundles were identical, and the arrangement is referred to as configuration 11-4 and was as follows:

- Bundle configuration 11-4:
  - Cable A: XLPE/CSPE, 12 AWG, 7/C (Item #10)
  - Cable B: PVC/PVC, 12 AWG, 7/C (Item #1)
  - Cable C: PE/PVC, 12 AWG, 7/C (Item #15)
  - Cable D: EPR/CPE, 12 AWG, 7/C (Item #2)
  - Cable E: XLPE/PVC, 12 AWG, 7/C (Item #3)
  - Cable F: XLPO/XLPO, 12 AWG, 7/C (Item #8)

One bundle was monitored for thermal response. Cable B (PVC-insulated) in the second bundle was connected to SCUD-3 in the MOV-1 wiring configuration.

### 6.15.2 Test Results IT-11

The fuel gas volume flow rate and the corresponding nominal HRR for IT-11 are illustrated in Figure 6.65. The same data from IT-12 are shown in Figure 6.66. Note that the two plots match quite closely as had been intended. The only significant difference was that the burn duration for IT-12 was about 200s longer than for IT-11.

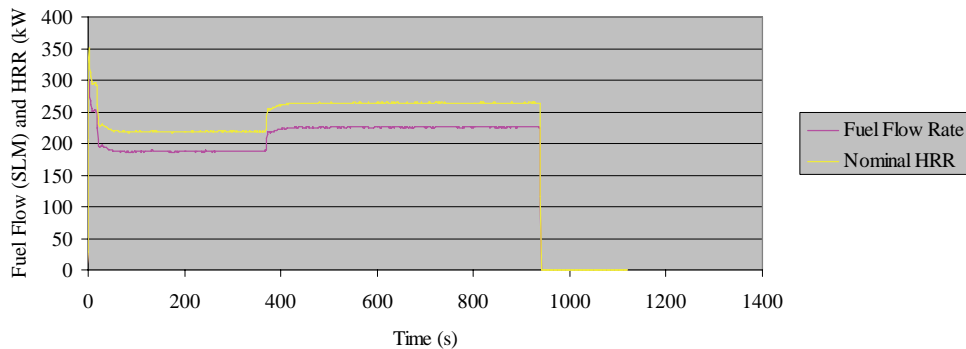


Figure 6.65: Fuel flow rate and nominal HRR for IT-11.

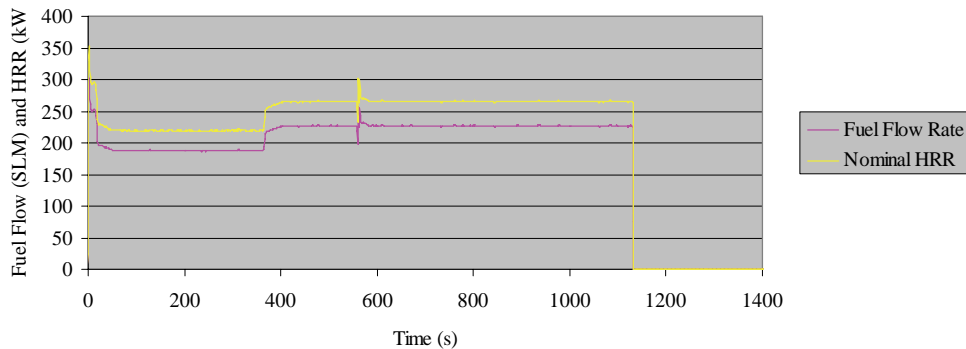
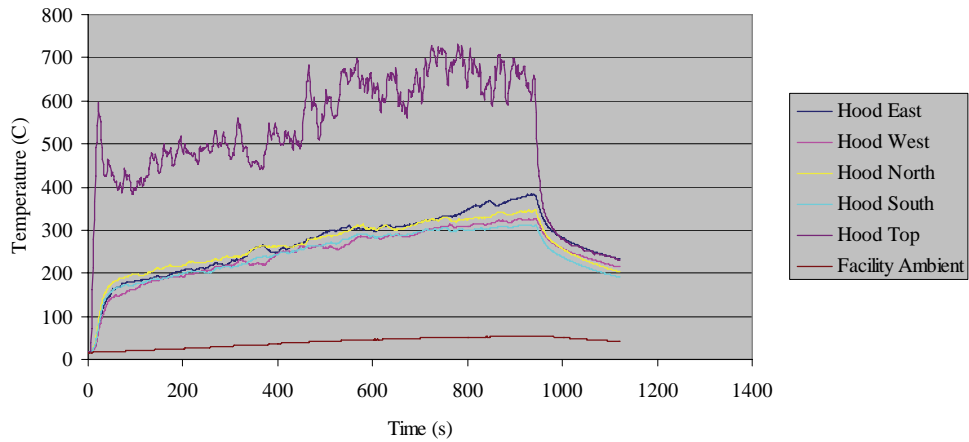
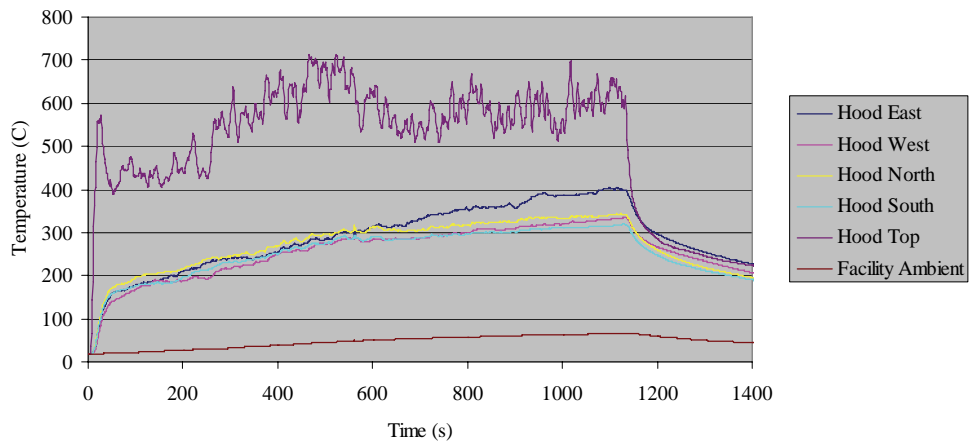


Figure 6.66: Fuel flow rate and nominal HRR for IT-12.

The corresponding temperatures measured under the test structure hood for IT-11 and IT-12 are illustrated in Figures 6.67 and 6.68 respectively. Again, the tests show a rather good match between the two tests. The “hood top” TC readings do vary between tests, but this is not entirely unexpected because of the location directly above the burner. Minor variations in the fluctuation of the fire would generally account for the differences. The various TC locations all show reasonable repeatability, again with the exception that the burn extended for a longer time in IT-12 than in IT-11.



**Figure 6.67: Hood temperatures measured during IT-11.**



**Figure 6.68: Hood temperatures measured during IT-12.**

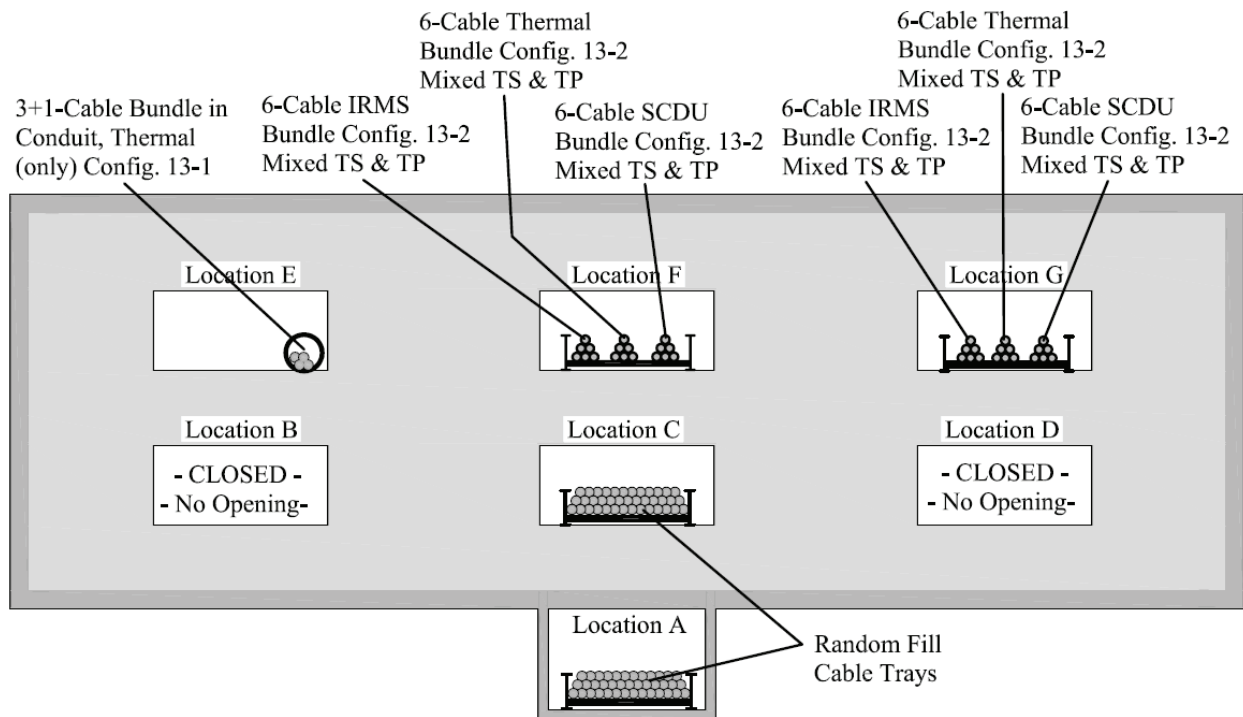


Figure 6.69: Test setup for IT-13.

## 6.16 Test IT-13

### 6.16.1 Test Conditions

For the final two tests in the series, IT-13 and IT-14, testing returned to the use of random fill cable trays similar to that used in IT-1. However, for the final two tests, random fill cable trays were used in both Locations A&C (IT-1 used only one random fill tray at Location A). The general test setup for IT-13 is illustrated in Figure 6.69. Cable bundles were also placed at Locations E, D, and F. Tests IT-13 and IT-14 had the largest quantities of cable present of any of the tests conducted and their setups were quite similar.

#### Locations A&C:

Random fill cable trays were placed at Location A and Location C. These trays were monitored only for thermal response with three TCs placed as described in Section 3.3.4 above. Note that in this case the TC configuration that has TCs at three locations in the cable mass (rather than 4) was used. The fill for the two trays was the same, and was made up of the following combination of cables:

- Random fill composition for IT-13 (both trays A&C):
  - Eight lengths of XLPE/CSPE, 12 AWG, 7/C (Item #10)
  - Eight lengths of EPR/CPE, 12 AWG, 7/C (Item #2)
  - Eight lengths of PE/PVC, 12 AWG, 7/C (Item #15)

- Eight lengths of XLPE/PVC, 12 AWG, 7/C (Item #3)
- Eight lengths of TEF/TEF, 12 AWG, 7/C (Item #12)
- Eight lengths of XLPO/XLPO, 12 AWG, 7/C (Item #8)
- Eight lengths of VITA-LINK, 14 AWG, 7/C (Item #11)

Note that the cables were all cut to a length of 6' so that only the central portion of each tray was actually filled with cables.

### **Location E:**

For IT-13, a conduit was again placed at Location E. A 3+1-cable bundle (thermal response only) was placed in the conduit. This bundle is referred to as configuration 13-1 and was comprised of the following cables:

- Bundle configuration 13-1:
  - Cable A: XLPE/CSPE, 12 AWG, 7/C (Item #10)
  - Cable B: EPR/CPE, 12 AWG, 7/C (Item #2)
  - Cable C: EPR/CPE, 12 AWG, 7/C (Item #2)
  - Cable 1 (TC cable): XLPE/CSPE, 12 AWG, 7/C (Item #10)

### **Location F:**

For IT-13 a cable tray was used at Location F. In this case, there were three 6-cable bundles present. These bundles were identical, and the arrangement is referred to as configuration 13-2 and was as follows:

- Bundle configuration 13-2:
  - Cable A: XLPE/CSPE, 12 AWG, 7/C (Item #10)
  - Cable B: EPR/CPE, 12 AWG, 7/C (Item #2)
  - Cable C: VITA-LINK, 14 AWG, 7/C (Item #11)
  - Cable D: XLPO/XLPO, 12 AWG, 7/C (Item #8)
  - Cable E: PE/PVC, 12 AWG, 7/C (Item #15)
  - Cable F: TEF/TEF, 12 AWG, 7/C (Item #12)

One bundle was monitored for thermal response. The other two bundles were monitored for electrical performance as follows:

- For one bundle, Cables A (XLPE-insulated), B (EPR-insulated), and C (VL) were connected to IRMS-1.
- For the second bundle, Cable A (XLPE-insulated) was connected to SCDU-1 and Cable C (VL) was connected to SCDU-2. Both SCDUs were in the MOV-1 wiring configuration.

### **Location G:**

For IT-13, a cable tray was again used at location G. However, in this case there were three (rather than two) 6-cable bundles present. All three bundles were arranged consistent with configuration 13-2 as described above. One bundle was monitored for thermal response. The other two bundles were monitored for electrical performance as follows:

- For one bundle, Cables A (XLPE-insulated), B (EPR-insulated), and C (VL) were connected to IRMS-2.
- For the second bundle, Cable A (XLPE-insulated) was connected to SCDU-3 and Cable C (VL) was connected to SCDU-4. Both SCDUs were in the MOV-1 wiring configuration.

### **Water Spray:**

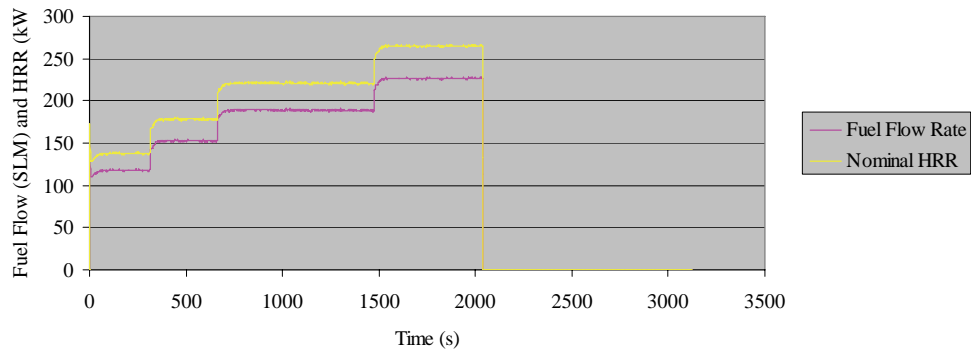
Water spray was activated during IT-13. The gas burner was shut off after a 2041 s (34 minute) burn period. At this time, none of the four electrically monitored Vita-Link cables had experienced electrical failure. Two of these cables were at Location F which was near the ceiling of the test structure directly above the fire source (and above the random fill trays at Locations A and C) and directly below the sprinkler. The other two cables were in the tray at Location G. After the burner was shut down, water spray was activated.

Neither of the two cables connected to the SCDUs experienced electrical failures leading to either a fuse blow or spurious actuation failure for those circuits. The IRMS did detect some signs of degradation for the other two VL cables. In the case of the IRMS cable at location F, a single data point was noted where the IR between one conductor group and ground dropped to about 883 ohms. Recall that an IR of less than 1000 ohms was nominally taken as indicative of cable failure for the IRMS data. The value did recover at the next measurement cycle to above 1000 ohms. The VL cable at Location G also experienced some level of degradation, but the cable IR remained above 1000 ohms throughout.

### **6.16.2 Test Results**

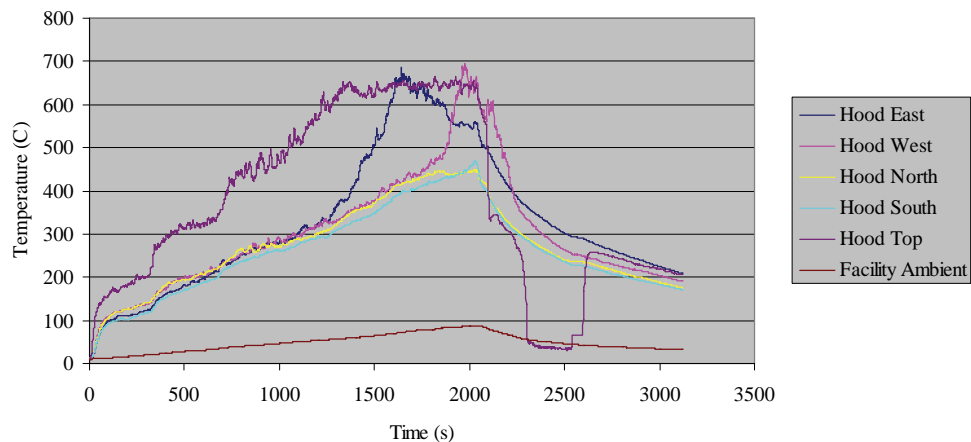
The fuel gas volume flow rate and the corresponding nominal HRR for IT-13 are illustrated in Figure 6.70. The corresponding temperatures measured under the test structure hood are illustrated in Figure 6.71.





**Figure 6.70: Fuel flow rate and nominal HRR for IT-13.**

Note the sharp temperature rises recorded on both the “hood east” and “hood west” TCs at about 1400 s and 1890 s respectively. This was an indication that the fire in the random fill cable trays likely spread to the east and west ends of the cable trays at A&C at these respective times. Post-test examination did reveal that essentially all of the cable insulation and jacket materials in these two trays, as well as the other two cable trays at Locations F&G had, indeed, burned in the fire.

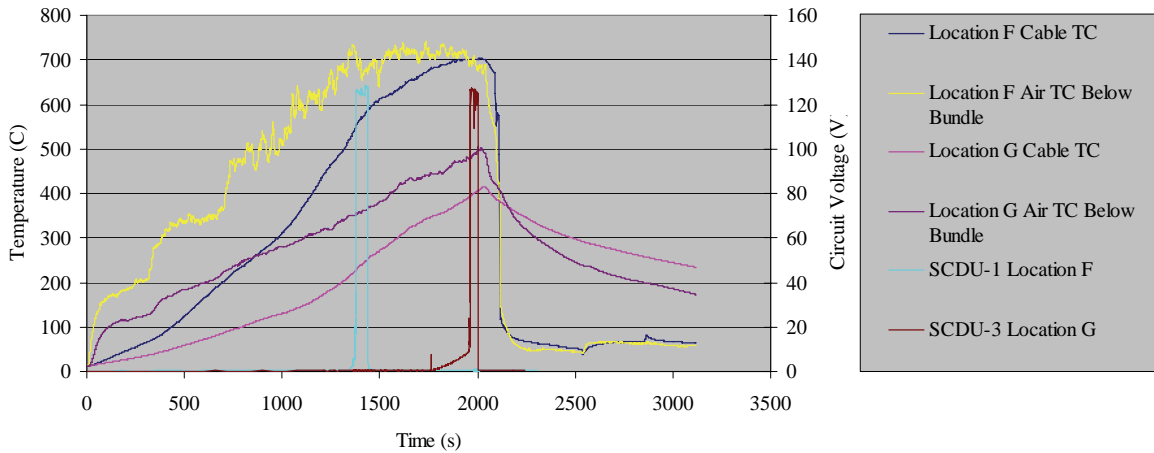


**Figure 6.71: Hood temperatures measured during IT-13.**

Also note that the peak temperatures recorded on the “hood top” TC were actually lower than corresponding temperatures measured in various other tests (about 650°C (1202°F) as compared to in excess of 700°C (1292°F) measured in various other tests). This was taken as an indication that the large mass of cables present may actually have led to oxygen-limited combustion in the upper regions of the test structure’s enclosed hood. Indeed, the technicians did note the smoke volumes leaving the test facility exhaust stack were substantially higher in this test than in other previous tests, included IT-1. The copious smoke production was another indication of poor-efficiency combustion for this test.

Figure 6.72 illustrates the temperature response and electrical performance data for the cable bundles at Locations F&G. Recall that per the test setup discussion above, all of the 6-cable bundles at these

two locations were identical in composition. The data illustrated are for SCDU-1 (Location F) and SCDU-3 (Location G). Both of these SCDUs were connected to XLPE-insulated cables, and the two cables were in the same positions within the cable bundle (i.e., Cable ‘A’ at the peak of the 6-cable bundle). Also shown is the temperature response data for Cable ‘E’ in the corresponding thermal bundles and the air TC just below each thermal bundle. In this case both of the SCDUs experience a spurious actuation failure followed by a fuse blow, and this is illustrated in the figure based on the voltage trace for the impacted target conductor (circuit path 5 in both cases). Note that the effect of the raceway location on cable thermal response and electrical failure was again evident. The cable at Location G failed 584 s or nearly 10 minutes later than did the cable at location F.

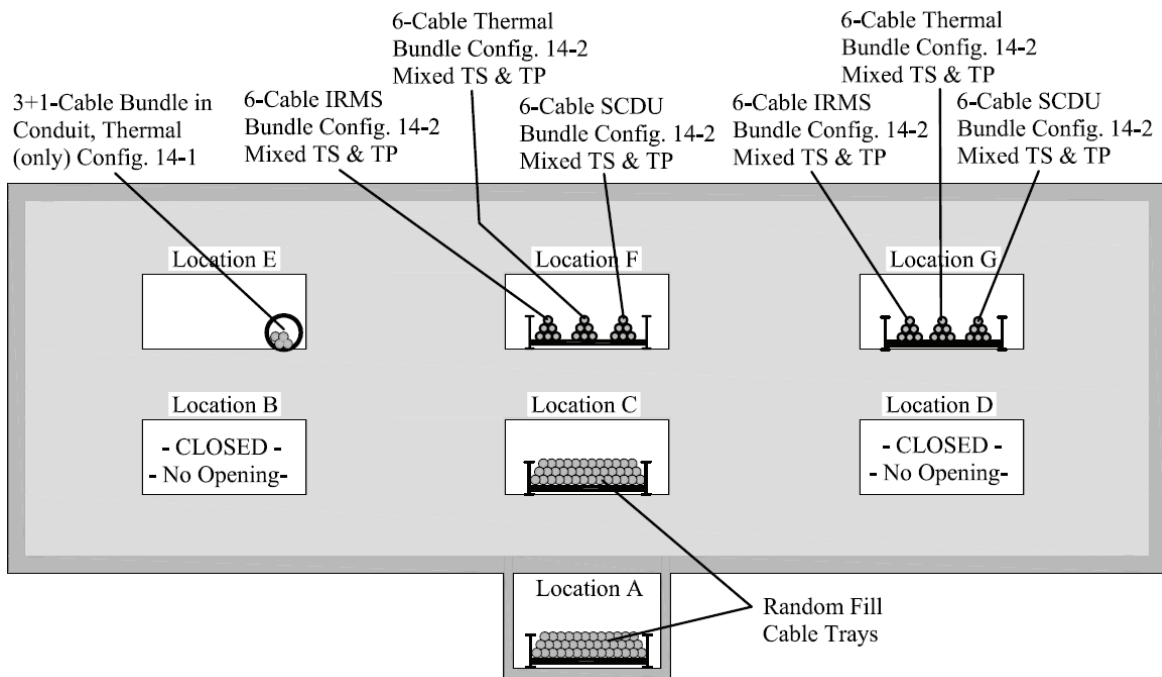


**Figure 6.72: Thermal response and electrical failure data for the cable bundles at Locations F&G during IT-13.**

## 6.17 Test IT-14

### 6.17.1 Test Conditions

IT-14 was similar to IT-13 and the test setup is illustrated in Figure 6.73. Again, random fill cable trays were placed at locations A&C. The main differences were the makeup of the various cable bundles at Location E, F and G.



**Figure 6.73: Test setup for IT-14.**

### Locations A&C:

Random fill cable trays were placed at Location A and Location C. These trays were monitored only for thermal response with three TCs placed as described in Section 3.2.4 above. Note that in this case the TC configuration that has TCs at three locations in the cable mass (rather than 4) was used. The fill for the two trays was the same. The fill was nearly identical to that used for IT-13, except in that the Vita-Link cables were replaced with PVC/PVC cables. The fill was made up of the following combination of cables:

- Random fill composition for IT-14 (both trays A&C):
  - Eight lengths of XLPE/CSPE, 12 AWG, 7/C (Item #10)
  - Eight lengths of EPR/CPE, 12 AWG, 7/C (Item #2)
  - Eight lengths of PE/PVC, 12 AWG, 7/C (Item #15)
  - Eight lengths of XLPE/PVC, 12 AWG, 7/C (Item #3)
  - Eight lengths of TEF/TEF, 12 AWG, 7/C (Item #12)
  - Eight lengths of XLPO/XLPO, 12 AWG, 7/C (Item #8)
  - Eight lengths of PVC/PVC, 12 AWG, 7/C (Item #1)

Note that the cables were all cut to a length of 6' so that only the central portion of each tray was actually filled with cables.

### **Location E:**

For IT-13, a conduit was again placed at Location E. A 3+1-cable bundle (thermal response only) was placed in the conduit. This bundle is referred to as configuration 14-1 and was comprised of the following cables:

- Bundle configuration 14-1:
  - Cable A: PE/PVC, 12 AWG, 7/C (Item #15)
  - Cable B: XLPE/PVC, 12 AWG, 7/C (Item #3)
  - Cable C: PVC/PVC, 12 AWG, 7/C (Item #1)
  - Cable 1 (TC cable): PE/PVC, 12 AWG, 7/C (Item #15)

### **Location F:**

For IT-14 a cable tray was used at Location F. In this case, there were three 6-cable bundles present. These bundles were identical, and the arrangement is referred to as configuration 14-2 and was as follows:

- Bundle configuration 14-2:
  - Cable A: XLPE/CSPE, 12 AWG, 7/C (Item #10)
  - Cable B: EPR/CPE, 12 AWG, 7/C (Item #2)
  - Cable C: PE/PVC, 12 AWG, 7/C (Item #15)
  - Cable D: PVC/PVC, 12 AWG, 7/C (Item #1)
  - Cable E: XLPE/PVC, 12 AWG, 7/C (Item #3)
  - Cable F: TEF/TEF, 12 AWG, 7/C (Item #12)

One bundle was monitored for thermal response. The other two bundles were monitored for electrical performance as follows:

- For one bundle, Cables A (XLPE-insulated), B (EPR-insulated), and C (PE-insulated) were connected to IRMS-1.
- For the second bundle, Cable A (XLPE-insulated) was connected to SCUDU-1 and Cable B (EPR-insulated) was connected to SCUDU-2. Both SCUDUs were in the MOV-1 wiring configuration.

### **Location G:**

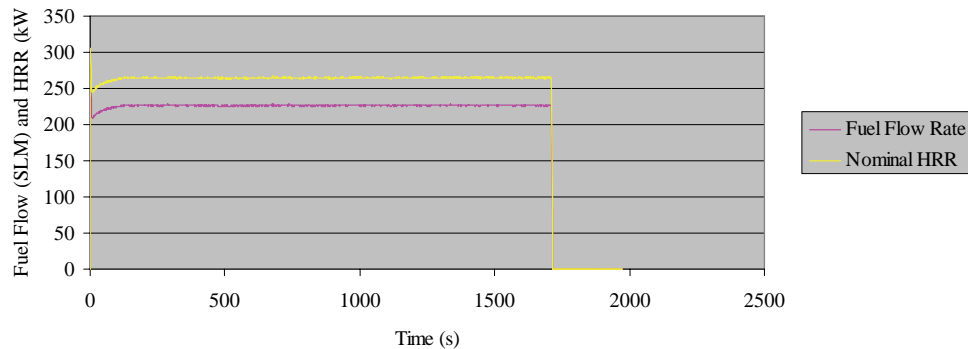
For IT-14, a cable tray was again used at location G. However, in this case there were three (rather than two) 6-cable bundles present. All three bundles were arranged consistent with configuration 13-2 as described above. One bundle was monitored for thermal response. The other two bundles were monitored for electrical performance as follows:

- For one bundle, Cables A (XLPE-insulated), B (EPR-insulated), and C (PE-insulated) were connected to IRMS-2.

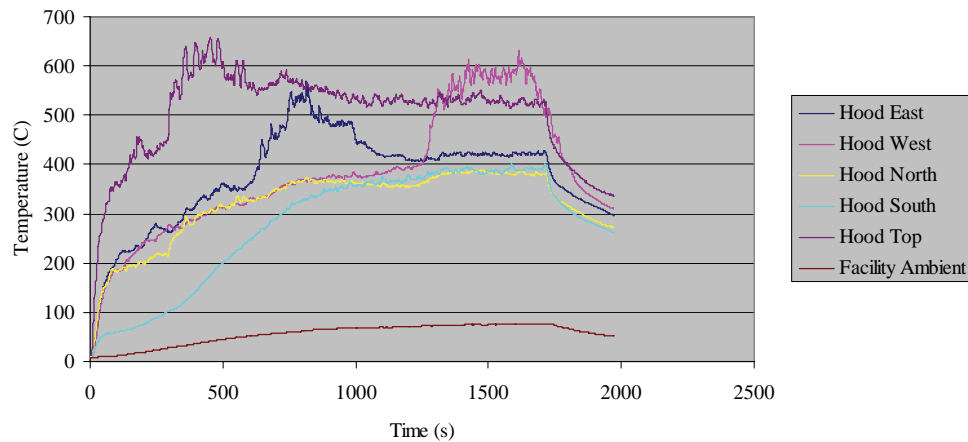
- For the second bundle, Cable A (XLPE-insulated) was connected to SCDU-3 and Cable B (EPR-insulated) was connected to SCDU-4. Both SCDUs were in the MOV-1 wiring configuration.

### 6.17.2 Test Results

The fuel gas volume flow rate and the corresponding nominal HRR for IT-14 are illustrated in Figure 6.74. The corresponding temperatures measured under the test structure hood are illustrated in Figure 6.75.



**Figure 6.74: Fuel flow rate and nominal HRR for IT-14.**

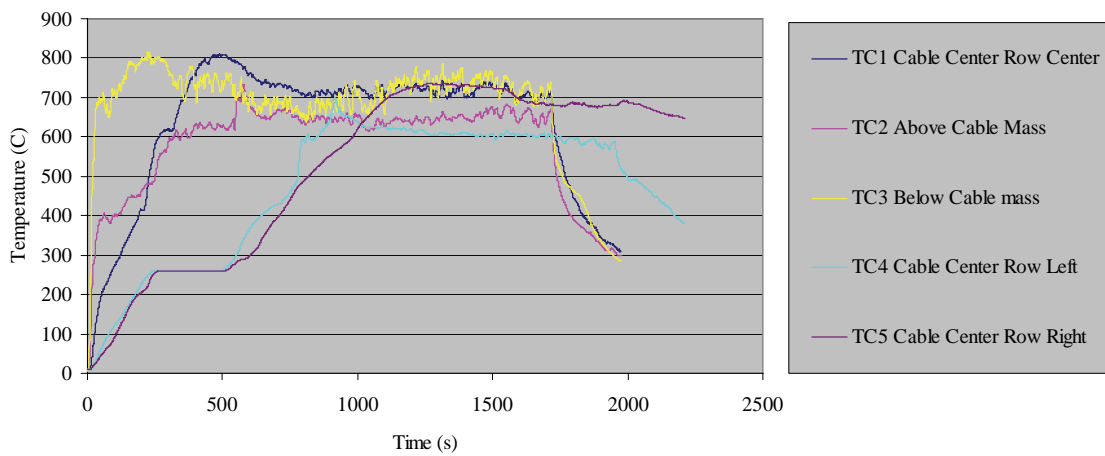


**Figure 6.75: Hood temperatures measured during IT-14.**

Figure 6.76 illustrates the temperatures measured for the random fill cable tray at Location C. As noted previously, all of the cables located directly above the gas burner generally burned during the intermediate-scale tests, and this case was no exception. Note that most of the temperatures fall off quickly after the gas burner was extinguished. However, TC-5 (installed below a cable jacket in the central row of cables vertically and to the right (or south) side of the cable tray) shows evidence of continued combustion beyond this time. It was likely that smoldering combustion in the cable mass

continued for some time after the burner was extinguished. TC-4 (center-left) appears to show similar behavior, but appears to drop off more quickly than did TC-5.

In contrast, based on TC-1 (the ‘center-center’ cable TC) it would appear that the central portion of the cable mass burned within the first 10-12 minutes. Prior to this time, the TC installed in the “center-center” cable exceeds the general air temperatures indicating that the cables were likely burning. After about 10-12 minutes, however, TC1 essentially mirrors the air temperature TCs below the cable mass (TC-3) indicating that the combustion at that particular location had likely stopped. As noted, the fire did continue to spread along the length of the tray, and ultimately, all the cable jacket and insulation materials were consumed in the fire. This was also evident from the behavior of the “hood east” and “hood west” TCs from Figure 6.75 (as has been noted previously).



**Figure 6.76: Temperatures measured in and around the random fill cable tray at Location C.**

## 7 SUMMARY

In the field of fire PRA and other NPP regulatory fire modeling applications, the fire scenarios being analyzed very often involve a fire source whose burning is postulated to cause the failure of electrical cables supporting plant safety equipment. Hence, there is a need for fire modeling tools capable of supporting cable thermal response and electrical failure analyses. Under CAROLFIRE a total of 96 small- and intermediate-scale cable fire tests were completed. The data from these tests are expected to support the development of improved models with reduced uncertainty able to predict cable thermal response and electrical failure under fire exposure conditions. The early stages of the model development work have already been undertaken as documented in Volume 3 of this report.

Under CAROLFIRE, data were collected to characterize both the thermal response and electrical performance of electrical cables under a fairly wide range of fire environments from idealized but very well-characterized conditions (i.e., the Penlight small-scale tests) to rather complex conditions involving actual fires (the intermediate scale tests). Volume 1 of this report has summarized the data and insights gained relative to the electrical performance aspects of the testing. This volume (Volume 2) has provided detailed descriptions of the test conditions and the various data gathering systems deployed in the tests as well as examples highlighting key aspects of the test data. Volume 3 of this report, which was prepared by NIST, documents NIST's efforts to develop an initial cable thermal response and electrical failure model.

All of the data from the CAROLFIRE tests is freely available in the public domain. CD-ROMs containing all of the raw and processed data for all of the tests conducted under CAROLFIRE have been provided as a companion to the printed version of this report. The data are presented in the form of Microsoft Excel® spreadsheets. In addition to the test data, each spreadsheet also provides a summary of the specific test conditions, detailed maps documenting instrument placement, and test event time-lines. In addition, the spreadsheets document the data analysis work conducted as a part of the reporting process and all of the data plots presented in this report.

## 8 REFERENCES

1. *Risk-informed Approach for Post-Fire Safe-Shutdown Circuit Inspections*, Regulatory Issue Summary (RIS) 2004-03, Rev. 1, U.S. NRC, Washington, DC, Dec. 29, 2004.
2. Nowlen, S.P., *An Investigation of the Effects of Thermal Aging on the Fire Damageability of Electric Cables*, NUREG/CR-5546, U.S. NRC, Washington, DC, 1991.
3. ASTM: *Standard Guide for Room Fire Experiments*, Standard E 603-06, ASTM, 100 Barr Harbor Drive, PO Box C700, West Conshohocken, PA 19428-2959, 2006.
4. EPRI: *Characterization of Fire-Induced Circuit Faults – Results of Cable Fire Testing*, TR 1003326, EPRI, Palo Alto, CA, Dec. 2002.
5. ISO: *Fire Tests – Full-Scale Room Test for Surface Products*, Standard 9705:1993(E), ISO, Geneva, Switzerland, 1993 (see ‘Annex A’ for cited material).
6. Nowlen, S.P., *A Summary of Nuclear Power Plant Fire Safety Research at Sandia National Laboratories, 1975-1987*, NUREG/CR-5384, SAND89-1359, U.S. NRC, Dec. 1989.
7. Iqbal, N. and Salley, M.H., *Fire Dynamics Tools (FDT<sup>®</sup>) Quantitative Fire Hazard Analysis Methods for the U.S. Nuclear Regulatory Commission Fire Protection Inspection Program*, U.S. NRC, Washington, DC, NUREG-1805, June 2003.
8. Huggett, C., “Estimation of Rate of Heat Release by Means of Oxygen Consumption Measurements,” *Fire and Materials*, 4, 61-65 (1980).
9. LaChance, J.L., Nowlen, S.P., Wyant, F.J., and Dandini, V.J., *Circuit Analysis - Failure Mode and Likelihood Analysis*, NUREG/CR-6834, SAND2002-1942P, U.S. NRC, Sept. 2003.



NUREG/CR-6931, V2  
SAND2007-600/V2

**BIBLIOGRAPHIC DATA SHEET**  
(See instructions on the reverse)

2. TITLE AND SUBTITLE

Cable Response to Live Fire (CAROLFIRE) Volume 2:  
Cable Fire Response Data for Fire Model Improvement

3. DATE REPORT PUBLISHED

MONTH	YEAR
April	2008

4. FIN OR GRANT NUMBER

USNRC JCN N6125

5. AUTHOR(S)

Steven P. Nowlen and Francis J. Wyant

6. TYPE OF REPORT

Technical

7. PERIOD COVERED (Inclusive Dates)

9/1/2005-9/30/2007

8. PERFORMING ORGANIZATION - NAME AND ADDRESS (If NRC, provide Division, Office or Region, U.S. Nuclear Regulatory Commission, and mailing address; if contractor, provide name and mailing address.)

Sandia National Laboratories  
Risk and Reliability Analysis Department 6761  
PO Box 5800  
Albuquerque, NM 87185

9. SPONSORING ORGANIZATION - NAME AND ADDRESS (If NRC, type "Same as above", if contractor, provide NRC Division, Office or Region, U.S. Nuclear Regulatory Commission, and mailing address.)

Division of Risk Analysis  
Office of Nuclear Regulatory Research  
U.S. Nuclear Regulatory Commission  
Washington, DC 20555

10. SUPPLEMENTARY NOTES

H. Woods, NRC Project Manager

11. ABSTRACT (200 words or less)

This report documents the electrical performance and fire-induced failure cable test results from the Cable Response to Live Fire Project (CAROLFIRE). CAROLFIRE testing included a series of 78 small-scale tests, and a second series of 18 intermediate-scale open burn tests. The tests were designed to address two needs; namely, to provide data supporting (1) resolution of the 'Bin 2' items as identified in Regulatory Issue Summary 2004-03 Revision 1 - Risk informed Approach for Post Fire Safe Shutdown Circuit Inspections and (2) improvements to fire modeling in the area of cable response to fires. In both test series cables were tested as individual lengths of cable, in bundles of from 3 to 12 cables, and in a limited number of tests, fully loaded electrical raceways. Cables were tested in cable trays, in conduits, and in air drop configurations. A broad range of representative cable types were tested including both thermoset and thermoplastic insulated cables that are typical of the cable types and configurations currently used in U.S. nuclear power plants. This volume of the three volume project report focuses on the second need area, namely, the fire modeling improvement. The test data gathered are presented and discussed in this context.

12. KEY WORDS/DESCRIPTORS (List words or phrases that will assist researchers in locating the report.)

Electric cables, cables, fire, cable failure, fire risk, fire PRA, fire PSA post-fire safe shutdown analysis, spurious actuation, spurious operation

13. AVAILABILITY STATEMENT

Unlimited

14. SECURITY CLASSIFICATION

(this page)  
unclassified

this report)  
unclassified

15. NUMBER OF PAGES

16. PRICE



Federal Recycling Program