

# **Clean Coal Reference Plants: Pulverized Coal Boiler With Flue Gas Desulfurization**

**Topical Report  
September 1995**

Work Performed Under Contract No.: DE-AM21-94MC311 66

For  
U.S. Department of Energy  
Office of Fossil Energy  
Morgantown Energy Technology Center  
P.O. Box 880  
Morgantown, West Virginia 26507-0880

By  
Gilbert/Commonwealth, Inc.  
2675 Morgantown Road  
Reading, Pennsylvania 19607

## **Disclaimer**

This report was prepared as an account of work sponsored by an agency of the United States Government. Neither the United States Government nor any agency thereof, nor any of their employees, makes any warranty, express or implied, or assumes any legal liability or responsibility for the accuracy, completeness, or usefulness of any information, apparatus, product, or process disclosed, or represents that its use would not infringe privately owned rights. Reference herein to any specific commercial product, process, or service by trade name, trademark, manufacturer, or otherwise does not necessarily constitute or imply its endorsement, recommendation, or favoring by the United States Government or any agency thereof. The views and opinions of authors expressed herein do not necessarily state or reflect those of the United States Government or any agency thereof.

## ACKNOWLEDGEMENT

This report was prepared by Gilbert/Commonwealth, Inc. (G/C) under US DOE Contract No. DE-AM21-94MC3 1166, with technical direction by the Morgantown Energy Technology Center (METC). The following organizations and individuals' have contributed to the development and preparation of this report:

US DOE METC

Mark D. Freier, PhD.

Gilbert/Commonwealth, Inc.

David F. Becker, P.E.  
Thomas L. Buchanan  
Harvey N. Goldstein, PE  
Lawrence E. Harvey, PE  
Jay S. White

Babcock & Wilcox

Stan Whitney

**CLEAN COAL REFERENCE PLANTS  
PULVERIZED COAL BOILER WITH FLUE GAS DESULFURIZATION  
REFERENCE PLANT  
REPORT TABLE OF CONTENTS**

<u>Section</u>		<u>Page Number</u>
	<b>List of Figures</b>	iv
	<b>List of Tables</b>	vi
	<b>EXECUTIVE SUMMARY</b>	E-1
<b>1.0</b>	<b>INTRODUCTION</b>	<b>1-1</b>
<b>2.0</b>	<b>REFERENCE PLANT TECHNOLOGY SELECTION</b>	<b>2-1</b>
2.1	Reference Plant Steam Generator Selection and Rationale	2-
2.2	Flue Gas Desulfurization Process Selection and Rationale	2-
2.3	Design for Low NO <sub>x</sub> Emissions	2-
2.4	Steam Cycle Considerations	2-
<b>3.0</b>	<b>REFERENCE PLANT DESIGN DESCRIPTION</b>	<b>3-1</b>
3.1	Design Basis	3-
3.1.1	Plant Site and Ambient Design Conditions	3-
3.1.2	Fuel and Sorbent	3-
3.1.3	Design Capacity and Spare Capacity	3-
3.1.4	Plant Life	3-
3.1.5	Plant Availability and Capacity Factor	3-
3.1.6	Maturity of Plant Technology	3-
3.1.7	Steam Conditions	3-
3.1.8	insulation and Lagging	3-
3.1.9	Preheating	3-
3.1.10	Modes of Operation	3-
3.1.11	Control Systems	3-
3.1.12	Plant Services	3-
3.1.13	Structures and Foundations	3-
3.1.14	Heat Recovery	3-
3.1.15	Codes and Standards	3-
3.2	Heat and Mass Balance	3-
3.3	Environmental Standards	3-
3.3.1	Air Quality Standards	3-
3.3.2	Water Quality Standards	3-
3.3.3	Solid Waste Disposal	3-
3.3.4	Noise	3-
3.4	Description of Steam Generation Systems	3-
3.4.1	Steam Generator and Ancillary Equipment	3-
3.4.2	Coal Handling System	3-
3.4.3	Limestone Handling and Reagent Preparation System	3-
3.4.4	Flue Gas Desulfurization	3-
3.4.5	Byproduct Dewatering	3-
3.4.6	Ash Handling System	3-

## REPORT TABLE OF CONTENTS (Continued)

<u>Section</u>		<u>Page Number</u>
3.5	Balance of Plant	3-
3.5.1	Turbine Generator and Auxiliaries	3-
3.5.2	Condensate and Feedwater Systems	3-
3.5.3	Main, Reheat, and Extraction Steam Systems	3-
3.5.4	Circulating Water System	3-
3.5.5	Miscellaneous BOP Systems	3-
3.5.6	Piping and Valves	3-
3.6	Plant Control and Monitoring Systems	3-
3.6.1	Design Basis	3-
3.6.2	Control Room	3-
3.6.3	Automation and Operation	3-
3.6.4	Data Gathering, Reduction and Retrieval	3-
3.6.5	Continuous Emission Monitoring System	3-
3.6.6	Start-Up Testing and Tuning	3-
3.7	Layout Arrangement	3-
3.7.1	Assumptions	3-
3.7.2	Overall Site Plan	3-
3.7.3	Power Block - Plan	3-
3.7.4	Power Island Cross Section	3-
<b>4.0</b>	<b>REFERENCE PLANT ECONOMIC ANALYSIS</b>	<b>4-1</b>
4.1	Methodology	4-
4.2	Capital Costs	4-
4.2.1	Bare Erected Cost	4-
4.2.2	Total Plant Cost (TPC)	4-
4.2.3	Capital Cost Estimate Exclusions	4-
4.3	Operating Costs and Expenses	4-
4.3.1	Operating Labor	4-
4.3.2	Maintenance	4-
4.3.3	Consumables	4-
4.4	Cost of Electricity (COE)	4-
<b>5.0</b>	<b>CONCLUSIONS AND RECOMMENDATIONS</b>	<b>5-1</b>
<b>6.0</b>	<b>REFERENCES</b>	<b>6-1</b>
<b>7.0</b>	<b>BIBLIOGRAPHY</b>	<b>7-1</b>

**APPENDIX A - Reference Plant Major Equipment List**

**APPENDIX B - Total Plant Cost - Detail**

## LIST OF FIGURES

<b><u>Figure</u></b>		<b><u>Page Number</u></b>
3-1	Reference Plant - Heat and Mass Balance - 100%	3-
3-2	Reference Plant - Heat and Mass Balance - VWO, 59'6 O.P.	3-
3-3	Typical Boiler Cross Section	3-
3-4	Air and Gas Flow Schematic	3-
3-5	Steam/Water Flow Schematic	3-
3-6	Low NO <sub>x</sub> Burner Cross-Section	3-
3-7	Low NO <sub>x</sub> Burner Combustion Zones	3-
3-8	Roll and Race Type Pulverizer Cutaway View	3-
3-9	Roll and Race Pulverizer Cross Section	3-
3-10	Sootblower Locations	3-
3-11	Coal Handling System Flow Diagram	3-
3-12	Limestone Handling and Reagent Prep, System Flow Diagram	3-
3-13	Flue Gas Desulfurization System Flow Diagram	3-
3-14	Scrubber Module Cross Section	3-
3-15	Byproduct Dewatering System Flow Diagram	3-
3-16	Ash Handling System Flow Diagram	3-
3-17	Main, Reheat and Extraction Steam System Flow Diagram	3-
3-18	Condensate, Feedwater and Circulating Water System Flow Diagram	3-
3-19	Site Plan	3-
3-20	Plant General Arrangement	3-
3-21	Turbine Building Plan	3-
3-22	Boiler Plan	3-
3-23	Precipitator Area Plan	3-
3-24	Flue Gas Desulfurization Area Plan	3-
3-25	Dewatering Building Plans	3-
3-26	Dewatering Building Sections	3-
3-27	Plant Longitudinal Section	3-

## LIST OF TABLES

<u>Table</u>		<u>Page Number</u>
3-1	Pittsburgh No. 8 Coal Analysis	3-
3-2	Greer Limestone Analysis	3-
3-3	Typical Design Codes and Standards	3-
3-4	Plant Performance Summary -100 Percent Load	3-
3-5	Plant Performance Summary - VWO, 5% O.P.	3-
3-6	Applicable Environmental Regulations	3-
3-7	Pulverized Coal Fired Boiler Reference Plant Emissions	3-
4-1	Code of Direct Accounts Summary	4-
4-2	Total Plant Cost	4-
4-3	Operating Labor Requirements	4-
4-4	Maintenance Factors	4-
4-5	Consumables, By-Products and Fuels Data	4-
4-6	Estimate Basis/Financial Criteria for Revenue Requirement Calc.	4-
4-7	Capital Investment and Revenue Requirements Summary	4-
5-1	PC Plant Economic Summary	5-
5-2	Economic Assumption Comparison	5-

## EXECUTIVE SUMMARY

The Clean Coal Technology Demonstration Program is a government and industry cofunded technology development effort to demonstrate a new generation of innovative coal utilization processes in a series of full-scale facilities. The goal of the program is to provide the U.S. energy marketplace with a number of advanced, more efficient and environmentally responsive coal-using technologies.

The Morgantown Energy Technology Center (METC) has the responsibility for monitoring the CCT Projects within certain technology categories, which correspond to the center's areas of technology development. These categories include atmospheric **fluidized** bed combustion, pressurized **fluidized** bed combustion, integrated gasification combined cycle, mild gasification, and industrial applications.

A measure of success in the CCT program will be the commercial acceptance of the new technologies being demonstrated. The dissemination of project information to potential users is being accomplished by producing a series of reference plant designs which will provide the users a basis for the selection of technologies applicable to their future energy requirements.

As a part of DOE's monitoring and evaluation of the CCT Projects, Gilbert/Commonwealth (G/C) has been contracted to assist in this effort by producing the design of a commercial size Reference Plant, utilizing technologies developed in the CCT Program. This report, the second in a series, describes the design of a 400 MW electric power plant, utilizing a current state of the art, pulverized coal fired boiler supplying steam to a steam turbine generator, with flue gas cleanup accomplished by wet scrubbing using limestone as a sorbent material.

The intent of the reference plant design effort was to portray a commercial power plant with attributes considered important to the utility industry. The design used for the Reference Plant is based on commercially available components from established vendors with recent sales in the U.S. utility market. This Reference Fossil Plant provides a commercially sound basis for comparison with the plants based on other **clean** coal technologies in this series.

The nominal size of the Reference Plant is 400 MWe, net output, which is comprised of one 100% capacity turbine generator and one 100% capacity boiler. The flue gas particulate removal and **desulphurization** system utilizes two 50 percent capacity components for items such as fans, and precipitators, and three 50 percent capacity scrubber modules to enhance plant availability.

Section 3 provides a detailed description of the Reference Plant. Heat balances are shown as well as system diagrams for the major systems and plant layouts showing equipment arrangements. An equipment list is contained in the Appendix A.

To provide uniformity in comparisons of Clean Coal Technologies, a consistent design basis was applied, including the following factors:

- Plant Site and Ambient Design Conditions
- Fuel and Sorbent Characteristics
- Plant Capacity and Design Life
- Plant Availability, Approach to Redundancy



- Mature Plant Technology
- Design Steam Conditions
- Approach to Insulation and Lagging
- Preheating/Start-up Requirements
- Modes of Operation, Turndown, Minimum Load
- Control System Design Approach
- Plant Services Requirements
- Structures and Foundations, Soil Bearing Loads
- Heat Recovery Approach
- Applicable Codes and Standards

### Reference Plant Design

The Reference Pulverized Coal (PC) Plant design utilizes a balanced draft, natural circulation type, pulverized coal fired boiler. The boiler design and performance reflect current commercial practice in the U.S. utility industry,

The flue gas scrubber is a wet limestone type system, with scrubbing and **demisting** occurring in the same vessel. An organic acid is added to the circulating reagent to enhance scrubbing performance. Air is blown into the scrubber module sump to promote forced oxidation of the sulfite to sulfate, The gypsum byproduct is dried to a cake-like consistency in a train of centrifuges, and is ready for **landfilling**.

The Reference PC Plant is designed to meet applicable Federal, State, and Local environmental standards relating to air, water, solid waste and noise. A calcium-in-the-limestone to **sulfur-in-the-coal** ratio of 2.5 to 1 ensures an **SO<sub>2</sub>** emission rate of less than 0,371 lb/10' Btu (92% reduction). The use of **low NO<sub>x</sub>** burner **technology**, combined with overfire air, results in **NO<sub>x</sub>** emissions of less than 0,30 lb/10' Btu. Air quality regulations concerning other compounds such as CO, CO<sub>2</sub> and air **toxics** now being considered may have an effect on the design of plants in the time frame being considered here, However, details of the end results of these considerations are not clear at the present time and are not included in this report. The control or reduction of **N<sub>2</sub>O** has not been addressed in this design because **N<sub>2</sub>O** levels are presently unregulated.

The turbine-generator is a tandum compound machine, with high pressure (HP), intermediate pressure (1P), and low pressure (**LP**) sections, The LP turbine is comprised of two double flow sections exhausting downward into two condenser sections.

The Reference Plant uses a 2400 **psig/1000° F/1 000° F** single reheat steam power cycle. The boiler and turbine are designed for a main steam flow of 2,734,000 **lbs** of steam per hour at 2520 psig and 1000° F at the superheater outlet, throttled to 2415 psia at the inlet to the high pressure turbine. The cold reheat flow is 2,425,653 lb/h of steam at 604 psia and **635° F**, which is reheated to 1000° F before entering the intermediate pressure turbine section. The net plant output power, after plant auxiliary power requirements are deducted, is nominally 401 MWe. The overall net plant (**HHV**) efficiency is nominally 38.5 percent,

The plant is designed to produce additional power output at a combined 5 percent overpressure, valves wide open condition (**5% OP/VWO**). At this combined condition, plant net output is

436 MWe with an efficiency of 38,7 percent. This combined condition is expected to be used on relatively infrequent occasions, to support severe sustained demand conditions.

Economic Analysis

Following the design of the PC Reference Plant, an economic analysis was performed to provide capital and O&M costs. Section 4.0 contains this analysis and Appendix C has second level cost details. A brief summary of the costs in December 1994 dollars, is given below:

	<u>\$ x 1000</u>	<u>\$/kW</u>
Total Capital Requirement	515,576	1,285
Fixed O&M (1st year)	33.54	\$/kW-yr
Variable O&M (1st year)	3.17	mills/kWh
Total consumables (1st year)	6,147	2.69
Fuel cost (1st year)	32,362	14.17
Levelized Busbar Cost of Power	74.2	mills/kWh

The PC fired plant, described herein, can be compared to the other Reference Plants in this series of reports even though the plant sizes may vary somewhat. Both the Pressurized Fluidized Bed Combustor Reference Plant and the Atmospheric Circulating Fluidized Bed Reference Plant are close enough in size for direct comparison on a cost per kW hr. basis.

Conclusions

The Pulverized Coal Reference Plant described herein represents current U.S. electric utility practice for a subcritical pressure design suitable for base loading. The economic parameters characterizing this design may be used as a point of reference for comparison with other Clean Coal Technologies. Many design options available to increase efficiency, (such as a supercritical cycle), or to decrease emissions, (such as Selective Catalytic Reduction), are applicable to the other technologies in the Clean Coal Reference series. The economic and emission related effects of each design option may be applied on an individual basis to a specific candidate technology/site combination, to determine its desirability.

Users of this report and others in this series should apply adjustments to the technical factors as well as the economic parameters to suit their own circumstances and expectations. This report, and others in this series, will provide a well defined point of reference for each technology, to facilitate informed and soundly based comparisons and decisions.

## 1.0 INTRODUCTION

The Clean Coal Technology Demonstration Program (CCT) is a government and industry cofunded technology development effort to demonstrate a new generation of innovative coal utilization processes in a series of full-scale facilities. The goal of the program is to provide the U.S. energy marketplace with a number of advanced, more efficient, and environmentally responsive coal-using technologies. To achieve this goal, a multiphased effort consisting of five separate solicitations has been completed.

The Morgantown Energy Technology Center (METC) has the responsibility for monitoring the CCT Projects within certain technology categories, which, in general, correspond to the center's areas of technology development. Primarily the categories of METC CCT projects are: atmospheric fluid bed combustion, pressurized fluidized bed combustion, integrated gasification combined cycle, mild gasification, and industrial applications.

A measure of success in the CCT Program will be the commercial acceptance of the new technologies being demonstrated. In order to achieve this commercial acceptance it is necessary to provide the potential technology users with project information in a format which allows the technology users to translate the results from the demonstration project to their particular circumstances,

DOE is monitoring project performance and evaluating project operating results. Based on this data, technology vendor input, and in-house expertise, Gilbert/Commonwealth, Inc., was contracted by DOE/METC to assist in this effort, and has developed a 400 MWe Pulverized Coal Reference Plant with Flue Gas Desulphurization design. This Reference Plant design will be comparable with other reference plants. One objective of this work is to produce a series of reference plant designs which will enable the end user to compare and select the technologies to be applied to meet future energy requirements,

This report describes the results of the effort to design a mature, commercial power plant utilizing current state of the art technology and commercially available components. This design will serve as a reference for comparison to other, emerging technologies. The plant design and cost estimate provided are of sufficient detail to allow potential technology users to adjust the results to their specific conditions. This report, and others in this series, will provide a well defined point of reference for each technology, to facilitate informed and soundly based comparisons and decisions,

## 2.0 REFERENCE PLANT TECHNOLOGY APPLICATION

The current state of the art for pulverized coal (PC) fired electric utility generating plants has developed for over a century. Over the last two and one-half decades, environmental protection requirements imposed by legislation and public demand have become progressively more stringent. In response, a variety of technological enhancements have been introduced and applied to the design of the PC fired boiler to clean up the atmospheric discharges and assure compliance with the law. For this report, the selection of an illustrative example for a PC fired boiler, and air pollution control techniques required for environmental compliance, was made based on the ready availability of information from current commercial applications. The specific rationale is discussed for each topic in the following subsections.

In addition to air pollution control technology applications, other design aspects of the PC Reference Plant were also based on current practice, with additional consideration given to maintaining consistency, where applicable, to the AFB Reference Plant described in the first report issued in this series,

## 2.1 REFERENCE PLANT STEAM GENERATOR SELECTION AND RATIONALE

The pulverized coal fired utility boiler has been refined and developed over a long period of time into the highly efficient and sophisticated equipment available in the commercial market today. In the U.S., three major vendors dominate the marketplace. Their products share many design features, and match performance in a highly competitive manner. The selection of a particular Babcock & Wilcox boiler for the purposes of illustration in this report was based on the availability of current technical and dimensional information.

For a nominal 400 MWe size, PC fired, subcritical unit, a natural circulation type boiler is offered by Babcock & Wilcox and by Foster-Wheeler. Both units are wall fired, with arrays of burners on each of two opposing walls of the furnace. Water circulation occurs by natural circulation induced by thermal (density) gradients. The type of coal to be fired influences numerous design features and parameters, especially regarding the furnace bottom, ash collection and disposal, soot blowing provisions, and tube spacing.

An alternative to the natural circulation, wall fired unit is offered by Combustion Engineering, Inc. (CE). The comparable CE unit in terms of size, pressure, and fuel type, utilizes canned pumps which provide forced circulation of feedwater through the boiler's water passages. (CE also offers natural circulation type boilers up to a certain size.)

Another distinguishing feature is the arrangement of burners in relation to the furnace. CE offers a tangential firing arrangement, wherein the burners are mounted near the corners of the furnace. The fuel and combustion air are introduced into the furnace from four corners, with the flow axes offset from the furnace center. The net effect is to produce a highly turbulent **cyclonic** region near the center of the furnace. The fuel and air nozzles maybe tilted to control flame position within the boiler, which in turn influences steam temperatures in the superheater and reheater sections,

## 2.2 FLUE GAS **DESULFURIZATION** PROCESS SELECTION AND **RATIONALE**

The selection of a Flue Gas **Desulfurization (FGD)** process for the Reference Fossil Plant was based on the following factors.

1. Availability of data and information from current in-house design efforts.
2. Industry ordering trends,
3. Demonstrated performance capability with respect to current Clean Air Act amendment requirements for a new unit.
4. Incorporation of design and/or operating enhancements is limited to those believed to be required to meet the performance requirements established for the Reference Plant. Potential additional enhancements or design features are briefly discussed in this section; application is considered to be project-specific.

The FGD process selected for this Reference Plant (Pulverized Coal Fired Boiler, Pittsburgh No. 8 Coal) utilizes a wet limestone based scrubber, with forced oxidation of the sulfite to sulfate in the absorber module sump, The sulfate is dewatered by centrifuging to produce a dry cake byproduct (gypsum) suitable for disposal to a landfill. The Reference Plant FGD System is described in detail in Section 3.4 of this document.

The FGD system chemistry design parameters are predicated on the addition of an organic acid to the recirculating reagent. The acid provides buffering capability for the reagent pH, thereby maintaining good balance between  $\text{SO}_2$  absorption and limestone volatility.

The FGD system described herein operates with a “wet stack (saturated flue gas conditions). Duct and flue materials are selected to withstand the corrosive conditions inherent in this mode of operation; the thermodynamic penalty of flue gas reheat is avoided. The decision to use a wet stack was based on a review of FGD installations made in recent years, especially as a result of Phase I of the Acid Rain Control program under the Clean Air Act. A very large portion of these plants have wet stacks, which result in an economic gain to either or both the plant capital cost and operating cost. The wet stack appears to be acceptable to both the environmental permit authorities and the utility industry, and hence has been included in this plant design.

The use of lime, or Mg-enhanced lime as a sorbent, represent other sorbent choices for the wet scrubber, The Mg-enhanced system offers the potential of achieving higher  $\text{SO}_2$  removal rates (up to 98%) while reducing the size of the absorber vessel. However, an increase in operating costs would be incurred, The Reference Plant FGD system does not require enhanced performance levels to meet the target emission levels and therefore this enhancement was not selected. A nominal design value of 92%  $\text{SO}_2$  removal was selected for this study.

## 2.3 DESIGN FOR LOW **NO<sub>x</sub>** EMISSIONS

The control of **NO<sub>x</sub>** production in the boiler furnace depends on the precise manner in which the fuel is **devolatilized** and burned in the furnace. Minimization of **NO<sub>x</sub>** production relies on the following techniques, which may be utilized separately or in combination.

1. Low  $\text{NO}_x$  Burners - produce a fuel rich zone in the core or center of the flame. Secondary air is introduced to the flame at particular locations to maintain a progressive arrangement of zones in the flame that inhibit formation of  $\text{NO}_x$ , decompose it, and allow the carbon (char) reactions to proceed to completion.
2. Air Overfiring - introduces additional air above the flame zone (by a separate array of ports located above the top row of burners). The overfire air (OFA) is introduced into the furnace at specific locations, determined by numerical modeling and testing, that affect the progression of combustion reactions to inhibit the formation of NO and  $\text{NO}_2$ . The OFA ports are provided with control dampers to regulate the flow so that optimum  $\text{NO}_x$  reduction is achieved over the load range.
3. Flue Gas Recirculation - Reduces the amount of  $\text{O}_2$  available to react with nitrogen and reduces flame temperature.  $\text{NO}_x$  producing reactions have slower kinetics than carbon and hydrogen oxidation reactions; at lower temperatures the NO, reactions are retarded and  $\text{NO}_x$  production is limited.
4. Selective Catalytic Reduction (SCR) - Relies on a catalyst such as vanadium pentoxide ( $\text{V}_2\text{O}_5$ ) or titanium dioxide ( $\text{TiO}_2$ ) arranged in a fixed bed. A nitrogen bearing compound such as ammonia or urea is introduced into the exhaust gas from the boiler, downstream of the economizer (other locations are possible, depending on gas temperature, dust loading, etc.). The ammonia bearing exhaust gas then passes over the catalyst bed, where NO, formed in the combustion process is reformed to  $\text{N}_2$  and  $\text{H}_2\text{O}$ . The gas then passes through the air heater, electrostatic precipitator, ID fan, FGD system, and stack.
5. Selective Non-Catalytic Reduction - This process utilizes the injection of a nitrogen bearing substance such as urea or ammonia into the furnace at a particular location with respect to the flame zones to reduce NO, to  $\text{N}_2$  and  $\text{H}_2\text{O}$  without the use of a catalyst.

Summary - the SCR or SNCR process is not employed in the reference PC unit described in Chapter 3 of this report. Provision of low  $\text{NO}_x$  burners and overfire air ports will control NO, to less than 0.3 lb/106 Btu in the type of boiler selected for the reference design. This is within the limits established for this study. For sites that require lower limits on  $\text{NO}_x$  emissions, SCR and/or SNCR are options with reasonably well defined performance and cost parameters. Either of these approaches may be added on to the basic plant defined herein, as required.

## 2.4 STEAM CYCLE CONSIDERATIONS

Design of a PC fired electric generating station presents the designer with a number of choices regarding the configuration of the steam power cycle and the materials of construction for piping, valves and components. The reference fossil plant described in Section 3 of this report is based on maintaining consistency with the Atmospheric Fluidized Bed unit described in the first volume in the Clean Coal Technology Series, and utilizes input from current fossil plant design activities. Several significant steam-power cycle configuration and material issues are discussed below,

## 1. Main Steam Throttle Pressure and Temperature

The selection of 2400 psig/1000°F for main steam, and single reheat to 1000°F, is based on the wide acceptance enjoyed by this set of design parameters in fossil plant applications. The subcritical pressure reduces initial capital costs relative to those required for a **supercritical** unit, at some penalty in cycle efficiency. Temperature cycling due to unit startups and shutdowns is more readily tolerated due to use of reduced wall thicknesses in major pressure retaining parts (HP turbine casings, main steam piping, etc.). Condensate/Feedwater chemistry requirements are somewhat less stringent for a subcritical unit, as dissolved solids, for the most part, remain in the liquid phase and are removed from the system by blowdown.

The selection of 1000° F as operating temperature for main steam and reheat is based on a long history of application in fossil steam cycles. This temperature permits utilization of proven materials of construction **with** reasonable wall thicknesses. (See discussion below re: Materials of Construction).

The use of single reheat reflects current prevailing practice, with penalty in **cycle efficiency** accepted in exchange for reduced capital costs and system complexity.

## 2. Materials of Construction

The most commonly used materials of construction for piping and valves at 1000° F steam temperature are the low alloy steels in the 2-1/4% chromium -170 molybdenum series (ASTM A335 Gr. P22) and **austenitic** stainless steel in the Type 316 series (typically ASTM A376 Type 316 and 316N). The austenitic stainless steel possesses a significantly higher allowable design stress value at the design temperature of 1000°F than the Cr-Mo P-22 material, in accordance with the ANSI B3. 1 Power Piping Code.

Design allowable stress values are 17400 psi for Type 316N **austenitic** stainless steel (for welded systems only; flanged systems are permitted a substantially lower value) and 7800 psi for the **chrome-moly** steel. The stainless steel piping and valves will have a significantly reduced wall thickness compared to the chrome-moly components. This reduction in wall thickness results in lower costs for supports and lower reaction loads on nozzles. However, unit material costs are significantly higher for the stainless steel.

Determination of optimum material selection is best achieved by a detailed comparative cost study based on a reasonably definitive design, including physical **pipe routings** validated by **preliminary** thermal and dead weight stress analyses. This type of effort is beyond the scope of this conceptual design report.

For the purposes of this report, P-22 **Cr-Mo** material was selected as the reference material. This is a widely accepted choice, and it is consistent with the design and costing basis for the AFB reference design.

## 3. Cycle Configuration - Number of Feedwater Heaters

The feedwater heating arrangement used for the reference design, consisting of four stages of low pressure units, a **deaerating** heater, and two stages of high pressure units, is

typical for base loaded fossil fired central station design. For plants **designed** for cycling or load following duty, one or more stages of feedwater heating is sometimes eliminated. This reduces cycle efficiency but also reduces capital costs.

The use of a **deaerating** direct contact type heater with storage tank in the cycle provides several advantages. The deaerator assists in maintaining low levels of dissolved oxygen in the feedwater, while the storage tank provides an enhanced ability to tolerate certain transients, such as trip of a condensate pump. Cascading of HP heater drains to the **deaerator**, and LP drains to the condenser, eliminates the need for heater drain pumps for forwarding of heater drains, typically a difficult type of service for the pumps and controls, as the water is at saturated conditions.

#### 4. Condenser Configuration, Cooling System Design Parameters

Several choices confront a steam cycle power plant regarding the turbine steam condenser. One significant area of design involves the arrangement of condenser tubes and circulating water circuits with respect to the LP turbine exhausts, The type of arrangement selected depends on the turbine configuration and size, and in turn, affects cycle power output and efficiency, The reference plant described in Section 3 of this document utilizes a dual pressure design with transverse tubes (relative to the turbine shaft). The circulating water circuits are divided into two parallel paths, each of half capacity. The selection of a dual pressure for condensing is logical for this size and type of power plant; however, it is inconsistent with the **AFB** design. The change was made to provide a more economical plant design.

The selection of temperature rise across the condenser in the cooling water circuit of 22°F was based on a recent application for a PC unit of this size. Typically, for a temperature rise of ~22°F, a net benefit accrues if the condenser is divided into two separate pressure regions, one associated with each LP turbine housing, The relationship of net power produced by the Turbine-Generator (T-G) versus **backpressure** is somewhat non-linear; the use of two distinct pressures results in greater overall generation than does selection of a single pressure. The additional power produced by the lower back pressure portion of the T-G more than offsets the loss in the higher pressure portion, both relative to an average single pressure.

Selection of condenser temperature rise, condensing pressure configuration, terminal temperature difference in the condenser, and cooling tower design parameters (selection of design values of ambient wet bulb temperature and approach to the wet bulb) are normally investigated in a comprehensive optimization study. This study accounts for capital costs of equipment, energy costs associated with circulating water system pumps and fans, and also incorporates generation output influences of **backpressure**. This type of study is beyond the scope of this Reference Plant design report. However, reasonable values for the above noted parameters have been selected based on design experience.

#### 5. Blowdown Heat Recovery

Boiler blowdown consists of relatively high energy fluid; typically saturated water at the design pressure. Drum type boilers typically utilize a steady state blowdown flow equivalent to approximately 0.5% of feedwater flow, Recovery of a significant part of this



energy is possible by inclusion of a flash tank venting steam to a point in the steam cycle, typically the **deaerator**. The flash tank drains flow can be dumped to the condenser (if a full flow condensate demineralize is provided) or disposed of with other waste streams. Heat **recovery** from the drains flow is usually beneficial and is accomplished by exchanging heat with a side stream of condensate.

This Reference Design does not incorporate heat recovery from the blowdown either by a flash tank or a heat exchanger. The net affect is a decrease of one or two tenths of a percent in overall **cycle** efficiency relative to the case with heat recovery. The heat balance presented in this report is consistent with the **AFB** design, and reflects a focus on more significant items, along with a desire to simplify items not involved in the differences between the various Clean Coal Technologies,

### 3.0 REFERENCE PLANT DESIGN DESCRIPTION

The Reference Plant Design is based on current state of the art technology deployed in recently designed pulverized coal burning power plants, and is described in this section.

#### 3.1 DESIGN BASIS

The plant design basis has a significant influence on equipment selection, plant construction and operation, and resulting capital and operating costs. The following sections describe the basis which has been established for this plant.

##### 3.1.1 Plant Site and Ambient Design Conditions

The plant site is assumed to be in the Ohio River Valley of western Pennsylvania/eastern Ohio/northern West Virginia. The site consists of approximately 300 usable acres (not including ash disposal) within 15 miles of a medium sized metropolitan area, with a well-established infrastructure capable of supporting the required construction work force. The area immediately surrounding the site has a mixture of agricultural and light industrial uses. The site is served by a river of adequate quantity for use as makeup cooling water with minimal pretreatment and for the receipt of cooling system blowdown discharges.

A railroad line suitable for unit coal trains passes within 2-1/2 miles of the site boundary. The site is served by a well developed road network capable of carrying AASHTO H-20 S-16 loads and with overhead restriction of not less than 16 ft (Interstate Standard).

The site is on relatively flat land with a maximum difference in elevation within the site of about 30 ft. The topography of the area surrounding the site is rolling hills with elevations within 2000 yards not more than 300 feet above the site elevation.

The site is within Seismic Zone 1, as defined by the Uniform Building Code, and the ambient design conditions will be:

- Pressure 14.4 psia
- Dry bulb temperature 60°F
- Dry bulb temperature range (-) 10 to (+) 110°F
- Wet bulb temperature 52°F

A sufficient number of well-trained construction laborers are available within a 50-mile radius of the site. Labor conditions are such that a "Project Work Agreement" can be obtained from labor organizations and contractors,

All commodities of bulk construction material are available locally and can be delivered within a reasonable period of time.

##### 3.1.2 Fuel and Sorbent

Plant performance will be based on the Pittsburgh coal and Greer limestone compositions and data listed in Tables 3-1 and 3-2. No. 2 fuel oil will be used for unit start-up.

**Table 3.1  
PITTSBURGH NO. 8 COAL ANALYSIS**

<u>Constituent</u>	<u>Air Dry. %</u>	<u>Dry. %</u>	<u>As Received. %</u>
Carbon	71.88	73.79	69.36
Hydrogen	4.97	4.81	5.18
Nitrogen	1.26	1.29	1.22
Sulfur	2.99	3.07	2.89
Ash	10.30	10.57	9.94
Oxygen	<u>8.60</u>	<u>6.47</u>	<u>11.41</u>
Total	100.00	100.00	100.00
		<u>Dry Basis. %</u>	<u>As Received. %</u>
Moisture		--	6.00
Ash		10.57	9.94
Volatile Matter		38.20	35.91
Fixed Carbon		<u>51.23</u>	<u>48.15</u>
Total		100.00	100.00
Sulfur		3.07	2.89
Btu Content		13,244	12,450
Moisture and Ash Free (W), Btu		14,810	
		<u>Ash Analysis. %</u>	
Silica, SiO <sub>2</sub>		48.1	
Aluminum Oxide, Al <sub>2</sub> O <sub>3</sub>		22.3	
Iron Oxide, Fe <sub>2</sub> O <sub>3</sub>		24.2	
Titanium Dioxide, TiO <sub>2</sub>		1.3	
Calcium Oxide, MgO		1.3	
Magnesium Oxide, MgO		0.6	
Sodium Oxide, Na <sub>2</sub> O		0.3	
Potassium Oxide, K <sub>2</sub> O		1.5	
Sulfur Trioxide, SO <sub>3</sub>		0.8	
Phosphorous Pentoxide, P <sub>2</sub> O <sub>5</sub>		<u>0.1</u>	
Total		100.5	
		<u>Ash Fusion Temperature, °F</u>	
		<u>Reducing Atmosphere</u>	<u>Oxidizing Atmosphere</u>
Initial Deformation		2015	2570
Spherical		2135	2614
Hemispherical		2225	2628
Fluid		2450	2685

**Table 3.2**  
**GREER LIMESTONE ANALYSIS**

	<u>Dry Basis, %</u>
Calcium Carbonate, CaCO <sub>3</sub>	80.4
Magnesium Carbonate, MgCO <sub>3</sub>	3.5
Silica, SiO <sub>2</sub>	10.32
Aluminum Oxide, Al <sub>2</sub> O <sub>3</sub>	3.16
Iron Oxide, Fe <sub>2</sub> O <sub>3</sub>	1.24
Sodium Oxide, Na <sub>2</sub> O	0.23
Potassium Oxide, K <sub>2</sub> O	0.72
Balance	0.43

### 3.13 Design Capacity and Spare Capacity

The plant will consist of one pulverized coal fired, balanced draft, natural circulation boiler coupled to a steam turbine generator that will produce approximately 400 MWe net output. The turbine generator (T-G) is sized and rated at a 100% load heat balance guarantee point. At this design point, the T-G typically operates with some turbine control valve travel remaining to full open. This permits the T-G control system to modulate T-G output in response to signals from the utility load dispatcher.

The T-G is capable of additional generation output above the 100% load guarantee point, which is obtained by operation with the inlet control valves in the maximum travel or wide open position. This condition is commonly referred to as the “valves wide open” or VWO condition. T-G performance is typically predicted (but not guaranteed) at the VWO condition at about 105% load.

Further additional output is possible by increasing the main steam pressure at the turbine inlet by 5 percent, by running the main feed pumps at a higher output (increasing speed of the feedpump turbine drives). This overpressure condition, commonly referred to as 5% overpressure or 5% OP, yields an additional 3 to 5 percent in output.

For the purposes of this report, it is assumed that the plant **will** be operated most of the time at the 100% guarantee point, with the VWO capability used for normal peak demand periods, or when other **baseloaded** units are in forced outages. The 5% OP capability is held in reserve for severe system wide demand periods.

In order to realize the full potential of VWO and/or 5% OP operation, the remaining portions of the plant must be capable of supporting this level of generation. For the purposes of this report, the following design approach is assumed:

- Boiler - designed to support VWO output of the T-G as the guaranteed maximum continuous rating (MCR) of the boiler and its auxiliary equipment (fans, pulverizers, etc.). The 5% OP condition performance is predicted, but not guaranteed. The boiler design must **account** for this condition for pressure boundary integrity and code compliance.

- Feedwater heater string, condensate pumps, FW pumps and FW booster pumps, main condenser, and any equipment that may directly limit T-G output, are designed with nominal guarantee ratings at the coincident 5% **OP/VWO** design condition,
- Circulating Water System, including main circulating water pumps and cooling towers, is designed based on an economic optimization at a specific design ambient wet bulb temperature condition. This optimization is typically based on the 100% guarantee output; the 5% **OP/VWO** condition output is indirectly limited by a higher condensing **backpressure** than what is obtained at the 100% load guarantee point, at the design ambient wet bulb temperature. Lower values of ambient wet bulb temperature will result in lower condenser **backpressure** and higher T-G output, up to a limit imposed by the turbine generator.
- Coal/Sorbent/Ash Handling Systems are designed to support the coincident 5% **OP/VWO** condition. Additional design margins are applied to cover the expected range of coal and sorbent properties, which affect ash content, sulfur content, etc.
- Pollution Control Equipment is designed to support the 100% load condition for maximum continuous operation, with the capability of operating for limited time periods at the coincident 5% **OP/VWO** condition.
- Piping Design (pressure drops and velocities) are established at the 100% guarantee point, Higher pressure drops and velocities prevail at the 5% **OP/VWO** point, but do not directly limit output, Pressure ratings (pressure and temperature) are established at the **VWO** condition for continuous operation, The principal piping code (**ANSI B31. 1.0 Power Piping**) permits limited time excursions at higher stresses. This allowance maybe utilized to accommodate the **570 OP** condition,
- The plant is designed with spare equipment and capacity based on historic potential for failures and service interruptions, Equipment items that are more likely to experience unplanned outages are represented by additional installed capacity. Examples of this type of equipment are (1) coal handling equipment, where 100% redundancy is provided up to the coal silos, and (2) condensate pumps (3 are provided at 5070 capacity each). Other components, that historically have not significantly impacted plant availability, are provided with sufficient capacity to support plant operation at the coincident 570 **OP/VWO** condition, without installed spares, for short term operation (less than one day), and with sufficient capacity to support continuous operation at 100% load for extended time periods.

#### 3.1.4 Plant Life

The plant will utilize components suitable for a 30-year life, with provision for periodic maintenance and replacement of critical parts. Major components requiring periodic maintenance during the **plant** life will be identified and the cost for the work included in the plant economic analysis,

### **3.1.5 Plant Availability and Capacity Factor**

A **levelized** capacity factor of 65% is used for the economic evaluation (Section 4) of the PC Reference Plant described in this report. This factor is based on methodology presented in the Electric Power Research Institute (EPRI) Technical Assessment Guide (TAG).

However, the subject power plant is expected to be capable of achieving a 75 percent **levelized** capacity factor over its service life operating in a utility system. This represents the actual net plant output as a percent of a hypothetical, but unattainable value of 100%, which represents a plant that is on-line producing power at its design maximum continuous rating for 100 percent of the time. The value of 75 percent is arrived at by consideration of two broad factors: plant availability and utility dispatch preferences,

Plant availability is a measure of the amount of time a given plant is available to produce power, and is generally expressed on an annualized basis. Based on historic data from such sources as the North American Electric Reliability Council, availability for a modern pulverized coal fired electric power plant is expected to be in the range of 83 to 86 percent, considering planned and forced outages. The major historical contributor to both forced and planned outages is the boiler with about 9 percent, and the turbine-generator with about a 6 percent contribution. All other factors combined represent approximately 2 percent of unavailability.

The availability of a given plant varies somewhat over the service life, being somewhat lower during the first year or two of operation as the plant undergoes normal “shakedown,” and infant mortality for various items is experienced. Availability may also be reduced in a plant’s later years, as equipment wears out. These influences tend to produce a **levelized** availability at the lower end of the range noted above, or about in the low 80’s percent,

The influence of utility dispatching preferences depends on the units operating costs and emissions in relation to the system in which it is embedded. Fuel costs represent about three quarters of a typical coal fired unit’s operating costs; therefore, plant thermal efficiency or heat rate plays a major role in determination of dispatch priority. The PC Reference Plant defined in this report is assumed to be baseloaded for the majority of its service life with a high dispatch priority. Load following operation is assumed for a period of time as the unit enters its third decade of service, with final operation as a reserve unit,

Consideration of the above factors results in an expected value for **levelized** capacity factor of 75 percent over the unit’s service life. However, as noted above, a 65 percent value has been used for economic evaluations in this report, based on EPRI practice. Individual power generators may apply their own expectations and adjust the economic data accordingly.

### **3.1.6 Maturity of Plant Technology**

**The** plant design will be for a mature technology (i.e., the n<sup>th</sup> plant). First-of-a-kind considerations such as high design margins, excessive test instrumentation, etc., will not be included in the design. It is expected that sufficient operating and maintenance data will be available to provide guidance on sparing of essential components, and that the design will reflect adequate provisions for maintenance such as pull space, platforms, cranes and hoists, etc.

### **3.1.7 Steam Conditions**

A single reheat steam turbine will be used, with the following nominal steam conditions:

- Main steam: 2400 psig/1000° F
- Reheat steam: 530 psig/1000° F

Plant performance is based on the nominal 2400 psig throttle steam pressure conditions (i.e., pressures, temperatures, and flow rates) with an assumed 1.4/2.0 in. Hg condenser back pressure. Plant design is based on the VWO, 5% OP conditions.

Condensing steam cycle calculations will account for pressure drops in the equipment ducts and piping. The following pressure drops through the steam system piping will be assumed for the heat balance if more accurate estimates cannot be made:

- Main steam: 5 percent
- Cold and hot reheat steam: 5 percent (reheater excluded)
- Extraction steam to feedwater heaters:
  - Extractions below 100 psia 5 percent
  - Extractions above 100 psia 3 percent

### **3.1.8 Insulation and Lagging**

Insulation and lagging will be provided on pressure vessels, piping, valves, and all other plant components that are potentially a significant heat-loss source to ambient and that require protection for personnel. The outside surface temperature will be limited to 145° F, with an ambient air temperature and velocity of 100° F and 160 ft /rein respectively. If higher temperatures are used, appropriate personnel protection, such as a surrounding cage, will be specified and included.

### **3.1.9 Preheating**

No. 2 oil-fired igniters are provided as the primary means for unit preheat and start-up. Where required, additional preheat sources such as electric/steam trace heaters or steam coil air heaters are provided to prevent cold-end acid corrosion, to preheat refractory, etc. If required, an auxiliary boiler firing No. 2 fuel oil will be provided to meet preheat requirements.

### **3.1.10 Modes of Operation**

The plant is designed for base-load operation with occasional turndown to 25% plant load. The normal operating load range is from 25 to 100% Below 25% load, the plant is in a start-up or shutdown mode. The high-pressure steam turbine operates at constant pressure over the operating load range. Sliding pressure operation may be considered as an option if and when significant time periods of operation at reduced load are scheduled.

Heat and material balances were prepared for the plant for the 100% load condition. Control/load following, start-up, and shutdown procedures are established.

### **3.1.11 Control Systems**

An integrated plant wide control and monitoring system (DCS) is provided. The DCS is a redundant micro-processor based, functionally distributed system. The control room consists of multiple video monitor (CRT) and keyboard units. The CRT/keyboard units are the primary interface between the generating process and operations personnel. Minimal dedicated control and monitoring instrumentation is provided to safely shut-down (trip) the unit on a loss of the DCS. The DCS incorporates plant monitoring and control functions for all the major plant equipment. Control of minor plant equipment is included where economically practical,

The following control functions are implemented in the DCS: boiler and combustion controls, burner management, and plant logic. The following monitoring functions, as a minimum, are incorporated: alarming, trending, historical storage and retrieval, sequence of events, logging, and performance calculations.

The design of the DCS complies with the applicable standards of ASME, IEEE, ISA NEMA and NFPA.

The DCS is designed to provide a unit operating availability of 99.5%. Geographic distribution of portions of the DCS is implemented where a cost/benefit analysis identifies an installed cost saving while maintaining the design criteria and availability required above,

The plant equipment and the DCS are designed for automatic response to load changes from minimum load to 100%, Start-up and shut-down routines are implemented as supervised manual with operator selection of modular automation routines available.

### **3.1.12 Plant Services**

The following services/support systems are available at the plant as a part of the balance-of-plant systems, Any additional services required will be identified.

- **Auxiliary Power Systems**

- 7200-v system for motors above 3000 hp.
- 4160-v system for motors from 250 to 3000 hp.
- 480-v system for motors 0 to 250 hp and miscellaneous loads.
- Emergency diesel generator (480 v) to supply loads required for safe and orderly plant shutdown. Instruments and controls and other loads requiring regulated (1 percent) 208/120 vac power are supplied from this source.
- 250 vdc system motors and, via static inverters, uninterruptible ac power for the integrated control and monitoring system, intercommunication.
- 125 vdc system for dc controls, emergency lighting, and critical tripping circuits including the plant shutdown system.

- **Cooling Water**

- Cooling water (from the cooling towers) is available at between 20 and 30 psig, 90°F maximum temperature. The water is periodically chlorinated, and pH is



maintained at **6.5 to 7.5**. The **cooling** towers receive makeup water from the river,

- Auxiliary cooling water, which uses demineralized water treated for corrosion control, at 60 to 80 psig and 105° F, is available for small heat loads (e.g., control oil coolers). The **pH** is maintained at about 8.5.

- Compressed Air

- Instrument air filtered and dried to -40°F dewpoint at 80 to 100 psig and 110°F (maximum).
- Service air at 80 to 100 psig and 110°F (maximum).

- Lube Oil

Lube oil from the conditioning system, with particulate matter removed to 10  $\mu\text{m}$  or lower.

- Hydrogen and Carbon Dioxide

H<sub>2</sub> and CO, for generator cooling and purging from storage.

- Nitrogen

N, for equipment blanketing against corrosion during shutdown and layup.

- Raw Water

Filtered river water. Additional water treatment will be included for potable water, etc.

### **3.1.13 Structures and Foundations**

A structure or structures are provided to support and permit access to all plant components requiring support to conform with the site criteria defined in Section 3,1.1. The structure(s) are enclosed if deemed necessary to conform with the environmental conditions.

Foundations are provided for the support structures, pumps, tanks, and other plant components. A soil-bearing load of 5000 **lb/ft<sup>2</sup>** is used for foundation design.

### **3.1.14 Heat Recovery**

Sensible heat in solids streams discharged from the plant is recovered to the extent economically practical.

### **3.1.15 Codes and Standards**

Recognized design codes and standards that are commonly used for the design of commercial fossil-fuel-fired power plants are applied to the extent of ensuring that their requirements are met. Where the existing codes and standards cannot be applied to the design and fabrication of

a component, the components will be designed using accepted industry standards. Some of the more important applicable codes and standards are listed in Table 3-3.

Table 3.3  
TYPICAL DESIGN CODES AND STANDARDS

<ul style="list-style-type: none"><li>. ASME Boiler and Pressure Vessel Code: Section I, Power Boilers, Section VIII, Divisions 1 and 2, Unfired Pressure Vessels</li><li>•ASME/ANSI B31. 1, Power Piping Codes and Addenda</li><li>•National Fire Code (NFPA) 1992</li><li>•OSHA Regulations, 29CFR1910</li><li>•Uniform Building Code</li><li>•ASCE-7, 1988, Minimum Design Loads for Buildings and Other Structures (Revisions and Redesignation of ANSI A58.1-1982)</li><li>•National Electrical Code</li></ul>
---

### 3.2 HEAT AND MASS BALANCE

The steam power cycle is shown schematically in the 100 percent load Heat and Mass Balance diagram, Figure 3-1. The diagram shows state points at each of the major components for the conventional plant. Overall performance is summarized in Table 3-4 which includes auxiliary power requirements.

The plant uses a 2400 psig/1000° F/1 000° F single reheat steam power cycle. The high pressure turbine uses 2,734,000 lb/h steam at 2415 psia and 1000° F. The cold reheat flow is 2,425,653 lb/h of steam at 604 psia and 635° F, which is reheated to 1000° F before entering the intermediate pressure turbine section.

Tandem high, intermediate, and low pressure turbines drive one 3600 rpm hydrogen-cooled generator. The low pressure turbines consist of two condensing turbine sections. They employ a dual-pressure condenser operating at 1.4 and 2.0 in Hg at the nominal 100% load design point at an ambient wet bulb temperature of 52° F. For the low pressure turbines, the last stage bucket length is 30.0 inches, the pitch diameter is 85.0, and the annulus area per end is 55.6 square feet.

The feedwater train consists of six closed feedwater heaters (four low pressure and two high pressure), and one open feedwater heater (**deaerator**). Extractions for feedwater heating, **deaerating**, and the boiler feed pump, are taken from **all** of the turbine cylinders.



**Table 3-4  
PLANT PERFORMANCE SUMMARY -100 PERCENT LOAD**

STEAM CYCLE	
Throttle Pressure, psig	<b>2,400</b>
Throttle Temperature, °F	1,000
Reheat Outlet Temperature, °F	1,000
POWER SUMMARY	
3600 rpm Generator	
GROSS POWER, kWe (Generator terminals)	<b>427,060</b>
AUXILIARY LOAD SUMMARY, kWe	
Pulverizers	<b>1,600</b>
Primary Air Fans	<b>1,390</b>
Forced Draft Fans	1,010
Induced Draft Fans	5,660
Seal Air Blowers	50
<b>Main Feed Pump (Note 1)</b>	<b>8,660</b>
Steam Turbine Auxiliaries	700
Condensate Pumps	800
Circulating Water Pumps	3,360
Cooling Tower Fans	1,900
Coal Handling	200
Limestone Handling & Reagent Prep.	900
FGD Pumps and Agitators	2,250
Ash Handling	1,500
Dewatering Centrifuges (FGD byproduct)	800
Precipitators	800
Soot Blowers (Note 2)	neg.
Miscellaneous Balance of Plant (Note 3)	2,000
Transformer Loss	1,020
TOTAL AUXILIARIES, kWe	25,940
Net Power, kWe	401,120
Net Efficiency, % HHV	38.5
Net Heat Rate, Btu/kWh (HHV)	8,856
CONDENSER COOLING DUTY, 10' Btu/h	1,722
CONSUMABLES	
As-Received Coal Feed, lb/h	285,320
Sorbent, lb/h	35,255

Note 1- Driven by auxiliary steam turbine, electric equivalent not included in total

Note 2- Soot blowing medium is boiler steam, Electric power consumption is negligible.

Note 3- Includes plant control systems, lighting, HVAC, etc.

The net plant output power, after plant auxiliary power requirements are deducted, is nominally 401 MWe. The overall net plant efficiency is 38.5 percent.

The major features of this plant include the following:

- boiler feed pumps are steam turbine driven
- turbine configuration is a 3600 rpm tandem compound, four flow exhaust
- plant has six stages of closed feedwater heaters plus a deaerator

A 5% O, P., VWO Heat and Mass Balance (Figure 3-2) was prepared, on which the design of the plant is based. The net power output increased by 8.5 percent with the efficiency increasing from 38.6 to 38.7 percent. Overall performance is summarized in Table 3-5 which includes auxiliary power requirements.

### 3.3 ENVIRONMENTAL STANDARDS

Environmental standards applicable to the design of an electric utility power plant relate primarily to air, water, solid waste, and noise (Table 3-6), Both State and Federal regulations control emissions, effluents, and solid waste discharged from the **plant**. Additional environmental regulations may apply on a site-specific basis (National Environmental Policy Act, Endangered Species Act, National Historic Preservation Act, etc.) but will not be considered for this project.

#### 3.3.1 Air Quality Standards

**The** plant pollution emission requirements under New Source Performance Standards (NSPS), prior to the Clean Air Act Amendments (CAA) of 1990, were as follows:

- SO<sub>2</sub>: 90-percent removal\* Particulates:0.03 lb/ 10<sup>6</sup> Btu
- NO<sub>x</sub>: 0.6 lb/10<sup>6</sup> Btu • Visibility:20-percent opacity

The 1990 CAA imposed a two phase capping of SO<sub>2</sub> emissions on a nationwide basis. For a new green grass plant, the reduction of SO<sub>2</sub> emissions that would be required depends on possession or availability of SO<sub>2</sub> allowances by the utility, and on local site conditions. In many cases, Prevention of Significant Deterioration (PSD) Regulations will apply, requiring that Best Available Control Technology (BACT) be used. BACT is applied separately for each site, and results in different values for different sites, In general, the emission limits set by BACT will be significantly lower than NSPS limits. The following ranges will generally cover most cases:

- SO<sub>2</sub>: 92 to 95% reduction
- NO<sub>x</sub>: 0.2 to 0.45 lb/10<sup>6</sup> Btu
- Particulate: 0.015 to 0.03 lb/10<sup>6</sup> Btu
- Opacity: 10-20%

For this study, plant emissions are capped at values shown in Table 3-7 below.

Best Available Control Technology is not applied to the plant described in this report, since it is a site and time dependent issue. Selective adjustments for additional SO<sub>2</sub> and/or NO<sub>x</sub> reduction



**Table 3-5  
PLANT PERFORMANCE SUMMARY - VWO,5% O.P.**

STEAM CYCLE Throttle Pressure, psig Throttle Temperature, °F Reheat Outlet Temperature, °F	2,521 1,000 1,000
POWER SUMMARY 3600 rpm Generator GROSS POWER, kWe (Generator terminals)	463,806
AUXILIARY LOAD SUMMARY, kWe Pulverizers Primary Air Fans Forced Draft Fans Induced Draft Fans Seal Air Blowers <i>Main Feed Pump (Note 2)</i> Steam Turbine Auxiliaries Condensate Pumps Circulating Water Pumps Cooling Tower Fans Coal Handling Limestone Handling & Reagent Prep. FGD Pumps and Agitators Ash Handling Dewatering Centrifuges (FGD byproduct) Precipitators Soot Blowers (Note 2) Miscellaneous Balance of Plant (Note 3) Transformer Loss	1,740 1,500 1,092 6,120 54 <b>10,320</b> 760 996 3,650 2,060 220 980 2,440 1,630 870 870 neg. 2,170 1,113
TOTAL AUXILIARIES, kWe Net Power, kWe Net Efficiency, % HHV Net Heat Rate, Btu/kWh (HHV)	28,265 435,541 <b>38.7</b> 8,825
CONDENSER COOLING DUTY, 10 <sup>6</sup> Btu/h	1,865
CONSUMABLES As-Received Coal Feed, lb/h Sorbent, lb/h	308,731 38,148

Note 1- Driven by auxiliary steam turbine, electric equivalent not included in total

Note 2- Soot blowing medium is boiler steam. Electric power consumption is negligible.

Note 3- Includes plant control systems, lighting, HVAC, etc.

**Table 3-6  
APPLICABLE ENVIRONMENTAL REGULATIONS**

<p>Clean Air Act as amended in 1990, including:</p> <ul style="list-style-type: none"> <li>•New Source Performance Standards</li> <li>•National Ambient Air Quality Standards</li> <li>•Best Available Control Technology</li> <li>•Lowest Achievable Emission Rate</li> </ul> <p>Federal Water Pollution Control Act (as amended by the Clean Water Act of 1977), including:</p> <ul style="list-style-type: none"> <li>•Section 404 Dredge and Fill</li> <li>•National Pollution Discharge Elimination System</li> <li>•Best Available Technology Economically Achievable</li> <li>•Effluent Guidelines and Standards 40 CFR423</li> </ul> <p>Resource Conservation and Recovery Act (RCRA)</p> <p>OSHA Regulations 29CFR1910</p> <p>State Regulations</p> <ul style="list-style-type: none"> <li>•Air Quality Standards</li> <li>•Water Quality Discharge Standards</li> <li>•Solid Waste Disposal Standards</li> </ul>
--

**Table 3-7  
PULVERIZED COAL FIRED BOILER REFERENCE PLANT EMISSIONS**

	<u>lb/10<sup>6</sup> Btu</u>	tons/year @ 400 MWe, <u>65% capacity factor</u>
<b>SO<sub>2</sub></b>	0.38	4080
<b>NO<sub>x</sub></b>	0.30	3200

may be applied by users of this report by applying specific technology increments that suit each case.

Air quality regulations concerning other compounds such as CO, CO<sub>2</sub> and air toxics are being considered by federal authorities at the present time, and may have an effect on the design of



plants in the time frame being considered here, However, details of the end results of these considerations are not clear at the present time and are not included in this report.

### **3.3.2 Water Quality Standards**

Waste water, principally cooling tower blowdown, boiler blowdown, ash transport water, and process condensate or purge water, will be discharged following treatment to comply with the Environmental Protection Agency Effluent Guidelines and Standards (Title 40CFR).

### **3.3.3 Solid Waste Disposal**

Spent sorbent, ash, air-pollutant emission control waste, and sludge produced from water treatment will be disposed of according to the nonhazardous waste disposal guidelines of Sections 1008 and 4004 of the Resource Conservation and Recovery Act (RCRA), and applicable state standards, appropriate for the actual plants' location.

Several potential avenues are presently available to dispose of solid wastes from FGD systems. These include disposal in a landfill or sale to a manufacturer of building products. The latter approach requires careful control of the quality of the sulfate (gypsum) produced by the dewatering of spent scrubber reagent. Local business factors will play a significant role in determining the viability of this option. For this conceptual design, disposal to a landfill is the approach taken.

### **3.3.4 Noise**

In-plant equipment will be designed to meet the noise exposure regulations of the Occupational Safety and Health Administration (OSHA), Noise levels from major noise sources (e.g., fans, motors, gas turbines, valves, pumps, and piping) will not exceed 95 dBA at 3 ft. Outdoor noise criteria for on-site sources of noise will be an integrated equivalent level (Leq) of 55 dBA at the property boundary. The minimum distance to the property line will be assumed to be 1000 ft.

## **3.4 DESCRIPTION OF STEAM GENERATION SYSTEMS**

The following sections contain descriptions of the steam generation systems in the plant. The boiler description is based on a commercially available, pulverized coal fired, natural circulation type steam generator. At least two major U.S. manufacturers offer this type of unit; in addition, a forced circulation type boiler is offered by a third US. firm. Any one of these units is capable of performing in the plant described herein. For illustrative purposes, a Babcock & Wilcox boiler and accessories are described herein. The balance of the steam generation systems are conventional for this size plant.

### **3.4.1 Steam Generator and Ancillary Equipment**

The 400 MWe pulverized coal fired steam generator described herein is a B&W Carolina Type Radiant Boiler. This section provides brief descriptions of this type of boiler and its principal accessories.

A description of the equipment is included in Appendix A, Major Equipment list. Figure 3-3 illustrates the cross section of a typical boiler.

**FIGURE 3-3**

**Typical Boiler Cross Section**

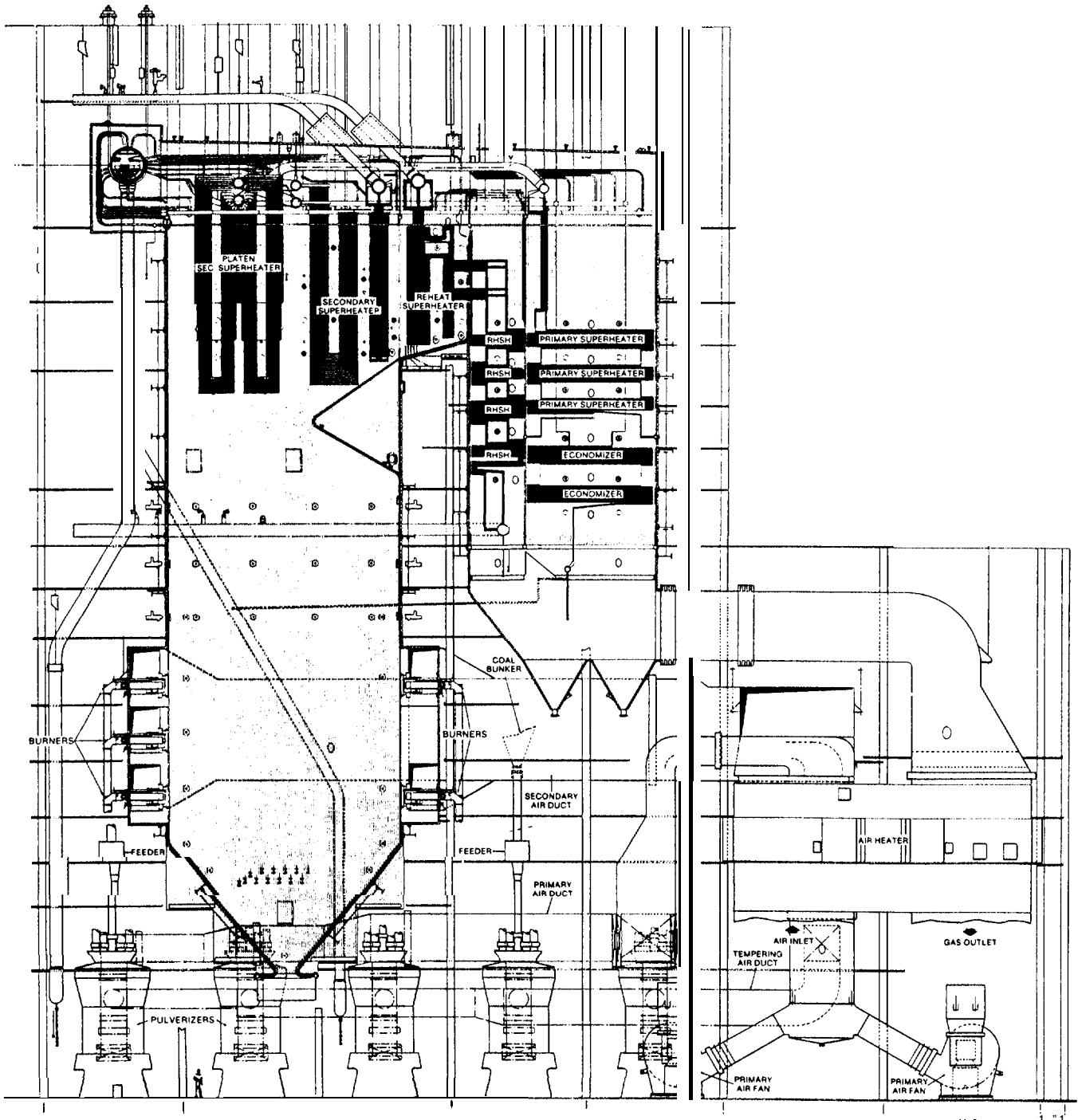

### 3.4.1.1 General Description

The steam generating unit described herein is a balanced draft Babcock & Wilcox Carolina Type Radiant Boiler. It is arranged with a water cooled dry-bottom furnace, superheater, reheater, economizer, and air heater components. The unit is designed to utilize fuel that is similar in composition to Pittsburgh No. 8 coal.

#### Fuel Flow

Raw coal is discharged from the feeders to the pulverizers where the primary air is introduced and the fuel is pulverized. The pulverized coal is transported by the primary air to the burners through a system of pressurized coal-air piping. The pulverizers are described in Section 3.4.1.5.

#### Air and Gas Flow (Figure 3-4)

Air from a forced draft fan is heated in the regenerative air heaters and is distributed to the burner windbox as secondary air. A portion of the combustion air is taken from atmosphere by the primary air fans which provide the pressure to pass this air through the primary air heater and pulverizers to the burners. A portion of the air from the primary air fans is passed unheated around the primary air heater as tempering primary air. The preheated and tempering primary air are mixed at each pulverizer to obtain the desired pulverizer fuel-air mixture outlet temperature.

Hot gas from the furnace passes successively over the platen and pendant sections of the secondary superheater and reheater, located in the convection pass, and out of the high radiant heat transfer zone of the furnace. The gas turns down and crosses in parallel to the horizontal primary superheater and economizer surface on the back pass, and horizontal reheat and economizer surface on the front pass. Gas flows are adjusted by dampers at the outlet of each pass to control reheat steam temperature across the load range. The flue gas then turns horizontal across an outlet hopper and enters the air heaters.

#### Water and Steam Flow (Figure 3-5)

Feedwater enters the bottom header of the economizer. The water passes upward through the economizer and discharges through the outlet header into piping which conducts it to the steam drum. By means of natural circulation, the water flows down through downcomer pipes connecting supply distributor tubes to the lower furnace headers. From the furnace wall headers, the fluid rises through the furnace tubes to the upper enclosure headers. The flow then passes through riser tubes into the steam drum.

The water and steam mixture in the steam drum is separated by cyclone steam separators which provide essentially steam-free water in the downcomers. The steam is further purified by passing it through the primary and secondary steam scrubbers,

Steam from the steam drum passes through multiple connections to the headers supplying the furnace roof tubes and pendant convection pass sidewall tubes. From the furnace roof outlet headers and pendant convection pass sidewall outlet headers, steam passes to the horizontal convection enclosure inlet headers, wall tubes and outlet headers in succession and then flows to the primary superheater.

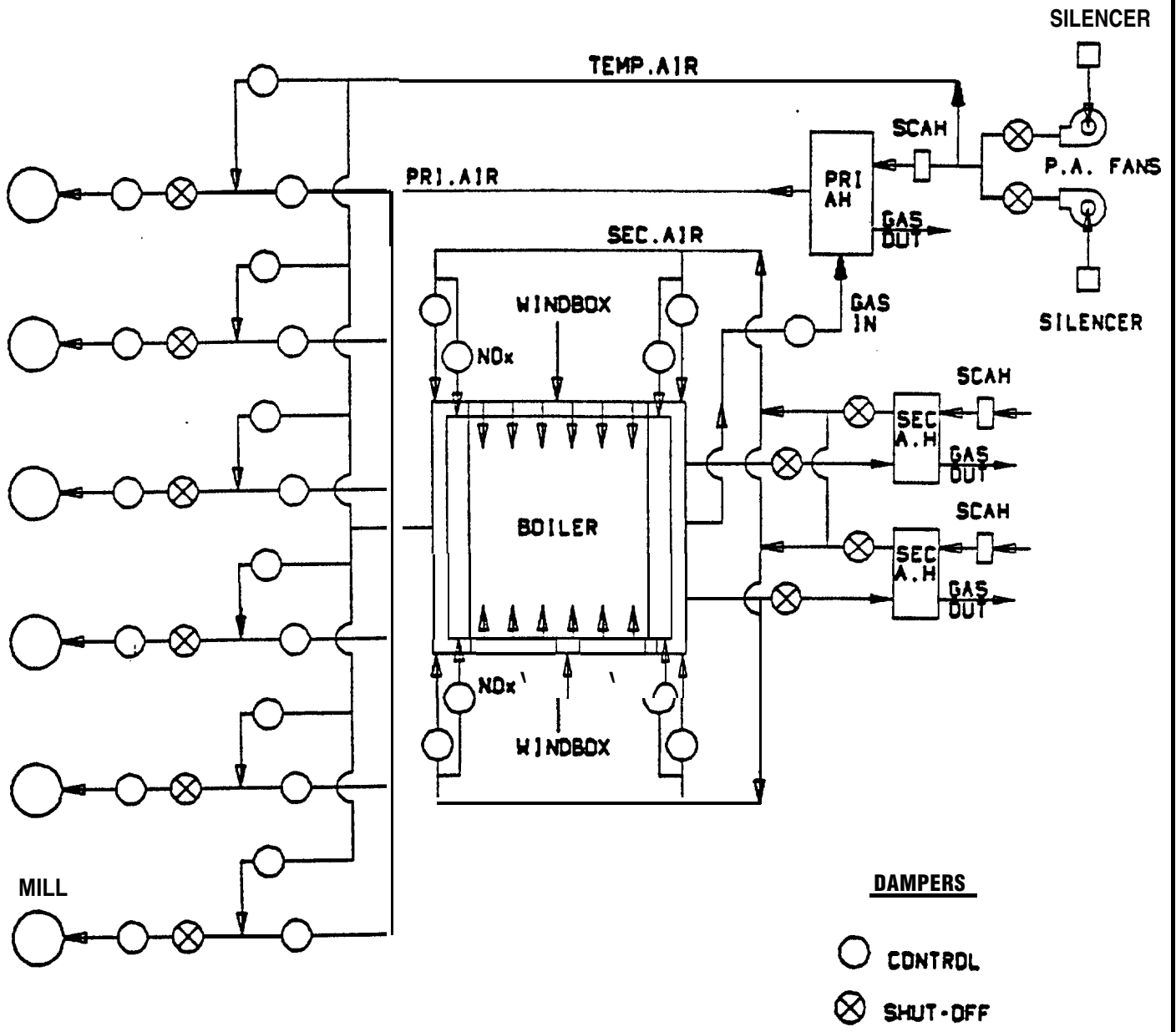

AIR AND GAS SCHEMATIC

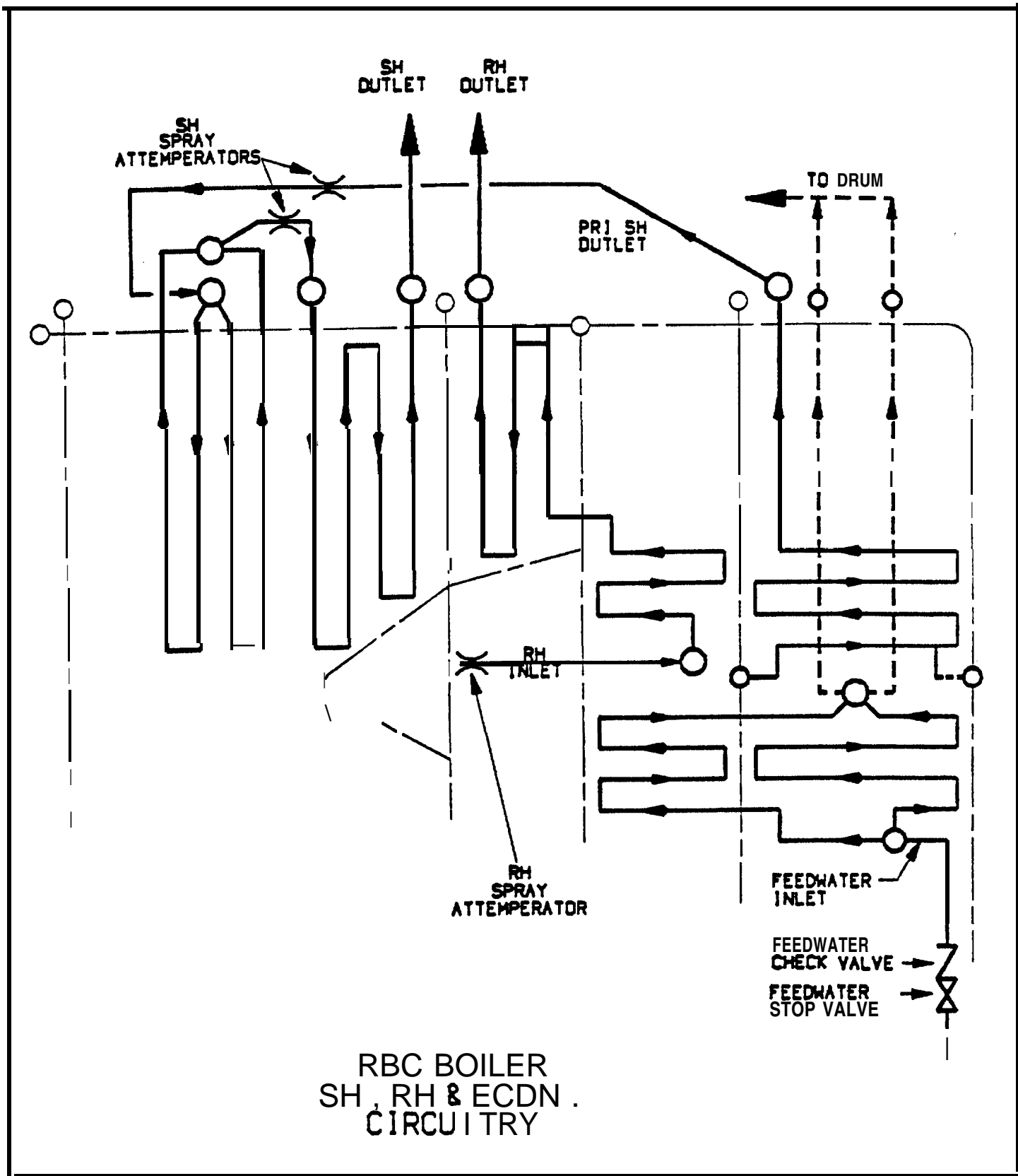

STEAM/WATER FLOW SCHEMATIC

**FIGURE 3-5**

Steam flow rises through the primary superheater and discharges through its outlet header and through connecting piping equipped with spray attemperators. The steam then enters the secondary superheater inlet header and flows through the secondary superheater sections to the outlet header and to the main steam piping.

Cold reheat steam returning from the turbine passes through the reheat attemperators located in the inlet piping to the reheat superheater, It then flows through the reheat superheater sections to the outlet headers and the hot reheat piping.

### **3.4.1.2 Furnace and Burner Design**

The furnace is a single water cooled chamber that is approximately 50 ft wide, 45 ft deep, and 170 ft in height. The furnace geometry is optimized to provide adequate burner spacings, burner zone cooling surface and burner zone residence time for the required  $\text{NO}_x$  levels.

The low  $\text{NO}_x$  burners are arranged on the front and back wall in three rows of six burners per wall, All burners supplied with fuel from each pulverizer are arranged in a single row.

As shown in Figures 3-6 and 3-7, the B&W XCL burner makes use of air staging and fuel staging technology by virtue of its design, The coal nozzle is centrally located in the burner in an arrangement which carefully limits air/fuel interaction in the root of the flame. The fuel element is housed in a single, central flame stabilizer which results in excellent flame stability and turndown, while separating the fuel elements from the combustion air. The coal nozzle features a conical diffuser for even coal distribution. Secondary air introduction to the fuel is regulated by dual air zones with adjustable inner and outer swirl vanes.

Peak  $\text{NO}_x$  formation is reduced by controlling the rate of combustion and apparent stoichiometry. Hydrocarbon radicals are produced which react with the  $\text{NO}_x$  formed early in the flame and further reduce  $\text{NO}_x$  emissions. Combustion air gradually mixes with these products of combustion further downstream to complete char reactions while minimizing  $\text{NO}_x$  re-formation.

Additional air staging is accomplished by introducing a portion of the combustion air above the uppermost level of burners. This further reduces the formation of  $\text{NO}_x$  in the combustion zone.

### **3.4.1.3 Air Heater**

The air heater is comprised of two Ljungstrom regenerative type units, which are driven by air motors and rotate at approximately one rpm. Seal leakage is within reasonable tolerances for this balanced draft application,

### **3.4.1.4 Bottom Ash Removal**

Approximately 20 percent of the ash in the fuel is withdrawn as bottom ash, This material falls by gravity to the bottom of a pair of water impounded hoppers located beneath the furnace, at which point it enters a clinker grinder, which reduces the ash into moderate size particles, The ash material is discharged at the bottom of the clinker grinder into the suction entrance of a sluice water motivated jet ejector. The sluice water stream entrains and cools the ash, which is routed to the ash pond. Refer to Section 3.4.6 for additional information regarding other ash collection points in the boiler system.

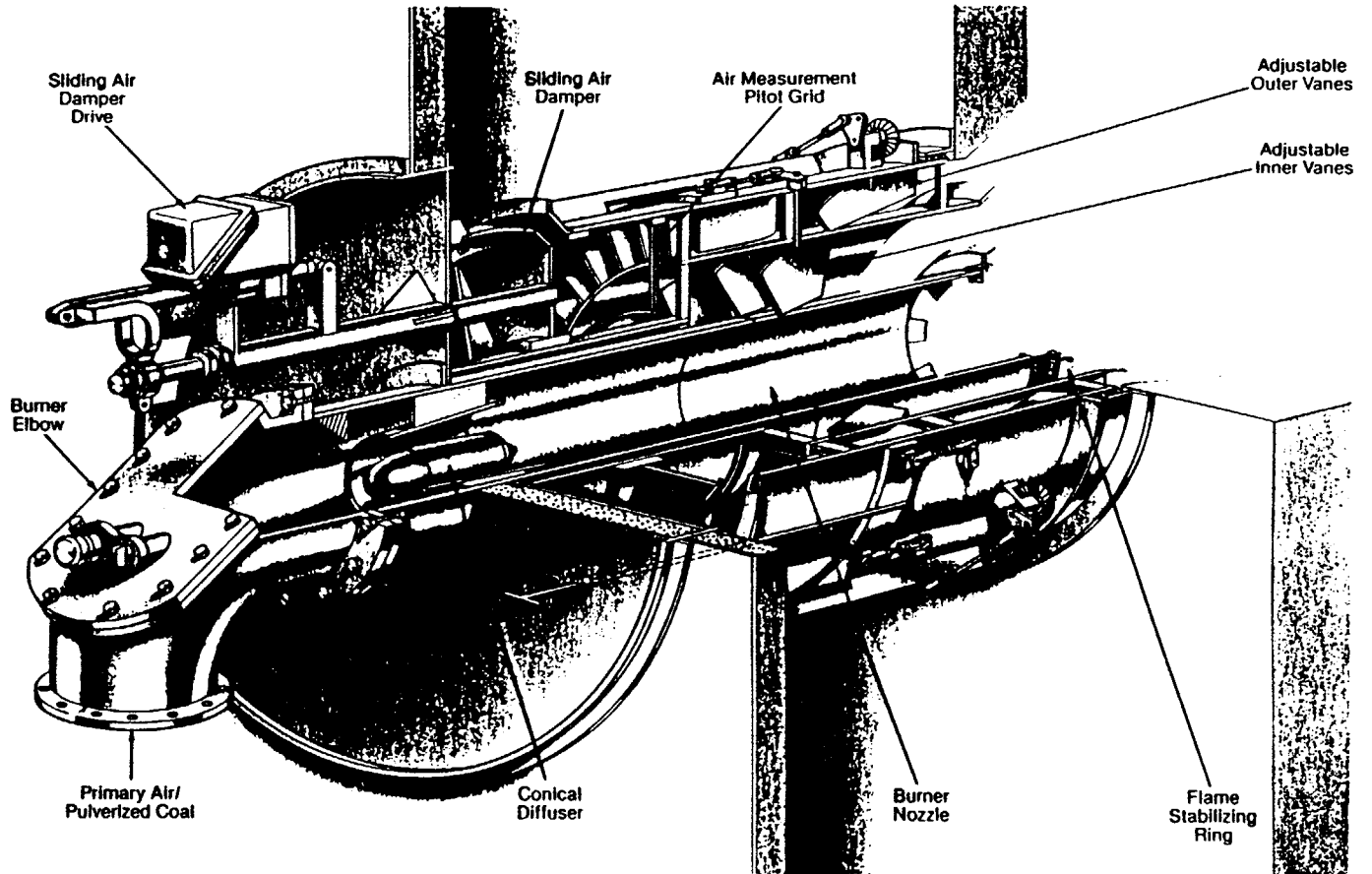

Fig. 9 DRB-XCL™ low NO<sub>x</sub> burner for pulverized coal firing.

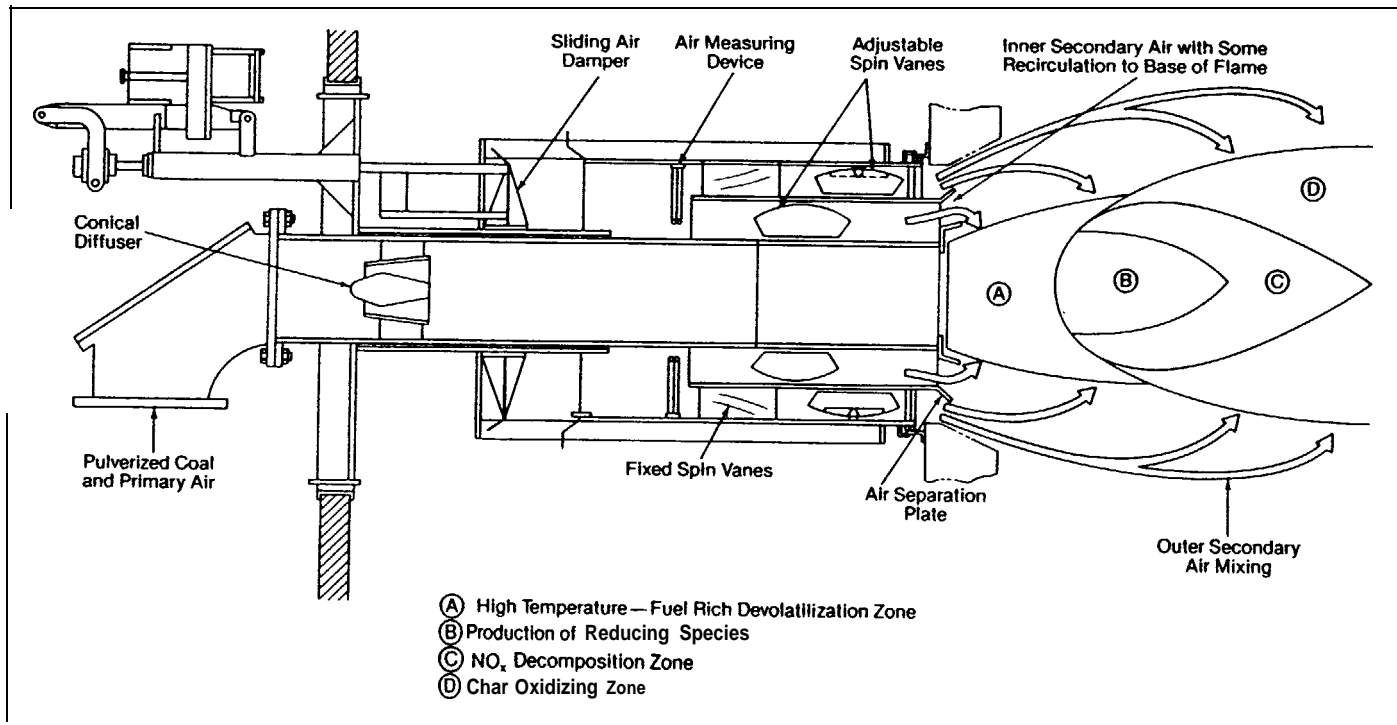

Fig. 11 DRB-XCL™ low NO<sub>x</sub> combustion zones.



### 3.4.1.5 Coal Feed System

The coal feed system supplied by the boiler manufacturer interfaces with the balance of plant coal handling system at the inlet connection in the top center of each coal pulverizer. Coal, which has been crushed into an appropriate size (1-1/4 inch X O) by the coal handling system, is fed by a Gravimetric type feeder into each pulverizer. Five of the six pulverizers provided are required to operate to sustain the boiler at 100 percent capacity.

The B&W roll and race type MPS pulverizer, shown in Figures 3-8 and 3-9, employs the roller principle of grinding with a hydraulically loaded spring system providing the required loading to the roller grinding elements. The required capacity is provided by large, low speed grinding elements. The grinding elements of wear resistant Elverite material consist of three rollers and lower grinding ring. The B&W pulverizer is designed to accept a raw coal feed sized to pass through a 1.25 inch ring.

Raw coal enters the pulverizer, passes through the grinding elements and is partially pulverized. A stream of preheated primary air picks up the partially pulverized coal from the grinding zone and carries it to the classifier. There the coarse particles are separated from the fines and returned to the grinding zone while the fines are air-borne through the coal-air piping to the burners. Pyrites are rejected to a discharge hopper from which they are sluiced and routed to the Economizer/Pyrites transfer tank.

Preheated air at the required temperature is obtained by proportioning hot and cold primary air to each pulverizer. Pulverizer isolation is accomplished by means of a double damper arrangement in the primary air connection to each mill. Sealing air is admitted between the two dampers to guard against leakage of hot primary air into an idle pulverizer.

### 3.4.1.6 Startup Igniter System

A startup igniter using No. 2 oil is provided in conjunction with each pulverized coal burner for light-off and to stabilize the main burner during start-up and at low loads. The igniters are electrically ignited and air atomized, and are capable of supporting up to 20% of full load when operated as the sole boiler energy input. Natural gas, if it is available, can also be used for startup fuel. Economics, based on geographical location should be used to make the choice,

### 3.4.1.7 Sootblower System (Figure 3-10)

The PC boiler is furnished with an automatic sequential soot blowing system, using steam as the blowing medium in an array of approximately 70 electrically driven and operated soot blowers. The system uses a combination of short retractable, long retractable, and long retractable (with extended lance) type blowers to clean the furnace walls, superheater, reheater, air heater and economizer. The system utilizes main steam from the boiler at 2700 psig/790°F; with a total steam consumption of approximately 220,000 lb in each 24 hour period at rated power.

### 3.4.1.8 Particulate Collection

The flue gas discharged from the boiler (air preheater) is directed through an electrostatic precipitator array comprised of two rigid frame single stage units. Each precipitator unit is divided into five field sections, each in turn, containing four cells. Each cell contains a number

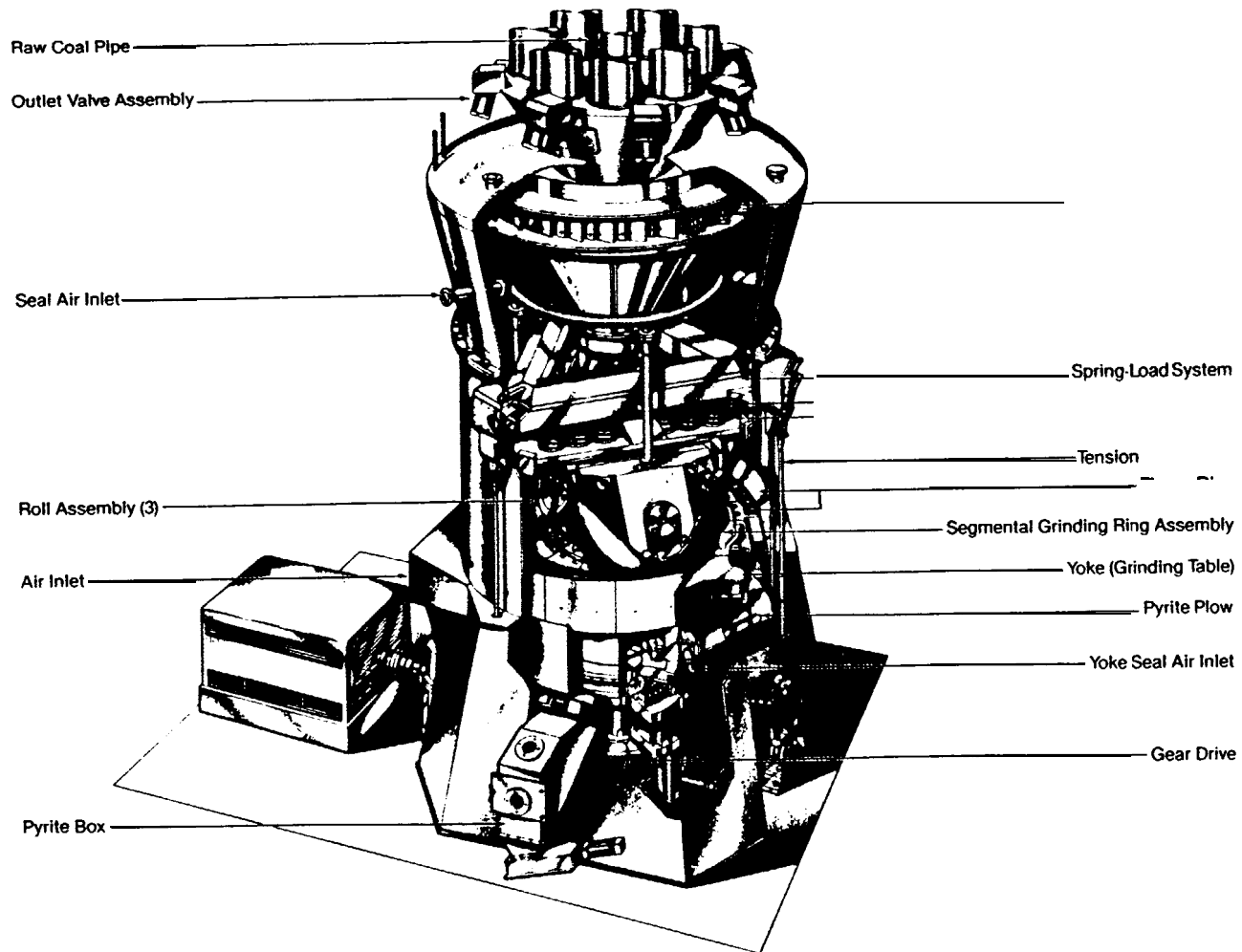
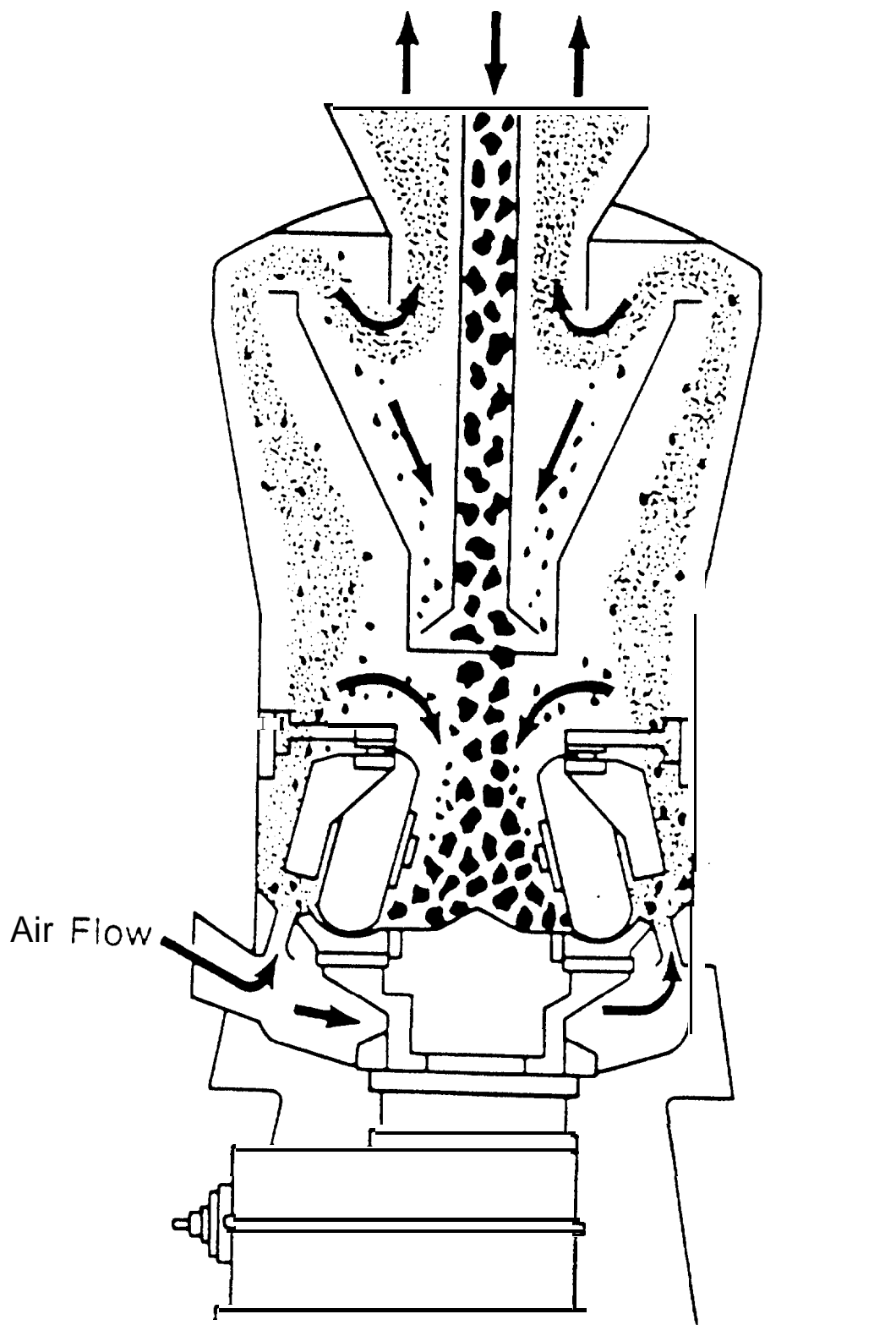

Fig. 1 Babcock & Wilcox MPS pulverizer.



Roll and Race Pulverizer Cross Section

**FIGURE 3-9**



of gas passages comprised of discharge electrodes, collecting plates, and ash hoppers supported by a rigid steel casing. Each cell and ash hopper is provided with a rapping system which periodically provides a mechanical shock to the unit to cause the fly ash particles to drop into the hopper, and then out into the collection piping. The precipitators are provided with necessary electrical power and control devices, inlet gas distribution devices, insulators, inlet and outlet nozzles, expansion joints, and other items as required.

Electrostatic precipitators have a long and successful application history on medium to high sulfur coal, and provide very high (up to 99.9%) collection efficiencies with a modest electric power consumption and minimal flue gas pressure drop. Their use on this reference pulverized coal fired boiler application represents current and typical electric utility practice.

### **3.42 Coal Handling System**

The function of the coal handling system is to provide the equipment required for unloading, conveying, preparing, and storing the coal delivered to the plant. The scope of the system is from the rotary car damper and coal receiving hoppers up to the pulverizer fuel inlet. A schematic diagram of the system is shown on the Coal Handling Flow Diagram, Figure 3-11. The system is designed to support short term operation at the 5% OP/VWO condition (16 hours) and long term operation at the 100% guarantee point (90 days or more).

#### **3.4.2.1 Operation Description**

The 6 x 0 inch bituminous coal will be delivered to the site by unit trains of 100-ton rail cars. The choice of delivery system is site-dependent and may involve other means, such as trucks or barges. For this study, unit trains were selected as the most appropriate. Each unit train consists of 100, 100-ton rail cars, The unloading will be done by a rotary car dumper with a hydraulic car positioner. The rotary car dumper will unload the coal to four receiving hoppers. Coal from each hopper is fed by a vibratory feeder onto a belt conveyor. The 6 x 0 inch coal is conveyed into a transfer building where a sample of coal is taken from each consignment by a coal sampling system, The main stream of coal feeds onto the coal stacker conveyor.

The coal is fed into a traversing, double-wing stacker. The coal can be diverted to either the active pile boom conveyor or the dead pile boom conveyor. Each fixed boom conveyor has luffing capabilities for discharging the coal into a longitudinal **pile**. The double-wing stacker traverses on a track between the active and dead coal storage piles. Each coal storage pile is lined and provided with a runoff treatment system.

The dead pile boom conveyor discharges the coal onto the dead coal storage pile where a bulldozer moves and compacts the coal. The dead storage area will have an emergency reclaim hopper with a vibratory feeder feeding a belt conveyor. The conveyor discharges the reclaimed coal into the crusher building's surge bin.

The active pile boom conveyor discharges the coal onto the active coal storage pile and is reclaimed via three reclaim hoppers, The coal is then discharged onto a belt conveyor.

The coal is conveyed from the reclaim hoppers to the crusher building and is fed into a two-compartment surge bin, provided with a vent filter to reduce dust emissions. Each compartment of the surge bin supplies coal to a full size vibratory feeder, At the inlet of each



primary crusher, a bypass flop gate allows coal to be fed to either the primary crusher, or to a crusher by-pass when **presized** coal is being used. The primary crusher is a ring granulator type crusher while the secondary reduction of the coal is performed by an **impactor** type crusher.

Coal taken from the crusher discharge, is sampled by a two-strand, swing-hammer type sampling system before entering the boiler building.

Conveyors then feed the sized and sampled coal to either of the tripper conveyors, Each tripper discharges coal into a coal bunker for storage. The coal bunkers are sized for 16-hour total storage capacity, Conveyors are sized to fill the 16 hour bunkers in less than 6 hours while the plant is operating at full load. The fuel is discharged into the pulverizers via **gravimetric** feeders.

### **3.4.2.2 Technical Requirements and Design Basis**

#### 1. Coal Burn Rate

- Maximum Coal Burn Rate = 309,223 lb/h = 155 tph  
(based on the boiler operating at 5 percent OP, VWO continuously)
- Average Coal Burn Rate = 200,995 lb/h = 101 tph  
(based on Maximum Coal Burn Rate multiplied by an assumed capacity factor)

#### 2. Coal Delivered to the Plant by Unit Trains

- Three (3) Unit Trains Per Week at Maximum Burn Rate  
Two (2) Unit trains Per Week at Average Burn Rate
- Each Unit Train Shall Have 10,000 Tons (100-Ton Cars) Capacity
- Unloading Rate = 900 tph
- Total Unloading Time Per Unit Train = 13 hours
- Conveying Rate to Storage Piles = 900 tph
- Reclaim Rate = 620 tph

#### 3. Storage Piles with liners, Run-off Collection, and Treatment Systems:

- Active Storage = 7,250 tons (72 hours)
- Dead Storage = 217,000 tons (90 days)

System design reflects the concern for maintenance of the coal handling equipment in that redundant equipment is provided in critical areas, Reclaiming and conveying belts, crushers, and bunker **loading** equipment fall into this category.

Access platforms and catwalks are provided to permit the periodic lubrication, and observation of all rotating or moving equipment. Conveyors have a main access aisle either on one side or, in the case of two conveyors, between them with grease fittings directed toward this aisle.

On conveyor bridges or in tunnels, small access platforms or aisles on the outboard side give access to idlers for replacement. Monorails serve the conveyor head shafts and their accompanying drive assembly (gear and motor), permitting the removal of heavy pieces to grade.

The crusher building has monorails serving each crusher for rotor, motor, and drive assembly maintenance. For installations with a rotary car dumper, monorails serve the hydraulic pumps that operate the car positioner, A maintenance aisle adjacent to the pumps and their monorail system supports forklift truck traffic,

A hatch, strategically located in the car dumper, allows access to the lowest level in that structure. Equipment below the hoppers is winched or skidded into the hatch area, then hoisted to the surface with a “cherry picker” or truck crane.

### **3.43 Limestone Handling and Reagent Preparation System**

The function of the limestone handling and reagent preparation system is to receive, store, convey and pulverize the limestone delivered to the plant, and mix it with water to form a slurry for feeding to the Flue Gas **Desulfurization** System. The scope of the system is from the storage pile up to the FGD absorber module inlet. A schematic diagram of the limestone flow is shown on the Limestone Handling and Reagent Preparation System Flow Diagram, Figure 3-12. The system is designed to support short term operation at the 5% OP/VWO condition (16 hours) and long term operation at the 100% guarantee point (90 days or more).

#### **3.43.1 Operation Description**

Limestone will be delivered to the plant by 25-ton trucks.

The limestone is unloaded onto a storage pile located above vibrating feeders. The limestone is fed onto belt conveyors via vibrating feeders and then to two day bins equipped with vent filters. Each day bin supplies a 100% capacity size ball mill via a weigh feeder.

Typically the ball mills pulverize the limestone to 90-95% passing 325 mesh (44 microns) and discharge the reduced material into a mill slurry tank. Mill recycle pumps, two per tank, pump the limestone water slurry to an assembly of hydroclones and distribution boxes. The slurry is classified into several streams, based on suspended solids content and size distribution.

The hydroclone underflow is directed to the mills for further grinding. The hydroclone overflow is routed to a reagent storage tank. Reagent distribution pumps direct slurry from the tank to the absorber modules.



10

9

8

7

6

5

4

3

2

87-HAR-1994-12-01  
14600014622101.DGN

DD

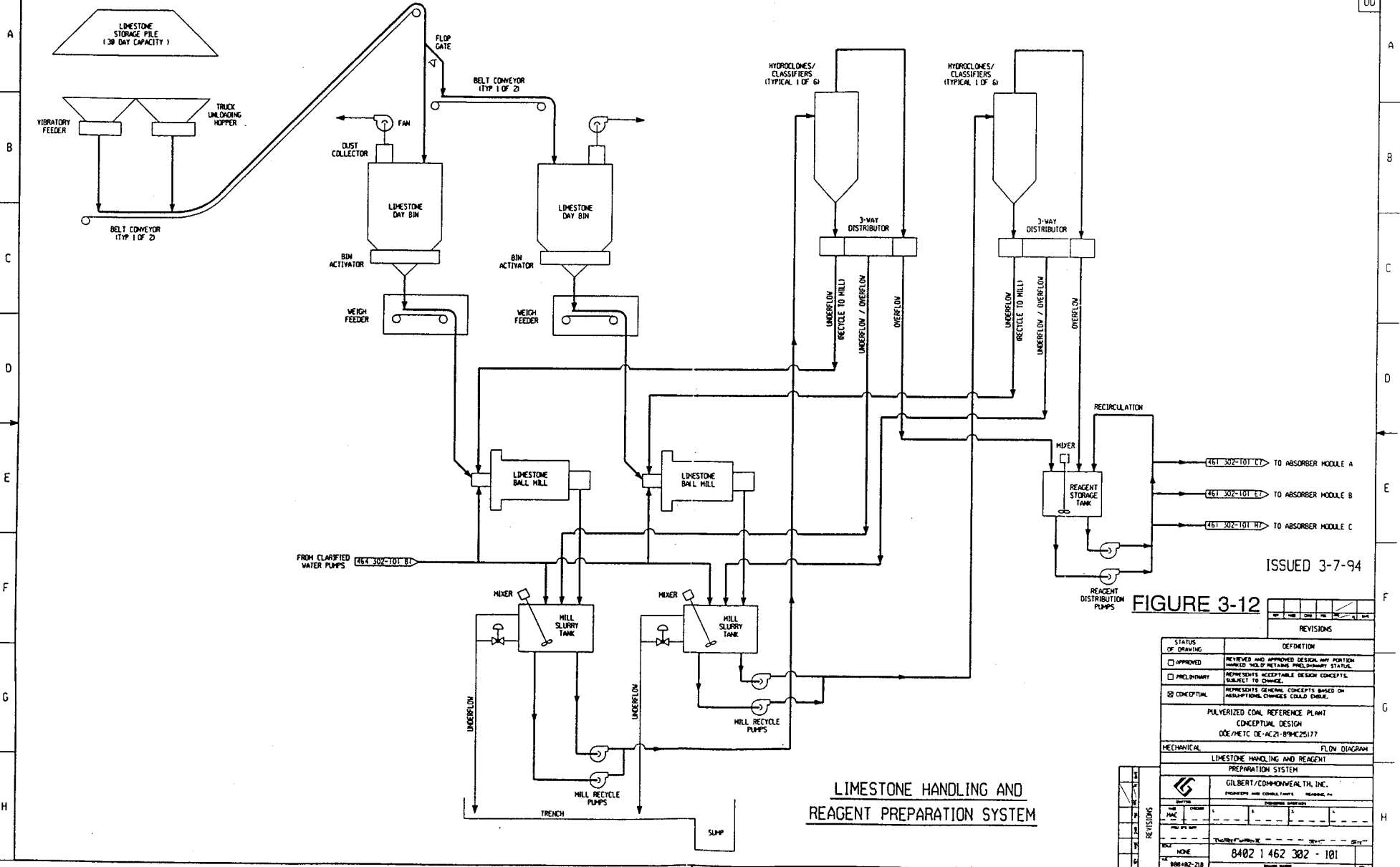

ISSUED 3-7-94

FIGURE 3-12

REVISIONS	
NO.	DESCRIPTION

STATUS OF DRAWING	DEFINITION												
<input type="checkbox"/> APPROVED	REVIEWED AND APPROVED DESIGN. ANY PORTION MARKED "NO OF RETAINS" PRELIMINARY STATUS. SUBJECT TO CHANGE.												
<input type="checkbox"/> PRELIMINARY	REPRESENTS ACCEPTABLE DESIGN CONCEPT. SUBJECT TO CHANGE.												
<input checked="" type="checkbox"/> CONCEPTUAL	REPRESENTS GENERAL CONCEPTS BASED ON ASSUMPTIONS. CHANGES COULD ENSUE.												
PULVERIZED COAL REFERENCE PLANT CONCEPTUAL DESIGN D06/MTC DE-AC21-BPMC25177													
MECHANICAL FLOW DIAGRAM													
LIMESTONE HANDLING AND REAGENT PREPARATION SYSTEM													
GILBERT/COMMONWEALTH, INC. ENGINEERS AND CONSULTANTS													
<table border="1"> <thead> <tr> <th>DATE</th> <th>BY</th> <th>CHKD BY</th> <th>DATE</th> <th>DATE</th> <th>DATE</th> </tr> </thead> <tbody> <tr> <td> </td> <td> </td> <td> </td> <td> </td> <td> </td> <td> </td> </tr> </tbody> </table>		DATE	BY	CHKD BY	DATE	DATE	DATE						
DATE	BY	CHKD BY	DATE	DATE	DATE								
<table border="1"> <thead> <tr> <th>NO.</th> <th>DESCRIPTION</th> <th>DATE</th> </tr> </thead> <tbody> <tr> <td> </td> <td> </td> <td> </td> </tr> </tbody> </table>		NO.	DESCRIPTION	DATE									
NO.	DESCRIPTION	DATE											
TITLE: 8402 1 462 302 - 101 PROJECT: 8402-210													

LIMESTONE HANDLING AND REAGENT PREPARATION SYSTEM

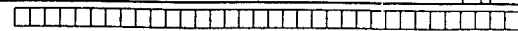
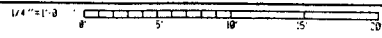

### 3.4.3.2 Technical Requirements and Design Basis

#### 1. Limestone Usage Rate:

- Maximum Limestone Usage Rate = 38,021 lb/h = 19 tph  
(based on operating at 5% OP, VWO continuously; 155 tph firing rate for design coal and 80% CaCO<sub>3</sub> in the limestone)
- Average Limestone Usage Rate = 24,714 lb/h = 12.4 tph  
(based on Maximum limestone usage rate multiplied by assumed capacity factor)

#### 2. Limestone Delivered to the Plant by 25-Ton Dump Trucks

#### 3. Total Number of Trucks Per Day = 19

#### 4. Total Unloading Time Per Day = 3.2 hours

#### 5. Total Time, Interval per Truck = 10 min./truck

#### 6. Receiving Hopper Capacity = 35 tons

#### 7. Limestone Received = 1" x O"

#### 8. Limestone Storage Capacity = 13,750 tons (30 days supply @ maximum burn rate)

#### 9. Storage Pile Size = 211 ft. x 90 ft. x 40 ft. high.

#### 10 Day Bin Storage = 306 Tons (16 hr supply @ maximum burn rate, total for 2 bins)

#### 11 Conveying Rate to Day Bins = 115 tph

#### 12 Weigh Feeder/Limestone Ball Mill Capacity, 27 tph (based on two shifts per day of grinding operations)

#### 13. Mill Slurry Tank Capacity, 5,000 gallons, each of 2 tanks

#### 14. Mill Recycle Pump Capacity, 600 gpm, each of 4 pumps, two per mill

#### 15. No. of hydroclones, 1 assembly for each mill, rated at 600 gpm

#### 16. Reagent Storage Tank Capacity, 110,000 gallons, 1 tank

#### 17. Reagent Distribution Pump Capacity, 500 gpm, each of 2 pumps

Access platforms and catwalks are provided to permit the periodic greasing, lubrication, and observation of all rotating or moving equipment. Conveyors have a main access aisle on one side with grease fittings directed toward this aisle,

On conveyor bridges or in tunnels, small access platforms or aisles on the outboard side give access to idlers for replacement. Monorails serve the conveyor head shafts and their accompanying drive assembly (gear and motor), permitting the removal of heavy pieces to grade.

#### 3.4.4 Flue Gas Desulfurization

The function of the Flue Gas Desulfurization (FGD) system is to scrub the boiler exhaust gases to remove most of the SO<sub>2</sub> content prior to release to the environment. The scope of the FGD system is from the outlet of the Induced Draft (ID) Fans to the stack inlet. A schematic diagram showing the major equipment is shown on Figure 3-13 and a cutaway view of a typical scrubber absorber module is shown in Figure 3-14. The system is designed to support short term operation at the 5% OP/VWO condition (16 hours) and long term operation at the 100% guarantee point (90 days or more),

##### 3.4.4.1 Operation Description

The flue gas exiting the air preheater section of the boiler passes through a pair of electrostatic precipitator units, then through the ID fans and into two of the three 50% capacity absorber modules. The modules are designed to operate with counter-current flow of gas and reagent. Upon entering the absorber vessel, the gas stream is subjected to an initial quenching spray of reagent. The gas flows upward through a tray, which provides enhanced contact between gas and reagent. Multiple sprays above the tray maintain a consistent reagent concentration in the tray zone. Continuing upward, the reagent laden gas passes through several levels of moisture separators. These typically consist of chevron-shaped vanes that direct the gas flow through several abrupt changes in direction, which separates entrained droplets of liquid by inertial effects. The scrubbed and dried flue gas exits at the top of the absorber vessel and is then routed to the plant stack. The FGD system for this reference plant is designed to continuously remove 92% of the SO<sub>2</sub> with a high circulating liquid to gas ratio and the use of formic acid,

Guillotine type isolation dampers, with seal air, are provided to isolate the absorber modules. A 50% capacity bypass duct is provided for startup and emergency upset conditions. The bypass duct is normally isolated by a double louver damper, which uses seal air for shaft sealing.

The scrubbing slurry falls to the lower portion of the absorber vessel, which contains a large inventory of liquid. Multiple agitators operate continuously to prevent settling of solids. A blower forces air, taken from the atmosphere, through a sparger in the bottom of the vessel. This promotes oxidation of the calcium sulfite to calcium sulfate or gypsum. The gypsum may be disposed of in a landfill or may be used to produce a commercially saleable wallboard. For this reference plant, the gypsum is disposed of in a local landfill.

The absorber chemical equilibrium is maintained by continuous makeup of fresh reagent, and blowdown of spent reagent via the bleed pumps. The spent reagent is routed to the Byproduct Dewatering System, Section 3.4.5. The circulating reagent is continuously monitored, with pH and density the principal parameters of interest.

This FGD system is design for “wet stack operation (i.e., no reheat or scrubber bypass is employed to raise exhaust gas temperature at the stack above saturation). This is acceptable for most siting conditions since new scrubbers have improved mist eliminator efficiency, and

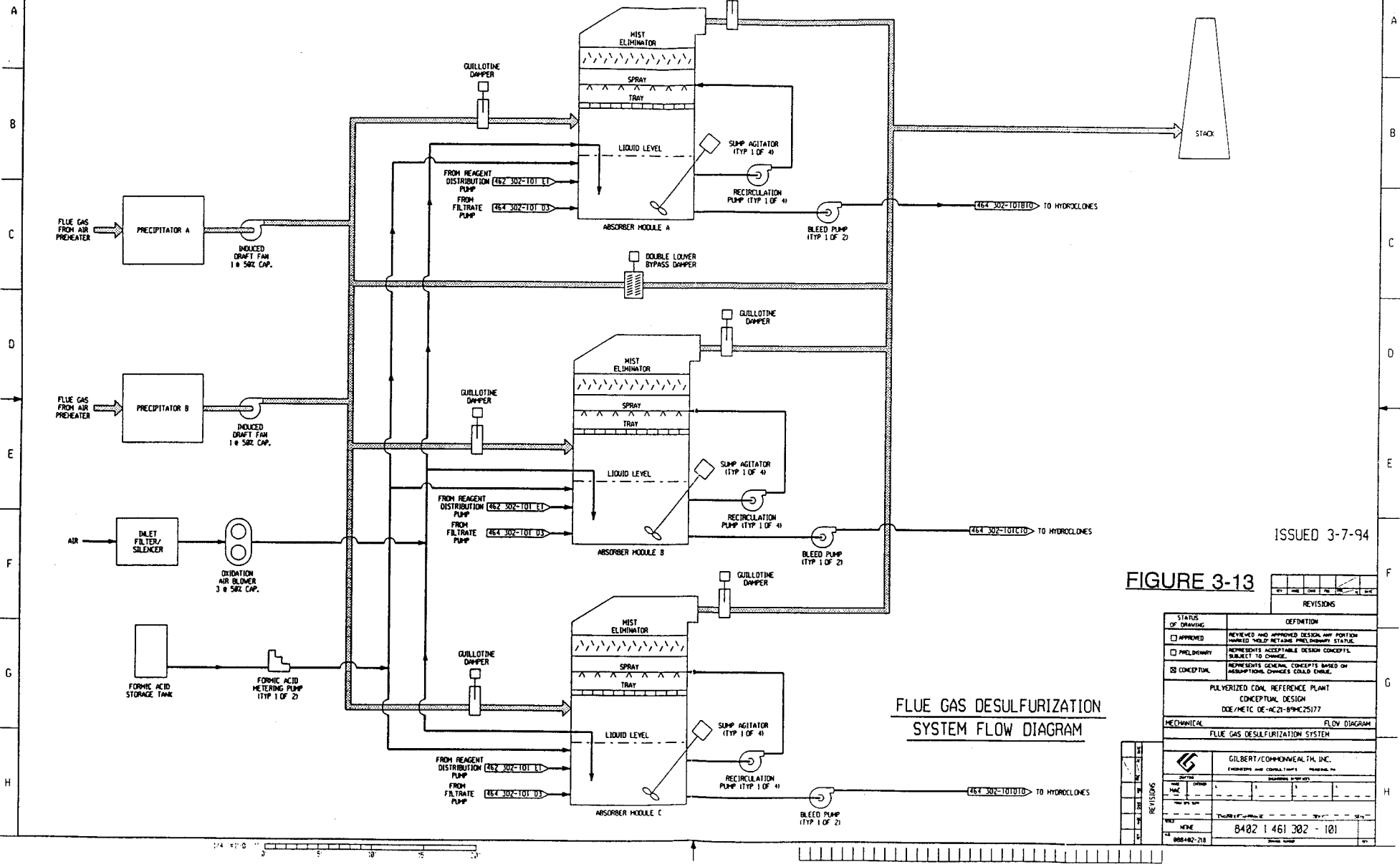

ISSUED 3-7-94

FIGURE 3-13

**FLUE GAS DESULFURIZATION  
SYSTEM FLOW DIAGRAM**

REVISIONS	
NO.	DESCRIPTION
1	ISSUED
2	
3	
4	
5	
6	
7	
8	
9	
10	

STATUS OF DRAWING	DEFINITION
<input type="checkbox"/> APPROVED	REVIEWED AND APPROVED DESIGN AND PORTION MARKED "NOT REVISION" PRELIMINARY STATUS.
<input type="checkbox"/> PRELIMINARY	REPRESENTS ACCEPTABLE DESIGN CONCEPT, SUBJECT TO CHANGE.
<input type="checkbox"/> CONCEPTUAL	REPRESENTS GENERAL CONCEPTS BASED ON ASSUMPTIONS, CHANGES COULD OCCUR.
PULVERIZED COAL REFERENCE PLANT CONCEPTUAL DESIGN DOE/NETC DE-AC21-89-FC25177	
MECHANICAL FLOW DIAGRAM	
FLUE GAS DESULFURIZATION SYSTEM	
GILBERT/COMMONWEALTH, INC. ENGINEERS AND CONSULTANTS	
PROJECT NO. 8402 1 461 382 - 101 SHEET NO. 888-482-218	

# Babcock & Wilcox Absorber Module

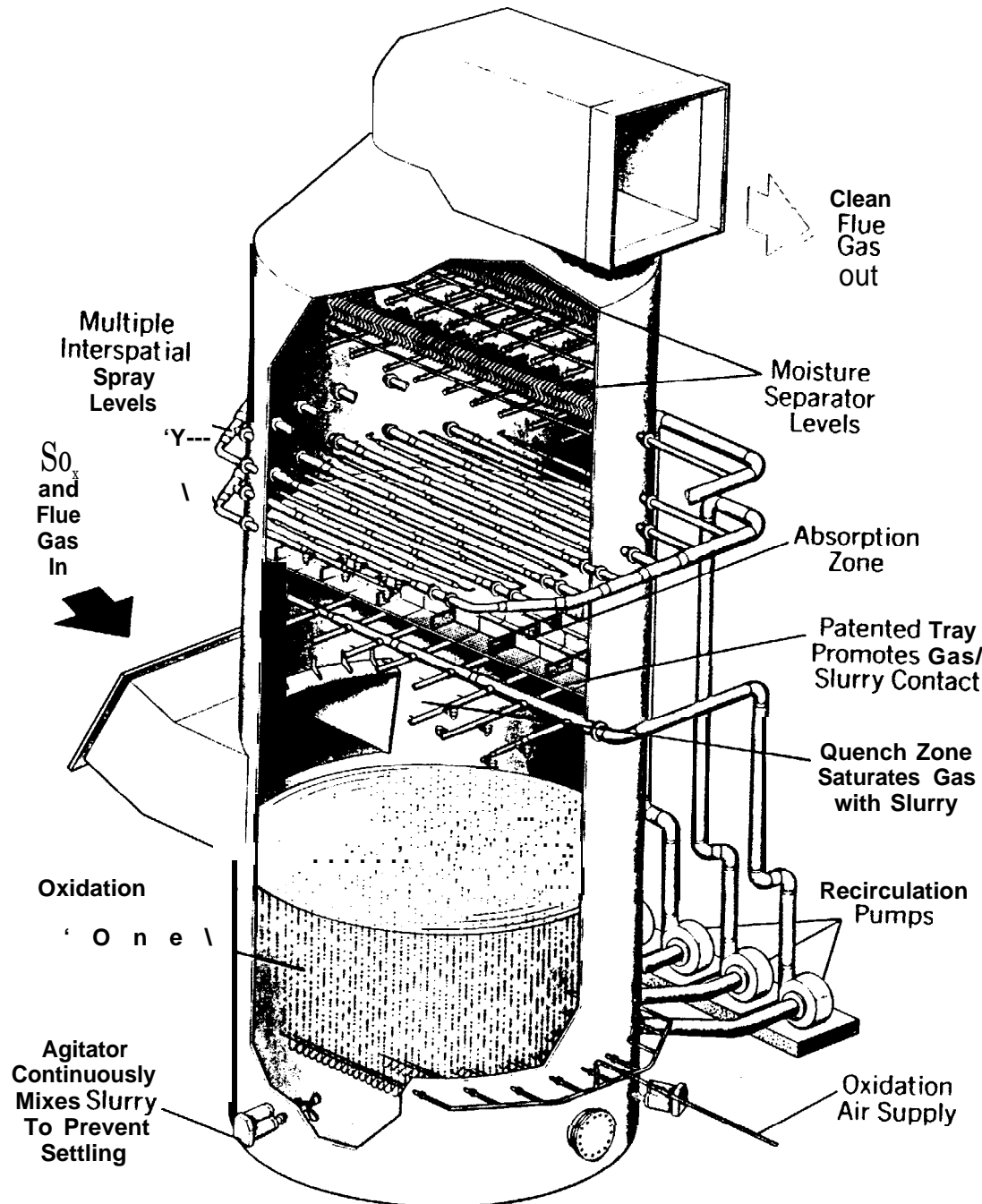

SCRUBBER MODULE CROSS SECTION

**FIGURE 3-14**

detailed flow modeling of the flue interior enables the placement of gutters and drains to intercept moisture that may be present and convey it to a drain.

#### **3.4.4.2 Technical Requirements and Design Basis**

1. Number and Type of Absorber Modules - Three, 50% capacity, counter-current tower design, including quench, absorption and moisture separation zones, recirculated slurry inventory in lower portion of absorber vessel. Each vessel is 33 ft in diameter by 100 ft high.
2. Slurry Recirculation Pumps - Four at 50% capacity each per absorber module, 17,500 gpm each.
3. Slurry Bleed Pumps - Two at 100% capacity each per absorber module, 650 gpm each.
4. Oxidation Air Blowers - Three at 50% capacity each, 5,650 cfm.
5. Absorber Tank Agitator - Four per absorber module, each with 20 hp motor.
6. Stack - One reinforced concrete shell, 70 ft outside diameter at the base, 480 ft high with two fiberglass reinforced plastic (FRP) chimney liners, each 19.5 feet in diameter. The second liner is to accommodate a future unit,
7. Absorber Inlet Isolation Dampers, one per absorber module, guillotine type with seal air.
8. Absorber Outlet Isolation Dampers, one per absorber module, guillotine type with seal air.
9. Bypass Damper - one at 50% capacity, double louver type with seal air.
10. Formic Acid Tank - one at 1,000 gallons (one week of consumption).
11. Formic Acid Pumps, two at 100% capacity, metering type, 0.1 gpm.

#### **3.4.5 Byproduct Dewatering**

The function of the byproduct dewatering system is to dewater the bleed slurry from the FGD absorber modules. The dewatering process selected for the Reference PC plant produces a highly dewatered end product, (90 to 95% solids) suitable for disposal to a landfill. The scope of the system is from the bleed pump discharge connections to the dewatered byproduct storage pile. A schematic diagram of the system is shown on the Byproduct Dewatering System Flow Diagram, Figure 3-15. The system is designed to support short term operation at the 5% OP/VWO condition (16 hours) and long term operation at the 100% guarantee point (90 days or more).

##### **3.4.5.1 Operation Description**

The recirculating reagent in the FGD absorber vessels accumulates dissolved and suspended solids on a continuous basis, as byproducts from the SO<sub>2</sub> absorption reactions proceed. Maintenance of the recirculating reagent requires that a portion be withdrawn and replaced by



fresh reagent. This is accomplished on a continuous basis, except for periodic intervals when the spent reagent density may be below predefined limits.

**a. Primary Hydroclones**

The bleed pumps remove slurry from the absorber vessel liquid inventory and pump it to a hydroclone feed tank. Hydroclone feed pumps take suction from this tank and pump the slurry to the primary hydroclone manifolds, where the slurry is distributed among a complement of primary hydroclones. Underflow from the hydroclones (at about 25% solids) passes to the centrifuge feed tanks, and then is pumped to an array of vertical basket centrifuges. The centrifuges and their feed pumps are sized so that five of the six units support full load operation, when operating with design coal (3.1 % sulfur),

**b. Centrifuge; Solids to Storage Pile**

Each centrifuge operates on a timed cycle comprised of the following steps: filling; spin drying; discharge of the solids. During the spin drying process, liquid is forced through a filter by centrifugal action of the centrifuge basket; the solids cannot pass through the filter and form a cake lining the filter wall.

The discharge of the dewatered solids is accomplished by rotation of the centrifuge at a low speed while a peeling knife is deployed to scrape the solids from the filter lining the centrifuge basket. The solids fall through a bottom discharge chute onto a collecting conveyor which discharges to a transfer conveyor and then to the storage pile via a radial stacker. For design coal, about 23 tph of gypsum is produced,

The liquid filtrate from each centrifuge is discharged to a filtrate tank where it is combined with other liquid streams for return to the absorber modules.

**c. Primary Hydroclones, Overflow**

The overflow from the primary hydroclones is routed to a secondary hydroclone feed tank from which it is pumped to an array of secondary hydroclones. The underflow from these units passes to the filtrate tanks,

**d. Secondary Hydroclones, Overflow**

The overflow from the secondary hydroclones, which is relatively free of suspended solids, is passed to a clarified water tank for interim storage. The clarified water is returned to the Limestone Handling and Reagent Preparation System for use in preparation of fresh reagent.

**3.4.5.2 Technical Requirements and Design Bases**

1. Primary Hydroclones - Two radial arrays, each at 650 gpm capacity,
2. Centrifuge Feed Tank - Two, each at 3,100 gal.
3. Centrifuge Feed Pumps - Two, horizontal centrifugal, each at 1,300 gpm.
4. Vertical Basket Centrifuges - Six, each at 100 gpm capacity,
5. Secondary Hydroclone Feed Tank - Two, each at 9,100 gal,



6. Secondary Hydroclone Feed Pumps - Two, horizontal centrifugal, each at 260 gpm.
7. Secondary Hydroclones - Two radial arrays, each at 260 gpm capacity.
8. Filtrate Tanks - Two, each at 26,500 gal.
9. Filtrate Pumps - Two, horizontal centrifugal, each at 1,130 gpm.
10. Clarified Water Tanks - Two, each at 53,800 gal.
11. Clarified Water Pumps - Two, horizontal centrifugal, each at 200 gpm.
12. Collecting Conveyors - Two, each with 30 inch belt rated at 130 tph.
13. Transfer Conveyors - Two, each with 30 inch belt, rated at 130 tph.
14. Radial Stacker - One, rated at 130 tph

#### 3.4.6 **Ash Handling System**

The function of the ash handling system is to provide the equipment required for conveying, preparing, storing, and disposing the **flyash** and bottom ash produced on a daily basis by the boiler. The scope of the system is from the precipitator hoppers, air heater hopper collectors, and bottom ash hoppers to the ash pond (for bottom ash) and truck filling stations (for fly ash). A schematic diagram of the **flyash** and bottom ash flow is shown on the Ash Handling Flow Diagram, Figure 3-16. The system is designed to support short term operation at the 5% OP/VWO condition (16 hours) and long term operation at the 100% guarantee point (90 days or more).

##### 3.4.6.1 **Operation Description**

The **flyash** collected in the precipitators and the air heaters is conveyed to the **flyash** storage silo. A pneumatic transport system using low pressure air from a blower provides the transport mechanism for the **flyash**. **Flyash** is discharged through a wet unloader, which conditions the **flyash** and conveys it through a telescopic unloading chute into a truck for disposal.

The bottom ash from the boiler is fed into a clinker grinder. The clinker grinder is provided to break up any clinkers that may form, From the clinker grinders the bottom ash is discharged via a hydro-ejector and ash discharge piping to the ash pond.

Ash from the economizer hoppers and pyrites (rejected from the coal pulverizers) are conveyed by hydraulic means (water) to the economizer/pyrites transfer tank. This material is then sluiced, on a periodic basis, to the ash pond.

##### 3.4.6.2 **Technical Requirements and Design Basis**

###### A. Bottom Ash:

###### 1. Bottom Ash And **Flyash** Rates:

- Bottom Ash Generation Rate, 6,316 lb/hr = 3.2 tph
- **Flyash** Generation Rate, 25,265 lb/hr = 12.6 tph

2. Clinker Grinder Capacity = 10 tph

3. Conveying Rate To Ash Pond = 10 tph

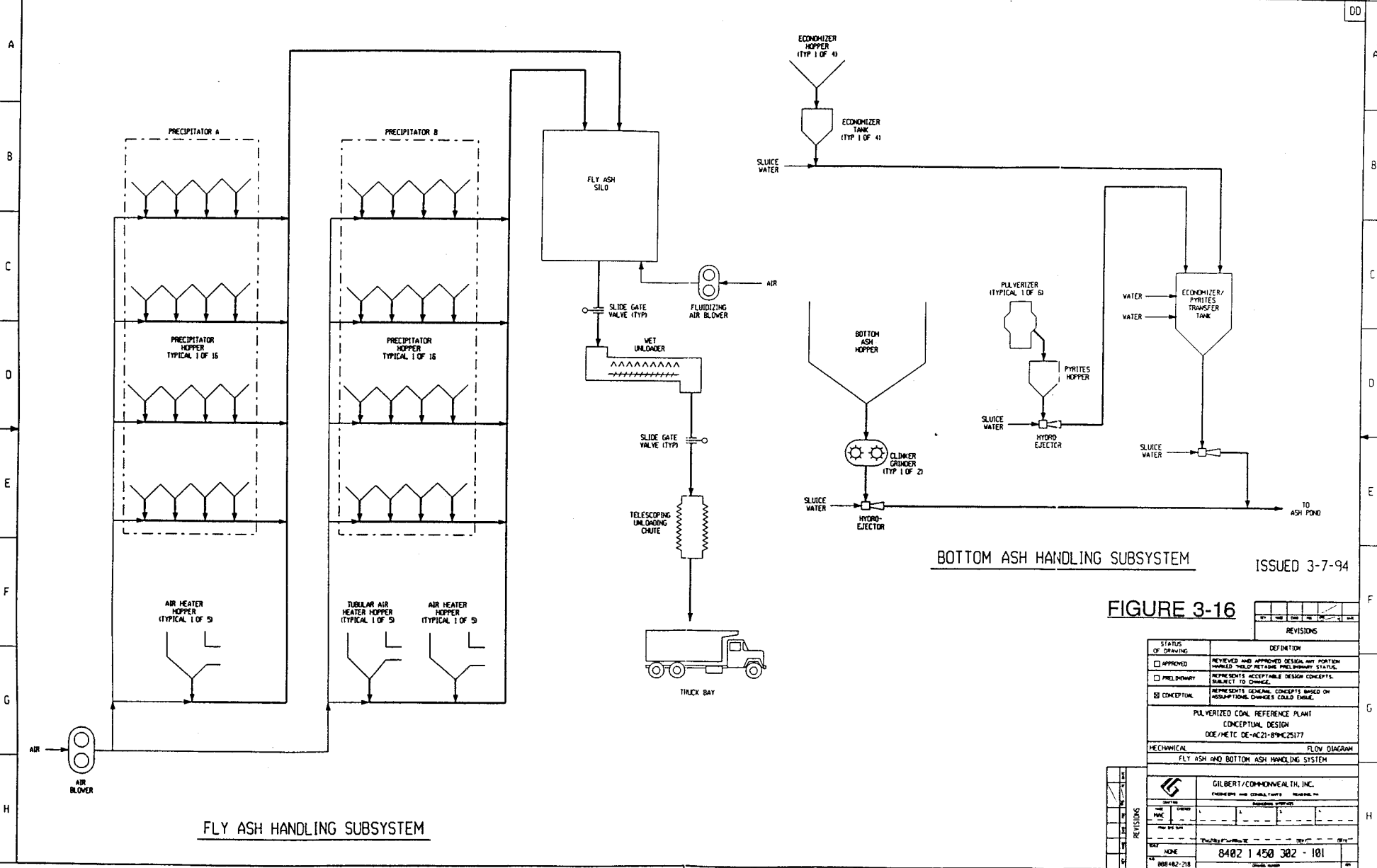

STATUS OF DRAWING	DEFINITION
<input type="checkbox"/> APPROVED	REVIEWED AND APPROVED DESIGN ANY PORTION HANDED OVER TO FIELD RETAINING PRELIMINARY STATUS.
<input type="checkbox"/> PRELIMINARY	REPRESENTS ACCEPTABLE DESIGN CONCEPTS SUBJECT TO CHANGE.
<input checked="" type="checkbox"/> CONCEPTUAL	REPRESENTS GENERAL CONCEPTS BASED ON ASSUMPTIONS CHANGES COULD OCCUR.

PULVERIZED COAL REFERENCE PLANT CONCEPTUAL DESIGN DOE/NETC DE-AC21-89MC25177	
MECHANICAL FLOW DIAGRAM FLY ASH AND BOTTOM ASH HANDLING SYSTEM	
GILBERT/COMMONWEALTH, INC. ENGINEERS AND CONSULTANTS	
PROJECT NO. 8402 1 450 302 - 101	SHEET NO. 8402-218

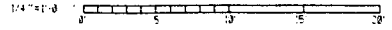

## B. Flyash:

1. Collection Rate = 12.6 tph
2. Conveying Rate From Precipitator and Air Heaters = 50 tph
3. Flyash Silo Capacity = 890 Tons (72 Hour Storage)
4. Wet Unloader Capacity = 30 tph

### 3.5 BALANCE OF PLANT

The following section provides a description of the plant outside the PC boiler system and its auxiliaries. Flow diagrams for the balance of plant are provided in Figure 3-17, Main, Reheat and Extraction Steam, and Figure 3-18, Condensate, Feedwater and Circulating Water.

#### 3.5.1 Turbine-Generator and Auxiliaries

The turbine consists of an high pressure (HP) section, intermediate pressure (IP) section and two double flow low pressure (LP) sections all connected to the generator by a common shaft. Main steam from the boiler passes through the stop valves and control valves and enters the turbine at 2400 psig/ 1000°F. The steam initially enters the turbine near the middle of the high pressure span, flows through the turbine and returns to the boiler for reheating. The reheat steam flows through the reheat stop valves and intercept valves and enters the IP section at 530 psig/1000°F. After passing through the IP section, the steam enters a cross-over pipe which transports the steam to the two LP sections, The steam divides into four paths and flows through the LP sections exhausting downward into the condenser.

The heat balance for this reference plant reflects the use of a steam turbine-generator that incorporates current state-of-the-art design and manufacturing techniques. Significant gains in turbine adiabatic efficiency have been achieved in the last decade by improved aerodynamic design for the steam path, and by reducing parasitic losses such as shaft seal leakages, and tip and root leakages. The cycle performance, based on use of a steam turbine incorporating these advances, results in an improvement of several percent in heat rate relative to the turbine cycle heat rate calculated based on long established steam turbine performance prediction methods. This is a change from the methods used to define steam cycle performance presented in the AFBC Clean Coal Reference Plant report issued in 1992, and represents a 3 % improvement in adiabatic efficiency for the overall turbine.

Turbine bearings are lubricated by a closed loop water cooled pressurized oil system. The oil is contained in a reservoir located below the turbine floor. During startup or unit trip the oil is pumped by an emergency oil pump mounted on the reservoir, When the turbine reaches 95 percent of synchronous speed, oil is pumped by the main pump mounted on the turbine shaft. The oil flows through water cooled heat exchangers prior to entering the bearings. The oil then flows through the bearings and returns by gravity to the lube oil reservoir.

Turbine shafts are sealed against air in-leakage or steam blow out using a labyrinth gland arrangement connected to a low pressure steam seal system, During startup, seal steam is provided from the main steam line. As the unit increases load, HP turbine gland leakage

10

9

8

7

6

5

4

3

2

1

87-400-1594 1/31/2  
140086-0403102.DCM

DD

A

B

C

D

E

F

G

H

A

B

C

D

E

F

G

H

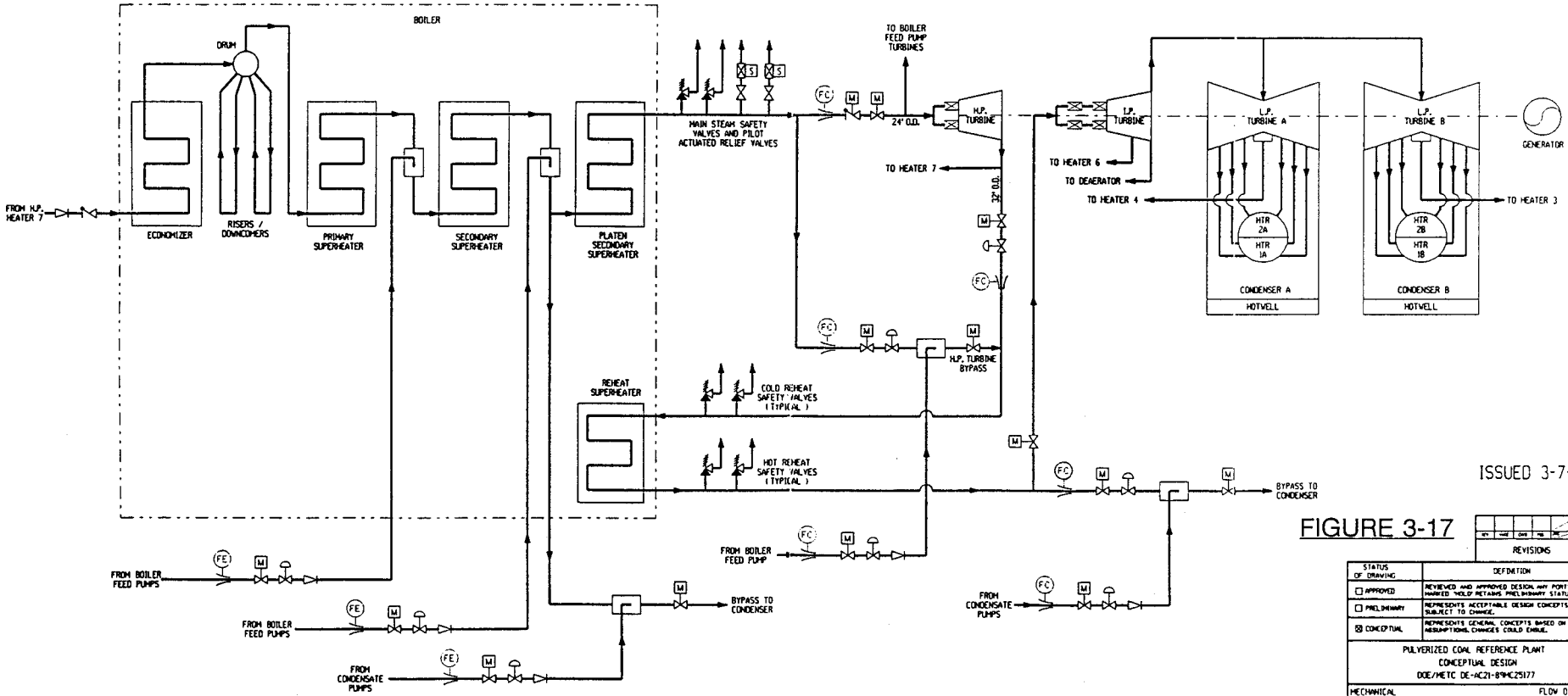

ISSUED 3-7-94

FIGURE 3-17

REVISIONS	
NO.	DESCRIPTION

STATUS OF DRAWING	DEFINITION
<input type="checkbox"/> APPROVED	REVIEWED AND APPROVED DESIGN AND PORTION MARKED "NOT TO BE BUILT" PRELIMINARY STATUS.
<input type="checkbox"/> PRELIMINARY	REPRESENTS ACCEPTABLE DESIGN CONCEPTS, SUBJECT TO CHANGE.
<input checked="" type="checkbox"/> CONCEPTUAL	REPRESENTS GENERAL CONCEPTS BASED ON ASSUMPTIONS, CHANGES COULD ENTAIL.

PULVERIZED COAL REFERENCE PLANT  
CONCEPTUAL DESIGN  
DOE/NETC DE-AC21-89-PC25177

MECHANICAL FLOW DIAGRAM  
MAIN REHEAT AND EXTRACTION STEAM SYSTEMS

GILBERT/COMMONWEALTH, INC. <small>ENGINEERS AND CONSULTANTS</small>																			
<table border="1"> <tr> <th>NO.</th> <th>DATE</th> <th>BY</th> <th>DESCRIPTION</th> </tr> <tr> <td> </td> <td> </td> <td> </td> <td> </td> </tr> </table>	NO.	DATE	BY	DESCRIPTION					<table border="1"> <tr> <td> <table border="1"> <tr> <td> </td> <td> </td> <td> </td> <td> </td> </tr> </table> </td> <td> <table border="1"> <tr> <td> </td> <td> </td> <td> </td> <td> </td> </tr> </table> </td> </tr> </table>	<table border="1"> <tr> <td> </td> <td> </td> <td> </td> <td> </td> </tr> </table>					<table border="1"> <tr> <td> </td> <td> </td> <td> </td> <td> </td> </tr> </table>				
NO.	DATE	BY	DESCRIPTION																
<table border="1"> <tr> <td> </td> <td> </td> <td> </td> <td> </td> </tr> </table>					<table border="1"> <tr> <td> </td> <td> </td> <td> </td> <td> </td> </tr> </table>														
TITLE: NONE NO: 84021540302-102 800-402-210																			

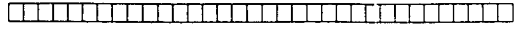
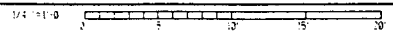

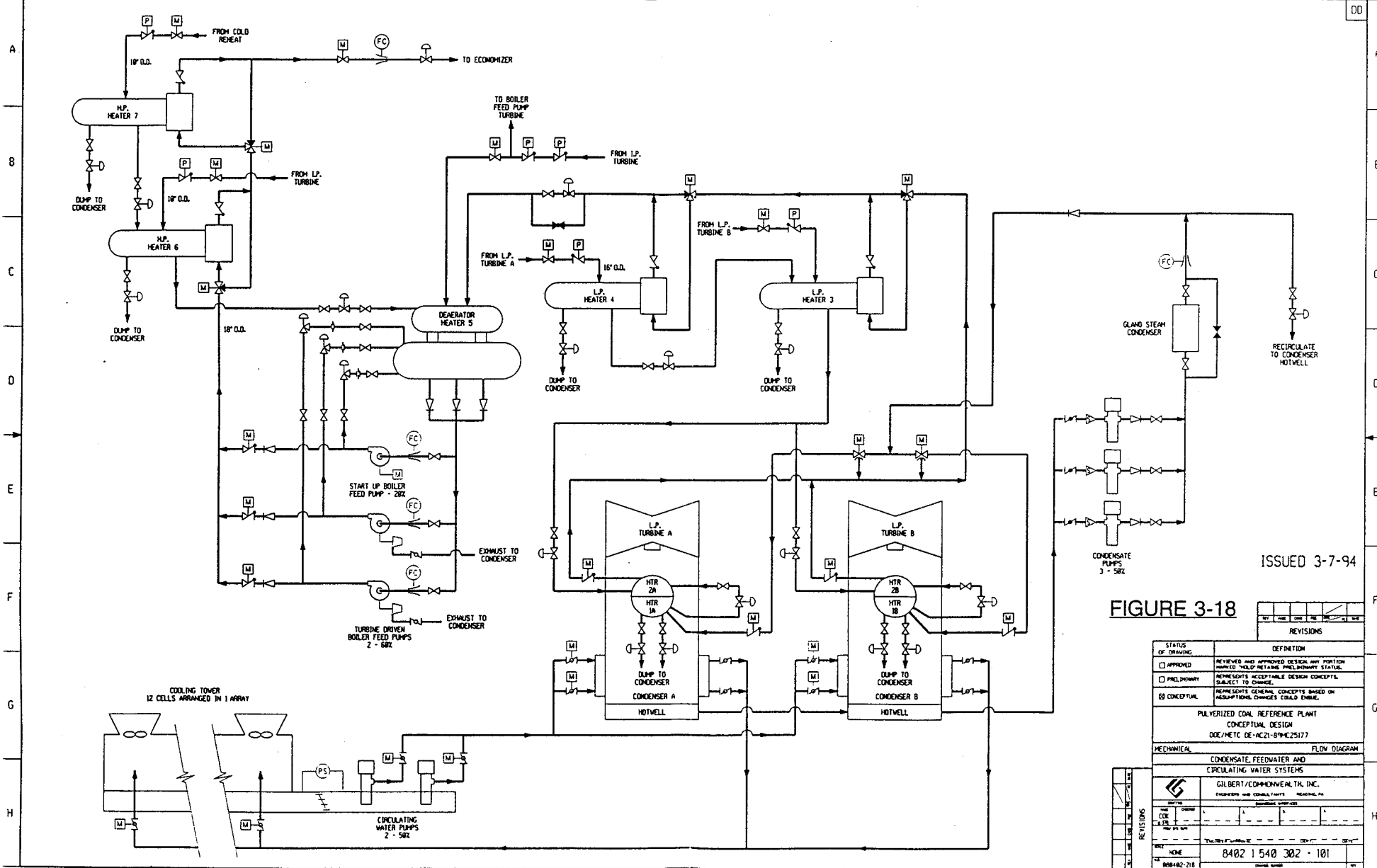

ISSUED 3-7-94

FIGURE 3-18

NO.	DATE	BY	CHKD	REVISIONS

STATUS OF DRAWING	DEFINITION
<input type="checkbox"/> APPROVED	REVIEWED AND APPROVED DESIGN AND PORTION SHOWN; HOLDING PRELIMINARY STATUS.
<input type="checkbox"/> PRELIMINARY	DESIGNER'S ACCEPTABLE DESIGN CONCEPTS, SUBJECT TO CHANGE.
<input checked="" type="checkbox"/> CONCEPTUAL	DESIGNER'S GENERAL CONCEPTS BASED ON ASSUMPTIONS; CHANGES COULD ENTAIL.

PULVERIZED COAL REFERENCE PLANT  
 CONCEPTUAL DESIGN  
 DOE/NETC DE-AC21-89MC25177

MECHANICAL CONDENSATE, FEEDWATER AND CIRCULATING WATER SYSTEMS FLOW DIAGRAM

GILBERT/COMMONWEALTH, INC.  
 ENGINEERS AND CONSULTANTS READING, PA.

DATE	
SCALE	
REVISED BY	
DATE	

PROJECT: NONE

8402 1 540 302 - 101

888482-218

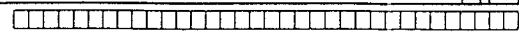
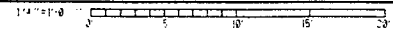

provides the seal steam. Pressure regulating valves control the gland header pressure and dump any excess steam to the condenser. A steam packing **exhauster** maintains a vacuum at the outer gland seals to prevent leakage of steam into the turbine room. **Any** steam collected is condensed in the packing **exhauster** and returned to the condensate system.

The generator stator is cooled with a closed loop water system consisting of circulating pumps, shell and tube or plate and frame type heat exchangers, filters and deionizes, all skid mounted.

Water temperature is controlled by regulating heat exchanger bypass water flow. Stator cooling water flow is controlled by regulating stator inlet pressure.

The generator rotor is cooled with a hydrogen gas recirculation system using fans mounted on the generator rotor shaft. The heat absorbed by the gas is removed as it passes over finned tube gas coolers mounted in the stator frame. Stator cooling water flows through these coils. Gas is prevented from escaping at the rotor shafts using a closed loop oil seal system. The oil seal system consists of a storage tank, pumps, filters and pressure controls, all skid mounted.

### 3S1.1 Operation Description

The turbine stop valves, control valves, reheat stop valves and intercept valves are controlled by an **electro-hydraulic** control system,

The turbine is designed to operate at constant inlet steam pressure over the entire load range and is capable of being converted in the future to sliding pressure operation for economic unit cycling.

### 3.5.1.2 Technical Requirements and Design Basis

#### Design Basis

1. Full Load Heat Balance 8402-1-400-314-101 (Figure 3-1)
2. 5% Overpressure, VWO Heat Balance -8402-1-400-314-102 (Figure 3-2)

#### Components

- |   |  |
|---|--|
| <ol style="list-style-type: none"> <li>1. Turbine Generator <ul style="list-style-type: none"> <li>•Quantity</li> <li>•Type</li> </ul> </li> </ol>  | <p>1</p> <p>Tandem compound, four flow exhaust, single reheat, 30 inch last stage buckets, with direct connected hydrogen cooled generator</p> |
| <p>Design Data</p>  |  |
| <ul style="list-style-type: none"> <li>•Guarantee Rating</li> <li>•Max. Expected Rating</li> <li>•Speed</li> <li>•Throttle Pressure</li> <li style="padding-left: 20px;">- Guarantee</li> </ul> | <p><b>434,500 kw</b> (at Generator Terminals)</p> <p>468,400 kw (5% O.P. VWO)</p> <p>3600 rpm</p> <p><b>2400</b> psig</p>                      |

- 5% O.P.	2520 psig
•Main Steam Temp.	1000°F
•Reheat Steam Temp.	1000°F
•Throttle Flow	
- Guarantee	2,734,000lb/h
- 5% O.P.	3,014,185 lb/h
•Exhaust Pressure	1.4/2.0 inch Hg
•Number of Extractions	7

2. Auxiliary Equipment
  - Bearing Lube Oil System
  - Gland Steam Seal System
  - Generator Cooling Water System
  - Generator Hydrogen Cooling System
  - Hydrogen Seal Oil System
  - Electro-Hydraulic Control System
  - Exciter

### 3.5.2 Condensate and Feedwater Systems

The Condensate and Feedwater systems are designed to support continuous operation at the 5% OP/VWO coincident condition.

#### Condensate

The function of the condensate system is to pump condensate from the condenser hotwell through the steam packing exhauster and four stages of low pressure (LP) feedwater heaters to the deaerator.

The system consists of one main condenser; three 50 percent capacity, motor driven vertical condensate pumps with solid state controlled, variable frequency variable speed electric drives; one gland steam exhauster; four stages of feedwater heaters with the first two stages located in the condenser neck; one deaerator with storage tank; three 50 percent capacity vacuum pumps; and one 250,000 gallon condensate storage tank,

The first two stages of feedwater heating are comprised of two 50 percent capacity, parallel flow, duplex, U-tube exchangers installed in the condenser necks. Heaters Nos. 3 and 4 are 100% capacity, shell and U-tube heat exchangers. The fifth stage is the deaerator.

Condensate is delivered to a common discharge header through three separate pump discharge lines, each with a check valve and a gate valve. A common minimum flow recirculation line discharging to the condenser is provided to maintain minimum flow requirements for the gland steam exhauster and the condensate pumps.

Each LP feedwater heater is provided with inlet/outlet isolation valves and a full capacity bypass. LP feedwater heater drains cascade down to the next lowest extraction pressure heater and finally discharge into the condenser. Normal drain level in the heaters are controlled by pneumatic level control valves. High heater level dump lines discharging to the condenser are

provided for each heater for turbine water induction protection. Dump line flow is controlled by pneumatic level control valves.

### **Feedwater**

**The** function of the feedwater system is to pump feedwater from the **deaerator** storage tank through two stages of high pressure (HP) feedwater heaters to the economizer inlet on the boiler,

The system consists of two 60 percent capacity turbine driven boiler feed pumps; one 25 percent capacity motor driven startup boiler feed pump and two stages of high pressure feedwater heaters.

Each pump is provided with inlet and outlet isolation valves, outlet check valves and individual minimum flow recirculation lines discharging back to the **deaerator** storage tank. The recirculation flow is controlled by pneumatic flow control valves. In addition, the suctions of the boiler feed pumps are equipped with startup strainers, which are utilized during initial startup and following major outages or system maintenance.

Each HP feedwater heater is provided with inlet/outlet isolation valves and a full capacity bypass. Feedwater heater drains cascade down to the next lowest extraction pressure heater and finally discharge into the **deaerator**. Normal drain level in the heaters are controlled by pneumatic level control valves. High heater level dump lines discharging to the condenser are provided for each heater for turbine water induction protection. Dump line flow is controlled by pneumatic level control valves.

#### **3.5.2.1 Operation Description**

### **Condensate**

Condenser vacuum pump operation is initiated by the operator at local panels, After initiation, vacuum pump operation is automatic throughout the design range of the vacuum pumps. The local panels include alarms for monitoring the performance of the vacuum pumps, with common annunciation in the main control room,

After the initial vacuum is established, and condensate system valves are aligned for normal operation, the system is monitored from the main control board for startup, shutdown, and all load swings. The condensate pumps and heater bypass valves are controlled from the main control room. The condensate transfer pump is arranged for local starting and stopping only, with automatic minimum flow recirculation.

### **Feedwater**

**The** boiler feed pumps are controlled by the **DCS**. AU critical system malfunctions are alarmed. In the event of heater failure, automatic controls are actuated to prevent turbine water induction damage. An individual heater can be isolated and bypassed from the main control room.

During a startup, the motor driven startup boiler feed pump is used to allow the boiler to be fired. When main steam becomes available, a turbine driven feed pump can be operated to



bring the turbine-generator on line, As the main turbine exceeds 60 percent load, the steam source automatically switches over to turbine extraction. If one of the turbine driven feed pumps fails, the motor driven startup feed pump can be operated in parallel with the remaining main feed pump to support approximately 95 percent total plant load.

### 3.5.2.2 Technical Requirements and Design Basis

#### Design Basis

1. The systems are sized to pass the flow rates occurring at 5 percent overpressure, valves wide open condition. System components are specified with design margins such as additional head and flow for pumps, and tubes/tube surface for tube plugging and fouling in heaters and condensers.
2. All piping is designed in accordance with ANSI B31, 1. All valves are designed in accordance with ANSI B16.34.
3. All heaters, the deaerator/storage tank, and the condenser are designed in accordance with ASME B&PV Code, Section VIII, Div. 1 and HEI Standards.
4. The condensate storage tank is designed in accordance with AWWA D100.

#### Components (nominal values at 100% load)

##### **Condenser**

•Quantity	1
• Type	Two shell, transverse, dual pressure with divided waterbox for each shell
•Steam to Condensate at 1.4/2.0 in Hg	1,834,438 lb/h (Note 1)
•Net Heat Transfer	1,718 x 10 <sup>6</sup> Btu/h
•Circulating Water Flow	202,000 gpm
•Circulating Water Inlet Temp.	75°F
•Circulating Water Temp. Rise	20°F
•Terminal Temp Diff,	6°F
•Condenser <b>Shell</b> Pressure	1.4/2.0 inch Hg. abs.
•Tube Material	90-10 CuNi (main section), 70-30 CuNi (air removal section)

Note 1- Main and Boiler Feed Pump Turbines

##### **Vacuum Pumps**

•Quantity	2
•Type	Rotary-Water sealed
•Holding Capacity at 1 inch Hg abs	25 scfm
•Hogging Capacity at 15 inch Hg abs	2500 scfm
•Speed	470 rpm
•Horsepower	100 hp

- Construction

iron

### Condensate Storage Tanks

- Quantity
- Type
- Capacity
- Diameter
- Height
- Internal Coatings

1  
Field erected, flat roof, internal diaphragm  
200,000 gallons, usable volume  
36 ft.  
30 ft.  
**Epoxy-phenolic-Plastic 7155** or equal

### Condensate Pumps

- Quantity
- Type
- Capacity
- Total Head
- Horsepower (at design)
- Speed (max)
- Impeller Material

**3 @ 50%** capacity  
Vertical canned centrifugal with variable speed drive (solid state controlled, variable frequency)  
2500 gpm  
800 ft.  
650 hp  
1750 rpm  
Bronze

### L.P. Feedwater Heaters

- Quantity
- Type
- Feedwater Flow
- Terminal Temp Diff
- Tube Material

**4**  
Horizontal, 2 pass, U-tube  
2,249,030 lb/hr  
8°F  
Welded type 304 S.S. with .03% max carbon

### Heater No. 1A/1B (Combined Flows)

- Feedwater Inlet Temp.
- Steam Enthalpy
- Shell Sat. Temp/Pressure
- Drains Cooler Approach
- Drains Inlet Flow
- Drains Inlet Enthalpy
- Shell Design Condition
- Tube Design Condition

**98.2°F**  
**1095 Btu/lb**  
**170.1 °F/6.0 psia**  
**8°F**  
**263,913 lb/h**  
**143.4 Btu/lb**  
**50 psig/300°F**  
**500 psig/300°F**

### Heater No. 2A/2B (Combined Flows)

- Feedwater Inlet Temp
- Steam Enthalpy

**167.4°F**  
**1140.4 Btu/lb**

•Shell Sat. Temp/Pressure	201.5 °F/11.9 psia
•Drain Cooler Approach	8°F
•Drain Inlet Flow	199,567 lb/h
•Drains Inlet Enthalpy	174.9 Btu/lb
•Shell Design Conditions	100 psig/400°F
•Tube Design Conditions	500 psig/250°F

### Heater No. 3

•Feedwater Inlet Temp	198.7°F
•Steam Enthalpy	1185.2 Btu/lb
•Shell Sat. Temp/Pressure	234 °F/22.4 psia
•Drains Cooler Approach	8°F
•Drains Inlet Flow	131,258 lb/h
•Drains Inlet Enthalpy	207.6 Btu/lb
•Shell Design Conditions	100 psig/500°F
•Tube Design Conditions	500 psig/350°F

### Heater No. 4

•Feedwater Inlet Temp	231.1°F
•Steam Enthalpy	1272.1 Btu/lb
•Shell Sat. Temp/Pressure	295.3° F/62.4 psia
•Shell Design Conditions	150 psig/650°F
•Tube Design Conditions	500 psig/400°F

### Deaerator and Storage Tank

•Quantity	1
• Type	Horizontal, spray tray type with internal direct contact stainless steel vent condenser and storage tank
•Design Condition	200 psig/400°F
•Outlet Feedwater Flow	2,747,265 lb/h
•Saturation Temp/Pressure	365.9 °F/164.8 psia
•Steam Enthalpy	1373.9 Btu/lb
•Steam Flow	160,693 lb/h
•Condensate Inlet Flow	2,249,030 lb/h
•Condensate Inlet Enthalpy	262.2 Btu/lb
•Drains Inlet Flow	337,796 lb/h
•Drains Inlet Enthalpy	354.1 Btu/lb
•Storage Tank Live Volume	30,000 gal,

### Boiler Feed Pumps - Turbine Driven (at 100% design condition T=364°F)

•Quantity	2 at 60% capacity
•Type	Staged high pressure centrifugal

•Capacity	3,400 gpm
•Total Head	7,500 ft.
•Horsepower	7,100 hp
•Speed	5,500 rpm

**Startup Boiler Feed Pumps - Motor Driven**  
(at cold startup  $T_{H_2O} = 90^\circ\text{F}$ )

•Quantity	1 at 25% capacity
• Type	Staged high pressure centrifugal
•Capacity	1,500 gpm
•Total Head	7,200 ft.
•Horsepower	3,500 hp
•Speed	3,600 rpm

**HP Feedwater Heaters**

•Quantity	2
•Type	Horizontal 2 pass U-tube
•Feedwater Flow	2,652,909 lb/h (total)
•Terminal Temp Diff	+ 8° F
•Drains Cooler Approach	+ 15° F
•Tube Material	Welded type 304 S.S. with .03% max carbon

**Heater No. 6**

•Feedwater Inlet Temp	372.3°F
•Steam Enthalpy	1430.7 Btu/lb
•Shell Sat, Temp./Pressure	405.7 °F/263.8 psia
•Drains Inlet Flow	255,918 lb/h
•Drains inlet Enthalpy	392.3 Btu/lb
•Shell Design Condition	300 psig/(900°F skirt/650°F shell)
•Tube Design Condition	3600 psig/450°F

**Heater No. 7**

•Feedwater Inlet Temp	407.5°F
•Steam Enthalpy	1312.2 Btu/lb
•Shell Sat, Temp./Press	484, 10 F/588.5 psia
•Shell Design Condition	650 psig/650°F
•Tube Design Condition	3600 psig/550°F

### **3.5.3 Main, Reheat and Extraction Steam Systems**

The Main, Reheat and Extraction Steam systems are designed to support continuous operation at the **570 OP/VWO** coincident condition.

#### **Main and Reheat Steam**

The function of the main steam system is to convey main steam from the boiler superheater outlet to the high pressure turbine stop valves. The function of the reheat system is to convey steam from the HP turbine exhaust to the boiler reheater and from the boiler reheater outlet to the turbine reheat stop valves.

Main steam at approximately 2620 psig/1000°F exits the boiler superheater through a motor operated stop/check valve and a motor operated gate valve, and is routed in a single line feeding the HP turbine. A branch line off the main steam line feeds the two boiler feed pump turbines during unit operation up to 60 percent load.

Cold reheat steam at approximately 539 psig/635°F exits the HP turbine, flows through a motor operated isolation gate valve, a flow control valve and enters the boiler reheater. Hot reheat steam at approximately 530 psig/ 1000° F exits the boiler reheater through a motor operated gate valve and is routed in a single line feeding the 1P turbine. A branch connection from the cold reheat piping supplies steam to feedwater heater No. 7.

A two stage turbine bypass system is provided for the boiler. The system permits bypassing steam around the HP turbine and around the IP/LP turbine. The system is utilized to start up the boiler.

#### **Extraction Steam**

The function of the extraction steam system is to convey steam from turbine extraction points through the following routes:

- from 1P turbine exhaust to the boiler feed pump turbines
- from HP turbine exhaust (cold reheat) to Heater 7
- from 1P turbine to Heater 6
- from 1P turbine to **Deaerator**
- from LP turbine to Heaters 1,2,3 and 4

The turbine is protected from overspeed on turbine trip, and from flash steam reverse flow from the heaters through the extraction piping to the turbine. This protection is provided by positive closing, balanced disc non-return valves located in all extraction lines except the lines to the low pressure feedwater heaters in the condenser neck. The extraction non-return valves are located only in horizontal runs of piping and as close to the turbine as possible.

Water is prevented from entering the turbine through the use of motor-operated gate valves in each branch of the extraction piping. The header to the **deaerator** and boiler feed pump turbines has two extraction non-return valves, and the lines to the boiler feed pump turbines each have a **manually** operated gate valve and a swing check valve. The motor-operated gate valves close automatically on an emergency high-level signal from a level switch located on the

heater being supplied with steam or the respective line drain pot. The emergency high water level switch will also energize the solenoid of the air cylinder to close the non-return valve, and actuate an alarm in the control room. The motor-operated gate valve position limit switch opens the drain valves on the corresponding extraction steam drain manifold, which drains to the condenser. The valves cannot be returned to their normal positions until the emergency high water level switch indicates that the water level has fallen below the emergency level.

The turbine trip signal automatically trips the non-return valves through relay dumps. The remote manual control for each heater level control system is used to release the non-return valves to normal check valve service when required to restart the system.

### 3.53.1 Operation Description

All motor operated isolation valves can be operated locally or from the main control room. In the event of high water level in the respective steam line, the valve closes automatically.

All extraction non-return valves close automatically either on a unit trip or when high water level in the respective steam line is detected.

All pneumatic drain pot valves operate automatically during unit startup or on high level.

### 3.53.2 Technical Requirements and Design Basis

#### Design Basis

1. The systems are sized to pass the flow rates occurring at 5 percent overpressure, valves wide open condition (VWO).
2. All piping is designed in accordance with ANSI B3 1.1. All valves are designed in accordance with ANSI B 16.34.
3. The main steam line is designed for a total pressure drop of 100 psi at VWO, while limiting velocities to 20,000 fpm.
4. The cold reheat line is designed for a total pressure drop of 10 psi at VWO, while limiting velocities to 15,000 fpm.
5. The hot reheat line is designed for a total pressure drop of 20 psi at VWO, while limiting velocities to 20,000 fpm.
6. The extraction steam lines are designed for a total pressure drop of 5 percent of the extraction nozzle pressure while limiting velocities to 1,000 fpm per inch of pipe I.D.

### 3s.4 Circulating Water System

The function of the circulating water system is to supply cooling water to condense the main turbine exhaust steam,

The system consists of one **counterflow**, mechanical draft cooling tower comprised of 12 cells; two 50% capacity vertical circulating water pumps; and carbon steel cement lined interconnecting piping. The cooling tower structure is concrete, with PVC fill and fiberglass fan stacks. The circulating water system is designed based on economic optimization at the 100% load guarantee condition at the specified ambient wet bulb temperature.

The condenser is a twin shell, dual pressure type with divided water boxes arranged for series flow of the circulating water. There are two separate circulating water circuits in each box. The water enters condenser A then reverses flow into condenser B, where the discharge returns to the cooling tower. There are two separate cooling circuits through the condensers. One half of each condenser can be removed from service for cleaning or plugging tubes. This can be done during normal operation at reduced load.

The warm water leaving the condenser is passed through the cooling tower to transfer heat to the atmosphere by evaporation. The air flow is induced by the fans. Drift eliminators are used to remove entrained water droplets. Makeup water, to replace evaporated water, **blowdown** and drift, enters the cooling tower basin through a motor operated, automatic, level control valve. The tower is equipped with a fill bypass system to prevent freeze-up during cold weather,

The cooling tower discharge water flows to the circulating water pumps. A double set of removable screens, which remove large objects such as leaves, sticks, logs and ice to protect the circulating water pumps and condenser tubes, is installed upstream of the pump suction. These may be pulled out one at a time for cleaning as required, A bubbler type pressure differential switch monitors high pressure drop as an indication of plugging.

Each pump has a motor operated discharge butterfly valve. The pump discharge valve is interlocked with the pump motor starting circuit so that the valve is first opened approximately 15°, The motor starts automatically when the valve reaches that position. After the pump is up to speed, the system is full and stable flow is established, the valve is opened to 90°. On shutdown, the valve closes fully and as it passes the 15° open position, trips the pump automatically, The valve closes automatically on loss of power to avoid hydraulic surges.

#### **3.5.4.1 Operation Description**

Prior to operation, the circulating water lines and tower basin are filled using the tower makeup system, During filling the piping and condenser water boxes are manually vented,

Normal operation is with two circulating water pumps in service. One pump can be used during startup, during periods of reduced load or when half of each condenser shell is out of service for inspection or tube plugging,

#### **3.5.4.2 Technical Requirements and Design Basis**

##### Design Basis

1. **The** system is sized to pass the flow rates occurring at 5 percent overpressure, WO condition.
2. The circulating water piping is sized for a maximum velocity between 8 to 10 **fps**.

3. The cooling tower is designed in accordance with CTI standards.

Components (at nominal 100% design point)

**Cooling Tower**

- Quantity 1
- Type Rectangular, counter flow, concrete, mechanical draft
- Water Flow 202,000 **gpm**
- Inlet Temp. 95°F
- Outlet Temp. 75°F
- Wet Bulb Temp. 52°F

**Circulating Water Pumps**

- Quantity 2
- Type Vertical wet pit
- Capacity 101,000 gpm
- Total Head 80 ft.
- Horsepower 2,600 hp
- Speed 450 rpm
- Impeller Material 316 S.S.

**3.5.5 Miscellaneous BOP Systems**

Many ancillary systems and subsystems support the operation of a power plant such as presented in this report. Descriptions of some of the more prominent systems are described within this section, including liquid waste treatment, auxiliary boiler, fuel oil, service and instrument air, and service water.

**3.5.5.1 Liquid Waste Treatment**

Industrial wastewater from station operations **will** be collected, treated in an on-site treatment system, and discharged to an adjacent stream. The industrial waste treatment system will treat wastewater from the following sources:

- Coal pile leachate and runoff
- Limestone storage runoff
- Contaminated yard drains
- Maintenance cleaning wastes
- Cooling tower blowdown
- Demineralize regenerants
- Filter backwash
- Miscellaneous low volume wastes

The treated effluent will meet U.S. Environmental Protection Agency standards for total suspended solids, oil and grease, pH, and miscellaneous metals,



The industrial waste treatment system employs the following unit processes and operations:

#### Flow equalization

Contaminated rainfall runoff from the 10 yr -24 hr. storm is collected in a synthetic-membrane lined 700,000 gallon earthen basin (approximate 167 ft x 80 ft x 7 ft deep) and is pumped to the treatment system at a controlled rate. This basin also equalizes flow from maintenance cleaning wastes. In addition, the 4500 gallon raw waste sump has sufficient surge capacity to equal short-term peak flows such as filter backwashes, Three raw waste pumps are provided, each 280 gpm.

#### Neutralization

Acidic wastewater is neutralized with hydrated lime in a two-stage system, Each neutralization tank is a 6000 gallon fiberglass tank providing a 7.5 minute reaction time at design flow. Each tank is equipped with a pH probe and controller which automatically feeds lime slurry to the respective tank to control pH. Each tank is equipped with a fixed-mount mixer to completely mix lime slurry with the wastewater. An integral lime storage silo/lime slurry makeup system with 50 ton lime silo, a O-1000 lb/h dry lime feeder, a 5,000 gallon lime slurry tank, slurry tank mixer, and 25 gpm lime slurry feed pumps is provided.

#### Oxidation

Air is fed to the second stage neutralization tank through a sparger pipe to oxidize any remaining ferrous iron to the ferric state. The air is supplied by a 50 scfm compressor which also furnishes air for operation of sludge pumps and the filter press.

#### Flocculation

Flocculation to promote particle size growth is provided in a 7,600 gallon fiberglass tank with a 10 minute retention time at design flow. The tank is equipped with a low rpm, variable speed agitator. Polymer emulsion is drawn directly from a 55-gallon drum and is diluted and fed to the flocculation tank by a 100 gallon/h polymer feed unit.

#### Clarification/Thickening

Overflow from the flocculation tank enters a plate-type clarifier/thickener for suspended solids separation. Solids settle between the inclined plates to the thickener zone while the clarified supernatant rises from the plates to discharge through flow-distribution orifices. The integral thickener section includes a picket-fence type scraper mechanism which further concentrates the sludge.

#### Sludge Dewatering

Thickener sludge is pumped to an 8,000 gallon holding tank which allows one-shift operation of the dewatering equipment and provides some further thickening. From the holding tank, the sludge is pumped to a plate-and-frame filter press for dewatering. The filter press produces a sludge cake of 35 percent by weight dry solids or higher. Filter press cake is dropped from the press into a sludge dump truck or dumpster. Filtrate is returned to the raw waste sump.

The coal pile runoff basin, the raw waste sump, and the lime storage and feed system are located outdoors. The remaining treatment system components are located in a heated building.

### **3.5.5.1 Auxiliary Boiler Steam System**

The auxiliary boiler supplies steam to all plant components normally requiring steam during periods of unit or station shutdown, startup, or in certain cases, normal plant operation. The major interfacing components and systems with the **auxiliary** boiler are the feedpumps, **deaerator**, fuel oil storage and supply, forced-draft fan(s), and stack.

The siting and selection of steam conditions for the auxiliary boiler were based on a review of potential system demands, including such components as fuel oil atomizers, fuel oil tank heating, turbine seals, building heating, etc. An auxiliary watertube boiler sized to produce 100,000 lb/h of 400 psig/650° F superheated steam was selected for this installation.

### **3.5.5.3 Fuel Oil Supply System**

A fuel oil storage and supply system sized to accommodate the boiler startup burners and auxiliary boiler was included in the estimate. Number 2 grade fuel oil was selected for use due to anticipated usage and cost considerations, as well as providing future fuel flexibility benefits.

A storage tank capacity of 300,000 gallons was selected, providing an on-site supply of approximately 15 days when firing the auxiliary boiler at maximum rating. Delivery of fuel oil to the station site is designed for receipt by truck. The tank storage area is diked for spill containment, and is located away from buildings, hazardous equipment and materials, and power lines, for reasons of safety.

Unloading pumps, transfer pumps, strainers, regulators, controls, instrumentation, valves, piping, and fittings are included in the design of this system.

### **3.5.5.4 Station Air Service**

#### Service and Instrument Air System

Service air is provided by any of three, 100 percent capacity single-stage, jacketed, double-acting compressors sized to deliver 800 scfm of air at a discharge pressure of 100 psig. The service air system is also equipped with a common air receiver tank, automatic start pressure control, controls, instrumentation, valving, piping, and fittings. Instrumentation air is provided by the service air system, and is conditioned using duplex regenerative air dryers sized to deliver 400 scfm.

### **3.5.5.3 Station Service Water**

The pumps provided for the various station water services generally take water from either of two suction headers connected directly to the circulating water pump basin.

### Service Water

Two service water pumps at 100% capacity each provide the general water requirements for the station. These pumps are single stage, double suction centrifugal pumps, with each pump designated to deliver 6000 gpm of water against an estimated head of 100 feet. The service water system consists of a loop header around the plant, fitted with segregating valves so that portions of the loop may be closed off while the remainder stays in service.

Cooling water is supplied from this system to equipment such as generator hydrogen and turbine lube oil coolers, FD fans, compressors, mills, boiler feed pumps, etc. Service Water is also used to cool the closed cycle cooling water system loop. A separate header takes water to the ash and dust unloading systems, and car dumper house.

### Closed Cycle Cooling Water

A closed cycle cooling water system is used to cool smaller cooling loads and those that require a higher pressure, such as coolers located higher in the plant. Condensate quality water is used as the cooling fluid. System capacity is set at 600 gpm, with two 100% capacity pumps rated at 600 gpm/185 ft of head.

### Fire Service Water

The fire service water piping supplies the various hose reels throughout the plant, fire hydrants and the transformer fire fog system. The system is normally under house service water pressure. For fire fighting it receives water from the fire service booster pump and/or the engine driven fire pump.

The fire service booster pump is a two stage centrifugal pump, capable of delivering 700 gpm at 250 feet total head. The engine driven fire pump takes suction directly from the circulating pump suction chamber. The pump is a vertical turbine type, diesel engine drive, and delivers 1,000 gpm of water at a total head of 350 feet.

### Makeup Pumps

Two pumps at 100% capacity each are installed to supply water for makeup to the circulating water system, filtered water, service water and ash pond. They are centrifugal pumps equipped with single suction, cast iron vertically split casings. Each pump delivers 5,750 gpm of water against a total head of 100 feet.

### Filtered Water Pumps

Two filtered water pumps take water from the clearwell and supply the filtered water tank and the demineralizes. The pumps are centrifugal pumps constructed with single suction, cast iron vertically split casings. Each pump will deliver 200 gpm against a total head of 200 feet.

A filtered and sterile water storage tank is provided, and has a capacity of 15,000 gallons.

AU water except that flowing to the demineralizes is taken directly to the storage tank to provide a constant head on the system and to prevent stagnation of water in the tank.

### **3.5.6 Piping and Valves**

Generally, piping and valves will conform to the requirements of ANSI B31. 1, Power Piping. Carbon steel piping material will be A106, Gr. B or C, and Chrome Moly piping will be A335, Gr. P22.

In addition to the general requirements, the following are specifics concerning the more critical piping in the plant:

- Condensate Pump Suction - (Design-50 psig/100° F)  
Class- 150; carbon steel-A1 06 Gr B, all std. wall.
- Condensate Pump Discharge Before Heaters (Design-500 psig/150° F)  
Class 300; carbon steel - A106 Gr B, 2 inch and under-sch-80, 2 1/2 to 18 inch - std. wall
- Boiler Feed Pump Suction (240 psig/400° F)  
Class 300; carbon steel A106 Gr B, std. wall
- Boiler Feed Pump Discharge Before Heaters (3600 psig/450° F)  
Class 2500, carbon steel A1 06 Gr C, 1/2 to 2 inch - sch 160, 2 1/2 to 6 inch - double extra strong wall, 18 inch - 1.875 inch min. wall.
- Boiler Feed Pump Discharge After Heater (3600 psig/550° F)  
Class 2500, carbon steel A 106 Gr C, 1/2 to 2 inch - sch 160, 2 1/2 to 6 inch - double extra strong wall, 8 to 18 inch - 1.875 inch min. wall
- Main Steam Pipe and Valves (Design 2750 psig/1000° F)  
Chrome-Moly A335 Gr P22 pipe, 22 inch O.D. - 3.5 inch min. wall (special wall pipe);  
Class 4500 chrome-moly A217 Gr WC9 valves,
- Hot Reheat Pipe and Valves (Design 650 psig/1000° F)  
Chrome-moly A335 Gr P22 pipe, 28 inch O.D.-1 .25 inch min. wall; Class 900  
chrome-moly A2 17 Gr WC9 valves.
- Cold Reheat Pipe and Valves (Design 725 psig/700° F)  
Carbon steel A106 Gr C, 28 inch O, D., 0.875 inch min. wall; Class 600 carbon steel  
A216 Gr WC9 valves
- Extraction Steam Pipe to Heater No. 6 (Design 350 psig/900° F)  
Chrome-moly A335 P22 pipe, sch 40; Class 300 chrome moly A217 Gr WC6 valves
- Extraction Steam Pipe from Cross Over (Design 200 psig/750° F)  
Carbon steel A1 06 Gr B pipe, standard wall; Class 300 carbon steel A216 Gr WCB  
Valves,
- Extraction Steam Pipe from LP Turbine (100 psig/600° F)  
Carbon steel A 106 Gr B pipe, standard wall; Class 300 carbon steel A 216 WCB valves
- Circulating Water Pipe (Design 60 psig/100° F)

Carbon Steel, API5L, 102 inch O. D., extra strong (1/2" nominal wall) with 1/2 inch thick cement lining.

### 3.6 PLANT CONTROL AND MONITORING SYSTEMS (6, 7)

#### 3.6.1 Design Basis

Control and monitoring functions will be implemented in an integrated multi-function distributed control system (DCS). This system will use multiple redundant micro-processors to execute closed loop control strategies, alarm monitoring and reporting, data presentation, data recording, data storage and data retrieval. Conventional panel instrumentation will be held to a minimum, to be used solely for plant shutdown in the case of a major multi-element DCS failure. Geographical distribution of both micro-processor modules and I/O units will be implemented wherever practical to reduce plant wiring and cabling costs. Control valves, transmitters and control drives (actuators) will be standardized and purchased in lots from a single manufacturer to the greatest extent possible.

Proprietary control strategies will be safeguarded via confidentiality agreements to allow implementation in the DCS. Use of specialty control or monitoring systems will be minimized (eliminated if possible). If the required function cannot be technically implemented in the DCS due to processing (execution speed) shortcomings on the part of the DCS, or if the control strategy is programmed in a language where the cost of the conversion to the DCS control language is prohibitive, exceptions may be made. In this case the specialty system supplier will be held responsible to provide either a hardwired interface to the DCS or a communication link compatible with the DCS.

#### 3.6.2 Control Room

The Control Room will utilize cathode ray tube (CAT) and keyboard units for operator interface. Touchscreens will be used to improve operator access to data and control functions. The final number of CAT's and keyboards will be determined from an analysis of the plant's operating modes (baseload, on-off, cycling, on-line load following). Between six and twelve CAT's are envisioned. Color printers will be used for logging data, alarm hardcopy, CAT screen copies, data trending hardcopy, and reports. Minimal hardwired panel instrumentation will be utilized to safely shutdown the plant due to a major multi-element DCS failure.

#### 3.6.3 Automation and Operation

The DCS will be configured to operate all plant equipment in an automated closed loop mode. Plant operators will initiate start-up and shut-down sequences. Operation of individual pieces of equipment will be automated to the greatest extent possible. Operator initiation of the starting and/or stopping of individual equipment will be automated to require as few operator actions as necessary. This will minimize the variations in start-up and shutdown procedures which impact equipment operating life and availability.

The design of the combustion control systems will be a joint, integrated process involving the boiler supplier, the plant designer, the operator/user and the DCS supplier.

The DCS shall be configured to provide closed loop automatic control of the following loops:

- Throttle Pressure
- Coordinated Load Control
- Unit (turbine) Load
- HP Turbine Bypass
- IP/LP Turbine Bypass
- Secondary Pressure/Flow
- Primary Air Pressure/Flow
- Fuel (Coal) Feed/Limestone Feed
- Superheat Steam Temperature
- Reheat Steam Temperature
- Furnace Pressure
- Feedwater Flow and Drum Level
- Deaerator Level
- Feedwater Heater Level
- Supplemental Oil Firing
- Coal/Limestone Ratio (SO<sub>2</sub> Control)
- Excess Air/Oxygen
- Condensate Pump Recirculation Flow
- Boiler Feed Pump Recirculation
- Hotwell Level
- Condensate Storage Tank Level
- Generator Hydrogen Temperature
- Turbine Lube Oil Temperature

Conventional logic and control strategies will be used for the majority of the control loops.

Initially the boiler is fired via the start-up oil burners, This operation provides the steam conditions necessary to warm-up and roll the turbine, bring up to speed and synchronize it. As the transition from start-up burners to coal combustion is made, the steam bypass systems **will** be used to smoothly initiate and stabilize the unit.

Deaerator storage tank level is controlled by condensate pump speed modulation to minimize energy consumption. Condenser **hotwell** level is controlled by either discharging condensate back to the storage tank through a spillover line connected to the discharge of the condensate pumps or by admitting condensate by gravity from the storage tank. Control is accomplished using pneumatic control valves.

The boiler's feedwater flow and drum level are controlled by pneumatic control valves in conjunction with pump speed modulation to minimize energy consumption. Hot reheat temperature is controlled by spraying intermediate stage boiler feed pump discharge water into the reheater desuperheaters using pneumatic temperature control valves.

The turbine control system provides the following basic turbine control functions:

- Automatic control of turbine speed and acceleration through the entire speed range, with several discrete speed and acceleration rate settings.
- Automatic control of load and loading rate from no load to full load, with continuous load adjustment and discrete loading rates.

- Standby manual control of speed and load when it becomes necessary to take the primary automatic control out of service while continuing to supply power to the network via the turbine-generator.
- Detection of dangerous or undesirable operating conditions, annunciation of the detected condition, and initiation of proper control response to the condition.
- Monitoring of the status of the control system, including the power supplies and redundant control circuits,
- Testing of valves and controls,
- Prewarming of valve chest and turbine rotor using main or auxiliary steam supply.

The DCS shall be configured to provide on/off control of the following equipment. This control shall be both automatic (process logic) and manual (operator).

- Condensate Pumps
- Boiler Feed Pump Turbines
- Motor Driven BFP
- Secondary Air Fans
- Primary Air Fans
- ID Fan
- Circulating Water Pumps
- Motor Operated Valves
- Motor Operated Dampers
- All Pneumatically Operated Dampers
- Turbine Water Induction Prevention Valves
- Coal Feeders
- Oil Pumps
- Oil Burners
- Cooling Tower Fans

#### 3.6.4 **Data Gathering, Reduction and Retrieval**

Operating data will be stored for future retrieval and analysis by utilizing the latest, most reliable technology from among magtape, optical disk and other available technologies. Redundant storage devices and mediums may be provided to insure complete one-hundred percent availability of operating data for retrieval and analysis. The types of data to be stored will include the following:

- Turbine Start-Up Log
- Turbine Shut-Down Log
- Boiler Start Up Log
- Boiler Shutdown Log
- Post Trip Logs
- Sequence of Event Logs
- Periodic (Hourly and Daily) Logs
- All Trend Data

- Process Data by Exception Reporting

Means shall be provided to allow plant personnel to **modify** the collection and storage of data both from a quantity (points to be stored) and a quality (data collection frequency) perspective.

Retrieval of data for analysis shall make allowance for both retrieval at the plant site and at remote locations. Plant site retrieval shall use personal computers for access to and analysis of historical data from the **DCS**. Personal computer software will be provided to enable spreadsheet analyses and statistical correlation analysis. Remote site data retrieval shall be based on utilizing a mini-computer environment such as **DEC Micro-Vax** or **Hewlett Packard**.

### 3.6.5 Continuous Emission Monitoring System

#### 3.6.5.1 Introduction

The Continuous Emissions Monitoring System (**CEMS**) consists of four major parts: the flue gas emission analyzers, the opacity monitor, the flue gas flow rate monitor, and the data acquisition and reporting system (**DAS**). The CEMS provides the plant with the ability to monitor and report emissions in compliance with the Environmental Protection Agency's (EPA) Clean Air Act Amendments.

#### 3.6.5.2 Function

The function of the CEMS is to continuously monitor the emissions of the plant in compliance with the Clean Air Act. The system will provide an accurate measurement of the levels of Sulfur Dioxide (**SO<sub>2</sub>**), Nitrogen Oxides (**NO<sub>x</sub>**), and Carbon Dioxide (**CO<sub>2</sub>**) in the flue gas as well as a measurement of the flue gas opacity and flow. In addition to providing emissions monitoring capabilities, the system will provide emissions and system calibration reports for submittal to the regulatory agency as required by the Clean Air Act.

#### 3.6.5.3 Description

The Continuous Emissions Monitoring System will consist of an Opacity Monitoring System, a CEM Analyzer System, a Flue Gas Flow Rate Monitoring System, and a Data Acquisition System (**DAS**) as further described below. These systems will provide the control, monitoring, and reporting functions of the CEMS.

The CEM Analyzer System will be a dilution **extractive** system with the capabilities of monitoring sulfur dioxide (**SO<sub>2</sub>**), nitrogen oxides (**NO<sub>x</sub>**) and carbon dioxide (**CO<sub>2</sub>**) in the flue gas. The system consists of a Sample Dilution Probe, an Umbilical Line, a Sample Conditioning Controller and the analyzers for monitoring **SO<sub>2</sub>**, **NO<sub>x</sub>** and **CO<sub>2</sub>**. The sample dilution probe is mounted on the stack and is connected via the umbilical line to the sample conditioning controller. The controller, along with the analyzers, are mounted in the analyzer rack in the CEM Enclosure.

The CEM Analyzer System automatically samples and analyzes the flue gas and performs automatic calibration checks once every 24 hours using certified calibration gases.



The Flue Gas Flow Rate Monitoring System will utilize an across the stack ultrasonic velocity measurement technique to monitor flue gas flow, The system consists of a stack mounted transducer assembly, an electronics enclosure and a remote monitoring display. The transducer and the remote monitoring display **will** be located in instrument racks in the CEMS Enclosure. In addition to measuring the flue gas flow rate, the flow gas monitoring system measures the flue gas temperature. The flue gas temperature, along with a separately measured stack pressure, are used to provide an output in standard cubic feet per minute (**SCFM**) corrected for temperature and pressure,

The CEM Data Acquisition System will provide the control, monitoring, and reporting functions of the CEM system. **All** of the outputs from the above systems are provided as inputs to the DAS for control and monitoring, The DAS consists of a Data Logger, Programmable Controller, (including the necessary software) and two operator/technician stations. The DAS Data Loggers will be located in the analyzer rack in the CEMS enclosure. The DAS Data Logger not only monitors and stores emissions data from the opacity, flue gas analyzer, and flow rate monitoring systems but provides the sample/calibration sequence control program for the system.

The PC, located in the Environmental Engineers office, polls the DAS Data Logger for emissions data and generates the emissions reports. One of the two Operator/Technician stations will be located in the CEMS Enclosure, the other **will** be located in the Control Room. A backup Data Logger in conjunction with the PC creates redundant data files for use in the event of a failure of the Primary Data Logger. The analyzers and alarm signals will be interfaced into the plant distributive control system via hard wiring. Other miscellaneous equipment/requirements associated with the CEMS is summarized below,

- Barometric Pressure Transmitter
- Stack Pressure Transmitter
- Calibration Gas Bottles (one set of three)
- Uninterruptible Electric Power Source
- Clean, dry instrument type air

### 3.6.6 **Start-IJr) Testing and Tuning**

Sufficient time will be allotted in the start-up schedule for the complete tuning of the control system in order to meet the operational requirements. Modifications to control strategies will probably be required. These will be generated by the equipment supplier and reviewed with the DCS equipment personnel and plant operating personnel. Modification of software based control strategies shall be made and documented by personnel from the DCS supplier and further tested as to their improved capabilities. The objective of this testing and tuning is to provide complete automatic control of the process by the DCS control system.

## **3.7 LAYOUT ARRANGEMENT**

The arrangement of equipment, systems and structures on site are shown in this section, and the basis for this arrangement is described,

### **3.7.1 Assumptions**

The following assumptions were taken into consideration when developing the site layout arrangement.

- Initially a single unit facility is to be constructed which includes a single pulverized coal fired boiler connected to a single turbine generator, with a Flue Gas Desulfurization (FGD) system integrated into the facility layout.
- Make provisions in the initial unit site layout arrangement to provide for the addition of a future second unit and the necessary support facilities.
- The circulating water heat sink is a mechanical draft cooling tower.
- Make up and potable water for plant use is filtered and treated on site.
- Plant and sanitary wastes are held and treated on site.

### **3.7.2 Overall Site Plan**

The site layout arrangement is shown in Figure 3-19, and is arranged to include the following considerations.

#### **General**

The location of structures, facilities, equipment and systems are arranged with consideration given to process flows, costs, construction requirements, rail access, roadways and future unit requirements. The site is approximately 320 acres.

Facilities required for the operation of the first unit which are located in a manner to allow for the addition of a future unit include the following.

- Coal unloading, storage, and conveying system
- Limestone unloading, storage, and conveying system
- Permanent warehouse
- Waste treatment system
- Water supply system and primary treatment equipment
- Administration/service building
- Oil unloading and storage facilities
- Auxiliary boilers
- Diesel generators

The on-site railroad system completely loops around the station. The location of the railroad main line turnout is determined by the length of a unit train of 100 cars, with each car having a capacity of 100 tons. The length of track must be sufficient to store a fully loaded unit train in front of the dumping facility and an empty unit train beyond the dumping facility, with both completely clearing the first station turnout.



## **Plant Waste**

The spatial requirements of the plant waste system are site-related, The size of this system is largely determined by the quality of the makeup water and, to a lesser extent, the amount of rainfall. This system will be arranged to handle coal pile runoff along with other plant discharges.

A storage area is provided for accumulation of dewatered FGD byproduct (gypsum). Removal by truck on a regularly scheduled basis is assumed.

## **Coal Handling**

Coal unloading and handling occupy a large percentage of the plant's total land area requirements. An automatic unloading system was selected for illustration on the Plot Plans, using unit trains with swivel-coupled cars, a rotary car dumper, a car positioner, and a thaw shed. The coal is dumped and conveyed to a transfer tower where it is placed on the belt of a double wing traveling stacker. The two coal piles which are created are for active and dead storage. Coal is reclaimed from the active storage pile through under pile hoppers, feeders and a conveyor belt. Reclamation from dead storage piles is by dozing into the emergency reclaim hopper located at the dead storage pile. The area of the dead storage pile is determined by the 90-day minimum requirement and the active pile is determined by the 72 hour active coal requirement. The coal is conveyed to the crusher building where crushers reduce the coal to the maximum size accepted by the pulverizers. After crushing the coal is transferred to the power block using two redundant conveying systems, with each utilizing a tripper conveyor which discharges the coal to the bunkers for in-plant storage.

## **Limestone Handling**

Limestone is delivered to the site by truck and is dumped on the limestone pile, above a pair of vibratory feeders. From the vibratory feeders the limestone is conveyed to the limestone dry bin using an inclined belt conveyor. The limestone is conveyed from the day bins by weigh feeders into a pair of limestone ball mills. Refer to Section 3,4.3 for a more detailed description of this system.

## **Power Block**

The power block contains the following major areas.

- Steam Turbine Building (one steam turbine)
- Boiler Building
- Flue Gas Desulfurization System
- Byproduct Dewatering System
- Control Complex
- Machine Shop
- Auxiliary Boiler and Diesel Generator Building
- Administration and Service Building
- Fly Ash Precipitators (2)
- Stack
- Transformer Area

## **Yard Area**

The following are additional facilities located in the yard.

- Substation
- Cooling Tower
- Cooling Tower Pump House
- Makeup Water and Pretreatment Building
- Industrial Waste Treatment Building
- Coal Pile Runoff Pond and Pump House
- Limestone Pile Runoff Pond and Pump House
- Warehouse
- Coal Yard Vehicle Maintenance Garage
- River Water Intake Structure
- Guard House

### **3.73 Power Block - Plan**

#### **General**

The layout of the power block is shown on Figure 3-20. The building housing the turbine generator is 324 ft long and 135 ft wide, including the heater bay as shown on Figure 3-21. The turbine building is sized to provide sufficient clear area to completely disassemble the turbine-generator and provide adequate laydown space for all parts.

The turbine room width is set taking into consideration the width of the turbine foundation, the physical requirements of the turbine-driven boiler feed pumps located at the grand floor along with sufficient space to locate additional equipment and route systems. Additionally, maintenance provisions and spatial requirements were considered. An equipment access hatch located at the southwest corner of the turbine room provides for truck and railcar access. The turbine room bridge crane which spans the width and travels the length of the turbine room is sized to handle the weight of the turbine generator rotor.

The boiler side of the turbine generator has been designated for the steam seal feed system and the opposite side for the steam seal drains and turbine lube oil system. The boiler feed pump turbines exhaust directly into the main condenser on the boiler side of the machine and the low pressure heater extraction points exit from the low pressure turbine cylinders on the opposite side. The low pressure heaters No. 3 and No. 4 are located on the opposite side of the turbine generator at the mezzanine floor level.

Isolated phase bus ducts are routed directly from the generator end of the machine to the transformer area which is located outside and adjacent to the turbine room.

#### **Heater Bay**

The heater bay is 30 ft wide and extends for most of the length of the turbine room. The purpose of the heater bay is to house components of the feedwater cycle such as the high pressure heaters and deaerator and to provide a pipe chase for major piping between the boiler

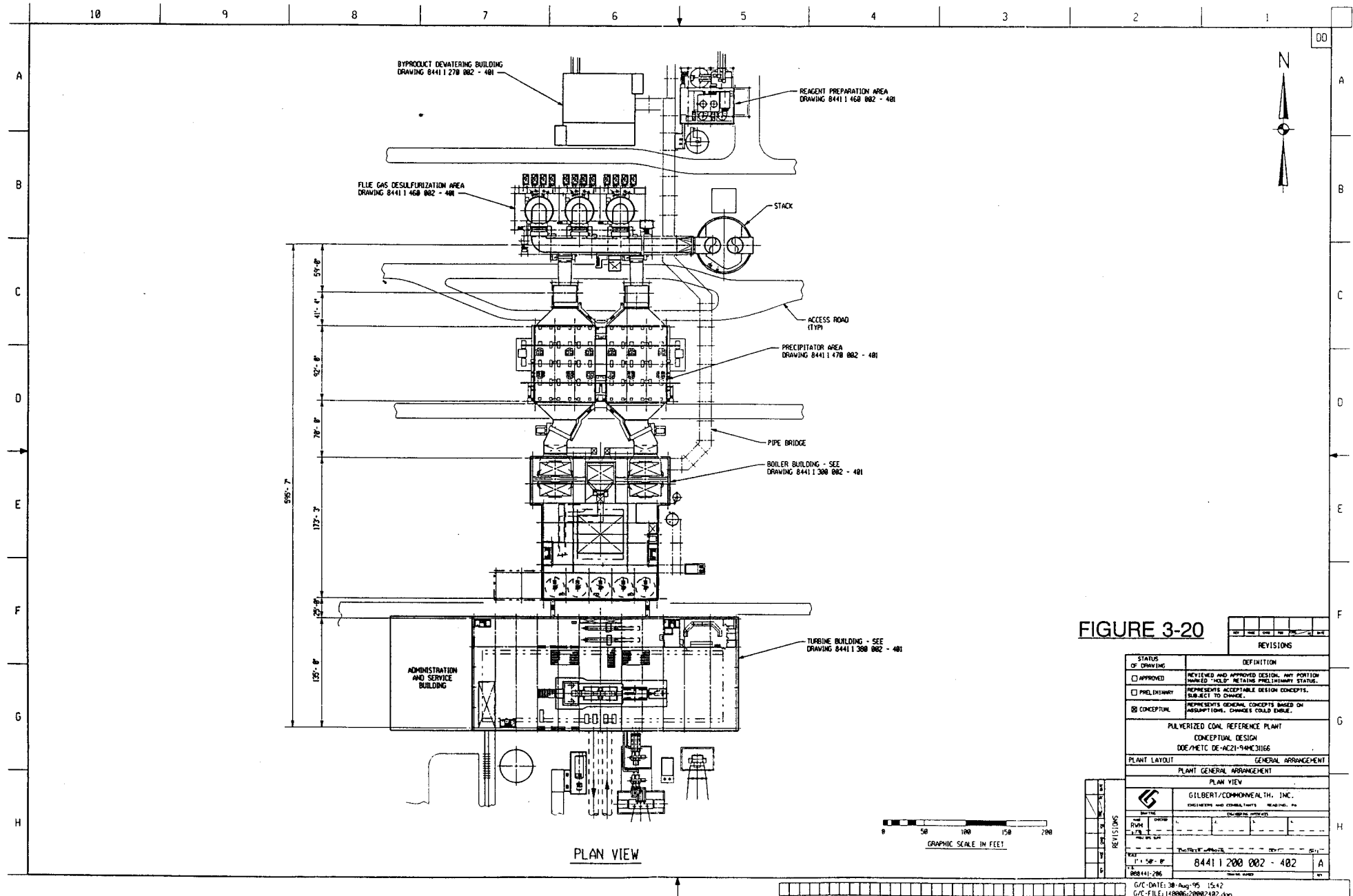



FIGURE 3-20

REVISIONS	

STATUS OF DRAWING	DEFINITION										
<input type="checkbox"/> APPROVED	REVIEWED AND APPROVED DESIGN, ANY PORTION MARKED "AS IS" RETAINS PRELIMINARY STATUS.										
<input type="checkbox"/> PRELIMINARY	REPRESENTS ACCEPTABLE DESIGN CONCEPTS, SUBJECT TO CHANGE.										
<input checked="" type="checkbox"/> CONCEPTUAL	REPRESENTS GENERAL CONCEPTS BASED ON ASSUMPTIONS, CHANGES COULD ENSUE.										
PULVERIZED COAL REFERENCE PLANT CONCEPTUAL DESIGN DOE/NETC DE-AC21-94MC31066											
PLANT LAYOUT GENERAL ARRANGEMENT PLANT GENERAL ARRANGEMENT											
PLAN VIEW											
 GILBERT/COMMONWEALTH, INC. <small>ENGINEERS AND ARCHITECTS - WASHINGTON, DC</small>											
<table border="1"> <tr> <th>DATE</th> <th>BY</th> <th>CHKD</th> <th>APP'D</th> </tr> <tr> <td> </td> <td> </td> <td> </td> <td> </td> </tr> </table>		DATE	BY	CHKD	APP'D						
DATE	BY	CHKD	APP'D								
<table border="1"> <tr> <th>NO.</th> <th>DATE</th> <th>DESCRIPTION</th> <th>BY</th> <th>CHKD</th> </tr> <tr> <td> </td> <td> </td> <td> </td> <td> </td> <td> </td> </tr> </table>		NO.	DATE	DESCRIPTION	BY	CHKD					
NO.	DATE	DESCRIPTION	BY	CHKD							
TYPICAL SCALE: 1" = 50'-0" PROJECT NO: 8441 1 200 002 - 402 DRAWING NO: 8441 1 200											

G/C-DATE: 30-Aug-95 15:42  
G/C-FILE: I:\0006\20002402.dwg



and turbine generator. This location within the station provides the most economical piping and equipment arrangement.

Additionally, the heater bay will provide dedicated space for routing horizontal and vertical runs of pipe and cable trays. At the grade floor level, space is reserved to provide a maintenance corridor which interconnects vital equipment areas with the machine shop, repair facilities and to provide for equipment removal capability from the plant.

The heater bay height is established to meet the requirements of the feedwater system requirements including **NPSH** considerations of the boiler feed pumps.

### **Boiler Area**

The boiler is arranged so that the pulverizers and the coal bunkers/silos are located between the heater bay and the front of the boiler, as shown on Figure 3-22. Flue gas exits on the back side through the electrostatic precipitators and then to the FGD system,

The length (or depth) of the boiler area is determined by the boiler vendor. A 30 ft wide bay between the boiler and turbine buildings house the coal silos, **gravimetric** feeders, pulverizers, and coal piping to the burners. Additionally, a twenty foot wide bay is provided on the outboard sides of the boiler. These bays house the primary and secondary air fans, associated duct work and in addition, also provide space for routing of systems,

Directly in back of and adjacent to the back of the boiler are the electrostatic precipitators, I.D. fans, and interconnecting duct work (See Figure 3-23). The intent of the arrangement is to keep these facilities as close to the gas outlet ducts of the boiler as possible, but also provide reasonable space for operations and maintenance,

### **Flue Gas Desulfurization (FGD) Area**

The FGD area is located directly north (plant coordinates) of the electrostatic precipitators, as shown on Figure 3-24. The three absorber modules are lined up east to west, with supporting equipment located close by to provide a compact and functional arrangement. The plant stack is located to the east of the absorber modules, in a location that accommodates a potential second unit. The **dewatering** area (See Figures 3-25 & 3-26) and gypsum stackout area are located north of the absorber modules.

### **Control Complex**

The control complex is located at the east end of the turbine building to place it adjacent to the future plant facilities in the event the plant is expanded. The location provides for convenient routing of control systems from **all** areas of the power block to the control complex.

The control bays of the turbine building will most likely contain the machine shop facility at the grade floor elevation. The upper floors of the complex will contain cable spreading areas, termination areas, control room, office and lavatories, instrument shop and mechanical equipment room containing HVAC for the control complex. The size and arrangement and the exact types of areas required will be dependent upon the type of control system selected.



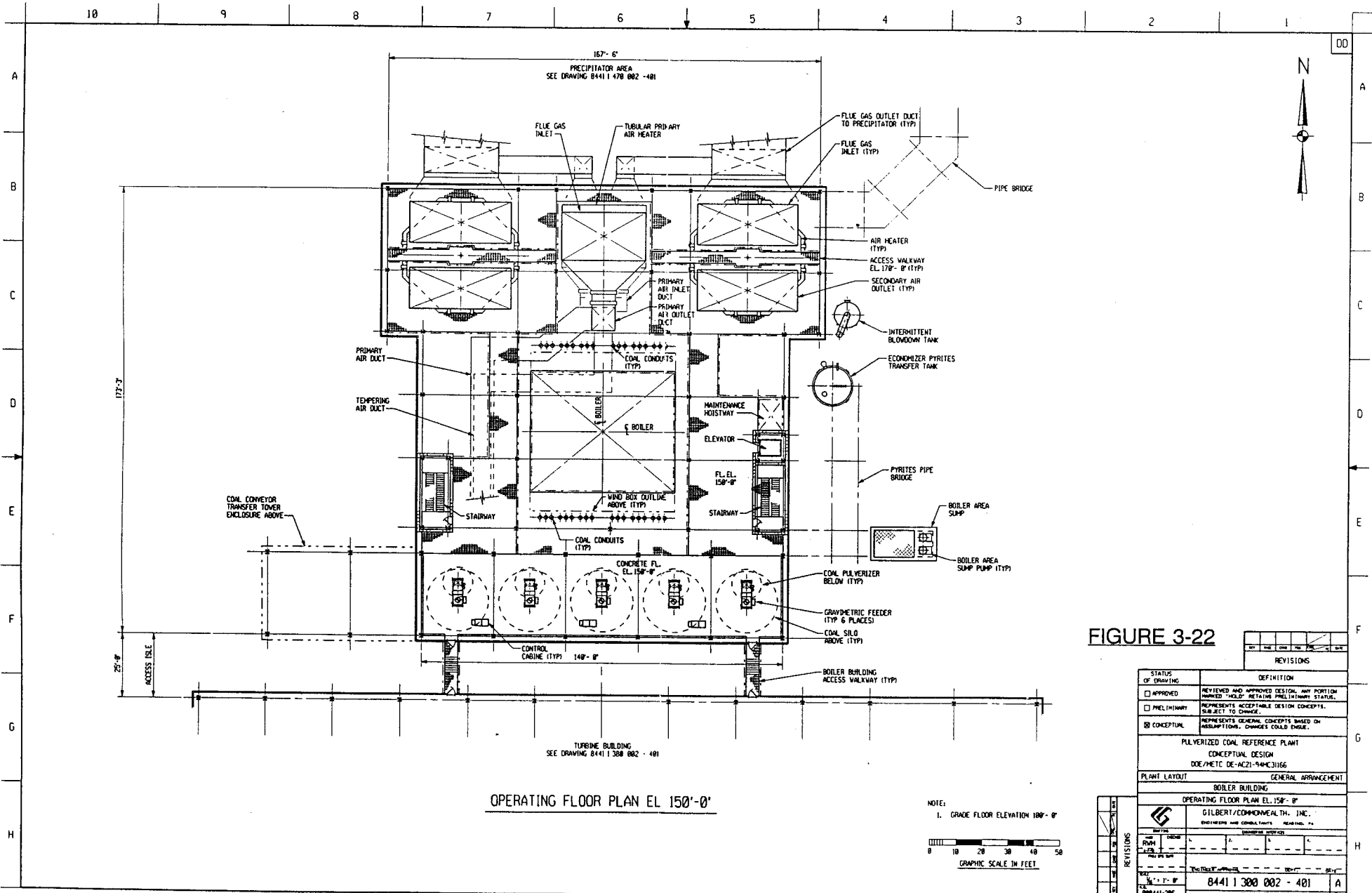

OPERATING FLOOR PLAN EL. 150'-0"

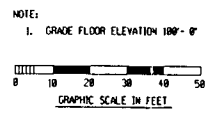

FIGURE 3-22

REVISIONS	
NO.	DESCRIPTION

STATUS OF DRAWING	DEFINITION
<input type="checkbox"/> APPROVED	REVIEWED AND APPROVED DESIGN. ANY PORTION MARKED "HOLD" RELATING PRELIMINARY STATUS, SUBJECT TO CHANGE.
<input type="checkbox"/> PRELIMINARY	REPRESENTS ACCEPTABLE DESIGN CONCEPTS. REPRESENTS GENERAL CONCEPTS BASED ON ASSUMPTIONS. CHANGES COULD BE MADE.
<input checked="" type="checkbox"/> CONCEPTUAL	REPRESENTS GENERAL CONCEPTS BASED ON ASSUMPTIONS. CHANGES COULD BE MADE.

POLYMERIZED COAL REFERENCE PLANT CONCEPTUAL DESIGN DOE/NETC DE-AC21-94NC31166	
PLANT LAYOUT GENERAL ARRANGEMENT	
BOILER BUILDING	
OPERATING FLOOR PLAN EL. 150'-0"	
GILBERT/COMMONWEALTH, INC. ENGINEERS AND CONSULTANTS, INC.	
PROJECT NO. 84411300002-401	
DRAWING NO. 84411300002-401	
DATE: 10/15/95	
DRAWN BY: [Signature]	
CHECKED BY: [Signature]	
SCALE: AS SHOWN	



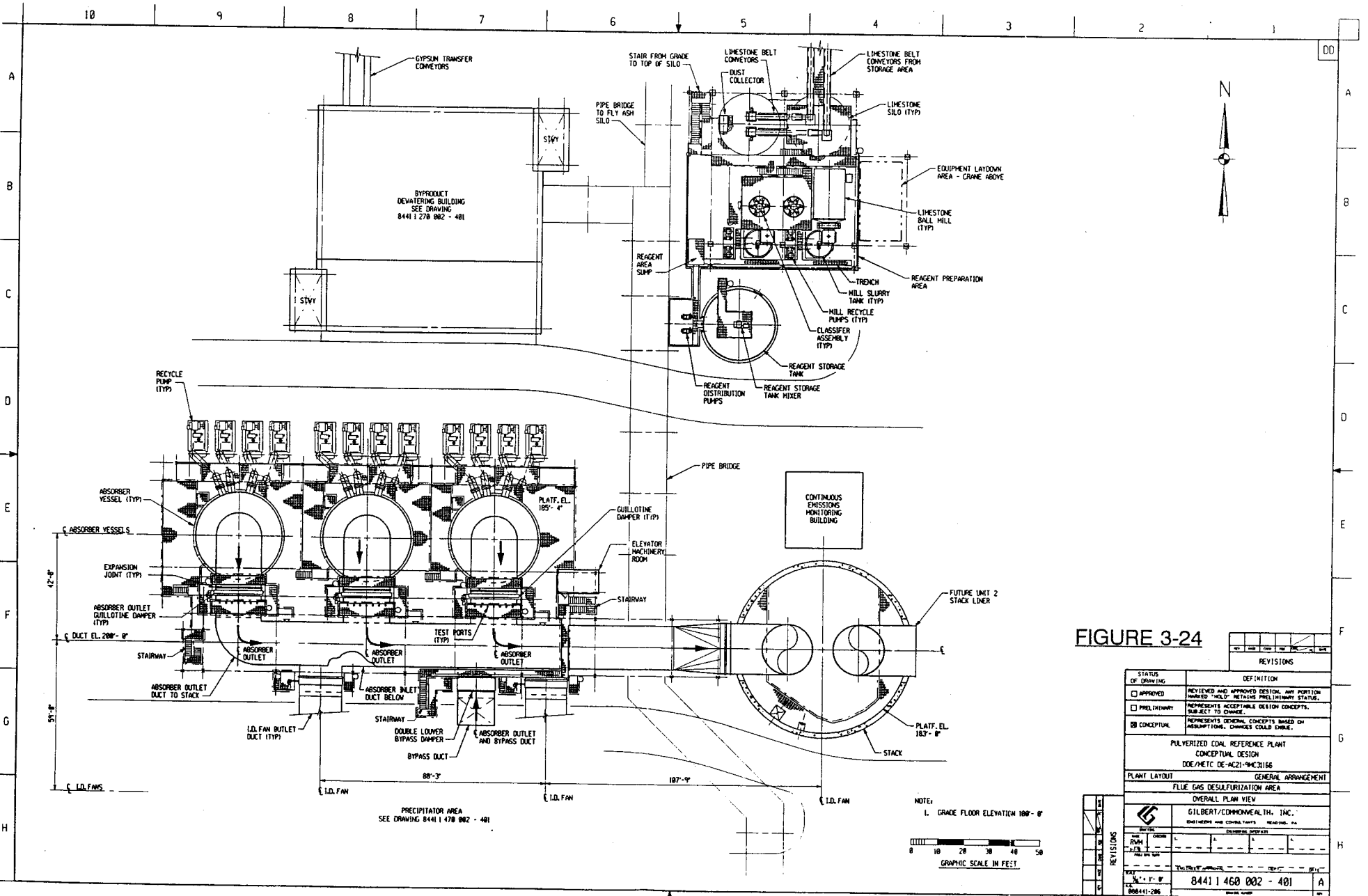

FIGURE 3-24

REVISIONS	
STATUS OF DRAWING	DEFINITION
<input type="checkbox"/> APPROVED	REVIEWED AND APPROVED DESIGN. ANY PORTION MARKED "HOLD" REMAINS PRELIMINARY STATUS.
<input type="checkbox"/> PRELIMINARY	REPRESENTS ACCEPTABLE DESIGN CONCEPTS. SUBJECT TO CHANGE.
<input checked="" type="checkbox"/> CONCEPTUAL	REPRESENTS GENERAL CONCEPTS BASED ON ASSUMPTIONS. CHANGES COULD OCCUR.
PULVERIZED COAL REFERENCE PLANT CONCEPTUAL DESIGN DOE/NETC DE-AC21-94C31166	
PLANT LAYOUT FLUE GAS DESULFURIZATION AREA	
OVERALL PLAN VIEW	
GILBERT/COMMONWEALTH, INC. ENGINEERS AND CONSULTANTS HEADQUARTERS	
PROJECT NO. 8441 1 460 002 - 401	
SHEET NO. A	

NOTE:  
L. GRADE FLOOR ELEVATION 100'-0"

0 10 20 30 40 50  
GRAPHIC SCALE IN FEET



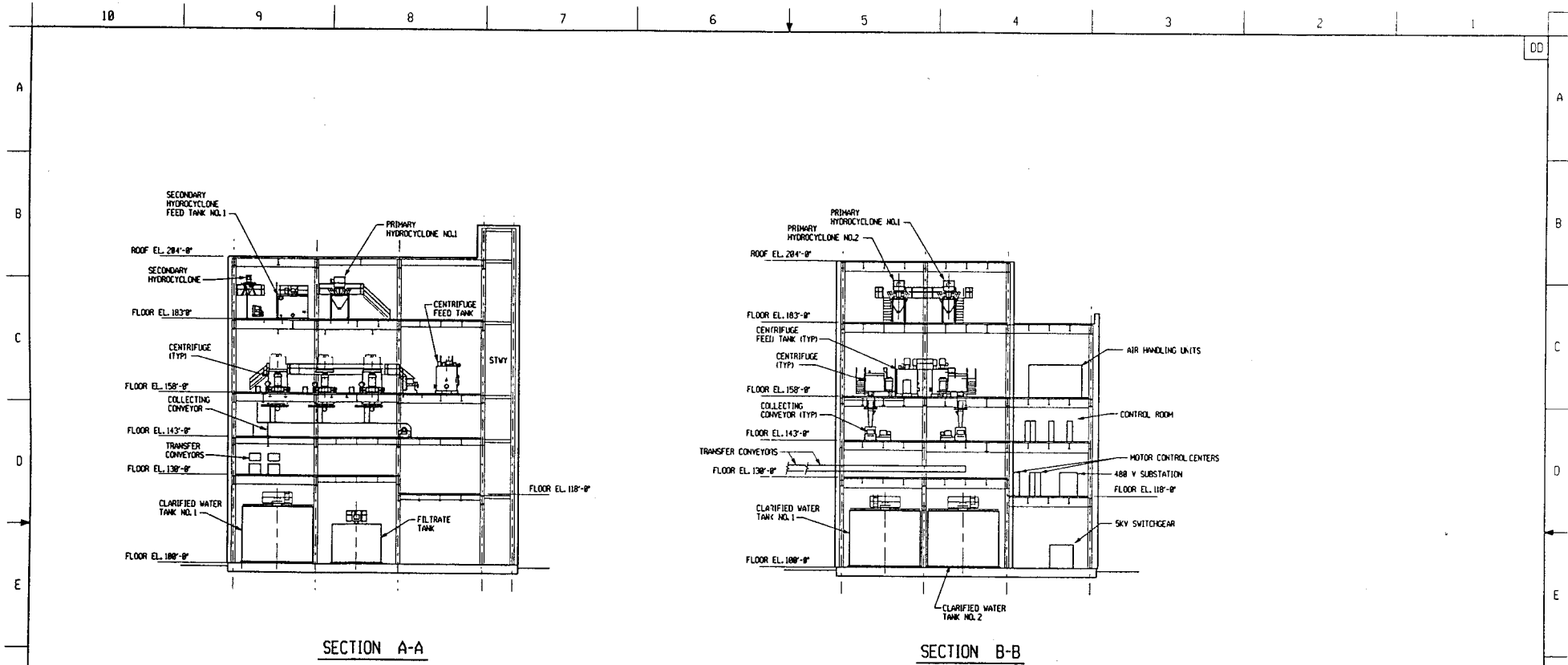

SECTION A-A

SECTION B-B

FIGURE 3-26

REVISIONS	
NO.	DATE

STATUS OF DRAWING	DEFINITION
<input type="checkbox"/> APPROVED	REVIEWED AND APPROVED DESIGN. ANY PORTION MARKED "VOID" REMAINS PRELIMINARY STATUS.
<input type="checkbox"/> PRELIMINARY	REPRESENTS ACCEPTABLE DESIGN CONCEPTS. SUBJECT TO CHANGE.
<input checked="" type="checkbox"/> CONCEPTUAL	REPRESENTS GENERAL CONCEPTS BASED ON ASSUMPTIONS. CHANGES COULD EMERGE.

PULVERIZED COAL REFERENCE PLANT  
CONCEPTUAL DESIGN  
DOE/NETC DE-AC21-94MC3166

PLANT LAYOUT GENERAL ARRANGEMENT  
BYPRODUCT DEWATERING BUILDING  
SECTION A-A AND B-B

		GILBERT/COMMONWEALTH, INC. ENGINEERS AND CONSULTANTS	
PROJECT NO. 84411270	DRAWING NO. 002-402	SHEET NO. A	TOTAL SHEETS 17

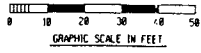

### **3.7.4 Power Island Cross Section**

The cross section shown in Figure 3-27 illustrates the elevation differences through the major areas of the plant. The cross section indicates the elevational relationships between the turbine building and heater bay, the heater bay to the area containing the coal bunkers and limestone day bins, and the elevational relationship of the boiler area to the adjacent areas.



## 4.0 REFERENCE PLANT ECONOMIC ANALYSIS

The economics of the Pulverized Coal Fired Reference Power Plant were developed on the basis of consistently evaluating the capital and operating costs and then performing an economic analysis based on the cost of electricity (COE) as the figure of merit. The conceptual cost estimate was determined on the basis of several major data sources including the detail estimate data from a recently completed major PC fossil plant, the AFBC Reference Power Plant, the estimate details of the FGD system recently completed, major equipment quotes, and inhouse cost data and conceptual estimating of scope not compatible with the above source plant scopes.

The emphasis of this effort was placed on obtaining good cost results at the Total Plant Cost (TPC) level. The capital costs at the Total Plant Cost (TPC) level include equipment, materials, labor, indirect construction costs, engineering and contingencies.

Operation and maintenance (O&M) cost values were determined on a first year basis and subsequently **levelized** over the 30 year plant life to form a part of the economic analysis, Consumables were evaluated on the basis of the quantity required, operation cost was determined on the basis of the number of operators, and maintenance was evaluated on the basis of maintenance costs required for each major plant section. These operating costs were then converted to unit values of \$/kW-yr or mills/kWh.

In addition, the following economic assumptions were made:

- Plant book life is 30 years
- Capacity factor is 65 percent
- Plant **inservice** date is January 1995
- COE determined on a **levelized**, current dollar basis
- COE methodology was based on EPRI TAG methodology

The capital and operating costs of the plant are combined with plant performance in the comprehensive evaluation of cost of **electricity**(COE).

### 4.1 METHODOLOGY

This section describes the approach, basis, and methods that were used to perform capital and operating cost evaluations of the PC power plant. Included in this section are descriptions of

- Capital Costs (Section 4.2)
  - Bare Erected Cost (Section 4.2, 1)
  - **Total Plant Cost** (Section 4.2.2)
  - Capital Cost Estimate Exclusions (Section 4.2.3)
- Operating Costs and Expenses (Section 4.3)
  - Operating Labor (Section 4.3.1)
  - Maintenance (Section 4.3.2)
  - Consumables, including fuel costs (Section 4.3.3)
- Economic Evaluation (Section 4.4)



The capital costs, operating costs, and expenses were established consistent with **EPRI** Technical Assessment Guide (TAG) methodology and the plant scope identified in Section 3. The cost of each component was quantitatively developed to enhance credibility and establish a basis for subsequent comparisons and modification as the technology is further developed.

- Total plant cost values are expressed in December 1993 dollars.
- The estimates represent mature **technology** plant, or “n<sup>b</sup> plant” (i.e., it does not include costs associated with a first-of-a-kind plant).
- The estimate represents a complete power plant facility with the exception of the exclusions listed **in** Section 4.2.3.
- The estimate boundary limit is defined as the total plant facility within the “fence line,” including coal receiving and water supply system but terminating at the high side of the main power transformers.
- Site is located within the Ohio River Valley, southwestern Pennsylvania/eastern Ohio, but not specifically sited within the region except that it is considered to be located on a major navigable waterway.
- Terms used in connection with the estimate are consistent with the **EPRI TAG**.
- Costs are grouped according to a process/system-oriented code of accounts; all reasonably allocable components of a system or process are included in the specific system account in contrast to a facility, area, or commodity account structure.
- The basis for equipment, materials, and labor costing is described in Section 4.2.
- Design engineering services, including construction management and contingencies basis, are examined in Section 4.2.2.
- The operating and maintenance expenses and consumables costs were developed on a quantitative basis.
  - The operating labor cost was determined on the basis of the number of operators required.
  - The maintenance cost was evaluated on the basis of historical relationships of maintenance cost to initial capital cost.
  - The cost of consumables, including fuel, was determined on the basis of individual rates of consumption, the unit cost of each consumable, and the plant annual operating hours.
  - The by-product credit for the gypsum is considered to be zero due to the poor marketability of this commodity.

Each of these expenses and costs is determined on a first year basis and subsequently **levelized** over the life of the plant through application of a **levelizing** factor to determine the value that forms a part of the economic evaluation. This amount when combined with fuel cost and capital charges results in the figure of merit, **COE**.

## **4.2 CAPITAL COSTS**

The capital cost, specifically referred to as Total **Plant Cost (TPC)** for the PC power plant, was estimated using the **EPRI** structure. The major components of TPC consist of bare erected cost, engineering and home office overheads and fee plus contingencies.

The capital cost was determined through the process of estimating the cost of every significant piece of equipment, component, and bulk quantity. A Code of Accounts was developed to provide the required structure for the estimate. The Code facilitates the consistent allocation of individual costs that were developed and will serve as the basis for future evaluation of other clean coal sponsored technologies and permit future cost comparisons if desired. The Code facilitates recognition of estimated battery limits and the scope included in each account. This Code is presented as Table 4-1 along with a listing of scope included in each account.

### **4.2.1 Bare Erected Cost**

The bare erected cost level of the estimate, also referred to as the sum of process capital and general facilities capital, consists of the cost of factory equipment, field materials and supplies, direct labor, indirect field labor, and indirect construction costs

Major equipment prices were based on vendor furnished budget cost information. They include the following

- PC Boiler.
- Steam Turbine-Generator,
- Condenser.
- Feedwater Heater.
- Deaerator.
- Stack.
- **CEMS**.
- Transformers,
- Batteries,
- UPS.

Other process equipment, minor secondary systems, and materials were estimated by G/Con the basis of the source PC plant and in-house data consisting of other cost data and relationships, catalog data, and standard utility unit cost data.

The piping system costs for the PC reference plant were estimated on the basis of the corresponding systems in the source PC plant, the AFBC reference plant and in house information on the source FGD system.

**Table 4-1**  
**Code of Direct Accounts Summary**

<u>Account Number</u>	<u>Account Title</u>
1	<p><b>COAL and SORBENT HANDLING</b></p> <ul style="list-style-type: none"> <li>Coal Receiving and Unloading Equipment</li> <li>Coal <b>Stockout</b> and Reclaim Equipment</li> <li>Coal Storage Bin and Yard Crushers</li> <li>Other Coal-Handling Equipment</li> <li>Sorbent Receiving and Unloading Equipment</li> <li>Sorbent Stockout and Reclaim Equipment</li> <li>Sorbent Storage Bin and Yard Crusher</li> <li>Other Sorbent Handling Equipment</li> <li>Coal and Sorbent Handling Foundations and Structures</li> </ul>
2	<p><b>COAL and SORBENT PREPARATION and FEED</b></p> <ul style="list-style-type: none"> <li>Coal Crushing and Drying Equipment</li> <li>Prepared Coal Storage and Feed Equipment</li> <li>Coal Injection System</li> <li>Miscellaneous Coal Preparation and Feed</li> <li>Sorbent Preparation</li> <li>Prepared Sorbent Storage and Feed Equipment</li> <li>Sorbent injection System</li> <li>Booster Air Supply System</li> <li>Foundations and Structures</li> </ul>
3	<p><b>FEEDWATER and MISCELLANEOUS SYSTEMS and EQUIPMENT</b></p> <ul style="list-style-type: none"> <li>Feedwater System</li> <li>Makeup Treatment, Pretreating, and Storage</li> <li>Other Feedwater and Condensate Subsystems</li> <li>Service Water Systems</li> <li>Other Boiler Plant Systems</li> <li>Fuel Oil Supply System</li> <li>Waste Treatment Equipment</li> <li>Miscellaneous Power Plant Equipment</li> </ul>
4	<p><b>PC BOILER, and ACCESSORIES</b></p>

**Table 4-1 (Continued)**  
**Code of Direct Accounts Summary**

<u>Account Number</u>	<u>Account Title</u>
5	FLUE GAS CLEAN-UP FGD System and Accessories ESP Product <b>Dewatering</b> System Foundations and Supports
6	COMBUSTION TURBINE and ACCESSORIES
7	WASTE HEAT BOILER, DUCTING and STACK Ductwork Stack Foundations
8	STEAM TURBINE GENERATOR, and AUXILIARIES Steam Turbine Generator and Accessories Turbine Plant Auxiliaries Condenser and Auxiliaries Steam Piping Foundations
9	COOLING WATER SYSTEM Cooling Towers Circulating Water Pumps Circulating Water System Auxiliaries Circulating Water Piping Make-Up Water System Component Cooling Water System Circulating Water Foundations and Structures
10	ASH/SPENT SORBENT RECOVERY and HANDLING Ash Coolers Other Ash Recovery Equipment Ash Storage Silos Ash Transport and Feed Equipment Miscellaneous Ash Handling Equipment Foundations and Structures

**Table 4-1 (Continued)**  
**Code of Direct Accounts Summary**

<u>Account Number</u>	<u>Account Title</u>
11	ACCESSORY ELECTRIC PLANT Generator Equipment Station Service Equipment <b>Switchgear</b> and Control Equipment Conduit and Gable Tray Wire and Cable Protective Equipment Standby Equipment Main Power Transformer Foundations
12	INSTRUMENTATION and CONTROL PC Control Equipment Combustion Turbine Control Equipment Steam Turbine Control Equipment Other Major Component Control Equipment Signal Processing Equipment Control Boards, Panels, and Racks Computer and Auxiliaries Instrument Wiring and Tubing Other Instrumentation and Controls Equipment
13	IMPROVEMENTS TO SITE Site Preparation Site Improvements Site Facilities
14	BUILDINGS and STRUCTURES Boiler Building Steam Turbine Building Administration Building Circulating Water <b>Pumphouse</b> Water Treatment Buildings Machine Shop Warehouse Other Buildings and Structures Waste Treatment Buildings and Structures

The electrical and I&C portion of the PC estimate was developed using material and equipment types and sizes typically used to construct a domestic utility owned and operated power plant.

In most cases the costs for bulk materials and major electrical equipment for this estimate were derived from recent vendor or manufacturer's quotes for similar items on other projects. Where actual or specific information regarding equipment specifications was available, that information was used to size and quantify material and equipment requirements. Where information was not furnished or was not adequate, requirements were assumed and estimated based on information available from project estimates of similar type and size. Areas such as cable and raceway, lighting, paging, heat tracing, and unit heating were done based on project experience for a plant of comparable size with enclosed boiler and turbine buildings in a climate range similar to that of the proposed general location of this plant. Grounding for the project is included in the estimate assuming that a design for a loop type system attached to ground pads on structural steel and installed in slabs will be the accepted method. The section of our estimate for the Distributed Control System was developed from a system specified and designed for a plant of comparable capacity. The cabling for this system is included in the bulk cable portion of the estimate,

The labor cost to install the equipment and materials was estimated on the basis of labor manhours. Labor costing was determined on a multiple contract labor basis with the labor cost including direct and indirect labor costs plus fringe benefits and allocations for contractor expenses and markup. This was supplemented in limited cases, as required, with equipment labor relationship data to determine the labor cost, The relationships used were based on the in-house historical data and the source plants,

The indirect labor cost was estimated at 7 percent of direct labor to recognize the cost of construction services and facilities not provided by the individual contractors, The latter cost represents the estimate for miscellaneous temporary facilities such as construction road and parking area construction and maintenance; installation of construction power; installation of construction water supply and general sanitary facilities; and general and miscellaneous labor services such as jobsite cleanup and construction of general safety and access items.

#### **4.2.2 Total Plant Cost (TPC)**

The TPC level of the estimate consists of the bare erected cost plus engineering and contingencies,

The engineering costs represent the cost of architect/engineer (A/E) services for design, procurement, drafting, and project construction management services. The cost was determined at 12 percent applied to the bare erected cost on an individual account basis. The cost for engineering services provided by the equipment manufacturers and vendors is included directly in the equipment costs.

Allowances for project contingencies are also considered as part of the TPC. Since none of the various systems are still in the development stage, no process contingency was added to the estimated cost of systems.

Consistent with conventional power plant practices, the general project contingency was added to the total plant cost to cover project uncertainty and the cost of any additional equipment that could result from a detailed design. Based on EPRI criteria, the cost estimate contains elements of Classes I, II, and 111 level estimates, As a result, on the basis of the EPRI guidelines, a nominal value of 15 percent was used to arrive at the plant nominal cost value. This project contingency is intended to cover the uncertainty in the cost estimate itself. The contingencies represent costs that are expected to occur,

Table 4-2 provides cost results at the level of the code of accounts for each component of TPC. Appendix B contains a detail estimate listing in the same format as Table 4-2.

In addition to the TPC cost level, the Total Plant Investment (TPI) and Total Capital Requirement (TCR) were determined.

TPI at date of start-up includes escalation of construction costs and allowance for funds used during construction (AFDC), formerly called interest during construction, over the construction period. TPI is computed from the TPC which is expressed on an “overnight” or instantaneous construction basis. For the construction cash flow, a uniform expenditure rate was assumed, with all expenditures taking place at the end of the year. The construction period is estimated to be 3 years. Given TPC, cash flow assumptions, nominal interest, and escalation rates, TPI was calculated using:

$$TPI = TPC \times A[(R^3-1)/(R-1)]$$

where:

A	=	% cost expended per year = 33.33%
R	=	Compound adjustment factor = $(1 + i)/(1 + ea)$
i	=	Weighted cost of capital, 9.2%
ea	=	Inflation rate, 4.1%

The apparent escalation rate and the weighted cost of capital (discount rate) are the standard values currently proposed by EPRI.

The TCR includes all capital necessary to complete the entire project, TCR consists of TPI, prepaid royalties, preproduction (or start-up) costs, inventory capital, initial chemical and catalyst charge, and land cost:

- Royalties costs are assumed inapplicable to the mature PC plant and thus are not included.
- Preproduction U.S. costs are intended to cover operator training, equipment checkout, major changes in plant equipment, extra maintenance, and inefficient use of fuel and other materials during plant start-up, They are estimated as follows:
  - 1 month fixed operating costs - operating and maintenance labor, administrative and support labor, and maintenance materials.
  - 1 month of variable operating costs as full capacity (excluding fuel) - includes chemicals, water, and other consumables and waste disposal charges,

**Table 4-2**

**Client:** DOE- METC  
**Project:** CLEAN COAL REFEREWE PIAN

**Report Date:** 01-Sep-95  
 10:33 AM

**TOTAL PLANT COST SUMMARY**

**Case:** PC ( Base Case)  
**Plant Size:** 401.2 MW<sub>net</sub>

**Estimate Type:** Conceptual

**Cost Year:** 1994: \$x1000

Acct No.	Item/Description	Equipment cost	Material cost	Labor		Sales Tax	Sara Erected cost \$	Eng'g CM H.O.& Fee	contingencies		TOTAL PLANT COST	
				Direct	Indirect				Process	Project	\$	\$/kW
1	COAL & SORBENT HANDLING	11,030	3,161	8,302	581		\$23,074	2,769		3,878	<b>\$29,719</b>	74
2	COAL & SORBENT PREP & FEED	13,113		3,991	279		\$17,364	2,066		2,920	<b>\$22,390</b>	56
3	FEEDWATER & MISC. BOP SYSTEMS	16,813		7,341	514		\$24,666	2,960		4,144	<b>\$31,773</b>	79
4	PC BOILER & ACCESSORIES											
4.1	PC Boiler	43,471		16,553	1,259		<b>\$63,323</b>	7,599		10,636	<b>\$81,560</b>	203
4.2	Open											
4.3	open											
4.4	Secondary Air System											
5	FLUE GAS CLEANUP	42,875		16,949	1,326		<b>\$62,881</b>	7,547		10,566	<b>\$81,003</b>	202
6	COMBUSTION TURBINE/ACCESSORIES											
6.1	Combustion Turbine Generator	N/A		N/A								
6.2	Combustion Turbine Accessories											
7	HRSG.DUCTING & STACK											
7.1	Heat Recovery Steam Generator	N/A		N/A								
7.2	HRSG Accessories	13,036	273	6,415	569		\$22,315	2,678		3,749	<b>\$28,742</b>	72
6	STEAM TURBINE GENERATOR											
6.1	Steam TG & Accessorial	35,365		4,607	336		\$10,509	4,661		6,605	\$52,175	130
6.2	Turbine Plant Auxiliaries	11,490	344	6,319	442		<b>\$18,595</b>	2,231		3,124	\$23,951	60
9	COOLING WATER SYSTEM	7,713	3,561	7,127	499		<b>\$18,921</b>	2,270		3,179	\$24,370	61
10	ASH/SPENT SORBENT HANDLING SYS	5,756	73	10,618	743		\$17,190	2,063		2,666	\$22,141	55
11	ACCESSORY ELECTRIC PLANT	12,952	4,278	10,205	714		<b>\$28,150</b>	3,376		4,729	\$30,257	90
12	INSTRUMENTATION & CONTROL	9,504		5,651	410		\$15,764	1,692		2,646	\$20,304	51
13	IMPROVEMENTS TO SITE	1,818	1,015	3,636	254		\$6,723	607		1,130	<b>\$8,660</b>	22
14	BUILDINGS & STRUCTURES		17,639	21,446	1,501		<b>\$40,788</b>	4,694		6,852	\$52,532	131
	<b>TOTAL COST</b>	<b>\$224,679</b>	<b>\$30,563</b>	<b>\$135,560</b>	<b>\$9,469</b>		<b>\$400,292</b>	<b>\$48,035</b>		<b>\$67,249</b>	<b>\$515,576</b>	<b>1265</b>



- 25% of full capacity fuel cost for 1 month - covers inefficient operation that occurs during the start-up period.
- 2% of **TPI** - covers expected changes and modifications to equipment that will be needed to bring the plant up to full capacity.
- Inventory capital is the value of inventories of fuel, other consumables, and by-products, which are capitalized and included in the inventory capital account. The inventory capital is estimated as follows: Fuel inventory is based on full-capacity operation for 60 days. Inventory of other consumables (excluding water) is normally based on full-capacity operation at the same number of days as specified for the fuel. In addition, an allowance of 1/2% of the TPC equipment cost is included for spare parts,
- Initial catalyst and chemical charge covers the initial cost of any catalyst or chemicals that are contained in the process equipment (but not on storage, which is covered in inventory capital). No value is shown because costs are minimal and included directly in the component equipment capital cost.
- Land cost is based on 320 acres of land at \$1,500 per acre.

Each of the TCR cost components, as well as the summary TPC components and the TPI, is shown separately in the Section 4.4.

#### 4.23 Capital Cost Estimate Exclusions

Although the estimate is intended to represent a complete power plant, there remain several qualifications/exclusions as follows:

- Sales tax is not included (considered to be exempt),
- On-site fuel transportation equipment (such as barge tug, barges, yard locomotive, bulldozers) is not included.
- Allowances for unusual site conditions (such as piling, extensive site access, excessive dewatering, extensive inclement weather) are not included.
- Switchyard (transmission plant) is not included. The costed scope terminates at the high side of the main power transformer.
- Ash disposal facility is excluded, other than the 3-day storage in the ash-storage silos and ash pond, (The ash disposal cost is accounted for in the ash disposal charge as part of consumables costs)
- Royalties are not included.

## 43 OPERATING COSTS AND EXPENSES

The operating costs and related maintenance expenses (O&M) described in this section pertain to those charges associated with operating and maintaining the PC power plant over its expected life.

The costs and expenses associated with operating and maintaining the plant include:

- Operating labor
- Maintenance
  - Material
  - Labor
- Administrative and support labor
- Consumables
- Fuel cost

The values for these items were determined consistent with EPRI TAG methodology. These costs and expenses are estimated on a first year basis, in December 1993 dollars. The first year costs assume normal operation and do not include the initial startup costs.

The operating labor, maintenance material and labor, and other labor related costs are combined and then divided into two components; fixed O&M, which is independent of power generation, and variable O&M, which is proportional to power generation. The first year operating and maintenance cost estimate allocation is based on the plant capacity factor.

The other operating costs, consumables and fuel, are determined on a daily 100 percent operating capacity basis and adjusted to an annual plant operation basis.

The development of the actual values was performed on a G/G model that is consistent with TAG. The inputs for each category of operating costs and expenses are identified in the succeeding subsections along with more specific discussion of the evaluation processes.

### 43.1 Operating Labor

The cost of operating labor was estimated on the basis of the number of operating jobs (OJ) required to operate the plant (on an average per-shift basis). The operating labor charge (OLC) expressed in first year \$/kW was then computed using the average labor rates:

$$OL = \frac{(OJ) \times (\text{labor rate} \times \text{labor burden}) \times (8760 \text{ h/yr})}{(\text{net capacity of plant at full load in kW})}$$

The operating labor requirements were determined on the basis of in-house representative data for the major plant sections (such as coal handling and steam turbine plant). These data were combined to arrive at total plant operating requirements as indicated on Table 4-3.

### 43.2 Maintenance

Since the development of the maintenance labor and maintenance material costs are so interrelated in this methodology, their cost bases are discussed together. Annual maintenance costs are estimated as a percentage of the installed capital cost. The percentage varies widely, depending on the nature of the processing conditions and the type of design.

**Table 4-3**

OPERATING LABOR REQUIREMENTS		
<b>PC ( Base Case )</b>		
Operating Labor Rate(base):	25,20 \$/hour	
Operating Labor Burden:	35,00 % of base	
Labor O-H Charge Rate:	30,00 % of labor	
Operating Labor Requirements(O. J.)per Shift:		Total
<u>Category</u>	<u>1 unit/mod.</u>	<u>Plant</u>
Skilled Operator	2.0	2\$0
Operator	19.0	19,0
Foreman	1.0	1,0
Lab Tech 's, etc.	3.0	3.0
<b>TOTAL – O.J.'s</b>	<b>25,0</b>	<b>25.0</b>

On the basis of G/C in-house data and EPRI guidelines for determining maintenance costs , representative values expressed as a percentage of system cost were specified for each major system, The rates were applied against individual estimate values. Using the corresponding TPC values, a total annual (first year) maintenance cost was calculated, including both material and labor components. The rates for calculation of maintenance are indicated in Table 4-4.

Since the maintenance costs are expressed as maintenance labor and maintenance materials, a maintenance labor/materials ratio of 40/60 was used for this breakdown. The operating costs, excluding consumable operating costs, are further divided into fixed and variable components. Fixed costs are essentially independent of capacity factor and are expressed in \$/kW-y. Variable costs are incremental, directly proportional to the amount of power produced, and expressed in mills/kWh(\$/MWh). The equations for these calculations are:

$$\text{Fixed O\&M} = \text{Capacity Factor (CF)} \times \text{Total O\&M (\$/kWyr)}$$

$$\text{Variable O\&M} = \frac{(1 - \text{CF}) \times \text{Total O\&M (\$/kW-yr)} \times 1000 \text{ mills/\$}}{(\text{CF} \times 8760 \text{ h/yr})}$$

### 4.3.3 Consumables

The feedstock and disposal costs are those consumable expenses associated with power plant operation. Consumable operating costs are developed on a first year basis and subsequently levelized over the 30 year life of the plant. The consumables category consists of water, chemicals, other consumables, and waste disposal as shown on Table 4.5

The “water” component pertains to the water acquisition charge for water required for the plant steam cycle, and for miscellaneous services.

The “chemicals” component consists of

- A composite water makeup and treating chemicals requirement in which unit cost and the ratio of chemicals to water were based on data from comparable plants

**Table 4-4**

MAINTENANCE FACTORS	
<b>PC ( Base Case )</b>	
<u>Item/Description</u>	<u>Maintenance %</u>
COAL & SORBENT HANDLING	<b>2.1</b>
COAL & SORBENT PREP & FEED	3,8
FEEDWATER & MISC. BOP SYSTEMS	2.3
PC BOILER & ACCESSORIES	
PC Boiler	3.5
Open	
Open	
Secondary Air System	
FLUE GAS CLEANUP	3,8
COMBUSTION TURBINE/ACCESSORIES	
Combustion Turbine Generator	
Combustion Turbine Accessories	
HRSG, DUCTING & STACK	
Heat Recovery Steam Generator	
HRSG Accessories	1.5
STEAM TURBINE GENERATOR	
Steam TG & Accessories	1,5
Turbine Plant Auxiliaries	1,7
COOLING WATER SYSTEM	1.3
ASH/SPENT SORBENT HANDLING SYS	<b>3.9</b>
ACCESSORY ELECTRIC PLANT	1.5
INSTRUMENTATION & CONTROL	<b>1.6</b>
IMPROVEMENTS TO SITE	1,2
BUILDINGS & STRUCTURES	1.5

**Table 4-5**

CONSUMABLES, BY-PRODUCTS & FUELS DATA			
PC ( Base Case )			
Item/Description	Consumption		Unit Cost
	Initial	/Day	
Water(/1000 gallons)		12,655	0.78
Chemicals*			
MU & WT Chem.(lbs)**	735,103	12,252	0.18
Liquid Eff.Chem.(lbs)**	1,518,607	25,310	0.13
Limestone(ton)**	25,384	423	16.72
Other			
Supplemental Fuel(MBtu)**			
Gases,N2 etc.(/100scf)			1.50
L.P.Steam(/1 000 pounds)			
Waste Disposal			
Sludge(ton)			
Ash(ton)		339	10.00
By-products			
Sulfuric Acid(pounds)			
Sulfur(pounds)			
Fuel(ton)		3,424	39.84

- The liquid effluent chemical category, representing the composite chemical requirement for wastewater treating, in which unit cost and quality were developed similar to the water makeup and treating chemicals
- The limestone, required for the FGD system, unit cost is the EPRI standard limestone cost.

The "other consumables" component consists of startup fuel, gases, primarily the nitrogen required for transport and blanketing and steam but does not contain any significant quantities.

The "waste disposal" component pertains to the cost allowance for off-site disposal of plant solid wastes. The unit cost for disposal is based on an adjusted EPRI value.

The Fuel (coal) cost was developed on the basis of delivered coal of \$1.60/10<sup>6</sup> Btu (FC), the plant net heat rate Btu/KWh (HR) and the coal higher heating value (HHV) of 12,450 Btu/lb. For the coal as well as for all feedstock and disposal costs, the quantity per day represents the 100% capacity requirement, while the annual cost values are adjusted for the designated 65% plant capacity factor. The calculation of first year fuel cost occurred as follows:

- Fuel (ton/day) =  $\frac{HR \times kW(\text{plant new capacity}) \times 24 \text{ hours}}{HHV \times 2000 \text{ lb/ton}}$
- Fuel Unit (per ton) Cost =  $\frac{HHV \times 2000 \text{ lb/ton} \times FC}{1 \times 10^6 \text{ Btu}}$
- Fuel Cost (1st year) = Fuel (t/d) x Fuel Unit Cost (\$/t) x 365 days x 0,65 (capacity factor)

Table 4-4 summarizes the quantities and unit costs used to determine the consumable costs including fuel.

#### 4.4 COST OF ELECTRICITY (COE)

The revenue requirement method of performing an economic analysis of a prospective power plant is widely used in the electric utility industry. This method permits the incorporation of the various dissimilar components for a potential new plant into a single value that can be compared to various alternatives. The revenue requirement figure of merit is COE that is the **levelized** (over plant life) coal **pile-to-busbar** cost of power expressed in **mills/kWh**. The value, based on EPRI definitions and methodology, includes the TCR, which is represented in the **levelized** carrying charge (sometimes referred to as the fixed charges), **levelized** fixed variable operating and maintenance costs, **levelized** consumable operating costs, and the **levelized** fuel cost.

The **levelized** carrying charge, applied to TCR, establishes the required revenues to cover return on equity, interest on debt, depreciation, income tax, property tax, and insurance. **Levelizing** factors are applied to the first year **fuel**, **O&M** costs, and consumable costs to yield **levelized** costs over the life of the project. A long term inflation rate of 4.1 %/yr. was assumed in estimating the cost of capital and in estimating the life cycle revenue requirements for other expenses (except that fuel was escalated at 0%/yr, this is a change in the recent TAG.). To represent these varying revenue requirements for fixed and variable costs, a "levelized" value was computed using the "present worth" concept of money based on the assumptions shown in the basis table resulting in a **levelized** carrying charge of 16.9% and **levelization** factor of 1.541 for **all** except coal and 1,0 for coal,

By combining costs, carrying charges, and **levelizing** factors, a **levelized** busbar COE for the 65% design capacity factor was calculated along with the **levelized** constituent values. The format for this cost calculation is:

$$\text{Power Cost (COE)} = \frac{(\text{LCC} + \text{LFOM}) \times 1000 \text{ mills}/\$}{\text{CF} \times 8760 \text{ h/y}} + \text{LVOM} + \text{LCM} - \text{LB} + \text{LFC}$$

where:

LCC	=	Levelized carrying charge, \$/kW-y
LFOM	=	Levelized fixed O&M, \$/kW-y
LVOM	=	Levelized variable O&M, mills/kWh
LCM	=	Levelized consumable, mills/kWh
LB	=	Levelized byproducts (if any), mills/kWh
LFC	=	Levelized fueled costs, mills/kWh
CF	=	Plant capacity factor, %

The consolidated basis for calculating capital investment and revenue requirements is given in Table 4-6, titled Estimate Basis/Financial Criteria for Revenue Requirement Calculations. The principle cost and economics output for this study are presented in Table 4-7, Capital Investment and Revenue Requirement Summary, which provides key **TPC** values and other significant capital costs, operating costs, maintenance costs, consumables, fuel cost and the **levelized busbar COE**.

**Table 4-6**

<b>ESTIMATE BASIS/FINANCIAL CRITERIA for REVENUE REQUIREMENT CALCULATIONS</b>			
<b>GENERAL DATA/CHARACTERISTICS</b>			
Case Title:	PC ( Base Case)		
Unit Size :/Plant Size:	401.2 MW, net	401,2 MWe	
Location:	Ohio River Valley		
Fuel: Coal/Secondary	<b>Pitts #8</b>		
Energy From Primary/Secondary Fuels	8,854 Btu/kWh	Btu/kWh	
Levelized Capacity Factor:	65 %		
Capital Cost Year Dollars:	1994 (December)		
Delivered Cost of Coal/Secondary	1.60 \$/MBtu	\$/MBtu	
Design/Construction Period:	3 years		
Plant Startup Date(year):	1995 (January)		
Land Area/Unit Cost	320 acre	\$1,500 /acre	
<b>FINANCIAL -CRITERIA</b>			
Project Book Life:	30 years		
Book Salvage Value:	%		
Project Tax Life:	20 years		
Tax Depreciation Method:	ACRS		
Property Tax Rate:	1,0 % per year		
Insurance Tax Rate:	1.0 % per year		
Federal Income Tax Rate:	34,0 %		
State Income Tax Rate:	6,0 %		
Investment Tax Credit/% Eligible	%	%	
	<u>% of Total</u>	<u>cost(%)</u>	
Capital Structure			
Common Equity	46		13.0
Preferred Stock	8		8.4
Debt	46		9.1
Weighted Cost of Capital: (after tax)		9.4 %	
Escalation Rates(Apparent)			
General Escalation:	4.1% per year		
Coal/Secondary Fuel Price Escalation:		% per year	% per year



Table 4-7

<b>CAPITAL INVESTMENT &amp; REVENUE REQUIREMENT SUMMARY</b>			
<b>TITLE/DEFINITION</b>			
Case:	PC ( Base Case)		
Plant Size:	401.2 (MW,net)	HeatRate:	8,854 (Btu/kWh)
Fuel(type):	Pitts #8	cost:	1.60 (\$/MMBtu)
Design/Construction:	3 (years)	BookLife:	30 (years)
TPC(Plant Cost) Year:	1994 (Dec,)	TPI Year:	1995 (Jan,)
Capacity Factor:	65 (%)		
<b>CAPITAL INVESTMENT</b>		<b>\$x1000</b>	<b>\$/kW</b>
Process Capital & Facilities		400,292	997.7
Engineering(incl. C, M., H, O. & Fee)		48,035	119.7
Process Contingency			
Project Contingency		67,249	167.6
TOTAL PLANT COST(TPC)		\$515,576	1285.1
TOTAL CASH EXPENDED	\$495,536		
AFDC	\$46,610		
TOTAL PLANT INVESTMENT(TPI)		\$542,346	1351.8
Royalty Allowance			
Preproduction Costs		14,397	35.9
Inventory Capital		10,180	25.4
Initial Catalyst & Chemicals(w/equip.)			
Land Cost		480	1.2
TOTAL CAPITAL REQUIREMENT(TCR)		\$567,403	1414.3
<b>OPERATING &amp; MAINTENANCE COSTS(First Year)</b>		<b>\$x1000</b>	<b>\$/kW-yr</b>
Operating Labor		7,450	18.6
Maintenance Labor		3,935	9.8
Maintenance Material		5,902	14.7
Administrative & Support Labor		3,416	8.5
TOTAL OPERATION & MAINTENANCE(1 st yr.)		\$20,703	51.6
FIXED O & M (1st yr.)			33,54 \$/kW-yr
VARIABLE O & M (1st yr.)			3.17 mills/kWh
<b>CONSUMABLE OPERATING COSTS(less Fuel)</b>		<b>\$x1000</b>	<b>mills/kWh</b>
Water		2,343	1.03
Chemicals		3,000	1.31
Other Consumables			
Waste Disposal		804	0.35
TOTAL CONSUMABLES(1 st yr., -fuel)		\$6,147	2.69
BY – PRODUCT CREDITS(First Year)			
FUEL COST(First Year)		\$32,362	14.17
<b>LEVELIZED OPERATION &amp; MAINTENANCE COSTS</b>			
Fixed O & M	51.4 \$/kW-yr		9.0 mills/kWh
Variable O & M			4.9 mills/kWh
Consumables			4.1 mills/kWh
By-product Credit			mills/kWh
Fuel			14.2 mills/kWh
<b>LEVELIZED CARRYING CHARGES(Capital)</b>	239.0 \$/kW-yr		42,0 mills/kWh
<b>LEVELIZED BUSBAR COST OF POWER</b>			
30 Year at a Capacity Factor of:	65%		74.2 mills/kWh

## 5.0 CONCLUSIONS AND RECOMMENDATIONS

The Pulverized Coal Reference Plant described herein represents an example of current practice for large, central station generating facilities. Many design parameters involving the steam cycle were selected to provide consistency between the various plants in the Clean Coal technology (CCT) series. Although various alternatives are possible for many of the design selections applied herein, these alternatives represent variations on a common theme. Economic parameters and emissions permitting criteria have also been selected for uniformity among the various CCT units.

The PC Reference Plant described in this report is expected to require a capital expenditure of 1,285 \$/kW, and to produce electricity for a **levelized** cost of 74.2 mills/kWh. Table 5-1 provides a summary of pertinent economic parameters for this Reference Plant, in December 1994 dollars.

**Table 5-1  
PC Plant Economic Summary**

	<u>\$ x 1000</u>	<u>\$/kW</u>
Total Capital Requirement	515,576	1,285
Fixed O&M (1st year)		33.54 \$/kW-yr
Variable O&M (1st year)		3.17 mills/kWh
Total consumables (1st year)	6,147	2.69
Fuel cost (1st year)	32,362	14.17
<b>Levelized Busbar Cost of Power</b>		<b>74.2 mills/kWh</b>

In comparing these costs with those of the other Reference Plants in this series, several factors should be considered:

1. The Atmospheric Circulating Fluid Bed Combustor (ACFB) Reference Plant design developed for this series of Reference Plants is based on cost data available in early 1992, compared to the PC Reference data date in December 1994.
2. Assumptions regarding capital market conditions and inflation rates vary between the ACFB and PC evaluations. The cost of fuel and sorbent is also different, to suit current market conditions and projections. Table 5-2, below, summarizes these parameters for the two units.

Users of this report and others in this series should apply adjustments to the technical factors as well as the economic parameters to suit their own circumstances and expectations. This report, and the others in this series, will provide a well defined point of reference for each technology, to facilitate informed and soundly based comparisons and decisions.

**Table 5-2**  
**ECONOMIC ASSUMPTION COMPARISON**

<u>Unit</u>	<u>ACFB</u>	<u>PC</u>
Weighted Cost of Capital	11.5%	9.2%
Inflation Rate	5.0%	4.1%
Fuel Cost, \$/10 <sup>6</sup> Btu	1.60	1.60
Sorbent Cost, \$/ton	16.50	15.0

## 6.0 REFERENCES

1. Reference Fossil **Plant, Design** Documentation, Gilbert/Commonwealth, Inc., 1980 through present.
2. Cross Station **Unit No. 1**, South Carolina Public Service Authority, G/C Design Documentation as Architect/Engineer of Record, 550 MWe pulverized coal fired plant with wet limestone scrubber Flue Gas **Desulfurization** System.
3. **Milliken Station**, New York State Electric & Gas Co., G/C design Documentation as Architect/Engineer for retrofit of wet scrubber Flue Gas **Desulfurization** System.
4. Special Report, Controlling SO<sub>2</sub> Emissions, Power Magazine, March 1993.
5. Special Report, Reducing NO<sub>x</sub> Emissions from Today's Power Plants, Power Magazine, May 1993,
6. North American Electric Reliability Council, Generating Availability Data System, Performance Statistics and Operating States for Fossil Units.
7. Electric Power Research Institute (EPRI), Technical Assessment Guide, EPRI P-4463-SR, December 1986.

## 7.0 BIBLIOGRAPHY

Steam/It's Generation and Use, Babcock & Wilcox, 1972 (thirty-eight edition).

Combustion - Fossil Power Systems, Combustion Engineering, Inc., 1981 (third edition).

**APPENDIX A**

**REFERENCE PLANT**

**MAJOR EQUIPMENT LIST**

## CONDENSATE AND FEEDWATER SYSTEM

<u>Equipment No.</u>	<u>Description</u>	<u>Type</u>	<u>Design Condition</u>	<u>Qty.</u>
1	Cond. Storage Tank	Field Fab.	200,000 gal.	1
2	Surface Condenser	Two Shell, Transverse Tubes	1.83 x 10' lb/hr 1.4/2.0 in Hg	1
3	Cond. Vacuum Pumps	Rotary Water Sealed	2500/25 scfm	2
4	Condensate Pumps	Vert. Canned	2500 gpm @ 800 ft	3
5	L.P.F.W. Htr. 1A/1B	Horiz. U tube	2,249,030 lb/hr 98.2°F to 167.4°F	2
6	L.P.F.W. Htr. 2A/2B	Horiz. U tube	2,249,030 lb/hr 167.4°F to 198.7°F	2
7	L.P.F.W. Htr. 3	Horiz. U tube	2,249,030 lb/hr 198.7°F to 231.1°F	1
8	L.P.F.W. Htr. 4	Horiz. U tube	2,249,030 lb/hr 231.1°F to 292.3°F	1
9	Deaerator and Storage Tank	Horiz. Spray Type	2,249,030 lb/hr 292.3°F to 365.9°F	1
10	B.F. Pumps/Turbines	Barrel Type, Multi-staged, Centr.	3400 gpm @ 7200 ft	2
11	Startup B.F. Pump	Barrel Type, Multi-staged Centr.	1,500 gpm @ 7200 ft	1
12	H.P.F.W. Htr. 6	Horiz. U tube	2,652,909 lb/hr 365.9°F to 407.5°F	1
13	H.P.F.W. Htr. 7	Horiz. U tube	2,652,909 lb/hr 407.5°F to 488.9°F	1

## CIRCULATING WATER SYSTEM

<u>Equipment No.</u>	<u>Description</u>	<u>Type</u>	<u>Design Condition</u>	<u>Qty.</u>
1	Cooling Tower	Mech Draft	202,000 gpm 95°F to 75°F	1
2	Circ. W. Pumps	Vert. Wet Pit	101,000 gpm @ 80 ft	2

COAL RECEIVING AND HANDLING SYSTEM

<u>Equipment No.</u>	<u>Description</u>	<u>Type</u>	<u>Desire Condition</u>	<u>Qty.</u>
1	Rotary Car Dumper and Receiving Hoppers	N/A	100 Ton	4
2	Feeder	Vibratory	225 TPH	4
3	Conveyor #1	54" Belt	900 TPH	1
4	As-Received Coal Sampling System	Two Stage	N/A	1
5	Conveyor #2	54" Belt	900 TPH	1
6	Coal Stacker	Double Wing	900 TPH	1
7	Active Pile Reclaim Hopper	N/A	40 Ton	3
8	Feeder	Vibratory	620 TPH	3
9	Emergency Coal Hopper	N/A	30 Ton	1
10	Feeder	Vibratory	620 TPH	1
11	Conveyor #3A	48" Belt	620 TPH	1
12	Conveyor #3B	48" Belt	620 TPH	1
13	Coal Bin W/ Vent Filter	Compartment	340 Ton	1
14	Feeder	Vibratory	620 TPH	2
15	Flop Gate	N/A	620 TPH	2
16	Crusher	Granulator Reduction	6"x0"-3"x0"	2
17	Crusher	Impactor Reduction	3"x0"-1¼"x0"	2
18	Conveyor #4A	48" Belt	620 TPH	1
19	Conveyor #4B	48" Belt	620 TPH	1
20	As-Fired Coal Sampling System	Swing Hammer	620 TPH	2
21	Conveyor #5A	48" Belt	620 TPH	1
22	Conveyor #5B	48" Belt	620 TPH	1
23	Tripper #1 & 2	N/A	620 TPH	2
24	Coal Silo W/ Vent Filter and Slide Gates	N/A	450 Ton	6
25	Feeder	Gravimetric	40 TPH	5
26	Pulverizer	B&W Type MPS-75	40 TPH	5



## LIMESTONE HANDLING AND REAGENT PREPARATION SYSTEM

<u>Equipment No.</u>	<u>Description</u>	<u>Type</u>	<u>Desire Condition</u>	<u>Qty.</u>
1	Truck Unloading Hopper	N/A	35 Ton	2
2	Feeder	Vibratory	115 TPH	2
3	Conveyor #1	30" Belt	115 TPH	1
4	Conveyor #2	30" Belt	115 TPH	1
5	Limestone Day Bin		306 Tons	2
6	Bin Activator		27 TPH	2
7	Weigh Feeder	Gravimetric	27 TPH	2
8	Limestone Ball Mill	Rotary	27 TPH	2
9	Mill Slurry Tank with Agitator		5000 gal	2
10	Mill Recycle Pumps	Horizontal Centrifugal	600 gpm	4
11	Hydroclones	Radial Assembly		2
12	Distribution Box	3-Way		2
13	Reagent Storage Tank with Agitator	Field erected	110,000 gal	1
14	Reagent Distribution Pumps	Horizontal Centrifugal	500 gpm	2

## EXHAUST GAS SCRUBBER SYSTEM

<u>Equipment No.</u>	<u>Description</u>	<u>Type</u>	<u>Design Condition</u>	<u>Qty.</u>
1	Absorber Module	Spray/Tray	590,615 acfm	3
2	Recirculation Pump	Horizontal Centrifugal	17,500 gpm	12
3	Bleed Pump	Horizontal Centrifugal	650 gpm	6
4	Oxidation Air Blower	Centrifugal	5650 scfm	3
5	Agitators	Side Entering	20 hp motor	12
6	Absorber Inlet Dampers	Guillotine	590,615 acfm	3
7	Absorber Outlet Dampers	Guillotine	502,000 acfm	3
8	Bypass Damper	Double Louver	590,615 acfm	1
9	Formic Acid Storage Tank	Vertical, Diked	1000 gal	1
10	Formic Acid Pumps	Metering	0.1 gpm	2

## BYPRODUCT DEWATERING SYSTEM

<u>Equipment No.</u>	<u>Description</u>	<u>Type</u>	<u>Design Condition</u>	<u>Qty.</u>
1	Primary Hydroclones	Radial Manifold	650 gpm	2
2	Centrifuge Feed Tank		3100 gal	2
3	Centrifuge Feed Pumps	Horizontal Centrifugal	1300 gpm	2
4	Centrifuges with Hoppers and Unloaders	Vertical Basket	<b>100</b> gpm	6
5	Collecting Conveyor	30 in belt	130 tph	2
6	Transfer Conveyor	30 in belt	130 tph	2
7	Stacker	Radial	130 tph	1
8	Secondary Hydroclone Feed Tank		9,100 gal	2
9	Secondary Hydroclones	Radial Manifold	260 gpm	2
10	Secondary Hydroclone Feed Pumps	Horizontal Centrifugal	260 gpm	2
11	Filtrate Tank		26,500 gal	1
12	Filtrate Pumps	Horizontal Centrifugal	1130 gpm	2
13	Clarified Water Tank		53,000 gal	2
14	Clarified Water Pumps	Horizontal Centrifugal	200 gpm	2

ASH HANDLING SYSTEM (Flyash)

<u>Equipment No.</u>	<u>Description</u>	<u>Type</u>	<u>Design</u>	<u>Condition</u>	<u>Qty.</u>
1	Precipitator Hopper (part of Precipitator scope of supply)				24
2	Air Heater Hopper (part of Boiler scope of supply)				10
3	Air Blower		1800 scfm		2
4	Flyash Silo	Reinf. Concrete	890 tons		1
5	Slide Gate Valves				2
6	Unloader		30 tph		1
7	Telescoping Unloading Chute				1

ASH HANDLING SYSTEM (Bottom Ash)

<u>Equipment No.</u>	<u>Description</u>	<u>Type</u>	<u>Design</u>	<u>Condition</u>	<u>Qty.</u>
1	Economizer Hopper (part of Boiler scope of supply)				4
2	Bottom Ash Hopper (part of Boiler scope of supply)				2
3	Clinker Grinder		10 tph		2
4	Pyrites Hopper (part of Pulverizer scope of supply included with Boiler)				6
5	Hydroejectors				13
6	Economizer/Pyrites Transfer Tank		40,000 gal		1
7	Ash Sluice Pumps	Vertical, wet pit	1000 gpm		2
8	Ash Seal Water Pumps	Vertical, wet pit	1000 gpm		2

## STEAM GENERATOR AND ANCILLARY EQUIPMENT

<u>Equipment No.</u>	<u>Description</u>	<u>Type</u>	<u>Desire Condition</u>	<u>Qty.</u>
1	Boiler with Air Heater	Natural Circ., Wall Fired	472 MWe, 3,014,185 PPH steam at 2660 PSIG/1000°F	1
2	Primary Air Fan	Axial	427,376 PPH, 92,500 ACFM, 45" WG, 800 HP	2
3	F.D. Fan	Cent.	1,706,323 PPH, 387,500 ACFM, 11" WG, 850 HP	2
4				
5	I.D. Fan	Cent.	2,013,094 PPH, 639,000 ACFM, 32" WG 410(I HP	2
6	Electrostatic Precipitator	Rigid Frame, Single Stage	639,000 ACFM 300,000 ft <sup>2</sup> plate area	2
7	Stack	Reinf. Concrete, two FRP flues	60 fps exit velocity 480 ft High x 19.5 ft Dia. (flue)	1

## TURBINE GENERATOR AND AUXILIARY EQUIPMENT

<u>Equipment No.</u>	<u>Description</u>	<u>Type</u>	<u>Design Condition</u>	<u>Qty.</u>
1	435 MW Turbine Generator	TC4F30	2400 psig, 1000°F/1000°F	1
2	Bearing Lube Oil Coolers	Shell & Tube		2
3	Bearing Lube Oil Conditioner	Pressure Filter Closed Loop	-	1
4	Control System	Electro Hydraulic	1600 psig	1
5	Generator Coolers	Shell & Tube	.	2
6	Hydrogen Seal Oil System	Closed loop	.	1
7	Generator Exciter	Solid State brushless	-	1

## MISCELLANEOUS EQUIPMENT

<u>Equipment No.</u>	<u>Description</u>	<u>Type</u>	<u>Desire Condition</u>	<u>Qty.</u>
1	Auxiliary Boiler	Shop Fab. Water Tube	400 psig, 650° F	1
2	Fuel Oil Storage Tank	Vertical, Cylindrical	300,000 gal	1
3	Fuel Oil Unloading Pump	Gear	150 ft, 800 gpm	1
4	Fuel Oil Supply Pump	Gear	400 ft, 80 gpm	2
5	Service Air Compressors	S. S., Double Acting	100 psig, 800 SCFM	3
6	Inst. Air Dryers	Duplex, Regenerative	400 SCFM	1
7	Service Water Pumps	S. S., Double Suction	100 ft, 6000 gpm	2
8	Closed Cycle Cooling Heat Exch.	Shell & Tube	50% Cap. each	2
9	Closed Cycle Cooling Water Pumps	Horizontal Centrifugal	185 ft, 600 gpm	2
11	Fire Service Booster Pump	2 stage cent,	250 ft, 700 gpm	1
12	Engin. Driven Fire Pump	Vert. Turbine, diesel engine	350 ft, 1000 gpm	1
13	Riverwater Makeup Pumps	S. S., Single Suction	100 ft, 5,750 gpm	2
14	Filtered Water Pumps	S. S., Single Suction	200 ft, 200 gpm	2
15	Filtered Water Tank	Vertical, Cylindrical	15,000 gal	1
16	Makeup Demineralize	Anion, Cation, and Mixed Bed	125 gpm	2
17	Liquid Waste Treatment System	.	10 years, 25 hr. storm	1
18	Condensate Demineralize	Mixed bed	1600 gpm	1

**APPENDIX B**

**PULVERIZED COAL REFERENCE PLANT**

**TOTAL PLANT COST - DETAIL**

TOTAL PIANT COST SUMMARY

Case: PC ( Base Case )  
 Plant Size: 401.2 MW.net

Estimate Type: Conceptual

Cost Year 1994 ; \$X1000

Acct No.	Item/Description	Equipment cost	Material cost	Labor		sales Tax	Bare Enacted cost \$	Eng'g CM H. O.& Fee	Contingencies		TOTAL PLANT COST		
				Direct	In direct				Process	Project	\$	\$/kW	
1	<b>COAL &amp; SORBENT HANDLING</b>												
	1.1 Coal Receive & Unload	2,666		1,495	105		\$4,288	515		720		\$5,522	14
	1.2 Coal Stackout & Reclaim	3,523		972	66		\$4,563	546		767		\$5,677	15
	1.3 Coal Conveyors & 'id Cmsh	3,276		962	67		\$4,305	517		723		\$5,544	14
	1.4 Other Coal Handling	657		223	16		\$1,095	131		184		\$1,410	4
	1.5 Sorbent Receive & Unload	71		26	2		\$99	12		17		\$127	0
	1.6 Sorbent Stackout & Reclaim												
	1.7 Sorbent Conveyors	615		184	13		\$612	97		136		\$1,046	3
	1.6 Other Sorbent Handling												
	1.9 Coal & Sorbent Hnd. Foundations		3,161	4,441	311		\$7,913	950		1,329		\$10,192	25
	<b>SUBTOTAL 1.</b>	<b>\$11,030</b>	<b>\$3,161</b>	<b>\$6,302</b>	<b>\$561</b>		<b>\$23,074</b>	<b>\$2,769</b>		<b>\$3,876</b>		<b>\$29,719</b>	<b>74</b>
2	<b>COAL &amp; SORBENT PREP &amp; FEED</b>												
	2.1 Coal Crushing & Drying	1,695		402	28		\$2,125	255		357		\$2,737	7
	2.2 Coal Conveyor / Storage	6,022		2,132	149		\$10,303	1,235		1,731		\$13,270	33
	2.3 Coal Injection System												
	2.4 Mist. Coal Prep & Feed												
	2.5 Sorbent Prep Equipment												
	2.6 Sorbent Storage & Feed	227		761	53		\$1,040	125		175		\$1,340	3
	2.7 Sorbent Injection Sytam	3,170		697	49		\$3,916	470		656		\$5,044	13
	2.8 Booster Air Supply System												
	2.9 Coal & Sorbent Faad Foundation												
	<b>SUBTOTAL 2.</b>	<b>\$13,113</b>		<b>\$3,991</b>	<b>\$279</b>		<b>\$17,364</b>	<b>\$2,086</b>		<b>\$2,920</b>		<b>\$22,390</b>	<b>56</b>
3	<b>FEEDWATER &amp; MISC. 80P SYSTEMS</b>												
	3.1 Feedwater System	5,060		1,624	114		\$6,796	616		1,142		\$8,756	22
	3.2 Water Makeup & Pretreating	2,364		852	60		\$3,295	395		554		\$4,244	11
	3.3 Other Feedwater Subsystems	3,684		1,316	92		\$5,072	609		852		\$6,533	16
	3.4 Service Water Systems	440		271	19		\$730	6a		123		\$940	2
	3.5 Other Boiler Plant Systems	1,615		1,516	106		\$3,437	412		577		\$4,427	11
	3.6 FO Supply Sys & Nat Gas	166		246	17		\$431	52		72		\$556	1
	3.7 Waste Treatment Equipment	1,674		962	69		\$2,725	327		456		\$3,509	9
	3.8 Misc. Power Plant Equipment	1,608		535	37		\$2,160	262		366		\$2,808	7
	<b>SUBTOTAL 3.</b>	<b>\$16,813</b>		<b>\$7,341</b>	<b>\$514</b>		<b>\$24,666</b>	<b>\$2,960</b>		<b>\$4,144</b>		<b>\$31,773</b>	<b>7s</b>
4	<b>PC BOILER &amp; ACCESSORIES</b>												
	4.1 PC Boiler	43,471		16,553	1,299		\$63,323	7,599		10,636		\$81,560	203
	4.2 Open												
	4.3 Open												
	4.4 Interconnecting Pipe	w/4.1		w/4.1									
	4.5 Primary Air System	w/4.1		w/4.1									
	4.6 Secondary Air System	w/4.1		w/4.1									
	4.6 Major Component Riggng		w/4.1	w/4.1									
	4.9 PC Foundations		w/14.1	w/14.1									
	<b>SUBTOTAL 4.</b>	<b>\$43,471</b>		<b>\$16,553</b>	<b>\$1,299</b>		<b>\$63,323</b>	<b>\$7,599</b>		<b>\$10,638</b>		<b>\$81,560</b>	<b>203</b>

TOTAL PLANT COST SUMMARY

Case: PC ( Base Case )  
 Plant Size: 401.2 MW,net Estimate Type: Conceptual Cost Year 1994: \$x1000

Acct No.	Item/Description	Equipment Cost	Material cost	Labor		Sales Tax	Bare Erected cost \$	Eng'g CM H.O.& Fee	Contingencies		TOTM PLANT COST	
				Direct	Indirect				Process	Project	s	\$/KW
5	FLUE GAS CLEANUP											
5.1	Absorber Vessels & Accessories	20,735		5,466	384		\$26,607	3,193	4,470		\$34,270	85
5.2	Other FGD	1,821		2,255	158		\$4,234	506	711		\$5,453	14
5.3	ESP & Accessories	12,466		4,756	333		\$17,557	2,107	2,950		\$22,613	56
5.4	Other ESP	3,241		5,606	393		\$9,242	1,109	1,553		\$11,903	30
5.5	Product Dewatering	4,351		642	59		\$5,251	630	662		\$6,764	17
5.6	Open											
5.9	Open											
	SUBTOTAL 5.	\$42,815		\$18,949	\$1,326		\$82,691	\$7,547	\$10,566		\$81,003	202
6	COMBUSTION TURBINE/ACCESSORIES											
6.1	Combustion Turbine Generator	N/A		N/A								
6.2	Combustion Turbine Accessories	N/A		N/A								
6.3	Compressed Air Piping											
6.9	Combustion Turbine Foundations											
	SUBTOTAL 8.											
7	HRSG, DUCTING & STACK											
7.1	Heat Recovery Steam Generator	N/A		N/A								
7.2	HRSG Accessories											
7.3	Ductwork	7,337		4,425	310		\$12,072	1,449	2,026		\$15,549	39
7.4	Stack	5,701		3,645	255		\$9,601	1,152	1,613		\$12,366	31
7.9	HRSG, Duct & Stack Foundations		273	345	24		\$642	77	108		\$627	2
	SUBTOTAL 7.	\$13,036	\$273	\$8,415	\$589		\$22,315	\$2,878	\$3,749		\$26,742	72
6	STEAM TURBINE GENERATOR											
8.1	Steam TG & Accessories	35,365		4,607	336		\$40,509	4,861	6,805		\$52,175	130
8.2	Turbine Plant Auxiliaries	176		416	29		\$626	75	105		\$806	2
8.3	condenser & Auxiliaries	4,787		1,339	94		\$6,220	746	1,045		\$6,012	20
8.4	Steam Piping	6,524		3,475	243		\$10,243	1,229	1,721		\$13,193	33
8.9	TG Foundations		344	1,086	76		\$7,507	761	253		\$1,941	5
	SUBTOTAL 8.	\$46,655	\$344	\$11,288	\$779		\$59,104	\$7,092	\$9,929		\$76,126	190
9	COOLING WATER SYSTEM											
9.1	Cooling Towers	6,226		1,397	98		\$7,722	927	1,297		\$9,946	25
9.2	Circulating Water Pumps	667		66	6		\$979	118	165		\$1,261	3
9.3	Circ. Water System Auxiliaries	111		16	1		\$126	15	22		\$165	0
9.4	Circ. Water Piping		2,051	2,331	163		\$4,546	545	764		\$5,855	15
9.5	Make-up Water System	246		375	26		\$649	76	109		\$636	2
9.6	Component Cooling Water Sys	240		215	15		\$470	56	79		\$605	2
9.9	Circ. Water System Foundations		1,530	2,707	169		\$4,425	531	744		\$5,700	14
	SUBTOTAL 9.	\$7,713	\$3,581	\$7,127	\$499		\$18,921	\$2,270	\$3,179		\$24,370	61



TOTAL PLANT COST SUMMARY

Case: PC ( Base Case)  
 Plant Size: 401.2 MW.net

Estimate Type: Conceptual

Cost Year 1994: \$x1000

Acct No.	Item/Description	Equipment cost	Material cost	Labor		sales Tax	Sara Erected cost \$	Eng'g CM H.O.& Fee	Contingencies		TOTAL PLANT COST	
				Direct	Indirect				Process	Project	\$	\$/kW
10	ASH/SPENT SORBENT HANDLING SYS											
	10.1 Ash Coolers	N/A		N/A								
	10.2 Cyclone Ash Letdown	N/A		N/A								
	10.3 HGCU Ash Letdown	N/A		N/A								
	10.4 High Temperature Ash Piping	N/A		N/A								
	10.5 Other Ash Recovery Equipment	N/A		N/A								
	10.6 Ash Storage Silos	157		529	37		\$723	67		121		\$931 2
	10.7 Ash Transport & Feed Equipment	5,599		9,993	699		\$16,291	1,955		2,737		\$20,963 52
	10.8 Misc. Ash Handling Equipment											
	10.9 Ash/Spent Sorbent Foundation		73	96	7		\$176	21		30		\$227 1
	<b>SUBTOTAL 10.</b>	<b>\$5,756</b>	<b>\$73</b>	<b>\$10,618</b>	<b>\$743</b>		<b>\$17,190</b>	<b>\$2,063</b>		<b>\$2,888</b>		<b>\$22,141 55</b>
11	ACCESSORY ELECTRIC PLANT											
	11.1 Generator Equipment	1,491		232	16		\$1,739	209		292		\$2,240 6
	11.2 Station Service Equipment	2,491		786	55		\$3,332	400		560		\$4,291 11
	11.3 Switch gear & Motor Control	4,334		872	61		\$5,236	632		665		\$6,763 17
	11.4 Conduit & Cable Tray		1,423	4,410	309		\$6,152	736		1,033		\$7,923 20
	11.5 Wire & Cable		2,642	2,588	181		\$5,411	649		909		\$6,970 17
	11.6 Protective Equipment	178		562	41		\$801	96		135		\$1,031 3
	11.7 Standby Equipment	1,232		27	2		\$1,281	151		212		\$1,624 4
	11.8 Main Power Transformers	3,227		147	10		\$3,364	406		589		\$4,359 11
	11.9 Electrical Foundations		203	561	39		\$604	96		135		\$1,035 3
	<b>SUSTOTAL 11.</b>	<b>\$12,952</b>	<b>\$4,276</b>	<b>\$10,205</b>	<b>\$714</b>		<b>\$28,150</b>	<b>\$3,378</b>		<b>\$4,729</b>		<b>\$36,257 90</b>
12	INSTRUMENTATION & CONTROL											
	12.1 PC Control Equipment	w/12.7		w/12.7								
	12.2 Combustion Turbine Control	N/A		N/A								
	12.3 Steam Turbine Control	w/8.1		w/8.1								
	12.4 Other Major Component Control											
	12.5 Signal Processing Equipment	w/12.7		w/12.7								
	12.6 Control Boards, Panels & Racks	296		170	12		\$478	57		80		\$616 2
	12.7 Computer & Accessories	6,199		176	12		\$6,390	767		1,074		\$6,230 21
	12.8 Instrument Wiring & Tubing	1,604		4,890	342		\$6,636	620		1,148		\$6,605 22
	12.9 Other I & C Equipment	1,404		612	43		\$2,080	247		346		\$2,653 7
	<b>SUBTOTAL 12.</b>	<b>\$9,504</b>		<b>\$5,851</b>	<b>\$410</b>		<b>\$15,764</b>	<b>\$1,692</b>		<b>\$2,646</b>		<b>\$20,304 51</b>
13	IMPROVEMENTS TO SITE											
	13.1 Site Preparation			608	42		\$649	78		109		\$636 2
	13.2 Site Improvements		1,015	1,250	66		\$2,353	262		395		\$3,030 8
	13.3 Site Facilities	1,616		1,779	125		\$3,722	447		625		\$4,794 12
	<b>SUSTOTAL 13.</b>	<b>\$1,818</b>	<b>\$1,015</b>	<b>\$3,636</b>	<b>\$254</b>		<b>\$5,723</b>	<b>\$807</b>		<b>\$1,130</b>		<b>\$6,660 22</b>
14	BUILDINGS & STRUCTURES											
	14.1 Bolter Building		12,236	12,799	656		\$25,930	3,112		4,356		\$33,398 83
	14.2 Turbine Building		4,034	6,366	447		\$10,870	1,304		1,829		\$14,000 35
	14.3 Administration Building		522	656	46		\$1,224	147		206		\$1,577 4
	14.4 Circulation Water Pump House		22	21	1		\$45	5		8		\$58 0
	14.5 Water Treatment Buildings		216	214	15		\$446	54		75		\$575 1
	14.6 Machine Shop		279	223	16		\$516	62		67		\$667 2
	14.7 Warehouse		189	226	16		\$431	52		72		\$555 1
	14.6 Other Buildings & structures		116	117	6		\$242	29		41		\$311 1
	14.9 Waste Treating Building & Str.		222	801	56		\$1,080	130		161		\$1,391 3
	<b>SUBTOTAL 14.</b>		<b>\$17,639</b>	<b>\$21,448</b>	<b>\$1,501</b>		<b>\$40,766</b>	<b>\$4,894</b>		<b>\$6,852</b>		<b>\$52,532 131</b>
<b>TOTAL COST</b>		<b>\$224,679</b>	<b>\$30,563</b>	<b>\$135,560</b>	<b>\$9,489</b>		<b>\$400,292</b>	<b>\$48,135</b>		<b>\$67,249</b>		<b>% 15.578 126.5</b>