

DOE/METC/C-96/7208

Stamet Solids Pump Feeds Coal into 210 psig in a DOE Supported Project

Authors:

Donald L. Bonk

Andrew Hay

Conference Title:

Power-Gen America 1995

Conference Location:

Anaheim, California

Conference Dates:

December 5-7, 1995

Conference Sponsor:

Power Engineering, and Electric Light and Power

RECEIVED

JAN 30 1996

OSTI

**MASTER**

DISTRIBUTION OF THIS DOCUMENT IS UNLIMITED

*Dlc*

## DISCLAIMER

This report was prepared as an account of work sponsored by an agency of the United States Government. Neither the United States Government nor any agency thereof, nor any of their employees, makes any warranty, express or implied, or assumes any legal liability or responsibility for the accuracy, completeness, or usefulness of any information, apparatus, product, or process disclosed, or represents that its use would not infringe privately owned rights. Reference herein to any specific commercial product, process, or service by trade name, trademark, manufacturer, or otherwise does not necessarily constitute or imply its endorsement, recommendation, or favoring by the United States Government or any agency thereof. The views and opinions of authors expressed herein do not necessarily state or reflect those of the United States Government or any agency thereof.

This report has been reproduced directly from the best available copy.

Available to DOE and DOE contractors from the Office of Scientific and Technical Information, 175 Oak Ridge Turnpike, Oak Ridge, TN 37831; prices available at (615) 576-8401.

Available to the public from the National Technical Information Service, U.S. Department of Commerce, 5285 Port Royal Road, Springfield, VA 22161; phone orders accepted at (703) 487-4650.

**Stamet Solids Pump Feeds Coal into 210 psig in a  
DOE Supported Project**

Andrew Hay  
Vice-President of Research  
Stamet, Incorporated  
Gardena, California

Donald L. Bonk  
U.S. Department of Energy  
Morgantown Energy Technology Center  
Morgantown, West Virginia

DISTRIBUTION OF THIS DOCUMENT IS UNLIMITED

*DLB*

Stamet Solids Pump Feeds Coal into 210 psig in a  
DOE Supported Project

Andrew Hay  
Vice-President of Research  
Stamet, Incorporated  
Gardena, California

Donald L. Bonk  
U.S. Department of Energy  
Morgantown Energy Technology Center  
Morgantown, West Virginia

Abstract

This paper summarizes the efforts of Stamet, Incorporated, and the U.S. Department of Energy (DOE) to produce an innovative feed system for pressurized combustion power systems. DOE has been fostering the development of pressurized fluidized-bed combustion power systems which are 45 percent efficient and can deliver electricity at 20 percent below the cost of conventional power systems. A major capital cost factor in pressurized systems is the coal and limestone feed systems. DOE has been attempting to reduce the capital and operating cost of these components for a number of years. In 1995, Stamet, Incorporated, completed a 2-year Small Business Innovative Research grant from DOE and produced a precision metering feeder capable of delivering coal into a vessel at 210 pounds per square inch, gauge, (~14 atmospheres). The feeder is an elegantly simple machine with one moving part. The product provides continuous metering of fuel against pressure with instantaneous rate control.

Introduction -- Advanced Power Systems

The U.S. DOE has been supporting the development of advanced coal-fired power generation systems since its inception. Second Generation (advanced) Pressurized Fluidized Bed Combustion (PFBC) presents one of the most promising power generation technologies for the 21<sup>st</sup> century. Over the last 10 years, the projected economics of second generation PFBCs in utility applications indicates a 20 percent reduction in the cost of electricity and efficiencies of 45 percent or greater. Therefore, pressurized fluidized bed (PFBC) cycles, especially 2<sup>nd</sup> generation compared favorably to conventional pulverized coal power plants and other advanced technologies.

In the 2<sup>nd</sup> generation PFBC system shown in Figure 1, coal is fed

to a pressurized fluidized-bed partial gasifier<sup>1</sup> that produces a low-Btu gas and char. Char is then burned in a PFBC, and the flue gas is cleaned of particulate and sent to the topping combustor. Low-Btu fuel gas from the partial gasifier is also cleaned and piped to the topping combustor. In the topping combustor, any air required to complete combustion is mixed with the fuel gas and the flue gases. Steam is produced from heat transfer surfaces located in the PFBC and a heat recovery steam generator (HRSG). In cogeneration applications, coal can be fed simultaneously to the PFBC for increased steam production. As shown, the 2<sup>nd</sup> Generation PFBC uses the full power producing potential of modern gas and steam turbines in coal-fired combined cycle plants. Consistent with the high power output of modern gas turbines, gas turbine inlet temperatures of 2100 to 2500 °F are achieved via partial gasification of the coal and topping combustion of the fuel gas in 2<sup>nd</sup> generation systems. The combustion of char in the PFBC allows for the high heat flux and temperatures necessary to drive advanced steam turbines.

While the projected economics of the 2<sup>nd</sup> Generation PFBC concept compares favorably with other technologies, successful commercialization can only be assured by a superior economic position. Therefore, using the year 2010 as a commercialization target, the Morgantown Energy Technology Center, U.S. DOE has performed an in-depth risk assessment built upon reliability, maintenance, economic, and technical risk factors. This assessment indicated that overall capital cost and the wholesale cost of electricity are the priority issues for potential PFBC owners. Review of individual components and subsystems revealed that solid feed systems rank third as an area where potential cost impacts could be negative without additional development to improve reliability and simplicity.

Historically, coal feeders have been singled out as a major cause of power plant downtime or production curtailment, since without these key components coal-fired plants cannot operate. In advanced power systems the coal feeder or feeder system must not only meter coal and maintain a coal feed rate, but do so across a large pressure differential. Conventional coal-fired plants operate at or near atmospheric pressure (14.7 psia), while the advanced combustion and gasification plants may operate at pressures over 24 atmospheres (352 psia). Therefore, coal at atmospheric pressure must, by some means, be continuously injected into these pressurized systems.

DOE funded research and development efforts have brought about numerous improvements in lockhopper feed systems and commercial

---

<sup>1</sup> While this paper describes the Stamet pump in conjunction with pressurized fluidized bed combustion, the pump can be applied just as well to advanced pressurized gasification systems.

scale demonstrations of coal paste<sup>2</sup> feed systems at approximately 14 atmospheres. The use of paste feed systems in place of lockhoppers can result in a 10 percent reduction in plant costs. Unfortunately, the substitution of paste feeders is not possible in all cases and is impractical for low rank coal with high moisture and ash content. Regardless of improvements in existing pressurized coal feed systems, many designers continue to search for simpler more reliable systems.

### DOE's SBIR Program

One of DOE's methods for obtaining new concepts which support the Nation's energy policy is the Small Business Innovation Research (SBIR) program managed by the Office of Energy Research. Under this program, small businesses with strong research or engineering capabilities can submit proposals to undertake specific research activities. There are three phases<sup>3</sup> in the SBIR program. In the first phase, DOE solicits proposals, and out of over 1400 proposals awards approximately 200 \$75,000 grants for determinations of feasibility.

Upon completion of the feasibility study, the Phase 1 awardee may submit an application for a \$750,000 Phase 2 award. Historically about 1/3 of the Phase 1 awardees receive Phase 2 awards. The Stamet pump, the subject of this paper has successfully completed both phases of the SBIR program and appears to be a viable high pressure coal feeder for 2<sup>nd</sup> generation PFBC applications.

### The Stamet Story

The Stamet Solids Pump project started in the 1980's when the TOSCO Corporation of the U.S. was developing techniques for retorting oil shale. One of the systems required for this continuous retorting process was a solids transport system to continually pre-heat and elevate the supply of shale to the top of the retort structure. A pneumatic system was selected and a means of injecting the -1/4" oil shale into the pneumatic lift pipe was sought. Screw conveyers and star valves were not reliable. They were short-lived and maintenance costs soared. A simplified design of solids injection techniques was therefore required.

Donald Firth conceived of the single rotor friction pump with multiple chokes, which became a patented design. Stamet acquired the infant technology in 1987, and with Donald Firth who joined

---

<sup>2</sup> Coal paste consists of a mixture of not less than 70 percent by weight coal solids to not more than 30 percent water. Pastes are readily pumped using positive displacement pumps

<sup>3</sup> Under Phase 3, it is intended that non-Federal capital be used to pursue commercial applications of the R&D, but follow on non-SBIR grants or contracts are possible if the product or process furthers an agency's mission.

Stamet, tested the pump on coal. The pump worked satisfactorily at atmospheric pressure. At differential gas pressure of up to 9 psi, however, it would only pump intermittently.

This paper is about the development process which has taken the proven 'zero-differential-metering-pump' of Stamet and raised its pressure pumping capability to over 210 pounds per square inch, in its present prototype form.

### Principles of The Stamet Pump

Imagine a 1-inch bore pipe filled with dry particulate solids (e.g., dry rice) and with a loose piston fitted into the bottom of the pipe, see Figure 2. It will be observed that if the piston is lowered then the solids follows the piston smoothly downwards. If, on the other hand, an attempt is made to raise the piston, then it will be observed that the piston becomes instantly locked against the particles and cannot be raised to push the solids up the pipe.

This locking effect only occurs if there is a sufficient length of particles in the pipe, i.e., the solids plug must be of a certain minimum length to ensure adequate lock up.

The same system is used in the pump, see Figure 3, although in this case, the disadvantage of this solids lock up is used to good effect. In the pump the pipe becomes the slowly rotating spool and the particles become locked in this spool and are carried around to the discharge zone.

The pump has only one moving part which is the spool (also known as the "reel" or "runner") which carries the solids around to the discharge zone and in which the solids pressure increases from the entry point to the discharge point.

As the work progressed, it became apparent that there were several key areas in the design and operation of the solids pump which presented individual, unique challenges.

The principal areas are:

1. **The pump feed system.** Solids to be pumped vary over a very wide range of flowability and porosity. At the inlet, flowability is a critical characteristic which affects the design and cost of the pump. The feed hopper, which supplies solids to the pump, has to be capable of continuously feeding. However, as the pump relies on particle to particle interlocking within the pump, it is important not to aerate the mixture to the pump. Suitable feed systems devised by Stamet may include vibration or mechanical actuation, and air assistance is possible, provided that this does not aerate and, thus, destroy the pumpability of the solids material.

2. **Pump inlet configuration.** As the material enters the Stamet pump, it changes direction, and this change in direction is accompanied by a shearing of the solids within

the pump. The geometry and angles of the inlet of the pump are significantly affected by the flowability of the material and by the design of the specific pump. Stamet again has devised suitable angles for numerous solids (crushed coal, rice, cement powder, etc.).

3. **Pump drive wheel.** The cross section of this wheel in terms of shape and size in relation to the diameter of the wheel is dependent on a number of factors, particularly on the pressure ratio required between the inlet and outlet of the pump. Surface finish and surface geometry of the wheel are also critically affected by the type of material to be pumped and the pressure differential required.

4. **The solids/disc disengagement zone.** At the discharge area from the pump, the solids are once again sheared, only this time, they are sheared under a particle pressure which is at least as high as the discharge gas pressure.

5. **Static Discharge Duct.** Once the solids have left the pump, they then enter the discharge duct, which is formed in a way as to provide the correct balance between (a) a length sufficient to provide appropriate sealing for this particular solids and (b) a cross sectioned area which diverges at a rate which is appropriate to the surface friction created by this solids with the duct's surface.

Provided each of the aforementioned critical areas is designed correctly, it is possible to pump solids from a pressure of zero psi to 210 psi in a reliable, precise, and energy efficient way.

### Stamet Pump -- Historical Development

In 1989, the pump concept was taken to the National Engineering Laboratory (NEL) in East Kilbride Scotland where author Andrew Hay worked on a small experimental pump in an endeavor to increase the pressure pumping range of the machine. Testing at NEL included both coal and dry cement powder.

During the development work at NEL, a number of configurations for the inlet system were investigated, and the principles of design were developed. The surfaces of the disks and the geometry of the disks were also investigated and this included different surface finish, surface machining, and compliant surface materials. The use of multiple choke plates which could vary the amount of compression and the dilation experienced by the solids as they passed around the pump were also investigated in some detail.

By the end of 1989, a considerable amount of experimental data had been obtained from this small pump and pressure pumping had been achieved to approximately 10 psi. But at that stage, it was not a consistent performance. In 1990, the experimental work was moved to California, initially at Fremont, north of San Jose, California. For this experimental work, a much larger pump with 26 inch diameter disks was commissioned. This pump was built



into a rig, and modifications were made to the surface finish, the discharge duct shape, the abutment, the surface finish of the disks, the style, and the hub.

The incremental process of development modified the inlet feed system, modified the shape of the chokes, of the disks, of the disk grooves, of the abutment and of the discharge duct. In each case, the modifications produced useful increase in reliable pressure pumping capabilities. By the time the Fremont facility was closed in January 1991, the pressure pumping capability of the machine had risen to 26 psi and looked as if it could go higher. This, however, was the maximum limit of the test facility in use at the time. However pressure pumping had been achieved in a consistent way and higher targets were possible.

In 1992, the company had installed and commenced operations of test facilities in the South Los Angeles site of Gardena, California (Stamet's present location), and an SBIR Grant was obtained to design an experimental pump and locate it within a test facility capable of testing to pressures in excess of 210 psi. This was the target pressure fixed by the SBIR grant and deemed appropriate for pressurized fluidized bed combustor systems.

In 1992, the design work for the rig commenced, and the whole facility was installed and operational by 1993, see Figure 4. Test work commenced in July 1993 and continued for 15 months. During this test period: the pump duct form was modified; the discharge duct was modified; on several occasions, the surface finish and heat treatment and metrology of the critical wear components were modified; the drive power was increased and full state of the art digital recording was introduced for all experimental data.

On the 14th of February, 1995 the pump achieved a pressure run of 210 psi, which has been repeated on many occasions and the indications are that higher pressures will be achieved in the future.

Figure 5 shows two graphs of a typical high pressure performance run. To test the susceptibility of the machine to pressure variation the gas pressure is raised and lowered in graph 1. Graph 2 is of the same test run and shows that the discharge continues steadily and is totally unaffected by air pressure up to 230psi.

### Conclusions

- ◆ The pump is now capable of injecting coal in a continuous and precisely controlled way into a gas pressure of 210 psi.
- ◆ The rate of input is directly proportional to the rate of rotation of the wheel and is independent of the pressure loading.
- ◆ The machine is a simple design compared with the alternative

of lock hoppers and/or mixers and paste feeders.

### Future

In the near future, Stamet intends to:

- ♦ Complete a detailed economic comparison of Stamet pumps to lockhoppers and paste feeders on a PFBC system.
- ♦ Investigate the pump's ability to inject solids into systems operating at 20 to 30 atmospheres (294 to 441 psia).
- ♦ Negotiate installation of a Stamet pump at Southern Company Services/DOE's Power System Development Facility or a DOE Clean Coal project to demonstrate long-term operation.
- ♦ Continue to pursue other markets.

In addition to the combustion market, applications are currently in negotiation for food processing, pneumatic transport, and chemical processing. Due to the pump's elegantly simple design compared with the alternative of lockhoppers and/or mixers and paste feeders, it is assured of a significant place in any application where solids have to be injected into pressurized environments for chemical conversion, combustion, pneumatic or liquid transport.

### References

1. A. Robertson, et al; "Second-Generation Pressurized Fluidized Bed Combustion Plant Conceptual Design and Optimization of a Second-Generation PFB Combustion Plant, Phase 1, Task 1, Volume 1, 2, and 3"; September 1989, DE90000412.
2. J. Shenker, et al; "Second-Generation Pressurized Fluidized Bed Combustion - Small Gas Turbine Industrial Plant Study"; July 1992, DE3000230.
3. R.L. Gall and E.K. Johnson; "An Overview of Coal-Feed Systems"; May 1983; Chemical Engineering Progress.
4. U.S. Department of Energy; "Small Business Innovative Research - Program Solicitation"; Closing Date March 1, 1995; DOE/ER-0629
5. D.A. Hauer and H.K. Strogan; "Second Year Of Operation of the Tidd PFBC Demonstration Plant"; Pittsburgh Coal Conference; October 1992

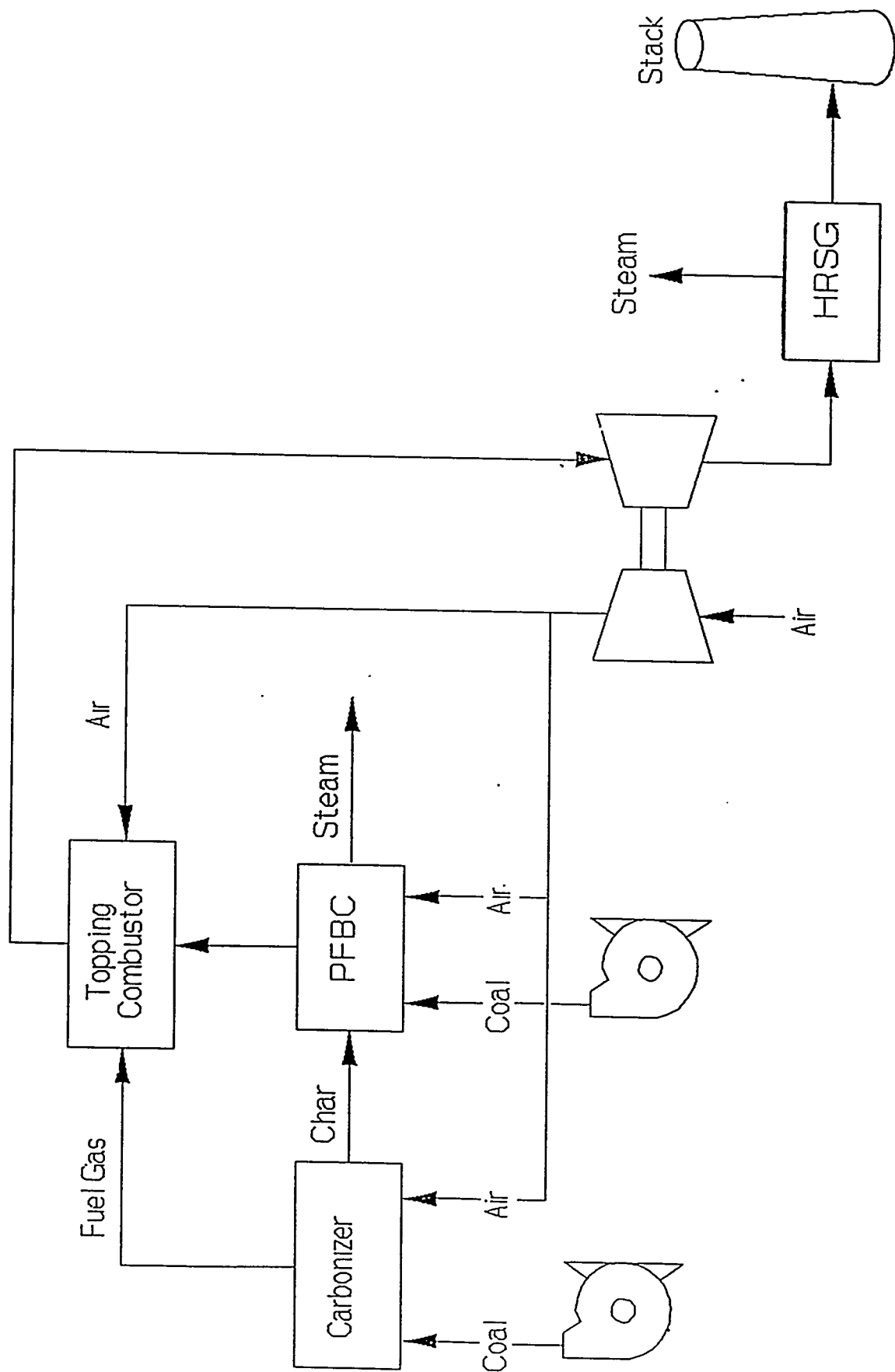

Simplified Second-Generation PFBC Process Diagram

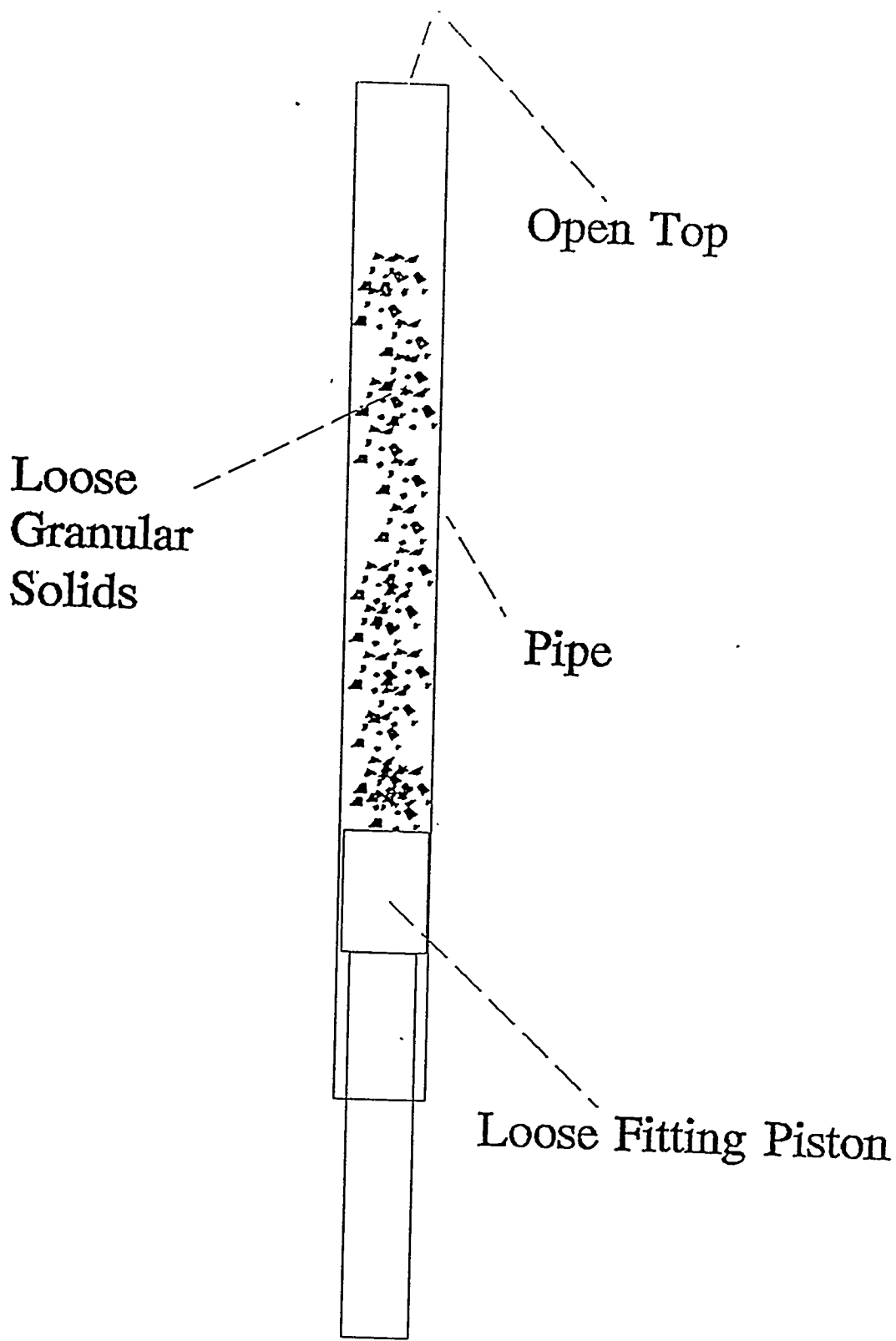

# The Solids Lock Principle

FIGURE 2

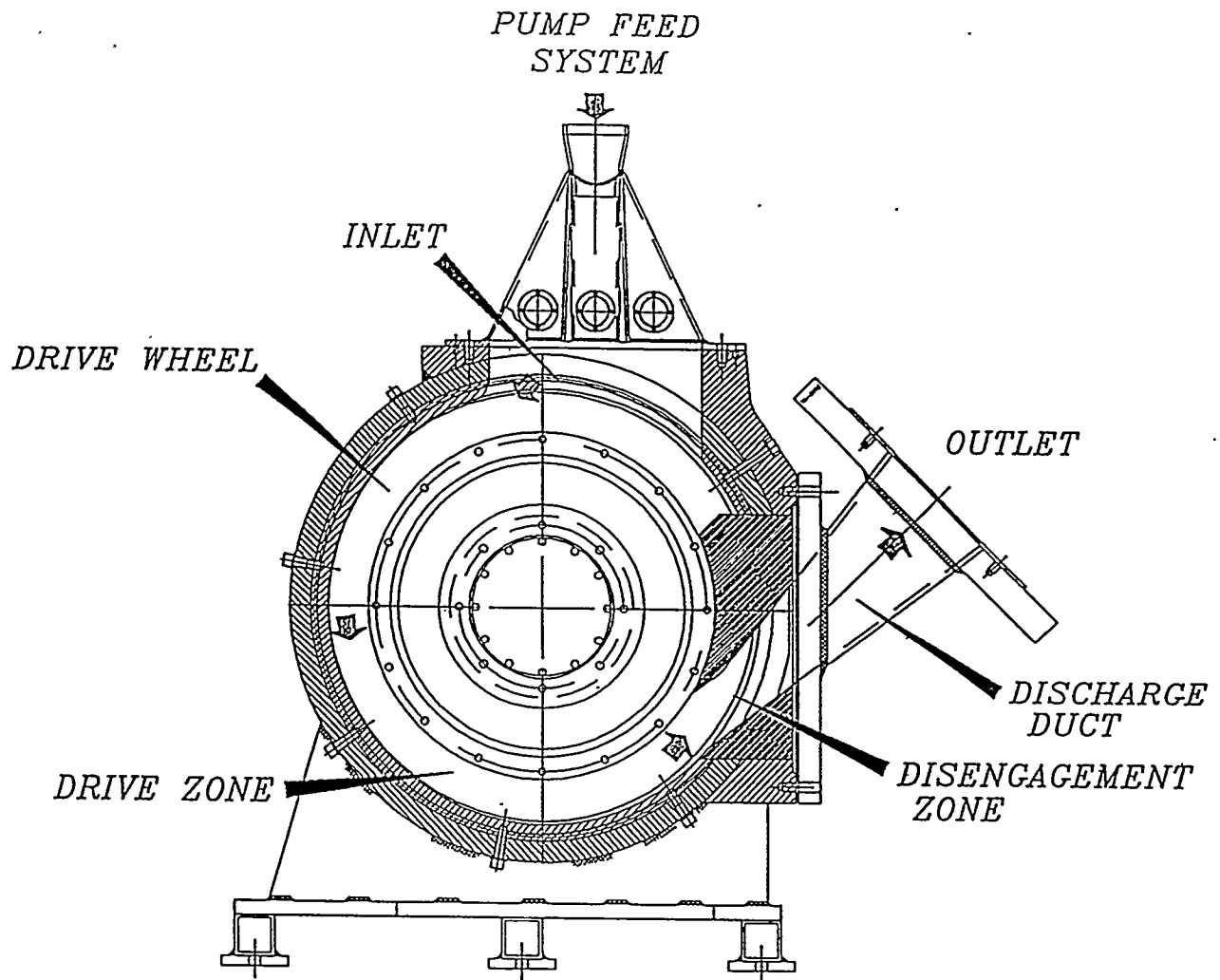

*STAMET EXPERIMENTAL ROTARY HIGH  
PRESSURE SOLIDS FEEDER.*

FIGURE 3

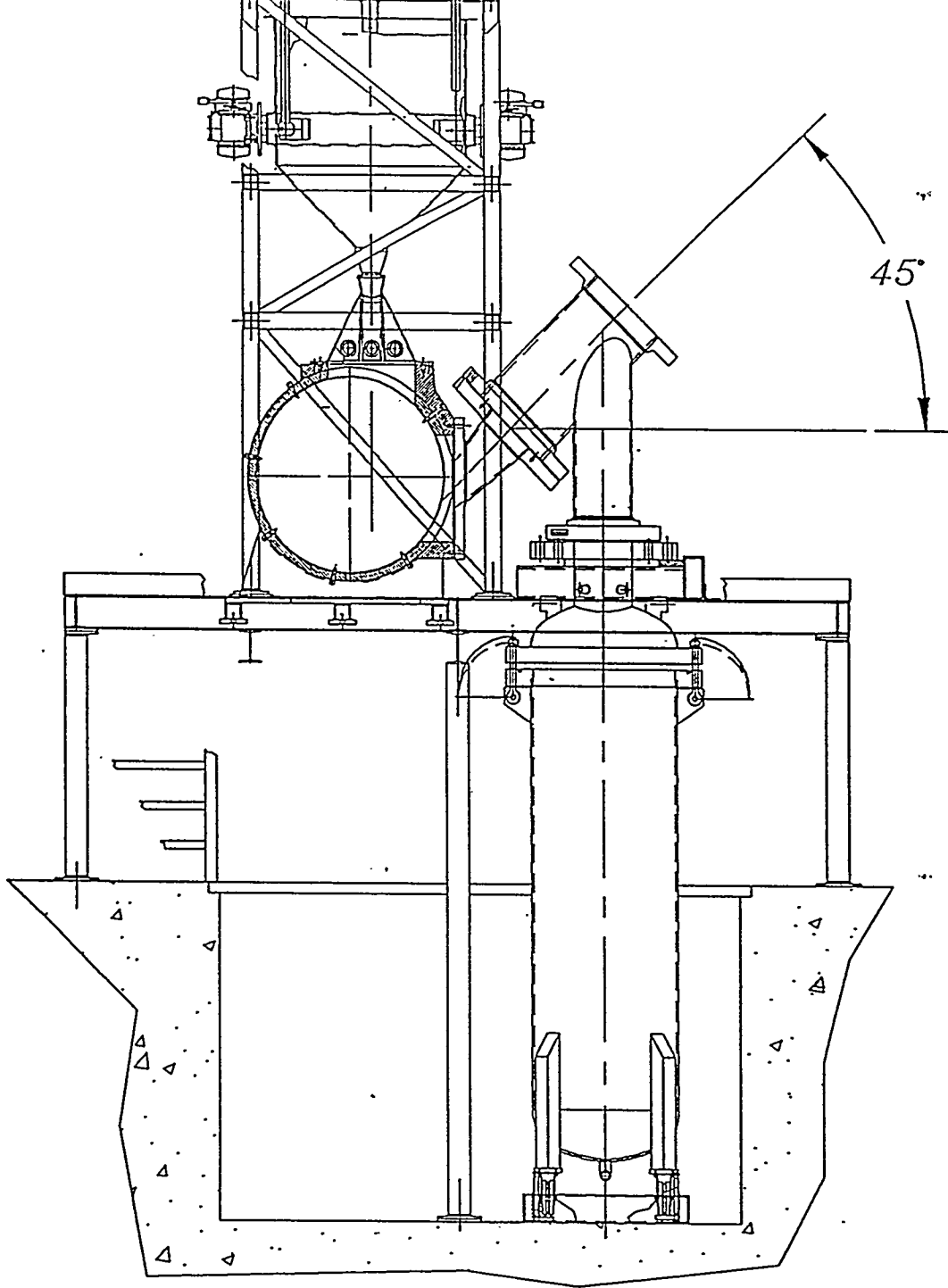

*STAMET HIGH PRESSURE SOLIDS PUMP  
TEST FACILITY*

FIGURE 4

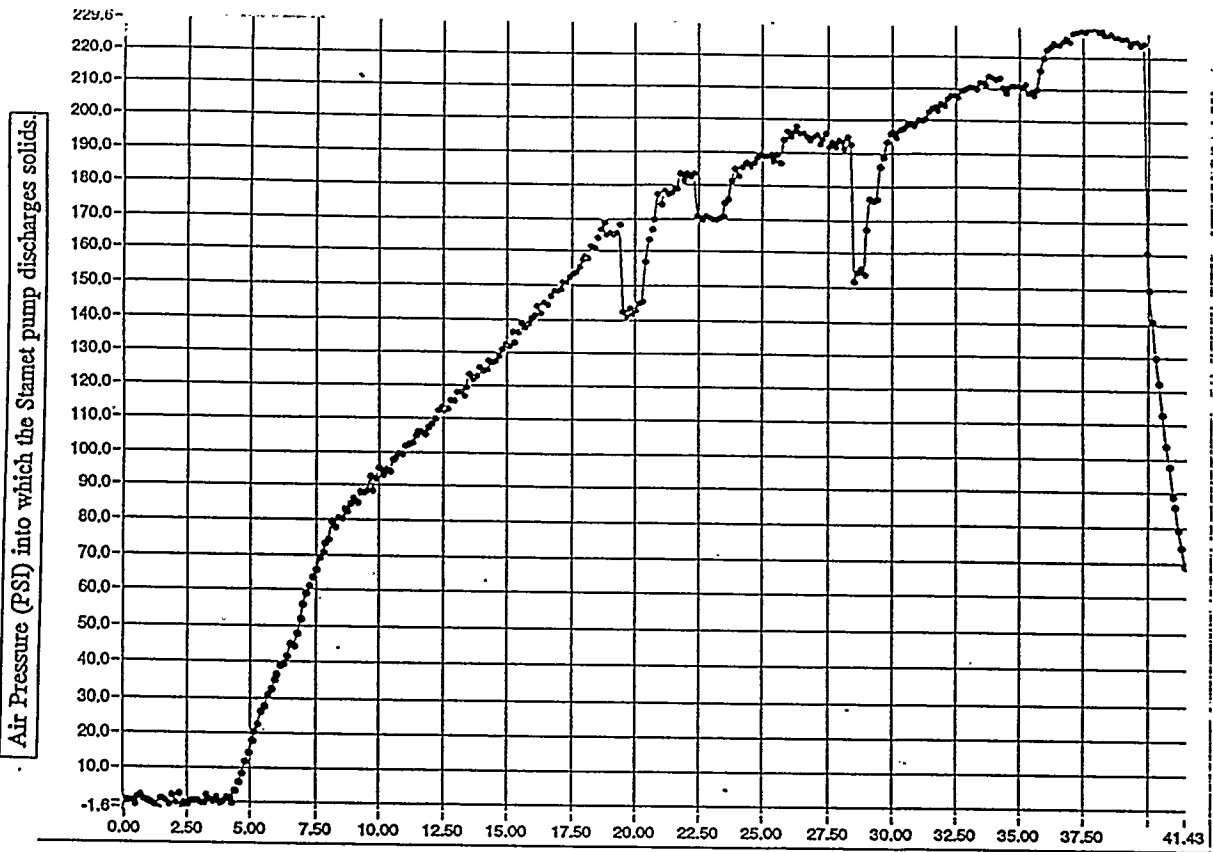

Graph 1

Revolutions Turned by the Stamet Solids Pump.

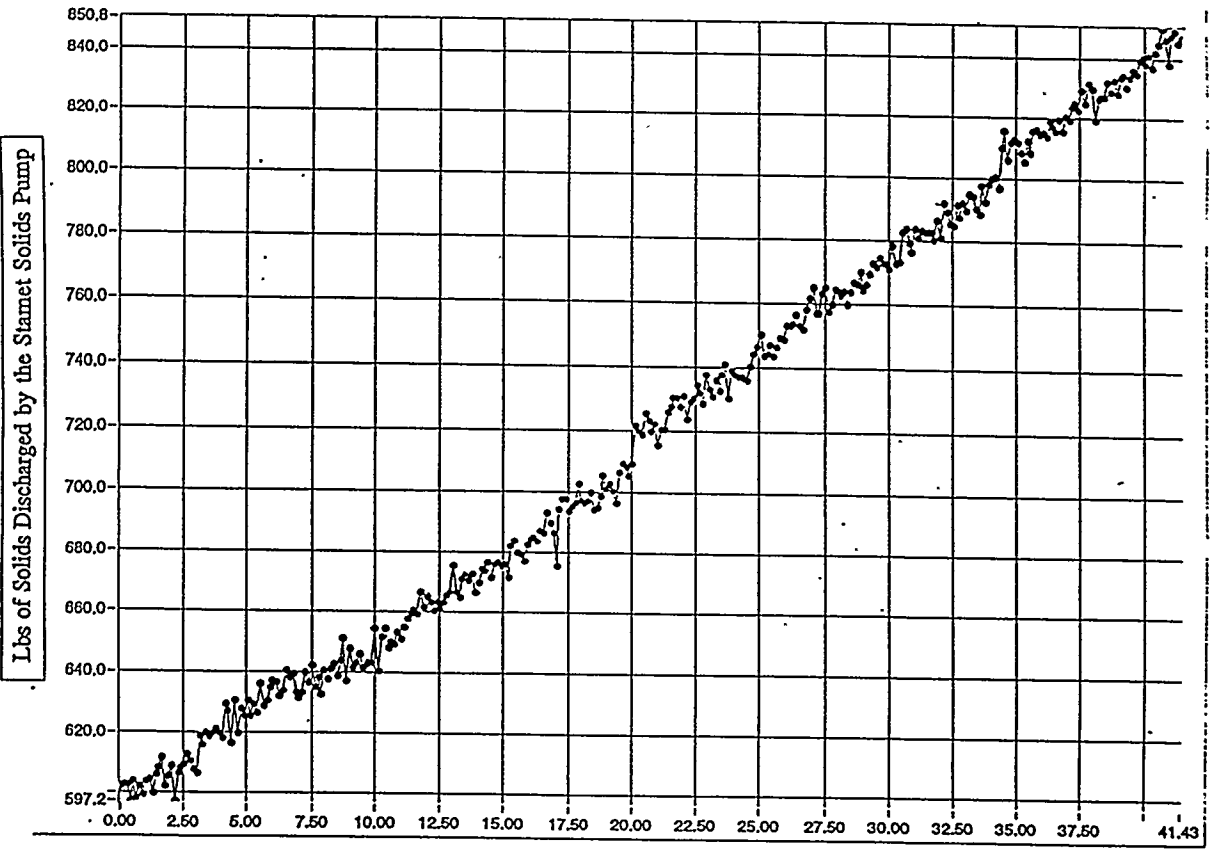

Graph 2

Revolutions Turned by the Stamet Solids Pump.

FIGURE 5