

Solar Neutrinos & BOREXINO

Extraordinary Neutrino Beam Free of Charge

For NEUTRINO PHYSICS:

- WELL DEFINED HIGHEST FLUX ($\sim 10^{11} \text{cm}^{-2}\text{s}^{-1}$)
- PURE FLAVOR SOURCE - ν_e only
- LONGEST BASELINE (10^8 km)
- HIGH DENSITY UP TO 160 g/cm^3 ; $\sim 10^{11} \text{ g/cm}^2$ path
- LOWEST ENERGIES (keV to MeV)
- PRESENCE OF HIGH MAGNETIC FIELDS
- FULL SPECTRUM: ENERGY DEPENDENT EFFECTS

Best tools for investigating neutrino flavor phenomena in
Vacuum and in Matter

For ASTROPHYSICS

Best tool for unprecedented look at how a real Star works
- in the past, present and future

Solar Neutrinos

What we know:

- **Standard Solar Model**
- Missing ν_e (Cl, Ga, SK, SNO)
- Flavor mixing happens (SNO)

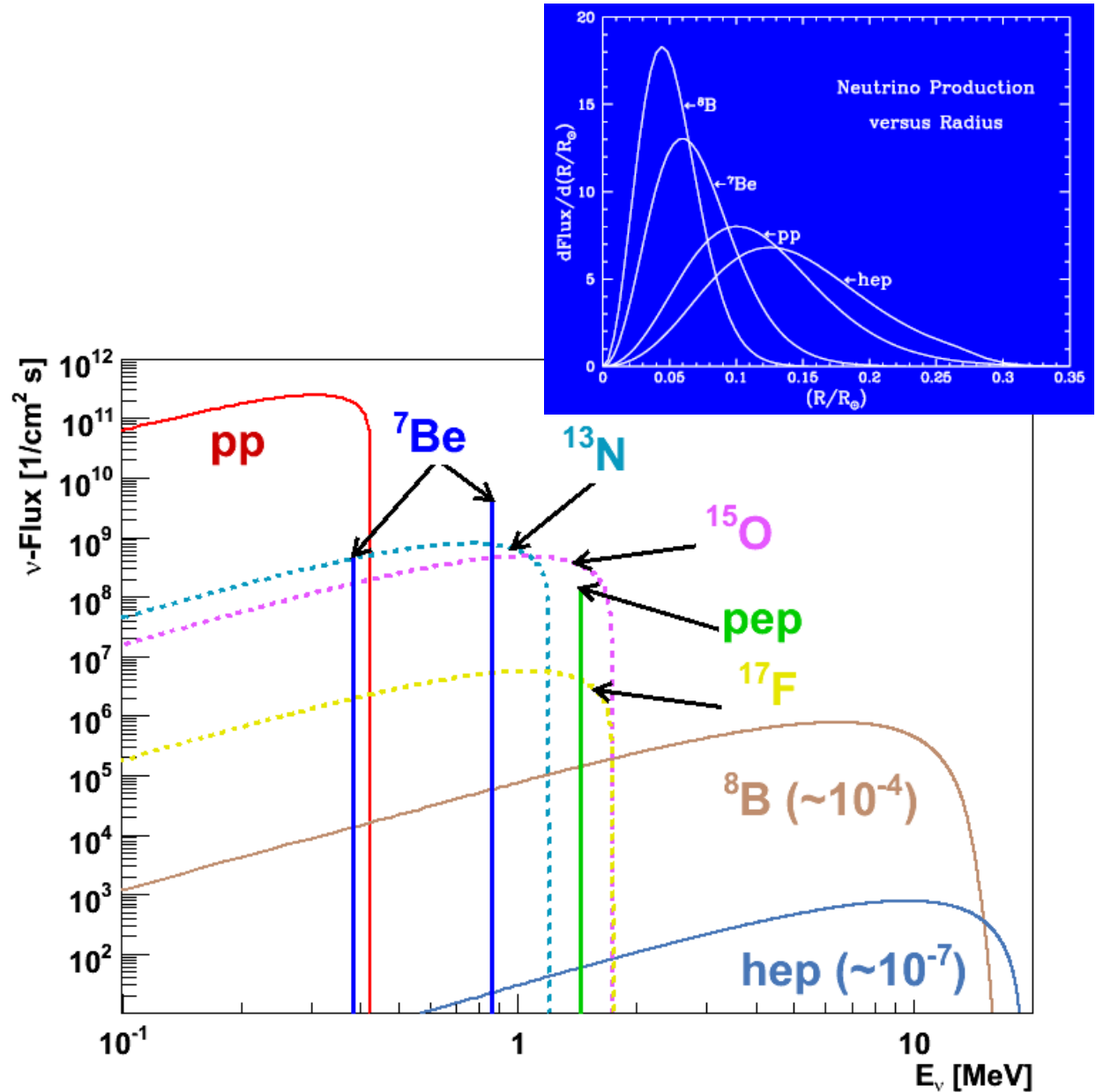

Solar Neutrinos

What we know:

- Standard Solar Model
- **Missing ν_e (Cl, Ga, SK, SNO)**
- Flavor mixing happens (SNO)

Total Rates: Standard Model vs. Experiment
Bahcall-Serenelli 2005 [BS05(OP)]

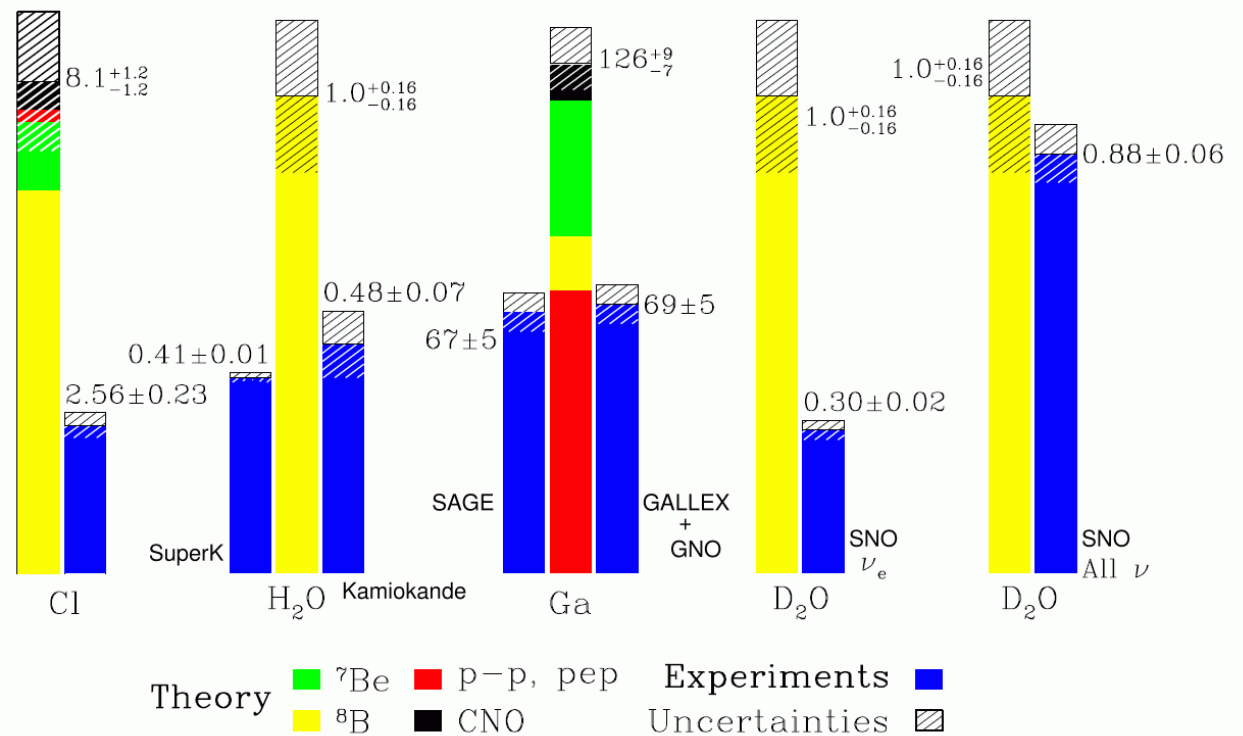

Solar Neutrinos

What we know:

- Standard Solar Model
- Missing ν_e (Cl, Ga, SK, SNO)
- **Flavor mixing happens (SNO)**

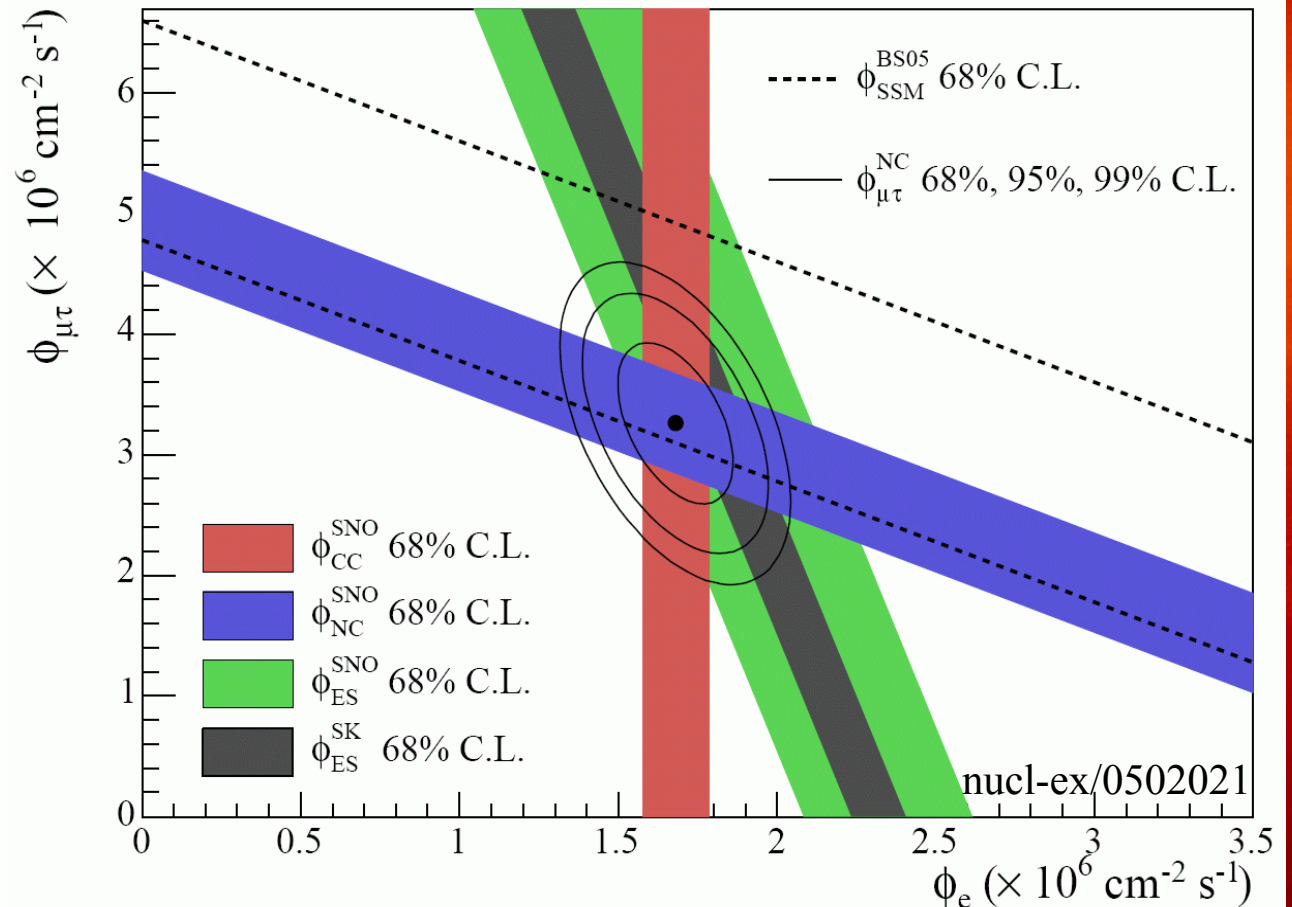

Neutrino Oscillation Explanation

MSW explanation: resonant conversion at ^8B energies

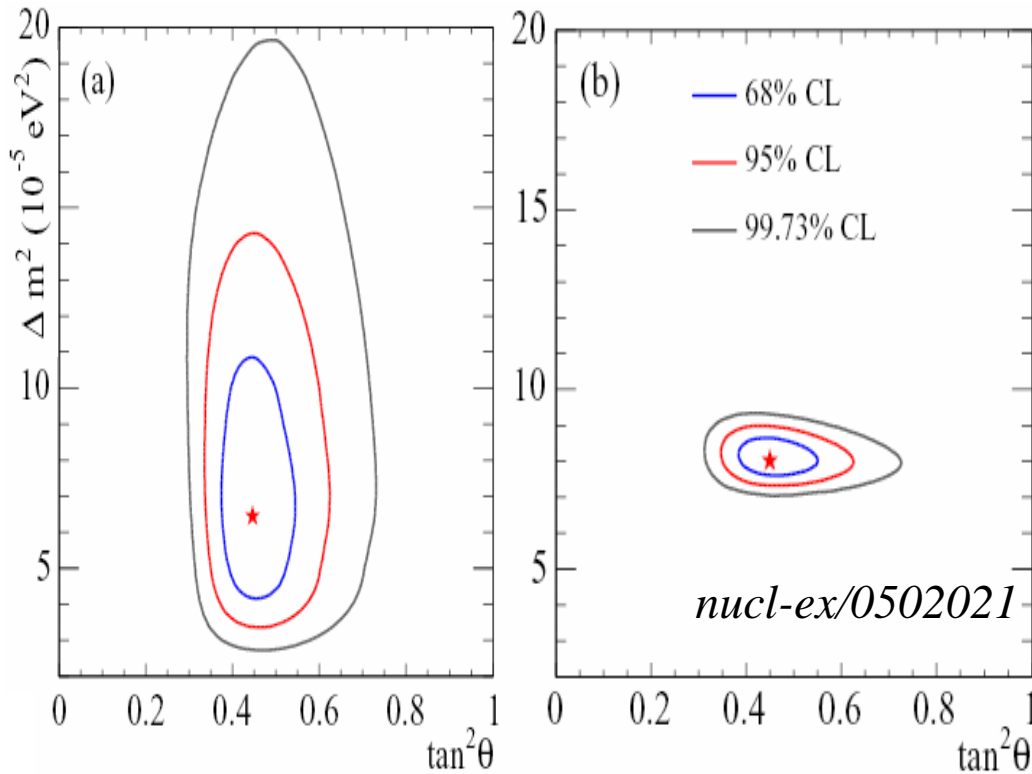

Adding atmospheric neutrino oscillations...

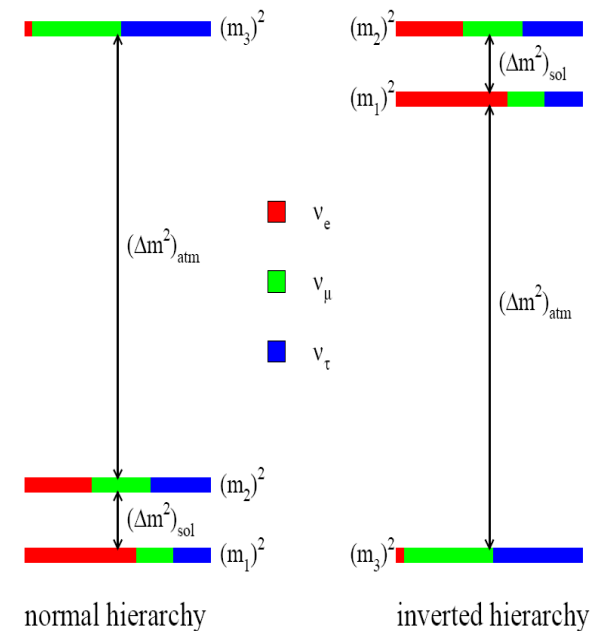

Solar data: $\Delta m_{12}^2, \theta$ add anti-neutrinos (KamLAND)
 (assumes CPT): $\Delta m_{12}^2, \theta$

MSW-LMA is based on the *combined* results from many complementary experiments

Solar ν 's have already demonstrated neutrino oscillations, but that's just the beginning...

“Is this picture really correct?”

“Do nuclear reactions fully account for the Sun's energy output today?”

“What *e*/se don't we know about neutrinos?”

Current measurements and luminosity constraint indicate a transition between vacuum and matter dominated (MSW) oscillations around 2 MeV:

Critical Measurements:
Be-7 neutrinos
pep neutrinos

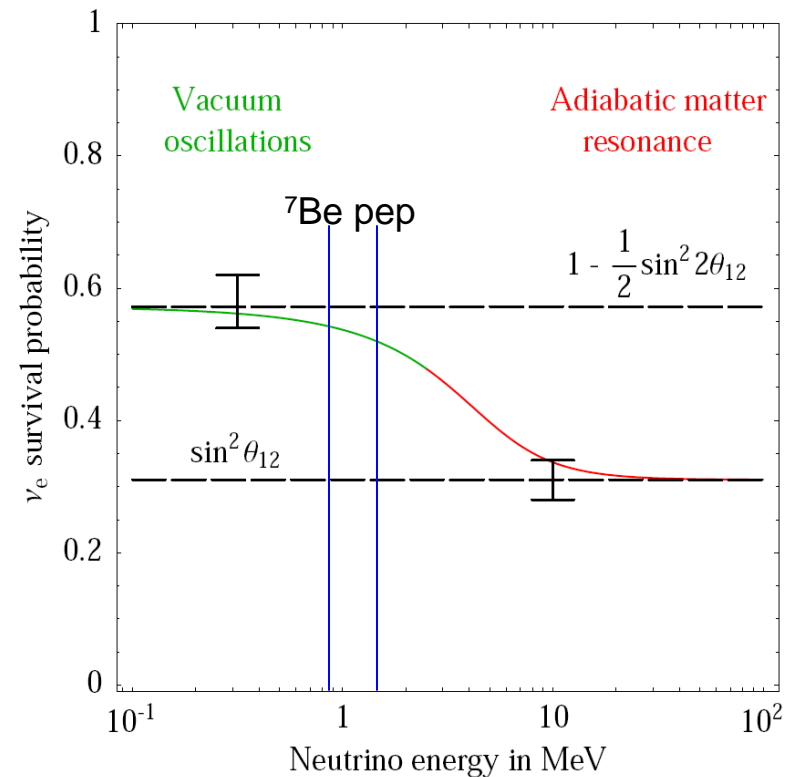

Are there non-standard mechanisms involved?

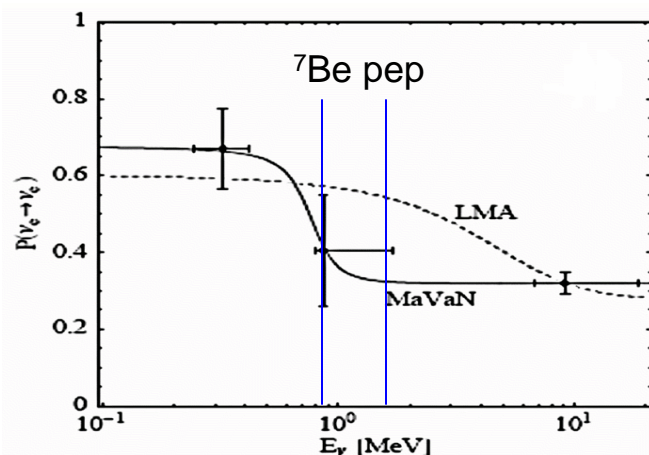

Mass-varying neutrinos

Barger, Huber, Marfatia, arXiv:hep-ph/0502196v2 30 sep 2005

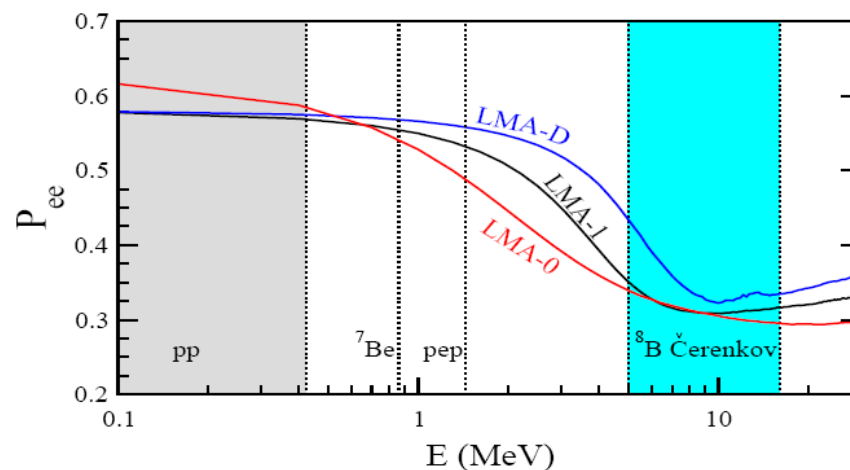

Non-standard interactions

A.Friedland, C.Lunardini and C.Pena-Garay, Phys. Lett. B 594, 347 (2004) [arXiv:hep-ph/0402266].
O.G.Miranda, M.A.Tortola and J.W.F.Valle, arXiv:hep-ph/0406280.

open questions?

Are there sterile neutrinos?

P. C. de Holanda and A. Yu. Smirnov, Phys.Rev.D 69, 113002 (2004).

what if LSND proves to be correct?

Is CPT violated in the neutrino sector?

do ν_e and $\bar{\nu}_e$ (from KamLAND) observations give the same results?

Measuring the ${}^7\text{Be}$ flux: **BOREXINO**

CC interaction

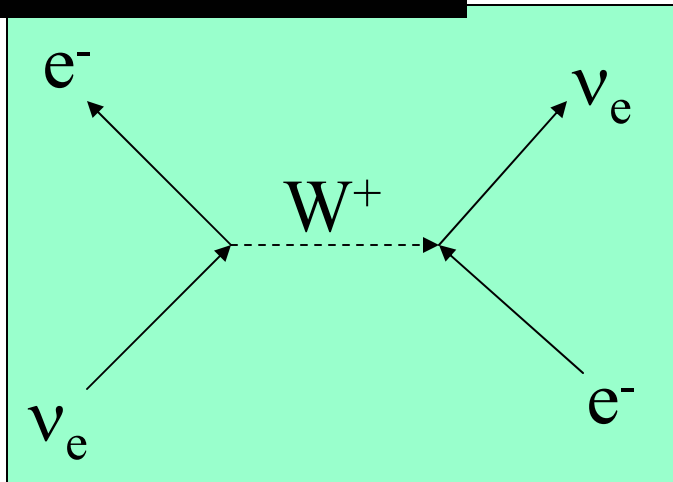

+ NC interaction

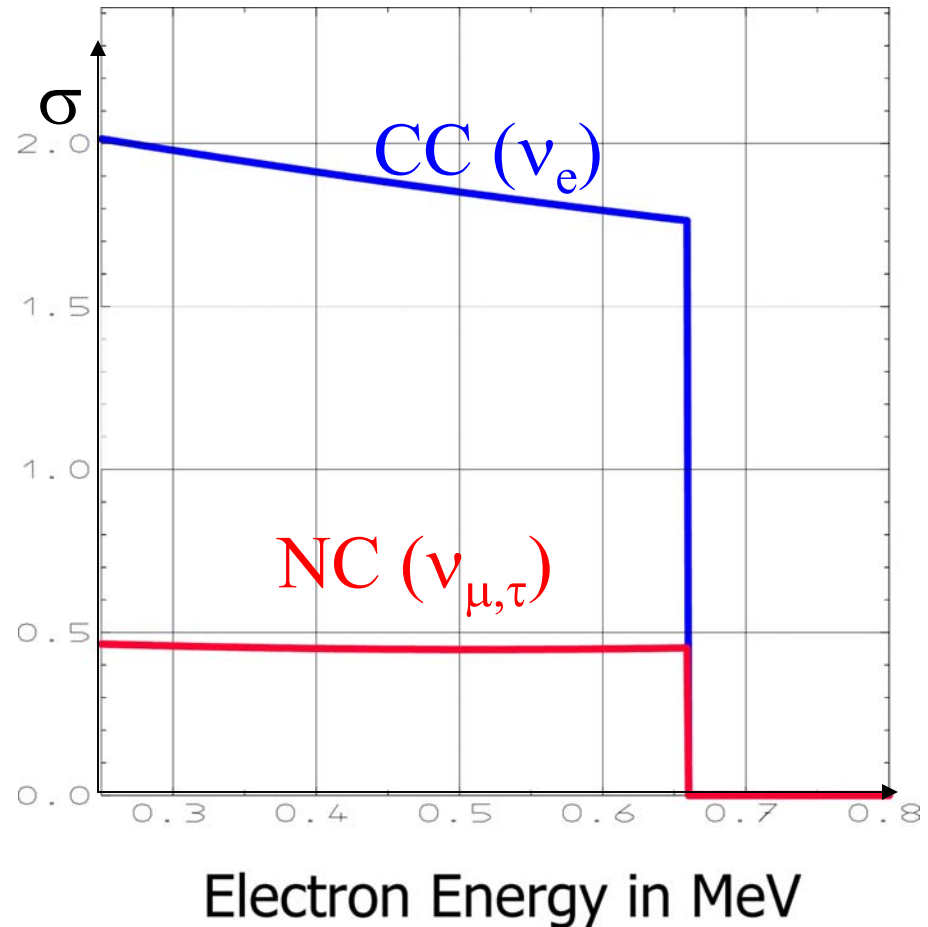
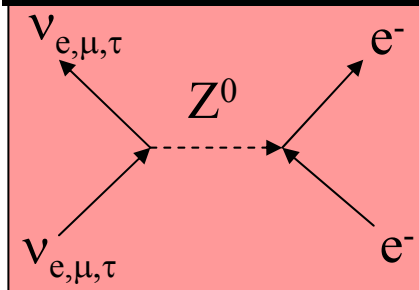

Borexino Collaboraton

- **Italy**
 - Genova
 - Gran Sasso Laboratory
 - Milano
 - Perugia, Pavia, Ferrara
 - **France**
 - College de France
 - **Germany**
 - Munich
 - Heidelberg
 - **USA**
 - Princeton
 - Virginia Tech
 - **Canada**
 - Queens University
 - **Russia**
 - Moscow Kurchatov
 - Dubna
 - **Poland**
 - University of Krakow
- ~ 50 FTE total**

NSF support for US groups

Methodology and Signal



expect 35 ${}^7\text{Be}$ ν per day in
100 ton FV (LMA)

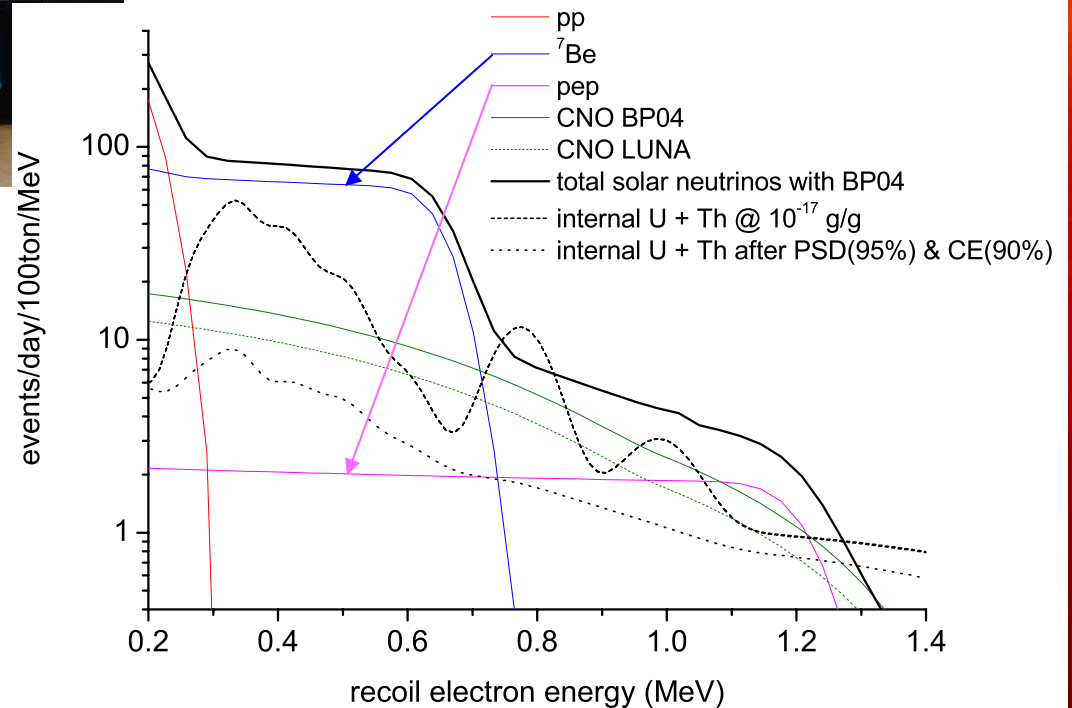
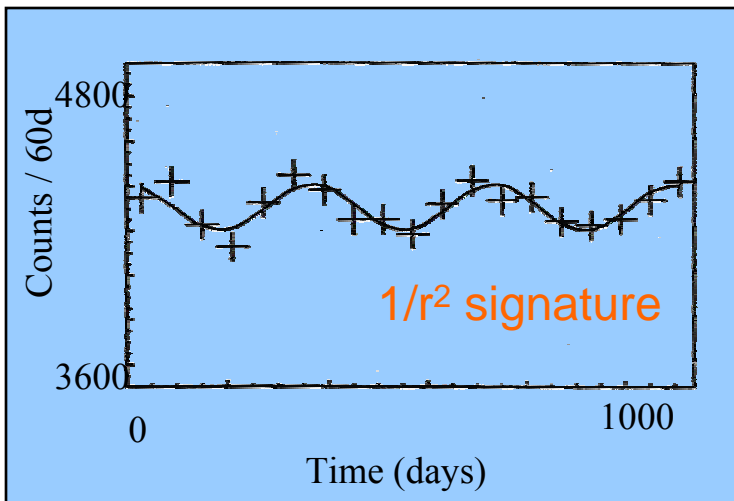

Design:

- 100 ton FV
- 5% ^7Be measurement: spectral and annual variation signature
- 10^{-16} g/g U,Th (in secular equilibrium); 95% psd; 90% stat. sub.

Advantages:

- real time detection of ^7Be neutrinos
- high rate: 35/d for LMA solution
- mono-energetic neutrino spectrum
- non-polar solvent – low background
- active muon veto; 4000 mwe depth

Disadvantages:

- no directionality
- can not extract charged current contribution
- no unique signature for individual events
- “Compton profile” due to scatter

Tools:

- radiopurity; α / β / γ separation; energy and position reconstruction

Challenges @ 10^{-16} g/g purity

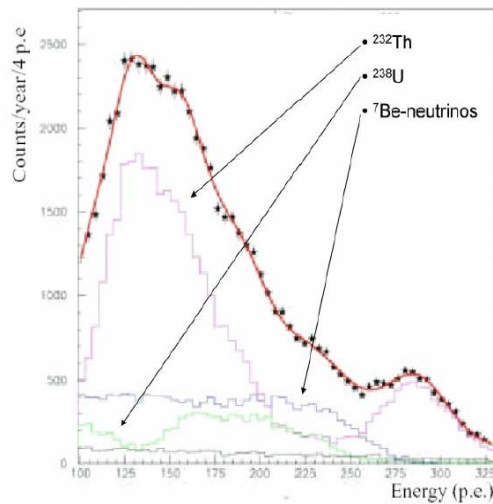

raw spectra expected at 10^{-16} g/g U,Th

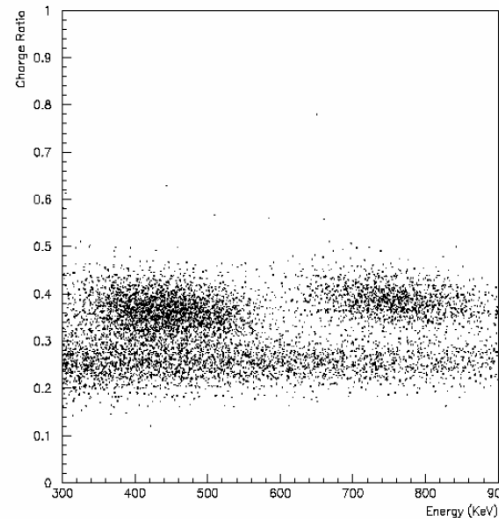

alpha/beta separation

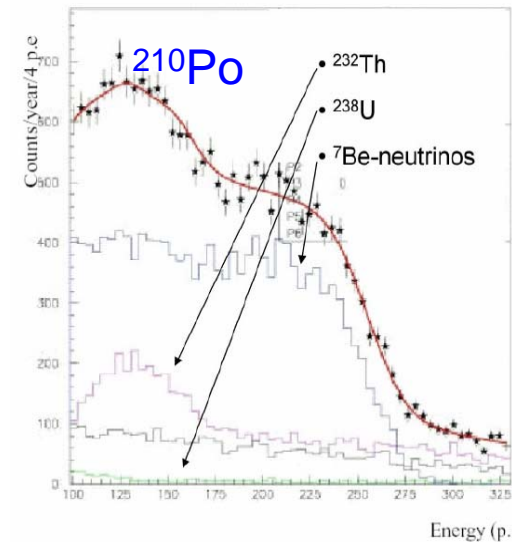

residual spectra *after* all background cuts have been made

built "Counting Test Facility"



^{238}U : $^{238}\text{U}(\alpha)$ $^{234}\text{Th}(\beta)$ $^{234}\text{Pa}(\beta)$ $^{234}\text{U}(\alpha)$ $^{230}\text{Th}(\alpha)$
 $^{226}\text{Ra}(\alpha)$ $^{222}\text{Rn}(\alpha)$ $^{218}\text{Po}(\alpha)$ $^{214}\text{Pb}(\beta)$ $^{214}\text{Bi}(\beta)$
 $^{214}\text{Po}(\alpha)$ $^{210}\text{Pb}(\beta)$ $^{210}\text{Bi}(\beta)$ $^{210}\text{Po}(\alpha)$ ^{206}Pb

^{232}Th : $^{232}\text{Th}(\alpha)$ $^{228}\text{Ra}(\beta)$ $^{228}\text{Ac}(\beta)$ $^{228}\text{Th}(\alpha)$ $^{224}\text{Ra}(\alpha)$
 $^{220}\text{Rn}(\alpha)$ $^{216}\text{Po}(\alpha)$ $^{212}\text{Pb}(\beta)$ $^{212}\text{Bi}(\beta)$ $^{212}\text{Po}(\alpha)$ ^{208}Pb

Best in CTF I & II:

^{238}U : $(3.0 \pm 0.3) \times 10^{-16}$ g/g

^{232}Th : $(6.5 \pm 0.9) \times 10^{-16}$ g/g

(inferred, assuming equil)

Solution: on-line Purification

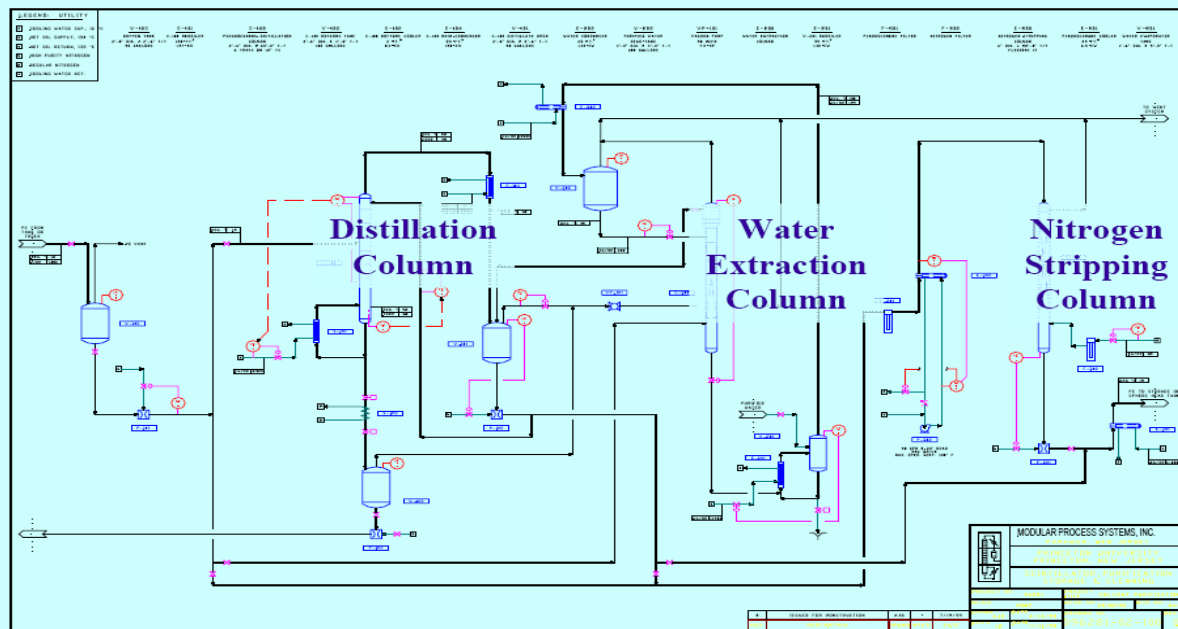

... and Si Gel column purification option

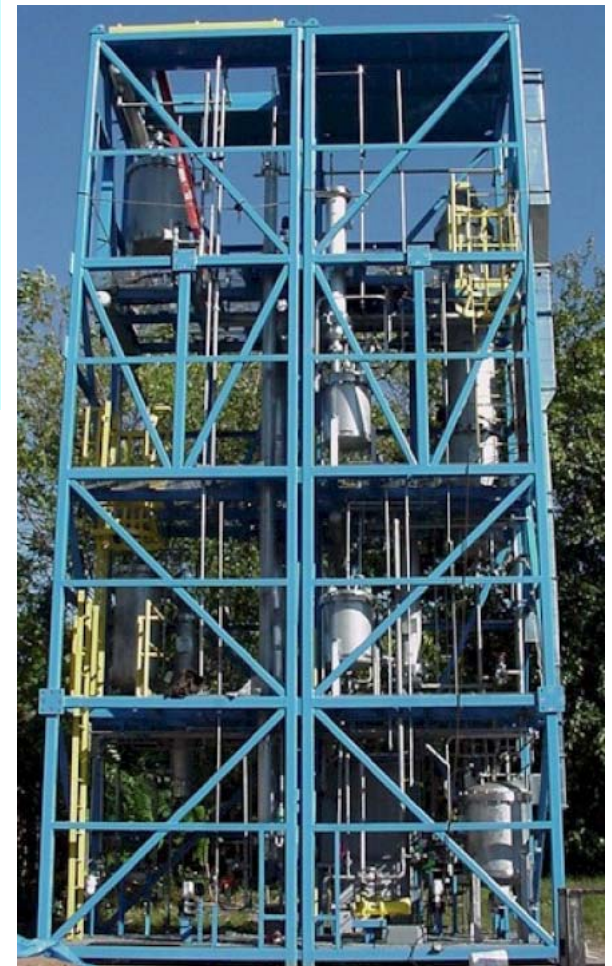

Status, August 2002

- CTF results confirmed anticipated intrinsic purity levels
- Borexino vessels nearing completion
- testing distillation purification
- accidental release of ~50 liters PC into environment (Borexino operations shut down)
- discover cross-contamination in Gran Sasso waste and drinking water supplies (lab shut down)
- LNGS begins process of general safety and infrastructure improvements in coordination with INFN and government agencies

Gran Sasso improvements

took a long time....

- Water drainage from laboratory



- Floor sealing

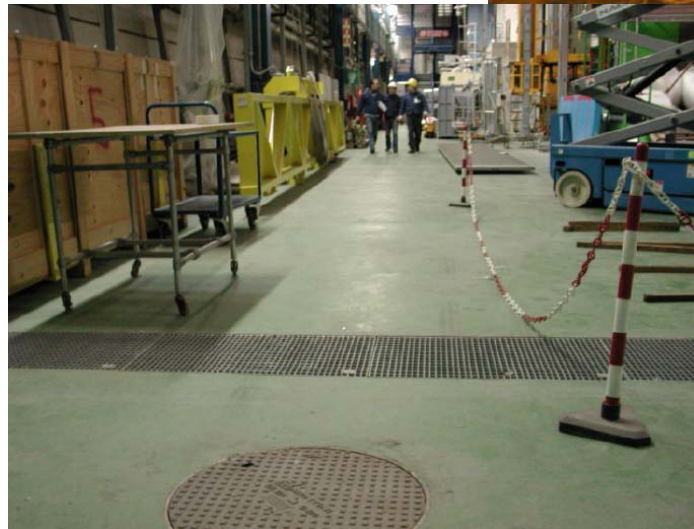

Gran Sasso renovations

Buffer Tank



Inter-Hall coupling



- Permitting

~\$100M expenditure

despite earlier delays, firm
completion date of July 31, 2006

meanwhile...

Radiopurity improvements

- **Low ^{39}Ar , ^{85}Kr Nitrogen (LAKN)** - Heidelberg
 - developed method to *measure* Ar and Kr at 1 ppb Ar/N₂ and 0.1 ppt Kr/N₂ (need 0.3 ppm Ar; 0.15 ppt Kr for 1 cts/day in neutrino window)
 - identified reliable source for LAKN < 5ppb Ar/N₂; < 0.05ppt Kr/N₂
 - developed methods to avoid recontamination
- **^{210}Po challenge**
 - ^{210}Pb removable by distillation but ^{210}Po likely comes from prior surface contamination (ongoing tests)
- **Cleaning Procedures refined**
 - efficacy of various cleaning procedures checked
 - developed ‘precision’ cleaning techniques and modules (hot detergent 3%; water rinse)

Comparison to KamLAND

KamLAND (solar phase)

closely follows Borexino design

inspired by success of CTF radiopurity results

300 ton FV scintillator

purification to start Sept 06

need $\sim 10^5$ reduction

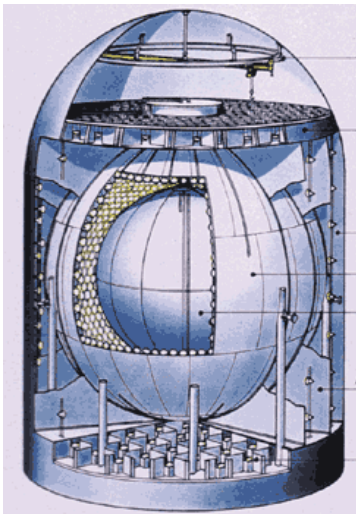
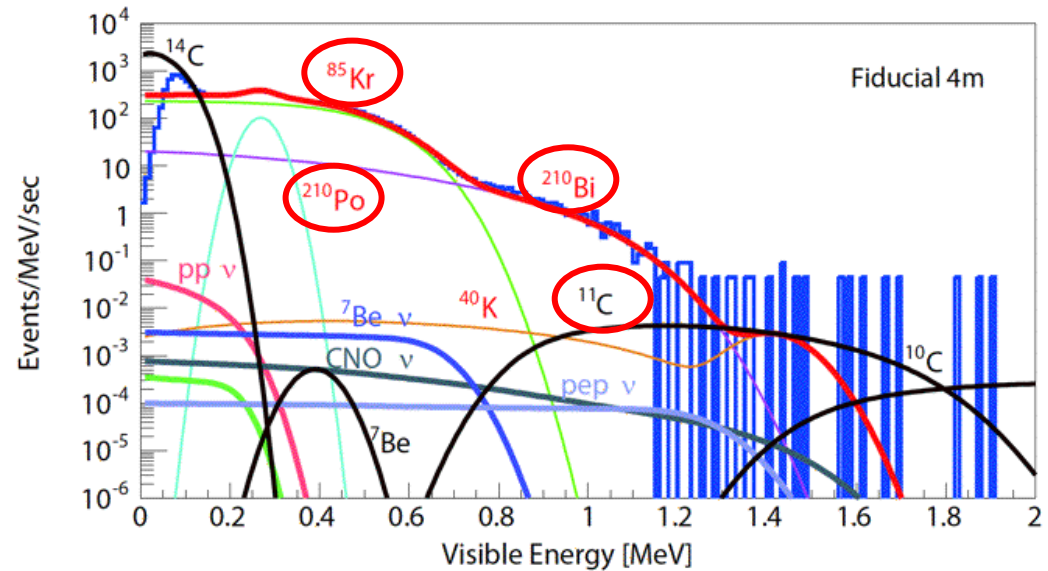

BOREXINO Initial Backgrounds (100 ton FV)

Isotope	initial	solution options
$^{85}\text{Kr}/^{39}\text{Ar}$	< 1 ct/day (1/30 x signal)	
^{210}Bi	< 100 cts/day (3x signal)	distillation (^{210}Pb)
^{210}Po	~ 8500 cts/day (200x signal)	x 0.2 w.e.; x 0.1 $\alpha:\beta$; decay (138d)
^{11}C	calculate 15 produced/day	neutron tagging
upper neutrino window	600-1200 keV only < 800 cts/day (mostly penetrating gammas - CTF)	

Advances in Analysis

- Refined and expanded CTF IV results: ^{238}U : $< 2.3 \times 10^{-16}$ g/g
 ^{232}Th : $(1.1 \pm 0.4) \times 10^{-16}$ g/g
- Alpha/Beta separation methods: ratio, Gatti, Skew (CTF), SVM

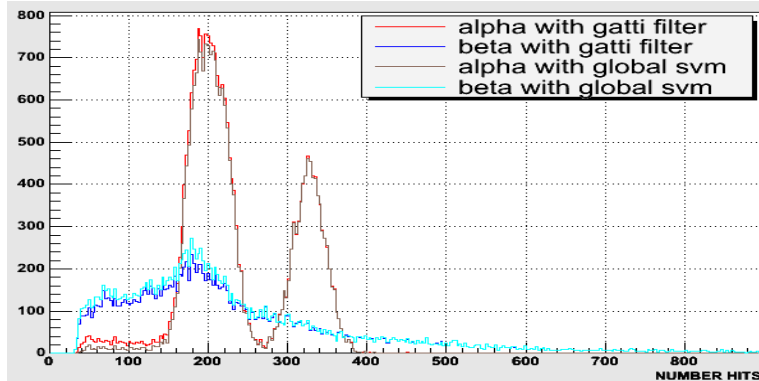

- dominant singles bkgd identified: ^{210}Po
short life-time issue resolved:
plating out onto vessel
(one advantage of being 'shut down' are LONG runs!)

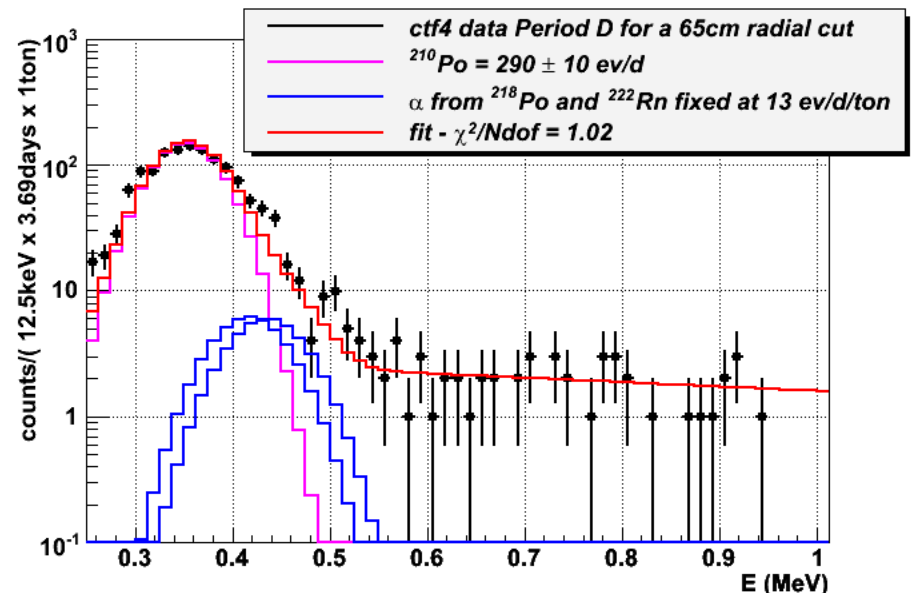

Advances in Analysis

- Surface – vs – Volume contamination:
pulse-height defect; radial fits
- ^{11}C prediction (important for pep neutrinos)
 - KamLAND 107 cts/day/100ton
 - Borexino 15
 - SNO+ 0.15
- ^{11}C neutron tagging shown to work in CTF

[Cosmogenic \$^{11}\text{C}\$ production and sensitivity of organic scintillator detectors to pep and CNO neutrinos](#)

Cristiano Galbiati, Andrea Pocar, Davide Franco, Aldo Ianni, Laura Cadonati, Stefan Schönert
Phys. Rev. C 71, 055805 (2005).

[CNO and pep neutrino spectroscopy in Borexino: measurement of the cosmogenic \$^{11}\text{C}\$ background with the Counting Test Facility](#)

Borexino Collaboration arXiv:hep-ex/0601035 v1 19 Jan 2006

Advances in Analysis

- demonstrated event by event (rather than statistical) subtraction for “slow” correlated decays (McCarty)
- software upgrade “Echidna” – and transition to Geant 4

Publications (since 2002)

- [Cosmogenic \$^{11}\text{C}\$ production and sensitivity of organic scintillator detectors to \$pep\$ and CNO neutrinos](#)
 - Cristiano Galbiati, Andrea Pocar, Davide Franco, Aldo Ianni, Laura Cadonati, Stefan Schönert
Phys. Rev. C 71, 055805 (2005).
- [Radon permeability through nylon at various humidities used in the Borexino experiment.](#)
 - M. Wójcik, G. Zuzel.
Nuclear Instruments and Methods in Physics Research A 524 (2004) 355-365.
- [New experimental limits on violations of the Pauli exclusion principle obtained with the Borexino Counting Test Facility](#)
 - European Physical Journal C37 (2004) 421.
- [Ultra-traces of \$^{226}\text{Ra}\$ in nylon used in the Borexino solar neutrino experiment.](#)
 - G. Zuzel, M. Wójcik, C. Buck, W. Rau, G. Heusser.
Nuclear Instruments and Methods in Physics Research A 498 (2003) 240-255.
- [A Sampling Board Optimized for Pulse Shape Discrimination in Liquid Scintillator Applications](#)
 - G. Ranucci, R. Dossi, P. Inzani, G. Korga, P. Lombardi, E. Meroni, and M. E. Monzani
IEEE TRANSACTIONS ON NUCLEAR SCIENCE, VOL. 51, NO. 4, AUGUST 2004
- [The measurements of 2200 ETL9351 type photomultipliers for the Borexino experiment with the photomultiplier testing facility at LNGS](#)
 - A.Ianni, P.Lombardi, G.Ranucci, O.Ju.Smirnov
arXiv:physics/0406138; Nucl.Instrum.Meth. A537 (2005) 683-697
- [The photomultiplier tube testing facility for the Borexino experiment at LNGS](#)
 - A.Brigatti, A.Ianni, P.Lombardi, G.Ranucci, O.Ju.Smirnov
arXiv:physics/0406106; Nucl.Instrum.Meth. A537 (2005) 521-536
- [Precision measurements of time characteristics of the 8" ETL9351 series photomultiplier](#)
 - O.Ju.Smirnov, P.Lombardi, G.Ranucci
Instruments and Experimental Techniques, Vol.47 No.1 (2004) pp.69-79.
- [A multiplexed optical-fiber system for the PMT calibration of the Borexino experiment.](#)
 - B.Caccianiga, D.Franco, D.Giugni, P.Lombardi, S.Malvezzi, J.Maneira, G.Manusardi, L.Miramonti, G.Ranucci O.Smirnov
NIM A496 (2003) 353-361.

- [Search for the Solar pp- neutrinos with an ungrade of CTF detector](#)
 - Smirnov O., Zaimidoroga O., Derbin A.
Phys.At.Nucl. Vol 66, No4 (2003) 712-723.
- [Setting of the Predefined Multiplier Gain of a Photomultiplier.](#)
 - O. Ju. Smirnov
Instruments and Experimental Techniques, Vol.45 No3 (2002)363.
- [New experimental limits on heavy neutrino mixing in B-8 decay obtained with the Prototype of the Borexino Detector](#)
 - JETP Lett. Vol 78, No 5 (2003) 261-266.
- [Study of the neutrino electromagnetic properties with the Prototype of the Borexino Detector](#)
 - Physics Letters B 563 (2003) 37.
- [New limits on nucleon decays into invisible channels with the BOREXINO Counting Test Facility](#)
 - Physics Letters B 563 (2003) 23.
- [Search for electron decay mode \$e \rightarrow \gamma + \nu\$ with prototype of Borexino detector.](#)
 - Physics Letters B 525 (2002) 29.
- [Measurements of extremely low radioactivity levels in BOREXINO.](#)
 - Astroparticle Physics 18 (2002) 1.
- [Science and Technology of Borexino: A Real Time Detector for Low Energy Solar Neutrinos](#)
 - Astroparticle Physics 16 (2002) 205.
- [Search for neutrino radiative decay with a prototype Borexino detector](#)
 - Derbin A., Smirnov O.
JETP Lett. Vol 76, No 7 (2002) 409-413.
- [Resolutions of a large volume liquid scintillator detector.](#)
 - O. Ju. Smirnov.
Instruments and Experimental Techniques, 2003 No 2
- [Effects of absorption and reemission of photons in large scintillation counters on the quantities measured by an observing phototubes.](#)
 - G. Ranucci.
Nuclear Instruments and Methods A487 (2002) 535.

Theses since 2002

- Tristan Beau [PhD. Thesis](#). Collège de France, 2002 (French language).
- Olivier Dadoun [PhD. Thesis](#). Université Paris VII, 2003 (French language).
- Andrea Pocar [PhD. Thesis](#). Princeton University, 2003.
- Daniela Manuzio [PhD. Thesis](#). University of Genova, 2004.
- Henning Olling Back [PhD. Thesis](#). Virginia Polytechnic Institute and State University, 2004.
- Christian Grieb [PhD. Thesis](#). Technische Universität München, 2004.
- Davide Franco [PhD. Thesis](#). University of Milano, 2005.
- Maria Elena Monzani [PhD. Thesis](#). University Paris VII and Milano, 2005.
- Ludwig Stefan Niedermeier [PhD. Thesis](#). Technische Universität München, 2005.
- Kevin B. McCarty [PhD. Thesis](#). Princeton University, 2006.
- Mike Leung [PhD. Thesis](#). Princeton University, 2006.
- Davide D'Angelo [PhD. Thesis](#). Technische Universität München, 2006.

Current Status

- Vessels installed and LAKN purged (major advantage for Kr, Ar)
- Borexino PMTs tested
- Muon Veto tested
- Water Plants tested (inside/outside SSS)
- Purification Systems tested
- Calibration Cameras installed and working
- 250 tons PC in long-term storage underground (no ^7Be)
- 900 tons PC in storage at Polimera Europa; new production run this January
- fluid systems precision cleaned
- HALL C infrastructure completed
- expanded CTF results understood (reached limit of sensitivity: betas in neutrino window $< 24/\text{ton}/\text{day}$ @ 3σ)
- **Permission to start water fill Aug 1 received (July 19, 2006)**

Schedule

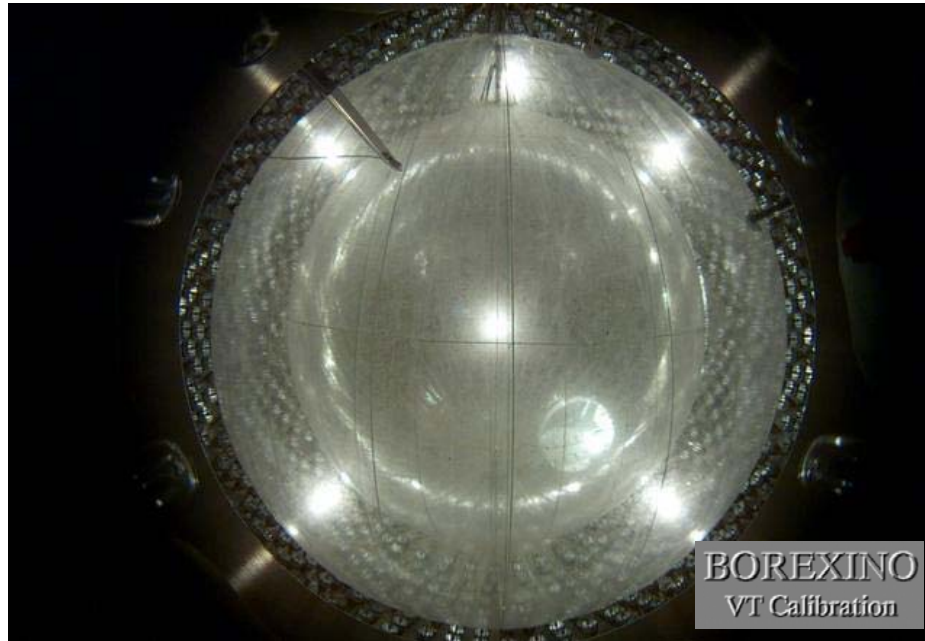

Task	# of weeks
Water Fill SSS	12 start Aug 1, 2006
SSS Water Data Run	10
Fill Water Tank	8
Water Tank Water Data Run	4
Scintillator Fill	24

Strategic Plan

- Fill SSS with water
 - perhaps see CNGS neutrino beam
 - final water soak; practice for scintillator filling
- Fill Outer Tank with water
- Displace water from SSS with scintillator
 - fully shielded detector
 - allows careful examination of scintillator radiopurity *before* completely full
- very different approach from KamLAND

BOREXINO will:

- provide first direct spectroscopic measurement of ^7Be neutrinos – poorly predicted, 7% contribution to L_{solar}
- test the assumptions underlying the MSW explanation
- be sensitive to signs of new neutrino properties and interactions
- provide best chance (currently) to see the pep neutrinos
- detect geoneutrinos in the European continental crust (using anti-neutrino spectroscopy - deeper and no reactors in Italy)

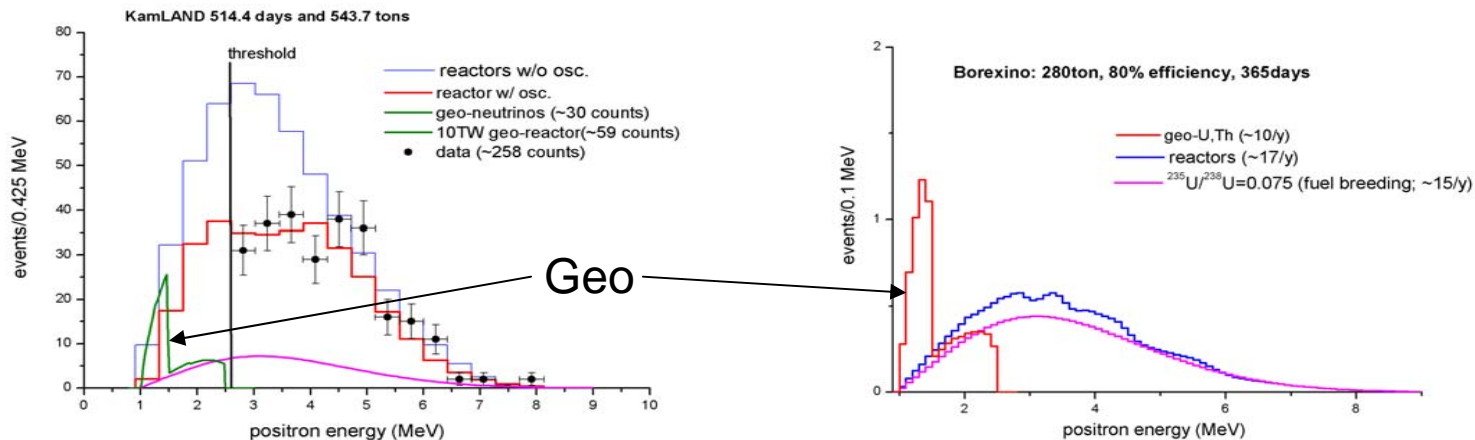

We are following in the footsteps of Bahcall and Davis, who have shown the impact of studying solar neutrinos has far reaching and profound consequences.