

# Ground-Commanded Television Assembly (GCTA)

## Final Report

Prepared for:  
NASA Manned Space Center  
R&D Procurement Branch  
Houston, Texas 77058

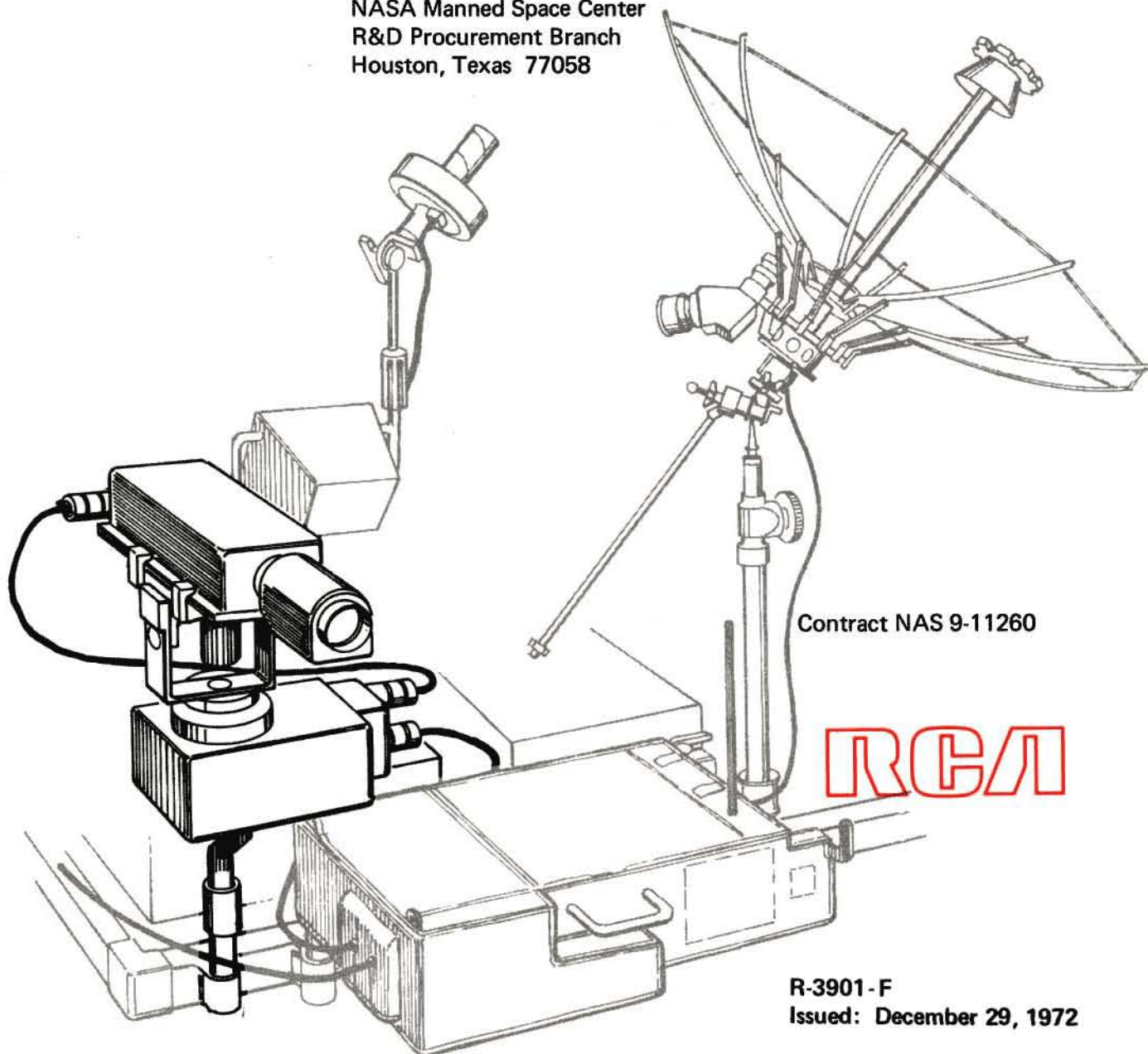

RCA I Government and Commercial Systems  
Astro-Electronics Division I Princeton, New Jersey 08540

## PREFACE

The spectacular television coverage of lunar surface explorations during the Apollo 15, 16, and 17 missions demonstrated the exceptional performance of the RCA Ground-Commanded Television Assembly (GCTA). The GCTA more than satisfied all anticipated requirements for lunar surface television and was fully compliant with NASA specifications.

An initial Interim Report on the GCTA program was issued in February 1972. The document summarized the work performed under Contract NAS 9-11260 from contract award on July 31, 1970 through February 15, 1972.

A second Interim Report was issued on July 31, 1972 to summarize the work performed by RCA to improve the performance and reliability of the GCTA for use during the Apollo 17 mission. The report covered the period from February 16 through July 31, 1972.

The present document finalizes the work performed by RCA under Contract NAS 9-11260 for the NASA Manned Spacecraft Center in Houston, Texas. The report covers the period from July 31 through December 29, 1972.

## CONTENTS

Section		Page
I	INTRODUCTION . . . . .	1
II	YOKE/FACEPLATE QUALIFICATION DATA . . . . .	6
III	ELEVATION DRIVE IMPROVEMENT PROGRAM. . . . .	39
IV	APOLLO 17 THERMAL DATA. . . . .	70
V	EQUIPMENT STATUS . . . . .	92
VI	DRAWING STATUS . . . . .	100
APPENDIX A	16 mm SIT QUALIFICATION TEST PROCEDURE . . .	102

## ILLUSTRATIONS

Figure		Page
Frontispiece	RCA Ground-Commanded Television Assembly . . . . .	
1	CTV Functional Block Diagram . . . . .	4
2	TCU Functional Block Diagram . . . . .	5
3	Predicted TCU Elevation Drive Torque Curve . . . . .	40
4	Peak Torque Contour for Serial No. 006 . . . . .	41
5	Peak Torque Contour for Serial No. 003 . . . . .	42
6	Serial No. 006 Torque Curve after Rework . . . . .	43
7	Serial No. 006 Post Rework Torque with Damping Springs . . . . .	44
8	CTV Temperature Telemetry Waveform . . . . .	70
9	Flight 3 CTV Temperature Telemetry Calibration . . .	81
10	CTV Vidicon Temperature During EVA-1. . . . .	83
11	CTV Vidicon Temperature During EVA-2. . . . .	84
12	CTV Vidicon Temperature During EVA-3. . . . .	85
13	CTV Vidicon Temperature Prior to and During Lunar Liftoff. . . . .	86
14	Overall Plot of CTV Temperature on Lunar Surface . .	87
15	SIT Tube Temperature Prediction Curves . . . . .	88
16	TCU Board Temperature Prediction Curves . . . . .	89

## TABLES

Table		Page
1	SIT Performance Characteristics . . . . .	2
2	Performance Summary of RCA GCTA . . . . .	3
3	Elevation Drive Design Parameters . . . . .	39
4	Elevation Drive Test Program . . . . .	46
5	Summary of CTV Operating Temperatures . . . . .	71
6	GCTA Operating Time (1) . . . . .	90
7	GCTA Operating Time (2) . . . . .	91

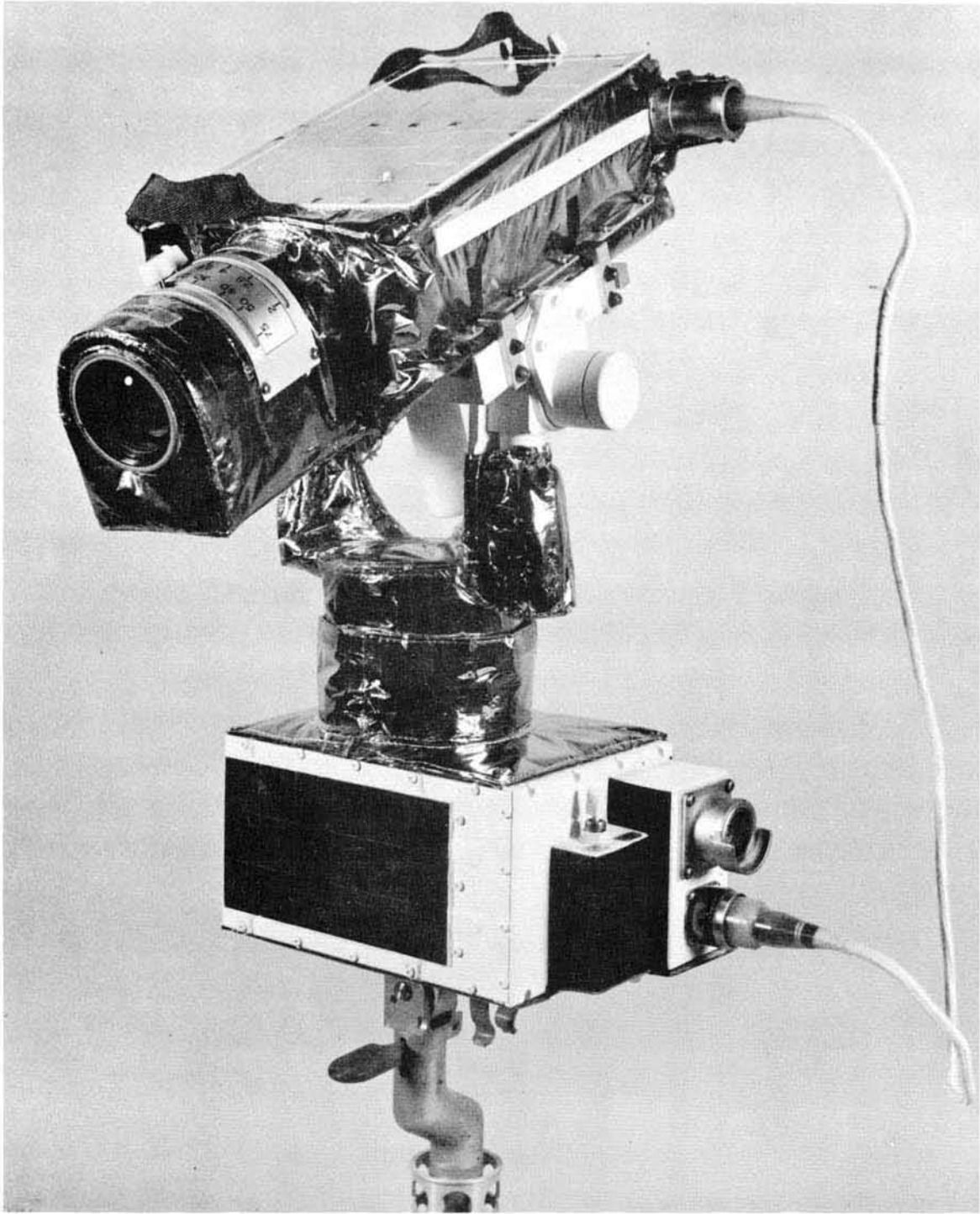

Frontispiece. RCA Ground-Commanded Television Assembly

## SECTION I

### INTRODUCTION

The RCA Ground-Commanded Television Assembly (GCTA) consists of a Color Television Camera (CTV), a Television Control Unit (TCU) and associated cabling, bracketry, and hardware. The GCTA design is based on the RCA Lunar Surface Color Camera produced for NASA under Contract NAS 9-10781. Both systems use a Silicon Intensifier Target (SIT) sensor and field-sequential color wheel to generate color television images.

The present RCA GCTA system illustrated in the Frontispiece was designed to provide maximum flexibility, potential growth, and ability to withstand the environmental extremes encountered on the lunar surface. Use of the SIT sensor provided high sensitivity, wide intra-scene dynamic range, freedom from microphonics, and rugged construction. Performance of the SIT sensor is summarized in Table 1. An overall summary of GCTA performance is provided in Table 2.

Functional block diagrams of the GCTA Color Television Camera (CTV) and the Television Control Unit (TCU) are provided in Figures 1 and 2.

The Color Television Camera (CTV) uses basic monochrome techniques to produce **high-quality, field-sequential color television at standard (NTSC) line and frame rates.** The camera uses a single silicon intensifier target (SIT) tube and a synchronous rotating filter wheel to generate color video data. A zoom lens is incorporated with provisions for manual or remote control of zoom and iris settings. Automatic light control (ALC) operating on average or peak scene luminance also is incorporated. ALC may be selected manually or by remote control.

The Television Control Unit (TCU) permits ground-commanded operation of the CTV. A 70-kHz modulated subcarrier signal is sent to the TCU from the LCRU, and the TCU decodes this signal and executes valid real-time commands. The TCU cradle, mechanically driven in azimuth and elevation, holds the CTV for remote pointing in response to ground commands. The TCU electronics provide control signals to operate the zoom, iris, and ALC functions of the camera, and provides CTV power ON/OFF control in response to ground command or manual switch operation. Commands to the LCRU for ON/OFF control of the FM transmitter and ON/OFF control of the 1.25-MHz voice subcarrier also are generated in the TCU. After adding a vertical-interval test signal on line 17 of each field, the TCU routes the CTV composite video output signal to the LCRU.

A short staff at the base of the TCU electronics box mounts the GCTA to a fitting on the LRV chassis frame. The mounting staff has a swing-away capability to allow removal of the LCRU from the LRV chassis frame without removing the GCTA.

TABLE 1. SIT PERFORMANCE CHARACTERISTICS

Parameter	Value
• Spectral Response	3500-7000 Angstroms
• Resolution	Minimum 40% @ 200 TVL
• Signal Current	Typical 400 nA
• Dark Current	Maximum 15 nA @ 30°C
• Sensitivity & Dynamic Range Typical	1 to 10,000 foot-lambert Scene
• Gamma	1.0
• Scene Dynamic Range	32:1 Minimum
• Shading	Maximum 20%
• Operating Temperature	(-10°C to +50°C)
• Life	Minimum 500 Hours



TABLE 2. PERFORMANCE SUMMARY OF RCA GCTA

Parameter	Characteristic
Sensor	Silicon Intensifier Target (SIT) Tube
Sensitivity	Better than 32-dB signal-to-noise ratio at 3 foot-lamberts
Resolution	80 percent response at 200 TVL
ALC Dynamic Range	1000 to 1 (minimum)
Non-linearity	3 percent (maximum)
Shading	20 percent (maximum)
Gray Scale	Ten $\sqrt{2}$ steps
Video Output Level	1 volt p-p into 75-ohm load Full EIA sync
ALC	PEAK or AVERAGE detection modes Remote control with manual override
Optics Zoom ratio Iris control Pan angle Tilt angle	6:1 f/2.2 to f/22 +214(R), -134(L) +85 degrees from horizontal -45
Power	16.65 watts (operate), 7.95 watts (standby)
Physical Characteristics Weight Volume	18.24 pounds 455 cubic inches

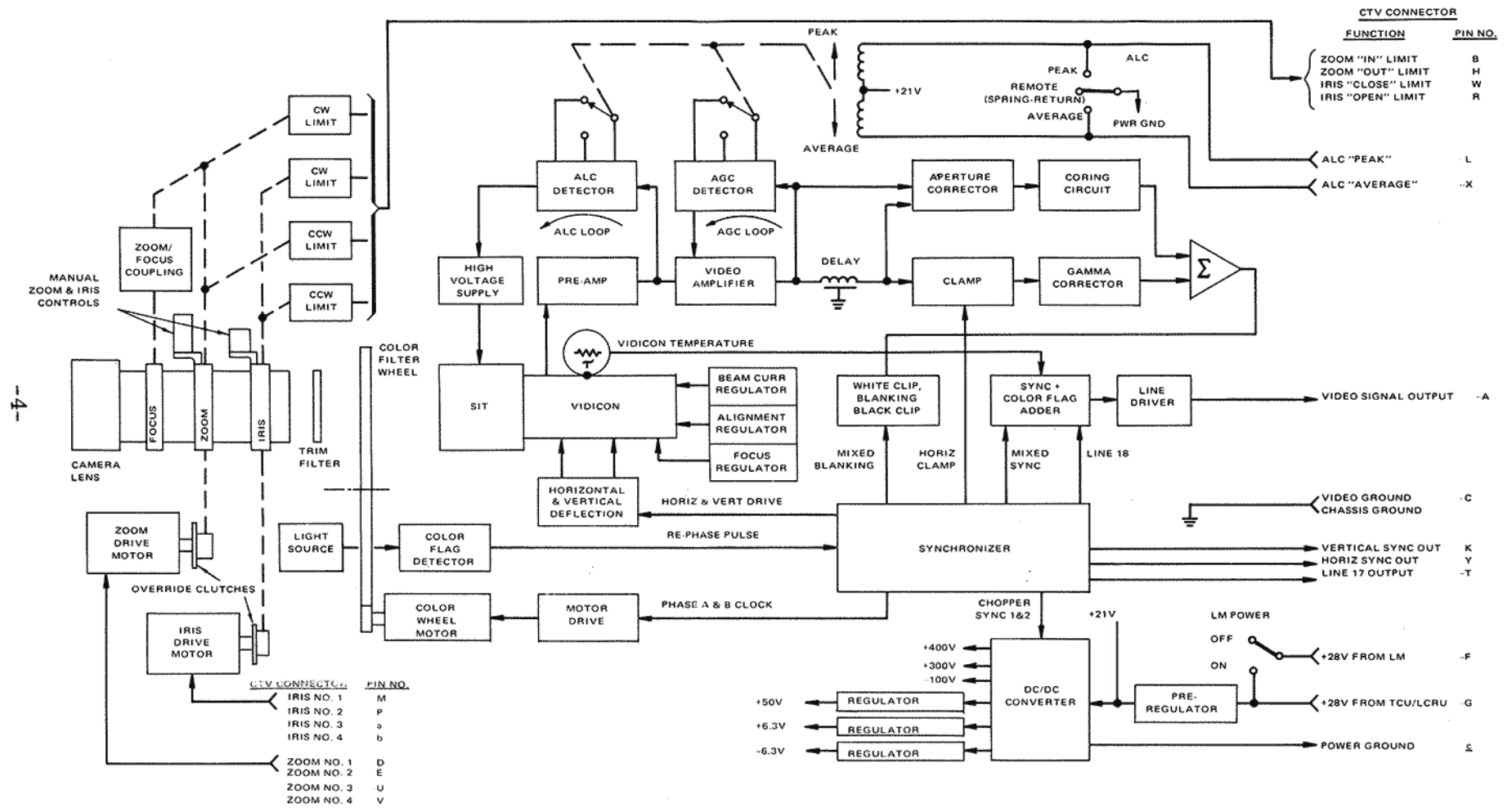

Figure 1. CTV Functional Block Diagram

LCRM CONNECTOR

CTV CONNECTOR

PIN NO. FUNCTION

- C VIDEO SIGNAL GROUND
- A VIDEO SIGNAL OUTPUT
- F FM TRANSMITTER CONTROL
- N SUBCARRIER CONTROL (+14V)
- S SUBCARRIER CONTROL RETURN
- J 70 KHz SUBCARRIER
- L 70 KHz SUBCARRIER
- G + 28V POWER
- 6 POWER GROUND
- Z CHASSIS GROUND

FUNCTION PIN NO.

- VIDEO SIGNAL GROUND C
- VIDEO SIGNAL INPUT A
- CHASSIS GROUND Z
- LINE 17 INPUT T
- POWER GROUND 5
- RD - RELAY DRIVER
- S/C ON
- S/C OFF
- POWER ON
- MANUAL POWER SWITCH
- POWER OFF
- POWER ON
- POWER OFF
- LEVEL SHIFTER
- ALC PEAK
- POWER ON
- ALC AVERAGE
- IRIS OPEN LIMIT R
- IRIS CLOSE LIMIT W
- IRIS NO. 1 M
- IRIS NO. 2 P
- IRIS NO. 3 a
- IRIS NO. 4 b
- ZOOM NO. 1 D
- ZOOM NO. 2 E
- ZOOM NO. 3 U
- ZOOM NO. 4 V
- ZOOM IN LIMIT B
- ZOOM OUT LIMIT H
- VERT. SYNC IN K
- HORIZ SYNC IN Y

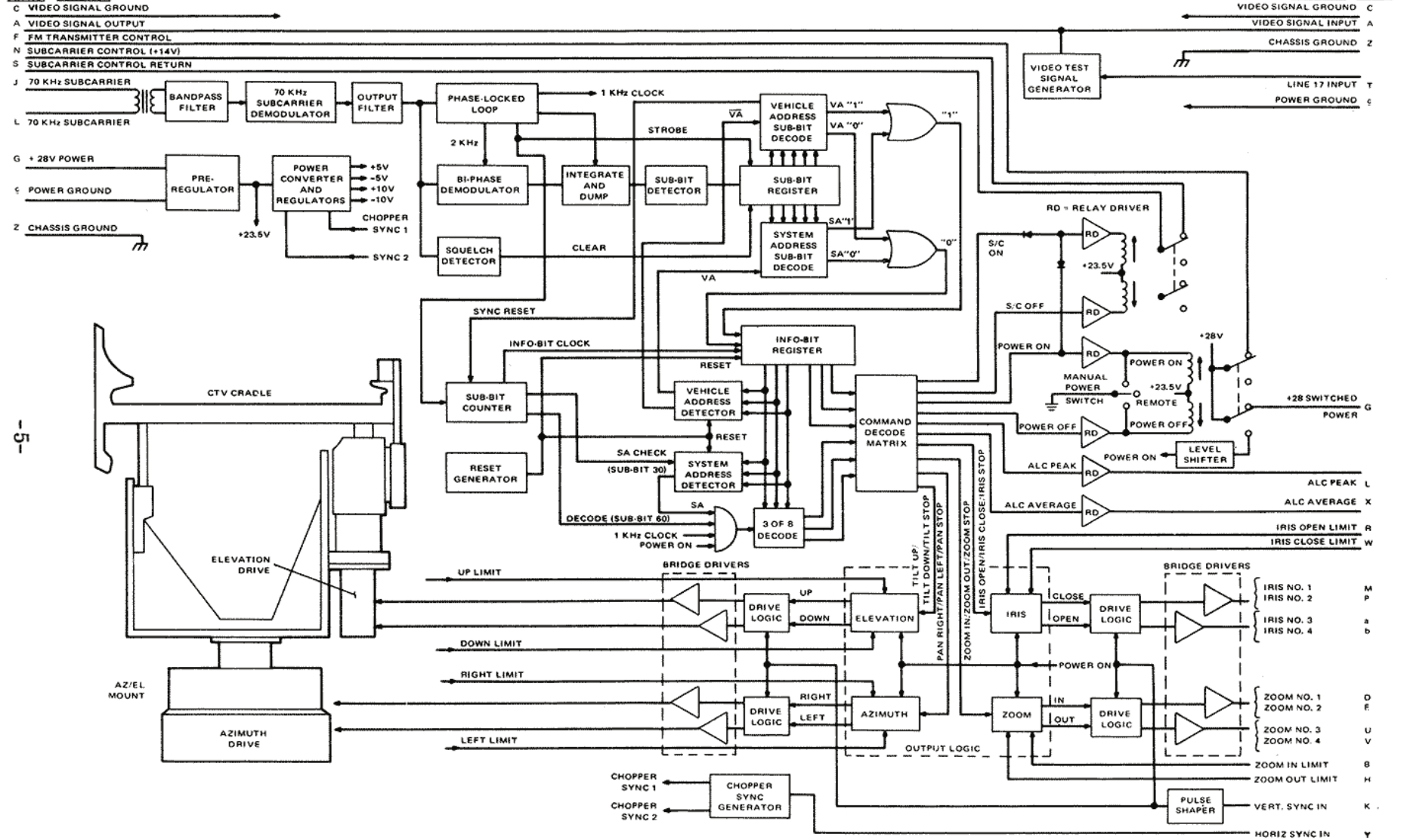

Figure 2. TCU Functional Block Diagram

SECTION II  
YOKE/FACEPLATE QUALIFICATION DATA

The GCTA Interim Report issued July 31, 1972 describes the details of design modifications to the Apollo yoke and the addition of a bonded protective faceplate with an integral spectral filter. The yoke modifications were intended to eliminate problems encountered during test of the cameras where open circuits had developed at the connection points on two yoke assemblies. The protective faceplate is intended to eliminate the possibility of discharge phenomena from or through the SIT fiber optics faceplate. By incorporating a spectral filter within the protective faceplate, undesired SIT response to near IR radiation from the color flag detector emitter or from the imaged scene also is eliminated. The protective faceplate filter assembly is detailed in RCA drawing 2269728-501.

To verify the design suitability and integrity of the modifications, qualification tests were conducted on individual yoke assemblies and on a total tube assembly containing a yoke of the new design and a bonded faceplate. The tube assembly qualification procedure was performed in accordance with Appendix A of this report (Qualification Test Procedure), and consisted of the following operations:

1. Sinusoidal Vibration
2. Random Vibration
3. Acceleration
4. Shock
5. Temperature Cycling

The qualification procedure for the yoke assembly is provided as Appendix A in the referenced report. The tests consisted of the following items:

1. Hot step stress testing (to +100° C)
2. Cold step stress testing (to -70° C)
3. Cyclic temperature fatigue tests (-10° C to +65° C)
4. Power ON/OFF cycling fatigue test (-10° C to +65° C)

It was initially planned to start a new yoke at each step above, to isolate the mode in the event of a failure. Printed circuit material constraints limited the availability of new yokes so that a single yoke of new configuration was exposed to all of the qualification tests. Both the yoke and tube assembly have successfully completed their respective qualification tests, thus providing confidence in the integrity of the modifications.

The test data obtained on the total tube assembly prior to, during, and after exposure to the required environmental tests is shown on the following Data Sheets (1 through 8). Spurious signal photographs show that no changes occurred in spots or blemishes. Integrity of the faceplate bond was assured by examining these photographs for interference patterns, and by visual examination of the tube assembly. No evidence of separation was found. The parameter data sheets showed no significant changes at each of the test steps. Dark current variations within  $\pm 15$  percent are considered normal based on measurement accuracy and small temperature variations at the time of measurement. All dark current values are below the specification maximum (15 nA). The small changes in recorded alignment current reflect operator setup for performance data and do not suggest a change in tube characteristics.

During initial assembly of the test tube/yoke assembly (S/N 710-Q3), high voltage arcing was encountered at the first application of power. The photocathode bleeder resistor was found to be improperly positioned in the assembly, permitting arcing to the ground connection. The resistors were replaced and no further problems were encountered.

Two yoke assemblies were subjected to testing in accordance with the procedure in Appendix A. Serial Number 3-72-1 was of the original design configuration, while S/N 7-31-3 was of the modified design as illustrated in the referenced interim report. On the attached recorder traces, the unit windings are designated as follows:

<u>Test</u>	<u>New</u>	<u>Old</u>
HOT STRESS	V2/H2	V1/H1
COLD STRESS	V1/H1	V2/H2
ON/OFF CYCLING	V2/H2	V1/H1
FATIGUE CYCLING	V2/H2	V1/H1

Data Sheets 9 and 10 present a summary of the data obtained for all of the tests. Several erratic readings are noted on the recorder traces. These were identified as being caused by a noisy potentiometer in the bridge circuit used to establish the current through the windings. The recorder traces are annotated as follows:

<u>Data Sheet No.</u>	<u>Test</u>
11	Hot Stress (NEW)
12	Hot Stress (OLD)
13,14	Cold Stress (NEW)
15,16	Cold Stress (OLD)
17,18	ON/OFF Cycling (OLD)
19,20	ON/OFF Cycling (NEW)
21-26	FATIGUE Cycling (OLD)
27-31	FATIGUE Cycling (NEW)

INDIVIDUAL TEST DATA  
PART I

DATA SHEET

Pre-Environmental Test

Unit: SIT C21129B  
Serial No: 710-Q3  
Date: 9/29/72  
Test Personnel: CAL  
Inspector: BJB

Electrical and Performance

Test Para.	Name	Limits		Result	Units
		Min	Max		
2.1	Lag	-	10	6	%
2.2	Amplitude Response				
	Center	40	-	78	%
	Corner	25	-	30	%
2.3	Cutoff	-120	-65	-80	Vdc
2.4	Sensitivity	100	-	123	uA/lm
2.5	Target Gain	1000	-	1860*	-
2.6	Image Section Gain Change	100	-	84.1*	-
2.7	Dark Current	-	15	7.5	nAdc
2.8	Alignment Field				
	Horizontal	-	20	+15	mAdc
	Vertical	-	20	-18	mAdc
2.9	Shading	-	20	18	%
2.10	Spots or Blemishes (See Para 2.10)			OK (see photos)	

Mechanical Tests

Test Para.	Name	Limits		Result	Units
		Min	Max		
3.0	Dimensions				
	PC Lead	0.90	-	1.2	inch
	Faceplate to flange	4.895	4.915	4.909	inches
3.1	Weight		24	25.2	ounces

\*Data taken at initial tube test

SPURIOUS SIGNAL, PRE ENVIRONMENTAL TESTS

Serial No. 710-Q3

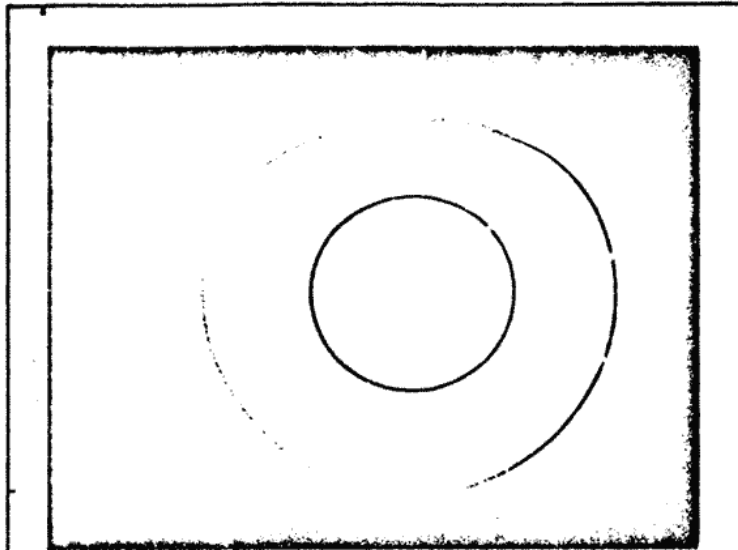

P \_\_\_\_\_

$E_{pc}$  3 KV

$I_t$  300 nA



P \_\_\_\_\_

Sweep \_\_\_\_\_ /cm

Sens \_\_\_\_\_ /cm

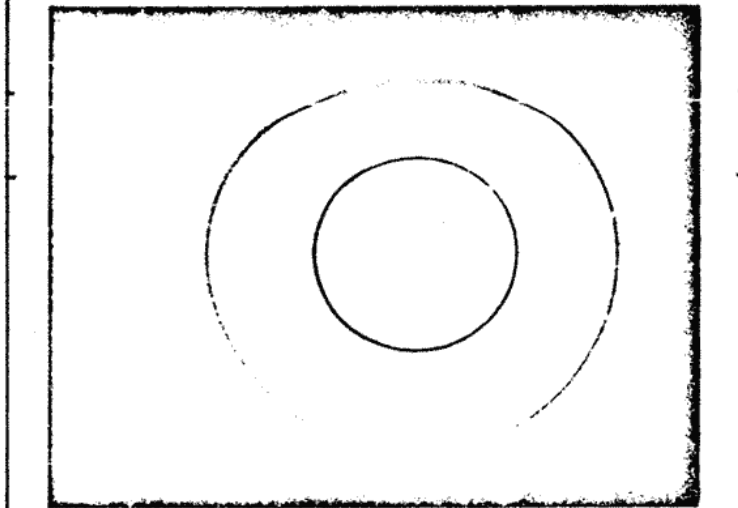

P \_\_\_\_\_

$E_{pc}$  8 KV

$I_t$  300 nA

Attached by \_\_\_\_\_

Date \_\_\_\_\_

SIZE

A

CODE IDENT NO.

49671

DATA SHEET 2

SHEET

INDIVIDUAL TEST DATA  
PART I

DATA SHEET

Vibrated

Unit: SJT G21129B  
Serial No: 710-Q3  
Date: 10/1/72  
Test Personnel: CAL  
Inspector: BJB

Electrical and Performance

Test Para.	Name	Limits		Result	Units
		Min	Max		
2.1	Lag	-	10	8	%
2.2	Amplitude Response				
	Center	40	-	78	%
	Corner	25	-	32	%
2.3	Cutoff	-120	-65	-80	Vdc
2.4	Sensitivity	100	-	124	$\mu\text{A}/\text{lm}$
2.5	Target Gain	1000	-	1860*	-
2.6	Image Section Gain Change	100	-	84.1*	-
2.7	Dark Current	-	15	5.8	nAdc
2.8	Alignment Field				
	Horizontal	-	20	+16	mAdc
	Vertical	-	20	-18	mAdc
2.9	Shading	-	20	18	%
2.10	Spots or Blemishes (See Para 2.10)			No change (see photos)	

Mechanical Tests

Test Para.	Name	Limits		Result	Units
		Min	Max		
3.0	Dimensions				
	PC Lead	0.90	-	1.2	inch
	Faceplate to flange	4.825	4.915	4.909	inches
3.1	Weight		24	25.2	ounces

\*Data taken at initial tube test



SPURIOUS SIGNAL, POST VIBRATION

Serial No. 710-Q3

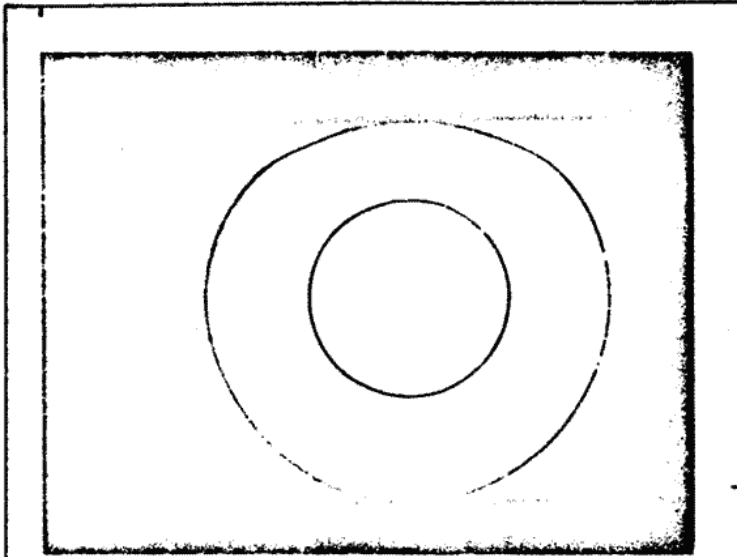

P \_\_\_\_\_

E<sub>pc</sub> 3 KV

I<sub>t</sub> 300 nA



P \_\_\_\_\_

Sweep \_\_\_\_\_ /cm

Sens \_\_\_\_\_ /cm

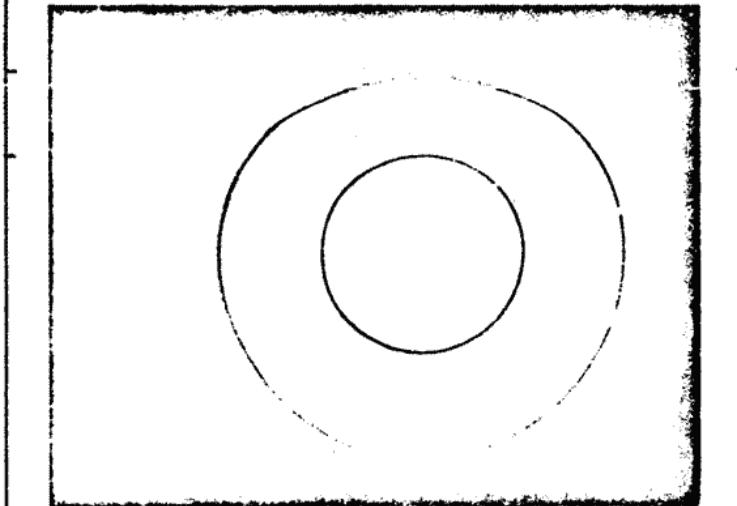

P \_\_\_\_\_

E<sub>pc</sub> 3 KV

I<sub>t</sub> 300 nA

Attached by BMS  
Date 11/13/72

SIZE  
A

CODE IDENT NO.  
49671

DATA SHEET 4

SHEET

INDIVIDUAL TEST DATA  
PART I

DATA SHEET

Shocked & Accelerated

Unit: SJT C21129B  
Serial No: 710-Q3  
Date: 10/2/72  
Test Personnel: CAL  
Inspector: BJB

Electrical and Performance

Test Para.	Name	Limits		Result	Units
		Min	Max		
2.1	Lag	-	10	6	%
2.2	Amplitude Response				
	Center	40	-	78	%
	Corner	25	-	30	%
2.3	Cutoff	-120	-65	-80	Vdc
2.4	Sensitivity	100	-	123	uA/in
2.5	Target Gain	1000	-	1860*	-
2.6	Image Section Gain Change	100	-	84.1*	-
2.7	Dark Current	-	15	6.1	nA/dc
2.8	Alignment Field				
	Horizontal	-	20	+12	mA/dc
	Vertical	-	20	-16	mA/dc
2.9	Shading	-	20	18	%
2.10	Spots or Blemishes (See Para 2.10)				

Mechanical Tests

Test Para.	Name	Limits		Result	Units
		Min	Max		
3.0	Dimensions				
	PC Lead	0.90	-	1.2	inch
	Faceplate to flange	4.825	4.915	4.909	inches
3.1	Weight		24	25.2	ounces

\*Data taken at initial tube test

SPURIOUS SIGNAL, POST SHOCK & ACCELERATION

Serial No. 710-Q3

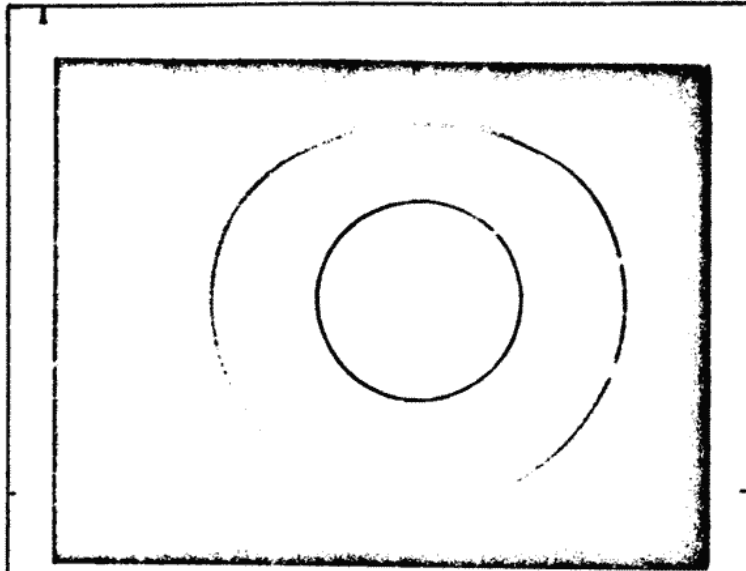

P \_\_\_\_\_

$E_{pc}$  3KV

$I_t$  300 nA



P \_\_\_\_\_

Sweep \_\_\_\_\_ /cm

Sens \_\_\_\_\_ /cm

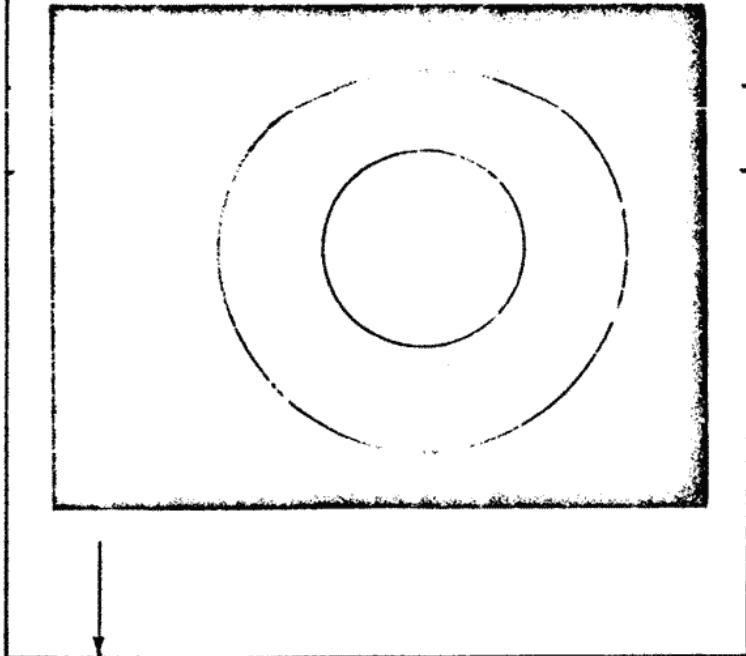

P \_\_\_\_\_

$E_{pc}$  8KV

$I_t$  300 nA

Attached by BmJ

Date 11/13/72

SIZE

A

CODE IDENT NO.

49671

DATA SHEET 6

SHEET

INDIVIDUAL TEST DATA  
PART I

DATA SHEET  
Temperature Cycled

Unit: SJT C21129B  
Serial No: 710-Q3  
Date: 10/4/72  
Test Personnel: CAL  
Inspector: BJB

Electrical and Performance

Test Para.	Name	Limits		Result	Units
		Min	Max		
2.1	Lag	-	10	8	%
2.2	Amplitude Response				
	Center	40	-	78	%
	Corner	25	-	35	%
2.3	Cutoff	-120	-65	-80	Vdc
2.4	Sensitivity	100	-	122	uA/in
2.5	Target Gain	1000	-	1860*	-
2.6	Image Section Gain Change	100	-	84.1*	-
2.7	Dark Current	-	15	5.8	nAdc
2.8	Alignment Field				
	Horizontal	-	20	+11	mAdc
	Vertical	-	20	-20	mAdc
2.9	Shading	-	20	14	%
2.10	Spots or Blemishes (See Para 2.10)			No change (see photos)	

Mechanical Tests

Test Para.	Name	Limits		Result	Units
		Min	Max		
3.0	Dimensions				
	PC Lead	0.90	-	1.2	inch
	Faceplate to flange	4.825	4.915	4.909	inches
3.1	Weight		24	25.2	ounces

\*Data taken at initial tube test

# SPURIOUS SIGNAL, POST THERMAL CYCLING

Serial No. 710-Q3

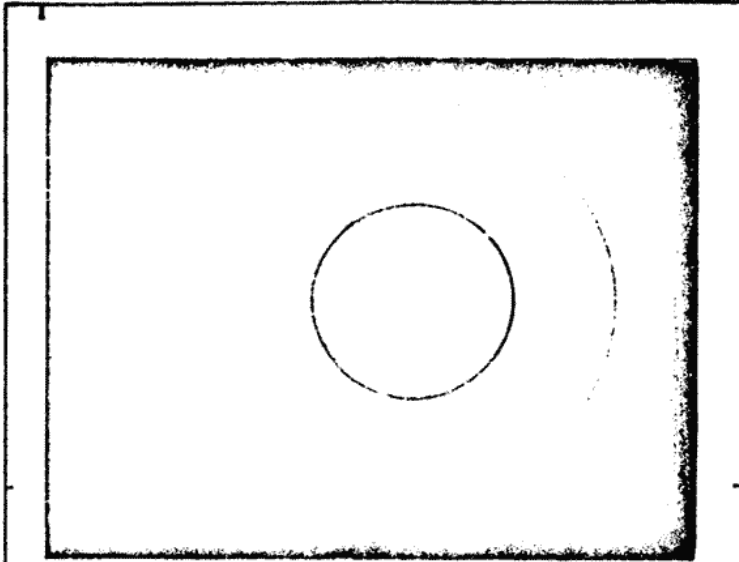

P \_\_\_\_\_  
E<sub>pc</sub> 3kV  
I<sub>t</sub> 300nA



P \_\_\_\_\_  
Sweep \_\_\_\_\_ /cm  
Sens \_\_\_\_\_ /cm

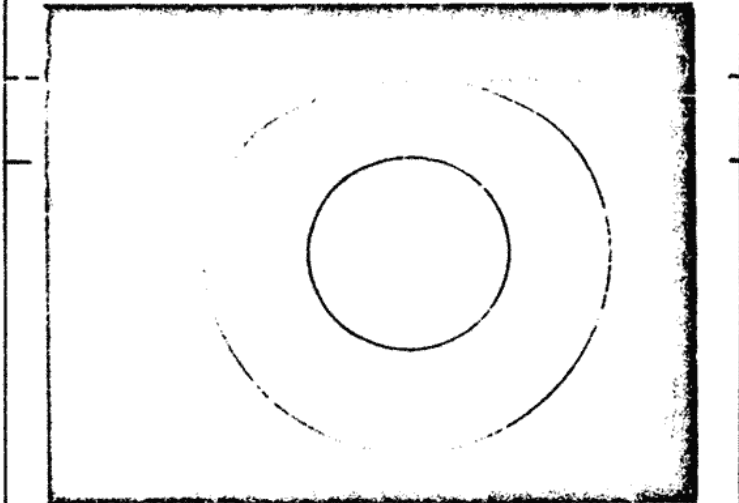

P \_\_\_\_\_  
E<sub>pc</sub> 8kV  
I<sub>t</sub> 300nA

Attached by pmg  
Date 11/13/72

SIZE  
**A**

CODE IDENT NO.  
**49671**

**DATA SHEET 8**

SHEET

Apollo Environmental Yeaw Testing Data Sheets

	Pre Test Data	LH (mh)	LV (mh)	RH (ohms)	RV (ohms)
Unit #1	<u>7-31-3</u>	<u>1.9</u>	<u>1.9</u>	<u>28.6</u>	<u>28.2</u>
Unit #2	<u>3-72-1 (old)</u>	<u>1.96</u>	<u>2.02</u>	<u>30.5</u>	<u>31.4</u>

Hot Temp. Stress	Ambient <sup>(26.7°C)</sup>	+10°C	+50°C	+60°C	+70°C	+80°C	+90°C	+100°C		Inductance (mh)	
Unit #1 <u>7-13-3</u> Hor	<u>28.92</u>	<u>30.32</u>	<u>31.32</u>	<u>32.36</u>	<u>33.36</u>	<u>34.36</u>	<u>35.4</u>	<u>36.48</u>	ohms	<u>1.98</u>	
Ver	<u>27.60</u>	<u>28.92</u>	<u>29.88</u>	<u>30.88</u>	<u>31.84</u>	<u>32.80</u>	<u>33.8</u>	<u>34.76</u>	"	<u>1.91</u>	
Unit #2 <u>3-72-1</u> Hor	<u>30.64</u>	<u>32.04</u>	<u>33.12</u>	<u>34.24</u>	<u>35.32</u>	<u>36.32</u>	<u>37.44</u>	<u>38.56</u>	"	<u>1.98</u>	
Ver	<u>32.28</u>	<u>33.8</u>	<u>34.88</u>	<u>36.08</u>	<u>37.20</u>	<u>38.28</u>	<u>39.44</u>	<u>40.6</u>	"	<u>2.01</u>	
Cold Temp. Stress	Ambient <sup>(23°C)</sup>	+10°C	0°C	-10°C	-20°C	-30°C	-40°C	-50°C	-60°C	-70°C	Inductance (mh)
Unit #1 <u>7-13-3</u> Hor	<u>27.4</u>	<u>26.3</u>	<u>25.5</u>	<u>24.4</u>	<u>23.4</u>	<u>22.3</u>	<u>21.2</u>	<u>20.3</u>	<u>19.2</u>	<u>18.0</u>	ohms
Ver	<u>27.6</u>	<u>26.3</u>	<u>25.2</u>	<u>24.1</u>	<u>23.1</u>	<u>22.0</u>	<u>21.0</u>	<u>20.0</u>	<u>19.0</u>	<u>17.7</u>	"
Unit #2 <u>3-72-1</u> Hor	<u>30.8</u>	<u>29.2</u>	<u>28.0</u>	<u>26.7</u>	<u>25.7</u>	<u>24.5</u>	<u>23.3</u>	<u>22.3</u>	<u>21.1</u>	<u>19.7</u>	"
Ver	<u>31.5</u>	<u>29.9</u>	<u>28.6</u>	<u>27.3</u>	<u>26.2</u>	<u>25.0</u>	<u>23.8</u>	<u>22.8</u>	<u>21.6</u>	<u>20.1</u>	"

-16-

Fatigue Eval.	Cycle 1		Cycle 2		Cycle 3		Cycle 4		Cycle 5		Cycle 6		Cycle 7		Cycle 8		Cycle 9		Cycle 10		
	+65	-10	+65	-10	+55	-10	+65	-10	+65	-10	+65	-10	+65	-10	+65	-10	+65	-10	+65	-10	
Unit #1 <u>7-13-3</u> Hor	<u>29.1</u>	<u>32.6</u>	<u>24.8</u>	<u>32.7</u>	<u>24.8</u>	<u>31.5</u>	<u>24.9</u>	<u>32.7</u>	<u>24.8</u>	<u>32.8</u>	<u>24.9</u>	<u>32.8</u>	<u>25.0</u>	<u>32.7</u>	<u>24.9</u>	<u>32.7</u>	<u>24.9</u>	<u>32.8</u>	<u>25.0</u>	<u>32.9</u>	<u>24.9</u>
Ver	<u>28.0</u>	<u>31.4</u>	<u>23.9</u>	<u>31.5</u>	<u>23.8</u>	<u>32.8</u>	<u>24.0</u>	<u>31.5</u>	<u>23.8</u>	<u>31.4</u>	<u>24.0</u>	<u>31.6</u>	<u>24.1</u>	<u>31.5</u>	<u>23.9</u>	<u>31.5</u>	<u>23.9</u>	<u>31.5</u>	<u>24.0</u>	<u>31.5</u>	<u>23.9</u>
Unit #2 <u>3-72-1</u> Hor	<u>30.8</u>	<u>34.6</u>	<u>26.3</u>	<u>34.7</u>	<u>26.2</u>	<u>34.7</u>	<u>26.4</u>	<u>34.7</u>	<u>26.3</u>	<u>34.8</u>	<u>26.4</u>	<u>34.7</u>	<u>26.4</u>	<u>34.6</u>	<u>26.3</u>	<u>34.6</u>	<u>26.4</u>	<u>34.8</u>	<u>26.4</u>	<u>34.7</u>	<u>26.3</u>
Ver	<u>32.5</u>	<u>36.4</u>	<u>27.7</u>	<u>36.6</u>	<u>27.6</u>	<u>36.6</u>	<u>27.7</u>	<u>36.6</u>	<u>27.7</u>	<u>36.6</u>	<u>27.8</u>	<u>36.6</u>	<u>27.9</u>	<u>36.5</u>	<u>27.7</u>	<u>36.5</u>	<u>27.8</u>	<u>36.7</u>	<u>27.9</u>	<u>36.5</u>	<u>27.7</u>

On-Off Cycles @ -25°C

	#1	#2	#3	#4	#5	#6	#7	#8	#9	#10	#11	#12	#13	#14	#15	#16	#17	#18	#19	#20	
Unit #1 <u>7-13-3</u> Hor	32.4	32.5	32.5	32.5	32.6	32.7	32.7	32.7	32.7	32.7	32.7	32.7	32.7	32.6	32.6	32.7	32.7	32.7	32.7	32.7	ohms
Ver	31.2	31.2	31.3	31.3	31.3	31.2	31.4	31.4	31.4	31.4	31.4	31.3	31.3	31.3	31.3	31.4	31.4	31.4	31.4	31.4	"
Unit #2 <u>3-72-1</u> Hor	34.6	34.6	34.4	34.6	34.6	34.7	34.7	34.7	34.7	34.6	34.6	34.6	34.6	34.6	34.6	34.7	34.7	34.7	34.6	34.6	"
Ver	36.4	36.4	36.4	36.4	36.4	36.4	36.4	36.5	36.5	36.5	36.5	36.4	36.4	36.4	36.4	36.5	36.4	36.4	36.4	36.4	"

On-Off Cycles @ -10°C

	#1	#2	#3	#4	#5	#6	#7	#8	#9	#10	#11	#12	#13	#14	#15	#16	#17	#18	#19	#20	
Unit #1 <u>7-13-3</u> Hor	25.0	25.0	24.9	24.9	24.9	24.9	24.9	24.9	24.9	24.9	24.9	24.8	24.8	24.8	24.8	24.8	24.8	24.8	24.8	24.8	ohms
Ver	24.0	24.0	23.9	23.9	23.9	23.9	23.9	23.9	23.9	23.9	23.9	23.8	23.8	23.8	23.8	23.8	23.8	23.8	23.8	23.8	"
Unit #2 <u>3-72-1</u> Hor	26.4	26.4	26.3	26.3	26.3	26.3	26.3	26.3	26.3	26.3	26.3	26.3	26.3	26.3	26.2	26.2	26.2	26.2	26.2	26.2	"
Ver	27.8	27.8	27.7	27.7	27.8	27.8	27.8	27.8	27.8	27.8	27.8	27.8	27.7	27.7	27.7	27.6	27.6	27.6	27.6	27.6	"

On-Off Cycles @ +25°C

	#1	#2	#3	#4	#5	#6	#7	#8	#9	#10	#11	#12	#13	#14	#15	#16	#17	#18	#19	#20	
Unit #1 <u>7-13-3</u> Hor	28.5	28.4	28.4	28.4	28.4	28.3	28.4	28.3	28.3	28.4	28.4	28.3	28.3	28.3	28.3	28.4	28.4	28.3	28.4	28.4	ohms
Ver	27.4	27.3	27.2	27.2	27.2	27.2	27.2	27.2	27.2	27.2	27.2	27.2	27.2	27.2	27.2	27.2	27.2	27.2	27.2	27.2	"
Unit #2 <u>3-72-1</u> Hor	30.1	30.1	30	30	30	30	30	30	30	30	30	30	30	30	30	30	30	30	30	30	"
Ver	31.7	31.6	31.6	31.6	31.6	31.5	31.5	31.5	31.5	31.6	31.6	31.6	31.5	31.5	31.5	31.5	31.6	31.5	31.5	31.5	"

L Hor

L Ver

Unit #1 7-13-3

2.0mh

2.0mh

Unit #2 3-72-1

1.98mh

2.05mh

New Unit

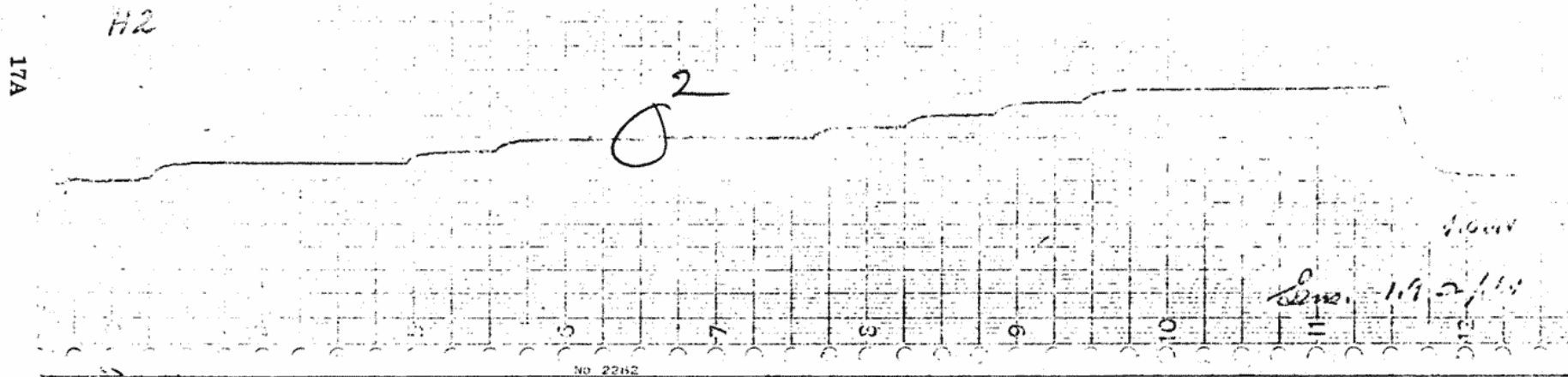

1. Trace jumped while recording data. It is strongly felt that technician caused jump by bumping potentiometer in circuitry.
2. Circuit box intentionally jerved causing slight jump in trace.

DATA SHEET 11



old Unit

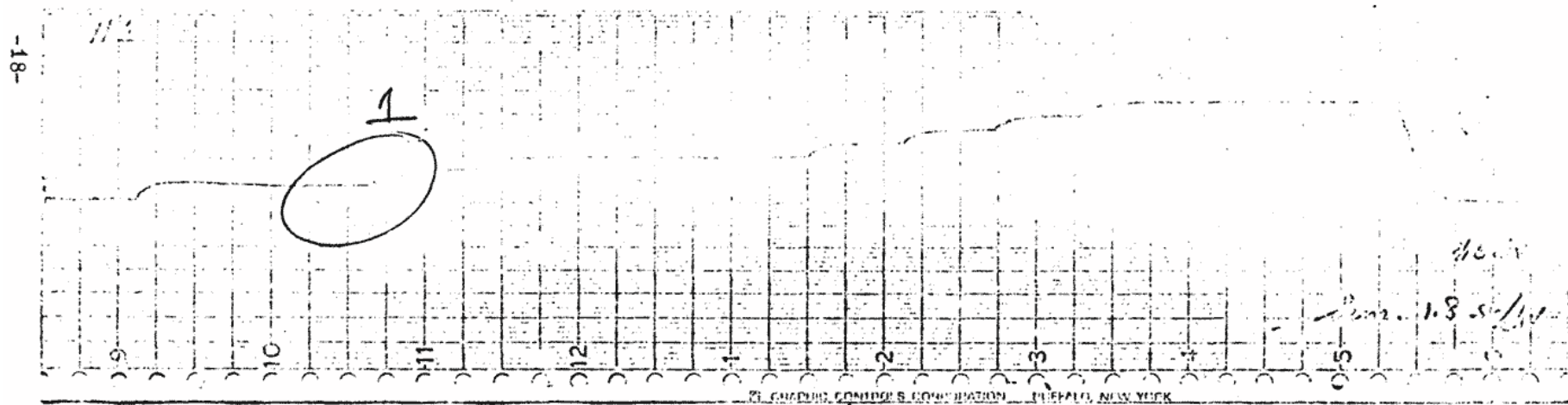

1 Strip Recorder Paper Drive Inoperative causing skip in trace.

DATA SHEET 12

Page 1 of 2  
page H1 and  
V1 recordings  
(NEW YORK)

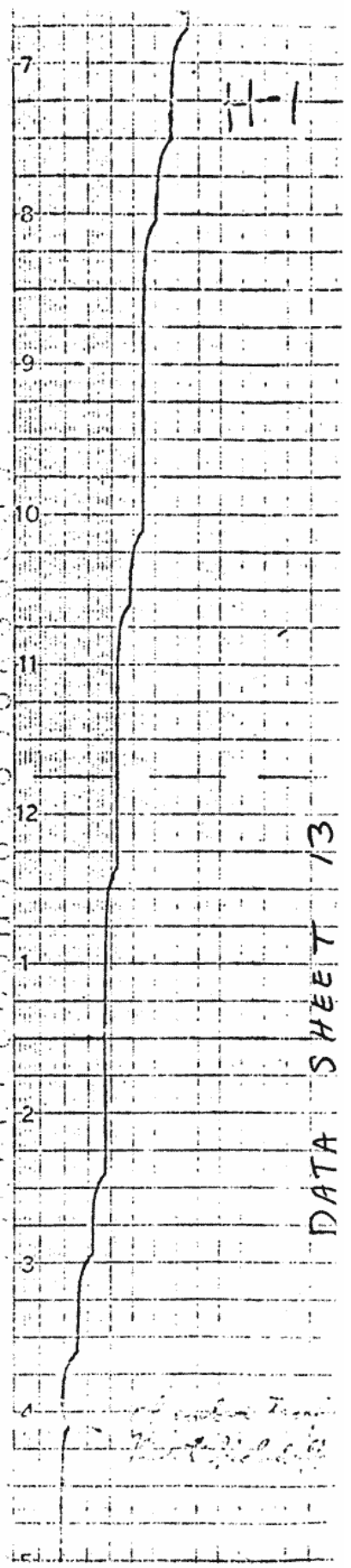
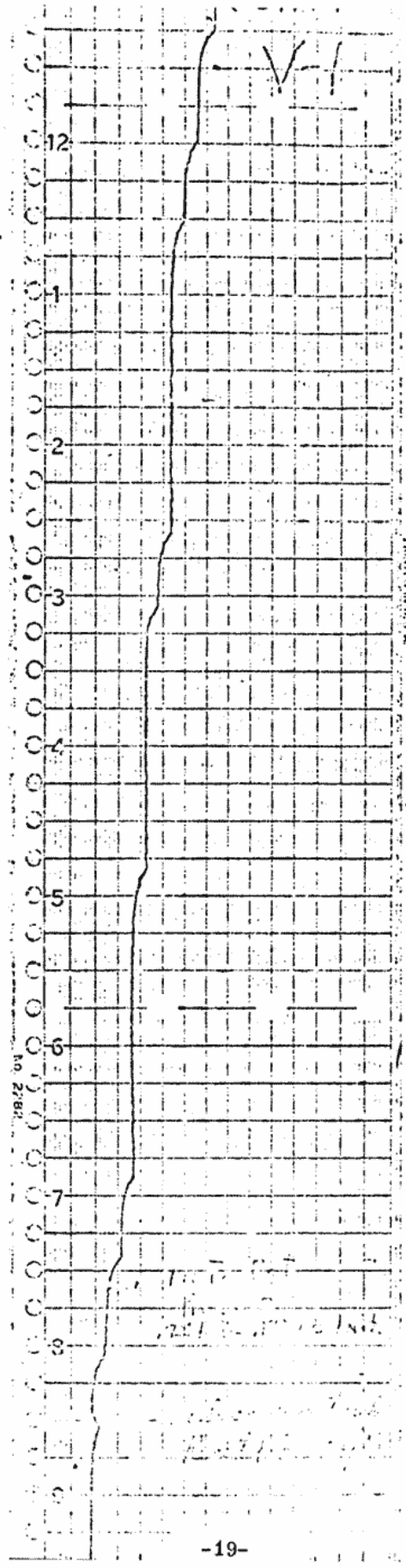

DATA SHEET 13

1. H-1.  
 recordings  
 (NEW YORK)

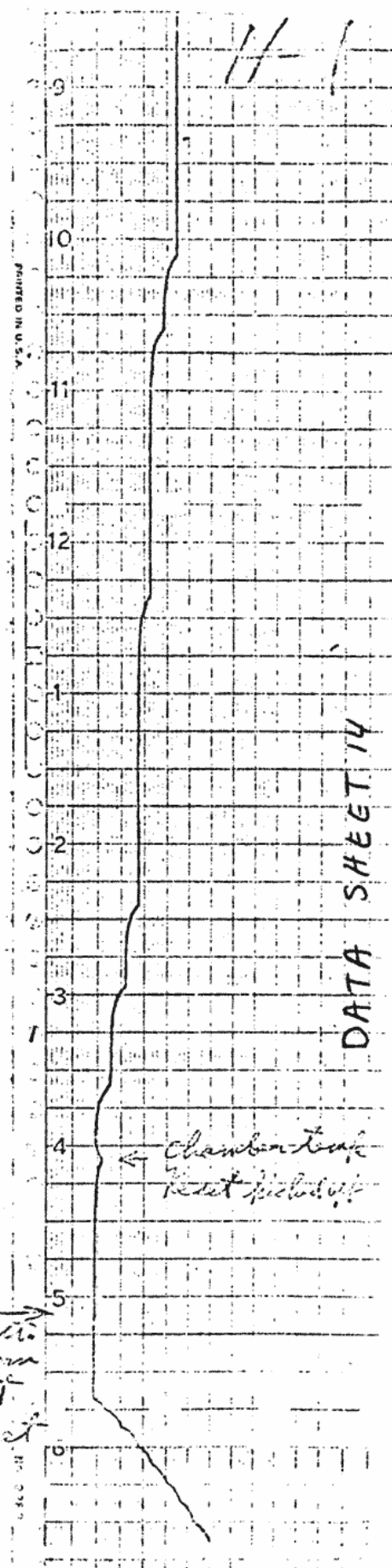
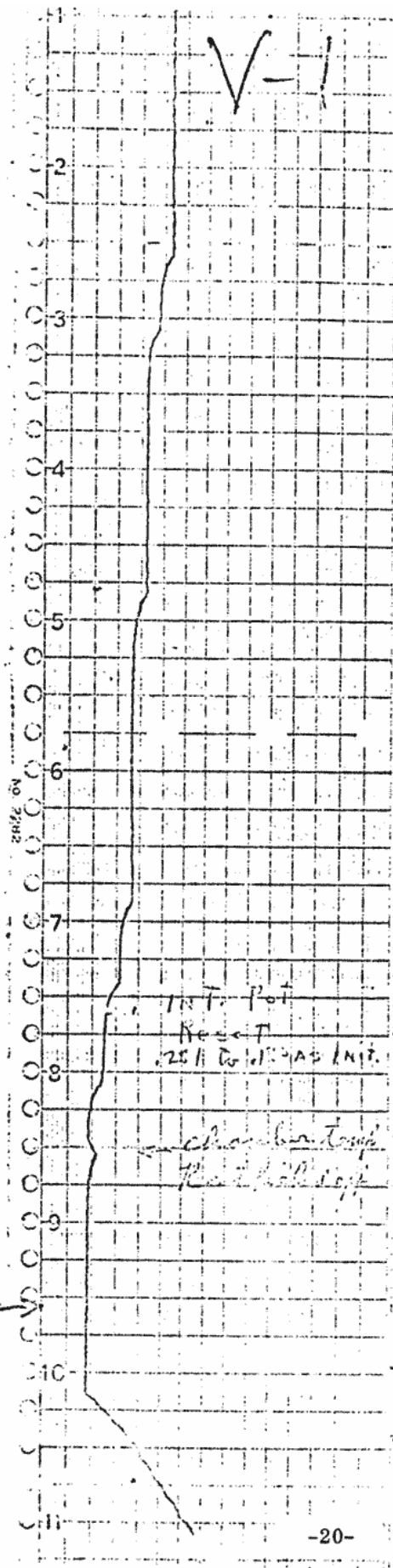

Page 1 of  
 v page H2  
 V2 recordings  
 (OLD YOKE)

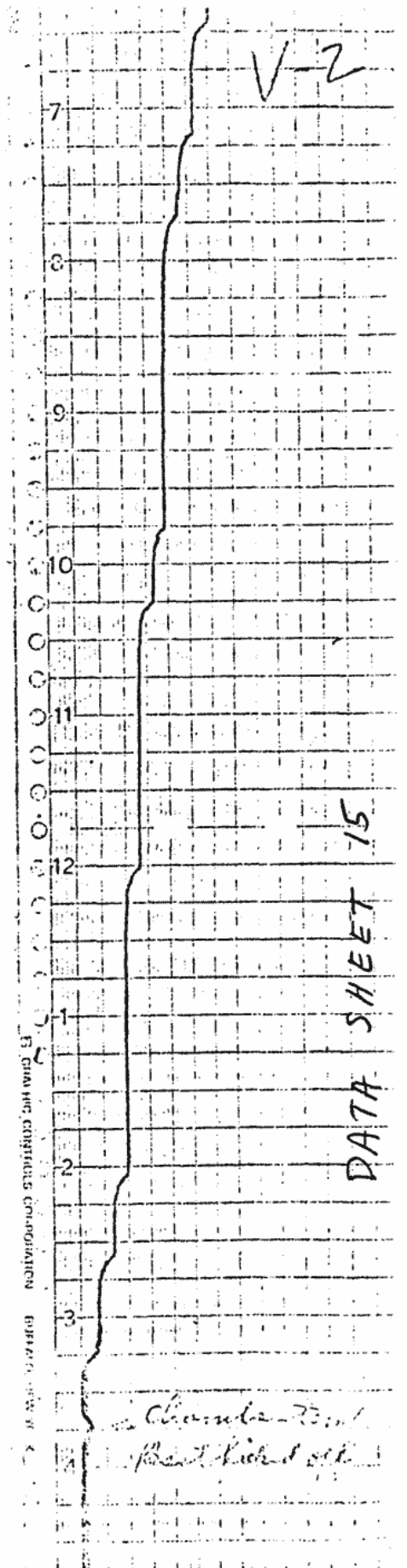
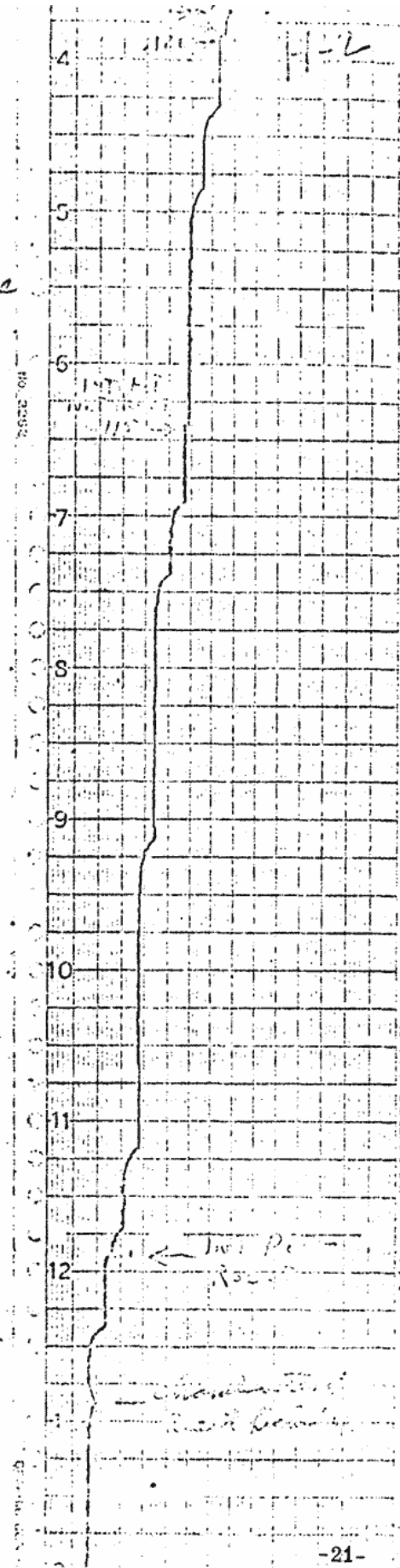

1 copy of  
V2 H2  
recordings  
(OLD YOKE)

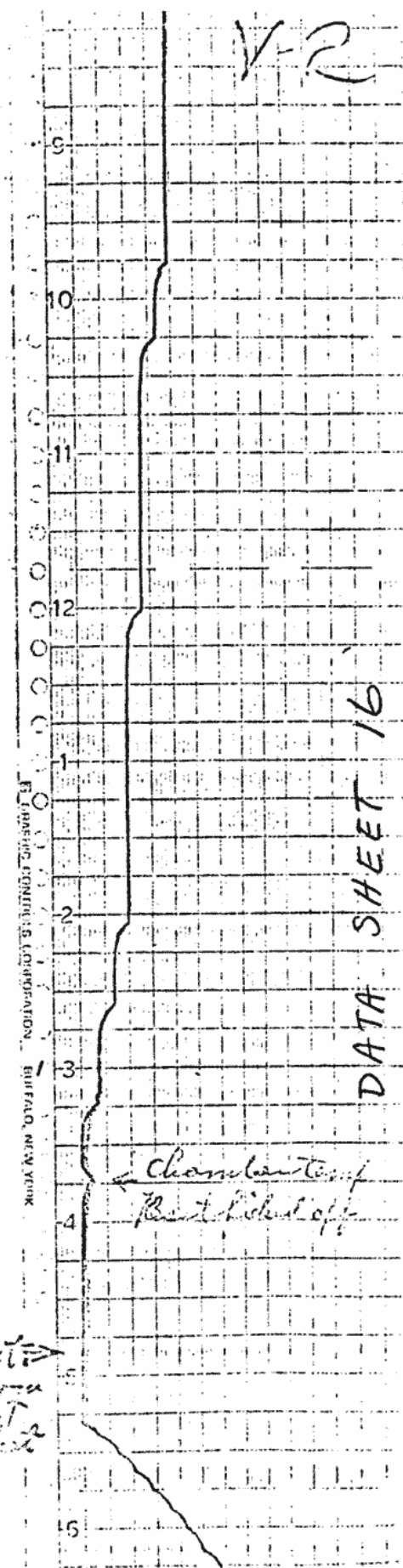
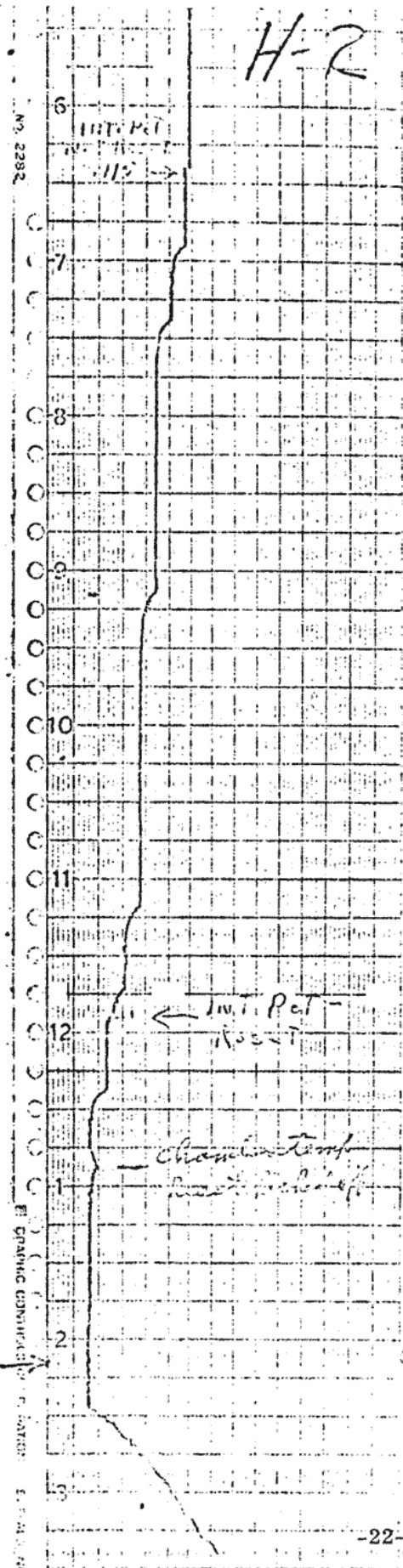

ON/OFF

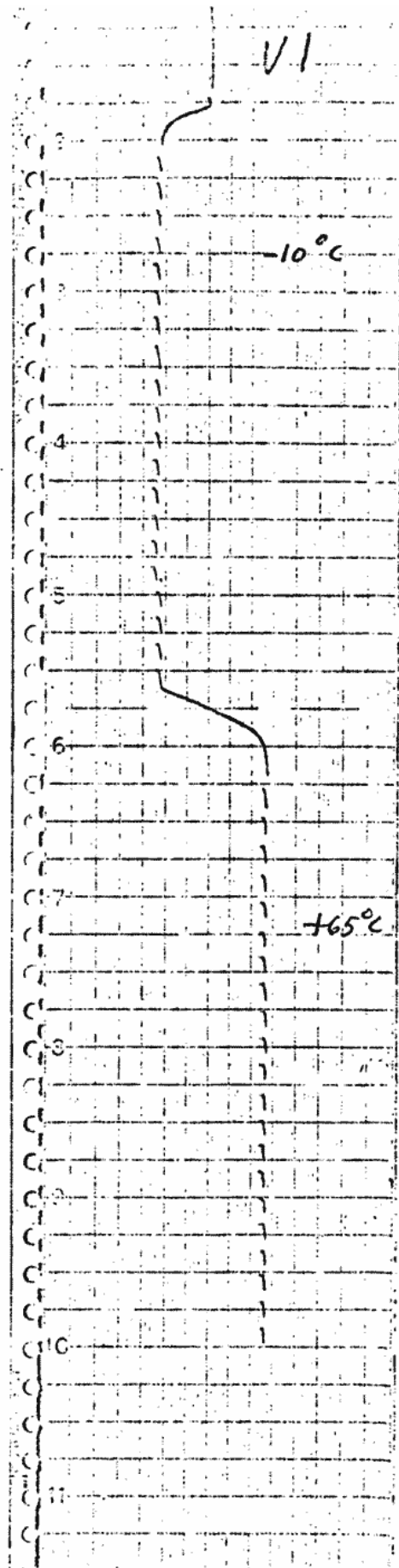
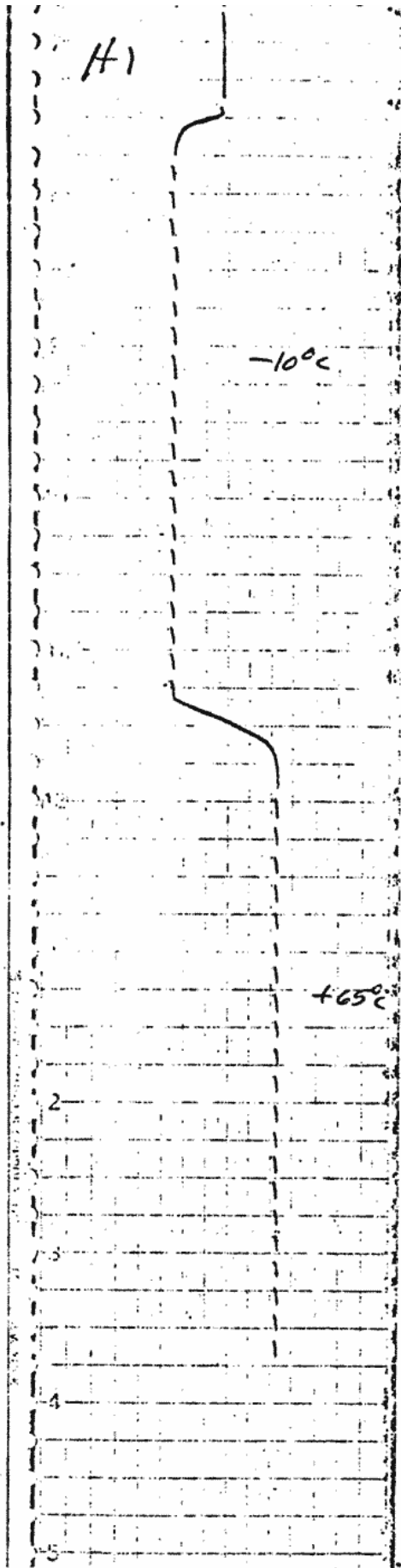

DATA SHEET 17

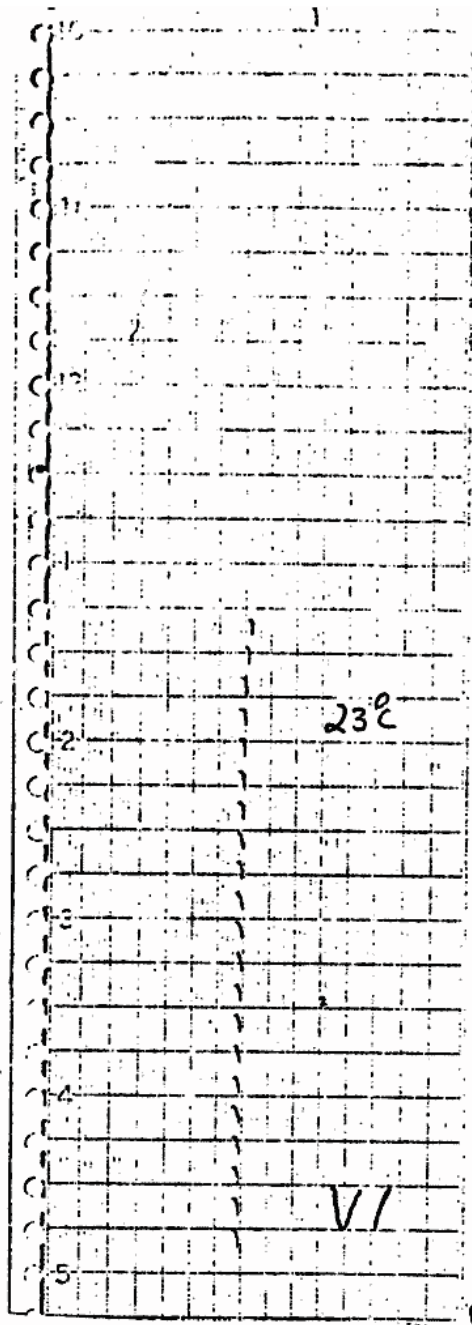
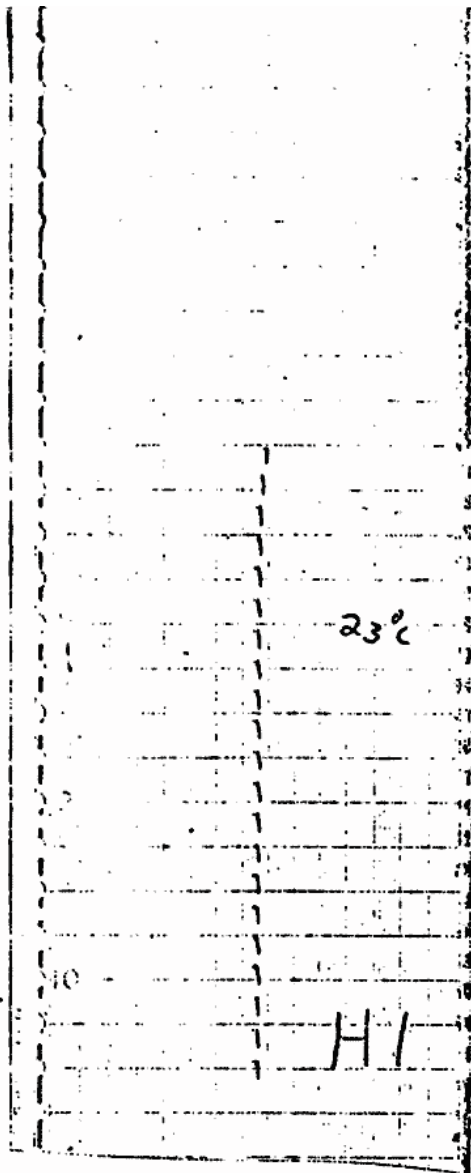

DATA SHEET 18

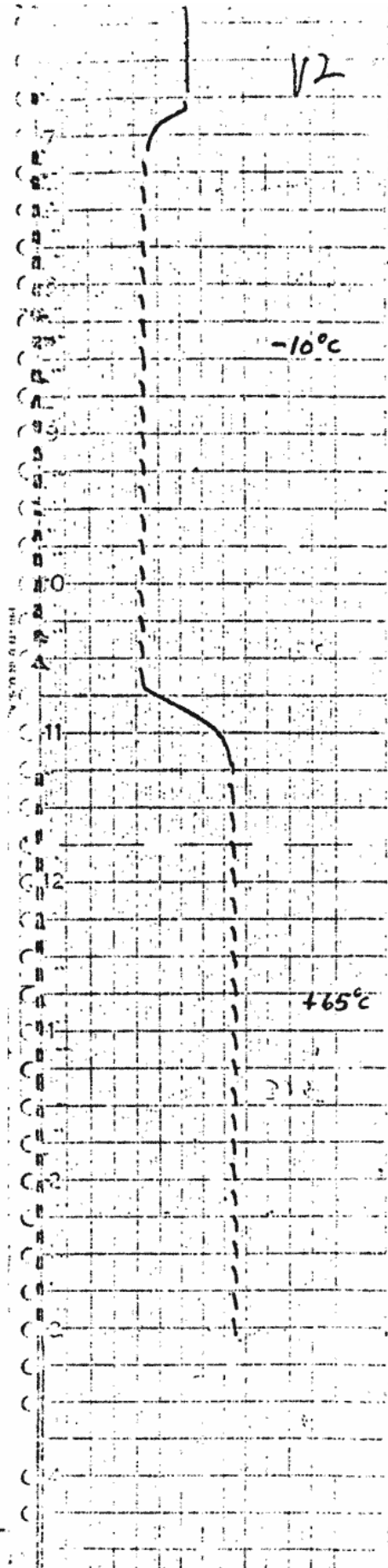
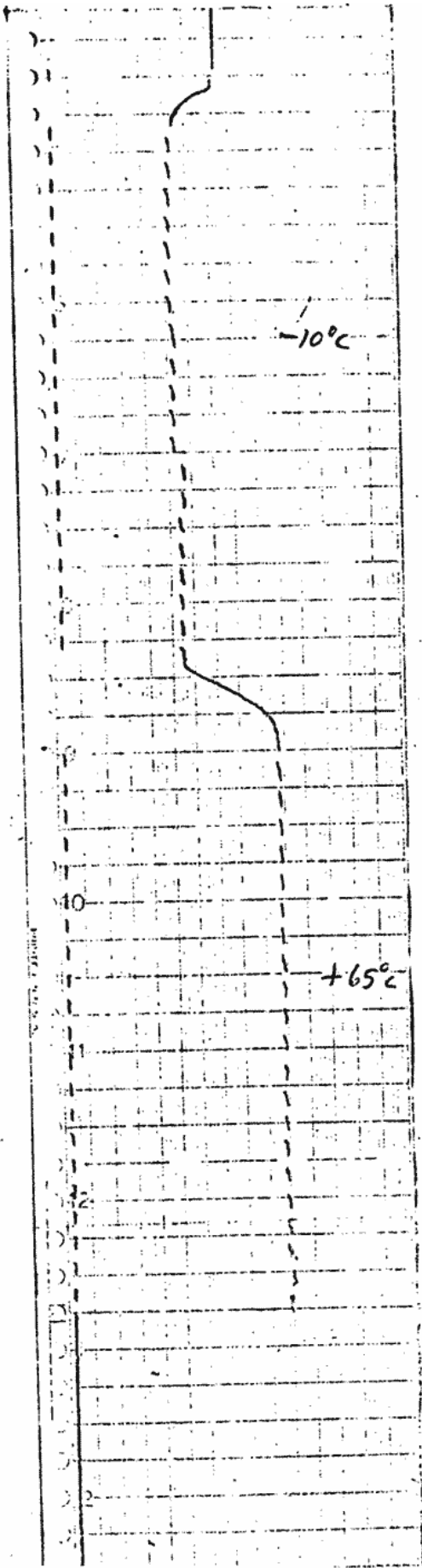

DATA SHEET 19



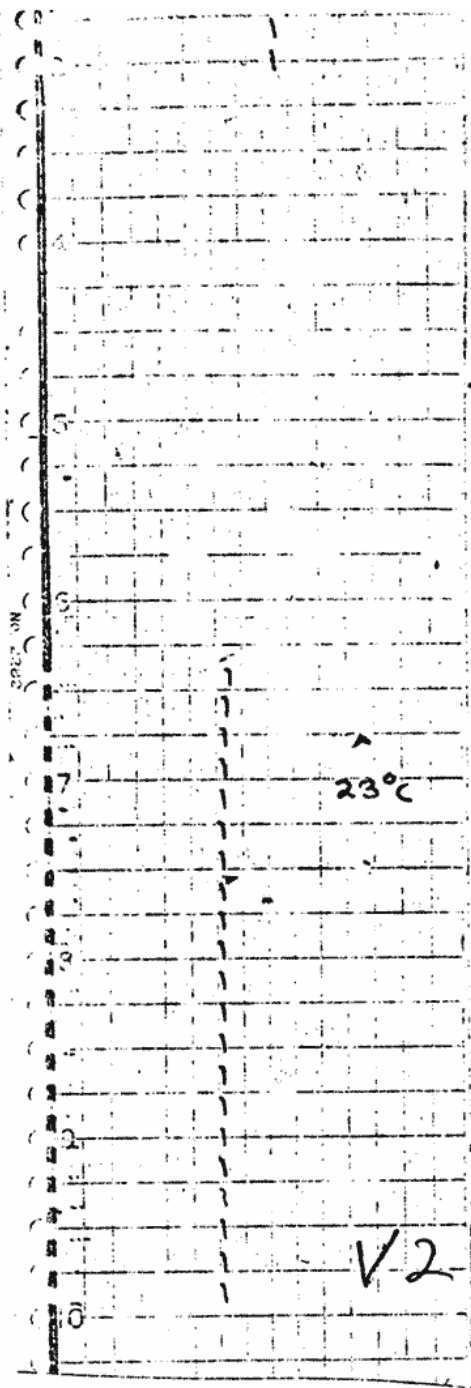
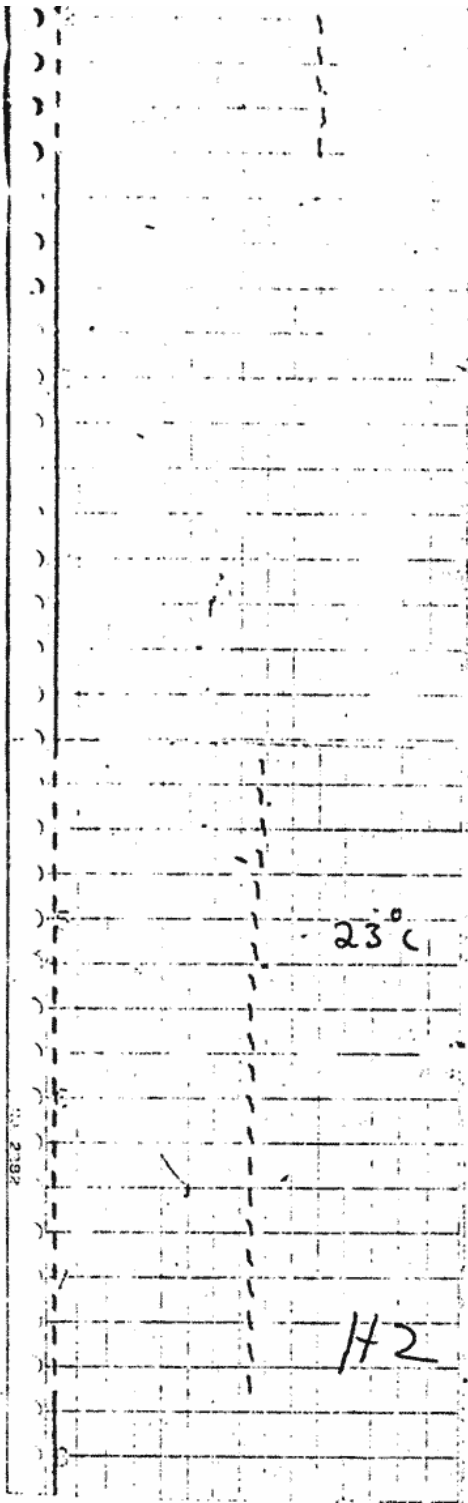

DATA SHEET 20

Fatigue

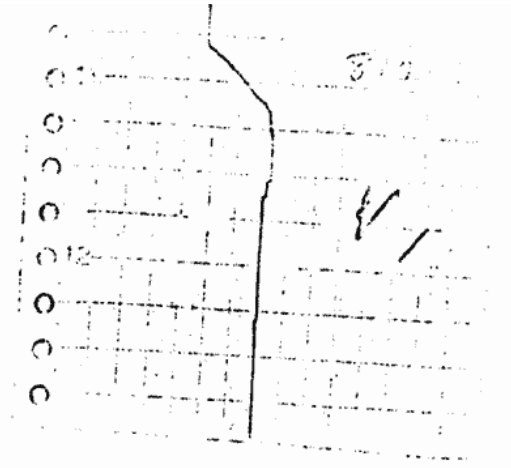

DATA SHEET 21

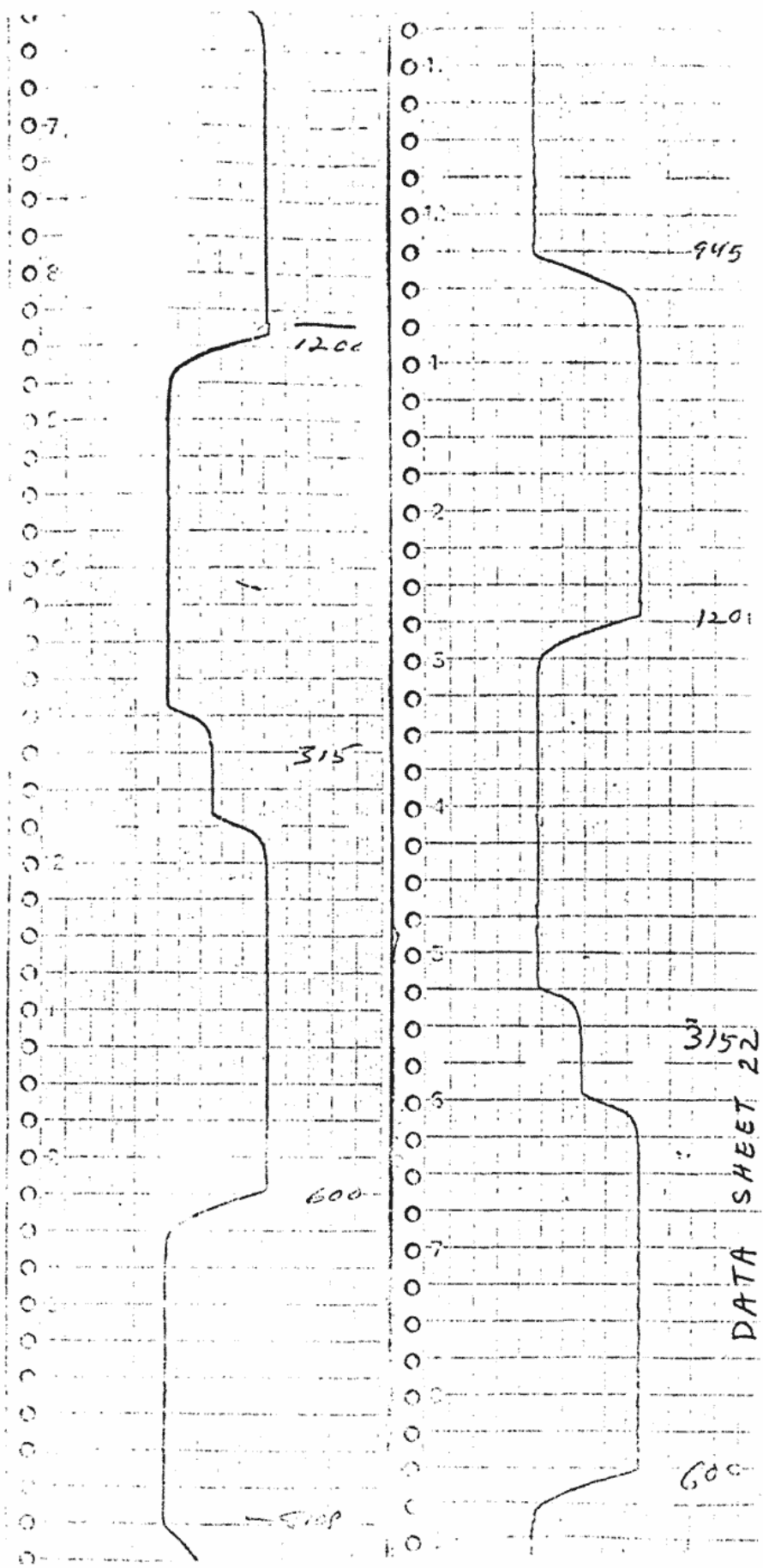

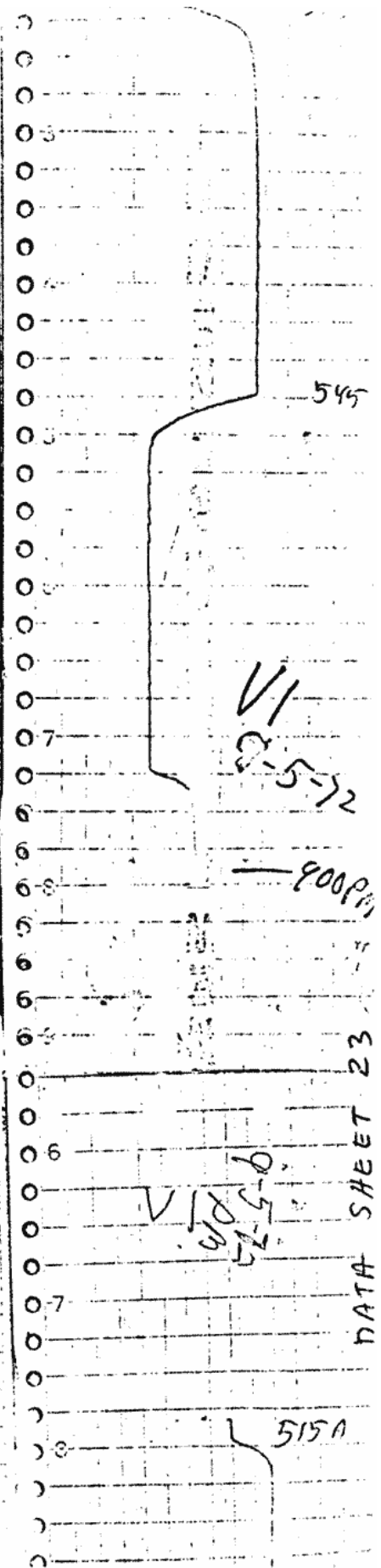
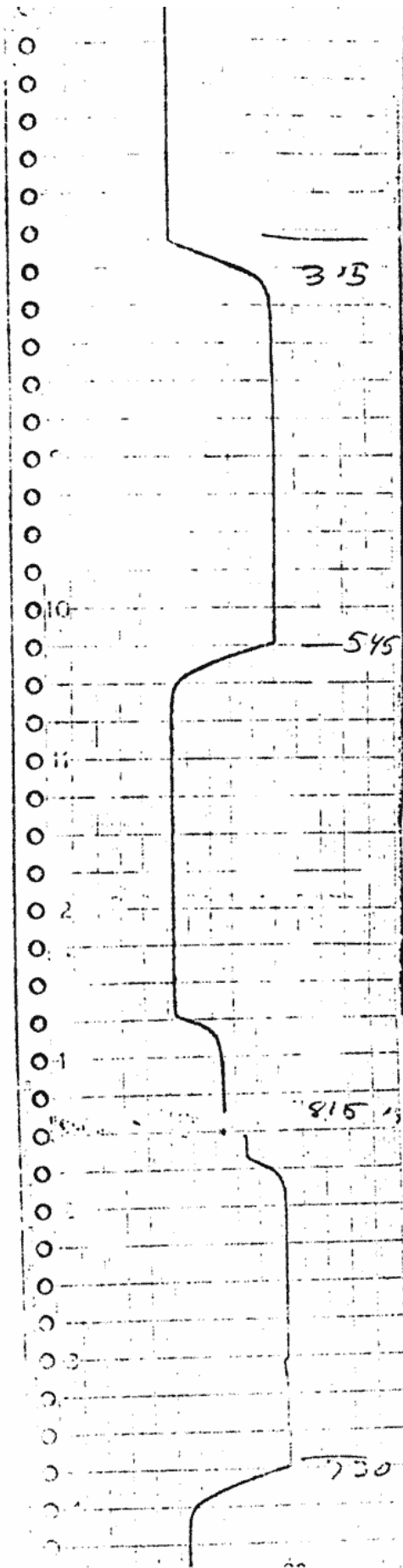

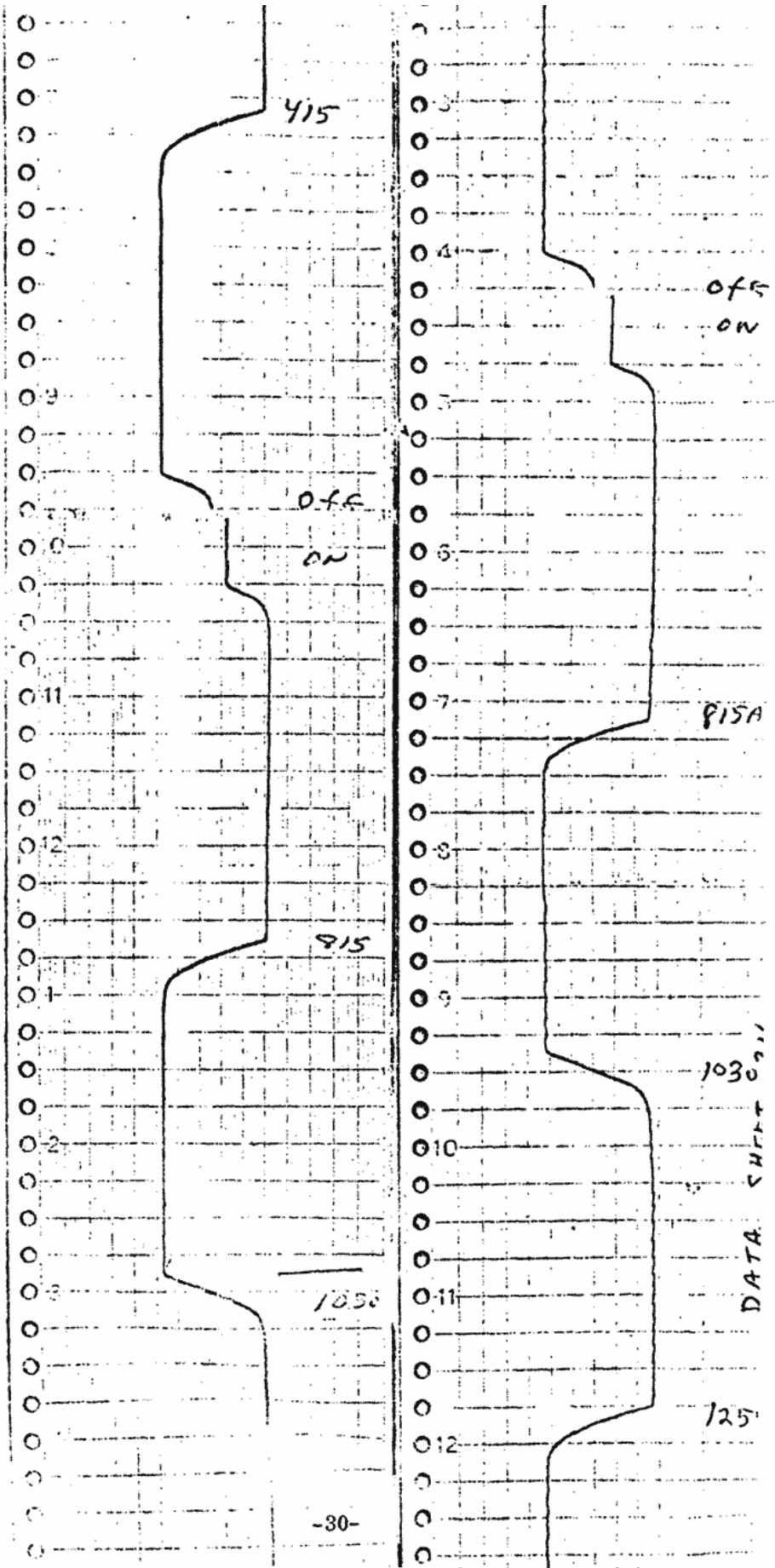

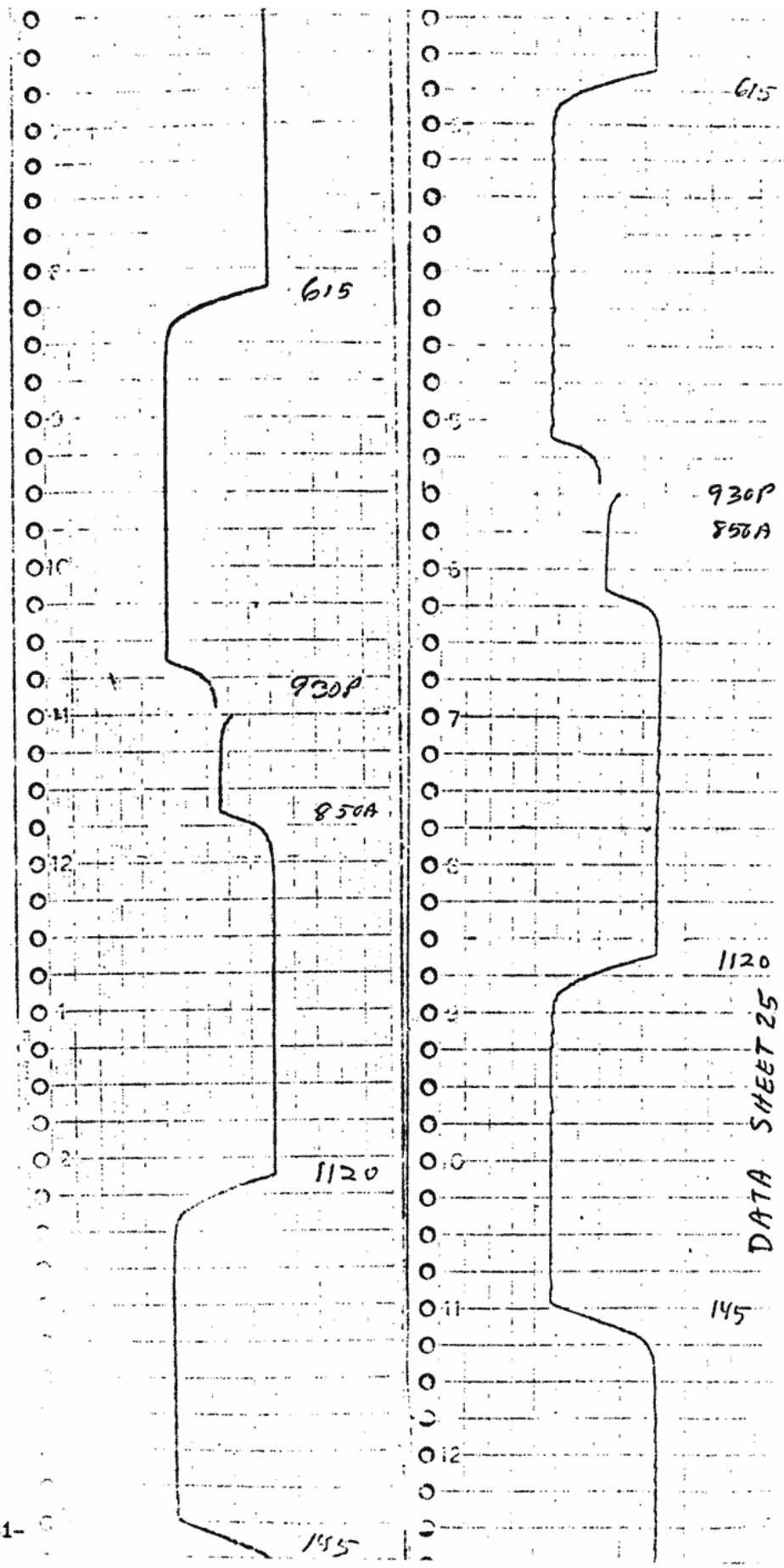

DATA SHEET 25

H1

V1

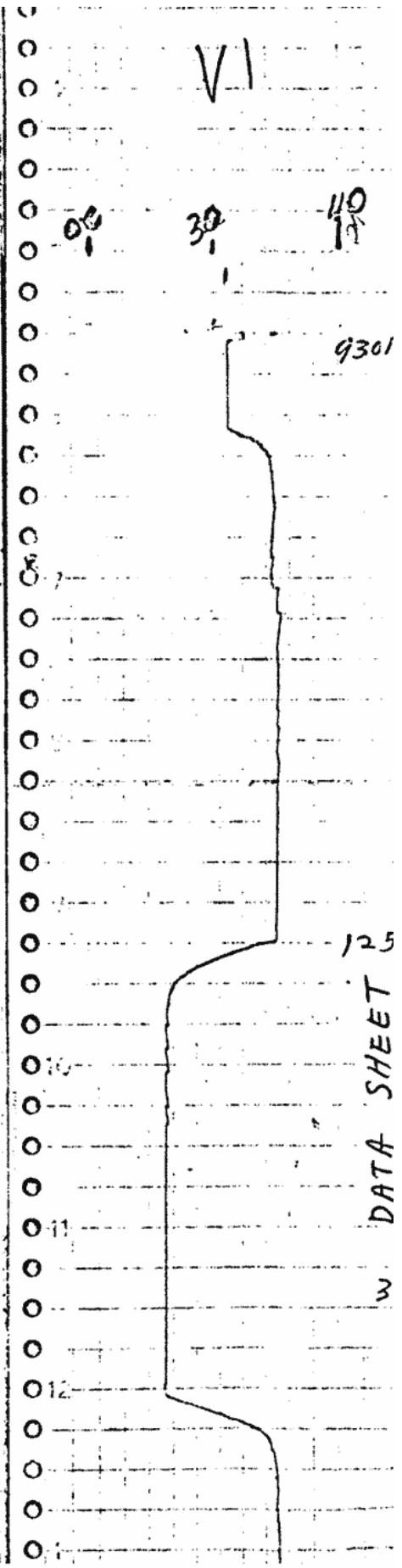
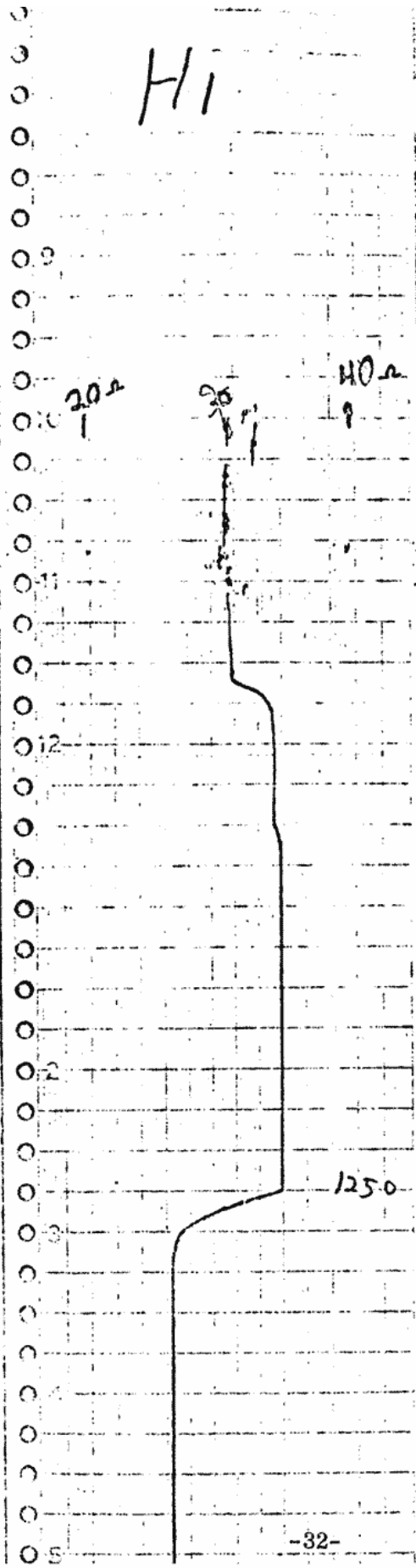

DATA SHEET

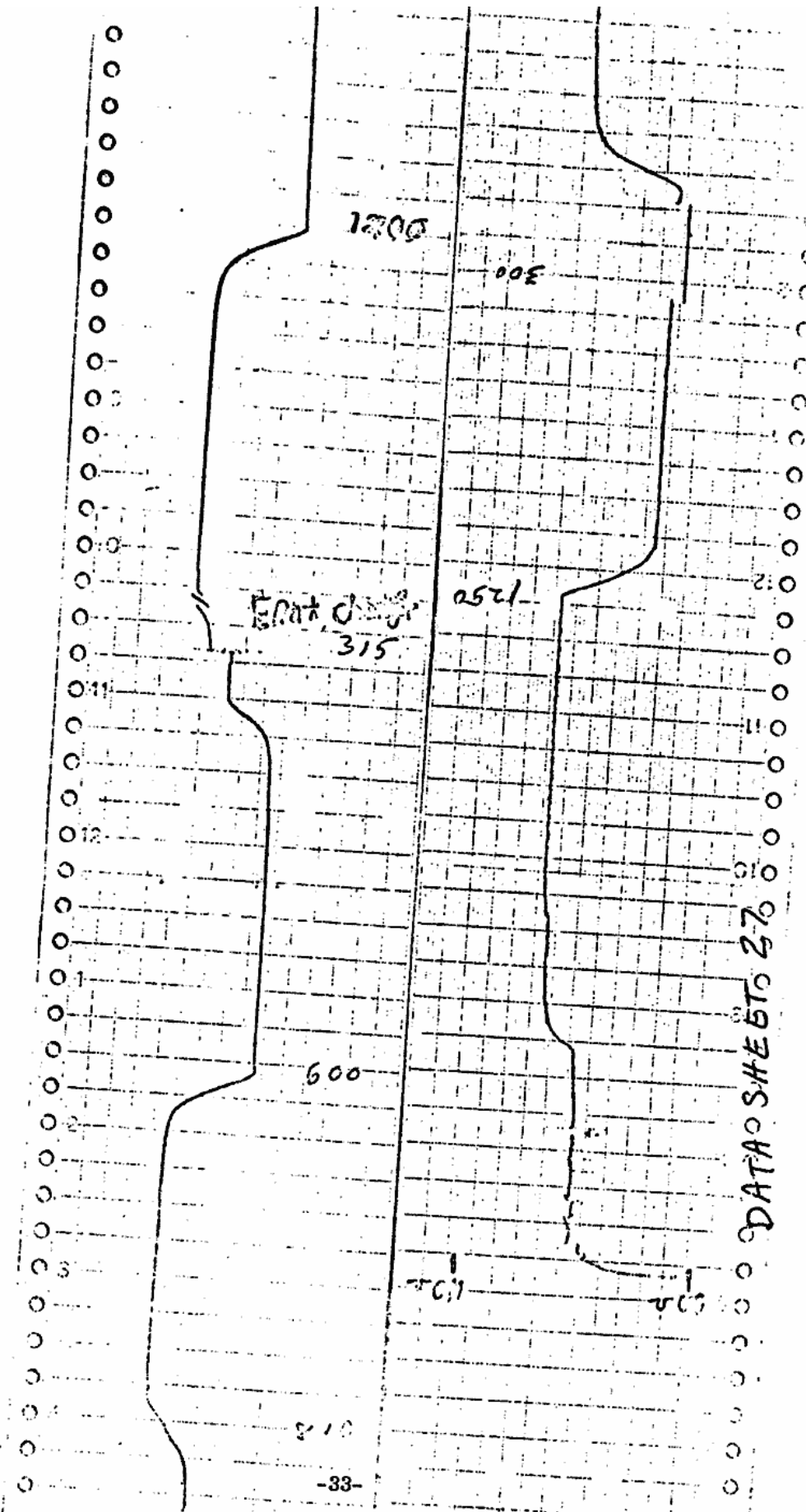

DATA SHEET 27

100



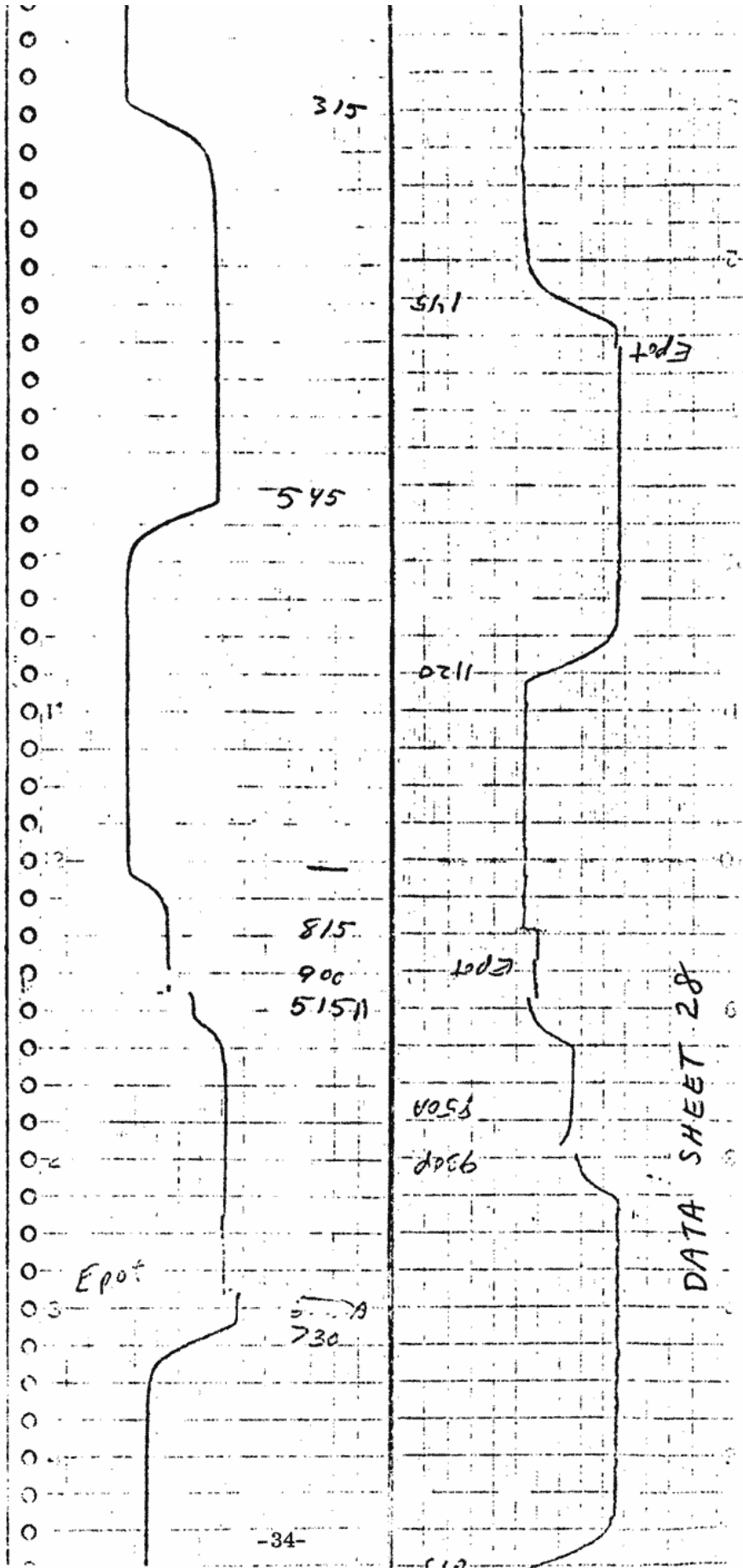

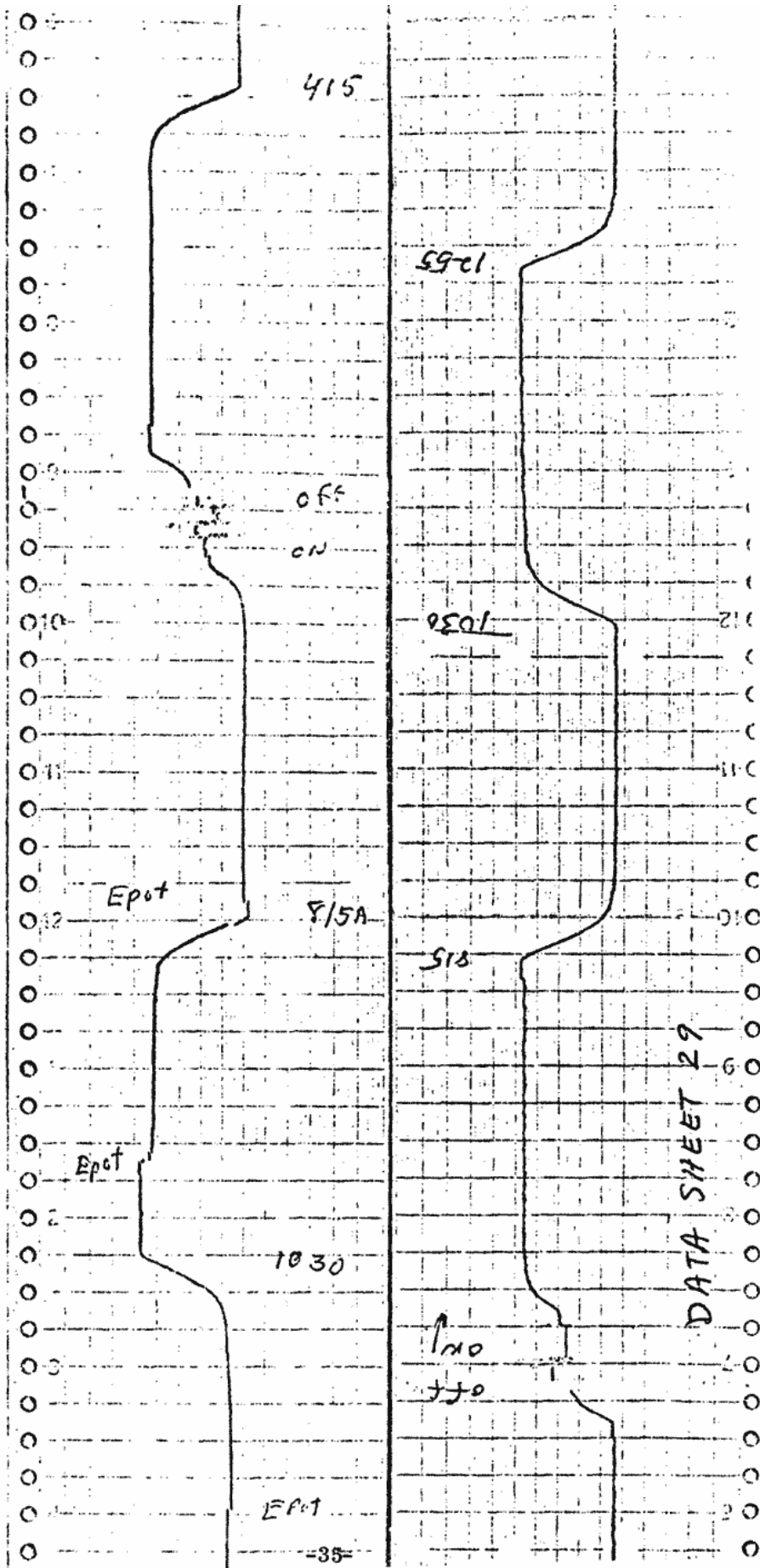

415

5901

off  
on

1030

Epot

8/5A

518

Epot

1030

DATA SHEET 29

120  
110

Epot

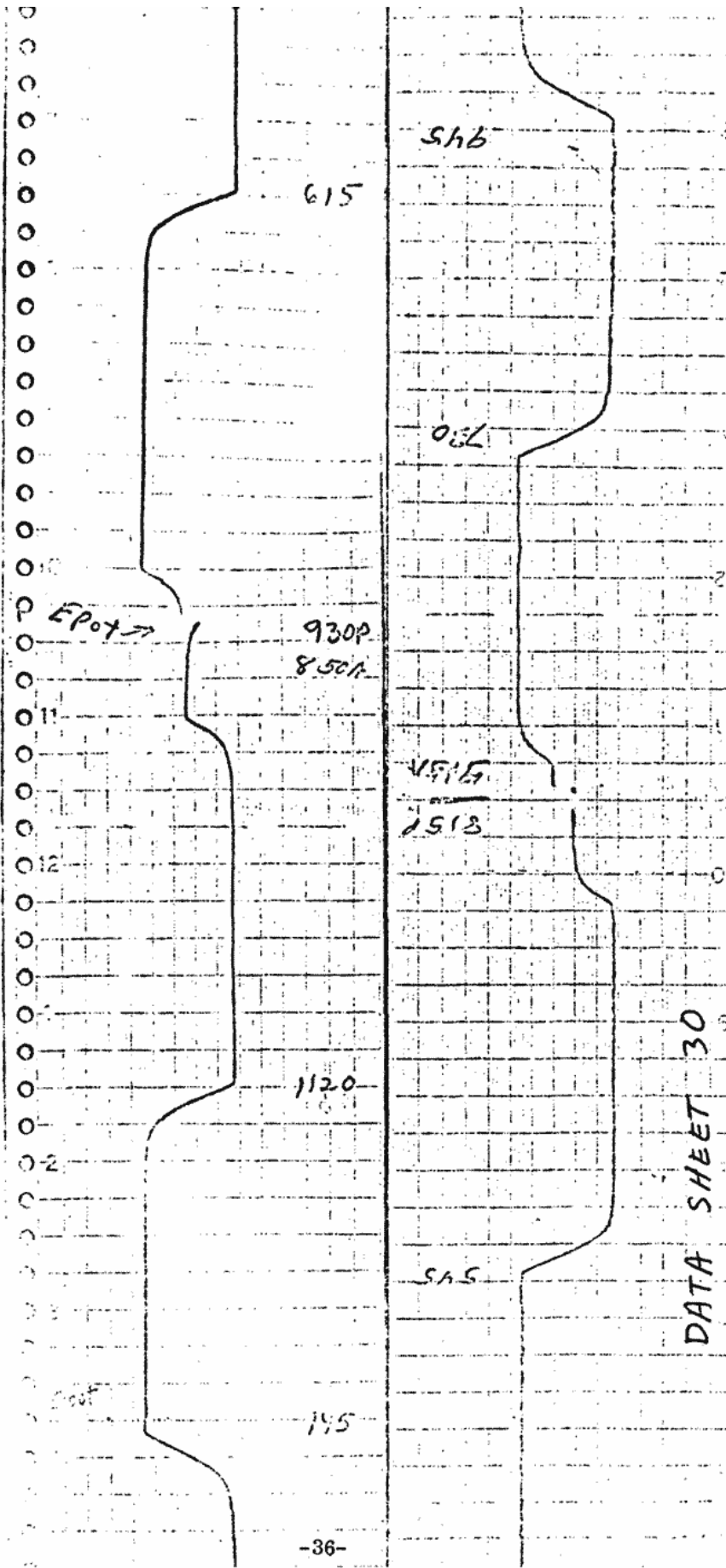

DATA SHEET 30

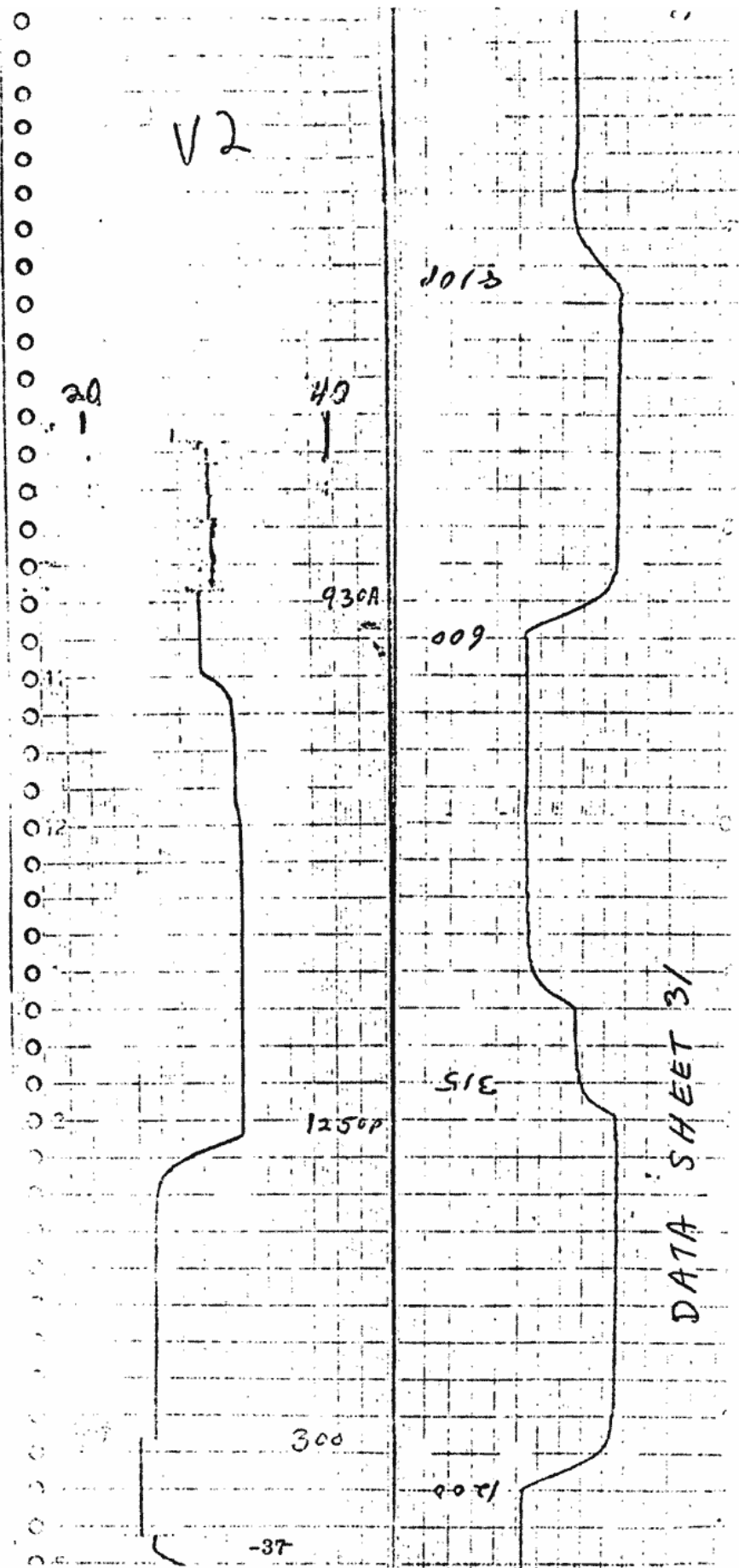

V2

20

40

930A

009

315

1250P

300

1200

DATA SHEET 31

The test program has successfully demonstrated the ability of the redesigned yoke, and the protective faceplate design, to meet the Apollo requirements. Since a yoke of old design also passed all of the tests, there is a strong indication that handling and assembly techniques contributed to the original problem. The new design provides greater strength in the area of the flying leads and will be specified on any future procurement.

### SECTION III

#### ELEVATION DRIVE IMPROVEMENT PROGRAM

The TCU elevation drive rotates the CTV carriage  $-45^\circ$  to  $+85^\circ$  from the horizontal at a rate of approximately  $3^\circ$  per second. The driver is a  $90^\circ$  per step 60-hertz permanent magnet stepper motor coupled to a 48:1 integral gearhead. A 36:1 spiroid skew axis gear set coupled to the gearhead output by a bellows coupling drives the CTV carriage directly. A clutch is incorporated between the output of the gear set and the carriage to permit manual override of the elevation function.

TABLE 3. ELEVATION DRIVE DESIGN PARAMETERS

Component	Efficiency	Gear Ratio	Dev. Torque (oz. in.)	Speed (rpm)	Max. Load Torque (oz. in.)	Margin (oz. in)
Motor			0.5	900	0.09	5:1
Gearhead	80%	48:1	19	18.7	3.5	5.4:1
Spiroid Pinion	50%	36:1	340	0.52	120	2.8:1
Spiroid Ring Gear						
Load at $85^\circ$ Position			340		120	2.8:1

The following data were collected during tests performed on TCU F-3 (Serial Number 006) and TCU F-5 (Serial Number 008) to determine the cause of jitter observed in the TCU elevation drive. During the course of the investigation into the problem with Serial Nos. 002, and 003 which showed that the design numbers were conservative in motor output torque (minimum - 0.7 oz. in.) and gearhead efficiency (83 percent). Some variations between units were observed in spiroid and carriage efficiency, particularly on Flight III. Serial No. 006 measured higher torque than the other TCU's.

Serial Nos. 002 and 003 were found to be close to the predicted curve, Figure 3, for the torque at the spiroid pinion. Graphs, Figures 4 and 5 show peak torque contours for the various assemblies as measured with a strain gage load cell applied to the spiroid pinion in place on a motor gearhead. Figure 6 shows the Serial No. 006 curve after rework and Figure 7, Serial No. 006 post rework with damping springs installed. It is significant and not yet clear why Serial No. 006 initially showed higher torque than the other units in spite of the modifications in finishes, alignments and adjustment. The higher torque level on Serial No. 006 apparently had little effect on the system with a good motor installed. Serial No. 003's motor and drive electronics operated Serial No. 006 spiroid and carriage mechanisms with three times the normal  $1/6$  g test weight in place. From the onset of the problem on Serial No. 006 during acceptance testing, many modifications and cures were tried. Table 4 shows the test program that was initiated.

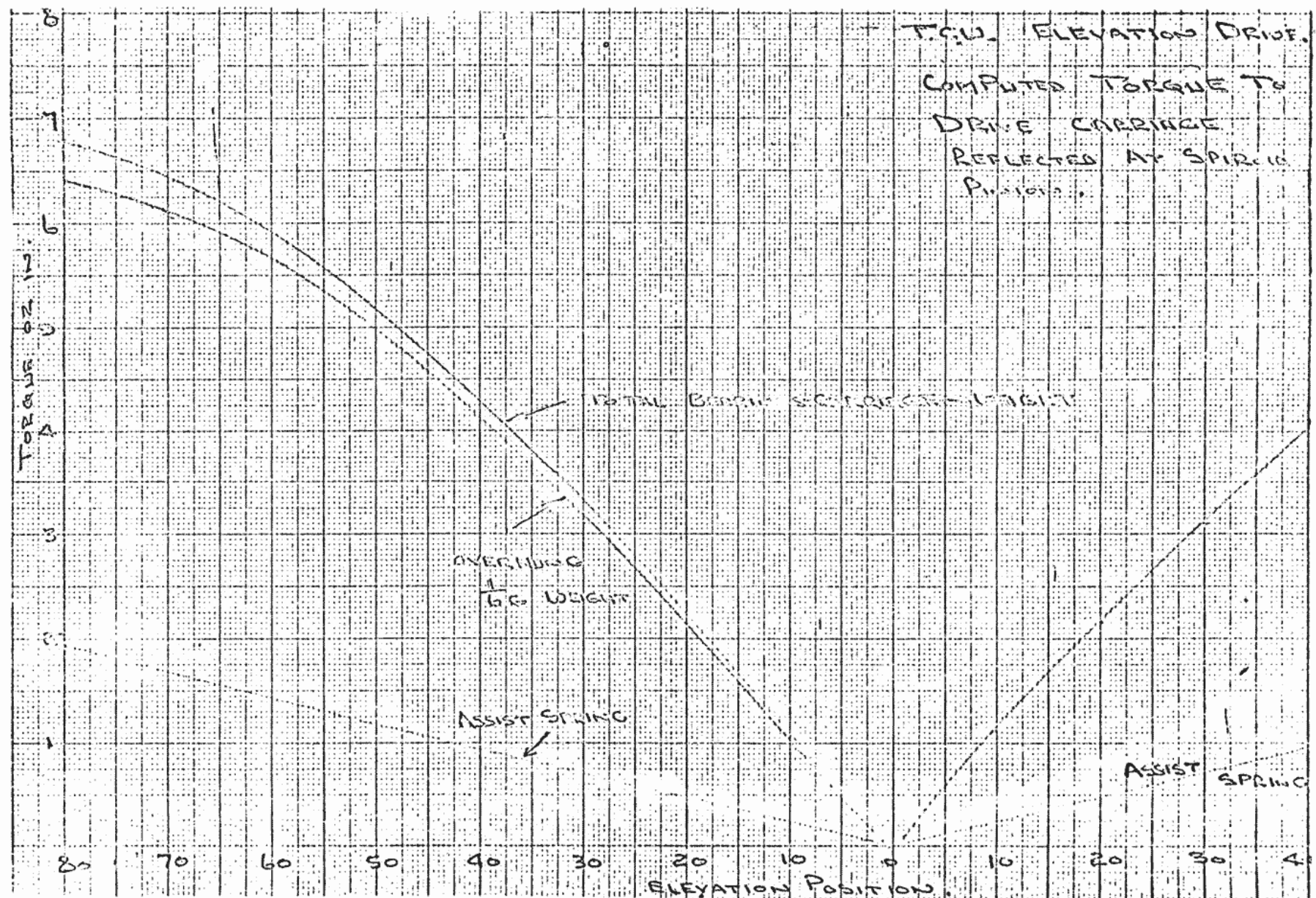

Figure 3. Predicted TCU Elevation Drive Torque Curve

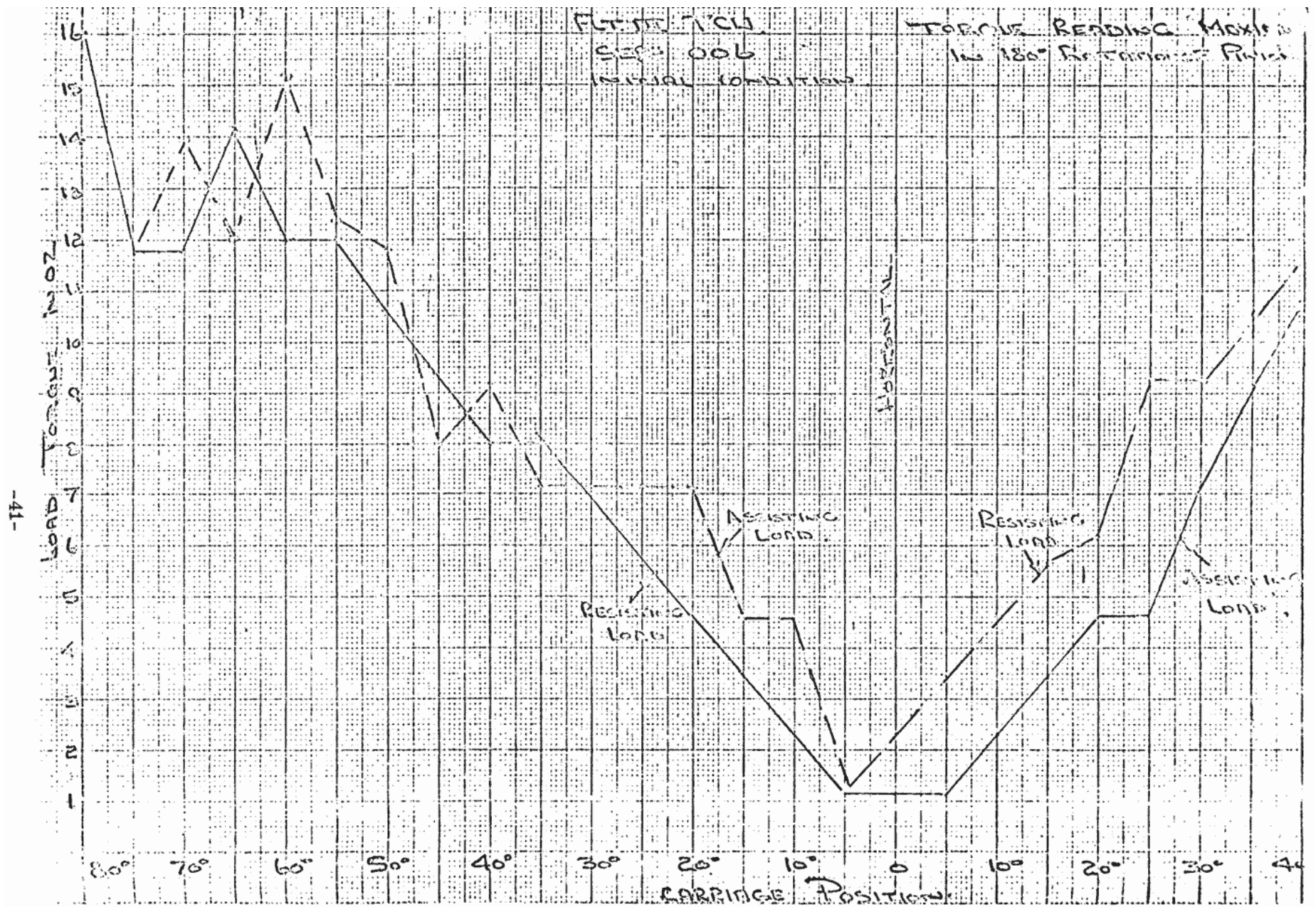

Figure 4. Peak Torque Contour for Serial No. 006



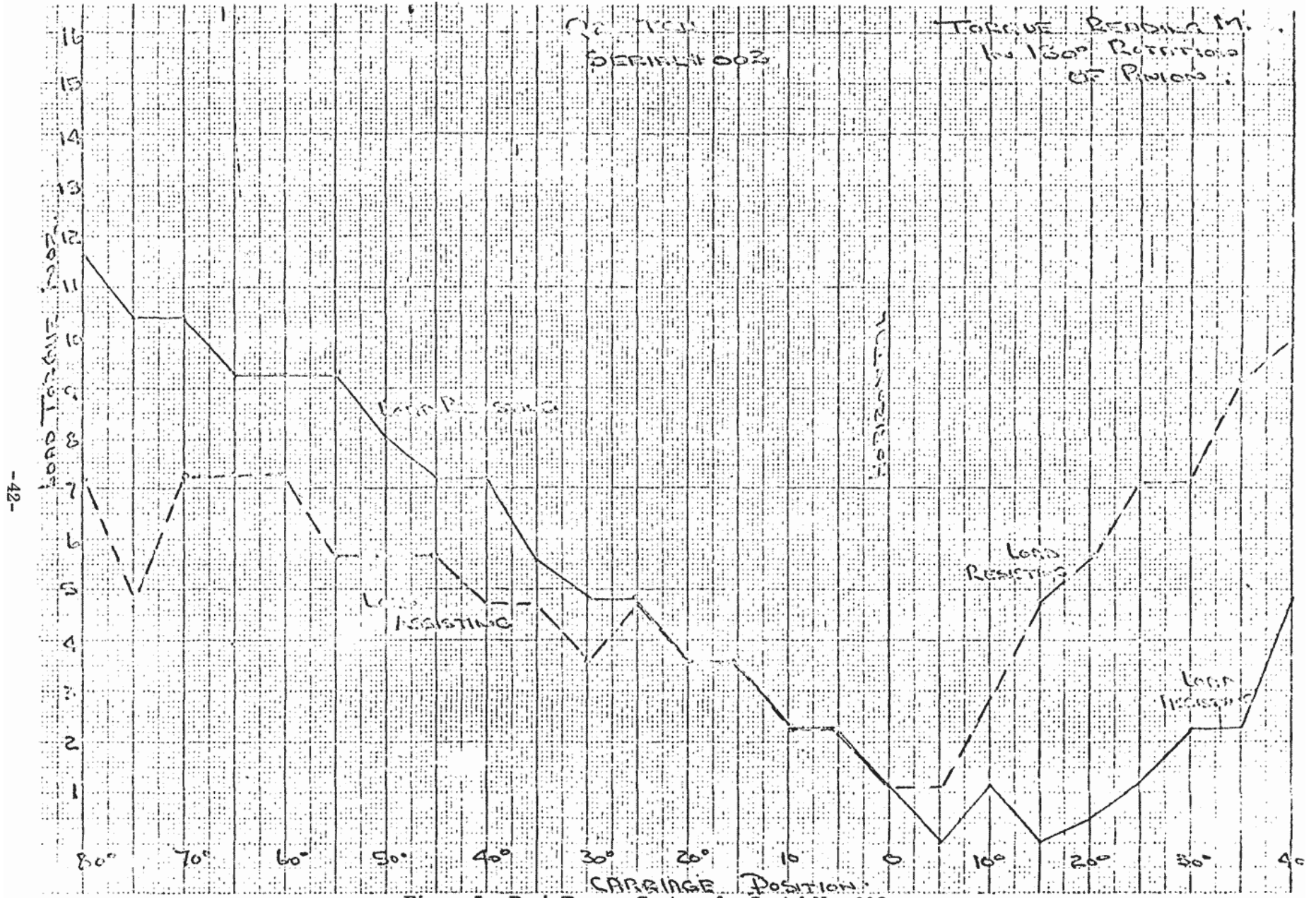

Figure 5. Peak Torque Contour for Serial No. 003

Fig. III SER 006 REWORKED  
NO DAMPING SPRINGS

STEEL GEAR  
S. STEEL PIVOTS  
NO LUBRIC

17 - 10 BARS  
LUBRICATED  
1000 RPM

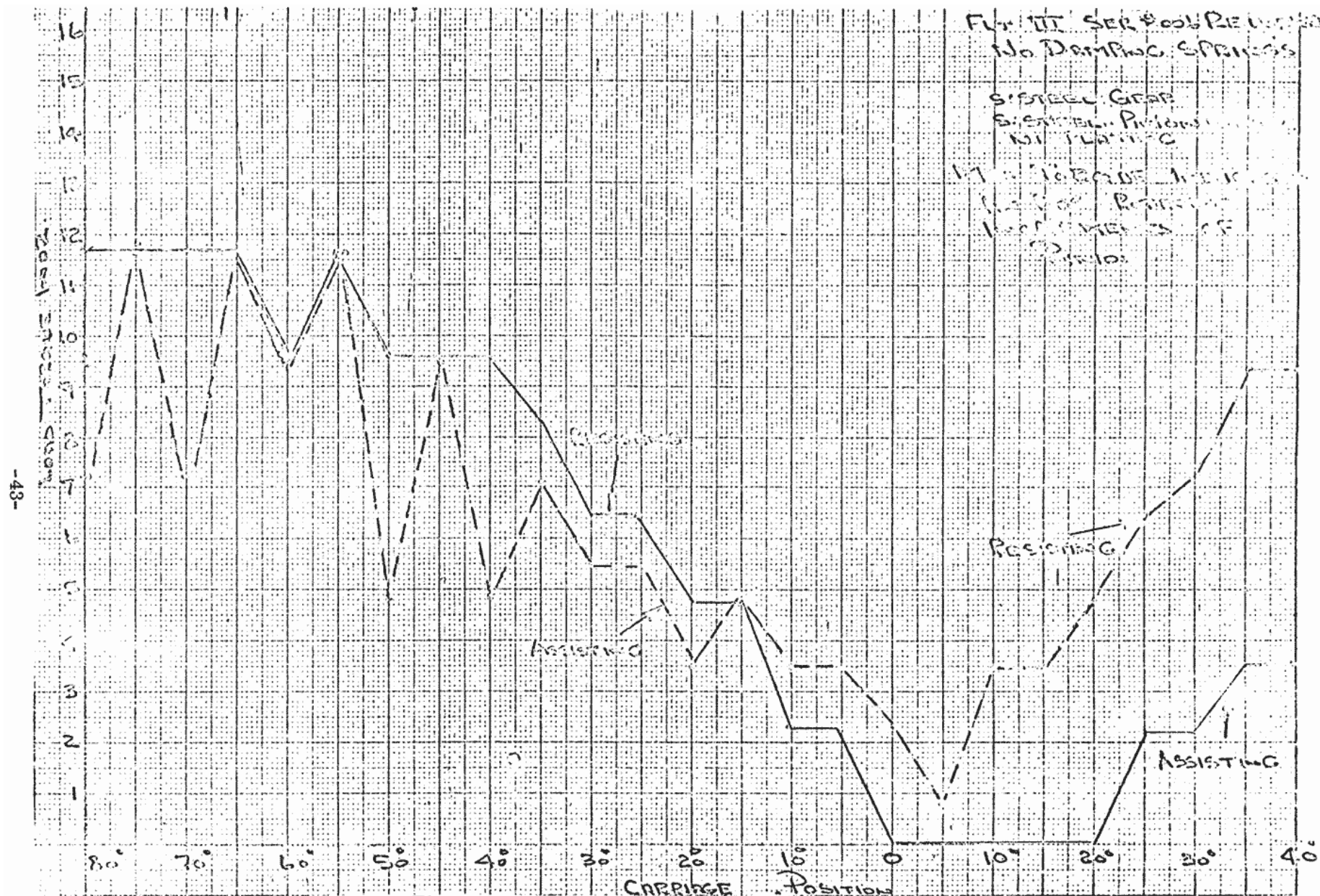

Figure 6. Serial No. 006 Torque Curve After Rework

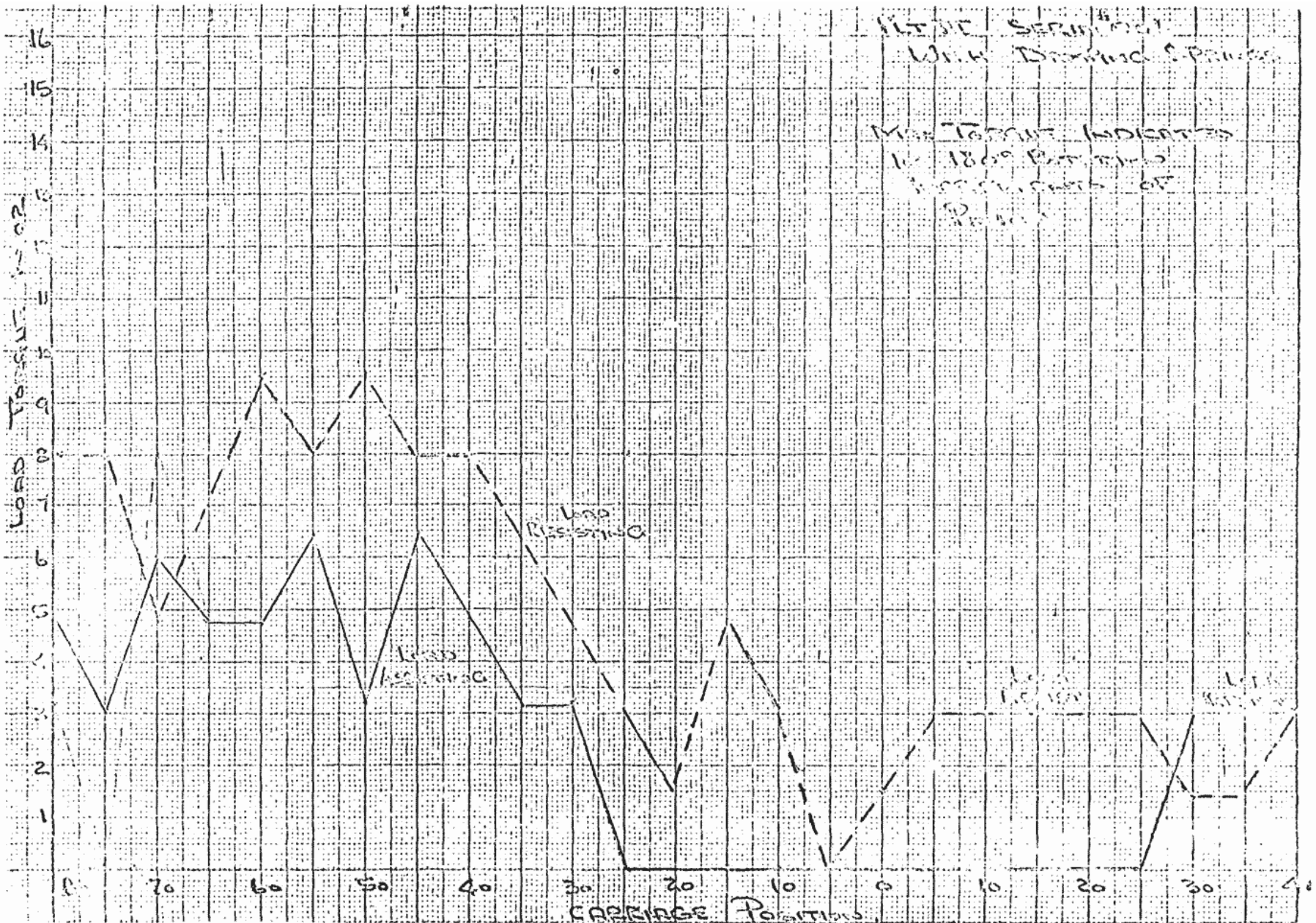

Figure 7. Serial No. 006 Post Rework Torque with Damping Springs

Initially the jitter was quite random in occurrence, always occurring in vacuum, and it would heal after a period of up to 50 minutes from repressurizing the chamber. As the various modifications to reduce friction, improve efficiency, and correct alignments were made, the problem worsened to the point where one cycle of the mechanism in vacuum would induce the jitter. The jitter was occurring at progressively lower elevation angle to the point where it occurred in the up and down direction (load assisting) at approximately 20°. This indicated that we were encountering a threshold position where load (overhung angle) was very sensitive. If stick slip or gear efficiency were the problem, some improvement would have been seen with the many improvements in fit and surface condition. In no instance did the gear surfaces exhibit galling or particle transfer expected if asperity welding had reduced the gearhead efficiency to the measured level. The lubricant film was intact on gear and pinion surfaces following the many disassemblies. The possibility of a resonance in the motor gearhead or in the upper drive train was investigated. A soft coupling was added between the motor/gearhead and the spiroid pinion. No change was seen in the jitter condition during a vacuum test.

Two further tests were conducted to investigate the resonance theory. In one, the TCU assembly was vibrated at 0.5 g level from 5 to 60 hertz while operating in an attempt to induce jitter. This was followed by a test where the input frequency to step the motor was varied from 10 to 100 hertz; in neither case was the jitter induced or, in the latter test eliminated. Some improvement was noted at the lower motor stepping frequency which at the time was not significant. However, it is predictable when considering the motor overshoot theory.

Following the test series called for in Table 4, no conclusive cause could be found for the jitter phenomenon. Indications were that it was load sensitive (position of carriage), and was aggravated during vacuum exposure. The effect of vacuum is partly due to the overall loss of efficiency in vacuum (threshold torque condition) and more probably due to the loss of viscous damping at the small air gap between the rotor and stator.

In discussing the problem with Kearfott engineers, several questions arose on the behavior of the motor when stalled. Further testing revealed the motors could be degraded by stalling and/or backdriving.

Measurement on the Serial No. 006 motor gearhead revealed that the stall torque was 24 ounce inches. However, the measuring torque-watch would backdrive the motor rotor in excess of 10 revolutions before it regained the original stall torque level. An oscillating mode was set up. Further investigation at the Kearfott plant and RCA found the cause to be low (almost zero) detent torque in the unpowered state.

TABLE 4. ELEVATION DRIVE TEST PROGRAM

POSSIBLE PROBLEM AREA	INVESTIGATION ACTION	COMMENTS
1. Stick Slip	Measure torque variations with 1/6 g load on carriage at normal speed.	No conclusion from torque measurements No improvement following mass treatment to gear set.
2. Torsional Resonance in drive train	Accelerate on carriage - Measure frequency and "Q"	Predominant frequency 15 hertz not measured for "Q"
3. Lubrication	Analysis - Spectral analysis of grease from serial #006 TCU and new sample. Compatibility with G300 and stainless steel	Quantity as lubricated No changes in IR Scans of used and new
4. Spiroid - Gearform Assem	Measurement of components - Blue gear teeth to verify mesh - efficiency measurement of gear set	Set up verified - blue showed good contact - efficiency 50% as predicted
5. Gearhead	Verify assembly modified to insure motor engagement	Assembly at Kearfott - Torque Test
6. Motor	Torque test motor and motor gearhead	In Air at AED & Kearfott - Showed greater than specified torque
7. Torque Margin	Find max load available - Torque will drive by calc. & measurement	Measured margin worst case verified 2.8:1
8. Rubber Sealing (VMPBL)	Verify dimensions - investigate vacuum compatibility	Size verified - material properties better in vacuum.
9. Dimensional Analysis	Check dimensionally -- all parts in elevation - drive assembly	Misalignment in carriage and #006 gearhead corrected
10. Electrical		No indication of improper drive conditions

TABLE 4. ELEVATION DRIVE TEST PROGRAM (Continued)

11.	Axial Motion of Pinion	Underload w/dial indicator	Initially .0025 freeplay - bearing preloaded with no improvement
12.	Change Preload	Loosen gear endcap	No improvement
13.	External Vibration Induced	Put on vibration table 10-60 Hz less than 1/2 g input	TCU operating with amp without 1/6 g load no jitter varying from 10-60 Hz and dwell for 1 minute at 15 Hz.
14.	Examine Bellows Q-2/F-5	Measure stiffness and similarity	met specification
15.	Add torsionally soft coupling between motor and Spiroid pinion	Operate system in vacuum	no change in jitter condition
16.	Change motor stepping frequency	Vary frequency 10 Hz to 100 Hz	Slight improvement at lower frequency No significant change.

This condition was related to the jitter problem after the motor and driver from Serial No. 003 was used to drive the Serial No. 006 elevation assembly. Three times the normal 1/6 g load was carried without jitter or noticeable change in the current trace. The Serial No. 006 motor had jittered previously with the normal 1/6 g load. The Serial No. 003 motor was demagnetized by manually moving the rotor with the stator energized. On reinstalling the motor in the Serial No. 006 elevation drive, the jitter occurred at the normal load level.

A theory on the effect of the low detent torque is that in the back driving mode (load assisting the motor), the rotor overshoots the pole position and greatly reduces torque developed in the motor. The overshoot is generated by the free falling overhung weight loading the spiroid pinion after a step increment has been completed. A small rotation of the spiroid pinion is magnified 48 times. The motor detent torque acts as a damper to this overshoot by permitting the motor to step discrete increments, starting at a pole position, thus developing full rated torque.

The spring damper assembly (RCA Drawing No. 2275697) achieves a similar effect by reducing the acceleration of the overhung weight, reducing the back-drive force and the tendency to overshoot. The spring also provides damping by the significant hysteresis inherent in a low rate torsion spring wrapped around a center hub. The spring applies a force of 2.2 inch pounds at a maximum elevation position of 85 degrees. This force is approximately 1/3 of the nominal overhung moment. The spring rate is low enough to avoid carriage resonant problems.

No penalty is foreseen in installing the damper spring. In addition, the spring reduces the required drive torque by storing energy in the motor assisting direction which is returned when the motor is lifting the weight when opposing gravity. All interface and storage requirements are met with the springs installed on the TCU.

Other methods of damping were considered: - damping of the motor and coulomb damping at the CTV carriage. These methods introduce parasitic loads which are very difficult to control under the extreme environmental conditions, and they also degrade the available torque margin.

The fully-magnetized motor will operate the TCU and meet design requirements without problem. The demagnetization phenomenon is not fully understood at this time. To insure that inadvertent reduction in the motor performance does not affect the use of the TCU, it is recommended that the damping springs described be fitted to all flight TCU's.

For future procurement, the current rotor material (Alinco V) will be changed to a more stable magnet material having a greatly reduced tendency to demagnetize. A discrete detent torque requirement also will be specified.

During the elevation drive improvement program, a variety of tests were performed. The following material is a short chronological history of the tests performed on the Flight 3 (006) and Flight 5 (008) TCU's (date of the test, the configuration of the TCU under test, the test conditions, and the results of the tests are included) .



PROBLEM	DATE	CTV	TCU	GEAR DRIVE	MOTOR	SYMPTOM	TEST CONDITIONS		REMARKS
							Enviorn.	Temp.	
1	9/1	006	Flt III	Flt III	Flt III	No jitter	Air	Ambient	Thermal vacuum setup
								Jitter	Vacuum
	9/5					Jitter	Vacuum	+25°C	f. Pumped down to pressure spec g. Jitter observed on 1st cycle of evaluation up, repeatable on every up cycle h. Vented bell jar i. Jitter occurred for 2 up cycles after venting, but not reprovable after 2 cycle
2	9/5	003	Flt III	Flt III	Flt III	Spurious Signal	Air	Ambient	a. Disassembled Elev. drive, examined, relubricated gears reassembled elev. drive, adj. back lash b. Retested after assembly for $13\frac{1}{2}$ up/down cycles. No jitter observed c. Retested TCU-006 per minutes of T.R.B. (T.D.R. 54-380) d. During retest observed spurious signal (not jitter) - tests not satisfactory due to spurious signal e. Tested TCU-008 (same test outlined for TCU-006) Tests satisfactory, no jitter
	9/6								f. Assembled TCU-006 with 008 gear drive & motor Retested, results satisfactory, no jitter

PROBLEM	DATE	CTV	TCU	GEAR DRIVE	MOTOR	SYMPTOM	TEST CONDITIONS		REMARKS
							Enviorn.	Temp.	
3	9/7	006	Flt III	Flt V (no rework)	Flt V	No jitter	Air	Ambient	a. Thermal vacuum setup - no jitter observed
	9/8					No jitter	Vacuum	+25°C	a. One hour after turn on, commanded elevation down for 36 sec. - no jitter b. Elevation drive activated 1½ up/down cycles 4 hrs after turn on - no jitter observed c. Elevation drive activated 10 up/down cycles 4.4 hrs after turn on - no jitter observed
	9/9					a. No jitter	Vacuum	+50°C	a. Elevation drive activated 1 down/up cycles 5.2 hrs after turn on - no jitter observed b. 5.6 hrs after turn on, conducted elevation drive test. Elevation activated 12 down, up cycles - No jitter observed c. Up limit switch not engaged. Drove into mechanical stop. Cradle momentarily hung up when down command sent d. On 8th & 12th up cycle, drove into mechanical stop
	9/9					a. Up limit switch not activated b. Cradle hang up			a. Elevation drive activated immediately after turn on. Up limit switch not activated b. Elevation drive activated 4 hrs after turn on - no jitter observed c. Elevation drive activated 4.6 hrs after turn on for 5 up/down cycles - no jitter observed. Elev. d. Drove into mechanical up stop. Momentary cradle hang up when down command sent

PROBLEM	DATE	CTV	TCU	GEAR DRIVE	MOTOR	SYMPTOM	TEST CONDITIONS		REMARKS
							Enviorn.	Temp.	
						No jitter	Vacuum	-10°C	a.Elevation drive activated for 1½ down/up cycles 3.7 hrs after turn on - no ji b.Up limit activated normal c.Elevation drive activated for 5 up/down cycles - no jitter observed d.Up limit switch activated normally
	9/10						Vacuum	0°C	a.Elevation drive activated 1½ down/up cycles 3.5 hrs after turn on No jitter observed. Up li switch activated normally b.Elevation drive activated for 5 down/up cycles 3.7 after turn on - no jitter observed Up limit switch activated normally
						Jitter	Vacuum	+25°C	a.Elevation drive activated 2.5 hrs after turn on. Jitter observed in first cycle, and observed in following 5 up cycles. No jitter observed in elevat down b.Up limit switch activated normally c.Elevation drive activated additional up/down cycles jitter observed in all up cycles No jitter in elevation do
	9/11					Jitter	Vacuum	+25°C	a.Completed test per TP-OP-2265826, started engineer evaluation, system turned 15.3 hrs after last opera b.Elevation drive activated no jitter observed on 1st cycle. Limit switch OK. ( served jitter on 2nd up

PROBLEM DATE	CTV	TCU	GEAR DRIVE	MOTOR	SYMPTOM	TEST CONDITIONS		REMARKS
						Enviorn.	Temp.	
					Intermittent Jitter	Air	Ambient	<p>cycle, spike @ 34 sec.</p> <p>c.Elevation drive cycled up/down - jitter got progressively worse</p> <p>a.Vented chamber. System turned on 1.7 hrs after venting. Bell down</p> <p>b.Elevation drive activated No jitter on 1st &amp; 2nd up cycle. Jitter observed on 3rd &amp; 4th up cycle, not on 5th &amp; 6th up cycle. Spike observed on 7th up cycle. No jitter observed on 8th through 15th up cycle</p> <p>c.Raised bell. Elevation drive activated for approximately 20 cycles. No jitter observed</p>

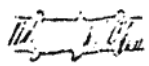

PROBLEM	DATE	CTV	TCU	GEAR DRIVE	MOTOR	SYMPTOM	TEST CONDITIONS		REMARKS
							Enviorn.	Temp.	
0	9.20	003	FLT III Rebuilt	T III Gear Heads	FLT III	Spurious Signal 	Air	Amb.	a. Replaced pinion, ring gear, reset gear (thermal vacuum setup). b. TCU instrumented to monitor elevation motor drive waveforms during T/V testing (at motor samping board). c. Monitored CTV input current & GCTA input current. d. Spurious signal observed during elevation up, observed simultaneously on CTV input current. No jitter observed.
	9/21					Jitter Spurious Signal	Vacuum	+25°C	a. Approx. 1 hr after turn on at +25°C, elevation activated for 17 sec in up direction. Turned off before limit switch. No jitter observed. b. 1.4 hrs after turn on at +25°C, elevation activated. Jitter observed on all up cycles. Recorder monitoring elevation motor drive voltages showed no abnormality during jitter period. System turned off. c. Terminated tests per TP-OP-2265826. System turned on (vacuum) after 3 hrs off period. Jitter observed on 1st up cycle. Jitter observed on following 7 up cycles. Observed spurious signal. d. Vented bell jar slowly, allowing TCU to operate during pressure rise to 1 atmosphere. Jitter observed on all up cycles to 1 atmosphere.
	9.22	003	006-F3	006-F3 Rebuilt Gear Heads	FLT III	Jitter	Air	Amb.	a. TCU in chamber, bell raised. TCU in air 16 hrs before turn on. b. Jitter observed on 1st elevation up cycle.

PROBLEM	DATE	CTV	TCU	GEAR DRIVE	MOTOR	SYMPTOM	TEST CONDITIONS		REMARKS
							Enviorn.	Temp.	
10 (cont'd)									c. Removed 2-lb weight, no jitter observed on elevation up cycles (2). d. Replaced 2-lb weight, jitter observed on 1st elevation up cycle.
11	9/22	003	FLT V	FLT III	-	No Jitter	Air	Amb.	a. Thermal vacuum setup. CTV 003 outside chamber. No jitter observed. b. Thermal vacuum test not
	9/30	003	FLT III	FLT III	FLT III	Spurious Signal	Air	Amb.	a. Thermal vacuum setup. CTV 003 outside chamber. b. Observed 1 occurrence of spurious signal. c. No jitter observed.
	10/1					Spurious Signal	Vacuum	+25°C	a. 1 full cycle of elevation up. No jitter observed. b. 2 occurrences of spurious signal. c. 2 hrs operation @ +25°C.
						Spurious Signal	Vacuum	+50°C	a. 1 hr after turn on at +50°C, elevation drive activated up for 10 sec. No jitter. b. 1.4 hrs after turn on @ +50°C, elevation drive activated up to limit (12 sec operation). Jitter observed on next up cycle. (Occurred @ 34 sec.) Jitter on next up cycle. TCU platform level horiz. System turned off. c. 2 hrs operation @ +50°C.
						Spurious Signal	Vacuum	+40°C	a. 1 hr after turn on @ +40°C, elevation drive activated up for 12 sec. No jitter. b. 1.5 hrs after turn on @ +40°C, elevation up activated. Jitter observed @ 15 sec up from horiz. Jitter observed on next elev. up cycle @ 28 sec. Jitter observed on next up cycle.

PROBLEM	DATE	CTV	TCU	GEAR DRIVE	MOTOR	SYMPTOM	TEST CONDITIONS		REMARKS
							Enviorn.	Temp.	
12 (cont'd)									c. 2 hrs operation @ +40°C.
	10/2	003	006-F3	006-F3	FLT III	No Jitter	Vacuum	-10°C	a. Activated elevation drive up 3 cycles immediately after temp stabilization. No jitter. Platform left in horizontal position. b. 1 hr after turn on @ -10°C activated elevation up for 15 sec. No jitter. c. 1.5 hrs after turn on at -10°C activated elevation up 1½ cycles. No jitter. d. At turn off activated elevation up 1 cycle - No jitter. Platform left in horizontal position. e. Returned to +25°C.
						Spurious Signal	Air	Amb.	a. Vented chamber. b. Turned unit on. Activated elevation up 2 cycles; no jitter observed. c. Turn chamber brine unit on to increase chamber vibration activated elevation up for 4 up cycles - no jitter.
	10/3					No Jitter	Air	Amb.	a. Attempts to reproduce jitter failed. b. Operated TCU elevation, with & without weight, changed C.G. - no jitter. c. Obtained jitter waveform by physically stalling TCU platform.
	10/5	Reworked (Gear Head Replaced) Tested Motor Torque							a. Removed elev. drive assembly removed gear train from motor & inspected.
	10/6	Clutch Backlash at .004"							Reduced backlash at clutch drive to .004" max. b. Replaced S/N 006 elev. drive assembly with S/N 008 drive assembly Retained existing motor and gearhead (S/N 009-3)



PROBLEM	DATE	CTV	TCU	GEAR DRIVE	MOTOR	SYMPTOM	TEST CONDITIONS		REMARKS
							Enviorn.	Temp.	
13	10, 7	003	FLT III	FLT V	FLT III	No Jitter	Air	Amb.	a. Thermal vacuum setup CTV-003 outside chamber. No jitter observed.
							Vacuum	+25°C	a. Elevation drive activated up 1 cycle after turn on; no jitter observed. b. Elevation drive up activated 1.5 hrs and at turn off. No jitter. c. 2 hrs of operation @ +25°C
	10/10	006-F3	006-F3	FLT V	FLT III	No Jitter	Vacuum	+50°C	a. Elevation drive activated 2 up cycles during 2 hr test period. No jitter.
						No Jitter	Vacuum	+40°C	a. Elevation drive activated 1 cycle at turn on; no jitter observed. b. Elevation drive activated 1 cycle 1.5 hrs after turn on No jitter. c. Just prior to turn off, elevation activated up 1½ cycles observed glitch on each cycle near max. up limit. d. Total operating time at +40°C - 2 hrs.
						No Jitter	Vacuum	-10°C	a. Elevation drive activated up from horiz. position to max. up. At turn on - No Jitter observed. b. Approx. 1.5 hrs from turn on, elevation up activated 2 cycles; no jitter observed c. Just prior to turn off, elevation activated up for 1½ cycles. No jitter observed. Platform left in horiz. pos. d. 2 hrs operation at -10°C.

PROBLEM	DATE	CTV	TCU	GEAR DRIVE	MOTOR	SYMPTOM	TEST CONDITIONS		REMARKS
							Enviorn.	Temp.	
13 cont'd)						Spurious Signal Jitter	Vacuum	0°C	a. After 1.5 hrs of operation at 0°C, elevation up activated 1 cycle, jitter observed on 1st cycle @ 34 sec. Elevation activated up. Jitter observed on both cycles. b. 2 hrs operation at 0°C.
						Jitter	Vacuum	+25°C	a. Jitter observed on 1st up cycle, and on all following cycles. Jitter starts $\approx 20^\circ$ up from Horiz. b. Brine unit and pump turned off. Jitter still present.
						Jitter	Air	Amb.	a. Vented chamber. Jitter observed on 3rd up cycle. Spike on 7th up cycle. Elevation up activated several more times - jitter observed.
	10/11	FLT III	FLT III	FLT V	FLT III	Jitter	Air	Amb.	a. Raised bell jar. Elevation cycled several times; jitter observed on all up cycles (5) Jitter appeared to reduce in severity, prior to jitter disappearing, observed only spike on two preceding up cycles. b. Elevation drive cycled up 17 times. No jitter observed Cycled up/down rapidly, on 19th up cycle observed jitter No further jitter observed on up cycles. c. Increased TCU platform loading by 200 gms, 500 gms, cycled elevation up/down - no jitter observed.
14	10/11	003-	FLT V	FLT III	FLT V	No Jitter	Air	Amb.	a. Thermal vacuum setup. No jitter observed.
	10/12					No Jitter	Vacuum	+25°C	a. Elevation drive up cycled $1\frac{1}{2}$ times after turn on - no jitter.

PROBLEM	DATE	CTV	TCU	GEAR DRIVE	MOTOR	SYMPTOM	TEST CONDITIONS		REMARKS
							Enviorn.	Temp.	
14 (cont'd)	10/12	003	FLT V	FLT III	FLT V	No Jitter			b. 1½ hrs after turn on, elevation up cycled 1½ times - no jitter.
						Jitter			c. Just prior to turn off, after 2 hrs operation cycle elevation up. observed slight jitter on 1st up cycle.
						Jitter			d. Cycled elevation up 2.5 hrs after turn on - jitter observed.
						Jitter			e. Cycled elevation up 3 hr after turn on - jitter observed (much larger in amplitude). Set TCU platform to point where jitter just started. Turned system off.
						Jitter	Air	Amb.	a. Vented bell jar. Elevation drive cycled up/down 5 times (not full up or down travel). Observed jitter on all up cycles. System cycled OFF/Activated elevation down command, observed jitter on down cycle. Jitter on next elevation up cycle. Cycled elevation up 4 more cycles - jitter observed. Removed 2-lb CTV simulated weight, cycled elevation drive up - no jitter observed. Replaced weight, changed CG, jitter observed. No further jitter on elevation down observed.
									b. Removed TCU from chamber for bench test.
									c. Set up TCU on bench for testing. Cycled elevation, jitter observed on 1st up cycle. Jitter observed on following 6 up cycles. System turned off, removed elevation motor, measured torque required to drive TCU platform.

PROBLEM	DATE	CTV	TCU	GEAR DRIVE	MOTOR	SYMPTOM	TEST CONDITIONS		REMARKS
							Enviorn.	Temp.	
14 ont'd)	10.12	003	FLT V	FLT III	FLT V	Jitter	Air	Amb.	c. (continued) with weight. Stalled motor by hand, obtained signature; replaced motor; cycled elevation up 5 cycles; no jitter observed

PROBLEM	DATE	CTV	TCU	GEAR DRIVE	MOTOR	SYMPTOM	TEST CONDITIONS		REMARKS
							Enviorn.	Temp.	
15	10/12	003	Flt III Flt III	Flt V Q II	Flt III Q II		Air Air	Ambient Ambient	a. Engineering tests as follows: 1. Flt III TCU (vacuum) + Flt V elev. drive (vacuum) 2. Flt III TC (vacuum) + Q elev. drive (air). 3. Q II TCU (air) + Flt V elev. drive (vacuum). b. Set-up Test - No jitter observed.
	10/13	003	Flt III	Flt V	Flt III	Jitter	Vacuum	+25°C	a. No jitter on first up cycle. Jitter observed on second and third up cycle. b. Turned system off replaced Flt III TCU with QII TCU
		003	Q II	Flt V	Flt III	No Jitter	Vacuum	+25°C	a. No jitter observed on three elevation up cycles. Replaced QII TCU with Flt III TCU.
		003	Flt III	Flt V	Flt III	Jitter	Vacuum	+25°C	a. Jitter observed on first elevation up cycle (27 sec up from max down position) jitter observed as stall and run. Jitter observed on all 5 elevation up cycles. b. Replaced Flt III TCU with Q2 TCU.
		003	Q II	Flt V	Flt III	No Jitter	Vacuum	+25°C	a. No jitter observed on 2 elevation up cycles.
		003	Flt III	Q II	Q II	No Jitter	Vacuum	+25°C	a. No jitter observed on three elevation up cycles. b. Compensating springs on Q TCU. c. System cycled OFF/ON; elev. cycled up 4 times - no jitter observed.
		003	Flt III	Flt V	Flt III	Spike	Vacuum	+25°C	a. Elevation cycled up 6 times no jitter observed. 2 spikes observed on fifth up cycle. b. System cycled OFF/ON, elev. cycled up four times, no jitter.
						No Jitter			

PROBLEM	DATE	CTV	TCU	GEAR DRIVE	MOTOR	SYMPTOM	TEST CONDITIONS		REMARKS
							Enviorn.	Temp.	
15 (contd.)	10/13	003	Flt III	Flt V	Flt III	No Jitter	Vacuum	+25°C	c. After 20 minute inactive period, elev. cycled up four times, no jitter observed.
						No Jitter			d. System cycled OFF/ON; 1 up cycle, no jitter
						Jitter			e. Lowered system input voltage to +25 volts, cycled elev up, jitter observed on first, second cycle.
						Jitter			f. Raised system input voltage to +28 volts, cycled elev. up 9 times, jitter observed on 5th up cycle.
						No Jitter			g. System cycled OFF/ON, elev up cycled 9 times, no jitter
						Jitter (Elev. Up)			h. Lowered input supply voltage to +25 volts. Cycled elev. up/down jitter observed on 2nd through 6th up cycle. Jitter observed on 4th, 5th, 7th, 8th, 9th, 10th, 11th, 13th, 14th, 15th down cycles.
						Jitter (Elev. Down)			i. Lowered input voltage to +25 volts, cycled elev. up/down jitter observed on first up cycle, no jitter on second up cycle. Jitter observed on 1st & 2nd down cycles.
						↓			
						Jitter			j. Raised input supply voltage to +28 volts. Jitter observed on 1st & 2nd up cycles. No jitter on 2 down cycles. System turned off.
			QII	Flt V	Flt III	Jitter			k. Jitter observed on 2nd, 4th, 6th up cycle. No jitter observed on elev. down cycle. System turned off.
			Flt III	Flt V	Flt III	Jitter			l. Jitter observed on 1st, 2nd, 3rd. Elevation up cycle. No jitter observed on down cycle.

PROBLEM	DATE	CTV	TCU	GEAR DRIVE	MOTOR	SYMPTOM	TEST CONDITIONS		REMARKS
							Enviorn.	Temp.	
15 (Contd.)	10/13	003	Flt III	Flt V	Flt III	Jitter			m. Lowered input voltage to +25 volts. Jitter observed on 1st, 2nd, 3rd up/down cycles.
									n. Raised input voltage to +28 volts. No jitter observed 2 cycles up/down.
						Glitch			o. Raised input voltage to 33.75 volts. Spike observed on 2nd up cycle.
				Jitter			p. Lowered input voltage to +28 volts. Elev. cycled five times. Jitter observed on third up cycle. System turned off.		
	10/14	003	Flt III	Flt V	Flt III	No Jitter			a. 10 up/down cycles, no jitter. Turned off one hr.
						Jitter	Vacuum	+25°C	b. Cycled elev. up/down 12 times. Spikes observed on 4th up cycle. Jitter observed on 8th, 9th, 10th, 11th, 12th down cycles. System turned off for 1/2 hour.
									a. Cycled up/down, measured torque.
									a. Cycled elev. up/down 3 1/2 times. Jitter observed on 2nd, 3rd up cycles. Spike on 4th down cycle.
									a. Jitter on 1st up cycle. No jitter on down cycle. Change to Flt III TCU QII motor, gear drive.
									a. Cycled elev. up/down two cycles. No jitter.
								a. Stalled TCU carriage by 1/2 inch to obtain stall signature.	
		Flt III	-	004 (Spare)	-	Air	Ambient		
		Flt III	Flt V	Flt III	Jitter	Vacuum	+25°C		
		QII	Flt V	Flt III	Jitter				
		Flt III	QII	QII	No Jitter				
		Flt III	QII	QII	Introduce Jitter				

PROBLEM	DATE	CTV	TCU	GEAR DRIVE	MOTOR	SYMPTOM	TEST CONDITIONS		REMARKS
							Enviorn.	Temp.	
15 (contd.)	10/14	003	Flt III	Flt V	Flt III	Jitter			a. Jitter observed on 1st elev up cycle. Obtained stall signature on expanded scale. No jitter on down cycle. Repeated cycling up/down. Jitter observed on all up cycles.
			QII	Flt V	Flt III	Jitter			a. Cycled elev. up/down. Jitter observed on all up cycles.
			Flt III	Flt III	Flt III	Jitter	Air	Ambient	a. System turned on two hours after venting. b. Jitter observed on 3rd up cycle. c. Bypassed bell jar feed thru connectors. Jitter present. d. Obtained motor stall signature in up/down positions (hand stall). After hand stalling observed jitter on elevation down.
	10/17		Flt III	Flt III	Flt III	No Jitter	Air	Ambient	a. eleven up/down cycles - no jitter.



PROBLEM	DATE	CTV	TCU	GEAR DRIVE	MOTOR	SYMPTOM	TEST CONDITIONS		REMARKS	
							Enviorn.	Temp.		
16	10/17 72	003	F3-006			No Resonance	Air	Ambient	<ul style="list-style-type: none"> <li>a. Low frequency vibration of TCU, 0.5 G from 5 Hz to 60 Hz at ½ octave/minute. TCU elevation operational during vibration, slight indication of resonance at 14, &amp; 23 Hz. No weight in TCU cradle.</li> <li>b. Dwelled at 14 and 23 Hz to check for resonance. None indicated.</li> <li>c. Added 2 lb. weight to TCU cradle, operate TCU elevation during vibration swept from 6 to 30 Hz @ ½ octave/minute. No resonan indicated.</li> </ul>	
17	10/23 72	003 (Air)	Q2-003 (Air)	F-3	(006)	F-3 (009)	No Loss of motor Torque in Vacuum	Vacuum	+25°C	<ul style="list-style-type: none"> <li>a. Vacuum test of F-3 elevation gear drive and motor.</li> <li>b. Test Set-up <ul style="list-style-type: none"> <li>1. Fixed load attached to output of elevation gear drive utilizing elevation clutch as load.</li> <li>2. Strain guage used to monitor performance of motor in vacuum.</li> </ul> </li> <li>c. 63.5 hrs total time in vacuum, 5.2 hrs. total operating time of motor. Motor cycled in both directions.</li> <li>d. Results: Measured a decrease of 7% in motor torque.</li> </ul>
18	10/28 72	003	F3-(006)			No Jitter	Air	Ambient	<ul style="list-style-type: none"> <li>a. Pre vibration, post vibration, &amp; thermal vacuum setup. No TCU elevation drive jitter observed CTV-003-Q2 placed in chamber.</li> </ul>	

PROBLEM	DATE	CTV	TCU	GEAR DRIVE	MOTOR	SYMPTOM	TEST CONDITIONS		REMARKS
							Enviorn.	Temp.	
(Cont.)	10/31 72	003	F3-006			Jitter	Vacuum	+25°C	a. No jitter on 1st elev. up cycle. Jitter observed on 2nd up cycle.
						Jitter	Air	Ambient	b. Jitter observed on elev. up after chamber vented. TCU operated for 10 minutes then turned off.
						No Jitter	Air	Ambient	c. 35 minutes after chamber vented, elevation jitter now existant.
19 nt les in llows, gear using	10/31 72	003	F3-006	F3	ip	No Jitter	Air	Ambient	a. Drilled vent holes in bellows, & gear housing. b. Observed single spike in elevation up, observed decrease in AC component or current during last 8 sec. of up travel.
						Jitter	Vacuum	+25°C	a. Jitter observed on 5th up cycle, spike on 4th up cycle.
						Jitter	Air	Ambient	b. Vented bell jar after 3 hr operation in vacuum. Jitter observed on 1st up cycle action venting. Jitter present 20 minutes after venting chamber. TCU observed to vibrate with elev. drive.
						No Jitter	Air	Ambient	c. Remove TCU from fixture, turned TCU on side with gear housing up, TCU put in normal position. No jitter in either case. d. Unable to reproduce jitter with TCU bolted to fixture.
20 vacuum with TCU	11/1 72	003	Q2-003			No Jitter	Air	Ambient	a. Thermal vacuum setup. No jitter observed.
	↓					No Jitter	Vacuum	+25°C	b. Thermal vacuum testing - 50 up/down elevation cycle.
	11/3/ 72								c. Total time in vacuum 27 h

PROBLEM	DATE	CTV	TCU	GEAR DRIVE	MOTOR	SYMPTOM	TEST CONDITIONS		REMARKS
							Enviorn.	Temp.	
21 vacuum test TCU N007-F4 1/6 G weight	11/4 72 ↓ 11/6 72	003	F4-007			No Jitter	Air	Ambient	a. Thermal vacuum setup. Drc into up mechanical stop. Misaligned limit switch accurately repaired. No elevation jitter.
						No Jitter	Vacuum	+25°C	b. No jitter observed. Performed 4 tests on TCU per TP-OP-2265825. 1/6 G weight. c. Total time in vacuum _____
	11/6 72	003				No Jitter	Air	Ambient	a. Thermal vacuum setup. 2 elevation up cycles with 1/3 G weight. No jitter.
	↓ 11/7 72					No Jitter	Vacuum	+25°C	b. Turned TCU on for 1 hr before testing elevation drive. c. 2 elevation up cycles, w/ 1/3 G weight. No jitter d. Total time in vacuum _____
23 vacuum test of TCU SN 006-F3. tested as follows, a. Staff mounted on staff b. Staff mounted on low frequenc. s. ixture	11/3 72 11/4 72 11/5 72	002- Q1 (out side cham- ber)	006-F3			No Jitter	Air	Ambient	Thermal Vacuum setup.
						Jitter	Vacuum	+25°C	Jitter on 3rd elevation cycle.
						Jitter	Vacuum	+25°C	Jitter on 1st elevation cycle.
						Jitter	Vacuum	+25°C	Elevation motor synced from external source. cycled elevation up @ frequencies from 55Hz to 100 hz. Jitter observed all up cycles.
						Jitter	Vacuum	+25°C	Elevation motor synced from external source. Cycled elevation up, swe motor frequencies from 2 to 100 Hz. Jitter present at all frequencies. Returned to integral motor sync, elev. Jitter present in up & down positions.

PROBLEM	DATE	CTV	TCU	GEAR DRIVE	MOTOR	SYMPTOM	TEST CONDITIONS		REMARKS
							Enviorn.	Temp.	
23 cont'd) .Nitrogen atmosphere						Jitter	Nitrogen	+25°C	Vented chamber by back filling with nitrogen. Jitter present. Cycled elevation up 40 cycles, jitter present on all cycles of elevation. Ele drive cycled in nitrogen atmosphere over a period of 4 hrs.
1/6 G springs						No Jitter	Air	Ambient	Raised Bell. added 1/6 G compensator springs. No jitter observed. Jitter present with springs removed. Cycled elevati 10 up/down cycles with 1 G springs on, no jitter present.
24 1/6 G Compen- sator Springs Soft, Bellows TCU on staff, Staff on for reg Fix.	11/6 72	002- Q1	006-F3			No Jitter	Vacuum	+25°C	a. Cycled elevation 30 up/down cycles. No Jitter observed.
						Jitter (removed 1/6 G springs)	Air	Ambient	b. 1/6 G springs removed after venting, jitter observed.
25	11/15 11/16 11/17	003	006-F3	Flt III		No Jitter	ATP Air Vacuum Air		a. F3 tested with damping spring on each test. No discrepancies encountered

## SECTION IV

### APOLLO 17 THERMAL DATA

The GCTA CTV used during the Apollo 17 mission included a temperature sensor to measure vidicon sleeve temperatures near the SIT target. The temperature telemetry information was contained in a pulse, modulated to indicate temperature level, inserted in line 18 of the CTV composite video output signal. Figure 8 illustrates the telemetry waveform.

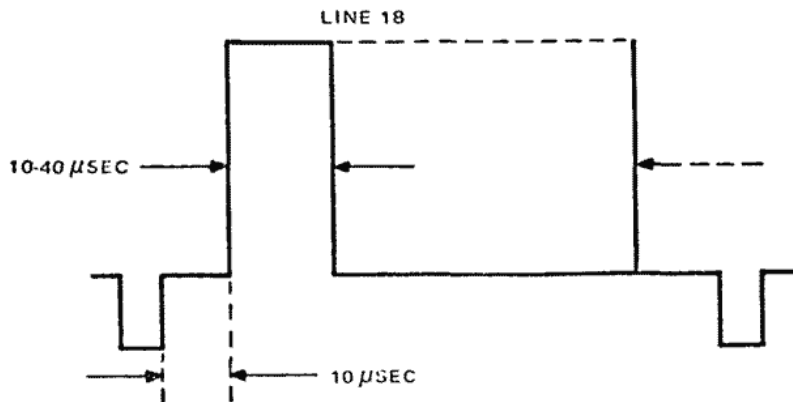

**Figure 8. CTV Temperature Telemetry Waveform**

A summary of CTV temperature measurements obtained during the Apollo 17 mission EVA-1, EVA-2, EVA-3 and lunar liftoff is shown in Table 5. The temperatures obtained were based on the calibration curve shown in Figure 9, which was obtained during the CTV alignment test. The dotted portion of the calibration curve is a theoretical projection. The temperature telemetry was calibrated to a maximum temperature of 122°F.

The initial temperature of the CTV at the start of EVA-1 was measured to be 53.6°F. The predicted temperature at turn on was 50°F. During the course of EVA-1, the CTV reached a maximum temperature of 86.0°F. The predicted temperature was 87°F for an  $\alpha$  of 0.2 (slight dust). The CTV had operated within the predicted temperature extremes at the conclusion of the first EVA. The CTV lens was pointed down 45° with the radiator away from the sun after the EVA.

TABLE 5. SUMMARY OF CTV OPERATING TEMPERATURES

Time from LM Touchdown (hr: min)	EVA ELAPSED TIME hr: min	TEMPERATURE TELEMETRY PULSE WIDTH (μsec.)	Vision Temperature OF	NOTES
4:01	0:00	—	—	BEGINNING OF EVA, No T.V.
5:11	1:10	29.1	53.6	T.V. ON - LM SIGHT
5:16	1:15	29.0	54.0	
5:21	1:20	29.0	54.0	
5:26	1:25	28.9	55.0	
5:31	1:30	28.7	56.0	
5:36	1:35	28.5	57.2	
5:41	1:40	28.3	58.5	
5:46	1:45	28.1	59.5	
5:51	1:50	28.0	60.0	
5:56	1:55	27.8	61.2	
6:01	2:00	27.7	61.7	
6:02	2:01	—	—	T.V. OFF
6:10	2:07	27.7	61.7	T.V. ON ALSEP SIGHT
6:16	2:15	27.7	61.7	
6:21	2:20	27.5	62.6	
6:26	2:25	27.3	63.8	
6:31	2:30	27.1	64.7	
6:36	2:35	26.8	66.1	
6:41	2:40	26.7	66.5	
6:46	2:45	26.5	67.5	
6:51	2:50	26.2	69.0	
6:56	2:55	26.2	69.0	

EVA-1

TIME FROM LM Touchdown	EVA ELAPSED TIME	TEMPERATURE TELEMETRY PULSE WIDTH	VIBISON TEMPERATURE	NOTES
(hr: min)	HR: MIN	( $\mu$ SEC)	OF	
7:01	3:00	26.1	69.5	
7:06	3:05	26.0	69.8	
7:11	3:10	25.8	71.8	
7:16	3:15	25.6	71.7	
7:21	3:20	25.4	72.5	
7:26	3:25	25.2	73.5	
7:31	3:30	25.0	74.5	
7:36	3:35	24.8	75.3	
7:41	3:40	24.6	76.0	
7:46	3:45	24.4	77.2	
7:51	3:50	24.2	78.0	
7:56	3:55	23.9	79.3	
8:01	4:00	23.5	81.0	
8:06	4:05	23.2	82.5	
8:11	4:10	23.0	83.5	
8:16	4:15	22.8	84.4	
8:21	4:20	22.7	84.7	
8:26	4:25	22.5	85.7	
8:31	4:30	22.4	86.0	
8:34	4:33	22.4	86.0	TV OFF
9:04	5:03	23.9	79.3	TV ON - STATION 1
9:11	5:10	23.6	80.7	
9:16	5:15	23.5	81.0	

EVA-1

TIME FROM LM Touchdown	EVA ELAPSED TIME	TEMPERATURE TELEMETRY PULSE WIDTH	VIBICON TEMPERATURE	NOTES
HR: MIN)	HR: MIN	( $\mu$ SEC.)	OF	
9:21	5:20	23.4	81.6	
9:26	5:25	23.3	82.0	
9:30	5:29	—	—	T.V. OFF
9:52	5:51	23.8	79.8	TV ON - SEP SIGHT
9:55	5:55	23.8	79.8	
10:01	6:00	23.7	80.3	
10:06	6:05	23.7	80.3	
10:11	6:10	23.5	81.0	TV OFF
10:16	6:14	23.5	81.0	TV ON - LM SIGHT
10:21	6:20	23.2	82.5	
10:26	6:25	23.0	83.5	
10:29	6:28	22.8	84.4	TV OFF - EVA CLOSE OUT
:	:	.	.	
:	:	.	.	
:	:	.	.	
:	:	.	.	
:	:	.	.	
:	:	.	.	
:	:	.	.	
:	:	.	.	
:	:	.	.	
:	:	.	.	
:	:	.	.	
:	:	.	.	
:	:	.	.	
:	:	.	.	
:	:	.	.	
:	:	.	.	
:	:	.	.	



EVA-2

TIME FROM LM TOUCHDOWN	EVA ELAPSED TIME	TEMPERATURE TELEMETRY PULSE WIDTH	VIBICON TEMPERATURE	NOTES
(hr: min)	hr: min	(μsec.)	°F	
27:41	0:04	28.5	57.2	TV ON - LM SIGHT
27:47	0:10	28.5	59.5	
27:52	0:15	27.5	61.2	
27:57	0:20	27.4	63.3	
28:02	0:25	27.1	64.7	
28:07	0:30	26.7	66.5	
28:12	0:35	26.2	69.0	
28:15	0:38	26.0	69.8	TV OFF
29:40	2:03	26.5	67.5	TV ON - STATION 2
29:42	2:05	26.4	68.0	
29:47	2:10	26.1	69.5	
29:52	2:15	25.8	71.8	
29:57	2:20	25.4	72.5	
30:04	2:27	25.0	74.5	
30:07	2:30	24.7	75.7	
30:13	2:36	24.3	77.5	
30:17	2:40	24.0	79.0	
30:22	2:45	23.5	81.0	
30:27	2:50	23.1	83.0	
30:32	2:55	22.8	84.4	
30:37	3:00	22.4	86.0	
30:40	3:03	22.3	86.5	TV OFF
31:24	3:47	22.5 -74	85.7	TV ON - STATION 3

EVA-2

Time From LM Touchdown	EVA ELAPSED TIME	TEMPERATURE TELEMETRY PULSE WIDTH	Vidicon TEMPERATURE	NOTES
(hr: min)	hr: min	(μsec.)	°F	
31:27	3:50	22.4	86.0	
31:32	3:55	22.1	87.5	
31:37	4:00	21.9	88.4	
31:42	4:05	21.6	89.6	
31:47	4:10	21.2	91.4	
31:52	4:15	20.9	92.7	
31:57	4:20	20.6	94.0	TV OFF
32:18	4:41	20.8	93.2	TV ON STATION 4
32:22	5:45	20.4	95.8	
32:27	5:50	20.1	96.0	
32:32	5:55	19.8	97.5	
32:37	5:00	19.6	98.3	
32:42	5:05	19.4	99.0	MANUAL OVERRIDE OF CTV
32:47	5:10	19.3	99.5	
32:49	5:12	—	—	TV OFF
33:20	5:43	20.1	96.0	TV ON - STATION 5
33:22	5:45	20.0	96.8	
33:27	5:50	19.8	97.5	
33:31	5:55	19.6	98.3	
33:37	6:00	19.4	99.0	
33:42	6:05	19.2	100.0	
33:47	6:10	19.0	100.8	TV OFF
34:09	6:22	19.5 -75+	98.2	TV ON - LM SIGHT



EVA-3

TIME FROM LM TOUCHDOWN	EVA ELAPSED TIME	TEMPERATURE TELEMETRY PULSE WIDTH	VISION TEMPERATURE	NOTES
(hr: min)	hr: min	(μsec.)	OF	
50:37	0:10	28.2	59.0	TV ON - LM SIGHT
50:42	0:15	27.8	61.2	
50:47	0:20	27.4	63.3	
50:52	0:25	27.0	65.0	
50:57	0:30	26.5	67.5	
51:00	0:33	26.4	68.0	TV OFF
51:40	1:13	24.9	75.0	TV ON - STATION 6
51:47	1:20	24.7	75.7	
51:52	1:25	24.2	78.0	
51:57	1:30	23.7	83.3	
52:02	1:35	23.1	83.0	
52:07	1:40	22.5	85.7	
52:12	1:45	22.1	87.5	
52:17	1:50	21.7	89.3	
52:22	1:55	21.2	91.0	
52:27	2:00	20.7	93.5	
52:32	2:05	20.2	95.6	
52:37	2:10	19.6	98.3	
52:42	2:15	18.9	101.3	
52:47	2:20	18.5	103.0	
52:50	2:23	18.3	104.0	TV OFF
53:00	2:33	18.2	104.3	TV ON - STATION 7
53:02	2:35	18.1 -77-	104.5	

EVA-3

TIME FROM LM TOUCHDOWN	EVA ELAPSED TIME	TEMPERATURE TELEMETRY PULSE WIDTH	VIBICON TEMPERATURE	NOTES
hr: min)	hr: min	(μsec.)	OF	
53:07	2:40	17.8	105.9	
53:42	2:45	17.5	107.3	
53:47	2:50	17.1	109.0	
53:49	2:52	17.0	109.4	TV OFF
53:40	3:13	17.2	108.5	TV ON - STATION 8
53:47	3:20	16.8	110.3	
53:52	3:25	16.5	111.5	
53:57	3:30	16.2	113.0	
54:07	3:40	15.7	115.0	
54:12	3:45	15.5	116.5	
54:17	3:50	15.2	117.5	
54:21	3:54	15.0	118.0	TV OFF
54:45	4:18	15.6	115.7	TV ON - STATION 9
54:52	4:25	15.3	117.0	
54:57	4:30	15.1	118.3	
55:02	4:35	14.9	119.3	
55:07	4:40	14.7	120.0	
55:12	4:45	14.4	122.0	
55:17	4:50	14.2	123.0	
55:22	4:55	14.1	123.7	
55:27	5:00	13.8	125.0	
55:36	5:09	13.5	126.5	TV OFF
56:09	5:42	14.8	119.8	TV ON - LM SIGHT

EVA-3

TIME FROM LM TOUCHDOWN	EVA ELAPSED TIME	TEMPERATURE TELEMETRY PULSE WIDTH	VIBICON TEMPERATURE	NOTES
HR: MIN)	HR: MIN	(USEC.)	OF	
56:17	5:50	14.5	121.3	
56:22	5:55	14.4	122.0	
56:27	6:00	14.1	123.7	
56:32	6:05	14.0	124.0	
56:37	6:10	13.8	125.0	
56:42	6:15	13.6	126.0	TV OFF
56:45	6:18	_____	_____	TV ON, TV OFF 6:21
56:48	6:21	_____	_____	TRAVERSE TV TO R.I.P SPOT
56:51	6:24	13.3	127.5	TV ON - ROVER R.I.P SPOT
56:57	6:30	13.1	128.5	
57:02	6:35	12.9	129.7	
57:07	6:40	12.7	131.0	
57:09	6:42	12.4	132.5	
57:17	6:50	12.5	134.5	
57:22	6:55	12.5	133.0	
57:27	7:00	12.4	132.5	
57:32	7:05	12.3	133.0	TV OFF
57:33	7:06	12.3	133.0	TV ON
57:34	7:07	12.3	133.0	TV OFF
:	:	.	.	
:	:	.	.	
:	:	.	.	
:	:	.	.	

~~---~~ LIFTOFF

TIME FROM LM Touchdown	EVA ELAPSED TIME	TEMPERATURE TELEMETRY PULSE WIDTH	Vidicon TEMPERATURE	
hr: min)	hr: min	(μsec.)	°F	NOTES
74:20	0:00	23.4	81.6	TV ON- PRE LIFT OFF
74:25	:05	23.3	82.0	
74:30	:10	23.0	83.5	
74:35	:15	22.7	84.7	
74:40	:20	22.2	86.0	
74:45	:25	21.9	88.4	
74:50	:30	21.5	90.0	
74:53	:33	21.2	91.4	
74:55	:35	21.1	91.8	
74:56	:36	21.0	92.3	
74:57	:37	21.0	92.3	
74:58	:38	20.1	92.7	
74:59	:39	20.8	93.2	
75:00	:40	20.7	93.5	LM LIFTOFF
75:02	:42	20.3	95.3	
75:03	:43	20.3	95.3	TV OFF
:	:	.	.	
:	:	.	.	
:	:	.	.	
:	:	.	.	
:	:	.	.	
:	:	.	.	
:	:	.	.	
:	:	.	.	
:	:	.	.	

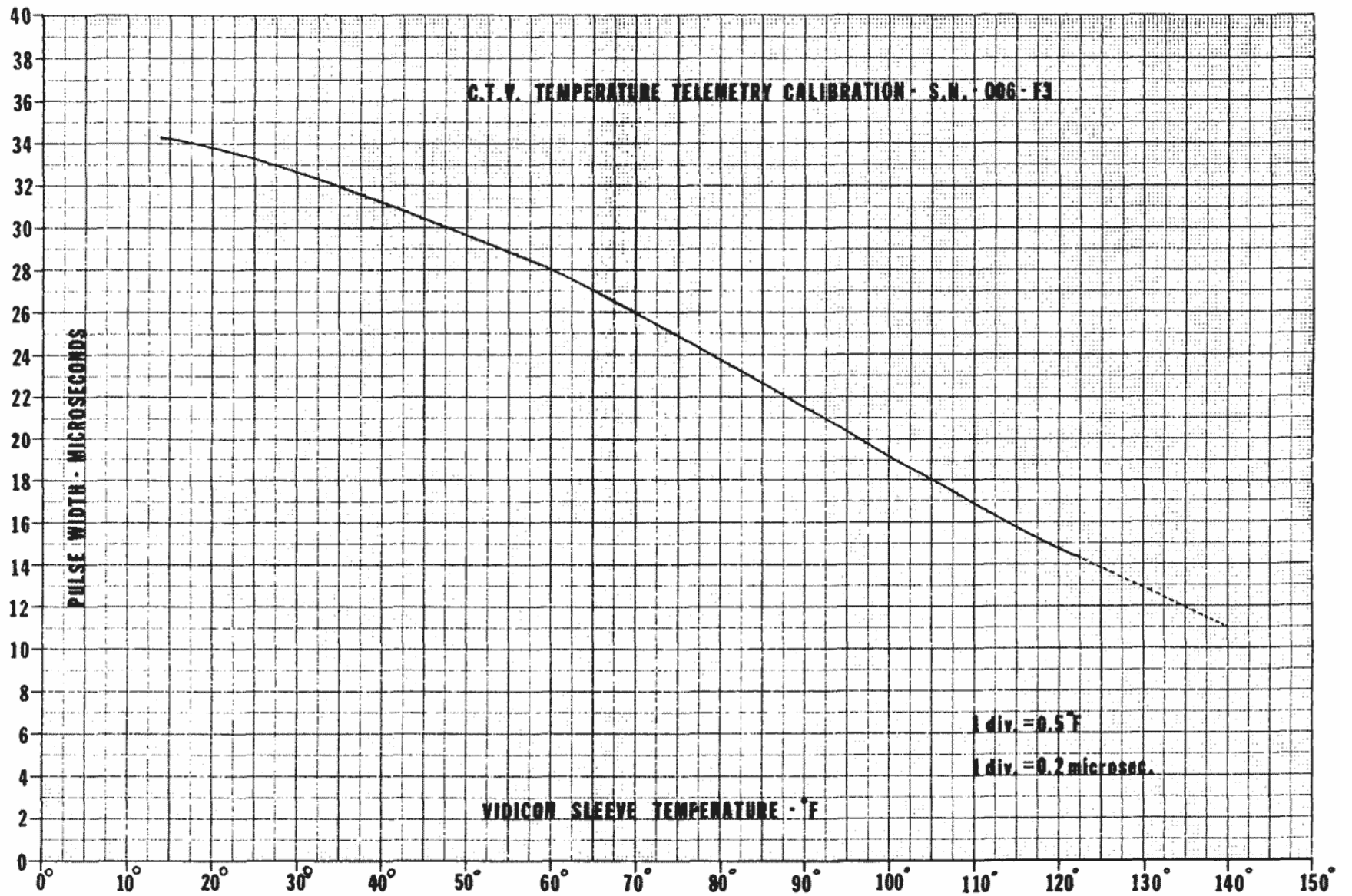

Figure 9. Flight 3 CTV Temperature Telemetry Calibration



After being off for 17 hours and 12 minutes, the GCTA was turned ON for EVA-2. At turn on, the CTV temperature was measured to be 57.2° F, approximately 26° hotter than predicted (for an  $\alpha$  of 0.2). A maximum temperature of 90° F ( $\alpha = 0.2$ ) had been predicted for the end of EVA-2. However, the CTV reached a maximum temperature of 104.5° F, approximately 14° hotter than predicted. At the conclusion of EVA-2, the lens was pointed down 45° with the radiator away from the sun for maximum cooling.

After a cool down period of 16 hours and 1 minute, the GCTA was again turned ON for EVA-3. It had been predicted that the CTV would cool down to 52° F ( $\alpha = 0.2$ ) at the beginning of EVA-3. This prediction was exceeded by 7° F with a CTV temperature of 59° F at turn on. During EVA-3 the CTV reached a maximum temperature of 134.5° F. The predicted maximum was 122° F ( $\alpha = 0.2$ ). Although the CTV operated above predicted temperature levels no apparent degradation occurred in picture quality. At the conclusion of EVA-3, the lunar rover was moved to its final lunar position, and the CTV was stowed with its radiator horizontal.

The CTV was turned on 43 minutes prior to LM liftoff. At this time, the CTV temperature was 81.6° F. At liftoff, the CTV reached a temperature of 95.3° F. The predicted maximum temperature at liftoff was 106° F ( $\alpha = 0.2$ ).

A plot of CTV temperature vs EVA time for EVA-1, EVA-2, and EVA-3 is shown in Figures 10, 11 and 12 respectively. Figure 13 is a plot of the CTV temperature prior to liftoff. The CTV temperatures during EVA-1, EVA-2, EVA-3 and liftoff have been plotted on a single graph and are shown in Figure 14. Included for reference are the temperature prediction curves shown in Figures 15 and 16 for the CTV SIT tube and the TCU component boards. The curves were obtained from LCRU/GCTA thermal control data by E. T. Chementi dated 11/15/72.

During the lunar mission, the GCTA operating time was thirteen hours and twenty-two minutes (13:22). A summary of GCTA operating times is provided in Tables 6 and 7.

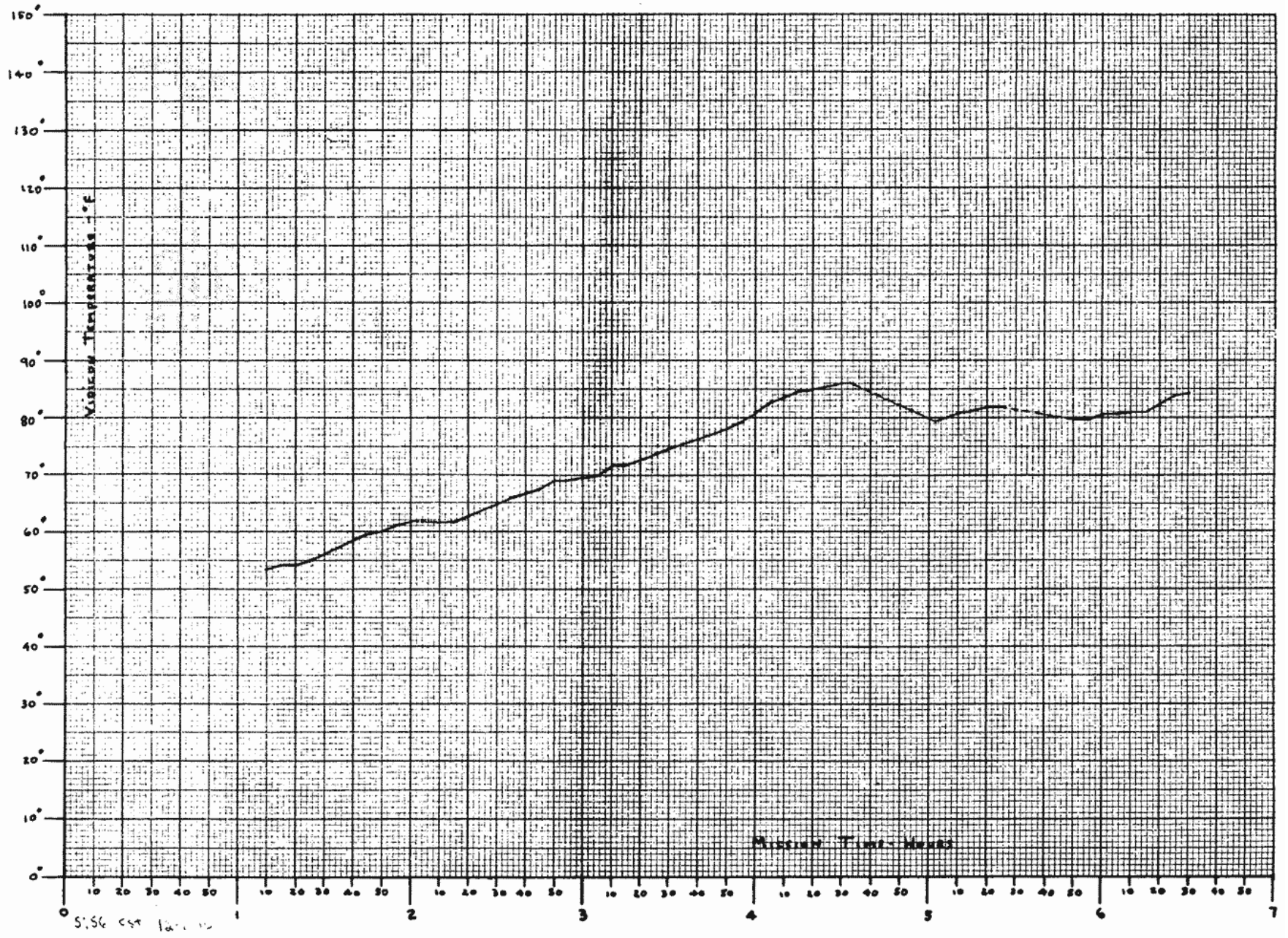

Figure 10. CTV Vidicon Temperature During EVA-1

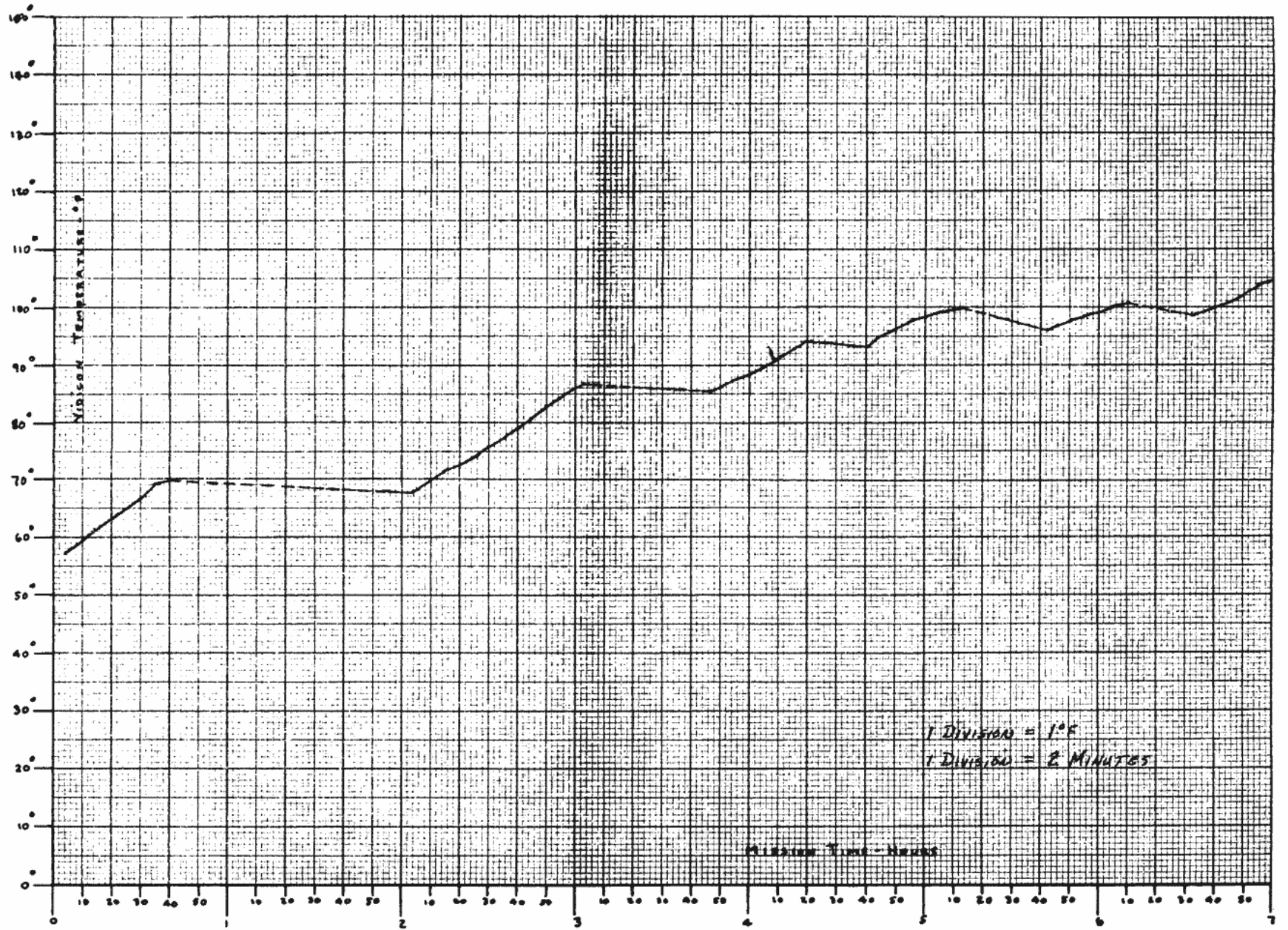

Figure 11. CTV Vidicon Temperature During EVA-2

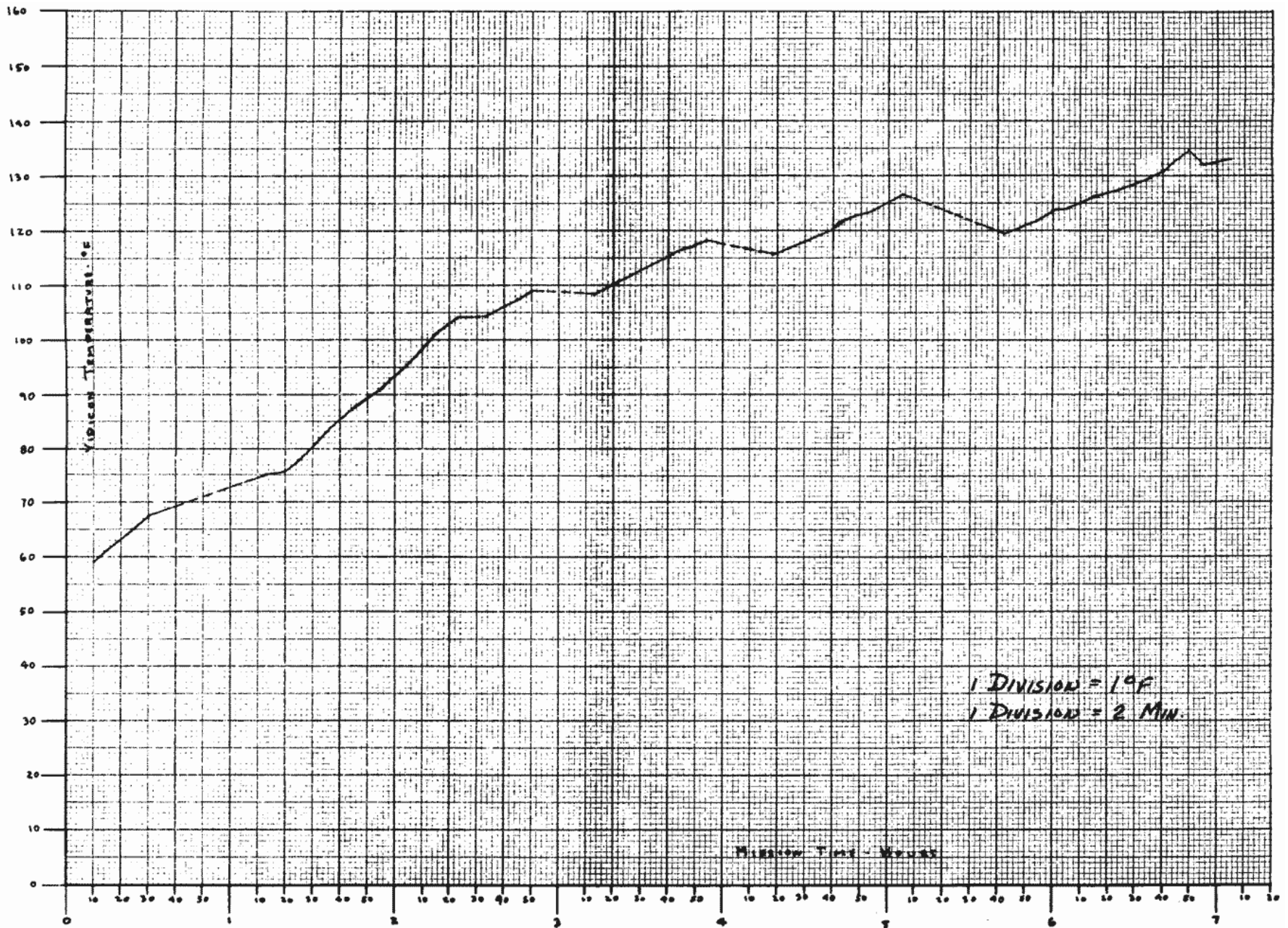

Figure 12. CTV Vidicon Temperature During EVA-3

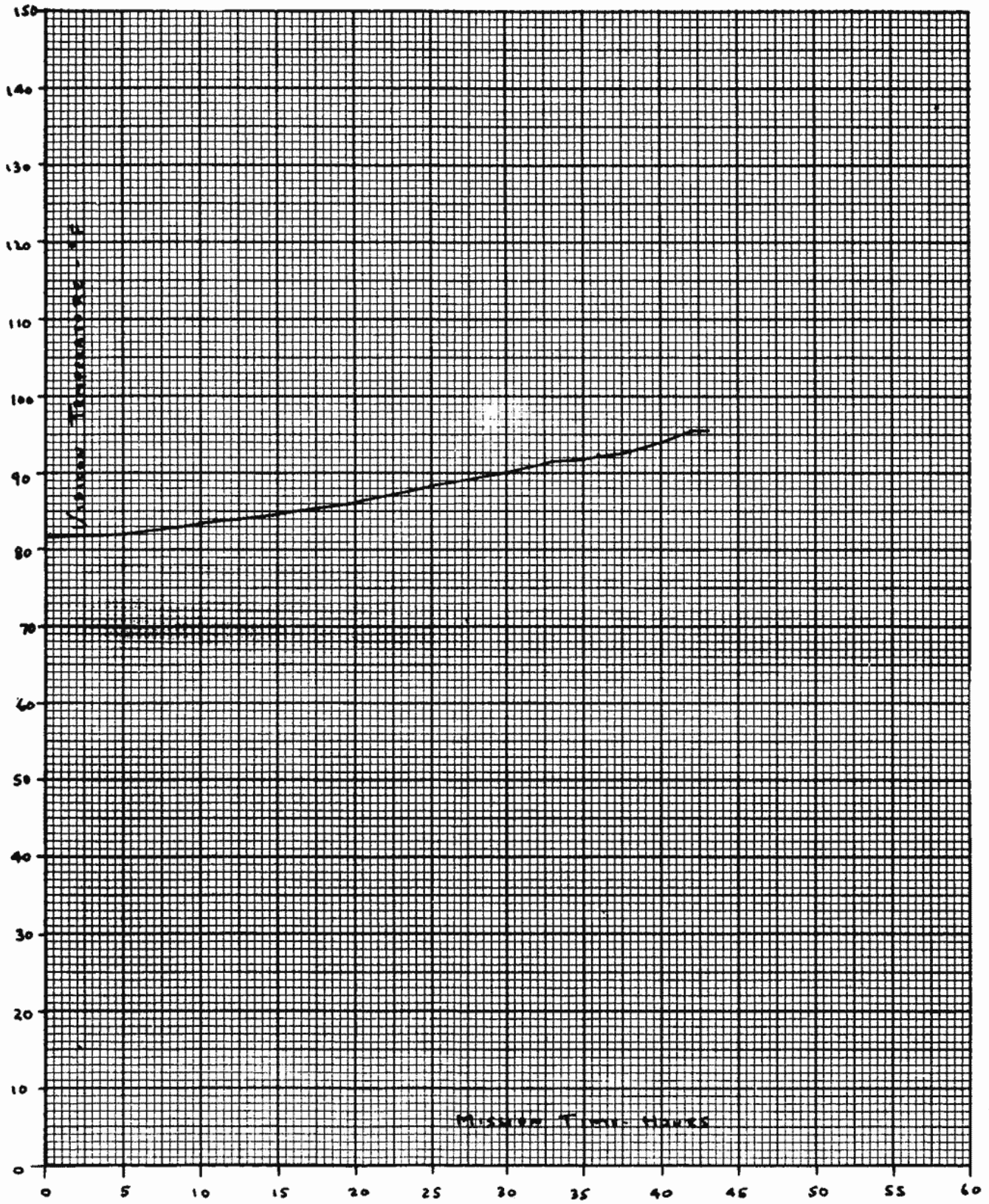

Figure 13. CTV Vidicon Temperature Prior to and During Lunar Liftoff

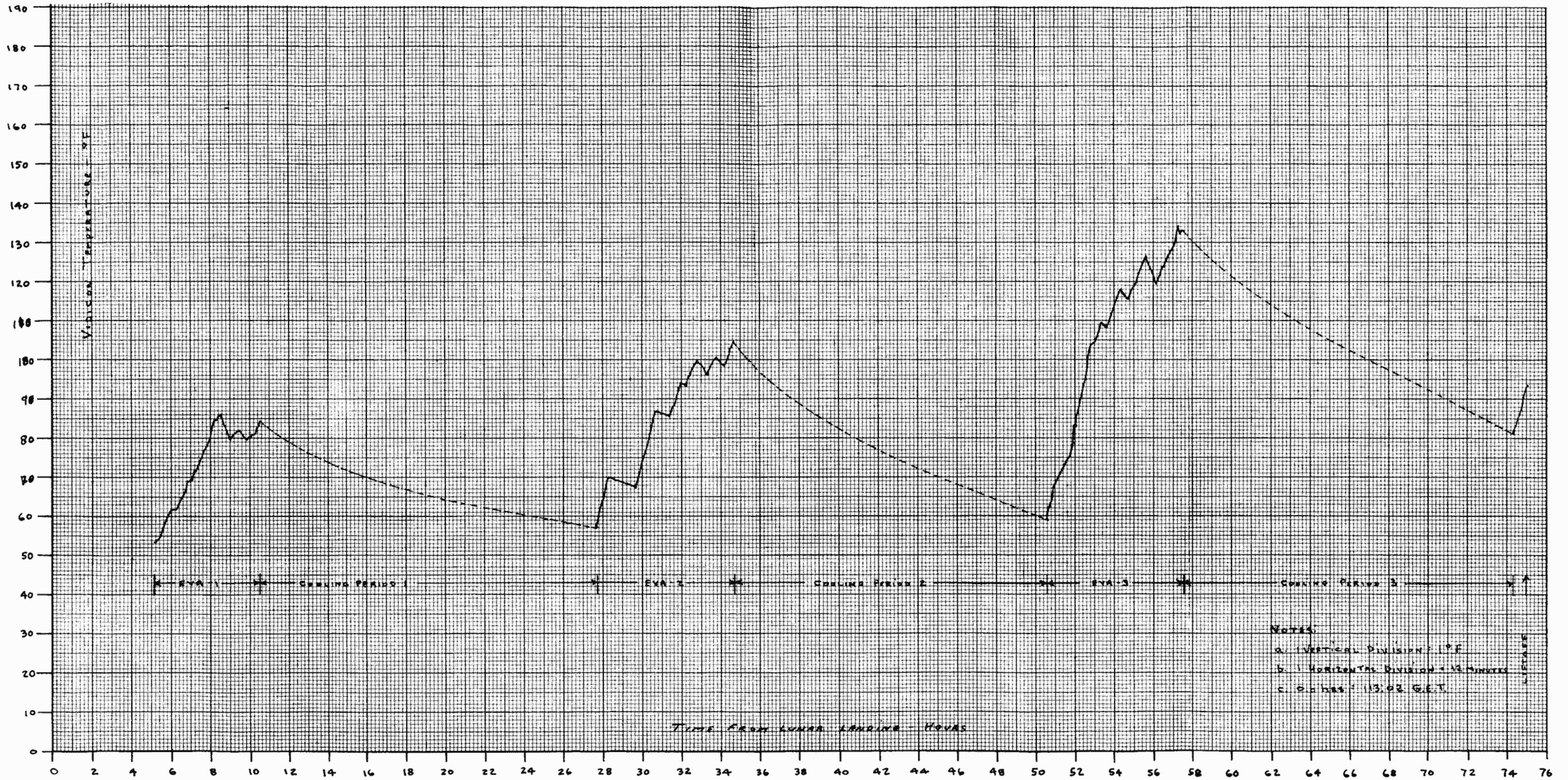

Figure 14. Overall Plot of CTV Temperature on Lunar Surface

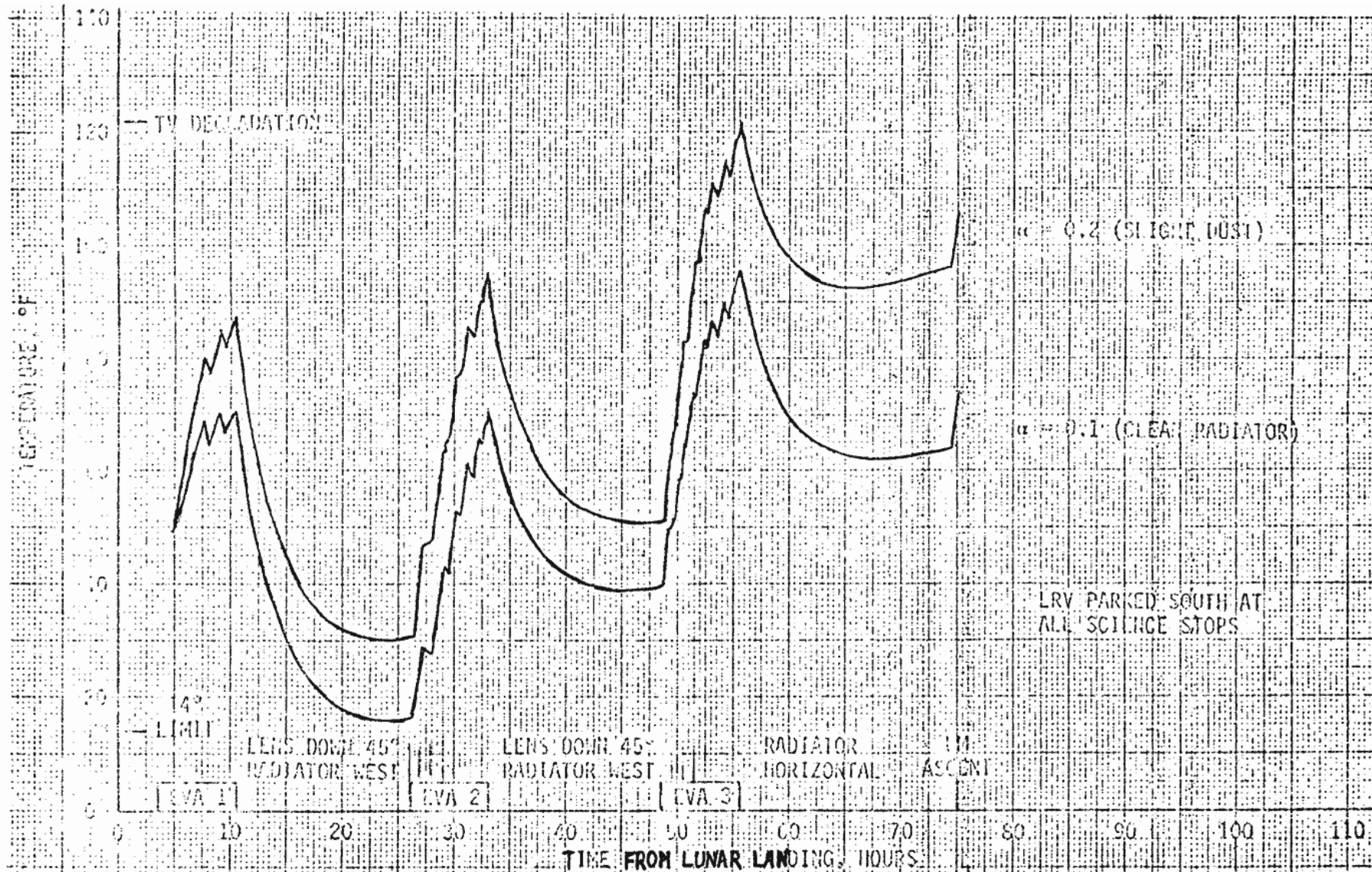

Figure 15. SIT Tube Temperature Prediction Curves

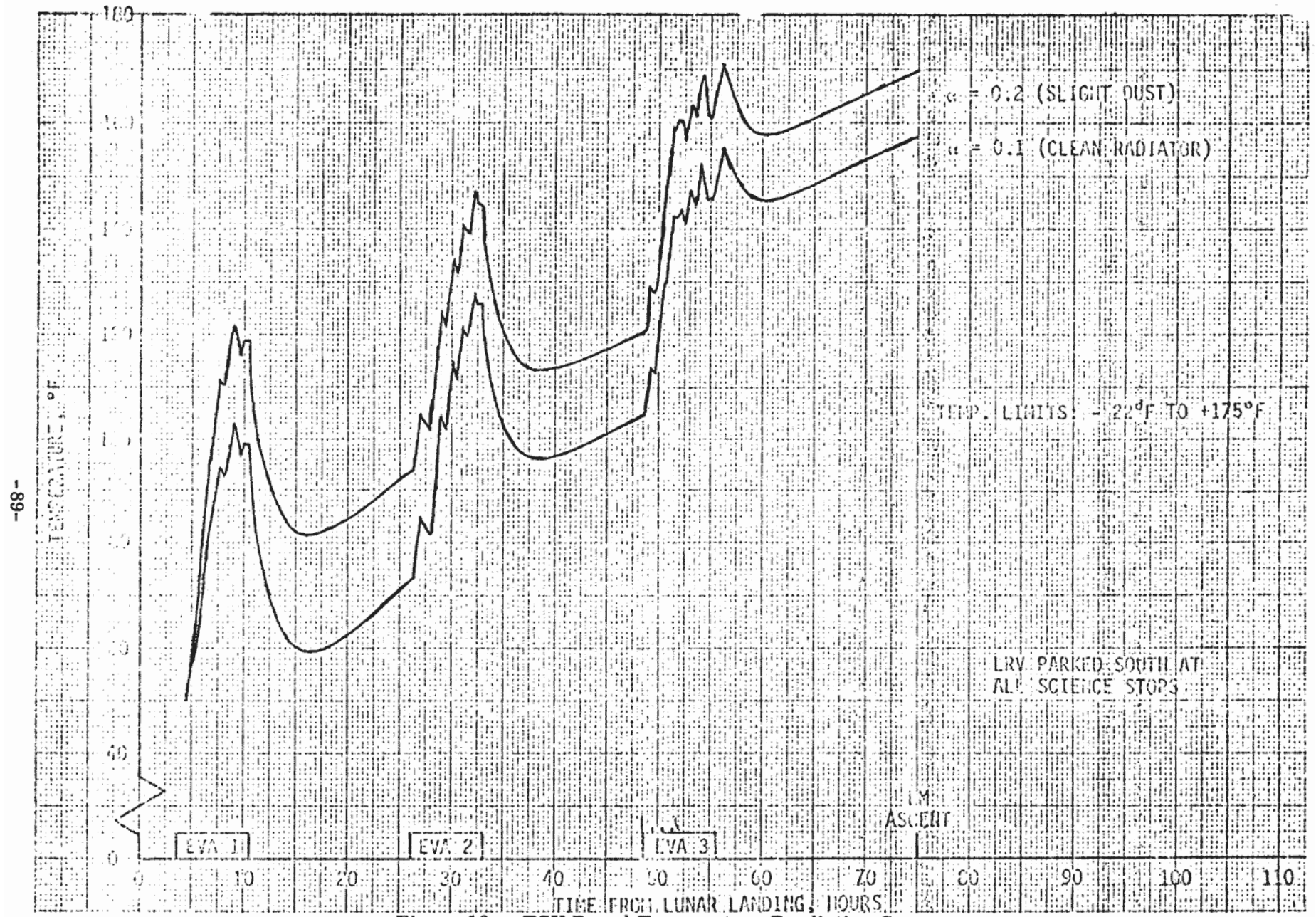

Figure 16. TCU Board Temperature Prediction Curves



TABLE 6. GCTA OPERATING TIME (1)

EVA-1	EVA ELAPSED TIME (HR:MIN)		TV ON TIME HR:MIN
	TV ON	TV OFF	
	1:10	2:01	0:51
2:09	4:33	2:24	
5:03	5:29	0:26	
6:51	6:10	0:19	
6:14	6:28	0:14	
TOTAL ON HR:MIN	—	—	4:14

EVA-2	EVA ELAPSED TIME (HR:MIN)		TV ON TIME HR:MIN
	TV ON	TV OFF	
	0:04	0:38	0:34
2:03	3:03	1:00	
3:47	4:20	0:33	
4:41	5:12	0:31	
5:43	6:10	0:27	
6:32	6:59	0:27	
TOTAL ON HR:MIN	—	—	3:32

EVA-3	EVA ELAPSED TIME (HR:MIN)		TV ON TIME HR:MIN
	TV ON	TV OFF	
	0:10	0:33	0:23
1:13	2:33	1:10	
2:33	2:52	0:19	
3:13	3:54	0:41	
4:18	5:09	0:51	
5:42	6:15	0:33	
6:18	7:05	0:47	
7:06	7:07	0:01	
TOTAL ON HR:MIN	—	—	4:45

LIFT OFF			TV ON TIME HR:MIN
	TV ON	TV OFF	
TOTAL	0:00	0:43	0:43

TOTAL TV "ON" TIME 13:14

TABLE 7. GCTA OPERATING TIME (2)

			G.S.T.	Time from LUNAR LAUNCH
12-11-72	LUNAR LAUNCH		13:55	0:00
	EVA-1	TV ON	19:06	5:11
		TV OFF	20:57	6:02
		TV ON	20:05	6:10
		TV OFF	22:29	8:34
		TV ON	22:59	9:04
		TV OFF	23:25	9:30
		TV ON	23:47	9:52
		TV OFF	00:06	10:11
		TV ON	00:10	10:15
TV OFF		00:24	10:29	
12-12-72	EVA-2	TV ON	17:36	27:41
		TV OFF	18:10	28:15
		TV ON	19:35	29:40
		TV OFF	20:35	30:40
		TV ON	21:19	31:24
		TV OFF	21:52	31:57
		TV ON	22:13	31:18
		TV OFF	22:44	32:49
		TV ON	23:15	33:20
		TV OFF	23:42	33:47
	TV ON	24:04	34:09	
	TV OFF	00:31	34:36	
12-13-72	EVA-3	ON	16:32	50:37
		OFF	16:55	51:00
		ON	17:35	51:40
		OFF	18:45	52:50
		ON	18:55	53:00
		OFF	19:14	53:19
		ON	19:25	53:40
		OFF	20:16	54:21
		ON	20:40	54:45
		OFF	21:31	55:36
		ON	22:04	56:09
		OFF	22:37	56:42
		ON	22:40	56:45
		OFF	23:27	57:32
ON	23:28	57:33		
OFF	23:29	57:34		
12-14-72	LIFT OFF	ON	16:12	74:20
		LIFT OFF	16:55	75:00
		OFF	16:58	75:03

**SECTION V**  
**EQUIPMENT STATUS**

The following GCTA indentured serial number list indicates the latest numbers assigned to GCTA equipment and piece parts that are serialized. The revision status of each unit or part manufactured also is shown. The list has been updated to reflect all product improvement effort.

INDENTURED SERIAL NUMBER LIST - GROUND COMMANDED TELEVISION ASSEMBLY (GCTA)

DATE OF ISSUE 11/21/72

PART NO.	DESCRIPTION	A S S Y	EMC		Q1		Q2		F1		F2		F3		F4		F5			
			S/N 001		S/N 002		S/N 003		S/N 004		S/N 005		S/N 006		S/N 007		S/N 008			
			REV.	S/N	REV.	S/N	REV.	S/N	REV.	S/N	REV.	S/N	REV.	S/N	REV.	S/N	REV.	S/N	REV.	S/N
			Deg. PL		Deg. PL		Deg. PL		Deg. PL		Deg. PL		Deg. PL		Deg. PL		Deg. PL		Deg. PL	
			1	2	3	4	5	6	7	8	9	10	11	12	13	14	15	16	17	18
2265826-501	GCTA	*1	+	+	+	+	+	+	+	+	+	+	+	+	+	+	+	+	+	+
2265826-502	GCTA	1	+	+	+	D D	002	D D	003	+	+	+	D D	005	D D	006	D D	007	D D	008
2265261-502	Stowage Mt. Ass'y	2	+	+	+	D D	002	D D	003	C C	004	D D	005	D D	006	D D	007	D D	008	
1578797-501	Hinge Ass'y	3	+	+	+	C B	002	C B	003	B A	004	C B	005	C B	006	C B	007	C B	008	
2268164-501	Cable Ass'y	*3	+	+	+	+	+	+	+	+	+	+	+	+	+	+	+	+	+	+
2268164-502	Cable Ass'y	3	+	+	+	A A	002	A A	003	+	+	+	A A	005	A A	006	A A	007	A A	008
2265825-501	TCU	*2	+	+	+	+	+	+	+	+	+	J G	004	+	+	+	+	+	+	
2265825-502	TCU	2	+	+	+	M K	002	M K	003	+	+	+	L J	005	M K	006	M K	007	M K	008
2262457-501	Comp Bd.-Motor Damping	*3	+	+	+	+	+	+	+	+	+	B B	004	+	+	+	+	+	+	
2262457-503	Comp Bd.-Motor Damping	3	+	+	+	C C	005	C C	004	+	+	+	C C	007	C C	009	C C	015	C C	
2264250-501	Azimuth Drive Ass'y	*3	+	+	+	+	+	+	+	+	+	C C	004	+	+	+	+	+	+	
2260194-102	Motor Gearhead Ass'y	*4	+	+	+	+	+	+	+	+	+	A +	NA	+	+	+	+	+	+	
2270885-502	Cable Ass'y (3.5 ft)	3	+	+	+	D D	006	D D	005	D D	003	D D	001	D D	004	D D	009	D D	010	
2270661-501	Azimuth Drive Ass'y	3	+	+	+	A A	002	A A	003	+	+	+	A A	005	A A	006	A A	007	A A	
2260594-3	Mot. Gearhead Ass'y	5	+	+	+	B +	025-2	B +	036-1	B +	+	B +	028-3	B +	015-10	B +	023-7	B +	D11-9	
2265822-501	Elect. Encl. Ass'y	*3	+	+	+	+	+	+	+	+	+	H E	004	+	+	+	+	+	+	
2265823-502	Elect. Encl. Ass'y	3	+	+	+	K G	002	K G	003	+	+	+	K G	005	K G	006	K G	007	K G	
2265857-501	Mot. Damping Network	4	+	+	+	C C	003	C C	008	B B	004	C C	011	C C	012	C C	016	C C		
2265296-501	BI-Finans Demod.	4	+	+	+	D E	002	D E	003	D E	004	D E	005	D E	006	D E	007	D E		
2265406-501	Mod.-DC/DC Conv.	*4	+	+	+	+	+	+	+	+	+	H K	004	+	+	+	+	+	+	
2265606-504	Mod.-DC/DC Conv.	4	+	+	+	J L	002	J L	003	+	+	+	J L	005	J L	006	J L	007	J L	
2265607-501	Command Control	4	+	+	+	C E	002	C E	003	C E	004	C E	005	C E	006	C E	007	C E		
2265608-501	Demod.-70 kHz	4	+	+	+	E H	002	E H	003	E H	004	E H	005	E H	006	E H	007	E H		
2265613-501	Digital Decoder Bd.	4	+	+	+	D D	002	G E	003	G E	004	G E	005	G E	006	G E	007	G E		
2265615-501	Voltage Reg. Bd.	4	+	+	+	F G	002	F G	003	F G	004	F G	005	F G	006	F G	007	F G		
2265811-501	Decoder, Matrix Bd.	4	+	+	+	D D	002	D D	003	D D	004	D D	005	D D	006	D D	007	D D		
2265899-501	Test Sig. Gen. Bd.	4	+	+	+	J G	002	J G	003	J G	004	J G	005	J G	006	J G	007	J G		
2270362-501	Noise Filter Bd.	4	+	+	+	-	005	-	003	-	001	-	002	-	004	-	006	-		
2271061-501	Motor Drive Bd.	4	+	+	+	D C	002	D C	003	C B	004	D C	005	D C	006	D C	007	D C		
2271061-503	Motor Drive Bd.	*4	+	+	+	+	+	+	+	+	+	+	+	+	+	+	+	+	+	
2271061-504	Motor Drive Bd.	4	+	+	+	D C	002	D C	003	+	+	D C	005	D C	006	D C	007	D C		
2265824-501	Mast Ass'y	3	+	+	+	E E	002	E E	003	D C	004	E E	008	E E	006	E E	007	E E		
2260594-1	Mot. & Gearhead Ass'y	*5	+	+	+	+	+	+	+	+	+	B +	NA	+	+	+	+	+	+	
2260594-3	Mot. & Gearhead	5	+	+	+	B +	025-2	B +	036-1	+	+	B +	028-3	B +	015-10	B +	023-7	B +		

Sive  
 A  
 Code Ident No.  
 49671  
 1972482  
 Sheet 3

Indented  
Serial Number List

RCA | Government and Commercial Systems  
Astro Electronics Division | Princeton, New Jersey

Date of Issue 11/21/72



Part Number	Description	A/S Level	S/N 001		S/N 002		S/N 003		S/N 004		S/N 005		S/N 006		S/N 007		S/N 008			
			Rev	S/N	Rev	S/N	Rev	S/N	Rev	S/N	Rev	S/N	Rev	S/N	Rev	S/N	Rev	S/N	Rev	S/N
			Dwg	PL	Dwg	PL	Dwg	PL	Dwg	PL	Dwg	PL	Dwg	PL	Dwg	PL	Dwg	PL	Dwg	PL
2265834-501	Elev. Drive Ass'y	*3	+	+	+	+	+	+	+	C	C	004	+	+	+	+	+	+	+	
2260594-1	Mot & Gearhead Ass'y	*4	+	+	+	+	+	+	+	+	+	+	+	+	+	+	+	+	+	
2271330-501	Elev. Drive Ass'y	3	+	+	B	A	002	B	A	003	+	+	+	B	A	005	B	A	006	
2260594-4	Mot & Gearhead Ass'y	4	+	+	B	A	001-1	B	A	008-10	+	+	+	B	A	005-6	B	A	009-3	
2265840-501	CTV	*2	+	+	+	+	+	+	+	E	D	004	+	+	+	+	+	+	+	
2265840-502	CTV	2	+	+	H	G	002	K	G	003	+	+	+	K	H	005	N	L	006	
2260510-1	H.V. Power Supply	3	+	+	D	+	010	D	+	012	D	+	004	D	+	015	E	+	016	
2260594-2	Motor, Gearhead	4	+	+	B	+	035-3	B	+	033-4	-	+	002-17	B	+	003-18	B	+	019-12	
2260594-2	Motor, Gearhead	4	+	+	B	+	037-6	B	+	017-1	B	+	007-16	B	+	005-1	B	+	010-0	
1978748-1	Lens, Modified	5	+	+	A	+	NA	A	+	NA	A	+	125EM6	A	+	128EM8	A	+	129H31	
2260450-501	Mot Damp. Net. Ass'y	3	+	+	C	+	002	C	+	003	C	+	005	C	+	004	C	+	007	
2260450-501	Conn. Block Ass'y	3	+	+	F	D	002	F	D	003	F	D	005	F	D	004	F	D	006	
1974876-501	Diode Bd Ass'y	4	+	+	B	E	002	B	E	003	B	E	004	B	E	005	B	E	006	
2244701-501	Handle Ass'y	3	+	+	D	A	002	B	A	003	B	A	004	B	A	005	B	A	006	
2241779-501	Filter Wheel Dr Ass'y	3	+	+	-	-	003	-	-	002	-	-	004	A	A	005	A	A	006	
1971981-1	Motor	4	+	+	C	+	71-2-19	C	+	71-3-18	C	+	71-3-30	C	+	71-3-24	C	+	71-3-27	
2264297-501	Mod. Color Flag Det.	4	+	+	A	C	002	A	C	003	A	C	004	B	D	011	B	D	014	
2264785-501	Vidicon Yoke Ass'y	3	+	+	D	A	002	D	A	003	D	A	004	D	A	005	B	A	006	
2260102-1	Vidicon	4	+	+	D	-	2G-15	D	-	161	C	-	165	D	-	202	D	-	202	
2264785-502	Vidicon Yoke Ass'y	3	+	+	+	+	+	+	+	+	+	+	+	+	+	E	B	005	+	
2260102-2	Vidicon	4	+	+	+	+	+	+	+	+	+	+	+	+	+	E	-	694-F8	+	
2264785-503	Vidicon Yoke Ass'y	3	+	+	+	+	+	+	+	+	+	+	+	+	+	+	+	+	+	
2260102-3	Vidicon	4	+	+	+	+	+	+	+	+	+	+	+	+	+	+	+	+	E	
2265800-501	Mod-Electrode Div.	4	+	+	A	A	002	A	A	003	A	A	004	A	A	005	A	A	113	
2265815-501	Sync Gen Ass'y	3	+	+	B	E	002	B	E	003	B	E	004	B	E	005	B	E	007	
2265817-501	Video Ass'y	*3	+	+	+	+	+	+	+	H	H	004	+	+	+	+	+	+	+	
2265817-503	Video Ass'y	3	+	+	J	J	002	J	J	003	+	+	J	J	005	J	J	006	J	
2265828-501	Current Reg Ass'y	3	+	+	D	D	002	D	D	003	D	D	004	D	D	005	D	D	006	
2265829-501	Motor Drive Ass'y	3	+	+	C	D	002	C	D	003	C	D	004	C	D	005	C	D	007	

- = No Revision  
\* = Equipment Unique to S/N 004, F1  
NA = Information Not Available  
+ = Not Applicable

AED 1403 4 72

Size  
A  
Code Issue No.  
49671

1972482

Sheet 4

Indented  
Serial Number List

RCA | Government and Commercial Systems  
Astro Electronics Division | Princeton, New Jersey

Date of Issue 8/21/72



Part Number	Description	Assy Level	S/N 001		S/N 002		S/N 003		S/N 004		S/N 005		S/N 006		S/N 007		S/N 008								
			Rev	S/N	Rev	S/N	Rev	S/N	Rev	S/N	Rev	S/N	Rev	S/N	Rev	S/N	Rev	S/N	Rev	S/N					
			Dwg	PL	Dwg	PL	Dwg	PL	Dwg	PL	Dwg	PL	Dwg	PL	Dwg	PL	Dwg	PL	Dwg	PL					
2265930-501	Pwr Supply Reg Ass'y	3	+	+	G	K	003	G	K	002	G	K	004	G	K	005	G	K	006	G	K	007	G	K	008
2265831-501	Pwr Supply, DC Conv.	3	+	+	E	D	002	E	D	003	E	D	004	E	D	005	E	D	006	E	D	007	E	D	008
2265832-501	Vert & Horiz Defl Ass'y	3	+	+	J	J	002	J	J	003	J	J	004	J	J	005	J	J	006	J	J	007	J	J	008
2270011-501	Pre-Amp Ass'y	3	+	+	E	E	002	F	E	003	E	E	005	E	E	004	E	E	008	E	E	007	E	E	006
2271057-501	ALC Comp Bd	3	+	+	J	H	002	J	H	003	H	H	004	J	H	005	J	H	006	J	H	007	J	H	008
2270066-501	Cable Ass'y (100-ft)	2	+	+	D	A	002	D	A	001	D	A	003	D	A	006	D	A	005	D	A	007	D	A	NA

- = No Revision  
 \* = Equipment Unique to S/N 004, F1  
 NA = Information Not Available  
 + = Not Applicable

AEO 1403 4/72

Size  
**A**  
Code Ident No.  
**49871**

1972482

Sheet 5

CONFIGURATION DIFFERENCES ON GCTA

NOTES:

		Incorp. Rev.	
	<u>Part No.</u>	<u>Dwg</u>	<u>PL</u>
1.	<u>Q1(S/N002) Differences</u>		
		D	D
a.	Digital Decoder Bd., Not Changed	2265613-501	D D
b.	CTV, Partially Changed	2265840-502	H G
c.	Filter Wheel Drive Ass'y.	2264779-501	- -
d.	Mod. Color Flag Det.	2264293-501	A C
e.	Thermal Control Blanket (Velcro) Not Changed	2271424-505	- -
f.	Shaft, Not Changed	1974845-1	D +
g.	H.V. Pwr. Supply, Not Changed	2260510-1	D +
h.	Changed Strap Handle	2269344-502	A A
2.	<u>Q2(S/N003) Differences</u>		
		2265826-502	D D
a.	CTV, Partially Changed	2265840-502	K G
b.	Filter Wheel Dr. Ass'y.	2264779-501	- -
c.	Mod. Color Flag Det.	2264293-501	A C
d.	Thermal Control Blanket (Velcro) Not Changed	2271424-505	- -
e.	Shaft, Not Changed	1974845-1	D +
f.	H.V. Pwr. Supply, Not Changed	2260510-1	D +
g.	Changed Strap Handle	2269344-502	A A
3.	<u>F1(S/N004) Differences</u>		
		2265826-501	A C
a.	Cable Ass'y.	2268104-501	- -

SIZE	CONFIDENT NO.	
A	49671	1972482
-96-		SECRET G

CONFIGURATION DIFFERENCES ON GCTA (Continued)

	<u>Part No.</u>	<u>Dwg</u>	<u>PL</u>	Incorp. Rev.
b. TCU	2265825-50T	J	G	
c. Comb. Bd. - Motor Damping	2262457-501	B	B	
d. Azimuth Drive Ass'y.	2264290-501	C	C	
e. Motor Gearhead Ass'y.	2260194-102	A	+	
f. Elect. Encl. Ass'y.	2265823-501	H	E	
g. Mod. - DC/DC Conv.	2265606-501	H	K	
h. Motor Drive Bd.	2271061-503	C	B	
i. Motor & Gearhead Ass'y.	2260594-1	B	+	
j. Elevation Drive Ass'y.	2265834-501	C	C	
k. Motor & Gearhead Ass'y.	2260594-1	-	+	
l. CTV	2265840-501	E	D	
m. Filter Wheel Dr. Ass'y.	2264779-501	-	-	
n. Mod. Color Flag. Det.	2264293-501	A	C	
o. Vidicon	2260102-1	C	+	
p. Video Ass'y.	2265817-501	H	H	
q. ALC Comp. Bd.	2271057-501	H	H	
r. Shaft, Not Changed	1974845-1	D	+	
s. H.V. Pwr. Supply, Not Changed	2260510-1	D	+	

Size A	Code Ident No. 48371	1972482
-97-		Sheet 7



CONFIGURATION DIFFERENCES ON GCTA (Continued)

	<u>Part No.</u>	<u>Incorp.</u>	
		<u>Dwg</u>	<u>Rev.</u>
4. <u>F2(S/N005) Differences</u>	2265826-502	D	D
a. Shaft, Not Changed	1974845-1	D	-
b. H.V. Power Supply, Not Changed	2260510-1	D	-
5. <u>F3(S/N006) Differences</u>	2265826-502	D	D
a. All changes are Cut-In			
b. H.V. Power Supply, Changed	2260510-1	E	-
c. Color Camera Ass'y, Changed	2265840-502	N	L
d. Spacer, Incorporated	2268311-1	-	-
e. Revised Thermal Blankets	2271424-508, 509	B	A
f. Revised Vidicon Yoke Ass'y	2264795-502	E	B
g. Vidicon	2260102-2	E	-
h. Revised Lens Actuator Ass'y	2262410-502	D	C
i. Changed Bracket-Adapter	1974442-2	D	+
j. Changed Bracket	2262910-2	C	-
k. Revised to New Retainer Lens	2275192-1	A	+
l. Changed Switch Bracket	1974484-2	C	+
m. Added New Spacer Gear Housing	2269681-2	B	+
n. Changed Strap Handle	2269344-502	A	A
o. Added Kit-Assy Spring Damper	2275697-501	-	-
6. <u>F4 (S/N007) Differences</u>	2265826-502	D	D
a. H.V. Power Supply, Not Changed	2260510-1	D	+
b. Color Camera Assy, Changed	2265840-502	L	J
c. Spacer, Not Incorporated	2268311-1	+	-
d. Revised Thermal Blankets	2271424-508 -509	B	A
e. Changed Strap Handle	2269344-502	A	A
f. Added Kit Assy Spring Damper	2275697-501	-	-

Size A	Cont. Ident. No. 48671	19724S2
-98-		Sheet 5

CONFIGURATION DIFFERENCES ON GCTA (Continued)

	<u>Part No.</u>	<u>Incorp. Rev.</u>	
		<u>Dwg</u>	<u>PL</u>
7. <u>F5(S/N008) Differences</u>	2265826-502	D	D
a. All Changes are Cut-In			
b. H.V. Power Supply, Changed	2260510-1	E	+
c. Color Camera Ass'y, Changed	2265840-502	N	L
d. Spacer, Incorporated	2268311-1	-	+
e. Revised Thermal Blankets	2271424-508 509	B	A
f. Revised Vidicon Yoke Ass'y	2265795-503	E	B
g. Vidicon	2260102-3	E	-
h. Revised Lens Actuator Ass'y	2262410-502	D	C
i. Changed Bracket Adapter	1974442-2	D	+
j. Changed Bracket	2262910-2	C	+
k. Revised to New Retainer Lens	2275192-1	A	+
l. Changed Switch Bracket	1974484-2	C	+
m. Added New Spacer Gear Housing	2269681-1	B	+
n. Added New Spacer Gear Housing	2269681-2	B	+
o. Changed Strap Handle	2269344-502	A	A
p. Added Kit Assy, Spring Damper	2275697-501	-	-

Size <b>A</b>	Code Ident No. <b>49671</b>	1972482
-99-		Sheet 9

**SECTION VI**  
**DRAWING STATUS**

Updated drawings generated since July 31, 1972 have been forwarded to NASA/ MSC to reflect product improvement changes in GCTA equipment. The following Contract Class I and Class II changes have been submitted:

Class I Changes

<u>Drawing No.</u>	<u>Rev.</u>	<u>Remarks</u>
1972482*	F	Changes will delineate new strap handle, kit assembly, and S/N changes for elevation drive and motor gearhead assembly, resulting from F. I. A. Report No. P-RC-0043, approved by TWX No. 5106852652 dated 11-20-72.
2265825*	M	
PL-2265825*	K	
PD-2265826*	H	
2269344*	A	
PL-2269344*	A	

Class II Changes

<u>Drawing No.</u>	<u>Rev.</u>	<u>Remarks</u>
1972482*	C, D	Changes will provide clearance under worst case dimension conditions and clearance for IRIS/ZOOM knobs.
1974442*	D	
1974487*	B	
2262410*	D	
PL-2262410*	D	
2262910*	C	
2265840*	N	
PL-2265840*	L	
PD-2265840*	J, K	
2269681*	A	
2275192*	A	

---

\*Multiple ECN

Class II Changes (continued)

<u>Drawing No.</u>	<u>Rev.</u>	<u>Remarks</u>
TP-2265825*	A	Make minor corrections, revise temperature time profile and limits. This will now conform to the requirements of Qualification/Acceptance Test Procedure, TP-OP-2265826.
TP-ET-2265826*	E	
TP-2265840*	B	
1972482	E	Interchange S/N callout of elevation drive and motor gearhead assembly for F-3 and F-5.
1974878	B	Correct number of teeth callout for gear
2268311	A	Correct dimension of hole location
2275697	A	Add, in lbs. to notes 3, 4 and 5.

---

\*Multiple ECN

APOLLO PROJECT

P.O. No. IDT GX-1F5210-0665-F37

Qualification Test Procedure

for

16mm Silicon Intensifier Target Tube, Type C21129B

Manufacturer - RCA Corporation  
Industrial Tube Division

August 3, 1972

Supersedes: October 9, 1970

Table of Tests

<u>Test</u>	<u>Test Name</u>
2.1	Sinusoidal Vibration
2.2	Random Vibration
2.3	Acceleration
2.4	Shock
2.5	Temperature Cycling

List of Test Equipment

<u>Test Equipment</u>	<u>Characteristics Required</u>
1. Vibration Exciter	Ling (3500# or 2000# system)
2. Random Motion Console #892090	MB Model T 388
3. Rotary Accelerator #892083	Schaevitz Model B-10-D
4. Medium Impact Shock Machine	Barry Control Model 16805
5. Temperature Chamber	Am. RSCH. Corp. 5036-100400
6. Special Holding Fixture	Model 1191

## Test Procedures

1. General - Unless otherwise specified, all tests shall be performed on a potted tube assembly under the conditions listed below. Upon completion of the qualification test program, the tube assembly shall meet the optical and electrical performance requirements of part 1 Acceptance Test Procedure for Center Resolution, Dark Current, Grid 1 cutoff voltage and alignment field current.
  - 1.1 No voltages are applied to the tube assembly as the tests are non-operative.
  - 1.2 Axes orientation according to Figure 1.
2. Qualification tests.
  - 2.1 Sinusoidal Vibration
    - a) Requirement - The tube assembly shall withstand sinusoidal vibration in X, Y, and Z axes.
    - b) Conditions - The tube assembly, non-operating, will be suitably clamped in a special holding fixture such that the assembly Z axis will be either horizontal or with the faceplate up. Vibration shall be at a peak displacement amplitude of 0.25 inch or 6.0 g peak (whichever gives less acceleration) from 5 to 100 to 5 Hz at a rate of two octaves per minute.
    - c) Measurement - See General, Section 1.
  - 2.2 Random Vibration
    - a) Requirement - The tube assembly shall withstand random vibration in the X, Y, and Z axes.
    - b) Conditions - The tube assembly, non-operating, will be suitably clamped in a special holding fixture such that the assembly Z axis will be either horizontal or with the faceplate up. Vibration in the range of 20 to 2000 Hz for a duration of two minutes per axis and with a flat spectrum at 0.01 g<sup>2</sup>/Hz in the Z axis, at 0.10 g<sup>2</sup>/Hz from 20-1300 Hz with -12 db/oct rolloff from 1300 to 2000 in the Y axis, and at 0.03 g<sup>2</sup>/Hz 20-100 with increase to 150 Hz and at 0.10 g<sup>2</sup>/Hz 150-250 with decrease to 400 Hz and 0.03 g<sup>2</sup>/Hz 400-650 with -12db/oct rolloff 650-2000 in X axis.
    - c) Measurement - See General, Section 1.
  - 2.3 Acceleration
    - a) Requirement - The tube assembly shall be capable of withstanding 20g of acceleration in each axis.
    - b) Conditions - The tube assembly, non-operating, will be suitably clamped in a special holding fixture. Acceleration level will be essentially uniform throughout the assembly and for the Z axis will be in the negative direction only. After obtaining 20g, the level will be maintained for three minutes. One run will be made in each axis.
    - c) Measurement - See General, Section 1.



## Test Procedures

### 2.4 Shock

- a) Requirement - The tube assembly shall be capable of withstanding three shocks of  $20 \pm 2g$  for  $11 \pm 2.2$  milliseconds (half-sine pulses) in each direction of the three mutually perpendicular axes for a total of 18 shocks.
- b) Conditions - The tube assembly, non-operating, will be suitably clamped in a special holding fixture.
- c) Measurement - See General, Section 1.

### 2.5 Temperature Cycling

- a) Requirement - The tube assembly shall withstand high and low temperature cycling with the upper temperature of  $+65^{\circ}C$  and the lower temperature of  $-15^{\circ}C$ .
- b) Conditions - The tube assembly, non-operating, will be maintained at  $-15^{\circ}C$  for at least five minutes. The temperature will then be increased to  $+65^{\circ}C$  in less than 100 minutes and the assembly will be maintained at  $+65^{\circ}C$  for at least five minutes before returning to room temperature. Cycling will be conducted between  $-15^{\circ}C$  and  $+65^{\circ}C$  for a minimum of five cycles.
- c) Measurement - See General, Section 1.

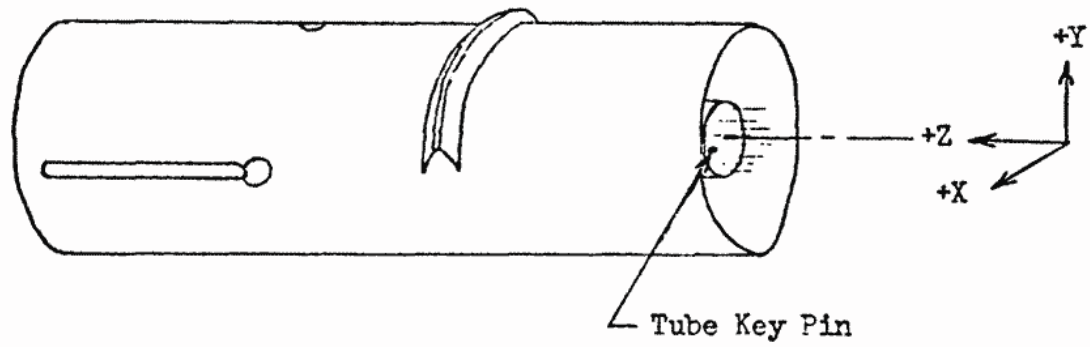

Figure 1. Axis Orientation

