

DVORSCAK
Ravalopal
Sarla

ENHANCING THE USE OF COALS BY GAS REBURNING-SORBENT INJECTION

Volume 3 - Gas Reburning-Sorbent Injection
at Edwards Unit 1
Central Illinois Light Company

Prepared Under:

U. S. Department of Energy Cooperative Agreement DE-FC22-87PC79796
Gas Research Institute Contract No. 5087-254-149
Illinois Department of Commerce and Community Affairs

Prepared by:

Energy and Environmental Research Corporation
18 Mason 1345 N. Main Street
Irvine, CA 92718 Orrville, OH 44667

Final Report
U.S. DOE Patent Clearance is Not Required Prior to the
Publication of this Document

U.S.D.O.E.
I.P.C.

96 MAY 9 ALL : 03

RECEIVED

March, 1996

Energy and
Environmental
Research Corporation

DISCLAIMER

Portions of this document may be illegible in electronic image products. Images are produced from the best available original document.

DISCLAIMERS

U.S. Department of Energy

This report was prepared by Energy and Environmental Research Corporation pursuant to a cooperative agreement funded partially by the U. S. Department of Energy, and neither Energy and Environmental Research Corporation nor any of its subcontractors nor the U. S. Department of Energy, nor any person acting on behalf of either:

- (a) Makes any warranty or representation, express or implied, with respect to the accuracy, completeness, or usefulness of the information contained in this report, or that the use of any information, apparatus, method, or process disclosed in this report may not infringe privately owned rights; or
- (b) Assumes any liabilities with respect to the use of, or for damages resulting from the use of, any information, apparatus, method or process disclosed in this report.

Reference herein to any specific product, process, or service by trade name, trademark, manufacturer, or otherwise, does not necessarily constitute or imply its endorsement, recommendation, or favoring by the U. S. Department of Energy. The views and opinions of authors herein do not necessarily state or reflect those of the U. S. Department of Energy.

Gas Research Institute

LEGAL NOTICE: This report was prepared by Energy and Environmental Research Corporation (EER) as an account of work sponsored by the Gas Research Institute (GRI). Neither GRI, members of GRI, nor any person acting on behalf of either:

- a. Makes any warranty or representation, either express or implied, with respect to the accuracy, completeness, or usefulness of the information contained in this report or that the use of any information, apparatus, method, or process disclosed in this report may not infringe on privately-owned rights; or
- b. Assumes any liability with respect to the use of, or for damages resulting from the use of, any information, apparatus, method, or process disclosed in this report.

ABSTRACT

Design work has been completed for a Gas Reburning-Sorbent Injection (GR-SI) system to reduce emissions of NO_x and SO_2 from a wall fired unit. Under the co-sponsorship of the U. S. Department of Energy, the Gas Research Institute, and the Illinois Department of Commerce and Community Affairs, a GR-SI system was designed for Central Illinois Light Company's Edwards Station Unit 1, located in Bartonville, Illinois. The unit is rated at 117 MW_e (net) and is front wall fired with a pulverized bituminous coal blend. The goal of the project was to reduce emissions of NO_x by 60%, from the "as found" baseline of 0.98 lb/MBtu (420 mg/MJ), and to reduce emissions of SO_2 by 50%. Since the unit currently fires a blend of high sulfur Illinois coal and low sulfur Kentucky coal to meet an SO_2 limit of 1.8 lb/MBtu (770 mg/MJ), the goal at this site was amended to meeting this limit while increasing the fraction of high sulfur coal to 57% from the current 15% level. GR-SI requires injection of natural gas into the furnace at the level of the top burner row, creating a fuel-rich zone in which NO_x formed in the coal zone is reduced to N_2 . The design natural gas input corresponds to 18% of the total heat input. Burnout (overfire) air is injected at a higher elevation to burn out fuel combustible matter at a normal excess air level of 18%. Recycled flue gas is used to increase the reburning fuel jet momentum, resulting in enhanced mixing. Recycled flue gas is also used to cool the top row of burners which would not be in service during GR operation. Dry hydrated lime sorbent is injected into the upper furnace to react with SO_2 , forming solid CaSO_4 and CaSO_3 , which are collected by the ESP. The system was designed to inject sorbent at a rate corresponding to a calcium (sorbent) to sulfur (coal) molar ratio of 2.0. The SI system design was optimized with respect to gas temperature, injection air flow rate, and sorbent dispersion. Sorbent injection air flow is equal to 3% of the combustion air. The design includes modifications of the ESP, sootblowing, and ash handling systems. The GR-SI system is expected to achieve its goals of emission reduction with only minor impacts on thermal performance, unit and plant equipment wear, and the local environment. The major waste product is a high calcium solid waste which would be collected dry and disposed of at a nearby landfill.

Extensive design work for the GR-SI system has been completed, but the project did not reach succeeding phases including construction and testing. The primary reason for its discontinuation

is the extensive ESP upgrade required for SI at this site. Edwards Station Unit 1 is equipped with a small ESP (SCA of 137 ft²/1000 acfm [27.0 m² / m³/s]) which is barely adequate for its current operation. Injection of sorbent would require addition of 2 collecting plate fields and upgrade of an existing SO₃ injection system. Due to the capital cost requirement of the ESP upgrade, the project at Edwards Station Unit 1 was discontinued. GR-SI has been successfully demonstrated at two other sites.

POINTS OF CONTACT

For more information regarding GR-SI or GR technologies, please contact:

Dr. Blair A. Folsom
Senior Vice President
Energy and Environmental Research Corporation
18 Mason
Irvine, California 92718
Ph. (714) 859-8851
Fax (714) 859-3194

or

Mr. Todd M. Sommer
Vice President
Energy and Environmental Research Corporation
1345 N. Main St.
Orrville, Ohio 44667
Ph. (216) 682-4007
Fax (216) 684-2110

AUTHORS

The following EER personnel contributed in the writing of this report:

Mr. Rafik Z. Beshai

Dr. Blair A. Folsom

Dr. Charles C. Hong

Mr. Robert T. Keen

Mr. James C. Opatrny

Dr. Roy Payne

Dr. Anupam Sanyal

Mr. Todd M. Sommer

ACKNOWLEDGEMENTS

Energy and Environmental Research Corporation wishes to express appreciation to the project sponsors and their project managers for assistance received in conducting this project:

U. S. Department of Energy - Mr. Harry Ritz

Gas Research Institute - Mr. John Pratapas

Illinois State Department of Commerce and Community Affairs - Mr. Paul Pierre-Louis

The assistance and cooperation of the personnel of Central Illinois Light Company are also appreciated.

LIST OF ABBREVIATIONS

ACH	Archeological, Cultural and Historical
ACS	Archeological Consulting Services
ASME	American Society of Mechanical Engineers
CCT	Clean Coal Technology
CE	Combustion Engineering
CFR	Code of Federal Regulations
CILCO	Central Illinois Light Company
CWLP	City Water Light and Power
DOE	U. S. Department of Energy
EER	Energy and Environmental Research Corporation
EHSS	Environmental, Health, Safety and Socioeconomic
ENR	State of Illinois Department of Energy and Natural Resources
ESP	Electrostatic Precipitator
FEGT	Furnace Exit Gas Temperature
FGR	Flue Gas Recirculation
GR	Gas Reburning
GRI	Gas Research Institute
GR-LNB	Gas Reburning-Low NO _x Burners
GR-SI	Gas Reburning-Sorbent Injection
IEPA	Illinois Environmental Protection Agency
IHPA	Illinois Historic Preservation Agency
MCR	Maximum Continuous Rating
NG	Natural Gas
NSPS	New Source Performance Standards
OFA	Overfire Air
OSHA	Occupational Safety and Health Administration
PSD	Prevention of Significant Deterioration
PTC	Power Test Code
RCRA	Resource Conservation and Recovery Act

SCA	Specific Collection Area
SCR	Selective Catalytic Reduction
SHPO	State Historic Preservation Officer
SI	Sorbent Injection
SNCR	Selective Noncatalytic Reduction
SRI	Southern Research Institute
TBD	To Be Determined
USEPA	United States Environmental Protection Agency
2D Code	2 Dimensional Heat Transfer Code

LIST OF UNITS

acfm	Actual Cubic Foot per Minute
Btu	British Thermal Unit
Btu/kWh	British Thermal Unit per Kilowatt-hour
°C	Degree Celsius
cm	Centimeter
cm ² /g	Centimeter Square per Gram
°F	Degree Fahrenheit
ft	Foot
g	Gram
g/cm ³	Gram per Cubic Centimeter
HP	Horsepower
kg/s	Kilogram per Second
kJ/kWh	Kilojoule per Kilowatt-hour
klb/hr	Thousand Pounds per Hour
kPa	Kilopascal
KVA	Kilovolt-Ampere
kW	Kilowatt
lb/ft ³	Pound per Cubic Foot
lb/hr	Pound per Hour
lb/MBtu	Pound per Million British Thermal Units
m	Meter
m ³ /s	Actual Cubic Meter per Second
MBtu	Million British Thermal Units
MBtu/hr	Million British Thermal Units per Hour
MGD	Million Gallons per Day
mg/l	Milligram per Liter
mg/MJ	Milligram per Megajoule
MJ/s	Megajoule per Second
MW _e	Megawatt Electric

Nm ³ /s	Normal Cubic Meter per Second
scfm	Standard Cubic Foot per Minute
PM ₁₀	Particulate Matter with an Aerodynamic Diameter under 10 Micrometers
pH	Negative Logarithm of the Hydrogen Ion Concentration
ppm	Part per Million
psig	Pound per Square Inch Gauge
tonne/a	Metric Ton per Year
tpy	Ton per Year
TSS	Total Suspended Solids
V	Volt
W.C.	Water Column
%	Percent
'	Foot
"	Inch

LIST OF SYMBOLS

Al_2O_3	Aluminum Oxide (Alumina)
CaCO_3	Calcium Carbonate
CaO	Calcium Oxide
Ca(OH)_2	Calcium Hydroxide
Ca/S	Molar Ratio of Calcium (Sorbent) to Sulfur (Coal)
CaSO_4	Calcium Sulfate
CH_4	Methane
CO	Carbon Monoxide
CO_2	Carbon Dioxide
Fe_2O_3	Ferric Oxide
H_2O	Water
Mg(OH)_2	Magnesium Hydroxide
N_2	Nitrogen (Molecular)
Na_2O	Sodium Oxide
NO_x	Nitrogen Oxides
O_2	Oxygen (Molecular)
SiO_2	Silicon Dioxide (Silica)
SO_2	Sulfur Dioxide
SO_3	Sulfur Trioxide
V_2O_5	Vanadium Pentoxide

TABLE OF CONTENTS

<u>Section</u>	<u>Page</u>
1.0 EXECUTIVE SUMMARY	1-1
2.0 INTRODUCTION	2-1
2.1 Project Overview	2-1
2.1.1 Purpose of the Design Report	2-1
2.1.2 Description of the Project	2-2
2.1.3 Objectives of the Project	2-3
2.1.4 Significance of the Project	2-3
2.1.5 Role of the DOE, GRI and ENR in the Project	2-4
2.1.6 Technology Demonstrations at Other Sites	2-4
2.2 Host Unit Description	2-5
3.0 GR-SI PROCESS	3-1
3.1 GR-SI Technology Overview	3-1
3.2 Edwards Station Unit 1 GR-SI Process Design	3-9
3.3 Edwards Station Unit 1 GR-SI System Performance Goals	3-13
3.4 Expected GR-SI Environmental Impacts	3-21
4.0 GR-SI SYSTEM ENGINEERING DESIGN	4-1
4.1 Engineering Design Overview	4-1
4.2 Edwards Station Unit 1 GR-SI System Engineering Design	4-5
4.2.1 Natural Gas Pipeline and Injection System	4-5
4.2.2 Flue Gas Recirculation System	4-5
4.2.3 Overfire Air System	4-6
4.2.4 Sorbent Injection System	4-7
4.2.5 GR-SI Auxiliary Power and GR-SI Control System	4-9
4.2.6 Sootblowing System Modifications	4-10
4.2.7 Electrostatic Precipitator Performance Enhancement	4-10
5.0 EDWARDS STATION UNIT 1 GR-SI PROJECT STATUS	5-1

REFERENCES

LIST OF FIGURES

<u>Section</u>		<u>Page</u>
2-1	Schematic of Edwards Station Unit 1	2-7
3-1	Overview of Gas Reburning process	3-3
3-2	Overview of Sorbent Injection process	3-5
3-3	Key sorbent properties, sulfation mechanisms and typical SO ₂ control	3-6
3-4	GR-SI injector specification for Edwards Unit 1	3-8
3-5	Mean gas temperature profile at 100% load at Edwards Unit	3-15
3-6	Predicted NO _x reduction due to Gas Reburning at Edwards Unit 1	3-19
3-7	Predicted SO ₂ capture at Edwards Unit 1	3-20
4-1	Overview of Edwards Unit 1 GR-SI system	4-2
4-2	Full load GR-SI material balance for Edwards Unit 1	4-3
4-3	Full load GR-SI energy balance	4-4
4-4	Edwards Unit 1 new sootblower locations	4-11
4-5	Schematic of SO ₃ injection system	4-13

LIST OF TABLES

<u>Section</u>		<u>Page</u>
2-1	Edwards Unit 1 boiler specifications	2-8
3-1	GR-SI process design criteria for Edwards Unit 1	3-10
3-2	Fuel compositions used in Edwards Unit 1 GR-SI Process Design	3-11
3-3	Edwards boiler performance predictions	3-16
3-4	Thermal efficiency using the ASME Abbreviated Heat Loss Method	3-18
3-5	RCRA EP chemical characteristics	3-27
3-6	Environmental monitoring in Phases I and II	3-28
3-7	Environmental monitoring in Phase III	3-29
4-1	Properties of Marblehead calcitic hydrate	4-8

1.0 EXECUTIVE SUMMARY

The Energy and Environmental Research Corporation (EER) completed Phase I work in a U.S. Department of Energy (DOE) Clean Coal Technology (CCT) project entitled "Enhancing the Use of Coals by Gas Reburning-Sorbent Injection." Project co-sponsors include the Gas Research Institute (GRI) and the Illinois State Department of Energy and Natural Resources (ENR). Phase I includes design and permitting activities for retrofitting a pulverized coal-fired utility boiler with a Gas Reburning-Sorbent Injection (GR-SI) system to reduce emissions of nitrogen oxides (NO_x) and sulfur dioxide (SO_2). The goals of the project were to reduce NO_x and SO_2 by 60 and 50%, respectively, from "as found" baseline emissions. The host unit is Central Illinois Light Company's (CILCO) Edwards Station Unit 1, located in Bartonville, Illinois. It is a front wall fired unit rated at 117 MW_e (net) which fires a blend of high sulfur Illinois coal and low sulfur Kentucky coal in a 15/85 weight ratio, to meet its SO_2 emissions limit of 1.8 lb/MBtu (770 mg/MJ). The SO_2 reduction goal of 50% for GR-SI, has been amended at Edwards Unit 1 to meeting the emissions limit, while firing a blend of high sulfur coal and low sulfur coal in a 57/43 ratio. EER has successfully completed two other GR-SI demonstrations, at a tangentially fired unit and at a cyclone fired unit, both in Illinois. EER is also in the process of completing a combined demonstration of GR and Low NO_x Burners (GR-LNB) on a wall fired unit in Colorado. The project at Edwards Unit 1 was suspended, after completion of design work, due to funding constraints associated with an extensive ESP upgrade required for sorbent injection.

GR-SI is the co-application of two technologies, Gas Reburning (GR) for NO_x emissions control and Sorbent Injection (SI) for reduction of SO_2 emissions. GR requires injection of natural gas, as a reburning fuel, into the furnace in the region above the coal burners. A fuel-rich reburning zone is created in which NO_x formed in the primary coal zone is reduced to molecular nitrogen (N_2). Substoichiometric combustion (i.e. with a deficiency in air required for complete combustion) of natural gas results in formation of hydrocarbon fragments and other free radicals which reduce NO_x . The reburning gas typically accounts for 15 to 25% of the total heat input. Flue Gas Recirculation (FGR) provides a carrier gas to enhance the mixing of the reburning fuel. Burnout overfire air (OFA) is injected at a higher point in the furnace to fully burn out the fuels

under a normal excess air level. SI involves injection of a calcium based sorbent (e.g. $\text{Ca}(\text{OH})_2$) into the upper furnace for reaction with SO_2 . The sorbent reacts with SO_2 to form calcium sulfate (CaSO_4) and calcium sulfite (CaSO_3) solids, which are entrained in the boiler flue gas and captured in ash hoppers and the ESP. The micron sized sorbent is injected dry with transport/injection air to provide the jet momentum for rapid mixing. The GR-SI process is cost effective in comparison to other SO_2 and NO_x control technologies, such as wet scrubbing for SO_2 control and Selective Catalytic Reduction (SCR) or Selective Noncatalytic Reduction (SNCR) for NO_x control.

A detailed design of the Edwards Unit 1 GR-SI system has been completed. Due to the limited furnace space in the Edwards boiler, natural gas is injected at the elevation of the top burner row (4 burner rows total) through nine nozzles from the rear wall of the unit. The gas injection system design incorporates nozzles of two sizes, for both shallow and deep penetration into the furnace. Because natural gas injection is at the elevation of the upper coal burner row, this row of coal burners will be out of service during GR operation. FGR is used as a cooling gas to these burners. This prevents the flow of additional air into the coal zone which would require use of more reburning fuel to reach the optimum reburning zone stoichiometric ratio. The GR process also requires the injection of OFA at a higher elevation in the unit. Burnout air is injected through front wall ports at a point in the furnace corresponding to a mean reburning zone residence time of 0.6 seconds. The burnout air injection location was selected to allow sufficient reburning zone residence time and to inject air at a point where the gas temperature is high enough to completely burn out fuel combustible matter.

Micron sized sorbent is injected into the upper furnace above the OFA injection plane. Sorbent sulfation occurs optimally in the temperature range of 2200°F (1200°C) to 1600°F (870°C). The process requires rapid mixing of sorbent with furnace gas and a slow temperature quench rate. A 1 second residence time in this temperature window is preferred. If the sorbent is exposed to gas temperatures above 2350°F (1290°C), a loss in reactivity occurs due to sorbent sintering. The injection point was selected based on these requirements, with the plane at the bottom of the furnace arch corresponding to the appropriate injection temperature. A carrier gas

is required to inject the sorbent with sufficient jet momentum for rapid mixing. SI air, corresponding to 3% of the total combustion air, is used for this purpose.

The project at Edwards Unit 1 has been suspended due to the required ESP upgrade, but GR-SI demonstrations at two other sites has been successfully completed. Injection of sorbent impacts ESP performance due to an increase in ESP inlet particulate loading, an increase in fly ash resistivity, and an increase in gas temperature at the ESP inlet. The Edwards Unit 1 ESP is relatively small with a specific collection area of 137 ft²/ 1000 acfm (27.0 m²/m³/s). Generally, the unit is operated at a maximum load of 95 MW_e (gross) to maintain stack opacity below the 30% limit. The design work performed by EER and an evaluation conducted by a contractor to EER, indicate that an extensive upgrade is required to enhance its performance during SI. The required modifications include addition of two collecting fields and an upgrade of the sulfur trioxide (SO₃) injection system currently in use. The ESP retrofit would also require a lengthy outage period of approximately 9 weeks. Because of the ESP upgrade requirement, EER recommended suspension of the project at Edwards Unit 1.

EER has conducted GR-SI and GR-LNB retrofit projects at other facilities. A GR-SI demonstration has been completed at a 71 MW_e (net) tangentially fired unit (Illinois Power Company's Hennepin Station Unit 1). The demonstration was completed in three phases, which included GR-SI system design, construction and start-up, and long-term testing over a one-year period. NO_x reductions of 67% and SO₂ reductions of 53% were achieved during long-term testing with gas heat input of 18% of the total and sorbent input corresponding to Ca/S molar ratio of 1.76. A GR-SI demonstration has also been completed at a 33 MW_e (gross) cyclone fired unit (City Water, Light and Power Company's Lakeside Station Unit 7, in Springfield, Illinois). At Lakeside Unit 7, the average NO_x reduction was 66% (52 to 77% range), at gas heat input of 20 to 26%, while SO₂ reduction averaged 58%. GR-LNB has been evaluated at a wall fired unit (Public Service Company of Colorado's, Cherokee Station Unit 3). NO_x reductions of 60 to 73% from the baseline without LNB have been achieved. A second-generation GR system, which has improved technical features as well as economic benefits, is currently undergoing testing at the Cherokee Station.

2.0 INTRODUCTION

2.1 Project Overview

The Energy and Environmental Research Corporation (EER) completed process design work and engineering plans for a Gas Reburning-Sorbent Injection (GR-SI) system for Central Illinois Light Company's (CILCO) Edwards Station Unit 1. Phase I, which includes Design and Permitting activities, was completed in this Clean Coal Technology (CCT) project sponsored principally by the U. S. Department of Energy. Co-sponsors of the project were the Gas Research Institute (GRI) and the State of Illinois Department of Energy and Natural Resources (ENR). The project at this site did not progress into succeeding phases including construction/start-up and testing of the GR-SI system. This is due primarily to funding constraints, associated with the ESP upgrade required for sorbent injection.

2.1.1 Purpose of the Design Report

The primary purpose of this report is to provide design information for the GR-SI system. The report includes information on both the process and engineering design of the system. It also presents analyses of expected impacts on various areas of unit operation and environmental impacts. The report does not contain process capital costs or estimated operating costs, which will be presented in a subsequent volume.

This is Volume 3 of a five volume set prepared by EER to fulfill requirements of its CCT Round 1 project. Volume 1 is an overview of the GR-SI application to the three units and highlights results from the two completed demonstrations in the areas of emissions, thermal performance, and environmental impacts. Volumes 2 and 4 detail the results of GR-SI demonstrations at Hennepin Unit 1 and Lakeside Unit 7, respectively. These contain data and analyses from both short parametric tests and the extended (9 to 12 months) demonstrations. Volume 5 is a guideline manual which contains detailed economic analyses including all capital and operating costs and an evaluation of the market for the GR-SI technology.

2.1.2 Description of the Project

The goal of this project was to demonstrate an advanced NO_x and SO₂ emissions control technology for application to coal fired boilers. The technology in used is a co-application of two complimentary technologies, Gas Reburning (GR) for NO_x reduction and Sorbent Injection (SI) for SO₂ emissions reduction. GR requires injection of natural gas as a reburning fuel above the coal burners for reduction of nitrogen oxides (NO_x) to molecular nitrogen (N₂). Burnout (overfire) air is injected higher up in the furnace to burn out fuel combustible matter, resulting in low levels of unburned carbon in ash and CO emissions. The nominal design gas input is 18% of the total heat input. SI involves injection of a calcium based sorbent, such as hydrated lime (Ca(OH)₂), into the upper furnace for reaction with sulfur dioxide (SO₂). Front wall injectors are used to inject sorbent at a rate corresponding to a calcium to sulfur molar ratio of 2.0. The products of the sorbent-SO₂ reaction are calcium sulfate (CaSO₄) and calcium sulfite (CaSO₃) which are captured by the particulate control device - an ESP in the case of Edwards Unit 1. GR achieves an incremental SO₂ reduction, since natural gas contains no sulfur.

This project was initiated in June 1987 and the design work (Phase I) was completed in March 1989. Full process and engineering designs for the Edwards Unit 1 GR-SI system have been prepared. The program did not enter into succeeding phases, including construction/start-up and field testing of the GR-SI system. This is due primarily to funding constraints specific to this site. GR-SI results in a significant increase in particulate loading into the ESP and an increase in the fly ash electrical resistivity. Edwards Station Unit 1 is equipped with a small ESP, which currently limits its maximum operating load. An analysis of the expected ESP performance under GR-SI operation, indicated that a significant upgrade of the ESP is required. The upgrade includes addition of 2 collection fields and upgrade of the SO₃ injection system currently in use. The costs of these ESP upgrades made the GR-SI program at Edwards Unit 1 prohibitive. While a reduction in the scope of the project, to application of GR only, was considered, it was decided to evaluate GR-SI at other host sites, where extensive ESP upgrades were not required.

2.1.3 Objectives of the Project

The project goals at this site were to reduce NO_x emissions by 60% and to limit SO₂ emissions to 1.8 lb/MBtu (770 mg/MJ), while firing a greater proportion of high sulfur Illinois coal. The NO_x emissions would be reduced from a full load baseline of 0.98 lb/MBtu (420 mg/MJ) to 0.39 lb/MBtu (170 mg/MJ). Edwards Unit 1 currently meets its SO₂ emissions limit of 1.8 lb/MBtu (770 mg/MJ) by using a blend of high sulfur Illinois coal and low sulfur Kentucky coal. A coal blend of 15% high sulfur coal, containing 2.5% sulfur (as fired basis), and 85% low sulfur coal, which has a sulfur content of 0.7%, results in 0.9% sulfur coal blend. The goal was to apply GR-SI while increasing the fraction of high sulfur Illinois coal to 57%, which corresponds to a coal blend sulfur content of 1.7%. Greater use of Illinois coal would be expected to have a positive economic impact on midwestern coal mining regions, which have suffered from a reduced demand for their coal, as utilities have switched to coal with a lower sulfur content.

2.1.4 Significance of the Project

The CCT project was initiated by the DOE to assist in development of technologies which reduce emissions of acid rain precursor gases, NO_x and SO₂. These gases, emitted from a variety of sources including coal fired utility boilers, are thought to contribute to the acid rain problem which has reportedly damaged lakes, streams and vegetation in the northeastern U.S. and eastern Canada. The emissions of NO_x and SO₂ were generally not controlled in units constructed before 1971, unless they were located in regions where standards for ambient ozone levels were not attained. Newer units have been required to comply with New Source Performance Standards (NSPS). The CCT projects undertaken by EER demonstrate GR-SI at three types of units which make up the majority of the firing configurations of older units in service. The project at Edwards Station Unit 1 was to demonstrate the feasibility of the GR-SI process for wall fired units, while the GR-SI process feasibility is demonstrated for tangentially fired and cyclone boilers at Hennepin and Lakeside Stations, respectively.

The GR-SI demonstration projects at the Hennepin and Lakeside Stations are among the first full scale applications of GR in the U.S. At these sites, GR has been shown to reduce NO_x emissions by more than the target level of 60%, with 67% reduction achieved over the long-term at tangentially-fired Hennepin Unit 1 and 66% reduction measured in long-term testing at cyclone-fired Lakeside Unit 7. At Hennepin, testing of advanced sorbents prepared by EER and the Illinois State Geological Survey (ISGS), showed that under optimum conditions calcium utilization in excess of 40% and SO₂ reduction up to 80% can be achieved. Conventional sorbents, in comparison, have utilization in the 20 to 30% range, with typical SO₂ reduction of 30 to 50%.

2.1.5 Role of the DOE, GRI, and ENR in the Project

The DOE, GRI and ENR played two key roles in the project, as the principal funding organizations and as technology reviewers and advisors. The DOE provided approximately 50% of project funds used for Phase I activities, including evaluation of baseline operation, process design work, preparation of engineering drawings, and presentation of the design work to project sponsors and the utility. The remainder of the funds were provided by GRI, ENR, and the host utilities. These organizations also reviewed the work completed by EER at several stages of the project. This included review of design work and expected impacts on various areas of unit performance and on the environment. In this role, they helped insure that the project objectives would be met without adverse impacts. Plans for transfer of the technology were also evaluated.

2.1.6 Technology Demonstrations at Other Sites

EER has demonstrated GR-SI at two other facilities and is completing a co-application of GR-LNB at a third facility. The goals of the GR-SI demonstrations were the same as for this site, 60% NO_x reduction and 50% SO₂ reduction. A GR-SI demonstration program has been completed at Illinois Power's Hennepin Station Unit 1, a 71 MW_e (net) tangentially fired unit burning medium to high sulfur coal. During the year-long GR-SI demonstration, NO_x reduction averaged 67.3% and the SO₂ reduction averaged 52.6%. Only minor impacts on the unit's

thermal performance, other areas of unit operation, equipment wear, and the local environment were determined. EER has also been conducted a GR-SI demonstration at a cyclone fired unit, Lakeside Station Unit 7, owned by City Water, Light and Power (CWLP) of Springfield, Illinois. This is a 33 MW_e (gross) cyclone fired unit. Long-term GR-SI testing at Lakeside Unit 7 achieved NO_x and SO₂ reductions of 66% and 58%, respectively. Therefore, the NO_x and SO₂ reduction goals have been met at both sites, with minor impacts on other areas of unit performance.

EER is completing a demonstration of GR and LNB at a wall fired unit in Denver, Colorado. Public Service Company of Colorado's Cherokee Station Unit 3, a 172 MW_e (gross) unit, has been retrofitted with low NO_x burners supplied by a commercial vendor and a GR system designed by EER. NO_x reductions of 60 to 73% have been achieved. Over 14 months of GR-LNB testing, NO_x reduction has averaged 64% at a gas heat input of 12%. A second-generation GR system, which has modifications to reburning fuel and burnout air ports, is currently undergoing testing. The second-generation GR system also offers significant savings in capital and operating costs.

2.2 Host Unit Description

Edwards Unit 1 is a 117 MW_e (net) front wall fired unit supplied by the Riley Stoker Corporation. At its Maximum Continuous Rating (MCR), the unit produces steam at a rate of 870,000 lb/hr (110 kg/s) at a design temperature of 1000°F (540°C) and pressure of 1840 psig (12,700 kPa). The unit reheats steam at a rate of 750,000 lb/hr (95 kg/s), also to a design temperature of 1000°F (540°C). The unit was designed to fire Illinois bituminous coal containing 3% sulfur. Due an SO₂ emissions limit it fires a blend of high sulfur and low sulfur coals. The coal blend has a sulfur content 0.9%, which corresponds to an SO₂ level of 1.4 lb/MBtu. Coal is pulverized by four CE-Raymond mills to a fineness of 70% passing 200 mesh U.S. standard sieve and then fed to sixteen burners--four burners at each of four levels. These are Riley Stoker flare type burners which produce short wide flames in the 24 ft (7.3 m) deep by 35 ft (10.7 m) wide radiant zone. Combustion gases flow up the water wall section and then

through pendant superheater and reheater convective sections, an economizer and a regenerative air heater. The flue gas is then ducted into the ESP for control of particulate matter emissions. Figure 2-1 is a schematic of Edwards Unit 1 and boiler design data are presented in Table 2-1.

The convective pass consists of primary and secondary superheaters, low and high temperature reheaters, an economizer and an air heater. The secondary superheater and high temperature reheater sections have a vertical configuration and are located just above the boiler arch. Gases flow horizontally across these sections and then through the primary superheater and low temperature reheater located in the backpass. The low temperature reheater and primary superheater have a parallel configuration in the backpass and are separated by a steam cooled baffle wall. Gas from the high temperature reheater is split in the backpass, flowing through either the low temperature reheater (front) or primary superheater (rear). Louver dampers control the fraction of gas flow to the front and rear of the backpass. Flue gas from both the low temperature reheater and primary superheater then pass through the economizer. This flue gas partitioning feature and superheater attemperation spray are used to control the superheat (main) and reheat steam temperatures.

The unit is equipped with 44 sootblowers supplied by Diamond Power Specialty Company. There are 26 wall blowers (model type "IR") located on the two side walls and rear wall and 18 long retractable (model type "IK") for cleaning of convective sections. Openings exist for 21 additional sootblowers: 9 wall blowers and 12 convective pass blowers. Sootblowers have also been installed in the air heater for maintaining air heater performance. The sootblowers use 150 psig (1030 kPa) compressed air as the cleaning medium.

The unit is equipped with an American Standard Series 371 Design 20-9P ESP for control of particulate matter emissions. The ESP provides 137 ft² of collecting plate area per 1000 acfm (27.0 m²/m³/s) at the unit's rated capacity of 117 MW_e (net). The ESP has an effective total plate area of 63,630 ft² (5910 m²) and has a design collection efficiency of 97%. It is the original particulate control device and barely meets the requirements of normal operation. The unit was

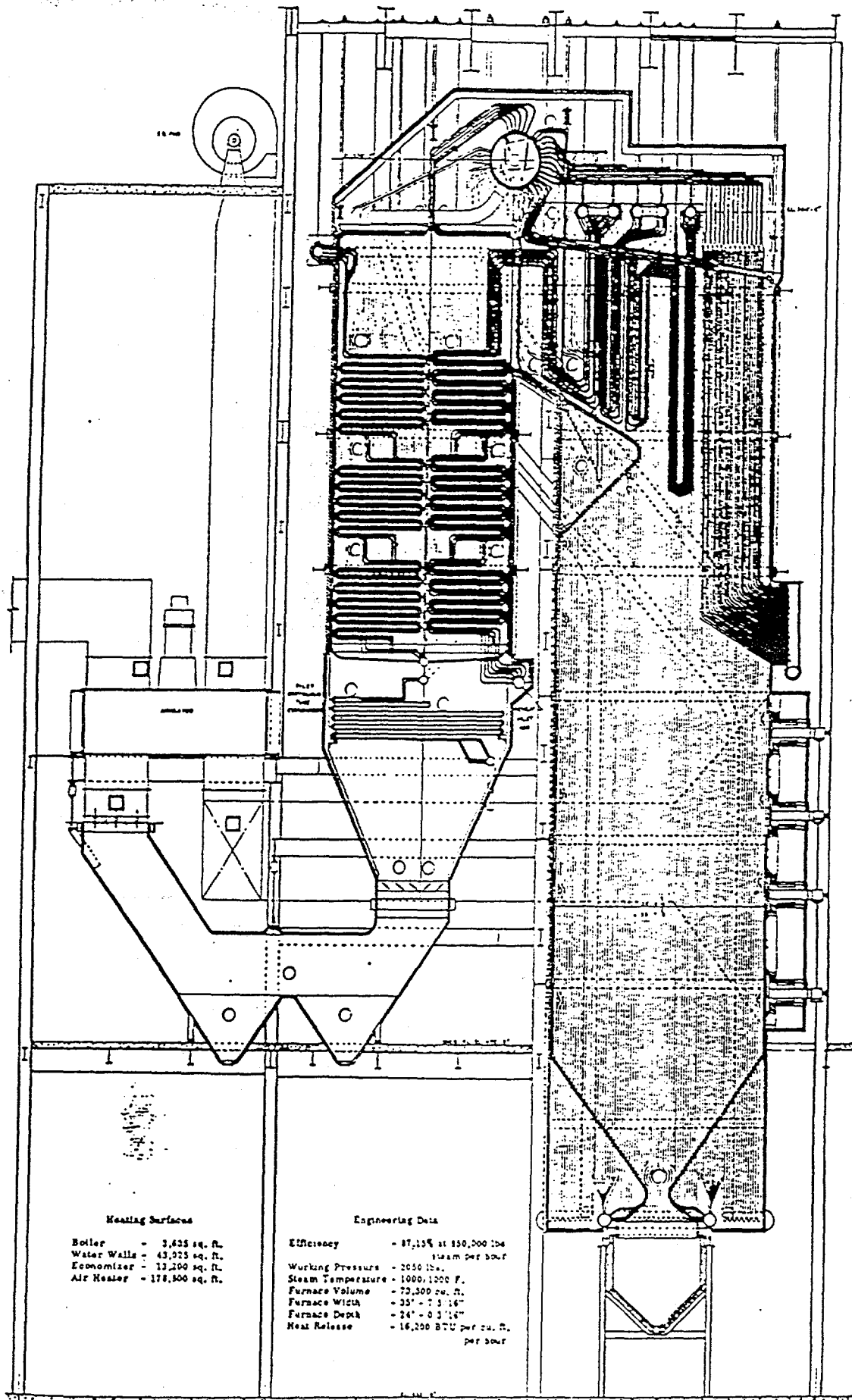

Heating Surfaces

Boiler - 3,635 sq. ft.
 Water Walls - 43,925 sq. ft.
 Economizer - 13,200 sq. ft.
 Air Heater - 178,800 sq. ft.

Engineering Data

Efficiency - 87.15% at 850,000 lbs
 steam per hour
 Working Pressure - 2050 lbs.
 Steam Temperature - 1000, 1020 F.
 Furnace Volume - 73,300 cu. ft.
 Furnace Width - 35' - 7.5" 16"
 Furnace Depth - 24' - 0.3" 16"
 Heat Release - 16,200 BTU per cu. ft.
 per hour

Figure 2-1. Schematic of Edwards Station Unit 1.

TABLE 2-1. EDWARDS UNIT 1 BOILER SPECIFICATIONS

Manufacturer	Riley Stoker
Design Fuel	Pulverized Coal, Illinois Bituminous
Boiler Firing Configuration	Single Wall Fired
Number of Pulverizers	4, with 4 Burner Elevations (16 Burners)
Superheat Steam Flow Rate	850,000 lb/hr at Maximum Continuous Rating
Superheat Steam Temperature	1000°F
Steam Pressure	1840 psig
Reheater Steam Flow	750,000 lb/hr
Design Efficiency	87.15%
Furnace Dimensions	35 ft. wide, 24 ft. deep
Furnace Volume	73,500 ft ³
Furnace Heat Release Rate	16,200 Btu/ft ³ hr

Heating Surface Areas of Boiler Components

- Boiler	4,911 ft ² (wing walls)
- Economizer	13,590 ft ²
- Water Walls	43,699 ft ² (total)
- Water Walls	26,487 ft ² (exposed to hot gases)
- Superheater	42,230 ft ²
- Reheater	45,606 ft ²
- Air Heater	178,800 ft ²

designed to fire coal containing 3% sulfur, but currently fires a 0.9% sulfur coal blend. The reduced coal sulfur content results in a reduction in flue gas SO₃ concentration which degrades ESP operation due to a significant increase in fly ash resistivity. To maintain stack plume opacity at the 30% limit, the unit is typically operated at a maximum load of 95 MW_e (gross) and SO₃ is injected at a rate corresponding to concentrations of 10 to 15 ppm. Baseline operating conditions, thermal performance, and emissions have been quantified during several test periods.

3.0 GR-SI PROCESS

3.1 GR-SI Technology Overview

The GR-SI process requires injection of natural gas into the furnace for chemical reduction of NO_x and injection of calcium based sorbent, such as $\text{Ca}(\text{OH})_2$, for capture of SO_2 . Natural gas is injected at a point above the coal burners to create a fuel rich zone in which NO_x is reduced to N_2 . The process requires rapid mixing of the reburning fuel with the primary combustion products; therefore, an inert carrier gas (FGR) is injected with the natural gas. FGR is used as a low O_2 injection gas to improve jet penetration into the furnace and reduce mixing time. The GR process has been extensively evaluated in bench and pilot scale studies which have shown the significance of several parameters including zone stoichiometric ratios (which quantify the excess or deficiency in combustion air compared to the theoretical demand), reburning zone residence time, and gas temperature. Micron sized sorbent (mass mean diameter under 5 microns) is injected into the upper furnace cavity for SO_2 capture. The parameters which control the sorbent- SO_2 reaction process are the gas temperature, sorbent reactivity, and gas temperature quench rate. The utilization of the calcium based sorbent is relatively low, requiring injection of large amounts to achieve modest SO_2 reductions. The high SI rates result in additional burden on the particulate matter collection device (baghouse fabric filter or ESP); therefore, sufficient particulate matter collection capacity must exist or upgrade of the system is required.

The GR process has been developed over the last twenty-five years. A flue gas NO_x incinerator using natural gas was patented by the John Zink Company (Reed, 1969). The term "reburning" was originally coined by researchers at Shell Development Company, who reduced NO produced by a laboratory flat flame by adding methane or ammonia to the combustion products. The process, which was originally developed in the United States was first applied at full-scale by Mitsubishi Heavy Industries Ltd. and Ishikawajima-Harima Heavy Industries Ltd. of Japan (Takahashi, et al., 1981). EER, with funding from the DOE, EPA, and GRI, has conducted extensive bench and pilot scale testing to establish the process parameters and to develop appropriate scaling methodology for applying GR to U. S. boilers (Chen et al., 1983; Greene

et al., 1985; McCarthy et al., 1985; Chen et al., 1986).

The GR process divides the furnace into three zones in which primary coal combustion, reburning, and fuel burnout take place. The process is shown in Figure 3-1 and described below:

Primary Combustion Zone - Coal is fired at a rate corresponding to 75 to 85% of the total heat input. The primary combustion zone is typically operated at a stoichiometric ratio of 1.10. This is the optimum coal zone stoichiometric ratio with respect to flame stability, primary NO_x formation and ash carbon loss.

Reburning Zone - Natural gas is injected, corresponding to 15 to 25% of the total heat input. Natural gas injection results in formation of a fuel rich (stoichiometric ratio of 0.9) zone wherein NO_x formed in the primary combustion zone is reduced. Hydrocarbon fragments, other reducing species and free radicals reduce NO_x to N_2 . The reburning fuel injection location is optimum for completion of coal combustion and to maximize the reburning zone residence time.

Burnout Zone - OFA is injected higher up in the furnace, to complete fuel combustion at normal excess air levels (e.g. 18% excess air: stoichiometric ratio of 1.18). The air is taken from the secondary air ducts. The injection location is optimized with respect to gas temperature and burnout zone residence time, to limit emissions of CO and unburned carbon in ash. The gas temperature in this zone is generally not high enough for additional NO_x formation.

Care must be taken in the design of both the reburning fuel and OFA injection systems to prevent entrainment downward into the primary and reburning zones, respectively. Both injected streams must be mixed rapidly with the furnace gas to form suitable zones in which reburning and burnout take place. The systems are optimized with respect to injection location, number of injectors, size of injectors, and injection velocity. The presence of CO in an oxidizing

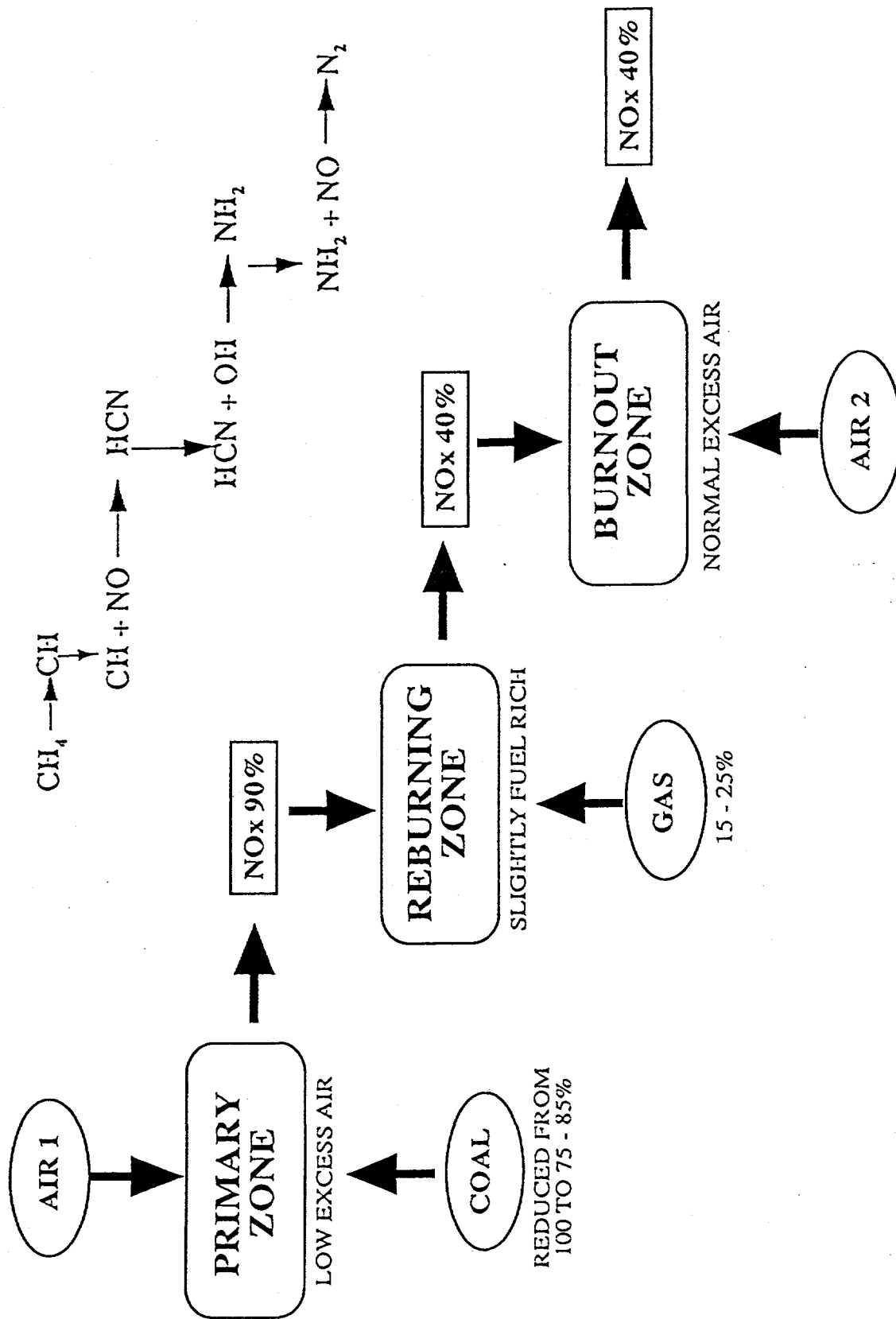

Figure 3-1. Overview of Gas Reburning process.

environment is a function of temperature. At temperatures normally associated with burnout(overfire) air, 2400 to 2500°F (1320 to 1370°C), burnout of CO to CO₂ is rapid. Therefore, the process is controlled by the rate and completeness of mixing of burnout air with the furnace gas.

The reburning fuel injectors are not burners, i.e. the fuel is not premixed with combustion air. The reburning fuel is "reburned" or partially oxidized with excess air from the primary combustion zone. The primary method by which safety is ensured is injection into a location where gas temperature is sufficiently high that rapid reaction between the injected fuel and the residual oxygen in the flue gas is assured. The control system also includes a series of permissives (conditions which must be satisfied for injection of natural gas) and trips (unacceptable conditions under which natural gas injection is shut off).

The sorbent sulfation process must also be optimized with respect to the same parameters as those for the GR process - mixing and dispersion rates. The process, which is illustrated in Figure 3-2, involves two steps, sorbent calcination followed by sulfation. In the first step, calcium hydroxide or calcium carbonate undergo calcination to form highly reactive calcium oxide (CaO). In the second step, the CaO reacts with SO₂ and oxygen to form solid CaSO₄ and CaSO₃, which are entrained in the flue gas with coal ash. The SI system must be optimized with respect to gas temperature (injection location), injector momentum (i.e. amount of injection air), and gas temperature quench rate. Sorbent sulfation occurs optimally in the 2200°F to 1600°F (1200°C to 870°C) temperature range. If the sorbent is exposed to gas temperatures in excess of 2350°F (1290°C) a loss in effective surface area occurs, resulting in reduced reactivity (deadburning). Sorbent sulfation is also impacted by the rate of gas temperature quench, with an optimal residence time of 1.0 second in the 2200°F to 1600°F (1200°C to 870°C) temperature window. To achieve rapid mixing of sorbent jets with the flue gas, injection air corresponding nominally to 3% of the combustion air is used. The key sorbent properties, sulfation mechanisms and typical SO₂ reduction are summarized in Figure 3-3. The key to high utilization is in the structure of the porous CaO, with Ca(OH)₂ producing the most reactive CaO particles. SO₂ must be transported to the particles and the transport in the pores limits the

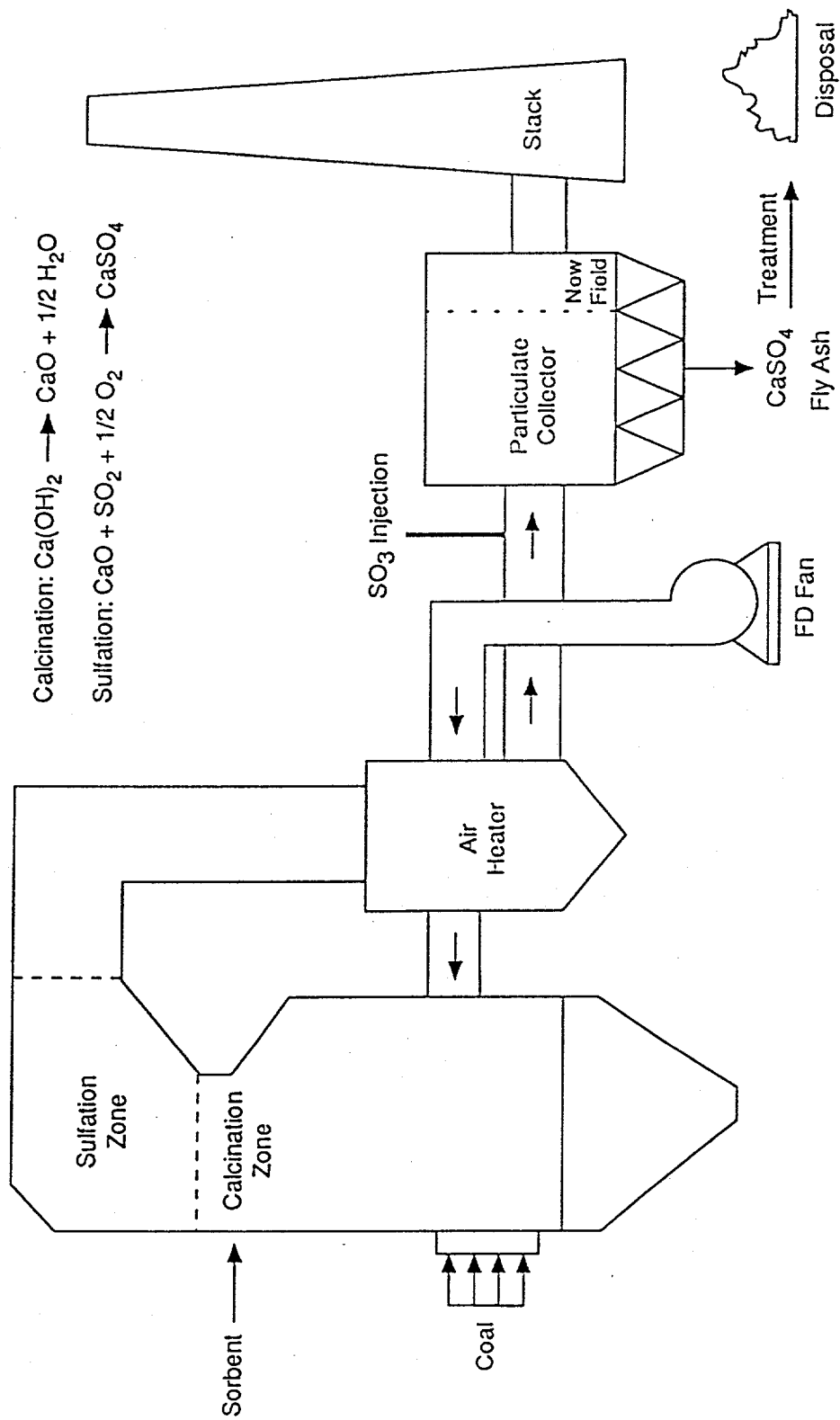
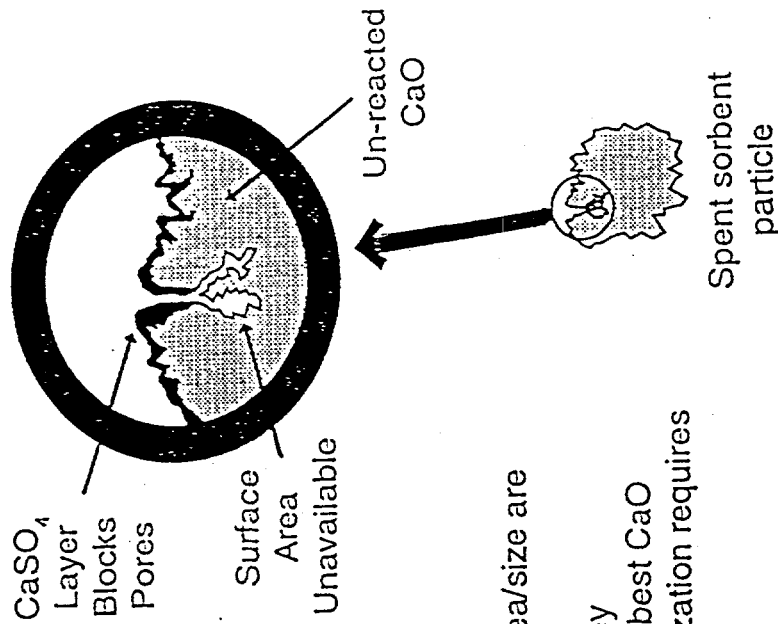

Figure 3-2. Overview of Sorbent Injection process.

Mechanisms

- SO₂ transport to particle
- SO₂ Transport in pores (limiting)
- Sulfation reactions



Sorbent Properties

- Sorbent surface area/size are second order
- CaO structure is key
- Ca(OH)₂ produces best CaO
- Sorbent characterization requires combustion test

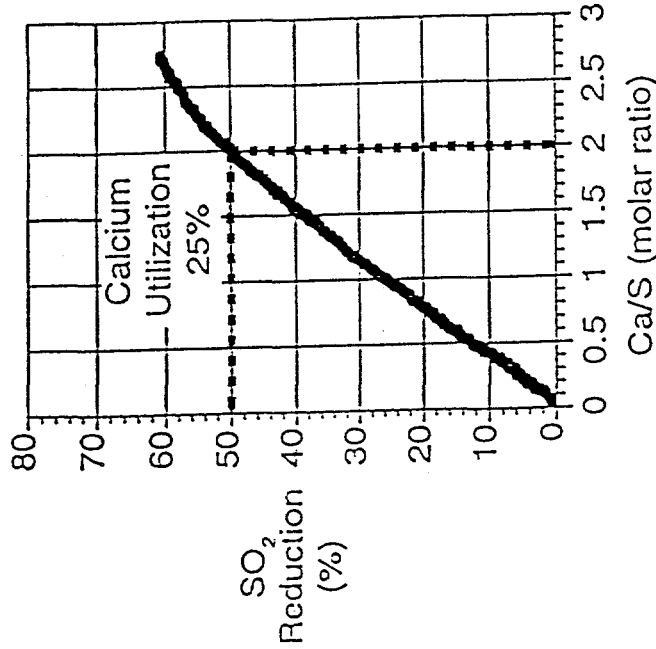

Figure 3-3. Key sorbent properties, sulfation mechanisms and typical SO₂ control

process. Enhanced utilization occurs with smaller sorbent particles which have higher surface area. Sorbent utilization is generally in the 20 to 30% range. At a calcium to sulfur molar ratio of 2.0, 50% SO₂ reduction may be expected.

The Edwards GR-SI system design involved the use of several design tools developed by EER. These include isothermal physical flow modeling, heat transfer modeling, and chemical reaction modeling. Both GR and SI processes require optimization with respect to mixing rates and chemical dispersion. Candidate injector configurations were evaluated with a 1/14th scale isothermal physical flow model. The suitability of injector configurations was determined through visual observation of smoke and neutrally buoyant bubbles and through measurement of tracer dispersion.

Visual observation of smoke and helium bubbles were used to determine if the jet configuration and momentum flux were sufficient to fully penetrate the furnace depth, while chemical tracers (such as methane) were used to measure the extent of dispersion of the injected gases at several furnace planes. The GR-SI system injector specification for Edwards Unit 1 is shown in Figure 3-4.

Heat transfer modeling was conducted with a 2-dimensional heat transfer code (2D Code), which calculates both radiative and convective heat transfer to various heat exchangers. The heart of the code is a radiative heat transfer model, which accounts for radiative beams through the processes of emission, gas-phase attenuation, absorption, and reflection to a numerical tolerance. The 2D Code does not calculate steam side heat balance; therefore, a boiler code was used in conjunction with the 2D Code. The boiler code accounts for steam heat balance in each heat exchanger and calculates both gas phase and steam side heat balance in heat exchangers which are beyond the domain of the 2D Code (primary superheater and low temperature reheater).

Chemical modeling of the CaO sulfation and NO_x reduction processes was also performed to estimate theoretical SO₂ and NO_x emissions reductions. Sulfation modeling was conducted both empirically, based on test furnace results, and theoretically with a more sophisticated technique

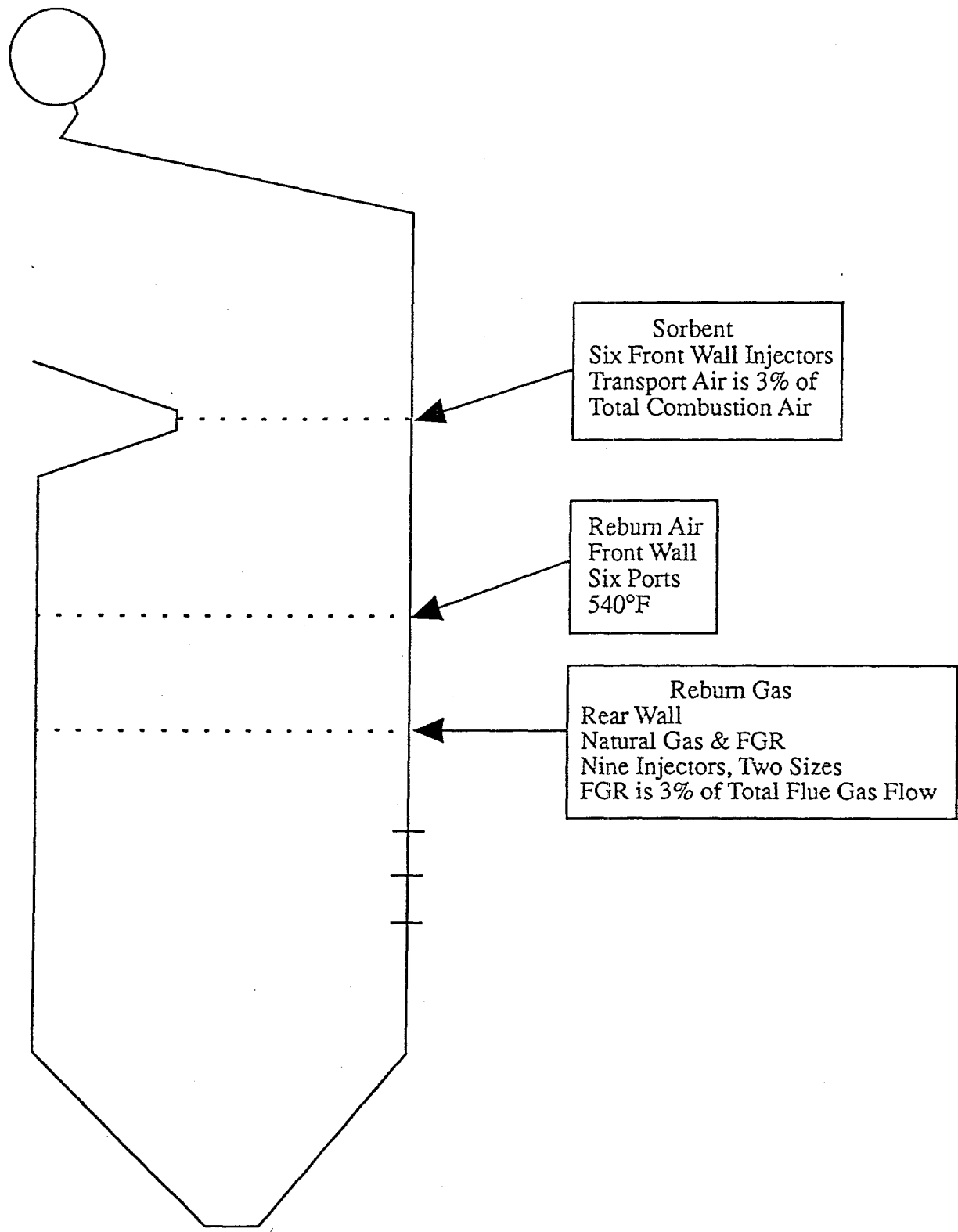

Figure 3-4. GR-SI injector specification for Edwards Unit 1.

in which sulfation, heat transfer and jet-in-cross-flow models were superimposed. NO_x reductions were also estimated from the results of extensive bench and pilot scale studies conducted by EER.

3.2 Edwards Station Unit 1 GR-SI Process Design

The GR-SI system for Edwards Unit 1 was designed to meet the performance goals of emissions reduction, with limited impacts on steam generation and other areas of unit operation/performance. The Edwards Unit 1 GR-SI process design criteria are shown in Table 3-1. The GR-SI system design is based on full load 117 MW_e (net) operation, but the system was designed to follow load over a wide range, from 45 MW_e to 117 MW_e (net). The unit generates power with a baseline net heat rate of 10,800 Btu/kWh (11,400 kJ/kWh); the baseline full load heat input is 1,260 MBtu/hr (369 MJ/s). The nominal GR condition requires replacement of 18% of the coal heat input with natural gas, requiring 3870 scfm (1.83 Nm^3/s) at full load. For the Edwards Unit 1 GR-SI system the design zone stoichiometric ratios are: 1.10 in the primary zone, 0.90 in the reburning zone, and 1.18 in the burnout zone. These were determined to be optimum for coal zone burner operation, reburning zone NO_x reduction, and burnout of combustible matter in the final zone. The nominal SI condition requires injection of sorbent to achieve a Ca/S molar ratio of 2.0, while sulfation modeling predicted a Ca/S molar ratio of 1.5 would be sufficient for meeting the SO_2 emissions limit of 1.8 lb/MBtu (770 mg/MJ) when firing a higher fraction of high sulfur Illinois coal. The process design task also evaluated suitable coal blends with the blend of 57% high sulfur Illinois coal and 43% low sulfur coal selected. The composition of coal fired at Edwards Unit 1 and a typical natural gas composition are listed in Table 3-2. The sorbent to be used is hydrated lime, $\text{Ca}(\text{OH})_2$. The design basis assumed 78% of the fly ash and virtually 100% of the sorbent would flow into the ESP.

Reburning fuel and FGR are injected through two sizes of injectors from the rear wall of the furnace at the elevation of the upper burner row. This elevation was selected due to the limited space in the furnace and the reburning zone residence time requirement. Reburning fuel will be injected through two sizes of nozzles for both shallow and deep penetration. During GR,

TABLE 3-1. GR-SI PROCESS DESIGN CRITERIA FOR EDWARDS UNIT 1

Gas Reburning

NO _x Reduction	60%
Natural Gas Input	18% of total heat input
Stoichiometric Ratios	
Primary Burner Zone	1.10
Reburning Zone	0.90
Burnout (Exit) Zone	1.18
Overfire Air	21% of total combustion air
Flue Gas Recirculation (Total)	6% of flue gas

Sorbent Injection

SO ₂ Reduction (total)	50%
SO ₂ Reduction (sorbent)	39%
Ca/S Molar Ratio	2.0
Sorbent Composition	Ca(OH) ₂
Sorbent Injection Air	3% of combustion air

Flue Gas Handling

Total Flue Gas	261,163 scfm (@ 640°F, -3" W.C.)
SO ₃ Injection Rate	50 ppm
Particulate Removal	99.8%

TABLE 3-2. FUEL COMPOSITIONS USED IN EDWARDS UNIT 1
GR-SI PROCESS DESIGN

Coal Composition and Properties

	Eastern	Illinois	Blend	
Proximate Analysis (%)	Bituminous	(Midland Mine)	(57/32: Illinois/Eastern)	
Fixed Carbon, (Dry)	57.40	49.52	53.14	
Volatile Matter, (Dry)	36.65	39.28	38.07	
Ash, (Dry)		5.95	11.20	8.79
Moisture, (As Received)	6.15	16.59	12.10	
Heating Value (As Fired) (Btu/lb)	13,438	10,635	11,840	
Ultimate Analysis (%)				
Carbon, (Dry)	79.99	71.05	75.15	
Hydrogen, (Dry)	5.09	4.99	5.04	
Nitrogen, (Dry)	1.45	1.03	1.22	
Chlorine, (Dry)	0.13	0.04	0.08	
Sulfur, (Dry)	0.69	2.99	1.93	
Oxygen, (Dry)	6.70	8.49	7.66	
Ash, (Dry)		5.95	11.20	8.79
Ash Fusion Temperature, Reducing (°F)				
Initial Deformation	2370-2700+	1975		
Softening	2540-2700+	2090		
Hemispherical	2630-2700+	2195		
Fluid	2700+	2305		

Natural Gas Composition and Properties

<u>Constituent</u>	<u>Volume (%)</u>	<u>Constituent</u>	<u>Volume (%)</u>
CH ₄	90.60	i-C ₅ H ₁₂	0.03
C ₂ H ₆	2.70	Other Hydrocarbons	0.11
C ₃ H ₈	0.60	CO ₂	0.75
n-C ₄ H ₁₀	0.06	N ₂	4.0
i-C ₄ H ₁₀	0.12	Specific Gravity	0.6092
n-C ₅ H ₁₂	0.03	HHV (Btu/SCF)	996

only the three lower rows of burners will be in service. This will result in higher heat release through the lower three rows of burners (80 to 82% of the total heat input, instead of 75% under normal 4-mill operation). FGR will be used for two purposes, to provide the necessary momentum flux for the reburning fuel and to provide burner cooling of the top row of burners. Approximately 3% of the flue gas will be recycled with the reburning fuel injectors and a smaller quantity will be directed through the top row of burners for cooling. During the GR process design, front wall reburning fuel injection, rear wall injection, and injection from both walls were considered. Rear wall injection was selected because it was expected to minimize entrainment downward into the burner zone.

OFA will be injected through front wall ports at a higher point in the furnace. The elevation was selected as optimum both for reburning zone residence time and for a sufficiently high gas temperature to burn out CO and fly ash carbon. Heat transfer modeling indicated that the gas temperature at the OFA injection plane under full load GR-SI operation would be 2400 to 2500°F (1320 to 1370°C). In this temperature range, CO rapidly burns out in an oxidizing environment; therefore, the process is controlled by the speed and completion of the mixing. The number of injectors was limited by the presence of wingwalls, requiring placement of ports between wingwall sections. During the process design work, three OFA velocity to burner velocity ratios were evaluated: $V_{\text{OFA}}/V_{\text{BURNER}} = 4$, $V_{\text{OFA}}/V_{\text{BURNER}} = 2$, and $V_{\text{OFA}}/V_{\text{BURNER}} = 1$. The highest OFA velocity case resulted in complete furnace penetration but some entrainment down into the reburning zone; the lowest velocity case (which corresponded to that of the normal secondary air ducts) indicated that flow was insufficient to fully penetrate the furnace flow field; and the intermediate velocity resulted in good mixing with the furnace flow field. Front wall ports inject 50,000 scfm (23.7 Nm³/s) air at 540°F (280°C) under full load nominal GR conditions. The OFA is taken from the secondary air ducts, and booster fans increase the pressure to the level required to overcome flow (friction) and injection losses.

Sorbent is injected in the upper furnace at an elevation appropriate for the sulfation process. Front wall injectors are used with the injection air stream corresponding to 3% of the total

combustion air. The injection plane is the bottom of the boiler arch, where the gas temperature was estimated to be near the optimum for sorbent sulfation, 2200°F (1200°C). The sorbent must be mixed rapidly with furnace gas, requiring use of a significant amount of transport air. SI was also optimized with respect to injection velocity, since the furnace gas velocity is relatively high at the furnace arch. The SI system requires an additional injection configuration through the OFA ports, for 50% load GR-SI operation. This is the optimum elevation with respect to gas temperature at part load. Sidewall injection is not possible due to the presence of convective heat transfer elements.

One of the major concerns in applying GR-SI to Edwards Unit 1 was in maintaining proper particulate matter control. The ESP is small, resulting in a maximum operating load of 95 MW_e (gross), while firing the 0.9% sulfur coal blend. The unit was designed to fire 3% sulfur coal and the reduction in coal sulfur reduces the flue gas SO₃ concentration. SO₃ reacts with water to form low concentration of acids which condense on the surface of fly ash, enhancing its electrical conductivity. Therefore, utilization of low sulfur coals degrades ESP performance, resulting in lower maximum operating voltages. At Edwards Unit 1, SO₃ injection is used to enhance ESP performance. Injection of sorbent and switching toward utilization of more Illinois coal (which has higher ash content than the low sulfur coal) will result in a substantial increase in the ESP inlet loading and higher fly ash electrical resistivity. Therefore, significant effort was given to determine the extent of ESP performance degradation and necessary enhancement. To maintain the required particulate emissions and stack opacity while operating GR-SI, ESP performance enhancement by addition of two electric fields and upgrade of the current SO₃ injection system, from approximately 15 ppm to 100 ppm of SO₃, was found to be necessary.

3.3 Edwards Station Unit 1 GR-SI System Performance Goals

The GR-SI system was designed to reduce emissions of NO_x and SO₂ by 60 and 50%, respectively, with minor impacts on unit capacity, steam temperatures, and other areas of operation/performance. Emissions of CO₂, a contributor to the greenhouse-global warming effect, would be expected to decrease by approximately 8% due to the differences in

carbon/hydrogen ratios of the fuels fired. Emissions of CO would be maintained relatively low (below 150 ppm) by effective use of the OFA system. Emissions of particulate matter would be maintained by upgrade of the ESP. The process design work indicated that relatively minor impacts on steam temperature, the gas temperature profile and furnace exit gas temperature (FEGT) would result. A modest reduction in unit efficiency and a corresponding increase in heat rate will also result from GR-SI operation. A potential impact on slagging and fouling was also addressed.

Heat transfer modeling was used to determine the impacts on the unit's thermal performance. The predicted temperature profiles for baseline, GR, and GR-SI operation are compared in Figure 3-5. The GR profiles indicate that the gas temperature will be higher in the lower furnace due to increase in the heat input through the lower three burner rows and to reduction in the burner stoichiometric ratio. The gas temperature will be shifted downward relative to the baseline level, at the plane of top burner row due to the effect of FGR injection. A modest reduction in gas temperature results from overfire air injection.

The impacts of GR-SI on steam output, steam temperature, superheater attemperation rate, heat absorption by the various heat exchangers, and gas temperatures at full load are listed in Table 3-3. GR-SI operation results in a shift in the fraction of the flue gas passing through the primary superheater side (instead of the cold reheater) in the backpass. The percentage of flue gas flowing through the superheater side will be increased from 76.9 to 78.7%, to compensate for the fouling effect of SI. A relatively small reduction in the steam output of both the main steam and the reheated steam will result. The main steam output will decrease from 842,300 to 831,000 lb/hr (106.2 to 104.8 kg/s) and the reheated steam flow will decrease from 743,200 to 733,300 lb/hr (93.7 to 92.5 kg/s). Superheater attemperation spray will increase by 5,000 lb/hr (0.63 kg/s). The design steam temperature of 1000°F (540°C) will be maintained both for the main and reheat steam. Intermediate steam temperature (i.e. primary superheater outlet) is higher than in the baseline case. This is due to a shift in heat absorption, with higher than baseline heat absorption at the economizer and primary superheater. Heat absorption rates in other areas are reduced, particularly at the secondary superheater and waterwall. The gas

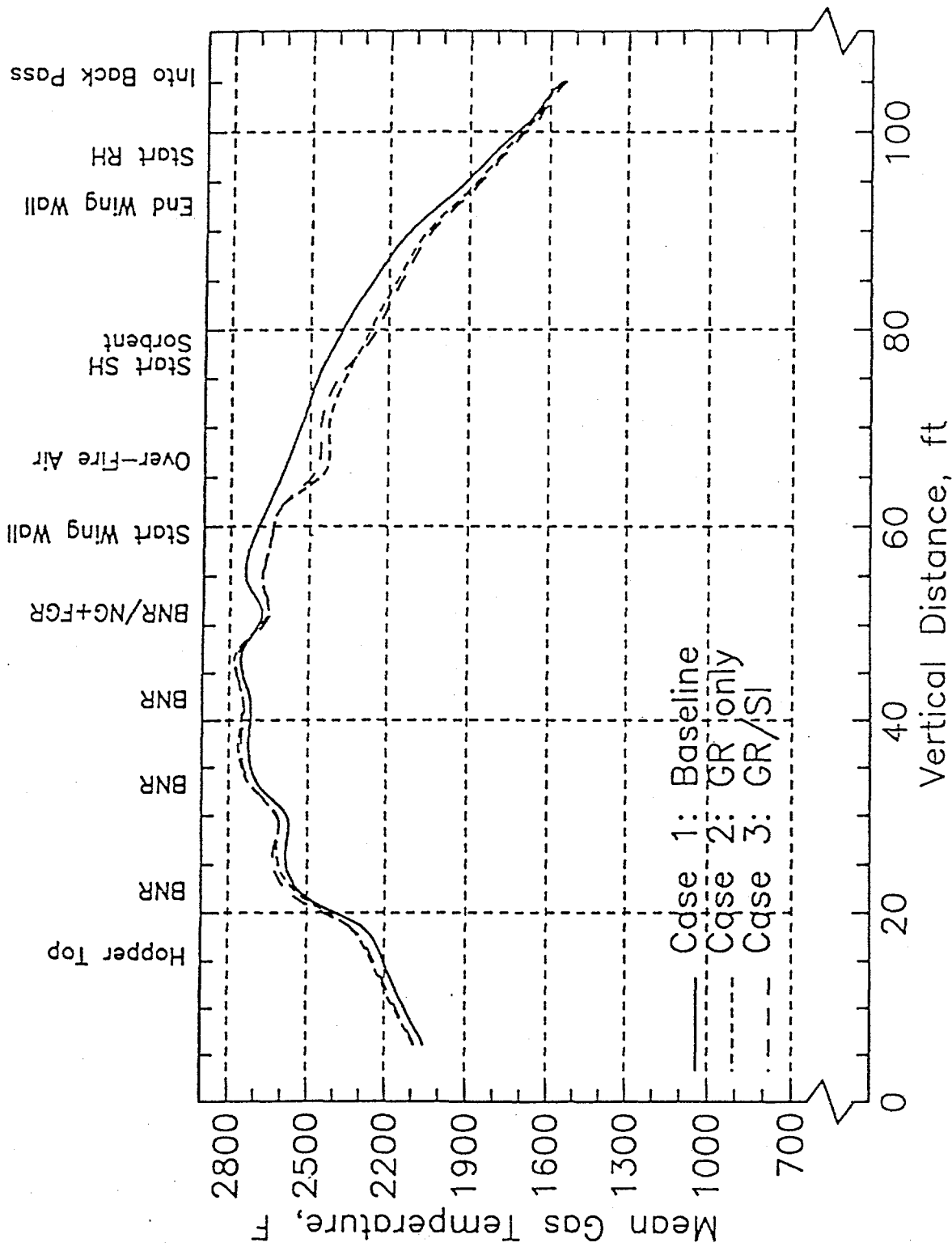

Figure 3-5. Mean gas temperature profile at 100% load at Edwards Unit 1, under Baseline, Gas Reburning, and GR-SI conditions

TABLE 3-3. EDWARDS UNIT 1 BOILER PERFORMANCE PREDICTIONS
EFFECT OF GAS REBURNING AND SORBENT INJECTION AT 100% LOAD

	<u>BASELINE</u>	<u>GR-SI</u>
Back Pass Split Ratio		
Percent of Flue Gas to SH Side	76.9	78.7
Steam Mass Flows (klb/hr)		
Into Economizer	784.6	768.3
SH Attenuation Spray	57.7	62.7
Exit Superheater	842.3	831.0
Reheater	743.2	733.3
Steam Side Temperatures (°F)		
Into Economizer	406	406
Exit Economizer	447	453
Into Primary Superheater	633	633
Exit Primary Superheater	800	829
SH Attemp. Spray Water	406	406
Into Secondary Superheater	728	738
Exit Secondary Superheater	1000	1000
Into Low Temperature Reheater	645	645
Exit Low Temperature Reheater	788	790
Exit High Temperature Reheater	1000	1000
Heat Transfer to Steam (MBtu/hr)		
Economizer	35.3	39.2
Waterwall	560.6	544.3
Primary Superheater	162.6	175.4
Secondary Superheater	167.8	154.9
Low Temperature Reheater	57.2	57.0
High Temperature Reheater	82.9	81.2
Gas Side Temperatures (°F)		
Into Back Pass	1538	1522
Exit Primary Superheater	861	877
Exit Low Temperature Reheater	681	680
Exit Economizer	708	723
Exit Air Heater	320	343

temperatures at several locations have been calculated. The primary difference between the baseline case and the GR-SI case is that GR-SI is expected to result in a 23°F (13°C) increase in the air heater gas outlet temperature.

The expected impact of GR-SI operation on the thermal efficiency is presented in Table 3-4. The thermal efficiency, as calculated by the "ASME Test Form for Abbreviated Test" (PTC 4.1-a and 4.1-b), is expected to decrease by 2.66%, from 88.55 to 85.89%. The primary reason for this reduction is the increase in flue gas moisture, resulting from combustion of natural gas. The second greatest contributor to the increase in heat loss is from dry gas heat loss, associated with the increased air heater gas outlet temperature. The moisture from fuel is expected to increase due to firing more Illinois coal, which has a higher moisture content than the low sulfur coal. Some increase in ash combustible matter is also expected under GR-SI operation.

Reductions in emissions of NO_x and SO₂ by 60 and 50%, respectively, would be expected. At full load, NO_x emissions would decrease from 0.98 lb/MBtu (420 mg/MJ) to 0.39 lb/MBtu (170 mg/MJ). The NO_x reduction achieved is likely to be dependent on the extent of primary zone combustion completion. Poor primary zone combustion would be expected to increase the oxygen concentration in the reburning zone, resulting in a decrease in reburning efficiency. As shown in Figure 3-6, good primary zone combustion would be expected to result in full load NO_x emissions of 0.39 lb/MBtu (170 mg/MJ) and poor primary zone combustion would be expected to result in emissions of 0.54 lb/MBtu (230 mg/MJ).

The goal of the GR-SI program at Edwards Unit 1 is to maintain SO₂ emissions below 1.8 lb/MBtu (770 mg/MJ), while firing a 57/43 high to low sulfur coal blend. A 50% reduction in SO₂ emissions from the uncontrolled level is expected. Since 18% of the coal heat input is replaced with natural gas, which contains no sulfur, a sorbent SO₂ reduction of 39% is needed. Figure 3-7 illustrates the predictions for SO₂ capture under full load, 75% load and 50% load operation. The 39% capture level, denoted by the line, is required to achieve 50% total reduction. The expected Ca/S molar ratio operating band of 1.5 to 2.2 is shown, for the 50% to 100% load range. These results are expected for upper configuration SI and show the impact

TABLE 3-4 THERMAL EFFICIENCY CALCULATED BY THE
ASME ABBREVIATED HEAT LOSS METHOD

Effect of Gas Reburning and Sorbent Injection at 100% Load

	<u>BASELINE</u>	<u>GR-SI</u>
Heat Loss (%)		
Dry Gas	4.85	5.29
Moisture in Fuel	0.67	0.95
Moisture from Combustion	3.68	5.15
Combustible in Refuse	0.50	0.97
Radiation	0.25	0.25
Unmeasured	<u>1.50</u>	<u>1.50</u>
 Total Losses	 11.45	 14.11
 Thermal Efficiency (%)	 88.55	 85.89

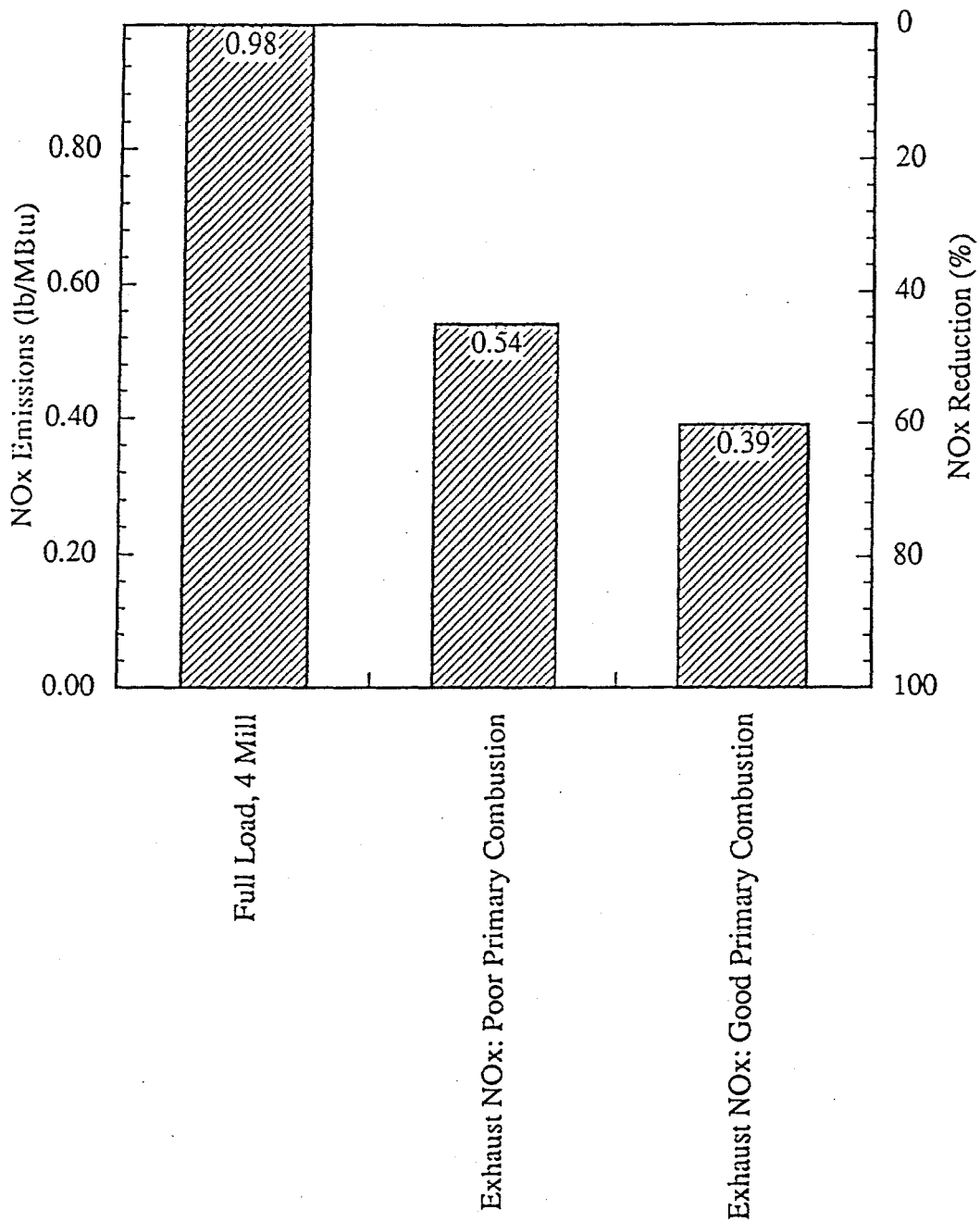

Figure 3-6. Predicted NOx reduction due to Gas Reburning at Edwards Unit 1

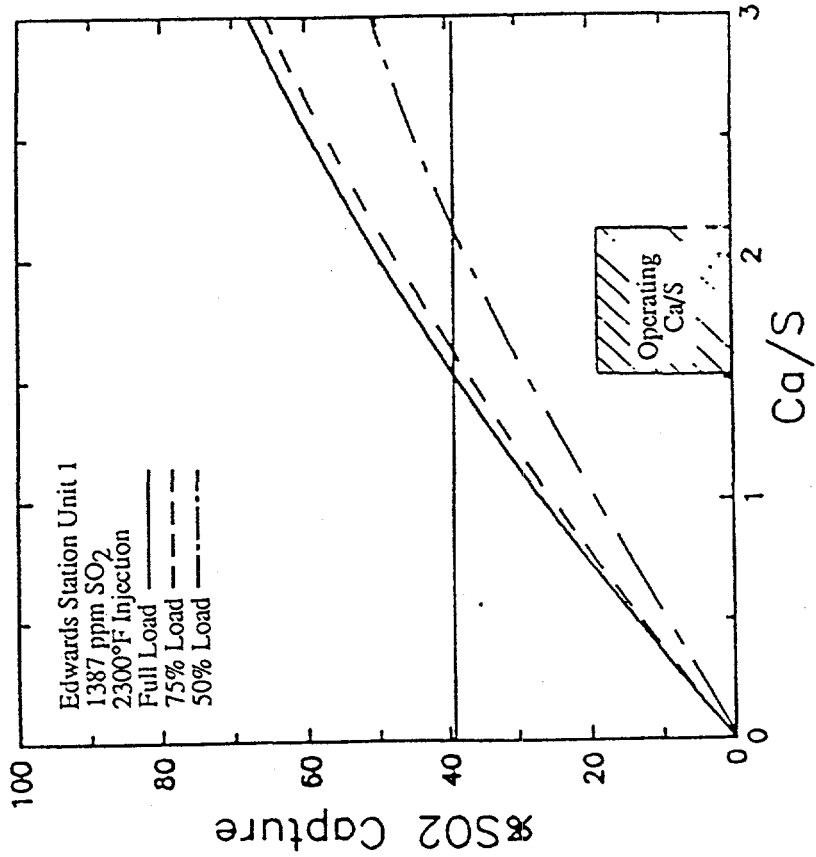
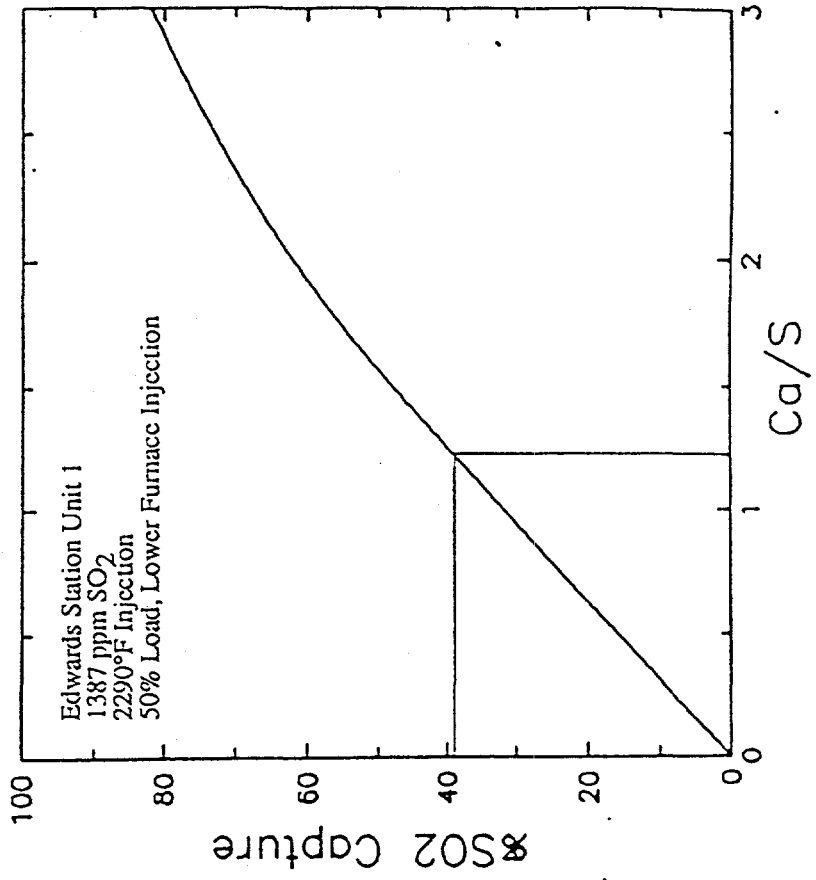

Figure 3-7. Predicted SO₂ capture at Edwards Unit 1

of gas temperature on sorbent sulfation, i.e. sulfation rates drop with gas temperature as load is reduced. At 50% load, SI would be shifted to the lower furnace (OFA port) location, which is expected to enhanced SO₂ capture.

The process design studies addressed other areas including ESP performance, furnace slagging, convective pass fouling, and tube wall wastage rates. The ESP upgrade would be expected to maintain particulate matter emissions and stack opacity well below the compliance limits of 0.2 lb/MBtu (86 mg/MJ) and 30%, respectively. A potential increase in lower furnace slagging may result from a higher heat release through the lower three rows of burners and slightly reducing conditions in the reburning zone. The initial deformation temperature of the high sulfur coal is somewhat lower than that for the low sulfur coal. This may result in increased slagging since high sulfur coal will account for a greater percentage of coal fired. Fouling of convective heat exchangers, especially the secondary superheater and high temperature reheater, would be expected to increase due to sorbent deposition. But, the design calls for installation of additional sootblowers, which would operate over greater periods of time, resulting in reduction in fouling rates. Tube wall wastage in the convection pass is impacted by the gas velocity, particulate matter composition (especially silica and alumina content) and sootblower operation. Since the unit is operated at lower overall excess air levels, the gas velocity would be expected to decrease, resulting in lower wastage. The particulate matter flow into the upper furnace would be expected to significantly increase under GR-SI operation, but the sorbent material is less erosive than normal fly ash. Increased sootblower operation, due to sorbent fouling, has the potential to increase tube wall wastage but this may be limited by sootblower air pressure and frequency of operation since additional sootblowers will be installed. An extensive monitoring plan has been devised to determine the extent of any adverse impacts of GR-SI operation.

3.4 Expected GR-SI Environmental Impacts

Environmental and permitting requirements of the project have been determined. The areas addressed include environmental, health, safety, and socioeconomic (EHSS) concerns; floodplain/wetlands impacts; the impacts of pipeline construction on archeological, cultural and

historical (ACH) resources; management of GR-SI byproducts; permitting requirements; and environmental monitoring to ensure environmental and process acceptability. The project involves several temporary and permanent modifications to the facility configuration which require approval from the state regulatory authority, the Illinois Environmental Protection Agency (IEPA). The project involves retrofitting Edwards Station Unit 1 with GR and SI systems as well as modifications of the ESP. The ESP upgrades include addition of two collecting fields and upgrade of the SO₃ injection system. The temporary changes include reductions in NO_x emissions and a possible increase in PM₁₀ emissions (particulate matter with an aerodynamic diameter under 10 microns). The SI process also generates a mixture of fly ash, unreacted sorbent (CaO), and spent sorbent (CaSO₄/CaSO₃). This is the most significant waste material to be discarded, prompting evaluation of several options, with dry collection and off-site disposal selected. Current practice is to dispose of both the bottom and fly ash from Units 1, 2, and 3 by wet sluicing to an on-site pond. The dry fly ash disposal technique will result in a reduction in the sluice water requirement and total amount of particulate matter sluiced to the pond.

The project is expected to have only minor environmental impacts. The project will result in reduction in NO_x emissions, no change in SO₂ emissions, and a possible increase in PM₁₀ emissions due to injection of micron sized sorbent. The NO_x emissions would be reduced by 60%, from 0.98 to 0.39 lb/MBtu (420 to 170 mg/MJ). SO₂ emissions would be held below the regulatory limit of 1.8 lb/MBtu (770 mg/MJ), while firing a higher fraction of high sulfur Illinois coal. SI results in a doubling of the particulate loading to the ESP, with a higher fraction of the particulate matter of smaller size than normal fly ash. This may result in an increase in PM₁₀ emissions, depending on the success of the ESP enhancement measures. The increase in PM₁₀ would be expected to be small, below the 15 tpy (14 tonne/a) level which would trigger Prevention of Significant Deterioration (PSD) measures of the Clean Air Act Amendments. The GR-SI process will also result in a small increase in the stack gas temperature (approximately 15°F [8°C]), due to fouling of heat transfer surfaces. This should improve dispersion of gases and therefore would be positive from an environmental standpoint. The GR-SI process also results in production of a mixture of normal coal fly ash and

unreacted/spent sorbent. This mixture has unique properties which require the special disposal techniques described below. Since the fly ash will no longer be sluiced to the on-site pond as is the current practice, the project will result in a reduction in Unit 1 sluice water usage, from 0.6 million gallons per day (MGD) to 0.1 MGD (2.3 to 0.4 million liters per day). There will also be a corresponding reduction in the solid matter sluiced, thereby extending the life of the ash pond.

One concern which was addressed is that the temporary reduction in NO_x may trigger new source review or PSD provisions upon completion of the test project. Section 60.14 of Title 40 of the Code of Federal Regulations (40 CFR 60.14) states that "any physical or operational change to the existing facility which results in an increase in the emission rate to the atmosphere of any pollutant to which a standard applies shall be considered a modification," necessitating permitting of the facility as a new source. In addition, 40 CFR 52.21 states that an increase in NO_x emissions of 40 tpy (36 tonne/a) will require application of PSD provisions of the Clean Air Act Amendments. The PSD provisions for PM_{10} apply for an increase of 15 tpy (14 tonne/a). Since the potential application of either provision would be a significant hindrance to the evaluation of the GR-SI technology, the permitting analysis indicated that a "no action" assurance should be solicited from the IEPA. A precedent has been set for this in the case of a reburning program at Ohio Edison's Niles Plant, in which EPA gave such an assurance. It was expected that IEPA would also allow the temporary increase in PM_{10} emissions, since the primary purpose of the project is to reduce NO_x and SO_2 emissions and since measures will be taken to minimize the PM_{10} increase. In the GR-SI project completed at Illinois Power's Hennepin Station Unit 1, IEPA ruled (with the concurrence of the U.S. EPA), in its permit to construct, that the GR-SI retrofit is not a modification necessitating review as a new source.

Two areas relating to worker health were considered. These are the expected noise levels from construction and GR-SI operation and exposure to sorbent and other dust emitted during construction. The noise created from construction activities is excluded from regulation. The GR-SI system design includes several fans which would be expected to increase the noise levels experienced by the workers. The fan noise would be in addition to background noise from

normal plant operation and would not be expected to exceed the 85 decibel limit set by the Department of Labor's Occupational Safety and Health Administration (OSHA). A pipeline must be erected to carry natural gas to Edwards Unit 1, since the station currently has no gas firing capacity. Pipeline construction would be limited to a 35 foot (11 m) wide path and will result in some temporary dust emissions. Fugitive emissions of the calcium based sorbent are of greater concern and are limited by the dustless pneumatic transport system. The transport system is equipped with air vents, but these are equipped with bag filters to prevent fugitive dust emissions. If the sorbent is to be handled directly by workers, handling procedures will be required including dust filters and tight fitting goggles.

The socioeconomic impacts of the project have been estimated. Edwards Station is in the vicinity of the Peoria, Illinois, metropolitan area. There is adequate availability of housing and other resources. The project requires 7760 man-hours, over a 29 month period, which has a small positive impact on the local labor pool, even though the construction/testing would be directed by non-local EER employees. The project will also require the local purchase of various equipment during construction and testing, thereby assisting the local economy. The GR-SI demonstration at the Edwards Station results in an increase in the truck traffic, with Unit 1 requiring 20 trucks per day instead of 12. The dry ash handling requires 4 trucks per day and additional truck transport is required for the sorbent. The total number of trucks to the station will increase from 91 to 99 per day. The truck traffic would be along a major highway (Highway 24), on which the additional traffic would be very minor. The GR-SI demonstration will enable midwestern utilities to fire a larger amount of the local high sulfur coal, while maintaining compliance with SO₂ emissions limits. This will increase the demand and usage of Illinois coal, which would be expected to significantly improve the economy of Illinois coal mining areas.

The impacts on energy and materials have also been quantified. The GR-SI equipment will require a maximum auxiliary power of 1,063 kW which is 0.9% of the unit generating capacity and 0.15% of the station capacity. The replacement of 18% of coal with natural gas heat input will require 3870 scfm (1.83 Nm³/s) of natural gas, which is 0.06% of the 6.5x10⁶ scfm (3080

Nm³/s) available beyond the current U. S. consumption. Coal usage in Unit 1 will decrease by approximately 18% during GR-SI operation, from a full load coal flow of 100,000 lb/hr (12.6 kg/s). The year-long demonstration also will require approximately 10,600 tons (9640 tonne) of sorbent, which is 0.06% of the 17 million ton (15.5 million tonne) capacity of the U. S. market.

The project at Edwards Station was not expected to significantly impact floodplain/wetlands areas. Federal regulations require that adequate consideration be given to floodplain/wetlands impacts when changes in the site configuration are undertaken. While pipeline construction will be through some areas in a 100 year floodplain, these activities will be temporary and the pipeline will be covered with at least 42 inches (110 cm) of soil, resulting in no permanent change to the floodplain. Several authorities including the U.S. Fish and Wildlife Service and the U.S. Army Corps of Engineers have indicated that pipeline construction will have minimal impacts on the floodplain/wetlands. The majority of construction activities will be in the boiler area which are not in the floodplain.

Consideration of the impact of pipeline construction on archeological, historical, and cultural (ACH) resources has also been investigated. Since federal funds will be used, federal regulations (36 CFR 800: "Protection of Historic Properties") require that the Illinois Historic Preservation Agency (IHPA) and the State Historic Preservation Officer (SHPO) evaluate and minimize archeological/cultural impacts. An archeological survey of the proposed gas pipeline route was conducted by Archeological Consulting Services (ACS) of Madison, Wisconsin. The survey found one large and two small prehistoric sites and one cluster of buildings in the pipeline route. ACS recommended to the SHPO that the larger site be further examined and no action be taken with respect to the smaller sites. The cluster of buildings appears to be of recent origin, therefore of no historic significance. If a significant site is found, then the artifacts may be moved to another site. If a highly significant site is found, then the pipeline may be rerouted. In either case no major impediments to the construction of the pipeline are apparent and ACH resources will be preserved.

The most significant waste produced by the GR-SI process is the particulate waste, which is a mixture of normal coal ash, unreacted sorbent (CaO), and spent sorbent (CaSO₄). This waste is similar to fly ash produced from firing high calcium western coal and necessitated evaluation of composition, leaching characteristics, pozzolanic activity, and temperature rise upon addition of water. Coal obtained from the Edwards Station was fired in EER's test furnace under baseline and simulated GR-SI conditions. The composition of the baseline ash was 50% silica, 25% alumina, 9% ferric oxide, and various other materials. The GR-SI ash was 44% CaO and 11% CaSO₄, indicating that the mixture was approximately 50% normal coal ash and 50% unreacted/spent sorbent. This is the expected ratio of coal ash/sorbent from nominal GR-SI operation. The pozzolanic activity was evaluated in two tests, 7-day and 28-day tests. The test involves a replacement of 35% of cement in a mix with the material evaluated. The 7-day test compressive strength is 784 psi (5400 kPa) and the 28-day test result expressed as a percentage of the pure cement control case is 134%. This indicates that the mixture forms a very hard material. The temperature rise upon addition of water was 0.9°F (0.5°C) for the baseline ash and 14°F (8°C) for the GR-SI ash. The leaching characteristics were evaluated with the EPA's EP toxicity test. The results, shown in Table 3-5, indicate that the metals concentrations are all below levels under which the ash would be considered toxic. Several waste management alternatives were considered, and dry collection and disposal at an off-site landfill was selected.

To ensure environmental and project acceptability and to develop a data base for the GR-SI technology, an extensive environmental monitoring plan was developed. The plan, which includes monitoring each phase of the project, is outlined in Tables 3-6 and 3-7. Both normal compliance measurements and supplemental measurements will be taken. The compliance measurements include discharge water quality, coal composition, opacity and SO₂ emissions measurement during GR-SI operation. The more extensive supplemental measurements include detailed water quality measurements, gaseous emissions, noise and worker health monitoring.

TABLE 3-5. RCRA EP CHEMICAL CHARACTERISTICS

Concentration (mg/l)	Baseline Ash	GR-SI Ash	EPA Hazard Level
Arsenic	<0.1	<0.1	5.0
Barium	<0.2	<0.2	100.0
Cadmium	0.11	<0.1	1.0
Chromium	0.48	0.15	5.0
Hexavalent Chromium	<0.04	<0.04	---
Lead	<0.05	<0.05	5.0
Mercury	<0.0005	<0.0005	5.0
Selenium	<0.1	<0.1	1.0
Silver	0.03	0.09	5.0
Sample Weight (g)	100.04	100.03	
Volume of 0.5N acetic acid required for pH adjustment (ml)	300	400	
Volume of deionized water added to the extract (ml)	1700	1600	
Final volume of the extract (ml)	2000	2000	
Initial pH	10.41	12.12	
Final pH	4.84	12.09	

RCRA: Resource Conservation and Recovery Act

TABLE 3-6. ENVIRONMENTAL MONITORING IN PHASES I AND II

<u>MEASUREMENT</u>	<u>SAMPLE TYPE</u>	<u>FREQUENCY</u>	<u>LOCATION</u>
COMPLIANCE			
<u>WATER</u>			
Flow Rate	24 hr total	once/wk	ash pond discharge
pH	grab sample	once/wk	ash pond discharge
TSS	8 hr composite	once/wk	ash pond discharge
Oil and Grease	grab sample	once/mo	ash pond discharge
<u>GASEOUS EMISSIONS</u>			
Coal Composition	24 hr	daily, as	coal belt to hopper
sulfur	composite	bunker is	
ash		loaded	
Btu/lb			
moisture			
Opacity	in-situ optical	continuous	stack breeching
SUPPLEMENTAL			
<u>WATER</u>			
General Use Water	grab sample	twice ¹	Illinois River - 100 feet
Quality Standards			upstream and downstream
			of ash pond discharge
pH	grab sample	twice ¹	ash pond influent
Effluent Water	grab sample	twice ¹	ash pond discharge
Standards			
<u>GASEOUS EMISSIONS</u>			
NO _x	in-situ	continuous ²	economizer exit/stack
CO	in-situ NDIR	continuous ²	breeching
O ₂	in-situ paramagnetic	continuous ²	
SO ₂	in-situ NDUV	continuous ²	
<u>AIR</u>			
Noise	sound level meter	once ³	near equipment installation
<u>WORKER HEALTH</u>			
Hearing	N/A	once ¹	TBD
Pulmonary Function	N/A	once ¹	TBD
Vital Signs	N/A	once ¹	TBD

- 1) Must occur prior to initiation of GR-SI start-up in Phase 3.
- 2) Measurements taken during two-week period in Phase 1.
- 3) During GR-SI system start-up.

TABLE 3-7. ENVIRONMENTAL MONITORING IN PHASE III

<u>MEASUREMENT</u>	<u>SAMPLE TYPE</u>	<u>FREQUENCY</u>	<u>LOCATION</u>
COMPLIANCE			
<u>WATER</u>			
Flow Rate	24 hr total	once/wk	ash pond discharge
pH	grab sample	once/wk	ash pond discharge
TSS	8 hr composite	once/wk	ash pond discharge
Oil and Grease	grab sample	once/mo	ash pond discharge
<u>GASEOUS EMISSIONS</u>			
Coal Composition: sulfur, ash, H ₂ O, Btu/lb	24 hr composite	daily	coal belt to hopper
Opacity	in-situ optical	continuous	stack breeching
SO ₂	(1)		
SUPPLEMENTAL			
<u>WATER</u>			
General Use Water Quality Standards	grab sample	as required	Illinois River - 100 feet upstream & downstream of ash pond discharge
pH	grab sample	as required	Within ash pond and at discharge
TSS	grab sample	as required	ash pond discharge
<u>GASEOUS EMISSIONS</u>			
NO _x	in-situ chemiluminescent	continuous	economizer exit/stack
CO	in-situ NDIR	continuous	breeching
CO ₂	in-situ NDIR	continuous	
O ₂	in-situ paramagnetic	continuous	
SO ₂	in-situ NDUV	continuous	
Particulate	Method 17	(2)	ESP Inlet
	Method 5	(2)	ESP Outlet
Particulate Size	Cascade Impactors	(2)	ESP Inlet & Outlet
Resistivity	Cyclonic flow probe	(2)	ESP Inlet
Velocity	Method 2	(2)	ESP Inlet
<u>SOLID WASTE</u>			
Ash	grab sample	sample daily	ESP hopper/economizer
Chemical components		analysis as	hopper
EP toxicity test		required	
<u>WORKER HEALTH</u>			
Hearing	N/A	once/yr	TBD
Pulmonary Function	N/A	once/yr	TBD
Vital Signs	N/A	once/yr	TBD

1. SO₂ compliance requirements will be determined by CILCO and IEPA
2. Measurements taken once during Phase III - baseline, parametric, and long-term testing.

4.0 GR-SI SYSTEM ENGINEERING DESIGN

4.1 Engineering Design Overview

The GR-SI system process design for Edwards Unit 1 led to detailed engineering design in several areas, including:

- Gas Reburning
- Sorbent Injection
- Gas Pipeline Construction
- GR-SI Power and Control Systems
- ESP Upgrade
- SO₃ Injection System Upgrade
- Sootblowing System Upgrade

This section presents the Edwards Unit 1 GR-SI System Engineering Design. The system was designed to convey natural gas to the boiler through rear wall nozzles at the elevation of the top row of burners. Recycled flue gas is used as both an inert carrier gas for the natural gas and as a cooling gas to the top row burners. The top row of burners would not be in service during GR operation, to allow separation of the primary coal combustion and GR processes. OFA is injected at a higher elevation to provide the necessary oxygen level to fully burn out the fuels. The preheated combustion air is redirected into the upper furnace at a rate corresponding to approximately 21% of the total combustion air. The system was also designed to store, meter, and convey micron sized hydrated lime sorbent into the upper furnace for capture of SO₂. Extensive upgrades of the ESP and SO₃ injection systems were also planned as well as installation of additional sootblowers to enhance heat transfer to devices affected by sorbent fouling. Figure 4-1 is an overview of the GR and SI systems. Figure 4-2 is a full load material balance, showing all process stream flow rates, pressures, and temperatures. Figure 4-3 shows a full load energy balance predicted for GR-SI operation.

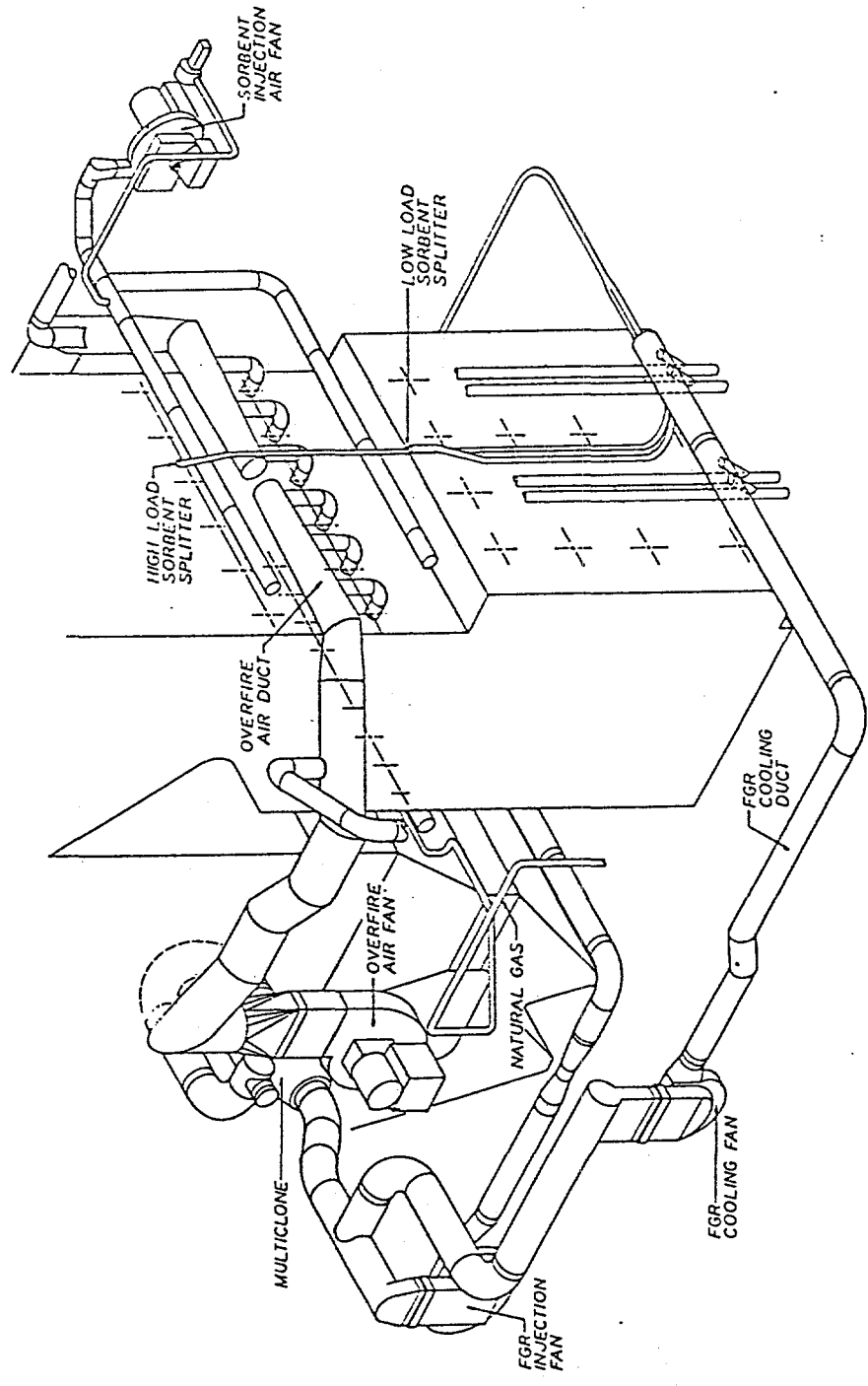
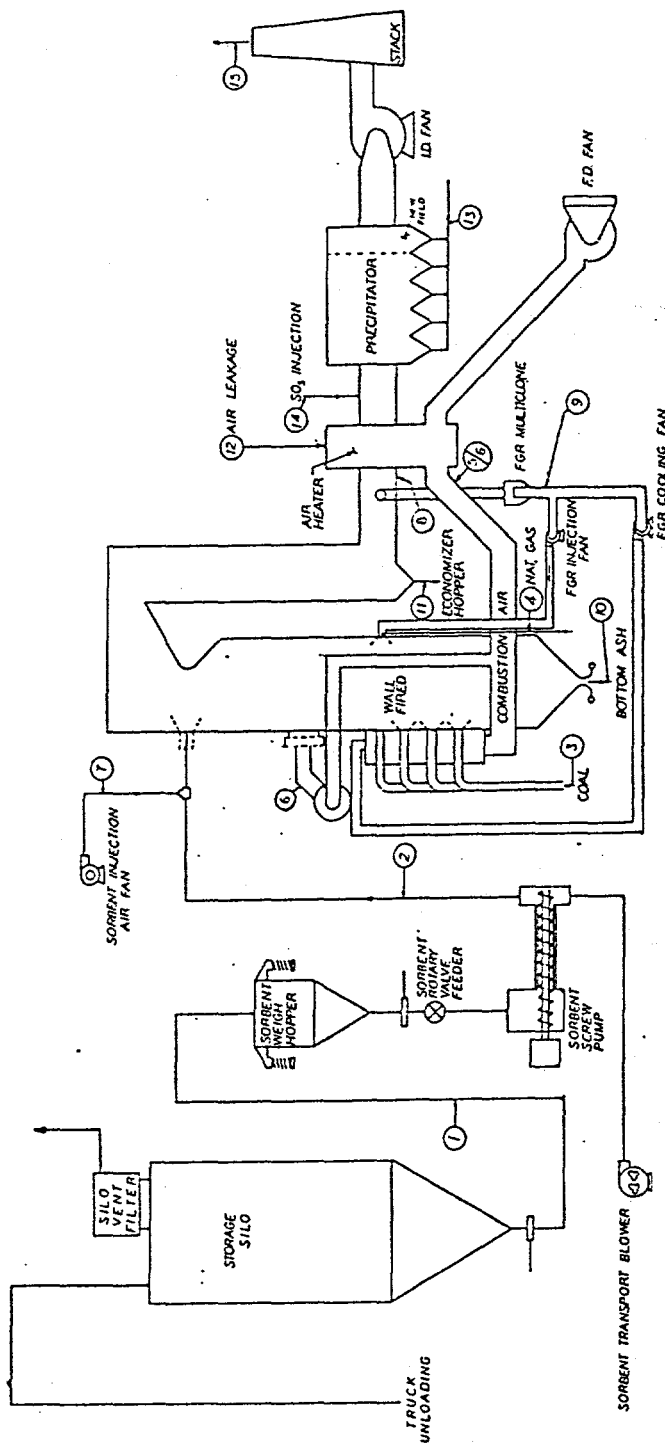

Figure 4-1. Overview of Edwards Unit 1 GR-SI system



4-3

STREAM NUMBER	1	2	3	4	5	6	7	8	9	10	11	12	13	14	15
DESCRIPTION	STORAGE SILO TRANSFER	SORBENT FEED	COAL	NATURAL GAS	COAL COMBUSTION AIR	OVERFIRE AIR	SORBENT INJECTION AIR	FLUE GAS	FLUE GAS RECIRCULATION	BOTTOM ASH	ECONOMIZER	AIR LEAKAGE	ESP	SO ₂ INJECTION	STACK GAS
GAS SIDE:															
AIR LBS/HR		1372			855170	232416	32265					97000			
AIR SCFM		299			186474	50679	7036					21151			
NATURAL GAS LBS/HR				10786											
NATURAL GAS SCFM				3870											
FLUE GAS LBS/HR								1212513	71000						1309513
FLUE GAS SCFM								261163	15292						282312
SO ₂ LBS/HR								1.43							
SO ₂ LBS/MTU								0.4						50	
NO _x LBS/MTU															
H ₂ O LBS/HR								640°F	640°F						
TEMPERATURE					550°F	550°F	120°F	640°F	640°F						
PRESSURE				15 PSIG	1.5"	10"	75"	NFG 3.0"	48" 7"						
SOLID SIDE:															
COAL (COMBUSTIBLES) LBS/HR			80504												
FUEL INERTS LBS/HR			6744							1349	135		5260		
SORBENT LBS Ca(OH) ₂ /HR	6860	6860													
CaSO ₄ LBS/HR															
CaO LBS/HR										1349	135		2458		
TOTAL SOLIDS LBS/HR	6860	6860	87248										4179		
MAXIMUM DESIGN FLOW LBS/HR	10290	10290		15410									11894		
BASES		3:1 Ca/S		25% G.I.I.		25% G.I.I.	40000		85000				14490		
							120% CAP		120% CAP				3:1 Ca/S		

Figure 4-2. Full load GR-SI material balance for Edwards Unit 1.

* SCFM @ 14.7 PSIA 60°F

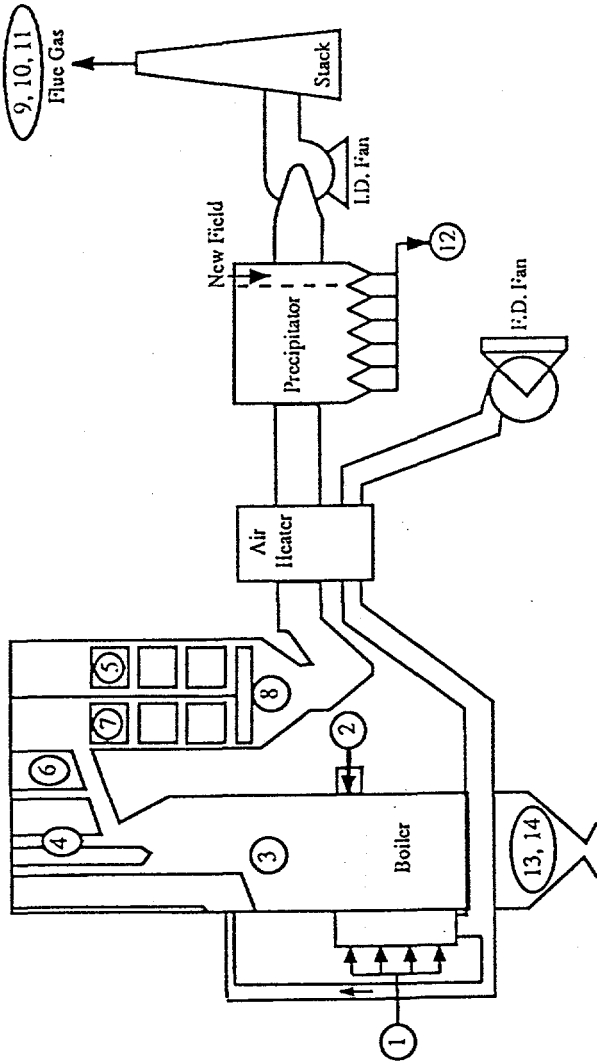

No.	Source/ Device	Heat Input (MBtu/hr)	Heat Input (% of Total)	Steam Heat Absorption (MBtu/hr)	Steam Heat Absorption (% of input)	Heat Loss (MBtu/hr)	Heat Loss (% of input)
1	Coal	1033.0	81.7				
2	Natural Gas	231.3	18.3				
3	Waterwall			544.3	43.1		
4	Secondary Superheater			154.9	12.3		
5	Primary Superheater			175.4	13.9		
6	High Temp. Reheater			81.2	6.4		
7	Low Temp. Reheater			57.0	4.5		
8	Economizer			39.2	3.1		
9	Dry Gas					66.9	5.3
10	Moisture in Fuel					12.0	1.0
11	Moisture from Combustion					65.1	5.2
12	Combustible in Refuse					12.3	1.0
13	Radiation					3.2	0.3
14	Unmeasured					19.0	1.5
Total		1264.3	100.0	1052.0	83.2	178.4	14.1

Figure 4-3. Full load GR-SI energy balance.

4.2 Edwards Station Unit 1 GR-SI Engineering Design

4.2.1 Natural Gas Pipeline and Injection System

The GR system was designed to inject natural gas at a rate corresponding to 18% of the total heat input under normal conditions and at 25% of the total in the maximum design case. These correspond to normal and maximum design natural gas flows of 3870 scfm (1.83 Nm³/s) and 5530 scfm (2.61 Nm³/s), respectively. The gas train incorporates automatic and manual shut-off valves, a pressure reducing valve, a gas flowmeter, a flow control valve, and safety shut-off valves. The normal and maximum design pressures are 7.5 psig (52 kPa) and 15 psig (103 kPa), respectively. Edwards Station currently does not have a natural gas supply; therefore, the system includes the installation of an 8" (20 cm) pipeline to transport natural gas a distance of 5,400 ft (1650 m) from a 24" (61 cm) high pressure pipeline. While only a 6" (15 cm) pipeline is actually required, the larger size was chosen since CILCO had desired to provide gas for light-off burners to other units from this supply. The reburning fuel is injected through nine rear wall injectors with FGR. Due to the limited upper furnace residence time, the natural gas is injected at the elevation of the upper burners. GR operation would be limited to the three lower elevations of burners. The natural gas and FGR are injected from the rear wall through two sizes of injectors for both shallow and deep penetration of reburning fuel jets. The smaller nozzles have a nominal injection velocity of 150% of the larger nozzles. Since these are gas injectors and not gas burners, no luminous flame is produced; therefore, the normal flame safety techniques were not applicable. Special GR operation/safety techniques were incorporated into the control system design.

4.2.2 Flue Gas Recirculation System

Flue gas is recirculated from the breeching between the economizer outlet and the air heater inlet. The economizer outlet location was selected due to the low oxygen level, since it is upstream of the air heater, where air leakage contributes to the flue gas oxygen concentration. It is directed to a multiclone, for removal of particulate matter, then to booster fans. The

multiclone is used to reduce the particulate grain loading by approximately 80%, from 6 gr/dscf (13.7 g/m³) to 1.2 gr/dscf (2.7 g/m³). This is done to reduce wear on the booster fans and other downstream equipment. FGR is used both to increase the reburning fuel mass flow, thereby improving the mixing time, and to cool the top row of burners. The normal FGR-injection flow (for injection of reburning fuel) requirement is 37,500 lb/hr (4.73 kg/s) at a pressure of 29" W.C. (7.2 kPa), while the maximum design case is 45,000 lb/hr (5.67 kg/s) at a pressure of 41" W.C. (10.2 kPa). The fan boosts the pressure from -6" W.C. (-1.5 kPa) to provide the required pressure head for injection. The gas temperature is approximately 640°F (340°C), which is sufficiently high to prevent quenching of the combustion process but is not optimum for the cooling application. FGR-cooling gas, used to cool the top row of burners, requires a smaller flow rate of 11,500 lb/hr (1.45 kg/s) under normal operation and a maximum design case of 13,700 lb/hr (1.73 kg/s). The pressure increase required is much less, from -6" W.C. (-1.5 kPa) to +10" W.C. (+2.49 kPa), allowing the use of a smaller fan. Tight shut-off dampers are incorporated into the design to ensure no backward leakage from the boiler to the economizer outlet, when FGR is off. The FGR-cooling gas is directed to the burner lines which will be equipped with an air shroud device to prevent air leakage to the burners.

4.2.3 Overfire Air System

OFA is injected through front wall ports at a location corresponding to a reburning zone residence time of 0.6 seconds. The 550°F (290°C) burnout air is injected at a much lower velocity than was required for reburning fuel injection. Modeling was conducted to evaluate three overfire air injection rates, at jet-to-burner velocity ratio with the furnace gas of 1, 2, and 4. The low velocity, corresponding to the present windbox pressure, was insufficient to mix with the furnace flow field. The high velocity jets impacted the rear wall and were entrained downward into the reburning zone. The intermediate velocity was effective in rapidly mixing with the furnace gas before flow into the convective section. The air is taken from the secondary air ducts with two booster fans used to increase the pressure. Air flow through each fan is approximately 133,000 lb/hr (16.8 kg/s), a total flow of 266,000 lb/hr (33.5 kg/s), and the pressure is increased from approximately +1.5" W.C. (0.4 kPa) to +10" W.C. (2.5 kPa).

4.2.4 Sorbent Injection System

The SI system was designed to inject dry micron sized sorbent at a rate of 1,000 lb/hr (0.13 kg/s) to 10,500 lb/hr (1.32 kg/s) through front wall injectors. The 57/43 high-to-low sulfur coal blend results in an average sulfur content of 1.7%. A nominal Ca/S molar ratio of 2.0 requires a SI rate of 6,860 lb/hr (0.86 kg/s). The system includes two injection configurations to be used at full and reduced loads. The sorbent and transport air stream is carried pneumatically to each nozzle. It is introduced into the center of the nozzle and a more substantial SI air stream is added to provide the necessary jet momentum and mixing time.

Sorbent is transported to the site by heavy trucks which have a capacity of 20 to 25 tons (18 to 23 tonne) and unloaded pneumatically to a storage silo. The trucks are weighed on a scale, then the sorbent is unloaded via a truck mounted blower into the silo. The sorbent is stored in a converted ash silo which has a capacity for three days supply at a nominal Ca/S molar ratio of 2.0. Table 4-1 lists physical properties and composition of one type of sorbent, Marblehead Calcitic Hydrate. The sorbent silo has a diameter of 25 feet (7.6 m) and a height of 41 feet - 8 inches (12.7 m), with a total volume of 20,500 ft³ (580 m³). The sorbent metering and transport system include an automatic gate valve, a sorbent weigh hopper mounted on four load cells, a slide gate/diverter valve, a rotary valve feeder, fabric filter collectors, and sorbent screw pump to deliver the sorbent into the flexible transport line. Fluidizing air slides and pads are used to facilitate the sorbent flow and fabric filters are used to prevent fugitive dust emissions. Transport air is provided by a positive displacement blower, rated at 760 scfm (0.36 Nm³/s) at 15 psig (103 kPa); the system design including two blowers to allow maintenance of one while the other is in service. The sorbent and transport air are carried by a bulk conveying hose, which is black abrasion-resistant 1/8 inch (3.2 mm) thick static conductive NR/SBR (rubber) with a wire helix, to the high and low load splitters. The high and low (50%) load splitters divide the sorbent stream into equally to each injection nozzle. SI air, provided by a SI fan, is added at the outer core of the stainless steel nozzles.

SI results in significant changes in the characteristics and amount of ash/sorbent to be disposed

TABLE 4-1. PROPERTIES OF MARBLEHEAD CALCITIC HYDRATE

Surface Area (cm ² /g)	15.5
Density (g/cm ³)	2.26
Mass Median Particle Size (microns)	4.1
Bulk Density (lb/ft ³)	
Loose	23.0
Settled	33.0

ANALYSIS (Weight Percent)

Ca(OH) ₂	90.0%
Mg(OH) ₂	1.6%
CaCO ₃	6.1%
SiO ₂	1.1%
Fe ₂ O ₃	0.6%
Al ₂ O ₃	0.3%
SO ₃	0.2%
Na ₂ O	0.1%

of. The spent sorbent is a mixture of CaO and CaSO₄ and results in ash with characteristics are similar to high calcium western coal ash. When mixed with water, it would be expected to exhibit pozzolanic activity, i.e. forming hard cement-like deposits upon addition of water. Both wet handling and dry handling of the fly ash were considered, and dry handling and off-site disposal were selected. The design called for continued wet handling of the bottom ash, but collection of the fly ash in a previously abandoned silo. United Conveyor Corporation, which had installed the original dry handling system, was contracted to provide a revamped dry handling system. This included several tie-ins to new collection points including the multiclone and the upgraded ESP, which are described below.

4.2.5 GR-SI Auxiliary Power and GR-SI Control System

The auxiliary power distribution system was designed to provide power to all GR-SI equipment with overload and fault protection. The power is distributed from a new 1500 kVA transformer station which transforms generated power at a voltage of 16,800 V to 4,160 V. All 200 HP motors are supplied with 4,160 V power, motors of 1 to 200 HP are provided power at 480 V, while smaller motors are supplied 110 V power. An electric power meter is included to meter the GR-SI electrical power utilization. The maximum GR-SI system power requirement was expected to be 1,063 kW.

EER undertook an extensive evaluation of the requirements of the GR-SI control system. The control system included extensive control logic to ensure safe and efficient start-up and operation of the GR and SI systems. The control logic was discussed with several knowledgeable people in the boiler, utility, insurance, and control equipment industries. The system incorporated necessary changes in hardware and software. Both SI and GR require continuous monitoring and control of process stream flows. Flame safety is ensured by a series of permissives and trip sequences. Permissives are logic elements which must be satisfied to initiate GR and trips are signals to shut down GR because unacceptable or unsafe conditions exist. These interlocks provide specific operating sequences for GR-SI equipment and the trip sequences ensure system shutdown in case of equipment malfunction. The required modifications were relatively simple

since Edwards Unit 1 was recently retrofitted with a state-of-the-art digital control system.

4.2.6 Sootblowing System Modifications

An evaluation of required sootblowing modifications indicated that additional sootblowers would be needed in the down-flow backpass areas to offset the impact of sorbent fouling. The current system incorporates 26 short wall blowers (model type IR) and 18 long retractable sootblowers (model type IK). There are 6 wall blowers on each side wall and 14 on the rear wall and the sootblowers are located on the side walls of the upper furnace and in the down-flow convective sections. They were supplied by the Diamond Power Specialty Company. The IR blowers are currently only used on an as-needed basis and the IKs are operated for one cycle per 8 hour shift, requiring approximately 2 hours. The GR-SI design includes 12 additional sootblowers in the backpass, also to be supplied by Diamond Power. EER expects that two cycles per 8 hour shift will be required, due to sorbent fouling. This will result in IK sootblowing for approximately 6 of the 8 hours per shift. The new sootblowers use the normal 150 psig (1,030 kPa) compressed air supply of the other blowers. The locations of the new sootblowers are shown in Figure 4-4.

4.2.7 Electrostatic Precipitator Performance Enhancement

An extensive ESP upgrade will be required due to the impacts of injecting sorbent. SI results in a significant increase in the ESP inlet loading. Under the design case GR-SI operation full load, nearly 100% of the sorbent flow of 6860 lb/hr (0.86 kg/s) and approximately 80% of the total coal ash 6,700 lb/hr (0.84 kg/s) would be expected to flow into the ESP. The sorbent particles are more difficult to capture because they are smaller than coal ash, with a mass mean diameter under 5 microns. SI also increases the fly ash resistivity, by as much as two orders of magnitude. This is due to a reduction in SO₃ concentration. SO₃ lowers resistivity by condensing as sulfuric acid on the fly ash surface. The condensation of low levels of sulfuric acid onto the fly ash surface leads to enhanced surface conductivity and therefore higher operating ESP currents and greater particulate matter collection. GR-SI also results in an

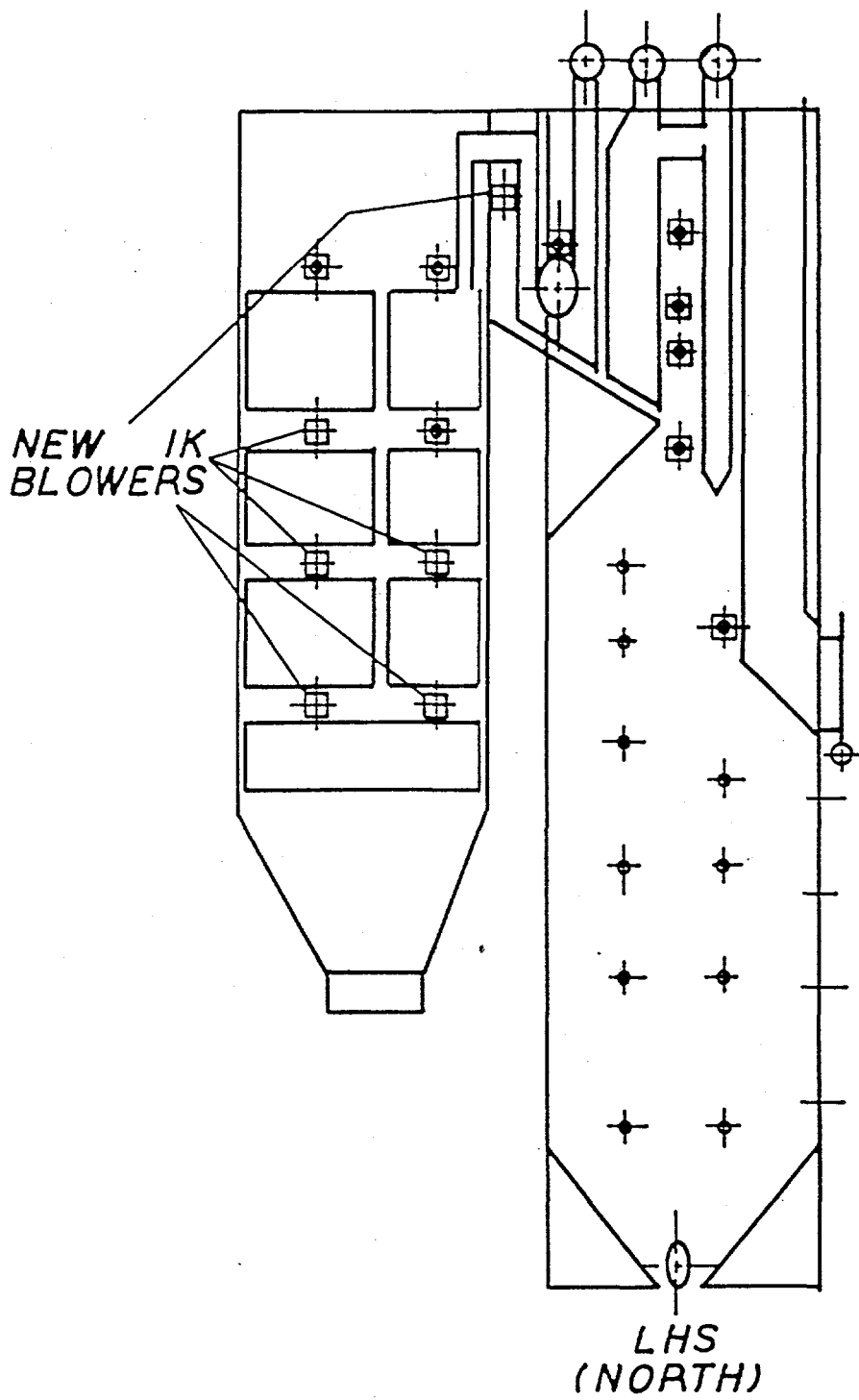

Figure 4-4. Edwards Unit 1 new sootblower locations

increase in the flue gas temperature at the ESP inlet due to fouling of heat transfer surfaces, resulting in higher fly ash resistivity.

The ESP requires significant upgrade to enhance its performance. Currently, the ESP barely meets the operating demands, therefore the unit load is typically kept under 95 MW_e (gross) to maintain stack opacity below the 30% limit. The ESP is an American Standard Series 371, Design 20-9P which provides 137 ft²/1000 acfm (27.0 m²/m³/s), at the units rated capacity. It has a total treatment length of 18 ft (5.5 m) and an effective plate area of 63,630 ft² (5,910 m²). Because of the additional demand placed on it under SI, performance modeling under this condition was performed by a contractor. The modeling results indicated that one 9 foot (2.7 m) plate addition would barely meet the new demands and two additional fields or 18 feet of treatment length (5.5 m) would restore particulate emissions to baseline levels. Therefore, EER's design calls for the addition of two collecting plates, resulting in a minimum effective treatment length of 36 ft (11 m), minimum effective total plate area of 127,720 ft² (11,870 m²), and a specific collection area of 282 ft²/1000 acfm (55.5 m²/m³/s).

Flue gas conditioning in the form of SO₃ injection is currently used to offset the impact of low sulfur coal firing. The SO₃ injection system, supplied by Wahlco, is illustrated in Figure 4-5. The process basically consists of burning liquid sulfur at high excess air levels to produce SO₂. The SO₂ is then converted to SO₃ by passing it over a catalyst bed made of vanadium pentoxide (V₂O₅) at a temperature of 800°F (427°C) to 825°F (441°C). The original capacity of the system was 40 ppm SO₃, but was reduced to 20 ppm when satisfactory operation was achieved with SO₃ concentration in the range of 10 to 15 ppm. An increase in SO₃ injection capacity to reach SO₃ levels up to 100 ppm is required. This would involve modest changes in the present equipment, but includes an additional parallel catalytic converter.

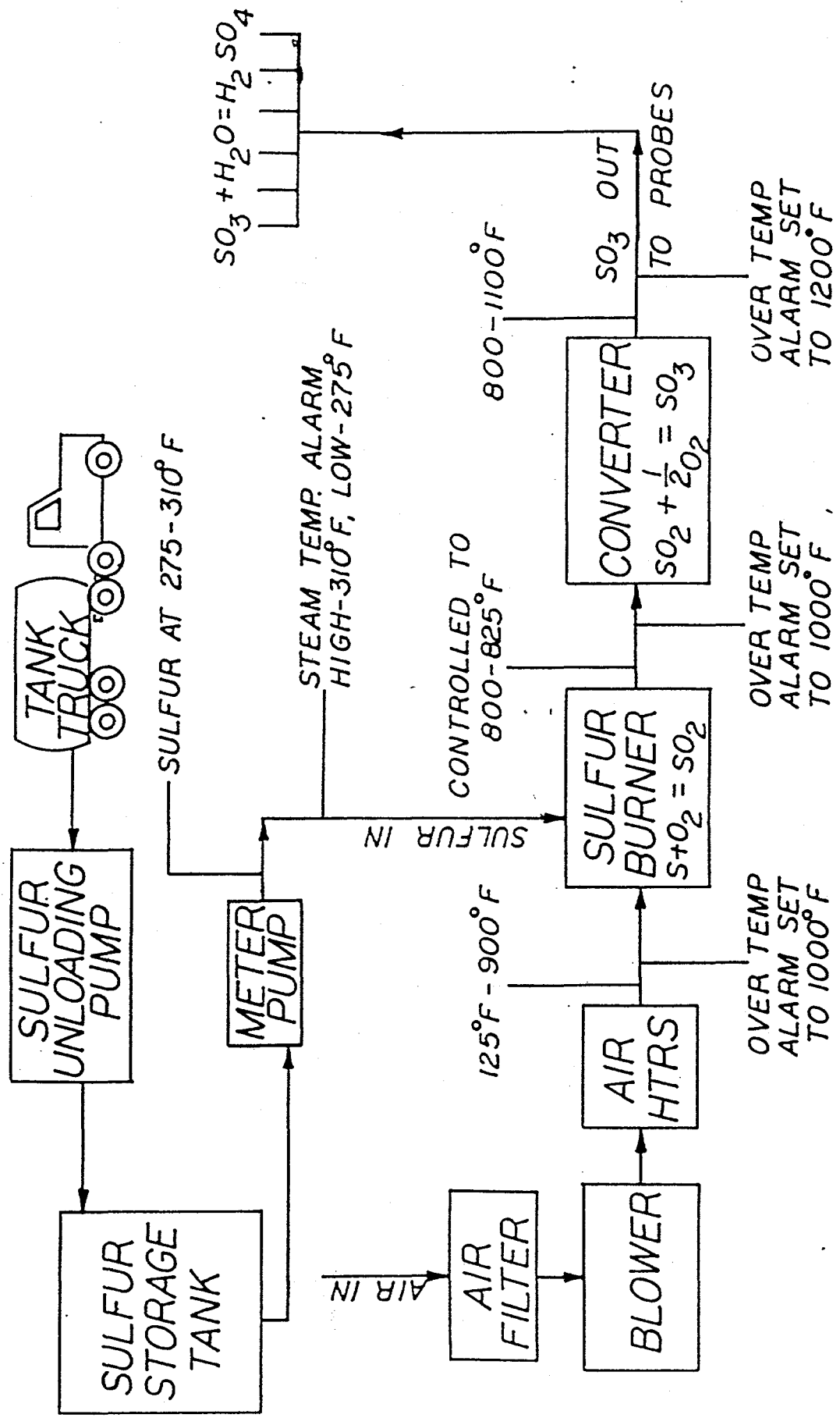

Figure 4-5. Schematic of SO₃ injection system

5.0 EDWARDS STATION UNIT 1 GR-SI PROJECT STATUS

Phase I activities, including GR-SI system process and engineering designs, have been completed for Edwards Station Unit 1. Upon completion of the design work and evaluation of construction costs, it was decided to suspend the GR-SI project at Edwards Unit 1. This is due primarily to the expected costs to upgrade the ESP. A more modest scope was considered, that of applying GR only, but it was decided to proceed with GR-SI demonstrations at the other firing configurations at the Hennepin and Lakeside Stations, where no extensive ESP upgrades were required. At Hennepin, flue gas humidification was used for ESP enhancement, while at Lakeside no enhancement was required due to the large size of the ESP.

REFERENCES

Chen, S. L., M. P. Heap, and D. W. Pershing, The Nineteenth Symposium (International) on Combustion, The Combustion Institute, 1983.

Chen, S. L., M. P. Heap, D. W. Pershing, and G. B. Martin, Fuel, 61, p. 1218, 1982.

Energy and Environmental Research Corporation, Comprehensive Report to Congress Clean Coal Technology Demonstration Program, Enhancing the Use of Coals by Gas Reburning and Sorbent Injection, a Project Proposed by Energy and Environmental Research Corporation to the U.S. Department of Energy, Office of Fossil Energy, May 1987.

Glass, J. W., and J. O. L. Wendt, Nineteenth Symposium (International) on Combustion, p. 1243, The Combustion Institute, 1982.

Greene, S. B., S. L. Chen, D. W. Pershing, M. P. Heap, and W. R. Seeker, "Bench Scale Process Evaluation of Reburning for In-Furnace NO_x Reduction," ASME Transactions Journal of Engineering for Gas Turbines and Power, 1985.

Howard, J. B., G. C. Williams, and D. H. Fine, The Fourteenth Symposium (International) on Combustion, The Combustion Institute, p. 975, 1973.

McCarthy, J. M., B. J. Overmore, S. L. Chen, W. R. Seeker, and D. W. Pershing, "Pilot Scale Process Evaluation of Reburning for In-Furnace NO_x Reduction, "Final Report, EPA Contracts 68-02-3925 and 68-02-3995 Work Assignment No. 10, 1985.

Reed, R. D., "Process for the Disposal of Nitrogen Oxide," John Zink Company, U. S. Patent 1274637, 1969.

Takahashi, Y., et al., "Development of Mitsubishi 'MACT' In-Furnace NO_x Removal Process," Presented at the U.S.-Japan NO_x Information Exchange, Tokyo, Japan, May 25-30, 1981. Published in Mitsubishi Heavy Industries, Ltd. Technical Review, Vol. 18, No. 2.