

FOSIL

DOE/MC/27362 -- 4089
(DE95009736)

**Blast Furnace Granular Coal
Injection Project**

**Annual Report
January - December 1994**

July 1995

Work Performed Under Contract No.: DE-FC21-91MC27362

For
U.S. Department of Energy
Office of Fossil Energy
Morgantown Energy Technology Center
Morgantown, West Virginia

By
Bethlehem Steel Corporation
Bethlehem, Pennsylvania

DISCLAIMER

This report was prepared as an account of work sponsored by an agency of the United States Government. Neither the United States Government nor any agency thereof, nor any of their employees, makes any warranty, express or implied, or assumes any legal liability or responsibility for the accuracy, completeness, or usefulness of any information, apparatus, product, or process disclosed, or represents that its use would not infringe privately owned rights. Reference herein to any specific commercial product, process, or service by trade name, trademark, manufacturer, or otherwise does not necessarily constitute or imply its endorsement, recommendation, or favoring by the United States Government or any agency thereof. The views and opinions of authors expressed herein do not necessarily state or reflect those of the United States Government or any agency thereof.

This report has been reproduced directly from the best available copy.

Available to DOE and DOE contractors from the Office of Scientific and Technical Information, 175 Oak Ridge Turnpike, Oak Ridge, TN 37831; prices available at (615) 576-8401.

Available to the public from the National Technical Information Service, U.S. Department of Commerce, 5285 Port Royal Road, Springfield, VA 22161; phone orders accepted at (703) 487-4650.

DOE/MC/27362 -- 4089
(DE95009736)
Distribution Category UC-102

Blast Furnace Granular Coal Injection Project

**Annual Report
January - December 1994**

Work Performed Under Contract No.: DE-FC21-91MC27362

For
U.S. Department of Energy
Office of Fossil Energy
Morgantown Energy Technology Center
P.O. Box 880
Morgantown, West Virginia 26507-0880

By
Bethlehem Steel Corporation
701 East Third Street
Bethlehem, Pennsylvania 18016

July 1995

TABLE OF CONTENTS

		<u>Page</u>
1.0	INTRODUCTION	1
2.0	BACKGROUND	1
3.0	TECHNOLOGY DESCRIPTION	2
4.0	INSTALLATION DESCRIPTION	4
5.0	PROJECT TEST PLAN	5
6.0	FIRST QUARTER ACCOMPLISHMENTS	6
7.0	SECOND QUARTER ACCOMPLISHMENTS	7
8.0	THIRD QUARTER ACCOMPLISHMENTS	8
9.0	FOURTH QUARTER ACCOMPLISHMENTS	8
10.0	SUMMARY	9
11.0	REFERENCES	9

LIST OF FIGURES AND PHOTOGRAPHS

- Figure 1. Project Milestone Dates
- Figure 2. The Blast Furnace Complex
- Figure 3. Zones in the Blast Furnace
- Figure 4. Application of Coal Injection
- Figure 5. Preparation and Injection Facilities - Burns Harbor Plant

CONSTRUCTION PROGRESS PHOTOGRAPHS

- 1. Reclaim tunnel looking west, prior to soil backfilling.
- 2. Process building during erection, raw coal bins and product coal bins in place.
- 3. Coal injector cluster during erection.
- 4. Grinding mill and classifier during erection.
- 5. Reclaim tunnel conveyor during erection.
- 6. Raw coal precrusher transfer structure during construction.
- 7. Raw coal feed system during construction.
- 8. Air compressors during installation.
- 9. Raw coal radial stacker during construction.
- 10. Raw coal feed system during construction.
- 11. Raw coal stockpile.
- 12. Injection pipe bridge from process building to "C" blast furnace.
- 13. Raw coal stockpile and process structure in background.

CONSTRUCTION COMPLETION PHOTOGRAPHS

- 14. Underground raw coal reclaim tunnel.
- 15. Process and Utility buildings.
- 16. Process and Utility buildings, "D" blast furnace on right.

17. Raw coal conveyor above raw coal silos.
18. Raw coal bin for #1 mill.
19. Grinding Mills #1 and #2.
20. Exhaust fan for #2 mill system.
21. Cyclone separators for #1 & #2 mill systems.
22. Product coal silo screw feeders.
23. Product coal weigh bin and distribution bin.
24. Distribution bin and coal injectors.
25. Coal injection cast elbows.
26. Coal injection piping for "C" blast furnace.
27. Coal injection pipe bridge for "C" blast furnace.
28. Coal injection hose at blast furnace.
29. Coal injection lance at blast furnace tuyere.

1.0 INTRODUCTION

This annual report describes the Blast Furnace Granular Coal Injection project being implemented at Bethlehem Steel Corporation's (BSC) Burns Harbor Plant. The project is receiving cost-sharing from the U.S. Department of Energy (DOE), and is being administrated by the Morgantown Energy Technology Center in accordance with the DOE Cooperative Agreement No. DE-FC21-91MC27362.

This installation is the first in the United States to employ British Steel technology that uses granular coal to provide part of the fuel requirement of blast furnaces. The project will demonstrate/assess a broad range of technical/economic issues associated with the use of coal for this purpose. These include: coal grind size, coal injection rate, coal source (type) and blast furnace conversion method. To achieve the program objectives, the demonstration project is divided into the following three Phases:

- Phase I - Design
- Phase II - Construction
- Phase III - Operation

Preliminary Design (Phase I) began in 1991 with detailed design commencing in 1993. Construction at Burns Harbor (Phase II) began in August 1993 and was completed at the end of 1994. The demonstration test program (Phase III) will start in the fourth quarter of 1995.

2.0 BACKGROUND

Bethlehem Steel Corporation's Burns Harbor Plant operates two blast furnaces which produce molten iron in support of steelmaking operations. The furnaces are fueled with coke as part of the raw materials charged through the top of the furnace. The coke was supplemented by natural gas injected along with the combustion air through ports (tuyeres) near the base of the furnace. Each furnace produces about 7000 tons per day of molten iron with the injected fuel providing about 15 percent of the total fuel requirements.

Because of the uncertainty of the long-term supply and cost of natural gas, Bethlehem submitted a proposal in response to DOE's CCT-III solicitation that will demonstrate the conversion for, optimization of, and commercial performance characteristics of granular coal as a supplemental fuel for steel industry blast furnaces. Operating blast furnaces with coal injected directly through the tuyeres into the combustion zone as a supplemental fuel will result in reduced coke consumption, thereby decreasing the environmental emissions associated with cokemaking. The environmental problems normally associated with the combustion of coal will also be virtually eliminated by direct injection of coal into the blast furnaces as the potential contaminants, e.g., sulfur, are captured in the blast furnace slag.

Economic benefits will be realized by the reduced demand for coke, the primary blast furnace fuel, and for natural gas and oil, the "conventional" supplementary fuels. Presuming that: (a) the granular coal injection system can be successfully operated at rates of several hundred pounds of coal injected per net ton of hot metal (liquid pig iron produced by the blast furnaces), and that (b) costs for the competing supplemental fuels, natural gas and oil, escalate in a manner projected by the U.S. Department of Energy (DOE), then the annual operating cost savings should make this an attractive investment as well as a technical advancement.

Bethlehem's Blast Furnace Granular Coal Injection System Demonstration Project was one of 13 demonstration projects accepted for funding in the Clean Coal Technology Program third round of competition. A cooperative agreement with a total estimated cost of \$143,800,000 was awarded to Bethlehem on November 26, 1990. Under this cooperative agreement, Bethlehem would provide 78.3 percent of the total funding requirements for the demonstration project with the DOE providing the remaining 21.7 percent. As project details were refined, the cost estimate was increased from \$143,800,000 to \$190,650,000. Major project milestone dates are shown in Figure 1. Additional details on the project were presented at the 1993 and 1994 Clean Coal Technology Conferences.^{3,4}

3.0 TECHNOLOGY DESCRIPTION

The ironmaking blast furnace is at the heart of integrated steelmaking operations. As shown in Figure 2, the raw materials are charged to the top of the furnace through a lock hopper arrangement to prevent the escape of pressurized hot reducing gases. Air needed for the combustion of coke to generate the heat and reducing gases for the process is passed through stoves and heated to 1500-2300°F. The heated air (hot blast) is conveyed to a refractory-lined bustle pipe located around the perimeter of the furnace. The hot blast then enters the furnace through a series of ports (tuyeres) around and near the base of the furnace. The molten iron and slag are discharged through openings (tapholes) located below the tuyeres. The molten iron flows to refractory-lined ladles for transport to the basic oxygen furnaces.

A schematic of the various zones inside the blast furnace is shown in Figure 3. As can be seen, the raw materials, which are charged to the furnace in batches, create discrete layers of ore and coke. As the hot blast reacts with and consumes coke at the tuyere zone, the burden descends in the furnace resulting in a molten pool of iron flowing around unburned coke just above the furnace bottom (bosh area). Reduction of the descending ore occurs by reaction with the rising hot reducing gas that is formed when coke is burned at the tuyeres.

The cohesive zone directly above the tuyeres is so called because here the partially reduced ore is being melted and passes through layers of unburned coke. The coke layers provide the permeability needed for the hot gases to pass through this zone to the upper portion of the furnace. Unlike coal, coke has the high temperature properties needed to retain its integrity in this region and is the reason that blast furnaces cannot be operated without coke in the burden.

The hot gas leaving the top of the furnace is cooled and cleaned. Since it has a significant heating value (80-100 Btu/scf), it is used to heat the hot blast stoves. The excess is used to generate steam and power and for other uses within the plant.

Over the years many injectants (natural gas, tar, oils, etc.) have been used in blast furnaces to reduce the amount of coke used. Their use is a matter of economics with each location making choices by considering the costs of coke and injectants. Natural gas has been a common injectant used in this country. Recent technological developments in Europe and Asia, where coal has been widely used as an injectant, have established that the highest levels of injection and subsequent displacement of coke can be obtained by using coal.

The joint development between British Steel and Simon-Macawber of a process for the injection of granular coal into blast furnaces began in 1982 on the Queen Mary Blast Furnace at the Scunthorpe Works.^(1,2) The objective of the development work was to inject granular coal into the furnace and test the performance of the Simon-Macawber equipment with a wide range of coal sizes and specifications. Based on Queen Mary's performance, coal injection systems were installed on Scunthorpe's Queen Victoria, Queen Anne and Queen Bess blast furnaces and on furnaces 1 and 2 at the Ravenscraig Works.

Bethlehem decided to utilize the Simon Macawber Blast Furnace Granular Coal Injection (BFGGI) System, because unlike more widely used systems that utilize only pulverized coal, it is capable of injecting both granular and pulverized coal. Bethlehem believes that the Simon Macawber system offers a variety of technical and economic advantages which make this system potentially very attractive for application in the US basic steel industry. A schematic showing the application of the technology to the blast furnace is shown in Figure 4. Some of the advantages of this technology include:

- The injection system has been used with granular coal as well as with pulverized coal. No other system has been utilized over this range of coal sizes.
- The potential costs for granular coal systems are less than for pulverized systems.
- Granular coal is easier to handle in pneumatic conveying systems. Granular coals are not as likely to stick to conveying pipes if moisture control is not adequately maintained.
- Research tests conducted by British Steel indicate that granular coal is more easily maintained in the blast furnace raceway (combustion zone) and is less likely to pass through the coke bed. Coke replacement ratios obtained by British Steel have not been bettered in any worldwide installation.
- Granular coal's coarseness delays gas evolution and temperature rise associated with coal combustion in the raceway. Consequently, it is less likely to generate high temperatures and gas flows at the furnace walls which result in high heat losses, rapid refractory wear and poor utilization of reducing gases.
- System availability has exceeded 99 percent during several years of operation at British Steel.
- The unique variable speed, positive displacement Simon-Macawber injectors provide superior flow control and measurement compared to other coal injection systems.

4.0 INSTALLATION DESCRIPTION

The coal preparation and injection facility has been retrofitted to the C and D blast furnaces at the Burns Harbor Plant. The Plant is located in Porter County, Indiana on the south shore of Lake Michigan.

A simplified flow diagram of the coal handling system at Burns Harbor is shown in Figure 5. The Raw Coal Handling Equipment and the Coal Preparation Facility includes the equipment utilized for the transportation and preparation of the coal from an existing railroad car dumper until it is prepared and stored prior to passage into the Coal Injection Facility; the Coal Injection Facility delivers the prepared coal to the blast furnace tuyeres.

Raw Coal Handling. Coal for this project is transported by rail from coal mines to Burns Harbor similar to the way in which the plant now receives coal shipments for the coke ovens. The coal is unloaded using an existing railroad car dumper, which is currently part of the blast furnace material handling system. A modification to the current conveyor was made to enable the coal to reach either the coke ovens or the coal pile for use at the Coal Preparation Facility.

This modification required a new 60-inch wide transfer conveyor from the existing conveyor and to a junction house. There the coal is transferred to a new 60-inch wide stockpile conveyor for the raw coal storage pile. The coal pile is formed with a radial stacker capable of building a 10-day storage pile (approximately 28,000 tons). The material handling system from the car dumper to the coal storage pile is sized at 2,300 tons per hour to match the output of the car dumper.

Raw Coal Reclaim. The raw coal reclaim tunnel beneath the coal storage pile contains four reclaim hoppers in the top of the tunnel. The reclaim hoppers, which are directly beneath the coal pile, feed a 36-inch wide conveyor in the tunnel. The reclaim conveyor transports the coal at a rate of 400 tons per hour above ground to the south of the storage pile. A magnetic separator is located at the tail end of the conveyor to remove tramp ferrous metals. The conveyor discharges the coal onto a vibrating screen to separate coal over 2 inches from the main stream of minus 2-inch coal. The oversized coal passes through a precrusher which discharges minus 2-inch coal. The coal from the precrusher joins the coal that passed through the screen and is conveyed from ground level by a 36-inch wide plant feed conveyor to the top of the building that houses the Coal Preparation Facility.

Coal Preparation. The plant feed conveyor terminates at the top of the process building that houses the Coal Preparation Facility. Coal is transferred to a distribution conveyor, which enables the coal to be discharged into either of two steel raw coal storage silos. The raw coal silos are cylindrical with conical bottoms and are completely enclosed with a vent filter on top. Each silo holds 240 tons of coal, which is a four-hour capacity at maximum injection levels. Air cannons are located in the conical section to loosen the coal to assure that mass flow is maintained through the silo.

Coal from each raw coal silo flows into a feeder which controls the flow of coal to the preparation mill. In the preparation mill, the coal is ground to the desired particle size. Products of combustion from a natural gas fired burner are mixed with recycled air from the downstream side of the process and are swept through the mill grinding chamber. The air lifts the ground coal from the mill vertically through a classifier where oversized particles are circulated back to the mill for further grinding. The proper sized particles are carried away from the mill in a 52-inch pipe. During this transport phase, the coal is dried to 1-1.5% moisture. The drying gas is controlled to maintain oxygen levels below combustible concentrations. There are two grinding mill systems; each system produces 30 tons per hour of pulverized coal or 60 tons per hour of granular coal.

The prepared coal is then screened to remove any remaining oversize material. Below the screens, screw feeders transport the product coal into one of four 180-ton product storage silos and then into a weigh hopper in two-ton batches. The two-ton batches are dumped from the weigh hopper into the distribution bins which are part of the Coal Injection Facility.

Coal Injection. The Coal Injection Facility includes four distribution bins located under the weigh hoppers described above. Each distribution bin contains 14 conical-shaped pant legs. Each pant leg feeds an injector which allows small amounts of coal to pass continually to an injection line. Inside the injection line, the coal is mixed with high-pressure air and is carried through approximately 600 feet of 1-1/2-inch pipe to an injection lance mounted on each of the 28 blowpipes at each furnace. At the injection lance tip, the coal is mixed with the hot blast and carried into the furnace raceway. The 14 injectors at the bottom of the distribution bin feed alternate tuyeres. Each furnace requires two parallel series of equipment, each containing one product coal silo, one weigh hopper, one distribution bin and 14 injector systems.

5.0 PROJECT TEST PLAN

The objective of the test program is to determine the effect of coal grind and coal type on blast furnace performance. The start-up operation has been conducted to date with high volatile coal from eastern Kentucky. The coal has 36% volatile matter, 8% ash and 0.63% sulfur. The coal preparation system has been operated to provide granular coal with nominal size of 30% minus 200 mesh (74 microns). A trial will be conducted to determine the effect of using pulverized coal with a nominal size of 80% minus 200 mesh. The results of this trial will be of great interest to blast furnace operators and could have a significant effect on the type of coal injection facilities that will be installed in the future.

Another series of trials will be conducted to determine the effect of coal types and coal chemistry on furnace performance. Candidate coals for these trials are high volatile coals with moderately higher sulfur and ash than the eastern Kentucky coal presently being used, low volatile coals and Illinois Basic coals.

The important furnace performance parameters that will be closely monitored during these trials are coke rate, raw material movement in the furnace, pressure drop in the furnace, gas composition profiles, iron analyses and slag analyses. All results of the blast furnace trials will be evaluated and documented in a comprehensive report.

6.0 FIRST QUARTER ACCOMPLISHMENTS

Engineering progressed 26% during the quarter and was 80% complete, as planned, at the end of the quarter. Engineering work for Civil Structural, Architectural, Fire Protection, Equipment and Process was essentially completed. Emphasis was placed on computerized three-dimensional modeling of piping, HVAC and electrical associated with the coal preparation mill and injection systems for the purpose of interference checking and coordination between the disciplines.

Procurement emphasis shifted from placing orders to expediting all open purchase orders. All requests for quotation had been issued, 97% of purchase orders had been placed, 77% of subcontract packages had been placed and 40% of the equipment was received at the job site. Major pieces of equipment received include: remaining sections of raw coal silos and cyclones, vibrating screens, four-way splitter, coal injectors, dryer mill equipment, mill bag filters, electrical transformers, switchgear, motor control centers and first conveyor sections.

Construction progressed 20% during the quarter and was 35% complete, as planned, at the end of the quarter. Difficult conditions existed due to record setting cold temperatures. Civil and earthwork was 88% complete. Concrete was 57% complete, with 5,630 cubic yards in place. Structural steel erection was 57% complete with 1,254 tons in place. Equipment, piping and electrical were at 31%, 13%, and 22% respectively. An additional mechanical and electrical engineer arrived at the site to assist in construction. A three-dimensional terminal was installed at the site for use by field engineers and foreman in viewing the layout and arrangement of facilities in the process building.

Construction activities completed were:

- Placed four distribution bins
- Utility building foundations
- Pipe bridge to "C" furnace
- Process structure equipment foundations
- Erection of utility pipe bridge
- Plant feed conveyor foundations
- Process and utility building foundation slabs
- Topped out process building structure
- Raw coal silo erection

The final HAZOPS review was held and a 90% design review meeting was held in January with DOE, Fluor Daniel, ATSI/Simon Macawber and Bethlehem Steel engineers.

Efforts continued on the development of spare parts data lists and the preparation of documents to be used for operator and maintenance training. Initial activities began on the development of a start-up plan. (Photos 1, 2, 3 and 4)

7.0 SECOND QUARTER ACCOMPLISHMENTS

Engineering progressed 16% during the quarter and was 96% complete, as planned, at the end of the quarter. All piping isometrics and electrical power conduit and cable drawings were issued for construction. Remaining engineering involved electrical and control systems focused on developing screens for the man-machine interface (MMI) to be used by the operator and process control software to be used by the programmable logic controllers (PLC).

Purchasing emphasis continued on expediting outstanding purchase orders and the receipt of vendor spare parts information. Special attention was given to expediting the air compressors, prefabricated conveyor galleries, and injection piping system cast elbows and straights which were late in arriving at the site and caused delays to the construction schedule. All purchase orders had been placed, 93% of subcontract packages had been placed and 95% of the equipment was received at the job site. Major pieces of equipment received include: remaining coal injectors, screw feeders, PLC's, MMI's, some conveyor sections, air handling units, bin vent filters, air receiver tank, and air dryers.

Construction progressed 34% during the quarter and was 69% complete, compared to a scheduled 72%. The slight fall down in construction progress was due to late arrival of some major pieces of equipment and the field repair of a significant number of quality defects found in the prefabricated conveyor galleries. Civil and earthwork was 100% complete. Concrete was 99% complete with 7,120 cubic yards in place. Structural steel erection was 96% complete with 1,697 tons in place. Other disciplines were complete as follows: architectural - 28%, equipment - 69%, piping - 61%, electrical - 63%, and instrumentation - 4%. Piping and instrumentation were significantly behind schedule and a recovery plan involving overtime was put in place. An additional piping designer, mechanical engineer, and project engineer arrived at the site to support field construction activities.

Construction activities completed were:

- Underground piping systems
- Radial stacker foundations
- Placed cyclone separators, dryer mills, and recycle gas heaters
- Erection of coal injectors
- Erection of mill bag filters
- Erection of radial stacker
- Installation of air dryers
- Installation of reclaim conveyors
- All masonry block installation

A 50% construction review meeting was held in June and attended by DOE, Fluor Daniel and Bethlehem Steel Engineers.

Work continued on the development of a spare data base including equipment lubrication recommendations. Coordination of training material development and vendor supplied training continued on schedule. Preparation of start-up scope of work packages continued on schedule to match specific system start-up sequences. The high voltage power supply to the process building was activated. (Photos 5, 6 and 7)

8.0 THIRD QUARTER ACCOMPLISHMENTS

Engineering and procurement activities were completed during this period.

Construction progressed 29% during the period and was 98% complete compared to a scheduled 99.9%. Civil and earthwork was 100% complete. Concrete was 100% complete with 7,125 cubic yards in place. Structural steel erection was 100% complete with 1,722 tons in place. Other disciplines were complete as follows: architectural - 98%, equipment - 99%, piping - 98%, electrical - 95%, and instrumentation - 93%.

Construction activities completed were:

- Erection of stockpile conveyor and plant feed conveyor
- Lake water, instrument air, high & low pressure nitrogen, and plant air piping
- Dense phase conveying system
- Fire water pump house
- Large diameter piping for the dryer mill system
- Process structure elevator
- Radial stacker
- Plant air piping system
- No. 7 conveyor rebuild
- Membrane roofing on all buildings
- HVAC for the process and utility buildings

The spare parts data base was completed and spare parts were purchased by Fluor Daniel and Bethlehem Steel.

Training of Bethlehem's operating and maintenance personnel was complete during the period. Some Bethlehem personnel spent two weeks in the UK at British Steel Scunthorpe Works to get acquainted with coal injection equipment operation and maintenance and to observe the operation of the furnace with coal injection. Also completed were extensive on-site operator and maintenance training conducted by Fluor Daniel and vendor representatives.

The start-up and commissioning plan was implemented. A systematic approach for dry commissioning and wet commissioning of each system was begun. (Photos 8, 9, 10 and 11)

9.0 FOURTH QUARTER ACCOMPLISHMENTS

Construction continued during the period was 100% complete by the end of the year.

Construction activities completed were:

- Heating and ventilation systems in process and utility buildings
- Fire protection system
- Explosion suppression system
- Injection piping to "C" and "D" furnace
- Installation of in-burden probe on "C" furnace
- Installation of high density stack cooling on "C" furnace
- Installation of bosh and mantle cooling on "C" furnace

A 100% construction review meeting was held in December and attended by representatives of DOE, Fluor Daniel and Bethlehem Steel.

A major effort was directed at preparing each system for start-up following the prescribed commissioning activities. The coal unloading and stacking system was commissioned by unloading 10,000 tons of coal. The reclaim system was commissioned by filling the raw coal bins inside the process building. The coal preparation systems were started and tuned using coal. On December 19, 1994, the injection system to "D" blast furnace was partially started up to gradually dispose of the coal generated during the tuning of the two coal preparation mills.

Delays to start-up were experienced. Repairs were required to the coal separation cyclone for #1 mill system which was damaged due to a lower than expected internal pressure during start-up testing. Structural repairs were required to the coal radial stacker when it accidentally struck the coal pile. Vibration problems with the air compressors prevented reliable operation until the problem was resolved. Flow from the raw coal silos was unreliable until additional air cannons were added to each of the two silos. (Photos 12 and 13)

Construction completion photographs are shown in Photos 14 through 29.

10.0 SUMMARY

All engineering, procurement and construction was completed during the year. The coal preparation mills were started up in December, 1994, and the first coal was injected into "D" blast furnace on December 19, 1994. Near the end of the year, the grinding mills and injection facility were being prepared for performance testing during the first quarter of 1995.

11.0 REFERENCES

1. D. S. Gathergood, "Coal Injection Into the Blast Furnace", International Iron & Steel Institute Committee on Technology, April 26, 1988.
2. D. S. Gathergood and G. Cooper, "Blast Furnace Injection - Why Granular Coal"? Steel Technology International, 1988.
3. D. Kwasnoski and L. L. Walter, "Blast Furnace Granular Coal Injection", Second Annual Clean Coal Technology Conference, Atlanta, GA, September 1993.
4. D. Kwasnoski and L. L. Walter, "Blast Furnace Granular Coal Injection", Third Annual Coal Technology Conference, Chicago, IL, September 1994.

FIGURE 1

PROJECT MILESTONE DATES

Begin Detailed Construction Engineering	April 1, 1993
Received State Environmental Construction Permit	August 4, 1993
Start Construction	August 31, 1993
90% Design Review	January 12, 1994
50% Construction Review	June 1994
100% Construction Review	December 1994
Begin Coal Testing Demonstration	November 1995
Complete Coal Testing Demonstration	January 1998

FIGURE 2
THE BLAST FURNACE COMPLEX

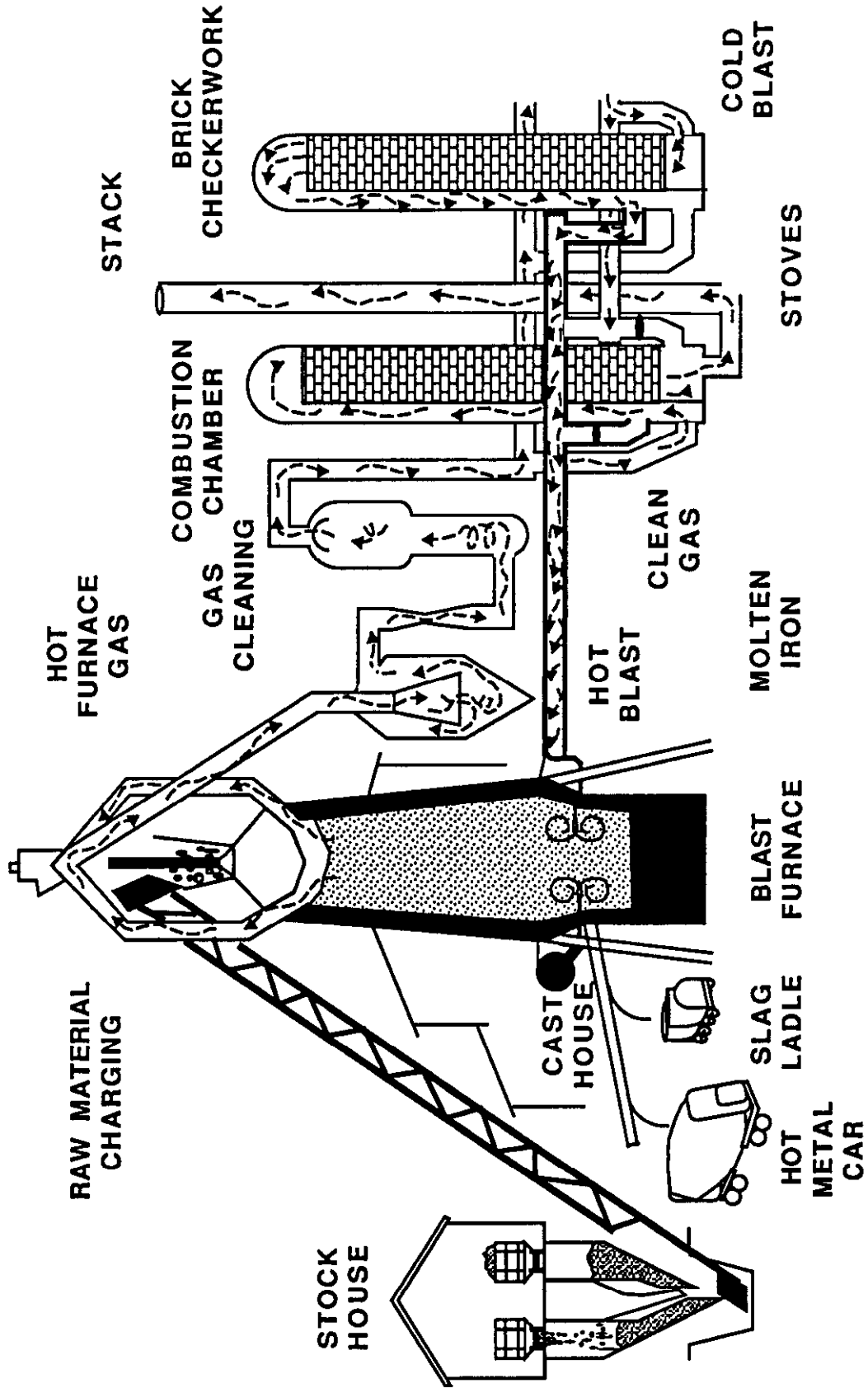
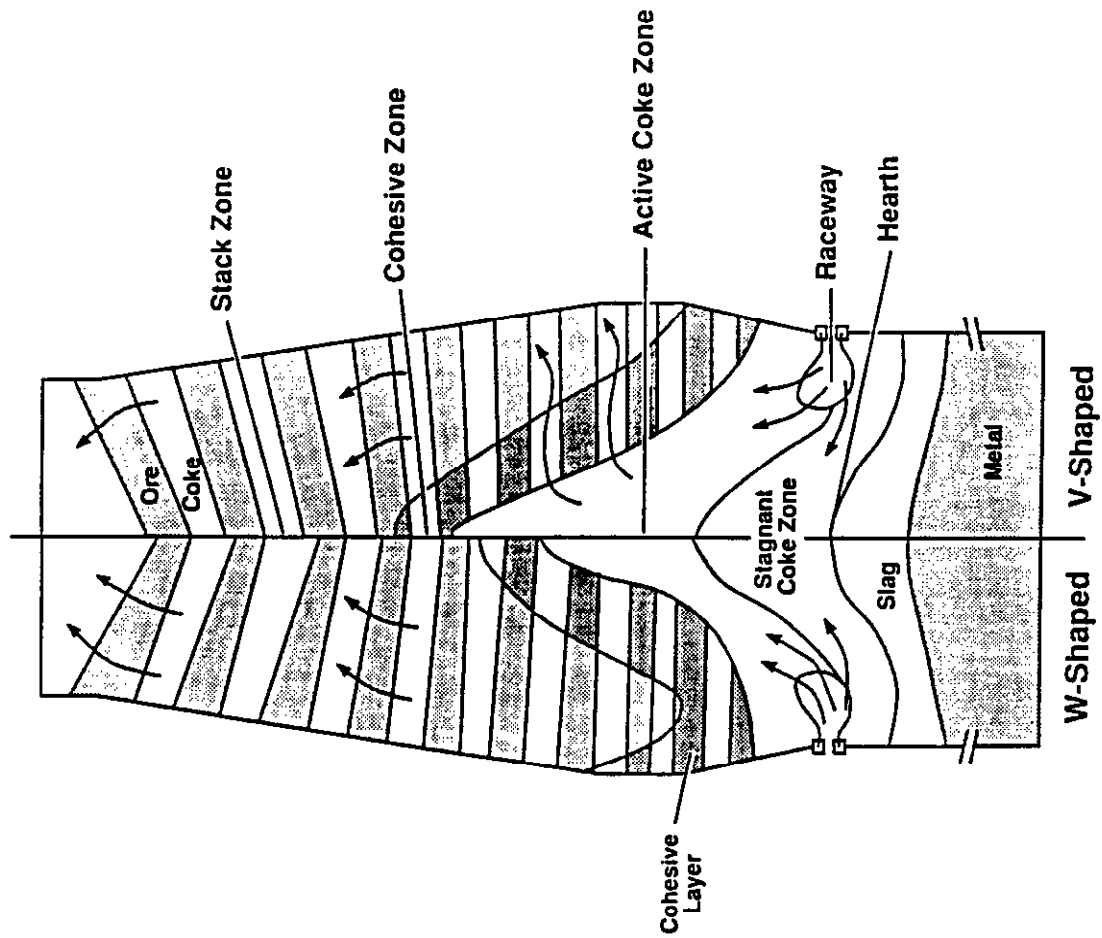

FIGURE 3

ZONES IN THE BLAST FURNACE



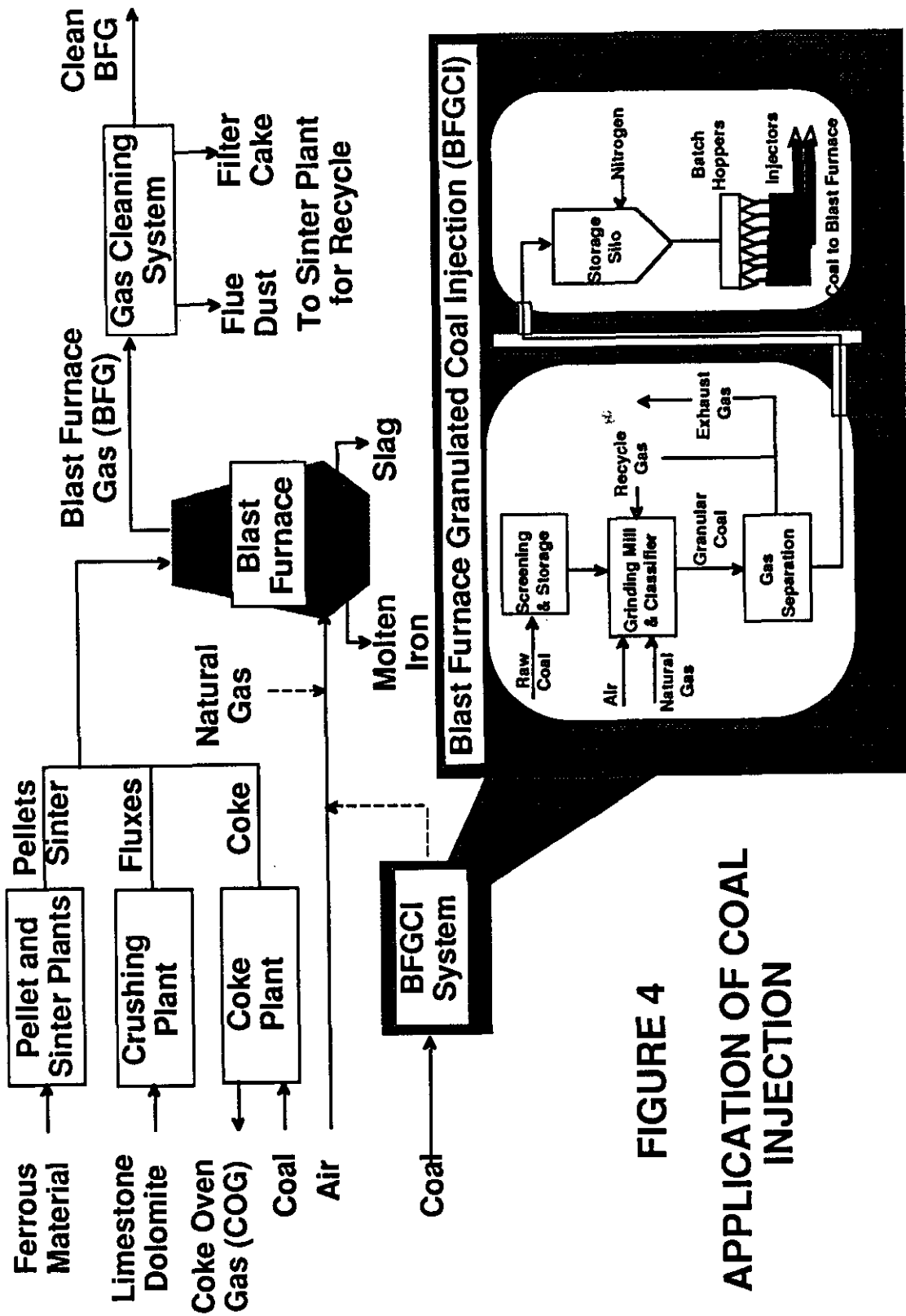

FIGURE 4
APPLICATION OF COAL
INJECTION

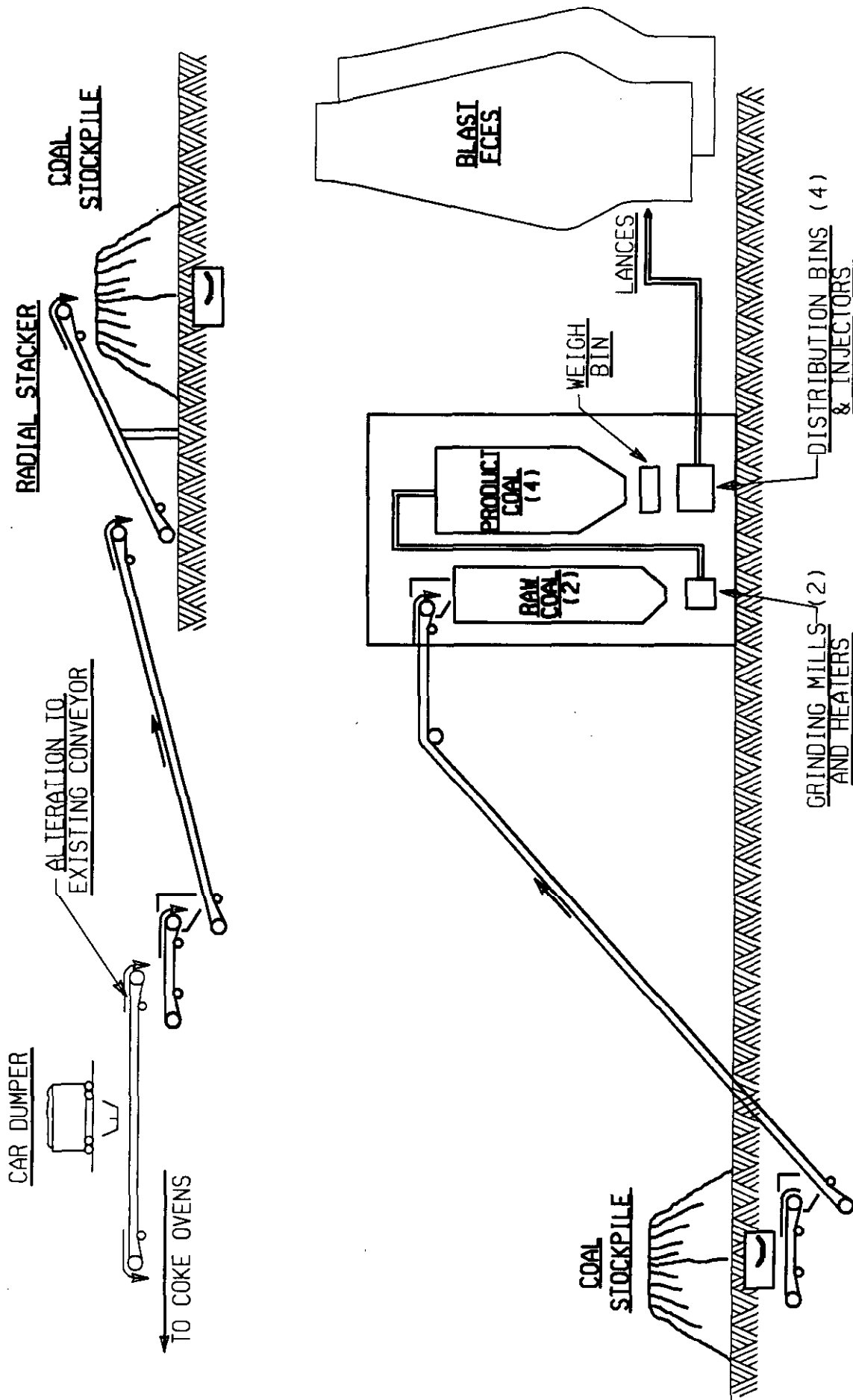
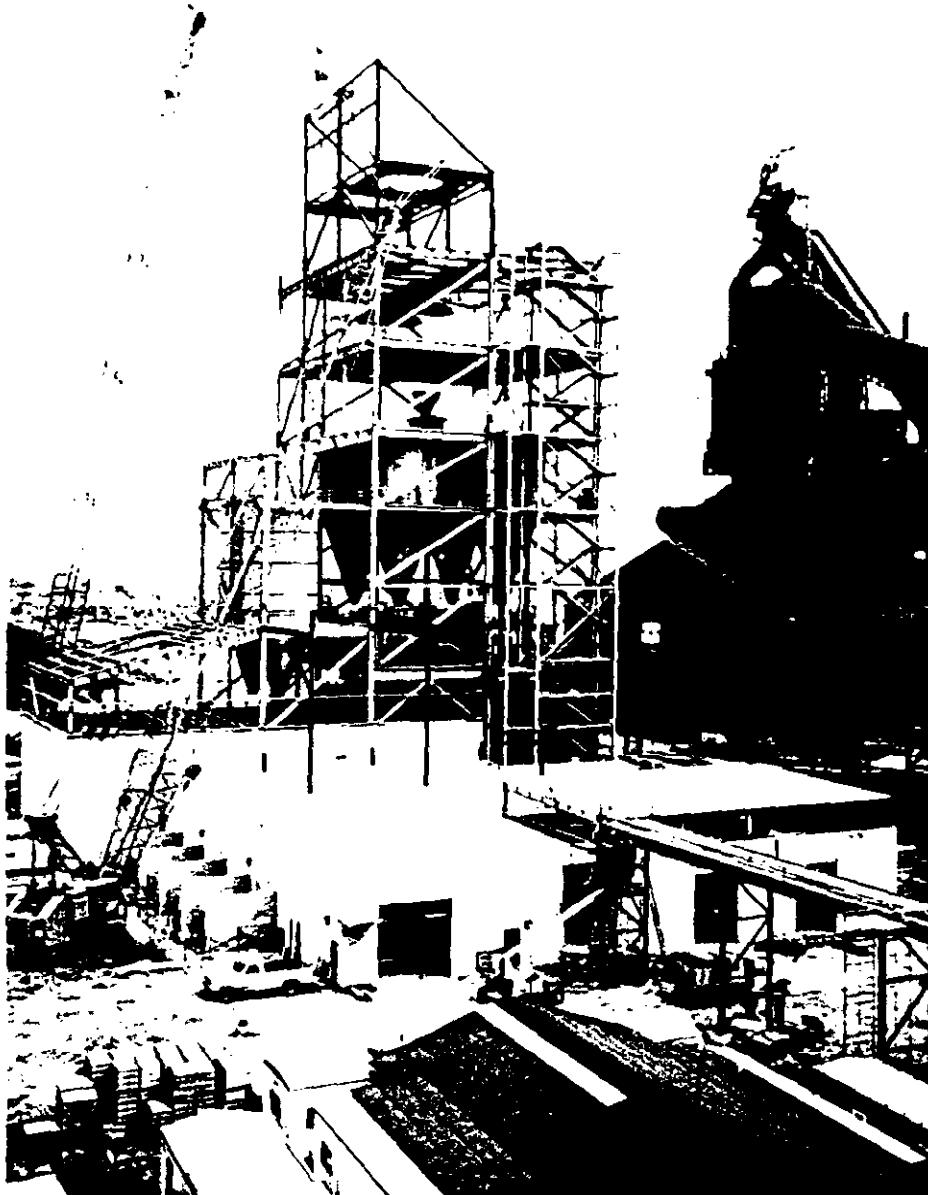

FIGURE 5 - COAL PREPARATION AND INJECTION FACILITIES
BURNS HARBOR PLANT



Construction of concrete underground raw coal reclaim tunnel prior to placing soil back fill material which will cover all but the tunnel opening in the foreground. Tunnel is 12' wide x 16' high x 400' long. Construction progress photo. January 1994.



Erection of the Process Building (high structure) and Utility Building (low structure). Note the two raw coal bins and four product coal bins within the process building structure. "D" blast furnace is in the right background. Construction progress photo, February 1994.

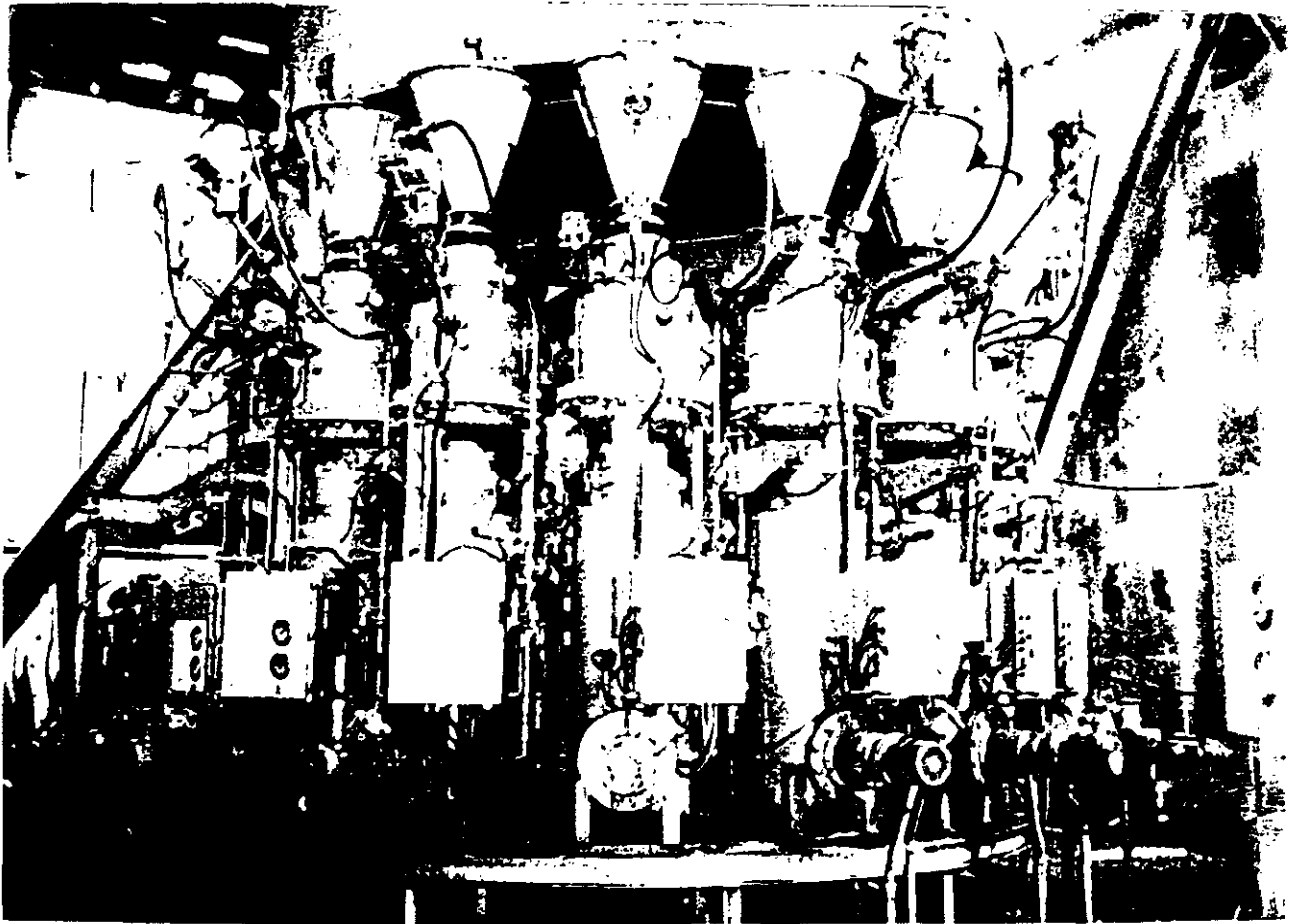

One of four clusters of fourteen coal injectors beneath the distribution bin (top of photo). Coal flows by gravity from the cylindrical-shaped distribution pant leg into the injector lockhopper. The lockhopper discharges into the injector vessel containing the motor driven screw feeder at the bottom. Construction progress photo, March 1994.



Installation of two Williams crusher/dryer mills with spinner separator on top of the mill. Gear box located between the concrete pedestals. Mill drive motor not yet installed. Construction progress photo, March 1994.

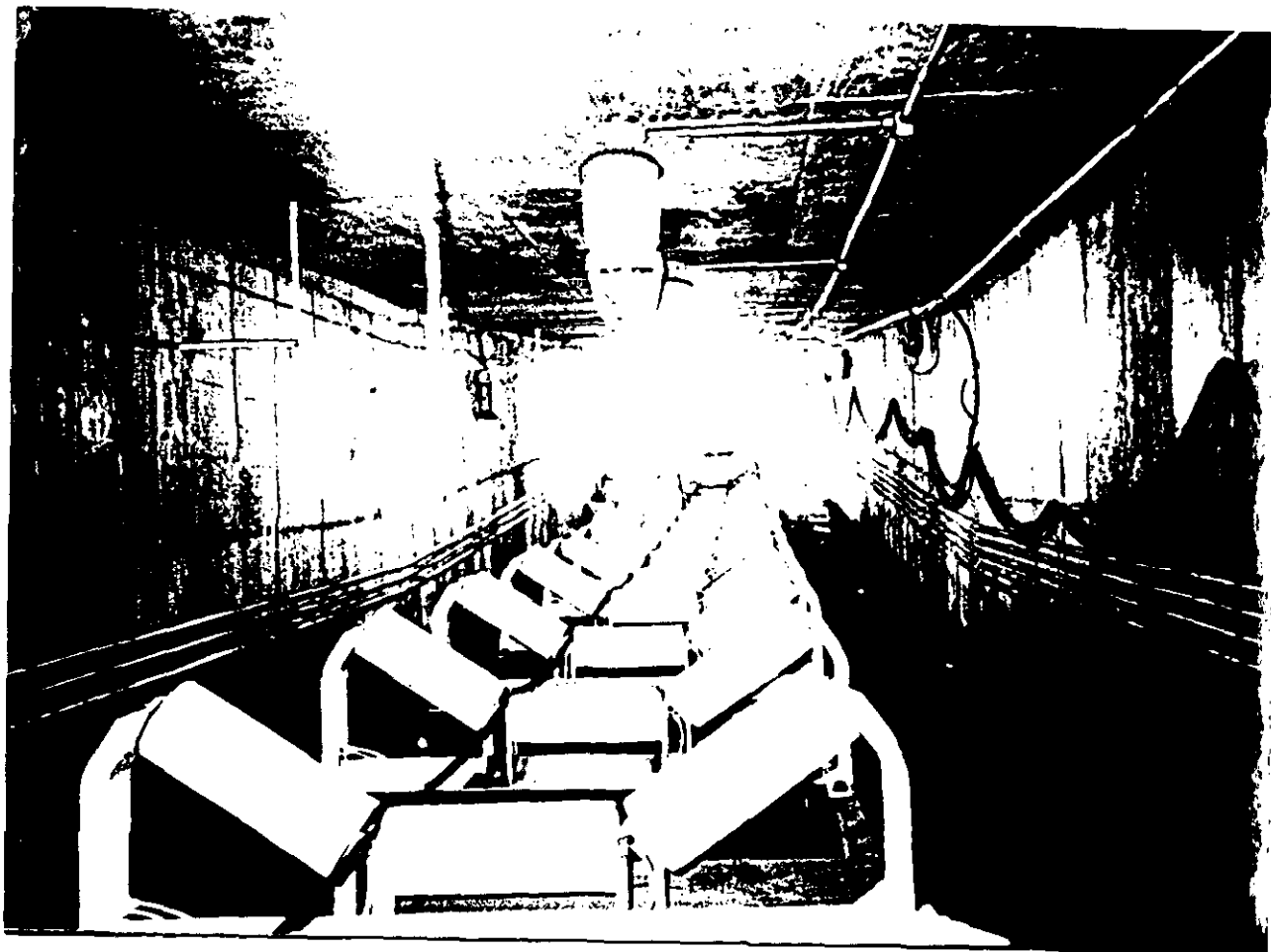

Raw coal reclaim tunnel looking from inside towards above ground opening. Conveyor belt not yet installed. Construction progress photo, April 1994.

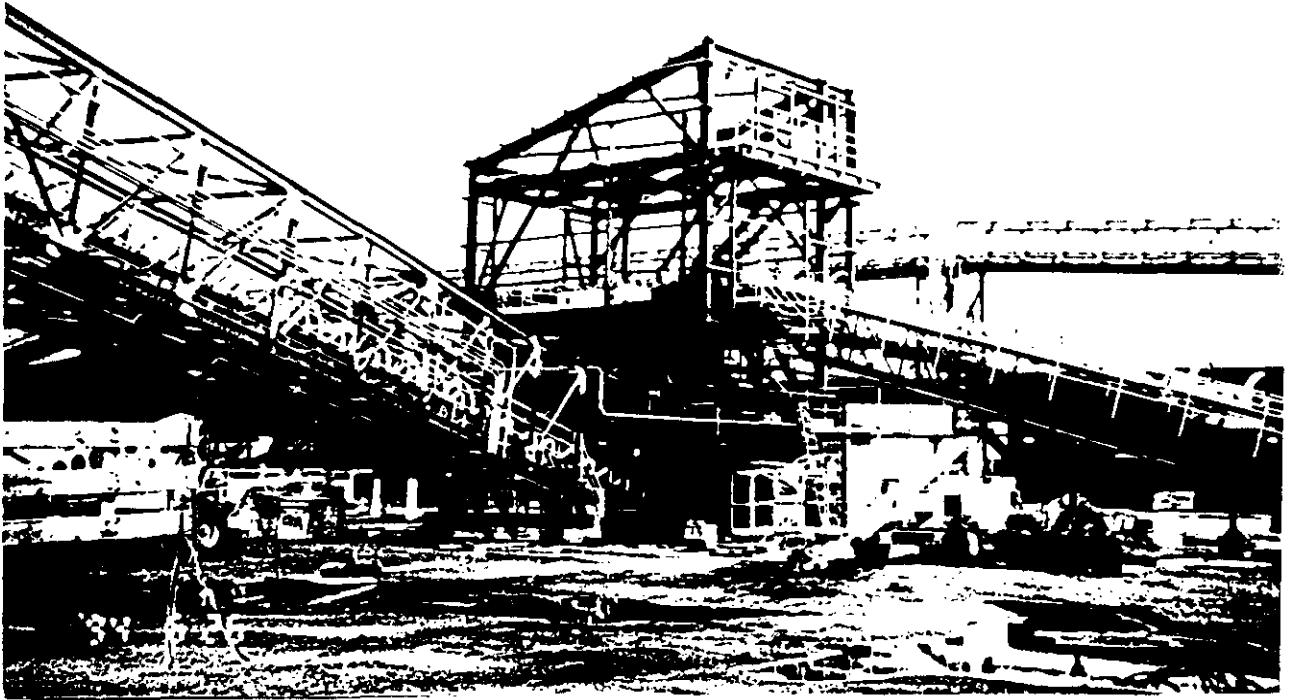

Precrusher building showing reclaim conveyor entering from the right side and plant feed conveyor exiting from the left bottom. Raw coal stockpile conveyor can be seen in the background. Construction progress photo, May 1994.

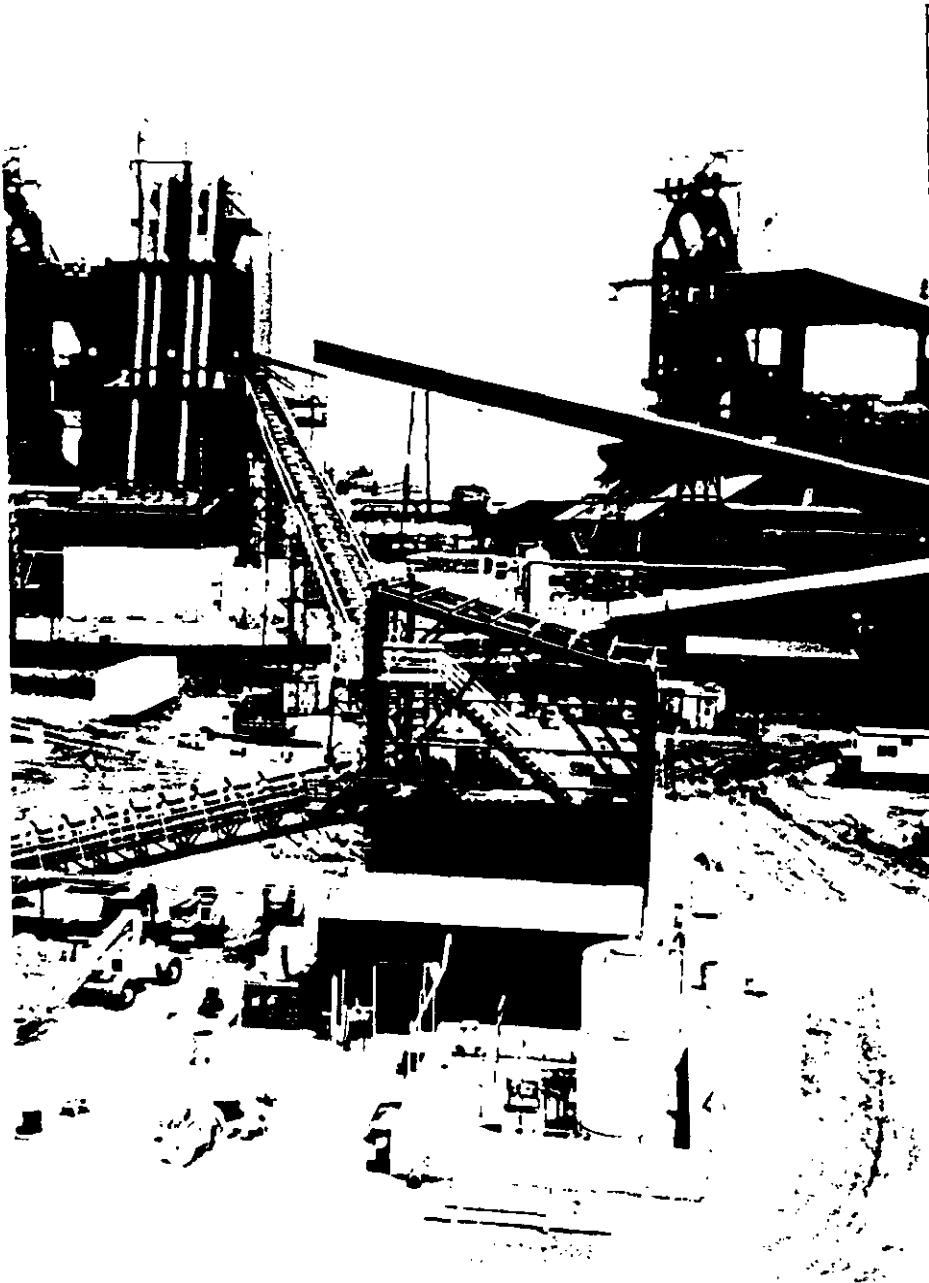

Precrusher building in foreground and process building in background connected by the plant feed conveyor. Note "C" blast furnace right background. Construction progress photo, June 1994.

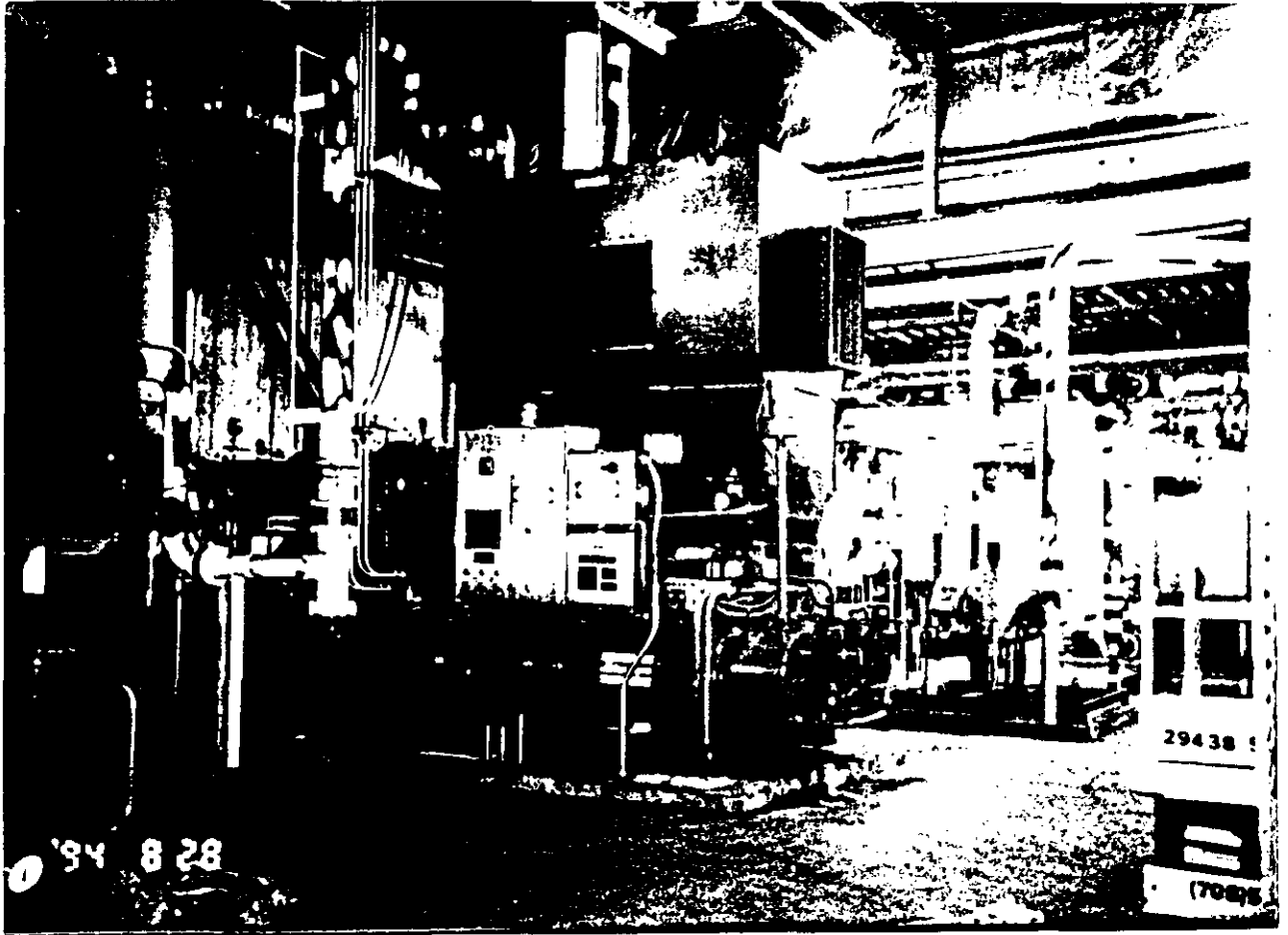

Motor driven, 3 stage, centrifugal air compressor in center. Afterfilters and dryer can be seen in the right background. Construction progress photo, August 1994.

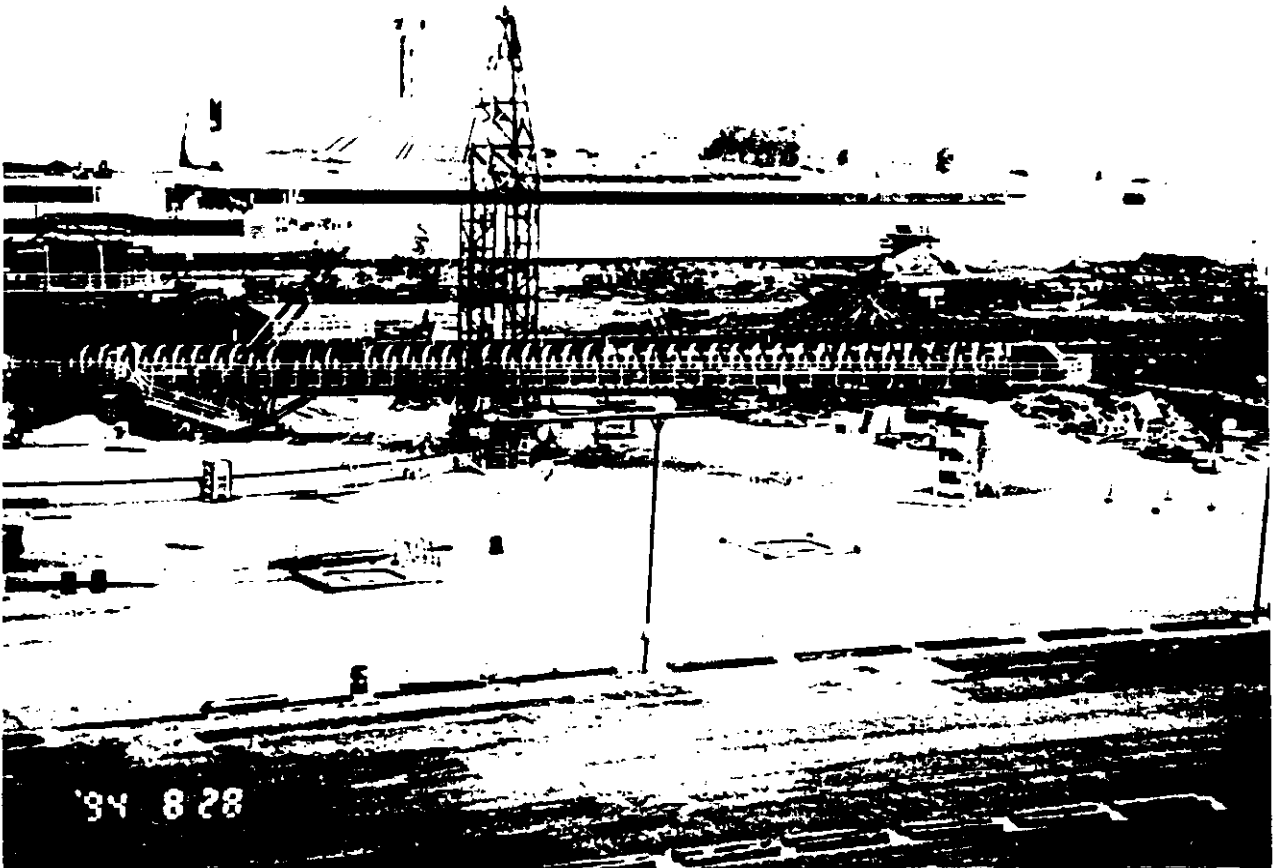

Raw coal radial stacker conveyor. Three of the four hoppers feeding coal to the underground reclaim tunnel can be seen at ground level. Construction progress photo, August 1994.

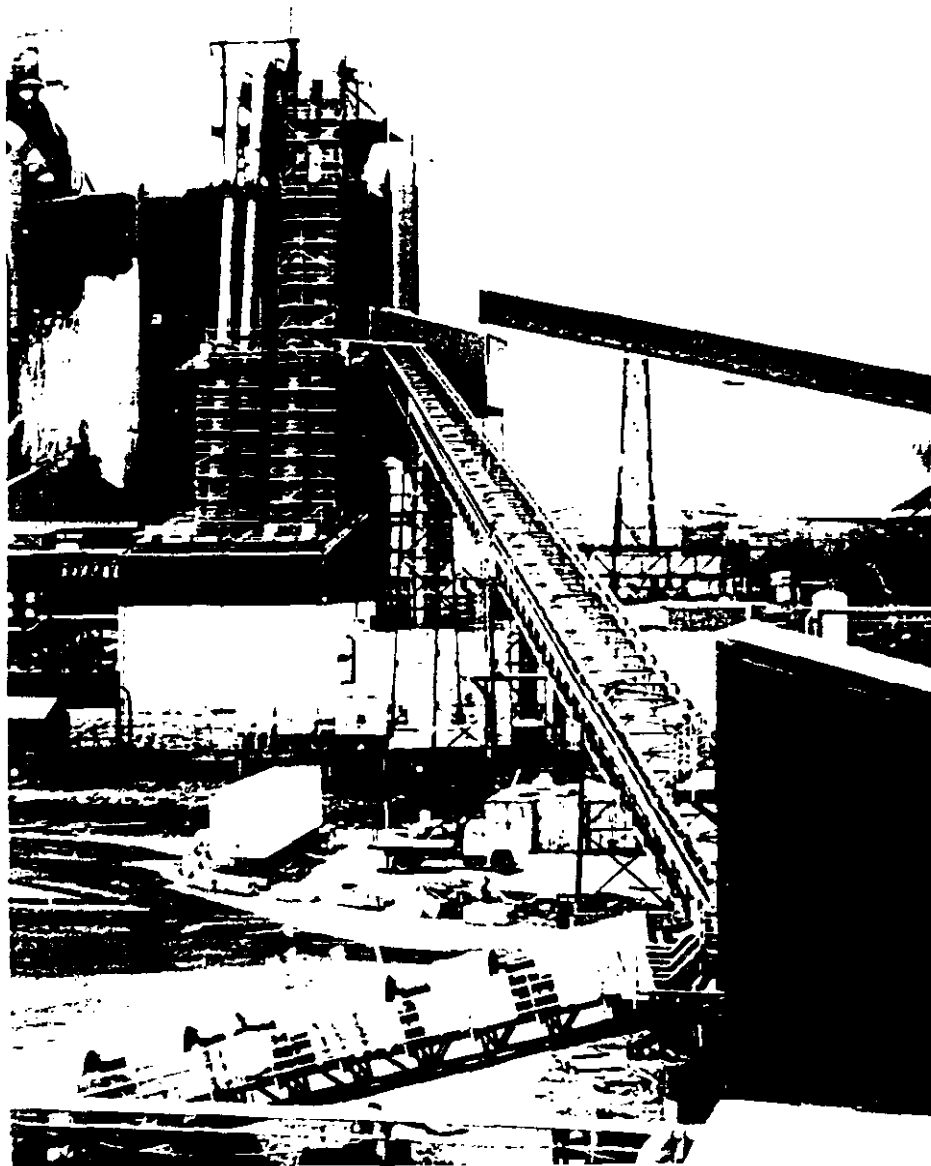

Precrusher building in the right foreground. Process building in the background. "D" blast furnace can be partially seen in the left background. Construction progress photo, August 1994.

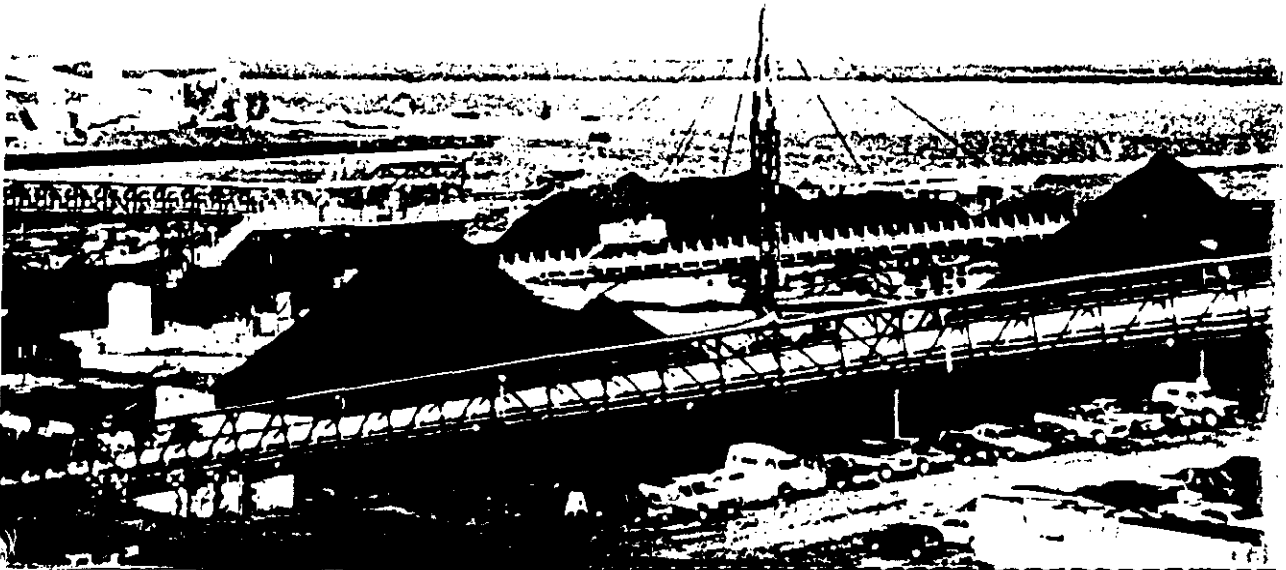

Radial stacker and raw coal stockpile area after delivery of the first train load of coal. The radial stacker is in the lowered position. Construction progress photo, September 1994.



Coal injection pipe bridge from the process building to "C" blast furnace. Injection pipe bridge to "D" blast furnace can be seen in the lower background. Construction progress photo, October, 1994

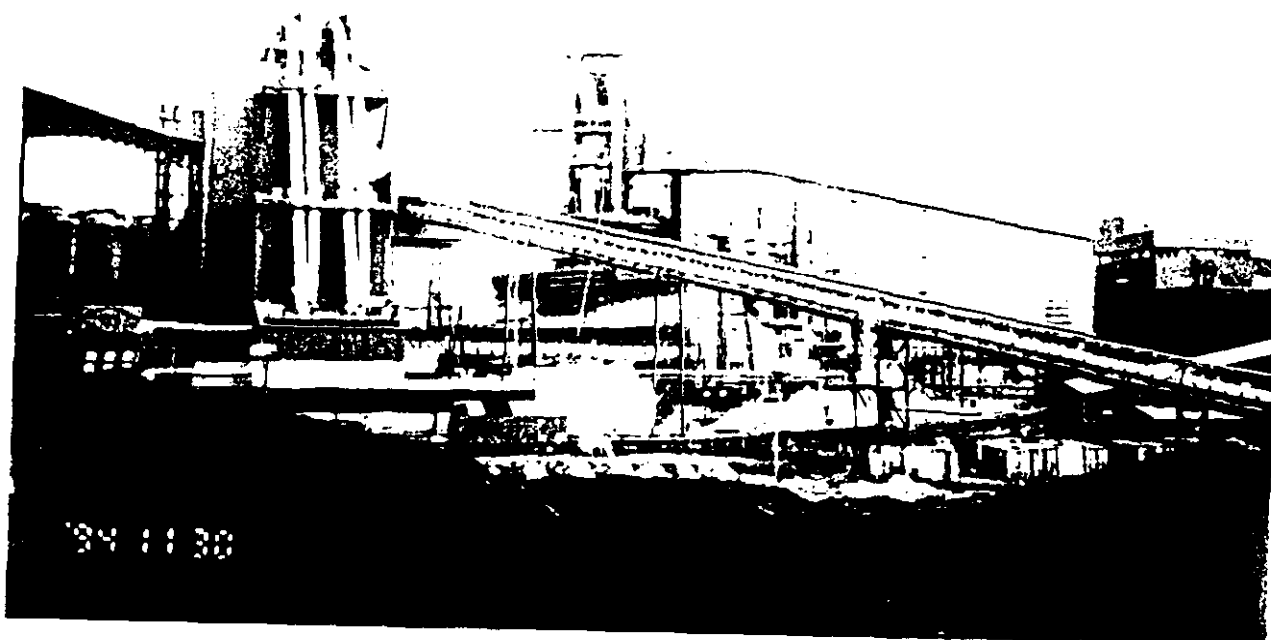

Plant feed conveyor to the process building looking from the raw coal storage pile. "C" blast furnace is in the center background. Construction progress photo, November 1994.

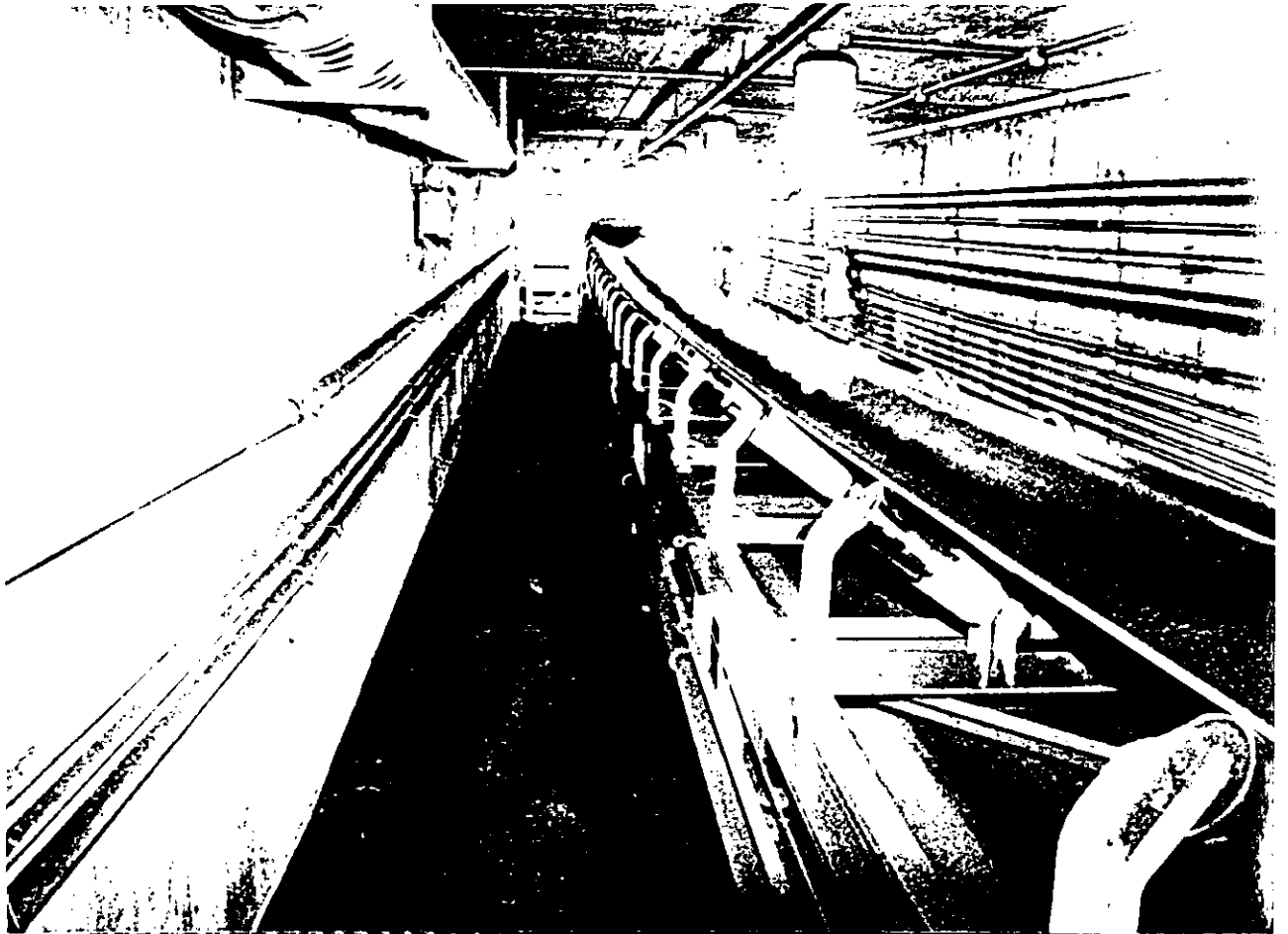

Raw coal reclaim conveyor looking from inside the tunnel towards the above ground entrance. February 1995



West side of Process Building (tall structure) and Utility Building (low structure to right of the process building). Coal feed conveyor enters the Process Building on the west side. February 1995.

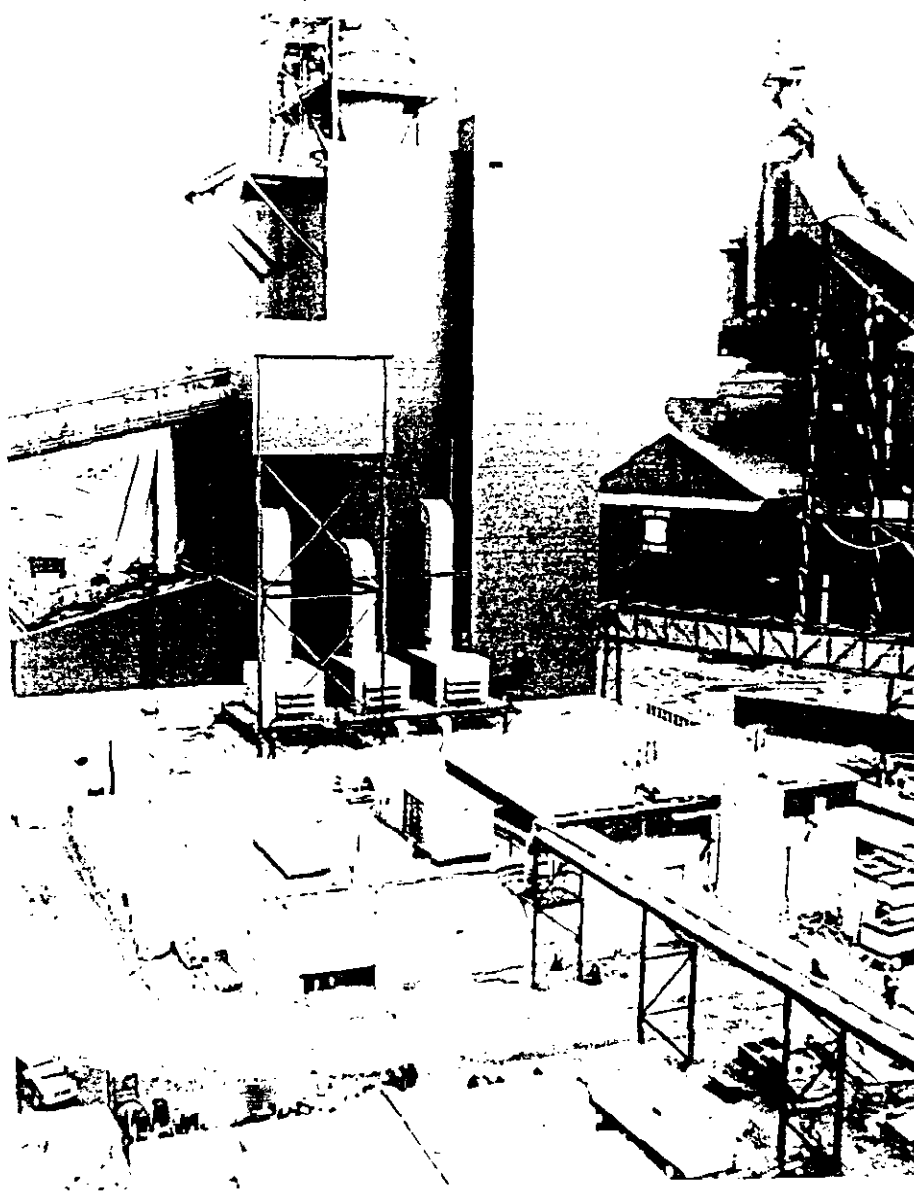

South side of Process Building and Utility Building. Utility pipe bridge enters the Utility Building on the lower right. Note mill system cyclone separators on top of Process Building. "D" blast furnace can be seen to the right of the Process Building. February 1995.

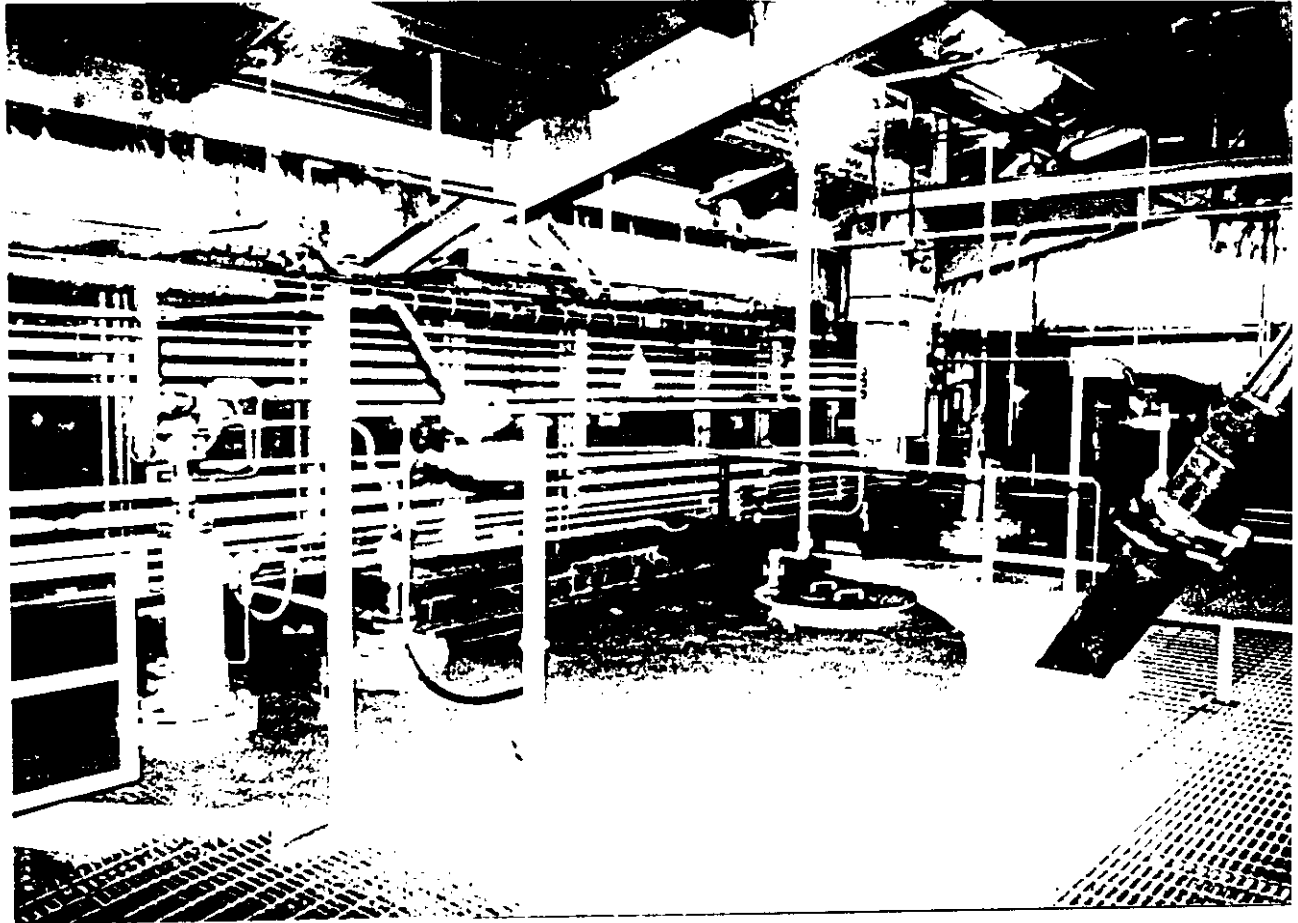

Raw coal drag conveyor feeding into the top of the two - 240 ton capacity raw coal storage bins inside the Process Building. February 1995.

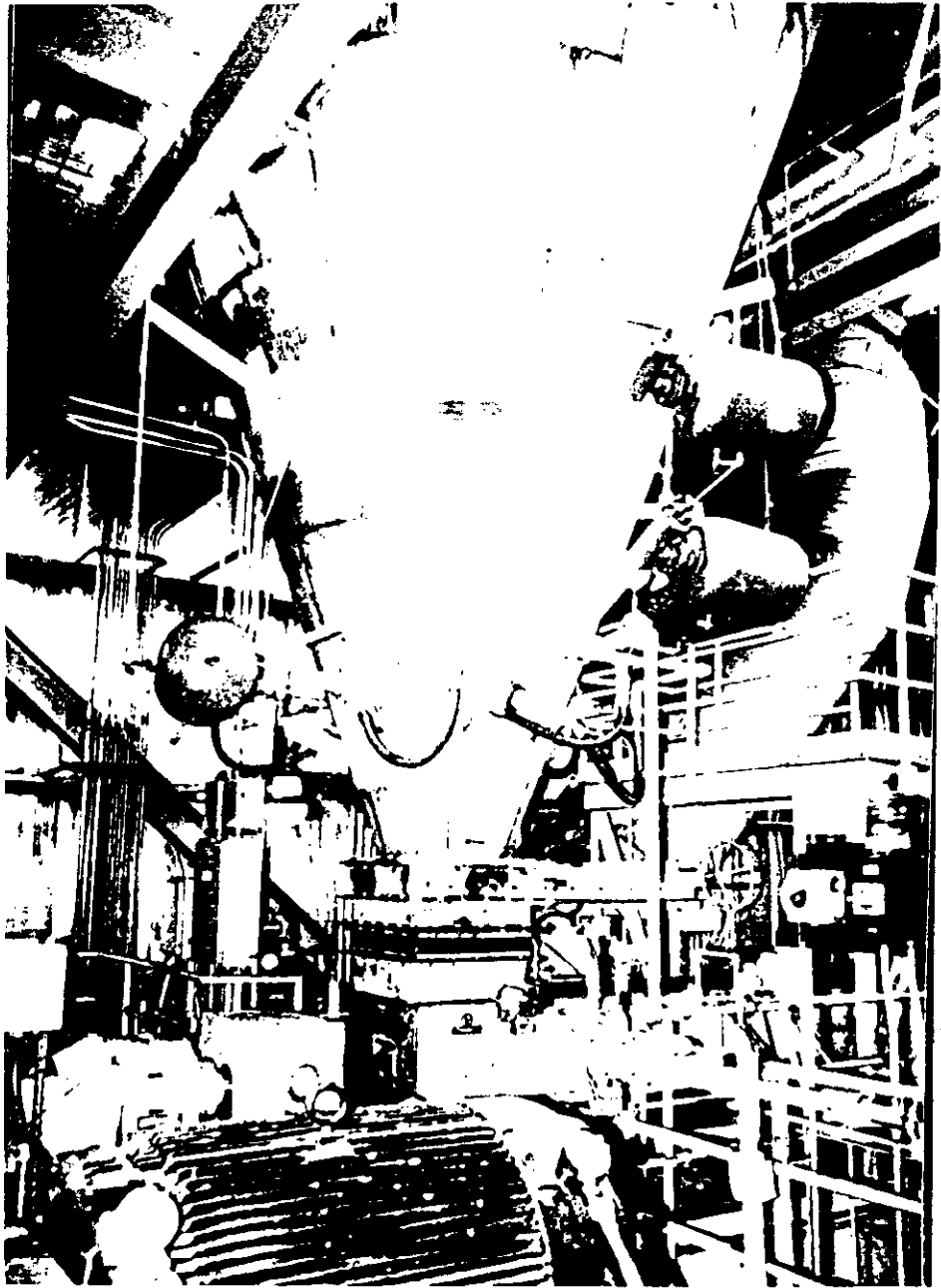

Bottom of the south 240 ton raw coal storage bin. A screw feeder takes coal from the bin bottom to the coal preparation mill.
February 1995.

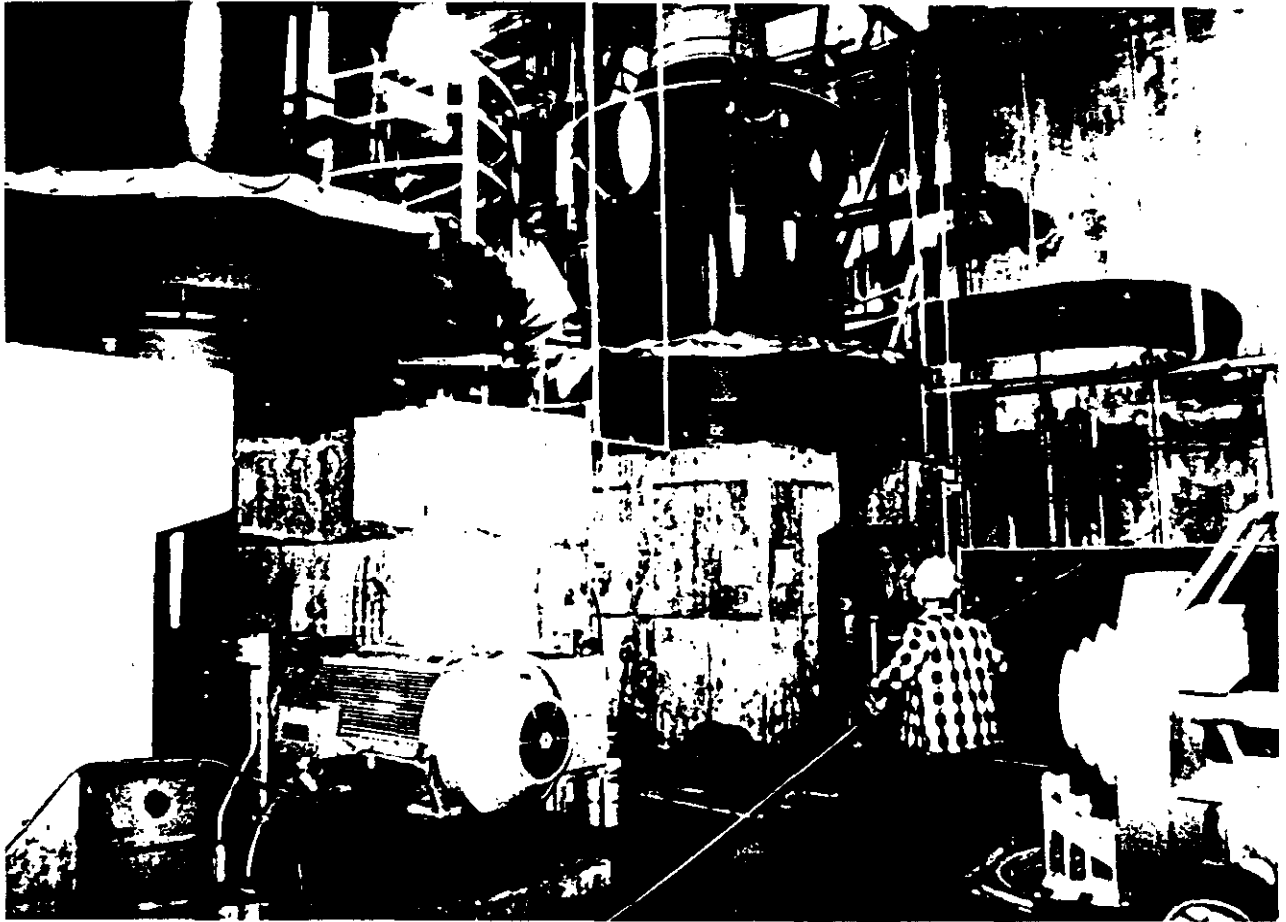

The two - 60 ton per hour Williams coal crusher and dryer mills.
Mill drive motor and speed reducer is located below the mill
between the concrete foundations. February 1995.

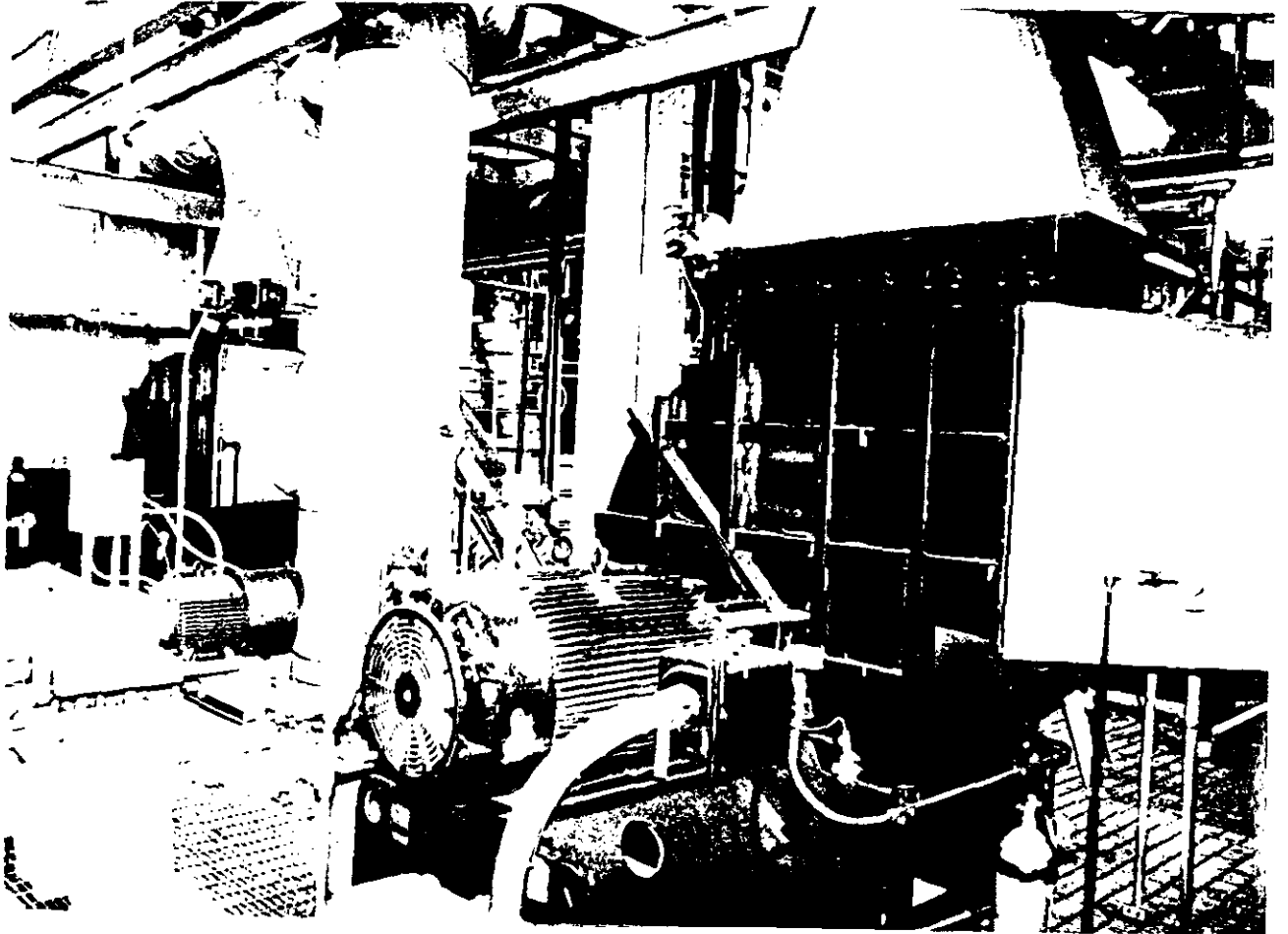

The mill system, motor driven, exhaust fan circulates a portion of the coal drying air through a dust collector located outside the building.
February 1995.



Mill system cyclone separators located on top of the Process Building. Most of the coal is removed from the drying air in these units. Coal flows from the bottom of the separator to the product coal screen inside the building. February 1995.

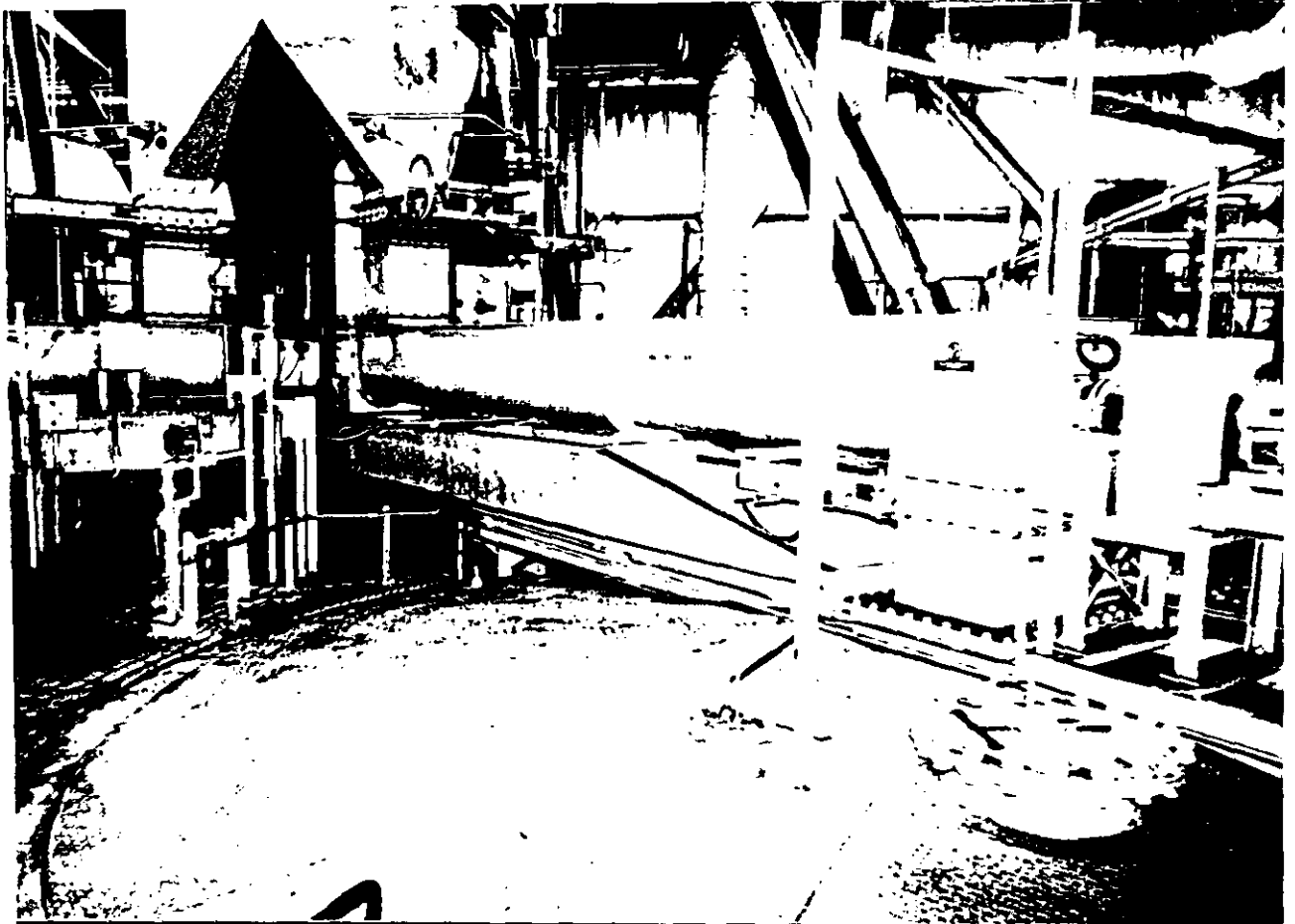

Product coal 4-way splitter (upper left) and screw feeders discharging coal from the screens (on the floor above) into four 180 ton product coal bins. February 1995.

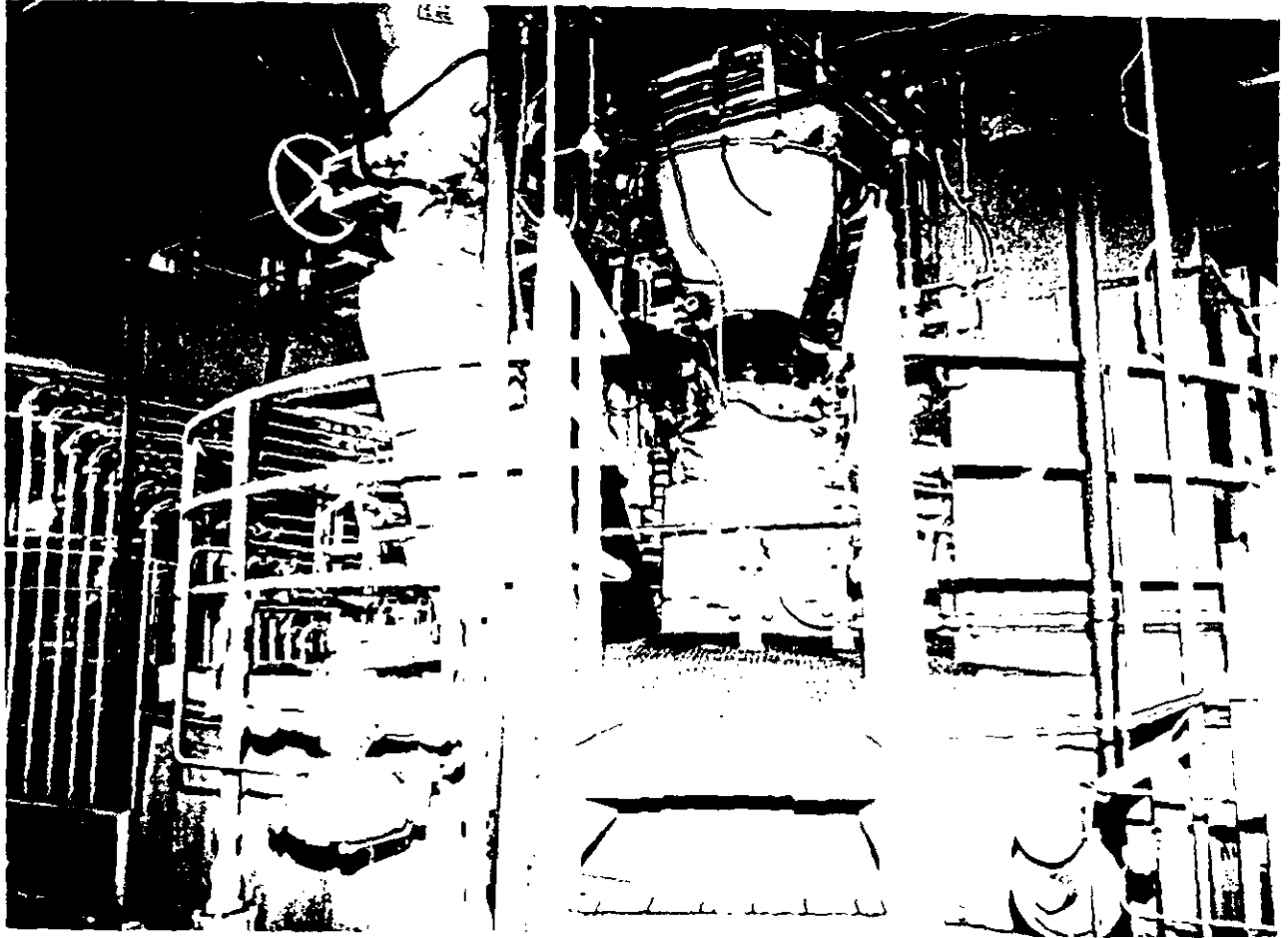

Bottom of one of four weigh bins (which takes coal from the product coal bin) discharging into the top of the distribution bin.
February 1995.

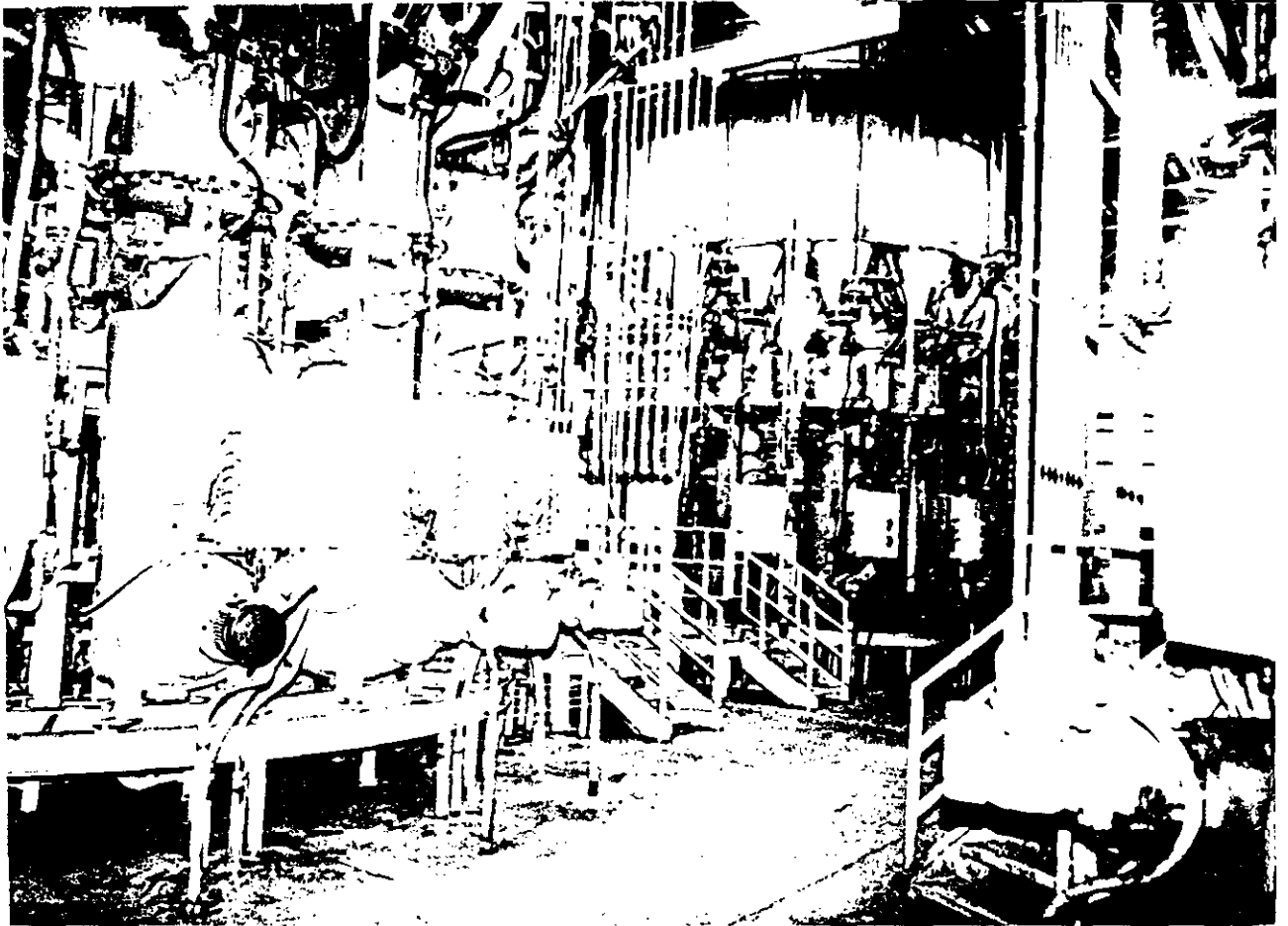

Coal injectors for "C" blast furnace beneath the distribution bin. Two clusters of 14 injectors each are required to feed each blast furnace. February 1995.



Coal injection piping inside the process building. Special hardened pipe elbows are necessary at each change in coal flow direction.
February 1995.

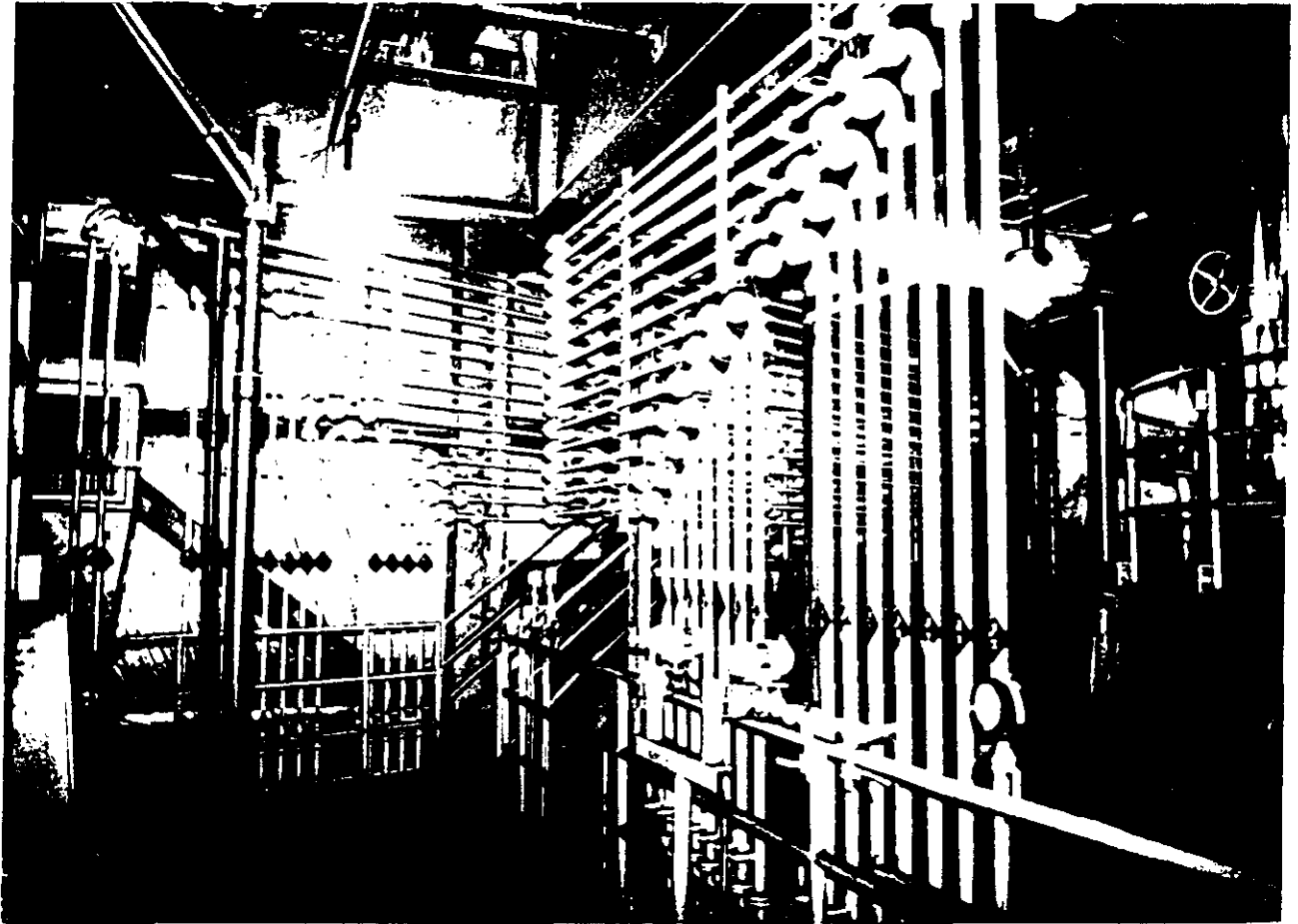

"C" furnace coal injection piping inside the process building.
28 injection pipes are required to supply coal to the furnace.
February 1995.



Injection pipe bridge from the Process Building to "C" blast furnace.
February 1995.

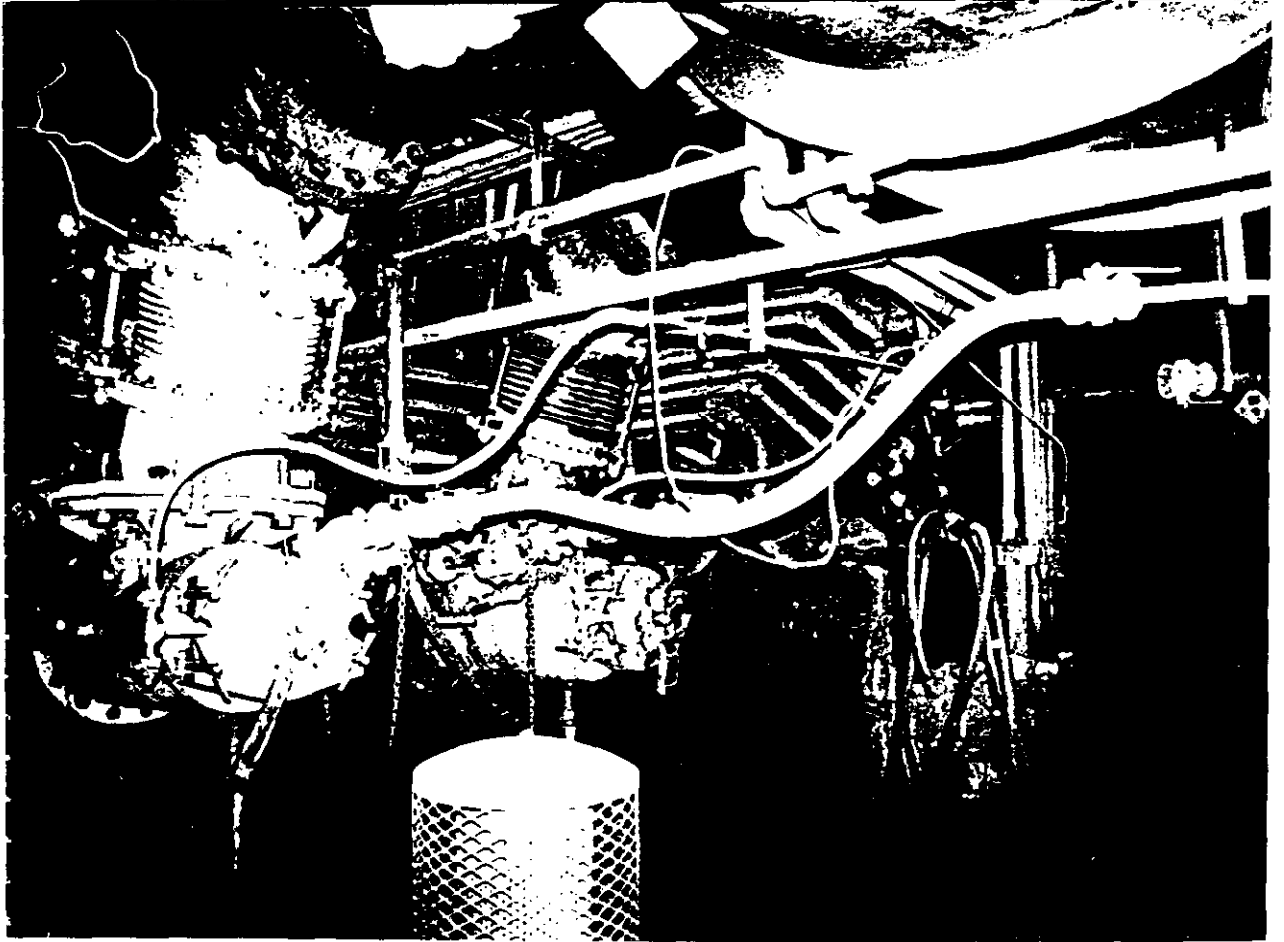

Coal injection flexible hose between the hard pipe on the right
and coal injection lance at the blast furnace.
February 1995.

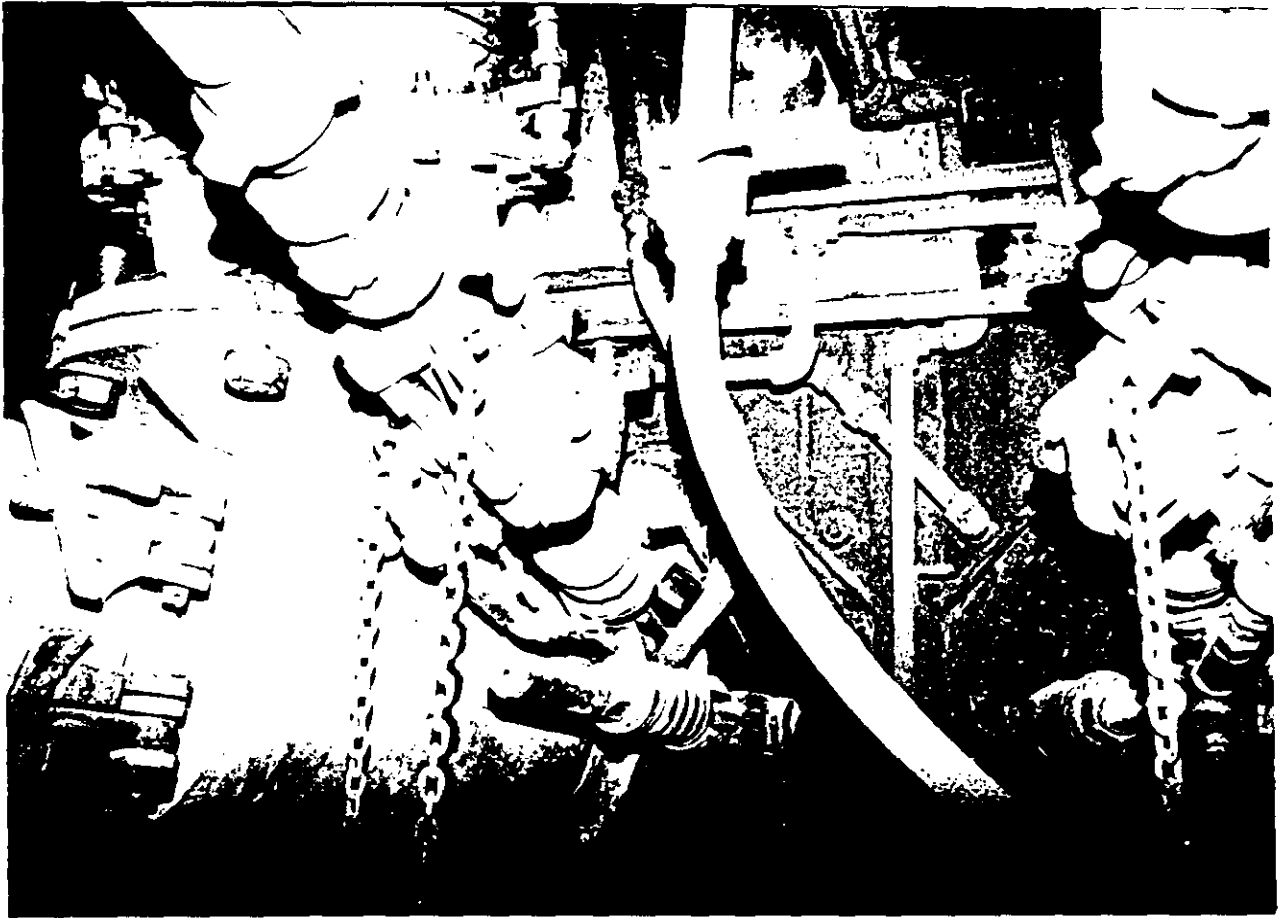

Coal injection lance attachment to the blast furnace hot blast blow pipe.
February 1995.

