

Appendix M

Data Capture Standards

January 2008



Table of Contents

M.1	Overview	1
M.1.1	Introduction.....	1
M.1.2	Scoping	1
M.1.3	Base Map	1
M.1.4	Terrain.....	2
M.1.5	Survey	2
M.1.6	Hydrology	2
M.1.7	Hydraulics.....	2
M.1.8	Alluvial Fan	2
M.1.9	Coastal	3
M.1.10	Floodplain Mapping.....	3
M.1.11	GIS Spatial Requirements.....	3
M.2	Scoping Submittal Standards.....	5
M.3	Base Map Submittal Standards.....	6
M.3.1	Overview.....	6
M.3.2	Requirements	6
M.3.2.1	Data Files.....	6
M.3.2.2	General Correspondence	6
M.3.2.3	Certification of Work	7
M.3.2.4	Accepted File Formats.....	7
M.3.2.5	Metadata	7
M.3.2.6	Transfer Media	7
M.3.2.7	Transfer Methodology (DEFINE WHERE IT IS).....	8
M.3.2.8	Directory Structure and Folder Naming Conventions.....	8
M.4	Terrain Submittal Standards.....	9
M.4.1	Overview.....	9
M.4.2	Requirements	9
M.4.2.1	Data Files.....	9
M.4.2.2	General Correspondence	10
M.4.2.3	Certification of Work	10
M.4.2.4	Accepted File Formats.....	10
M.4.2.5	Metadata	11
M.4.2.6	Transfer Media	11
M.4.2.7	Transfer Methodology	11

Appendix M: Data Capture Standards

M.4.2.8	Directory Structure and Folder Naming Conventions	11
M.5	Survey Submittal Standards	13
M.5.1	Overview	13
M.5.2	Requirements	14
M.5.2.1	Data Files	14
M.5.2.2	General Correspondence	26
M.5.2.3	Certification of Work	26
M.5.2.4	Acceptable File Formats	26
M.5.2.5	Metadata	26
M.5.2.6	Transfer Media	26
M.5.2.7	Transfer Methodology	27
M.5.2.8	Directory Structure and Folder Naming Conventions	27
M.6	Hydrology Submittal Standards	28
M.6.1	Overview	28
M.6.2	Requirements	28
M.6.2.1	Data Files	28
M.6.2.2	General Correspondence	30
M.6.2.3	Certification of Work	30
M.6.2.4	Acceptable File Formats	31
M.6.2.5	Metadata	31
M.6.2.6	Transfer Media	31
M.6.2.7	Transfer Methodology	32
M.6.2.8	Directory Structure and Folder Naming Conventions	32
M.7	Hydraulics Submittal Standards	33
M.7.1	Overview	33
M.7.2	Requirements	33
M.7.2.1	Data Files	33
M.7.2.2	General Correspondence	35
M.7.2.3	Certification of Work	35
M.7.2.5	Metadata	36
M.7.2.6	Transfer Media	36
M.7.2.7	Transfer Methodology	36
M.7.2.8	Directory Structure and Folder Naming Conventions	36
M.8	Alluvial Fan Submittal Standards	38
M.8.1	Overview	38
M.8.2	Requirements	39

Guidelines and Specifications

M.8.2.1	Data Files.....	39
M.8.2.2	General Correspondence	39
M.8.2.3	Certification of Work	40
M.8.2.4	Accepted File Formats.....	40
M.8.2.5	Metadata	40
M.8.2.6	Transfer Media	40
M.8.2.7	Transfer Methodology	41
M.8.2.8	Directory Structure and Folder Naming Conventions	41
M.9	Coastal Submittal Standards.....	43
M.9.1	Overview.....	43
M.9.2	Requirements	43
M.9.2.1	Data Files.....	43
M.9.2.2	1-Percent-Annual-Chance Wave Envelop.....	45
M.9.2.4	Summary of Coastal Stillwater Elevations.....	45
M.9.2.5	Surge Station Location Map.....	45
M.9.2.6	Transect Location Map.....	45
M.9.2.7	Transect Description Table.....	46
M.9.2.8	Transect Data Table.....	46
M.9.2.9	General Correspondence	46
M.9.2.10	Certification of Work.....	46
M.9.2.11	Acceptable File Formats	47
M.9.2.12	Metadata.....	47
M.9.2.13	Transfer Media.....	47
M.9.2.14	Transfer Methodology.....	48
M.9.2.15	Directory Structure and Folder Naming Conventions	48
M.10	Floodplain Mapping Submittal Standards.....	49
M.10.1	Overview.....	49
M.10.2	Requirements	49
M.10.2.1	Data Files	49
M.10.2.2	Draft FIS	49
M.10.2.3	Redelineation	50
M.10.2.4	Digital Conversion	50
M.10.2.5	General Correspondence.....	51
M.10.2.6	Certification of Work.....	52
M.10.2.7	Acceptable File Formats.....	52
M.10.2.8	Metadata.....	52

Appendix M: Data Capture Standards

M.10.2.9	Transfer Media.....	54
M.10.2.10	Transfer Methodology.....	54
M.10.2.11	Directory Structure and Folder Naming Conventions	54
M.11	GIS Spatial Requirements	57
M.11.1	Floodplain Mapping Spatial Files - General	57
M.11.1.1	Submittal Information	57
M.11.2	Floodplain Mapping Spatial Files – Riverine Studies	58
M.11.2.1	Sub Basins.....	58
M.11.2.2	Nodes	58
M.11.2.3	Profile Baseline.....	59
M.11.2.4	Cross Sections.....	60
M.11.2.5	Base Flood Elevations (BFEs).....	62
M.11.2.6	Alluvial Fan Spatial File	63
M.11.2.7	Floodplain Mapping Spatial File.....	63
M.11.2.8	Floodplain Boundary Standard Self-Certification	65
M.11.3	Required Floodplain Mapping Spatial Files – Coastal Studies.....	67
M.11.3.1	Coastal Transects	67
M.11.3.2	Coastal Water Levels	68
M.11.3.3	Tide Gage Data	69
M.11.3.4	Wave Buoy Data	70
M.11.3.5	Wind Data	71
M.11.3.6	Shoreline	71
M.11.3.7	CBRS and Otherwise Protected Areas (OPAs).....	72
M.11.3.8	Primary Frontal Dunes.....	72
M.11.3.9	Limit of Moderate Wave Action (LiMWA).....	72
M.11.3.10	Coastal Structures	73
M.12	Domain Tables	74
M.12	References	85

Tables

Table M-1.	Survey Data File Example	15
Table M-2.	Survey Codes	16
Table M-3.	S_Submittal_Info Spatial File.....	57
Table M-4.	S_Subbasins Spatial File.....	58
Table M-5.	S_Nodes Spatial File.....	59
Table M-6.	S_Profil_Basln Spatial File.....	60
Table M-7.	S_XS Spatial File.....	61
Table M-8.	S_BFE Spatial File.....	62

Guidelines and Specifications

Table M-9. S_Alluvial Spatial File.....	63
Table M-10. S_Fld_Haz_Ar Spatial File.....	63
Table M-11. S_Cst_Tsct_Ln Spatial File.....	68
Table M-12. L_Cst_WaterLv File.....	69
Table M-13. S_TideGage Spatial File.....	70
Table M-14. S_Buoy Spatial File.....	70
Table M-15. S_WindSta Spatial File.....	71
Table M-16. S_Shore_Ln Spatial File.....	71
Table M-17. S_CBRS Spatial File.....	72
Table M-18. S_PFD Spatial File.....	72
Table M-19. S_LIMWA Spatial File.....	73
Table M-20. S_Cst_Struc Spatial File.....	73

Figures

Figure M-1. Typical Cross-section Data (Displays Survey Code Locations).....	19
Figure M-2. Typical Cross-section Sketch (IND-6600-SKETCH).....	20
Figure M-3. Typical Bridge Data (Displays Survey Code Locations).....	21
Figure M-4. Typical Bridge Sketch.....	22
Figure M-5. Typical Culvert Data (Displays Survey Code Locations).....	23
Figure M-6. Typical Culvert Sketch.....	24
Figure M-7. Typical Dam Data (Displays Survey Code Locations).....	25
Figure M-8 Certification of Compliance Form.....	53
Figure M-9. Figure with Nodes, Stream Centerline, and the Basins.....	66
Figure M-10. Figure Depicting Profile Baseline.....	66

M.1 Overview

M.1.1 Introduction

The purpose of the Data Capture Standards (DCS) in this Appendix is to provide a consistent framework for submittal, storage, and retrieval of the technical and administrative data needed for a Flood Insurance Study (FIS) or Flood Insurance Rate Map (FIRM) revision. Providing this framework is intended to make the study assessment process more efficient; provide easier retrieval of the study data; and preserve the investment made in the data.

The data standards are provided in subsections. Each subsection corresponds to major production data capture points in the Mapping Information Platform (MIP) workflow and includes guidance on submitting the following deliverables: scoping, base map, terrain, survey, hydrologic, hydraulic, alluvial fan, coastal, and floodplain mapping data for studies. These sections describe the minimum dataset of deliverables established by the Federal Emergency Management Agency (FEMA) for floodplain mapping submittals. This Appendix replaces the previously published *Appendix M: Guidance for Preparing and Maintaining Technical and Administrative Support Data*, *Appendix N: Data Capture Standards*, and *Appendix N: Data Capture Guidelines*.

After the reviews and quality assurance processes have been completed, the information specified in this appendix must be uploaded as the last step in the workflow process by the contractor assigned to performing the work. This guidance is not intended for drafts, preliminary, and interim submittals that may be uploaded. The final data that Mapping Partners upload to the MIP should be the final deliverable required by the Mapping Activity Statement (MAS) and must comply with the DCS.

This guidance applies to FEMA-funded studies and restudies conducted by FEMA's Mapping Partners, including contractors as well as those studies performed by communities, regional agencies, and State agencies participating in the Cooperating Technical Partners (CTP) program.

M.1.2 Scoping

This section is reserved for further updates to scoping DCS pending completion of the CNMS Data Model.

M.1.3 Base Map

The Base Map section describes data needed to develop the Digital Flood Insurance Rate Map (DFIRM) product for mapping activities. This information includes aerial photographs, community boundaries, bench marks, transportation, and other data to aid in the study process.

Guidelines and Specifications

M.1.4 Terrain

The Terrain section describes the information needed to capture the digital topographic data used for the FIS. This information includes the pre-processed and processed data for the terrain. For coastal studies, bathymetric data used for the analysis of offshore areas and coastal waters are needed for submission. Once the required data are provided, FEMA will be able to account for the origins of the flood study elevation data. The requirements in Appendix A of these Guidelines also must be met to define the quality of the topographic data used. Certification of the digital topographic data is required for those datasets funded by FEMA. This data must be uploaded by the Mapping Partner at the end of the data development process.

M.1.5 Survey

The Survey section describes the data necessary to digitally represent information collected in the survey phase of the study for those survey efforts funded by FEMA. The survey phase has traditionally been one of the most expensive portions of the study. These standards describe how the survey data for features such as dams, culverts, bridges, transects, structures, and channels must be submitted. If funded by FEMA, a certification of the work is required. If a study uses survey data previously collected but not funded by FEMA, the information does not need to be translated to the deliverable format listed in this appendix. The survey data must be uploaded regardless of the data format at the perform field survey workflow step.

M.1.6 Hydrology

The Hydrology section describes the data necessary to document the hydrologic procedures for estimating flood discharges for the FIS. The goal of this section is to describe the format and type of hydrologic data expected by FEMA for new and updated studies other than coastal and alluvial fan studies. The hydrologic data must be certified.

M.1.7 Hydraulics

The Hydraulics section describes the format and type of hydraulic data to be provided to FEMA for riverine FISs. This section also provides standards for FIS report components including Floodway Data Tables (FDTs), profiles, and FIS narrative text. The hydraulic data must be certified.

M.1.8 Alluvial Fan

The Alluvial Fan section describes data submittal requirements when a study includes an alluvial fan analysis. This section also includes FIS elements and certification. The type of data deliverables and formats required are described in this section.

M.1.9 Coastal

The Coastal section outlines data and certification submittal requirements for coastal studies. This data must be submitted at the end of the study process once the contractual requirements regarding quality control reviews have been completed. The type of data deliverables and formats required are described in this section.

M.1.10 Floodplain Mapping

The Floodplain Mapping section describes types of deliverables and formats for floodplains and associated mapping products that are created by redelineating floodplains using updated topographic data and conversion of non-revised effective FIRM information to digital format. Data in this section also includes submittal of Floodplain Boundary Standard (FBS) self-certification information.

M.1.11 GIS Spatial Requirements

This section details the components required in the geospatial submittals that are referenced throughout this appendix. This section covers the field names, size, and type for the attribute information to be delivered to FEMA. The required items are listed in sections 2 through 10 and only the specifics of the deliverable are listed in section 11.

M.2 Scoping Submittal Standards

This section is reserved for further updates to scoping DCS pending completion of the CNMS Data Model.

M.3 Base Map Submittal Standards

M.3.1 Overview

The goal of this subsection is to describe the format and type of base map data required to be submitted to FEMA for FISs. All data must be submitted in digital format. The Mapping Partner performing “Acquire Base Map” is required to submit the data in this section.

The submitting Mapping Partner must retain copies of all Project-related data for a period of 3 years. The submitting Partner will need these data for responding to the following:

- Questions from FEMA or the receiving Mapping Partner during the review of the final draft materials;
- Comments and appeals submitted to FEMA during the 90-day appeal period following the issuance of preliminary maps; and
- Other concerns and issues that may develop during the processing of the revised FIS report and FIRM.

M.3.2 Requirements

M.3.2.1 Data Files

The minimum required data for the basic mapping data submission is the source mapping data used in the study. This data can be contained in a single file or in tiled files. These submissions must be compliant with the base map files in Appendix L. The following information must be submitted:

- Orthophotos;
- Road and railroad centerline data;
- Political boundaries; and
- A narrative describing the scope of work, direction from FEMA, issues, information for next Mapping Partner, etc.

M.3.2.2 General Correspondence

A file that compiles general correspondence must be submitted by the Mapping Partner performing “Acquire Base Map.” General correspondence is the written correspondence generated or received by the Mapping Partner assigned to fulfill the requirements of acquiring base map. Correspondence includes any documentation generated during this task such as letters; transmittals; memoranda; general status reports and queries; special problem reports (SPRs); technical issues that need to be documented; direction given by FEMA; and internal communications, routing slips, and notes that were relevant to the performance of this task. Contractual documents, such as a signed Statement of Work (SOW) or MAS, are not to be submitted as a part of this appendix.

M.3.2.3 Certification of Work

FEMA-funded base map data development must be certified using the form provided in Figure M-8. A PDF of the form with the original signature, data, and seal affixed to the form must be submitted digitally. This form must be signed by a registered Professional Engineer or Surveyor from the firm contracted to perform the work, or by the responsible official of a government agency. A digital version of this form is available at www.fema.gov.

M.3.2.4 Accepted File Formats

Base map data must be submitted in a georeferenced, digital format. This data can be contained in a single file or in a tiled set of files. Any tiled data must have an accompanying index spatial file. The following formats are acceptable for files:

- ESRI Geodatabase
- ESRI Shapefile
- GeoTIFF - TIFF variant enriched with GIS relevant metadata
- IMG - ERDAS IMAGINE image file format
- MrSID - Multi-Resolution Seamless Image Database
- PDF - For general correspondence and project narrative
- PNG and JPEG -georeferenced
- JPEG2000

M.3.2.5 Metadata

A metadata file that complies with the FEMA/FGDC Metadata Profiles (available on the MIP via “Tools and Links”) in XML format must be included with the submittal. The profiles follow the FGDC Content Standard for metadata and define additional domains and business rules for some elements that are mandatory for FEMA, based on the specific submittal type. For each spatial data source in the metadata file, the Mapping Partner must assign a Source Citation Abbreviation.

M.3.2.6 Transfer Media

Mapping Partners must submit files on one of the following electronic media or via the internet by uploading to the MIP (<http://www.hazards.fema.gov>):

- CD-ROM
- DVD
- External Hard Drive (for very large data submissions)

Guidelines and Specifications

In special situations or as technology changes, other media may be acceptable if coordinated with FEMA.

When data is mailed to FEMA, all submitted electronic media must be labeled with at least the following information:

- Mapping Partner's name;
- Community name and State for which the FIS was prepared;
- Base Mapping Data;
- Date of submission (formatted mm/dd/yyyy); and
- Disk [*sequential number*] of [*number of disks*]. The media must be numbered sequentially, starting at Disk 1. [Number of disks] represents the total number of disks in the submission

M.3.2.7 Transfer Methodology (DEFINE WHERE IT IS)

Base Map Data artifacts can be uploaded to the MIP by following the guidelines for data submission located on the MIP (<https://hazards.fema.gov>).

M.3.2.8 Directory Structure and Folder Naming Conventions

The files in section M.3.2 Requirements must be submitted to the MIP within the following directory structure. The following folders can be created either on a local work space (i.e., a personal computer) or within the work space for the community on the MIP. If the following folders are generated locally, these newly created folders and their contents must be uploaded to the MIP.

- \General
 - XML_format metadata file
 - Project narrative
- \Correspondence
 - Letters; transmittals; memoranda; general status reports and queries; SPRs; technical issues; direction by FEMA; and internal communications, routing slips, and notes.
- \Base Map\Spatial Files
 - Road and railroad centerline data
 - Political boundaries
 - Orthophotos

M.4 Terrain Submittal Standards

M.4.1 Overview

This section describes the format and type of terrain data required to be submitted to FEMA for FISs. All data must be submitted in digital format. The Mapping Partner performing “Develop Topographic Data” is required to submit the data in this section.

The Mapping Partner should refer to Appendix A of these Guidelines for guidance on terrain data production. This section is not intended to detail the specifications and procedures for coastal hydrographic surveys. The reader is referred to the following sources for details on coastal surveys.

- National Oceanic and Atmospheric Administration (NOAA) NOS Hydrographic Survey Specifications and Deliverables (April 2007);
- NOAA Office of Coast Survey Hydrographic Surveys Division Field Procedures Manual (March 2007); and
- U.S. Army Corps of Engineers (USACE) National Coastal Mapping Program Joint LiDAR Bathymetry Technical Center for Expertise.

The submitting Mapping Partner must retain copies of all Project-related data for a period of 3 years. The submitting Mapping Partner will need these data for responding to the following:

- Questions from FEMA or the receiving Mapping Partner during the review of the final draft materials;
- Comments and appeals submitted to FEMA during the 90-day appeal period following the issuance of preliminary maps; and
- Other concerns and issues that may develop during the processing of the revised FIS report and FIRM.

M.4.2 Requirements

M.4.2.1 Data Files

The minimum data required for the terrain data submission are the source terrain and mapping data used in the study. This data can be contained in a single file or in tiled files. When tiled files are submitted, they must be accompanied by a tiling index file. If any processing has been performed, the intermediate and final files must be submitted as well. This information is required to be a georeferenced digital submittal. The following information must be submitted when it is used to perform a study:

- LiDAR data (bare earth and all returns);
- Tiling index for data files;
- Breaklines and Mass Points;
- Contours;

Guidelines and Specifications

- Bathymetry;
- Digital Elevation Models (DEMs);
- Hydro-corrected DEMs;
- Triangulated Irregular Networks (TINs);
- Hydro-corrected TINs;
- USGS topographic data;
- All other terrain data; and
- A narrative describing the scope of work, direction from FEMA, issues, information for next Mapping Partner, etc.

LiDAR-generated data must be submitted as two separate files: one for bare earth only, and one for all returns if bare earth processing was performed as part of this project. For existing LiDAR data not processed as part of the project, the bare earth data must be submitted. The submittal of the all returns data (if available) is optional.

M.4.2.2 General Correspondence

A file that compiles general correspondence must be submitted by the Mapping Partner performing “Develop Topographic Data.” General correspondence is the written correspondence generated or received by the Mapping Partner to fulfill the requirements of developing topographic data.

Correspondence include any documentation generated during this task such as letters; transmittals; memoranda; general status reports and queries; SPRs; technical issues that need to be documented; direction given by FEMA; and internal communications, routing slips, and notes that were relevant to the performance of this task. Contractual documents, such as a signed SOW or MAS, are not to be submitted as a part of this appendix.

M.4.2.3 Certification of Work

FEMA-funded topographic data development must be certified using the form provided in Figure M-8. A PDF of the form with the original signature, data, and seal affixed to the form must be submitted digitally. This form must be signed by a registered Professional Engineer or Surveyor from the firm contracted to perform the work, or by the responsible official of a government agency. A digital version of this form is available at www.fema.gov.

M.4.2.4 Accepted File Formats

Terrain data used to perform the study must be submitted in a georeferenced, digital format as listed below. This data can be contained in a single file or in a tiled set of files. Any tiled data must have an accompanying index spatial file.

- Contours, Masspoints, and breaklines – ESRI File or personal geodatabase, DXF, or shapefile
- DEMs – ESRI grid, GeoTIFF, or ASCII grid
- LiDAR - LAS file, ASCII x, y, z file
- PDF for the project narrative, correspondence, and certification

M.4.2.5 Metadata

A metadata file that complies with the FEMA/FGDC Metadata Profiles (available on the MIP via “Tools and Links”) in XML format must be included with the submittal. The profiles follow the FGDC Content Standard for metadata and define additional domains and business rules for some elements that are mandatory for FEMA, based on the specific submittal type. For each spatial data source in the metadata file, the Mapping Partner must assign a Source Citation Abbreviation.

M.4.2.6 Transfer Media

Mapping Partners must submit files on one of the following electronic media or via the internet by uploading to the MIP (<http://www.hazards.fema.gov>):

- CD-ROM
- DVD
- Portable hard drive

In special situations or as technology changes, other media may be acceptable if coordinated with FEMA.

When data is mailed to FEMA, all submitted digital media must be labeled with at least the following information:

- Mapping Partner’s name;
- Community name and State for which the FIS was prepared;
- Terrain Data;
- Date of submission (formatted mm/dd/yyyy); and
- Disk [*sequential number*] of [*number of disks*]. The media must be numbered sequentially, starting at Disk 1. [Number of disks] represents the total number of disks in the submission.

M.4.2.7 Transfer Methodology

Terrain data can be uploaded to the MIP by following the guidelines for data submission located on the MIP (<https://hazards.fema.gov>).

M.4.2.8 Directory Structure and Folder Naming Conventions

The files in section M.4.2 Requirements must be submitted to the MIP within the following directory structure. The following folders can be created either on a local work space (i.e., a personal computer) or within the work space for the community on the MIP. If the following folders are generated locally, these newly created folders and their contents must be uploaded to the MIP. Terrain files are arranged into appropriate directories based on data type.

- \General
 - XML_format metadata file
 - Certification

Guidelines and Specifications

- Project narrative
- \Correspondence
 - Letters; transmittals; memoranda; general status reports and queries; SPRs; technical issues; direction by FEMA; and internal communications, routing slips, and notes.
- \Terrain\All_Returns
 - LIDAR data – All Returns
 - LIDAR Tile Index spatial file (if used)
- \Terrain\Bare_Earth
 - LIDAR data – Bare Earth Points
 - LIDAR Tile Index spatial file (if used)
- \Terrain\Breaklines
 - 3D breakline spatial files
 - 3D breakline Tile Index spatial file (if used)
 - 2D breakline spatial files
 - 2D breakline Tile Index spatial file (if used)
 - Mass Points
- \Terrain\Contours
 - Contour spatial files with a contour interval of xx_xx (i.e. “Contour_5_ft”)
 - Contour Tile Index spatial file (if used)
 - Bathymetric files
 - Bathymetric Tile Index spatial file (if used)
- \Terrain\DEM
 - Uncorrected DEM files with a minor cell spacing of xx_xx (i.e. “DEM_50_ft”)
 - Tile Index spatial file (if used)
- \Terrain\HDEM
 - Hydrologically correct DEM files with a minor cell spacing of xx_xx (i.e. “HDEM_50_ft”)
 - Tile Index spatial file (if used)
- \Terrain\TIN
 - Uncorrected TIN files
 - Tile index spatial file (if used)
- \Terrain\HTIN
 - Hydrologically correct TIN files
 - Tile Index spatial file (if used)
- \Terrain\Final
 - Final terrain data
 - Final terrain Tile Index spatial file (if used)

M.5 Survey Submittal Standards

M.5.1 Overview

The purpose of this section is to provide the type and format of survey data that must be submitted to FEMA for FISs. All data must be submitted in digital format. The Mapping Partner contracted to “Perform Field Survey” is required to submit the data in this section.

This section is not intended to specify in-process compilation or procedures, but rather to present the specifications and requirements for output and deliverables. The Mapping Partner should refer to Appendix A of these Guidelines for guidance on the performance of surveying. The formats specified in this section are required for new surveys for FEMA-funded studies. Surveys taken from previous studies, or not associated with the current study, do not need to be translated to the format specified in this section. This survey data must be uploaded in the native data format.

This section will focus on the data that is obtained during the survey of the following features:

- Cross Sections
- Transects
- Temporary Bench Marks
- High Water Marks
- Structures
 - Bridges
 - Channels
 - Culverts
 - Dams
 - Levees
 - Coastal Structures

Survey data must be referenced to a standard coordinate system, employ a standard projection, and specify the horizontal and the vertical datums used. These positional references are established prior to the field data collection and topographic mapping phase of the project. All planimetric and topographic features must be collected and referenced to this coordinate system and projection. A detailed discussion of aerial mapping and surveying specifications, which includes horizontal and vertical control for new mapping, is provided in Appendix A of these Guidelines. A discussion of vertical datum selection and conversion is provided in Appendix B of these Guidelines.

The submitting Mapping Partner must retain copies of all project-related data for a period of 3 years. The submitting Mapping Partner will need these data for responding to the following:

- Questions from FEMA or the receiving Mapping Partner during the review of the final draft materials;
- Comments and appeals submitted to FEMA during the 90-day appeal period; and

Guidelines and Specifications

- Other concerns and issues that may develop during the processing of the revised FIS report and FIRM.

M.5.2 Requirements

M.5.2.1 Data Files

The following deliverables are required for survey submittal:

- Survey Files
- Digital Photographs
- Digital Sketches
- A narrative describing the scope of work, direction from FEMA, issues, information for next Mapping Partner, etc.

Consistent data collection methods must be followed for FEMA-funded survey data collection in support of FISs. All survey data must be collected and delivered in the appropriate coordinate system and vertical datum and use standard description codes (data dictionary) and standard naming and file types.

M.5.2.1.1 Naming Conventions

All structures and cross sections must have a unique alpha three character ID as a feature name. A feature name (three character ID) must have the abbreviated stream name followed by the number of the feature on that stream. All numbers must start from the downstream limit and increase upstream. Names must begin with an abbreviation consisting of the first three letters of the stream name. For example, **Swift** Creek would be **SWI**. In numbering structures and cross sections, it is suggested to use a numbering system that allows for intermediate numbers to be added later in cases where a structure or cross section is skipped or added (e.g. 100, 200, 300, etc.). Some variation is allowable if multiple streams in the same study area begin with the same three letters.

As part of the reconnaissance process, Mapping Partners must review all the stream names to determine the best way to name the files and streams. Before collecting survey data, basic naming and location for each hydraulic feature to be surveyed should be set and sketched out on work sheets.

M.5.2.1.2 Survey Data File Naming Convention and Format

Survey data files must also be organized and named based on the stream name (Swift Creek 3-15-07.txt). The date in the file name is the date the deliverable file was created. Data files must be stored in a comma delimited text file, spreadsheet or database format and include all hydraulic feature data and bench marks surveyed for that stream. The file must be developed in a tabular format that includes columns for point number, northing, easting, elevation, and description code. Northing and easting column headings must include coordinate system and units. The elevation column heading must include datum and units. The description column must list the description code per the data dictionary. An example file is shown in Table M-1. All point data associated with structures or features may be listed in one table.

Table M-1. Survey Data File Example

(Hydraulic Feature SWI-32400 on Swift Creek)

PT NO.	NORTHING WV SPC S NAD 1983 (SFT)	EASTING WV SPC S NAD 1983 (SFT)	ELEV NAVD 1988 (FT)	CODE
32400	468854.208	1737859.314	607.66	GR
32401	468865.357	1737850.764	602.14	GR
32402	468875.480	1737842.719	597.75	GR
32403	468881.852	1737838.918	593.52	TOBL
32404	468887.119	1737835.142	591.86	TOSL
32405	468897.284	1737830.623	581.12	CH
32406	468900.368	1737828.459	581.48	CHCL
32407	468905.686	1737824.840	581.16	CH
32408	468912.298	1737821.658	583.91	TOSR
32409	468917.314	1737816.902	592.42	TOBR
32410	468926.152	1737809.303	596.96	GR
32411	468931.695	1737804.390	598.74	GR
32412	468942.672	1737796.103	605.24	GR

M.5.2.1.3 Survey Photos and Sketches

Every hydraulic feature must have a unique identification name that will also be shared by the photos with additional suffixes to indicate location. Five digital photos must be taken for each structure and two digital photos taken for each cross section. For example, a structure on Swift Creek identified as “SWI-100” would be as follows:

- SWI-100-DSCH.jpg – downstream channel (from the structure looking downstream)
- SWI-100-DSFACE.jpg – downstream face of the structure
- SWI-100-OTXS.jpg – overtopping cross section looking left to right
- SWI-100-USFACE.jpg – upstream face of the structure
- SWI-100-USCH.jpg – upstream channel

For example, a cross section on Swift Creek would be as follows:

- SWI-100-DSCH.jpg – downstream channel (from the structure looking downstream)
- SWI-100-USCH.jpg – upstream channel

The surveyor must keep a photo log for each stream surveyed so that photo naming and completeness can be checked. The photo log does not have to be submitted as a deliverable.

Photos must be limited to 1 megabyte in size and stored in .jpg (jpeg) format for maximum compression. Photos are critical and are used to determine Manning’s roughness coefficient and

Guidelines and Specifications

hydraulic model development. Photos must be taken with the clearest view and reviewed for clarity, especially in low light conditions, before leaving the site.

A survey sketch must be prepared at all hydraulic features, including cross sections (e.g., Figure M-3 and M-5). The sketch must include notations and measurements representing the structural geometry and the natural ground and show description codes and shot numbers from the field survey so that the sketch can be related to the field survey. Each sketch must include a planimetric and profile view (viewed looking downstream left to right, upstream face of structures) and show the following items: piers/piles, channel banks, channel, direction of flow, rails, deck, footings, abutments, culvert inverts, shape and size of opening, bench mark location, skew to flow, and north arrow.

Sketches must be scanned and named. Scans must be limited to 1 megabyte (approximately 200 dpi) and stored in PDF or .jpg (jpeg) format. File names must be based on stream and structure/cross-section number (e.g., SWI-100-SKETCH.jpg).

Digital deliverables including points, photos, and sketches must be organized by stream name.

M.5.2.1.4 Survey Codes

Table M-2 lists the required survey codes and description that must be used for new survey data submissions. Figures M-1 through M-7 show specific examples for some of the field survey point locations and the corresponding survey codes in the table. Annotation of photographs such as those provided in Figure M-1 and M-3 are not required. All annotated photographs provided in this subsection are for informational purposes only and show the locations of data points with corresponding survey codes for reference.

Table M-2. Survey Codes

CODE	DESCRIPTION	FIELD SURVEY LOCATION
ABT	Abutment	face/foot of abutment of bridge
ALPT1	Alignment Point One	upstream left side of structure and combined with ALPT2 to determine skew
ALPT2	Alignment Point Two	upstream right side of structure and combined with ALPT1 to determine skew
BM	Bench Mark	Permanent elevation monument
BOCEDS	Back Of Curb Edge Down Stream	where slope meets top of culvert or top of headwall above culvert centerline on downstream end for determining outlet projection
BOCEUS	Back Of Curb Edge Up Stream	where slope meets top of culvert or top of headwall above culvert centerline on upstream end for determining inlet projection
CH	Channel	Stream bottom between TOS shots
CHCL	Channel Centerline	Center of the main flow area of the stream
CULDSCR	Culvert Down Stream Crown	the highest point of the downstream end of a culvert
CULDSINV	Culvert Down Stream Invert	the lowest point of the downstream end of a culvert
CULUSCR	Culvert Up Stream Crown	the highest point of the upstream end of a culvert
CULUSINV	Culvert Up Stream Invert	the lowest point of the upstream end of a culvert

Appendix M: Data Capture Standards

CODE	DESCRIPTION	FIELD SURVEY LOCATION
DAMCL	Dam Centerline	the high point of a dam
EOP	Edge Of Pavement	edge of pavement to provide tie in with aerial photogrammetry or LiDAR
FBCL	Foot Bridge Centerline	centerline of non-vehicular bridges
GDR	Guardrail	top of guardrail and base of guardrail at ends to define limit and height
GR	Ground	on ground to show elevation changes, used outside TOB shots, between TOB and TOS, and to indicate islands or bars within the channel
HDWL	Headwall	top front face of headwall
HWMARK	High Water Mark	historical high water marks-mud/stain lines, drift lines, parole evidence etc.
INVDS	Invert Down Stream	channel invert at downstream end of structure
INVUS	Invert Up Stream	channel invert at upstream end of structure
LC	Low Cord	change in bridge deck thickness usually at center of a pile row or pier
LCDSL	Low Chord Down Stream Left	bottom of deck and beam at the down stream left corner of bridge ¹
LCDSR	Low Chord Down Stream Right	bottom of deck and beam at the down stream right corner of bridge ¹
LCUSL	Low Chord Up Stream Left	bottom of deck and beam at the up stream left corner of bridge ¹
LCUSR	Low Chord Up Stream Right	bottom of deck and beam at the up stream right corner of bridge ¹
PIER	Pier	the up and down stream centerline of a pier
PILE	Pile	the up and down stream centerline of a row of piles
RDCL	Road Centerline	the centerline on a crowned road or the high side of a road with super elevation
SFLOOR	Sea Floor	Shots either direct or combination of bathymetric and conventional/GPS survey of coastal area
TEMP	Temporary Control Point	Temporary control point used to for data collection of cross sections and structures
TOB	Top Of Bank	top of bank in a multiple channel scenario
TOBL	Top Of Bank Left	break point from over bank to channel on the left side when looking down stream
TOBR	Top Of Bank Right	break point from over bank to channel on the right side when looking down stream
TOD	Top Of Deck	to show an irregular arch or dip in a bridge deck between the bridge corner shots
TODDSL	Top Of Deck Down Stream Left	downstream left corner of a bridge on the deck directly above the LCDSL shot to measure deck thickness and width ¹
TODDSR	Top Of Deck Down Stream Right	downstream right corner of a bridge on the deck directly above the LCDSR shot to measure deck thickness and width ¹
TODUSL	Top Of Deck Up Stream Left	upstream left corner of a bridge on the deck directly above the LCUSL shot to measure deck thickness and width ¹
TODUSR	Top Of Deck Up Stream Right	upstream right corner of a bridge on the deck directly above the LCUSR shot to measure deck thickness and width ¹
TOS	Toe Of Slope	the toe in a multiple channel scenario
TOSL	Toe Of Slope Left	break point from channel bank to channel bed on the left side when looking down stream
TOSR	Toe Of Slope Right	break point from channel bank to channel bed on the right side when looking down stream
WALL	Wall	top and base of a retaining wall, also used outside TOBL and TOBR to when the stream banks are vertical walls or rock cuts

Guidelines and Specifications

CODE	DESCRIPTION	FIELD SURVEY LOCATION
WEIR	Weir	top of dam spillways and outlet structures
WW	Wing Wall	top face and base of each end of a wing wall on a structure to define height and length

¹ The four bridge corner shots need to be taken outside of any rail to accurately measure hydraulic length.

Appendix M: Data Capture Standards

Figure M-1. Typical Cross-section Data (Displays Survey Code Locations)



Guidelines and Specifications

Figure M-2. Typical Cross-section Sketch (IND-6600-SKETCH)

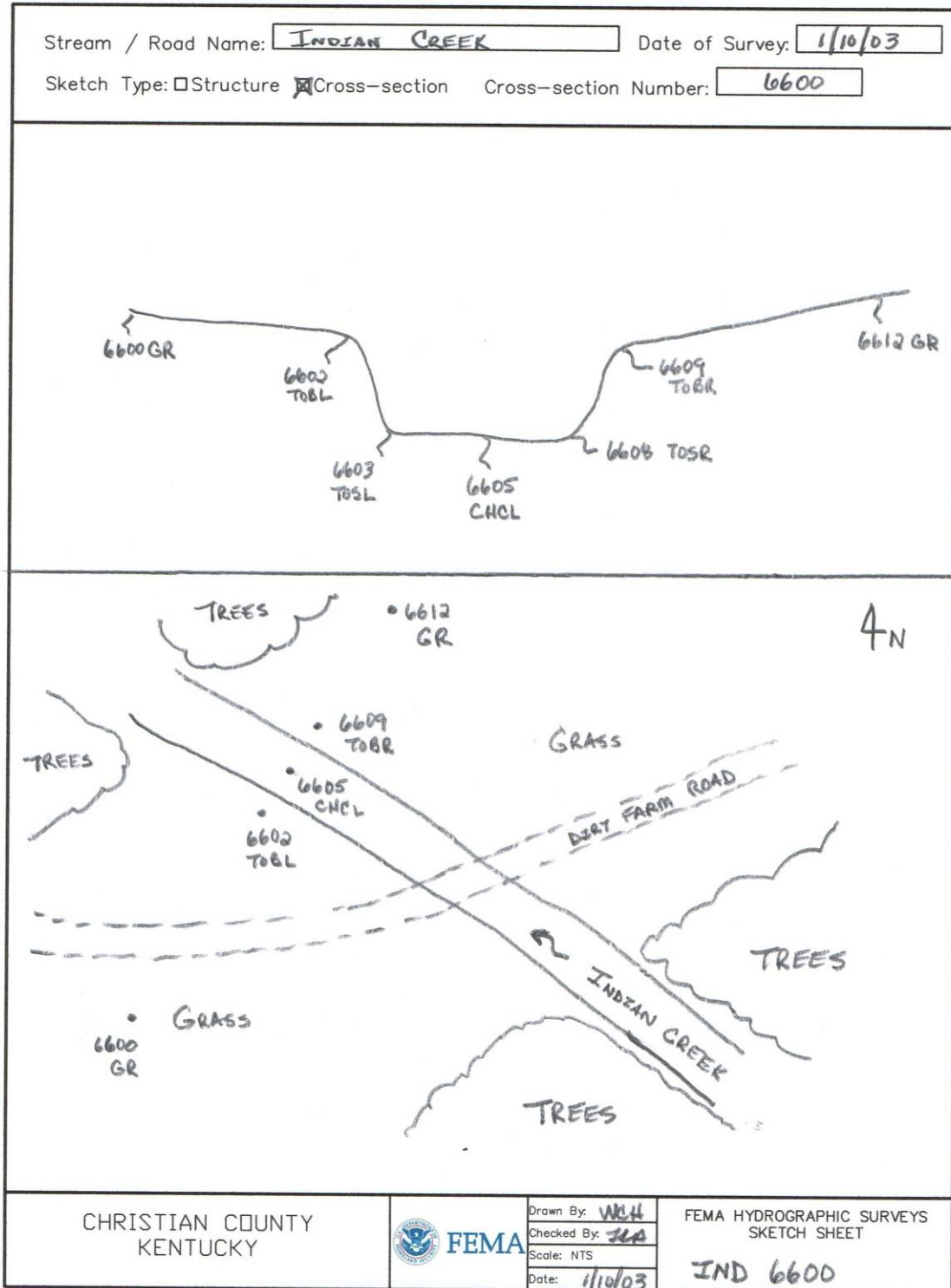

Guidelines and Specifications

Figure M-4. Typical Bridge Sketch

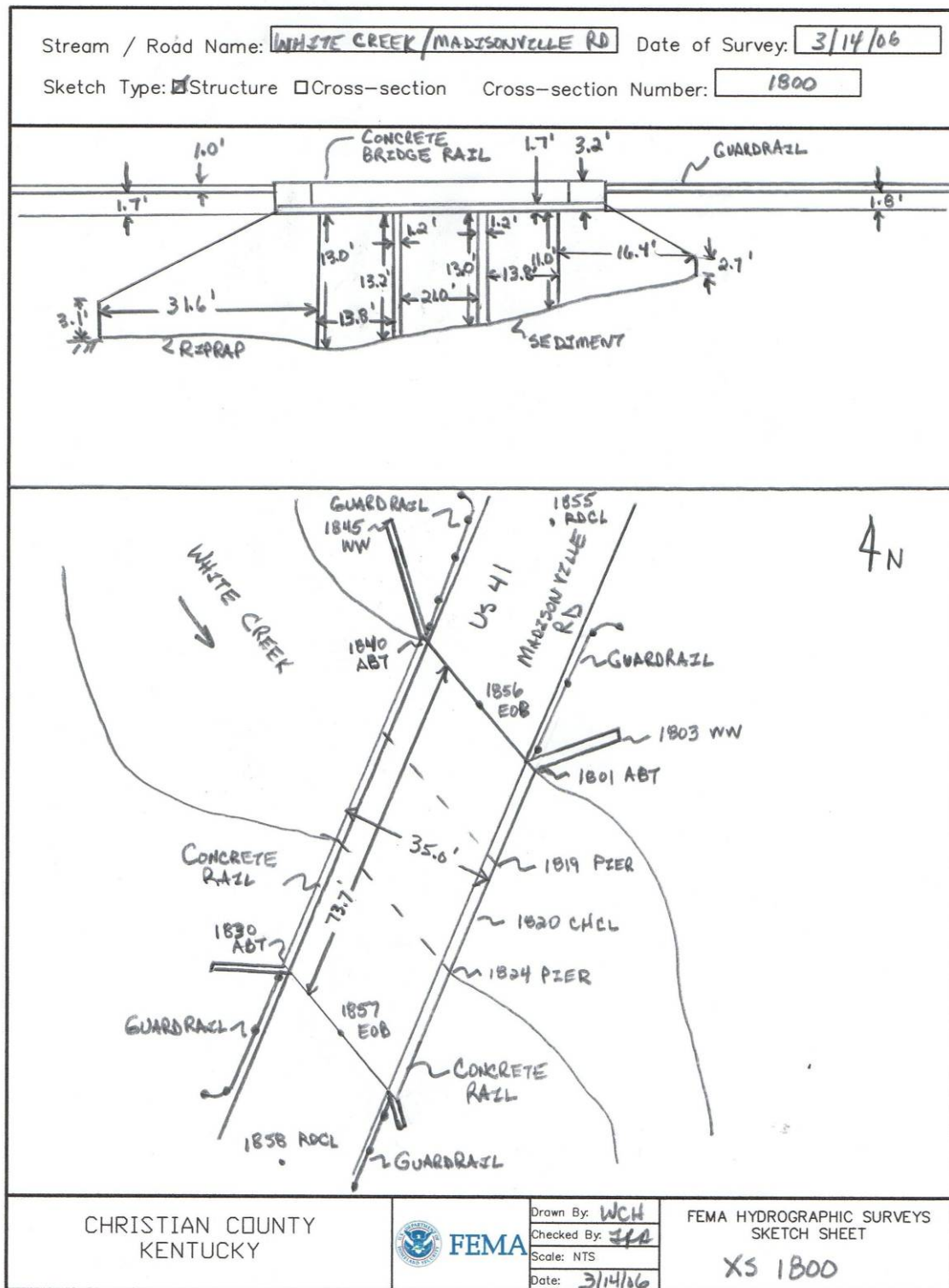

Guidelines and Specifications

Figure M-6. Typical Culvert Sketch

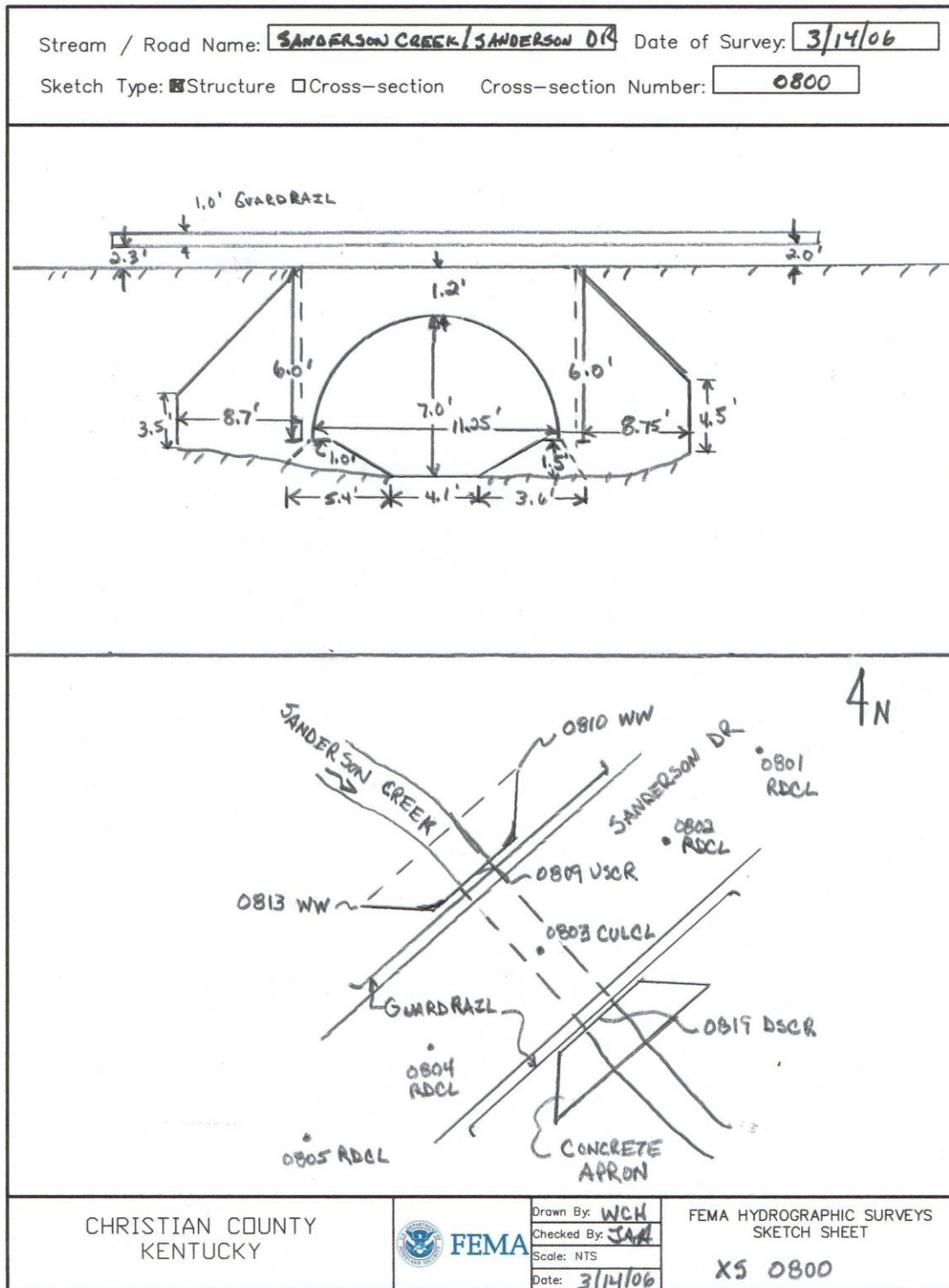
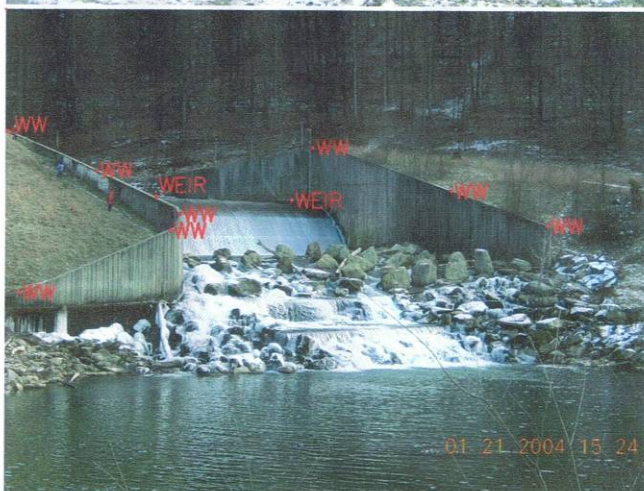

Figure M-7. Typical Dam Data (Displays Survey Code Locations)

DAM CENTERLINE



SPILLWAY



OUTLET STRUCTURE

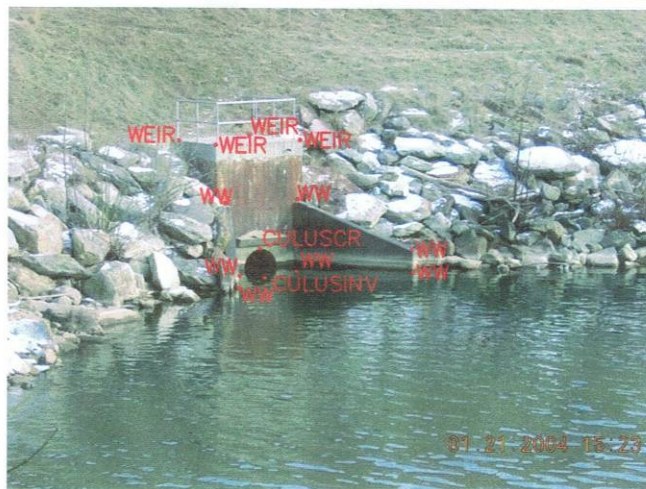

Guidelines and Specifications

M.5.2.2 General Correspondence

A file that compiles general correspondence must be submitted by the Mapping Partner performing “Perform Field Survey.” General correspondence is the written correspondence generated or received by the Mapping Partner assigned to fulfill the requirements of performing field survey. Correspondence includes any documentation generated during this task such as letters; transmittals; memoranda; general status reports and queries; SPRs; technical issues that need to be documented; direction given by FEMA; and internal communications, routing slips, and notes that were relevant to the performance of this task. Contractual documents, such as a signed SOW or MAS, are not to be submitted as a part of the DCS.

M.5.2.3 Certification of Work

Any FEMA-funded survey data developed and submitted by Mapping Partners must be certified using the form in Figure M-8. A PDF of the form, which has the original signature, data, and seal affixed to the form, must be submitted digitally. This form must be signed by a registered Professional Engineer or Surveyor from the firm contracted to perform the work, or by the responsible official of a government agency.

M.5.2.4 Acceptable File Formats

The spatial data submitted for survey must be in a georeferenced digital format. The following formats are acceptable for files:

- PDF or JPG image files (for sketches, photos, and certification)
- MDB/GDB – Microsoft Access / ESRI personal or file geodatabase (for X, Y, Z points)
- XLS – Microsoft Excel (for X, Y, Z points)
- DBF – Microsoft Access Database
- ASCII format (comma delimited for X, Y, Z points)

M.5.2.5 Metadata

A metadata file in XML format that complies with the FEMA/FGDC Metadata Profiles (available on the MIP via “Tools and Links”) must be included with the submittal. The profiles follow the FGDC Content Standard for metadata and define additional domains and business rules for some elements that are mandatory for FEMA based on the specific submittal type. For each spatial data source in the metadata file, the Mapping Partner must assign a Source Citation Abbreviation.

M.5.2.6 Transfer Media

Mapping Partners must submit files on one of the following electronic media or via the internet by uploading to the MIP (<http://www.hazards.fema.gov>):

- CD-ROM
- DVD
- External Hard Drive (for very large data submissions)

In special situations or as technology changes, other media may be acceptable if coordinated with FEMA.

When data is mailed to FEMA, all digital media submitted must be labeled with at least the following information:

- Mapping Partner name;
- Community name and State for which the FIS was prepared;
- Survey Data;
- Date of submission (formatted mm/dd/yyyy); and
- Disk [*sequential number*] of [*number of disks*]. The media must be numbered sequentially, starting at Disk 1. [Number of disks] represents the total number of disks in the submission.

M.5.2.7 Transfer Methodology

Survey Data artifacts can be uploaded to the MIP by following the guidelines for data submission located on the MIP (<https://hazards.fema.gov>).

M.5.2.8 Directory Structure and Folder Naming Conventions

The files in section M.5.2 Requirements must be submitted to the MIP within the following directory structure. The following folders can be created either on a local work space (i.e., a personal computer) or within the work space for the community on the MIP. If the following folders are generated locally, these newly created folders and their contents must be uploaded to the MIP.

- \General
 - XML-format metadata file
 - Certification
 - Project narrative
- \Correspondence
 - Letters; transmittals; memoranda; general status reports and queries; SPRs; technical issues; direction by FEMA; and internal communications, routing slips, and notes.
- \Survey\Photos
 - All digital photographs
- \Survey\Sketches
 - All digital sketches
- \Survey\Data
 - All survey files

M.6 Hydrology Submittal Standards

M.6.1 Overview

This section describes the type and format of hydrologic data that must be submitted to FEMA for riverine FISs. All data must be submitted in digital format. The Mapping Partner(s) contracted to “Develop Hydrologic Data” is required to submit the data in this section.

Appendix C of the Guidelines describes three broad categories of hydrologic procedures used in the NFIP:

- Flood-frequency analyses for gaged streams using Bulletin 17B, “Guidelines For Determining Flood Flow Frequency” (Interagency Advisory Committee on Water Data, 1982);
- Regional regression equations for ungaged streams, generally those developed by the USGS (<http://water.usgs.gov/software/nff.html>); and
- Rainfall runoff models

Within the category of rainfall runoff models, the HEC-HMS model (or its predecessor HEC-1) developed by the USACE Hydrologic Engineering Center (HEC) is used most frequently in the NFIP. In addition to the USACE models, FEMA accepts hydrologic results from over a dozen other rainfall runoff models (see http://www.fema.gov/plan/prevent/fhm/en_hydro.shtm for a list of accepted models) and it is likely that new models will be added in the future.

The submitting Mapping Partner must retain copies of all project-related data for a period of 3 years. The submitting Mapping Partner will need these data for responding to the following:

- Questions from FEMA or the receiving Mapping Partner during the review of the final draft materials;
- Comments and appeals submitted to FEMA during the 90-day appeal period following the issuance of preliminary maps; and
- Other concerns and issues that may develop during the processing of the revised FIS report and FIRM.

M.6.2 Requirements

M.6.2.1 Data Files

There are three levels of studies that are generally performed for flood hazard identification: detailed, limited detailed and approximate studies. These study types are defined in Appendix C of these Guidelines. For limited detailed and approximate studies, the flood discharges are typically estimated using data from stream gages or regional regression equations. The following data requirements are predicated on this assumption. However, this does not preclude using an existing rainfall-runoff model to estimate the flood discharges for limited detailed and/or approximate studies.

Appendix M: Data Capture Standards

The following data files are required for detailed, limited detailed, and approximate studies:

Detailed Studies

- A georeferenced point dataset (S_Node described in section M.11) showing the locations of computed discharges for 10-, 2-, 1-, and 0.2-percent-annual-chance floods with their associated drainage area and the flood discharges used in the hydrologic analysis that can be converted to an FIS Discharge Summary Table;
- Floodplain Mapping submittal information (S_Submittal_Info described in Section M.11);
- Input and output files for the hydrologic model(s) used in the study;
- A hydrology report that documents the methodology, assumptions, and data used in hydrologic analyses;
- A draft text file that provides the required information for inclusion in Section 3.1 Hydrologic Analyses of the FIS report;
- A georeferenced/projected polygon file (S_Basin described in Section M.11) of watershed or subwatershed areas contributing runoff to the discharge points linked to the S_Node file;
- Files of backup data and analyses, for example, computations for time of concentration, such as the National Resources Conservation Service (NRCS) travel time computations, and curve number (percent of watershed with various land uses and NRCS hydrologic soil types) for rainfall-runoff models; hourly rainfall and discharge data used to calibrate the rainfall-runoff model; and computations of watershed and climatic characteristics for regional regression equations such as drainage area, channel slope, impervious area, and mean annual precipitation. These files support and complement the input files for the hydrologic model; and
- A project narrative describing the scope of work, direction from FEMA, issues, information for next Mapping Partner, etc.

Limited Detailed Studies

- A georeferenced point dataset (S_Node described in section M.11) showing the locations of computed discharges for the 1-percent-annual-chance flood with their associated drainage area and the flood discharges used in the hydrologic analysis that can be converted to an FIS Discharge Summary Table;
- Floodplain Mapping submittal information (S_Submittal_Info described in Section M.11);
- A georeferenced/projected polygon file (S_Basin described in Section M.10) of watershed or subwatershed areas contributing runoff to the discharge points linked to the S_Node file;
- Input and output files for the hydrologic model(s) used in the study;
- A hydrology report that documents the methodology, assumptions, and data used in hydrologic analyses;
- A draft text file that provides the required information for inclusion in Section 3.1 Hydrologic Analyses in the FIS report;

Guidelines and Specifications

- Files of backup data and analyses, for example: computations of watershed and climatic characteristics for regional regression equations such as drainage area, channel slope, impervious area, and mean annual precipitation; and
- A project narrative describing the scope of work, direction from FEMA, issues, information for next Mapping Partner, etc.

Approximate Studies

- A georeferenced point dataset (S_Node described in section M.11) showing the locations of computed discharges for 1-percent-annual-chance flood with their associated drainage areas and the flood discharges used in the hydrologic analysis;
- Floodplain Mapping submittal information (S_Submittal_Info described in Section M.11);
- A georeferenced/projected polygon file (S_Basin described in Section M.11) of watershed or subwatershed areas contributing runoff to the discharge points identified in the S_Node file;
- A project description outlining how the 1-percent-annual-chance flood discharges were determined;
- A draft text file that provides the required information for inclusion in Section 3.1 Hydrologic Analyses in the FIS report;
- Any files of backup data and supporting analyses for stream gages such as annual peak data for the USGS PeakFQ Program or for the USACE HEC-SSP Program that implement Bulletin 17B; and computations of watershed characteristics for regional regression equations such as drainage area, channel slope, impervious area, and mean annual precipitation; and
- A project narrative describing the scope of work, direction from FEMA, issues, information for next Mapping Partner, etc.

M.6.2.2 General Correspondence

A file that compiles general correspondence must be submitted by the Mapping Partner performing “Develop Hydrologic Data.” General correspondence is the written correspondence generated or received by the Mapping Partner assigned to fulfill the requirements of developing hydrologic data.” Correspondence includes any documentation generated during this task such as letters; transmittals; memoranda; general status reports and queries; SPRs; technical issues that need to be documented; direction given by FEMA; and internal communications, routing slips, and notes that were relevant to the performance of this task. A narrative should be prepared that describes the scope of the work, direction from FEMA, assumptions and issues, and any information that may be useful for the Mapping Partner performing the hydraulic analyses. Contractual documents, such as a signed SOW or MAS, are not to be submitted as a part of this appendix.

M.6.2.3 Certification of Work

FEMA-funded hydrologic data development must be certified using the form provided in Figure M-8. A PDF of the form, which has the original signature, data, and seal affixed to the form, must be

submitted digitally. This form must be signed by a registered Professional Engineer or Surveyor from the firm contracted to perform the work, or by the responsible official of a government agency.

M.6.2.4 Acceptable File Formats

Any supporting documentation and data can be submitted in native format. The following formats are accepted for files:

- PDF for hydrology report, project narrative and other supporting information
- Shapefiles for spatial files
- Personal geodatabase for all hydrology spatial files
- Native format for input and output files for hydrologic models

M.6.2.5 Metadata

A metadata file that complies with the FEMA/FGDC metadata (available on the MIP via “Tools and Links”) profiles in XML-format must be included with the submittal. The profiles follow the FGDC content standard for metadata and define additional domains and business rules for those elements that are mandatory for FEMA, based on the specific submittal type. For each spatial data source in the metadata file, the Mapping Partner must assign a Source Citation Abbreviation.

M.6.2.6 Transfer Media

Mapping Partners must submit files via the internet by uploading to MIP (<http://www.hazards.fema.gov>) or on one of the following electronic media:

- CD-ROM
- DVD
- External Hard Drive (for very large data submissions)

In special situations or as technology changes, other media may be acceptable if coordinated with FEMA.

When data is mailed to FEMA, all digital media submitted must be labeled with the following information:

- Mapping Partner name;
- Community name and State for which the FIS was prepared;
- Hydrologic Data;
- Date of submission (formatted mm/dd/yyyy); and
- Disk [sequential number] of [number of disks]. Disk [*sequential number*] of [*number of disks*]. The media must be numbered sequentially, starting at Disk 1. [Number of disks] represents the total number of disks in the submission.

Guidelines and Specifications

M.6.2.7 Transfer Methodology

Hydrology Data artifacts can be uploaded to the MIP by following the guidelines for data submission located on the MIP (<https://hazards.fema.gov>).

M.6.2.8 Directory Structure and Folder Naming Conventions

The files in section M.6.2 Requirements must be submitted within the following directory structure. The following folders can be created either on a local work space (i.e., a personal computer) or within the work space for the community on the MIP. If the following folders are generated locally, these newly created folders and their contents must be uploaded to the MIP.

The Mapping Partner is required to submit the input and output files for any study using detailed hydrologic models. If the data that was used to estimate the hydrologic parameters are available, they must be documented in the hydrology report and submitted in the database files.

Models must be organized by stream, with all model files in the *Simulations* folder and support spatial files in the *Spatial Files* folder. Database files are stored in a *Hydrology Data* folder. Data must be located in the appropriate directory, as follows:

- \General
 - XML_format metadata file
 - Hydrology report
 - Certification
 - Draft FIS Section 3.1
 - Project narrative
- \Correspondence
 - Letters; transmittals; memoranda; general status reports and queries; SPRs; technical issues; direction by FEMA; and internal communications, routing slips, and notes.
- \Hydrology Data
 - Database file(s) such as analyses for stream gages and computations for regional regression equations
- \Hydrology Models\“Stream Name”\Simulations
 - Model input and output files
- \Hydrology Models\“Stream Name”\Spatial Files
 - Spatial files

M.7 Hydraulics Submittal Standards

M.7.1 Overview

This section describes the type and format of hydraulic data that must be submitted to FEMA as a result of a riverine FIS. All data must be submitted in digital format. The Mapping Partner(s) contracted to “Develop Hydraulic Data” is required to submit the data in this section.

Hydraulic methods include normal depth computations and other simplified methods, as well as a variety of steady and unsteady hydraulic models representing one-dimensional (1-D) or two-dimensional (2-D) flow conditions. The 1-D models utilize cross-sectional data while the 2-D models utilize a grid of ground-elevation points. Information on the procedures used to develop hydraulic models is provided in Appendix C of these Guidelines. FEMA-accepted hydraulic models can be found at http://www.fema.gov/plan/prevent/fhm/en_hydro.shtm.

The submitting Mapping Partner must retain copies of all Project-related data for a period of 3 years. The submitting Partner will need these data in order to respond to the following:

- Questions from FEMA or the receiving Mapping Partner during the review of the final draft materials;
- Comments and appeals submitted to FEMA during the 90-day appeal period following the issuance of preliminary maps; and
- Other concerns and issues that may develop during the processing of the revised FIS report and FIRM.

M.7.2 Requirements

M.7.2.1 Data Files

There are three levels of studies that are generally performed for flood hazard identification: detailed, limited detailed and approximate studies. These study types are defined in Appendix C of these Guidelines. For limited detailed studies, it is assumed that a hydraulic model such as HEC-RAS is used to estimate the base flood elevations. For approximate studies, it is assumed that a hydraulic model is not used. The following data requirements are predicated on these assumptions. The following data files are required for detailed, limited detailed, and approximate studies:

Detailed Studies

- A georeferenced stream channel network used for modeling (S_Pofil_BasIn spatial file described in Section M.11) or a node-link GIS file (structure at the submitting Mapping Partner’s discretion) for storm sewer or pond routing;
- A georeferenced line dataset that shows the cross sections used for the computation of water surface profiles for simplified hydraulic methods or 1-D models (S_XS spatial file described in Section M.11);
- Georeferenced datasets that show the regulatory floodway , 1-percent-annual-chance floodplain boundaries, and 0.2-percent-annual-chance floodplain boundaries (S_Flood_Haz_Ar spatial file described in section M.11);

Guidelines and Specifications

- Floodplain Mapping submittal information (S_Submittal_Info described in Section M.11);
- Input and output files for the hydraulic model used for the study that include data for the 10-, 2-, 1-, 0.2-percent annual chance flood profiles (if applicable, 1-percent-annual-chance profiles with and without levees) and the floodway analysis;
- A hydraulics report that describes the hydraulic analyses and assumptions;
- A draft text file that provides the required information for inclusion in Section 3.2 Hydraulic Analyses of the FIS report;
- A file containing profiles for the 10-, 2-, 1-, and 0.2-percent annual chance floods and floodway data tables;
- Additional geospatial and database tables, if utilized (i.e., overbank distances used in certain models such as HEC-RAS; calibration information, such as high water-marks; spatial files of n-value polygons). The structure of these tables is at the discretion of the submitting Mapping Partner; and
- A project narrative describing the scope of work, direction from FEMA, issues, information for next Mapping Partner, etc.

Limited Detailed Studies

- A georeferenced stream channel network used for modeling (S_Pofil_BasIn spatial file described in Section M.11);
- A georeferenced line dataset that shows the cross sections used for the computation of water surface profiles for simplified hydraulic methods or 1-D models (S_XS spatial file described in Section M.11);
- A georeferenced dataset that shows the 1-percent-annual-chance floodplain boundaries (S_Flood_Haz_Ar spatial file described in Section M.11);
- Input and output files for the hydraulic model used in the analysis that include data for the 1-percent-annual-chance flood profile;
- Floodplain Mapping submittal information (S_Submittal_Info described in Section M.11);
- A hydraulics report that describes the hydraulic analyses and assumptions;
- A draft text file that provides the required information for inclusion in Section 3.2 Hydraulic Analyses of the FIS report;
- A file containing profiles for the 1-percent-annual-chance flood;
- A file containing Limited Detailed Flood Hazard Data table (as described in Appendix C), if applicable;
- All backup data used in the analysis such as spatial files of n-value polygons; and
- A project narrative describing the scope of work, direction from FEMA, issues, information for next Mapping Partner, etc.

Approximate Studies

- A georeferenced stream channel network used for modeling (S_Pofil_BasIn spatial file described in Section M.11);
- Floodplain Mapping submittal information (S_Submittal_Info described in Section M.11);

Appendix M: Data Capture Standards

- Georeferenced datasets that show the 1-percent-annual-chance floodplain boundaries (S_Flood_Haz_Ar spatial file described in Section M.11);
- A file containing a description of how the floodplain boundaries were determined;
- A draft text file that provides the required information for inclusion in Section 3.2 Hydraulic Analyses of the FIS report;
- All backup data used in the analysis such as the cross-sectional data and the computations for the 1-percent-annual-chance elevations at the cross sections used in the analysis; and
- A project narrative describing the scope of work, direction from FEMA, issues, information for next Mapping Partner, etc.

M.7.2.2 General Correspondence

A file that compiles general correspondence must be submitted by the Mapping Partner performing “Develop Hydraulic Data.” General correspondence is the written correspondence generated or received by the Mapping Partner assigned to fulfill the requirements of developing hydraulic data. Correspondence includes any documentation generated during this task such as letters; transmittals; memoranda; general status reports and queries; SPRs; technical issues that need to be documented; direction given by FEMA; and internal communications, routing slips, and notes that were relevant to the performance of this task. A narrative should be prepared that describes the scope of the work, direction from FEMA, assumptions and issues, and any information that may be useful for the Mapping Partner preparing the preliminary DFIRM. Contractual documents, such as a signed SOW or MAS, are not to be submitted.

M.7.2.3 Certification of Work

FEMA-funded hydraulic data development must be certified using the form provided in Figure M-8. A PDF of the form must be submitted digitally and must have the original signature, data, and seal affixed to the form. This form must be signed by a registered professional engineer or licensed land surveyor from the firm contracted to perform the work, or by the appropriate government agency official. A digital version of this form is available at www.fema.gov.

M.7.2.4 Acceptable File Formats

Any supporting documentation can be submitted in native format. The following formats are acceptable for files:

- PDF for hydraulics report, project narrative and other supporting information
- Shapefiles for all hydraulics spatial files
- Personal geodatabase for all hydraulics spatial files
- Input and output files for hydraulic models in native formats
- DWG for profiles

Guidelines and Specifications

M.7.2.5 Metadata

A metadata file that complies with the FEMA/FGDC Metadata Profiles (available on the MIP via “Tools and Links”) in XML format must be included with the submittal. The profiles follow the FGDC Content Standard for metadata and define the additional domains and business rules for those elements mandatory for FEMA based on the specific submittal type. For each spatial data source in the metadata file, the Mapping Partner must assign a Source Citation Abbreviation.

M.7.2.6 Transfer Media

Mapping Partners must submit files via the internet by uploading to MIP (<http://www.hazards.fema.gov>) or through one of the following electronic media:

- CD-ROM
- DVD
- External Hard Drive (for very large data submissions)

In special situations or as technology changes, other media may be acceptable if coordinated with FEMA.

When data is mailed to FEMA, all submitted digital media must be labeled with the following information:

- Mapping partner name;
- Community name and State for which the FIS was prepared;
- Hydraulic data;
- Date of submission (formatted mm/dd/yyyy); and
- Disk [sequential number] of [number of disks]. Disk [*sequential number*] of [*number of disks*]. The media must be numbered sequentially, starting at Disk 1. [Number of disks] represents the total number of disks in the submission.

M.7.2.7 Transfer Methodology

Hydraulic Data artifacts can be uploaded to the MIP by following the guidelines for data submission located on the MIP (<https://hazards.fema.gov>).

M.7.2.8 Directory Structure and Folder Naming Conventions

The files under section M.7.2 Requirements must be submitted in the following directory structure created by the contractor in their workspace prior to upload. The following folders can be created either on a local work space (i.e., a personal computer) or within the work space for the community on the MIP. If the following folders are generated locally, these newly created folders and their contents must be uploaded to the MIP.

Models are organized by stream, with all model files in the *Simulations* folder and all support spatial files in the *Spatial Files* folder. Any additional data not described by these specifications

Appendix M: Data Capture Standards

and used to assist in the modeling of this study must be submitted in the *Hydraulic Databases* folder. Data must be located in the appropriate directories as follows:

- \General
 - Metadata file in XML format
 - Hydraulics report in PDF format
 - Certification
 - Draft FIS Section 3.2
 - Project narrative
- \Correspondence
 - Letters; transmittals; memoranda; general status reports and queries; SPRs; technical issues; direction by FEMA; and internal communications, routing slips, and notes
- \Hydraulic Models\“Stream Name”\Simulations
 - Model input and output files by stream for the 10-, 2-, 1-, 0.2-percent annual chance floods and floodway analysis
- \Hydraulic Models\“Stream Name”\Spatial Files
 - Spatial files by stream
- \Hydraulic Models\”Stream Name”\Profiles
 - Profiles in DWG format
- \Hydraulic Models\”Stream Name”\FWDT
 - Floodway data tables
 - Limited Detailed Flood Hazard Risk table
- \Hydraulic Models\”Stream Name”\Hydraulic Databases
 - Database file(s) such as high water mark data for model calibration

Guidelines and Specifications

M.8 Alluvial Fan Submittal Standards

M.8.1 Overview

This section describes the type and format of data needed to map the 1-percent-annual-chance flood associated with alluvial fans. All data must be submitted in digital format. The Mapping Partner(s) contracted to “Perform Alluvial Fan Analysis” is required to submit the data in this section.

Appendix G of these Guidelines provides guidance for the identification and mapping of flood hazards that occur on alluvial fans. As described in Appendix G, the approach for the identification and mapping of alluvial fan flooding can be divided into three stages:

Stage 1 – Recognizing and characterizing alluvial fan landforms;

Stage 2 – Defining the nature of the alluvial fan environment and identifying active and inactive areas of the fan; and

Stage 3 – Defining and characterizing the 1-percent-annual-chance flood within the defined areas.

Under Stage 3, there are several acceptable methods for defining the base flood depending on the characteristics of the alluvial fan. These methods are as follows, and are also described in Appendix G of these Guidelines:

- FAN computer program (FEMA, 1990 http://www.fema.gov/plan/prevent/fhm/en_stat.shtm): used for highly active, conical fans – definition of Zone AO areas with depths and velocities;
- Sheetflow analysis: used for shallow flooding across uniformly sloping surfaces – definition of Zone AO with depths;
- Hydraulic Analytical Methods: used for entrenched channel networks or constructed channels (one-dimensional model) or uncertain flow paths (two-dimensional model) – definition of Zone A, Zone AE, and/or Zone X;
- Geomorphic Data, Post-Flood Hazard Verification, and Historical Information: used for alluvial fans with little or no urbanization – definition of Zone X and/or Zone A areas; and
- Composite Methods: used for fans with unique physical features in some locations – some combination of the above methods.

The submitting Mapping Partner must retain copies of all Project-related data for a period of 3 years. The submitting Partner will need these data for responding to the following:

- Questions from FEMA or the receiving Mapping Partner during the review of the final draft materials;
- Comments and appeals submitted to FEMA during the 90-day appeal period following the issuance of preliminary maps; and
- Other concerns and issues that may develop during the processing of the revised FIS report and FIRM.

M.8.2 Requirements

M.8.2.1 Data Files

The following files and data must be submitted for alluvial fan analysis:

- Under Stage 1, materials such as geologic maps, field reconnaissance reports, topographic maps, and aerial photos used to identify the landform as an alluvial fan must be submitted;
- Under Stage 2, historic records of flooding, photographs, time-sequence aerial photography, and geomorphic information must be submitted to illustrate either active or inactive alluvial fan flooding;
- Under Stage 3, input and output files for the FAN program (FEMA, 1990) or 1-D or 2-D hydraulic programs must be submitted, including the following datasets:
 - Floodplain Mapping submittal information (S_Submittal_Info described in Section M.11)
 - A georeferenced stream channel network used for floodplain mapping (S_Profil_Basln described in Section M.11) if hydraulic models were utilized
 - A georeferenced line dataset showing the locations of cross sections (if applicable) used for the computation of water surface profiles for 1-D models (S_XS spatial file described in Section M.11);
 - Georeferenced datasets showing the 1-percent annual chance flood boundaries with depths and velocities and base flood elevations for 1-D and 2-D models, if applicable (S_Alluvial described in section M.11);
 - A file containing profiles for the 1-percent-annual-chance flood. Profiles created as DXF files can be imported into a template AutoCAD drawing file (DWG) and edited for content;
 - Input and output files for the 1-percent-annual-chance flood for the hydraulic model used in the analysis; and
 - All geospatial datasets used for parameter calculation, if applicable, such as a spatial file of n-value polygons
- A draft text file that provides the required information for inclusion in Section 3.2 Hydraulic Analyses of the FIS report
- A technical report that describes the processes for identifying the alluvial fan, the areas of active and inactive alluvial fan flooding, and the procedures for determining the aerial extent and/or elevation of the base flood; and
- A project narrative describing the scope of work, direction from FEMA, issues, information for next Mapping Partner, etc.

M.8.2.2 General Correspondence

A file that compiles general correspondence must be submitted by the Mapping Partner performing “Develop Hydrologic Data.” General correspondence is the written correspondence generated or received by the Mapping Partner assigned to fulfill the requirements of performing alluvial analysis. Correspondence include any documentation generated during this task such as letters; transmittals; memoranda; general status reports and queries; SPRs; technical issues that need to be documented;

Guidelines and Specifications

direction given by FEMA; and internal communications, routing slips, and notes that were relevant to the performance of this task. A narrative should be prepared that describes the scope of the work, direction from FEMA, assumptions and issues, and any information that may be useful for the Mapping Partner performing the mapping analyses. Contractual documents, such as a signed SOW or MAS, are not to be submitted as a part of the DCS.

M.8.2.3 Certification of Work

FEMA-funded alluvial fan data development must be certified using the form provided in Figure M-8. A PDF of the form must be submitted digitally which has the original signature, data, and seal affixed to the form. This form must be signed by a registered professional engineer or licensed land surveyor from the firm contracted to perform the work or by a responsible government agency official. A digital version of this form is available at www.fema.gov.

M.8.2.4 Accepted File Formats

Any supporting documentation and data can be submitted in model or native format. The following formats are acceptable for files:

- PDF for the technical report, project narrative and other supporting information
- Shapefiles for all alluvial fan spatial files
- Personal geodatabase for all alluvial fan spatial files
- Native formats for hydraulic model input and output files
- DWG for profiles

M.8.2.5 Metadata

A metadata file in XML format that complies with the FEMA/FGDC Metadata Profiles (available on the MIP via “Tools and Links”) must be included with the submittal. The profiles follow the FGDC Content Standard for metadata and define additional domains and business rules for some elements that are mandatory for FEMA based on the specific submittal type. For each spatial data source in the metadata file, the Mapping Partner must assign a Source Citation Abbreviation.

M.8.2.6 Transfer Media

Mapping Partners must submit files on one of the following electronic media or via the internet by uploading to the MIP (<http://www.hazards.fema.gov>):

- CD-ROM
- DVD
- External Hard Drive (for very large data submissions)

In special situations or as technology changes, other media may be acceptable if coordinated with FEMA.

When data is mailed to FEMA, all submitted digital media must be labeled with the following information:

- Mapping Partner's name
- Community name and State for which the FIS was prepared
- Alluvial Fan Data
- Date of submission (formatted mm/dd/yyyy)
- Disk [*sequential number*] of [*number of disks*]. The media must be numbered sequentially, starting at Disk 1. [Number of disks] represents the total number of disks in the submission.

M.8.2.7 Transfer Methodology

Alluvial fan data artifacts can be uploaded to the MIP by following the guidelines for data submission located on the MIP (<https://hazards.fema.gov>).

M.8.2.8 Directory Structure and Folder Naming Conventions

The files in section M.8.2 Requirements must be submitted within the following directory structure. The following folders can be created either on a local work space (i.e., a personal computer) or within the work space for the community on the MIP. If the following folders are generated locally, these newly created folders and their contents must be uploaded to the MIP.

Models are usually organized by stream, with all model files in the *Simulations* folder and supporting spatial files in the *Spatial Files* folder. Data must be located in the appropriate directories as follows:

- \General
 - XML_format metadata file
 - Alluvial fan technical report in PDF format
 - Draft FIS Section 3.2
 - Certification
 - Project narrative
- \Correspondence
 - Letters; transmittals; memoranda; general status reports and queries; SPRs; technical issues; direction by FEMA; and internal communications, routing slips, and notes
- \Alluvial Fan\Hydraulic Models\“Stream Name”\Simulations
 - Model input and output files in native format
- \Alluvial Fan \Hydraulic Models\“Stream Name”\Profiles
 - Profiles in DWG format
- \Alluvial Fan \Hydraulic Models\“Stream Name”\Spatial Files
 - Spatial files
- \Alluvial Fan \Hydraulic Databases
 - Database file(s)

Guidelines and Specifications

- \FAN program files\“Stream Name”\Simulations
 - Model input and output files in native format

M.9 Coastal Submittal Standards

M.9.1 Overview

This section describes the type and format of data that must be submitted to FEMA for coastal FISs. All data must be submitted in digital format. The Mapping Partner(s) contracted to “Perform Coastal Analysis” is required to submit the data in this section. Details on FEMA guidance for coastal flood hazard analyses and mapping are provided in Appendix D of these Guidelines.

The submitting Mapping Partner must retain copies of all Project-related data for a period of 3 years. The submitting Partner will need these data for responding to the following:

- Questions from FEMA or the receiving Mapping Partner during the review of the final draft materials;
- Comments and appeals submitted to FEMA during the 90-day appeal period; and
- Other concerns and issues that may develop during the processing of the revised FIS report and FIRM.

M.9.2 Requirements

M.9.2.1 Data Files

The following data files must be submitted for coastal studies:

- Storm climatology and meteorological event selection
 - A text or ESRI-compatible file containing the regional historical storm database
 - A text or ESRI-compatible file containing storm events selected and their storm parameters
 - A report describing the technical approach for storm event selection
- Stillwater elevations
 - Grid files of storm windfield data for selected events (model input files – if water levels are simulated/hindcast)
 - A report describing the hydrodynamic model calibration and validation (if water levels are simulated/hindcast)
 - Model input files, in their native format, of the calibrated hydrodynamic model (grid and parameter specifications – if water levels are simulated/hindcast)
 - A text, Excel file or ESRI-compatible file containing water level maxima at surge station locations for each storm event (if water levels are simulated/hindcast)
 - A text, Excel file or ESRI-compatible file containing water level maxima at available tide gage locations for each storm event (if historical data used for statistical analyses or model calibration)
 - A report describing the technical approach for flood frequency analyses
 - A report describing the approach adopted for sheltered water areas (if applicable)
 - A text, Excel file or ESRI-compatible file containing the 10-percent, 2-percent, 1-percent and 0.2-percent-annual-chance stillwater levels at the surge station locations

Guidelines and Specifications

- Offshore wave characteristics
 - Grid files of wave model windfield data (model input files – if waves are simulated/hindcast)
 - A report describing the wave model calibration and validation (if waves are simulated/hindcast)
 - Model input files, in their native format, of the calibrated wave model (grid and parameter specifications – if waves are simulated/hindcast)
 - A text, Excel file or ESRI-compatible file containing the controlling wave height and peak wave period at surge station locations for each storm event (if waves are simulated/hindcast)
 - A text, Excel file or ESRI-compatible file containing water heights and wave periods at available wave stations/buoys (if historical wave data was used or if used for model calibration)
 - A report describing the technical approach for wave simulation and/or statistical analyses
 - A report describing the approach adopted for sheltered water areas
 - A text, Excel file or ESRI-compatible file containing the 1-percent-annual-chance controlling wave heights and wave periods (by transect)
- Nearshore hydraulics
 - Model input and output files from WHAFIS or CHAMP (if applicable)
 - A text or Excel file or ESRI-compatible file containing pre- and post- eroded transect profiles (if applicable)
 - A report describing the technical approach adopted for wave-height, wave setup, wave run-up and wave-overtopping calculations
 - Input and output files for any other models used in coastal hydraulic analyses
- Spatial Files
 - Floodplain Mapping submittal information (S_Submittal_Info described in Section M.11)
 - BFEs (S_BFE spatial file described in Section M.11)
 - Flood hazard zone map boundary delineations (S_Fld_Haz_Ar spatial file described in Section M.11)
 - Primary frontal dune delineations (S_PFD spatial file described in Section M.11)
 - Transects (S_Cst_Tsct_Ln spatial file described in Section M.11)
 - Coastal Water Levels (L_Cst_WaterLv spatial file described in Section M.11)
 - Tide Gage Data (S_TideGage spatial file described in Section M.11)
 - Wave Buoy Data (S_Buoy spatial file described in Section M.11)
 - Wind Data (S_WindSta spatial file described in Section M.11)
 - Shoreline (S_Shore_Ln spatial file described in Section M.11)
 - CBRS and OPAs (S_S_CBRS spatial file described in Section M.11)
 - Coastal Structures (S_Cst_Struc spatial file described in Section M.11)
 - Limit of Moderate Wave Action (S_LIMWA spatial file described in Section M.11)
- A draft text for inclusion in the FIS report that provides the required information for Section 3.1 Hydrologic Analyses and Section 3.3 Coastal Analysis

- A project narrative describing the scope of work, direction from FEMA, issues, information for next Mapping Partner, etc.

M.9.2.2 1-Percent-Annual-Chance Wave Envelop

A 1-percent-annual-chance wave envelop for each transect must be submitted showing the wave heights, wave runup elevation, SWELs, zone gutter locations, and where applicable, the location of primary frontal dunes, pre-and post eroded ground profile, and the location of coastal structures included in analyses. If the modeled transect numbers differ than those shown on the work map, then a transect key, correlating the modeled transects to the mapped transects, should also be submitted. These files must be submitted in PDF or DWG format and located in the simulations folder of this submittal.

M.9.2.3 0.2-Percent-Annual-Chance Wave Envelop

Calculating the 0.2-percent-annual-chance wave height is an optional coastal study task. When included as part of the coastal studies, profiles showing the 0.2-percent-annual-chance wave envelope and ground elevations are added to the end of the FIS. All profiles must be submitted using a file name convention of “County_TransectNumber***,” in an AutoCad DWG or ESRI-compatible file format, to allow for graphic format changes, and as a PDF file for the FIS narrative report. These files must be located in the simulations folder of this submittal.

M.9.2.4 Summary of Coastal Stillwater Elevations

A Coastal Stillwater Elevation Table, which is a direct product of the storm surge modeling, must be provided in the FIS report narrative. This table must be submitted in a Microsoft Word format named “Stillwater_Summary.doc”. These files must be located in the coastal database directory of the submittal. The specifications for the Coastal Stillwater Elevation Table are provided in the sample report in Appendix J, Section J.6, of these Guidelines.

M.9.2.5 Surge Station Location Map

A Surge Station Location Map, a direct product of storm-surge modeling that shows the locations of the modeled 1-percent-annual-chance stillwater elevations, should be provided in the FIS report narrative. The model output locations should be summarized appropriately for clarity on the map. The surge station locations may or may not coincide with the transect locations. This map must be submitted in a .jpeg or PDF file format, named “Surge_Stations.***.” These files must be located in the coastal database directory of the submittal. The specifications for the Surge Station Location Map are provided in the sample report in Section J.6 of Appendix J.

M.9.2.6 Transect Location Map

A Transect Location Map illustrates the location of transects used in coastal analyses and should be provided in the FIS report narrative. This map must be submitted in jpeg or PDF file format, named “Transect_Location.***.” Transect location maps are only needed in the FIS if transects are not shown on the FIRM. If a Transect location map is included in the FIS, only transects used for

Guidelines and Specifications

mapping should be shown. These files must be located in the coastal database directory of the submittal. The specifications for the Transect Location Map are provided in the sample report in Section J.6 of Appendix J.

M.9.2.7 Transect Description Table

A Transect Description Table describes the physical location of each transect shown in the Transect Location map, the associated 1-percent-annual-chance stillwater elevation, and the maximum 1-percent-annual-chance wave crest elevation for each transect, and is to be provided in the FIS report narrative. This table must be submitted in a Microsoft Word format named “Transect_Description.doc.” These files must be located in the coastal database directory of this submittal. The specifications for the Transect Description Table are provided in the sample report in Section J.6 of Appendix J.

M.9.2.8 Transect Data Table

A Transect Data Table describes the: flood source, transect identifier, stillwater elevations (10-, 2-, 1- and 0.2-percent annual chance), flood hazard zone, and BFE range, for each transect, and is to be provided in the FIS report narrative. This table should also indicate if a primary frontal dune is mapped. This table must be submitted in a Microsoft Word document named “Transect_Data.doc”. These files must be located in the coastal database directory of this submittal. The specifications for the Transect Data Table are provided in the sample report in Appendix J, Section J.6, of these Guidelines.

M.9.2.9 General Correspondence

A file that compiles general correspondence must be submitted by the Mapping Partner performing coastal analysis. General correspondence is the written correspondence generated or received by the Mapping Partner assigned to fulfill the requirements of performing coastal analysis. Correspondence include any documentation generated during this task such as letters; transmittals; memoranda; general status reports and queries; SPRs; technical issues that need to be documented; direction given by FEMA; and internal communications, routing slips, and notes that were relevant to the performance of this task. A narrative should be prepared that describes the scope of the work, direction from FEMA, assumptions and issues, and any information that may be useful for the Mapping Partner performing the mapping analyses. Contractual documents, such as a signed SOW or MAS, are not to be submitted as a part of the DCS.

M.9.2.10 Certification of Work

Coastal work that was funded by FEMA must be certified using the form provided in Figure M-8. A PDF of the form must be submitted digitally which has the original signature, data, and seal affixed to the form. This form must be signed by a registered professional engineer or licensed land surveyor from the firm contracted to perform the work, or by the appropriate government agency official. A digital version of this form is available at www.fema.gov.

M.9.2.11 Acceptable File Formats

Any spatial features must be stored in an ESRI compatible format. Model input and output files and other data files used to support the study can be provided in their native format.

- PDF for reports, correspondence, and certifications,
- Shapefiles for all coastal spatial files
- Personal geodatabase for all coastal spatial files
- Models in native formats
- 0.2-percent annual chance wave envelop profiles in PDF and Autocad (DWG) or ESRI compatible file.

M.9.2.12 Metadata

A metadata file that complies with the FEMA/FGDC metadata profiles (available on the MIP via “Tools and Links”) in XML-format must be included with the submittal. The profiles follow the FGDC content standard for metadata and define additional domains and business rules for those elements mandatory for FEMA based on the specific submittal type. For each spatial data source in the metadata file, the Mapping Partner must assign a Source Citation Abbreviation.

M.9.2.13 Transfer Media

Mapping Partners must submit files via the internet by uploading to the MIP (<http://www.hazards.fema.gov>) or on one of the following electronic media:

- CD-ROM
- DVD
- External Hard Drive (for very large data submissions)

In special situations or as technology changes, other media may be acceptable if coordinated with FEMA.

When data is mailed to FEMA, all digital media submitted must be labeled with the following information:

- Mapping partner name;
- Community name and State for which the FIS was prepared;
- Coastal data;
- Date of submission (formatted mm/dd/yyyy); and
- Disk [*sequential number*] of [*number of disks*]. The media must be numbered sequentially, starting at Disk 1. [Number of disks] represents the total number of disks in the submission.

Guidelines and Specifications

M.9.2.14 Transfer Methodology

Coastal Data artifacts can be uploaded to the MIP by following the guidelines for data submission located on the MIP (<https://hazards.fema.gov>).

M.9.2.15 Directory Structure and Folder Naming Conventions

The files in section M.9.2 Requirements must be submitted in the following directory structure. The following folders can be created either on a local work space (i.e., a personal computer) or within the work space for the community on the MIP. If the following folders are generated locally, these newly created folders and their contents must be uploaded to the MIP.

In addition to the other requirements outlined in this section, the Mapping Partner is required to submit the input and output files for coastal computer models. If the data used to estimate the model parameters is available, it must be submitted as well.

Models are organized with all model files in the *Simulations* folder and support spatial files in the *Spatial Files* folder. Data must be located in the appropriate directories, as follows:

- \General
 - XML_format metadata file
 - Certification
 - Coastal analyses and mapping reports
 - Draft FIS Sections 3.1 and 3.3
 - Transect_Location Map
 - Transect_Description Table
 - Transect_Data Table
 - Surge_Stations Map
 - Stillwater_Summary Table
 - 0.2-Percent Annual Chance Wave Envelop (if applicable)
 - Project narrative
- \Correspondence
 - Letters; transmittals; memoranda; general status reports and queries; SPRs; technical issues; direction by FEMA; and internal communications, routing slips, and note
- \Coastal Models\Coast Name\Simulations
 - Model input and output files
 - Wave envelop files
- \Coastal Models\Coast Name\Spatial Files
 - Spatial files
- \Coastal Databases
 - Database file(s)
- \Transects
 - Transects (If one-dimensional model was used)

M.10 Floodplain Mapping Submittal Standards

M.10.1 Overview

This section describes the type and format of data that must be submitted to FEMA for floodplain mapping performed by redelineation of floodplains using updated topographic data and conversion of non-revised effective FIRM information to digital format. All data must be submitted in digital format. The Mapping Partner performing “Floodplain Mapping” is required to submit the data in this section.

The submitting Mapping Partner must retain copies of all project-related data for a period of three years. The submitting Mapping Partner will need these data in order to respond to the following:

- Questions from FEMA or the receiving Mapping Partner during the review of the final draft materials;
- Comments and appeals submitted to FEMA during the 90-day appeal period following the issuance of the preliminary maps; and
- Other concerns and issues that may develop during the processing of the revised FIS report and FIRM.

M.10.2 Requirements

M.10.2.1 Data Files

The following files must be submitted for floodplain mapping:

- A draft FIS report
- Certification of Work
- FBS self-certification documentation
- Redelineation files described in Section M.10.2.3
- Digital conversion files described in Section M.10.2.4

M.10.2.2 Draft FIS

The Mapping Partner performing “Floodplain Mapping” must produce the draft FIS report by updating relevant section of the effective FIS report, including all profiles and tables converted to NAVD88, as well as any other necessary items for the preparation of the preliminary FIS. The submitting Mapping Partner must ensure the draft FIS report complies with Appendix J of these Guidelines.

Guidelines and Specifications

M.10.2.3 Redelineation

M.10.2.3.1 Riverine Redelineation

If the floodplain mapping involves the redelineation process for riverine areas, then the following files must be submitted:

- The following spatial files, where applicable, compliant with Appendix L of the Guidelines:
 - Floodplain Mapping submittal information (S_Submittal_Info described in Section M.11)
 - Cross sections (S_XS described in Section M.11)
 - Base Flood Elevations (S_BFE described in Section M.11)
 - Profile baseline (S_Profil_Basln described in Section M.11)
 - Floodplain mapping (S_Flood_Haz_Ar described in Section M.11)
- Topographic data files as described in Section M.4 (if not submitted under “Develop Topographic Data” described in Section M.4)
- A project narrative describing the scope of work, direction from FEMA, issues, etc.

M.10.2.3.2 Coastal Redelineation

If the floodplain mapping involves the redelineation process for coastal areas, then the following files must be submitted:

- Spatial files, where applicable, compliant with Appendix L of the Guidelines:
 - Floodplain Mapping submittal information (S_Submittal_Info described in Section M.11)
 - Shoreline (S_Shore_Ln described in Section M.11)
 - Coastal transects (S_Cst_Tsct_Ln described in Section M.11)
 - Floodplain mapping (S_Flood_Haz_Ar described in Section M.11)
 - Base Flood Elevations (S_BFE described in Section M.11)
 - Limit of Moderate Wave Action (S_LIMWA described in Section M.11)
 - Primary frontal dune delineations (S_PFD described in Section M.11)
 - CBRS and OPAs (S_S_CBRS described in Section M.11)
- Topographic data files as described in Section M.4 (if not submitted under “Develop Topographic Data” described in Section M.4)
- A project narrative describing the scope of work, direction from FEMA, issues, etc.

M.10.2.4 Digital Conversion

M.10.2.4.1 Riverine Digital Conversion

If the floodplain mapping involves conversion of non-revised effective FIRM information to digital format for riverine areas, then the following files must be submitted:

Appendix M: Data Capture Standards

- The following spatial files, where applicable, compliant with Appendix L of the Guidelines:
 - Floodplain Mapping submittal information (S_Submittal_Info described in Section M.11)
 - Cross sections (S_XS described in Section M.11)
 - Base Flood Elevations (S_BFE described in Section M.11)
 - Profile baseline (S_Profil_Basln described in Section M.11)
 - Floodplain mapping (S_Flood_Haz_Ar described in Section M.11)
- Base map data files as described in Section M.3 (if not submitted under “Acquire Base Map” described in Section M.3)
- A project narrative describing the scope of work, direction from FEMA, issues, etc.

M.10.2.4.2 Coastal Digital Conversion

If the floodplain mapping involves conversion of non-revised effective FIRM information to digital format for coastal areas, then the following files must be submitted:

- Spatial files, where applicable, compliant with Appendix L of the Guidelines:
 - Floodplain Mapping submittal information (S_Submittal_Info described in Section M.11)
 - Shoreline (S_Shore_Ln described in Section M.11)
 - Coastal transects (S_Cst_Tsct_Ln described in Section M.11)
 - Floodplain mapping (S_Flood_Haz_Ar described in Section M.11)
 - Base Flood Elevations (S_BFE described in Section M.11)
 - CBRS and OPAs (S_S_CBRS described in Section M.11)
- Base map data files as described in Section M.3 (if not submitted under “Acquire Base Map” described in Section M.3)
- A project narrative describing the scope of work, direction from FEMA, issues, etc.

M.10.2.5 General Correspondence

A file that compiles general correspondence must be submitted by the Mapping Partner performing floodplain mapping described in this section. General correspondence is the written correspondence generated or received by the Mapping Partner assigned to fulfill the requirements of performing UPDATE. Correspondence include any documentation generated during this task such as letters; transmittals; memoranda; general status reports and queries; SPRs; technical issues that need to be documented; direction given by FEMA; and internal communications, routing slips, and notes that were relevant to the performance of this task. A narrative should be prepared that describes the scope of the work, direction from FEMA, assumptions and issues, and any information that may be useful for FEMA. Contractual documents, such as a signed SOW or MAS, are not to be submitted as a part of the DCS.

Guidelines and Specifications

M.10.2.6 Certification of Work

Work funded by FEMA must be certified using the form provided in Figure M-8. A PDF of the form must be submitted digitally with the original signature, data, and seal affixed to the form. This form must be signed by a registered professional engineer or licensed land surveyor from the firm contracted to perform the work, or by the appropriate government agency official. A digital version of this form is available at www.fema.gov.

M.10.2.7 Acceptable File Formats

Any supporting documentation and data can be submitted in model or native format. The following formats are accepted for files:

- Shapefiles for all riverine and coastal spatial files
- Personal geodatabase for all riverine and coastal spatial files
- PDF for correspondence and certifications
- Word or PDF for draft FIS report and Word, Excel, Access and PDF for FWDT
- DWG or DXF format for stream profiles (redelineation)

M.10.2.8 Metadata

A metadata file that complies with the FEMA/FGDC Metadata Profiles (available on the MIP via “Tools and Links”) in XML format must be included with the submittal. The profiles follow the FGDC Content Standard for metadata and define additional domains and business rules for those elements mandatory for FEMA based on the specific submittal type. For each spatial data source in the metadata file, the Mapping Partner must assign a Source Citation Abbreviation.

Appendix M: Data Capture Standards

Figure M-8 Certification of Compliance Form

Project Name:	
Statement of Work No.:	
Interagency Agreement No.:	
CTP Agreement No.:	
Statement/Agreement Date:	
Certification Date:	
Tasks/Activities Covered by This Certification (Check All That Apply)	
<input type="checkbox"/>	Base Map
<input type="checkbox"/>	Topographic Data Development
<input type="checkbox"/>	Survey
<input type="checkbox"/>	Hydrologic Analysis
<input type="checkbox"/>	Hydraulic Analysis
<input type="checkbox"/>	Alluvial Fan Analysis
<input type="checkbox"/>	Coastal Analysis
<input type="checkbox"/>	Floodplain Mapping
	This is to certify that the work summarized above was completed in accordance with the statement/agreement cited above and all amendments thereto, together with all such modifications, either written or oral, as the Regional Project Officer and/or Assistance Officer or their representative have directed, as such modifications affect the statement/agreement, and that all such work has been accomplished in accordance with the provisions contained in <i>Guidelines and Specifications for Flood Hazard Mapping Partners</i> cited in the contract document, and in accordance with sound and accepted engineering practices within the contract provisions for respective phases of the work.
Name:	
Title:	
Firm/Agency Represented:	
Registration No.:	
Signature:	
This form must be signed by a representative of the firm contracted to perform the work, who is registered as a Professional Engineer, or by the responsible official of a government agency.	

Guidelines and Specifications

M.10.2.9 Transfer Media

- Mapping Partners must submit files via the internet by uploading to the MIP (<http://www.hazards.fema.gov>) or on one of the following electronic media:
- CD-ROM
- DVD
- External Hard Drive (for very large data submissions)

In special situations or as technology changes, other media may be acceptable if coordinated with FEMA.

When data is mailed to FEMA, all digital media submitted must be labeled with the following information:

- Mapping partner name
- Community name and State for which the FIS was prepared
- Coastal data
- Date of submission (formatted mm/dd/yyyy)
- Disk [*sequential number*] of [*number of disks*]. The media must be numbered sequentially, starting at Disk 1. [Number of disks] represents the total number of disks in the submission.

M.10.2.10 Transfer Methodology

Floodplain Mapping data artifacts can be uploaded to the MIP by following the guidelines for data submission located on the MIP (<https://hazards.fema.gov>).

M.10.2.11 Directory Structure and Folder Naming Conventions

The files in section M.10.2 Requirements must be submitted within the following directory structure which is created by the contractor within their workspace prior to upload. The following folders can be created either on a local work space (i.e., a personal computer) or within the work space available for the community on the MIP. If the following folders are generated locally, these newly created folders and their contents must be uploaded to the MIP.

Data must be located in the appropriate directories as follows:

- \General
 - XML_format metadata file
 - Draft FIS report
 - Project narrative
 - Certification of work
- \Correspondence

Appendix M: Data Capture Standards

- Letters; transmittals; memoranda; general status reports and queries; SPRs; technical issues; direction by FEMA; and internal communications, routing slips, and note
- \Mapping\FBS
 - FBS Self-Certification Documentation
 - FBS Self-Certification Spatial Files
- \Mapping\Redelineation\Spatial Files
 - Spatial files
- \Mapping\Redelineation\Topographic Data
 - Topographic data files (if not submitted as part of data requirements described in Section M.4)
- \Mapping\Digital Conversion\Spatial Files
 - Spatial files
- \Mapping\Digital Conversion \Base Map
 - Base map data files (if not submitted as part of data requirements described in Section M.3)

M.11 GIS Spatial Requirements

This section describes the spatial files referenced in this document. This section will be transferred to and merged with Appendix L of the Guidelines when the update of Appendix L is completed and a draft is issued.

M.11.1 Floodplain Mapping Spatial Files - General

The following section describes the spatial file required for floodplain mapping submittals from Mapping Partners.

M.11.1.1 Submittal Information

The S_Submittal_Info spatial table contains essential information about the FEMA case. This table is required to capture the spatial extent of the study areas. The S_Submittal_Info contains the attributes shown in Table M-3.

Table M-3. S_Submittal_Info Spatial File

Field	Type	Length	Required	Description
SUBINF_ID	Long		Yes	Primary key for this table.
SHAPE	Geometry		Yes	Polygon(s) showing the limits of the study area(s). These can be one or multiple irregular shaped polygons to capture the extent of the study area(s). If multiple polygons are required, the attributes of each polygon should be set appropriate for the area covered and all polygons for that project should contain the same FEMA case number. In cases where the flood hazards for the entire County or Community included in the DFIRM have been re-delineated and no new/updated study information was created, a single polygon that matches the extent of the S_Pol_AR polygon (see Appendix L) should be created and attributed correctly. For the case where the flood hazards for a given DFIRM were from both new/updated study data and re-delineated areas, the polygon(s) for the re-delineated areas should not overlap with the polygons for the new/re-study areas, and the outer edges should not extend beyond the S_Pol_AR polygon (see Appendix L) for the DFIRM.
CASE_NO	Text	12	Yes	FEMA Case Number for study. The FEMA case number is used to get access to the engineering backup data associated with the map revision(s) that intersect any given S_Submittal_Info.
CASE_DESC	Text	254	Yes	General description of the study area outlining the scope performed. This description should include the study location with limits of study, methods used, and any unique circumstances associated with this study.
EFF_DATE	Date		Yes	Effective date of this map revision.
HYDRO_DESC	Text	254	Yes	Name of hydrologic model used. The version and year of the model must be specified. See Domain Table D_Hdro.
HYDRA_DESC	Text	254	Yes	Name of hydraulics model used. The version and year of the model must be specified. See Domain Table D_Hdra.
CST_DESC	Text	254	Yes	Name of coastal model used. The version and year of the model must be specified. See Domain Table D_Hdra.

Guidelines and Specifications

SOURCE_CIT	Text	100	Yes	Abbreviation used in the metadata file when describing the source information.
------------	------	-----	-----	--

M.11.2 Floodplain Mapping Spatial Files - Riverine Studies

The following sections describe the spatial files required for riverine floodplain mapping submittals from Mapping Partners.

M.11.2.1 Sub Basins

The S_Subbasins spatial file is required for all types of hydrologic analyses. The sub basins must contain the attributes shown in Table M-4.

Table M-4. S_Subbasins Spatial File

Field	Type	Length	Required	Description
SUBBAS_ID	Long		Yes	Primary key for table.
SHAPE	Geometry		Yes	Polygon Geometry
SUBBAS_NM	Text	254	Yes	Name of subbasin
AREA	Double	12	Yes	Area in square miles of sub-basin
SOURCE_CIT	Text	100	Yes	Source Citation. Abbreviation used in the metadata file when describing the source information for S_Subbasins.

M.11.2.2 Nodes

The S_Nodes spatial file is required for all types of hydrologic analyses. Each point in this spatial data must have associated computed discharge values. The contributing drainage area and the 10-, 2-, 1-, and 0.2-percent-annual-chance flood discharges must be stored as attributes for each node. The points or nodes must lie on the stream. Nodes can represent sub basin pour points or confluences. The work map in Figure M-9 illustrates the proper placement of nodes. Note that nodes are required at basin outlet points and at all flow change locations.

For hydraulic models that use nodes, such as SWMM or ICPR, the nodes can be used to represent structures or hydraulic elements. In these cases, the nodes and the profile baseline file are used to represent the hydraulic connectivity of the network. Nodes can also represent more detailed inventory, such as manholes or curb inlets. For situations where cross sections are not integral to modeling, the cross section spatial file should not be submitted and the water surface elevations must be reported in the nodes file. The S_Nodes contains the attributes shown in Table M-5.

Appendix M: Data Capture Standards

Table M-5. S_Nodes Spatial File

Field	Type	Length	Required	Description
NODE_ID	Long		Yes	Primary key for this table. Assigned by table creator.
SHAPE	Geometry			Point Geometry
NODENAME	Text	254	Yes	Description of the location. This information will be included in the FIS text. Must be unique across a watershed.
NODE_TYP	Short	4	Yes	Nodes Type can be basin outlets/pour points, confluences, or hydraulic elements. See Domain Table D_Nodes
WTR_NM	Text	100	Yes	Name of the stream or water body.
DRAIN_AREA	Double	10	Yes	Contributing drainage area in square miles
DISCH_10PCT	Double	10	Yes, for Detailed Studies	Discharge (cfs) for the 10%-annual-chance flood at the node
DISCH_2PCT	Double	10	Yes, for Detailed Studies	Discharge (cfs) for the 2%-annual-chance flood at the node
DISCH_1PCT	Double	10	Yes	Discharge (cfs) for the 1%-annual-chance flood at the node
DISCH_PT2PCT	Double	10	Yes, for Detailed Studies	Discharge (cfs) for the 0.2%-annual-chance flood at the node
WSEL_10PCT	Double	10	Yes, for Detailed Studies	Water surface elevation for the 10%-annual-chance flood at the node (If cross sections not used for modeling)
WSEL_2PCT	Double	10	Yes, for Detailed Studies	Water surface elevation for the 2%-annual-chance flood at the node (If cross sections not used for modeling)
WSEL_1PCT	Double	10	Yes, for Detailed studies	Water surface elevation for the 1%-annual-chance flood at the node (If cross sections not used for modeling)
WSEL_PT2PCT	Double	10	Yes, for Detailed Studies	Water surface elevation for the 0.2-%-annual-chance flood at the node (If cross sections not used for modeling)
SOURCE_CIT	Text	100	Yes	Source Citation. Abbreviation used in the metadata file when describing the source information for S_Nodes.

M.11.2.3 Profile Baseline

The profile baseline shows the line used for stationing of the profiles found in the FIS. Figure M-10 illustrates the difference between the profile baseline to the stream centerline used in the hydraulic study. The S_Pofil_Basln contains the attributes shown in Table M-6.

Guidelines and Specifications

Table M-6. S_Profil_BasIn Spatial File

Field	Type	Length	Required	Description
BASELN_ID	Long		Yes	Primary key
SHAPE	Geometry		Yes	Polyline Geometry
WTR_NM	Text	254	Yes	Name of the stream or water body.
SEGNAME	Text	254	No	An optional identification string for each reach. If used, this must be unique for a stream.
UP_NODE	Text	11	Yes	Upstream Node. This is the node ID at the upstream end of the reach. This ID field must contain a number that matches the NODE_ID field in the S_Nodes table, which documents points used to define the topology of the hydrologic network. This field is only populated when WATER_LID's value equals "PROFILE BASELINE"
DN_NODE	Text	11	Yes	Downstream Node. This is the node ID at the downstream end of the reach. This ID field must contain a number that matches the NODE_ID field for a record in the S_Nodes table, which documents points used to define the topology of the hydrologic network. This field is only populated when WATER_LID's value equals "PROFILE BASELINE"
ROUTE_METH	Text	254	Yes	Hydrologic Routing Method. This is the hydrologic routing method used for the reach. This field is only populated if hydrologic routing is used for the reach.
WATER_TYP	Text	40	Yes	Surface Water Feature Type. The type value describes the kind of watercourse represented. See Domain Table D_Water_Typ.
SOURCE_CIT	Text	100	Yes	Abbreviation used in the metadata file when describing the source information.

M.11.2.4 Cross Sections

The S_XS spatial file is required for models that utilize cross sections. This file must not be submitted for two-dimensional models that do not employ cross sections for simulating water surfaces. Cross sections are only associated with one stream flow path and must intersect that flow path at only one point. Multi-part shapes are not allowed. The S_XS contains the attributes shown in Table M-7.

Appendix M: Data Capture Standards

Table M-7. S_XS Spatial File

Field	Type	Length	Decimal Places	Required	Description
XS_LN_ID	Text	11		Yes	Primary key for this table. Assigned by table creator.
SHAPE	Polyline			Yes	Polyline of the cross section
XS_SRC	Short	4		Yes	Terrain or Survey data See Domain Table D_Method
STREAM_STN	Text	12	-	Yes	Stream Station. This is the measurement along the stream to the cross-section location. Normally this information is available in the Floodway Data table in the FIS report. When no Floodway Data table is published, this value can be read from the horizontal scale of the flood profile. The units are clarified in the description in the START_DESC field in the L_Stn_Start table.
XS_LTR	Text	12		No	Cross-Section Letter. The letter or number that is assigned to the cross section on the hardcopy FIRM and in the FIS report. This attribute is blank if the cross section is not shown on the FIRM. For a digital conversion, only cross sections that are shown on the FIRM will be available.
XS_LN_TYP	Text	20		No	Cross section line type. This attribute should contain 'LETTERED' for cross sections that are shown on the hardcopy FIRM. If the cross section will not be shown on the hardcopy FIRM, this attribute should contain 'NOT LETTERED' to indicate that the cross section is part of the backup data for the study, but is not shown on the FIRM.
WTR_NM	Text	100	-	Yes	Surface Water Feature Name. This is the formal name of the surface water feature, as it will appear on the hardcopy FIRM.
WSEL_10PCT	Double	8	2	Yes, for Detailed Studies	Water surface elevation for the 10%-annual-chance flood at the cross section
WSEL_2PCT	Double	8	2	Yes, for Detailed Studies	Water surface elevation for the 2%-annual-chance flood at the cross section
WSEL_1PCT	Double	8	2	Yes	Water surface elevation for the 1%-annual-chance flood at the cross section
WSEL_PT2PCT	Double	8	2	Yes, for Detailed Studies	Water surface elevation for the 0.2%-annual-chance flood at the cross section
VEL_10PCT	Double	8	2	Yes, for Detailed Studies	Velocity for the 10%-annual-chance flood at the cross section

Guidelines and Specifications

VEL_2PCT	Double	8	2	Yes, for Detailed Studies	Velocity for the 2%-annual-chance flood at the cross section
VEL_1PCT	Double	8	2	Yes	Velocity for the 1%-annual-chance flood at the cross section
VEL_PT2PCT	Double	8	2	Yes, for Detailed Studies	Velocity for the 0.2%-annual-chance flood at the cross section
VEL_UNIT	Text	20	-	Yes	Velocity Measurement. This unit specifies the unit of measurement for the velocity of the floodway. Acceptable values for this field are listed in the D_Velocity_Units table.
LEN_UNIT	Text	20	-	Yes	Water Surface Elevation Units. This unit indicates the measurement system used for the water surface elevation. Normally this would be feet. Acceptable values for this field are listed in the D_Length_Units table.
V_DATUM	Text	6		Yes	Vertical Datum. The vertical datum indicates the reference surface from which the flood elevations are measured. Normally this would be North American Vertical Datum of 1988 for new studies. Acceptable values for this field are listed in the D_V_Datum table.
SOURCE_CIT	Text	100		Yes.	Source Citation. Abbreviation used in the metadata file when describing the source information for the S_XS table. Table.

M.11.2.5 Base Flood Elevations (BFEs)

This spatial file contains information about the BFEs within a study area. BFE lines indicate the rounded whole-foot water-surface elevation of the 1-percent-annual-chance flood. The S_BFE contains the attributes shown in Table M-8.

Table M-8. S_BFE Spatial File

Field	Type	Length	Decimal Places	Required	Description
BFE_LN_ID	Text	11		Yes	Primary key for table. Assigned by table creator.
ELEV	Numeric (double)	8	2	Yes	Base Flood Elevation. The rounded, whole foot elevation of the 1-percent-annual-chance flood. This is the value of the BFE that is printed next to the BFE line on the FIRM.
SHAPE	Geometry			Yes	Polyline geometry (riverine) or Polygon geometry (coastal)
LEN_UNIT	Text	20		Yes	Length Unit Lookup Identification. See Domain Table D_Length_Units
V_DATUM	Text	6		Yes	Vertical Datum. The vertical datum indicates the reference surface from which the flood elevations are measured. Normally this would be North American Vertical

Appendix M: Data Capture Standards

					Datum of 1988 for new studies. Acceptable values for this field are listed in the D_V_Datum table.
SOURCE_CIT	Text	100		Yes.	Abbreviation used in the metadata file when describing the source information

M.11.2.6 Alluvial Fan Spatial File

The following information is required if modeling includes alluvial fans. The S_Alluvial contains the attributes shown in Table M-9.

Table M-9. S_Alluvial Spatial File

Field	Type	Length	Required	Description
S_AL_ID	Long	4	Yes	Primary key
SHAPE	Geometry		Yes	Polygon Geometry
VELOCITY	Numeric	4	Yes	Velocity in ft/sec
DEPTH	Numeric	4	Yes	Depth in feet
FLD_ZONE	Text	55	Yes	Flood Zone See domain table D_Zone
SOURCE_CIT	Text	100	Yes	Abbreviation used in the metadata file when describing the source information

M.11.2.7 Floodplain Mapping Spatial File

The floodplain mapping spatial file is a polygon spatial file submitted for each flooding event mapped. It contains the draft floodway and the 1-percent (1PCT) annual chance and 0.2-percent (PT2PCT) annual-chance floodplain boundaries that are the pre-cursors to preliminary maps. Additionally, it is possible to store flood data for storms with results other than the 1-percent and 0.2 percent boundaries. The S_Fld_Haz_Ar contains the attributes shown in Table M-10.

Table M-10. S_Fld_Haz_Ar Spatial File

Field	Type	Length	Required	Description
FLD_AR_ID	Long		Yes	Primary Key for this table. Assigned by table creator.
SHAPE	Geometry		Yes	Polygon Geometry
FLD_ZONE	Text	55	Yes	Flood Zone. This is a flood zone designation. These zones are used by FEMA to designate the SFHAs and for insurance rating purposes. NOTE: The symbol '%' is a reserved symbol in most software packages so the word 'percent' was abbreviated to 'PCT'. Acceptable values for this field are listed in the D_Zone table.
FLOODWAY	Text	30	Yes	Floodway Type. Floodway areas are designated by FEMA and adopted by communities to provide an area that will remain free of development to moderate increases in flood heights due to encroachment on the floodplain. Normal floodway areas are 'floodway'. Special cases will have a note on the hardcopy FIRM. If

Guidelines and Specifications

				the corresponding area is not designated as a floodway, this field is null. Acceptable values for this field are listed in the D_Floodway table.
SFHA_TF	Text	1	Yes	Special Flood Hazard Area. If the area is within SFHA this field would be True. This field will be true for any area that is coded for any A or V zone flood areas. It should be false for any X or D zone flood areas. Enter "T" for true or "F" for false.
STATIC_BFE	Number (double)	8,2	Yes	Static Base Flood Elevation. For areas of constant Base Flood Elevation (BFE), the BFE value is shown beneath the zone label rather than on a BFE line. In this situation the same BFE applies to the entire polygon. This is normally occurs in lakes or coastal zones. This field is only populated where a static BFE is shown on the FIRM.
V_DATUM	Text	6	Yes	Vertical Datum. The vertical datum indicates the reference surface from which the flood elevations are measured. Normally this would be North American Vertical Datum of 1988 for new studies. This field is only populated if the STATIC_BFE field is populated. Acceptable values for this field are listed in the D_V_Datum table.
DEPTH	Number (double)	8,2	Yes	Depth Value for Zone AO Areas. This is shown beneath the zone label on the FIRM. This field is only populated if a depth is shown on the FIRM.
LEN_UNIT	Text	20	Yes	Length Units. This unit indicates the measurement system used for the BFEs and/or depths. Normally this would be feet. This field is only populated if the STATIC_BFE or DEPTH field is populated. Acceptable values for this field are listed in the D_Length_Units table.
VELOCITY	Number (double)	8,2	Yes	Velocity Measurement. This is shown beneath the zone label on the FIRM for alluvial fan areas (certain Zone AO areas). This value represents the velocity of the flood flow in this area. This field is only populated when a velocity is shown on the FIRM.
VEL_UNIT	Text	20	Yes	Unit of Measurement for the Velocity Attribute. This is shown in the legend where alluvial fans are present. This field is only populated if the VELOCITY field is populated. Acceptable values for this field are listed in the D_Velocity_Units table.
AR_REVERT	Text	6	Yes	If the area is Zone AR, this field would hold the zone that the area would revert to if the AR zone were removed. This field is only populated if the corresponding area is Zone AR. Acceptable values for this field are listed in the D_Zone table.
BFE_REVERT	Number (double)	8,2	Yes	If Zone is Zone AR, this field would hold the static base flood elevation for the reverted zone. This field is populated when Zone

Appendix M: Data Capture Standards

				equals AR and the reverted zone has a static BFE.
DEP_REVERT	Number (double)	8,2	Yes	If Zone is Zone AR, this field would hold that flood depth for the reverted zone. This field is populated when Zone equals AR and the reverted zone has a depth assigned.
SOURCE_CIT	Text	100	Yes	Source Citation. Abbreviation used in the metadata file when describing the source information for the S_Fld_Haz_Ar table. Normally, the flood hazard area polygon will be divided to distinguish areas modified by the most recent revision from areas based on the effective FIRM prior to the most recent revision. Revisions and sources prior to the most recent revision will not be tracked for individual polygons in the flood hazard areas table in the standard database.

M.11.2.8 Floodplain Boundary Standard Self-Certification

The Floodplain Boundary Standard (FBS) self-certification documentation and data must be submitted with the floodplains when required in sections 7 through 10 using the upload step in the MIP workflow for each Flood Map Project funded in FY06 and later. The *Floodplain Boundary Standard Audit Procedures* – located on FEMA’s web site – outline the documentation needed for FBS compliance through self-certification. The following data must be captured and submitted for each Flood Mapping Project in the report format provided in Attachment B of the *Floodplain Boundary Standard Audit Procedures*:

- Self-Certification review type (GIS or WISE)
- Description of materials used to perform the audit
- Mapping partner performing the audit
- Self-Certification date
- Date submitted to Region
- Names of stream reaches audited
- Total stream length audited
- Number of floodplain boundary points audited
- Number of floodplain boundary points passed
- Number of floodplain boundary points failed
- Shapefile of points tested including exceptions
- Pass/Fail percentages for study FBS risk classes
- 100k NHD Subbasin Pass/Fail shapefile if reporting results below study level pass
- Stream name and length that passed audit

Guidelines and Specifications

Figure M-9. Figure with Nodes, Stream Centerline, and the Basins

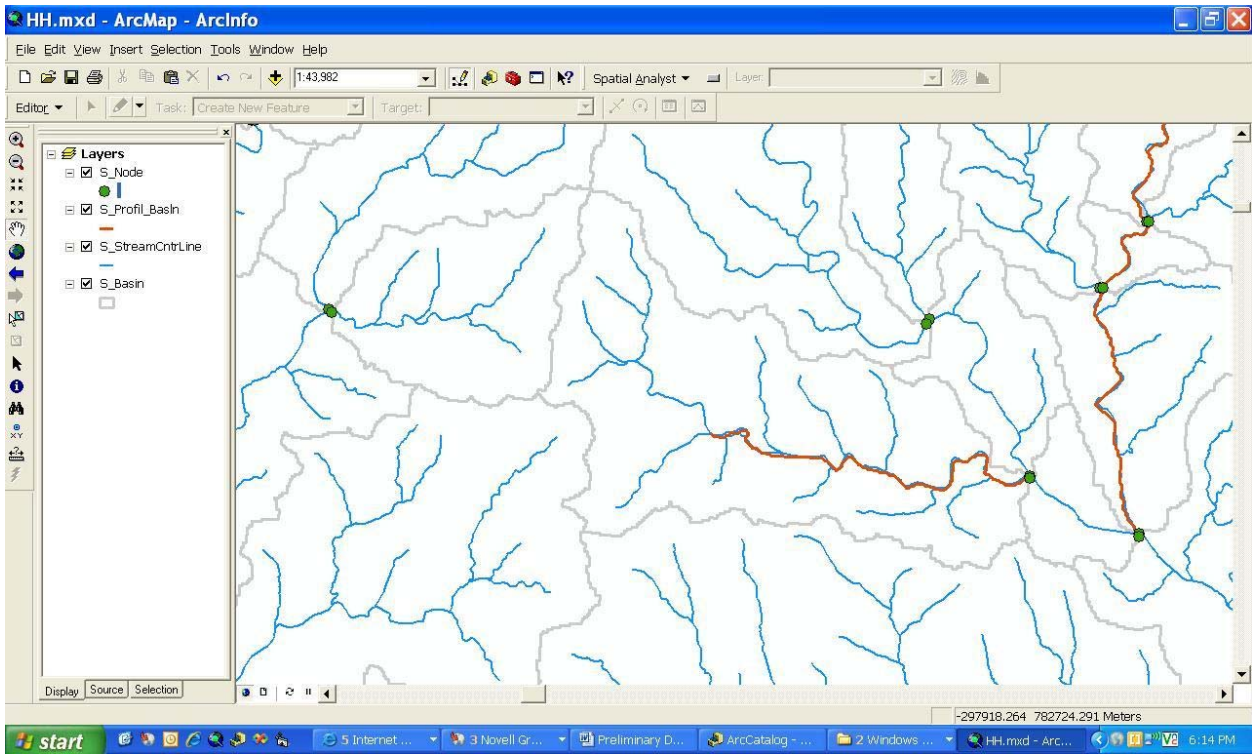
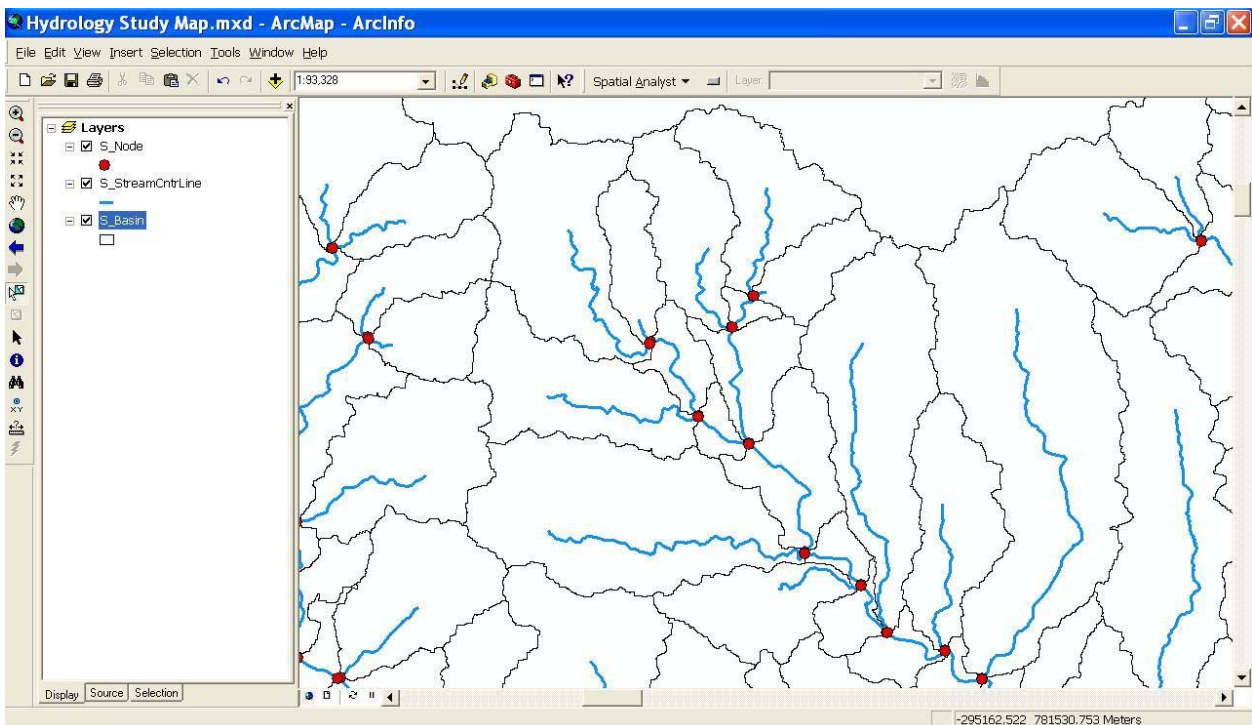

Figure M-10. Figure Depicting Profile Baseline



M.11.3 Required Floodplain Mapping Spatial Files - Coastal Studies

The following are the required spatial files for coastal submittals. Mapping partners should note that not all fields are relevant to all studies.

M.11.3.1 Coastal Transects

The S_Cst_Tsct_Ln file is required for all coastal studies for which transect-based analyses are performed. Hydraulic analyses of coastal flood effects are executed along transects, which are cross-sections taken perpendicular to the shoreline to represent a segment of coast with similar characteristics. Data are compiled primarily for transects, which, in turn, are situated on work maps at the final scale of the DFIRM. Work maps are used to locate and develop transects and to interpolate and delineate the flood zones and elevations. The spatial elements representing coastal transects are lines extending from offshore across the coastal floodplain. The S_Cst_Tsct_Ln contains the attributes shown in Table M-11.

Guidelines and Specifications

Table M-11. S_Cst_Tsct_Ln Spatial File

Field	Type	Length	Required	Description
TRAN_LN_ID	Text	11	Yes	Primary key for this table. Assigned by table creator.
SHAPE	Geometry			Polyline Geometry
SOURCE_CIT	Text	100	Yes	Source Citation. Abbreviation used in the metadata file when describing the source information for the S_Cst_Tsct_Ln table.
PREV_YN	Text	1	Yes	Is the coastal transect part of the previous study? (T/F)
EROS_METH	Text	15	Yes	Erosion Methodology. See D_EROSION .
LOC_DESC	Text	250	Yes	Coastal transect location description.
SHOWN_FIRM	Text	1	Yes	Is the transect shown on the FIRM? (T/F)
LU_SOURCE	Text	254	Yes	Description of land use data source along transect
TRAN_NO	Text	4	Yes	Transect Number (as shown on FIRM or in FIS), Each transect is normally numbered sequentially.
TRANSOURCE	Text	20	Yes	Was Terrain or Survey data used to cut transect? See domain table D_METHOD
V_DATUM	Text	6	Yes	Vertical Datum. See domain table D_VDATUM_
CST_TYPE	Text	50	Yes	Type of coastline. See domain table D_CST_TYPE
FLD_SOURCE	Text	25	Yes	Flooding Sources (Primary and Secondary)
FTCHLENGTH	Numeric	8	Yes	Starting fetch length
FTCHLNUNIT	Text	15	Yes	Fetch length units, e.g., miles, kilometers. See D_Length Units
CON_HT	Numeric	8	Yes	Controlling wave height
CON_HT_Unit	Text	20	Yes	Controlling wave height unit. See D_Length Units
CON_PD	Numeric	8	Yes	Peak wave period (seconds)
SWEL_100	Numeric	10	Yes	Starting 1% Stillwater Elevation
EL_UNIT	Text	11	Yes	Elevation units, e.g., feet, meters . See D_Length Units
WAVE_500	Short	4	No	Were 0.2% Wave calculations performed? (Y/N) (optional task) See domain table D_Boolean_TF

M.11.3.2 Coastal Water Levels

The L_Cst_WaterLv file is required for all coastal studies. Water levels, also known as Stillwater Elevations (SWELs), are a fundamental component of the BFE and may be calculated at multiple locations, independent of transect locations. It is comprised of the mean sea level (MSL), tidal fluctuations about the MSL and the storm surge and wave setup. It excludes wave heights. SWELs may be defined by statistical analyses of tide gage records or by numerical simulation methods. The L_Cst_WaterLv contains the attributes shown in Table M-12.

Appendix M: Data Capture Standards

Table M-12. L_Cst_WaterLv File

Field	Type	Length	Required	Description
CST_WLV_ID	Long	50	Yes	Primary key to identify water level analysis. Assigned by table creator.
ELNINO	Numeric	6	Pacific	El Nino component of total water level
EXTDIST	Text	50	Yes	Type of extreme value distribution used to compute 1% stillwater elevation
LANDSUB	Numeric	6	No	Land subsidence (ft/yr)
LEN_UNITS	Short	4	Yes	Length Unit. See domain table D_Length_Units
SURGEMDL	Text	50	Yes	Type of surge model used in analysis. See domain table D_SURGE_MDL
SEALVRISE	Numeric	4	No	Sea level rise used in analysis (millimeters/yr)
SGRNFF	Text	20	Yes	Method used to compute combined effect of surge and runoff. See domain table D_SURGERNFF
SGTIDE	Text	20	Yes	Method used to compute combined effect of surge and tide. See domain table D_SURGETIDE
V_DATUM	Text	6	Yes	Vertical Datum. See domain table D_VDATUM_
STILLWT_EL	Text	50	Yes	<Filename.zip> of 10%, 2%, 1% and 0.2% Stillwater Elevations and locations.
STMSURGE	Text	50	Yes	<Filename.zip> of storm surge component of total water level if available.
WINDSETUP	Text	1	Yes	- Wind setup used? (T/F)
EL_UNIT	Text	11	Yes	Elevation units, e.g., feet, meters . See D_Length Units

M.11.3.3 Tide Gage Data

The S_TideGage spatial file is required when gage information is used to support the calibration and validation of hydrodynamic models or when it is used in the determination of flood elevations by statistical analyses of annual extrema. The S_TideGage spatial file contains information about coastal gages for the study area. The spatial location of these gages may be some distance from the areas for which coastal flood hazards were determined. The spatial elements representing the coastal gages are points. The S_TideGage contains the attributes shown in Table M-13.

Guidelines and Specifications

Table M-13. S_TideGage Spatial File

Field	Type	Length	Required	Description
TDGAGE_ID	Long	10	Yes	Primary key
SHAPE	Geometry			Point Geometry
END_PD	Date/Time	Default	Yes	End of record used in analysis (MM/DD/YYYY hh:mm)
GAGENAME	Text	254	Yes	Tide gage name and description
OWNER	Text	254	Yes	Owner/Agency that operates gage
RECTIMEINT	Numeric	4	Yes	Recording Interval Time
RESTIDE	Text	11	Yes	<Filename.zip> Residual time series
V_DATUM	Text	6	Yes	Vertical Datum. See domain table D_VDATUM
SOURCE_CIT	Text	100	Yes	Source Citation (Abbreviation used in the metadata file)
START_PD	Date/Time		Yes	Start of record used in analysis (MM/DD/YYYY hh:mm)
TIDEBNCHVM	Long	10	Yes	Tide benchmark Vertical Marker ID
TIDEEPOCH	Text	11	Yes	Tidal epoch date range
TIDEFILENM	Text	15	Yes	<Filename.zip> Tide elevation time series used in analysis
TIME_UNIT	Text	11	Yes	Recording interval time unit. See domain table D_TIMEUNIT

M.11.3.4 Wave Buoy Data

The S_Buoy spatial file is required where wave data have been used in the estimation of offshore wave conditions or for calibration and validation of a numerical wave model. This spatial file holds information regarding the wave climate in the locale. Whenever possible, wave heights, wave period and spectral parameters computed during the study must be compared with observed data from wave buoys. The S_Buoy contains the attributes shown in Table M-14.

Table M-14. S_Buoy Spatial File

Field	Type	Length	Required	Description
BUOY_ID	Long	10	Yes	Primary key for this table. Assigned by table creator.
SHAPE	Geometry			Point Geometry
BUOY_DESC	Text	100	Yes	Buoy description
END_PD	Date/Time	17	Yes	End of record used in analysis (MM/DD/YYYY hh:mm)
OWNER	Text	100	Yes	Owner/Agency that operates buoy
RECTIMEINT	Numeric	4	Yes	Recording Interval Time
SOURCE_CIT	Text	100	Yes	Source Citation (Abbreviation used in the metadata file)
START_PD	Date/Time	17	Yes	Start of record used in analysis (MM/DD/YYYY hh:mm)
TIME_UNIT	Short	4	Yes	Recording interval time unit. See domain table D_TIME_UNIT
WVSPEC	Short	4	No	Wave spectra description. See domain table D_WVSPEC.

M.11.3.5 Wind Data

The S_WindSta spatial file is required where data from wind stations have been used for water level hindcasts or wave estimation. The file holds information regarding the spatial and temporal variation of wind speeds and directions during storm periods. It is essential that the height of the wind measuring instrument above the ground elevation be reported with wind data. The wind data are also used in data assimilation into numerical wind models and for wind model calibration and verification. The S_WindSta contains the attributes shown in Table M-15.

Table M-15. S_WindSta Spatial File

Field	Type	Length	Required	Description
WINDSTA_ID	Long	10	Yes	Primary key for this table. Assigned by table creator.
SHAPE	Geometry			Point Geometry
END_PD	Date/Time	17	Yes	End of record used in analysis (MM/DD/YYYY hh:mm)
OWNER	Text	100	Yes	Owner/Agency that operates wind station
RECTIMEINT	Numeric	4	Yes	Recording Interval Time
SOURCE_CIT	Text	100	Yes	Source Citation (Abbreviation used in the metadata file)
START_PD	Date/Time	17	Yes	Start of record used in analysis (MM/DD/YYYY hh:mm)
TIME_UNIT	Short	4	Yes	Recording interval time unit. See domain table D_TIME_UNIT
STA_HEIGHT	Numeric	6	Yes	Height of Station above ground elevation.

M.11.3.6 Shoreline

The S_Shore_Ln spatial file is required for all coastal studies. The S_Shore_Ln spatial file contains information about the shoreline used in the coastal flood hazard model. Typically, the S_Shore_Ln represents the 0.0-foot elevation contour. The spatial elements representing the shorelines are lines. The file describes the shoreline profile setting and must also include the reference to vertical datum. The S_Shore_Ln contains the attributes shown in Table M-16.

Table M-16. S_Shore_Ln Spatial File

Field	Type	Length	Required	Description
SHR_LN_ID	Long	4	Yes	Primary Key for this table. Assigned by table creator.
SHAPE	Geometry			Polyline Geometry
BEACHSET	Short	4	Yes	See domain table D_BEACHSET
V_DATUM	Short	4	Yes	Vertical Datum. See domain table D_VDATUM
SOURCE_CIT	Text	100	Yes	Source Citation (Abbreviation used in the metadata file)

Guidelines and Specifications

M.11.3.7 CBRS and Otherwise Protected Areas (OPAs)

This spatial file only applies to coastal areas that have specially protected areas designated by Congress on John H. Chafee Coastal Barrier Resources System (CBRS) maps. Authoritative CBRS boundary locations are shown on maps administered by the U.S. Fish and Wildlife Service. Normally these areas are already shown on existing FIRMs for the area. CBRS areas have restrictions on Federal funding (including flood insurance coverage) after specified dates for new or substantially improved structures. See Appendix K of these Guidelines for more detailed information about CBRS areas. The S_CBRS contains the attributes shown in Table M-17.

Table M-17. S_CBRS Spatial File

Field	Type	Length	Required	Description
CBRS_ID	Long	4	Yes	Primary Key for this table. Assigned by table creator.
Shape	Geometry			Polygon Geometry
CBRS	Short	4	No	CBRS type. See domain table D_CBRS_TYP
CBRS_DATE	Date/Time	8	No	CBRS Date. Legislative or administrative date on which prohibitions for the CBRS area apply. This should be indicated on the FIRM with a note or with a fill pattern indicated on the legend.
SOURCE_CIT	Text	100	Yes	Source Citation (Abbreviation used in the metadata file)

M.11.3.8 Primary Frontal Dunes

This spatial file is required when a primary frontal dune (PFD) is present along portions or the entire coastline within the modeled coastal floodplain. PFDs are not required to be continuous along the length of the studied shoreline. The S_PFD spatial file contains information about the primary frontal dune features for the coastal study area. Primary frontal dunes are not shown on the FIRM but are used in the coastal floodplain analysis. They are lines that represent the landward dune heel or where the gradient changes from steep to gentle. The spatial elements representing the primary frontal dunes are lines. The S_PFD contains the attributes shown in Table M-18.

Table M-18. S_PFD Spatial File

Field	Type	Length	Required	Description
PFD_ID	Long	4	True	Primary Key for this table. Assigned by table creator.
SHAPE	Geometry			Polyline Geometry
SOURCE_CIT	Text	100	True	Source Citation (Abbreviation used in the metadata file)

M.11.3.9 Limit of Moderate Wave Action (LiMWA)

This spatial file is required when a Limit of Moderate Wave Action (LiMWA), or Coastal A Zone, is delineated within the coastal floodplain.. The S_LiMWA contains the attributes shown in Table M-19.

Appendix M: Data Capture Standards

Table M-19. S_LIMWA Spatial File

Field	Type	Length	Required	Description
LIMWA_ID	Long	4	True	Primary Key for this table. Assigned by table creator.
Shape	Geometry			Polyline Geometry
SOURCE_CIT	Text	100	True	Source Citation (Abbreviation used in the metadata file when describing the source information for the S_LiMWA table.)

M.11.3.10 Coastal Structures

This spatial file is required whenever coastal armoring structures or levees are included in the coastal analyses shown on the wave envelop. The S_Cst_Struc table contains information about the coastal structures within the study area. Spatial elements representing coastal structures are represented by lines. The lines should represent the primary characteristic of the structure. For example, levees should be represented by a line corresponding to the top of levee. The S_Cst_Struc contains the attributes shown in Table M-20.

Table M-20. S_Cst_Struc Spatial File

Field	Type	Length	Required	Description
CST_STR_ID	Long	4	Yes	Primary key for this table. Assigned by table creator.
SHAPE	Geometry		Yes	Polyline Geometry
TRAN_LN_ID	Long	50	Yes	Foreign key to Cst_Tsct_Ln table
CERTDOC	Text	11	No	<Filename.zip> of FEMA certification documentation
CERTST	Short	4	Yes	Certification Status . See domain table D_CERTSTAT
COMMENTS	Text	254	No	General comments or notes.
LEN_UNITS	Short	4	Yes	Length units. See domain table D_LEN_UNIT.
LENGTH	Numeric	8	Yes	Length of structure
SOURCE_CIT	Text	100	Yes	Source Citation (Abbreviation used in the metadata file)
STRMTL	Short	4	Yes	Structure material type. See domain table D_STRMTL
STRUCT_NM	Text	50	Yes	Field name of the structure
SURVEYDT	Date/Time	17	Yes	Date and time of survey
SURVEYFILE	Text	11	Yes	<Filename.zip> of survey documentation

Guidelines and Specifications

M.12 Domain Tables

Domain Name	Description
D_BEACHSET	BEACHSET Sandy beach backed by low sand berm or high sand dune formation Sandy beach backed by shore protection structures Cobble, gravel, shingle, or mixed grain sized beach and berms Erodible coastal bluffs Non-erodible coastal cliffs and bluffs Tidal flats and wetlands
D_Boolean_TF	TRUE-FALSE FALSE TRUE
D_CERTSTAT	CERTSTAT Meets existing FEMA certification policy Certified prior to existing FEMA policy Certified by another Federal Agency Not certified: Failure of vertical structure Not certified: Failure of revetment Not certified: Failure of levee Not Applicable
D_CBRS_TYP	CBRS COASTAL BARRIER RESOURCES SYSTEM OTHERWISE PROTECTED AREA

Appendix M: Data Capture Standards

D_ClsTyp	Type of Closure
	Combination
	Floodgates
	Other
	Sandbags
	Stop logs
	None

D_CST_TYPE	CST_TYPE
	Open Coast
	Sheltered Waters
	Combined Open Coast and Sheltered Waters

D_EROSION	EROSION
	MK-A
	K-D
	SBEACH
	EBEACH
	COSMOS
	Dune Removal
	Dune Retreat
	None Applied
	Other

D_Hydra	Type of Hydraulic Model (see accepted models list on FEMA's Web site)
	ADVANCED ICPR 2.20 (OCTOBER 2000) and 3.02 (November 2002)
	DHM 21 and 34 (AUGUST 1987)
	FEQ 8.92 (1999) and FEQ 9.98 (2005)
	FEQUTL 4.68 (1999) and FEQUTL 5.46 (2005)
	FESWMS 2DH 1.1 and up (JUNE 1995)
	FLDWAV (NOVEMBER 1998)

Guidelines and Specifications

FLO-2D V.2003.6, 2004.10 and 2006.1
GAGE ANALYSIS
HCSWMM 4.31B (AUGUST 2000)
HEC-2 4.6.2 (MAY 1991)
HEC-RAS 3.1.1 and up
HY8 4.1 (November 1992) and up
MIKE 11 HD (2002 D, 2004)
MIKE Flood HD (2002 D and 2004)
QUICK-2 1.0 (January 1995) and up
S2DMM (February 2005)
SWMM 4.30 (MAY 1994)
SWMM 4.31 (JANUARY 1997)
TABS-RMA2 V.4.3 (OCTOBER 1996)
TABS-RMA4 V.4.5 (JULY 2000)
SWMM 5 Version 5.0.005 (May 2005) and up
WSPGW 12.96 (OCTOBER 2000)
WSPRO (JUNE 1988) and up
StormCAD v.4 (June 2002) and up
PondPack v. 8 (May 2002) and up
Culvert Master v. 2.0 (September 2002) and up
XP-SWMM 8.52 and up
Xpstorm 10.0 (May 2006)
NETWORK (June 2002)
CHAN for Windows v. 2.03 (1997)

D_Hydro

Type of Hydrologic Model (see accepted models list on FEMA's Web site)

AHYMO 97 (AUGUST 1997)
CUHPF/PC (MAY 1996 and May 2002)
FAN
HEC-FFA 3.1 (February 3.1)

Appendix M: Data Capture Standards

HEC-1 4.0.1 (May 1991) and up
 HEC-HMS 1.1 (March 1998) and up
 HSPF 10.10 (December 1993) and up
 MIKE 11 RR (2002 D and 2004)
 MIKE 11 UHM (2002 D and 2004)
 PEAKFQ 2.4 (APRIL 1998) and up
 SWMM (RUNOFF) 4.30 (MAY 1994)
 SWMM (RUNOFF) 4.31 (JANUARY 1997)
 SWMM 5 Version 5.0.005 (May 2005) and up
 TR-20 (FEBRUARY 1992)
 TR-20 Win 1.00.002 (January 2005)
 TR-55 (JUNE 1986)
 Win TR-55 1.0.08 (January 2005)
 PRMS Version 2.1 (January 1996)
 PondPack v.8 (May 2002) and up
 XP-SWMM 8.52 and up
 Xpstorm 10.0 (May 2006)

D_LEN_UNIT	LEN_UNIT
	CENTIMETERS
	FEET
	INCHES
	KILOMETERS
	METERS
	MILES
	MILLIMETERS
D_METHOD	Type of coastal transect elevation method
	CUT FROM TOPO
	DIGITIZED FROM FIRM

Guidelines and Specifications

FIELD SURVEY

D_Nodes	Type of Node
	DIVERSION
	JUNCTION
	RESERVOIR
	STRUCTURE
D_STRMTL	STRMTL
	Stone
	Asphalt
	Concrete
	Earthen
	Timber
	Steel
	Sand
	Other
	Unknown
D_SURGERNFF	SGRNFF
	Independent
	Correlation
	Other
D_SURGETIDE	SGTIDE
	Linear combination
	High/low
	EST approach
	1-D Monte Carlo approach
	2-D surge modeling

Appendix M: Data Capture Standards

D_State	USA State Name
	ALABAMA
	ALASKA
	ARIZONA
	ARKANSAS
	CALIFORNIA
	COLORADO
	CONNECTICUT
	DELAWARE
	DISTRICT OF COLUMBIA
	FLORIDA
	GEORGIA
	HAWAII
	IDAHO
	ILLINOIS
	INDIANA
	IOWA
	KANSAS
	KENTUCKY
	LOUISIANA
	MAINE
	MARYLAND
	MASSACHUSETTS
	MICHIGAN
	MINNESOTA
	MISSISSIPPI
	MISSOURI
	MONTANA
	NEBRASKA
	NEVADA

Guidelines and Specifications

NEW HAMPSHIRE
NEW JERSEY
NEW MEXICO
NEW YORK
NORTH CAROLINA
NORTH DAKOTA
OHIO
OKLAHOMA
OREGON
PENNSYLVANIA
RHODE ISLAND
SOUTH CAROLINA
SOUTH DAKOTA
TENNESSEE
TEXAS
UTAH
VERMONT
VIRGINIA
WASHINGTON
WEST VIRGINIA
WISCONSIN
WYOMING
AMERICAN SAMOA
GUAM
PUERTO RICO
VIRGIN ISLANDS

D_StudyDetail

Type of FHM Study

Approximate

Limited Detailed

Appendix M: Data Capture Standards

Detail
Redelineation
Digital Conversion

D_TIME_UNIT	TIME_UNIT
-------------	-----------

DAYS
HOURS
MINUTES
MONTHS
SECONDS
WEEKS
YEARS

D_VDatum	VDATUM
----------	--------

MSL
NAVD88
NGVD29

D_Water_Typ	Type of Water Feature
-------------	-----------------------

AREA OF COMPLEX CHANNELS
ARTIFICIAL PATH
BAY / INLET
BAYOU
BOG
BYPASS / DIVERSION
CANAL / DITCH
CHANNEL
CONCRETE / EARTHEN CHANNEL
CONCRETE / EARTHEN DITCH
CONCRETE CHANNEL
CONCRETE DITCH

Guidelines and Specifications

CONNECTOR
CREEK
CREVASSE FIELD
DETENTION POND
EARTHEN CHANNEL
EARTHEN DITCH
ESTUARY
FISH LADDER
FLUME
GULCH
HATCHERY
ICE MASS / GLACIER
INTERMITTENT RIVER / STREAM
LAKE / POND
LOCK CHAMBER
MUD POT
NONEARTHEN SHORE
OVERFLOW
PERENNIAL RIVER / STREAM
PLAYA
PROFILE BASELINE
RACE
RESERVOIR
RETENTION POND
SAND PIT
SEA / OCEAN
SHORELINE / COASTLINE
SPILLWAY
STREAM / RIVER
SUBMERGED STREAM

Appendix M: Data Capture Standards

SWAMP / MARSH
 TAILINGS POND
 UNDERPASS
 WASH
 WASTE WATER LAGOON / POND
 WATER SEPARATION LINE
 WATERFALL
 WATERWAY
 WETLANDS
 NAVIGABLE WATERWAY
 SOUND
 ISLAND
 CHANNEL CONTAINS 1 PCT FLOOD EVENT
 HYDROLOGIC LINK
 PROFILE BASELINE AND STREAM CENTERLINE
 STREAM CENTERLINE

D_Zone	Type of Flood Zone
	A
	AE
	AH
	AO
	AR
	1 PCT ANNUAL CHANCE FLOOD HAZARD CONTAINED IN CHANNEL
	1 PCT FUTURE CONDITIONS
	A99
	V
	VE
	0.2 PCT ANNUAL CHANCE FLOOD HAZARD
	0.2 PCT ANNUAL CHANCE FLOOD HAZARD CONTAINED IN CHANNEL

Guidelines and Specifications

AREA NOT INCLUDED

D

X PROTECTED BY LEVEE

X

X AREA OF SPECIAL CONSIDERATION

OPEN WATER

M.12 References

Federal Geographic Data Committee, FGDC-STD-001-1998. *Content Standard for Digital Geospatial Metadata (version 2.0)*, FGDC, c/o USGS, Reston, VA
<http://www.fgdc.gov/metadata/metadata.html>

U.S. Department of the Army, Corps of Engineers, Hydrologic Engineering Center, *HEC-1 Flood Hydrograph Package, User's Manual*, Davis, CA, 1990.

U.S. Department of the Army, Corps of Engineers, Hydrologic Engineering Center, *HEC-RAS, River Analysis System, User's Manual*, Version 3.0, Davis, CA, 2001.

U.S. Department of the Army, Corps of Engineers, Hydrologic Engineering Center, *Hydrologic Modeling System, HEC-HMS, User's Manual*, Version 2.1, Davis, CA, 2001.

Federal Emergency Management Agency, 1990, *FAN – An Alluvial Fan Flooding Computer Program, User's Manual and Program Disk*: available from Michael Baker, Jr., Alexandria, Virginia.

Federal Emergency Management Agency, 2007, *Floodplain Boundary Standard Audit Procedures – Version 2.0*: available on FEMA's web site
http://www.fema.gov/plan/prevent/fhm/gs_main.shtm

Federal Emergency Management Agency, 2007, *Draft Scoping Guidelines*: available from Michael Baker, Jr., Alexandria, Virginia.