

Hot-Gas Filter Ash Characterization Project

Bruce A. Dockter (bdockter@eerc.und.nodak.edu, 701-777-4102)
John P. Hurley (jhurley@eerc.und.nodak.edu, 701-777-5159)
Tina A. Watne (twatne@eerc.und.nodak.edu, 701-777-2233)
Karen A. Katrinak (kkatrinak@eerc.und.nodak.edu, 701-777-5283)
Catherine A. O'Keefe (cokeefe@eerc.und.nodak.edu, 701-777-5238)
Energy & Environmental Research Center
University of North Dakota
PO Box 9018
Grand Forks, ND 58202-9018

Introduction

Large-scale hot-gas testing over the past several years has revealed numerous cases of cake buildup on filter elements that have been difficult, if not impossible, to remove. At times, the cake can bridge between candle filters, leading to high filter failure rates. Physical factors, including particle-size distribution, particle shape, the aerodynamics of deposition, and system temperature contribute to difficulty in removing the cake. It is speculated that chemical as well as physical effects are playing a role in leading the ash to bond to the filter or to itself.

The Energy & Environmental Research Center (EERC) at the University of North Dakota is working with Electric Power Research Institute (EPRI) and a consortium of companies in partnership with the U. S. Department of Energy (DOE) to perform the research necessary to determine the factors that cause hot-gas cleanup filters to be blinded by ash or to develop deposits that can bridge the filters and cause them to fail. The consortium sponsors are Novem/ECN (Netherlands), PowerGen (Great Britain), Electricité de France (EDF) (France), Lurgi-Lentjes-Babcock (LLB) (Germany), Schumacher America (Germany/USA), Westinghouse (USA), ABB Carbon (Sweden), and Electric Power Development Corporation (EPDC) (Japan).

Objective

The objectives of the overall project are threefold: first, to determine the mechanisms by which difficult-to-clean ash is formed; second, to develop a method to determine the rate of blinding/bridging based on fuel and sorbent properties and operating conditions; finally, to provide suggestions for ways to prevent filter blinding by the troublesome ash.

Project Description

The research effort is composed of the following four tasks.

Task 1 – Field Sampling and Archive Sample Analyses. The American Electric Power Service Corporation (AEP) and the Ohio Power Company donated filter ash samples from several test series of the Westinghouse Advanced Particle Filter (APF) at the Tidd pressurized fluidized-bed

combustor (PFBC) demonstration plant. Residual ash samples were taken from the APF in May and October 1994. APF hopper ash (filter fines) was collected in February 1995 by AEP. The EERC also collected residual filter cake samples in May 1995 after the March 1995 shutdown of the facility.

Task 2 – Laboratory-Scale Testing. Extensive thermochemical equilibrium modeling is used to determine system, ash, and filter parameters that must be included in the experimental matrix to ensure that the experimental work reflects realistic conditions. In modeling of ash sticking, an accurate description of the chemistry of multicomponent coal ash systems implies the use of an ideal-solution model such as that derived from the FACT (Facility for the Analysis of Chemical Thermodynamics) computer code.

In other Task 2 activity, ash collected from the field and produced in the bench-scale work in Task 3 will be treated to hot-gas conditions to determine the effects of ash particle size, ash distribution, gas composition, temperature, and exposure time on ash sintering. To accomplish this portion of Task 2, laboratory methods were developed to assess tensile strength development of ash samples. First, prepared ash cakes were subjected to elevated temperatures and a simulated combustion gas environment and tested for powder tensile strength in order to identify initial levels of ash stickiness. Second, ash pellets were exposed to simulated gas conditions for extended time intervals and then tested in diametral compression mode. Finally, experiments were performed to assess ash-filter interactions after long-term exposure to gas conditions.

Task 3 – Bench-Scale Testing. The objective of Task 3 is to perform dynamic testing of ash and ash cake formation in PFBC conditions in order to help in the development of methods to predict possible filter blinding and bridging conditions. Bench-scale hot-gas filter testing is performed with the pressurized fluidized-bed reactor (PFBR), located at the EERC, under combustion conditions.

Task 4 – Model and Database Development Testing. The goal of Task 4 is to create a user-friendly computer program to predict the effects of fuel, bed material, filter type, and operating conditions on the formation of ash bridges and to create a user-friendly database for use as a research and reference tool. Potential applications of the computer program include coal selection, bed material selection, optimization of operating conditions, and design of a cleanup system. The database was designed to provide researchers with a quick and efficient tool for studying the large amounts of information generated during the course of this project.

This paper presents preliminary data from Task 2 on determining the tensile strengths of coal ash particles at elevated temperatures and simulated combustor gas conditions.

Approach

Many factors control the ultimate adhesive properties of ash deposition and the ultimate formation of cakes on rigid ceramic filters. Numerous physical properties coupled with intrinsic forces of attraction create an extremely complicated scenario for laboratory determination. Some of the

most pertinent discussions for the description of significant particle characteristics and how they interact to form adhesive properties are addressed in this paper.

The prediction of the ways in which a powder will agglomerate and form cakes is not just a matter of understanding all the ways in which particles can attract one another, but of understanding the way in which the particles fit together in the bulk. Particle shape and size are of importance in controlling the packing and caking properties of powders. Because most particles are not spherical, the first problem is the mathematical representation of the shape of the particles. The term “sphericity” has been defined as the ratio of the surface area of a sphere having the same volume as a given particle to the actual surface area of that particle (Parfitt and Sing, 1976). Particle size and shape are generally expressed as some kind of equivalent spherical diameter.

If the interparticle forces were known, the strength of the cake compact could then be calculated by specifying three-dimensional shapes with specified surface forces and then calculating the strength of the resulting cake compact. The problem is then reduced to size and shape studies on one hand and packing studies on the other. Any attempt to sum the microscopic contributions made by the particles themselves must take into account three factors, all associated with the nature of the particle surface: interparticle forces, the three-dimensional shape of the particle, and the way in which the particle interacts geometrically to form a packed structure.

Most powders are not easily characterized in terms of these microscopic quantities. If the size of a single particle is given as its equivalent spherical diameter, then the definition of particle size by a single parameter is somewhat arbitrary, and in any theoretical study, it will be necessary to use a description of the particle that will define its shape equivalencies. The situation is no less complicated with interparticle forces that are subject to changes in environment and to the effect of their previous history. In real powders, these forces can be of a variety of types (Berbner and Löffler, 1994), including the following:

- Mechanical forces caused by interlocking of irregular particles
- Surface tension forces, particularly with powder containing a variable moisture content
- Forces arising from plastic welding caused by contact points between particles coalescing under high loads
- Electrostatic forces, particularly for surfaces that easily become charged
- Solid bridge forces, where crystallization at contact points causes joining of the particles
- Molecular (or van der Waals) forces, particularly significant for particles of small diameters, say less than 10 μm

It has been stated (Christ et al., 1995) that the main cohesive forces between particles in filter cakes are van der Waals forces. This is especially true for elevated temperatures and small filtration velocities when capillary forces or sinter effects are negligible. The interparticle forces

causing hot-gas filter ashes to become “sticky” are subject to changes in a combustion environment. These forces can be of varying types including those previously identified.

Earlier results show that tensile strength, aerated porosity, and packed porosity measurements are appropriate methods to quantify the adhesive properties for coal ashes. Ash cakes with tensile strengths of less than 50 N/m² (0.5 g/cm²) are likely to have significantly greater dispersement of fine particles after backpulsing than ash cakes with tensile strengths greater than 250 N/m² (Miller and Laudal, 1992).

In general, a filter cake detaches from the filter medium when it is subjected to a tensile stress that exceeds its strength. The cake “fails in tension” when the imposed stress exceeds either the internal cohesive strength of the cake or the strength of adhesion to the medium or to a residual dust layer. Most commonly, the cake detaches from a residual dust layer, which is finer and more strongly held by the medium. Regardless of how the cake is cleaned from the filter, the maximum stress in the cake occurs at the junction between the cake and the medium.

At present, it is not possible to predict the stresses required to detach an ash cake from a filter medium. One approach is to predict qualitatively the tensile strength of a particle compact by using the classic model of Rumpf (Koch et al., 1992). He obtained the tensile forces by summing the strengths of the particle-to-particle contacts that must be broken across a surface in the compact. If the particles are spheres of diameter d_p , the tensile strength is determined by

$$\delta = \frac{f(\epsilon)}{d_p^2} F_H$$

where F_H is the interparticle force action at each contact and $f(\epsilon)$ relates the number of contacts to the void fraction. According to Rumpf:

$$F_H = \frac{(1 - \epsilon)}{\epsilon}$$

In terms of the surface energy of the particles (γ), the strength of each contact is given by:

$$F_H = \pi\gamma d_p$$

Other models of particle-to-particle contact give slightly different numerical values, but predict the same dependence on γ and d_p for F_H . Combining the three previous equations:

$$\delta = \frac{\pi (1 - \epsilon)}{\epsilon} \frac{\gamma}{d_p}$$

At present, it is necessary to measure cake detachment stresses directly, because γ depends on dust surface composition, while ϵ and the proportion of active contacts depend on the conditions under which the cake is deposited. The measurements must again be made under conditions as close as possible to those in the real application.

Accomplishments

Filter Ash Characterization. The American Electric Power Service Corporation (AEP) and Ohio Power Company have furnished ash samples from the Westinghouse advanced particle filter (APF) assembly at the Tidd pressurized fluidized-bed combustor (PFBC) demonstration plant. The APF vessel at the Tidd PFBC demonstration plant is approximately 3.0 meters in diameter and 13.4 meters in length. The vessel can contain up to 384 candle filters. The candles can be arranged in three clusters to three different levels. Each cluster contains three plenums, with 38 candles in each of the top and middle plenums and 52 candles in each of the lower plenums.

The APF experienced ash bridging and pressure drop increase during a series of test runs while firing Pittsburgh No. 8 coal and a Plum Run greenfield (PRG) dolomite. There was extensive buildup of ash on all filters. Four series of ash samples have been collected from the Tidd Station. The operation conditions are described in Table 1. During the last part of 1994, less ash buildup occurred on the filters, primarily because of the detuning of the P11 cyclone upstream of the APF. Testing at Tidd during 1995 has shown little ash buildup on filters. One reason is the complete spoiling of the P11 cyclone in 1995, but coals and sorbents were also changed during the last series of tests. Additional archived samples have been added to the characterization testing program. However, the most substantial testing to date has been on the Tidd samples. Therefore, this paper concentrates on laboratory results from the Tidd Station.

The particle sizes of Tidd ash sampled in May 1994 were much smaller than the February 1995 ash samples. The finer-particle sizes resulted in the “stickier” 1994 ash sample. The upset condition in 1995 resulted in more coarse-grained ash particles getting into the APF vessel, causing the agglomerated ash deposits to be less adhesive than previously observed.

Tensile Testing. A measurement of the tensile strength of powder deposits is useful for determining the magnitude of the cohesive forces that cause the powder to agglomerate. Key cohesive characteristics that are well defined and can be quantitatively measured are tensile strength and porosity (Miller and Laudal, 1993). A direct correlation exists between the porosity of a powder bed and the tensile forces required to fracture the bed. At ambient-temperature testing conditions, as porosity decreases, the tensile strength increases. Meanwhile, porosity is a function of bed compaction and particle-size distribution.

Several procedures and methods exist for determining tensile strengths of powder beds. One such method in use at the EERC is a commercially available instrument called a Cohetester, from Hosokawa Micron International Inc. This instrument directly measures the tensile strength of bulk powders as a function of compaction pressure. It consists of a horizontal split cell, 5 cm in diameter, with one-half of the cell movable and the other half fixed. The cell is suspended so

TABLE 1

Operating Conditions at the Tidd PFBC

Parameter	May 1994	October 1994	February 1995	May 1995
Coal	Pittsburgh No. 8	Pittsburgh No. 8	Pittsburgh No. 8	Consol and Pittsburgh No. 8
Sorbent	PRG dolomite	PRG dolomite and Bucyrus limestone	Mulzer dolomite	PRG dolomite
Bed Temp., °C (°F)	818 (1504)	855 (1571)	861 (1581)	856 (1572)
Cyclone Inlet Temp., °C (°F)	748 (1378)	793 (1385)	799 (1471)	787 (1449)
APF Inlet Temp., °C (°F)	727 (1340)	760 (1400)	802 (1475)	NA
APF Pressure, kPa (psig)	890 (129)	890 (129)	945 (137)	NA
Upstream P11 Cyclone	Partially spoiled	Partially spoiled	Completely spoiled	Completely spoiled
Filter Cakes	Difficult to clean	Difficult to clean	Easy to clean	Easy to clean

that it can be pulled apart with minimal force when no sample is in the cell, minimizing error from external friction forces. The Cohetester, like all other tensile-testing apparatuses, is designed to evaluate powder beds under ambient temperatures. However, for the hot-gas filter ash characterization project, tensile strength testing needs to be performed at elevated temperatures (700°–900°C) and in atmospheres similar to PFBC conditions.

To evaluate tensile strengths of powders in elevated-temperature testing environments, a modification to the Cohetester is used. A schematic of the high-temperature powder tensile strength tester is shown in Figure 1. As in the design of the Cohetester, alleviation of friction problems is accomplished by using a movable split cylinder suspended and free to move with minimal resistance. The oven is split in half, with the top portion retractable to allow the

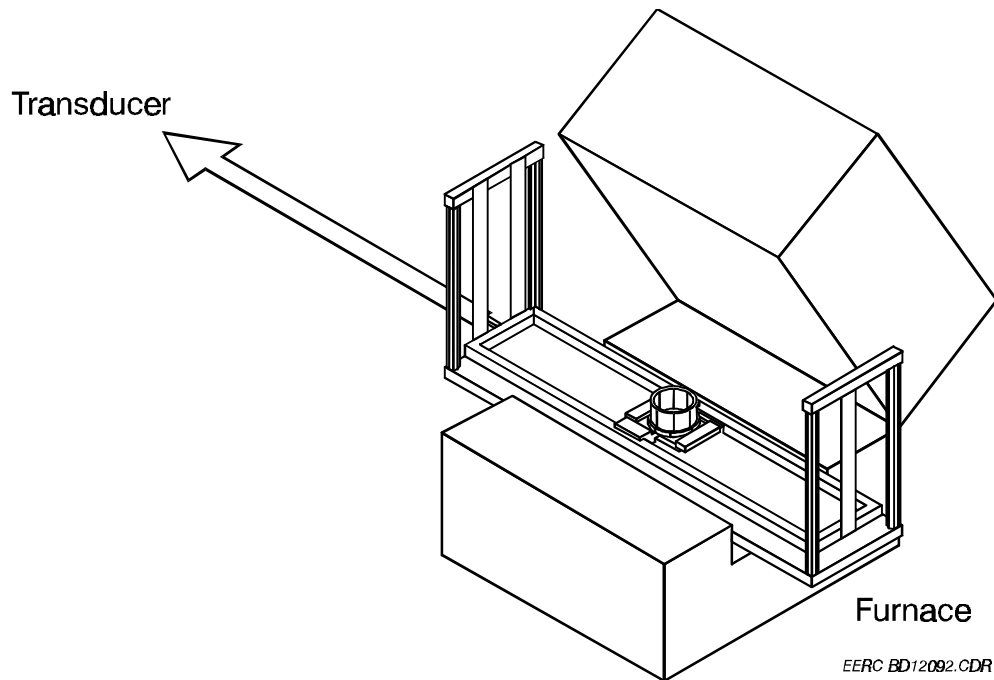

Figure 1. Schematic of the high-temperature powder tensile strength tester.

specimen chamber to be prepared for sample testing. The suspended split-cylinder half is pulled away from the stationary cylinder half, and the load is measured with a transducer or load cell. Several blank loads, i.e., cylinder chamber containing no ash cake sample, have been measured at a range of temperatures. The blank loads are highly consistent regardless of testing temperature, generally 10–12 grams of force.

The ash samples were prepared for testing by first baking them in a 200°C oven. They were then placed directly into the sample holder in the high-temperature tensile tester and allowed to cool for ambient tests. The results of the Tidd ash evaluation from February 1995, at elevated temperatures, is given in Figure 2. In general, strength increases considerably as the ash cakes are compressed and porosity decreases. The blank-load testing (using no ash) showed that the increases in strength were not due to the effects of the higher temperature of the sample cell on the instruments.

There is a noticeable trend in tensile strength increase with increasing temperature and decreasing void fraction. In addition, the prepared ash cakes have exhibited substantial sintering action at the higher levels of compaction (lower porosity). This indicates that at higher levels of particle packing, which is a function of size distribution, the ash cakes will sinter and gain strength at a higher rate. The cake porosity, which seems to correlate to sintering action, can be correlated to pressure drop as well.

The bulk ash from the Tidd Station (February 1995) is also being classified into size fractions for evaluating the effects of size distribution on tensile strength. The size distribution bands are of a

caliper diameter greater than 10 μm , 3–10 μm , 1–3 μm , and less than 1.0 μm . It is a general understanding that the finer size particles, particularly submicron, have a significant impact on the stickiness behavior of problematic ash. However, introducing larger-size ash particles is not necessarily the solution because of the increased potential for candle filter damage and subsequent corrosion of the gas turbine. A specific particle-size range is necessary to allow an ash cake to form on a candle with sufficient adhesive strength to allow the cake bed to be detached without redistributing the residual ash particles elsewhere in the system. All of these properties need to be understood at atmospheres similar to those in the actual system.

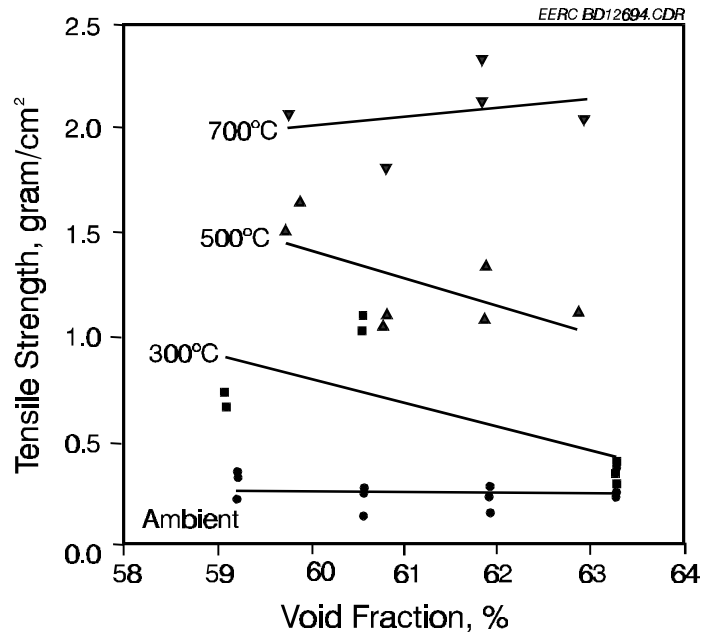

Figure 2. Tensile strength of February 1995 Tidd ash at elevated temperatures.

The high-temperature tensile tester is designed to evaluate powder cake tensile strength while exposed to elevated temperatures and simulated gas environments for short periods of time (less than 1 hour), as for the active cake on a filter. However, passive ash deposits such as residual cake or shroud deposits may be present for much longer times, possibly sintering to greater strength than can be measured by the high-temperature tensile tester. To test ash strength development over long periods, the long-duration sintering test was developed. A schematic of the sintering chamber is shown in Figure 3. This apparatus allows the preparation of multiple samples simultaneously. The specimens measure 1.0 cm in diameter by approximately 1.5 cm in length. The sintered specimens are tested in diametral compression (Figure 4). This method is commonly used for predicting tensile forces while testing is performed in a compressive mode.

Two tests have been completed thus far for long-term pellet sintering. The first test, using February 1995 Tidd ash, was run at 900°C for 50 hours in an air atmosphere. The second test, using May 1994 Tidd ash, was also run at 900°C, but lasted 120 hours and was in an atmosphere of 30% O₂, 15% H₂O, 3300 ppmv SO₂, 1100 ppmv HCl, 10 ppmv NaCl, and a N₂ balance. In the air atmosphere, little or no

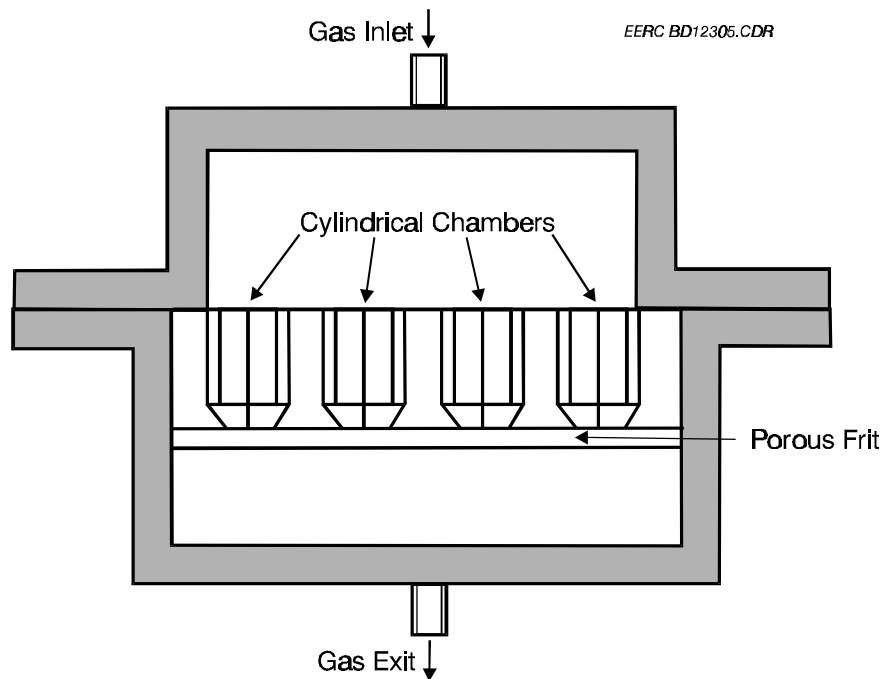

Figure 3. The long-duration ash-sintering chamber.

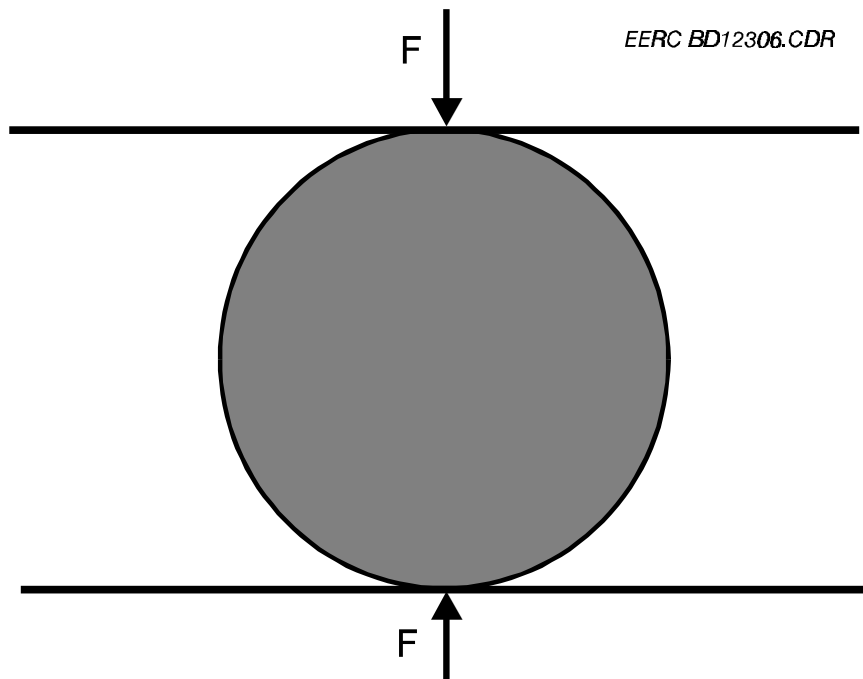

Figure 4. Schematic of the diametral compression test: the stress state is tensile (directed perpendicularly) along the diameter joining the loading points.

sintering occurred. In the simulated PFBC atmosphere, slight sintering does appear to occur, but the resulting strength is still very small. Work on thermochemical equilibrium modeling has indicated that eutectic temperatures present in hot-gas cleaning environments might be causing softening of particle surfaces and, consequently, causing the surface stickiness. However, this assessment is made at the very early stages of the thermochemical equilibrium task and needs further development. Now that sintering has been correlated to cake porosity and particle packing, pellet sintering can be performed on variable compaction levels and particle-size distributions. More tests will be run at 900°C under the corrosive environment previously mentioned, but for longer periods of time.

Contract Information and Acknowledgments

The METC Contracting Officer's Representative is Dr. Hubert Veringa. The DOE contract number is RP 3910-01, and the period of performance is from July 1, 1994, to March 31, 1997. The Electric Power Research Institute (EPRI) is the prime project contractor. All research is carried out by the Energy & Environmental Research Center (EERC). The EERC, through its Cooperative Agreement with the U.S. Department of Energy (DOE) Morgantown Energy Technology Center (METC), is able to approximately match funds contributed by the commercial sponsors.

References

Berbner, S.; Löffler, F. "Influence of High Temperatures on Particle Adhesion," *Powder Technology* **1994**, 78, 273–280.

Christ, A.; Gierneth, B.; Renz, U. "Possible Improvements to the Back-Pulse Cleaning of Ceramic Candle Filters," *In Proceedings of the 13th International Conference on Fluidized Bed Combustion*; ASME, 1995, Vol. 1.

Koch, D.; Cheung, W.; Seville, J. P.K.; Clift, R. "Effects of Dust Properties on Gas Cleaning Using Rigid Ceramic Filters," *Filtration & Separation* **1992**, 29 (4).

Miller, S.J.; Laudal, D.L. "Pulse-Jet Baghouse Performance Improvement with Flue Gas Conditioning," EERC publication; Oct. 1992.

Miller, S.J.; Laudal, D.L.; Heidt, M.K. "Cohesive Properties of Fly Ash and How They Affect Particle Control Optimization," Presented at 10th Particle Control Symposium, Washington, DC April 5–8, 1993.

Parfitt, G.D.; Sing, K.S.W. *Characterization of Powder Surfaces*; Academic Press: London, 1976.