

# Advanced Turbine Systems

## Annual Program Review

### November, 1999

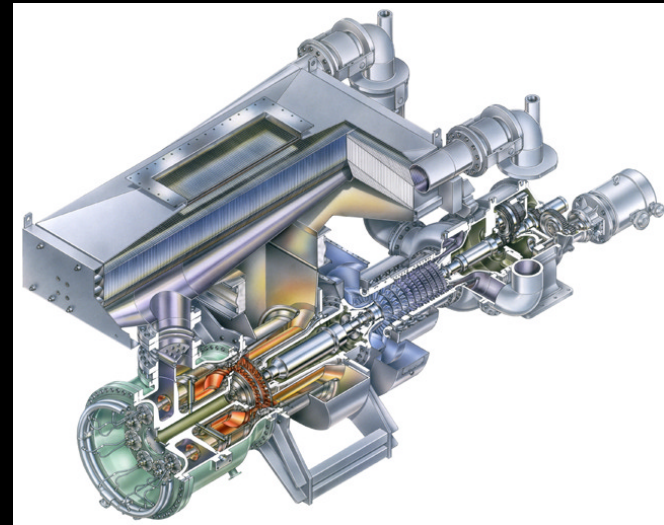
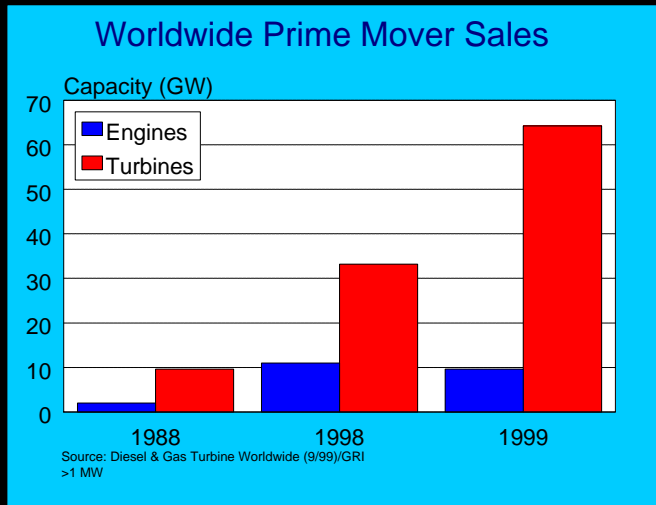

**William E. Liss**  
**GRI**

# Gas Turbine Market Situation - 1999

## HOT! HOT! HOT!

---

### ■ 1999 Was HOT!

- **“GAS TURBINES GALORE!”** Diesel & Gas Turbine Worldwide
- New Turbine Orders Soared To 64 GW
- 90-10 Rule:
  - 90% For Turbines >60 MW
- Over 80% of Turbine Orders Gas-Fired or Dual-Fuel Units
- Key North American Segments
  - 3.5 - 7.5 MW
  - 30-180 MW

# Worldwide Prime Mover Sales

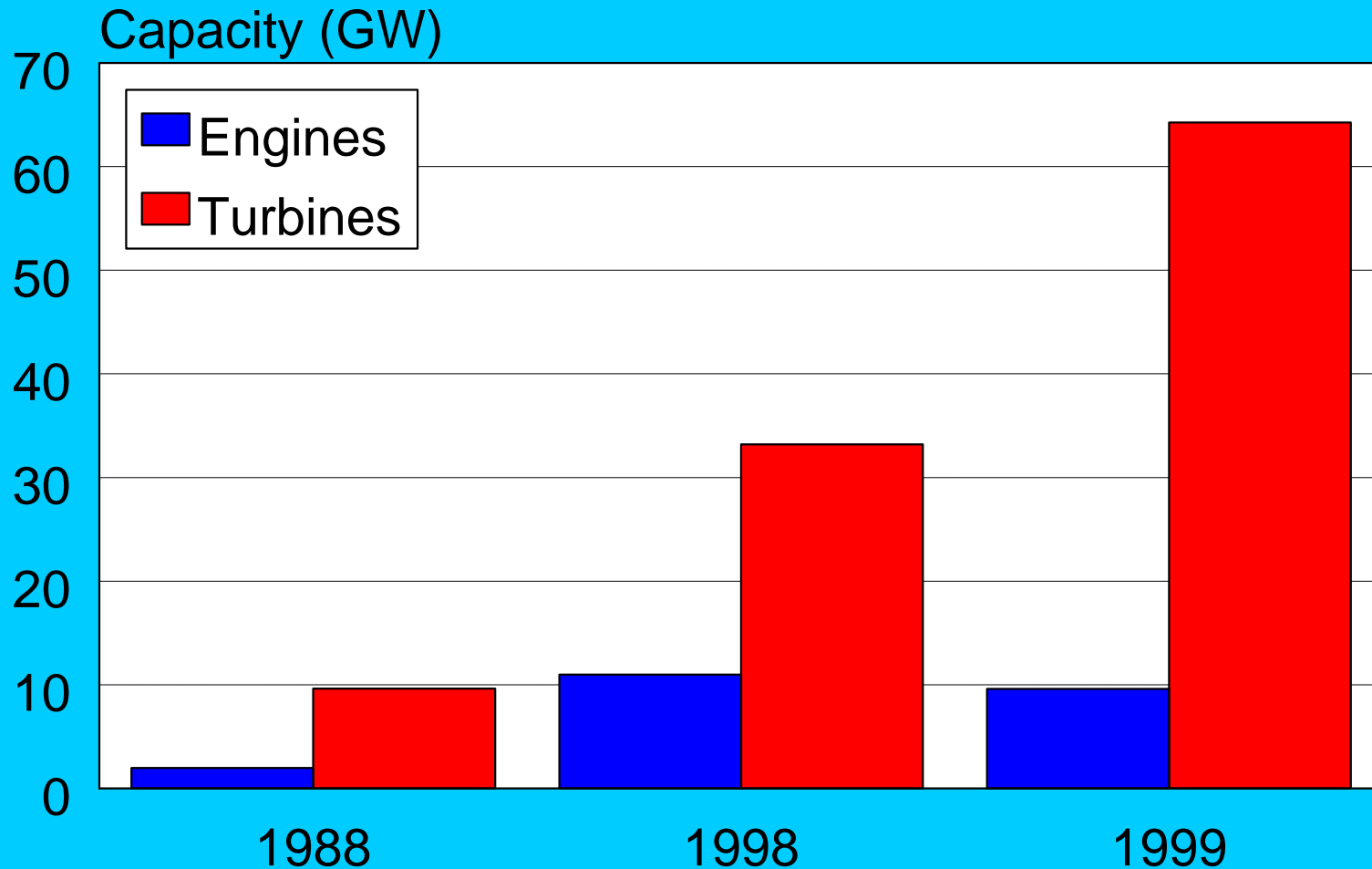

Source: Diesel & Gas Turbine Worldwide (9/99)/GRI  
>1 MW

# Worldwide Gas Turbine Orders

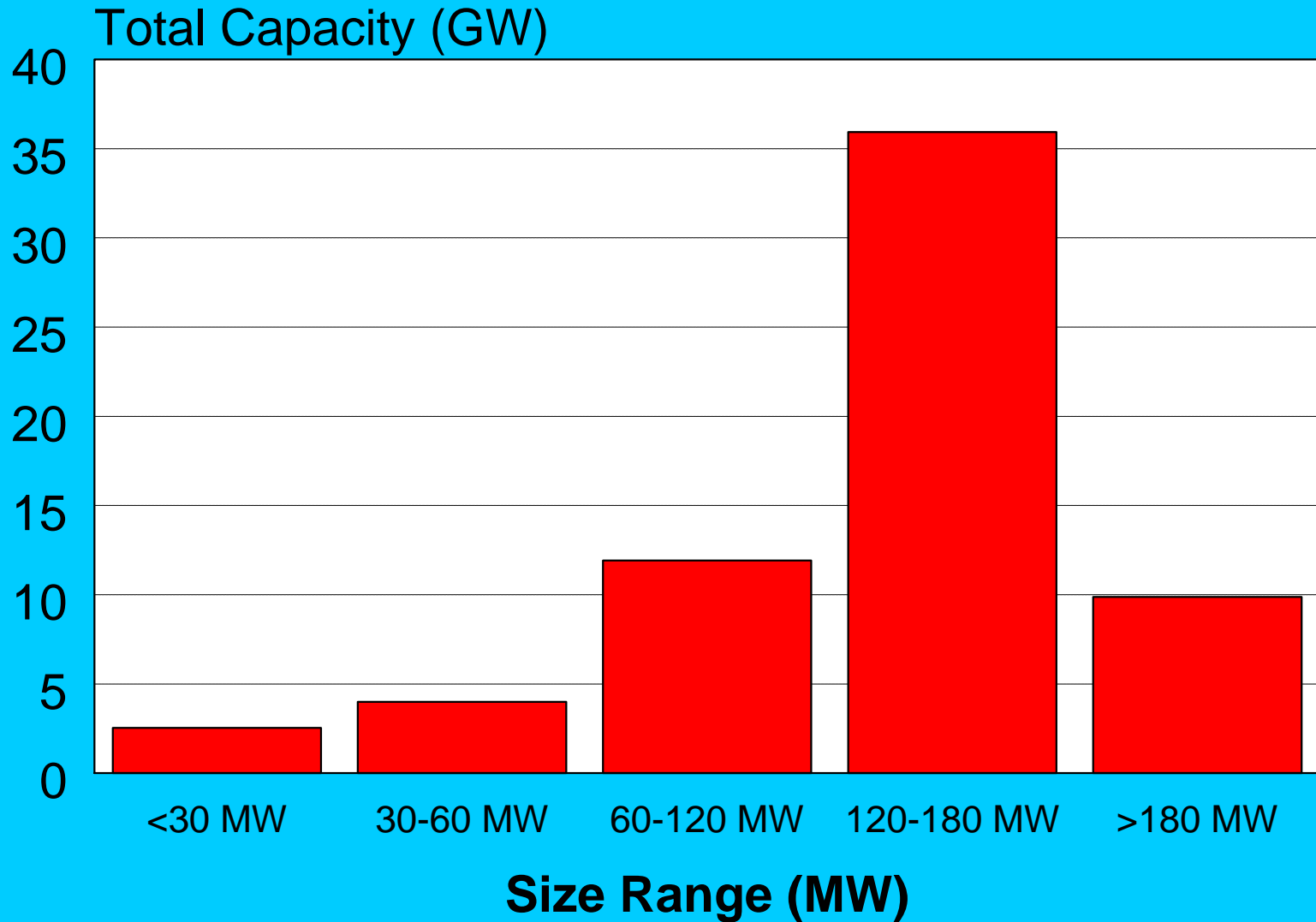

Source: Diesel & Gas Turbine Worldwide (10/99)/GRI

# GRI Gas Turbine Activities

---

- **Advanced Gas Turbine Project Development Software Released**
  - SOAPP CT.25 Program... Turbines Under 25 MW
  - Fully Integrated Analysis
    - Heat & Material Balance
    - Equipment Sizing
    - Cost Estimation
    - Financial Analysis
    - Scheduling, Reports
    - [see www.soapp.com](http://www.soapp.com)

The logo for SOAPP, featuring the letters 'SOAPP' in a bold, italicized, sans-serif font with a metallic or 3D effect.

# GRI Gas Turbine Activities

---

- **Completion of DLN Combustor Developments...  
All Commercially Available**
  - **Solar Turbines**
  - **Rolls-Royce Allison**
  - **General Electric**
  - Pending GE/GRI reports:
    - “Low NOx Gas Turbine Combustion Program”
    - “Field Testing of Automated Fuel Quality Monitors”
    - “Development and Testing of a Non-Optical Fuel Quality Monitor”
    - “Effects of Contaminants on Autoignition of Natural Gas”

# GRI Gas Turbine Activities

---

- **GRI Has Supported Catalytic Combustion For 15 Years**
  - Nearing Market Application
- **Working With Catalytica, DOE, CEC, and other Stakeholders**
  - Validating XONON Combustor
  - Supporting Application To Different Machines

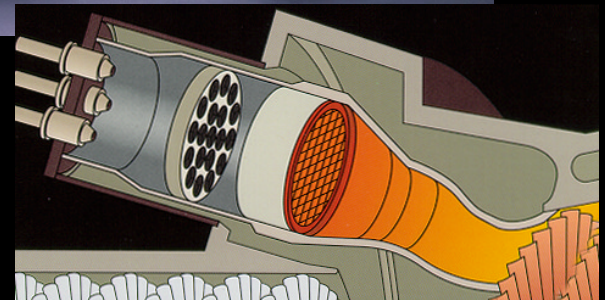

# GRI Gas Turbine Activities

- **Microturbine Products**
  - **NREC POWERWORKS**
  - Collaborative Effort With NREC/IR, SoCal Gas, NYGAS
- **Information Products - Joint EPRI/GRI**
  - Assessment of Recuperators For Microturbines & Industrial Gas Turbines
  - Assessment of Fuel Gas Booster Compressors
- **Microturbine Modified Delphi Market Research**
  - Input From Cross-Section of Industry Leaders





# Summary

---

- **Gas Turbines Are HOT!**
  - Prime Mover of Choice for Large Power Systems
- **Emission Signature Moving Forward**
  - DLN Combustion Technologies & Strategies
  - Next Generation? -- e.g., Catalytic Combustion
- **Key Market Issues**
  - Driving Down Cost...Increasing Specific Output
  - Inching Out Efficiency Improvements
  - Ensuring High RAM-D
- **Maintain Continued Federal Support for Turbines**

---

**William E. Liss**  
**Team Leader,**  
**Energy Conversion**

**GRI**  
**8600 West Bryn Mawr Avenue**  
**Chicago, Illinois 60631-3562**  
**Telephone: 773/399-8352**  
**FAX: 773/864-3551**  
**E-mail: [wliiss@gri.org](mailto:wliiss@gri.org)**

