

Log R40 DOT 973C Rec R-73-13 and 14
UNITED STATES OF AMERICA
NATIONAL TRANSPORTATION SAFETY BOARD
WASHINGTON, D.C.

ISSUED: April 25, 1973

Adopted by the NATIONAL TRANSPORTATION SAFETY BOARD
at its office in Washington, D. C.
on the 11th day of April 1973

FORWARDED TO:)
Honorable John W. Ingram)
Administrator)
Federal Railroad Administration)
Washington, D.C. 20590)

SAFETY RECOMMENDATION R-73-13 & 14

The National Transportation Safety Board developed evidence at the public hearing in Chicago, Illinois, during the week of December 4-8, 1972, concerning the design of the highliner cars. The cars referred to were manufactured by the St. Louis Car Division of the General Steel Industries Inc., and are owned by the Chicago South Suburban Mass Transit District. The Urban Mass Transportation Administration made a capital grant for a portion of the cost of these cars.

An analysis since the hearing indicates that the main vertical members (collision posts) in the highliner car involved in the collision of two commuter trains in Chicago, on October 30, 1972, did not meet the requirements of the Federal regulations. The conditions found indicate that the crash resistance of one collision post was reduced below the strength required by 49 CFR 230.457 and that this condition may exist in a number of other highliner cars. The Board believes, however, that this condition can be corrected.

It was disclosed at the hearing that there was incomplete fusion in about 75 percent of the weld attaching one collision post to the underframe. The collision post was secured to the underframe by a 1/2-inch-thick attachment plate, the bottom edge of which was beveled at a 45° angle for welding purposes. The depth of the bevel was only 5/16th of an inch instead of the full 1/2-inch thickness of the plate as originally designed and shown on the drawing. The

depth of the bevel did not provide access to permit welding over the full ½-inch thickness. In addition, only 25-percent fusion was achieved in the accessible area.

The possibility of not achieving a good weld with full penetration was quickly determined during the construction of the cars by the production department of St. Louis Car Division. The bevel was reduced in depth and an additional weld adjacent to the weld in the beveled area was added in an effort to compensate for any deficiencies of penetration. This effective design change was not, however, changed on the drawing. These factors are illustrated by the attached sketches based upon exhibits in evidence. The added weld is visible in this exhibit.

The added weld did not solve the problem. First, as can be seen in the sketch, the added weld material was distant from the location at which it could add to the strength of the weakest section. This section was limited by the 5/16-inch bevel. Second, the poor fusion at the weakest section could not be corrected by metal added to the outside of the plate.

Fusion to the full depth of the plate was assumed in the calculations for the collision posts based on the original drawing. Any reduction of cross section, such as that produced by the smaller bevel or poor fusion, would reduce the shear strength of the collision post to below the required 300,000 pounds.

It also appears that the welding design for the attachment of the collision post to the underframe relied upon assumptions not justified by documents of the current engineering practice. Specifically, the weld strength calculations made in allegedly meeting the Federal requirements assumed ideal welding conditions, whereas weaknesses of the actual conditions had been warned against in the American Welding Society's Welding Handbook, Sixth Edition, Section One, Paragraph 8.14. This paragraph states that joints made with single-bevel welds from one side:

- "1. Are difficult to obtain a sound weld due to one perpendicular groove face. Vee and U grooves are preferred.
2. * * * should not be used when tension due to bending is concentrated at the root of the weld or when subject to fatigue, impact loading or service at low temperature.

* * * * *

4. Strength depends on degree of joint penetration, which is usually less than the depth of chamfering.
* * *"

The reinforcing plate of the collision posts is attached to the underframe by welds of the type cited in the American Welding Society Handbook. A sound weld was not obtained in this case. The impact of a collision can subject these welds to severe bending stresses, as well as impact loading, both of which are warned against. The calculations assumed joint penetration to the full $\frac{1}{2}$ inch depth of chamfering, although this is not supported by the handbook.

It appears that the reduced bevel of the attachment plate and the use of a single-bevel welds from one side were features of the method employed in welding the collision post attachment plate to the underframe in many of the Highliner cars. The Board has examined samples of welds taken from another Highliner car and found the smaller bevel in one of two welds.

In summary, because of the design of the attachment weld, incomplete fusion in the welding process and a reduced cross section of weld are likely to be present in other cars. Further, the assumptions as to the strength of the weld, even if properly fused, could not be fulfilled by the bevel actually used in construction. The added weld did not solve either the reduced dimension of the bevel or the poor fusion. The assumption that the original design weld would be fully effective does not appear justified, since competent welding manuals have warned against the single bevel weld in joints subject to bending or impact conditions.

The effect of these shortcomings in terms of fatalities and injuries in this accident has not been determined. This crash also involved a mismatch between the physical features of the older and newer cars, and the collision posts might have carried away, even if at full strength. However, there should be assurance that all collision posts meet current FRA requirements, which are at present the only defined form of crash protection. This assurance probably cannot be provided by visual inspection because the original design assumptions were deficient. However, it appears that retrofitted changes such as the addition of welded reinforcement could assure that the requirements are met.

The Safety Board has not determined whether compliance with current Federal regulations would have provided strength sufficient to resist this crash. The analysis of the evidence in that regard and any resulting recommendations will be included in the Board's final report.

The problem of the inadequately attached collision posts does not imply that the cars are unsafe to be operated in the sense that a crash would be caused. It does, however, imply that crash resistance of many collision posts would be found substantially below that intended to be provided by

Federal requirements, and that crash resistance could be inadequate, should a crash occur.

The hearing disclosed that the FRA relies on the railroad companies to comply with the requirements dealing with the strength design of locomotives and MU cars. This accident raises the question of whether this reliance is effective and suggests that specific enforcement action by the FRA to insure that regulations are complied with may be necessary.

The National Transportation Safety Board recommends that the Federal Railroad Administration:

1. Review the current design of collision posts used on highliner cars and determine whether the attachments comply with the requirements of 49 CFR 230.457.
2. Take the necessary enforcement action to assure that highliner cars meet the requirements of 49 CFR 230.457.

These recommendations will be released to the public on the issue date shown above. No public dissemination of the contents of this document should be made prior to that date.

Reed, Chairman, McAdams, Thayer, Burgess, and Haley, Members, concurred in the above recommendations.

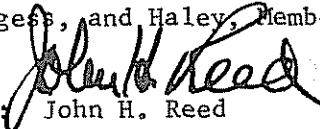
By: John H. Reed
Chairman

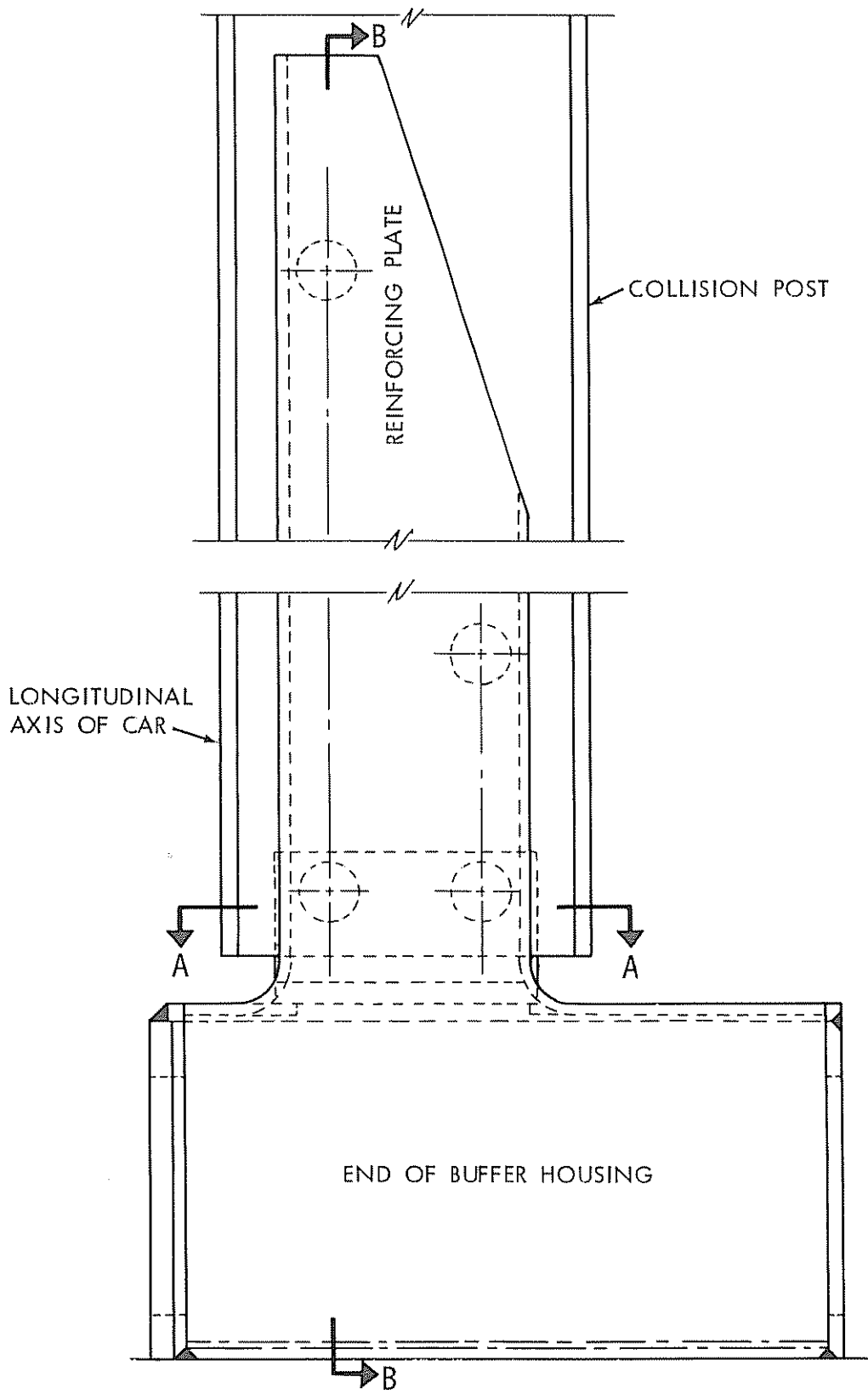

ELEVATION OF COLLISION POSTS
 ILLINOIS CENTRAL GULF RR CAR NO. 1509
 Figure 1

PLAN OF COLLISION POSTS
ILLINOIS CENTRAL GULF RR CAR NO. 1509

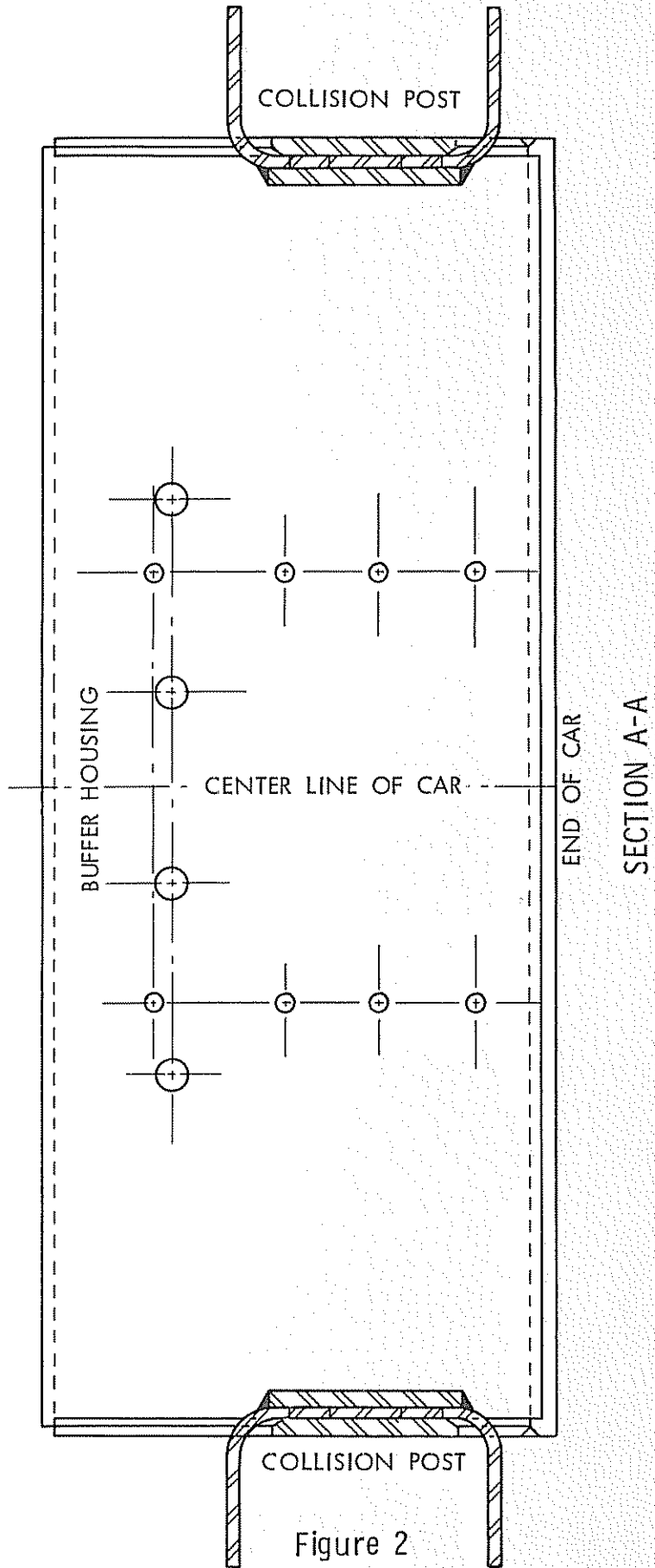
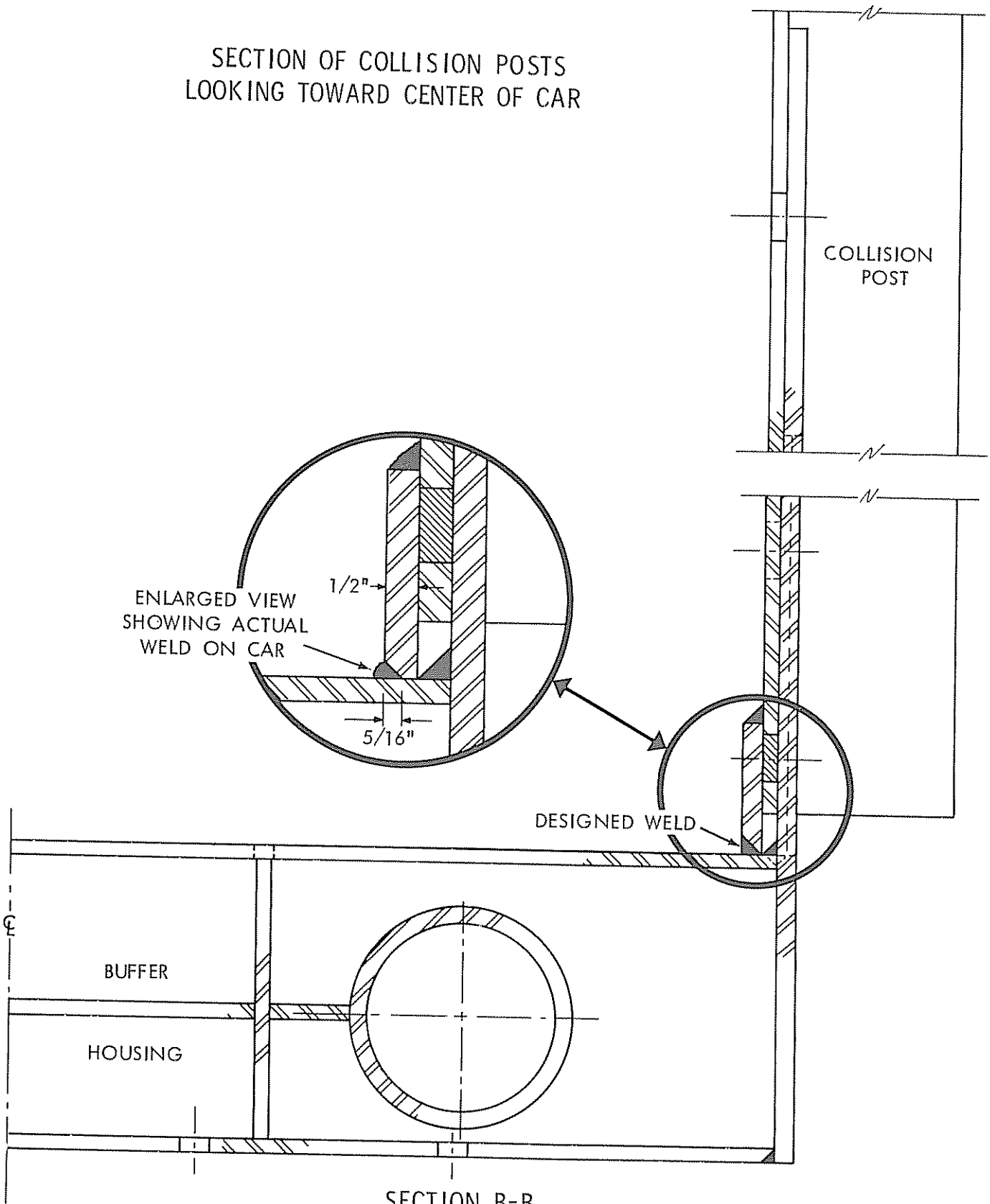

Figure 2

SECTION OF COLLISION POSTS
LOOKING TOWARD CENTER OF CAR



SECTION B-B
Figure 3