



National Transportation Safety Board

Washington, D.C. 20594

Safety Recommendation

Date: May 5, 1999

In reply refer to: A-99-32 through -34

Honorable Jane F. Garvey
Administrator
Federal Aviation Administration
Washington, D.C. 20591

On July 9, 1998, an Airbus Industrie A300B4-605R airplane, N80057, powered by two General Electric Aircraft Engines (GEAE) CF6-80C2A5 engines and operated as American Airlines (AA) flight 574, experienced a fire in the No. 1 (left) engine shortly after takeoff from San Juan, Puerto Rico. The flight crew declared an emergency, initiated the in-flight engine fire procedures, and returned to San Juan, where an emergency evacuation was performed and the fire was extinguished with the assistance of airport fire department personnel. Of the 252 passengers and crew members on board, 28 passengers received minor injuries during the evacuation. Flight 574 was conducted as a regularly scheduled passenger flight from San Juan to Miami, Florida, under the provisions of 14 Code of Federal Regulations Part 121.

Examination of the airplane revealed that the fire damaged the No. 1 engine's fan cowls, thrust reverser, core cowls, engine core compartment external to the engine cases, and the fire detection systems. The airframe experienced minimal heat damage that included wrinkling and blistering of the pylon and flap actuating fairing surfaces.

The investigation revealed that the flight crew received a No. 1 engine fire warning¹ shortly after takeoff and immediately retarded the No. 1 engine throttle. According to the flight data recorder (FDR), the fire warning ceased after 88 seconds. The flight crew subsequently selected the No. 1 engine's fuel lever to OFF and discontinued the engine fire procedures without discharging the fire extinguishing bottles.² During the airplane's final approach, the flight crew was unaware that the engine was still on fire until alerted by the flight attendants. After landing, the flight crew discharged the fire bottles.

¹ A No. 1 (left) engine fire is indicated in the cockpit by the illumination of the master warning, the left fire handle, the left engine fuel lever, one or more loop detection light(s), the left Electronic Centralized Aircraft Monitoring (ECAM) display of engine fire procedures, and a continuous chime.

² Retarding the affected engine throttle to idle and selecting the fuel lever to OFF are the first two steps in the AA in-flight engine fire emergency procedure. (The fuel lever closes the high pressure shut-off valve in the main engine control and effectively shuts down the engine.)

The Engine Fire

Examination of the engine revealed that all the accessory gearbox (AGB) adapter attachment bolt inserts had backed out, allowing fuel lines (cross-over tubes) to unseat from the adapter (See figure 1). This allowed pressurized fuel to spray onto hot engine parts and ignite, resulting in the nacelle fire. Examination of the adapter revealed that it had been reworked per GEAE Service Bulletin (SB) 72-743, which called for the installation of new adapter inserts to permit a higher and more consistent bolt torque that would improve the clamping interface and eliminate fuel leaks from the adapter cross-over tube interface.

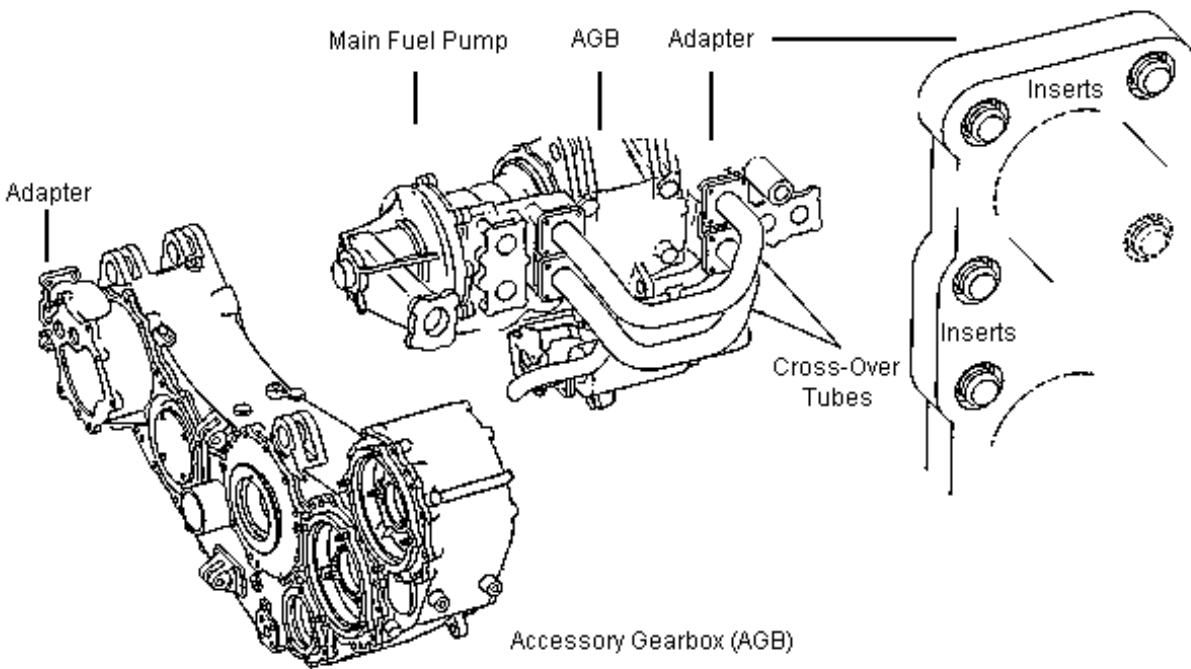

Figure 1. Accessory Gearbox Adapter Configuration and Insert Locations

GEAE issued SB 72-743 on August 25, 1994, and AA approved the SB for incorporation in March 1995; however, AA discovered in September 1995 that the replacement insert specified in SB 72-743 was much smaller than the hole, allowing it to slide completely through. AA notified GEAE of the error and an alternate insert was authorized, but GEAE did not revise the SB. AA issued Supplement 1 to its SB 72-743 instructions to specify the new insert in October 1995. Meanwhile, the incident adapter had already been reworked to the original SB. Motoren- und Turbinen-Union (MTU) in Hannover, Germany, reworked the incident adapter on September 26, 1995, but installed inserts different than those specified in the SB. However, as with the inserts specified in the SB, the inserts from the incident adapter were also too small for the

adapter holes and were not the correct thread pitch. Consequently, the insert threads did not have the proper engagement with the housing and allowed fuel leakage. MTU did not notify GEAE or AA of any difficulties in complying with the SB or of its installation of alternate inserts not specified in the SB.

Although the Safety Board's investigation continues, it supports the corrective actions taken by GEAE and the Federal Aviation Administration (FAA) after the incident to address the cause of the engine fire. Specifically, GEAE has issued two all operators wires (AOWs) to inform all CF6-80C operators of the San Juan incident, the investigation's findings, and GEAE's and FAA's planned follow-on actions. These actions include suspension of SB 72-743; advance notification of Alert Service Bulletin (ASB) 73-A283³ and SB 73-284; and advance notification of the FAA's plan to issue an airworthiness directive (AD). On January 6, 1999, the FAA issued AD 99-01-01 to require compliance with GEAE SB 73-284.

Notwithstanding these actions and because the fire detection systems on the A310 and A300-600 airplanes are similar, this incident raises broader concerns about the A300-600 and A310 fire detection systems and in-flight engine fire emergency procedures that the Safety Board believes the FAA should also take action to address.

Fire Detection System

The engine fire detection system in the A300-600 consists of two identical but independent (A and B) heat-sensitive fire loops and a fire detection control (FDC) unit. The fire detection loops for each engine are mounted in parallel and are located along the bottom of the engine between the aft fan case and the compressor rear frame. Each loop consists of a stainless steel tube containing helium and a hydrogen-charged core material connected to a responder assembly. The responder assembly contains two pressure switches — an alarm switch and an integrity switch — and is connected to the FDC unit via an airplane electrical harness, which triggers appropriate warnings in the cockpit when temperature limits are exceeded inside the nacelle.

Application of heat to the fire loop causes an increase in internal gas pressure, which acts on a pressure diaphragm inside the responder assembly. If the gas pressure within the loop increases sufficiently, the alarm switch is closed (See figure 2), and a fire signal is sent to the FDC unit. A pressure drop inside the loop because of a gas leak causes the integrity switch to open, sending a fault signal to the FDC unit. A loss of electrical continuity from the responder will also send a fault signal.

³ GEAE issued AOWs on September 11, 1998, and October 23, 1998, to inform customers of the incident and forthcoming documents and actions: ASB 73-A283, dated September 18, 1998, to provide instructions to inspect for rework marking and a data sheet to report all findings to GEAE; and SB 73-284, dated October 30, 1998, to provide rework instructions to replace inserts removed as a result of inspections from ASB 73-A283.

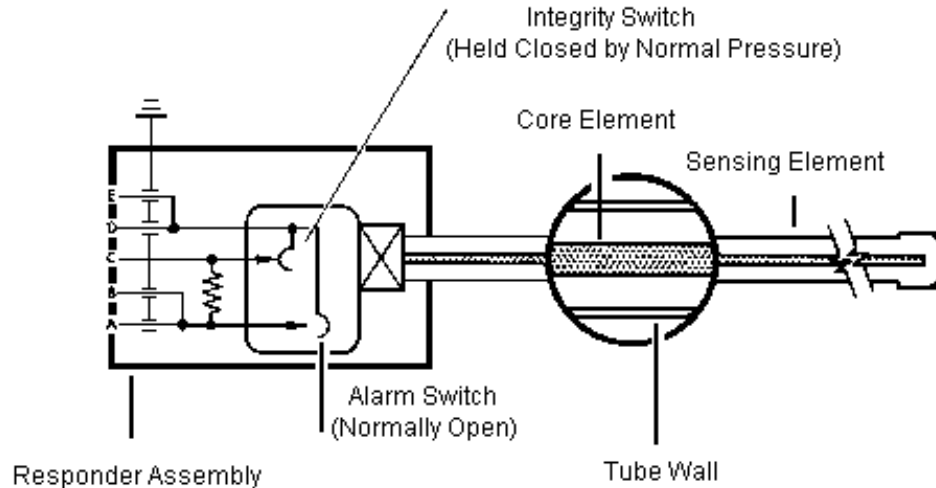

Figure 2. Internal Components of the Engine Fire Detection Loop Assembly

The FDC unit contains two electronic control circuit cards, one for each loop. Each card has two separate circuits: a fault circuit that interprets faults involving the fire loops or the associated electrical harness and a fire circuit that interprets the fire signal. The FDC unit triggers corresponding warnings in the cockpit.⁴

Operation of the fire loops is controlled by pushbutton switches located on the overhead panel in the cockpit. When both loops are selected ON,⁵ each loop must provide either an overheat or a fault signal to the FDC unit to trigger the fire warnings. If only one of the loops senses an overheat, a loop fault signal is generated. Additionally, if a loop failure occurs when a fire warning is active, the fire warning will cease, and a loop fault signal will be indicated. Should this occur, the faulty loop must be manually selected OFF to reacquire the fire warning.

Examination of the fire detection system from the incident airplane revealed extensive fire damage to the No. 1 engine's core wiring harness (loop B),⁶ which would have caused the loss of responder signal to the FDC unit. Because both loops were selected ON in the cockpit, the FDC unit would have interpreted the signal loss as a loop fault and consequently disengaged the fire warning and activated the loop fault warning in the cockpit.

To address the potential of a loop fault canceling a valid fire warning on A310 airplanes, Airbus reported that it was working on a possible SB that would provide a modification to the

⁴ A loop fault is indicated by illumination of the master caution and the respective loop detection light, left ECAM display of loop fault procedures, and a single chime.

⁵ Normal operation is with both loop switches ON.

⁶ The loop was tested and operated satisfactorily.

fire detection system on *all* A310 airplanes that would automatically arm the remaining loop for fire detection in the event of a single loop fault in the engines or auxiliary power unit (APU).⁷ Because the fire detection systems on the A310 and A300-600 airplanes are similar, Airbus also reported that it is working on issuing an SB to provide a similar modification for A300-600 airplanes. The A300-600 and A310 are the only Airbus airplane models with fire detection systems that are designed to trigger the fire warning only if both loops from the same engine detect the fire.

The Safety Board is concerned that, under circumstances similar to the San Juan incident, flight crews of A300-600 and A310 airplanes may be misled to believe that a fire has been extinguished when a fire warning is replaced by a loop fault. Therefore, the Safety Board believes that the FAA should issue an AD to require that all operators of Airbus A300-600 and A310 airplanes modify the engine and APU fire detection systems to automatically arm the remaining loop for fire detection in the event of a single loop fault in the engines or APU. Further, the Safety Board believes that the FAA should issue a flight standards information bulletin requiring principal operations inspectors to emphasize — 1) the importance of flight crews deactivating the faulted fire detection loop if an engine or APU fire warning changes to a loop fault and 2) the proper methods for identifying a failed fire detection loop — to all operators of Airbus A300-600 and A310 airplanes that have not been modified to automatically arm the remaining loop for fire detection in the event of a single fire detection loop fault in the engine or APU.

Flight Crew Procedures

The investigation of the San Juan incident also revealed inadequacies in the A300-600's in-flight engine fire emergency procedures. At the time of the incident, the in-flight engine fire emergency procedure in AA's A300 Operating Manual (which was based on the Airbus Flight Crew Operating Manual (FCOM) procedure) was as follows:

THROTTLE.....	IDLE
Pilot-flying will retard Throttle to idle. This procedure may be discontinued if fire warning disappears after the affected Throttle is retarded.	
FUEL LEVER (on Captain's command).....	OFF
Pilot-not-flying will position the Fuel Lever OFF.	
FIRE HANDLE (on Captain's command).....	PULL
1 st AGENT (after 10 sec).....	DISCH
Pilot-not-flying will pull the Fire Handle.	
■ If fire after further 30 sec:	
2 nd AGENT.....	DISCH
LAND ASAP	
SINGLE ENG OPER PROC (ENG 6).....	APPLY

⁷ Airbus has already issued a similar SB that applied only to a single operator that requested the modification.

The FDR from the incident airplane indicated that the No. 1 engine throttle was retarded within seconds of the fire warning and that the engine fire warning ceased after 88 seconds. However, 2 seconds more had elapsed before the flight crew moved the No. 1 engine fuel lever to the OFF position. Although AA's engine fire emergency procedure clearly stated that the fire procedure could be terminated if the fire warning ceased before the fuel lever is selected OFF, it did not specify the amount of time the flight crew should wait for the fire warning to cease before selecting the fuel lever to OFF.

In an August 20, 1998, telex message to all A300-600 and A310 operators, Airbus reiterated the need for immediate crew action following an engine fire warning. Airbus stated that crew action should only be delayed for the duration necessary to properly stabilize the airplane but did not specify how long the flight crew should wait for the fire warning to cease after the throttle has been retarded to idle before continuing with the remainder of the procedure.⁸

In October 1998, Airbus revised the A300-600 and A310 FCOM's engine/APU fire procedure to include a note that the fire handle must be pulled if the fuel lever is selected OFF but still retained the provision to discontinue the fire procedure if the fire warning disappeared after the affected throttle is retarded and before the fuel lever is selected OFF. The FCOMs included supplemental text that stated that setting the throttle to idle could resolve fire warnings caused by hot bleed air leaks. Following the incident, AA modified the A300-600 in-flight engine fire procedure in its operating manual to delete the provision for discontinuation of the procedure if the warning disappears after the affected throttle is retarded, thereby requiring that flight crews complete all steps up to the discharge of the first extinguishing agent any time a fire warning appears.

The Safety Board notes that AA's revised A300-600 and A310 in-flight engine fire procedure might result in unnecessary engine shutdowns because of fire warnings related to hot bleed air leaks or false warnings.⁹ An unnecessary engine shutdown (and loss of associated electrical, hydraulic, and pneumatic systems) could adversely affect the continued safe operation of the airplane, especially during extended over-water routes often flown by this type of airplane. The Safety Board is also concerned that engine and APU fires may not be adequately and timely addressed because, as discussed above, flight crews are not provided with a specific amount of time indicating how long they should wait for the fire warning to cease after retarding the throttle. Therefore, the Safety Board believes that the FAA should require that Airbus include supplementary information to the in-flight engine fire procedure specified in the A300-600 and A310 FCOMs that indicates an appropriate amount of time flight crews should wait after the throttle is retarded to idle before the fuel lever is selected OFF and that all operators of A300-600 and A310 airplanes adopt the new Airbus in-flight engine fire procedure.

⁸ Airbus is currently evaluating the adequacy of the current FCOM procedure.

⁹ Data provided by Airbus showed that only 2 of the 20 documented cases of engine fire indications in A300 and A310 airplanes between January 1996 and July 1998 were attributed to an actual fire. Thirteen were attributed to hot bleed air leaks and five were determined to be false warnings.

Therefore, the National Transportation Safety Board recommends that the Federal Aviation Administration:

Issue an airworthiness directive to require that all operators of Airbus A300-600 and A310 airplanes modify the engine and auxiliary power unit (APU) fire detection systems to automatically arm the remaining loop for fire detection in the event of a single loop fault in the engines or APU. (A-99-32)

Issue a flight standards information bulletin requiring principal operations inspectors to emphasize — 1) the importance of flight crews deactivating the faulted fire detection loop if an engine or auxiliary power unit (APU) fire warning changes to a loop fault and 2) the proper methods for identifying a failed fire detection loop — to all operators of Airbus A300-600 and A310 airplanes that have not been modified to automatically arm the remaining loop for fire detection in the event of a single fire detection loop fault in the engine or APU. (A-99-33)

Require that Airbus include supplementary information to the in-flight engine fire procedure specified in the A300-600 and A310 Flight Crew Operating Manuals that indicates an appropriate amount of time flight crews should wait after the throttle is retarded to idle before the fuel lever is selected OFF and that all operators of A300-600 and A310 airplanes adopt the new Airbus in-flight engine fire procedure. (A-99-34)

Chairman HALL, Vice Chairman FRANCIS, and Members HAMMERSCHMIDT, GOGLIA, and BLACK concurred in these recommendations.

By: Jim Hall
Chairman