

WATER OPERATION AND MAINTENANCE

BULLETIN NO. 161

September 1992



LAST COPY - DO NOT REMOVE

IN THIS ISSUE

- California Municipalities Battle Drought
- Pit Stop for Power Washers
- Crack Repairs in Concrete Structures
- Repair Welding of Cast Irons
- Where Do You Put That Fence?
- Repair and Control of Chronic and Acute Canal Leakage/Seepage
- Algae Identification in Irrigation Systems
- Conveyor Belt Material Provides Sealing Surface to Bulkhead Gate
- Managing Moles
- The Stubble Maker
- Hoover Dam

LAST COPY - DO NOT REMOVE

**UNITED STATES DEPARTMENT OF THE INTERIOR
Bureau of Reclamation**

The Water Operation and Maintenance Bulletin is published quarterly for the benefit of those operating water supply systems. Its principal purpose is to serve as a medium of exchanging information for use by Bureau personnel and water user groups for operating and maintaining project facilities.

While every attempt is made to insure high quality and accurate information, Reclamation cannot warrant nor be responsible for the use or misuse of information that is furnished in this bulletin.

* * * * *

Ferne Studer, Managing Editor
Bill Bouley, Technical Editor
Operations and Maintenance Engineering Branch
General Sciences Division
Denver Office, Code D-5850
PO Box 25007, Denver CO 80225
Telephone: (303) 236-8087



Cover photograph:

Hoover Dam, Boulder Canyon
Project, Nevada/Arizona.

Any information contained in this bulletin regarding commercial products may not be used for advertisement or promotional purposes and is not to be construed as an endorsement of any product or firm by the Bureau of Reclamation.

CONTENTS
WATER OPERATION AND MAINTENANCE BULLETIN

No. 161

September 1992

	Page
California Municipalities Battle Drought	1
Pit Stop for Power Washers	3
Crack Repairs in Concrete Structures	7
Repair Welding of Cast Irons	9
Where Do You Put That Fence?	19
Repair and Control of Chronic and Acute Canal Leakage/Seepage	22
Algae Identification in Irrigation Systems	31
Conveyor Belt Material Provides Sealing Surface to Bulkhead Gate	33
Managing Moles	34
The Stubble Maker	39
Hoover Dam	42

CALIFORNIA MUNICIPALITIES BATTLE DROUGHT¹

With the drought continuing to deplete municipal water supplies throughout California, numerous cities have eliminated unnecessary water waste by installing linestopping machines from Hydra-Stop, Inc., Blue Island, Illinois. These machines create a bubble-tight seal to control waterflow, enabling repairs by isolating sections of pipe without having to drain many feet of pipe or cut off water supplies to customers.

According to Mark Carney of the Los Angeles County Department of Public Works:

“We purchased our Hydra-Stop unit approximately 2 years ago to replace existing valves, or where none existed, to install a valve without disrupting water service to the customer. Now with California in the fifth year of a drought, we find an additional benefit from our unit. We do not have to drain hundreds of feet of main, or in some cases blocks, to do our work. We also, because it is not drained, do not have to chlorinate and flush these same long distances, saving even more water. The districts are now also using the unit to minimize water loss in conjunction with contractors and developers working on our systems.”



Utilities doing their part during drought.—Water works crews throughout California, such as this one in Palo Alto, are making water pipeline repairs without loss of water by using Hydra-Stop linestopping machines to create a bubble-tight seal and isolate sections of pipe for maintenance.

Increases in population and erosion put a constant strain on water distribution systems. Most demand regular maintenance and pipeline alterations and extensions to meet consumer needs. While it saves water, the unit also saves money by minimizing service

¹ Reprinted with permission from the Associate Editor, Public Works, November 1991 issue.

disruption. Down water lines mean limited fire protection, the added public expense of nighttime repair crews, potential contamination and backflow problems, and liability risks for the city.

PIT STOP FOR POWER WASHERS¹

by Larry Reichenberger

(Most portable washers don't have ground-fault circuit interrupters. Retrofitting yours could save your life.)

High-pressure washers that are so handy in the farm shop or livestock barn can quickly turn deadly. "At least 10 people have been electrocuted by spraying into electrical enclosures or by shocks resulting from a failed electrical component," says ag engineer LaVerne Stetson.

Retrofitting your power washer with a ground-fault circuit interrupter (GFCI) is easy and "would have invaluable life-saving potential," says Stetson, who works at USDA's Agricultural Research Service in Lincoln, Nebraska.

Electrical safety begins with proper grounding of power cords and receptacles and proper sizing of circuit breakers. "However, even with these standard safety features, shocks and electrocutions can occur and that's why a GFCI is needed," Stetson explains.



LaVerne Stetson shows GFCI's, from left: 230-V circuit breaker, 20-amp cord set, inline GFCI receptacle, 20-amp duplex cord or 15-amp cord set. Upper right: 37-ft GFCI cord from Leviton Mfg. Co. (1-800-323-8920), should be hard-wired into the washer for best shock protection.

¹ Reprinted with permission from the Managing Editor, Farm Journal, 230 Washington Square, Philadelphia PA 19105, November 1991 issue.

GFCI's detect differences between the current supplied to a load and the current returning from that load. A difference in the two means electrical current has "leaked out" of the normal circuit path and a shock could result.

Safety experts measure electrical currents in milliamps (mA), which are 1/1,000ths of an amp. A current of 7 to 10 mA through a person's muscles prevents them from releasing an object. About 70 mA can be fatal. GFCI's open an electrical circuit, cutting off power, when leakage goes above 5 mA.

Most power washers are not equipped with GFCI's. In 1987, a section was added to the National Electrical Code requiring them on all new washers. However, when Jerry Bodman, Extension engineer at the University of Nebraska, surveyed the many power washers displayed at the 1990 World Pork Expo, he found only one manufacturer offered GFCI's as standard equipment, and then on only some models. Others had GFCI's available only as options, and none had them listed in their product literature.

In addition, the vast majority of older units already on farms are not equipped with GFCI's. This led Stetson and Bodman to concentrate on retrofitting the safety devices.

"Most portable power washers are rated at 125 V or less and have a 1-hp or smaller motor," says Stetson. "To retrofit GFCI protection, the best approach is to replace the power cord with a GFCI cord. These cords have a GFCI unit permanently wired into them. This way the device stays with the washer at all times. They're rated at 15 amps, and you can expect to pay from \$75 to \$125 for them. The cords are new, and may be ordered directly from an electrical supply house or through your local electrician."

"Another choice would be to mount a 15-amp GFCI receptacle on the frame of the power washer. This ensures that the GFCI stays with the unit," says Bodman. "Install the GFCI receptacle in a weatherproof, nonmetallic box with a watertight cover and wire the cord supplying power to the motor directly to it. Use weatherproof connectors or liquid-tight flexible conduit between the box and the motor, and use only cord labeled type SEO for good sunlight and chemical protection—do not use cords labeled type SJEW. Cost: \$50."

GFCI cord sets, available in lengths from 2 to 25 feet are another option, though Bodman worries these can get misplaced. Cord sets simply plug into the power washer cord at one end and the electrical source at the other. They are rated at 15 or 20 amps and sell for \$25 to \$50 at farm supply stores, electrical supply houses, or through your local electrician.

For larger power washers, those with motors above 1 hp at 115 V or ratings of 230 V, the best GFCI devices are circuit breakers. These range from 15 to 60 amps and are selected based on the motor size and voltage of the washer, as shown in the table. "These circuit breakers should be mounted in an enclosure made for either a 1- or 2-pole breaker," says Stetson. "Mount this breaker assembly into a nonmetallic, watertight enclosure fastened to the portable washer. These boxes are larger, so if you can't attach them to the washer, and the washer is used only in one location, mount them on a wall near the outlet."

Power washer retrofittings

Power washer		GFCI	
Voltage	Power (hp)	Rating (amps)	Type*
115	1/2	15-20	C,R,B
	1	20-30	C,R,B
	2	25-30	B
230	1	15-20	B
	2	15-30	B
	3	20-40	B
	5	30-60	B
	7-1/2	40-60	B

*C = GFCI cord,
 R = GFCI receptacle,
 B = GFCI circuit breaker.

This table gives the recommended type and amp rating for retrofitting GFCI's to various sizes of power washers. For any voltages from 110 V to 125 V use the 115-V recommendation and for 220 V to 240 V use the 230-V rating.

Protect your well from "backsiphon"

Pressure washers post impressive numbers on the output side—up to 3,000 lb/in² for some models. However, it's what happens on the input side that has caught the eye of some health experts.

"To many people's surprise, we've found that pressure washers cause suction in the water-supply system that feeds them," says Wisconsin Division of Health milk certification specialist Jim Wickert. "That's a potentially hazardous situation because it creates a negative pressure that could allow contamination to enter the water system."

Such a situation could arise if the farmstead well were to fail while a pressure washer was in use, Wickert says. The washer would continue to draw water from the well's pressure tank and from other supply lines on the farm. If a hose on a distant water hydrant were lying in a spray tank, chemicals from the tank could be sucked out and into the water system.

While admitting the odds of such an occurrence are slim, Wickert says the health and financial implications are huge. "Farmers would be well advised to protect themselves. In fact, such protection is required by the Food and Drug Administration on all Grade A dairy farms."

There are basically three ways to prevent the pressure washer from causing backsiphoning, says Wickert. "One obvious way is for the pressure washer to be on a separate water system.

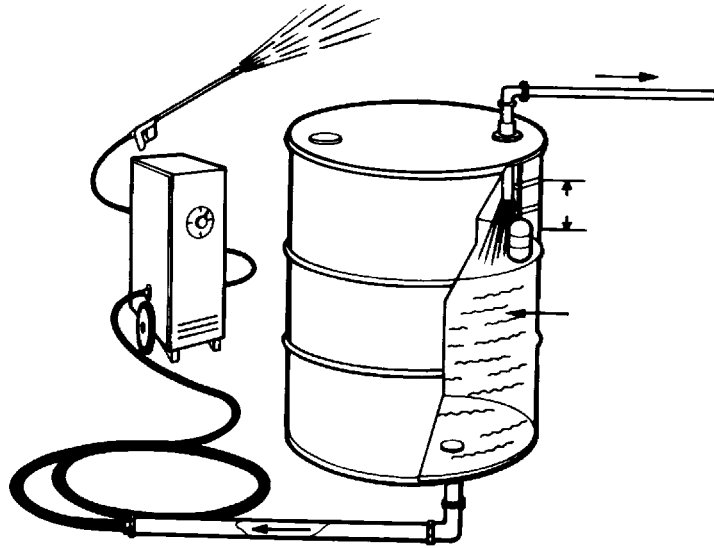

An air gap should be maintained in the water reservoir that supplies a power washer. This protects the main water system from contamination caused by backsiphoning.

"A second method is to build a simple water reservoir to feed the pressure washer while isolating it from the rest of the water system. This is probably the best approach and some new pressure washers are already equipped with internal reservoirs." The diagram details this approach. It uses a 55-gallon drum as the reservoir. A float near the top maintains the water level below the inlet from the water system. The resulting "air gap" ensures no siphonage can occur.

A third method is to install a low-pressure cutoff switch immediately upstream on the suction side of the pressure washer. "This switch cuts off power to the pressure washer when water pressure in the supply line drops below a certain level," says Wickert.

CRACK REPAIRS IN CONCRETE STRUCTURES¹

Economic Times Dictate Change

Concrete irrigation structures, unlike fine wine, do not get better with age. Usually it's the opposite, with age, cracks begin to appear and must be repaired if deterioration is to be slowed. For 10 years, the Bow River Irrigation District (BRID) has been contracting out to private industry to have cracks in their structures injected with Sika Canada Inc. epoxy. Results have been good.

Now, in what district engineer Steve Topping calls a "cost-saving venture," they have gone ahead and purchased their own epoxy injection equipment and had their ditchrider staff trained in injection practices and safety. Total cost for equipment and training was \$9,885. Since shutdown of the irrigation system in October, Topping says their three-man crew has been repairing three to four structures a week.

Repair begins by sandblasting the area around repairable cracks. Cracks that are larger than the width of a pencil cannot be sealed using Sikadur 35 Hi-Mod LV[®] resin, says Topping (large cracks must be routed out and filled with Sika-flex 1a[®]). If a crack appears to go right through the wall of a structure, the district often removes the earth backfill to expose the crack from both sides. The repair crew hoards the structure by draping plastic tarps over the walls and a portable propane heater is installed.

Next, says Topping, the repair crew applies a gel paste (Sikadur 31[®]) on the wall and over the crack. When this hardens overnight, it prevents the epoxy from leaking from the crack. During this process, injection ports are installed every 300 mm (approximately 1 foot) along the crack.

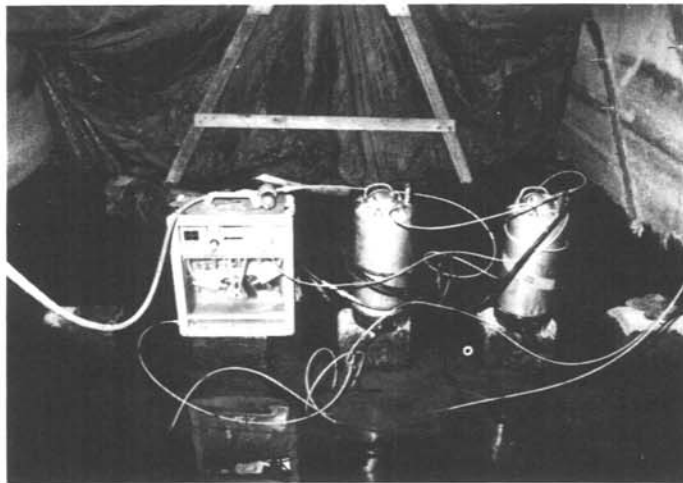

Injection pump with resin canisters.

Pressure-injection begins at the bottom of the crack. The epoxy resin is pumped through a special pump (made by Lily Corporation) and is injected until it begins to bleed out

¹ Reprinted with permission from the Editor, Water Hauler's Bulletin, Alberta Agriculture, Lethbridge, Alberta, Canada T1J 4C7; Winter 1992 issue.

of the next injection port immediately above. Two or three cracks can be simultaneously injected. Curing, says Frank Laquinta, technical representative with Sika Canada Inc., should take place for 24 hours at 10 °C. After curing, the hardened gel paste is ground off for esthetic purposes.



Dave Nolan of the BRID points to resin beginning to bleed from crack.

In addition to the crack repair, says Topping, two steel struts are fabricated and installed between the walls (above the water level) to reduce tension. We also pour a new basin and blocks if the structure requires it, he adds.

Costs to repair a structure are running between \$4,100 and \$5,550. These include fabrication and installation of the steel struts, labor, materials, machine time, and miscellaneous appurtenances. Topping estimates the district savings are about 50 percent. A substantial saving comes from the fact that the repair crew lives in the area and does not need to charge out travel and accommodation. Another economic benefit to the three ditchriders is that they have year-round employment.

The BRID feels that by yearly inspection and maintenance of their concrete structures and repairing any visible cracks that appear, will pay big dividends in years to come when many extra years of service are gained. We estimate we can get an additional 20 years' life out of a structure for an investment in maintenance of about 10 percent of its capital cost, concludes Topping.

For more information, please contact Steve Topping, P.Eng., District Engineer, Bow River Irrigation District, PO Box 140, Vauxhall, Alberta T0K 2K0; telephone (403) 654-2111.

REPAIR WELDING OF CAST IRONS

by Joseph P. Martino, P.E.¹

1. Introduction

If you have ever tried to weld cast iron using traditional methods for mild steel, then you have probably experienced one of the major difficulties associated with this process, which is post-weld cracking of the parent material adjacent to the weld itself along the fusion zone. This problem is of much concern because the seemingly simple task of repairing a crack in a casting can become a relatively complex job when the crack caused by the weld repair is worse than the initial one. Often, maintenance personnel are reluctant to take on such a repair for this very reason. However with the proper weld rod selection, technique, and a little patience, a successful repair can be made with quality and consistency time after time. The two main problems associated with welding cast irons are their small thermal expansion coefficients and large amounts of free carbon (graphite).

This article will outline the basic types of cast irons and how to identify them, electrode selection for use in shielded metal arc welding (SMAW), joint preparation, weld procedure, and brazing. As with any welding process, proper safety procedures should always be followed. The Bureau of Reclamation's *Construction Safety Standards* [1]², section 21, or other standards, as applicable should be consulted whenever safety questions arise.

2. Types of Cast Irons

The term *cast irons* is used to describe a large family of ferrous alloys which normally contain between 2 and 4 percent carbon, more than 1/2 of 1 percent silicon, and are not malleable at any temperature. All cast irons flow easily in their liquid state during manufacturing processes and remain liquid for a long time during cooling. As a result, they are generally used to cast intricate shapes at a reasonable cost and require a minimum of machining to produce the final product. Cast irons are rarely used as structural members except those loaded only in compression.

Although many types of cast irons have been utilized over the years, only four major types were and are most widely used in industry. These include *white*, *gray*, *malleable*, and *ductile (nodular)* cast irons. One other type of material that was widely used throughout the United States prior to World War I is known as semi-steel. Its properties most closely resemble those of gray cast iron.

White cast iron.—White cast iron is a particularly hard material, produced by pouring molten metal against metal or graphite cooling surfaces which have been inserted in the mold. Because the material is rapidly cooled during this process, much of the carbon remains in solution rather than precipitating out as free carbon. The resulting structure contains a high amount of iron-carbide which is very hard and brittle.

¹ Joseph P. Martino is a Mechanical Engineer, Facilities Engineering Branch, Bureau of Reclamation, Denver, Colorado.
² Numbers in brackets refer to references at end of article.

White cast iron is a hard, wear-resistant material that is extremely brittle and difficult to machine. It is very difficult to weld and takes on a silvery-white appearance when fractured. Fortunately, it is most often heat treated to produce malleable cast iron and is rarely used as cast.

Malleable cast iron.—Malleable cast iron is produced by annealing white cast iron at a temperature above 1600 °F for periods greater than 6 hours. The resulting structure contains free carbon in the form of irregularly shaped graphite nodules. This new structure gives malleable cast iron greater tensile strength, ductility, and toughness when compared with white cast iron.

Malleable cast iron is widely used in parts such as plows, scrapers, earth-moving equipment, pipe fittings, automotive crankshafts, transmission parts, connecting rods, and universal joints. Its weldability and machinability is much greater than that of white cast iron, but still requires care in order to produce a sound, crack-free weld.

Gray cast iron.—When cast iron is cooled slowly, carbon will precipitate out of the solution to form graphite flakes at the grain boundaries. This process is used to make gray iron castings. Gray cast iron usually contains about 0.8 percent combined carbon, with the remainder in the flake graphite form. It is this flake graphite that gives this material its gray surface appearance and contributes to its low toughness and ductility.

Gray cast iron is the most frequently used material of the cast irons and the most likely to be encountered by the repair welder. It is widely used in the automotive industry for parts such as engine blocks and heads, differential housings, pump housings, and brake drums. It is also frequently used for the bases of machinery such as grinders and lathes because of its vibration and damping characteristics. With the proper joint preparation and interpass temperature, very good weld repairs can be performed on gray cast iron.

Ductile cast iron.—Ductile cast iron, also known as nodular cast iron, also contains free graphite, but in the form of small spheroids. The spheroidal graphite structure is produced by adding small amounts of magnesium, aluminum, or cerium (or other rare earths) to certain molten gray iron compositions. This structure helps improve the toughness and strength of this material over that of gray cast iron. Ductile cast iron has properties similar to those of cast steel but with the low cost, the wear resistance, and the damping characteristics of cast iron.

Table 1.-Compositions of cast irons (% of constituents)[2].

	Fe	Total C	Si	S	P	Mn
Gray iron	Balance	2.0-4.0	1.0 min	0.2	0.6	1.0 max
Malleable iron	Balance	2.0-3.0	0.9-1.8	0.2 max	0.2 max	0.25-1.25
Ductile iron	Balance	3.2-4.1	1.8-2.8	0.03 max	0.01 max	0.80 max
White iron	Balance	2.5-4.0	0.4-1.6	0.15	0.4	0.3-0.8

[Fe = iron, C = carbon, Si = silicon, S = sulfur, P = phosphorus, Mn = manganese]

Table 2 below shows how to readily field identify the types of cast iron utilizing an ordinary grinder and observing the resulting spark stream.

Table 2.-Cast iron identification[3].

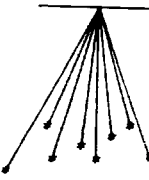
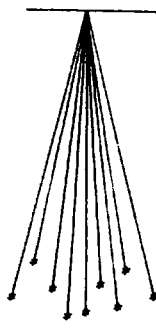
	White cast iron	Gray cast iron	Malleable cast iron
			
Spark stream	Very small volume stream with only a few small, repeating sparklers.	Small volume stream with many small, repeating sparklers.	Moderate volume stream with long shafts that end in many small, repeating sparklers.
Chip appearance	Small, broken fragments.	Can chip a fairly smooth groove, but chip size small (1/8 inch).	Longer, more ductile, less easily broken chips (1/4 - 3/8 inch).
Surface appearance	Fractured surface: silvery-white. Unfinished surface: dull gray. Machined surface: not generally machined.	Fractured surface: dark gray. Unfinished surface: very dull gray. Machined surface: light gray.	Fractured surface: dark gray. Unfinished surface: dull gray. Machined surface: light gray.

3. Electrode Selection

The most frequently used method for the repair of cast irons that consistently yields the best results is the Shielded Metal Arc Welding (SMAW) method. The remainder of this article will focus on this method, although a short section on brazing is also

presented. This section contains a discussion of the consumables or weld rods used for repair of cast irons. Specific rod designations and compositions are available in the American Welding Society (AWS) Specification A5.15, "Welding Electrodes and Rods for Cast Iron" [4]. A variety of covered electrodes are available for SMAW of iron castings. Availability, economic considerations, and weld requirements will help determine the best product for each application.

The AWS classifies covered electrodes using a cast iron rod as the core material as *ECI*. They are relatively inexpensive and produce a weldment with chemical and physical properties similar to those of the base metal. Color match is excellent. Among the disadvantages of this type of rod is that ease of operation is marginal and proper procedures must be strictly adhered to in order to avoid brittle or cracked weldments. Graphite flakes or spheroids can also form in the weld upon cooling and the ductility of a repaired malleable or ductile iron casting may be less in the weld area than that of the parent metal. These rods are usually used on small parts such as sprockets, brackets, and levers which can be easily preheated and welded on a work bench and usually require no subsequent machining. Rods with steel cores which produce similar results are designated as *ESi*. They are usually of somewhat better quality because they are manufactured using an extrusion process.

Because of their widespread availability, low cost, ease of operation, and excellent color match, low-hydrogen types of electrodes; e.g., *E7018* and *E7028*, are also used for welding iron castings. Use of these electrodes on cast iron produces a high carbon content weld which is hard, brittle, and crack sensitive. As a result, these products are normally used only for cosmetic surface repairs in non-structural areas where subsequent machining is not required.

Nickel-based electrodes have become widely accepted for use with iron castings. Unlike iron, nickel has a low solubility for free carbon in the solid state. As a result, carbon precipitates to the grain boundaries upon cooling causing the actual weld bead to increase slightly in volume. This helps to reduce thermal stresses in the fusion zone of the non-ductile parent material. Electrodes classified as *ENi-CI* use a core of commercially pure nickel and thus deposit a weld of high nickel content. This weld will remain ductile and machinable even when diluted by the base metal. *ENiFe-CI* electrodes have a steel core with an outer layer of nickel which makes up 45-60 percent of the rod composition. These electrodes have several advantages over the mostly nickel electrodes:

- The deposits are stronger and more ductile making the product suitable for higher strength gray and ductile irons.
- Nickel-iron deposits are more tolerant of phosphorus than pure nickel; therefore, *ENiFe-CI* electrodes are preferred for welding gray iron casting with a high content of phosphorus.
- The thermal coefficient of expansion is less for the nickel-iron mixture than that of pure nickel so *ENiFe-CI* electrodes are better suited for welding larger sections of material. The lower expansion coefficient helps prevent fusion-line cracking due to expansion differences in the consumable and parent metal.
- *ENiFe-CI* electrodes are less expensive than *ENi-CI* electrodes.

Welding electrodes for SMAW of cast iron with nickel-iron and nickel should meet AWS Standard A5.15.

Table 3.-Welding-current ranges for SMAW of cast iron with nickel-iron and nickel electrodes. (The welding currents shown should be reduced by 5 to 15 A for overhead welding and 10 to 20 A for vertical welding unless otherwise specified by the manufacturer.)[5]

Electrode diameter, in	<i>ENiFe-CI</i> electrodes		<i>ENi-CI</i> electrodes	
	Current (DC-either polarity), A	Current (AC), A	Current (DC-either polarity), A	Current (AC), A
3/32	40-70	40-70	40-80	40-80
1/8	70-100	70-100	80-110	70-110
5/32	100-140	110-140	110-140	110-150
3/16	120-180	130-180	120-160	120-170

Electrodes containing relatively large amounts of copper (25 to 45 percent) are designated by the AWS as *ENiCu-A* and *ENiCu-B*. Because of their sensitivity to iron dilution and resulting brittleness, they have been replaced largely by the nickel and nickel-iron electrodes.

Bronze covered electrodes, which are of the copper-tin or copper-aluminum type can also be used for welding iron castings. A low-melting point allows their use at low current levels which serves to reduce weld metal dilution, heat input, and thermal stresses in the parent metal. Reducing these factors increases the chances of obtaining a quality crack-free weld. Deposits are soft and machinable, but color match is poor. If excessive contamination is present when using this type of electrode, it can cause cracking.

4. Joint and Surface Preparation

Most repairs involving cast irons usually will be repair of a crack due to the brittle nature of these materials. Other typical repairs include replacement of cavitated or eroded material. In crack repair it is very important to remove all of the bad material as well as stop-drill the ends of the crack to prevent further propagation. Normally a 1/8-inch-diameter hole drilled within 1/2 inch of the end and to the depth of the crack, prior to preparation, is sufficient.

There are several methods available for the removal of cracked or damaged material; however, methods which leave excess free carbon in the weld area should be avoided. Popular methods include grinding, gouging, or machining. Air carbon arc gouging is often used successfully on iron castings for removing defects. If this method is used, an additional 1/16 inch of material should be removed from the arc-gouged surface by grinding in order to remove the resulting hardened zone. On materials where this method tends to concentrate carbon, the crack should be gouged out using a burr grinder or a metal removing rod. Experimenting with different methods will clarify which will give the best results for a particular application.

The third step in the process is to examine the material to ensure that all of the crack has been removed. Dye penetrant can be used to detect cracks and other defects in castings that are not readily visible to the naked eye. Penetrants containing low levels of phosphorus should be utilized when nickel based consumables are to be used.

When the defect is completely removed, the preparation of the joint should be completed. Metals $3/16$ inch or less in thickness can be welded with square-groove joints. Thicker metals require the use of V- or U-groove preparation. For V-groove joints, an included angle of 60-70 degrees is required for most filler materials. On sections more than $3/16$ inch thick, the edges should be beveled so that the root of the joint is $1/8$ to $3/16$ inch wide. If the crack extends through the section, leave about a $1/8$ -inch gap and a $1/16$ -inch root face as illustrated in figure 1.

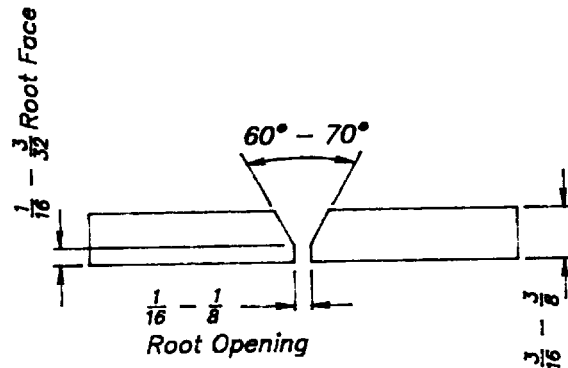

FIGURE 1

Ends of narrow grooves completely contained within a surface should be beveled to allow for good fusion in those areas. Weld joint size should be kept to a minimum, thereby reducing the likelihood of thermal expansion cracking, but should also allow for full penetration resulting in maximum load-carrying ability and reduction of stress concentrations under the weld bead.

The casting should be cleaned to a minimum of $1/2$ inch to either side of the weld joint. The hard oxidized skin, which may contain contaminants such as paint and burned-in sand, should be ground away and any oil or grease should be removed by steam cleaning or by use of a commercial degreaser. Repeated degreasing may be needed for castings normally in contact with grease and oil. If possible, heating the casting to 700 to 900 °F aids in the removal of moisture and grease impregnated in the material. All liquid penetrants should be removed prior to welding.

Closed chambers in the casting near the weld area should be vented to prevent distortion by heating and cooling. Drilling small holes in cored areas will prevent distortion from occurring.

5. Weld Procedure

Once the weld joint has been properly prepared, the actual welding procedure can begin. Using preheat when welding cast iron can be very beneficial in reducing thermal stresses; however, under field conditions, preheating can often be difficult or impossible. In many cases good weld quality can be achieved without preheat and sometimes preheating is not even beneficial. Many factors, such as material composition and cross-sectional

thickness and complexity, contribute to the selection of the proper preheat temperature. Unfortunately, no single temperature is satisfactory for all base-metal shapes and compositions under all welding conditions. Before beginning to weld, a qualified reference (such as the "Metals Handbook"[5] on welding, brazing, and soldering) should be consulted in reference to preheat. The following steps assume no preheating of the parent metal is done:

- a. Set the amperage as recommended by the weld rod manufacturer or as given in table 3 (for *ENiFe-CI* and *ENi-CI* electrodes). Generally, amperage values shown in table 3 should be reduced 10 to 20 A for vertical welding and 5 to 15 for overhead welding. A short trial bead should be run on the part, if possible, starting with the low range of the amperage setting. Amperage settings should be kept as low as possible while still obtaining good fusion without voids or slag inclusions. Every attempt should be made to reduce the amount of cast iron melted into the weld. Free carbon in the cast iron will tend to form a brittle structure when combined with steel and rapidly cooled. This will leave the weld virtually unmachinable.
- b. Start the weld 2 to 3 inches from the end of the joint and weld back to the start of the joint. Strike the arc in the weld groove and use a 5 to 10 degree travel angle (see figure 2) with a medium arc length. Backfill all craters and back up 1/4 inch, slowly withdrawing the rod and allowing the arc to extinguish itself.

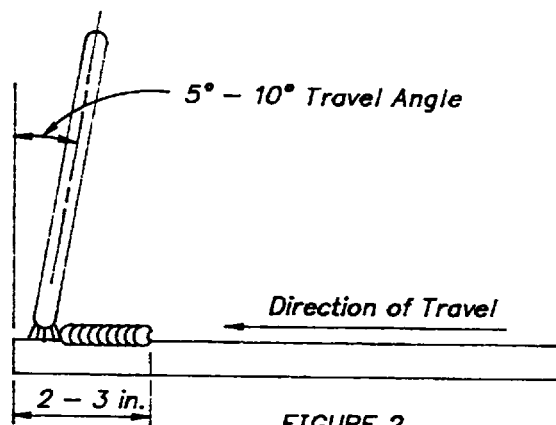

FIGURE 2
First Weld Bead

- c. Peen the weld while it is still in the dull red state using a 1/2- or 3/4-inch-diameter round-nosed hammer. Repeated moderate blows should be used rather than a few heavy blows. Since the parent metal and the consumable have different rates of thermal contraction, peening helps to reduce the effects of shrinkage stress and minimizes distortion.
- d. Allow the weld and parent metal to cool slowly. The maximum interpass temperature for welding cast iron without preheat should be 100 °F. Slow cooling should take between 3 and 5 minutes. If accurate surface temperature readings cannot be taken, a good rule of thumb is to allow the weld to cool until you can place and comfortably leave your bare hand on it.
- e. Once the area has cooled, remove any slag, move 2 to 3 inches ahead of the end of the last bead, restart the arc, and work back to the end of the previous deposit. Backfill all craters, overlapping the end of the previous weld by 1/4 inch, and then

back up 1/4 inch, slowly withdrawing the rod and allowing the arc to extinguish itself (see figure 3).

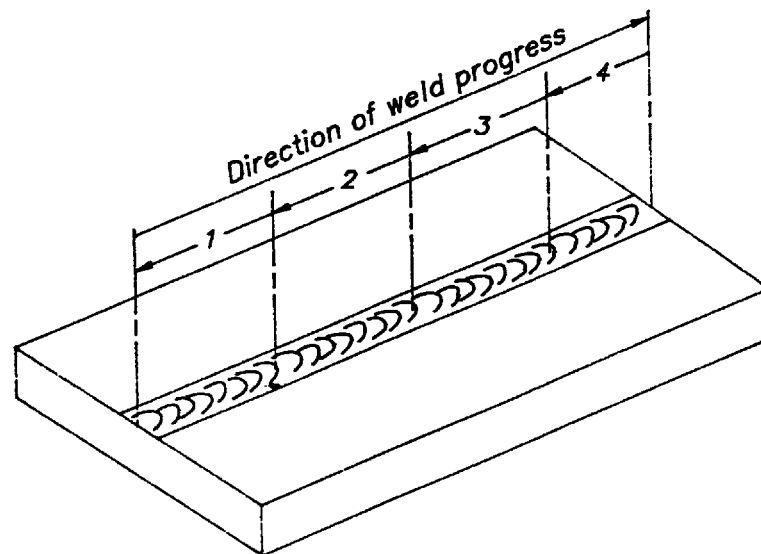

FIGURE 3
Backstep Sequence

f. Continue with steps c. through e. until the weld is completed. This technique is known as the backstep method and will help to reduce the cumulative effects of transverse and longitudinal weld shrinkage stresses.

g. Once the weld is completed, allow the area to cool slowly to room temperature by covering it with a fireproof insulating material. Be sure to heat the insulating material before placing it on the casting or a quenching effect will take place, resulting in a brittle weld and heat affected zone and possibly causing longitudinal cracks in the parent material.

h. Check the weld for surface porosity which can result from the mixing of impurities from the casting surface with the weld metal. If the weld appears unsound, remove it and begin again.

The following general practices have been found to be effective and should be observed when welding castings:

- When no preheat is used, the maximum interpass temperature should not exceed 100 °F.
- When preheat is used, the maximum interpass temperature should not exceed the preheat temperature by more than 100 °F.
- A backstep technique should be used for long welds with stringer beads of no more than 2 to 3 inches in length. Each deposit should be allowed to cool to warm-to-the-touch before making the next deposit.
- Avoid melting any more of the cast iron than is necessary.

- Whenever possible, deposit two or more layers to improve machinability. The first layer will serve as a preheat for the second layer, which will tend to produce a slower cooling rate and anneal the fusion zone, resulting in a softer, more machinable deposit.
- Always strike the arc in the prepared groove.
- The arc length should not exceed the rod diameter.

Similar techniques can be used for larger welds by stacking and overlapping short stringer beads, peening them, and allowing them to cool before starting another, as in the above procedure. The key is to take your time and minimize the heat input into the casting so that thermal stresses caused by the difference in expansion coefficients between the weld metal and the casting will be significantly reduced.

6. Brazing

Oftentimes when a crack develops in an area of a casting which is not under stress or pressurized, but is simply used as an oil or fluid containment device, it is often cheaper, easier, and faster to braze instead of weld. Brazing gray, ductile, and malleable cast irons differs from brazing steel in two major respects. The first is that special surface precleaning is necessary when brazing cast irons to remove surface contamination and free carbon. The second is that brazing temperature is kept as low as possible to avoid reduction in the strength and hardness of the iron.

Since most cast irons are brazed at relatively low temperatures, the filler metals used are almost always silver brazing alloys. Of the silver brazing alloys, one designated *B_{Ag}-1* is most often used because it has the lowest brazing-temperature range. A fluoride-type flux, such as the AWS type 3A, is used with the *B_{Ag}-1* filler metal.

Relatively high silicon content as well as sand inclusions on as-cast surfaces can reduce the brazeability of cast irons, but excess carbon reduces bond strength more than any other factor. Malleable cast iron is generally considered the most brazeable of these types of materials, followed by ductile iron, and then gray iron. Steel shot or grit blasting is used for surface preparation of malleable and ductile cast irons, but is rarely used to prepare gray iron surfaces because this method cannot remove the excess flake graphite. Methods such as degreasing, detergent washing, and acid pickling also help to improve bond strength, but do not remove excess carbon. However, in some cases, relatively low bond strength is not critical, as long as oil or fluid cannot escape past the brazed joint. The only extremely effective way to remove both carbon and surface impurities is by fused salt cleaning. This is mostly used during manufacturing processes and really does not apply to field repairs.

Joint designs for brazing cast irons are generally the same as those for steel. Diametral clearances of 0.002 to 0.005 inch will yield the best results. Clearances of up to 0.010 inch can be used, but will result in lower bond strength and an increase in the consumption of filler metal. Much more information on brazing cast irons is contained in reference [5], pp. 996-1000.

7. Summary

The techniques and materials presented in this article are not just for crack repair, but can be extended to joining, cavitation repair, and erosion repair. Specifics for many types of repair also can be found in the referenced literature.

References

1. *Construction Safety Standards*, revised reprint 1987. Bureau of Reclamation.
2. *The Procedure Handbook of Arc Welding*, by the Lincoln Electric Company, twelfth edition, 1973, pp. 8.1-1-8.1-6.
3. "Repair Welding of Cast Iron Using Nickel Alloy Filler," by David Van Buskirk, Eutectic Corporation, 1991.
4. "Specification for Welding Electrodes and Rods for Cast Iron," American Welding Society Specification No. A5.15-90.
5. *Metals Handbook*, American Society for Metals, volume 6, ninth edition, 1983, pp. 307-319 and 996-1000.
6. *Modern Welding Technology*, by Howard B. Cary, second edition, 1989, pp. 538-542.

WHERE DO YOU PUT THAT FENCE?¹

PLACEMENT VARIES BETWEEN DISTRICTS

Editor's Note: *In this article, the districts are referring only to fencing required to protect rehabilitated works from livestock. A canal in a fill section was used as an example.*

Fencing with barbed wire to keep livestock out of irrigation works is as old and motherhood to irrigation districts as is cattle to the western Canadian farmer. It's not that cattle intentionally damage things, but with the animals' continual need to rub and with all that weight and sharp hooves, things soon get damaged.

In order to protect the investment under the Irrigation Rehabilitation and Expansion Program, says Gerhardt Hartman, P.Eng., manager of the Irrigation Secretariat, the Irrigation Council of Alberta has a policy in place today that requires irrigation districts to protect rehabilitated works. The policy states that "All rehabilitated works that may be damaged by livestock shall be fenced if they are likely to be in the proximity of livestock." This would apply, says Hartman, to open canals, lined or unlined, and structures. Fencing would not likely be required for pipelines except for those above-ground appurtenances which might be damaged by livestock rubbing. To encourage acceptance of fencing, Council has determined that livestock crossings, dugouts, stockwatering turnouts and the like are fundable under the program if required.



SMRID fencing along Coaldale Lateral.

¹ Reprinted with permission from the Editor, Water Hauler's Bulletin, Alberta Agriculture, Lethbridge, Alberta, Canada T1J 4C7; Winter 1992 issue.

The location of the fence is left up to the individual districts and placements do vary considerably. In past, adjacent landowners often used the entire grassed canal banks for additional pasture. After rehabilitation, district boards were often faced with adjacent landowners who still wanted the use of at least some of the right-of-way or easement. This has led to individual districts varying placement of their fences.

The Lethbridge Northern Irrigation District (LNID) and the Western Irrigation District (WID) usually fence along surveyed right-of-way lines. Craig Gordon, manager of the WID, says, "This usually eliminates any problems with the farmers and makes future canal maintenance easier." Lawrence McCune of the LNID agrees and adds that "landowners or renters, over the years, may begin to think that because they have used some part of a district's right-of-way for many years, they may have forgotten or not realized or never known that they don't own it and when the district finds it must do maintenance, it often becomes difficult."

Rick Ross, manager of the LNID says, "We tried fencing on top of the bank to give farmers the maximum grazing use but it was a nightmare when district staff tried to do maintenance."

Five of the more westerly districts, Aetna (AID), Leavitt (LID), Magrath (MID), Mountain View (MVID), and United (UID) Irrigation Districts all place their fences on the top of the inside bank. This allows, says Kirt Woolf, manager of the UID, the landowners to graze their cattle over all but the trapezoidal canal section itself. It keeps the weeds under control and hasn't posed a problem to the outside slope by cattle trampling it. Woolf feels with today's large equipment, cleaning their fenced canals will be no problem as the operator will simply reach over the fence, excavate the material, swing and deposit the spoil in the adjacent field—to be later spread when dry. Magrath's manager, Dean Anderson, says their district does not build driving banks, thus farmers are allowed to farm or graze cattle right up to the canal section. The MID has only easement agreements and doesn't purchase right-of-way, so access is sometimes difficult during growing seasons as farmers get pretty upset if you drive along the canals where their crops are growing.



Fencing along MID's Highline Canal.

The Bow River (BRID) and Taber (TID) Irrigation Districts try and locate their fences on the driving-bank side at a distance determined by the farthest outside toe, putting the fence in a straight line at a minimum of 1 meter from the outside toe. Both districts place the opposite-side fence anywhere from 0 to 5 meters from the outside toe. The BRID used to fence on top of the embankment, but Steve Topping, P.Eng., district engineer, says their policy was changed about 1 year ago because maintenance was too difficult.

The St. Mary River Irrigation District (SMRID) fences both sides of their canals that need protection. The fence location, depending upon the height of fill, can be from 0 to 5 meters from the outside toe. Ron Renwick, P.Eng., district engineer, says when cleaning becomes necessary, there is a good possibility that the material will have to be hauled away or the fence removed.

In the Eastern Irrigation District (EID), there is a 10-page "Fencing Policy" in place which goes into great detail on all aspects of fencing: location, maintenance, construction standards, etc. Earl Wilson, P.Eng., district engineer, says on most irrigation rehabilitated projects that require protection from livestock, the EID likes to maintain both fences about 9 meters from the inside shoulder. If a district canal parallels a municipal road, they usually don't bother fencing the road side.

Gordon Zobell, manager of the Raymond Irrigation District (RID), says the district has no set guidelines but is site specific. If fencing is required, then it would likely be placed on top of the bank, he adds.

In conclusion, there seems no utopian place to construct a fence along a canal. If it's located on top of the banks, more grazing is available and weed problems may be reduced but maintenance is likely to be more difficult. In very wet weather, the banks and slopes may suffer damage from the hooves of the heavy animals as they sink in. When fences are located on legal boundary lines, they certainly provide for the best protection to the works and make maintenance operations easier but weed mowing and spraying become necessary.

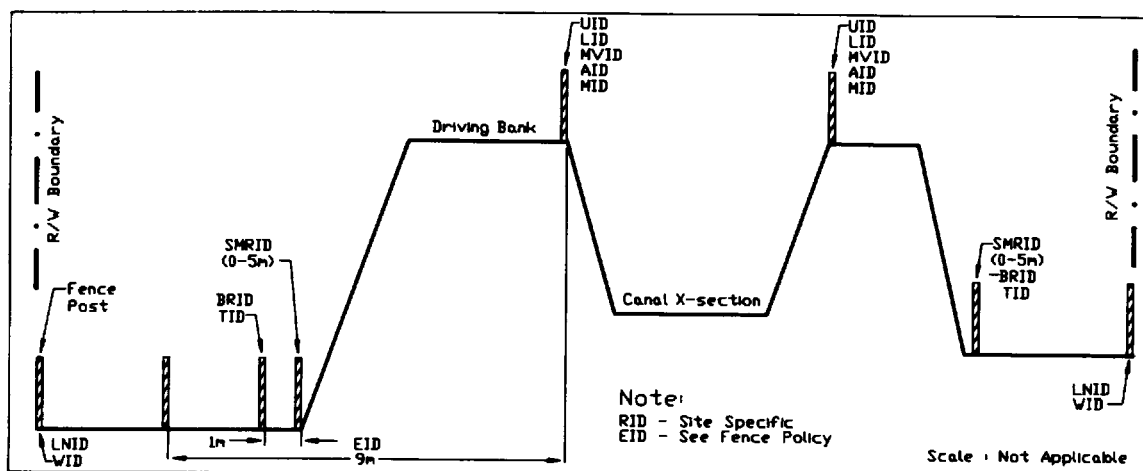

REPAIR AND CONTROL OF CHRONIC AND ACUTE CANAL LEAKAGE/SEEPAGE

by Roberta Lewis¹

The following are two instances of repair and rehabilitation of the concrete lining of the Putah South Canal (hereinafter referred to as canal), Solano Project, California, by the Solano Irrigation District (District). The canal was constructed in 1958 and was concrete lined at that time. The concrete lining has been repaired many times during the years since construction. The District is responsible for the operation and maintenance of the canal.

Chronic Leakage/Seepage Repair

September 1989, test — November 1989, actual use

The leakiest section of the canal was upslope of a developed area and had been leaking since the canal was constructed in 1958. Although the lining of the canal was designed to be 2-1/2 inches thick, the actual thickness of the lining in the section varied from 1/2 inch to 2-1/2 inches. Water seeping through expansion/contraction joints and cracks in the thin lining entered cracks in the rock foundation and traveled to the toe of the natural embankment slope below the canal. The seepage flow had the potential to cause serious property damage and has provoked complaints from downslope landowners for many years. (The structures affected by the seepage predate the canal.) The District installed a check structure (Van Every check) at the upper end of the leaky section to permit lowering of the operating water surface in the leaky section. Attempts to prevent seepage by lowering the operating water surface of the canal reduced the amount of water delivered.

The leak repair and crack sealing methods used in the past were not durable; the cracks either did not seal at all or reopened and seepage continued. The methods included use of Chevron Soil Sealant (around 1960), which worked for a few years (done under Specifications 200C-425); bituminous sealant in cracks plus 2-inch concrete overlay of bottom (1965); polysulfide joint sealer (1965); sump pump to remove seepage water from downslope field and return it to the canal (1965); interceptor drain (1965); and mastic in cracks (1972). The various methods were either not effective or were effective for only limited periods of time. Cracks were sealed as they were discovered but reappeared over the years; new cracks continued to form up until the time the new liner system was installed. None of the methods used provided a long-term cure for the seepage.

This method of seepage repair was tested in a section of a small lateral ditch, then was used in the canal (capacity about 180 ft³/s in the section repaired). One mile of the canal was relined by this method in November 1989. The May 1991 RO&M (Review of Operation and Maintenance) examination indicated that the repairs were entirely successful; the hairline cracks that appeared in the shotcrete do not reduce seepage resistance. The District is very pleased with the work. The lining program will be applied to other seepage prone areas in approximately mile-long sections. Both shotcrete and

¹ Roberta Lewis is a Civil Engineer, Bureau of Reclamation, 2800 Cottage Way, Sacramento, California 95825.

membranes have each been used as seepage-proof lining materials in the past; however, the materials have not been used together as a system. Reclamation conducted tests of shotcrete and membranes for canal lining and seepage control in the early 1960's (*Linings for Irrigation Canals*, USBR, 1963). The most recent work incorporating both a membrane and shotcrete, was done at a cost of about \$300,000 and appears to be the most effective, by far, in halting seepage.

The existing lining was structurally sound despite many small cracks. The HDPE (high-density polyethylene) membrane was installed to provide an impermeable barrier, over which 2 inches of fiber-reinforced shotcrete overlay was placed to protect it from the elements. (Membrane liners are virtually waterproof when properly installed but can deteriorate from exposure to sunlight, abrasive materials, and vandals. Exposed membrane liners in metal flumes in the Klamath Project have been punctured and cut by vandals.) A textured form of high-density polyethylene (HDT-HDPE), manufactured by the Gundle Company of Houston, Texas, was used to encourage the shotcrete to adhere to rather than to slide down the 1-1/2:1 sloped sides of the lining. Heat-welded seams were used to ensure that the membrane was leakproof. The 7-sack/yard shotcrete mix was reinforced with 2 pounds of 50-mm-long polypropylene fibers per cubic yard of concrete.

Following 6 weeks of site preparation, including O&M (operation and maintenance) road improvements and construction of an equipment staging area, the steps followed in installing the new lining were as follows:

- a. Unwater canal
- b. Thoroughly clean canal lining
- c. Remove loose concrete and repair holes in canal lining
- d. Cut membrane to proper lengths
- e. Place loosely in canal
- f. Lap and weld membrane at 22-foot intervals to form continuous liner
- g. Nail membrane to canal lining at 4-foot intervals
- h. Add necessary structures, ladders
- i. Seal membrane around structure bases, patching and welding as necessary
- j. Spray shotcrete over membrane (sides first, bottom last)
- k. Smooth and finish shotcrete (sides first, bottom last)

The work progressed at an average rate of 350 lin ft/day, and reached a maximum of 528 linear feet in 1 day. A crew of 3 workers was able to place the membrane, and about 15 to 18 workers usually applied and finished the shotcrete.

Expansion/contraction joints in the shotcrete were placed on 12-foot centers at a 6-foot offset from the old joint. After the canal was unwatered, the steps listed above proceeded in succession down the repair section. Membrane placement was usually only a few dozen yards ahead of shotcrete placement. The 5,000-foot-long project was completed rapidly during two 1-1/2-week shutdowns of the canal. The District was able to run water through the repaired reach within 12 hours after the repair was completed. All work was done in November and December during a period of minimum irrigation and M&I (municipal and industrial) demands. Water was run over the partially complete lining and 300 to 400 feet of exposed membrane for 4 days between the shutdown periods.

Canal capacity was reduced slightly by the shotcrete which reduced the cross-sectional area of the canal prism; however, this did not impact the District's water deliveries since this reach has never been operated at full capacity. A large area of land originally served by this reach was detached from the District many years ago.

Acute Leakage Repair

August — November 1987

Serious damage to the concrete lining of the Putah South Canal occurred when a 36-inch-diameter storm sewer pipe being jacked under the canal in August 1987 drifted off grade and disturbed the gravel fill material under the lining. When the fill moved out of place, a lining panel dropped down and water leakage began. The leakage undermined a group of lining panels which fell into the void. The lining was reportedly built a bit low at the problem point, and the pipe jacking had started about a foot too high. Only 1- to 4-inch clearance was available between the canal invert and the top of the pipe. Since the canal delivers municipal water, work had to be carefully scheduled in order to be done in the small windows of opportunity during brief shutdowns of the canal. The repairs were performed during two day-long shutdowns of the canal.

The cutting head of the boring machine used to place the storm sewer pipe got stuck in the pipe and could not be removed normally. Workers had to cut through one canal embankment, then place pipe in an open cut, repair the canal embankment, and replace the lining. The new pipe was connected to pipe jacked through the opposite embankment behind the cutting head. The contractor used a temporary lining material (sacked riprap) so the canal could be watered up between the time the pipe was placed and the embankment restored, and when new concrete lining panels were placed. The initial work was done early November 3, and the canal was watered up by 5 p.m. that day.

The canal embankment was reconstructed by placing fill in 6-inch-thick compacted lifts up to the top of the existing lining, then cutting the fill down to the proper cross-section. A total of three panels (39 feet total length) plus a 12- by 17-foot bottom section of concrete lining were removed and replaced. The costs of all repairs were borne by the contractor who caused the damage, and the developer for whom the sewer pipe was being installed.

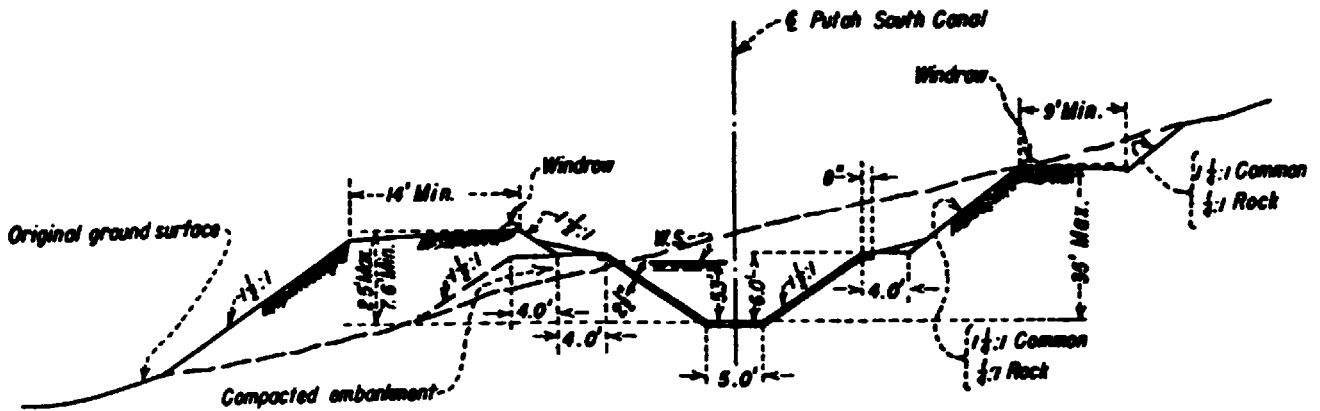

LINED SECTION NO. 5
WHERE CROSS SLOPE IS 10%

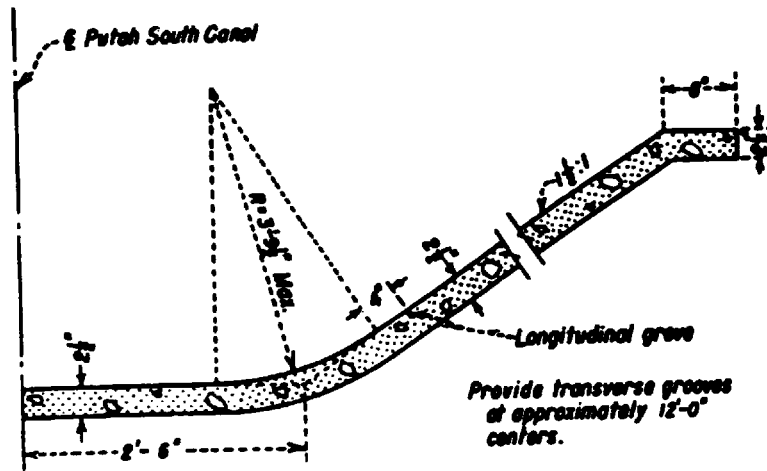

CONCRETE LINING DETAIL

HYDRAULIC PROPERTIES

CANAL SECTION	A	V	Q	F	R	S
Lined Section No. 5	68.68	2.62	180	2.88	.014	.00015

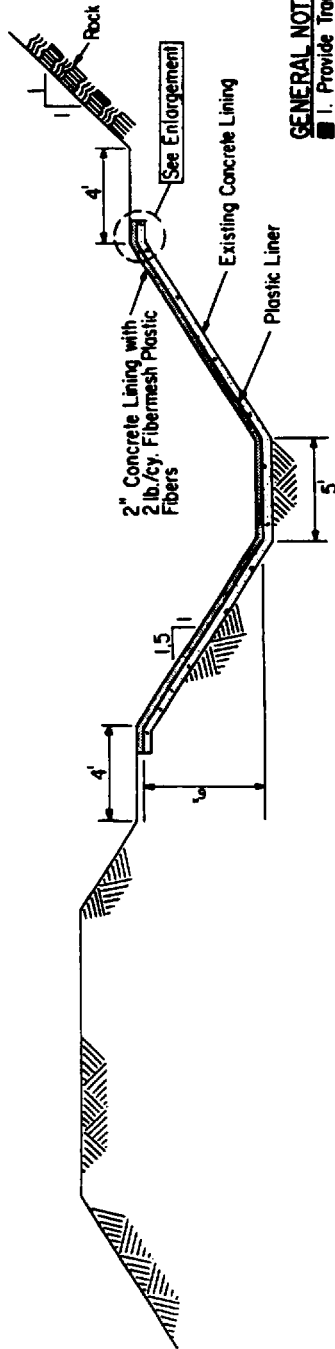

TYPICAL 2" LINING CROSS SECTION

GENERAL NOTES

- 1. Provide Transverse Grooves at 12 cent-ers. See Groove Detail.
- 2. Provide Cutoff Walls 18" depth min. at each end.
- 3. Provide a Non-Pigmented Curing Com-pound.

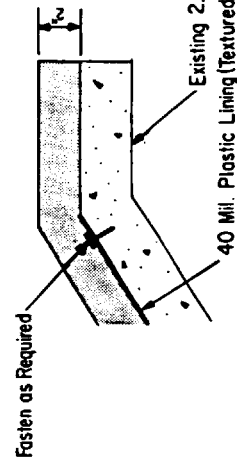

ENLARGEMENT

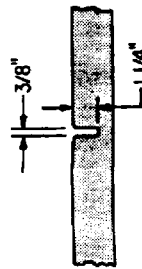

GROOVE DETAIL

DO NOT SCALE FROM DRAWINGS ON THIS SHEET

SOLANO IRRIGATION DISTRICT
VACAVILLE

PUTAH SOUTH CANAL
LINING PROJECT

Van Emory Weir to Rectville Check
S16.1559+00 (M.P. 23.07) to S16.1610+16 (M.P. 30.02)

SUMMERS ENGINEERING, INC.
HAYWARD CONSULTING ENGINEERS CALIFORNIA

DATE: OCT 1989
DRAWN: JEB
CHECKED: BJS
PROJECT: PSC-LP-89

NO.	REV.	DATE	BY	CHKD.	DESCRIPTION



Photo 1.-Original concrete lining before repair.



Photo 2.-HDPE liner seamed and in place.

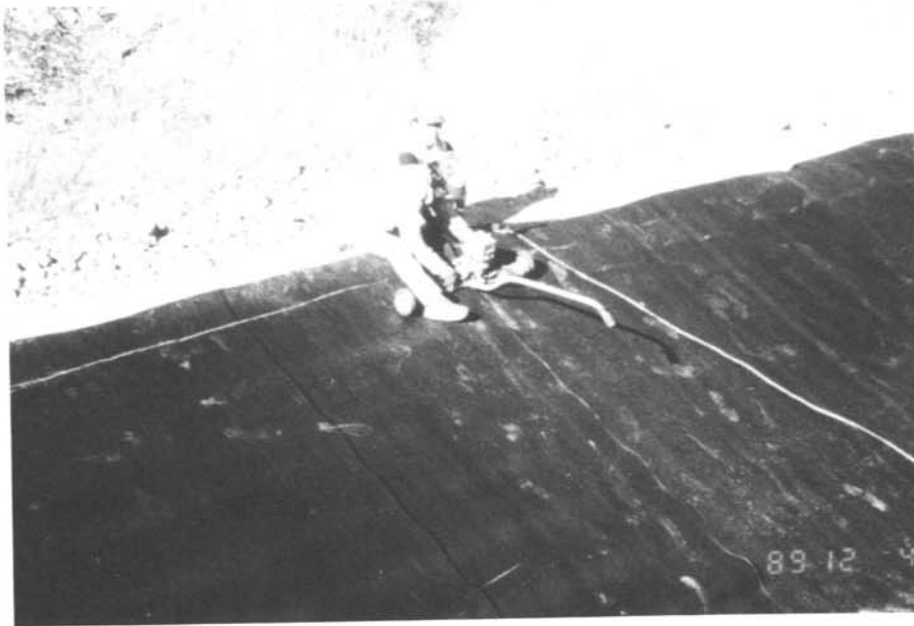

Photo 3.-Workers seaming HDPE liner.



Photo 4.-Closeup view of seam in HDPE liner.



Photo 5.-Finishing surface of shotcrete.

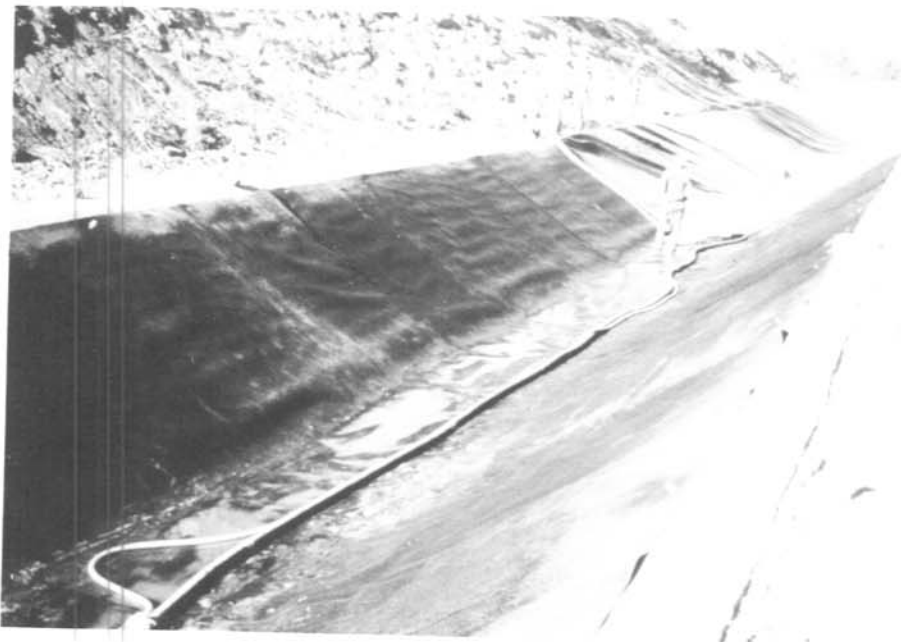

Photo 6-HDPE liner and shotcrete progressing down canal.



Photo 7.-Finished lining with escape ladder shown.

ALGAE IDENTIFICATION IN IRRIGATION SYSTEMS¹

Fresh-water algae are simple plant forms, meaning that single plants are not differentiated into separate functional parts such as roots, stems, leaves, or flowers. Individually, algal plants are extremely small. Often a microscope is needed to identify the different types. How then, can such tiny simple plant forms seriously impact on the operation of an irrigation system? The answer, says Robert Burland, a biologist with the pollution control division, Alberta Environment, can be found in the old cliché "there is strength in numbers." "The 'problem' species of fresh-water algae," states Burland, "can grow and multiply so quickly that before we realize it, problems are being caused."

In irrigation systems, algae are responsible for affecting flows in concrete lined canals, and for plugging equipment such as pump screens and trash racks. In ponds and lakes, algae can taint the water so that it is unpalatable. Algae can cause fish kills by depleting oxygen and can even impart toxic substances into the water.

Although there are thousands of species of algae that exist in fresh water, it is possible to group them into three categories: filamentous, planktonic, and branching, based on their general characteristics.



Filamentous algae

The type of algae that raises the most havoc in irrigation canals is the filamentous type, says Burland. When checked under a microscope, individual filamentous alga look like slender filaments or threads. The filaments may have branches and may have a single "hold-fast" cell at one end enabling attachment to rocks, concrete, or other objects.

¹ Reprinted with permission from the Editor, Water Hauler's Bulletin, Alberta Agriculture, Lethbridge, Alberta, Canada T1J 4C7; Spring 1991 issue.

When seen collectively and in abundance, the filamentous algae appear as long stringy masses attached to objects or to other vegetation. In the standing waters of ditches, lakes, or ponds, filamentous algae appear as a cottony mass or surface scum that is filled with air bubbles. The filamentous algae vary in color from green to yellow.

Filamentous algae that are of concern in irrigation canals begin growth attached to concrete, rocks, or other plants. As they grow and multiply via cell division, the entire mass of algae becomes such that current, wind, or wave action may cause large chunks to break off and float away. Individual filaments may also break off and float downstream. It is these free-floating pieces and chunks that "wrap around" underwater structures, and in general, plug things up. Because their stringy nature results in this "wrap around" effect, algae are very difficult to clean off.

Filamentous algae can reproduce and spread in several ways. The individual fragments of algae are capable of reproducing and forming additional algal masses in other locations. They may also form spores which can move to other areas and begin new colonies. The spores which are resistant to drying and freezing are the means by which algae can survive periods of drought and cold weather such as during the winter draw-down season. Both fragments and spores can also be moved from place to place by waterfowl or other aquatic life.

Planktonic and branching types of algae may cause occasional problems in canals, says Burland, but are more of a concern in lakes and ponds. The planktonic forms of algae are free floating so they are not able to establish themselves in flowing systems. In lakes, reservoirs, and ponds, however, these types of algae can cause serious problems, he states.

The most notorious of the planktonic algae are the blue-greens. Under the right conditions, blue-green algae can multiply so rapidly so as to cause the water to look like pea soup. This is referred to as an algae bloom. When this happens, oxygen depletion can occur, causing a fish kill. Some types of blue-green algae can add toxins to the water under bloom conditions, making the water poisonous to livestock.

The branching algae are larger in size and appear to have stems and branches. They are often crusty in texture as a result of calcium deposits and have a skunk-like odor when brought into the air. Branching algae (Chara is the most common type) inhabit the bottom of lakes, ponds, and streams, are attached to objects and grow only 1 to 2 feet in size. Chara does not normally become a problem in canals, says Burland.

For more information, please contact Robert Burland, Pollution Control Division, Alberta Environment, Provincial Building, 200 - 5 Avenue South, Lethbridge, Alberta T1J 4C7; telephone (403) 381-5511.

CONVEYOR BELT MATERIAL PROVIDES SEALING SURFACE TO BULKHEAD GATE

By Galan K. Hanson¹

Operations and maintenance personnel at Elephant Butte Dam recently completed the replacement of the service gate and sluice gate operating cylinders. To facilitate the work, a shutter or bulkhead gate was lowered down concrete slots on the upstream face of the dam to the inlets of the various outlet conduits. The sealing surfaces of the inlets are formed concrete placed as the dam was built, between 1912 and 1916, and are very rough in texture. The lowest inlets are about 190 feet below the top of the dam.

Since there is not a method for equalizing the pressure before raising the bulkhead gate, the friction forces exerted on the sealing surfaces became greater. This resulted in accelerated abrasion to the solid music-note-type rubber seals when the bulkhead gate was removed from the first conduit. The seals were too damaged for another use.

Personnel were considering replacing the seals, but the manufacturer had none readily available. Rather than wait for another set of music-note-type seals to be produced, the crew selected some thick conveyor belt material to make the seals. The conveyor belt material was 10 inches wide and could be folded over to form a sealing bulb similar to the music-note-type seals. The belt material was held in place by clamp bars.

With the belt material for a sealing surface, the remaining three gate operators were replaced without further incident. The belt material could not provide a watertight seal at the corners, but the leakage did not affect the cylinder replacements.

Under conditions where pressure for a bulkhead gate cannot be equalized and the sealing surface of the structure is very rough, the conveyor belt material has proven highly effective, with the exception of the leakage at the corners of the bulkhead gate. The cost of the conveyor belt material was a third of the \$24/ft for solid music-note-type rubber seals. Another advantage to the belt material was the availability, resulting in less delays to the replacement work. For additional information on the belt material, contact David McAfee, Chief, Power and Storage Division, Bureau of Reclamation (505) 894-6661.

¹ Galan K. Hanson is a Civil Engineer presently with the International Boundary and Water Commission at Falcon Dam, Texas/Mexico.

MANAGING MOLES¹

by David J. Pehling²

MOLES! The very word strikes terror in the hearts of farmers, gardeners, and landscapers. Just what are these little critters and why do they plow up our lawns, gardens, and pastures?

The mole is not a rodent as is commonly thought, but an insectivore of the taxonomic family Talpidae and the Pacific Northwest is blessed with four separate species; the shrew-mole (*Neurotrichus gibbsi*); the Pacific mole (*Scapanus orarius*); the California mole (*S. latimanus*), and one of the largest moles in the world, the Townsend mole (*S. townsendi*).

For all practical purposes, we can ignore the harmless little shrew-mole and concentrate on the larger, tunneling species.



A Pacific mole

¹ Reprinted with permission from the Managing Editor, Pacific Farmer-Stockman, February 1992 issue.
² David Pehling is an assistant with the WSU/Snohomish County Cooperative Extension, Washington State.

Almost all of our mole problems in the Pacific Northwest are caused by the Pacific and Townsend moles. These two animals are very similar except for size. Both of them have very small ears and eyes, naked tails, broad forefeet, and a beautiful velvety coat of gray-black fur.

Moles are seldom seen, but they are well known by their large, volcano-like molehills that are pushed up periodically along their tunnel systems during excavation. These mounds are unsightly in lawns and can cause damage to farm machinery. In the '60's, one county in Oregon estimated annual losses to the dairy industry alone at over \$100,000!

The mole's tunnels can injure plants by disturbing the roots and exposing them to air. Occasionally, moles may sample bulbs, root crops, and sprouting seeds; but there is much disagreement on this point. Most plant damage blamed on the mole is actually caused by meadow mice (*Microtus sp.*). These rodents often use the mole's tunnel systems and tunnel extensively themselves, although they never leave soil mounds.

The mole's tunnel serves two purposes. It provides shelter for the animal and acts as a trap for burrowing worms or insects to fall into. Once a tunnel system is established, the mole spends most of its time patrolling the runs and collecting the invertebrates that have blundered in. If there are more worms than the mole can eat at one time, it will bite the head of the worm to paralyze it and store the bodies in a special larder chamber. Sometimes the mole will make ridge-like surface runs. These are temporary hunting tunnels and are often used only once.

Moles are active all year round, although visible tunneling only occurs during certain times of the year. Moles follow their food supply so most of the molehills are made during the spring and fall when earthworms are near the surface. In times of drought or freezing weather, the worms go deep and so do the moles. If you watch closely for fresh molehills, you will notice that there is often a flurry of activity after a rain or thaw.

Moles are solitary animals and will often fight to the death if they meet. However, they do get together once a year to mate — usually during February and March, and an average of three young are born about 28 days later, late March to early May, in underground nest chambers lined with grass.

The young are born blind and naked, nursed for 4 or 5 weeks, and then kicked out of the nest. These young moles must migrate to find their own territory and mortality is high. They will often move into abandoned tunnel systems which might have been empty for decades or only days before the new tenant moves in.

From an ecological point of view, moles are actually beneficial animals. Their constant tunneling and mound-building that makes them so disliked can actually improve soil aeration and drainage in wild areas. It also brings mineral-rich subsoil to the surface where it can mix with the humus and improve soil quality.

Control Methods

Where moles are a definite problem, the only sure way to control them is by trapping. In the old days, there was even a market for the skins. Some of you may remember mole-skin collars and cuffs. There are many types of traps, including:

Gopher traps.—Stay away from these. They are often found attractively priced but do not work well for moles which have a different tunneling technique.

Harpoon traps.—Developed for trapping the smaller Eastern mole. These will work but are more difficult to set in rocky ground and need constant maintenance to keep in working order as they tend to jam.

Choker-loop traps.—Should work well, especially for smaller moles. Difficult to set in rocky ground.

Scissor-type traps.—Generally considered the most effective. Most scissor traps work quite well right from the box. The easiest way to test the sensitivity is to set the trap and drop it on the ground from about a foot. If the trap does not spring, it needs adjustment. (Smoothing the trigger surfaces, rounding the base of the set-wire, slightly bending the set-wire inward — all will increase sensitivity. *Don't over-do it.*) Some mole-trappers occasionally oil the trap to keep it rust-free and in good working order.

Trapping With the Scissors-Jaw Trap

Trying to trap a mole can be a long, frustrating experience if not done correctly. Success only comes with practice and a lot of patience.

One of the most important rules in mole trapping is to make your set in a tunnel that is active. Moles are most active after a rain or a thaw when the soil is soft and worms are near the surface.

These active runs can be easily located by stomping down the molehills in the afternoon. By the next morning, the runs that are being used will have a fresh mound.

Next, locate a deep run between two mounds by probing the soil 6 to 8 inches away from the molehill. A steel rod or a screwdriver will work as a probe. Even better are commercial or homemade gopher probes. Sharp-ended dandelion weeders also work well as a probe.

Force the probe into the soil about every 2 inches around the molehill. When the tunnel is struck, the probe will suddenly drop a couple inches as it breaks through the roof.

At this point, cut out a section of turf and soil exactly the width of the trap — about 5 x 5 inches and at least 1/2 inch deeper than the run.

Locate the tunnel holes with your fingers or a stick — moles do not seem to mind human odor. If you have a straight section of tunnel, it is a good place to make a set.

Place the set trap (with the *safety on*) in the hole to check for fit — the tunnel *must* line up with *both* sets of jaws. Enlarge or adjust the hole as necessary.

Next, build a firm plug of soil across the center of the hole for the trigger to rest on. In very sandy soil, you may have to wet the dirt to make it hold together.

Holding the trap open with the set levers, carefully place the trap in the hole to check the height of the soil plug. Add or subtract soil as necessary. The pan should be in contact with the plug when the trap is in place.

Place the set trap with the *safety catch on* in the hole, making sure that the trigger rests on the plug (many people press down on the trigger while placing to ensure pan is firmly in contact with plug) and that the tunnel passes between both sets of jaws. The points of the scissors should be slightly embedded into the soil. In addition, be sure there are no rocks to jam the trap and the trigger set wire has room to function. Remove the safety catch and sift just enough loose soil onto the trap to exclude light and cover the jaws. When children or pets are present, put a weighted tub or something over the trap to protect them and the trap. If there are no results within several days, move the trap to another fresh location. *Be persistent!*

This set will also usually work for small moles, although you may get better results by building a wider plug under the trigger or placing a piece of shingle or a tin can lid between the trigger pan and the soil plug. Other styles of mole trap can be set in a similar manner.

Whatever trap you choose, be persistent! Moles have a knack for avoiding even good sets so you may have to move your trap several times before you make a catch. The most common mistakes made while trying to trap a mole are:

- Making the hole too big (mole can go around or push out trap);
- Making the hole too shallow (mole does not hit trigger or trap closes above the mole);
- Setting trap in abandoned tunnel; and
- Using a trap with a stiff trigger.

Although trapping is the only consistently successful method for reducing mole problems, there are many other tricks that have been tried. Some are more successful than others.

A mole problem can sometimes be solved by destroying the mole's food source. The application of soil insecticides that kill earthworms and grubs will often cause moles to move out. However, this method can be quite expensive and may take several weeks to show results. The insecticide must be applied according to label directions! (*Always read the label before using any pesticide!*)

Another way to drive the moles away, at least for a short time, is to use repellents and poisons. Most of the mole poisons on the market probably work more as repellents than as killers, if at all. Remember that moles live on soft invertebrates — mole baits are all hard and vegetable based. Research has shown that they are only 10 to 15 percent effective.

Lye, creosote, carbide, mothballs, dog repellent, broken glass, razor blades, and tankage are just a few of the things that have been shoved down moleholes in desperate attempts to kill or drive these little animals away. None of these items have been scientifically proven to have any effect on mole populations, nor are they registered for such use. Who would want broken glass or razor blades in their garden anyway?

Next we have the "high tech" methods. There are a variety of electronic noisemakers and vibrators on the market for driving away moles. None of these, when tested, have been effective in dealing with any pest species.

Finally, we come to the weird home remedies. It seems like every few years a new "miracle cure" for mole problems shows up. In the 1960's little windmills were the thing. In the 1970's chocolate laxatives were in vogue. In the past several years, chewing gum has become popular (supposedly, the mole is supposed to eat this stuff and fatally mess up his innards — hard to believe for a worm-eating animal)! As far as I know, these methods have not been tested scientifically (that is, using a test population and a control population), so no one knows for sure if they work or not.

All in all, managing our moles can be a difficult and time-consuming process. Some of us just learn to live with them, others become proficient at trapping or hire a professional. Sometimes, moles just disappear for no apparent reason or seem to avoid certain areas.

If you have mole problems or just want to learn more about this interesting little animal, WSU Cooperative Extension has a bulletin available on the subject for a small fee. Contact your county extension office and ask for EB1028 — Moles.

THE STUBBLE MAKER¹

Erosion Control Using Oat Straw

Ever thought of creating your own stubble field to prevent water and wind erosion while waiting for grass to grow on newly constructed steep hard-packed embankments? June Carrington, a consultant overseeing site restoration at the Oldman River Dam site has, and hired Alberta Agri-Services Ltd. of Olds, Alberta to create a "stubble field effect" on the downstream slopes of the dam. "Keeping the topsoil in place until plants take hold will be a very big challenge on the 1:3 side slopes. Wind velocities are high across these huge embankments," she concludes.

Alberta Public Works elected to go with a unique restoration plan. Carrington says that "native prairie topsoil from the area was stripped and placed to a depth of 150 mm (approximately 6 inches) on the slopes of the embankment. We hope there are enough propagules in the soil to establish native flora within a couple of years." To get some vegetation growing almost immediately, Carrington had 10 kg/ha (approximately 9 lbs/acre) of oats sown along with 5 kg/ha (approximately 4-1/2 lbs/acre) of Slender, Western and Northern wheat grasses. After seeding, Carrington next had straw spread over the seed bed followed by crimping.



June Carrington and Ken Schaber examine oat straw after "Crimping."

¹ Reprinted with permission from the Editor, Water Hauler's Bulletin, Alberta Agriculture, Lethbridge, Alberta, Canada T1J 4C7; Spring 1991 issue.



Chopping and blowing oat straw.

Ken Schaber, owner of Alberta Agri-Services Ltd. designed and built his own "stubble maker" or Crimper as he prefers to call it. He has a patent pending. His Crimper attaches to a tractor's three-point hitch and looks much like an ordinary farm disc. Its 12 discs spaced 200 mm (approximately 8 inches) apart can independently fluctuate up or down. Ease of operation is important to Schaber, the independent discs allow his machine to turn on steep slopes and in a 6-metre (approximately 19.7-foot) radius.

After seeding, says Schaber, "we spread good quality oat straw over the entire area. Oat straw is used because it is more flexible than wheat or barley and less likely to break when it is 'hairpinned' into the ground by the Crimper," he adds. Hairpinning the straw is accomplished by the Crimper's discs cutting the ground and pushing straw in to a depth of about 40 mm (approximately 1-1/2 inches). Upon completion of one pass with the Crimper, the area takes on the look of a stubble field with its straw standing vertical in neat 200-mm (approximately 8-inch) spaced rows.

Schaber says "the cost of seeding and crimping (Can\$1200/ha) (US\$400/acre) versus hydro-seeding at Can\$2700-2800/ha (US\$900-\$950/acre) makes this a very viable alternative for steep canal embankments."



Overview of downstream slopes of Oldman River Dam. Light areas have straw spread and await crimping.

Carrington hopes to have a good stand of native vegetation growing back on the slopes by next year; however, she concedes it may take a couple years.

For more information, please contact June Carrington at the Oldman River Dam site at telephone (403) 627-3765 or Ken Schaber of Alberta Agri-Services Ltd., Olds, Alberta at telephone (403) 556-2084.

***Editor's Note:** Two weeks after seeding, germination of the wheat grasses and oats can be seen across the slopes.*

HOOVER DAM

Nevada/Arizona

For years, Hoover Dam has been touted as one of the engineering wonders of modern man. Spanning the Colorado River between Nevada and Arizona, the arch-gravity concrete structure has been the object of world-wide recognition and study for over five decades. As one of the world's outstanding engineering achievements, it was selected by the American Society of Civil Engineers in 1955 as one of America's seven modern civil engineering wonders. Majestic in its clean graceful lines, the dam stands with one shoulder against the Nevada wall and the other against the Arizona wall of Black Canyon, harnessing the Colorado River.

Hoover Dam was constructed during the hardest of times. Man would move across the continent for employment only to labor long days under the most difficult of conditions in an unsettled, scorching desert. And the result, taming a river so fierce and powerful that it had, over millions of years, carved the mighty Grand Canyon.

In 1985, the country celebrated Hoover Dam's 50th anniversary. While the dam is a monument to engineering, equally marvelous are the benefits mankind has derived from it over the past half-century.

Prior to construction of the dam, the 1,400-mile-long Colorado River, winding its way from the Colorado Rocky Mountains to the Gulf of California, was unreliable and unpredictable — too much or too little water. Upper basin spring snowmelts and summer runoffs fed and swelled the river, but as summer rolled on into winter, the river became slightly more than a trickle. Attempts to use the river for settlement and development were unsuccessful, for without a stable source of water, there was no guarantee of tomorrow in the desert southwest.

In 1928, Congress passed the Boulder Canyon Project Act authorizing the construction of Hoover Dam. Construction began in 1931 and was completed in 1935, 2 years ahead of schedule. Innovative techniques were developed to build the structure, the grandest dam in its time. Every state in the nation furnished supplies and materials during construction, and out of it grew the small, nearby community of Boulder City, Nevada, which became home to the workers and their families.

President Franklin D. Roosevelt dedicated the dam on September 30, 1935. The dream was accomplished. Nature relented its authority — control of the river became man's.

Operated by the Department of the Interior's Bureau of Reclamation, Hoover Dam is a multi-purpose water resource project. Its benefits are manifested in many phases of the nation's economy. The purpose of the dam was to provide flood control.

Hoover Dam is about 36 miles from Las Vegas, Nevada. It is a concrete thick-arch structure, 726.4 feet high and 1,244 feet long at the crest. The dam contains about 3,250,000 yd³ of concrete; total concrete in the dam and appurtenant works is 4,400,000 yd³.

Lake Mead, the reservoir created behind the dam, originally had a total capacity of 32,471,000 acre-feet. Based on the 1963-64 sedimentation survey with the water surface at elevation 1221.4 feet, the capacity had been reduced to 28,537,000 acre-feet, 88 percent of the original volume. Lake Mead can store nearly 2 years of normal Colorado River flow. The water is released, as needed, in a year-round, regulated flow for downstream users. When full, the lake is 110 miles long, stretching to the lower end of the Grand Canyon.

Over 12 million people use water from the Colorado River. The Lake Mead national recreation area is one of the nation's largest playgrounds. Each year, about 6 million people trek to this desert oasis to fish, boat, ski, and play in its cool soothing waters. Concessions provide facilities such as lodge and trailer accommodations, boats for hire, and sightseeing boat trips.

Hoover Dam is one of the world's largest producers of electric power. Energy generated at the Hoover Powerplant has been a boon to industrial expansion and has made living more comfortable in thousands of homes.

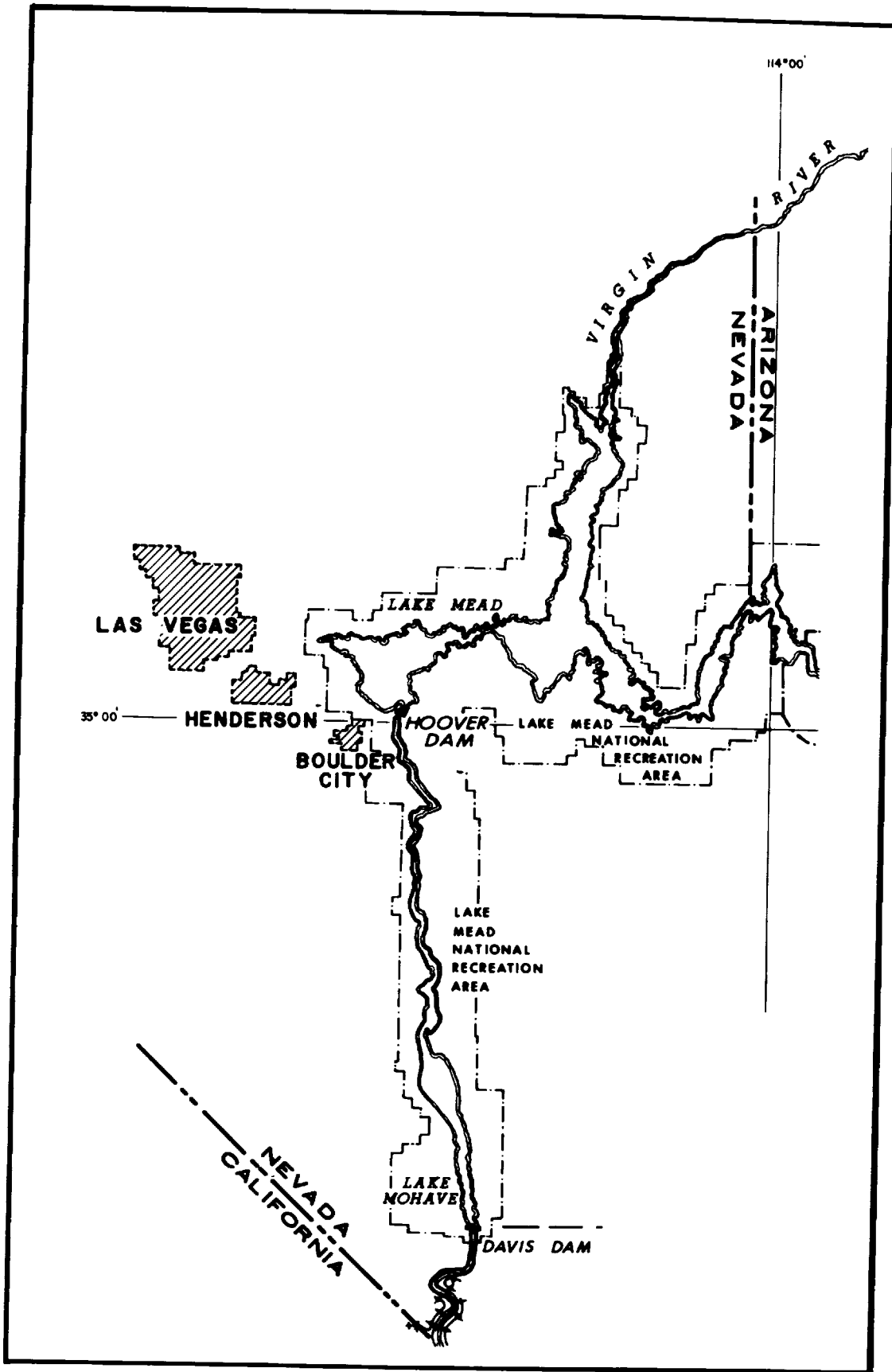

Hoover Dam, Boulder Canyon Project

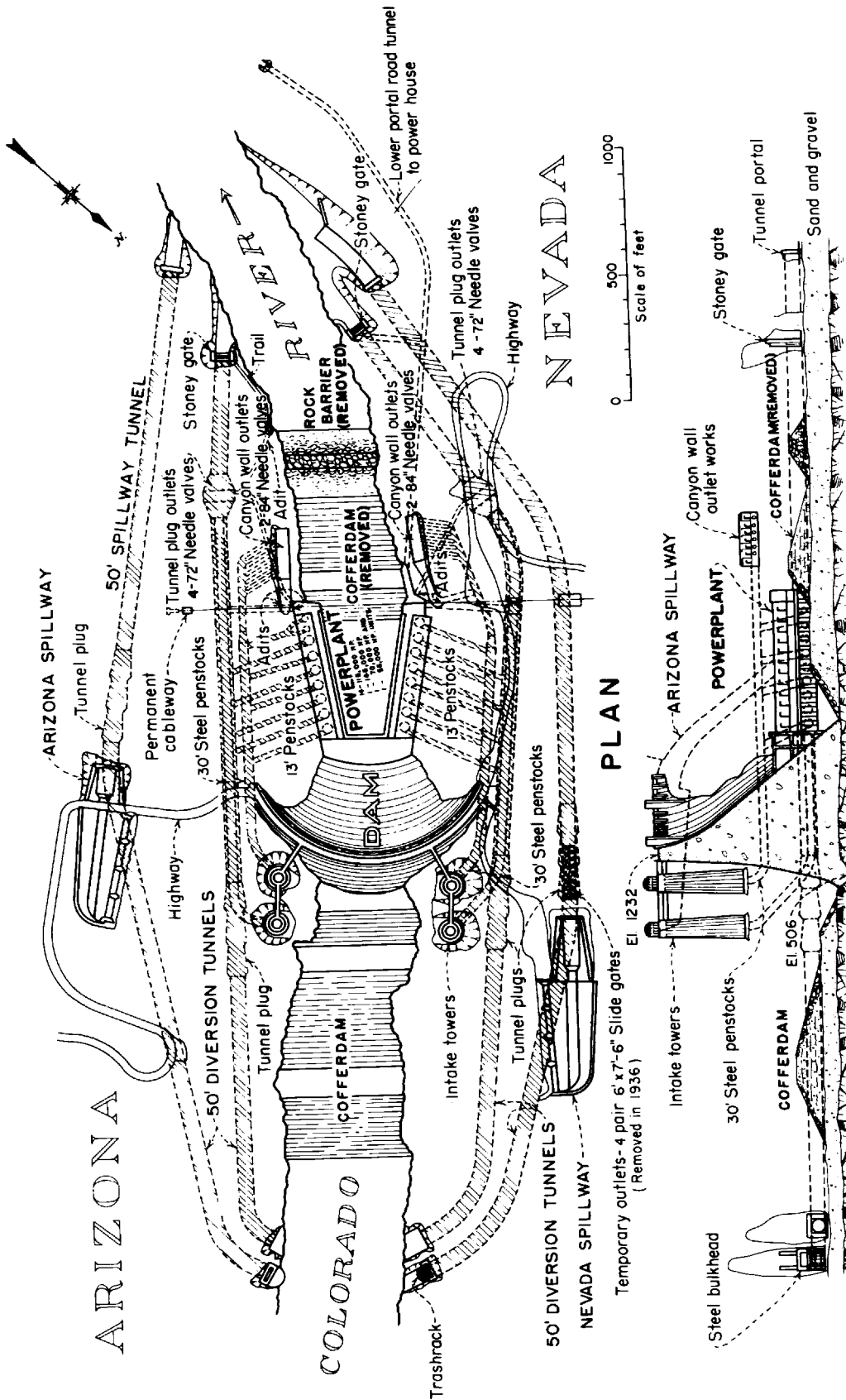

Hoover Dam, Plan and Section

Mission

The mission of the Bureau of Reclamation is to manage, develop, and protect water and related resources in an environmentally and economically sound manner in the interest of the American public.



The purpose of this Bulletin is to serve as a medium of exchanging operation and maintenance information. Its success depends upon your help in obtaining and submitting new and useful O&M ideas.

Advertise your district's or project's resourcefulness by having an article published in the bulletin! So let us hear from you soon.

Prospective material should be submitted through your Bureau of Reclamation Regional office.