

United States Department of the Interior, Bureau of Reclamation

# IRRIGATION OPERATION AND MAINTENANCE

BULLETIN NO. 70

October, November, December 1969

LAST COPY - DO NOT REMOVE

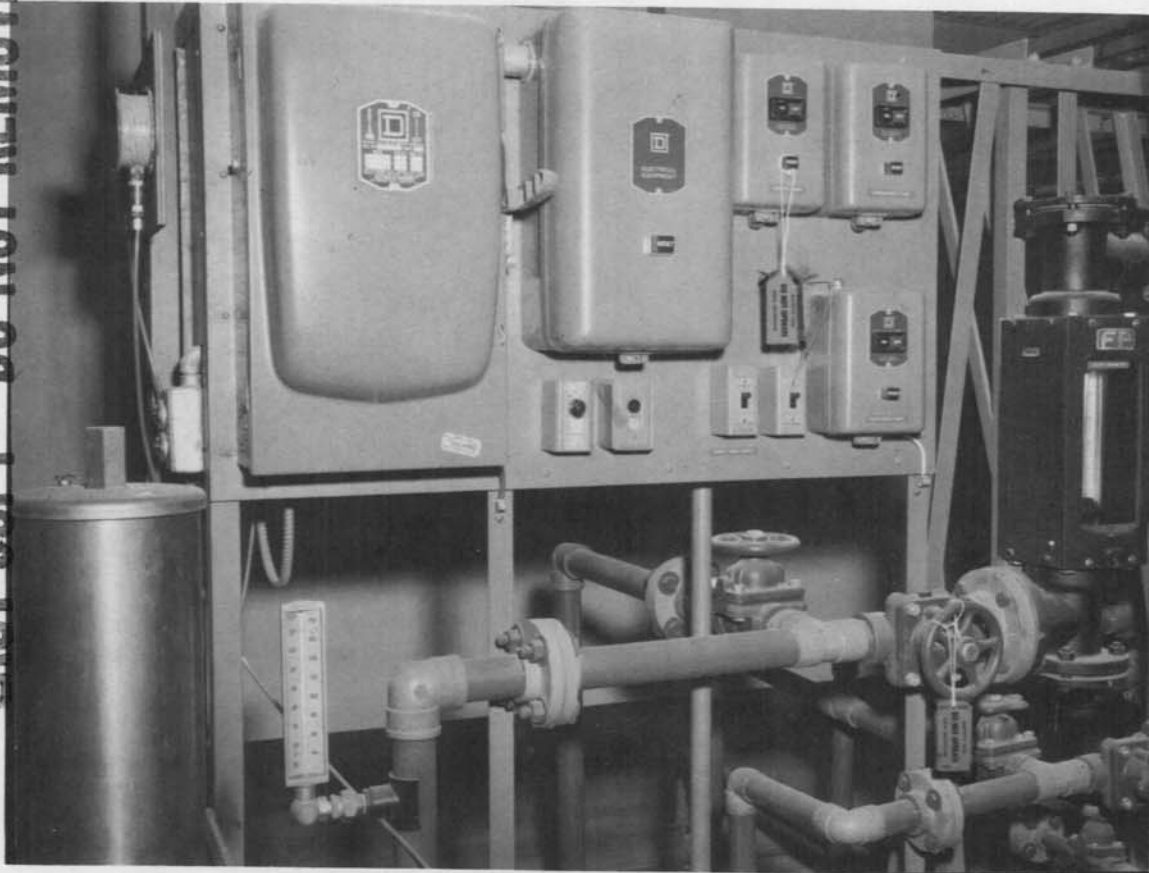

## In This Issue:

Use of Safety Tags on Operation and Maintenance  
of Irrigation Structures

Radial Gate Pipe Drain

Maintaining Radial Gates and Hoists

Rubber Oil Tanks

Float Tapes for Orifice Head Measurement

Asphaltic Tape Seal for Leaking Gates

Water Flow Measuring Device

Cleaning Air Filter Elements

The Use of Lasers in the Construction Industry

On the Job Inspection of Chain Hoists

LAST COPY - DO NOT REMOVE

The Irrigation Operation and Maintenance bulletin is published quarterly, for the benefit of irrigation project people. Its principal purpose is to serve as a medium of exchanging operation and maintenance information. It is hoped that the reports herein concerning labor-saving devices and less costly equipment and procedures, developed by resourceful project people, will result in improved efficiency and reduced costs of the systems for those operators adapting these ideas to their needs.

To assure proper recognition of those individuals whose suggestions are published in the bulletins, the suggestion number as well as the person's name is given. All Bureau offices are reminded to notify their Suggestions Award Committee when a suggestion is adopted.

\* \* \* \* \*

Division of Irrigation Operations  
Office of Chief Engineer  
Denver, Colorado 80225

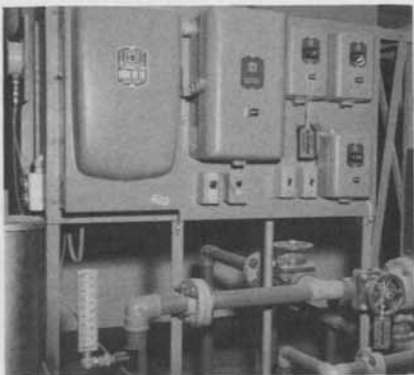

COVER PHOTOGRAPH:

The cover photograph shows a typical control board used in the Bureau Engineering Laboratory, Denver, Colorado. Note the two safety tags, one hanging from the upper middle switch-box and the other hanging from the valve at lower right, used when machinery is shutdown for repairs. Photo PX-D-65571

IRRIGATION OPERATION AND MAINTENANCE  
BULLETIN No. 70

October, November, December 1969

INTRODUCTION

The first article starting on page 1 provides a guide for irrigation districts and others in the use of safety tags as a warning signal not to start equipment that is shutdown for repair or to indicate that some operation limitation has been imposed.

A top seal radial gate drain developed by the Yuma Projects Office, Yuma, Arizona, is described on page 7. This unique device was made to bypass water leaking through the top seal of a closed radial gate. It not only reduces maintenance costs but also gives the gate a much better appearance by preventing rust and paint streaking.

"Maintaining Radial Gates and Hoists" is the title of this article on page 10; it sets forth recently issued recommendations for the proper maintenance of radial gates and hoists.

An article on page 11 describes how the Salt River Project, Phoenix, Arizona, utilizes rubber oil tanks in their day-to-day operation of the project.

On page 12, a suggestion from the Kansas River Projects Office, McCook, Nebraska, on the use of float tapes for orifice head measurement saves time for all concerned when the necessary readings are made at the stilling wells.

A simple method to stop leaking gates on lateral and farm turnouts by using asphaltic tape can be found on page 14.

The results of a suggestion submitted jointly by two employees of the Division of Water and Land Operations, Region 7, Denver, Colorado, entitled "Water Flow Measuring Device" can be found on page 15.

How to clean filter elements is presented in a short article found on page 17.

Starting on page 18, an article from the National Safety Council's Construction Safety Release points out the DO's and DON'T's for the use of lasers in the construction industry.

Most chain hoist defects can be avoided by following a few simple rules and regulations as described in the last article found on page 21.

USE OF SAFETY TAGS IN  
OPERATION AND MAINTENANCE  
STRUCTURES<sup>1/</sup>

These procedures are to establish, under controlled discipline, a safe environment within which people can perform their assigned tasks. All Bureau-constructed facilities shall be operated and maintained with maximum safety to personnel and equipment. Bureau personnel are charged with the responsibility of performing their assigned tasks in the safest possible manner. Operations will be guided and tested by the fundamental principle, "Start with the correct procedure and follow it exactly."

These procedures are to provide guides to operating personnel at all irrigation facilities, but more particularly at storage and diversion dams and pumping plants. They are not intended to supersede previously issued instructions published for power operations but are to provide instructions for the operation of facilities that are not operated by the Bureau of Reclamation Power Division. The practices and procedures outlined in this article were originally developed by Region 7 and made mandatory to all Bureau offices by letter from the Chief Engineer to all Regional Directors dated March 15, 1967. Also, they provide a guide for the operation and maintenance of Bureau-constructed facilities transferred to irrigation districts or other irrigation entities.

Definition of Terms

Bureau-constructed Facilities - This includes storage dams, diversion dams, pumping plants, canal systems, and accessory electrical equipment.

Authorized Operators - Individuals qualified by their supervisor to operate a specific structure or facility.

Operating Supervisor - Individuals directly responsible for the actions of authorized operators.

Special Conditions - This is an unusual or temporary condition which effects the operation of equipment or a facility and is not associated with other protective procedures. This term indicates the requirement for a special operating procedure. Special operating conditions may be implemented to protect equipment or a structure because of certain existing limitations.

General Responsibility and Authority

Each project supervisory staff has the responsibility to insure that these procedures are (1) understood by all concerned, (2) properly

<sup>1/</sup>This article was adapted for this Bulletin from a brochure, dated March 1968, published by the Regional Director, USBR, Region 7, Denver, Colorado.

applied, and (3) strictly adhered to. Each supervisor shall make certain that all persons under his jurisdiction are instructed concerning these procedures and their application.

The supervisor shall determine, through training, observations, or other acceptable evidence, that his personnel understand and are following procedures. All employees shall be subject to examination at any time to check their knowledge of the safe clearance procedures.

### Procedures

These procedures are for the safety of personnel in and around structures. Even though one man is usually responsible for the operation of a specific structure, other authorized or unauthorized persons could be severely or fatally injured by an incorrect operation. Furthermore, improper operation of a facility or structure might create a situation which would be harmful to the public's image of the operating organization.

Conditions at Bureau structures sometimes warrant the use of special procedures to protect personnel and equipment. This perhaps occurs most often during the inspection or repair of structures and equipment. Periodically, pipes through dams are drained for inspection or maintenance. If, as an example, the emergency gate was opened while the pipe was being inspected, people in the pipe would be drowned. To avoid this, a "DO NOT OPERATE" tag should be attached to the emergency gate controls. Likewise, if a limitation is imposed on the amount of water that can be discharged through a pipe in a dam, a tag should be attached to the emergency gate controls. Also, if a limitation is imposed on the amount of water that can be discharged through a pipe in a dam, a tag should be attached to the controls indicating the special conditions imposed on the operation of the facility.

### Tagging Procedures

When conditions at a Bureau structure warrant the use of a "DO NOT OPERATE" or "SPECIAL CONDITIONS" tag, the authorized operator will attach the appropriate tag at the operating source. This may be the control valves on a spillway gate or on the electrical control panel which provides energy for the operation of equipment. The operator shall, as soon as practical after the tagging action has been accomplished, enter in a log book the date, time, and place that the tag was attached.

He shall briefly describe the reason for taking the action and sign his name to the entry. If the action is initiated by the authorized operator because of unsafe or unstable conditions observed by him, he will notify his supervisor immediately of action taken. If the action is initiated by the supervisor either by written or oral communication to the operator, the operator will attach the appropriate tags and make an entry in the log book.

### Restoring Equipment to Normal Operation

If the tagging action is initiated by the operator, it is his responsibility to remove the tags when there is no longer need for the tags. Upon removing the tags, he will enter a record of the action in the log book. If tagging action is initiated by the supervisor, the tags will only be removed after the supervisor has directed the operator to do so. Again, a record of the action will be placed in the log book.

### DO NOT OPERATE Safety Tags

As shown in the cover, protection is provided by systematically isolating equipment from all sources of hazardous energy (electrical, mechanical, and hydraulic) by attaching a "DO NOT OPERATE" safety tag, similar to that in Figure 1, page 4, to the operating points at the source of energy. A safety tag shall be the same as a lock, and the tag point is not to be operated while the tag is in place. The tagging is primarily for the protection of personnel but may provide protection for equipment. This safe clearance procedure is intended to accomplish this protection with as little delay and inconvenience as possible.

Example: The outlet pipe through a dam is to be inspected. The emergency gate is closed, the operating gates are open, and the pipe is drained. Before the inspection party enters, the pipe and the manhole covers on the pipes are removed, the authorized operator will establish a safe clearance by attaching "DO NOT OPERATE" safety tags to the oil pump motor starting controls and the four-way valve handles that control the emergency and operating gates, and then inform the inspection party that it is safe to proceed. The safe clearance will not be removed by the operator until he has definitely determined that all members of the inspection party are out of the pipe and the manhole covers are properly secured to the pipe.

### SPECIAL CONDITION Safety Tags

Whenever an operation limitation is imposed on any equipment or facility, "SPECIAL CONDITION" tags, similar to that shown on page 5, should be attached to the controls of the equipment or facility. The tags should be placed in a conspicuous location on the controls. Although a "SPECIAL CONDITIONS" tag may serve as temporary protection for the equipment, it shall not be used for the protection of people. The authorized operator of a feature or facility will attach a "SPECIAL CONDITIONS" tag to the controls when conditions warrant or when he has received orders to do so from his supervisor.

When the condition requiring a "SPECIAL CONDITIONS" tag no longer exists, the authorized operator will remove the tag after he has received permission from his supervisor to do so. The operator will enter in the log book a record of all action taken in connection with "SPECIAL CONDITIONS" tags.



**FIGURE 1**

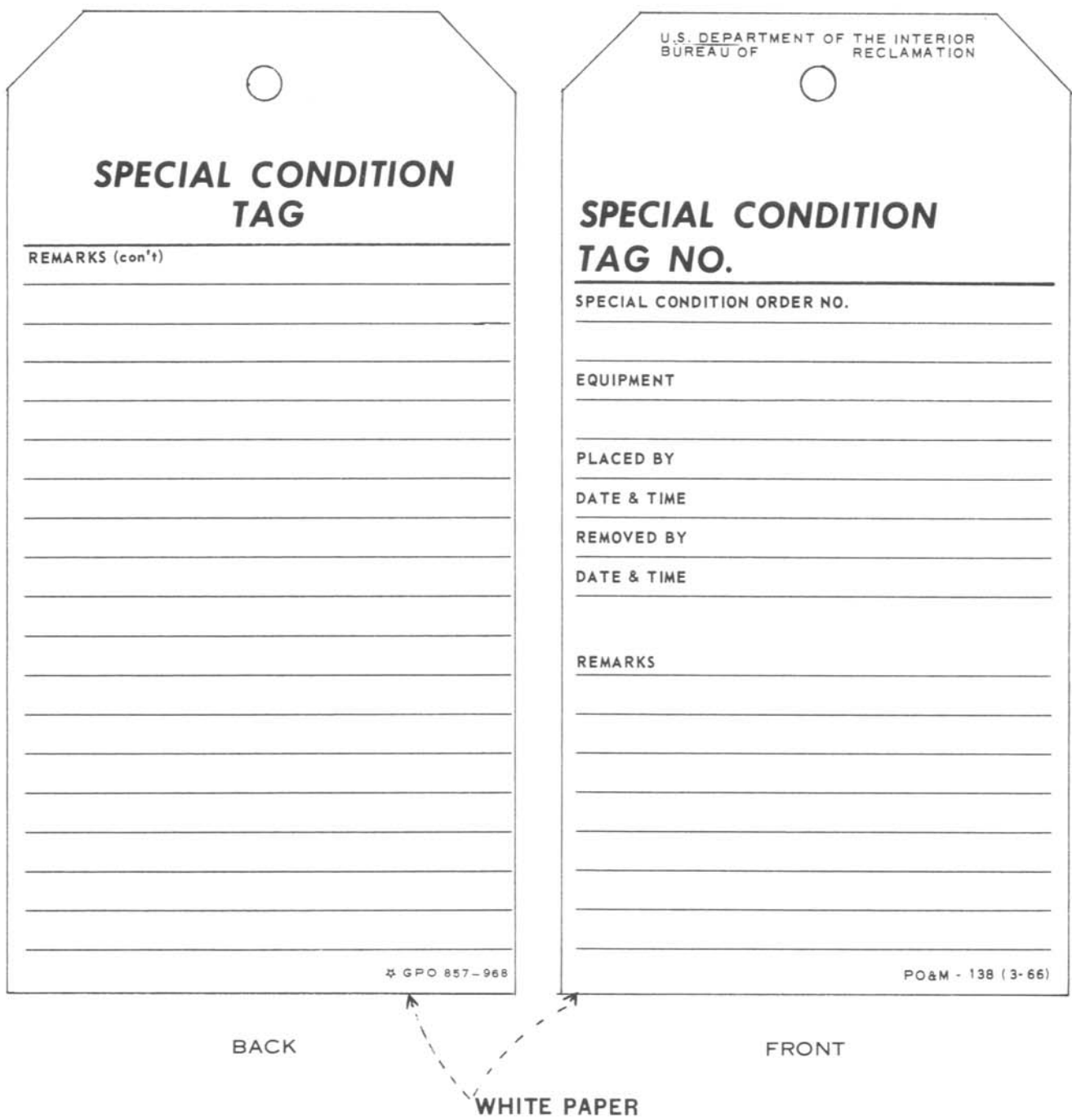

FIGURE 2



Example: Releases to the river from the river outlet works must not be reduced below 100 cfs during the month of April. The reservoir superintendent will attach a "SPECIAL CONDITIONS" tag to the river outlet controls on April 1 and will remove the tag on May 1.

#### Log Book Entries

All entries shall be made in the log book with ink or other permanent marking material. Entries shall be made as soon as practical after tagging action has been accomplished. All persons making entries in the log book shall sign their names after the entry. Entries shall be made as follows:

1. Placement Action: After the tags have been attached, the operator shall log the date, time, and type of tag used.
2. Removal Action: After the clearance has been made and the tag removed, the operator shall log the date and time the tags were removed.

#### Application of Procedures when Maintenance is Performed by Contract

When contractor's forces perform maintenance on or around Bureau structures, the above-described procedures shall be followed. All safety precautions should be explained to the contractor and he shall be furnished a copy of this publication. Safety tags will be installed by the regular operator, and the equipment shall not be operated until such time as the operator removes the tags. If the contractor desires to test the equipment that is being repaired and a "DO NOT OPERATE" tag has been attached to the controls, he shall request the Bureau operator to perform the operation. If conditions are favorable, the operator will remove the tag and perform the necessary operation requested for the testing. After the tests have been completed, the "DO NOT OPERATE" tag will be replaced on the controls.

#### Availability of Tags

The tags referred to in this article (PO&M-137) and (PO&M-138) are available to Bureau personnel by requisition from the Office of Chief Engineer, Attention: Code 822, Denver Federal Center, Denver, Colorado.

\* \* \* \* \*

## TOP SEAL RADIAL GATE PIPE DRAIN

Radial gates may be subject to wetting on the downstream side due to a leaky top seal or for other reasons. Under this condition, maintenance problems are increased because protective coatings deteriorate quickly. The drain described in this article has been devised to contain and control the leaking water and thus reduce maintenance costs.

Photograph 1 below shows a gate that was recently repaired and the 4-inch dam and pipe drain installed. The spots visible on the backside of the skinplate are weld holes cut through the old skinplate to facilitate installation of a new one.



Photograph 1 - PX-D-65572

Photograph 2 on the next page shows water leaking past the top seal at the right top corner of the picture and then flowing out of the pipe drain below.

This modification of the downstream side of radial gates was conceived by Mr. Hubert Malberg, Plant Mechanic Foreman, Yuma Projects Office, Yuma, Arizona, and built by Mr. Malberg and members of his crew. The modification was first made on the California River Gates

at Imperial Dam. Pipe drains were then installed on the radial gates at all automatic wasteways on the Gila Gravity Main Canal where they proved most beneficial because of the necessity for having a loose fit on the top seal. When the top seals are installed tight enough to preclude leakage, the gate will not operate automatically.



Photograph 2 - PX-D-65573

The minor cost involved in making this modification probably will be more than compensated for by the increased protective coating life on the downstream side of the gate. A sketch of this modification is shown on the next page.

If additional information is desired regarding this radial gate pipe drain, please write to the Bureau of Reclamation, Regional Office, Region 3, Boulder City, Nevada 89005.

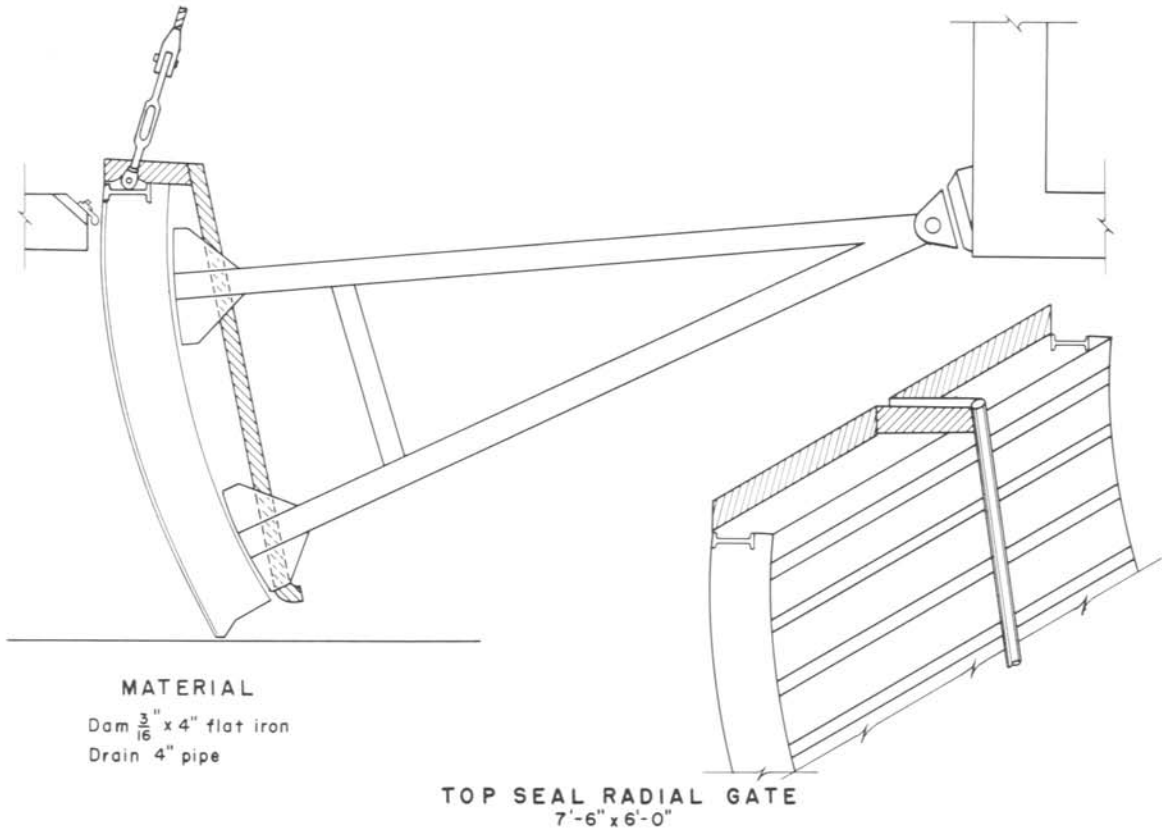

Sketch

\* \* \* \* \*

KEEP IT LEGAL

The Law prohibits reproduction of certain items by any means, including copiers. In addition to the obvious ones - currency and stamps - there are others:

- a. Passports, immigration papers, citizenship or naturalization papers
- b. Automobile registrations, drivers' licenses
- c. Badges, ID cards, passes or insignia carried by Armed Forces personnel or federal employees
- d. Draft cards, amateur radio operators' licenses
- e. Obligations of any foreign government, bank, or corporation.

## MAINTAINING RADIAL GATES AND HOISTS

These current recommendations for the maintenance of radial gates and hoists were recently issued by the Office of Chief Engineer, based on additional operating experience and the use of modern lubricants. The recommendations are as follows:

Where grease fittings are provided for lubrication of the gate trunnion pin bearings, the bearings shall be lubricated at least twice a year. Grease equivalent to Texaco All-temp or Fiske Brothers Refining Company Lubriplate No. 630-AA shall be used where a specific type of grease is not called for on the drawings or in the Designers' Operating Criteria.

Gate seals shall be inspected once a year and shall be repaired, adjusted, or replaced when necessary. If seal adjustments are changed, care shall be taken to be sure the adjustment does not prevent free movement of the gate.

The gate hoists should be tested at least twice a year to be sure the controls and motors are operating properly. The limit switch should be inspected periodically to see that it is functioning properly.

The gate hoist worm gear reduction unit should be lubricated with grease equivalent to Lubriplate APG 140 or Texaco Maropa Lubricant 3. The gear reduction unit of the gear motor and the spur gearing in the drum units should be lubricated with a good grade of nondetergent SAE 20 oil. Drain plugs should be removed annually to be sure there is no water present. The gear boxes should be drained at 5-year intervals and refilled with fresh oil. High-pressure grease fittings and flexible couplings should be lubricated with Texaco All-temp Lubriplate No. 630-AA or its equivalent at least twice a year.

Wire ropes with galvanized sockets should be inspected annually for deteriorating effects such as corrosion, kinking, breaking of individual wires, or loosening in the sockets, which may make replacement necessary. The wire ropes should be lubricated annually, or more often if found necessary, with a good lubricant which will penetrate into the rope, will not dry out or flake off, and will not drip off on warm days. Grease equivalent to Texaco All-temp or Lubriplate No. 630-AA dissolved in sufficient solvent to permit brush application has been found satisfactory as a wire rope lubricant. This has the necessary penetrating quality at application, after which the solvent evaporates, leaving the grease inside the rope where needed.

\* \* \* \* \*

## RUBBER OIL TANKS

Although this idea would have limited use on Bureau Irrigation Projects, we feel it is worth bringing to the attention of Operation and Maintenance people.

These rubber tanks are being utilized by the Salt River Project in Phoenix, Arizona, to transport oil to substations. After the oil is delivered, these tanks, such as the 4,600-gallon tank shown at left, can be removed freeing the truck for other purposes.



The Project has purchased two of these rubber tanks and is utilizing them for oil transport, rather than renting tankers as in the past.

A 15,000-gallon pillow tank is also used by the Project, as shown in the photograph at lower left. This particular tank is used for oil storage.

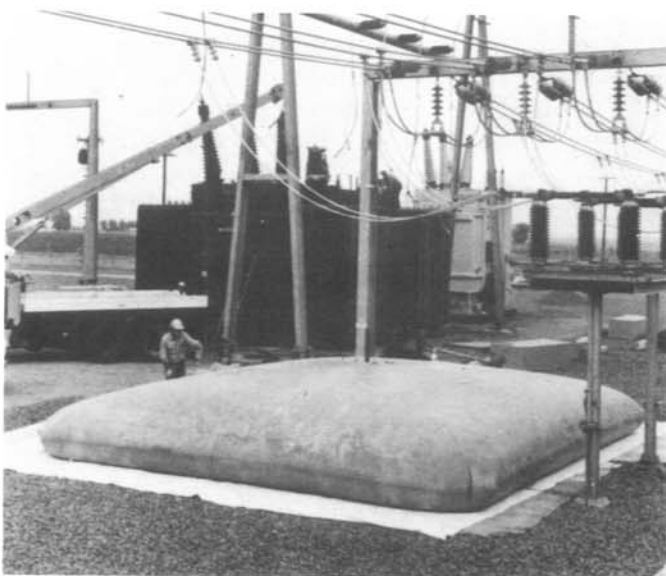

One of the leading rubber companies in Phoenix manufactures these tanks, and we are told that similar tanks have been used by the military in South Vietnam.

If further information is desired regarding these tanks, please write to the Bureau of Reclamation, Regional Director, Region 3, Boulder City, Nevada 89005.

FLOAT TAPES FOR ORIFICE HEAD MEASUREMENT  
(Suggestion R7-68S-39)

The use of two float tapes on the upstream and downstream stilling wells of an orifice check water measurement structure has been suggested by Mr. Edward Hlavinka, Hydraulic Engineering Technician,

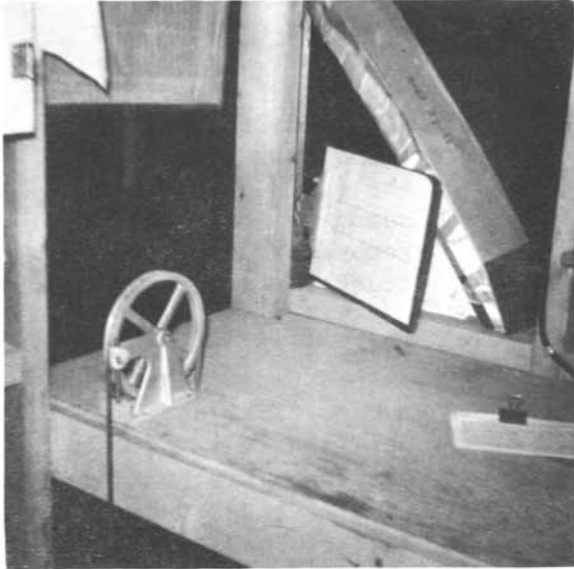

Photograph 1 - PX-D-65576

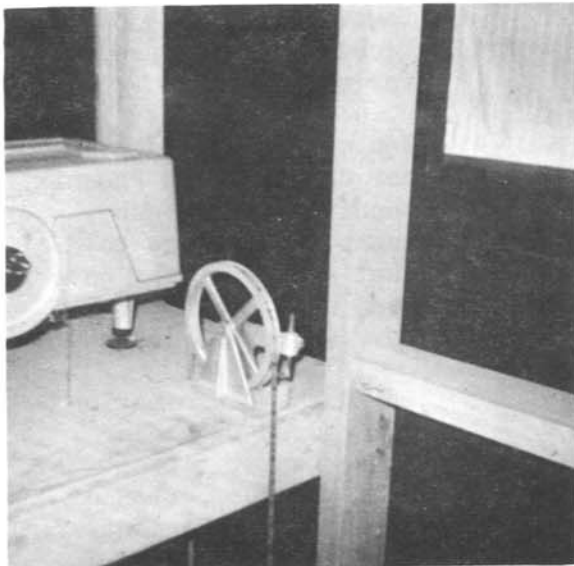

Photograph 2 - PX-D-65577

Kansas River Projects Office, McCook, Nebraska. Although this idea may have limited application, Mr. Hlavinka stated that this type of installation has proved to be a time saver for all personnel involved when readings are made to determine the effective head on the orifice gates, such as the ditchrider, the damtender, or the hydrographer who calibrates the structure. He also stated that this idea can be installed in Parshall flumes, if well room permits.

When installing the two automatic float tape indicators, it is necessary to weigh the 8-inch floats and counterweights and pair them up to be sure they weigh exactly the same. The floats and tapes can be zeroed in by the use of a carpenter's level. Water levels can also be used as a check.

Photograph 1 at upper left shows the upstream weight tape installation as it appears on the recorder bench at the orifice check measuring structure, and Photograph 2 shows the downstream weight tape installation and the differential head recorder.

A sketch of this automatic float tape indicator is shown on the next page. It was

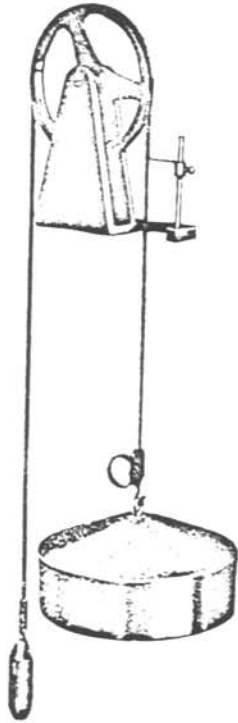

reported that this device was much superior to the weight tape indicators previously used.

The float tapes being installed in close proximity to each other afford an instantaneous reading of both wells and eliminate any possibility of error introduced by the time delay of other methods such as a reel and weighted tape.

This material mentioned in the article can be purchased from companies supplying water level recorder and related types of equipment.

SKETCH

\* \* \* \* \*

#### SIX-FOLD ECONOMIC BENEFIT FROM IRRIGATION

An analysis recently issued by the University of Nebraska Bureau of Business Research shows that in 1963 for each \$1.00 in net increase in crop production due to irrigation, a total of \$6.68 in new business activity was generated throughout Nebraska. This is one of the basic conclusions of the report titled "Economic Impact of Irrigated Agriculture on the Economy of Nebraska." The study was performed under contract with the Bureau of Reclamation and published by: The Bureau of Business Research, The University of Nebraska, Lincoln, Nebraska 68508.

\* \* \* \* \*



## ASPHALTIC TAPE SEAL FOR LEAKING GATES

The Ainsworth Irrigation District in northern Nebraska has solved their problem of leaking gates on lateral and farm turnouts by using asphaltic tape.

A leak was discovered by the District personnel, and water was seeping between the cast iron gate seat and the concrete breast wall on the second or regulating gate in the constant head orifice structure.



This particular gate was not set flush with the concrete and water leaked out through the cracks. The tape acts as a gasket between the cast iron gate seat and the concrete breast wall. A typical installation is shown in the photograph at left.

The tape used to seal the gates is a commercial product made of a heavy-duty asphaltic mastic, preformed in tape shape, 3/16-inch thick by 2-, 3-, or 4-inch widths and comes in standard lengths of 4 feet extruded between two protective wrappers. A layer of glass fabric is imbedded in the plastic tape to provide dimensional stability and reinforcement. It is commonly used for sealing hairline cracks in concrete canal linings.

Installation is simple as indicated below:

- a. The gate frame is removed to allow sufficient space to place the tape on the concrete.
- b. Gate frame is reinstalled.

When gate frame is reinstalled, it pushes out the excess tape material as shown in the above photograph. A 4-inch tape was used on this initial installation; however, it was felt that a 2-inch strip would have been sufficient to seal the gate frame against the concrete structure.

If additional information is desired on this subject, please write to the Regional Director, Region 7, Attention: Code 7-430, Building 20, Denver Federal Center, Denver, Colorado 80225.

\* \* \* \* \*

WATERFLOW MEASURING DEVICE  
(Suggestion R7-68S-22)

In many locations, such as at river gaging stations, canals, laterals, and in research studies, it is required that a flow of water be measured with accuracy. In any measuring device, even though suited to the location, the water level may vary considerably in a period of 24 hours. Fluctuation in the flow causes this variation in water level. To accurately measure the total volume in a given period, some means of continually recording the water level must be provided. This is sometimes accomplished by connecting a stilling well to a measuring device with a small intake pipe, as shown in the sketch on the following page, and using a float that operates in the well and is connected to a recorder.

When the water is carrying sediment, the intake has a tendency to become plugged. When this occurs, the water level in the flume and in the stilling well will not be the same. The recorded water level accordingly will be in error. A means of preventing deposition of silt in the intake pipe is the subject of this suggestion made jointly by Messrs. Neil W. Schild and Fred C. Corey of the Division of Water and Land Operations, Regional Office, Region 7, Denver, Colorado.

Additional equipment necessary for this device consists of a tank of compressed air, a single-stage regulator, and approximately 10 feet of plastic tubing. The compressed air can be obtained from any local welding supplier, and the single-stage regulator may be purchased for approximately \$20 to \$50. The plastic tubing used in one particular installation was obtained from the Geological Survey which uses the tubing for Servo-manometer installations, and each office usually has short pieces available. However, plastic tubing suitable for this installation can be purchased locally. One-quarter-inch outside-diameter thick wall tubing is required.

One end of the tubing must be attached to the regulator and the other end plugged with a small woodscrew. A small needle can be heated and used to penetrate the walls of the plastic tube to provide holes about 1-1/2 inches apart. The plastic tubing should then be inserted into the stilling well and the intake so that the holes are located in the section of tube which will be in the intake pipe between the stilling well and the flume. The tubing should be held in the invert of the intake by a small spring clip. The small size tubing allows sufficient opening for transfer of water and also to insert another tube to periodically clean the intake.

The amount of air used by this device is dependent on the pressure and the size of holes in the walls of the plastic tube. As air bubbles through the small holes, turbulence in the intake pipe will remove heavy sediment or keep it in suspension. This provides for good movement of water, maintaining a constant level between the flume and the stilling well.

The device as shown and described was installed and used in a Water Use Study Area on the North Platte Project near Torrington, Wyoming, in the fall of 1967, and may be moved from one location to another as needed. It provided very good records at a station where previous records had been doubtful because of heavy sediment in the water. Some of these particles which plugged the intake were approximately 1/16 to 1/18 inch in size. Pressure used for normal operation was about 4 psi. However, when visiting the measuring device once a day, the pressure in the tube can be increased for a short period of time to completely clean the intake pipe.

Cost per installation

Regulator \$20 to \$50

Plastic tubing (minimum cost)

Tank of compressed air, \$4, including tank rental

If additional information is desired, please write to the Regional Director, Bureau of Reclamation, Building 20, Denver Federal Center, Denver, Colorado 80225.

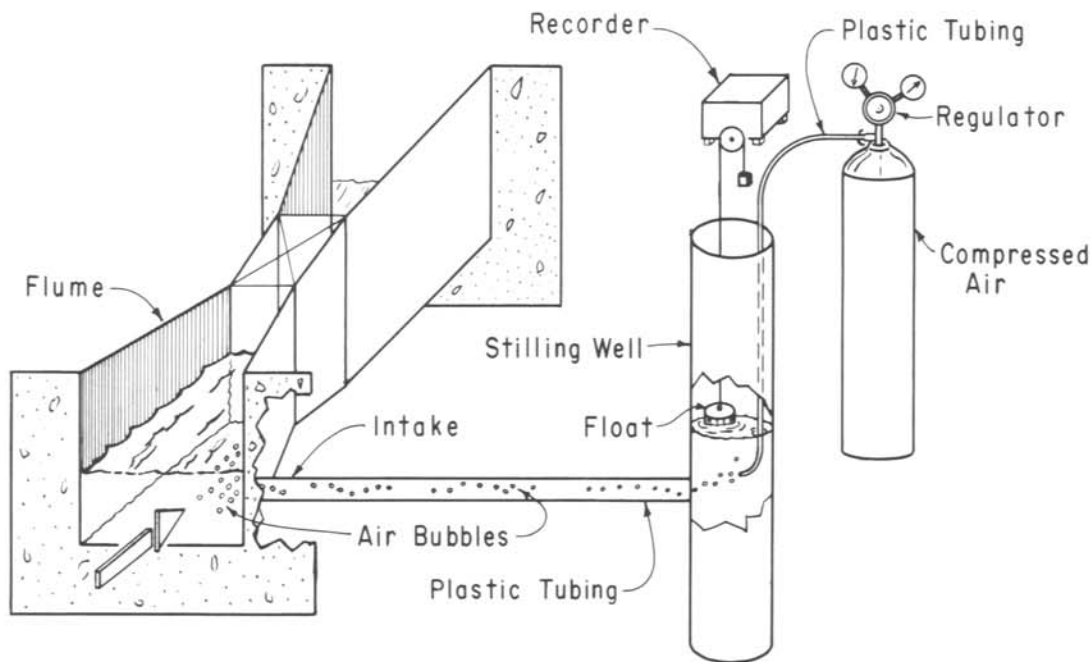

\* \* \* \* \*

CLEANING AIR FILTER ELEMENTS  
(Suggestion R1-68S-46)

An idea for cleaning filter elements is presented in this article by Mr. Warren D. Heldenbrand of the Chief Joseph Dam Project, Greater Wenatchee Division, Oroville, Washington. The suggestion states that the air filters for the ventilating fans at the Booster Pumping Plant are of the reusable type and have to be cleaned and a film of oil placed on the elements at least once a year. In the past, each filter element was washed in cleaning solvent with a brush and then soaked in oil, and the excess oil had to be drained away.

This new method of cleaning suggested by Mr. Heldenbrand calls for the use of compressed air in combination with cleaning solvent to clean the filter elements. The idea could also be used to clean ball bearings, only the device would have to be circular in design. See sketch below.

As shown in the sketch, the filter elements should be raised with blocks approximately an inch above the device and enough cleaning solvent placed in the cleaning container to almost cover the filter element. Air from an air compressor is then forced into the device, and air from the 1/16-inch holes flows up through the filter carrying solvent and debris with it. The air compressor used has to be of sufficient size to operate at 80 psi continually.

A paint sprayer can be used to place the oil film on the filter elements at the end of the cleaning cycle. Caution should be used when using a flammable type of cleaning solvent. However, a nonflammable nontoxic solvent is available.

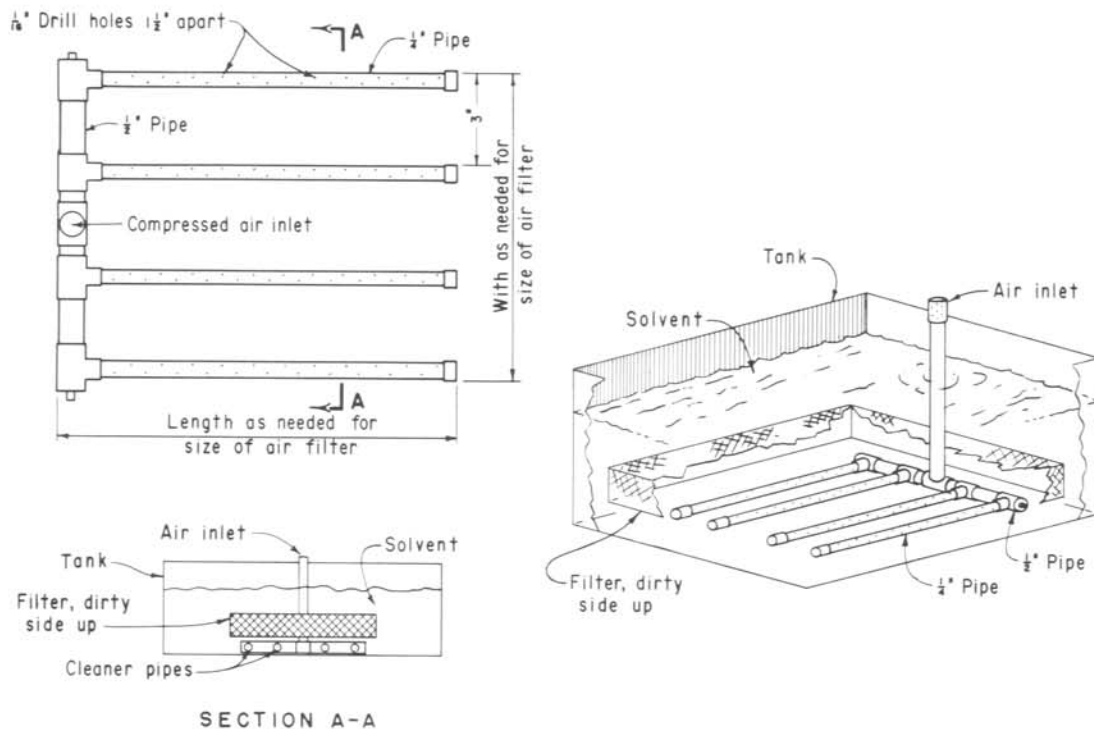

\* \* \* \* \*

THE USE OF LASERS  
IN THE CONSTRUCTION INDUSTRY<sup>1/</sup>

The number of lasers in use in tunnels and on construction projects is now mounting rapidly. To date, no single standard has been adopted for laser exposure. The State of Illinois has passed laws aimed at reducing the number of laser accidents. Generally, those lasers are excluded where there is a low level energy output where the public health hazard of the laser system is absent or negligible.

The helium-neon gas lasers used in construction are very low-power lasers because all that is required is a visible beam of light to use as a reference. The intense beam of light provides a precise alinement for laying pipe, leveling, tunneling, grading, plumbing, pile driving, and dozens of similar tasks. People work in the presence of intense light sources all the time. Every man in construction knows that he should not stare at a welder's torch. The hazards of low-power lasers should not be overly exaggerated with respect to other types of construction hazards.

Obviously, if the dangers of laser radiation are understood and a safety program initiated in accordance with the dangers, hazardous conditions will be avoided. It is unlikely that the general public or transient personnel would be exposed to hazardous levels if proper precautions are taken. For example, the laser attenuator cap may protect the worker at 200 feet; but if curious bystanders manage to get in close to the laser and peer directly into the beam at 20 feet, injury may result.

The risks for our personnel can be reduced if a few simple rules are followed. Unfortunately, they are sometimes neglected, either through lack of knowledge but more often through carelessness.

What to Do to Avoid Accidents

DO assign only those persons to set up, adjust, and operate equipment that are qualified to follow appropriate procedures related to lasers.

DO provide twist lock connectors and proper grounding for all noncurrent carrying conductive parts of the equipment. Respect laser equipment as you would any other electrical equipment. This aspect of the safety problem must be stressed insofar as the potential electrical hazard is usually greater than that posed by the low-power laser beam itself.

<sup>1/</sup>This article is taken from the National Safety Council's Construction Safety Release No. 69 and was written by Charles R. Nelson.

DO instruct all personnel in areas using lasers with respect to the dangers of the equipment and the laser beam, both direct and reflected.

DO alert personnel within the vicinity of lasers prior to the using of any laser device in order that they may take precautions to shield or otherwise protect their eyes.

DO placard danger areas to inform of potential danger those members of the general public or other transient persons who may otherwise be exposed. The placard should warn persons not to stare at the beam if they should see it.

DO require employees to wear antilaser eyeglasses if there is no alternative to exposure. Generally, antilaser glasses are worn only with very powerful lasers not the low-powered construction type. Most susceptible to laser-beam damage is the eye. When necessary, use laser goggles that are marked as suitable for the particular wavelength and power density. A word of caution - goggles may severely restrict or hinder the worker's vision in some way that jeopardizes his safety from other hazards of the job.

DO require personnel assigned to lasers to receive a complete eye examination prior to such assignment. Subsequent eye examinations should be given each year. Any persisting after-images of a light source should be reported to a physician. Eye examinations should help in protecting a company against unjust compensation claims.

DO keep the output down as low as possible to suit the construction work.

DO above all, DO follow the manufacturer's instructions on the use of lasers.

#### Recommended DONT's to Avoid Accidents

DON'T stare directly into the laser beam. If operators whose work requires observation of the beam must work close to the equipment, the intensity of the light should be reduced by attenuator caps supplied by the manufacturer or antilaser goggles.

DON'T allow reflective material around the area of the beam (Good Housekeeping). If the reflecting surface is flat, the characteristics of the reflected beam may be considered identical to those of the direct beam.

DON'T attempt to locate the laser beam with the eye. This is especially important where the beam is traveling long distances. Use some type of reflective material to intercept the beam and thereby locate its position. Aiming the laser with the eye should be avoided to prevent looking along the axis of the beam, which increases the hazard from reflections.

DON'T operate the laser in rain, snow, fog, or dust unless safety eye wear is utilized.

DON'T use Radio Frequency excited lasers near blasting caps.

DON'T leave the laser equipment unattended while in the energized state.

A booklet entitled, "Guide for Uniform Industrial Hygiene Codes or Regulations for Laser Installations," can be obtained by writing to the American Conference of Governmental Industrial Hygienists, 1014 Broadway, Cincinnati, Ohio 45202.

\* \* \* \* \*

#### ICE AND SNOW CENSUS

Glaciologists are to make a survey of the quantity of ice and snow on the earth's surface as a contribution to the International Hydrological Decade. The president of the International Commission on Snow and Ice, which is supervising the survey, recently stated that of the 1,360 million cubic kilometers of water in all its forms on earth, only 35 million cubic kilometers consists of fresh water, 80 percent in the form of ice or snow.

- The Unesco Courier

\* \* \* \* \*

## ON-THE-JOB INSPECTION OF CHAIN HOISTS<sup>1/</sup>

On-the-job inspection of chain hoists is mighty important. Many unsafe conditions can develop on the job. We are whistling in the dark if we depend on the hoist to stay in good condition on the job without doing something about it.

Common sense tells us that whenever we spot STRETCHED CHAIN, WORN LINKS, OR OPEN HOOKS, the safest thing to do is to replace them. Why gamble with lives and equipment? Here are some suggestions for on-the-job inspection of chain hoists:

1. Check chain for wear, stretch, or damage to links.
2. Check hooks for opening.
3. See that both top and bottom hooks are carrying the load at the hook center and not on the hook tip.
4. Check handwheel action. The handwheel has a back movement (or play) of one to one and a half pockets before the handwheel strikes the check washer lug. If it has to turn three pockets or more, some of the brake parts are worn and need replacing.
5. Check action of hoist. If it lowers hard, it usually means lack of lubrication in brake. If you have excessive pull in both directions, it can mean lubrication or it may be a bent driving pin.

Many \* \* \* in fact, perhaps most \* \* \* chain hoist defects can be detected and remedied before serious trouble develops.

<sup>1/</sup>Reprinted from Reclamation Safety News, Second Quarter 1969, written by Thomas J. Laskowski, Transit Insurance Administrators.

\* \* \* \* \*

The following idea was included in the Biennial Review of Maintenance Examination Report of Corning Canal and Pumping Plant, Central Valley Project of February 5, 1968:

"Several wasp and spider nests were found in the electrical control boxes for the check gates on the canal. It was suggested that mothballs be placed in these boxes. Experience by operators along the Frient-Kern Canal had indicated they had success with this method."