

# Mechanical Compliance

---

## Mechanical Requirements

You can use *COMcheck-EZ*<sup>TM</sup> to demonstrate that your commercial or high-rise residential building design complies with the 1998 Edition of the IECC.

### Mechanical Compliance Options

*COMcheck-EZ* offers two separate methods for showing compliance—a manual method and a software method. This Mechanical Compliance Guide contains the energy code requirements for mechanical systems and equipment, and instructions on how to manually demonstrate and document that your proposed design complies with code requirements.

This guide has three major sections – Simple Systems, Complex Systems, and Water-Heating Systems. Generally, you can use the Simple Systems section with single-zone systems but need to use the Complex Systems section if your building contains any multiple-zone systems. The Simple Systems section is shorter and less technical and therefore is the preferred approach for any buildings that qualify. The brief Water-Heating Systems section provides code requirements for service water-heating systems for all types of commercial buildings.

The *COMcheck-EZ* software offers an alternative compliance method. The software uses a "wizard" approach that enables you to readily generate a checklist of mechanical requirements applicable to your building design. Refer to the *COMcheck-EZ* Software Compliance Guide for instructions on using the software method.

### ***Demonstrating Compliance***

To demonstrate compliance, indicate on your project plans equipment efficiencies, system controls, outdoor-air ventilation rates, duct insulation levels, duct sealing, and water-heating components that comply. Complete a *Mechanical Compliance Certificate*—either for simple or complex systems—provided with this guide and include it with the permit submittal materials.

## Qualifying for Simple Systems Method

COMcheck-EZ provides a simple way to demonstrate compliance with energy code requirements. You can use this simple method if your design uses the following equipment types:

- cooling – new unitary-packaged, split-system or packaged terminal air conditioner or heat pump
- warm-air heating – new unitary-packaged, split-system or packaged terminal heat pump; new fuel-fired furnace or electric-resistance heater
- hydronic heating – 2-pipe hot water radiators, baseboard heaters, fan coils, or other individual terminal heating units with new central boiler and no cooling system installed in the building
- variable-air volume (VAV) changeover system if it ensures the required ventilation is continuously provided to each space.

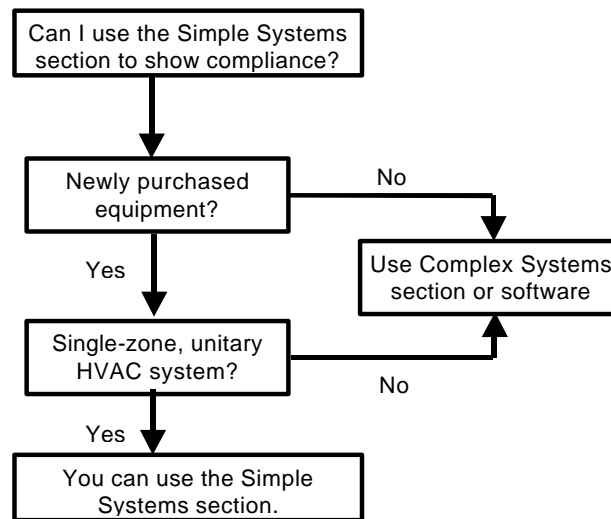

You cannot use the *Simple Systems* section with the following equipment types:

- packaged VAV reheat
- built-up VAV reheat
- built-up single-fan, dual-duct VAV
- built-up or packaged dual-fan, dual-duct VAV
- 4-pipe fan coil system with central plant
- hydronic heat pump with central plant
- other multiple-zone or built-up systems
- all other hydronic space-heating systems
- any combination of different types of allowed systems such as hydronic heating and unitary-packaged cooling.

To determine compliance for equipment types not covered in the *Simple Systems* section, refer to the *Complex Systems* section of this guide, the COMcheck-EZ software, or other compliance method acceptable to your local building department.

---

## Simple Systems

This section applies only to buildings that meet all of the qualifying criteria in the previous section *Qualifying for Simple Systems Method*.

To promote the use of energy-efficient mechanical systems and equipment in commercial and high-rise residential buildings, the energy code requires

- minimum equipment efficiency at peak- and (in some cases) part-load conditions
- acceptable levels of outdoor-air ventilation to ensure occupant comfort and health
- use of outside-air economizers where appropriate
- ducts that are insulated and sealed to minimize heating and cooling energy losses
- hydronic heating system features that reduce distribution losses and increase part-load efficiency.

### Mechanical Equipment Efficiencies

The 1998 IECC requires that mechanical equipment meet minimum efficiency ratings. However, virtually all equipment types compatible with this Simple Systems section are covered by manufacturing standards and must meet these minimums to be sold in the United States. For this and other reasons, all new equipment can be assumed to meet or exceed these minimum equipment efficiency levels. You still need to indicate the proposed equipment efficiencies on the mechanical plans and project specifications.

### Heating and Cooling System Control Requirements

Thermostats are required for heating and cooling systems to control indoor temperatures. In some climates, air economizer systems are used to provide outdoor air for free cooling.

#### ***Thermostats***

A thermostat is required in each zone to control heating and/or cooling. Thermostats must have the capability to automatically set back or shut down heating and cooling systems when appropriate. Thermostats must also have an accessible override so occupants can operate the system during off-hours. Heat pumps with supplementary electric-resistance heaters must have thermostats specifically designed for heat pump operation; i.e., to use resistance heaters only when the heat pump operating alone is inadequate to meet the load.

A programmable thermostat must be used to meet these requirements. These thermostats are available for heating only, cooling only, heating and cooling, and heat pump systems. They can set back or shut down the system during nights and weekends. In addition, occupants can temporarily override the thermostat and it will return to the original schedule without reprogramming.

Thermostats that control the temperature in residences, hotel/motel guest rooms, or areas where heating and/or cooling systems must operate continuously do not require a setback or shutoff control.

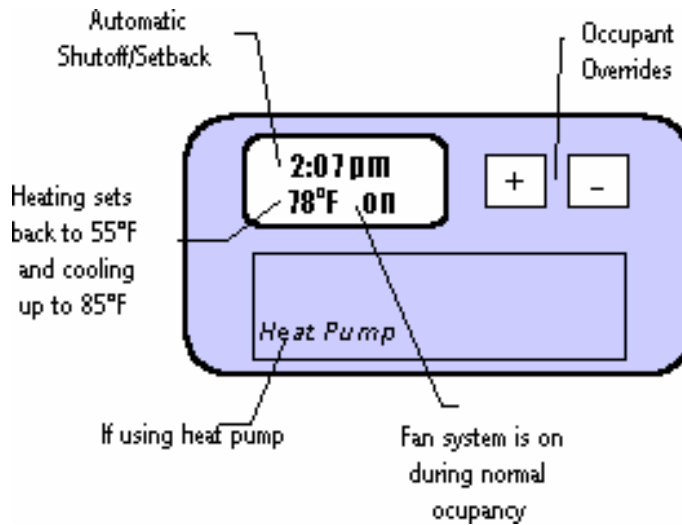

#### *Thermostat Requirements*

### **Air Economizer Systems**

Air economizer systems take advantage of favorable weather conditions to reduce mechanical cooling by introducing cooler outdoor air into a building. They are common on packaged rooftop heating and cooling systems. When properly installed and maintained, these systems can reduce mechanical cooling by up to 75% in favorable climates.

The 1998 IECC requires air economizers capable of delivering at least 85% of the supply air directly from outdoors.

Typical economizer controls include a two-stage thermostat and an economizer controller using dry-bulb temperature or enthalpy, or a combination of both. A control is also included to prevent ice from forming on cooling coils. This control arrangement allows outdoor-air cooling, mechanical cooling, or outdoor-air plus mechanical cooling—a feature known as “integrated control.” Field- and factory-installed economizers supplied by major equipment manufacturers include integrated controls.

The 1998 IECC requires the use of economizers for all systems but does not require that they include integrated controls.

Exceptions to this requirement are

- buildings in climate zones 1a, 1b, 2a, 2b, 3b.
- cooling systems with a total cooling capacity less than 90,000 Btu per hour
- systems serving residential spaces, supermarkets, or hotel/motel guest rooms
- if the proposed equipment meets the minimum qualifying cooling energy efficiency ratio (EER) for economizer tradeoff (see table below).

Total Cooling Capacity of Equipment	Building Location		
	Zones 6a, 9a, 10a, 11a, 12a, 12b, 13a, 13b, 14a, 14b, 15-19	Zones 3a, 4a, 7a, 8, 9b, 10b, 11b	Zones 4b, 5a, 5b, 6b, 7b
90,000 Btu/h to 134,999 Btu/h	N/A	11.4 EER	10.4 EER
135,000 Btu/h to 759,999 Btu/h	N/A	10.9 EER	9.9 EER
760,000 Btu/h or more	N/A	10.5 EER	9.6 EER

*Minimum Energy Efficiency Ratio for Economizer Tradeoff*

To identify the minimum EER necessary to trade off the economizer:

1. find the climate zone for your building location in the table
2. determine if this tradeoff is applicable to your zone
3. if so, find the appropriate cooling capacity of the proposed equipment and find the corresponding minimum EER.

## Outdoor-Air Ventilation Requirements

Outdoor-air ventilation rates necessary to maintain indoor-air quality while minimizing energy use are currently being debated. The concerns of designers and health professionals regarding indoor-air quality were considered in developing this guide, thus outdoor-air ventilation and control requirements are included. However, the designer is ultimately responsible for recognizing building features that may cause poor indoor-air quality. Adherence to requirements in this guide cannot alone ensure that good indoor-air quality will be maintained.

All enclosed spaces where people are expected to remain for extended periods of time must be continuously ventilated with outdoor air. A space can be ventilated naturally or mechanically. These spaces must be ventilated according to the applicable building or mechanical code required by state or local statutes. In the absence of a local ventilation requirement, this compliance method requires that designers use Chapter 4 of the 1996 International Code Council (ICC) *International Mechanical Code* (IMC) or values from the table below.

In addition, spaces that may contain unusual sources of contaminants must be designed with enclosures to contain the contaminants. These spaces must also have local exhaust systems to directly vent the contaminants (see the state or local mechanical code or Chapter 5 of the IMC.)

### **Mechanical Ventilation**

If your design is mechanically ventilated, it must

- meet minimum ventilation rates
- meet provisions for operating the system at those rates
- include dampers to prevent air infiltration during periods of building nonuse.

### Minimum Outdoor-Air Requirements

Your design's heating and/or cooling system must supply the minimum-required outdoor air to a space (refer to your state or local code or Chapter 4 of the IMC for required rates). A supply- and return-air system or an exhaust system must supply the outdoor air. Refer to Chapter 4 of the IMC or use outdoor-air ventilation rates from the following table.

Building Type	Ventilation Rate (cfm per sq ft)
Auto Repair Workshop	1.5
Auditorium	2.25
Barber Shop	0.38
Bar, Cocktail Lounge, Casino	3.0
Beauty Shop	0.63
Cafeteria/Fast Food	2.0
Dry Cleaning	0.9
High-Rise Residential	Per IMC Section 403.3
Hotel Guest Room	30 cfm/room
Office	0.14
Retail Store (basement and street)	0.30
Retail Store (upper floors)/Mall	0.20
All Others	Per IMC Section 403.3

*Required Outdoor-Air Ventilation Rates (IMC)*

### Ventilation Controls

When the heating and/or cooling system is controlled by a thermostat with a fan On/Auto switch, the switch must be set to the On position. Outdoor air is then supplied to the building whenever the system is operating. If a thermostat with a built-in time-switch is used, the thermostat must be capable of setting back or shutting off the fan during periods of nonuse.

Some ventilation systems are designed to supply outdoor-air quantities exceeding minimum levels. These systems must also be capable of reducing outdoor-air flow to minimum levels. Devices such as return ducts, mechanically or automatically operated control dampers, or fan volume controls can be used to reduce air flow.

### Shutoff Dampers

Outdoor-air supply and exhaust systems with design air flow rates greater than 3000 cubic feet per minute of outdoor air must have dampers that automatically close while the equipment is not operating. This requirement will mainly affect dedicated outdoor-air supply systems in paint shops, restaurants, and auditoriums. This requirement does not apply to automatic dampers mandated by health and life safety codes.

### Natural Ventilation

Windows, doors, louvers, or other openings to outdoor air can provide natural ventilation to interior spaces. Refer to your state or local code or Section 402 of the IMC to find minimum area requirements for above- and below-grade openings, adjoining spaces, and spaces containing contaminants. The codes typically require that a free opening of at least 4% of the floor area be available for natural ventilation.

<b>Question</b>
What is the window area required to ventilate a 30 x 32-ft classroom?
<b>Answer</b>
<p>The area of the opening must be</p> $(30 \times 32 \text{ ft}) \times 4\% = 38.4 \text{ sq ft}$ <p>The actual window area must be at least 76.8 sq ft if only half the window opens.</p> <p>This calculation is based on free area. With framing, the actual window area is approximately 80 sq ft.</p>

## Refrigerant Pipe Insulation

For refrigerant pipe insulation, refer to the section *Pipe Insulation Requirements* in the *Complex Systems* section.

## Duct Requirements

Ducts must be properly insulated and sealed to reduce energy loss.

### ***Insulation***

All supply- and return-air ducts and plenums must be insulated with a minimum of R-5 insulation when located in unconditioned spaces (e.g., attics, crawl spaces, unheated basements, unheated garages) and with a minimum of R-8 when located outside the building envelope. When located within a building envelope assembly, the duct or plenum shall be separated from the building exterior or unconditioned spaces by a minimum of R-5 insulation.

Exceptions:

- when located within equipment
- exhaust-air ducts
- when the design temperature difference between the interior and exterior of the duct or plenum does not exceed 15°F (8°C).

### ***Sealing***

Ducts are sealed to ensure quantities of air are not lost before they are delivered to the space. Flexible and metal ducts are common in small- to medium-size commercial buildings.

Properly sealing plenums, air handlers, and ducts is the key to eliminating leaks. In duct systems, all joints, longitudinal and transverse seams, and connections must be securely fastened and sealed with welds, gaskets, mastics (adhesives), mastic-plus-embedded-fabric systems, or tapes. Duct mastic-plus-embedded-fabric is the preferred flexible sealant. Tapes and mastics used to seal duct work must be listed and labeled in accordance with UL 181A or UL 181B.

Although the code does not require duct mastic, its use is strongly encouraged. Conventional duct tape must not be used except to seal the joints on duct access doors and air-handler panels.

Additionally, duct registers, grilles, and diffusers must be sealed to the gypsum board or other interior finish. Penetrations into the supply or return plenum (taps, takeoffs, and

starting collars) and any structural cavities used for air plenums or ducts must also be sealed.

In the diagram, an exterior-duct sealant is used to seal both transverse and longitudinal seams. Pressure-sensitive tape (duct tape) cannot be used as the primary sealant.

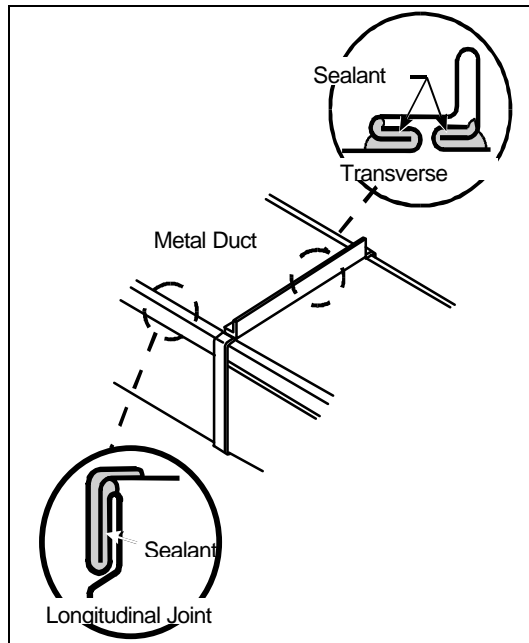

*Sealing Metal Duct Transverse Seams*

## Hydronic Heating Requirements

The requirements listed in this section apply to systems that provide heating only through the use of individually controlled radiators or fan-coils and are served by a central hot water boiler. The following components are required on zonal heating systems:

1. thermostats meeting requirements for each individual heating zone
2. new equipment boilers and circulation pumps
3. pipe insulation - to reduce distribution and standby losses
4. variable-flow controls on the circulation pump or temperature reset controls for systems with capacities over 600,000 Btu per hour to increase efficiency during part-load operation.

For hydronic system part-load control requirements, refer to *Part-Load Control Requirements for Hydronic Systems* in the *Complex Systems* section.

*(A blank compliance certificate for simple systems, instructions for using the certificate, and a filled-out sample can be found at the end of this Mechanical Guide.)*



---

## Complex Systems

This section is designed to provide a relatively simple process for demonstrating compliance with energy code requirements that apply to multi-zone HVAC systems. It is designed for use with any of the following system or equipment types:

- single-duct VAV distribution with zone reheat
- dual-duct VAV (either with a single supply fan or separate fans for heating and cooling ducts)
- constant-volume, single-zone with chilled water, hot water, or built-up direct expansion coils or electric or fuel-fired furnaces
- three-duct, constant- or variable-volume air distribution
- 4-pipe fan coil
- hydronic heat pump
- all types of central plant equipment, including electric- and heat-operated water chillers, boilers, and central refrigeration compressors serving one or more direct-expansion cooling coils.

This section can also be used with the following system types, although they are covered more simply under the *Simple Systems* section:

- packaged air conditioners – new unitary-packaged, split-system or packaged terminal air conditioner or heat pump
- packaged warm-air furnaces – new unitary-packaged, split-system or packaged terminal heat pump; new fuel-fired furnace or electric resistance heater.

Because of provisions that prohibit mixing hot and chilled water, you cannot use *COMcheck-EZ* for 2-pipe (systems that provide both heating and cooling) or 3-pipe fan coil or radiator systems.

You can use *COMcheck-EZ* for either of the multi-zone systems listed below only if all thermostatic control zones served by the system meet one of the exceptions to the requirement for VAV systems (see *Multiple-Zone System Requirements*)

- constant-volume, multiple-zone systems with reheat
- constant-volume, dual-duct systems.

To promote the use of energy-efficient systems and equipment in commercial and high-rise residential buildings, the energy code requires

- minimum equipment efficiency at peak- and part-load conditions
- controls that maximize air and hydronic system efficiency at part-load conditions
- controls that eliminate or minimize system operation during periods of nonuse
- water or air economizers on most systems
- minimum duct and pipe insulation levels and duct sealing measures
- efficient technologies and control strategies for variable-flow and multiple-zone systems

- acceptable levels of outdoor-air ventilation.

*Note: While the Simple Systems section closely matches IECC Chapter 7, this Complex Systems section was developed to implement the ASHRAE 90.1 ('89) Code and reflects a larger scope than Chapter 7. However, use of these materials with the 1998 IECC is appropriate as Chapter 6 references the ASHRAE 90.1 ('89) Code and Section 103 authorizes use of implementation materials when approved by the building official as meeting the intent of the IECC.*

## Equipment Efficiency Requirements

Heating and cooling equipment must meet the minimum efficiencies listed in the tables provided at the end of this guide. Equipment types not listed in these tables have no minimum efficiency requirements.

Federal manufacturing standards cover many of the equipment types listed in the tables, as is clearly noted. You can assume new equipment covered by these standards meet minimum efficiency requirements. Construction documents must include rated efficiencies for noncovered equipment and it is advisable to include ratings for all specified equipment. Enforcing jurisdictions may require that documentation, such as manufacturers' literature, be submitted in support of efficiencies reported in the construction documents.

### **Field-Assembled Equipment Requirements**

Some complex systems use combinations of components to perform a cooling or heating function. For example, the system uses a separate heat exchanger and compressor for chilling water instead of a package water chiller. You must show that these systems meet the same requirements as the equipment listed in the tables for the comparable equipment type. Total energy input to the equipment must consider all the energy use of all components and accessories such as compressors, internal circulating pumps, condenser-fans, integral cooling water pumps, purge devices, crank case heaters, and controls. An enforcing jurisdiction may require that the registered engineer responsible for equipment specification stamp, sign, and date calculations.

## Equipment Sizing

To determine the required size of heating and cooling equipment, designers must calculate the maximum heating and cooling loads for a building in accordance with the *1997 ASHRAE Handbook – Fundamentals*, and ensure that heating and cooling equipment is sized no larger than needed to meet those loads. The enforcing jurisdiction may require that the registered engineer responsible for equipment sizing stamp, sign, and date calculations and supporting documentation.

Some building owners want additional equipment (for example, an additional chiller of the same capacity) in case the primary equipment goes out of service. Standby equipment is allowed as long as it is separate equipment and is controlled to be always off when the primary equipment is operating.

Multiple units of the same equipment type with a combined capacity in excess of the calculated loads are also allowed if they are controlled to operate in sequence. In this case, additional units must be controlled to only operate as the load increases and cannot be controlled to turn on all at the same time.

# System Control Requirements

## Temperature Controls

Each thermostatic control zone must be equipped with a thermostat or other device that controls heating and cooling to the zone and responds to environmental conditions within the controlled zone.

### Exception: Perimeter Systems

Some complex mechanical systems have a separate system to handle envelope loads (mainly heat loss through the walls and windows and heat gain through windows), and serve interior spaces with a separate system. Individual zone controls are not required for perimeter systems if the controls for the perimeter system meet the following conditions:

- at least one temperature control must be installed for each perimeter area with exterior walls facing one orientation for 50 contiguous feet or more
- the thermostatic system control must be located within the space being served by the system.

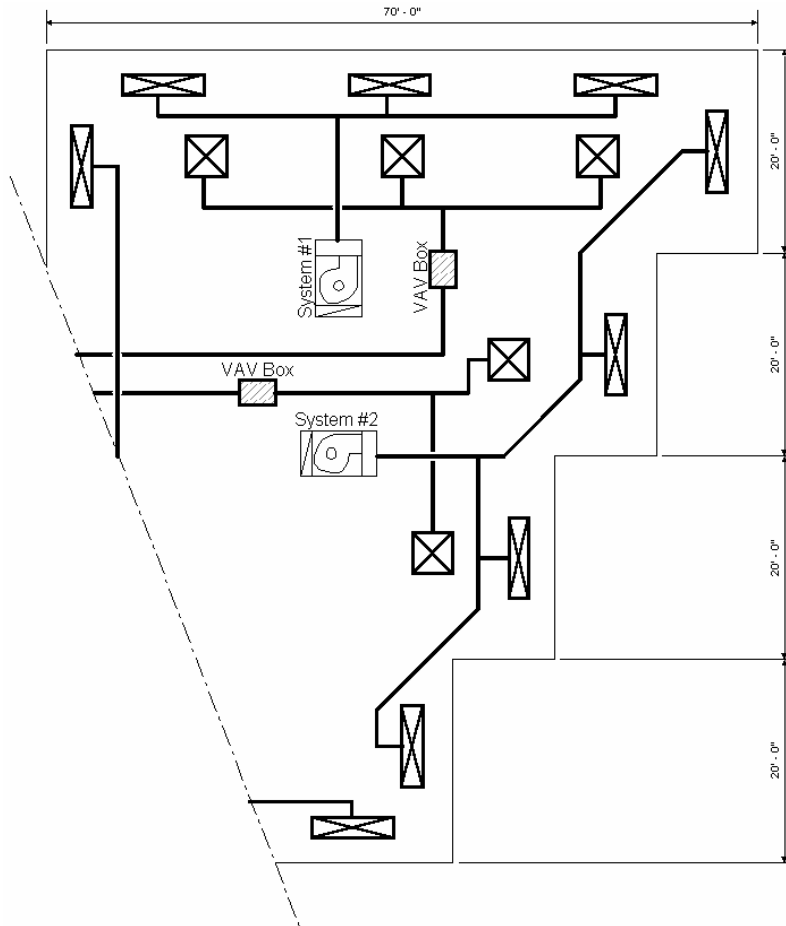

**System #1:** At least one temperature control within the controlled space must be installed since the contiguous length of the building facade faces one orientation and is greater than 50 feet in length

**System #2:** All supply air outlets may be controlled with one controller within the space. Though the building facades of the spaces served by this system face different orientations, none is 50 feet or more in length.

*Independent Perimeter System*

## Heat Pump Thermostats

Thermostats for air-to-air heat pumps must be specifically designed for heat pump operation. The thermostat must use the compressor as the first stage of heat and electric-resistance heat as the second stage. Controls must automatically prevent the operation of the supplementary electric-resistance heat when the heating load can be met by the heat pump alone.

## Thermostat Deadband Requirements

Thermostats that control both heating and cooling must be capable of having a "deadband" or range of temperature of at least 5°F where no heating and cooling is available. (Exception: thermostats requiring manual changeover between heating and cooling modes.)

## Automatic System Controls During Periods of Non-Use

Single-zone systems and each zone served by multiple-zone systems must have controls that automatically reduce heating and cooling use during periods of non-use. Automatic controls can be time clocks that shut down systems or zones, time-controlled automatic setback controls, or occupancy sensors. Time controls and automatic time clocks must

- be able to start and stop systems, or turn on and shut off the supply of heating and cooling to each zone, for seven different day schedules per week
- retain programmed set points and time settings for at least 10 hours during power outages
- include or be installed in conjunction with a manual override that allows occupants to turn heating and cooling on for up to two hours during periods when the heating and cooling would otherwise be automatically off.

Thermostatic controls must be able to automatically set up the cooling set point to at least 85°F and set back the heating set point to a temperature no greater than 55°F.

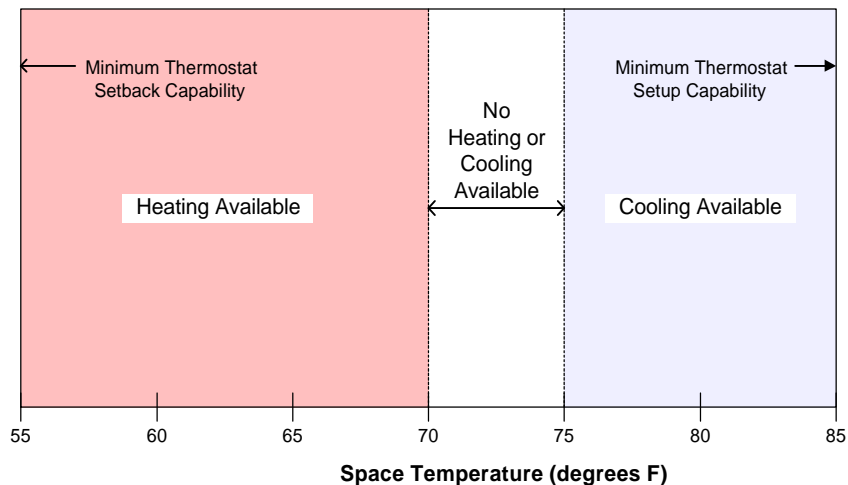

*Typical Thermostat Deadband and Required Setback/Setup Capabilities*

## Outside-Air Shutoff Controls

Even when a building is unoccupied and ventilation fans are not operating, outside air entering the building can significantly change the indoor temperature and humidity. This change in temperature and humidity can cause unnecessary energy use when the building

is reoccupied and the mechanical systems are restarted. All supply- and exhaust-air systems must include a way to automatically close outside-air intakes when mechanical ventilation fans shut off. In smaller fan systems (less than 5,000 cfm), gravity dampers or dampers weighted to close when air is not moving through them are common. On larger systems, electric motors or pneumatic actuators are typically used to open and close outside-air dampers. Systems with total air volume of 3,000 cfm and less are not required to have automatic outside-air shutoff controls.

## Cooling with Outdoor Air (Economizers)

All systems with supply-air quantities greater than 3,000 cfm and nominal cooling capacities greater than 90,000 Btu per hour must be equipped with an air economizer, or meet one of the economizer exceptions described in the Simple Systems section. Alternatively, complex mechanical systems may be equipped with water economizers designed to meet the design cooling load calculated as follows:

- cooling loads calculated according to the Equipment Sizing section
- water economizer outdoor operation temperatures of 50°F dry-bulb and 45°F wet-bulb.

The enforcing jurisdiction may require that the engineer responsible for system design authenticate and submit water economizer designs and supporting documentation.

The following figures show the most common types of water economizer systems:

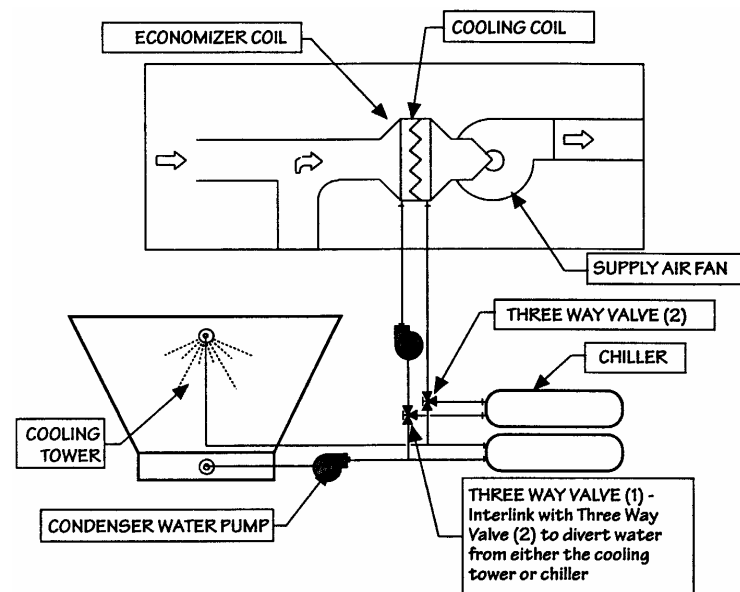

*Direct Water Economizer System*

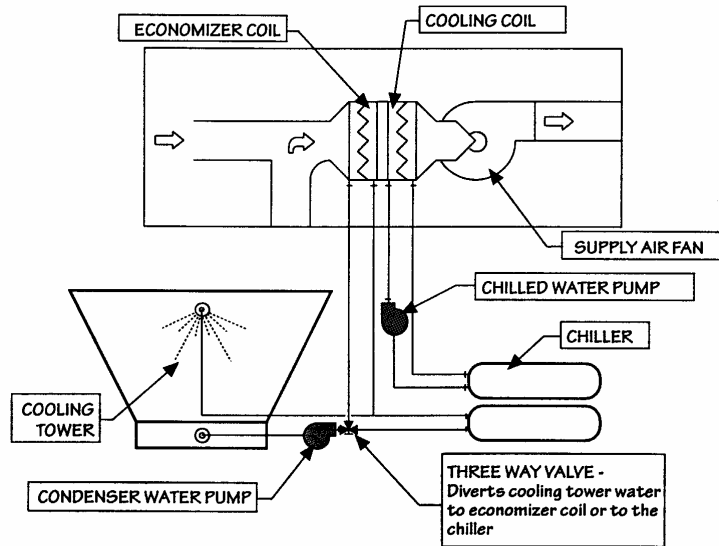

*Indirect Water Economizer System*

## Variable-Flow Fans

Fans capable of varying their airflow are common on systems serving multiple thermostatic control zones and are sometimes used in exhaust applications. These fans must use one of the following airflow control methods:

- a mechanical adjustable-speed drive, which usually varies air flow by varying the diameter of one of the pulleys in the motor/belt drive system for the fan
- an electrical adjustable-speed drive, which uses electronic controls to vary the speed of the fan motor
- a vane-axial (or propeller style) fan with variable-pitch blades
- other variable-flow technologies that limit fan power to 50% of peak design fan power when air flow is 50% of design flow rate and static pressure is one-third of peak design static pressure. (An enforcing jurisdiction may require that calculations, data, or manufacturers' literature be submitted to document compliance using this method.)

## Hydronic System Requirements

Systems with hydronic heating for both heating and cooling must have separate supply and return lines for hot and chilled water. The following types of hydronic piping systems are not allowed:

- 2-pipe systems, or systems that can supply and return hot or chilled water through the same piping system
- 3-pipe systems, or systems that have separate hot and chilled water supply piping but have a common return line.

Except as needed for humidity control, hydronic systems must have controls capable of preventing simultaneous supply of hot and chilled water to the system.

## Part-Load Control Requirements for Hydronic Systems

Most systems operate at peak-load only during a small portion of the heating and cooling seasons. The energy code requires one of the following approaches for increasing hydronic heating and cooling system efficiency during part-load operation:

1. Water Temperature Reset – Using this approach, controls must be installed to decrease the temperature of the water leaving the heating plant as the overall demand for heating decreases, and increase the temperature of the water leaving the cooling plant as the overall demand for cooling decreases. Controls must be capable of decreasing (or increasing) water temperature by at least 25% of the difference between the design supply and return water temperatures.

Question
What is the reset requirement for a hot water distribution system if the design water temperature is 160°F and the design return temperature is 120°F?
Answer
The minimum amount of reset is $(160^{\circ}\text{F} - 120^{\circ}\text{F}) \times 25\% = 10^{\circ}\text{F}$ Therefore, controls must be able to reset the water temperature to $160^{\circ}\text{F} - 10^{\circ}\text{F} = 150^{\circ}\text{F}$

2. Variable Flow – Using this approach, controls must be installed that will reduce the flow of water as the overall demand for heating (or cooling) decreases. Acceptable methods for reducing flow are a) variable-frequency drives on pumps, which vary the speed of the pump; b) multiple, staged pumps, which vary the number of pumps used to circulate water; or c) control valves, which modulate to vary the flow of water.

## Multiple-Zone System Requirements

Most larger buildings have HVAC systems that can heat and cool multiple independently controlled zones at the same time. Commonly called multiple-zone systems, these systems typically will reheat cool air, recool warm air, or mix warm and cool air to meet individual zone temperature requirements. Multiple-zone systems must have VAV controls capable of reducing the supply of warm (or cool) air to any zone before reheating, recooling, or mixing warm and cool air streams occurs.

Under some conditions, simultaneous heating and cooling is allowed without the need for individual VAV controls at the zone. The six exceptions below permit the use of constant-volume reheating, recooling, or mixing for individual zones. Except for Exception 6, these exceptions are not intended to allow the installation of constant-volume, multiple-zone systems, but rather to allow individual zones to have constant volume with reheating, recooling, or mixing on an otherwise complying VAV system.

### ***Exception 1 – Zone Pressurization Requirements***

If VAV operation will create unacceptable pressure relationships between a sensitive zone and other zones, simultaneous heating and cooling is allowed without VAV, but only for the sensitive zone.

### **Exception 2 – Site-Recovered or Site Solar Energy**

Constant volume with reheat or mixing is allowed if 75% or more of energy for reheat or warm-air mixing is from any of the following sources:

- site-recovered energy such as heat recovery coils on an exhaust-air system or water chiller condenser
- site-generated solar energy such as solar water-heating collectors or photovoltaic panels.

### **Exception 3 – Special Humidity Requirements**

In zones where specific humidity levels must be maintained for noncomfort purposes, simultaneous heating or cooling is allowed without VAV operation. Examples include areas of museums where sensitive materials are displayed or stored, or areas for manufacturing processes where precise humidity ranges are necessary. In these cases, the exception applies to the special zone and not to the entire system.

### **Exception 4 – Less than 300 cfm Zone Supply Air**

If the supply-air quantity to a zone is less than 300 cfm, simultaneous heating or cooling is allowed without VAV operation. This exception allows reheat to be used for small subzones of a larger zone. This exception is available only with air-handling systems serving multiple zones. It cannot be used to permit constant-volume, single-zone systems with subzone reheat.

### **Exception 5 – Ventilation Requirements**

In some cases, mechanical codes (e.g., the *International Mechanical Code*) require that 100% outside air be supplied to a zone. VAV controls are not required for zones with 100% outside-air requirements.

### **Exception 6 – Sequencing Heating and Cooling to the Zone**

VAV controls are not required if zone and system controls can sequence the supply of heating and cooling energy to the zone so that simultaneous heating and cooling never occurs. For example, a three-duct air distribution system consists of separate ducts for return air, cool air, and warm air. Zone controls will mix warm air with return air and cool air with return air but never warm air with cool air.

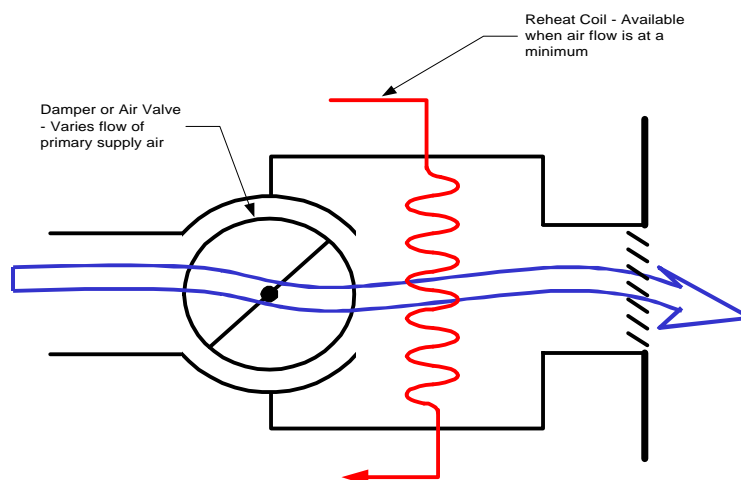



## Other Requirements for Multi-Zone Systems

In addition to the requirement for VAV zone controls, multi-zone systems must meet applicable requirements described below, depending on the distribution system design and the total number of supply fans.

## Single-Duct VAV Systems

Single-duct VAV systems use a single supply-air duct with branches to individual zones. Thermostatically controlled terminal units are then used to vary the flow of air to the zone, and reheat or recool the air if necessary to meet the environmental control requirements for a zone. Single-duct VAV terminal units must be capable of reducing the supply of primary supply air to the zone to a minimum before reheating or recooling can occur. Single-duct VAV terminal units may also be equipped with a fan to draw air from a return-air plenum to for additional heat. The figures below show fan- and nonfan-powered VAV terminal units and their required features.

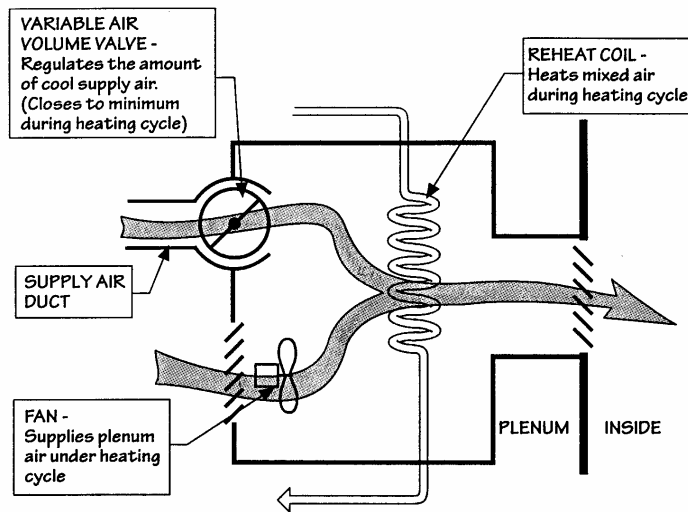

*Fan-Power VAV Box*

## Dual-Duct VAV Systems

Dual-duct systems provide two separate supply air streams—cool air and warm air—that are mixed in each terminal unit and supplied to the zone as a single air stream. The system can have a single fan for both supply-air ducts or a separate fan for each duct. Dual-duct zone terminal units must be capable of reducing the air supply from one duct to a minimum prior to mixing with the other duct. These units require a damper or other way to reduce the airflow, as well as controls that prevent mixing with the other air stream until the minimum is reached. The figure below provides a schematic of a dual-duct terminal unit.

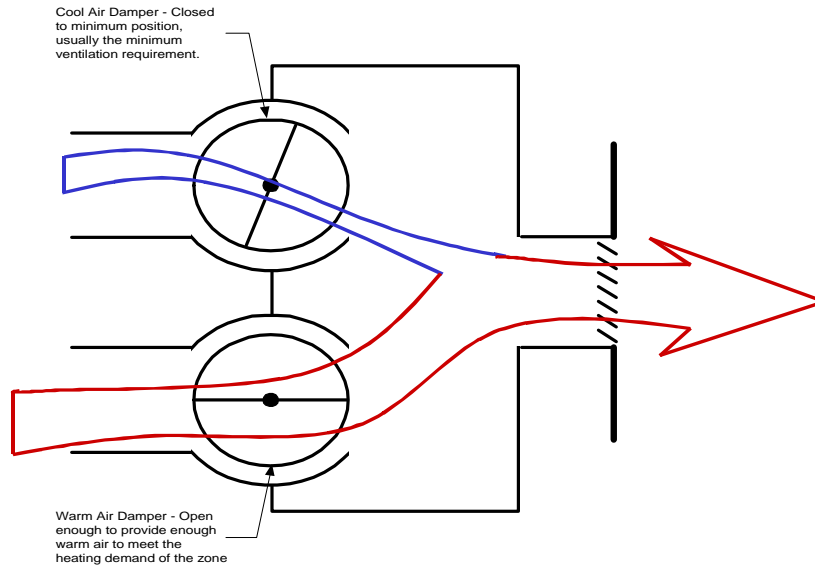

*Dual-Duct VAV Mixing Box in Heating Mode*

## Dual-Duct and Mixing Systems with One Fan, Economizer Requirements

Single-fan, dual-duct systems use a single supply fan to blow air over two separate coils—one for heating and one for cooling. If an air economizer is used, outside air rather than return air is passed through the heating coil, thereby increasing energy use for heating. To avoid this additional energy use, dual-duct and other mixing systems (such as three-duct systems) with single supply fans cannot be equipped with air economizers. With no air economizer, only return air and minimum outside ventilation air need to be heated.

To meet economizer requirements with these systems, a water economizer must be installed. If the water economizer uses an additional cooling coil in the supply-air stream, then this coil must be installed in the system's cool-air duct and not in the return- or mixed-air portion of the ductwork.

## Multiple-Zone Systems – Supply-Air Temperature Reset

An important way to minimize the use of mechanical cooling or heating energy in multiple-zone systems is to raise the cooling supply-air temperature (or lower the heating supply-air temperature) during periods when cooling and heating loads are not at their design peak. Multiple-zone systems must have controls capable of resetting the cooling and heating supply-air temperatures. The supply-air temperature must be reset by at least 25% of the difference between the design supply-air temperature and the design room temperature. For example, if the design supply-air temperature for a system is 55°F and the design space temperature for cooling is 75°F, the system must be capable of resetting the supply-air temperature up by 25% of 75 minus 55, or 5°F.

While many control strategies exist for meeting this requirement, the three most common methods are described below. Regardless of the control method, the enforcing jurisdiction may require additional documentation, such as manufacturer's literature or control diagrams to demonstrate compliance with reset requirements.

### **Method 1 – Supply-Air Reset Warmest (Coldest) Zone**

Method 1 requires that zone thermostats for a system be connected to a central controller. With this method, a controller identifies the highest (or lowest) thermostat signal, which corresponds to the zone with the largest cooling (or heating) demand, and then controls the system supply-air temperature to meet the load in that zone.

### **Method 2 – Supply-Air Reset Reference Zone**

Method 2 requires that the thermostat or temperature sensor for a representative zone be connected to the controller for supply-air temperature. A representative zone is often used when the supply-air temperature operates within a fixed range (such as from 55°F to 60°F). In this case, the reference zone is usually selected because it is expected to require the lowest supply-air temperatures for cooling or the highest supply-air temperatures for heating.

### **Method 3 – Supply-Air Reset Outside-Air Temperature**

Method 3 requires that an outside-air temperature sensor be connected to the controller for the reference zone. Method 3 is most commonly used with heating systems where loads will vary closely with changes in outside temperature. Using this method, as the outside-air temperature drops (or rises) the supply-air temperature is reset up (or down). This method is sometimes used for cooling systems if the supply-air temperature operates within a narrow range (such as 55°F to 60°F).

## **Ventilation Requirements**

Refer to the *Simple Systems* section for minimum outside-air ventilation requirements.

## **Duct Requirements**

Refer to the *Simple Systems Duct Requirements* section for duct insulation, sealing, and installation requirements. In addition, all ducts designed to operate at static pressures in excess of 3 inches of water column must be leak-tested in accordance with methods published by the Sheet Metal and Air Conditioning Contractors of North America (SMACNA). A report and certificate must be submitted demonstrating that representative sections totaling at least 25% of the duct area have been tested and that all tested sections meet the duct-sealing requirements.

Leak tests and reports must demonstrate that the duct system meets the following criterion:

$$F < 6 \times P^{0.65}$$

where F = the measured leakage rate in cfm per 100 square feet of duct surface

P = the static pressure used in the test.

0.65 = the exponent (or power) to which the static pressure is raised in this equation

For example, the maximum leakage rate for a duct section operating at 4 inches water column static is

$$6 \times 4^{0.65} \text{ or } 15 \text{ cfm per } 100 \text{ square feet of duct surface area.}$$

## Pipe Insulation Requirements

Pipe insulation requirements depend on the fluid type and nominal pipe diameter. The following table shows pipe insulation requirements based on an insulation thermal conductivity of 0.27 Btu-in/(h·ft<sup>2</sup>·°F) [roughly R-4 per inch]:

Fluid	Pipe Diameter (in.)	
	not greater than 1.5	greater than 1.5
Steam	1.5	3.0
Hot Water	1.0	2.0
Chilled Water, Brine, Refrigerant	1.0	1.5

Insulation is not required with the following types of piping:

- factory-installed piping within HVAC equipment that has been tested and rated in accordance with a referenced test procedure to determine equipment efficiency
- piping conveying fluids having design operating temperatures between 55°F and 105°F
- piping conveying fluids that have not been heated or cooled through the use of fossil fuels or electric power
- runout piping no longer than 4 feet and no greater than 1 inch in diameter installed between the control valve and heating or cooling coil in an HVAC unit.

## Air System Balancing

Proper system design and equipment selection is essential for long-term functionality and energy efficiency of mechanical systems. All systems need some type of verification in the field (both at start-up and periodically throughout the life of the building) to ensure they are operating as intended.

To facilitate field verification, the energy code requires that duct systems be equipped for easy testing and balancing after installation. Each supply-air outlet and zone-air terminal device must be equipped with balancing dampers, air valves, or other means for balancing. Balancing dampers that are integral to supply-air diffusers are acceptable for supply-air outlets.

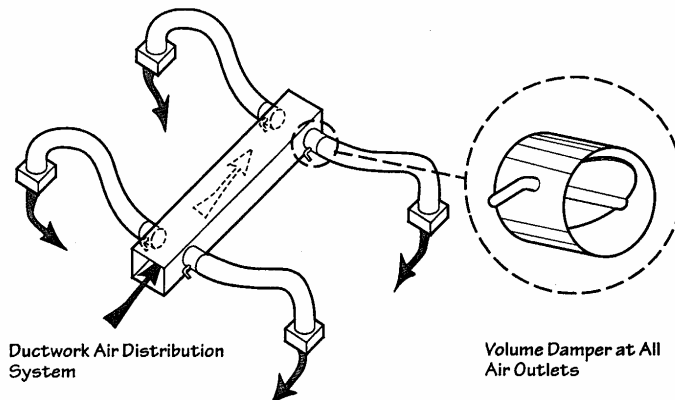

*Air Balancing Device*

## Hydronic Systems Balancing

To facilitate proper balancing and long-term efficient operation of hydronic systems, all hydronic terminal devices must be equipped with balancing valves or other means of hydronic system balancing.

## Manuals and System Documentation

The code requires building plans, specifications, or other construction documents to require the mechanical contractor to provide an operating and maintenance manual to the building owner. This manual must include at least the following information about the design and intended operation of all mechanical systems in the building:

- equipment capacity (input and output) and required maintenance items and their required service interval
- equipment operation and maintenance manuals
- HVAC system control maintenance and calibration information, including
  - wiring diagrams
  - schematics
  - control sequence descriptions.

Desired or field-determined set points must be permanently recorded on control drawings, at control devices, or, for digital control systems, in programming comments.

- a complete narrative of how each system is intended to operate.

*(A blank compliance certificate for complex systems can be found at the end of this Mechanical Guide.)*

---

## Water-Heating Systems

This section contains code requirements for service water-heating systems and equipment, and instructions on how to manually demonstrate that your proposed design complies with these requirements.

The requirements listed in this section apply to service and domestic water-heating systems. They do not apply to systems used for comfort heating or to systems designed to meet manufacturing, industrial, or commercial process requirements. The following components are required on water-heating systems (components shown in the following diagram by number):

1. heat traps - to reduce standby losses
2. pipe insulation - to reduce distribution and standby losses
3. circulation loop temperature control - to reduce distribution losses.

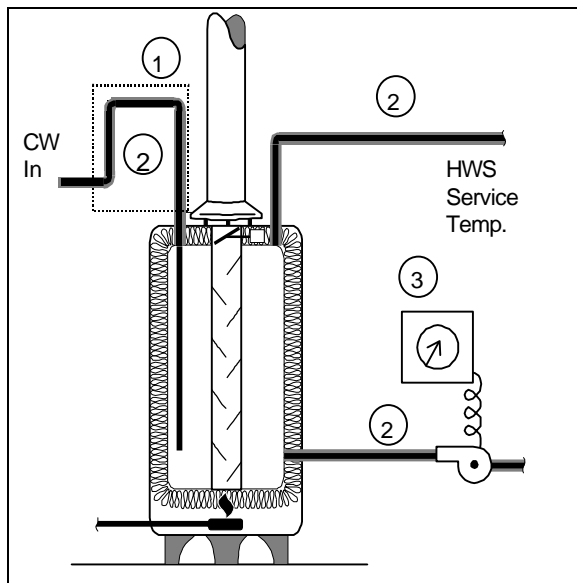

*Water-Heating System Requirements*

## Equipment Efficiency Requirements

Heating and cooling equipment must meet the minimum efficiencies listed in the table provided at the end of this guide. Equipment not listed in these tables has no minimum efficiency requirements.

Federal manufacturing standards cover all of the equipment types listed in the table. Therefore, you can assume that any new service water-heating equipment will meet minimum efficiency requirements. Any reused equipment may not meet these requirements. Construction documents should include efficiency ratings for all service water-heating equipment.

## Heat Traps

Heat traps stop hot water from rising into the distribution pipes and forming a natural convection loop.

Heat traps are required in the inlet and outlet piping of noncirculating water heaters. Some water-heating equipment has integral factory-installed heat traps. For equipment without integral factory-installed heat traps, heat traps must be purchased and installed in the inlet and outlet connections or field-fabricated by creating a loop or inverted U-shaped arrangement of the inlet and outlet piping.

Heat traps are not required on circulating systems.

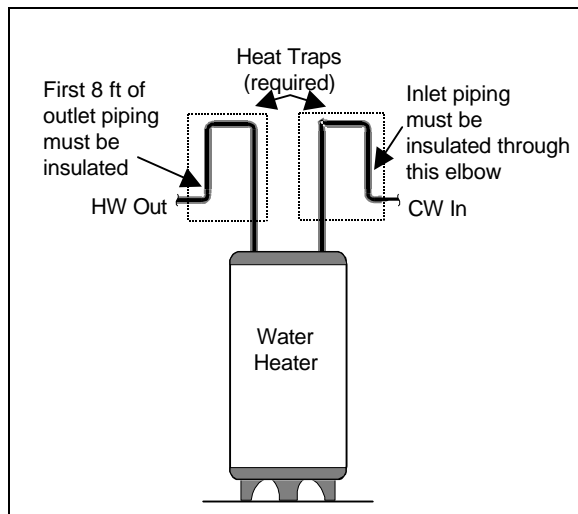

*Field-Fabricated Heat Traps*

## Pipe Insulation

The following pipe insulation levels are required:

- 1 in. on circulating water-heating systems
- ½ in. on the first 8 feet of outlet piping from any constant-temperature noncirculating storage system
- ½ in. on the inlet piping between the storage tank and a heat trap in a noncirculating storage system.

## Circulation Loop Controls

Automatic time-switch controls must be installed to shut down the pump on circulating water-heating systems during periods of nonuse.

## Demonstrating Compliance

To demonstrate compliance, indicate on your project plans the equipment efficiencies, system controls, and other water-heating components that comply. Also, fill in applicable items under *Water Heating Systems* on the *Simple Systems Certificate*. Blank copies of these certificates appear at the end of this guide.

---

# Completing Mechanical Compliance Certificate for Simple Systems

These instructions explain the information to include in the *COMcheck-EZ* Mechanical Compliance Certificate for Simple Systems, identify the appropriate contact or reference if you have questions, and provide *EZ* tips for completing the certificate. A sample certificate is also provided. The instructions have numbered circles that correspond to those on the sample certificate. For code enforcement officials, *EZ* tips for plan check and field inspection are included at the end of this guide.

## General Guidelines

- **For Documentation Authors** - provide all information in unshaded sections, enter “NA” if a particular requirement is not applicable; submits the completed certificate to the authority having jurisdiction with the building permit application package.
- **For Plan Checkers** - verify that proposed values listed on the certificate are consistent with the plans and specifications and meet the requirements in this guide.
- **For Field Inspectors** - inspect and approve building construction against each requirement in Section 3 of the certificate.



---

## **Completing Mechanical Compliance Certificate for Complex Systems**

The process for filling in the mechanical compliance certificate for complex systems is very similar to that for simple systems. Because they are so similar, neither a sample certificate nor step-by-step instructions are provided for the complex systems certificate. See the sample mechanical certificate for simple systems and instruction beginning on page 25 for guidance in completing the mechanical compliance certificate for complex systems.