

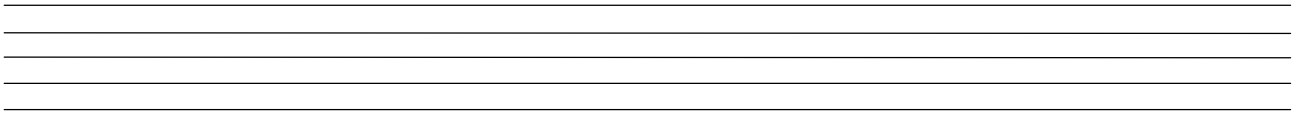

US DEPARTMENT OF ENERGY
BUILDING ENERGY CODES PROGRAM



DOE/EE/OBT-28432
PNNL-SA-33166-Ver. 2.4



COMcheck-EZ™

Compliance Guides

Commercial and High-Rise Residential
Energy Code Compliance
Version 2.4 for 1998 IECC

May 2003

ACKNOWLEDGMENTS

This document and accompanying software were produced with Government support under Contract Number DE-AC06-76RLO 1830 awarded by the United States Department of Energy. The Government retains a paid-up non-exclusive, irrevocable worldwide license to reproduce, prepare derivative works, perform publicly and display publicly by or for the Government, including the right to distribute to other Government contractors.

The user is authorized to use, duplicate, and redistribute the COMcheck-EZ materials in their original form without royalty. Any unauthorized modification to the guides, software, and support files is strictly prohibited.

Program Managers

Ron Majette

Jean Boulin

Principal Authors/Editors

Cathy Anderson
Rosemarie Bartlett
Rob Briggs

Krishnan Gowri
Jeffrey Johnson
Kevin Madison

Technical Assistance

James Bowman
Craig Conner
Linda Connell
Dave Conover
Mark Halverson
Carol Jones
Bob Lucas

Eric Makela
Jeff McCullough
Eric Richman
David Smith
Dave Winiarski
Andrea Wood

Production

Kay Hass

Additional Reviewers/Contributors

While responsibility for the content of these materials lies entirely with the authors, we would like to gratefully acknowledge the assistance of the following individuals in providing critical review:

Ross DePaola
Charles Eley
John Gajda
Douglas Gehring
Daniel Harkins
Bob McEntire

Eugene Romsos
Maureen Scanlon
Bruce Wilcox
Jim Yeoman
Jerry Zinger

DISCLAIMER

These materials were prepared as an account of work sponsored by an agency of the United States Government. Neither the United States Government nor any agency thereof, nor any of their employees, makes any warranty, express or implied, or assumes any legal liability of responsibility for the accuracy, completeness, or usefulness of any information, apparatus, product or process disclosed, or represents that its use would not infringe privately owned rights. Reference herein to any specific commercial product, process or service by trade name, trademark, manufacturer, or otherwise does not constitute or imply its endorsement, recommendation, or favoring by the United States Government or any agency thereof.

For more information about the Building Energy Codes Program, call the hotline at 1-800-270-CODE.

PACIFIC NORTHWEST NATIONAL LABORATORY
operated by
BATTELLE
for the
UNITED STATES DEPARTMENT OF ENERGY,
ENERGY EFFICIENCY AND RENEWABLE ENERGY,
OFFICE OF BUILDING TECHNOLOGY, STATE AND COMMUNITY PROGRAMS



COMcheck-EZ™

Compliance Guides

Commercial and High-Rise Residential
Energy Code Compliance
Version 2.4 for 1998 IECC

May 2003

Inside Version 2.4

Scope and Application Guide
Envelope Compliance Guide
Mechanical Compliance Guide
Lighting Compliance Guide
Field Inspection Checklist
Glossary

Scope and Application

About COMcheck-EZ Materials

COMcheck-EZ™ is an optional way to demonstrate compliance with energy codes for commercial and high-rise residential buildings. It is applicable to most commercial buildings and high-rise residential buildings three stories or more above grade.

Use this version of COMcheck-EZ to demonstrate that your commercial or high-rise residential building design complies with the 1998 Edition of the International Energy Conservation Code (IECC). Other versions are available for the 2000 IECC, codes based on the ASHRAE 90.1 ('89) Code, and several state energy codes.

Residential buildings, townhouses, and garden apartments with three stories or fewer are covered under the residential chapters of the code. REScheck, a companion product to COMcheck-EZ, is available to demonstrate compliance for low-rise residential buildings.

The COMcheck-EZ materials simplify and clarify energy code requirements. Although they have a somewhat different format than the IECC itself, the requirements presented in this guide generally match those found in Chapter 7 of the 1998 IECC. However, COMcheck-EZ should be used only if approved by the building authority having jurisdiction.

COMcheck-EZ includes a manual method (prescriptive compliance path) and a software method (system performance compliance path). You can use either method to demonstrate that a proposed building design complies with the energy code requirements.

Only construction referenced in the building permit application must comply with the code requirements. Each system—envelope, mechanical, and lighting—can comply separately. For example, if the building permit application is for only the lighting system, then the envelope and mechanical provisions do not apply.

COMcheck-EZ can be used in conjunction with other compliance methods available under the IECC. For example, Chapter 6 of the IECC references the ASHRAE/IES Energy Code for Commercial and High-Rise Residential Buildings as well as IECC Chapter 7, Design by Acceptable Practice for Commercial Buildings. You can mix requirements but not within major sections (envelope, mechanical, and lighting) unless separate permits are being requested for each system. For example, an applicant can apply for a shell permit using COMcheck-EZ to demonstrate envelope compliance. When requesting a permit for the mechanical system, the applicant can show compliance with IECC Chapter 7 using COMcheck-EZ or show compliance with the ASHRAE/IES code but cannot pick and choose mechanical requirements from either source.

Note: While this guide generally matches Chapter 7 of the IECC, it includes a section on Complex HVAC Systems that is outside of the scope of Chapter 7. (The 2000 IECC

commercial design by acceptable practice chapter has an expanded scope that matches these materials.) However, it is still appropriate to use that section with the 1998 IECC because the *COMcheck-EZ* materials are designed for use with codes based on the ASHRAE 90.1 ('89) Code, which is referenced in Chapter 6 of the 1998 IECC.

This Scope and Application guide gives building design professionals and code enforcement officials an overview of the *COMcheck-EZ* materials and explains how the energy code requirements apply to a variety of commercial building situations.

You can access a U.S. Department of Energy Building Energy Codes Program (BECP) web site at <http://www.energycodes.gov> to learn about *COMcheck-EZ* and get free downloads of the complete package of materials. If you have questions about the materials, contact BECP at techsupport@becp.pnl.gov.

Disclaimer and Terms of Use

These materials were prepared as an account of work sponsored by an agency of the United States Government. Neither the United States Government nor the United States Department of Energy, nor Battelle Memorial Institute, nor any of their employees, makes any warranty, express or implied, or assumes any legal liability or responsibility for the accuracy, completeness, or usefulness of any information, apparatus, product, software, or process disclosed, or represents that its use would not infringe privately owned rights. Reference herein to any specific commercial product, process, or service by trade name, trademark, manufacturer, or otherwise does not constitute or imply its endorsement, recommendation, or favoring by the United States Government or any agency thereof, or Battelle Memorial Institute.

This software and its documentation were produced with Government support under Contract Number DE-AC06-76RLO-1830 awarded by the United States Department of Energy. The Government retains a paid-up non-exclusive, irrevocable worldwide license to reproduce, prepare derivative works, perform publicly and display publicly by or for the Government, including the right to distribute to other Government contractors.

The user is authorized to use, duplicate, and redistribute *COMcheck-EZ* in its original form without royalty. Any unauthorized modification to the software and support files is strictly prohibited.

COMcheck-EZ Materials

The *COMcheck-EZ* materials include

- Scope and Application Guide
- Envelope Compliance Guide
- Mechanical Compliance Guide
 - Simple HVAC Systems
 - Complex HVAC Systems
 - Service Water Heating Systems
- Lighting Compliance Guide
- Software Compliance Guide
- State Maps and Prescriptive Packages

- Field Inspection Checklist
- Software CD-ROM

The *Envelope, Mechanical, and Lighting Compliance Guides* contain energy efficiency requirements. They provide direction in completing each compliance certificate used to demonstrate code compliance. These guides limit you to a prescriptive compliance path with no performance tradeoffs.

When performance tradeoffs and greater design flexibility are desired for one or more systems (envelope, mechanical, or lighting), the *COMcheck-EZ* software provides a performance path alternative for each system and generates a report used to demonstrate compliance.

For code enforcement officials, EZ tips for plan check and field inspection are included at the end of each compliance guide. The *Field Inspection Checklist* is useful when inspecting buildings for *COMcheck-EZ* compliance.

Envelope Compliance

The *Envelope Compliance Guide* contains energy efficiency requirements related to the building envelope. General requirements are included for limiting air leakage, certifying components, and installing vapor retarders. Climate-specific insulation and window requirements are provided in the prescriptive packages for each climate zone.

Mechanical Compliance

The *Mechanical Compliance Guide* contains energy efficiency requirements for heating, cooling, ventilating, and water heating. Included are requirements for heating and cooling system controls, outdoor-air ventilation, duct construction, and service water-heating systems. This guide also contains instructions for trading off economizers with higher-efficiency cooling equipment.

Lighting Compliance

The *Lighting Compliance Guide* contains basic energy efficiency requirements for lighting systems. This guide identifies control, switching, and wiring requirements and types of exterior-lighting sources that comply. It also shows you how to demonstrate compliance with building- or area-specific interior-lighting power limits.

Software Compliance

The *Software Compliance Guide* provides instructions on obtaining, installing, and using the *COMcheck-EZ* software. The software is a highly flexible way to demonstrate compliance with minimal input. The software is designed to run on most Windows-based computers. The envelope portion allows roof, wall, window, floor, and skylight performance tradeoffs within the permit stage. The lighting portion allows you to quickly determine if your lighting design meets the interior-lighting power limits. The mechanical portion displays and prints a checklist of mechanical requirements based on descriptions of the HVAC systems, plants, and water-heating systems used in the building. The software automatically generates a report that can be affixed to project plans and submitted to code enforcement personnel to demonstrate compliance.

State Maps and Prescriptive Packages

The *Envelope* and *Mechanical Compliance Guides* contain requirements that vary with climate. Use the State Maps and Prescriptive Packages to identify the climate zone and corresponding prescriptive package number for your proposed design used in determining climate-specific requirements.

Field Inspection Checklist

The *Field Inspection Checklist* helps ensure required energy efficiency measures are properly installed in the building in accordance with the building plans and specifications.

The checklist helps ensure required energy efficiency measures are properly installed in the building in accordance with the building plans and specifications.

Scope

You can use *COMcheck-EZ* to demonstrate energy code compliance in the design and construction of most types of commercial and high-rise residential buildings. However, you must use the *COMcheck-EZ* software method to demonstrate envelope compliance for buildings having a window-wall ratio (WWR) of more than 40%.

Applicable building types include

- offices
- retail, grocery, and wholesale stores
- restaurants
- assembly and conference areas
- industrial work buildings
- commercial or industrial warehouses
- schools and churches
- theaters
- apartment buildings and condominiums with four or more habitable stories
- hotels and motels

Code requirements do not apply to

- very low energy use buildings (i.e., peak energy usage less than 3.4 Btu per hour per square foot or 1 watt per square foot of floor area)
- buildings or portions of buildings that are neither heated nor cooled
- buildings designated as historic.

Applications

The following sections explain how *COMcheck-EZ* applies to a variety of typical building situations. While these examples can help illustrate various code applications, your local building department is the final authority on how the code applies to a project.

Unconditioned Spaces

Unconditioned spaces are exempt from the envelope requirements of the code. To be considered unconditioned, a space must have no heating or cooling system and not be conditioned indirectly by an adjacent space. Generally, if the conductance of heat between a space with no heating or cooling system and adjacent conditioned space is greater than the conductance between it and the outdoors, the space is considered conditioned.

A problem can occur when a building owner erects an unconditioned shell building and fails to comply with energy efficiency requirements. When a future tenant applies for a permit to install heating and cooling equipment, the building envelope must be brought into compliance, possibly requiring significant alterations. The lighting system, if installed in conjunction with the shell building, must also be brought into compliance in a similar situation.

Many code enforcement jurisdictions require that building owners sign an affidavit when applying for the initial building permit for a shell building. The owner acknowledges in the affidavit the potential difficulties associated with postponing envelope or lighting compliance. To minimize these difficulties, permit applicants should demonstrate compliance when each system is installed.

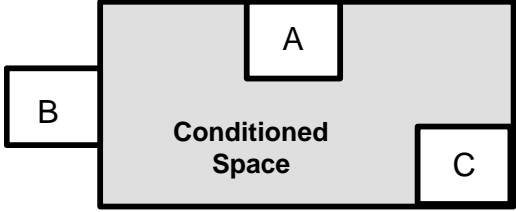
Question
<p>The sketch below shows a one-story building with four different spaces. Spaces A, B, and C do not have installed heating or cooling equipment and are not controlled for human comfort. Are any of these spaces considered <i>unconditioned</i> and hence not subject to the envelope requirements of the code?</p> 
Answer
<p>The conductance of heat is based on the wall area and the amount of insulation in the walls. Space A is in contact with conditioned space on three sides. Space C is in contact with conditioned space on two sides. Space B is in contact with conditioned space on only one side. If we ignore the roof and assume that all of the walls shown have the same amount of insulation, the conductance of the walls between the conditioned space and space A is greater than the conductance of the walls in contact with the outdoors. Space A is considered conditioned space, and all requirements applicable to conditioned space apply. For Space B, the conductance of its wall adjacent to conditioned space is less than the conductance of walls in contact with outdoors, so B is considered unconditioned. For Space C, the conductances are equal, so C is also considered unconditioned.</p>

Newly Conditioned Spaces

When an unconditioned space becomes conditioned, the space is considered an addition. All envelope, lighting, and mechanical systems and components associated with the

addition must comply with the energy code requirements as if the addition were a new building.

New Construction in Existing Buildings

Tenant improvements in an existing building (the base building has been constructed, but the individual tenant spaces have not been completed) are considered new construction. All envelope, lighting, and mechanical systems and components being installed must comply with some or all of the energy code requirements.

Existing systems and components not subject to the current permit application must comply with the energy code requirements only when conditioning previously unconditioned space.

Changes in Occupancy

Generally, if a change in occupancy does not include physical changes to the building and does not result in an increase in energy use, energy code requirements do not apply. If the occupancy change would result in increased demand for energy, compliance with the energy code (or approval by the code authority having jurisdiction) is required. Your code enforcement official may need to evaluate these changes on a case-by-case basis to determine which code requirements apply.

Alterations to Existing Conditioned Spaces

Alterations to existing conditioned spaces must comply with the following criteria:

- New systems in any alteration must comply with the energy code requirements.
- Altered components of existing systems must comply with the energy code requirements; unchanged components do not have to comply.
- If an alteration is made to an existing system and the resulting system does not comply, all altered components must comply, and the altered systems must use no more energy than before the alteration.

Determining how to apply these alteration requirements can be confusing, particularly with existing building envelope and lighting systems where some requirements apply at the system level. Just remember that each altered component (e.g., window or lighting fixture) must comply, and, if the entire building envelope or building lighting system is not being brought into compliance, the alteration cannot result in greater energy use.

Question
A building owner wants to install a new window in an old building, which will increase the glazing area in a building that already does not comply with building envelope requirements in the code. What requirements must be met to demonstrate compliance for this alteration?
Answer
The new window will increase building energy use even though the new window complies with code requirements; e.g., for U-factor. Therefore, the increased glazing area must be offset with other envelope improvements. You can use the <i>COMcheck-EZ</i> software to identify an alteration, such as adding insulation that will offset the added glazing. This is done by showing that the envelope compliance index is no worse with the new glazing and insulation than it was without the alterations.

Question
A building owner wants to rearrange some interior partitions and reposition the light fixtures in the affected rooms. Do any requirements apply to this alteration?
Answer
Because the alteration does not change the connected lighting load, the lighting system will use no more energy than before, so the overall lighting system does not need to comply. Only the control, switching, and wiring requirements apply. In this example, each newly arranged room must have a light switch, and any one- or three-lamp ballast must be tandem-wired.

Additions

Additions are newly constructed conditioned spaces or previously unconditioned spaces after heating or cooling equipment has been installed. All additions that are not exempted under the code must comply with the energy code requirements.

Envelope, lighting, and mechanical systems and components in additions are treated the same as they are for new buildings. Existing systems whose services are simply extended into an addition do not have to meet current code requirements, although the code does apply to new components of the system in the addition.

For additions, you can use two options to demonstrate compliance:

1. Treat the addition as a stand-alone building, ignoring the common walls between the existing building and the addition, and show compliance for only the addition. You can use either the *COMcheck-EZ* manual or software method to demonstrate compliance using this option.
2. Treat the existing building and the addition as a single building. In this case, the addition must not increase annual energy costs for the combined building (existing plus addition) beyond those for the existing building (in its pre-existing condition) with an otherwise identical addition whose components and window-wall ratio do comply with the code. This option provides greater design flexibility as improvements to the existing building can be used to offset noncompliant features in the addition.

However, we recommend that you consult with the building department before using this option to verify their acceptance of the compliance method. In addition, this option is not supported by the current *COMcheck-EZ* materials.

Buildings with Multiple-Occupancy Types

The energy code addresses buildings with multiple-occupancy types as follows:

- **Minor Occupancy** - If an occupancy type takes up less than 10 percent of a building's conditioned floor area, then the area devoted to that occupancy type must meet the same requirements as the major-occupancy type.
- **Multiple and Single Occupancy** - The same compliance process is used for commercial buildings with multiple-occupancy types as for those with a single-occupancy type. The *COMcheck-EZ* manual and software methods allow you to specify multiple-occupancy types.

- **Mixed Residential and Commercial Occupancy** - This occupancy type occurs when a building has three or fewer stories and contains both residential and commercial occupants, with the minor-occupancy type taking up more than 10 percent of the building's conditioned floor area. The residential and commercial occupancies are considered separately because they fall under two different scopes. Thus, two compliance submittals must be prepared using the appropriate calculations and forms from the respective codes for each type. Mixed residential and commercial buildings having more than three stories must comply as commercial buildings, regardless of the number of stories that are classified as residential occupancy.

Envelope Compliance

Envelope Requirements

You can use *COMcheck-EZ*TM to demonstrate that your commercial or high-rise residential building design complies with the 1998 Edition of the IECC.

This guide covers the energy code requirements for building envelope and provides a simple prescriptive method (manual method) for demonstrating compliance. Most envelope requirements vary with climate. This guide contains requirements for all climate locations within the United States, as well as instructions on how to demonstrate compliance with these requirements.

The *COMcheck-EZ* software is an alternative compliance method offering greater design flexibility by allowing tradeoffs between envelope components, including roofs, walls, windows, floors, and skylights. You can demonstrate compliance with minimal inputs and generate a compliance report to submit with your building permit application. Refer to the *COMcheck-EZ Software Compliance Guide* for instructions on obtaining and using the software.

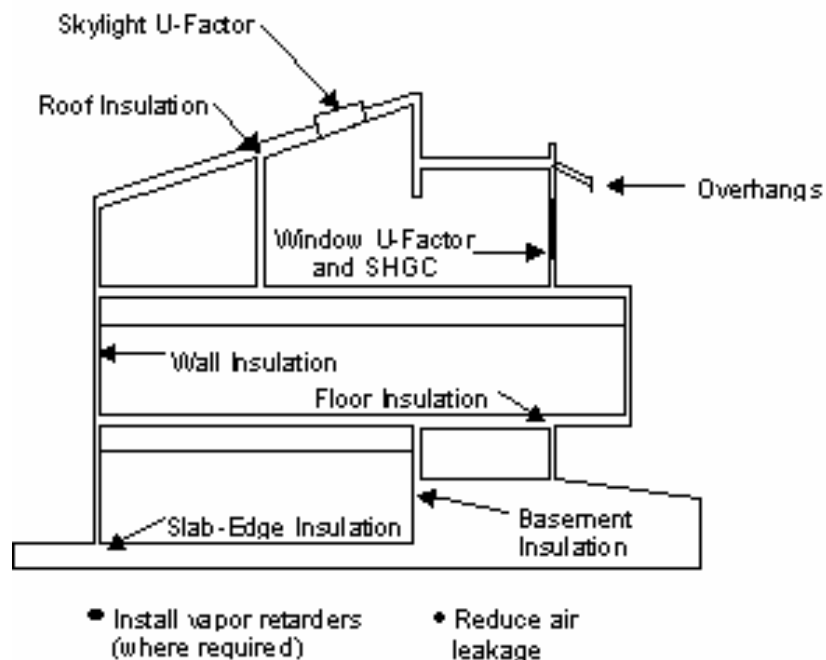

What the Energy Code Covers

To promote energy efficiency in building envelopes of commercial and high-rise residential buildings, the energy code requires that

- air leakage be limited through the building envelope. This guide contains requirements for limiting air leakage.
- insulation R-values and glazing and door U-factors be certified. This guide contains requirements for certified building components.
- vapor retarders be installed in nonvented framed ceiling, wall, and floor areas in many climates. This guide contains requirements for vapor retarders.
- insulation levels for walls, roofs, and below-grade walls and glazing areas, and U-factors for windows and skylights meet or exceed minimum efficiency levels – these minimums are listed in prescriptive package tables for specific climate locations. This guide contains instructions on how to determine if your design complies with these levels.

Demonstrating Compliance

The *COMcheck-EZ* manual method (prescriptive compliance path) requires minimal calculations and is the simplest way to comply. It is a package approach that requires all components in your design to meet or exceed prescribed efficiency levels contained in the prescriptive package table for your building's climate zone. If one component does not meet the prescribed efficiency level, you must use the *COMcheck-EZ* software method (or other compliance option available under the code) to demonstrate compliance. In addition, the prescriptive packages are restricted to use with buildings three stories or less in height. For taller buildings you must use the software method.

State maps showing climate zones, prescriptive package tables for each zone, and instructions are provided separately from this guide. You must have the appropriate prescriptive package table for your building's climate zone to use this method. To demonstrate compliance, complete the *Envelope Compliance Certificate* included with this guide.

Air Leakage

All joints and penetrations in the building envelope that are potential sources of air leakage must be caulked, gasketed, weatherstripped, or otherwise sealed in an approved manner.

The following areas in the building envelope must be sealed:

- exterior joints around window and door frames
- areas between wall sole plates, floors, and exterior-wall panels
- openings for plumbing, electricity, refrigerant, and gas lines in exterior walls, floors, and roofs
- openings in the attic floor (e.g., where ceiling panels meet interior and exterior walls and masonry fireplaces)
- service and access doors or hatches
- all other similar openings in the building envelope.

Recessed-lighting fixtures must be gasketed and IC rated; i.e., rated for direct contact with insulation.

The code specifies maximum air leakage rates for manufactured windows and doors. Windows and doors certified by an accredited laboratory (such as the National Wood Window and Door Association [NWWDA] or the Architectural Aluminum Manufacturers Association [AAMA]) meet these requirements and are labeled. For noncertified windows and doors, check manufacturers' test reports to verify compliance with these air leakage requirements.

Frame Type	Windows (cfm per ft of operable sash crack)	Doors (cfm per ft of door area)	
		Sliding	Swinging
Wood	0.25	N/A	0.25
Aluminum	0.37	0.37	1.25
PVC	0.06	0.37	N/A

Maximum Allowed Air Leakage Rates

Building Component Certification

Insulation R-values and glazing and door U-factors must be clearly marked on building plans or specifications. If two or more different insulation levels exist for the same building component, record each level separately on the plans or specifications. For example, if the walls adjacent to an unheated warehouse have less insulation than the building's exterior walls, record both insulation levels.

You must provide component R-values and U-factors so compliance can be determined. These values may be provided on

- product labels - For example, the R-value of the insulation is often printed directly on the insulation or can be determined from a striping code. Window U-factors are often included on the manufacturer label posted directly on the window.
- contractor statements certifying the products they have installed - For example, the insulation contractor should certify the R-value of the installed insulation.

For blown or sprayed insulation, the initial installed thickness, settled thickness, coverage area, and number of bags used must be clearly posted at the job site. For components having a manufacturer's guaranteed R-value rating, thickness markers must be placed at least every 300 ft². For components without a manufacturer's guaranteed R-value rating, contact the Insulation Contractors Association of America for an approved way to ensure proper insulation levels are obtained.

Finally, check with your code enforcement official having jurisdiction for requirements on certifying building components.

Standard Insulation Thicknesses

Insulation can be compressed if not properly installed. The insulation R-value is dependent on the installed thickness of the insulation. All COMcheck-EZ insulation requirements assume the insulation is installed at its standard thickness. If insulation is compressed, the R-value is reduced and the building may not meet the requirements. This situation is of particular concern in metal building construction because of the way the insulation is installed to create a clean-finish appearance. The following table shows the R-values and standard thicknesses of fiberglass batts. However, when using an R-19 batt in a typical 2x6 wall, you can assume the full R-value of 19.

Insulation R-Value	Standard Thickness (in.)
R-11	3 ½
R-13	3 5/8
R-15	3 ½
R-19	6 ¼
R-21	5 ½
R-22	6 ¼
R-30	9 ½
R-38	12

Vapor Retarders

Except in specified climate zones, vapor retarders must be installed in all nonvented framed areas in ceilings, walls, and floors. Nonvented areas are framed cavities without vents or other openings to allow for free air movement. The vapor retarder must have a perm rating of 1.0 or less and must be installed on the warm-in-winter side of the insulation (between the insulation and conditioned space).

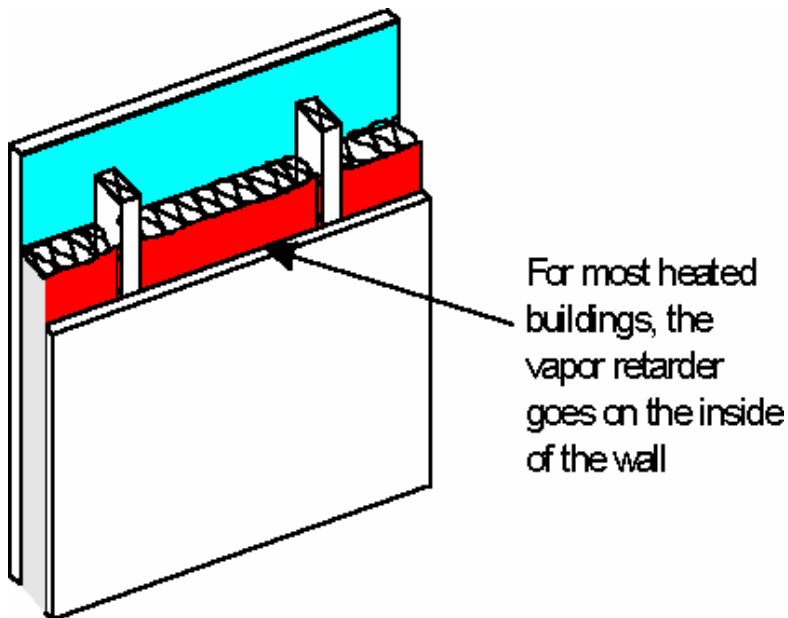

Location of Vapor Retarders

These vapor retarder requirements do not apply in Climate Zones 1 through 7—roughly the warmest third of the United States.

[See the State Maps available with (or at the end of) these guides to determine the appropriate climate zone for your building.]

Insulation and Window Requirements

The *COMcheck-EZ* methods contain climate-specific envelope requirements for walls, windows, skylights, roofs, floors, and basement walls. The manual method prescribes insulation levels, glazing areas, and glazing U-factors. The software method provides additional flexibility because these requirements can be traded against each other.

The WWR is the gross window area divided by the gross wall area.

The gross wall area includes

- the opaque area of all above-grade exterior walls enclosing conditioned spaces (including above-grade portions of basement wall assemblies but excluding walls separating conditioned from unconditioned space)
- the area of the band joist and subfloor between floors
- the area of all doors and windows.

The gross window area includes the rough-opening area of the window, not just the transparent-glass area.

To determine if your proposed design complies with the climate-specific requirements

- determine the WWR category for your design (0-10%, 10-25%, 25-40%)
- determine the climate zone for your proposed building's location from the appropriate state map
- find the prescriptive package table for your building's climate zone
- select the package from the table that best fits your design's construction characteristics based on WWR
- find the corresponding requirements for walls, windows, skylights, roof, floors, and basement walls
- determine if your design complies based on criteria contained in the following sections.

You cannot use the manual method for buildings with WWR over 40%. For these buildings, use the *COMcheck-EZ* software or another compliance method permitted under the code.

Note About Prescriptive Package Tables: The 40% to 50% WWR packages (right-most column) and the table footnotes related to use with buildings with more than three stories are not applicable to compliance based on Chapter 7 of the 1998 IECC. However, both of these features of the tables are based on equivalence with the 90.1 ('89) Code, and hence, their use may be permitted based on Chapter 6, which references the 90.1 ('89) Code. We recommend that you consult your local building department for approval before using those features to demonstrate compliance with the 1998 IECC.

Walls

Your design complies with the wall insulation requirement if the proposed wall insulation has an R-value equal to or greater than the requirement in the prescriptive package. Wall insulation requirements apply to both exterior and interior walls that separate conditioned from unconditioned space. The wall type, WWR, and whether the wall is on the exterior or just separating conditioned from unconditioned space, may affect the wall insulation requirement.

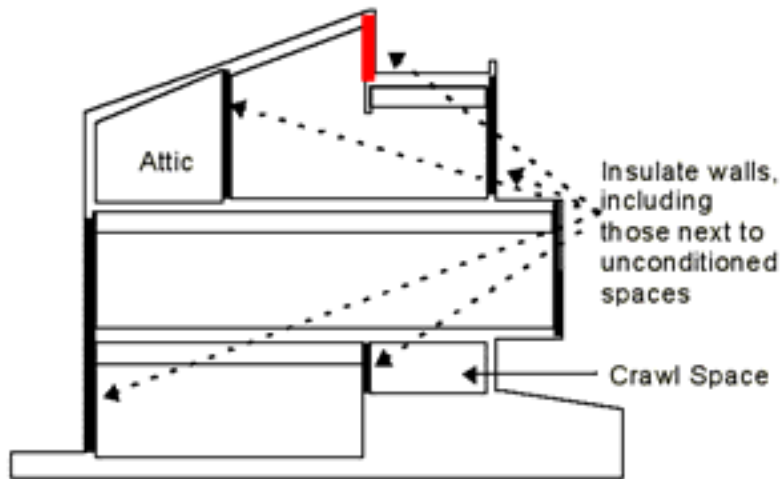

Location of Wall Insulation

To demonstrate compliance, enter the R-value of the insulation to be installed in each wall component in the *Proposed R-Value* column on the *Envelope Compliance Certificate*. R-values for walls represent wall cavity insulation and/or continuous insulation (insulating sheathing), depending on the package selected. For example, if R-13 batt insulation is to be used with R-6 insulating sheathing, enter "R-13 + R-6" in the *Proposed R-Value* column.

All wall components with the same R-value may be combined and entered as a single component on the certificate, provided these walls are of the same construction class (i.e., wood, metal, masonry).

Concrete Masonry Unit Walls

Concrete masonry unit walls may be insulated by filling the empty core with perlite, vermiculite, or some other insulating material. In some cases, even with filled cores, these wall types require additional insulation.

Metal Building Walls and Roofs

Special attention to the design and construction of metal buildings is required to ensure these buildings meet the code requirements. Two key elements exist in metal buildings that are not found in other building classes—thermally broken connections between the purlin and metal roof sheet and compression of insulation behind wall girths and roof purlins.

COMcheck-EZ includes requirements for metal building walls and roofs. These requirements are specified in the “Walls Framed - Metal Framing” category and in the “Roofs Metal Purlin” category in the Prescriptive Packages. There are two classes of metal building roofs. One class uses traditional techniques that drape the insulation over the purlin and fasten the metal roof sheets through the insulation directly to the purlin. The second class requires that a thermal block be placed between the metal roof sheet and purlin.

A thermal block consists of foam blocks or other materials/techniques that prevent heat from migrating from the purlin directly to the metal roof sheet. Compressed fiberglass batt insulation does not qualify as a thermal block.

Windows

Your design complies with the window U-factor requirement if the proposed windows have a U-factor less than or equal to that in the prescriptive package. In most cases, the WWR will affect the window requirement.

A window U-factor is based on the interior-surface area of the entire assembly, including glazing, sash, and other framing elements. Center-of-glass U-factors cannot be used.

Your design must also have a Solar Heat Gain Coefficient (SHGC) less than or equal to that shown in the prescriptive package. The SHGC specifies the glazing's effectiveness in rejecting solar heat gain. SHGC is part of a system for rating window performance used by the National Fenestration Rating Council (NFRC). SHGC is gradually replacing the older index, shading coefficient (SC), in product literature and design standards. If you are using glass whose performance is listed in terms of SC, you may convert to SHGC by multiplying the SC value by 0.87. The SHGC requirement is affected by the projection factor (PF) of qualifying overhangs.

The projection factor is based on the ratio of the overhang depth to the overhang height above the window sill.

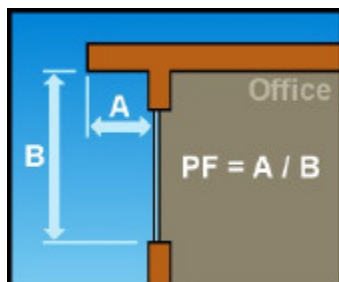

Projection Factor

Question
What is the projection factor of an overhang that extends 3 ft out and is 6 ft above the bottom window sill?
Answer
The projection factor is A divided by B. If A is 3 ft and B is 6 ft, the projection factor is 3/6 or 0.5.

For compliance, the SHGC cannot be modified to account for the effects of interior-shading devices. It can be modified for permanently attached devices that shade the exterior of the window. Examples of these devices include shade screens and architectural shade structures.

U-factors and SHGCs for glazing must be tested and documented by the manufacturer in accordance with the NFRC test procedure. Typical U-factor and SHGC values for windows and skylights are shown in the tables below. You may use these values to check compliance prior to selecting actual glazing products. However, the actual ratings for products installed in the building must meet or exceed (i.e., be no higher than) the values you assume in the compliance analysis.

Glazing Layers	Window Frame Type		
	Metal	Metal with Thermal Break	Wood or Vinyl
Single	1.2	1.1	1.0
Double	0.7	0.7	0.6
Double Low-e	0.6	0.6	0.5
Triple	0.6	0.5	0.5
Triple Low-e	0.5	0.5	0.4

Typical Window U-Factors

Glazing Layers	Glass Type		
	Clear	Tinted	Reflective
Single	0.8	0.7	0.5
Double	0.7	0.6	0.4
Double Low-e	0.7	0.6	0.4
Triple	0.7	0.5	0.4
Triple Low-e	0.7	0.5	0.4

Typical Glass SHGC Values

To demonstrate compliance, enter the proposed window U-factors in the *Proposed U-Factor* column and the proposed SHGC in the *Proposed SHGC* column on the *Envelope Compliance Certificate*.

Doors

There are no specific insulation requirements for opaque doors in the 1998 IECC, but glass doors, such as sliding-glass doors and atrium doors, must meet the same SHGC and U-factor requirements as windows from the prescriptive package tables, or compliance must be demonstrated using the COMcheck-EZ software (or other approved method).

Skylights

Your design complies with the skylight U-factor requirement if the proposed skylights have a U-factor less than or equal to that in the prescriptive package. The packages restrict the total skylight area to 3% or less of the gross roof area.

A skylight U-factor is based on the interior-surface area of the entire assembly, including glazing, sash, curbing, and other framing elements. Center-of-glass U-factors cannot be used.

Glazing Layers	Skylight Frame Type		
	Metal	Metal with Thermal Break	Wood or Vinyl
Single	2.0	1.9	1.5
Double	1.3	1.1	0.9
Double Low-e	1.2	1.0	0.8
Triple	1.2	0.9	0.7
Triple Low-e	1.1	0.9	0.6

Typical Skylight U-Factors

U-factors for skylights must be tested and documented by the manufacturer in accordance with the NFRC test procedure. If an NFRC U-factor rating is available for your skylight, you should use its BB-Size (i.e., 48 by 48 in.) rating.

To demonstrate compliance, enter the proposed skylight U-factors in the *U-Factor* column on the *Envelope Compliance Certificate*.

Roofs

Your design complies with the roof insulation requirement if the proposed roof insulation has an R-value equal to or greater than that in the prescriptive package. In some cases, the WWR will affect the roof insulation requirement.

Roof insulation in buildings with attics must be installed to allow for free circulation of air through the attic eave vents. To demonstrate compliance, enter the R-value of the insulation to be installed in each roof component in the *Proposed R-Value* column on the *Envelope Compliance Certificate*. R-values for roofs represent cavity insulation and/or insulating sheathing (depending on the package selected). For example, if R-19 batt insulation is to be used with R-4 insulating sheathing, enter "R-19 + R-4" in the *Proposed R-Value* column.

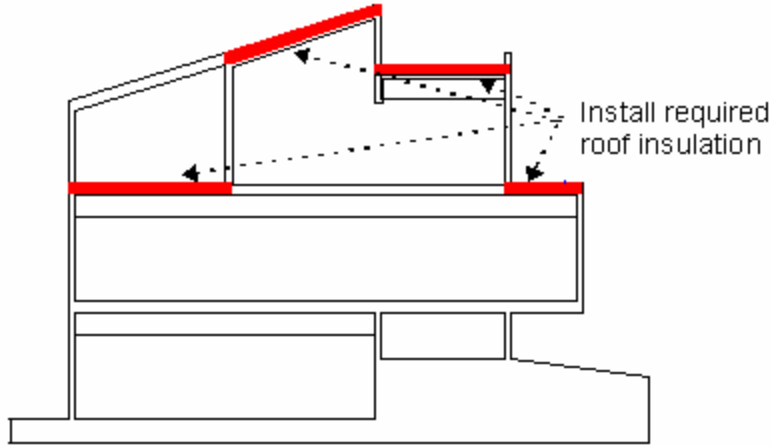

Location of Roof Insulation

All roof components with the same R-value and construction class may be combined and entered as a single component on the certificate.

Floors

Your design complies with the floor insulation requirement if the proposed floor insulation has an R-value equal to or greater than that in the prescriptive package. Floor insulation requirements apply where the underside of a floor is exposed to the outdoors or unconditioned space.

To demonstrate compliance, enter the R-value of the insulation to be installed in each floor component in the *Proposed R-Value* column on the *Envelope Compliance Certificate*. R-values for floors represent cavity insulation, spray-on insulation, and insulating sheathing (depending on the package selected).

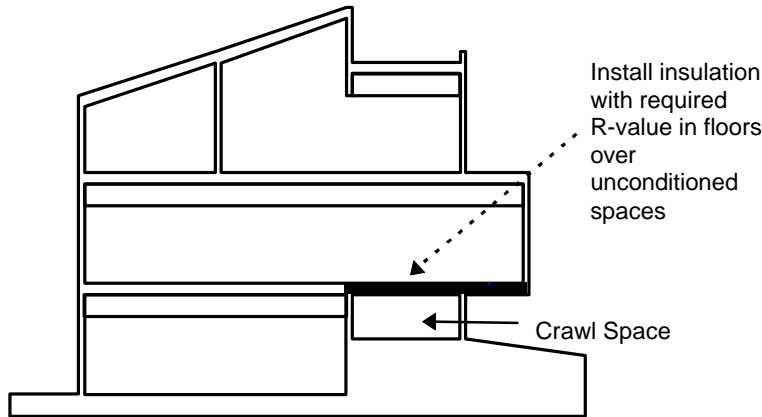

Location of Raised-Floor Insulation

All floor components with the same R-values and construction class may be combined and entered as a single component on the certificate.

Slab-On-Grade

In some cases, the edges of concrete slab floors must be insulated. The following diagram shows several common ways to effectively insulate a slab edge.

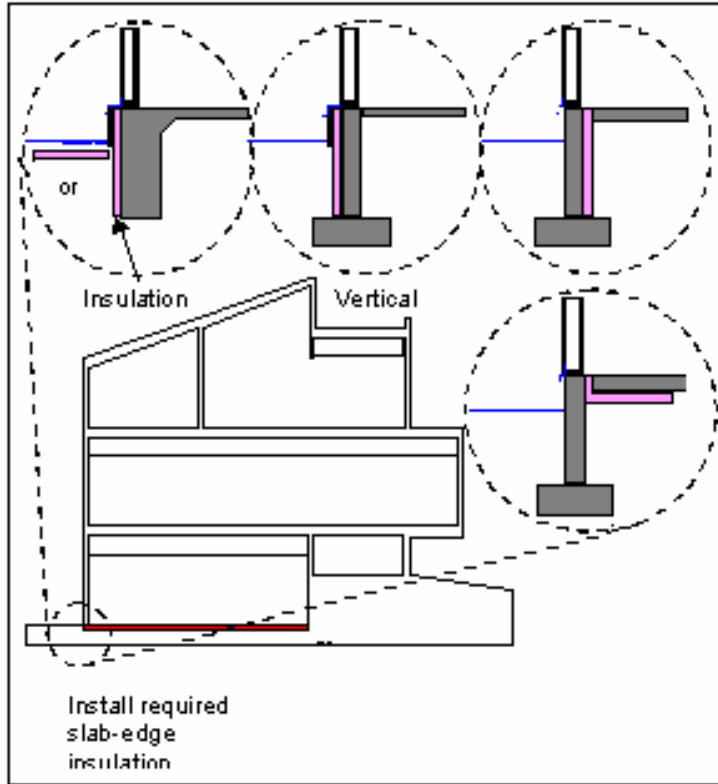

Location of Slab-Edge Insulation

Slab-edge insulation may be installed vertically or horizontally on the inside or outside of foundation walls. If installed vertically, it must extend downward from the top of the slab to the top of the footing (or 48 in., whichever is less). If installed horizontally, it must cover the slab edge and then extend horizontally (to the interior or exterior) for a minimum distance of 40 in.

Below-Grade Walls

In some cases, basement walls must be insulated. For purpose of this requirement, a wall is considered to be below grade when its surface area is in direct contact with the earth. The insulation must extend 10 ft below finish grade or to the level of the below-grade floor (i.e., the lowest floor), whichever is less. Your design complies with the basement wall insulation requirement if the proposed insulation has an R-value equal to or greater than that in the prescriptive package.

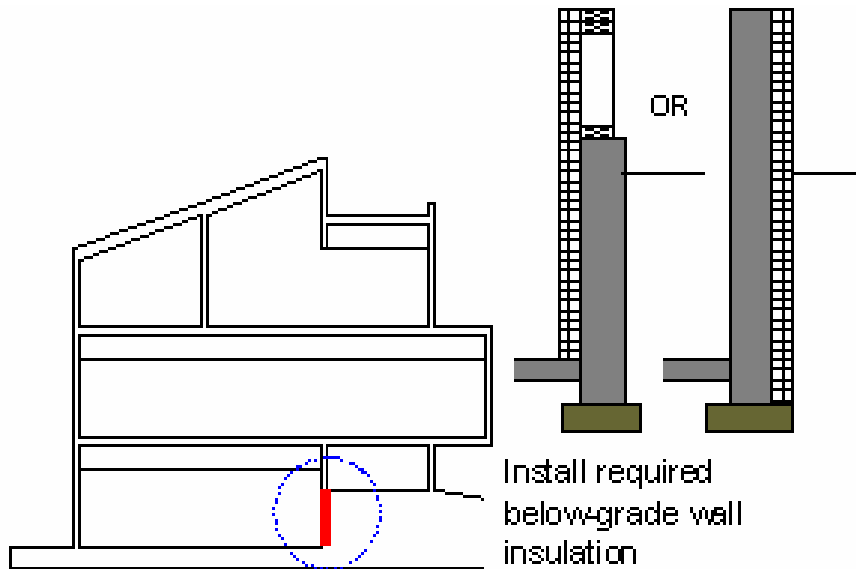

Location of Basement Wall Insulation

To demonstrate compliance, enter the R-value of the insulation to be installed in the basement wall component in the *Proposed R-Value* column on the *Envelope Compliance Certificate*. R-values for basement walls represent cavity insulation or insulating sheathing (depending on the package selected).

All basement wall components with the same R-value and construction class may be combined and entered as a single component on the certificate.

Completing Envelope Compliance Certificate

These instructions explain the information to include in the Envelope Compliance Certificate, identify the appropriate contact or reference if you have questions, and provide *EZ* tips for completing the certificate. A sample certificate is also provided. The instructions have numbered circles that correspond to those on the sample certificate. For code enforcement officials, *EZ* tips for plan check and field inspection are included at the end of this guide.

General Guidelines

For Documentation Authors: Provide all information in unshaded sections, entering "NA" if a particular requirement is not applicable; submit the completed certificate to the authority having jurisdiction with the building permit application package.

For Plan Checkers: Verify that proposed values listed on the certificate are consistent with the plans and specifications and with the requirements of this guide or the code.

For Field Inspectors: Inspect and approve building construction against each requirement in Section 3 of the certificate.

Prequalifying Project Design

Before using the *Envelope Compliance Certificate*, determine if your proposed design is qualified to use the *COMcheck-EZ* manual method to demonstrate compliance.

To determine if your design qualifies, calculate the WWR for the design using the following equation. If the design WWR exceeds 40%, or the prescriptive path cannot be followed in its entirety, a nonprescriptive code approach must be used. The *COMcheck-EZ* software provides an optional way to demonstrate compliance through a system performance path. Refer to the *COMcheck-EZ Software Compliance Guide* for instructions on using the software.

Gross Fenestration Area) Gross Exterior Wall Area X 100 = Design WWR%

Low Fenestration (WWR 0%-10%)

Medium Fenestration (WWR 10%-25%)

High Fenestration (WWR 25%-40%)

Mechanical Compliance

Mechanical Requirements

You can use *COMcheck-EZ*TM to demonstrate that your commercial or high-rise residential building design complies with the 1998 Edition of the IECC.

Mechanical Compliance Options

COMcheck-EZ offers two separate methods for showing compliance—a manual method and a software method. This Mechanical Compliance Guide contains the energy code requirements for mechanical systems and equipment, and instructions on how to manually demonstrate and document that your proposed design complies with code requirements.

This guide has three major sections – Simple Systems, Complex Systems, and Water-Heating Systems. Generally, you can use the Simple Systems section with single-zone systems but need to use the Complex Systems section if your building contains any multiple-zone systems. The Simple Systems section is shorter and less technical and therefore is the preferred approach for any buildings that qualify. The brief Water-Heating Systems section provides code requirements for service water-heating systems for all types of commercial buildings.

The *COMcheck-EZ* software offers an alternative compliance method. The software uses a "wizard" approach that enables you to readily generate a checklist of mechanical requirements applicable to your building design. Refer to the *COMcheck-EZ* Software Compliance Guide for instructions on using the software method.

Demonstrating Compliance

To demonstrate compliance, indicate on your project plans equipment efficiencies, system controls, outdoor-air ventilation rates, duct insulation levels, duct sealing, and water-heating components that comply. Complete a *Mechanical Compliance Certificate*—either for simple or complex systems—provided with this guide and include it with the permit submittal materials.

Qualifying for Simple Systems Method

COMcheck-EZ provides a simple way to demonstrate compliance with energy code requirements. You can use this simple method if your design uses the following equipment types:

- cooling – new unitary-packaged, split-system or packaged terminal air conditioner or heat pump
- warm-air heating – new unitary-packaged, split-system or packaged terminal heat pump; new fuel-fired furnace or electric-resistance heater
- hydronic heating – 2-pipe hot water radiators, baseboard heaters, fan coils, or other individual terminal heating units with new central boiler and no cooling system installed in the building
- variable-air volume (VAV) changeover system if it ensures the required ventilation is continuously provided to each space.

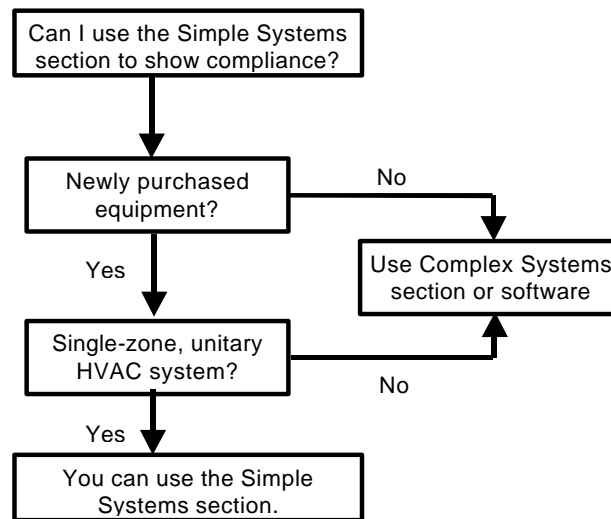

You cannot use the *Simple Systems* section with the following equipment types:

- packaged VAV reheat
- built-up VAV reheat
- built-up single-fan, dual-duct VAV
- built-up or packaged dual-fan, dual-duct VAV
- 4-pipe fan coil system with central plant
- hydronic heat pump with central plant
- other multiple-zone or built-up systems
- all other hydronic space-heating systems
- any combination of different types of allowed systems such as hydronic heating and unitary-packaged cooling.

To determine compliance for equipment types not covered in the *Simple Systems* section, refer to the *Complex Systems* section of this guide, the COMcheck-EZ software, or other compliance method acceptable to your local building department.

Simple Systems

This section applies only to buildings that meet all of the qualifying criteria in the previous section *Qualifying for Simple Systems Method*.

To promote the use of energy-efficient mechanical systems and equipment in commercial and high-rise residential buildings, the energy code requires

- minimum equipment efficiency at peak- and (in some cases) part-load conditions
- acceptable levels of outdoor-air ventilation to ensure occupant comfort and health
- use of outside-air economizers where appropriate
- ducts that are insulated and sealed to minimize heating and cooling energy losses
- hydronic heating system features that reduce distribution losses and increase part-load efficiency.

Mechanical Equipment Efficiencies

The 1998 IECC requires that mechanical equipment meet minimum efficiency ratings. However, virtually all equipment types compatible with this Simple Systems section are covered by manufacturing standards and must meet these minimums to be sold in the United States. For this and other reasons, all new equipment can be assumed to meet or exceed these minimum equipment efficiency levels. You still need to indicate the proposed equipment efficiencies on the mechanical plans and project specifications.

Heating and Cooling System Control Requirements

Thermostats are required for heating and cooling systems to control indoor temperatures. In some climates, air economizer systems are used to provide outdoor air for free cooling.

Thermostats

A thermostat is required in each zone to control heating and/or cooling. Thermostats must have the capability to automatically set back or shut down heating and cooling systems when appropriate. Thermostats must also have an accessible override so occupants can operate the system during off-hours. Heat pumps with supplementary electric-resistance heaters must have thermostats specifically designed for heat pump operation; i.e., to use resistance heaters only when the heat pump operating alone is inadequate to meet the load.

A programmable thermostat must be used to meet these requirements. These thermostats are available for heating only, cooling only, heating and cooling, and heat pump systems. They can set back or shut down the system during nights and weekends. In addition, occupants can temporarily override the thermostat and it will return to the original schedule without reprogramming.

Thermostats that control the temperature in residences, hotel/motel guest rooms, or areas where heating and/or cooling systems must operate continuously do not require a setback or shutoff control.

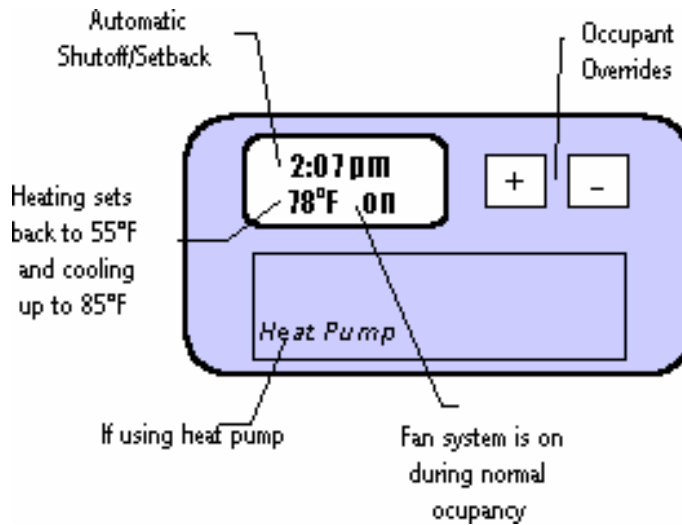

Thermostat Requirements

Air Economizer Systems

Air economizer systems take advantage of favorable weather conditions to reduce mechanical cooling by introducing cooler outdoor air into a building. They are common on packaged rooftop heating and cooling systems. When properly installed and maintained, these systems can reduce mechanical cooling by up to 75% in favorable climates.

The 1998 IECC requires air economizers capable of delivering at least 85% of the supply air directly from outdoors.

Typical economizer controls include a two-stage thermostat and an economizer controller using dry-bulb temperature or enthalpy, or a combination of both. A control is also included to prevent ice from forming on cooling coils. This control arrangement allows outdoor-air cooling, mechanical cooling, or outdoor-air plus mechanical cooling—a feature known as “integrated control.” Field- and factory-installed economizers supplied by major equipment manufacturers include integrated controls.

The 1998 IECC requires the use of economizers for all systems but does not require that they include integrated controls.

Exceptions to this requirement are

- buildings in climate zones 1a, 1b, 2a, 2b, 3b.
- cooling systems with a total cooling capacity less than 90,000 Btu per hour
- systems serving residential spaces, supermarkets, or hotel/motel guest rooms
- if the proposed equipment meets the minimum qualifying cooling energy efficiency ratio (EER) for economizer tradeoff (see table below).

Total Cooling Capacity of Equipment	Building Location		
	Zones 6a, 9a, 10a, 11a, 12a, 12b, 13a, 13b, 14a, 14b, 15-19	Zones 3a, 4a, 7a, 8, 9b, 10b, 11b	Zones 4b, 5a, 5b, 6b, 7b
90,000 Btu/h to 134,999 Btu/h	N/A	11.4 EER	10.4 EER
135,000 Btu/h to 759,999 Btu/h	N/A	10.9 EER	9.9 EER
760,000 Btu/h or more	N/A	10.5 EER	9.6 EER

Minimum Energy Efficiency Ratio for Economizer Tradeoff

To identify the minimum EER necessary to trade off the economizer:

1. find the climate zone for your building location in the table
2. determine if this tradeoff is applicable to your zone
3. if so, find the appropriate cooling capacity of the proposed equipment and find the corresponding minimum EER.

Outdoor-Air Ventilation Requirements

Outdoor-air ventilation rates necessary to maintain indoor-air quality while minimizing energy use are currently being debated. The concerns of designers and health professionals regarding indoor-air quality were considered in developing this guide, thus outdoor-air ventilation and control requirements are included. However, the designer is ultimately responsible for recognizing building features that may cause poor indoor-air quality. Adherence to requirements in this guide cannot alone ensure that good indoor-air quality will be maintained.

All enclosed spaces where people are expected to remain for extended periods of time must be continuously ventilated with outdoor air. A space can be ventilated naturally or mechanically. These spaces must be ventilated according to the applicable building or mechanical code required by state or local statutes. In the absence of a local ventilation requirement, this compliance method requires that designers use Chapter 4 of the 1996 International Code Council (ICC) *International Mechanical Code* (IMC) or values from the table below.

In addition, spaces that may contain unusual sources of contaminants must be designed with enclosures to contain the contaminants. These spaces must also have local exhaust systems to directly vent the contaminants (see the state or local mechanical code or Chapter 5 of the IMC.)

Mechanical Ventilation

If your design is mechanically ventilated, it must

- meet minimum ventilation rates
- meet provisions for operating the system at those rates
- include dampers to prevent air infiltration during periods of building nonuse.

Minimum Outdoor-Air Requirements

Your design's heating and/or cooling system must supply the minimum-required outdoor air to a space (refer to your state or local code or Chapter 4 of the IMC for required rates). A supply- and return-air system or an exhaust system must supply the outdoor air. Refer to Chapter 4 of the IMC or use outdoor-air ventilation rates from the following table.

Building Type	Ventilation Rate (cfm per sq ft)
Auto Repair Workshop	1.5
Auditorium	2.25
Barber Shop	0.38
Bar, Cocktail Lounge, Casino	3.0
Beauty Shop	0.63
Cafeteria/Fast Food	2.0
Dry Cleaning	0.9
High-Rise Residential	Per IMC Section 403.3
Hotel Guest Room	30 cfm/room
Office	0.14
Retail Store (basement and street)	0.30
Retail Store (upper floors)/Mall	0.20
All Others	Per IMC Section 403.3

Required Outdoor-Air Ventilation Rates (IMC)

Ventilation Controls

When the heating and/or cooling system is controlled by a thermostat with a fan On/Auto switch, the switch must be set to the On position. Outdoor air is then supplied to the building whenever the system is operating. If a thermostat with a built-in time-switch is used, the thermostat must be capable of setting back or shutting off the fan during periods of nonuse.

Some ventilation systems are designed to supply outdoor-air quantities exceeding minimum levels. These systems must also be capable of reducing outdoor-air flow to minimum levels. Devices such as return ducts, mechanically or automatically operated control dampers, or fan volume controls can be used to reduce air flow.

Shutoff Dampers

Outdoor-air supply and exhaust systems with design air flow rates greater than 3000 cubic feet per minute of outdoor air must have dampers that automatically close while the equipment is not operating. This requirement will mainly affect dedicated outdoor-air supply systems in paint shops, restaurants, and auditoriums. This requirement does not apply to automatic dampers mandated by health and life safety codes.

Natural Ventilation

Windows, doors, louvers, or other openings to outdoor air can provide natural ventilation to interior spaces. Refer to your state or local code or Section 402 of the IMC to find minimum area requirements for above- and below-grade openings, adjoining spaces, and spaces containing contaminants. The codes typically require that a free opening of at least 4% of the floor area be available for natural ventilation.

Question
What is the window area required to ventilate a 30 x 32-ft classroom?
Answer
<p>The area of the opening must be</p> $(30 \times 32 \text{ ft}) \times 4\% = 38.4 \text{ sq ft}$ <p>The actual window area must be at least 76.8 sq ft if only half the window opens.</p> <p>This calculation is based on free area. With framing, the actual window area is approximately 80 sq ft.</p>

Refrigerant Pipe Insulation

For refrigerant pipe insulation, refer to the section *Pipe Insulation Requirements* in the *Complex Systems* section.

Duct Requirements

Ducts must be properly insulated and sealed to reduce energy loss.

Insulation

All supply- and return-air ducts and plenums must be insulated with a minimum of R-5 insulation when located in unconditioned spaces (e.g., attics, crawl spaces, unheated basements, unheated garages) and with a minimum of R-8 when located outside the building envelope. When located within a building envelope assembly, the duct or plenum shall be separated from the building exterior or unconditioned spaces by a minimum of R-5 insulation.

Exceptions:

- when located within equipment
- exhaust-air ducts
- when the design temperature difference between the interior and exterior of the duct or plenum does not exceed 15°F (8°C).

Sealing

Ducts are sealed to ensure quantities of air are not lost before they are delivered to the space. Flexible and metal ducts are common in small- to medium-size commercial buildings.

Properly sealing plenums, air handlers, and ducts is the key to eliminating leaks. In duct systems, all joints, longitudinal and transverse seams, and connections must be securely fastened and sealed with welds, gaskets, mastics (adhesives), mastic-plus-embedded-fabric systems, or tapes. Duct mastic-plus-embedded-fabric is the preferred flexible sealant. Tapes and mastics used to seal duct work must be listed and labeled in accordance with UL 181A or UL 181B.

Although the code does not require duct mastic, its use is strongly encouraged. Conventional duct tape must not be used except to seal the joints on duct access doors and air-handler panels.

Additionally, duct registers, grilles, and diffusers must be sealed to the gypsum board or other interior finish. Penetrations into the supply or return plenum (taps, takeoffs, and

starting collars) and any structural cavities used for air plenums or ducts must also be sealed.

In the diagram, an exterior-duct sealant is used to seal both transverse and longitudinal seams. Pressure-sensitive tape (duct tape) cannot be used as the primary sealant.

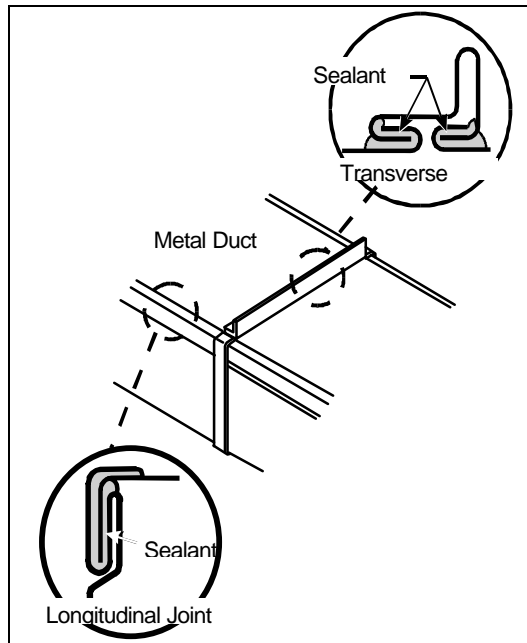

Sealing Metal Duct Transverse Seams

Hydronic Heating Requirements

The requirements listed in this section apply to systems that provide heating only through the use of individually controlled radiators or fan-coils and are served by a central hot water boiler. The following components are required on zonal heating systems:

1. thermostats meeting requirements for each individual heating zone
2. new equipment boilers and circulation pumps
3. pipe insulation - to reduce distribution and standby losses
4. variable-flow controls on the circulation pump or temperature reset controls for systems with capacities over 600,000 Btu per hour to increase efficiency during part-load operation.

For hydronic system part-load control requirements, refer to *Part-Load Control Requirements for Hydronic Systems* in the *Complex Systems* section.

(A blank compliance certificate for simple systems, instructions for using the certificate, and a filled-out sample can be found at the end of this Mechanical Guide.)

Complex Systems

This section is designed to provide a relatively simple process for demonstrating compliance with energy code requirements that apply to multi-zone HVAC systems. It is designed for use with any of the following system or equipment types:

- single-duct VAV distribution with zone reheat
- dual-duct VAV (either with a single supply fan or separate fans for heating and cooling ducts)
- constant-volume, single-zone with chilled water, hot water, or built-up direct expansion coils or electric or fuel-fired furnaces
- three-duct, constant- or variable-volume air distribution
- 4-pipe fan coil
- hydronic heat pump
- all types of central plant equipment, including electric- and heat-operated water chillers, boilers, and central refrigeration compressors serving one or more direct-expansion cooling coils.

This section can also be used with the following system types, although they are covered more simply under the *Simple Systems* section:

- packaged air conditioners – new unitary-packaged, split-system or packaged terminal air conditioner or heat pump
- packaged warm-air furnaces – new unitary-packaged, split-system or packaged terminal heat pump; new fuel-fired furnace or electric resistance heater.

Because of provisions that prohibit mixing hot and chilled water, you cannot use *COMcheck-EZ* for 2-pipe (systems that provide both heating and cooling) or 3-pipe fan coil or radiator systems.

You can use *COMcheck-EZ* for either of the multi-zone systems listed below only if all thermostatic control zones served by the system meet one of the exceptions to the requirement for VAV systems (see *Multiple-Zone System Requirements*)

- constant-volume, multiple-zone systems with reheat
- constant-volume, dual-duct systems.

To promote the use of energy-efficient systems and equipment in commercial and high-rise residential buildings, the energy code requires

- minimum equipment efficiency at peak- and part-load conditions
- controls that maximize air and hydronic system efficiency at part-load conditions
- controls that eliminate or minimize system operation during periods of nonuse
- water or air economizers on most systems
- minimum duct and pipe insulation levels and duct sealing measures
- efficient technologies and control strategies for variable-flow and multiple-zone systems

- acceptable levels of outdoor-air ventilation.

Note: While the Simple Systems section closely matches IECC Chapter 7, this Complex Systems section was developed to implement the ASHRAE 90.1 ('89) Code and reflects a larger scope than Chapter 7. However, use of these materials with the 1998 IECC is appropriate as Chapter 6 references the ASHRAE 90.1 ('89) Code and Section 103 authorizes use of implementation materials when approved by the building official as meeting the intent of the IECC.

Equipment Efficiency Requirements

Heating and cooling equipment must meet the minimum efficiencies listed in the tables provided at the end of this guide. Equipment types not listed in these tables have no minimum efficiency requirements.

Federal manufacturing standards cover many of the equipment types listed in the tables, as is clearly noted. You can assume new equipment covered by these standards meet minimum efficiency requirements. Construction documents must include rated efficiencies for noncovered equipment and it is advisable to include ratings for all specified equipment. Enforcing jurisdictions may require that documentation, such as manufacturers' literature, be submitted in support of efficiencies reported in the construction documents.

Field-Assembled Equipment Requirements

Some complex systems use combinations of components to perform a cooling or heating function. For example, the system uses a separate heat exchanger and compressor for chilling water instead of a package water chiller. You must show that these systems meet the same requirements as the equipment listed in the tables for the comparable equipment type. Total energy input to the equipment must consider all the energy use of all components and accessories such as compressors, internal circulating pumps, condenser-fans, integral cooling water pumps, purge devices, crank case heaters, and controls. An enforcing jurisdiction may require that the registered engineer responsible for equipment specification stamp, sign, and date calculations.

Equipment Sizing

To determine the required size of heating and cooling equipment, designers must calculate the maximum heating and cooling loads for a building in accordance with the *1997 ASHRAE Handbook – Fundamentals*, and ensure that heating and cooling equipment is sized no larger than needed to meet those loads. The enforcing jurisdiction may require that the registered engineer responsible for equipment sizing stamp, sign, and date calculations and supporting documentation.

Some building owners want additional equipment (for example, an additional chiller of the same capacity) in case the primary equipment goes out of service. Standby equipment is allowed as long as it is separate equipment and is controlled to be always off when the primary equipment is operating.

Multiple units of the same equipment type with a combined capacity in excess of the calculated loads are also allowed if they are controlled to operate in sequence. In this case, additional units must be controlled to only operate as the load increases and cannot be controlled to turn on all at the same time.

System Control Requirements

Temperature Controls

Each thermostatic control zone must be equipped with a thermostat or other device that controls heating and cooling to the zone and responds to environmental conditions within the controlled zone.

Exception: Perimeter Systems

Some complex mechanical systems have a separate system to handle envelope loads (mainly heat loss through the walls and windows and heat gain through windows), and serve interior spaces with a separate system. Individual zone controls are not required for perimeter systems if the controls for the perimeter system meet the following conditions:

- at least one temperature control must be installed for each perimeter area with exterior walls facing one orientation for 50 contiguous feet or more
- the thermostatic system control must be located within the space being served by the system.

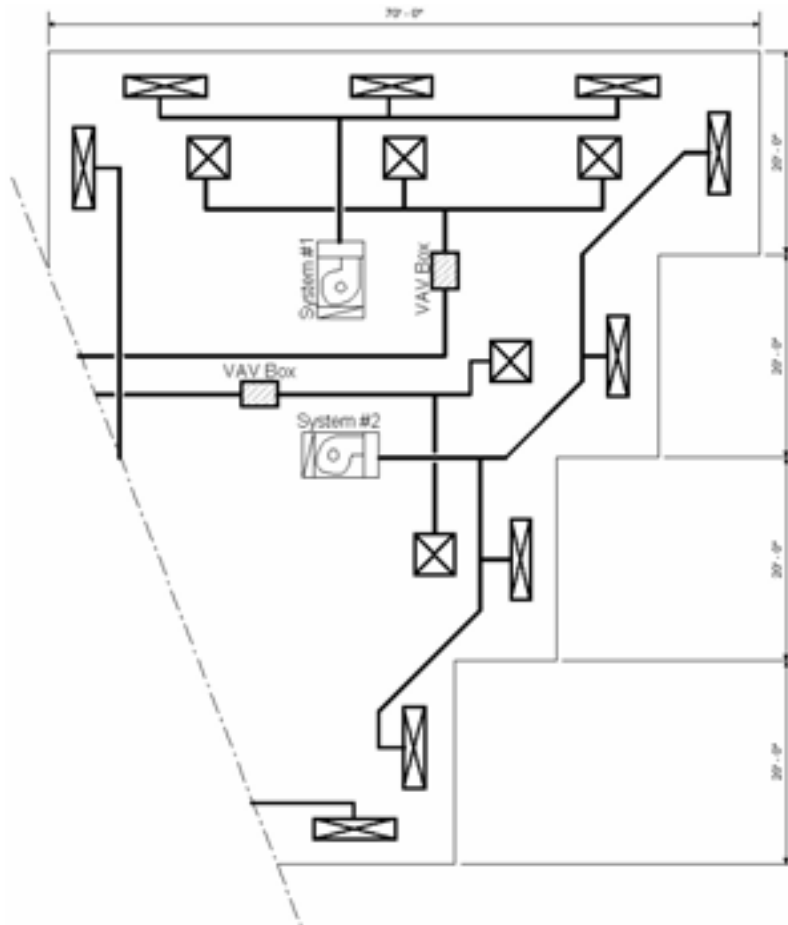

System #1: At least one temperature control within the controlled space must be installed since the contiguous length of the building facade faces one orientation and is greater than 50 feet in length

System #2: All supply air outlets may be controlled with one controller within the space. Though the building facades of the spaces served by this system face different orientations, none is 50 feet or more in length.

Independent Perimeter System

Heat Pump Thermostats

Thermostats for air-to-air heat pumps must be specifically designed for heat pump operation. The thermostat must use the compressor as the first stage of heat and electric-resistance heat as the second stage. Controls must automatically prevent the operation of the supplementary electric-resistance heat when the heating load can be met by the heat pump alone.

Thermostat Deadband Requirements

Thermostats that control both heating and cooling must be capable of having a "deadband" or range of temperature of at least 5°F where no heating and cooling is available. (Exception: thermostats requiring manual changeover between heating and cooling modes.)

Automatic System Controls During Periods of Non-Use

Single-zone systems and each zone served by multiple-zone systems must have controls that automatically reduce heating and cooling use during periods of non-use. Automatic controls can be time clocks that shut down systems or zones, time-controlled automatic setback controls, or occupancy sensors. Time controls and automatic time clocks must

- be able to start and stop systems, or turn on and shut off the supply of heating and cooling to each zone, for seven different day schedules per week
- retain programmed set points and time settings for at least 10 hours during power outages
- include or be installed in conjunction with a manual override that allows occupants to turn heating and cooling on for up to two hours during periods when the heating and cooling would otherwise be automatically off.

Thermostatic controls must be able to automatically set up the cooling set point to at least 85°F and set back the heating set point to a temperature no greater than 55°F.

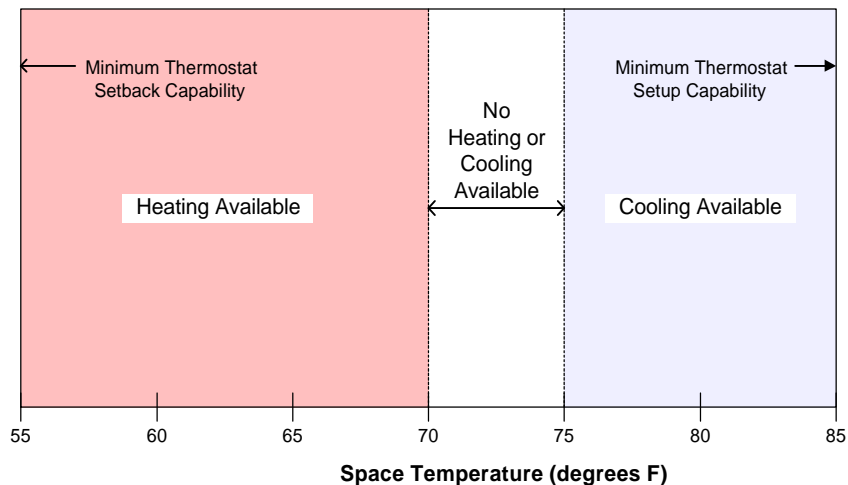

Typical Thermostat Deadband and Required Setback/Setup Capabilities

Outside-Air Shutoff Controls

Even when a building is unoccupied and ventilation fans are not operating, outside air entering the building can significantly change the indoor temperature and humidity. This change in temperature and humidity can cause unnecessary energy use when the building

is reoccupied and the mechanical systems are restarted. All supply- and exhaust-air systems must include a way to automatically close outside-air intakes when mechanical ventilation fans shut off. In smaller fan systems (less than 5,000 cfm), gravity dampers or dampers weighted to close when air is not moving through them are common. On larger systems, electric motors or pneumatic actuators are typically used to open and close outside-air dampers. Systems with total air volume of 3,000 cfm and less are not required to have automatic outside-air shutoff controls.

Cooling with Outdoor Air (Economizers)

All systems with supply-air quantities greater than 3,000 cfm and nominal cooling capacities greater than 90,000 Btu per hour must be equipped with an air economizer, or meet one of the economizer exceptions described in the Simple Systems section. Alternatively, complex mechanical systems may be equipped with water economizers designed to meet the design cooling load calculated as follows:

- cooling loads calculated according to the Equipment Sizing section
- water economizer outdoor operation temperatures of 50°F dry-bulb and 45°F wet-bulb.

The enforcing jurisdiction may require that the engineer responsible for system design authenticate and submit water economizer designs and supporting documentation.

The following figures show the most common types of water economizer systems:

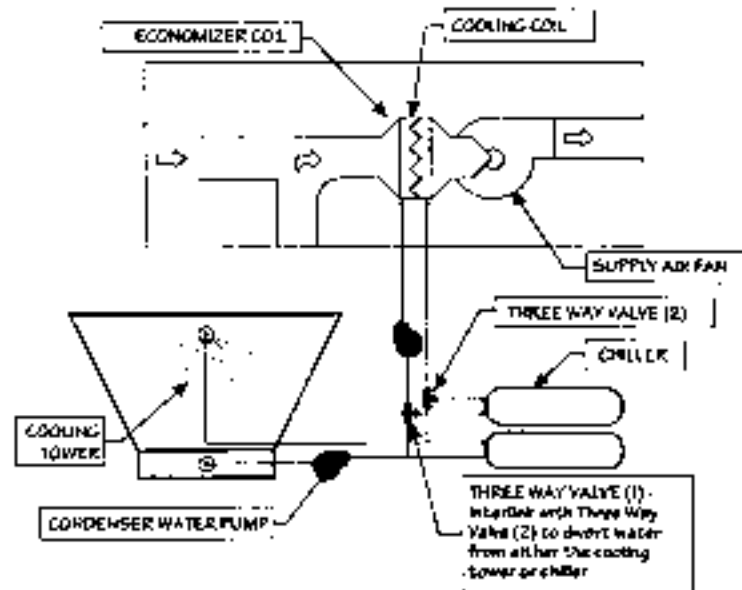

Direct Water Economizer System

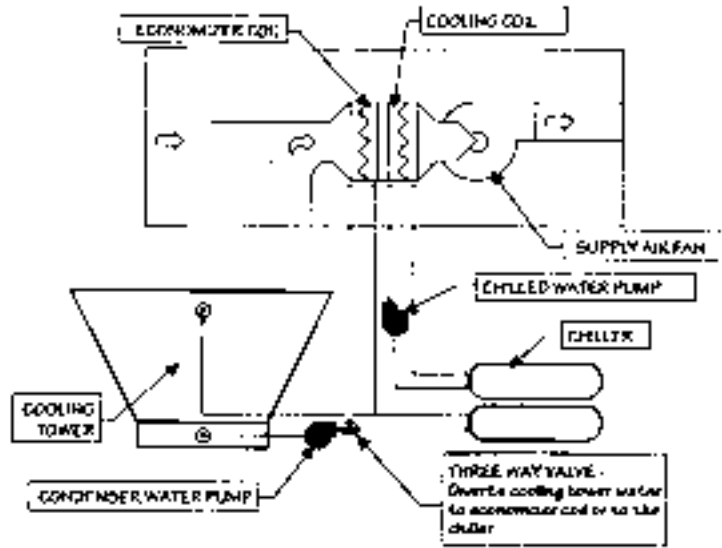

Indirect Water Economizer System

Variable-Flow Fans

Fans capable of varying their airflow are common on systems serving multiple thermostatic control zones and are sometimes used in exhaust applications. These fans must use one of the following airflow control methods:

- a mechanical adjustable-speed drive, which usually varies air flow by varying the diameter of one of the pulleys in the motor/belt drive system for the fan
- an electrical adjustable-speed drive, which uses electronic controls to vary the speed of the fan motor
- a vane-axial (or propeller style) fan with variable-pitch blades
- other variable-flow technologies that limit fan power to 50% of peak design fan power when air flow is 50% of design flow rate and static pressure is one-third of peak design static pressure. (An enforcing jurisdiction may require that calculations, data, or manufacturers' literature be submitted to document compliance using this method.)

Hydronic System Requirements

Systems with hydronic heating for both heating and cooling must have separate supply and return lines for hot and chilled water. The following types of hydronic piping systems are not allowed:

- 2-pipe systems, or systems that can supply and return hot or chilled water through the same piping system
- 3-pipe systems, or systems that have separate hot and chilled water supply piping but have a common return line.

Except as needed for humidity control, hydronic systems must have controls capable of preventing simultaneous supply of hot and chilled water to the system.

Part-Load Control Requirements for Hydronic Systems

Most systems operate at peak-load only during a small portion of the heating and cooling seasons. The energy code requires one of the following approaches for increasing hydronic heating and cooling system efficiency during part-load operation:

1. Water Temperature Reset – Using this approach, controls must be installed to decrease the temperature of the water leaving the heating plant as the overall demand for heating decreases, and increase the temperature of the water leaving the cooling plant as the overall demand for cooling decreases. Controls must be capable of decreasing (or increasing) water temperature by at least 25% of the difference between the design supply and return water temperatures.

Question
What is the reset requirement for a hot water distribution system if the design water temperature is 160°F and the design return temperature is 120°F?
Answer
The minimum amount of reset is $(160^{\circ}\text{F} - 120^{\circ}\text{F}) \times 25\% = 10^{\circ}\text{F}$ Therefore, controls must be able to reset the water temperature to $160^{\circ}\text{F} - 10^{\circ}\text{F} = 150^{\circ}\text{F}$

2. Variable Flow – Using this approach, controls must be installed that will reduce the flow of water as the overall demand for heating (or cooling) decreases. Acceptable methods for reducing flow are a) variable-frequency drives on pumps, which vary the speed of the pump; b) multiple, staged pumps, which vary the number of pumps used to circulate water; or c) control valves, which modulate to vary the flow of water.

Multiple-Zone System Requirements

Most larger buildings have HVAC systems that can heat and cool multiple independently controlled zones at the same time. Commonly called multiple-zone systems, these systems typically will reheat cool air, recool warm air, or mix warm and cool air to meet individual zone temperature requirements. Multiple-zone systems must have VAV controls capable of reducing the supply of warm (or cool) air to any zone before reheating, recooling, or mixing warm and cool air streams occurs.

Under some conditions, simultaneous heating and cooling is allowed without the need for individual VAV controls at the zone. The six exceptions below permit the use of constant-volume reheating, recooling, or mixing for individual zones. Except for Exception 6, these exceptions are not intended to allow the installation of constant-volume, multiple-zone systems, but rather to allow individual zones to have constant volume with reheating, recooling, or mixing on an otherwise complying VAV system.

Exception 1 – Zone Pressurization Requirements

If VAV operation will create unacceptable pressure relationships between a sensitive zone and other zones, simultaneous heating and cooling is allowed without VAV, but only for the sensitive zone.

Exception 2 – Site-Recovered or Site Solar Energy

Constant volume with reheat or mixing is allowed if 75% or more of energy for reheat or warm-air mixing is from any of the following sources:

- site-recovered energy such as heat recovery coils on an exhaust-air system or water chiller condenser
- site-generated solar energy such as solar water-heating collectors or photovoltaic panels.

Exception 3 – Special Humidity Requirements

In zones where specific humidity levels must be maintained for noncomfort purposes, simultaneous heating or cooling is allowed without VAV operation. Examples include areas of museums where sensitive materials are displayed or stored, or areas for manufacturing processes where precise humidity ranges are necessary. In these cases, the exception applies to the special zone and not to the entire system.

Exception 4 – Less than 300 cfm Zone Supply Air

If the supply-air quantity to a zone is less than 300 cfm, simultaneous heating or cooling is allowed without VAV operation. This exception allows reheat to be used for small subzones of a larger zone. This exception is available only with air-handling systems serving multiple zones. It cannot be used to permit constant-volume, single-zone systems with subzone reheat.

Exception 5 – Ventilation Requirements

In some cases, mechanical codes (e.g., the *International Mechanical Code*) require that 100% outside air be supplied to a zone. VAV controls are not required for zones with 100% outside-air requirements.

Exception 6 – Sequencing Heating and Cooling to the Zone

VAV controls are not required if zone and system controls can sequence the supply of heating and cooling energy to the zone so that simultaneous heating and cooling never occurs. For example, a three-duct air distribution system consists of separate ducts for return air, cool air, and warm air. Zone controls will mix warm air with return air and cool air with return air but never warm air with cool air.

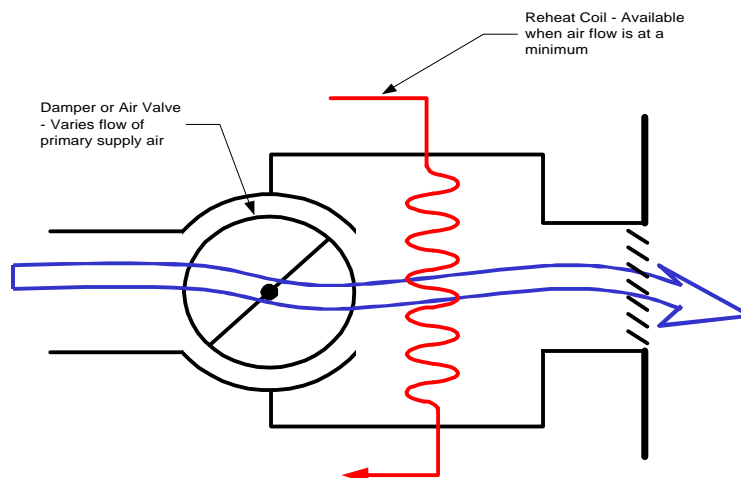

Other Requirements for Multi-Zone Systems

In addition to the requirement for VAV zone controls, multi-zone systems must meet applicable requirements described below, depending on the distribution system design and the total number of supply fans.

Single-Duct VAV Systems

Single-duct VAV systems use a single supply-air duct with branches to individual zones. Thermostatically controlled terminal units are then used to vary the flow of air to the zone, and reheat or recool the air if necessary to meet the environmental control requirements for a zone. Single-duct VAV terminal units must be capable of reducing the supply of primary supply air to the zone to a minimum before reheating or recooling can occur. Single-duct VAV terminal units may also be equipped with a fan to draw air from a return-air plenum to for additional heat. The figures below show fan- and nonfan-powered VAV terminal units and their required features.

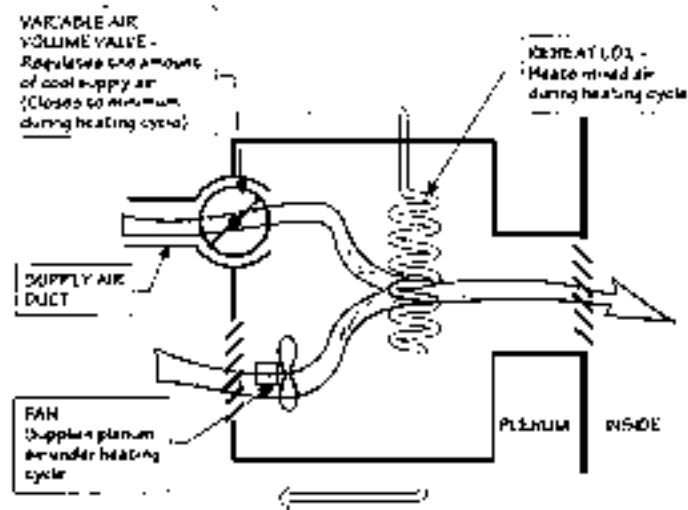

Fan-Power VAV Box

Dual-Duct VAV Systems

Dual-duct systems provide two separate supply air streams—cool air and warm air—that are mixed in each terminal unit and supplied to the zone as a single air stream. The system can have a single fan for both supply-air ducts or a separate fan for each duct. Dual-duct zone terminal units must be capable of reducing the air supply from one duct to a minimum prior to mixing with the other duct. These units require a damper or other way to reduce the airflow, as well as controls that prevent mixing with the other air stream until the minimum is reached. The figure below provides a schematic of a dual-duct terminal unit.

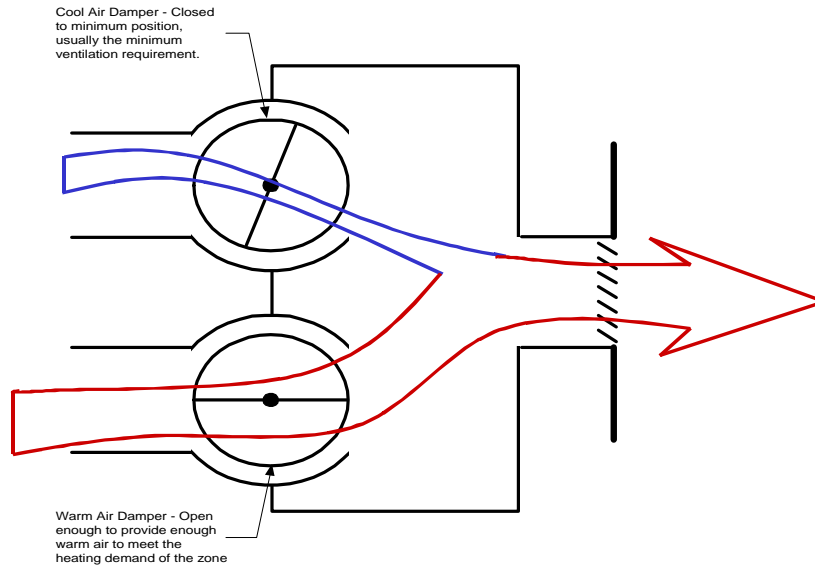

Dual-Duct VAV Mixing Box in Heating Mode

Dual-Duct and Mixing Systems with One Fan, Economizer Requirements

Single-fan, dual-duct systems use a single supply fan to blow air over two separate coils—one for heating and one for cooling. If an air economizer is used, outside air rather than return air is passed through the heating coil, thereby increasing energy use for heating. To avoid this additional energy use, dual-duct and other mixing systems (such as three-duct systems) with single supply fans cannot be equipped with air economizers. With no air economizer, only return air and minimum outside ventilation air need to be heated.

To meet economizer requirements with these systems, a water economizer must be installed. If the water economizer uses an additional cooling coil in the supply-air stream, then this coil must be installed in the system's cool-air duct and not in the return- or mixed-air portion of the ductwork.

Multiple-Zone Systems – Supply-Air Temperature Reset

An important way to minimize the use of mechanical cooling or heating energy in multiple-zone systems is to raise the cooling supply-air temperature (or lower the heating supply-air temperature) during periods when cooling and heating loads are not at their design peak. Multiple-zone systems must have controls capable of resetting the cooling and heating supply-air temperatures. The supply-air temperature must be reset by at least 25% of the difference between the design supply-air temperature and the design room temperature. For example, if the design supply-air temperature for a system is 55°F and the design space temperature for cooling is 75°F, the system must be capable of resetting the supply-air temperature up by 25% of 75 minus 55, or 5°F.

While many control strategies exist for meeting this requirement, the three most common methods are described below. Regardless of the control method, the enforcing jurisdiction may require additional documentation, such as manufacturer's literature or control diagrams to demonstrate compliance with reset requirements.

Method 1 – Supply-Air Reset Warmest (Coldest) Zone

Method 1 requires that zone thermostats for a system be connected to a central controller. With this method, a controller identifies the highest (or lowest) thermostat signal, which corresponds to the zone with the largest cooling (or heating) demand, and then controls the system supply-air temperature to meet the load in that zone.

Method 2 – Supply-Air Reset Reference Zone

Method 2 requires that the thermostat or temperature sensor for a representative zone be connected to the controller for supply-air temperature. A representative zone is often used when the supply-air temperature operates within a fixed range (such as from 55°F to 60°F). In this case, the reference zone is usually selected because it is expected to require the lowest supply-air temperatures for cooling or the highest supply-air temperatures for heating.

Method 3 – Supply-Air Reset Outside-Air Temperature

Method 3 requires that an outside-air temperature sensor be connected to the controller for the reference zone. Method 3 is most commonly used with heating systems where loads will vary closely with changes in outside temperature. Using this method, as the outside-air temperature drops (or rises) the supply-air temperature is reset up (or down). This method is sometimes used for cooling systems if the supply-air temperature operates within a narrow range (such as 55°F to 60°F).

Ventilation Requirements

Refer to the *Simple Systems* section for minimum outside-air ventilation requirements.

Duct Requirements

Refer to the *Simple Systems Duct Requirements* section for duct insulation, sealing, and installation requirements. In addition, all ducts designed to operate at static pressures in excess of 3 inches of water column must be leak-tested in accordance with methods published by the Sheet Metal and Air Conditioning Contractors of North America (SMACNA). A report and certificate must be submitted demonstrating that representative sections totaling at least 25% of the duct area have been tested and that all tested sections meet the duct-sealing requirements.

Leak tests and reports must demonstrate that the duct system meets the following criterion:

$$F < 6 \times P^{0.65}$$

where F = the measured leakage rate in cfm per 100 square feet of duct surface

P = the static pressure used in the test.

0.65 = the exponent (or power) to which the static pressure is raised in this equation

For example, the maximum leakage rate for a duct section operating at 4 inches water column static is

$$6 \times 4^{0.65} \text{ or } 15 \text{ cfm per } 100 \text{ square feet of duct surface area.}$$

Pipe Insulation Requirements

Pipe insulation requirements depend on the fluid type and nominal pipe diameter. The following table shows pipe insulation requirements based on an insulation thermal conductivity of 0.27 Btu-in/(h·ft²·°F) [roughly R-4 per inch]:

Fluid	Pipe Diameter (in.)	
	not greater than 1.5	greater than 1.5
Steam	1.5	3.0
Hot Water	1.0	2.0
Chilled Water, Brine, Refrigerant	1.0	1.5

Insulation is not required with the following types of piping:

- factory-installed piping within HVAC equipment that has been tested and rated in accordance with a referenced test procedure to determine equipment efficiency
- piping conveying fluids having design operating temperatures between 55°F and 105°F
- piping conveying fluids that have not been heated or cooled through the use of fossil fuels or electric power
- runout piping no longer than 4 feet and no greater than 1 inch in diameter installed between the control valve and heating or cooling coil in an HVAC unit.

Air System Balancing

Proper system design and equipment selection is essential for long-term functionality and energy efficiency of mechanical systems. All systems need some type of verification in the field (both at start-up and periodically throughout the life of the building) to ensure they are operating as intended.

To facilitate field verification, the energy code requires that duct systems be equipped for easy testing and balancing after installation. Each supply-air outlet and zone-air terminal device must be equipped with balancing dampers, air valves, or other means for balancing. Balancing dampers that are integral to supply-air diffusers are acceptable for supply-air outlets.

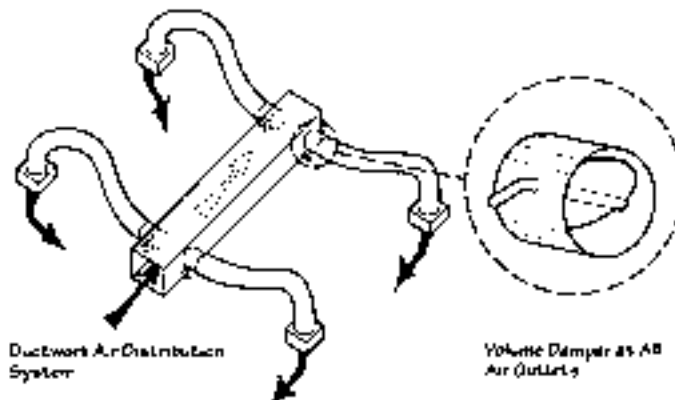

Air Balancing Device

Hydronic Systems Balancing

To facilitate proper balancing and long-term efficient operation of hydronic systems, all hydronic terminal devices must be equipped with balancing valves or other means of hydronic system balancing.

Manuals and System Documentation

The code requires building plans, specifications, or other construction documents to require the mechanical contractor to provide an operating and maintenance manual to the building owner. This manual must include at least the following information about the design and intended operation of all mechanical systems in the building:

- equipment capacity (input and output) and required maintenance items and their required service interval
- equipment operation and maintenance manuals
- HVAC system control maintenance and calibration information, including
 - wiring diagrams
 - schematics
 - control sequence descriptions.

Desired or field-determined set points must be permanently recorded on control drawings, at control devices, or, for digital control systems, in programming comments.

- a complete narrative of how each system is intended to operate.

(A blank compliance certificate for complex systems can be found at the end of this Mechanical Guide.)

Water-Heating Systems

This section contains code requirements for service water-heating systems and equipment, and instructions on how to manually demonstrate that your proposed design complies with these requirements.

The requirements listed in this section apply to service and domestic water-heating systems. They do not apply to systems used for comfort heating or to systems designed to meet manufacturing, industrial, or commercial process requirements. The following components are required on water-heating systems (components shown in the following diagram by number):

1. heat traps - to reduce standby losses
2. pipe insulation - to reduce distribution and standby losses
3. circulation loop temperature control - to reduce distribution losses.

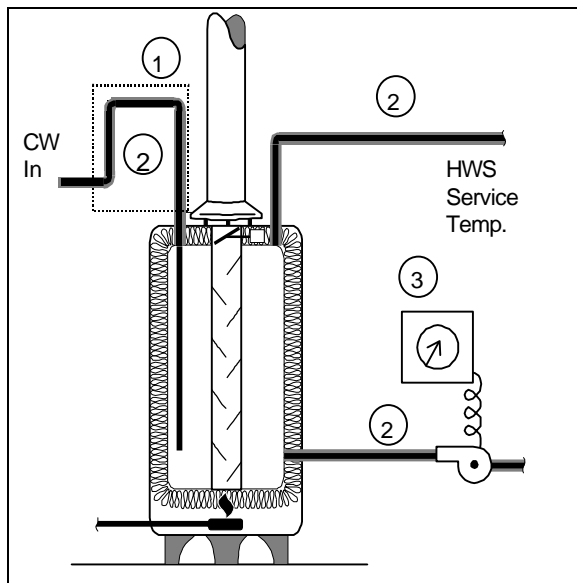

Water-Heating System Requirements

Equipment Efficiency Requirements

Heating and cooling equipment must meet the minimum efficiencies listed in the table provided at the end of this guide. Equipment not listed in these tables has no minimum efficiency requirements.

Federal manufacturing standards cover all of the equipment types listed in the table. Therefore, you can assume that any new service water-heating equipment will meet minimum efficiency requirements. Any reused equipment may not meet these requirements. Construction documents should include efficiency ratings for all service water-heating equipment.

Heat Traps

Heat traps stop hot water from rising into the distribution pipes and forming a natural convection loop.

Heat traps are required in the inlet and outlet piping of noncirculating water heaters. Some water-heating equipment has integral factory-installed heat traps. For equipment without integral factory-installed heat traps, heat traps must be purchased and installed in the inlet and outlet connections or field-fabricated by creating a loop or inverted U-shaped arrangement of the inlet and outlet piping.

Heat traps are not required on circulating systems.

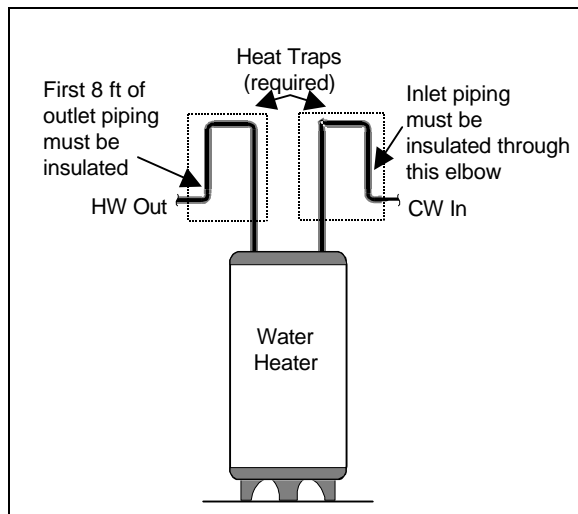

Field-Fabricated Heat Traps

Pipe Insulation

The following pipe insulation levels are required:

- 1 in. on circulating water-heating systems
- ½ in. on the first 8 feet of outlet piping from any constant-temperature noncirculating storage system
- ½ in. on the inlet piping between the storage tank and a heat trap in a noncirculating storage system.

Circulation Loop Controls

Automatic time-switch controls must be installed to shut down the pump on circulating water-heating systems during periods of nonuse.

Demonstrating Compliance

To demonstrate compliance, indicate on your project plans the equipment efficiencies, system controls, and other water-heating components that comply. Also, fill in applicable items under *Water Heating Systems* on the *Simple Systems Certificate*. Blank copies of these certificates appear at the end of this guide.

Completing Mechanical Compliance Certificate for Simple Systems

These instructions explain the information to include in the *COMcheck-EZ* Mechanical Compliance Certificate for Simple Systems, identify the appropriate contact or reference if you have questions, and provide *EZ* tips for completing the certificate. A sample certificate is also provided. The instructions have numbered circles that correspond to those on the sample certificate. For code enforcement officials, *EZ* tips for plan check and field inspection are included at the end of this guide.

General Guidelines

- **For Documentation Authors** - provide all information in unshaded sections, enter “NA” if a particular requirement is not applicable; submits the completed certificate to the authority having jurisdiction with the building permit application package.
- **For Plan Checkers** - verify that proposed values listed on the certificate are consistent with the plans and specifications and meet the requirements in this guide.
- **For Field Inspectors** - inspect and approve building construction against each requirement in Section 3 of the certificate.

Completing Mechanical Compliance Certificate for Complex Systems

The process for filling in the mechanical compliance certificate for complex systems is very similar to that for simple systems. Because they are so similar, neither a sample certificate nor step-by-step instructions are provided for the complex systems certificate. See the sample mechanical certificate for simple systems and instruction beginning on page 25 for guidance in completing the mechanical compliance certificate for complex systems.

Lighting Compliance

Lighting Requirements

You can use COMcheck-EZ™ to demonstrate that your commercial or high-rise residential building design complies with the 1998 Edition of the IECC.

This guide covers the energy code requirements for lighting systems and equipment. It includes necessary tables, worksheets, and instructions for demonstrating compliance using an entirely manual method. All you need is a pencil and copies of the *Lighting Compliance Certificate* and *Lighting Application Worksheet* at the end of this guide.

The COMcheck-EZ software provides an alternative compliance method to using this guide. The compliance calculation used in the software is identical to the manual version in this guide. The software simply automates the calculation of the lighting power allowance for the building and the connected load of the lighting systems you specify. It also generates a compliance report to submit with your building permit application. Refer to the *COMcheck-EZ Software Compliance Guide* for instructions on obtaining and using the software.

What the Energy Code Covers

To promote the use of energy-efficient lighting in commercial and high-rise residential buildings, the energy code requires

- manual or automatic controls or switches that allow occupants to dim lights and turn them on or off when appropriate. This guide identifies control, switching, and wiring requirements that apply to all buildings.
- total connected loads for indoor lighting systems that do not exceed power allowances for the building. This guide shows how to demonstrate compliance with interior-lighting power limits using the *Lighting Application Worksheet*.
- energy-efficient exterior lighting. This guide contains criteria for complying with exterior-lighting requirements.

Demonstrating Compliance

To demonstrate compliance,

- indicate on your project plans switching schemes, fixture types, and lamp/ballast types that comply.

- complete the *Lighting Application Worksheet* included with this guide to indicate compliance with indoor-lighting power limits.
- complete the *Lighting Compliance Certificate* included with this guide. Use the actual fixture wattages or, if actual fixture wattages are unavailable, typical wattages from the *Typical Lighting Wattage* table at the end of this guide.

Control, Switching, and Wiring Requirements

All lighting systems must have controls or switches that allow occupants to manually or automatically dim lights or turn them on or off.

Interior-Lighting Controls

Independent interior-lighting controls are required for each area enclosed by ceiling-height partitions. These controls can be any of the following:

- a switch located so the occupant can see the area controlled by the switch
- a switch that indicates whether the lights are on or off when it is impossible to see the controlled area from the switch location
- an occupant-sensing device.

Exceptions to this requirement are

- areas that must be continuously illuminated for building security or emergency exits. These areas must be designated as security or emergency exit areas on the plans, and the lights must be controlled by switches accessible only to authorized personnel.
- public areas, such as building lobbies and retail stores. These lights can be controlled by a single switch for the entire area.

Master Switches in Hotel and Motel Guest Rooms

One or more master light switches are required at the entry door of hotel and motel guest rooms. Master switches operate all permanently wired luminaires and switched receptacles. These switches are usually three-way devices wired in combination with local controls. In multiple-room suites, a standard control device is required at the entrance to each separate room.

Bathroom lighting systems in hotel and motel guest rooms are exempt from these requirements.

Bi-Level Switching

Lighting within a space must be switched so the occupant can reduce the connected lighting load by at least 50% in a reasonably uniform illumination pattern. Bi-level switching requirements may be met by

- switching alternate luminaires in a row or alternate rows of luminaires
- separately switching half of the lamps in each luminaire or two lamps in three-lamp luminaires

- using dimming controls on all lamps or luminaires.

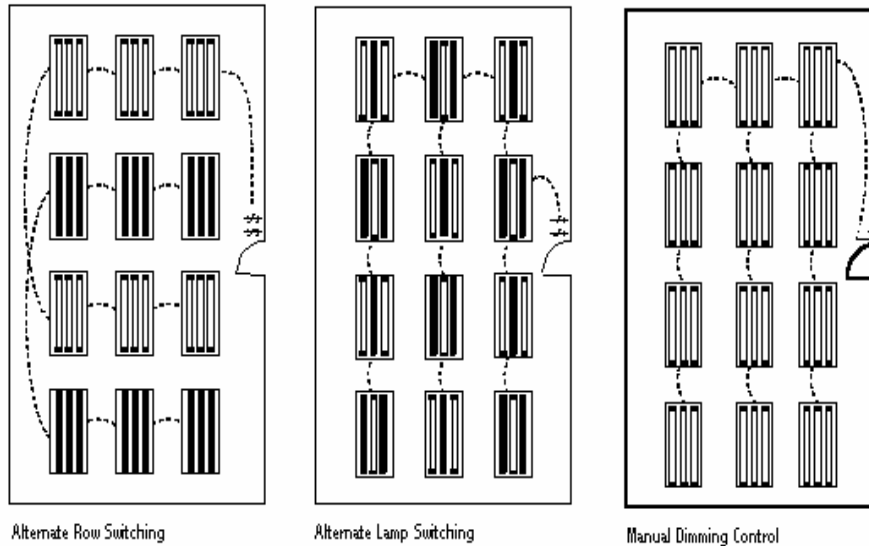

Bi-level switching is not required if

- the area has only one luminaire
- an occupant-sensing device controls the area
- the area is a corridor, storage area, restroom, or lobby.

Exterior Lighting Controls

Automatic controls are required for all exterior lights. The control may be a directional photocell, an astronomical time switch, or a building automation system with astronomical time switch capabilities. The control must automatically turn off exterior lighting when daylight is available. Lights in parking garages, tunnels, and other large-covered areas that must be on during daylight hours are exempt from this requirement.

Tandem Wiring

A two-lamp ballast is the most efficient conventional ballast type. The following types of one-lamp or three-lamp fluorescent fixtures must be tandem-wired:

- pendant- or surface-mounted luminaires in continuous rows
- recess-mounted luminaires located within 10 ft of each other and served by the same switch.

Exempted from this requirement are

- luminaires that use electronic high-frequency ballasts
- luminaires that are not on the same switch control or in the same area.

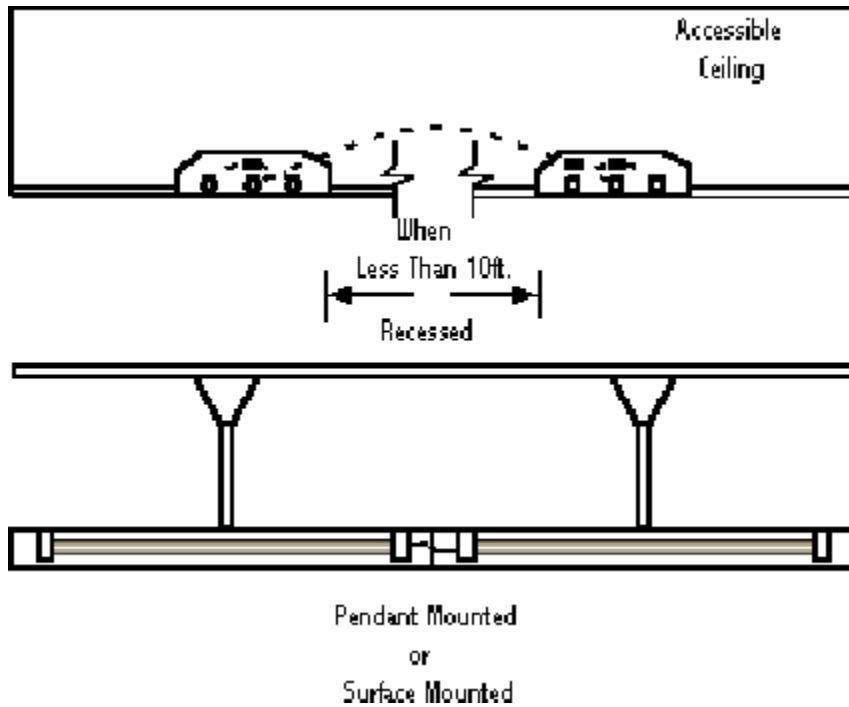

Tandem Wiring

Interior Lighting Requirements

Interior lighting must not exceed allowed power limits. Interior lighting includes all permanently installed general and task lighting shown on the plans.

It does not include specialized lighting for medical, dental, or research purposes and display lighting for exhibits in galleries, museums, and monuments.

To determine if your project complies with the interior-lighting power limits, follow the steps outlined below using the *Lighting Application Worksheet* included with this guide.

Determining Allowed Watts for an Entire Building

First, if your project applies to the entire building, determine if an appropriate building type category is listed in Section 1, Column A on the Lighting Application Worksheet. Next, determine if Column B assigns a value for the entire building. If so, enter the square footage of the entire building in Column D. (If the value in Column B is N/A, follow the steps for tenant area or portion of building in the following section.) Multiply the watts per sq ft in Column B by the square footage in Column D to determine the allowed watts. Enter the results in Column E.

This example shows how to calculate the total allowed watts for new general office space occupying an entire building totaling 10,000 sq ft. This building has a 1.7 watt per sq ft allowance. The total allowed watts value for the building is determined by multiplying Column B by Column D (17,000 watts).

Section 1 – Allowed Lighting Power Calculation				
A	B	C	D	E
Building or Area Type	Entire Building (watts per sq ft)	Tenant Area or Portion of Building (watts per sq ft)	Building or Space (sq ft)	Allowed Watts** (B or C x D)
Office	1.7	1.8	10,000	17,000
Total Allowed Watts				17,000
**May use only Column B or Column C to qualify project. Do not use more than one column.				

Example - Determining Allowed Watts for an Entire Building

This example shows how to calculate the total allowed watts for new general office space occupying tenant area totaling 10,000 sq ft. The watts per sq ft allowance for this building is a combination of general office and corridor, restroom, and support areas. The total allowed watts value for the building is determined by multiplying the watts per sq ft for each area in Column C by the square footage of each area in Column D. The total allowed watts value is determined by adding the values in Column E (17,000 watts).

Section 1 – Allowed Lighting Power Calculation				
A	B	C	D	E
Building or Area Type	Entire Building (watts per sq ft)	Tenant Area or Portion of Building (watts per sq ft)	Building or Space (sq ft)	Allowed Watts** (B or C x D)
Corridor, Restroom, Support Area	N/A	0.8	1,000	800
Office	1.7	1.8	9,000	16,200
Total Allowed Watts				17,000
**May use only Column B or Column C to qualify project. Do not use more than one column.				

Example - Determining Allowed Watts for Tenant Area or Portion of Building

Determining Allowed Watts for Tenant Area or Portion of Building

If your project applies to only a portion of the entire building, is not listed as a building type, or has more than one occupancy type, circle the appropriate value for each type in Section 1, Column C on the *Lighting Application Worksheet*. Next, determine the total area of each type and enter the square footage for each in Column D. Multiply the watts per sq ft in Column C by the square footage in Column D. Enter the results in Column E. Sum the values in Column E to determine the total allowed watts.

Determining Total Actual Watts and Compliance

Next, complete Section 2 on the *Lighting Application Worksheet* to determine the total actual watts. For each fixture type in your project, list the fixture type, fixture description, quantity, and watts per fixture, including ballasts.

If actual input wattages are not known, you may use values from the *Typical Lighting Wattage* tables at the end of this section; however, actual fixtures used in the building must meet or exceed the efficiency of the fixtures assumed in the compliance analysis.

Multiply the value in Column D by the value in Column E to calculate the total watts for each fixture type. Enter the results in Column F. Sum the values in Column F to determine the total actual watts. If you need to list more equipment, use additional worksheets as continuation sheets.

Finally, determine if your project complies by completing Section 3 on the *Lighting Application Worksheet*. First, enter the total allowed watts on line 1. If you used additional worksheets as continuation sheets, don't forget to include values from each additional sheet in this total. Next, enter the total actual watts on line 2. Subtract line 1 from line 2 to determine compliance. The project complies if line 3 is zero or greater.

This example shows how to complete Sections 2 and 3 of the <i>Lighting Application Worksheet</i> . The interior of this example building is lit with two high-efficiency lighting groups—recessed PL downlights and a 2x4 fixture with electronic ballasts and T-8 lamps. This system also includes standard incandescent lamps. Adding the values in Column F shows that this project will have 16,660 total actual watts of installed interior lighting.					
Section 2 – Actual Lighting Power Calculation					
A	B	C	D	E	F
Fixture ID	Fixture Description	Lamp/Ballast	Quantity	Watts per Fixture	D x E
F1	2x4 Recessed Troffer	T8/Electronic	110	121	13,310
F2	Recessed CFL Fixture	CFL 18	50	22	1,100
F3	Medium-Base Socket	100 W	30	75	2,250
Total Actual Watts					16,660
The value resulting from subtracting the total actual watts from the total allowed watts indicates if the project complies. Our example project complies by 340 watts and, if properly switched, controlled, and wired, complies with the lighting requirements.					
Section 3 – Compliance Calculation					
1	Total Allowed Watts				17,000
2	Total Actual Watts				16,660
3	Project Compliance (line 1 – line 2; must be zero or greater)				340

Example - Determining Total Actual Watts and Lighting Compliance

Exterior Lighting Requirements

Exterior lighting must meet the following criteria to comply:

- All lighting supplied through the building electrical service must comply.

- Energy-efficient lighting must be used when illuminating paths, walkways, and parking areas. Complying types of energy-efficient lighting sources include fluorescent lamps and ballasts, compact fluorescents, metal halide lamps and ballasts, and high-pressure sodium lamps and ballasts.
- Any lighting that has an efficacy of 45 lumens per watt or greater is allowed for exterior lighting.

These requirements do not apply to

- specialized signal, directional, and marker lighting associated with air, rail, water, and road transportation
- lighting used to highlight features of registered historic landmark structures or buildings
- lighting used for safety or security specifically designed to meet health or life safety requirements
- low-voltage lighting used exclusively for landscaping.

Completing Lighting Compliance Certificate

These instructions explain the information to include in the *COMcheck-EZ* Lighting Compliance Certificate, identify the appropriate contact or reference if you have questions, provide *EZ* tips for completing the certificate, and provide instructions for completing the Lighting Power Calculation. A sample certificate and worksheet are also provided. The instructions have numbered circles that correspond to those on the sample certificate and worksheet. For code enforcement officials, *EZ* tips for plan check and field inspection are included at the end of this guide.

General Guidance

For Documentation Authors: Provide all information in unshaded sections, entering "N/A" if a particular requirement is not applicable; submit the completed certificate to the authority having jurisdiction with the building permit application package.

For Plan Checkers: Verify that proposed values listed on the certificate are consistent with the plans and specifications and with the requirements in this guide.

For Field Inspectors: Inspect and approve building construction against each requirement in Section 3 of the certificate.

Field Inspection Checklist

<i>REFER TO COMPLIANCE CERTIFICATES FOR PROJECT-SPECIFIC REQUIREMENTS</i>		
Foundation and/or Slab/Under-Floor Inspection		
Requirement	Verify	Reference
Slab-edge insulation installed	R-value of insulation	Envelope Certificate
Below-grade wall insulation installed	R-value of insulation	Envelope Certificate
Under-floor insulation installed	R-value of insulation	Envelope Certificate
Ducts insulated and sealed/pipes insulated	R-value of insulation	Mechanical Certificate
Frame Inspection		
Requirement	Verify	Reference
All joints and penetrations are caulked, gasketed, weatherstripped, or otherwise sealed	Caulking/sealing	Envelope Certificate
Windows, doors, and skylights certified as meeting leakage req.	Label	Envelope Certificate
Window and skylight areas per plans	Area of windows/skylights	Envelope Certificate
Window and skylight U-factors acceptable	U-factors of windows/skylights	Envelope Certificate
Window SHGC factors acceptable	SHGC of windows	Envelope Certificate
Window shading installed per plans/specifications	Overhang or shade screen	Envelope Certificate
Insulation Inspection		
Requirement	Verify	Reference
Wall insulation installed	Wall construction type R-value of insulation	Envelope Certificate
Ceiling/roof insulation installed	Ceiling/roof construction type R-value of insulation	Envelope Certificate
Vapor retarders installed	Kraft paper or equal	Envelope Certificate
Exception: exempted zones/states (generally Zones 2-7)		
Final Mechanical Inspection		
Requirement	Verify	Reference
Heating and Cooling System Controls		
One setback thermostat with occupant override per zone	Thermostat with battery back-up and accessible override	Mechanical Certificate
Setback requirement exceptions: Residences & hotel/motel guest rooms areas that operate continuously		
Heat-pump thermostat used with heat pumps		
Air economizer on systems greater than 90,000 Btu/h	Economizer installed or HVAC make and model matches plans	Mechanical Certificate
Exceptions: exempted climate zones residences, supermarkets, hotel guest rooms high-efficiency cooling equipment tradeoff minimum EER: _____ EER: _____		
Outdoor-Air Ventilation		
Outdoor air provided to each space	Outdoor-air intake on HVAC system or required area of operable openings	Mechanical Certificate
Shutoff dampers in restaurant make-up air systems	Damper installed	Mechanical Certificate
Duct Construction		
Duct insulation installed	R-value of insulation	Mechanical Certificate
Duct sealed	Transverse joints of metal ducts and mechanical connections on other duct joints	Mechanical Certificate
Hydronic Heating Systems		
Pipe insulation	½ in. on heating coil branches 1½ in. on circulation loops	Mechanical Certificate Mechanical Certificate
Part-load efficiency method	Temp reset/variable flow	Mechanical Certificate
NOTE: <i>Final Mechanical Inspection (contd) and Final Electrical Inspection checklist on other side.</i>		

Field Inspection Checklist (contd)

Final Mechanical Inspection (contd)		
Requirement	Verify	Reference
Other Multiple-Zone Mechanical Requirements		
See Complex Systems Certificate		
Water-Heating Systems		
Heat traps	Integral to water heater or field-fabricated	Mechanical Certificate
Pipe insulation on inlet/outlet pipes	Insulation thickness	Mechanical Certificate
Recirculating systems	Insulation thickness Automatic time-switch	Mechanical Certificate Mechanical Certificate
Final Electrical Inspection		
Requirement	Verify	Reference
Controls, Switching, and Wiring		
Independent lighting controls Exceptions: security lighting building lobby/retail store/mall	Switch in each room	Lighting Certificate
Hotel/motel guest rooms At least two lighting levels in each space Exceptions: only one luminaire in space corridor, storage area, restroom, or lobby area	Master switch at entry Two switches, dimmer, or occupancy sensor in each space	Lighting Certificate Lighting Certificate
Exterior lighting controls Exception: large covered areas requiring lighting during daylight hours	Photocell or astronomical time-switch on exterior lights	Lighting Certificate
One-lamp and three-lamp ballasted luminaires Exceptions: electronic high-frequency ballasted luminaires luminaires not on same switch	Tandem-wired ballasts	Lighting Certificate
Interior Lighting		
Fixtures, lamps, and ballasts	Match plans and specs	Lighting Certificate
Exterior Lighting		
Power for lighting from electrical service	Exterior-lighting circuit	Lighting Certificate
Exterior-lighting source: Exceptions: specialized signal, directional, and marker lighting lighting highlighting exterior features of historic building advertising signage safety or security lighting low-voltage landscape lighting source efficacy greater than 45 lumens per watt	Fluorescent Metal halide High-pressure sodium	Lighting Certificate
NOTE: <i>This form is required to be under the front seat of the inspection vehicle.</i>		

Glossary

AAMA

Architectural Aluminum Manufacturers Association

Air Economizer Systems

Ducting arrangements and automatic control systems that allow a cooling supply fan system to supply outdoor (outside) air to reduce or eliminate the need for mechanical refrigeration during mild or cold weather.

Alteration

Any change to a building's water heating system, space conditioning system, lighting system, or envelope that is not classified as an addition.

ASHRAE/IES Standard 90.1-1989

The American Society of Heating, Refrigerating and Air-Conditioning Engineers/Illumination Engineering Society Standard 90.1-1989.

Automatic Time-Switch Controls

Controls that automatically switch lights or equipment on and off.

Automatically Operated Control Damper

A damper which automatically opens and closes.

Ballast

A device used to operate fluorescent and HID lamps. The ballast provides the necessary starting voltage, while limiting and regulating the lamp current during operation.

Below-Grade Wall

Portions of the wall below grade.

Boiler

A pressurized system in which water is vaporized to steam by heat transferred from a source of higher temperature, usually the products of combustion from burning fuels. Steam thus generated may be used directly as a heating medium, or as the working fluid in a prime mover to convert thermal energy to mechanical work, which in turn may be converted to electrical energy.

Building Envelope

The elements of a building that enclose conditioned spaces through which thermal energy may be transferred to or from the exterior or to or from unconditioned spaces.

Ceiling

Those portions of the building envelope, including all opaque surfaces, fenestration, doors, and hatches, that are above conditioned space and are horizontal or titled at less than 60 degrees from horizontal.

Circulation Pumps

Pumps that are used to keep hot water circulating through the distribution system.

Circulating Water Heater

Hot water continuously circulates through the distribution system.

Commercial Building

Includes but is not limited to occupancies for assembly, business, education, institutions, merchants, and storage.

Compact Fluorescents

Small fluorescent lamps that are often used as an alternative to incandescent lighting. The lamp life is about 10 times longer than incandescent lamps and is 3-4 times more efficacious.

Concrete Masonry Unit Walls

Concrete masonry unit walls may be insulated by filling the empty core with perlite, vermiculite, or some other insulative material. In some cases, even with filled cores, these wall types require additional insulation.

Conditioned Floor Area

The horizontal projection of that portion of interior space which is contained within exterior walls and which is conditioned directly or indirectly by an energy-using system.

Conditioned Space

A cooled or heated space, or an indirectly conditioned space.

Connected Lighting Load

The sum of all non-exempt interior lighting power, measured in watts.

Cooled Space

An enclosed space within a building that is cooled by a cooling system whose capacity (a) exceeds 6 Btu per hour per square foot or (b) is capable of maintaining a space dry-bulb temperature of 90 degrees F or less at design cooling conditions.

Domestic Water Heating System

DHW systems may be circulating or non-circulating.

Economizer

A ducting arrangement and automatic control system that allow a cooling supply fan system to supply outdoor air to reduce or eliminate the need for mechanical refrigeration during mild or cold weather.

Efficacy

A metric used to compare light output to energy consumption. Efficacy is measured in lumens per watt. Efficacy is similar to efficiency, but is expressed in dissimilar units. For example, if a 100-watt source produces 9000 lumens, then the efficacy is 90 lumens per watt.

Electronic High-Frequency Ballasts

Electronic ballasts improve fluorescent system efficacy by converting the standard 60 Hz input frequency to a higher frequency, usually 25,000 to 40,000 Hz. Lights operating on these frequencies produce about the same amount of light, while consuming up to 30% less power than a standard magnetic ballast.

Enclosed Space

A volume substantially surrounded by solid surfaces such as walls, floors, roofs, and openable devices such as doors and operable windows. Spaces not meeting these criteria for enclosure are considered to be exterior to the building for purposes of determining envelope requirements. For example, most parking garages do not qualify as enclosed space.

Envelope Components

The building assemblies that provide a barrier between conditioned space and unconditioned space. This includes the floors, walls, and ceiling/roof assemblies of the building.

EER

The energy efficiency ratio is the ratio of net equipment cooling capacity in Btu/h to total rate of electric input in watts under designated operating conditions. When consistent units are used, this ratio becomes equal to coefficient of performance.

Fan Coil

A fan-coil terminal is essentially a small air-handling unit which serves a single space without a ducted distribution system. One or more independent terminals are typically located in each room connected to a supply of hot and/or chilled water. At each terminal, a fan in the unit draws room air (sometimes mixed with outside air) through a filter and blows it across a coil of hot water or chilled water and back into the room.

Fenestration

The terms "fenestration", "window", and "glazing" are often used interchangeably. However, fenestration refers to the design and position of windows, doors and other structural openings in a building.

Floor

A horizontal exterior partition, or a horizontal demising partition, under conditioned space which separates conditioned space from unconditioned space.

Fluorescent Lamps

A light source consisting of a tube filled with argon, along with krypton or other inert gas. When electrical current is applied, the resulting arc emits ultraviolet radiation that excites the phosphors inside the lamp wall, causing them to radiate visible light.

Fuel-Fired Furnace

A self-contained, indirect-fired furnace that supplies heated air through ducts to spaces that require it.

Glazing

The terms "fenestration", "window", and "glazing" are often used interchangeably. However, glazing is the transparent component of glass or plastic windows, doors, clerestories, or skylights.

Glazing U-Factor

Based on the interior-surface area of the entire assembly, including glazing, sash, curbing, and other framing elements. Center-of-glass U-factors cannot be used.

Gross Wall Area

Includes the opaque area of all above-grade exterior walls enclosing conditioned spaces (including above-grade portions of below-grade wall assemblies but excluding walls separating conditioned from unconditioned space); the area of the band joist and subfloor between floors; and the area of all doors and windows.

Gross Window Area

Includes the rough-opening area of the window, not just the transparent-glass area.

Heat Pump

One or more factory-made assemblies which include an indoor conditioning coil, compressor(s) and outdoor coil or refrigerant-to-water heat exchanger, including means to provide both heating and cooling functions.

Heat Traps

Devices or piping arrangements that effectively restrict the natural tendency of hot water to rise in vertical pipes during standby periods. Examples are the U-shaped arrangement of elbows or a 360-degree loop of tubing.

Heated Space

An enclosed space within a building that is heated by a heating system whose output capacity (a) exceeds 10 Btu per hour per square foot and (b) is capable of maintaining a space dry-bulb temperature of 50 degrees F or more at design heating conditions.

HID

High intensity discharge. Generic term describing mercury vapor, metal halide, high pressure sodium, and (informally) low pressure sodium light sources and luminaires.

High-Pressure Sodium Lamps

High-intensity discharge (HID) lamps whose light is produced by radiation from sodium vapor (and mercury).

High-Rise Residential Buildings

Hotels, motels, apartments, condominiums, dormitories, and other residential-type facilities that provide complete housekeeping or transient living quarters and are over three stories in height above grade. Hotels, motels, and other buildings with itinerant occupancies are covered by the "commercial" code regardless of height.

HVAC

Heating, ventilating, and air-conditioning

HVAC System

The equipment, distribution network, and terminals that provide either collectively or individually the processes of heating, ventilating, or air conditioning to a building.

ICAA

Insulation Contractors Association of America

ICC

International Code Council

IMC

International Mechanical Code

Indirectly Conditioned Space

An enclosed space within a building that is not a heated or cooled space, whose area-weighted heat transfer coefficient to heated or cooled spaces exceeds that to the outdoors or to unconditioned spaces; or through which air from heated or cooled spaces is transferred at a rate exceeding three air changes per hour. (Also see Heated Space, Cooled Space, and Unconditioned Space.)

Insulation R-Values

R-values are used to rate insulation and are a measurement of the insulation's resistance to heat flow. The higher the R-value, the better the insulation.

Integrated-Control Economizers

Allows the cooling load of a building or space to be partially met by supplying outside air while the rest of the load is met by the refrigeration equipment within an HVAC system. Field- and factory-installed economizers supplied by major equipment manufacturers include integrated controls.

Interior-Lighting Controls

Offer the ability for systems to be turned on and off either manually or automatically and include switches, time clocks, occupancy sensors and other devices that regulate a lighting system.

Interior Lighting Power Limits

The maximum total wattage for a building or space that can be installed to meet the provisions of the energy code.

Longitudinal Seam

A duct seam that is parallel to the direction of air flow.

Luminaire

A complete lighting unit consisting of a lamp or lamps, along with the parts designed to distribute the light, hold the lamps, and connect the lamps to a power source. Also called a fixture.

Mechanical System

The system and equipment used to provide heating, ventilating, and air conditioning functions as well as additional functions not related to space conditioning, such as, but not limited to, freeze protection in fire protection systems and water heating.

Metal Building Walls and Roofs

Special attention to the design and construction of metal buildings is required to ensure these buildings meet the COM*check-EZ* requirements. Two key elements exist in metal buildings that are not found in other building classes – thermally broken connections between the purlin and metal roof sheet and compression of insulation behind wall girths and roof purlins.

COM*check-EZ* includes requirements for metal building walls and roofs. These requirements are specified in the "Walls Framed – Metal Framing" category and in the "Roofs Metal Purlin" category in the Prescriptive Packages. There are two classes of metal building roofs. One class uses traditional techniques that drape the insulation over the purlin and fasten the metal roof sheets through the insulation directly to the purlin. The second class requires that a thermal block be placed between the metal roof sheet and purlin.

A thermal block consists of foam blocks or other materials/techniques that prevent heat from migrating from the purlin directly to the metal roof sheet. Compressed fiberglass batt insulation does not qualify as a thermal block.

Metal Halide Lamps

A type of high intensity discharge (HID) lamp in which most of the light is produced by radiation of metal halide and mercury vapors in the arc tube. Available in clear and phosphor-coated lamps.

NWWDA

National Wood Window and Door Association

Occupancy Type

The type of activity occurring within a building.

Occupant-Sensing Device

A device that detects the presence or absence of people within an area and causes any combination of lighting, equipment, or appliances to be adjusted accordingly.

Packaged Boiler

A self-contained unit that generally requires little maintenance.

Packaged Terminal Air Conditioner

A factory-selected wall sleeve and separate unencased combination of heating and cooling components, assemblies, or sections (intended for mounting through the wall to serve a single room or zone). It includes heating capability by hot water, steam, or electricity.

Packaged Terminal Heat Pump

A packaged terminal air conditioner capable of using the refrigeration system in a reverse cycle or heat pump mode to provide heat.

Permanently Wired Luminaires

Light fixtures physically attached to a surface (e.g. ceiling or wall) using a permanent mounting system and wired directly to a power source. Examples include fluorescent fixtures located in a ceiling grid and wall sconces.

Perm Rating

The amount of water vapor that passes through an area in a certain period of time.

Photocell

A light sensing device used to control luminaires and dimmers in response to detected light levels.

Plenum

An enclosure that is part of the air-handling system and is distinguished by having a very low air velocity. A plenum often is formed in part or in total by portions of the building.

Projection Factor

The exterior horizontal shading projection depth divided by the sum of the height of the fenestration and the distance from the top of the fenestration to the bottom of the external shading projection in units consistent with the projection depth.

Residential Buildings

Detached one and two family dwellings. A building containing multiple (i.e., three or more) dwelling units where the occupants are primarily permanent in nature, such as townhouses, row houses, apartment houses, convents, monasteries, rectories, fraternities and sororities, dormitories, and rooming houses, all of which are three stories or less in height above grade.

Roof

Those portions of the building envelope, including all opaque surfaces, fenestration, doors, and hatches, that are above conditioned space and are horizontal or tilted at less than 60 degrees from horizontal.

R-Value

Thermal resistance to heat flow. A larger number means less heat flow.

Service Water Heating

The supply of hot water for purposes other than comfort heating and process requirements.

Single-zone, Unitary HVAC Systems

Unitary HVAC systems that serve a single zone. Single zone systems can provide either heating or cooling, but provide supply air at the same volume and temperature to the entire zone which they serve.

Skylight

Glazing that is horizontal or tilted less than 60 degrees from horizontal.

Shading Coefficient

The ratio of solar heat gain through fenestration, with or without integral shading devices, to that occurring through unshaded 1/8-in.-thick double-strength glass.

Solar Heat Gain Coefficient

The glazing's effectiveness in rejecting solar heat gain. SHGC is part of a system for rating window performance used by the National Fenestration Rating Council (NFRC). SHGC is gradually replacing shading coefficient (SC) in product literature and design standards.

Split System

Split-system HVAC equipment has the indoor and outdoor coils within separate cabinets. For a cooling only system, the outdoor cabinet would contain the condenser coil and the indoor cabinet would contain the evaporator coil.

Structural Masonry Wall

A wall construction category used with masonry, precast and poured-in-place concrete, and concrete masonry units. You can select from among six specific types of masonry wall constructions by clicking the *Ext. Wall* button and selecting *Structural Masonry Wall* or by clicking the *Basement* button.

Switched Receptacles

The ability to turn power on and off to an electrical outlet by using a control switch.

Tandem Wiring

A wiring option in which a ballast is shared by two or more luminaires. This reduces labor, materials, and energy costs.

Temperature Reset Controls

Controls that automatically reset supply water temperatures by representative building loads (including return water temperature) or by outside air temperature.

Thermostat

An automatic control device responsive to temperature.

Thermostat Set Back

Usually done at night to reduce the amount of conditioning provided at night by allowing the interior temperature to drift naturally to a marginal temperature during the night and then to recondition it to normal conditions in the morning.

Transverse Seam

All duct seams other than the longitudinal seam (which runs parallel to the direction of air flow).

U-Factor

The amount of heat in Btu that flows each hour through one square foot, when there is a 1 degree F temperature difference across the surface. The smaller the number, the less heat flow.

UL 181A

A test procedure for tapes and mastics used to seal ductwork.

UL 181B

A test procedure for tapes and mastics used to seal ductwork.

Unconditioned Space

An enclosed space within a building that is not a conditioned space.

Unitary-Packaged

Each package is a standalone system which provides all of the heating and cooling requirements for the area of the building which it serves.

Vapor Retarder

A component that retards water vapor diffusion, but does not totally prevent its transmission. Vapor retarder material is usually a thin sheet or coating. However, a construction of several materials, some perhaps of substantial thickness, could also constitute a vapor retarder system.

Variable-Air Volume (VAV) System

HVAC system that controls the dry-bulb temperature within a space by varying the volume of heated or cooled supply air to the space.

Variable-Frequency Drive

Changes the speed of the motor by changing the voltage and frequency of the electricity supplied to the motor based upon system requirements.

Ventilated Naturally

The process of supplying or removing air by natural means to or from any space.

Ventilated Mechanically

The process of supplying or removing air by mechanical means to or from any space. Such air may or may not have been conditioned.

Visible Light Transmittance

The fraction of solar radiation in the visible light spectrum that passes through the fenestration.

Wall

Opaque portion of the building envelope.

Water Heating

The process or system used to heat service water.

Water Temperature Reset

Temperature shall be reset by at least 25% of the design supply-to-return water temperature difference.

Window

The terms "fenestration", "window", and "glazing" are often used interchangeably. However, window actually describes a system of several components. Window is the term given to an entire assembly comprised of the sash, glazing, and frame.

Window-Wall Ratio

The gross window area divided by the gross wall area.

Zone

A space or group of spaces within a building with any combination of heating, cooling, or lighting requirements sufficiently similar so that desired conditions can be maintained throughout by a single controlling device.