

LICENSE RENEWAL APPLICATION

**PALO VERDE NUCLEAR GENERATING STATION
UNIT 1, UNIT 2, AND UNIT 3**

**Facility Operating License Nos.
NPF- 41, NPF- 51, and NPF-74**

This Page Intentionally Left Blank

Table of Contents

Table of Contents.....	i
List of Tables.....	vii
List of Figures	xii
1.0	ADMINISTRATIVE INFORMATION 1-1
1.1	GENERAL INFORMATION 1-1
1.1.1	Names of Applicant and Co-Owners 1-1
1.1.2	Addresses of Applicant and Co-Owners..... 1-1
1.1.3	Descriptions of Business or Occupation of Applicant and Co-Owners 1-2
1.1.4	Descriptions of Organization and Management of Applicant and Co-Owners ... 1-3
1.1.5	Class of Licenses, Use of the Facility, and Period of Time for Which the Licenses Is Sought 1-14
1.1.6	Earliest and Latest Dates for Alterations, If Proposed 1-14
1.1.7	Restricted Data 1-15
1.1.8	Regulatory Agencies 1-15
1.1.9	Local News Publications..... 1-15
1.1.10	Conforming Changes To Standard Indemnity Agreement 1-16
1.2	GENERAL LICENSE INFORMATION..... 1-17
1.2.1	Application Updates, Renewed Licenses, and Renewal Term Operation..... 1-17
1.2.2	Contact Information 1-17
1.3	PURPOSE 1-19
1.4	DESCRIPTION OF PLANT..... 1-20
1.5	APPLICATION STRUCTURE 1-21
1.6	ACRONYMS 1-24
1.7	GENERAL REFERENCES 1-28
2.0	SCOPING AND SCREENING METHODOLOGY FOR IDENTIFYING STRUCTURES AND COMPONENTS SUBJECT TO AGING MANAGEMENT REVIEW AND IMPLEMENTATION RESULTS..... 2.1-1
2.1	SCOPING AND SCREENING METHODOLOGY 2.1-1
2.1.1	Introduction 2.1-1
2.1.2	Scoping Criteria..... 2.1-4
2.1.3	Scoping Methodology 2.1-12
2.1.4	Screening Methodology..... 2.1-18
2.1.5	Interim Staff Guidance..... 2.1-23
2.1.6	Generic Safety Issues 2.1-26
2.1.7	Conclusions 2.1-27
2.2	PLANT-LEVEL SCOPING RESULTS 2.2-1
2.3	SCOPING AND SCREENING RESULTS: MECHANICAL SYSTEMS 2.3-1
2.3.1	Reactor Vessel, Internals, and Reactor Coolant System 2.3-2
2.3.2	Engineered Safety Features 2.3-12
2.3.3	Auxiliary Systems..... 2.3-20
2.3.4	Steam and Power Conversion System..... 2.3-84
2.4	SCOPING AND SCREENING RESULTS: STRUCTURES..... 2.4-1
2.4.1	Containment Building 2.4-2
2.4.2	Control Building..... 2.4-7
2.4.3	Diesel Generator Building..... 2.4-9

Table of Contents

2.4.4	Turbine Building	2.4-11
2.4.5	Auxiliary Building	2.4-12
2.4.6	Radwaste Building	2.4-14
2.4.7	Main Steam Support Structure	2.4-15
2.4.8	Station Blackout Generator Turbine Structures	2.4-17
2.4.9	Fuel Building	2.4-18
2.4.10	Spray Pond and Associated Water Control Structures	2.4-20
2.4.11	Tank Foundations and Shells	2.4-21
2.4.12	Transformer Foundations and Electrical Structures	2.4-23
2.4.13	Yard structures (in-scope)	2.4-24
2.4.14	Supports	2.4-27
2.5	SCOPING AND SCREENING RESULTS: ELECTRICAL AND INSTRUMENTATION AND CONTROL SYSTEMS	2.5-1
2.5.1	Electrical Component Groups	2.5-2
2.5.2	Electrical Component Groups Subject to Aging Management Review	2.5-5
3.0	AGING MANAGEMENT REVIEW RESULTS	3.0-1
3.1	AGING MANAGEMENT OF REACTOR VESSEL, INTERNALS, AND REACTOR COOLANT SYSTEM	3.1-1
3.1.1	Introduction	3.1-1
3.1.2	Results	3.1-1
3.1.3	Conclusions	3.1-14
3.2	AGING MANAGEMENT OF ENGINEERED SAFETY FEATURES	3.2-1
3.2.1	Introduction	3.2-1
3.2.2	Results	3.2-1
3.2.3	Conclusions	3.2-9
3.3	AGING MANAGEMENT OF AUXILIARY SYSTEMS	3.3-1
3.3.1	Introduction	3.3-1
3.3.2	Results	3.3-2
3.3.3	Conclusions	3.3-41
3.4	AGING MANAGEMENT OF STEAM AND POWER CONVERSION SYSTEM	3.4-1
3.4.1	Introduction	3.4-1
3.4.2	Results	3.4-1
3.4.3	Conclusions	3.4-8
3.5	AGING MANAGEMENT OF CONTAINMENTS, STRUCTURES AND COMPONENT SUPPORTS	3.5-1
3.5.1	Introduction	3.5-1
3.5.2	Results	3.5-1
3.5.3	Conclusions	3.5-29
3.6	AGING MANAGEMENT OF ELECTRICAL AND INSTRUMENTATION AND CONTROLS	3.6-1
3.6.1	Introduction	3.6-1
3.6.2	Results	3.6-2
3.6.3	Conclusions	3.6-13
4.0	TIME-LIMITED AGING ANALYSES	4.1-1
4.1	INTRODUCTION	4.1-1
4.1.1	Identification of TLAAs	4.1-2
4.1.2	Aging Management Review	4.1-4

Table of Contents

4.1.3	Summary of Results	4.1-5
4.1.4	Identification of Exemptions	4.1-10
4.2	REACTOR VESSEL NEUTRON EMBRITTLEMENT ANALYSIS	4.2-1
4.2.1	Neutron Fluence, Upper Shelf Energy and Adjusted Reference Temperature (Fluence, USE, and ART)	4.2-2
4.2.2	Pressurized Thermal Shock (PTS).....	4.2-11
4.2.3	Pressure-Temperature (P-T) Limits	4.2-19
4.2.4	Low Temperature Overpressure Protection (LTOP)	4.2-20
4.3	METAL FATIGUE ANALYSIS.....	4.3-1
4.3.1	Fatigue Aging Management Program	4.3-2
4.3.2	ASME III Class 1 Fatigue Analysis of Vessels, Piping, and Components.....	4.3-30
4.3.3	Fatigue and Cycle-Based TLAAs of ASME III Subsection NG Reactor Pressure	4.3-73
4.3.4	Effects of the Reactor Coolant System Environment on Fatigue Life of Piping and Components (Generic Safety Issue 190)	4.3-76
4.3.5	Assumed Thermal Cycle Count for Allowable Secondary Stress Range Reduction Factor in ANSI B31.1 and ASME III Class 2 and 3 Piping.....	4.3-84
4.4	ENVIRONMENTAL QUALIFICATION (EQ) OF ELECTRIC EQUIPMENT.....	4.4-1
4.5	CONCRETE CONTAINMENT TENDON PRESTRESS.....	4.5-1
4.6	CONTAINMENT LINER PLATE, EQUIPMENT HATCH AND PERSONNEL AIR LOCKS, PENETRATIONS, AND POLAR CRANE BRACKETS	4.6-1
4.6.1	Absence of a TLAA for Containment Liner Plate, Polar Crane Brackets	4.6-2
4.6.2	Design Cycles for the Main Steam and Main Feedwater Penetrations.....	4.6-4
4.6.3	Design Cycles for the Recirculation Sump Suction Line Penetrations.....	4.6-8
4.7	PLANT-SPECIFIC TIME-LIMITED AGING ANALYSIS.....	4.7-1
4.7.1	Load Cycle Limits of Cranes, Lifts, and Fuel Handling Equipment Designed for a Stated Number of Lifetime Lifts or to CMAA 70	4.7-1
4.7.2	Absence of TLAAs for Metal Corrosion Allowances and Corrosion Effects	4.7-5
4.7.3	Inservice Flaw Growth Analyses that Demonstrate Structural Stability for 40 Years	4.7-6
4.7.4	Fatigue Crack Growth and Fracture Mechanics Stability Analyses of Half-Nozzle Repairs to Alloy 600 Material in Reactor Coolant Hot Legs; Absence of a TLAA for Supporting Corrosion Analyses.....	4.7-7
4.7.5	Absence of a TLAA in Corrosion Analyses of Pressurizer Ferritic Materials Exposed to Reactor Coolant by Half-Nozzle Repairs of Pressurizer Heater Sleeve Alloy 600 Nozzles	4.7-9
4.7.6	Absence of a TLAA for Reactor Vessel Underclad Cracking Analyses	4.7-10
4.7.7	Absence of a TLAA for a Reactor Coolant Pump Flywheel Fatigue Crack Growth Analysis.....	4.7-10
4.7.8	Building Absolute or Differential Heave or Settlement, including Possible Effects of Changes in a Perched Groundwater Lens.....	4.7-11
4.8	ABSENCE OF TLAAS SUPPORTING 10 CFR 50.12 EXEMPTIONS.....	4.8-1
4.9	REFERENCES.....	4.9-1

APPENDIX A UPDATED FINAL SAFETY ANALYSIS REPORT SUPPLEMENT

	Appendix A Table of Contents	A-i
A0	APPENDIX A INTRODUCTION.....	A-1
A1	SUMMARY DESCRIPTIONS OF AGING MANAGEMENT PROGRAMS.....	A-2
A1.1	ASME Section XI Inservice Inspection, Subsections IWB, IWC, and IWD.....	A-2
A1.2	Water Chemistry	A-2

Table of Contents

A1.3	Reactor Head Closure Studs	A-3
A1.4	Boric Acid Corrosion.....	A-3
A1.5	Nickel-Alloy Penetration Nozzles Welded To the Upper Reactor Vessel Closure Heads of Pressurized Water Reactors.....	A-3
A1.6	Flow-Accelerated Corrosion	A-4
A1.7	Bolting Integrity	A-4
A1.8	Steam Generator Tube Integrity	A-5
A1.9	Open-Cycle Cooling Water System	A-5
A1.10	Closed-Cycle Cooling Water System	A-6
A1.11	Inspection of Overhead Heavy Load and Light Load (Related to Refueling) Handling Systems	A-6
A1.12	Fire Protection.....	A-6
A1.13	Fire Water System.....	A-7
A1.14	Fuel Oil Chemistry.....	A-8
A1.15	Reactor Vessel Surveillance.....	A-9
A1.16	One-Time Inspection	A-9
A1.17	Selective Leaching of Materials	A-10
A1.18	Buried Piping and Tanks Inspection.....	A-11
A1.19	One-Time Inspection of ASME Code Class 1 Small-Bore Piping.....	A-11
A1.20	External Surfaces Monitoring Program	A-12
A1.21	Reactor Coolant System Supplement.....	A-12
A1.22	Inspection of Internal Surfaces in Miscellaneous Piping and Ducting Components.....	A-13
A1.23	Lubricating Oil Analysis	A-13
A1.24	Electrical Cables and Connections Not Subject to 10 CFR 50.49 Environmental Qualification Requirements	A-14
A1.25	Electrical Cables and Connections Not Subject to 10 CFR 50.49 Environmental Qualification Requirements Used in Instrumentation Circuits.....	A-15
A1.26	Inaccessible Medium Voltage Cables Not Subject to 10 CFR 50.49 Environmental Qualification Requirements	A-15
A1.27	ASME Section XI, Subsection IWE	A-16
A1.28	ASME Section XI, Subsection IWL	A-16
A1.29	ASME Section XI, Subsection IWF	A-17
A1.30	10 CFR 50, Appendix J	A-17
A1.31	Masonry Wall Program.....	A-17
A1.32	Structures Monitoring Program.....	A-18
A1.33	RG 1.127, Inspection of Water-Control Structures Associated with Nuclear Power Plants.....	A-18
A1.34	Nickel Alloy Aging Management Program	A-19
A1.35	Electrical Cable Connections Not Subject to 10 CFR 50.49 Environmental Qualification Requirements.....	A-19
A1.36	Metal Enclosed Bus.....	A-20
A2	SUMMARY DESCRIPTIONS OF TIME-LIMITED AGING ANALYSIS AGING MANAGEMENT PROGRAMS	A-21
A2.1	Metal Fatigue of Reactor Coolant Pressure Boundary.....	A-21
A2.2	Environmental Qualification (EQ) of Electrical Components	A-23
A2.3	Concrete Containment Tendon Prestress	A-23
A3	EVALUATION SUMMARIES OF TIME-LIMITED AGING ANALYSES.....	A-25
A3.1	Reactor Vessel Neutron Embrittlement Analysis	A-25
A3.1.1	Neutron Fluence, Upper Shelf Energy and Adjusted Reference Temperature (Fluence, USE, and ART).....	A-25

Table of Contents

A3.1.2	Pressurized Thermal Shock (PTS).....	A-26
A3.1.3	Pressure-Temperature (P-T) Limits	A-26
A3.1.4	Low Temperature Overpressure Protection (LTOP)	A-26
A3.2	Metal Fatigue Analysis	A-27
A3.2.1	ASME Section III Class 1 Fatigue Analysis of Vessels, Piping, and Components.....	A-28
A3.2.2	ASME Section III Subsection NG Fatigue Analysis of Reactor Pressure Vessel Internals.....	A-35
A3.2.3	Effects of the Reactor Coolant System Environment on Fatigue Life of Piping and Components (Generic Safety Issue 190)	A-35
A3.2.4	Assumed Thermal Cycle Count for Allowable Secondary Stress Range Reduction Factor in ANSI B31.1 and ASME Section III Class 2 and 3 Piping.....	A-37
A3.3	Environmental Qualification (EQ) of Electrical Components	A-37
A3.4	Concrete Containment Tendon Prestress	A-38
A3.5	Containment Liner Plate, Equipment Hatches, Personnel Air Locks, Penetrations, and Polar Crane Brackets	A-38
A3.5.1	Design Cycles for the Main Steam and Main Feedwater Penetrations.....	A-39
A3.5.2	Design Cycles for the Recirculation Sump Suction Line Penetrations.....	A-39
A3.6	Plant-Specific Time-Limited Aging Analyses	A-40
A3.6.1	Load Cycle Limits of Cranes, Lifts, and Fuel Handling Equipment to CMAA 70.....	A-40
A3.6.2	Fatigue Crack Growth and Fracture Mechanics Stability Analyses of Half-Nozzle Repairs to Alloy 600 Material in Reactor Coolant Hot Legs.....	A-40
A3.6.3	Building Absolute or Differential Heave or Settlement Including Possible Effects of Changes in a Perched Groundwater Lens.....	A-40
A4	LICENSE RENEWAL COMMITMENTS	A-42

APPENDIX B AGING MANAGEMENT PROGRAMS

	Appendix B Table of Contents	B-i
B1	APPENDIX B INTRODUCTION.....	B-1
B1.1	Overview.....	B-1
B1.2	Method of Discussion	B-1
B1.3	Quality Assurance Program and Administrative Controls	B-2
B1.4	Operating Experience.....	B-3
B1.5	Aging Management Programs	B-4
B1.6	Time-Limited Aging Analysis Programs	B-5
B2	AGING MANAGEMENT PROGRAMS	B-7
B2.1	Aging Management Program Details	B-12
B2.1.1	ASME Section XI Inservice Inspection, Subsections IWB, IWC, and IWD.....	B-12
B2.1.2	Water Chemistry	B-14
B2.1.3	Reactor Head Closure Studs	B-17
B2.1.4	Boric Acid Corrosion.....	B-19
B2.1.5	Nickel-Alloy Penetration Nozzles Welded to the Upper Reactor Vessel Closure Heads of Pressurized Water Reactors.....	B-21
B2.1.6	Flow-Accelerated Corrosion	B-24
B2.1.7	Bolting Integrity	B-27
B2.1.8	Steam Generator Tube Integrity	B-30
B2.1.9	Open-Cycle Cooling Water System	B-34
B2.1.10	Closed-Cycle Cooling Water System	B-37

Table of Contents

B2.1.11	Inspection of Overhead Heavy Load and Light Load (Related to Refueling) Handling Systems	B-43
B2.1.12	Fire Protection.....	B-45
B2.1.13	Fire Water System.....	B-48
B2.1.14	Fuel Oil Chemistry.....	B-51
B2.1.15	Reactor Vessel Surveillance.....	B-54
B2.1.16	One-Time Inspection.....	B-56
B2.1.17	Selective Leaching of Materials	B-58
B2.1.18	Buried Piping and Tanks Inspection.....	B-60
B2.1.19	One-Time Inspection of ASME Code Class 1 Small-Bore Piping.....	B-62
B2.1.20	External Surfaces Monitoring Program	B-64
B2.1.21	Reactor Coolant System Supplement	B-66
B2.1.22	Inspection of Internal Surfaces in Miscellaneous Piping and Ducting Components.....	B-67
B2.1.23	Lubricating Oil Analysis	B-69
B2.1.24	Electrical Cables and Connections Not Subject to 10 CFR 50.49 Environmental Qualification Requirements	B-72
B2.1.25	Electrical Cables and Connections Not Subject to 10 CFR 50.49 Environmental Qualification Requirements Used in Instrumentation Circuits.....	B-74
B2.1.26	Inaccessible Medium Voltage Cables Not Subject to 10 CFR 50.49 Environmental Qualification Requirements	B-76
B2.1.27	ASME Section XI, Subsection IWE	B-78
B2.1.28	ASME Section XI, Subsection IWL	B-82
B2.1.29	ASME Section XI, Subsection IWF	B-84
B2.1.30	10 CFR 50, Appendix J	B-86
B2.1.31	Masonry Wall Program.....	B-89
B2.1.32	Structures Monitoring Program	B-92
B2.1.33	RG 1.127, Inspection of Water-Control Structures Associated with Nuclear Power Plants.....	B-95
B2.1.34	Nickel Alloy Aging Management Program	B-97
B2.1.35	Electrical Cable Connections Not Subject to 10 CFR 50.49 Environmental Qualification Requirements.....	B-110
B2.1.36	Metal-Enclosed Bus	B-112
B3	TLAA SUPPORT ACTIVITIES.....	B-114
B3.1	Metal Fatigue of Reactor Coolant Pressure Boundary.....	B-114
B3.2	Environmental Qualification (EQ) of Electrical Components	B-120
B3.3	Concrete Containment Tendon Prestress	B-123

Appendix C Not Used

Appendix D Technical Specification Changes (No changes requested)

Appendix E Environmental Information (Provided Under Separate Cover)

Table of Contents

List of Tables

Table 2.1-1	Intended Functions: Abbreviations and Definitions	2.1-20
Table 2.1-2	NRC Interim Staff Guidance Associated with License Renewal	2.1-24
Table 2.2-1	PVNGS Scoping Results	2.2-2
Table 2.3.1-1	Reactor Vessel and Internals	2.3-3
Table 2.3.1-2	Reactor Coolant System	2.3-6
Table 2.3.1-3	Pressurizer	2.3-8
Table 2.3.1-4	Steam Generators	2.3-9
Table 2.3.1-5	Reactor Core	2.3-11
Table 2.3.2-1	Containment Leak Test System	2.3-13
Table 2.3.2-2	Containment Purge System	2.3-14
Table 2.3.2-3	Containment Hydrogen Control System	2.3-16
Table 2.3.2-4	Safety Injection and Shutdown Cooling System	2.3-19
Table 2.3.3-1	Fuel Handling and Storage System	2.3-22
Table 2.3.3-2	Spent Fuel Pool Cooling and Cleanup System	2.3-24
Table 2.3.3-3	Essential Cooling Water System	2.3-26
Table 2.3.3-4	Essential Chilled Water System	2.3-28
Table 2.3.3-5	Normal Chilled Water System	2.3-30
Table 2.3.3-6	Nuclear Cooling Water System	2.3-32
Table 2.3.3-7	Essential Spray Pond System	2.3-34
Table 2.3.3-8	Nuclear Sampling System	2.3-36
Table 2.3.3-9	Compressed Air System	2.3-38
Table 2.3.3-10	Chemical and Volume Control System	2.3-40
Table 2.3.3-11	Control Building HVAC System	2.3-43
Table 2.3.3-12	Auxiliary Building HVAC System	2.3-45
Table 2.3.3-13	Fuel Building HVAC System	2.3-47
Table 2.3.3-14	Containment Building HVAC System	2.3-51
Table 2.3.3-15	Diesel Generator Building HVAC System	2.3-53
Table 2.3.3-16	Radwaste Building HVAC System	2.3-54
Table 2.3.3-17	Turbine Building HVAC System	2.3-55
Table 2.3.3-18	Miscellaneous Site Structures/Spray Pond Pump House HVAC System	2.3-57
Table 2.3.3-19	Fire Protection System	2.3-58
Table 2.3.3-20	Diesel Generator Fuel Oil Storage and Transfer System	2.3-60
Table 2.3.3-21	Diesel Generator System	2.3-63
Table 2.3.3-22	Domestic Water System	2.3-65
Table 2.3.3-23	Demineralized Water System	2.3-67
Table 2.3.3-24	WRF Fuel System	2.3-68
Table 2.3.3-25	Service Gases (N ₂ and H ₂) System	2.3-69
Table 2.3.3-26	Gaseous Radwaste System	2.3-71
Table 2.3.3-27	Radioactive Waste Drains System	2.3-73
Table 2.3.3-28	Station Blackout Generator System	2.3-74
Table 2.3.3-29	Cranes, Hoists, and Elevators System	2.3-76
Table 2.3.3-30	Miscellaneous Auxiliary Systems In-Scope ONLY based on Criterion 10 CFR 54.4(a) (2)	2.3-83
Table 2.3.4-1	Main Steam System	2.3-86
Table 2.3.4-2	Condensate Storage and Transfer System	2.3-88
Table 2.3.4-3	Auxiliary Feedwater System	2.3-90
Table 2.3.4-4	Condensate System	2.3-92
Table 2.3.4-5	Feedwater System	2.3-93
Table 2.3.4-6	Main Turbine System	2.3-94
Table 2.3.4-7	Steam Generator Feedwater Pump Turbine System	2.3-95

Table of Contents

Table 2.3.4-8	Feedwater Heater Extraction Steam, Drains, and Vents System	2.3-96
Table 2.4-1	Containment Building	2.4-6
Table 2.4-2	Control Building	2.4-8
Table 2.4-3	Diesel Generator Building	2.4-10
Table 2.4-4	Turbine Building	2.4-12
Table 2.4-5	Auxiliary Building	2.4-13
Table 2.4-6	Radwaste Building	2.4-15
Table 2.4-7	Main Steam Support Structure	2.4-16
Table 2.4-8	Station Blackout Generator Structure	2.4-18
Table 2.4-9	Fuel Building	2.4-19
Table 2.4-10	Spray Pond and Associated Water Control Structures	2.4-21
Table 2.4-11	Tank Foundations and Shells	2.4-23
Table 2.4-12	Transformer Foundations and Electrical Structures	2.4-24
Table 2.4-13	Yard Structures (In-Scope)	2.4-26
Table 2.4-14	Supports	2.4-29
Table 2.4-15	Component Types Assigned to Supports by Building/Structure	2.4-31
Table 2.5-1	Electrical and Instrument and Control Component Types Requiring Aging Management Review	2.5-6
Table 3.0-1	Mechanical Environments	3.0-6
Table 3.0-2	Structural Environments	3.0-11
Table 3.0-3	Electrical and Instrument and Controls Environments	3.0-13
Table 3.1.1	Summary of Aging Management Evaluations in Chapter IV of NUREG-1801 for Reactor Vessel, Internals, and Reactor Coolant System	3.1-15
Table 3.1.2-1	Reactor Vessel, Internals, and Reactor Coolant System – Summary of Aging Management Evaluation – Reactor Vessel and Internals	3.1-40
Table 3.1.2-2	Reactor Vessel, Internals, and Reactor Coolant System – Summary of Aging Management Evaluation – Reactor Coolant System	3.1-59
Table 3.1.2-3	Reactor Vessel, Internals, and Reactor Coolant System – Summary of Aging Management Evaluation – Pressurizer	3.1-73
Table 3.1.2-4	Reactor Vessel, Internals, and Reactor Coolant System – Summary of Aging Management Evaluation – Steam Generators	3.1-85
Table 3.2.1	Summary of Aging Management Evaluations in Chapter V of NUREG-1801 for Engineered Safety Features	3.2-10
Table 3.2.2-1	Engineered Safety Features – Summary of Aging Management Evaluation – Containment Leak Test	3.2-28
Table 3.2.2-2	Engineered Safety Features – Summary of Aging Management Evaluation – Containment Purge	3.2-29
Table 3.2.2-3	Engineered Safety Features – Summary of Aging Management Evaluation – Containment Hydrogen Control	3.2-32
Table 3.2.2-4	Engineered Safety Features – Summary of Aging Management Evaluation – Safety Injection and Shutdown Cooling	3.2-37
Table 3.3.1	Summary of Aging Management Evaluations in Chapter VII of NUREG-1801 for Auxiliary Systems	3.3-42
Table 3.3.2-1	Auxiliary Systems – Summary of Aging Management Evaluation – Fuel Handling and Storage	3.3-73
Table 3.3.2-2	Auxiliary Systems – Summary of Aging Management Evaluation – Spent Fuel Pool Cooling and Cleanup	3.3-76
Table 3.3.2-3	Auxiliary Systems – Summary of Aging Management Evaluation – Essential Cooling Water	3.3-83
Table 3.3.2-4	Auxiliary Systems – Summary of Aging Management Evaluation – Essential Chilled Water	3.3-89

Table of Contents

Table 3.3.2-5	Auxiliary Systems – Summary of Aging Management Evaluation – Normal Chilled Water	3.3-101
Table 3.3.2-6	Auxiliary Systems – Summary of Aging Management Evaluation – Nuclear Cooling Water	3.3-104
Table 3.3.2-7	Auxiliary Systems – Summary of Aging Management Evaluation – Essential Spray Pond	3.3-107
Table 3.3.2-8	Auxiliary Systems – Summary of Aging Management Evaluation – Nuclear Sampling	3.3-114
Table 3.3.2-9	Auxiliary Systems – Summary of Aging Management Evaluation – Compressed Air	3.3-122
Table 3.3.2-10	Auxiliary Systems – Summary of Aging Management Evaluation – Chemical and Volume Control	3.3-124
Table 3.3.2-11	Auxiliary Systems – Summary of Aging Management Evaluation – Control Building HVAC	3.3-139
Table 3.3.2-12	Auxiliary Systems – Summary of Aging Management Evaluation – Auxiliary Building HVAC	3.3-145
Table 3.3.2-13	Auxiliary Systems – Summary of Aging Management Evaluation – Fuel Building HVAC.....	3.3-151
Table 3.3.2-14	Auxiliary Systems – Summary of Aging Management Evaluation – Containment Building HVAC.....	3.3-155
Table 3.3.2-15	Auxiliary Systems – Summary of Aging Management Evaluation – Diesel Generator Building HVAC	3.3-160
Table 3.3.2-16	Auxiliary Systems – Summary of Aging Management Evaluation – Radwaste Building HVAC.....	3.3-164
Table 3.3.2-17	Auxiliary Systems – Summary of Aging Management Evaluation – Turbine Building HVAC.....	3.3-165
Table 3.3.2-18	Auxiliary Systems – Summary of Aging Management Evaluation – Miscellaneous Site Structures/Spray Pond Pump House HVAC.....	3.3-167
Table 3.3.2-19	Auxiliary Systems – Summary of Aging Management Evaluation – Fire Protection.....	3.3-169
Table 3.3.2-20	Auxiliary Systems – Summary of Aging Management Evaluation – Diesel Generator Fuel Oil Storage and Transfer	3.3-182
Table 3.3.2-21	Auxiliary Systems – Summary of Aging Management Evaluation – Diesel Generator.....	3.3-186
Table 3.3.2-22	Auxiliary Systems – Summary of Aging Management Evaluation – Domestic Water.....	3.3-203
Table 3.3.2-23	Auxiliary Systems – Summary of Aging Management Evaluation – Demineralized Water.....	3.3-208
Table 3.3.2-24	Auxiliary Systems – Summary of Aging Management Evaluation – WRF Fuel.....	3.3-210
Table 3.3.2-25	Auxiliary Systems – Summary of Aging Management Evaluation – Service Gases (N2 and H2).....	3.3-214
Table 3.3.2-26	Auxiliary Systems – Summary of Aging Management Evaluation – Gaseous Radwaste	3.3-216
Table 3.3.2-27	Auxiliary Systems – Summary of Aging Management Evaluation – Radioactive Waste Drains	3.3-218
Table 3.3.2-28	Auxiliary Systems – Summary of Aging Management Evaluation – Station Blackout Generator.....	3.3-222
Table 3.3.2-29	Auxiliary Systems – Summary of Aging Management Evaluation – Cranes, Hoists, and Elevators	3.3-231

Table of Contents

Table 3.3.2-30	Auxiliary Systems – Summary of Aging Management Evaluation – Miscellaneous Auxiliary Systems In-Scope ONLY based on Criterion 10 CFR 54.4(a) (2)	3.3-233
Table 3.4.1	Summary of Aging Management Evaluations in Chapter VIII of NUREG-1801 for Steam and Power Conversion System	3.4-9
Table 3.4.2-1	Steam and Power Conversion System – Summary of Aging Management Evaluation – Main Steam.....	3.4-22
Table 3.4.2-2	Steam and Power Conversion System – Summary of Aging Management Evaluation – Condensate Storage and Transfer.....	3.4-28
Table 3.4.2-3	Steam and Power Conversion System – Summary of Aging Management Evaluation – Auxiliary Feedwater.....	3.4-34
Table 3.5.1	Summary of Aging Management Evaluations In Chapters II And III of NUREG-1801 For Containments, Structures, And Component Supports.....	3.5-30
Table 3.5.2-1	Containments, Structures, and Component Supports - Summary of Aging Management Evaluation - Containment Building.....	3.5-48
Table 3.5.2-2	Containments, Structures, and Component Supports - Summary of Aging Management Evaluation - Control Building.....	3.5-57
Table 3.5.2-3	Containments, Structures, and Component Supports - Summary of Aging Management Evaluation - Diesel Generator Building.....	3.5-65
Table 3.5.2-4	Containments, Structures, and Component Supports - Summary of Aging Management Evaluation - Turbine Building	3.5-73
Table 3.5.2-5	Containments, Structures, and Component Supports - Summary of Aging Management Evaluation - Auxiliary Building.....	3.5-79
Table 3.5.2-6	Containments, Structures, and Component Supports - Summary of Aging Management Evaluation - Radwaste Building	3.5-87
Table 3.5.2-7	Containments, Structures, and Component Supports - Summary of Aging Management Evaluation – Main Steam Support Structure.....	3.5-92
Table 3.5.2-8	Containments, Structures, and Component Supports - Summary of Aging Management Evaluation – Station Blackout Generator Structures	3.5-99
Table 3.5.2-9	Containments, Structures, and Component Supports - Summary of Aging Management Evaluation – Fuel Building	3.5-102
Table 3.5.2-10	Containments, Structures, and Component Supports - Summary of Aging Management Evaluation – Spray Pond and Associated Water Control Structures	3.5-109
Table 3.5.2-11	Containments, Structures, and Component Supports - Summary of Aging Management Evaluation – Tank Foundations and Shells	3.5-114
Table 3.5.2-12	Containments, Structures, and Component Supports - Summary of Aging Management Evaluation – Transformer Foundations and Electrical Structures.....	3.5-119
Table 3.5.2-13	Containments, Structures, and Component Supports - Summary of Aging Management Evaluation – Yard Structures (In-Scope)	3.5-123
Table 3.5.2-14	Containments, Structures, and Component Supports - Summary of Aging Management Evaluation - Supports	3.5-129
Table 3.6.1	Summary of Aging Management Evaluations in Chapter VI of NUREG-1801 for Electrical and Instrument and Controls	3.6-14
Table 3.6.2-1	Electrical and Instrument and Controls – Summary of Aging Management Evaluation – Electrical Components	3.6-18
Table 4.1-1	List of TLAAs.....	4.1-5
Table 4.1-2	Review of Analyses Listed in NUREG 1800 Tables 4.1 2 and 4.1 3	4.1-9
Table 4.2-1	PVNGS Reactor Vessel Peak Beltline Neutron Fluences >1 MeV	4.2-5
Table 4.2-2	Results of Examination of PVNGS 230° Capsule 5 Coupons	4.2-7

Table of Contents

Table 4.2-3	PVNGS Unit 1 Vessel Material USE Projected at 60 Years (54 EFPY).....	4.2-13
Table 4.2-4	PVNGS Unit 2 Vessel Material USE Projected at 60 Years (54 EFPY).....	4.2-14
Table 4.2-5	PVNGS Unit 3 Vessel Material USE Projected at 60 Years (54 EFPY).....	4.2-15
Table 4.2-6	PVNGS Unit 1 Reactor Vessel Limiting RTPTS at 60 Years (54 EFPY)	4.2-16
Table 4.2-7	PVNGS Unit 2 Reactor Vessel Limiting RTPTS at 60 Years (54 EFPY)	4.2-17
Table 4.2-8	PVNGS Unit 3 Reactor Vessel Limiting RTPTS at 60 Years (54 EFPY)	4.2-18
Table 4.3-1	PVNGS Unit 1, 2, and 3 Licensing and Design Basis Transient Citations from UFSAR 3.9.1.1.....	4.3-5
Table 4.3-2	PVNGS Unit 1, 2, and 3 Licensing and Design Basis Transients	4.3-6
Table 4.3-3	Significant Transient Cycle Limits Tracked by the PVNGS FatiguePro® Aging Management Program	4.3-12
Table 4.3-4	Summary of Fatigue Usage from Class 1 Analyses and Method of Management by the PVNGS Fatigue Management Program	4.3-26
Table 4.3-5	PVNGS Class 1 Components and Piping.....	4.3-30
Table 4.3-6	Fatigue Analysis Results for Reactor Pressure Vessel Components	4.3-32
Table 4.3-7	Summary of PVNGS Pressurizer ASME III Class 1 Analyses and Fatigue Usage Factors	4.3-44
Table 4.3-8	PVNGS Steam Generator Uprated Fatigue Comparison	4.3-49
Table 4.3-9	Summary of PVNGS Class 1 Valve Fatigue Analyses.....	4.3-53
Table 4.3-10	PVNGS Main Steam Safety Valve Cyclic Design Criteria	4.3-68
Table 4.3-11	Summary of Fatigue Usage Factors at NUREG/CR 6260 Sample Locations, Adapted to PVNGS.....	4.3-81
Table 4.5-1	Tendon Regression Analysis Input Data for PVNGS Units 1, 2, and 3.....	4.5-5
Table 4.7-1	Estimated Maximum Number of Significant Crane Lifts	4.7-4
Table 4.7-2	Settlement Monitoring Surveillance Results: Total Settlement, Differential Settlement, and Containment Tilt	4.7-15
Table A4-1	License Renewal Commitments	A-42

Table of Contents

List of Figures

Figure 2.1-1	Scoping and Screening Process Flow.....	2.1-28
Figure 2.1-2	SBO Recovery Path	2.1-29
Figure 4.3 1	Cross Section of Pressurizer Heater Sleeve Penetration Showing the Half-Nozzle Repair Method, and the Unit 3 Heater Location Fabrication Error.....	4.3-41
Figure 4.5-1	Regression Analysis of Unit 1 Horizontal Tendon Lift-off Data through the 15-Year Surveillance; With Reg Guide 1.35.1 Predicted Prestress	4.5-11
Figure 4.5-2	Regression Analysis of Unit 1 Vertical Tendon Lift-off Data through the 15-Year Surveillance; With Reg Guide 1.35.1 Predicted Prestress	4.5-12
Figure 4.5-3	Regression Analysis of Unit 3 Horizontal Tendon Lift-off Data through the 15-Year Surveillance; With Reg Guide 1.35.1 Predicted Prestress	4.5-13
Figure 4.5-4	Regression Analysis of Unit 3 Vertical Tendon Lift-off Data through the 15-Year Surveillance; With Reg Guide 1.35.1 Predicted Prestress	4.5-14
Figure 4.5-5	Joint Regression Analysis of Unit 1, 2, and 3 Horizontal Tendon Lift-off Data through the Unit 2 20-Year Surveillance; With Reg Guide 1.35.1 Predicted Prestress	4.5-15
Figure 4.5-6	Joint Regression Analysis of Unit 1, 2, and 3 Vertical Tendon Lift-off Data through the Unit 2 20-Year Surveillance; With Reg Guide 1.35.1 Predicted Prestress.....	4.5-16

CHAPTER 1

ADMINISTRATIVE INFORMATION

This Page Intentionally Left Blank

1.0 ADMINISTRATIVE INFORMATION

1.1 GENERAL INFORMATION

1.1.1 Names of Applicant and Co-Owners

Arizona Public Service Company (APS), acting on behalf of itself and the co-owners described below, hereby applies for renewed operating licenses for the Palo Verde Nuclear Generating Station (PVNGS), Unit 1, Unit 2, and Unit 3.

PVNGS is owned by Arizona Public Service Company (29.1 percent), Salt River Project Agricultural Improvement and Power District (17.49 percent), Southern California Edison Company (15.8 percent), El Paso Electric Company (15.8 percent), Public Service Company of New Mexico (10.2 percent), Southern California Public Power Authority (5.91 percent), and the Los Angeles Department of Water and Power (5.70 percent). APS is the plant operator and is authorized to act as agent for the owners and has exclusive responsibility and control over the physical construction, operation, and maintenance of the facility.

Neither APS nor the PVNGS co-owners are owned, controlled, or dominated by an alien, a foreign corporation, or a foreign government.

1.1.2 Addresses of Applicant and Co-Owners

Arizona Public Service Company
400 North 5th Street, P.O. Box 53999
Phoenix, Arizona 85072-3999

Salt River Project Agricultural Improvement and Power District
P.O. Box 52025
Phoenix, Arizona 85072-2025

Southern California Edison Company
2244 Walnut Grove Avenue
Rosemead, California 91770

El Paso Electric Company
100 N. Stanton Street
El Paso, Texas 79901

Public Service Company of New Mexico
Alvarado Square
Albuquerque, New Mexico 87158

Southern California Public Power Authority
225 South Lake Avenue, Suite 1250
Pasadena, California 91101

Los Angeles Department of Water and Power
111 North Hope Street
Los Angeles, California 90012

1.1.3 Descriptions of Business or Occupation of Applicant and Co-Owners

Arizona Public Service Company

Arizona Public Service Company is in the regulated electricity business, which consists of traditional regulated retail and wholesale electricity businesses and related activities, and includes electricity generation, transmission and distribution.

Salt River Project Agricultural Improvement and Power District

The Salt River Project Agricultural Improvement and Power District is an agricultural improvement district, organized under the laws of the State of Arizona, which provides electric service in a 2,900 square mile service territory in parts of Maricopa, Gila and Pinal Counties in Arizona, plus mine loads in an adjacent 2,400 square mile area in Gila and Pinal Counties.

Southern California Edison Company

Southern California Edison Company is a public utility primarily engaged in the business of supplying electric energy to a 50,000 square mile area of central, coastal and southern California, excluding the City of Los Angeles and certain other cities. This service territory includes approximately 430 cities and communities and a population of more than 13 million people. Edison International owns all of the common stock of Southern California Edison Company.

El Paso Electric Company

El Paso Electric Company is a public utility engaged in the generation, transmission and distribution of electricity in an area of approximately 10,000 square miles in west Texas and southern New Mexico. The Company also serves a wholesale customer in Texas and from time to time in the Republic of Mexico. The Company owns or has significant ownership interests in six electrical generating facilities providing it with a net dependable generating

**Section 1
ADMINISTRATIVE INFORMATION**

capability of approximately 1,503 MW. The Company serves approximately 360,000 residential, commercial, industrial and wholesale customers.

Public Service Company of New Mexico

Public Service Company of New Mexico serves approximately 487,000 electricity and 490,000 natural gas customers in about 100 communities statewide and also sells electricity on the wholesale market. The Company, New Mexico's largest electricity and natural gas provider, is based in Albuquerque and has offices in more than 20 cities.

Southern California Public Power Authority

Southern California Public Power Authority is a joint powers agency comprising eleven municipal utilities and one irrigation district. The members consist of the municipal utilities of Anaheim, Azusa, Banning, Burbank, Cerritos, Colton, Glendale, Los Angeles, Pasadena, Riverside, Vernon, and the Imperial Irrigation District. Together they deliver electricity to over two million customers in the Southern California Basin, covering an area of 7,000 square miles and with a total population exceeding five million.

Los Angeles Department of Water and Power

The Los Angeles Department of Water and Power is a department organized and existing under the Charter of the City of Los Angeles. The Company is the sole water and electricity provider for the City of Los Angeles. It is now the largest municipally owned electric utility in the nation, serving a population of 4.0 million residents over a 465 square mile area.

1.1.4 Descriptions of Organization and Management of Applicant and Co-Owners

The directors and principal officers of APS and Co-owners and their addresses are presented below. All persons listed are U. S. citizens and seven of the following officers hold dual citizenship.

Arizona Public Service Company Board of Directors	
Name	Address
Edward N. Basha, Jr.	400 North 5 th Street P.O. Box 53999 Phoenix, AZ 85072-3999
Susan Clark-Johnson	400 North 5 th Street P.O. Box 53999 Phoenix, AZ 85072-3999

**Section 1
ADMINISTRATIVE INFORMATION**

Arizona Public Service Company Board of Directors	
Name	Address
Michael L. Gallagher	400 North 5 th Street P.O. Box 53999 Phoenix, AZ 85072-3999
Pamela Grant	400 North 5 th Street P.O. Box 53999 Phoenix, AZ 85072-3999
Roy A. Herberger, Jr.	400 North 5 th Street P.O. Box 53999 Phoenix, AZ 85072-3999
William S. Jamieson	400 North 5 th Street P.O. Box 53999 Phoenix, AZ 85072-3999
Humberto S. Lopez	400 North 5 th Street P.O. Box 53999 Phoenix, AZ 85072-3999
Kathryn L. Munro	400 North 5 th Street P.O. Box 53999 Phoenix, AZ 85072-3999
Bruce J. Nordstrom	400 North 5 th Street P.O. Box 53999 Phoenix, AZ 85072-3999
W. Douglas Parker	400 North 5 th Street P.O. Box 53999 Phoenix, AZ 85072-3999
William J. Post	400 North 5 th Street P.O. Box 53999 Phoenix, AZ 85072-3999
William L. Stewart	400 North 5 th Street P.O. Box 53999 Phoenix, AZ 85072-3999

Arizona Public Service Company Principal Officers		
Name	Title	Address
Donald E. Brandt	President and Chief Executive Officer	400 North 5 th Street P.O. Box 53999 Phoenix, AZ 85072-3999
John R. Denman	Senior Vice President, Fossil Operations	400 North 5 th Street P.O. Box 53999 Phoenix, AZ 85072-3999
Randall K. Edington	Executive Vice President and Chief Nuclear Officer	400 North 5 th Street P.O. Box 53999 Phoenix, AZ 85072-3999

Section 1
ADMINISTRATIVE INFORMATION

Arizona Public Service Company Principal Officers		
Name	Title	Address
Daniel Froetscher	Vice President, Energy Delivery	400 North 5 th Street P.O. Box 53999 Phoenix, AZ 85072-3999
Nancy C. Loftin	Senior Vice President, General Counsel and Secretary	400 North 5 th Street P.O. Box 53999 Phoenix, AZ 85072-3999
William J. Post	Chairman of the Board	400 North 5 th Street P.O. Box 53999 Phoenix, AZ 85072-3999
Donald G. Robinson	Senior Vice President, Planning and Administration	400 North 5 th Street P.O. Box 53999 Phoenix, AZ 85072-3999
Steven M. Wheeler	Executive Vice President, Customer Service and Regulation	400 North 5 th Street P.O. Box 53999 Phoenix, AZ 85072-3999

Salt River Project Agricultural Improvement and Power District Board of Directors	
Name	Address
Larry D. Rovey	P.O. Box 52025 Phoenix, AZ 85072-2025
Arthur L Freeman	P.O. Box 52025 Phoenix, AZ 85072-2025
Mario J. Herrera	P.O. Box 52025 Phoenix, AZ 85072-2025
Lloyd E. Banning	P.O. Box 52025 Phoenix, AZ 85072-2025
Carl E. Weiler	P.O. Box 52025 Phoenix, AZ 85072-2025
Jack M. White Jr.	P.O. Box 52025 Phoenix, AZ 85072-2025
Keith B. Woods	P.O. Box 52025 Phoenix, AZ 85072-2025
Deborah S. Hendrickson	P.O. Box 52025 Phoenix, AZ 85072-2025
Dwayne E. Dobson	P.O. Box 52025 Phoenix, AZ 85072-2025
Carolyn Pendergast	P.O. Box 52025 Phoenix, AZ 85072-2025
William W. Arnett	P.O. Box 52025 Phoenix, AZ 85072-2025
Fred J. Ash	P.O. Box 52025 Phoenix, AZ 85072-2025

Section 1
ADMINISTRATIVE INFORMATION

Salt River Project Agricultural Improvement and Power District Board of Directors	
Name	Address
Wendy L. Marshall	P.O. Box 52025 Phoenix, AZ 85072-2025

**Section 1
ADMINISTRATIVE INFORMATION**

Salt River Project Agricultural Improvement and Power District Officers		
Name	Title	Address
John M. Williams Jr.	President	P.O. Box 52025 Phoenix, AZ 85072-2025
David Rousseau	Vice President	P.O. Box 52025 Phoenix, AZ 85072-2025
Terrill A. Lonon	Corporate Secretary	P.O. Box 52025 Phoenix, AZ 85072-2025
Steven J. Hulet	Corporate Treasurer	P.O. Box 52025 Phoenix, AZ 85072-2025

Southern California Edison Board of Directors	
Name	Address
Alan J. Fohrer	2244 Walnut Grove Avenue Rosemead, CA 91770
John E. Bryson	2244 Walnut Grove Avenue Rosemead, CA 91770
Vanessa C.L. Chang	136 North Irvine Boulevard Los Angeles, CA 90004
France A. Córdova	Hovde Hall, 610 Purdue Mall West Lafayette, IN 47907-2040
Charles B. Curtis	1747 Pennsylvania Ave, N.W., 7th Flr. Washington, DC 20006
Bradford M. Freeman	11100 Santa Monica Blvd, Ste 1900 Los Angeles, CA 90025
Luis G. Nogales	9229 West Sunset Blvd, Ste 900 Los Angeles, CA 90069
Ronald L. Olson	355 South Grand Ave, 35th Floor Los Angeles, CA 90071
James M. Rosser	5151 State University Drive Los Angeles, CA 90032
Richard T. Schlosberg, III	9901 IH-10 West, Suite 800 San Antonio, TX 78230
Thomas C. Sutton	700 Newport Center Drive Newport Beach, CA 92660
Brett White	11150 Santa Monica Blvd, Suite 1600 Los Angeles, CA 90025

Section 1
ADMINISTRATIVE INFORMATION

Southern California Edison Officers		
Name	Title	Address
Alan J. Fohrer	Chairman of the Board and Chief Executive Officer	2244 Walnut Grove Avenue Rosemead, CA 91770
John R. Fielder	President	2244 Walnut Grove Avenue Rosemead, CA 91770
Polly L. Gault	Executive Vice President	2244 Walnut Grove Avenue Rosemead, CA 91770
Diane L. Featherstone	Senior Vice President	2244 Walnut Grove Avenue Rosemead, CA 91770
Bruce C. Foster	Senior Vice President	2244 Walnut Grove Avenue Rosemead, CA 91770
Cecil R. House	Senior Vice President	2244 Walnut Grove Avenue Rosemead, CA 91770
Thomas M. Noonan	Senior Vice President and Chief Financial Officer	2244 Walnut Grove Avenue Rosemead, CA 91770
Barbara J. Parsky	Senior Vice President	2244 Walnut Grove Avenue Rosemead, CA 91770
Stephen E. Pickett	Senior Vice President and General Counsel	2244 Walnut Grove Avenue Rosemead, CA 91770
Pedro J. Pizarro	Executive Vice President	2244 Walnut Grove Avenue Rosemead, CA 91770
Richard M. Rosenblum	Senior Vice President	2244 Walnut Grove Avenue Rosemead, CA 91770
Mahvash Yazdi	Senior Vice President and Chief Information Officer	2244 Walnut Grove Avenue Rosemead, CA 91770
Lynda L. Ziegler	Senior Vice President	2244 Walnut Grove Avenue Rosemead, CA 91770
Jeffrey L. Barnett	Vice President	2244 Walnut Grove Avenue Rosemead, CA 91770
Robert C. Boada	Vice President and Treasurer	2244 Walnut Grove Avenue Rosemead, CA 91770
Lisa D. Cagnolatti	Vice President	2244 Walnut Grove Avenue Rosemead, CA 91770
Kevin R. Cini	Vice President	2244 Walnut Grove Avenue Rosemead, CA 91770
Ann P. Cohn	Vice President and Associate General Counsel	2244 Walnut Grove Avenue Rosemead, CA 91770
Jodi M. Collins	Vice President	2244 Walnut Grove Avenue Rosemead, CA 91770
Paul J. De Martini	Vice President	2244 Walnut Grove Avenue Rosemead, CA 91770
Erwin G. Furukawa	Vice President	2244 Walnut Grove Avenue Rosemead, CA 91770

**Section 1
ADMINISTRATIVE INFORMATION**

Southern California Edison Officers		
Name	Title	Address
Stuart R. Hemphill	Vice President	2244 Walnut Grove Avenue Rosemead, CA 91770
Harry B. Hutchison	Vice President	2244 Walnut Grove Avenue Rosemead, CA 91770
Akbar Jazayeri	Vice President	2244 Walnut Grove Avenue Rosemead, CA 91770
Walter J. Johnston	Vice President	2244 Walnut Grove Avenue Rosemead, CA 91770
James A. Kelly	Senior Vice President	2244 Walnut Grove Avenue Rosemead, CA 91770
Russell W. Krieger	Vice President	2244 Walnut Grove Avenue Rosemead, CA 91770
Barbara E. Mathews	Vice President, Associate General Counsel, Chief Governance Officer and Corporate Secretary	2244 Walnut Grove Avenue Rosemead, CA 91770
David ZL. Mead	Vice President	2244 Walnut Grove Avenue Rosemead, CA 91770
Kevin M. Payne	Vice President	2244 Walnut Grove Avenue Rosemead, CA 91770
Frank J. Quevedo	Vice President	2244 Walnut Grove Avenue Rosemead, CA 91770
James T. Reilly	Vice President	2244 Walnut Grove Avenue Rosemead, CA 91770
Ross T. Ridenoure	Vice President	2244 Walnut Grove Avenue Rosemead, CA 91770
Tommy Ross	Vice President	2244 Walnut Grove Avenue Rosemead, CA 91770
Megan E. Scott-Kakures	Vice President and General Auditor	2244 Walnut Grove Avenue Rosemead, CA 91770
Leslie E. Starck	Vice President	2244 Walnut Grove Avenue Rosemead, CA 91770
Kenneth S. Stewart	Vice President and Chief Ethics and Compliance Officer	2244 Walnut Grove Avenue Rosemead, CA 91770
Linda G. Sullivan	Vice President and Controller	2244 Walnut Grove Avenue Rosemead, CA 91770

Section 1
ADMINISTRATIVE INFORMATION

El Paso Electric Company. Board of Directors	
Name	Address
George W. Edwards, Jr.	100 N. Stanton Street El Paso, TX 79901
J. Robert Brown	100 N. Stanton Street El Paso, TX 79901
James W. Cicconi	100 N. Stanton Street El Paso, TX 79901
Ramiro Guzmán	100 N. Stanton Street El Paso, TX 79901
James W. Harris	100 N. Stanton Street El Paso, TX 79901
Gary R. Hedrick	100 N. Stanton Street El Paso, TX 79901
Kenneth R. Heitz	100 N. Stanton Street El Paso, TX 79901
Patricia Zangwill Holland-Branch	100 N. Stanton Street El Paso, TX 79901
Michael K. Parks	100 N. Stanton Street El Paso, TX 79901
Eric B. Siegel	100 N. Stanton Street El Paso, TX 79901
Stephen N. Wertheimer	100 N. Stanton Street El Paso, TX 79901
Charles A. Yamarone	100 N. Stanton Street El Paso, TX 79901

El Paso Electric Company Officers		
Name	Title	Address
David W. Stevens	Chief Executive Officer	100 N. Stanton Street El Paso, TX 79901
J. Frank Bates	President and Chief Operating Officer	100 N. Stanton Street El Paso, TX 79901
Steven T. Buraczyk	Vice President, Power Marketing and Fuels	100 N. Stanton Street El Paso, TX 79901
Steven P. Busser	Vice President, Treasurer & Chief Risk Officer	100 N. Stanton Street El Paso, TX 79901
David Carpenter	Vice President, Regulatory Services & Controller	100 N. Stanton Street El Paso, TX 79901
Robert C. Doyle	Vice President, New Mexico Affairs	100 N. Stanton Street El Paso, TX 79901
Richard G. Gonzalez	Vice President, Human Resources	100 N. Stanton Street El Paso, Texas 79901

Section 1
ADMINISTRATIVE INFORMATION

El Paso Electric Company Officers		
Name	Title	Address
Helen Knopp	Vice President, Public Affairs	100 N. Stanton Street El Paso, TX 79901
Kerry B. Lore	Vice President, Administration	100 N. Stanton Street El Paso, TX 79901
Rocky Miracle	Vice President, Corporate Planning	100 N. Stanton Street El Paso, TX 79901
Hector R. Puente	Vice President, Transmission & Distribution	100 N. Stanton Street El Paso, TX 79901
Andy Ramirez	Vice President, Power Generation	100 N. Stanton Street El Paso, TX 79901
Gary D. Sanders	Senior Vice President and General Counsel	100 N. Stanton Street El Paso, TX 79901
Guillermo Silva, Jr.	Corporate Secretary	100 N. Stanton Street El Paso, TX 79901
John A. Whitacre	Vice President, System Operations & Planning	100 N. Stanton Street El Paso, TX 79901
Scott D. Wilson	Executive Vice President, Chief Financial & Administrative Officer	100 N. Stanton Street El Paso, TX 79901

Public Service Company of New Mexico. Board of Directors	
Name	Address
Jeffry E. Sterba	Alvarado Square, MS 2824 Albuquerque, NM 87158
Alice A. Cobb	Alvarado Square, MS 2810 Albuquerque, NM 87158
Patricia K. Collawn	Alvarado Square, MS 2826 Albuquerque, NM 87158
Charles N. Eldred	Alvarado Square, MS 2818 Albuquerque, NM 87158
E. James Ferland	Alvarado Square, MS 2826 Albuquerque, NM 87158
Cindy E. McGill	Alvarado Square, MS 2812 Albuquerque, NM 87158

Section 1
ADMINISTRATIVE INFORMATION

Public Service Company of New Mexico Officers		
Name	Title	Address
Jeffry E. Sterba	Chairman, President and CEO	Alvarado Square, MS 2824 Albuquerque, NM 87158
Charles N. Eldred	Executive Vice President & CFO	Alvarado Square, MS 2818 Albuquerque, NM 87158
Alice A. Cobb	Senior Vice President & CAO	Alvarado Square, MS 2810 Albuquerque, NM 87158
Cindy E. McGill	Senior Vice President, Public Policy & Strategy	Alvarado Square, MS 2812 Albuquerque, NM 87158
Patrick T. Ortiz	Senior Vice President, General Counsel and Secretary	Alvarado Square, MS 2822 Albuquerque, NM 87158
E. James Ferland	Senior Vice President, Utility Operations	Alvarado Square, MS 2826 Albuquerque, NM 87158
Patricia K. Collawn	President, Utilities	Alvarado Square, MS 2826 Albuquerque, NM 87158
Thomas G. Sategna	Vice President and Corporate Controller	Alvarado Square, MS 2701 Albuquerque, NM 87158
Terry R. Horn	Vice President & Treasurer	Alvarado Square, MS 2702 Albuquerque, NM 87158
Ernie C'deBaca	Vice President, Governmental Affairs	Alvarado Square, MS 1112 Albuquerque, NM 87158
Joel K. Ivy	Vice President, New Mexico Operations	4201 Edith Blvd. NE, MS-ES24 Albuquerque, NM 87107
John H. Myers	Vice President, Power Production	2401 Aztec Rd. NE, MS- Z110 Albuquerque, NM 87107
Melvin J. Christopher	Vice President, Regulatory Policy	Alvarado Square, MS 0920 Albuquerque, NM 87158
Thomas J. Olesen	Vice President, Supply Chain	4201 Edith Blvd. NE, MS-ES22 Albuquerque, NM 87107
Eddie Padilla, Jr.	Vice President, Utility Services	4201 Edith Blvd. NE, MS-GS66 Albuquerque, NM 87107

Section 1
ADMINISTRATIVE INFORMATION

Southern California Public Power Authority Board of Directors	
Name	Address
Marcie L. Edwards	Anaheim Public Utilities Department 201 South Anaheim Bl. Anaheim, CA 92805
Joseph F. Hsu	City of Azusa Light & Water 729 North Azusa Avenue Azusa, CA 91702
James D. Earhart	City of Banning 176 East Lincoln Banning, CA 92220
Ronald E. Davis	Burbank Water and Power 164 West Magnolia Bl. Burbank, CA 91502
Art Gallucci	City of Cerritos 18125 Bloomfield Avenue Cerritos, CA 90703
Jeannette Olko	City of Colton 850 North La Cadena Drive Colton, CA 92324
Glenn Steiger	Glendale Water and Power 141 North Glendale Avenue Glendale, CA 91206
Mario Escalera	Imperial Irrigation District 333 East Baroni Bl. Imperial, CA 92251
H. David Nahai	Los Angeles Department of Water & Power 111 North Hope Street Los Angeles, CA 90051
Phyllis E. Currie	Pasadena Water and Power 150 South Los Robles Avenue, Suite 200 Pasadena, CA 91101
David H. Wright	Riverside Public Utilities Department 3900 Main Street Riverside, CA 92522
Donal O'Callaghan	City of Vernon 4305 Santa Fe Avenue Vernon, CA 90058

Section 1
ADMINISTRATIVE INFORMATION

Southern California Public Power Authority Officers		
Name	Title	Address
David H. Wright	President	Public Utilities Director Riverside Public Utilities Department 3900 Main Street Riverside, CA 92522
Marcie L. Edwards	Vice President	General Manager Anaheim Public Utilities Department 201 South Anaheim Bl. Anaheim, CA 92805
(Vacant)	Secretary	Chief Financial Officer Los Angeles Department of Water & Power 111 North Hope Street Los Angeles, CA 90051
Bill D. Carnahan	Executive Director, Treasurer, Auditor	225 South Lake Avenue, Suite 1250 Pasadena, CA 91101

Los Angeles Department of Water and Power Board of Commissioners	
Name	Address
Nick Patsaouras	111 North Hope Street Room 1555 Los Angeles, CA 90012
Edith Ramirez	111 North Hope Street Room 1555 Los Angeles, CA 90012
Lee Kanon Alpert	111 North Hope Street Room 1555 Los Angeles, CA 90012
Wally Knox	111 North Hope Street Room 1555 Los Angeles, CA 90012
Forescee Hogan-Rowles	111 North Hope Street Room 1555 Los Angeles, CA 90012

Los Angeles Department of Water and Power Officers		
Name	Title	Address
H. David Nahai	Chief Executive Office and General Manager	111 North Hope Street Room 1550 Los Angeles, CA 90012
Raman Raj	Chief Operating Officer	111 North Hope Street Room 1550 Los Angeles, CA 90012
Robert Rozanski	Chief Administrative Officer	111 North Hope Street Room 1550 Los Angeles, CA 90012
Aram Benyamin	Senior Assistant General Manager – Power System	111 North Hope Street Room 1550 Los Angeles, CA 90012
James McDaniel	Senior Assistant General Manager – Water System	111 North Hope Street Room 1550 Los Angeles, CA 90012
Ronald Vazquez	Chief Financial Officer	111 North Hope Street Room 1550 Los Angeles, CA 90012
Richard Brown	Senior Assistant City Attorney	111 North Hope Street Room 1550 Los Angeles, CA 90012

1.1.5 Class of Licenses, Use of the Facility, and Period of Time for Which the Licenses Is Sought

APS requests renewal of the Class 103 operating licenses for Palo Verde Nuclear Generating Station, Units 1, 2, and 3 (License Nos. NPF-41, NPF-51, and NPF-74) for a period of 20 years beyond the expirations of the current licenses which are at midnight on June 1, 2025 (Unit 1), April 24, 2026 (Unit 2), and November 25, 2027 (Unit 3).

Because the current licensing basis is carried forward with the possible exception of some aging issues, APS expects the form and content of the licenses to be generally the same as presently exists. APS, thus, requests similar extensions of specific licenses under 10 CFR 30, 40, and 70 that are contained in the current operating licenses.

1.1.6 Earliest and Latest Dates for Alterations, If Proposed

No physical plant alterations or modifications have been identified as necessary in order to implement the provisions of the application.

1.1.7 Restricted Data

With regard to the requirements of 10 CFR 54.17(f), this application does not contain any "Restricted Data," as that term is defined in the Atomic Energy Act of 1954, as amended, or other defense information, and it is not expected that any such information will become involved in these licensed activities.

In accordance with the requirements of 10 CFR 54.17(g), APS will not permit any individual to have access to, or any facility to possess restricted data or classified national security information until the individual and/or facility has been approved for such access under the provisions of 10 CFR 25 and/or 95.

1.1.8 Regulatory Agencies

Regulatory agencies with jurisdiction over rates and services for PVNGS are listed below:

Arizona Corporation Commission
1200 West Washington Ave.
Phoenix, AZ 85007

Federal Energy Regulatory Commission
San Francisco Regional Office
901 Market St.
Suite 350
San Francisco, CA 94103

Securities and Exchange Commission
Los Angeles Regional Office
5670 Wilshire Boulevard, 11th Floor
Los Angeles, CA 90036-3648

1.1.9 Local News Publications

News publications in circulation near PVNGS that are considered appropriate to give reasonable notice of the application are as follows:

The Arizona Republic
200 E. Van Buren St.
Phoenix, AZ 85004

1.1.10 Conforming Changes to Standard Indemnity Agreement

10 CFR 54.19(b) requires that License Renewal applications include, "...conforming changes to the standard indemnity agreement, 10 CFR 140.92, Appendix B, to account for the expiration term of the proposed renewed licenses". The current indemnity agreement for Palo Verde states in Article VII that the agreement shall terminate "at the time of expiration of that license specified in Item 3 of the Attachment to the agreement". Item 3 of the Attachment to the indemnity agreement, as amended, lists license numbers NPF-41, NPF-51, and NPF-74.

APS requests that conforming changes be made to the indemnity agreement, and/or the Attachment to the agreement, as required, to ensure that the indemnity agreement continues to apply during both the terms of the current licenses and the terms of the renewed licenses. APS understands that no changes may be necessary for this purpose if the current license numbers are retained.

1.2 GENERAL LICENSE INFORMATION

1.2.1 Application Updates, Renewed Licenses, and Renewal Term Operation

In accordance with 10 CFR 54.21(b), during NRC review of this application, an annual update to the application to reflect any change to the current licensing basis that materially affects the contents of the license renewal application will be provided.

In accordance with 10 CFR 54.21(d), APS will maintain a summary list in the PVNGS Updated Final Safety Analysis Report (UFSAR) of activities that are required to manage the effects of aging for the systems, structures or components in the scope of license renewal during the period of extended operation and summaries of the time-limited aging analyses evaluations.

1.2.2 Contact Information

Any notices, questions, or correspondence in connection with this filing should be directed to:

Mr. Randall K. Edington
Executive Vice President Nuclear and Chief Nuclear Officer
Palo Verde Nuclear Generating Station
Mail Station 7602
P.O. Box 52034
Phoenix, AZ 85072-2034

with copies to:

Mr. Scott Bauer
Director, Regulatory Affairs
Palo Verde Nuclear Generating Station
Mail Station 7636
P.O. Box 52034
Phoenix, AZ 85072-2034

Mr. Dwight C. Mims
Vice President, Regulatory Affairs and Plant Improvement
Palo Verde Nuclear Generating Station
Mail Station 7605
P.O. Box 52034
Phoenix, AZ 85072-2034

Section 1
ADMINISTRATIVE INFORMATION

Mr. Richard F. Schaller, PE
License Renewal Project Manager
1626 North Litchfield Road
Suite 230
Goodyear, AZ 85395

1.3 PURPOSE

This document provides information required by 10 CFR 54 to support the application for renewed licenses for PVNGS. The application contains technical information required by 10 CFR 54.21, technical specification changes required by 10 CFR 54.22 (no changes are requested), and environmental information required by 10 CFR 54.23. The information contained herein is intended to provide the NRC with an adequate basis to make the findings required by 10 CFR 54.29.

1.4 DESCRIPTION OF THE PLANT

PVNGS is located on a site situated in Section 34 and portions of Sections 26, 27, 28, 33, and 35 in Township One North, Range Six West of the Gila and Salt River Base and Meridian, and Section 3 and portions of Sections 2, 4, 9, and 10 in Township One South, Range Six West of the Gila and Salt River Base and Meridian, Maricopa County, Arizona.

This location is approximately 26 miles west of the nearest boundary of the Phoenix metropolitan area. The nearest population is the Phoenix metropolitan area which includes the following major cities: Tempe, Glendale, Peoria, Scottsdale, and Sun City. The small town of Buckeye is approximately 16 miles to the east.

PVNGS is a three-unit nuclear-powered steam electric generating facility that began commercial operation between January 1986 (Unit 1) and January 1988 (Unit 3). The nuclear reactor for each unit is a Combustion Engineering System 80 pressurized water reactor (PWR) producing a reactor core power of 3,990 megawatts-thermal (MWt). The nominal net electrical capacity is 1,346 megawatts-electric (MWe).

The containment for each unit is a single containment system consisting of a steel-lined, prestressed concrete, cylindrical structure, with a hemispherical dome.

1.5 APPLICATION STRUCTURE

This license renewal application is structured in accordance with Regulatory Guide 1.188, “Standard Format and Content for Applications to Renew Nuclear Plant Operating Licenses,” and NEI 95-10, “Industry Guideline on Implementing the Requirements of 10 CFR 54 - The License Renewal Rule”, Revision 6. In addition, [Section 3](#), “Aging Management Review Results” and [Appendix B](#), “Aging Management Programs” are structured to address the guidance provided in NUREG-1800, “Standard Review Plan for the Review of License Renewal Applications for Nuclear Power Plants”. NUREG-1800 references NUREG-1801, “Generic Aging Lessons Learned (GALL) Report”. NUREG-1801 was used to determine the adequacy of existing aging management programs and which programs should be augmented for license renewal. The results of the aging management review, using NUREG-1801, have been documented and are illustrated in table format in [Chapter 3](#), “Aging Management Review Results” of this application.

PVNGS Unit 1, Unit 2, and Unit 3 are constructed of similar materials with similar environments. Unless otherwise noted throughout this application, plant systems and structures discussed in this application apply to PVNGS Units 1, 2 and 3.

The application is divided into the following major chapters:

Chapter 1 – Administrative Information

This Chapter provides the administrative information required by 10 CFR 54.17 and 10 CFR 54.19. It describes the plant and states the purpose for this application. Included in this Chapter are the names, addresses, business descriptions, and organization and management descriptions of the applicant, as well as other administrative information. This Chapter also provides an overview of the structure of the application, and a listing of acronyms and general references used throughout the application.

Chapter 2 – Scoping and Screening Methodology for Identifying Structures and Components Subject to Aging Management Review and Implementation Results

This Chapter describes and justifies the methods used in the integrated plant assessment to identify those structures and components subject to an aging management review in accordance with the requirements of 10 CFR 54.21(a)(2). These methods consist of: 1) scoping, which identifies the systems, structures, and components that are within the scope of 10 CFR 54.4(a), and 2) screening under 10 CFR 54.21(a)(1), which identifies those in-scope structures and components that perform their intended function without moving parts or a change in configuration or properties, and that are not subject to replacement based on a qualified life or specified time period.

Additionally, the scoping results for systems and structures are described in this Chapter. Scoping results are presented in [Section 2.2](#), [Table 2.2-1](#), “PVNGS Scoping Results”. Screening results are presented in [Sections 2.3](#), [2.4](#), and [2.5](#).

The screening results consist of lists of component types that require aging management review. Brief descriptions of mechanical systems and structures within the scope of license renewal are provided as background information. For each in-scope system and structure, component types requiring an aging management review are identified, associated component intended functions are identified, and appropriate reference to the [Chapter 3](#) Table reference providing the aging management review results is made.

Selected structural and electrical component types, such as component supports and cables, were evaluated as commodities. Under the commodity approach, selected structural and electrical component types were evaluated based upon common environments and materials. For each of these commodities, the component types requiring aging management are presented in [Sections 2.4](#) and [2.5](#).

Chapter 3 – Aging Management Review Results

10 CFR 54.21(a)(3) requires a demonstration that the effects of aging will be adequately managed so that the intended functions will be maintained consistent with the current licensing basis throughout the period of extended operation. [Chapter 3](#) presents the results of the aging management reviews. [Chapter 3](#) is the link between the scoping and screening results provided in [Chapter 2](#) and the aging management activities provided in [Appendix B](#).

Aging management review results are presented in tabular form, in a format in accordance with NUREG-1800, “*Standard Review Plan for Review of License Renewal Applications for Nuclear Power Plants*”. For mechanical systems, aging management review results are provided in [Sections 3.1](#) through [3.4](#) for the reactor vessel, internals, and reactor coolant system, engineered safety features, auxiliary systems, and steam and power conversion system. Aging management review results for containments, structures, and component supports are provided in [Section 3.5](#). Aging management review results for electrical and instrumentation and controls are provided in [Section 3.6](#).

Chapter 4 – Time-Limited Aging Analyses

Time-limited aging analyses (TLAAs), as defined by 10 CFR 54.3, are listed in this section. This section includes each of the TLAAs identified in NUREG-1800 and in plant-specific analyses. This Chapter includes a summary of the time-dependent aspects of the analyses. A demonstration is provided to show that: 1) each of the analyses remains valid for the period of extended operation, 2) the analyses have been projected to the end of the period of extended operation, or 3) the effects of aging on the intended function(s) will be adequately managed for the period of extended operation.

Appendix A – Updated Final Safety Analysis Report Supplement

As required by 10 CFR 54.21(d), the Updated Final Safety Analysis Report (UFSAR) supplement contains a summary of activities credited for managing the effects of aging for the period of extended operation. In addition, summary descriptions and dispositions of time-limited aging analyses evaluations and a summary of license renewal commitments are provided.

Appendix B – Aging Management Programs

[Appendix B](#) describes the programs and activities that are credited for managing aging effects for components or structures during the period of extended operation based upon the aging management review results provided in [Chapter 3](#) and the time-limited aging analyses results provided in [Chapter 4](#).

Appendix C – Commodity Groups (Optional)

Appendix C is not used.

Appendix D – Technical Specification Changes

This Appendix satisfies the requirements of 10 CFR 54.22 to identify whether any technical specification changes or additions are necessary to manage the effects of aging during the period of extended operation. No technical specification changes are requested.

Appendix E – Environmental Information

This Appendix satisfies the requirements of 10 CFR 54.23 to provide a supplement to the environmental report that complies with the requirements of subpart A of 10 CFR 51 for PVNGS.

1.6 ACRONYMS

Acronym	Meaning
AC	Alternating current
AFU	Air filtration unit
AHU	Air handling unit
AMR	Aging management review
APS	Arizona Public Service Company
ART	Adjusted reference temperature
ASME	American Society of Mechanical Engineers
ATWS	Anticipated transients without scram
BOP	Balance of plant
BWR	Boiling water reactor
CAS	Compressed air system
CBF	Cycle based fatigue
CCCW	Closed-cycle cooling water
CRDRs	Condition Reporting/Disposition Requests
CE	Combustion Engineering, also ABB/CE
CESSAR	Combustion Engineering System 80 Standard Safety Analysis Report
CEA	Control element assembly
CED(M)	Control element drive (mechanism)
CEOG	Combustion Engineering Owners Group
CIAS	Containment isolation actuation signal
CLB	Current licensing basis
CLC	Cold leg corner
CPIAS	Containment purge isolation activation signal
CORs	Component observations reports
CST	Condensate storage tank
CUF	Cumulative usage factor
CVCS	Chemical volume and control system
DBA (E)	Design basis accident (event)
ECT	Eddy current testing
ECWS	Essential chilled water system

Section 1
ADMINISTRATIVE INFORMATION

Acronym	Meaning
EDG	Emergency diesel generator
EFPY	Effective full power year
EHC	Electrohydraulic control
EOL	End of life
EQ	Environmental qualification
EQL	Equipment qualification list
ESF	Engineered safety features
ESP	Essential spray pond
ESFAS	Engineered safety feature actuation signal
GSI	Generic Safety Issue
HAZ	Heat affected zone
HELB	High energy line break
HPSI	High pressure safety injection
HVAC	Heating, ventilation, and air conditioning
I & C	Instrument and controls
IGSCC	Intergranular stress corrosion cracking
ILRT	Integrated leakage rate test
IPA	Integrated plant assessment
ISG	Interim staff guidance
ISI	Inservice inspection
LBB	Leak before break
LEFM	Linear elastic fracture mechanics
LOCA	Loss of coolant accident
LOOP	Loss of offsite power
LLRT	Local leak rate test
LPSI	Low pressure safety injection
LRA	License renewal application
LTOP	Low-temperature overpressure protection
MCC	Motor control center
MEB	Metal enclosed bus
MIC	Microbiologically influenced corrosion
MNSA	Mechanical nozzle seal assembly
MRVs	Minimum required values

Section 1
ADMINISTRATIVE INFORMATION

Acronym	Meaning
MSIP	Mechanical stress improvement process
MSIV	Main steam isolation valve
MSLB	Main steam line break
MWe	Megawatt electric
MWt	Megawatt thermal
NDE	Non-destructive examination
NEI	Nuclear Energy Institute
NFPA	National Fire Protection Association
NRC	Nuclear Regulatory Commission
NPP	Nuclear power plant
NSSS	Nuclear steam supply system
OBE	Operating basis earthquake
P&ID	Piping and instrumentation diagram
PI	Project instruction
PLL	Predicted lower limit
PTS	Pressurized thermal shock
PUR	Power uprate
PVNGS	Palo Verde Nuclear Generating Station
PWR	Pressurized water reactor
PWSCC	Primary water stress corrosion cracking
PZR	pressurizer
RCP	Reactor coolant pump
RCS	Reactor coolant system
RI-ISI	Risk-informed inservice inspection
RSG	Replacement steam generator
RMWT	Reactor makeup water tank
RPV	Reactor pressure vessel
RVI	Reactor vessel and internals
RWT	Refueling water tank
SBF	Stress based fatigue
SBO	Station blackout
SBOG	Station blackout generator (system)
SCC	Stress corrosion cracking

Section 1
ADMINISTRATIVE INFORMATION

Acronym	Meaning
SER	Safety evaluation report
SG	Steam generator
SIAS	Safety injection actuation signal
SRP	Standard Review Plan
SSCs	Systems, structures, and components
SSE	Safe shutdown earthquake
SSR	Sub-synchronous resonance
TLAAs	Time-limited aging analyses
UHS	Ultimate heat sink
UFSAR	Updated Final Safety Analysis Report
USE	Upper shelf energy
WRF	Water reclamation facility
WRSS	Water reclamation supply system

1.7 GENERAL REFERENCES

1. 10 CFR 54, "*Requirements for Renewal of Operating Licenses for Nuclear Power Plants*"
2. NEI 95-10, "*Industry Guideline for Implementing the Requirements of 10 CFR Part 54 - The License Renewal Rule*," Revision 6
3. Regulatory Guide 1.188, "*Standard Format and Content for Applications to Renew Nuclear Power Plant Operating Licenses*," Revision 1, September 2005
4. NUREG-1800, "*Standard Review Plan for Review of License Renewal Applications for Nuclear Power Plants*," United States Nuclear Regulatory Commission, Revision 1 – September 2005
5. NUREG-1801, "*Generic Aging Lessons Learned (GALL) Report*," United States Nuclear Regulatory Commission, Revision 1 – September 2005
6. 10 CFR 50.48, "*Fire Protection*"
7. 10 CFR 50.49, "*Environmental Qualification of Electric Equipment Important to Safety for Nuclear Power Plants*"
8. 10 CFR 50.62, "*Requirements for Reduction of Risk from Anticipated Transients Without Scram (ATWS) Events for Light-Water-Cooled Nuclear Power Plants*"
9. 10 CFR 50.63, "*Loss of All Alternating Current Power*"
10. 10 CFR 50.65, "*Requirements for Monitoring the Effectiveness of Maintenance at Nuclear Power Plants*"
11. 10 CFR 50, Appendix B, "*Quality Assurance Criteria for Nuclear Power Plants and Fuel Reprocessing Plants*"
12. 10 CFR 51, "*Environmental Protection Regulations for Domestic Licensing and Related Regulatory Functions*"

This Page Intentionally Left Blank

CHAPTER 2

SCOPING AND SCREENING METHODOLOGY FOR IDENTIFYING STRUCTURES AND COMPONENTS SUBJECT TO AGING MANAGEMENT REVIEW AND IMPLEMENTATION RESULTS

This Page Intentionally Left Blank

2.0 SCOPING AND SCREENING METHODOLOGY FOR IDENTIFYING STRUCTURES AND COMPONENTS SUBJECT TO AGING MANAGEMENT REVIEW AND IMPLEMENTATION RESULTS

Chapter 2 provides the following information that is required by 10 CFR 54, the license renewal rule, and described in NUREG-1800, “*Standard Review Plan (SRP) for Review of License Renewal Applications for Nuclear Power Plants*”:

- Scoping and Screening Methodology ([Section 2.1](#))
- Plant-Level Scoping Results ([Section 2.2](#))
- Scoping and Screening Results: Mechanical Systems ([Section 2.3](#))
- Scoping and Screening Results: Structures ([Section 2.4](#))
- Scoping and Screening Results: Electrical and Instrumentation and Controls Systems ([Section 2.5](#))

2.1 SCOPING AND SCREENING METHODOLOGY

For systems, structures and components (SSCs) within the scope of license renewal, 10 CFR 54.21(a)(1) requires the license renewal applicant to identify and list the structures and components subject to an aging management review (AMR). 10 CFR 54.21(a)(2) further requires that the methods used to implement the requirements of 10 CFR 54.21(a)(1) be described and justified.

This section of the application provides a description and justification of the methodology used to identify and list structures and components at PVNGS that are within the scope of license renewal and subject to an AMR.

PVNGS Unit 1, Unit 2, and Unit 3 are constructed of similar materials with similar environments. Unless otherwise noted throughout this application, plant systems and structures discussed in this application apply to PVNGS Units 1, 2 and 3.

2.1.1 Introduction

The first step in the integrated plant assessment (IPA) process identified the plant SSCs within the scope of 10 CFR 54. This step is called scoping. For those SSCs identified to be within the scope of the license renewal rule, the second step of the IPA process then identified and listed the structures and components that are subject to an AMR. This step of the process is called screening.

Section 2.1 SCOPING AND SCREENING METHODOLOGY

The scoping and screening steps have been performed consistent with the requirements of 10 CFR 54, the Statements of Consideration supporting the license renewal rule, and the guidance provided in NEI 95-10, *"Industry Guideline for Implementing the Requirements of 10 CFR Part 54 - The License Renewal Rule"*. [Section 2.1.1.1](#) provides a discussion of the documentation used to perform scoping and screening.

[Section 2.1.2](#) discusses the application of the 10 CFR 54.4(a) scoping criteria. [Section 2.1.3](#) describes the scoping methodology. [Section 2.1.4](#) describes the screening methodology. The NRC staff's license renewal interim staff guidance (ISG) documents were considered as described in [Section 2.1.5](#). [Section 2.1.6](#) describes the evaluation of NRC Generic Safety Issues (GSI), and [Section 2.1.7](#) provides conclusions.

An overview of the Scoping and Screening Process is presented in [Figure 2.1-1](#), Scoping and Screening Process Flow.

2.1.1.1 Documentation Sources Used for Scoping and Screening

Various documentation sources were used during the scoping and screening process. These documentation sources are listed below and described in the following sections.

- Current licensing basis documents
- Engineering drawings
- License renewal position papers
- Plant equipment database

2.1.1.1.1 Current Licensing Basis Documents

The current licensing basis (CLB) is defined in 10 CFR 54.3. A variety of CLB documents were used to confirm or to determine additional SSC functions and evaluate them against the criteria of 10 CFR 54.4(a). These document types are:

- Palo Verde Nuclear Generating Station Updated Final Safety Analysis Report ([UFSAR](#)) was used as a source of CLB information for the plant.
- Safety Evaluation Reports (SERs) reflect the NRC Staff evaluation of plant SSC functional requirements, performance characteristics, and related regulatory commitments. SERs were reviewed, as needed, to obtain information relevant to scoping and screening.
- Technical specifications provide safety limits, limiting conditions for operation, and surveillance requirements applicable to plant SSCs whose functions are critical to nuclear safety. Technical specification bases provide discussions of SSC functional characteristics that underlie the limits and requirements. The technical specification

requirements and bases were reviewed to obtain additional information supporting the functional evaluation of SSCs.

- Licensing correspondence reflecting PVNGS commitments related to various SSCs and programs was reviewed.

2.1.1.1.2 Engineering Drawings

Engineering drawings that provide layout and configuration details were reviewed for systems and structures. This included electrical, mechanical, and structural drawings.

2.1.1.1.3 Technical Position Papers

Technical position papers were prepared as part of the preparation for the license renewal project to support scoping evaluations.

The following license renewal position papers were prepared and are discussed further in [Sections 2.1.2.2](#) and [2.1.2.3](#):

- Criterion (a)(2) License Renewal Position Paper
- Fire Protection License Renewal Position Paper
- Environmental Qualification License Renewal Position Paper
- Pressurized Thermal Shock License Renewal Position Paper
- Anticipated Transients Without Scram License Renewal Position Paper
- Station Blackout License Renewal Position Paper
- Electrical/I&C Plant Spaces Approach Position Paper
- Design Basis Events Position Paper
- Plant Systems and Aging Management Programs Position Paper
- Thermal Insulation License Renewal Position Paper

2.1.1.1.4 Plant Equipment Database

PVNGS maintains a plant equipment database. The plant equipment database provides the quality classification for each component.

2.1.2 Scoping Criteria

Systems, structures, and components which satisfy the criteria in 10 CFR 54.4(a)(1), (a)(2) or (a)(3) are within the scope of license renewal. Specifically, 10 CFR 54.4 states:

“(a) Plant systems, structures, and components within the scope of this part are-

(1) Safety-related systems, structures, and components which are those relied upon to remain functional during and following design-basis events (as defined in 10 CFR 50.49(b)(1)) to ensure the following functions-

(i) The integrity of the reactor coolant pressure boundary;

(ii) The capability to shut down the reactor and maintain it in a safe shutdown condition; or

(iii) The capability to prevent or mitigate the consequences of accidents which could result in potential offsite exposures comparable to those referred to in §50.34(a)(1), §50.67(b)(2), or §100.11 of this chapter, as applicable.

(2) All nonsafety-related systems, structures, and components whose failure could prevent satisfactory accomplishment of any of the functions identified in paragraphs (a)(1) (i), (ii), or (iii) of this section.

(3) All systems, structures, and components relied on in safety analyses or plant evaluations to perform a function that demonstrates compliance with the Commission’s regulations for fire protection (10 CFR 50.48), environmental qualification (10 CFR 50.49), pressurized thermal shock (10 CFR 50.61), anticipated transients without scram (10 CFR 50.62), and station blackout (10 CFR 50.63).

(b) The intended functions that these systems, structures, and components must be shown to fulfill in §54.21 are those functions that are the bases for including them within the scope of license renewal as specified in paragraphs (a)(1) – (3) of this section.”

The application of each of these criteria to plant SSCs is discussed in [Section 2.1.2.1](#), [Section 2.1.2.2](#), and [Section 2.1.2.3](#), respectively.

2.1.2.1 Title10 CFR 54.4(a)(1) – Safety-related

10 CFR 54.4(a)(1) requires that plant SSCs within the scope of license renewal include safety-related SSCs which are those relied upon to remain functional during and following design-basis events (as defined in 10 CFR 50.49(b)(1)) to ensure the following functions:

(i) The integrity of the reactor coolant pressure boundary;

(ii) The capability to shutdown the reactor and maintain it in a safe shutdown condition;

or,

(iii) The capability to prevent or mitigate the consequences of accidents that could result in potential offsite exposure comparable to the guidelines in 50.34(a)(1), 50.67(b)(2), or 100.11, as applicable.

PVNGS Safety-related Classifications

Safety-related classifications for systems and structures at PVNGS are reported in the UFSAR or in design basis documents such as engineering drawings, evaluations, or calculations. Safety-related classifications for components are documented on engineering drawings and in a plant equipment database. The safety-related classification as reported in these source documents has been relied upon to identify SSCs satisfying one or more of the criteria of 10 CFR 54.4(a)(1). These SSCs have been identified as within the scope of license renewal.

PVNGS [UFSAR Appendix 17.2C](#) “*Terms and Definitions*” defines safety-related (Q) as the equipment, systems, and structures that are relied upon to remain functional during and following design bases events to ensure:

- The integrity of the reactor coolant boundary
- The capability to shut down the reactor and maintain it in a safe condition
- The capability to prevent or mitigate the consequences of accident which could result in potential offsite exposures comparable to the guideline exposures of 10 CFR 100.

Design Basis Events

The PVNGS UFSAR and procedures governing safety-related classifications refer to “design basis events (DBEs)” while 10 CFR 54.4(a)(1) is more specific referring to design basis events as defined in 10 CFR 50.49(b)(1). DBEs are defined in 10 CFR 50.49(b)(1) as conditions of normal operation, including anticipated operational occurrences, design basis accidents, external events, and natural phenomena for which the plant must be designed to ensure the functions described under 10 CFR 54.4(a)(1). As part of the PVNGS scoping methodology, an additional Position Paper was prepared to confirm that all applicable design basis events were considered. The UFSAR identifies the design basis events for PVNGS.

PVNGS conducted a search for DBEs to be considered during the scoping process. UFSAR Chapters 6 and 15 are the main source of the PVNGS DBEs. Non-Chapter 15 events included natural phenomena and external events described in Chapter 2, and design basis events, natural phenomena, and external events associated with the design of structures in Chapter 3. DBEs were also identified within other UFSAR chapters. The PVNGS UFSAR review identified the set of DBEs and confirmed that the PVNGS license renewal process had evaluated the associated SSCs consistent with the criteria of the Rule.

Exposure Guidelines

The exposure guidelines used for PVNGS license renewal are the same as 10 CFR 54.4 with the exception of the guidelines cited for off-site exposures. In addition to the guidelines of 10 CFR 100, 10 CFR 54.4(a)(1)(iii) references the dose guidelines of 10 CFR 50.34(a)(1) and 10 CFR 50.67(b)(2). These different exposure guidelines appear in three different Code sections to address similar accident analyses performed by licensees for different reasons. The guidelines of 10 CFR 50.34(a)(1) are applicable to facilities seeking a construction permit, and are therefore not applicable to PVNGS license renewal. The exposure guidelines of 10 CFR 50.67(b)(2) address the use of alternate source terms, which are not applicable under the PVNGS CLB. Therefore, use of the PVNGS safety-related classification designators are consistent with 10 CFR 54.4(a)(1) scoping criteria.

2.1.2.2 Title 10 CFR 54.4(a)(2) – Nonsafety-Related Affecting Safety-Related

10 CFR 54.4(a)(2) requires that plant SSCs within the scope of license renewal include all nonsafety-related SSCs whose failure could prevent satisfactory accomplishment of any of the functions identified for safety-related SSCs. The guidance provided in NEI 95-10, Appendix F was used to develop the methodology for scoping to the criterion of 10 CFR 54.4(a)(2).

The methodology includes identification of nonsafety-related SSCs that are connected to safety-related SSCs and nonsafety-related SSCs that could spatially interact with safety-related SSCs. Determination and identification of any other SSCs satisfying criterion 10 CFR 54.4(a)(2) was completed as described below based on review of applicable CLB documents, plant specific and industry operating experience, and by system and structure functional evaluations.

Functional Support for Safety-Related SSCs 10 CFR 54(a)(1) functions

The PVNGS UFSAR and other current licensing basis documents were reviewed for every nonsafety-related plant system or structure, to determine whether the system or structure was credited with supporting satisfactory accomplishment of a safety-related function. Nonsafety-related systems or structures credited in CLB documents with supporting accomplishment of a safety-related function were classified as satisfying criterion 10 CFR 54.4(a)(2) and were included within the scope of license renewal.

Nonsafety-Related SSCs Directly Connected to Safety-Related SSCs

Nonsafety-related SSCs were included within the scope of license renewal, as applicable, up to the first seismic anchor past the safety/nonsafety interface for those nonsafety-related mechanical SSCs that are connected to a safety-related SSC and must provide structural integrity. In most cases, an actual seismic anchor exists to serve as the boundary for the nonsafety structural integrity feature. In cases where seismic anchors were not available to serve as the license renewal boundary, other methods as provided for in NEI 95-10,

Section 2.1 SCOPING AND SCREENING METHODOLOGY

including equivalent anchors were utilized to establish the license renewal boundary. Other methods included:

- A combination of restraints or supports such that the nonsafety-related piping and associated structures and components attached to safety-related piping is included in-scope up to a boundary point that encompasses two (2) supports in each of three (3) orthogonal directions.
- A base-mounted component (e.g., pump, heat exchanger, tank, etc). that is a rugged component and is designed not to impose loads on connecting piping is included in-scope as it has a support function for the safety-related piping.
- A flexible connection that is considered a pipe stress analysis model end point when the flexible connection effectively decouples the piping system (i.e. does not support loads or transfer loads across it to connected piping).
- A free end of nonsafety-related piping, such as a drain pipe that ends at an open floor drain.
- A point where buried piping exits the ground. The buried portion of the piping should be included in the scope of license renewal. A determination that the buried piping is well founded on compacted soil that is not susceptible to liquefaction must be documented.
- Nonsafety-related piping runs that are connected at both ends to safety-related piping include the entire run of nonsafety-related piping.

Nonsafety-Related SSCs with Spatial Interaction with Safety-Related SSCs

Nonsafety-related SSCs which are not connected to safety-related piping and/or which are not required for structural integrity, but have a spatial relationship such that their failure could adversely impact the performance of a safety-related SSC intended function, were included in the scope of license renewal per NEI 95-10, Appendix F. PVNGS applied the preventative option for 10 CFR 54.4(a)(2) scoping.

The preventative option as implemented at PVNGS is based on a “spaces” approach for scoping of nonsafety-related systems with potential spatial interaction with safety-related SSCs. Potential spatial interaction is assumed in any structure that contains active or passive safety-related SSCs. The structures of concern for potential spatial interaction were identified based on the review of the CLB to determine which structures contained safety-related SSCs. Plant walkdowns were performed as required to confirm that all structures containing safety-related SSCs had been identified.

For structures that contain safety-related SSCs, there may be selected rooms within the structure that do not contain any safety-related SSCs. CLB document reviews and plant

Section 2.1
SCOPING AND SCREENING METHODOLOGY

walkdowns were utilized as appropriate to confirm that these rooms did not contain safety-related SSCs, thereby eliminating spatial interactions concerns from these rooms.

Nonsafety-related systems and components that contain water, oil, or steam, and are located inside structures that contain safety-related SSCs are included in-scope for potential spatial interaction under criterion 10 CFR 54.4(a)(2), unless located in an excluded room. All high-energy lines located inside primary containment are included within the scope of license renewal. High-energy lines located outside primary containment are included within the scope of license renewal if their failure could adversely impact any safety-related SSC's. Safety-related high-energy lines are in-scope under 10 CFR 54.4(a)(1), and nonsafety-related high-energy lines are in-scope under 10 CFR 54.4(a)(2). The potential effects of flooding as a consequence of a pipe break or critical crack were analyzed on a case-by-case basis to ensure that the operability of safety-related equipment would not be impaired. Floor drains and curbs required for flood mitigation are within the scope of license renewal under 10 CFR 54.4(a)(2). System piping and components containing steam below atmospheric pressure, i.e., under vacuum conditions, do not pose a potential spray hazard and are therefore not included in the scope of license renewal for potential spatial interaction with safety-related components. Supports for all nonsafety-related SSCs within these structures are included within the scope of license renewal.

Air and gas systems (non-liquid) are not a hazard to other plant equipment, and have been determined not to have spatial interactions with safety-related SSCs. PVNGS and industry operating experience has not identified failures due to aging that have adversely impacted the accomplishment of a safety function. SSCs containing air or gas cannot adversely affect safety-related SSCs due to leakage or spray, since gas systems contain no fluids that could spray or leak onto safety-related systems causing shorts or other malfunctions. Gas systems do not contain sufficient energy to cause pipe whip or jet impingement. The nonsafety-related systems containing air or gas (except portions attached to safety-related SSCs and required for structural support) are not included in the scope of license renewal for 10 CFR 54.4(a)(2). The supports are included in-scope to prevent the nonsafety-related piping from falling down and potentially impacting safety-related SSCs.

2.1.2.3 Title 10 CFR 54.4(a)(3) – Regulated Events

10 CFR 54.4(a)(3) requires that plant SSCs within the scope of license renewal include all SSCs relied on in safety analyses or plant evaluations to perform a function that demonstrates compliance with the regulations for fire protection (10 CFR 50.48), environmental qualification (10 CFR 50.49), pressurized thermal shock (10 CFR 50.61), anticipated transients without scram (10 CFR 50.62), and station blackout (10 CFR 50.63).

Position papers were prepared to provide input to the SSC scoping process. The purpose of these position papers was to evaluate the PVNGS CLB relative to the regulated events, identify the systems and structures that are relied upon to demonstrate compliance with each of these regulations, and document the results of this review. Guidance provided by the position papers was used during system and structure scoping to identify system and

Section 2.1
SCOPING AND SCREENING METHODOLOGY

structure intended functions for Criterion (a)(3), and again during component scoping as necessary to determine which components are credited in the regulated events. SSCs credited in the regulated events have been classified as satisfying criterion 10 CFR 54.4(a)(3) and have been identified as within the scope of license renewal.

2.1.2.3.1 Fire Protection

Criterion 10 CFR 54.4(a)(3) requires that plant SSCs within the scope of license renewal include all SSCs relied on in safety analyses or plant evaluations to perform a function that demonstrates compliance with the regulations for fire protection (10 CFR 50.48). 10 CFR 50.48 requires each operating nuclear power plant to have a fire protection plan that satisfies the requirement of Criterion 3 of 10 CFR 50 Appendix A, and further requires all nuclear power plants licensed to operate prior to January 1, 1979, to comply with Sections III.G, III.J and III.O of Appendix R to 10 CFR 50.

The PVNGS Fire Protection Program licensing basis is based on Appendix A to Branch Technical Position (BTP) APCS 9.5-1, "*Guidelines for Fire Protection for Nuclear Power Plants Docketed Prior to July 1, 1976*" and 10 CFR 50, Appendix R, "*Fire Protection Program for Nuclear Power Facilities Operating Prior to January 1, 1979*".

The primary CLB document for PVNGS is [UFSAR Section 9.5.1](#), "Fire Protection System". [Appendices 9A](#) and [9B](#) of the UFSAR provide the fire hazards analysis and other information concerning the design and license bases, including comparisons to Appendix A to BTP APCS 9.5-1 and to 10 CFR 50 Appendix R. PVNGS Fire Hazards Analysis is presented in UFSAR [Appendix 9B.2](#). The Fire Hazards Analysis shows that redundant safety systems required to achieve and maintain hot standby and cold shutdown are adequately protected against fire damage.

The position paper summarizes the results of a detailed review performed on the fire protection program documents demonstrating compliance with the requirements of 10 CFR 50.48 for the plant. The position paper provides a list of systems and structures credited in the fire protection program documents.

All SSCs classified as satisfying criterion 10 CFR 54.4(a)(3) related to fire protection were identified as within the scope of license renewal.

2.1.2.3.2 Environmental Qualification

Criterion 10 CFR 54.4(a)(3) requires that plant SSCs within the scope of license renewal include all SSCs relied on in safety analyses or plant evaluations to perform a function that demonstrates compliance with the regulations for environmental qualification (10 CFR 50.49). The PVNGS environmental qualification (EQ) program applies to electrical equipment important to safety that is located in a harsh environment.

Section 2.1
SCOPING AND SCREENING METHODOLOGY

The [UFSAR Section 3.11](#) states that environmental design criteria for PVNGS conform to 10 CFR 50, Appendix A, General Design Criterion 4, “Environmental and Missile Design Bases”. The safety-related systems and components required to mitigate the consequences of a design basis accident (DBA), or to attain a safe shutdown of the reactor, are designed to remain functional during and after exposure to normal operation environmental conditions and following the specific DBA which they are intended to mitigate.

The environmental qualification position paper provides lists of systems that include EQ components.

All components within the scope of the PVNGS EQ program which demonstrate compliance with 10 CFR 50.49 and the systems containing those components were classified as satisfying criterion 10 CFR 54.4(a)(3) and were identified as within the scope of license renewal.

2.1.2.3.3 Pressurized Thermal Shock

Criterion 10 CFR 54.4(a)(3) requires that plant SSCs within the scope of license renewal include all SSCs relied on in safety analyses or plant evaluations to perform a function that demonstrates compliance with the regulations for pressurized thermal shock (10 CFR 50.61).

A position paper was developed to review the licensing basis for pressurized thermal shock at PVNGS. For PVNGS, the only component within the scope of the license renewal rule for pressurized thermal shock is the reactor pressure vessel.

The calculation of nil-ductility transition reference temperature RT_{PTS} is a time-limited aging analysis (TLAA) as defined by 10 CFR 54.3(a) and is addressed separately in [Chapter 4](#).

2.1.2.3.4 Anticipated Transients Without Scram

Criterion 10 CFR 54.4(a)(3) requires that plant SSCs within the scope of license renewal include all SSCs relied upon in safety analyses or plant evaluations to perform a function that demonstrates compliance with the regulations for anticipated transients without scram (10 CFR 50.62). An anticipated transient without scram (ATWS) is a postulated operational transient that generates an automatic scram signal accompanied by a failure of the reactor protection system to shutdown the reactor.

The ATWS Rule required improvements in the design to reduce the probability of failure to shutdown the reactor following anticipated transients, and to mitigate the consequences of an ATWS event. Each pressurized water reactor was required to have equipment from sensor output to final actuation device, which is diverse from the reactor trip system, to automatically initiate the auxiliary feedwater system and initiate a turbine trip under conditions indicative of ATWS. This equipment is designed to perform its function in a reliable manner and be independent (from sensor output to the final actuation device) from

Section 2.1
SCOPING AND SCREENING METHODOLOGY

the existing reactor trip system. Each Combustion Engineering (CE) pressurized water reactor was required to have a diverse scram system from the sensor output to interruption of power to the control rods. This scram system is designed to perform its function in a reliable manner and be independent from the existing reactor trip system (from sensor output to interruption of power to the control rods). The following equipment is required by the ATWS Rule for reduction of risk from an ATWS event at PVNGS:

- Supplementary protection system which includes the diverse scram system
- Diverse auxiliary feedwater actuation system
- Diverse turbine trip circuitry

ATWS equipment required by 10 CFR 50.62 for PVNGS compliance with the ATWS Rule is described in [UFSAR Sections 7.2.5](#) and [7.3.5](#).

All ATWS SSCs are within the scope of license renewal.

2.1.2.3.5 Station Blackout

Criterion 10 CFR 54.4(a)(3) requires that plant SSCs within the scope of license renewal include all SSCs relied on in safety analyses or plant evaluations to perform a function that demonstrates compliance with the regulations for station blackout (10 CFR 50.63).

The SBO rule (10 CFR 50.63) requires that nuclear power plants have the capability to withstand and recover from the loss of offsite and onsite AC power of a specified duration (the coping duration). Regulatory Guide 1.155 provides guidance on selecting the time period for which a licensee must cope with the SBO. PVNGS used RG 1.155 to calculate a plant-specific coping time period. A "sixteen hour" coping duration was determined for PVNGS based on expected frequency of loss of offsite power and the probable time needed for its restoration. Redundancy and reliability in onsite emergency AC power source (emergency diesel generators) was also factored in the evaluation.

Three startup transformers supply primary and backup offsite power to each of the PVNGS units. Startup transformer AE-NAN-X01 is connected to the switchyard through disconnects 920, 924, 926 and 927 which are connected to the switchyard via switchyard breakers 925 and 928. Startup transformer AR-NAN-X02 is connected to the switchyard through disconnects 940, 944, 946 and 947 which are connected to the switchyard via switchyard breakers 945 and 948. Startup transformer AE-NAN-X03 is connected to the switchyard through disconnects 990, 994, 996 and 997 which are connected to the switchyard via switchyard breakers 995 and 998. The startup transformers, the overhead transmission lines, the disconnects, the overhead lines from the disconnects to and including the switchyard breakers and the switchyard breaker control cables and connections are within the scope of license renewal.

The primary offsite power source for PVNGS Unit 1 13.8KV buses is from startup transformers AE-NAN-X03 and AE-NAN-X02 through disconnects AE-NAN-W03B and AE-NAN-W02A. Disconnects AE-NAN-W03B and AE-NAN-W02A, the overhead lines from the startup transformers to the disconnects and the overhead lines to and including the 13.8KV

Section 2.1 SCOPING AND SCREENING METHODOLOGY

buses are within the scope of license renewal. The backup offsite power source for PVNGS Unit 1 13.8KV buses is from startup transformer AE-NAN-X01 through disconnects AE-NAN-W01A and AE-NAN-W01B. Disconnects AE-NAN-W01A and AE-NAN-W01B, the overhead lines from the startup transformer to the disconnects and the overhead lines to and including the 13.8KV buses are within the scope of license renewal.

The primary offsite power source for PVNGS Unit 2 13.8KV buses is from startup transformers AE-NAN-X01 and AE-NAN-X03 through disconnects AE-NAN-W01B and AE-NAN-W03A. Disconnects AE-NAN-W01B and AE-NAN-W03A, the overhead lines from the startup transformers to the disconnects and the overhead lines to and including the 13.8KV buses are within the scope of license renewal. The backup offsite power source for PVNGS Unit 2 13.8KV buses is from startup transformer AE-NAN-X02 through disconnects AE-NAN-W02A and AE-NAN-W02B. Disconnects AE-NAN-W02A and AE-NAN-W02B, the overhead lines from the startup transformer to the disconnects and the overhead lines to and including the 13.8KV buses are within the scope of license renewal.

The primary offsite power source for PVNGS Unit 3 13.8KV buses is from startup transformers AE-NAN-X01 and AE-NAN-X02 through disconnects AE-NAN-W01A and AE-NAN-W02B. Disconnects AE-NAN-W01A and AE-NAN-W02B, the overhead lines from the startup transformers to the disconnects and the overhead lines to and including the 13.8KV buses are within the scope of license renewal. The backup offsite power source for PVNGS Unit 3 13.8KV buses is from startup transformer AE-NAN-X03 through disconnects AE-NAN-W03A and AE-NAN-W03B. Disconnects AE-NAN-W03A and AE-NAN-W03B, the overhead lines from the startup transformer to the disconnects and the overhead lines to and including the 13.8KV buses are within the scope of license renewal.

The SBO recovery path is identified on [Figure 2.1-2](#), "SBO Recovery Path".

A position paper was created to summarize the results of a detailed review of the SBO documentation for PVNGS. The PVNGS position paper identifies the SSCs credited with coping and recovering from a station blackout. The SSCs identified in the SBO position paper were used in scoping evaluations to identify SSCs that demonstrate compliance with 10 CFR 50.63.

All SSCs classified as satisfying criterion 10 CFR 54.4(a)(3) related to station blackout were identified as within the scope of license renewal.

2.1.3 Scoping Methodology

Scoping of the PVNGS SSCs was performed to the criteria of 10 CFR 54.4(a) to identify those SSCs within the scope of the license renewal rule. The PVNGS scoping evaluation results have been retained in the license renewal database. The following sections describe the methodology used for scoping. Separate discussions of mechanical system scoping methodology, structures scoping methodology, and electrical and I&C system scoping methodology are provided.

2.1.3.1 Mechanical System Scoping Methodology

A list of all mechanical systems was developed using the plant equipment database and system plant numbering procedure and is documented in the Plant Systems and Aging Management Programs Position Paper. These mechanical systems were evaluated to each of the criteria of 10 CFR 54.4(a). The list of mechanical systems and the results of the scoping process are provided in [Section 2.2](#).

For every mechanical system listed in [Table 2.2-1](#), “PVNGS Scoping Results,” the following scoping process was applied.

- Identification of the system purpose and functions
- Determination of the system evaluation boundary
- Comparison of system intended functions against criteria of 10 CFR 54.4(a)(1-3)
- Identification of supporting systems
- Creation of license renewal drawings
- Component level scoping
- Document scoping results and references

Identification of the System Purpose and Functions

A description was prepared for each mechanical system that included the purpose and summarized the functions that the system was designed to perform. This summary description was prepared using information obtained from the UFSAR system descriptions, current licensing basis documents, design basis documents (including P&IDs), and system operating descriptions.

Determination of the System Evaluation Boundary

After the system functions were identified, the system evaluation boundary was determined and marked-up on P&IDs. All of the components needed for the system to perform its intended functions are included within the license renewal boundary. Mechanical system P&IDs that show the system configuration, including component equipment identification numbers, were used to define the evaluation boundary of a system to support the scoping and screening evaluations of mechanical components. The system scoping summaries included in [Section 2.3](#) provide a description of the evaluation boundary for each mechanical system in the scope of the Rule.

The process to determine the system evaluation boundary required close examination of interfaces with other systems. System interfaces were closely evaluated to ensure that all components were included in the evaluation boundary of one of the interfacing systems.

Section 2.1
SCOPING AND SCREENING METHODOLOGY

Comparison of System Functions Against 10 CFR 54.4(a)(1-3)

All system functions were compared against the criteria of 10 CFR 54.4(a)(1), (a)(2) and (a)(3). The system functions were identified from the information sources previously described. Each of the system functions satisfying the scoping criteria in 10 CFR 54.4(a) was identified as a system intended function. Functions performed by safety-related portions of the evaluated system were identified as satisfying criterion (a)(1) and were classified as intended functions. Functions performed by nonsafety-related systems or parts of systems that are required to ensure success of a safety-related function were identified as satisfying criterion (a)(2) and classified as intended functions. Functions that were credited in one of the regulated events were identified as satisfying criterion (a)(3) and classified as intended functions. A function may have been classified as an intended function under more than one of the three criteria in 10 CFR 54.4.

Any system that performed one or more intended functions (i.e. satisfying criterion (a)(1), (a)(2), or (a)(3)) was classified as a system within the scope of the license renewal rule. Those systems for which no functions were identified as satisfying any of the three scoping criteria were classified as systems outside the scope of the Rule. For systems classified as outside the scope of the Rule, no further evaluation was performed, and the system description documented earlier in the license renewal database was augmented to state that the system was determined to not be within the scope of the Rule. When a system was determined to be outside the scope of the Rule, all of the components for that system listed in the license renewal database were identified as outside the scope of the Rule and were excluded from further scoping or screening evaluations.

Identification of Supporting Systems

After a system was determined to be in the scope of the Rule for criteria (a)(1) or (a)(3), an evaluation was performed to identify all of its supporting systems. Each of the supporting systems was then reviewed to determine if its failure could prevent satisfactory accomplishment of any intended functions of the in-scope system. When it was determined that a supporting system was needed to maintain an intended function of the in-scope system, the supporting system was determined to be in-scope. When a supporting system was identified as being in-scope, the scoping evaluation for the supporting system was reviewed and revised as necessary. This step in the scoping process ensured that all supporting systems' intended functions were identified.

Creation of License Renewal Drawings

License renewal drawings were created for each mechanical system determined to be within the scope of license renewal. The license renewal drawings were created in conjunction with the component scoping. License renewal drawings reflect the system evaluation boundary. The diagrams were created by marking-up the plant piping and instrumentation diagrams (P&IDs) associated with the mechanical system being evaluated. License renewal drawings include: 1) the system evaluation boundary; 2) the in-scope components whose function is required to ensure success of the system intended functions; and 3) the out-of-

Section 2.1
SCOPING AND SCREENING METHODOLOGY

scope components whose function is not required to ensure success of the system-level intended functions. Nonsafety-related SSCs included in the scope of the rule solely for 10 CFR 54.4(a)(2) are shown on the license renewal drawings.

Components that are required to support a safety-related function or a function that demonstrates compliance with one of the license renewal regulated events are identified on the License Renewal drawings by green highlighting. Nonsafety-related components that are connected to safety-related components and are required to provide structural support at the safety/nonsafety interface or components whose failure could prevent satisfactory accomplishment of a safety-related function due to spatial interaction with safety-related SSCs are identified with red highlighting.

Unit 1 P&ID(s) or Combined Unit P&ID(s) were marked-up to show the license renewal boundary. PVNGS uses Combined Unit P&IDs to depict all three units on a single P&ID. When Unit 1 P&IDs were used, Unit 2 and Unit 3 P&IDs were reviewed to confirm the similarity of the boundaries/interfaces and the absence of unit specific differences. Component level scoping results from the plant equipment database also confirmed P&ID information for each unit's boundaries/interfaces and components within the license renewal boundary.

Component Level Scoping

The system component list obtained from the plant equipment database was extracted into the license renewal database component table. System components are uniquely identified by the combination of plant name, unit, system name, system identification, component descriptions, and component types that are included in each record of the license renewal database.

Every safety-related component meeting scoping criterion (a)(1) was included within the scope of the license renewal rule. All other components in the license renewal database for a given system were reviewed to determine if they supported any of the intended functions for a given system. This was done by reviewing the system functions, drawings, and other information sources to determine if failure of the component would result in failure of a system intended function.

A component was determined to be in-scope if it was determined that the component was needed to fulfill a system intended function meeting the safety-related criteria of 10 CFR 54.4(a)(1), the nonsafety-related affecting safety-related criterion of 10 CFR 54.4(a)(2), and/or if the component was needed to support the criteria of 10 CFR 54.4(a)(3) for regulated events. The results of the component scoping are documented in the license renewal database.

The license renewal drawing for each in-scope system was reviewed to identify those components within the system required to support the system intended functions. Not all components on the P&IDs are included in the plant component and license renewal databases. Each system license renewal drawing was reviewed and any commodity types

Section 2.1 SCOPING AND SCREENING METHODOLOGY

indicated on the drawing to be in-scope for license renewal were added to the component list in the license renewal database. These components were identified as within the scope of license renewal.

The license renewal database includes uniquely identified components that are not shown on the P&IDs or on the license renewal drawings. Each of these components was evaluated individually to determine whether the component supports a system level intended function, meets the criteria of 10 CFR 54.4(a)(2), or is credited for a regulated event. Components meeting one of these three criteria were identified in the license renewal database as within the scope of the Rule. Components not meeting one of these three criteria were identified in the license renewal database as out-of-scope.

The component scoping methodology described above was performed for every mechanical component found within an in-scope system. All electrical and instrument and control components within the evaluation boundary of in-scope mechanical systems were included within the scope of license renewal and evaluated using the “spaces” approach described in [Section 2.1.3.3](#). The electrical and instrument and control components from all plant systems and structures were scoped collectively. This conservative scoping approach was applied to all electrical and instrument and control components provided the component did not have a mechanical component function for instruments such as flow elements, flow indicators, flow orifices, and sight gauges. In those instances, the components were evaluated individually for aging along with other components in the mechanical system.

All mechanical system components in the license renewal database that were identified as in-scope for license renewal were then screened against the criteria of 10 CFR 54.21(a)(1) to determine whether they were subject to an aging management review. The screening methodology is discussed in [Section 2.1.4](#).

Document Scoping Results and References

Throughout the scoping process described above, scoping results were documented in the license renewal database for each mechanical system. The current licensing basis and design basis documents reviewed in support of the scoping activities were also documented in the database for each system.

2.1.3.2 Structure Scoping Methodology

A list of all structures at PVNGS was developed that included buildings, tank foundations, and other miscellaneous structures. These structures are listed in [Section 2.2](#), [Table 2.2-1](#), “PVNGS Scoping Results”. The list of structures used for scoping was developed through review of site plot drawings in conjunction with a walkdown of the property. The PVNGS UFSAR was relied upon to identify the safety classifications of structures and structural components. Category I structures and structural components were considered safety-related.

Section 2.1 SCOPING AND SCREENING METHODOLOGY

The scoping methodology utilized for structures was similar to the mechanical system-level scoping described in [Section 2.1.3.1](#). Structure descriptions were prepared, including the structure purpose and all functions. Structure evaluation boundaries were determined, including examination of structure interfaces. This information was included in the license renewal database. All structure functions were evaluated against the criteria of 10 CFR 54.4(a)(1), (a)(2) and (a)(3) and the results of this evaluation were documented in the license renewal database. In those instances where the structure intended functions required support from other structures or systems, the supporting systems or structures were identified and evaluated against the criteria in 10 CFR 54.4(a)(2). A list of references supporting the evaluation of each structure was documented in the license renewal database.

Structural Boundary Drawings

Unlike mechanical systems, individual license renewal drawings were not created for structures. However, a single drawing based on the site plot plan was created. The license renewal drawing displays all of the structures in relation to one another.

Structural Component Scoping

Although the controlled plant equipment database does include some structural components, it does not include most of the structural components that are evaluated during an aging management review. For structures determined to be within the scope of license renewal, structural drawings were reviewed to identify structural elements (such as steel structures, foundations, floors, walls, ceilings, penetrations, stairways or curbs). For in-scope structures, all structural components that are required to support the intended functions of the structure were entered into the license renewal database and were identified as in-scope of license renewal. Some individual structural components fabricated from the same material and exposed to the same environment were replaced in the database with a generic component, such as "Structural Steel" to represent all of the carbon steel beams and columns in a given building. For each in-scope structure, all of the structural components listed in the license renewal database were evaluated and a determination was made as to whether the structural component was required to support the intended functions of the structure. Structural components that support the intended functions of the structure were identified in the license renewal database as within the scope of license renewal.

2.1.3.3 Electrical and I&C System Scoping Methodology

A list of electrical and I&C systems was developed and the systems were scoped against the criteria of 10 CFR 54.4(a). The list of electrical and instrument and control systems and the results of the scoping are provided in [Table 2.2-1](#), "PVNGS Scoping Results".

System Level Scoping

At the system level, the scoping methodology utilized for electrical and instrument and control systems was similar to the mechanical system-level scoping described in

Section 2.1 SCOPING AND SCREENING METHODOLOGY

Section 2.1.3.1. The UFSAR descriptions, database records, current licensing basis documents and design basis documents applicable to the system were reviewed to determine the system safety classification and to identify all of the system functions. System level functions were evaluated against the criteria of 10 CFR 54.4(a)(1), (a)(2) and (a)(3). The supporting systems needed to maintain the in-scope system intended functions were identified and evaluated against the criteria in 10 CFR 54.4(a)(2). The results of the system level scoping along with a list of references supporting the evaluation of each electrical and instrument and control system were documented in the license renewal database.

Electrical Boundary Drawings

Unlike mechanical systems, individual license renewal drawings were not created for each electrical and I&C system. A license renewal drawing was created from the plant one-line diagram. The plant one-line diagram schematically shows the portions of the plant AC electrical distribution system, including the Station Blackout recovery path, that are included in the scope of license renewal.

Component Level Scoping

All electrical and I&C components that perform an intended function as described in 10 CFR 54.4 for in-scope systems were included within the scope of license renewal.

The controlled plant equipment database does not list electrical component types such as cable, connections, fuse holders, terminal blocks, high-voltage transmission conductor, connections and insulators, switchyard bus and connections. During scoping the installed electrical components were identified by reviewing documents such as plant drawings and databases. Additionally industry documents, such as NEI 95-10 provide a list of typical electrical components found in nuclear power plants. These lists were reviewed against engineering information for the plant to determine which electrical component types are installed at PVNGS. The electrical component types installed at PVNGS but not listed in the plant equipment database were added into the license renewal database for evaluation during component screening.

2.1.4 Screening Methodology

Screening is the process of identifying, and listing the structures and components that are subject to an aging management review. This section, and the accompanying subsections for mechanical systems, electrical and instrument and control systems, and structures, describes the process used to perform screening for PVNGS.

All SSCs listed in the PVNGS license renewal database were scoped to the criteria of 10 CFR 54.4(a). All of the structures and components categorized as within the scope of license renewal were screened against the criteria of 10 CFR 54.21(a)(1)(i) and (1)(ii) to determine whether they are subject to aging management review. The screening methodology utilized is described in this section of the application.

Section 2.1
SCOPING AND SCREENING METHODOLOGY

Title 10 CFR 54.21 states that the structures and components subject to an AMR shall encompass those structures and components within the scope of the license renewal rule if they perform an intended function, as described in 10 CFR 54.4, without moving parts or without a change in configuration or properties; and are not subject to replacement based on a qualified life or specified time period. For simplicity, the word “passive” is used in the screening process for all components that perform intended functions without moving parts, or a change in configuration or properties. All components that are not “passive” are known as “active”. Also for simplicity, the word “long-lived” is used in the screening process for all components that are not subject to replacement based on qualified life or specific time period. Components that are not “long-lived” are known as “short-lived”.

NEI 95-10, Appendix B, “*Typical Structure, Component and Commodity Groupings and Active/Passive Determinations for the Integrated Plant Assessment*,” provides industry guidance for screening structures and components. The guidance provided in NEI 95-10, Appendix B, has been incorporated into the PVNGS license renewal screening process. Slightly differing screening methodologies have been applied for mechanical systems, electrical and instrument and control systems, and structures. The screening methodology applied for each category of system and for structures is described in the following paragraphs.

2.1.4.1 Mechanical System Component Screening Methodology

In mechanical systems, component screening was a continuation of the component scoping activity. After a mechanical system component was categorized in the license renewal database as in-scope, the classification as an active or passive component was determined based on evaluation of the component description and type. The active/passive component determinations documented in NEI 95-10, Appendix B, provided guidance for this activity. In-scope components that were determined to be passive and long-lived were identified in the license renewal database as subject to aging management review.

Each component that was identified as subject to an aging management review was evaluated to determine its component intended function(s). The component intended function(s) was identified based on an evaluation of the component type and the way(s) in which the component supports the system intended functions. Most in-scope passive components perform only one intended function. However, a few in-scope component types may perform more than one function. The results of the component screening were recorded in the license renewal database. The list of component intended functions utilized in the screening of mechanical system components can be found in [Table 2.1-1](#), “Intended Functions Abbreviations and Definitions”.

Table 2.1-1 Intended Functions: Abbreviations and Definitions

Intended Function Abbreviation	Function	Description
AN	Absorb Neutrons	Absorb neutrons
DF	Direct Flow	Provide spray shield, curbs, or mechanical components for directing flow (e.g., safety injection flow to containment sump)
EC	Electrical Continuity	Provide electrical connections to specified sections of an electrical circuit to deliver voltage, current or signals
ES	Expansion/ Separation	Provide for thermal expansion and/or seismic separation
FB	Fire Barrier	Provide rated fire barrier to confine or retard a fire from spreading to or from adjacent areas of the plant
FIL	Filter	Provide filtration
FLB	Flood Barrier	Provide flood protection barrier (internal and external flooding event)
GR	Gaseous Release Path	Provide path for release of filtered and unfiltered gaseous discharge
HLBS	HELB Shielding	Provide shielding against high energy line breaks
HS	Heat Sink	Provide heat sink during SBO or design basis accidents
HT	Heat Transfer	Provide heat transfer
IN	Insulate (electrical)	Insulate and support an electrical conductor
INS	Insulate	Control heat loss

Section 2.1
SCOPING AND SCREENING METHODOLOGY

Table 2.1-1 Intended Functions: Abbreviations and Definitions (Continued)

Intended Function Abbreviation	Function	Description
LBS	Leakage Boundary (Spatial)	Nonsafety-related component that maintains mechanical and structural integrity to prevent spatial interactions that could cause failure of safety-related SSCs
MB	Missile Barrier	Provide missile barrier (internally or externally generated)
NSRS	Nonsafety-related Structural Support	Provide structural support to nonsafety-related components whose failure could prevent satisfactory accomplishment of required safety functions.
PB	Pressure Boundary	Provide pressure-retaining boundary so that sufficient flow at adequate pressure is delivered, or provide fission product barrier for containment pressure boundary, or provide containment isolation for fission product retention
PR	Pressure Relief	Provide over-pressure protection
PWR	Pipe Whip Restraint	Provide pipe whip restraint
SH	Shelter, Protection	Provide shelter/protection to safety-related components
SIA	Structural Integrity (Attached)	Nonsafety-related component that maintains mechanical and structural integrity to provide structural support to attached safety-related piping and components
SLD	Shielding	Provide shielding against radiation
SP	Spray	Convert fluid into spray
SPB	Structural Pressure Boundary	Provide pressure boundary or essentially leak tight barrier to protect public health and safety in the event of any postulated design basis events
SS	Structural Support	Provide structural and / or functional support to safety-related components
TH	Throttle	Provide flow restriction

Section 2.1 SCOPING AND SCREENING METHODOLOGY

During the screening process, a few in-scope passive components were identified in the screening process as short-lived components. Components that were identified during screening as short-lived were eliminated from the aging management review process and the basis for the classification as short-lived was documented in the license renewal database. All other in-scope passive components were identified in the license renewal database as subject to an aging management review. During the aging management review process, if detailed review of maintenance procedures and requirements determined that a component previously categorized as long-lived was subject to replacement based on a qualified life or specified time period; the component was re-categorized as short-lived and eliminated from the aging management review evaluation process.

Consumables were considered in the process for determining the structures and components subject to an aging management review. Consumables comprise the following four categories: (a) packing, gaskets, component seals, O-rings; (b) structural sealants; (c) oil, grease and component filters; (d) system filters, fire extinguishers, fire hoses and air packs. Consumables were considered based on the guidelines of NEI 95-10, "4.1-2, Treatment of Consumables" and NUREG-1800, Table 2.1-3, "*Specific Staff Guidance on Screening*".

Thermal insulation was treated as a passive, long-lived component during the scoping and screening process. For systems where it has an intended function, insulation was considered in the scope of license renewal and subject to aging management review, and is included as a component type in each appropriate in-scope system.

2.1.4.2 Structural Component Screening Methodology

Structures and structural components typically perform their functions without moving parts and without a change in configuration or properties. When a structure or structural component was determined to be in-scope of license renewal by the scoping process described in [Section 2.1.3.2](#), the structure screening methodology classified the component as passive. This is consistent with guidance found in NEI 95-10, Appendix B. During the structural screening process, the intended function(s) of structural components were determined and recorded in the license renewal database. In the structure screening process, an evaluation was made to determine whether in-scope structural components were subject to replacement based on a qualified time period. If an in-scope structural component was determined to be subject to replacement based on a qualified time period, the component was identified as short-lived and was excluded from an aging management review. In such a case, the basis for determining that the structural component was short-lived was documented in the license renewal database. The list of component intended functions utilized in the screening of structural components is found in [Table 2.1-1](#), "*Intended Functions Abbreviations and Definitions*".

2.1.4.3 Electrical and I&C System Component Screening Methodology

The screening of electrical and I&C components used the spaces approach which is consistent with the guidance in NEI 95-10. The spaces approach to aging management review is based on areas where bounding environmental conditions are identified. The bounding environmental conditions are applied during aging management review to evaluate the aging effects on electrical component types that are located within the bounding area. Use of the spaces approach for aging management review of electrical components types eliminates the need to associate electrical and I&C components with specific systems that are within the scope of license renewal. The in-scope electrical components were categorized as “active” or “passive” based on the determinations documented in NEI 95-10, Appendix B. The passive long-lived electrical and I&C components that perform an intended function without moving parts or without change in configuration or properties were grouped into component types such as cable, connections, fuse holders, terminal blocks, high-voltage transmission conductor, connections and insulators, metal enclosed bus, switchyard bus and connections. Component-level intended function(s) were determined for each in-scope passive electrical component group and recorded in the license renewal database. The passive in-scope electrical component types were identified in the license renewal database as subject to an aging management review. A list of the passive in-scope electrical component types subject to aging management is provided in [Table 2.5-1](#), “Electrical and Instrument and Control Component Types Requiring Aging Management Review”.

2.1.5 Interim Staff Guidance

As lessons are learned during license renewal application reviews, the NRC staff has developed guidance documents to capture new insights or address emerging issues. To document these lessons learned, the staff has developed an interim staff guidance (ISG) process that provides guidance to future license renewal applicants until the emerging issues can be incorporated into the next revision of the license renewal guidance documents. Many of the previous issues have been closed and incorporated into license renewal guidance documents. [Table 2.1-2](#), “NRC Interim Staff Guidance Associated with License Renewal” provides the status of open ISGs.

Section 2.1
SCOPING AND SCREENING METHODOLOGY

Table 2.1-2 NRC Interim Staff Guidance Associated with License Renewal

Issue Number	Purpose	Discussion Status
LR-ISG-19B	Cracking of nickel-alloy components in the reactor coolant pressure boundary	This LR-ISG is under development. NEI and Electric Power Research Institute Materials Reliability Program (EPRI-MRP) is to develop an augmented inspection program. This ISG will be issued by the NRC following its review of the industry program.
LR-ISG-23	Replacement parts necessary to meet 10 CFR 50.48 (Fire Protection) To provide guidance on how to handle replacement parts for 10 CFR 50.48	The staff has determined LR-ISG-23 is not needed.
LR-ISG-2006-01	Corrosion of the Mark I Steel Containment Drywell Shell	The staff has issued final LR-ISG-2006-01
LR-ISG-2006-02	Staff Guidance on Acceptance Review for Environmental Requirements	The staff has issued for public comments proposed LR-ISG-2006-02. Acceptance Review Checklist for Environmental Reports Associated with License Renewal Applications.
LR-ISG-2006-03	Staff Guidance for Preparing Severe Accident Mitigation Alternatives (SAMA) Analyses	The staff has issued LR-ISG-2006-03
LR-ISG-2007-01	Updating the LR-ISG Process to Include References to the Environmental Review Guidance Documents, References for the Recent Publication of Revision 1 of the License Renewal Guidance Documents, and Minor Revisions to Be Consistent with Current Staff Practices	The staff is developing this LR-ISG.
LR-ISG-2007-02	Changes to Generic Aging Lesson Learned (GALL) Report Aging Management Program (AMP) XI.E6, "Electrical Cable Connections Not Subject to 10 CFR 50.49 Environmental Qualification Requirements"	The staff has issued for public comment LR-ISG – 2007-02
LR-ISG-2008-01	Staff Guidance Regarding Station Blackout Rule (10 CFR 50.63) Associated with License Renewal Applications	The staff has issued for public comment LR-ISG-2008-01

The following sections provide a summary discussion of each Interim Staff Guidance issues.

2.1.5.1 (LR-ISG-19B) Cracking of nickel-alloy components in the reactor coolant pressure boundary

This LR-ISG is open pending preparation of an augmented inspection program by the industry (i.e., NEI and EPRI). Guidance will be issued by the NRC following its review of the proposed industry program. The PVNGS Nickel-Alloy Penetration Nozzles Welded to the Upper Reactor Vessel Closure Heads of the Pressurized Water Reactors Program is addressed in [Section B2.1.5](#). The Plant-Specific Nickel-Alloy Aging Management Program, which manages the aging effects of the reactor coolant pressure boundary nickel-alloy components other than the reactor head penetrations is addressed in [Section B2.1.34](#).

2.1.5.2 (LR-ISG-2006-01) Corrosion of the Mark I Steel Containment Drywell Shell

This ISG is only applicable to certain BWRs and not applicable to PVNGS.

2.1.5.3 (LR-ISG-2006-02) Staff Guidance on Acceptance Review for Environmental Requirements

This ISG has been issued for comment by the NRC.

2.1.5.4 (LR-ISG-2006-03) Staff Guidance for Preparing Severe Accident Mitigation Alternatives (SAMA) Analyses

This ISG was issued as final and is applicable to PVNGS. The PVNGS severe accident mitigation alternatives analysis, provided as a part of [Appendix E](#) of this application, is consistent with the guidance of NEI 05-01, "*Severe Accident Mitigation Alternatives (SAMA) Analysis Guidance Document*", as discussed in this ISG.

2.1.5.5 (LR-ISG-2007-01) Updating the LR-ISG Process to Include References to the Environmental Review Guidance Documents, References for the Recent Publication of Revision 1 of the License Renewal Guidance Documents, and Minor Revisions to Be Consistent with Current Staff Practices

The staff is developing this ISG.

2.1.5.6 (LR-ISG-2007-02) Changes to Generic Aging Lesson Learned (GALL) Report Aging Management Program (AMP) XI.E6, “Electrical Cable Connections Not Subject to 10 CFR 50.49 Environmental Qualification Requirements

The staff has issued this ISG for public comment. The PVNGS Electrical Cable Connections Not Subject to 10 CFR 50.49 Environmental Qualification Requirements program is addressed in [Section B2.1.35](#).

2.1.5.7 (LR-ISG-2008-01) Staff Guidance Regarding Station Blackout Rule (10 CFR 50.63) Associated with License Renewal Applications

The staff has issued this ISG for public comment. License Renewal scoping for Station Blackout is addressed in [Section 2.1.2.3.5](#).

2.1.6 Generic Safety Issues

In accordance with the guidance in NEI 95-10 and Appendix A.3 of NUREG-1800, “*Standard Review Plan for the Review of License Renewal Applications for Nuclear Power Plants*”, review of NRC Generic Safety Issues (GSIs) as part of the License Renewal process is required to satisfy a finding per 10 CFR 54.29. GSIs that involve issues related to license renewal aging management reviews or time-limited aging analyses are to be addressed in the LRA. As a result of the review of NUREG-0933, Supplement 31, dated September 2007, the following GSIs have been evaluated for License Renewal:

1. GSI-156.6.1, Pipe Break Effects on Systems and Components

This GSI involves assumed high energy line breaks in which the effects of the resulting pipe break prevent the operation of systems required to mitigate the effects of the break. The aspects of pipe breaks that are associated with degradation are addressed in the aging management review tables associated with mechanical systems in [Chapter 3.0](#). TLAA evaluations of high energy line breaks are presented in [Section 4.3.2.14](#), High Energy Line Break Postulation Based on Fatigue Cumulative Usage Factor.

2. GSI-163, Multiple Steam Generator Tube Leakage

This GSI involves the potential multiple steam generator tube leaks during a main steam line break that cannot be isolated. Steam generator tubes are part of the reactor coolant pressure boundary and are the subject of an aging management review and TLAA evaluation as documented in [Section 3.1](#) and [Chapter 4.0](#). Aging management of steam generator tubes is addressed within the current licensing basis of the plant and will continue to be addressed during the period of extended operation by the Steam Generator Tube Integrity program discussed in [Section B2.1.8](#).

3. GSI-190, Fatigue Evaluation of Metal Components for 60-year Plant Life

This GSI addresses fatigue life of metal components and was closed by the NRC. However, the NRC concluded that license renewal applicants should address the effects of reactor coolant environment on component fatigue life. Accordingly, the issue of environmental effects on component fatigue life is addressed in [Section 4.3](#) of this application.

4. GSI-191, Assessment of Debris Accumulation on PWR Sump Performance

GSI-191 addresses the potential for blockage of containment sump strainers that filter debris from cooling water supplied to the safety injection and containment spray pumps following a postulated LOCA. The issue is based on containment strainer design and on the identification of new potential sources of debris that may block the sump strainers.

By letter no. 102-05336, dated September 1, 2005, APS submitted to the NRC a response to Generic Letter (GL) 2004-02, *"Potential Impact of Debris Blockage on Emergency Recirculation During Design Basis Accidents at Pressurized-Water Reactors"*. The issues identified in GSI-191 and Generic Letter 2004-02 are not aging-related issues. Also, the issues are not related to the 40-year term of the current operating license, and, therefore, are not time-limited aging analyses. The containment sumps are evaluated in [Section 2.5.1](#), Containment Building.

2.1.7 Conclusions

The scoping and screening methodology described above was used for the PVNGS integrated plant assessment to identify SSCs that are within the scope of license renewal and require an aging management review. The methods are consistent with the requirements of 10 CFR 54.4 and 10 CFR 54.21(a)(1).

**Figure 2.1-1
Scoping and Screening Process Flow**

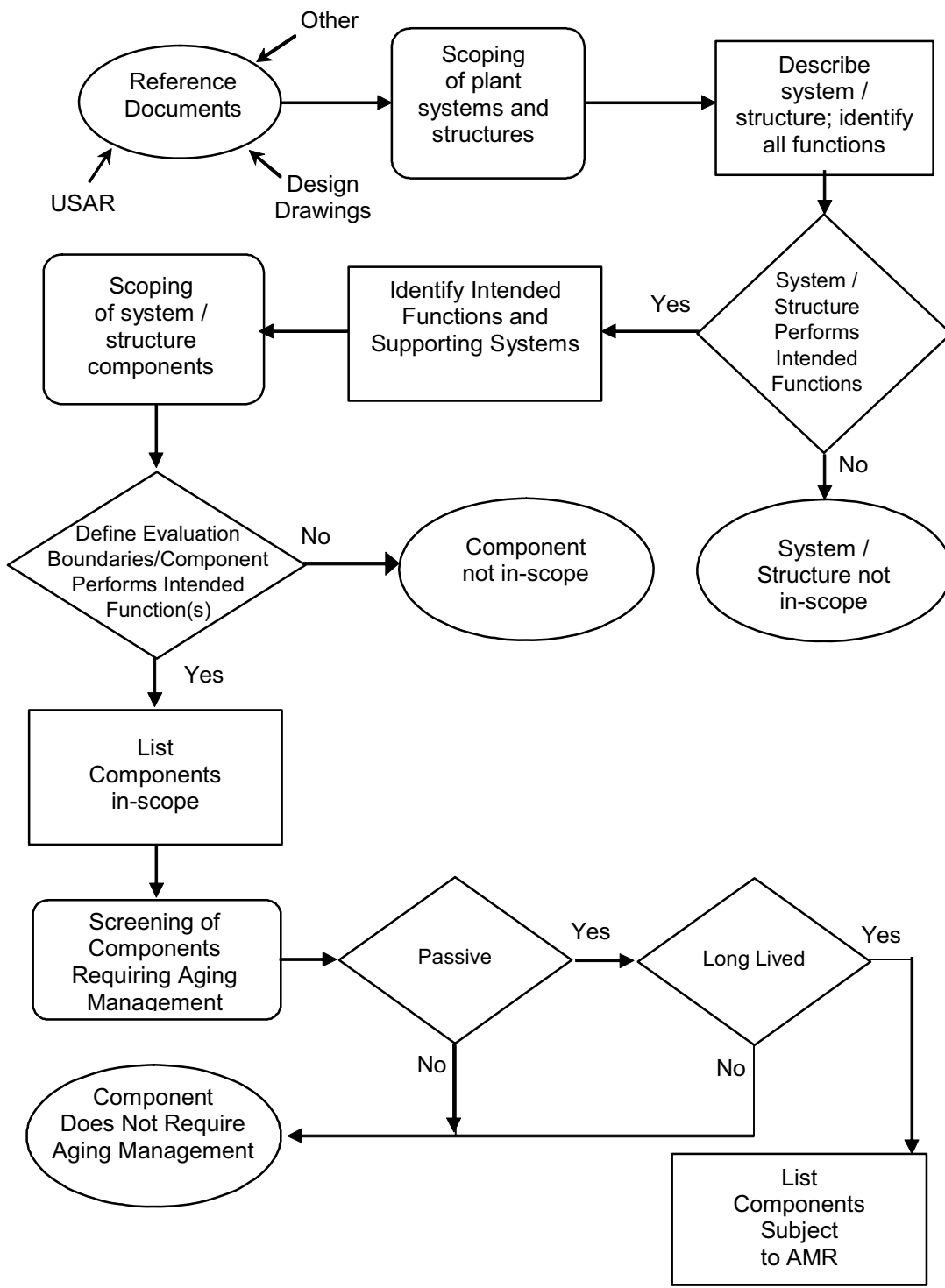
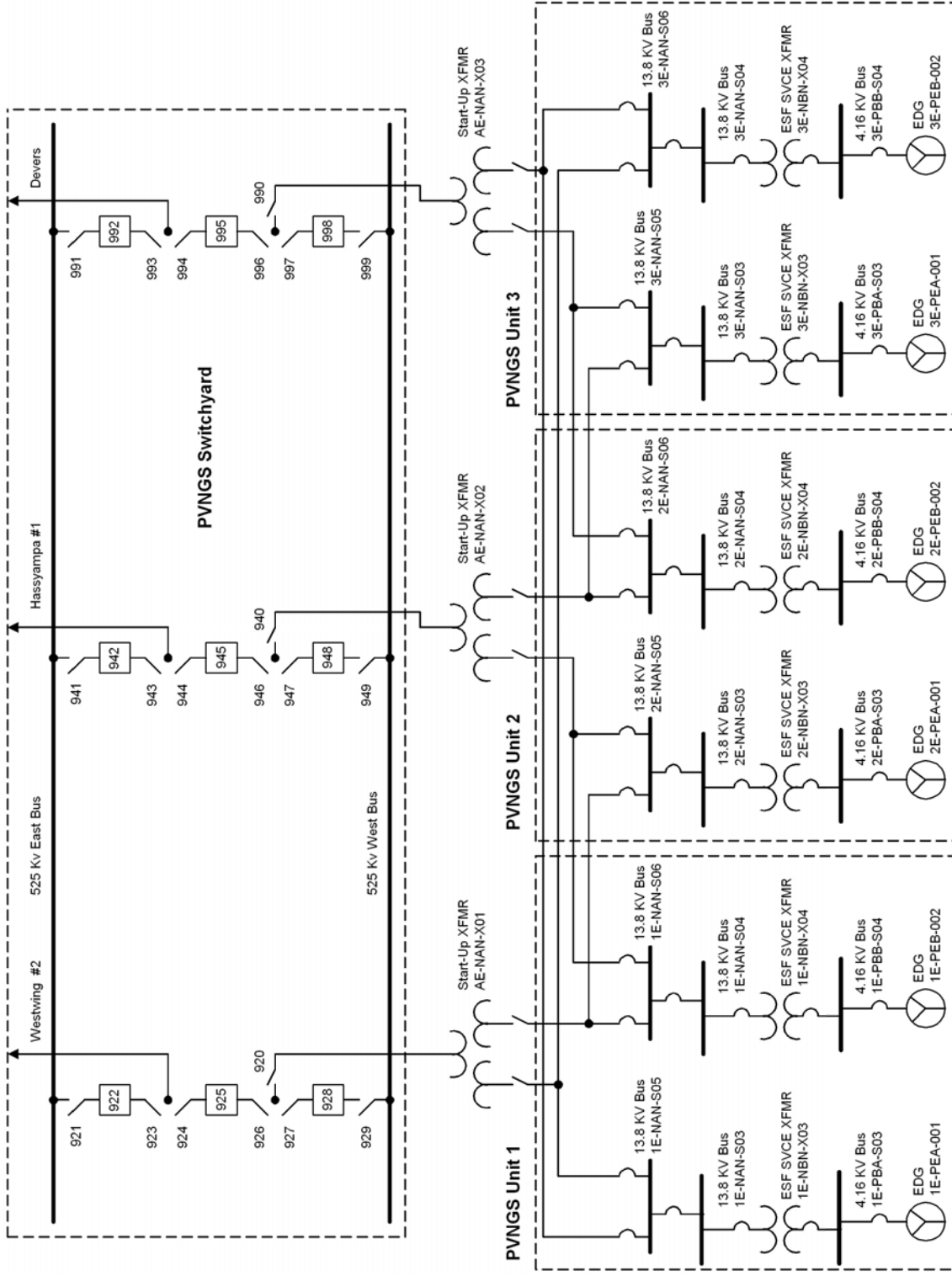

Figure 2.1-2
SBO Recovery Path



2.2 PLANT-LEVEL SCOPING RESULTS

[Table 2.2-1](#), “PVNGS Scoping Results” provides the results of the PVNGS assessment to identify the plant systems and structures that are within the scope of license renewal. For in-scope mechanical systems and structures, a reference is given to the appropriate section that provides a description and the screening results of the system or structure. For electrical and I&C systems, no description is necessary since these systems were evaluated based on the “spaces” approach as described in [Section 2.5](#).

For each system and structure within the scope of license renewal, components subject to aging management review are highlighted on license renewal boundary drawings, as noted in [Section 2.1.3](#), indicating the evaluation boundaries of the systems and structures.

Section 2.2
PLANT-LEVEL SCOPING RESULTS

Table 2.2-1 PVNGS Scoping Results

System/Structure	In Scope	Section 2 Scoping Results
Reactor Vessel, Internals, and Reactor Coolant System		
Pressurizer	Yes	2.3.1.3
Reactor coolant	Yes	2.3.1.2
Reactor core	Yes	2.3.1.5
Reactor vessel and internals	Yes	2.3.1.1
Steam generators	Yes	2.3.1.4
Engineered Safety Features		
Containment leak test	Yes	2.3.2.1
Containment hydrogen control	Yes	2.3.2.3
Containment purge	Yes	2.3.2.2
Safety injection and shutdown cooling, includes:	Yes	2.3.2.4
Containment spray		
Auxiliary Systems		
Auxiliary building HVAC, includes:	Yes	2.3.3.12
Normal auxiliary building HVAC subsystem		
Essential auxiliary building HVAC subsystem		
Chemical and volume control	Yes	2.3.3.10
Compressed air system, includes:	Yes	2.3.3.9
Instrument air		
Service and breathing air		
Containment building HVAC, includes:	Yes	2.3.3.14
Containment building normal cooling subsystem		
Containment building normal cleanup subsystem		
CEDM cooling subsystem		
Reactor cavity cooling subsystem		

Section 2.2
PLANT-LEVEL SCOPING RESULTS

Table 2.2-1 PVNGS Scoping Results (Continued)

System/Structure	In Scope	Section 2 Scoping Results
Pressurizer cooling subsystem		
Tendon gallery ventilation subsystem		
Main steam support structure ventilation subsystem		
Control building HVAC, includes:	Yes	2.3.3.11
Normal control room HVAC subsystem		
Essential control room HVAC subsystem		
Normal control building HVAC subsystem		
Essential control building HVAC subsystem		
Cranes, hoists, and elevators	Yes	2.3.3.29
Diesel generator, includes:	Yes	2.3.3.21
Diesel generator cooling water		
Diesel generator combustion air intake and exhaust		
Diesel generator starting		
Diesel generator lube		
Diesel generator fuel oil storage and transfer	Yes	2.3.3.20
Diesel generator building HVAC, includes:	Yes	2.3.3.15
Diesel generator building normal HVAC		
Diesel generator building essential HVAC		
Domestic water	Yes	2.3.3.22
Demineralized water	Yes	2.3.3.23
Essential chilled water	Yes	2.3.3.4
Essential cooling water	Yes	2.3.3.3
Essential spray ponds	Yes	2.3.3.7
Fuel building HVAC, includes:	Yes	2.3.3.13
Normal fuel building HVAC subsystem		
Essential fuel building HVAC subsystem		

Section 2.2
PLANT-LEVEL SCOPING RESULTS

Table 2.2-1 PVNGS Scoping Results (Continued)

System/Structure	In Scope	Section 2 Scoping Results
Fuel handling and storage	Yes	2.3.3.1
Fire protection	Yes	2.3.3.19
Station blackout generator	Yes	2.3.3.28
Gaseous radwaste	Yes	2.3.3.26
Miscellaneous auxiliary systems in-scope ONLY for criterion 10 CFR 54.4(a)(2), includes:	Yes	2.3.3.30
Auxiliary steam		
Chemical waste		
Liquid radwaste		
Oily waste and non-radioactive waste		
Solid radwaste		
Sanitary sewage and treatment		
Secondary chemical control, includes: Ecodyne Graver		
Misc. Site Structures/Spray Pond Pump House HVAC	Yes	2.3.3.18
Normal chilled water	Yes	2.3.3.5
Nuclear cooling water	Yes	2.3.3.6
Nuclear sampling	Yes	2.3.3.8
Radioactive waste drains	Yes	2.3.3.27
Radwaste building HVAC	Yes	2.3.3.16
Service gases (N ₂ and H ₂)	Yes	2.3.3.25
Spent fuel pool cooling and cleanup	Yes	2.3.3.2
Turbine building HVAC	Yes	2.3.3.17
WRF fuel	Yes	2.3.3.24
Chemical production, includes:	No	N/A
Hypochlorite subsystem		
Caustic subsystem		
Lube oil storage, transfer and purification	No	N/A

Section 2.2
PLANT-LEVEL SCOPING RESULTS

Table 2.2-1 PVNGS Scoping Results (Continued)

System/Structure	In Scope	Section 2 Scoping Results
Miscellaneous cooling water, includes:	No	N/A
Circulating water		
Chlorine injection		
Cooling tower makeup and blowdown		
Turbine cooling water		
Mechanical miscellaneous (inspection sump pit valves)	No	N/A
Miscellaneous drains and waste, includes:	No	N/A
Radiation filter handling		
Radioactive laundry		
Turbine building storm drains		
Miscellaneous HVAC, includes:	No	N/A
Chlorine building HVAC		
Ancillary buildings HVAC, includes:		
Technical Support Center HVAC subsystem		
Emergency Operations Facility subsystem		
Dry Active Waste Processing and Storage Facility HVAC subsystem		
Service Building HVAC subsystem		
Administrative Building HVAC subsystem		
Security Building (Guardhouse) HVAC subsystem		
Plant Cooling Water	No	NA
Water Reclamation Facility (WRF) mechanical, includes:	No	N/A
WRF sulfuric acid		
WRF instrument and service air		
WRF carbon dioxide		
WRF chlorination		
WRF solids contact clarifiers		

Section 2.2
PLANT-LEVEL SCOPING RESULTS

Table 2.2-1 PVNGS Scoping Results (Continued)

System/Structure	In Scope	Section 2 Scoping Results
WRF gravity filtration system		
HVAC – WRF operations building		
WRF control and monitoring		
WRF lime		
WRF polymer		
WRF process water		
WRF reclaiming		
WRF solids/liquid separation		
WRF soda ash		
WRF trickling filter		
Steam and Power Conversion System		
Auxiliary feedwater	Yes	2.3.4.3
Condensate	Yes	2.3.4.4
Condensate transfer and storage	Yes	2.3.4.2
Feedwater	Yes	2.3.4.5
Feedwater heater extraction, drains and vents	Yes	2.3.4.8
Main steam	Yes	2.3.4.1
Main turbine	Yes	2.3.4.6
Steam generator feedwater pump turbine	Yes	2.3.4.7
Condenser air removal	No	N/A
Main turbine control oil	No	N/A
Turbine generator auxiliaries, includes:	No	N/A
Stator cooling		
Gland generator hydrogen and CO ₂		
Turbine steam seal and drain		
Lube oil		

Section 2.2
PLANT-LEVEL SCOPING RESULTS

Table 2.2-1 PVNGS Scoping Results (Continued)

System/Structure	In Scope	Section 2 Scoping Results
Turbine generator seal oil		
Containments, Structures, and Component Supports		
Auxiliary building	Yes	2.4.5
Containment building	Yes	2.4.1
Control building	Yes	2.4.2
Diesel generator building	Yes	2.4.3
Fuel building	Yes	2.4.9
Main steam support structure	Yes	2.4.7
Yard structures (in-scope), includes: Condensate and essential pipe tunnels Condensate storage tank pump house Diesel fuel oil tank vault Fire pump house	Yes	2.4.13
Radwaste building	Yes	2.4.6
Spray pond and associated water control structures	Yes	2.4.10
Station blackout generator structures	Yes	2.4.8
Supports	Yes	2.4.14
Tank foundations and shells	Yes	2.4.11
Transformer foundations and electrical structures	Yes	2.4.12
Turbine building	Yes	2.4.4
Independent spent fuel storage Installation/dry cask storage	No	N/A
Miscellaneous structures (not in-scope) includes:	No	N/A
APS carpenter shop		
Coating facility, includes: Main building and material building		
Combination shop		
Concrete test lab		

**Section 2.2
PLANT-LEVEL SCOPING RESULTS**

Table 2.2-1 PVNGS Scoping Results (Continued)

System/Structure	In Scope	Section 2 Scoping Results
Field construction office (North Annex)		
Guard house		
Holdup tank pump house		
Interim On-Site Low Level Radwaste Storage Warehouse/Dry Active, Waste Processing and Storage (DAWPS)		
Instrument metrology lab		
Low level radioactive material storage facility		
Lube oil storage tank dike		
Outside areas (Civil/structural SSC's on-site, outside the protected area)		
Visitor's center		
Warehouses A, B, and C		
Weld test shop Unit 3		
Water Reclamation Facility (WRF) and WRF supply system, includes:	No	N/A
Acid building		
WRF chlorination system shelter		
WRF operations building		
WRF chemical feed area		
WRF operations, shops, warehouse buildings		
WRF pumping and piping		
WRF Hassayampa pumping station		
WRF warehouses		
WRF railroad		
WRF supply system/Buckeye Irrigation Company interface		
WRSS 91st Ave. Wastewater Treatment Plant interface		
WRSS gravity flow pressure pipeline		

Section 2.2
PLANT-LEVEL SCOPING RESULTS

Table 2.2-1 PVNGS Scoping Results (Continued)

System/Structure	In Scope	Section 2 Scoping Results
WRSS pump flow pressure pipeline		
Electrical and Instrumentation and Controls		
Class 1E 4.16 KV power	Yes	N/A
Class 1E standby generator	Yes	N/A
Class 1E 480 V power switchgear	Yes	N/A
Class 1E 480 V power – MCC	Yes	N/A
Class 1E 125 VDC power	Yes	N/A
Class 1E instrument AC power	Yes	N/A
Essential lighting	Yes	N/A
Emergency lighting	Yes	N/A
ESF actuation	Yes	N/A
Emergency response facility data acquisition and data system	Yes	N/A
Excore neutron monitoring	Yes	N/A
Fire detection and alarm	Yes	N/A
Incore instrumentation	Yes	N/A
In-plant communications	Yes	N/A
Main control board	Yes	N/A
Main generation	Yes	N/A
Non-class 1E 13.8 KV power	Yes	N/A
Non-class 1E 4.16 KV power	Yes	N/A
Non-Class 1E 480 V switchgear and MCC	Yes	N/A
Non-Class 1E 125VDC power	Yes	N/A
Non-Class 1E instrument AC power	Yes	N/A
Plant Annunciator	Yes	N/A
Quality safety parameter display system	Yes	N/A
Radiation monitoring	Yes	N/A
Reactor control	Yes	N/A

Section 2.2
PLANT-LEVEL SCOPING RESULTS

Table 2.2-1 PVNGS Scoping Results (Continued)

System/Structure	In Scope	Section 2 Scoping Results
Reactor protection	Yes	N/A
Safety equipment status system	Yes	N/A
Special process trace heating	Yes	N/A
Standby power (SBO)	Yes	N/A
Switchyard/Grid	Yes	N/A
Communications	No	N/A
Plant offsite communications		
Private offsite communications		
Instrumentation system (non-class 1E), includes:	No	N/A
Meteorological instrumentation		
Seismic instrumentation		
Loose parts and vibration monitoring		
Lighting system, includes:	No	N/A
Normal lighting		
Yard, roadway, and fence lighting		
Miscellaneous electrical, includes:	No	N/A
Excitation and voltage regulation		
Grounding (entire site ground grid – personnel safety		
Cathodic protection		
Freeze protection system	No	N/A
Non-Class 1E uninterruptible AC power	No	N/A
Nonsafety-related power systems, includes:	No	N/A
Auxiliary power supply		
HPS non-class 1E 4.16 KV power system		
Plant computer systems	No	N/A
SRP plant multiplexer		

**Section 2.2
PLANT-LEVEL SCOPING RESULTS**

Table 2.2-1 PVNGS Scoping Results (Continued)

System/Structure	In Scope	Section 2 Scoping Results
Remote multiplex systems		
SWMS/MMIS (computer uninterruptible AC power)		
Plant simulator		
Radiation exposure and maintenance system		
Plant computer		
Radiological records and access control		
Chemical and radiological analysis computer system		
Plant security	No	N/A
Water Reclamation Facility (WRF) and WRF supply system (WRSS) electrical, includes:	No	N/A
WRF alarm and annunciator		
WRF graphic display system		
WRF control and monitoring		
WRF non-Class 1E 13.8 KV power system		
WRF non-Class 1E 4.16 KV power system		
WRF non-Class 1E 480 V power switchgear System		
WRF non-Class 1E 480 V power MCC system		
WRF non-Class 1E 125 V DC power system		
WRF non-Class 1E uninterruptible AC power system		
WRF area, roadway and fence lighting system		
WRF Normal 480/277 V lighting and 208/120 V power system		
WRF standby lighting DC system		
WRF freeze protection		

2.3 SCOPING AND SCREENING RESULTS: MECHANICAL SYSTEMS

The scoping and screening results for mechanical systems consist of lists of components and component groups that require aging management review, arranged by system. Brief descriptions of mechanical systems within the scope of license renewal are provided as background information. Mechanical system intended functions are provided for in-scope systems. For each in-scope system, components or component groups requiring an aging management review are provided.

Specifically, this section provides the results of the scoping and screening process for mechanical systems including:

- A general description of the system, its purpose, and system intended function,
- A reference to the applicable PVNGS UFSAR section(s),
- A reference to the applicable license renewal boundary drawing(s),
- A listing of mechanical component types that are subject to an aging management review with the associated component intended functions.

The mechanical scoping and screening results are provided in four subsections:

- Reactor vessel, internals, and reactor coolant system
- Engineered safety features
- Auxiliary systems
- Steam and power conversion systems

2.3.1 Reactor Vessel, Internals, and Reactor Coolant System

This section of the application addresses scoping and screening results for the following systems:

- [Reactor vessel and internals](#)
- [Reactor coolant](#)
- [Pressurizer](#)
- [Steam generators](#)
- [Reactor core](#)

2.3.1.1 Reactor Vessel and Internals

System Description

The reactor is a pressurized water reactor with two reactor coolant loops. The reactor core is composed of 241 fuel assemblies and 89 control element assemblies (CEAs). Each fuel assembly has 5 guide tubes, 4 of which provide channels to guide the CEAs over their entire length of travel. In-core instrumentation is inserted in the central guide tube of selected fuel assemblies and is routed into the bottom of the fuel assemblies through the bottom head of the reactor vessel.

The reactor coolant enters the inlet nozzles of the reactor vessel, flows downward between the reactor vessel wall and the core barrel, and passes through the flow skirt section where the flow distribution is equalized, and into the lower plenum. The coolant then flows upward through the core, removing heat from the fuel rods. The heated coolant enters the core outlet region where the coolant flows around the outside of the CEA shroud tubes to the reactor vessel outer nozzles.

The reactor internals consist of the following component groups to support and orient the fuel assemblies, CEAs, and in-core instrumentation, and guide the reactor coolant through the reactor vessel:

- (a) Core support structure (CSS), consisting of:
 - Core support barrel assembly
 - Lower support structure assembly
 - Core shroud assembly

- (b) Upper guide structure (UGS), consisting of:
 - UGS support barrel assembly
 - UGS CEA shroud assembly
 - UGS holddown ring

- (c) Flow skirt (flow baffle)

Section 2.3
SCOPING AND SCREENING RESULTS: MECHANICAL SYSTEMS

(d) Incore instrumentation support structures.

System Intended Function

The reactor vessel supports the reactor core and control rod drive mechanisms and provides a pressure boundary for reactor coolant. The reactor internals support the core, maintain fuel alignment, direct coolant flow and provide gamma and neutron shielding. The reactor vessel and internals are within the scope of license renewal based on the criteria of 10 CFR 54.4(a)(1).

Portions of the reactor vessel and internals support fire protection, pressurized thermal shock, and station blackout requirements based on the criteria of 10 CFR 54.4(a)(3).

PVNGS UFSAR References

Additional details of the reactor vessel and internals are included in [UFSAR Sections 3.9.5, 4.1 and 5.3](#).

License Renewal Drawings

There are no license renewal drawings for reactor vessel and internals.

Component-Function Relationship Table

The component types subject to aging management review are indicated in [Table 2.3.1-1 - Reactor Vessel and Internals](#).

Table 2.3.1-1 Reactor Vessel and Internals

Component Type	Intended Function
Closure Bolting	Pressure Boundary
RV CEDM Housing (Lower)	Pressure Boundary
RV CEDM Housing (Upper)	Pressure Boundary
RV CEDM Nozzles	Pressure Boundary
RV Closure Head	Pressure Boundary Structural Support
RV Closure Head Bolts	Pressure Boundary
RV Flange Leak Monitoring Tube	Pressure Boundary
RV Head Vent Penetration	Pressure Boundary

Table 2.3.1-1 Reactor Vessel and Internals (Continued)

Component Type	Intended Function
RV ICI Guide Tube	Pressure Boundary
RV ICI Nozzle	Pressure Boundary
RV Nozzle Safe Ends and Welds	Pressure Boundary
RV Nozzles	Pressure Boundary
RV Shell	Pressure Boundary
RV Shell Bottom Head	Pressure Boundary
RV Support Pads and Shear Keys	Structural Support
RVI Core Stop Lug and Surv Capsule Holder	Structural Support
RVI CSS Core Shroud Assembly	Direct Flow Structural Support
RVI CSS Core Support Barrel Assembly	Direct Flow Structural Support
RVI CSS Core Support Barrel Snubber Assembly	Structural Support
RVI CSS Lower Support Structure Assembly	Direct Flow Structural Support
RVI Flow Skirt	Direct Flow
RVI ICI Support Structures	Structural Support
RVI UGS CEA Shroud Assembly	Structural Support
RVI UGS Holddown Ring	Structural Support
RVI UGS Support Barrel Assembly	Structural Support

2.3.1.2 Reactor Coolant System

System Description

The reactor is a pressurized water reactor with two coolant loops. The reactor coolant system circulates water in a closed cycle, removing heat from the reactor core and internals and transferring it to a secondary (steam generating) system. The steam generators provide the interface between the reactor coolant (primary) system and the main steam (secondary) system. Reactor coolant is prevented from mixing with the secondary steam by the steam

Section 2.3

SCOPING AND SCREENING RESULTS: MECHANICAL SYSTEMS

generator tubes and the steam generator tube sheet. The reactor coolant system a closed system, thus forming a barrier to the release of radioactive materials from the core to the containment building.

System pressure is controlled by the pressurizer, where steam and water are maintained in thermal equilibrium. Steam is formed by energizing immersion heaters in the pressurizer, or is condensed by the pressurizer spray to limit pressure variations caused by contraction or expansion of the reactor coolant.

Reactor coolant loop penetrations include a charging and a letdown nozzle; the pressurizer surge line in one reactor vessel outlet pipe; the four safety injection inlet nozzles, one in each reactor vessel inlet pipe; two outlet nozzles to the shutdown cooling system, one in each reactor vessel outlet pipe; pressurizer spray nozzle; vent and drain connections; and sample and instrument connections.

Overpressure protection for the reactor coolant pressure boundary is provided by four spring-loaded ASME Code safety valves connected to the top of the pressurizer. These valves discharge to the reactor drain tank.

The reactor coolant pump lube oil collection system provides components needed to contain reactor coolant pump lube oil.

The major components of the reactor coolant system are the reactor vessel and internals; two parallel heat transfer loops, each containing one steam generator and two reactor coolant pumps; a pressurizer connected to one of the reactor vessel outlet pipes; and associated piping, valves, and instrumentation. All components are located inside the containment building.

The reactor vessel and internals, pressurizer and steam generators are evaluated separately in [Sections 2.3.1.1](#), [2.3.1.3](#), and [2.3.1.4](#), respectively.

System Intended Function

The reactor coolant system maintains reactor coolant system pressure during normal operation and maintains system integrity, transfers heat from the reactor to other systems during certain design basis events for core cooling, heat sink and reactivity control, allows for removal of non-condensable gases which could impact accomplishment of core heat removal, and provides a barrier against release of radioactivity generated within the reactor. The reactor coolant system is within the scope of license renewal based on the criteria of 10 CFR 54.4(a)(1).

Portions of the reactor coolant system are within the scope of license renewal as nonsafety-related affecting safety-related components based on the criterion of 10 CFR 54.4(a)(2) for spatial interaction and structural integrity - attached.

Portions of the reactor coolant system support fire protection, environmental qualification, ATWS, and station blackout requirements based on the criteria of 10 CFR 54.4(a)(3).

PVNGS UFSAR References

Additional details of the reactor coolant system are included in [UFSAR Sections 5.1](#) and [5.2](#).

License Renewal Drawings

The license renewal drawings for the reactor coolant system are listed below:

- [LR-PVNGS-RC-01-M-RCP-001](#)
- [LR-PVNGS-RC-01-M-RCP-002](#)
- [LR-PVNGS-RC-01-M-RCP-003](#)

Component-Function Relationship Table

The component types subject to aging management review are indicated in [Table 2.3.1-2 - Reactor Coolant](#)

Table 2.3.1-2 Reactor Coolant

Component Type	Intended Function
Class 1 Piping <= 4in	Pressure Boundary
Closure Bolting	Leakage Boundary (Spatial) Pressure Boundary Structural Integrity (Attached)
Filter	Filter Pressure Boundary
Flame Arrestor	Pressure Boundary
Flexible Hoses	Leakage Boundary (Spatial)
Heat Exchanger (RCP High Pressure Cooler)	Heat Transfer Pressure Boundary
Heat Exchanger (RCP Seal Cooler)	Heat Transfer Pressure Boundary
Orifice	Pressure Boundary Throttle
Piping	Leakage Boundary (Spatial) Pressure Boundary Structural Integrity (Attached)
Pump	Pressure Boundary

Table 2.3.1-2 Reactor Coolant (Continued)

Component Type	Intended Function
Sight Gauge	Pressure Boundary
Tank	Pressure Boundary
Thermowell	Pressure Boundary
Tubing	Pressure Boundary
Valve	Leakage Boundary (Spatial) Pressure Boundary Structural Integrity (Attached)

2.3.1.3 Pressurizer

System Description

The purpose of the pressurizer is to maintain the reactor coolant system operating pressure within acceptable limits. The pressurizer includes one pressurizer vessel connected to one of the primary coolant loops for each unit, and is part of the reactor coolant pressure boundary. The pressurizer contains components for maintaining reactor coolant system pressure, which consist of electric heaters to increase reactor coolant system pressure and an internal spray nozzle to reduce reactor coolant system pressure. Steam is formed by the pressurizer electric heaters to increase reactor coolant system pressure or condensed by the pressurizer spray to reduce reactor coolant system pressure.

The reactor coolant system contains the piping system components associated with the pressurizer, excluding the pressurizer vessel and its internals. The safety valves, which are connected to the pressurizer to provide overpressure protection for the reactor coolant system, are also evaluated with the reactor coolant system. The pressurizer is located in the containment building.

System Intended Function

The pressurizer is part of the reactor coolant pressure boundary. It also functions to maintain the reactor coolant system operating pressure within acceptable limits to mitigate the consequences of accidents by regulating the temperature/pressure of the coolant in the pressurizer where steam and water are held in thermal equilibrium. The pressurizer is within the scope of license renewal based on the criteria of 10 CFR 54.4(a)(1).

The pressurizer supports fire protection and station blackout requirements based on the criteria of 10 CFR 54.4(a)(3).

PVNGS UFSAR References

Additional details of the pressurizer are included in [UFSAR Sections 5.1](#) and [5.4.10](#).

License Renewal Drawings

There are no license renewal drawings for the pressurizer.

Component-Function Relationship Table

The component types subject to aging management review are indicated in [Table 2.3.1-3](#) - Pressurizer.

Table 2.3.1-3 Pressurizer

Component Type	Intended Function
Closure Bolting	Pressure Boundary
PZR Heater Bundle Diaphragm Plate	Structural Support
PZR Heater Sheaths and Sleeves	Pressure Boundary
PZR Instrument Penetrations	Pressure Boundary
PZR Integral Support	Structural Support
PZR Lower Head	Pressure Boundary
PZR Manways and Covers	Pressure Boundary
PZR Nozzle Thermal Sleeves	Shelter, Protection
PZR Nozzles	Pressure Boundary
PZR Safe Ends	Pressure Boundary
PZR Shell and Upper Head	Pressure Boundary

2.3.1.4 Steam Generators

System Description

The purpose of the steam generator system is to provide heat removal from the reactor coolant system through the generation of steam and also to act as an assured source of steam to the steam driven auxiliary feedwater pump. The system consists of the primary and secondary pressure boundaries of the steam generators including all pieces and parts within the pressure boundary and all penetrations out to the safe ends of the penetration nozzles.

System Intended Function

The steam generator system provides heat removal by the generation of steam for design basis event mitigation, station black out and fire safe shutdown requirements. The steam generator system also provides an assured source of steam to the turbine driven auxiliary feedwater pump. The steam generator primary channel head and tubes form part of the reactor coolant pressure boundary. The steam generator outlet nozzles restrict main steam flow in the event of a main steam line break. The steam generator system is within the scope of license renewal based on the criteria of 10 CFR 54.4(a)(1).

Portions of the steam generator are within the scope of license renewal as nonsafety affecting safety-related components based on the criterion of 10 CFR 54.4(a)(2).

The steam generator system supports fire protection, ATWS and station blackout requirements based on the criteria of 10 CFR 54.4(a)(3).

PVNGS UFSAR References

Additional details of the steam generators are included in [UFSAR Sections 5.4.2, 5.4.4, and 10.3](#).

License Renewal Drawings

There are no license renewal drawings for the steam generators.

Component-Function Relationship Table

The component types subject to aging management review are indicated in [Table 2.3.1-4 - Steam Generators](#).

Table 2.3.1-4 Steam Generators

Component Type	Intended Function
SG Closure Bolting	Pressure Boundary
SG Feeding	Direct Flow
SG Flow Distribution Baffle	Direct Flow
SG Internal Structures	Direct Flow Structural Support
SG Plugs and Stakes	Pressure Boundary Structural Support
SG Primary Head	Pressure Boundary

Table 2.3.1-4 Steam Generators (Continued)

Component Type	Intended Function
SG Primary Head Divider Plate	Direct Flow
SG Primary Manways and Flanges	Pressure Boundary
SG Primary Nozzle Dam Retention Ring	Non-S/R Structural Support
SG Primary Nozzles and Safe Ends	Pressure Boundary
SG Secondary Manways and Flanges	Pressure Boundary
SG Secondary Nozzles and Safe Ends	Pressure Boundary Throttle
SG Secondary Shell	Pressure Boundary
SG Tubes	Heat Transfer Pressure Boundary
SG Tubesheet	Pressure Boundary
Tubing	Pressure Boundary

2.3.1.5 Reactor Core

System Description

The reactor core is composed of 241 fuel assemblies and 89 control element assemblies (CEAs). The fuel assembly, which provides for 236 fuel rod and 20 guide tube positions (16 x 16 array), consists of 5 guide tubes welded to 11 fuel rod spacer grids and is closed at the top and bottom by end fittings. Each of the 5 guide tubes displace four fuel rod positions and provides guidance channels for the CEAs over their entire length of travel with incore instrumentation inserted in the central guide tube of selected fuel assemblies. The incore instrumentation is routed into the bottom of the fuel assemblies through the bottom head of the reactor vessel.

Each fuel rod consists of slightly enriched uranium in the form of sintered uranium dioxide pellets, enclosed in a pressurized zircaloy or ZIRLO tube that forms a hermetic enclosure.

System Intended Function

Each fuel rod in the reactor core allows efficient heat transfer to the coolant and cladding and provides a fission product barrier. The control element assemblies (CEAs) together with the guide tubes control short-term reactivity changes and are used for rapid reactor

Section 2.3

SCOPING AND SCREENING RESULTS: MECHANICAL SYSTEMS

shutdown. The reactor core is within the scope of license renewal based on the criteria of 10 CFR 54.4(a)(1).

Based on the safe shutdown analysis, the initial reactor reactivity control relies on the CEAs which are inserted when the reactor trip breaker is de-energized. Portions of the system support fire protection requirements based on the criteria of 10 CFR 54.4(a)(3).

However, the CEA fingers are considered to be short-lived with a lifetime of about 5 cycles due to accumulative neutron burnup. The fuel assemblies are also considered to be short-lived since they are typically replaced at regular interval based on plant fuel cycle.

Thus, no components of the reactor core system are subject to aging management review.

PVNGS UFSAR References

Additional details of the reactor core are included in [UFSAR Sections 4.1, 4.2, and 4.3](#).

License Renewal Drawings

There are no license renewal drawings for the reactor core.

Component-Function Relationship Table

The component types subject to aging management review are indicated in [Table 2.3.1-5 - Reactor Core](#).

Table 2.3.1-5 Reactor Core

Component Type	Intended Function
None	N/A

2.3.2 Engineered Safety Features

This section of the application addresses scoping and screening results for the following systems:

- [Containment leak test](#)
- [Containment purge](#)
- [Containment hydrogen control](#)
- [Safety injection and shutdown cooling](#)

2.3.2.1 Containment Leak Test System

System Description

The purpose of the containment leak test system is to provide a means for periodic testing of containment leakage by pressurizing the containment building and monitoring leakage to the atmosphere. The system consists of filters, dryers, instrumentation, piping and valves associated with delivering compressed air to the containment for conducting the integrated leak rate test. PVNGS uses portable compressors and dryer skids for delivery of compressed air to the containment during testing. The system containment penetrations are isolated with blank flanges during normal plant operation and form part of the containment boundary.

System Intended Function

The containment leak test system provides a containment integrity function by normally installed blank flanges inboard and outboard of all containment leak test system penetrations through the containment wall. Portions of the containment integrated leak rate test system are within the scope of license renewal based on the criteria of 10 CFR 54.4(a)(1).

PVNGS UFSAR References

Additional details of the containment leak test system are included in [UFSAR Sections 6.2.1, 6.2.4, and 6.2.6](#).

License Renewal Drawings

The license renewal drawing for the containment leak test system is listed below: [LR-PVNGS-CL-01-M-CLP-001](#)

Component-Function Relationship Table

The component types subject to aging management review are indicated in [Table 2.3.2-1 - Containment Leak Test System](#).

Table 2.3.2-1 Containment Leak Test System

Component Type	Intended Function
Closure Bolting	Pressure Boundary
Piping	Pressure Boundary

2.3.2.2 Containment Purge System

System Description

The normal purge system for the containment consists of a refueling purge and a power access purge. The refueling purge train is used for high flow rate purge during refueling and is closed during normal power generation. It consists of a supply air handling unit and an exhaust fan.

The power access purge is used for low flow rate purge prior to and during power access periods. It consists of a supply air handling unit and charcoal exhaust filtration unit. The purge supply and exhaust units are located on the roof of the auxiliary building. Containment supply and exhaust penetrations and isolation valves for refueling purge are 42-inch diameter, and for power access purge they are 8-inch diameter. A containment isolation actuation signal (CIAS) or a containment purge isolation activation signal (CPIAS) from the ESFAS automatically initiates closure of these valves.

System Intended Function

The containment isolation function is provided by two isolation valves (one inside and one outside of the containment building) at each supply and exhaust line associated with the containment refueling purge and containment power access purge systems. The containment purge system is within the scope of license renewal based on the criteria of 10 CFR 54.4(a)(1).

Portions of the containment purge system are within the scope of license renewal as nonsafety affecting safety-related components based on the criterion of 10 CFR 54.4(a)(2).

Portions of the containment purge system support environmental qualification requirements based on the criteria of 10 CFR 54.4(a)(3).

PVNGS UFSAR References

Additional details of the containment purge system are included in [UFSAR Sections 6.2.4.2.3, 9.4.6.2.2, and 7.3.1.1.10.1](#).

License Renewal Drawings

The license renewal drawing for the containment purge system is listed below:

LR-PVNGS-CP-01-M-CPP-001

Component-Function Relationship Table

The component types subject to aging management review are indicated in [Table 2.3.2-2—Containment Purge System](#).

Table 2.3.2-2 Containment Purge System

Component Type	Intended Function
Closure Bolting	Pressure Boundary Structural Integrity (Attached)
Ductwork	Non-S/R Structural Support Pressure Boundary Structural Integrity (Attached)
Flex Connectors	Pressure Boundary
Heater	Structural Integrity (Attached)
Orifice	Non-S/R Structural Support Pressure Boundary
Piping	Pressure Boundary Structural Integrity (Attached)
Valve	Non-S/R Structural Support Pressure Boundary

2.3.2.3 Containment Hydrogen Control System

System Description

The containment hydrogen control system is designed to maintain the containment hydrogen concentration below 4.0% by volume. Two hydrogen recombiners, their associated control cabinets, and one hydrogen purge exhaust air filtration unit (AFU) are staged in Unit 1 and shared by all three units at the site. Each units system is designed with the necessary electrical and mechanical connections to accommodate the shared equipment. The design includes provisions to install the system, with all required services connected, within 72 hours following a loss-of-coolant-accident (LOCA), and have the system operable within 100 hours of the same LOCA.

The containment hydrogen control system consists of a hydrogen monitoring subsystem that measures the containment atmosphere hydrogen concentration, a hydrogen recombiner subsystem that provides the primary means of reducing hydrogen concentrations, and a hydrogen purge subsystem that provides a backup capability for a controlled purge of the containment atmosphere.

Section 2.3

SCOPING AND SCREENING RESULTS: MECHANICAL SYSTEMS

The redundant hydrogen monitoring system is designed to measure hydrogen concentration inside the containment building at two independent locations and to alert the operator in the control room of the need to start the hydrogen recombiners or the hydrogen purge system.

There are two portable, independent and redundant containment hydrogen recombiners. Only one recombiner is required to reduce the post-LOCA hydrogen concentration in the containment building. Each takes suction on a separate 2-inch supply line and discharges to a separate 2-inch return line. However, cross connections allow use of either recombiner on either pair of supply and return lines.

The hydrogen purge exhaust AFU serves as a backup to the hydrogen recombiners. The hydrogen purge system would only be utilized in the event of the combined failure of both hydrogen recombiners.

Except for the required periodic testing, the containment hydrogen control system is not in service during normal plant operations.

System Intended Function

The containment hydrogen control system monitors the hydrogen concentration in the containment building and maintains the hydrogen concentration inside the containment below the lower combustible limit of 4 percent by volume in air following a LOCA. The containment isolation function is provided by two isolation valves (one inside and one outside) at the containment penetrations of each 2-inch supply and 2-inch return line associated with each hydrogen recombiner. The containment hydrogen control system is within the scope of license renewal based on the criteria of 10 CFR 54.4(a)(1).

Portions of the containment hydrogen control system support environmental qualification requirements based on the criteria of 10 CFR 54.4(a)(3).

PVNGS UFSAR References

Additional details of the containment hydrogen control system are included in [UFSAR Sections 1.2.4, 6.2.4, 6.2.5, Table 3.9-25, Table 3.9-27, and Table 6.2.4-1.](#)

License Renewal Drawings

The license renewal drawing for the containment hydrogen control system are listed below:
[LR-PVNGS-HP-01-M-HPP-001](#)
[LR-PVNGS-SS-01-N-SSP-002-1](#)

Component-Function Relationship Table

The component types subject to aging management review are indicated in [Table 2.3.2-3—Containment Hydrogen Control System.](#)

Section 2.3
SCOPING AND SCREENING RESULTS: MECHANICAL SYSTEMS

Table 2.3.2-3 Containment Hydrogen Control System

Component Type	Intended Function
Blower	Pressure Boundary
Closure Bolting	Pressure Boundary Structural Integrity (Attached)
Damper	Fire Barrier Pressure Boundary
Ductwork	Pressure Boundary
Filter	Filter Pressure Boundary
Flexible Hoses	Pressure Boundary
Flow Element	Pressure Boundary
Heat Exchanger (H2 Recombiner Airblast)	Heat Transfer Pressure Boundary
Orifice	Pressure Boundary Throttle
Piping	Pressure Boundary Structural Integrity (Attached)
Pump	Pressure Boundary
Reaction Chamber	Pressure Boundary
Tubing	Pressure Boundary
Valve	Pressure Boundary Structural Integrity (Attached)

2.3.2.4 Safety Injection and Shutdown Cooling System

System Description

The safety injection and shutdown cooling system provides the high pressure and low pressure safety injection functions, the shutdown cooling function and the containment spray function. The majority of the mechanical components are located in the auxiliary building with some major components located in the containment building.

The safety injection and shutdown cooling system also includes the trisodium phosphate baskets which are installed near the vicinity of the containment sumps to hold trisodium phosphate. The trisodium phosphate is designed to maintain post-LOCA sump fluid pH levels within acceptable limits. The safety injection and shutdown cooling system also includes the containment sumps (and screens and liners) which provide a source of water for safety injection pump suction. The system contains piping which penetrates containment and contains the necessary containment isolation valves.

SCOPING AND SCREENING RESULTS: MECHANICAL SYSTEMS

There are a total of two safety injection trains per unit. Each train's major components consist of one high-pressure pump, one low-pressure pump, one containment spray pump, one heat exchanger and safety injection tanks. The safety injection tanks and the pump trains discharge borated water to the reactor coolant system. The shutdown cooling function utilizes the low-pressure and containment spray pumps with a reactor coolant system suction path, discharge through a heat exchanger and then to a reactor coolant system injection path. The containment spray function utilizes the containment spray pump with a discharge path to one of two containment spray headers inside of the primary containment.

There are four safety injection tanks per unit which contain pressurized nitrogen and borated water. These tanks passively discharge their borated water contents to the reactor coolant system through check valves following reactor coolant system depressurization.

The high pressure and low pressure trains each consist of pumps with a suction from either the refueling water tank or from the containment sumps (i.e. when in the recirculation mode) and discharge to the reactor coolant system through injection valves in the high-pressure or low-pressure injection headers, respectively.

The shutdown cooling trains each consist of a low-pressure safety injection pump and a containment spray pump with a suction from the reactor coolant system, flow through the shutdown cooling heat exchanger (which is cooled by the essential cooling water system) and a return path of the reactor coolant back to the reactor coolant system through injection valves to the low-pressure injection header.

The containment spray trains each consist of a pump with suction from either the refueling water tank or from the containment sumps (when in the recirculation mode). The spray water is cooled by the shutdown cooling heat exchanger (which receives its cooling water from the essential cooling water system) and is then discharged to the train's spray header into containment. There is no introduction of chemicals into the containment spray trains to reduce the containment iodine levels.

System Intended Function

The function of the safety injection and shutdown cooling system is to provide the safety injection, shutdown cooling and containment spray functions. The safety injection tanks provide core cooling, inventory control and reactivity control to the reactor coolant system as a result of a design basis event. The high pressure and low pressure reactor coolant injection trains provide core cooling, inventory control and reactivity control to the reactor coolant system as a result of a design basis event. The low pressure pumps and the containment spray pumps also provide the motive force for the shutdown cooling function. The shutdown cooling trains provide core cooling, inventory control and reactivity control via flow from and to the reactor coolant system. The containment spray trains provide containment cooling, containment pressure control, hydrogen mixing to prevent local hydrogen buildup, and iodine removal as a result of a design basis event. The containment spray pumps can also provide the motive force for the shutdown cooling function. The

SCOPING AND SCREENING RESULTS: MECHANICAL SYSTEMS

safety injection and shutdown cooling system is within the scope of license renewal based on the criteria of 10 CFR 54(a)(1).

Portions of the safety injection and shutdown cooling system are within the scope of license renewal as nonsafety affecting safety-related components based on the criterion of 10 CFR 54(a)(2).

Portions of the safety injection and shutdown cooling system support fire protection, environmental qualification and station blackout requirements based on the criteria of 10 CFR 54(a)(3).

PVNGS UFSAR References

Additional details of the safety injection and shutdown cooling system are included in [UFSAR Sections 5.4.7, 6.2.2, 6.2.4, 6.3, 6.5.2, and 8.3.1.1.10](#).

License Renewal Drawings

The license renewal drawings for the safety injection and shutdown cooling system are listed below:

[LR-PVNGS-CH-01-M-CHP-001](#)
[LR-PVNGS-CH-01-M-CHP-002](#)
[LR-PVNGS-CH-01-M-CHP-003](#)
[LR-PVNGS-DW-01-M-DWP-0002](#)
[LR-PVNGS-GA-02-M-GAP-001](#)
[LR-PVNGS-PC-01-M-PCP-001](#)
[LR-PVNGS-SI-01-M-SIP-001](#)
[LR-PVNGS-SI-01-M-SIP-002](#)
[LR-PVNGS-SI-01-M-SIP-003](#)
[LR-PVNGS-SS-01-N-SSP-002-1](#)

Component-Function Relationship Table

The component types subject to aging management review are indicated in [Table 2.3.2-4 - Safety Injection and Shutdown Cooling System](#).

Section 2.3
SCOPING AND SCREENING RESULTS: MECHANICAL SYSTEMS

Table 2.3.2-4 Safety Injection and Shutdown Cooling System

Component Type	Intended Function
Accumulator	Pressure Boundary
Closure Bolting	Pressure Boundary
Filter	Filter Structural Support
Flow Element	Pressure Boundary
Flow Indicator	Leakage Boundary (Spatial)
Heat Exchanger (Shutdown Cooling)	Heat Transfer Pressure Boundary
Insulation	Insulate (Mechanical)
Orifice	Pressure Boundary Throttle
Piping	Leakage Boundary (Spatial) Pressure Boundary Structural Integrity (Attached)
Pump	Pressure Boundary
Screen	Filter Structural Support
Spray Nozzle	Pressure Boundary Spray
Sump Liner	Structural Pressure Boundary
Tubing	Leakage Boundary (Spatial) Pressure Boundary
Valve	Leakage Boundary (Spatial) Pressure Boundary

2.3.3 Auxiliary Systems

This section of the application addresses scoping and screening results for the following systems:

- Fuel handling and storage
- Spent fuel pool cooling and cleanup
- Essential cooling water
- Essential chilled water
- Normal chilled water
- Nuclear cooling water
- Essential spray pond
- Nuclear sampling
- Compressed air
- Chemical and volume control
- Control building HVAC
- Auxiliary building HVAC
- Fuel building HVAC
- Containment building HVAC
- Diesel generator building HVAC
- Radwaste building HVAC
- Turbine building HVAC
- Miscellaneous site structures/spray pond pump house HVAC
- Fire protection
- Diesel generator fuel oil storage and transfer
- Diesel generator
- Domestic water
- Demineralized water
- WRF fuel system
- Service gases (N₂ and H₂)
- Gaseous radwaste
- Radioactive waste drains
- Station blackout generator
- Cranes, hoists, and elevators
- Miscellaneous auxiliary systems in-scope only for criterion 10 CFR 54.4(a)(2):
 - Auxiliary steam
 - Chemical waste
 - Liquid radwaste
 - Oily waste and non-radioactive waste
 - Solid radwaste
 - Sanitary sewage and treatment

- Secondary chemical control

2.3.3.1 Fuel Handling and Storage System

System Description

The purpose of the fuel handling and storage system is to provide on site storage of new and spent fuel assemblies, provide manipulation of fuel assemblies and control element assemblies, provide radiation shielding for spent fuel and provide for the servicing of the reactor vessel closure head and internals. Crane supports are evaluated with their appropriate structure. The system consists of cranes, elevators, fuel storage racks, lift rigs, machines, transfer systems and trolleys. The following components are within the scope of license renewal:

- containment building polar crane
- 150/15 ton dry cask crane
- 10 ton new fuel handling crane
- spent fuel handling machine
- new fuel elevator
- refueling machine
- CEA change platform
- upper guide structure lift rig
- core support barrel lift rig
- reactor vessel head lift rig
- new fuel storage racks
- spent fuel storage racks
- fuel transfer carriage and trolley assembly (rails)

System Intended Function

The fuel handling and storage system is within the scope of license renewal based on the criteria of 10 CFR 54(a)(1).

Portions of the fuel handling and storage system have spatial interaction as nonsafety affecting safety-related components in the fuel and the containment buildings and are in-scope based on the criterion of 10 CFR 54(a)(2).

PVNGS UFSAR References

Additional details of the fuel handling and storage system are included in [UFSAR Sections 9.1.1, 9.1.2, and 9.1.4](#).

License Renewal Drawings

There are no license renewal drawings for the fuel handling and storage system.

Component-Function Relationship Table

The component types subject to aging management review are indicated in [Table 2.3.3-1](#) - Fuel Handling and Storage System.

Table 2.3.3-1 Fuel Handling and Storage System

Component Type	Intended Function
Crane	Non-S/R Structural Support Structural Support
Cranes - Rails	Non-S/R Structural Support Structural Support
Elevator	Non-S/R Structural Support
Fuel Handling Equipment	Leakage Boundary (Spatial) Non-S/R Structural Support
Hoist	Non-S/R Structural Support
New Fuel Racks	Non-S/R Structural Support
Spent Fuel Racks	Structural Support
Trolley	Non-S/R Structural Support Structural Support

2.3.3.2 Spent Fuel Pool Cooling and Cleanup System

System Description

The spent fuel pool cooling and clean up system consists of two sub-systems, corresponding to the system's two major functions which include removal of decay heat from spent fuel and removal of materials from spent fuel pool water to maintain pool clarity and reduce radiation at the pool surface. The spent fuel pool cooling and cleanup system also provides borated water from the spent fuel pool to the chemical and volume control system. Spent fuel pool liner and associated spent fuel pool gates are evaluated with the fuel building structure in [Section 2.4.9](#).

The spent fuel pool cooling system consists of two independent, full capacity trains. Each train includes a spent fuel cooling pump, a fuel pool heat exchanger and related piping, valves and instrumentation. Both pumps are connected to a common suction header and a common return header. The spent fuel pool cooling pumps circulate fuel pool water through the two fuel pool heat exchangers. During normal operation the water is cooled by nuclear cooling water. When nuclear cooling water is not available cooling is provided by the essential cooling water system.

The spent fuel pool cleanup system also consists of two independent, full capacity trains each having a strainer, a pump, a filter, an ion exchanger and related piping and

instrumentation. Each of the trains may be aligned to continuously clean the water in the spent fuel pool or thru refueling water tank. During refueling the spent fuel pool cleanup system can be aligned to the refueling pool.

System Intended Function

The spent fuel pool cooling and cleanup system maintains the spent fuel storage pool water temperature below prescribed limits by removing decay heat generated by stored spent fuel assemblies. Fuel pool cooling and cleanup system includes two piping penetrations providing containment isolation. The spent fuel pool cooling and cleanup system provides a backup source of borated water to the chemical and volume control system via the spent fuel pool to achieve safe shutdown by supporting reactivity control. The spent fuel pool cooling and cleanup system is within the scope of license renewal based on the criteria of 10 CFR 54(a)(1).

Portions of the spent fuel pool cooling and cleanup system have spatial interaction as nonsafety affecting safety-related components in the fuel, auxiliary, and containment buildings and are in-scope based on the criterion of 10 CFR 54(a)(2).

Portions of the spent fuel pool cooling and cleanup system support station blackout requirements based on the criteria of 10 CFR 54(a)(3).

PVNGS UFSAR References

Additional details of the spent fuel pool cooling and cleanup system are included in [UFSAR Sections 9.1.3](#) and [9.3.4.5](#).

License Renewal Drawings

The license renewal drawing for the spent fuel pool cooling and cleanup system is listed below:

[LR-PVNGS-PC-01-M-PCP-001](#)

Component-Function Relationship Table

The component types subject to aging management review are indicated in [Table 2.3.3-2 - Spent Fuel Pool Cooling and Cleanup System](#).

Table 2.3.3-2 Spent Fuel Pool Cooling and Cleanup System

Component Type	Intended Function
Closure Bolting	Leakage Boundary (Spatial) Pressure Boundary Structural Integrity (Attached)
Demineralizer	Leakage Boundary (Spatial)
Expansion Joint	Leakage Boundary (Spatial) Pressure Boundary Structural Integrity (Attached)
Filter	Leakage Boundary (Spatial)
Flow Element	Pressure Boundary
Heat Exchanger (Fuel Pool Cooling)	Heat Transfer Pressure Boundary
Piping	Leakage Boundary (Spatial) Pressure Boundary Structural Integrity (Attached)
Pump	Leakage Boundary (Spatial) Pressure Boundary Structural Integrity (Attached)
Sight Gauge	Leakage Boundary (Spatial)
Strainer	Leakage Boundary (Spatial)
Tubing	Leakage Boundary (Spatial) Pressure Boundary
Valve	Leakage Boundary (Spatial) Pressure Boundary Structural Integrity (Attached)

2.3.3.3 Essential Cooling Water System

System Description

The essential cooling water system removes heat from all essential components required for normal and emergency shutdown of the plant (with the exception of the diesel generator units) and rejects the heat to the essential spray ponds through the essential cooling water heat exchanger. The system also provides a back-up source of cooling water for the fuel pool cooling heat exchangers, reactor coolant pumps, CEDM normal air cooling units, nuclear sample coolers and normal chillers when the nuclear cooling water system is not available. The system provides an intermediate barrier between the reactor coolant system

Section 2.3
SCOPING AND SCREENING RESULTS:
MECHANICAL SYSTEMS

and the essential spray pond system to reduce the possibility of radioactive leakage to the environment.

The essential cooling water system consists of two separate, independent, redundant, safety-related flow trains. Either flow train can supply sufficient cooling water to allow a safe plant shutdown independent of the other flow train. Each train includes a heat exchanger, surge tank, pump, chemical addition tank, piping, valves, and associated instrumentation and controls.

System Intended Function

The essential cooling water system provides cooling water to transfer heat from plant components, to accomplish core cooling and safe shutdown of the reactor, to the essential spray ponds. The essential cooling water system also provides an emergency back-up source of cooling water for the fuel pool cooling heat exchangers. The essential cooling water system is within the scope of license renewal based on the criteria of 10 CFR 54.4(a)(1).

Portions of the essential cooling water system in the auxiliary building and control building contains nonsafety-related components that are spatially oriented such that their failure could prevent the satisfactory accomplishment of a safety-related function associated with a safety-related component. Also, portions of the essential cooling water system attach to safety-related piping such that their structural failure could prevent satisfactory accomplishment of safety-related system functions. Therefore, portions of the system are within the scope of license renewal as nonsafety-related affecting safety-related components based on the criterion of 10 CFR 54.4(a)(2).

Portions of the essential cooling water system support fire protection, environmental qualification and station blackout requirements based on the criteria of 10 CFR 54.4(a)(3).

PVNGS UFSAR References

Additional details of the essential cooling water system are included in [UFSAR Section 9.2.2.1](#).

License Renewal Drawings

The license renewal drawing for the essential cooling water system is listed below: [LR-PVNGS-EW-01-M-EWP-001](#)

Component-Function Relationship Table

The component types subject to aging management review are indicated in [Table 2.3.3-3 - Essential Cooling Water System](#).

Section 2.3
SCOPING AND SCREENING RESULTS:
MECHANICAL SYSTEMS

Table 2.3.3-3 Essential Cooling Water System

Component Type	Intended Function
Chamber (sample)	Pressure Boundary
Closure Bolting	Leakage Boundary (Spatial) Pressure Boundary Structural Integrity (Attached)
Flow Element	Pressure Boundary
Heat Exchanger (ECWS Heat Exchanger)	Heat Transfer Pressure Boundary
Orifice	Pressure Boundary Throttle
Piping	Leakage Boundary (Spatial) Pressure Boundary Structural Integrity (Attached)
Pump	Pressure Boundary
Sight Gauge	Leakage Boundary (Spatial) Pressure Boundary Structural Integrity (Attached)
Strainer	Leakage Boundary (Spatial) Structural Integrity (Attached)
Tank	Leakage Boundary (Spatial) Pressure Boundary Structural Integrity (Attached)
Tubing	Pressure Boundary
Valve	Leakage Boundary (Spatial) Pressure Boundary

2.3.3.4 Essential Chilled Water System

System Description

The essential chilled water system provides cooling to engineered safety features air handling equipment so that a suitable environment can be maintained for personnel and equipment during a design basis accident or transient.

The essential chilled water system is a closed loop system consisting of two independent trains. Each 100% capacity train consists of a chilled water refrigeration unit, a chilled water circulation pump, an expansion tank, control valves, instrumentation and insulated piping. Each 100% capacity refrigeration unit consists of a compressor, evaporator, refrigerant condenser/receiver, instrumentation and controls. The chilled water refrigeration unit, pump and expansion tank for each train are located in the control building.

Section 2.3
SCOPING AND SCREENING RESULTS:
MECHANICAL SYSTEMS

The essential chilled water system does not function during normal plant operation. Following an engineered safety features actuation signal, the normally operating nonsafety-related chilled water system is secured and the essential chilled water system is started to provide cooling to engineered safety features air handling units in the following areas: control room complex, DC equipment room, ESF switchgear room, safety injection pump rooms, containment spray pump rooms, auxiliary feedwater pump rooms, essential cooling water pump rooms and electrical penetration rooms.

System Intended Function

The essential chilled water system provides cooling to ESF air handling equipment so that a suitable environment can be maintained for personnel and equipment during a design basis accident or transient. The essential chilled water system is within the scope of license renewal based on the criteria of 10 CFR 54.4(a)(1).

Nonsafety-related portions of the essential chilled water system located in the auxiliary and control buildings have spatial relationships such that their failure could adversely impact the performance of safety-related components' intended functions. Also, nonsafety-related portions of the essential chilled water system attach to safety-related components such that their structural failure could prevent satisfactory accomplishment of safety-related system functions. Therefore, portions of the essential chilled water system are within the scope of license renewal as nonsafety affecting safety-related components based on the criterion of 10 CFR 54.4(a)(2).

The essential chilled water system supports fire protection and station blackout requirements based on the criteria of 10 CFR 54.4(a)(3).

PVNGS UFSAR References

Additional details of the essential chilled water system are included in [UFSAR Sections 6.4, 9.2.9.2 and 9.5.1](#).

License Renewal Drawings

The license renewal drawings for the essential chilled water system are listed below:
[LR-PVNGS-CT-01-M-CTP-001](#)
[LR-PVNGS-DW-01-M-DWP-0002](#)
[LR-PVNGS-EC-01-M-ECP-001](#)
[LR-PVNGS-EW-01-M-EWP-001](#)
[LR-PVNGS-GA-02-M-GAP-001](#)
[LR-PVNGS-RD-01-M-RDP-002](#)

Component-Function Relationship Table

The component types subject to aging management review are indicated in [Table 2.3.3-4 – Essential Chilled Water System](#).

Section 2.3
SCOPING AND SCREENING RESULTS:
MECHANICAL SYSTEMS

Table 2.3.3-4 Essential Chilled Water System

Component Type	Intended Function
Closure Bolting	Leakage Boundary (Spatial) Pressure Boundary Structural Integrity (Attached)
Compressor	Pressure Boundary
Filter	Pressure Boundary
Flexible Hoses	Pressure Boundary
Flow Element	Pressure Boundary
Heat Exchanger (EC Chiller Compressor Oil Cooler)	Heat Transfer Pressure Boundary
Heat Exchanger (EC Chiller Condenser)	Heat Transfer Pressure Boundary
Heat Exchanger (EC Chiller Contact Economizer)	Heat Transfer Pressure Boundary
Heat Exchanger (EC Chiller Water Cooler)	Heat Transfer Pressure Boundary
Heat Exchanger (EC Pump-Out Unit Condenser)	Non-S/R Structural Support
Orifice	Pressure Boundary Throttle
Piping	Leakage Boundary (Spatial) Pressure Boundary Structural Integrity (Attached)
Pump	Pressure Boundary
Sight Gauge	Leakage Boundary (Spatial) Non-S/R Structural Support Pressure Boundary Structural Integrity (Attached)
Strainer	Leakage Boundary (Spatial) Pressure Boundary Structural Integrity (Attached)
Tank	Leakage Boundary (Spatial) Non-S/R Structural Support Pressure Boundary Structural Integrity (Attached)
Tubing	Leakage Boundary (Spatial) Non-S/R Structural Support Pressure Boundary
Valve	Leakage Boundary (Spatial) Non-S/R Structural Support Pressure Boundary Structural Integrity (Attached)

2.3.3.5 Normal Chilled Water System

System Description

The normal chilled water system provides cooling to air handling equipment so that plant ventilation can maintain a suitable environment for personnel and equipment.

The normal chilled water system is a closed-loop system. It consists of chilled water refrigeration units, chilled water circulation pumps, an expansion tank, control valves, instrumentation and insulated piping. Three 50% capacity refrigeration units are provided each consisting of a compressor, evaporator, condenser/receiver, instrumentation and controls. The normal chilled water system operates during normal plant operations, during hot standby and during programmed refueling or maintenance shutdown periods. Chilled water is circulated by the chilled water pumps from the chillers to the air cooling coils of the individual normal air handling units. The normal chilled water system supplies the chilled water to the cooling coils in the normally operating air handling units in the containment, control, radwaste, auxiliary buildings, and to non-nuclear process sampling points in the turbine building.

Upon receipt of an ESF system actuation signal, the normal chilled water system ceases operation. Upon receipt of a containment isolation actuation signal, the normal chilled water system supply and return lines penetrating containment are isolated.

System Intended Function

The normal chilled water system includes safety-related components required to achieve the containment integrity during accident conditions. Portions of the normal chilled water system provide a containment isolation function. The normal chilled water system is within the scope of license renewal based on the criteria of 10 CFR 54.4(a)(1).

Nonsafety-related portions of the normal chilled water system located in the containment building, the auxiliary building and the control building have spatial relationships such that their failure could adversely impact the performance of safety-related components' intended functions. Also, nonsafety-related portions of the normal chilled water system attach to safety-related piping such that their structural failure could prevent satisfactory accomplishment of safety-related system functions. Therefore, portions of the normal chilled water system are within the scope of license renewal as nonsafety affecting safety-related components based on the criterion of 10 CFR 54(a)(2).

Portions of the normal chilled water system support environmental qualification requirements based on the criteria of 10 CFR 54(a)(3).

PVNGS UFSAR References

Additional details of the normal chilled water system are included in [UFSAR Section 9.2.9.1](#) and [Table 6.2.4-1](#).

License Renewal Drawings

The license renewal drawings for the normal chilled water system are listed below:
[LR-PVNGS-WC-01-M-SCP-006-4](#)
[LR-PVNGS-WC-01-M-WCP-001](#)

Component-Function Relationship Table

The component types subject to aging management review are indicated in [Table 2.3.3-5 – Normal Chilled Water System](#).

Table 2.3.3-5 Normal Chilled Water System

Component Type	Intended Function
Closure Bolting	Leakage Boundary (Spatial) Pressure Boundary Structural Integrity (Attached)
Flexible Hoses	Leakage Boundary (Spatial)
Flow Element	Leakage Boundary (Spatial)
Orifice	Leakage Boundary (Spatial)
Piping	Leakage Boundary (Spatial) Pressure Boundary Structural Integrity (Attached)
Strainer	Leakage Boundary (Spatial)
Tubing	Leakage Boundary (Spatial)
Valve	Leakage Boundary (Spatial) Pressure Boundary

2.3.3.6 Nuclear Cooling Water System

System Description

The nuclear cooling water system provides heat removal for the cooling of plant auxiliary systems and components including the reactor coolant pumps, the boric acid concentrator, the waste gas compressor, the radwaste evaporator, the normal chilled water chillers, the letdown heat exchanger, the fuel pool heat exchangers, the control element drive mechanisms, the auxiliary steam vent condenser and various sample coolers.

The nuclear cooling water system consists of one closed-loop flow train with full unit cooling capacity. The single loop includes redundant 100% capacity pumps, redundant 100% heat exchangers, an expansion tank, heat exchangers associated with nonsafety-related plant auxiliary systems and components, instrumentation and associated piping. The nuclear

Section 2.3
SCOPING AND SCREENING RESULTS:
MECHANICAL SYSTEMS

cooling water system is required to operate during normal plant power generation operation and during normal shutdown. The nuclear cooling water system is located in the auxiliary, containment, fuel, radwaste, and turbine buildings, piping tunnels and outside areas.

Upon receipt of a containment isolation actuation signal, the nuclear cooling water system supply and return lines penetrating containment are isolated.

System Intended Function

Portions of the nuclear cooling water system provide a containment isolation function. The nuclear cooling water system is within the scope of license renewal based on the criteria of 10 CFR 54.4(a)(1).

Portions of the nuclear cooling water system located in the containment, auxiliary, and fuel buildings and the piping tunnels have spatial relationships such that their failure could adversely impact the performance of safety-related components' intended functions. Portions of the nuclear cooling water system attach to safety-related piping such that their structural failure could prevent satisfactory accomplishment of safety-related system functions. Therefore, portions of the nuclear cooling water system are within the scope of license renewal as nonsafety affecting safety-related components based on the criterion of 10 CFR 54.4(a)(2).

The nuclear cooling water system supports fire protection and environmental qualification requirements based on the criteria of 10 CFR 54.4(a)(3).

PVNGS UFSAR References

Additional details of the nuclear cooling water system are included in [UFSAR Sections 6.2.4, 8.3.1.1.3, 9.2.2.2, 9.5.1, and 15.6.5](#).

License Renewal Drawings

The license renewal drawings for the nuclear cooling water system are listed below:

- [LR-PVNGS-EW-01-M-EWP-001](#)
- [LR-PVNGS-NC-01-M-NCP-001](#)
- [LR-PVNGS-NC-01-M-NCP-002](#)
- [LR-PVNGS-NC-01-M-NCP-003](#)
- [LR-PVNGS-SC-01-M-SCP-006-01](#)

Component-Function Relationship Table

The component types subject to aging management review are indicated in [Table 2.3.3-6 – Nuclear Cooling Water System](#).

Table 2.3.3-6 Nuclear Cooling Water System

Component Type	Intended Function
Closure Bolting	Leakage Boundary (Spatial) Pressure Boundary Structural Integrity (Attached)
Flexible Hoses	Leakage Boundary (Spatial) Pressure Boundary
Flow Element	Leakage Boundary (Spatial) Pressure Boundary
Flow Indicator	Leakage Boundary (Spatial) Pressure Boundary
Piping	Leakage Boundary (Spatial) Pressure Boundary Structural Integrity (Attached)
Tubing	Leakage Boundary (Spatial)
Valve	Leakage Boundary (Spatial) Pressure Boundary Structural Integrity (Attached)

2.3.3.7 Essential Spray Pond System

System Description

The purpose of the essential spray pond system is to remove heat from engineered safety features and safety-related components and dissipate it to the atmosphere via the essential spray ponds (ultimate heat sink) under normal and accident conditions.

The essential spray pond system consists of two separate and redundant trains each comprised of a pump, piping, valves, instrumentation and controls and pond required to provide cooling water to its associated train of nuclear safety-related components. Cooling is provided directly to the cooling systems of the diesel generators and indirectly to other systems through the essential cooling water system heat exchangers.

Cooling water for each train is supplied from a separate essential spray pond, which serves as the ultimate heat sink. Each essential spray pond is a vertical walled, reinforced concrete structure 345 ft by 172 ft with a depth of 15.5 ft capable of holding sufficient water to provide 26 days of cooling without make-up. Spray heads over each of the essential spray ponds are arranged to minimize interference between sprays and designed to develop optimum spray drop size spectrum to maximize cooling and to minimize drift losses. Each train alone has a 100% heat dissipation capacity for safe shutdown. Both trains are automatically actuated by the ESF actuation system and manually by control room operators. Upon receipt of an actuation signal, each essential spray pond pump starts, taking suction on its associated essential spray pond via a separate intake structure and discharging in parallel through the associated diesel generator cooling systems and through the associated

Section 2.3
SCOPING AND SCREENING RESULTS:
MECHANICAL SYSTEMS

essential cooling water system heat exchanger. Valves in the supply lines from the pumps and in the return lines to the essential spray ponds are manually and locally operated and are locked open.

Essential spray pond systems, structures and components are primarily located outdoors in or adjacent to the essential spray ponds or within the adjacent essential spray pond pump houses. Other components are located in the essential pipe tunnels, in the diesel generator building and in the auxiliary building.

System Intended Function

The essential spray pond system provides the ultimate heat sink for the removal of process and operating heat from safety-related components during a DBA or transient and also during normal operating conditions. Each essential spray pond system train independently is designed to remove sufficient heat to ensure a safe reactor shutdown coincident with a loss of offsite power. The essential spray pond system provides for a gradual reduction in the temperature of the containment sump fluid as it is supplied to the reactor coolant system by the safety injection pumps. Additionally, the essential spray pond system functions as a backup to the spent fuel pool cooling system when the nuclear cooling water system is unavailable. The essential spray pond system is within the scope of license renewal based on the criteria of 10 CFR 54.4(a)(1).

Portions of the essential spray pond system have spatial interaction as nonsafety affecting safety-related components in the auxiliary building and the diesel generator building. Portions of the essential spray pond system provide structural integrity attached to safety-related equipment. Therefore, portions of the essential spray pond system are within the scope of license renewal as nonsafety affecting safety-related components based on the criterion of 10 CFR 54(a)(2).

The essential spray pond system supports fire protection and station blackout requirements based on the criteria of 10 CFR 54.4(a)(3).

PVNGS UFSAR References

Additional details of the essential spray pond system are included in [UFSAR Sections 9.2.1](#) and [9.2.5](#).

License Renewal Drawings

The license renewal drawings of the essential spray pond system are listed below:
[LR-PVNGS-DG-01-M-DGP-001-5](#)
[LR-PVNGS-EW-01-M-EWP-001](#)
[LR-PVNGS-SP-01-M-SPP-001-1](#)
[LR-PVNGS-SP-01-M-SPP-002](#)

Component-Function Relationship Table

The component types subject to aging management review are indicated in [Table 2.3.3-7](#) - Essential Spray Pond System.

Table 2.3.3-7 Essential Spray Pond System

Component Type	Intended Function
Closure Bolting	Pressure Boundary
Corrosion Test Rack	Leakage Boundary (Spatial)
Expansion Joint	Pressure Boundary
Flexible Hoses	Leakage Boundary (Spatial) Pressure Boundary
Flow Element	Pressure Boundary
Flow Indicator	Leakage Boundary (Spatial)
Instrument Bellows	Leakage Boundary (Spatial) Pressure Boundary
Orifice	Pressure Boundary Throttle
Piping	Leakage Boundary (Spatial) Pressure Boundary Structural Integrity (Attached)
Pump	Pressure Boundary
Spray Nozzle	Pressure Boundary Spray
Strainer	Leakage Boundary (Spatial)
Tubing	Leakage Boundary (Spatial) Pressure Boundary
Valve	Leakage Boundary (Spatial) Pressure Boundary

2.3.3.8 Nuclear Sampling System

System Description

The nuclear sampling system provides the capability to collect samples from the reactor coolant system and auxiliary systems for analysis without requiring access to the containment during normal and post-accident conditions. Sample extraction points include the reactor coolant system hot leg, pressurizer surge line, pressurizer steam space, and

Section 2.3
SCOPING AND SCREENING RESULTS:
MECHANICAL SYSTEMS

various locations within the safety injection and shutdown cooling and chemical and volume control systems.

The nuclear sampling system consists of sampling lines, heat exchangers, sample vessels, sample sinks or racks, analysis equipment and instrumentation. The nuclear sampling system is required to operate to provide sampling capability during normal plant power generation operation and during cooldown as well as under post-accident conditions. The sample extraction points located in the auxiliary, containment, and radwaste buildings. The primary station for collecting and analyzing liquid samples is the hot analysis laboratory in the auxiliary building; remote sample collection points for liquid and containment atmosphere samples are provided in the auxiliary building for use under post-accident conditions. The primary station for the analysis of gaseous samples is located in the radwaste building.

Upon receipt of a containment isolation actuation signal (CIAS), the nuclear sampling system piping lines penetrating containment are isolated.

System Intended Function

Portions of the nuclear sampling system provide a containment isolation function. The nuclear sampling system is within the scope of license renewal based on the criteria of 10 CFR 54.4(a)(1).

Portions of the nuclear sampling system located in the containment and auxiliary buildings have spatial relationships such that their failure could adversely impact the performance of safety-related components' intended functions. Portions of the nuclear sampling system attach to safety-related piping such that their structural failure could prevent satisfactory accomplishment of safety-related system functions. Therefore, portions of the nuclear sampling system are within the scope of license renewal as nonsafety affecting safety-related components based on the criterion of 10 CFR 54.4(a)(2).

The nuclear sampling system supports fire protection and environmental qualification requirements based on the criteria of 10 CFR 54.4(a)(3).

PVNGS UFSAR References

Additional details of the nuclear sampling system are included in [UFSAR Sections 15.6.5, 3.11, 6.2.4, 8.3.2.1, 9.3.2, and 9.5.1.](#)

License Renewal Drawings

The license renewal drawings of the nuclear sampling system are listed below:
[LR-PVNGS-CH-01-M-CHP-001](#)
[LR-PVNGS-CH-01-M-CHP-002](#)
[LR-PVNGS-CH-01-M-CHP-003](#)
[LR-PVNGS-CM-01-M-CMP-001](#)

LR-PVNGS-DW-01-M-DWP-0002
 LR-PVNGS-HP-01-M-HPP-001
 LR-PVNGS-NC-01-M-NCP-002
 LR-PVNGS-RC-01-M-RCP-001
 LR-PVNGS-RD-01-M-RDP-001
 LR-PVNGS-RD-01-M-RDP-002
 LR-PVNGS-SI-01-M-SIP-001
 LR-PVNGS-SS-01-N-SSP-001-1
 LR-PVNGS-SS-01-N-SSP-002-1
 LR-PVNGS-SS-03-N-SSP-003-1
 LR-PVNGS-SS-03-N-SSP-004

Component-Function Relationship Table

The component types subject to aging management review are indicated in [Table 2.3.3-8 - Nuclear Sampling System](#).

Table 2.3.3-8 Nuclear Sampling System

Component Type	Intended Function
Closure Bolting	Leakage Boundary (Spatial) Pressure Boundary Structural Integrity (Attached)
Flow Indicator	Leakage Boundary (Spatial) Structural Integrity (Attached)
Heat Exchanger (Pressurizer Steam Space Sample Cooler)	Leakage Boundary (Spatial) Structural Integrity (Attached)
Heat Exchanger (Pressurizer Surge Line Sample Cooler)	Leakage Boundary (Spatial) Structural Integrity (Attached)
Heat Exchanger (Reactor Hot Leg Sample Cooler)	Heat Transfer Pressure Boundary
Heat Exchanger (Safety Injection Sample Cooler)	Leakage Boundary (Spatial) Structural Integrity (Attached)
Orifice	Leakage Boundary (Spatial)
Piping	Leakage Boundary (Spatial) Pressure Boundary Structural Integrity (Attached)
Sample Vessel	Leakage Boundary (Spatial) Structural Integrity (Attached)
Tubing	Leakage Boundary (Spatial) Pressure Boundary Structural Integrity (Attached)
Valve	Leakage Boundary (Spatial) Pressure Boundary Structural Integrity (Attached)

2.3.3.9 Compressed Air System

System Description

The compressed air system is divided into two independent subsystems, the instrument air system and service/breathing air system. The instrument air subsystem provides a continuous supply of filtered, dry, oil-free air for pneumatic instrument operation and the control of pneumatic actuators from three air compressors, three air receivers, and six air dryer units. The instrument air subsystem also has nitrogen backup capability in the event the air compressors cannot maintain system pressure. The service/breathing air subsystem supplies oil-free breathable air from one air compressor, two air receivers, and one refrigerated air dryer to service air stations and breathing air stations located throughout the plant. The instrument air subsystem is required for normal plant operation but is not required for safe shutdown of the plant. The instrument air subsystem is nonsafety-related except for the two safety-related containment building penetrations from the auxiliary building and the backup air supply piping and components for the spent fuel pool gate seals in the fuel building.

System Intended Function

Portions of the compressed air system provide containment isolation for instrument air piping containment penetration IAE-U31 and service and breathing air piping penetration IAE-U59. The compressed air system is in the scope of license renewal based on the criteria of 10 CFR 54.4(a)(1).

Nonsafety-related portions of the instrument air subsystem in the auxiliary and containment buildings attach to safety-related containment building penetration piping (IAE-U31 and IAE-U59) and the safety-related backup nitrogen supply tubing to the spent fuel pool gate seals. Portions of the instrument air subsystem are within the scope of license renewal as nonsafety-related components affecting safety-related components based on the criterion of 10 CFR 54.4(a)(2).

Portions of the instrument air subsystem support fire protection, equipment qualification, and station blackout requirements based on the criteria of 10 CFR 54.4(a)(3).

PVNGS UFSAR References

Additional details of the compressed air system are included in [UFSAR Section 9.3.1](#).

License Renewal Drawings

The license renewal drawings for the compressed air system are listed below:
[LR-PVNGS-IA-01-M-IAP-002](#)
[LR-PVNGS-IA-01-M-IAP-003-1](#)
[LR-PVNGS-IA-01-M-IAP-003-2](#)

Component-Function Relationship Table

The component types subject to aging management review are indicated in [Table 2.3.3-9](#) – Compressed Air System.

Table 2.3.3-9 Compressed Air System

Component Type	Intended Function
Accumulator	Pressure Boundary
Closure Bolting	Pressure Boundary Structural Integrity (Attached)
Orifice	Pressure Boundary Structural Integrity (Attached) Throttle
Piping	Pressure Boundary Structural Integrity (Attached)
Tubing	Pressure Boundary
Valve	Pressure Boundary Structural Integrity (Attached)

2.3.3.10 Chemical Volume and Control System

System Description

The chemical volume and control system is composed of various tanks, pumps, piping, valves and electrical logics necessary to control the purity, volume and boric acid content of the reactor coolant. The major components are the refueling water tank (RWT), the reactor drain tank, the equipment drain tank, the gas stripper, the boric acid concentrator, heat exchangers, filters, ion exchangers, piping and valves and various pumps, including the charging pumps.

The majority of the mechanical components are located in the auxiliary building with some major components also located in the containment building or in yard areas. The system contains piping which penetrates containment and contains the necessary containment isolation valves.

System Intended Function

The chemical and volume control system is designed to perform the following intended functions: 1) maintain the chemistry and purity of the reactor coolant during normal operation and during shutdowns, 2) maintain the required volume of water in the reactor coolant system, 3) receive, store, separate and process reactor grade, borated waste for reuse or discharge, 4) provide, via the RWT, borated water to the emergency core cooling system for injection to the reactor coolant system, 5) control the boron concentration in the

Section 2.3
SCOPING AND SCREENING RESULTS:
MECHANICAL SYSTEMS

reactor coolant system, 6) provide auxiliary pressurizer spray for manual control of pressurizer pressure and pressurizer cooling, 7) provide/receive injection water to/from the reactor coolant pump seals, 8) supply demineralized reactor makeup water to various auxiliary equipment, 9) provide a means for continuous removal of noble gases from the reactor coolant, 10) provide, via the RWT, borated water to the emergency core cooling system, 11) provide makeup to the spent fuel pool, 12) provide purification of shutdown cooling flow, 13) provide makeup to the reactor coolant system for losses from small leaks in the reactor coolant system, and 14) provide water to the auxiliary feedwater system for secondary-side makeup for reactor heat removal. The chemical and volume control system is within the scope of license renewal based on the criteria of 10 CFR 54(a)(1).

Portions of the chemical volume control system are in-scope as nonsafety affecting safety-related components based on the criteria of 10 CFR 54(a)(2), for spatial interaction and structural integrity concerns in the containment building, the auxiliary building and yard areas.

Portions of the chemical and volume control system support environmental qualification, fire protection, and station blackout requirements based on criteria of 10 CFR 54(a)(3).

PVNGS UFSAR References

Additional details of the chemical volume and control system are included in [UFSAR Sections 1.2.10.2, 3.11, 6.2.4, 8.3.1.1.10, and 9.3.4.](#)

License Renewal Drawings

The license renewal drawings for the chemical volume and control system are listed below:

LR-PVNGS-CH-01-M-CHP-001
LR-PVNGS-CH-01-M-CHP-002
LR-PVNGS-CH-01-M-CHP-003
LR-PVNGS-CH-01-M-CHP-005
LR-PVNGS-GR-01-N-GRP-0001
LR-PVNGS-LR-01-N-LRP-002-02
LR-PVNGS-PC-01-M-PCP-001
LR-PVNGS-RC-01-M-RCP-001
LR-PVNGS-RC-01-M-RCP-002
LR-PVNGS-RD-01-M-RDP-001
LR-PVNGS-RD-01-M-RDP-002
LR-PVNGS-RD-01-M-RDP-003
LR-PVNGS-SI-01-M-SIP-001
LR-PVNGS-SI-01-M-SIP-002
LR-PVNGS-SR-01-N-SRP-001
LR-PVNGS-SS-01-N-SSP-001-1
LR-PVNGS-SS-01-N-SSP-002-1

Component-Function Relationship Table

The component types subject to aging management review are indicated in [Table 2.3.3-10](#) - Chemical Volume and Control System.

Table 2.3.3-10 Chemical Volume and Control System

Component Type	Intended Function
Accumulator	Leakage Boundary (Spatial) Pressure Boundary
Closure Bolting	Leakage Boundary (Spatial) Pressure Boundary Structural Integrity (Attached)
Compressible Joints/Seals	Direct Flow
Demineralizer	Pressure Boundary
Filter	Filter Leakage Boundary (Spatial) Pressure Boundary
Flow Element	Leakage Boundary (Spatial) Pressure Boundary
Flow Indicator	Leakage Boundary (Spatial) Structural Integrity (Attached)
Heat Exchanger (Boric Acid Concentrator)	Leakage Boundary (Spatial)
Heat Exchanger (Letdown)	Pressure Boundary
Heat Exchanger (Regenerative)	Pressure Boundary
Heat Exchanger (Seal Injection)	Pressure Boundary Structural Support
Heater	Pressure Boundary
Insulation	Insulate (Mechanical)
Orifice	Leakage Boundary (Spatial) Pressure Boundary Throttle
Piping	Leakage Boundary (Spatial) Pressure Boundary Structural Integrity (Attached)
Pump	Leakage Boundary (Spatial) Pressure Boundary
Sight Gauge	Leakage Boundary (Spatial)

Table 2.3.3-10 Chemical Volume and Control System (Continued)

Component Type	Intended Function
Strainer	Filter Leakage Boundary (Spatial) Pressure Boundary
Tank	Leakage Boundary (Spatial) Pressure Boundary Structural Integrity (Attached)
Tank Liner	Leakage Boundary (Spatial) Pressure Boundary
Tubing	Leakage Boundary (Spatial) Pressure Boundary
Valve	Leakage Boundary (Spatial) Pressure Boundary Structural Integrity (Attached)

2.3.3.11 Control Building HVAC System

System Description

The control building HVAC system consists of the following four subsystems:

- control room normal HVAC subsystem
- control building normal HVAC subsystem
- control room essential HVAC subsystem
- control building essential HVAC subsystem

The control room normal HVAC subsystem operates during normal modes of operation and distributes cooled, filtered outside air to the control room complex (computer rooms, cabinet areas, offices, conference room, instrument repair room, kitchen and halls), the communication equipment room and inverter room for personnel comfort and equipment operation.

The control room normal HVAC subsystem has no safety-related design basis.

The control building normal HVAC subsystem operates during normal modes of operation and provides conditioned air to the upper and lower cable spreading rooms, ESF equipment rooms, ESF switchgear rooms, battery rooms, control building basement/HVAC equipment room area, 140' elevation corridor area, 100' elevation switchgear rooms, and the microwave equipment room. Upon receipt of an ESF actuation signal, the control building normal HVAC subsystem is automatically stopped and isolated. Although smoke removal capability is provided, only portable smoke removal equipment is credited for smoke removal.

Section 2.3
SCOPING AND SCREENING RESULTS:
MECHANICAL SYSTEMS

The control building normal HVAC subsystem has no safety-related design basis.

The control room essential HVAC subsystem consists of two separate, redundant, essential flow trains. The control room essential HVAC subsystem is automatically started upon receipt of a control room ventilation isolation actuation signal, control room essential filtration actuation signal, safety injection signal, or loss of offsite power. The control room essential subsystem provides conditioned air to the control room complex (but does not supply the communication equipment room or the inverter room) to maintain conditions for prolonged occupancy throughout the duration of any design basis accident.

The control room HVAC essential subsystem is safety-related.

The control building essential HVAC subsystem consists of two separate, redundant, essential flow trains. The control building essential HVAC subsystem is automatically started upon receipt of a safety injection signal or loss of offsite power. The control building essential HVAC subsystem provides conditioned air to the ESF switchgear rooms, ESF equipment rooms and battery rooms. The control building essential HVAC subsystem maintains suitable room temperatures during accident conditions and provides ventilation and exhaust for battery rooms keeping hydrogen gas concentrations below flammable concentration.

The control building essential HVAC subsystem is safety-related.

System Intended Functions

The functions of the control building HVAC system are to maintain a thermal environment in the control room complex, suitable for prolonged occupancy throughout the duration of postulated accidents, to provide control room isolation to prevent intrusion of poisonous gases, smoke or airborne radioactivity, to maintain a suitable environment for the ESF switchgear, ESF equipment rooms and battery rooms during postulated accidents, and to ventilate and exhaust battery rooms to maintain hydrogen below flammable concentrations. The control building HVAC system is within the scope of license renewal based on the criteria of 10 CFR 54.4(a)(1).

Portions of the control building HVAC system are in-scope as nonsafety affecting safety-related components based on the criterion of 10 CFR 54.4(a)(2).

Portions of the control building HVAC system support fire protection and station blackout requirements based on criteria of 10 CFR 54.4(a)(3).

PVNGS UFSAR References

Additional details of the control building HVAC system are included in [UFSAR Sections 6.4](#) and [9.4.1](#).

License Renewal Drawings

The license renewal drawings for the control building HVAC system are listed below:

[LR-PVNGS-HJ-02-M-HJP-001](#)
[LR-PVNGS-HJ-02-M-HJP-002](#)

Component-Function Relationship Table

The component types subject to aging management review are indicated in [Table 2.3.3-11](#) - Control Building HVAC System.

Table 2.3.3-11 Control Building HVAC System

Component Type	Intended Function
Blower	Non-S/R Structural Support Pressure Boundary
Closure Bolting	Leakage Boundary (Spatial) Non-S/R Structural Support Pressure Boundary
Damper	Fire Barrier Non-S/R Structural Support Pressure Boundary
Ductwork	Non-S/R Structural Support Pressure Boundary
Flex Connectors	Non-S/R Structural Support Pressure Boundary
Heat Exchanger (Control Bldg AHU)	Heat Transfer Leakage Boundary (Spatial) Pressure Boundary
Heat Exchanger (ESF Equipment Room AHU)	Heat Transfer Pressure Boundary
Heat Exchanger (ESF Switchgear Room AHU)	Heat Transfer Leakage Boundary (Spatial) Pressure Boundary
Heater	Non-S/R Structural Support
Piping	Leakage Boundary (Spatial) Pressure Boundary
Pump	Leakage Boundary (Spatial)
Silencer	Pressure Boundary
Tubing	Pressure Boundary
Valve	Leakage Boundary (Spatial) Non-S/R Structural Support

2.3.3.12 Auxiliary Building HVAC System

System Description

The auxiliary building HVAC system consists of two subsystems:

- auxiliary building normal HVAC subsystem
- auxiliary building essential HVAC subsystem

The auxiliary building normal HVAC subsystem is designed to maintain environmental conditions suitable for personnel comfort and safe operation of equipment during normal plant operation. Air is supplied to the auxiliary building from outside-air on a once-through basis. The exhaust air passes through air filtration units (AFUs) and is continuously monitored for airborne radioactivity during normal operation. The auxiliary building is maintained at a slight negative pressure to control the release of airborne radioactivity to the environment. The auxiliary building normal HVAC subsystem can provide smoke removal; however, only portable smoke removal equipment is credited for smoke removal.

The auxiliary building normal HVAC subsystem is not safety-related. Auxiliary building normal HVAC ducting and ducting components at elevations below 140' are designed to retain their structural integrity, but are not required to function during and after a safe shutdown earthquake.

The auxiliary building essential HVAC subsystem maintains the required thermal environment for the ESF equipment rooms and auxiliary feedwater pump rooms during accident conditions. Upon receipt of an SIAS signal, ESF equipment rooms and the auxiliary feedwater pump rooms are automatically isolated at the 100' elevation from the auxiliary building normal HVAC subsystem and essential cooling units are started to maintain equipment room temperatures. The air from below the 100' elevation flows through a connecting tunnel to the fuel building essential exhaust AFUs where it is filtered and released to the environment. Auxiliary building pressure below the 100' elevation is maintained slightly negative by the fuel building essential AFUs.

The auxiliary building essential HVAC subsystem is safety-related.

System Intended Function

The safety-related functions of the auxiliary building HVAC system are to maintain the required thermal environment for the ESF equipment rooms and auxiliary feedwater pump rooms during accident conditions and to isolate the auxiliary building normal HVAC subsystem and maintain negative pressure below the 100' elevation following receipt of a safety injection actuation signal. The auxiliary building HVAC system is within the scope of license renewal based on the criteria of 10 CFR 54.4(a)(1).

Portions of the auxiliary building HVAC system are within the scope of license renewal as nonsafety affecting safety-related components based on the criterion of 10 CFR 54.4(a)(2).

Section 2.3
SCOPING AND SCREENING RESULTS:
MECHANICAL SYSTEMS

Portions of the auxiliary building HVAC system support fire protection, environmental qualification, and station blackout requirements based on criteria of 10 CFR 54.4(a)(3).

PVNGS UFSAR References

Additional details of the auxiliary building HVAC system are included in [UFSAR Section 9.4.2](#).

License Renewal Drawings

The license renewal drawings for the auxiliary building HVAC system are listed below:

- [LR-PVNGS-HA-02-M-HAP-001](#)
- [LR-PVNGS-HA-02-M-HAP-002](#)
- [LR-PVNGS-HA-02-M-HAP-003](#)
- [LR-PVNGS-HA-02-M-HAP-004](#)

Component-Function Relationship Table

The component types subject to aging management review are indicated in [Table 2.3.3-12](#) - Auxiliary Building HVAC System.

Table 2.3.3-12 Auxiliary Building HVAC System

Component Type	Intended Function
Blower	Non-S/R Structural Support Pressure Boundary
Closure Bolting	Leakage Boundary (Spatial) Non-S/R Structural Support Pressure Boundary
Damper	Fire Barrier Non-S/R Structural Support Pressure Boundary
Ductwork	Non-S/R Structural Support Pressure Boundary
Flex Connectors	Non-S/R Structural Support Pressure Boundary
Heat Exchanger (Aux Feedwater Room)	Heat Transfer Pressure Boundary
Heat Exchanger (CEDM Equip Room)	Leakage Boundary (Spatial)
Heat Exchanger (Charging Pump Room)	Leakage Boundary (Spatial) Non-S/R Structural Support
Heat Exchanger (CS Pump Room)	Heat Transfer Pressure Boundary

Table 2.3.3-12 Auxiliary Building HVAC System (Continued)

Component Type	Intended Function
Heat Exchanger (ECW Pump Room)	Heat Transfer Pressure Boundary
Heat Exchanger (Electrical Penetration Room)	Heat Transfer Pressure Boundary
Heat Exchanger (HPSI Pump Room)	Heat Transfer Pressure Boundary
Heat Exchanger (LPSI Pump Room)	Heat Transfer Pressure Boundary

2.3.3.13 Fuel Building HVAC System

System Description

The fuel building HVAC system consists of two subsystems:

- fuel building normal HVAC subsystem
- fuel building essential HVAC subsystem

The fuel building normal HVAC subsystem operates during normal modes of operation and distributes tempered outside air throughout the building. The subsystem is designed to maintain environmental conditions suitable for personnel comfort and safe operation of equipment during normal operation. Air is continuously exhausted to the fuel building vent. The fuel building is maintained under a negative pressure to ensure that all leakage is into the building.

The fuel building normal HVAC subsystem has no safety-related design basis.

The fuel building essential HVAC subsystem operates only in the event of a fuel handling accident or a LOCA. The fuel building essential HVAC subsystem is a filtered exhaust system. The filtered exhaust is directed to the fuel building vent to minimize release of airborne radioactivity to the environment. When radiation monitors in either the normal exhaust ductwork or in the fuel pool area detect high radiation levels, a fuel building essential ventilation actuation signal (FBEVAS) automatically isolates the fuel building, starts essential air filtration units (AFUs) and secures the normal AHUs. The fuel building essential HVAC subsystem creates a negative pressure in the fuel building to ensure that any air leakage is into the building. The fuel building essential HVAC subsystem is also actuated by a Safety Injection Actuation Signal (SIAS) or Containment Spray Actuation Signal (CSAS). In the case of an SIAS or CSAS signal, air from below the 100' elevation of the auxiliary building is drawn through a connecting plenum and tunnel to the fuel building essential exhaust AFUs where it is filtered and released to the environment. Auxiliary

building pressure below the 100' elevation is maintained slightly negative by the fuel building essential AFUs.

The fuel building essential HVAC subsystem is safety-related.

System Intended Function

The functions of the fuel building HVAC system are to limit the potential release of airborne radioactivity from the fuel building to the environment following a fuel handling accident and from areas below the 100' elevation of the auxiliary building to the environment following a loss of coolant accident. The fuel building HVAC system is within the scope of license renewal based on the criteria of 10 CFR 54.4(a)(1).

Portions of the fuel building HVAC system are within the scope of license renewal as nonsafety affecting safety-related components based on the criterion of 10 CFR 54.4(a)(2).

Portions of the fuel building HVAC system support fire protection and environmental qualification requirements based on criteria of 10 CFR 54.4(a)(3).

PVNGS UFSAR References

Additional details of the fuel building HVAC system are included in [UFSAR Sections 6.5.1](#) and [9.4.5](#).

License Renewal Drawings

The license renewal drawing for the fuel building HVAC system is listed below: [LR-PVNGS-HF-01-M-HFP-001](#)

Component-Function Relationship Table

The component types subject to aging management review are indicated in [Table 2.3.3-13](#) - Fuel Building HVAC System.

Table 2.3.3-13 Fuel Building HVAC System

Component Type	Intended Function
Blower	Pressure Boundary
Closure Bolting	Non-S/R Structural Support Pressure Boundary
Damper	Fire Barrier Non-S/R Structural Support Pressure Boundary

Table 2.3.3-13 Fuel Building HVAC System (Continued)

Component Type	Intended Function
Ductwork	Non-S/R Structural Support Pressure Boundary
Flex Connectors	Non-S/R Structural Support Pressure Boundary
Flow Element	Pressure Boundary
Piping	Non-S/R Structural Support Pressure Boundary
Tubing	Pressure Boundary
Valve	Non-S/R Structural Support Pressure Boundary

2.3.3.14 Containment Building HVAC System

System Description

The containment building HVAC system functions during normal plant operations, containment pre-access periods, or during extended shutdowns. The containment building HVAC system is designed to control containment building air temperature to ensure operability of containment building equipment, provide filtration to maintain airborne radioactivity levels below permissible limits, and to provide an environment suitable for maintenance and refueling activities. The containment building HVAC system is not required for safe reactor shutdown.

The containment building HVAC system consists of the following subsystems:

- containment building normal cooling subsystem
- containment building normal cleanup subsystem
- CEDM cooling subsystem
- reactor cavity cooling subsystem
- pressurizer cooling subsystem
- tendon gallery ventilation subsystem
- main steam support structure ventilation subsystem

The containment building normal cooling subsystem maintains suitable containment temperature during normal plant operation, pre-access periods and during plant shutdown by cooling and distributing recirculated containment air. The normal chilled water system provides chilled water to the cooling coils.

The containment building normal cooling subsystem has no safety-related design basis.

Section 2.3
SCOPING AND SCREENING RESULTS:
MECHANICAL SYSTEMS

The containment building normal cleanup subsystem, together with the containment purge system, is designed to control airborne radioactivity below the level required for personnel access for inspection, maintenance and refueling operations. The cleanup subsystem will clean up internal air during normal recirculation; new makeup air is not required.

The containment building normal cleanup subsystem has no safety-related design basis.

The CEDM cooling subsystem maintains suitable temperature conditions for CEDM operation. Normally only one of the two ACUs are operating with the other on standby. Each ACU has two exhaust fans. Normally both fans are operating with the inservice ACU, but only one fan is required to maintain CEDM temperatures. The subsystem is operated continuously during normal plant operation and may be running during shutdown depending upon heat load. The system functions by inducting air through the CEDMs, cooling it, and then discharging the air back to the containment atmosphere. The nuclear cooling water system provides water to the cooling coils.

The CEDM cooling subsystem has no safety-related design basis.

The reactor cavity cooling subsystem operates in conjunction with the containment normal cooling ACUs and provides cooling to the primary shield and reactor cavity to maintain the concrete temperature below the 150 °F maximum. Cooling is accomplished using fans which recirculate ambient containment air. Normally two of the four cavity cooling fans are operated and the subsystem functions continuously during normal plant operation. Portions of the subsystem may be running during plant shutdown periods depending upon heat load.

The reactor cavity cooling subsystem has no safety-related design basis.

The pressurizer cooling subsystem takes air from within the pressurizer missile shield and exhausts it out to the surrounding containment atmosphere.

The pressurizer cooling subsystem has no safety-related design basis.

The tendon gallery ventilation subsystem maintains a habitable environment in the tendon gallery area for personnel access. One supply and one exhaust fan (operated manually) use outside air to ventilate the tendon gallery. The tendon gallery subsystem is not within the scope of license renewal.

The main steam support structure ventilation subsystem provides cooling above the 100 ft containment elevations and in the main steam line and feedwater line penetration areas. One supply and one exhaust fan circulate filtered outside air.

The main steam support structure ventilation subsystem has no safety-related design basis.

The containment building HVAC system also includes safety-related containment pressure and containment atmosphere radiation monitoring piping and piping components. These components are not part of any subsystem described above, but are assigned containment

Section 2.3
SCOPING AND SCREENING RESULTS:
MECHANICAL SYSTEMS

building HVAC tag numbers and thus are included in the evaluation of the containment building HVAC system. Piping and piping components penetrating containment are used to monitor containment pressure, containment particulate and gaseous radioactivity levels. Containment pressure signals are provided to the reactor protection system and initiate a reactor trip upon reaching the appropriate high containment pressure setpoints. Containment pressure signals are also used for open permissives to containment power access purge valves. Containment particulate and gaseous radioactivity levels are used as methods for identifying RCS leakage. Piping which penetrates the containment is classified as seismic class I and is relied upon to maintain containment integrity during a design basis event, minimizing the potential for offsite exposure.

System Intended Function

The containment building HVAC system monitors containment pressure and provides signals to the reactor protection system for initiating reactor trip upon high containment pressure. It monitors containment atmosphere gaseous and particulate radioactivity. High radiation signals from the containment atmosphere radiation monitor are used as an indicator of reactor coolant system leakage. Containment pressure and containment atmosphere radiation monitoring piping which penetrates the containment is classified as seismic Category I and is relied upon to maintain containment integrity and remain functional following a design basis event, minimizing the potential for offsite exposure. The containment building HVAC system is within the scope of license renewal based on the criteria of 10 CFR 54.4(a)(1).

Portions of the containment building HVAC system are within the scope of license renewal as nonsafety affecting safety-related components based on the criterion of 10 CFR 54.4(a)(2).

Portions of the containment building HVAC system support fire protection and environmental qualification requirements based on criteria of 10 CFR 54.4(a)(3).

PVNGS UFSAR References

Additional details of the containment building HVAC system are included in [UFSAR Sections 6.2.4](#) and [9.4.6](#).

License Renewal Drawings

The license renewal drawings for the containment building HVAC system are listed below:
[LR-PVNGS-HC-02-M-HCP-001](#)
[LR-PVNGS-HC-02-M-HCP-002](#)
[LR-PVNGS-HC-02-M-HCP-003](#)

Component-Function Relationship Table

The component types subject to aging management review are indicated in [Table 2.3.3-14](#) -- Containment Building HVAC System.

Table 2.3.3-14 Containment Building HVAC System

Component Type	Intended Function
Blower	Non-S/R Structural Support
Closure Bolting	Leakage Boundary (Spatial) Non-S/R Structural Support Pressure Boundary
Damper	Non-S/R Structural Support
Ductwork	Non-S/R Structural Support
Flex Connectors	Non-S/R Structural Support
Flexible Hoses	Pressure Boundary
Heat Exchanger (Containment Bldg)	Leakage Boundary (Spatial) Non-S/R Structural Support
Heat Exchanger (Containment CEDM)	Leakage Boundary (Spatial) Non-S/R Structural Support
Heater	Non-S/R Structural Support
Piping	Pressure Boundary Structural Integrity (Attached)
Tubing	Pressure Boundary
Valve	Pressure Boundary

2.3.3.15 Diesel Generator Building HVAC System

System Description

The diesel generator building HVAC system consists of two separate independent HVAC trains, one for each of the two diesel generator compartments per diesel generator building. Each train of the system consists of the following subsystems:

- diesel generator building normal HVAC subsystem
- diesel generator building essential HVAC subsystem

The diesel generator building normal HVAC subsystem is designed to maintain environmental conditions suitable for personnel comfort and safe operation of equipment

Section 2.3
SCOPING AND SCREENING RESULTS:
MECHANICAL SYSTEMS

when the diesel generator is not running during normal plant operation. The diesel generator building normal HVAC subsystem has no safety-related design basis.

The diesel generator building essential HVAC subsystem maintains the required thermal environment for the diesel generator, its auxiliaries and associated electrical equipment during emergency conditions when the diesel generator is running. The diesel generator room essential exhaust fan and control equipment room essential AHU start automatically upon startup of their respective diesel. Both units will continue to run until the diesel is shutdown and their respective room temperatures are reduced. During essential operation, the fuel oil tank and compressor rooms continue to be ventilated by the diesel generator building normal HVAC. The diesel generator building essential HVAC subsystem is safety-related.

System Intended Function

The diesel generator building HVAC system maintains the required thermal environment for the diesel generator, its auxiliaries and associated electrical equipment to ensure operability during emergency conditions. The diesel generator building HVAC system is within the scope of license renewal based on the criteria of 10 CFR 54.4(a)(1).

Portions of the diesel generator building HVAC system are in scope as nonsafety affecting safety-related components based on the criterion of 10 CFR 54.4(a)(2).

Portions of the diesel generator building HVAC system support fire protection and station blackout requirements based on criteria of 10 CFR 54.4(a)(3).

PVNGS UFSAR References

Additional details of the diesel generator building HVAC system are included in [UFSAR Section 9.4.7](#).

License Renewal Drawings

The license renewal drawing for the diesel generator building HVAC system is listed below: [LR-PVNGS-HD-01-M-HDP-001](#)

Component-Function Relationship Table

The component types subject to aging management review are indicated in [Table 2.3.3-15](#) – Diesel Generator Building HVAC System.

Table 2.3.3-15 Diesel Generator Building HVAC System

Component Type	Intended Function
Blower	Non-S/R Structural Support Pressure Boundary
Closure Bolting	Non-S/R Structural Support Pressure Boundary
Damper	Fire Barrier Non-S/R Structural Support Pressure Boundary
Ductwork	Non-S/R Structural Support Pressure Boundary
Flex Connectors	Non-S/R Structural Support Pressure Boundary
Heater	Non-S/R Structural Support
Piping	Leakage Boundary (Spatial) Non-S/R Structural Support
Strainer	Leakage Boundary (Spatial)
Tubing	Pressure Boundary
Valve	Leakage Boundary (Spatial) Non-S/R Structural Support

2.3.3.16 Radwaste Building HVAC System

System Description

The radwaste building HVAC system is designed to provide a suitable environment for personnel comfort and safe operation of equipment. The radwaste building air-flow patterns are designed to inhibit the spread of airborne radioactivity and maintain a slight negative pressure in the building. The radwaste building HVAC system is a once-through ventilation system with no recirculation, with the exception of the radwaste control room which has a recirculation air handling unit. Exhaust air from the radwaste building normal air filtration units is discharged to the plant vent stack.

System Intended Function

Portions of the radwaste building HVAC system are within the scope of license renewal as nonsafety affecting safety-related components based on the criterion of 10 CFR 54.4(a)(2).

Radwaste building fire dampers associated with UFSAR described fire-rated boundaries support of fire protection requirements based on criteria of 10 CFR 54.4(a)(3).

PVNGS UFSAR References

Additional details of the radwaste building HVAC system are included in [UFSAR Section 9.4.3](#) and [Appendix 9B.2.10](#).

License Renewal Drawings

The license renewal drawings for the radwaste building HVAC system are listed below:
[LR-PVNGS-HR-01-M-HRP-001](#)
[LR-PVNGS-OW-01-M-OWP-003](#)

Component-Function Relationship Table

The component types subject to aging management review are indicated in [Table 2.3.3-16](#) – Radwaste Building HVAC System.

Table 2.3.3-16 Radwaste Building HVAC System

Component Type	Intended Function
Closure Bolting	Pressure Boundary
Damper	Fire Barrier
Piping	Leakage Boundary (Spatial)

2.3.3.17 Turbine Building HVAC System

System Description

The turbine building HVAC system consists of three major subsystems:

- turbine building general area HVAC subsystem
- turbine building battery and switchgear room HVAC subsystem
- turbine building lube oil room HVAC subsystem

The turbine building general area HVAC subsystem is designed to maintain environmental conditions suitable for equipment operation during normal plant operations and shutdown periods depending upon heat removal requirements. Outside air is filtered, adiabatically cooled (or heated) and distributed via ductwork to various areas of the turbine building.

The turbine building general area HVAC subsystem has no safety-related design basis.

The battery and switchgear room HVAC subsystem is designed to prevent the accumulation of hydrogen gas in the battery room during normal plant operation and shutdown periods. Two 100% capacity exhaust fans are mounted in the exterior wall of the battery room and discharge through backdraft dampers to the outside atmosphere.

Section 2.3
SCOPING AND SCREENING RESULTS:
MECHANICAL SYSTEMS

The turbine building battery and switchgear room HVAC subsystem has no safety-related design bases. Turbine building battery and switchgear room fire dampers and exhaust fans are in-scope to support fire protection intended functions. The battery room exhaust fan is within the scope of license renewal to support station blackout coping intended functions.

The turbine building lube oil room HVAC subsystem is designed to remove combustible gases and heat from the lube oil room during normal plant operation and shutdown periods. Two 100% capacity exhaust fans (duct-mounted) discharge through backdraft dampers to the outside atmosphere.

The turbine building lube oil room HVAC subsystem has no safety-related design bases. Turbine building lube oil room fire dampers are within the scope of license renewal to support fire protection intended functions.

System Intended Function

Portions of the turbine building HVAC system support fire protection and station blackout requirements based on criteria of 10 CFR 54.4(a)(3).

PVNGS UFSAR References

Additional details of the turbine building HVAC system are included in [UFSAR Section 9.4.4](#) and [Appendix 9B.2.20.1](#).

License Renewal Drawings

The license renewal drawing for the turbine building HVAC system is listed below: [LR-PVNGS-HT-01-M-HTP-001](#)

Component-Function Relationship Table

The component types subject to aging management review are indicated in [Table 2.3.3-17](#)– Turbine Building HVAC System.

Table 2.3.3-17 Turbine Building HVAC System

Component Type	Intended Function
Blower	Pressure Boundary
Closure Bolting	Pressure Boundary
Damper	Fire Barrier Pressure Boundary

2.3.3.18 Miscellaneous Site Structures/Spray Pond Pump House HVAC System

System Description

The miscellaneous site structures HVAC system consists of the following subsystems:

- fire pump house HVAC subsystem
- water treatment building HVAC subsystem
- reservoir control building HVAC subsystem
- decontamination facility HVAC subsystem
- hot instrument calibration facility HVAC subsystem
- instrument repair facility HVAC subsystem
- chemical injection pump house HVAC subsystem
- spray pond metering pump house HVAC subsystem
- holdup tank pump house HVAC subsystem
- turbine building maintenance annex HVAC subsystem
- subsynchronous resonance (SSR) equipment building HVAC subsystem
- cooling towers electrical switchgear buildings HVAC subsystem
- spray pond pump house HVAC subsystem

With the exception of the spray pond pump house subsystem, all of the miscellaneous site structures HVAC subsystems are not within the scope of license renewal.

The spray pond pump house HVAC system is located next to the essential spray ponds. Each of the two redundant essential spray pond pump houses (per unit) is equipped with one essential ventilation exhaust fan. The essential ventilation exhaust fan maintains room temperature at or below the spray pond qualification temperature during emergency or post accident operation of the essential spray pond system. Portable smoke removal equipment will be used in the spray pond pump house in the event of fire in the pump house.

The spray pond pump house HVAC system is safety-related.

System Intended Function

The spray pond pump house HVAC system provides the required thermal environment for maintaining operability of equipment in the essential spray pond pump house during emergency or post-accident operation of the essential spray pond system. The spray pond pump house HVAC system is within the scope of license renewal based on the criteria of 10 CFR 54.4(a)(1).

Portions of the spray pond pump house HVAC system support fire protection and station blackout requirements based on criteria of 10 CFR 54.4(a)(3).

PVNGS UFSAR References

Additional details of the spray pond pump house HVAC system are included in [UFSAR Section 9.4.8](#) and [Appendices 9B.2.7](#) and [9B.2.8](#).

License Renewal Drawings

The license renewal drawing for the spray pond pump house HVAC system is listed below: [LR-PVNGS-HS-01-M-HSP-006](#)

Component-Function Relationship Table

The component types subject to aging management review are indicated in [Table 2.3.3-18](#) – Miscellaneous Site Structures/Spray Pond Pump House HVAC System.

Table 2.3.3-18 Miscellaneous Site Structures/Spray Pond Pump House HVAC System

Component Type	Intended Function
Blower	Pressure Boundary
Closure Bolting	Pressure Boundary
Ductwork	Pressure Boundary
Flex Connectors	Pressure Boundary

2.3.3.19 Fire Protection System

System Description

The purpose of the fire protection system is to minimize the effects of fire on plant structures, systems, and components important to safety to the extent that a fire will not compromise the ability to achieve safe shutdown of the plant.

The fire protection system consists of (1) two 50% diesel driven fire water pumps, one 50% motor driven fire pump, fire water pump drivers, fire water tanks, and underground distribution system including outside loop, hydrants, sectional control valves, and isolation valves (2) Hose stations, standpipes, halon, CO₂, deluge, and preaction systems within the power block, including control valves, spray nozzles, and sprinkler heads (3) diesel fuel oil supply to the two 50% capacity engine driven fire pumps and (4) the jockey pump with associated piping. Safety-related components at the containment penetration are included in this system.

System Intended Function

The fire protection system provides containment isolation for a containment penetration and is within the scope of license renewal based on the criteria of 10 CFR 54(a)(1).

Portions of the fire protection system are within the scope of license renewal as nonsafety affecting safety-related components for spatial interaction in the auxiliary, fuel, and control buildings and for seismic II/I interaction in the containment building based on the criterion of 10 CFR 54.4(a)(2).

Portions of the fire protection system support fire protection requirements based on the criteria of 10 CFR 54.4(a)(3).

PVNGS UFSAR References

Additional details of the fire protection system are included in [UFSAR Section 9.5.1](#) and [Appendix 9B](#).

License Renewal Drawings

The license renewal drawings for the fire protection system are listed below:
[LR-PVNGS-DS-A0-M-DSP-001-3](#)
[LR-PVNGS-FP-A0-M-FPP-001](#)
[LR-PVNGS-FP-A0-M-FPP-005](#)
[LR-PVNGS-FP-01-M-FPP-002](#)
[LR-PVNGS-FP-01-M-FPP-003](#)
[LR-PVNGS-FP-01-M-FPP-004](#)
[LR-PVNGS-FP-01-M-FPP-006](#)

Component-Function Relationship Table

The component types subject to aging management review are indicated in [Table 2.3.3-19](#) - Fire Protection System.

Table 2.3.3-19 Fire Protection System

Component Type	Intended Function
Closure Bolting	Leakage Boundary (Spatial) Pressure Boundary
Expansion Joint	Pressure Boundary
Filter	Filter Pressure Boundary
Flame Arrestor	Pressure Boundary
Flexible Hoses	Pressure Boundary

Table 2.3.3-19 Fire Protection System (Continued)

Component Type	Intended Function
Flow Element	Pressure Boundary
Hydrant	Pressure Boundary
Piping	Leakage Boundary (Spatial) Non-S/R Structural Support Pressure Boundary
Pump	Pressure Boundary
Silencer	Pressure Boundary
Spray Nozzle	Pressure Boundary Spray
Sprinkler Head	Pressure Boundary Spray
Strainer	Filter Pressure Boundary
Tank	Pressure Boundary
Tubing	Leakage Boundary (Spatial) Pressure Boundary
Valve	Leakage Boundary (Spatial) Non-S/R Structural Support Pressure Boundary

2.3.3.20 Diesel Generator Fuel Oil Storage and Transfer System

System Description

The purpose of the diesel generator fuel oil storage and transfer system is to provide fuel oil for the emergency diesel generators. The system consists of an underground diesel fuel oil storage tank, diesel fuel oil transfer pump, diesel fuel oil day tank, piping, valves, and instrumentation for each diesel generator.

The diesel fuel oil day tank is evaluated as part of the diesel generator system described in [Section 2.3.3.21](#).

System Intended Function

The diesel generator fuel oil storage and transfer system provides onsite storage and delivery of fuel oil for the operation of the two diesel generators for each unit and which are required as a consequence of a loss of offsite power. The diesel generator fuel oil storage and transfer system is within the scope of license renewal based on the criteria of 10 CFR 54.4(a)(1).

Section 2.3
SCOPING AND SCREENING RESULTS:
MECHANICAL SYSTEMS

Portions of the system are within the scope of license renewal as nonsafety affecting safety-related components due to spatial interactions inside the diesel generator building based on the criterion of 10 CFR 54.4(a)(2).

Portions of the system support fire protection requirements based on criteria of 10 CFR 54.4(a)(3).

PVNGS UFSAR References

Additional details of the diesel generator fuel oil storage and transfer system are included in [UFSAR Section 9.5.4](#) and [Appendix 9B.2.1](#).

License Renewal Drawings

The license renewal drawings for the diesel generator fuel oil storage and transfer system are listed below:

- [LR-PVNGS-DF-01-M-DFP-001](#)
- [LR-PVNGS-DG-01-M-DGP-001-1](#)

Component-Function Relationship Table

The component types subject to aging management review are indicated in [Table 2.3.3-20](#) - Diesel Generator Fuel Oil Storage and Transfer System.

Table 2.3.3-20 Diesel Generator Fuel Oil Storage and Transfer System

Component Type	Intended Function
Closure Bolting	Pressure Boundary
Flame Arrestor	Pressure Boundary
Flow Element	Pressure Boundary
Piping	Leakage Boundary (Spatial) Pressure Boundary Structural Integrity (Attached)
Pump	Pressure Boundary
Strainer	Filter Pressure Boundary Structural Integrity (Attached)
Tank	Pressure Boundary
Tubing	Leakage Boundary (Spatial) Pressure Boundary
Valve	Pressure Boundary Structural Integrity (Attached)

2.3.3.21 Diesel Generator

System Description

The diesel generator system contains two diesel generators per unit that provide a dependable onsite power source capable of starting and supplying the essential loads necessary to shut down the plant safely and to maintain it in a safe shutdown condition under loss of offsite power conditions. The diesel generators are physically and electrically isolated from each other and each is driven by a four-cycle, 20-cylinder diesel engine.

Each diesel generator has the following subsystems:

- diesel generator cooling water system (DGCWS)
- diesel generator starting system (DGSS)
- diesel generator lubrication system (DGLS)
- diesel generator combustion air intake and exhaust system (DGCAIES)
- fuel oil system

The DGCWS removes waste heat of combustion from the diesel generator engine and transfers this heat to the essential spray pond system through the jacket water heat exchanger. The DGCWS consists of a combustion air (intake) air cooler, a closed loop jacket cooling system consisting of an engine-driven cooling water pump, a water-cooled jacket water heat exchanger, recirculation jacket water pump and heater, a surge tank (jacket water stand pipe), valves, instrumentation and controls.

The DGSS provides a stored compressed air supply for accomplishing a diesel generator start, and is designed to remain functional after a safe shutdown event. The DGSS consists of two independent and redundant networks of compressed air, each consisting of a motor-driven air compressor, air dryer, air receiver, pneumatic control valve and solenoid valves.

The DGLS provides clean, temperature-controlled, lubricating oil to the diesel engine for standby and operating modes. The DGLS for each engine consists of an integral engine-driven circulating lubricating oil pump, a standby lube oil circulating pump, standby oil heaters, a filter, basket strainers, a water-cooled lube oil cooler, valves, and instrumentation.

The DGCAIES supplies combustion air and disposes of exhaust products to permit continuous long-term operation of the diesel generator. The major components within the DGCAIES include an air intake filter, intake silencer, an exhaust silencer, combustion air cooler/heaters, and associated piping and flexible connections.

The fuel oil subsystem delivers fuel from the day tank to the engine. The fuel oil subsystem consists of an engine driven booster pump, water-cooled fuel oil cooler, suction strainers, discharge filters, valves, piping and tubing. The diesel generator fuel oil storage and transfer system is evaluated in [Section 2.3.3.20](#). However, the diesel fuel oil day tanks and the piping, valves, and other components between the day tanks and the diesel generator engines are evaluated with the diesel generator system.

System Intended Function

The diesel generator system provides a dependable onsite power source capable of starting and supplying the essential loads necessary to shut down the plant safely and to maintain it in a safe shutdown condition under loss of offsite power conditions. Portions of the diesel generator system are within the scope of license renewal based on criteria 10 CFR 54.4(a)(1).

Portions of the diesel generator system are within the scope of license renewal as nonsafety affecting safety-related components based on the criterion of 10 CFR 54.4(a)(2).

Portions of the diesel generator system support fire protection and station blackout requirements based on criteria of 10 CFR 54.4(a)(3).

PVNGS UFSAR References

Additional details of the diesel generator are included in [UFSAR Sections 7.4.1.1.1, 8.3.1.1.4, 9.5.4, 9.5.5, 9.5.6, 9.5.7, and 9.5.8.](#)

License Renewal Drawings

The license renewal drawings for the diesel generator are listed below:

[LR-PVNGS-CT-01-M-CTP-001](#)
[LR-PVNGS-DF-02-M-DFP-001](#)
[LR-PVNGS-DG-01-M-DGP-001-1](#)
[LR-PVNGS-DG-01-M-DGP-001-2](#)
[LR-PVNGS-DG-01-M-DGP-001-3](#)
[LR-PVNGS-DG-01-M-DGP-001-4](#)
[LR-PVNGS-DG-01-M-DGP-001-5](#)
[LR-PVNGS-DG-01-M-DGP-001-7](#)
[LR-PVNGS-DG-01-M-DGP-001-8](#)
[LR-PVNGS-DG-01-M-DGP-001-9](#)
[LR-PVNGS-DG-02-M-DGP-001-6](#)
[LR-PVNGS-DW-01-M-DWP-0002](#)

Component-Function Relationship Table

The component types subject to aging management review are indicated in [Table 2.3.3-21- Diesel Generator.](#)

Section 2.3
SCOPING AND SCREENING RESULTS:
MECHANICAL SYSTEMS

Table 2.3.3-21 Diesel Generator

Component Type	Intended Function
Accumulator	Pressure Boundary Structural Integrity (Attached)
Blower	Heat Transfer Pressure Boundary
Closure Bolting	Pressure Boundary
Dryer	Structural Integrity (Attached)
Expansion Joint	Pressure Boundary
Filter	Filter Pressure Boundary Structural Integrity (Attached)
Flame Arrestor	Pressure Boundary
Heat Exchanger (DG Fuel Oil)	Pressure Boundary
Heat Exchanger (DG Jacket Water)	Heat Transfer Pressure Boundary
Heat Exchanger (DG Lube Oil)	Heat Transfer Pressure Boundary
Heat Exchanger (DG Turbo Air Intercooler)	Heat Transfer Pressure Boundary
Heat Exchanger (Governor Oil Cooler)	Heat Transfer Pressure Boundary
Heater	Pressure Boundary
Insulation	Insulate (Mechanical)
Piping	Leakage Boundary (Spatial) Pressure Boundary Structural Integrity (Attached)
Pump	Pressure Boundary
Sight Gauge	Leakage Boundary (Spatial) Non-S/R Structural Support Pressure Boundary
Strainer	Filter Leakage Boundary (Spatial) Pressure Boundary

Table 2.3.3-21 Diesel Generator (Continued)

Component Type	Intended Function
Tank	Pressure Boundary
Tubing	Leakage Boundary (Spatial) Pressure Boundary Structural Integrity (Attached)
Valve	Leakage Boundary (Spatial) Non-S/R Structural Support Pressure Boundary Structural Integrity (Attached)

2.3.3.22 Domestic Water System

System Description

The purpose of the domestic water system is to process local onsite well water to remove suspended solids and part of the dissolved solids, chlorinate and neutralize the processed water, and to store and transfer the domestic water to each PVNGS unit and to common facilities in the plant. The domestic water system consists of a well water supply subsystem, a water treatment subsystem, and a storage and transfer subsystem which are shared facilities. Each PVNGS unit has a hot and cold water distribution system. Domestic water is also distributed to facilities in the water reclamation facility and the water treatment area. Waste water from operation of the treatment subsystem is directed to the water reclamation facility for recovery.

System Intended Function

Portions of the domestic water system in the auxiliary, control, diesel generator, and fuel buildings contain nonsafety-related components that are spatially oriented such that their failure could prevent the satisfactory accomplishment of a safety-related function associated with a safety-related component. Therefore, portions of the domestic water system are within the scope of license renewal as nonsafety-related affecting safety-related components based on the criterion of 10 CFR 54.4(a)(2).

Portions of the domestic water system are within the scope of license renewal to support fire protection requirements based on criteria of 10 CFR 54.4(a)(3).

PVNGS UFSAR References

Additional details of the domestic water system are included in [UFSAR Section 9.2.4](#).

License Renewal Drawings

The license renewal drawings for the domestic water system are listed below:

- LR-PVNGS-DS-01-M-DSP-002
- LR-PVNGS-DS-13-P-KDE-001
- LR-PVNGS-DS-13-P-KDE-002
- LR-PVNGS-DS-13-P-KDE-003
- LR-PVNGS-DS-13-P-KDE-004
- LR-PVNGS-DS-A0-M-DSP-001-3
- LR-PVNGS-FP-A0-M-FPP-001
- LR-PVNGS-HD-01-M-HDP-001
- LR-PVNGS-HJ-02-M-HJP-001
- LR-PVNGS-OW-01-M-OWP-002

Component-Function Relationship Table

The component types subject to aging management review are indicated in [Table 2.3.3-22](#) – Domestic Water System.

Table 2.3.3-22 Domestic Water System

Component Type	Intended Function
Closure Bolting	Leakage Boundary (Spatial) Pressure Boundary
Flow Indicator	Leakage Boundary (Spatial) Pressure Boundary
Piping	Leakage Boundary (Spatial) Pressure Boundary
Pump	Leakage Boundary (Spatial) Pressure Boundary
Strainer	Leakage Boundary (Spatial)
Tank	Leakage Boundary (Spatial)
Valve	Leakage Boundary (Spatial) Pressure Boundary

2.3.3.23 Demineralized Water System

System Description

The purpose of the demineralized water system is to process product water from the reverse osmosis units of the domestic water system to remove dissolved gas and solids. The demineralized water system then stores and transfers demineralized water to multiple systems in each unit and to common facilities in the chemical production system. The

demineralized water system is composed of piping components, pumps, tanks and demineralizers.

System Intended Function

Demineralized water system components providing containment isolation include one piping penetration. The demineralized water system is within the scope of license renewal based on the criteria of 10 CFR 54(a)(1).

Portions of the demineralized water system have spatial interaction as nonsafety affecting safety-related components in the auxiliary building, the containment building, the control building, the diesel generator building, the fuel building, the main steam support structure, the condensate water storage tank tunnel area, the hold-up tank area and in the yard between the turbine building and the containment building. Portions of the demineralized water system provide structural integrity attached to safety-related equipment. These portions of the demineralized water system are in-scope as nonsafety affecting safety-related components based on the criterion of 10 CFR 54(a)(2).

PVNGS UFSAR References

Additional details of the demineralized water system are included in [UFSAR Section 9.2.3](#) and [Table 6.2.4-1](#).

License Renewal Drawings

The license renewal drawings for the demineralized water system are listed below:

[LR-PVNGS-DG-01-M-DGP-001-1](#)
[LR-PVNGS-DW-01-M-DWP-0002](#)
[LR-PVNGS-EC-01-M-ECP-001](#)
[LR-PVNGS-EW-01-M-EWP-001](#)
[LR-PVNGS-OW-01-M-OWP-003](#)
[LR-PVNGS-RD-01-M-RDP-002](#)
[LR-PVNGS-SI-01-M-SIP-003](#)
[LR-PVNGS-SS-01-N-SSP-001-1](#)
[LR-PVNGS-SS-01-N-SSP-002-1](#)

Component-Function Relationship Table

The component types subject to aging management review are indicated in [Table 2.3.3-23- Demineralized Water System](#).

Table 2.3.3-23 Demineralized Water System

Component Type	Intended Function
Closure Bolting	Leakage Boundary (Spatial) Pressure Boundary Structural Integrity (Attached)
Piping	Leakage Boundary (Spatial) Pressure Boundary Structural Integrity (Attached)
Valve	Leakage Boundary (Spatial) Pressure Boundary Structural Integrity (Attached)

2.3.3.24 WRF Fuel System

System Description

The Water Reclamation Facility (WRF) fuel system receives, stores and supplies No. 2 fuel oil for the WRF lime recalcining furnaces, the Nuclear Power Plant auxiliary boilers, and the station blackout generators which provide an alternate AC power source for essential loads during a station blackout event.

The Nuclear Power Plant auxiliary boilers are part of the auxiliary steam system discussed in [Section 2.3.3.30](#) and the station blackout generators are addressed in the station blackout generators system discussed in [Section 2.3.3.28](#).

System Intended Function

Portions of the WRF fuel system support station blackout based on the requirements of 10 CFR 54.4(a)(3).

PVNGS UFSAR References

Additional details of the WRF fuel system are included in [UFSAR Sections 1.2.10.3.9](#) and [8.3.1.1.10](#).

License Renewal Drawings

The license renewal drawings for the WRF fuel system are listed below:
[LR-PVNGS-FS-A0-W-FSP-300](#)
[LR-PVNGS-GT-A0-M-GTP-001](#)

Component-Function Relationship Table

The component types subject to aging management review are indicated in [Table 2.3.3-24](#)– WRF Fuel System.

Table 2.3.3-24 WRF Fuel System

Component Type	Intended Function
Closure Bolting	Pressure Boundary
Filter	Filter Pressure Boundary
Flame Arrestor	Pressure Boundary
Flexible Hoses	Pressure Boundary
Flow Indicator	Pressure Boundary
Piping	Pressure Boundary
Pump	Pressure Boundary
Sight Gauge	Pressure Boundary
Strainer	Pressure Boundary
Tank	Pressure Boundary
Valve	Pressure Boundary Pressure Relief
Vent (Emergency)	Pressure Boundary Pressure Relief

2.3.3.25 Service Gases (N2 and H2) System

System Description

The service gases system consists of two separate subsystems that supply nitrogen and hydrogen gas to a variety of systems within the power block. The nitrogen subsystem vaporizes liquid nitrogen to supply both high and low pressure gas headers. The hydrogen subsystem contains two banks of high pressure storage cylinders supplying one low pressure hydrogen header. The service gases system is required for normal plant operation but is not required for safe shutdown of the plant. The service gases system is nonsafety-related except for the two safety-related containment building penetrations from the auxiliary building and safety-related piping to the essential chilled water system surge tanks.

System Intended Function

Safety-related portions of the service gases system provide containment building isolation for service gas high pressure nitrogen piping penetration IAE-U30 and service gas low pressure nitrogen piping penetration IAE-U29. The service gases system is within the scope of license renewal based on the criteria of 10 CFR 54.4(a)(1).

Nonsafety-related portions of the service gases system in the auxiliary building attach to safety-related essential cooling water system piping and attach to safety-related containment building penetration piping (IAE-U30 and IAE-U29). Nonsafety-related portions of the service gases system in the auxiliary building, main steam support structure, and containment building attach to safety-related essential chilled water system, main steam system, and safety injection system piping. Nonsafety-related portions of the service gases system in the containment building attach to nonsafety-related main steam system piping. These portions of the service gases system are in-scope as nonsafety-related components affecting safety-related components based on the criterion of 10 CFR 54.4(a)(2).

Portions of the service gases system support equipment qualification and station blackout requirements based on the criteria of 10 CFR 54.4(a)(3).

PVNGS UFSAR References

Additional details of the service gases system are included in [UFSAR Sections 6.2.4, 9.3.6,](#) and [Table 6.4.2-1](#).

License Renewal Drawings

The license renewal drawings for the service gases system are listed below:
[LR-PVNGS-GA-01-M-GAP-002](#)
[LR-PVNGS-GA-02-M-GAP-001](#)

Component-Function Relationship Table

The component types subject to aging management review are indicated in [Table 2.3.3-25](#) – Service Gases System.

Table 2.3.3-25 - Service Gases System

Component Type	Intended Function
Closure Bolting	Structural Integrity (Attached)
Filter	Pressure Boundary
Flexible Hoses	Pressure Boundary

Table 2.3.3-25 - Service Gases System (Continued)

Component Type	Intended Function
Orifice	Structural Integrity (Attached)
Piping	Pressure Boundary Structural Integrity (Attached)
Valve	Pressure Boundary Structural Integrity (Attached)

2.3.3.26 Gaseous Radwaste System

System Description

The purpose of the gaseous radwaste system is to collect and process radioactive and potentially radioactive waste gas. The gaseous radwaste system also limits the release of gaseous activity so that personnel exposure and activity releases in restricted and unrestricted areas are as low as reasonably achievable. The gaseous radwaste system consists of piping runs, valves, two waste gas compressors, a waste gas surge tank and three waste gas decay tanks.

System Intended Function

Gaseous radwaste system components providing containment isolation include one piping penetration. The gaseous radwaste system is within the scope of license renewal based on the criteria of 10 CFR 54(a)(1).

Portions of the gaseous radwaste system have spatial interaction as nonsafety affecting safety-related components in the auxiliary building. Portions of the gaseous radwaste system provide structural integrity attached to safety-related equipment in the gaseous radwaste system and in the chemical and volume control system. These portions of the gaseous radwaste system are in-scope as nonsafety affecting safety-related components based on the criterion of 10 CFR 54(a)(2).

Portions of the gaseous radwaste system support environmental qualification requirements based on the criteria of 10 CFR 54(a)(3).

PVNGS UFSAR References

Additional details of the gaseous radwaste system are included in [UFSAR Section 11.3](#) and [Table 6.2.4-1](#).

License Renewal Drawings

The license renewal drawing for the gaseous radwaste system is listed below:
[LR-PVNGS-GR-01-N-GRP-001](#)

Component-Function Relationship Table

The component types subject to aging management review are indicated in
[Table 2.3.3-26](#) – Gaseous Radwaste System.

Table 2.3.3-26 – Gaseous Radwaste System

Component Type	Intended Function
Closure Bolting	Leakage Boundary (Spatial) Pressure Boundary Structural Integrity (Attached)
Piping	Leakage Boundary (Spatial) Pressure Boundary Structural Integrity (Attached)
Sight Gauge	Leakage Boundary (Spatial)
Tubing	Leakage Boundary (Spatial)
Valve	Leakage Boundary (Spatial) Pressure Boundary

2.3.3.27 Radioactive Waste Drains System

System Description

The radioactive waste drains system collects and transports non-corrosive, radioactive or potentially radioactive liquid wastes from equipment and floor drains of the containment building, the auxiliary building, the fuel building, the main steam support structure, the radwaste building, the hold up tank area and the decontamination and laundry facilities. The wastes collected are pumped to the liquid radwaste system for processing.

The purpose of the radioactive waste drains system is to provide for leakage detection, collection of radioactive and potential radioactive liquid wastes and their transfer for processing. Additionally, the radioactive waste drains system prevents a backflow of water that might exist from maximum flood levels resulting from external or system leakage to areas of the plant containing ESF equipment. Equipment and floor drainage systems provided for ESF equipment and floor drainage do not interconnect unless check valves are in place to prevent cross-flow. The radioactive waste drains system also provides for the indication of the flooding of watertight rooms, which are designed to contain flood water until the room can be drained into the normal drainage system. A leakage detection system is also provided to determine refueling pool and fuel pool liner plate leakage.

Section 2.3
SCOPING AND SCREENING RESULTS:
MECHANICAL SYSTEMS

The radioactive waste drains system contains one containment penetration (Penetration 9). The radioactive waste drains system is composed of piping components, valves, filters, drains and pumps.

System Intended Function

Portions of the radioactive waste drains system provide a containment isolation function. The radioactive waste drains system is within the scope of license renewal based on the criteria of 10 CFR 54(a)(1).

Portions of the radioactive waste drains system have spatial interaction as nonsafety affecting safety-related components in the auxiliary building, the containment building, fuel building, the main steam support structure and the hold up tank area. Portions of the radioactive waste drains system provide structural integrity attached to safety-related equipment. These portions of the radioactive waste drains system are in-scope as nonsafety affecting safety-related components based on the criterion of 10 CFR 54(a)(2).

Portions of the radioactive waste drains system are required to support environmental qualification based on the criteria of 10 CFR 54(a)(3).

PVNGS UFSAR References

Additional details of the radioactive waste drains system are included in [UFSAR Section 9.3.3](#) and [Table 6.2.4-1](#).

License Renewal Drawings

The license renewal drawings for the radioactive waste drains system are listed below:

[LR-PVNGS-CH-01-M-CHP-001](#)
[LR-PVNGS-CH-01-M-CHP-002](#)
[LR-PVNGS-CH-01-M-CHP-003](#)
[LR-PVNGS-CM-01-M-CMP-001](#)
[LR-PVNGS-CP-01-M-CPP-001](#)
[LR-PVNGS-DW-01-M-DWP-0002](#)
[LR-PVNGS-EC-01-M-ECP-001](#)
[LR-PVNGS-GR-01-N-GRP-0001](#)
[LR-PVNGS-HA-02-M-HAP-001](#)
[LR-PVNGS-HA-02-M-HAP-002](#)
[LR-PVNGS-LR-01-N-LRP-001](#)
[LR-PVNGS-NC-01-M-NCP-002](#)
[LR-PVNGS-PC-01-M-PCP-001](#)
[LR-PVNGS-RC-01-M-RCP-001](#)
[LR-PVNGS-RD-01-M-RDP-001](#)
[LR-PVNGS-RD-01-M-RDP-002](#)
[LR-PVNGS-RD-01-M-RDP-003](#)

LR-PVNGS-RD-01-M-RDP-005
 LR-PVNGS-SI-01-M-SIP-001
 LR-PVNGS-SS-01-N-SSP-002-1

Component-Function Relationship Table

The component types subject to aging management review are indicated in [Table 2.3.3-27](#)– Radioactive Waste Drains System.

Table 2.3.3-27 – Radioactive Waste Drains System

Component Type	Intended Function
Closure Bolting	Leakage Boundary (Spatial)
Orifice	Leakage Boundary (Spatial)
Piping	Leakage Boundary (Spatial) Pressure Boundary Structural Integrity (Attached)
Sight Gauge	Leakage Boundary (Spatial)
Strainer	Leakage Boundary (Spatial)
Tubing	Leakage Boundary (Spatial) Pressure Boundary
Valve	Leakage Boundary (Spatial) Pressure Boundary

2.3.3.28 Station Blackout Generator System

System Description

The station blackout generator system is available to provide AC power to the station loads that have been identified as important to the mitigation of a station blackout in any one unit of PVNGS. Two redundant 100-percent capacity turbine generators are available for providing power to one of the safety-related 4.16kv buses in each unit.

System Intended Function

Portions of the station blackout generator system (alternate AC power source) support station blackout requirements based on the criteria of 10 CFR 54.4(a)(3).

PVNGS UFSAR References

Additional details of the station blackout generator system are included in [UFSAR Section 1.2.10.3.9](#).

License Renewal Drawings

The license renewal drawings for the station blackout generator system are listed below:

- [LR-PVNGS-GT-A0-EN609-106-6](#)
- [LR-PVNGS-GT-A0-EN609-A109-5](#)
- [LR-PVNGS-GT-A0-EN609-A114-5](#)
- [LR-PVNGS-GT-A0-M-GTP-001](#)

Component-Function Relationship Table

The component types subject to aging management review are indicated in [Table 2.3.3-28](#) – Station Blackout Generator System.

Table 2.3.3-28 – Station Blackout Generator System

Component Type	Intended Function
Accumulator	Pressure Boundary
Closure Bolting	Pressure Boundary
Filter	Filter Pressure Boundary
Heat Exchanger (Generator Bearing Oil)	Heat Transfer Pressure Boundary
Heat Exchanger (Lube Oil)	Heat Transfer Pressure Boundary
Orifice	Pressure Boundary Throttle
Piping	Pressure Boundary
Pump	Pressure Boundary
Sight Gauge	Pressure Boundary
Tank	Pressure Boundary
Tubing	Pressure Boundary
Turbine	Pressure Boundary
Valve	Pressure Boundary

2.3.3.29 Cranes, Hoists, and Elevators

System Description

The purpose of the cranes, hoists and elevators group is to provide lifting and maneuvering capacity in the auxiliary building, the containment building, the control building, the diesel generator building, the fuel building, the MSSS building, the radwaste building and the turbine building. This group consists of multiple cranes, elevators, hoists and trolleys. Crane supports are evaluated with their appropriate structure. The following cranes and trolleys are within the scope of license renewal.

- Auxiliary Building 4-Ton Trolleys
- MSSS South Room 140' El. Hoist Assemblies
- Diesel Generator Building Train A 5-Ton Bridge Crane
- Diesel Generator Building Train B 5-Ton Bridge Crane
- Diesel Generator Building Room 1, 25 Ton Trolley
- Diesel Generator Building Room 2, 25 Ton Trolley.

System Intended Function

Portions of the cranes, hoists and elevators group have spatial interaction as nonsafety affecting safety-related components in the auxiliary building, the containment building, diesel generator building and in the MSSS building. Portions of the cranes, hoists and elevators group are in-scope as nonsafety affecting safety-related components based on the criterion of 10 CFR 54.4(a)(2).

PVNGS UFSAR References

Additional details of the cranes, hoists, and elevators system are not discussed in the UFSAR.

License Renewal Drawings

There are no license renewal drawings for the cranes, hoists, and elevators system.

Component-Function Relationship Table

The component types subject to aging management review are indicated in [Table 2.3.3-29](#) – Cranes, Hoists, and Elevators System.

Table 2.3.3-29 – Cranes, Hoists, and Elevators System

Component Type	Intended Function
Crane	Non-S/R Structural Support
Cranes - Rails	Non-S/R Structural Support
Hoist	Non-S/R Structural Support
Trolley	Non-S/R Structural Support

2.3.3.30 Miscellaneous Auxiliary Systems in-scope ONLY for Criterion 10 CFR 54.4(a)(2)

Auxiliary systems within the scope of license renewal based upon the criterion of 10 CFR 54.4(a)(2) were identified using the methods described in [Section 2.1.2.2](#). A review of each mechanical system was performed to identify nonsafety-related systems or nonsafety-related portions of safety-related systems with the potential for adverse spatial interaction with safety-related systems or components. Components subject to aging management review due only to scoping criterion 10 CFR 54.4(a)(2) are evaluated in this section.

The following auxiliary systems are within the scope of license renewal only based on the criterion of 10 CFR 54.4(a)(2):

- [Auxiliary steam](#)
- [Chemical waste](#)
- [Liquid radwaste](#)
- [Oily waste and non-radioactive waste](#)
- [Solid radwaste](#)
- [Sanitary sewage and treatment](#)
- [Secondary chemical control](#)

System Descriptions/System Intended Functions

Auxiliary steam

The purpose of the auxiliary steam system is to provide a source of steam for various nonsafety-related functions during plant startup, shutdown, normal operations, and testing evolutions. The auxiliary steam system consists of an auxiliary boiler, transfer pumps, receivers, tanks, piping, and valves.

Portions of the auxiliary steam system in the auxiliary building contain nonsafety-related components that are spatially oriented such that their failure could prevent the satisfactory

Section 2.3
SCOPING AND SCREENING RESULTS:
MECHANICAL SYSTEMS

accomplishment of a safety-related function associated with a safety-related component. The auxiliary steam system attaches to nonsafety-related auxiliary feedwater system piping such that the structural failure of the auxiliary steam system piping could prevent satisfactory accomplishment of safety-related auxiliary feedwater system functions. These portions of the auxiliary steam system are within the scope of license renewal as nonsafety-related components affecting safety-related components based on the criterion of 10 CFR 54.4(a)(2).

Chemical waste

The chemical waste system consists of five sub-systems:

(1) The radioactive chemical waste sub-system that collects the corrosive radioactive waste from the chemical laboratory and decontamination stations. The sub-system transports the liquid waste and drainage from decontamination room, sample hood and hot lab fume hoods, instrumentation respirator maintenance and issue room, cold lab fume hood, to the chemical drain tanks by gravity flow.

(2) The cooling water waste sub-system that collects the chemically treated cooling water from the auxiliary and radwaste buildings for reuse or disposal. In addition to collecting leakage, the sub-system accepts drainage during maintenance of plant equipment containing chemically treated cooling water, and collects in the cooling water holdup tank by gravity flow. The sub-system is normally aligned to transfer the contents to the chemical waste neutralizer tanks of the radwaste system. Branch lines are provided for diverting the contents of the cooling water holdup tank to the essential cooling water surge tanks or to the nuclear cooling water surge tanks, for use only during maintenance, to return the drainage from the equipment to the appropriate cooling water loop.

(3) The condensate polisher regeneration waste sub-system that collects the rinse washes from the condensate polisher demineralizers and neutralizes the waste for disposal to the retention basin if it is non-radioactive, or discharges to the liquid radwaste system if the waste exceeds the release limits.

(4) The spent regenerate waste sub-system that collects and neutralizes the rinse washes from the makeup demineralizers for disposal.

(5) The yard areas chemical tank drains sub-system. The yard area chemical tanks and pumps are installed on concrete slabs with retaining curbs. Small sumps are provided inside the curbs to collect equipment leakage.

All sub-systems of chemical waste system have no safety-related functions.

Portions of the chemical waste system in the auxiliary building and pipe tunnel contain nonsafety-related components that are spatially oriented such that their failure could prevent the satisfactory accomplishment of the safety-related functions associated with the surrounding safety-related components. Portions of the chemical waste system attach to

Section 2.3
SCOPING AND SCREENING RESULTS:
MECHANICAL SYSTEMS

safety-related essential cooling water system piping such that the structural failure of the chemical waste system piping could prevent satisfactory accomplishment of safety-related essential cooling water system functions. These portions of the chemical waste system are within the scope of license renewal as nonsafety-related components affecting safety-related components based on the criterion of 10 CFR 54.4(a)(2).

Liquid Radwaste

The purpose of the liquid radwaste system is to collect, process, monitor and recycle or dispose of liquid radwaste. Liquid radwaste is sampled and analyzed for radioactivity. Based on the analysis, liquid radwaste is recycled for eventual reuse in the plant, retained for further processing or dispatched to the solid radwaste system or to the onsite evaporation pond under controlled conditions. Plant design precludes the release of radioactive liquids to the environment. The liquid radwaste system is composed of instrumentation and process components such as piping, filters, pumps, tanks and an evaporator.

Portions of the liquid radwaste system have spatial interaction as nonsafety affecting safety-related components in the fuel building and in the auxiliary building and are within the scope of license renewal as nonsafety affecting safety-related components based on the criterion of 10 CFR 54(a)(2).

Oily waste and non-radioactive waste

The oily waste and non-radioactive waste system collects and transports liquid waste from equipment and floor drains of the turbine building, the control building, the diesel generator buildings, the fire pump house, and the yard area. The system removes entrained oil from the wastewater for disposal and conveys the oil-free water to the evaporation pond.

The turbine building oil/water separator receives effluent from the turbine building sumps, the control building sumps, and the diesel generator building sumps. A duplex retention basin is provided to act as a storage basin for the wastewater from the turbine building oil/water separator. When the chemistry of the waste in the retention basin is acceptable, the waste in the retention basin is discharged to the evaporation pond. A connection for a portable ion exchanger is provided in the unlikely event that radioactivity greater than the release limits are detected in one of the retention basins. The waste oil is sampled to detect any activity before being manually transferred to the external waste oil container for disposal.

The oily waste and non-radioactive waste system for the fire pump house is entirely separate from the other parts of the oily waste and non-radioactive waste system. The collected waste is treated in the fire pump house oil/water separator. The oily waste and non-radioactive waste system in the yard area receives drainage and liquid waste from the areas associated with the demineralized water storage tank and pumps, the auxiliary boiler,

Section 2.3
SCOPING AND SCREENING RESULTS:
MECHANICAL SYSTEMS

and turbine building normal air handling units. The collected waste from the yard area is discharged to the circulating water intake structure.

Portions of the oily waste and non-radioactive waste system that are located in the auxiliary building, diesel generator building and control building have effects of spatial interaction with safety-related components and are in-scope as nonsafety affecting safety-related components based on the criteria of 10 CFR 54.4(a)(2).

Portions of the floor drains in the diesel generator building and control building are credited for protection of safety-related equipment from flooding in an event of pipe break in the associated areas. They are included in-scope for the criteria of 10 CFR 54.4(a)(2).

Portions of the oily waste and non-radioactive waste system attach to safety-related essential chilled water system piping through demineralized water system such that the structural failure of the oily waste and non-radioactive waste system piping could prevent satisfactory accomplishment of safety-related essential chilled water system functions. These portions of the oily waste and non-radioactive waste system are within the scope of license renewal as nonsafety components affecting safety-related components based on the criterion of 10 CFR 54.4(a)(2).

Solid Radwaste

The purpose of the solid radwaste system is to provide processing and packaging capability for concentrated waste solutions and spent resins. The system provides a means for packaging and disposal of spent radioactive cartridge filters and solid wastes from the liquid radwaste system and the chemical and volume control system. Additionally, the solid radwaste system provides a means of compacting and packaging miscellaneous dry radioactive materials such as paper, rags, clothing and tools. The solid radwaste system is made up of multiple piping runs, valves, tanks and pumps and consists of the following subsystems: spent resin transfer subsystem, wet waste processing subsystem, dry waste disposal subsystem and the filter handling and disposal subsystem.

Portions of the solid radwaste system have spatial interaction as nonsafety affecting safety-related components in the auxiliary building. Portions of the solid radwaste system provide structural integrity attached to safety-related equipment in the fuel pool cooling and cleanup system and in the chemical and volume control system. These portions of the solid radwaste system are in-scope as nonsafety affecting safety-related components based on the criterion of 10 CFR 54(a)(2).

Sanitary Sewage and Treatment

The sanitary sewage and treatment system collects the sanitary wastewater from facilities throughout the plant through drain piping and transports it through one wet well, one sewage lift station, one surge tank, to the three package sewage treatment units, where the waste is treated and clarified. The wastewater is then transported to the chlorine contact chamber for

Section 2.3
SCOPING AND SCREENING RESULTS:
MECHANICAL SYSTEMS

chlorination before being transported to the sanitary waste water sump. Two sump pumps, with automatic level control, pump the wastewater from the sanitary waste water sump to the water reclamation plant for further treatment and reuse.

Portions of the sanitary sewage and treatment system that are located in the auxiliary building and control building have effects of spatial interaction with safety-related components and are within the scope of license renewal as nonsafety affecting safety-related components based on the criteria of 10 CFR 54.4(a)(2).

Secondary Chemical Control

The secondary chemical control system is an integrated system comprised of a condensate demineralizer subsystem, a steam generator blowdown processing subsystem, the chemical monitoring and addition subsystem, and the online process sampling subsystem. These subsystems operating concurrently maintain the required operating water chemistry of the condensate and feedwater under all normal operating and upset or abnormal conditions.

The purpose of the condensate demineralizer subsystem is to maintain required water chemistry of the condensate/feedwater loop during upset or abnormal conditions. Dissolved solids are removed by ion exchange and suspended solids are removed by filtration. The demineralizer is normally on standby, and is placed in service only during startup, shutdown, excessive condenser leakage, or other condition requiring polishing of the condensate to maintain required chemistry.

The purpose of the steam generator blowdown subsystem is to compensate for the concentrating effect of the steam generators by continuous blowdown and processing for reuse of a portion of the fluid from each steam generator. This subsystem is also part of a system which maintains the steam generator in wet lay-up by providing the capability to adequately mix, sample and add chemicals to the steam generator.

The purpose of the chemical addition subsystem is to establish and maintain the proper chemistry within the condensate, feedwater, and steam generator secondary side water. The additives serve to control the pH, establish a reducing environment, and to scavenge any dissolved oxygen. In addition, boric acid may be injected into the secondary system for mitigating denting and intergranular attack/stress corrosion cracking in the steam generator.

The chemical monitoring subsystem provides continuous indication of significant chemical parameters in the secondary system and to alert the operator of faulty chemistry or equipment malfunction. Continuous online samples are taken from the main condenser, condensate demineralizers, main feedwater lines, steam generator blowdown lines and downcomer, and circulating water lines for analysis by the chemical monitoring system.

All components and piping associated with steam generator blowdown and blowdown sampling between the steam generator and the containment isolation valves are designed to

Section 2.3
SCOPING AND SCREENING RESULTS:
MECHANICAL SYSTEMS

seismic Category I with ASME Class 2 requirements and are assigned to and are evaluated with the main steam system.

Portions of the secondary chemical control system in the auxiliary building and pipe tunnel contain nonsafety-related components that are spatially oriented such that their failure could prevent the satisfactory accomplishment of the safety-related functions associated with the surrounding safety-related components. Portions of the secondary control system attach to safety-related main steam system piping such that the structural failure of the secondary chemical control system piping could prevent satisfactory accomplishment of safety-related main steam system functions. These portions of the secondary chemical control system are within the scope of license renewal as nonsafety-related components affecting safety-related components based on the criterion of 10 CFR 54.4(a)(2).

PVNGS UFSAR References

Details of the auxiliary steam system are not discussed in the UFSAR.

Additional details of the chemical waste system are included in [UFSAR Section 9.3.3](#).

Additional details of the liquid radwaste system are included in [UFSAR Section 11.2.2.3](#).

Additional details of the oily waste and non-radioactive waste are included in [UFSAR Sections 3.6](#) and [9.3.3](#).

Additional details of the solid radwaste system are included in [UFSAR Section 11.4](#).

Additional details of the sanitary sewage and treatment system are included in [UFSAR Section 9.3.3](#).

Additional details of the secondary chemical control system are provided in [UFSAR Sections 9.3.2](#) and [10.4.6](#).

License Renewal Drawings

The license renewal drawings for the auxiliary steam system are listed below:

[LR-PVNGS-AS-01-M-ASP-001](#)
[LR-PVNGS-CH-01-M-CHP-001](#)
[LR-PVNGS-CH-01-M-CHP-005](#)
[LR-PVNGS-HA-02-M-HAP-001](#)

The license renewal drawings for the chemical waste system are listed below:

[LR-PVNGS-CM-01-M-CMP-001](#)
[LR-PVNGS-CM-01-M-CMP-002](#)
[LR-PVNGS-EW-01-M-EWP-001](#)

Section 2.3
SCOPING AND SCREENING RESULTS:
MECHANICAL SYSTEMS

The license renewal drawings for the liquid radwaste system are listed below:

[LR-PVNGS-LR-01-N-LRP-001](#)
[LR-PVNGS-LR-01-N-LRP-002-02](#)

The license renewal drawings for the oily waste and non-radioactive waste system are listed below:

[LR-PVNGS-OW-01-M-OWP-001](#)
[LR-PVNGS-OW-01-M-OWP-002](#)
[LR-PVNGS-OW-01-M-OWP-003](#)

The license renewal drawings for the solid radwaste system are listed below:

[LR-PVNGS-SR-01-N-SRP-001](#)
[LR-PVNGS-LR-01-N-LRP-002-02](#)

The license renewal drawings for the sanitary sewage and treatment system are listed below:

[LR-PVNGS-ST-13-P-ZAE-204](#)
[LR-PVNGS-ST-13-P-ZAE-205](#)
[LR-PVNGS-ST-13-P-ZAE-209-01](#)
[LR-PVNGS-ST-13-P-ZJE-304](#)

The license renewal drawings for the secondary chemical control system are listed below:

[LR-PVNGS-SC-01-M-SCP-005-01](#)
[LR-PVNGS-SC-01-M-SCP-006-01](#)
[LR-PVNGS-SC-01-M-SCP-006-02](#)
[LR-PVNGS-SG-01-M-SGP-002](#)

Component-Function Relationship Table

The component types subject to aging management review are indicated in [Table 2.3.3-30](#) - Miscellaneous Auxiliary Systems In-Scope ONLY based on Criterion 10 CFR 54.4(a)(2).

Section 2.3
SCOPING AND SCREENING RESULTS:
MECHANICAL SYSTEMS

Table 2.3.3-30 Miscellaneous Auxiliary Systems In-Scope ONLY based on Criterion 10 CFR 54.4(a)(2)

Component Type	Intended Function
Closure Bolting	Leakage Boundary (Spatial) Structural Integrity (Attached)
Filter	Leakage Boundary (Spatial)
Heat Exchanger (AS Condensate Vent Condenser)	Leakage Boundary (Spatial)
Heat Exchanger (Sample Cooler)	Leakage Boundary (Spatial)
Orifice	Leakage Boundary (Spatial)
Piping	Leakage Boundary (Spatial) Structural Integrity (Attached)
Pump	Leakage Boundary (Spatial)
Sight Gauge	Leakage Boundary (Spatial) Structural Integrity (Attached)
Strainer	Leakage Boundary (Spatial) Structural Integrity (Attached)
Tank	Leakage Boundary (Spatial)
Tubing	Leakage Boundary (Spatial)
Valve	Leakage Boundary (Spatial) Structural Integrity (Attached)

2.3.4 Steam and Power Conversion Systems

This section of the application addresses scoping and screening results for the following systems:

- [Main steam](#)
- [Condensate storage and transfer](#)
- [Auxiliary feedwater](#)
- [Condensate](#)
- [Feedwater](#)
- [Main turbine](#)
- [Steam generator feedwater pump turbine](#)
- [feedwater heater extraction, drains, and vents system](#)

2.3.4.1 Main Steam System

System Description

The main steam system consists of main steam supply system, turbine bypass system, portions of feedwater system and portions of the steam generator blowdown system.

The main steam system consists of the piping systems that deliver steam from the steam generators to the high-pressure turbine for a range of flows and pressure varying from system warm-up to maximum operating conditions. Branch piping provides steam to moisture separator reheaters, main and feedwater pump turbine gland steam sealing systems, the feedwater pump turbines, the auxiliary feedwater pump turbine, and the turbine bypass steam to the condenser and to atmosphere.

Each main steam line is equipped with one pneumatically-operated atmospheric dump valve, five spring-loaded safety valves, one main steam isolation valves (MSIV), a cross-tie header downstream of the MSIVs, and the associated vent/drain valves. The main steam lines including the piping system from the MSIVs to the main turbine stop valves are evaluated with the main steam system. Part of the branches that supply steam to the turbine gland seals, moisture separator reheaters, the main feedwater pump turbines and auxiliary feedwater pump turbine are evaluated with the main steam system. Major portions of the steam supply piping systems for the main feedwater pump turbines and auxiliary feedwater pump turbine are evaluated with the steam generator feedwater pump turbine system ([Section 2.3.4.7](#)) and the auxiliary feedwater system ([Section 2.3.4.3](#)), respectively.

The turbine bypass system consists of eight air-operated valves that branch from each main steam line down stream of the MSIV. It has the capability to remove the heat from the steam generators to the main condenser or atmosphere to minimize transient effects on the reactor coolant system of startup, hot shutdown, cooldown, and load rejection.

Section 2.3
SCOPING AND SCREENING RESULTS:
MECHANICAL SYSTEMS

The portions of feedwater piping from the ultrasonic feedwater flow elements through feedwater isolation valve to the steam generator nozzles, including interface with the auxiliary feedwater system, are included in the evaluation of main steam system. Portions of the steam generator blowdown piping system that interface with the steam generators, including containment isolation, are also evaluated with the main steam system.

System Intended Function

The main steam system provides a means of dissipating heat generated in the nuclear steam supply system during transients, accidents and post accident conditions even if the main condenser is unavailable. Portions of the main steam system provide containment isolation and overpressure protection for the secondary side of the steam generators and the main steam piping. Each steam generator steam outlet is equipped with a flow limiting device to limit steam flow in the event of a main steam line break. The main steam system also provides steam as a motive force to support the operation of the turbine-driven auxiliary feedwater pump. Portions of the main steam system and portions of the feedwater piping system and steam generator blowdown piping system that are included in main steam system are in the scope of license renewal based on the criteria of 10 CFR 54.4(a)(1).

Several nonsafety-related components beyond the safety class break points are credited for structural integrity of the subject safety-related components and/or have spatial interaction effect on adjacent safety-related components. These portions of the main steam system are within scope as nonsafety-related components affecting safety-related components based on the criterion of 10 CFR 54.4(a)(2).

Portions of the piping systems evaluated in the main steam system support fire protection, station blackout, ATWS and environmental qualification requirements based on the criteria 10 CFR 54.4(a)(3).

PVNGS UFSAR References

Additional details of the main steam system can be found in [UFSAR Sections 10.3, 10.4.4, 10.4.7, and 10.4.9.](#)

License Renewal Drawings

The license renewal drawings for the main steam system are listed below:
[LR-PVNGS-SG-01-M-SGP-001-01](#)
[LR-PVNGS-SG-01-M-SGP-001-02](#)
[LR-PVNGS-SG-01-M-SGP-002](#)

Component-Function Relationship Table

The component types subject to aging management review are indicated in [Table 2.3.4-1 - Main Steam System.](#)

Table 2.3.4-1 Main Steam System

Component Type	Intended Function
Accumulator	Pressure Boundary
Closure Bolting	Leakage Boundary (Spatial) Pressure Boundary Structural Integrity (Attached)
Filter	Leakage Boundary (Spatial) Structural Integrity (Attached)
Flexible Hoses	Pressure Boundary
Insulation	Insulate (Mechanical)
Orifice	Pressure Boundary Throttle
Piping	Leakage Boundary (Spatial) Pressure Boundary Structural Integrity (Attached)
Pump	Leakage Boundary (Spatial) Structural Integrity (Attached)
Tubing	Pressure Boundary
Valve	Leakage Boundary (Spatial) Pressure Boundary Structural Integrity (Attached)

2.3.4.2 Condensate Storage and Transfer System

System Description

The condensate storage and transfer system provides the source of feedwater in the condensate storage tank (CST) for the auxiliary feedwater system for removal of reactor decay heat during hot standby conditions and for cooling the reactor to the point where the shutdown cooling system can assume the heat load. The condensate storage and transfer system also maintains feedwater inventory in the secondary system during startup, shutdown, hot standby, and normal power generation operations. The condensate storage and transfer system provides water makeup for the essential cooling water system, essential chilled water system, diesel generator system, and the spent fuel pool. The system consists of one CST, two condensate transfer pumps and associated piping, valves, instrumentation and controls. The CST is constructed with a pressure boundary stainless steel liner inside a concrete missile barrier with a composite roof that covers the top of the liner and concrete walls. The concrete and roof are structural components and are evaluated with Tank Foundations and Shells ([Section 2.4.11](#)). The tank liner is evaluated with the condensate storage and transfer system. The CST is located outside. Safety-related pumps, piping, valves, and instrumentation are located inside the condensate transfer pump house, the

CST tunnel, and on the CST exterior. The remaining safety-related equipment is located in the auxiliary building, diesel generator building, and control building.

System Intended Function

The condensate storage and transfer system provides the source of feedwater supply from the CST to the steam generators through the auxiliary feedwater system to maintain a secondary heat sink for design basis event mitigation. The feedwater source for the auxiliary feedwater system for normal, design basis event mitigation, and station blackout requirements is from the CST. Most of the condensate storage and transfer system is safety-related. The condensate storage and transfer system is within the scope of license renewal based on the criteria of 10 CFR 54.4(a)(1).

Portions of the system contain nonsafety-related piping and components in the condensate transfer pump house, and CST tunnel that are spatially oriented such that their failure could prevent the satisfactory accomplishment of a safety-related function associated with a safety-related component. Some of the condensate storage and transfer system nonsafety-related piping and components in the condensate transfer pump house, CST tunnel, and the CST exterior attach to safety-related system piping such that the structural failure of the nonsafety-related piping and components could prevent accomplishment of a safety-related function associated with a safety-related component. These portions of the condensate storage and transfer system are within scope as nonsafety-related components affecting safety-related components based on the criterion of 10 CFR 54.4(a)(2).

Portions of the condensate storage and transfer system support fire protection and station blackout requirements based on the criteria of 10 CFR 54.4(a)(3).

PVNGS UFSAR References

Additional details of the condensate storage and transfer system are included in [UFSAR Sections 3.8.4.1.7](#) and [9.2.6](#).

License Renewal Drawings

The license renewal drawings for the condensate storage and transfer system are listed below:

[LR-PVNGS-CT-01-M-CTP-001](#)
[LR-PVNGS-DG-01-M-DGP-001-9](#)

Component-Function Relationship Table

The component types subject to aging management review are indicated in [Table 2.3.4-2 – Condensate Storage and Transfer System](#).

Table 2.3.4-2 Condensate Storage and Transfer System

Component Type	Intended Function
Closure Bolting	Leakage Boundary (Spatial) Pressure Boundary Structural Integrity (Attached)
Flow Element	Pressure Boundary
Orifice	Pressure Boundary
Piping	Leakage Boundary (Spatial) Pressure Boundary Structural Integrity (Attached)
Pump	Pressure Boundary
Tank Liner	Pressure Boundary
Tubing	Leakage Boundary (Spatial)
Valve	Leakage Boundary (Spatial) Pressure Boundary Structural Integrity (Attached)

2.3.4.3 Auxiliary Feedwater System

System Description

The purpose of the auxiliary feedwater system is to supply feedwater from the condensate storage tank (CST) to the steam generators during initial fill, startup, hot standby, normal shutdown, and emergency conditions. The CST is evaluated with the condensate transfer and storage system. One safety-related motor-driven auxiliary feedwater pump and one safety-related turbine-driven pump are available to ensure the required feedwater flow to the steam generators is available. The steam turbine drive for the turbine-driven auxiliary feedwater pump is safety-related and is evaluated with the auxiliary feedwater system. Steam for the steam turbine drive is supplied by the main steam system. Piping, valves, and components associated with the safety-related motor-driven and steam driven pumps from the CST to the feedwater piping interfaces are safety-related. A third auxiliary feedwater train including a motor-driven pump and associated piping, valves, and components is used for normal plant operations and is nonsafety-related.

System Intended Function

The auxiliary feedwater system is relied upon as the source of feedwater supply to the steam generators to maintain a secondary heat sink for emergency conditions. The

Section 2.3
SCOPING AND SCREENING RESULTS:
MECHANICAL SYSTEMS

feedwater source for the auxiliary feedwater system for normal, emergency conditions, and station blackout requirements is from the CST. Most of the auxiliary feedwater system serves a safety-related function. The auxiliary feedwater system is within the scope of license renewal based on the criteria of 10 CFR 54.4(a)(1).

Portions of the auxiliary feedwater system in the auxiliary building contain nonsafety-related components that are spatially oriented such that their failure could prevent the satisfactory accomplishment of a safety-related function associated with a safety-related component. Also, portions of the safety-related auxiliary feedwater system attach to nonsafety-related piping such that the structural failure of the nonsafety-related piping could prevent satisfactory accomplishment of safety-related System Intended Functions. These portions of auxiliary feedwater system are within scope as nonsafety affecting safety-related components based on the criterion of 10 CFR 54.4(a)(2).

Portions of auxiliary feedwater system support fire protection, equipment qualification, ATWS, and station blackout requirements based on the criteria of 10 CFR 54.4(a)(3).

PVNGS UFSAR References

Additional details of the auxiliary feedwater system are included in [UFSAR Sections 7.3.5, 9.2.6 and 10.4.9](#).

License Renewal Drawings

The license renewal drawings for the auxiliary feedwater system are listed below:
[LR-PVNGS-AF-01-M-AFP-001](#)
[LR-PVNGS-CT-01-M-CTP-001](#)
[LR-PVNGS-SG-01-M-SGP-002](#)

Component-Function Relationship Table

The component types subject to aging management review are indicated in [Table 2.3.4-3 - Auxiliary Feedwater System](#).

Table 2.3.4-3 Auxiliary Feedwater System

Component Type	Intended Function
Closure Bolting	Leakage Boundary (Spatial) Pressure Boundary Structural Integrity (Attached)
Filter	Pressure Boundary
Flexible Hoses	Pressure Boundary
Flow Element	Pressure Boundary Throttle
Heat Exchanger (AF Turbine Oil Cooler)	Heat Transfer Pressure Boundary
Insulation	Insulate (Mechanical)
Orifice	Pressure Boundary Throttle
Piping	Leakage Boundary (Spatial) Pressure Boundary Structural Integrity (Attached)
Pump	Pressure Boundary
Sight Gauge	Leakage Boundary (Spatial)
Strainer	Leakage Boundary (Spatial) Structural Integrity (Attached)
Tubing	Pressure Boundary
Turbine	Pressure Boundary
Valve	Leakage Boundary (Spatial) Pressure Boundary Structural Integrity (Attached)

2.3.4.4 Condensate System

System Description

The purpose of the condensate system is to collect the condensate from the exhaust steam of main turbines and feedwater pump turbines and the steam cycle drains in the main condenser hotwell and to deliver deaerated water from the main condenser hotwells to the suction of the main feedwater pumps. Together with the feedwater system, the feedwater is

Section 2.3
SCOPING AND SCREENING RESULTS:
MECHANICAL SYSTEMS

delivered to the steam generators at required pressure and temperature through regenerative feedwater heaters.

The main condenser, in conjunction with circulating water system, provides a heat sink for the exhaust steam from the main turbines and feedwater pump turbines, as well as for turbine bypass steam. The condensate is received in the condenser hotwell. The condensate pumps take suction from the condenser hotwell and discharge through, or bypass, the condensate demineralizers if desired. The condensate demineralizers are evaluated as part of the secondary chemistry control system.

At the condensate pump discharge the condensate system interfaces with the chemical monitoring and addition system for oxygen and pH control, which is also evaluated with the secondary chemistry control system. Downstream of the condensate demineralizers are three trains with four stages each of low-pressure feedwater heaters, which join together at a common header for the suction of the main feedwater pumps. The systems from this common header to the inlet of steam generators are evaluated with the feedwater system and main steam system. The condensate storage tank, which provides makeup and surge capacity to compensate for changes in condensate system inventory, is evaluated with the condensate transfer and storage system.

System Intended Function

Portions of the condensate system support fire protection requirements based on the criteria of 10 CFR 54.4(a)(3).

The function to meet these requirements is performed solely by electrical components. No mechanical components are relied upon to perform this function. Thus, there are no mechanical components in the condensate system that requires aging management review.

PVNGS UFSAR References

Additional details of the condensate system are included in [UFSAR Sections 10.4.1](#) and [10.4.7](#).

License Renewal Drawings

There are no license renewal drawings for the condensate system.

Component-Function Relationship Table

The component types subject to aging management review are indicated in [Table 2.3.4-4](#) - Condensate System.

Table 2.3.4-4 Condensate System

Component Type	Intended Function
None	N/A

2.3.4.5 Feedwater System

System Description

The purpose of the feedwater system is to receive condensate from the condensate system and heater drain pumps of the feedwater heater extraction steam and drain system and to deliver feedwater, at required pressure and temperature, to the steam generators. The system is made up of two interconnected trains with turbine-driven feedwater pumps for normal power operation, three stages of high-pressure feedwater heaters in two parallel trains, and the associated piping, valves, and other components.

Feedwater piping beyond the feedwater flow sensors for the ultrasonic flow meters, including the safety-related portions associated with the feedwater isolation valves and continuing to the steam generator nozzles, including interface with the auxiliary feedwater system, is considered part of the main steam system, and is evaluated therein for license renewal.

The steam generator level monitoring components that provide monitoring of the steam generator level for power operations and safe plant shutdown are also included in the evaluation of main steam system.

The steam supply to the feedwater pump driving turbines is included in the evaluation of feedwater pump turbine system.

System Intended Function

Portions of the feedwater system support fire protection requirements based on the criteria of 10 CFR 54.4(a)(3).

The function to meet the requirements is performed solely by electrical components and active portions of the main feedwater pump turbine stop valves. No passive mechanical components are relied upon to perform this function. Thus, there are no mechanical components in the feedwater system that requires aging management review.

PVNGS UFSAR References

Additional details of the feedwater system are included in [UFSAR Section 10.4.7](#).

License Renewal Drawings

There are no license renewal drawings for the feedwater system.

Component-Function Relationship Table

The component types subject to aging management review are indicated in [Table 2.3.4-5 - Feedwater System](#).

Table 2.3.4-5 Feedwater System

Component Type	Intended Function
None	N/A

2.3.4.6 Main Turbine System

System Description

The main turbine system consists of one double-flow high-pressure turbine, three double-flow low-pressure turbines, four moisture separator-reheaters, and the associated piping, valves, and instrumentation. Steam from the main steam system enters the high-pressure turbine through four stop and governing control valves. After expansion in the high-pressure turbine, the steam flows through the moisture separator-reheaters to remove entrained moisture and to superheat the steam, thus improving cycle efficiency. Hot reheat steam is distributed equally to the three low-pressure turbines through combined reheat stop and intercept valves. After expansion in the low-pressure turbines, the steam is discharged to the main condensers. The main turbine system is equipped with an electrohydraulic control (EHC) system to control steam flow through the turbine.

The function of main turbine system is to convert steam thermal energy from the main steam system to mechanical energy to drive the main generator. It also provides extraction steam for feedwater heating and hot reheat steam to the main feedwater pump turbines. These functions are not safety-related functions.

System Intended Function

Portions of the main turbine system are required to support ATWS requirements based on criteria of 10 CFR 54.4(a)(3).

The function to meet the requirements is performed solely by electrical components. No passive mechanical components are relied upon to perform this function. Thus there are no mechanical components in the main turbine system that requires aging management review.

PVNGS UFSAR References

Additional details of the main turbine system are included in [UFSAR Section 10.2](#).

License Renewal Drawings

There are no license renewal drawings for the main turbine system.

Component-Function Relationship Table

The component types subject to aging management review are indicated in [Table 2.3.4-6](#) – Main Turbine System.

Table 2.3.4-6 Main Turbine System

Component Type	Intended Function
None	N/A

2.3.4.7 Steam Generator Feedwater Pump Turbine System

System Description

The purpose of the steam generator feedwater pump turbines is to provide motive force to drive the steam generator feedwater pumps. Components reviewed to determine the scope of license renewal include the pump turbines, hydraulic actuator systems, and the associated piping systems that provide the steam supply for the turbines. Steam for the turbines is supplied from the main steam header at low loads, and from the hot reheat line during normal operation. The other source is auxiliary steam from the auxiliary steam system. Auxiliary steam is used during secondary side startup and for turbine testing.

System Intended Function

Portions of the steam generator feedwater pump turbine system support fire protection requirements based on the criteria of 10 CFR 54.4(a)(3).

The function to meet the requirements is performed solely by electrical components and active portions of the main feedwater pump turbine stop valves. No passive mechanical components are relied upon to perform this function. Thus there are no mechanical components in the steam generator feedwater pump turbine system that requires aging management review.

PVNGS UFSAR References

Additional details of the steam generator feedwater pump turbine system are included in [UFSAR Section 10.4.7](#).

License Renewal Drawings

There are no license renewal drawings for the steam generator feedwater pump turbine system.

Component-Function Relationship Table

The component types subject to aging management review are indicated in [Table 2.3.4-7](#) - Steam Generator Feedwater Pump Turbine System.

Table 2.3.4-7 Steam Generator Feedwater Pump Turbine System

Component Type	Intended Function
None	N/A

2.3.4.8 Feedwater Heater Extraction, Drains, and Vents System

System Description

The purpose of the feedwater heater extraction, drains, and vents system is to provide preheated feedwater to the steam generators to improve cycle efficiency and to minimize thermal stresses on the feedwater piping and steam generator feedwater nozzles. The condensate is heated through three trains of four-stage low-pressure heaters, and is further heated up through two trains of three-stage high-pressure heaters.

High pressure turbine extraction steam supplies the heat sources for the sixth and seventh stage high-pressure heaters. High pressure turbine exhaust steam is fed to the fifth stage heaters. Extraction steam from the low pressure turbines supplies the low-pressure heaters. Bleeder trip valves are installed to guard against the backflow of steam and overspeed of the main turbine upon loss of load. Extraction of high moisture content steam from the main turbine also protects the turbine blades from erosion induced by water droplets.

The drains of the four-stage low-pressure heaters are cascaded to the next lower stage with the last stage dumped to the main condenser. The three-stage high-pressure heaters are eventually drained to the heater drain tanks which, in turn, are pumped to the suction of the steam generator feedwater pumps. The system also collects the condensates from the moisture separator/reheaters and routes it to the heater drain tanks. Non-condensable gases from the shell side of the heaters, moisture separator/reheaters, and heater drain tanks are continuously vented to the main condenser for removal from the plant.

System Intended Function

Portions of the feedwater heater extraction, drains and vents system support fire protection requirements based on the criteria of 10 CFR 54.4(a)(3).

Section 2.3
SCOPING AND SCREENING RESULTS:
MECHANICAL SYSTEMS

The function to meet the requirements of the feedwater heater extraction, drains and vents system is performed solely by electrical components. No mechanical components are relied upon to perform this function. Thus there are no mechanical components in the feedwater heater extraction steam, drains, and vents system that requires aging management review.

PVNGS UFSAR References

Additional details of the feedwater heater extraction steam, drains, and vents system are included in [UFSAR Sections 10.2.2](#) and [10.4.7](#).

License Renewal Drawings

There are no license renewal drawings for the feedwater heater extraction steam, drains, and vents system.

Component-Function Relationship Table

The component types subject to aging management review are indicated in [Table 2.3.4-8](#) - Feedwater Heater Extraction Steam, Drains, and Vents System.

Table 2.3.4-8 Feedwater Heater Extraction Steam, Drains, and Vents System

Component Type	Intended Function
None	N/A

2.4 SCOPING AND SCREENING RESULTS: STRUCTURES

The containments, structures, and component supports scoping and screening results consist of lists of component types that require aging management review, arranged by structure. Brief descriptions and intended functions are provided for structures within the scope of license renewal. For each in-scope structure, component types requiring an aging management review are provided.

In addition to the structures within the scope of license renewal presented in this section, the component supports are evaluated as a commodity.

A single license renewal drawing ([LR-PVNGS-STR-OOB-001](#)) was created for structures based on the site plan.

This section provides the following information for each structure within the scope of license renewal:

- A description of the structure,
- Structure purpose and intended function(s)
- Reference to the applicable UFSAR section(s), and
- A listing of the component types requiring aging management review and associated component intended functions.

For component supports, this section provides the following information:

- A general description of commodity,
- Purpose and intended function of the commodity,
- Reference to the applicable UFSAR section(s), and
- A listing of the component types requiring aging management review and associated component intended functions.

The containments, structures, and component supports scoping and screening results are provided for the following structures and commodity group:

- [Containment building](#)
- [Control building](#)
- [Diesel generator building](#)
- [Turbine building](#)
- [Auxiliary building](#)
- [Radwaste building](#)
- [Main steam support structure](#)
- [Station blackout generator structures](#)
- [Fuel building](#)
- [Spray pond and associated water control structures](#)
- [Tank foundations and shells](#)

- [Transformer foundations and electrical structures](#)
- [Yard structures \(in-scope\)](#)
- [Supports](#)

2.4.1 Containment Building

Structure Description

The containment building is a seismic Category I structure. The shell of the building is a prestressed, reinforced concrete, cylindrical structure with a hemispherical dome roof. The containment building foundation is a conventionally reinforced concrete mat, circular in plan that is constructed separately from other structures. The basemat has a circular pit and instrumentation cavity extending below the basemat, and a continuous tendon gallery at the periphery provided for installation and inspection of vertical prestressing tendons. The base slab is founded on undisturbed soil, which consists of undeformed native basin sediments. Where over-excavation was done, the excavation was backfilled with lean concrete or compacted granular backfill. Interaction between the containment building and other structures is minimized by specified seismic gaps. Expansion bellows at both the interior and exterior faces of the containment shell permit thermal expansion of the fuel transfer tube and differential movement between structures. These bellows do not form part of the containment building pressure boundary and are evaluated as expansion joints with the spent fuel pool cooling and clean up system in [Section 2.3.3.2](#).

The interior of the containment building shell is lined with carbon steel plates welded together to form a barrier which is essentially leak tight. The liner is thickened locally around the penetrations, large brackets, and major attachments which transfer loads through the liner plate to the concrete structure. Attachments to the shell wall are brackets for support of the polar crane, electrical conduit and cable tray, spray piping, lighting and ventilation. A leak chase system, attached at seam welds, covers the entire interior basemat. These welds are inaccessible to nondestructive examination after construction due to a concrete slab cast in place on top of the liner plate. This concrete slab protects the liner, reduces the thermal effects in the basemat, and provides the foundation for some small equipment and steel columns so that their anchorage does not have to penetrate the liner plate underneath.

The major structural components of the containment building are discussed in the following sections:

- Post-tensioning system
- Steel liner plate
- Penetrations
- Containment building internal structures
- Emergency sumps

Post-Tensioning System

The containment shell wall and dome are prestressed by vertical and horizontal unbonded tendons. The vertical tendons are anchored at the base slab and extend up and over the dome to form an inverted U-shape. They are arranged to produce two families of tendons across the dome, mutually intersecting each other at 90° on the horizontal projected plane. The horizontal tendons are hoops anchored at three buttresses that are equally spaced around the cylinder, extending over the dome. Hoop tendons extend up the cylindrical shell and into the hemispherical region to provide a two-way pattern up to the 90° solid angle of the dome.

Steel Liner Plate

A welded steel liner plate covers the entire inside surface of the containment (excluding penetrations) to satisfy the leak-tight criteria. The liner is typically 1/4 inch thick and is thickened locally around penetration sleeves, large brackets, and attachments to the basemat and shell wall. The stability of the liner plate is controlled by anchoring it to the concrete structure.

Penetrations

In general, a containment penetration consists of a sleeve embedded in the concrete wall or floor, anchored to the concrete, and welded to the containment building liner plate. Loads on the penetration are transferred to the concrete containment building. The component that must penetrate the containment, such as process pipe, airlock assembly, or cable feed-through assembly, passes through the sleeve and is seal welded to the sleeve via an appropriate adapter. Additional detail is provided below.

A circular equipment hatch and two personnel airlock assemblies penetrate the concrete cylinder walls. Hatch and air lock doors are provided with double-gasketed flanges with provisions for leak testing the flange-gasket combinations. One of the two personnel air locks is for emergency access. Each personnel air lock has a door at each end and is an ASME Code-stamped pressure vessel. During plant operation, the two doors of each personnel air lock are interlocked to prevent both being opened simultaneously. The equipment hatch is protected during plant operation by an exterior concrete missile barrier.

Single barrier piping penetrations are provided for all piping passing through the containment walls. The closure for process piping to the liner plate is accomplished with a special flanged head welded into the piping system and to the penetration sleeve which is, in turn, welded to a reinforced section of the liner plate. In the case of piping carrying hot fluid, the pipe is insulated to prevent excessive concrete temperatures and to prevent excessive heat loss from the fluid.

Electrical penetration assemblies provide means for carrying one or more electric circuits through a single aperture (nozzle) in the containment pressure barrier while maintaining the

Section 2.4
SCOPING AND SCREENING RESULTS:
STRUCTURES

integrity of the pressure barrier. The penetration is flange-mounted to the outside containment wall with the aperture seal formed between the header plate and the flange with two concentric O-rings. Feed-through subassemblies, containing electrical conductors, pass through the header plate and are secured and sealed with special compression fittings.

A fuel transfer tube penetration is provided for refueling. An inner pipe acts as the refueling tube with an outer pipe as the housing. The tube is fitted with a double-gasketed blind flange in the refueling canal and a standard gate valve in the spent fuel pool. The transfer tube penetrates the refueling canal wall, the containment shell, and the exterior wall of the fuel handling building. The sleeves are anchored into each wall and welded to each wall's liner plate. The housing is supported by the sleeves in the vertical and horizontal directions.

Containment Building Internal Structures

Structural and miscellaneous steel is installed inside the containment building to provide support for various safety-related and non safety-related systems and components, including platforms, stairways, and ladders, which facilitate access to the various elevations and areas for inspection and maintenance. During operation, a concrete missile barrier is installed above the reactor head to provide missile and biological shielding.

Supports for the reactor vessel, steam generators, reactor coolant pumps, pressurizer, and reactor coolant system pipe are attached to the steel framing and to the concrete structures of the containment building. These supports are addressed by a separate evaluation. Also supported by the internal containment structures, and likewise evaluated elsewhere, are supports for piping, ducts, miscellaneous equipment, electrical cable trays and conduit, instruments and tubing, and electrical and instrumentation enclosures and racks.

The primary shield is a heavily reinforced concrete structure that houses the reactor and provides the primary radiation shielding. The massive primary shield walls provide a support for the refueling pool walls above the reactor cavity. Penetrations in the primary shield walls are provided for the primary loop and cavity ventilation system.

The refueling pool is a reinforced concrete structure that is flooded during the reactor refueling operation. The refueling pool is lined with stainless steel plate and is connected with the spent fuel pool, in the fuel building, through the fuel transfer tube.

The secondary shield is a heavily reinforced concrete structure enclosing (together with the refueling pool walls) the steam generators. The massive secondary shield walls are anchored into the basemat of the containment in order to allow for load transfer to the foundation. Each of the two enclosed secondary shield compartments houses a steam generator and two reactor coolant pumps. The pressurizer compartment is attached to one of the secondary shield structures and is covered by a three-section removable reinforced concrete missile shield.

Section 2.4
SCOPING AND SCREENING RESULTS:
STRUCTURES

The operating and intermediate floors inside the containment consist of both concrete slab construction and steel grating supported by structural steel framing. The steel framing is supported by perimeter steel columns. The internal structure, including attachments, is separated from the liner plate and its attachments by a specified gap for seismic displacement allowances.

Emergency Sumps

Two emergency core cooling system sumps and screens are provided for water recirculation as part of the containment heat removal systems. The two sumps are independent, one for each safety-related train. The sump liners, screens, trash racks, associated frames, suction piping, motor-operated valves, and anti-vortex intakes are evaluated with the safety injection and shutdown cooling system.

Structure Intended Function

The purpose of the containment building is to withstand temperature and pressure loads, to provide biological shielding, and to minimize leakage of airborne radioactive materials during normal operations and following a postulated accident. The containment building also provides physical support for itself, the reactor coolant system, engineered safety features, and other systems and equipment within the structure. The exterior walls and dome provide shelter and protection for the reactor vessel and other safety-related SSCs. The containment building is within the scope of license renewal based on the criteria of 10 CFR 54.4(a)(1).

The containment building shelters and protects nonsafety-related SSCs whose failure could prevent performance of a safety-related function. Therefore, it is within the scope of license renewal based on the criterion of 10 CFR 54.4(a)(2).

The containment building supports fire protection, station blackout, environmental qualification, and ATWS requirements based on the criteria of 10 CFR 54.4(a)(3).

PVNGS UFSAR References

Additional details of the containment building are included in [UFSAR Sections 2.5.4.5, 3.8.1, 6.2.2, 6.2.6.2](#) and [Appendix 9B.2.11](#).

Component-Function Relationship Table

The component types subject to aging management review are indicated in [Table 2.4-1 - Containment Building](#).

Section 2.4
SCOPING AND SCREENING RESULTS:
STRUCTURES

Table 2.4-1 Containment Building

Component Type	Intended Function
Compressible Joints/Seals	Shelter, Protection Structural Pressure Boundary
Concrete Elements	Fire Barrier Flood Barrier HELB Shielding Missile Barrier Shelter, Protection Shielding Structural Pressure Boundary Structural Support
Fire Barrier Coatings/Wraps	Fire Barrier
Fire Barrier Seals	Expansion/Separation Fire Barrier Shelter, Protection
Hatch - Emergency Airlock	Missile Barrier Shielding Structural Pressure Boundary Structural Support
Hatch - Equipment	Missile Barrier Shielding Structural Pressure Boundary Structural Support
Hatch - Personnel Airlock	Fire Barrier Missile Barrier Shielding Structural Pressure Boundary Structural Support
Liner Containment	Shelter, Protection Structural Pressure Boundary
Liner Refueling	Shelter, Protection
Penetration	Shielding Structural Pressure Boundary Structural Support
Pipe Whip Restraints and Jet Shields	Missile Barrier Structural Support
Stairs/Platforms/Grates	Non-S/R Structural Support
Structural Steel	Structural Support
Tendons	Structural Support

2.4.2 Control Building

Structure Description

The control building is a reinforced concrete structure that houses the control room, computer room, upper and lower cable spreading rooms, battery rooms, electrical equipment rooms, and the ventilation equipment rooms. This evaluation also includes the adjacent corridor building, which is a structural steel framed and reinforced concrete building on a concrete foundation. Both buildings are supported on granular backfill with the lowest floor elevation 26 ft below yard grade.

Structure Intended Function

The control building is a safety-related, seismic Category I structure that provides support, shelter, and protection to engineered safety features and nuclear auxiliary systems. In the event of a safe shutdown earthquake or fire that renders the control room uninhabitable and incapable of performing its necessary functions, the remote shutdown panels are located in the remote shutdown room in the control building to ensure that the plant is able to reach a safe shutdown condition. An aluminum barrier, concrete elements, doors, fire barrier doors, hatches, and structural steel provide protection of safety-related components against internal and external missiles. The control building is within the scope of license renewal based on the criteria of 10 CFR 54.4(a)(1).

The control building shelters and protects nonsafety-related SSCs whose failure could prevent performance of a safety-related function. Therefore, it is within the scope of license renewal based on the criterion of 10 CFR 54.4(a)(2). The effects of a postulated collapse of the corridor building were analyzed to verify that the integrity of the auxiliary and control buildings would not be impaired, therefore, criterion established in 10 CFR 54.4(a)(2) is not applicable for the corridor building.

Portions of the control and corridor buildings support fire protection, ATWS, and station blackout requirements based on the criteria of 10 CFR 54.4(a)(3).

PVNGS UFSAR References

Additional details of the control building are included in [UFSAR Sections 2.5.4.8.1, 3.8.4.1.3, and 3.8.4.4.](#)

Component-Function Relationship Table

The component types subject to aging management review are indicated in [Table 2.4-2—Control Building.](#)

Section 2.4
SCOPING AND SCREENING RESULTS:
STRUCTURES

Table 2.4-2 Control Building

Component Type	Intended Function
Barrier	Missile Barrier
Caulking/Sealant	HELB Shielding Shelter, Protection Structural Pressure Boundary
Compressible Joints/Seals	Shelter, Protection
Concrete Block (Masonry Walls)	Fire Barrier Shelter, Protection Structural Support
Concrete Elements	Fire Barrier Flood Barrier Missile Barrier Shelter, Protection Structural Pressure Boundary Structural Support
Doors	Missile Barrier Shelter, Protection Structural Pressure Boundary
Fire Barrier Coatings/Wraps	Fire Barrier
Fire Barrier Doors	Fire Barrier HELB Shielding Missile Barrier Shelter, Protection Structural Pressure Boundary
Fire Barrier Seals	Fire Barrier
Gypsum/Plaster Barrier	Fire Barrier Non-S/R Structural Support Shelter, Protection Structural Pressure Boundary
Hatch	Flood Barrier Missile Barrier Shelter, Protection Structural Pressure Boundary

Table 2.4-2 Control Building (Continued)

Component Type	Intended Function
Hatches/Plugs	Shelter, Protection
Metal Siding	Shelter, Protection
Penetrations Electrical	Structural Support
Penetrations Mechanical	Structural Support
Roofing Membrane	Shelter, Protection
Stairs/Platforms/Grates	Non-S/R Structural Support
Structural Steel	Missile Barrier Shelter, Protection Structural Support

2.4.3 Diesel Generator Building

Structure Description

The diesel generator building is a seismic Category I, multi-story, box-type, structural steel and reinforced concrete structure that houses the emergency diesel generators, fuel oil day tanks, exhaust silencers, and exhaust stacks. The building is supported by a reinforced concrete base mat founded on natural sands. The diesel generators are supported by reinforced concrete foundations that are physically isolated from each other and from the building foundation. The roof is a reinforced concrete slab supported by reinforced concrete bearing walls. A two foot thick reinforced concrete barrier wall separates the two emergency diesel generators and diesel auxiliaries.

Structure Intended Function

The diesel generator building provides structural support and shelter/protection of components relied upon to provide the capability to shutdown the reactor and maintain it in a safe shutdown condition. The diesel generator building is within the scope of license renewal based on the criteria of 10 CFR 54.4(a)(1).

The diesel generator building shelters and protects nonsafety-related SSCs whose failure could prevent performance of a safety-related function. Therefore, it is within the scope of license renewal based on the criterion of 10 CFR 54.4(a)(2).

Portions of the diesel generator building support station blackout requirements and provide support, shelter, and protection for components necessary to demonstrate compliance with fire protection requirements. The diesel generator building is within the scope of license renewal based on the criteria of 10 CFR 54.4(a)(3).

PVNGS UFSAR References

Additional details of the diesel generator building are included in [UFSAR Section 3.8.4.1.4](#) and [Appendix 9B2.4](#).

Component-Function Relationship Table

The component types subject to aging management review are indicated in [Table 2.4-3](#) - Diesel Generator Building.

Table 2.4-3 Diesel Generator Building

Component Type	Intended Function
Caulking/Sealant	Flood Barrier Shelter, Protection
Compressible Joints/Seals	Expansion/Separation Shelter, Protection
Concrete Elements	Fire Barrier Flood Barrier Missile Barrier Shelter, Protection Structural Support
Doors	Missile Barrier Shelter, Protection
Fire Barrier Doors	Fire Barrier Flood Barrier Missile Barrier Shelter, Protection
Fire Barrier Seals	Fire Barrier
Hatch	Missile Barrier Shelter, Protection
Hatches/Plugs	Missile Barrier Shelter, Protection
Penetrations Electrical	Structural Support
Penetrations Mechanical	Structural Support
Roofing Membrane	Shelter, Protection
Stairs/Platforms/Grates	Non-S/R Structural Support
Structural Steel	Shelter, Protection Structural Support

2.4.4 Turbine Building

Structure Description

The turbine building is a rectangular, braced steel and concrete structure, enclosed with metal siding, with a built-up roof over metal decking, and a reinforced concrete basemat. It houses the turbine generator, condensers, and associated equipment. It is adjacent to the auxiliary building and the main steam support structure. None of the equipment located in the turbine building is safety-related.

Structure Intended Function

The turbine building is a seismic Category II structure, whose behavior was analyzed under the extreme environmental (tornado/SSE) loads to verify that a collapse would not occur. This ensures that external safety-related SSCs would not be damaged by the turbine building during a design basis event. The turbine building is within the scope of license renewal based on the criterion of 10 CFR 54.4(a)(2).

The turbine building physically supports and protects systems and components that are required for fire protection and station blackout based on the criteria of 10 CFR 54.4(a)(3).

PVNGS UFSAR References

Additional details of the turbine building are included in [UFSAR Sections 3.3.2.3, 3.8.4.4,](#) and [Appendix 9B.2.20.1.](#)

Component-Function Relationship Table

The component types subject to aging management review are indicated in [Table 2.4-4 - Turbine Building.](#)

Table 2.4-4 Turbine Building

Component Type	Intended Function
Concrete Block (Masonry Walls)	Fire Barrier Shelter, Protection Structural Support
Concrete Elements	Shelter, Protection Structural Support
Doors	Shelter, Protection
Fire Barrier Coatings/Wraps	Fire Barrier
Fire Barrier Doors	Fire Barrier Shelter, Protection
Fire Barrier Seals	Fire Barrier
Hatch	Shelter, Protection
Metal Siding	Shelter, Protection
Penetrations Electrical	Structural Support
Penetrations Mechanical	Structural Support
Roofing Membrane	Shelter, Protection
Structural Steel	Shelter, Protection Structural Support

2.4.5 Auxiliary Building

Structure Description

The auxiliary building is a multistory, structural steel and reinforced concrete seismic Category I structure supported by a reinforced concrete basemat founded on hard non-liquefiable soil. Some interior walls are constructed with concrete masonry. The building houses the safety injection system, containment spray system, containment combustible gas control system, chemical and volume control systems and containment isolation system.

Structure Intended Functions

The auxiliary building is a safety-related, seismic Category I structure that provides support, shelter, and protection to engineered safety features and nuclear auxiliary systems. The auxiliary building is within the scope of license renewal based on the criteria of 10 CFR 54.4(a)(1).

Section 2.4
SCOPING AND SCREENING RESULTS:
STRUCTURES

The auxiliary building shelters and protects nonsafety-related SSCs whose failure could prevent performance of a safety-related function. Therefore, it is within the scope of license renewal based on the criterion of 10 CFR 54.4(a)(2).

The auxiliary building is a safety-related structure that provides support, shelter, and protection for components required to demonstrate compliance with requirements for fire protection, and is relied upon to demonstrate compliance with anticipated transients without scram and station blackout requirements based on the criteria of 10 CFR 54.4(a)(3).

PVNGS UFSAR References

Additional details of the auxiliary building are included in [UFSAR Sections 2.5.4.8.1](#) and [3.8.4.1](#).

Component-Function Relationship Table

The component types subject to aging management review are indicated in [Table 2.4-5](#) - Auxiliary Building.

Table 2.4-5 Auxiliary Building

Component Type	Intended Function
Caulking/Sealant	Flood Barrier Shelter, Protection
Compressible Joints/Seals	Expansion/Separation Shelter, Protection
Concrete Block (Masonry Walls)	Fire Barrier Shelter, Protection Structural Support
Concrete Elements	Fire Barrier Flood Barrier HELB Shielding Missile Barrier Shelter, Protection Shielding Structural Pressure Boundary Structural Support
Doors	Flood Barrier Shelter, Protection Structural Pressure Boundary

Table 2.4-5 Auxiliary Building (Continued)

Component Type	Intended Function
Fire Barrier Coatings/Wraps	Fire Barrier
Fire Barrier Doors	Fire Barrier HELB Shielding Missile Barrier Shelter, Protection Structural Pressure Boundary
Fire Barrier Seals	Fire Barrier
Gypsum/Plaster Barrier	Fire Barrier Shelter, Protection
Hatch	Shelter, Protection Structural Pressure Boundary
Hatches/Plugs	Flood Barrier Missile Barrier Shelter, Protection
Penetrations Electrical	Structural Support
Penetrations Mechanical	Structural Support
Roofing Membrane	Shelter, Protection
Stairs/Platforms/Grates	Non-S/R Structural Support
Structural Steel	Shelter, Protection Structural Support

2.4.6 Radwaste Building

Structure Description

The radwaste building is a rectangular, multistory, reinforced concrete structure that houses radioactive waste treatment facilities, tanks, filters, and other miscellaneous equipment. The building extends below plant grade and is supported on a reinforced concrete mat foundation constructed on granular backfill.

Structure Intended Function

The radwaste building is a seismic Category II structure, whose behavior was checked under the extreme environmental (tornado/SSE) loads to verify that a collapse would not occur. This ensures that external safety-related SSCs would not be damaged by the radwaste building during a design basis event. The radwaste building is within the scope of license renewal based on the criterion of 10 CFR 54.4(a)(2).

The radwaste building physically supports and protects systems and components that required for fire protection based on the criteria of 10 CFR 54.4(a)(3).

PVNGS UFSAR References

Additional details of the radwaste building are included in [UFSAR Section 3.8.4.4](#) and [Table 9B3-1](#).

Component-Function Relationship Table

The component types subject to aging management review are indicated in [Table 2.4-6](#) - Radwaste Building.

Table 2.4-6 Radwaste Building

Component Type	Intended Function
Concrete Elements	Fire Barrier Shelter, Protection Structural Support
Doors	Shelter, Protection
Fire Barrier Doors	Fire Barrier Shelter, Protection
Fire Barrier Seals	Fire Barrier
Hatch	Shelter, Protection
Hatches/Plugs	Shelter, Protection
Roofing Membrane	Shelter, Protection
Structural Steel	Shelter, Protection Structural Support

2.4.7 Main Steam Support Structure

Structure Description

The main steam support structure is a box-type reinforced concrete seismic Category I structure supported by a reinforced concrete basemat founded on granular backfill. It houses the atmospheric dump valves, main steam isolation valves, feedwater isolation valves, essential auxiliary feedwater pumps and their equipment.

Structure Intended Function

The main steam support structure is a safety-related, seismic Category I structure that provides support, shelter, and protection to engineered safety features and nuclear auxiliary

systems. The main steam support structure is within the scope of license renewal based on the criteria of 10 CFR 54.4(a)(1).

The main steam support structure shelters and protects nonsafety-related SSCs whose failure could prevent performance of a safety-related function. Therefore, it is within the scope of license renewal based on the criterion of 10 CFR 54.4(a)(2).

Portions of the main steam support structure support fire protection and station blackout requirements based on the criteria of 10 CFR 54.4(a)(3).

PVNGS UFSAR References

Additional details of the main steam support structure are included in [UFSAR Sections 2.5.4.8.1](#), and [3.8.4.1.5](#)

Component-Function Relationship Table

The component types subject to aging management review are indicated in [Table 2.4-7— Main Steam Support Structure](#)

Table 2.4-7 Main Steam Support Structure

Component Type	Intended Function
Caulking/Sealant	Flood Barrier Shelter, Protection
Compressible Joints/Seals	Expansion/Separation Shelter, Protection
Concrete Elements	Fire Barrier Flood Barrier HELB Shielding Missile Barrier Shelter, Protection Shielding Structural Pressure Boundary Structural Support
Doors	Flood Barrier HELB Shielding Missile Barrier Shelter, Protection Structural Pressure Boundary
Fire Barrier Doors	Fire Barrier Shelter, Protection

Table 2.4-7 Main Steam Support Structure (Continued)

Component Type	Intended Function
Fire Barrier Seals	Fire Barrier
Hatch	Flood Barrier HELB Shielding Shelter, Protection Structural Pressure Boundary
Hatches/Plugs	Missile Barrier Shelter, Protection
Penetrations Electrical	Structural Support
Penetrations Mechanical	Structural Support
Roofing Membrane	Shelter, Protection
Stairs/Platforms/Grates	Non-S/R Structural Support
Structural Steel	Shelter, Protection Structural Support

2.4.8 Station Blackout Generator Structures

Structure Description

The station blackout generator structures consist of the station blackout generator concrete foundation and the turbine control building, which is a steel structure with metal siding and concrete foundation. The fuel oil tanks, which are located plant north of the station blackout generators, are founded directly on compacted backfill and there are no structural components that require aging management.

Structure Intended Function

The station blackout generator structures are nonsafety-related structures that provide support, shelter, and protection for components required to demonstrate compliance with station blackout requirements. The station blackout generator structures are within the scope of license renewal based on the criteria of 10 CFR 54.4(a)(3).

PVNGS UFSAR References

Additional details of the station blackout generator structures are included in [UFSAR Section 8.3.1.1.10](#).

Component-Function Relationship Table

The component types subject to aging management review are indicated in [Table 2.4-8](#) - Station Blackout Generator Structures.

Table 2.4-8 Station Blackout Generator Structures

Component Type	Intended Function
Concrete Elements	Structural Support
Doors	Shelter, Protection
Metal Siding	Shelter, Protection
Structural Steel	Shelter, Protection Structural Support

2.4.9 Fuel Building

Structure Description

The fuel building is a seismic Category I rectangular reinforced concrete structure supported on a reinforced concrete base slab founded on granular backfill. The elevated floors and roof are reinforced concrete and supported by reinforced concrete bearing walls.

The fuel building contains the spent fuel pool, new fuel storage area, the dry spent fuel storage system loading and transfer equipment, the spent fuel pool cooling heat exchangers and pumps, and other miscellaneous equipment. The spent fuel pool receives spent fuel from the containment building through the fuel transfer tube. The spent fuel pool, including the transfer canal, cask loading pit, and cask wash down area consist of reinforced concrete walls and floors lined with stainless steel plates.

The cask loading pit and cask wash down area gate seals are designed as seismic Category I. These seals are designed to remain functional during and after accident conditions. The fuel transfer canal gate seals are designed as seismic Category II. During accident conditions, water elevation would remain above the pool cooling system suction piping and more than 10 feet of water coverage would be available to shield the spent fuel assemblies.

Structure Intended Function

The fuel building provides structural support, shelter, and protection of components required to mitigate the consequences of accidents that could result in potential offsite exposure. It is within the scope of license renewal based on the criteria of 10 CFR 54(a)(1).

Section 2.4
SCOPING AND SCREENING RESULTS:
STRUCTURES

The fuel building shelters and protects nonsafety-related SSCs whose failure could prevent performance of a safety-related function. Therefore, it is within the scope of license renewal based on the criterion of 10 CFR 54.4(a)(2).

Portions of the fuel building support fire protection requirements based on the criteria of 10 CFR 54(a)(3).

PVNGS UFSAR References

Additional details of the fuel building are included in [UFSAR Sections 1.2.12.4, 3.8.4.1.2, and 9.1.](#)

Component-Function Relationship Table

The component types subject to aging management review are indicated in [Table 2.4-9 - Fuel Building.](#)

Table 2.4-9 Fuel Building

Component Type	Intended Function
Caulking/Sealant	Flood Barrier Shelter, Protection
Compressible Joints/Seals	Shelter, Protection Structural Pressure Boundary
Concrete Elements	Fire Barrier Flood Barrier Missile Barrier Shelter, Protection Structural Support
Doors	Missile Barrier Shelter, Protection
Fire Barrier Doors	Fire Barrier HELB Shielding Shelter, Protection
Fire Barrier Seals	Fire Barrier
Gate	Structural Pressure Boundary

Table 2.4-9 Fuel Building (Continued)

Component Type	Intended Function
Hatch	Fire Barrier Flood Barrier Missile Barrier Shelter, Protection
Hatches/Plugs	Missile Barrier Shelter, Protection
Liner Spent Fuel Pool	Structural Pressure Boundary
Penetrations Electrical	Structural Support
Penetrations Mechanical	Structural Support
Roofing Membrane	Shelter, Protection
Stairs/Platforms/Grates	Non-S/R Structural Support
Structural Steel	Expansion/Separation Shelter, Protection Structural Support

2.4.10 Spray Pond and Associated Water Control Structures

Structure Description

The spray pond and associated water control structures include two essential spray ponds (ESP) per unit. Each pond has an intake structure to feed the cooling loop and a pond inlet for the return line. The ESPs, the pump houses, the intake structures, and the sumps are safety-related, seismic Category I, reinforced concrete structures, founded on natural sands. Each pond serves one train of the ESP system to provide the ultimate heat sink for cooling auxiliary systems required for safe reactor shutdown.

Structure Intended Function

The seismic Category I ESPs provides structural support for SSCs required to achieve safe shutdown of the reactor and to maintain a safe shutdown. The seismic Category I ESP pump houses and intake structures provide structural support, shelter, and protection for SSCs required to achieve safe shutdown of the reactor and to maintain a safe shutdown. They are within the scope of license renewal based on the criteria of 10 CFR 54.4(a)(1).

The spray pond and associated water control structures shelter and protect nonsafety-related SSCs whose failure could prevent performance of a safety-related function.

Therefore, they are within the scope of license renewal based on the criterion of 10 CFR 54.4(a)(2).

The ESPs, the pump houses, and the intake structures provide structural support fire protection and station blackout requirements and are within the scope of license renewal based on the criteria of 10 CFR 54.4(a)(3).

PVNGS UFSAR References

Additional details of the spray pond and associated water control structures are included in [UFSAR Sections 2.4.11.6](#) and [3.8.4.1.6](#).

Component-Function Relationship Table

The component types subject to aging management review are indicated in [Table 2.4-10](#) - Spray Pond and Associated Water Control Structures.

Table 2.4-10 Spray Pond and Associated Water Control Structures

Component Type	Intended Function
Caulking/Sealant	Heat Sink Shelter, Protection Structural Pressure Boundary
Concrete Elements	Fire Barrier Heat Sink Missile Barrier Shelter, Protection Structural Support
Hatch	Shelter, Protection
Hatches/Plugs	Missile Barrier Shelter, Protection
Screen	Filter
Structural Steel	Direct Flow Missile Barrier Non-S/R Structural Support Shelter, Protection Structural Support

2.4.11 Tank Foundations and Shells

Structure Description

The tank foundations are reinforced concrete structures that provide structural support for the condensate storage tank (CST), refueling water tank (RWT), RWT valve pit, and reactor makeup water tank (RMWT). The CST and RWT, which are seismic Category I structures,

Section 2.4
SCOPING AND SCREENING RESULTS:
STRUCTURES

have concrete shells, builtup roofs, and stainless steel liners. A steel missile shield is installed over the RWT valve. The RMWT is a steel tank supported by a reinforced concrete ring wall that slopes from the high side to a sump on the other side. Inside of the ring wall, the tank is supported on compacted granular backfill. The RWT and RMWT foundations are supported on granular backfill. The configuration of the CST and RWT shells are such that rain water cannot accumulate under the tanks. The CST foundation is supported on natural sands. The steel RMWT and the steel liners for the CST and the RWT are evaluated with their respective mechanical systems.

Structure Intended Function

The function of the CST, RWT, and RMWT foundations is to provide structural support for the tanks. The concrete shells of the CST and RWT also provide missile protection for the tank liners. The CST is safety-related and provides the required water storage for the auxiliary feedwater pumps to perform their safety function. The RWT is safety-related and provides the required volume of borated water for safety injection following a LOCA. The CST and RWT foundations, shells, and roofs are within the scope of license renewal based on the criteria of 10 CFR 54.4(a)(1).

The tank foundations and shells shelter and protect nonsafety-related SSCs whose failure could prevent performance of a safety-related function. Therefore, they are within the scope of license renewal based on the criterion of 10 CFR 54.4(a)(2).

The CST, RWT, and RMWT foundations and shells provide structural support and protection for SSCs required for fire protection. The CST and RWT foundations and shells provide structural support and protection for SSCs required for station blackout. They are within the scope of license renewal based on the criteria of 10 CFR 54.4(a)(3).

PVNGS UFSAR References

Additional details of the tank foundations and shells are included in [UFSAR Sections 3.5D, 3.8.4.1.7, 3.8.4.1.8](#) and [Appendix 9B.2.20.3, 9B.2.20.5, and 9B.2.9.3](#).

Component-Function Relationship Table

The component types subject to aging management review are indicated in [Table 2.4-11 - Tank Foundations and Shells](#).

Table 2.4-11 Tank Foundations and Shells

Component Type	Intended Function
Concrete (Condensate Storage Tank)	Missile Barrier Structural Support
Concrete (Reactor Makeup Water Tank)	Structural Support
Concrete (Refueling Water Tank)	Missile Barrier Structural Support
Hatch	Shelter, Protection
Roofing Membrane	Shelter, Protection
Structural Steel	Missile Barrier Structural Support

2.4.12 Transformer Foundations and Electrical Structures

Structure Description

The foundations for the ESF and startup transformers are reinforced concrete pads founded on granular backfill.

Outdoor switchgear in the startup transformer yard, and adjacent to the switchgear room in the turbine building, and all equipment from the startup transformer yard to the first breakers in the SRP 500 kV switchyard, are supported on reinforced concrete pads founded on granular backfill.

All of the transmission towers to the first breakers in the SRP 500 kV switchyard and the towers supporting the transmission lines to the ESF and startup transformers are steel towers with reinforced concrete drilled caisson foundations.

Electrical cables from the transformers are installed in buried concrete duct banks. Manholes are provided along these duct banks for cable installation and access.

The ESF, main, normal, and auxiliary transformers are separated by concrete fire barrier walls.

Structure Intended Function

The concrete pads for the ESF and startup transformers provide structural support of the ESF and startup transformers and support equipment. The concrete pads for the outdoor switchgear provide structural support for the outdoor switchgear. The reinforced concrete caissons provide structural support for the transmission towers, which provide structural

Section 2.4
SCOPING AND SCREENING RESULTS:
STRUCTURES

support for the transmission lines. The concrete duct banks and manholes provide structural support, shelter and protection for the electrical cables.

The concrete pads for the ESF and startup transformers, the concrete pads for the outdoor switchgear, the reinforced concrete caissons, the transmission towers, the concrete duct banks, and the manholes provide structural support for SSCs required for station blackout recovery. The concrete duct banks and the manholes provide shelter and protection for SSCs required for station blackout recovery. They are within the scope of license renewal based on the criteria of 10 CFR 54.4(a)(3).

The concrete fire barrier walls separating the ESF, main, normal, and auxiliary transformers provide spatial separation and fire barriers to meet the requirements for fire protection. They are within the scope of license renewal based on the criteria of 10 CFR 54.4(a)(3).

PVNGS UFSAR References

Additional details of the transformer foundations and electrical structures are included in [UFSAR Section 2.5.4.8.1](#) and [Appendix 9B.2.21](#).

Component-Function Relationship Table

The component types subject to aging management review are indicated in [Table 2.4-12](#) - Transformer Foundations and Electrical Structures.

Table 2.4-12 Transformer Foundations and Electrical Structures

Component Type	Intended Function
Caulking/Sealant	Shelter, Protection
Concrete Elements	Fire Barrier Non-S/R Structural Support Structural Support
Duct Banks and Manholes	Shelter, Protection
Fire Barrier Seals	Fire Barrier
Structural Steel	Non-S/R Structural Support Shelter, Protection
Transmission Tower	Non-S/R Structural Support

2.4.13 Yard structures (in-scope)

Structure Description

The yard structures (in-scope) include the following structures:

Section 2.4
SCOPING AND SCREENING RESULTS:
STRUCTURES

The condensate and essential pipe tunnels are rectangular, seismic Category I, reinforced concrete structures housing conduit and piping.

The condensate storage tank pump house is a seismic Category I, reinforced concrete structure housing the pumps for the condensate storage tank.

The diesel fuel oil tank vault above the diesel generator fuel oil storage tank is a seismic Category I, reinforced concrete structure that provides access to, and missile protection for, the diesel fuel oil tank. The vault also houses piping, pumps, and valves. The vault, which is supported independently from the tank, is located below grade and is accessible from a hatch in the concrete roof.

The fire pump house is a concrete block structure with a built-up roof over metal decking on a concrete foundation housing three fire pumps, each separated by concrete block walls.

A number of the fire protection pressure isolation valves are housed in below-grade, reinforced concrete vaults.

Structure Intended Function

The condensate and essential pipe tunnels, the condensate storage tank pump house, and the diesel fuel oil tank vault provide structural support and shelter/protection for safety-related components relied upon to shutdown the reactor and maintain it in a safe shutdown condition. These structures are within the scope of license renewal based on the criteria of 10 CFR 54.4(a)(1).

The yard structures (in-scope) shelter and protect nonsafety-related SSCs whose failure could prevent performance of a safety-related function. Therefore, they are within the scope of license renewal based on the criterion of 10 CFR 54.4(a)(2).

The condensate and essential pipe tunnels, the condensate storage tank pump house, the diesel fuel oil tank vault, and the fire pump house provide spatial fire barriers and structural support for fire suppression components. The pressure isolation valves vaults provide structural support and shelter/protection for fire protection components. These structures are within the scope of license renewal based on the criteria of 10 CFR 54.4(a)(3).

The essential pipe tunnel, the condensate tunnel, and the condensate storage tank pump house provide shelter and protection for SSCs required for station blackout recovery. These structures are within the scope of license renewal based on the criteria of 10 CFR 54.4(a)(3).

PVNGS UFSAR References

Additional details of the yard structures (in-scope) are included in [Appendix 9B \(9B.2.18, 9B.2.19, 9B.2.20.4, 9B.2.21, and 9B.2.9.3\)](#) and [Tables 3.5-9, 9.5.2, and 9B.3-1](#).

Component-Function Relationship Table

The component types subject to aging management review are indicated in [Table 2.4-13](#) - Yard Structures (in-scope).

Table 2.4-13 Yard Structures (in-scope)

Component Type	Intended Function
Caulking/Sealant	Flood Barrier Shelter, Protection Structural Pressure Boundary
Compressible Joints/Seals	Expansion/Separation Shelter, Protection
Concrete Block (Masonry Walls)	Fire Barrier Shelter, Protection Structural Support
Concrete Elements	Fire Barrier Flood Barrier Missile Barrier Shelter, Protection Structural Pressure Boundary Structural Support
Doors	Shelter, Protection Structural Pressure Boundary
Fire Barrier Doors	Fire Barrier Shelter, Protection
Gypsum/Plaster Barrier	Fire Barrier Shelter, Protection
Hatch	Flood Barrier Missile Barrier Shelter, Protection Structural Pressure Boundary
Hatches/Plugs	Flood Barrier Missile Barrier Shelter, Protection Structural Pressure Boundary
Penetrations Electrical	Structural Support
Penetrations Mechanical	Structural Support
Roofing Membrane	Shelter, Protection
Structural Steel	Structural Support

2.4.14 Supports

Structure Description

Mechanical and Electrical Supports

Structural supports for mechanical and electrical components are an integral part of all systems. Many of these supports are not uniquely identified with component identification numbers. However, characteristics of the supports, such as design, materials of construction, environments, and anticipated stressors, are similar. Therefore, structural supports for mechanical and electrical components are evaluated as commodities across system boundaries.

The commodity evaluation applies to structural supports within structures identified as within the scope of license renewal. The following structural supports for mechanical components are addressed:

- Supports for ASME Class 1 piping and components
- Supports for ASME Class 2 and 3 piping and components
- Supports for HVAC ducts, tube track, instrument tubing, instruments, and non-ASME piping and components

The following electrical components and supports are addressed:

- Cable Trays and Supports
- Conduit and Supports
- Electrical Panels and Enclosures
- Instrument Panels and Racks

Structural Supports

Structural support evaluation boundaries are based upon the following:

- Integral attachments (such as plate welded to pipe at anchor points, saddles welded to heat exchangers, etc.) are evaluated with the specific component (pipe, pump, heat exchanger, etc.).
- All pins, bolting, and other removable hardware that are part of the connection to component integral attachments are evaluated with the structural support, except high strength bolts for Class 1 NSSS supports, which are evaluated separately. A separate component for these high strength bolts has been included in the scope of this package.
- The exposed portions of embedded components (i.e., end portion of the threaded anchor and nut) are evaluated with the component supports, except high strength bolts for Class 1 NSSS supports, as noted above.
- Concrete and supporting structural hardware (including the embedded portion of threaded anchors) are evaluated with the structure. The concrete around anchorages must be evaluated with the supports to identify any concrete degradation that would impair the function of the anchors. This package

includes a separate component for the anchorage concrete for in-scope mechanical and electrical components in each building.

The following reactor coolant system component supports are included with the ASME Class 1 piping and component commodity group:

Reactor Vessel Supports

The reactor vessel is supported by four vertical columns located under the vessel inlet nozzles. These columns are designed to flex in the direction of horizontal thermal expansion and thus allow unrestrained heatup and cooldown. They also act as holddown devices for the vessel. Horizontal keyways located alongside the upper portion of the column guide the vessel during thermal expansion and contraction of the reactor coolant system and maintain the vessel centerline. The supports are designed to accept normal loads and seismic and pipe rupture accident loads.

Steam Generator Supports

The steam generator is supported at the bottom by a sliding base bolted to an integrally attached conical skirt. The sliding base rests on low friction bearings which allow unrestrained thermal expansion of the reactor coolant system. Two keyways within the sliding base mate with embedded keys to guide the movement of the steam generator during expansion and contraction of the reactor coolant system and, together with a stop and anchor bolts, limit movement of the bottom of the steam generator during seismic events and following a LOCA. A system of keys and snubbers located on the steam drum guide the top of the steam generator during expansion and contraction of the reactor coolant system and provide support during seismic events and following a LOCA or a steam line break.

Reactor Coolant Pump Supports

Each reactor coolant pump is provided with four vertical support columns, four horizontal support columns, and two horizontal snubbers. The rigid structural columns provide support for the pumps during normal operation, earthquake conditions, and any design basis pipe breaks in either the pump suction or discharge line. For the case of pipe break in the pump discharge line, a structural stop is provided to limit the pump motion. Pipe stop structures which limit pipe motion also prevent overloading of the pump support columns due to a pipe rupture at either the steam generator or reactor vessel nozzles.

Pressurizer supports

The pressurizer is supported by a cylindrical skirt welded to the pressurizer and bolted to the support structure. The skirt is designed to withstand deadweight and normal operating loads as well as the loads due to earthquakes and LOCA. Four keys welded to the upper shell provide additional restraint during a postulated seismic event.

[Table 2.4-15](#) “Component Types Assigned to Building/Structures” is provided to identify support component types by structure. Note: there is an associated concrete anchorage component for each of the supports listed in [Table 2.4-15](#).

Structure Intended Functions

Structural supports are in the scope of license renewal because they support and protect components that are within the scope of license renewal. Safety-related supports meet the criteria of 10 CFR 54.4(a)(1).

Nonsafety-related supports meet the criterion 10 CFR 54.4(a)(2) when they prevent interaction between safety-related and nonsafety-related components.

Other supports meet the criteria of 10 CFR 54.4(a)(3) because they provide support for components credited for fire protection, station blackout and pressurized thermal shock.

PVNGS UFSAR References

Additional details of supports are included in [UFSAR Section 3.8.3.1](#) and [5.4.14](#).

Component-Function Relationship Table

The component types subject to aging management review are indicated in [Table 2.4-14](#) - Supports.

Table 2.4-14 Supports

Component Type	Intended Function
Cable Trays and Supports	Non-S/R Structural Support Structural Support
Conduit And Supports	Non-S/R Structural Support Shelter, Protection Structural Support
Electrical Panels and Enclosures	Non-S/R Structural Support Shelter, Protection Structural Support
High Strength Bolting	Structural Support
Instrument Panels and Racks	Non-S/R Structural Support Shelter, Protection Structural Support
Supports	Expansion/Separation Structural Support
Supports ASME 1	Structural Support
Supports ASME 2 and 3	Structural Support

Table 2.4-14 Supports (Continued)

Component Type	Intended Function
Supports HVAC Duct	Non-S/R Structural Support Structural Support
Supports Instrument	Non-S/R Structural Support Structural Support
Supports Insulation	Structural Support
Supports Mech Equip Class 1	Structural Support
Supports Mech Equip Class 2 and 3	Structural Support
Supports Mech Equip Non ASME	Non-S/R Structural Support
Supports Non ASME	Non-S/R Structural Support

Section 2.4
SCOPING AND SCREENING RESULTS:
STRUCTURES

Table 2.4-15 Component Types Assigned to Supports by Building/Structure

Support Components Associated with Structures	Elect/Instrument Components					Mechanical Components								
	Cable Tray and Supports	Conduit and Supports	Electrical Panel and Enclosure	Instrument Panel and Rack Supports	Instrument Supports	ASME Class 1 Pipe Supports	ASME Class 2 and 3 Pipe Supports	Non-ASME Pipe Supports	Mechanical Equipment Class 1 Supports	Mechanical Equipment Class 2 and 3 Supports	Mechanical Equip Non-Code Supports	HVAC Duct Supports	High Strength Bolting	Insulation Supports
Containment Building	X	X	X	X	X	X	X	X	X	X	X	X	X	X
Control Building	X	X	X	X	X		X	X		X	X	X		
Diesel Generator Building	X	X	X	X	X		X	X		X	X	X		
Turbine Building	X	X	X	X	X		X	X		X	X	X		
Auxiliary Building	X	X	X	X	X		X	X		X	X	X		
Radwaste Building	X	X	X					X				X		
MSSS	X	X	X		X			X		X				X
SBO Generator Structures	X	X	X	X	X			X			X			
Fuel Building	X	X	X	X	X			X		X	X	X		
Spray Pond		X	X		X							X		
Tank Foundations										X	X			
Transformer Foundations	X	X	X											
Yard Structures (In-Scope)		X	X	X	X			X		X	X			

2.5 SCOPING AND SCREENING RESULTS: ELECTRICAL AND INSTRUMENTATION AND CONTROL SYSTEMS

The scoping and screening results for electrical and instrument and control system components consist of a list ([Table 2.5-1](#), “Electrical and I&C Component Groups Requiring Aging Management Review”) of component types that require aging management review.

Using the plant “spaces” approach, all electrical and instrument and control components were reviewed as a group regardless of the system assigned to each component. Bounding environmental conditions were used to evaluate the identified aging effect(s) with respect to component function(s) to determine the component groups that require aging management review. This methodology is discussed in [Section 2.1.3.3](#) and is consistent with the guidance in NEI 95-10.

The interface of electrical and instrument and control components with other types of components and the assessments of these interfacing components are provided in the appropriate mechanical or structural sections. The evaluation of electrical racks, panels, frames, cabinets, cable trays, conduit, manhole, duct banks, transmission towers and their supports is provided in the structural assessment documented in [Section 2.4](#).

The following electrical component groups were evaluated to determine the groups that require aging management review:

- [Connections](#) (metallic parts)
- [Connector](#)
- [Fuse Holder](#) (Not Part of a Larger Assembly)
- [High Voltage Insulator](#)
- [Insulated Cable and Connections](#) (includes the following):
 - Electrical cables and connections not subject to 10 CFR 50.49 EQ requirements
 - Electrical cables and connections used in instrumentation circuits not subject to 10 CFR 50.49 EQ requirements that are sensitive to reduction in conductor insulation resistance
 - Inaccessible Medium-Voltage Electrical Cables not subject to 10 CFR 50.49 EQ requirements
- [Metal Enclosed Bus](#) (including the following):
 - Bus bar and connections
 - Bus enclosure

Section 2.5
**SCOPING AND SCREENING RESULTS:
ELECTRICAL AND INSTRUMENTATION AND CONTROLS SYSTEMS**

- Bus Insulation and insulators
 - Penetrations Electrical
 - Switchyard Bus and Connections
 - Terminal Block
 - Transmission Conductors and Connections
 - Electrical equipment subject to 10 CFR 50.49 environmental qualification (EQ) requirements
 - Grounding conductors
 - Cable Tie Wraps

License renewal drawing ([LR-PVGS-ELEC-E-MAA-001](#)) was created based on the electrical one-line diagram.

2.5.1 Electrical Component Groups

2.5.1.1 Connections (metallic parts)

The cable connections component type includes the metallic portions of cable connections that are located within passive and active equipment.

The function of the cable connections (metallic parts) is to electrically connect specified sections of an electrical circuit to deliver voltage, current or signals.

2.5.1.2 Connectors

The connector component type includes the connector contacts for electrical connectors exposed to borated water leakage. The function of the connectors is to electrically connect specified sections of an electrical circuit to deliver voltage, current or signals.

2.5.1.3 Fuse Holders (not part of larger assembly)

All fuse holders including those installed for electrical penetration protection are part of larger assemblies and are managed as part of the active component.

2.5.1.4 High Voltage Insulators

The high voltage insulators within the scope of license renewal are those associated with the power feeds from the switchyard to the plant that are used to connect the plant to the offsite power. These power feeds are required for the restoration of offsite power to meet the station blackout requirements.

Section 2.5

**SCOPING AND SCREENING RESULTS:
ELECTRICAL AND INSTRUMENTATION AND CONTROLS SYSTEMS**

The function of the high voltage insulators is to support and insulate the high voltage transmission conductors and switchyard bus.

2.5.1.5 Insulated Cable and Connections

All electrical insulated cables and connections not subject to environmental qualification requirements of 10 CFR 50.49 were evaluated for aging management based on the comparison of material property capability with environmental conditions. All electrical cables routed within raceway containing cables that feed electrical components that perform license renewal functions are in the scope of license renewal. Electrical cables not routed with in-scope cables were excluded from aging management if they were identified as feeding an electrical component that performed no license renewal intended function.

The function of insulated cables and connections is to electrically connect specified sections of an electrical circuit to deliver voltage, current or signals. The types of insulated cables includes medium voltage power cables, low voltage power cables, control cables, instrumentation cables and insulated ground cables. The types of insulated connections included in this review are splices, connectors, insulating material of fuse holders, and terminal blocks.

2.5.1.6 Metal Enclosed Bus

Electrical phase bus is bus that is enclosed and not part of an active component such as switchgear, load centers or motor control centers. There are typically three types of phase bus:

- Isolated Phase Bus
- Non-Segregated Phase Bus
- Segregated Phase Bus

The isolated phase bus is not within the scope of license renewal. The isolated phase bus performs no intended function that meets the criteria of 10 CFR 54.4(a)

The non-segregated phase bus that supports the restoration of offsite power to meet the station blackout requirements is in the scope of license renewal. The following component types are part of the non-segregated phase bus.

- Bus bar and connections
- Bus enclosure
- Bus Insulation and insulators

The function of the non-segregated phase bus and connections is to electrically connect specified sections of an electrical circuit to deliver voltage and current.

PVNGS does not use segregated phase bus.

Section 2.5
**SCOPING AND SCREENING RESULTS:
ELECTRICAL AND INSTRUMENTATION AND CONTROLS SYSTEMS**

2.5.1.7 Penetrations Electrical

All primary containment electrical penetrations are within the scope of license renewal. The electrical continuity of the environmental qualified penetrations is managed under the Environmental Qualification (EQ) Program which is evaluated as a time-limited aging analysis. The electrical continuity of the non-environmental qualified penetrations is managed under the Electrical Cables and Connections Not Subject to 10 CFR 50.49 Environmental Qualification Requirements program. The pressure boundary function of all electrical penetrations is evaluated in [Section 2.4.1](#), "Containment Building".

The functions of the primary containment electrical penetrations are to perform the function of primary containment boundary (structural pressure boundary) and electrical continuity across the primary containment boundary.

2.5.1.8 Switchyard Bus and Connections

The switchyard buses within the scope of license renewal are those associated with the power feeds from the switchyard to the plant that are used to connect the plant to the offsite power sources. These power feeds are required for the restoration of offsite power to meet the station blackout requirements. The switchyard bus connects the high voltage transmission conductors to the switchyard circuit breakers.

The function of the switchyard buses is to electrically connect specified sections of an electrical circuit to deliver voltage and current.

2.5.1.9 Terminal Blocks

The terminal block component type includes terminal blocks not subject to environmental qualification requirements of 10 CFR 50.49 that are not part of active equipment. The function of the terminal block is to electrically connect specified sections of an electrical circuit to deliver voltage, current or signals.

2.5.1.10 Transmission Conductors and Connections

The high voltage conductors and connections within the scope of license renewal are those associated with the power feeds from the switchyard to the plant that are used to connect the plant to the offsite power. These power feeds are required for the restoration of offsite power to meet the station blackout requirements.

The function of the high voltage conductors and connectors is to supply offsite power to various plant systems.

2.5.1.11 Electrical Equipment Subject to 10 CFR 50.49 Environmental Qualification (EQ) Requirements

Electrical equipment subject to 10 CFR 50.49 environmental qualification (EQ) requirements is evaluated as a time-limited aging analysis in [Section 4.4](#) and is managed under the Environmental Qualification (EQ) of Electrical Components program ([B3.2](#)).

2.5.1.12 Grounding Conductors

Uninsulated grounding conductors bond metal raceways, building structural steel, and plant equipment to earth ground through an installed grounding grid. The uninsulated grounding conductors are nonsafety-related and provide for personnel and equipment protection. In the event of a fault in an electrical circuit or component, the grounding conductors provide a direct path to ground for the fault currents to minimize equipment damage. The grounding conductors do not prevent faults and are not required for equipment operation. Failure of a grounding conductor cannot affect the accomplishment of any safety functions. Therefore, the grounding conductors do not perform an intended function that meets the criteria of 10 CFR 54.4(a) and are not within the scope of license renewal.

2.5.1.13 Cable Tie Wraps

Cable tie wraps are used as an aid during cable installation to establish power cable spacing in cable trays. Once the cables have been installed and in place, the cable's own weight in the tray and the inherent rigidity of the Class B copper stranding will continue to maintain the spacing. The power cables are sized to carry currents well in excess of load requirements with margin considering worst case routing. Tie wraps are not credited in PVNG seismic qualification of the cable tray support system.

The current licensing basis (CLB) and design documents were reviewed to determine that cable tie wraps perform no license renewal functions and failure of cable tie wraps would not prevent any safety-related equipment from performing its intended functions. PVNGS has no CLB requirements that cable tie wraps remain functional during and following design-basis events. Therefore, the tie wraps do not perform an intended function that meets the criteria of 10 CFR 54.4(a) and are not within the scope of license renewal.

2.5.2 Electrical Component Groups Subject to Aging Management Review

The electrical and instrument and control component groups requiring an AMR and their intended functions are indicated in [Table 2.5-1](#), Electrical and I&C Component Groups Requiring Aging Management Review.

Section 2.5
**SCOPING AND SCREENING RESULTS:
 ELECTRICAL AND INSTRUMENTATION AND CONTROLS SYSTEMS**

Table 2.5 – 1 Electrical and I&C Component Groups Requiring Aging Management Review

Component Type	Intended Function
Cable Connections (Metallic Parts)	Electrical Continuity
Connector	Electrical Continuity
High Voltage Insulator	Insulate (Electrical) Non-S/R Structural Support
Insulated Cable and Connections	Electrical Continuity Insulate (Electrical)
Metal Enclosed Bus (Bus/Connections)	Electrical Continuity
Metal Enclosed Bus (Enclosure)	Expansion/Separation Non-S/R Structural Support
Metal Enclosed Bus (Insulation/Insulators)	Insulate (Electrical)
Penetrations Electrical	Electrical Continuity Insulate (Electrical)
Switchyard Bus and Connections	Electrical Continuity
Terminal Block	Insulate (Electrical)
Transmission Conductors and Connections	Electrical Continuity

This Page Intentionally Left Blank

CHAPTER 3

AGING MANAGEMENT REVIEW RESULTS

This Page Intentionally Left Blank

3.0 AGING MANAGEMENT REVIEW RESULTS

Chapter 3 provides the results of the aging management review for those structures and component types identified in [Chapter 2](#) as being subject to aging management review. Organization of this chapter is based on Tables 1 through 6 of Volume 1 of NUREG-1801, “*Generic Aging Lessons Learned (GALL)*”, dated September 2005 and Chapter 3, Aging Management Review Results, of NUREG-1800, “*Standard Review Plan for the Review of License Renewal Applications for Nuclear Power Plants (SRP-LR)*”, Revision 1, dated September 2005.

The major sections of this chapter are:

- [3.1 Aging Management of Reactor Vessel, Internals, and Reactor Coolant System](#)
- [3.2 Aging Management of Engineered Safety Features](#)
- [3.3 Aging Management of Auxiliary Systems](#)
- [3.4 Aging Management of Steam and Power Conversion System](#)
- [3.5 Aging Management of Containments, Structures, and Component Supports](#)
- [3.6 Aging Management of Electrical and Instrument and Controls](#)

Descriptions of the internal and external service environments which were used in the aging management review to determine aging effects requiring management are included in [Table 3.0-1](#), Mechanical Environments, [Table 3.0-2](#), Structural Environments, and [Table 3.0-3](#), Electrical Environments. The environments used in the aging management reviews are listed in the Evaluated Environment column.

The aging management review results in Chapter 3 are presented in the following two types of tables:

- **Table 3.x.1** - where '3.x' indicates the LRA section number from NUREG 1800, and '1' indicates that this is the first table type in Section 3.x. For example, in the [Reactor Coolant System](#) subsection, this table would be number [3.1.1](#). For ease of discussion, this table type will hereafter be referred to in this Section as "Table 1".
- **Table 3.x.2-y** - where '3.x' indicates the LRA section number from NUREG 1800, and '2' indicates that this is the second table type in Section 3.x; and 'y' indicates the system table number. For example, for the [Reactor Vessel and Internals](#), within the [Reactor Vessel, Internals, and Reactor Coolant System](#) subsection, the Table would be [Table 3.1.2-1](#) and for the [Reactor Coolant System](#), it would be [Table 3.1.2-2](#). For the [Containment Leak Test System](#), within the [Engineered Safety Features](#) subsection, this Table would be [3.2.2-1](#). This table type will hereafter be referred to in this section as "Table 2".

TABLE DESCRIPTION

NUREG-1801 contains the staff's generic evaluation of existing plant programs. It documents the technical basis for determining where existing programs are adequate without modification, and where existing programs should be augmented for the extended period of operation. The evaluation results documented in the report indicate that many of the existing programs are adequate to manage the aging effects for particular structures or components, within the scope of license renewal, without change. The report also contains recommendations on specific areas for which existing programs should be augmented for license renewal. In order to take full advantage of NUREG-1801, a comparison between the AMR results and the tables of NUREG-1801 has been made. The results of that comparison are provided in the two tables.

Table 1

The purpose of Table 1 is to provide a summary comparison of how PVNGS aligns with the corresponding tables of NUREG-1801, Volume 1. The table is essentially the same as Tables 1 through 6 provided in NUREG-1801, Volume 1, except that the "Type" column and the "Unique Item" column are not included. The "ID" column has been replaced by an "Item Number" column and the "Related Generic Item" column has been replaced by a "Discussion" column. The "Item Number" column provides the reviewer with a means to cross-reference from Table 2 to Table 1. The "Discussion" column is used to provide clarifying/amplifying information. The following are examples of information that might be contained within this column:

- "Further Evaluation Recommended" information or reference to where that information is located. The name of a plant specific program being used.
- Exceptions to the NUREG-1801 assumptions
- A discussion of how the line is consistent with the corresponding line item in NUREG-1801, Volume 1
- A discussion of how the item is different than the corresponding line item in NUREG-1801, Volume 1, when it may appear to be consistent (e.g., when there is exception taken to an aging management program that is listed in NUREG-1801, Volume 1)

The format of Table 1 provides the reviewer with a means of aligning a specific Table 1 row with the corresponding NUREG-1801, Volume 1 table row, thereby allowing for the ease of review.

Table 2

Table 2 provides the detailed results of the aging management reviews for those component types identified in [Chapter 2](#) as being subject to aging management review. There will be a Table 2 for each of the systems and structures identified in [Chapter 2](#) that have component types within the scope of license renewal.

Table 2 consists of the following nine columns:

- [Component Type](#)
- [Intended Function](#)
- [Material](#)
- [Environment](#)
- [Aging Effect Requiring Management](#)
- [Aging Management Program](#)
- [NUREG-1801 Volume 2 Item](#)
- [Table 1 Item](#)
- [Notes](#)

Component Type

The first column identifies all of the component types from [Chapter 2](#) that are subject to aging management review. They are listed in alphabetical order.

Intended Function

The second column contains the license renewal intended functions (including abbreviations where applicable) for the listed component type. Definitions and abbreviations of intended functions are contained in [Table 2.1-1](#), “Intended Functions – Abbreviations and Definitions”.

Material

The third column lists the particular materials of construction for the component types.

Environment

The fourth column lists the environments to which the component types are exposed. Internal and external service environments are indicated and a listing and descriptions of these environments is provided in [Table 3.0-1](#), Mechanical Environments, [Table 3.0-2](#), Structural Environments, and [Table 3.0-3](#), Electrical and Instrument and Control Environments.

Aging Effect Requiring Management

As part of the aging management review process, aging effects requiring management for the material and environment combination in order to maintain the intended function of the component type are determined. These aging effects requiring management are listed in column five.

Aging Management Programs

The aging management programs used to manage the aging effects requiring management are listed in column six of Table 2.

NUREG-1801 Vol. 2 Item

Each combination of component type, material, environment, aging effect requiring management, and aging management program that is listed in Table 2, is compared to NUREG-1801, Volume 2 with consideration given to the standard notes, to identify consistencies. When they are identified, they are documented by noting the appropriate NUREG-1801, Volume 2 item number in column seven of Table 2. If there is no corresponding item number in NUREG-1801, Volume 2, this row in column seven is marked "none". That way, a reviewer can readily identify where there is correspondence between the plant specific tables and the NUREG-1801, Volume 2 tables.

Table 1 Item

Each combination of component, material, environment, aging effect requiring management, and aging management program that has an identified NUREG-1801 Volume 2 item number must also have a Table 3.x.1 line item reference number. The corresponding line item from Table 1 is listed in column eight of Table 2. If there is no corresponding item in NUREG-1801, Volume 1, this row in column eight is marked "none". That way, the information from the two tables can be correlated.

Notes

In order to realize the full benefit of NUREG-1801, a series of notes is established to identify how the information in Table 2 aligns with the information in NUREG-1801, Volume 2. All note references with letters are standard notes that will be the same from application to application throughout the industry. Any notes the plant requires which are in addition to the standard notes will be identified by a number and deemed plant specific.

Standard Notes used in this application include:

- A. Consistent with NUREG-1801 item for component, material, environment and aging effect. AMP is consistent with NUREG-1801 AMP.
- B. Consistent with NUREG-1801 item for component, material, environment and aging effect. AMP takes some exceptions to NUREG-1801 AMP.
- C. Component is different, but consistent with NUREG-1801 item for material, environment and aging effect. AMP is consistent with NUREG-1801 AMP.
- D. Component is different, but consistent with NUREG-1801 item for material, environment and aging effect. AMP takes some exceptions to NUREG-1801 AMP.
- E. Consistent with NUREG-1801 item for material, environment and aging effect, but a different aging management program is credited.

AGING MANAGEMENT REVIEW RESULTS

- F. Material not in NUREG-1801 for this component.
- G. Environment not in NUREG-1801 for this component and material.
- H. Aging effect not in NUREG-1801 for this component, material, and environment combination.
- I. Aging effect in NUREG-1801 for this component, material and environment combination is not applicable.
- J. Neither the component nor the material and environment combination are evaluated in NUREG-1801.

TABLE USAGE*Table 1*

The reviewer evaluates each row in Table 1 by moving from left to right across the table. Since the Component Type, Aging Effect/Mechanism, Aging Management Programs and Further Evaluation Recommended information is taken from NUREG-1801, Volume 1, no further analysis of those columns is required. The information intended to help the reviewer in this table is contained within the Discussion column. Here the reviewer is given information necessary to determine, in summary, how the PVNGS evaluations and programs align with NUREG-1801, Volume 1. This may be in the form of descriptive information within the Discussion column or the reviewer may be referred to other locations within the LRA.

Table 2

Table 2 contains all of the Aging Management Review information for the plant, whether or not it aligns with NUREG-1801. For a given row within the table, the reviewer is able to see the intended function, material, environment, aging effect requiring management and aging management program combination for a particular component type within a system. In addition, if there is a correlation between the combination in Table 2 and a combination in NUREG-1801, Volume 2, this will be identified by a referenced item number in column seven, NUREG-1801, Volume 2 Item. The reviewer can refer to the item number in NUREG-1801, Volume 2, if desired, to verify the correlation. If the column is blank, the corresponding combination in NUREG-1801, Volume 2 is marked as "none". As the reviewer continues across the table from left to right, within a given row, the next column is labeled Table 1 Item. If there is a reference number in this column, the reviewer is able to use that reference number to locate the corresponding row in Table 1 and see how the aging management program for this particular combination aligns with NUREG-1801.

Table 2 provides the reviewer with a means to navigate from the component types subject to aging management review in [Chapter 2](#) all the way through the evaluation of the programs that will be used to manage the effects of aging of those component types.

A listing of the acronyms used in this chapter is provided in [Section 1.6](#).

**Section 3.0
AGING MANAGEMENT REVIEW RESULTS**

Table 3.0-1 Mechanical Environments

Mechanical Environments		
Evaluated Environment	NUREG-1801 Environment	Description
Internal		
Demineralized Water	Treated Water	Demineralized water or chemically purified water which is the source for water in all clean systems such as the primary or secondary coolant systems. Demineralized water is monitored for quality under the Water Chemistry Aging Management Program and depending on the system; demineralized water may require additional processing.
Treated Borated Water	Treated Borated Water	Treated water with boric acid that is monitored for quality under the Water Chemistry Aging Management Program.
	Treated Borated Water >60 ° C (140 ° F) [SCC Threshold for Stainless Steel]	
	Treated Borated Water >250 ° C (482 ° F) [CASS in ECCS Systems]	

Table 3.0-1 Mechanical Environments (Continued)

Mechanical Environments		
Evaluated Environment	NUREG-1801 Environment	Description
Reactor Coolant	Reactor Coolant	Water in reactor coolant systems at or near full operating temperature that is treated and monitored for quality under the Water Chemistry Aging Management Program.
	Reactor Coolant >250 ° C (>482 ° F) [CASS]	
	Reactor Coolant and Neutron Flux [Neutron Irradiation Embrittlement]	
	Reactor Coolant >250 ° C (>482 ° F) and Neutron Flux [CASS and Neutron Irradiation Embrittlement]	
	Reactor Coolant and Secondary Feedwater/Steam [TLAA IV.D1-21]	
	Reactor Coolant/Steam	
	[RCS Piping IV.C2-13 and Pressurizer IV. C2-24]	
Secondary Water	Steam	Steam generator secondary systems water (including condensate, feedwater and steam) that is treated and monitored for quality under the Water Chemistry Aging Management Program and controlled for protection of steam generators.
	Treated Water	
	Treated Water >60 ° C (140 ° F) [SCC Threshold for Stainless Steel]	
	Secondary Feedwater/Steam	
	Secondary Feedwater	
Closed-Cycle Cooling Water	Closed Cycle Cooling Water	Water for component cooling that is treated and monitored for quality under the Closed-Cycle Cooling Water System Aging Management Program.
	Closed Cycle Cooling Water >60 ° C (140 ° F) [SCC Threshold for Stainless Steel]	
	Treated Water	

Table 3.0-1 Mechanical Environments (Continued)

Mechanical Environments	
Evaluated Environment	NUREG-1801 Environment
Raw Water	Raw Water Water from the circulating water system or ultimate heat sink for use in open-cycle cooling systems. Floor drains and building sumps may be exposed to a variety of untreated water that is classified as raw water for the determination of aging effects. Raw water may contain contaminants, including oil and boric acid, as well as originally treated water that is not monitored by a chemistry program.
Lubricating Oil	Lubricating Oil Lubricating oils, including hydraulic oils, are low to medium viscosity hydrocarbons, with the possibility of containing contaminants and/or moisture, used for bearing, gear and engine lubrication and, in the case of hydraulic oil, power transmission. Lubricating and hydraulic oils are monitored for the possibility of water by the Lubricating Oil Analysis program.
Fuel Oil	Fuel Oil Diesel fuel oil or liquid hydrocarbons used to fuel diesel engines. Fuel oil is monitored for the possibility of water by the Fuel Oil Chemistry program.
Dry Gas	Dried Air [Common Miscellaneous Material/Environments] Gas [Common Miscellaneous Material/Environments] Internal gas environments from dry air (conditioned to reduce the dew point well below the system operating temperature), inert or non-reactive gases. Includes compressed instrument air, nitrogen, oxygen, hydrogen, helium, Halon or Freon.
Diesel Exhaust	Diesel Exhaust [VII H2-1 & H2-2] Gases, fluids, particles present in diesel engine exhaust.
Ventilation Atmosphere	Air – Indoor Uncontrolled Condensation (Internal) Air – Indoor Uncontrolled (Internal/External) Air – Indoor Controlled (external) Atmospheric/room/building air for ventilation systems with temperatures higher than the dew point, i.e. condensation can occur but only rarely, equipment surfaces are normally dry. Condensation on the surfaces of systems with temperatures below the dew point is considered raw water due to the potential for surface contamination. Also the environment to which the external surface of components inside HVAC systems is exposed.

Table 3.0-1 Mechanical Environments (Continued)

Mechanical Environments		Description
Evaluated Environment	NUREG-1801 Environment	
Wetted Gas	Condensation (Internal)	Non-dried compressed air or gas, may contain moisture. Air with enough moisture to facilitate loss of material in steel caused by general, pitting, and crevice corrosion. Moist air in the absence of condensation is also potentially aggressive, e.g., under conditions where hygroscopic surface contaminants are present.
	Air [Glass Piping Elements VII.J-7 and VIII.I-4]	
	Moist Air or Condensation [Diesel Piping Components VII.H2-21]	
Potable Water	This Environment is not in NUREG-1801	Water treated for drinking or other personnel uses.
Silicone Fluid	This Environment is not in NUREG-1801	Silicone based fluid that is thermally stable, resists oxidation, and is chemically inert.
External		
Plant Indoor Air	Air – Indoor Uncontrolled (External)	The environment to which the internal and external surface of the component is exposed. Indoor air on systems with temperatures higher than the dew point, i.e., condensation can occur but only rarely, equipment surfaces are normally dry. Condensation on the surfaces of systems with temperatures below the dew point is considered raw water due to the potential for surface contamination.
	Air – Indoor Uncontrolled (Internal/External)	
	Air Indoor	
	Air – Indoor Controlled (External) [VII.J-1 and VIII.I-13]	
	Air With Leaking Secondary Side Water and/or Steam [Steam Generator (Once Through) – IV.D2-5]	
	Air With Steam or Water Leakage [Closure Bolting]	
	Condensation (External)	
Borated Water Leakage	Air With Reactor Coolant Leakage.	The borated water leakage environment applies in plant indoor and outdoor areas that include components and systems that contain borated water and that could leak on nearby components or structures. This environment is specified in the aging management review results only for materials susceptible to boric acid corrosion (carbon steel, low-alloy steels, and copper alloys).
	Air With Borated Water Leakage.	
	Air With Reactor Coolant Leakage (Internal) (RPV Leak Detection Line IV.A2-5)	
	Air With Metal Temperature up to 288 ° C (550 ° F) [Pressurizer Integral Support - IV.C2-16]	

Table 3.0-1 Mechanical Environments (Continued)

Mechanical Environments		Description
Evaluated Environment	NUREG-1801 Environment	
Atmosphere /weather	System Temperature up to 340 ° C (644 ° F) [Steam Generator Closure Bolting and TLAA] Air – Outdoor Air – Outdoor (External) Air – Indoor and Outdoor	The atmosphere/weather environment consists of moist, ambient precipitation and wind. The component is exposed to air and local weather conditions. Temperature extremes range from 11°F to 121°F. There is no exposure to salt spray or other aggressive contaminants.
Buried	Soil	Components/equipment that are buried in soil. Soil is a mixture of inorganic materials produced by the weathering of rocks and clays, and organic material produced by decomposition of vegetation. Voids containing air and moisture occupy about 50% of the soil volume. Properties of soil that can affect aging include water content, pH, ion exchange capacity, density, and permeability. External environment for components exposed to soil (including air/soil interface) or buried in the soil, including groundwater in the soil. The ground water has been determined to be non-aggressive.
Submerged (Note: Use Appropriate Internal Environment)	Use Appropriate Internal Environment	Components/equipment that are completely or partially submerged in: <ul style="list-style-type: none"> • Water (operating or process fluid) • Oil/fluids (lube, fuel, EHC, etc.) The environment for submerged components will be identified using one of the internal environments previously identified.
Encased in Concrete	Concrete	Piping or components that are encased in concrete.

Section 3.0
AGING MANAGEMENT REVIEW RESULTS

Table 3.0-2 Structural Environments

Structural Environments		Description
Evaluated Environment	NUREG-1801 Environment	
Plant Indoor Air	Any [Reaction With Aggregates]	Structures are subject to the same conditions covered in Plant Indoor Air External Mechanical Environment. Indoor air on structures with temperatures higher than the dew point, i.e., condensation can occur but only rarely, structural surfaces are normally dry. Condensation on the surfaces of structures with temperatures below the dew point is considered raw water due to the potential for surface contamination.
	Air - Indoor Uncontrolled	
	Soil [Cracks and Distortion Due to Increased Stress Levels From Settlement]	
	Various [Elastomers III A6-12]	
Atmosphere/ Weather	Any [Reaction With Aggregates]	Structures are subject to the same conditions covered in Atmosphere/Weather External Mechanical Environment. The atmosphere/weather environment consists of moist, ambient temperatures, humidity, and exposure to weather, including precipitation and wind. The component is exposed to air and local weather conditions. Temperature extremes range from 11°F to 121°F.
	Air – Outdoor	
	Soil [Cracks and Distortion Due to Increased Stress Levels From Settlement]	
	Water - Flowing[Leaching of Calcium Hydroxide]	
	Various [Elastomers III A6-12]	
Borated Water Leakage	Air With Borated Water Leakage [Supports]	The borated water leakage environment applies in plant indoor and outdoor areas that include components and systems that contain borated water and that could leak on nearby components or structures. This environment is specified in the aging management review results only for materials susceptible to boric acid corrosion (carbon steel, low-alloy steels, and copper alloys).

Table 3.0-2 Structural Environments (Continued)

Structural Environments	
Evaluated Environment	NUREG-1801 Environment
Encased in Concrete	Not a NUREG-1801 Structural Environment: See NUREG-1801 Mechanical Item
Buried	Any [Reaction With Aggregates]
	Groundwater/Soil
	Soil [Cracks and Distortion Due to Increased Stress Levels From Settlement]
	Water - Flowing [Leaching of Calcium Hydroxide]
	Air – Outdoor [Freeze Thaw]
	Water - Flowing Under Foundation [Porous Concrete Sub-foundation]
Submerged (Note: Use Appropriate Internal Mechanical Environment)	Various [Elastomers III A6-12]
	Water – Standing [Tanks, Earthen Water Control Structures, and Water Control Structures Metal Components]
	Water - Flowing [Abrasion/Cavitation (concrete), Earthen Water Control Structures, and Water Control Structures Metal Components]
	Treated Water or Treated Borated Water [Fuel Pool Liner]
	Treated Water <60 ° C (<140 ° F) [Supports]

Description

Components that are encased in concrete.

Structures/components that are buried in soil. Soil is a mixture of inorganic materials produced by the weathering of rocks and clays, and organic material produced by decomposition of vegetation. Voids containing air and moisture occupy about 50% of the soil volume. Properties of soil that can affect aging include water content, pH, ion exchange capacity, density, and permeability. The groundwater has been determined to be non-aggressive.

Structures/components that are buried and may be exposed to:

- Soil, dry under normal conditions
- Soil with ground water present
- Flowing water causing possible leaching condition
- Foundation aging
- Soft soil and settlement issues
- An aggressive environment caused by contaminants in the soil

Structures that are completely or partially covered, or structures that are partially filled (such as tanks, sumps, etc.) with:

- Water (operating or process fluid)
- Oil/fluids (lube, fuel, EHC, etc.)

Structures that are exposed to flowing water potentially causing:

- Abrasion
- Cavitation
- Leaching

The environment for submerged components will be identified using one of the mechanical environments previously identified.

Section 3.0
AGING MANAGEMENT REVIEW RESULTS

Table 3.0-3 Electrical and Instrument and Controls Environments

Electrical Environments		Description
Evaluated Environment	NUREG-1801 Environment	
Plant Indoor Air	Air Indoor	Indoor air on electrical components with temperatures higher than the dew point, i.e., condensation can occur but only rarely, equipment surfaces are normally dry.
Atmosphere/Weather	Air Outdoors	The atmosphere/weather environment consists of moist, ambient temperatures, humidity, and exposure to weather, including precipitation and wind. The component is exposed to air and local weather conditions. Temperature extremes range from 11°F to 127°F. There is no exposure to salt spray, industry air pollution or other aggressive contaminants.
Borated Water Leakage	Air with Borated Water Leakage	The borated water leakage environment applies in plant indoor and outdoor areas that include components and systems that contain borated water and that could leak on nearby components or structures. This environment is specified in the aging management review results only for materials susceptible to boric acid corrosion (carbon steel, low-alloy steels, and copper alloys).
Adverse Localized Environment	Adverse localized environment caused by heat, radiation, or moisture in the presence of oxygen	Adverse localized environments can be due to any of the following: (1) exposure to moisture and voltage (2) heat, radiation, or moisture, in the presence of oxygen (3) heat, radiation, or moisture, in the presence of oxygen or >60-year service limiting temperature, or (4) adverse localized environment caused by heat, radiation, oxygen, moisture, or voltage. The term ">60-year service limiting temperature" refers to that temperature that exceeds the temperature below which the material has a 60-year or greater service lifetime.

3.1 AGING MANAGEMENT OF REACTOR VESSEL, INTERNALS, AND REACTOR COOLANT SYSTEM

3.1.1 Introduction

Section 3.1 provides the results of the aging management reviews (AMRs) for those component types identified in [Section 2.3.1](#), Reactor Vessel, Internals, and Reactor Coolant System, subject to aging management review. These systems are described in the following sections:

- Reactor Vessel and Internals ([Section 2.3.1.1](#))
- Reactor Coolant ([Section 2.3.1.2](#))
- Pressurizer ([Section 2.3.1.3](#))
- Steam Generators ([Section 2.3.1.4](#))

[Table 3.1.1](#), Summary of Aging Management Evaluations in Chapter IV of NUREG-1801 for Reactor Vessel, Internals, and Reactor Coolant System, provides the summary of the programs evaluated in NUREG-1801 that are applicable to the component types in this section. [Table 3.1.1](#) uses the format of [Table 3.x.1](#) (Table 1) described in [Section 3.0](#).

3.1.2 Results

The following tables summarize the results of the aging management review for the systems in the Reactor Vessel, Internals, and Reactor Coolant System area:

- [Table 3.1.2-1](#) Reactor Vessel, Internals, and Reactor Coolant System – Summary of Aging Management Evaluation – Reactor Vessel and Internals
- [Table 3.1.2-2](#) Reactor Vessel, Internals, and Reactor Coolant System – Summary of Aging Management Evaluation – Reactor Coolant System
- [Table 3.1.2-3](#) Reactor Vessel, Internals, and Reactor Coolant System – Summary of Aging Management Evaluation – Pressurizer
- [Table 3.1.2-4](#) Reactor Vessel, Internals, and Reactor Coolant System – Summary of Aging Management Evaluation – Steam Generators

These tables use the format of [Table 2](#) discussed in [Section 3.0](#).

3.1.2.1 Materials, Environment, Aging Effects Requiring Management and Aging Management Programs

The materials from which the component types are fabricated, the environments to which they are exposed, the potential aging effects requiring management, and the aging management programs used to manage these aging effects are provided for each of the above systems in the following subsections.

3.1.2.1.1 Reactor Vessel and Internals

Materials

The materials of construction for the reactor vessel and internals component types are:

- Carbon Steel
- Carbon Steel with Stainless Steel Cladding
- High Strength Low Alloy Steel (Bolting)
- Nickel Alloys
- Stainless Steel

Environment

The reactor vessel and internals components are exposed to the following environments:

- Borated Water Leakage
- Reactor Coolant

Aging Effects Requiring Management

The following reactor vessel and internals aging effects require management:

- Changes in dimensions
- Cracking
- Loss of fracture toughness
- Loss of material
- Loss of preload

Aging Management Programs

The following aging management programs manage the aging effects for the reactor vessel and internals component types:

Section 3.1
**AGING MANAGEMENT OF REACTOR VESSEL,
INTERNALS, AND REACTOR COOLANT SYSTEM**

- ASME Section XI Inservice Inspection, Subsections IWB, IWC, and IWD ([B2.1.1](#))
- Bolting Integrity ([B2.1.7](#))
- Boric Acid Corrosion ([B2.1.4](#))
- Nickel Alloy Aging Management Program ([B2.1.34](#))
- Nickel-Alloy Penetration Nozzles Welded To The Upper Reactor Vessel Closure Heads Of Pressurized Water Reactors ([B2.1.5](#))
- Reactor Coolant System Supplement ([B2.1.21](#))
- Reactor Head Closure Studs ([B2.1.3](#))
- Reactor Vessel Surveillance ([B2.1.15](#))
- Water Chemistry ([B2.1.2](#))

3.1.2.1.2 Reactor Coolant System

Materials

The materials of construction for the reactor coolant system component types are:

- Carbon Steel
- Carbon Steel with Stainless Steel Cladding
- Glass
- Nickel Alloys
- Stainless Steel
- Stainless Steel Cast Austenitic

Environment

The reactor coolant system component types are exposed to the following environments:

- Borated Water Leakage
- Closed-Cycle Cooling Water
- Lubricating Oil
- Plant Indoor Air
- Reactor Coolant
- Treated Borated Water

Aging Effects Requiring Management

The following reactor coolant system aging effects require management:

- Cracking
- Loss of fracture toughness
- Loss of material
- Loss of preload
- Reduction of heat transfer

Aging Management Programs

The following aging management programs manage the aging effects for the reactor coolant system component types:

- ASME Section XI Inservice Inspection, Subsections IWB, IWC, and IWD ([B2.1.1](#))
- Bolting Integrity ([B2.1.7](#))
- Boric Acid Corrosion ([B2.1.4](#))
- Closed-Cycle Cooling Water System ([B2.1.10](#))
- External Surfaces Monitoring Program ([B2.1.20](#))
- Lubricating Oil Analysis ([B2.1.23](#))
- Nickel Alloy Aging Management ([B2.1.34](#))
- One-Time Inspection ([B2.1.16](#))
- One-Time Inspection Of ASME Code Class 1 Small-Bore Piping ([B2.1.19](#))
- Reactor Coolant System Supplement ([B2.1.21](#))
- Water Chemistry ([B2.1.2](#))

3.1.2.1.3 Pressurizer

Materials

The materials of construction for the pressurizer component types are:

- Carbon Steel
- Carbon Steel with Nickel-Alloy Cladding
- Carbon Steel with Stainless Steel Cladding

Section 3.1
**AGING MANAGEMENT OF REACTOR VESSEL,
INTERNALS, AND REACTOR COOLANT SYSTEM**

- High Strength Low Alloy Steel (Bolting)
- Nickel Alloys
- Stainless Steel

Environment

The pressurizer component types are exposed to the following environments:

- Borated Water Leakage
- Reactor Coolant

Aging Effects Requiring Management

The following pressurizer aging effects require management:

- Cracking
- Loss of material
- Loss of preload

Aging Management Programs

The following aging management programs manage the aging effects for the pressurizer component types:

- ASME Section XI Inservice Inspection, Subsections IWB, IWC, and IWD ([B2.1.1](#))
- Bolting Integrity ([B2.1.7](#))
- Boric Acid Corrosion ([B2.1.4](#))
- Nickel Alloy Aging Management ([B2.1.34](#))
- Reactor Coolant System Supplement ([B2.1.21](#))
- Water Chemistry ([B2.1.2](#))

3.1.2.1.4 Steam Generators

Materials

The materials of construction for the steam generator component types are:

- Carbon Steel
- Carbon Steel with Nickel-Alloy Cladding

Section 3.1
**AGING MANAGEMENT OF REACTOR VESSEL,
INTERNALS, AND REACTOR COOLANT SYSTEM**

- Carbon Steel with Stainless Steel Cladding
- Nickel Alloys
- Stainless Steel

Environment

The steam generator component types are exposed to the following environments:

- Borated Water Leakage
- Plant Indoor Air
- Reactor Coolant
- Secondary Water

Aging Effects Requiring Management

The following steam generator aging effects require management:

- Cracking
- Denting
- Loss of material
- Loss of preload
- Wall thinning

Aging Management Programs

The following aging management programs manage the aging effects for the steam generator component types:

- ASME Section XI Inservice Inspection, Subsections IWB, IWC, and IWD ([B2.1.1](#))
- Bolting Integrity ([B2.1.7](#))
- Boric Acid Corrosion ([B2.1.4](#))
- External Surfaces Monitoring Program ([B2.1.20](#))
- Flow-Accelerated Corrosion ([B2.1.6](#))
- Nickel Alloy Aging Management ([B2.1.34](#))
- One-Time Inspection ([B2.1.16](#))
- Reactor Coolant System Supplement ([B2.1.21](#))

- Steam Generator Tube Integrity ([B2.1.8](#))
- Water Chemistry ([B2.1.2](#))

3.1.2.2 Further Evaluation of Aging Management as Recommended by NUREG-1801

NUREG-1801 provides the basis for identifying those programs that warrant further evaluation by the reviewer in the LRA. For the reactor vessel, internals, and reactor coolant system, those evaluations are addressed in the following subsections.

3.1.2.2.1 Cumulative Fatigue Damage

Analysis of cumulative fatigue damage in the reactor pressure vessel and internals; reactor coolant pumps, pressurizer; primary side of the steam generators; reactor coolant pressure boundary piping, valves, and other components; and of those steam generator secondary-side components with a fatigue analysis are TLAAAs as defined in 10 CFR 54.3. TLAAAs are evaluated in accordance with 10 CFR 54.21(c)(1).

[3.1.1.05] PVNGS reactor vessel internals are designed to ASME III Subsection NG, some with a fatigue analysis. [Section 4.3.3](#) describes the evaluation of these TLAAAs.

[3.1.1.06] Cumulative fatigue damage of steam generator tubes is not a TLAA as defined in 10 CFR 54.3. See [Section 4.3.2.5](#).

[3.1.1.07] Reactor coolant pressure boundary closure bolting (RPV head studs, pump, valve, and pressurizer and steam generator manway and port bolting) and pressurizer vessel support skirts and attachment welds are designed to ASME III Class 1, with a fatigue analysis. Both the steam generator primary and secondary shells, integral supports, nozzles, and bolting have a Class 1 fatigue analysis. The pressurizer relief tank is not an ASME III Class 1 component, nor is it designed to other fatigue or cyclic design rules, and therefore has no fatigue TLAA.

- [Section 4.3.2.1](#) describes the evaluation of these TLAAAs for reactor vessel closure bolting and welded attachments.
- [Section 4.3.2.3](#) describes the evaluation of these TLAAAs for the reactor coolant pump, its closure bolting, and its integral supports.
- [Section 4.3.2.4](#) describes the evaluation of these TLAAAs for pressurizer closure bolting, its support skirt, and welded attachments.
- [Section 4.3.2.5](#) describes the evaluation of these TLAAAs for steam generator primary and secondary-side pressure boundaries, feedwater nozzles, closure bolting and welded attachments.

Section 3.1
AGING MANAGEMENT OF REACTOR VESSEL,
INTERNALS, AND REACTOR COOLANT SYSTEM

- [Section 4.3.2.6](#) describes the evaluation of these TLAAAs for Class 1 valves, including their bolting.
- [Section 4.3.2.7](#) describes the evaluation of these TLAAAs for piping and piping components.

[3.1.1.08] Reactor coolant pressure boundary piping and the pressurizer are designed to ASME III Class 1, with fatigue analyses.

- [Section 4.3.2.4](#) describes the evaluation of these TLAAAs for the pressurizer and pressurizer nozzles.
- [Section 4.3.2.7](#) describes the evaluation of these TLAAAs for piping and other piping components.

[3.1.1.09] The reactor vessel pressure boundary is designed to ASME III Class 1, with fatigue analyses.

- [Section 4.3.2.1](#) describes the evaluation of these TLAAAs for the reactor vessel, including the shell, heads, flanges, penetrations, welds, nozzles, and safe end butters.
- [Section 4.3.2.2](#) describes the evaluation of these TLAAAs for the control element assembly (CEA) housings.

[3.1.1.10] The steam generator primary and secondary pressure boundaries are designed respectively to ASME III Class 1 and 2, but both the steam generator primary and secondary shells and nozzles have a Class 1 fatigue analysis.

- [Section 4.3.2.5](#) describes the evaluation of these TLAAAs for steam generator primary and secondary-side pressure boundaries including the heads, feedwater nozzles, other nozzles and safe end butters, and closures.

3.1.2.2.2 Loss of Material due to General, Pitting, and Crevice Corrosion

3.1.2.2.2.1 PWR steam generator shell assembly exposed to feedwater and steam

Not applicable. PVNGS has a recirculating steam generator, not a once-through steam generator, so the applicable NUREG-1801 row was not used.

3.1.2.2.2.2 BWR isolation condenser components exposed to reactor coolant

Not applicable to PVNGS, applicable to BWR only.

3.1.2.2.2.3 Reactor vessel components exposed to reactor coolant

Not applicable to PVNGS, applicable to BWR only.

Section 3.1
AGING MANAGEMENT OF REACTOR VESSEL,
INTERNALS, AND REACTOR COOLANT SYSTEM

3.1.2.2.2.4 Steam generator shell and transition cone exposed to secondary feedwater and steam

Augmented inspection is recommended for Westinghouse Model 44 and 51 steam generators, where a high stress region exists at the shell to transition cone weld, if general and pitting corrosion of the shell is known to exist. The steam generators at PVNGS are Combustion Engineering modified System 80, so the augmented inspection is not applicable.

3.1.2.2.3 Loss of Fracture Toughness due to Neutron Irradiation Embrittlement

3.1.2.2.3.1 Loss of Fracture Toughness due to Neutron Irradiation Embrittlement - TLAA

Due primarily to low-leakage cores, the revised 54 EFPY fluence projections are less than the original 32 EFPY CESSAR projections. Recent coupon examinations demonstrated that beltline materials will remain limiting, and that more than adequate adjusted reference temperature, upper shelf energy, and pressurized thermal shock screening temperature margin will remain at the end of a 60-year period of operation; and therefore that subsequent revisions to pressure-temperature limits will provide adequate operating margin, without the use of special methods.

Since beltline materials remain limiting, nozzles were not evaluated separately. [Section 4.2](#) describes the evaluation of these neutron embrittlement TLAAAs.

Loss of fracture toughness for the reactor pressure vessel shell and nozzles is managed with the Reactor Vessel Surveillance program ([B2.1.15](#)).

3.1.2.2.3.2 Loss of Fracture Toughness due to Neutron Irradiation Embrittlement – Reactor Vessel Surveillance program

The Reactor Vessel Surveillance program ([B2.1.15](#)) manages loss of fracture toughness due to neutron irradiation embrittlement of carbon steel components clad with stainless steel exposed to reactor coolant. Due primarily to low-leakage cores, the revised 54 EFPY fluence projections are less than the original 32 EFPY CESSAR projections. Recent coupon examinations demonstrated that beltline materials will remain limiting, and that more than adequate adjusted reference temperature, upper shelf energy, and pressurized thermal shock screening temperature margin will remain at the end of a 60-year period of operation; and therefore that subsequent revisions to pressure-temperature limits will provide adequate operating margin, without the use of special methods.

Since beltline materials remain limiting, nozzles were not evaluated separately. [Section 4.2](#) describes the evaluation of these neutron embrittlement TLAAAs.

Section 3.1
AGING MANAGEMENT OF REACTOR VESSEL,
INTERNALS, AND REACTOR COOLANT SYSTEM

PVNGS vessels contain coupons sufficient to support the program for the period of extended operation. APS will revise the coupon withdrawal and examination schedule to be consistent with recommendations of ASTM E 185-82. PVNGS retains sufficient unexposed archived material "... to provide two additional sets of test specimens for each material..." (UFSAR §5.3.1.6.1).

3.1.2.2.4 Cracking due to Stress Corrosion Cracking (SCC) and Intergranular Stress Corrosion Cracking (IGSCC)

3.1.2.2.4.1 BWR top head enclosure, vessel flange leak detection lines

Not applicable to PVNGS, applicable to BWR only.

3.1.2.2.4.2 BWR isolation condenser components exposed to reactor coolant

Not applicable to PVNGS, applicable to BWR only.

3.1.2.2.5 Cracking Growth due to Cyclic Loading

An analysis of crack growth of underclad flaws in reactor vessel forgings due to cyclic loading to qualify them for the current licensed operating period would be a TLAA. TLAA's are evaluated in accordance with 10 CFR 54.21(c)(1). However, there are no underclad flaw TLAA's for the PVNGS reactor vessel.

Although no underclad flaws have been detected or analyzed for the PVNGS vessel, in the absence of which there are no TLAA's of this sort, [Section 4.7.6](#) describes the disposition of this effect in the PVNGS reactor vessel for the period of extended operation.

The PVNGS vessel does include some SA 508 Class 2 forgings, but clad with low heat input processes and therefore not susceptible to underclad cracking [[UFSAR § 5.2.3.3.2.1](#)].

3.1.2.2.6 Loss of Fracture Toughness due to Neutron Irradiation Embrittlement and Void Swelling

Loss of fracture toughness due to neutron irradiation embrittlement and void swelling for stainless steel reactor internals components exposed to reactor coolant will be managed by (1) participating in the industry programs for investigating and managing aging effects on reactor internals; (2) evaluating and implementing the results of the industry programs as applicable to the reactor internals; and (3) upon completion of these programs, but not less than 24 months before entering the period of extended operation, submitting an inspection plan for reactor internals to the NRC for review and approval. (See Reactor Coolant System Supplement ([B2.1.21](#))).

3.1.2.2.7 Cracking due to Stress Corrosion Cracking

3.1.2.2.7.1 PWR stainless steel reactor vessel flange leak detection lines

For managing the aging of cracking due to stress corrosion cracking for stainless steel bottom-mounted instrument guide tubes exposed to reactor coolant, Water Chemistry program (B2.1.2) will be augmented by ASME Section XI Inservice Inspection, Subsections IWB, IWC, and IWD program (B2.1.1) to ensure detection of cracks. The PVNGS reactor vessel flange leak detection line is made of nickel alloy.

3.1.2.2.7.2 CASS reactor coolant system piping and components exposed to reactor coolant

Not applicable. PVNGS reactor coolant system does not have cast austenitic stainless steel piping, piping components and piping elements exposed to reactor coolant, so the applicable NUREG-1801 line was not used.

3.1.2.2.8 Cracking due to Cyclic Loading

3.1.2.2.8.1 BWR jet pump sensing lines

Not applicable to PVNGS, applicable to BWR only.

3.1.2.2.8.2 BWR isolation condenser components exposed to reactor coolant

Not applicable to PVNGS, applicable to BWR only.

3.1.2.2.9 Loss of Preload due to Stress Relaxation

Loss of preload due to stress relaxation for PVNGS stainless steel screws, bolts, tie rods of the CEA shroud assembly components exposed to reactor coolant will be managed by (1) participating in the industry programs for investigating and managing aging effects on reactor internals; (2) evaluating and implementing the results of the industry programs as applicable to the reactor internals; and (3) upon completion of these programs, but not less than 24 months before entering the period of extended operation, submitting an inspection plan for reactor internals to the NRC for review and approval. (See Reactor Coolant System Supplement (B2.1.21)).

3.1.2.2.10 Loss of Material due to Erosion

Not applicable. PVNGS steam generator does not have a feedwater impingement plate, so the applicable NUREG-1801 line was not used.

3.1.2.2.11 Cracking due to Flow Induced Vibration

Not applicable to PVNGS, applicable to BWR only.

3.1.2.2.12 Cracking due to Stress Corrosion Cracking and Irradiation-Assisted Stress Corrosion Cracking (IASCC)

For managing the aging of cracking due to stress corrosion cracking and irradiation-assisted stress corrosion cracking of stainless steel reactor internals components exposed to reactor coolant, water chemistry will be augmented by (1) participating in the industry programs for investigating and managing aging effects on reactor internals; (2) evaluating and implementing the results of the industry programs as applicable to the reactor internals; and (3) upon completion of these programs, but not less than 24 months before entering the period of extended operation, submitting an inspection plan for reactor internals to the NRC for review and approval. (See Reactor Coolant System Supplement ([B2.1.21](#))).

3.1.2.2.13 Cracking due to Primary Water Stress Corrosion Cracking (PWSCC)

For managing the aging of cracking due to primary water stress corrosion cracking of nickel alloy components exposed to reactor coolant, water chemistry and inservice inspection will be augmented by a plant-specific Nickel Alloy aging management program, and by implementing applicable (1) NRC Orders, Bulletins and Generic Letters associated with nickel alloys and (2) staff-accepted industry guidelines. (See Reactor Coolant System Supplement ([B2.1.21](#))).

3.1.2.2.14 Wall Thinning due to Flow-Accelerated Corrosion

Feeding wall thinning was described in NRC IN 91-19. This condition is not applicable to the model steam generators installed at PVNGS and no action is required, however, the Water Chemistry program ([B2.1.2](#)) and the Steam Generator Tubing Integrity program ([B2.1.8](#)) are conservatively credited to manage wall thinning due to flow-accelerated corrosion for the feeding.

3.1.2.2.15 Changes in dimensions due to Void Swelling

Changes in dimensions due to void swelling for stainless steel reactor internals components exposed to reactor coolant will be managed by (1) participating in the industry programs for investigating and managing aging effects on reactor internals; (2) evaluating and implementing the results of the industry programs as applicable to the reactor internals; and (3) upon completion of these programs, but not less than 24 months before entering the period of extended operation, submitting an inspection plan for reactor internals to the NRC for review and approval. (See Reactor Coolant System Supplement ([B2.1.21](#))).

3.1.2.2.16 Cracking due to Stress Corrosion Cracking and Primary Water Stress Corrosion Cracking

3.1.2.2.16.1 Steam generator heads, tubesheets, and welds made or clad with stainless steel

For managing the aging effect of cracking due to SCC and PWSCC of nickel alloy components of CEDM housings exposed to reactor coolant (but not for stainless steel components), water chemistry and inservice inspection will be augmented by a plant-specific Nickel Alloy aging management program (pressure boundary components only), and by implementing applicable (1) NRC Orders, Bulletins and Generic Letters associated with nickel alloys and (2) staff-accepted industry guidelines. (See Reactor Coolant System Supplement (B2.1.21)).

The Water Chemistry program (B2.1.2) and ASME Section XI Inservice Inspection, Subsections IWB, IWC, and IWD program (B2.1.1) will manage cracking due to SCC of stainless steel components of CEDM housings exposed to reactor coolant.

3.1.2.2.16.2 Pressurizer spray head cracking

Not applicable. PVNGS has determined that the pressurizer spray heads are not included in scope of license renewal, so the applicable NUREG-1801 line was not used.

3.1.2.2.17 Cracking due to Stress Corrosion Cracking, Primary Water Stress Corrosion Cracking, and Irradiation-Assisted Stress Corrosion Cracking

For managing the aging of cracking due to stress corrosion cracking, primary water stress corrosion cracking, and irradiation-assisted stress corrosion cracking of stainless steel reactor internals components exposed to reactor coolant, water chemistry will be augmented by (1) participating in the industry programs for investigating and managing aging effects on reactor internals; (2) evaluating and implementing the results of the industry programs as applicable to the reactor internals; and (3) upon completion of these programs, but not less than 24 months before entering the period of extended operation, submitting an inspection plan for reactor internals to the NRC for review and approval. (See Reactor Coolant System Supplement (B2.1.21)).

3.1.2.2.18 Quality Assurance for Aging Management of Nonsafety-Related Components

Quality Assurance Program and Administrative Controls are discussed in [Section B1.3](#).

3.1.2.3 Time-Limited Aging Analysis

The Time-Limited Aging Analyses identified below are associated with the Reactor Vessel, Internals, and Reactor Coolant System components. The section of [Chapter 4](#) that contains the TLAA review results is indicated in parenthesis.

- Cumulative fatigue damage ([Section 4.3](#), Metal Fatigue Analysis)
- Loss of fracture toughness due to neutron embrittlement ([Section 4.2](#), Reactor Vessel Neutron Embrittlement Analysis)

3.1.3 Conclusions

The Reactor Vessel, Internals and Reactor Coolant System component types that are subject to aging management review have been evaluated. The aging management programs selected to manage the aging effects for the Reactor Vessel, Internals, and Reactor Coolant System component types are identified in the summary Tables and in [Section 3.1.2.1](#).

A description of these aging management programs is provided in [Appendix B](#), along with a demonstration that the identified aging effects will be managed for the period of extended operation.

Therefore, based on the demonstration provided in [Appendix B](#), the effects of aging associated with the Reactor Vessel, Internals and Reactor Coolant System component types will be adequately managed so that there is reasonable assurance that the intended functions will be maintained consistent with the current licensing basis during the period of extended operation.

Section 3.1
AGING MANAGEMENT OF REACTOR VESSEL,
INTERNALS, AND REACTOR COOLANT SYSTEM

Table 3.1.1 Summary of Aging Management Evaluations in Chapter IV of NUREG-1801 for Reactor Vessel, Internals, and Reactor Coolant System

Item Number	Component Type	Aging Effect / Mechanism	Aging Management Program	Further Evaluation Recommended	Discussion
3.1.1.01	Steel pressure vessel support skirt and attachment welds	Cumulative fatigue damage	TLAA, evaluated in accordance with 10 CFR 54.21(c)	Yes, TLAA	This is a Combustion Engineering vessel with no support skirt, so the applicable NUREG-1801 line was not used.
3.1.1.02					Not applicable - BWR only
3.1.1.03					Not applicable - BWR only
3.1.1.04					Not applicable - BWR only
3.1.1.05	Stainless steel and nickel alloy reactor vessel internals components	Cumulative fatigue damage	TLAA, evaluated in accordance with 10 CFR 54.21(c)	Yes, TLAA	Fatigue of metal components is a TLAA. See further evaluation in subsection 3.1.2.2.1 .

Section 3.1
AGING MANAGEMENT OF REACTOR VESSEL,
INTERNALS, AND REACTOR COOLANT SYSTEM

Table 3.1.1 *Summary of Aging Management Evaluations in Chapter IV of NUREG-1801 for Reactor Vessel, Internals, and Reactor Coolant System (Continued)*

Item Number	Component Type	Aging Effect / Mechanism	Aging Management Program	Further Evaluation Recommended	Discussion
3.1.1.06	Nickel Alloy tubes and sleeves in a reactor coolant and secondary feedwater/steam environment	Cumulative fatigue damage	TLAA, evaluated in accordance with 10 CFR 54.21(c)	Yes, TLAA	Cumulative fatigue damage of steam generator tubes is not a TLAA as defined in 10 CFR 54.3. See further evaluation in subsection 3.1.2.2.1.
3.1.1.07	Steel and stainless steel reactor coolant pressure boundary closure bolting, head closure studs, support skirts and attachment welds, pressurizer relief tank components, steam generator components, piping and components and external surfaces and bolting	Cumulative fatigue damage	TLAA, evaluated in accordance with 10 CFR 54.21(c)	Yes, TLAA	Fatigue of metal components is a TLAA. However, the Pressurizer relief tank components are not Class 1 and have no fatigue or cyclic design TLAA's. See further evaluation in subsection 3.1.2.2.1.

Section 3.1
AGING MANAGEMENT OF REACTOR VESSEL,
INTERNALS, AND REACTOR COOLANT SYSTEM

Table 3.1.1 Summary of Aging Management Evaluations in Chapter IV of NUREG-1801 for Reactor Vessel, Internals, and Reactor Coolant System (Continued)

Item Number	Component Type	Aging Effect / Mechanism	Aging Management Program	Further Evaluation Recommended	Discussion
3.1.1.08	Steel; stainless steel; and nickel-alloy reactor coolant pressure boundary piping, piping components, piping elements; flanges; nozzles and safe ends; pressurizer vessel shell heads and welds; heater sheaths and sleeves; penetrations; and thermal sleeves	Cumulative fatigue damage	TLAA, evaluated in accordance with 10 CFR 54.21(c) and environmental effects are to be addressed for Class 1 components	Yes, TLAA	Fatigue of metal components is a TLAA. See further evaluation in subsection 3.1.2.2.1.
3.1.1.09	Steel; stainless steel; steel with nickel-alloy or stainless steel cladding; nickel-alloy reactor vessel components; flanges; nozzles; penetrations; pressure housings; safe ends; thermal sleeves; vessel shells, heads and welds	Cumulative fatigue damage	TLAA, evaluated in accordance with 10 CFR 54.21(c) and environmental effects are to be addressed for Class 1 components	Yes, TLAA	Fatigue of metal components is a TLAA. See further evaluation in subsection 3.1.2.2.1.

Section 3.1
AGING MANAGEMENT OF REACTOR VESSEL,
INTERNALS, AND REACTOR COOLANT SYSTEM

Table 3.1.1 Summary of Aging Management Evaluations in Chapter IV of NUREG-1801 for Reactor Vessel, Internals, and Reactor Coolant System (Continued)

Item Number	Component Type	Aging Effect / Mechanism	Aging Management Program	Further Evaluation Recommended	Discussion
3.1.1.10	Steel; stainless steel; steel with nickel-alloy or stainless steel cladding; nickel-alloy steam generator components (flanges; penetrations; nozzles; safe ends, lower heads and welds)	Cumulative fatigue damage	TLAA, evaluated in accordance with 10 CFR 54.21(c) and environmental effects are to be addressed for Class 1 components	Yes, TLAA	Fatigue of metal components is a TLAA. See further evaluation in subsection 3.1.2.2.1.
3.1.1.11					Not applicable - BWR only
3.1.1.12	Steel steam generator shell assembly exposed to secondary feedwater and steam	Loss of material due to general, pitting and crevice corrosion	Water Chemistry (B2.1.2) and One-Time Inspection (B2.1.16)	Yes	Not applicable. PVNGS has recirculating steam generators, so the applicable NUREG-1801 line was not used.
3.1.1.13					Not applicable - BWR only
3.1.1.14					Not applicable - BWR only
3.1.1.15					Not applicable - BWR only
3.1.1.16	Steel steam generator upper and lower shell and transition cone exposed to secondary feedwater and steam	Loss of material due to general, pitting and crevice corrosion	Inservice Inspection (IWB, IWC, and IWD) (B2.1.1), and Water Chemistry (B2.1.2) and, for Westinghouse Model 44 and 51 S/G, if general and pitting corrosion of the shell is known to exist, additional inspection procedures are to be developed.	Yes	Consistent with NUREG-1801. See further evaluation in subsection 3.1.2.2.4.

Section 3.1
AGING MANAGEMENT OF REACTOR VESSEL,
INTERNALS, AND REACTOR COOLANT SYSTEM

Table 3.1.1 Summary of Aging Management Evaluations in Chapter IV of NUREG-1801 for Reactor Vessel, Internals, and Reactor Coolant System (Continued)

Item Number	Component Type	Aging Effect / Mechanism	Aging Management Program	Further Evaluation Recommended	Discussion
3.1.1.17	Steel (with or without stainless steel cladding) reactor vessel beltline shell, nozzles, and welds	Loss of fracture toughness due to neutron irradiation embrittlement	TLAA, evaluated in accordance with Appendix G of 10 CFR Part 50 and RG 1.99. The applicant may choose to demonstrate that the materials of the nozzles are not controlling for the TLAA evaluations.	Yes, TLAA	Fracture toughness due to neutron irradiation embrittlement is a TLAA. See further evaluation in subsection 3.1.2.2.3.1.
3.1.1.18	Steel (with or without stainless steel cladding) reactor vessel beltline shell, nozzles, and welds; safety injection nozzles	Loss of fracture toughness due to neutron irradiation embrittlement	Reactor Vessel Surveillance (B.2.1.15)	Yes	Consistent with NUREG-1801. See further evaluation in subsection 3.1.2.2.3.2.
3.1.1.19					Not applicable - BWR only
3.1.1.20					Not applicable - BWR only
3.1.1.21	Reactor vessel shell fabricated of SA508-CI 2 forgings clad with stainless steel using a high-heat-input welding process	Crack growth due to cyclic loading	TLAA	Yes, TLAA	Not applicable. The reactor vessel was constructed using a low-heat-input welding process. See further evaluation in subsection 3.1.2.2.5.

Section 3.1
AGING MANAGEMENT OF REACTOR VESSEL,
INTERNALS, AND REACTOR COOLANT SYSTEM

Table 3.1.1 Summary of Aging Management Evaluations in Chapter IV of NUREG-1801 for Reactor Vessel, Internals, and Reactor Coolant System (Continued)

Item Number	Component Type	Aging Effect / Mechanism	Aging Management Program	Further Evaluation Recommended	Discussion
3.1.1.22	Stainless steel and nickel alloy reactor vessel internals components exposed to reactor coolant and neutron flux	Loss of fracture toughness due to neutron irradiation embrittlement, void swelling	FSAR supplement commitment to (1) participate in industry RVI aging programs (2) implement applicable results (3) submit for NRC approval > 24 months before the extended period an RVI inspection plan based on industry recommendation. Reactor Coolant Supplement (B2.1.21)	No	Consistent with NUREG-1801. See further evaluation in subsection 3.1.2.2.6.
3.1.1.23	Stainless steel reactor vessel closure head flange leak detection line and bottom-mounted instrument guide tubes	Cracking due to stress corrosion cracking	A plant-specific aging management program is to be evaluated.	Yes	Consistent with NUREG-1801. The plant-specific aging management program(s) used to manage the aging include: Water Chemistry (B2.1.2) and ASME Section XI Inservice Inspection, Subsections IWB, IWC, and IWD (B2.1.1). See further evaluation in subsection 3.1.2.2.7.1.

Section 3.1
AGING MANAGEMENT OF REACTOR VESSEL,
INTERNALS, AND REACTOR COOLANT SYSTEM

Table 3.1.1 Summary of Aging Management Evaluations in Chapter IV of NUREG-1801 for Reactor Vessel, Internals, and Reactor Coolant System (Continued)

Item Number	Component Type	Aging Effect / Mechanism	Aging Management Program	Further Evaluation Recommended	Discussion
3.1.1.24	Class 1 cast austenitic stainless steel piping, piping components, and piping elements exposed to reactor coolant	Cracking due to stress corrosion cracking	Water Chemistry (B2.1.2) and, for CASS components that do not meet the NUREG-0313 guidelines, a plant specific aging management program	Yes	Not applicable. PVNGS reactor coolant system does not have cast austenitic stainless steel piping, piping components or piping elements exposed to reactor coolant, so the applicable NUREG-1801 line was not used.
3.1.1.25					Not applicable - BWR only
3.1.1.26					Not applicable - BWR only
3.1.1.27	Stainless steel and nickel alloy reactor vessel internals screws, bolts, tie rods, and hold-down springs	Loss of preload due to stress relaxation	FSAR supplement commitment to (1) participate in industry RVI aging programs (2) implement applicable results (3) submit for NRC approval > 24 months before the extended period an RVI inspection plan based on industry recommendation. Reactor Coolant Supplement (B2.1.21)	No	Consistent with NUREG-1801. See further evaluation in subsection 3.1.2.2.9.
3.1.1.28	Steel steam generator feedwater impingement plate and support exposed to secondary feedwater	Loss of material due to erosion	A plant-specific aging management program is to be evaluated.	Yes	Not applicable. PVNGS steam generators do not have feedwater impingement plates, so the applicable NUREG-1801 line was not used.
3.1.1.29					Not applicable - BWR only

Palo Verde Nuclear Generating Station
License Renewal Application

Section 3.1
AGING MANAGEMENT OF REACTOR VESSEL,
INTERNALS, AND REACTOR COOLANT SYSTEM

Table 3.1.1 Summary of Aging Management Evaluations in Chapter IV of NUREG-1801 for Reactor Vessel, Internals, and Reactor Coolant System (Continued)

Item Number	Component Type	Aging Effect / Mechanism	Aging Management Program	Further Evaluation Recommended	Discussion
3.1.1.30	Stainless steel reactor vessel internals components (e.g., Upper internals assembly, RCCA guide tube assemblies, Baffle/former assembly, Lower internal assemblies, shroud assemblies, Plenum cover and plenum cylinder, Upper grid assembly, Control rod guide tube (CRGT) assembly, Core support shield assembly, Core barrel assembly, Lower grid assembly, Flow distributor assembly, Thermal shield, Instrumentation support structures)	Cracking due to stress corrosion cracking, irradiation-assisted stress corrosion cracking	Water Chemistry (B2.1.2) and FSAR supplement commitment to (1) participate in industry RVI aging programs (2) implement applicable results (3) submit for NRC approval > 24 months before the extended period an RVI inspection plan based on industry recommendation. Reactor Coolant Supplement (B2.1.21)	No	Consistent with NUREG-1801. See further evaluation in subsection 3.1.2.2.12.

Section 3.1
AGING MANAGEMENT OF REACTOR VESSEL,
INTERNALS, AND REACTOR COOLANT SYSTEM

Table 3.1.1 Summary of Aging Management Evaluations in Chapter IV of NUREG-1801 for Reactor Vessel, Internals, and Reactor Coolant System (Continued)

Item Number	Component Type	Aging Effect / Mechanism	Aging Management Program	Further Evaluation Recommended	Discussion
3.1.1.31	Nickel alloy and steel with nickel-alloy cladding piping, piping component, piping elements, penetrations, nozzles, safe ends, and welds (other than reactor vessel head); pressurizer heater sheaths, sleeves, diaphragm plate, manways and flanges; core support pads/core guide lugs	Cracking due to primary water stress corrosion cracking	Inservice Inspection (IWB, IWC, and IWD) (B2.1.1) and Water Chemistry (B2.1.2) and for nickel alloy, comply with applicable NRC Orders and provide a commitment in the FSAR supplement to implement applicable (1) Bulletins and Generic Letters and (2) staff-accepted industry guidelines. (Reactor Coolant Supplement (B2.1.21)).	No	Consistent with NUREG-1801 for material, environment, and aging effect, but a different aging management program Nickel Alloy Aging Management (B2.1.34), ASME Section XI Inservice Inspection, Subsections IWB, IWC, and IWD (B2.1.1) for Class 1 components, Water Chemistry (B2.1.2), and Comply with applicable NRC Orders and FSAR Commitment (Reactor Coolant Supplement (B2.1.21)) is credited. See further evaluation in subsection 3.1.2.2.13.
3.1.1.32	Steel steam generator feedwater inlet ring and supports	Wall thinning due to flow-accelerated corrosion	A plant-specific aging management program is to be evaluated.	Yes	Consistent with NUREG-1801. The plant-specific aging management program(s) used to manage the aging include: Steam Generator Tubing Integrity (B2.1.8) and Water Chemistry (B2.1.2) See further evaluation in subsection 3.1.2.2.14.

Section 3.1
AGING MANAGEMENT OF REACTOR VESSEL,
INTERNALS, AND REACTOR COOLANT SYSTEM

Table 3.1.1 Summary of Aging Management Evaluations in Chapter IV of NUREG-1801 for Reactor Vessel, Internals, and Reactor Coolant System (Continued)

Item Number	Component Type	Aging Effect / Mechanism	Aging Management Program	Further Evaluation Recommended	Discussion
3.1.1.33	Stainless steel and nickel alloy reactor vessel internals components	Changes in dimensions due to void swelling	FSAR supplement commitment to (1) participate in industry RVI aging programs (2) implement applicable results (3) submit for NRC approval > 24 months before the extended period an RVI inspection plan based on industry recommendation. (Reactor Coolant Supplement (B2.1.21))	No	Consistent with NUREG-1801. See further evaluation in subsection 3.1.2.2.15.

Section 3.1
AGING MANAGEMENT OF REACTOR VESSEL,
INTERNALS, AND REACTOR COOLANT SYSTEM

Table 3.1.1 Summary of Aging Management Evaluations in Chapter IV of NUREG-1801 for Reactor Vessel, Internals, and Reactor Coolant System (Continued)

Item Number	Component Type	Aging Effect / Mechanism	Aging Management Program	Further Evaluation Recommended	Discussion
3.1.1.34	Stainless steel and nickel alloy reactor control rod drive head penetration pressure housings	Cracking due to stress corrosion cracking and primary water stress corrosion cracking	Inservice Inspection (IWB, IWC, and IWD) (B2.1.1) and Water Chemistry (B2.1.2) and for nickel alloy, comply with applicable NRC Orders and provide a commitment in the FSAR supplement to implement applicable (1) Bulletins and Generic Letters and (2) staff-accepted industry guidelines (Reactor Coolant Supplement (B2.1.21)).	No	Consistent with NUREG-1801. For managing cracking due to SCC and PWSCC of nickel alloy components of CEDM housings exposed to reactor coolant, Water Chemistry (B2.1.2) and ASME Section XI Inservice Inspection, Subsections IWB, IWC, and IWD (B2.1.1) for Class 1 components, will be augmented by a plant-specific Nickel Alloy Aging Management (B2.1.34) and by complying with applicable NRC Orders and FSAR Commitment (B2.1.21). The Water Chemistry (B2.1.2) and ASME XI Inservice Inspection program (B2.1.1) will manage cracking due to SCC and PWSCC of stainless steel components of CEDM housings exposed to reactor coolant. See further evaluation in subsection 3.1.2.2.16.1.

Section 3.1
AGING MANAGEMENT OF REACTOR VESSEL,
INTERNALS, AND REACTOR COOLANT SYSTEM

Table 3.1.1 Summary of Aging Management Evaluations in Chapter IV of NUREG-1801 for Reactor Vessel, Internals, and Reactor Coolant System (Continued)

Item Number	Component Type	Aging Effect / Mechanism	Aging Management Program	Further Evaluation Recommended	Discussion
3.1.1.35	Steel with stainless steel or nickel alloy cladding primary side components; steam generator upper and lower heads, tubesheets and tube-to-tube sheet welds	Cracking due to stress corrosion cracking and primary water stress corrosion cracking	Inservice Inspection (IWB, IWC, and IWD) (B2.1.1) and Water Chemistry (B2.1.2) and for nickel alloy, comply with applicable NRC Orders and provide a commitment in the FSAR supplement to implement applicable (1) Bulletins and Generic Letters and (2) staff-accepted industry guidelines (Reactor Coolant Supplement (B2.1.21)).	No	Not applicable. PVNGS has recirculating steam generators, so the applicable NUREG-1801 line was not used.
3.1.1.36	Nickel alloy, stainless steel pressurizer spray head	Cracking due to stress corrosion cracking and primary water stress corrosion cracking	Water Chemistry (B2.1.2) and One-Time Inspection (B2.1.16) and, for nickel alloy welded spray heads, comply with applicable NRC Orders and provide a commitment in the FSAR supplement to implement applicable (1) Bulletins and Generic Letters and (2) staff-accepted industry guidelines (Reactor Coolant Supplement (B2.1.21)).	No	Not applicable. PVNGS has determined that the pressurizer spray heads are not included in the scope of license renewal, so the applicable NUREG-1801 line was not used.

Section 3.1
AGING MANAGEMENT OF REACTOR VESSEL,
INTERNALS, AND REACTOR COOLANT SYSTEM

Table 3.1.1 Summary of Aging Management Evaluations in Chapter IV of NUREG-1801 for Reactor Vessel, Internals, and Reactor Coolant System (Continued)

Item Number	Component Type	Aging Effect / Mechanism	Aging Management Program	Further Evaluation Recommended	Discussion
3.1.1.37	Stainless steel and nickel alloy reactor vessel internals components (e.g., Upper internals assembly, RCCA guide tube assemblies, Lower internal assembly, CEA shroud assemblies, Core shroud assembly, Core support shield assembly, Core barrel assembly, Lower grid assembly, Flow distributor assembly)	Cracking due to stress corrosion cracking, primary water stress corrosion cracking, irradiation-assisted stress corrosion cracking	Water Chemistry (B2.1.2) and FSAR supplement commitment to (1) participate in industry RVI aging programs (2) implement applicable results (3) submit for NRC approval > 24 months before the extended period an RVI inspection plan based on industry recommendation (Reactor Coolant Supplement (B2.1.21)).	No	Consistent with NUREG-1801. See further evaluation in subsection 3.1.2.2.17.
3.1.1.38					Not applicable - BWR only
3.1.1.39					Not applicable - BWR only
3.1.1.40					Not applicable - BWR only
3.1.1.41					Not applicable - BWR only
3.1.1.42					Not applicable - BWR only
3.1.1.43					Not applicable - BWR only
3.1.1.44					Not applicable - BWR only
3.1.1.45					Not applicable - BWR only
3.1.1.46					Not applicable - BWR only
3.1.1.47					Not applicable - BWR only
3.1.1.48					Not applicable - BWR only

Section 3.1
AGING MANAGEMENT OF REACTOR VESSEL,
INTERNALS, AND REACTOR COOLANT SYSTEM

Table 3.1.1 Summary of Aging Management Evaluations in Chapter IV of NUREG-1801 for Reactor Vessel, Internals, and Reactor Coolant System (Continued)

Item Number	Component Type	Aging Effect / Mechanism	Aging Management Program	Further Evaluation Recommended	Discussion
3.1.1.49					Not applicable - BWR only
3.1.1.50					Not applicable - BWR only
3.1.1.51					Not applicable - BWR only
3.1.1.52	Steel and stainless steel reactor coolant pressure boundary (RCPB) pump and valve closure bolting, manway and holding bolting, flange bolting, and closure bolting in high-pressure and high-temperature systems	Cracking due to stress corrosion cracking, loss of material due to wear, loss of preload due to thermal effects, gasket creep, and self-loosening	Bolting Integrity (B2.1.7)	No	Consistent with NUREG-1801 with aging management program exceptions. The aging management program(s) with exceptions to NUREG-1801 include: Bolting Integrity (B2.1.7)
3.1.1.53	Steel piping, piping components, and piping elements exposed to closed cycle cooling water	Loss of material due to general, pitting and crevice corrosion	Closed-Cycle Cooling Water System (B2.1.10)	No	Consistent with NUREG-1801 with aging management program exceptions. The aging management program(s) with exceptions to NUREG-1801 include: Closed-Cycle Cooling Water System (B2.1.10)

Section 3.1
AGING MANAGEMENT OF REACTOR VESSEL,
INTERNALS, AND REACTOR COOLANT SYSTEM

Table 3.1.1 Summary of Aging Management Evaluations in Chapter IV of NUREG-1801 for Reactor Vessel, Internals, and Reactor Coolant System (Continued)

Item Number	Component Type	Aging Effect / Mechanism	Aging Management Program	Further Evaluation Recommended	Discussion
3.1.1.54	Copper alloy piping, piping components, and piping elements exposed to closed cycle cooling water	Loss of material due to pitting, crevice, and galvanic corrosion	Closed-Cycle Cooling Water System (B2.1.10)	No	Not applicable. PVNGS has no in-scope copper alloy piping, piping components or piping elements exposed to closed cycle cooling water in the reactor coolant system, so the applicable NUREG-1801 line was not used.
3.1.1.55	Cast austenitic stainless steel Class 1 pump casings, and valve bodies and bonnets exposed to reactor coolant >250°C (>482°F)	Loss of fracture toughness due to thermal aging embrittlement	Inservice inspection (IWB, IWC, and IWD) (B2.1.1). Thermal aging susceptibility screening is not necessary, inservice inspection requirements are sufficient for managing these aging effects. ASME Code Case N-481 also provides an alternative for pump casings.	No	Consistent with NUREG-1801.
3.1.1.56	Copper alloy >15% Zn piping, piping components, and piping elements exposed to closed cycle cooling water	Loss of material due to selective leaching	Selective Leaching of Materials (B2.1.17)	No	Not applicable. PVNGS has no in-scope copper alloy >15% Zn components exposed to closed cycle cooling water in the reactor coolant system, so the applicable NUREG-1801 line was not used.

Section 3.1
AGING MANAGEMENT OF REACTOR VESSEL,
INTERNALS, AND REACTOR COOLANT SYSTEM

Table 3.1.1 Summary of Aging Management Evaluations in Chapter IV of NUREG-1801 for Reactor Vessel, Internals, and Reactor Coolant System (Continued)

Item Number	Component Type	Aging Effect / Mechanism	Aging Management Program	Further Evaluation Recommended	Discussion
3.1.1.57	Cast austenitic stainless steel Class 1 piping, piping component, and piping elements and control rod drive pressure housings exposed to reactor coolant >250°C (>482°F)	Loss of fracture toughness due to thermal aging embrittlement	Thermal Aging Embrittlement of CASS	No	Not applicable. PVNGS reactor coolant system does not have cast austenitic stainless steel piping, piping components or piping elements exposed to reactor coolant. The control rod drive pressure housings are made of stainless steel and nickel alloy. So the applicable NUREG-1801 lines were not used. Consistent with NUREG-1801.
3.1.1.58	Steel reactor coolant pressure boundary external surfaces exposed to air with borated water leakage	Loss of material due to Boric acid corrosion	Boric Acid Corrosion (B2.1.4)	No	
3.1.1.59	Steel steam generator steam nozzle and safe end, feedwater nozzle and safe end, AFW nozzles and safe ends exposed to secondary feedwater/steam	Wall thinning due to flow-accelerated corrosion	Flow-Accelerated Corrosion (B2.1.6)	No	Consistent with NUREG-1801 with aging management program exceptions. The aging management program(s) with exceptions to NUREG-1801 include: Flow-Accelerated Corrosion (B2.1.6).

Section 3.1
AGING MANAGEMENT OF REACTOR VESSEL,
INTERNALS, AND REACTOR COOLANT SYSTEM

Table 3.1.1 Summary of Aging Management Evaluations in Chapter IV of NUREG-1801 for Reactor Vessel, Internals, and Reactor Coolant System (Continued)

Item Number	Component Type	Aging Effect / Mechanism	Aging Management Program	Further Evaluation Recommended	Discussion
3.1.1.60	Stainless steel flux thimble tubes (with or without chrome plating)	Loss of material due to Wear	Flux Thimble Tube Inspection (B2.1.21)	No	Not applicable. PVNGS has CE-design reactor vessel and internals. The subject NUREG-1801 line is applicable to Westinghouse-design reactor vessel and internals only.
3.1.1.61	Stainless steel, steel pressurizer integral support exposed to air with metal temperature up to 288°C (550°F)	Cracking due to cyclic loading	Inservice Inspection (IWB, IWC, and IWD) (B2.1.1)	No	Consistent with NUREG-1801.
3.1.1.62	Stainless steel, steel with stainless steel cladding reactor coolant system cold leg, hot leg, surge line, and spray line piping and fittings exposed to reactor coolant	Cracking due to cyclic loading	Inservice Inspection (IWB, IWC, and IWD) (B2.1.1)	No	Consistent with NUREG-1801.

Section 3.1
AGING MANAGEMENT OF REACTOR VESSEL,
INTERNALS, AND REACTOR COOLANT SYSTEM

Table 3.1.1 Summary of Aging Management Evaluations in Chapter IV of NUREG-1801 for Reactor Vessel, Internals, and Reactor Coolant System (Continued)

Item Number	Component Type	Aging Effect / Mechanism	Aging Management Program	Further Evaluation Recommended	Discussion
3.1.1.63	Steel reactor vessel flange, stainless steel and nickel alloy reactor vessel internals exposed to reactor coolant (e.g., upper and lower internals and assembly, CEA shroud assembly, core support barrel, upper grid assembly, core support shield assembly, lower grid assembly)	Loss of material due to Wear	Inservice Inspection (IWB, IWC, and IWD) (B2.1.1)	No	Consistent with NUREG-1801.
3.1.1.64	Stainless steel and steel with stainless steel or nickel alloy cladding pressurizer components	Cracking due to stress corrosion cracking, primary water stress corrosion cracking	Inservice Inspection (IWB, IWC, and IWD) (B2.1.1), and Water Chemistry (B2.1.2)	No	Consistent with NUREG-1801.
3.1.1.65	Nickel alloy reactor vessel upper head and control rod drive penetration nozzles, instrument tubes, head vent pipe (top head), and welds	Cracking due to primary water stress corrosion cracking	Inservice Inspection (IWB, IWC, and IWD) (B2.1.1) and Water Chemistry (B2.1.2) and Nickel-Alloy Penetration Nozzles Welded to the Upper Reactor Vessel Closure Heads of Pressurized Water Reactors (B2.1.5)	No	Consistent with NUREG-1801.

Section 3.1
AGING MANAGEMENT OF REACTOR VESSEL,
INTERNALS, AND REACTOR COOLANT SYSTEM

Table 3.1.1 Summary of Aging Management Evaluations in Chapter IV of NUREG-1801 for Reactor Vessel, Internals, and Reactor Coolant System (Continued)

Item Number	Component Type	Aging Effect / Mechanism	Aging Management Program	Further Evaluation Recommended	Discussion
3.1.1.66	Steel steam generator secondary manways and handholds (cover only) exposed to air with leaking secondary-side water and/or steam	Loss of material due to erosion	Inservice Inspection (IWB, IWC, and IWD) for Class 2 components (B2.1.1)	No	Not applicable. PVNGS has recirculating steam generators, so the applicable NUREG-1801 line was not used.
3.1.1.67	Steel with stainless steel or nickel alloy cladding; or stainless steel pressurizer components exposed to reactor coolant	Cracking due to cyclic loading	Inservice Inspection (IWB, IWC, and IWD) (B2.1.1), and Water Chemistry (B2.1.2)	No	Consistent with NUREG-1801.

Section 3.1
AGING MANAGEMENT OF REACTOR VESSEL,
INTERNALS, AND REACTOR COOLANT SYSTEM

Table 3.1.1 Summary of Aging Management Evaluations in Chapter IV of NUREG-1801 for Reactor Vessel, Internals, and Reactor Coolant System (Continued)

Item Number	Component Type	Aging Effect / Mechanism	Aging Management Program	Further Evaluation Recommended	Discussion
3.1.1.68	Stainless steel, steel with stainless steel cladding Class 1 piping, fittings, pump casings, valve bodies, nozzles, safe ends, manways, flanges, CRD housing; pressurizer heater sheaths, sleeves, diaphragm plate; pressurizer relief tank components, reactor coolant system cold leg, hot leg, surge line, and spray line piping and fittings	Cracking due to stress corrosion cracking	Inservice Inspection (IWB, IWC, and IWD) (B2.1.1), and Water Chemistry (B2.1.2)	No	Consistent with NUREG-1801.
3.1.1.69	Stainless steel, nickel alloy safety injection nozzles, safe ends, and associated welds and buttering exposed to reactor coolant	Cracking due to stress corrosion cracking, primary water stress corrosion cracking	Inservice Inspection (IWB, IWC, and IWD) (B2.1.1), and Water Chemistry (B2.1.2)	No	Consistent with NUREG-1801

Section 3.1
AGING MANAGEMENT OF REACTOR VESSEL,
INTERNALS, AND REACTOR COOLANT SYSTEM

Table 3.1.1 Summary of Aging Management Evaluations in Chapter IV of NUREG-1801 for Reactor Vessel, Internals, and Reactor Coolant System (Continued)

Item Number	Component Type	Aging Effect / Mechanism	Aging Management Program	Further Evaluation Recommended	Discussion
3.1.1.70	Stainless steel; steel with stainless steel cladding Class 1 piping, fittings and branch connections < NPS 4 exposed to reactor coolant	Cracking due to stress corrosion cracking, thermal and mechanical loading	Inservice Inspection (IWB, IWC, and IWD) (B2.1.1), Water chemistry (B2.1.2), and One-Time Inspection of ASME Code Class 1 Small-bore Piping (B2.1.19)	No	Consistent with NUREG-1801 with aging management program exceptions. The aging management program(s) with exceptions to NUREG-1801 include: One-Time Inspection Of ASME Code Class 1 Small-Bore Piping (B2.1.19). Consistent with NUREG-1801.
3.1.1.71	High-strength low alloy steel closure head stud assembly exposed to air with reactor coolant leakage	Cracking due to stress corrosion cracking; loss of material due to wear	Reactor Head Closure Studs(B2.1.3)	No	Consistent with NUREG-1801.
3.1.1.72	Nickel alloy steam generator tubes and sleeves exposed to secondary feedwater/steam	Cracking due to OD stress corrosion cracking and intergranular attack, loss of material due to fretting and wear	Steam Generator Tube Integrity (B2.1.8) and Water Chemistry (B.2.1.2)	No	Consistent with NUREG-1801.
3.1.1.73	Nickel alloy steam generator tubes, repair sleeves, and tube plugs exposed to reactor coolant	Cracking due to primary water stress corrosion cracking	Steam Generator Tube Integrity (B2.1.8) and Water Chemistry (B.2.1.2)	No	Consistent with NUREG-1801.

Section 3.1
AGING MANAGEMENT OF REACTOR VESSEL,
INTERNALS, AND REACTOR COOLANT SYSTEM

Table 3.1.1 Summary of Aging Management Evaluations in Chapter IV of NUREG-1801 for Reactor Vessel, Internals, and Reactor Coolant System (Continued)

Item Number	Component Type	Aging Effect / Mechanism	Aging Management Program	Further Evaluation Recommended	Discussion
3.1.1.74	Chrome plated steel, nickel stainless steel, nickel alloy steam generator anti-vibration bars exposed to secondary feedwater/ steam	Cracking due to stress corrosion cracking, loss of material due to crevice corrosion and fretting	Steam Generator Tube Integrity (B.2.1.8) and Water Chemistry (B.2.1.2)	No	Consistent with NUREG-1801.
3.1.1.75	Nickel alloy once-through steam generator tubes exposed to secondary feedwater/ steam	Denting due to corrosion of carbon steel tube support plate	Steam Generator Tube Integrity (B.2.1.8) and Water Chemistry (B.2.1.2)	No	Not applicable. PVNGS has recirculating steam generators, so the applicable NUREG-1801 line was not used.
3.1.1.76	Steel steam generator tube support plate, tube bundle wrapper exposed to secondary feedwater/steam	Loss of material due to erosion, general, pitting, and crevice corrosion, ligament cracking due to corrosion	Steam Generator Tube Integrity (B.2.1.8) and Water Chemistry (B.2.1.2)	No	Consistent with NUREG-1801.
3.1.1.77	Nickel alloy steam generator tubes and sleeves exposed to phosphate chemistry in secondary feedwater/ steam	Loss of material due to wastage and pitting corrosion	Steam Generator Tube Integrity (B.2.1.8) and Water Chemistry (B.2.1.2)	No	Not applicable. PVNGS does not operate on phosphate chemistry in secondary feedwater or steam with the replacement steam generators, so the applicable NUREG-1801 line was not used.
3.1.1.78	Steel steam generator tube support lattice bars exposed to secondary feedwater/ steam	Wall thinning due to flow-accelerated corrosion	Steam Generator Tube Integrity (B.2.1.8) and Water Chemistry (B.2.1.2)	No	Not applicable. PVNGS steam generators do not contain steel tube support lattice bars, so the applicable NUREG-1801 line was not used.

Section 3.1
AGING MANAGEMENT OF REACTOR VESSEL,
INTERNALS, AND REACTOR COOLANT SYSTEM

Table 3.1.1 Summary of Aging Management Evaluations in Chapter IV of NUREG-1801 for Reactor Vessel, Internals, and Reactor Coolant System (Continued)

Item Number	Component Type	Aging Effect / Mechanism	Aging Management Program	Further Evaluation Recommended	Discussion
3.1.1.79	Nickel alloy steam generator tubes exposed to secondary feedwater/ steam	Denting due to corrosion of steel tube support plate	Steam Generator Tube Integrity (B.2.1.8); Water Chemistry (B.2.1.2) and, for plants that could experience denting at the upper support plates, evaluate potential for rapidly propagating cracks and then develop and take corrective actions consistent with Bulletin 88-02.	No	Consistent with NUREG-1801.
3.1.1.80	Cast austenitic stainless steel reactor vessel internals (e.g., upper internals assembly, lower internal assembly, CEA shroud assemblies, control rod guide tube assembly, core support shield assembly, lower grid assembly)	Loss of fracture toughness due to thermal aging and neutron irradiation embrittlement	Thermal Aging and Neutron Irradiation Embrittlement of CASS	No	Not applicable. PVNGS does not have cast austenitic stainless steel reactor vessel internals, so the applicable NUREG-1801 lines were not used.
3.1.1.81	Nickel alloy or nickel-alloy clad steam generator divider plate exposed to reactor coolant	Cracking due to primary water stress corrosion cracking	Water Chemistry (B.2.1.2)	No	Consistent with NUREG-1801.

Section 3.1
AGING MANAGEMENT OF REACTOR VESSEL,
INTERNALS, AND REACTOR COOLANT SYSTEM

Table 3.1.1 Summary of Aging Management Evaluations in Chapter IV of NUREG-1801 for Reactor Vessel, Internals, and Reactor Coolant System (Continued)

Item Number	Component Type	Aging Effect / Mechanism	Aging Management Program	Further Evaluation Recommended	Discussion
3.1.1.82	Stainless steel steam generator primary side divider plate exposed to reactor coolant	Cracking due to stress corrosion cracking	Water Chemistry (B.2.1.2)	No	Not applicable. The PVNGS steam generator primary channel dividers are made of nickel alloy, so the applicable NUREG-1801 line was not used.
3.1.1.83	Stainless steel; steel with nickel-alloy or stainless steel cladding; and nickel-alloy reactor vessel internals and reactor coolant pressure boundary components exposed to reactor coolant	Loss of material due to pitting and crevice corrosion	Water Chemistry (B.2.1.2)	No	Consistent with NUREG-1801.
3.1.1.84	Nickel alloy steam generator components such as, secondary side nozzles (vent, drain, and instrumentation) exposed to secondary feedwater/ steam	Cracking due to stress corrosion cracking	Water Chemistry (B.2.1.2) and One-Time Inspection (B.2.1.16) or Inservice Inspection (IWB, IWC, and IWD) (B.2.1.1).	No	Consistent with NUREG-1801.

Section 3.1
AGING MANAGEMENT OF REACTOR VESSEL,
INTERNALS, AND REACTOR COOLANT SYSTEM

Table 3.1.1 *Summary of Aging Management Evaluations in Chapter IV of NUREG-1801 for Reactor Vessel, Internals, and Reactor Coolant System (Continued)*

Item Number	Component Type	Aging Effect / Mechanism	Aging Management Program	Further Evaluation Recommended	Discussion
3.1.1.85	Nickel alloy piping, piping components, and piping elements exposed to air – indoor uncontrolled (external)	None	None	NA	Consistent with NUREG-1801.
3.1.1.86	Stainless steel piping, piping components, and piping elements exposed to air – indoor uncontrolled (External); air with borated water leakage; concrete; gas	None	None	NA	Consistent with NUREG-1801.
3.1.1.87	Steel piping, piping components, and piping elements in concrete	None	None	NA	Not applicable. The PVNGS reactor vessel, internals, and reactor coolant systems have no in-scope steel piping, piping components or piping elements embedded in concrete, so the applicable NUREG-1801 line was not used.

Section 3.1
AGING MANAGEMENT OF REACTOR VESSEL,
INTERNALS, AND REACTOR COOLANT SYSTEM

Table 3.1.2-1 Reactor Vessel, Internals, and Reactor Coolant System – Summary of Aging Management Evaluation – Reactor Vessel and Internals

Component Type	Intended Function	Material	Environment	Aging Effect Requiring Management	Aging Management Program	NUREG-1801 Vol. 2 Item	Table 1 Item	Notes
Closure Bolting	PB	Stainless Steel	Borated Water Leakage (Ext)	Cracking	Bolting Integrity (B2.1.7)	IV.A2-6	3.1.1.52	D
Closure Bolting	PB	Stainless Steel	Borated Water Leakage (Ext)	Loss of preload	Bolting Integrity (B2.1.7)	IV.A2-8	3.1.1.52	D
RV CEDM Housing (Lower)	PB	Nickel Alloys	Borated Water Leakage (Ext)	None	None	None	None	G, 2
RV CEDM Housing (Lower)	PB	Nickel Alloys	Reactor Coolant (Int)	Cracking	Nickel Alloy Aging Management (B2.1.34), ASME Section XI Inservice Inspection, Subsections IWB, IWC, and IWD (B2.1.1) for Class 1 components, Water Chemistry (B2.1.2), and Comply with applicable NRC Orders and FSAR Commitment (B2.1.21)	IV.A2-11	3.1.1.34	E, 1
RV CEDM Housing (Lower)	PB	Nickel Alloys	Reactor Coolant (Int)	Loss of material	Water Chemistry (B2.1.2)	IV.A2-14	3.1.1.83	A

Section 3.1
AGING MANAGEMENT OF REACTOR VESSEL,
INTERNALS, AND REACTOR COOLANT SYSTEM

Table 3.1.2-1 Reactor Vessel, Internals, and Reactor Coolant System – Summary of Aging Management Evaluation – Reactor Vessel and Internals (Continued)

Component Type	Intended Function	Material	Environment	Aging Effect Requiring Management	Aging Management Program	NUREG-1801 Vol. 2 Item	Table 1 Item	Notes
RV CEDM Housing (Lower)	PB	Stainless Steel	Borated Water Leakage (Ext)	None	None	IV.E-3	3.1.1.86	C
RV CEDM Housing (Lower)	PB	Stainless Steel	Reactor Coolant (Int)	Cracking	Water Chemistry (B2.1.2) and ASME Section XI Inservice Inspection, Subsections IWB, IWC, and IWD (B2.1.1)	IV.A2-11	3.1.1.34	A
RV CEDM Housing (Lower)	PB	Stainless Steel	Reactor Coolant (Int)	Loss of material	Water Chemistry (B2.1.2)	IV.A2-14	3.1.1.83	A
RV CEDM Housing (Lower)	SS	Stainless Steel	Reactor Coolant (Int)	Cumulative fatigue damage	Time-Limited Aging Analysis evaluated for the period of extended operation	IV.A2-21	3.1.1.09	A
RV CEDM Housing (Upper)	PB	Stainless Steel	Borated Water Leakage (Ext)	None	None	IV.E-3	3.1.1.86	C
RV CEDM Housing (Upper)	PB	Stainless Steel	Reactor Coolant (Int)	Cracking	Water Chemistry (B2.1.2) and ASME Section XI Inservice Inspection, Subsections IWB, IWC, and IWD (B2.1.1)	IV.A2-11	3.1.1.34	A

Section 3.1
AGING MANAGEMENT OF REACTOR VESSEL,
INTERNALS, AND REACTOR COOLANT SYSTEM

Table 3.1.2-1 Reactor Vessel, Internals, and Reactor Coolant System – Summary of Aging Management Evaluation – Reactor Vessel and Internals (Continued)

Component Type	Intended Function	Material	Environment	Aging Effect Requiring Management	Aging Management Program	NUREG-1801 Vol. 2 Item	Table 1 Item	Notes
RV CEDM Housing (Upper)	PB	Stainless Steel	Reactor Coolant (Int)	Loss of material	Water Chemistry (B2.1.2)	IV.A2-14	3.1.1.83	A
RV CEDM Nozzles	PB	Nickel Alloys	Borated Water Leakage (Ext)	None	None	None	None	G, 2
RV CEDM Nozzles	PB	Nickel Alloys	Reactor Coolant (Int)	Cracking	ASME Section XI Inservice Inspection, Subsections IWB, IWC, and IWD (B2.1.1), Water Chemistry (B2.1.2), and XI.M1 1-A, Nickel-Alloy Penetration Nozzles Welded to the Upper Reactor Vessel Closure Heads of Pressurized Water Reactors (B2.1.5)	IV.A2-9	3.1.1.65	A
RV CEDM Nozzles	PB	Nickel Alloys	Reactor Coolant (Int)	Loss of material	Water Chemistry (B2.1.2)	IV.A2-14	3.1.1.83	A
RV Closure Head	SS	Carbon Steel	Borated Water Leakage (Ext)	Loss of material	Boric Acid Corrosion (B2.1.4)	IV.A2-13	3.1.1.58	A
RV Closure Head	PB	Carbon Steel with Stainless Steel Cladding	Borated Water Leakage (Ext)	Loss of material	Boric Acid Corrosion (B2.1.4)	IV.A2-13	3.1.1.58	A

Section 3.1
AGING MANAGEMENT OF REACTOR VESSEL,
INTERNALS, AND REACTOR COOLANT SYSTEM

Table 3.1.2-1 Reactor Vessel, Internals, and Reactor Coolant System – Summary of Aging Management Evaluation – Reactor Vessel and Internals (Continued)

Component Type	Intended Function	Material	Environment	Aging Effect Requiring Management	Aging Management Program	NUREG-1801 Vol. 2 Item	Table 1 Item	Notes
RV Closure Head	PB	Carbon Steel with Stainless Steel Cladding	Reactor Coolant (Int)	Loss of material	Water Chemistry (B2.1.2)	IV.A2-14	3.1.1.83	A
RV Closure Head	PB	Carbon Steel with Stainless Steel Cladding	Reactor Coolant (Int)	Cracking	ASME Section XI Inservice Inspection, Subsections IWB, IWC, and IWD for Class 1 components (B2.1.1) and Water Chemistry (B2.1.2)	IV.A2-15	3.1.1.69	C
RV Closure Head	PB	Carbon Steel with Stainless Steel Cladding	Reactor Coolant (Int)	Cumulative fatigue damage	Time-Limited Aging Analysis evaluated for the period of extended operation	IV.A2-21	3.1.1.09	A
RV Closure Head	PB	Carbon Steel with Stainless Steel Cladding	Reactor Coolant (Int)	Loss of material	ASME Section XI Inservice Inspection, Subsections IWB, IWC, and IWD (B2.1.1)	IV.A2-25	3.1.1.63	A
RV Closure Head Bolts	PB	High Strength Low Alloy Steel (Bolting)	Borated Water Leakage (Ext)	Cracking	Reactor Head Closure Studs (B2.1.3)	IV.A2-2	3.1.1.71	A

Section 3.1
AGING MANAGEMENT OF REACTOR VESSEL,
INTERNALS, AND REACTOR COOLANT SYSTEM

Table 3.1.2-1 *Reactor Vessel, Internals, and Reactor Coolant System – Summary of Aging Management Evaluation – Reactor Vessel and Internals (Continued)*

Component Type	Intended Function	Material	Environment	Aging Effect Requiring Management	Aging Management Program	NUREG-1801 Vol. 2 Item	Table 1 Item	Notes
RV Closure Head Bolts	PB	High Strength Low Alloy Steel (Bolting)	Borated Water Leakage (Ext)	Loss of material	Reactor Head Closure Studs (B2.1.3)	IV.A2-3	3.1.1.71	A
RV Closure Head Bolts	PB	High Strength Low Alloy Steel (Bolting)	Borated Water Leakage (Ext)	Cumulative fatigue damage	Time-Limited Aging Analysis evaluated for the period of extended operation	IV.A2-4	3.1.1.07	A
RV Closure Head Bolts	PB	High Strength Low Alloy Steel (Bolting)	Borated Water Leakage (Ext)	Loss of material	Boric Acid Corrosion (B2.1.4)	IV.A2-13	3.1.1.58	A
RV Flange Leak Monitoring Tube	PB	Nickel Alloys	Borated Water Leakage (Ext)	None	None	None	None	G, 2
RV Flange Leak Monitoring Tube	PB	Nickel Alloys	Borated Water Leakage (Int)	None	None	None	None	G, 2
RV Head Vent Penetration	PB	Nickel Alloys	Borated Water Leakage (Ext)	None	None	None	None	G, 2
RV Head Vent Penetration	PB	Nickel Alloys	Reactor Coolant (Int)	Loss of material	Water Chemistry (B2.1.2)	IV.A2-14	3.1.1.83	A

Section 3.1
AGING MANAGEMENT OF REACTOR VESSEL,
INTERNALS, AND REACTOR COOLANT SYSTEM

Table 3.1.2-1 Reactor Vessel, Internals, and Reactor Coolant System – Summary of Aging Management Evaluation – Reactor Vessel and Internals (Continued)

Component Type	Intended Function	Material	Environment	Aging Effect Requiring Management	Aging Management Program	NUREG-1801 Vol. 2 Item	Table 1 Item	Notes
RV Head Vent Penetration	PB	Nickel Alloys	Reactor Coolant (Int)	Cracking	ASME Section XI Inservice Inspection, Subsections IWB, IWC, and IWD (B2.1.1), Water Chemistry (B2.1.2), and XI.M11-A, Nickel-Alloy Penetration Nozzles Welded to the Upper Reactor Vessel Closure Heads of Pressurized Water Reactors (B2.1.5)	IV.A2-18	3.1.1.65	A
RV Head Vent Penetration	PB	Nickel Alloys	Reactor Coolant (Int)	Cumulative fatigue damage	Time-Limited Aging Analysis evaluated for the period of extended operation	IV.A2-21	3.1.1.09	A
RV ICI Guide Tube	PB	Stainless Steel	Borated Water Leakage (Ext)	None	None	IV.E-3	3.1.1.86	A
RV ICI Guide Tube	PB	Stainless Steel	Reactor Coolant (Int)	Cracking	Water Chemistry (B2.1.2) and ASME Section XI Inservice Inspection, Subsections IWB, IWC, and IWD (B2.1.1)	IV.A2-1	3.1.1.23	E
RV ICI Guide Tube	PB	Stainless Steel	Reactor Coolant (Int)	Loss of material	Water Chemistry (B2.1.2)	IV.A2-14	3.1.1.83	A
RV ICI Nozzle	PB	Nickel Alloys	Borated Water Leakage (Ext)	None	None	None	None	G, 2

Palo Verde Nuclear Generating Station
License Renewal Application

Section 3.1
AGING MANAGEMENT OF REACTOR VESSEL,
INTERNALS, AND REACTOR COOLANT SYSTEM

Table 3.1.2-1 Reactor Vessel, Internals, and Reactor Coolant System – Summary of Aging Management Evaluation – Reactor Vessel and Internals (Continued)

Component Type	Intended Function	Material	Environment	Aging Effect Requiring Management	Aging Management Program	NUREG-1801 Vol. 2 Item	Table 1 Item	Notes
RV ICI Nozzle	PB	Nickel Alloys	Reactor Coolant (Int)	Loss of material	Water Chemistry (B2.1.2)	IV.A2-14	3.1.1.83	A
RV ICI Nozzle	PB	Nickel Alloys	Reactor Coolant (Int)	Cracking	Nickel Alloy Aging Management (B2.1.34), ASME Section XI Inservice Inspection, Subsections IWB, IWC, and IWD (B2.1.1) for Class 1 components, Water Chemistry (B2.1.2), and Comply with applicable NRC Orders and FSAR Commitment (B2.1.22)	IV.A2-19	3.1.1.31	E, 1
RV ICI Nozzle	PB	Nickel Alloys	Reactor Coolant (Int)	Cumulative fatigue damage	Time-Limited Aging Analysis evaluated for the period of extended operation	IV.A2-21	3.1.1.09	A
RV Nozzle Safe Ends and Welds	PB	Carbon Steel with Stainless Steel Cladding	Borated Water Leakage (Ext)	Loss of material	Boric Acid Corrosion (B2.1.4)	IV.A2-13	3.1.1.58	A
RV Nozzle Safe Ends and Welds	PB	Carbon Steel with Stainless Steel Cladding	Reactor Coolant (Int)	Loss of material	Water Chemistry (B2.1.2)	IV.A2-14	3.1.1.83	A

Section 3.1
AGING MANAGEMENT OF REACTOR VESSEL,
INTERNALS, AND REACTOR COOLANT SYSTEM

Table 3.1.2-1 Reactor Vessel, Internals, and Reactor Coolant System – Summary of Aging Management Evaluation – Reactor Vessel and Internals (Continued)

Component Type	Intended Function	Material	Environment	Aging Effect Requiring Management	Aging Management Program	NUREG-1801 Vol. 2 Item	Table 1 Item	Notes
RV Nozzle Safe Ends and Welds	PB	Carbon Steel with Stainless Steel Cladding	Reactor Coolant (Int)	Cracking	ASME Section XI Inservice Inspection, Subsections IWB, IWC, and IWD for Class 1 components (B2.1.1) and Water Chemistry (B2.1.2)	IV.A2-15	3.1.1.69	A
RV Nozzle Safe Ends and Welds	PB	Carbon Steel with Stainless Steel Cladding	Reactor Coolant (Int)	Loss of fracture toughness	Reactor Vessel Surveillance (B2.1.15)	IV.A2-17	3.1.1.18	C
RV Nozzle Safe Ends and Welds	PB	Carbon Steel with Stainless Steel Cladding	Reactor Coolant (Int)	Cumulative fatigue damage	Time-Limited Aging Analysis evaluated for the period of extended operation	IV.A2-21	3.1.1.09	A
RV Nozzles	PB	Carbon Steel with Stainless Steel Cladding	Borated Water Leakage (Ext)	Loss of material	Boric Acid Corrosion (B2.1.4)	IV.A2-13	3.1.1.58	A
RV Nozzles	PB	Carbon Steel with Stainless Steel Cladding	Reactor Coolant (Int)	Loss of material	Water Chemistry (B2.1.2)	IV.A2-14	3.1.1.83	A

Section 3.1
AGING MANAGEMENT OF REACTOR VESSEL,
INTERNALS, AND REACTOR COOLANT SYSTEM

Table 3.1.2-1 Reactor Vessel, Internals, and Reactor Coolant System – Summary of Aging Management Evaluation – Reactor Vessel and Internals (Continued)

Component Type	Intended Function	Material	Environment	Aging Effect Requiring Management	Aging Management Program	NUREG-1801 Vol. 2 Item	Table 1 Item	Notes
RV Nozzles	PB	Carbon Steel with Stainless Steel Cladding	Reactor Coolant (Int)	Cracking	ASME Section XI Inservice Inspection, Subsections IWB, IWC, and IWD for Class 1 components (B2.1.1) and Water Chemistry (B2.1.2)	IV.A2-15	3.1.1.69	A
RV Nozzles	PB	Carbon Steel with Stainless Steel Cladding	Reactor Coolant (Int)	Loss of fracture toughness	Reactor Vessel Surveillance (B2.1.15)	IV.A2-17	3.1.1.18	A
RV Nozzles	PB	Carbon Steel with Stainless Steel Cladding	Reactor Coolant (Int)	Cumulative fatigue damage	Time-Limited Aging Analysis evaluated for the period of extended operation	IV.A2-21	3.1.1.09	A
RV Shell	PB	Carbon Steel	Borated Water Leakage (Ext)	Loss of material	Boric Acid Corrosion (B2.1.4)	IV.A2-13	3.1.1.58	A
RV Shell	PB	Carbon Steel with Stainless Steel Cladding	Borated Water Leakage (Ext)	Loss of material	Boric Acid Corrosion (B2.1.4)	IV.A2-13	3.1.1.58	A

Section 3.1
AGING MANAGEMENT OF REACTOR VESSEL,
INTERNALS, AND REACTOR COOLANT SYSTEM

Table 3.1.2-1 Reactor Vessel, Internals, and Reactor Coolant System – Summary of Aging Management Evaluation – Reactor Vessel and Internals (Continued)

Component Type	Intended Function	Material	Environment	Aging Effect Requiring Management	Aging Management Program	NUREG-1801 Vol. 2 Item	Table 1 Item	Notes
RV Shell	PB	Carbon Steel with Stainless Steel Cladding	Reactor Coolant (Int)	Loss of material	Water Chemistry (B2.1.2)	IV.A2-14	3.1.1.83	A
RV Shell	PB	Carbon Steel with Stainless Steel Cladding	Reactor Coolant (Int)	Cracking	ASME Section XI Inservice Inspection, Subsections IWB, IWC, and IWD for Class 1 components (B2.1.1) and Water Chemistry (B2.1.2)	IV.A2-15	3.1.1.69	C
RV Shell	PB	Carbon Steel with Stainless Steel Cladding	Reactor Coolant (Int)	Cumulative fatigue damage	Time-Limited Aging Analysis evaluated for the period of extended operation	IV.A2-21	3.1.1.09	A
RV Shell	PB	Carbon Steel with Stainless Steel Cladding	Reactor Coolant (Int)	Loss of fracture toughness	Time-Limited Aging Analysis evaluated for the period of extended operation	IV.A2-23	3.1.1.17	A
RV Shell	PB	Carbon Steel with Stainless Steel Cladding	Reactor Coolant (Int)	Loss of fracture toughness	Reactor Vessel Surveillance (B2.1.15)	IV.A2-24	3.1.1.18	A

Section 3.1
AGING MANAGEMENT OF REACTOR VESSEL,
INTERNALS, AND REACTOR COOLANT SYSTEM

Table 3.1.2-1 Reactor Vessel, Internals, and Reactor Coolant System – Summary of Aging Management Evaluation – Reactor Vessel and Internals (Continued)

Component Type	Intended Function	Material	Environment	Aging Effect Requiring Management	Aging Management Program	NUREG-1801 Vol. 2 Item	Table 1 Item	Notes
RV Shell	PB	Carbon Steel with Stainless Steel Cladding	Reactor Coolant (Int)	Loss of material	ASME Section XI Inservice Inspection, Subsections IWB, IWC, and IWD (B2.1.1)	IV.A2-25	3.1.1.63	A
RV Shell Bottom Head	PB	Carbon Steel with Stainless Steel Cladding	Borated Water Leakage (Ext)	Loss of material	Boric Acid Corrosion (B2.1.4)	IV.A2-13	3.1.1.58	A
RV Shell Bottom Head	PB	Carbon Steel with Stainless Steel Cladding	Reactor Coolant (Int)	Loss of material	Water Chemistry (B2.1.2)	IV.A2-14	3.1.1.83	A
RV Shell Bottom Head	PB	Carbon Steel with Stainless Steel Cladding	Reactor Coolant (Int)	Cracking	ASME Section XI Inservice Inspection, Subsections IWB, IWC, and IWD for Class 1 components (B2.1.1) and Water Chemistry (B2.1.2)	IV.A2-15	3.1.1.69	C
RV Shell Bottom Head	PB	Carbon Steel with Stainless Steel Cladding	Reactor Coolant (Int)	Cumulative fatigue damage	Time-Limited Aging Analysis evaluated for the period of extended operation	IV.A2-21	3.1.1.09	A

Section 3.1
AGING MANAGEMENT OF REACTOR VESSEL,
INTERNALS, AND REACTOR COOLANT SYSTEM

Table 3.1.2-1 Reactor Vessel, Internals, and Reactor Coolant System – Summary of Aging Management Evaluation – Reactor Vessel and Internals (Continued)

Component Type	Intended Function	Material	Environment	Aging Effect Requiring Management	Aging Management Program	NUREG-1801 Vol. 2 Item	Table 1 Item	Notes
RV Shell Bottom Head	PB	Carbon Steel with Stainless Steel Cladding	Reactor Coolant (Int)	Loss of fracture toughness	Reactor Vessel Surveillance (B2.1.15)	IV.A2-24	3.1.1.18	A
RV Shell Bottom Head	PB	Carbon Steel with Stainless Steel Cladding	Reactor Coolant (Int)	Loss of material	ASME Section XI Inservice Inspection, Subsections IWB, IWC, and IWD (B2.1.1)	IV.A2-25	3.1.1.63	A
RV Support Pads and Shear Keys	SS	Carbon Steel	Borated Water Leakage (Ext)	Loss of material	Boric Acid Corrosion (B2.1.4)	IV.A2-13	3.1.1.58	A
RVI Core Stop Lug and Surv Capsule Holder	SS	Nickel Alloys	Reactor Coolant (Ext)	Cracking	Water Chemistry (B2.1.2) and FSAR Commitment (B2.1.21)	IV.B3-23	3.1.1.37	C
RVI Core Stop Lug and Surv Capsule Holder	SS	Nickel Alloys	Reactor Coolant (Ext)	Loss of material	Water Chemistry (B2.1.2)	IV.B3-25	3.1.1.83	A
RVI Core Support Structure	SS	Stainless Steel	Reactor Coolant (Ext)	Cumulative fatigue damage	Time-Limited Aging Analysis evaluated for the period of extended operation	IV.B3-24	3.1.1.05	A
RVI CSS Core Shroud Assembly	DF, SS	Stainless Steel	Reactor Coolant (Ext)	Cracking	Water Chemistry (B2.1.2) and FSAR Commitment (B2.1.21)	IV.B3-11	3.1.1.30	A

Section 3.1
AGING MANAGEMENT OF REACTOR VESSEL,
INTERNALS, AND REACTOR COOLANT SYSTEM

Table 3.1.2-1 Reactor Vessel, Internals, and Reactor Coolant System – Summary of Aging Management Evaluation – Reactor Vessel and Internals (Continued)

Component Type	Intended Function	Material	Environment	Aging Effect Requiring Management	Aging Management Program	NUREG-1801 Vol. 2 Item	Table 1 Item	Notes
RVI CSS Core Shroud Assembly	DF, SS	Stainless Steel	Reactor Coolant (Ext)	Loss of fracture toughness	FSAR Commitment (B2.1.21)	IV.B3-12	3.1.1.22	A
RVI CSS Core Shroud Assembly	DF, SS	Stainless Steel	Reactor Coolant (Ext)	Changes in dimensions	FSAR Commitment (B2.1.21)	IV.B3-13	3.1.1.33	A
RVI CSS Core Shroud Assembly	DF, SS	Stainless Steel	Reactor Coolant (Ext)	Loss of material	Water Chemistry (B2.1.2)	IV.B3-25	3.1.1.83	A
RVI CSS Core Support Barrel Assembly	DF, SS	Stainless Steel	Reactor Coolant (Ext)	Changes in dimensions	FSAR Commitment (B2.1.21)	IV.B3-14	3.1.1.33	A
RVI CSS Core Support Barrel Assembly	DF, SS	Stainless Steel	Reactor Coolant (Ext)	Cracking	Water Chemistry (B2.1.2) and FSAR Commitment (B2.1.21)	IV.B3-15	3.1.1.30	A
RVI CSS Core Support Barrel Assembly	DF, SS	Stainless Steel	Reactor Coolant (Ext)	Loss of fracture toughness	FSAR Commitment (B2.1.21)	IV.B3-16	3.1.1.22	A
RVI CSS Core Support Barrel Assembly	DF, SS	Stainless Steel	Reactor Coolant (Ext)	Loss of material	ASME Section XI Inservice Inspection, Subsections IWB, IWC, and IWD (B2.1.1)	IV.B3-17	3.1.1.63	A
RVI CSS Core Support Barrel Assembly	DF, SS	Stainless Steel	Reactor Coolant (Ext)	Loss of material	Water Chemistry (B2.1.2)	IV.B3-25	3.1.1.83	A

Section 3.1
AGING MANAGEMENT OF REACTOR VESSEL,
INTERNALS, AND REACTOR COOLANT SYSTEM

Table 3.1.2-1 Reactor Vessel, Internals, and Reactor Coolant System – Summary of Aging Management Evaluation – Reactor Vessel and Internals (Continued)

Component Type	Intended Function	Material	Environment	Aging Effect Requiring Management	Aging Management Program	NUREG-1801 Vol. 2 Item	Table 1 Item	Notes
RVI CSS Core Support Barrel Snubber Assembly	SS	Nickel Alloys	Reactor Coolant (Ext)	Changes in dimensions	FSAR Commitment (B2.1.21)	IV.B3-19	3.1.1.33	A
RVI CSS Core Support Barrel Snubber Assembly	SS	Nickel Alloys	Reactor Coolant (Ext)	Loss of fracture toughness	FSAR Commitment (B2.1.21)	IV.B3-20	3.1.1.22	A
RVI CSS Core Support Barrel Snubber Assembly	SS	Nickel Alloys	Reactor Coolant (Ext)	Loss of material	ASME Section XI Inservice Inspection, Subsections IWB, IWC, and IWD (B2.1.1)	IV.B3-22	3.1.1.63	A
RVI CSS Core Support Barrel Snubber Assembly	SS	Nickel Alloys	Reactor Coolant (Ext)	Cracking	Water Chemistry (B2.1.2) and FSAR Commitment (B2.1.21)	IV.B3-23	3.1.1.37	C
RVI CSS Core Support Barrel Snubber Assembly	SS	Nickel Alloys	Reactor Coolant (Ext)	Loss of material	Water Chemistry (B2.1.2)	IV.B3-25	3.1.1.83	A
RVI CSS Core Support Barrel Snubber Assembly	SS	Stainless Steel	Reactor Coolant (Ext)	Changes in dimensions	FSAR Commitment (B2.1.21)	IV.B3-19	3.1.1.33	A

Section 3.1
AGING MANAGEMENT OF REACTOR VESSEL,
INTERNALS, AND REACTOR COOLANT SYSTEM

Table 3.1.2-1 Reactor Vessel, Internals, and Reactor Coolant System – Summary of Aging Management Evaluation – Reactor Vessel and Internals (Continued)

Component Type	Intended Function	Material	Environment	Aging Effect Requiring Management	Aging Management Program	NUREG-1801 Vol. 2 Item	Table 1 Item	Notes
RVI CSS Core Support Barrel Snubber Assembly	SS	Stainless Steel	Reactor Coolant (Ext)	Loss of fracture toughness	FSAR Commitment (B2.1.21)	IV.B3-20	3.1.1.22	A
RVI CSS Core Support Barrel Snubber Assembly	SS	Stainless Steel	Reactor Coolant (Ext)	Cracking	Water Chemistry (B2.1.2) and FSAR Commitment (B2.1.21)	IV.B3-21	3.1.1.30	A
RVI CSS Core Support Barrel Snubber Assembly	SS	Stainless Steel	Reactor Coolant (Ext)	Loss of material	ASME Section XI Inservice Inspection, Subsections IWB, IWC, and IWD (B2.1.1)	IV.B3-22	3.1.1.63	A
RVI CSS Core Support Barrel Snubber Assembly	SS	Stainless Steel	Reactor Coolant (Ext)	Loss of material	Water Chemistry (B2.1.2)	IV.B3-25	3.1.1.83	A
RVI CSS Lower Support Structure Assembly	DF, SS	Stainless Steel	Reactor Coolant (Ext)	Changes in dimensions	FSAR Commitment (B2.1.21)	IV.B3-19	3.1.1.33	A
RVI CSS Lower Support Structure Assembly	DF, SS	Stainless Steel	Reactor Coolant (Ext)	Loss of fracture toughness	FSAR Commitment (B2.1.21)	IV.B3-20	3.1.1.22	A

Section 3.1
AGING MANAGEMENT OF REACTOR VESSEL,
INTERNALS, AND REACTOR COOLANT SYSTEM

Table 3.1.2-1 Reactor Vessel, Internals, and Reactor Coolant System – Summary of Aging Management Evaluation – Reactor Vessel and Internals (Continued)

Component Type	Intended Function	Material	Environment	Aging Effect Requiring Management	Aging Management Program	NUREG-1801 Vol. 2 Item	Table 1 Item	Notes
RVI CSS Lower Support Structure Assembly	DF, SS	Stainless Steel	Reactor Coolant (Ext)	Cracking	Water Chemistry (B2.1.2) and FSAR Commitment (B2.1.21)	IV.B3-21	3.1.1.30	A
RVI CSS Lower Support Structure Assembly	DF, SS	Stainless Steel	Reactor Coolant (Ext)	Loss of material	ASME Section XI Inservice Inspection, Subsections IWB, IWC, and IWD (B2.1.1)	IV.B3-22	3.1.1.63	A
RVI CSS Lower Support Structure Assembly	DF, SS	Stainless Steel	Reactor Coolant (Ext)	Loss of material	Water Chemistry (B2.1.2)	IV.B3-25	3.1.1.83	A
RVI Flow Skirt	DF	Nickel Alloys	Reactor Coolant (Ext)	Cracking	Water Chemistry (B2.1.2) and FSAR Commitment (B2.1.21)	IV.B3-23	3.1.1.37	C
RVI Flow Skirt	DF	Nickel Alloys	Reactor Coolant (Ext)	Loss of material	Water Chemistry (B2.1.2)	IV.B3-25	3.1.1.83	A
RVI ICI Support Structures	SS	Stainless Steel	Reactor Coolant (Ext)	Changes in dimensions	FSAR Commitment (B2.1.21)	IV.B3-19	3.1.1.33	A
RVI ICI Support Structures	SS	Stainless Steel	Reactor Coolant (Ext)	Loss of fracture toughness	FSAR Commitment (B2.1.21)	IV.B3-20	3.1.1.22	A
RVI ICI Support Structures	SS	Stainless Steel	Reactor Coolant (Ext)	Cracking	Water Chemistry (B2.1.2) and FSAR Commitment (B2.1.21)	IV.B3-21	3.1.1.30	A

Section 3.1
AGING MANAGEMENT OF REACTOR VESSEL,
INTERNALS, AND REACTOR COOLANT SYSTEM

Table 3.1.2-1 Reactor Vessel, Internals, and Reactor Coolant System – Summary of Aging Management Evaluation – Reactor Vessel and Internals (Continued)

Component Type	Intended Function	Material	Environment	Aging Effect Requiring Management	Aging Management Program	NUREG-1801 Vol. 2 Item	Table 1 Item	Notes
RVI ICI Support Structures	SS	Stainless Steel	Reactor Coolant (Ext)	Loss of material	ASME Section XI Inservice Inspection, Subsections IWB, IWC, and IWD (B2.1.1)	IV.B3-22	3.1.1.63	A
RVI ICI Support Structures	SS	Stainless Steel	Reactor Coolant (Ext)	Loss of material	Water Chemistry (B2.1.2)	IV.B3-25	3.1.1.83	A
RVI UGS CEA Shroud Assembly	SS	Stainless Steel	Reactor Coolant (Ext)	Cracking	Water Chemistry (B2.1.2) and FSAR Commitment (B2.1.21)	IV.B3-2	3.1.1.30	A
RVI UGS CEA Shroud Assembly	SS	Stainless Steel	Reactor Coolant (Ext)	Changes in dimensions	FSAR Commitment (B2.1.21)	IV.B3-4	3.1.1.33	A
RVI UGS CEA Shroud Assembly	SS	Stainless Steel	Reactor Coolant (Ext)	Cracking	Water Chemistry (B2.1.2) and FSAR Commitment (B2.1.21)	IV.B3-5	3.1.1.37	A
RVI UGS CEA Shroud Assembly	SS	Stainless Steel	Reactor Coolant (Ext)	Loss of preload	FSAR Commitment (B2.1.21)	IV.B3-6	3.1.1.27	A
RVI UGS CEA Shroud Assembly	SS	Stainless Steel	Reactor Coolant (Ext)	Loss of material	Water Chemistry (B2.1.2)	IV.B3-25	3.1.1.83	A
RVI UGS Holddown Ring	SS	Stainless Steel	Reactor Coolant (Ext)	Loss of material	Water Chemistry (B2.1.2)	IV.B3-25	3.1.1.83	A

Section 3.1
AGING MANAGEMENT OF REACTOR VESSEL,
INTERNALS, AND REACTOR COOLANT SYSTEM

Table 3.1.2-1 Reactor Vessel, Internals, and Reactor Coolant System – Summary of Aging Management Evaluation – Reactor Vessel and Internals (Continued)

Component Type	Intended Function	Material	Environment	Aging Effect Requiring Management	Aging Management Program	NUREG-1801 Vol. 2 Item	Table 1 Item	Notes
RVI UGS Holddown Ring	SS	Stainless Steel	Reactor Coolant (Ext)	Loss of material	ASME Section XI Inservice Inspection, Subsections IWB, IWC, and IWD (B2.1.1)	IV.B3-26	3.1.1.63	A
RVI UGS Holddown Ring	SS	Stainless Steel	Reactor Coolant (Ext)	Changes in dimensions	FSAR Commitment (B2.1.21)	IV.B3-27	3.1.1.33	A
RVI UGS Holddown Ring	SS	Stainless Steel	Reactor Coolant (Ext)	Cracking	Water Chemistry (B2.1.2) and FSAR Commitment (B2.1.21)	IV.B3-28	3.1.1.30	A
RVI UGS Support Barrel Assembly	SS	Stainless Steel	Reactor Coolant (Ext)	Loss of material	Water Chemistry (B2.1.2)	IV.B3-25	3.1.1.83	A
RVI UGS Support Barrel Assembly	SS	Stainless Steel	Reactor Coolant (Ext)	Loss of material	ASME Section XI Inservice Inspection, Subsections IWB, IWC, and IWD (B2.1.1)	IV.B3-26	3.1.1.63	A
RVI UGS Support Barrel Assembly	SS	Stainless Steel	Reactor Coolant (Ext)	Changes in dimensions	FSAR Commitment (B2.1.21)	IV.B3-27	3.1.1.33	A
RVI UGS Support Barrel Assembly	SS	Stainless Steel	Reactor Coolant (Ext)	Cracking	Water Chemistry (B2.1.2) and FSAR Commitment (B2.1.21)	IV.B3-28	3.1.1.30	A
RVI Upper Guide Structure Assembly	SS	Stainless Steel	Reactor Coolant (Ext)	Cumulative fatigue damage	Time-Limited Aging Analysis evaluated for the period of extended operation	IV.B3-24	3.1.1.05	A

Section 3.1
**AGING MANAGEMENT OF REACTOR VESSEL,
INTERNALS, AND REACTOR COOLANT SYSTEM**

Notes for Table 3.1.2-1:

Standard Notes:

- A Consistent with NUREG-1801 item for component, material, environment, and aging effect. AMP is consistent with NUREG-1801 AMP.
- C Component is different, but consistent with NUREG-1801 item for material, environment, and aging effect. AMP is consistent with NUREG-1801 AMP.
- D Component is different, but consistent with NUREG-1801 item for material, environment, and aging effect. AMP takes some exceptions to NUREG-1801 AMP.
- E Consistent with NUREG-1801 for material, environment, and aging effect, but a different aging management program is credited or NUREG-1801 identifies a plant-specific aging management program.
- G Environment not in NUREG-1801 for this component and material.

Plant Specific Notes:

- 1 Note E was used to include the plant specific Nickel Alloy Aging Management Program (B2.1.34).
- 2 NUREG-1801 does not include air with borated water leakage for nickel alloy components. Similar to IV.E-3 for stainless steel, there are no aging effects for nickel alloy in air with borated water leakage.

Section 3.1
AGING MANAGEMENT OF REACTOR VESSEL,
INTERNALS, AND REACTOR COOLANT SYSTEM

Table 3.1.2-2 Reactor Vessel, Internals, and Reactor Coolant System – Summary of Aging Management Evaluation – Reactor Coolant System

Component Type	Intended Function	Material	Environment	Aging Effect Requiring Management	Aging Management Program	NUREG-1801 Vol. 2 Item	Table 1 Item	Notes
Class 1 Piping <= 4in	PB	Stainless Steel	Borated Water Leakage (Ext)	None	None	IV.E-3	3.1.1.86	A
Class 1 Piping <= 4in	PB	Stainless Steel	Reactor Coolant (Int)	Cracking	ASME Section XI Inservice Inspection, Subsections IWB, IWC, and IWD for Class 1 components (B2.1.1) and Water Chemistry (B2.1.2) and One-Time Inspection Of ASME Code Class 1 Small-Bore Piping (B2.1.19)	IV.C2-1	3.1.1.70	B
Class 1 Piping <= 4in	PB	Stainless Steel	Reactor Coolant (Int)	Loss of material	Water Chemistry (B2.1.2)	IV.C2-15	3.1.1.83	A
Closure Bolting	LBS, PB, S/A	Carbon Steel	Plant Indoor Air (Ext)	Loss of material	Bolting Integrity (B2.1.7)	VII.I-4	3.3.1.43	B
Closure Bolting	LBS, PB, S/A	Carbon Steel	Plant Indoor Air (Ext)	Loss of preload	Bolting Integrity (B2.1.7)	VII.I-5	3.3.1.45	B
Closure Bolting	LBS, PB, S/A	Stainless Steel	Borated Water Leakage (Ext)	Cracking	Bolting Integrity (B2.1.7)	IV.C2-7	3.1.1.52	B
Closure Bolting	LBS, PB, S/A	Stainless Steel	Borated Water Leakage (Ext)	Loss of preload	Bolting Integrity (B2.1.7)	IV.C2-8	3.1.1.52	B

Section 3.1
AGING MANAGEMENT OF REACTOR VESSEL,
INTERNALS, AND REACTOR COOLANT SYSTEM

Table 3.1.2-2 *Reactor Vessel, Internals, and Reactor Coolant System – Summary of Aging Management Evaluation – Reactor Coolant System(Continued)*

Component Type	Intended Function	Material	Environment	Aging Effect Requiring Management	Aging Management Program	NUREG-1801 Vol. 2 Item	Table 1 Item	Notes
Filter	FIL, PB	Stainless Steel Cast Austenitic	Borated Water Leakage (Ext)	None	None	IV.E-3	3.1.1.86	A
Filter	FIL, PB	Stainless Steel Cast Austenitic	Reactor Coolant (Int)	Cracking	ASME Section XI Inservice Inspection, Subsections IWB, IWC, and IWD for Class 1 components (B2.1.1) and Water Chemistry (B2.1.2)	IV.C2-5	3.1.1.68	C
Filter	FIL, PB	Stainless Steel Cast Austenitic	Reactor Coolant (Int)	Loss of fracture toughness	ASME Section XI Inservice Inspection, Subsections IWB, IWC, and IWD (B2.1.1)	IV.C2-6	3.1.1.55	C
Filter	FIL, PB	Stainless Steel Cast Austenitic	Reactor Coolant (Int)	Loss of material	Water Chemistry (B2.1.2)	IV.C2-15	3.1.1.83	A
Flame Arrestor	PB	Carbon Steel	Lubricating Oil (Int)	Loss of material	Lubricating Oil Analysis (B2.1.23) and One-Time Inspection (B2.1.16)	VII.G-26	3.3.1.15	B
Flame Arrestor	PB	Carbon Steel	Plant Indoor Air (Ext)	Loss of material	External Surfaces Monitoring Program (B2.1.20)	VII.I-8	3.3.1.58	A
Flexible Hoses	LBS	Stainless Steel	Borated Water Leakage (Ext)	None	None	IV.E-3	3.1.1.86	A

Section 3.1
AGING MANAGEMENT OF REACTOR VESSEL,
INTERNALS, AND REACTOR COOLANT SYSTEM

Table 3.1.2-2 Reactor Vessel, Internals, and Reactor Coolant System – Summary of Aging Management Evaluation – Reactor Coolant System(Continued)

Component Type	Intended Function	Material	Environment	Aging Effect Requiring Management	Aging Management Program	NUREG-1801 Vol. 2 Item	Table 1 Item	Notes
Flexible Hoses	LBS	Stainless Steel	Treated Borated Water (Int)	Cracking	ASME Section XI Inservice Inspection, Subsections IWB, IWC, and IWD for Class 1 components (B2.1.1) and Water Chemistry (B2.1.2)	IV.C2-22	3.1.1.68	C
Flexible Hoses	LBS	Stainless Steel	Treated Borated Water (Int)	Loss of material	Water Chemistry (B2.1.2)	V.D1-30	3.2.1.49	A
Heat Exchanger (RCP High Pressure Cooler)	PB	Carbon Steel	Closed Cycle Cooling Water (Int)	Loss of material	Closed-Cycle Cooling Water System (B2.1.10)	V.D1-6	3.2.1.27	B
Heat Exchanger (RCP High Pressure Cooler)	PB	Carbon Steel	Plant Indoor Air (Ext)	Loss of material	External Surfaces Monitoring Program (B2.1.20)	VII.I-8	3.3.1.58	A
Heat Exchanger (RCP High Pressure Cooler)	HT, PB	Stainless Steel	Closed Cycle Cooling Water (Ext)	Loss of material	Closed-Cycle Cooling Water System (B2.1.10)	V.D1-4	3.2.1.28	B

Section 3.1
AGING MANAGEMENT OF REACTOR VESSEL,
INTERNALS, AND REACTOR COOLANT SYSTEM

Table 3.1.2-2 Reactor Vessel, Internals, and Reactor Coolant System – Summary of Aging Management Evaluation – Reactor Coolant System(Continued)

Component Type	Intended Function	Material	Environment	Aging Effect Requiring Management	Aging Management Program	NUREG-1801 Vol. 2 Item	Table 1 Item	Notes
Heat Exchanger (RCP High Pressure Cooler)	HT, PB	Stainless Steel	Closed Cycle Cooling Water (Ext)	Reduction of heat transfer	Closed-Cycle Cooling Water System (B2.1.10)	V.D1-9	3.2.1.30	B
Heat Exchanger (RCP High Pressure Cooler)	HT, PB	Stainless Steel	Closed Cycle Cooling Water (Ext)	Cracking	Closed-Cycle Cooling Water System (B2.1.10)	V.D1-23	3.2.1.25	B
Heat Exchanger (RCP High Pressure Cooler)	HT, PB	Stainless Steel	Reactor Coolant (Int)	Cracking	ASME Section XI Inservice Inspection, Subsections IWB, IWC, and IWD for Class 1 components (B2.1.1) and Water Chemistry (B2.1.2)	IV.C2-2	3.1.1.68	C
Heat Exchanger (RCP High Pressure Cooler)	HT, PB	Stainless Steel	Reactor Coolant (Int)	Loss of material	Water Chemistry (B2.1.2)	IV.C2-15	3.1.1.83	C
Heat Exchanger (RCP Seal Cooler)	PB	Carbon Steel	Closed Cycle Cooling Water (Int)	Loss of material	Closed-Cycle Cooling Water System (B2.1.10)	V.D1-6	3.2.1.27	B

Section 3.1
AGING MANAGEMENT OF REACTOR VESSEL,
INTERNALS, AND REACTOR COOLANT SYSTEM

Table 3.1.2-2 Reactor Vessel, Internals, and Reactor Coolant System – Summary of Aging Management Evaluation – Reactor Coolant System(Continued)

Component Type	Intended Function	Material	Environment	Aging Effect Requiring Management	Aging Management Program	NUREG-1801 Vol. 2 Item	Table 1 Item	Notes
Heat Exchanger (RCP Seal Cooler)	PB	Carbon Steel	Plant Indoor Air (Ext)	Loss of material	External Surfaces Monitoring Program (B2.1.20)	VII.I-8	3.3.1.58	A
Heat Exchanger (RCP Seal Cooler)	HT, PB	Stainless Steel	Closed Cycle Cooling Water (Ext)	Loss of material	Closed-Cycle Cooling Water System (B2.1.10)	V.D1-4	3.2.1.28	B
Heat Exchanger (RCP Seal Cooler)	HT, PB	Stainless Steel	Closed Cycle Cooling Water (Ext)	Cracking	Closed-Cycle Cooling Water System (B2.1.10)	V.D1-23	3.2.1.25	B
Heat Exchanger (RCP Seal Cooler)	HT, PB	Stainless Steel	Closed Cycle Cooling Water (Ext)	Reduction of heat transfer	Closed-Cycle Cooling Water System (B2.1.10)	VII.C2-3	3.3.1.52	B
Heat Exchanger (RCP Seal Cooler)	HT, PB	Stainless Steel	Reactor Coolant (Int)	Cracking	ASME Section XI Inservice Inspection, Subsections IWB, IWC, and IWD for Class 1 components (B2.1.1) and Water Chemistry (B2.1.2)	IV.C2-2	3.1.1.68	C
Heat Exchanger (RCP Seal Cooler)	HT, PB	Stainless Steel	Reactor Coolant (Int)	Loss of material	Water Chemistry (B2.1.2)	IV.C2-15	3.1.1.83	C

Section 3.1
AGING MANAGEMENT OF REACTOR VESSEL,
INTERNALS, AND REACTOR COOLANT SYSTEM

Table 3.1.2-2 Reactor Vessel, Internals, and Reactor Coolant System – Summary of Aging Management Evaluation – Reactor Coolant System(Continued)

Component Type	Intended Function	Material	Environment	Aging Effect Requiring Management	Aging Management Program	NUREG-1801 Vol. 2 Item	Table 1 Item	Notes
Orifice	PB, TH	Stainless Steel	Borated Water Leakage (Ext)	None	None	IV.E-3	3.1.1.86	A
Orifice	PB, TH	Stainless Steel	Reactor Coolant (Int)	Cracking	ASME Section XI Inservice Inspection, Subsections IWB, IW/C, and IWD for Class 1 components (B2.1.1) and Water Chemistry (B2.1.2)	IV.C2-2	3.1.1.68	A
Orifice	PB, TH	Stainless Steel	Reactor Coolant (Int)	Loss of material	Water Chemistry (B2.1.2)	IV.C2-15	3.1.1.83	A
Piping	LBS, PB	Carbon Steel	Closed Cycle Cooling Water (Int)	Loss of material	Closed-Cycle Cooling Water System (B2.1.10)	IV.C2-14	3.1.1.53	B
Piping	PB	Carbon Steel	Lubricating Oil (Int)	Loss of material	Lubricating Oil Analysis (B2.1.23) and One-Time Inspection (B2.1.16)	VII.G-26	3.3.1.15	B
Piping	LBS, PB	Carbon Steel	Plant Indoor Air (Ext)	Loss of material	External Surfaces Monitoring Program (B2.1.20)	VII.I-8	3.3.1.58	A
Piping	PB	Carbon Steel with Stainless Steel Cladding	Borated Water Leakage (Ext)	Loss of material	Boric Acid Corrosion (B2.1.4)	IV.C2-09	3.1.1.58	A

Section 3.1
AGING MANAGEMENT OF REACTOR VESSEL,
INTERNALS, AND REACTOR COOLANT SYSTEM

Table 3.1.2-2 Reactor Vessel, Internals, and Reactor Coolant System – Summary of Aging Management Evaluation – Reactor Coolant System(Continued)

Component Type	Intended Function	Material	Environment	Aging Effect Requiring Management	Aging Management Program	NUREG-1801 Vol. 2 Item	Table 1 Item	Notes
Piping	PB	Carbon Steel with Stainless Steel Cladding	Reactor Coolant (Int)	Loss of material	Water Chemistry (B2.1.2)	IV.C2-15	3.1.1.83	A
Piping	PB, SIA	Carbon Steel with Stainless Steel Cladding	Reactor Coolant (Int)	Cumulative fatigue damage	Time-Limited Aging Analysis evaluated for the period of extended operation	IV.C2-25	3.1.1.08	A
Piping	PB	Carbon Steel with Stainless Steel Cladding	Reactor Coolant (Int)	Cracking	ASME Section XI Inservice Inspection, Subsections IWB, IWC, and IWD (B2.1.1)	IV.C2-26	3.1.1.62	A
Piping	PB	Carbon Steel with Stainless Steel Cladding	Reactor Coolant (Int)	Cracking	ASME Section XI Inservice Inspection, Subsections IWB, IWC, and IWD for Class 1 components (B2.1.1) and Water Chemistry (B2.1.2)	IV.C2-27	3.1.1.68	A
Piping	LBS, PB	Nickel Alloys	Borated Water Leakage (Ext)	None	None	None	None	G, 3

Section 3.1
AGING MANAGEMENT OF REACTOR VESSEL,
INTERNALS, AND REACTOR COOLANT SYSTEM

Table 3.1.2-2 Reactor Vessel, Internals, and Reactor Coolant System – Summary of Aging Management Evaluation – Reactor Coolant System(Continued)

Component Type	Intended Function	Material	Environment	Aging Effect Requiring Management	Aging Management Program	NUREG-1801 Vol. 2 Item	Table 1 Item	Notes
Piping	LBS, PB	Nickel Alloys	Reactor Coolant (Int)	Cracking	Nickel Alloy Aging Management (B2.1.34), ASME Section XI Inservice Inspection, Subsections IWB, IWC, and IWD (B2.1.1) for Class 1 components, Water Chemistry (B2.1.2), and Comply with applicable NRC Orders and FSAR Commitment (B2.1.21)	IV.C2-13	3.1.1.31	E, 1
Piping	LBS, PB	Nickel Alloys	Reactor Coolant (Int)	Loss of material	Water Chemistry (B2.1.2)	IV.C2-15	3.1.1.83	A
Piping	LBS, PB, S/A	Stainless Steel	Borated Water Leakage (Ext)	None	None	IV.E-3	3.1.1.86	A
Piping	PB	Stainless Steel	Lubricating Oil (Int)	Loss of material	Lubricating Oil Analysis (B2.1.23) and One-Time Inspection (B2.1.16)	VII.G-18	3.3.1.33	B
Piping	PB, S/A	Stainless Steel	Plant Indoor Air (Ext)	None	None	IV.E-2	3.1.1.86	A
Piping	S/A	Stainless Steel	Plant Indoor Air (Int)	None	None	IV.E-2	3.1.1.86	A, 2

Section 3.1
AGING MANAGEMENT OF REACTOR VESSEL,
INTERNALS, AND REACTOR COOLANT SYSTEM

Table 3.1.2-2 Reactor Vessel, Internals, and Reactor Coolant System – Summary of Aging Management Evaluation – Reactor Coolant System(Continued)

Component Type	Intended Function	Material	Environment	Aging Effect Requiring Management	Aging Management Program	NUREG-1801 Vol. 2 Item	Table 1 Item	Notes
Piping	LBS, PB, S/A	Stainless Steel	Reactor Coolant (Int)	Cracking	ASME Section XI Inservice Inspection, Subsections IWB, IWC, and IWD for Class 1 components (B2.1.1) and Water Chemistry (B2.1.2)	IV.C2-2	3.1.1.68	A
Piping	LBS, PB, S/A	Stainless Steel	Reactor Coolant (Int)	Loss of material	Water Chemistry (B2.1.2)	IV.C2-15	3.1.1.83	A
Piping	LBS, PB, S/A	Stainless Steel	Treated Borated Water (Int)	Cracking	ASME Section XI Inservice Inspection, Subsections IWB, IWC, and IWD for Class 1 components (B2.1.1) and Water Chemistry (B2.1.2)	IV.C2-22	3.1.1.68	C
Piping	LBS, PB, S/A	Stainless Steel	Treated Borated Water (Int)	Loss of material	Water Chemistry (B2.1.2)	V.D1-30	3.2.1.49	A
Pump	PB	Carbon Steel with Stainless Steel Cladding	Borated Water Leakage (Ext)	Loss of material	Boric Acid Corrosion (B2.1.4)	IV.C2-09	3.1.1.58	A

Section 3.1
AGING MANAGEMENT OF REACTOR VESSEL,
INTERNALS, AND REACTOR COOLANT SYSTEM

Table 3.1.2-2 Reactor Vessel, Internals, and Reactor Coolant System – Summary of Aging Management Evaluation – Reactor Coolant System(Continued)

Component Type	Intended Function	Material	Environment	Aging Effect Requiring Management	Aging Management Program	NUREG-1801 Vol. 2 Item	Table 1 Item	Notes
Pump	PB	Carbon Steel with Stainless Steel Cladding	Reactor Coolant (Int)	Cracking	ASME Section XI Inservice Inspection, Subsections IWB, IWC, and IWD for Class 1 components (B2.1.1) and Water Chemistry (B2.1.2)	IV.C2-5	3.1.1.68	A
Pump	PB	Carbon Steel with Stainless Steel Cladding	Reactor Coolant (Int)	Loss of material	Water Chemistry (B2.1.2)	IV.C2-15	3.1.1.83	A
Pump	PB	Carbon Steel with Stainless Steel Cladding	Reactor Coolant (Int)	Cumulative fatigue damage	Time-Limited Aging Analysis evaluated for the period of extended operation	IV.C2-25	3.1.1.08	A
Sight Gauge	PB	Carbon Steel	Lubricating Oil (Int)	Loss of material	Lubricating Oil Analysis (B2.1.23) and One-Time Inspection (B2.1.16)	VII.G-26	3.3.1.15	B
Sight Gauge	PB	Carbon Steel	Plant Indoor Air (Ext)	Loss of material	External Surfaces Monitoring Program (B2.1.20)	VII.I-8	3.3.1.58	A
Sight Gauge	PB	Glass	Lubricating Oil (Int)	None	None	V.F-7	3.2.1.52	A
Sight Gauge	PB	Glass	Plant Indoor Air (Ext)	None	None	V.F-6	3.2.1.52	A

Section 3.1
AGING MANAGEMENT OF REACTOR VESSEL,
INTERNALS, AND REACTOR COOLANT SYSTEM

Table 3.1.2-2 Reactor Vessel, Internals, and Reactor Coolant System – Summary of Aging Management Evaluation – Reactor Coolant System(Continued)

Component Type	Intended Function	Material	Environment	Aging Effect Requiring Management	Aging Management Program	NUREG-1801 Vol. 2 Item	Table 1 Item	Notes
Tank	PB	Carbon Steel	Lubricating Oil (Int)	Loss of material	Lubricating Oil Analysis (B2.1.23) and One-Time Inspection (B2.1.16)	VII.G-27	3.3.1.16	B
Tank	PB	Carbon Steel	Plant Indoor Air (Ext)	Loss of material	External Surfaces Monitoring Program (B2.1.20)	VII.I-8	3.3.1.58	A
Thermowell	PB	Nickel Alloys	Borated Water Leakage (Ext)	None	None	None	None	G
Thermowell	PB	Nickel Alloys	Reactor Coolant (Int)	Cracking	Nickel Alloy Aging Management (B2.1.34), ASME Section XI Inservice Inspection, Subsections IWB, IWC, and IWD (B2.1.1) for Class 1 components, Water Chemistry (B2.1.2), and Comply with applicable NRC Orders and FSAR Commitment (B2.1.21)	IV.C2-13	3.1.1.31	E, 1
Thermowell	PB	Nickel Alloys	Reactor Coolant (Int)	Loss of material	Water Chemistry (B2.1.2)	IV.C2-15	3.1.1.83	A
Tubing	PB	Stainless Steel	Borated Water Leakage (Ext)	None	None	IV.E-3	3.1.1.86	A

Section 3.1
AGING MANAGEMENT OF REACTOR VESSEL,
INTERNALS, AND REACTOR COOLANT SYSTEM

Table 3.1.2-2 Reactor Vessel, Internals, and Reactor Coolant System – Summary of Aging Management Evaluation – Reactor Coolant System(Continued)

Component Type	Intended Function	Material	Environment	Aging Effect Requiring Management	Aging Management Program	NUREG-1801 Vol. 2 Item	Table 1 Item	Notes
Tubing	PB	Stainless Steel	Reactor Coolant (Int)	Cracking	ASME Section XI Inservice Inspection, Subsections IW/B, IW/C, and IWD for Class 1 components (B2.1.1) and Water Chemistry (B2.1.2)	IV.C2-2	3.1.1.68	A
Tubing	PB	Stainless Steel	Reactor Coolant (Int)	Loss of material	Water Chemistry (B2.1.2)	IV.C2-15	3.1.1.83	A
Valve	LBS	Carbon Steel	Closed Cycle Cooling Water (Int)	Loss of material	Closed-Cycle Cooling Water System (B2.1.10)	IV.C2-14	3.1.1.53	B
Valve	PB	Carbon Steel	Lubricating Oil (Int)	Loss of material	Lubricating Oil Analysis (B2.1.23) and One-Time Inspection (B2.1.16)	VII.G-26	3.3.1.15	B
Valve	LBS, PB	Carbon Steel	Plant Indoor Air (Ext)	Loss of material	External Surfaces Monitoring Program (B2.1.20)	VII.I-8	3.3.1.58	A
Valve	LBS, PB, S/A	Stainless Steel	Borated Water Leakage (Ext)	None	None	IV.E-3	3.1.1.86	A
Valve	S/A	Stainless Steel	Plant Indoor Air (Ext)	None	None	IV.E-2	3.1.1.86	A
Valve	S/A	Stainless Steel	Plant Indoor Air (Int)	None	None	IV.E-2	3.1.1.86	A, 2

Section 3.1
AGING MANAGEMENT OF REACTOR VESSEL,
INTERNALS, AND REACTOR COOLANT SYSTEM

Table 3.1.2-2 Reactor Vessel, Internals, and Reactor Coolant System – Summary of Aging Management Evaluation – Reactor Coolant System(Continued)

Component Type	Intended Function	Material	Environment	Aging Effect Requiring Management	Aging Management Program	NUREG-1801 Vol. 2 Item	Table 1 Item	Notes
Valve	PB	Stainless Steel	Reactor Coolant (Int)	Cracking	ASME Section XI Inservice Inspection, Subsections IWB, IWC, and IWD for Class 1 components (B2.1.1) and Water Chemistry (B2.1.2)	IV.C2-5	3.1.1.68	A
Valve	PB	Stainless Steel	Reactor Coolant (Int)	Loss of material	Water Chemistry (B2.1.2)	IV.C2-15	3.1.1.83	A
Valve	PB	Stainless Steel	Reactor Coolant (Int)	Cumulative fatigue damage	Time-Limited Aging Analysis evaluated for the period of extended operation	IV.C2-25	3.1.1.08	A
Valve	LBS, PB, SIA	Stainless Steel	Treated Borated Water (Int)	Cracking	ASME Section XI Inservice Inspection, Subsections IWB, IWC, and IWD for Class 1 components (B2.1.1) and Water Chemistry (B2.1.2)	IV.C2-22	3.1.1.68	C
Valve	LBS, PB, SIA	Stainless Steel	Treated Borated Water (Int)	Loss of material	Water Chemistry (B2.1.2)	V.D1-30	3.2.1.49	A

Section 3.1
**AGING MANAGEMENT OF REACTOR VESSEL,
INTERNALS, AND REACTOR COOLANT SYSTEM**

Notes for Table 3.1.1.2-2:

Standard Notes:

- A Consistent with NUREG-1801 item for component, material, environment, and aging effect. AMP is consistent with NUREG-1801 AMP.
- B Consistent with NUREG-1801 item for component, material, environment, and aging effect. AMP takes some exceptions to NUREG-1801 AMP.
- C Component is different, but consistent with NUREG-1801 item for material, environment, and aging effect. AMP is consistent with NUREG-1801 AMP.
- E Consistent with NUREG-1801 for material, environment, and aging effect, but a different aging management program is credited or NUREG-1801 identifies a plant-specific aging management program.
- G Environment not in NUREG-1801 for this component and material.

Plant Specific Notes:

- 1 Note E was used to include the plant specific AMP for nickel-alloy aging management.
- 2 These items are assigned the environment of "Plant Indoor Air (Internal)". The items are vented or open to the plant atmosphere so the distinction between internal and external is not relevant for aging purposes.
- 3 NUREG-1801 does not include air with borated water leakage for nickel-alloy components. Similar to IV.E-3 for stainless steel, there are no aging effects for nickel alloy in air with borated water leakage.

Section 3.1
AGING MANAGEMENT OF REACTOR VESSEL,
INTERNALS, AND REACTOR COOLANT SYSTEM

Table 3.1.2-3 Reactor Vessel, Internals, and Reactor Coolant System – Summary of Aging Management Evaluation – Pressurizer

Component Type	Intended Function	Material	Environment	Aging Effect Requiring Management	Aging Management Program	NUREG-1801 Vol. 2 Item	Table 1 Item	Notes
Closure Bolting	PB	High Strength Low Alloy Steel (Bolting)	Borated Water Leakage (Ext)	Cracking	Bolting Integrity (B2.1.7)	IV.C2-7	3.1.1.52	B
Closure Bolting	PB	High Strength Low Alloy Steel (Bolting)	Borated Water Leakage (Ext)	Loss of preload	Bolting Integrity (B2.1.7)	IV.C2-8	3.1.1.52	B
Closure Bolting	PB	High Strength Low Alloy Steel (Bolting)	Borated Water Leakage (Ext)	Loss of material	Boric Acid Corrosion (B2.1.4)	IV.C2-09	3.1.1.58	A
PZR Heater Bundle Diaphragm Plate	SS	Nickel Alloys	Reactor Coolant (Ext)	Loss of material	Water Chemistry (B2.1.2)	IV.C2-15	3.1.1.83	C

Section 3.1
AGING MANAGEMENT OF REACTOR VESSEL,
INTERNALS, AND REACTOR COOLANT SYSTEM

Table 3.1.2-3 Reactor Vessel, Internals, and Reactor Coolant System – Summary of Aging Management Evaluation – Pressurizer
(Continued)

Component Type	Intended Function	Material	Environment	Aging Effect Requiring Management	Aging Management Program	NUREG-1801 Vol. 2 Item	Table 1 Item	Notes
PZR Heater Bundle Diaphragm Plate	SS	Nickel Alloys	Reactor Coolant (Ext)	Cracking	Nickel Alloy Aging Management (B2.1.34), ASME Section XI Inservice Inspection, Subsections IWB, IWC, and IWD (B2.1.1) for Class 1 components, Water Chemistry (B2.1.2), and Comply with applicable NRC Orders and FSAR Commitment (B2.1.21)	IV.C2-21	3.1.1.31	E, 1
PZR Heater Bundle Diaphragm Plate	SS	Stainless Steel	Reactor Coolant (Ext)	Loss of material	Water Chemistry (B2.1.2)	IV.C2-15	3.1.1.83	C
PZR Heater Bundle Diaphragm Plate	SS	Stainless Steel	Reactor Coolant (Ext)	Cracking	ASME Section XI Inservice Inspection, Subsections IWB, IWC, and IWD for Class 1 components (B2.1.1) and Water Chemistry (B2.1.2)	IV.C2-18	3.1.1.67	A

Section 3.1
AGING MANAGEMENT OF REACTOR VESSEL,
INTERNALS, AND REACTOR COOLANT SYSTEM

Table 3.1.2-3 Reactor Vessel, Internals, and Reactor Coolant System – Summary of Aging Management Evaluation – Pressurizer
(Continued)

Component Type	Intended Function	Material	Environment	Aging Effect Requiring Management	Aging Management Program	NUREG-1801 Vol. 2 Item	Table 1 Item	Notes
PZR Heater Bundle Diaphragm Plate	SS	Stainless Steel	Reactor Coolant (Ext)	Cracking	ASME Section XI Inservice Inspection, Subsections IWB, IWC, and IWD for Class 1 components (B2.1.1) and Water Chemistry (B2.1.2)	IV.C2-20	3.1.1.68	A
PZR Heater Sheaths and Sleeves	PB	Nickel Alloys	Borated Water Leakage (Ext)	None	None	None	None	G, 2
PZR Heater Sheaths and Sleeves	PB	Nickel Alloys	Reactor Coolant (Int)	Loss of material	Water Chemistry (B2.1.2)	IV.C2-15	3.1.1.83	A
PZR Heater Sheaths and Sleeves	PB	Nickel Alloys	Reactor Coolant (Int)	Cracking	Nickel Alloy Aging Management (B2.1.34), ASME Section XI Inservice Inspection, Subsections IWB, IWC, and IWD (B2.1.1) for Class 1 components, Water Chemistry (B2.1.2), and Comply with applicable NRC Orders and FSAR Commitment (B2.1.21)	IV.C2-21	3.1.1.31	E, 1

Section 3.1
AGING MANAGEMENT OF REACTOR VESSEL,
INTERNALS, AND REACTOR COOLANT SYSTEM

Table 3.1.2-3 Reactor Vessel, Internals, and Reactor Coolant System – Summary of Aging Management Evaluation – Pressurizer
(Continued)

Component Type	Intended Function	Material	Environment	Aging Effect Requiring Management	Aging Management Program	NUREG-1801 Vol. 2 Item	Table 1 Item	Notes
PZR Heater Sheaths and Sleeves	PB	Nickel Alloys	Reactor Coolant (Int)	Cumulative fatigue damage	Time-Limited Aging Analysis evaluated for the period of extended operation	IV.C2-25	3.1.1.08	A
PZR Heater Sheaths and Sleeves	PB	Stainless Steel	Borated Water Leakage (Ext)	None	None	IV.E-3	3.1.1.86	C
PZR Heater Sheaths and Sleeves	PB	Stainless Steel	Reactor Coolant (Int)	Loss of material	Water Chemistry (B2.1.2)	IV.C2-15	3.1.1.83	A
PZR Heater Sheaths and Sleeves	PB	Stainless Steel	Reactor Coolant (Int)	Cracking	ASME Section XI Inservice Inspection, Subsections IWB, IWC, and IWD for Class 1 components (B2.1.1) and Water Chemistry (B2.1.2)	IV.C2-18	3.1.1.67	A
PZR Heater Sheaths and Sleeves	PB	Stainless Steel	Reactor Coolant (Int)	Cracking	ASME Section XI Inservice Inspection, Subsections IWB, IWC, and IWD for Class 1 components (B2.1.1) and Water Chemistry (B2.1.2)	IV.C2-20	3.1.1.68	A
PZR Heater Sheaths and Sleeves	PB	Stainless Steel	Reactor Coolant (Int)	Cumulative fatigue damage	Time-Limited Aging Analysis evaluated for the period of extended operation	IV.C2-25	3.1.1.08	A

Section 3.1
AGING MANAGEMENT OF REACTOR VESSEL,
INTERNALS, AND REACTOR COOLANT SYSTEM

Table 3.1.2-3 Reactor Vessel, Internals, and Reactor Coolant System – Summary of Aging Management Evaluation – Pressurizer
(Continued)

Component Type	Intended Function	Material	Environment	Aging Effect Requiring Management	Aging Management Program	NUREG-1801 Vol. 2 Item	Table 1 Item	Notes
PZR Instrument Penetrations	PB	Nickel Alloys	Borated Water Leakage (Ext)	None	None	None	None	G, 2
PZR Instrument Penetrations	PB	Nickel Alloys	Reactor Coolant (Int)	Loss of material	Water Chemistry (B2.1.2)	IV.C2-15	3.1.1.83	A
PZR Instrument Penetrations	PB	Nickel Alloys	Reactor Coolant (Int)	Cracking	Nickel Alloy Aging Management (B2.1.34), ASME Section XI Inservice Inspection, Subsections IWB, IWC, and IWD (B2.1.1) for Class 1 components, Water Chemistry (B2.1.2), and Comply with applicable NRC Orders and FSAR Commitment (B2.1.21)	IV.C2-21	3.1.1.31	E, 1
PZR Instrument Penetrations	PB	Nickel Alloys	Reactor Coolant (Int)	Cumulative fatigue damage	Time-Limited Aging Analysis evaluated for the period of extended operation	IV.C2-25	3.1.1.08	A
PZR Integral Support	SS	Carbon Steel	Borated Water Leakage (Ext)	Loss of material	Boric Acid Corrosion (B2.1.4)	IV.C2-09	3.1.1.58	A
PZR Integral Support	SS	Carbon Steel	Borated Water Leakage (Ext)	Cracking	ASME Section XI Inservice Inspection, Subsections IWB, IWC, and IWD (B2.1.1)	IV.C2-16	3.1.1.61	A

Palo Verde Nuclear Generating Station
License Renewal Application

Section 3.1
AGING MANAGEMENT OF REACTOR VESSEL,
INTERNALS, AND REACTOR COOLANT SYSTEM

Table 3.1.2-3 Reactor Vessel, Internals, and Reactor Coolant System – Summary of Aging Management Evaluation – Pressurizer
(Continued)

Component Type	Intended Function	Material	Environment	Aging Effect Requiring Management	Aging Management Program	NUREG-1801 Vol. 2 Item	Table 1 Item	Notes
PZR Lower Head	PB	Carbon Steel with Nickel-Alloy Cladding	Borated Water Leakage (Ext)	Loss of material	Boric Acid Corrosion (B2.1.4)	IV.C2-09	3.1.1.58	A
PZR Lower Head	PB	Carbon Steel with Nickel-Alloy Cladding	Reactor Coolant (Int)	Loss of material	Water Chemistry (B2.1.2)	IV.C2-15	3.1.1.83	A
PZR Lower Head	PB	Carbon Steel with Nickel-Alloy Cladding	Reactor Coolant (Int)	Cracking	ASME Section XI Inservice Inspection, Subsections IWB, IWC, and IWD for Class 1 components (B2.1.1) and Water Chemistry (B2.1.2)	IV.C2-18	3.1.1.67	A
PZR Lower Head	PB	Carbon Steel with Nickel-Alloy Cladding	Reactor Coolant (Int)	Cracking	ASME Section XI Inservice Inspection, Subsections IWB, IWC, and IWD for Class 1 components (B2.1.1) and Water Chemistry (B2.1.2)	IV.C2-19	3.1.1.64	A
PZR Lower Head	PB	Carbon Steel with Nickel-Alloy Cladding	Reactor Coolant (Int)	Cumulative fatigue damage	Time-Limited Aging Analysis evaluated for the period of extended operation	IV.C2-25	3.1.1.08	A
PZR Manways and Covers	PB	Carbon Steel	Borated Water Leakage (Ext)	Loss of material	Boric Acid Corrosion (B2.1.4)	IV.C2-09	3.1.1.58	A

Section 3.1
AGING MANAGEMENT OF REACTOR VESSEL,
INTERNALS, AND REACTOR COOLANT SYSTEM

Table 3.1.2-3 Reactor Vessel, Internals, and Reactor Coolant System – Summary of Aging Management Evaluation – Pressurizer
(Continued)

Component Type	Intended Function	Material	Environment	Aging Effect Requiring Management	Aging Management Program	NUREG-1801 Vol. 2 Item	Table 1 Item	Notes
PZR Manways and Covers	PB	Stainless Steel	Borated Water Leakage (Ext)	None	None	IV.E-3	3.1.1.86	C
PZR Manways and Covers	PB	Stainless Steel	Reactor Coolant (Int)	Loss of material	Water Chemistry (B2.1.2)	IV.C2-15	3.1.1.83	C
PZR Manways and Covers	PB	Stainless Steel	Reactor Coolant (Int)	Cracking	ASME Section XI Inservice Inspection, Subsections IWB, IWC, and IWD for Class 1 components (B2.1.1) and Water Chemistry (B2.1.2)	IV.C2-18	3.1.1.67	A
PZR Manways and Covers	PB	Stainless Steel	Reactor Coolant (Int)	Cracking	ASME Section XI Inservice Inspection, Subsections IWB, IWC, and IWD for Class 1 components (B2.1.1) and Water Chemistry (B2.1.2)	IV.C2-19	3.1.1.64	A
PZR Nozzle Thermal Sleeves	SH	Nickel Alloys	Reactor Coolant (Ext)	Loss of material	Water Chemistry (B2.1.2)	IV.C2-15	3.1.1.83	A

Section 3.1
AGING MANAGEMENT OF REACTOR VESSEL,
INTERNALS, AND REACTOR COOLANT SYSTEM

Table 3.1.2-3 Reactor Vessel, Internals, and Reactor Coolant System – Summary of Aging Management Evaluation – Pressurizer
(Continued)

Component Type	Intended Function	Material	Environment	Aging Effect Requiring Management	Aging Management Program	NUREG-1801 Vol. 2 Item	Table 1 Item	Notes
PZR Nozzle Thermal Sleeves	SH	Nickel Alloys	Reactor Coolant (Ext)	Cracking	Nickel Alloy Aging Management (B2.1.34), ASME Section XI Inservice Inspection, Subsections IWB, IWC, and IWD (B2.1.1) for Class 1 components, Water Chemistry (B2.1.2), and Comply with applicable NRC Orders and FSAR Commitment (B2.1.21)	IV.C2-24	3.1.1.31	E, 1
PZR Nozzle Thermal Sleeves	SH	Nickel Alloys	Reactor Coolant (Int)	Loss of material	Water Chemistry (B2.1.2)	IV.C2-15	3.1.1.83	A
PZR Nozzle Thermal Sleeves	SH	Nickel Alloys	Reactor Coolant (Int)	Cracking	Nickel Alloy Aging Management (B2.1.34), ASME Section XI Inservice Inspection, Subsections IWB, IWC, and IWD (B2.1.1) for Class 1 components, Water Chemistry (B2.1.2), and Comply with applicable NRC Orders and FSAR Commitment (B2.1.21)	IV.C2-24	3.1.1.31	E, 1

Section 3.1
AGING MANAGEMENT OF REACTOR VESSEL,
INTERNALS, AND REACTOR COOLANT SYSTEM

Table 3.1.2-3 Reactor Vessel, Internals, and Reactor Coolant System – Summary of Aging Management Evaluation – Pressurizer
(Continued)

Component Type	Intended Function	Material	Environment	Aging Effect Requiring Management	Aging Management Program	NUREG-1801 Vol. 2 Item	Table 1 Item	Notes
PZR Nozzles	PB	Carbon Steel with Stainless Steel Cladding	Borated Water Leakage (Ext)	Loss of material	Boric Acid Corrosion (B2.1.4)	IV.C2-09	3.1.1.58	A
PZR Nozzles	PB	Carbon Steel with Stainless Steel Cladding	Reactor Coolant (Int)	Loss of material	Water Chemistry (B2.1.2)	IV.C2-15	3.1.1.83	C
PZR Nozzles	PB	Carbon Steel with Stainless Steel Cladding	Reactor Coolant (Int)	Cracking	ASME Section XI Inservice Inspection, Subsections IWB, IWC, and IWD for Class 1 components (B2.1.1) and Water Chemistry (B2.1.2)	IV.C2-18	3.1.1.67	A
PZR Nozzles	PB	Carbon Steel with Stainless Steel Cladding	Reactor Coolant (Int)	Cracking	ASME Section XI Inservice Inspection, Subsections IWB, IWC, and IWD for Class 1 components (B2.1.1) and Water Chemistry (B2.1.2)	IV.C2-19	3.1.1.64	A

Section 3.1
AGING MANAGEMENT OF REACTOR VESSEL,
INTERNALS, AND REACTOR COOLANT SYSTEM

Table 3.1.2-3 Reactor Vessel, Internals, and Reactor Coolant System – Summary of Aging Management Evaluation – Pressurizer
(Continued)

Component Type	Intended Function	Material	Environment	Aging Effect Requiring Management	Aging Management Program	NUREG-1801 Vol. 2 Item	Table 1 Item	Notes
PZR Nozzles	PB	Carbon Steel with Stainless Steel Cladding	Reactor Coolant (Int)	Cumulative fatigue damage	Time-Limited Aging Analysis evaluated for the period of extended operation	IV.C2-25	3.1.1.08	A
PZR Safe Ends	PB	Stainless Steel	Borated Water Leakage (Ext)	None	None	IV.E-3	3.1.1.86	A
PZR Safe Ends	PB	Stainless Steel	Reactor Coolant (Int)	Loss of material	Water Chemistry (B2.1.2)	IV.C2-15	3.1.1.83	A
PZR Safe Ends	PB	Stainless Steel	Reactor Coolant (Int)	Cracking	ASME Section XI Inservice Inspection, Subsections IWB, IWC, and IWD for Class 1 components (B2.1.1) and Water Chemistry (B2.1.2)	IV.C2-18	3.1.1.67	A
PZR Safe Ends	PB	Stainless Steel	Reactor Coolant (Int)	Cracking	ASME Section XI Inservice Inspection, Subsections IWB, IWC, and IWD for Class 1 components (B2.1.1) and Water Chemistry (B2.1.2)	IV.C2-19	3.1.1.64	A
PZR Safe Ends	PB	Stainless Steel	Reactor Coolant (Int)	Cumulative fatigue damage	Time-Limited Aging Analysis evaluated for the period of extended operation	IV.C2-25	3.1.1.08	A

Section 3.1
AGING MANAGEMENT OF REACTOR VESSEL,
INTERNALS, AND REACTOR COOLANT SYSTEM

Table 3.1.2-3 Reactor Vessel, Internals, and Reactor Coolant System – Summary of Aging Management Evaluation – Pressurizer
(Continued)

Component Type	Intended Function	Material	Environment	Aging Effect Requiring Management	Aging Management Program	NUREG-1801 Vol. 2 Item	Table 1 Item	Notes
PZR Shell and Upper Head	PB	Carbon Steel with Stainless Steel Cladding	Borated Water Leakage (Ext)	Loss of material	Boric Acid Corrosion (B2.1.4)	IV.C2-09	3.1.1.58	A
PZR Shell and Upper Head	PB	Carbon Steel with Stainless Steel Cladding	Reactor Coolant (Int)	Loss of material	Water Chemistry (B2.1.2)	IV.C2-15	3.1.1.83	A
PZR Shell and Upper Head	PB	Carbon Steel with Stainless Steel Cladding	Reactor Coolant (Int)	Cracking	ASME Section XI Inservice Inspection, Subsections IWB, IWC, and IWD for Class 1 components (B2.1.1) and Water Chemistry (B2.1.2)	IV.C2-18	3.1.1.67	A
PZR Shell and Upper Head	PB	Carbon Steel with Stainless Steel Cladding	Reactor Coolant (Int)	Cracking	ASME Section XI Inservice Inspection, Subsections IWB, IWC, and IWD for Class 1 components (B2.1.1) and Water Chemistry (B2.1.2)	IV.C2-19	3.1.1.64	A

Section 3.1
AGING MANAGEMENT OF REACTOR VESSEL,
INTERNALS, AND REACTOR COOLANT SYSTEM

Table 3.1.2-3 Reactor Vessel, Internals, and Reactor Coolant System – Summary of Aging Management Evaluation – Pressurizer
(Continued)

Component Type	Intended Function	Material	Environment	Aging Effect Requiring Management	Aging Management Program	NUREG-1801 Vol. 2 Item	Table 1 Item	Notes
PZR Shell and Upper Head	PB	Carbon Steel with Stainless Steel Cladding	Reactor Coolant (Int)	Cumulative fatigue damage	Time-Limited Aging Analysis evaluated for the period of extended operation	IV.C2-25	3.1.1.08	A

Notes for Table 3.1.2-3:

Standard Notes:

- A Consistent with NUREG-1801 item for component, material, environment, and aging effect. AMP is consistent with NUREG-1801 AMP.
- B Consistent with NUREG-1801 item for component, material, environment, and aging effect. AMP takes some exceptions to NUREG-1801 AMP.
- C Component is different, but consistent with NUREG-1801 item for material, environment, and aging effect. AMP is consistent with NUREG-1801 AMP.
- E Consistent with NUREG-1801 for material, environment, and aging effect, but a different aging management program is credited or NUREG-1801 identifies a plant-specific aging management program.
- G Environment not in NUREG-1801 for this component and material.

Plant Specific Notes:

- 1 Note E was used to include the plant specific AMP for nickel alloy aging management.
- 2 NUREG-1801 does not include air with borated water leakage for nickel alloy components. Similar to IV.E-3 for stainless steel, there are no aging effects for nickel alloy in air with borated water leakage.

Section 3.1
AGING MANAGEMENT OF REACTOR VESSEL,
INTERNALS, AND REACTOR COOLANT SYSTEM

Table 3.1.2-4 Reactor Vessel, Internals, and Reactor Coolant System – Summary of Aging Management Evaluation – Steam Generators

Component Type	Intended Function	Material	Environment	Aging Effect Requiring Management	Aging Management Program	NUREG-1801 Vol. 2 Item	Table 1 Item	Notes
SG Closure Bolting	PB	Carbon Steel	Borated Water Leakage (Ext)	Cracking	Bolting Integrity (B2.1.7)	IV.D1-2	3.1.1.52	B
SG Closure Bolting	PB	Carbon Steel	Borated Water Leakage (Ext)	Loss of material	Boric Acid Corrosion (B2.1.4)	IV.D1-3	3.1.1.58	A
SG Closure Bolting	PB	Carbon Steel	Borated Water Leakage (Ext)	Loss of preload	Bolting Integrity (B2.1.7)	IV.D1-10	3.1.1.52	B
SG Closure Bolting	PB	Carbon Steel	Plant Indoor Air (Ext)	Loss of material	Bolting Integrity (B2.1.7)	V.E-4	3.2.1.23	B
SG Closure Bolting	PB	Carbon Steel	Plant Indoor Air (Ext)	Loss of preload	Bolting Integrity (B2.1.7)	V.E-5	3.2.1.24	B
SG Feeding	DF	Carbon Steel	Secondary Water (Ext)	Wall thinning	Steam Generator Tubing Integrity (B2.1.8) and Water Chemistry (B2.1.2)	IV.D1-26	3.1.1.32	E, 1
SG Feeding	DF	Carbon Steel	Secondary Water (Int)	Wall thinning	Steam Generator Tubing Integrity (B2.1.8) and Water Chemistry (B2.1.2)	IV.D1-26	3.1.1.32	E, 1
SG Flow Distribution Baffle	DF	Stainless Steel	Secondary Water (Ext)	Cracking	Steam Generator Tubing Integrity (B2.1.8) and Water Chemistry (B2.1.2)	IV.D1-14	3.1.1.74	C

Section 3.1
AGING MANAGEMENT OF REACTOR VESSEL,
INTERNALS, AND REACTOR COOLANT SYSTEM

Table 3.1.2-4 Reactor Vessel, Internals, and Reactor Coolant System – Summary of Aging Management Evaluation – Steam Generators (Continued)

Component Type	Intended Function	Material	Environment	Aging Effect Requiring Management	Aging Management Program	NUREG-1801 Vol. 2 Item	Table 1 Item	Notes
SG Flow Distribution Baffle	DF	Stainless Steel	Secondary Water (Ext)	Loss of material	Steam Generator Tubing Integrity (B2.1.8) and Water Chemistry (B2.1.2)	IV.D1-15	3.1.1.74	C
SG Internal Structures	DF	Carbon Steel	Secondary Water (Ext)	Loss of material	Steam Generator Tubing Integrity (B2.1.8) and Water Chemistry (B2.1.2)	IV.D1-9	3.1.1.76	A
SG Internal Structures	SS	Carbon Steel	Secondary Water (Ext)	Loss of material	Steam Generator Tubing Integrity (B2.1.8) and Water Chemistry (B2.1.2)	IV.D1-9	3.1.1.76	C
SG Internal Structures	SS	Stainless Steel	Secondary Water (Ext)	Cracking	Steam Generator Tubing Integrity (B2.1.8) and Water Chemistry (B2.1.2)	IV.D1-14	3.1.1.74	C
SG Internal Structures	SS	Stainless Steel	Secondary Water (Ext)	Loss of material	Steam Generator Tubing Integrity (B2.1.8) and Water Chemistry (B2.1.2)	IV.D1-15	3.1.1.74	C
SG Plugs and Stakes	PB	Nickel Alloys	Reactor Coolant (Int)	Cracking	Steam Generator Tubing Integrity (B2.1.8) and Water Chemistry (B2.1.2)	IV.D1-18	3.1.1.73	A

Section 3.1
AGING MANAGEMENT OF REACTOR VESSEL,
INTERNALS, AND REACTOR COOLANT SYSTEM

Table 3.1.2-4 Reactor Vessel, Internals, and Reactor Coolant System – Summary of Aging Management Evaluation – Steam Generators (Continued)

Component Type	Intended Function	Material	Environment	Aging Effect Requiring Management	Aging Management Program	NUREG-1801 Vol. 2 Item	Table 1 Item	Notes
SG Plugs and Stakes	PB	Nickel Alloys	Secondary Water (Ext)	Cracking	Steam Generator Tubing Integrity (B2.1.8) and Water Chemistry (B2.1.2)	IV.D1-22	3.1.1.72	C
SG Plugs and Stakes	SS	Stainless Steel	Secondary Water (Ext)	Cracking	Steam Generator Tubing Integrity (B2.1.8) and Water Chemistry (B2.1.2)	IV.D1-14	3.1.1.74	C
SG Plugs and Stakes	SS	Stainless Steel	Secondary Water (Ext)	Loss of material	Steam Generator Tubing Integrity (B2.1.8) and Water Chemistry (B2.1.2)	IV.D1-15	3.1.1.74	C
SG Primary Head	PB	Carbon Steel with Stainless Steel Cladding	Borated Water Leakage (Ext)	Loss of material	Boric Acid Corrosion (B2.1.4)	IV.D1-3	3.1.1.58	A
SG Primary Head	PB	Carbon Steel with Stainless Steel Cladding	Reactor Coolant (Int)	Cracking	ASME Section XI Inservice Inspection, Subsections IWB, IWC, and IWD for Class 1 components (B2.1.1) and Water Chemistry (B2.1.2)	IV.D1-1	3.1.1.68	A

Section 3.1
AGING MANAGEMENT OF REACTOR VESSEL,
INTERNALS, AND REACTOR COOLANT SYSTEM

Table 3.1.2-4 Reactor Vessel, Internals, and Reactor Coolant System – Summary of Aging Management Evaluation – Steam Generators (Continued)

Component Type	Intended Function	Material	Environment	Aging Effect Requiring Management	Aging Management Program	NUREG-1801 Vol. 2 Item	Table 1 Item	Notes
SG Primary Head	PB	Carbon Steel with Stainless Steel Cladding	Reactor Coolant (Int)	Cumulative fatigue damage	Time-Limited Aging Analysis evaluated for the period of extended operation	IV.D1-8	3.1.1.10	A
SG Primary Head Divider Plate	DF	Nickel Alloys	Reactor Coolant (Ext)	Cracking	Water Chemistry (B2.1.2)	IV.D1-6	3.1.1.81	A
SG Primary Manways and Flanges	PB	Carbon Steel with Stainless Steel Cladding	Borated Water Leakage (Ext)	Loss of material	Boric Acid Corrosion (B2.1.4)	IV.D1-3	3.1.1.58	A
SG Primary Manways and Flanges	PB	Carbon Steel with Stainless Steel Cladding	Reactor Coolant (Int)	Cracking	ASME Section XI Inservice Inspection, Subsections IWB, IWC, and IWD for Class 1 components (B2.1.1) and Water Chemistry (B2.1.2)	IV.D1-1	3.1.1.68	A
SG Primary Manways and Flanges	PB	Carbon Steel with Stainless Steel Cladding	Reactor Coolant (Int)	Cumulative fatigue damage	Time-Limited Aging Analysis evaluated for the period of extended operation	IV.D1-8	3.1.1.10	A
SG Primary Nozzle Dam Retention Ring	NSRS	Nickel Alloys	Reactor Coolant (Ext)	Cracking	Water Chemistry (B2.1.2)	IV.D1-6	3.1.1.81	C

Palo Verde Nuclear Generating Station
License Renewal Application

Section 3.1
AGING MANAGEMENT OF REACTOR VESSEL,
INTERNALS, AND REACTOR COOLANT SYSTEM

Table 3.1.2-4 Reactor Vessel, Internals, and Reactor Coolant System – Summary of Aging Management Evaluation – Steam Generators (Continued)

Component Type	Intended Function	Material	Environment	Aging Effect Requiring Management	Aging Management Program	NUREG-1801 Vol. 2 Item	Table 1 Item	Notes
SG Primary Nozzles and Safe Ends	PB	Carbon Steel with Stainless Steel Cladding	Borated Water Leakage (Ext)	Loss of material	Boric Acid Corrosion (B2.1.4)	IV.D1-3	3.1.1.58	A
SG Primary Nozzles and Safe Ends	PB	Carbon Steel with Stainless Steel Cladding	Reactor Coolant (Int)	Cracking	ASME Section XI Inservice Inspection, Subsections IWB, IWC, and IWD for Class 1 components (B2.1.1) and Water Chemistry (B2.1.2)	IV.D1-1	3.1.1.68	A
SG Primary Nozzles and Safe Ends	PB	Carbon Steel with Stainless Steel Cladding	Reactor Coolant (Int)	Cumulative fatigue damage	Time-Limited Aging Analysis evaluated for the period of extended operation	IV.D1-8	3.1.1.10	A
SG Primary Nozzles and Safe Ends	PB	Nickel Alloys	Borated Water Leakage (Ext)	None	None	None	None	G

Section 3.1
AGING MANAGEMENT OF REACTOR VESSEL,
INTERNALS, AND REACTOR COOLANT SYSTEM

Table 3.1.2-4 Reactor Vessel, Internals, and Reactor Coolant System – Summary of Aging Management Evaluation – Steam Generators (Continued)

Component Type	Intended Function	Material	Environment	Aging Effect Requiring Management	Aging Management Program	NUREG-1801 Vol. 2 Item	Table 1 Item	Notes
SG Primary Nozzles and Safe Ends	PB	Nickel Alloys	Reactor Coolant (Int)	Cracking	Nickel Alloy Aging Management (B2.1.34), ASME Section XI Inservice Inspection, Subsections IWB, IWC, and IWD (B2.1.1) for Class 1 components, Water Chemistry (B2.1.2), and Comply with applicable NRC Orders and FSAR Commitment (B2.1.21)	IV.D1-4	3.1.1.31	E, 2
SG Secondary Manways and Flanges	PB	Carbon Steel	Plant Indoor Air (Ext)	Loss of material	External Surfaces Monitoring Program (B2.1.20)	V.E-7	3.2.1.31	A
SG Secondary Manways and Flanges	PB	Carbon Steel	Secondary Water (Int)	Cumulative fatigue damage	Time-Limited Aging Analysis evaluated for the period of extended operation	IV.D1-11	3.1.1.07	A
SG Secondary Manways and Flanges	PB	Carbon Steel	Secondary Water (Int)	Loss of material	ASME Section XI Inservice Inspection, Subsections IWB, IWC, and IWD for Class 2 components (B2.1.1) and Water Chemistry (B2.1.2)	IV.D1-12	3.1.1.16	A

Section 3.1
AGING MANAGEMENT OF REACTOR VESSEL,
INTERNALS, AND REACTOR COOLANT SYSTEM

Table 3.1.2-4 Reactor Vessel, Internals, and Reactor Coolant System – Summary of Aging Management Evaluation – Steam Generators (Continued)

Component Type	Intended Function	Material	Environment	Aging Effect Requiring Management	Aging Management Program	NUREG-1801 Vol. 2 Item	Table 1 Item	Notes
SG Secondary Nozzles and Safe Ends	PB, TH	Carbon Steel	Plant Indoor Air (Ext)	Loss of material	External Surfaces Monitoring Program (B2.1.20)	V.E-7	3.2.1.31	A
SG Secondary Nozzles and Safe Ends	PB, TH	Carbon Steel	Secondary Water (Int)	Wall thinning	Flow-Accelerated Corrosion (B2.1.6)	IV.D1-5	3.1.1.59	B
SG Secondary Nozzles and Safe Ends	PB	Carbon Steel	Secondary Water (Int)	Cumulative fatigue damage	Time-Limited Aging Analysis evaluated for the period of extended operation	IV.D1-11	3.1.1.07	A
SG Secondary Nozzles and Safe Ends	PB, TH	Carbon Steel	Secondary Water (Int)	Loss of material	ASME Section XI Inservice Inspection, Subsections IWB, IWC, and IWD for Class 2 components (B2.1.1) and Water Chemistry (B2.1.2)	IV.D1-12	3.1.1.16	C
SG Secondary Nozzles and Safe Ends	PB	Nickel Alloys	Plant Indoor Air (Ext)	None	None	IV.E-1	3.1.1.85	A
SG Secondary Nozzles and Safe Ends	PB	Nickel Alloys	Secondary Water (Int)	Cracking	ASME Section XI Inservice Inspection, Subsections IWB, IWC, and IWD for Class 1 components (B2.1.1) and Water Chemistry (B2.1.2)	IV.D2-9	3.1.1.84	A

Section 3.1
AGING MANAGEMENT OF REACTOR VESSEL,
INTERNALS, AND REACTOR COOLANT SYSTEM

Table 3.1.2-4 Reactor Vessel, Internals, and Reactor Coolant System – Summary of Aging Management Evaluation – Steam Generators (Continued)

Component Type	Intended Function	Material	Environment	Aging Effect Requiring Management	Aging Management Program	NUREG-1801 Vol. 2 Item	Table 1 Item	Notes
SG Secondary Shell	PB	Carbon Steel	Plant Indoor Air (Ext)	Loss of material	External Surfaces Monitoring Program (B2.1.20)	V.E-7	3.2.1.31	A
SG Secondary Shell	PB	Carbon Steel	Secondary Water (Int)	Cumulative fatigue damage	Time-Limited Aging Analysis evaluated for the period of extended operation	IV.D1-11	3.1.1.07	A
SG Secondary Shell	PB	Carbon Steel	Secondary Water (Int)	Loss of material	ASME Section XI Inservice Inspection, Subsections IWB, IWC, and IWD for Class 2 components (B2.1.1) and Water Chemistry (B2.1.2)	IV.D1-12	3.1.1.16	A
SG Tubes	HT, PB	Nickel Alloys	Reactor Coolant (Int)	Cracking	Steam Generator Tubing Integrity (B2.1.8) and Water Chemistry (B2.1.2)	IV.D1-20	3.1.1.73	A
SG Tubes	HT, PB	Nickel Alloys	Secondary Water (Ext)	Denting	Steam Generator Tubing Integrity (B2.1.8) and Water Chemistry (B2.1.2)	IV.D1-19	3.1.1.79	A
SG Tubes	HT, PB	Nickel Alloys	Secondary Water (Ext)	Cracking	Steam Generator Tubing Integrity (B2.1.8) and Water Chemistry (B2.1.2)	IV.D1-22	3.1.1.72	A

Section 3.1
AGING MANAGEMENT OF REACTOR VESSEL,
INTERNALS, AND REACTOR COOLANT SYSTEM

Table 3.1.2-4 Reactor Vessel, Internals, and Reactor Coolant System – Summary of Aging Management Evaluation – Steam Generators (Continued)

Component Type	Intended Function	Material	Environment	Aging Effect Requiring Management	Aging Management Program	NUREG-1801 Vol. 2 Item	Table 1 Item	Notes
SG Tubes	HT, PB	Nickel Alloys	Secondary Water (Ext)	Cracking	Steam Generator Tubing Integrity (B2.1.8) and Water Chemistry (B2.1.2)	IV.D1-23	3.1.1.72	A
SG Tubes	HT, PB	Nickel Alloys	Secondary Water (Ext)	Loss of material	Steam Generator Tubing Integrity (B2.1.8) and Water Chemistry (B2.1.2)	IV.D1-24	3.1.1.72	A
SG Tubesheet	PB	Carbon Steel with Nickel-Alloy Cladding	Reactor Coolant (Ext)	Cracking	Nickel Alloy Aging Management (B2.1.34), ASME Section XI Inservice Inspection, Subsections IWB, IWC, and IWD (B2.1.1) for Class 1 components, Water Chemistry (B2.1.2), and Comply with applicable NRC Orders and FSAR Commitment (B2.1.21)	IV.D1-4	3.1.1.31	E, 2
SG Tubesheet	PB	Carbon Steel with Nickel-Alloy Cladding	Reactor Coolant (Int)	Cumulative fatigue damage	Time-Limited Aging Analysis evaluated for the period of extended operation	IV.D1-8	3.1.1.10	A

Section 3.1
AGING MANAGEMENT OF REACTOR VESSEL,
INTERNALS, AND REACTOR COOLANT SYSTEM

Table 3.1.2-4 Reactor Vessel, Internals, and Reactor Coolant System – Summary of Aging Management Evaluation – Steam Generators (Continued)

Component Type	Intended Function	Material	Environment	Aging Effect Requiring Management	Aging Management Program	NUREG-1801 Vol. 2 Item	Table 1 Item	Notes
SG Tubesheet	PB	Carbon Steel with Nickel-Alloy Cladding	Secondary Water (Int)	Loss of material	ASME Section XI Inservice Inspection, Subsections IWB, IW/C, and IWD for Class 2 components (B2.1.1) and Water Chemistry (B2.1.2)	IV.D1-12	3.1.1.16	C
Tubing	PB	Stainless Steel	Plant Indoor Air (Ext)	None	None	IV.E-2	3.1.1.86	A
Tubing	PB	Stainless Steel	Secondary Water (Int)	Loss of material	Water Chemistry (B2.1.2) and One-Time Inspection (B2.1.16)	VIII.B1-4	3.4.1.16	A
Tubing	PB	Stainless Steel	Secondary Water (Int)	Cracking	Water Chemistry (B2.1.2) and One-Time Inspection (B2.1.16)	VIII.B1-5	3.4.1.14	A

Notes for Table 3.1.2-4:

Standard Notes:

- A Consistent with NUREG-1801 item for component, material, environment, and aging effect. AMP is consistent with NUREG-1801 AMP.
- B Consistent with NUREG-1801 item for component, material, environment, and aging effect. AMP takes some exceptions to NUREG-1801 AMP.
- C Component is different, but consistent with NUREG-1801 item for material, environment, and aging effect. AMP is consistent with NUREG-1801 AMP.
- E Consistent with NUREG-1801 for material, environment, and aging effect, but a different aging management program is credited or NUREG-1801 identifies a plant-specific aging management program.
- G Environment not in NUREG-1801 for this component and material.

**Section 3.1
AGING MANAGEMENT OF REACTOR VESSEL,
INTERNALS, AND REACTOR COOLANT SYSTEM**

Plant Specific Notes:

- 1 Feeding wall thinning was described in NRC Information Notice 91-19. This form of degradation has been detected only in certain Combustion Engineering pre-System 80 steam generators. The PVNGS steam generators are Combustion Engineering modified System 80. No operating experience at PVNGS or other units with Combustion Engineering modified System 80 steam generators suggests that degradation of the feedings is occurring; therefore PVNGS has determined this condition is not applicable to PVNGS and no action is required.
- 2 Note E was used to include the plant specific AMP for nickel alloy aging management.

3.2 AGING MANAGEMENT OF ENGINEERED SAFETY FEATURES

3.2.1 Introduction

Section 3.2 provides the results of the aging management reviews for those component types identified in [Section 2.3.2](#), Engineered Safety Features, subject to aging management review. These systems are described in the following sections:

- Containment leak test ([Section 2.3.2.1](#))
- Containment purge ([Section 2.3.2.2](#))
- Containment hydrogen control ([Section 2.3.2.3](#))
- Safety injection and shutdown cooling ([Section 2.3.2.4](#))

[Table 3.2.1](#), Summary of Aging Management Evaluations in Chapter V of NUREG-1801 for Engineered Safety Features, provides the summary of the programs evaluated in NUREG-1801 that are applicable to the component types in this section. [Table 3.2.1](#) uses the format of [Table 3.x.1](#) (Table 1) described in [Section 3.0](#).

3.2.2 Results

The following tables summarize the results of the aging management review for the systems in the Engineered Safety Features area:

- [Table 3.2.2-1](#), Engineered Safety Features – Summary of Aging Management Evaluation – Containment Leak Test System
- [Table 3.2.2-2](#), Engineered Safety Features – Summary of Aging Management Evaluation – Containment Purge System
- [Table 3.2.2-3](#), Engineered Safety Features – Summary of Aging Management Evaluation – Containment Hydrogen Control System
- [Table 3.2.2-4](#), Engineered Safety Features – Summary of Aging Management Evaluation – Safety Injection and Shutdown Cooling System

These tables use the format of [Table 2](#) discussed in [Section 3.0](#).

3.2.2.1 Materials, Environment, Aging Effects Requiring Management and Aging Management Programs

The materials from which the component types are fabricated, the environments to which they are exposed, the potential aging effects requiring management, and the aging

management programs used to manage these aging effects are provided for each of the above systems in the following subsections.

3.2.2.1.1 Containment Leak Test System

Materials

The materials of construction for the containment leak test system component types are:

- Carbon Steel

Environment

The containment leak test system components are exposed to the following environments:

- Atmosphere / Weather
- Plant Indoor Air
- Ventilation Atmosphere

Aging Effects Requiring Management

The following containment leak test system aging effects require management:

- Loss of material
- Loss of preload

Aging Management Programs

The following aging management programs manage the aging effects for the containment leak test system component types:

- Bolting Integrity ([B2.1.7](#))
- External Surfaces Monitoring Program ([B2.1.20](#))
- Inspection Of Internal Surfaces In Miscellaneous Piping And Ducting Components ([B2.1.22](#))

3.2.2.1.2 Containment Purge System

Materials

The materials of construction for the containment purge system component types are:

- Carbon Steel
- Carbon Steel (Galvanized)

Section 3.2

AGING MANAGEMENT OF ENGINEERED SAFETY FEATURES

- Elastomer
- Stainless Steel
- Stainless Steel Cast Austenitic

Environment

The containment purge system component types are exposed to the following environments:

- Atmosphere/ Weather
- Plant Indoor Air
- Ventilation Atmosphere

Aging Effects Requiring Management

The following containment purge system aging effects require management:

- Hardening and loss of strength
- Loss of material
- Loss of preload

Aging Management Programs

The following aging management programs manage the aging effects for the containment purge system component types:

- Bolting Integrity ([B2.1.7](#))
- External Surfaces Monitoring Program ([B2.1.20](#))
- Inspection of Internal Surfaces in Miscellaneous Piping and Ducting Components ([B2.1.22](#))

3.2.2.1.3 Containment Hydrogen Control System

Materials

The material of construction for the containment hydrogen control system component types is:

- Aluminum
- Carbon Steel
- Carbon Steel (Galvanized)
- Nickel Alloys

- Stainless Steel

Environment

The containment hydrogen control system component types are exposed to the following environments:

- Dry Gas
- Encased in Concrete
- Plant Indoor Air
- Ventilation Atmosphere

Aging Effects Requiring Management

The following containment hydrogen control system aging effects require management:

- Loss of material
- Loss of preload

Aging Management Programs

The following aging management programs manage the aging effects for the containment hydrogen control system component types:

- Bolting Integrity ([B2.1.7](#))
- External Surfaces Monitoring Program ([B2.1.20](#))
- Inspection of Internal Surfaces in Miscellaneous Piping and Ducting Components ([B2.1.22](#))

3.2.2.1.4 Safety Injection and Shutdown Cooling System

Materials

The materials of construction for the safety injection and shutdown cooling system component types are:

- Carbon Steel
- Carbon Steel with Stainless Steel Cladding
- Glass
- Insulation Calcium Silicate
- Insulation Mineral Wool
- Nickel Alloys

- Stainless Steel

Environment

The safety injection and shutdown cooling system components are exposed to the following environments:

- Borated Water Leakage
- Closed Cycle Cooling Water
- Demineralized Water
- Dry Gas
- Plant Indoor Air
- Reactor Coolant
- Treated Borated Water
- Wetted Gas

Aging Effects Requiring Management

The following safety injection and shutdown cooling system aging effects require management:

- Cracking
- Loss of material
- Loss of preload
- Reduction of heat transfer

Aging Management Programs

The following aging management programs manage the aging effects for the safety injection and shutdown cooling system component types:

- ASME Section XI Inservice Inspection, Subsections IWB, IWC, and IWD ([B2.1.1](#))
- Bolting Integrity ([B2.1.7](#))
- Boric Acid Corrosion ([B2.1.4](#))
- Closed-Cycle Cooling Water System ([B2.1.10](#))
- External Surfaces Monitoring Program ([B2.1.20](#))
- Inspection of Internal Surfaces in Miscellaneous Piping and Ducting Components ([B2.1.22](#))
- Nickel Alloy Aging Management ([B2.1.34](#))

Section 3.2

AGING MANAGEMENT OF ENGINEERED SAFETY FEATURES

- One-Time Inspection ([B2.1.16](#))
- One-Time Inspection Of ASME Code Class 1 Small-Bore Piping ([B2.1.19](#))
- Reactor Coolant System Supplement ([B2.1.21](#))
- Water Chemistry ([B2.1.2](#))

3.2.2.2 Further Evaluation of Aging Management as Recommended by NUREG-1801

NUREG-1801 provides the basis for identifying those programs that warrant further evaluation. For the engineered safety features, those evaluations are addressed in the following subsections.

3.2.2.2.1 Cumulative Fatigue Damage

Evaluation of fatigue is a time-limited aging analysis (TLAA) as defined in 10 CFR 54.3. TLAA's are evaluated in accordance with 10 CFR 54.21(c)(1). PVNGS piping designed to ASME III Class 2, Class 3, and ANSI B31.1 assumes a reduction in the allowable secondary stress range if more than 7,000 full-range thermal cycles are expected in a design lifetime. [Section 4.3.5](#) describes the evaluation of these cyclic design TLAA's.

HPSI and LPSI pumps are ASME III Class 2 components designed with a specified number of thermal transient cycles. [Section 4.3.2.11](#) describes the evaluation of these cyclic design TLAA's.

3.2.2.2.2 Loss of material due to Cladding

Not applicable. PVNGS has no in-scope steel with stainless steel cladding pump casing exposed to treated borated water in the emergency core cooling system, so the applicable NUREG-1801 line was not used.

3.2.2.2.3 Loss of Material due to Pitting and Crevice Corrosion

3.2.2.2.3.1 Internal surfaces of stainless steel containment isolation piping and components exposed to treated water

Not applicable. PVNGS has no in-scope stainless steel components exposed to treated water in the engineered safety features systems, so the applicable NUREG-1801 line was not used.

Section 3.2

AGING MANAGEMENT OF ENGINEERED SAFETY FEATURES

3.2.2.2.3.2 Stainless steel piping and components exposed to soil

Not applicable. PVNGS has no in-scope stainless steel piping, piping components, and piping elements exposed to soil in the emergency core cooling system, so the applicable NUREG-1801 line was not used.

3.2.2.2.3.3 BWR stainless steel and aluminum piping and components exposed to treated water

Not applicable to PVNGS, applicable to BWR only.

3.2.2.2.3.4 Stainless steel and copper piping and components exposed to lubricating oil

Not applicable. PVNGS has no in-scope stainless steel and copper alloy piping, piping components, and piping elements exposed to lubricating oil.

3.2.2.2.3.5 Partially encased stainless steel tanks exposed to raw water

Not applicable. PVNGS has no in-scope stainless steel tanks with a moisture barrier configuration exposed to raw water in the emergency core cooling system, so the applicable NUREG-1801 line was not used.

3.2.2.2.3.6 Stainless steel piping, components, and tanks exposed to internal condensation

The stainless steel piping, piping components, piping elements internal surfaces exposed to condensation are managed by Inspection of Internal Surfaces In Miscellaneous Piping and Ducting Components program ([B2.1.22](#)).

3.2.2.2.4 Reduction of Heat Transfer due to Fouling

3.2.2.2.4.1 Stainless steel and copper heat exchanger tubes exposed to lubricating oil

Not applicable. PVNGS has no in-scope steel, stainless steel, and copper alloy heat exchanger tubes exposed to lubricating oil in the engineered safety features systems, so the applicable NUREG-1801 lines were not used.

3.2.2.2.4.2 Stainless steel heat exchanger tubes exposed to treated water

Not applicable. PVNGS has no in-scope stainless steel heat exchanger tubes exposed to treated water with the aging effect of reduction of heat transfer in the Engineered Safety Features systems, so the applicable NUREG-1801 line was not used.

3.2.2.2.5 Hardening and Loss of Strength due to Elastomer Degradation

Not applicable to PVNGS, applicable to BWR only.

3.2.2.2.6 Loss of Material due to Erosion

Not applicable. PVNGS does not use the high-pressure safety injection pumps for normal charging and the aging effect due to erosion is not applicable, so the subject NUREG-1801 line was not used.

3.2.2.2.7 Loss of Material due to General Corrosion and Fouling

Not applicable to PVNGS, applicable to BWR only.

3.2.2.2.8 Loss of Material due to General, Pitting, and Crevice Corrosion

3.2.2.2.8.1 BWR piping and components exposed to treated water

Not applicable to PVNGS, applicable to BWR only.

3.2.2.2.8.2 Internal surfaces of containment isolation piping and components exposed to treated water

Not applicable. The subject NUREG-1801 line was not used since the containment isolation components were evaluated in the systems in which the components were found to have the function of containment integrity.

3.2.2.2.8.3 Steel piping and components exposed to lubricating oil

Not applicable. PVNGS has no in-scope carbon steel components exposed to lubricating oil in the engineered safety features systems, so the applicable NUREG-1801 lines were not used.

3.2.2.2.9 Loss of Material due to General, Pitting, Crevice, and Microbiologically-Influenced Corrosion (MIC)

Not applicable to PVNGS, applicable to BWR only.

3.2.2.2.10 Quality Assurance for Aging Management of Nonsafety-Related Components

Quality Assurance Program and Administrative Controls are discussed in [Section B1.3](#).

3.2.2.3 Time-Limited Aging Analysis

The Time-Limited Aging Analyses identified below are associated with the engineered safety features component types. The section of [Chapter 4](#) that contains the TLAA review results is indicated in parenthesis.

Section 3.2

AGING MANAGEMENT OF ENGINEERED SAFETY FEATURES

- Cumulative fatigue damage ([Section 4.3](#), Metal Fatigue Analysis)

3.2.3 Conclusions

The engineered safety features component types that are subject to aging management review have been evaluated. The aging management programs selected to manage the aging effects for the engineered safety features component types are identified in the summary Tables and in [Section 3.2.2.1](#).

A description of these aging management programs is provided in [Appendix B](#), along with a demonstration that the identified aging effects will be managed for the period of extended operation.

Therefore, based on the demonstration provided in [Appendix B](#), the effects of aging associated with the engineered safety features component types will be adequately managed so that there is reasonable assurance that the intended functions will be maintained consistent with the current licensing basis during the period of extended operation.

Section 3.2
AGING MANAGEMENT OF ENGINEERED SAFETY FEATURES

Table 3.2.1 Summary of Aging Management Evaluations in Chapter V of NUREG-1801 for Engineered Safety Features

Item Number	Component Type	Aging Effect / Mechanism	Aging Management Program	Further Evaluation Recommended	Discussion
3.2.1.01	Steel and stainless steel piping, piping components, and piping elements in emergency core cooling system	Cumulative fatigue damage	TLAA, evaluated in accordance with 10 CFR 54.21(c)	Yes, TLAA	Fatigue of metal components is a TLAA. See further evaluation in subsection 3.2.2.2.1.
3.2.1.02	Steel with stainless steel cladding pump casing exposed to treated borated water	Loss of material due to cladding breach	A plant-specific aging management program is to be evaluated. Reference NRC Information Notice 94-63, "Boric Acid Corrosion of Charging Pump Casings Caused by Cladding Cracks"	Yes	Not applicable. PVNGS has no in-scope steel with stainless steel cladding pump casing exposed to treated borated water in the emergency core cooling system, so the applicable NUREG-1801 line was not used.

Section 3.2
AGING MANAGEMENT OF ENGINEERED SAFETY FEATURES

Table 3.2.1 Summary of Aging Management Evaluations in Chapter V of NUREG-1801 for Engineered Safety Features (Continued)

Item Number	Component Type	Aging Effect / Mechanism	Aging Management Program	Further Evaluation Recommended	Discussion
3.2.1.03	Stainless steel containment isolation piping and components internal surfaces exposed to treated water	Loss of material due to pitting and crevice corrosion	Water Chemistry (B2.1.2) and One-Time Inspection (B2.1.16)	Yes	Not applicable. PVNGS has no in-scope stainless steel components exposed to treated water in the engineered safety features systems, so the applicable NUREG-1801 line was not used.
3.2.1.04	Stainless steel piping, piping components, and piping elements exposed to soil	Loss of material due to pitting and crevice corrosion	A plant-specific aging management program is to be evaluated.	Yes	Not applicable. PVNGS has no in-scope stainless steel piping, piping components, and piping elements exposed to soil in the emergency core cooling system, so the applicable NUREG-1801 line was not used.
3.2.1.05					Not applicable - BWR only
3.2.1.06	Stainless steel and copper alloy piping, piping components, and piping elements exposed to lubricating oil	Loss of material due to pitting and crevice corrosion	Lubricating Oil Analysis (B2.1.23) and One-Time Inspection (B.2.1.16)	Yes	Not applicable. PVNGS has no in-scope stainless steel and copper alloy piping, piping components, and piping elements exposed to lubricating oil.

Section 3.2
AGING MANAGEMENT OF ENGINEERED SAFETY FEATURES

Table 3.2.1 Summary of Aging Management Evaluations in Chapter V of NUREG-1801 for Engineered Safety Features (Continued)

Item Number	Component Type	Aging Effect / Mechanism	Aging Management Program	Further Evaluation Recommended	Discussion
3.2.1.07	Partially encased stainless steel tanks with breached moisture barrier exposed to raw water	Loss of material due to pitting and crevice corrosion	A plant-specific aging management program is to be evaluated for pitting and crevice corrosion of tank bottoms because moisture and water can egress under the tank due to cracking of the perimeter seal from weathering.	Yes	Not applicable. PVNGS has no stainless steel tanks with a moisture barrier configuration exposed to raw water in the emergency core cooling system, so the applicable NUREG-1801 line was not used.
3.2.1.08	Stainless steel piping, piping components, and tank internal surfaces exposed to condensation (internal)	Loss of material due to pitting and crevice corrosion	A plant-specific aging management program is to be evaluated.	Yes	Consistent with NUREG-1801. The plant-specific aging management program(s) used to manage the aging include: Inspection Of Internal Surfaces In Miscellaneous Piping And Ducting Components (B2.1.22). See further evaluation in subsection 3.2.2.2.3.6.

Section 3.2
AGING MANAGEMENT OF ENGINEERED SAFETY FEATURES

Table 3.2.1 Summary of Aging Management Evaluations in Chapter V of NUREG-1801 for Engineered Safety Features
(Continued)

Item Number	Component Type	Aging Effect / Mechanism	Aging Management Program	Further Evaluation Recommended	Discussion
3.2.1.09	Steel, stainless steel, and copper alloy heat exchanger tubes exposed to lubricating oil	Reduction of heat transfer due to fouling	Lubricating Oil Analysis (B2.1.23) and One-Time Inspection (B.2.1.16)	Yes	Not applicable. PVNGS has no in-scope steel, stainless steel, and copper alloy heat exchanger tubes exposed to lubricating oil in the engineered safety features systems, so the applicable NUREG-1801 lines were not used.
3.2.1.10	Stainless steel heat exchanger tubes exposed to treated water	Reduction of heat transfer due to fouling	Water Chemistry (B2.1.2) and One-Time Inspection (B2.1.16)	Yes	Not applicable. PVNGS has no in-scope stainless steel heat exchanger tubes exposed to treated water with the aging effect of reduction of heat transfer in the engineered safety features systems, so the applicable NUREG-1801 line was not used.
3.2.1.11					Not applicable - BWR only
3.2.1.12	Stainless steel high-pressure safety injection (charging) pump miniflow orifice exposed to treated borated water	Loss of material due to erosion	A plant-specific aging management program is to be evaluated for erosion of the orifice due to extended use of the centrifugal HPSI pump for normal charging.	Yes	Not applicable. PVNGS does not use the high-pressure safety injection pumps for normal charging and the aging effect due to erosion is not applicable, so the subject NUREG-1801 line was not used.

Section 3.2
AGING MANAGEMENT OF ENGINEERED SAFETY FEATURES

Table 3.2.1 Summary of Aging Management Evaluations in Chapter V of NUREG-1801 for Engineered Safety Features (Continued)

Item Number	Component Type	Aging Effect / Mechanism	Aging Management Program	Further Evaluation Recommended	Discussion
3.2.1.13					Not applicable - BWR only
3.2.1.14					Not applicable - BWR only
3.2.1.15	Steel containment isolation piping, piping components, and piping elements internal surfaces exposed to treated water	Loss of material due to general, pitting, and crevice corrosion	Water Chemistry (B.2.1.2) and One-Time Inspection (B.2.1.16)	Yes	Not applicable. The containment isolation components were evaluated in the systems in which the components were found to have the function of containment integrity, so the applicable NUREG-1801 line was not used.
3.2.1.16	Steel piping, piping components, and piping elements exposed to lubricating oil	Loss of material due to general, pitting, and crevice corrosion	Lubricating Oil Analysis (B.2.1.23) and One-Time Inspection (B.2.1.16)	Yes	Not applicable. PVNGS has no in-scope carbon steel components exposed to lubricating oil in the engineered safety features systems, so the applicable NUREG-1801 lines were not used.
3.2.1.17					Not applicable - BWR only
3.2.1.18					Not applicable - BWR only
3.2.1.19					Not applicable - BWR only
3.2.1.20					Not applicable - BWR only

Section 3.2
AGING MANAGEMENT OF ENGINEERED SAFETY FEATURES

Table 3.2.1 Summary of Aging Management Evaluations in Chapter V of NUREG-1801 for Engineered Safety Features (Continued)

Item Number	Component Type	Aging Effect / Mechanism	Aging Management Program	Further Evaluation Recommended	Discussion
3.2.1.21	High-strength steel closure bolting exposed to air with steam or water leakage	Cracking due to cyclic loading, stress corrosion cracking	Bolting Integrity (B2.1.7)	No	Not applicable. PVNGS has no in-scope high-strength steel closure bolting exposed to air with steam or water leakage in the engineered safety features systems, so the applicable NUREG-1801 line was not used.
3.2.1.22	Steel closure bolting exposed to air with steam or water leakage	Loss of material due to general corrosion	Bolting Integrity (B2.1.7)	No	Not applicable. PVNGS has no closure bolting in Engineered Safety Features Systems that is exposed to an environment of water with steam or water leakage, so the applicable NUREG-1801 line was not used.
3.2.1.23	Steel bolting and closure bolting exposed to air – outdoor (external), or air – indoor uncontrolled (external)	Loss of material due to general, pitting, and crevice corrosion	Bolting Integrity (B2.1.7)	No	Consistent with NUREG-1801 with aging management program exceptions. The aging management program(s) with exceptions to NUREG-1801 include: Bolting Integrity (B2.1.7)

Section 3.2
AGING MANAGEMENT OF ENGINEERED SAFETY FEATURES

Table 3.2.1 Summary of Aging Management Evaluations in Chapter V of NUREG-1801 for Engineered Safety Features (Continued)

Item Number	Component Type	Aging Effect / Mechanism	Aging Management Program	Further Evaluation Recommended	Discussion
3.2.1.24	Steel closure bolting exposed to air – indoor uncontrolled (external)	Loss of preload due to thermal effects, gasket creep, and self-loosening	Bolting Integrity (B2.1.7)	No	Consistent with NUREG-1801 with aging management program exceptions. The aging management program(s) with exceptions to NUREG-1801 include: Bolting Integrity (B2.1.7)
3.2.1.25	Stainless steel piping, and piping elements exposed to closed cycle cooling water >60°C (>140°F)	Cracking due to stress corrosion cracking	Closed-Cycle Cooling Water System (B2.1.10)	No	Consistent with NUREG-1801 with aging management program exceptions. The aging management program(s) with exceptions to NUREG-1801 include: Closed-Cycle Cooling Water System (B2.1.10)
3.2.1.26	Steel piping, piping components, and piping elements exposed to closed cycle cooling water	Loss of material due to general, pitting, and crevice corrosion	Closed-Cycle Cooling Water System (B2.1.10)	No	Not applicable. PVNGS has no in-scope steel piping, piping components, and piping elements exposed to closed cycle cooling water in the engineered safety features systems, so the applicable NUREG-1801 line was not used.

Section 3.2
AGING MANAGEMENT OF ENGINEERED SAFETY FEATURES

Table 3.2.1 Summary of Aging Management Evaluations in Chapter V of NUREG-1801 for Engineered Safety Features (Continued)

Item Number	Component Type	Aging Effect / Mechanism	Aging Management Program	Further Evaluation Recommended	Discussion
3.2.1.27	Steel heat exchanger components exposed to closed cycle cooling water	Loss of material due to general, pitting, crevice, and galvanic corrosion	Closed-Cycle Cooling Water System (B2.1.10)	No	Consistent with NUREG-1801 with aging management program exceptions. The aging management program(s) with exceptions to NUREG-1801 include: Closed-Cycle Cooling Water System (B2.1.10)
3.2.1.28	Stainless steel piping, piping elements, and heat exchanger components exposed to closed-cycle cooling water	Loss of material due to pitting and crevice corrosion	Closed-Cycle Cooling Water System (B2.1.10)	No	Consistent with NUREG-1801 with aging management program exceptions. The aging management program(s) with exceptions to NUREG-1801 include: Closed-Cycle Cooling Water System (B2.1.10)
3.2.1.29	Copper alloy piping, piping components, and heat exchanger components exposed to closed cycle cooling water	Loss of material due to pitting, crevice, and galvanic corrosion	Closed-Cycle Cooling Water System (B2.1.10)	No	Not applicable. PVNGS has no in-scope copper alloy piping, piping components, piping elements, and heat exchanger components exposed to closed-cycle cooling water in the engineered safety features systems, so the applicable NUREG-1801 lines were not used.

Section 3.2
AGING MANAGEMENT OF ENGINEERED SAFETY FEATURES

Table 3.2.1 Summary of Aging Management Evaluations in Chapter V of NUREG-1801 for Engineered Safety Features (Continued)

Item Number	Component Type	Aging Effect / Mechanism	Aging Management Program	Further Evaluation Recommended	Discussion
3.2.1.30	Stainless steel and copper alloy heat exchanger tubes exposed to closed cycle cooling water	Reduction of heat transfer due to fouling	Closed-Cycle Cooling Water System (B2.1.10)	No	Consistent with NUREG-1801 with aging management program exceptions. The aging management program(s) with exceptions to NUREG-1801 include: Closed-Cycle Cooling Water System (B2.1.10)
3.2.1.31	External surfaces of steel components including ducting, piping, ducting closure bolting, and containment isolation piping external surfaces exposed to air - indoor uncontrolled (external); condensation (external) and air - outdoor (external)	Loss of material due to general corrosion	External Surfaces Monitoring (B2.1.20)	No	Consistent with NUREG-1801 with aging management program exceptions. The aging management program(s) with exceptions to NUREG-1801 include: External Surfaces Monitoring Program (B2.1.20)

Section 3.2
AGING MANAGEMENT OF ENGINEERED SAFETY FEATURES

Table 3.2.1 Summary of Aging Management Evaluations in Chapter V of NUREG-1801 for Engineered Safety Features (Continued)

Item Number	Component Type	Aging Effect / Mechanism	Aging Management Program	Further Evaluation Recommended	Discussion
3.2.1.32	Steel piping and ducting components and internal surfaces exposed to air – indoor uncontrolled (Internal)	Loss of material due to general corrosion	Inspection of Internal Surfaces in Miscellaneous Piping and Ducting Components (B2.1.22)	No	Consistent with NUREG-1801 with aging management program exceptions. The aging management program(s) with exceptions to NUREG-1801 include: Inspection Of Internal Surfaces In Miscellaneous Piping And Ducting Components (B2.1.22)
3.2.1.33	Steel encapsulation components exposed to air-indoor uncontrolled (internal)	Loss of material due to general, pitting, and crevice corrosion	Inspection of Internal Surfaces in Miscellaneous Piping and Ducting Components (B2.1.22)	No	Not applicable. PVNGS has no in-scope steel encapsulation components exposed to air-indoor uncontrolled (internal) in the engineered safety features systems, so the applicable NUREG-1801 line was not used.
3.2.1.34	Steel piping, piping components, and piping elements exposed to condensation (internal)	Loss of material due to general, pitting, and crevice corrosion	Inspection of Internal Surfaces in Miscellaneous Piping and Ducting Components (B2.1.22)	No	Not applicable - BWR only

Section 3.2
AGING MANAGEMENT OF ENGINEERED SAFETY FEATURES

Table 3.2.1 Summary of Aging Management Evaluations in Chapter V of NUREG-1801 for Engineered Safety Features (Continued)

Item Number	Component Type	Aging Effect / Mechanism	Aging Management Program	Further Evaluation Recommended	Discussion
3.2.1.35	Steel containment isolation piping and components internal surfaces exposed to raw water	Loss of material due to general, pitting, crevice, and microbiologically-influenced corrosion, and fouling	Open-Cycle Cooling Water System (B.2.1.9)	No	Not applicable. The containment isolation components were evaluated in the systems in which the components were found to have the function of containment integrity, so the applicable NUREG-1801 line was not used.
3.2.1.36	Steel heat exchanger components exposed to raw water	Loss of material due to general, pitting, crevice, galvanic, and microbiologically-influenced corrosion, and fouling	Open-Cycle Cooling Water System (B.2.1.9)	No	Not applicable. PVNGS has no in-scope steel heat exchanger components exposed to raw water in the engineered safety features systems, so the applicable NUREG-1801 lines were not used.
3.2.1.37	Stainless steel piping, piping components, and piping elements exposed to raw water	Loss of material due to pitting, crevice, and microbiologically-influenced corrosion	Open-Cycle Cooling Water System (B.2.1.9)	No	Not applicable. PVNGS has no in-scope stainless steel piping, piping components, and piping elements exposed to raw water in the emergency core cooling system, so the applicable NUREG-1801 line was not used.

Section 3.2
AGING MANAGEMENT OF ENGINEERED SAFETY FEATURES

Table 3.2.1 Summary of Aging Management Evaluations in Chapter V of NUREG-1801 for Engineered Safety Features (Continued)

Item Number	Component Type	Aging Effect / Mechanism	Aging Management Program	Further Evaluation Recommended	Discussion
3.2.1.38	Stainless steel containment isolation piping and components internal surfaces exposed to raw water	Loss of material due to pitting, crevice, and microbiologically-influenced corrosion, and fouling	Open-Cycle Cooling Water System (B.2.1.9)	No	Not applicable. PVNGS has no in-scope stainless steel components exposed to raw water in the engineered safety features systems, so the applicable NUREG-1801 line was not used.
3.2.1.39	Stainless steel heat exchanger components exposed to raw water	Loss of material due to pitting, crevice, and microbiologically-influenced corrosion, and fouling	Open-Cycle Cooling Water System (B.2.1.9)	No	Not applicable. PVNGS has no in-scope stainless steel heat exchanger components exposed to raw water in the engineered safety features systems, so the applicable NUREG-1801 lines were not used.
3.2.1.40	Steel and stainless steel heat exchanger tubes (serviced by open-cycle cooling water) exposed to raw water	Reduction of heat transfer due to fouling	Open-Cycle Cooling Water System (B.2.1.9)	No	Not applicable. PVNGS has no in-scope steel and stainless steel heat exchanger tubes (serviced by open-cycle cooling water) exposed to raw water in the engineered safety features systems, so the applicable NUREG-1801 lines were not used.

Section 3.2
AGING MANAGEMENT OF ENGINEERED SAFETY FEATURES

Table 3.2.1 *Summary of Aging Management Evaluations in Chapter V of NUREG-1801 for Engineered Safety Features (Continued)*

Item Number	Component Type	Aging Effect / Mechanism	Aging Management Program	Further Evaluation Recommended	Discussion
3.2.1.41	Copper alloy > 15% Zn piping, piping components, piping elements, and heat exchanger components exposed to closed cycle cooling water	Loss of material due to selective leaching	Selective Leaching of Materials (B2.1.17)	No	Not applicable. PVNGS has no in-scope copper alloy >15% Zn piping, piping components, piping elements, and heat exchanger components exposed to closed cycle cooling water in the engineered safety features systems, so the applicable NUREG-1801 lines were not used.
3.2.1.42	Gray cast iron piping, piping components, piping elements exposed to closed-cycle cooling water	Loss of material due to selective leaching	Selective Leaching of Materials (B2.1.17)	No	Not applicable. PVNGS has no in-scope gray cast iron piping, piping components, and piping elements exposed to closed cycle cooling water in the engineered safety features systems, so the applicable NUREG-1801 line was not used.

Section 3.2
AGING MANAGEMENT OF ENGINEERED SAFETY FEATURES

Table 3.2.1 Summary of Aging Management Evaluations in Chapter V of NUREG-1801 for Engineered Safety Features (Continued)

Item Number	Component Type	Aging Effect / Mechanism	Aging Management Program	Further Evaluation Recommended	Discussion
3.2.1.43	Gray cast iron piping, piping components, and piping elements exposed to soil	Loss of material due to selective leaching	Selective Leaching of Materials (B2.1.17)	No	Not applicable. PVNGS has no in-scope gray cast iron piping, piping components and piping elements exposed to soil in the engineered safety features systems, so the applicable NUREG-1801 line was not used.
3.2.1.44	Gray cast iron motor cooler exposed to treated water	Loss of material due to selective leaching	Selective Leaching of Materials (B2.1.17)	No	Not applicable. PVNGS has no in-scope gray cast iron motor cooler exposed to treated water in the engineered safety features systems, so the applicable NUREG-1801 lines were not used.
3.2.1.45	Aluminum, copper alloy >15% Zn, and steel external surfaces, bolting, and piping, piping components, and piping elements exposed to air with borated water leakage	Loss of material due to Boric acid corrosion	Boric Acid Corrosion (B2.1.4)	No	Consistent with NUREG-1801.

Section 3.2
AGING MANAGEMENT OF ENGINEERED SAFETY FEATURES

Table 3.2.1 Summary of Aging Management Evaluations in Chapter V of NUREG-1801 for Engineered Safety Features (Continued)

Item Number	Component Type	Aging Effect / Mechanism	Aging Management Program	Further Evaluation Recommended	Discussion
3.2.1.46	Steel encapsulation components exposed to air with borated water leakage (internal)	Loss of material due to general, pitting, crevice and boric acid corrosion	Inspection of Internal Surfaces in Miscellaneous Piping and Ducting Components (B2.1.22)	No	Not applicable. PVNGS has no in-scope steel encapsulation components exposed to air with borated water leakage (internal) in the engineered safety features systems, so the applicable NUREG-1801 line was not used.
3.2.1.47	Cast austenitic stainless steel piping, piping components, and piping elements exposed to treated borated water >250°C (>482°F)	Loss of fracture toughness due to thermal aging embrittlement	Thermal Aging Embrittlement of CASS	No	Not applicable. PVNGS has no in-scope cast austenitic stainless steel piping, piping components, and piping elements exposed to treated borated water > 250 °C in the emergency core cooling system, so the applicable NUREG-1801 line was not used.

Section 3.2
AGING MANAGEMENT OF ENGINEERED SAFETY FEATURES

Table 3.2.1 Summary of Aging Management Evaluations in Chapter V of NUREG-1801 for Engineered Safety Features
(Continued)

Item Number	Component Type	Aging Effect / Mechanism	Aging Management Program	Further Evaluation Recommended	Discussion
3.2.1.48	Stainless steel or stainless-steel-clad steel piping, piping components, piping elements, and tanks (including safety injection tanks/accumulators) exposed to treated borated water >60°C (>140°F)	Cracking due to stress corrosion cracking	Water Chemistry (B.2.1.2)	No	Consistent with NUREG-1801.
3.2.1.49	Stainless steel piping, piping components, and piping elements, and tanks exposed to treated borated water	Loss of material due to pitting and crevice corrosion	Water Chemistry (B.2.1.2)	No	Consistent with NUREG-1801.
3.2.1.50	Aluminum piping, piping components, and piping elements exposed to air- indoor uncontrolled (internal/external)	None	None	NA	Consistent with NUREG-1801.
3.2.1.51	Galvanized steel ducting exposed to air – indoor controlled (external)	None	None	NA	Consistent with NUREG-1801.

Section 3.2
AGING MANAGEMENT OF ENGINEERED SAFETY FEATURES

Table 3.2.1 Summary of Aging Management Evaluations in Chapter V of NUREG-1801 for Engineered Safety Features (Continued)

Item Number	Component Type	Aging Effect / Mechanism	Aging Management Program	Further Evaluation Recommended	Discussion
3.2.1.52	Glass piping elements exposed to air – indoor uncontrolled (external), lubricating oil, raw water, treated water, or treated borated water	None	None	NA	Consistent with NUREG-1801.
3.2.1.53	Stainless steel, copper alloy, and nickel alloy piping, piping components, and piping elements exposed to air – indoor uncontrolled (external)	None	None	NA	Consistent with NUREG-1801.
3.2.1.54	Steel piping, piping components, and piping elements exposed to air – indoor controlled (external)	None	None	NA	Not applicable. PVNGS has no in-scope steel piping, piping components, and piping elements exposed to Air-Indoor Controlled (external) in the engineered safety features systems, so the applicable NUREG-1801 line was not used.
3.2.1.55	Steel and stainless steel piping, piping components, and piping elements in concrete	None	None	NA	Consistent with NUREG-1801.

Section 3.2
AGING MANAGEMENT OF ENGINEERED SAFETY FEATURES

Table 3.2.1 Summary of Aging Management Evaluations in Chapter V of NUREG-1801 for Engineered Safety Features
(Continued)

Item Number	Component Type	Aging Effect / Mechanism	Aging Management Program	Further Evaluation Recommended	Discussion
3.2.1.56	Steel, stainless steel, and copper alloy piping, piping components, and piping elements exposed to gas	None	None	NA	Consistent with NUREG-1801.
3.2.1.57	Stainless steel and copper alloy <15% Zn piping, piping components, and piping elements exposed to air with borated water leakage	None	None	NA	Consistent with NUREG-1801.

Section 3.2
AGING MANAGEMENT OF ENGINEERED SAFETY FEATURES

Table 3.2.2-1 Engineered Safety Features – Summary of Aging Management Evaluation – Containment Leak Test System

Component Type	Intended Function	Material	Environment	Aging Effect Requiring Management	Aging Management Program	NUREG-1801 Vol. 2 Item	Table 1 Item	Notes
Closure Bolting	PB	Carbon Steel	Plant Indoor Air (Ext)	Loss of material	Bolting Integrity (B2.1.7)	V.E-4	3.2.1.23	B
Closure Bolting	PB	Carbon Steel	Plant Indoor Air (Ext)	Loss of preload	Bolting Integrity (B2.1.7)	V.E-5	3.2.1.24	B
Piping	PB	Carbon Steel	Atmosphere/Weather (Ext)	Loss of material	External Surfaces Monitoring Program (B2.1.20)	V.E-8	3.2.1.31	B
Piping	PB	Carbon Steel	Plant Indoor Air (Ext)	Loss of material	External Surfaces Monitoring Program (B2.1.20)	V.C-1	3.2.1.31	B
Piping	PB	Carbon Steel	Ventilation Atmosphere (Int)	Loss of material	Inspection Of Internal Surfaces In Miscellaneous Piping And Ducting Components (B2.1.22)	VII.F3-3	3.3.1.72	D

Notes for Table 3.2.2-1:

Standard Notes:

B Consistent with NUREG-1801 item for component, material, environment, and aging effect. AMP takes some exceptions to NUREG-1801 AMP.

D Component is different, but consistent with NUREG-1801 item for material, environment, and aging effect. AMP takes some exceptions to NUREG-1801 AMP.

Plant Specific Notes:

None

Section 3.2
AGING MANAGEMENT OF ENGINEERED SAFETY FEATURES

Table 3.2.2-2 Engineered Safety Features – Summary of Aging Management Evaluation – Containment Purge System

Component Type	Intended Function	Material	Environment	Aging Effect Requiring Management	Aging Management Program	NUREG-1801 Vol. 2 Item	Table 1 Item	Notes
Closure Bolting	SIA	Carbon Steel	Atmosphere/ Weather (Ext)	Loss of preload	Bolting Integrity (B2.1.7)	None	None	G, 1
Closure Bolting	SIA	Carbon Steel	Atmosphere/ Weather (Ext)	Loss of material	Bolting Integrity (B2.1.7)	V.E-1	3.2.1.23	B
Closure Bolting	PB, SIA	Carbon Steel	Plant Indoor Air (Ext)	Loss of material	Bolting Integrity (B2.1.7)	V.E-4	3.2.1.23	B
Closure Bolting	PB, SIA	Carbon Steel	Plant Indoor Air (Ext)	Loss of preload	Bolting Integrity (B2.1.7)	V.E-5	3.2.1.24	B
Closure Bolting	PB, SIA	Carbon Steel	Plant Indoor Air (Ext)	Loss of material	External Surfaces Monitoring Program (B2.1.20)	VII.F3-4	3.3.1.55	B
Ductwork	SIA	Carbon Steel (Galvanized)	Atmosphere/ Weather (Ext)	Loss of material	External Surfaces Monitoring Program (B2.1.20)	V.E-8	3.2.1.31	B
Ductwork	NSRS, PB, SIA	Carbon Steel (Galvanized)	Plant Indoor Air (Ext)	None	None	V.F-1	3.2.1.51	A
Ductwork	NSRS, PB, SIA	Carbon Steel (Galvanized)	Ventilation Atmosphere (Int)	None	None	VII.J-6	3.3.1.92	C
Flex Connectors	PB	Elastomer	Plant Indoor Air (Ext)	Hardening and loss of strength	External Surfaces Monitoring Program (B2.1.20)	VII.F3-7	3.3.1.11	E
Flex Connectors	PB	Elastomer	Ventilation Atmosphere (Int)	Hardening and loss of strength	Inspection Of Internal Surfaces In Miscellaneous Piping And Ducting Components (B2.1.22)	VII.F3-7	3.3.1.11	E

Section 3.2
AGING MANAGEMENT OF ENGINEERED SAFETY FEATURES

Table 3.2.2-2 Engineered Safety Features – Summary of Aging Management Evaluation - Containment Purge System (Continued)

Component Type	Intended Function	Material	Environment	Aging Effect Requiring Management	Aging Management Program	NUREG-1801 Vol. 2 Item	Table 1 Item	Notes
Heater	SIA	Carbon Steel (Galvanized)	Plant Indoor Air (Ext)	None	None	V.F-1	3.2.1.51	C
Heater	SIA	Carbon Steel (Galvanized)	Ventilation Atmosphere (Int)	None	None	VII.J-6	3.3.1.92	C
Orifice	NSRS, PB	Stainless Steel	Plant Indoor Air (Ext)	None	None	V.F-12	3.2.1.53	A
Orifice	NSRS, PB	Stainless Steel	Ventilation Atmosphere (Int)	None	None	V.F-12	3.2.1.53	A, 2
Piping	PB, SIA	Carbon Steel	Plant Indoor Air (Ext)	Loss of material	External Surfaces Monitoring Program (B2.1.20)	V.C-1	3.2.1.31	B
Piping	PB, SIA	Carbon Steel	Ventilation Atmosphere (Int)	Loss of material	Inspection Of Internal Surfaces In Miscellaneous Piping And Ducting Components (B2.1.22)	VII.F3-3	3.3.1.72	D
Piping	PB, SIA	Stainless Steel	Plant Indoor Air (Ext)	None	None	V.F-12	3.2.1.53	A
Piping	PB, SIA	Stainless Steel	Ventilation Atmosphere (Int)	None	None	V.F-12	3.2.1.53	A, 2
Valve	NSRS, PB	Carbon Steel	Plant Indoor Air (Ext)	Loss of material	External Surfaces Monitoring Program (B2.1.20)	V.C-1	3.2.1.31	B
Valve	NSRS, PB	Carbon Steel	Ventilation Atmosphere (Int)	Loss of material	Inspection Of Internal Surfaces In Miscellaneous Piping And Ducting Components (B2.1.22)	VII.F3-3	3.3.1.72	D

Table 3.2.2-2 Engineered Safety Features – Summary of Aging Management Evaluation - Containment Purge System (Continued)

Component Type	Intended Function	Material	Environment	Aging Effect Requiring Management	Aging Management Program	NUREG-1801 Vol. 2 Item	Table 1 Item	Notes
Valve	PB	Stainless Steel Cast Austenitic	Plant Indoor Air (Ext)	None	None	V.F-12	3.2.1.53	A
Valve	PB	Stainless Steel Cast Austenitic	Ventilation Atmosphere (Int)	None	None	V.F-12	3.2.1.53	A, 2

Notes for Table 3.2.2-2:

Standard Notes:

- A Consistent with NUREG-1801 item for component, material, environment, and aging effect. AMP is consistent with NUREG-1801 AMP.
- B Consistent with NUREG-1801 item for component, material, environment, and aging effect. AMP takes some exceptions to NUREG-1801 AMP.
- C Component is different, but consistent with NUREG-1801 item for material, environment, and aging effect. AMP is consistent with NUREG-1801 AMP.
- D Component is different, but consistent with NUREG-1801 item for material, environment, and aging effect. AMP takes some exceptions to NUREG-1801 AMP.
- E Consistent with NUREG-1801 for material, environment, and aging effect, but a different aging management program is credited or NUREG-1801 identifies a plant-specific aging management program.
- G Environment not in NUREG-1801 for this component and material.

Plant Specific Notes:

- 1 Loss of Preload is considered to be applicable for all closure bolting.
- 2 Stainless steel piping and piping components associated with the containment purge system have an internal environment of ventilation air. Condensation is not expected in this environment. The NUREG-1801 line referenced for the aging evaluation is V.F-12 which is for Air-Indoor-Uncontrolled (external). In ventilation systems, the internal and external air environments are evaluated as one and the same.

Section 3.2
AGING MANAGEMENT OF ENGINEERED SAFETY FEATURES

Table 3.2.2-3 Engineered Safety Features – Summary of Aging Management Evaluation – Containment Hydrogen Control System

Component Type	Intended Function	Material	Environment	Aging Effect Requiring Management	Aging Management Program	NUREG-1801 Vol. 2 Item	Table 1 Item	Notes
Blower	PB	Carbon Steel	Plant Indoor Air (Ext)	Loss of material	External Surfaces Monitoring Program (B2.1.20)	V.E-7	3.2.1.31	B
Blower	PB	Carbon Steel	Ventilation Atmosphere (Int)	Loss of material	Inspection Of Internal Surfaces In Miscellaneous Piping And Ducting Components (B2.1.22)	VII.F3-3	3.3.1.72	B
Closure Bolting	PB	Carbon Steel	Plant Indoor Air (Ext)	Loss of material	Bolting Integrity (B2.1.7)	V.E-4	3.2.1.23	B
Closure Bolting	PB	Carbon Steel	Plant Indoor Air (Ext)	Loss of preload	Bolting Integrity (B2.1.7)	V.E-5	3.2.1.24	B
Closure Bolting	PB	Carbon Steel	Plant Indoor Air (Ext)	Loss of material	External Surfaces Monitoring Program (B2.1.20)	VII.I-7	3.3.1.55	B
Closure Bolting	PB, SIA	Stainless Steel	Plant Indoor Air (Ext)	Loss of preload	Bolting Integrity (B2.1.7)	None	None	G, 1
Damper	FB, PB	Carbon Steel (Galvanized)	Encased in Concrete (Ext)	None	None	V.F-17	3.2.1.55	C
Damper	PB	Carbon Steel (Galvanized)	Plant Indoor Air (Ext)	None	None	V.F-1	3.2.1.51	A
Damper	FB, PB	Carbon Steel (Galvanized)	Ventilation Atmosphere (Int)	None	None	VII.J-6	3.3.1.92	C
Ductwork	PB	Carbon Steel (Galvanized)	Plant Indoor Air (Ext)	None	None	V.F-1	3.2.1.51	A
Ductwork	PB	Carbon Steel (Galvanized)	Ventilation Atmosphere (Int)	None	None	VII.J-6	3.3.1.92	C

Section 3.2
AGING MANAGEMENT OF ENGINEERED SAFETY FEATURES

Table 3.2.2-3 Engineered Safety Features – Summary of Aging Management Evaluation - Containment Hydrogen Control System (Continued)

Component Type	Intended Function	Material	Environment	Aging Effect Requiring Management	Aging Management Program	NUREG-1801 Vol. 2 Item	Table 1 Item	Notes
Filter	FIL, PB	Carbon Steel (Galvanized)	Plant Indoor Air (Ext)	None	None	V.F-1	3.2.1.51	A
Filter	FIL, PB	Carbon Steel (Galvanized)	Ventilation Atmosphere (Int)	None	None	VII.J-6	3.3.1.92	C
Flexible Hoses	PB	Nickel Alloys	Dry Gas (Int)	None	None	None	None	G
Flexible Hoses	PB	Nickel Alloys	Plant Indoor Air (Ext)	None	None	V.F-11	3.2.1.53	A
Flexible Hoses	PB	Stainless Steel	Dry Gas (Int)	None	None	V.F-15	3.2.1.56	A
Flexible Hoses	PB	Stainless Steel	Plant Indoor Air (Ext)	None	None	V.F-12	3.2.1.53	A
Flow Element	PB	Stainless Steel	Plant Indoor Air (Ext)	None	None	V.F-12	3.2.1.53	A
Flow Element	PB	Stainless Steel	Ventilation Atmosphere (Int)	None	None	V.F-12	3.2.1.53	A, 2
Heat Exchanger (H2 Recombiner Airblast)	PB	Carbon Steel	Plant Indoor Air (Ext)	Loss of material	External Surfaces Monitoring Program (B2.1.20)	V.E-7	3.2.1.31	B
Heat Exchanger (H2 Recombiner Airblast)	PB	Carbon Steel	Ventilation Atmosphere (Int)	Loss of material	Inspection Of Internal Surfaces In Miscellaneous Piping And Ducting Components (B2.1.22)	VII.F3-3	3.3.1.72	D

Section 3.2
AGING MANAGEMENT OF ENGINEERED SAFETY FEATURES

Table 3.2.2-3 Engineered Safety Features – Summary of Aging Management Evaluation - Containment Hydrogen Control System
(Continued)

Component Type	Intended Function	Material	Environment	Aging Effect Requiring Management	Aging Management Program	NUREG-1801 Vol. 2 Item	Table 1 Item	Notes
Heat Exchanger (H2 Recombiner Airblast)	HT, PB	Stainless Steel	Ventilation Atmosphere (Ext)	None	None	V.F-12	3.2.1.53	C
Heat Exchanger (H2 Recombiner Airblast)	HT, PB	Stainless Steel	Ventilation Atmosphere (Int)	None	None	V.F-12	3.2.1.53	C, 2
Orifice	PB, TH	Stainless Steel	Plant Indoor Air (Ext)	None	None	V.F-12	3.2.1.53	A
Orifice	PB, TH	Stainless Steel	Ventilation Atmosphere (Int)	None	None	V.F-12	3.2.1.53	A, 2
Piping	S/A	Stainless Steel	Dry Gas (Int)	None	None	V.F-15	3.2.1.56	A
Piping	PB, S/A	Stainless Steel	Plant Indoor Air (Ext)	None	None	V.F-12	3.2.1.53	A
Piping	PB, S/A	Stainless Steel	Ventilation Atmosphere (Int)	None	None	V.F-12	3.2.1.53	A, 2
Pump	PB	Aluminum	Plant Indoor Air (Ext)	None	None	V.F-2	3.2.1.50	A
Pump	PB	Aluminum	Ventilation Atmosphere (Int)	None	None	V.F-2	3.2.1.50	A, 3
Reaction Chamber	PB	Stainless Steel	Plant Indoor Air (Ext)	None	None	V.F-12	3.2.1.53	A
Reaction Chamber	PB	Stainless Steel	Ventilation Atmosphere (Int)	None	None	V.F-12	3.2.1.53	A, 2
Tubing	PB	Stainless Steel	Dry Gas (Int)	None	None	V.F-15	3.2.1.56	A

Table 3.2.2-3 Engineered Safety Features – Summary of Aging Management Evaluation - Containment Hydrogen Control System (Continued)

Component Type	Intended Function	Material	Environment	Aging Effect Requiring Management	Aging Management Program	NUREG-1801 Vol. 2 Item	Table 1 Item	Notes
Tubing	PB	Stainless Steel	Plant Indoor Air (Ext)	None	None	V.F-12	3.2.1.53	A
Tubing	PB	Stainless Steel	Ventilation Atmosphere (Int)	None	None	V.F-12	3.2.1.53	A, 2
Valve	PB, SIA	Stainless Steel	Dry Gas (Int)	None	None	V.F-15	3.2.1.56	A
Valve	PB, SIA	Stainless Steel	Plant Indoor Air (Ext)	None	None	V.F-12	3.2.1.53	A
Valve	PB, SIA	Stainless Steel	Ventilation Atmosphere (Int)	None	None	V.F-12	3.2.1.53	A, 2

Notes for Table 3.2.2-3:

Standard Notes:

- A Consistent with NUREG-1801 item for component, material, environment, and aging effect. AMP is consistent with NUREG-1801 AMP.
- B Consistent with NUREG-1801 item for component, material, environment, and aging effect. AMP takes some exceptions to NUREG-1801 AMP.
- C Component is different, but consistent with NUREG-1801 item for material, environment, and aging effect. AMP is consistent with NUREG-1801 AMP.
- D Component is different, but consistent with NUREG-1801 item for material, environment, and aging effect. AMP takes some exceptions to NUREG-1801 AMP.
- G Environment not in NUREG-1801 for this component and material.

Plant Specific Notes:

- 1 Loss of Preload is considered to be applicable for all closure bolting.
- 2 Stainless steel piping and piping components associated with the containment hydrogen control system have an internal environment of ventilation air. The NUREG-1801 line referenced for the aging evaluation is V.F-12 which is for Air-Indoor Uncontrolled (External). In ventilation systems, the internal and external air environments are evaluated as one and the same.

Section 3.2
AGING MANAGEMENT OF ENGINEERED SAFETY FEATURES

- 3 Aluminum piping and piping components associated with the containment hydrogen control system have an internal environment of ventilation air. The NUREG-1801 line referenced for the aging evaluation is V.F-2 which is for Air-Indoor-Uncontrolled (Internal/External). In ventilation systems, the internal and external air environments are evaluated as one and the same.

Section 3.2
AGING MANAGEMENT OF ENGINEERED SAFETY FEATURES

Table 3.2.2-4 Engineered Safety Features – Summary of Aging Management Evaluation – Safety Injection and Shutdown Cooling System

Component Type	Intended Function	Material	Environment	Aging Effect Requiring Management	Aging Management Program	NUREG-1801 Vol. 2 Item	Table 1 Item	Notes
Accumulator	PB	Carbon Steel with Stainless Steel Cladding	Borated Water Leakage (Ext)	Loss of material	Boric Acid Corrosion (B2.1.4)	V.D1-1	3.2.1.45	A
Accumulator	PB	Carbon Steel with Stainless Steel Cladding	Dry Gas (Int)	None	None	V.F-15	3.2.1.56	C
Accumulator	PB	Carbon Steel with Stainless Steel Cladding	Treated Borated Water (Int)	Loss of material	Water Chemistry (B2.1.2)	V.D1-30	3.2.1.49	A
Closure Bolting	PB	Stainless Steel	Borated Water Leakage (Ext)	Loss of preload	Bolting Integrity (B2.1.7)	IV.C2-8	3.1.1.52	B
Filter	FIL, SS	Stainless Steel	Plant Indoor Air (Ext)	None	None	V.F-12	3.2.1.53	A
Flow Element	PB	Stainless Steel	Borated Water Leakage (Ext)	None	None	V.F-13	3.2.1.57	A
Flow Element	PB	Stainless Steel	Treated Borated Water (Int)	Loss of material	Water Chemistry (B2.1.2)	V.D1-30	3.2.1.49	A
Flow Indicator	LBS	Glass	Borated Water Leakage (Ext)	None	None	None	None	G

Section 3.2
AGING MANAGEMENT OF ENGINEERED SAFETY FEATURES

Table 3.2.2-4 Engineered Safety Features – Summary of Aging Management Evaluation – Safety Injection and Shutdown Cooling System (Continued)

Component Type	Intended Function	Material	Environment	Aging Effect Requiring Management	Aging Management Program	NUREG-1801 Vol. 2 Item	Table 1 Item	Notes
Flow Indicator	LBS	Glass	Treated Borated Water (Int)	None	None	V.F-9	3.2.1.52	A
Flow Indicator	LBS	Stainless Steel	Borated Water Leakage (Ext)	None	None	V.F-13	3.2.1.57	A
Flow Indicator	LBS	Stainless Steel	Treated Borated Water (Int)	Loss of material	Water Chemistry (B2.1.2)	V.D1-30	3.2.1.49	A
Flow Indicator	LBS	Stainless Steel	Treated Borated Water (Int)	Cracking	Water Chemistry (B2.1.2)	V.D1-31	3.2.1.48	A
Heat Exchanger (Shutdown Cooling)	PB	Carbon Steel	Closed Cycle Cooling Water (Int)	Loss of material	Closed-Cycle Cooling Water System (B2.1.10)	V.D1-6	3.2.1.27	B
Heat Exchanger (Shutdown Cooling)	PB	Carbon Steel	Plant Indoor Air (Ext)	Loss of material	External Surfaces Monitoring Program (B2.1.20)	V.E-7	3.2.1.31	B
Heat Exchanger (Shutdown Cooling)	PB	Carbon Steel with Stainless Steel Cladding	Closed Cycle Cooling Water (Ext)	Loss of material	Closed-Cycle Cooling Water System (B2.1.10)	V.D1-6	3.2.1.27	B
Heat Exchanger (Shutdown Cooling)	PB	Carbon Steel with Stainless Steel Cladding	Treated Borated Water (Int)	Loss of material	Water Chemistry (B2.1.2)	V.D1-30	3.2.1.49	A

Section 3.2
AGING MANAGEMENT OF ENGINEERED SAFETY FEATURES

Table 3.2.2-4 Engineered Safety Features – Summary of Aging Management Evaluation – Safety Injection and Shutdown Cooling System (Continued)

Component Type	Intended Function	Material	Environment	Aging Effect Requiring Management	Aging Management Program	NUREG-1801 Vol. 2 Item	Table 1 Item	Notes
Heat Exchanger (Shutdown Cooling)	PB	Carbon Steel with Stainless Steel Cladding	Treated Borated Water (Int)	Cracking	Water Chemistry (B2.1.2)	V.D1-31	3.2.1.48	A
Heat Exchanger (Shutdown Cooling)	HT, PB	Stainless Steel	Closed Cycle Cooling Water (Ext)	Loss of material	Closed-Cycle Cooling Water System (B2.1.10)	V.D1-4	3.2.1.28	B
Heat Exchanger (Shutdown Cooling)	HT, PB	Stainless Steel	Closed Cycle Cooling Water (Ext)	Reduction of heat transfer	Closed-Cycle Cooling Water System (B2.1.10)	V.D1-9	3.2.1.30	B
Heat Exchanger (Shutdown Cooling)	HT, PB	Stainless Steel	Closed Cycle Cooling Water (Ext)	Cracking	Closed-Cycle Cooling Water System (B2.1.10)	V.D1-23	3.2.1.25	D
Heat Exchanger (Shutdown Cooling)	HT, PB	Stainless Steel	Treated Borated Water (Int)	Reduction of heat transfer	Water Chemistry (B2.1.2) and One-Time Inspection (B2.1.16)	None	None	H, 1
Heat Exchanger (Shutdown Cooling)	HT, PB	Stainless Steel	Treated Borated Water (Int)	Loss of material	Water Chemistry (B2.1.2)	V.D1-30	3.2.1.49	C

Section 3.2
AGING MANAGEMENT OF ENGINEERED SAFETY FEATURES

Table 3.2.2-4 Engineered Safety Features – Summary of Aging Management Evaluation – Safety Injection and Shutdown Cooling System (Continued)

Component Type	Intended Function	Material	Environment	Aging Effect Requiring Management	Aging Management Program	NUREG-1801 Vol. 2 Item	Table 1 Item	Notes
Heat Exchanger (Shutdown Cooling)	HT, PB	Stainless Steel	Treated Borated Water (Int)	Cracking	Water Chemistry (B2.1.2)	V.D1-31	3.2.1.48	C
Insulation	INS	Insulation Calcium Silicate	Borated Water Leakage (Ext)	None	None	None	None	J
Insulation	INS	Insulation Mineral Wool	Borated Water Leakage (Ext)	None	None	None	None	J
Orifice	PB, TH	Stainless Steel	Borated Water Leakage (Ext)	None	None	V.F-13	3.2.1.57	A
Orifice	PB, TH	Stainless Steel	Treated Borated Water (Int)	Loss of material	Water Chemistry (B2.1.2)	V.D1-30	3.2.1.49	A
Piping	PB	Nickel Alloys	Borated Water Leakage (Ext)	None	None	None	None	G
Piping	PB	Nickel Alloys	Reactor Coolant (Int)	Cracking	Nickel Alloy Aging Management (B2.1.34), ASME Section XI Inservice Inspection, Subsections IWB, IWC, and IWD (B2.1.1) for Class 1 components, Water Chemistry (B2.1.2), and Comply with applicable NRC Orders and FSAR Commitment (B2.1.21)	IV.C2-13	3.1.1.31	E, 2

Section 3.2
AGING MANAGEMENT OF ENGINEERED SAFETY FEATURES

Table 3.2.2.4 Engineered Safety Features – Summary of Aging Management Evaluation – Safety Injection and Shutdown Cooling System (Continued)

Component Type	Intended Function	Material	Environment	Aging Effect Requiring Management	Aging Management Program	NUREG-1801 Vol. 2 Item	Table 1 Item	Notes
Piping	LBS, PB, SIA	Stainless Steel	Borated Water Leakage (Ext)	None	None	V.F-13	3.2.1.57	A
Piping	PB	Stainless Steel	Demineralized Water (Int)	Loss of material	Water Chemistry (B2.1.2) and One-Time Inspection (B2.1.16)	VIII.E-29	3.4.1.16	A
Piping	PB	Stainless Steel	Dry Gas (Int)	None	None	V.F-15	3.2.1.56	A
Piping	LBS, PB, SIA	Stainless Steel	Plant Indoor Air (Ext)	None	None	V.F-12	3.2.1.53	A
Piping	PB	Stainless Steel	Plant Indoor Air (Int)	None	None	V.F-12	3.2.1.53	A
Piping	PB	Stainless Steel	Reactor Coolant (Int)	Cracking	ASME Section XI Inservice Inspection, Subsections IWB, IWC, and IWD for Class 1 components (B2.1.1) and Water Chemistry (B2.1.2) and One-Time Inspection Of ASME Code Class 1 Small-Bore Piping (B2.1.19)	IV.C2-1	3.1.1.70	B
Piping	PB	Stainless Steel	Reactor Coolant (Int)	Loss of material	Water Chemistry (B2.1.2)	IV.C2-15	3.1.1.83	A
Piping	PB	Stainless Steel	Treated Borated Water (Int)	Cumulative fatigue damage	Time-Limited Aging Analysis evaluated for the period of extended operation	V.D1-27	3.2.1.01	A

Section 3.2
AGING MANAGEMENT OF ENGINEERED SAFETY FEATURES

Table 3.2.2-4 Engineered Safety Features – Summary of Aging Management Evaluation – Safety Injection and Shutdown Cooling System (Continued)

Component Type	Intended Function	Material	Environment	Aging Effect Requiring Management	Aging Management Program	NUREG-1801 Vol. 2 Item	Table 1 Item	Notes
Piping	LBS, PB, SIA	Stainless Steel	Treated Borated Water (Int)	Loss of material	Water Chemistry (B2.1.2)	V.D1-30	3.2.1.49	A
Piping	PB	Stainless Steel	Treated Borated Water (Int)	Cracking	Water Chemistry (B2.1.2)	V.D1-31	3.2.1.48	A
Piping	LBS, PB, SIA	Stainless Steel	Wetted Gas (Int)	Loss of material	Inspection Of Internal Surfaces In Miscellaneous Piping And Ducting Components (B2.1.22)	V.A-26	3.2.1.08	E
Pump	PB	Stainless Steel	Borated Water Leakage (Ext)	None	None	V.F-13	3.2.1.57	A
Pump	PB	Stainless Steel	Treated Borated Water (Int)	Cumulative fatigue damage	Time-Limited Aging Analysis evaluated for the period of extended operation	V.D1-27	3.2.1.01	C
Pump	PB	Stainless Steel	Treated Borated Water (Int)	Loss of material	Water Chemistry (B2.1.2)	V.D1-30	3.2.1.49	A
Pump	PB	Stainless Steel	Treated Borated Water (Int)	Cracking	Water Chemistry (B2.1.2)	V.D1-31	3.2.1.48	A
Screen	SS	Carbon Steel	Plant Indoor Air (Ext)	Loss of material	External Surfaces Monitoring Program (B2.1.20)	V.E-7	3.2.1.31	B
Screen	FIL, SS	Stainless Steel	Plant Indoor Air (Ext)	None	None	V.F-12	3.2.1.53	C
Spray Nozzle	PB, SP	Stainless Steel	Plant Indoor Air (Ext)	None	None	V.F-12	3.2.1.53	A
Spray Nozzle	PB, SP	Stainless Steel	Plant Indoor Air (Int)	None	None	V.F-12	3.2.1.53	A

Section 3.2
AGING MANAGEMENT OF ENGINEERED SAFETY FEATURES

Table 3.2.2-4 Engineered Safety Features – Summary of Aging Management Evaluation – Safety Injection and Shutdown Cooling System (Continued)

Component Type	Intended Function	Material	Environment	Aging Effect Requiring Management	Aging Management Program	NUREG-1801 Vol. 2 Item	Table 1 Item	Notes
Sump Liner	SPB	Stainless Steel	Plant Indoor Air (Ext)	None	None	V.F-12	3.2.1.53	C
Tubing	LBS, PB	Stainless Steel	Borated Water Leakage (Ext)	None	None	V.F-13	3.2.1.57	A
Tubing	LBS, PB	Stainless Steel	Treated Borated Water (Int)	Loss of material	Water Chemistry (B2.1.2)	V.D1-30	3.2.1.49	A
Valve	LBS, PB	Stainless Steel	Borated Water Leakage (Ext)	None	None	V.F-13	3.2.1.57	A
Valve	PB	Stainless Steel	Dry Gas (Int)	None	None	V.F-15	3.2.1.56	A
Valve	PB	Stainless Steel	Plant Indoor Air (Ext)	None	None	V.F-12	3.2.1.53	A
Valve	LBS, PB	Stainless Steel	Treated Borated Water (Int)	Loss of material	Water Chemistry (B2.1.2)	V.D1-30	3.2.1.49	A
Valve	PB	Stainless Steel	Treated Borated Water (Int)	Cracking	Water Chemistry (B2.1.2)	V.D1-31	3.2.1.48	A

Notes for Table 3.2.2-4:

Standard Notes:

- A Consistent with NUREG-1801 item for component, material, environment, and aging effect. AMP is consistent with NUREG-1801 AMP.
- B Consistent with NUREG-1801 item for component, material, environment, and aging effect. AMP takes some exceptions to NUREG-1801 AMP.
- C Component is different, but consistent with NUREG-1801 item for material, environment, and aging effect. AMP is consistent with NUREG-1801 AMP.
- D Component is different, but consistent with NUREG-1801 item for material, environment, and aging effect. AMP takes some exceptions to NUREG-1801 AMP.

Section 3.2
AGING MANAGEMENT OF ENGINEERED SAFETY FEATURES

- E Consistent with NUREG-1801 for material, environment, and aging effect, but a different aging management program is credited or NUREG-1801 identifies a plant-specific aging management program.
- G Environment not in NUREG-1801 for this component and material.
- H Aging effect not in NUREG-1801 for this component, material and environment combination.
- J Neither the component nor the material and environment combination is evaluated in NUREG-1801

Plant Specific Notes:

- 1 Reduction in heat transfer due to fouling is a potential aging effect for stainless steel heat exchanger components in treated borated water. This non-NUREG-1801 line is based upon the component, material, aging effects and aging management program combination of NUREG-1801 line VII.E1-4.
- 2 Note E was used to include the plant specific Nickel Alloy Aging Management Program (B2.1.34).

3.3 AGING MANAGEMENT OF AUXILIARY SYSTEMS

3.3.1 Introduction

Section 3.3 provides the results of the aging management reviews for those component types identified in [Section 2.3.3](#), Auxiliary Systems, subject to aging management review. These systems are described in the following sections:

- Fuel handling and storage ([Section 2.3.3.1](#))
- Spent fuel pool cooling and cleanup ([Section 2.3.3.2](#))
- Essential cooling water ([Section 2.3.3.3](#))
- Essential chilled water ([Section 2.3.3.4](#))
- Normal chilled water ([Section 2.3.3.5](#))
- Nuclear cooling water ([Section 2.3.3.6](#))
- Essential spray pond ([Section 2.3.3.7](#))
- Nuclear sampling ([Section 2.3.3.8](#))
- Compressed air ([Section 2.3.3.9](#))
- Chemical and volume control ([Section 2.3.3.10](#))
- Control building HVAC ([Section 2.3.3.11](#))
- Auxiliary building HVAC ([Section 2.3.3.12](#))
- Fuel building HVAC ([Section 2.3.3.13](#))
- Containment building HVAC ([Section 2.3.3.14](#))
- Diesel generator building HVAC ([Section 2.3.3.15](#))
- Radwaste building HVAC ([Section 2.3.3.16](#))
- Turbine building HVAC ([Section 2.3.3.17](#))
- Miscellaneous site structures/Spray pond pump house HVAC ([Section 2.3.3.18](#))
- Fire protection ([Section 2.3.3.19](#))
- Diesel generator fuel oil storage and transfer ([Section 2.3.3.20](#))
- Diesel generator ([Section 2.3.3.21](#))
- Domestic water ([Section 2.3.3.22](#))
- Demineralized water ([Section 2.3.3.23](#))
- WRF fuel system ([Section 2.3.3.24](#))
- Service gases (N₂ and H₂) ([Section 2.3.3.25](#))
- Gaseous Radwaste ([Section 2.3.3.26](#))
- Radioactive waste drains ([Section 2.3.3.27](#))
- Station blackout generator ([Section 2.3.3.28](#))
- Cranes, hoists, and elevators ([Section 2.3.3.29](#))
- Miscellaneous auxiliary systems in-scope only for criterion 10 CFR 54.4(a)(2) ([Section 2.3.3.30](#)):
 - [Auxiliary steam](#)
 - [Chemical waste](#)

Section 3.3
AGING MANAGEMENT OF AUXILIARY SYSTEMS

- [Liquid radwaste](#)
- [Oily waste and non-radioactive waste](#)
- [Solid radwaste](#)
- [Sanitary sewage and treatment](#)
- [Secondary chemical control](#)

Table 3.3.1, Summary of Aging Management Evaluations in Chapter VII of NUREG-1801 for Auxiliary Systems, provides the summary of the programs evaluated in NUREG-1801 that are applicable to the component types in this section. [Table 3.3.1](#) uses the format of [Table 3.x.1](#) (Table 1) described in [Section 3.0](#).

3.3.2 Results

The following tables summarize the results of the aging management review for the systems in the Auxiliary Systems area:

- [Table 3.3.2-1](#) Auxiliary Systems – Summary of Aging Management Evaluation – Fuel Handling and Storage System
- [Table 3.3.2-2](#) Auxiliary Systems – Summary of Aging Management Evaluation – Spent Fuel Pool Cooling and Cleanup System
- [Table 3.3.2-3](#) Auxiliary Systems – Summary of Aging Management Evaluation – Essential Cooling Water System
- [Table 3.3.2-4](#) Auxiliary Systems – Summary of Aging Management Evaluation – Essential Chilled Water System
- [Table 3.3.2-5](#) Auxiliary Systems – Summary of Aging Management Evaluation – Normal Chilled Water System
- [Table 3.3.2-6](#) Auxiliary Systems – Summary of Aging Management Evaluation – Nuclear Cooling Water System
- [Table 3.3.2-7](#) Auxiliary Systems – Summary of Aging Management Evaluation – Essential Spray Pond System
- [Table 3.3.2-8](#) Auxiliary Systems – Summary of Aging Management Evaluation – Nuclear Sampling System
- [Table 3.3.2-9](#) Auxiliary Systems – Summary of Aging Management Evaluation – Compressed Air System
- [Table 3.3.2-10](#) Auxiliary Systems – Summary of Aging Management Evaluation – Chemical and Volume Control System
- [Table 3.3.2-11](#) Auxiliary Systems – Summary of Aging Management Evaluation – Control Building HVAC System
- [Table 3.3.2-12](#) Auxiliary Systems – Summary of Aging Management Evaluation – Auxiliary Building HVAC System

AGING MANAGEMENT OF AUXILIARY SYSTEMS

- [Table 3.3.2-13](#) Auxiliary Systems – Summary of Aging Management Evaluation – Fuel Building HVAC System
- [Table 3.3.2-14](#) Auxiliary Systems – Summary of Aging Management Evaluation – Containment Building HVAC System
- [Table 3.3.2-15](#) Auxiliary Systems – Summary of Aging Management Evaluation – Diesel Generator Building HVAC System
- [Table 3.3.2-16](#) Auxiliary Systems – Summary of Aging Management Evaluation – Radwaste Building HVAC System
- [Table 3.3.2-17](#) Auxiliary Systems – Summary of Aging Management Evaluation – Turbine Building HVAC System
- [Table 3.3.2-18](#) Auxiliary Systems – Summary of Aging Management Evaluation – Miscellaneous site structures/Spray Pond Pump House HVAC System
- [Table 3.3.2-19](#) Auxiliary Systems – Summary of Aging Management Evaluation – Fire Protection Systems
- [Table 3.3.2-20](#) Auxiliary Systems – Summary of Aging Management Evaluation – Diesel Generator Fuel Oil Storage and Transfer System
- [Table 2.3.3-21](#) Auxiliary Systems – Summary of Aging Management Evaluation – Diesel Generator System
- [Table 3.3.2-22](#) Auxiliary Systems – Summary of Aging Management Evaluation – Domestic Water System
- [Table 3.3.2-23](#) Auxiliary Systems – Summary of Aging Management Evaluation – Demineralized Water System
- [Table 3.3.2-24](#) Auxiliary Systems – Summary of Aging Management Evaluation – WRF Fuel System
- [Table 3.3.2-25](#) Auxiliary Systems – Summary of Aging Management Evaluation – Service Gases (N₂ and H₂) System
- [Table 3.3.2-26](#) Auxiliary Systems – Summary of Aging Management Evaluation – Gaseous Radwaste System
- [Table 3.3.2-27](#) Auxiliary Systems – Summary of Aging Management Evaluation – Radioactive Waste Drains System
- [Table 3.3.2-28](#) Auxiliary Systems – Summary of Aging Management Evaluation – Station Blackout Generator System
- [Table 3.3.2-29](#) Auxiliary Systems – Summary of Aging Management Evaluation – Cranes, Hoists, and Elevators System

Section 3.3
AGING MANAGEMENT OF AUXILIARY SYSTEMS

- [Table 3.3.2-30](#) Auxiliary Systems – Summary of Aging Management Evaluation – Miscellaneous Auxiliary Systems In-Scope ONLY based on Criterion 10 CFR 54.4(a) (2).

These tables use the format of [Table 2](#) discussed in [Section 3.0](#).

3.3.2.1 Materials, Environment, Aging Effects Requiring Management and Aging Management Programs

The materials from which the component types are fabricated, the environments to which they are exposed, the potential aging effects requiring management, and the aging management programs used to manage these aging effects are provided for each of the above systems in the following subsections.

3.3.2.1.1 Fuel Handling and Storage System

Materials

The materials of construction for the fuel handling and storage system component types are:

- Carbon Steel
- Stainless Steel

Environment

The fuel handling and storage system components are exposed to the following environments:

- Borated Water Leakage
- Plant Indoor Air
- Submerged (Structural)
- Treated Borated Water

Aging Effects Requiring Management

The following fuel handling and storage system aging effects require management:

- Cracking
- Loss of material

Aging Management Programs

The following aging management programs manage the aging effects for the fuel handling - and storage system component types:

- Inspection of Overhead Heavy Load and Light Load (Related to Refueling) Handling Systems ([B2.1.11](#))
- Water Chemistry ([B2.1.2](#))

3.3.2.1.2 Spent Fuel Pool Cooling and Cleanup System

Materials

The materials of construction for the spent fuel pool cooling and cleanup system component types are:

- Carbon Steel
- Stainless Steel
- Stainless Steel Cast Austenitic

Environment

The spent fuel pool cooling and cleanup system component types are exposed to the following environments:

- Borated Water Leakage
- Closed-Cycle Cooling Water
- Encased in Concrete
- Plant Indoor Air
- Treated Borated Water

Aging Effects Requiring Management

The following spent fuel pool cooling and cleanup system aging effects require management:

- Cracking
- Loss of material
- Reduction of heat transfer

Aging Management Programs

The following aging management programs manage the aging effects for the spent fuel pool cooling and cleanup system component types:

- Closed-Cycle Cooling Water System ([B2.1.10](#))
- External Surfaces Monitoring Program ([B2.1.20](#))
- One-Time Inspection ([B2.1.16](#))

- Water Chemistry ([B2.1.2](#))

3.3.2.1.3 Essential Cooling Water System

Materials

The materials of construction for the essential cooling water system component types are:

- Aluminum
- Carbon Steel
- Copper Alloy
- Copper Alloy (Zinc >15%)
- Glass
- Stainless Steel

Environment

The essential cooling water system component types are exposed to the following environments:

- Closed-Cycle Cooling Water
- Demineralized Water
- Dry Gas
- Plant Indoor Air
- Raw Water
- Wetted Gas

Aging Effects Requiring Management

The following essential cooling water system aging effects require management:

- Loss of material
- Loss of preload
- Reduction of heat transfer

Aging Management Programs

The following aging management programs manage the aging effects for the essential cooling water system component types:

- Bolting Integrity ([B2.1.7](#))
- Closed-Cycle Cooling Water System ([B2.1.10](#))

- External Surfaces Monitoring Program ([B2.1.20](#))
- Inspection Of Internal Surfaces In Miscellaneous Piping And Ducting Components ([B2.1.22](#))
- One-Time Inspection ([B2.1.16](#))
- Open-Cycle Cooling Water System ([B2.1.9](#))
- Selective Leaching of Materials ([B2.1.17](#))
- Water Chemistry ([B2.1.2](#))

3.3.2.1.4 Essential Chilled Water System

Materials

The materials of construction for the essential chilled water system component types are:

- Carbon Steel
- Cast Iron
- Copper Alloy
- Copper Alloy (Zinc >15%)
- Glass
- Nickel Alloys
- Stainless Steel

Environment

The essential chilled water system components are exposed to the following environments:

- Closed-Cycle Cooling Water
- Demineralized Water
- Dry Gas
- Lubricating Oil
- Plant Indoor Air
- Wetted Gas

Aging Effects Requiring Management

The following essential chilled water system aging effects require management:

- Loss of material
- Loss of preload

- Reduction of heat transfer

Aging Management Programs

The following aging management programs manage the aging effects for the essential chilled water system component types:

- Bolting Integrity ([B2.1.7](#))
- Closed-Cycle Cooling Water System ([B2.1.10](#))
- External Surfaces Monitoring Program ([B2.1.20](#))
- Inspection Of Internal Surfaces In Miscellaneous Piping And Ducting Components ([B2.1.22](#))
- Lubricating Oil Analysis ([B2.1.23](#))
- One-Time Inspection ([B2.1.16](#))
- Selective Leaching of Materials ([B2.1.17](#))
- Water Chemistry ([B2.1.2](#))

3.3.2.1.5 Normal Chilled Water System

Materials

The materials of construction for the normal chilled water system component types are:

- Carbon Steel
- Copper Alloy
- Nickel Alloys
- Stainless Steel

Environment

The normal chilled water system component types are exposed to the following environments:

- Closed-Cycle Cooling Water
- Plant Indoor Air

Aging Effects Requiring Management

The following normal chilled water system aging effects require management:

- Loss of material
- Loss of preload

Aging Management Programs

The following aging management programs manage the aging effects for the normal chilled water system component types:

- Bolting Integrity ([B2.1.7](#))
- Closed-Cycle Cooling Water System ([B2.1.10](#))
- External Surfaces Monitoring Program ([B2.1.20](#))

3.3.2.1.6 Nuclear Cooling Water System

Materials

The materials of construction for the nuclear cooling water system component types are:

- Carbon Steel
- Copper Alloy
- Nickel Alloys
- Stainless Steel

Environment

The nuclear cooling water system components are exposed to the following environments:

- Closed-Cycle Cooling Water
- Plant Indoor Air
- Wetted Gas

Aging Effects Requiring Management

The following nuclear cooling water system aging effects require management:

- Loss of material
- Loss of preload

Aging Management Programs

The following aging management programs manage the aging effects for the nuclear cooling water system component types:

- Bolting Integrity ([B2.1.7](#))
- Closed-Cycle Cooling Water System ([B2.1.10](#))
- External Surfaces Monitoring Program ([B2.1.20](#))

- Inspection of Internal Surfaces in Miscellaneous Piping and Ducting Components ([B2.1.22](#))

3.3.2.1.7 Essential Spray Pond System

Materials

The materials of construction for the essential spray pond system component types are:

- Carbon Steel
- Copper Alloy
- Copper Alloy (Aluminum > 8%)
- Nickel Alloys
- Polyvinyl Chloride (PVC)
- Stainless Steel
- Stainless Steel Cast Austenitic

Environment

The essential spray pond system component types are exposed to the following environments:

- Atmosphere/ Weather
- Buried
- Plant Indoor Air
- Raw Water
- Wetted Gas

Aging Effects Requiring Management

The following essential spray pond system aging effects require management:

- Loss of material
- Loss of preload

Aging Management Programs

The following aging management programs manage the aging effects for the essential spray pond system component types:

- Bolting Integrity ([B2.1.7](#))
- Buried Piping and Tanks Inspection ([B2.1.18](#))

- External Surfaces Monitoring Program ([B2.1.20](#))
- Inspection Of Internal Surfaces In Miscellaneous Piping And Ducting Components ([B2.1.22](#))
- Open-Cycle Cooling Water System ([B2.1.9](#))
- Selective Leaching of Materials ([B2.1.17](#))

3.3.2.1.8 Nuclear Sampling System

Materials

The materials of construction for the nuclear sampling system component types are:

- Carbon Steel
- Stainless Steel

Environment

The nuclear sampling system component types are exposed to the following environments:

- Borated Water Leakage
- Closed-Cycle Cooling Water
- Demineralized Water
- Plant Indoor Air
- Raw Water
- Treated Borated Water
- Ventilation Atmosphere
- Wetted Gas

Aging Effects Requiring Management

The following nuclear sampling system aging effects require management:

- Cracking
- Loss of material
- Loss of preload
- Reduction of heat transfer

Aging Management Programs

The following aging management programs manage the aging effects for the nuclear sampling system component types:

- Bolting Integrity ([B2.1.7](#))
- Closed-Cycle Cooling Water System ([B2.1.10](#))
- External Surfaces Monitoring Program ([B2.1.20](#))
- Inspection of Internal Surfaces in Miscellaneous Piping and Ducting Components ([B2.1.22](#))
- One-Time Inspection ([B2.1.16](#))
- Water Chemistry ([B2.1.2](#))

3.3.2.1.9 Compressed Air System

Materials

The materials of construction for the compressed air system component types are:

- Carbon Steel
- Copper Alloy
- Stainless Steel

Environment

The compressed air system component types are exposed to the following environments:

- Dry Gas
- Plant Indoor Air

Aging Effects Requiring Management

The following compressed air system aging effects require management:

- Loss of material
- Loss of preload

Aging Management Programs

The following aging management programs manage the aging effects for the compressed air system component types:

- Bolting Integrity ([B2.1.7](#))
- External Surfaces Monitoring Program ([B2.1.20](#))

3.3.2.1.10 Chemical and Volume Control System

Materials

The materials of construction for the chemical and volume control system component types are:

- Carbon Steel
- Cast Iron
- Elastomer
- Glass
- Insulation Calcium Silicate
- Insulation Mineral Wool
- Nickel Alloys
- Stainless Steel
- Stainless Steel Cast Austenitic

Environment

The chemical and volume control system component types are exposed to the following environments:

- Atmosphere/ Weather
- Borated Water Leakage
- Buried
- Closed-Cycle Cooling Water
- Demineralized Water
- Dry Gas
- Encased in Concrete
- Plant Indoor Air
- Raw Water
- Reactor Coolant
- Secondary Water
- Treated Borated Water
- Wetted Gas

Aging Effects Requiring Management

The following chemical and volume control system aging effects require management:

- Cracking
- Hardening and loss of strength
- Loss of material
- Loss of preload

Aging Management Programs

The following aging management programs manage the aging effects for the chemical and volume control system component types:

- ASME Section XI Inservice Inspection, Subsections IWB, IWC, and IWD ([B2.1.1](#))
- Bolting Integrity ([B2.1.7](#))
- Boric Acid Corrosion ([B2.1.4](#))
- Buried Piping and Tanks Inspection ([B2.1.18](#))
- Closed-Cycle Cooling Water System ([B2.1.10](#))
- External Surfaces Monitoring Program ([B2.1.20](#))
- Inspection of Internal Surfaces in Miscellaneous Piping and Ducting Components ([B2.1.22](#))
- Nickel Alloy Aging Management ([B2.1.34](#))
- One-Time Inspection ([B2.1.16](#))
- One-Time Inspection Of ASME Code Class 1 Small-Bore Piping ([B2.1.19](#))
- Reactor Coolant System Supplement ([B2.1.21](#))
- Water Chemistry ([B2.1.2](#))

3.3.2.1.11 Control Building HVAC System

Materials

The materials of construction for the control building HVAC system component types are:

- Carbon Steel
- Carbon Steel (Galvanized)
- Cast Iron
- Copper Alloy

- Elastomer
- Glass
- Stainless Steel

Environment

The control building HVAC system component types are exposed to the following environments:

- Closed-Cycle Cooling Water
- Encased in Concrete
- Plant Indoor Air
- Potable Water
- Ventilation Atmosphere
- Wetted Gas

Aging Effects Requiring Management

The following control building HVAC system aging effects require management:

- Hardening and loss of strength
- Loss of material
- Loss of preload
- Reduction of heat transfer

Aging Management Programs

The following aging management programs manage the aging effects for the control building HVAC system component types:

- Bolting Integrity ([B2.1.7](#))
- Closed-Cycle Cooling Water System ([B2.1.10](#))
- External Surfaces Monitoring Program ([B2.1.20](#))
- Inspection of Internal Surfaces in Miscellaneous Piping and Ducting Components ([B2.1.22](#))

3.3.2.1.12 Auxiliary Building HVAC System

Materials

The materials of construction for the auxiliary building HVAC system component types are:

- Carbon Steel
- Carbon Steel (Galvanized)
- Copper Alloy
- Elastomer
- Stainless Steel

Environment

The auxiliary building HVAC system component types are exposed to the following environments:

- Closed-Cycle Cooling Water
- Encased in Concrete
- Plant Indoor Air
- Ventilation Atmosphere

Aging Effects Requiring Management

The following auxiliary building HVAC system aging effects require management:

- Hardening and loss of strength
- Loss of material
- Loss of preload
- Reduction of heat transfer

Aging Management Programs

The following aging management programs manage the aging effects for the auxiliary building HVAC system component types:

- Bolting Integrity ([B2.1.7](#))
- Closed-Cycle Cooling Water System ([B2.1.10](#))
- External Surfaces Monitoring Program ([B2.1.20](#))
- Inspection of Internal Surfaces in Miscellaneous Piping and Ducting Components ([B2.1.22](#))

3.3.2.1.13 Fuel Building HVAC System

Materials

The materials of construction for the fuel building HVAC system component types are:

- Carbon Steel
- Carbon Steel (Galvanized)
- Elastomer
- Stainless Steel

Environment

The fuel building HVAC system component types are exposed to the following environments:

- Atmosphere/ Weather
- Encased in Concrete
- Plant Indoor Air
- Ventilation Atmosphere
- Wetted Gas

Aging Effects Requiring Management

The following fuel building HVAC system aging effects require management:

- Hardening and loss of strength
- Loss of material
- Loss of preload

Aging Management Programs

The following aging management programs manage the aging effects for the fuel building HVAC system component types:

- Bolting Integrity ([B2.1.7](#))
- External Surfaces Monitoring Program ([B2.1.20](#))
- Inspection of Internal Surfaces in Miscellaneous Piping and Ducting Components ([B2.1.22](#))

3.3.2.1.14 Containment Building HVAC System

Materials

The materials of construction for the containment building HVAC system component types are:

- Carbon Steel

- Carbon Steel (Galvanized)
- Copper Alloy
- Elastomer
- Stainless Steel

Environment

The containment building HVAC system component types are exposed to the following environments:

- Closed-Cycle Cooling Water
- Plant Indoor Air
- Ventilation Atmosphere

Aging Effects Requiring Management

The following containment building HVAC system aging effects require management:

- Hardening and loss of strength
- Loss of material
- Loss of preload

Aging Management Programs

The following aging management programs manage the aging effects for the containment building HVAC system component types:

- Bolting Integrity ([B2.1.7](#))
- Closed-Cycle Cooling Water System ([B2.1.10](#))
- External Surfaces Monitoring Program ([B2.1.20](#))
- Inspection of Internal Surfaces in Miscellaneous Piping and Ducting Components ([B2.1.22](#))

3.3.2.1.15 Diesel Generator Building HVAC System

Materials

The materials of construction for the diesel generator building HVAC system component types are:

- Carbon Steel
- Carbon Steel (Galvanized)

- Copper Alloy
- Elastomer

Environment

The diesel generator building HVAC system component types are exposed to the following environments:

- Encased in Concrete
- Plant Indoor Air
- Ventilation Atmosphere
- Wetted Gas

Aging Effects Requiring Management

The following diesel generator building HVAC system aging effects require management:

- Hardening and loss of strength
- Loss of material
- Loss of preload

Aging Management Programs

The following aging management programs manage the aging effects for the diesel generator building HVAC system component types:

- Bolting Integrity ([B2.1.7](#))
- External Surfaces Monitoring Program ([B2.1.20](#))
- Inspection Of Internal Surfaces In Miscellaneous Piping And Ducting Components ([B2.1.22](#))

3.3.2.1.16 Radwaste Building HVAC System

Materials

The materials of construction for the radwaste building HVAC system component types are:

- Carbon Steel
- Carbon Steel (Galvanized)

Environment

The radwaste building HVAC system component types are exposed to the following environments:

- Encased in Concrete
- Plant Indoor Air
- Ventilation Atmosphere
- Wetted Gas

Aging Effects Requiring Management

The following radwaste building HVAC system aging effects require management:

- Loss of material
- Reduction of heat transfer

Aging Management Programs

The following aging management programs manage the aging effects for the radwaste building HVAC system component types:

- Bolting Integrity ([B2.1.7](#))
- External Surfaces Monitoring Program ([B2.1.20](#))
- Inspection of Internal Surfaces in Miscellaneous Piping and Ducting Components ([B2.1.22](#))

3.3.2.1.17 Turbine Building HVAC System

Materials

The materials of construction for the turbine building HVAC system component types are:

- Aluminum
- Carbon Steel
- Carbon Steel (Galvanized)

Environment

The turbine building HVAC system component types are exposed to the following environments:

- Atmosphere/ Weather
- Encased in Concrete
- Plant Indoor Air
- Ventilation Atmosphere

Aging Effects Requiring Management

The following turbine building HVAC system aging effects require management:

- Loss of material
- Loss of preload

Aging Management Programs

The following aging management programs manage the aging effects for the turbine building HVAC system component types:

- Bolting Integrity ([B2.1.7](#))
- External Surfaces Monitoring Program ([B2.1.20](#))
- Inspection of Internal Surfaces in Miscellaneous Piping and Ducting Components ([B2.1.22](#))

3.3.2.1.18 Miscellaneous Site Structures/Spray Pond Pump House HVAC System

Materials

The materials of construction for the miscellaneous site structures/spray pond pump house HVAC system component types are:

- Carbon Steel
- Carbon Steel (Galvanized)
- Elastomer

Environment

The miscellaneous site structures/spray pond pump house HVAC system component types are exposed to the following environments:

- Plant Indoor Air
- Ventilation Atmosphere

Aging Effects Requiring Management

The following miscellaneous site structures/spray pond pump house HVAC system aging effects require management:

- Hardening and loss of strength
- Loss of material
- Loss of preload

Aging Management Programs

The following aging management programs manage the aging effects for the miscellaneous site structures/spray pond pump house HVAC system component types:

- Bolting Integrity ([B2.1.7](#))
- External Surfaces Monitoring Program ([B2.1.20](#))
- Inspection of Internal Surfaces in Miscellaneous Piping and Ducting Components ([B2.1.22](#))

3.3.2.1.19 Fire Protection Systems

Materials

The material of construction for the fire protection systems component types is:

- Aluminum
- Carbon Steel
- Carbon Steel (Galvanized)
- Cast Iron
- Cast Iron (Gray Cast Iron)
- Copper Alloy
- Copper Alloy (Zinc >15%)
- Ductile Iron
- Fiberglass Reinforced Plastic
- Stainless Steel

Environment

The fire protection systems component types are exposed to the following environments:

- Atmosphere/ Weather
- Buried
- Diesel Exhaust
- Dry Gas
- Fuel Oil
- Plant Indoor Air
- Raw Water

- Wetted Gas

Aging Effects Requiring Management

The following fire protection systems aging effect requires management:

- Cracking
- Loss of material
- Loss of preload

Aging Management Programs

The following aging management program manages the aging effects for the fire protection systems component types:

- Bolting Integrity ([B2.1.7](#))
- Buried Piping and Tanks Inspection ([B2.1.18](#))
- External Surfaces Monitoring Program ([B2.1.20](#))
- Fire Water System ([B2.1.13](#))
- Fuel Oil Chemistry ([B2.1.14](#))
- Inspection Of Internal Surfaces In Miscellaneous Piping And Ducting Components ([B2.1.22](#))
- One-Time Inspection ([B2.1.16](#))
- Selective Leaching of Materials ([B2.1.17](#))

3.3.2.1.20 Diesel Generator Fuel Oil Storage and Transfer System

Materials

The materials of construction for the diesel generator fuel oil storage and transfer system component types are:

- Aluminum
- Carbon Steel
- Copper Alloy
- Stainless Steel

Environment

The diesel generator fuel oil storage and transfer system component types are exposed to the following environments:

- Atmosphere/ Weather
- Buried
- Encased in Concrete
- Fuel Oil
- Plant Indoor Air
- Wetted Gas

Aging Effects Requiring Management

The following diesel generator fuel oil storage and transfer system aging effects require management:

- Loss of material
- Loss of preload

Aging Management Programs

The following aging management programs manage the aging effects for the diesel generator fuel oil storage and transfer system component types:

- Bolting Integrity ([B2.1.7](#))
- Buried Piping and Tanks Inspection ([B2.1.18](#))
- External Surfaces Monitoring Program ([B2.1.20](#))
- Fuel Oil Chemistry ([B2.1.14](#))
- Inspection of Internal Surfaces in Miscellaneous Piping and Ducting Components ([B2.1.22](#))
- One-Time Inspection ([B2.1.16](#))

3.3.2.1.21 Diesel Generator System

Materials

The materials of construction for the diesel generator system component types are:

- Aluminum
- Carbon Steel
- Carbon Steel (Galvanized)
- Cast Iron
- Copper Alloy

- Copper Alloy (Zinc >15%)
- Glass
- Insulation Mineral Wool
- Nickel Alloys
- Stainless Steel

Environment

The diesel generator system component types are exposed to the following environments:

- Atmosphere/ Weather
- Closed-Cycle Cooling Water
- Demineralized Water
- Diesel Exhaust
- Dry Gas
- Fuel Oil
- Lubricating Oil
- Plant Indoor Air
- Raw Water
- Secondary Water
- Ventilation Atmosphere
- Wetted Gas

Aging Effects Requiring Management

The following diesel generator system aging effects require management:

- Cracking
- Hardening and loss of strength
- Loss of material
- Loss of preload
- Reduction of heat transfer

Aging Management Programs

The following aging management programs manage the aging effects for the diesel generator system component types:

- Bolting Integrity ([B2.1.7](#))
- Closed-Cycle Cooling Water System ([B2.1.10](#))
- External Surfaces Monitoring Program ([B2.1.20](#))
- Fuel Oil Chemistry ([B2.1.14](#))
- Inspection of Internal Surfaces in Miscellaneous Piping and Ducting Components ([B2.1.22](#))
- Lubricating Oil Analysis ([B2.1.23](#))
- One-Time Inspection ([B2.1.16](#))
- Open-Cycle Cooling Water System ([B2.1.9](#))
- Selective Leaching of Materials ([B2.1.17](#))
- Water Chemistry ([B2.1.2](#))

3.3.2.1.22 Domestic Water System

Materials

The materials of construction for the domestic water system component types are:

- Carbon Steel
- Carbon Steel with Elastomer Lining
- Cast Iron
- Copper Alloy
- Polyethylene
- Stainless Steel

Environment

The domestic water system component types are exposed to the following environments:

- Atmosphere/ Weather
- Buried
- Plant Indoor Air
- Potable Water
- Raw Water

Aging Effects Requiring Management

The following domestic water system aging effects require management:

- Loss of material
- Loss of preload

Aging Management Programs

The following aging management programs manage the aging effects for the domestic water system component types:

- Bolting Integrity ([B2.1.7](#))
- Buried Piping and Tanks Inspection ([B2.1.18](#))
- External Surfaces Monitoring Program ([B2.1.20](#))
- Fire Water System ([B2.1.13](#))
- Inspection of Internal Surfaces in Miscellaneous Piping and Ducting Components ([B2.1.22](#))

3.3.2.1.23 Demineralized Water System

Materials

The materials of construction for the demineralized water system component types are:

- Carbon Steel
- Stainless Steel

Environment

The demineralized water system component types are exposed to the following environments:

- Atmosphere/ Weather
- Demineralized Water
- Plant Indoor Air

Aging Effects Requiring Management

The following demineralized water system aging effects require management:

- Loss of material
- Loss of preload

Aging Management Programs

The following aging management programs manage the aging effects for the demineralized water system component types:

- Bolting Integrity ([B2.1.7](#))
- One-Time Inspection ([B2.1.16](#))
- Water Chemistry ([B2.1.2](#))

3.3.2.1.24 WRF Fuel System

Materials

The materials of construction for the WRF fuel system component types are:

- Aluminum
- Carbon Steel
- Cast Iron (Gray Cast Iron)
- Copper Alloy
- Glass
- Stainless Steel

Environment

The WRF fuel system component types are exposed to the following environments:

- Atmosphere/ Weather
- Buried
- Encased in Concrete
- Fuel Oil

Aging Effects Requiring Management

The following WRF fuel system aging effects require management:

- Loss of material
- Loss of preload

Aging Management Programs

The following aging management programs manage the aging effects for the WRF fuel system component types:

- Bolting Integrity ([B2.1.7](#))
- Buried Piping and Tanks Inspection ([B2.1.18](#))
- External Surfaces Monitoring Program ([B2.1.20](#))

- Fuel Oil Chemistry ([B2.1.14](#))
- One-Time Inspection ([B2.1.16](#))

3.3.2.1.25 Service Gases (N2 and H2) System

Materials

The material of construction for the service gases (N2 and H2) systems component types is:

- Carbon Steel
- Stainless Steel

Environment

The service gases (N2 and H2) systems component types are exposed to the following environments:

- Dry Gas
- Plant Indoor Air

Aging Effects Requiring Management

The following service gases (N2 and H2) system aging effect requires management:

- Loss of material
- Loss of preload

Aging Management Programs

The following aging management program manages the aging effects for the service gases (N2 and H2) systems component types:

- Bolting Integrity ([B2.1.7](#))
- External Surfaces Monitoring Program ([B2.1.20](#))

3.3.2.1.26 Gaseous Radwaste System

Materials

The materials of construction for the gaseous radwaste system component types are:

- Carbon Steel
- Glass
- Stainless Steel

Environment

The gaseous radwaste system component types are exposed to the following environments:

- Plant Indoor Air
- Raw Water
- Wetted Gas

Aging Effects Requiring Management

The following gaseous radwaste system aging effects require management:

- Loss of material
- Loss of preload

Aging Management Programs

The following aging management programs manage the aging effects for the gaseous radwaste system component types:

- Bolting Integrity ([B2.1.7](#))
- Inspection of Internal Surfaces in Miscellaneous Piping and Ducting Components ([B2.1.22](#))

3.3.2.1.27 Radioactive Waste Drains System

Materials

The materials of construction for the radioactive waste drains system component types are:

- Carbon Steel
- Cast Iron
- Glass
- Stainless Steel

Environment

The radioactive waste drains system component types are exposed to the following environments:

- Atmosphere/ Weather
- Borated Water Leakage
- Demineralized Water
- Encased in Concrete

- Plant Indoor Air
- Raw Water
- Treated Borated Water

Aging Effects Requiring Management

The following radioactive waste drains system aging effects require management:

- Loss of material
- Loss of preload

Aging Management Programs

The following aging management programs manage the aging effects for the radioactive waste drains system component types:

- Bolting Integrity ([B2.1.7](#))
- Boric Acid Corrosion ([B2.1.4](#))
- External Surfaces Monitoring Program ([B2.1.20](#))
- Inspection of Internal Surfaces in Miscellaneous Piping and Ducting Components ([B2.1.22](#))
- One-Time Inspection ([B2.1.16](#))
- Water Chemistry ([B2.1.2](#))

3.3.2.1.28 Station Blackout Generator System

Materials

The materials of construction for the station blackout generator system component types are:

- Aluminum
- Carbon Steel
- Cast Iron
- Copper Alloy
- Ductile Iron
- Glass
- Stainless Steel

Environment

The station blackout generator system component types are exposed to the following environments:

- Atmosphere/ Weather
- Fuel Oil
- Hydraulic Fluid
- Lubricating Oil
- Plant Indoor Air
- Ventilation Atmosphere
- Wetted Gas

Aging Effects Requiring Management

The following station blackout generator system aging effect requires management:

- Loss of material
- Loss of preload
- Reduction of heat transfer

Aging Management Programs

The following aging management program manages the aging effects for the station blackout generator system component types:

- Bolting Integrity ([B2.1.7](#))
- External Surfaces Monitoring Program ([B2.1.20](#))
- Fuel Oil Chemistry ([B2.1.14](#))
- Inspection Of Internal Surfaces In Miscellaneous Piping And Ducting Components ([B2.1.22](#))
- Lubricating Oil Analysis ([B2.1.23](#))
- One-Time Inspection ([B2.1.16](#))

3.3.2.1.29 Cranes, Hoists and Elevators System

Materials

The material of construction for the cranes, hoists, and elevator system component types is:

- Carbon Steel

Environment

The cranes, hoists, and elevator system component types are exposed to the following environment:

- Plant Indoor Air

Aging Effects Requiring Management

The following cranes, hoists, and elevator system aging effect requires management:

- Loss of material

Aging Management Programs

The following aging management program manages the aging effects for the cranes, hoists, and elevator system component types:

- Inspection of Overhead Heavy Load and Light Load (Related to Refueling) Handling Systems ([B2.1.11](#))

3.3.2.1.30 Miscellaneous Auxiliary Systems In-Scope ONLY based on Criterion 10 CFR 54.4(a)(2)

Materials

The materials of construction for the miscellaneous auxiliary systems in-scope ONLY based on Criterion 10 CFR 54.4(a) (2) component types are:

- Carbon Steel
- Carbon Steel with Elastomer Lining
- Cast Iron
- Cast Iron (Gray Cast Iron)
- Copper Alloy
- Copper Alloy (Brass Copper < 85%)
- Glass
- Stainless Steel

Environment

The miscellaneous auxiliary systems in-scope ONLY based on Criterion 10 CFR 54.4(a)(2) component types are exposed to the following environments:

- Borated Water Leakage
- Closed-Cycle Cooling Water

- Demineralized Water
- Plant Indoor Air
- Potable Water
- Raw Water
- Secondary Water
- Treated Borated Water
- Wetted Gas

Aging Effects Requiring Management

The following miscellaneous auxiliary systems in-scope ONLY based on Criterion 10 CFR 54.4(a)(2) aging effects require management:

- Cracking
- Loss of material
- Loss of preload
- Wall thinning

Aging Management Programs

The following aging management programs manage the aging effects for the miscellaneous auxiliary systems in-scope ONLY based on Criterion 10 CFR 54.4(a)(2) component types:

- Bolting Integrity ([B2.1.7](#))
- Boric Acid Corrosion ([B2.1.4](#))
- Closed-Cycle Cooling Water System ([B2.1.10](#))
- External Surfaces Monitoring Program ([B2.1.20](#))
- Flow-Accelerated Corrosion ([B2.1.6](#))
- Inspection of Internal Surfaces in Miscellaneous Piping and Ducting Components ([B2.1.22](#))
- One-Time Inspection ([B2.1.16](#))
- Selective Leaching of Materials ([B2.1.17](#))
- Water Chemistry ([B2.1.2](#))

3.3.2.2 Further Evaluation of Aging Management as Recommended by NUREG-1801

NUREG-1801 provides the basis for identifying those programs that warrant further evaluation. For the auxiliary systems, those evaluations are addressed in the following subsections.

3.3.2.2.1 Cumulative Fatigue Damage

[3.3.1.01] Evaluation of cumulative fatigue damage of auxiliary system piping and heat exchangers, and the number of significant lifts assumed for design of fuel handling equipment is a time-limited aging analysis (TLAA) as defined in 10 CFR 54.3. TLAA's are evaluated in accordance with 10 CFR 54.21(c)(1).

Section 4.7.1 describes the evaluation of fuel handling equipment TLAA's.

[3.3.1.02] PVNGS piping outside the reactor coolant pressure boundary is designed to ASME III Class 2, Class 3, and ANSI B31.1, all of which require a reduction in the allowable secondary stress range if more than 7,000 full-range thermal cycles are expected in a design lifetime. Section 4.3.5 describes the evaluation of these cyclic piping design TLAA's.

A survey of other than ASME III Class 1 pressure-retaining components (vessels, heat exchangers, pumps, and valves) discovered two Class 2 heat exchangers in each unit, the CVCS letdown and regenerative heat exchangers. Section 4.3.2.9 describes the evaluation of this TLAA.

3.3.2.2.2 Reduction of Heat Transfer due to Fouling

Not applicable to PVNGS, applicable to BWR only.

3.3.2.2.3 Cracking due to Stress Corrosion Cracking (SCC)

3.3.2.2.3.1 Stainless steel piping and components of BWR standby liquid control system exposed to sodium pentaborate

Not applicable to PVNGS, applicable to BWR only.

3.3.2.2.3.2 Stainless steel heat exchanger components exposed to treated water

Not applicable to PVNGS, applicable to BWR only.

3.3.2.2.3.3 Stainless steel diesel engine exhaust piping and components exposed to diesel exhaust

Section 3.3
AGING MANAGEMENT OF AUXILIARY SYSTEMS

The Inspection of Internal Surfaces in Miscellaneous Piping and Ducting Components program (B2.1.22) will manage cracking from stress corrosion cracking for stainless steel internal surfaces exposed to diesel exhaust.

3.3.2.2.4 Cracking due to Stress Corrosion Cracking and Cyclic Loading

3.3.2.2.4.1 Stainless steel PWR non-regenerative heat exchanger components exposed to borated water

The Water Chemistry program (B2.1.2) and the One-Time Inspection program (B2.1.16) will manage cracking due to stress corrosion cracking and cyclic loading for the stainless steel CVCS letdown (non-regenerative) heat exchanger components exposed to treated borated water. Temperature and radioactivity of the shell-side water are monitored by installed instrumentation. The One-Time Inspection program (B2.1.16) is selected in lieu of eddy-current testing of tubes.

This position was found acceptable to the NRC staff in NUREG-1785, "Safety Evaluation Report Related to the License Renewal of H. B. Robinson Steam Electric Plant, Unit 2".

3.3.2.2.4.2 Stainless steel PWR regenerative heat exchanger components exposed to borated water

The Water Chemistry program (B2.1.2) and the One-Time Inspection program (B2.1.16) will manage cracking due to stress corrosion cracking and cyclic loading for the stainless steel CVCS and nuclear sampling systems heat exchanger components exposed to treated borated water. The one-time inspection will include selected components at susceptible locations.

3.3.2.2.4.3 Stainless steel pump casings in the chemical and volume control system

The Water Chemistry program (B2.1.2) and the One-Time Inspection program (B2.1.16) will manage cracking due to stress corrosion cracking and cyclic loading for stainless steel pump casings exposed to treated borated water. The one-time inspection will include selected components at susceptible locations.

3.3.2.2.4.4 High strength bolting exposed to steam or water leakage

Not applicable. PVNGS has no in-scope high-strength steel closure bolting exposed to air with steam or water leakage in the chemical and volume control system, so the applicable NUREG-1801 line was not used.

3.3.2.2.5 Hardening and Loss of Strength due to Elastomer Degradation

3.3.2.2.5.1 Elastomer seals of HVAC systems exposed to air-indoor (uncontrolled)

The External Surfaces Monitoring Program (B2.1.20) will manage the hardening and loss of strength from elastomer degradation for elastomer external surfaces exposed to plant indoor

Section 3.3
AGING MANAGEMENT OF AUXILIARY SYSTEMS

air (uncontrolled) in locations where the ambient temperature cannot be shown to be less than 95° F.

The Inspection of Internal Surfaces in Miscellaneous Piping and Ducting Components program ([Section B2.1.22](#)) will manage the hardening and loss of strength from elastomer degradation for elastomer internal surfaces exposed to ventilation atmosphere in locations where the ambient temperature cannot be shown to be less than 95° F.

3.3.2.2.5.2 Elastomers in Auxiliary Systems Exposed to a Treated Borated Water Environment

The Inspection of Internal Surfaces in Miscellaneous Piping and Ducting Components aging management program ([B2.1.22](#)) will manage hardening and loss of strength for the elastomer boot seal for the Safety Injection Pump Suction Strainer in the Refueling Water Tank that is exposed to treated borated water.

3.3.2.2.6 Reduction of Neutron-Absorbing Capacity and Loss of Material due to General Corrosion

Not applicable. PVNGS uses soluble boron to maintain spent fuel pool subcriticality per [UFSAR section 9.1.2.1.1](#). PVNGS does not employ boral or boron steel in spent fuel storage racks to maintain subcriticality.

3.3.2.2.7 Loss of Material due to General, Pitting, and Crevice Corrosion

3.3.2.2.7.1 Steel piping and components in the reactor coolant pump oil collection system exposed to lubricating oil

The Lubricating Oil Analysis program ([B2.1.23](#)) and the One-Time Inspection program ([B2.1.16](#)) will manage loss of material due to stress corrosion cracking for carbon steel (including galvanized) and cast iron components exposed to lubricating oil in auxiliary systems. The one-time inspection will include selected components at susceptible locations where contaminants such as water could accumulate.

In addition, the one-time inspection will evaluate the thickness of the lower portion of a representative sample of RCP lubricating oil collection tanks. The PVNGS RCP lubricating oil collection system is part of the reactor coolant system.

3.3.2.2.7.2 Steel piping and components in BWR reactor water cleanup and shutdown cooling systems exposed to treated water

Not applicable to PVNGS, applicable to BWR only.

3.3.2.2.7.3 Steel diesel exhaust piping and components exposed to diesel exhaust

The Inspection of Internal Surfaces in Miscellaneous Piping and Ducting Components program ([Section B2.1.22](#)) will manage the loss of material due to general (steel only),

pitting, and crevice corrosion for carbon steel and stainless steel internal surfaces exposed to diesel exhaust.

3.3.2.2.8 Loss of Material due to General, Pitting, Crevice, and Microbiologically-Influenced Corrosion (MIC)

The Buried Piping and Tanks Inspection program (B2.1.18) will manage the loss of material due to general, pitting, crevice corrosion, and microbiologically-influenced corrosion (MIC) for the carbon steel (including cast iron and ductile iron) external surfaces of buried components.

3.3.2.2.9 Loss of Material due to General, Pitting, Crevice, and Microbiologically-Influenced Corrosion and Fouling

3.3.2.2.9.1 Steel piping and components exposed to fuel oil

The Fuel Oil Chemistry program (B2.1.14) and the One-Time Inspection program (B2.1.16) will manage loss of material due to general, pitting, crevice, microbiologically-influenced corrosion, and fouling for carbon steel components in the fuel oil system. The one-time inspection will include selected components at susceptible locations where contaminants could accumulate (e.g. stagnant flow locations and tank bottoms).

3.3.2.2.9.2 Steel heat exchanger components exposed to lubricating oil

The Lubricating Oil Analysis program (B2.1.23) and the One-Time Inspection program (B2.1.16) will manage loss of material due to general, pitting, crevice, microbiologically-influenced corrosion, and fouling for carbon steel components exposed to lubricating oil. The one-time inspection will include selected components at susceptible locations where contaminants such as water could accumulate.

3.3.2.2.10 Loss of Material due to Pitting and Crevice Corrosion

3.3.2.2.10.1 Elastomer lined and stainless steel clad components exposed to treated or treated borated water

Not applicable. PVNGS has no in-scope components constructed of steel with elastomer lining or steel with stainless steel cladding exposed to treated or treated borated water in the fuel pool cooling and cleanup system, so the applicable NUREG-1801 lines were not used.

3.3.2.2.10.2 Stainless steel, aluminum, and stainless steel clad heat exchanger components exposed to treated water

Not applicable to PVNGS, applicable to BWR only.

Section 3.3
AGING MANAGEMENT OF AUXILIARY SYSTEMS

3.3.2.2.10.3 Copper alloy HVAC piping and components exposed to condensation (external)

The External Surfaces Monitoring Program (B2.1.20) will manage the loss of material due to pitting and crevice corrosion for copper alloy external surfaces exposed to plant indoor air.

The Inspection of Internal Surfaces in Miscellaneous Piping and Ducting Components program (Section B2.1.22) will manage the loss of material due to pitting and crevice corrosion for copper alloy internal surfaces exposed to ventilation atmosphere.

3.3.2.2.10.4 Copper alloy piping and components exposed to lubricating oil

The Lubricating Oil analysis program (B2.1.23) and the One-Time Inspection program (B2.1.16) will manage loss of material due to pitting and crevice corrosion for copper components exposed to lubricating oil. The one-time inspection will include selected components at susceptible locations where contaminants such as water could accumulate.

3.3.2.2.10.5 HVAC aluminum piping and components and stainless steel ducting and components exposed to condensation

The Inspection of Internal Surfaces in Miscellaneous Piping and Ducting Components program (Section B2.1.22) will manage the loss of material due to pitting and crevice corrosion for stainless steel and aluminum internal surfaces exposed to ventilation atmosphere and wetted gas.

3.3.2.2.10.6 Copper alloy piping and components exposed to internal condensation

The Inspection of Internal Surfaces in Miscellaneous Piping and Ducting Components program (Section B2.1.22) will manage the loss of material due to pitting and crevice corrosion for copper alloy internal surfaces exposed to wetted gas.

3.3.2.2.10.7 Stainless steel piping and components exposed to soil

The Buried Piping and Tanks Inspection program (B2.1.18) will manage the loss of material due to pitting and crevice corrosion for the stainless steel external surfaces of buried components.

3.3.2.2.10.8 Stainless steel piping and components of BWR standby liquid control system exposed to sodium pentaborate

Not applicable to PVNGS, applicable to BWR only.

3.3.2.2.11 Loss of Material due to Pitting, Crevice, and Galvanic Corrosion

Not applicable to PVNGS, applicable to BWR only.

3.3.2.2.12 Loss of Material due to Pitting, Crevice, and Microbiologically-Influenced Corrosion

3.3.2.2.12.1 Stainless steel, aluminum, and copper alloy piping and components exposed to fuel oil

The Fuel Oil Chemistry program (B2.1.14) and the One-Time Inspection program (B2.1.16) will manage loss of material due to pitting, crevice, and microbiologically influenced corrosion for stainless steel, aluminum, and copper components exposed to fuel oil. The one-time inspection will include selected components at susceptible locations where contaminants could accumulate (e.g. stagnant flow locations).

3.3.2.2.12.2 Stainless steel piping and components exposed to lubricating oil

The Lubricating Oil Analysis program (B2.1.23) and the One-Time Inspection program (B2.1.16) will manage loss of material due to pitting, crevice, and microbiologically influenced corrosion for stainless steel components exposed to lubricating oil. The one-time inspection will include selected components at susceptible locations where contaminants such as water could accumulate.

3.3.2.2.13 Loss of Material due to Wear

Not applicable. PVNGS has no in-scope elastomer components exposed to air - indoor uncontrolled (internal or external) with relative motion with other components to produce an aging effect of loss of material due to wear. Therefore, the applicable NUREG-1801 lines were not used.

3.3.2.2.14 Loss of Material due to Cladding Breach

Not applicable. PVNGS has no in-scope pumps in the chemical and volume control system that are steel with stainless steel cladding exposed to treated borated water, so the NUREG-1801 line was not used.

3.3.2.2.15 Quality Assurance for Aging Management of Nonsafety-Related Components

Quality Assurance Program and Administrative Controls are discussed in [Section B1.3](#).

3.3.2.3 Time-Limited Aging Analysis

The time-limited aging analyses identified below are associated with the auxiliary systems components. The section of [Chapter 4](#) that contains the TLAA review results is indicated in parenthesis.

- Cumulative fatigue damage ([Section 4.3](#), Metal Fatigue Analysis)

Section 3.3
AGING MANAGEMENT OF AUXILIARY SYSTEMS

- Crane load cycle limits ([Section 4.7.1](#), Load Cycle Limits of Cranes, Lifts, and Fuel Handling Equipment Designed for a Stated Number of Lifetime Lifts or to CMAA 70)

3.3.3 Conclusions

The auxiliary systems component types that are subject to aging management review have been evaluated. The aging management programs selected to manage the aging effects for the auxiliary systems component types are identified in the summary Tables and in [Section 3.3.2.1](#).

A description of these aging management programs is provided in [Appendix B](#), along with a demonstration that the identified aging effects will be managed for the period of extended operation.

Therefore, based on the demonstration provided in [Appendix B](#), the effects of aging associated with the auxiliary systems component types will be adequately managed so that there is reasonable assurance that the intended functions will be maintained consistent with the current licensing basis during the period of extended operation.

Section 3.3
AGING MANAGEMENT OF AUXILIARY SYSTEMS

Table 3.3.1 Summary of Aging Management Evaluations in Chapter VII of NUREG-1801 for Auxiliary Systems

Item Number	Component Type	Aging Effect / Mechanism	Aging Management Program	Further Evaluation Recommended	Discussion
3.3.1.01	Steel cranes - structural girders exposed to air – indoor uncontrolled (external)	Cumulative fatigue damage	TLAA to be evaluated for structural girders of cranes. See the Standard Review Plan, Section 4.7 for generic guidance for meeting the requirements of 10 CFR 54.21(c)(1).	Yes, TLAA	Fatigue of metal components is a TLAA. See further evaluation in subsection 3.3.2.2.1.
3.3.1.02	Steel and stainless steel piping, piping components, piping elements, and heat exchanger components exposed to air – indoor uncontrolled, treated borated water or treated water	Cumulative fatigue damage	TLAA, evaluated in accordance with 10 CFR 54.21(c)	Yes, TLAA	Fatigue of metal components is a TLAA. See further evaluation in subsection 3.3.2.2.1.
3.3.1.03					Not applicable - BWR only
3.3.1.04					Not applicable - BWR only

Section 3.3
AGING MANAGEMENT OF AUXILIARY SYSTEMS

Table 3.3.1 Summary of Aging Management Evaluations in Chapter VII of NUREG-1801 for Auxiliary Systems (Continued)

Item Number	Component Type	Aging Effect / Mechanism	Aging Management Program	Further Evaluation Recommended	Discussion
3.3.1.05					Not applicable - BWR only
3.3.1.06	Stainless steel diesel engine exhaust piping, and piping elements exposed to diesel exhaust	Cracking due to stress corrosion cracking	A plant specific aging management program is to be evaluated.	Yes	Consistent with NUREG-1801. The plant-specific aging management program(s) used to manage the aging include: Inspection Of Internal Surfaces In Miscellaneous Piping And Ducting Components (B2.1.22). See further evaluation in subsection 3.3.2.2.3.3.
3.3.1.07	Stainless steel non-regenerative heat exchanger components exposed to treated borated water >60°C (>140°F)	Cracking due to stress corrosion cracking and cyclic loading	Water Chemistry (B.2.1.2) and a plant-specific verification program. An acceptable verification program is to include temperature and radioactivity monitoring of the shell side water, and eddy current testing of tubes.	Yes	Consistent with NUREG-1801 with one exception for eddy current testing. PVNGS will manage cracking of the CVCS Letdown (non-regenerative) heat exchanger with: Water Chemistry (B2.1.2) and One-Time Inspection (B2.1.16). Temperature and radioactivity of shell-side water are monitored by installed plant instrumentation. See further evaluation in subsection 3.3.2.2.4.1.

Section 3.3
AGING MANAGEMENT OF AUXILIARY SYSTEMS

Table 3.3.1 Summary of Aging Management Evaluations in Chapter VII of NUREG-1801 for Auxiliary Systems (Continued)

Item Number	Component Type	Aging Effect / Mechanism	Aging Management Program	Further Evaluation Recommended	Discussion
3.3.1.08	Stainless steel regenerative heat exchanger components exposed to treated borated water >60°C (>140°F)	Cracking due to stress corrosion cracking and cyclic loading	Water Chemistry (B.2.1.2) and a plant-specific verification program. The AMP is to be augmented by verifying the absence of cracking due to stress corrosion cracking and cyclic loading. A plant specific aging management program is to be evaluated.	Yes	Consistent with NUREG-1801. The plant-specific aging management program(s) used to manage the aging include: Water Chemistry (B.2.1.2) and One-Time Inspection (B2.1.16). See further evaluation in subsection 3.3.2.2.4.2.
3.3.1.09	Stainless steel high-pressure pump casing in PWR chemical and volume control system	Cracking due to stress corrosion cracking and cyclic loading	Water Chemistry (B.2.1.2) and a plant-specific verification program. The AMP is to be augmented by verifying the absence of cracking due to stress corrosion cracking and cyclic loading. A plant specific aging management program is to be evaluated.	Yes	Consistent with NUREG-1801. The plant-specific aging management program(s) used to manage the aging include: Water Chemistry (B.2.1.2) and One-Time Inspection (B2.1.16). See further evaluation in subsection 3.3.2.2.4.3.
3.3.1.10	High-strength steel closure bolting exposed to air with steam or water leakage.	Cracking due to stress corrosion cracking, cyclic loading	Bolting Integrity (B.2.1.7) The AMP is to be augmented by appropriate inspection to detect cracking if the bolts are not otherwise replaced during maintenance.	Yes	Not applicable. PVNGS has no in-scope high-strength steel closure bolting exposed to air with steam or water leakage in auxiliary systems, so the applicable NUREG-1801 line was not used.

Section 3.3
AGING MANAGEMENT OF AUXILIARY SYSTEMS

Table 3.3.1 Summary of Aging Management Evaluations in Chapter VII of NUREG-1801 for Auxiliary Systems (Continued)

Item Number	Component Type	Aging Effect / Mechanism	Aging Management Program	Further Evaluation Recommended	Discussion
3.3.1.11	Elastomer seals and components exposed to air – indoor uncontrolled (internal/external)	Hardening and loss of strength due to elastomer degradation	A plant specific aging management program is to be evaluated.	Yes	Consistent with NUREG-1801. The plant-specific aging management programs used to manage aging include: Inspection of Internal Surfaces in Miscellaneous Piping and Ducting Components (B2.1.22) for internal surface exposure and External Surfaces Monitoring (B2.1.20) for external surface exposure. See further evaluation in subsection 3.3.2.5.1.
3.3.1.12	Elastomer lining exposed to treated water or treated borated water	Hardening and loss of strength due to elastomer degradation	A plant-specific aging management program is to be evaluated.	Yes	Consistent with NUREG-1801. The plant-specific aging management program(s) used to manage the aging include: Inspection Of Internal Surfaces In Miscellaneous Piping And Ducting Components (B2.1.22). See further evaluation in subsection 3.3.2.5.2.

Section 3.3
AGING MANAGEMENT OF AUXILIARY SYSTEMS

Table 3.3.1 Summary of Aging Management Evaluations in Chapter VII of NUREG-1801 for Auxiliary Systems (Continued)

Item Number	Component Type	Aging Effect / Mechanism	Aging Management Program	Further Evaluation Recommended	Discussion
3.3.1.13	Boral, boron steel spent fuel storage racks neutron-absorbing sheets exposed to treated water or treated borated water	Reduction of neutron-absorbing capacity and loss of material due to general corrosion	A plant specific aging management program is to be evaluated.	Yes	Not applicable. PVNGS uses soluble boron to maintain spent fuel pool subcriticality per UFSAR section 9.1.2.1.1. PVNGS does not employ boral or boron steel in spent fuel storage racks to maintain subcriticality.
3.3.1.14	Steel piping, piping component, and piping elements exposed to lubricating oil	Loss of material due to general, pitting, and crevice corrosion	Lubricating Oil Analysis (B.2.1.23) and One-Time Inspection (B.2.1.16)	Yes	Consistent with NUREG-1801 with aging management program exceptions. The aging management program(s) with exceptions to NUREG-1801 include: Lubricating Oil Analysis (B.2.1.23). See further evaluation in subsection 3.3.2.2.7.1.
3.3.1.15	Steel reactor coolant pump oil collection system piping, tubing, and valve bodies exposed to lubricating oil	Loss of material due to general, pitting, and crevice corrosion	Lubricating Oil Analysis (B.2.1.23) and One-Time Inspection (B.2.1.16)	Yes	Consistent with NUREG-1801 with aging management program exceptions. The aging management program(s) with exceptions to NUREG-1801 include: Lubricating Oil Analysis (B.2.1.23). See further evaluation in subsection 3.3.2.2.7.1.

Section 3.3
AGING MANAGEMENT OF AUXILIARY SYSTEMS

Table 3.3.1 Summary of Aging Management Evaluations in Chapter VII of NUREG-1801 for Auxiliary Systems (Continued)

Item Number	Component Type	Aging Effect / Mechanism	Aging Management Program	Further Evaluation Recommended	Discussion
3.3.1.16	Steel reactor coolant pump oil collection system tank exposed to lubricating oil	Loss of material due to general, pitting, and crevice corrosion	Lubricating Oil Analysis (B2.1.23) and One-Time Inspection (B.2.1.16) to evaluate the thickness of the lower portion of the tank	Yes	Consistent with NUREG-1801 with aging management program exceptions. The aging management program(s) with exceptions to NUREG-1801 include: Lubricating Oil Analysis (B2.1.23). See further evaluation in subsection 3.3.2.2.7.1.
3.3.1.17					Not applicable - BWR only
3.3.1.18	Stainless steel and steel diesel engine exhaust piping, piping components, and piping elements exposed to diesel exhaust	Loss of material/ general (steel only), pitting and crevice corrosion	A plant specific aging management program is to be evaluated.	Yes	Consistent with NUREG-1801. The plant-specific aging management program(s) used to manage the aging include: Inspection Of Internal Surfaces In Miscellaneous Piping And Ducting Components (B2.1.22). See further evaluation in subsection 3.3.2.2.7.3.

Section 3.3
AGING MANAGEMENT OF AUXILIARY SYSTEMS

Table 3.3.1 Summary of Aging Management Evaluations in Chapter VII of NUREG-1801 for Auxiliary Systems (Continued)

Item Number	Component Type	Aging Effect / Mechanism	Aging Management Program	Further Evaluation Recommended	Discussion
3.3.1.19	Steel (with or without coating or wrapping) piping, piping components, and piping elements exposed to soil	Loss of material due to general, pitting, crevice, and microbiologically influenced corrosion	Buried Piping and Tanks Inspection (B2.1.18)	Yes	Consistent with NUREG-1801 with aging management program exceptions. The aging management program(s) with exceptions to NUREG-1801 include: Buried Piping and Tanks Inspection (B2.1.18). See further evaluation in subsection 3.3.2.2.8.
3.3.1.20	Steel piping, piping components, piping elements, and tanks exposed to fuel oil	Loss of material due to general, pitting, crevice, and microbiologically influenced corrosion, and fouling	Fuel Oil Chemistry (B2.1.14) and One-Time Inspection (B2.1.16)	Yes	Consistent with NUREG-1801 with aging management program exceptions. The aging management program(s) with exceptions to NUREG-1801 include: Fuel Oil Chemistry (B2.1.14). See further evaluation in subsection 3.3.2.2.9.1.

Section 3.3
AGING MANAGEMENT OF AUXILIARY SYSTEMS

Table 3.3.1 Summary of Aging Management Evaluations in Chapter VII of NUREG-1801 for Auxiliary Systems (Continued)

Item Number	Component Type	Aging Effect / Mechanism	Aging Management Program	Further Evaluation Recommended	Discussion
3.3.1.21	Steel heat exchanger components exposed to lubricating oil	Loss of material due to general, pitting, crevice, and microbiologically influenced corrosion, and fouling	Lubricating Oil Analysis (B2.1.23) and One-Time Inspection (B.2.1.16)	Yes	Consistent with NUREG-1801 with aging management program exceptions. The aging management program(s) with exceptions to NUREG-1801 include: Lubricating Oil Analysis (B2.1.23). See further evaluation in subsection 3.3.2.9.2.
3.3.1.22	Steel with elastomer lining or stainless steel cladding piping, piping components, and piping elements exposed to treated water and treated borated water	Loss of material due to pitting and crevice corrosion (only for steel after lining/cladding degradation)	Water Chemistry (B2.1.2) and One-Time Inspection (B2.1.16)	Yes	Not applicable. PVNGS has no in-scope components constructed of steel with elastomer lining or steel with stainless steel cladding exposed to treated or treated borated water in the fuel pool cooling and cleanup system, so the applicable NUREG-1801 lines were not used.
3.3.1.23					Not applicable - BWR only
3.3.1.24					Not applicable - BWR only

Section 3.3
AGING MANAGEMENT OF AUXILIARY SYSTEMS

Table 3.3.1 Summary of Aging Management Evaluations in Chapter VII of NUREG-1801 for Auxiliary Systems (Continued)

Item Number	Component Type	Aging Effect / Mechanism	Aging Management Program	Further Evaluation Recommended	Discussion
3.3.1.25	Copper alloy HVAC piping, piping components, piping elements exposed to condensation (external)	Loss of material due to pitting and crevice corrosion	A plant-specific aging management program is to be evaluated.	Yes	Consistent with NUREG-1801. The plant-specific aging management programs used to manage aging include: Inspection of Internal Surfaces in Miscellaneous Piping and Ducting Components (B2.1.22) for internal surface exposure and External Surfaces Monitoring (B2.1.20) for external surface exposure. See further evaluation in subsection 3.3.2.2.10.3.
3.3.1.26	Copper alloy piping, piping components, and piping elements exposed to lubricating oil	Loss of material due to pitting and crevice corrosion	Lubricating Oil Analysis (B2.1.23) and One-Time Inspection (B.2.1.16)	Yes	Consistent with NUREG-1801 with aging management program exceptions. The aging management program(s) with exceptions to NUREG-1801 include: Lubricating Oil Analysis (B2.1.23). See further evaluation in subsection 3.3.2.2.10.4.

Section 3.3
AGING MANAGEMENT OF AUXILIARY SYSTEMS

Table 3.3.1 Summary of Aging Management Evaluations in Chapter VII of NUREG-1801 for Auxiliary Systems (Continued)

Item Number	Component Type	Aging Effect / Mechanism	Aging Management Program	Further Evaluation Recommended	Discussion
3.3.1.27	Stainless steel HVAC ducting and aluminum HVAC piping, piping components and piping elements exposed to condensation	Loss of material due to pitting and crevice corrosion	A plant-specific aging management program is to be evaluated.	Yes	Consistent with NUREG-1801. The plant-specific aging management program(s) used to manage the aging include: Inspection Of Internal Surfaces In Miscellaneous Piping And Ducting Components (B2.1.22). See further evaluation in subsection 3.3.2.2.10.5.
3.3.1.28	Copper alloy fire protection piping, piping components, and piping elements exposed to condensation (internal)	Loss of material due to pitting and crevice corrosion	A plant-specific aging management program is to be evaluated.	Yes	Consistent with NUREG-1801. The plant-specific aging management program(s) used to manage the aging include: Inspection Of Internal Surfaces In Miscellaneous Piping And Ducting Components (B2.1.22). See further evaluation in subsection 3.3.2.2.10.6.

Section 3.3
AGING MANAGEMENT OF AUXILIARY SYSTEMS

Table 3.3.1 Summary of Aging Management Evaluations in Chapter VII of NUREG-1801 for Auxiliary Systems (Continued)

Item Number	Component Type	Aging Effect / Mechanism	Aging Management Program	Further Evaluation Recommended	Discussion
3.3.1.29	Stainless steel piping, piping components, and piping elements exposed to soil	Loss of material due to pitting and crevice corrosion	A plant-specific aging management program is to be evaluated.	Yes	Consistent with NUREG-1801. The plant-specific aging management program(s) used to manage the aging include: Buried Piping and Tanks Inspection (B2.1.18). See further evaluation in subsection 3.3.2.2.10.7.
3.3.1.30					Not applicable - BWR only
3.3.1.31					Not applicable - BWR only
3.3.1.32	Stainless steel, aluminum and copper alloy piping, piping components, and piping elements exposed to fuel oil	Loss of material due to pitting, crevice, and microbiologically influenced corrosion	Fuel Oil Chemistry (B2.1.14) and One-Time Inspection (B2.1.16)	Yes	Consistent with NUREG-1801 with aging management program exceptions. The aging management program(s) with exceptions to NUREG-1801 include: Fuel Oil Chemistry (B2.1.14). See further evaluation in subsection 3.3.2.2.12.1.

Section 3.3
AGING MANAGEMENT OF AUXILIARY SYSTEMS

Table 3.3.1 Summary of Aging Management Evaluations in Chapter VII of NUREG-1801 for Auxiliary Systems (Continued)

Item Number	Component Type	Aging Effect / Mechanism	Aging Management Program	Further Evaluation Recommended	Discussion
3.3.1.33	Stainless steel piping, piping components, and piping elements exposed to lubricating oil	Loss of material due to pitting, crevice, and microbiologically influenced corrosion	Lubricating Oil Analysis (B.2.1.23) and One-Time Inspection (B.2.1.16)	Yes	Consistent with NUREG-1801 with aging management program exceptions. The aging management program(s) with exceptions to NUREG-1801 include: Lubricating Oil Analysis (B.2.1.23). See further evaluation in subsection 3.3.2.2.12.2.
3.3.1.34	Elastomer seals and components exposed to air – indoor uncontrolled (internal or external)	Loss of material due to Wear	A plant specific aging management program is to be evaluated.	Yes	Not applicable. PVNGS has no in-scope elastomer components exposed to air - indoor uncontrolled (internal or external) with relative motion with other components to produce an aging effect of loss of material due to wear. Therefore, the applicable NUREG-1801 lines were not used.

Section 3.3
AGING MANAGEMENT OF AUXILIARY SYSTEMS

Table 3.3.1 Summary of Aging Management Evaluations in Chapter VII of NUREG-1801 for Auxiliary Systems (Continued)

Item Number	Component Type	Aging Effect / Mechanism	Aging Management Program	Further Evaluation Recommended	Discussion
3.3.1.35	Steel with stainless steel cladding pump casing exposed to treated borated water	Loss of material due to cladding breach	A plant-specific aging management program is to be evaluated. Reference NRC Information Notice 94-63, "Boric Acid Corrosion of Charging Pump Casings Caused by Cladding Cracks".	Yes	Not applicable. PVNGS has no in-scope pumps in the chemical and volume control system that are steel with stainless steel cladding exposed to treated borated water, so the NUREG-1801 line was not used.
3.3.1.36					Not applicable - BWR only
3.3.1.37					Not applicable - BWR only
3.3.1.38					Not applicable - BWR only
3.3.1.39					Not applicable - BWR only
3.3.1.40	Steel tanks in diesel fuel oil system exposed to air - outdoor (external)	Loss of material due to general, pitting, and crevice corrosion	Aboveground Steel Tanks	No	Not applicable. PVNGS has no in-scope steel tanks in the emergency diesel generator fuel oil storage and transfer system that are exposed to the air-outdoor (external) environment; the applicable NUREG-1801 line was not used.
3.3.1.41	High-strength steel closure bolting exposed to air with steam or water leakage	Cracking due to cyclic loading, stress corrosion cracking	Bolting Integrity (B2.1.7)	No	Not applicable. PVNGS has no in-scope high-strength steel closure bolting in the auxiliary systems, so the applicable NUREG-1801 line was not used.

Section 3.3
AGING MANAGEMENT OF AUXILIARY SYSTEMS

Table 3.3.1 Summary of Aging Management Evaluations in Chapter VII of NUREG-1801 for Auxiliary Systems (Continued)

Item Number	Component Type	Aging Effect / Mechanism	Aging Management Program	Further Evaluation Recommended	Discussion
3.3.1.42	Steel closure bolting exposed to air with steam or water leakage	Loss of material due to general corrosion	Bolting Integrity (B2.1.7)	No	Not applicable. PVNGS has no in-scope steel closure bolting exposed to air with steam or water leakage in the auxiliary systems, so the applicable NUREG-1801 line was not used.
3.3.1.43	Steel bolting and closure bolting exposed to air – indoor uncontrolled (external) or air – outdoor (External)	Loss of material due to general, pitting, and crevice corrosion	Bolting Integrity (B2.1.7)	No	Consistent with NUREG-1801 with aging management program exceptions. The aging management program(s) with exceptions to NUREG-1801 include: Bolting Integrity (B2.1.7)
3.3.1.44	Steel compressed air system closure bolting exposed to condensation	Loss of material due to general, pitting, and crevice corrosion	Bolting Integrity (B2.1.7)	No	Not applicable. PVNGS has no in-scope steel closure bolting exposed to condensation in the compressed air system, so the applicable NUREG-1801 line was not used.
3.3.1.45	Steel closure bolting exposed to air – indoor uncontrolled (external)	Loss of preload due to thermal effects, gasket creep, and self-loosening	Bolting Integrity (B2.1.7)	No	Consistent with NUREG-1801 with aging management program exceptions. The aging management program(s) with exceptions to NUREG-1801 include: Bolting Integrity (B2.1.7)

Section 3.3
AGING MANAGEMENT OF AUXILIARY SYSTEMS

Table 3.3.1 Summary of Aging Management Evaluations in Chapter VII of NUREG-1801 for Auxiliary Systems (Continued)

Item Number	Component Type	Aging Effect / Mechanism	Aging Management Program	Further Evaluation Recommended	Discussion
3.3.1.46	Stainless steel and stainless clad steel piping, piping components, piping elements, and heat exchanger components exposed to closed cycle cooling water >60°C (>140°F)	Cracking due to stress corrosion cracking	Closed-Cycle Cooling Water System (B2.1.10)	No	Consistent with NUREG-1801 with aging management program exceptions. The aging management program(s) with exceptions to NUREG-1801 include: Closed-Cycle Cooling Water System (B2.1.10)
3.3.1.47	Steel piping, piping components, piping elements, tanks, and heat exchanger components exposed to closed cycle cooling water	Loss of material due to general, pitting, and crevice corrosion	Closed-Cycle Cooling Water System (B2.1.10)	No	Consistent with NUREG-1801 with aging management program exceptions. The aging management program(s) with exceptions to NUREG-1801 include: Closed-Cycle Cooling Water System (B2.1.10)
3.3.1.48	Steel piping, piping components, piping elements, tanks, and heat exchanger components exposed to closed cycle cooling water	Loss of material due to general, pitting, crevice, and galvanic corrosion	Closed-Cycle Cooling Water System (B2.1.10)	No	Consistent with NUREG-1801 with aging management program exceptions. The aging management program(s) with exceptions to NUREG-1801 include: Closed-Cycle Cooling Water System (B2.1.10)
3.3.1.49					Not applicable - BWR only

Section 3.3
AGING MANAGEMENT OF AUXILIARY SYSTEMS

Table 3.3.1 Summary of Aging Management Evaluations in Chapter VII of NUREG-1801 for Auxiliary Systems (Continued)

Item Number	Component Type	Aging Effect / Mechanism	Aging Management Program	Further Evaluation Recommended	Discussion
3.3.1.50	Stainless steel piping, piping components, and piping elements exposed to closed cycle cooling water	Loss of material due to pitting and crevice corrosion	Closed-Cycle Cooling Water System (B2.1.10)	No	Consistent with NUREG-1801 with aging management program exceptions. The aging management program(s) with exceptions to NUREG-1801 include: Closed-Cycle Cooling Water System (B2.1.10)
3.3.1.51	Copper alloy piping, piping components, and heat exchanger components exposed to closed cycle cooling water	Loss of material due to pitting, crevice, and galvanic corrosion	Closed-Cycle Cooling Water System (B2.1.10)	No	Consistent with NUREG-1801 with aging management program exceptions. The aging management program(s) with exceptions to NUREG-1801 include: Closed-Cycle Cooling Water System (B2.1.10)
3.3.1.52	Steel, stainless steel, and copper alloy heat exchanger tubes exposed to closed cycle cooling water	Reduction of heat transfer due to fouling	Closed-Cycle Cooling Water System (B2.1.10)	No	Consistent with NUREG-1801 with aging management program exceptions. The aging management program(s) with exceptions to NUREG-1801 include: Closed-Cycle Cooling Water System (B2.1.10)

Section 3.3
AGING MANAGEMENT OF AUXILIARY SYSTEMS

Table 3.3.1 Summary of Aging Management Evaluations in Chapter VII of NUREG-1801 for Auxiliary Systems (Continued)

Item Number	Component Type	Aging Effect / Mechanism	Aging Management Program	Further Evaluation Recommended	Discussion
3.3.1.53	Steel compressed air system piping, piping components, and piping elements exposed to condensation (internal)	Loss of material due to general and pitting corrosion	Compressed Air Monitoring	No	Not applicable. PVNGS has no in-scope steel compressed air system piping, piping components and piping elements exposed to condensation (internal), so the applicable NUREG-1801 line was not used.
3.3.1.54	Stainless steel compressed air system piping, piping components, and piping elements exposed to internal condensation	Loss of material due to pitting and crevice corrosion	Compressed Air Monitoring	No	Not applicable. PVNGS has no in-scope steel compressed air system piping, piping components and piping elements exposed to condensation (internal), so the applicable NUREG-1801 line was not used.
3.3.1.55	Steel ducting closure bolting exposed to air – indoor uncontrolled (external)	Loss of material due to general corrosion	External Surfaces Monitoring (B2.1.20)	No	Consistent with NUREG-1801 with aging management program exceptions. The aging management program(s) with exceptions to NUREG-1801 include: External Surfaces Monitoring Program (B2.1.20).

Section 3.3
AGING MANAGEMENT OF AUXILIARY SYSTEMS

Table 3.3.1 Summary of Aging Management Evaluations in Chapter VII of NUREG-1801 for Auxiliary Systems (Continued)

Item Number	Component Type	Aging Effect / Mechanism	Aging Management Program	Further Evaluation Recommended	Discussion
3.3.1.56	Steel HVAC ducting and components exposed to air – indoor uncontrolled (external)	Loss of material due to general corrosion	External Surfaces Monitoring (B2.1.20)	No	Consistent with NUREG-1801 with aging management program exceptions. The aging management program(s) with exceptions to NUREG-1801 include: External Surfaces Monitoring Program (B2.1.20).
3.3.1.57	Steel piping and components external surfaces exposed to air – indoor uncontrolled (External)	Loss of material due to general corrosion	External Surfaces Monitoring (B2.1.20)	No	Consistent with NUREG-1801 with aging management program exceptions. The aging management program(s) with exceptions to NUREG-1801 include: External Surfaces Monitoring Program (B2.1.20).

Section 3.3
AGING MANAGEMENT OF AUXILIARY SYSTEMS

Table 3.3.1 Summary of Aging Management Evaluations in Chapter VII of NUREG-1801 for Auxiliary Systems (Continued)

Item Number	Component Type	Aging Effect / Mechanism	Aging Management Program	Further Evaluation Recommended	Discussion
3.3.1.58	Steel external surfaces exposed to air – indoor uncontrolled (external), air - outdoor (external), and condensation (external)	Loss of material due to general corrosion	External Surfaces Monitoring (B2.1.20)	No	Consistent with NUREG-1801 for all components except a different AMP has been credited for the Fire Protection System components that are normally vented to atmosphere eliminating the difference between the internal and external environments. Inspection of Internal Surfaces in Miscellaneous Piping And Ducting Components (B2.1.22) is credited to manage the aging of the internal surfaces of the fire protection components under this condition.
3.3.1.59	Steel heat exchanger components exposed to air – indoor uncontrolled (external) or air -outdoor (external)	Loss of material due to general, pitting, and crevice corrosion	External Surfaces Monitoring (B2.1.20)	No	Consistent with NUREG-1801 with aging management program exceptions. The aging management program(s) with exceptions to NUREG-1801 include: External Surfaces Monitoring Program (B2.1.20).

Section 3.3
AGING MANAGEMENT OF AUXILIARY SYSTEMS

Table 3.3.1 Summary of Aging Management Evaluations in Chapter VII of NUREG-1801 for Auxiliary Systems (Continued)

Item Number	Component Type	Aging Effect / Mechanism	Aging Management Program	Further Evaluation Recommended	Discussion
3.3.1.60	Steel piping, piping components, and piping elements exposed to air - outdoor (external)	Loss of material due to general, pitting, and crevice corrosion	External Surfaces Monitoring (B2.1.20)	No	Consistent with NUREG-1801 with aging management program exceptions. The aging management program(s) with exceptions to NUREG-1801 include: External Surfaces Monitoring Program (B2.1.20).
3.3.1.61	Elastomer fire barrier penetration seals exposed to air – outdoor or air - indoor uncontrolled	Increased hardness, shrinkage and loss of strength due to weathering	Fire Protection (B2.1.12)	No	Consistent with NUREG-1801 with aging management program exceptions. The aging management program(s) with exceptions to NUREG-1801 include: Fire Protection (B2.1.12)
3.3.1.62	Aluminum piping, piping components, and piping elements exposed to raw water	Loss of material due to pitting and crevice corrosion	Fire Protection (B2.1.12)	No	Not applicable. PVNGS has no in-scope aluminum components exposed to raw water in the fire protection system, so the applicable NUREG-1801 line was not used.

Section 3.3
AGING MANAGEMENT OF AUXILIARY SYSTEMS

Table 3.3.1 Summary of Aging Management Evaluations in Chapter VII of NUREG-1801 for Auxiliary Systems (Continued)

Item Number	Component Type	Aging Effect / Mechanism	Aging Management Program	Further Evaluation Recommended	Discussion
3.3.1.63	Steel fire rated doors exposed to air – outdoor or air - indoor uncontrolled	Loss of material due to Wear	Fire Protection (B2.1.12)	No	Consistent with NUREG-1801 with aging management program exceptions. The aging management program(s) with exceptions to NUREG-1801 include: Fire Protection (B2.1.12)
3.3.1.64	Steel piping, piping components, and piping elements exposed to fuel oil	Loss of material due to general, pitting, and crevice corrosion	Fire Protection (B2.1.12) and Fuel Oil Chemistry (B2.1.14)	No	Not applicable. Other available applicable NUREG-1801 lines were used.
3.3.1.65	Reinforced concrete structural fire barriers – walls, ceilings and floors exposed to air – indoor uncontrolled	Concrete cracking and spalling due to aggressive chemical attack, and reaction with aggregates	Fire Protection (B2.1.12) and Structures Monitoring Program (B2.1.32)	No	Consistent with NUREG-1801 with aging management program exceptions. The aging management program(s) with exceptions to NUREG-1801 include: Fire Protection (B2.1.12)
3.3.1.66	Reinforced concrete structural fire barriers – walls, ceilings and floors exposed to air – outdoor	Concrete cracking and spalling due to freeze thaw, aggressive chemical attack, and reaction with aggregates	Fire Protection (B2.1.12) and Structures Monitoring Program (B2.1.32)	No	Consistent with NUREG-1801 with aging management program exceptions. The aging management program(s) with exceptions to NUREG-1801 include: Fire Protection (B2.1.12)

Section 3.3
AGING MANAGEMENT OF AUXILIARY SYSTEMS

Table 3.3.1 Summary of Aging Management Evaluations in Chapter VII of NUREG-1801 for Auxiliary Systems (Continued)

Item Number	Component Type	Aging Effect / Mechanism	Aging Management Program	Further Evaluation Recommended	Discussion
3.3.1.167	Reinforced concrete structural fire barriers – walls, ceilings and floors exposed to air – outdoor or air - indoor uncontrolled	Loss of material due to corrosion of embedded steel	Fire Protection (B2.1.12) and Structures Monitoring Program (B2.1.32)	No	Consistent with NUREG-1801 with aging management program exceptions. The aging management program(s) with exceptions to NUREG-1801 include: Fire Protection (B2.1.12)
3.3.1.168	Steel piping, piping components, and piping elements exposed to raw water	Loss of material due to general, pitting, crevice, and microbiologically influenced corrosion, and fouling	Fire Water System (B2.1.13)	No	Consistent with NUREG-1801 with aging management program exceptions. The aging management program(s) with exceptions to NUREG-1801 include: Fire Water System (B2.1.13)
3.3.1.169	Stainless steel piping, piping components, and piping elements exposed to raw water	Loss of material due to pitting and crevice corrosion, and fouling	Fire Water System (B2.1.13)	No	Consistent with NUREG-1801 with aging management program exceptions. The aging management program(s) with exceptions to NUREG-1801 include: Fire Water System (B2.1.13)

Section 3.3
AGING MANAGEMENT OF AUXILIARY SYSTEMS

Table 3.3.1 Summary of Aging Management Evaluations in Chapter VII of NUREG-1801 for Auxiliary Systems (Continued)

Item Number	Component Type	Aging Effect / Mechanism	Aging Management Program	Further Evaluation Recommended	Discussion
3.3.1.70	Copper alloy piping, piping components, and piping elements exposed to raw water	Loss of material due to pitting, crevice, and microbiologically influenced corrosion, and fouling	Fire Water System (B2.1.13)	No	Consistent with NUREG-1801 with aging management program exceptions. The aging management program(s) with exceptions to NUREG-1801 include: Fire Water System (B2.1.13)
3.3.1.71	Steel piping, piping components, and piping elements exposed to moist air or condensation (Internal)	Loss of material due to general, pitting, and crevice corrosion	Inspection of Internal Surfaces in Miscellaneous Piping and Ducting Components (B2.1.22)	No	Consistent with NUREG-1801 with aging management program exceptions. The aging management program(s) with exceptions to NUREG-1801 include: Inspection Of Internal Surfaces In Miscellaneous Piping And Ducting Components (B2.1.22).
3.3.1.72	Steel HVAC ducting and components internal surfaces exposed to condensation (Internal)	Loss of material due to general, pitting, crevice, and (for drip pans and drain lines) microbiologically influenced corrosion	Inspection of Internal Surfaces in Miscellaneous Piping and Ducting Components (B2.1.22)	No	Consistent with NUREG-1801 with aging management program exceptions. The aging management program(s) with exceptions to NUREG-1801 include: Inspection Of Internal Surfaces In Miscellaneous Piping And Ducting Components (B2.1.22).

Section 3.3
AGING MANAGEMENT OF AUXILIARY SYSTEMS

Table 3.3.1 Summary of Aging Management Evaluations in Chapter VII of NUREG-1801 for Auxiliary Systems (Continued)

Item Number	Component Type	Aging Effect / Mechanism	Aging Management Program	Further Evaluation Recommended	Discussion
3.3.1.73	Steel crane structural girders in load handling system exposed to air-indoor uncontrolled (external)	Loss of material due to general corrosion	Inspection of Overhead Heavy Load and Light Load (Related to Refueling) Handling Systems (B2.1.11)	No	Consistent with NUREG-1801.
3.3.1.74	Steel cranes - rails exposed to air – indoor uncontrolled (external)	Loss of material due to Wear	Inspection of Overhead Heavy Load and Light Load (Related to Refueling) Handling Systems (B2.1.11)	No	Consistent with NUREG-1801.
3.3.1.75	Elastomer seals and components exposed to raw water	Hardening and loss of strength due to elastomer degradation; loss of material due to erosion	Open-Cycle Cooling Water System (B.2.1.9)	No	Not applicable. PVNGS has no in-scope elastomer components exposed to raw water in the open-cycle cooling water systems, so the applicable NUREG-1801 lines were not used.

Section 3.3
AGING MANAGEMENT OF AUXILIARY SYSTEMS

Table 3.3.1 Summary of Aging Management Evaluations in Chapter VII of NUREG-1801 for Auxiliary Systems (Continued)

Item Number	Component Type	Aging Effect / Mechanism	Aging Management Program	Further Evaluation Recommended	Discussion
3.3.1.76	Steel piping, piping components, and piping elements (without lining/coating or with degraded lining/coating) exposed to raw water	Loss of material due to general, pitting, crevice, and microbiologically influenced corrosion, fouling, and lining/coating degradation	Open-Cycle Cooling Water System (B.2.1.9)	No	Consistent with NUREG-1801 for all components except that a different aging management program is credited for piping and piping components in the secondary chemical waste, oily waste and radioactive waste drain systems. The aging of component surfaces exposed to the raw water environment of the secondary chemical waste, oily waste and radioactive waste drain systems will be managed by Inspection Of Internal Surfaces in Miscellaneous Piping And Ducting Components (B.2.1.22).
3.3.1.77	Steel heat exchanger components exposed to raw water	Loss of material due to general, pitting, crevice, galvanic, and microbiologically influenced corrosion, and fouling	Open-Cycle Cooling Water System (B.2.1.9)	No	Consistent with NUREG-1801.

Section 3.3
AGING MANAGEMENT OF AUXILIARY SYSTEMS

Table 3.3.1 Summary of Aging Management Evaluations in Chapter VII of NUREG-1801 for Auxiliary Systems (Continued)

Item Number	Component Type	Aging Effect / Mechanism	Aging Management Program	Further Evaluation Recommended	Discussion
3.3.1.78	Stainless steel, nickel alloy, and copper alloy piping, piping components, and piping elements exposed to raw water	Loss of material due to pitting and crevice corrosion	Open-Cycle Cooling Water System (B.2.1.9)	No	Consistent with NUREG-1801.
3.3.1.79	Stainless steel piping, piping components, and piping elements exposed to raw water	Loss of material due to pitting and crevice corrosion, and fouling	Open-Cycle Cooling Water System (B.2.1.9)	No	Consistent with NUREG-1801 for material, environment, and aging effect, but a different aging management program Inspection Of Internal Surfaces In Miscellaneous Piping And Ducting Components (B2.1.22) is credited.
3.3.1.80	Stainless steel and copper alloy piping, piping components, and piping elements exposed to raw water	Loss of material due to pitting, crevice, and microbiologically influenced corrosion	Open-Cycle Cooling Water System (B.2.1.9)	No	Consistent with NUREG-1801.

Section 3.3
AGING MANAGEMENT OF AUXILIARY SYSTEMS

Table 3.3.1 Summary of Aging Management Evaluations in Chapter VII of NUREG-1801 for Auxiliary Systems (Continued)

Item Number	Component Type	Aging Effect / Mechanism	Aging Management Program	Further Evaluation Recommended	Discussion
3.3.1.81	Copper alloy piping, piping components, and piping elements, exposed to raw water	Loss of material due to pitting, crevice, and microbiologically influenced corrosion, and fouling	Open-Cycle Cooling Water System (B.2.1.9)	No	Consistent with NUREG-1801 for material, environment, and aging effect, but a different aging management program Inspection Of Internal Surfaces In Miscellaneous Piping And Ducting Components (B2.1.22) is credited.
3.3.1.82	Copper alloy heat exchanger components exposed to raw water	Loss of material due to pitting, crevice, galvanic, and microbiologically influenced corrosion, and fouling	Open-Cycle Cooling Water System (B.2.1.9)	No	Consistent with NUREG-1801.
3.3.1.83	Stainless steel and copper alloy heat exchanger tubes exposed to raw water	Reduction of heat transfer due to fouling	Open-Cycle Cooling Water System (B.2.1.9)	No	Consistent with NUREG-1801.
3.3.1.84	Copper alloy >15% Zn piping, piping components, piping elements, and heat exchanger components exposed to raw water, treated water, or closed cycle cooling water	Loss of material due to selective leaching	Selective Leaching of Materials (B2.1.17)	No	Consistent with NUREG-1801 with aging management program exceptions. The aging management program(s) with exceptions to NUREG-1801 include: Selective Leaching of Materials (B2.1.17)

Section 3.3
AGING MANAGEMENT OF AUXILIARY SYSTEMS

Table 3.3.1 Summary of Aging Management Evaluations in Chapter VII of NUREG-1801 for Auxiliary Systems (Continued)

Item Number	Component Type	Aging Effect / Mechanism	Aging Management Program	Further Evaluation Recommended	Discussion
3.3.1.85	Gray cast iron piping, piping components, and piping elements exposed to soil, raw water, treated water, or closed-cycle cooling water	Loss of material due to selective leaching	Selective Leaching of Materials (B2.1.17)	No	Consistent with NUREG-1801 with aging management program exceptions. The aging management program(s) with exceptions to NUREG-1801 include: Selective Leaching of Materials (B2.1.17)
3.3.1.86	Structural steel (new fuel storage rack assembly) exposed to air – indoor uncontrolled (external)	Loss of material due to general, pitting, and crevice corrosion	Structures Monitoring Program (B2.1.32)	No	Not applicable. The new fuel storage rack assemblies at PVNGS are stainless steel components. NUREG-1801 lines applicable to stainless steel components were used.
3.3.1.87	Boraflex spent fuel storage racks neutron-absorbing sheets exposed to treated borated water	Reduction of neutron-absorbing capacity due to boraflex degradation	Boraflex Monitoring	No	Not applicable. PVNGS has no boraflex spent fuel storage racks exposed to treated borated water, so the applicable NUREG-1801 line was not used.

Section 3.3
AGING MANAGEMENT OF AUXILIARY SYSTEMS

Table 3.3.1 Summary of Aging Management Evaluations in Chapter VII of NUREG-1801 for Auxiliary Systems (Continued)

Item Number	Component Type	Aging Effect / Mechanism	Aging Management Program	Further Evaluation Recommended	Discussion
3.3.1.88	Aluminum and copper alloy >15% Zn piping, and piping elements exposed to air with borated water leakage	Loss of material due to Boric acid corrosion	Boric Acid Corrosion (B2.1.4)	No	Not applicable. PVNGS has no in-scope aluminum or copper alloy > 15% Zn piping, piping components, or piping elements exposed to air with borated water leakage in the auxiliary systems, so the applicable NUREG-1801 lines were not used.
3.3.1.89	Steel bolting and external surfaces exposed to air with borated water leakage	Loss of material due to Boric acid corrosion	Boric Acid Corrosion (B2.1.4)	No	Consistent with NUREG-1801.
3.3.1.90	Stainless steel and steel with stainless steel cladding piping, piping components, piping elements, tanks, and fuel storage racks exposed to treated borated water >60°C (>140°F)	Cracking due to stress corrosion cracking	Water Chemistry (B.2.1.2)	No	Consistent with NUREG-1801.
3.3.1.91	Stainless steel and steel with stainless steel cladding piping, piping components, and piping elements exposed to treated borated water	Loss of material due to pitting and crevice corrosion	Water Chemistry (B.2.1.2)	No	Consistent with NUREG-1801.

Section 3.3
AGING MANAGEMENT OF AUXILIARY SYSTEMS

Table 3.3.1 Summary of Aging Management Evaluations in Chapter VII of NUREG-1801 for Auxiliary Systems (Continued)

Item Number	Component Type	Aging Effect / Mechanism	Aging Management Program	Further Evaluation Recommended	Discussion
3.3.1.92	Galvanized steel piping, piping components, and piping elements exposed to air – indoor uncontrolled	None	None	NA	Consistent with NUREG-1801.
3.3.1.93	Glass piping elements exposed to air, air – indoor uncontrolled (external), fuel oil, lubricating oil, raw water, treated water, and treated borated water	None	None	NA	Consistent with NUREG-1801.
3.3.1.94	Stainless steel and nickel alloy piping, piping components, and piping elements exposed to air – indoor uncontrolled (external)	None	None	NA	Consistent with NUREG-1801.
3.3.1.95	Steel and aluminum piping, piping components, and piping elements exposed to air – indoor controlled (external)	None	None	NA	Consistent with NUREG-1801.

Section 3.3
AGING MANAGEMENT OF AUXILIARY SYSTEMS

Table 3.3.1 Summary of Aging Management Evaluations in Chapter VII of NUREG-1801 for Auxiliary Systems (Continued)

Item Number	Component Type	Aging Effect / Mechanism	Aging Management Program	Further Evaluation Recommended	Discussion
3.3.1.96	Steel and stainless steel piping, piping components, and piping elements in concrete	None	None	NA	Consistent with NUREG-1801.
3.3.1.97	Steel, stainless steel, aluminum, and copper alloy piping, piping components, and piping elements exposed to gas	None	None	NA	Consistent with NUREG-1801.
3.3.1.98	Steel, stainless steel, and copper alloy piping, piping components, and piping elements exposed to dried air	None	None	NA	Consistent with NUREG-1801.
3.3.1.99	Stainless steel and copper alloy <15% Zn piping, piping components, and piping elements exposed to air with borated water leakage	None	None	NA	Consistent with NUREG-1801.

Section 3.3
AGING MANAGEMENT OF AUXILIARY SYSTEMS

Table 3.3.2-1 Auxiliary Systems – Summary of Aging Management Evaluation - Fuel Handling – Fuel Handling and Storage System

Component Type	Intended Function	Material	Environment	Aging Effect Requiring Management	Aging Management Program	NUREG-1801 Vol. 2 Item	Table 1 Item	Notes
Crane	NSRS, SS	Carbon Steel	Plant Indoor Air (Ext)	Loss of material	Inspection of Overhead Heavy Load and Light Load (Related to Refueling) Handling Systems (B2.1.11)	VII.B-3	3.3.1.73	A
Cranes - Rails	NSRS, SS	Carbon Steel	Plant Indoor Air (Ext)	Loss of material	Inspection of Overhead Heavy Load and Light Load (Related to Refueling) Handling Systems (B2.1.11)	VII.B-1	3.3.1.74	A
Cranes - Rails	NSRS, SS	Carbon Steel	Plant Indoor Air (Ext)	Loss of material	Inspection of Overhead Heavy Load and Light Load (Related to Refueling) Handling Systems (B2.1.11)	VII.B-3	3.3.1.73	C
Elevator	NSRS	Stainless Steel	Treated Borated Water (Ext)	Loss of material	Water Chemistry (B2.1.2)	VII.A2-1	3.3.1.91	C
Elevator	NSRS	Stainless Steel	Treated Borated Water (Ext)	Cracking	Water Chemistry (B2.1.2)	VII.A2-7	3.3.1.90	C
Fuel Handling Equip	NSRS	Carbon Steel	Plant Indoor Air (Ext)	Loss of material	Inspection of Overhead Heavy Load and Light Load (Related to Refueling) Handling Systems (B2.1.11)	VII.B-3	3.3.1.73	C

Section 3.3
AGING MANAGEMENT OF AUXILIARY SYSTEMS

Table 3.3.2-1 Auxiliary Systems – Summary of Aging Management Evaluation - Fuel Handling and Storage System
(Continued)

Component Type	Intended Function	Material	Environment	Aging Effect Requiring Management	Aging Management Program	NUREG-1801 Vol. 2 Item	Table 1 Item	Notes
Fuel Handling Equip	SS	Carbon Steel	Plant Indoor Air (Structural) (Ext)	Cumulative fatigue damage	Time-Limited Aging Analysis evaluated for the period of extended operation	VII.B-2	3.3.1.01	A
Fuel Handling Equip	LBS	Stainless Steel	Borated Water Leakage (Ext)	None	None	VII.J-16	3.3.1.99	C
Fuel Handling Equip	NSRS	Stainless Steel	Plant Indoor Air (Ext)	None	None	VII.J-15	3.3.1.94	C
Fuel Handling Equip	SS	Stainless Steel	Plant Indoor Air (Structural) (Ext)	Cumulative fatigue damage	Time-Limited Aging Analysis evaluated for the period of extended operation	VII.B-2	3.3.1.01	A
Fuel Handling Equip	LBS	Stainless Steel	Submerged (Structural) (Ext)	Cracking	Water Chemistry (B2.1.2) and Monitoring of the Spent Fuel Pool Water Level	III.A5-13	3.5.1.46	A
Fuel Handling Equip	NSRS	Stainless Steel	Treated Borated Water (Ext)	Loss of material	Water Chemistry (B2.1.2)	VII.A2-1	3.3.1.91	C
Fuel Handling Equip	NSRS	Stainless Steel	Treated Borated Water (Ext)	Cracking	Water Chemistry (B2.1.2)	VII.A2-7	3.3.1.90	C
Hoist	NSRS	Carbon Steel	Plant Indoor Air (Ext)	Loss of material	Inspection of Overhead Heavy Load and Light Load (Related to Refueling) Handling Systems (B2.1.11)	VII.B-3	3.3.1.73	C
New Fuel Racks	NSRS	Stainless Steel	Plant Indoor Air (Ext)	None	None	VII.J-15	3.3.1.94	C

Section 3.3
AGING MANAGEMENT OF AUXILIARY SYSTEMS

Table 3.3.2-1 Auxiliary Systems – Summary of Aging Management Evaluation - Fuel Handling and Storage System
(Continued)

Component Type	Intended Function	Material	Environment	Aging Effect Requiring Management	Aging Management Program	NUREG-1801 Vol. 2 Item	Table 1 Item	Notes
Spent Fuel Racks	SS	Stainless Steel	Treated Borated Water (Ext)	Loss of material	Water Chemistry (B2.1.2)	VII.A2-1	3.3.1.91	C
Spent Fuel Racks	SS	Stainless Steel	Treated Borated Water (Ext)	Cracking	Water Chemistry (B2.1.2)	VII.A2-7	3.3.1.90	A
Trolley	NSRS, SS	Carbon Steel	Plant Indoor Air (Ext)	Loss of material	Inspection of Overhead Heavy Load and Light Load (Related to Refueling) Handling Systems (B2.1.11)	VII.B-3	3.3.1.73	C
Trolley	NSRS	Stainless Steel	Treated Borated Water (Ext)	Loss of material	Water Chemistry (B2.1.2)	VII.A2-1	3.3.1.91	C
Trolley	NSRS	Stainless Steel	Treated Borated Water (Ext)	Cracking	Water Chemistry (B2.1.2)	VII.A2-7	3.3.1.90	C

Notes for Table 3.3.2-1:

Standard Notes:

- A Consistent with NUREG-1801 item for component, material, environment, and aging effect. AMP is consistent with NUREG-1801 AMP.
- C Component is different, but consistent with NUREG-1801 item for material, environment, and aging effect. AMP is consistent with NUREG-1801 AMP.

Plant Specific Notes:

None.

Section 3.3
AGING MANAGEMENT OF AUXILIARY SYSTEMS

Table 3.3.2-2 Auxiliary Systems – Summary of Aging Management Evaluation – Spent Fuel Pool Cooling and Cleanup System

Component Type	Intended Function	Material	Environment	Aging Effect Requiring Management	Aging Management Program	NUREG-1801 Vol. 2 Item	Table 1 Item	Notes
Closure Bolting	LBS, PB, SIA	Stainless Steel	Borated Water Leakage (Ext)	Loss of preload	Bolting Integrity (B2.1.7)	IV.C2-8	3.1.1.52	B
Closure Bolting	LBS, PB, SIA	Stainless Steel	Borated Water Leakage (Ext)	None	None	VII.J-16	3.3.1.99	C
Closure Bolting	LBS, PB, SIA	Stainless Steel	Treated Borated Water (Ext)	Loss of preload	Bolting Integrity (B2.1.7)	None	None	G, 1
Closure Bolting	LBS, PB, SIA	Stainless Steel	Treated Borated Water (Ext)	Cracking	Water Chemistry (B2.1.2)	VII.A2-7	3.3.1.90	C
Closure Bolting	LBS, PB, SIA	Stainless Steel	Treated Borated Water (Ext)	Loss of material	Water Chemistry (B2.1.2)	VII.A3-8	3.3.1.91	C
Deminerализer	LBS	Stainless Steel	Borated Water Leakage (Ext)	None	None	VII.J-16	3.3.1.99	C
Deminerализer	LBS	Stainless Steel	Treated Borated Water (Int)	Cracking	Water Chemistry (B2.1.2)	VII.A2-7	3.3.1.90	C
Deminerализer	LBS	Stainless Steel	Treated Borated Water (Int)	Loss of material	Water Chemistry (B2.1.2)	VII.A3-8	3.3.1.91	C
Expansion Joint	LBS, PB, SIA	Stainless Steel	Borated Water Leakage (Ext)	None	None	VII.J-16	3.3.1.99	C
Expansion Joint	LBS	Stainless Steel	Borated Water Leakage (Int)	None	None	VII.J-16	3.3.1.99	C
Expansion Joint	LBS	Stainless Steel	Treated Borated Water (Ext)	Cracking	Water Chemistry (B2.1.2)	VII.A2-7	3.3.1.90	C
Expansion Joint	LBS	Stainless Steel	Treated Borated Water (Ext)	Loss of material	Water Chemistry (B2.1.2)	VII.A3-8	3.3.1.91	C

Section 3.3
AGING MANAGEMENT OF AUXILIARY SYSTEMS

Table 3.3.2-2 Auxiliary Systems – Summary of Aging Management Evaluation – Spent Fuel Pool Cooling and Cleanup System
(Continued)

Component Type	Intended Function	Material	Environment	Aging Effect Requiring Management	Aging Management Program	NUREG-1801 Vol. 2 Item	Table 1 Item	Notes
Expansion Joint	LBS, PB, S/A	Stainless Steel	Treated Borated Water (Int)	Cracking	Water Chemistry (B2.1.2)	VII.A2-7	3.3.1.90	C
Expansion Joint	LBS, PB, S/A	Stainless Steel	Treated Borated Water (Int)	Loss of material	Water Chemistry (B2.1.2)	VII.A3-8	3.3.1.91	C
Filter	LBS	Stainless Steel	Borated Water Leakage (Ext)	None	None	VII.J-16	3.3.1.99	A
Filter	LBS	Stainless Steel	Treated Borated Water (Int)	Cracking	Water Chemistry (B2.1.2)	VII.A2-7	3.3.1.90	C
Filter	LBS	Stainless Steel	Treated Borated Water (Int)	Loss of material	Water Chemistry (B2.1.2)	VII.A3-8	3.3.1.91	A
Flow Element	PB	Stainless Steel	Borated Water Leakage (Ext)	None	None	VII.J-16	3.3.1.99	A
Flow Element	PB	Stainless Steel	Treated Borated Water (Int)	Cracking	Water Chemistry (B2.1.2)	VII.A2-7	3.3.1.90	C
Flow Element	PB	Stainless Steel	Treated Borated Water (Int)	Loss of material	Water Chemistry (B2.1.2)	VII.A3-8	3.3.1.91	A
Heat Exchanger (Fuel Pool Cooling)	PB	Carbon Steel	Closed-Cycle Cooling Water (Int)	Loss of material	Closed-Cycle Cooling Water System (B2.1.10)	VII.C2-1	3.3.1.48	B
Heat Exchanger (Fuel Pool Cooling)	PB	Carbon Steel	Plant Indoor Air (Ext)	Loss of material	External Surfaces Monitoring Program (B2.1.20)	VII.I-8	3.3.1.58	B

Section 3.3
AGING MANAGEMENT OF AUXILIARY SYSTEMS

Table 3.3.2-2 Auxiliary Systems – Summary of Aging Management Evaluation – Spent Fuel Pool Cooling and Cleanup System
(Continued)

Component Type	Intended Function	Material	Environment	Aging Effect Requiring Management	Aging Management Program	NUREG-1801 Vol. 2 Item	Table 1 Item	Notes
Heat Exchanger (Fuel Pool Cooling)	HT, PB	Stainless Steel	Closed-Cycle Cooling Water (Ext)	Reduction of heat transfer	Closed-Cycle Cooling Water System (B2.1.10)	VII.C2-3	3.3.1.52	B
Heat Exchanger (Fuel Pool Cooling)	HT, PB	Stainless Steel	Closed-Cycle Cooling Water (Ext)	Loss of material	Closed-Cycle Cooling Water System (B2.1.10)	VII.C2-10	3.3.1.50	D
Heat Exchanger (Fuel Pool Cooling)	HT, PB	Stainless Steel	Treated Borated Water (Int)	Reduction of heat transfer	Water Chemistry (B2.1.2) and One-Time Inspection (B2.1.16)	None	None	H, 2
Heat Exchanger (Fuel Pool Cooling)	HT, PB	Stainless Steel	Treated Borated Water (Int)	Cracking	Water Chemistry (B2.1.2)	VII.A2-7	3.3.1.90	C
Heat Exchanger (Fuel Pool Cooling)	HT, PB	Stainless Steel	Treated Borated Water (Int)	Loss of material	Water Chemistry (B2.1.2)	VII.A3-8	3.3.1.91	C
Piping	LBS, PB, S/A	Stainless Steel	Borated Water Leakage (Ext)	None	None	VII.J-16	3.3.1.99	A
Piping	PB	Stainless Steel	Borated Water Leakage (Int)	None	None	VII.J-16	3.3.1.99	A
Piping	PB	Stainless Steel	Encased in Concrete (Ext)	None	None	VII.J-17	3.3.1.96	A
Piping	PB	Stainless Steel	Plant Indoor Air (Ext)	None	None	VII.J-15	3.3.1.94	A

Section 3.3
AGING MANAGEMENT OF AUXILIARY SYSTEMS

Table 3.3.2-2 Auxiliary Systems – Summary of Aging Management Evaluation – Spent Fuel Pool Cooling and Cleanup System
(Continued)

Component Type	Intended Function	Material	Environment	Aging Effect Requiring Management	Aging Management Program	NUREG-1801 Vol. 2 Item	Table 1 Item	Notes
Piping	PB	Stainless Steel	Plant Indoor Air (Int)	None	None	VII.J-15	3.3.1.94	A
Piping	PB	Stainless Steel	Treated Borated Water (Ext)	Cracking	Water Chemistry (B2.1.2)	VII.A2-7	3.3.1.90	C
Piping	PB	Stainless Steel	Treated Borated Water (Ext)	Loss of material	Water Chemistry (B2.1.2)	VII.A3-8	3.3.1.91	A
Piping	LBS, PB, SIA	Stainless Steel	Treated Borated Water (Int)	Cracking	Water Chemistry (B2.1.2)	VII.A2-7	3.3.1.90	C
Piping	LBS, PB, SIA	Stainless Steel	Treated Borated Water (Int)	Loss of material	Water Chemistry (B2.1.2)	VII.A3-8	3.3.1.91	A
Pump	LBS, SIA	Stainless Steel	Borated Water Leakage (Ext)	None	None	VII.J-16	3.3.1.99	A
Pump	LBS, SIA	Stainless Steel	Treated Borated Water (Int)	Cracking	Water Chemistry (B2.1.2)	VII.A2-7	3.3.1.90	C
Pump	LBS, SIA	Stainless Steel	Treated Borated Water (Int)	Loss of material	Water Chemistry (B2.1.2)	VII.A3-8	3.3.1.91	A
Pump	PB	Stainless Steel Cast Austenitic	Borated Water Leakage (Ext)	None	None	VII.J-16	3.3.1.99	A
Pump	PB	Stainless Steel Cast Austenitic	Treated Borated Water (Int)	Cracking	Water Chemistry (B2.1.2)	VII.A2-7	3.3.1.90	C
Pump	PB	Stainless Steel Cast Austenitic	Treated Borated Water (Int)	Loss of material	Water Chemistry (B2.1.2)	VII.A3-8	3.3.1.91	A
Sight Gauge	LBS	Stainless Steel	Borated Water Leakage (Ext)	None	None	VII.J-16	3.3.1.99	A

Section 3.3
AGING MANAGEMENT OF AUXILIARY SYSTEMS

Table 3.3.2-2 Auxiliary Systems – Summary of Aging Management Evaluation – Spent Fuel Pool Cooling and Cleanup System
(Continued)

Component Type	Intended Function	Material	Environment	Aging Effect Requiring Management	Aging Management Program	NUREG-1801 Vol. 2 Item	Table 1 Item	Notes
Sight Gauge	LBS	Stainless Steel	Treated Borated Water (Int)	Cracking	Water Chemistry (B2.1.2)	VII.A2-7	3.3.1.90	C
Sight Gauge	LBS	Stainless Steel	Treated Borated Water (Int)	Loss of material	Water Chemistry (B2.1.2)	VII.A3-8	3.3.1.91	A
Strainer	LBS	Stainless Steel Cast Austenitic	Borated Water Leakage (Ext)	None	None	VII.J-16	3.3.1.99	A
Strainer	LBS	Stainless Steel Cast Austenitic	Treated Borated Water (Int)	Cracking	Water Chemistry (B2.1.2)	VII.A2-7	3.3.1.90	C
Strainer	LBS	Stainless Steel Cast Austenitic	Treated Borated Water (Int)	Loss of material	Water Chemistry (B2.1.2)	VII.A3-8	3.3.1.91	A
Tubing	LBS, PB	Stainless Steel	Borated Water Leakage (Ext)	None	None	VII.J-16	3.3.1.99	A
Tubing	LBS, PB	Stainless Steel	Treated Borated Water (Int)	Cracking	Water Chemistry (B2.1.2)	VII.A2-7	3.3.1.90	C
Tubing	LBS, PB	Stainless Steel	Treated Borated Water (Int)	Loss of material	Water Chemistry (B2.1.2)	VII.A3-8	3.3.1.91	A
Valve	LBS, PB, SIA	Stainless Steel	Borated Water Leakage (Ext)	None	None	VII.J-16	3.3.1.99	A
Valve	LBS, PB, SIA	Stainless Steel	Treated Borated Water (Int)	Cracking	Water Chemistry (B2.1.2)	VII.A2-7	3.3.1.90	C
Valve	LBS, PB, SIA	Stainless Steel	Treated Borated Water (Int)	Loss of material	Water Chemistry (B2.1.2)	VII.A3-8	3.3.1.91	A
Valve	LBS, PB	Stainless Steel Cast Austenitic	Borated Water Leakage (Ext)	None	None	VII.J-16	3.3.1.99	A

Table 3.3.2-2 Auxiliary Systems – Summary of Aging Management Evaluation – Spent Fuel Pool Cooling and Cleanup System
(Continued)

Component Type	Intended Function	Material	Environment	Aging Effect Requiring Management	Aging Management Program	NUREG-1801 Vol. 2 Item	Table 1 Item	Notes
Valve	PB	Stainless Steel Cast Austenitic	Treated Borated Water (Ext)	Cracking	Water Chemistry (B2.1.2)	VII.A2-7	3.3.1.90	C
Valve	PB	Stainless Steel Cast Austenitic	Treated Borated Water (Ext)	Loss of material	Water Chemistry (B2.1.2)	VII.A3-8	3.3.1.91	A
Valve	LBS, PB	Stainless Steel Cast Austenitic	Treated Borated Water (Int)	Cracking	Water Chemistry (B2.1.2)	VII.A2-7	3.3.1.90	C
Valve	LBS, PB	Stainless Steel Cast Austenitic	Treated Borated Water (Int)	Loss of material	Water Chemistry (B2.1.2)	VII.A3-8	3.3.1.91	A

Notes for Table 3.3.2-2:

Standard Notes:

- A Consistent with NUREG-1801 item for component, material, environment, and aging effect. AMP is consistent with NUREG-1801 AMP.
- B Consistent with NUREG-1801 item for component, material, environment, and aging effect. AMP takes some exceptions to NUREG-1801 AMP.
- C Component is different, but consistent with NUREG-1801 item for material, environment, and aging effect. AMP is consistent with NUREG-1801 AMP.
- D Component is different, but consistent with NUREG-1801 item for material, environment, and aging effect. AMP takes some exceptions to NUREG-1801 AMP.
- G Environment not in NUREG-1801 for this component and material.
- H Aging effect not in NUREG-1801 for this component, material and environment combination.

Section 3.3
AGING MANAGEMENT OF AUXILIARY SYSTEMS

Plant Specific Notes:

- 1 Loss of Preload is considered to be applicable for all closure bolting.
- 2 Reduction in heat transfer due to fouling is a potential aging effect for stainless steel heat exchanger components in treated borated water. This non-NUREG-1801 line is based upon the component, material, aging effects and aging management program combination of NUREG-1801 line VII.E1-4.

Section 3.3
AGING MANAGEMENT OF AUXILIARY SYSTEMS

Table 3.3.2-3 Auxiliary Systems – Summary of Aging Management Evaluation – Essential Cooling Water System

Component Type	Intended Function	Material	Environment	Aging Effect Requiring Management	Aging Management Program	NUREG-1801 Vol. 2 Item	Table 1 Item	Notes
Chamber	PB	Aluminum	Closed-Cycle Cooling Water (Int)	Loss of material	Inspection Of Internal Surfaces In Miscellaneous Piping And Ducting Components (B2.1.22)	None	None	G
Chamber	PB	Aluminum	Plant Indoor Air (Ext)	None	None	VII.J-1	3.3.1.95	A
Closure Bolting	LBS, PB, SIA	Carbon Steel	Plant Indoor Air (Ext)	Loss of material	Bolting Integrity (B2.1.7)	VII.I-4	3.3.1.43	B
Closure Bolting	LBS, PB, SIA	Carbon Steel	Plant Indoor Air (Ext)	Loss of preload	Bolting Integrity (B2.1.7)	VII.I-5	3.3.1.45	B
Closure Bolting	LBS, PB, SIA	Stainless Steel	Plant Indoor Air (Ext)	Loss of preload	Bolting Integrity (B2.1.7)	None	None	G, 1
Flow Element	PB	Carbon Steel	Closed-Cycle Cooling Water (Int)	Loss of material	Closed-Cycle Cooling Water System (B2.1.10)	VII.C2-14	3.3.1.47	B
Flow Element	PB	Carbon Steel	Plant Indoor Air (Ext)	Loss of material	External Surfaces Monitoring Program (B2.1.20)	VII.I-8	3.3.1.58	B
Flow Element	PB	Stainless Steel	Closed-Cycle Cooling Water (Int)	Loss of material	Closed-Cycle Cooling Water System (B2.1.10)	VII.C2-10	3.3.1.50	B
Flow Element	PB	Stainless Steel	Plant Indoor Air (Ext)	None	None	VII.J-15	3.3.1.94	A

Section 3.3
AGING MANAGEMENT OF AUXILIARY SYSTEMS

Table 3.3.2-3 Auxiliary Systems – Summary of Aging Management Evaluation – Essential Cooling Water System (Continued)

Component Type	Intended Function	Material	Environment	Aging Effect Requiring Management	Aging Management Program	NUREG-1801 Vol. 2 Item	Table 1 Item	Notes
Heat Exchanger (ECWS Heat Exchanger)	PB	Carbon Steel	Closed-Cycle Cooling Water (Int)	Loss of material	Closed-Cycle Cooling Water System (B2.1.10)	VII.C2-1	3.3.1.48	B
Heat Exchanger (ECWS Heat Exchanger)	PB	Carbon Steel	Plant Indoor Air (Ext)	Loss of material	External Surfaces Monitoring Program (B2.1.20)	VII.I-8	3.3.1.58	B
Heat Exchanger (ECWS Heat Exchanger)	PB	Carbon Steel	Raw Water (Int)	Loss of material	Open-Cycle Cooling Water System (B2.1.9)	VII.C1-5	3.3.1.77	A
Heat Exchanger (ECWS Heat Exchanger)	PB	Copper Alloy	Closed-Cycle Cooling Water (Ext)	Loss of material	Closed-Cycle Cooling Water System (B2.1.10)	VII.C2-4	3.3.1.51	D
Heat Exchanger (ECWS Heat Exchanger)	PB	Copper Alloy	Raw Water (Int)	Loss of material	Open-Cycle Cooling Water System (B2.1.9)	VII.C1-3	3.3.1.82	A
Heat Exchanger (ECWS Heat Exchanger)	HT, PB	Copper Alloy (Zinc > 15%)	Closed-Cycle Cooling Water (Ext)	Reduction of heat transfer	Closed-Cycle Cooling Water System (B2.1.10)	VII.C2-2	3.3.1.52	B
Heat Exchanger (ECWS Heat Exchanger)	HT, PB	Copper Alloy (Zinc > 15%)	Closed-Cycle Cooling Water (Ext)	Loss of material	Closed-Cycle Cooling Water System (B2.1.10)	VII.C2-4	3.3.1.51	D, 2

Section 3.3
AGING MANAGEMENT OF AUXILIARY SYSTEMS

Table 3.3.2-3 Auxiliary Systems – Summary of Aging Management Evaluation – Essential Cooling Water System (Continued)

Component Type	Intended Function	Material	Environment	Aging Effect Requiring Management	Aging Management Program	NUREG-1801 Vol. 2 Item	Table 1 Item	Notes
Heat Exchanger (ECWS Heat Exchanger)	HT, PB	Copper Alloy (Zinc > 15%)	Raw Water (Int)	Loss of material	Open-Cycle Cooling Water System (B2.1.9)	VII.C1-3	3.3.1.82	A, 2
Heat Exchanger (ECWS Heat Exchanger)	HT, PB	Copper Alloy (Zinc > 15%)	Raw Water (Int)	Reduction of heat transfer	Open-Cycle Cooling Water System (B2.1.9)	VII.C1-6	3.3.1.83	A
Orifice	PB, TH	Stainless Steel	Closed-Cycle Cooling Water (Int)	Loss of material	Closed-Cycle Cooling Water System (B2.1.10)	VII.C2-10	3.3.1.50	B
Orifice	PB, TH	Stainless Steel	Plant Indoor Air (Ext)	None	None	VII.J-15	3.3.1.94	A
Piping	LBS, PB, SIA	Carbon Steel	Closed-Cycle Cooling Water (Int)	Loss of material	Closed-Cycle Cooling Water System (B2.1.10)	VII.C2-14	3.3.1.47	B
Piping	PB	Carbon Steel	Dry Gas (Int)	None	None	VII.J-23	3.3.1.97	A
Piping	LBS, PB, SIA	Carbon Steel	Plant Indoor Air (Ext)	Loss of material	External Surfaces Monitoring Program (B2.1.20)	VII.I-8	3.3.1.58	B
Piping	SIA	Carbon Steel	Wetted Gas (Int)	Loss of material	Inspection Of Internal Surfaces In Miscellaneous Piping And Ducting Components (B2.1.22)	VIII.B1-7	3.4.1.30	B
Piping	LBS, PB, SIA	Stainless Steel	Closed-Cycle Cooling Water (Int)	Loss of material	Closed-Cycle Cooling Water System (B2.1.10)	VII.C2-10	3.3.1.50	B
Piping	PB	Stainless Steel	DeminerIALIZED Water (Int)	Loss of material	Water Chemistry (B2.1.2) and One-Time Inspection (B2.1.16)	VIII.E-29	3.4.1.16	A

Section 3.3
AGING MANAGEMENT OF AUXILIARY SYSTEMS

Table 3.3.2-3 Auxiliary Systems – Summary of Aging Management Evaluation – Essential Cooling Water System (Continued)

Component Type	Intended Function	Material	Environment	Aging Effect Requiring Management	Aging Management Program	NUREG-1801 Vol. 2 Item	Table 1 Item	Notes
Piping	LBS, PB, SIA	Stainless Steel	Plant Indoor Air (Ext)	None	None	VII.J-15	3.3.1.94	A
Pump	PB	Carbon Steel	Closed-Cycle Cooling Water (Int)	Loss of material	Closed-Cycle Cooling Water System (B2.1.10)	VII.C2-14	3.3.1.47	B
Pump	PB	Carbon Steel	Plant Indoor Air (Ext)	Loss of material	External Surfaces Monitoring Program (B2.1.20)	VII.I-8	3.3.1.58	B
Sight Gauge	LBS, PB, SIA	Carbon Steel	Closed-Cycle Cooling Water (Int)	Loss of material	Closed-Cycle Cooling Water System (B2.1.10)	VII.C2-14	3.3.1.47	B
Sight Gauge	LBS, PB, SIA	Carbon Steel	Plant Indoor Air (Ext)	Loss of material	External Surfaces Monitoring Program (B2.1.20)	VII.I-8	3.3.1.58	B
Sight Gauge	LBS, PB	Glass	Closed-Cycle Cooling Water (Int)	None	None	VII.J-13	3.3.1.93	A
Sight Gauge	LBS, PB	Glass	Plant Indoor Air (Ext)	None	None	VII.J-8	3.3.1.93	A
Strainer	LBS, SIA	Carbon Steel	Closed-Cycle Cooling Water (Int)	Loss of material	Closed-Cycle Cooling Water System (B2.1.10)	VII.C2-14	3.3.1.47	B
Strainer	LBS, SIA	Carbon Steel	Plant Indoor Air (Ext)	Loss of material	External Surfaces Monitoring Program (B2.1.20)	VII.I-8	3.3.1.58	B
Tank	LBS, PB, SIA	Carbon Steel	Closed-Cycle Cooling Water (Int)	Loss of material	Closed-Cycle Cooling Water System (B2.1.10)	VII.C2-14	3.3.1.47	B
Tank	PB	Carbon Steel	Dry Gas (Int)	None	None	VII.J-23	3.3.1.97	A
Tank	LBS, PB, SIA	Carbon Steel	Plant Indoor Air (Ext)	Loss of material	External Surfaces Monitoring Program (B2.1.20)	VII.I-8	3.3.1.58	B
Tubing	PB	Stainless Steel	Closed-Cycle Cooling Water (Int)	Loss of material	Closed-Cycle Cooling Water System (B2.1.10)	VII.C2-10	3.3.1.50	B

Section 3.3
AGING MANAGEMENT OF AUXILIARY SYSTEMS

Table 3.3.2-3 Auxiliary Systems – Summary of Aging Management Evaluation – Essential Cooling Water System (Continued)

Component Type	Intended Function	Material	Environment	Aging Effect Requiring Management	Aging Management Program	NUREG-1801 Vol. 2 Item	Table 1 Item	Notes
Tubing	PB	Stainless Steel	Plant Indoor Air (Ext)	None	None	VII.J-15	3.3.1.94	A
Valve	LBS, PB	Carbon Steel	Closed-Cycle Cooling Water (Int)	Loss of material	Closed-Cycle Cooling Water System (B2.1.10)	VII.C2-14	3.3.1.47	B
Valve	PB	Carbon Steel	Dry Gas (Int)	None	None	VII.J-23	3.3.1.97	A
Valve	LBS, PB	Carbon Steel	Plant Indoor Air (Ext)	Loss of material	External Surfaces Monitoring Program (B2.1.20)	VII.I-8	3.3.1.58	B
Valve	PB	Stainless Steel	Closed-Cycle Cooling Water (Int)	Loss of material	Closed-Cycle Cooling Water System (B2.1.10)	VII.C2-10	3.3.1.50	B
Valve	PB	Stainless Steel	DeminerIALIZED Water (Int)	Loss of material	Water Chemistry (B2.1.2) and One-Time Inspection (B2.1.16)	VIII.E-29	3.4.1.16	A
Valve	PB	Stainless Steel	Dry Gas (Int)	None	None	VII.J-19	3.3.1.97	A
Valve	PB	Stainless Steel	Plant Indoor Air (Ext)	None	None	VII.J-15	3.3.1.94	A

Notes for Table 3.3.2-3:

Standard Notes:

- A Consistent with NUREG-1801 item for component, material, environment, and aging effect. AMP is consistent with NUREG-1801 AMP.
- B Consistent with NUREG-1801 item for component, material, environment, and aging effect. AMP takes some exceptions to NUREG-1801 AMP.
- D Component is different, but consistent with NUREG-1801 item for material, environment, and aging effect. AMP takes some exceptions to NUREG-1801 AMP.
- G Environment not in NUREG-1801 for this component and material.

Section 3.3
AGING MANAGEMENT OF AUXILIARY SYSTEMS

Plant Specific Notes:

- 1 Loss of Preload is considered to be applicable for all closure bolting.
- 2 The DG Jacket Water Cooler, DG Lube Oil Cooler and ECWS Heat Exchanger heat exchanger tubes are fabricated of Admiralty Brass (nominal Cu-71%, Zn-28%, Sn-1%, As-Present). EPRI Report 1010639 "Non-Class 1 Mechanical Implementation Guideline and Mechanical Tools" Rev. 4, Appendices A, B and C state that the addition of tin to brass effectively inhibits dezincification and significantly reduces the susceptibility of the material to selective leaching. This is consistent with NUREG-1801 IX.C which states that selective leaching is not a consideration for inhibited brass. Therefore, loss of material due to selective leaching has not been selected as an aging effect for Admiralty Brass heat exchanger tubes in Closed-Cycle Cooling Water, Raw Water and Lubricating Oil environments.

Section 3.3
AGING MANAGEMENT OF AUXILIARY SYSTEMS

Table 3.3.2-4 Auxiliary Systems – Summary of Aging Management Evaluation – Essential Chilled Water System

Component Type	Intended Function	Material	Environment	Aging Effect Requiring Management	Aging Management Program	NUREG-1801 Vol. 2 Item	Table 1 Item	Notes
Closure Bolting	LBS, PB, SIA	Carbon Steel	Plant Indoor Air (Ext)	Loss of material	Bolting Integrity (B2.1.7)	VII.I-4	3.3.1.43	B
Closure Bolting	LBS, PB, SIA	Carbon Steel	Plant Indoor Air (Ext)	Loss of preload	Bolting Integrity (B2.1.7)	VII.I-5	3.3.1.45	B
Closure Bolting	LBS, PB, SIA	Stainless Steel	Plant Indoor Air (Ext)	Loss of preload	Bolting Integrity (B2.1.7)	None	None	G, 1
Closure Bolting	LBS, PB, SIA	Stainless Steel	Plant Indoor Air (Ext)	None	None	VII.J-15	3.3.1.94	C
Compressor	PB	Cast Iron	Dry Gas (Int)	None	None	VII.J-23	3.3.1.97	A
Compressor	PB	Cast Iron	Plant Indoor Air (Ext)	Loss of material	External Surfaces Monitoring Program (B2.1.20)	VII.I-8	3.3.1.58	B
Filter	PB	Carbon Steel	Dry Gas (Int)	None	None	VII.J-23	3.3.1.97	A
Filter	PB	Carbon Steel	Plant Indoor Air (Ext)	Loss of material	External Surfaces Monitoring Program (B2.1.20)	VII.I-8	3.3.1.58	B
Filter	PB	Copper Alloy (Zinc >15%)	Dry Gas (Int)	None	None	VII.J-4	3.3.1.97	A
Filter	PB	Copper Alloy (Zinc >15%)	Lubricating Oil (Int)	Loss of material	Lubricating Oil Analysis (B2.1.23) and One-Time Inspection (B2.1.16)	VII.C2-5	3.3.1.26	B
Filter	PB	Copper Alloy (Zinc >15%)	Plant Indoor Air (Ext)	None	None	VIII.I-2	3.4.1.41	A
Filter	PB	Stainless Steel	Dry Gas (Int)	None	None	VII.J-19	3.3.1.97	A
Filter	PB	Stainless Steel	Plant Indoor Air (Ext)	None	None	VII.J-15	3.3.1.94	A

Section 3.3
AGING MANAGEMENT OF AUXILIARY SYSTEMS

Table 3.3.2-4 Auxiliary Systems – Summary of Aging Management Evaluation – Essential Chilled Water System (Continued)

Component Type	Intended Function	Material	Environment	Aging Effect Requiring Management	Aging Management Program	NUREG-1801 Vol. 2 Item	Table 1 Item	Notes
Flexible Hoses	PB	Nickel Alloys	Closed Cycle Cooling Water (Int)	Loss of material	Closed-Cycle Cooling Water System (B2.1.10)	None	None	G
Flexible Hoses	PB	Nickel Alloys	Plant Indoor Air (Ext)	None	None	VII.J-14	3.3.1.94	A
Flexible Hoses	PB	Stainless Steel	Closed Cycle Cooling Water (Int)	Loss of material	Closed-Cycle Cooling Water System (B2.1.10)	VII.C2-10	3.3.1.50	B
Flexible Hoses	PB	Stainless Steel	Plant Indoor Air (Ext)	None	None	VII.J-15	3.3.1.94	A
Flow Element	PB	Stainless Steel	Closed Cycle Cooling Water (Int)	Loss of material	Closed-Cycle Cooling Water System (B2.1.10)	VII.C2-10	3.3.1.50	B
Flow Element	PB	Stainless Steel	Plant Indoor Air (Ext)	None	None	VII.J-15	3.3.1.94	A
Heat Exchanger (EC Chiller Compr Oil Cooler)	HT, PB	Stainless Steel	Closed Cycle Cooling Water (Int)	Reduction of heat transfer	Closed-Cycle Cooling Water System (B2.1.10)	VII.C2-3	3.3.1.52	B
Heat Exchanger (EC Chiller Compr Oil Cooler)	HT, PB	Stainless Steel	Closed Cycle Cooling Water (Int)	Loss of material	Closed-Cycle Cooling Water System (B2.1.10)	VII.C2-10	3.3.1.50	D
Heat Exchanger (EC Chiller Compr Oil Cooler)	HT, PB	Stainless Steel	Lubricating Oil (Ext)	Loss of material	Lubricating Oil Analysis (B2.1.23) and One-Time Inspection (B2.1.16)	VII.C2-12	3.3.1.33	D
Heat Exchanger (EC Chiller Compr Oil Cooler)	PB	Stainless Steel	Lubricating Oil (Int)	Loss of material	Lubricating Oil Analysis (B2.1.23) and One-Time Inspection (B2.1.16)	VII.C2-12	3.3.1.33	D

Section 3.3
AGING MANAGEMENT OF AUXILIARY SYSTEMS

Table 3.3.2-4 Auxiliary Systems – Summary of Aging Management Evaluation – Essential Chilled Water System (Continued)

Component Type	Intended Function	Material	Environment	Aging Effect Requiring Management	Aging Management Program	NUREG-1801 Vol. 2 Item	Table 1 Item	Notes
Heat Exchanger (EC Chiller Compr Oil Cooler)	PB	Stainless Steel	Plant Indoor Air (Ext)	None	None	VII.J-15	3.3.1.94	C
Heat Exchanger (EC Chiller Condenser)	PB	Carbon Steel	Closed Cycle Cooling Water (Int)	Loss of material	Closed-Cycle Cooling Water System (B2.1.10)	VII.C2-1	3.3.1.48	B
Heat Exchanger (EC Chiller Condenser)	PB	Carbon Steel	Dry Gas (Ext)	None	None	VII.J-23	3.3.1.97	C
Heat Exchanger (EC Chiller Condenser)	PB	Carbon Steel	Dry Gas (Int)	None	None	VII.J-23	3.3.1.97	C
Heat Exchanger (EC Chiller Condenser)	PB	Carbon Steel	Plant Indoor Air (Ext)	Loss of material	External Surfaces Monitoring Program (B2.1.20)	VII.I-8	3.3.1.58	B
Heat Exchanger (EC Chiller Condenser)	HT, PB	Copper Alloy	Closed Cycle Cooling Water (Int)	Reduction of heat transfer	Closed-Cycle Cooling Water System (B2.1.10)	VII.C2-2	3.3.1.52	B
Heat Exchanger (EC Chiller Condenser)	HT, PB	Copper Alloy	Closed Cycle Cooling Water (Int)	Loss of material	Closed-Cycle Cooling Water System (B2.1.10)	VII.C2-4	3.3.1.51	D

Section 3.3
AGING MANAGEMENT OF AUXILIARY SYSTEMS

Table 3.3.2-4 Auxiliary Systems – Summary of Aging Management Evaluation – Essential Chilled Water System (Continued)

Component Type	Intended Function	Material	Environment	Aging Effect Requiring Management	Aging Management Program	NUREG-1801 Vol. 2 Item	Table 1 Item	Notes
Heat Exchanger (EC Chiller Condenser)	HT, PB	Copper Alloy	Dry Gas (Ext)	None	None	VII.J-4	3.3.1.97	A
Heat Exchanger (EC Chiller Contact Economizer)	HT, PB	Carbon Steel	Dry Gas (Int)	None	None	VII.J-23	3.3.1.97	C
Heat Exchanger (EC Chiller Contact Economizer)	HT, PB	Carbon Steel	Plant Indoor Air (Ext)	Loss of material	External Surfaces Monitoring Program (B2.1.20)	VII.I-8	3.3.1.58	B
Heat Exchanger (EC Chiller Water Cooler)	PB	Carbon Steel	Closed Cycle Cooling Water (Int)	Loss of material	Closed-Cycle Cooling Water System (B2.1.10)	VII.C2-1	3.3.1.48	B
Heat Exchanger (EC Chiller Water Cooler)	PB	Carbon Steel	Dry Gas (Ext)	None	None	VII.J-23	3.3.1.97	C
Heat Exchanger (EC Chiller Water Cooler)	PB	Carbon Steel	Dry Gas (Int)	None	None	VII.J-23	3.3.1.97	C
Heat Exchanger (EC Chiller Water Cooler)	PB	Carbon Steel	Plant Indoor Air (Ext)	Loss of material	External Surfaces Monitoring Program (B2.1.20)	VII.I-8	3.3.1.58	B

Section 3.3
AGING MANAGEMENT OF AUXILIARY SYSTEMS

Table 3.3.2-4 Auxiliary Systems – Summary of Aging Management Evaluation – Essential Chilled Water System (Continued)

Component Type	Intended Function	Material	Environment	Aging Effect Requiring Management	Aging Management Program	NUREG-1801 Vol. 2 Item	Table 1 Item	Notes
Heat Exchanger (EC Chiller Water Cooler)	HT, PB	Copper Alloy	Closed Cycle Cooling Water (Int)	Reduction of heat transfer	Closed-Cycle Cooling Water System (B2.1.10)	VII.C2-2	3.3.1.52	B
Heat Exchanger (EC Chiller Water Cooler)	HT, PB	Copper Alloy	Closed Cycle Cooling Water (Int)	Loss of material	Closed-Cycle Cooling Water System (B2.1.10)	VII.C2-4	3.3.1.51	D
Heat Exchanger (EC Chiller Water Cooler)	HT, PB	Copper Alloy	Dry Gas (Ext)	None	None	VII.J-4	3.3.1.97	A
Heat Exchanger (EC Pump-Out Unit Condenser)	NSRS	Carbon Steel	Dry Gas (Int)	None	None	VII.J-23	3.3.1.97	C
Heat Exchanger (EC Pump-Out Unit Condenser)	NSRS	Carbon Steel	Plant Indoor Air (Ext)	Loss of material	External Surfaces Monitoring Program (B2.1.20)	VII.I-8	3.3.1.58	B
Orifice	PB, TH	Copper Alloy (Zinc > 15%)	Dry Gas (Int)	None	None	VII.J-4	3.3.1.97	A
Orifice	PB, TH	Copper Alloy (Zinc > 15%)	Plant Indoor Air (Ext)	None	None	VIII.I-2	3.4.1.41	C
Piping	LBS, PB, SIA	Carbon Steel	Closed Cycle Cooling Water (Int)	Loss of material	Closed-Cycle Cooling Water System (B2.1.10)	VII.C2-14	3.3.1.47	B
Piping	PB, SIA	Carbon Steel	Dry Gas (Int)	None	None	VII.J-23	3.3.1.97	A

Section 3.3
AGING MANAGEMENT OF AUXILIARY SYSTEMS

Table 3.3.2-4 Auxiliary Systems – Summary of Aging Management Evaluation – Essential Chilled Water System (Continued)

Component Type	Intended Function	Material	Environment	Aging Effect Requiring Management	Aging Management Program	NUREG-1801 Vol. 2 Item	Table 1 Item	Notes
Piping	LBS, PB, SIA	Carbon Steel	Plant Indoor Air (Ext)	Loss of material	External Surfaces Monitoring Program (B2.1.20)	VII.I-8	3.3.1.58	B
Piping	LBS, SIA	Carbon Steel	Wetted Gas (Int)	Loss of material	Inspection Of Internal Surfaces In Miscellaneous Piping And Ducting Components (B2.1.22)	VII.F2-3	3.3.1.72	D
Piping	PB, SIA	Carbon Steel	Wetted Gas (Int)	Loss of material	Inspection Of Internal Surfaces In Miscellaneous Piping And Ducting Components (B2.1.22)	VII.G-23	3.3.1.71	B
Piping	PB	Copper Alloy	Dry Gas (Int)	None	None	VII.J-4	3.3.1.97	A
Piping	PB, SIA	Copper Alloy	Plant Indoor Air (Ext)	None	None	VIII.I-2	3.4.1.41	A
Piping	SIA	Copper Alloy	Wetted Gas (Int)	Loss of material	Inspection Of Internal Surfaces In Miscellaneous Piping And Ducting Components (B2.1.22)	VII.G-9	3.3.1.28	E
Piping	PB	Copper Alloy (Zinc > 15%)	DeminerIALIZED Water (Int)	Loss of material	Selective Leaching of Materials (B2.1.17)	VII.C2-7	3.3.1.84	B
Piping	PB	Copper Alloy (Zinc > 15%)	DeminerIALIZED Water (Int)	Loss of material	Water Chemistry (B2.1.2) and One-Time Inspection (B2.1.16)	VIII.A-5	3.4.1.15	A
Piping	PB	Copper Alloy (Zinc > 15%)	Plant Indoor Air (Ext)	None	None	VIII.I-2	3.4.1.41	A

Section 3.3
AGING MANAGEMENT OF AUXILIARY SYSTEMS

Table 3.3.2-4 Auxiliary Systems – Summary of Aging Management Evaluation – Essential Chilled Water System (Continued)

Component Type	Intended Function	Material	Environment	Aging Effect Requiring Management	Aging Management Program	NUREG-1801 Vol. 2 Item	Table 1 Item	Notes
Piping	LBS, PB	Stainless Steel	Closed Cycle Cooling Water (Int)	Loss of material	Closed-Cycle Cooling Water System (B2.1.10)	VII.C2-10	3.3.1.50	B
Piping	LBS, PB, SIA	Stainless Steel	DeminerIALIZED Water (Int)	Loss of material	Water Chemistry (B2.1.2) and One-Time Inspection (B2.1.16)	VIII.B1-4	3.4.1.16	A
Piping	PB	Stainless Steel	Dry Gas (Int)	None	None	VII.J-19	3.3.1.97	A
Piping	LBS, PB, SIA	Stainless Steel	Plant Indoor Air (Ext)	None	None	VII.J-15	3.3.1.94	A
Pump	PB	Carbon Steel	Closed Cycle Cooling Water (Int)	Loss of material	Closed-Cycle Cooling Water System (B2.1.10)	VII.C2-14	3.3.1.47	B
Pump	PB	Carbon Steel	Plant Indoor Air (Ext)	Loss of material	External Surfaces Monitoring Program (B2.1.20)	VII.I-8	3.3.1.58	B
Pump	PB	Cast Iron	Lubricating Oil (Int)	Loss of material	Lubricating Oil Analysis (B2.1.23) and One-Time Inspection (B2.1.16)	VII.C2-13	3.3.1.14	B
Pump	PB	Cast Iron	Plant Indoor Air (Ext)	Loss of material	External Surfaces Monitoring Program (B2.1.20)	VII.I-8	3.3.1.58	B
Sight Gauge	LBS, SIA	Carbon Steel	Closed Cycle Cooling Water (Int)	Loss of material	Closed-Cycle Cooling Water System (B2.1.10)	VII.C2-14	3.3.1.47	B
Sight Gauge	LBS, SIA	Carbon Steel	Plant Indoor Air (Ext)	Loss of material	External Surfaces Monitoring Program (B2.1.20)	VII.I-8	3.3.1.58	B
Sight Gauge	LBS	Glass	Closed Cycle Cooling Water (Int)	None	None	VII.J-13	3.3.1.93	A
Sight Gauge	PB	Glass	Dry Gas (Int)	None	None	None	None	G

Section 3.3
AGING MANAGEMENT OF AUXILIARY SYSTEMS

Table 3.3.2-4 Auxiliary Systems – Summary of Aging Management Evaluation – Essential Chilled Water System (Continued)

Component Type	Intended Function	Material	Environment	Aging Effect Requiring Management	Aging Management Program	NUREG-1801 Vol. 2 Item	Table 1 Item	Notes
Sight Gauge	NSRS	Glass	Lubricating Oil (Int)	None	None	VII.J-10	3.3.1.93	A
Sight Gauge	LBS, NSRS, PB	Glass	Plant Indoor Air (Ext)	None	None	VII.J-8	3.3.1.93	A
Sight Gauge	PB	Glass	Wetted Gas (Int)	None	None	VII.J-7	3.3.1.93	C
Strainer	LBS, SIA	Carbon Steel	Closed Cycle Cooling Water (Int)	Loss of material	Closed-Cycle Cooling Water System (B2.1.10)	VII.C2-14	3.3.1.47	B
Strainer	LBS, SIA	Carbon Steel	Plant Indoor Air (Ext)	Loss of material	External Surfaces Monitoring Program (B2.1.20)	VII.I-8	3.3.1.58	B
Strainer	PB	Copper Alloy	Dry Gas (Int)	None	None	VII.J-4	3.3.1.97	A
Strainer	PB	Copper Alloy	Plant Indoor Air (Ext)	None	None	VIII.I-2	3.4.1.41	A
Strainer	PB	Copper Alloy (Zinc >15%)	Dry Gas (Int)	None	None	VII.J-4	3.3.1.97	A
Strainer	PB	Copper Alloy (Zinc >15%)	Plant Indoor Air (Ext)	None	None	VIII.I-2	3.4.1.41	C
Tank	LBS, PB, SIA	Carbon Steel	Closed Cycle Cooling Water (Int)	Loss of material	Closed-Cycle Cooling Water System (B2.1.10)	VII.C2-14	3.3.1.47	B
Tank	NSRS, PB	Carbon Steel	Dry Gas (Int)	None	None	VII.J-23	3.3.1.97	C
Tank	LBS, NSRS, PB, SIA	Carbon Steel	Plant Indoor Air (Ext)	Loss of material	External Surfaces Monitoring Program (B2.1.20)	VII.I-8	3.3.1.58	B
Tank	PB	Cast Iron	Lubricating Oil (Int)	Loss of material	Lubricating Oil Analysis (B2.1.23) and One-Time Inspection (B2.1.16)	VII.C2-13	3.3.1.14	D
Tank	PB	Cast Iron	Plant Indoor Air (Ext)	Loss of material	External Surfaces Monitoring Program (B2.1.20)	VII.I-8	3.3.1.58	B

Section 3.3
AGING MANAGEMENT OF AUXILIARY SYSTEMS

Table 3.3.2-4 Auxiliary Systems – Summary of Aging Management Evaluation – Essential Chilled Water System (Continued)

Component Type	Intended Function	Material	Environment	Aging Effect Requiring Management	Aging Management Program	NUREG-1801 Vol. 2 Item	Table 1 Item	Notes
Tank	PB	Stainless Steel	Dry Gas (Int)	None	None	VII.J-19	3.3.1.97	C
Tank	PB	Stainless Steel	Plant Indoor Air (Ext)	None	None	VII.J-15	3.3.1.94	C
Tubing	LBS	Carbon Steel	Closed Cycle Cooling Water (Int)	Loss of material	Closed-Cycle Cooling Water System (B2.1.10)	VII.C2-14	3.3.1.47	B
Tubing	LBS	Carbon Steel	Plant Indoor Air (Ext)	Loss of material	External Surfaces Monitoring Program (B2.1.20)	VII.I-8	3.3.1.58	B
Tubing	PB	Copper Alloy	Dry Gas (Int)	None	None	VII.J-4	3.3.1.97	A
Tubing	PB	Copper Alloy	Plant Indoor Air (Ext)	None	None	VIII.I-2	3.4.1.41	A
Tubing	PB	Copper Alloy (Zinc >15%)	Dry Gas (Int)	None	None	VII.J-4	3.3.1.97	A
Tubing	PB	Copper Alloy (Zinc >15%)	Plant Indoor Air (Ext)	None	None	VIII.I-2	3.4.1.41	A
Tubing	LBS, PB	Stainless Steel	Closed Cycle Cooling Water (Int)	Loss of material	Closed-Cycle Cooling Water System (B2.1.10)	VII.C2-10	3.3.1.50	B
Tubing	NSRS, PB	Stainless Steel	Dry Gas (Int)	None	None	VII.J-19	3.3.1.97	A
Tubing	PB	Stainless Steel	Lubricating Oil (Int)	Loss of material	Lubricating Oil Analysis (B2.1.23) and One-Time Inspection (B2.1.16)	VII.C2-12	3.3.1.33	B
Tubing	LBS, NSRS, PB	Stainless Steel	Plant Indoor Air (Ext)	None	None	VII.J-15	3.3.1.94	A

Section 3.3
AGING MANAGEMENT OF AUXILIARY SYSTEMS

Table 3.3.2-4 Auxiliary Systems – Summary of Aging Management Evaluation – Essential Chilled Water System (Continued)

Component Type	Intended Function	Material	Environment	Aging Effect Requiring Management	Aging Management Program	NUREG-1801 Vol. 2 Item	Table 1 Item	Notes
Tubing	NSRS	Stainless Steel	Wetted Gas (Int)	Loss of material	Inspection Of Internal Surfaces In Miscellaneous Piping And Ducting Components (B2.1.22)	VII.F2-1	3.3.1.27	E
Valve	LBS, PB	Carbon Steel	Closed Cycle Cooling Water (Int)	Loss of material	Closed-Cycle Cooling Water System (B2.1.10)	VII.C2-14	3.3.1.47	B
Valve	LBS	Carbon Steel	DeminerIALIZED Water (Int)	Loss of material	Water Chemistry (B2.1.2) and One-Time Inspection (B2.1.16)	VIII.B1-11	3.4.1.04	A
Valve	PB, SIA	Carbon Steel	Dry Gas (Int)	None	None	VII.J-23	3.3.1.97	A
Valve	PB	Carbon Steel	Lubricating Oil (Int)	Loss of material	Lubricating Oil Analysis (B2.1.23) and One-Time Inspection (B2.1.16)	VII.C2-13	3.3.1.14	B
Valve	LBS, PB, SIA	Carbon Steel	Plant Indoor Air (Ext)	Loss of material	External Surfaces Monitoring Program (B2.1.20)	VII.I-8	3.3.1.58	B
Valve	PB	Carbon Steel	Wetted Gas (Int)	Loss of material	Inspection Of Internal Surfaces In Miscellaneous Piping And Ducting Components (B2.1.22)	VII.G-23	3.3.1.71	B
Valve	PB	Cast Iron	Dry Gas (Int)	None	None	VII.J-23	3.3.1.97	A
Valve	PB	Cast Iron	Plant Indoor Air (Ext)	Loss of material	External Surfaces Monitoring Program (B2.1.20)	VII.I-8	3.3.1.58	B
Valve	NSRS	Copper Alloy	Dry Gas (Int)	None	None	VII.J-4	3.3.1.97	A

Section 3.3
AGING MANAGEMENT OF AUXILIARY SYSTEMS

Table 3.3.2-4 Auxiliary Systems – Summary of Aging Management Evaluation – Essential Chilled Water System (Continued)

Component Type	Intended Function	Material	Environment	Aging Effect Requiring Management	Aging Management Program	NUREG-1801 Vol. 2 Item	Table 1 Item	Notes
Valve	PB	Copper Alloy	Lubricating Oil (Int)	Loss of material	Lubricating Oil Analysis (B2.1.23) and One-Time Inspection (B2.1.16)	VII.C2-5	3.3.1.26	B
Valve	NSRS, PB	Copper Alloy	Plant Indoor Air (Ext)	None	None	VIII.I-2	3.4.1.41	A
Valve	LBS	Copper Alloy (Zinc > 15%)	Closed Cycle Cooling Water (Int)	Loss of material	Selective Leaching of Materials (B2.1.17)	VII.C2-6	3.3.1.84	B
Valve	NSRS, PB	Copper Alloy (Zinc > 15%)	Dry Gas (Int)	None	None	VII.J-4	3.3.1.97	A
Valve	PB	Copper Alloy (Zinc > 15%)	Lubricating Oil (Int)	Loss of material	Lubricating Oil Analysis (B2.1.23) and One-Time Inspection (B2.1.16)	VII.C2-5	3.3.1.26	B
Valve	LBS, NSRS, PB	Copper Alloy (Zinc > 15%)	Plant Indoor Air (Ext)	None	None	VIII.I-2	3.4.1.41	A
Valve	PB	Stainless Steel	Closed Cycle Cooling Water (Int)	Loss of material	Closed-Cycle Cooling Water System (B2.1.10)	VII.C2-10	3.3.1.50	B
Valve	LBS, PB	Stainless Steel	DeminerIALIZED Water (Int)	Loss of material	Water Chemistry (B2.1.2) and One-Time Inspection (B2.1.16)	VIII.B1-4	3.4.1.16	A
Valve	NSRS, PB	Stainless Steel	Dry Gas (Int)	None	None	VII.J-19	3.3.1.97	A
Valve	LBS, NSRS, PB	Stainless Steel	Plant Indoor Air (Ext)	None	None	VII.J-15	3.3.1.94	A
Valve	LBS, NSRS, PB	Stainless Steel	Wetted Gas (Int)	Loss of material	Inspection Of Internal Surfaces In Miscellaneous Piping And Ducting Components (B2.1.22)	VII.F2-1	3.3.1.27	E

Section 3.3
AGING MANAGEMENT OF AUXILIARY SYSTEMS

Notes for Table 3.3.2-4:

Standard Notes:

- A Consistent with NUREG-1801 item for component, material, environment, and aging effect. AMP is consistent with NUREG-1801 AMP.
- B Consistent with NUREG-1801 item for component, material, environment, and aging effect. AMP takes some exceptions to NUREG-1801 AMP.
- C Component is different, but consistent with NUREG-1801 item for material, environment, and aging effect. AMP is consistent with NUREG-1801 AMP.
- D Component is different, but consistent with NUREG-1801 item for material, environment, and aging effect. AMP takes some exceptions to NUREG-1801 AMP.
- E Consistent with NUREG-1801 for material, environment, and aging effect, but a different aging management program is credited or NUREG-1801 identifies a plant-specific aging management program.
- G Environment not in NUREG-1801 for this component and material.

Plant Specific Note:

- 1 Loss of Preload is considered to be applicable for all closure bolting.

Section 3.3
AGING MANAGEMENT OF AUXILIARY SYSTEMS

Table 3.3.2-5 Auxiliary Systems – Summary of Aging Management Evaluation – Normal Chilled Water System

Component Type	Intended Function	Material	Environment	Aging Effect Requiring Management	Aging Management Program	NUREG-1801 Vol. 2 Item	Table 1 Item	Notes
Closure Bolting	LBS, PB	Carbon Steel	Plant Indoor Air (Ext)	Loss of material	Bolting Integrity (B2.1.7)	VII.I-4	3.3.1.43	B
Closure Bolting	LBS, PB	Carbon Steel	Plant Indoor Air (Ext)	Loss of preload	Bolting Integrity (B2.1.7)	VII.I-5	3.3.1.45	B, 1
Closure Bolting	LBS, SIA	Stainless Steel	Plant Indoor Air (Ext)	Loss of preload	Bolting Integrity (B2.1.7)	None	None	G, 1
Closure Bolting	LBS, SIA	Stainless Steel	Plant Indoor Air (Ext)	None	None	VII.J-15	3.3.1.94	C
Flexible Hoses	LBS	Nickel Alloys	Closed Cycle Cooling Water (Int)	Loss of material	Closed-Cycle Cooling Water System (B2.1.10)	None	None	G, 2
Flexible Hoses	LBS	Nickel Alloys	Plant Indoor Air (Ext)	None	None	VII.J-14	3.3.1.94	A
Flexible Hoses	LBS	Stainless Steel	Closed Cycle Cooling Water (Int)	Loss of material	Closed-Cycle Cooling Water System (B2.1.10)	VII.C2-10	3.3.1.50	B
Flexible Hoses	LBS	Stainless Steel	Plant Indoor Air (Ext)	None	None	VII.J-15	3.3.1.94	A
Flow Element	LBS	Stainless Steel	Closed Cycle Cooling Water (Int)	Loss of material	Closed-Cycle Cooling Water System (B2.1.10)	VII.C2-10	3.3.1.50	B
Flow Element	LBS	Stainless Steel	Plant Indoor Air (Ext)	None	None	VII.J-15	3.3.1.94	A
Orifice	LBS	Stainless Steel	Closed Cycle Cooling Water (Int)	Loss of material	Closed-Cycle Cooling Water System (B2.1.10)	VII.C2-10	3.3.1.50	B
Orifice	LBS	Stainless Steel	Plant Indoor Air (Ext)	None	None	VII.J-15	3.3.1.94	A
Piping	LBS, PB, SIA	Carbon Steel	Closed Cycle Cooling Water (Int)	Loss of material	Closed-Cycle Cooling Water System (B2.1.10)	VII.C2-14	3.3.1.47	B

Section 3.3
AGING MANAGEMENT OF AUXILIARY SYSTEMS

Table 3.3.2-5 Auxiliary Systems – Summary of Aging Management Evaluation – Normal Chilled Water System (Continued)

Component Type	Intended Function	Material	Environment	Aging Effect Requiring Management	Aging Management Program	NUREG-1801 Vol. 2 Item	Table 1 Item	Notes
Piping	LBS, PB, SIA	Carbon Steel	Plant Indoor Air (Ext)	Loss of material	External Surfaces Monitoring Program (B2.1.20)	VII.I-8	3.3.1.58	B
Piping	LBS	Carbon Steel	Wetted Gas (Int)	Loss of material	Inspection Of Internal Surfaces In Miscellaneous Piping And Ducting Components (B2.1.22)	VII.F2-3	3.3.1.72	D
Piping	LBS	Stainless Steel	Closed Cycle Cooling Water (Int)	Loss of material	Closed-Cycle Cooling Water System (B2.1.10)	VII.C2-10	3.3.1.50	B
Piping	LBS	Stainless Steel	Plant Indoor Air (Ext)	None	None	VII.J-15	3.3.1.94	A
Strainer	LBS	Copper Alloy	Closed Cycle Cooling Water (Int)	Loss of material	Closed-Cycle Cooling Water System (B2.1.10)	VII.C2-4	3.3.1.51	B
Strainer	LBS	Copper Alloy	Plant Indoor Air (Ext)	None	None	VIII.I-2	3.4.1.41	A
Tubing	LBS	Stainless Steel	Closed Cycle Cooling Water (Int)	Loss of material	Closed-Cycle Cooling Water System (B2.1.10)	VII.C2-10	3.3.1.50	B
Tubing	LBS	Stainless Steel	Plant Indoor Air (Ext)	None	None	VII.J-15	3.3.1.94	A
Valve	LBS, PB	Carbon Steel	Closed Cycle Cooling Water (Int)	Loss of material	Closed-Cycle Cooling Water System (B2.1.10)	VII.C2-14	3.3.1.47	B
Valve	LBS, PB	Carbon Steel	Plant Indoor Air (Ext)	Loss of material	External Surfaces Monitoring Program (B2.1.20)	VII.I-8	3.3.1.58	B
Valve	LBS	Stainless Steel	Closed Cycle Cooling Water (Int)	Loss of material	Closed-Cycle Cooling Water System (B2.1.10)	VII.C2-10	3.3.1.50	B

Section 3.3
AGING MANAGEMENT OF AUXILIARY SYSTEMS

Table 3.3.2-5 Auxiliary Systems – Summary of Aging Management Evaluation – Normal Chilled Water System (Continued)

Component Type	Intended Function	Material	Environment	Aging Effect Requiring Management	Aging Management Program	NUREG-1801 Vol. 2 Item	Table 1 Item	Notes
Valve	LBS	Stainless Steel	Plant Indoor Air (Ext)	None	None	VII.J-15	3.3.1.94	A

Notes for Table 3.3.2-5:

Standard Notes:

- A Consistent with NUREG-1801 item for component, material, environment, and aging effect. AMP is consistent with NUREG-1801 AMP.
- B Consistent with NUREG-1801 item for component, material, environment, and aging effect. AMP takes some exceptions to NUREG-1801 AMP.
- C Component is different, but consistent with NUREG-1801 item for material, environment, and aging effect. AMP is consistent with NUREG-1801 AMP.
- D Component is different, but consistent with NUREG-1801 item for material, environment, and aging effect. AMP takes some exceptions to NUREG-1801 AMP.
- G Environment not in NUREG-1801 for this component and material.

Plant Specific Notes:

- 1 Loss of Preload is considered to be applicable for all closure bolting.
- 2 NUREG-1801 does not consider nickel-alloy piping components in a closed cooling water environment for PWR auxiliary systems. This line is based upon the aging effects of NUREG-1801 line VII.C2-10 managed by Closed-Cycle Cooling Water System program (B2.1.10) and is consistent with EPRI Report 1010639, Appendix A, Figure 1.

Section 3.3
AGING MANAGEMENT OF AUXILIARY SYSTEMS

Table 3.3.2-6 Auxiliary Systems – Summary of Aging Management Evaluation – Nuclear Cooling Water System

Component Type	Intended Function	Material	Environment	Aging Effect Requiring Management	Aging Management Program	NUREG-1801 Vol. 2 Item	Table 1 Item	Notes
Closure Bolting	LBS, PB, SIA	Carbon Steel	Plant Indoor Air (Ext)	Loss of material	Bolting Integrity (B2.1.7)	VII.I-4	3.3.1.43	B
Closure Bolting	LBS, PB, SIA	Carbon Steel	Plant Indoor Air (Ext)	Loss of preload	Bolting Integrity (B2.1.7)	VII.I-5	3.3.1.45	B
Flexible Hoses	LBS, PB	Nickel Alloys	Closed-Cycle Cooling Water (Int)	Loss of material	Closed-Cycle Cooling Water System (B2.1.10)	None	None	G
Flexible Hoses	LBS, PB	Nickel Alloys	Plant Indoor Air (Ext)	None	None	VII.J-14	3.3.1.94	A
Flexible Hoses	LBS, PB	Stainless Steel	Closed-Cycle Cooling Water (Int)	Loss of material	Closed-Cycle Cooling Water System (B2.1.10)	VII.C2-10	3.3.1.50	B
Flexible Hoses	LBS, PB	Stainless Steel	Plant Indoor Air (Ext)	None	None	VII.J-15	3.3.1.94	A
Flow Element	LBS, PB	Stainless Steel	Closed-Cycle Cooling Water (Int)	Loss of material	Closed-Cycle Cooling Water System (B2.1.10)	VII.C2-10	3.3.1.50	B
Flow Element	LBS, PB	Stainless Steel	Plant Indoor Air (Ext)	None	None	VII.J-15	3.3.1.94	A
Flow Indicator	LBS, PB	Stainless Steel	Closed-Cycle Cooling Water (Int)	Loss of material	Closed-Cycle Cooling Water System (B2.1.10)	VII.C2-10	3.3.1.50	B
Flow Indicator	LBS, PB	Stainless Steel	Plant Indoor Air (Ext)	None	None	VII.J-15	3.3.1.94	A
Piping	LBS, PB, SIA	Carbon Steel	Closed-Cycle Cooling Water (Int)	Loss of material	Closed-Cycle Cooling Water System (B2.1.10)	VII.C2-14	3.3.1.47	B

Section 3.3
AGING MANAGEMENT OF AUXILIARY SYSTEMS

Table 3.3.2-6 Auxiliary Systems – Summary of Aging Management Evaluation – Nuclear Cooling Water System (Continued)

Component Type	Intended Function	Material	Environment	Aging Effect Requiring Management	Aging Management Program	NUREG-1801 Vol. 2 Item	Table 1 Item	Notes
Piping	LBS, PB, SIA	Carbon Steel	Plant Indoor Air (Ext)	Loss of material	External Surfaces Monitoring Program (B2.1.20)	VII.I-8	3.3.1.58	B
Piping	SIA	Carbon Steel	Wetted Gas (Int)	Loss of material	Inspection Of Internal Surfaces In Miscellaneous Piping And Ducting Components (B2.1.22)	VIII.B1-7	3.4.1.30	B
Piping	LBS, PB	Stainless Steel	Closed-Cycle Cooling Water (Int)	Loss of material	Closed-Cycle Cooling Water System (B2.1.10)	VII.C2-10	3.3.1.50	B
Piping	LBS, PB	Stainless Steel	Plant Indoor Air (Ext)	None	None	VII.J-15	3.3.1.94	A
Tubing	LBS	Stainless Steel	Closed-Cycle Cooling Water (Int)	Loss of material	Closed-Cycle Cooling Water System (B2.1.10)	VII.C2-10	3.3.1.50	B
Tubing	LBS	Stainless Steel	Plant Indoor Air (Ext)	None	None	VII.J-15	3.3.1.94	A
Valve	LBS, PB, SIA	Carbon Steel	Closed-Cycle Cooling Water (Int)	Loss of material	Closed-Cycle Cooling Water System (B2.1.10)	VII.C2-14	3.3.1.47	B
Valve	LBS, PB, SIA	Carbon Steel	Plant Indoor Air (Ext)	Loss of material	External Surfaces Monitoring Program (B2.1.20)	VII.I-8	3.3.1.58	B
Valve	LBS	Copper Alloy	Closed-Cycle Cooling Water (Int)	Loss of material	Closed-Cycle Cooling Water System (B2.1.10)	VII.C2-4	3.3.1.51	B
Valve	LBS	Copper Alloy	Plant Indoor Air (Ext)	None	None	VIII.I-2	3.4.1.41	A
Valve	LBS, PB	Stainless Steel	Closed-Cycle Cooling Water (Int)	Loss of material	Closed-Cycle Cooling Water System (B2.1.10)	VII.C2-10	3.3.1.50	B

Section 3.3
AGING MANAGEMENT OF AUXILIARY SYSTEMS

Table 3.3.2-6 Auxiliary Systems – Summary of Aging Management Evaluation – Nuclear Cooling Water System (Continued)

Component Type	Intended Function	Material	Environment	Aging Effect Requiring Management	Aging Management Program	NUREG-1801 Vol. 2 Item	Table 1 Item	Notes
Valve	LBS, PB	Stainless Steel	Plant Indoor Air (Ext)	None	None	VII.J-15	3.3.1.94	A

Notes for Table 3.3.2-6:

Standard Notes:

- A Consistent with NUREG-1801 item for component, material, environment, and aging effect. AMP is consistent with NUREG-1801 AMP.
- B Consistent with NUREG-1801 item for component, material, environment, and aging effect. AMP takes some exceptions to NUREG-1801 AMP.
- G Environment not in NUREG-1801 for this component and material.

Plant Specific Notes:

None

Section 3.3
AGING MANAGEMENT OF AUXILIARY SYSTEMS

Table 3.3.2-7 Auxiliary Systems – Summary of Aging Management Evaluation – Essential Spray Pond System

Component Type	Intended Function	Material	Environment	Aging Effect Requiring Management	Aging Management Program	NUREG-1801 Vol. 2 Item	Table 1 Item	Notes
Closure Bolting	PB	Carbon Steel	Plant Indoor Air (Ext)	Loss of material	Bolting Integrity (B2.1.7)	VII.I-4	3.3.1.43	B
Closure Bolting	PB	Carbon Steel	Plant Indoor Air (Ext)	Loss of preload	Bolting Integrity (B2.1.7)	VII.I-5	3.3.1.45	B
Closure Bolting	PB	Copper Alloy (Aluminum > 8%)	Plant Indoor Air (Ext)	Loss of preload	Bolting Integrity (B2.1.7)	None	None	F, 1
Closure Bolting	PB	Copper Alloy (Aluminum > 8%)	Plant Indoor Air (Ext)	None	None	VIII.I-2	3.4.1.41	C
Closure Bolting	PB	Stainless Steel	Plant Indoor Air (Ext)	Loss of preload	Bolting Integrity (B2.1.7)	None	None	G, 1
Closure Bolting	PB	Stainless Steel	Raw Water (Ext)	Loss of preload	Bolting Integrity (B2.1.7)	None	None	G, 1
Closure Bolting	PB	Stainless Steel	Raw Water (Ext)	Loss of material	Open-Cycle Cooling Water System (B2.1.9)	VII.C3-7	3.3.1.78	C
Corrosion Test Rack	LBS	Polyvinyl Chloride (PVC)	Plant Indoor Air (Ext)	None	None	None	None	F, 7
Corrosion Test Rack	LBS	Polyvinyl Chloride (PVC)	Raw Water (Int)	None	None	None	None	F, 6
Expansion Joint	PB	Nickel Alloys	Plant Indoor Air (Ext)	None	None	VII.J-14	3.3.1.94	A
Expansion Joint	PB	Nickel Alloys	Raw Water (Int)	Loss of material	Open-Cycle Cooling Water System (B2.1.9)	VII.C3-6	3.3.1.78	A

Section 3.3
AGING MANAGEMENT OF AUXILIARY SYSTEMS

Table 3.3.2-7 Auxiliary Systems – Summary of Aging Management Evaluation – Essential Spray Pond System (Continued)

Component Type	Intended Function	Material	Environment	Aging Effect Requiring Management	Aging Management Program	NUREG-1801 Vol. 2 Item	Table 1 Item	Notes
Expansion Joint	PB	Stainless Steel	Plant Indoor Air (Ext)	None	None	VII.J-15	3.3.1.94	A
Expansion Joint	PB	Stainless Steel	Raw Water (Int)	Loss of material	Open-Cycle Cooling Water System (B2.1.9)	VII.C3-7	3.3.1.78	A
Flexible Hoses	LBS, PB	Nickel Alloys	Plant Indoor Air (Ext)	None	None	VII.J-14	3.3.1.94	A
Flexible Hoses	LBS, PB	Nickel Alloys	Raw Water (Int)	Loss of material	Open-Cycle Cooling Water System (B2.1.9)	VII.C3-6	3.3.1.78	A
Flexible Hoses	LBS, PB	Stainless Steel	Plant Indoor Air (Ext)	None	None	VII.J-15	3.3.1.94	A
Flexible Hoses	LBS, PB	Stainless Steel	Raw Water (Int)	Loss of material	Open-Cycle Cooling Water System (B2.1.9)	VII.C3-7	3.3.1.78	A
Flow Element	PB	Stainless Steel	Plant Indoor Air (Ext)	None	None	VII.J-15	3.3.1.94	A
Flow Element	PB	Stainless Steel	Raw Water (Int)	Loss of material	Open-Cycle Cooling Water System (B2.1.9)	VII.C3-7	3.3.1.78	A
Flow Indicator	LBS	Polyvinyl Chloride (PVC)	Plant Indoor Air (Ext)	None	None	None	None	F, 7
Flow Indicator	LBS	Polyvinyl Chloride (PVC)	Raw Water (Int)	None	None	None	None	F, 6
Instrument Bellows	LBS, PB	Stainless Steel	Plant Indoor Air (Ext)	None	None	VII.J-15	3.3.1.94	A
Instrument Bellows	LBS, PB	Stainless Steel	Raw Water (Int)	Loss of material	Open-Cycle Cooling Water System (B2.1.9)	VII.C3-7	3.3.1.78	A
Orifice	PB, TH	Stainless Steel	Plant Indoor Air (Ext)	None	None	VII.J-15	3.3.1.94	A

Section 3.3
AGING MANAGEMENT OF AUXILIARY SYSTEMS

Table 3.3.2-7 Auxiliary Systems – Summary of Aging Management Evaluation – Essential Spray Pond System (Continued)

Component Type	Intended Function	Material	Environment	Aging Effect Requiring Management	Aging Management Program	NUREG-1801 Vol. 2 Item	Table 1 Item	Notes
Orifice	PB, TH	Stainless Steel	Raw Water (Int)	Loss of material	Open-Cycle Cooling Water System (B2.1.9)	VII.C3-7	3.3.1.78	A
Piping	PB	Carbon Steel	Buried (Ext)	Loss of material	Buried Piping and Tanks Inspection (B2.1.18)	VII.C3-9	3.3.1.19	B
Piping	PB	Carbon Steel	Plant Indoor Air (Ext)	Loss of material	External Surfaces Monitoring Program (B2.1.20)	VII.I-8	3.3.1.58	B
Piping	PB	Carbon Steel	Raw Water (Int)	Loss of material	Open-Cycle Cooling Water System (B2.1.9)	VII.C3-10	3.3.1.76	A
Piping	PB	Nickel Alloys	Plant Indoor Air (Ext)	None	None	VII.J-14	3.3.1.94	A
Piping	PB	Nickel Alloys	Raw Water (Int)	Loss of material	Open-Cycle Cooling Water System (B2.1.9)	VII.C3-6	3.3.1.78	A
Piping	LBS	Polyvinyl Chloride (PVC)	Plant Indoor Air (Ext)	None	None	None	None	F, 7
Piping	LBS	Polyvinyl Chloride (PVC)	Raw Water (Int)	None	None	None	None	F, 6
Piping	PB	Stainless Steel	Atmosphere/Weather (Ext)	None	None	None	None	G, 2
Piping	PB	Stainless Steel	Atmosphere/Weather (Int)	None	None	None	None	G, 3
Piping	LBS, PB, S/A	Stainless Steel	Plant Indoor Air (Ext)	None	None	VII.J-15	3.3.1.94	A
Piping	PB, S/A	Stainless Steel	Raw Water (Ext)	Loss of material	Open-Cycle Cooling Water System (B2.1.9)	VII.C3-7	3.3.1.78	A
Piping	LBS, PB, S/A	Stainless Steel	Raw Water (Int)	Loss of material	Open-Cycle Cooling Water System (B2.1.9)	VII.C3-7	3.3.1.78	A

Section 3.3
AGING MANAGEMENT OF AUXILIARY SYSTEMS

Table 3.3.2-7 Auxiliary Systems – Summary of Aging Management Evaluation – Essential Spray Pond System (Continued)

Component Type	Intended Function	Material	Environment	Aging Effect Requiring Management	Aging Management Program	NUREG-1801 Vol. 2 Item	Table 1 Item	Notes
Piping	S/A	Stainless Steel	Wetted Gas (Int)	Loss of material	Inspection Of Internal Surfaces In Miscellaneous Piping And Ducting Components (B2.1.22)	VII.F2-1	3.3.1.27	E
Pump	PB	Copper Alloy	Plant Indoor Air (Ext)	None	None	VIII.I-2	3.4.1.41	A
Pump	PB	Copper Alloy	Raw Water (Int)	Loss of material	Open-Cycle Cooling Water System (B2.1.9)	VII.C3-2	3.3.1.78	A
Pump	PB	Copper Alloy (Aluminum > 8%)	Plant Indoor Air (Ext)	None	None	VIII.I-2	3.4.1.41	A
Pump	PB	Copper Alloy (Aluminum > 8%)	Raw Water (Int)	Loss of material	Open-Cycle Cooling Water System (B2.1.9)	VII.C3-2	3.3.1.78	A
Pump	PB	Copper Alloy (Aluminum > 8%)	Raw Water (Int)	Loss of material	Selective Leaching of Materials (B2.1.17)	VII.C3-3	3.3.1.84	B
Spray Nozzle	PB, SP	Nickel Alloys	Atmosphere/Weather (Ext)	None	None	None	None	G, 4
Spray Nozzle	PB, SP	Nickel Alloys	Atmosphere/Weather (Int)	None	None	None	None	G, 5
Spray Nozzle	PB, SP	Nickel Alloys	Raw Water (Int)	Loss of material	Open-Cycle Cooling Water System (B2.1.9)	VII.C3-6	3.3.1.78	A
Strainer	LBS	Polyvinyl Chloride (PVC)	Plant Indoor Air (Ext)	None	None	None	None	F, 7

Section 3.3
AGING MANAGEMENT OF AUXILIARY SYSTEMS

Table 3.3.2-7 Auxiliary Systems – Summary of Aging Management Evaluation – Essential Spray Pond System (Continued)

Component Type	Intended Function	Material	Environment	Aging Effect Requiring Management	Aging Management Program	NUREG-1801 Vol. 2 Item	Table 1 Item	Notes
Strainer	LBS	Polyvinyl Chloride (PVC)	Raw Water (Int)	None	None	None	None	F, 6
Tubing	PB	Stainless Steel	Atmosphere/Weather (Ext)	None	None	None	None	G
Tubing	LBS, PB	Stainless Steel	Plant Indoor Air (Ext)	None	None	VII.J-15	3.3.1.94	A
Tubing	LBS, PB	Stainless Steel	Raw Water (Int)	Loss of material	Open-Cycle Cooling Water System (B2.1.9)	VII.C3-7	3.3.1.78	A
Valve	PB	Carbon Steel	Plant Indoor Air (Ext)	Loss of material	External Surfaces Monitoring Program (B2.1.20)	VII.I-8	3.3.1.58	B
Valve	PB	Carbon Steel	Raw Water (Int)	Loss of material	Open-Cycle Cooling Water System (B2.1.9)	VII.C3-10	3.3.1.76	A
Valve	PB	Copper Alloy (Aluminum > 8%)	Plant Indoor Air (Ext)	None	None	VIII.I-2	3.4.1.41	A
Valve	PB	Copper Alloy (Aluminum > 8%)	Raw Water (Int)	Loss of material	Open-Cycle Cooling Water System (B2.1.9)	VII.C3-2	3.3.1.78	A
Valve	PB	Copper Alloy (Aluminum > 8%)	Raw Water (Int)	Loss of material	Selective Leaching of Materials (B2.1.17)	VII.C3-3	3.3.1.84	B
Valve	LBS	Polyvinyl Chloride (PVC)	Plant Indoor Air (Ext)	None	None	None	None	F, 7
Valve	LBS	Polyvinyl Chloride (PVC)	Raw Water (Int)	None	None	None	None	F, 6

Section 3.3
AGING MANAGEMENT OF AUXILIARY SYSTEMS

Table 3.3.2-7 Auxiliary Systems – Summary of Aging Management Evaluation – Essential Spray Pond System (Continued)

Component Type	Intended Function	Material	Environment	Aging Effect Requiring Management	Aging Management Program	NUREG-1801 Vol. 2 Item	Table 1 Item	Notes
Valve	PB	Stainless Steel	Plant Indoor Air (Ext)	None	None	VII.J-15	3.3.1.94	A
Valve	PB	Stainless Steel	Raw Water (Int)	Loss of material	Open-Cycle Cooling Water System (B2.1.9)	VII.C3-7	3.3.1.78	A
Valve	PB	Stainless Steel Cast Austenitic	Raw Water (Ext)	Loss of material	Open-Cycle Cooling Water System (B2.1.9)	VII.C3-7	3.3.1.78	A
Valve	PB	Stainless Steel Cast Austenitic	Raw Water (Int)	Loss of material	Open-Cycle Cooling Water System (B2.1.9)	VII.C3-7	3.3.1.78	A

Notes for Table 3.3.2-7:

Standard Notes:

- A Consistent with NUREG-1801 item for component, material, environment, and aging effect. AMP is consistent with NUREG-1801 AMP.
- B Consistent with NUREG-1801 item for component, material, environment, and aging effect. AMP takes some exceptions to NUREG-1801 AMP.
- C Component is different, but consistent with NUREG-1801 item for material, environment, and aging effect. AMP is consistent with NUREG-1801 AMP.
- E Consistent with NUREG-1801 for material, environment, and aging effect, but a different aging management program is credited or NUREG-1801 identifies a plant-specific aging management program.
- F Material not in NUREG-1801 for this component.
- G Environment not in NUREG-1801 for this component and material.

Plant Specific Notes:

- 1 Loss of Preload is considered to be applicable for all closure bolting.
- 2 These stainless steel components are located outside with an uncontrolled external air environment and are not exposed to aggressive chemical species. The PVNGS plant outdoor environment is not subject to industry air pollution or saline environment. Alternate wetting and drying has shown a tendency to "wash" the exterior surface material rather than concentrate contaminants. Stainless steel does not experience any appreciable aging effects in this environment.

Section 3.3
AGING MANAGEMENT OF AUXILIARY SYSTEMS

Industry precedent includes SER for Browns Ferry fuel oil system. It includes stainless steel fittings in an outdoor environment with no resultant aging effects. Also, Point Beach SER identified stainless steel valve bodies in an outdoor environment in their emergency power system with no resultant aging effects.

3 These items are assigned the environment of "Atmosphere/ Weather (Internal)". The items are vented or open to the outside atmosphere so the distinction between internal and external is not relevant for aging purposes. These stainless steel components are located outside with an uncontrolled external air environment and are not exposed to aggressive chemical species. The PVNGS plant outdoor environment is not subject to industry air pollution or saline environment. Alternate wetting and drying has shown a tendency to "wash" the surface material rather than concentrate contaminants. Stainless steel does not experience any appreciable aging effects in this environment. Industry precedent includes SER for Browns Ferry fuel oil system. It includes stainless steel fittings in an outdoor environment with no resultant aging effects. Also, Ser for Point Beach identified stainless steel valve bodies in an outdoor environment in their emergency power system with no resultant aging effects.

4 These nickel-alloy components are located outside with an uncontrolled external air environment and are not exposed to aggressive chemical species. The PVNGS plant outdoor environment is not subject to industry air pollution or saline environment. Alternate wetting and drying has shown a tendency to "wash" the exterior surface material rather than concentrate contaminants. Nickel-alloys do not experience any appreciable aging effects in this environment.

5 These items are assigned the environment of "Atmosphere/ Weather (Internal)". The items are vented or open to the outside atmosphere so the distinction between internal and external is not relevant for aging purposes.

These nickel alloy components are located outside with an uncontrolled external air environment and are not exposed to aggressive chemical species. The PVNGS plant outdoor environment is not subject to industry air pollution or saline environment. Alternate wetting and drying has shown a tendency to "wash" the surface material rather than concentrate contaminants. Nickel alloys do not experience any appreciable aging effects in this environment.

6 "PVC is relatively unaffected by water, concentrated alkalis, and non-oxidizing acids, oils, and ozone" per EPRI Rpt 1010639 "Mechanical Tools" Rev. 4, Appendix A, Section 2.1.8.

7 "PVC is relatively unaffected by water, concentrated alkalis, and non-oxidizing acids, oils, and ozone" per EPRI Rpt 1010639 "Mechanical Tools" Rev. 4, Appendix E, Section 2.1.9.

Section 3.3
AGING MANAGEMENT OF AUXILIARY SYSTEMS

Table 3.3.2-8 Auxiliary Systems – Summary of Aging Management Evaluation – Nuclear Sampling System

Component Type	Intended Function	Material	Environment	Aging Effect Requiring Management	Aging Management Program	NUREG-1801 Vol. 2 Item	Table 1 Item	Notes
Closure Bolting	LBS, PB, SIA	Carbon Steel	Plant Indoor Air (Ext)	Loss of material	Bolting Integrity (B2.1.7)	VII.I-4	3.3.1.43	B
Closure Bolting	LBS, PB, SIA	Carbon Steel	Plant Indoor Air (Ext)	Loss of preload	Bolting Integrity (B2.1.7)	VII.I-5	3.3.1.45	B
Closure Bolting	LBS, PB, SIA	Stainless Steel	Borated Water Leakage (Ext)	Loss of preload	Bolting Integrity (B2.1.7)	IV.C2-8	3.1.1.52	B
Closure Bolting	LBS, PB, SIA	Stainless Steel	Borated Water Leakage (Ext)	None	None	VII.J-16	3.3.1.99	C
Flow Indicator	LBS, SIA	Stainless Steel	Borated Water Leakage (Ext)	None	None	VII.J-16	3.3.1.99	A
Flow Indicator	LBS, SIA	Stainless Steel	Treated Borated Water (Int)	Loss of material	Water Chemistry (B2.1.2)	VII.E1-17	3.3.1.91	A
Heat Exchanger (Pzr Steam Space Sample Cooler)	LBS, SIA	Carbon Steel	Closed-Cycle Cooling Water (Int)	Loss of material	Closed-Cycle Cooling Water System (B2.1.10)	VII.C2-1	3.3.1.48	B
Heat Exchanger (Pzr Steam Space Sample Cooler)	LBS, SIA	Carbon Steel	Plant Indoor Air (Ext)	Loss of material	External Surfaces Monitoring Program (B2.1.20)	VII.I-8	3.3.1.58	B

Section 3.3
AGING MANAGEMENT OF AUXILIARY SYSTEMS

Table 3.3.2-8 Auxiliary Systems – Summary of Aging Management Evaluation – Nuclear Sampling System (Continued)

Component Type	Intended Function	Material	Environment	Aging Effect Requiring Management	Aging Management Program	NUREG-1801 Vol. 2 Item	Table 1 Item	Notes
Heat Exchanger (Pzr Steam Space Sample Cooler)	LBS, SIA	Stainless Steel	Closed-Cycle Cooling Water (Ext)	Loss of material	Closed-Cycle Cooling Water System (B2.1.10)	VII.C2-10	3.3.1.50	D
Heat Exchanger (Pzr Steam Space Sample Cooler)	LBS, SIA	Stainless Steel	Closed-Cycle Cooling Water (Ext)	Cracking	Closed-Cycle Cooling Water System (B2.1.10)	VII.C2-11	3.3.1.46	D
Heat Exchanger (Pzr Steam Space Sample Cooler)	LBS, SIA	Stainless Steel	Treated Borated Water (Int)	Cracking	Water Chemistry (B2.1.2) and One-Time Inspection (B2.1.16)	VII.E1-5	3.3.1.08	E, 3
Heat Exchanger (Pzr Steam Space Sample Cooler)	LBS, SIA	Stainless Steel	Treated Borated Water (Int)	Loss of material	Water Chemistry (B2.1.2)	VII.E1-17	3.3.1.91	C
Heat Exchanger (Pzr Surge Line Sample Cooler)	LBS, SIA	Carbon Steel	Closed-Cycle Cooling Water (Int)	Loss of material	Closed-Cycle Cooling Water System (B2.1.10)	VII.C2-1	3.3.1.48	B

Section 3.3
AGING MANAGEMENT OF AUXILIARY SYSTEMS

Table 3.3.2-8 Auxiliary Systems – Summary of Aging Management Evaluation – Nuclear Sampling System (Continued)

Component Type	Intended Function	Material	Environment	Aging Effect Requiring Management	Aging Management Program	NUREG-1801 Vol. 2 Item	Table 1 Item	Notes
Heat Exchanger (Pzr Surge Line Sample Cooler)	LBS, SIA	Carbon Steel	Plant Indoor Air (Ext)	Loss of material	External Surfaces Monitoring Program (B2.1.20)	VII.I-8	3.3.1.58	B
Heat Exchanger (Pzr Surge Line Sample Cooler)	LBS, SIA	Stainless Steel	Closed-Cycle Cooling Water (Ext)	Loss of material	Closed-Cycle Cooling Water System (B2.1.10)	VII.C2-10	3.3.1.50	D
Heat Exchanger (Pzr Surge Line Sample Cooler)	LBS, SIA	Stainless Steel	Closed-Cycle Cooling Water (Ext)	Cracking	Closed-Cycle Cooling Water System (B2.1.10)	VII.C2-11	3.3.1.46	D
Heat Exchanger (Pzr Surge Line Sample Cooler)	LBS, SIA	Stainless Steel	Treated Borated Water (Int)	Cracking	Water Chemistry (B2.1.2) and One-Time Inspection (B2.1.16)	VII.E1-5	3.3.1.08	E, 3
Heat Exchanger (Pzr Surge Line Sample Cooler)	LBS, SIA	Stainless Steel	Treated Borated Water (Int)	Loss of material	Water Chemistry (B2.1.2)	VII.E1-17	3.3.1.91	C
Heat Exchanger (Rx Hot Leg Sample Cooler)	PB	Carbon Steel	Closed-Cycle Cooling Water (Int)	Loss of material	Closed-Cycle Cooling Water System (B2.1.10)	VII.C2-1	3.3.1.48	B

Section 3.3
AGING MANAGEMENT OF AUXILIARY SYSTEMS

Table 3.3.2-8 Auxiliary Systems – Summary of Aging Management Evaluation – Nuclear Sampling System (Continued)

Component Type	Intended Function	Material	Environment	Aging Effect Requiring Management	Aging Management Program	NUREG-1801 Vol. 2 Item	Table 1 Item	Notes
Heat Exchanger (Rx Hot Leg Sample Cooler)	PB	Carbon Steel	Plant Indoor Air (Ext)	Loss of material	External Surfaces Monitoring Program (B2.1.20)	VII.I-8	3.3.1.58	B
Heat Exchanger (Rx Hot Leg Sample Cooler)	HT, PB	Stainless Steel	Closed-Cycle Cooling Water (Ext)	Reduction of heat transfer	Closed-Cycle Cooling Water System (B2.1.10)	VII.C2-3	3.3.1.52	B
Heat Exchanger (Rx Hot Leg Sample Cooler)	HT, PB	Stainless Steel	Closed-Cycle Cooling Water (Ext)	Loss of material	Closed-Cycle Cooling Water System (B2.1.10)	VII.C2-10	3.3.1.50	D
Heat Exchanger (Rx Hot Leg Sample Cooler)	HT, PB	Stainless Steel	Closed-Cycle Cooling Water (Ext)	Cracking	Closed-Cycle Cooling Water System (B2.1.10)	VII.C2-11	3.3.1.46	D
Heat Exchanger (Rx Hot Leg Sample Cooler)	HT, PB	Stainless Steel	Treated Borated Water (Int)	Reduction of heat transfer	Water Chemistry (B2.1.2) and One-Time Inspection (B2.1.16)	None	None	H, 1
Heat Exchanger (Rx Hot Leg Sample Cooler)	HT, PB	Stainless Steel	Treated Borated Water (Int)	Cracking	Water Chemistry (B2.1.2) and One-Time Inspection (B2.1.16)	VII.E1-5	3.3.1.08	E, 3

Section 3.3
AGING MANAGEMENT OF AUXILIARY SYSTEMS

Table 3.3.2-8 Auxiliary Systems – Summary of Aging Management Evaluation – Nuclear Sampling System (Continued)

Component Type	Intended Function	Material	Environment	Aging Effect Requiring Management	Aging Management Program	NUREG-1801 Vol. 2 Item	Table 1 Item	Notes
Heat Exchanger (Rx Hot Leg Sample Cooler)	HT, PB	Stainless Steel	Treated Borated Water (Int)	Loss of material	Water Chemistry (B2.1.2)	VII.E1-17	3.3.1.91	C
Heat Exchanger (SI Sample Cooler)	LBS, SIA	Carbon Steel	Closed-Cycle Cooling Water (Int)	Loss of material	Closed-Cycle Cooling Water System (B2.1.10)	VII.C2-1	3.3.1.48	B
Heat Exchanger (SI Sample Cooler)	LBS, SIA	Carbon Steel	Plant Indoor Air (Ext)	Loss of material	External Surfaces Monitoring Program (B2.1.20)	VII.I-8	3.3.1.58	B
Heat Exchanger (SI Sample Cooler)	LBS, SIA	Stainless Steel	Closed-Cycle Cooling Water (Ext)	Loss of material	Closed-Cycle Cooling Water System (B2.1.10)	VII.C2-10	3.3.1.50	D
Heat Exchanger (SI Sample Cooler)	LBS, SIA	Stainless Steel	Treated Borated Water (Int)	Cracking	Water Chemistry (B2.1.2) and One-Time Inspection (B2.1.16)	VII.E1-5	3.3.1.08	E, 3
Heat Exchanger (SI Sample Cooler)	LBS, SIA	Stainless Steel	Treated Borated Water (Int)	Loss of material	Water Chemistry (B2.1.2)	VII.E1-17	3.3.1.91	C
Orifice	LBS	Stainless Steel	Borated Water Leakage (Ext)	None	None	VII.J-16	3.3.1.99	A
Orifice	LBS	Stainless Steel	Treated Borated Water (Int)	Loss of material	Water Chemistry (B2.1.2)	VII.E1-17	3.3.1.91	A

Section 3.3
AGING MANAGEMENT OF AUXILIARY SYSTEMS

Table 3.3.2-8 Auxiliary Systems – Summary of Aging Management Evaluation – Nuclear Sampling System (Continued)

Component Type	Intended Function	Material	Environment	Aging Effect Requiring Management	Aging Management Program	NUREG-1801 Vol. 2 Item	Table 1 Item	Notes
Piping	LBS	Carbon Steel	Closed-Cycle Cooling Water (Int)	Loss of material	Closed-Cycle Cooling Water System (B2.1.10)	VII.C2-14	3.3.1.47	B
Piping	LBS	Carbon Steel	Plant Indoor Air (Ext)	Loss of material	External Surfaces Monitoring Program (B2.1.20)	VII.I-8	3.3.1.58	B
Piping	LBS, PB, SIA	Stainless Steel	Borated Water Leakage (Ext)	None	None	VII.J-16	3.3.1.99	A
Piping	LBS	Stainless Steel	Demineralized Water (Int)	Loss of material	Water Chemistry (B2.1.2) and One-Time Inspection (B2.1.16)	VIII.B1-4	3.4.1.16	A
Piping	LBS, SIA	Stainless Steel	Plant Indoor Air (Ext)	None	None	VII.J-15	3.3.1.94	A
Piping	LBS, SIA	Stainless Steel	Raw Water (Int)	Loss of material	Inspection Of Internal Surfaces In Miscellaneous Piping And Ducting Components (B2.1.22)	VII.C1-15	3.3.1.79	E, 2
Piping	LBS, PB, SIA	Stainless Steel	Treated Borated Water (Int)	Loss of material	Water Chemistry (B2.1.2)	VII.E1-17	3.3.1.91	A
Piping	LBS, PB, SIA	Stainless Steel	Treated Borated Water (Int)	Cracking	Water Chemistry (B2.1.2)	VII.E1-20	3.3.1.90	A
Piping	SIA	Stainless Steel	Ventilation Atmosphere (Int)	None	None	VII.J-15	3.3.1.94	A
Piping	PB	Stainless Steel	Wetted Gas (Int)	Loss of material	Inspection Of Internal Surfaces In Miscellaneous Piping And Ducting Components (B2.1.22)	VII.F1-1	3.3.1.27	E

Section 3.3
AGING MANAGEMENT OF AUXILIARY SYSTEMS

Table 3.3.2-8 Auxiliary Systems – Summary of Aging Management Evaluation – Nuclear Sampling System (Continued)

Component Type	Intended Function	Material	Environment	Aging Effect Requiring Management	Aging Management Program	NUREG-1801 Vol. 2 Item	Table 1 Item	Notes
Sample Vessel	LBS, SIA	Stainless Steel	Borated Water Leakage (Ext)	None	None	VII.J-16	3.3.1.99	C
Sample Vessel	LBS, SIA	Stainless Steel	Treated Borated Water (Int)	Loss of material	Water Chemistry (B2.1.2)	VII.E1-17	3.3.1.91	C
Tubing	LBS, PB, SIA	Stainless Steel	Borated Water Leakage (Ext)	None	None	VII.J-16	3.3.1.99	A
Tubing	LBS, PB, SIA	Stainless Steel	Treated Borated Water (Int)	Loss of material	Water Chemistry (B2.1.2)	VII.E1-17	3.3.1.91	A
Tubing	LBS, PB, SIA	Stainless Steel	Treated Borated Water (Int)	Cracking	Water Chemistry (B2.1.2)	VII.E1-20	3.3.1.90	A
Valve	LBS	Carbon Steel	Closed-Cycle Cooling Water (Int)	Loss of material	Closed-Cycle Cooling Water System (B2.1.10)	VII.C2-14	3.3.1.47	B
Valve	LBS	Carbon Steel	Plant Indoor Air (Ext)	Loss of material	External Surfaces Monitoring Program (B2.1.20)	VII.I-8	3.3.1.58	B
Valve	LBS, PB, SIA	Stainless Steel	Borated Water Leakage (Ext)	None	None	VII.J-16	3.3.1.99	A
Valve	LBS	Stainless Steel	Closed-Cycle Cooling Water (Int)	Loss of material	Closed-Cycle Cooling Water System (B2.1.10)	VII.C2-10	3.3.1.50	B
Valve	LBS, PB, SIA	Stainless Steel	DeminerIALIZED Water (Int)	Loss of material	Water Chemistry (B2.1.2) and One-Time Inspection (B2.1.16)	VIII.B1-4	3.4.1.16	A
Valve	LBS, PB, SIA	Stainless Steel	Plant Indoor Air (Ext)	None	None	VII.J-15	3.3.1.94	A
Valve	LBS	Stainless Steel	Raw Water (Int)	Loss of material	Inspection Of Internal Surfaces In Miscellaneous Piping And Ducting Components (B2.1.22)	VII.C1-15	3.3.1.79	E, 2

Table 3.3.2-8 Auxiliary Systems – Summary of Aging Management Evaluation – Nuclear Sampling System (Continued)

Component Type	Intended Function	Material	Environment	Aging Effect Requiring Management	Aging Management Program	NUREG-1801 Vol. 2 Item	Table 1 Item	Notes
Valve	LBS, PB, S/A	Stainless Steel	Treated Borated Water (Int)	Loss of material	Water Chemistry (B2.1.2)	VII.E1-17	3.3.1.91	A
Valve	LBS, PB, S/A	Stainless Steel	Treated Borated Water (Int)	Cracking	Water Chemistry (B2.1.2)	VII.E1-20	3.3.1.90	A
Valve	S/A	Stainless Steel	Ventilation Atmosphere (Int)	None	None	VII.J-15	3.3.1.94	A

Notes for Table 3.3.2-8:

Standard Note Text

- A Consistent with NUREG-1801 item for component, material, environment, and aging effect. AMP is consistent with NUREG-1801 AMP.
- B Consistent with NUREG-1801 item for component, material, environment, and aging effect. AMP takes some exceptions to NUREG-1801 AMP.
- C Component is different, but consistent with NUREG-1801 item for material, environment, and aging effect. AMP is consistent with NUREG-1801 AMP.
- D Component is different, but consistent with NUREG-1801 item for material, environment, and aging effect. AMP takes some exceptions to NUREG-1801 AMP.
- E Consistent with NUREG-1801 for material, environment, and aging effect, but a different aging management program is credited or NUREG-1801 identifies a plant-specific aging management program.
- H Aging effect not in NUREG-1801 for this component, material and environment combination.

Plant Specific Note

- 1 Reduction in heat transfer due to fouling is a potential aging effect for stainless steel heat exchanger components in treated borated water. This non-NUREG-1801 line is based upon the component, material, aging effects and aging management program combination of NUREG-1801 line VII.E1-4.
- 2 The component environment is contaminated sump, sample sink drains, resin slurry and other waste water that has been evaluated as a raw water environment that cannot be managed by Open-Cycle Cooling Water System program (B2.1.9). Loss of material on internal component surfaces exposed to this raw water environment is managed by Inspection of Internal Surfaces in Miscellaneous Piping and Ducting Components program (B2.1.22) instead of the Open-Cycle Cooling Water System program (B2.1.9).
- 3 One-Time Inspection program (B2.1.16) is selected as the Plant Specific aging management program to monitor the effectiveness of the Water Chemistry program (B2.1.2) for managing cracking in this Component-Material-Environment.

Section 3.3
AGING MANAGEMENT OF AUXILIARY SYSTEMS

Table 3.3.2-9 Auxiliary Systems – Summary of Aging Management Evaluation – Compressed Air System

Component Type	Intended Function	Material	Environment	Aging Effect Requiring Management	Aging Management Program	NUREG-1801 Vol. 2 Item	Table 1 Item	Notes
Accumulator	PB	Carbon Steel	Dry Gas (Int)	None	None	VII.J-22	3.3.1.98	A
Accumulator	PB	Carbon Steel	Plant Indoor Air (Ext)	Loss of material	External Surfaces Monitoring Program (B2.1.20)	VII.D-3	3.3.1.57	B
Closure Bolting	PB, SIA	Carbon Steel	Plant Indoor Air (Ext)	Loss of material	Bolting Integrity (B2.1.7)	VII.I-4	3.3.1.43	B
Closure Bolting	PB, SIA	Carbon Steel	Plant Indoor Air (Ext)	Loss of preload	Bolting Integrity (B2.1.7)	VII.I-5	3.3.1.45	B
Closure Bolting	SIA	Copper Alloy	Plant Indoor Air (Ext)	Loss of preload	Bolting Integrity (B2.1.7)	None	None	F
Closure Bolting	SIA	Copper Alloy	Plant Indoor Air (Ext)	None	None	V.F-3	3.2.1.53	C
Orifice	PB, SIA, TH	Stainless Steel	Dry Gas (Int)	None	None	VII.J-18	3.3.1.98	A
Orifice	PB, SIA, TH	Stainless Steel	Plant Indoor Air (Ext)	None	None	VII.J-15	3.3.1.94	A
Piping	PB, SIA	Carbon Steel	Dry Gas (Int)	None	None	VII.J-22	3.3.1.98	A
Piping	PB, SIA	Carbon Steel	Plant Indoor Air (Ext)	Loss of material	External Surfaces Monitoring Program (B2.1.20)	VII.D-3	3.3.1.57	B
Piping	SIA	Copper Alloy	Dry Gas (Int)	None	None	VII.J-3	3.3.1.98	A
Piping	SIA	Copper Alloy	Plant Indoor Air (Ext)	None	None	V.F-3	3.2.1.53	A
Piping	PB, SIA	Stainless Steel	Dry Gas (Int)	None	None	VII.J-18	3.3.1.98	A
Piping	PB, SIA	Stainless Steel	Plant Indoor Air (Ext)	None	None	VII.J-15	3.3.1.94	A

Section 3.3
AGING MANAGEMENT OF AUXILIARY SYSTEMS

Table 3.3.2-9 Auxiliary Systems – Summary of Aging Management Evaluation – Compressed Air System (Continued)

Component Type	Intended Function	Material	Environment	Aging Effect Requiring Management	Aging Management Program	NUREG-1801 Vol. 2 Item	Table 1 Item	Notes
Tubing	PB	Stainless Steel	Dry Gas (Int)	None	None	VII.J-18	3.3.1.98	A
Tubing	PB	Stainless Steel	Plant Indoor Air (Ext)	None	None	VII.J-15	3.3.1.94	A
Valve	PB, SIA	Carbon Steel	Dry Gas (Int)	None	None	VII.J-22	3.3.1.98	A
Valve	PB, SIA	Carbon Steel	Plant Indoor Air (Ext)	Loss of material	External Surfaces Monitoring Program (B2.1.20)	VII.D-3	3.3.1.57	B
Valve	SIA	Copper Alloy	Dry Gas (Int)	None	None	VII.J-3	3.3.1.98	A
Valve	SIA	Copper Alloy	Plant Indoor Air (Ext)	None	None	V.F-3	3.2.1.53	A
Valve	PB, SIA	Stainless Steel	Dry Gas (Int)	None	None	VII.J-18	3.3.1.98	A
Valve	PB, SIA	Stainless Steel	Plant Indoor Air (Ext)	None	None	VII.J-15	3.3.1.94	A

Notes for Table 3.3.2-9:

Standard Notes:

- A Consistent with NUREG-1801 item for component, material, environment, and aging effect. AMP is consistent with NUREG-1801 AMP.
- B Consistent with NUREG-1801 item for component, material, environment, and aging effect. AMP takes some exceptions to NUREG-1801 AMP.
- C Component is different, but consistent with NUREG-1801 item for material, environment, and aging effect. AMP is consistent with NUREG-1801 AMP.
- F Material not in NUREG-1801 for this component.

Plant Specific Notes:

None

Section 3.3
AGING MANAGEMENT OF AUXILIARY SYSTEMS

Table 3.3.2-10 Auxiliary Systems – Summary of Aging Management Evaluation – Chemical and Volume Control System

Component Type	Intended Function	Material	Environment	Aging Effect Requiring Management	Aging Management Program	NUREG-1801 Vol. 2 Item	Table 1 Item	Notes
Accumulator	LBS, PB	Stainless Steel	Borated Water Leakage (Ext)	None	None	VII.J-16	3.3.1.99	C
Accumulator	PB	Stainless Steel	Treated Borated Water (Int)	Loss of material	Water Chemistry (B2.1.2)	VII.E1-17	3.3.1.91	C
Accumulator	LBS	Stainless Steel	Treated Borated Water (Int)	Loss of material	Water Chemistry (B2.1.2)	VII.E1-17	3.3.1.91	A
Closure Bolting	LBS, SIA	Carbon Steel	Borated Water Leakage (Ext)	Loss of preload	Bolting Integrity (B2.1.7)	IV.C2-8	3.1.1.52	B
Closure Bolting	LBS, SIA	Carbon Steel	Borated Water Leakage (Ext)	Loss of material	Boric Acid Corrosion (B2.1.4)	VII.I-10	3.3.1.89	A
Closure Bolting	PB	Stainless Steel	Borated Water Leakage (Ext)	Cracking	Bolting Integrity (B2.1.7)	IV.C2-7	3.1.1.52	B
Closure Bolting	PB	Stainless Steel	Borated Water Leakage (Ext)	Loss of preload	Bolting Integrity (B2.1.7)	IV.C2-8	3.1.1.52	B
Compressible Joints/Seals	DF	Elastomer	Treated Borated Water (Ext)	Hardening and loss of strength	Inspection Of Internal Surfaces In Miscellaneous Piping And Ducting Components (B2.1.22)	VII.A3-1	3.3.1.12	E
Deminerlizer	PB	Stainless Steel	Borated Water Leakage (Ext)	None	None	VII.J-16	3.3.1.99	C
Deminerlizer	PB	Stainless Steel	Treated Borated Water (Int)	Loss of material	Water Chemistry (B2.1.2)	VII.E1-17	3.3.1.91	A

Section 3.3
AGING MANAGEMENT OF AUXILIARY SYSTEMS

Table 3.3.2-10 Auxiliary Systems – Summary of Aging Management Evaluation – Chemical and Volume Control System(Continued)

Component Type	Intended Function	Material	Environment	Aging Effect Requiring Management	Aging Management Program	NUREG-1801 Vol. 2 Item	Table 1 Item	Notes
Filter	LBS	Carbon Steel	Demineralized Water (Int)	Loss of material	Water Chemistry (B2.1.2) and One-Time Inspection (B2.1.16)	VIII.E-34	3.4.1.04	A
Filter	LBS	Carbon Steel	Plant Indoor Air (Ext)	Loss of material	External Surfaces Monitoring Program (B2.1.20)	VII.I-8	3.3.1.58	B
Filter	FIL, LBS, PB	Stainless Steel	Borated Water Leakage (Ext)	None	None	VII.J-16	3.3.1.99	A
Filter	LBS	Stainless Steel	Demineralized Water (Int)	Loss of material	Water Chemistry (B2.1.2) and One-Time Inspection (B2.1.16)	VIII.E-29	3.4.1.16	A
Filter	LBS	Stainless Steel	Plant Indoor Air (Ext)	None	None	VII.J-15	3.3.1.94	A
Filter	FIL, LBS, PB	Stainless Steel	Treated Borated Water (Int)	Loss of material	Water Chemistry (B2.1.2)	VII.E1-17	3.3.1.91	A
Flow Element	LBS	Carbon Steel	Demineralized Water (Int)	Loss of material	Water Chemistry (B2.1.2) and One-Time Inspection (B2.1.16)	VIII.E-34	3.4.1.04	A
Flow Element	LBS	Carbon Steel	Plant Indoor Air (Ext)	Loss of material	External Surfaces Monitoring Program (B2.1.20)	VII.I-8	3.3.1.58	B
Flow Element	LBS, PB	Stainless Steel	Borated Water Leakage (Ext)	None	None	VII.J-16	3.3.1.99	A
Flow Element	LBS	Stainless Steel	Demineralized Water (Int)	Loss of material	Water Chemistry (B2.1.2) and One-Time Inspection (B2.1.16)	VIII.E-29	3.4.1.16	A

Section 3.3
AGING MANAGEMENT OF AUXILIARY SYSTEMS

Table 3.3.2-10 Auxiliary Systems – Summary of Aging Management Evaluation – Chemical and Volume Control System(Continued)

Component Type	Intended Function	Material	Environment	Aging Effect Requiring Management	Aging Management Program	NUREG-1801 Vol. 2 Item	Table 1 Item	Notes
Flow Element	LBS	Stainless Steel	Plant Indoor Air (Ext)	None	None	VII.J-15	3.3.1.94	A
Flow Element	LBS, PB	Stainless Steel	Treated Borated Water (Int)	Loss of material	Water Chemistry (B2.1.2)	VII.E1-17	3.3.1.91	A
Flow Indicator	LBS	Cast Iron	Demineralized Water (Int)	Loss of material	Water Chemistry (B2.1.2) and One-Time Inspection (B2.1.16)	VIII.E-34	3.4.1.04	A
Flow Indicator	LBS	Cast Iron	Plant Indoor Air (Ext)	Loss of material	External Surfaces Monitoring Program (B2.1.20)	VII.I-8	3.3.1.58	B
Flow Indicator	LBS	Glass	Borated Water Leakage (Ext)	None	None	None	None	G
Flow Indicator	LBS	Glass	Demineralized Water (Int)	None	None	VII.J-13	3.3.1.93	A
Flow Indicator	LBS	Glass	Plant Indoor Air (Ext)	None	None	VII.J-8	3.3.1.93	A
Flow Indicator	LBS	Glass	Treated Borated Water (Int)	None	None	VII.J-12	3.3.1.93	A
Flow Indicator	LBS, SIA	Stainless Steel	Borated Water Leakage (Ext)	None	None	VII.J-16	3.3.1.99	A
Flow Indicator	LBS	Stainless Steel	Demineralized Water (Int)	Loss of material	Water Chemistry (B2.1.2) and One-Time Inspection (B2.1.16)	VIII.E-29	3.4.1.16	A
Flow Indicator	LBS	Stainless Steel	Plant Indoor Air (Ext)	None	None	VII.J-15	3.3.1.94	A
Flow Indicator	LBS, SIA	Stainless Steel	Treated Borated Water (Int)	Loss of material	Water Chemistry (B2.1.2)	VII.E1-17	3.3.1.91	A

Section 3.3
AGING MANAGEMENT OF AUXILIARY SYSTEMS

Table 3.3.2-10 Auxiliary Systems – Summary of Aging Management Evaluation – Chemical and Volume Control System(Continued)

Component Type	Intended Function	Material	Environment	Aging Effect Requiring Management	Aging Management Program	NUREG-1801 Vol. 2 Item	Table 1 Item	Notes
Heat Exchanger	PB	Stainless Steel	Treated Borated Water (Int)	Cumulative fatigue damage	Time Limited Aging Analysis evaluated for the period of extended operation	VII.E1-4	3.3.1.02	A
Heat Exchanger (Boric Acid Concentrator)	LBS	Carbon Steel	DeminerIALIZED Water (Int)	Loss of material	Water Chemistry (B2.1.2) and One-Time Inspection (B2.1.16)	VIII.E-34	3.4.1.04	A
Heat Exchanger (Boric Acid Concentrator)	LBS	Carbon Steel	Plant Indoor Air (Ext)	Loss of material	External Surfaces Monitoring Program (B2.1.20)	VII.I-8	3.3.1.58	B
Heat Exchanger (Boric Acid Concentrator)	LBS	Stainless Steel	Borated Water Leakage (Ext)	None	None	VII.J-16	3.3.1.99	C
Heat Exchanger (Boric Acid Concentrator)	LBS	Stainless Steel	DeminerIALIZED Water (Int)	Loss of material	Water Chemistry (B2.1.2) and One-Time Inspection (B2.1.16)	VIII.E-36	3.4.1.16	A
Heat Exchanger (Boric Acid Concentrator)	LBS	Stainless Steel	Plant Indoor Air (Ext)	None	None	VII.J-15	3.3.1.94	C
Heat Exchanger (Boric Acid Concentrator)	LBS	Stainless Steel	Treated Borated Water (Int)	Cracking	Water Chemistry (B2.1.2) and One-Time Inspection (B2.1.16)	VII.E1-5	3.3.1.08	E, 3

Section 3.3
AGING MANAGEMENT OF AUXILIARY SYSTEMS

Table 3.3.2-10 Auxiliary Systems – Summary of Aging Management Evaluation – Chemical and Volume Control System(Continued)

Component Type	Intended Function	Material	Environment	Aging Effect Requiring Management	Aging Management Program	NUREG-1801 Vol. 2 Item	Table 1 Item	Notes
Heat Exchanger (Boric Acid Concentrator)	LBS	Stainless Steel	Treated Borated Water (Int)	Loss of material	Water Chemistry (B2.1.2)	VII.E1-17	3.3.1.91	C
Heat Exchanger (Letdown)	PB	Carbon Steel	Borated Water Leakage (Ext)	Loss of material	Boric Acid Corrosion (B2.1.4)	VII.E1-1	3.3.1.89	A
Heat Exchanger (Letdown)	PB	Carbon Steel	Closed Cycle Cooling Water (Int)	Loss of material	Closed-Cycle Cooling Water System (B2.1.10)	VIII.E-5	3.4.1.24	B
Heat Exchanger (Letdown)	PB	Stainless Steel	Borated Water Leakage (Ext)	None	None	VII.J-16	3.3.1.99	C
Heat Exchanger (Letdown)	PB	Stainless Steel	Closed Cycle Cooling Water (Ext)	Loss of material	Closed-Cycle Cooling Water System (B2.1.10)	VII.C2-10	3.3.1.50	B
Heat Exchanger (Letdown)	PB	Stainless Steel	Treated Borated Water (Int)	Cracking	Water Chemistry (B2.1.2) and One-Time Inspection (B2.1.16)	VII.E1-9	3.3.1.07	E, 3
Heat Exchanger (Letdown)	PB	Stainless Steel	Treated Borated Water (Int)	Loss of material	Water Chemistry (B2.1.2)	VII.E1-17	3.3.1.91	A
Heat Exchanger (Regenerative)	PB	Stainless Steel	Borated Water Leakage (Ext)	None	None	VII.J-16	3.3.1.99	C
Heat Exchanger (Regenerative)	PB	Stainless Steel	Treated Borated Water (Ext)	Cracking	Water Chemistry (B2.1.2) and One-Time Inspection (B2.1.16)	VII.E1-5	3.3.1.08	E, 3

Section 3.3
AGING MANAGEMENT OF AUXILIARY SYSTEMS

Table 3.3.2-10 Auxiliary Systems – Summary of Aging Management Evaluation – Chemical and Volume Control System(Continued)

Component Type	Intended Function	Material	Environment	Aging Effect Requiring Management	Aging Management Program	NUREG-1801 Vol. 2 Item	Table 1 Item	Notes
Heat Exchanger (Regenerative)	PB	Stainless Steel	Treated Borated Water (Ext)	Loss of material	Water Chemistry (B2.1.2)	VII.E1-17	3.3.1.91	C
Heat Exchanger (Regenerative)	PB	Stainless Steel	Treated Borated Water (Int)	Cracking	Water Chemistry (B2.1.2) and One-Time Inspection (B2.1.16)	VII.E1-5	3.3.1.08	E, 3
Heat Exchanger (Regenerative)	PB	Stainless Steel	Treated Borated Water (Int)	Loss of material	Water Chemistry (B2.1.2)	VII.E1-17	3.3.1.91	A
Heat Exchanger (Seal Injection)	SS	Carbon Steel	Borated Water Leakage (Ext)	Loss of material	Boric Acid Corrosion (B2.1.4)	IV.C2-09	3.1.1.58	A, 4
Heat Exchanger (Seal Injection)	SS	Carbon Steel	Borated Water Leakage (Int)	Loss of material	Inspection Of Internal Surfaces In Miscellaneous Piping And Ducting Components (B2.1.22)	None	None	G, 4
Heat Exchanger (Seal Injection)	PB	Stainless Steel	Borated Water Leakage (Ext)	None	None	VII.J-16	3.3.1.99	C, 4
Heat Exchanger (Seal Injection)	PB	Stainless Steel	Treated Borated Water (Int)	Loss of material	Water Chemistry (B2.1.2)	VII.E1-17	3.3.1.91	C, 4
Heater	PB	Stainless Steel	Atmosphere/Weather (Ext)	None	None	None	None	G
Heater	PB	Stainless Steel	Deminerlized Water (Int)	Loss of material	Water Chemistry (B2.1.2) and One-Time Inspection (B2.1.16)	VIII.E-36	3.4.1.16	A

Section 3.3
AGING MANAGEMENT OF AUXILIARY SYSTEMS

Table 3.3.2-10 Auxiliary Systems – Summary of Aging Management Evaluation – Chemical and Volume Control System(Continued)

Component Type	Intended Function	Material	Environment	Aging Effect Requiring Management	Aging Management Program	NUREG-1801 Vol. 2 Item	Table 1 Item	Notes
Insulation	INS	Insulation Calcium Silicate	Borated Water Leakage (Ext)	None	None	None	None	J
Insulation	INS	Insulation Mineral Wool	Borated Water Leakage (Ext)	None	None	None	None	J
Orifice	PB, TH	Stainless Steel	Borated Water Leakage (Ext)	None	None	VII.J-16	3.3.1.99	A
Orifice	PB, TH	Stainless Steel	Treated Borated Water (Int)	Loss of material	Water Chemistry (B2.1.2)	VII.E1-17	3.3.1.91	A
Orifice	LBS	Stainless Steel Cast Austenitic	DeminerIALIZED Water (Int)	Loss of material	Water Chemistry (B2.1.2) and One-Time Inspection (B2.1.16)	VIII.E-29	3.4.1.16	A
Orifice	LBS	Stainless Steel Cast Austenitic	Plant Indoor Air (Ext)	None	None	VII.J-15	3.3.1.94	A
Piping	LBS	Carbon Steel	DeminerIALIZED Water (Int)	Loss of material	Water Chemistry (B2.1.2) and One-Time Inspection (B2.1.16)	VIII.E-34	3.4.1.04	A
Piping	LBS	Carbon Steel	Plant Indoor Air (Ext)	Loss of material	External Surfaces Monitoring Program (B2.1.20)	VII.I-8	3.3.1.58	B
Piping	PB	Nickel Alloys	Borated Water Leakage (Ext)	None	None	None	None	G

Section 3.3
AGING MANAGEMENT OF AUXILIARY SYSTEMS

Table 3.3.2-10 Auxiliary Systems – Summary of Aging Management Evaluation – Chemical and Volume Control System(Continued)

Component Type	Intended Function	Material	Environment	Aging Effect Requiring Management	Aging Management Program	NUREG-1801 Vol. 2 Item	Table 1 Item	Notes
Piping	PB	Nickel Alloys	Reactor Coolant (Int)	Cracking	Nickel Alloy Aging Management (B2.1.34), ASME Section XI Inservice Inspection, Subsections IWB, IWC, and IWD (B2.1.1) for Class 1 components, Water Chemistry (B2.1.2), and Comply with applicable NRC Orders and FSAR Commitment (B2.1.21)	IV.C2-13	3.1.1.31	E, 1
Piping	LBS, PB, S/A	Stainless Steel	Borated Water Leakage (Ext)	None	None	VII.J-16	3.3.1.99	A
Piping	PB	Stainless Steel	Buried (Ext)	Loss of material	Buried Piping and Tanks Inspection (B2.1.18)	VII.C1-16	3.3.1.29	E
Piping	LBS, PB, S/A	Stainless Steel	DeminerIALIZED Water (Int)	Loss of material	Water Chemistry (B2.1.2) and One-Time Inspection (B2.1.16)	VIII.E-29	3.4.1.16	A
Piping	PB, S/A	Stainless Steel	Dry Gas (Int)	None	None	VII.J-19	3.3.1.97	A
Piping	PB	Stainless Steel	Encased in Concrete (Ext)	None	None	VII.J-17	3.3.1.96	A
Piping	LBS, PB, S/A	Stainless Steel	Plant Indoor Air (Ext)	None	None	VII.J-15	3.3.1.94	A

Section 3.3
AGING MANAGEMENT OF AUXILIARY SYSTEMS

Table 3.3.2-10 Auxiliary Systems – Summary of Aging Management Evaluation – Chemical and Volume Control System(Continued)

Component Type	Intended Function	Material	Environment	Aging Effect Requiring Management	Aging Management Program	NUREG-1801 Vol. 2 Item	Table 1 Item	Notes
Piping	LBS, PB, S/A	Stainless Steel	Raw Water (Int)	Loss of material	Inspection Of Internal Surfaces In Miscellaneous Piping And Ducting Components (B2.1.22)	VII.C1-15	3.3.1.79	E, 2
Piping	PB	Stainless Steel	Reactor Coolant (Int)	Cracking	ASME Section XI Inservice Inspection, Subsections IWB, IWC, and IWD for Class 1 components (B2.1.1) and Water Chemistry (B2.1.2) and One-Time Inspection Of ASME Code Class 1 Small-Bore Piping (B2.1.19)	IV.C2-1	3.1.1.70	B
Piping	PB	Stainless Steel	Reactor Coolant (Int)	Loss of material	Water Chemistry (B2.1.2)	IV.C2-15	3.1.1.83	A
Piping	PB	Stainless Steel	Treated Borated Water (Int)	Cumulative fatigue damage	Time Limited Aging Analysis evaluated for the period of extended operation	VII.E1-16	3.3.1.02	A
Piping	LBS, PB, S/A	Stainless Steel	Treated Borated Water (Int)	Loss of material	Water Chemistry (B2.1.2)	VII.E1-17	3.3.1.91	A
Piping	PB	Stainless Steel	Treated Borated Water (Int)	Cracking	Water Chemistry (B2.1.2)	VII.E1-20	3.3.1.90	A

Section 3.3
AGING MANAGEMENT OF AUXILIARY SYSTEMS

Table 3.3.2-10 Auxiliary Systems – Summary of Aging Management Evaluation – Chemical and Volume Control System(Continued)

Component Type	Intended Function	Material	Environment	Aging Effect Requiring Management	Aging Management Program	NUREG-1801 Vol. 2 Item	Table 1 Item	Notes
Piping	LBS, PB, SIA	Stainless Steel	Wetted Gas (Int)	Loss of material	Inspection Of Internal Surfaces In Miscellaneous Piping And Ducting Components (B2.1.22)	V.D1-29	3.2.1.08	E
Pump	LBS, PB	Stainless Steel	Borated Water Leakage (Ext)	None	None	VII.J-16	3.3.1.99	A
Pump	LBS	Stainless Steel	Demineralized Water (Int)	Loss of material	Water Chemistry (B2.1.2) and One-Time Inspection (B2.1.16)	VIII.E-29	3.4.1.16	A
Pump	LBS	Stainless Steel	Plant Indoor Air (Ext)	None	None	VII.J-15	3.3.1.94	A
Pump	PB	Stainless Steel	Treated Borated Water (Int)	Cracking	Water Chemistry (B2.1.2) and One-Time Inspection (B2.1.16)	VII.E1-7	3.3.1.09	E, 3
Pump	LBS, PB	Stainless Steel	Treated Borated Water (Int)	Loss of material	Water Chemistry (B2.1.2)	VII.E1-17	3.3.1.91	A
Pump	LBS, PB	Stainless Steel Cast Austenitic	Borated Water Leakage (Ext)	None	None	VII.J-16	3.3.1.99	A
Pump	LBS, PB	Stainless Steel Cast Austenitic	Treated Borated Water (Int)	Loss of material	Water Chemistry (B2.1.2)	VII.E1-17	3.3.1.91	A
Sight Gauge	LBS	Glass	Borated Water Leakage (Ext)	None	None	None	None	G
Sight Gauge	LBS	Glass	Treated Borated Water (Int)	None	None	VII.J-12	3.3.1.93	A

Section 3.3
AGING MANAGEMENT OF AUXILIARY SYSTEMS

Table 3.3.2-10 Auxiliary Systems – Summary of Aging Management Evaluation – Chemical and Volume Control System(Continued)

Component Type	Intended Function	Material	Environment	Aging Effect Requiring Management	Aging Management Program	NUREG-1801 Vol. 2 Item	Table 1 Item	Notes
Sight Gauge	LBS	Stainless Steel	Borated Water Leakage (Ext)	None	None	VII.J-16	3.3.1.99	A
Sight Gauge	LBS	Stainless Steel	Treated Borated Water (Int)	Loss of material	Water Chemistry (B2.1.2)	VII.E1-17	3.3.1.91	A
Strainer	LBS	Carbon Steel	Demineralized Water (Int)	Loss of material	Water Chemistry (B2.1.2) and One-Time Inspection (B2.1.16)	VIII.E-34	3.4.1.04	A
Strainer	LBS	Carbon Steel	Plant Indoor Air (Ext)	None	None	VII.J-20	3.3.1.95	A
Strainer	FIL, LBS, PB	Stainless Steel	Borated Water Leakage (Ext)	None	None	VII.J-16	3.3.1.99	A
Strainer	FIL, PB	Stainless Steel	Treated Borated Water (Ext)	Loss of material	Water Chemistry (B2.1.2)	VII.E1-17	3.3.1.91	A
Strainer	FIL, LBS, PB	Stainless Steel	Treated Borated Water (Int)	Loss of material	Water Chemistry (B2.1.2)	VII.E1-17	3.3.1.91	A
Tank	PB	Stainless Steel	Atmosphere/Weather (Ext)	None	None	None	None	G
Tank	PB	Stainless Steel	Borated Water Leakage (Ext)	None	None	VII.J-16	3.3.1.99	C
Tank	SIA	Stainless Steel	Borated Water Leakage (Ext)	None	None	VII.J-16	3.3.1.99	A
Tank	LBS	Stainless Steel	Borated Water Leakage (Ext)	None	None	VII.J-16	3.3.1.99	C
Tank	LBS	Stainless Steel	Borated Water Leakage (Ext)	None	None	VII.J-16	3.3.1.99	A
Tank	LBS, PB	Stainless Steel	Demineralized Water (Int)	Loss of material	Water Chemistry (B2.1.2) and One-Time Inspection (B2.1.16)	VIII.E-29	3.4.1.16	A

Section 3.3
AGING MANAGEMENT OF AUXILIARY SYSTEMS

Table 3.3.2-10 Auxiliary Systems – Summary of Aging Management Evaluation – Chemical and Volume Control System(Continued)

Component Type	Intended Function	Material	Environment	Aging Effect Requiring Management	Aging Management Program	NUREG-1801 Vol. 2 Item	Table 1 Item	Notes
Tank	LBS, PB	Stainless Steel	Dry Gas (Int)	None	None	VII.J-19	3.3.1.97	A
Tank	LBS, PB	Stainless Steel	Plant Indoor Air (Ext)	None	None	VII.J-15	3.3.1.94	A
Tank	S/A	Stainless Steel	Treated Borated Water (Int)	Loss of material	Water Chemistry (B2.1.2)	VII.E1-17	3.3.1.91	A
Tank	LBS	Stainless Steel	Treated Borated Water (Int)	Loss of material	Water Chemistry (B2.1.2)	VII.E1-17	3.3.1.91	C
Tank	LBS	Stainless Steel	Treated Borated Water (Int)	Loss of material	Water Chemistry (B2.1.2)	VII.E1-17	3.3.1.91	A
Tank	PB	Stainless Steel	Treated Borated Water (Int)	Loss of material	Water Chemistry (B2.1.2)	VII.E1-17	3.3.1.91	C
Tank Liner	PB	Stainless Steel	Borated Water Leakage (Ext)	None	None	VII.J-16	3.3.1.99	C
Tank Liner	LBS, PB	Stainless Steel	Encased in Concrete (Ext)	None	None	VII.J-17	3.3.1.96	C
Tank Liner	LBS, PB	Stainless Steel	Treated Borated Water (Int)	Loss of material	Water Chemistry (B2.1.2)	VII.E1-17	3.3.1.91	C
Tubing	LBS, PB	Stainless Steel	Borated Water Leakage (Ext)	None	None	VII.J-16	3.3.1.99	A
Tubing	LBS, PB	Stainless Steel	Treated Borated Water (Int)	Loss of material	Water Chemistry (B2.1.2)	VII.E1-17	3.3.1.91	A
Valve	LBS	Carbon Steel	Demineralized Water (Int)	Loss of material	Water Chemistry (B2.1.2) and One-Time Inspection (B2.1.16)	VIII.E-34	3.4.1.04	A
Valve	LBS	Carbon Steel	Plant Indoor Air (Ext)	Loss of material	External Surfaces Monitoring Program (B2.1.20)	VII.I-8	3.3.1.58	B

Section 3.3
AGING MANAGEMENT OF AUXILIARY SYSTEMS

Table 3.3.2-10 Auxiliary Systems – Summary of Aging Management Evaluation – Chemical and Volume Control System(Continued)

Component Type	Intended Function	Material	Environment	Aging Effect Requiring Management	Aging Management Program	NUREG-1801 Vol. 2 Item	Table 1 Item	Notes
Valve	LBS	Carbon Steel	Secondary Water (Int)	Loss of material	Water Chemistry (B2.1.2) and One-Time Inspection (B2.1.16)	VIII.E-34	3.4.1.04	A
Valve	LBS, PB	Stainless Steel	Borated Water Leakage (Ext)	None	None	VII.J-16	3.3.1.99	A
Valve	LBS	Stainless Steel	Demineralized Water (Int)	Loss of material	Water Chemistry (B2.1.2) and One-Time Inspection (B2.1.16)	VIII.E-29	3.4.1.16	A
Valve	SIA	Stainless Steel	Dry Gas (Int)	None	None	VII.J-19	3.3.1.97	A
Valve	LBS, SIA	Stainless Steel	Plant Indoor Air (Ext)	None	None	VII.J-15	3.3.1.94	A
Valve	PB	Stainless Steel	Reactor Coolant (Int)	Cracking	ASME Section XI Inservice Inspection, Subsections IWB, IWC, and IWD for Class 1 components (B2.1.1) and Water Chemistry (B2.1.2)	IV.C2-5	3.1.1.68	A
Valve	PB	Stainless Steel	Reactor Coolant (Int)	Loss of material	Water Chemistry (B2.1.2)	IV.C2-15	3.1.1.83	A
Valve	LBS	Stainless Steel	Treated Borated Water (Int)	Loss of material	Water Chemistry (B2.1.2)	VII.E1-17	3.3.1.91	A
Valve	PB	Stainless Steel Cast Austenitic	Atmosphere/Weather (Ext)	None	None	None	None	G

Section 3.3
AGING MANAGEMENT OF AUXILIARY SYSTEMS

Table 3.3.2-10 Auxiliary Systems – Summary of Aging Management Evaluation – Chemical and Volume Control System(Continued)

Component Type	Intended Function	Material	Environment	Aging Effect Requiring Management	Aging Management Program	NUREG-1801 Vol. 2 Item	Table 1 Item	Notes
Valve	LBS, PB, SIA	Stainless Steel Cast Austenitic	Borated Water Leakage (Ext)	None	None	VII.J-16	3.3.1.99	A
Valve	LBS, PB	Stainless Steel Cast Austenitic	Deminerlized Water (Int)	Loss of material	Water Chemistry (B2.1.2) and One-Time Inspection (B2.1.16)	VIII.E-29	3.4.1.16	A
Valve	PB	Stainless Steel Cast Austenitic	Dry Gas (Int)	None	None	VII.J-19	3.3.1.97	A
Valve	SIA	Stainless Steel Cast Austenitic	Plant Indoor Air (Ext)	None	None	VII.J-14	3.3.1.94	A
Valve	LBS, PB	Stainless Steel Cast Austenitic	Plant Indoor Air (Ext)	None	None	VII.J-15	3.3.1.94	A
Valve	LBS, PB, SIA	Stainless Steel Cast Austenitic	Treated Borated Water (Int)	Loss of material	Water Chemistry (B2.1.2)	VII.E1-17	3.3.1.91	A
Valve	PB	Stainless Steel Cast Austenitic	Treated Borated Water (Int)	Cracking	Water Chemistry (B2.1.2)	VII.E1-20	3.3.1.90	A
Valve	SIA	Stainless Steel Cast Austenitic	Wetted Gas (Int)	Loss of material	Inspection Of Internal Surfaces In Miscellaneous Piping And Ducting Components (B2.1.22)	VII.F2-1	3.3.1.27	E

Section 3.3
AGING MANAGEMENT OF AUXILIARY SYSTEMS

Notes for Table 3.3.2-10:

Standard Notes:

- A Consistent with NUREG-1801 item for component, material, environment, and aging effect. AMP is consistent with NUREG-1801 AMP.
- B Consistent with NUREG-1801 item for component, material, environment, and aging effect. AMP takes some exceptions to NUREG-1801 AMP.
- C Component is different, but consistent with NUREG-1801 item for material, environment, and aging effect. AMP is consistent with NUREG-1801 AMP.
- E Consistent with NUREG-1801 for material, environment, and aging effect, but a different aging management program is credited or NUREG-1801 identifies a plant-specific aging management program.
- G Environment not in NUREG-1801 for this component and material.
- J Neither the component nor the material and environment combination is evaluated in NUREG-1801.

Plant Specific Notes:

- 1 Note E was used to include the plant specific program for nickel alloy aging management.
- 2 Inspection of Internal Surfaces in Miscellaneous Piping and Ducting Components program (B2.1.22) is credited instead of Open-Cycle Cooling Water System program (B2.1.9), for aging management of the components exposed to uncontrolled water streams such as drains, sumps and waste water/slurry flows.
- 3 One-Time Inspection program (B2.1.16) is selected as the plant specific program to monitor the effectiveness of Water Chemistry (B2.1.2) in managing cracking in this Component-Material-Environment.
- 4 The shell side of the seal water heat exchanger is abandoned in place with the steam supply to the shell flanged off (UFSAR 9.3.4.2.2(aa)). Seal injection flow is through the tubes. The shell is treated as physically necessary to support the tube pressure boundary intended function. The internal and external environments are evaluated as borated water leakage from the tubes.

Section 3.3
AGING MANAGEMENT OF AUXILIARY SYSTEMS

Table 3.3.2-11 Auxiliary Systems – Summary of Aging Management Evaluation – Control Building HVAC System

Component Type	Intended Function	Material	Environment	Aging Effect Requiring Management	Aging Management Program	NUREG-1801 Vol. 2 Item	Table 1 Item	Notes
Blower	NSRS, PB	Carbon Steel	Plant Indoor Air (Ext)	Loss of material	External Surfaces Monitoring Program (B2.1.20)	VII.F1-2	3.3.1.56	B
Blower	NSRS, PB	Carbon Steel	Ventilation Atmosphere (Int)	Loss of material	Inspection Of Internal Surfaces In Miscellaneous Piping And Ducting Components (B2.1.22)	VII.F1-3	3.3.1.72	B
Closure Bolting	NSRS, PB	Carbon Steel	Plant Indoor Air (Ext)	Loss of material	External Surfaces Monitoring Program (B2.1.20)	VII.F1-4	3.3.1.55	B
Closure Bolting	LBS, NSRS, PB	Carbon Steel	Plant Indoor Air (Ext)	Loss of material	Bolting Integrity (B2.1.7)	VII.I-4	3.3.1.43	B
Closure Bolting	LBS, NSRS, PB	Carbon Steel	Plant Indoor Air (Ext)	Loss of preload	Bolting Integrity (B2.1.7)	VII.I-5	3.3.1.45	B
Damper	FB, NSRS, PB	Carbon Steel (Galvanized)	Encased in Concrete (Ext)	None	None	VII.J-21	3.3.1.96	C
Damper	NSRS, PB	Carbon Steel (Galvanized)	Plant Indoor Air (Ext)	None	None	VII.J-6	3.3.1.92	C
Damper	FB, NSRS, PB	Carbon Steel (Galvanized)	Ventilation Atmosphere (Int)	None	None	VII.J-6	3.3.1.92	C
Ductwork	NSRS, PB	Carbon Steel (Galvanized)	Plant Indoor Air (Ext)	None	None	VII.J-6	3.3.1.92	C
Ductwork	NSRS, PB	Carbon Steel (Galvanized)	Ventilation Atmosphere (Int)	None	None	VII.J-6	3.3.1.92	C
Ductwork	PB	Glass	Plant Indoor Air (Ext)	None	None	VII.J-8	3.3.1.93	C

Section 3.3
AGING MANAGEMENT OF AUXILIARY SYSTEMS

Table 3.3.2-11 Auxiliary Systems – Summary of Aging Management Evaluation – Control Building HVAC System (Continued)

Component Type	Intended Function	Material	Environment	Aging Effect Requiring Management	Aging Management Program	NUREG-1801 Vol. 2 Item	Table 1 Item	Notes
Ductwork	PB	Glass	Ventilation Atmosphere (Int)	None	None	VII.J-7	3.3.1.93	C
Flex Connectors	NSRS, PB	Elastomer	Plant Indoor Air (Ext)	Hardening and loss of strength	External Surfaces Monitoring Program (B2.1.20)	VII.F1-7	3.3.1.11	E
Flex Connectors	NSRS, PB	Elastomer	Ventilation Atmosphere (Int)	Hardening and loss of strength	Inspection Of Internal Surfaces In Miscellaneous Piping And Ducting Components (B2.1.22)	VII.F1-7	3.3.1.11	E
Heat Exchanger (Control Bldg AHU)	HT, LBS, PB	Copper Alloy	Closed-Cycle Cooling Water (Int)	Loss of material	Closed-Cycle Cooling Water System (B2.1.10)	VII.F1-8	3.3.1.51	B
Heat Exchanger (Control Bldg AHU)	HT, PB	Copper Alloy	Closed-Cycle Cooling Water (Int)	Reduction of heat transfer	Closed-Cycle Cooling Water System (B2.1.10)	VII.F1-12	3.3.1.52	B
Heat Exchanger (Control Bldg AHU)	HT, LBS, PB	Copper Alloy	Ventilation Atmosphere (Ext)	Loss of material	Inspection Of Internal Surfaces In Miscellaneous Piping And Ducting Components (B2.1.22)	VII.F1-16	3.3.1.25	E
Heat Exchanger (ESF Equipment Room AHU)	HT, PB	Copper Alloy	Closed-Cycle Cooling Water (Int)	Loss of material	Closed-Cycle Cooling Water System (B2.1.10)	VII.F1-8	3.3.1.51	B

Section 3.3
AGING MANAGEMENT OF AUXILIARY SYSTEMS

Table 3.3.2-11 Auxiliary Systems – Summary of Aging Management Evaluation – Control Building HVAC System (Continued)

Component Type	Intended Function	Material	Environment	Aging Effect Requiring Management	Aging Management Program	NUREG-1801 Vol. 2 Item	Table 1 Item	Notes
Heat Exchanger (ESF Equipment Room AHU)	HT, PB	Copper Alloy	Closed-Cycle Cooling Water (Int)	Reduction of heat transfer	Closed-Cycle Cooling Water System (B2.1.10)	VII.F1-12	3.3.1.52	B
Heat Exchanger (ESF Equipment Room AHU)	HT, PB	Copper Alloy	Ventilation Atmosphere (Ext)	Loss of material	Inspection Of Internal Surfaces In Miscellaneous Piping And Ducting Components (B2.1.22)	VII.F1-16	3.3.1.25	E
Heat Exchanger (ESF Switchgear Room AHU)	HT, LBS, PB	Copper Alloy	Closed-Cycle Cooling Water (Int)	Loss of material	Closed-Cycle Cooling Water System (B2.1.10)	VII.F1-8	3.3.1.51	B
Heat Exchanger (ESF Switchgear Room AHU)	HT, PB	Copper Alloy	Closed-Cycle Cooling Water (Int)	Reduction of heat transfer	Closed-Cycle Cooling Water System (B2.1.10)	VII.F1-12	3.3.1.52	B
Heat Exchanger (ESF Switchgear Room AHU)	HT, LBS, PB	Copper Alloy	Ventilation Atmosphere (Ext)	Loss of material	Inspection Of Internal Surfaces In Miscellaneous Piping And Ducting Components (B2.1.22)	VII.F1-16	3.3.1.25	E
Heater	NSRS	Carbon Steel	Plant Indoor Air (Ext)	Loss of material	External Surfaces Monitoring Program (B2.1.20)	VII.F1-2	3.3.1.56	B

Section 3.3
AGING MANAGEMENT OF AUXILIARY SYSTEMS

Table 3.3.2-11 Auxiliary Systems – Summary of Aging Management Evaluation – Control Building HVAC System (Continued)

Component Type	Intended Function	Material	Environment	Aging Effect Requiring Management	Aging Management Program	NUREG-1801 Vol. 2 Item	Table 1 Item	Notes
Heater	NSRS	Carbon Steel	Ventilation Atmosphere (Int)	Loss of material	Inspection Of Internal Surfaces In Miscellaneous Piping And Ducting Components (B2.1.22)	VII.F1-3	3.3.1.72	B
Piping	LBS	Carbon Steel	Plant Indoor Air (Ext)	Loss of material	External Surfaces Monitoring Program (B2.1.20)	VII.I-8	3.3.1.58	B
Piping	LBS	Carbon Steel	Wetted Gas (Int)	Loss of material	Inspection Of Internal Surfaces In Miscellaneous Piping And Ducting Components (B2.1.22)	VII.F1-3	3.3.1.72	B
Piping	LBS	Copper Alloy	Plant Indoor Air (Ext)	Loss of material	External Surfaces Monitoring Program (B2.1.20)	VII.F1-16	3.3.1.25	E
Piping	LBS	Copper Alloy	Wetted Gas (Int)	Loss of material	Inspection Of Internal Surfaces In Miscellaneous Piping And Ducting Components (B2.1.22)	VII.G-9	3.3.1.28	E
Piping	PB	Stainless Steel	Plant Indoor Air (Ext)	None	None	VII.J-15	3.3.1.94	A
Piping	PB	Stainless Steel	Plant Indoor Air (Int)	None	None	VII.J-15	3.3.1.94	A, 1
Pump	LBS	Cast Iron	Plant Indoor Air (Ext)	Loss of material	External Surfaces Monitoring Program (B2.1.20)	VII.I-8	3.3.1.58	B

Section 3.3
AGING MANAGEMENT OF AUXILIARY SYSTEMS

Table 3.3.2-11 Auxiliary Systems – Summary of Aging Management Evaluation – Control Building HVAC System (Continued)

Component Type	Intended Function	Material	Environment	Aging Effect Requiring Management	Aging Management Program	NUREG-1801 Vol. 2 Item	Table 1 Item	Notes
Pump	LBS	Cast Iron	Potable Water (Int)	Loss of material	Inspection Of Internal Surfaces In Miscellaneous Piping And Ducting Components (B2.1.22)	None	None	G
Silencer	PB	Carbon Steel (Galvanized)	Plant Indoor Air (Ext)	None	None	VII.J-6	3.3.1.92	C
Silencer	PB	Carbon Steel (Galvanized)	Ventilation Atmosphere (Int)	None	None	VII.J-6	3.3.1.92	C
Tubing	PB	Stainless Steel	Plant Indoor Air (Ext)	None	None	VII.J-15	3.3.1.94	A
Tubing	PB	Stainless Steel	Ventilation Atmosphere (Int)	None	None	VII.J-15	3.3.1.94	A, 1
Valve	NSRS	Carbon Steel	Plant Indoor Air (Ext)	Loss of material	External Surfaces Monitoring Program (B2.1.20)	VII.I-8	3.3.1.58	B
Valve	NSRS	Carbon Steel	Wetted Gas (Int)	Loss of material	Inspection Of Internal Surfaces In Miscellaneous Piping And Ducting Components (B2.1.22)	VII.F1-3	3.3.1.72	B
Valve	LBS	Copper Alloy	Plant Indoor Air (Ext)	Loss of material	External Surfaces Monitoring Program (B2.1.20)	VII.F1-16	3.3.1.25	E
Valve	LBS	Copper Alloy	Wetted Gas (Int)	Loss of material	Inspection Of Internal Surfaces In Miscellaneous Piping And Ducting Components (B2.1.22)	VII.G-9	3.3.1.28	E

Section 3.3
AGING MANAGEMENT OF AUXILIARY SYSTEMS

Notes for Table 3.3.2-11

Standard Notes:

- A Consistent with NUREG-1801 item for component, material, environment, and aging effect. AMP is consistent with NUREG-1801 AMP.
- B Consistent with NUREG-1801 item for component, material, environment, and aging effect. AMP takes some exceptions to NUREG-1801 AMP.
- C Component is different, but consistent with NUREG-1801 item for material, environment, and aging effect. AMP is consistent with NUREG-1801 AMP.
- E Consistent with NUREG-1801 for material, environment, and aging effect, but a different aging management program is credited or NUREG-1801 identifies a plant-specific aging management program.
- G Environment not in NUREG-1801 for this component and material.

Plant Specific Notes:

- 1 Stainless steel valves and tubing in HVAC systems with an internal environment of ventilation atmosphere are used for air sampling and as differential pressure instrument lines. Condensation is not expected in these applications. The NUREG-1801 line referenced for the aging evaluation is VII.J-15 which is for Air-Uncontrolled (external). In ventilation systems, the internal and external air environments are evaluated as equivalent.

Section 3.3
AGING MANAGEMENT OF AUXILIARY SYSTEMS

Table 3.3.2-12 Auxiliary Systems – Summary of Aging Management Evaluation – Auxiliary Building HVAC System

Component Type	Intended Function	Material	Environment	Aging Effect Requiring Management	Aging Management Program	NUREG-1801 Vol. 2 Item	Table 1 Item	Notes
Blower	NSRS, PB	Carbon Steel	Plant Indoor Air (Ext)	Loss of material	External Surfaces Monitoring Program (B2.1.20)	VII.F2-2	3.3.1.56	B
Blower	NSRS, PB	Carbon Steel	Ventilation Atmosphere (Int)	Loss of material	Inspection Of Internal Surfaces In Miscellaneous Piping And Ducting Components (B2.1.22)	VII.F2-3	3.3.1.72	B
Closure Bolting	NSRS, PB	Carbon Steel	Plant Indoor Air (Ext)	Loss of material	External Surfaces Monitoring Program (B2.1.20)	VII.F2-4	3.3.1.55	B
Closure Bolting	LBS, NSRS, PB	Carbon Steel	Plant Indoor Air (Ext)	Loss of material	Bolting Integrity (B2.1.7)	VII.I-4	3.3.1.43	B
Closure Bolting	LBS, NSRS, PB	Carbon Steel	Plant Indoor Air (Ext)	Loss of preload	Bolting Integrity (B2.1.7)	VII.I-5	3.3.1.45	B
Damper	FB, NSRS, PB	Carbon Steel (Galvanized)	Encased in Concrete (Ext)	None	None	VII.J-21	3.3.1.96	C
Damper	PB	Carbon Steel (Galvanized)	Plant Indoor Air (Ext)	None	None	VII.J-6	3.3.1.92	C
Damper	FB, NSRS, PB	Carbon Steel (Galvanized)	Ventilation Atmosphere (Int)	None	None	VII.J-6	3.3.1.92	C
Damper	FB	Stainless Steel	Plant Indoor Air (Ext)	None	None	VII.J-15	3.3.1.94	C
Damper	FB	Stainless Steel	Ventilation Atmosphere (Int)	None	None	VII.J-15	3.3.1.94	A, 1
Ductwork	NSRS, PB	Carbon Steel (Galvanized)	Plant Indoor Air (Ext)	None	None	VII.J-6	3.3.1.92	C

Section 3.3
AGING MANAGEMENT OF AUXILIARY SYSTEMS

Table 3.3.2-12 Auxiliary Systems – Summary of Aging Management Evaluation – Auxiliary Building HVAC System (Continued)

Component Type	Intended Function	Material	Environment	Aging Effect Requiring Management	Aging Management Program	NUREG-1801 Vol. 2 Item	Table 1 Item	Notes
Ductwork	NSRS, PB	Carbon Steel (Galvanized)	Ventilation Atmosphere (Int)	None	None	VII.J-6	3.3.1.92	C
Flex Connectors	NSRS, PB	Elastomer	Plant Indoor Air (Ext)	Hardening and loss of strength	External Surfaces Monitoring Program (B2.1.20)	VII.F2-7	3.3.1.11	E
Flex Connectors	NSRS, PB	Elastomer	Ventilation Atmosphere (Int)	Hardening and loss of strength	Inspection Of Internal Surfaces In Miscellaneous Piping And Ducting Components (B2.1.22)	VII.F2-7	3.3.1.11	E
Heat Exchanger (Aux Feedwater Room)	HT, PB	Copper Alloy	Closed-Cycle Cooling Water (Int)	Reduction of heat transfer	Closed-Cycle Cooling Water System (B2.1.10)	VII.F2-10	3.3.1.52	B
Heat Exchanger (Aux Feedwater Room)	HT, PB	Copper Alloy	Closed-Cycle Cooling Water (Int)	Loss of material	Closed-Cycle Cooling Water System (B2.1.10)	VII.F2-13	3.3.1.51	D
Heat Exchanger (Aux Feedwater Room)	HT, PB	Copper Alloy	Ventilation Atmosphere (Ext)	Loss of material	Inspection Of Internal Surfaces In Miscellaneous Piping And Ducting Components (B2.1.22)	VII.F2-14	3.3.1.25	E

Section 3.3
AGING MANAGEMENT OF AUXILIARY SYSTEMS

Table 3.3.2-12 Auxiliary Systems – Summary of Aging Management Evaluation – Auxiliary Building HVAC System (Continued)

Component Type	Intended Function	Material	Environment	Aging Effect Requiring Management	Aging Management Program	NUREG-1801 Vol. 2 Item	Table 1 Item	Notes
Heat Exchanger (CEDM Equip Room)	LBS	Copper Alloy	Closed-Cycle Cooling Water (Int)	Loss of material	Closed-Cycle Cooling Water System (B2.1.10)	VII.F2-13	3.3.1.51	D
Heat Exchanger (CEDM Equip Room)	LBS	Copper Alloy	Ventilation Atmosphere (Ext)	Loss of material	Inspection Of Internal Surfaces In Miscellaneous Piping And Ducting Components (B2.1.22)	VII.F2-14	3.3.1.25	E
Heat Exchanger (Chg Pump Room)	LBS, NSRS	Copper Alloy	Closed-Cycle Cooling Water (Int)	Loss of material	Closed-Cycle Cooling Water System (B2.1.10)	VII.F2-13	3.3.1.51	D
Heat Exchanger (Chg Pump Room)	LBS, NSRS	Copper Alloy	Ventilation Atmosphere (Ext)	Loss of material	Inspection Of Internal Surfaces In Miscellaneous Piping And Ducting Components (B2.1.22)	VII.F2-14	3.3.1.25	E
Heat Exchanger (CS Pump Room)	HT, PB	Copper Alloy	Closed-Cycle Cooling Water (Int)	Reduction of heat transfer	Closed-Cycle Cooling Water System (B2.1.10)	VII.F2-10	3.3.1.52	B
Heat Exchanger (CS Pump Room)	HT, PB	Copper Alloy	Closed-Cycle Cooling Water (Int)	Loss of material	Closed-Cycle Cooling Water System (B2.1.10)	VII.F2-13	3.3.1.51	D
Heat Exchanger (CS Pump Room)	HT, PB	Copper Alloy	Ventilation Atmosphere (Ext)	Loss of material	Inspection Of Internal Surfaces In Miscellaneous Piping And Ducting Components (B2.1.22)	VII.F2-14	3.3.1.25	E

Section 3.3
AGING MANAGEMENT OF AUXILIARY SYSTEMS

Table 3.3.2-12 Auxiliary Systems – Summary of Aging Management Evaluation – Auxiliary Building HVAC System (Continued)

Component Type	Intended Function	Material	Environment	Aging Effect Requiring Management	Aging Management Program	NUREG-1801 Vol. 2 Item	Table 1 Item	Notes
Heat Exchanger (ECW Pump Room)	HT, PB	Copper Alloy	Closed-Cycle Cooling Water (Int)	Reduction of heat transfer	Closed-Cycle Cooling Water System (B2.1.10)	VII.F2-10	3.3.1.52	B
Heat Exchanger (ECW Pump Room)	HT, PB	Copper Alloy	Closed-Cycle Cooling Water (Int)	Loss of material	Closed-Cycle Cooling Water System (B2.1.10)	VII.F2-13	3.3.1.51	D
Heat Exchanger (ECW Pump Room)	HT, PB	Copper Alloy	Ventilation Atmosphere (Ext)	Loss of material	Inspection Of Internal Surfaces In Miscellaneous Piping And Ducting Components (B2.1.22)	VII.F2-14	3.3.1.25	E
Heat Exchanger (Elec Penetration Room)	HT, PB	Copper Alloy	Closed-Cycle Cooling Water (Int)	Reduction of heat transfer	Closed-Cycle Cooling Water System (B2.1.10)	VII.F2-10	3.3.1.52	B
Heat Exchanger (Elec Penetration Room)	HT, PB	Copper Alloy	Closed-Cycle Cooling Water (Int)	Loss of material	Closed-Cycle Cooling Water System (B2.1.10)	VII.F2-13	3.3.1.51	D
Heat Exchanger (Elec Penetration Room)	HT, PB	Copper Alloy	Ventilation Atmosphere (Ext)	Loss of material	Inspection Of Internal Surfaces In Miscellaneous Piping And Ducting Components (B2.1.22)	VII.F2-14	3.3.1.25	E

Section 3.3
AGING MANAGEMENT OF AUXILIARY SYSTEMS

Table 3.3.2-12 Auxiliary Systems – Summary of Aging Management Evaluation – Auxiliary Building HVAC System (Continued)

Component Type	Intended Function	Material	Environment	Aging Effect Requiring Management	Aging Management Program	NUREG-1801 Vol. 2 Item	Table 1 Item	Notes
Heat Exchanger (HPSI Pump Room)	HT, PB	Copper Alloy	Closed-Cycle Cooling Water (Int)	Reduction of heat transfer	Closed-Cycle Cooling Water System (B2.1.10)	VII.F2-10	3.3.1.52	B
Heat Exchanger (HPSI Pump Room)	HT, PB	Copper Alloy	Closed-Cycle Cooling Water (Int)	Loss of material	Closed-Cycle Cooling Water System (B2.1.10)	VII.F2-13	3.3.1.51	D
Heat Exchanger (HPSI Pump Room)	HT, PB	Copper Alloy	Ventilation Atmosphere (Ext)	Loss of material	Inspection Of Internal Surfaces In Miscellaneous Piping And Ducting Components (B2.1.22)	VII.F2-14	3.3.1.25	E
Heat Exchanger (LPSI Pump Room)	HT, PB	Copper Alloy	Closed-Cycle Cooling Water (Int)	Reduction of heat transfer	Closed-Cycle Cooling Water System (B2.1.10)	VII.F2-10	3.3.1.52	B
Heat Exchanger (LPSI Pump Room)	HT, PB	Copper Alloy	Closed-Cycle Cooling Water (Int)	Loss of material	Closed-Cycle Cooling Water System (B2.1.10)	VII.F2-13	3.3.1.51	D
Heat Exchanger (LPSI Pump Room)	HT, PB	Copper Alloy	Ventilation Atmosphere (Ext)	Loss of material	Inspection Of Internal Surfaces In Miscellaneous Piping And Ducting Components (B2.1.22)	VII.F2-14	3.3.1.25	E

Section 3.3
AGING MANAGEMENT OF AUXILIARY SYSTEMS

Notes for Table 3.3.2-12:

Standard Notes:

- A Consistent with NUREG-1801 item for component, material, environment, and aging effect. AMP is consistent with NUREG-1801 AMP.
- B Consistent with NUREG-1801 item for component, material, environment, and aging effect. AMP takes some exceptions to NUREG-1801 AMP.
- C Component is different, but consistent with NUREG-1801 item for material, environment, and aging effect. AMP is consistent with NUREG-1801 AMP.
- D Component is different, but consistent with NUREG-1801 item for material, environment, and aging effect. AMP takes some exceptions to NUREG-1801 AMP.
- E Consistent with NUREG-1801 for material, environment, and aging effect, but a different aging management program is credited or NUREG-1801 identifies a plant-specific aging management program.

Plant Specific Notes:

- 1 The component is a stainless steel damper housing with an internal environment of ventilation atmosphere. Condensation is not expected. NUREG-1801 line VII.J-15 is for Air-Uncontrolled (external). In ventilation systems, the internal and external air environments are evaluated as equivalent.

Section 3.3
AGING MANAGEMENT OF AUXILIARY SYSTEMS

Table 3.3.2-13 Auxiliary Systems – Summary of Aging Management Evaluation – Fuel Building HVAC System

Component Type	Intended Function	Material	Environment	Aging Effect Requiring Management	Aging Management Program	NUREG-1801 Vol. 2 Item	Table 1 Item	Notes
Blower	PB	Carbon Steel	Plant Indoor Air (Ext)	Loss of material	External Surfaces Monitoring Program (B2.1.20)	VII.F2-2	3.3.1.56	B
Blower	PB	Carbon Steel	Ventilation Atmosphere (Int)	Loss of material	Inspection Of Internal Surfaces In Miscellaneous Piping And Ducting Components (B2.1.22)	VII.F2-3	3.3.1.72	B
Closure Bolting	NSRS, PB	Carbon Steel	Atmosphere/Weather (Ext)	Loss of preload	Bolting Integrity (B2.1.7)	None	None	G, 1
Closure Bolting	NSRS, PB	Carbon Steel	Atmosphere/Weather (Ext)	Loss of material	Bolting Integrity (B2.1.7)	VII.I-1	3.3.1.43	B
Closure Bolting	NSRS, PB	Carbon Steel	Plant Indoor Air (Ext)	Loss of material	External Surfaces Monitoring Program (B2.1.20)	VII.F2-4	3.3.1.55	B
Closure Bolting	NSRS, PB	Carbon Steel	Plant Indoor Air (Ext)	Loss of material	Bolting Integrity (B2.1.7)	VII.I-4	3.3.1.43	B
Closure Bolting	NSRS, PB	Carbon Steel	Plant Indoor Air (Ext)	Loss of preload	Bolting Integrity (B2.1.7)	VII.I-5	3.3.1.45	B
Damper	NSRS	Carbon Steel (Galvanized)	Atmosphere/Weather (Ext)	Loss of material	External Surfaces Monitoring Program (B2.1.20)	VII.I-9	3.3.1.58	B
Damper	FB, NSRS	Carbon Steel (Galvanized)	Encased in Concrete (Ext)	None	None	VII.J-21	3.3.1.96	C
Damper	PB	Carbon Steel (Galvanized)	Plant Indoor Air (Ext)	None	None	VII.J-6	3.3.1.92	C

Section 3.3
AGING MANAGEMENT OF AUXILIARY SYSTEMS

Table 3.3.2-13 Auxiliary Systems – Summary of Aging Management Evaluation – Fuel Building HVAC System (Continued)

Component Type	Intended Function	Material	Environment	Aging Effect Requiring Management	Aging Management Program	NUREG-1801 Vol. 2 Item	Table 1 Item	Notes
Damper	PB	Carbon Steel (Galvanized)	Ventilation Atmosphere (Ext)	None	None	VII.J-6	3.3.1.92	C
Damper	FB, NSRS, PB	Carbon Steel (Galvanized)	Ventilation Atmosphere (Int)	None	None	VII.J-6	3.3.1.92	C
Ductwork	NSRS, PB	Carbon Steel (Galvanized)	Atmosphere/Weather (Ext)	Loss of material	External Surfaces Monitoring Program (B2.1.20)	VII.I-9	3.3.1.58	B
Ductwork	NSRS, PB	Carbon Steel (Galvanized)	Plant Indoor Air (Ext)	None	None	VII.J-6	3.3.1.92	C
Ductwork	NSRS, PB	Carbon Steel (Galvanized)	Ventilation Atmosphere (Int)	None	None	VII.J-6	3.3.1.92	C
Flex Connectors	NSRS, PB	Elastomer	Plant Indoor Air (Ext)	Hardening and loss of strength	External Surfaces Monitoring Program (B2.1.20)	VII.F2-7	3.3.1.11	E
Flex Connectors	PB	Elastomer	Ventilation Atmosphere (Ext)	Hardening and loss of strength	Inspection Of Internal Surfaces In Miscellaneous Piping And Ducting Components (B2.1.22)	VII.F2-7	3.3.1.11	E
Flex Connectors	NSRS, PB	Elastomer	Ventilation Atmosphere (Int)	Hardening and loss of strength	Inspection Of Internal Surfaces In Miscellaneous Piping And Ducting Components (B2.1.22)	VII.F2-7	3.3.1.11	E
Flow Element	PB	Stainless Steel	Plant Indoor Air (Ext)	None	None	VII.J-15	3.3.1.94	A
Flow Element	PB	Stainless Steel	Ventilation Atmosphere (Int)	None	None	VII.J-15	3.3.1.94	A, 2

Section 3.3
AGING MANAGEMENT OF AUXILIARY SYSTEMS

Table 3.3.2-13 Auxiliary Systems – Summary of Aging Management Evaluation – Fuel Building HVAC System (Continued)

Component Type	Intended Function	Material	Environment	Aging Effect Requiring Management	Aging Management Program	NUREG-1801 Vol. 2 Item	Table 1 Item	Notes
Piping	NSRS	Carbon Steel	Plant Indoor Air (Ext)	Loss of material	External Surfaces Monitoring Program (B2.1.20)	VII.I-8	3.3.1.58	B
Piping	NSRS	Carbon Steel	Wetted Gas (Int)	Loss of material	Inspection Of Internal Surfaces In Miscellaneous Piping And Ducting Components (B2.1.22)	VII.F2-3	3.3.1.72	B
Piping	PB	Stainless Steel	Atmosphere/Weather (Ext)	None	None	None	None	G
Piping	PB	Stainless Steel	Plant Indoor Air (Ext)	None	None	VII.J-15	3.3.1.94	A
Piping	PB	Stainless Steel	Ventilation Atmosphere (Int)	None	None	VII.J-15	3.3.1.94	A, 2
Tubing	PB	Stainless Steel	Atmosphere/Weather (Ext)	None	None	None	None	G
Tubing	PB	Stainless Steel	Plant Indoor Air (Ext)	None	None	VII.J-15	3.3.1.94	A
Tubing	PB	Stainless Steel	Ventilation Atmosphere (Int)	None	None	VII.J-15	3.3.1.94	A, 2
Valve	NSRS	Carbon Steel	Plant Indoor Air (Ext)	Loss of material	External Surfaces Monitoring Program (B2.1.20)	VII.I-8	3.3.1.58	B
Valve	NSRS	Carbon Steel	Wetted Gas (Int)	Loss of material	Inspection Of Internal Surfaces In Miscellaneous Piping And Ducting Components (B2.1.22)	VII.F2-3	3.3.1.72	B

Section 3.3
AGING MANAGEMENT OF AUXILIARY SYSTEMS

Table 3.3.2-13 Auxiliary Systems – Summary of Aging Management Evaluation – Fuel Building HVAC System (Continued)

Component Type	Intended Function	Material	Environment	Aging Effect Requiring Management	Aging Management Program	NUREG-1801 Vol. 2 Item	Table 1 Item	Notes
Valve	PB	Stainless Steel	Atmosphere/Weather (Ext)	None	None	None	None	G
Valve	PB	Stainless Steel	Plant Indoor Air (Ext)	None	None	VII.J-15	3.3.1.94	A
Valve	PB	Stainless Steel	Ventilation Atmosphere (Int)	None	None	VII.J-15	3.3.1.94	A, 2

Notes for Table 3.3.2-13:

Standard Notes:

- A Consistent with NUREG-1801 item for component, material, environment, and aging effect. AMP is consistent with NUREG-1801 AMP.
- B Consistent with NUREG-1801 item for component, material, environment, and aging effect. AMP takes some exceptions to NUREG-1801 AMP.
- C Component is different, but consistent with NUREG-1801 item for material, environment, and aging effect. AMP is consistent with NUREG-1801 AMP.
- E Consistent with NUREG-1801 for material, environment, and aging effect, but a different aging management program is credited or NUREG-1801 identifies a plant-specific aging management program.
- G Environment not in NUREG-1801 for this component and material.

Plant Specific Notes:

- 1 Line VII.I-5 has loss of preload/thermal effects, gasket creep, and self-loosening for steel closure bolting in indoor uncontrolled (external) air. This aging effect would also exist in the environment or outdoor (external) air, therefore this non-NUREG-1801 line has been added to also address loss of preload for the component/material/environment of line VII.I-1.
- 2 Stainless steel valves and tubing in HVAC systems with an internal environment of ventilation atmosphere are used for air sampling, flow measurement and as differential pressure instrument lines. Condensation is not expected in these applications. The NUREG-1801 line referenced for the aging evaluation is VII.J-15 which is for Air-Uncontrolled (external). In ventilation systems, the internal and external air environments are evaluated as equivalent.

Section 3.3
AGING MANAGEMENT OF AUXILIARY SYSTEMS

Table 3.3.2-14 Auxiliary Systems – Summary of Aging Management Evaluation – Containment Building HVAC System

Component Type	Intended Function	Material	Environment	Aging Effect Requiring Management	Aging Management Program	NUREG-1801 Vol. 2 Item	Table 1 Item	Notes
Blower	NSRS	Carbon Steel	Plant Indoor Air (Ext)	Loss of material	External Surfaces Monitoring Program (B2.1.20)	VII.F3-2	3.3.1.56	B
Blower	NSRS	Carbon Steel	Ventilation Atmosphere (Int)	Loss of material	Inspection Of Internal Surfaces In Miscellaneous Piping And Ducting Components (B2.1.22)	VII.F3-3	3.3.1.72	B
Closure Bolting	NSRS	Carbon Steel	Plant Indoor Air (Ext)	Loss of material	External Surfaces Monitoring Program (B2.1.20)	VII.F3-4	3.3.1.55	B
Closure Bolting	LBS, NSRS, PB	Carbon Steel	Plant Indoor Air (Ext)	Loss of material	Bolting Integrity (B2.1.7)	VII.I-4	3.3.1.43	B
Closure Bolting	LBS, NSRS, PB	Carbon Steel	Plant Indoor Air (Ext)	Loss of preload	Bolting Integrity (B2.1.7)	VII.I-5	3.3.1.45	B
Damper	NSRS	Carbon Steel (Galvanized)	Plant Indoor Air (Ext)	None	None	VII.J-6	3.3.1.92	C
Damper	NSRS	Carbon Steel (Galvanized)	Ventilation Atmosphere (Int)	None	None	VII.J-6	3.3.1.92	C
Ductwork	NSRS	Carbon Steel (Galvanized)	Plant Indoor Air (Ext)	None	None	VII.J-6	3.3.1.92	C
Ductwork	NSRS	Carbon Steel (Galvanized)	Ventilation Atmosphere (Int)	None	None	VII.J-6	3.3.1.92	C

Section 3.3
AGING MANAGEMENT OF AUXILIARY SYSTEMS

Table 3.3.2-14 Auxiliary Systems – Summary of Aging Management Evaluation – Containment Building HVAC System (Continued)

Component Type	Intended Function	Material	Environment	Aging Effect Requiring Management	Aging Management Program	NUREG-1801 Vol. 2 Item	Table 1 Item	Notes
Ductwork	NSRS	Stainless Steel	Plant Indoor Air (Ext)	None	None	VII.J-15	3.3.1.94	C
Ductwork	NSRS	Stainless Steel	Ventilation Atmosphere (Int)	Loss of material	Inspection Of Internal Surfaces In Miscellaneous Piping And Ducting Components (B2.1.22)	VII.F3-1	3.3.1.27	E
Flex Connectors	NSRS	Elastomer	Plant Indoor Air (Ext)	Hardening and loss of strength	External Surfaces Monitoring Program (B2.1.20)	VII.F3-7	3.3.1.11	E
Flex Connectors	NSRS	Elastomer	Ventilation Atmosphere (Int)	Hardening and loss of strength	Inspection Of Internal Surfaces In Miscellaneous Piping And Ducting Components (B2.1.22)	VII.F3-7	3.3.1.11	E
Flexible Hoses	PB	Stainless Steel	Plant Indoor Air (Ext)	None	None	VII.J-15	3.3.1.94	A
Flexible Hoses	PB	Stainless Steel	Plant Indoor Air (Int)	None	None	VII.J-15	3.3.1.94	A, 1
Heat Exchanger (Containment Bldg)	LBS, NSRS	Copper Alloy	Closed-Cycle Cooling Water (Int)	Loss of material	Closed-Cycle Cooling Water System (B2.1.10)	VII.F3-8	3.3.1.51	B
Heat Exchanger (Containment Bldg)	LBS, NSRS	Copper Alloy	Ventilation Atmosphere (Ext)	Loss of material	Inspection Of Internal Surfaces In Miscellaneous Piping And Ducting Components (B2.1.22)	VII.F3-16	3.3.1.25	E

Section 3.3
AGING MANAGEMENT OF AUXILIARY SYSTEMS

Table 3.3.2-14 Auxiliary Systems – Summary of Aging Management Evaluation – Containment Building HVAC System (Continued)

Component Type	Intended Function	Material	Environment	Aging Effect Requiring Management	Aging Management Program	NUREG-1801 Vol. 2 Item	Table 1 Item	Notes
Heat Exchanger (Containment CEDM)	LBS, NSRS	Copper Alloy	Closed-Cycle Cooling Water (Int)	Loss of material	Closed-Cycle Cooling Water System (B2.1.10)	VII.F3-8	3.3.1.51	B
Heat Exchanger (Containment CEDM)	LBS, NSRS	Copper Alloy	Ventilation Atmosphere (Ext)	Loss of material	Inspection Of Internal Surfaces In Miscellaneous Piping And Ducting Components (B2.1.22)	VII.F3-16	3.3.1.25	E
Heater	NSRS	Stainless Steel	Plant Indoor Air (Ext)	None	None	VII.J-15	3.3.1.94	C
Heater	NSRS	Stainless Steel	Ventilation Atmosphere (Int)	Loss of material	Inspection Of Internal Surfaces In Miscellaneous Piping And Ducting Components (B2.1.22)	VII.F3-1	3.3.1.27	E
Piping	PB	Carbon Steel	Plant Indoor Air (Ext)	Loss of material	External Surfaces Monitoring Program (B2.1.20)	VII.I-8	3.3.1.58	B
Piping	PB	Carbon Steel	Plant Indoor Air (Int)	Loss of material	Inspection Of Internal Surfaces In Miscellaneous Piping And Ducting Components (B2.1.22)	V.A-19	3.2.1.32	B
Piping	PB, SIA	Stainless Steel	Plant Indoor Air (Ext)	None	None	VII.J-15	3.3.1.94	A
Piping	PB, SIA	Stainless Steel	Plant Indoor Air (Int)	None	None	VII.J-15	3.3.1.94	A, 1

Section 3.3
AGING MANAGEMENT OF AUXILIARY SYSTEMS

Table 3.3.2-14 Auxiliary Systems – Summary of Aging Management Evaluation – Containment Building HVAC System (Continued)

Component Type	Intended Function	Material	Environment	Aging Effect Requiring Management	Aging Management Program	NUREG-1801 Vol. 2 Item	Table 1 Item	Notes
Tubing	PB	Stainless Steel	Plant Indoor Air (Ext)	None	None	VII.J-15	3.3.1.94	A
Tubing	PB	Stainless Steel	Plant Indoor Air (Int)	None	None	VII.J-15	3.3.1.94	A, 1
Valve	PB	Carbon Steel	Plant Indoor Air (Ext)	Loss of material	External Surfaces Monitoring Program (B2.1.20)	VII.I-8	3.3.1.58	B
Valve	PB	Carbon Steel	Plant Indoor Air (Int)	Loss of material	Inspection Of Internal Surfaces In Miscellaneous Piping And Ducting Components (B2.1.22)	V.A-19	3.2.1.32	B
Valve	PB	Stainless Steel	Plant Indoor Air (Ext)	None	None	VII.J-15	3.3.1.94	A
Valve	PB	Stainless Steel	Plant Indoor Air (Int)	None	None	VII.J-15	3.3.1.94	A, 1

Notes for Table 3.3.2-14:

Standard Notes:

- A Consistent with NUREG-1801 item for component, material, environment, and aging effect. AMP is consistent with NUREG-1801 AMP.
- B Consistent with NUREG-1801 item for component, material, environment, and aging effect. AMP takes some exceptions to NUREG-1801 AMP.
- C Component is different, but consistent with NUREG-1801 item for material, environment, and aging effect. AMP is consistent with NUREG-1801 AMP.
- E Consistent with NUREG-1801 for material, environment, and aging effect, but a different aging management program is credited or NUREG-1801 identifies a plant-specific aging management program.

Section 3.3
AGING MANAGEMENT OF AUXILIARY SYSTEMS

Plant Specific Note:

1 Stainless steel piping and piping components associated with containment building HVAC are used in containment pressure monitoring instrument lines. Condensation is not expected in these applications. The NUREG-1801 line referenced for the aging evaluation is VII.J-15 which is for Air-Uncontrolled (external). In this application, the internal and external air environments are evaluated as equivalent.

Section 3.3
AGING MANAGEMENT OF AUXILIARY SYSTEMS

Table 3.3.2-15 Auxiliary Systems – Summary of Aging Management Evaluation – Diesel Generator Building HVAC System

Component Type	Intended Function	Material	Environment	Aging Effect Requiring Management	Aging Management Program	NUREG-1801 Vol. 2 Item	Table 1 Item	Notes
Blower	NSRS, PB	Carbon Steel	Plant Indoor Air (Ext)	Loss of material	External Surfaces Monitoring Program (B2.1.20)	VII.F4-1	3.3.1.56	B
Blower	NSRS, PB	Carbon Steel	Ventilation Atmosphere (Int)	Loss of material	Inspection Of Internal Surfaces In Miscellaneous Piping And Ducting Components (B2.1.22)	VII.F4-2	3.3.1.72	B
Closure Bolting	NSRS, PB	Carbon Steel	Plant Indoor Air (Ext)	Loss of material	External Surfaces Monitoring Program (B2.1.20)	VII.F4-3	3.3.1.55	B
Closure Bolting	NSRS, PB	Carbon Steel	Plant Indoor Air (Ext)	Loss of material	Bolting Integrity (B2.1.7)	VII.I-4	3.3.1.43	B
Closure Bolting	NSRS, PB	Carbon Steel	Plant Indoor Air (Ext)	Loss of preload	Bolting Integrity (B2.1.7)	VII.I-5	3.3.1.45	B
Damper	FB, NSRS	Carbon Steel (Galvanized)	Encased in Concrete (Ext)	None	None	VII.J-21	3.3.1.96	C
Damper	NSRS, PB	Carbon Steel (Galvanized)	Plant Indoor Air (Ext)	None	None	VII.J-6	3.3.1.92	C
Damper	FB, NSRS, PB	Carbon Steel (Galvanized)	Ventilation Atmosphere (Int)	None	None	VII.J-6	3.3.1.92	C
Ductwork	NSRS, PB	Carbon Steel (Galvanized)	Plant Indoor Air (Ext)	None	None	VII.J-6	3.3.1.92	C
Ductwork	NSRS, PB	Carbon Steel (Galvanized)	Ventilation Atmosphere (Int)	None	None	VII.J-6	3.3.1.92	C

Section 3.3
AGING MANAGEMENT OF AUXILIARY SYSTEMS

Table 3.3.2-15 Auxiliary Systems – Summary of Aging Management Evaluation – Diesel Generator Building HVAC System
(Continued)

Component Type	Intended Function	Material	Environment	Aging Effect Requiring Management	Aging Management Program	NUREG-1801 Vol. 2 Item	Table 1 Item	Notes
Flex Connectors	NSRS, PB	Elastomer	Plant Indoor Air (Ext)	Hardening and loss of strength	External Surfaces Monitoring Program (B2.1.20)	VII.F4-6	3.3.1.11	E
Flex Connectors	NSRS, PB	Elastomer	Ventilation Atmosphere (Int)	Hardening and loss of strength	Inspection Of Internal Surfaces In Miscellaneous Piping And Ducting Components (B2.1.22)	VII.F4-6	3.3.1.11	E
Heater	NSRS	Carbon Steel	Plant Indoor Air (Ext)	Loss of material	External Surfaces Monitoring Program (B2.1.20)	VII.F4-1	3.3.1.56	B
Heater	NSRS	Carbon Steel	Ventilation Atmosphere (Int)	Loss of material	Inspection Of Internal Surfaces In Miscellaneous Piping And Ducting Components (B2.1.22)	VII.F4-2	3.3.1.72	B
Piping	LBS, NSRS	Copper Alloy	Plant Indoor Air (Ext)	None	None	VIII.I-2	3.4.1.41	A
Piping	LBS, NSRS	Copper Alloy	Wetted Gas (Int)	Loss of material	Inspection Of Internal Surfaces In Miscellaneous Piping And Ducting Components (B2.1.22)	VII.G-9	3.3.1.28	E
Strainer	LBS	Copper Alloy	Plant Indoor Air (Ext)	None	None	VII.I-2	3.4.1.41	A

Section 3.3
AGING MANAGEMENT OF AUXILIARY SYSTEMS

Table 3.3.2-15 Auxiliary Systems – Summary of Aging Management Evaluation – Diesel Generator Building HVAC System
(Continued)

Component Type	Intended Function	Material	Environment	Aging Effect Requiring Management	Aging Management Program	NUREG-1801 Vol. 2 Item	Table 1 Item	Notes
Strainer	LBS	Copper Alloy	Wetted Gas (Int)	Loss of material	Inspection Of Internal Surfaces In Miscellaneous Piping And Ducting Components (B2.1.22)	VII.G-9	3.3.1.28	E
Tubing	PB	Copper Alloy	Plant Indoor Air (Ext)	None	None	VIII.I-2	3.4.1.41	A
Tubing	PB	Copper Alloy	Ventilation Atmosphere (Int)	None	None	VIII.I-2	3.4.1.41	A, 1
Valve	LBS, NSRS	Copper Alloy	Plant Indoor Air (Ext)	None	None	VIII.I-2	3.4.1.41	A
Valve	LBS, NSRS	Copper Alloy	Wetted Gas (Int)	Loss of material	Inspection Of Internal Surfaces In Miscellaneous Piping And Ducting Components (B2.1.22)	VII.G-9	3.3.1.28	E

Notes for Table 3.3.2-15:

Standard Notes:

- A Consistent with NUREG-1801 item for component, material, environment, and aging effect. AMP is consistent with NUREG-1801 AMP.
- B Consistent with NUREG-1801 item for component, material, environment, and aging effect. AMP takes some exceptions to NUREG-1801 AMP.
- C Component is different, but consistent with NUREG-1801 item for material, environment, and aging effect. AMP is consistent with NUREG-1801 AMP.
- E Consistent with NUREG-1801 for material, environment, and aging effect, but a different aging management program is credited or NUREG-1801 identifies a plant-specific aging management program.

Section 3.3
AGING MANAGEMENT OF AUXILIARY SYSTEMS

Plant Specific Note:

1 Copper alloy valves and tubing in HVAC systems with an internal environment of ventilation atmosphere are used for air sampling, flow measurement and as differential pressure instrument lines. Condensation is not expected in these applications. The NUREG-1801 line referenced for the aging evaluation is VIII.1-2 which is for Air-Indoor-Uncontrolled (External). In ventilation systems, the internal and external air environments are evaluated as equivalent.

Section 3.3
AGING MANAGEMENT OF AUXILIARY SYSTEMS

Table 3.3.2-16 Auxiliary Systems – Summary of Aging Management Evaluation – Radwaste Building HVAC System

Component Type	Intended Function	Material	Environment	Aging Effect Requiring Management	Aging Management Program	NUREG-1801 Vol. 2 Item	Table 1 Item	Notes
Closure Bolting	PB	Carbon Steel	Plant Indoor Air (Ext)	Loss of material	External Surfaces Monitoring Program (B2.1.20)	VII.F2-4	3.3.1.55	B
Closure Bolting	PB	Carbon Steel	Plant Indoor Air (Ext)	Loss of material	Bolting Integrity (B2.1.7)	VII.I-4	3.3.1.43	B
Closure Bolting	PB	Carbon Steel	Plant Indoor Air (Ext)	Loss of preload	Bolting Integrity (B2.1.7)	VII.I-5	3.3.1.45	B
Damper	FB	Carbon Steel (Galvanized)	Encased in Concrete (Ext)	None	None	VII.J-21	3.3.1.96	C
Damper	FB	Carbon Steel (Galvanized)	Ventilation Atmosphere (Int)	None	None	VII.J-6	3.3.1.92	C
Piping	LBS	Carbon Steel	Plant Indoor Air (Ext)	Loss of material	External Surfaces Monitoring Program (B2.1.20)	VII.I-8	3.3.1.58	B
Piping	LBS	Carbon Steel	Wetted Gas (Int)	Loss of material	Inspection Of Internal Surfaces In Miscellaneous Piping And Ducting Components (B2.1.22)	VII.F2-3	3.3.1.72	B

Notes for Table 3.3.2-16:

Standard Notes:

B Consistent with NUREG-1801 item for component, material, environment, and aging effect. AMP takes some exceptions to NUREG-1801 AMP.

C Component is different, but consistent with NUREG-1801 item for material, environment, and aging effect. AMP is consistent with NUREG-1801 AMP.

Plant Specific Notes:

None

Section 3.3
AGING MANAGEMENT OF AUXILIARY SYSTEMS

Table 3.3.2-17 Auxiliary Systems – Summary of Aging Management Evaluation – Turbine Building HVAC System

Component Type	Intended Function	Material	Environment	Aging Effect Requiring Management	Aging Management Program	NUREG-1801 Vol. 2 Item	Table 1 Item	Notes
Blower	PB	Aluminum	Plant Indoor Air (Ext)	None	None	VII.J-1	3.3.1.95	C
Blower	PB	Aluminum	Ventilation Atmosphere (Int)	Loss of material	Inspection Of Internal Surfaces In Miscellaneous Piping And Ducting Components (B2.1.22)	VII.F2-12	3.3.1.27	E
Closure Bolting	PB	Carbon Steel	Atmosphere/Weather (Ext)	Loss of preload	Bolting Integrity (B2.1.7)	None	None	G
Closure Bolting	PB	Carbon Steel	Atmosphere/Weather (Ext)	Loss of material	Bolting Integrity (B2.1.7)	VII.I-1	3.3.1.43	B
Closure Bolting	PB	Carbon Steel	Plant Indoor Air (Ext)	Loss of material	External Surfaces Monitoring Program (B2.1.20)	VII.F2-4	3.3.1.55	B
Closure Bolting	PB	Carbon Steel	Plant Indoor Air (Ext)	Loss of material	Bolting Integrity (B2.1.7)	VII.I-4	3.3.1.43	B
Closure Bolting	PB	Carbon Steel	Plant Indoor Air (Ext)	Loss of preload	Bolting Integrity (B2.1.7)	VII.I-5	3.3.1.45	B
Damper	PB	Aluminum	Atmosphere/Weather (Ext)	Loss of material	External Surfaces Monitoring Program (B2.1.20)	None	None	G
Damper	PB	Aluminum	Ventilation Atmosphere (Int)	Loss of material	Inspection Of Internal Surfaces In Miscellaneous Piping And Ducting Components (B2.1.22)	VII.F2-12	3.3.1.27	E
Damper	FB, PB	Carbon Steel (Galvanized)	Encased in Concrete (Ext)	None	None	VII.J-21	3.3.1.96	C
Damper	FB, PB	Carbon Steel (Galvanized)	Ventilation Atmosphere (Int)	None	None	VII.J-6	3.3.1.92	C

Section 3.3
AGING MANAGEMENT OF AUXILIARY SYSTEMS

Notes for Table 3.3.2-17:

Standard Notes:

- B Consistent with NUREG-1801 item for component, material, environment, and aging effect. AMP takes some exceptions to NUREG-1801 AMP.
- C Component is different, but consistent with NUREG-1801 item for material, environment, and aging effect. AMP is consistent with NUREG-1801 AMP.
- E Consistent with NUREG-1801 for material, environment, and aging effect, but a different aging management program is credited or NUREG-1801 identifies a plant-specific aging management program.
- G Environment not in NUREG-1801 for this component and material.

Plant Specific Notes:

None

Section 3.3
AGING MANAGEMENT OF AUXILIARY SYSTEMS

Table 3.3.2-18 Auxiliary Systems – Summary of Aging Management Evaluation – Miscellaneous Site Structures/Spray Pond Pump House HVAC System

Component Type	Intended Function	Material	Environment	Aging Effect Requiring Management	Aging Management Program	NUREG-1801 Vol. 2 Item	Table 1 Item	Notes
Blower	PB	Carbon Steel	Plant Indoor Air (Ext)	Loss of material	External Surfaces Monitoring Program (B2.1.20)	VII.F2-2	3.3.1.56	B
Blower	PB	Carbon Steel	Ventilation Atmosphere (Int)	Loss of material	Inspection Of Internal Surfaces In Miscellaneous Piping And Ducting Components (B2.1.22)	VII.F2-3	3.3.1.72	B
Closure Bolting	PB	Carbon Steel	Plant Indoor Air (Ext)	Loss of material	External Surfaces Monitoring Program (B2.1.20)	VII.F2-4	3.3.1.55	B
Closure Bolting	PB	Carbon Steel	Plant Indoor Air (Ext)	Loss of material	Bolting Integrity (B2.1.7)	VII.I-4	3.3.1.43	B
Closure Bolting	PB	Carbon Steel	Plant Indoor Air (Ext)	Loss of preload	Bolting Integrity (B2.1.7)	VII.I-5	3.3.1.45	B
Ductwork	PB	Carbon Steel (Galvanized)	Plant Indoor Air (Ext)	None	None	VII.J-6	3.3.1.92	C
Ductwork	PB	Carbon Steel (Galvanized)	Ventilation Atmosphere (Int)	None	None	VII.J-6	3.3.1.92	C
Flex Connectors	PB	Elastomer	Plant Indoor Air (Ext)	Hardening and loss of strength	External Surfaces Monitoring Program (B2.1.20)	VII.F2-7	3.3.1.11	E
Flex Connectors	PB	Elastomer	Ventilation Atmosphere (Int)	Hardening and loss of strength	Inspection Of Internal Surfaces In Miscellaneous Piping And Ducting Components (B2.1.22)	VII.F2-7	3.3.1.11	E

Section 3.3
AGING MANAGEMENT OF AUXILIARY SYSTEMS

Notes for Table 3.3.2-18

Standard Notes:

- B Consistent with NUREG-1801 item for component, material, environment, and aging effect. AMP takes some exceptions to NUREG-1801 AMP.
- C Component is different, but consistent with NUREG-1801 item for material, environment, and aging effect. AMP is consistent with NUREG-1801 AMP.
- E Consistent with NUREG-1801 for material, environment, and aging effect, but a different aging management program is credited or NUREG-1801 identifies a plant-specific aging management program.

Plant Specific Notes:

None

Section 3.3
AGING MANAGEMENT OF AUXILIARY SYSTEMS

Table 3.3.2-19 Auxiliary Systems – Summary of Aging Management Evaluation – Fire Protection System

Component Type	Intended Function	Material	Environment	Aging Effect Requiring Management	Aging Management Program	NUREG-1801 Vol. 2 Item	Table 1 Item	Notes
Closure Bolting	PB	Carbon Steel	Atmosphere/ Weather (Ext)	Loss of preload	Bolting Integrity (B2.1.7)	None	None	G, 1
Closure Bolting	PB	Carbon Steel	Atmosphere/ Weather (Ext)	Loss of material	Bolting Integrity (B2.1.7)	VII.I-1	3.3.1.43	B
Closure Bolting	PB	Carbon Steel	Buried (Ext)	Loss of material	Buried Piping and Tanks Inspection (B2.1.18)	VII.G-25	3.3.1.19	D
Closure Bolting	LBS, PB	Carbon Steel	Plant Indoor Air (Ext)	Loss of material	Bolting Integrity (B2.1.7)	VII.I-4	3.3.1.43	B
Closure Bolting	LBS, PB	Carbon Steel	Plant Indoor Air (Ext)	Loss of preload	Bolting Integrity (B2.1.7)	VII.I-5	3.3.1.45	B
Expansion Joint	PB	Stainless Steel	Diesel Exhaust (Int)	Cracking	Inspection Of Internal Surfaces In Miscellaneous Piping And Ducting Components (B2.1.22)	VII.H2-1	3.3.1.06	E
Expansion Joint	PB	Stainless Steel	Diesel Exhaust (Int)	Loss of material	Inspection Of Internal Surfaces In Miscellaneous Piping And Ducting Components (B2.1.22)	VII.H2-2	3.3.1.18	E
Expansion Joint	PB	Stainless Steel	Fuel Oil (Int)	Loss of material	Fuel Oil Chemistry (B2.1.14) and One-Time Inspection (B2.1.16)	VII.G-17	3.3.1.32	B
Expansion Joint	PB	Stainless Steel	Plant Indoor Air (Ext)	None	None	VII.J-15	3.3.1.94	A
Filter	FIL, PB	Aluminum	Dry Gas (Int)	None	None	VII.J-2	3.3.1.97	A

Section 3.3
AGING MANAGEMENT OF AUXILIARY SYSTEMS

Table 3.3.2-19 Auxiliary Systems – Summary of Aging Management Evaluation – Fire Protection System (Continued)

Component Type	Intended Function	Material	Environment	Aging Effect Requiring Management	Aging Management Program	NUREG-1801 Vol. 2 Item	Table 1 Item	Notes
Filter	FIL, PB	Aluminum	Plant Indoor Air (Ext)	None	None	V.F-2	3.3.1.50	A
Flame Arrestor	PB	Aluminum	Atmosphere/Weather (Ext)	Loss of material	External Surfaces Monitoring Program (B2.1.20)	None	None	G
Flame Arrestor	PB	Aluminum	Atmosphere/Weather (Int)	Loss of material	External Surfaces Monitoring Program (B2.1.20)	None	None	G, 4
Flexible Hoses	PB	Stainless Steel	Dry Gas (Int)	None	None	VII.J-19	3.3.1.97	A
Flexible Hoses	PB	Stainless Steel	Plant Indoor Air (Ext)	None	None	VII.J-15	3.3.1.94	A
Flow Element	PB	Stainless Steel	Plant Indoor Air (Ext)	None	None	VII.J-15	3.3.1.94	A
Flow Element	PB	Stainless Steel	Raw Water (Int)	Loss of material	Fire Water System (B2.1.13)	VII.G-19	3.3.1.69	B
Hydrant	PB	Cast Iron (Gray Cast Iron)	Atmosphere/Weather (Ext)	Loss of material	External Surfaces Monitoring Program (B2.1.20)	VII.I-9	3.3.1.58	B
Hydrant	PB	Cast Iron (Gray Cast Iron)	Buried (Ext)	Loss of material	Selective Leaching of Materials (B2.1.17)	VII.G-15	3.3.1.85	B
Hydrant	PB	Cast Iron (Gray Cast Iron)	Buried (Ext)	Loss of material	Buried Piping and Tanks Inspection (B2.1.18)	VII.G-25	3.3.1.19	B
Hydrant	PB	Cast Iron (Gray Cast Iron)	Raw Water (Int)	Loss of material	Selective Leaching of Materials (B2.1.17)	VII.G-14	3.3.1.85	B

Section 3.3
AGING MANAGEMENT OF AUXILIARY SYSTEMS

Table 3.3.2-19 Auxiliary Systems – Summary of Aging Management Evaluation – Fire Protection System (Continued)

Component Type	Intended Function	Material	Environment	Aging Effect Requiring Management	Aging Management Program	NUREG-1801 Vol. 2 Item	Table 1 Item	Notes
Hydrant	PB	Cast Iron (Gray Cast Iron)	Raw Water (Int)	Loss of material	Fire Water System (B2.1.13)	VII.G-24	3.3.1.68	B
Piping	PB	Carbon Steel	Atmosphere/Weather (Ext)	Loss of material	External Surfaces Monitoring Program (B2.1.20)	VII.I-9	3.3.1.58	B
Piping	PB	Carbon Steel	Atmosphere/Weather (Int)	Loss of material	Inspection Of Internal Surfaces In Miscellaneous Piping And Ducting Components (B2.1.22)	VII.I-9	3.3.1.58	E, 4
Piping	PB	Carbon Steel	Buried (Ext)	Loss of material	Buried Piping and Tanks Inspection (B2.1.18)	VII.G-25	3.3.1.19	B
Piping	PB	Carbon Steel	Diesel Exhaust (Int)	Loss of material	Inspection Of Internal Surfaces In Miscellaneous Piping And Ducting Components (B2.1.22)	VII.H2-2	3.3.1.18	E
Piping	PB	Carbon Steel	Dry Gas (Int)	None	None	VII.J-22	3.3.1.98	A
Piping	PB	Carbon Steel	Fuel Oil (Int)	Loss of material	Fuel Oil Chemistry (B2.1.14) and One-Time Inspection (B2.1.16)	VII.H2-24	3.3.1.20	B
Piping	LBS, NSRS, PB	Carbon Steel	Plant Indoor Air (Ext)	Loss of material	External Surfaces Monitoring Program (B2.1.20)	VII.I-8	3.3.1.58	B

Section 3.3
AGING MANAGEMENT OF AUXILIARY SYSTEMS

Table 3.3.2-19 Auxiliary Systems – Summary of Aging Management Evaluation – Fire Protection System (Continued)

Component Type	Intended Function	Material	Environment	Aging Effect Requiring Management	Aging Management Program	NUREG-1801 Vol. 2 Item	Table 1 Item	Notes
Piping	PB	Carbon Steel	Plant Indoor Air (Int)	Loss of material	Inspection Of Internal Surfaces In Miscellaneous Piping And Ducting Components (B2.1.22)	VII.I-8	3.3.1.58	E, 2
Piping	LBS, PB	Carbon Steel	Raw Water (Int)	Loss of material	Fire Water System (B2.1.13)	VII.G-24	3.3.1.68	B
Piping	NSRS, PB	Carbon Steel	Wetted Gas (Int)	Loss of material	Inspection Of Internal Surfaces In Miscellaneous Piping And Ducting Components (B2.1.22)	VII.G-23	3.3.1.71	B
Piping	PB	Carbon Steel (Galvanized)	Atmosphere/Weather (Ext)	Loss of material	External Surfaces Monitoring Program (B2.1.20)	VII.I-9	3.3.1.58	B
Piping	PB	Carbon Steel (Galvanized)	Dry Gas (Int)	None	None	VII.J-22	3.3.1.98	A
Piping	PB	Carbon Steel (Galvanized)	Plant Indoor Air (Ext)	None	None	VII.J-6	3.3.1.92	A
Piping	PB	Carbon Steel (Galvanized)	Plant Indoor Air (Int)	None	None	VII.J-6	3.3.1.92	A
Piping	PB	Carbon Steel (Galvanized)	Raw Water (Int)	Loss of material	Fire Water System (B2.1.13)	VII.G-24	3.3.1.68	B
Piping	PB	Cast Iron	Dry Gas (Int)	None	None	VII.J-22	3.3.1.98	A
Piping	PB	Cast Iron	Plant Indoor Air (Ext)	Loss of material	External Surfaces Monitoring Program (B2.1.20)	VII.I-8	3.3.1.58	B

Section 3.3
AGING MANAGEMENT OF AUXILIARY SYSTEMS

Table 3.3.2-19 Auxiliary Systems – Summary of Aging Management Evaluation – Fire Protection System (Continued)

Component Type	Intended Function	Material	Environment	Aging Effect Requiring Management	Aging Management Program	NUREG-1801 Vol. 2 Item	Table 1 Item	Notes
Piping	PB	Cast Iron (Gray Cast Iron)	Plant Indoor Air (Ext)	Loss of material	External Surfaces Monitoring Program (B2.1.20)	VII.I-8	3.3.1.58	B
Piping	PB	Cast Iron (Gray Cast Iron)	Raw Water (Int)	Loss of material	Selective Leaching of Materials (B2.1.17)	VII.G-14	3.3.1.85	B
Piping	PB	Cast Iron (Gray Cast Iron)	Raw Water (Int)	Loss of material	Fire Water System (B2.1.13)	VII.G-24	3.3.1.68	B
Piping	PB	Copper Alloy (Zinc > 15%)	Atmosphere/ Weather (Ext)	Loss of material	External Surfaces Monitoring Program (B2.1.20)	None	None	G
Piping	PB	Copper Alloy (Zinc > 15%)	Plant Indoor Air (Ext)	None	None	VIII.I-2	3.4.1.41	A
Piping	PB	Copper Alloy (Zinc > 15%)	Raw Water (Int)	Loss of material	Fire Water System (B2.1.13)	VII.G-12	3.3.1.70	B
Piping	PB	Copper Alloy (Zinc > 15%)	Raw Water (Int)	Loss of material	Selective Leaching of Materials (B2.1.17)	VII.G-13	3.3.1.84	B
Piping	PB	Copper Alloy (Zinc > 15%)	Wetted Gas (Int)	Loss of material	Selective Leaching of Materials (B2.1.17)	None	None	G
Piping	PB	Ductile Iron	Buried (Ext)	Loss of material	Buried Piping and Tanks Inspection (B2.1.18)	VII.G-25	3.3.1.19	B
Piping	PB	Ductile Iron	Raw Water (Int)	Loss of material	Fire Water System (B2.1.13)	VII.G-24	3.3.1.68	B
Piping	PB	Fiberglass Reinforced Plastic	Buried (Ext)	None	None	None	None	F, 3

Section 3.3
AGING MANAGEMENT OF AUXILIARY SYSTEMS

Table 3.3.2-19 Auxiliary Systems – Summary of Aging Management Evaluation – Fire Protection System (Continued)

Component Type	Intended Function	Material	Environment	Aging Effect Requiring Management	Aging Management Program	NUREG-1801 Vol. 2 Item	Table 1 Item	Notes
Piping	PB	Fiberglass Reinforced Plastic	Raw Water (Int)	None	None	None	None	F, 3
Piping	PB	Stainless Steel	Atmosphere/Weather (Ext)	None	None	None	None	G
Piping	PB	Stainless Steel	Buried (Ext)	Loss of material	Buried Piping and Tanks Inspection (B2.1.18)	VII.G-20	3.3.1.29	E
Piping	PB	Stainless Steel	Raw Water (Int)	Loss of material	Fire Water System (B2.1.13)	VII.G-19	3.3.1.69	B
Pump	PB	Cast Iron (Gray Cast Iron)	Plant Indoor Air (Ext)	Loss of material	External Surfaces Monitoring Program (B2.1.20)	VII.I-8	3.3.1.58	B
Pump	PB	Cast Iron (Gray Cast Iron)	Raw Water (Int)	Loss of material	Selective Leaching of Materials (B2.1.17)	VII.G-14	3.3.1.85	B
Pump	PB	Cast Iron (Gray Cast Iron)	Raw Water (Int)	Loss of material	Fire Water System (B2.1.13)	VII.G-24	3.3.1.68	B
Silencer	PB	Stainless Steel	Diesel Exhaust (Int)	Cracking	Inspection Of Internal Surfaces In Miscellaneous Piping And Ducting Components (B2.1.22)	VII.H2-1	3.3.1.06	E
Silencer	PB	Stainless Steel	Diesel Exhaust (Int)	Loss of material	Inspection Of Internal Surfaces In Miscellaneous Piping And Ducting Components (B2.1.22)	VII.H2-2	3.3.1.18	E

Section 3.3
AGING MANAGEMENT OF AUXILIARY SYSTEMS

Table 3.3.2-19 Auxiliary Systems – Summary of Aging Management Evaluation – Fire Protection System (Continued)

Component Type	Intended Function	Material	Environment	Aging Effect Requiring Management	Aging Management Program	NUREG-1801 Vol. 2 Item	Table 1 Item	Notes
Silencer	PB	Stainless Steel	Plant Indoor Air (Ext)	None	None	V.F-12	3.2.1.53	A
Spray Nozzle	PB	Copper Alloy (Zinc > 15%)	Plant Indoor Air (Ext)	None	None	VIII.I-2	3.4.1.41	A, 2
Spray Nozzle	SP	Copper Alloy (Zinc > 15%)	Plant Indoor Air (Ext)	None	None	VIII.I-2	3.4.1.41	A, 2
Spray Nozzle	SP	Copper Alloy (Zinc > 15%)	Plant Indoor Air (Ext)	None	None	VIII.I-2	3.4.1.41	A
Spray Nozzle	SP	Copper Alloy (Zinc > 15%)	Plant Indoor Air (Int)	None	None	VIII.I-2	3.4.1.41	A, 2
Spray Nozzle	SP	Copper Alloy (Zinc > 15%)	Plant Indoor Air (Int)	None	None	VIII.I-2	3.4.1.41	A
Spray Nozzle	PB	Copper Alloy (Zinc > 15%)	Plant Indoor Air (Int)	None	None	VIII.I-2	3.4.1.41	A
Spray Nozzle	SP	Stainless Steel	Atmosphere/Weather (Ext)	None	None	None	None	G
Spray Nozzle	SP	Stainless Steel	Atmosphere/Weather (Int)	None	None	None	None	G, 4
Spray Nozzle	SP	Stainless Steel	Plant Indoor Air (Ext)	None	None	VII.J-15	3.3.1.94	A
Spray Nozzle	SP	Stainless Steel	Plant Indoor Air (Int)	None	None	VII.J-15	3.3.1.94	A, 2
Sprinkler Head	PB, SP	Copper Alloy (Zinc > 15%)	Plant Indoor Air (Ext)	None	None	VIII.I-2	3.4.1.41	A
Sprinkler Head	PB, SP	Copper Alloy (Zinc > 15%)	Raw Water (Int)	Loss of material	Fire Water System (B2.1.13)	VII.G-12	3.3.1.70	B
Sprinkler Head	PB, SP	Copper Alloy (Zinc > 15%)	Raw Water (Int)	Loss of material	Selective Leaching of Materials (B2.1.17)	VII.G-13	3.3.1.84	B

Section 3.3
AGING MANAGEMENT OF AUXILIARY SYSTEMS

Table 3.3.2-19 Auxiliary Systems – Summary of Aging Management Evaluation – Fire Protection System (Continued)

Component Type	Intended Function	Material	Environment	Aging Effect Requiring Management	Aging Management Program	NUREG-1801 Vol. 2 Item	Table 1 Item	Notes
Strainer	PB	Cast Iron (Gray Cast Iron)	Plant Indoor Air (Ext)	Loss of material	External Surfaces Monitoring Program (B2.1.20)	VII.I-8	3.3.1.58	B
Strainer	PB	Cast Iron (Gray Cast Iron)	Raw Water (Int)	Loss of material	Selective Leaching of Materials (B2.1.17)	VII.G-14	3.3.1.85	B
Strainer	PB	Cast Iron (Gray Cast Iron)	Raw Water (Int)	Loss of material	Fire Water System (B2.1.13)	VII.G-24	3.3.1.68	B
Strainer	FIL, PB	Copper Alloy	Dry Gas (Int)	None	None	VII.J-3	3.3.1.98	A
Strainer	FIL, PB	Copper Alloy	Plant Indoor Air (Ext)	None	None	VIII.I-2	3.4.1.41	A
Strainer	FIL, PB	Copper Alloy	Raw Water (Int)	Loss of material	Fire Water System (B2.1.13)	VII.G-12	3.3.1.70	B
Strainer	FIL	Stainless Steel	Raw Water (Ext)	Loss of material	Fire Water System (B2.1.13)	VII.G-19	3.3.1.69	B
Tank	PB	Carbon Steel	Atmosphere/Weather (Ext)	Loss of material	External Surfaces Monitoring Program (B2.1.20)	VII.I-9	3.3.1.58	B
Tank	PB	Carbon Steel	Dry Gas (Int)	None	None	VII.J-22	3.3.1.98	C
Tank	PB	Carbon Steel	Fuel Oil (Int)	Loss of material	Fuel Oil Chemistry (B2.1.14) and One-Time Inspection (B2.1.16)	VII.H2-24	3.3.1.20	B
Tank	PB	Carbon Steel	Plant Indoor Air (Ext)	Loss of material	External Surfaces Monitoring Program (B2.1.20)	VII.I-8	3.3.1.58	B
Tank	PB	Carbon Steel	Raw Water (Int)	Loss of material	Fire Water System (B2.1.13)	VII.G-24	3.3.1.68	D
Tubing	PB	Copper Alloy	Dry Gas (Int)	None	None	VII.J-3	3.3.1.98	A

Section 3.3
AGING MANAGEMENT OF AUXILIARY SYSTEMS

Table 3.3.2-19 Auxiliary Systems – Summary of Aging Management Evaluation – Fire Protection System (Continued)

Component Type	Intended Function	Material	Environment	Aging Effect Requiring Management	Aging Management Program	NUREG-1801 Vol. 2 Item	Table 1 Item	Notes
Tubing	LBS, PB	Copper Alloy	Plant Indoor Air (Ext)	None	None	VIII.I-2	3.4.1.41	A
Tubing	LBS, PB	Copper Alloy	Raw Water (Int)	Loss of material	Fire Water System (B2.1.13)	VII.G-12	3.3.1.70	B
Tubing	LBS, PB	Copper Alloy (Zinc > 15%)	Plant Indoor Air (Ext)	None	None	VIII.I-2	3.4.1.41	A
Tubing	LBS, PB	Copper Alloy (Zinc > 15%)	Raw Water (Int)	Loss of material	Fire Water System (B2.1.13)	VII.G-12	3.3.1.70	B
Tubing	LBS, PB	Copper Alloy (Zinc > 15%)	Raw Water (Int)	Loss of material	Selective Leaching of Materials (B2.1.17)	VII.G-13	3.3.1.84	B
Tubing	LBS, PB	Stainless Steel	Plant Indoor Air (Ext)	None	None	VII.J-15	3.3.1.94	A
Tubing	LBS, PB	Stainless Steel	Raw Water (Int)	Loss of material	Fire Water System (B2.1.13)	VII.G-19	3.3.1.69	B
Valve	PB	Carbon Steel	Atmosphere/Weather (Ext)	Loss of material	External Surfaces Monitoring Program (B2.1.20)	VII.I-9	3.3.1.58	B
Valve	PB	Carbon Steel	Dry Gas (Int)	None	None	VII.J-22	3.3.1.98	A
Valve	PB	Carbon Steel	Fuel Oil (Int)	Loss of material	Fuel Oil Chemistry (B2.1.14) and One-Time Inspection (B2.1.16)	VII.H2-24	3.3.1.20	B
Valve	NSRS, PB	Carbon Steel	Plant Indoor Air (Ext)	Loss of material	External Surfaces Monitoring Program (B2.1.20)	VII.I-8	3.3.1.58	B
Valve	PB	Carbon Steel	Plant Indoor Air (Int)	Loss of material	Inspection Of Internal Surfaces In Miscellaneous Piping And Ducting Components (B2.1.22)	VII.I-8	3.3.1.58	E, 2

Section 3.3
AGING MANAGEMENT OF AUXILIARY SYSTEMS

Table 3.3.2-19 Auxiliary Systems – Summary of Aging Management Evaluation – Fire Protection System (Continued)

Component Type	Intended Function	Material	Environment	Aging Effect Requiring Management	Aging Management Program	NUREG-1801 Vol. 2 Item	Table 1 Item	Notes
Valve	PB	Carbon Steel	Raw Water (Int)	Loss of material	Fire Water System (B2.1.13)	VII.G-24	3.3.1.68	B
Valve	NSRS, PB	Carbon Steel	Wetted Gas (Int)	Loss of material	Inspection Of Internal Surfaces In Miscellaneous Piping And Ducting Components (B2.1.22)	VII.G-23	3.3.1.71	B
Valve	PB	Cast Iron	Dry Gas (Int)	None	None	VII.J-22	3.3.1.98	A
Valve	PB	Cast Iron	Plant Indoor Air (Ext)	Loss of material	External Surfaces Monitoring Program (B2.1.20)	VII.I-8	3.3.1.58	B
Valve	PB	Cast Iron (Gray Cast Iron)	Atmosphere/Weather (Ext)	Loss of material	External Surfaces Monitoring Program (B2.1.20)	VII.I-9	3.3.1.58	B
Valve	PB	Cast Iron (Gray Cast Iron)	Buried (Ext)	Loss of material	Selective Leaching of Materials (B2.1.17)	VII.G-15	3.3.1.85	B
Valve	PB	Cast Iron (Gray Cast Iron)	Buried (Ext)	Loss of material	Buried Piping and Tanks Inspection (B2.1.18)	VII.G-25	3.3.1.19	B
Valve	LBS, PB	Cast Iron (Gray Cast Iron)	Plant Indoor Air (Ext)	Loss of material	External Surfaces Monitoring Program (B2.1.20)	VII.I-8	3.3.1.58	B
Valve	PB	Cast Iron (Gray Cast Iron)	Plant Indoor Air (Int)	Loss of material	Inspection Of Internal Surfaces In Miscellaneous Piping And Ducting Components (B2.1.22)	VII.I-8	3.3.1.58	E, 2

Section 3.3
AGING MANAGEMENT OF AUXILIARY SYSTEMS

Table 3.3.2-19 Auxiliary Systems – Summary of Aging Management Evaluation – Fire Protection System (Continued)

Component Type	Intended Function	Material	Environment	Aging Effect Requiring Management	Aging Management Program	NUREG-1801 Vol. 2 Item	Table 1 Item	Notes
Valve	LBS, PB	Cast Iron (Gray Cast Iron)	Raw Water (Int)	Loss of material	Selective Leaching of Materials (B2.1.17)	VII.G-14	3.3.1.85	B
Valve	LBS, PB	Cast Iron (Gray Cast Iron)	Raw Water (Int)	Loss of material	Fire Water System (B2.1.13)	VII.G-24	3.3.1.68	B
Valve	PB	Copper Alloy	Atmosphere/Weather (Ext)	Loss of material	External Surfaces Monitoring Program (B2.1.20)	None	None	B
Valve	PB	Copper Alloy	Dry Gas (Int)	None	None	VII.J-3	3.3.1.98	A
Valve	PB	Copper Alloy	Fuel Oil (Int)	Loss of material	Fuel Oil Chemistry (B2.1.14) and One-Time Inspection (B2.1.16)	VII.G-10	3.3.1.32	B
Valve	LBS, PB	Copper Alloy	Plant Indoor Air (Ext)	None	None	VIII.I-2	3.4.1.41	A
Valve	LBS, PB	Copper Alloy	Raw Water (Int)	Loss of material	Fire Water System (B2.1.13)	VII.G-12	3.3.1.70	B
Valve	PB	Copper Alloy (Zinc > 15%)	Atmosphere/Weather (Ext)	Loss of material	External Surfaces Monitoring Program (B2.1.20)	None	None	B
Valve	PB	Copper Alloy (Zinc > 15%)	Dry Gas (Int)	None	None	VII.J-3	3.3.1.98	A
Valve	LBS, PB	Copper Alloy (Zinc > 15%)	Plant Indoor Air (Ext)	None	None	VIII.I-2	3.4.1.41	A
Valve	LBS, PB	Copper Alloy (Zinc > 15%)	Raw Water (Int)	Loss of material	Fire Water System (B2.1.13)	VII.G-12	3.3.1.70	B
Valve	LBS, PB	Copper Alloy (Zinc > 15%)	Raw Water (Int)	Loss of material	Selective Leaching of Materials (B2.1.17)	VII.G-13	3.3.1.84	B

Table 3.3.2-19 Auxiliary Systems – Summary of Aging Management Evaluation – Fire Protection System (Continued)

Component Type	Intended Function	Material	Environment	Aging Effect Requiring Management	Aging Management Program	NUREG-1801 Vol. 2 Item	Table 1 Item	Notes
Valve	PB	Copper Alloy (Zinc > 15%)	Wetted Gas (Int)	Loss of material	Selective Leaching of Materials (B2.1.17)	None	None	G
Valve	PB	Stainless Steel	Atmosphere/Weather (Ext)	None	None	None	None	G
Valve	PB	Stainless Steel	Raw Water (Int)	Loss of material	Fire Water System (B2.1.13)	VII.G-19	3.3.1.69	B

Notes for Table 3.3.2-19:

Standard Notes:

- A Consistent with NUREG-1801 item for component, material, environment, and aging effect. AMP is consistent with NUREG-1801 AMP.
- B Consistent with NUREG-1801 item for component, material, environment, and aging effect. AMP takes some exceptions to NUREG-1801 AMP.
- C Component is different, but consistent with NUREG-1801 item for material, environment, and aging effect. AMP is consistent with NUREG-1801 AMP.
- D Component is different, but consistent with NUREG-1801 item for material, environment, and aging effect. AMP takes some exceptions to NUREG-1801 AMP.
- E Consistent with NUREG-1801 for material, environment, and aging effect, but a different aging management program is credited or NUREG-1801 identifies a plant-specific aging management program.
- F Material not in NUREG-1801 for this component.
- G Environment not in NUREG-1801 for this component and material.

Plant Specific Notes:

- 1 Loss of Preload is considered to be applicable for all closure bolting.
- 2 These items are assigned the environment of "Plant Indoor Air (internal)". The items are vented or open to the plant atmosphere so the distinction between internal and external is not relevant for aging purposes.

Section 3.3
AGING MANAGEMENT OF AUXILIARY SYSTEMS

- 3 Millstone Unit 2 SER Section 3.3A.2.3.2 notes "The NRC's review of the applicant's technical report, current industry research, and operating experience, finds that fiberglass components in air and seawater environments are not exposed to high levels of ultraviolet radiation, high temperatures, or ozone, and therefore has no aging effects that require aging management. Fiberglass reinforced plastic in Atmosphere/ Weather and Soil environments are not exposed to high levels of ultraviolet radiation, high temperatures, or ozone, and therefore do not have aging effects that require aging management".
- 4 These items are assigned the environment of "Atmosphere/ Weather (internal)". The items are vented or open to the outside atmosphere so the distinction between internal and external is not relevant for aging purposes.

Section 3.3
AGING MANAGEMENT OF AUXILIARY SYSTEMS

Table 3.3.2-20 Auxiliary Systems – Summary of Aging Management Evaluation – Diesel Generator Fuel Oil Storage and Transfer System

Component Type	Intended Function	Material	Environment	Aging Effect Requiring Management	Aging Management Program	NUREG-1801 Vol. 2 Item	Table 1 Item	Notes
Closure Bolting	PB	Carbon Steel	Atmosphere/ Weather (Ext)	Loss of preload	Bolting Integrity (B2.1.7)	None	None	G
Closure Bolting	PB	Carbon Steel	Atmosphere/ Weather (Ext)	Loss of material	Bolting Integrity (B2.1.7)	VII.I-1	3.3.1.43	B
Closure Bolting	PB	Carbon Steel	Fuel Oil (Ext)	Loss of preload	Bolting Integrity (B2.1.7)	None	None	G, 1
Closure Bolting	PB	Carbon Steel	Fuel Oil (Ext)	Loss of material	Fuel Oil Chemistry (B2.1.14) and One-Time Inspection (B2.1.16)	VII.H1-10	3.3.1.20	D
Closure Bolting	PB	Carbon Steel	Plant Indoor Air (Ext)	Loss of material	Bolting Integrity (B2.1.7)	VII.I-4	3.3.1.43	B
Closure Bolting	PB	Carbon Steel	Plant Indoor Air (Ext)	Loss of preload	Bolting Integrity (B2.1.7)	VII.I-5	3.3.1.45	B
Flame Arrestor	PB	Aluminum	Atmosphere/ Weather (Ext)	Loss of material	External Surfaces Monitoring Program (B2.1.20)	None	None	G
Flame Arrestor	PB	Aluminum	Fuel Oil (Int)	Loss of material	Fuel Oil Chemistry (B2.1.14) and One-Time Inspection (B2.1.16)	VII.H1-1	3.3.1.32	D
Flow Element	PB	Stainless Steel	Fuel Oil (Int)	Loss of material	Fuel Oil Chemistry (B2.1.14) and One-Time Inspection (B2.1.16)	VII.H1-6	3.3.1.32	B
Flow Element	PB	Stainless Steel	Plant Indoor Air (Ext)	None	None	VII.J-15	3.3.1.94	A
Piping	LBS, PB, SIA	Carbon Steel	Atmosphere/ Weather (Ext)	Loss of material	External Surfaces Monitoring Program (B2.1.20)	VII.H1-8	3.3.1.60	B

Section 3.3
AGING MANAGEMENT OF AUXILIARY SYSTEMS

Table 3.3.2-20 Auxiliary Systems – Summary of Aging Management Evaluation –Diesel Generator Fuel Oil Storage and Transfer System (Continued)

Component Type	Intended Function	Material	Environment	Aging Effect Requiring Management	Aging Management Program	NUREG-1801 Vol. 2 Item	Table 1 Item	Notes
Piping	PB	Carbon Steel	Buried (Ext)	Loss of material	Buried Piping and Tanks Inspection (B2.1.18)	VII.H1-9	3.3.1.19	B
Piping	PB	Carbon Steel	Encased in Concrete (Ext)	None	None	VII.J-21	3.3.1.96	A
Piping	PB	Carbon Steel	Fuel Oil (Ext)	Loss of material	Fuel Oil Chemistry (B2.1.14) and One-Time Inspection (B2.1.16)	VII.H1-10	3.3.1.20	B
Piping	LBS, PB, SIA	Carbon Steel	Fuel Oil (Int)	Loss of material	Fuel Oil Chemistry (B2.1.14) and One-Time Inspection (B2.1.16)	VII.H1-10	3.3.1.20	B
Piping	LBS, PB, SIA	Carbon Steel	Plant Indoor Air (Ext)	Loss of material	External Surfaces Monitoring Program (B2.1.20)	VII.I-8	3.3.1.58	B
Piping	PB	Carbon Steel	Wetted Gas (Int)	Loss of material	Inspection Of Internal Surfaces In Miscellaneous Piping And Ducting Components (B2.1.22)	VII.H2-21	3.3.1.71	B
Pump	PB	Stainless Steel	Fuel Oil (Ext)	Loss of material	Fuel Oil Chemistry (B2.1.14) and One-Time Inspection (B2.1.16)	VII.H1-6	3.3.1.32	B
Pump	PB	Stainless Steel	Fuel Oil (Int)	Loss of material	Fuel Oil Chemistry (B2.1.14) and One-Time Inspection (B2.1.16)	VII.H1-6	3.3.1.32	B
Strainer	FIL, PB, SIA	Carbon Steel	Fuel Oil (Int)	Loss of material	Fuel Oil Chemistry (B2.1.14) and One-Time Inspection (B2.1.16)	VII.H1-10	3.3.1.20	B

Section 3.3
AGING MANAGEMENT OF AUXILIARY SYSTEMS

Table 3.3.2-20 Auxiliary Systems – Summary of Aging Management Evaluation – Diesel Generator Fuel Oil Storage and Transfer System (Continued)

Component Type	Intended Function	Material	Environment	Aging Effect Requiring Management	Aging Management Program	NUREG-1801 Vol. 2 Item	Table 1 Item	Notes
Strainer	FIL, PB, S/A	Carbon Steel	Plant Indoor Air (Ext)	Loss of material	External Surfaces Monitoring Program (B2.1.20)	VII.I-8	3.3.1.58	B
Strainer	FIL	Stainless Steel	Fuel Oil (Ext)	Loss of material	Fuel Oil Chemistry (B2.1.14) and One-Time Inspection (B2.1.16)	VII.H1-6	3.3.1.32	B
Strainer	FIL	Stainless Steel	Fuel Oil (Int)	Loss of material	Fuel Oil Chemistry (B2.1.14) and One-Time Inspection (B2.1.16)	VII.H1-6	3.3.1.32	B
Tank	PB	Carbon Steel	Buried (Ext)	Loss of material	Buried Piping and Tanks Inspection (B2.1.18)	VII.H1-9	3.3.1.19	D
Tank	PB	Carbon Steel	Encased in Concrete (Ext)	None	None	VII.J-21	3.3.1.96	C
Tank	PB	Carbon Steel	Fuel Oil (Int)	Loss of material	Fuel Oil Chemistry (B2.1.14) and One-Time Inspection (B2.1.16)	VII.H1-10	3.3.1.20	B
Tank	PB	Carbon Steel	Plant Indoor Air (Ext)	Loss of material	External Surfaces Monitoring Program (B2.1.20)	VII.I-8	3.3.1.58	D
Tubing	LBS	Copper Alloy	Fuel Oil (Int)	Loss of material	Fuel Oil Chemistry (B2.1.14) and One-Time Inspection (B2.1.16)	VII.H1-3	3.3.1.32	B
Tubing	LBS	Copper Alloy	Plant Indoor Air (Ext)	None	None	VIII.I-2	3.4.1.41	A
Tubing	PB	Stainless Steel	Fuel Oil (Int)	Loss of material	Fuel Oil Chemistry (B2.1.14) and One-Time Inspection (B2.1.16)	VII.H1-6	3.3.1.32	B

Table 3.3.2-20 Auxiliary Systems – Summary of Aging Management Evaluation – Diesel Generator Fuel Oil Storage and Transfer System (Continued)

Component Type	Intended Function	Material	Environment	Aging Effect Requiring Management	Aging Management Program	NUREG-1801 Vol. 2 Item	Table 1 Item	Notes
Tubing	PB	Stainless Steel	Plant Indoor Air (Ext)	None	None	VII.J-15	3.3.1.94	A
Valve	PB, SIA	Carbon Steel	Fuel Oil (Int)	Loss of material	Fuel Oil Chemistry (B2.1.14) and One-Time Inspection (B2.1.16)	VII.H1-10	3.3.1.20	B
Valve	PB, SIA	Carbon Steel	Plant Indoor Air (Ext)	Loss of material	External Surfaces Monitoring Program (B2.1.20)	VII.I-8	3.3.1.58	B
Valve	PB	Stainless Steel	Fuel Oil (Int)	Loss of material	Fuel Oil Chemistry (B2.1.14) and One-Time Inspection (B2.1.16)	VII.H1-6	3.3.1.32	B
Valve	PB	Stainless Steel	Plant Indoor Air (Ext)	None	None	VII.J-15	3.3.1.94	A

Notes for Table 3.3.2-20:

Standard Notes:

- A Consistent with NUREG-1801 item for component, material, environment, and aging effect. AMP is consistent with NUREG-1801 AMP.
- B Consistent with NUREG-1801 item for component, material, environment, and aging effect. AMP takes some exceptions to NUREG-1801 AMP.
- C Component is different, but consistent with NUREG-1801 item for material, environment, and aging effect. AMP is consistent with NUREG-1801 AMP.
- D Component is different, but consistent with NUREG-1801 item for material, environment, and aging effect. AMP takes some exceptions to NUREG-1801 AMP.
- G Environment not in NUREG-1801 for this component and material.

Plant Specific Note:

- 1 Loss of Preload is considered to be applicable for all closure bolting.

Section 3.3
AGING MANAGEMENT OF AUXILIARY SYSTEMS

Table 3.3.2-21 Auxiliary Systems – Summary of Aging Management Evaluation – Diesel Generator System

Component Type	Intended Function	Material	Environment	Aging Effect Requiring Management	Aging Management Program	NUREG-1801 Vol. 2 Item	Table 1 Item	Notes
Accumulator	PB, S/A	Carbon Steel	Dry Gas (Int)	None	None	VII.J-22	3.3.1.98	C
Accumulator	PB, S/A	Carbon Steel	Plant Indoor Air (Ext)	Loss of material	External Surfaces Monitoring Program (B2.1.20)	VII.I-8	3.3.1.58	B
Blower	HT, PB	Cast Iron	Closed Cycle Cooling Water (Int)	Reduction of heat transfer	Closed-Cycle Cooling Water System (B2.1.10)	VII.F4-9	3.3.1.52	D
Blower	HT, PB	Cast Iron	Closed Cycle Cooling Water (Int)	Loss of material	Closed-Cycle Cooling Water System (B2.1.10)	VII.H2-23	3.3.1.47	D
Blower	PB	Cast Iron	Diesel Exhaust (Int)	Loss of material	Inspection Of Internal Surfaces In Miscellaneous Piping And Ducting Components (B2.1.22)	VII.H2-2	3.3.1.18	E
Blower	PB	Cast Iron	Plant Indoor Air (Ext)	Loss of material	External Surfaces Monitoring Program (B2.1.20)	VII.H2-3	3.3.1.59	B
Blower	HT, PB	Cast Iron	Ventilation Atmosphere (Ext)	Loss of material	External Surfaces Monitoring Program (B2.1.20)	VII.I-8	3.3.1.58	D
Blower	PB	Cast Iron	Wetted Gas (Int)	Loss of material	Inspection Of Internal Surfaces In Miscellaneous Piping And Ducting Components (B2.1.22)	VII.H2-21	3.3.1.71	D
Closure Bolting	PB	Carbon Steel	Plant Indoor Air (Ext)	Loss of material	Bolting Integrity (B2.1.7)	VII.I-4	3.3.1.43	B

Section 3.3
AGING MANAGEMENT OF AUXILIARY SYSTEMS

Table 3.3.2-21 Auxiliary Systems – Summary of Aging Management Evaluation – Diesel Generator System (Continued)

Component Type	Intended Function	Material	Environment	Aging Effect Requiring Management	Aging Management Program	NUREG-1801 Vol. 2 Item	Table 1 Item	Notes
Closure Bolting	PB	Carbon Steel	Plant Indoor Air (Ext)	Loss of preload	Bolting Integrity (B2.1.7)	VII.I-5	3.3.1.45	B
Closure Bolting	PB	Stainless Steel	Plant Indoor Air (Ext)	Loss of preload	Bolting Integrity (B2.1.7)	None	None	G
Dryer	S/A	Carbon Steel	Dry Gas (Int)	None	None	VII.J-22	3.3.1.98	A
Dryer	S/A	Carbon Steel	Plant Indoor Air (Ext)	Loss of material	External Surfaces Monitoring Program (B2.1.20)	VII.I-8	3.3.1.58	B
Expansion Joint	PB	Carbon Steel	Lubricating Oil (Int)	Loss of material	Lubricating Oil Analysis (B2.1.23) and One-Time Inspection (B2.1.16)	VII.H2-20	3.3.1.14	B
Expansion Joint	PB	Carbon Steel	Plant Indoor Air (Ext)	Loss of material	External Surfaces Monitoring Program (B2.1.20)	VII.I-8	3.3.1.58	B
Expansion Joint	PB	Stainless Steel	Closed Cycle Cooling Water (Int)	Loss of material	Closed-Cycle Cooling Water System (B2.1.10)	VII.C2-10	3.3.1.50	B
Expansion Joint	PB	Stainless Steel	Diesel Exhaust (Int)	Cracking	Inspection Of Internal Surfaces In Miscellaneous Piping And Ducting Components (B2.1.22)	VII.H2-1	3.3.1.06	E
Expansion Joint	PB	Stainless Steel	Diesel Exhaust (Int)	Loss of material	Inspection Of Internal Surfaces In Miscellaneous Piping And Ducting Components (B2.1.22)	VII.H2-2	3.3.1.18	E

Section 3.3
AGING MANAGEMENT OF AUXILIARY SYSTEMS

Table 3.3.2-21 Auxiliary Systems – Summary of Aging Management Evaluation – Diesel Generator System (Continued)

Component Type	Intended Function	Material	Environment	Aging Effect Requiring Management	Aging Management Program	NUREG-1801 Vol. 2 Item	Table 1 Item	Notes
Expansion Joint	PB	Stainless Steel	Lubricating Oil (Int)	Loss of material	Lubricating Oil Analysis (B2.1.23) and One-Time Inspection (B2.1.16)	VII.H2-17	3.3.1.33	B
Expansion Joint	PB	Stainless Steel	Plant Indoor Air (Ext)	None	None	VII.J-15	3.3.1.94	A
Expansion Joint	PB	Stainless Steel	Wetted Gas (Int)	Loss of material	Inspection Of Internal Surfaces In Miscellaneous Piping And Ducting Components (B2.1.22)	V.D1-29	3.2.1.08	E
Filter	FIL, PB, SIA	Aluminum	Dry Gas (Int)	None	None	VII.J-2	3.3.1.97	A
Filter	FIL, PB	Aluminum	Plant Indoor Air (Ext)	None	None	V.F-2	3.2.1.50	A
Filter	SIA	Aluminum	Plant Indoor Air (Ext)	None	None	VII.J-1	3.3.1.95	A
Filter	FIL, PB	Carbon Steel	Diesel Exhaust (Int)	Loss of material	Inspection Of Internal Surfaces In Miscellaneous Piping And Ducting Components (B2.1.22)	VII.H2-2	3.3.1.18	E
Filter	FIL, PB	Carbon Steel	Fuel Oil (Int)	Loss of material	Fuel Oil Chemistry (B2.1.14) and One-Time Inspection (B2.1.16)	VII.H2-24	3.3.1.20	B
Filter	FIL, PB	Carbon Steel	Lubricating Oil (Int)	Loss of material	Lubricating Oil Analysis (B2.1.23) and One-Time Inspection (B2.1.16)	VII.H2-20	3.3.1.14	B

Section 3.3
AGING MANAGEMENT OF AUXILIARY SYSTEMS

Table 3.3.2-21 Auxiliary Systems – Summary of Aging Management Evaluation – Diesel Generator System (Continued)

Component Type	Intended Function	Material	Environment	Aging Effect Requiring Management	Aging Management Program	NUREG-1801 Vol. 2 Item	Table 1 Item	Notes
Filter	FIL, PB	Carbon Steel	Plant Indoor Air (Ext)	Loss of material	External Surfaces Monitoring Program (B2.1.20)	VII.I-8	3.3.1.58	B
Filter	FIL, PB	Carbon Steel	Wetted Gas (Int)	Loss of material	Inspection Of Internal Surfaces In Miscellaneous Piping And Ducting Components (B2.1.22)	VII.H2-21	3.3.1.71	B
Flame Arrestor	PB	Aluminum	Fuel Oil (Int)	Loss of material	Fuel Oil Chemistry (B2.1.14) and One-Time Inspection (B2.1.16)	VII.H2-7	3.3.1.32	D
Flame Arrestor	PB	Aluminum	Plant Indoor Air (Ext)	None	None	V.F-2	3.2.1.50	C
Heat Exchanger (DG Fuel Oil)	PB	Aluminum	Fuel Oil (Int)	Loss of material	Fuel Oil Chemistry (B2.1.14) and One-Time Inspection (B2.1.16)	VII.H2-7	3.3.1.32	D
Heat Exchanger (DG Fuel Oil)	PB	Aluminum	Plant Indoor Air (Ext)	None	None	V.F-2	3.2.1.50	A
Heat Exchanger (DG Fuel Oil)	PB	Copper Alloy	Fuel Oil (Ext)	Loss of material	Fuel Oil Chemistry (B2.1.14) and One-Time Inspection (B2.1.16)	VII.H2-9	3.3.1.32	B
Heat Exchanger (DG Fuel Oil)	PB	Copper Alloy	Raw Water (Int)	Loss of material	Open-Cycle Cooling Water System (B2.1.9)	VII.H2-11	3.3.1.80	A
Heat Exchanger (DG Jacket Water)	PB	Carbon Steel	Closed Cycle Cooling Water (Int)	Loss of material	Closed-Cycle Cooling Water System (B2.1.10)	VII.C2-1	3.3.1.48	B

Section 3.3
AGING MANAGEMENT OF AUXILIARY SYSTEMS

Table 3.3.2-21 Auxiliary Systems – Summary of Aging Management Evaluation – Diesel Generator System (Continued)

Component Type	Intended Function	Material	Environment	Aging Effect Requiring Management	Aging Management Program	NUREG-1801 Vol. 2 Item	Table 1 Item	Notes
Heat Exchanger (DG Jacket Water)	PB	Carbon Steel	Plant Indoor Air (Ext)	Loss of material	External Surfaces Monitoring Program (B2.1.20)	VII.H2-3	3.3.1.59	B
Heat Exchanger (DG Jacket Water)	HT, PB	Copper Alloy (Zinc > 15%)	Closed Cycle Cooling Water (Ext)	Reduction of heat transfer	Closed-Cycle Cooling Water System (B2.1.10)	VII.C2-2	3.3.1.52	B, 1
Heat Exchanger (DG Jacket Water)	HT, PB	Copper Alloy (Zinc > 15%)	Closed Cycle Cooling Water (Ext)	Loss of material	Closed-Cycle Cooling Water System (B2.1.10)	VII.H2-8	3.3.1.51	D, 1
Heat Exchanger (DG Jacket Water)	HT, PB	Copper Alloy (Zinc > 15%)	Raw Water (Int)	Reduction of heat transfer	Open-Cycle Cooling Water System (B2.1.9)	VII.C1-6	3.3.1.83	A, 1
Heat Exchanger (DG Jacket Water)	HT, PB	Copper Alloy (Zinc > 15%)	Raw Water (Int)	Loss of material	Open-Cycle Cooling Water System (B2.1.9)	VII.H2-11	3.3.1.80	C, 1
Heat Exchanger (DG Lube Oil)	PB	Carbon Steel	Lubricating Oil (Int)	Loss of material	Lubricating Oil Analysis (B2.1.23) and One-Time Inspection (B2.1.16)	VII.H2-5	3.3.1.21	B
Heat Exchanger (DG Lube Oil)	PB	Carbon Steel	Plant Indoor Air (Ext)	Loss of material	External Surfaces Monitoring Program (B2.1.20)	VII.H2-3	3.3.1.59	B
Heat Exchanger (DG Lube Oil)	HT, PB	Copper Alloy (Zinc > 15%)	Lubricating Oil (Ext)	Loss of material	Lubricating Oil Analysis (B2.1.23) and One-Time Inspection (B2.1.16)	VII.H2-10	3.3.1.26	B, 1
Heat Exchanger (DG Lube Oil)	HT, PB	Copper Alloy (Zinc > 15%)	Lubricating Oil (Ext)	Reduction of heat transfer	Lubricating Oil Analysis (B2.1.23) and One-Time Inspection (B2.1.16)	VIII.G-8	3.4.1.10	B, 1

Section 3.3
AGING MANAGEMENT OF AUXILIARY SYSTEMS

Table 3.3.2-21 Auxiliary Systems – Summary of Aging Management Evaluation – Diesel Generator System (Continued)

Component Type	Intended Function	Material	Environment	Aging Effect Requiring Management	Aging Management Program	NUREG-1801 Vol. 2 Item	Table 1 Item	Notes
Heat Exchanger (DG Lube Oil)	HT, PB	Copper Alloy (Zinc > 15%)	Raw Water (Int)	Reduction of heat transfer	Open-Cycle Cooling Water System (B2.1.9)	VII.C1-6	3.3.1.83	A
Heat Exchanger (DG Lube Oil)	HT, PB	Copper Alloy (Zinc > 15%)	Raw Water (Int)	Loss of material	Open-Cycle Cooling Water System (B2.1.9)	VII.H2-11	3.3.1.80	C, 1
Heat Exchanger (DG Turbo Air Intercooler)	HT	Aluminum	Ventilation Atmosphere (Ext)	None	None	V.F-2	3.2.1.50	C
Heat Exchanger (DG Turbo Air Intercooler)	PB	Carbon Steel	Plant Indoor Air (Ext)	Loss of material	External Surfaces Monitoring Program (B2.1.20)	VII.H2-3	3.3.1.59	B
Heat Exchanger (DG Turbo Air Intercooler)	PB	Carbon Steel	Wetted Gas (Int)	Loss of material	Inspection Of Internal Surfaces In Miscellaneous Piping And Ducting Components (B2.1.22)	VII.H2-21	3.3.1.71	D
Heat Exchanger (DG Turbo Air Intercooler)	HT, PB	Copper Alloy	Closed Cycle Cooling Water (Int)	Reduction of heat transfer	Closed-Cycle Cooling Water System (B2.1.10)	VII.C2-2	3.3.1.52	B
Heat Exchanger (DG Turbo Air Intercooler)	HT, PB	Copper Alloy	Closed Cycle Cooling Water (Int)	Loss of material	Closed-Cycle Cooling Water System (B2.1.10)	VII.H2-8	3.3.1.51	D

Section 3.3
AGING MANAGEMENT OF AUXILIARY SYSTEMS

Table 3.3.2-21 Auxiliary Systems – Summary of Aging Management Evaluation – Diesel Generator System (Continued)

Component Type	Intended Function	Material	Environment	Aging Effect Requiring Management	Aging Management Program	NUREG-1801 Vol. 2 Item	Table 1 Item	Notes
Heat Exchanger (DG Turbo Air Intercooler)	HT, PB	Copper Alloy	Raw Water (Int)	Reduction of heat transfer	Open-Cycle Cooling Water System (B2.1.9)	VII.C1-6	3.3.1.83	A
Heat Exchanger (DG Turbo Air Intercooler)	HT, PB	Copper Alloy	Ventilation Atmosphere (Ext)	None	None	VIII.I-2	3.4.1.41	C
Heat Exchanger (Governor Oil Cooler)	PB	Aluminum	Lubricating Oil (Int)	Loss of material	Lubricating Oil Analysis (B2.1.23) and One-Time Inspection (B2.1.16)	None	None	G
Heat Exchanger (Governor Oil Cooler)	PB	Aluminum	Plant Indoor Air (Ext)	None	None	V.F-2	3.2.1.50	C
Heat Exchanger (Governor Oil Cooler)	HT, PB	Copper Alloy	Closed Cycle Cooling Water (Int)	Reduction of heat transfer	Closed-Cycle Cooling Water System (B2.1.10)	VII.C2-2	3.3.1.52	B
Heat Exchanger (Governor Oil Cooler)	HT, PB	Copper Alloy	Closed Cycle Cooling Water (Int)	Loss of material	Closed-Cycle Cooling Water System (B2.1.10)	VII.C2-4	3.3.1.51	D
Heat Exchanger (Governor Oil Cooler)	PB	Copper Alloy	Closed Cycle Cooling Water (Int)	Loss of material	Closed-Cycle Cooling Water System (B2.1.10)	VII.H2-8	3.3.1.51	B

Section 3.3
AGING MANAGEMENT OF AUXILIARY SYSTEMS

Table 3.3.2-21 Auxiliary Systems – Summary of Aging Management Evaluation – Diesel Generator System (Continued)

Component Type	Intended Function	Material	Environment	Aging Effect Requiring Management	Aging Management Program	NUREG-1801 Vol. 2 Item	Table 1 Item	Notes
Heat Exchanger (Governor Oil Cooler)	HT, PB	Copper Alloy	Lubricating Oil (Ext)	Loss of material	Lubricating Oil Analysis (B2.1.23) and One-Time Inspection (B2.1.16)	VII.H2-10	3.3.1.26	D
Heat Exchanger (Governor Oil Cooler)	HT, PB	Copper Alloy	Lubricating Oil (Ext)	Reduction of heat transfer	Lubricating Oil Analysis (B2.1.23) and One-Time Inspection (B2.1.16)	VIII.G-8	3.4.1.10	B
Heat Exchanger (Governor Oil Cooler)	PB	Copper Alloy	Plant Indoor Air (Ext)	None	None	VIII.I-2	3.4.1.41	A
Heater	PB	Carbon Steel	Lubricating Oil (Int)	Loss of material	Lubricating Oil Analysis (B2.1.23) and One-Time Inspection (B2.1.16)	VII.H2-20	3.3.1.14	D
Heater	PB	Carbon Steel	Plant Indoor Air (Ext)	Loss of material	External Surfaces Monitoring Program (B2.1.20)	VII.H2-3	3.3.1.59	D
Heater	PB	Carbon Steel (Galvanized)	Closed Cycle Cooling Water (Int)	Loss of material	Closed-Cycle Cooling Water System (B2.1.10)	VII.H2-23	3.3.1.47	B
Heater	PB	Carbon Steel (Galvanized)	Plant Indoor Air (Ext)	None	None	VII.J-6	3.3.1.92	C
Heater	PB	Stainless Steel	Lubricating Oil (Int)	Loss of material	Lubricating Oil Analysis (B2.1.23) and One-Time Inspection (B2.1.16)	VII.H2-17	3.3.1.33	D
Heater	PB	Stainless Steel	Plant Indoor Air (Ext)	None	None	VII.J-15	3.3.1.94	C
Insulation	INS	Insulation Mineral Wool	Plant Indoor Air (Ext)	None	None	None	None	J

Section 3.3
AGING MANAGEMENT OF AUXILIARY SYSTEMS

Table 3.3.2-21 Auxiliary Systems – Summary of Aging Management Evaluation – Diesel Generator System (Continued)

Component Type	Intended Function	Material	Environment	Aging Effect Requiring Management	Aging Management Program	NUREG-1801 Vol. 2 Item	Table 1 Item	Notes
Piping	LBS, SIA	Carbon Steel	Atmosphere/ Weather (Ext)	Loss of material	External Surfaces Monitoring Program (B2.1.20)	VII.I-9	3.3.1.58	B
Piping	LBS, PB, SIA	Carbon Steel	Closed Cycle Cooling Water (Int)	Loss of material	Closed-Cycle Cooling Water System (B2.1.10)	VII.H2-23	3.3.1.47	B
Piping	PB, SIA	Carbon Steel	Diesel Exhaust (Int)	Loss of material	Inspection Of Internal Surfaces In Miscellaneous Piping And Ducting Components (B2.1.22)	VII.H2-2	3.3.1.18	E
Piping	PB, SIA	Carbon Steel	Dry Gas (Int)	None	None	VII.J-22	3.3.1.98	A
Piping	LBS, PB, SIA	Carbon Steel	Fuel Oil (Int)	Loss of material	Fuel Oil Chemistry (B2.1.14) and One-Time Inspection (B2.1.16)	VII.H2-24	3.3.1.20	B
Piping	LBS, PB, SIA	Carbon Steel	Lubricating Oil (Int)	Loss of material	Lubricating Oil Analysis (B2.1.23) and One-Time Inspection (B2.1.16)	VII.H2-20	3.3.1.14	B
Piping	LBS, PB, SIA	Carbon Steel	Plant Indoor Air (Ext)	Loss of material	External Surfaces Monitoring Program (B2.1.20)	VII.I-8	3.3.1.58	B
Piping	LBS, PB, SIA	Carbon Steel	Wetted Gas (Int)	Loss of material	Inspection Of Internal Surfaces In Miscellaneous Piping And Ducting Components (B2.1.22)	VII.H2-21	3.3.1.71	B
Piping	PB	Stainless Steel	Closed Cycle Cooling Water (Int)	Loss of material	Closed-Cycle Cooling Water System (B2.1.10)	VII.C2-10	3.3.1.50	B

Section 3.3
AGING MANAGEMENT OF AUXILIARY SYSTEMS

Table 3.3.2-21 Auxiliary Systems – Summary of Aging Management Evaluation – Diesel Generator System (Continued)

Component Type	Intended Function	Material	Environment	Aging Effect Requiring Management	Aging Management Program	NUREG-1801 Vol. 2 Item	Table 1 Item	Notes
Piping	LBS, PB, S/A	Stainless Steel	DeminerIALIZED Water (Int)	Loss of material	Water Chemistry (B2.1.2) and One-Time Inspection (B2.1.16)	VIII.E-29	3.4.1.16	A
Piping	PB	Stainless Steel	Diesel Exhaust (Int)	Cracking	Inspection Of Internal Surfaces In Miscellaneous Piping And Ducting Components (B2.1.22)	VII.H2-1	3.3.1.06	E
Piping	PB	Stainless Steel	Diesel Exhaust (Int)	Loss of material	Inspection Of Internal Surfaces In Miscellaneous Piping And Ducting Components (B2.1.22)	VII.H2-2	3.3.1.18	E
Piping	PB	Stainless Steel	Lubricating Oil (Int)	Loss of material	Lubricating Oil Analysis (B2.1.23) and One-Time Inspection (B2.1.16)	VII.H2-17	3.3.1.33	B
Piping	LBS, PB, S/A	Stainless Steel	Plant Indoor Air (Ext)	None	None	VII.J-15	3.3.1.94	A
Piping	S/A	Stainless Steel	Plant Indoor Air (Int)	None	None	VII.J-15	3.3.1.94	A
Piping	PB	Stainless Steel	Secondary Water (Int)	Loss of material	Water Chemistry (B2.1.2) and One-Time Inspection (B2.1.16)	VIII.E-29	3.4.1.16	A
Piping	LBS, PB	Stainless Steel	Wetted Gas (Int)	Loss of material	Inspection Of Internal Surfaces In Miscellaneous Piping And Ducting Components (B2.1.22)	V.D1-29	3.2.1.08	E

Section 3.3
AGING MANAGEMENT OF AUXILIARY SYSTEMS

Table 3.3.2-21 Auxiliary Systems – Summary of Aging Management Evaluation – Diesel Generator System (Continued)

Component Type	Intended Function	Material	Environment	Aging Effect Requiring Management	Aging Management Program	NUREG-1801 Vol. 2 Item	Table 1 Item	Notes
Pump	PB	Carbon Steel	Fuel Oil (Int)	Loss of material	Fuel Oil Chemistry (B2.1.14) and One-Time Inspection (B2.1.16)	VII.H2-24	3.3.1.20	B
Pump	PB	Carbon Steel	Lubricating Oil (Int)	Loss of material	Lubricating Oil Analysis (B2.1.23) and One-Time Inspection (B2.1.16)	VII.H2-20	3.3.1.14	B
Pump	PB	Carbon Steel	Plant Indoor Air (Ext)	Loss of material	External Surfaces Monitoring Program (B2.1.20)	VII.I-8	3.3.1.58	B
Pump	PB	Cast Iron	Closed Cycle Cooling Water (Int)	Loss of material	Closed-Cycle Cooling Water System (B2.1.10)	VII.H2-23	3.3.1.47	B
Pump	PB	Cast Iron	Plant Indoor Air (Ext)	Loss of material	External Surfaces Monitoring Program (B2.1.20)	VII.I-8	3.3.1.58	B
Pump	PB	Stainless Steel	Lubricating Oil (Int)	Loss of material	Lubricating Oil Analysis (B2.1.23) and One-Time Inspection (B2.1.16)	VII.H2-17	3.3.1.33	B
Pump	PB	Stainless Steel	Plant Indoor Air (Ext)	None	None	VII.J-15	3.3.1.94	A
Sight Gauge	LBS, NSRS	Carbon Steel	Fuel Oil (Int)	Loss of material	Fuel Oil Chemistry (B2.1.14) and One-Time Inspection (B2.1.16)	VII.H2-24	3.3.1.20	B
Sight Gauge	LBS, NSRS	Carbon Steel	Plant Indoor Air (Ext)	Loss of material	External Surfaces Monitoring Program (B2.1.20)	VII.I-8	3.3.1.58	B
Sight Gauge	PB	Glass	Closed Cycle Cooling Water (Int)	None	None	VII.J-13	3.3.1.93	A
Sight Gauge	LBS, NSRS	Glass	Fuel Oil (Int)	None	None	VII.J-9	3.3.1.93	C

Section 3.3
AGING MANAGEMENT OF AUXILIARY SYSTEMS

Table 3.3.2-21 Auxiliary Systems – Summary of Aging Management Evaluation – Diesel Generator System (Continued)

Component Type	Intended Function	Material	Environment	Aging Effect Requiring Management	Aging Management Program	NUREG-1801 Vol. 2 Item	Table 1 Item	Notes
Sight Gauge	LBS, NSRS, PB	Glass	Plant Indoor Air (Ext)	None	None	VII.J-8	3.3.1.93	A
Sight Gauge	PB	Stainless Steel	Closed Cycle Cooling Water (Int)	Loss of material	Closed-Cycle Cooling Water System (B2.1.10)	VII.C2-10	3.3.1.50	B
Sight Gauge	PB	Stainless Steel	Plant Indoor Air (Ext)	None	None	VII.J-15	3.3.1.94	A
Strainer	LBS	Carbon Steel	Atmosphere/Weather (Ext)	Loss of material	External Surfaces Monitoring Program (B2.1.20)	VII.I-9	3.3.1.58	B
Strainer	FIL, LBS, PB	Carbon Steel	Fuel Oil (Int)	Loss of material	Fuel Oil Chemistry (B2.1.14) and One-Time Inspection (B2.1.16)	VII.H2-24	3.3.1.20	B
Strainer	FIL, PB	Carbon Steel	Lubricating Oil (Int)	Loss of material	Lubricating Oil Analysis (B2.1.23) and One-Time Inspection (B2.1.16)	VII.H2-20	3.3.1.14	B
Strainer	FIL, PB	Carbon Steel	Plant Indoor Air (Ext)	Loss of material	External Surfaces Monitoring Program (B2.1.20)	VII.I-8	3.3.1.58	B
Strainer	FIL, PB	Stainless Steel	Lubricating Oil (Int)	Loss of material	Lubricating Oil Analysis (B2.1.23) and One-Time Inspection (B2.1.16)	VII.H2-17	3.3.1.33	B
Strainer	FIL, PB	Stainless Steel	Plant Indoor Air (Ext)	None	None	VII.J-15	3.3.1.94	A
Tank	PB	Carbon Steel	Fuel Oil (Int)	Loss of material	Fuel Oil Chemistry (B2.1.14) and One-Time Inspection (B2.1.16)	VII.H2-24	3.3.1.20	B
Tank	PB	Carbon Steel	Plant Indoor Air (Ext)	Loss of material	External Surfaces Monitoring Program (B2.1.20)	VII.I-8	3.3.1.58	B

Section 3.3
AGING MANAGEMENT OF AUXILIARY SYSTEMS

Table 3.3.2-21 Auxiliary Systems – Summary of Aging Management Evaluation – Diesel Generator System (Continued)

Component Type	Intended Function	Material	Environment	Aging Effect Requiring Management	Aging Management Program	NUREG-1801 Vol. 2 Item	Table 1 Item	Notes
Tank	PB	Cast Iron	Lubricating Oil (Int)	Loss of material	Lubricating Oil Analysis (B2.1.23) and One-Time Inspection (B2.1.16)	VII.H2-20	3.3.1.14	D
Tank	PB	Cast Iron	Plant Indoor Air (Ext)	Loss of material	External Surfaces Monitoring Program (B2.1.20)	VII.I-8	3.3.1.58	B
Tubing	PB	Carbon Steel	Fuel Oil (Int)	Loss of material	Fuel Oil Chemistry (B2.1.14) and One-Time Inspection (B2.1.16)	VII.H2-24	3.3.1.20	B
Tubing	PB	Carbon Steel	Plant Indoor Air (Ext)	Loss of material	External Surfaces Monitoring Program (B2.1.20)	VII.I-8	3.3.1.58	B
Tubing	PB	Copper Alloy	Dry Gas (Int)	None	None	VII.J-3	3.3.1.98	A
Tubing	PB	Copper Alloy	Plant Indoor Air (Ext)	None	None	VIII.I-2	3.4.1.41	A
Tubing	LBS, PB, SIA	Stainless Steel	Closed Cycle Cooling Water (Int)	Loss of material	Closed-Cycle Cooling Water System (B2.1.10)	VII.C2-10	3.3.1.50	B
Tubing	PB, SIA	Stainless Steel	Dry Gas (Int)	None	None	VII.J-18	3.3.1.98	A
Tubing	LBS, PB, SIA	Stainless Steel	Fuel Oil (Int)	Loss of material	Fuel Oil Chemistry (B2.1.14) and One-Time Inspection (B2.1.16)	VII.H2-16	3.3.1.32	B
Tubing	LBS, PB, SIA	Stainless Steel	Lubricating Oil (Int)	Loss of material	Lubricating Oil Analysis (B2.1.23) and One-Time Inspection (B2.1.16)	VII.H2-17	3.3.1.33	B
Tubing	LBS, PB, SIA	Stainless Steel	Plant Indoor Air (Ext)	None	None	VII.J-15	3.3.1.94	A

Section 3.3
AGING MANAGEMENT OF AUXILIARY SYSTEMS

Table 3.3.2-21 Auxiliary Systems – Summary of Aging Management Evaluation – Diesel Generator System (Continued)

Component Type	Intended Function	Material	Environment	Aging Effect Requiring Management	Aging Management Program	NUREG-1801 Vol. 2 Item	Table 1 Item	Notes
Valve	LBS, NSRS, PB, SIA	Aluminum	Dry Gas (Int)	None	None	VII.J-2	3.3.1.97	A
Valve	LBS, NSRS, PB, SIA	Aluminum	Plant Indoor Air (Ext)	None	None	V.F-2	3.2.1.50	A
Valve	LBS, SIA	Carbon Steel	Atmosphere/Weather (Ext)	Loss of material	External Surfaces Monitoring Program (B2.1.20)	VII.I-9	3.3.1.58	B
Valve	PB	Carbon Steel	Closed Cycle Cooling Water (Int)	Loss of material	Closed-Cycle Cooling Water System (B2.1.10)	VII.H2-23	3.3.1.47	B
Valve	PB	Carbon Steel	Diesel Exhaust (Int)	Loss of material	Inspection Of Internal Surfaces In Miscellaneous Piping And Ducting Components (B2.1.22)	VII.H2-2	3.3.1.18	E
Valve	PB, SIA	Carbon Steel	Dry Gas (Int)	None	None	VII.J-22	3.3.1.98	A
Valve	LBS, PB, SIA	Carbon Steel	Fuel Oil (Int)	Loss of material	Fuel Oil Chemistry (B2.1.14) and One-Time Inspection (B2.1.16)	VII.H2-24	3.3.1.20	B
Valve	PB	Carbon Steel	Lubricating Oil (Int)	Loss of material	Lubricating Oil Analysis (B2.1.23) and One-Time Inspection (B2.1.16)	VII.H2-20	3.3.1.14	B
Valve	LBS, PB, SIA	Carbon Steel	Plant Indoor Air (Ext)	Loss of material	External Surfaces Monitoring Program (B2.1.20)	VII.I-8	3.3.1.58	B

Section 3.3
AGING MANAGEMENT OF AUXILIARY SYSTEMS

Table 3.3.2-21 Auxiliary Systems – Summary of Aging Management Evaluation – Diesel Generator System (Continued)

Component Type	Intended Function	Material	Environment	Aging Effect Requiring Management	Aging Management Program	NUREG-1801 Vol. 2 Item	Table 1 Item	Notes
Valve	LBS, PB	Carbon Steel	Wetted Gas (Int)	Loss of material	Inspection Of Internal Surfaces In Miscellaneous Piping And Ducting Components (B2.1.22)	VII.H2-21	3.3.1.71	B
Valve	PB	Cast Iron	Dry Gas (Int)	None	None	VII.J-22	3.3.1.98	A
Valve	PB	Cast Iron	Fuel Oil (Int)	Loss of material	Fuel Oil Chemistry (B2.1.14) and One-Time Inspection (B2.1.16)	VII.H2-24	3.3.1.20	B
Valve	PB	Cast Iron	Lubricating Oil (Int)	Loss of material	Lubricating Oil Analysis (B2.1.23) and One-Time Inspection (B2.1.16)	VII.H2-20	3.3.1.14	B
Valve	PB	Cast Iron	Plant Indoor Air (Ext)	Loss of material	External Surfaces Monitoring Program (B2.1.20)	VII.I-8	3.3.1.58	B
Valve	PB, SIA	Copper Alloy	Dry Gas (Int)	None	None	VII.J-3	3.3.1.98	A
Valve	PB, SIA	Copper Alloy	Plant Indoor Air (Ext)	None	None	VIII.I-2	3.4.1.41	A
Valve	PB	Copper Alloy	Wetted Gas (Int)	Loss of material	Inspection Of Internal Surfaces In Miscellaneous Piping And Ducting Components (B2.1.22)	VII.G-9	3.3.1.28	E
Valve	LBS	Copper Alloy (Zinc > 15%)	Plant Indoor Air (Ext)	None	None	VIII.I-2	3.4.1.41	A
Valve	LBS	Copper Alloy (Zinc > 15%)	Wetted Gas (Int)	Loss of material	Selective Leaching of Materials (B2.1.17)	None	None	G
Valve	PB	Nickel Alloys	Dry Gas (Int)	None	None	None	None	G

Section 3.3
AGING MANAGEMENT OF AUXILIARY SYSTEMS

Table 3.3.2-21 Auxiliary Systems – Summary of Aging Management Evaluation – Diesel Generator System (Continued)

Component Type	Intended Function	Material	Environment	Aging Effect Requiring Management	Aging Management Program	NUREG-1801 Vol. 2 Item	Table 1 Item	Notes
Valve	PB	Nickel Alloys	Plant Indoor Air (Ext)	None	None	VII.J-14	3.3.1.94	A
Valve	PB	Stainless Steel	Closed Cycle Cooling Water (Int)	Loss of material	Closed-Cycle Cooling Water System (B2.1.10)	VII.C2-10	3.3.1.50	B
Valve	PB	Stainless Steel	DeminerIALIZED Water (Int)	Loss of material	Water Chemistry (B2.1.2) and One-Time Inspection (B2.1.16)	VIII.E-29	3.4.1.16	A
Valve	PB, SIA	Stainless Steel	Dry Gas (Int)	None	None	VII.J-18	3.3.1.98	A
Valve	PB	Stainless Steel	Fuel Oil (Int)	Loss of material	Fuel Oil Chemistry (B2.1.14) and One-Time Inspection (B2.1.16)	VII.H2-16	3.3.1.32	B
Valve	PB	Stainless Steel	Lubricating Oil (Int)	Loss of material	Lubricating Oil Analysis (B2.1.23) and One-Time Inspection (B2.1.16)	VII.H2-17	3.3.1.33	B
Valve	PB, SIA	Stainless Steel	Plant Indoor Air (Ext)	None	None	VII.J-15	3.3.1.94	A
Valve	PB	Stainless Steel	Secondary Water (Int)	Loss of material	Water Chemistry (B2.1.2) and One-Time Inspection (B2.1.16)	VIII.E-29	3.4.1.16	A
Valve	PB	Stainless Steel	Wetted Gas (Int)	Loss of material	Inspection Of Internal Surfaces In Miscellaneous Piping And Ducting Components (B2.1.22)	V.D1-29	3.2.1.08	E

Section 3.3
AGING MANAGEMENT OF AUXILIARY SYSTEMS

Notes for Table 3.3.2-21:

Standard Notes:

- A Consistent with NUREG-1801 item for component, material, environment, and aging effect. AMP is consistent with NUREG-1801 AMP.
- B Consistent with NUREG-1801 item for component, material, environment, and aging effect. AMP takes some exceptions to NUREG-1801 AMP.
- C Component is different, but consistent with NUREG-1801 item for material, environment, and aging effect. AMP is consistent with NUREG-1801 AMP.
- D Component is different, but consistent with NUREG-1801 item for material, environment, and aging effect. AMP takes some exceptions to NUREG-1801 AMP.
- E Consistent with NUREG-1801 for material, environment, and aging effect, but a different aging management program is credited or NUREG-1801 identifies a plant-specific aging management program.
- G Environment not in NUREG-1801 for this component and material.
- J Neither the component nor the material and environment combination is evaluated in NUREG-1801.

Plant Specific Note:

- 1 The DG Jacket Water Cooler and DG Lube Oil Cooler heat exchanger tubes are fabricated of Admiralty Brass (nominal Cu-71%, Zn-28%, Sn-1%). EPRI Rpt 1010639 "Non-Class 1 Mechanical Implementation Guideline and Mechanical Tools" Rev. 4, Appendices A, B and C state that the addition of tin to brass effectively inhibits dezincification and significantly reduces the susceptibility of the material to selective leaching. This is consistent with NUREG 1801, IX.C which states that selective leaching is not a consideration for inhibited brass. Therefore, loss of material due to selective leaching has not been selected as an aging effect for Admiralty Brass heat exchanger tubes in Closed-Cycle Cooling Water, Raw Water and Lubricating Oil environments.

Section 3.3
AGING MANAGEMENT OF AUXILIARY SYSTEMS

Table 3.3.2-22 Auxiliary Systems – Summary of Aging Management Evaluation – Domestic Water System

Component Type	Intended Function	Material	Environment	Aging Effect Requiring Management	Aging Management Program	NUREG-1801 Vol. 2 Item	Table 1 Item	Notes
Closure Bolting	LBS	Carbon Steel	Plant Indoor Air (Ext)	Loss of material	Bolting Integrity (B2.1.7)	VII.I-4	3.3.1.43	B
Closure Bolting	LBS	Carbon Steel	Plant Indoor Air (Ext)	Loss of preload	Bolting Integrity (B2.1.7)	VII.I-5	3.3.1.45	B
Closure Bolting	LBS	Copper Alloy	Plant Indoor Air (Ext)	Loss of preload	Bolting Integrity (B2.1.7)	None	None	G
Closure Bolting	PB	Stainless Steel	Plant Indoor Air (Ext)	Loss of preload	Bolting Integrity (B2.1.7)	None	None	G
Flow Indicator	LBS, PB	Cast Iron	Plant Indoor Air (Ext)	Loss of material	External Surfaces Monitoring Program (B2.1.20)	VII.I-8	3.3.1.58	B
Flow Indicator	LBS	Cast Iron	Potable Water (Int)	Loss of material	Inspection Of Internal Surfaces In Miscellaneous Piping And Ducting Components (B2.1.22)	None	None	G
Flow Indicator	PB	Cast Iron	Raw Water (Int)	Loss of material	Fire Water System (B2.1.13)	VII.G-24	3.3.1.68	B

Section 3.3
AGING MANAGEMENT OF AUXILIARY SYSTEMS

Table 3.3.2-22 Auxiliary Systems – Summary of Aging Management Evaluation – Domestic Water System (Continued)

Component Type	Intended Function	Material	Environment	Aging Effect Requiring Management	Aging Management Program	NUREG-1801 Vol. 2 Item	Table 1 Item	Notes
Piping	LBS	Carbon Steel	Plant Indoor Air (Ext)	Loss of material	External Surfaces Monitoring Program (B2.1.20)	VII.I-8	3.3.1.58	B
Piping	LBS	Carbon Steel	Potable Water (Int)	Loss of material	Inspection Of Internal Surfaces In Miscellaneous Piping And Ducting Components (B2.1.22)	None	None	G
Piping	PB	Carbon Steel with Elastomer Lining	Plant Indoor Air (Ext)	Loss of material	External Surfaces Monitoring Program (B2.1.20)	VII.I-8	3.3.1.58	B
Piping	PB	Carbon Steel with Elastomer Lining	Raw Water (Int)	Loss of material	Fire Water System (B2.1.13)	VII.G-24	3.3.1.68	B
Piping	LBS	Copper Alloy	Plant Indoor Air (Ext)	None	None	VIII.I-2	3.4.1.41	A
Piping	LBS	Copper Alloy	Potable Water (Int)	Loss of material	Inspection Of Internal Surfaces In Miscellaneous Piping And Ducting Components (B2.1.22)	None	None	G
Piping	PB	Polyethylene	Buried (Ext)	None	None	None	None	F
Piping	PB	Polyethylene	Plant Indoor Air (Ext)	None	None	None	None	F
Piping	PB	Polyethylene	Raw Water (Int)	None	None	None	None	F

Section 3.3
AGING MANAGEMENT OF AUXILIARY SYSTEMS

Table 3.3.2-22 Auxiliary Systems – Summary of Aging Management Evaluation – Domestic Water System (Continued)

Component Type	Intended Function	Material	Environment	Aging Effect Requiring Management	Aging Management Program	NUREG-1801 Vol. 2 Item	Table 1 Item	Notes
Piping	PB	Stainless Steel	Plant Indoor Air (Ext)	None	None	VII.J-15	3.3.1.94	A
Piping	PB	Stainless Steel	Raw Water (Int)	Loss of material	Fire Water System (B2.1.13)	VII.G-19	3.3.1.69	B
Pump	PB	Cast Iron	Raw Water (Ext)	Loss of material	Fire Water System (B2.1.13)	VII.G-24	3.3.1.68	B
Pump	PB	Cast Iron	Raw Water (Int)	Loss of material	Fire Water System (B2.1.13)	VII.G-24	3.3.1.68	B
Pump	LBS	Copper Alloy	Plant Indoor Air (Ext)	None	None	VIII.I-2	3.4.1.41	A
Pump	LBS	Copper Alloy	Potable Water (Int)	Loss of material	Inspection Of Internal Surfaces In Miscellaneous Piping And Ducting Components (B2.1.22)	None	None	G
Strainer	LBS	Carbon Steel	Plant Indoor Air (Ext)	Loss of material	External Surfaces Monitoring Program (B2.1.20)	VII.I-8	3.3.1.58	B
Strainer	LBS	Carbon Steel	Potable Water (Int)	Loss of material	Inspection Of Internal Surfaces In Miscellaneous Piping And Ducting Components (B2.1.22)	None	None	G
Strainer	LBS	Copper Alloy	Plant Indoor Air (Ext)	None	None	VIII.I-2	3.4.1.41	A

Section 3.3
AGING MANAGEMENT OF AUXILIARY SYSTEMS

Table 3.3.2-22 Auxiliary Systems – Summary of Aging Management Evaluation – Domestic Water System (Continued)

Component Type	Intended Function	Material	Environment	Aging Effect Requiring Management	Aging Management Program	NUREG-1801 Vol. 2 Item	Table 1 Item	Notes
Strainer	LBS	Copper Alloy	Potable Water (Int)	Loss of material	Inspection Of Internal Surfaces In Miscellaneous Piping And Ducting Components (B2.1.22)	None	None	G
Tank	LBS	Carbon Steel	Plant Indoor Air (Ext)	Loss of material	External Surfaces Monitoring Program (B2.1.20)	VII.I-8	3.3.1.58	B
Tank	LBS	Carbon Steel	Potable Water (Int)	Loss of material	Inspection Of Internal Surfaces In Miscellaneous Piping And Ducting Components (B2.1.22)	None	None	G
Valve	PB	Cast Iron	Buried (Ext)	Loss of material	Buried Piping and Tanks Inspection (B2.1.18)	VII.G-25	3.3.1.19	B
Valve	PB	Cast Iron	Plant Indoor Air (Ext)	Loss of material	External Surfaces Monitoring Program (B2.1.20)	VII.I-8	3.3.1.58	B
Valve	PB	Cast Iron	Raw Water (Int)	Loss of material	Fire Water System (B2.1.13)	VII.G-24	3.3.1.68	B
Valve	LBS	Copper Alloy	Atmosphere/Weather (Ext)	Loss of material	External Surfaces Monitoring Program (B2.1.20)	None	None	G
Valve	LBS	Copper Alloy	Plant Indoor Air (Ext)	None	None	VIII.I-2	3.4.1.41	A

Section 3.3
AGING MANAGEMENT OF AUXILIARY SYSTEMS

Table 3.3.2-22 Auxiliary Systems – Summary of Aging Management Evaluation – Domestic Water System (Continued)

Component Type	Intended Function	Material	Environment	Aging Effect Requiring Management	Aging Management Program	NUREG-1801 Vol. 2 Item	Table 1 Item	Notes
Valve	LBS	Copper Alloy	Potable Water (Int)	Loss of material	Inspection Of Internal Surfaces In Miscellaneous Piping And Ducting Components (B2.1.22)	None	None	G
Valve	LBS, PB	Stainless Steel	Plant Indoor Air (Ext)	None	None	VII.J-15	3.3.1.94	A
Valve	LBS	Stainless Steel	Potable Water (Int)	Loss of material	Inspection Of Internal Surfaces In Miscellaneous Piping And Ducting Components (B2.1.22)	None	None	G
Valve	PB	Stainless Steel	Raw Water (Int)	Loss of material	Fire Water System (B2.1.13)	VII.G-19	3.3.1.69	B

Notes for Table 3.3.2-22:

Standard Notes:

- A Consistent with NUREG-1801 item for component, material, environment, and aging effect. AMP is consistent with NUREG-1801 AMP.
- B Consistent with NUREG-1801 item for component, material, environment, and aging effect. AMP takes some exceptions to NUREG-1801 AMP.
- F Material not in NUREG-1801 for this component.
- G Environment not in NUREG-1801 for this component and material.

Plant Specific Notes:

None

Section 3.3
AGING MANAGEMENT OF AUXILIARY SYSTEMS

Table 3.3.2-23 Auxiliary Systems – Summary of Aging Management Evaluation – Demineralized Water System

Component Type	Intended Function	Material	Environment	Aging Effect Requiring Management	Aging Management Program	NUREG-1801 Vol. 2 Item	Table 1 Item	Notes
Closure Bolting	LBS, SIA	Carbon Steel	Atmosphere/ Weather (Ext)	Loss of preload	Bolting Integrity (B2.1.7)	None	None	G, 1
Closure Bolting	LBS, SIA	Carbon Steel	Atmosphere/ Weather (Ext)	Loss of material	Bolting Integrity (B2.1.7)	VII.I-1	3.3.1.43	B
Closure Bolting	LBS, PB, SIA	Carbon Steel	Plant Indoor Air (Ext)	Loss of material	Bolting Integrity (B2.1.7)	VII.I-4	3.3.1.43	B
Closure Bolting	LBS, PB, SIA	Carbon Steel	Plant Indoor Air (Ext)	Loss of preload	Bolting Integrity (B2.1.7)	VII.I-5	3.3.1.45	B
Closure Bolting	LBS, SIA	Stainless Steel	Plant Indoor Air (Ext)	Loss of preload	Bolting Integrity (B2.1.7)	None	None	G, 1
Piping	LBS, SIA	Stainless Steel	Atmosphere/ Weather (Ext)	None	None	None	None	G, 2
Piping	LBS, PB, SIA	Stainless Steel	Demineralized Water (Int)	Loss of material	Water Chemistry (B2.1.2) and One-Time Inspection (B2.1.16)	VIII.E-29	3.4.1.16	A
Piping	LBS, PB, SIA	Stainless Steel	Plant Indoor Air (Ext)	None	None	VII.J-15	3.3.1.94	A
Valve	LBS	Stainless Steel	Atmosphere/ Weather (Ext)	None	None	None	None	G, 2
Valve	LBS, PB, SIA	Stainless Steel	Demineralized Water (Int)	Loss of material	Water Chemistry (B2.1.2) and One-Time Inspection (B2.1.16)	VIII.E-29	3.4.1.16	A
Valve	LBS, PB, SIA	Stainless Steel	Plant Indoor Air (Ext)	None	None	VII.J-15	3.3.1.94	A

Section 3.3
AGING MANAGEMENT OF AUXILIARY SYSTEMS

Notes for Table 3.3.2-23:

Standard Notes:

- A Consistent with NUREG-1801 item for component, material, environment, and aging effect. AMP is consistent with NUREG-1801 AMP.
- B Consistent with NUREG-1801 item for component, material, environment, and aging effect. AMP takes some exceptions to NUREG-1801 AMP.
- G Environment not in NUREG-1801 for this component and material.

Plant Specific Notes:

- 1 Loss of Preload is considered to be applicable for all closure bolting.
- 2 The PVNGS plant outdoor environment is not subject to aggressive contaminants or saline environment. Stainless steel does not experience any appreciable aging effects in this environment.

Section 3.3
AGING MANAGEMENT OF AUXILIARY SYSTEMS

Table 3.3.2-24 Auxiliary Systems – Summary of Aging Management Evaluation – WRF Fuel System

Component Type	Intended Function	Material	Environment	Aging Effect Requiring Management	Aging Management Program	NUREG-1801 Vol. 2 Item	Table 1 Item	Notes
Closure Bolting	PB	Carbon Steel	Atmosphere/ Weather (Ext)	Loss of preload	Bolting Integrity (B2.1.7)	None	None	G, 1
Closure Bolting	PB	Carbon Steel	Atmosphere/ Weather (Ext)	Loss of material	Bolting Integrity (B2.1.7)	VII.I-1	3.3.1.43	B
Filter	FIL, PB	Carbon Steel	Atmosphere/ Weather (Ext)	Loss of material	External Surfaces Monitoring Program (B2.1.20)	VII.H1-8	3.3.1.60	B
Filter	FIL, PB	Carbon Steel	Fuel Oil (Int)	Loss of material	Fuel Oil Chemistry (B2.1.14) and One-Time Inspection (B2.1.16)	VII.H1-10	3.3.1.20	B
Flame Arrestor	PB	Aluminum	Atmosphere/ Weather (Ext)	Loss of material	External Surfaces Monitoring Program (B2.1.20)	None	None	G
Flame Arrestor	PB	Aluminum	Fuel Oil (Int)	Loss of material	Fuel Oil Chemistry (B2.1.14) and One-Time Inspection (B2.1.16)	VII.H1-1	3.3.1.32	D
Flexible Hoses	PB	Stainless Steel	Atmosphere/ Weather (Ext)	None	None	None	None	G
Flexible Hoses	PB	Stainless Steel	Fuel Oil (Int)	Loss of material	Fuel Oil Chemistry (B2.1.14) and One-Time Inspection (B2.1.16)	VII.H1-6	3.3.1.32	B
Flow Indicator	PB	Cast Iron (Gray Cast Iron)	Atmosphere/ Weather (Ext)	Loss of material	External Surfaces Monitoring Program (B2.1.20)	VII.H1-8	3.3.1.60	B, 2

Section 3.3
AGING MANAGEMENT OF AUXILIARY SYSTEMS

Table 3.3.2-24 Auxiliary Systems – Summary of Aging Management Evaluation – WRF Fuel System (Continued)

Component Type	Intended Function	Material	Environment	Aging Effect Requiring Management	Aging Management Program	NUREG-1801 Vol. 2 Item	Table 1 Item	Notes
Flow Indicator	PB	Cast Iron (Gray Cast Iron)	Fuel Oil (Int)	Loss of material	Fuel Oil Chemistry (B2.1.14) and One-Time Inspection (B2.1.16)	VII.H1-10	3.3.1.20	B
Piping	PB	Carbon Steel	Atmosphere/Weather (Ext)	Loss of material	External Surfaces Monitoring Program (B2.1.20)	VII.H1-8	3.3.1.60	B
Piping	PB	Carbon Steel	Buried (Ext)	Loss of material	Buried Piping and Tanks Inspection (B2.1.18)	VII.H1-9	3.3.1.19	B
Piping	PB	Carbon Steel	Encased in Concrete (Ext)	None	None	VII.J-21	3.3.1.96	A
Piping	PB	Carbon Steel	Fuel Oil (Int)	Loss of material	Fuel Oil Chemistry (B2.1.14) and One-Time Inspection (B2.1.16)	VII.H1-10	3.3.1.20	B
Pump	PB	Carbon Steel	Atmosphere/Weather (Ext)	Loss of material	External Surfaces Monitoring Program (B2.1.20)	VII.H1-8	3.3.1.60	B
Pump	PB	Carbon Steel	Fuel Oil (Int)	Loss of material	Fuel Oil Chemistry (B2.1.14) and One-Time Inspection (B2.1.16)	VII.H1-10	3.3.1.20	B
Sight Gauge	PB	Copper Alloy	Atmosphere/Weather (Ext)	Loss of material	External Surfaces Monitoring Program (B2.1.20)	None	None	G
Sight Gauge	PB	Copper Alloy	Fuel Oil (Int)	Loss of material	Fuel Oil Chemistry (B2.1.14) and One-Time Inspection (B2.1.16)	VII.H1-3	3.3.1.32	B
Sight Gauge	PB	Glass	Atmosphere/Weather (Ext)	None	None	None	None	G
Sight Gauge	PB	Glass	Fuel Oil (Int)	None	None	VII.J-9	3.3.1.93	A

Section 3.3
AGING MANAGEMENT OF AUXILIARY SYSTEMS

Table 3.3.2-24 Auxiliary Systems – Summary of Aging Management Evaluation – WRF Fuel System (Continued)

Component Type	Intended Function	Material	Environment	Aging Effect Requiring Management	Aging Management Program	NUREG-1801 Vol. 2 Item	Table 1 Item	Notes
Strainer	PB	Copper Alloy	Atmosphere/ Weather (Ext)	Loss of material	External Surfaces Monitoring Program (B2.1.20)	None	None	G
Strainer	PB	Copper Alloy	Fuel Oil (Int)	Loss of material	Fuel Oil Chemistry (B2.1.14) and One-Time Inspection (B2.1.16)	VII.H1-3	3.3.1.32	B
Tank	PB	Carbon Steel	Atmosphere/ Weather (Ext)	Loss of material	External Surfaces Monitoring Program (B2.1.20)	VII.H1-8	3.3.1.60	D
Tank	PB	Carbon Steel	Fuel Oil (Int)	Loss of material	Fuel Oil Chemistry (B2.1.14) and One-Time Inspection (B2.1.16)	VII.H1-10	3.3.1.20	B
Valve	PB, PR	Aluminum	Atmosphere/ Weather (Ext)	Loss of material	External Surfaces Monitoring Program (B2.1.20)	None	None	G
Valve	PB, PR	Aluminum	Fuel Oil (Int)	Loss of material	Fuel Oil Chemistry (B2.1.14) and One-Time Inspection (B2.1.16)	VII.H1-1	3.3.1.32	B
Valve	PB	Carbon Steel	Atmosphere/ Weather (Ext)	Loss of material	External Surfaces Monitoring Program (B2.1.20)	VII.H1-8	3.3.1.60	B
Valve	PB	Carbon Steel	Fuel Oil (Int)	Loss of material	Fuel Oil Chemistry (B2.1.14) and One-Time Inspection (B2.1.16)	VII.H1-10	3.3.1.20	B
Valve	PB	Copper Alloy	Atmosphere/ Weather (Ext)	Loss of material	External Surfaces Monitoring Program (B2.1.20)	None	None	G

Section 3.3
AGING MANAGEMENT OF AUXILIARY SYSTEMS

Table 3.3.2-24 Auxiliary Systems – Summary of Aging Management Evaluation – WRF Fuel System (Continued)

Component Type	Intended Function	Material	Environment	Aging Effect Requiring Management	Aging Management Program	NUREG-1801 Vol. 2 Item	Table 1 Item	Notes
Valve	PB	Copper Alloy	Fuel Oil (Int)	Loss of material	Fuel Oil Chemistry (B2.1.14) and One-Time Inspection (B2.1.16)	VII.H1-3	3.3.1.32	B
Vent (Emergency)	PB, PR	Aluminum	Atmosphere/Weather (Ext)	Loss of material	External Surfaces Monitoring Program (B2.1.20)	None	None	G
Vent (Emergency)	PB, PR	Aluminum	Fuel Oil (Int)	Loss of material	Fuel Oil Chemistry (B2.1.14) and One-Time Inspection (B2.1.16)	VII.H1-1	3.3.1.32	B
Vent (Emergency)	PB, PR	Carbon Steel	Atmosphere/Weather (Ext)	Loss of material	External Surfaces Monitoring Program (B2.1.20)	VII.I-9	3.3.1.58	B
Vent (Emergency)	PB, PR	Carbon Steel	Fuel Oil (Int)	Loss of material	Fuel Oil Chemistry (B2.1.14) and One-Time Inspection (B2.1.16)	VII.H1-10	3.3.1.20	B

Notes for Table 3.3.2-24

Standard Notes:

- A Consistent with NUREG-1801 item for component, material, environment, and aging effect. AMP is consistent with NUREG-1801 AMP.
- B Consistent with NUREG-1801 item for component, material, environment, and aging effect. AMP takes some exceptions to NUREG-1801 AMP.
- D Component is different, but consistent with NUREG-1801 item for material, environment, and aging effect. AMP takes some exceptions to NUREG-1801 AMP.
- G Environment not in NUREG-1801 for this component and material.

Plant Specific Notes:

- 1 Loss of Preload is considered to be applicable for all closure bolting.
- 2 The Mechanical Tools (EPRI Report 1010639), Revision 4, Appendix E, "External Surfaces", Section 4.4 states: "Cast iron is included with "steel" in NUREG-1801 for environments addressed by this tool, except where gray cast iron is identified in "soil" environments".

Section 3.3
AGING MANAGEMENT OF AUXILIARY SYSTEMS

Table 3.3.2-25 Auxiliary Systems – Summary of Aging Management Evaluation – Service Gases (N2 and H2) System

Component Type	Intended Function	Material	Environment	Aging Effect Requiring Management	Aging Management Program	NUREG-1801 Vol. 2 Item	Table 1 Item	Notes
Closure Bolting	S/A	Carbon Steel	Plant Indoor Air (Ext)	Loss of material	Bolting Integrity (B2.1.7)	VII.I-4	3.3.1.43	B
Closure Bolting	S/A	Carbon Steel	Plant Indoor Air (Ext)	Loss of preload	Bolting Integrity (B2.1.7)	VII.I-5	3.3.1.45	B
Filter	PB	Carbon Steel	Dry Gas (Int)	None	None	VII.J-22	3.3.1.98	A
Filter	PB	Carbon Steel	Plant Indoor Air (Ext)	Loss of material	External Surfaces Monitoring Program (B2.1.20)	VII.I-8	3.3.1.58	B
Flexible Hoses	PB	Stainless Steel	Dry Gas (Int)	None	None	VII.J-18	3.3.1.98	A
Flexible Hoses	PB	Stainless Steel	Plant Indoor Air (Ext)	None	None	VII.J-15	3.3.1.94	A
Orifice	S/A	Stainless Steel	Dry Gas (Int)	None	None	VII.J-18	3.3.1.98	A
Orifice	S/A	Stainless Steel	Plant Indoor Air (Ext)	None	None	VII.J-15	3.3.1.94	A
Piping	PB, S/A	Carbon Steel	Dry Gas (Int)	None	None	VII.J-22	3.3.1.98	A
Piping	PB, S/A	Carbon Steel	Plant Indoor Air (Ext)	Loss of material	External Surfaces Monitoring Program (B2.1.20)	VII.I-8	3.3.1.58	B
Piping	PB	Stainless Steel	Dry Gas (Int)	None	None	VII.J-18	3.3.1.98	A
Piping	PB	Stainless Steel	Plant Indoor Air (Ext)	None	None	VII.J-15	3.3.1.94	A
Valve	PB, S/A	Carbon Steel	Dry Gas (Int)	None	None	VII.J-22	3.3.1.98	A
Valve	PB, S/A	Carbon Steel	Plant Indoor Air (Ext)	Loss of material	External Surfaces Monitoring Program (B2.1.20)	VII.I-8	3.3.1.58	B

Section 3.3
AGING MANAGEMENT OF AUXILIARY SYSTEMS

Table 3.3.2-25 Auxiliary Systems – Summary of Aging Management Evaluation – Service Gases (N2 and H2) System (Continued)

Component Type	Intended Function	Material	Environment	Aging Effect Requiring Management	Aging Management Program	NUREG-1801 Vol. 2 Item	Table 1 Item	Notes
Valve	PB	Stainless Steel	Dry Gas (Int)	None	None	VII.J-18	3.3.1.98	A
Valve	PB	Stainless Steel	Plant Indoor Air (Ext)	None	None	VII.J-15	3.3.1.94	A

Notes for Table 3.3.2-25:

Standard Notes:

- A Consistent with NUREG-1801 item for component, material, environment, and aging effect. AMP is consistent with NUREG-1801 AMP.
- B Consistent with NUREG-1801 item for component, material, environment, and aging effect. AMP takes some exceptions to NUREG-1801 AMP.

Plant Specific Notes:

None

Section 3.3
AGING MANAGEMENT OF AUXILIARY SYSTEMS

Table 3.3.2-26 Auxiliary Systems – Summary of Aging Management Evaluation – Gaseous Radwaste System

Component Type	Intended Function	Material	Environment	Aging Effect Requiring Management	Aging Management Program	NUREG-1801 Vol. 2 Item	Table 1 Item	Notes
Closure Bolting	LBS, PB, SIA	Carbon Steel	Plant Indoor Air (Ext)	Loss of material	Bolting Integrity (B2.1.7)	VII.I-4	3.3.1.43	B
Closure Bolting	LBS, PB, SIA	Carbon Steel	Plant Indoor Air (Ext)	Loss of preload	Bolting Integrity (B2.1.7)	VII.I-5	3.3.1.45	B
Piping	LBS, PB, SIA	Stainless Steel	Plant Indoor Air (Ext)	None	None	VII.J-15	3.3.1.94	A
Piping	LBS	Stainless Steel	Raw Water (Int)	Loss of material	Inspection Of Internal Surfaces In Miscellaneous Piping And Ducting Components (B2.1.22)	VII.C1-15	3.3.1.79	E, 1
Piping	PB, SIA	Stainless Steel	Wetted Gas (Int)	Loss of material	Inspection Of Internal Surfaces In Miscellaneous Piping And Ducting Components (B2.1.22)	VII.F2-1	3.3.1.27	E
Sight Gauge	LBS	Glass	Plant Indoor Air (Ext)	None	None	VII.J-8	3.3.1.93	A
Sight Gauge	LBS	Glass	Raw Water (Int)	None	None	VII.J-11	3.3.1.93	A
Sight Gauge	LBS	Stainless Steel	Plant Indoor Air (Ext)	None	None	VII.J-15	3.3.1.94	A
Sight Gauge	LBS	Stainless Steel	Raw Water (Int)	Loss of material	Inspection Of Internal Surfaces In Miscellaneous Piping And Ducting Components (B2.1.22)	VII.C1-15	3.3.1.79	E, 1
Tubing	LBS	Stainless Steel	Plant Indoor Air (Ext)	None	None	VII.J-15	3.3.1.94	A
Tubing	LBS	Stainless Steel	Raw Water (Int)	Loss of material	Inspection Of Internal Surfaces In Miscellaneous Piping And Ducting Components (B2.1.22)	VII.C1-15	3.3.1.79	E, 1

Section 3.3
AGING MANAGEMENT OF AUXILIARY SYSTEMS

Table 3.3.2-26 Auxiliary Systems – Summary of Aging Management Evaluation – Gaseous Radwaste System (Continued)

Component Type	Intended Function	Material	Environment	Aging Effect Requiring Management	Aging Management Program	NUREG-1801 Vol. 2 Item	Table 1 Item	Notes
Valve	LBS, PB	Stainless Steel	Plant Indoor Air (Ext)	None	None	VII.J-15	3.3.1.94	A
Valve	LBS	Stainless Steel	Raw Water (Int)	Loss of material	Inspection Of Internal Surfaces In Miscellaneous Piping And Ducting Components (B2.1.22)	VII.C1-15	3.3.1.79	E, 1
Valve	PB	Stainless Steel	Wetted Gas (Int)	Loss of material	Inspection Of Internal Surfaces In Miscellaneous Piping And Ducting Components (B2.1.22)	VII.F2-1	3.3.1.27	E

Notes for Table 3.3.2-26:

Standard Notes:

- A Consistent with NUREG-1801 item for component, material, environment, and aging effect. AMP is consistent with NUREG-1801 AMP.
- B Consistent with NUREG-1801 item for component, material, environment, and aging effect. AMP takes some exceptions to NUREG-1801 AMP.

- E Consistent with NUREG-1801 for material, environment, and aging effect, but a different aging management program is credited or NUREG-1801 identifies a plant-specific aging management program.

Plant Specific Note:

- 1 The internal component environment of the gaseous radwaste system where gas that has condensed to water may be found is evaluated as a raw water environment. Loss of material on internal component surfaces exposed to the solid radwaste internal environment will be managed by Inspection of Internal Surfaces in Miscellaneous Piping and Ducting Components program (B2.1.22) instead of Open-Cycle Cooling Water System program (B2.1.9).

Section 3.3
AGING MANAGEMENT OF AUXILIARY SYSTEMS

Table 3.3.2-27 Auxiliary Systems – Summary of Aging Management Evaluation – Radioactive Waste Drains System

Component Type	Intended Function	Material	Environment	Aging Effect Requiring Management	Aging Management Program	NUREG-1801 Vol. 2 Item	Table 1 Item	Notes
Closure Bolting	LBS	Carbon Steel	Borated Water Leakage (Ext)	Loss of preload	Bolting Integrity (B2.1.7)	IV.C2-8	3.1.1.52	B
Closure Bolting	LBS	Carbon Steel	Borated Water Leakage (Ext)	Loss of material	Boric Acid Corrosion (B2.1.4)	VII.I-10	3.3.1.89	A
Closure Bolting	LBS	Stainless Steel	Plant Indoor Air (Ext)	Loss of preload	Bolting Integrity (B2.1.7)	None	None	G, 1
Orifice	LBS	Stainless Steel	Atmosphere/Weather (Ext)	None	None	None	None	G
Orifice	LBS	Stainless Steel	Plant Indoor Air (Ext)	None	None	VII.J-15	3.3.1.94	A
Orifice	LBS	Stainless Steel	Raw Water (Int)	Loss of material	Inspection Of Internal Surfaces In Miscellaneous Piping And Ducting Components (B2.1.22)	VII.C1-15	3.3.1.79	E, 2
Piping	LBS	Carbon Steel	Borated Water Leakage (Ext)	Loss of material	Boric Acid Corrosion (B2.1.4)	VII.I-10	3.3.1.89	A
Piping	LBS	Carbon Steel	Raw Water (Int)	Loss of material	Inspection Of Internal Surfaces In Miscellaneous Piping And Ducting Components (B2.1.22)	VII.C1-19	3.3.1.76	E, 2
Piping	LBS	Stainless Steel	Atmosphere/Weather (Ext)	None	None	None	None	G
Piping	LBS, SIA	Stainless Steel	Borated Water Leakage (Ext)	None	None	VII.J-16	3.3.1.99	A

Section 3.3
AGING MANAGEMENT OF AUXILIARY SYSTEMS

Table 3.3.2-27 Auxiliary Systems – Summary of Aging Management Evaluation – Radioactive Waste Drains System (Continued)

Component Type	Intended Function	Material	Environment	Aging Effect Requiring Management	Aging Management Program	NUREG-1801 Vol. 2 Item	Table 1 Item	Notes
Piping	LBS	Stainless Steel	DeminerIALIZED Water (Int)	Loss of material	Water Chemistry (B2.1.2) and One-Time Inspection (B2.1.16)	VIII.E-29	3.4.1.16	A
Piping	PB	Stainless Steel	Encased in Concrete (Ext)	None	None	VII.J-17	3.3.1.96	A
Piping	LBS, PB, S/A	Stainless Steel	Plant Indoor Air (Ext)	None	None	VII.J-15	3.3.1.94	A
Piping	LBS, PB, S/A	Stainless Steel	Raw Water (Int)	Loss of material	Inspection Of Internal Surfaces In Miscellaneous Piping And Ducting Components (B2.1.22)	VII.C1-15	3.3.1.79	E, 2
Piping	LBS, S/A	Stainless Steel	Treated Borated Water (Int)	Loss of material	Water Chemistry (B2.1.2)	VII.E1-17	3.3.1.91	A
Sight Gauge	LBS	Cast Iron	Plant Indoor Air (Ext)	Loss of material	External Surfaces Monitoring Program (B2.1.20)	VII.I-8	3.3.1.58	B
Sight Gauge	LBS	Cast Iron	Raw Water (Int)	Loss of material	Inspection Of Internal Surfaces In Miscellaneous Piping And Ducting Components (B2.1.22)	VII.C1-19	3.3.1.76	E, 2
Sight Gauge	LBS	Glass	Plant Indoor Air (Ext)	None	None	VII.J-8	3.3.1.93	A
Sight Gauge	LBS	Glass	Raw Water (Int)	None	None	VII.J-11	3.3.1.93	A
Strainer	LBS	Stainless Steel	Atmosphere/Weather (Ext)	None	None	None	None	G

Section 3.3
AGING MANAGEMENT OF AUXILIARY SYSTEMS

Table 3.3.2-27 Auxiliary Systems – Summary of Aging Management Evaluation – Radioactive Waste Drains System (Continued)

Component Type	Intended Function	Material	Environment	Aging Effect Requiring Management	Aging Management Program	NUREG-1801 Vol. 2 Item	Table 1 Item	Notes
Strainer	LBS	Stainless Steel	Demineralized Water (Int)	Loss of material	Water Chemistry (B2.1.2) and One-Time Inspection (B2.1.16)	VIII.E-29	3.4.1.16	A
Strainer	LBS	Stainless Steel	Plant Indoor Air (Ext)	None	None	VII.J-15	3.3.1.94	A
Tubing	LBS	Stainless Steel	Demineralized Water (Int)	Loss of material	Water Chemistry (B2.1.2) and One-Time Inspection (B2.1.16)	VIII.E-29	3.4.1.16	A
Tubing	LBS, PB	Stainless Steel	Plant Indoor Air (Ext)	None	None	VII.J-15	3.3.1.94	A
Tubing	LBS, PB	Stainless Steel	Raw Water (Int)	Loss of material	Inspection Of Internal Surfaces In Miscellaneous Piping And Ducting Components (B2.1.22)	VII.C1-15	3.3.1.79	E, 2
Valve	LBS	Carbon Steel	Borated Water Leakage (Ext)	Loss of material	Boric Acid Corrosion (B2.1.4)	VII.I-10	3.3.1.89	A
Valve	LBS	Carbon Steel	Raw Water (Int)	Loss of material	Inspection Of Internal Surfaces In Miscellaneous Piping And Ducting Components (B2.1.22)	VII.C1-19	3.3.1.76	E, 2
Valve	LBS	Stainless Steel	Atmosphere/Weather (Ext)	None	None	None	None	G
Valve	LBS	Stainless Steel	Borated Water Leakage (Ext)	None	None	VII.J-16	3.3.1.99	A
Valve	LBS	Stainless Steel	Demineralized Water (Int)	Loss of material	Water Chemistry (B2.1.2) and One-Time Inspection (B2.1.16)	VIII.E-29	3.4.1.16	A

Table 3.3.2-27 Auxiliary Systems – Summary of Aging Management Evaluation – Radioactive Waste Drains System (Continued)

Component Type	Intended Function	Material	Environment	Aging Effect Requiring Management	Aging Management Program	NUREG-1801 Vol. 2 Item	Table 1 Item	Notes
Valve	LBS, PB	Stainless Steel	Plant Indoor Air (Ext)	None	None	VII.J-15	3.3.1.94	A
Valve	LBS, PB	Stainless Steel	Raw Water (Int)	Loss of material	Inspection Of Internal Surfaces In Miscellaneous Piping And Ducting Components (B2.1.22)	VII.C1-15	3.3.1.79	E, 2
Valve	LBS	Stainless Steel	Treated Borated Water (Int)	Loss of material	Water Chemistry (B2.1.2)	VII.E1-17	3.3.1.91	A

Notes for Table 3.3.2-27:

Standard Notes:

- A Consistent with NUREG-1801 item for component, material, environment, and aging effect. AMP is consistent with NUREG-1801 AMP.
- B Consistent with NUREG-1801 item for component, material, environment, and aging effect. AMP takes some exceptions to NUREG-1801 AMP.
- E Consistent with NUREG-1801 for material, environment, and aging effect, but a different aging management program is credited or NUREG-1801 identifies a plant-specific aging management program.
- G Environment not in NUREG-1801 for this component and material.

Plant Specific Notes:

- 1 Loss of Preload is considered to be applicable for all closure bolting.
- 2 The component environment for radioactive waste drains that has been evaluated as a raw water environment. Loss of material on internal component surface exposed to floor and equipment drains environment will be managed by Inspection of Internal Surfaces in Miscellaneous Piping and Ducting Components program (B2.1.22) instead of the Open-Cycle Cooling Water System program (B2.1.9).

Section 3.3
AGING MANAGEMENT OF AUXILIARY SYSTEMS

Table 3.3.2-28 Auxiliary Systems – Summary of Aging Management Evaluation – Station Blackout Generator System

Component Type	Intended Function	Material	Environment	Aging Effect Requiring Management	Aging Management Program	NUREG-1801 Vol. 2 Item	Table 1 Item	Notes
Accumulator	PB	Carbon Steel	Plant Indoor Air (Ext)	Loss of material	External Surfaces Monitoring Program (B2.1.20)	VII.I-8	3.3.1.58	B
Accumulator	PB	Carbon Steel	Ventilation Atmosphere (Int)	Loss of material	Inspection Of Internal Surfaces In Miscellaneous Piping And Ducting Components (B2.1.22)	VII.G-23	3.3.1.71	B
Closure Bolting	PB	Carbon Steel	Plant Indoor Air (Ext)	Loss of material	Bolting Integrity (B2.1.7)	VII.I-4	3.3.1.43	B
Closure Bolting	PB	Carbon Steel	Plant Indoor Air (Ext)	Loss of preload	Bolting Integrity (B2.1.7)	VII.I-5	3.3.1.45	B
Closure Bolting	PB	Stainless Steel	Plant Indoor Air (Ext)	Loss of preload	Bolting Integrity (B2.1.7)	None	None	G
Filter	FIL, PB	Aluminum	Fuel Oil (Int)	Loss of material	Fuel Oil Chemistry (B2.1.14) and One-Time Inspection (B2.1.16)	VII.H2-7	3.3.1.32	B
Filter	FIL, PB	Aluminum	Plant Indoor Air (Ext)	None	None	V.F-2	3.2.1.50	A
Filter	FIL, PB	Aluminum	Ventilation Atmosphere (Int)	None	None	V.F-2	3.2.1.50	A
Filter	FIL, PB	Carbon Steel	Fuel Oil (Int)	Loss of material	Fuel Oil Chemistry (B2.1.14) and One-Time Inspection (B2.1.16)	VII.H2-24	3.3.1.20	B

Section 3.3
AGING MANAGEMENT OF AUXILIARY SYSTEMS

Table 3.3.2-28 Auxiliary Systems – Summary of Aging Management Evaluation – Station Blackout Generator System (Continued)

Component Type	Intended Function	Material	Environment	Aging Effect Requiring Management	Aging Management Program	NUREG-1801 Vol. 2 Item	Table 1 Item	Notes
Filter	FIL, PB	Carbon Steel	Hydraulic Fluid (Int)	Loss of material	Lubricating Oil Analysis (B2.1.23) and One-Time Inspection (B2.1.16)	VII.H2-20	3.3.1.14	B
Filter	FIL, PB	Carbon Steel	Lubricating Oil (Int)	Loss of material	Lubricating Oil Analysis (B2.1.23) and One-Time Inspection (B2.1.16)	VII.H2-20	3.3.1.14	B
Filter	FIL, PB	Carbon Steel	Plant Indoor Air (Ext)	Loss of material	External Surfaces Monitoring Program (B2.1.20)	VII.I-8	3.3.1.58	B
Filter	FIL, PB	Stainless Steel	Plant Indoor Air (Ext)	None	None	VII.J-15	3.3.1.94	A
Filter	FIL, PB	Stainless Steel	Wetted Gas (Int)	Loss of material	Inspection Of Internal Surfaces In Miscellaneous Piping And Ducting Components (B2.1.22)	V.D1-29	3.2.1.08	E
Heat Exchanger (Generator Bearing Oil)	HT, PB	Copper Alloy	Lubricating Oil (Int)	Loss of material	Lubricating Oil Analysis (B2.1.23) and One-Time Inspection (B2.1.16)	VII.H2-10	3.3.1.26	B
Heat Exchanger (Generator Bearing Oil)	HT, PB	Copper Alloy	Lubricating Oil (Int)	Reduction of heat transfer	Lubricating Oil Analysis (B2.1.23) and One-Time Inspection (B2.1.16)	VIII.G-8	3.4.1.10	B
Heat Exchanger (Generator Bearing Oil)	HT, PB	Copper Alloy	Plant Indoor Air (Ext)	None	None	VIII.I-2	3.4.1.41	C

Section 3.3
AGING MANAGEMENT OF AUXILIARY SYSTEMS

Table 3.3.2-28 Auxiliary Systems – Summary of Aging Management Evaluation – Station Blackout Generator System (Continued)

Component Type	Intended Function	Material	Environment	Aging Effect Requiring Management	Aging Management Program	NUREG-1801 Vol. 2 Item	Table 1 Item	Notes
Heat Exchanger (Lube Oil)	HT	Aluminum	Atmosphere/Weather (Ext)	Loss of material	External Surfaces Monitoring Program (B2.1.20)	None	None	G
Heat Exchanger (Lube Oil)	HT, PB	Carbon Steel	Atmosphere/Weather (Ext)	Loss of material	External Surfaces Monitoring Program (B2.1.20)	VII.H2-4	3.3.1.59	B
Heat Exchanger (Lube Oil)	HT, PB	Carbon Steel	Lubricating Oil (Int)	Loss of material	Lubricating Oil Analysis (B2.1.23) and One-Time Inspection (B2.1.16)	VII.H2-5	3.3.1.21	B
Heat Exchanger (Lube Oil)	HT, PB	Carbon Steel	Lubricating Oil (Int)	Reduction of heat transfer	Lubricating Oil Analysis (B2.1.23) and One-Time Inspection (B2.1.16)	VIII.G-15	3.4.1.10	B
Orifice	PB, TH	Carbon Steel	Fuel Oil (Int)	Loss of material	Fuel Oil Chemistry (B2.1.14) and One-Time Inspection (B2.1.16)	VII.H2-24	3.3.1.20	B
Orifice	PB, TH	Carbon Steel	Plant Indoor Air (Ext)	Loss of material	External Surfaces Monitoring Program (B2.1.20)	VII.I-8	3.3.1.58	B
Orifice	PB, TH	Stainless Steel	Fuel Oil (Int)	Loss of material	Fuel Oil Chemistry (B2.1.14) and One-Time Inspection (B2.1.16)	VII.H2-16	3.3.1.32	B
Orifice	PB, TH	Stainless Steel	Plant Indoor Air (Ext)	None	None	VII.J-15	3.3.1.94	A
Piping	PB	Carbon Steel	Fuel Oil (Int)	Loss of material	Fuel Oil Chemistry (B2.1.14) and One-Time Inspection (B2.1.16)	VII.H2-24	3.3.1.20	B
Piping	PB	Carbon Steel	Hydraulic Fluid (Int)	Loss of material	Lubricating Oil Analysis (B2.1.23) and One-Time Inspection (B2.1.16)	VII.H2-20	3.3.1.14	B

Section 3.3
AGING MANAGEMENT OF AUXILIARY SYSTEMS

Table 3.3.2-28 Auxiliary Systems – Summary of Aging Management Evaluation – Station Blackout Generator System (Continued)

Component Type	Intended Function	Material	Environment	Aging Effect Requiring Management	Aging Management Program	NUREG-1801 Vol. 2 Item	Table 1 Item	Notes
Piping	PB	Carbon Steel	Plant Indoor Air (Ext)	Loss of material	External Surfaces Monitoring Program (B2.1.20)	VII.I-8	3.3.1.58	B
Piping	PB	Carbon Steel	Ventilation Atmosphere (Int)	Loss of material	Inspection Of Internal Surfaces In Miscellaneous Piping And Ducting Components (B2.1.22)	VII.G-23	3.3.1.71	B
Piping	PB	Stainless Steel	Lubricating Oil (Int)	Loss of material	Lubricating Oil Analysis (B2.1.23) and One-Time Inspection (B2.1.16)	VII.H2-17	3.3.1.33	B
Piping	PB	Stainless Steel	Plant Indoor Air (Ext)	None	None	VII.J-15	3.3.1.94	A
Pump	PB	Aluminum	Fuel Oil (Int)	Loss of material	Fuel Oil Chemistry (B2.1.14) and One-Time Inspection (B2.1.16)	VII.H2-7	3.3.1.32	B
Pump	PB	Aluminum	Plant Indoor Air (Ext)	None	None	V.F-2	3.2.1.50	A
Pump	PB	Carbon Steel	Fuel Oil (Int)	Loss of material	Fuel Oil Chemistry (B2.1.14) and One-Time Inspection (B2.1.16)	VII.H2-24	3.3.1.20	B
Pump	PB	Carbon Steel	Lubricating Oil (Int)	Loss of material	Lubricating Oil Analysis (B2.1.23) and One-Time Inspection (B2.1.16)	VII.H2-20	3.3.1.14	B
Pump	PB	Carbon Steel	Plant Indoor Air (Ext)	Loss of material	External Surfaces Monitoring Program (B2.1.20)	VII.I-8	3.3.1.58	B

Section 3.3
AGING MANAGEMENT OF AUXILIARY SYSTEMS

Table 3.3.2-28 Auxiliary Systems – Summary of Aging Management Evaluation – Station Blackout Generator System (Continued)

Component Type	Intended Function	Material	Environment	Aging Effect Requiring Management	Aging Management Program	NUREG-1801 Vol. 2 Item	Table 1 Item	Notes
Pump	PB	Cast Iron	Fuel Oil (Int)	Loss of material	Fuel Oil Chemistry (B2.1.14) and One-Time Inspection (B2.1.16)	VII.H2-24	3.3.1.20	B
Pump	PB	Cast Iron	Lubricating Oil (Int)	Loss of material	Lubricating Oil Analysis (B2.1.23) and One-Time Inspection (B2.1.16)	VII.H2-20	3.3.1.14	B
Pump	PB	Cast Iron	Plant Indoor Air (Ext)	Loss of material	External Surfaces Monitoring Program (B2.1.20)	VII.I-8	3.3.1.58	B
Sight Gauge	PB	Glass	Lubricating Oil (Int)	None	None	VII.J-10	3.3.1.93	A
Sight Gauge	PB	Glass	Plant Indoor Air (Ext)	None	None	VII.J-8	3.3.1.93	A
Tank	PB	Carbon Steel	Fuel Oil (Int)	Loss of material	Fuel Oil Chemistry (B2.1.14) and One-Time Inspection (B2.1.16)	VII.H2-24	3.3.1.20	B
Tank	PB	Carbon Steel	Hydraulic Fluid (Int)	Loss of material	Lubricating Oil Analysis (B2.1.23) and One-Time Inspection (B2.1.16)	VII.H2-20	3.3.1.14	D
Tank	PB	Carbon Steel	Plant Indoor Air (Ext)	Loss of material	External Surfaces Monitoring Program (B2.1.20)	VII.I-8	3.3.1.58	B
Tubing	PB	Carbon Steel	Fuel Oil (Int)	Loss of material	Fuel Oil Chemistry (B2.1.14) and One-Time Inspection (B2.1.16)	VII.H2-24	3.3.1.20	B
Tubing	PB	Carbon Steel	Plant Indoor Air (Ext)	Loss of material	External Surfaces Monitoring Program (B2.1.20)	VII.I-8	3.3.1.58	B

Section 3.3
AGING MANAGEMENT OF AUXILIARY SYSTEMS

Table 3.3.2-28 Auxiliary Systems – Summary of Aging Management Evaluation – Station Blackout Generator System (Continued)

Component Type	Intended Function	Material	Environment	Aging Effect Requiring Management	Aging Management Program	NUREG-1801 Vol. 2 Item	Table 1 Item	Notes
Tubing	PB	Carbon Steel	Ventilation Atmosphere (Int)	Loss of material	Inspection Of Internal Surfaces In Miscellaneous Piping And Ducting Components (B2.1.22)	VII.G-23	3.3.1.71	B
Tubing	PB	Copper Alloy	Fuel Oil (Int)	Loss of material	Fuel Oil Chemistry (B2.1.14) and One-Time Inspection (B2.1.16)	VII.H2-9	3.3.1.32	B
Tubing	PB	Copper Alloy	Hydraulic Fluid (Int)	Loss of material	Lubricating Oil Analysis (B2.1.23) and One-Time Inspection (B2.1.16)	VII.H2-20	3.3.1.14	B
Tubing	PB	Copper Alloy	Lubricating Oil (Int)	Loss of material	Lubricating Oil Analysis (B2.1.23) and One-Time Inspection (B2.1.16)	VII.H2-10	3.3.1.26	B
Tubing	PB	Copper Alloy	Plant Indoor Air (Ext)	None	None	V.F-3	3.2.1.53	A
Tubing	PB	Stainless Steel	Lubricating Oil (Int)	Loss of material	Lubricating Oil Analysis (B2.1.23) and One-Time Inspection (B2.1.16)	VII.H2-17	3.3.1.33	B
Tubing	PB	Stainless Steel	Plant Indoor Air (Ext)	None	None	VII.J-15	3.3.1.94	A
Turbine	PB	Ductile Iron	Plant Indoor Air (Ext)	Loss of material	External Surfaces Monitoring Program (B2.1.20)	VII.I-8	3.3.1.58	B
Turbine	PB	Ductile Iron	Wetted Gas (Int)	Loss of material	Inspection Of Internal Surfaces In Miscellaneous Piping And Ducting Components (B2.1.22)	VII.H2-21	3.3.1.71	D

Section 3.3
AGING MANAGEMENT OF AUXILIARY SYSTEMS

Table 3.3.2-28 Auxiliary Systems – Summary of Aging Management Evaluation – Station Blackout Generator System (Continued)

Component Type	Intended Function	Material	Environment	Aging Effect Requiring Management	Aging Management Program	NUREG-1801 Vol. 2 Item	Table 1 Item	Notes
Valve	PB	Aluminum	Fuel Oil (Int)	Loss of material	Fuel Oil Chemistry (B2.1.14) and One-Time Inspection (B2.1.16)	VII.H2-7	3.3.1.32	B
Valve	PB	Aluminum	Lubricating Oil (Int)	Loss of material	Lubricating Oil Analysis (B2.1.23) and One-Time Inspection (B2.1.16)	None	None	G
Valve	PB	Aluminum	Plant Indoor Air (Ext)	None	None	V.F-2	3.2.1.50	A
Valve	PB	Aluminum	Ventilation Atmosphere (Int)	None	None	V.F-2	3.2.1.50	A
Valve	PB	Carbon Steel	Fuel Oil (Int)	Loss of material	Fuel Oil Chemistry (B2.1.14) and One-Time Inspection (B2.1.16)	VII.H2-24	3.3.1.20	B
Valve	PB	Carbon Steel	Hydraulic Fluid (Int)	Loss of material	Lubricating Oil Analysis (B2.1.23) and One-Time Inspection (B2.1.16)	VII.H2-20	3.3.1.14	B
Valve	PB	Carbon Steel	Lubricating Oil (Int)	Loss of material	Lubricating Oil Analysis (B2.1.23) and One-Time Inspection (B2.1.16)	VII.H2-20	3.3.1.14	B
Valve	PB	Carbon Steel	Plant Indoor Air (Ext)	Loss of material	External Surfaces Monitoring Program (B2.1.20)	VII.I-8	3.3.1.58	B
Valve	PB	Copper Alloy	Fuel Oil (Int)	Loss of material	Fuel Oil Chemistry (B2.1.14) and One-Time Inspection (B2.1.16)	VII.H2-9	3.3.1.32	B
Valve	PB	Copper Alloy	Hydraulic Fluid (Int)	Loss of material	Lubricating Oil Analysis (B2.1.23) and One-Time Inspection (B2.1.16)	VII.H2-10	3.3.1.26	B

Section 3.3
AGING MANAGEMENT OF AUXILIARY SYSTEMS

Table 3.3.2-28 Auxiliary Systems – Summary of Aging Management Evaluation – Station Blackout Generator System (Continued)

Component Type	Intended Function	Material	Environment	Aging Effect Requiring Management	Aging Management Program	NUREG-1801 Vol. 2 Item	Table 1 Item	Notes
Valve	PB	Copper Alloy	Lubricating Oil (Int)	Loss of material	Lubricating Oil Analysis (B2.1.23) and One-Time Inspection (B2.1.16)	VII.H2-10	3.3.1.26	B
Valve	PB	Copper Alloy	Plant Indoor Air (Ext)	None	None	V.F-3	3.2.1.53	A
Valve	PB	Copper Alloy	Wetted Gas (Int)	Loss of material	Inspection Of Internal Surfaces In Miscellaneous Piping And Ducting Components (B2.1.22)	VII.G-9	3.3.1.28	E
Valve	PB	Stainless Steel	Fuel Oil (Int)	Loss of material	Fuel Oil Chemistry (B2.1.14) and One-Time Inspection (B2.1.16)	VII.H2-16	3.3.1.32	B
Valve	PB	Stainless Steel	Hydraulic Fluid (Int)	Loss of material	Lubricating Oil Analysis (B2.1.23) and One-Time Inspection (B2.1.16)	VII.H2-17	3.3.1.33	B
Valve	PB	Stainless Steel	Lubricating Oil (Int)	Loss of material	Lubricating Oil Analysis (B2.1.23) and One-Time Inspection (B2.1.16)	VII.H2-17	3.3.1.33	B
Valve	PB	Stainless Steel	Plant Indoor Air (Ext)	None	None	VII.J-15	3.3.1.94	A
Valve	PB	Stainless Steel	Wetted Gas (Int)	Loss of material	Inspection Of Internal Surfaces In Miscellaneous Piping And Ducting Components (B2.1.22)	V.D1-29	3.2.1.08	E

Section 3.3
AGING MANAGEMENT OF AUXILIARY SYSTEMS

Notes for Table 3.3.2-28:

Standard Notes:

- A Consistent with NUREG-1801 item for component, material, environment, and aging effect. AMP is consistent with NUREG-1801 AMP.
- B Consistent with NUREG-1801 item for component, material, environment, and aging effect. AMP takes some exceptions to NUREG-1801 AMP.
- C Component is different, but consistent with NUREG-1801 item for material, environment, and aging effect. AMP is consistent with NUREG-1801 AMP.
- D Component is different, but consistent with NUREG-1801 item for material, environment, and aging effect. AMP takes some exceptions to NUREG-1801 AMP.
- E Consistent with NUREG-1801 for material, environment, and aging effect, but a different aging management program is credited or NUREG-1801 identifies a plant-specific aging management program.
- G Environment not in NUREG-1801 for this component and material.

Plant Specific Notes:

None.

Section 3.3
AGING MANAGEMENT OF AUXILIARY SYSTEMS

Table 3.3.2-29 Auxiliary Systems – Summary of Aging Management Evaluation – Cranes, Hoists, and Elevator System

Component Type	Intended Function	Material	Environment	Aging Effect Requiring Management	Aging Management Program	NUREG-1801 Vol. 2 Item	Table 1 Item	Notes
Crane	NSRS	Carbon Steel	Plant Indoor Air (Ext)	Loss of material	Inspection of Overhead Heavy Load and Light Load (Related to Refueling) Handling Systems (B2.1.11)	VII.B-3	3.3.1.73	A
Cranes - Rails	NSRS	Carbon Steel	Plant Indoor Air (Ext)	Loss of material	Inspection of Overhead Heavy Load and Light Load (Related to Refueling) Handling Systems (B2.1.11)	VII.B-1	3.3.1.74	A
Cranes - Rails	NSRS	Carbon Steel	Plant Indoor Air (Ext)	Loss of material	Inspection of Overhead Heavy Load and Light Load (Related to Refueling) Handling Systems (B2.1.11)	VII.B-3	3.3.1.73	C
Hoist	NSRS	Carbon Steel	Plant Indoor Air (Ext)	Loss of material	Inspection of Overhead Heavy Load and Light Load (Related to Refueling) Handling Systems (B2.1.11)	VII.B-3	3.3.1.73	C
Trolley	NSRS	Carbon Steel	Plant Indoor Air (Ext)	Loss of material	Inspection of Overhead Heavy Load and Light Load (Related to Refueling) Handling Systems (B2.1.11)	VII.B-3	3.3.1.73	C

Section 3.3
AGING MANAGEMENT OF AUXILIARY SYSTEMS

Notes for Table 3.3.2-29:

Standard Notes:

- A Consistent with NUREG-1801 item for component, material, environment, and aging effect. AMP is consistent with NUREG-1801 AMP.
- C Component is different, but consistent with NUREG-1801 item for material, environment, and aging effect. AMP is consistent with NUREG-1801 AMP.

Plant Specific Notes:

None.

Section 3.3
AGING MANAGEMENT OF AUXILIARY SYSTEMS

Table 3.3.2-30 Auxiliary Systems – Summary of Aging Management Evaluation - Miscellaneous Auxiliary Systems In-Scope ONLY based on Criterion 10 CFR 54.4(a)(2)

Component Type	Intended Function	Material	Environment	Aging Effect Requiring Management	Aging Management Program	NUREG-1801 Vol. 2 Item	Table 1 Item	Notes
Closure Bolting	LBS	Carbon Steel	Borated Water Leakage (Ext)	Loss of preload	Bolting Integrity (B2.1.7)	IV.C2-8	3.1.1.52	B
Closure Bolting	LBS	Carbon Steel	Borated Water Leakage (Ext)	Loss of material	Boric Acid Corrosion (B2.1.4)	V.E-2	3.2.1.45	A
Closure Bolting	LBS	Carbon Steel	Plant Indoor Air (Ext)	Loss of material	Bolting Integrity (B2.1.7)	VII.I-4	3.3.1.43	B
Closure Bolting	LBS	Carbon Steel	Plant Indoor Air (Ext)	Loss of preload	Bolting Integrity (B2.1.7)	VII.I-5	3.3.1.45	B
Closure Bolting	LBS, SIA	Carbon Steel	Plant Indoor Air (Ext)	Loss of material	Bolting Integrity (B2.1.7)	VIII.H-4	3.4.1.22	B
Closure Bolting	LBS, SIA	Carbon Steel	Plant Indoor Air (Ext)	Loss of preload	Bolting Integrity (B2.1.7)	VIII.H-5	3.4.1.22	B
Closure Bolting	LBS	Copper Alloy	Plant Indoor Air (Ext)	Loss of preload	Bolting Integrity (B2.1.7)	None	None	F, 1
Closure Bolting	LBS	Stainless Steel	Borated Water Leakage (Ext)	Loss of preload	Bolting Integrity (B2.1.7)	IV.C2-8	3.1.1.52	B
Closure Bolting	LBS, SIA	Stainless Steel	Plant Indoor Air (Ext)	Loss of preload	Bolting Integrity (B2.1.7)	None	None	G, 1
Filter	LBS	Stainless Steel	Borated Water Leakage (Ext)	None	None	V.F-13	3.2.1.57	A
Filter	LBS	Stainless Steel	Treated Borated Water (Int)	Loss of material	Water Chemistry (B2.1.2)	V.A-27	3.2.1.49	A

Section 3.3
AGING MANAGEMENT OF AUXILIARY SYSTEMS

Table 3.3.2-30 Auxiliary Systems – Summary of Aging Management Evaluation - Miscellaneous Auxiliary Systems In-Scope ONLY based on Criterion 10 CFR 54.4(a)(2) (Continued)

Component Type	Intended Function	Material	Environment	Aging Effect Requiring Management	Aging Management Program	NUREG-1801 Vol. 2 Item	Table 1 Item	Notes
Heat Exchanger (AS Condensate Vent Condenser)	LBS	Carbon Steel	Closed-Cycle Cooling Water (Int)	Loss of material	Closed-Cycle Cooling Water System (B2.1.10)	VIII.A-1	3.4.1.24	B
Heat Exchanger (AS Condensate Vent Condenser)	LBS	Carbon Steel	Plant Indoor Air (Ext)	Loss of material	External Surfaces Monitoring Program (B2.1.20)	VIII.H-7	3.4.1.28	B
Heat Exchanger (AS Condensate Vent Condenser)	LBS	Carbon Steel	Secondary Water (Int)	Loss of material	Water Chemistry (B2.1.2) and One-Time Inspection (B2.1.16)	VIII.E-37	3.4.1.03	A
Heat Exchanger (Sample Cooler)	LBS	Carbon Steel	Closed-Cycle Cooling Water (Int)	Loss of material	Closed-Cycle Cooling Water System (B2.1.10)	VIII.A-1	3.4.1.24	B
Heat Exchanger (Sample Cooler)	LBS	Carbon Steel	Closed-Cycle Cooling Water (Int)	Loss of material	Closed-Cycle Cooling Water System (B2.1.10)	VIII.F-4	3.4.1.24	B
Heat Exchanger (Sample Cooler)	LBS	Carbon Steel	Plant Indoor Air (Ext)	Loss of material	External Surfaces Monitoring Program (B2.1.20)	VIII.H-7	3.4.1.28	B

Section 3.3
AGING MANAGEMENT OF AUXILIARY SYSTEMS

Table 3.3.2-30 Auxiliary Systems – Summary of Aging Management Evaluation - Miscellaneous Auxiliary Systems In-Scope
ONLY based on Criterion 10 CFR 54.4(a)(2) (Continued)

Component Type	Intended Function	Material	Environment	Aging Effect Requiring Management	Aging Management Program	NUREG-1801 Vol. 2 Item	Table 1 Item	Notes
Heat Exchanger (Sample Cooler)	LBS	Stainless Steel	Closed-Cycle Cooling Water (Ext)	Loss of material	Closed-Cycle Cooling Water System (B2.1.10)	VIII.F-1	3.4.1.25	B
Heat Exchanger (Sample Cooler)	LBS	Stainless Steel	Secondary Water (Int)	Cracking	Water Chemistry (B2.1.2) and One-Time Inspection (B2.1.16)	VIII.F-3	3.4.1.14	A
Heat Exchanger (Sample Cooler)	LBS	Stainless Steel	Secondary Water (Int)	Loss of material	Water Chemistry (B2.1.2) and One-Time Inspection (B2.1.16)	VIII.F-27	3.4.1.16	A
Orifice	LBS	Carbon Steel	Plant Indoor Air (Ext)	Loss of material	External Surfaces Monitoring Program (B2.1.20)	VII.I-8	3.3.1.58	B
Orifice	LBS	Carbon Steel	Raw Water (Int)	Loss of material	Inspection Of Internal Surfaces In Miscellaneous Piping And Ducting Components (B2.1.22)	VII.C1-19	3.3.1.76	E, 2
Orifice	LBS	Stainless Steel	Plant Indoor Air (Ext)	None	None	VIII.I-10	3.4.1.41	A
Orifice	LBS	Stainless Steel	Secondary Water (Int)	Loss of material	Water Chemistry (B2.1.2) and One-Time Inspection (B2.1.16)	VIII.B1-4	3.4.1.16	A
Orifice	LBS	Stainless Steel	Secondary Water (Int)	Cracking	Water Chemistry (B2.1.2) and One-Time Inspection (B2.1.16)	VIII.B1-5	3.4.1.14	A

Section 3.3
AGING MANAGEMENT OF AUXILIARY SYSTEMS

Table 3.3.2-30 Auxiliary Systems – Summary of Aging Management Evaluation - Miscellaneous Auxiliary Systems In-Scope
ONLY based on Criterion 10 CFR 54.4(a)(2) (Continued)

Component Type	Intended Function	Material	Environment	Aging Effect Requiring Management	Aging Management Program	NUREG-1801 Vol. 2 Item	Table 1 Item	Notes
Piping	LBS, SIA	Carbon Steel	Plant Indoor Air (Ext)	Loss of material	External Surfaces Monitoring Program (B2.1.20)	VII.I-8	3.3.1.58	B
Piping	LBS, SIA	Carbon Steel	Plant Indoor Air (Ext)	Loss of material	External Surfaces Monitoring Program (B2.1.20)	VIII.H-7	3.4.1.28	B
Piping	LBS	Carbon Steel	Raw Water (Int)	Loss of material	Inspection Of Internal Surfaces In Miscellaneous Piping And Ducting Components (B2.1.22)	VII.C1-19	3.3.1.76	E, 2
Piping	LBS	Carbon Steel	Raw Water (Int)	Loss of material	Inspection Of Internal Surfaces In Miscellaneous Piping And Ducting Components (B2.1.22)	VII.C1-19	3.3.1.76	E, 2
Piping	SIA	Carbon Steel	Raw Water (Int)	Loss of material	Inspection Of Internal Surfaces In Miscellaneous Piping And Ducting Components (B2.1.22)	VII.C1-19	3.3.1.76	E, 2
Piping	LBS, SIA	Carbon Steel	Secondary Water (Int)	Loss of material	Water Chemistry (B2.1.2)	VIII.B1-8	3.4.1.37	A
Piping	LBS, SIA	Carbon Steel	Secondary Water (Int)	Wall thinning	Flow-Accelerated Corrosion (B2.1.6)	VIII.B1-9	3.4.1.29	B
Piping	LBS	Carbon Steel	Secondary Water (Int)	Loss of material	Water Chemistry (B2.1.2) and One-Time Inspection (B2.1.16)	VIII.B1-11	3.4.1.04	A

Section 3.3
AGING MANAGEMENT OF AUXILIARY SYSTEMS

Table 3.3.2-30 Auxiliary Systems – Summary of Aging Management Evaluation - Miscellaneous Auxiliary Systems In-Scope
ONLY based on Criterion 10 CFR 54.4(a)(2) (Continued)

Component Type	Intended Function	Material	Environment	Aging Effect Requiring Management	Aging Management Program	NUREG-1801 Vol. 2 Item	Table 1 Item	Notes
Piping	LBS	Carbon Steel	Wetted Gas (Int)	Loss of material	Inspection Of Internal Surfaces In Miscellaneous Piping And Ducting Components (B2.1.22)	VIII.B1-7	3.4.1.30	B
Piping	LBS	Carbon Steel with Elastomer Lining	Plant Indoor Air (Ext)	Loss of material	External Surfaces Monitoring Program (B2.1.20)	VII.I-8	3.3.1.58	B
Piping	LBS	Carbon Steel with Elastomer Lining	Raw Water (Int)	Loss of material	Inspection Of Internal Surfaces In Miscellaneous Piping And Ducting Components (B2.1.22)	VII.C1-19	3.3.1.76	E, 2
Piping	LBS	Copper Alloy	Plant Indoor Air (Ext)	None	None	VIII.I-2	3.4.1.41	A
Piping	LBS	Copper Alloy	Potable Water (Int)	Loss of material	Inspection Of Internal Surfaces In Miscellaneous Piping And Ducting Components (B2.1.22)	None	None	G
Piping	LBS	Copper Alloy	Raw Water (Int)	Loss of material	Inspection Of Internal Surfaces In Miscellaneous Piping And Ducting Components (B2.1.22)	VII.C1-9	3.3.1.81	E, 2
Piping	LBS	Stainless Steel	Borated Water Leakage (Ext)	None	None	V.F-13	3.2.1.57	A
Piping	LBS, S/A	Stainless Steel	Deminerlized Water (Int)	Loss of material	Water Chemistry (B2.1.2) and One-Time Inspection (B2.1.16)	VIII.E-29	3.4.1.16	A

Section 3.3
AGING MANAGEMENT OF AUXILIARY SYSTEMS

Table 3.3.2-30 Auxiliary Systems – Summary of Aging Management Evaluation - Miscellaneous Auxiliary Systems In-Scope
ONLY based on Criterion 10 CFR 54.4(a)(2) (Continued)

Component Type	Intended Function	Material	Environment	Aging Effect Requiring Management	Aging Management Program	NUREG-1801 Vol. 2 Item	Table 1 Item	Notes
Piping	LBS, SIA	Stainless Steel	Plant Indoor Air (Ext)	None	None	VII.J-15	3.3.1.94	A
Piping	LBS, SIA	Stainless Steel	Plant Indoor Air (Ext)	None	None	VIII.I-10	3.4.1.41	A
Piping	LBS	Stainless Steel	Raw Water (Int)	Loss of material	Inspection Of Internal Surfaces In Miscellaneous Piping And Ducting Components (B2.1.22)	VII.C1-15	3.3.1.79	E, 2
Piping	LBS	Stainless Steel	Raw Water (Int)	Loss of material	Inspection Of Internal Surfaces In Miscellaneous Piping And Ducting Components (B2.1.22)	VII.C1-15	3.3.1.79	E, 2
Piping	SIA	Stainless Steel	Raw Water (Int)	Loss of material	Inspection Of Internal Surfaces In Miscellaneous Piping And Ducting Components (B2.1.22)	VII.C1-15	3.3.1.79	E, 2
Piping	LBS	Stainless Steel	Secondary Water (Int)	Loss of material	Water Chemistry (B2.1.2) and One-Time Inspection (B2.1.16)	VIII.B1-4	3.4.1.16	A
Piping	LBS	Stainless Steel	Secondary Water (Int)	Cracking	Water Chemistry (B2.1.2) and One-Time Inspection (B2.1.16)	VIII.B1-5	3.4.1.14	A
Piping	LBS, SIA	Stainless Steel	Secondary Water (Int)	Loss of material	Water Chemistry (B2.1.2) and One-Time Inspection (B2.1.16)	VIII.F-23	3.4.1.16	A
Piping	LBS, SIA	Stainless Steel	Secondary Water (Int)	Cracking	Water Chemistry (B2.1.2) and One-Time Inspection (B2.1.16)	VIII.F-24	3.4.1.14	A

Section 3.3
AGING MANAGEMENT OF AUXILIARY SYSTEMS

Table 3.3.2-30 Auxiliary Systems – Summary of Aging Management Evaluation - Miscellaneous Auxiliary Systems In-Scope ONLY based on Criterion 10 CFR 54.4(a)(2) (Continued)

Component Type	Intended Function	Material	Environment	Aging Effect Requiring Management	Aging Management Program	NUREG-1801 Vol. 2 Item	Table 1 Item	Notes
Piping	LBS	Stainless Steel	Treated Borated Water (Int)	Loss of material	Water Chemistry (B2.1.2)	V.A-27	3.2.1.49	A
Pump	LBS	Cast Iron (Gray Cast Iron)	Plant Indoor Air (Ext)	Loss of material	External Surfaces Monitoring Program (B2.1.20)	VIII.H-7	3.4.1.28	B
Pump	LBS	Cast Iron (Gray Cast Iron)	Secondary Water (Int)	Wall thinning	Flow-Accelerated Corrosion (B2.1.6)	VIII.B1-9	3.4.1.29	B
Pump	LBS	Cast Iron (Gray Cast Iron)	Secondary Water (Int)	Loss of material	Water Chemistry (B2.1.2) and One-Time Inspection (B2.1.16)	VIII.B1-11	3.4.1.04	A
Pump	LBS	Cast Iron (Gray Cast Iron)	Secondary Water (Int)	Loss of material	Selective Leaching of Materials (B2.1.17)	VIII.E-23	3.4.1.36	B
Sight Gauge	LBS	Cast Iron	Borated Water Leakage (Ext)	Loss of material	Boric Acid Corrosion (B2.1.4)	V.E-9	3.2.1.45	A
Sight Gauge	LBS	Glass	Borated Water Leakage (Ext)	None	None	None	None	G
Sight Gauge	LBS, SIA	Glass	Plant Indoor Air (Ext)	None	None	VII.J-8	3.3.1.93	A
Sight Gauge	LBS	Glass	Plant Indoor Air (Ext)	None	None	VIII.I-5	3.4.1.40	A
Sight Gauge	LBS, SIA	Glass	Raw Water (Int)	None	None	VII.J-11	3.3.1.93	A
Sight Gauge	LBS	Glass	Secondary Water (Int)	None	None	VIII.I-8	3.4.1.40	A
Sight Gauge	LBS	Glass	Treated Borated Water (Int)	None	None	V.F-9	3.2.1.52	A

Section 3.3
AGING MANAGEMENT OF AUXILIARY SYSTEMS

Table 3.3.2-30 Auxiliary Systems – Summary of Aging Management Evaluation - Miscellaneous Auxiliary Systems In-Scope
ONLY based on Criterion 10 CFR 54.4(a)(2) (Continued)

Component Type	Intended Function	Material	Environment	Aging Effect Requiring Management	Aging Management Program	NUREG-1801 Vol. 2 Item	Table 1 Item	Notes
Sight Gauge	LBS	Stainless Steel	Borated Water Leakage (Ext)	None	None	V.F-13	3.2.1.57	A
Sight Gauge	LBS, SIA	Stainless Steel	Plant Indoor Air (Ext)	None	None	VII.J-15	3.3.1.94	A
Sight Gauge	LBS, SIA	Stainless Steel	Raw Water (Int)	Loss of material	Inspection Of Internal Surfaces In Miscellaneous Piping And Ducting Components (B2.1.22)	VII.C1-15	3.3.1.79	E, 2
Sight Gauge	LBS	Stainless Steel	Treated Borated Water (Int)	Loss of material	Water Chemistry (B2.1.2)	V.A-27	3.2.1.49	A
Strainer	LBS, SIA	Carbon Steel	Plant Indoor Air (Ext)	Loss of material	External Surfaces Monitoring Program (B2.1.20)	VII.I-8	3.3.1.58	B
Strainer	LBS, SIA	Carbon Steel	Raw Water (Int)	Loss of material	Inspection Of Internal Surfaces In Miscellaneous Piping And Ducting Components (B2.1.22)	VII.C1-19	3.3.1.76	E, 2
Strainer	LBS	Cast Iron (Gray Cast Iron)	Plant Indoor Air (Ext)	Loss of material	External Surfaces Monitoring Program (B2.1.20)	VIII.H-7	3.4.1.28	B
Strainer	LBS	Cast Iron (Gray Cast Iron)	Secondary Water (Int)	Wall thinning	Flow-Accelerated Corrosion (B2.1.6)	VIII.B1-9	3.4.1.29	B
Strainer	LBS	Cast Iron (Gray Cast Iron)	Secondary Water (Int)	Loss of material	Water Chemistry (B2.1.2) and One-Time Inspection (B2.1.16)	VIII.B1-11	3.4.1.04	A

Section 3.3
AGING MANAGEMENT OF AUXILIARY SYSTEMS

Table 3.3.2-30 Auxiliary Systems – Summary of Aging Management Evaluation - Miscellaneous Auxiliary Systems In-Scope
ONLY based on Criterion 10 CFR 54.4(a)(2) (Continued)

Component Type	Intended Function	Material	Environment	Aging Effect Requiring Management	Aging Management Program	NUREG-1801 Vol. 2 Item	Table 1 Item	Notes
Strainer	LBS	Cast Iron (Gray Cast Iron)	Secondary Water (Int)	Loss of material	Selective Leaching of Materials (B2.1.17)	VIII.E-23	3.4.1.36	B
Tank	LBS	Carbon Steel	Plant Indoor Air (Ext)	Loss of material	External Surfaces Monitoring Program (B2.1.20)	VIII.H-7	3.4.1.28	B
Tank	LBS	Carbon Steel	Secondary Water (Int)	Loss of material	Water Chemistry (B2.1.2) and One-Time Inspection (B2.1.16)	VIII.B1-11	3.4.1.04	A
Tubing	LBS	Carbon Steel	Plant Indoor Air (Ext)	Loss of material	External Surfaces Monitoring Program (B2.1.20)	VIII.H-7	3.4.1.28	B
Tubing	LBS	Carbon Steel	Secondary Water (Int)	Loss of material	Water Chemistry (B2.1.2) and One-Time Inspection (B2.1.16)	VIII.B1-11	3.4.1.04	A
Tubing	LBS	Stainless Steel	Borated Water Leakage (Ext)	None	None	V.F-13	3.2.1.57	A
Tubing	LBS	Stainless Steel	Treated Borated Water (Int)	Loss of material	Water Chemistry (B2.1.2)	V.A-27	3.2.1.49	A
Valve	LBS	Carbon Steel	Plant Indoor Air (Ext)	Loss of material	External Surfaces Monitoring Program (B2.1.20)	VII.I-8	3.3.1.58	B
Valve	LBS	Carbon Steel	Plant Indoor Air (Ext)	Loss of material	External Surfaces Monitoring Program (B2.1.20)	VIII.H-7	3.4.1.28	B

Section 3.3
AGING MANAGEMENT OF AUXILIARY SYSTEMS

Table 3.3.2-30 Auxiliary Systems – Summary of Aging Management Evaluation - Miscellaneous Auxiliary Systems In-Scope
ONLY based on Criterion 10 CFR 54.4(a)(2) (Continued)

Component Type	Intended Function	Material	Environment	Aging Effect Requiring Management	Aging Management Program	NUREG-1801 Vol. 2 Item	Table 1 Item	Notes
Valve	LBS	Carbon Steel	Raw Water (Int)	Loss of material	Inspection Of Internal Surfaces In Miscellaneous Piping And Ducting Components (B2.1.22)	VII.C1-19	3.3.1.76	E, 2
Valve	LBS	Carbon Steel	Raw Water (Int)	Loss of material	Inspection Of Internal Surfaces In Miscellaneous Piping And Ducting Components (B2.1.22)	VII.C1-19	3.3.1.76	E, 2
Valve	LBS	Carbon Steel	Secondary Water (Int)	Loss of material	Water Chemistry (B2.1.2)	VIII.B1-8	3.4.1.37	A
Valve	LBS	Carbon Steel	Secondary Water (Int)	Wall thinning	Flow-Accelerated Corrosion (B2.1.6)	VIII.B1-9	3.4.1.29	B
Valve	LBS	Carbon Steel	Secondary Water (Int)	Loss of material	Water Chemistry (B2.1.2) and One-Time Inspection (B2.1.16)	VIII.B1-11	3.4.1.04	A
Valve	LBS	Carbon Steel	Wetted Gas (Int)	Loss of material	Inspection Of Internal Surfaces In Miscellaneous Piping And Ducting Components (B2.1.22)	VIII.B1-7	3.4.1.30	B
Valve	LBS	Cast Iron (Gray Cast Iron)	Plant Indoor Air (Ext)	Loss of material	External Surfaces Monitoring Program (B2.1.20)	VIII.H-7	3.4.1.28	B
Valve	LBS	Cast Iron (Gray Cast Iron)	Secondary Water (Int)	Wall thinning	Flow-Accelerated Corrosion (B2.1.6)	VIII.B1-9	3.4.1.29	B
Valve	LBS	Cast Iron (Gray Cast Iron)	Secondary Water (Int)	Loss of material	Water Chemistry (B2.1.2) and One-Time Inspection (B2.1.16)	VIII.B1-11	3.4.1.04	A

Section 3.3
AGING MANAGEMENT OF AUXILIARY SYSTEMS

Table 3.3.2-30 Auxiliary Systems – Summary of Aging Management Evaluation - Miscellaneous Auxiliary Systems In-Scope ONLY based on Criterion 10 CFR 54.4(a)(2) (Continued)

Component Type	Intended Function	Material	Environment	Aging Effect Requiring Management	Aging Management Program	NUREG-1801 Vol. 2 Item	Table 1 Item	Notes
Valve	LBS	Cast Iron (Gray Cast Iron)	Secondary Water (Int)	Loss of material	Selective Leaching of Materials (B2.1.17)	VIII.E-23	3.4.1.36	B
Valve	LBS	Copper Alloy	Plant Indoor Air (Ext)	None	None	VIII.I-2	3.4.1.41	A
Valve	LBS	Copper Alloy	Potable Water (Int)	Loss of material	Inspection Of Internal Surfaces In Miscellaneous Piping And Ducting Components (B2.1.22)	None	None	G
Valve	LBS	Copper Alloy	Secondary Water (Int)	Loss of material	Water Chemistry (B2.1.2) and One-Time Inspection (B2.1.16)	VIII.A-5	3.4.1.15	A
Valve	LBS	Copper Alloy (Zinc >15%)	Plant Indoor Air (Ext)	None	None	VIII.I-2	3.4.1.41	A
Valve	LBS	Copper Alloy (Zinc >15%)	Secondary Water (Int)	Loss of material	Water Chemistry (B2.1.2) and One-Time Inspection (B2.1.16)	VIII.A-5	3.4.1.15	A
Valve	LBS	Copper Alloy (Zinc >15%)	Secondary Water (Int)	Loss of material	Selective Leaching of Materials (B2.1.17)	VIII.E-21	3.4.1.35	B
Valve	LBS	Stainless Steel	Borated Water Leakage (Ext)	None	None	V.F-13	3.2.1.57	A
Valve	LBS, SIA	Stainless Steel	Deminerlized Water (Int)	Loss of material	Water Chemistry (B2.1.2) and One-Time Inspection (B2.1.16)	VIII.E-29	3.4.1.16	A
Valve	LBS, SIA	Stainless Steel	Plant Indoor Air (Ext)	None	None	VII.J-15	3.3.1.94	A
Valve	LBS	Stainless Steel	Plant Indoor Air (Ext)	None	None	VIII.I-10	3.4.1.41	A

Section 3.3
AGING MANAGEMENT OF AUXILIARY SYSTEMS

Table 3.3.2-30 Auxiliary Systems – Summary of Aging Management Evaluation - Miscellaneous Auxiliary Systems In-Scope
ONLY based on Criterion 10 CFR 54.4(a)(2) (Continued)

Component Type	Intended Function	Material	Environment	Aging Effect Requiring Management	Aging Management Program	NUREG-1801 Vol. 2 Item	Table 1 Item	Notes
Valve	LBS	Stainless Steel	Raw Water (Int)	Loss of material	Inspection Of Internal Surfaces In Miscellaneous Piping And Ducting Components (B2.1.22)	VII.C1-15	3.3.1.79	E, 2
Valve	LBS	Stainless Steel	Raw Water (Int)	Loss of material	Inspection Of Internal Surfaces In Miscellaneous Piping And Ducting Components (B2.1.22)	VII.C1-15	3.3.1.79	E, 2
Valve	SIA	Stainless Steel	Raw Water (Int)	Loss of material	Inspection Of Internal Surfaces In Miscellaneous Piping And Ducting Components (B2.1.22)	VII.C1-15	3.3.1.79	E, 2
Valve	LBS	Stainless Steel	Secondary Water (Int)	Loss of material	Water Chemistry (B2.1.2) and One-Time Inspection (B2.1.16)	VIII.F-23	3.4.1.16	A
Valve	LBS	Stainless Steel	Secondary Water (Int)	Cracking	Water Chemistry (B2.1.2) and One-Time Inspection (B2.1.16)	VIII.F-24	3.4.1.14	A
Valve	LBS	Stainless Steel	Treated Borated Water (Int)	Loss of material	Water Chemistry (B2.1.2)	V.A-27	3.2.1.49	A

Section 3.3
AGING MANAGEMENT OF AUXILIARY SYSTEMS

Notes for Table 3.3.2-30:

Standard Notes:

- A Consistent with NUREG-1801 item for component, material, environment, and aging effect. AMP is consistent with NUREG-1801 AMP.
- B Consistent with NUREG-1801 item for component, material, environment, and aging effect. AMP takes some exceptions to NUREG-1801 AMP.
- E Consistent with NUREG-1801 for material, environment, and aging effect, but a different aging management program is credited or NUREG-1801 identifies a plant-specific aging management program.
- F Material not in NUREG-1801 for this component.
- G Environment not in NUREG-1801 for this component and material.

Plant Specific Notes:

- 1 Loss of Preload is considered to be applicable for all closure bolting.
- 2 Inspection of Internal Surfaces in Miscellaneous Piping and Ducting Components program (B2.1.22) is credited instead of Open-Cycle Cooling Water System program (B2.1.9) for aging management of the components of solid radwaste system, sanitary drains and treatment, chemical waste, oily waste systems.

3.4 AGING MANAGEMENT OF STEAM AND POWER CONVERSION SYSTEM

3.4.1 Introduction

Section 3.4 provides the results of the aging management reviews for those component types identified in [Section 2.3.4](#), Steam and Power Conversion System, subject to aging management review. These systems are described in the following sections:

- Main steam ([Section 2.3.4.1](#))
- Condensate storage and transfer ([Section 2.3.4.2](#))
- Auxiliary feedwater ([Section 2.3.4.3](#))

Table 3.4.1, Summary of Aging Management Evaluations in Chapter VIII of NUREG-1801 for Steam and Power Conversion System, provides the summary of the programs evaluated in NUREG-1801 that are applicable to the component types in this section. [Table 3.4.1](#) uses the format of [Table 3.x.1](#) (Table 1) described in [Section 3.0](#).

3.4.2 Results

The following tables summarize the results of the aging management review for the systems in the Steam and Power Conversion System area:

- [Table 3.4.2-1](#), Steam and Power Conversion System – Summary of Aging Management Evaluation – Main Steam System
- [Table 3.4.2-2](#), Steam and Power Conversion System – Summary of Aging Management Evaluation – Condensate Storage and Transfer System
- [Table 3.4.2-3](#), Steam and Power Conversion System – Summary of Aging Management Evaluation – Auxiliary Feedwater System

These tables use the format of [Table 2](#) discussed in [Section 3.0](#).

3.4.2.1 Materials, Environment, Aging Effects Requiring Management and Aging Management Programs

The materials from which the component types are fabricated, the environments to which they are exposed, the potential aging effects requiring management, and the aging management programs used to manage these aging effects are provided for each of the above systems in the following subsections.

3.4.2.1.1 Main Steam System

Materials

The materials of construction for the main steam system component types are:

- Aluminum
- Carbon Steel
- Copper Alloy
- Copper Alloy (Zinc >15%)
- Insulation Calcium Silicate
- Nickel Alloys
- Stainless Steel

Environment

The main steam system component types are exposed to the following environments:

- Dry Gas
- Plant Indoor Air
- Secondary Water
- Wetted Gas

Aging Effects Requiring Management

The following main steam system aging effects require management:

- Cracking
- Loss of material
- Loss of preload
- Wall thinning

Aging Management Programs

The following aging management programs manage the aging effects for the main steam system component types:

- Bolting Integrity ([B2.1.7](#))
- External Surfaces Monitoring Program ([B2.1.20](#))
- Flow-Accelerated Corrosion ([B2.1.6](#))

- Inspection Of Internal Surfaces In Miscellaneous Piping And Ducting Components ([B2.1.22](#))
- One-Time Inspection ([B2.1.16](#))
- Water Chemistry ([B2.1.2](#))

3.4.2.1.2 Condensate Storage and Transfer System

Materials

The materials of construction for the condensate storage and transfer system component types are:

- Carbon Steel
- Stainless Steel
- Stainless Steel Cast Austenitic

Environment

The condensate storage and transfer system components are exposed to the following environments:

- Atmosphere/ Weather
- Dry Gas
- Encased in Concrete
- Plant Indoor Air
- Secondary Water
- Wetted Gas

Aging Effects Requiring Management

The following condensate storage and transfer system aging effects require management:

- Loss of material
- Loss of preload

Aging Management Programs

The following aging management programs manage the aging effects for the condensate storage and transfer system component types:

- Bolting Integrity ([B2.1.7](#))
- External Surfaces Monitoring Program ([B2.1.20](#))

- Inspection Of Internal Surfaces In Miscellaneous Piping And Ducting Components ([B2.1.22](#))
- One-Time Inspection ([B2.1.16](#))
- Water Chemistry ([B2.1.2](#))

3.4.2.1.3 Auxiliary Feedwater System

Materials

The materials of construction for the auxiliary feedwater system component types are:

- Aluminum
- Carbon Steel
- Cast Iron
- Glass
- Insulation Calcium Silicate
- Nickel Alloys
- Stainless Steel
- Stainless Steel Cast Austenitic

Environment

The auxiliary feedwater system components are exposed to the following environments:

- Lubricating Oil
- Plant Indoor Air
- Secondary Water

Aging Effects Requiring Management

The following auxiliary feedwater system aging effects require management:

- Loss of material
- Loss of preload
- Reduction of heat transfer
- Wall thinning

Aging Management Programs

The following aging management programs manage the aging effects for the auxiliary feedwater system component types:

- Bolting Integrity ([B2.1.7](#))
- External Surfaces Monitoring Program ([B2.1.20](#))
- Flow-Accelerated Corrosion ([B2.1.6](#))
- Lubricating Oil Analysis ([B2.1.23](#))
- One-Time Inspection ([B2.1.16](#))
- Water Chemistry ([B2.1.2](#))

3.4.2.2 Further Evaluation of Aging Management as Recommended by NUREG-1801

NUREG-1801 provides the basis for identifying those programs that warrant further evaluation. For the Steam and Power Conversion System, those evaluations are addressed in the following subsections.

3.4.2.2.1 Cumulative Fatigue Damage

Evaluation of fatigue is a time-limited aging analysis (TLAA) as defined in 10 CFR 54.3. TLAA's are evaluated in accordance with 10 CFR 54.21(c)(1). PVNGS piping designed to ASME III Class 2, Class 3, and ANSI B31.1 assumes a reduction in the allowable secondary stress range if more than 7,000 full-range thermal cycles are expected in a design lifetime. [Section 4.3.5](#) describes the evaluation of these cyclic design TLAA's. The main steam safety valves are ASME III Class 2 components designed with a Class 1 fatigue analysis. [Section 4.3.2.12](#) describes the evaluation of this TLAA.

3.4.2.2.2 Loss of Material due to General, Pitting, and Crevice Corrosion

3.4.2.2.2.1 Steel piping and components, tanks, and heat exchangers exposed to treated water and steel piping and components exposed to steam

The Water Chemistry program ([B2.1.2](#)) and the One-Time Inspection program ([B2.1.16](#)) will manage loss of material due to general, pitting, and crevice corrosion for carbon steel and gray cast iron components exposed to secondary water and demineralized water. The one-time inspection will include selected components at susceptible locations where contaminants could accumulate (e.g. stagnant flow locations).

3.4.2.2.2.2 Steel piping and components exposed to lubricating oil

The Lubricating Oil Analysis program ([B2.1.23](#)) and the One-Time Inspection program ([B2.1.16](#)) will manage loss of material due to general, pitting, and crevice corrosion for carbon steel components exposed to lubricating oil. The one-time inspection will include selected components at susceptible locations where contaminants such as water could accumulate.

3.4.2.2.3 Loss of Material due to General, Pitting, Crevice, and Microbiologically-Influenced Corrosion (MIC), and Fouling

Not applicable. PVNGS has no in-scope components exposed to raw water in the auxiliary feedwater system, so the applicable NUREG-1801 line was not used.

3.4.2.2.4 Reduction of Heat Transfer due to Fouling

3.4.2.2.4.1 Stainless steel and copper alloy heat exchanger tubes exposed to treated water

Not applicable. PVNGS has no in-scope heat exchangers in the condensate or blowdown systems, and no in-scope heat exchangers with a heat transfer intended function in the auxiliary feedwater system, so the applicable NUREG-1801 lines were not used.

3.4.2.2.4.2 Stainless steel and copper alloy heat exchanger tubes exposed to lubricating oil

The Lubricating Oil Analysis program (B2.1.23) and the One-Time Inspection program (B2.1.16) will manage reduction of heat transfer due to fouling for carbon steel and copper alloy components exposed to lubricating oil. The one-time inspection will include selected components at susceptible locations where contaminants such as water could accumulate.

3.4.2.2.5 Loss of Material due to General, Pitting, Crevice, and Microbiologically-Influenced Corrosion

3.4.2.2.5.1 Steel piping and components and tanks exposed to soil

Not applicable. PVNGS has no in-scope buried steel components or tanks exposed to soil in the condensate or auxiliary feedwater systems, so the applicable NUREG-1801 lines were not used.

3.4.2.2.5.2 Steel heat exchanger components exposed to lubricating oil

The Lubricating Oil Analysis program (B2.1.23) and the One-Time Inspection program (B2.1.16) will manage loss of material due to general, pitting, crevice and microbiologically influenced corrosion for carbon steel components exposed to lubricating oil. The one-time inspection will include selected components at susceptible locations where contaminants such as water could accumulate.

3.4.2.2.6 Cracking due to Stress Corrosion Cracking

The Water Chemistry program (B2.1.2) and the One-Time Inspection program (B2.1.16) will manage cracking due to stress corrosion cracking for stainless steel components exposed to secondary water. The one-time inspection will include selected components at susceptible locations where contaminants could accumulate (e.g. stagnant flow locations).

3.4.2.2.7 Loss of Material due to Pitting and Crevice Corrosion

3.4.2.2.7.1 Stainless steel and copper alloy piping and components and stainless steel tanks and heat exchangers exposed to treated water

The Water Chemistry program ([B2.1.2](#)) and the One-Time Inspection program ([B2.1.16](#)) will manage loss of material due to pitting and crevice corrosion for stainless steel and copper alloy components exposed to secondary water and demineralized water. The one-time inspection will include selected components at susceptible locations where contaminants could accumulate (e.g. stagnant flow locations and tank bottoms).

3.4.2.2.7.2 Stainless steel piping and components exposed to soil

Not applicable. PVNGS has no in-scope stainless steel components exposed to soil in the condensate or auxiliary feedwater system, so the applicable NUREG-1801 lines were not used.

3.4.2.2.7.3 Copper alloy piping and components exposed to lubricating oil

Not applicable. PVNGS has no in-scope copper alloy components exposed to lube oil in the steam turbine, feedwater, condensate, or auxiliary feedwater systems, so the applicable NUREG-1801 lines were not used.

3.4.2.2.8 Loss of Material due to Pitting, Crevice, and Microbiologically-Influenced Corrosion

Not applicable. PVNGS has no in-scope stainless steel components exposed to lube oil in the steam turbine, feedwater, condensate, or auxiliary feedwater systems, so the applicable NUREG-1801 lines were not used.

3.4.2.2.9 Loss of Material due to General, Pitting, Crevice, and Galvanic Corrosion

Not applicable to PVNGS, applicable to BWR only.

3.4.2.2.10 Quality Assurance for Aging Management of Nonsafety-Related Components

Quality Assurance Program and Administrative Controls are discussed in [Section B1.3](#).

3.4.2.3 Time-Limited Aging Analysis

The time-limited aging analyses identified below are associated with the Steam and Power Conversion System component types. The section within [Chapter 4](#), Time-Limited Aging Analyses, is indicated in parenthesis.

- Cumulative fatigue damage ([Section 4.3](#), Metal Fatigue Analysis)

3.4.3 Conclusions

The Steam and Power Conversion System component types that are subject to aging management review have been evaluated. The aging management programs selected to manage the aging effects for the Steam and Power Conversion System component types are identified in the summary Tables and in [Section 3.4.2.1](#).

A description of these aging management programs is provided in [Appendix B](#), along with a demonstration that the identified aging effects will be managed for the period of extended operation.

Therefore, based on the demonstration provided in [Appendix B](#), the effects of aging associated with the Steam and Power Conversion System component types will be adequately managed so that there is reasonable assurance that the intended functions will be maintained consistent with the current licensing basis during the period of extended operation.

Section 3.4
AGING MANAGEMENT OF STEAM AND
POWER CONVERSION SYSTEM

Table 3.4.1 Summary of Aging Management Evaluations in Chapter VIII of NUREG-1801 for Steam and Power Conversion System

Item Number	Component Type	Aging Effect / Mechanism	Aging Management Program	Further Evaluation Recommended	Discussion
3.4.1.01	Steel piping, piping components, and piping elements exposed to steam or treated water	Cumulative fatigue damage	TLAA, evaluated in accordance with 10 CFR 54.21(c)	Yes, TLAA	Fatigue of metal components is a TLAA. See further evaluation in subsection 3.4.2.2.1.
3.4.1.02	Steel piping, piping components, and piping elements exposed to steam	Loss of material due to general, pitting and crevice corrosion	Water Chemistry (B2.1.2) and One-Time Inspection (B2.1.16)	Yes	Not applicable. PVNGS has no in-scope steel components exposed to steam in the steam turbine or extraction steam systems, so the applicable NUREG-1801 lines were not used.
3.4.1.03	Steel heat exchanger components exposed to treated water	Loss of material due to general, pitting and crevice corrosion	Water Chemistry (B2.1.2) and One-Time Inspection (B2.1.16)	Yes	Consistent with NUREG-1801. See further evaluation in subsection 3.4.2.2.1.
3.4.1.04	Steel piping, piping components, and piping elements exposed to treated water	Loss of material due to general, pitting and crevice corrosion	Water Chemistry (B2.1.2) and One-Time Inspection (B2.1.16)	Yes	Consistent with NUREG-1801. See further evaluation in subsection 3.4.2.2.1.
3.4.1.05					Not applicable - BWR only

Section 3.4
AGING MANAGEMENT OF STEAM AND
POWER CONVERSION SYSTEM

Table 3.4.1 Summary of Aging Management Evaluations in Chapter VIII of NUREG-1801 for Steam and Power Conversion System (Continued)

Item Number	Component Type	Aging Effect / Mechanism	Aging Management Program	Further Evaluation Recommended	Discussion
3.4.1.06	Steel and stainless steel tanks exposed to treated water	Loss of material due to general (steel only) pitting and crevice corrosion	Water Chemistry (B2.1.2) and One-Time Inspection (B2.1.16)	Yes	Consistent with NUREG-1801. See further evaluation in subsection 3.4.2.2.7.1.
3.4.1.07	Steel piping, piping components, and piping elements exposed to lubricating oil	Loss of material due to general, pitting and crevice corrosion	Lubricating Oil Analysis (B2.1.23) and One-Time Inspection (B.2.1.16)	Yes	Consistent with NUREG-1801 with aging management program exceptions. The aging management program(s) with exceptions to NUREG-1801 include: Lubricating Oil Analysis (B2.1.23). See further evaluation in subsection 3.4.2.2.2.2.
3.4.1.08	Steel piping, piping components, and piping elements exposed to raw water	Loss of material due to general, pitting, crevice, and microbiologically-influenced corrosion, and fouling	A plant-specific aging management program is to be evaluated.	Yes	Not applicable. PVNGS has no in-scope steel components exposed to raw water in the auxiliary feedwater system, so the applicable NUREG-1801 line was not used.

Section 3.4
AGING MANAGEMENT OF STEAM AND
POWER CONVERSION SYSTEM

Table 3.4.1 Summary of Aging Management Evaluations in Chapter VIII of NUREG-1801 for Steam and Power Conversion System (Continued)

Item Number	Component Type	Aging Effect / Mechanism	Aging Management Program	Further Evaluation Recommended	Discussion
3.4.1.09	Stainless steel and copper alloy heat exchanger tubes exposed to treated water	Reduction of heat transfer due to fouling	Water Chemistry (B2.1.2) and One-Time Inspection (B2.1.16)	Yes	Not applicable. PVNGS has no in-scope stainless steel or copper alloy heat exchangers exposed to treated water in the condensate, steam generator blowdown, or auxiliary feedwater systems, so the applicable NUREG-1801 lines were not used.
3.4.1.10	Steel, stainless steel, and copper alloy heat exchanger tubes exposed to lubricating oil	Reduction of heat transfer due to fouling	Lubricating Oil Analysis (B2.1.23) and One-Time Inspection (B.2.1.16)	Yes	Consistent with NUREG-1801 with aging management program exceptions. The aging management program(s) with exceptions to NUREG-1801 include: Lubricating Oil Analysis (B2.1.23). See further evaluation in subsection 3.4.2.2.4.2.
3.4.1.11	Buried steel piping, piping components, piping elements, and tanks (with or without coating or wrapping) exposed to soil	Loss of material due to general, pitting, crevice, and microbiologically-influenced corrosion	Buried Piping and Tanks Inspection (B2.1.18)	Yes	Not applicable. PVNGS has no in-scope buried steel components or tanks exposed to soil in the condensate or auxiliary feedwater systems, so the applicable NUREG-1801 lines were not used.

Section 3.4
AGING MANAGEMENT OF STEAM AND
POWER CONVERSION SYSTEM

Table 3.4.1 Summary of Aging Management Evaluations in Chapter VIII of NUREG-1801 for Steam and Power Conversion System (Continued)

Item Number	Component Type	Aging Effect / Mechanism	Aging Management Program	Further Evaluation Recommended	Discussion
3.4.1.12	Steel heat exchanger components exposed to lubricating oil	Loss of material due to general, pitting, crevice, and microbiologically-influenced corrosion	Lubricating Oil Analysis (B2.1.23) and One-Time Inspection (B.2.1.16)	Yes	Consistent with NUREG-1801 with aging management program exceptions. The aging management program(s) with exceptions to NUREG-1801 include: Lubricating Oil Analysis (B2.1.23). See further evaluation in subsection 3.4.2.2.5.2.
3.4.1.13					Not applicable - BWR only
3.4.1.14	Stainless steel piping, piping components, tanks, and heat exchanger components exposed to treated water >60°C (>140°F)	Cracking due to stress corrosion cracking	Water Chemistry (B2.1.2) and One-Time Inspection (B2.1.16)	Yes	Consistent with NUREG-1801. See further evaluation in subsection 3.4.2.2.6.
3.4.1.15	Aluminum and copper alloy piping, piping components, and piping elements exposed to treated water	Loss of material due to pitting and crevice corrosion	Water Chemistry (B2.1.2) and One-Time Inspection (B2.1.16)	Yes	Consistent with NUREG-1801. See further evaluation in subsection 3.4.2.2.7.1.

Section 3.4
AGING MANAGEMENT OF STEAM AND
POWER CONVERSION SYSTEM

Table 3.4.1 Summary of Aging Management Evaluations in Chapter VIII of NUREG-1801 for Steam and Power Conversion System (Continued)

Item Number	Component Type	Aging Effect / Mechanism	Aging Management Program	Further Evaluation Recommended	Discussion
3.4.1.16	Stainless steel piping, piping components, and piping elements; tanks, and heat exchanger components exposed to treated water	Loss of material due to pitting and crevice corrosion	Water Chemistry (B2.1.2) and One-Time Inspection (B2.1.16)	Yes	Consistent with NUREG-1801. See further evaluation in subsection 3.4.2.2.7.1.
3.4.1.17	Stainless steel piping, piping components, and piping elements exposed to soil	Loss of material due to pitting and crevice corrosion	A plant-specific aging management program is to be evaluated.	Yes	Not applicable. PVNGS has no in-scope stainless steel components exposed to soil in the condensate or auxiliary feedwater system, so the applicable NUREG-1801 lines were not used.
3.4.1.18	Copper alloy piping, piping components, and piping elements exposed to lubricating oil	Loss of material due to pitting and crevice corrosion	Lubricating Oil Analysis (B2.1.23) and One-Time Inspection (B2.1.16)	Yes	Not applicable. PVNGS has no in-scope copper alloy components exposed to lube oil in the steam turbine, feedwater, condensate, or auxiliary feedwater systems, so the applicable NUREG-1801 lines were not used.

Section 3.4
AGING MANAGEMENT OF STEAM AND
POWER CONVERSION SYSTEM

Table 3.4.1 Summary of Aging Management Evaluations in Chapter VIII of NUREG-1801 for Steam and Power Conversion System (Continued)

Item Number	Component Type	Aging Effect / Mechanism	Aging Management Program	Further Evaluation Recommended	Discussion
3.4.1.19	Stainless steel piping, piping components, piping elements, and heat exchanger components exposed to lubricating oil	Loss of material due to pitting, crevice, and microbiologically-influenced corrosion	Lubricating Oil Analysis (B2.1.23) and One-Time Inspection (B.2.1.16)	Yes	Not applicable. PVNGS has no in-scope stainless steel components exposed to lube oil in the steam turbine, feedwater, condensate, or auxiliary feedwater systems, so the applicable NUREG-1801 lines were not used. See further evaluation in subsection 3.4.2.2.8.
3.4.1.20	Steel tanks exposed to air – outdoor (external)	Loss of material/ general, pitting, and crevice corrosion	Aboveground Steel Tanks	No	Not applicable. PVNGS has no in-scope steel tanks exposed to outdoor air in the condensate or auxiliary feedwater systems, so the applicable NUREG-1801 lines were not used.
3.4.1.21	High-strength steel closure bolting exposed to air with steam or water leakage	Cracking due to cyclic loading, stress corrosion cracking	Bolting Integrity (B2.1.7)	No	Not applicable. PVNGS has no in-scope high strength bolting in the steam and power conversion systems, so the applicable NUREG-1801 line was not used.

Section 3.4
AGING MANAGEMENT OF STEAM AND
POWER CONVERSION SYSTEM

Table 3.4.1 Summary of Aging Management Evaluations in Chapter VIII of NUREG-1801 for Steam and Power Conversion System (Continued)

Item Number	Component Type	Aging Effect / Mechanism	Aging Management Program	Further Evaluation Recommended	Discussion
3.4.1.22	Steel bolting and closure bolting exposed to air with steam or water leakage, air – outdoor (external), or air – indoor uncontrolled (external);	Loss of material due to general, pitting and crevice corrosion; loss of preload due to thermal effects, gasket creep, and self-loosening	Bolting Integrity (B2.1.7)	No	Consistent with NUREG-1801 with aging management program exceptions. The aging management program(s) with exceptions to NUREG-1801 include: Bolting Integrity (B2.1.7)
3.4.1.23	Stainless steel piping, piping components, and piping elements exposed to closed-cycle cooling water >60°C (>140°F)	Cracking due to stress corrosion cracking	Closed-Cycle Cooling Water System (B2.1.10)	No	Not applicable. PVNGS has no in-scope stainless steel components exposed to closed cycle cooling water >140°F in the condensate, blowdown, or auxiliary feedwater systems, so the applicable NUREG-1801 lines were not used.
3.4.1.24	Steel heat exchanger components exposed to closed cycle cooling water	Loss of material due to general, pitting, crevice, and galvanic corrosion	Closed-Cycle Cooling Water System (B2.1.10)	No	Consistent with NUREG-1801 with aging management program exceptions. The aging management program(s) with exceptions to NUREG-1801 include: Closed-Cycle Cooling Water System (B2.1.10)

Section 3.4
AGING MANAGEMENT OF STEAM AND
POWER CONVERSION SYSTEM

Table 3.4.1 Summary of Aging Management Evaluations in Chapter VIII of NUREG-1801 for Steam and Power Conversion System (Continued)

Item Number	Component Type	Aging Effect / Mechanism	Aging Management Program	Further Evaluation Recommended	Discussion
3.4.1.25	Stainless steel piping, piping components, and heat exchanger components exposed to closed cycle cooling water	Loss of material due to pitting and crevice corrosion	Closed-Cycle Cooling Water System (B2.1.10)	No	Consistent with NUREG-1801 with aging management program exceptions. The aging management program(s) with exceptions to NUREG-1801 include: Closed-Cycle Cooling Water System (B2.1.10)
3.4.1.26	Copper alloy piping, piping components, and piping elements exposed to closed cycle cooling water	Loss of material due to pitting, crevice, and galvanic corrosion	Closed-Cycle Cooling Water System (B2.1.10)	No	Not applicable. PVNGS has no in-scope copper alloy components exposed to closed cycle cooling water in the condensate, blowdown, or auxiliary feedwater systems, so the applicable NUREG-1801 lines were not used.
3.4.1.27	Steel, stainless steel, and copper alloy heat exchanger tubes exposed to closed cycle cooling water	Reduction of heat transfer due to fouling	Closed-Cycle Cooling Water System (B2.1.10)	No	Not applicable. PVNGS has no in-scope copper alloy components exposed to closed cycle cooling water in the condensate, blowdown, or auxiliary feedwater systems, so the applicable NUREG-1801 lines were not used.

Section 3.4
AGING MANAGEMENT OF STEAM AND
POWER CONVERSION SYSTEM

Table 3.4.1 Summary of Aging Management Evaluations in Chapter VIII of NUREG-1801 for Steam and Power Conversion System (Continued)

Item Number	Component Type	Aging Effect / Mechanism	Aging Management Program	Further Evaluation Recommended	Discussion
3.4.1.28	Steel external surfaces exposed to air – indoor uncontrolled (external), condensation (external), or air outdoor (external)	Loss of material due to general corrosion	External Surfaces Monitoring (B2.1.20)	No	Consistent with NUREG-1801 with aging management program exceptions. The aging management program(s) with exceptions to NUREG-1801 include: External Surfaces Monitoring Program (B2.1.20).
3.4.1.29	Steel piping, piping components, and piping elements exposed to steam or treated water	Wall thinning due to flow-accelerated corrosion	Flow-Accelerated Corrosion (B2.1.6)	No	Consistent with NUREG-1801 with aging management program exceptions. The aging management program(s) with exceptions to NUREG-1801 include: Flow-Accelerated Corrosion (B2.1.6)
3.4.1.30	Steel piping, piping components, and piping elements exposed to air outdoor (internal) or condensation (internal)	Loss of material due to general, pitting, and crevice corrosion	Inspection of Internal Surfaces in Miscellaneous Piping and Ducting Components (B2.1.22)	No	Consistent with NUREG-1801 with aging management program exceptions. The aging management program(s) with exceptions to NUREG-1801 include: External Surfaces Monitoring Program (B2.1.20).

Section 3.4
AGING MANAGEMENT OF STEAM AND
POWER CONVERSION SYSTEM

Table 3.4.1 Summary of Aging Management Evaluations in Chapter VIII of NUREG-1801 for Steam and Power Conversion System (Continued)

Item Number	Component Type	Aging Effect / Mechanism	Aging Management Program	Further Evaluation Recommended	Discussion
3.4.1.31	Steel heat exchanger components exposed to raw water	Loss of material due to general, pitting, crevice, galvanic, and microbiologically-influenced corrosion, and fouling	Open-Cycle Cooling Water System (B.2.1.9)	No	Not applicable. PVNGS has no in-scope steel heat exchanger components exposed to raw water in the condensate, blowdown, or auxiliary feedwater systems, so the applicable NUREG-1801 lines were not used.
3.4.1.32	Stainless steel and copper alloy piping, piping components, and piping elements exposed to raw water	Loss of material due to pitting, crevice, and microbiologically-influenced corrosion	Open-Cycle Cooling Water System (B.2.1.9)	No	Not applicable. PVNGS has no in-scope stainless steel or copper alloy components exposed to raw water in the steam turbine, condensate, blowdown, or auxiliary feedwater systems, so the applicable NUREG-1801 lines were not used.
3.4.1.33	Stainless steel heat exchanger components exposed to raw water	Loss of material due to pitting, crevice, and microbiologically-influenced corrosion, and fouling	Open-Cycle Cooling Water System (B.2.1.9)	No	Not applicable. PVNGS has no in-scope stainless steel heat exchanger components exposed to raw water in the condensate, blowdown, or auxiliary feedwater systems, so the applicable NUREG-1801 lines were not used.

Section 3.4
AGING MANAGEMENT OF STEAM AND
POWER CONVERSION SYSTEM

Table 3.4.1 Summary of Aging Management Evaluations in Chapter VIII of NUREG-1801 for Steam and Power Conversion System (Continued)

Item Number	Component Type	Aging Effect / Mechanism	Aging Management Program	Further Evaluation Recommended	Discussion
3.4.1.34	Steel, stainless steel, and copper alloy heat exchanger tubes exposed to raw water	Reduction of heat transfer due to fouling	Open-Cycle Cooling Water System (B.2.1.9)	No	Not applicable. PVNGS has no in-scope heat exchanger components exposed to raw water in the condensate, blowdown, or auxiliary feedwater systems, so the applicable NUREG-1801 lines were not used.
3.4.1.35	Copper alloy >15% Zn piping, piping components, and piping elements exposed to closed cycle cooling water, raw water, or treated water	Loss of material due to selective leaching	Selective Leaching of Materials (B2.1.17)	No	Consistent with NUREG-1801 with aging management program exceptions. The aging management program(s) with exceptions to NUREG-1801 include: Selective Leaching of Materials (B2.1.17)
3.4.1.36	Gray cast iron piping, piping components, and piping elements exposed to soil, treated water, or raw water	Loss of material due to selective leaching	Selective Leaching of Materials (B2.1.17)	No	Consistent with NUREG-1801 with aging management program exceptions. The aging management program(s) with exceptions to NUREG-1801 include: Selective Leaching of Materials (B2.1.17)

Section 3.4
AGING MANAGEMENT OF STEAM AND
POWER CONVERSION SYSTEM

Table 3.4.1 Summary of Aging Management Evaluations in Chapter VIII of NUREG-1801 for Steam and Power Conversion System (Continued)

Item Number	Component Type	Aging Effect / Mechanism	Aging Management Program	Further Evaluation Recommended	Discussion
3.4.1.37	Steel, stainless steel, and nickel-based alloy piping, piping components, and piping elements exposed to steam	Loss of material due to pitting and crevice corrosion	Water Chemistry (B.2.1.2)	No	Consistent with NUREG-1801.
3.4.1.38	Steel bolting and external surfaces exposed to air with borated water leakage	Loss of material due to boric acid corrosion	Boric Acid Corrosion (B2.1.4)	No	Not applicable. PVNGS has no in-scope steel components exposed to borated water leakage in the steam and power conversion systems, so the applicable NUREG-1801 lines were not used.
3.4.1.39	Stainless steel piping, piping components, and piping elements exposed to steam	Cracking due to stress corrosion cracking	Water Chemistry (B.2.1.2)	No	Consistent with NUREG-1801.
3.4.1.40	Glass piping elements exposed to air, lubricating oil, raw water, and treated water	None	None	No	Consistent with NUREG-1801.

Section 3.4
AGING MANAGEMENT OF STEAM AND
POWER CONVERSION SYSTEM

Table 3.4.1 *Summary of Aging Management Evaluations in Chapter VIII of NUREG-1801 for Steam and Power Conversion System (Continued)*

Item Number	Component Type	Aging Effect / Mechanism	Aging Management Program	Further Evaluation Recommended	Discussion
3.4.1.41	Stainless steel, copper alloy, and nickel alloy piping, piping components, and piping elements exposed to air – indoor uncontrolled (external)	None	None	No	Consistent with NUREG-1801.
3.4.1.42	Steel piping, piping components, and piping elements exposed to air – indoor controlled (external)	None	None	No	Not applicable. PVNGS has no in-scope steel components exposed to indoor controlled air in the steam and power conversion systems, so the applicable NUREG-1801 line was not used. Consistent with NUREG-1801.
3.4.1.43	Steel and stainless steel piping, piping components, and piping elements in concrete	None	None	No	Consistent with NUREG-1801.
3.4.1.44	Steel, stainless steel, aluminum, and copper alloy piping, piping components, and piping elements exposed to gas	None	None	No	Consistent with NUREG-1801.

Section 3.4
AGING MANAGEMENT OF STEAM AND
POWER CONVERSION SYSTEM

Table 3.4.2-1 Steam and Power Conversion System – Summary of Aging Management Evaluation – Main Steam System

Component Type	Intended Function	Material	Environment	Aging Effect Requiring Management	Aging Management Program	NUREG-1801 Vol. 2 Item	Table 1 Item	Notes
Accumulator	PB	Carbon Steel	Dry Gas (Int)	None	None	VIII.I-15	3.4.1.44	C
Accumulator	PB	Carbon Steel	Plant Indoor Air (Ext)	Loss of material	External Surfaces Monitoring Program (B2.1.20)	VIII.H-7	3.4.1.28	B
Closure Bolting	LBS, PB, SIA	Carbon Steel	Plant Indoor Air (Ext)	Loss of material	Bolting Integrity (B2.1.7)	VIII.H-4	3.4.1.22	B
Closure Bolting	LBS, PB, SIA	Carbon Steel	Plant Indoor Air (Ext)	Loss of preload	Bolting Integrity (B2.1.7)	VIII.H-5	3.4.1.22	B
Closure Bolting	LBS, PB, SIA	Stainless Steel	Plant Indoor Air (Ext)	Loss of preload	Bolting Integrity (B2.1.7)	None	None	G, 1
Filter	LBS, SIA	Carbon Steel	Plant Indoor Air (Ext)	Loss of material	External Surfaces Monitoring Program (B2.1.20)	VIII.H-7	3.4.1.28	B
Filter	LBS, SIA	Carbon Steel	Secondary Water (Int)	Loss of material	Water Chemistry (B2.1.2) and One-Time Inspection (B2.1.16)	VIII.B1-11	3.4.1.04	A
Flexible Hoses	PB	Nickel Alloys	Dry Gas (Int)	None	None	None	None	G
Flexible Hoses	PB	Nickel Alloys	Plant Indoor Air (Ext)	None	None	V.F-11	3.2.1.53	A
Flexible Hoses	PB	Nickel Alloys	Secondary Water (Int)	Loss of material	Water Chemistry (B2.1.2)	VIII.B1-1	3.4.1.37	A
Insulation	INS	Aluminum	Plant Indoor Air (Ext)	None	None	V.F-2	3.2.1.50	C

Section 3.4
AGING MANAGEMENT OF STEAM AND
POWER CONVERSION SYSTEM

Table 3.4.2-1 Steam and Power Conversion System – Summary of Aging Management Evaluation – Main Steam System
(Continued)

Component Type	Intended Function	Material	Environment	Aging Effect Requiring Management	Aging Management Program	NUREG-1801 Vol. 2 Item	Table 1 Item	Notes
Insulation	INS	Insulation Calcium Silicate	Plant Indoor Air (Ext)	None	None	None	None	J, 2
Orifice	PB, TH	Carbon Steel	Plant Indoor Air (Ext)	Loss of material	External Surfaces Monitoring Program (B2.1.20)	VIII.H-7	3.4.1.28	B
Orifice	PB, TH	Carbon Steel	Secondary Water (Int)	Loss of material	Water Chemistry (B2.1.2) and One-Time Inspection (B2.1.16)	VIII.B1-11	3.4.1.04	A
Piping	LBS, PB, SIA	Carbon Steel	Plant Indoor Air (Ext)	Loss of material	External Surfaces Monitoring Program (B2.1.20)	VIII.H-7	3.4.1.28	B
Piping	LBS, PB, SIA	Carbon Steel	Secondary Water (Int)	Loss of material	Water Chemistry (B2.1.2)	VIII.B1-8	3.4.1.37	A
Piping	LBS, PB, SIA	Carbon Steel	Secondary Water (Int)	Wall thinning	Flow-Accelerated Corrosion (B2.1.6)	VIII.B1-9	3.4.1.29	B
Piping	PB	Carbon Steel	Secondary Water (Int)	Cumulative fatigue damage	Time-Limited Aging Analysis evaluated for the period of extended operation	VIII.B1-10	3.4.1.01	A
Piping	LBS, PB, SIA	Carbon Steel	Secondary Water (Int)	Loss of material	Water Chemistry (B2.1.2) and One-Time Inspection (B2.1.16)	VIII.B1-11	3.4.1.04	A

Section 3.4
AGING MANAGEMENT OF STEAM AND
POWER CONVERSION SYSTEM

Table 3.4.2-1 Steam and Power Conversion System – Summary of Aging Management Evaluation – Main Steam System
(Continued)

Component Type	Intended Function	Material	Environment	Aging Effect Requiring Management	Aging Management Program	NUREG-1801 Vol. 2 Item	Table 1 Item	Notes
Piping	LBS, PB, SIA	Carbon Steel	Wetted Gas (Int)	Loss of material	Inspection Of Internal Surfaces In Miscellaneous Piping And Ducting Components (B2.1.22)	VIII.B1-7	3.4.1.30	B
Piping	SIA	Copper Alloy	Dry Gas (Int)	None	None	VIII.I-3	3.4.1.44	A
Piping	SIA	Copper Alloy	Plant Indoor Air (Ext)	None	None	VIII.I-2	3.4.1.41	A
Piping	PB	Stainless Steel	Dry Gas (Int)	None	None	VIII.I-12	3.4.1.44	A
Piping	LBS, PB, SIA	Stainless Steel	Plant Indoor Air (Ext)	None	None	VIII.I-10	3.4.1.41	A
Piping	LBS, PB, SIA	Stainless Steel	Secondary Water (Int)	Cracking	Water Chemistry (B2.1.2)	VIII.B1-2	3.4.1.39	A
Piping	LBS, PB, SIA	Stainless Steel	Secondary Water (Int)	Loss of material	Water Chemistry (B2.1.2)	VIII.B1-3	3.4.1.37	A
Piping	LBS, PB, SIA	Stainless Steel	Secondary Water (Int)	Loss of material	Water Chemistry (B2.1.2) and One-Time Inspection (B2.1.16)	VIII.B1-4	3.4.1.16	A
Piping	LBS, PB, SIA	Stainless Steel	Secondary Water (Int)	Cracking	Water Chemistry (B2.1.2) and One-Time Inspection (B2.1.16)	VIII.B1-5	3.4.1.14	A
Piping	SIA	Stainless Steel	Wetted Gas (Int)	Loss of material	Inspection Of Internal Surfaces In Miscellaneous Piping And Ducting Components (B2.1.22)	V.D1-29	3.2.1.08	E

Section 3.4
AGING MANAGEMENT OF STEAM AND
POWER CONVERSION SYSTEM

Table 3.4.2-1 Steam and Power Conversion System – Summary of Aging Management Evaluation – Main Steam System
(Continued)

Component Type	Intended Function	Material	Environment	Aging Effect Requiring Management	Aging Management Program	NUREG-1801 Vol. 2 Item	Table 1 Item	Notes
Pump	LBS, SIA	Stainless Steel	Plant Indoor Air (Ext)	None	None	VIII.I-10	3.4.1.41	A
Pump	LBS, SIA	Stainless Steel	Secondary Water (Int)	Loss of material	Water Chemistry (B2.1.2) and One-Time Inspection (B2.1.16)	VIII.B1-4	3.4.1.16	A
Tubing	PB	Copper Alloy	Dry Gas (Int)	None	None	VIII.I-3	3.4.1.44	A
Tubing	PB	Copper Alloy	Plant Indoor Air (Ext)	None	None	VIII.I-2	3.4.1.41	A
Tubing	PB	Stainless Steel	Dry Gas (Int)	None	None	VIII.I-12	3.4.1.44	A
Tubing	PB	Stainless Steel	Plant Indoor Air (Ext)	None	None	VIII.I-10	3.4.1.41	A
Tubing	PB	Stainless Steel	Secondary Water (Int)	Loss of material	Water Chemistry (B2.1.2) and One-Time Inspection (B2.1.16)	VIII.B1-4	3.4.1.16	A
Tubing	PB	Stainless Steel	Secondary Water (Int)	Cracking	Water Chemistry (B2.1.2) and One-Time Inspection (B2.1.16)	VIII.B1-5	3.4.1.14	A
Valve	LBS, PB, SIA	Carbon Steel	Plant Indoor Air (Ext)	Loss of material	External Surfaces Monitoring Program (B2.1.20)	VIII.H-7	3.4.1.28	B
Valve	PB	Carbon Steel	Secondary Water (Int)	Loss of material	Water Chemistry (B2.1.2)	VIII.B1-8	3.4.1.37	A
Valve	PB	Carbon Steel	Secondary Water (Int)	Wall thinning	Flow-Accelerated Corrosion (B2.1.6)	VIII.B1-9	3.4.1.29	B

Section 3.4
AGING MANAGEMENT OF STEAM AND
POWER CONVERSION SYSTEM

Table 3.4.2-1 Steam and Power Conversion System – Summary of Aging Management Evaluation – Main Steam System
(Continued)

Component Type	Intended Function	Material	Environment	Aging Effect Requiring Management	Aging Management Program	NUREG-1801 Vol. 2 Item	Table 1 Item	Notes
Valve	PB	Carbon Steel	Secondary Water (Int)	Cumulative fatigue damage	Time-Limited Aging Analysis evaluated for the period of extended operation	VIII.B1-10	3.4.1.01	C
Valve	LBS, PB, SIA	Carbon Steel	Secondary Water (Int)	Loss of material	Water Chemistry (B2.1.2) and One-Time Inspection (B2.1.16)	VIII.B1-11	3.4.1.04	A
Valve	LBS, PB, SIA	Carbon Steel	Wetted Gas (Int)	Loss of material	Inspection Of Internal Surfaces In Miscellaneous Piping And Ducting Components (B2.1.22)	VIII.B1-7	3.4.1.30	B
Valve	PB	Copper Alloy (Zinc >15%)	Dry Gas (Int)	None	None	VIII.I-3	3.4.1.44	A
Valve	PB	Copper Alloy (Zinc >15%)	Plant Indoor Air (Ext)	None	None	VIII.I-2	3.4.1.41	A
Valve	PB	Stainless Steel	Dry Gas (Int)	None	None	VIII.I-12	3.4.1.44	A
Valve	PB, SIA	Stainless Steel	Plant Indoor Air (Ext)	None	None	VIII.I-10	3.4.1.41	A
Valve	PB	Stainless Steel	Secondary Water (Int)	Cracking	Water Chemistry (B2.1.2)	VIII.B1-2	3.4.1.39	A
Valve	PB	Stainless Steel	Secondary Water (Int)	Loss of material	Water Chemistry (B2.1.2)	VIII.B1-3	3.4.1.37	A
Valve	PB	Stainless Steel	Secondary Water (Int)	Loss of material	Water Chemistry (B2.1.2) and One-Time Inspection (B2.1.16)	VIII.B1-4	3.4.1.16	A

Section 3.4
AGING MANAGEMENT OF STEAM AND
POWER CONVERSION SYSTEM

Table 3.4.2-1 Steam and Power Conversion System – Summary of Aging Management Evaluation – Main Steam System
(Continued)

Component Type	Intended Function	Material	Environment	Aging Effect Requiring Management	Aging Management Program	NUREG-1801 Vol. 2 Item	Table 1 Item	Notes
Valve	PB	Stainless Steel	Secondary Water (Int)	Cracking	Water Chemistry (B2.1.2) and One-Time Inspection (B2.1.16)	VIII.B1-5	3.4.1.14	A
Valve	S/A	Stainless Steel	Wetted Gas (Int)	Loss of material	Inspection Of Internal Surfaces In Miscellaneous Piping And Ducting Components (B2.1.22)	V.D1-29	3.2.1.08	E

Notes for Table 3.4.2-1:
Standard Notes:

- A Consistent with NUREG-1801 item for component, material, environment, and aging effect. AMP is consistent with NUREG-1801 AMP.
- B Consistent with NUREG-1801 item for component, material, environment, and aging effect. AMP takes some exceptions to NUREG-1801 AMP.
- C Component is different, but consistent with NUREG-1801 item for material, environment, and aging effect. AMP is consistent with NUREG-1801 AMP.
- E Consistent with NUREG-1801 for material, environment, and aging effect, but a different aging management program is credited or NUREG-1801 identifies a plant-specific aging management program.
- G Environment not in NUREG-1801 for this component and material.
- J Neither the component nor the material and environment combination is evaluated in NUREG-1801.

Plant Specific Notes:

- 1 Loss of Preload is considered to be applicable for all closure bolting.
- 2 NUREG-1801 does not consider mechanical insulation. The thermal insulation in-scope for license renewal is located in areas with non-aggressive environments (the insulation is not exposed to contaminants). Based on the review of the SERs of recent license renewal applications (Millstone, Dresden and Quad Cities, Cook, ANO-2, and Robinson) and review of the site operating experience, stainless steel insulation, closed cell foam, quilted fiberglass insulation, calcium silicate and insulation jacketing in non-aggressive environments have no aging effects requiring management.

Section 3.4
AGING MANAGEMENT OF STEAM AND
POWER CONVERSION SYSTEM

Table 3.4.2-2 Steam and Power Conversion System – Summary of Aging Management Evaluation – Condensate Storage and Transfer System

Component Type	Intended Function	Material	Environment	Aging Effect Requiring Management	Aging Management Program	NUREG-1801 Vol. 2 Item	Table 1 Item	Notes
Closure Bolting	LBS, SIA	Carbon Steel	Atmosphere/ Weather (Ext)	Loss of preload	Bolting Integrity (B2.1.7)	None	None	G
Closure Bolting	LBS, SIA	Carbon Steel	Atmosphere/ Weather (Ext)	Loss of material	Bolting Integrity (B2.1.7)	VIII.H-1	3.4.1.22	B
Closure Bolting	LBS, PB, SIA	Carbon Steel	Plant Indoor Air (Ext)	Loss of material	Bolting Integrity (B2.1.7)	VIII.H-4	3.4.1.22	B
Closure Bolting	LBS, PB, SIA	Carbon Steel	Plant Indoor Air (Ext)	Loss of preload	Bolting Integrity (B2.1.7)	VIII.H-5	3.4.1.22	B
Closure Bolting	LBS, PB, SIA	Stainless Steel	Plant Indoor Air (Ext)	Loss of preload	Bolting Integrity (B2.1.7)	None	None	G, 1
Flow Element	PB	Stainless Steel	Plant Indoor Air (Ext)	None	None	VIII.I-10	3.4.1.41	A
Flow Element	PB	Stainless Steel	Secondary Water (Int)	Loss of material	Water Chemistry (B2.1.2) and One-Time Inspection (B2.1.16)	VIII.E-29	3.4.1.16	A

Section 3.4
AGING MANAGEMENT OF STEAM AND
POWER CONVERSION SYSTEM

Table 3.4.2-2 Steam and Power Conversion System – Summary of Aging Management Evaluation – Condensate Storage and Transfer System (Continued)

Component Type	Intended Function	Material	Environment	Aging Effect Requiring Management	Aging Management Program	NUREG-1801 Vol. 2 Item	Table 1 Item	Notes
Orifice	PB	Stainless Steel	Plant Indoor Air (Ext)	None	None	VIII.I-10	3.4.1.41	A
Orifice	PB	Stainless Steel	Secondary Water (Int)	Loss of material	Water Chemistry (B2.1.2) and One-Time Inspection (B2.1.16)	VIII.E-29	3.4.1.16	A
Piping	LBS, SIA	Carbon Steel	Plant Indoor Air (Ext)	Loss of material	External Surfaces Monitoring Program (B2.1.20)	VIII.H-7	3.4.1.28	B
Piping	LBS, SIA	Carbon Steel	Secondary Water (Int)	Loss of material	Water Chemistry (B2.1.2) and One-Time Inspection (B2.1.16)	VIII.E-34	3.4.1.04	A
Piping	PB, SIA	Stainless Steel	Atmosphere/Weather (Ext)	None	None	None	None	G
Piping	PB	Stainless Steel	Encased in Concrete (Ext)	None	None	VIII.I-11	3.4.1.43	A
Piping	LBS, PB, SIA	Stainless Steel	Plant Indoor Air (Ext)	None	None	VIII.I-10	3.4.1.41	A

Section 3.4
AGING MANAGEMENT OF STEAM AND
POWER CONVERSION SYSTEM

Table 3.4.2-2 Steam and Power Conversion System – Summary of Aging Management Evaluation – Condensate Storage and Transfer System (Continued)

Component Type	Intended Function	Material	Environment	Aging Effect Requiring Management	Aging Management Program	NUREG-1801 Vol. 2 Item	Table 1 Item	Notes
Piping	LBS, PB, SIA	Stainless Steel	Secondary Water (Int)	Loss of material	Water Chemistry (B2.1.2) and One-Time Inspection (B2.1.16)	VIII.E-29	3.4.1.16	A
Piping	PB, SIA	Stainless Steel	Wetted Gas (Int)	Loss of material	Inspection Of Internal Surfaces In Miscellaneous Piping And Ducting Components (B2.1.22)	V.D1-29	3.2.1.08	E
Pump	PB	Stainless Steel Cast Austenitic	Plant Indoor Air (Ext)	None	None	VIII.I-10	3.4.1.41	A
Pump	PB	Stainless Steel Cast Austenitic	Secondary Water (Int)	Loss of material	Water Chemistry (B2.1.2) and One-Time Inspection (B2.1.16)	VIII.E-29	3.4.1.16	A
Tank Liner	PB	Stainless Steel	Dry Gas (Int)	None	None	VIII.I-12	3.4.1.44	A
Tank Liner	PB	Stainless Steel	Encased in Concrete (Ext)	None	None	VIII.I-11	3.4.1.43	C
Tank Liner	PB	Stainless Steel	Plant Indoor Air (Ext)	None	None	VIII.I-10	3.4.1.41	C

Section 3.4
AGING MANAGEMENT OF STEAM AND
POWER CONVERSION SYSTEM

Table 3.4.2-2 Steam and Power Conversion System – Summary of Aging Management Evaluation – Condensate Storage and Transfer System (Continued)

Component Type	Intended Function	Material	Environment	Aging Effect Requiring Management	Aging Management Program	NUREG-1801 Vol. 2 Item	Table 1 Item	Notes
Tank Liner	PB	Stainless Steel	Secondary Water (Int)	Loss of material	Water Chemistry (B2.1.2) and One-Time Inspection (B2.1.16)	VIII.E-40	3.4.1.06	A
Tubing	LBS	Stainless Steel	Plant Indoor Air (Ext)	None	None	VIII.I-10	3.4.1.41	A
Tubing	LBS	Stainless Steel	Secondary Water (Int)	Loss of material	Water Chemistry (B2.1.2) and One-Time Inspection (B2.1.16)	VIII.E-29	3.4.1.16	A
Valve	LBS, PB	Carbon Steel	Plant Indoor Air (Ext)	Loss of material	External Surfaces Monitoring Program (B2.1.20)	VIII.H-7	3.4.1.28	B
Valve	LBS, PB	Carbon Steel	Secondary Water (Int)	Loss of material	Water Chemistry (B2.1.2) and One-Time Inspection (B2.1.16)	VIII.E-34	3.4.1.04	A
Valve	LBS, PB, SIA	Stainless Steel	Plant Indoor Air (Ext)	None	None	VIII.I-10	3.4.1.41	A

Section 3.4
AGING MANAGEMENT OF STEAM AND
POWER CONVERSION SYSTEM

Table 3.4.2-2 Steam and Power Conversion System – Summary of Aging Management Evaluation – Condensate Storage and Transfer System (Continued)

Component Type	Intended Function	Material	Environment	Aging Effect Requiring Management	Aging Management Program	NUREG-1801 Vol. 2 Item	Table 1 Item	Notes
Valve	LBS, PB, SIA	Stainless Steel	Secondary Water (Int)	Loss of material	Water Chemistry (B2.1.2) and One-Time Inspection (B2.1.16)	VIII.E-29	3.4.1.16	A
Valve	SIA	Stainless Steel Cast Austenitic	Atmosphere/ Weather (Ext)	None	None	None	None	G
Valve	PB	Stainless Steel Cast Austenitic	Plant Indoor Air (Ext)	None	None	VIII.I-10	3.4.1.41	A
Valve	PB	Stainless Steel Cast Austenitic	Secondary Water (Int)	Loss of material	Water Chemistry (B2.1.2) and One-Time Inspection (B2.1.16)	VIII.E-29	3.4.1.16	A
Valve	SIA	Stainless Steel Cast Austenitic	Wetted Gas (Int)	Loss of material	Inspection Of Internal Surfaces In Miscellaneous Piping And Ducting Components (B2.1.22)	V.D1-29	3.2.1.08	E

Section 3.4
**AGING MANAGEMENT OF STEAM AND
POWER CONVERSION SYSTEM**

Notes for Table 3.4.2-2:

Standard Notes:

- A Consistent with NUREG-1801 item for component, material, environment, and aging effect. AMP is consistent with NUREG-1801 AMP.
- B Consistent with NUREG-1801 item for component, material, environment, and aging effect. AMP takes some exceptions to NUREG-1801 AMP.
- C Component is different, but consistent with NUREG-1801 item for material, environment, and aging effect. AMP is consistent with NUREG-1801 AMP.
- E Consistent with NUREG-1801 for material, environment, and aging effect, but a different aging management program is credited or NUREG-1801 identifies a plant-specific aging management program.
- G Environment not in NUREG-1801 for this component and material.

Plant Specific Note:

- 1 Loss of Preload is considered to be applicable for all closure bolting.

Section 3.4
AGING MANAGEMENT OF STEAM AND
POWER CONVERSION SYSTEM

Table 3.4.2-3 Steam and Power Conversion System – Summary of Aging Management Evaluation – Auxiliary Feedwater System

Component Type	Intended Function	Material	Environment	Aging Effect Requiring Management	Aging Management Program	NUREG-1801 Vol. 2 Item	Table 1 Item	Notes
Closure Bolting	LBS, PB, S/A	Carbon Steel	Plant Indoor Air (Ext)	Loss of material	Bolting Integrity (B2.1.7)	VIII.H-4	3.4.1.22	B
Closure Bolting	LBS, PB, S/A	Carbon Steel	Plant Indoor Air (Ext)	Loss of preload	Bolting Integrity (B2.1.7)	VIII.H-5	3.4.1.22	B
Closure Bolting	LBS, PB, S/A	Stainless Steel	Plant Indoor Air (Ext)	Loss of preload	Bolting Integrity (B2.1.7)	None	None	G, 1
Filter	PB	Aluminum	Lubricating Oil (Int)	Loss of material	Lubricating Oil Analysis (B2.1.23) and One-Time Inspection (B2.1.16)	None	None	G
Filter	PB	Aluminum	Plant Indoor Air (Ext)	None	None	V.F-2	3.2.1.50	A
Filter	PB	Carbon Steel	Lubricating Oil (Int)	Loss of material	Lubricating Oil Analysis (B2.1.23) and One-Time Inspection (B2.1.16)	VIII.G-35	3.4.1.07	B
Filter	PB	Carbon Steel	Plant Indoor Air (Ext)	Loss of material	External Surfaces Monitoring Program (B2.1.20)	VIII.H-7	3.4.1.28	B
Flexible Hoses	PB	Nickel Alloys	Plant Indoor Air (Ext)	None	None	V.F-11	3.2.1.53	A
Flexible Hoses	PB	Nickel Alloys	Secondary Water (Int)	Loss of material	Water Chemistry (B2.1.2)	VIII.B1-1	3.4.1.37	A
Flow Element	PB, TH	Stainless Steel	Plant Indoor Air (Ext)	None	None	VIII.I-10	3.4.1.41	A

Section 3.4
AGING MANAGEMENT OF STEAM AND
POWER CONVERSION SYSTEM

Table 3.4.2-3 Steam and Power Conversion System – Summary of Aging Management Evaluation – Auxiliary Feedwater System
(Continued)

Component Type	Intended Function	Material	Environment	Aging Effect Requiring Management	Aging Management Program	NUREG-1801 Vol. 2 Item	Table 1 Item	Notes
Flow Element	PB, TH	Stainless Steel	Secondary Water (Int)	Loss of material	Water Chemistry (B2.1.2) and One-Time Inspection (B2.1.16)	VIII.G-32	3.4.1.16	A
Heat Exchanger (AF Turbine Oil Cooler)	HT, PB	Carbon Steel	Lubricating Oil (Ext)	Loss of material	Lubricating Oil Analysis (B2.1.23) and One-Time Inspection (B2.1.16)	VIII.G-6	3.4.1.12	B
Heat Exchanger (AF Turbine Oil Cooler)	HT, PB	Carbon Steel	Lubricating Oil (Ext)	Reduction of heat transfer	Lubricating Oil Analysis (B2.1.23) and One-Time Inspection (B2.1.16)	VIII.G-15	3.4.1.10	B
Heat Exchanger (AF Turbine Oil Cooler)	PB	Carbon Steel	Lubricating Oil (Int)	Loss of material	Lubricating Oil Analysis (B2.1.23) and One-Time Inspection (B2.1.16)	VIII.G-6	3.4.1.12	B
Heat Exchanger (AF Turbine Oil Cooler)	PB	Carbon Steel	Plant Indoor Air (Ext)	Loss of material	External Surfaces Monitoring Program (B2.1.20)	VIII.H-7	3.4.1.28	B
Heat Exchanger (AF Turbine Oil Cooler)	HT, PB	Carbon Steel	Secondary Water (Int)	Reduction of heat transfer	Water Chemistry (B2.1.2) and One-Time Inspection (B2.1.16)	None	None	G
Heat Exchanger (AF Turbine Oil Cooler)	HT, PB	Carbon Steel	Secondary Water (Int)	Loss of material	Water Chemistry (B2.1.2) and One-Time Inspection (B2.1.16)	VIII.G-38	3.4.1.04	C

Section 3.4
AGING MANAGEMENT OF STEAM AND
POWER CONVERSION SYSTEM

Table 3.4.2-3 Steam and Power Conversion System – Summary of Aging Management Evaluation – Auxiliary Feedwater System
(Continued)

Component Type	Intended Function	Material	Environment	Aging Effect Requiring Management	Aging Management Program	NUREG-1801 Vol. 2 Item	Table 1 Item	Notes
Insulation	INS	Aluminum	Plant Indoor Air (Ext)	None	None	V.F-2	3.2.1.50	C
Insulation	INS	Insulation Calcium Silicate	Plant Indoor Air (Ext)	None	None	None	None	J, 2
Orifice	PB, TH	Carbon Steel	Lubricating Oil (Int)	Loss of material	Lubricating Oil Analysis (B2.1.23) and One-Time Inspection (B2.1.16)	VIII.G-35	3.4.1.07	B
Orifice	PB, TH	Carbon Steel	Plant Indoor Air (Ext)	Loss of material	External Surfaces Monitoring Program (B2.1.20)	VIII.H-7	3.4.1.28	B
Orifice	PB, TH	Carbon Steel	Secondary Water (Int)	Loss of material	Water Chemistry (B2.1.2)	VIII.B1-8	3.4.1.37	A
Orifice	PB, TH	Carbon Steel	Secondary Water (Int)	Loss of material	Water Chemistry (B2.1.2) and One-Time Inspection (B2.1.16)	VIII.G-38	3.4.1.04	A
Orifice	PB, TH	Stainless Steel	Plant Indoor Air (Ext)	None	None	VIII.I-10	3.4.1.41	A
Orifice	PB, TH	Stainless Steel	Secondary Water (Int)	Loss of material	Water Chemistry (B2.1.2) and One-Time Inspection (B2.1.16)	VIII.G-32	3.4.1.16	A
Orifice	PB, TH	Stainless Steel Cast Austenitic	Plant Indoor Air (Ext)	None	None	VIII.I-10	3.4.1.41	A
Orifice	PB, TH	Stainless Steel Cast Austenitic	Secondary Water (Int)	Loss of material	Water Chemistry (B2.1.2) and One-Time Inspection (B2.1.16)	VIII.G-32	3.4.1.16	A

Table 3.4.2-3 Steam and Power Conversion System – Summary of Aging Management Evaluation – Auxiliary Feedwater System
(Continued)

Component Type	Intended Function	Material	Environment	Aging Effect Requiring Management	Aging Management Program	NUREG-1801 Vol. 2 Item	Table 1 Item	Notes
Piping	PB	Carbon Steel	Lubricating Oil (Int)	Loss of material	Lubricating Oil Analysis (B2.1.23) and One-Time Inspection (B2.1.16)	VIII.G-35	3.4.1.07	B
Piping	LBS, PB, SIA	Carbon Steel	Plant Indoor Air (Ext)	Loss of material	External Surfaces Monitoring Program (B2.1.20)	VIII.H-7	3.4.1.28	B
Piping	PB	Carbon Steel	Secondary Water (Int)	Loss of material	Water Chemistry (B2.1.2)	VIII.B1-8	3.4.1.37	A
Piping	PB	Carbon Steel	Secondary Water (Int)	Wall thinning	Flow-Accelerated Corrosion (B2.1.6)	VIII.B1-9	3.4.1.29	B
Piping	PB	Carbon Steel	Secondary Water (Int)	Cumulative fatigue damage	Time-Limited Aging Analysis evaluated for the period of extended operation	VIII.G-37	3.4.1.01	A
Piping	LBS, SIA	Carbon Steel	Secondary Water (Int)	Loss of material	Water Chemistry (B2.1.2) and One-Time Inspection (B2.1.16)	VIII.G-38	3.4.1.04	A
Piping	LBS, PB, SIA	Stainless Steel	Plant Indoor Air (Ext)	None	None	VIII.I-10	3.4.1.41	A
Piping	LBS, PB, SIA	Stainless Steel	Secondary Water (Int)	Loss of material	Water Chemistry (B2.1.2) and One-Time Inspection (B2.1.16)	VIII.G-32	3.4.1.16	A
Pump	PB	Carbon Steel	Lubricating Oil (Int)	Loss of material	Lubricating Oil Analysis (B2.1.23) and One-Time Inspection (B2.1.16)	VIII.G-35	3.4.1.07	B
Pump	PB	Carbon Steel	Plant Indoor Air (Ext)	Loss of material	External Surfaces Monitoring Program (B2.1.20)	VIII.H-7	3.4.1.28	B

Section 3.4
AGING MANAGEMENT OF STEAM AND
POWER CONVERSION SYSTEM

Table 3.4.2-3 Steam and Power Conversion System – Summary of Aging Management Evaluation – Auxiliary Feedwater System
(Continued)

Component Type	Intended Function	Material	Environment	Aging Effect Requiring Management	Aging Management Program	NUREG-1801 Vol. 2 Item	Table 1 Item	Notes
Pump	PB	Stainless Steel Cast Austenitic	Plant Indoor Air (Ext)	None	None	VIII.I-10	3.4.1.41	A
Pump	PB	Stainless Steel Cast Austenitic	Secondary Water (Int)	Loss of material	Water Chemistry (B2.1.2) and One-Time Inspection (B2.1.16)	VIII.G-32	3.4.1.16	A
Sight Gauge	LBS	Glass	Plant Indoor Air (Ext)	None	None	VIII.I-5	3.4.1.40	A
Sight Gauge	LBS	Glass	Secondary Water (Int)	None	None	VIII.I-8	3.4.1.40	A
Strainer	LBS, SIA	Carbon Steel	Plant Indoor Air (Ext)	Loss of material	External Surfaces Monitoring Program (B2.1.20)	VIII.H-7	3.4.1.28	B
Strainer	LBS, SIA	Carbon Steel	Secondary Water (Int)	Loss of material	Water Chemistry (B2.1.2) and One-Time Inspection (B2.1.16)	VIII.G-38	3.4.1.04	A
Tubing	PB	Carbon Steel	Lubricating Oil (Int)	Loss of material	Lubricating Oil Analysis (B2.1.23) and One-Time Inspection (B2.1.16)	VIII.G-35	3.4.1.07	B
Tubing	PB	Carbon Steel	Plant Indoor Air (Ext)	Loss of material	External Surfaces Monitoring Program (B2.1.20)	VIII.H-7	3.4.1.28	B
Tubing	PB	Stainless Steel	Plant Indoor Air (Ext)	None	None	VIII.I-10	3.4.1.41	A
Tubing	PB	Stainless Steel	Secondary Water (Int)	Loss of material	Water Chemistry (B2.1.2) and One-Time Inspection (B2.1.16)	VIII.G-32	3.4.1.16	A

Section 3.4
AGING MANAGEMENT OF STEAM AND
POWER CONVERSION SYSTEM

Table 3.4.2-3 Steam and Power Conversion System – Summary of Aging Management Evaluation – Auxiliary Feedwater System
(Continued)

Component Type	Intended Function	Material	Environment	Aging Effect Requiring Management	Aging Management Program	NUREG-1801 Vol. 2 Item	Table 1 Item	Notes
Turbine	PB	Carbon Steel	Plant Indoor Air (Ext)	Loss of material	External Surfaces Monitoring Program (B2.1.20)	VIII.H-7	3.4.1.28	B
Turbine	PB	Carbon Steel	Secondary Water (Int)	Loss of material	Water Chemistry (B2.1.2)	VIII.B1-8	3.4.1.37	A
Turbine	PB	Carbon Steel	Secondary Water (Int)	Wall thinning	Flow-Accelerated Corrosion (B2.1.6)	VIII.B1-9	3.4.1.29	B
Valve	PB	Carbon Steel	Lubricating Oil (Int)	Loss of material	Lubricating Oil Analysis (B2.1.23) and One-Time Inspection (B2.1.16)	VIII.G-35	3.4.1.07	B
Valve	LBS, PB, SIA	Carbon Steel	Plant Indoor Air (Ext)	Loss of material	External Surfaces Monitoring Program (B2.1.20)	VIII.H-7	3.4.1.28	B
Valve	LBS, PB, SIA	Carbon Steel	Secondary Water (Int)	Loss of material	Water Chemistry (B2.1.2)	VIII.B1-8	3.4.1.37	A
Valve	PB	Carbon Steel	Secondary Water (Int)	Wall thinning	Flow-Accelerated Corrosion (B2.1.6)	VIII.B1-9	3.4.1.29	B
Valve	LBS, PB, SIA	Carbon Steel	Secondary Water (Int)	Loss of material	Water Chemistry (B2.1.2) and One-Time Inspection (B2.1.16)	VIII.G-38	3.4.1.04	A
Valve	PB	Cast Iron	Lubricating Oil (Int)	Loss of material	Lubricating Oil Analysis (B2.1.23) and One-Time Inspection (B2.1.16)	VIII.G-35	3.4.1.07	B
Valve	PB	Cast Iron	Plant Indoor Air (Ext)	Loss of material	External Surfaces Monitoring Program (B2.1.20)	VIII.H-7	3.4.1.28	B
Valve	LBS, PB, SIA	Stainless Steel	Plant Indoor Air (Ext)	None	None	VIII.I-10	3.4.1.41	A

Table 3.4.2-3 Steam and Power Conversion System – Summary of Aging Management Evaluation – Auxiliary Feedwater System
(Continued)

Component Type	Intended Function	Material	Environment	Aging Effect Requiring Management	Aging Management Program	NUREG-1801 Vol. 2 Item	Table 1 Item	Notes
Valve	LBS, PB, SIA	Stainless Steel	Secondary Water (Int)	Loss of material	Water Chemistry (B2.1.2) and One-Time Inspection (B2.1.16)	VIII.G-32	3.4.1.16	A

Notes for Table 3.4.2-3:

Standard Notes:

- A Consistent with NUREG-1801 item for component, material, environment, and aging effect. AMP is consistent with NUREG-1801 AMP.
- B Consistent with NUREG-1801 item for component, material, environment, and aging effect. AMP takes some exceptions to NUREG-1801 AMP.
- C Component is different, but consistent with NUREG-1801 item for material, environment, and aging effect. AMP is consistent with NUREG-1801 AMP.
- G Environment not in NUREG-1801 for this component and material.
- J Neither the component nor the material and environment combination is evaluated in NUREG-1801.

Plant Specific Notes:

- 1 Loss of Preload is considered to be applicable for all closure bolting.
- 2 NUREG-1801 does not consider mechanical insulation. The thermal insulation in-scope for license renewal is located in areas with non-aggressive environments (meaning the insulation is not exposed to contaminants). Based on the review of the SERs of recent license renewal applications (Millstone, Dresden and Quad Cities, Cook, ANO-2, and Robinson) and review of the site operating experience, stainless steel insulation, closed cell foam, quilted fiberglass insulation, calcium silicate and insulation jacketing in non-aggressive environments have no aging effects requiring management.

3.5 AGING MANAGEMENT OF CONTAINMENTS, STRUCTURES AND COMPONENT SUPPORTS

3.5.1 Introduction

Section 3.5 provides the results of the aging management reviews for those component types identified in [Section 2.4](#), Scoping and Screening Results – Structures, subject to aging management review. The structures are described in the following sections:

- Containment building ([Section 2.4.1](#))
- Control building ([Section 2.4.2](#))
- Diesel generator building ([Section 2.4.3](#))
- Turbine building ([Section 2.4.4](#))
- Auxiliary building ([Section 2.4.5](#))
- Radwaste building ([Section 2.4.6](#))
- Main steam support structure ([Section 2.4.7](#))
- Station blackout generator structures ([Section 2.4.8](#))
- Fuel building ([Section 2.4.9](#))
- Spray pond and associated water control structures ([Section 2.4.10](#))
- Tank foundations and shells ([Section 2.4.11](#))
- Transformer foundations and electrical structures ([Section 2.4.12](#))
- Yard structures (in-scope) ([Section 2.4.13](#))
- Supports ([Section 2.4.14](#))

Table 3.5.1, Summary of Aging Management Evaluations in Chapter II and III of NUREG-1801 for Containments, Structures, and Component Supports, provides the summary of the programs evaluated in NUREG-1801 that are applicable to component types in this Section. [Table 3.5.1](#) uses the format of [Table 1](#) described in [Section 3.0](#).

3.5.2 Results

The following tables summarize the results of the aging management review for the systems in the containments, structures and component supports area:

- [Table 3.5.2-1](#) Containments, Structures, and Component Supports - Summary of Aging Management Evaluation - Containment Building

Section 3.5
**AGING MANAGEMENT OF CONTAINMENTS,
STRUCTURES AND COMPONENT SUPPORTS**

- [Table 3.5.2-2](#) Containments, Structures, and Component Supports - Summary of Aging Management Evaluation - Control Building
- [Table 3.5.2-3](#) Containments, Structures, and Component Supports - Summary of Aging Management Evaluation - Diesel Generator Building
- [Table 3.5.2-4](#) Containments, Structures, and Component Supports - Summary of Aging Management Evaluation - Turbine Building
- [Table 3.5.2-5](#) Containments, Structures, and Component Supports - Summary of Aging Management Evaluation - Auxiliary Building
- [Table 3.5.2-6](#) Containments, Structures, and Component Supports - Summary of Aging Management Evaluation - Radwaste Building
- [Table 3.5.2-7](#) Containments, Structures, and Component Supports - Summary of Aging Management Evaluation – Main Steam Support Structure
- [Table 3.5.2-8](#) Containments, Structures, and Component Supports - Summary of Aging Management Evaluation – Station Blackout Generator Structures
- [Table 3.5.2-9](#) Containments, Structures, and Component Supports - Summary of Aging Management Evaluation – Fuel Building
- [Table 3.5.2-10](#) Containments, Structures, and Component Supports - Summary of Aging Management Evaluation – Spray Pond and Associated Water Control Structures
- [Table 3.5.2-11](#) Containments, Structures, and Component Supports - Summary of Aging Management Evaluation – Tank Foundations and Shells
- [Table 3.5.2-12](#) Containments, Structures, and Component Supports - Summary of Aging Management Evaluation – Transformer Foundations and Electrical Structures
- [Table 3.5.2-13](#) Containments, Structures, and Component Supports - Summary of Aging Management Evaluation – Yard Structures (in-scope)
- [Table 3.5.2-14](#) Containments, Structures, and Component Supports - Summary of Aging Management Evaluation - Supports

These tables use the format of [Table 2](#) discussed in [Section 3.0](#).

3.5.2.1 Materials, Environment, Aging Effects Requiring Management and Aging Management Programs

The materials from which the component types are fabricated, the environments to which they are exposed, the potential aging effects requiring management, and the aging

Section 3.5
AGING MANAGEMENT OF CONTAINMENTS,
STRUCTURES AND COMPONENT SUPPORTS

management programs used to manage these aging effects are provided for each of the above structures and commodities in the following subsections.

3.5.2.1.1 Containment Building

Materials

The materials of construction for the containment building component types are:

- Carbon Steel
- Concrete
- Elastomer
- Glass
- Stainless Steel
- Thermo-Lag

Environment

The containment building component types are exposed to the following environments:

- Atmosphere/ Weather (Structural)
- Buried (Structural)
- Encased in Concrete
- Plant Indoor Air (Structural)
- Submerged (Structural)

Aging Effects Requiring Management

The following containment building aging effects require management:

- Concrete cracking and spalling
- Cracking
- Cracking due to expansion
- Cracking, loss of bond, and loss of material (spalling, scaling)
- Cracks and distortion
- Increase in porosity and permeability, cracking, loss of material (spalling, scaling)
- Increase in porosity, permeability
- Increased hardness, shrinkage and loss of strength

Section 3.5
AGING MANAGEMENT OF CONTAINMENTS,
STRUCTURES AND COMPONENT SUPPORTS

- Loss of leak tightness
- Loss of material
- Loss of material (spalling, scaling) and cracking
- Loss of material, cracking
- Loss of sealing; leakage through containment

Aging Management Programs

The following aging management programs manage the aging effects for the containment building component types:

- 10 CFR 50, Appendix J ([B2.1.30](#))
- ASME Section XI, Subsection IWE ([B2.1.27](#))
- ASME Section XI, Subsection IWL ([B2.1.28](#))
- Fire Protection ([B2.1.12](#))
- Structures Monitoring Program ([B2.1.32](#))
- Water Chemistry ([B2.1.2](#))

3.5.2.1.2 Control Building

Materials

The materials of construction for the control building component types are:

- Aluminum
- Carbon Steel
- Concrete
- Concrete Block (Masonry Walls)
- Elastomer
- Fire Barrier (Cementitious Coating)
- Fire Barrier (Ceramic Fiber)
- Gypsum/ Plaster

Environment

The control building component types are exposed to the following environments:

- Atmosphere/ Weather (Structural)

- Buried (Structural)
- Encased in Concrete
- Plant Indoor Air (Structural)

Aging Effects Requiring Management

The following control building aging effects require management:

- Concrete cracking and spalling
- Cracking
- Cracking due to expansion
- Cracking, loss of bond, and loss of material (spalling, scaling)
- Cracks and distortion
- Increase in porosity and permeability, cracking, loss of material (spalling, scaling)
- Increased hardness, shrinkage and loss of strength
- Loss of material
- Loss of material (spalling, scaling) and cracking
- Loss of material, cracking
- Loss of sealing

Aging Management Programs

The following aging management programs manage the aging effects for the control building component types:

- Fire Protection ([B2.1.12](#))
- Masonry Wall Program ([B2.1.31](#))
- Structures Monitoring Program ([B2.1.32](#))

3.5.2.1.3 Diesel Generator Building

Materials

The materials of construction for the diesel generator building component types are:

- Carbon Steel
- Concrete
- Elastomer

Environment

The diesel generator building component types are exposed to the following environments:

- Atmosphere/ Weather (Structural)
- Buried (Structural)
- Encased in Concrete
- Plant Indoor Air (Structural)

Aging Effects Requiring Management

The following diesel generator building aging effects require management:

- Concrete cracking and spalling
- Cracking due to expansion
- Cracking, loss of bond, and loss of material (spalling, scaling)
- Cracks and distortion
- Increase in porosity and permeability, cracking, loss of material (spalling, scaling)
- Increased hardness, shrinkage and loss of strength
- Loss of material
- Loss of material (spalling, scaling) and cracking
- Loss of sealing

Aging Management Programs

The following aging management programs manage the aging effects for the diesel generator building component types:

- Fire Protection ([B2.1.12](#))
- Structures Monitoring Program ([B2.1.32](#))

3.5.2.1.4 Turbine Building

Materials

The materials of construction for the turbine building component types are:

- Carbon Steel
- Concrete

- Concrete Block (Masonry Walls)
- Elastomer
- Fire Barrier (Cementitious Coating)

Environment

The turbine building component types are exposed to the following environments:

- Atmosphere/ Weather (Structural)
- Buried (Structural)
- Encased in Concrete
- Plant Indoor Air (Structural)

Aging Effects Requiring Management

The following turbine building aging effects require management:

- Cracking
- Cracking due to expansion
- Cracking, loss of bond, and loss of material (spalling, scaling)
- Cracks and distortion
- Increase in porosity and permeability, cracking, loss of material (spalling, scaling)
- Increased hardness, shrinkage and loss of strength
- Loss of material
- Loss of material (spalling, scaling) and cracking
- Loss of material, cracking
- Loss of sealing

Aging Management Programs

The following aging management programs manage the aging effects for the turbine building component types:

- Fire Protection ([B2.1.12](#))
- Masonry Wall Program ([B2.1.31](#))
- Structures Monitoring Program ([B2.1.32](#))

3.5.2.1.5 Auxiliary Building

Materials

The materials of construction for the auxiliary building component types are:

- Carbon Steel
- Concrete
- Concrete Block (Masonry Walls)
- Elastomer
- Fire Barrier (Cementitious Coating)
- Gypsum/ Plaster
- Stainless Steel

Environment

The auxiliary building component types are exposed to the following environments:

- Atmosphere/ Weather (Structural)
- Buried (Structural)
- Encased in Concrete
- Plant Indoor Air (Structural)

Aging Effects Requiring Management

The following auxiliary building aging effects require management:

- Concrete cracking and spalling
- Cracking
- Cracking due to expansion
- Cracking, loss of bond, and loss of material (spalling, scaling)
- Cracks and distortion
- Increase in porosity and permeability, cracking, loss of material (spalling, scaling)
- Increased hardness, shrinkage and loss of strength
- Loss of material
- Loss of material (spalling, scaling) and cracking
- Loss of material, cracking

- Loss of sealing

Aging Management Programs

The following aging management programs manage the aging effects for the auxiliary building component types:

- Fire Protection ([B2.1.12](#))
- Masonry Wall Program ([B2.1.31](#))
- Structures Monitoring Program ([B2.1.32](#))

3.5.2.1.6 Radwaste Building

Materials

The materials of construction for the radwaste building component types are:

- Aluminum
- Carbon Steel
- Concrete
- Elastomer

Environment

The radwaste building component types are exposed to the following environments:

- Atmosphere/ Weather (Structural)
- Buried (Structural)
- Plant Indoor Air (Structural)

Aging Effects Requiring Management

The following radwaste building aging effects require management:

- Concrete cracking and spalling
- Cracking due to expansion
- Cracking, loss of bond, and loss of material (spalling, scaling)
- Cracks and distortion
- Increase in porosity and permeability, cracking, loss of material (spalling, scaling)
- Increased hardness, shrinkage and loss of strength

- Loss of material
- Loss of material (spalling, scaling) and cracking
- Loss of sealing

Aging Management Programs

The following aging management programs manage the aging effects for the radwaste building component types:

- Fire Protection ([B2.1.12](#))
- Structures Monitoring Program ([B2.1.32](#))

3.5.2.1.7 Main Steam Support Structure

Materials

The materials of construction for the main steam support structure component types are:

- Carbon Steel
- Concrete
- Elastomer

Environment

The main steam support structure component types are exposed to the following environments:

- Atmosphere/ Weather (Structural)
- Buried (Structural)
- Encased in Concrete
- Plant Indoor Air (Structural)

Aging Effects Requiring Management

The following main steam support structure aging effects require management:

- Concrete cracking and spalling
- Cracking due to expansion
- Cracking, loss of bond, and loss of material (spalling, scaling)
- Cracks and distortion

Section 3.5
AGING MANAGEMENT OF CONTAINMENTS,
STRUCTURES AND COMPONENT SUPPORTS

- Increase in porosity and permeability, cracking, loss of material (spalling, scaling)
- Increased hardness, shrinkage and loss of strength
- Loss of material
- Loss of material (spalling, scaling) and cracking
- Loss of sealing

Aging Management Programs

The following aging management programs manage the aging effects for the main steam support structure component types:

- Fire Protection ([B2.1.12](#))
- Structures Monitoring Program ([B2.1.32](#))

3.5.2.1.8 Station Blackout Generator Structures

Materials

The materials of construction for the station blackout generator structures component types are:

- Carbon Steel
- Concrete

Environment

The station blackout generator structures component types are exposed to the following environments:

- Atmosphere/ Weather (Structural)
- Buried (Structural)
- Encased in Concrete
- Plant Indoor Air (Structural)

Aging Effects Requiring Management

The following station blackout generator structures aging effects require management:

- Cracking due to expansion
- Cracking, loss of bond, and loss of material (spalling, scaling)
- Cracks and distortion

Section 3.5
AGING MANAGEMENT OF CONTAINMENTS,
STRUCTURES AND COMPONENT SUPPORTS

- Increase in porosity and permeability, cracking, loss of material (spalling, scaling)
- Loss of material
- Loss of material (spalling, scaling) and cracking

Aging Management Programs

The following aging management program manages the aging effects for the station blackout generator structures component types:

- Structures Monitoring Program ([B2.1.32](#))

3.5.2.1.9 Fuel Building

Materials

The materials of construction for the fuel building component types are:

- Carbon Steel
- Concrete
- Elastomer
- Stainless Steel

Environment

The fuel building component types are exposed to the following environments:

- Atmosphere/ Weather (Structural)
- Buried (Structural)
- Encased in Concrete
- Plant Indoor Air (Structural)
- Treated Borated Water

Aging Effects Requiring Management

The following fuel building aging effects require management:

- Concrete cracking and spalling
- Cracking
- Cracking due to expansion
- Cracking, loss of bond, and loss of material (spalling, scaling)

Section 3.5
**AGING MANAGEMENT OF CONTAINMENTS,
STRUCTURES AND COMPONENT SUPPORTS**

- Cracks and distortion
- Increase in porosity and permeability, cracking, loss of material (spalling, scaling)
- Increased hardness, shrinkage and loss of strength
- Loss of material
- Loss of material (spalling, scaling) and cracking
- Loss of sealing

Aging Management Programs

The following aging management programs manage the aging effects for the fuel building component types:

- Fire Protection ([B2.1.12](#))
- Structures Monitoring Program ([B2.1.32](#))
- Water Chemistry ([B2.1.2](#))

3.5.2.1.10 Spray Pond and Associated Water Control Structures

Materials

The materials of construction for the spray pond and associated water control structures component types are:

- Carbon Steel
- Concrete
- Copper Alloy
- Elastomer
- Stainless Steel

Environment

The spray pond and associated water control structures component types are exposed to the following environments:

- Atmosphere/ Weather (Structural)
- Buried (Structural)
- Plant Indoor Air (Structural)
- Raw Water

- Submerged (Structural)

Aging Effects Requiring Management

The following spray pond and associated water control structures aging effects require management:

- Concrete cracking and spalling
- Cracking due to expansion
- Cracking, loss of bond, and loss of material (spalling, scaling)
- Cracks and distortion
- Increase in porosity and permeability, cracking, loss of material (spalling, scaling)
- Increase in porosity and permeability, loss of strength
- Loss of material
- Loss of material (spalling, scaling) and cracking
- Loss of sealing

Aging Management Programs

The following aging management programs manage the aging effects for the spray pond and associated water control structures component types:

- Fire Protection ([B2.1.12](#))
- Regulatory Guide 1.127, Inspection of Water-Control Structures Associated with Nuclear Power Plants ([B2.1.33](#))
- Structures Monitoring Program ([B2.1.32](#))

3.5.2.1.11 Tank Foundations and Shells

Materials

The materials of construction for tank foundations and shells component types are:

- Carbon Steel
- Concrete
- Elastomer

Environment

The tank foundations and shells component types are exposed to the following environments:

- Atmosphere/ Weather (Structural)
- Buried (Structural)
- Encased in Concrete
- Plant Indoor Air (Structural)

Aging Effects Requiring Management

The following tank foundations and shells aging effects require management:

- Cracking due to expansion
- Cracking, loss of bond, and loss of material (spalling, scaling)
- Cracks and distortion
- Increase in porosity and permeability, cracking, loss of material (spalling, scaling)
- Loss of material
- Loss of material (spalling, scaling) and cracking
- Loss of sealing

Aging Management Programs

The following aging management program manages the aging effects for the tank foundations and shells component types:

- Structures Monitoring Program ([B2.1.32](#))

3.5.2.1.12 Transformer Foundations and Electrical Structures

Materials

The materials of construction for the transformer foundations and electrical structures component types are:

- Carbon Steel
- Concrete
- Elastomer

Environment

The transformer foundations and electrical structures component types are exposed to the following environments:

- Atmosphere/ Weather (Structural)
- Buried (Structural)
- Encased in Concrete

Aging Effects Requiring Management

The following transformer foundations and electrical structures aging effects require management:

- Concrete cracking and spalling
- Cracking due to expansion
- Cracking, loss of bond, and loss of material (spalling, scaling)
- Cracks and distortion
- Increase in porosity and permeability, cracking, loss of material (spalling, scaling)
- Increased hardness, shrinkage and loss of strength
- Loss of material
- Loss of material (spalling, scaling) and cracking
- Loss of sealing

Aging Management Programs

The following aging management programs manage the aging effects for the transformer foundations and electrical structures component types:

- Fire Protection ([B2.1.12](#))
- Structures Monitoring Program ([B2.1.32](#))

3.5.2.1.13 Yard Structures (In-Scope)

Materials

The materials of construction for the yard structures (in-scope) component types are:

- Carbon Steel
- Concrete

Section 3.5
AGING MANAGEMENT OF CONTAINMENTS,
STRUCTURES AND COMPONENT SUPPORTS

- Concrete Block (Masonry Walls)
- Elastomer
- Gypsum/ Plaster

Environment

The yard structures (in-scope) component types are exposed to the following environments:

- Atmosphere/ Weather (Structural)
- Buried (Structural)
- Encased in Concrete
- Plant Indoor Air (Structural)

Aging Effects Requiring Management

The following yard structures (in-scope) aging effects require management:

- Concrete cracking and spalling
- Cracking
- Cracking due to expansion
- Cracking, loss of bond, and loss of material (spalling, scaling)
- Increase in porosity and permeability, cracking, loss of material (spalling, scaling)
- Loss of material
- Loss of material (spalling, scaling) and cracking
- Loss of sealing

Aging Management Programs

The following aging management programs manage the aging effects for the yard structures (in-scope) component types:

- Fire Protection ([B2.1.12](#))
- Masonry Wall Program ([B2.1.31](#))
- Structures Monitoring Program ([B2.1.32](#))

3.5.2.1.14 Supports

Materials

The materials of construction for the supports component types are:

- Aluminum
- Carbon Steel
- Concrete
- High Strength Low Alloy Steel (Bolting)
- Lubrite
- Stainless Steel

Environment

The supports component types are exposed to the following environments:

- Atmosphere/ Weather (Structural)
- Borated Water Leakage
- Fuel Oil
- Plant Indoor Air (Structural)
- Raw Water

Aging Effects Requiring Management

The following supports aging effects require management:

- Cracking
- Loss of material
- Loss of mechanical function
- Reduction in concrete anchor capacity

Aging Management Programs

The following aging management programs manage the aging effects for the supports component types:

- ASME Section XI, Subsection IWF ([B2.1.29](#))
- Bolting Integrity ([B2.1.7](#))
- Boric Acid Corrosion ([B2.1.4](#))

- Structures Monitoring Program ([B2.1.32](#))

3.5.2.2 Further Evaluation of Aging Management as Recommended by NUREG-1801

NUREG-1801 provides the basis for identifying those programs that warrant further evaluation. For the containments, structures and component supports areas, those evaluations are addressed in the following subsections.

3.5.2.2.1 PWR and BWR Containments

3.5.2.2.1.1 Aging of Inaccessible Concrete Areas

Aggressive Chemical Attack:

Reinforced concrete structures at PVNGS were designed, constructed, and inspected in accordance with ACI and ASTM standards, which provide for a good quality, dense, well-cured, and low permeability concrete. Procedural controls ensured quality throughout the batching, mixing, and placement processes. [UFSAR Section 3.8](#) discusses the design requirements for each major structure. Crack control was achieved through proper sizing, spacing, and distribution of reinforcing steel in accordance with ACI 318-71. Concrete structures at PVNGS are not subjected to groundwater for any sustained periods. An engineering study was performed to confirm that groundwater elevations are below the lowest structures. Therefore, further evaluation for the effects of aggressive chemical attack is not required.

Corrosion of Embedded Steel:

Reinforced concrete structures at PVNGS were designed, constructed, and inspected in accordance with ACI and ASTM standards, which provide for a good quality, dense, well-cured, and low permeability concrete. Procedural controls ensured quality throughout the batching, mixing, and placement processes. [UFSAR Section 3.8](#) discusses the design requirements for each major structure. Crack control was achieved through proper sizing, spacing, and distribution of reinforcing steel in accordance with ACI 318-71. Concrete structures at PVNGS are not subjected to groundwater for any sustained periods. An engineering study was performed to confirm that groundwater elevations are below the lowest structures. Therefore, further evaluation for the effects of corrosion of embedded steel is not required.

3.5.2.2.1.2 Cracks and Distortion due to Increased Stress Levels from Settlement; Reduction of Foundation Strength, Cracking, and Differential Settlement due to Erosion of Porous Concrete Subfoundations, if not Covered by the Structures Monitoring Program

Settlement:

Further evaluation for the effects of settlement is not required because the concrete components are evaluated under the Structures Monitoring Program, and no permanent de-watering system has been constructed at PVNGS. [UFSAR Section 2.5.4.13](#) describes PVNGS settlement monitoring, which is part of the Structures Monitoring Program.

Porous Concrete Subfoundations:

PVNGS does not have porous concrete subfoundations. Therefore, further evaluation for this effect is not required.

3.5.2.2.1.3 Reduction of Strength and Modulus of Concrete Structures due to Elevated Temperature

Elevated Temperatures:

At PVNGS, the reactor cavity cooling subsystem operates in conjunction with the containment normal cooling units and provides cooling of the primary shield and reactor cavity to limit the concrete temperature to less than the specified maximum of 150F. The system functions continuously during normal plant operation. The reactor cavity temperature is monitored with four cavity high temperature alarm channels that are annunciated in the control room ([UFSAR Section 9.4.6.2.2.E](#)). To ensure that temperatures remain below the specified limit, PVNGS Technical Specifications (LCO 3.6.5) require that the containment average air temperature shall not exceed 117° F. PVNGS Design Basis Manual HC, Containment Building HVAC System, Table 5-1, specifies instrumentation to provide control room indication of the reactor cavity temperature, and a control alarm on high temperature with a set point of 115 +/- 5° F. For high temperature pipe at PVNGS, penetrations have been designed to limit the local concrete temperature to 200° F. (Ref. [UFSAR Appendix 14A, Response 14A.34](#)). Process piping penetrations were designed with a special flued head and the pipe is insulated to prevent excessive concrete temperatures ([UFSAR Section 3.8.1.1.3.3](#)). Therefore, reduction of strength and modulus of concrete structures due to elevated temperature is not an aging effect that requires further evaluation. Accessible concrete components are monitored by the Structures Monitoring Program to confirm the absence of aging effects that could impact the structural integrity / intended function of the component.

3.5.2.2.1.4 Loss of Material due to General, Pitting, and Crevice Corrosion

Corrosion in inaccessible areas of steel containment liner:

Reinforced concrete structures at PVNGS were designed, constructed, and inspected in accordance with ACI and ASTM standards, which provide for a good quality, dense, well-cured, and low permeability concrete. Procedural controls ensured quality throughout the batching, mixing, and placement processes. [UFSAR Section 3.8](#) discusses the design requirements for each major structure. Concrete mixes were designed in accordance with ACI 211.1-74. The ASME Section XI, Subsection IWL Program will identify and manage any cracks in the concrete that could potentially provide a pathway for water to reach inaccessible portions of the steel containment liner. Procedural controls ensure that borated water spills are not common, and when detected are cleaned up in a timely manner. Therefore, further evaluation for corrosion in inaccessible areas of the steel containment liner is not required

3.5.2.2.1.5 Loss of Prestress due to Relaxation, Shrinkage, Creep, and Elevated Temperature

Loss of prestress forces due to relaxation, shrinkage, creep, and elevated temperature for PWR prestressed concrete containments and BWR Mark II prestressed concrete containments is a TLAA as defined in 10 CFR 54.3. TLAAs are evaluated in accordance with 10 CFR 54.21(c). The PVNGS containment is a prestressed concrete pressure vessel with ungrouted tendons. [Section 4.5](#) describes the evaluation of this TLAA.

3.5.2.2.1.6 Cumulative Fatigue Damage

Analysis of fatigue in containment penetrations are TLAAs as defined in 10 CFR 54.3 only if a CLB fatigue analysis exists. TLAAs are evaluated in accordance with 10 CFR 54.21(c). PVNGS containment penetrations for the main steam, main feedwater, and recirculation sump suction penetrations are supported by TLAAs. There are no penetration bellows within the scope of license renewal at PVNGS. [Section 4.6.2](#) describes the evaluation of the main steam and feedwater penetrations. [Section 4.6.3](#) describes the evaluation of the recirculation sump suction penetrations.

3.5.2.2.1.7 Cracking due to Stress Corrosion Cracking (SCC)

Not applicable. PVNGS has no in-scope stainless steel penetration sleeves, penetration bellows, or dissimilar metal welds subject to stress corrosion cracking, so the applicable NUREG-1801 lines were not used.

3.5.2.2.1.8 Cracking due to Cyclic Loading

Not applicable. Fatigue of metal components is a TLAA, evaluated in accordance with 10 CFR 54.21(c), so the applicable NUREG-1801 lines were not used.

3.5.2.2.1.9 Loss of Material (Scaling, Cracking, and Spalling) due to Freeze Thaw

Freeze-Thaw:

PVNGS is located in a weathering region classified as Negligible according to Figure 1 of ASTM C33-03. Therefore, further evaluation for the effects of freeze-thaw is not required.

3.5.2.2.1.10 Cracking due to Expansion, and Reaction with Aggregate, and Increase in Porosity and Permeability due to Leaching of Calcium Hydroxide

Reaction with Aggregates:

As noted in [UFSAR Section 3.8.1.6.1.B](#), source acceptance of aggregates was based, in part, on petrographic examination in accordance with ASTM C295. 13-CN-101, Technical Specification for Furnishing and Delivering Concrete for APS PVNGS Quality Class Q, Section 7.2.2.c, specifies that aggregate reactivity be determined by ASTM C289 and C227. The concrete aggregates were found to be non-reactive. Therefore, further evaluation for the effects of reaction with aggregates is not required.

Leaching of Calcium Hydroxide:

Reinforced concrete structures at PVNGS were designed, constructed, and inspected in accordance with ACI and ASTM standards, which provide for a good quality, dense, well-cured, and low permeability concrete. Procedural controls ensured quality throughout the batching, mixing, and placement processes. [UFSAR Section 3.8](#) discusses the design requirements for each major structure. Concrete mixes were designed in accordance with ACI 211.1-74. Concrete structures in groups 1-3, 5, 7-9 at PVNGS are not subjected to flowing water for any sustained periods. An engineering study was performed to confirm that groundwater elevations are below the lowest structures. Therefore, further evaluation for the effects of leaching of calcium hydroxide is not required.

3.5.2.2.2 Safety-Related and Other Structures and Component Supports

3.5.2.2.2.1 Aging of Structures Not Covered by Structures Monitoring Program

The following aging effects do not require further evaluation because the components are evaluated under the Structures Monitoring Program.

- Corrosion of embedded steel
- Aggressive chemical attack
- Loss of material due to corrosion

Section 3.5
AGING MANAGEMENT OF CONTAINMENTS,
STRUCTURES AND COMPONENT SUPPORTS

- Freeze-thaw
- Reaction with aggregates
- Settlement

Further evaluation for the effects of erosion of porous concrete subfoundations is not required because PVNGS does not have porous concrete subfoundations.

Further evaluation for lock up due to wear of sliding surfaces is not required because all in-scope sliding surfaces are evaluated under the Structures Monitoring Program (B2.1.32) or under ASME Section XI, Subsection IWF (B2.1.29).

3.5.2.2.2.2 Aging Management of Inaccessible Areas

3.5.2.2.2.2.1 Freeze-Thaw

Freeze-Thaw:

PVNGS is located in a weathering region classified as Negligible according to Figure 1 of ASTM C33-03. Therefore, further evaluation for the effects of freeze-thaw is not required.

3.5.2.2.2.2.2 Reaction with Aggregates

Reaction with Aggregates:

As noted in UFSAR Section 3.8.1.6.1.B, source acceptance of aggregates was based, in part, on petrographic examination in accordance with ASTM C295. 13-CN-101, Technical Specification for Furnishing and Delivering Concrete for APS PVNGS Quality Class Q, Section 7.2.2.c, specifies that aggregate reactivity be determined by ASTM C289 and C227. The concrete aggregates were found to be non-reactive. Therefore, further evaluation for the effects of reaction with aggregates is not required.

3.5.2.2.2.2.3 Settlement and settlement due to erosion of porous concrete subfoundations

Settlement:

Competent foundation materials were found to be present at PVNGS for establishing conservative design and construction criteria for support of the facilities. Major structures are founded either on engineered backfill or undeformed basin sediments with a minimum thickness in the power block areas of about 200 feet. These sediments are firm, consolidated, continuous, and show no evidence of shears, faults, joints, folds or other tectonic features. No permanent de-watering system has been constructed at PVNGS. As discussed in UFSAR Section 2.5.4, settlement of all major structures has been monitored since construction. Table 2.5-19 specifies a frequency for settlement monitoring of every five years, following more frequent intervals during the first three years post-construction. The most recent data were collected in December 2003. The total post-construction

Section 3.5
AGING MANAGEMENT OF CONTAINMENTS,
STRUCTURES AND COMPONENT SUPPORTS

settlements recorded have been well below the 1.5 inch maximum specified in [UFSAR Section 2.5.4.11](#). Therefore, further evaluation for the effects of settlement is not required.

Porous Concrete Subfoundations:

PVNGS does not have porous concrete subfoundations. Therefore, further evaluation for this effect is not required.

3.5.2.2.2.4 Aggressive chemical attack and corrosion of embedded steel

Aggressive Chemical Attack:

Reinforced concrete structures at PVNGS were designed, constructed, and inspected in accordance with ACI and ASTM standards, which provide for a good quality, dense, well-cured, and low permeability concrete. Procedural controls ensured quality throughout the batching, mixing, and placement processes. [UFSAR Section 3.8](#) discusses the design requirements for each major structure. Crack control was achieved through proper sizing, spacing, and distribution of reinforcing steel in accordance with ACI 318-71. Concrete structures at PVNGS are not subjected to groundwater for any sustained periods. An engineering study was performed to confirm that groundwater elevations are below the lowest structures. Therefore, further evaluation for the effects of aggressive chemical attack is not required.

Corrosion of Embedded Steel:

Reinforced concrete structures at PVNGS were designed, constructed, and inspected in accordance with ACI and ASTM standards, which provide for a good quality, dense, well-cured, and low permeability concrete. Procedural controls ensured quality throughout the batching, mixing, and placement processes. [UFSAR Section 3.8](#) discusses the design requirements for each major structure. Crack control was achieved through proper sizing, spacing, and distribution of reinforcing steel in accordance with ACI 318-71. Concrete structures at PVNGS are not subjected to groundwater for any sustained periods. An engineering study was performed to confirm that groundwater elevations are below the lowest structures. Therefore, further evaluation for the effects of corrosion of embedded steel is not required.

3.5.2.2.2.5 Leaching of Calcium Hydroxide

Leaching of Calcium Hydroxide:

Reinforced concrete structures at PVNGS were designed, constructed, and inspected in accordance with ACI and ASTM standards, which provide for a good quality, dense, well-cured, and low permeability concrete. Procedural controls ensured quality throughout the batching, mixing, and placement processes. [UFSAR Section 3.8](#) discusses the design requirements for each major structure. Concrete mixes were designed in accordance with ACI 211.1-74. Concrete structures in Groups 1-3, 5, 7-9 at PVNGS are not subjected to

Section 3.5
AGING MANAGEMENT OF CONTAINMENTS,
STRUCTURES AND COMPONENT SUPPORTS

flowing water for any sustained periods. An engineering study was performed to confirm that groundwater elevations are below the lowest structures. Therefore, further evaluation for the effects of leaching of calcium hydroxide is not required.

3.5.2.2.2.3 Reduction of Strength and Modulus of Concrete Structures due to Elevated Temperature

Containment:

At PVNGS, the reactor cavity cooling subsystem operates in conjunction with the containment normal cooling units and provides cooling of the primary shield and reactor cavity to limit the concrete temperature to less than the specified maximum of 150F. The system functions continuously during normal plant operation. The reactor cavity temperature is monitored with four cavity high temperature alarm channels that are annunciated in the control room (Ref. [UFSAR Section 9.4.6.2.2.E](#)). To ensure that temperatures remain below the specified limit, PVNGS Technical Specifications (LCO 3.6.5) require that the containment average air temperature shall not exceed 117°F. PVNGS Design Basis Manual HC, Containment Building HVAC System, Table 5-1, specifies instrumentation to provide control room indication of the reactor cavity temperature, and a control alarm on high temperature with a set point of 115 +/- 5°F. For high temperature pipe at PVNGS, penetrations have been designed to limit the local concrete temperature to 200°F. (Ref. [UFSAR Appendix 14A, Response 14A.34](#)). Process piping penetrations were designed with a special flued head and the pipe is insulated to prevent excessive concrete temperatures (Ref. [UFSAR Section 3.8.1.1.3.3](#)). Therefore, reduction of strength and modulus of concrete structures due to elevated temperature is not an aging effect that requires further evaluation. Accessible concrete components will be monitored by the Structures Monitoring Program to confirm the absence of aging that could impact the structural integrity / intended function of the component.

Main Steam Support Structure:

For high temperature pipe at PVNGS, penetrations have been designed to limit the local concrete temperature to 200°F. Process piping penetrations were designed with a 5-way whip restraint and air flowing around the pipe to prevent excessive concrete temperatures under normal operation. In the event of a loss in air flow the exhaust fans that provide air flow will be restored to service within a seven day period. During that time the local concrete temperature, of the affected penetrations shall be monitored on a daily basis to ensure that the maximum concrete temperature does not exceed 300°F. Therefore, reduction of strength and modulus of concrete structures due to elevated temperature is not an aging effect that requires further evaluation. Accessible concrete components are monitored by the Structures Monitoring Program to confirm the absence of aging that could impact the structural integrity / intended function of the component.

[UFSAR Table 3.6-2](#) – “High Energy Lines Outside Containment” identifies the lines outside of containment that have operating temperatures over 200 °F.

Section 3.5
AGING MANAGEMENT OF CONTAINMENTS,
STRUCTURES AND COMPONENT SUPPORTS

Turbine Building:

There are no high energy lines in the turbine building that penetrate concrete barriers, therefore no further evaluation for the effects of Elevated Temperatures are required. (Ref. [USFAR Figures 3.6-28 and -30](#))

Auxiliary Building:

Safety injection and shutdown cooling system operates at high temperature/pressure less than 2% of the time, therefore it is not considered a high energy line. ([UFSAR Table 3.6-2](#), See note E)

The high energy lines in the auxiliary building that penetrate concrete barriers are not subjected to high temperatures and therefore no further evaluation for the effects of Elevated Temperatures are required.

Other Structures:

Further evaluation for the effects of Elevated Temperatures is not required because high energy lines (Operating Pressure > 275°F and/or Operating Temperature > 200°F) outside Containment are only found in the MSSS, Turbine Building, and Auxiliary Building. ([UFSAR Table 3.6-2](#))

3.5.2.2.2.4 Aging Management of Inaccessible Areas for Group 6 Structures

3.5.2.2.2.4.1 Aggressive chemical attack and corrosion of embedded steel

Aggressive Chemical Attack:

Reinforced concrete structures at PVNGS were designed, constructed, and inspected in accordance with ACI and ASTM standards, which provide for a good quality, dense, well-cured, and low permeability concrete. Procedural controls ensured quality throughout the batching, mixing, and placement processes. [UFSAR Section 3.8](#) discusses the design requirements for each major structure. Crack control was achieved through proper sizing, spacing, and distribution of reinforcing steel in accordance with ACI 318-71. Concrete structures at PVNGS are not subjected to groundwater for any sustained periods. An engineering study was performed to confirm that groundwater elevations are below the lowest structures. Therefore, further evaluation for the effects of aggressive chemical attack is not required.

Corrosion of Embedded Steel:

Reinforced concrete structures at PVNGS were designed, constructed, and inspected in accordance with ACI and ASTM standards, which provide for a good quality, dense, well-cured, and low permeability concrete. Procedural controls ensured quality throughout the batching, mixing, and placement processes. [UFSAR Section 3.8](#) discusses the design

Section 3.5
AGING MANAGEMENT OF CONTAINMENTS,
STRUCTURES AND COMPONENT SUPPORTS

requirements for each major structure. Crack control was achieved through proper sizing, spacing, and distribution of reinforcing steel in accordance with ACI 318-71. Concrete structures at PVNGS are not subjected to groundwater for any sustained periods. An engineering study was performed to confirm that groundwater elevations are below the lowest structures. Therefore, further evaluation for the effects of corrosion of embedded steel is not required.

3.5.2.2.2.4.2 Freeze-Thaw

Freeze-Thaw:

PVNGS is located in a weathering region classified as Negligible according to Figure 1 of ASTM C33-03. Therefore, further evaluation for the effects of freeze-thaw is not required.

3.5.2.2.2.4.3 Reaction with Aggregates and Leaching of Calcium Hydroxide

Reaction with Aggregates:

As noted in [UFSAR Section 3.8.1.6.1.B](#), source acceptance of aggregates was based, in part, on petrographic examination in accordance with ASTM C295. 13-CN-101, Technical Specification for Furnishing and Delivering Concrete for APS PVNGS Quality Class Q, Section 7.2.2.c, specifies that aggregate reactivity be determined by ASTM C289 and C227. The concrete aggregates were found to be non-reactive. Therefore, further evaluation for the effects of reaction with aggregates is not required.

Leaching of Calcium Hydroxide:

Reinforced concrete structures at PVNGS were designed, constructed, and inspected in accordance with ACI and ASTM standards, which provide for a good quality, dense, well-cured, and low permeability concrete. Procedural controls ensured quality throughout the batching, mixing, and placement processes. [UFSAR Section 3.8](#) discusses the design requirements for each major structure. Concrete mixes were designed in accordance with ACI 211.1-74. Concrete structures in groups 1-3, 5, 7-9 at PVNGS are not subjected to flowing water for any sustained periods. An engineering study was performed to confirm that groundwater elevations are below the lowest structures. Therefore, further evaluation for the effects of leaching of calcium hydroxide is not required.

3.5.2.2.2.5 Cracking due to Stress Corrosion Cracking and Loss of Material due to Pitting and Crevice Corrosion

The in-scope tank liners at PVNGS were evaluated in the condensate and CVCS systems and assigned NUREG-1801 lines from chapters VII and VIII. Therefore, further evaluation for the effects of cracking due to stress corrosion cracking and loss of material due to pitting and crevice corrosion is not required.

3.5.2.2.2.6 Aging of Supports Not Covered by the Structures Monitoring Program

Further evaluation of the following components is not required because they will be inspected per the Structures Monitoring Program.

- Building concrete around support anchorages
- HVAC duct supports
- Instrument supports
- Non-ASME mechanical equipment supports
- Non-ASME supports
- Electrical panels and enclosures

3.5.2.2.2.7 Cumulative Fatigue Damage due to Cyclic Loading

Analyses of fatigue in component support members, anchor bolts, and welds for Group B1.1, B1.2, and B1.3 component supports (for ASME III Class 1, 2, and 3 piping and components, and for Class MC BWR containment supports) are TLAAs as defined in 10 CFR 54.3 only if a CLB fatigue analysis exists. The review identified no TLAAs supporting design of these components at PVNGS.

PVNGS ASME Class 1 piping is designed to code editions and addenda before 1986, which therefore precede cycle limits for allowable stress in supports. [Section 4.3.2.7](#) describes the absence of a cycle-based stress limit for ASME Class 1 supports.

PVNGS ASME Class 2 and 3 piping and components require no fatigue or cycle design analysis for their supports, and no other similar analysis exist for supports for those components at PVNGS.

PVNGS is a PWR and does not have Class MC BWR containment supports.

3.5.2.2.3 Quality Assurance for Aging Management of Nonsafety-Related Components

Quality Assurance Program and Administrative Controls are discussed in [Section B1.3](#).

3.5.2.3 Time-Limited Aging Analysis

The time-limited aging analyses identified below are associated with the containments, structures, and component supports component types. The section within Chapter 4, Time-Limited Aging Analyses, is indicated in parenthesis.

- Loss of prestress ([Section 4.5](#), Concrete Containment Tendon Prestress)

Section 3.5
AGING MANAGEMENT OF CONTAINMENTS,
STRUCTURES AND COMPONENT SUPPORTS

- Cumulative fatigue damage ([Section 4.6](#), Containment Liner Plate, Equipment Hatch And Personnel Air Locks, Penetrations, And Polar Crane Brackets)

3.5.3 Conclusions

The Containments, Structures and Component Supports component types that are subject to aging management review have been evaluated. The aging management programs selected to manage the aging effects for the Containment, Structures and Component Supports component types are identified in the summary Tables and in [Section 3.5.2.1](#).

A description of these aging management programs is provided in [Appendix B](#), along with a demonstration that the identified aging effects will be managed for the period of extended operation.

Therefore, based on the demonstration provided in [Appendix B](#), the effects of aging associated with the Containments, Structures and Component Supports component types will be adequately managed so that there is reasonable assurance that the intended functions will be maintained consistent with the current licensing basis during the period of extended operation.

Section 3.5
AGING MANAGEMENT OF CONTAINMENTS,
STRUCTURES AND COMPONENT SUPPORTS

Table 3.5.1 Summary of Aging Management Evaluations in Chapters II and III of NUREG-1801 for Containments, Structures, and Component Supports

Item Number	Component Type	Aging Effect / Mechanism	Aging Management Program	Further Evaluation Recommended	Discussion
3.5.1.01	Concrete elements: walls, dome, basemat, ring girder, buttresses, containment (as applicable)	Aging of accessible and inaccessible concrete areas due to aggressive chemical attack, and corrosion of embedded steel	ISI (IWL) (B2.1.28) and for inaccessible concrete, an examination of representative samples of below-grade concrete, and periodic monitoring of groundwater, if the environment is non-aggressive. A plant specific program is to be evaluated if environment is aggressive.	Yes	Consistent with NUREG-1801. See further evaluation in subsection 3.5.2.2.1.1.

Section 3.5
**AGING MANAGEMENT OF CONTAINMENTS,
STRUCTURES AND COMPONENT SUPPORTS**

Table 3.5.1 Summary of Aging Management Evaluations in Chapters II and III of NUREG-1801 for Containments, Structures, and Component Supports (Continued)

Item Number	Component Type	Aging Effect / Mechanism	Aging Management Program	Further Evaluation Recommended	Discussion
3.5.1.02	Concrete elements; All	Cracks and distortion due to increased stress levels from settlement	Structures Monitoring Program (B2.1.32). If a de-watering system is relied upon for control of settlement, then the licensee is to ensure proper functioning of the de-watering system through the period of extended operation.	Yes, if not within the scope of the applicant's structures monitoring program or a de-watering system is relied upon	Consistent with NUREG-1801. See further evaluation in subsection 3.5.2.2.1.2.
3.5.1.03	Concrete elements: foundation, sub-foundation	Reduction in foundation strength, cracking, differential settlement due to erosion of porous concrete subfoundation	Structures Monitoring Program (B2.1.32). If a de-watering system is relied upon for control of erosion of cement from porous concrete subfoundations, then the licensee is to ensure proper functioning of the de-watering system through the period of extended operation.	Yes, if not within the scope of the applicant's structures monitoring program or a de-watering system is relied upon	Not applicable. PVNGS has no porous concrete foundations, so the applicable NUREG-1801 lines were not used. See further evaluation in subsection 3.5.2.2.1.2.

Section 3.5
**AGING MANAGEMENT OF CONTAINMENTS,
STRUCTURES AND COMPONENT SUPPORTS**

Table 3.5.1 *Summary of Aging Management Evaluations in Chapters II and III of NUREG-1801 for Containments, Structures, and Component Supports (Continued)*

Item Number	Component Type	Aging Effect / Mechanism	Aging Management Program	Further Evaluation Recommended	Discussion
3.5.1.04	Concrete elements: dome, wall, basemat, ring girder, buttresses, containment, concrete fill-in annulus (as applicable)	Reduction of strength and modulus of concrete due to elevated temperature	A plant-specific aging management program is to be evaluated	Yes	Not applicable. PVNGS has no dome, wall, basemat, ring girder, buttresses, containment, or annulus concrete exposed to elevated temperatures, so the applicable NUREG-1801 lines were not used. See further evaluation in subsection 3.5.2.2.1.3.
3.5.1.05					Not applicable - BWR only
3.5.1.06	Steel elements: steel liner, liner anchors, integral attachments	Loss of material due to general, pitting and crevice corrosion	ISI (IWE) (B2.1.27), and 10 CFR 50, Appendix J (B2.1.30).	Yes, if corrosion is significant for inaccessible areas	Consistent with NUREG-1801 with aging management program exceptions. The aging management program(s) with exceptions to NUREG-1801 include: ASME Section XI, Subsection IWE (B2.1.27). See further evaluation in subsection 3.5.2.2.1.4.

Section 3.5
AGING MANAGEMENT OF CONTAINMENTS,
STRUCTURES AND COMPONENT SUPPORTS

Table 3.5.1 *Summary of Aging Management Evaluations in Chapters II and III of NUREG-1801 for Containments, Structures, and Component Supports (Continued)*

Item Number	Component Type	Aging Effect / Mechanism	Aging Management Program	Further Evaluation Recommended	Discussion
3.5.1.07	Prestressed containment tendons	Loss of prestress due to relaxation, shrinkage, creep, and elevated temperature	TLAA, evaluated in accordance with 10 CFR 54.21(c)	Yes, TLAA	Loss of prestress of containment tendons is a TLAA. See further evaluation in subsection 3.5.2.2.1.5.
3.5.1.08					Not applicable - BWR only
3.5.1.09	Steel, stainless steel elements, dissimilar metal welds: penetration sleeves, penetration bellows; suppression pool shell, unbraced downcomers	Cumulative fatigue damage (CLB fatigue analysis exists)	TLAA, evaluated in accordance with 10 CFR 54.21(c)	Yes, TLAA	Fatigue of metal components is a TLAA. However, only design of penetration sleeves is supported by a TLAA. See further evaluation in subsection 3.5.2.2.1.6.
3.5.1.10	Stainless steel penetration sleeves, penetration bellows, dissimilar metal welds	Cracking due to stress corrosion cracking	ISI (IWE) (B2.1.27), and 10 CFR 50, Appendix J (B2.1.30), and additional appropriate examinations/evaluations for bellows assemblies and dissimilar metal welds.	Yes	Not applicable. PVNGS has no in-scope stainless steel penetration sleeves, penetration bellows, or dissimilar metal welds subject to stress corrosion cracking, so the applicable NUREG-1801 lines were not used. See further evaluation in subsection 3.5.2.2.1.7.
3.5.1.11					Not applicable - BWR only

Section 3.5
AGING MANAGEMENT OF CONTAINMENTS,
STRUCTURES AND COMPONENT SUPPORTS

Table 3.5.1 Summary of Aging Management Evaluations in Chapters II and III of NUREG-1801 for Containments, Structures, and Component Supports (Continued)

Item Number	Component Type	Aging Effect / Mechanism	Aging Management Program	Further Evaluation Recommended	Discussion
3.5.1.12	Steel, stainless steel elements, dissimilar metal welds; penetration sleeves; penetration bellows; suppression pool shell, unbraced downcomers	Cracking due to cyclic loading	ISI (IWE) (B2.1.27), and 10 CFR 50, Appendix J (B2.1.30), and supplemented to detect fine cracks	Yes	Not applicable. Fatigue of metal components is a TLAA, evaluated in accordance with 10 CFR 54.21(c), so the applicable NUREG-1801 lines were not used. See further evaluation in subsection 3.5.2.2.1.8.
3.5.1.13					Not applicable - BWR only
3.5.1.14	Concrete elements: dome, wall, basemat ring girder, buttresses, containment (as applicable)	Loss of material (Scaling, cracking, and spalling) due to freeze-thaw	ISI (IWL) (B2.1.28). Evaluation is needed for plants that are located in moderate to severe weathering conditions (weathering index > 100 day-inch/yr) (NUREG-1557).	Yes	Consistent with NUREG-1801. See further evaluation in subsection 3.5.2.2.1.9.
3.5.1.15	Concrete elements: walls, dome, basemat, ring girder, buttresses, containment, concrete fill-in annulus (as applicable).	Cracking due to expansion and reaction with aggregate; increase in porosity, permeability due to leaching of calcium hydroxide	ISI (IWL) (B2.1.28) for accessible areas. None for inaccessible areas if concrete was constructed in accordance with the recommendations in ACI 201.2R.	Yes, if concrete was not constructed as stated for inaccessible areas	Consistent with NUREG-1801. See further evaluation in subsection 3.5.2.2.1.10.

Section 3.5
AGING MANAGEMENT OF CONTAINMENTS,
STRUCTURES AND COMPONENT SUPPORTS

Table 3.5.1 *Summary of Aging Management Evaluations in Chapters II and III of NUREG-1801 for Containments, Structures, and Component Supports (Continued)*

Item Number	Component Type	Aging Effect / Mechanism	Aging Management Program	Further Evaluation Recommended	Discussion
3.5.1.16	Seals, gaskets, and moisture barriers	Loss of sealing and leakage through containment due to deterioration of joint seals, gaskets, and moisture barriers (caulking, flashing, and other sealants)	ISI (IWE) (B2.1.27), and 10 CFR 50, Appendix J (B2.1.30).	No	Consistent with NUREG-1801 with aging management program exceptions. The aging management program(s) with exceptions to NUREG-1801 include: ASME Section XI, Subsection IWE (B2.1.27)
3.5.1.17	Personnel airlock, equipment hatch and CRD hatch locks, hinges, and closure mechanisms	Loss of leak tightness in closed position due to mechanical wear of locks, hinges and closure mechanisms	10 CFR 50, Appendix J (B2.1.30) and Plant Technical Specifications	No	Consistent with NUREG-1801.
3.5.1.18	Steel penetration sleeves and dissimilar metal welds; personnel airlock, equipment hatch and CRD hatch	Loss of material due to general, pitting, and crevice corrosion	ISI (IWE) (B2.1.27), and 10 CFR 50, Appendix J (B2.1.30).	No	Consistent with NUREG-1801 with aging management program exceptions. The aging management program(s) with exceptions to NUREG-1801 include: ASME Section XI, Subsection IWE (B2.1.27)
3.5.1.19					Not applicable - BWR only
3.5.1.20					Not applicable - BWR only
3.5.1.21					Not applicable - BWR only

Section 3.5
AGING MANAGEMENT OF CONTAINMENTS,
STRUCTURES AND COMPONENT SUPPORTS

Table 3.5.1 Summary of Aging Management Evaluations in Chapters II and III of NUREG-1801 for Containments, Structures, and Component Supports (Continued)

Item Number	Component Type	Aging Effect / Mechanism	Aging Management Program	Further Evaluation Recommended	Discussion
3.5.1.22	Prestressed containment: tendons and anchorage components	Loss of material due to corrosion	ISI (IWL) (B2.1.28)	No	Consistent with NUREG-1801.
3.5.1.23	All Groups except Group 6: interior and above grade exterior concrete	Cracking, loss of bond, and loss of material (spalling, scaling) due to corrosion of embedded steel	Structures Monitoring Program (B2.1.32)	Yes, if not within the scope of the applicant's structures monitoring program	Consistent with NUREG-1801. See further evaluation in subsection 3.5.2.2.2.1.
3.5.1.24	All Groups except Group 6: interior and above grade exterior concrete	Increase in porosity and permeability, cracking, loss of material (spalling, scaling) due to aggressive chemical attack	Structures Monitoring Program (B2.1.32)	Yes, if not within the scope of the applicant's structures monitoring program	Consistent with NUREG-1801. See further evaluation in subsection 3.5.2.2.2.1.
3.5.1.25	All Groups except Group 6: steel components: all structural steel	Loss of material due to corrosion	Structures Monitoring Program (B2.1.32). If protective coatings are relied upon to manage the effects of aging, the structures monitoring program is to include provisions to address protective coating monitoring and maintenance.	Yes, if not within the scope of the applicant's structures monitoring program	Consistent with NUREG-1801. See further evaluation in subsection 3.5.2.2.2.1.

Section 3.5
AGING MANAGEMENT OF CONTAINMENTS,
STRUCTURES AND COMPONENT SUPPORTS

Table 3.5.1 Summary of Aging Management Evaluations in Chapters II and III of NUREG-1801 for Containments, Structures, and Component Supports (Continued)

Item Number	Component Type	Aging Effect / Mechanism	Aging Management Program	Further Evaluation Recommended	Discussion
3.5.1.26	All Groups except Group 6: accessible and inaccessible concrete: foundation	Loss of material (spalling, scaling) and cracking due to freeze-thaw	Structures Monitoring Program (B2.1.32). Evaluation is needed for plants that are located in moderate to severe weathering conditions (weathering index > 100 day-inch/yr) (NUREG-1557).	Yes, if not within the scope of the applicant's structures monitoring program or for inaccessible areas of plants located in moderate to severe weathering conditions	Consistent with NUREG-1801. See further evaluation in subsection 3.5.2.2.2.1.
3.5.1.27	All Groups except Group 6: accessible and inaccessible interior/exterior concrete	Cracking due to expansion due to reaction with aggregates	Structures Monitoring Program (B2.1.32)	Yes, if not within the scope of the applicant's structures monitoring program or concrete was not constructed as stated for inaccessible areas	Consistent with NUREG-1801. See further evaluation in subsection 3.5.2.2.2.1.

Section 3.5
AGING MANAGEMENT OF CONTAINMENTS,
STRUCTURES AND COMPONENT SUPPORTS

Table 3.5.1 Summary of Aging Management Evaluations in Chapters II and III of NUREG-1801 for Containments, Structures, and Component Supports (Continued)

Item Number	Component Type	Aging Effect / Mechanism	Aging Management Program	Further Evaluation Recommended	Discussion
3.5.1.28	Groups 1-3, 5-9; All	Cracks and distortion due to increased stress levels from settlement	Structures Monitoring Program (B2.1.32). If a de-watering system is relied upon for control of settlement, then the licensee is to ensure proper functioning of the de-watering system through the period of extended operation.	Yes, if not within the scope of the applicant's structures monitoring program or a de-watering system is relied upon	Consistent with NUREG-1801. See further evaluation in subsection 3.5.2.2.2.1.
3.5.1.29	Groups 1-3, 5-9; foundation	Reduction in foundation strength, cracking, differential settlement due to erosion of porous concrete subfoundation	Structures Monitoring Program (B2.1.32). If a de-watering system is relied upon for control of settlement, then the licensee is to ensure proper functioning of the de-watering system through the period of extended operation.	Yes, if not within the scope of the applicant's structures monitoring program or a de-watering system is relied upon	Not applicable. PVNGS has no porous concrete foundations, so the applicable NUREG-1801 lines were not used.
3.5.1.30	Group 4: Radial beam seats in BWR drywell; RPV support shoes for PWR with nozzle supports; Steam generator supports	Lock-up due to wear	Structures Monitoring Program (B2.1.32)	Yes, if not within the scope of ISI or structures monitoring program	Not applicable. PVNGS did not use Lubrite on the RPV support shoes or steam generator supports, so the applicable NUREG-1801 line was not used.

Section 3.5
AGING MANAGEMENT OF CONTAINMENTS,
STRUCTURES AND COMPONENT SUPPORTS

Table 3.5.1 Summary of Aging Management Evaluations in Chapters II and III of NUREG-1801 for Containments, Structures, and Component Supports (Continued)

Item Number	Component Type	Aging Effect / Mechanism	Aging Management Program	Further Evaluation Recommended	Discussion
3.5.1.31	Groups 1-3, 5, 7-9: below-grade concrete components, such as exterior walls below grade and foundation	Increase in porosity and permeability, cracking, loss of material (spalling, scaling)/ aggressive chemical attack;	Structures Monitoring Program (B2.1.32); Examination of representative samples of below-grade concrete, and periodic monitoring of groundwater, if the environment is non-aggressive. A plant specific program is to be evaluated if environment is aggressive.	Yes	Consistent with NUREG-1801. See further evaluation in subsection 3.5.2.2.2.4.
3.5.1.32	Groups 1-3, 5, 7-9: exterior above and below grade reinforced concrete foundations	Increase in porosity and permeability, and loss of strength due to leaching of calcium hydroxide	Structures Monitoring Program (B2.1.32) for inaccessible areas. None for inaccessible areas if concrete was constructed in accordance with the recommendations in ACI 201.2R-77.	Yes, if concrete was not constructed as stated for inaccessible areas	Not applicable. Concrete structures in groups 1-3, 5, 7-9 at PVNGS are not subjected to flowing water for any sustained periods, so the applicable NUREG-1801 lines were not used. See further evaluation in subsection 3.5.2.2.2.5.

Section 3.5
AGING MANAGEMENT OF CONTAINMENTS, STRUCTURES AND COMPONENT SUPPORTS

Table 3.5.1 *Summary of Aging Management Evaluations in Chapters II and III of NUREG-1801 for Containments, Structures, and Component Supports (Continued)*

Item Number	Component Type	Aging Effect / Mechanism	Aging Management Program	Further Evaluation Recommended	Discussion
3.5.1.33	Groups 1-5: concrete	Reduction of strength and modulus of concrete due to elevated temperature	A plant-specific aging management program is to be evaluated	Yes	Not applicable. PVNGS has no concrete exposed to elevated temperatures, so the applicable NUREG-1801 lines were not used. See further evaluation in subsection 3.5.2.2.2.3.
3.5.1.34	Group 6: Concrete; all	Increase in porosity and permeability, cracking, loss of material due to aggressive chemical attack; cracking, loss of bond, loss of material due to corrosion of embedded steel	Inspection of Water-Control Structures (B2.1.33)	Yes	Consistent with NUREG-1801. See further evaluation in subsection 3.5.2.2.4.1.
3.5.1.35	Group 6: exterior above and below grade concrete foundation	Loss of material (spalling, scaling) and cracking due to freeze-thaw	Inspection of Water-Control Structures (B2.1.33)	Yes, for inaccessible areas of plants located in moderate to severe weathering conditions	Consistent with NUREG-1801. See further evaluation in subsection 3.5.2.2.4.2.

Section 3.5
AGING MANAGEMENT OF CONTAINMENTS,
STRUCTURES AND COMPONENT SUPPORTS

Table 3.5.1 Summary of Aging Management Evaluations in Chapters II and III of NUREG-1801 for Containments, Structures, and Component Supports (Continued)

Item Number	Component Type	Aging Effect / Mechanism	Aging Management Program	Further Evaluation Recommended	Discussion
3.5.1.36	Group 6: all accessible/inaccessible reinforced concrete	Cracking due to expansion/reaction with aggregates	Inspection of Water-Control Structures (B2.1.33)	Yes, if concrete was not constructed as stated for inaccessible areas	Consistent with NUREG-1801. See further evaluation in subsection 3.5.2.2.4.3.
3.5.1.37	Group 6: exterior above and below grade reinforced concrete foundation interior slab	Increase in porosity and permeability, loss of strength due to leaching of calcium hydroxide	Inspection of Water-Control Structures (B2.1.33)	Yes, if concrete was not constructed as stated for inaccessible areas	Consistent with NUREG-1801. See further evaluation in subsection 3.5.2.2.4.3.
3.5.1.38	Groups 7, 8: Tank liners	Cracking due to stress corrosion cracking; loss of material due to pitting and crevice corrosion	A plant-specific aging management program is to be evaluated	Yes	Not applicable. The in-scope tank liners at PVNGS were evaluated in the condensate and CVCS systems and assigned NUREG-1801 lines from Chapters VII and VIII. Therefore, the NUREG-1801 lines from Chapter III were not used.

Section 3.5
AGING MANAGEMENT OF CONTAINMENTS,
STRUCTURES AND COMPONENT SUPPORTS

Table 3.5.1 Summary of Aging Management Evaluations in Chapters II and III of NUREG-1801 for Containments, Structures, and Component Supports (Continued)

Item Number	Component Type	Aging Effect / Mechanism	Aging Management Program	Further Evaluation Recommended	Discussion
3.5.1.39	Support members; welds; bolted connections; support anchorage to building structure	Loss of material due to general and pitting corrosion	Structures Monitoring Program (B2.1.32)	Yes, if not within the scope of the applicant's structures monitoring program	Consistent with NUREG-1801. See further evaluation in subsection 3.5.2.2.2.6.
3.5.1.40	Building concrete at locations of expansion and grouted anchors; grout pads for support base plates	Reduction in concrete anchor capacity due to local concrete degradation/ service-induced cracking or other concrete aging mechanisms	Structures Monitoring Program (B2.1.32)	Yes, if not within the scope of the applicant's structures monitoring program	Consistent with NUREG-1801. See further evaluation in subsection 3.5.2.2.2.6.
3.5.1.41	Vibration isolation elements	Reduction or loss of isolation function/ radiation hardening, temperature, humidity, sustained vibratory loading	Structures Monitoring Program (B2.1.32)	Yes, if not within the scope of the applicant's structures monitoring program	Not applicable. PVNGS has no in-scope vibration isolation elements, so the applicable NUREG-1801 lines were not used.
3.5.1.42	Groups B1.1, B1.2, and B1.3: support members: anchor bolts, welds	Cumulative fatigue damage (CLB fatigue analysis exists)	TLAA, evaluated in accordance with 10 CFR 54.21(c)	Yes, TLAA	Fatigue of support members is not a TLAA as defined in 10 CFR 54.3. See further evaluation in subsection 3.5.2.2.2.7.

Section 3.5
AGING MANAGEMENT OF CONTAINMENTS,
STRUCTURES AND COMPONENT SUPPORTS

Table 3.5.1 Summary of Aging Management Evaluations in Chapters II and III of NUREG-1801 for Containments, Structures, and Component Supports (Continued)

Item Number	Component Type	Aging Effect / Mechanism	Aging Management Program	Further Evaluation Recommended	Discussion
3.5.1.43	Groups 1-3, 5, 6: all masonry block walls	Cracking due to restraint shrinkage, creep, and aggressive environment	Masonry Wall Program (B2.1.31)	No	Consistent with NUREG 1801 for inspections performed under the Masonry Wall Program (B2.1.31). NUREG 1801 does not provide a line in which concrete masonry is inspected per the Fire Protection program. Therefore, for CMU walls that provide a fire barrier function, the Fire Protection program (B2.1.12) has been added.
3.5.1.44	Group 6 elastomer seals, gaskets, and moisture barriers	Loss of sealing due to deterioration of seals, gaskets, and moisture barriers (caulking, flashing, and other sealants)	Structures Monitoring Program (B2.1.32)	No	Consistent with NUREG-1801.
3.5.1.45	Group 6: exterior above and below grade concrete foundation; interior slab	Loss of material due to abrasion, cavitation	Inspection of Water-Control Structures (B2.1.33)	No	Consistent with NUREG-1801.

Section 3.5
AGING MANAGEMENT OF CONTAINMENTS,
STRUCTURES AND COMPONENT SUPPORTS

Table 3.5.1 Summary of Aging Management Evaluations in Chapters II and III of NUREG-1801 for Containments, Structures, and Component Supports (Continued)

Item Number	Component Type	Aging Effect / Mechanism	Aging Management Program	Further Evaluation Recommended	Discussion
3.5.1.46	Group 5: Fuel pool liners	Cracking due to stress corrosion cracking; loss of material due to pitting and crevice corrosion	Water Chemistry (B2.1.2) and monitoring of spent fuel pool water level in accordance with technical specifications and leakage from the leak chase channels.	No	Consistent with NUREG-1801.
3.5.1.47	Group 6: all metal structural members	Loss of material due to general (steel only), pitting and crevice corrosion	Inspection of Water-Control Structures (B2.1.33)	No	Consistent with NUREG-1801 for material, environment, and aging effect, but a different aging management program, Structures Monitoring Program (B2.1.32) is credited.
3.5.1.48	Group 6: earthen water control structures - dams, embankments, reservoirs, channels, canals, and ponds	Loss of material, loss of form due to erosion, settlement, sedimentation, frost action, waves, currents, surface runoff, Seepage	Inspection of Water-Control Structures (B2.1.33)	No	Not applicable. PVNGS has no earthen dams, embankments, reservoirs, channels, canals, or ponds in-scope for license renewal, so the applicable NUREG-1801 lines were not used. The spray ponds are concrete structures.
3.5.1.49					Not applicable - BWR only

Section 3.5
AGING MANAGEMENT OF CONTAINMENTS,
STRUCTURES AND COMPONENT SUPPORTS

Table 3.5.1 *Summary of Aging Management Evaluations in Chapters II and III of NUREG-1801 for Containments, Structures, and Component Supports (Continued)*

Item Number	Component Type	Aging Effect / Mechanism	Aging Management Program	Further Evaluation Recommended	Discussion
3.5.1.50	Groups B2, and B4: galvanized steel, aluminum, stainless steel support members; welds; bolted connections; support anchorage to building structure	Loss of material due to pitting and crevice corrosion	Structures Monitoring Program (B2.1.32)	No	Consistent with NUREG-1801, except for the Class 2 and 3 components. For these, consistent for material, environment and aging effect, but a different aging management program was used. Class 2 and 3 components are evaluated under ASME Section XI, Subsection IWF (B2.1.29). For other components, Structures Monitoring Program (B2.1.32) is credited, which is consistent with NUREG-1801.
3.5.1.51	Group B1.1: high strength low-alloy bolts	Cracking due to stress corrosion cracking; loss of material due to general corrosion	Bolting Integrity (B2.1.7)	No	Consistent with NUREG-1801 with aging management program exceptions. The aging management program(s) with exceptions to NUREG-1801 include: Bolting Integrity (B2.1.7)

Section 3.5
AGING MANAGEMENT OF CONTAINMENTS,
STRUCTURES AND COMPONENT SUPPORTS

Table 3.5.1 Summary of Aging Management Evaluations in Chapters II and III of NUREG-1801 for Containments, Structures, and Component Supports (Continued)

Item Number	Component Type	Aging Effect / Mechanism	Aging Management Program	Further Evaluation Recommended	Discussion
3.5.1.52	Groups B2, and B4: sliding support bearings and sliding support surfaces	Loss of mechanical function due to corrosion, distortion, dirt, overload, fatigue due to vibratory and cyclic thermal loads	Structures Monitoring Program (B2.1.32)	No	Consistent with NUREG-1801.
3.5.1.53	Groups B1.1, B1.2, and B1.3: support members; welds; bolted connections; support anchorage to building structure	Loss of material due to general and pitting corrosion	ISI (IWF) (B2.1.29)	No	Consistent with NUREG-1801.
3.5.1.54	Groups B1.1, B1.2, and B1.3: Constant and variable load spring hangers; guides; stops;	Loss of mechanical function due to corrosion, distortion, dirt, overload, fatigue due to vibratory and cyclic thermal loads	ISI (IWF) (B2.1.29)	No	Consistent with NUREG-1801.
3.5.1.55	Steel, galvanized steel, and aluminum support members; welds; bolted connections; support anchorage to building structure	Loss of material due to boric acid corrosion	Boric Acid Corrosion (B2.1.4)	No	Consistent with NUREG-1801.

Section 3.5
AGING MANAGEMENT OF CONTAINMENTS,
STRUCTURES AND COMPONENT SUPPORTS

Table 3.5.1 Summary of Aging Management Evaluations in Chapters II and III of NUREG-1801 for Containments, Structures, and Component Supports (Continued)

Item Number	Component Type	Aging Effect / Mechanism	Aging Management Program	Further Evaluation Recommended	Discussion
3.5.1.56	Groups B1.1, B1.2, and B1.3: Sliding surfaces	Loss of mechanical function due to corrosion, distortion, dirt, overload, fatigue due to vibratory and cyclic thermal loads	ISI (IWF) (B2.1.29)	No	Consistent with NUREG-1801.
3.5.1.57	Groups B1.1, B1.2, and B1.3: Vibration isolation elements	Reduction or loss of isolation function/ radiation hardening, temperature, humidity, sustained vibratory loading	ISI (IWF) (B2.1.29)	No	Not applicable. PVNGS has no in-scope vibration isolation elements, so the applicable NUREG-1801 lines were not used.
3.5.1.58	Galvanized steel and aluminum support members; welds; bolted connections; support anchorage to building structure exposed to air - indoor uncontrolled	None	None	No	Consistent with NUREG-1801.
3.5.1.59	Stainless steel support members; welds; bolted connections; support anchorage to building structure	None	None	No	Consistent with NUREG-1801.

Section 3.5
AGING MANAGEMENT OF CONTAINMENTS,
STRUCTURES AND COMPONENT SUPPORTS

Table 3.5.2-1 *Containments, Structures, and Component Supports – Summary of Aging Management Evaluation - Containment Building*

Component Type	Intended Function	Material	Environment	Aging Effect Requiring Management	Aging Management Program	NUREG-1801 Vol. 2 Item	Table 1 Item	Notes
Compressible Joints/Seals	SH, SPB	Elastomer	Plant Indoor Air (Structural) (Ext)	Loss of sealing; Leakage through containment	ASME Section XI, Subsection IWE (B2.1.27) and 10 CFR 50, Appendix J (B2.1.30)	II.A3-7	3.5.1.16	B
Concrete Elements	FB, MB, SH, SLD, SPB, SS	Concrete	Atmosphere/Weather (Structural) (Ext)	Cracking due to expansion	ASME Section XI, Subsection IWL (B2.1.28)	II.A1-3	3.5.1.15	A
Concrete Elements	FB, MB, SH, SLD, SPB, SS	Concrete	Atmosphere/Weather (Structural) (Ext)	Cracks and distortion	Structures Monitoring Program (B2.1.32)	II.A1-5	3.5.1.02	A
Concrete Elements	FB, MB, SH, SLD, SPB, SS	Concrete	Atmosphere/Weather (Structural) (Ext)	Increase in porosity, permeability	ASME Section XI, Subsection IWL (B2.1.28)	II.A1-6	3.5.1.15	A
Concrete Elements	FB, MB, SH, SLD, SPB, SS	Concrete	Atmosphere/Weather (Structural) (Ext)	Cracking, loss of bond, and loss of material (spalling, scaling)	ASME Section XI, Subsection IWL (B2.1.28)	II.A1-7	3.5.1.01	A

Section 3.5
AGING MANAGEMENT OF CONTAINMENTS,
STRUCTURES AND COMPONENT SUPPORTS

Table 3.5.2-1 Containments, Structures, and Component Supports – Summary of Aging Management Evaluation – Containment Building (Continued)

Component Type	Intended Function	Material	Environment	Aging Effect Requiring Management	Aging Management Program	NUREG-1801 Vol. 2 Item	Table 1 Item	Notes
Concrete Elements	FB, MB, SH, SLD, SPB, SS	Concrete	Atmosphere/Weather (Structural) (Ext)	Concrete cracking and spalling	Fire Protection (B2.1.12) and Structures Monitoring Program (B2.1.32)	VII.G-30	3.3.1.66	B
Concrete Elements	FB, MB, SH, SLD, SPB, SS	Concrete	Atmosphere/Weather (Structural) (Ext)	Loss of material	Fire Protection (B2.1.12) and Structures Monitoring Program (B2.1.32)	VII.G-31	3.3.1.67	B
Concrete Elements	FLB, SH, SLD, SPB, SS	Concrete	Buried (Structural) (Ext)	Loss of material (spalling, scaling) and cracking	ASME Section XI, Subsection IWL (B2.1.28)	II.A1-2	3.5.1.14	A
Concrete Elements	FLB, SH, SLD, SPB, SS	Concrete	Buried (Structural) (Ext)	Cracking due to expansion	ASME Section XI, Subsection IWL (B2.1.28)	II.A1-3	3.5.1.15	A
Concrete Elements	FLB, SH, SLD, SPB, SS	Concrete	Buried (Structural) (Ext)	Increase in porosity and permeability, cracking, loss of material (spalling, scaling)	ASME Section XI, Subsection IWL (B2.1.28)	II.A1-4	3.5.1.01	A
Concrete Elements	FLB, SH, SLD, SPB, SS	Concrete	Buried (Structural) (Ext)	Cracks and distortion	Structures Monitoring Program (B2.1.32)	II.A1-5	3.5.1.02	A

Section 3.5
AGING MANAGEMENT OF CONTAINMENTS,
STRUCTURES AND COMPONENT SUPPORTS

Table 3.5.2-1 Containments, Structures, and Component Supports – Summary of Aging Management Evaluation – Containment Building (Continued)

Component Type	Intended Function	Material	Environment	Aging Effect Requiring Management	Aging Management Program	NUREG-1801 Vol. 2 Item	Table 1 Item	Notes
Concrete Elements	FLB, SH, SLD, SPB, SS	Concrete	Buried (Structural) (Ext)	Increase in porosity, permeability	ASME Section XI, Subsection IWL (B2.1.28)	II.A1-6	3.5.1.15	A
Concrete Elements	FB, MB, SH, SLD, SPB, SS	Concrete	Plant Indoor Air (Structural) (Ext)	Cracking due to expansion	ASME Section XI, Subsection IWL (B2.1.28)	II.A1-3	3.5.1.15	A
Concrete Elements	FB, MB, SH, SLD, SPB, SS	Concrete	Plant Indoor Air (Structural) (Ext)	Increase in porosity and permeability, cracking, loss of material (spalling, scaling)	ASME Section XI, Subsection IWL (B2.1.28)	II.A1-4	3.5.1.01	A
Concrete Elements	FB, HLBS, MB, SH, SLD, SPB, SS	Concrete	Plant Indoor Air (Structural) (Ext)	Cracks and distortion	Structures Monitoring Program (B2.1.32)	II.A1-5	3.5.1.02	A
Concrete Elements	FB, MB, SH, SLD, SPB, SS	Concrete	Plant Indoor Air (Structural) (Ext)	Cracking, loss of bond, and loss of material (spalling, scaling)	ASME Section XI, Subsection IWL (B2.1.28)	II.A1-7	3.5.1.01	A
Concrete Elements	FB, HLBS, MB, SLD, SS	Concrete	Plant Indoor Air (Structural) (Ext)	Cracking due to expansion	Structures Monitoring Program (B2.1.32)	III.A4-2	3.5.1.27	A

Section 3.5
AGING MANAGEMENT OF CONTAINMENTS,
STRUCTURES AND COMPONENT SUPPORTS

Table 3.5.2-1 Containments, Structures, and Component Supports – Summary of Aging Management Evaluation – Containment Building (Continued)

Component Type	Intended Function	Material	Environment	Aging Effect Requiring Management	Aging Management Program	NUREG-1801 Vol. 2 Item	Table 1 Item	Notes
Concrete Elements	FB, HLBS, MB, SLD, SS	Concrete	Plant Indoor Air (Structural) (Ext)	Cracking, loss of bond, and loss of material (spalling, scaling)	Structures Monitoring Program (B2.1.32)	III.A4-3	3.5.1.23	A
Concrete Elements	FB, HLBS, MB, SH, SLD, SPB, SS	Concrete	Plant Indoor Air (Structural) (Ext)	Concrete cracking and spalling	Fire Protection (B2.1.12) and Structures Monitoring Program (B2.1.32)	VII.G-28	3.3.1.65	B
Concrete Elements	FB, HLBS, MB, SH, SLD, SPB, SS	Concrete	Plant Indoor Air (Structural) (Ext)	Loss of material	Fire Protection (B2.1.12) and Structures Monitoring Program (B2.1.32)	VII.G-29	3.3.1.67	B
Fire Barrier Coatings/ Wraps	FB	Thermo-Lag	Plant Indoor Air (Structural) (Ext)	Loss of material, cracking	Fire Protection (B2.1.12)	None	None	J, 1
Fire Barrier Seals	ES, FB, SH	Elastomer	Atmosphere/ Weather (Structural) (Ext)	Increased hardness, shrinkage and loss of strength	Fire Protection (B2.1.12)	VII.G-2	3.3.1.61	B
Fire Barrier Seals	ES, FB	Elastomer	Plant Indoor Air (Structural) (Ext)	Increased hardness, shrinkage and loss of strength	Fire Protection (B2.1.12)	VII.G-1	3.3.1.61	B

Section 3.5
AGING MANAGEMENT OF CONTAINMENTS,
STRUCTURES AND COMPONENT SUPPORTS

Table 3.5.2-1 Containments, Structures, and Component Supports – Summary of Aging Management Evaluation – Containment Building (Continued)

Component Type	Intended Function	Material	Environment	Aging Effect Requiring Management	Aging Management Program	NUREG-1801 Vol. 2 Item	Table 1 Item	Notes
Hatch - Emergency Airlock	MB, SLD, SPB, SS	Carbon Steel	Atmosphere/ Weather (Structural) (Ext)	Loss of leak tightness	10 CFR 50, Appendix J (B2.1.30)	II.A3-5	3.5.1.17	A
Hatch - Emergency Airlock	MB, SLD, SPB, SS	Carbon Steel	Atmosphere/ Weather (Structural) (Ext)	Loss of material	ASME Section XI, Subsection IWE (B2.1.27) and 10 CFR 50, Appendix J (B2.1.30)	II.A3-6	3.5.1.18	B
Hatch - Emergency Airlock	MB, SLD, SPB, SS	Carbon Steel	Plant Indoor Air (Structural) (Ext)	Loss of leak tightness	10 CFR 50, Appendix J (B2.1.30)	II.A3-5	3.5.1.17	A
Hatch - Emergency Airlock	MB, SLD, SPB, SS	Carbon Steel	Plant Indoor Air (Structural) (Ext)	Loss of material	ASME Section XI, Subsection IWE (B2.1.27) and 10 CFR 50, Appendix J (B2.1.30)	II.A3-6	3.5.1.18	B
Hatch - Emergency Airlock	SPB	Glass	Plant Indoor Air (Structural) (Ext)	None	None	V.F-6	3.2.1.52	C
Hatch - Equipment	SPB, SS	Carbon Steel	Atmosphere/ Weather (Structural) (Ext)	Loss of leak tightness	10 CFR 50, Appendix J (B2.1.30)	II.A3-5	3.5.1.17	A

Section 3.5
AGING MANAGEMENT OF CONTAINMENTS,
STRUCTURES AND COMPONENT SUPPORTS

Table 3.5.2-1 Containments, Structures, and Component Supports – Summary of Aging Management Evaluation – Containment Building (Continued)

Component Type	Intended Function	Material	Environment	Aging Effect Requiring Management	Aging Management Program	NUREG-1801 Vol. 2 Item	Table 1 Item	Notes
Hatch - Equipment	SPB, SS	Carbon Steel	Atmosphere/ Weather (Structural) (Ext)	Loss of material	ASME Section XI, Subsection IWE (B2.1.27) and 10 CFR 50, Appendix J (B2.1.30)	II.A3-6	3.5.1.18	B
Hatch - Equipment	SPB, SS	Carbon Steel	Plant Indoor Air (Structural) (Ext)	Loss of leak tightness	10 CFR 50, Appendix J (B2.1.30)	II.A3-5	3.5.1.17	A
Hatch - Equipment	SPB, SS	Carbon Steel	Plant Indoor Air (Structural) (Ext)	Loss of material	ASME Section XI, Subsection IWE (B2.1.27) and 10 CFR 50, Appendix J (B2.1.30)	II.A3-6	3.5.1.18	B
Hatch - Equipment	MB, SLD	Concrete	Atmosphere/ Weather (Structural) (Ext)	Cracking due to expansion	Structures Monitoring Program (B2.1.32)	III.A7-1	3.5.1.27	A
Hatch - Equipment	MB, SLD	Concrete	Atmosphere/ Weather (Structural) (Ext)	Loss of material (spalling, scaling) and cracking	Structures Monitoring Program (B2.1.32)	III.A7-5	3.5.1.26	A
Hatch - Equipment	MB, SLD	Concrete	Atmosphere/ Weather (Structural) (Ext)	Cracking, loss of bond, and loss of material (spalling, scaling)	Structures Monitoring Program (B2.1.32)	III.A7-8	3.5.1.23	A

Section 3.5
AGING MANAGEMENT OF CONTAINMENTS,
STRUCTURES AND COMPONENT SUPPORTS

Table 3.5.2-1 Containments, Structures, and Component Supports – Summary of Aging Management Evaluation – Containment Building (Continued)

Component Type	Intended Function	Material	Environment	Aging Effect Requiring Management	Aging Management Program	NUREG-1801 Vol. 2 Item	Table 1 Item	Notes
Hatch - Equipment	MB, SLD	Concrete	Atmosphere/ Weather (Structural) (Ext)	Increase in porosity and permeability, cracking, loss of material (spalling, scaling)	Structures Monitoring Program (B2.1.32)	III.A7-9	3.5.1.24	A
Hatch - Personnel Airlock	FB, MB, SLD, SPB, SS	Carbon Steel	Plant Indoor Air (Structural) (Ext)	Loss of leak tightness	10 CFR 50, Appendix J (B2.1.30)	II.A3-5	3.5.1.17	A
Hatch - Personnel Airlock	FB, MB, SLD, SPB, SS	Carbon Steel	Plant Indoor Air (Structural) (Ext)	Loss of material	ASME Section XI, Subsection IWE (B2.1.27) and 10 CFR 50, Appendix J (B2.1.30)	II.A3-6	3.5.1.18	B
Hatch - Personnel Airlock	SPB	Glass	Plant Indoor Air (Structural) (Ext)	None	None	V.F-6	3.2.1.52	C
Liner Containment	SH, SPB	Carbon Steel	Encased in Concrete (Ext)	None	None	VII.J-21	3.3.1.96	C
Liner Containment	SH, SPB	Carbon Steel	Plant Indoor Air (Structural) (Ext)	Loss of material	ASME Section XI, Subsection IWE (B2.1.27) and 10 CFR 50, Appendix J (B2.1.30)	II.A1-11	3.5.1.06	B
Liner Refueling	SH	Stainless Steel	Encased in Concrete (Ext)	None	None	VII.J-17	3.3.1.96	C

Section 3.5
AGING MANAGEMENT OF CONTAINMENTS,
STRUCTURES AND COMPONENT SUPPORTS

Table 3.5.2-1 Containments, Structures, and Component Supports – Summary of Aging Management Evaluation – Containment Building (Continued)

Component Type	Intended Function	Material	Environment	Aging Effect Requiring Management	Aging Management Program	NUREG-1801 Vol. 2 Item	Table 1 Item	Notes
Liner Refueling	SH	Stainless Steel	Plant Indoor Air (Structural) (Ext)	None	None	VII.J-15	3.3.1.94	C
Liner Refueling	SH	Stainless Steel	Submerged (Structural) (Ext)	Cracking	Water Chemistry (B2.1.2) and Monitoring of the Spent Fuel Pool Water Level	III.A5-13	3.5.1.46	A
Penetration	SLD, SPB, SS	Carbon Steel	Plant Indoor Air (Structural) (Ext)	Loss of material	ASME Section XI, Subsection IWE (B2.1.27) and 10 CFR 50, Appendix J (B2.1.30)	II.A3-1	3.5.1.18	B
Penetration	SLD, SPB, SS	Carbon Steel	Plant Indoor Air (Structural) (Ext)	Cumulative fatigue damage	Time-Limited Aging Analysis evaluated for the period of extended operation	II.A3-4	3.5.1.09	A
Penetration	SLD, SPB, SS	Stainless Steel	Plant Indoor Air (Structural) (Ext)	None	None	VII.J-15	3.3.1.94	C
Pipe Whip Restraints & Jet Shields	MB, SS	Carbon Steel	Plant Indoor Air (Structural) (Ext)	Loss of material	Structures Monitoring Program (B2.1.32)	III.A4-5	3.5.1.25	A
Pipe Whip Restraints & Jet Shields	MB, SS	Stainless Steel	Plant Indoor Air (Structural) (Ext)	None	None	VII.J-15	3.3.1.94	C
Stairs/ Platforms/ Grates	NSRS	Carbon Steel	Plant Indoor Air (Structural) (Ext)	Loss of material	Structures Monitoring Program (B2.1.32)	III.A4-5	3.5.1.25	A

Section 3.5
AGING MANAGEMENT OF CONTAINMENTS,
STRUCTURES AND COMPONENT SUPPORTS

Table 3.5.2-1 Containments, Structures, and Component Supports – Summary of Aging Management Evaluation – Containment Building (Continued)

Component Type	Intended Function	Material	Environment	Aging Effect Requiring Management	Aging Management Program	NUREG-1801 Vol. 2 Item	Table 1 Item	Notes
Structural Steel	SS	Carbon Steel	Encased in Concrete (Ext)	None	None	VII.J-21	3.3.1.96	C
Structural Steel	SS	Carbon Steel	Plant Indoor Air (Structural) (Ext)	Loss of material	Structures Monitoring Program (B2.1.32)	III.A4-5	3.5.1.25	A
Tendons	SS	Carbon Steel	Atmosphere/Weather (Structural) (Ext)	Loss of prestress	Time-Limited Aging Analysis evaluated for the period of extended operation	II.A1-9	3.5.1.07	A
Tendons	SS	Carbon Steel	Atmosphere/Weather (Structural) (Ext)	Loss of material	ASME Section XI, Subsection IWL (B2.1.28)	II.A1-10	3.5.1.22	A

Notes for Table 3.5.2-1:

Standard Notes:

- A Consistent with NUREG-1801 item for component, material, environment, and aging effect. AMP is consistent with NUREG-1801 AMP.
- B Consistent with NUREG-1801 item for component, material, environment, and aging effect. AMP takes some exceptions to NUREG-1801 AMP.
- C Component is different, but consistent with NUREG-1801 item for material, environment, and aging effect. AMP is consistent with NUREG-1801 AMP.
- J Neither the component nor the material and environment combination is evaluated in NUREG-1801.

Plant Specific Notes:

- 1 NUREG-1801 does not address aging of Thermo-Lag materials.

Section 3.5
AGING MANAGEMENT OF CONTAINMENTS,
STRUCTURES AND COMPONENT SUPPORTS

Table 3.5.2-2 Containments, Structures, and Component Supports – Summary of Aging Management Evaluation - Control Building

Component Type	Intended Function	Material	Environment	Aging Effect Requiring Management	Aging Management Program	NUREG-1801 Vol. 2 Item	Table 1 Item	Notes
Barrier	MB	Aluminum	Atmosphere/ Weather (Structural) (Ext)	Loss of material	Structures Monitoring Program (B2.1.32)	III.B4-7	3.5.1.50	C
Caulking/ Sealant	HLBS, SH, SPB	Elastomer	Atmosphere/ Weather (Structural) (Ext)	Loss of sealing	Structures Monitoring Program (B2.1.32)	III.A6-12	3.5.1.44	A
Caulking/ Sealant	HLBS, SH, SPB	Elastomer	Plant Indoor Air (Structural) (Ext)	Loss of sealing	Structures Monitoring Program (B2.1.32)	III.A6-12	3.5.1.44	A
Compressible Joints/Seals	SH	Elastomer	Atmosphere/ Weather (Structural) (Ext)	Loss of sealing	Structures Monitoring Program (B2.1.32)	III.A6-12	3.5.1.44	A
Compressible Joints/Seals	SH	Elastomer	Buried (Structural) (Ext)	Loss of sealing	Structures Monitoring Program (B2.1.32)	III.A6-12	3.5.1.44	A
Compressible Joints/Seals	SH	Elastomer	Plant Indoor Air (Structural) (Ext)	Loss of sealing	Structures Monitoring Program (B2.1.32)	III.A6-12	3.5.1.44	A
Concrete Block (Masonry Walls)	FB, SH, SS	Concrete Block (Masonry Walls)	Plant Indoor Air (Structural) (Ext)	Cracking	Fire Protection (B2.1.12) and Masonry Wall Program (B2.1.31)	III.A1-11	3.5.1.43	E, 1
Concrete Elements	FB, MB, SH, SS	Concrete	Atmosphere/ Weather (Structural) (Ext)	Cracking due to expansion	Structures Monitoring Program (B2.1.32)	III.A1-2	3.5.1.27	A

Section 3.5
AGING MANAGEMENT OF CONTAINMENTS,
STRUCTURES AND COMPONENT SUPPORTS

Table 3.5.2-2 Containments, Structures, and Component Supports – Summary of Aging Management Evaluation - Control Building
(Continued)

Component Type	Intended Function	Material	Environment	Aging Effect Requiring Management	Aging Management Program	NUREG-1801 Vol. 2 Item	Table 1 Item	Notes
Concrete Elements	FB, MB, SH, SS	Concrete	Atmosphere/ Weather (Structural) (Ext)	Loss of material (spalling, scaling) and cracking	Structures Monitoring Program (B2.1.32)	III.A1-6	3.5.1.26	A
Concrete Elements	FB, MB, SH, SS	Concrete	Atmosphere/ Weather (Structural) (Ext)	Cracking, loss of bond, and loss of material (spalling, scaling)	Structures Monitoring Program (B2.1.32)	III.A1-9	3.5.1.23	A
Concrete Elements	FB, MB, SH, SS	Concrete	Atmosphere/ Weather (Structural) (Ext)	Increase in porosity and permeability, cracking, loss of material (spalling, scaling)	Structures Monitoring Program (B2.1.32)	III.A1-10	3.5.1.24	A
Concrete Elements	FB, MB, SH, SS	Concrete	Atmosphere/ Weather (Structural) (Ext)	Concrete cracking and spalling	Fire Protection (B2.1.12) and Structures Monitoring Program (B2.1.32)	VII.G-30	3.3.1.66	B
Concrete Elements	FB, MB, SH, SS	Concrete	Atmosphere/ Weather (Structural) (Ext)	Loss of material	Fire Protection (B2.1.12) and Structures Monitoring Program (B2.1.32)	VII.G-31	3.3.1.67	B
Concrete Elements	SH, SS	Concrete	Buried (Structural) (Ext)	Cracking due to expansion	Structures Monitoring Program (B2.1.32)	III.A1-2	3.5.1.27	A
Concrete Elements	SH, SS	Concrete	Buried (Structural) (Ext)	Cracks and distortion	Structures Monitoring Program (B2.1.32)	III.A1-3	3.5.1.28	A

Section 3.5
AGING MANAGEMENT OF CONTAINMENTS,
STRUCTURES AND COMPONENT SUPPORTS

Table 3.5.2-2 Containments, Structures, and Component Supports – Summary of Aging Management Evaluation – Control Building
(Continued)

Component Type	Intended Function	Material	Environment	Aging Effect Requiring Management	Aging Management Program	NUREG-1801 Vol. 2 Item	Table 1 Item	Notes
Concrete Elements	SH, SS	Concrete	Buried (Structural) (Ext)	Cracking, loss of bond, and loss of material (spalling, scaling)	Structures Monitoring Program (B2.1.32)	III.A1-4	3.5.1.31	A
Concrete Elements	SH, SS	Concrete	Buried (Structural) (Ext)	Increase in porosity and permeability, cracking, loss of material (spalling, scaling)	Structures Monitoring Program (B2.1.32)	III.A1-5	3.5.1.31	A
Concrete Elements	FB, FLB, SH, SPB, SS	Concrete	Plant Indoor Air (Structural) (Ext)	Cracking due to expansion	Structures Monitoring Program (B2.1.32)	III.A1-2	3.5.1.27	A
Concrete Elements	FB, FLB, SH, SPB, SS	Concrete	Plant Indoor Air (Structural) (Ext)	Cracking, loss of bond, and loss of material (spalling, scaling)	Structures Monitoring Program (B2.1.32)	III.A1-9	3.5.1.23	A
Concrete Elements	FB, FLB, SH, SPB, SS	Concrete	Plant Indoor Air (Structural) (Ext)	Increase in porosity and permeability, cracking, loss of material (spalling, scaling)	Structures Monitoring Program (B2.1.32)	III.A1-10	3.5.1.24	A
Concrete Elements	FB, FLB, SH, SPB, SS	Concrete	Plant Indoor Air (Structural) (Ext)	Concrete cracking and spalling	Fire Protection (B2.1.12) and Structures Monitoring Program (B2.1.32)	VII.G-28	3.3.1.65	B

Section 3.5
AGING MANAGEMENT OF CONTAINMENTS,
STRUCTURES AND COMPONENT SUPPORTS

Table 3.5.2-2 Containments, Structures, and Component Supports – Summary of Aging Management Evaluation - Control Building
(Continued)

Component Type	Intended Function	Material	Environment	Aging Effect Requiring Management	Aging Management Program	NUREG-1801 Vol. 2 Item	Table 1 Item	Notes
Concrete Elements	FB, FLB, SH, SPB, SS	Concrete	Plant Indoor Air (Structural) (Ext)	Loss of material	Fire Protection (B2.1.12) and Structures Monitoring Program (B2.1.32)	VII.G-29	3.3.1.67	B
Doors	SH	Carbon Steel	Atmosphere/Weather (Structural) (Ext)	Loss of material	Structures Monitoring Program (B2.1.32)	III.A1-12	3.5.1.25	A
Doors	MB, SH, SPB	Carbon Steel	Plant Indoor Air (Structural) (Ext)	Loss of material	Structures Monitoring Program (B2.1.32)	III.A1-12	3.5.1.25	A
Fire Barrier Coatings/Wraps	FB	Fire Barrier (Cementitious Coating)	Plant Indoor Air (Structural) (Ext)	Loss of material, cracking	Fire Protection (B2.1.12)	None	None	J, 2
Fire Barrier Doors	FB, HLBS, MB, SH, SPB	Carbon Steel	Plant Indoor Air (Structural) (Ext)	Loss of material	Structures Monitoring Program (B2.1.32)	III.A1-12	3.5.1.25	A
Fire Barrier Doors	FB, HLBS, MB, SH, SPB	Carbon Steel	Plant Indoor Air (Structural) (Ext)	Loss of material	Fire Protection (B2.1.12)	VII.G-3	3.3.1.63	B
Fire Barrier Seals	FB	Elastomer	Plant Indoor Air (Structural) (Ext)	Increased hardness, shrinkage and loss of strength	Fire Protection (B2.1.12)	VII.G-1	3.3.1.61	B
Fire Barrier Seals	FB	Fire Barrier (Ceramic Fiber)	Plant Indoor Air (Structural) (Ext)	Loss of material, cracking	Fire Protection (B2.1.12)	None	None	J, 2

Section 3.5
AGING MANAGEMENT OF CONTAINMENTS,
STRUCTURES AND COMPONENT SUPPORTS

Table 3.5.2-2 Containments, Structures, and Component Supports – Summary of Aging Management Evaluation - Control Building
(Continued)

Component Type	Intended Function	Material	Environment	Aging Effect Requiring Management	Aging Management Program	NUREG-1801 Vol. 2 Item	Table 1 Item	Notes
Gypsum/Plaster Barrier	FB, NSRS, SH, SPB	Gypsum/Plaster	Plant Indoor Air (Structural) (Ext)	Cracking	Fire Protection (B2.1.12)	None	None	J
Hatch	FLB, MB, SH	Carbon Steel	Atmosphere/Weather (Structural) (Ext)	Loss of material	Structures Monitoring Program (B2.1.32)	III.A1-12	3.5.1.25	A
Hatch	SH, SPB	Carbon Steel	Plant Indoor Air (Structural) (Ext)	Loss of material	Structures Monitoring Program (B2.1.32)	III.A1-12	3.5.1.25	A
Hatches/Plugs	SH	Concrete	Atmosphere/Weather (Structural) (Ext)	Cracking due to expansion	Structures Monitoring Program (B2.1.32)	III.A1-2	3.5.1.27	A
Hatches/Plugs	SH	Concrete	Atmosphere/Weather (Structural) (Ext)	Loss of material (spalling, scaling) and cracking	Structures Monitoring Program (B2.1.32)	III.A1-6	3.5.1.26	A
Hatches/Plugs	SH	Concrete	Atmosphere/Weather (Structural) (Ext)	Cracking, loss of bond, and loss of material (spalling, scaling)	Structures Monitoring Program (B2.1.32)	III.A1-9	3.5.1.23	A
Hatches/Plugs	SH	Concrete	Atmosphere/Weather (Structural) (Ext)	Increase in porosity and permeability, cracking, loss of material (spalling, scaling)	Structures Monitoring Program (B2.1.32)	III.A1-10	3.5.1.24	A
Hatches/Plugs	SH	Concrete	Plant Indoor Air (Structural) (Ext)	Cracking due to expansion	Structures Monitoring Program (B2.1.32)	III.A1-2	3.5.1.27	A

Section 3.5
AGING MANAGEMENT OF CONTAINMENTS,
STRUCTURES AND COMPONENT SUPPORTS

Table 3.5.2-2 Containments, Structures, and Component Supports – Summary of Aging Management Evaluation - Control Building
(Continued)

Component Type	Intended Function	Material	Environment	Aging Effect Requiring Management	Aging Management Program	NUREG-1801 Vol. 2 Item	Table 1 Item	Notes
Hatches/Plugs	SH	Concrete	Plant Indoor Air (Structural) (Ext)	Cracking, loss of bond, and loss of material (spalling, scaling)	Structures Monitoring Program (B2.1.32)	III.A1-9	3.5.1.23	A
Hatches/Plugs	SH	Concrete	Plant Indoor Air (Structural) (Ext)	Increase in porosity and permeability, cracking, loss of material (spalling, scaling)	Structures Monitoring Program (B2.1.32)	III.A1-10	3.5.1.24	A
Metal Siding	SH	Carbon Steel	Atmosphere/Weather (Structural) (Ext)	Loss of material	Structures Monitoring Program (B2.1.32)	III.A1-12	3.5.1.25	A
Metal Siding	SH	Carbon Steel	Plant Indoor Air (Structural) (Ext)	Loss of material	Structures Monitoring Program (B2.1.32)	III.A1-12	3.5.1.25	A
Penetrations Electrical	SS	Carbon Steel	Atmosphere/Weather (Structural) (Ext)	Loss of material	Structures Monitoring Program (B2.1.32)	III.A1-12	3.5.1.25	A
Penetrations Electrical	SS	Carbon Steel	Encased in Concrete (Ext)	None	None	VII.J-21	3.3.1.96	C
Penetrations Electrical	SS	Carbon Steel	Plant Indoor Air (Structural) (Ext)	Loss of material	Structures Monitoring Program (B2.1.32)	III.A1-12	3.5.1.25	A
Penetrations Mechanical	SS	Carbon Steel	Atmosphere/Weather (Structural) (Ext)	Loss of material	Structures Monitoring Program (B2.1.32)	III.A1-12	3.5.1.25	A

Section 3.5
AGING MANAGEMENT OF CONTAINMENTS,
STRUCTURES AND COMPONENT SUPPORTS

Table 3.5.2-2 Containments, Structures, and Component Supports – Summary of Aging Management Evaluation – Control Building
(Continued)

Component Type	Intended Function	Material	Environment	Aging Effect Requiring Management	Aging Management Program	NUREG-1801 Vol. 2 Item	Table 1 Item	Notes
Penetrations Mechanical	SS	Carbon Steel	Encased in Concrete (Ext)	None	None	VII.J-21	3.3.1.96	C
Penetrations Mechanical	SS	Carbon Steel	Plant Indoor Air (Structural) (Ext)	Loss of material	Structures Monitoring Program (B2.1.32)	III.A1-12	3.5.1.25	A
Roofing Membrane	SH	Elastomer	Atmosphere/Weather (Structural) (Ext)	Loss of sealing	Structures Monitoring Program (B2.1.32)	III.A6-12	3.5.1.44	A
Stairs/Platforms/Grates	NSRS	Carbon Steel	Plant Indoor Air (Structural) (Ext)	Loss of material	Structures Monitoring Program (B2.1.32)	III.A1-12	3.5.1.25	A
Structural Steel	MB, SS	Carbon Steel	Atmosphere/Weather (Structural) (Ext)	Loss of material	Structures Monitoring Program (B2.1.32)	III.A1-12	3.5.1.25	A
Structural Steel	SS	Carbon Steel	Encased in Concrete (Ext)	None	None	VII.J-21	3.3.1.96	C
Structural Steel	SH, SS	Carbon Steel	Plant Indoor Air (Structural) (Ext)	Loss of material	Structures Monitoring Program (B2.1.32)	III.A1-12	3.5.1.25	A

**Section 3.5
AGING MANAGEMENT OF CONTAINMENTS,
STRUCTURES AND COMPONENT SUPPORTS**

Notes for Table 3.5.2-2:

Standard Note Text

- A Consistent with NUREG-1801 item for component, material, environment, and aging effect. AMP is consistent with NUREG-1801 AMP.
- B Consistent with NUREG-1801 item for component, material, environment, and aging effect. AMP takes some exceptions to NUREG-1801 AMP.
- C Component is different, but consistent with NUREG-1801 item for material, environment, and aging effect. AMP is consistent with NUREG-1801 AMP.
- E Consistent with NUREG-1801 for material, environment, and aging effect, but a different aging management program is credited or NUREG-1801 identifies a plant-specific aging management program.
- J Neither the component nor the material and environment combination is evaluated in NUREG-1801.

Plant Specific Notes:

- 1 The NUREG-1801 does not provide a line in which Concrete Masonry is inspected per the Fire Protection program.
- 2 NUREG-1801 does not provide a line in which Fire Barriers (Ceramic Fiber or Cementitious Coating) are inspected per the Fire Protection program.

Section 3.5
AGING MANAGEMENT OF CONTAINMENTS,
STRUCTURES AND COMPONENT SUPPORTS

Table 3.5.2-3 Containments, Structures, and Component Supports – Summary of Aging Management Evaluation – Diesel Generator Building

Component Type	Intended Function	Material	Environment	Aging Effect Requiring Management	Aging Management Program	NUREG-1801 Vol. 2 Item	Table 1 Item	Notes
Caulking/Sealant	FLB, SH	Elastomer	Atmosphere/ Weather (Structural) (Ext)	Loss of sealing	Structures Monitoring Program (B2.1.32)	III.A6-12	3.5.1.44	A
Caulking/Sealant	FLB, SH	Elastomer	Buried (Structural) (Ext)	Loss of sealing	Structures Monitoring Program (B2.1.32)	III.A6-12	3.5.1.44	A
Caulking/Sealant	FLB, SH	Elastomer	Plant Indoor Air (Structural) (Ext)	Loss of sealing	Structures Monitoring Program (B2.1.32)	III.A6-12	3.5.1.44	A
Compressible Joints/Seals	ES, SH	Elastomer	Atmosphere/ Weather (Structural) (Ext)	Loss of sealing	Structures Monitoring Program (B2.1.32)	III.A6-12	3.5.1.44	A
Compressible Joints/Seals	ES, SH	Elastomer	Plant Indoor Air (Structural) (Ext)	Loss of sealing	Structures Monitoring Program (B2.1.32)	III.A6-12	3.5.1.44	A
Concrete Elements	FB, MB, SH, SS	Concrete	Atmosphere/ Weather (Structural) (Ext)	Cracking due to expansion	Structures Monitoring Program (B2.1.32)	III.A3-2	3.5.1.27	A
Concrete Elements	FB, MB, SH, SS	Concrete	Atmosphere/ Weather (Structural) (Ext)	Loss of material (spalling, scaling) and cracking)	Structures Monitoring Program (B2.1.32)	III.A3-6	3.5.1.26	A

Section 3.5
AGING MANAGEMENT OF CONTAINMENTS,
STRUCTURES AND COMPONENT SUPPORTS

Table 3.5.2-3 Containments, Structures, and Component Supports – Summary of Aging Management Evaluation - Diesel Generator Building (Continued)

Component Type	Intended Function	Material	Environment	Aging Effect Requiring Management	Aging Management Program	NUREG-1801 Vol. 2 Item	Table 1 Item	Notes
Concrete Elements	FB, MB, SH, SS	Concrete	Atmosphere/Weather (Structural) (Ext)	Cracking, loss of bond, and loss of material (spalling, scaling)	Structures Monitoring Program (B2.1.32)	III.A3-9	3.5.1.23	A
Concrete Elements	FB, MB, SH, SS	Concrete	Atmosphere/Weather (Structural) (Ext)	Increase in porosity and permeability, cracking, loss of material (spalling, scaling)	Structures Monitoring Program (B2.1.32)	III.A3-10	3.5.1.24	A
Concrete Elements	FB, MB, SH, SS	Concrete	Atmosphere/Weather (Structural) (Ext)	Concrete cracking and spalling	Fire Protection (B2.1.12) and Structures Monitoring Program (B2.1.32)	VII.G-30	3.3.1.66	B
Concrete Elements	FB, MB, SH, SS	Concrete	Atmosphere/Weather (Structural) (Ext)	Loss of material	Fire Protection (B2.1.12) and Structures Monitoring Program (B2.1.32)	VII.G-31	3.3.1.67	B
Concrete Elements	SH, SS	Concrete	Buried (Structural) (Ext)	Cracking due to expansion	Structures Monitoring Program (B2.1.32)	III.A3-2	3.5.1.27	A
Concrete Elements	SH, SS	Concrete	Buried (Structural) (Ext)	Cracks and distortion	Structures Monitoring Program (B2.1.32)	III.A3-3	3.5.1.28	A

Section 3.5
AGING MANAGEMENT OF CONTAINMENTS,
STRUCTURES AND COMPONENT SUPPORTS

Table 3.5.2-3 Containments, Structures, and Component Supports – Summary of Aging Management Evaluation - Diesel Generator Building (Continued)

Component Type	Intended Function	Material	Environment	Aging Effect Requiring Management	Aging Management Program	NUREG-1801 Vol. 2 Item	Table 1 Item	Notes
Concrete Elements	SH, SS	Concrete	Buried (Structural) (Ext)	Cracking, loss of bond, and loss of material (spalling, scaling)	Structures Monitoring Program (B2.1.32)	III.A3-4	3.5.1.31	A
Concrete Elements	SH, SS	Concrete	Buried (Structural) (Ext)	Increase in porosity and permeability, cracking, loss of material (spalling, scaling)	Structures Monitoring Program (B2.1.32)	III.A3-5	3.5.1.31	A
Concrete Elements	FB, FLB, SH, SS	Concrete	Plant Indoor Air (Structural) (Ext)	Cracking due to expansion	Structures Monitoring Program (B2.1.32)	III.A3-2	3.5.1.27	A
Concrete Elements	FB, FLB, SH, SS	Concrete	Plant Indoor Air (Structural) (Ext)	Cracking, loss of bond, and loss of material (spalling, scaling)	Structures Monitoring Program (B2.1.32)	III.A3-9	3.5.1.23	A
Concrete Elements	FB, FLB, SH, SS	Concrete	Plant Indoor Air (Structural) (Ext)	Increase in porosity and permeability, cracking, loss of material (spalling, scaling)	Structures Monitoring Program (B2.1.32)	III.A3-10	3.5.1.24	A
Concrete Elements	FB, FLB, SH, SS	Concrete	Plant Indoor Air (Structural) (Ext)	Concrete cracking and spalling	Fire Protection (B2.1.12) and Structures Monitoring Program (B2.1.32)	VII.G-28	3.3.1.65	B

Section 3.5
AGING MANAGEMENT OF CONTAINMENTS,
STRUCTURES AND COMPONENT SUPPORTS

Table 3.5.2-3 Containments, Structures, and Component Supports – Summary of Aging Management Evaluation - Diesel Generator Building (Continued)

Component Type	Intended Function	Material	Environment	Aging Effect Requiring Management	Aging Management Program	NUREG-1801 Vol. 2 Item	Table 1 Item	Notes
Concrete Elements	FB, FLB, SH, SS	Concrete	Plant Indoor Air (Structural) (Ext)	Loss of material	Fire Protection (B2.1.12) and Structures Monitoring Program (B2.1.32)	VII.G-29	3.3.1.67	B
Doors	MB, SH	Carbon Steel	Atmosphere/Weather (Structural) (Ext)	Loss of material	Structures Monitoring Program (B2.1.32)	III.A3-12	3.5.1.25	A
Doors	MB, SH	Carbon Steel	Plant Indoor Air (Structural) (Ext)	Loss of material	Structures Monitoring Program (B2.1.32)	III.A3-12	3.5.1.25	A
Fire Barrier Doors	FB, MB, SH	Carbon Steel	Atmosphere/Weather (Structural) (Ext)	Loss of material	Structures Monitoring Program (B2.1.32)	III.A3-12	3.5.1.25	A
Fire Barrier Doors	FB, MB, SH	Carbon Steel	Atmosphere/Weather (Structural) (Ext)	Loss of material	Fire Protection (B2.1.12)	VII.G-4	3.3.1.63	B
Fire Barrier Doors	FB, FLB, MB, SH	Carbon Steel	Plant Indoor Air (Structural) (Ext)	Loss of material	Structures Monitoring Program (B2.1.32)	III.A3-12	3.5.1.25	A
Fire Barrier Doors	FB, FLB, MB, SH	Carbon Steel	Plant Indoor Air (Structural) (Ext)	Loss of material	Fire Protection (B2.1.12)	VII.G-3	3.3.1.63	B
Fire Barrier Seals	FB	Elastomer	Atmosphere/Weather (Structural) (Ext)	Increased hardness, shrinkage and loss of strength	Fire Protection (B2.1.12)	VII.G-2	3.3.1.61	B

Section 3.5
AGING MANAGEMENT OF CONTAINMENTS,
STRUCTURES AND COMPONENT SUPPORTS

Table 3.5.2-3 Containments, Structures, and Component Supports – Summary of Aging Management Evaluation - Diesel Generator Building (Continued)

Component Type	Intended Function	Material	Environment	Aging Effect Requiring Management	Aging Management Program	NUREG-1801 Vol. 2 Item	Table 1 Item	Notes
Fire Barrier Seals	FB	Elastomer	Plant Indoor Air (Structural) (Ext)	Increased hardness, shrinkage and loss of strength	Fire Protection (B2.1.12)	VII.G-1	3.3.1.61	B
Hatch	MB, SH	Carbon Steel	Atmosphere/Weather (Structural) (Ext)	Loss of material	Structures Monitoring Program (B2.1.32)	III.A3-12	3.5.1.25	A
Hatch	SH	Carbon Steel	Plant Indoor Air (Structural) (Ext)	Loss of material	Structures Monitoring Program (B2.1.32)	III.A3-12	3.5.1.25	A
Hatches/Plugs	MB, SH	Concrete	Atmosphere/Weather (Structural) (Ext)	Cracking due to expansion	Structures Monitoring Program (B2.1.32)	III.A3-2	3.5.1.27	A
Hatches/Plugs	MB, SH	Concrete	Atmosphere/Weather (Structural) (Ext)	Loss of material (spalling, scaling) and cracking	Structures Monitoring Program (B2.1.32)	III.A3-6	3.5.1.26	A
Hatches/Plugs	MB, SH	Concrete	Atmosphere/Weather (Structural) (Ext)	Cracking, loss of bond, and loss of material (spalling, scaling)	Structures Monitoring Program (B2.1.32)	III.A3-9	3.5.1.23	A
Hatches/Plugs	MB, SH	Concrete	Atmosphere/Weather (Structural) (Ext)	Increase in porosity and permeability, cracking, loss of material (spalling, scaling)	Structures Monitoring Program (B2.1.32)	III.A3-10	3.5.1.24	A

Section 3.5
AGING MANAGEMENT OF CONTAINMENTS,
STRUCTURES AND COMPONENT SUPPORTS

Table 3.5.2-3 Containments, Structures, and Component Supports – Summary of Aging Management Evaluation - Diesel Generator Building (Continued)

Component Type	Intended Function	Material	Environment	Aging Effect Requiring Management	Aging Management Program	NUREG-1801 Vol. 2 Item	Table 1 Item	Notes
Hatches/Plugs	MB, SH	Concrete	Plant Indoor Air (Structural) (Ext)	Cracking due to expansion	Structures Monitoring Program (B2.1.32)	III.A3-2	3.5.1.27	A
Hatches/Plugs	MB, SH	Concrete	Plant Indoor Air (Structural) (Ext)	Cracking, loss of bond, and loss of material (spalling, scaling)	Structures Monitoring Program (B2.1.32)	III.A3-9	3.5.1.23	A
Hatches/Plugs	MB, SH	Concrete	Plant Indoor Air (Structural) (Ext)	Increase in porosity and permeability, cracking, loss of material (spalling, scaling)	Structures Monitoring Program (B2.1.32)	III.A3-10	3.5.1.24	A
Penetrations Electrical	SS	Carbon Steel	Atmosphere/Weather (Structural) (Ext)	Loss of material	Structures Monitoring Program (B2.1.32)	III.A3-12	3.5.1.25	A
Penetrations Electrical	SS	Carbon Steel	Encased in Concrete (Ext)	None	None	VII.J-21	3.3.1.96	C
Penetrations Electrical	SS	Carbon Steel	Plant Indoor Air (Structural) (Ext)	Loss of material	Structures Monitoring Program (B2.1.32)	III.A3-12	3.5.1.25	A
Penetrations Mechanical	SS	Carbon Steel	Atmosphere/Weather (Structural) (Ext)	Loss of material	Structures Monitoring Program (B2.1.32)	III.A3-12	3.5.1.25	A
Penetrations Mechanical	SS	Carbon Steel	Encased in Concrete (Ext)	None	None	VII.J-21	3.3.1.96	C

Section 3.5
AGING MANAGEMENT OF CONTAINMENTS,
STRUCTURES AND COMPONENT SUPPORTS

Table 3.5.2-3 Containments, Structures, and Component Supports – Summary of Aging Management Evaluation - Diesel Generator Building (Continued)

Component Type	Intended Function	Material	Environment	Aging Effect Requiring Management	Aging Management Program	NUREG-1801 Vol. 2 Item	Table 1 Item	Notes
Penetrations Mechanical	SS	Carbon Steel	Plant Indoor Air (Structural) (Ext)	Loss of material	Structures Monitoring Program (B2.1.32)	III.A3-12	3.5.1.25	A
Roofing Membrane	SH	Elastomer	Atmosphere/Weather (Structural) (Ext)	Loss of sealing	Structures Monitoring Program (B2.1.32)	III.A6-12	3.5.1.44	A
Stairs/Platforms/Grates	NSRS	Carbon Steel	Plant Indoor Air (Structural) (Ext)	Loss of material	Structures Monitoring Program (B2.1.32)	III.A3-12	3.5.1.25	A
Structural Steel	SS	Carbon Steel	Atmosphere/Weather (Structural) (Ext)	Loss of material	Structures Monitoring Program (B2.1.32)	III.A3-12	3.5.1.25	A
Structural Steel	SS	Carbon Steel	Encased in Concrete (Ext)	None	None	VII.J-21	3.3.1.96	C
Structural Steel	SH, SS	Carbon Steel	Plant Indoor Air (Structural) (Ext)	Loss of material	Structures Monitoring Program (B2.1.32)	III.A3-12	3.5.1.25	A

**Section 3.5
AGING MANAGEMENT OF CONTAINMENTS,
STRUCTURES AND COMPONENT SUPPORTS**

Notes for Table 3.5.2-3:

Standard Notes:

- A Consistent with NUREG-1801 item for component, material, environment, and aging effect. AMP is consistent with NUREG-1801 AMP.
- B Consistent with NUREG-1801 item for component, material, environment, and aging effect. AMP takes some exceptions to NUREG-1801 AMP.
- C Component is different, but consistent with NUREG-1801 item for material, environment, and aging effect. AMP is consistent with NUREG-1801 AMP.

Plant Specific Notes:

None

Section 3.5
AGING MANAGEMENT OF CONTAINMENTS,
STRUCTURES AND COMPONENT SUPPORTS

Table 3.5.2-4 Containments, Structures, and Component Supports – Summary of Aging Management Evaluation - Turbine Building

Component Type	Intended Function	Material	Environment	Aging Effect Requiring Management	Aging Management Program	NUREG-1801 Vol. 2 Item	Table 1 Item	Notes
Concrete Block (Masonry Walls)	FB, SH, SS	Concrete Block (Masonry Walls)	Atmosphere/Weather (Structural) (Ext)	Cracking	Fire Protection (B2.1.12) and Masonry Wall Program (B2.1.31)	III.A3-11	3.5.1.43	E, 1
Concrete Block (Masonry Walls)	FB, SH, SS	Concrete Block (Masonry Walls)	Plant Indoor Air (Structural) (Ext)	Cracking	Fire Protection (B2.1.12) and Masonry Wall Program (B2.1.31)	III.A3-11	3.5.1.43	E, 1
Concrete Elements	SS	Concrete	Atmosphere/Weather (Structural) (Ext)	Cracking due to expansion	Structures Monitoring Program (B2.1.32)	III.A3-2	3.5.1.27	A
Concrete Elements	SS	Concrete	Atmosphere/Weather (Structural) (Ext)	Loss of material (spalling, scaling) and cracking	Structures Monitoring Program (B2.1.32)	III.A3-6	3.5.1.26	A
Concrete Elements	SS	Concrete	Atmosphere/Weather (Structural) (Ext)	Cracking, loss of bond, and loss of material (spalling, scaling)	Structures Monitoring Program (B2.1.32)	III.A3-9	3.5.1.23	A
Concrete Elements	SS	Concrete	Atmosphere/Weather (Structural) (Ext)	Increase in porosity and permeability, cracking, loss of material (spalling, scaling)	Structures Monitoring Program (B2.1.32)	III.A3-10	3.5.1.24	A

Section 3.5
AGING MANAGEMENT OF CONTAINMENTS,
STRUCTURES AND COMPONENT SUPPORTS

Table 3.5.2-4 Containments, Structures, and Component Supports – Summary of Aging Management Evaluation – Turbine Building
(Continued)

Component Type	Intended Function	Material	Environment	Aging Effect Requiring Management	Aging Management Program	NUREG-1801 Vol. 2 Item	Table 1 Item	Notes
Concrete Elements	SS	Concrete	Buried (Structural) (Ext)	Cracking due to expansion	Structures Monitoring Program (B2.1.32)	III.A3-2	3.5.1.27	A
Concrete Elements	SS	Concrete	Buried (Structural) (Ext)	Cracks and distortion	Structures Monitoring Program (B2.1.32)	III.A3-3	3.5.1.28	A
Concrete Elements	SS	Concrete	Buried (Structural) (Ext)	Cracking, loss of bond, and loss of material (spalling, scaling)	Structures Monitoring Program (B2.1.32)	III.A3-4	3.5.1.31	A
Concrete Elements	SS	Concrete	Buried (Structural) (Ext)	Increase in porosity and permeability, cracking, loss of material (spalling, scaling)	Structures Monitoring Program (B2.1.32)	III.A3-5	3.5.1.31	A
Concrete Elements	SH, SS	Concrete	Plant Indoor Air (Structural) (Ext)	Cracking due to expansion	Structures Monitoring Program (B2.1.32)	III.A3-2	3.5.1.27	A
Concrete Elements	SH, SS	Concrete	Plant Indoor Air (Structural) (Ext)	Cracking, loss of bond, and loss of material (spalling, scaling)	Structures Monitoring Program (B2.1.32)	III.A3-9	3.5.1.23	A

Section 3.5
AGING MANAGEMENT OF CONTAINMENTS,
STRUCTURES AND COMPONENT SUPPORTS

Table 3.5.2-4 Containments, Structures, and Component Supports – Summary of Aging Management Evaluation – Turbine Building
(Continued)

Component Type	Intended Function	Material	Environment	Aging Effect Requiring Management	Aging Management Program	NUREG-1801 Vol. 2 Item	Table 1 Item	Notes
Concrete Elements	SH, SS	Concrete	Plant Indoor Air (Structural) (Ext)	Increase in porosity and permeability, cracking, loss of material (spalling, scaling)	Structures Monitoring Program (B2.1.32)	III.A3-10	3.5.1.24	A
Doors	SH	Carbon Steel	Atmosphere/Weather (Structural) (Ext)	Loss of material	Structures Monitoring Program (B2.1.32)	III.A3-12	3.5.1.25	A
Doors	SH	Carbon Steel	Plant Indoor Air (Structural) (Ext)	Loss of material	Structures Monitoring Program (B2.1.32)	III.A3-12	3.5.1.25	A
Fire Barrier Coatings/Wraps	FB	Fire Barrier (Cementitious Coating)	Plant Indoor Air (Structural) (Ext)	Loss of material, cracking	Fire Protection (B2.1.12)	None	None	J, 2
Fire Barrier Doors	FB, SH	Carbon Steel	Atmosphere/Weather (Structural) (Ext)	Loss of material	Structures Monitoring Program (B2.1.32)	III.A3-12	3.5.1.25	A
Fire Barrier Doors	FB, SH	Carbon Steel	Atmosphere/Weather (Structural) (Ext)	Loss of material	Fire Protection (B2.1.12)	VII.G-4	3.3.1.63	B
Fire Barrier Doors	FB, SH	Carbon Steel	Plant Indoor Air (Structural) (Ext)	Loss of material	Structures Monitoring Program (B2.1.32)	III.A3-12	3.5.1.25	A
Fire Barrier Doors	FB, SH	Carbon Steel	Plant Indoor Air (Structural) (Ext)	Loss of material	Fire Protection (B2.1.12)	VII.G-3	3.3.1.63	B

Section 3.5
AGING MANAGEMENT OF CONTAINMENTS,
STRUCTURES AND COMPONENT SUPPORTS

Table 3.5.2-4 Containments, Structures, and Component Supports – Summary of Aging Management Evaluation – Turbine Building
(Continued)

Component Type	Intended Function	Material	Environment	Aging Effect Requiring Management	Aging Management Program	NUREG-1801 Vol. 2 Item	Table 1 Item	Notes
Fire Barrier Seals	FB	Elastomer	Atmosphere/ Weather (Structural) (Ext)	Increased hardness, shrinkage and loss of strength	Fire Protection (B2.1.12)	VII.G-2	3.3.1.61	B
Fire Barrier Seals	FB	Elastomer	Plant Indoor Air (Structural) (Ext)	Increased hardness, shrinkage and loss of strength	Fire Protection (B2.1.12)	VII.G-1	3.3.1.61	B
Hatch	SH	Carbon Steel	Atmosphere/ Weather (Structural) (Ext)	Loss of material	Structures Monitoring Program (B2.1.32)	III.A3-12	3.5.1.25	A
Hatch	SH	Carbon Steel	Plant Indoor Air (Structural) (Ext)	Loss of material	Structures Monitoring Program (B2.1.32)	III.A3-12	3.5.1.25	A
Metal Siding	SH	Carbon Steel	Atmosphere/ Weather (Structural) (Ext)	Loss of material	Structures Monitoring Program (B2.1.32)	III.A3-12	3.5.1.25	A
Metal Siding	SH	Carbon Steel	Plant Indoor Air (Structural) (Ext)	Loss of material	Structures Monitoring Program (B2.1.32)	III.A3-12	3.5.1.25	A
Penetrations Electrical	SS	Carbon Steel	Encased in Concrete (Ext)	None	None	VII.J-21	3.3.1.96	C
Penetrations Electrical	SS	Carbon Steel	Plant Indoor Air (Structural) (Ext)	Loss of material	Structures Monitoring Program (B2.1.32)	III.A3-12	3.5.1.25	A
Penetrations Mechanical	SS	Carbon Steel	Encased in Concrete (Ext)	None	None	VII.J-21	3.3.1.96	C

Section 3.5
AGING MANAGEMENT OF CONTAINMENTS,
STRUCTURES AND COMPONENT SUPPORTS

Table 3.5.2-4 Containments, Structures, and Component Supports – Summary of Aging Management Evaluation – Turbine Building
(Continued)

Component Type	Intended Function	Material	Environment	Aging Effect Requiring Management	Aging Management Program	NUREG-1801 Vol. 2 Item	Table 1 Item	Notes
Penetrations Mechanical	SS	Carbon Steel	Plant Indoor Air (Structural) (Ext)	Loss of material	Structures Monitoring Program (B2.1.32)	III.A3-12	3.5.1.25	A
Roofing Membrane	SH	Elastomer	Atmosphere/Weather (Structural) (Ext)	Loss of sealing	Structures Monitoring Program (B2.1.32)	III.A6-12	3.5.1.44	A
Structural Steel	SH, SS	Carbon Steel	Atmosphere/Weather (Structural) (Ext)	Loss of material	Structures Monitoring Program (B2.1.32)	III.A3-12	3.5.1.25	A
Structural Steel	SS	Carbon Steel	Encased in Concrete (Ext)	None	None	VII.J-21	3.3.1.96	C
Structural Steel	SH, SS	Carbon Steel	Plant Indoor Air (Structural) (Ext)	Loss of material	Structures Monitoring Program (B2.1.32)	III.A3-12	3.5.1.25	A

Notes for Table 3.5.2-4:

Standard Notes:

- A Consistent with NUREG-1801 item for component, material, environment, and aging effect. AMP is consistent with NUREG-1801 AMP.
- B Consistent with NUREG-1801 item for component, material, environment, and aging effect. AMP takes some exceptions to NUREG-1801 AMP.
- C Component is different, but consistent with NUREG-1801 item for material, environment, and aging effect. AMP is consistent with NUREG-1801 AMP.
- E Consistent with NUREG-1801 for material, environment, and aging effect, but a different aging management program is credited or NUREG-1801 identifies a plant-specific aging management program.
- J Neither the component nor the material and environment combination is evaluated in NUREG-1801.

**Section 3.5
AGING MANAGEMENT OF CONTAINMENTS,
STRUCTURES AND COMPONENT SUPPORTS**

Plant Specific Notes:

- 1 NUREG-1801 does not provide a line in which Concrete Masonry is inspected per the Fire Protection program.
- 2 NUREG-1801 does not provide a line in which Fire Barriers (Ceramic Fiber or Cementitious Coating) are inspected per the Fire Protection program.

Section 3.5
AGING MANAGEMENT OF CONTAINMENTS,
STRUCTURES AND COMPONENT SUPPORTS

Table 3.5.2-5 Containments, Structures, and Component Supports – Summary of Aging Management Evaluation - Auxiliary Building

Component Type	Intended Function	Material	Environment	Aging Effect Requiring Management	Aging Management Program	NUREG-1801 Vol. 2 Item	Table 1 Item	Notes
Caulking/Sealant	SH	Elastomer	Atmosphere/Weather (Structural) (Ext)	Loss of sealing	Structures Monitoring Program (B2.1.32)	III.A6-12	3.5.1.44	A
Caulking/Sealant	FLB, SH	Elastomer	Plant Indoor Air (Structural) (Ext)	Loss of sealing	Structures Monitoring Program (B2.1.32)	III.A6-12	3.5.1.44	A
Compressible Joints/Seals	ES, SH	Elastomer	Atmosphere/Weather (Structural) (Ext)	Loss of sealing	Structures Monitoring Program (B2.1.32)	III.A6-12	3.5.1.44	A
Compressible Joints/Seals	ES, SH	Elastomer	Buried (Structural) (Ext)	Loss of sealing	Structures Monitoring Program (B2.1.32)	III.A6-12	3.5.1.44	A
Compressible Joints/Seals	ES, SH	Elastomer	Plant Indoor Air (Structural) (Ext)	Loss of sealing	Structures Monitoring Program (B2.1.32)	III.A6-12	3.5.1.44	A
Concrete Block (Masonry Walls)	FB, SH, SS	Concrete Block (Masonry Walls)	Plant Indoor Air (Structural) (Ext)	Cracking	Fire Protection (B2.1.12) and Masonry Wall Program (B2.1.31)	III.A3-11	3.5.1.43	E, 1
Concrete Elements	FB, FLB, MB, SH, SPB, SS	Concrete	Atmosphere/Weather (Structural) (Ext)	Cracking due to expansion	Structures Monitoring Program (B2.1.32)	III.A3-2	3.5.1.27	A
Concrete Elements	FB, FLB, MB, SH, SPB, SS	Concrete	Atmosphere/Weather (Structural) (Ext)	Loss of material (spalling, scaling) and cracking)	Structures Monitoring Program (B2.1.32)	III.A3-6	3.5.1.26	A

Section 3.5
AGING MANAGEMENT OF CONTAINMENTS,
STRUCTURES AND COMPONENT SUPPORTS

*Table 3.5.2-5 Containments, Structures, and Component Supports – Summary of Aging Management Evaluation - Auxiliary Building
(Continued)*

Component Type	Intended Function	Material	Environment	Aging Effect Requiring Management	Aging Management Program	NUREG-1801 Vol. 2 Item	Table 1 Item	Notes
Concrete Elements	FB, FLB, MB, SH, SPB, SS	Concrete	Atmosphere/Weather (Structural) (Ext)	Cracking, loss of bond, and loss of material (spalling, scaling)	Structures Monitoring Program (B2.1.32)	III.A3-9	3.5.1.23	A
Concrete Elements	FB, FLB, MB, SH, SPB, SS	Concrete	Atmosphere/Weather (Structural) (Ext)	Increase in porosity and permeability, cracking, loss of material (spalling, scaling)	Structures Monitoring Program (B2.1.32)	III.A3-10	3.5.1.24	A
Concrete Elements	FB, FLB, MB, SH, SPB, SS	Concrete	Atmosphere/Weather (Structural) (Ext)	Concrete cracking and spalling	Fire Protection and Structures Monitoring Program (B2.1.12)	VII.G-30	3.3.1.66	B
Concrete Elements	FB, FLB, MB, SH, SPB, SS	Concrete	Atmosphere/Weather (Structural) (Ext)	Loss of material	Fire Protection and Structures Monitoring Program (B2.1.12)	VII.G-31	3.3.1.67	B
Concrete Elements	FLB, SH, SS	Concrete	Buried (Structural) (Ext)	Cracking due to expansion	Structures Monitoring Program (B2.1.32)	III.A3-2	3.5.1.27	A
Concrete Elements	FLB, SH, SS	Concrete	Buried (Structural) (Ext)	Cracks and distortion	Structures Monitoring Program (B2.1.32)	III.A3-3	3.5.1.28	A

Section 3.5
AGING MANAGEMENT OF CONTAINMENTS,
STRUCTURES AND COMPONENT SUPPORTS

Table 3.5.2-5 Containments, Structures, and Component Supports – Summary of Aging Management Evaluation - Auxiliary Building
(Continued)

Component Type	Intended Function	Material	Environment	Aging Effect Requiring Management	Aging Management Program	NUREG-1801 Vol. 2 Item	Table 1 Item	Notes
Concrete Elements	FLB, SH, SS	Concrete	Buried (Structural) (Ext)	Cracking, loss of bond, and loss of material (spalling, scaling)	Structures Monitoring Program (B2.1.32)	III.A3-4	3.5.1.31	A
Concrete Elements	FLB, SH, SS	Concrete	Buried (Structural) (Ext)	Increase in porosity and permeability, cracking, loss of material (spalling, scaling)	Structures Monitoring Program (B2.1.32)	III.A3-5	3.5.1.31	A
Concrete Elements	FB, FLB, HLBS, SH, SLD, SPB, SS	Concrete	Plant Indoor Air (Structural) (Ext)	Cracking due to expansion	Structures Monitoring Program (B2.1.32)	III.A3-2	3.5.1.27	A
Concrete Elements	FB, FLB, HLBS, SH, SLD, SPB, SS	Concrete	Plant Indoor Air (Structural) (Ext)	Cracking, loss of bond, and loss of material (spalling, scaling)	Structures Monitoring Program (B2.1.32)	III.A3-9	3.5.1.23	A
Concrete Elements	FB, FLB, HLBS, SH, SLD, SPB, SS	Concrete	Plant Indoor Air (Structural) (Ext)	Increase in porosity and permeability, cracking, loss of material (spalling, scaling)	Structures Monitoring Program (B2.1.32)	III.A3-10	3.5.1.24	A

Section 3.5
AGING MANAGEMENT OF CONTAINMENTS,
STRUCTURES AND COMPONENT SUPPORTS

Table 3.5.2-5 Containments, Structures, and Component Supports – Summary of Aging Management Evaluation - Auxiliary Building
(Continued)

Component Type	Intended Function	Material	Environment	Aging Effect Requiring Management	Aging Management Program	NUREG-1801 Vol. 2 Item	Table 1 Item	Notes
Concrete Elements	FB, FLB, HLBS, SH, SLD, SPB, SS	Concrete	Plant Indoor Air (Structural) (Ext)	Concrete cracking and spalling	Fire Protection (B2.1.12) and Structures Monitoring Program (B2.1.32)	VII.G-28	3.3.1.65	B
Concrete Elements	FB, FLB, HLBS, SH, SLD, SPB, SS	Concrete	Plant Indoor Air (Structural) (Ext)	Loss of material	Fire Protection (B2.1.12) and Structures Monitoring Program (B2.1.32)	VII.G-29	3.3.1.67	B
Doors	FLB, SH, SPB	Carbon Steel	Plant Indoor Air (Structural) (Ext)	Loss of material	Structures Monitoring Program (B2.1.32)	III.A3-12	3.5.1.25	A
Doors	SH, SPB	Stainless Steel	Plant Indoor Air (Structural) (Ext)	None	None	VII.J-15	3.3.1.94	C
Fire Barrier Coatings/ Wraps	FB	Fire Barrier (Cementitious Coating)	Plant Indoor Air (Structural) (Ext)	Loss of material, cracking	Fire Protection (B2.1.12)	None	None	J
Fire Barrier Doors	FB, HLBS, SH, SPB	Carbon Steel	Atmosphere/ Weather (Structural) (Ext)	Loss of material	Structures Monitoring Program (B2.1.32)	III.A3-12	3.5.1.25	A
Fire Barrier Doors	FB, HLBS, SH, SPB	Carbon Steel	Atmosphere/ Weather (Structural) (Ext)	Loss of material	Fire Protection (B2.1.12)	VII.G-4	3.3.1.63	B
Fire Barrier Doors	FB, HLBS, MB, SH, SPB	Carbon Steel	Plant Indoor Air (Structural) (Ext)	Loss of material	Structures Monitoring Program (B2.1.32)	III.A3-12	3.5.1.25	A

Section 3.5
AGING MANAGEMENT OF CONTAINMENTS,
STRUCTURES AND COMPONENT SUPPORTS

Table 3.5.2-5 Containments, Structures, and Component Supports – Summary of Aging Management Evaluation - Auxiliary Building
(Continued)

Component Type	Intended Function	Material	Environment	Aging Effect Requiring Management	Aging Management Program	NUREG-1801 Vol. 2 Item	Table 1 Item	Notes
Fire Barrier Doors	FB, HLBS, MB, SH, SPB	Carbon Steel	Plant Indoor Air (Structural) (Ext)	Loss of material	Fire Protection (B2.1.12)	VII.G-3	3.3.1.63	B
Fire Barrier Seals	FB	Elastomer	Atmosphere/Weather (Structural) (Ext)	Increased hardness, shrinkage and loss of strength	Fire Protection (B2.1.12)	VII.G-2	3.3.1.61	B
Fire Barrier Seals	FB	Elastomer	Plant Indoor Air (Structural) (Ext)	Increased hardness, shrinkage and loss of strength	Fire Protection (B2.1.12)	VII.G-1	3.3.1.61	B
Gypsum/Plaster Barrier Hatch	FB, SH	Gypsum/Plaster	Plant Indoor Air (Structural) (Ext)	Cracking	Fire Protection (B2.1.12)	None	None	J, 2
Hatches/Plugs	SH, SPB	Carbon Steel	Plant Indoor Air (Structural) (Ext)	Loss of material	Structures Monitoring Program (B2.1.32)	III.A3-12	3.5.1.25	A
Hatches/Plugs	FLB, MB, SH	Concrete	Atmosphere/Weather (Structural) (Ext)	Cracking due to expansion	Structures Monitoring Program (B2.1.32)	III.A3-2	3.5.1.27	A
Hatches/Plugs	FLB, MB, SH	Concrete	Atmosphere/Weather (Structural) (Ext)	Loss of material (spalling, scaling) and cracking	Structures Monitoring Program (B2.1.32)	III.A3-6	3.5.1.26	A
Hatches/Plugs	FLB, MB, SH	Concrete	Atmosphere/Weather (Structural) (Ext)	Cracking, loss of bond, and loss of material (spalling, scaling)	Structures Monitoring Program (B2.1.32)	III.A3-9	3.5.1.23	A

Section 3.5
AGING MANAGEMENT OF CONTAINMENTS,
STRUCTURES AND COMPONENT SUPPORTS

Table 3.5.2-5 Containments, Structures, and Component Supports – Summary of Aging Management Evaluation - Auxiliary Building
(Continued)

Component Type	Intended Function	Material	Environment	Aging Effect Requiring Management	Aging Management Program	NUREG-1801 Vol. 2 Item	Table 1 Item	Notes
Hatches/Plugs	FLB, MB, SH	Concrete	Atmosphere/Weather (Structural) (Ext)	Increase in porosity and permeability, cracking, loss of material (spalling, scaling)	Structures Monitoring Program (B2.1.32)	III.A3-10	3.5.1.24	A
Hatches/Plugs	FLB, MB, SH	Concrete	Plant Indoor Air (Structural) (Ext)	Cracking due to expansion	Structures Monitoring Program (B2.1.32)	III.A3-2	3.5.1.27	A
Hatches/Plugs	FLB, MB, SH	Concrete	Plant Indoor Air (Structural) (Ext)	Cracking, loss of bond, and loss of material (spalling, scaling)	Structures Monitoring Program (B2.1.32)	III.A3-9	3.5.1.23	A
Hatches/Plugs	FLB, MB, SH	Concrete	Plant Indoor Air (Structural) (Ext)	Increase in porosity and permeability, cracking, loss of material (spalling, scaling)	Structures Monitoring Program (B2.1.32)	III.A3-10	3.5.1.24	A
Penetrations Electrical	SS	Carbon Steel	Atmosphere/Weather (Structural) (Ext)	Loss of material	Structures Monitoring Program (B2.1.32)	III.A3-12	3.5.1.25	A
Penetrations Electrical	SS	Carbon Steel	Encased in Concrete (Ext)	None	None	VII.J-21	3.3.1.96	C
Penetrations Electrical	SS	Carbon Steel	Plant Indoor Air (Structural) (Ext)	Loss of material	Structures Monitoring Program (B2.1.32)	III.A3-12	3.5.1.25	A

Section 3.5
AGING MANAGEMENT OF CONTAINMENTS,
STRUCTURES AND COMPONENT SUPPORTS

Table 3.5.2-5 Containments, Structures, and Component Supports – Summary of Aging Management Evaluation - Auxiliary Building
(Continued)

Component Type	Intended Function	Material	Environment	Aging Effect Requiring Management	Aging Management Program	NUREG-1801 Vol. 2 Item	Table 1 Item	Notes
Penetrations Mechanical	SS	Carbon Steel	Atmosphere/ Weather (Structural) (Ext)	Loss of material	Structures Monitoring Program (B2.1.32)	III.A3-12	3.5.1.25	A
Penetrations Mechanical	SS	Carbon Steel	Encased in Concrete (Ext)	None	None	VII.J-21	3.3.1.96	C
Penetrations Mechanical	SS	Carbon Steel	Plant Indoor Air (Structural) (Ext)	Loss of material	Structures Monitoring Program (B2.1.32)	III.A3-12	3.5.1.25	A
Roofing Membrane	SH	Elastomer	Atmosphere/ Weather (Structural) (Ext)	Loss of sealing	Structures Monitoring Program (B2.1.32)	III.A6-12	3.5.1.44	A
Stairs/ Platforms/ Grates	NSRS	Carbon Steel	Atmosphere/ Weather (Structural) (Ext)	Loss of material	Structures Monitoring Program (B2.1.32)	III.A3-12	3.5.1.25	A
Stairs/ Platforms/ Grates	NSRS	Carbon Steel	Plant Indoor Air (Structural) (Ext)	Loss of material	Structures Monitoring Program (B2.1.32)	III.A3-12	3.5.1.25	A
Structural Steel	SS	Carbon Steel	Atmosphere/ Weather (Structural) (Ext)	Loss of material	Structures Monitoring Program (B2.1.32)	III.A3-12	3.5.1.25	A
Structural Steel	SS	Carbon Steel	Encased in Concrete (Ext)	None	None	VII.J-21	3.3.1.96	C
Structural Steel	SH, SS	Carbon Steel	Plant Indoor Air (Structural) (Ext)	Loss of material	Structures Monitoring Program (B2.1.32)	III.A3-12	3.5.1.25	A

Section 3.5
AGING MANAGEMENT OF CONTAINMENTS,
STRUCTURES AND COMPONENT SUPPORTS

Notes for Table 3.5.2-5:

Standard Notes:

- A Consistent with NUREG-1801 item for component, material, environment, and aging effect. AMP is consistent with NUREG-1801 AMP.
- B Consistent with NUREG-1801 item for component, material, environment, and aging effect. AMP takes some exceptions to NUREG-1801 AMP.
- C Component is different, but consistent with NUREG-1801 item for material, environment, and aging effect. AMP is consistent with NUREG-1801 AMP.
- E Consistent with NUREG-1801 for material, environment, and aging effect, but a different aging management program is credited or NUREG-1801 identifies a plant-specific aging management program.
- J Neither the component nor the material and environment combination is evaluated in NUREG-1801.

Plant Specific Notes:

- 1 The NUREG-1801 does not provide a line in which Concrete Masonry is inspected per the Fire Protection program.
- 2 NUREG-1801 does not provide a line in which Gypsum/Plaster Barriers are inspected per the Fire Protection program.

Section 3.5
AGING MANAGEMENT OF CONTAINMENTS,
STRUCTURES AND COMPONENT SUPPORTS

Table 3.5.2-6 Containments, Structures, and Component Supports – Summary of Aging Management Evaluation - Radwaste Building

Component Type	Intended Function	Material	Environment	Aging Effect Requiring Management	Aging Management Program	NUREG-1801 Vol. 2 Item	Table 1 Item	Notes
Concrete Elements	SH, SS	Concrete	Atmosphere/ Weather (Structural) (Ext)	Cracking due to expansion	Structures Monitoring Program (B2.1.32)	III.A3-2	3.5.1.27	A
Concrete Elements	SH, SS	Concrete	Atmosphere/ Weather (Structural) (Ext)	Loss of material (spalling, scaling) and cracking	Structures Monitoring Program (B2.1.32)	III.A3-6	3.5.1.26	A
Concrete Elements	SH, SS	Concrete	Atmosphere/ Weather (Structural) (Ext)	Cracking, loss of bond, and loss of material (spalling, scaling)	Structures Monitoring Program (B2.1.32)	III.A3-9	3.5.1.23	A
Concrete Elements	SH, SS	Concrete	Atmosphere/ Weather (Structural) (Ext)	Increase in porosity and permeability, cracking, loss of material (spalling, scaling)	Structures Monitoring Program (B2.1.32)	III.A3-10	3.5.1.24	A
Concrete Elements	SH, SS	Concrete	Buried (Structural) (Ext)	Cracking due to expansion	Structures Monitoring Program (B2.1.32)	III.A3-2	3.5.1.27	A
Concrete Elements	SH, SS	Concrete	Buried (Structural) (Ext)	Cracks and distortion	Structures Monitoring Program (B2.1.32)	III.A3-3	3.5.1.28	A

Section 3.5
AGING MANAGEMENT OF CONTAINMENTS,
STRUCTURES AND COMPONENT SUPPORTS

Table 3.5.2-6 Containments, Structures, and Component Supports – Summary of Aging Management Evaluation – Radwaste Building (Continued)

Component Type	Intended Function	Material	Environment	Aging Effect Requiring Management	Aging Management Program	NUREG-1801 Vol. 2 Item	Table 1 Item	Notes
Concrete Elements	SH, SS	Concrete	Buried (Structural) (Ext)	Cracking, loss of bond, and loss of material (spalling, scaling)	Structures Monitoring Program (B2.1.32)	III.A3-4	3.5.1.31	A
Concrete Elements	SH, SS	Concrete	Buried (Structural) (Ext)	Increase in porosity and permeability, cracking, loss of material (spalling, scaling)	Structures Monitoring Program (B2.1.32)	III.A3-5	3.5.1.31	A
Concrete Elements	FB, SH, SS	Concrete	Plant Indoor Air (Structural) (Ext)	Cracking due to expansion	Structures Monitoring Program (B2.1.32)	III.A3-2	3.5.1.27	A
Concrete Elements	FB, SH, SS	Concrete	Plant Indoor Air (Structural) (Ext)	Cracking, loss of bond, and loss of material (spalling, scaling)	Structures Monitoring Program (B2.1.32)	III.A3-9	3.5.1.23	A
Concrete Elements	FB, SH, SS	Concrete	Plant Indoor Air (Structural) (Ext)	Increase in porosity and permeability, cracking, loss of material (spalling, scaling)	Structures Monitoring Program (B2.1.32)	III.A3-10	3.5.1.24	A

Section 3.5
AGING MANAGEMENT OF CONTAINMENTS,
STRUCTURES AND COMPONENT SUPPORTS

Table 3.5.2-6 Containments, Structures, and Component Supports – Summary of Aging Management Evaluation - Radwaste Building (Continued)

Component Type	Intended Function	Material	Environment	Aging Effect Requiring Management	Aging Management Program	NUREG-1801 Vol. 2 Item	Table 1 Item	Notes
Concrete Elements	FB, SH, SS	Concrete	Plant Indoor Air (Structural) (Ext)	Concrete cracking and spalling	Fire Protection (B2.1.12) and Structures Monitoring Program (B2.1.32)	VII.G-28	3.3.1.65	B
Concrete Elements	FB, SH, SS	Concrete	Plant Indoor Air (Structural) (Ext)	Loss of material	Fire Protection (B2.1.12) and Structures Monitoring Program (B2.1.32)	VII.G-29	3.3.1.67	B
Doors	SH	Carbon Steel	Atmosphere/Weather (Structural) (Ext)	Loss of material	Structures Monitoring Program (B2.1.32)	III.A3-12	3.5.1.25	A
Doors	SH	Carbon Steel	Plant Indoor Air (Structural) (Ext)	Loss of material	Structures Monitoring Program (B2.1.32)	III.A3-12	3.5.1.25	A
Fire Barrier Doors	FB, SH	Carbon Steel	Plant Indoor Air (Structural) (Ext)	Loss of material	Structures Monitoring Program (B2.1.32)	III.A3-12	3.5.1.25	A
Fire Barrier Doors	FB, SH	Carbon Steel	Plant Indoor Air (Structural) (Ext)	Loss of material	Fire Protection (B2.1.12)	VII.G-3	3.3.1.63	B
Fire Barrier Seals	FB	Elastomer	Plant Indoor Air (Structural) (Ext)	Increased hardness, shrinkage and loss of strength	Fire Protection (B2.1.12)	VII.G-1	3.3.1.61	B
Hatch	SH	Aluminum	Plant Indoor Air (Structural) (Ext)	None	None	III.B5-2	3.5.1.58	C
Hatch	SH	Carbon Steel	Atmosphere/Weather (Structural) (Ext)	Loss of material	Structures Monitoring Program (B2.1.32)	III.A3-12	3.5.1.25	A

Section 3.5
AGING MANAGEMENT OF CONTAINMENTS,
STRUCTURES AND COMPONENT SUPPORTS

Table 3.5.2-6 Containments, Structures, and Component Supports – Summary of Aging Management Evaluation - Radwaste Building (Continued)

Component Type	Intended Function	Material	Environment	Aging Effect Requiring Management	Aging Management Program	NUREG-1801 Vol. 2 Item	Table 1 Item	Notes
Hatch	SH	Carbon Steel	Plant Indoor Air (Structural) (Ext)	Loss of material	Structures Monitoring Program (B2.1.32)	III.A3-12	3.5.1.25	A
Hatches/Plugs	SH	Concrete	Atmosphere/Weather (Structural) (Ext)	Cracking due to expansion	Structures Monitoring Program (B2.1.32)	III.A3-2	3.5.1.27	A
Hatches/Plugs	SH	Concrete	Atmosphere/Weather (Structural) (Ext)	Loss of material (spalling, scaling) and cracking	Structures Monitoring Program (B2.1.32)	III.A3-6	3.5.1.26	A
Hatches/Plugs	SH	Concrete	Atmosphere/Weather (Structural) (Ext)	Cracking, loss of bond, and loss of material (spalling, scaling)	Structures Monitoring Program (B2.1.32)	III.A3-9	3.5.1.23	A
Hatches/Plugs	SH	Concrete	Atmosphere/Weather (Structural) (Ext)	Increase in porosity and permeability, cracking, loss of material (spalling, scaling)	Structures Monitoring Program (B2.1.32)	III.A3-10	3.5.1.24	A
Hatches/Plugs	SH	Concrete	Plant Indoor Air (Structural) (Ext)	Cracking due to expansion	Structures Monitoring Program (B2.1.32)	III.A3-2	3.5.1.27	A
Hatches/Plugs	SH	Concrete	Plant Indoor Air (Structural) (Ext)	Cracking, loss of bond, and loss of material (spalling, scaling)	Structures Monitoring Program (B2.1.32)	III.A3-9	3.5.1.23	A

Section 3.5
AGING MANAGEMENT OF CONTAINMENTS,
STRUCTURES AND COMPONENT SUPPORTS

Table 3.5.2-6 *Containments, Structures, and Component Supports – Summary of Aging Management Evaluation - Radwaste Building (Continued)*

Component Type	Intended Function	Material	Environment	Aging Effect Requiring Management	Aging Management Program	NUREG-1801 Vol. 2 Item	Table 1 Item	Notes
Hatches/Plugs	SH	Concrete	Plant Indoor Air (Structural) (Ext)	Increase in porosity and permeability, cracking, loss of material (spalling, scaling)	Structures Monitoring Program (B2.1.32)	III.A3-10	3.5.1.24	A
Roofing Membrane	SH	Elastomer	Atmosphere/Weather (Structural) (Ext)	Loss of sealing	Structures Monitoring Program (B2.1.32)	III.A6-12	3.5.1.44	A
Structural Steel	SH, SS	Carbon Steel	Atmosphere/Weather (Structural) (Ext)	Loss of material	Structures Monitoring Program (B2.1.32)	III.A3-12	3.5.1.25	A
Structural Steel	SH, SS	Carbon Steel	Plant Indoor Air (Structural) (Ext)	Loss of material	Structures Monitoring Program (B2.1.32)	III.A3-12	3.5.1.25	A

Notes for Table 3.5.2-6:

Standard Notes:

- A Consistent with NUREG-1801 item for component, material, environment, and aging effect. AMP is consistent with NUREG-1801 AMP.
- B Consistent with NUREG-1801 item for component, material, environment, and aging effect. AMP takes some exceptions to NUREG-1801 AMP.
- C Component is different, but consistent with NUREG-1801 item for material, environment, and aging effect. AMP is consistent with NUREG-1801 AMP.

Plant Specific Notes:

None

Section 3.5
AGING MANAGEMENT OF CONTAINMENTS,
STRUCTURES AND COMPONENT SUPPORTS

Table 3.5.2-7 Containments, Structures, and Component Supports – Summary of Aging Management Evaluation – Main Steam Support Structure

Component Type	Intended Function	Material	Environment	Aging Effect Requiring Management	Aging Management Program	NUREG-1801 Vol. 2 Item	Table 1 Item	Notes
Caulking/Sealant	SH	Elastomer	Atmosphere/Weather (Structural) (Ext)	Loss of sealing	Structures Monitoring Program (B2.1.32)	III.A6-12	3.5.1.44	A
Caulking/Sealant	SH	Elastomer	Buried (Structural) (Ext)	Loss of sealing	Structures Monitoring Program (B2.1.32)	III.A6-12	3.5.1.44	A
Caulking/Sealant	FLB, SH	Elastomer	Plant Indoor Air (Structural) (Ext)	Loss of sealing	Structures Monitoring Program (B2.1.32)	III.A6-12	3.5.1.44	A
Compressible Joints/Seals	ES, SH	Elastomer	Atmosphere/Weather (Structural) (Ext)	Loss of sealing	Structures Monitoring Program (B2.1.32)	III.A6-12	3.5.1.44	A
Compressible Joints/Seals	ES, SH	Elastomer	Buried (Structural) (Ext)	Loss of sealing	Structures Monitoring Program (B2.1.32)	III.A6-12	3.5.1.44	A
Compressible Joints/Seals	ES, SH	Elastomer	Plant Indoor Air (Structural) (Ext)	Loss of sealing	Structures Monitoring Program (B2.1.32)	III.A6-12	3.5.1.44	A
Concrete Elements	FB, HLBS, MB, SH, SS	Concrete	Atmosphere/Weather (Structural) (Ext)	Cracking due to expansion	Structures Monitoring Program (B2.1.32)	III.A3-2	3.5.1.27	A
Concrete Elements	FB, HLBS, MB, SH, SS	Concrete	Atmosphere/Weather (Structural) (Ext)	Loss of material (spalling, scaling) and cracking)	Structures Monitoring Program (B2.1.32)	III.A3-6	3.5.1.26	A

Section 3.5
AGING MANAGEMENT OF CONTAINMENTS,
STRUCTURES AND COMPONENT SUPPORTS

Table 3.5.2-7 Containments, Structures, and Component Supports – Summary of Aging Management Evaluation – Main Steam Support Structure (Continued)

Component Type	Intended Function	Material	Environment	Aging Effect Requiring Management	Aging Management Program	NUREG-1801 Vol. 2 Item	Table 1 Item	Notes
Concrete Elements	FB, HLBS, MB, SH, SS	Concrete	Atmosphere/Weather (Structural) (Ext)	Cracking, loss of bond, and loss of material (spalling, scaling)	Structures Monitoring Program (B2.1.32)	III.A3-9	3.5.1.23	A
Concrete Elements	FB, HLBS, MB, SH, SS	Concrete	Atmosphere/Weather (Structural) (Ext)	Increase in porosity and permeability, cracking, loss of material (spalling, scaling)	Structures Monitoring Program (B2.1.32)	III.A3-10	3.5.1.24	A
Concrete Elements	FB, HLBS, MB, SH, SS	Concrete	Atmosphere/Weather (Structural) (Ext)	Concrete cracking and spalling	Fire Protection (B2.1.12) and Structures Monitoring Program (B2.1.32)	VII.G-30	3.3.1.66	B
Concrete Elements	FB, HLBS, MB, SH, SS	Concrete	Atmosphere/Weather (Structural) (Ext)	Loss of material	Fire Protection (B2.1.12) and Structures Monitoring Program (B2.1.32)	VII.G-31	3.3.1.67	B
Concrete Elements	SH, SS	Concrete	Buried (Structural) (Ext)	Cracking due to expansion	Structures Monitoring Program (B2.1.32)	III.A3-2	3.5.1.27	A
Concrete Elements	SH, SS	Concrete	Buried (Structural) (Ext)	Cracks and distortion	Structures Monitoring Program (B2.1.32)	III.A3-3	3.5.1.28	A

Section 3.5
AGING MANAGEMENT OF CONTAINMENTS,
STRUCTURES AND COMPONENT SUPPORTS

Table 3.5.2-7 Containments, Structures, and Component Supports – Summary of Aging Management Evaluation – Main Steam Support Structure (Continued)

Component Type	Intended Function	Material	Environment	Aging Effect Requiring Management	Aging Management Program	NUREG-1801 Vol. 2 Item	Table 1 Item	Notes
Concrete Elements	SH, SS	Concrete	Buried (Structural) (Ext)	Cracking, loss of bond, and loss of material (spalling, scaling)	Structures Monitoring Program (B2.1.32)	III.A3-4	3.5.1.31	A
Concrete Elements	SH, SS	Concrete	Buried (Structural) (Ext)	Increase in porosity and permeability, cracking, loss of material (spalling, scaling)	Structures Monitoring Program (B2.1.32)	III.A3-5	3.5.1.31	A
Concrete Elements	FB, FLB, HLBS, SH, SLD, SPB, SS	Concrete	Plant Indoor Air (Structural) (Ext)	Cracking due to expansion	Structures Monitoring Program (B2.1.32)	III.A3-2	3.5.1.27	A
Concrete Elements	FB, FLB, HLBS, SH, SLD, SPB, SS	Concrete	Plant Indoor Air (Structural) (Ext)	Cracking, loss of bond, and loss of material (spalling, scaling)	Structures Monitoring Program (B2.1.32)	III.A3-9	3.5.1.23	A
Concrete Elements	FB, FLB, HLBS, SH, SLD, SPB, SS	Concrete	Plant Indoor Air (Structural) (Ext)	Increase in porosity and permeability, cracking, loss of material (spalling, scaling)	Structures Monitoring Program (B2.1.32)	III.A3-10	3.5.1.24	A

Section 3.5
AGING MANAGEMENT OF CONTAINMENTS,
STRUCTURES AND COMPONENT SUPPORTS

Table 3.5.2-7 Containments, Structures, and Component Supports – Summary of Aging Management Evaluation – Main Steam Support Structure (Continued)

Component Type	Intended Function	Material	Environment	Aging Effect Requiring Management	Aging Management Program	NUREG-1801 Vol. 2 Item	Table 1 Item	Notes
Concrete Elements	FB, FLB, HLBS, SH, SLD, SPB, SS	Concrete	Plant Indoor Air (Structural) (Ext)	Concrete cracking and spalling	Fire Protection (B2.1.12) and Structures Monitoring Program (B2.1.32)	VII.G-28	3.3.1.65	B
Concrete Elements	FB, FLB, HLBS, SH, SLD, SPB, SS	Concrete	Plant Indoor Air (Structural) (Ext)	Loss of material	Fire Protection (B2.1.12) and Structures Monitoring Program (B2.1.32)	VII.G-29	3.3.1.67	B
Doors	MB, SH	Carbon Steel	Atmosphere/Weather (Structural) (Ext)	Loss of material	Structures Monitoring Program (B2.1.32)	III.A3-12	3.5.1.25	A
Doors	FLB, HLBS, MB, SH, SPB	Carbon Steel	Plant Indoor Air (Structural) (Ext)	Loss of material	Structures Monitoring Program (B2.1.32)	III.A3-12	3.5.1.25	A
Fire Barrier Doors	FB, SH	Carbon Steel	Plant Indoor Air (Structural) (Ext)	Loss of material	Structures Monitoring Program (B2.1.32)	III.A3-12	3.5.1.25	A
Fire Barrier Doors	FB, SH	Carbon Steel	Plant Indoor Air (Structural) (Ext)	Loss of material	Fire Protection (B2.1.12)	VII.G-3	3.3.1.63	B
Fire Barrier Seals	FB	Elastomer	Atmosphere/Weather (Structural) (Ext)	Increased hardness, shrinkage and loss of strength	Fire Protection (B2.1.12)	VII.G-2	3.3.1.61	B

Section 3.5
AGING MANAGEMENT OF CONTAINMENTS,
STRUCTURES AND COMPONENT SUPPORTS

Table 3.5.2-7 Containments, Structures, and Component Supports – Summary of Aging Management Evaluation – Main Steam Support Structure (Continued)

Component Type	Intended Function	Material	Environment	Aging Effect Requiring Management	Aging Management Program	NUREG-1801 Vol. 2 Item	Table 1 Item	Notes
Fire Barrier Seals	FB	Elastomer	Plant Indoor Air (Structural) (Ext)	Increased hardness, shrinkage and loss of strength	Fire Protection (B2.1.12)	VII.G-1	3.3.1.61	B
Hatch	FLB, HLBS, SH, SPB	Carbon Steel	Plant Indoor Air (Structural) (Ext)	Loss of material	Structures Monitoring Program (B2.1.32)	III.A3-12	3.5.1.25	A
Hatches/Plugs	MB, SH	Concrete	Atmosphere/Weather (Structural) (Ext)	Cracking due to expansion	Structures Monitoring Program (B2.1.32)	III.A3-2	3.5.1.27	A
Hatches/Plugs	MB, SH	Concrete	Atmosphere/Weather (Structural) (Ext)	Loss of material (spalling, scaling) and cracking	Structures Monitoring Program (B2.1.32)	III.A3-6	3.5.1.26	A
Hatches/Plugs	MB, SH	Concrete	Atmosphere/Weather (Structural) (Ext)	Cracking, loss of bond, and loss of material (spalling, scaling)	Structures Monitoring Program (B2.1.32)	III.A3-9	3.5.1.23	A
Hatches/Plugs	MB, SH	Concrete	Atmosphere/Weather (Structural) (Ext)	Increase in porosity and permeability, cracking, loss of material (spalling, scaling)	Structures Monitoring Program (B2.1.32)	III.A3-10	3.5.1.24	A
Hatches/Plugs	MB, SH	Concrete	Plant Indoor Air (Structural) (Ext)	Cracking due to expansion	Structures Monitoring Program (B2.1.32)	III.A3-2	3.5.1.27	A

Section 3.5
AGING MANAGEMENT OF CONTAINMENTS,
STRUCTURES AND COMPONENT SUPPORTS

Table 3.5.2-7 Containments, Structures, and Component Supports – Summary of Aging Management Evaluation – Main Steam Support Structure (Continued)

Component Type	Intended Function	Material	Environment	Aging Effect Requiring Management	Aging Management Program	NUREG-1801 Vol. 2 Item	Table 1 Item	Notes
Hatches/Plugs	MB, SH	Concrete	Plant Indoor Air (Structural) (Ext)	Cracking, loss of bond, and loss of material (spalling, scaling)	Structures Monitoring Program (B2.1.32)	III.A3-9	3.5.1.23	A
Hatches/Plugs	MB, SH	Concrete	Plant Indoor Air (Structural) (Ext)	Increase in porosity and permeability, cracking, loss of material (spalling, scaling)	Structures Monitoring Program (B2.1.32)	III.A3-10	3.5.1.24	A
Penetrations Electrical	SS	Carbon Steel	Atmosphere/Weather (Structural) (Ext)	Loss of material	Structures Monitoring Program (B2.1.32)	III.A3-12	3.5.1.25	A
Penetrations Electrical	SS	Carbon Steel	Encased in Concrete (Ext)	None	None	VII.J-21	3.3.1.96	C
Penetrations Electrical	SS	Carbon Steel	Plant Indoor Air (Structural) (Ext)	Loss of material	Structures Monitoring Program (B2.1.32)	III.A3-12	3.5.1.25	A
Penetrations Mechanical	SS	Carbon Steel	Atmosphere/Weather (Structural) (Ext)	Loss of material	Structures Monitoring Program (B2.1.32)	III.A3-12	3.5.1.25	A
Penetrations Mechanical	SS	Carbon Steel	Encased in Concrete (Ext)	None	None	VII.J-21	3.3.1.96	C
Penetrations Mechanical	SS	Carbon Steel	Plant Indoor Air (Structural) (Ext)	Loss of material	Structures Monitoring Program (B2.1.32)	III.A3-12	3.5.1.25	A

Section 3.5
AGING MANAGEMENT OF CONTAINMENTS,
STRUCTURES AND COMPONENT SUPPORTS

Table 3.5.2-7 Containments, Structures, and Component Supports – Summary of Aging Management Evaluation – Main Steam Support Structure (Continued)

Component Type	Intended Function	Material	Environment	Aging Effect Requiring Management	Aging Management Program	NUREG-1801 Vol. 2 Item	Table 1 Item	Notes
Roofing Membrane	SH	Elastomer	Atmosphere/Weather (Structural) (Ext)	Loss of sealing	Structures Monitoring Program (B2.1.32)	III.A6-12	3.5.1.44	A
Stairs/Platforms/Grates	NSRS	Carbon Steel	Plant Indoor Air (Structural) (Ext)	Loss of material	Structures Monitoring Program (B2.1.32)	III.A3-12	3.5.1.25	A
Structural Steel	SS	Carbon Steel	Atmosphere/Weather (Structural) (Ext)	Loss of material	Structures Monitoring Program (B2.1.32)	III.A3-12	3.5.1.25	A
Structural Steel	SH, SS	Carbon Steel	Plant Indoor Air (Structural) (Ext)	Loss of material	Structures Monitoring Program (B2.1.32)	III.A3-12	3.5.1.25	A

Notes for Table 3.5.2-7:

Standard Notes:

- A Consistent with NUREG-1801 item for component, material, environment, and aging effect. AMP is consistent with NUREG-1801 AMP.
- B Consistent with NUREG-1801 item for component, material, environment, and aging effect. AMP takes some exceptions to NUREG-1801 AMP.
- C Component is different, but consistent with NUREG-1801 item for material, environment, and aging effect. AMP is consistent with NUREG-1801 AMP.

Plant Specific Notes:

None

Section 3.5
AGING MANAGEMENT OF CONTAINMENTS,
STRUCTURES AND COMPONENT SUPPORTS

Table 3.5.2-8 Containments, Structures, and Component Supports – Summary of Aging Management Evaluation – Station
Blackout Generator Structures

Component Type	Intended Function	Material	Environment	Aging Effect Requiring Management	Aging Management Program	NUREG-1801 Vol. 2 Item	Table 1 Item	Notes
Concrete Elements	SS	Concrete	Atmosphere/ Weather (Structural) (Ext)	Cracking due to expansion	Structures Monitoring Program (B2.1.32)	III.A3-2	3.5.1.27	A
Concrete Elements	SS	Concrete	Atmosphere/ Weather (Structural) (Ext)	Loss of material (spalling, scaling) and cracking	Structures Monitoring Program (B2.1.32)	III.A3-6	3.5.1.26	A
Concrete Elements	SS	Concrete	Atmosphere/ Weather (Structural) (Ext)	Cracking, loss of bond, and loss of material (spalling, scaling)	Structures Monitoring Program (B2.1.32)	III.A3-9	3.5.1.23	A
Concrete Elements	SS	Concrete	Atmosphere/ Weather (Structural) (Ext)	Increase in porosity and permeability, cracking, loss of material (spalling, scaling)	Structures Monitoring Program (B2.1.32)	III.A3-10	3.5.1.24	A
Concrete Elements	SS	Concrete	Buried (Structural) (Ext)	Cracking due to expansion	Structures Monitoring Program (B2.1.32)	III.A3-2	3.5.1.27	A
Concrete Elements	SS	Concrete	Buried (Structural) (Ext)	Cracks and distortion	Structures Monitoring Program (B2.1.32)	III.A3-3	3.5.1.28	A

Section 3.5
AGING MANAGEMENT OF CONTAINMENTS,
STRUCTURES AND COMPONENT SUPPORTS

Table 3.5.2-8 Containments, Structures, and Component Supports – Summary of Aging Management Evaluation – Station Blackout Generator Structures (Continued)

Component Type	Intended Function	Material	Environment	Aging Effect Requiring Management	Aging Management Program	NUREG-1801 Vol. 2 Item	Table 1 Item	Notes
Concrete Elements	SS	Concrete	Buried (Structural) (Ext)	Cracking, loss of bond, and loss of material (spalling, scaling)	Structures Monitoring Program (B2.1.32)	III.A3-4	3.5.1.31	A
Concrete Elements	SS	Concrete	Buried (Structural) (Ext)	Increase in porosity and permeability, cracking, loss of material (spalling, scaling)	Structures Monitoring Program (B2.1.32)	III.A3-5	3.5.1.31	A
Concrete Elements	SS	Concrete	Plant Indoor Air (Structural) (Ext)	Cracking due to expansion	Structures Monitoring Program (B2.1.32)	III.A3-2	3.5.1.27	A
Concrete Elements	SS	Concrete	Plant Indoor Air (Structural) (Ext)	Cracking, loss of bond, and loss of material (spalling, scaling)	Structures Monitoring Program (B2.1.32)	III.A3-9	3.5.1.23	A
Concrete Elements	SS	Concrete	Plant Indoor Air (Structural) (Ext)	Increase in porosity and permeability, cracking, loss of material (spalling, scaling)	Structures Monitoring Program (B2.1.32)	III.A3-10	3.5.1.24	A
Doors	SH	Carbon Steel	Atmosphere/Weather (Structural) (Ext)	Loss of material	Structures Monitoring Program (B2.1.32)	III.A3-12	3.5.1.25	A

Section 3.5
AGING MANAGEMENT OF CONTAINMENTS,
STRUCTURES AND COMPONENT SUPPORTS

Table 3.5.2-8 Containments, Structures, and Component Supports – Summary of Aging Management Evaluation – Station Blackout Generator Structures (Continued)

Component Type	Intended Function	Material	Environment	Aging Effect Requiring Management	Aging Management Program	NUREG-1801 Vol. 2 Item	Table 1 Item	Notes
Doors	SH	Carbon Steel	Plant Indoor Air (Structural) (Ext)	Loss of material	Structures Monitoring Program (B2.1.32)	III.A3-12	3.5.1.25	A
Metal Siding	SH	Carbon Steel	Atmosphere/Weather (Structural) (Ext)	Loss of material	Structures Monitoring Program (B2.1.32)	III.A3-12	3.5.1.25	A
Structural Steel	SH, SS	Carbon Steel	Atmosphere/Weather (Structural) (Ext)	Loss of material	Structures Monitoring Program (B2.1.32)	III.A3-12	3.5.1.25	A
Structural Steel	SH, SS	Carbon Steel	Encased in Concrete (Ext)	None	None	VII.J-21	3.3.1.96	C
Structural Steel	SH, SS	Carbon Steel	Plant Indoor Air (Structural) (Ext)	Loss of material	Structures Monitoring Program (B2.1.32)	III.A3-12	3.5.1.25	A

Notes for Table 3.5.2-8:

Standard Note Text

- A Consistent with NUREG-1801 item for component, material, environment, and aging effect. AMP is consistent with NUREG-1801 AMP.
- C Component is different, but consistent with NUREG-1801 item for material, environment, and aging effect. AMP is consistent with NUREG-1801 AMP.

Plant Specific Notes:

None

Section 3.5
**AGING MANAGEMENT OF CONTAINMENTS,
STRUCTURES AND COMPONENT SUPPORTS**

Table 3.5.2-9 Containments, Structures, and Component Supports – Summary of Aging Management Evaluation – Fuel Building

Component Type	Intended Function	Material	Environment	Aging Effect Requiring Management	Aging Management Program	NUREG-1801 Vol. 2 Item	Table 1 Item	Notes
Caulking/Sealant	FLB, SH	Elastomer	Atmosphere/Weather (Structural) (Ext)	Loss of sealing	Structures Monitoring Program (B2.1.32)	III.A6-12	3.5.1.44	A
Caulking/Sealant	FLB, SH	Elastomer	Buried (Structural) (Ext)	Loss of sealing	Structures Monitoring Program (B2.1.32)	III.A6-12	3.5.1.44	A
Caulking/Sealant	FLB, SH	Elastomer	Plant Indoor Air (Structural) (Ext)	Loss of sealing	Structures Monitoring Program (B2.1.32)	III.A6-12	3.5.1.44	A
Compressible Joints/Seals	SH, SPB	Elastomer	Treated Borated Water (Ext)	Loss of sealing	Structures Monitoring Program (B2.1.32)	III.A6-12	3.5.1.44	A
Concrete Elements	MB, SH, SS	Concrete	Atmosphere/Weather (Structural) (Ext)	Cracking due to expansion	Structures Monitoring Program (B2.1.32)	III.A5-2	3.5.1.27	A
Concrete Elements	MB, SH, SS	Concrete	Atmosphere/Weather (Structural) (Ext)	Loss of material (spalling, scaling) and cracking	Structures Monitoring Program (B2.1.32)	III.A5-6	3.5.1.26	A
Concrete Elements	MB, SH, SS	Concrete	Atmosphere/Weather (Structural) (Ext)	Cracking, loss of bond, and loss of material (spalling, scaling)	Structures Monitoring Program (B2.1.32)	III.A5-9	3.5.1.23	A
Concrete Elements	MB, SH, SS	Concrete	Atmosphere/Weather (Structural) (Ext)	Increase in porosity and permeability, cracking, loss of material (spalling, scaling)	Structures Monitoring Program (B2.1.32)	III.A5-10	3.5.1.24	A
Concrete Elements	SH, SS	Concrete	Buried (Structural) (Ext)	Cracking due to expansion	Structures Monitoring Program (B2.1.32)	III.A5-2	3.5.1.27	A

Section 3.5
AGING MANAGEMENT OF CONTAINMENTS,
STRUCTURES AND COMPONENT SUPPORTS

Table 3.5.2-9 Containments, Structures, and Component Supports – Summary of Aging Management Evaluation – Fuel Building
(Continued)

Component Type	Intended Function	Material	Environment	Aging Effect Requiring Management	Aging Management Program	NUREG-1801 Vol. 2 Item	Table 1 Item	Notes
Concrete Elements	SH, SS	Concrete	Buried (Structural) (Ext)	Cracks and distortion	Structures Monitoring Program (B2.1.32)	III.A5-3	3.5.1.28	A
Concrete Elements	SH, SS	Concrete	Buried (Structural) (Ext)	Cracking, loss of bond, and loss of material (spalling, scaling)	Structures Monitoring Program (B2.1.32)	III.A5-4	3.5.1.31	A
Concrete Elements	SH, SS	Concrete	Buried (Structural) (Ext)	Increase in porosity and permeability, cracking, loss of material (spalling, scaling)	Structures Monitoring Program (B2.1.32)	III.A5-5	3.5.1.31	A
Concrete Elements	FB, FLB, SH, SS	Concrete	Plant Indoor Air (Structural) (Ext)	Cracking due to expansion	Structures Monitoring Program (B2.1.32)	III.A5-2	3.5.1.27	A
Concrete Elements	FB, FLB, SH, SS	Concrete	Plant Indoor Air (Structural) (Ext)	Cracking, loss of bond, and loss of material (spalling, scaling)	Structures Monitoring Program (B2.1.32)	III.A5-9	3.5.1.23	A
Concrete Elements	FB, FLB, SH, SS	Concrete	Plant Indoor Air (Structural) (Ext)	Increase in porosity and permeability, cracking, loss of material (spalling, scaling)	Structures Monitoring Program (B2.1.32)	III.A5-10	3.5.1.24	A

Section 3.5
AGING MANAGEMENT OF CONTAINMENTS,
STRUCTURES AND COMPONENT SUPPORTS

*Table 3.5.2-9 Containments, Structures, and Component Supports – Summary of Aging Management Evaluation – Fuel Building
(Continued)*

Component Type	Intended Function	Material	Environment	Aging Effect Requiring Management	Aging Management Program	NUREG-1801 Vol. 2 Item	Table 1 Item	Notes
Concrete Elements	FB, FLB, SH, SS	Concrete	Plant Indoor Air (Structural) (Ext)	Concrete cracking and spalling	Fire Protection (B2.1.12) and Structures Monitoring Program (B2.1.32)	VII.G-28	3.3.1.65	B
Concrete Elements	FB, FLB, SH, SS	Concrete	Plant Indoor Air (Structural) (Ext)	Loss of material	Fire Protection (B2.1.12) and Structures Monitoring Program (B2.1.32)	VII.G-29	3.3.1.67	B
Doors	SH	Carbon Steel	Atmosphere/Weather (Structural) (Ext)	Loss of material	Structures Monitoring Program (B2.1.32)	III.A5-12	3.5.1.25	A
Doors	MB, SH	Carbon Steel	Plant Indoor Air (Structural) (Ext)	Loss of material	Structures Monitoring Program (B2.1.32)	III.A5-12	3.5.1.25	A
Fire Barrier Doors	FB, HLBS, SH	Carbon Steel	Plant Indoor Air (Structural) (Ext)	Loss of material	Structures Monitoring Program (B2.1.32)	III.A5-12	3.5.1.25	A
Fire Barrier Doors	FB, HLBS, SH	Carbon Steel	Plant Indoor Air (Structural) (Ext)	Loss of material	Fire Protection (B2.1.12)	VII.G-3	3.3.1.63	B
Fire Barrier Seals	FB	Elastomer	Atmosphere/Weather (Structural) (Ext)	Increased hardness, shrinkage and loss of strength	Fire Protection (B2.1.12)	VII.G-2	3.3.1.61	B
Fire Barrier Seals	FB	Elastomer	Plant Indoor Air (Structural) (Ext)	Increased hardness, shrinkage and loss of strength	Fire Protection (B2.1.12)	VII.G-1	3.3.1.61	B

Section 3.5
AGING MANAGEMENT OF CONTAINMENTS,
STRUCTURES AND COMPONENT SUPPORTS

*Table 3.5.2-9 Containments, Structures, and Component Supports – Summary of Aging Management Evaluation – Fuel Building
(Continued)*

Component Type	Intended Function	Material	Environment	Aging Effect Requiring Management	Aging Management Program	NUREG-1801 Vol. 2 Item	Table 1 Item	Notes
Gate	SPB	Stainless Steel	Treated Borated Water (Ext)	Cracking	Water Chemistry (B2.1.2) and Monitoring of the Spent Fuel Pool Water Level	III.A5-13	3.5.1.46	A
Hatch	MB, SH	Carbon Steel	Atmosphere/Weather (Structural) (Ext)	Loss of material	Structures Monitoring Program (B2.1.32)	III.A5-12	3.5.1.25	A
Hatch	FB, FLB, MB, SH	Carbon Steel	Plant Indoor Air (Structural) (Ext)	Loss of material	Structures Monitoring Program (B2.1.32)	III.A5-12	3.5.1.25	A
Hatch	FB, FLB, MB, SH	Carbon Steel	Plant Indoor Air (Structural) (Ext)	Loss of material	Fire Protection (B2.1.12)	VII.G-3	3.3.1.63	B
Hatches/Plugs	MB, SH	Concrete	Atmosphere/Weather (Structural) (Ext)	Cracking due to expansion	Structures Monitoring Program (B2.1.32)	III.A5-2	3.5.1.27	A
Hatches/Plugs	MB, SH	Concrete	Atmosphere/Weather (Structural) (Ext)	Loss of material (spalling, scaling) and cracking	Structures Monitoring Program (B2.1.32)	III.A5-6	3.5.1.26	A
Hatches/Plugs	MB, SH	Concrete	Atmosphere/Weather (Structural) (Ext)	Cracking, loss of bond, and loss of material (spalling, scaling)	Structures Monitoring Program (B2.1.32)	III.A5-9	3.5.1.23	A
Hatches/Plugs	MB, SH	Concrete	Atmosphere/Weather (Structural) (Ext)	Increase in porosity and permeability, cracking, loss of material (spalling, scaling)	Structures Monitoring Program (B2.1.32)	III.A5-10	3.5.1.24	A

Section 3.5
AGING MANAGEMENT OF CONTAINMENTS,
STRUCTURES AND COMPONENT SUPPORTS

*Table 3.5.2-9 Containments, Structures, and Component Supports – Summary of Aging Management Evaluation – Fuel Building
(Continued)*

Component Type	Intended Function	Material	Environment	Aging Effect Requiring Management	Aging Management Program	NUREG-1801 Vol. 2 Item	Table 1 Item	Notes
Hatches/Plugs	MB, SH	Concrete	Plant Indoor Air (Structural) (Ext)	Cracking due to expansion	Structures Monitoring Program (B2.1.32)	III.A5-2	3.5.1.27	A
Hatches/Plugs	MB, SH	Concrete	Plant Indoor Air (Structural) (Ext)	Cracking, loss of bond, and loss of material (spalling, scaling)	Structures Monitoring Program (B2.1.32)	III.A5-9	3.5.1.23	A
Hatches/Plugs	MB, SH	Concrete	Plant Indoor Air (Structural) (Ext)	Increase in porosity and permeability, cracking, loss of material (spalling, scaling)	Structures Monitoring Program (B2.1.32)	III.A5-10	3.5.1.24	A
Liner Spent Fuel Pool	SPB	Stainless Steel	Encased in Concrete (Ext)	None	None	VII.J-17	3.3.1.96	C
Liner Spent Fuel Pool	SPB	Stainless Steel	Plant Indoor Air (Structural) (Ext)	None	None	VII.J-15	3.3.1.94	C
Liner Spent Fuel Pool	SPB	Stainless Steel	Treated Borated Water (Ext)	Cracking	Water Chemistry (B2.1.2) and Monitoring of the Spent Fuel Pool Water Level	III.A5-13	3.5.1.46	A
Penetrations Electrical	SS	Carbon Steel	Atmosphere/Weather (Structural) (Ext)	Loss of material	Structures Monitoring Program (B2.1.32)	III.A5-12	3.5.1.25	A
Penetrations Electrical	SS	Carbon Steel	Encased in Concrete (Ext)	None	None	VII.J-21	3.3.1.96	C
Penetrations Electrical	SS	Carbon Steel	Plant Indoor Air (Structural) (Ext)	Loss of material	Structures Monitoring Program (B2.1.32)	III.A5-12	3.5.1.25	A

Section 3.5
AGING MANAGEMENT OF CONTAINMENTS,
STRUCTURES AND COMPONENT SUPPORTS

*Table 3.5.2-9 Containments, Structures, and Component Supports – Summary of Aging Management Evaluation – Fuel Building
(Continued)*

Component Type	Intended Function	Material	Environment	Aging Effect Requiring Management	Aging Management Program	NUREG-1801 Vol. 2 Item	Table 1 Item	Notes
Penetrations Mechanical	SS	Carbon Steel	Atmosphere/Weather (Structural) (Ext)	Loss of material	Structures Monitoring Program (B2.1.32)	III.A5-12	3.5.1.25	A
Penetrations Mechanical	SS	Carbon Steel	Encased in Concrete (Ext)	None	None	VII.J-21	3.3.1.96	C
Penetrations Mechanical	SS	Carbon Steel	Plant Indoor Air (Structural) (Ext)	Loss of material	Structures Monitoring Program (B2.1.32)	III.A5-12	3.5.1.25	A
Roofing Membrane	SH	Elastomer	Atmosphere Weather (Structural) (Ext)	Loss of sealing	Structures Monitoring Program (B2.1.32)	III.A6-12	3.5.1.44	A
Stairs/Platforms/Grates	NSRS	Carbon Steel	Plant Indoor Air (Structural) (Ext)	Loss of material	Structures Monitoring Program (B2.1.32)	III.A5-12	3.5.1.25	A
Structural Steel	SS	Carbon Steel	Atmosphere/Weather (Structural) (Ext)	Loss of material	Structures Monitoring Program (B2.1.32)	III.A5-12	3.5.1.25	A
Structural Steel	ES	Carbon Steel	Buried (Structural) (Ext)	Loss of material	Structures Monitoring Program (B2.1.32)	None	None	J
Structural Steel	SS	Carbon Steel	Encased in Concrete (Ext)	None	None	VII.J-21	3.3.1.96	C
Structural Steel	SH, SS	Carbon Steel	Plant Indoor Air (Structural) (Ext)	Loss of material	Structures Monitoring Program (B2.1.32)	III.A5-12	3.5.1.25	A

**Section 3.5
AGING MANAGEMENT OF CONTAINMENTS,
STRUCTURES AND COMPONENT SUPPORTS**

Notes for Table 3.5.2-9:

Standard Notes:

- A Consistent with NUREG-1801 item for component, material, environment, and aging effect. AMP is consistent with NUREG-1801 AMP.
- B Consistent with NUREG-1801 item for component, material, environment, and aging effect. AMP takes some exceptions to NUREG-1801 AMP.
- C Component is different, but consistent with NUREG-1801 item for material, environment, and aging effect. AMP is consistent with NUREG-1801 AMP.
- J Neither the component nor the material and environment combination is evaluated in NUREG-1801.

Plant Specific Notes:

None

Section 3.5
AGING MANAGEMENT OF CONTAINMENTS,
STRUCTURES AND COMPONENT SUPPORTS

Table 3.5.2-10 Containments, Structures, and Component Supports – Summary of Aging Management Evaluation – Spray Pond and Associated Water Control Structures

Component Type	Intended Function	Material	Environment	Aging Effect Requiring Management	Aging Management Program	NUREG-1801 Vol. 2 Item	Table 1 Item	Notes
Caulking/Sealant	SH	Elastomer	Atmosphere/Weather (Structural) (Ext)	Loss of sealing	Structures Monitoring Program (B2.1.32)	III.A6-12	3.5.1.44	A
Caulking/Sealant	HS, SPB	Elastomer	Buried (Structural) (Ext)	Loss of sealing	Structures Monitoring Program (B2.1.32)	III.A6-12	3.5.1.44	A
Caulking/Sealant	HS, SPB	Elastomer	Submerged (Structural) (Ext)	Loss of sealing	Structures Monitoring Program (B2.1.32)	III.A6-12	3.5.1.44	A
Concrete Elements	HS, MB, SH, SS	Concrete	Atmosphere/Weather (Structural) (Ext)	Cracking, loss of bond, and loss of material (spalling, scaling)	Regulatory Guide 1.127, Inspection of Water-Control Structures Associated with Nuclear Power Plants (B2.1.33)	III.A6-1	3.5.1.34	A
Concrete Elements	HS, MB, SH, SS	Concrete	Atmosphere/Weather (Structural) (Ext)	Cracking due to expansion	Regulatory Guide 1.127, Inspection of Water-Control Structures Associated with Nuclear Power Plants (B2.1.33)	III.A6-2	3.5.1.36	A
Concrete Elements	HS, MB, SH, SS	Concrete	Atmosphere/Weather (Structural) (Ext)	Loss of material (spalling, scaling) and cracking	Regulatory Guide 1.127, Inspection of Water-Control Structures Associated with Nuclear Power Plants (B2.1.33)	III.A6-5	3.5.1.35	A

Section 3.5
AGING MANAGEMENT OF CONTAINMENTS,
STRUCTURES AND COMPONENT SUPPORTS

Table 3.5.2-10 Containments, Structures, and Component Supports – Summary of Aging Management Evaluation – Spray Pond and Associated Water Control Structures (Continued)

Component Type	Intended Function	Material	Environment	Aging Effect Requiring Management	Aging Management Program	NUREG-1801 Vol. 2 Item	Table 1 Item	Notes
Concrete Elements	HS, SS	Concrete	Buried (Structural) (Ext)	Cracking due to expansion	Regulatory Guide 1.127, Inspection of Water-Control Structures Associated with Nuclear Power Plants (B2.1.33)	III.A6-2	3.5.1.36	A
Concrete Elements	HS, SS	Concrete	Buried (Structural) (Ext)	Increase in porosity and permeability, cracking, loss of material (spalling, scaling)	Regulatory Guide 1.127, Inspection of Water-Control Structures Associated with Nuclear Power Plants (B2.1.33)	III.A6-3	3.5.1.34	A
Concrete Elements	HS, SS	Concrete	Buried (Structural) (Ext)	Cracks and distortion	Structures Monitoring Program (B2.1.32)	III.A6-4	3.5.1.28	A
Concrete Elements	FB, HS, SH, SS	Concrete	Plant Indoor Air (Structural) (Ext)	Cracking, loss of bond, and loss of material (spalling, scaling)	Regulatory Guide 1.127, Inspection of Water-Control Structures Associated with Nuclear Power Plants (B2.1.33)	III.A6-1	3.5.1.34	A
Concrete Elements	FB, HS, SH, SS	Concrete	Plant Indoor Air (Structural) (Ext)	Cracking due to expansion	Regulatory Guide 1.127, Inspection of Water-Control Structures Associated with Nuclear Power Plants (B2.1.33)	III.A6-2	3.5.1.36	A

Section 3.5
AGING MANAGEMENT OF CONTAINMENTS,
STRUCTURES AND COMPONENT SUPPORTS

Table 3.5.2-10 Containments, Structures, and Component Supports – Summary of Aging Management Evaluation – Spray Pond and Associated Water Control Structures (Continued)

Component Type	Intended Function	Material	Environment	Aging Effect Requiring Management	Aging Management Program	NUREG-1801 Vol. 2 Item	Table 1 Item	Notes
Concrete Elements	FB, HS, SH, SS	Concrete	Plant Indoor Air (Structural) (Ext)	Concrete cracking and spalling	Fire Protection (B2.1.12) and Structures Monitoring Program (B2.1.32)	VII.G-28	3.3.1.65	B
Concrete Elements	FB, HS, SH, SS	Concrete	Plant Indoor Air (Structural) (Ext)	Loss of material	Fire Protection (B2.1.12) and Structures Monitoring Program (B2.1.32)	VII.G-29	3.3.1.67	B
Concrete Elements	HS, SS	Concrete	Submerged (Structural) (Ext)	Cracking due to expansion	Regulatory Guide 1.127, Inspection of Water-Control Structures Associated with Nuclear Power Plants (B2.1.33)	III.A6-2	3.5.1.36	A
Concrete Elements	HS, SS	Concrete	Submerged (Structural) (Ext)	Increase in porosity and permeability, loss of strength	Regulatory Guide 1.127, Inspection of Water-Control Structures Associated with Nuclear Power Plants (B2.1.33)	III.A6-6	3.5.1.37	A
Concrete Elements	HS, SS	Concrete	Submerged (Structural) (Ext)	Loss of material	Regulatory Guide 1.127, Inspection of Water-Control Structures Associated with Nuclear Power Plants (B2.1.33)	III.A6-7	3.5.1.45	A
Hatch	SH	Carbon Steel	Atmosphere/Weather (Structural) (Ext)	Loss of material	Structures Monitoring Program (B2.1.32)	III.A6-11	3.5.1.47	E, 1

Section 3.5
AGING MANAGEMENT OF CONTAINMENTS,
STRUCTURES AND COMPONENT SUPPORTS

Table 3.5.2-10 Containments, Structures, and Component Supports – Summary of Aging Management Evaluation – Spray Pond and Associated Water Control Structures (Continued)

Component Type	Intended Function	Material	Environment	Aging Effect Requiring Management	Aging Management Program	NUREG-1801 Vol. 2 Item	Table 1 Item	Notes
Hatch	SH	Carbon Steel	Plant Indoor Air (Structural) (Ext)	Loss of material	Structures Monitoring Program (B2.1.32)	III.A6-11	3.5.1.47	E, 1
Hatches/Plugs	SH	Concrete	Atmosphere/Weather (Structural) (Ext)	Cracking, loss of bond, and loss of material (spalling, scaling)	Regulatory Guide 1.127, Inspection of Water-Control Structures Associated with Nuclear Power Plants (B2.1.33)	III.A6-1	3.5.1.34	A
Hatches/Plugs	SH	Concrete	Atmosphere/Weather (Structural) (Ext)	Cracking due to expansion	Regulatory Guide 1.127, Inspection of Water-Control Structures Associated with Nuclear Power Plants (B2.1.33)	III.A6-2	3.5.1.36	A
Hatches/Plugs	SH	Concrete	Atmosphere/Weather (Structural) (Ext)	Loss of material (spalling, scaling) and cracking	Regulatory Guide 1.127, Inspection of Water-Control Structures Associated with Nuclear Power Plants (B2.1.33)	III.A6-5	3.5.1.35	A
Hatches/Plugs	MB, SH,	Concrete	Plant Indoor Air (Structural) (Ext)	Cracking, loss of bond, and loss of material (spalling, scaling)	Regulatory Guide 1.127, Inspection of Water-Control Structures Associated with Nuclear Power Plants (B2.1.33)	III.A6-1	3.5.1.34	A
Hatches/Plugs	MB, SH,	Concrete	Plant Indoor Air (Structural) (Ext)	Cracking due to expansion	Regulatory Guide 1.127, Inspection of Water-Control Structures Associated with Nuclear Power Plants (B2.1.33)	III.A6-2	3.5.1.36	A

Section 3.5
AGING MANAGEMENT OF CONTAINMENTS,
STRUCTURES AND COMPONENT SUPPORTS

Table 3.5.2-10 Containments, Structures, and Component Supports – Summary of Aging Management Evaluation – Spray Pond and Associated Water Control Structures (Continued)

Component Type	Intended Function	Material	Environment	Aging Effect Requiring Management	Aging Management Program	NUREG-1801 Vol. 2 Item	Table 1 Item	Notes
Screen	FIL	Copper Alloy	Raw Water (Ext)	Loss of material	Structures Monitoring Program (B2.1.32)	None	None	J, 2
Structural Steel	MB, SH, SS	Carbon Steel	Atmosphere/Weather (Structural) (Ext)	Loss of material	Structures Monitoring Program (B2.1.32)	III.A6-11	3.5.1.47	E, 1
Structural Steel	SH, SS	Carbon Steel	Plant Indoor Air (Structural) (Ext)	Loss of material	Structures Monitoring Program (B2.1.32)	III.A6-11	3.5.1.47	E, 1
Structural Steel	NSRS	Carbon Steel	Submerged (Structural) (Ext)	Loss of material	Structures Monitoring Program (B2.1.32)	III.A6-11	3.5.1.47	E, 1
Structural Steel	DF	Stainless Steel	Atmosphere/Weather (Structural) (Ext)	None	None	None	None	G

Notes for Table 3.5.2-10:

Standard Notes:

- A Consistent with NUREG-1801 item for component, material, environment, and aging effect. AMP is consistent with NUREG-1801 AMP.
- B Consistent with NUREG-1801 item for component, material, environment, and aging effect. AMP takes some exceptions to NUREG-1801 AMP.
- E Consistent with NUREG-1801 for material, environment, and aging effect, but a different aging management program is credited or NUREG-1801 identifies a plant-specific aging management program.
- G Environment not in NUREG-1801 for this component and material.
- J Neither the component nor the material and environment combination is evaluated in NUREG-1801.

Plant Specific Notes:

- 1 NUREG 1801, line III.A6-11 specifies Reg Guide 1.127 as the program for metal components in water-control structures. Reg Guide 1.127 does not address metal components, so the Structures Monitoring Program is used.
- 2 NUREG-1801 does not provide a line in which copper alloy screens are inspected per the Structures Monitoring Program.

Section 3.5
AGING MANAGEMENT OF CONTAINMENTS,
STRUCTURES AND COMPONENT SUPPORTS

Table 3.5.2-11 *Containments, Structures, and Component Supports – Summary of Aging Management Evaluation – Tank Foundations and Shells*

Component Type	Intended Function	Material	Environment	Aging Effect Requiring Management	Aging Management Program	NUREG-1801 Vol. 2 Item	Table 1 Item	Notes
Concrete (Condensate Storage Tank)	MB, SS	Concrete	Atmosphere/Weather (Structural) (Ext)	Cracking due to expansion	Structures Monitoring Program (B2.1.32)	III.A7-1	3.5.1.27	A
Concrete (Condensate Storage Tank)	MB, SS	Concrete	Atmosphere/Weather (Structural) (Ext)	Loss of material (spalling, scaling) and cracking	Structures Monitoring Program (B2.1.32)	III.A7-5	3.5.1.26	A
Concrete (Condensate Storage Tank)	MB, SS	Concrete	Atmosphere/Weather (Structural) (Ext)	Cracking, loss of bond, and loss of material (spalling, scaling)	Structures Monitoring Program (B2.1.32)	III.A7-8	3.5.1.23	A
Concrete (Condensate Storage Tank)	MB, SS	Concrete	Atmosphere/Weather (Structural) (Ext)	Increase in porosity and permeability, cracking, loss of material (spalling, scaling)	Structures Monitoring Program (B2.1.32)	III.A7-9	3.5.1.24	A
Concrete (Condensate Storage Tank)	SS	Concrete	Buried (Structural) (Ext)	Cracking due to expansion	Structures Monitoring Program (B2.1.32)	III.A7-1	3.5.1.27	A
Concrete (Condensate Storage Tank)	SS	Concrete	Buried (Structural) (Ext)	Cracks and distortion	Structures Monitoring Program (B2.1.32)	III.A7-2	3.5.1.28	A

Section 3.5
AGING MANAGEMENT OF CONTAINMENTS,
STRUCTURES AND COMPONENT SUPPORTS

Table 3.5.2-11 Containments, Structures, and Component Supports – Summary of Aging Management Evaluation – Tank Foundations and Shells (Continued)

Component Type	Intended Function	Material	Environment	Aging Effect Requiring Management	Aging Management Program	NUREG-1801 Vol. 2 Item	Table 1 Item	Notes
Concrete (Condensate Storage Tank)	SS	Concrete	Buried (Structural) (Ext)	Cracking, loss of bond, and loss of material (spalling, scaling)	Structures Monitoring Program (B2.1.32)	III.A7-3	3.5.1.31	A
Concrete (Condensate Storage Tank)	SS	Concrete	Buried (Structural) (Ext)	Increase in porosity and permeability, cracking, loss of material (spalling, scaling)	Structures Monitoring Program (B2.1.32)	III.A7-4	3.5.1.31	A
Concrete (Reactor Makeup Water Tank)	SS	Concrete	Atmosphere/Weather (Structural) (Ext)	Cracking due to expansion	Structures Monitoring Program (B2.1.32)	III.A8-1	3.5.1.27	A
Concrete (Reactor Makeup Water Tank)	SS	Concrete	Atmosphere/Weather (Structural) (Ext)	Loss of material (spalling, scaling) and cracking	Structures Monitoring Program (B2.1.32)	III.A8-5	3.5.1.26	A
Concrete (Reactor Makeup Water Tank)	SS	Concrete	Buried (Structural) (Ext)	Cracking due to expansion	Structures Monitoring Program (B2.1.32)	III.A8-1	3.5.1.27	A

Section 3.5
AGING MANAGEMENT OF CONTAINMENTS,
STRUCTURES AND COMPONENT SUPPORTS

Table 3.5.2-11 Containments, Structures, and Component Supports – Summary of Aging Management Evaluation – Tank Foundations and Shells (Continued)

Component Type	Intended Function	Material	Environment	Aging Effect Requiring Management	Aging Management Program	NUREG-1801 Vol. 2 Item	Table 1 Item	Notes
Concrete (Reactor Makeup Water Tank)	SS	Concrete	Buried (Structural) (Ext)	Cracks and distortion	Structures Monitoring Program (B2.1.32)	III.A8-2	3.5.1.28	A
Concrete (Reactor Makeup Water Tank)	SS	Concrete	Buried (Structural) (Ext)	Cracking, loss of bond, and loss of material (spalling, scaling)	Structures Monitoring Program (B2.1.32)	III.A8-3	3.5.1.31	A
Concrete (Reactor Makeup Water Tank)	SS	Concrete	Buried (Structural) (Ext)	Increase in porosity and permeability, cracking, loss of material (spalling, scaling)	Structures Monitoring Program (B2.1.32)	III.A8-4	3.5.1.31	A
Concrete (Refueling Water Tank)	MB, SS	Concrete	Atmosphere/Weather (Structural) (Ext)	Cracking due to expansion	Structures Monitoring Program (B2.1.32)	III.A7-1	3.5.1.27	A
Concrete (Refueling Water Tank)	MB, SS	Concrete	Atmosphere/Weather (Structural) (Ext)	Loss of material (spalling, scaling) and cracking	Structures Monitoring Program (B2.1.32)	III.A7-5	3.5.1.26	A
Concrete (Refueling Water Tank)	MB, SS	Concrete	Atmosphere/Weather (Structural) (Ext)	Cracking, loss of bond, and loss of material (spalling, scaling)	Structures Monitoring Program (B2.1.32)	III.A7-8	3.5.1.23	A

Section 3.5
AGING MANAGEMENT OF CONTAINMENTS,
STRUCTURES AND COMPONENT SUPPORTS

Table 3.5.2-11 Containments, Structures, and Component Supports – Summary of Aging Management Evaluation – Tank Foundations and Shells (Continued)

Component Type	Intended Function	Material	Environment	Aging Effect Requiring Management	Aging Management Program	NUREG-1801 Vol. 2 Item	Table 1 Item	Notes
Concrete (Refueling Water Tank)	MB, SS	Concrete	Atmosphere/Weather (Structural) (Ext)	Increase in porosity and permeability, cracking, loss of material (spalling, scaling)	Structures Monitoring Program (B2.1.32)	III.A7-9	3.5.1.24	A
Concrete (Refueling Water Tank)	SS	Concrete	Buried (Structural) (Ext)	Cracking due to expansion	Structures Monitoring Program (B2.1.32)	III.A7-1	3.5.1.27	A
Concrete (Refueling Water Tank)	SS	Concrete	Buried (Structural) (Ext)	Cracks and distortion	Structures Monitoring Program (B2.1.32)	III.A7-2	3.5.1.28	A
Concrete (Refueling Water Tank)	SS	Concrete	Buried (Structural) (Ext)	Cracking, loss of bond, and loss of material (spalling, scaling)	Structures Monitoring Program (B2.1.32)	III.A7-3	3.5.1.31	A
Concrete (Refueling Water Tank)	SS	Concrete	Buried (Structural) (Ext)	Increase in porosity and permeability, cracking, loss of material (spalling, scaling)	Structures Monitoring Program (B2.1.32)	III.A7-4	3.5.1.31	A
Hatch	SH	Carbon Steel	Atmosphere/Weather (Structural) (Ext)	Loss of material	Structures Monitoring Program (B2.1.32)	III.A8-8	3.5.1.25	A

Section 3.5
AGING MANAGEMENT OF CONTAINMENTS,
STRUCTURES AND COMPONENT SUPPORTS

Table 3.5.2-11 Containments, Structures, and Component Supports – Summary of Aging Management Evaluation – Tank Foundations and Shells (Continued)

Component Type	Intended Function	Material	Environment	Aging Effect Requiring Management	Aging Management Program	NUREG-1801 Vol. 2 Item	Table 1 Item	Notes
Roofing Membrane	SH	Elastomer	Atmosphere/Weather (Structural) (Ext)	Loss of sealing	Structures Monitoring Program (B2.1.32)	III.A6-12	3.5.1.44	A
Structural Steel	MB, SS	Carbon Steel	Atmosphere/Weather (Structural) (Ext)	Loss of material	Structures Monitoring Program (B2.1.32)	III.A7-10	3.5.1.25	A
Structural Steel	SS	Carbon Steel	Encased in Concrete (Ext)	None	None	VII.J-21	3.3.1.96	C
Structural Steel	SS	Carbon Steel	Plant Indoor Air (Structural) (Ext)	Loss of material	Structures Monitoring Program (B2.1.32)	III.A7-10	3.5.1.25	A

Notes for Table 3.5.2-11:

Standard Notes:

- A Consistent with NUREG-1801 item for component, material, environment, and aging effect. AMP is consistent with NUREG-1801 AMP.
- C Component is different, but consistent with NUREG-1801 item for material, environment, and aging effect. AMP is consistent with NUREG-1801 AMP.

Plant Specific Notes:

None

Section 3.5
AGING MANAGEMENT OF CONTAINMENTS,
STRUCTURES AND COMPONENT SUPPORTS

Table 3.5.2-12 *Containments, Structures, and Component Supports – Summary of Aging Management Evaluation – Transformer Foundations and Electrical Structures*

Component Type	Intended Function	Material	Environment	Aging Effect Requiring Management	Aging Management Program	NUREG-1801 Vol. 2 Item	Table 1 Item	Notes
Caulking/ Sealant	SH	Elastomer	Atmosphere/ Weather (Structural) (Ext)	Loss of sealing	Structures Monitoring Program (B2.1.32)	III.A6-12	3.5.1.44	A
Caulking/ Sealant	SH	Elastomer	Buried (Structural) (Ext)	Loss of sealing	Structures Monitoring Program (B2.1.32)	III.A6-12	3.5.1.44	A
Concrete Elements	FB, NSRS, SS	Concrete	Atmosphere/ Weather (Structural) (Ext)	Cracking due to expansion	Structures Monitoring Program (B2.1.32)	III.A3-2	3.5.1.27	A
Concrete Elements	FB, NSRS, SS	Concrete	Atmosphere/ Weather (Structural) (Ext)	Loss of material (spalling, scaling) and cracking	Structures Monitoring Program (B2.1.32)	III.A3-6	3.5.1.26	A
Concrete Elements	FB, NSRS, SS	Concrete	Atmosphere/ Weather (Structural) (Ext)	Cracking, loss of bond, and loss of material (spalling, scaling)	Structures Monitoring Program (B2.1.32)	III.A3-9	3.5.1.23	A
Concrete Elements	FB, NSRS, SS	Concrete	Atmosphere/ Weather (Structural) (Ext)	Increase in porosity and permeability, cracking, loss of material (spalling, scaling)	Structures Monitoring Program (B2.1.32)	III.A3-10	3.5.1.24	A

Section 3.5
AGING MANAGEMENT OF CONTAINMENTS,
STRUCTURES AND COMPONENT SUPPORTS

Table 3.5.2-12 Containments, Structures, and Component Supports – Summary of Aging Management Evaluation – Transformer Foundations and Electrical Structures (Continued)

Component Type	Intended Function	Material	Environment	Aging Effect Requiring Management	Aging Management Program	NUREG-1801 Vol. 2 Item	Table 1 Item	Notes
Concrete Elements	FB, SS	Concrete	Atmosphere/ Weather (Structural) (Ext)	Concrete cracking and spalling	Fire Protection (B2.1.12) and Structures Monitoring Program (B2.1.32)	VII.G-30	3.3.1.66	B
Concrete Elements	FB, SS	Concrete	Atmosphere/ Weather (Structural) (Ext)	Loss of material	Fire Protection (B2.1.12) and Structures Monitoring Program (B2.1.32)	VII.G-31	3.3.1.67	B
Concrete Elements	NSRS, SS	Concrete	Buried (Structural) (Ext)	Cracking due to expansion	Structures Monitoring Program (B2.1.32)	III.A3-2	3.5.1.27	A
Concrete Elements	SS	Concrete	Buried (Structural) (Ext)	Cracks and distortion	Structures Monitoring Program (B2.1.32)	III.A3-3	3.5.1.28	A
Concrete Elements	NSRS, SS	Concrete	Buried (Structural) (Ext)	Cracking, loss of bond, and loss of material (spalling, scaling)	Structures Monitoring Program (B2.1.32)	III.A3-4	3.5.1.31	A
Concrete Elements	NSRS, SS	Concrete	Buried (Structural) (Ext)	Increase in porosity and permeability, cracking, loss of material (spalling, scaling)	Structures Monitoring Program (B2.1.32)	III.A3-5	3.5.1.31	A
Duct Banks and Manholes	SH	Concrete	Atmosphere/ Weather (Structural) (Ext)	Cracking due to expansion	Structures Monitoring Program (B2.1.32)	III.A3-2	3.5.1.27	A

Section 3.5
**AGING MANAGEMENT OF CONTAINMENTS,
STRUCTURES AND COMPONENT SUPPORTS**

Table 3.5.2-12 Containments, Structures, and Component Supports – Summary of Aging Management Evaluation – Transformer Foundations and Electrical Structures (Continued)

Component Type	Intended Function	Material	Environment	Aging Effect Requiring Management	Aging Management Program	NUREG-1801 Vol. 2 Item	Table 1 Item	Notes
Duct Banks and Manholes	SH	Concrete	Atmosphere/Weather (Structural) (Ext)	Loss of material (spalling, scaling) and cracking	Structures Monitoring Program (B2.1.32)	III.A3-6	3.5.1.26	A
Duct Banks and Manholes	SH	Concrete	Atmosphere/Weather (Structural) (Ext)	Cracking, loss of bond, and loss of material (spalling, scaling)	Structures Monitoring Program (B2.1.32)	III.A3-9	3.5.1.23	A
Duct Banks and Manholes	SH	Concrete	Atmosphere/Weather (Structural) (Ext)	Increase in porosity and permeability, cracking, loss of material (spalling, scaling)	Structures Monitoring Program (B2.1.32)	III.A3-10	3.5.1.24	A
Duct Banks and Manholes	SH	Concrete	Buried (Structural) (Ext)	Cracking due to expansion	Structures Monitoring Program (B2.1.32)	III.A3-2	3.5.1.27	A
Duct Banks and Manholes	SH	Concrete	Buried (Structural) (Ext)	Cracks and distortion	Structures Monitoring Program (B2.1.32)	III.A3-3	3.5.1.28	A
Duct Banks and Manholes	SH	Concrete	Buried (Structural) (Ext)	Cracking, loss of bond, and loss of material (spalling, scaling)	Structures Monitoring Program (B2.1.32)	III.A3-4	3.5.1.31	A
Duct Banks and Manholes	SH	Concrete	Buried (Structural) (Ext)	Increase in porosity and permeability, cracking, loss of material (spalling, scaling)	Structures Monitoring Program (B2.1.32)	III.A3-5	3.5.1.31	A

Section 3.5
AGING MANAGEMENT OF CONTAINMENTS,
STRUCTURES AND COMPONENT SUPPORTS

Table 3.5.2-12 Containments, Structures, and Component Supports – Summary of Aging Management Evaluation – Transformer Foundations and Electrical Structures (Continued)

Component Type	Intended Function	Material	Environment	Aging Effect Requiring Management	Aging Management Program	NUREG-1801 Vol. 2 Item	Table 1 Item	Notes
Fire Barrier Seals	FB	Elastomer	Atmosphere/ Weather (Structural) (Ext)	Increased hardness, shrinkage and loss of strength	Fire Protection (B2.1.12)	VII.G-2	3.3.1.61	B
Structural Steel	NSRS, SH	Carbon Steel	Atmosphere/ Weather (Structural) (Ext)	Loss of material	Structures Monitoring Program (B2.1.32)	III.A3-12	3.5.1.25	A
Structural Steel	NSRS, SH	Carbon Steel	Encased in Concrete (Ext)	None	None	VII.J-21	3.3.1.96	C
Transmission Tower	NSRS	Carbon Steel	Atmosphere/ Weather (Structural) (Ext)	Loss of material	Structures Monitoring Program (B2.1.32)	III.A3-12	3.5.1.25	A

Notes for Table 3.5.2-12:

Standard Notes:

- A Consistent with NUREG-1801 item for component, material, environment, and aging effect. AMP is consistent with NUREG-1801 AMP.
- B Consistent with NUREG-1801 item for component, material, environment, and aging effect. AMP takes some exceptions to NUREG-1801 AMP.
- C Component is different, but consistent with NUREG-1801 item for material, environment, and aging effect. AMP is consistent with NUREG-1801 AMP.

Plant Specific Notes:

None

Section 3.5
AGING MANAGEMENT OF CONTAINMENTS,
STRUCTURES AND COMPONENT SUPPORTS

Table 3.5.2-13 Containments, Structures, and Component Supports – Summary of Aging Management Evaluation – Yard Structures (In-Scope)

Component Type	Intended Function	Material	Environment	Aging Effect Requiring Management	Aging Management Program	NUREG-1801 Vol. 2 Item	Table 1 Item	Notes
Caulking/Sealant	FLB, SH, SPB	Elastomer	Atmosphere/Weather (Structural) (Ext)	Loss of sealing	Structures Monitoring Program (B2.1.32)	III.A6-12	3.5.1.44	A
Caulking/Sealant	FLB, SH	Elastomer	Buried (Structural) (Ext)	Loss of sealing	Structures Monitoring Program (B2.1.32)	III.A6-12	3.5.1.44	A
Caulking/Sealant	FLB, SH, SPB	Elastomer	Plant Indoor Air (Structural) (Ext)	Loss of sealing	Structures Monitoring Program (B2.1.32)	III.A6-12	3.5.1.44	A
Compressible Joints/Seals	ES, SH	Elastomer	Atmosphere/Weather (Structural) (Ext)	Loss of sealing	Structures Monitoring Program (B2.1.32)	III.A6-12	3.5.1.44	A
Compressible Joints/Seals	ES, SH	Elastomer	Buried (Structural) (Ext)	Loss of sealing	Structures Monitoring Program (B2.1.32)	III.A6-12	3.5.1.44	A
Compressible Joints/Seals	ES, SH	Elastomer	Plant Indoor Air (Structural) (Ext)	Loss of sealing	Structures Monitoring Program (B2.1.32)	III.A6-12	3.5.1.44	A
Concrete Block (Masonry Walls)	SH, SS	Concrete Block (Masonry Walls)	Atmosphere/Weather (Structural) (Ext)	Cracking	Masonry Wall Program (B2.1.31)	III.A3-11	3.5.1.43	A
Concrete Block (Masonry Walls)	FB, SH, SS	Concrete Block (Masonry Walls)	Plant Indoor Air (Structural) (Ext)	Cracking	Fire Protection (B2.1.12) and Masonry Wall Program (B2.1.31)	III.A3-11	3.5.1.43	E, 1

Section 3.5
AGING MANAGEMENT OF CONTAINMENTS,
STRUCTURES AND COMPONENT SUPPORTS

Table 3.5.2-13 Containments, Structures, and Component Supports – Summary of Aging Management Evaluation – Yard Structures
(In-Scope) (Continued)

Component Type	Intended Function	Material	Environment	Aging Effect Requiring Management	Aging Management Program	NUREG-1801 Vol. 2 Item	Table 1 Item	Notes
Concrete Elements	FB, MB, SH, SPB, SS	Concrete	Atmosphere/Weather (Structural) (Ext)	Loss of material (spalling, scaling) and cracking	Structures Monitoring Program (B2.1.32)	III.A3-6	3.5.1.26	A
Concrete Elements	FB, MB, SH, SPB, SS	Concrete	Atmosphere/Weather (Structural) (Ext)	Cracking, loss of bond, and loss of material (spalling, scaling)	Structures Monitoring Program (B2.1.32)	III.A3-9	3.5.1.23	A
Concrete Elements	FB, MB, SH, SPB, SS	Concrete	Atmosphere/Weather (Structural) (Ext)	Increase in porosity and permeability, cracking, loss of material (spalling, scaling)	Structures Monitoring Program (B2.1.32)	III.A3-10	3.5.1.24	A
Concrete Elements	FB, MB, SH, SPB, SS	Concrete	Atmosphere/Weather (Structural) (Ext)	Concrete cracking and spalling	Fire Protection (B2.1.12) and Structures Monitoring Program (B2.1.32)	VII.G-30	3.3.1.66	B
Concrete Elements	FB, MB, SH, SPB, SS	Concrete	Atmosphere/Weather (Structural) (Ext)	Loss of material	Fire Protection (B2.1.12) and Structures Monitoring Program (B2.1.32)	VII.G-31	3.3.1.67	B
Concrete Elements	FLB, SH, SS	Concrete	Buried (Structural) (Ext)	Cracking due to expansion	Structures Monitoring Program (B2.1.32)	III.A3-2	3.5.1.27	A

Section 3.5
AGING MANAGEMENT OF CONTAINMENTS,
STRUCTURES AND COMPONENT SUPPORTS

Table 3.5.2-13 Containments, Structures, and Component Supports – Summary of Aging Management Evaluation – Yard Structures
(In-Scope) (Continued)

Component Type	Intended Function	Material	Environment	Aging Effect Requiring Management	Aging Management Program	NUREG-1801 Vol. 2 Item	Table 1 Item	Notes
Concrete Elements	FLB, SH, SS	Concrete	Buried (Structural) (Ext)	Cracking, loss of bond, and loss of material (spalling, scaling)	Structures Monitoring Program (B2.1.32)	III.A3-4	3.5.1.31	A
Concrete Elements	FLB, SH, SS	Concrete	Buried (Structural) (Ext)	Increase in porosity and permeability, cracking, loss of material (spalling, scaling)	Structures Monitoring Program (B2.1.32)	III.A3-5	3.5.1.31	A
Concrete Elements	FLB, SH, SPB, SS	Concrete	Plant Indoor Air (Structural) (Ext)	Cracking due to expansion	Structures Monitoring Program (B2.1.32)	III.A3-2	3.5.1.27	A
Concrete Elements	FLB, SH, SPB, SS	Concrete	Plant Indoor Air (Structural) (Ext)	Cracking, loss of bond, and loss of material (spalling, scaling)	Structures Monitoring Program (B2.1.32)	III.A3-9	3.5.1.23	A
Concrete Elements	FLB, SH, SPB, SS	Concrete	Plant Indoor Air (Structural) (Ext)	Increase in porosity and permeability, cracking, loss of material (spalling, scaling)	Structures Monitoring Program (B2.1.32)	III.A3-10	3.5.1.24	A
Doors	SH	Carbon Steel	Atmosphere/Weather (Structural) (Ext)	Loss of material	Structures Monitoring Program (B2.1.32)	III.A3-12	3.5.1.25	A

Section 3.5
AGING MANAGEMENT OF CONTAINMENTS,
STRUCTURES AND COMPONENT SUPPORTS

Table 3.5.2-13 Containments, Structures, and Component Supports – Summary of Aging Management Evaluation – Yard Structures
(In-Scope) (Continued)

Component Type	Intended Function	Material	Environment	Aging Effect Requiring Management	Aging Management Program	NUREG-1801 Vol. 2 Item	Table 1 Item	Notes
Doors	SH, SPB	Carbon Steel	Plant Indoor Air (Structural) (Ext)	Loss of material	Structures Monitoring Program (B2.1.32)	III.A3-12	3.5.1.25	A
Fire Barrier Doors	FB, SH	Carbon Steel	Plant Indoor Air (Structural) (Ext)	Loss of material	Structures Monitoring Program (B2.1.32)	III.A3-12	3.5.1.25	A
Fire Barrier Doors	FB, SH	Carbon Steel	Plant Indoor Air (Structural) (Ext)	Loss of material	Fire Protection (B2.1.12)	VII.G-3	3.3.1.63	B
Gypsum/Plaster Barrier	FB, SH	Gypsum/Plaster	Plant Indoor Air (Structural) (Ext)	Cracking	Fire Protection (B2.1.12)	None	None	J
Hatch	MB, SH, SPB	Carbon Steel	Atmosphere/Weather (Structural) (Ext)	Loss of material	Structures Monitoring Program (B2.1.32)	III.A3-12	3.5.1.25	A
Hatch	FLB, MB, SH, SPB	Carbon Steel	Plant Indoor Air (Structural) (Ext)	Loss of material	Structures Monitoring Program (B2.1.32)	III.A3-12	3.5.1.25	A
Hatches/Plugs	FLB, MB, SH, SPB	Concrete	Atmosphere/Weather (Structural) (Ext)	Cracking due to expansion	Structures Monitoring Program (B2.1.32)	III.A3-2	3.5.1.27	A
Hatches/Plugs	FLB, MB, SH, SPB	Concrete	Atmosphere/Weather (Structural) (Ext)	Cracking, loss of bond, and loss of material (spalling, scaling)	Structures Monitoring Program (B2.1.32)	III.A3-9	3.5.1.23	A
Hatches/Plugs	FLB, MB, SH, SPB	Concrete	Atmosphere/Weather (Structural) (Ext)	Increase in porosity and permeability, cracking, loss of material (spalling, scaling)	Structures Monitoring Program (B2.1.32)	III.A3-10	3.5.1.24	A

Section 3.5
AGING MANAGEMENT OF CONTAINMENTS,
STRUCTURES AND COMPONENT SUPPORTS

Table 3.5.2-13 Containments, Structures, and Component Supports – Summary of Aging Management Evaluation – Yard Structures
(In-Scope) (Continued)

Component Type	Intended Function	Material	Environment	Aging Effect Requiring Management	Aging Management Program	NUREG-1801 Vol. 2 Item	Table 1 Item	Notes
Hatches/Plugs	FLB, MB, SH, SPB	Concrete	Plant Indoor Air (Structural) (Ext)	Cracking due to expansion	Structures Monitoring Program (B2.1.32)	III.A3-2	3.5.1.27	A
Hatches/Plugs	FLB, MB, SH, SPB	Concrete	Plant Indoor Air (Structural) (Ext)	Cracking, loss of bond, and loss of material (spalling, scaling)	Structures Monitoring Program (B2.1.32)	III.A3-9	3.5.1.23	A
Hatches/Plugs	FLB, MB, SH, SPB	Concrete	Plant Indoor Air (Structural) (Ext)	Increase in porosity and permeability, cracking, loss of material (spalling, scaling)	Structures Monitoring Program (B2.1.32)	III.A3-10	3.5.1.24	A
Penetrations Electrical	SS	Carbon Steel	Atmosphere/Weather (Structural) (Ext)	Loss of material	Structures Monitoring Program (B2.1.32)	III.A3-12	3.5.1.25	A
Penetrations Electrical	SS	Carbon Steel	Encased in Concrete (Ext)	None	None	VII.J-21	3.3.1.96	C
Penetrations Electrical	SS	Carbon Steel	Plant Indoor Air (Structural) (Ext)	Loss of material	Structures Monitoring Program (B2.1.32)	III.A3-12	3.5.1.25	A
Penetrations Mechanical	SS	Carbon Steel	Atmosphere/Weather (Structural) (Ext)	Loss of material	Structures Monitoring Program (B2.1.32)	III.A3-12	3.5.1.25	A
Penetrations Mechanical	SS	Carbon Steel	Encased in Concrete (Ext)	None	None	VII.J-21	3.3.1.96	C
Penetrations Mechanical	SS	Carbon Steel	Plant Indoor Air (Structural) (Ext)	Loss of material	Structures Monitoring Program (B2.1.32)	III.A3-12	3.5.1.25	A

Section 3.5
AGING MANAGEMENT OF CONTAINMENTS,
STRUCTURES AND COMPONENT SUPPORTS

Table 3.5.2-13 *Containments, Structures, and Component Supports – Summary of Aging Management Evaluation – Yard Structures (In-Scope) (Continued)*

Component Type	Intended Function	Material	Environment	Aging Effect Requiring Management	Aging Management Program	NUREG-1801 Vol. 2 Item	Table 1 Item	Notes
Roofing Membrane	SH	Elastomer	Atmosphere/Weather (Structural) (Ext)	Loss of sealing	Structures Monitoring Program (B2.1.32)	III.A6-12	3.5.1.44	A
Structural Steel	SS	Carbon Steel	Atmosphere/Weather (Structural) (Ext)	Loss of material	Structures Monitoring Program (B2.1.32)	III.A3-12	3.5.1.25	A
Structural Steel	SS	Carbon Steel	Encased in Concrete (Ext)	None	None	VII.J-21	3.3.1.96	C
Structural Steel	SS	Carbon Steel	Plant Indoor Air (Structural) (Ext)	Loss of material	Structures Monitoring Program (B2.1.32)	III.A3-12	3.5.1.25	A

Notes for Table 3.5.2-13:

Standard Notes:

- A Consistent with NUREG-1801 item for component, material, environment, and aging effect. AMP is consistent with NUREG-1801 AMP.
- B Consistent with NUREG-1801 item for component, material, environment, and aging effect. AMP takes some exceptions to NUREG-1801 AMP.
- C Component is different, but consistent with NUREG-1801 item for material, environment, and aging effect. AMP is consistent with NUREG-1801 AMP.
- E Consistent with NUREG-1801 for material, environment, and aging effect, but a different aging management program is credited or NUREG-1801 identifies a plant-specific aging management program.
- J Neither the component nor the material and environment combination is evaluated in NUREG-1801.

Plant Specific Note:

- 1 The NUREG-1801 does not provide a line in which Concrete Masonry is inspected per the Fire Protection program.

Section 3.5
AGING MANAGEMENT OF CONTAINMENTS,
STRUCTURES AND COMPONENT SUPPORTS

Table 3.5.2-14 Containments, Structures, and Component Supports – Summary of Aging Management Evaluation – Supports

Component Type	Intended Function	Material	Environment	Aging Effect Requiring Management	Aging Management Program	NUREG-1801 Vol. 2 Item	Table 1 Item	Notes
Cable Trays & Supports	SS	Carbon Steel	Atmosphere/ Weather (Structural) (Ext)	Loss of material	Structures Monitoring Program (B2.1.32)	III.B2-10	3.5.1.39	A
Cable Trays & Supports	NSRS, SS	Carbon Steel	Plant Indoor Air (Structural) (Ext)	Loss of material	Structures Monitoring Program (B2.1.32)	III.B2-10	3.5.1.39	A
Cable Trays & Supports	SS	Concrete	Atmosphere/ Weather (Structural) (Ext)	Reduction in concrete anchor capacity	Structures Monitoring Program (B2.1.32)	III.B2-1	3.5.1.40	A
Cable Trays & Supports	NSRS, SS	Concrete	Plant Indoor Air (Structural) (Ext)	Reduction in concrete anchor capacity	Structures Monitoring Program (B2.1.32)	III.B2-1	3.5.1.40	A
Conduit And Supports	SS	Carbon Steel	Atmosphere/ Weather (Structural) (Ext)	Loss of material	Structures Monitoring Program (B2.1.32)	III.B2-10	3.5.1.39	A
Conduit And Supports	NSRS, SH, SS	Carbon Steel	Plant Indoor Air (Structural) (Ext)	Loss of material	Structures Monitoring Program (B2.1.32)	III.B2-10	3.5.1.39	A
Conduit And Supports	SS	Concrete	Atmosphere/ Weather (Structural) (Ext)	Reduction in concrete anchor capacity	Structures Monitoring Program (B2.1.32)	III.B2-1	3.5.1.40	A
Conduit And Supports	NSRS, SS	Concrete	Plant Indoor Air (Structural) (Ext)	Reduction in concrete anchor capacity	Structures Monitoring Program (B2.1.32)	III.B2-1	3.5.1.40	A

Section 3.5
AGING MANAGEMENT OF CONTAINMENTS,
STRUCTURES AND COMPONENT SUPPORTS

Table 3.5.2-14 *Containments, Structures, and Component Supports – Summary of Aging Management Evaluation – Supports*
(Continued)

Component Type	Intended Function	Material	Environment	Aging Effect Requiring Management	Aging Management Program	NUREG-1801 Vol. 2 Item	Table 1 Item	Notes
Electrical Panels & Enclosures	SS	Carbon Steel	Atmosphere/ Weather (Structural) (Ext)	Loss of material	Structures Monitoring Program (B2.1.32)	III.B3-7	3.5.1.39	A
Electrical Panels & Enclosures	NSRS, SH, SS	Carbon Steel	Plant Indoor Air (Structural) (Ext)	Loss of material	Structures Monitoring Program (B2.1.32)	III.B3-7	3.5.1.39	A
Electrical Panels & Enclosures	SS	Concrete	Atmosphere/ Weather (Structural) (Ext)	Reduction in concrete anchor capacity	Structures Monitoring Program (B2.1.32)	III.B3-1	3.5.1.40	A
Electrical Panels & Enclosures	NSRS, SS	Concrete	Plant Indoor Air (Structural) (Ext)	Reduction in concrete anchor capacity	Structures Monitoring Program (B2.1.32)	III.B3-1	3.5.1.40	A
High Strength Bolting	SS	High Strength Low Alloy Steel (Bolting)	Plant Indoor Air (Structural) (Ext)	Cracking	Bolting Integrity (B2.1.7)	III.B1.1-3	3.5.1.51	B
High Strength Bolting	SS	High Strength Low Alloy Steel (Bolting)	Plant Indoor Air (Structural) (Ext)	Loss of material	Bolting Integrity (B2.1.7)	III.B1.1-4	3.5.1.51	B
Instrument Panels & Racks	NSRS, SH, SS	Carbon Steel	Plant Indoor Air (Structural) (Ext)	Loss of material	Structures Monitoring Program (B2.1.32)	III.B3-7	3.5.1.39	A

Section 3.5
AGING MANAGEMENT OF CONTAINMENTS,
STRUCTURES AND COMPONENT SUPPORTS

Table 3.5.2-14 Containments, Structures, and Component Supports – Summary of Aging Management Evaluation – Supports
(Continued)

Component Type	Intended Function	Material	Environment	Aging Effect Requiring Management	Aging Management Program	NUREG-1801 Vol. 2 Item	Table 1 Item	Notes
Instrument Panels & Racks	NSRS, SS	Concrete	Plant Indoor Air (Structural) (Ext)	Reduction in concrete anchor capacity	Structures Monitoring Program (B2.1.32)	III.B3-1	3.5.1.40	A
Supports	ES, SS	Carbon Steel	Plant Indoor Air (Structural) (Ext)	Loss of mechanical function	ASME Section XI, Subsection IWF (B2.1.29)	III.B1.1-2	3.5.1.54	A
Supports	ES, SS	Carbon Steel	Plant Indoor Air (Structural) (Ext)	Loss of mechanical function	ASME Section XI, Subsection IWF (B2.1.29)	III.B1.2-2	3.5.1.54	A
Supports	ES, SS	Lubrite	Plant Indoor Air (Structural) (Ext)	Loss of mechanical function	ASME Section XI, Subsection IWF (B2.1.29)	III.B1.1-5	3.5.1.56	A
Supports	ES, SS	Lubrite	Plant Indoor Air (Structural) (Ext)	Loss of material, cracking	ASME Section XI, Subsection IWF (B2.1.29)	III.B1.2-3	3.5.1.56	A
Supports	ES, SS	Lubrite	Plant Indoor Air (Structural) (Ext)	Loss of mechanical function	Structures Monitoring Program (B2.1.32)	III.B2-2	3.5.1.52	A
Supports ASME 1	SS	Carbon Steel	Borated Water Leakage (Ext)	Loss of material	Boric Acid Corrosion (B2.1.4)	III.B1.1-14	3.5.1.55	A
Supports ASME 1	SS	Carbon Steel	Plant Indoor Air (Structural) (Ext)	Loss of material	ASME Section XI, Subsection IWF (B2.1.29)	III.B1.1-13	3.5.1.53	A
Supports ASME 1	SS	Concrete	Plant Indoor Air (Structural) (Ext)	Reduction in concrete anchor capacity	Structures Monitoring Program (B2.1.32)	III.B1.1-1	3.5.1.40	A

Section 3.5
AGING MANAGEMENT OF CONTAINMENTS,
STRUCTURES AND COMPONENT SUPPORTS

Table 3.5.2-14 Containments, Structures, and Component Supports – Summary of Aging Management Evaluation – Supports
(Continued)

Component Type	Intended Function	Material	Environment	Aging Effect Requiring Management	Aging Management Program	NUREG-1801 Vol. 2 Item	Table 1 Item	Notes
Supports ASME 1	SS	Stainless Steel	Borated Water Leakage (Ext)	None	None	III.B1.1-10	3.5.1.59	A
Supports ASME 1	SS	Stainless Steel	Plant Indoor Air (Structural) (Ext)	None	None	III.B1.1-9	3.5.1.59	A
Supports ASME 2 & 3	SS	Carbon Steel	Atmosphere/Weather (Structural) (Ext)	Loss of material	ASME Section XI, Subsection IWF (B2.1.29)	III.B1.2-10	3.5.1.53	A
Supports ASME 2 & 3	SS	Carbon Steel	Borated Water Leakage (Ext)	Loss of material	Boric Acid Corrosion (B2.1.4)	III.B1.2-11	3.5.1.55	A
Supports ASME 2 & 3	SS	Carbon Steel	Plant Indoor Air (Structural) (Ext)	Loss of material	ASME Section XI, Subsection IWF (B2.1.29)	III.B1.2-10	3.5.1.53	A
Supports ASME 2 & 3	SS	Carbon Steel	Raw Water (Ext)	Loss of material	ASME Section XI, Subsection IWF (B2.1.29)	None	None	G
Supports ASME 2 & 3	SS	Concrete	Plant Indoor Air (Structural) (Ext)	Reduction in concrete anchor capacity	Structures Monitoring Program (B2.1.32)	III.B1.2-1	3.5.1.40	A
Supports ASME 2 & 3	SS	Stainless Steel	Atmosphere/Weather (Structural) (Ext)	Loss of material	ASME Section XI, Subsection IWF (B2.1.29)	III.B4-7	3.5.1.50	E, 1
Supports ASME 2 & 3	SS	Stainless Steel	Borated Water Leakage (Ext)	None	None	III.B1.2-8	3.5.1.59	A
Supports ASME 2 & 3	SS	Stainless Steel	Plant Indoor Air (Structural) (Ext)	None	None	III.B1.2-7	3.5.1.59	A

Section 3.5
AGING MANAGEMENT OF CONTAINMENTS,
STRUCTURES AND COMPONENT SUPPORTS

Table 3.5.2-14 *Containments, Structures, and Component Supports – Summary of Aging Management Evaluation – Supports*
(Continued)

Component Type	Intended Function	Material	Environment	Aging Effect Requiring Management	Aging Management Program	NUREG-1801 Vol. 2 Item	Table 1 Item	Notes
Supports ASME 2 & 3	SS	Stainless Steel	Raw Water (Ext)	Loss of material	ASME Section XI, Subsection IWF (B2.1.29)	None	None	G
Supports HVAC Duct	SS	Carbon Steel	Atmosphere/Weather (Structural) (Ext)	Loss of material	Structures Monitoring Program (B2.1.32)	III.B2-10	3.5.1.39	A
Supports HVAC Duct	NSRS, SS	Carbon Steel	Plant Indoor Air (Structural) (Ext)	Loss of material	Structures Monitoring Program (B2.1.32)	III.B2-10	3.5.1.39	A
Supports HVAC Duct	NSRS, SS	Concrete	Plant Indoor Air (Structural) (Ext)	Reduction in concrete anchor capacity	Structures Monitoring Program (B2.1.32)	III.B2-1	3.5.1.40	A
Supports HVAC Duct	SS	Stainless Steel	Plant Indoor Air (Structural) (Ext)	None	None	III.B2-8	3.5.1.59	A
Supports Instrument	SS	Carbon Steel	Atmosphere/Weather (Structural) (Ext)	Loss of material	Structures Monitoring Program (B2.1.32)	III.B2-10	3.5.1.39	A
Supports Instrument	SS	Carbon Steel	Borated Water Leakage (Ext)	Loss of material	Boric Acid Corrosion (B2.1.4)	III.B2-11	3.5.1.55	A
Supports Instrument	NSRS, SS	Carbon Steel	Plant Indoor Air (Structural) (Ext)	Loss of material	Structures Monitoring Program (B2.1.32)	III.B2-10	3.5.1.39	A
Supports Instrument	NSRS, SS	Concrete	Plant Indoor Air (Structural) (Ext)	Reduction in concrete anchor capacity	Structures Monitoring Program (B2.1.32)	III.B2-1	3.5.1.40	A
Supports Instrument	SS	Stainless Steel	Atmosphere/Weather (Structural) (Ext)	Loss of material	Structures Monitoring Program (B2.1.32)	III.B2-7	3.5.1.50	A

Section 3.5
AGING MANAGEMENT OF CONTAINMENTS,
STRUCTURES AND COMPONENT SUPPORTS

Table 3.5.2-14 Containments, Structures, and Component Supports – Summary of Aging Management Evaluation – Supports
(Continued)

Component Type	Intended Function	Material	Environment	Aging Effect Requiring Management	Aging Management Program	NUREG-1801 Vol. 2 Item	Table 1 Item	Notes
Supports Instrument	SS	Stainless Steel	Borated Water Leakage (Ext)	None	None	III.B2-9	3.5.1.59	A
Supports Instrument	NSRS, SS	Stainless Steel	Plant Indoor Air (Structural) (Ext)	None	None	III.B2-8	3.5.1.59	A
Supports Insulation	SS	Aluminum	Plant Indoor Air (Structural) (Ext)	None	None	III.B1.1-6	3.5.1.58	A
Supports Mech Equip Class 1	SS	Carbon Steel	Borated Water Leakage (Ext)	Loss of material	Boric Acid Corrosion (B2.1.4)	III.B1.1-14	3.5.1.55	A
Supports Mech Equip Class 1	SS	Concrete	Plant Indoor Air (Structural) (Ext)	Reduction in concrete anchor capacity	Structures Monitoring Program (B2.1.32)	III.B1.1-1	3.5.1.40	A
Supports Mech Equip Class 1	SS	Stainless Steel	Borated Water Leakage (Ext)	None	None	III.B1.1-10	3.5.1.59	A
Supports Mech Equip Class 2 & 3	SS	Carbon Steel	Borated Water Leakage (Ext)	Loss of material	Boric Acid Corrosion (B2.1.4)	III.B1.2-11	3.5.1.55	A
Supports Mech Equip Class 2 & 3	SS	Carbon Steel	Fuel Oil (Ext)	Loss of material	ASME Section XI, Subsection IWF (B2.1.29)	None	None	G
Supports Mech Equip Class 2 & 3	SS	Carbon Steel	Plant Indoor Air (Structural) (Ext)	Loss of material	ASME Section XI, Subsection IWF (B2.1.29)	III.B1.2-10	3.5.1.53	A
Supports Mech Equip Class 2 & 3	SS	Concrete	Plant Indoor Air (Structural) (Ext)	Reduction in concrete anchor capacity	Structures Monitoring Program (B2.1.32)	III.B1.2-1	3.5.1.40	A

Section 3.5
AGING MANAGEMENT OF CONTAINMENTS,
STRUCTURES AND COMPONENT SUPPORTS

Table 3.5.2-14 Containments, Structures, and Component Supports – Summary of Aging Management Evaluation – Supports
(Continued)

Component Type	Intended Function	Material	Environment	Aging Effect Requiring Management	Aging Management Program	NUREG-1801 Vol. 2 Item	Table 1 Item	Notes
Supports Mech Equip Class 2 & 3	SS	Stainless Steel	Borated Water Leakage (Ext)	None	None	III.B1.2-8	3.5.1.59	A
Supports Mech Equip Class 2 & 3	SS	Stainless Steel	Fuel Oil (Ext)	Loss of material	ASME Section XI, Subsection IWF (B2.1.29)	None	None	G
Supports Mech Equip Class 2 & 3	SS	Stainless Steel	Plant Indoor Air (Structural) (Ext)	None	None	III.B1.2-7	3.5.1.59	A
Supports Mech Equip Non ASME	NSRS	Carbon Steel	Atmosphere/Weather (Structural) (Ext)	Loss of material	Structures Monitoring Program (B2.1.32)	III.B4-10	3.5.1.39	A
Supports Mech Equip Non ASME	NSRS	Carbon Steel	Borated Water Leakage (Ext)	Loss of material	Boric Acid Corrosion (B2.1.4)	III.B4-11	3.5.1.55	A
Supports Mech Equip Non ASME	NSRS	Carbon Steel	Plant Indoor Air (Structural) (Ext)	Loss of material	Structures Monitoring Program (B2.1.32)	III.B4-10	3.5.1.39	A
Supports Mech Equip Non ASME	NSRS	Concrete	Plant Indoor Air (Structural) (Ext)	Reduction in concrete anchor capacity	Structures Monitoring Program (B2.1.32)	III.B4-1	3.5.1.40	A
Supports Mech Equip Non ASME	NSRS	Stainless Steel	Atmosphere/Weather (Structural) (Ext)	Loss of material	Structures Monitoring Program (B2.1.32)	III.B4-7	3.5.1.50	A

Section 3.5
AGING MANAGEMENT OF CONTAINMENTS,
STRUCTURES AND COMPONENT SUPPORTS

Table 3.5.2-14 Containments, Structures, and Component Supports – Summary of Aging Management Evaluation – Supports
(Continued)

Component Type	Intended Function	Material	Environment	Aging Effect Requiring Management	Aging Management Program	NUREG-1801 Vol. 2 Item	Table 1 Item	Notes
Supports Mech Equip Non ASME	NSRS	Stainless Steel	Borated Water Leakage (Ext)	None	None	III.B4-9	3.5.1.59	A
Supports Mech Equip Non ASME	NSRS	Stainless Steel	Plant Indoor Air (Structural) (Ext)	None	None	III.B4-8	3.5.1.59	A
Supports Non ASME	NSRS	Carbon Steel	Atmosphere/Weather (Structural) (Ext)	Loss of material	Structures Monitoring Program (B2.1.32)	III.B2-10	3.5.1.39	A
Supports Non ASME	NSRS	Carbon Steel	Borated Water Leakage (Ext)	Loss of material	Boric Acid Corrosion (B2.1.4)	III.B2-11	3.5.1.55	A
Supports Non ASME	NSRS	Carbon Steel	Plant Indoor Air (Structural) (Ext)	Loss of material	Structures Monitoring Program (B2.1.32)	III.B2-10	3.5.1.39	A
Supports Non ASME	NSRS	Carbon Steel	Raw Water (Ext)	Loss of material	Structures Monitoring Program (B2.1.32)	None	None	G
Supports Non ASME	NSRS	Concrete	Plant Indoor Air (Structural) (Ext)	Reduction in concrete anchor capacity	Structures Monitoring Program (B2.1.32)	III.B2-1	3.5.1.40	A
Supports Non ASME	NSRS	Stainless Steel	Atmosphere/Weather (Structural) (Ext)	Loss of material	Structures Monitoring Program (B2.1.32)	III.B2-7	3.5.1.50	A
Supports Non ASME	NSRS	Stainless Steel	Borated Water Leakage (Ext)	None	None	III.B2-9	3.5.1.59	A
Supports Non ASME	NSRS	Stainless Steel	Plant Indoor Air (Structural) (Ext)	None	None	III.B2-8	3.5.1.59	A

Section 3.5
AGING MANAGEMENT OF CONTAINMENTS,
STRUCTURES AND COMPONENT SUPPORTS

Table 3.5.2-14 Containments, Structures, and Component Supports – Summary of Aging Management Evaluation – Supports
(Continued)

Component Type	Intended Function	Material	Environment	Aging Effect Requiring Management	Aging Management Program	NUREG-1801 Vol. 2 Item	Table 1 Item	Notes
Supports Non ASME	NSRS	Stainless Steel	Raw Water (Ext)	Loss of material	Structures Monitoring Program (B2.1.32)	None	None	G

Notes for Table 3.5.2-14:

Standard Notes:

- A Consistent with NUREG-1801 item for component, material, environment, and aging effect. AMP is consistent with NUREG-1801 AMP.
- B Consistent with NUREG-1801 item for component, material, environment, and aging effect. AMP takes some exceptions to NUREG-1801 AMP.
- E Consistent with NUREG-1801 for material, environment, and aging effect, but a different aging management program is credited or NUREG-1801 identifies a plant-specific aging management program.
- G Environment not in NUREG-1801 for this component and material.

Plant Specific Notes:

- 1 NUREG-1801 does not provide a line to evaluate stainless steel components outdoors under ASME Section XI, Subsection IWF.

3.6 AGING MANAGEMENT OF ELECTRICAL AND INSTRUMENTATION AND CONTROLS

3.6.1 Introduction

Section 3.6 provides the results of the aging management reviews for those component types identified in [Section 2.5](#), Scoping and Screening Results – Electrical and Instrument and Control Systems, subject to aging management review. The electrical component types subject to aging management review are discussed in the following sections:

- Connections (metallic parts) ([Section 2.5.1.1](#))
- Connector ([Section 2.5.1.2](#))
- High Voltage Insulators ([Section 2.5.1.4](#))
- Insulated Cable and Connections ([Section 2.5.1.5](#)) (includes the following):
 - Electrical cables and connections not subject to 10 CFR 50.49 EQ requirements
 - Electrical cables and connections used in instrumentation circuits not subject to 10 CFR 50.49 EQ requirements that are sensitive to reduction in conductor insulation resistance
 - Inaccessible Medium-Voltage Electrical Cables not subject to 10 CFR 50.49 EQ requirements
- Metal Enclosed Bus ([Section 2.5.1.6](#)) (includes the following):
 - Bus bar and connections
 - Bus enclosure
 - Bus Insulation and insulators
- Penetrations Electrical ([Section 2.5.1.7](#))
- Switchyard Bus and Connections ([Section 2.5.1.8](#))
- Terminal Block ([Section 2.5.1.9](#))
- Transmission Conductors and Connections ([Section 2.5.1.10](#))

Table 3.6.1, Summary of Aging Management Evaluations in Chapter VI of NUREG-1801 for Electrical Components, provides the summary of the programs evaluated in NUREG-1801 that are applicable to component types in this Section. [Table 3.6.1](#) uses the format of [Table 1](#) described in [Section 3.0](#).

3.6.2 Results

The following table summarizes the results of the aging management review for the component types in the Electrical and Instrumentation and Controls area.

- [Table 3.6.2-1](#) Electrical and Instrument and Controls – Summary of Aging Management Evaluation – Electrical Components

This table uses the format of [Table 2](#) discussed in [Section 3.0](#).

3.6.2.1 Materials, Environment, Aging Effects Requiring Management and Aging Management Programs

The materials from which the component types are fabricated, the environments to which they are exposed, the potential aging effects requiring management, and the aging management programs used to manage these aging effects are provided for each of the above electrical component commodities in the following subsections.

3.6.2.1.1 Cable Connections (Metallic Parts)

Materials

The materials of construction for the cable connections (metallic parts) are:

- Various Metals Used For Electrical Contacts

Environment

The cable connections (metallic parts) are exposed to the following environment:

- Plant Indoor Air
- Atmosphere/ Weather (Ext)

Aging Effects Requiring Management

The following cable connections (metallic parts) aging effect requires management:

- Loosening of bolted connections

Aging Management Programs

The following aging management program manages the aging effects for the cable connections (metallic parts):

- Electrical Connections Not Subject to 10 CFR 50.49 EQ Requirements ([B2.1.35](#))

3.6.2.1.2 Connectors

Materials

The materials of construction for the connectors are:

- Various Metals Used For Electrical Contacts

Environment

The connectors are exposed to the following environment:

- Borated Water Leakage

Aging Effects Requiring Management

The following connectors aging effect requires management:

- Corrosion Of Connector Contact Surfaces

Aging Management Programs

The following aging management program manages the aging effects for the connectors:

- Boric Acid Corrosion ([B2.1.4](#))

3.6.2.1.3 High Voltage Insulator

Materials

The materials of construction for the high voltage insulators are:

- Carbon Steel (Galvanized)
- Cement (Electrical Insulators)
- Porcelain

Environment

The high voltage insulators are exposed to the following environment:

- Atmosphere/ Weather (Ext)

Aging Effects Requiring Management

The following high voltage insulator aging effects require management:

- None

Aging Management Programs

The following aging management program manages the aging effects for the high voltage insulators:

- None

Technical justification for no aging effects requiring management

The PVNGS is located in an area where the outdoor environment is not subject to industry air pollution or salt spray. Contamination buildup on the high-voltage insulators is not a problem due to sufficient rainfall periodically washing the insulators. Additionally there is no salt spray at the plant since the plant is not located near the ocean. Degradation of insulator quality in the absence of salt deposits and surface contamination is not an aging effect requiring management.

Industry experience has shown that transmission conductors are designed and installed not to swing significantly and cause wear, due to wind induced abrasion and fatigue. The PVNGS transmission conductors are designed and installed not to swing significantly and cause wear due to wind induced abrasion and fatigue. Therefore, loss of material due to wind induced abrasion and fatigue is not an applicable aging effect requiring management.

3.6.2.1.4 Insulated Cables and Connections

3.6.2.1.4.1 Electrical cables and connections not subject to 10 CFR 50.49 EQ requirements

Materials

The materials of construction for the electrical cable and connections not subject to 10 CFR 50.49 EQ requirements are:

- Various Organic Polymers

Environment

The electrical cable and connections not subject to 10 CFR 50.49 EQ requirements are exposed to the following environment:

- Adverse Localized Environment

Aging Effects Requiring Management

The following electrical cable and connections not subject to 10 CFR 50.49 EQ requirements aging effects require management:

- Embrittlement, cracking, melting, discoloration, swelling, or loss of dielectric strength leading to reduced insulation resistance (IR); electrical failure

Aging Management Programs

The following aging management program manages the aging effects for the cable and connections not subject to 10 CFR 50.49 EQ requirements:

- Electrical Cables and Connections Not Subject to 10 CFR 50.49 EQ Requirements ([B2.1.24](#))

3.6.2.1.4.2 Electrical cables and connections used in instrumentation circuits not subject to 10 CFR 50.49 EQ requirements that are sensitive to reduction in conductor insulation resistance

Materials

The materials of construction for the electrical cables and connections used in sensitive instrumentation circuits not subject to 10 CFR 50.49 EQ requirements are:

- Various Organic Polymers

Environment

The electrical cables and connections used in sensitive instrumentation circuits not subject to 10 CFR 50.49 EQ requirements are exposed to the following environment:

- Adverse Localized Environment

Aging Effects Requiring Management

The following electrical cables and connections used in sensitive instrumentation circuits not subject to 10 CFR 50.49 EQ requirements aging effects require management:

- Embrittlement, cracking, melting, discoloration, swelling, or loss of dielectric strength leading to reduced insulation resistance (IR); electrical failure

Aging Management Programs

The following aging management program manages the aging effects for the cable and connections used in sensitive instrumentation circuits not subject to 10 CFR 50.49 EQ requirements:

- Electrical Cables and Connections Not Subject to 10 CFR 50.49 EQ Requirements Used in Instrumentation Circuits ([B2.1.25](#))

3.6.2.1.4.3 Inaccessible Medium Voltage Electrical Cables not subject to 10 CFR 50.49 EQ requirements

Materials

The materials of construction for the inaccessible medium voltage electrical cables not subject to 10 CFR 50.49 EQ requirements are:

- Various Organic Polymers

Environment

The inaccessible medium voltage electrical cables not subject to 10 CFR 50.49 EQ requirements are exposed to the following environment:

- Adverse Localized Environment

Aging Effects Requiring Management

The following inaccessible medium voltage electrical cables not subject to 10 CFR 50.49 EQ requirements aging effects require management:

- Localized damage and breakdown of insulation leading to electrical failure

Aging Management Programs

The following aging management program manages the inaccessible medium voltage electrical cables not subject to 10 CFR 50.49 EQ requirements:

- Inaccessible Medium Voltage Cables Not Subject to 10 CFR 50.49 EQ Requirements ([B2.1.26](#))

3.6.2.1.5 Metal Enclosed Bus

Materials

The materials of construction for metal enclosed bus are:

- Aluminum
- Carbon Steel
- Stainless Steel
- Various Metals Used for Electrical Contacts
- Elastomer
- Various Insulation Material (Electrical)

Environment

Metal enclosed bus is exposed to the following environment:

- Atmosphere/ Weather (Ext)

Aging Effects Requiring Management

The following metal enclosed bus aging effects require management:

- Loosening of bolted connections
- Loss of material
- Hardening and loss of strength
- Embrittlement, cracking, melting, discoloration, swelling, or loss of dielectric strength leading to reduced insulation resistance (IR); electrical failure

Aging Management Programs

The following aging management program manages the metal enclosed bus:

- Metal Enclosed Bus ([B2.1.36](#))

3.6.2.1.6 Penetrations Electrical

Materials

The materials of construction for the penetrations electrical are:

- Various Organic Polymers

Environment

The penetrations electrical are exposed to the following environment:

- Adverse Localized Environment (Ext)

Aging Effects Requiring Management

The following penetrations electrical aging effects require management:

- Embrittlement, cracking, melting, discoloration, swelling, or loss of dielectric strength leading to reduced insulation resistance (IR); electrical failure

Aging Management Programs

The following aging management program manages the penetrations electrical:

- Electrical Cables and Connections Not Subject to 10 CFR 50.49 EQ Requirements ([B2.1.24](#))

3.6.2.1.7 Switchyard Bus and Connections

Materials

The materials of construction for the switchyard bus and connections are:

- Aluminum
- Stainless Steel

Environment

The switchyard bus and connections are exposed to the following environment:

- Atmosphere/ Weather (Ext)

Aging Effects Requiring Management

The following switchyard bus and connections aging effect require management:

- None

Aging Management Programs

- None

Technical justification for no aging effects requiring management

The PVNGS outdoor environment is not subject to industry air pollution or saline environment. Aluminum bus material does not experience any appreciable aging effects in this environment.

Switchyard bus connections employ good bolting practices consistent with the recommendations of EPRI 1003471, "Electrical Connector Application Guidelines". The connections are treated with corrosion inhibitors to avoid connection oxidation and torqued to avoid loss of pre-load, at the time of installation. The switchyard bus bolted connections are designed and installed using lock washers that prevent loss of preload. The stainless steel connection material does not experience any appreciable aging effects in this environment.

3.6.2.1.8 Terminal Blocks

Materials

The materials of construction for the terminal blocks are:

- Various Insulation Materials (Electrical)

Environment

The terminal blocks are exposed to the following environment:

- Adverse Localized Environment (Ext)

Aging Effects Requiring Management

The following terminal blocks aging effects require management:

- Embrittlement, cracking, melting, discoloration, swelling, or loss of dielectric strength leading to reduced insulation resistance (IR); electrical failure

Aging Management Programs

The following aging management program manages the aging effects for the terminal blocks:

- Electrical Cables and Connections Not Subject to 10 CFR 50.49 EQ Requirements ([B2.1.24](#))

3.6.2.1.9 Transmission Conductors and Connections

Materials

The materials of construction for the transmission conductors and connections are:

- Aluminum Conductor Steel Reinforced

Environment

The transmission conductors and connections are exposed to the following environment:

- Atmosphere/ Weather (Ext)

Aging Effects Requiring Management

The following transmission conductors and connections aging effect require management:

- None

Aging Management Programs

- None

Technical justification for no aging effects requiring management

The most prevalent mechanism contributing to loss of conductor strength of an Aluminum Conductor Steel Reinforced (ACSR) transmission conductor is corrosion, which includes corrosion of the steel core and aluminum strand pitting. ACSR conductor degradation begins as a loss of zinc from the galvanized steel core wires. Corrosion rates depend largely on air quality, which involves suspended particles in the air, SO₂ concentration, rain, fog chemistry, and other weather conditions. The PVNGS outdoor environment is not subject to industry air pollution or saline environment that would cause significant corrosion of the transmission conductors.

The National Electrical Safety Code (NESC) requires that tension on installed conductors be a maximum of 60% of the ultimate conductor strength. The NESC also sets the maximum tension a conductor must be designed to withstand under medium load requirements, which includes consideration of ice, wind, and temperature.

At PVNGS, the ACSR transmission conductors are 2-2156 KCMIL per phase with a core of 19 steel strands having an ultimate conductor strength of 60,300 lbs. The PVNGS ACSR transmission conductors within the scope of license renewal are installed so that conductor tension does not exceed 18,000 lbs at the NESC medium loading condition (30% of the ultimate conductor strength).

Tests performed by Ontario Hydroelectric on ACSR transmission conductors with a core of 7 steel strands averaging 70 to 80 years old showed a 30% loss of ultimate conductor strength due to corrosion. Assuming a 30% loss of ultimate conductor strength (18,090 lbs) due to corrosion over 60 years the PVNGS ACSR transmission conductors have adequate design margin to offset the loss of strength due to corrosion and still meet the NESC requirement of not exceeding 60% of the ultimate conductor strength $((60,300 - 18,090) * 60\% = 25,326 \text{ lbs})$. Therefore, corrosion is not a credible aging effect that requires management for the period of extended operation.

Transmission conductor and switchyard bus connections at the time of installation are treated with corrosion inhibitors to avoid connection oxidation and torqued to avoid loss of pre-load. Based on temperature data in the [UFSAR Chapter 2.3](#), the transmission connections and switchyard bus does not experience thermal cycling. The transmission connections and switchyard bus are subject to average monthly temperatures ranging from 105 °F in July and August to 38 °F in January with minimal ohmic heating. Therefore, increased resistance of connections due to oxidation or loss of pre-load is not an aging effect requiring management for the period of extended operation. These connections are periodically evaluated via thermography as part of the preventive maintenance activities. The periodic thermography will continue into the period of extended operation.

3.6.2.2 Further Evaluation of Aging Management as Recommended by NUREG-1801

NUREG-1801 provides the basis for identifying those programs that warrant further evaluation. For the electrical and control systems, those evaluations are addressed in the following subsections.

3.6.2.2.1 Electrical Equipment Subject to Environmental Qualification

Environmental qualification (EQ) is a TLAA as defined in 10 CFR 54.3. Equipment qualification for degradation due to various aging mechanisms to which electrical equipment is subject is evaluated in accordance with 10 CFR 54.21(c)(1). The PVNGS EQ program meets requirements of 10 CFR 50.49.

[Section 4.4](#) describes the TLAA evaluation of electrical equipment subject to 10 CFR 50.49 environmental qualification.

3.6.2.2.2 Degradation of Insulator Quality due to Presence of Any Salt Deposits and Surface Contamination, and Loss of Material due to Mechanical Wear

The PVNGS is located in an area where the outdoor environment is not subject to industry air pollution or salt spray. Contamination buildup on the high-voltage insulators is not a problem due to sufficient rainfall in the spring and summer washing the insulators. Additionally there is no salt spray at the plant since the plant is not located near the ocean. Degradation of insulator quality in the absence of salt deposits and surface contamination is not an aging effect requiring management.

Industry experience has shown that transmission conductors are designed and installed not to swing significantly and cause wear, due to wind induced abrasion and fatigue. The PVNGS transmission conductors are designed and installed not to swing significantly and cause wear due to wind induced abrasion and fatigue. Therefore, loss of material due to wind induced abrasion and fatigue is not an applicable aging effect requiring management.

3.6.2.2.3 Loss of Material due to Wind Induced Abrasion and Fatigue, Loss of Conductor Strength due to Corrosion, and Increased Resistance of Connection due to Oxidation or Loss of Pre-load

Industry experience has shown that transmission conductors are designed and installed not to swing significantly and cause wear due to wind induced abrasion and fatigue. Therefore, loss of material due to wind induced abrasion and fatigue is not an applicable aging effect requiring management for the period of extended operation.

The most prevalent mechanism contributing to loss of conductor strength of an Aluminum Conductor Steel Reinforced (ACSR) transmission conductor is corrosion, which includes

Section 3.6
AGING MANAGEMENT OF ELECTRICAL AND
INSTRUMENTATION AND CONTROLS

corrosion of the steel core and aluminum strand pitting. ACSR conductor degradation begins as a loss of zinc from the galvanized steel core wires. Corrosion rates depend largely on air quality, which involves suspended particles in the air, SO₂ concentration, rain, fog chemistry, and other weather conditions. The PVNGS outdoor environment is not subject to industry air pollution or saline environment that would cause significant corrosion of the transmission conductors.

The National Electrical Safety Code (NESC) requires that tension on installed conductors be a maximum of 60% of the ultimate conductor strength. The NESC also sets the maximum tension a conductor must be designed to withstand under medium load requirements, which includes consideration of ice, wind, and temperature.

At PVNGS, the ACSR transmission conductors are 2-2156 KCMIL per phase with a core of 19 steel strands having an ultimate conductor strength of 60,300 lbs. The PVNGS ACSR transmission conductors within the scope of license renewal are installed so that conductor tension does not exceed 18,000 lbs at the NESC medium loading condition (30% of the ultimate conductor strength).

Tests performed by Ontario Hydroelectric on ACSR transmission conductors with a core of 7 steel strands averaging 70 to 80 years old showed a 30% loss of ultimate conductor strength due to corrosion. Assuming a 30% loss of ultimate conductor strength (18,090 lbs) due to corrosion over 60 years the PVNGS ACSR transmission conductors have adequate design margin to offset the loss of strength due to corrosion and still meet the NESC requirement of not exceeding 60% of the ultimate conductor strength $((60,300 - 18,090) \times 0.60) = 25,326$ lbs). Therefore, corrosion is not a credible aging effect that requires management for the period of extended operation.

Transmission conductor and switchyard bus connections at the time of installation are treated with corrosion inhibitors to avoid connection oxidation and torqued to avoid loss of pre-load. Based on temperature data in the [UFSAR Chapter 2.3](#), the transmission connections and switchyard bus does not experience thermal cycling. The transmission connections and switchyard bus are subject to average monthly temperatures ranging from 105 °F in July and August to 38 °F in January with minimal ohmic heating. Therefore, increased resistance of connections due to oxidation or loss of pre-load is not an aging effect requiring management for the period of extended operation. These connections are periodically evaluated via thermography as part of the preventive maintenance activities. The periodic thermography will continue into the period of extended operation.

The PVNGS outdoor environment is not subject to industry air pollution or saline environment. Aluminum bus material, galvanized steel support hardware and aluminum connection material do not experience any appreciable aging effects in this environment.

Switchyard bus connections employ good bolting practices consistent with the recommendations of EPRI 1003471, "Electrical Connector Application Guidelines". The connections are treated with corrosion inhibitors to avoid connection oxidation and torqued to avoid loss of pre-load, at the time of installation. The switchyard bus bolted connections

are designed and installed to prevent loss of preload. The aluminum connection material does not experience any appreciable aging effects in this environment.

3.6.2.2.4 Quality Assurance for Aging Management of Nonsafety-Related Components

Quality Assurance Program and Administrative Controls are discussed in [Section B1.3](#).

3.6.2.3 Time-Limited Aging Analysis

The time-limited aging analyses identified below are associated with the electrical and instrument and controls component types. The section within [Chapter 4](#), Time-Limited Aging Analyses, is indicated in parenthesis.

- Environmental Qualification of Electrical and Instrumentation and Control Equipment ([Section 4.4](#), Environmental Qualification (EQ) of Electric Equipment)

3.6.3 Conclusions

The Electrical and Instrument and Controls component types that are subject to aging management review have been evaluated. The aging management programs selected to manage the aging effects for the Electrical and Instrument and Controls component types are identified in the summary [Table 3.6.1](#) and in [Section 3.6.2.1](#).

A description of these aging management programs is provided in [Appendix B](#), along with a demonstration that the identified aging effects will be managed for the period of extended operation.

Therefore, based on the demonstration provided in [Appendix B](#), the effects of aging associated with the Electrical and Instrument and Controls component types will be adequately managed so that there is reasonable assurance that the intended functions will be maintained consistent with the current licensing basis during the period of extended operation.

Section 3.6
AGING MANAGEMENT OF ELECTRICAL AND INSTRUMENTATION AND CONTROLS

Table 3.6.1 Summary of Aging Management Evaluations in Chapter VI of NUREG-1801 for Electrical Components

Item Number	Component Type	Aging Effect / Mechanism	Aging Management Program	Further Evaluation Recommended	Discussion
3.6.1.01	Electrical equipment subject to 10 CFR 50.49 environmental qualification (EQ) requirements	Degradation due to various aging mechanisms	Environmental Qualification Of Electric Components (B3.2)	Yes, TLAA	Environmental qualification of electric components is a TLAA. See further evaluation in Section 3.6.2.2.1.
3.6.1.02	Electrical cables, connections and fuse holders (insulation) not subject to 10 CFR 50.49 EQ requirements	Reduced insulation resistance and electrical failure due to various physical, thermal, radiolytic, photolytic, and chemical mechanisms	Electrical Cables and Connections Not Subject To 10 CFR 50.49 EQ Requirements (B2.1.24)	No	Consistent with NUREG-1801.
3.6.1.03	Conductor insulation for electrical cables and connections used in instrumentation circuits not subject to 10 CFR 50.49 EQ requirements that are sensitive to reduction in conductor insulation resistance (IR)	Reduced insulation resistance and electrical failure due to various physical, thermal, radiolytic, photolytic, and chemical mechanisms	Electrical Cables And Connections Used In Instrumentation Circuits Not Subject To 10 CFR 50.49 EQ Requirements (B2.1.25)	No	Consistent with NUREG-1801.

Section 3.6
AGING MANAGEMENT OF ELECTRICAL AND INSTRUMENTATION AND CONTROLS

Table 3.6.1 Summary of Aging Management Evaluations in Chapter VI of NUREG-1801 for Electrical Components (Continued)

Item Number	Component Type	Aging Effect / Mechanism	Aging Management Program	Further Evaluation Recommended	Discussion
3.6.1.04	Conductor insulation for inaccessible medium voltage (2 kV to 35 kV) cables (e.g., installed in conduit or direct buried) not subject to 10 CFR 50.49 EQ requirements	Localized damage and breakdown of insulation leading to electrical failure due to moisture intrusion, water trees	Inaccessible Medium Voltage Cables Not Subject To 10 CFR 50.49 EQ Requirements (B2.1.26)	No	Consistent with NUREG-1801.
3.6.1.05	Connector contacts for electrical connectors exposed to borated water leakage	Corrosion of connector contact surfaces due to intrusion of borated water	Boric Acid Corrosion (B2.1.4)	No	Consistent with NUREG-1801.
3.6.1.06	Fuse Holders (Not Part of a Larger Assembly): Fuse holders – metallic clamp	Fatigue due to ohmic heating, thermal cycling, electrical transients, frequent manipulation, vibration, chemical contamination, corrosion, and oxidation	Fuse Holders	No	Not applicable. All fuse holders including the fuses installed for electrical penetration protection are part of larger assemblies, so the applicable NUREG-1801 lines were not used.
3.6.1.07	Metal enclosed bus - Bus/connections	Loosening of bolted connections due to thermal cycling and ohmic heating	Metal Enclosed Bus (B2.1.36)	No	Consistent with NUREG-1801.

Section 3.6
AGING MANAGEMENT OF ELECTRICAL AND INSTRUMENTATION AND CONTROLS

Table 3.6.1 Summary of Aging Management Evaluations in Chapter VI of NUREG-1801 for Electrical Components (Continued)

Item Number	Component Type	Aging Effect / Mechanism	Aging Management Program	Further Evaluation Recommended	Discussion
3.6.1.08	Metal enclosed bus – Insulation/insulators	Reduced insulation resistance and electrical failure due to various physical, thermal, radiolytic, photolytic, and chemical mechanisms	Metal Enclosed Bus (B2.1.36)	No	Consistent with NUREG-1801.
3.6.1.09	Metal enclosed bus – Enclosure assemblies	Loss of material due to general corrosion	Structures Monitoring Program (B2.1.32)	No	Consistent with NUREG-1801 for material, environment, and aging effect, but a different aging management program. Aging Management Program for Metal Enclosed Bus (B2.1.36) is credited.
3.6.1.10	Metal enclosed bus – Enclosure assemblies	Hardening and loss of strength due to elastomers degradation	Structures Monitoring Program (B2.1.32)	No	Consistent with NUREG-1801 for material, environment, and aging effect, but a different aging management program. Aging Management Program for Metal Enclosed Bus (B2.1.36) is credited.
3.6.1.11	High voltage insulators	Degradation of insulation quality due to presence of any salt deposits and surface contamination, Loss of material caused by mechanical wear due to wind blowing on transmission conductors	A plant-specific aging management program is to be evaluated.	Yes	Exception to NUREG-1801. Aging effect in NUREG-1801 for this material and environment combination is not applicable. See further evaluation in Section 3.6.2.2.2.

Section 3.6
AGING MANAGEMENT OF ELECTRICAL AND INSTRUMENTATION AND CONTROLS

Table 3.6.1 Summary of Aging Management Evaluations in Chapter VI of NUREG-1801 for Electrical Components (Continued)

Item Number	Component Type	Aging Effect / Mechanism	Aging Management Program	Further Evaluation Recommended	Discussion
3.6.1.12	Transmission conductors and Switchyard bus and connections	Loss of material due to wind induced abrasion and fatigue, Loss of conductor strength due to corrosion, Increased resistance of connection due to oxidation or loss of preload	A plant-specific aging management program is to be evaluated.	Yes	Exception to NUREG-1801. Aging effect in NUREG-1801 for this material and environment combination is not applicable. See further evaluation in Section 3.6.2.2.3.
3.6.1.13	Cable Connections – Metallic parts	Loosening of bolted connections due to thermal cycling, ohmic heating, electrical transients, vibration, chemical contamination, corrosion, and oxidation	Electrical Cable Connections Not Subject To 10 CFR 50.49 Environmental Qualification Requirements (B2.1.35)	No	Consistent with NUREG-1801.
3.6.1.14	Fuse Holders (Not Part of a Larger Assembly) Insulation material	None	None	NA – No AEM or AMP	Not applicable. All fuse holders including the fuses installed for electrical penetration protection are part of larger assemblies, so the applicable NUREG-1801 lines were not used.

Section 3.6
AGING MANAGEMENT OF ELECTRICAL AND INSTRUMENTATION AND CONTROLS

Table 3.6.2-1 – Electrical and Instrument and Controls – Summary of Aging Management Evaluation – Electrical Components

Component Type	Intended Function	Material	Environment	Aging Effect Requiring Management	Aging Management Program	NUREG-1801 Vol. 2 Item	Table 1 Item	Notes
10 CFR 50.49 Electrical Equipment	EC, IN	Various Organic Polymers and Metallic Materials	Adverse Localized Environment (Ext)	Various degradation	Time-Limited Aging Analysis evaluated for the period of extended operation.	VI.B-1	3.6.1.01	A
Cable Connections (Metallic Parts)	EC	Various Metals Used for Electrical Contacts	Atmosphere/Weather (Ext)	Loosening of bolted connections	Electrical Connections Not Subject to 10 CFR 50.49 Environmental Qualification Requirements (B2.1.35)	VI.A-1	3.6.1.13	A
Cable Connections (Metallic Parts)	EC	Various Metals Used for Electrical Contacts	Plant Indoor Air (Ext)	Loosening of bolted connections	Electrical Connections Not Subject to 10 CFR 50.49 Environmental Qualification Requirements (B2.1.35)	VI.A-1	3.6.1.13	A
Connector	EC	Various Metals Used for Electrical Contacts	Borated Water Leakage (Ext)	Corrosion of connector contact surfaces	Boric Acid Corrosion (B2.1.4)	VI.A-5	3.6.1.05	A
High Voltage Insulator	NSRS	Carbon Steel (Galvanized)	Atmosphere/Weather (Ext)	None	None	VI.A-9	3.6.1.11	I, 1
High Voltage Insulator	NSRS	Carbon Steel (Galvanized)	Atmosphere/Weather (Ext)	None	None	VI.A-10	3.6.1.11	I, 1

Section 3.6
AGING MANAGEMENT OF ELECTRICAL AND INSTRUMENTATION AND CONTROLS

Table 3.6.2-1 – Electrical and Instrument and Controls – Summary of Aging Management Evaluation – Electrical Components
(Continued)

Component Type	Intended Function	Material	Environment	Aging Effect Requiring Management	Aging Management Program	NUREG-1801 Vol. 2 Item	Table 1 Item	Notes
High Voltage Insulator	IN	Cement (Electrical Insulators)	Atmosphere/Weather (Ext)	None	None	VI.A-9	3.6.1.11	I, 1
High Voltage Insulator	IN	Cement (Electrical Insulators)	Atmosphere/Weather (Ext)	None	None	VI.A-10	3.6.1.11	I, 1
High Voltage Insulator	IN	Porcelain	Atmosphere/Weather (Ext)	None	None	VI.A-9	3.6.1.11	I, 1
High Voltage Insulator	IN	Porcelain	Atmosphere/Weather (Ext)	None	None	VI.A-10	3.6.1.11	I, 1
Insulated Cable and Connections	EC, IN	Various Organic Polymers	Adverse Localized Environment (Ext)	Embrittlement, cracking, melting, discoloration, swelling, or loss of dielectric strength leading to reduced insulation resistance (IR); electrical failure	Electrical Cables and Connections Not Subject to 10 CFR 50.49 EQ Requirements (B2.1.24)	VI.A-2	3.6.1.02	A

Section 3.6
AGING MANAGEMENT OF ELECTRICAL AND
INSTRUMENTATION AND CONTROLS

Table 3.6.2-1 – Electrical and Instrument and Controls – Summary of Aging Management Evaluation – Electrical Components
(Continued)

Component Type	Intended Function	Material	Environment	Aging Effect Requiring Management	Aging Management Program	NUREG-1801 Vol. 2 Item	Table 1 Item	Notes
Insulated Cable and Connections	EC, IN	Various Organic Polymers	Adverse Localized Environment (Ext)	Embrittlement, cracking, melting, discoloration, swelling, or loss of dielectric strength leading to reduced insulation resistance (IR); electrical failure	Electrical Cables and Connections Not Subject to 10 CFR 50.49 EQ Requirements Used in Instrumentation Circuits (B2.1.25)	VI.A-3	3.6.1.03	A
Insulated Cable and Connections	EC, IN	Various Organic Polymers	Adverse Localized Environment (Ext)	Localized damage and breakdown of insulation leading to electrical failure	Inaccessible Medium Voltage Cables Not Subject to 10 CFR 50.49 EQ Requirements (B2.1.26)	VI.A-4	3.6.1.04	A
Metal Enclosed Bus (Bus/Connections)	EC	Aluminum	Atmosphere/Weather (Ext)	Loosening of bolted connections	Metal Enclosed Bus (B2.1.36)	VI.A-11	3.6.1.07	A
Metal Enclosed Bus (Bus/Connections)	EC	Carbon Steel	Atmosphere/Weather (Ext)	Loosening of bolted connections	Metal Enclosed Bus (B2.1.36)	VI.A-11	3.6.1.07	A
Metal Enclosed Bus (Bus/Connections)	EC	Stainless Steel	Atmosphere/Weather (Ext)	Loosening of bolted connections	Metal Enclosed Bus (B2.1.36)	VI.A-11	3.6.1.07	A

Section 3.6
AGING MANAGEMENT OF ELECTRICAL AND
INSTRUMENTATION AND CONTROLS

Table 3.6.2-1 – *Electrical and Instrument and Controls – Summary of Aging Management Evaluation – Electrical Components*
(Continued)

Component Type	Intended Function	Material	Environment	Aging Effect Requiring Management	Aging Management Program	NUREG-1801 Vol. 2 Item	Table 1 Item	Notes
Metal Enclosed Bus (Bus/Connections)	EC	Various Metals Used for Electrical Contacts	Atmosphere/Weather (Ext)	Loosening of bolted connections	Metal Enclosed Bus (B2.1.36)	VI.A-11	3.6.1.07	A
Metal Enclosed Bus (Enclosure)	NSRS	Aluminum	Atmosphere/Weather (Ext)	Loss of material	Metal Enclosed Bus (B2.1.36)	None	None	J
Metal Enclosed Bus (Enclosure)	NSRS	Carbon Steel	Atmosphere/Weather (Ext)	Loss of material	Metal Enclosed Bus (B2.1.36)	VI.A-13	3.6.1.09	E, 3
Metal Enclosed Bus (Enclosure)	ES	Elastomer	Atmosphere/Weather (Ext)	Hardening and loss of strength	Metal Enclosed Bus (B2.1.36)	VI.A-12	3.6.1.10	E, 3
Metal Enclosed Bus (Insulation/Insulators)	IN	Various Insulation Material (Electrical)	Atmosphere/Weather (Ext)	Embrittlement, cracking, melting, discoloration, swelling, or loss of dielectric strength leading to reduced insulation resistance (IR); electrical failure	Metal Enclosed Bus (B2.1.36)	VI.A-14	3.6.1.08	A

Section 3.6
AGING MANAGEMENT OF ELECTRICAL AND INSTRUMENTATION AND CONTROLS

Table 3.6.2-1 – Electrical and Instrument and Controls – Summary of Aging Management Evaluation – Electrical Components
(Continued)

Component Type	Intended Function	Material	Environment	Aging Effect Requiring Management	Aging Management Program	NUREG-1801 Vol. 2 Item	Table 1 Item	Notes
Penetrations Electrical	EC, IN	Various Organic Polymers	Adverse Localized Environment (Ext)	Embrittlement, cracking, melting, discoloration, swelling, or loss of dielectric strength leading to reduced insulation resistance (IR); electrical failure	Electrical Cables and Connections Not Subject to 10 CFR 50.49 EQ Requirements (B2.1.24)	VI.A-2	3.6.1.02	C
Switchyard Bus and Connections	EC	Aluminum	Atmosphere/Weather (Ext)	None	None	VI.A-15	3.6.1.12	I, 2
Switchyard Bus and Connections	EC	Stainless Steel	Atmosphere/Weather (Ext)	None	None	VI.A-15	3.6.1.12	I, 2
Terminal Block	IN	Various Insulation Material (Electrical)	Adverse Localized Environment (Ext)	Embrittlement, cracking, melting, discoloration, swelling, or loss of dielectric strength leading to reduced insulation resistance (IR); electrical failure	Electrical Cables and Connections Not Subject to 10 CFR 50.49 EQ Requirements (B2.1.24)	VI.A-6	3.6.1.02	C

Section 3.6
AGING MANAGEMENT OF ELECTRICAL AND
INSTRUMENTATION AND CONTROLS

Table 3.6.2-1 – *Electrical and Instrument and Controls – Summary of Aging Management Evaluation – Electrical Components*
(Continued)

Component Type	Intended Function	Material	Environment	Aging Effect Requiring Management	Aging Management Program	NUREG-1801 Vol. 2 Item	Table 1 Item	Notes
Transmission Conductors and Connections	EC	Aluminum Conductor Steel Reinforced	Atmosphere/ Weather (Ext)	None	None	VI.A-16	3.6.1.12	1, 2

Notes for Table 3.6.2-1:

Standard Notes:

- A Consistent with NUREG-1801 item for component, material, environment, and aging effect. AMP is consistent with NUREG-1801 AMP.
- C Component is different, but consistent with NUREG-1801 item for material, environment, and aging effect. AMP is consistent with NUREG-1801 AMP.
- E Consistent with NUREG-1801 for material, environment, and aging effect, but a different aging management program is credited or NUREG-1801 identifies a plant-specific aging management program.
- I Aging effect in NUREG-1801 for this component, material and environment combination is not applicable.
- J Neither the component nor the material and environment combination is evaluated in NUREG-1801.

Plant Specific Notes:

- 1 See further evaluation 3.6.2.2.2
- 2 See further evaluation 3.6.2.2.3
- 3 PVNGS will use the Metal Enclosed Bus program (B2.1.36) to manage the aging effects for all metal enclosed bus components.

This Page Intentionally Left Blank

CHAPTER 4

TIME-LIMITED AGING ANALYSES

This Page Intentionally Left Blank

4.0 TIME-LIMITED AGING ANALYSIS

4.1 INTRODUCTION

Section 4.0 describes the Time-Limited Aging Analyses (TLAAs) for the Palo Verde Nuclear Generating Station (PVNGS), Units 1, 2, and 3, in accordance with 10 CFR 54.3(a) and 54.21(c). Subsequent sections describe TLAAs within these common general categories:

- Neutron Embrittlement of the Reactor Vessel
- Metal Fatigue of Vessels and Piping
- Environmental Qualification of Electrical Equipment (EQ)
- Loss of Prestress in Concrete Containment Tendons
- Fatigue of the Containment Liner and Penetrations
- Other Plant-Specific TLAAs

The information on each specific TLAA within these general categories is organized under three subheadings:

Summary Description

A brief description of the TLAA topic and of the affected components.

Analysis

A description of the current licensing basis analysis, that is, of the TLAA itself, including implications for the period of extended operation.

Disposition

The disposition of the TLAA for the period of extended operation, in accordance with 10 CFR 54.21(c)(1):

- Validation - 10 CFR 54.21(c)(1)(i) - The analysis remains valid for the period of extended operation, or
- Revision - 10 CFR 54.21(c)(1)(ii) - The analysis has been projected to the end of the period of extended operation, or

- Aging Management - 10 CFR 54.21(c)(1)(iii) - The effects of aging on the intended function(s) will be adequately managed for the period of extended operation.

4.1.1 Identification of TLAAs

Survey of Design and Licensing Bases

An analysis, calculation, or evaluation is a “Time-Limited Aging Analysis” (TLAA) under the 10 CFR 54 License Renewal Rule (the Rule) only if it meets all six of the 10 CFR 54.3(a) criteria:

Time-limited aging analyses, for the purposes of this part, are those licensee calculations and analyses that:

- 1) Involve systems, structures, and components within the scope of license renewal;
- 2) Consider the effects of aging;
- 3) Involve time-limited assumptions defined by the current operating term, for example, 40 years;
- 4) Were determined to be relevant by the licensee in making a safety determination;
- 5) Involve conclusions or provide the basis for conclusions related to the capability of the system, structure, and component to perform its intended functions; and
- 6) Are contained or incorporated by reference in the CLB (current licensing basis).

[10 CFR 54.3(a)]

10 CFR 54.21(c) requires that:

1. A list of time-limited aging analyses, as defined in §54.3, must be provided. The applicant shall demonstrate that: –
 - i. The analyses remain valid for the period of extended operation;
 - ii. The analyses have been projected to the end of the period of extended operation; or
 - iii. The effects of aging on the intended function(s) will be adequately managed for the period of extended operation.

Section 4
TIME-LIMITED AGING ANALYSES

2. A list must be provided of plant-specific exemptions granted pursuant to 10 CFR 50.12 and in effect that are based on time-limited aging analyses as defined in §54.3. The applicant shall provide an evaluation that justifies the continuation of these exemptions for the period of extended operation.

Section 4.0 provides these lists and dispositions, and their bases.

A list of potential TLAAs was assembled from regulatory guidance and industry experience, including:

- The NUREG-1800 *Standard Review Plan for Review of License Renewal Applications for Nuclear Power Plants*, Chapter 4
- The NEI 95-10 *Industry Guideline for Implementing the Requirements of 10 CFR 54, the License Renewal Rule*
- The 10 CFR 54 Final Rule “Statement of Considerations”
- Prior license renewal applications
- Plant-specific document reviews and interviews with plant personnel.

Keyword searches on the Palo Verde Licensing Research System examined the PVNGS current licensing basis (CLB) to determine whether the design or analysis feature of each potential TLAAs in fact exists at PVNGS and in its licensing basis, and to identify additional potential unit-specific TLAAs. The CLB search included

- The Updated Final Safety Analysis Report (UFSAR)
- Technical Specifications
- The NRC Safety Evaluation Reports (SERs) for the original operating licenses
- Subsequent NRC Safety Evaluations (SEs)
- APS and NRC docketed licensing correspondence.

Only those potential TLAAs meeting all six criteria of 10 CFR 54.3(a) are actual TLAAs requiring disposition in accordance with 54.21(c). The list of potential TLAAs was therefore reviewed (screened) against the six 10 CFR 54.3(a) criteria based on information in the CLB source documents, and from source documents for the potential TLAAs such as:

- The Combustion Engineering System 80 *Standard Safety Analysis Report* (CESSAR)
- Vendor, NRC-sponsored, and licensee topical reports

- Design calculations
- Code stress reports or code design reports
- Drawings
- Specifications

These TLAA source documents provided the information and the basis for the dispositions.

Licensing basis program documents, such as the inservice inspection and electrical equipment environmental qualification programs (ISI and EQ programs), were reviewed separately.

The EQ program includes qualification of some components for the licensed operating period. Since the scope of the EQ program is generally limited to safety-related or quality augmented components with safety functions or that support safety functions, and since these qualifications support safety determinations, EQ qualifications for the design lifetime are TLAAAs. The EQ program requires that the component Environmental Qualification Data File (EQDF) be examined prior to expiration of the qualified life of each component, and that each affected component be requalified, refurbished, or replaced as required

Disposition of indications discovered during inservice inspections may include qualifications for the licensed design life that are TLAAAs. These are typically identified during the review of licensing correspondence. See [Section 4.3.2.4](#) for an analysis of indications in a Unit 2 pressurizer support skirt forging weld. See [Section 4.7.3](#) for a summary of this TLAA; and of similar evaluations of postulated defects (rather than of existing defects discovered during inservice inspections).

4.1.2 Aging Management Review

The NUREG-1801 *Generic Aging Lessons Learned (GALL) Report* identifies numerous aging effects that require evaluation as possible TLAAAs in accordance with 10 CFR 54.21(c). Each of these was reviewed, and dispositioned as a TLAA if identified as such under the 10 CFR 54.3(a) criteria. Table 1 of each of [Sections 3.1](#) through [3.6](#) of this application lists the TLAA line items of the NUREG-1801 Volume 1 Summary Tables, and identifies the locations of their “further evaluations.”

4.1.3 Summary of Results

Sections 4.2 through 4.7 of this report list and describe six general categories of TLAAAs. They are listed in Table 4.1-1. They are presented in the order in which they appear in Sections 4.2 through 4.7 of the NUREG-1800 *Standard Review Plan for Review of License Renewal Applications for Nuclear Power Plants* (the SRP).

Standard Review Plan Tables 4.1-2 and 4.1-3 list examples of analyses that could be TLAAAs, depending on the applicant's current licensing basis (CLB). Table 4.1-2 summarizes the results of the PVNGS review of the analyses identified in SRP Tables 4.1-2 and 4.1-3.

Table 4.1-1 - List of TLAAAs

TLAA Category	Description	Disposition Category¹	Report Section
1.	Reactor Vessel Neutron Embrittlement Analysis	NA	4.2
	Neutron Fluence, Upper Shelf Energy and Adjusted Reference Temperature (Fluence, USE, and ART)	i, iii	4.2.1
	Pressurized Thermal Shock (PTS)	i	4.2.2
	Pressure-Temperature (P-T) Limits	i	4.2.3
	Low Temperature Overpressure Protection (LTOP)	i	4.2.4
2.	Metal Fatigue Analysis	NA	4.3
	Fatigue Aging Management Program	NA	4.3.1
	ASME III Class 1 Fatigue Analysis of Vessels, Piping, and Components	NA	4.3.2
	Reactor Pressure Vessel, Nozzles, Head, and Studs	ii, iii	4.3.2.1
	Control Element Drive Mechanism (CEDM) Nozzle Pressure Housings	i	4.3.2.2
	Reactor Coolant Pump Pressure Boundary Components	iii	4.3.2.3
	Pressurizer and Pressurizer Nozzles	iii	4.3.2.4

Section 4
TIME-LIMITED AGING ANALYSES

Table 4.1-1 - List of TLAAs

TLAA Category	Description	Disposition Category ¹	Report Section
	Steam Generator ASME III Class 1, Class 2 Secondary Side, and Feedwater Nozzle Fatigue Analyses	i, iii	4.3.2.5
	ASME III Class 1 Valves	i, iii ²	4.3.2.6
	ASME III Class 1 Piping and Piping Nozzles	iii	4.3.2.7
	Absence of Supplemental Fatigue Analysis TLAA's in Response to Bulletin 88-08 for Intermittent Thermal Cycles due to Thermal-Cycle-Driven Interface Valve Leaks and Similar Cyclic Phenomena	Included under 4.3.2.7	4.3.2.8
	Bulletin 88-11 Revised Fatigue Analysis of the Pressurizer Surge Line for Thermal Cycling and Stratification	iii	4.3.2.9
	Class 1 Fatigue Analyses of Class 2 Regenerative and Letdown Heat Exchangers	iii	4.3.2.10
	Class 1 Fatigue Analyses of Class 2 HPSI and LPSI Safety Injection Safeguard Pumps for Design Thermal Cycles	i	4.3.2.11
	Class 1 Analysis of Class 2 Main Steam Safety Valves	i	4.3.2.12
	Absence of TLAA's in Evaluations of Effects of Vibration on the Unit 1 Train A Shutdown Cooling System Suction Line Fatigue Analysis, and of Vibration Limits Established for its Isolation Valve Actuator	NA	4.3.2.13
	High Energy Line Break Postulation Based on Fatigue Cumulative Usage Factor	iii	4.3.2.14
	Absence of TLAA's in Fatigue Crack Growth Assessments and Fracture Mechanics Stability Analyses for the Leak-Before-Break (LBB) Elimination of Dynamic Effects of Primary Loop Piping Failures	NA	4.3.2.15

Section 4
TIME-LIMITED AGING ANALYSES

Table 4.1-1 - List of TLAAs

TLAA Category	Description	Disposition Category ¹	Report Section
	Fatigue and Cycle-Based TLAA of ASME III Subsection NG Reactor Pressure Vessel Internals	iii	4.3.3
	Effects of the Reactor Coolant System Environment on Fatigue Life of Piping and Components (Generic Safety Issue 190)	i, iii	4.3.4
	Assumed Thermal Cycle Count for Allowable Secondary Stress Range Reduction Factor in ANSI B31.1 and ASME III Class 2 and 3 Piping	i, ii	4.3.5
3.	Environmental Qualification (EQ) of Electric Equipment	iii	4.4
4.	Concrete Containment Tendon Prestress	ii, iii	4.5
5.	Containment Liner Plate, Equipment Hatch and Personnel Air Locks, Penetrations, and Polar Crane Brackets	NA	4.6
	Absence of a TLAA for Containment Liner Plate, Polar Crane Bracket, Equipment Hatch, Air Lock, and Containment Penetration Design (Except Main Steam, Main Feedwater, and Recirculation Sump Suction Penetrations)	NA	4.6.1
	Design Cycles for the Main Steam and Main Feedwater Penetrations	i	4.6.2
	Design Cycles for the Recirculation Sump Suction Line Penetrations	i	4.6.3
6.	Plant-specific Time-Limited Aging Analysis	NA	4.7
	Load Cycle Limits of Cranes, Lifts, and Fuel Handling Equipment Designed to CMAA-70	i	4.7.1
	Absence of TLAA for Metal Corrosion Allowances and Corrosion Effects	NA	4.7.2
	Inservice Flaw Growth Analyses that Demonstrate Structural Stability for 40 Years	Included in 4.3.2.4 and 4.7.4	4.7.3

Section 4
TIME-LIMITED AGING ANALYSES

Table 4.1-1 - List of TLAAs

TLAA Category	Description	Disposition Category ¹	Report Section
	Fatigue Crack Growth and Fracture Mechanics Stability Analyses of Half-Nozzle Repairs to Alloy 600 Material in Reactor Coolant Hot Legs; Absence of a TLAA for Supporting Corrosion Analyses	iii	4.7.4
	Absence of a TLAA in Corrosion Analyses of Pressurizer Ferritic Materials Exposed to Reactor Coolant by Half-Nozzle Repairs of Pressurizer Heater Sleeve Alloy 600 Nozzles	NA	4.7.5
	Absence of a TLAA for Reactor Vessel Underclad Cracking Analyses	NA	4.7.6
	Absence of a TLAA for a Reactor Coolant Pump Flywheel Fatigue Crack Growth Analysis	NA	4.7.7
	Building Absolute or Differential Heave or Settlement, including Possible Effects of Changes in a Perched Groundwater Lens	i, iii	4.7.8
Exemption List	Absence of TLAA's Supporting 10 CFR 50.12 Exemptions	NA	4.8

-
- ¹
- i - 10 CFR 54.21(c)(1)(i) – Validation: Demonstration that “The analyses remain valid for the period of extended operation,”
 - ii - 10 CFR 54.21(c)(1)(ii) – Revision: Demonstration that “The analyses have been projected to the end of the period of extended operation,” or
 - iii - 10 CFR 54.21(c)(1)(iii) – Aging Management: Demonstration that “The effects of aging on the intended function(s) will be adequately managed for the period of extended operation.”
- NA - Not Applicable – Section heading or no TLAA, disposition categories are not applicable

² Evaluations of valves to be completed before the end of the current licensed operating period may include revisions, in accordance with 10 CFR 54.21(c)(1)(ii).

Section 4
TIME-LIMITED AGING ANALYSES

Table 4.1-2 - Review of Analyses Listed in NUREG-1800 Tables 4.1-2 and 4.1-3

NUREG-1800 Examples	Applicability to PVNGS	Section
NUREG-1800, Table 4.1-2 – Potential TLAAs		
Reactor vessel neutron embrittlement	Yes	4.2
Concrete containment tendon prestress	Yes	4.5
Metal fatigue	Yes	4.3
Environmental qualification of electrical equipment	Yes	4.4
Metal corrosion allowance	No – No explicit 40-year licensing basis applies.	4.7.2 , 4.7.4 , 4.7.5
Inservice flaw growth analyses that demonstrate structure stability for 40 years	Yes	4.3.2.4 , 4.7.3 , 4.7.4
Inservice local metal containment corrosion analyses	No – No explicit 40-year licensing basis applies.	4.7.2
High-energy line-break postulation based on fatigue cumulative usage factor	Yes	4.3.2.14
NUREG-1800, Table 4.1-3 – Additional Examples of Plant-Specific TLAAs		
Intergranular separation in the heat-affected zone (HAZ) of reactor vessel low-alloy steel under austenitic SS cladding	No – No HAZ analyses were identified within the CLB.	4.7.6
Low-temperature overpressure (LTOP) analyses	Yes	4.2.4
Fatigue analysis for the main steam supply lines to the turbine-driven auxiliary feedwater pumps	Yes – 7000-cycle stress range reduction factor only.	4.3.5
Fatigue analysis for the reactor coolant pump flywheel	No – No explicit 40-year basis applies.	4.7.7

Section 4
TIME-LIMITED AGING ANALYSES

Table 4.1-2 - Review of Analyses Listed in NUREG-1800 Tables 4.1-2 and 4.1-3

NUREG-1800 Examples	Applicability to PVNGS	Section
Flow-induced vibration endurance limit for the reactor vessel internals	Yes – However, design to endurance limits is not a TLAA.	4.3.3
Transient cycle count assumptions for the reactor vessel internals	Yes – PVNGS is designed to ASME Section III Subsection NG.	4.3.3
Ductility reduction of fracture toughness for the reactor vessel internals	No – PVNGS is designed with no explicit 40-year embrittlement analysis for internals.	4.3.3
Leak before break	Yes – A leak before break analysis is used at PVNGS but without a TLAA. No explicit 40-year basis applies.	4.3.2.15
Fatigue analysis for the containment liner plate	No – No fatigue analysis of the liner plate exists.	4.6.1
Containment penetration pressurization cycles	Yes – Design cycles for main steam line penetrations, only.	4.6.2
Reactor vessel circumferential weld inspection relief (BWR)	No – PVNGS is a PWR.	NA

4.1.4 Identification of Exemptions

The License Renewal Rule requires a list of plant-specific exemptions granted pursuant to 10 CFR 50.12 and in effect that are based on time-limited aging analyses as defined in §54.3. The applicant shall provide an evaluation that justifies the continuation of these exemptions for the period of extended operation.

A search of docketed correspondence, the operating license, and the PVNGS UFSAR identified and listed all exemptions in effect. Each exemption in effect was then evaluated to determine whether it involved a TLAA as defined in 10 CFR 54.3.

The search found two exemptions “currently in effect” that have been granted pursuant to 10 CFR 50.12. Neither of these exemptions is supported by a TLAA.

4.2 REACTOR VESSEL NEUTRON EMBRITTLEMENT ANALYSIS

Reactor vessel materials are subject to embrittlement, primarily due to exposure to neutron radiation.

Absorbed energy increases with temperature up to a maximum (the “upper-shelf energy,” USE). Neutron embrittlement decreases USE.

Because fracture energy is low at low temperature, operating pressure-temperature limit curves (P-T curves) are included in the Technical Specifications, which dictate the limit to which the vessel can be pressurized at a given temperature. RT_{NDT} , nil-ductility transition reference temperature, is determined for vessel materials before irradiation and indicates temperatures above which impact tests will demonstrate an acceptable USE. Neutron embrittlement raises this transition temperature. This increase (ΔRT_{NDT}) means that higher temperatures are required for the material to continue to act in a ductile fashion. The P-T limit curves (Section 4.2.3) are determined by the limiting adjusted reference temperatures (ART; or if at end-of-life, EOL ART), equal to RT_{NDT} plus ΔRT_{NDT} plus a margin for uncertainty.

Low-temperature overpressure protection (LTOP) is provided by relief valves located in the shutdown cooling system suction lines [UFSAR, §5.2.2.11], whose setpoints are determined by the calculation of the ART P-T limit curves (Section 4.2.4).

Concerns for the possibility of thermal shock to the vessel while at high pressure have required evaluation of a ductile-brittle transition temperature screening parameter for PWR vessel material susceptibility to pressurized thermal shock, RT_{PTS} , similar to evaluations of EOL ART (Section 4.2.2).

These limits and effects depend on lifetime neutron fluence, are part of the licensing basis, and support safety determinations and Technical Specification operating limits. Their calculations are therefore TLAA. The supporting calculation of expected end-of-life vessel neutron fluence is similarly a TLAA (Section 4.2.1).

Summary of Results

The current licensing basis predictions of USE and ART in PVNGS vessel materials were based on the original CESSAR fluences predicted for a 32 EFPY life. The pressurized thermal shock evaluation assumed similar fluence values. P-T limit curves depend on ART, and the LTOP setpoints depend on the P-T limit curves and ART.

The most recent coupon surveillance test reports include fluence projections for a 54 EFPY, 60-year extended licensed operating period based on neutron transport and dosimetry evaluation methods that follow the guidance and meet the requirements of Regulatory Guide 1.190. Due primarily to low-leakage cores, these revised 54 EFPY fluence projections are less than the original 32 EFPY CESSAR projections. The recent

Section 4
TIME-LIMITED AGING ANALYSES

examination results also show that decreases in USE and increases in RT_{NDT} are less than projected. (With the exception of the Unit 3 weld coupons, which experienced a larger than expected ΔRT_{NDT} . However this is not the limiting material.)

The projected neutron fluence at the end of the period of extended operation is less than the fluence used to calculate the current licensing basis EOL embrittlement effects. The reduction in the projected fluence validates the current licensing basis analyses of these effects for the period of extended operation. The validity of these analyses will continue to be confirmed by the reactor vessel surveillance program, as required by 10 CFR 50 Appendix H. Continuing the program will require an enhancement to extend the coupon withdrawal and examination schedule.

4.2.1 Neutron Fluence, Upper Shelf Energy and Adjusted Reference Temperature (Fluence, USE, and ART)

Summary Description

The PVNGS reactor pressure vessels were designed, built, and analyzed by Combustion Engineering to ASME III, Subsection NB (Class 1), 1971 Edition with addenda through Winter 1973.

The scope of 10 CFR 50 Appendix G, "Fracture Toughness Requirements," includes all light water reactor coolant pressure boundary materials, specifically including vessel plate, nozzle, flange, weld, weld heat-affected zone (HAZ), and bolting materials. At PVNGS only the beltline plate, weld, and HAZ are subject to sufficient neutron fluence to require monitoring for changes in embrittlement parameters. Review of material outside the beltline is not required for PVNGS, because the most recent 54 EFPY fluence projections are less than the 32 EFPY fluence originally used to determine materials to be included in the beltline material subject to surveillance.

10 CFR 50 Appendix G Section IV requires operation within pressure-temperature limits (P-T limits, [Section 4.2.3](#)), which in turn depend on margins of safety and operating limits using ASME III Appendix G methods. The calculation of these margins depends on initial Charpy impact data in accordance with ASTM E 185-82, determinations of initial USE and RT_{NDT} in accordance with 10 CFR 50 Appendix G and ASME III Appendix G, and projections of irradiated USE and RT_{NDT} (or ART, including a margin for uncertainty), for which Regulatory Guide 1.99 Revision 2 provides acceptable methods. The projected values must be confirmed by a coupon surveillance program in accordance with 10 CFR 50 Appendix H and ASTM E 185-82.

[UFSAR Section 5.3](#) contains extensive data on vessel material composition, properties, and the vessel coupon surveillance program. See [UFSAR Tables 5.3-13, -14, and -15](#) for the Unit 1, 2, and 3 capsule surveillance programs. See [UFSAR Tables 5.3-18, -19, and -19A](#) for the Unit 1, 2, and 3 capsule removal and examination schedules. [UFSAR Section 4.3.3.3](#) describes the original reactor vessel fluence calculation model. The neutron

transport and dosimetry calculations confirmed that these original 32 EFPY fluences exceed those now expected for a 54 EFPY life.

Analysis

The PVNGS surveillance program is consistent with 10 CFR 50 Appendix H. The current projections of fluence at 54 EFPY are less than the originally projected fluence at 32 EFPY, and the recent surveillance data are consistent with projected effects. The original projections of fluence, USE, and ART therefore remain valid for the period of extended operation.

Selection of Surveillance Coupons, Determination of Initial and Projected USE and RT_{NDT}

The PVNGS limiting material selected as the basis for P-T limit curves and the coupons selected for surveillance fully conform to 10 CFR 50 Appendices G and H, and to ASTM E 185-82. The coupons are actual samples from the materials used in the vessels [[UFSAR 5.3.1.6.1](#)].

The PVNGS Unit 2 and 3 vessel surveillance coupons were taken from the vessel lower shell course plates, welds, and the plate heat-affected zones exposed to beltline neutron fluence, and whose composition indicated the highest predicted EOL ART.

The first set of Unit 1 coupons were also selected from lower shell course plates and their welds on a similar basis. However, the NRC review of the original program determined that an intermediate shell plate could be limiting, and a second set of coupons was added from this plate heat. The Unit 1 capsules therefore include coupons from two plate heats: lower shell plate M-4311-1 because its predicted 32 EFPY ΔRT_{NDT} was the highest, and intermediate shell plate M-6701-2 because it was one of two with the highest predicted 32 EFPY EOL RT_{NDT} . The M-6701-2 coupons were added because this heat had worse chemistry and a lower initial USE than the other intermediate shell plate with the same EOL RT_{NDT} .

Coupon Withdrawal and Examination Schedule

All withdrawals to date were performed according to the schedule found in [UFSAR §5.3.1.6.6](#). PVNGS coupon capsules are numbered 1 through 6. Unit 1 Capsule 1, Units 1 and 2 Capsule 3, Units 1, 2 and 3 Capsule 5, and Unit 3 Capsule 4 have been removed and examined. The 230°, Capsule 5 coupons were the most recently examined, in January of 2005, February of 2006, and August of 2005, for Units 1, 2, and 3 respectively.

Original Projection, Measurement, and Revised Projection of Neutron Fluence

The critical time-dependent parameter for determining radiation embrittlement effects is lifetime fluence of neutrons with energies greater than 1 MeV. The original design basis fluence predictions for a 32 EFPY life were the standard Combustion Engineering estimates for the CESSAR-80 plants. Power uprate (PUR) had no effect on these fluence projections

Section 4
TIME-LIMITED AGING ANALYSES

because this original analysis of record used a power level of 4200 MWt, which is higher than the PUR level of 3990 MWt.

Increased plant capacity factors prompted the increase in the lifetime capacity factor assumed for fluence estimates from 80 to 90 percent, and hence increased the assumed EFPY for the extended licensed operating period to 54 EFPY.

The analyses of the most-recently-examined 230°, Capsule 5 dosimeters from each of the three units, project the fluences to 54 EFPY, including effects of uprate. The revised fluences were determined with transport calculations using the DORT discrete ordinates code and the BUGLE-96 cross-section library which is derived from ENDF/B-VI. The neutron transport and dosimetry evaluation methodologies follow the guidance and meet the requirements of the most recent issue of Regulatory Guide 1.190, *Calculational and Dosimetry Methods for Determining Pressure Vessel Neutron Fluence*, and are consistent with Westinghouse WCAP-14040-NP-A, *Methodology Used to Develop Cold Overpressure Mitigating System Setpoints and RCS Heatup and Cooldown Limit Curves* [Ref. 11]. These 230°, Capsule 5 coupon examination reports include validations demonstrating that measured fluences are within the tolerance specified by Regulatory Guide 1.190 (20 percent of calculated and least-squares adjusted values). The dosimeter data were also used to characterize and predict future exposures in displacements per atom (dpa) as recommended by ASTM E 853, *Standard Practice for Analysis and Interpretation of Light-Water Reactor Surveillance Results*; using the energy-dependent dpa function specified by ASTM E 693, *Standard Practice for Characterizing Neutron Exposures in Iron and Low Alloy Steels in Terms of Displacements Per Atom (DPA)*; and the dpa gradient through the vessel wall from Regulatory Guide 1.99, Revision 2.

With continued use of low-leakage cores, the Unit 1, 2, and 3 clad-base metal interface fluences at 54 EFPY, projected from measured exposures and lead factors of Capsule 5, are 2.51×10^{19} , 2.83×10^{19} , and 2.93×10^{19} high-energy neutrons/cm², respectively; which are less than the original 32 EFPY projection of 3.15×10^{19} neutrons/cm² used for the PTS evaluation, or the 3.29×10^{19} neutrons/cm² used to determine the EOL ART and USE reported in the NRC Reactor Vessel Integrity Database. [Table 4.2-1](#) summarizes these fluence results.

Clad-base metal fluences are commonly reported for comparison purposes, although the 50 ft-lbf acceptance criterion for USE and the P-T limits based on ART depend on properties at the tip of the flaw assumed for the fracture mechanics analysis upon which the P-T limits are based, or ¼ and ¾-thickness at PVNGS.

Section 4
TIME-LIMITED AGING ANALYSES

Table 4.2-1 - PVNGS Reactor Vessel Peak Beltline Neutron Fluences >1 MeV

Case	EFPY	Fluence (Clad-BM, or as noted), x 10¹⁹ neutrons/cm²
Original 40-year design basis estimate at the clad-base metal interface (all three units) for PTS (Section 4.2.2 below)	32	3.15
Original 40-year design basis estimate (all three units) for EOL ART and P-T curves (Section 4.2.3 below)	32	3.29
230° Capsule dosimeter, calculated equivalent clad-base metal interface EFPY and measured capsule fluence	Equivalent ¹ U1: 18.67 U2: 19.95 U3: 18.01	At Capsule U1: 0.876 U2: 0.992 U3: 0.907
230° Capsule dosimeter, actual vessel EFPY and calculated fluence at the clad-base metal interface	Vessel U1: 13.83 U2: 14.35 U3: 13.75	U1: 0.647 U2: 0.714 U3: 0.695
230° Capsule dosimeter, 60-year calculated and best estimate projection at the clad-base metal interface (Maxima, at the n x 45° azimuths)	54	U1: 2.51 U2: 2.83 U3: 2.93
230° Capsule dosimeter 60-year calculated and best estimate projection at ¼ t through the vessel wall (Reg Guide 1.99 Revision 2 Section 1.1 Equation 3 attenuation)	54	¼ t U1: 1.398 U2: 1.559 U3: 1.617
230° Capsule dosimeter 60-year calculated and best estimate projection at ¾ t through the vessel wall (Reg Guide 1.99 Revision 2 Section 1.1 Equation 3 attenuation)	54	¾ t U1: 0.304 U2: 0.334 U3: 0.349

¹ Actual EFPY times the respective lead factors for the 230° capsule for each Unit, 1.35, 1.39, and 1.31 respectively.

Measurement and Projection of USE and ART

The current licensing basis predictions of USE and ART in PVNGS vessel materials were based on the original CESSAR fluences predicted for a 32 EFPY life. USE and ART were projected from actual reactor material tests and compositions using Regulatory Guide 1.99 Revision 2 methods, and are recorded in the NRC Reactor Vessel Integrity Database (RVID). The neutron transport and dosimetry calculations confirmed that these original 32 EFPY fluences exceed those now expected for a 54 EFPY life.

The initial evaluations of material properties and projections of them to the end of the 40-year, 32 EFPY initial licensed operating period found that Unit 1 plate materials will be most limiting for both USE and ART. The current pressure-temperature (P-T) operating limits were accordingly based on the projected effects in the limiting Unit 1 materials. See [Section 4.2.3](#). The recently-measured transition temperature and transition temperature changes (RT_{NDT} and ΔRT_{NDT}) listed in [Table 4.2-2](#) confirm that the limiting Unit 1 plate material should remain most limiting for adjusted reference temperature (ART), and that the limiting ART of these materials will not restrict P-T operating margins in the period of extended operation.

A first inspection of the USE measurements from the most recent coupon examinations, in [Table 4.2-2](#), suggests that the Unit 2 limiting HAZ material will be most limiting for USE, but a check of the change in USE in this same table indicates that this material will retain about the same USE, while that of others may decline below that of the limiting HAZ material. The weld and plate materials will therefore have the most limiting USE at end of life.

[Table 4.2-3](#) through [Table 4.2-5](#) show (1) that limiting values of $\frac{1}{4}$ t USE were projected to remain well above the 50 ft-lbf acceptance criterion at fluences originally projected for a 40-year life, (2) that current fluence projections for a 54 EFPY, 60-year life do not exceed those originally projected for a 40-year life, and therefore (3) that USE of the limiting material will remain adequate for the extended licensed operating period.

The most recent coupon examination results also show that the decline in USE and increase in RT_{NDT} in plate and weld materials are less than originally predicted by Regulatory Guide 1.99 Revision 2, with only one exception. The exception is the Unit 3 weld coupon set, for which ΔRT_{NDT} exceeds the prediction. However the shift (ΔRT_{NDT}) is less than the 2σ allowance of Regulatory Guide 1.99 Revision 2. These Unit 3 welds are also not the most limiting material.

Disposition: Validation, 10 CFR 54.21(c)(1)(i); and Aging Management, 10 CFR 54.21(c)(1)(iii)

Validation

In the absence of significant changes in vessel operating temperature and neutron spectrum, projected decreases in limiting USE and increases in limiting ART depend only on high-energy neutron fluence. Since current projections of neutron fluence for a 60-year,

Section 4
TIME-LIMITED AGING ANALYSES

54 EFPY extended licensed operating period are less than those used for the original licensing basis projections for 32 EFPY, the original projections remain valid for the period of extended operation.

In addition, since no increase in fluence is expected above the original licensing basis estimates, no other reactor pressure boundary materials will be exposed to increased neutron fluences, and therefore no additional materials require evaluation for these effects.

The evaluation of the acceptability of these parameters therefore remains valid for the period of extended operation, in accordance with 10 CFR 54.21(c)(1)(i).

Aging Management

Fluence, USE, and ART will be managed for the extended licensed operating period by continuing the Reactor Vessel Surveillance program (Section B2.1.15), with adjustments to the coupon examination schedule to withdraw the next capsule at an equivalent clad-base metal exposure of approximately 54 EFPY, and to withdraw remaining standby capsules at equivalent clad-base metal exposures not exceeding 72 EFPY. The validity of these parameters and the analyses that depend upon them will therefore be adequately managed for the period of extended operation in accordance with 10 CFR 54.21(c)(1)(iii).

Table 4.2-2 - Results of Examination of PVNGS 230° Capsule 5 Coupons

Parameter	Unit 1	Unit 2	Unit 3
Limiting Weld	90071	3P7317	4P7869
Limiting Plate	M-6701-2	F-773-1	F-6411-2
Actual EFPY at Removal	13.83	14.35	13.75
Measured Capsule Fluence 10^{19} n/cm² ⁽¹⁾	0.876	0.992	0.907
Equivalent EFPY at Clad-Base Metal Interface ⁽²⁾	18.67	19.95	18.01
Unirradiated measured mean 30 ft-lb transition temperatures of the limiting	°F 0 EFPY	°F 0 EFPY	°F 0 EFPY
Weld Metal	-53.5	-40.1	-38.7
HAZ (heat-affected zone of plate next to a weld)	-62.6	-11.3	-108.7
Longitudinal Plate Coupons (parallel to rolling direction)	8.0	0.5	-31.5
Transverse Plate Coupons	30.2	0.7	-25.7

Section 4
TIME-LIMITED AGING ANALYSES

Table 4.2-2 - Results of Examination of PVNGS 230° Capsule 5 Coupons

Parameter	Unit 1	Unit 2	Unit 3
Limiting Weld	90071	3P7317	4P7869
Limiting Plate	M-6701-2	F-773-1	F-6411-2
Actual EFPY at Removal	13.83	14.35	13.75
Measured Capsule Fluence 10^{19} n/cm² (1)	0.876	0.992	0.907
Equivalent EFPY at Clad-Base Metal Interface (2)	18.67	19.95	18.01
Calculated mean 30 ft-lb transition temperature shifts (ΔRT_{NDT}) of the limiting—	°F	°F	°F
Weld Metal	5.1	2.5	24.1
HAZ (heat-affected zone of plate next to a weld)	-32.8	46.3	10.3
Longitudinal Plate Coupons (parallel to rolling direction)	15.3	17.7	6.3
Transverse Plate Coupons	31.9	19.3	9.2
Measured mean 30 ft-lb transition temperatures of the limiting—	°F	°F	°F
Weld Metal	-48.4	-37.6	-14.6
HAZ (heat-affected zone of plate next to a weld)	-95.4	35.0	-98.4
Longitudinal Plate Coupons (parallel to rolling direction)	23.3	18.2	-25.2
Transverse Plate Coupons	62.1	20.0	-16.5
Unirradiated measured mean 50 ft-lb transition temperatures of the limiting—	°F 0 EFPY	°F 0 EFPY	°F 0 EFPY
Weld Metal	-33.6	-9.9	-0.3
HAZ (heat-affected zone of plate next to a weld)	-26.2	59.2	-71.6
Longitudinal Plate Coupons (parallel to rolling direction)	36.6	37.1	-6.3
Transverse Plate Coupons	71.4	31.7	4.4
Calculated mean 50 ft-lb transition temperature shifts of the limiting—	°F	°F	°F
Weld Metal	3.2	14.0	39.7
HAZ (heat-affected zone of plate next to a weld)	-35.9	19.8	12.8
Longitudinal Plate Coupons (parallel to rolling direction)	16.3	24.5	15.3
Transverse Plate Coupons	35.6	20.8	11.7

Section 4
TIME-LIMITED AGING ANALYSES

Table 4.2-2 - Results of Examination of PVNGS 230° Capsule 5 Coupons

Parameter	Unit 1	Unit 2	Unit 3
Limiting Weld	90071	3P7317	4P7869
Limiting Plate	M-6701-2	F-773-1	F-6411-2
Actual EFPY at Removal	13.83	14.35	13.75
Measured Capsule Fluence 10^{19} n/cm² (1)	0.876	0.992	0.907
Equivalent EFPY at Clad-Base Metal Interface (2)	18.67	19.95	18.01
Measured mean 50 ft-lb transition temperatures of the limiting—	°F	°F	°F
Weld Metal	-30.4	4.1	39.4
HAZ (heat-affected zone of plate next to a weld)	-62.1	79.0	-58.8
Longitudinal Plate Coupons (parallel to rolling direction)	52.9	61.6	9
Transverse Plate Coupons	107.0	52.5	16.1
Unirradiated measured mean 35 mil lateral expansion temperatures of the limiting—	°F 0 EFPY	°F 0 EFPY	°F 0 EFPY
Weld Metal	-30.8	-37.5	-24.3
HAZ (heat-affected zone of plate next to a weld)	-30.1	-2.7	-64.7
Longitudinal Plate Coupons (parallel to rolling direction)	35.9	10.6	-19.2
Transverse Plate Coupons	66.0	4.7	-13.0
Calculated mean 35 mil lateral expansion temperature shifts of the limiting—	°F	°F	°F
Weld Metal	-3.9	15.7	25.3
HAZ (heat-affected zone of plate next to a weld)	-28.9	62.3	5.3
Longitudinal Plate Coupons (parallel to rolling direction)	2.4	22.2	15.7
Transverse Plate Coupons	3.1	29.1	10.9
Measured mean 35 mil lateral expansion temperatures of the limiting—	°F	°F	°F
Weld Metal	-34.7	-21.8	1.0
HAZ (heat-affected zone of plate next to a weld)	-59.0	59.6	-59.4
Longitudinal Plate Coupons (parallel to rolling direction)	38.3	32.8	-3.5
Transverse Plate Coupons	69.1	33.8	-2.1

Section 4
TIME-LIMITED AGING ANALYSES

Table 4.2-2 - Results of Examination of PVNGS 230° Capsule 5 Coupons

Parameter	Unit 1	Unit 2	Unit 3
Limiting Weld	90071	3P7317	4P7869
Limiting Plate	M-6701-2	F-773-1	F-6411-2
Actual EFPY at Removal	13.83	14.35	13.75
Measured Capsule Fluence 10^{19} n/cm² ⁽¹⁾	0.876	0.992	0.907
Equivalent EFPY at Clad-Base Metal Interface ⁽²⁾	18.67	19.95	18.01
Unirradiated measured mean Charpy V-notch upper shelf energies (USE at 0 EFPY) of the limiting—	<i>ft-lbf</i> <i>0 EFPY</i>	<i>ft-lbf</i> <i>0 EFPY</i>	<i>ft-lbf</i> <i>0 EFPY</i>
Weld Metal	164	109	90
HAZ (heat-affected zone of plate next to a weld)	135	84	137.5
Longitudinal Plate Coupons (parallel to rolling direction)	151	112	134
Transverse Plate Coupons	98	136.5	127
Change in measured mean Charpy V-notch upper shelf energies (USE) of the limiting—	<i>ft-lbf</i>	<i>ft-lbf</i>	<i>ft-lbf</i>
Weld Metal	-16	-6	+5
HAZ (heat-affected zone of plate next to a weld)	-2	+6	-8.5
Longitudinal Plate Coupons (parallel to rolling direction)	-6	+28	-4
Transverse Plate Coupons	+1	-13.5	-7
Measured mean Charpy V-notch upper shelf energies (USE) of the limiting—	<i>ft-lbf</i>	<i>ft-lbf</i>	<i>ft-lbf</i>
Weld Metal	148	103	90
HAZ (heat-affected zone of plate next to a weld)	133	84	129
Longitudinal Plate Coupons (parallel to rolling direction)	145	112	130
Transverse Plate Coupons	98	123	120

¹ From Table 4.2-1.

² Stated EFPY times the respective lead factors for the 230° capsule for each Unit, 1.35, 1.39, and 1.31 respectively.

4.2.2 Pressurized Thermal Shock (PTS)

Summary Description

10 CFR 54.4(a)(3) requires that the licensee evaluate all structures, systems, and components (SSCs) relied on in safety analyses or plant evaluations to perform a function that demonstrates compliance with the Commission's regulations for pressurized thermal shock (10 CFR 50.61).

A Pressurized Thermal Shock Event is an event or transient in pressurized water reactors (PWRs) causing severe overcooling (thermal shock) concurrent with or followed by significant pressure in the reactor vessel.

[10 CFR 50.61(a)(2)]

If the reference temperature for pressurized thermal shock (RT_{PTS}) for each heat of material of the reactor pressure vessel does not exceed 270 °F for plates, forgings, and axial welds; or 300 °F for circumferential welds (the PTS screening criteria), only the reactor pressure vessel is "relied on to demonstrate compliance" with the 10 CFR 50.61 PTS rule.

The PVNGS reactor pressure vessels meet the PTS screening criteria and will continue to do so for the period of extended operation, and therefore will remain the only components relied upon to demonstrate compliance with 10 CFR 50.61.

10 CFR 50.61(b)(1) requires a re-evaluation of RT_{PTS} "...whenever there is a significant change in projected values of RT_{PTS} , or upon a request for a change in the expiration date for operation of the facility." License renewal therefore requires the re-evaluation of RT_{PTS} , even if the expected change is not significant.

Analysis

The PVNGS 10 CFR 50.61 PTS submittal [Ref. 12] projected an EOL RT_{PTS} of the limiting plate material of only 132 °F, at the 3.15×10^{19} high-energy neutrons/cm² clad-base metal interface fluence originally expected for a 32 EFPY, 40-year life; and only 143 °F at 6.3×10^{19} high-energy neutrons/cm², twice the original fluence projection. The 3.15×10^{19} fluence is greater than those fluences now projected at 54 EFPY. See Section 4.2.1. The highest projected 54 EFPY fluence is 2.93×10^{19} in Unit 3. The projected 54 EFPY fluence for limiting material in Unit 1 is 2.51×10^{19} high energy neutrons/cm².

Power uprate has not changed the original design basis predicted fluences (See Section 4.2.1), therefore the original limitations still apply.

Generic Letter 92-01 requested confirmation of reactor pressure vessel material data. The PVNGS responses provided additional and revised data but did not amend the conclusions of the original PTS submittal.

Section 4
TIME-LIMITED AGING ANALYSES

Transition temperature shifts of the most recent coupon examination results are consistent with RG 1.99 predictions. See [Section 4.2.1](#). Since the fluence is expected to remain within the values originally predicted for a 32 EFPY, 40-year life, RT_{PTS} is also expected to remain within the values originally predicted for a 32 EFPY, 40-year life, and will certainly remain within the acceptable values calculated at twice this fluence for the 10 CFR 50.61 PTS submittal.

[Table 4.2-6](#) through [Table 4.2-8](#) present the current RVID data that demonstrate compliance with 10 CFR 50.61 and 10 CFR 50 Appendix G.

Disposition: Validation, 10 CFR 54.21(c)(1)(i)

The original PTS evaluation of the PVNGS vessels demonstrated low values of the RT_{PTS} screening parameter even at twice the then-expected 32-EFPY lifetime neutron fluence. The design basis fluence originally used for an assumed 32-EFPY design life is not expected to be exceeded in a 54-EFPY life, and no changes to material composition information or to embrittlement assessment methods have affected the values, hence the conclusions of the original evaluation are unaffected. The original evaluation of the PTS screening parameter, and the conclusion, is therefore valid for the period of extended operation in accordance with 10 CFR 54.21(c)(1)(i).

Section 4
TIME-LIMITED AGING ANALYSES

Table 4.2-3 - PVNGS Unit 1 Vessel Material USE Projected at 60 Years (54 EFPY) (Note 1)

Material Description		Heat Number	Type	Cu wt%	Unirradiated USE ft-lbf	EOL ^{1/4} T Fluence 10 ¹⁹ n/cm ² (E>1 MeV)	% Drop in USE @ EOL ⁽²⁾	54 EFPY Projected USE ft-lbf	EOL USE Acceptance Criterion ft-lbf
Reactor Vessel Beltline Region Location									
Lower Shell Plate M-4311-1		62467-1	A 533B	0.040	134	1.681	21.44	105.3	≥50
Lower Shell Plate M-4311-2		62817-1	A 533B	0.030	127	1.681	21.44	99.8	≥50
Lower Shell Plate M-4311-3		62722-1	A 533B	0.030	142	1.681	21.44	111.6	≥50
Intermediate Shell Plate M-6701-1		C4142-1	A 533B	0.070	83	1.681	21.44	65.2	≥50
Intermediate Shell Plate M-6701-2		C4188-2	A 533B	0.060	96	1.681	21.44	78.6	≥50
Intermediate Shell Plate M-6701-3		C4188-1	A 533B	0.060	100	1.681	21.44	75.4	≥50
Intermediate Shell Axial Welds 101-124A, B, C		4P6052	Linde 0091	0.047 ⁽³⁾	200	1.681	21.44	157.1	≥50
Lower Shell Axial Welds 101-142A, B, C		90071	Linde 0091	0.035 ⁽³⁾	140	1.681	21.44	110.0	≥50
Circumferential Weld 101-171		4P7869	Linde 124	0.031 ⁽³⁾	90	1.681	21.44	70.7	≥50

¹ The information in this table is extracted from the RVID and generated assuming a clad-metal EOL fluence of 3.29 x 10¹⁹ high-energy neutrons/cm².
² % Drop in USE at EOL is determined using RG 1.99 Rev. 2, Position 1.2.
³ The weld information is the best-estimate value from CE-NPSD-1039, instead of the material's measured value.

Section 4
TIME-LIMITED AGING ANALYSES

Table 4.2-4 - PVNGS Unit 2 Vessel Material USE Projected at 60 Years (54 EFPY) (Note 1)

Material Description		Heat Number	Type	Cu wt%	Unirradiated USE ft-lbf	EOL ^{1/4} T Fluence 10 ¹⁹ n/cm ² (E>1.0MeV)	% Drop in USE @ EOL ⁽²⁾	54 EFPY Projected USE ft-lbf	EOL USE Acceptance Criterion ft-lbf
Reactor Vessel Beltline Region Location									
Lower Shell Plate F-773-1		64071-1	A 533B	0.030	134	1.681	21.44	82.5	≥50
Lower Shell Plate F-773-2		64065-1	A 533B	0.040	127	1.681	21.44	99.8	≥50
Lower Shell Plate F-773-3		63987-1	A 533B	0.050	142	1.681	21.44	101.3	≥50
Intermediate Shell Plate F-765-4		63427-1	A 533B	0.030	83	1.681	21.44	89.6	≥50
Intermediate Shell Plate F-765-5		63464-1	A 533B	0.030	96	1.681	21.44	95.1	≥50
Intermediate Shell Plate F-765-6		63716-1	A 533B	0.040	100	1.681	21.44	99.0	≥50
Intermediate Shell Axial Welds 101-124A, B, C		89833	Linde 124	0.046 ⁽³⁾	200	1.681	21.44	78.6	≥50
Lower Shell Axial Welds 101-142A, B, C		3P7317	Linde 124	0.074 ⁽³⁾	140	1.681	21.44	76.1	≥50
Circumferential Welds 101-171		3P7869	Linde 124	0.031 ⁽³⁾	90	1.681	21.44	74.6	≥50

¹ The information in this table is extracted from the RVID and generated assuming a clad-metal EOL fluence of 3.29 x 10¹⁹ high-energy neutrons/cm².

² % Drop in USE at EOL is determined using RG 1.99 Rev. 2, Position 1.2.

³ The weld information is the best-estimate value from CE-NPSD-1039, instead of the material's measured value.

Section 4
TIME-LIMITED AGING ANALYSES

Table 4.2-5 - PVNGS Unit 3 Vessel Material USE Projected at 60 Years (54 EFPY) (Note 1)

Material Description		Heat Number	Type	Cu wt%	Unirradiated USE ft-lbf	EOL $\frac{1}{4}$ T Fluence 10^{19} n/cm ² (E>1.0MeV)	% Drop in USE @ EOL ⁽²⁾	54 EFPY Projected USE ft-lbf	EOL USE Acceptance Criterion ft-lbf
Reactor Vessel Beltline Region Location									
Lower Shell Plate F-6411-1		79545-1	A 533B	0.040	156	1.681	21.44	122.6	≥50
Lower Shell Plate F-6411-2		79745-1	A 533B	0.040	111	1.681	21.44	87.2	≥50
Lower Shell Plate F-6411-3		79659-1	A 533B	0.040	107	1.681	21.44	84.1	≥50
Intermediate Shell Plate F-6407-4		65202-1	A 533B	0.040	129	1.681	21.44	101.3	≥50
Intermediate Shell Plate F-6407-5		65219-1	A 533B	0.050	114	1.681	21.44	89.6	≥50
Intermediate Shell Plate F-6407-6		79011-1	A 533B	0.040	133	1.681	21.44	104.5	≥50
Intermediate Shell Axial Welds 101-124A, B, C		4P7869	Linde 124 SAW	0.031 ⁽³⁾	100	1.681	21.44	78.6	≥50
Lower Shell Axial Welds 101-142A, B, C		4P7869	Linde 124 SAW	0.031 ⁽³⁾	100	1.681	21.44	78.6	≥50
Circumferential Weld 101-171		4P7869	Linde 124 SAW	0.031 ⁽³⁾	90	1.681	21.44	70.7	≥50

¹ The information in this table is extracted from the RVID and generated assuming a clad-metal EOL fluence of 3.29×10^{19} high-energy neutrons/cm².

² % Drop in USE at EOL is determined using RG 1.99 Rev. 2, Position 1.2.

³ The weld information is the best-estimate value from CE-NPSD-1039, instead of the material's measured value.

Section 4
TIME-LIMITED AGING ANALYSES

Table 4.2-6 - PVNGS Unit 1 Reactor Vessel Limiting RT_{PTS} at 60 Years (54 EFPY) (Note 1)

Material Description		Chemical Composition		Type	Heat Number	Initial RT_{NDT} °F	Chemistry Factors °F ⁽²⁾	Neutron Fluence @ EOL 10^{19} n/cm ² (E>1 MeV)	54 EFPY Fluence Factor	54 EFPY ΔRT_{PTS} °F	Margin °F ⁽²⁾	54 EFPY RT_{PTS} °F	Screening Criteria °F
		Cu wt%	Ni wt%										
Lower Shell Plate M-4311-1	62467-1	0.040	0.650	A 533B		-10	26	3.29	1.312	34.1	34.0	58.1	≤270
Lower Shell Plate M-4311-2	62817-1	0.030	0.620	A 533B		-40	20	3.29	1.312	26.2	26.2	12.5	≤270
Lower Shell Plate M-4311-3	62722-1	0.030	0.640	A 533B		-20	20	3.29	1.312	26.2	26.2	32.5	≤270
Intermediate Shell Plate M-6701-1	C4142-1	0.070	0.660	A 533B		30	44	3.29	1.312	57.7	34.0	121.7	≤270
Intermediate Shell Plate M-6701-2	C4188-2	0.060	0.610	A 533B		40	37	3.29	1.312	48.5	34.0	122.5	≤270
Intermediate Shell Plate M-6701-3	C4188-1	0.060	0.610	A 533B		40	37	3.29	1.312	48.5	34.0	122.5	≤270
Intermediate Shell Axial Welds 101-124A, B, C	4P6052	0.047	0.049	Linde 0091		-50	30.74	3.29	1.312	40.3	40.3	30.6	≤300
Lower Shell Axial Welds 101-142A, B, C	90071	0.035	0.035	Linde 0091		-80	29.32	3.29	1.312	38.5	38.5	-3.0	≤300
Circumferential Weld 101-171	4P7869	0.031	0.096	Linde 124		-70	28.73	3.29	1.312	37.7	37.7	5.4	≤300

¹ The information in this table is extracted from the RVID and generated assuming a clad-metal EOL fluence of 3.29×10^{19} high-energy neutrons/cm².

² The Chemistry Factors are determined using RG 1.99 Rev. 2, Position 1.1.

Section 4
TIME-LIMITED AGING ANALYSES

Table 4.2-7 - PVNGS Unit 2 Reactor Vessel Limiting RT_{PTS} at 60 Years (54 EFPY) (Note 1)

Material Description		Chemical Composition		Chemistry Factors $\circ F^{(2)}$	Initial RT_{NDT} $\circ F$	Neutron Fluence @ EOL 10^{19} n/cm ² (E>1 MeV)	54 EFPY Fluence Factor	54 EFPY ΔRT_{PTS} $\circ F$	Margin $\circ F^{(2)}$	54 EFPY RT_{PTS} $\circ F$	Screening Criteria $\circ F$
Reactor Vessel Beltline Region Location	Heat Number	Type	Cu wt%								
Lower Shell Plate F-773-1	64071-1	A 533B	0.030	0.670	20	10	1.312	26.2	26.2	62.5	≤270
Lower Shell Plate F-773-2	64065-1	A 533B	0.040	0.640	26	0	1.312	34.1	34.0	68.1	≤270
Lower Shell Plate F-773-3	63987-1	A 533B	0.050	0.660	31	-60	1.312	40.7	34.0	14.7	≤270
Intermediate Shell Plate F-765-4	63427-1	A 533B	0.030	0.670	20	-20	1.312	26.2	26.2	32.5	≤270
Intermediate Shell Plate F-765-5	63464-1	A 533B	0.030	0.650	20	10	1.312	26.2	26.2	62.5	≤270
Intermediate Shell Plate F-765-6	63716-1	A 533B	0.040	0.670	26	10	1.312	34.1	34.0	78.1	≤270
Intermediate Shell Axial Welds 101-124A, B, C	89833	Linde 124	0.046	0.059	31.51	-60	1.312	41.3	41.3	22.6	≤300
Lower Shell Axial Welds 101-142A, B, C	3P7317	Linde 124	0.074	0.067	41.17	-80	1.312	54.0	54.0	28.0	≤300
Circumferential Weld 101-171	3P7869	Linde 124	0.031	0.096	28.73	-30	1.312	37.7	37.7	45.4	≤300

¹ The information in this table is extracted from the RVID and generated assuming a clad-metal EOL fluence of 3.29×10^{19} high-energy neutrons/cm².

² The Chemistry Factors are determined using RG 1.99 Rev. 2, Position 1.1.

Section 4
TIME-LIMITED AGING ANALYSES

Table 4.2-8 - PVNGS Unit 3 Reactor Vessel Limiting RT_{PTS} at 60 Years (54 EFPY) (Note 1)

Material Description		Chemical Composition		Chemistry Factors $\circ F^{(2)}$	Initial RT_{NDT} $\circ F$	Neutron Fluence @ EOL 10^{19} n/cm ² (E>1 MeV)	54 EFPY Fluence Factor	54 EFPY ΔRT_{PTS} $\circ F$	Margin $\circ F^{(2)}$	54 EFPY RT_{PTS} $\circ F$	Screening Criteria $\circ F$
Reactor Vessel Beltline Region Location	Heat Number	Type	Cu wt%								
Lower Shell Plate F-6411-1	79545-1	A 533B	0.040	0.640	26	-40.0	1.312	34.1	34.0	38.1	≤270
Lower Shell Plate F-6411-2	79745-1	A 533B	0.040	0.660	26	0.0	1.312	34.1	34.0	54.7	≤270
Lower Shell Plate F-6411-3	79659-1	A 533B	0.040	0.650	26	-60.0	1.312	34.1	34.0	48.1	≤270
Intermediate Shell Plate F-6407-4	65202-1	A 533B	0.040	0.620	26	-30.0	1.312	34.1	34.0	28.1	≤270
Intermediate Shell Plate F-6407-5	65219-1	A 533B	0.050	0.610	31	-20.0	1.312	40.7	34.0	68.1	≤270
Intermediate Shell Plate F-6407-6	79011-1	A 533B	0.040	0.610	26	-20.0	1.312	34.1	34.0	8.1	≤270
Intermediate Shell Axial Welds 101-124A, B, C	4P7869	Linde 124 SAW	0.031	0.096	28.73	-50	1.312	37.7	37.7	25.4	≤300
Lower Shell Axial Welds 101-142A, B, C	4P7869	Linde 124 SAW	0.031	0.096	28.73	-50	1.312	37.7	37.7	25.4	≤300
Circumferential Weld 101-171	4P7869	Linde 124 SAW	0.031	0.096	28.73	-70	1.312	37.7	37.7	5.4	≤300

¹ The information in this table is extracted from the RVID and generated assuming a clad-metal EOL fluence of 3.29×10^{19} high-energy neutrons/cm².

² The Chemistry Factors are determined using RG 1.99 Rev. 2, Position 1.1.

4.2.3 Pressure-Temperature (P-T) Limits

Summary Description

P-T limit curves are operating limits, conditions of the operating license, and are included in the Technical Specifications §3.4.3, Figure 3.4.3-2. They dictate the limits to which the vessel can be pressurized at a given temperature and operating mode. They are valid up to a stated vessel fluence limit, and must be revised by the appropriate regulatory process prior to operating beyond that limit.

Analysis

UFSAR Section 5.3.2.1 and the P-T limit submittal [Ref. 9] describe the methods used to develop the curves. The P-T limit curves used linear elastic fracture mechanics (LEFM) methods and guidance from the ASME Boiler and Pressure Vessel Code, Section III, Appendix G as invoked by 10 CFR 50 Appendix G. The supporting end-of-life adjusted reference temperature projections (EOL ART) used Regulatory Guide 1.99 Revision 2 methods.

The current license includes P-T limit curves calculated for embrittlement effects originally determined to be valid up to 32 EFPY. However they were based on projections of EOL ART that depended on an originally-estimated 32 EFPY beltline high-energy neutron fluence of 3.29×10^{19} neutrons/cm², which exceeds the maximum fluence now expected at 54 EFPY, 2.93×10^{19} neutrons/cm².

New P-T limits and low-temperature overpressure limits (LTOP, see Section 4.2.4) will therefore not be required. APS will confirm the basis for 54 EFPY prior to operation beyond 32 EFPY and will update documents in accordance with the provisions of 10 CFR 50.59.

As described in Section 4.2.1 above, the analysis of the surveillance capsules also shows less-than-expected increases in reference temperatures (ΔRT_{NDT}), with a minor exception in Unit 3 welds, which are not the most limiting material. Adjusted reference temperature (ART) for the limiting material will therefore remain modest and will permit adequate operating margins to P-T limits until the end of the period of extended operation.

Disposition: Validation, 10 CFR 54.21(c)(1)(i)

The present P-T limit curves permit operation up to 32 EFPY, but were based on an assumed beltline neutron fluence in excess of the maximum now projected for 54 EFPY, and are therefore valid for the period of extended operation in accordance with 10 CFR 54.21(c)(1)(i). APS will confirm their basis for 54 EFPY prior to operation beyond 32 EFPY and will update documents in accordance with the provisions of 10 CFR 50.59.

4.2.4 Low Temperature Overpressure Protection (LTOP)

Summary Description

LTOP is required by Technical Specification Limited Condition for Operation 3.4.13, and is provided by relief valves in the two suction lines of the shutdown cooling system (SCS), or by operating with the reactor coolant system (RCS) depressurized and with an open RCS vent of sufficient size. One of these relief paths must be aligned to the RCS whenever the RCS cold leg temperature is below the applicable LTOP enable temperature. [UFSAR Section 5.2.2.11](#), "Overpressure Protection During Low Temperature Conditions," describes the analysis and protection provisions.

The LTOP enable temperatures (the temperatures below which LTOP must be established), and those analyses that confirm the ability to protect the system's pressure limits, depend on the P-T limit curves and the ART. The P-T limit curves and ART are time dependent analyses, as identified in previous subsections. Therefore, the LTOP enable temperatures and the supporting design basis calculations are TLAA's. However these LTOP analyses do not depend on any other time-dependent values beyond the ART and the P-T limits. Since the period of extended operation will not cause the PVNGS Unit 1, 2, and 3 ART and P-T limits to become more limiting, it will not cause the results of the LTOP analyses to become more limiting.

Analysis

LTOP Enable Temperatures

There are two LTOP enable temperatures, a cooldown enable temperature based on the limiting cooldown rate of 100 °F/hour or less, and a heatup enable temperature based on the limiting heatup rate of 75 °F/hour or less.

The LTOP enable temperatures are reactor coolant temperature limits, set at a margin above the limiting end-of-life adjusted reference temperature (ART) in order to prevent pressurization unless the vessel temperature is above the ART.

As described in [Section 4.2.1](#), the calculation of ART is a TLAA, hence the calculation of the LTOP temperatures is a TLAA.

Mass and Energy Addition Transients

LTOP design and licensing bases include analyses to protect the RCS and SCS from increases in pressure caused by the addition of mass or energy to an isolated water-solid system. The severity of the pressure transients depends upon the rate and total quantity of mass or energy added. These analyses demonstrate that a single SCS suction relief valve is sufficient to maintain SCS pressure within 110% of design. The most limiting transients initiated by a single operator error or equipment failure are:

- An inadvertent safety injection actuation (mass addition)

Section 4
TIME-LIMITED AGING ANALYSES

- A reactor coolant pump start with a positive steam generator to reactor vessel ΔT (energy addition)

Mass Addition Transient: The LTOP design and licensing bases include calculation of the effects of possible pressurization (“mass addition”) from high-pressure injection sources. The analysis includes effects of three charging pumps and two high pressure safety injection (HPSI) pumps operating simultaneously.

These calculations demonstrate that mass addition will not exceed the capacity of a single shutdown cooling relief valve at its setpoint to maintain system pressure below the design pressure of the most limiting location plus the 10 percent permitted for relief valve accumulation.

Energy Addition Transient: The LTOP design and licensing bases also include calculation of effects of possible pressurization (“energy addition”) from the start of a reactor coolant pump, including heat addition from a hotter secondary side. The results of the analyses show that a single SCS relief valve will provide sufficient relief capacity for the most limiting energy addition.

Neither the mass addition transient analysis nor the energy addition transient analysis is time dependent. However the enable temperatures and P-T heatup and cooldown limits are used as input to determine maximum system temperature at the time of the event and the heatup and cooldown rates with the system aligned.

Disposition: Validation, 10 CFR 54.21(c)(1)(i)

The only time-limited analyses upon which the LTOP setpoints are based are those for the P-T curves and ART. These will remain valid for the period of extended operation. Therefore the LTOP licensing and design basis analyses will remain valid for the period of extended operation, in accordance with 10 CFR 54.21(c)(1)(i).

4.3 METAL FATIGUE ANALYSIS

This section addresses design of mechanical system components supported by fatigue analyses; and also of components whose design depends on an assumed number of load cycles without a calculated fatigue usage factor.

[Section 4.6](#), “Containment Liner Plate, Equipment Hatch and Personnel Air Locks, Penetrations, and Polar Crane Brackets,” describes fatigue in the containment vessel.

[Section 4.7.4](#), “Fatigue Crack Growth and Fracture Mechanics Stability Analyses of Half-Nozzle Repairs to Alloy 600 Material in Reactor Coolant Hot Legs; Absence of a TLAA for Supporting Corrosion Analyses,” describes corrosion and fatigue crack growth and stability in the primary coolant nozzles.

Fatigue analyses are required for piping, vessels, and heat exchangers designed to the American Society of Mechanical Engineers *Boiler and Pressure Vessel Code*, Section III, *Rules for Construction of Nuclear Power Plant Components*, Division 1, “Metal Components,” Subsection NB, “Requirements for Class 1 Components” (ASME III Class 1).¹ Fatigue analyses may also be invoked for Class 1 pump and valve pressure boundaries.

Fatigue analyses are required for portions of the reactor pressure vessel internals designed to American Society of Mechanical Engineers *Boiler and Pressure Vessel Code*, Section III, *Rules for Construction of Nuclear Power Plant Components*, Division 1, “Metal Components,” Subsection NG, “Core Support Structures.”

The design of piping and vessels to certain other codes and code sections, including ASME III Class 2 and 3, ANSI-ASME B31.1, and ASME VIII Division 2, may assume a stated number of full-range thermal and displacement cycles.

[Section 4.3](#) also describes fatigue analyses and evaluations of a limited number of other non-Class 1 components that were evaluated to these and similar rules.

Basis of Fatigue Analyses

ASME III Class 1 design specifications define a set of static and transient load conditions for which components are to be designed. Although original design specifications commonly state that the transient conditions are for a 40-year design life, the fatigue analyses themselves are based on the specified number of occurrences of each transient rather than

¹ Titles are from the 1971 edition of the code, as used for the reactor vessel. Later editions reorganized the Section III material and removed the Division 1 title, so that this subsection became “Division 1 — Subsection NB, Class 1 Components”.

on this lifetime. The design number of occurrences of each transient for use in the fatigue analyses was specified to be larger than the number of occurrences expected during the 40-year licensed life of the plant, based on engineering experience and judgment. This provides an allowance for future changes in design or operation that may affect system design transients.

Operating experience at PVNGS and at other similar units has demonstrated that the assumed frequencies of design transients, and therefore the number of transient cycles assumed for a 40-year life, were conservative; and that with few exceptions the design numbers are not expected to be exceeded within a 60-year life. The exceptions are of two kinds.

First, the NRC, industry, and specific plants, including PVNGS, have identified some transient loads on some components that were not foreseen in the original design process; for example thermally stratified flow in the pressurizer surge line and feedwater system, and Combustion Engineering Infobulletin 88-09, "Nonconservative Calculation of Cumulative Fatigue Usage." These cases have required evaluations to assess their significance and some have required revision to design specifications and analyses.

Second, plant and industry operating experience has identified a few cases where cycles were being accumulated more rapidly than originally anticipated. At PVNGS, these were principally due to first-of-a-kind startup and shutdown cycles during the early plant life. The enhanced Metal Fatigue of Reactor Coolant Pressure Boundary program will track events to ensure that appropriate re-evaluation or other corrective action is initiated if an action limit is reached. Action limits will permit completion of corrective actions before the design basis number of events is exceeded. See "Corrective Action Limits and Corrective Actions" in [Section 4.3.1.5](#).

The Industry Operating Experience Review program ensures that industry experience is evaluated and incorporated in plant analyses and procedures. The program includes review of experience that may indicate concerns with fatigue effects. Any necessary evaluations are conducted under the plant corrective action program. The program has remained responsive to both industry and plant-specific emerging issues and concerns.

4.3.1 Fatigue Aging Management Program

Prior to the period of extended operation, the Metal Fatigue of Reactor Coolant Pressure Boundary program will be enhanced to include a FatiguePro[®] automated and computerized cycle counting and fatigue usage factor tracking and management program. FatiguePro[®] is an EPRI licensed product. The enhanced program will support safe operation of PVNGS for the period of extended operation, as summarized in [Section 4.3.1.5](#) and Appendix B, [Section B3.1](#). The enhanced program will monitor plant transients and cumulative usage factors (CUFs) for a subset of ASME III Class 1 reactor coolant pressure boundary vessel and piping locations, and Class 2 steam generator locations with Class 1 analyses, to ensure that reevaluation or other corrective action is initiated if an action limit is reached.

Action limits will permit completion of corrective actions before the licensing basis limits on fatigue effects, in all locations, are exceeded.

Scope

The PVNGS FatiguePro[®] program will monitor the components and piping listed in [Table 4.3-4](#).

Methods

The “Global” monitoring method in [Table 4.3-4](#) means that the fatigue management program will not periodically calculate accumulated fatigue usage at the location. However, transient event cycles affecting the location (e.g. plant heatup and plant cooldown) will be counted and tracked to ensure that the numbers of transient events assumed by the design basis calculations will not be exceeded. “Global - Replaceable” applies to bolting with predicted lifetime usage factors greater than 1.0, and which will therefore be replaced as required.

Stress-based fatigue (SBF) monitoring will compute a “real time” stress history for a given component from actual temperature, pressure, and flow histories. SBF is intended for those high-fatigue components where a more refined approach is necessary to show long-term structural acceptability. SBF monitoring depends on “global-to-local” correlation or “transfer” functions which calculate local transient pressures and temperatures from data collected by the limited number of plant instruments, and from them, local stresses and fatigue usage.

Cycle-based fatigue (CBF) monitoring will consist of (a) automated cycle counting; supported as needed by manual data entry for infrequent events, and (b) CUF computation based on the counted cycles. It is intended for components where long-term structural acceptability can readily be shown based on cycle counts alone. Three CBF methods will be, Per-Cycle CBF (CBF-C), Per-Cycle CBF with partial cycles (CBF-PC), and Event-Pairing CBF (CBF-EP).

The CBF-C and CBF-PC methods will compute fatigue usage for a component by determining a location-specific fatigue usage increment for each counted event, and then adding up those increments for all events in the cycle record. CBF-PC will be used for some components, where the fatigue severity of individual plant events can be scaled using partial-cycle curves. A partial-cycle curve assigns a fractional severity to a cycle, as compared to a full design cycle, based upon significant characteristics of that event, such as temperature difference or heatup rate.

CBF-EP is derived from the application of Miner’s rule for combining fatigue effects, under the guidance of ASME III, NB 3222.4. This method will use an event-pairing table which assumes that the effect of pairs of monitored events is equal to the effect of similar pairs of design basis events.

Corrective Action Limits

Corrective actions will be initiated whenever a cycle count or fatigue usage action limit is reached. Action limits will permit completion of corrective actions before the design basis number of events is exceeded, or before the cumulative usage factor exceeds the code limit of 1.0. See [Section 4.3.1.5](#) for the description of these actions and action limits, for the basis for the margins between the fatigue usage factor action limits and the code usage factor limit of 1.0, and for the basis for the margins between the cycle count action limits and the design basis cycle count assumptions.

Analytical Margins

Fatigue analyses incorporate several conservative assumptions and methods. These ensure that usage factors predicted by the design calculation will exceed (or “bound”) the usage factors actually accumulated by the components:

Fatigue Design Curve with Margin for Uncertainties and Moderate Environmental Effects: The ASME Section III fatigue S-N curves (allowable alternating stress intensity versus number of cycles) are based on regression analysis of a large number of fatigue data points for samples strain-cycled in air, with adjustments for the elastic modulus and departure from zero mean stress for elastic cycling, less a design margin for uncertainties, including modest environmental effects (ASME III - 1965, Par. N-415). The design margin is a factor of 2 on stress or 20 on cycles, whichever produced the lower, more conservative allowable for the data set.

Bounding Parameters for Transients: Fatigue analyses assume a given number of cycles of each of a set of transient events, each transient event is defined by limiting pressure and temperature transients and other load conditions. Actual event cycles are seldom as severe as those considered in the analysis; the resulting stress ranges are lower, and the contributions to cumulative usage factor are therefore lower.

Since the FatiguePro[®] stress-based fatigue calculation approximates stresses from the actual event severity, usage factors reported by FatiguePro[®] at locations for which the stress-based method is used are generally more realistic than values predicted by the code analysis for the same number of cycles, or which would be determined by cycle-count monitoring.

The FatiguePro[®] stress-based algorithms are conservative and therefore also bound the actual fatigue effects. An ASME III code analysis calculates a three-dimensional, six-component state of stress at critical locations. The FatiguePro[®] stress-based algorithms approximate the effects of this state of stress with a conservative approximation of the largest principal stress that would be expected in a given location for a given loading condition, and calculates alternating stress ranges and usage factors using this approximate largest principal stress. This ensures that the FatiguePro[®] stress-based algorithms are conservative and therefore also bound the actual fatigue effects. Test cases for several nuclear units in process of license renewal have demonstrated that the method produces

Section 4
TIME-LIMITED AGING ANALYSES

conservative values of this largest principal stress, and therefore of the calculated fatigue usage, when compared to a three-dimensional, six-component calculation using code methods.

Actual Number of Event Cycles: The analytical limit for a fatigue analysis is a cumulative usage factor at any location of 1.0, calculated as the sum of all contributing partial usage factors for the design basis number of cycles of each of the design basis cyclic loading events. Therefore, even if the analysis showed a calculated usage factor at the 1.0 limit for a location, and even if the design basis number of cycles were reached for one event of a set, the fact that all contributing cycle types will not simultaneously arrive at their assumed limit indicates that some margin would remain to the 1.0 limit.

For locations for which the program maintains a current estimate of fatigue usage factor based on cycle counting, action limits are set below the cycle count assumed by the analysis to ensure that actual plant experience remains bounded by the assumptions used in the design calculations, or that appropriate reevaluation or other corrective action is initiated if an action limit is reached. Action limits will permit completion of corrective actions before the design basis number of events is exceeded. Therefore, the program will ensure that there is ample margin to the cumulative usage factor analytic limit of 1.0.

4.3.1.1 Licensing and Design Basis of the PVNGS Component Cyclic and Transient Limit Program

The “Component Cyclic or Transient Limit” program is required by Technical Specification 5.5.5: “This program provides controls to track the [UFSAR Section 3.9.1.1](#) cyclic and transient occurrences to ensure that components are maintained within the design limits.”

[UFSAR Section 3.9.1.1](#) includes, by reference, information and transient definitions from several sections and tables, which represent conservative estimates for design purposes listed in [Table 4.3-1](#). The FSAR states that this information accounts for all expected transients, and that the number and severity of the design transients exceeds those which may be anticipated during the 40-year life of the plant.

Table 4.3-1 - PVNGS Unit 1, 2, and 3 Licensing and Design Basis Transient Citations from [UFSAR 3.9.1.1](#)

UFSAR Section or Table	Applicable Scope of Transient Data
Section 3.7.3.2	Operating Basis Earthquake (OBE) Cycles
Table 3.9.1-1	ASME III Class 1 Components by the NSSS Vendor (CE)
Table 3.9-1	ASME III Class 1 Piping Not by the NSSS Vendor (CE)
Section 3.9.3	ASME III Class 2 and 3 Components ¹
Section 5.4.1	Reactor Coolant Pumps
Section 5.4.2	Steam Generators

Table 4.3-1 - PVNGS Unit 1, 2, and 3 Licensing and Design Basis Transient Citations from UFSAR 3.9.1.1

UFSAR Section or Table	Applicable Scope of Transient Data
Section 5.4.3	Reactor Coolant Piping
Section 5.4.10	Pressurizer

¹ Although the title of UFSAR Section 3.9.3 is “ASME Code Class 1, 2, and 3 Components, Component Supports, and Core Support Structure,” the controlling Class 1 transients are described in the tables, and this section contains unique transient design information only for the remaining classes.

4.3.1.2 Enhanced PVNGS Fatigue Management Program

The enhanced fatigue management program (Metal Fatigue of Reactor Coolant Pressure Boundary program) includes a FatiguePro[®] automated and computerized program to support safe operation of PVNGS for the period of extended operation. The enhanced program will monitor fatigue effects for a subset of ASME III Class 1 reactor coolant pressure boundary vessel and piping locations, and Class 2 steam generator secondary-side locations with Class 1 analyses. [Table 4.3-2](#) lists those plant transients that form the basis for the cyclic duty for which components were designed.

If the limiting value for the transient is not stated in the UFSAR; the limiting value is determined by the limiting number of transients from design specifications of affected systems and components, unless otherwise noted.

Table 4.3-2 - PVNGS Unit 1, 2, and 3 Licensing and Design Basis Transients⁽¹⁾

Transient— (2)	Summary of Criteria	
	UFSAR	Limiting Number of Events ⁽³⁾
Normal Events		
1. Plant Heatup, 100 °F/hr	500	500
2. Plant Cooldown, 100 °F/hr	500	500
3. Plant Loading, 5 %/min	15,000	15,000
4. Plant Unloading, 5 %/min	15,000	15,000
5. 10% Step Load Increase	2,000	2,000
6. 10% Step Load Decrease	2,000	2,000
7. Normal Plant Variation	10 ⁶	10 ⁶

Section 4
TIME-LIMITED AGING ANALYSES

Table 4.3-2 - PVNGS Unit 1, 2, and 3 Licensing and Design Basis Transients⁽¹⁾

Transient— (2)	Summary of Criteria	
	UFSAR	Limiting Number of Events ⁽³⁾
8. Reactor Coolant Pump Starting	1,000	1,000
9. Reactor Coolant Pump Stopping	1,000	1,000
10. Cold Feedwater following Hot Standby (AFW)	NS ⁽⁴⁾	15,000
11. Pressurizer Heatup, 200 °F/hr	500	500
12. Pressurizer Cooldown, 200 °F/hr	500	500
13. Shift from Normal to Maximum Purification Flow at 100% Power	1,000	1,000
14. Low-Low Volume Control Tank or Charging Pump Suction Diversion to RWT	80	80
15. Pressure Level Control, Failure to Open	100	100
16. Unbolting/Bolting of Reactor Coolant Pump Casing Studs	NS ⁽⁴⁾	25
17. Detensioning/Tensioning of RV Head Studs	NS ⁽⁴⁾	50
18. Safety Injection Check Valve Test	160	160
19. High Pressure Safety Injection Header Check Valve Test	40	40
20. Turbine Roll Test at Hot Standby	10	10
21. Auxiliary Spray During Cooldown	500	500
22. Initiation of Shutdown Cooling	500 ⁽⁵⁾	500
Upset Events		
23. Reactor Coolant Pump Coastdown at 100% Power	10	10
24. Reactor Trip	50/240 ⁽⁷⁾	50
25. Loss of Reactor Coolant Flow	40	40
26. Loss of Load (Load Rejection from 100 to 15% Power)	40	40
27. Operating Basis Earthquake	200	200
28. Inadvertent Control Element Assembly Drop	40	40
29. Inadvertent Control Element Assembly Withdrawal	40	40
30. Loss of Charging and Recovery	200	200
31. Loss of Letdown and Recovery	300	300
32. Extended Loss of Letdown	800 ⁽⁷⁾	800
33. Depressurization by Spurious Actuation of Pressurizer Spray Control Valves at 100% Power (Main & Aux. Spray)	40	40
34. Partial Loss of Condenser Cooling at 100% Power	40	40
35. Excess Feedwater at 100% Power	40	40
36. Turbine Trip Without Reactor Trip	40/120 ⁽⁷⁾	40
37. Inadvertent Actuation of Main Steam Line Isolation Valve	5/40 ⁽⁶⁾	5/40 ⁽⁶⁾
38. Opening One Atmospheric Dump Valve or Steam Bypass Valve at 100% Power	40	40
39. Seismic Event Up to and Including One-Half of the Safe Shutdown Earthquake, at 100% Power	2	2
40. Initiation of Safety Injection	10	10
41. Inadvertent Isolation of Feedwater Heater	5	5

Section 4
TIME-LIMITED AGING ANALYSES

Table 4.3-2 - PVNGS Unit 1, 2, and 3 Licensing and Design Basis Transients⁽¹⁾

Transient— (2)	Summary of Criteria	
	UFSAR	Limiting Number of Events ⁽³⁾
42. Loss of Feedwater Flow to Steam Generators	85 ⁽⁷⁾	85
43. Loss of Reactor Coolant Pump Seal Coolant	NS ⁽⁴⁾	40
44. Loss of Reactor Coolant Pump Seal Injection	NS ⁽⁴⁾	40
45. Inadvertent Auxiliary Spray at 100% Power	5	5
46. System Leak due to Rupture of Instrument Line or Sampling Connection	40	40
47. Inadvertent Main Feedwater Isolation Valve Closure at 100% Power (One MFIV)	40	40
48. Inadvertent Feedwater or Condensate Pump Trip at 100% Power	40	40
49. Main Feedwater Isolation Valve Closures due to Loss of Air at 100% Power	5	5
50. Depressurization by Main Steam Safety Valve at 100% Power	10	10
51. Startup of One Reactor Coolant Pump at 50% Power	10	10
52. Loss of Electrical Bus Supplying two Reactor Coolant Pumps at 100% Power	40	40
53. Inadvertent Closure of All Main Feedwater Isolation Valves at 100% Power	NS ⁽⁴⁾	5
54. Spurious Startup or Shutdown of SI Pump, or Spurious Opening or Closing of SI Isolation Valve	40	40
Test Events		
55. Primary Side Hydrostatic Test, 3115 psia, 100 – 400 °F	10	10
56. Secondary Side Hydrostatic Test	10	10
57. Primary Side Leak Test, 2250 psia, 100 - 400 °F	200	200
58. Secondary Side Leak Test, 820 psia to Design Pressure	200	200
59. CVCS System Hydrostatic Test	40	40
60. Low Pressure Safety Injection Pump Test⁽⁸⁾	500 ⁽⁵⁾	500
61. High Pressure Safety Injection Pump Test⁽⁸⁾	500 ⁽⁵⁾	500

¹ The UFSAR and design specifications also include Faulted and Emergency transient events. These events are not included here because they are not used in ASME III Class 1 fatigue analyses.

² Un-bolded transients do not contribute significantly to fatigue and therefore are not necessary for calculation of fatigue usage by the fatigue management program.

³ Except as noted, the limiting number of events is the number stated in the UFSAR. If the UFSAR does not state a number the limiting number of events is the limiting design specification number for the event.

⁴ NS means “not stated,” “not separately stated,” or “not applicable to this component.”

⁵ The number in the UFSAR is for Safety Injection System components only.

⁶ UFSAR numbers are 5 events from 100% power, 40 events from unspecified power level.

⁷ The number in the UFSAR is for CVCS components only.

⁸ LPSI and HPSI (Low and High-Pressure Safety Injection) pump test transients are not listed as licensing and design basis transients. These are quarterly tests that add significant fatigue to the pumps and components upstream of the isolation valves.

4.3.1.3 Seismic History

Design analyses that compare seismic stresses against stress allowables, in the absence of any consideration of the number of cycles or of fatigue effects, are not TLAAs. However, design of structures, systems, and components may include seismic loads in fatigue analyses, or may assume a stated number of seismic load cycles for purposes of establishing an allowable stress or stress range. Significant earthquakes at the site can therefore increase the accumulated fatigue usage factor; or can reduce the analogous significant earthquake load cycles assumed, by the design, to be allowed for the remaining operating life.

The site seismic history can thereby affect the disposition of TLAAs. However, since construction no significant earthquakes have occurred at PVNGS to date.

For design purposes the PVNGS safe shutdown earthquake (SSE) and operating basis earthquake (OBE) are defined as 0.20 g and 0.10 g ground motion, respectively. Analyses of Seismic Category I structures used a conservative design basis 0.25 g SSE and 0.13 g OBE [[UFSAR 3.7](#)].

For purposes of evaluating actual events at PVNGS, an SSE is defined as one with a modified-Mercalli intensity level 8 (ground motion of 0.15 to 0.33 g or above); and an OBE is defined as one with a modified-Mercalli intensity level 7 (ground motion of 0.072 to 0.15 g). No SSE or OBE has occurred to date. The site has recorded seven minor earthquakes, some of these not strong enough to qualify as recordable "earthquake events." The strongest had a ground motion of only 0.015 g, or about 12% of the acceleration, and therefore the applied loads, of a design basis 0.13 g OBE.

4.3.1.4 Present and Projected Status of Monitored Locations

Summary Description

The fatigue management program transient cycle count procedure, 73ST-9RC02, recorded accumulated transient events for the 9 transients listed in Appendix J of the procedure since the Unit 1 startup in 1985. This transient list did not include every transient in the FSAR. Therefore, in 1995 (after 10 years of Unit 1 operation), the cycle count procedure was revised to include the 48 remaining FSAR transients listed in Appendix K of the procedure. In the 1995 record of the revised procedure, accumulation for all transient events not counted to date was assumed at 25% of the limiting value for the 40-year design. After the

1995 revision of the cycle count procedure, transients were recorded on a case-by-case basis and were added to the 25% accumulation assumed in 1995.

APS Fatigue Cycle Count Verification

The goal of the APS fatigue cycle count verification was to reduce the uncertainty created by the 25% accumulation assumed in 1995.

Scope

Transients adding significant fatigue to components were included in the APS transient recount. Transients not contributing significantly to fatigue were not included in the APS transient recount. The transients not included in the recount are retained in the composite worst-case unit accumulation, including the 25% accumulation assumed in 1995.

Recount Method

Unit 1 was the prototype Combustion Engineering System 80 plant. Due to a lack of operating experience, early Unit 1 operation included tests and events that did not generally occur as frequently in subsequent units. A cycle count record from Unit 1 should therefore be a conservative estimate for Unit 2 and Unit 3. However, Unit 1 had a 460-day outage, with Unit 2 running, but during which Unit 2 experienced many startup-shutdown transients. Therefore, APS has created a composite worst-case (composite-unit) envelope including only the highest accumulation of each transient experienced among the three units from 1985 through 2005.

APS performed a best effort retrieval of the transient count data recorded from 1985 through 1995 (the "APS transient recount"). Sources for this effort included (1) NRC Information Reports for all three units, (2) Unit 1 control room logs from 1985 through 1995, (3) Unit 2 control room logs from 1986 through 1995, and (4) interviews with plant personnel (for Unit 1 only). The result of this data retrieval is the "worst-case APS transient recount from 1985 through 1995." Unit 3 control room log data was not reviewed. Unit 3 did not experience the early-operation complications of Unit 1 and 2, therefore the Unit 1 and 2 composite worst-case transient recount (including Unit 3 NRC Information Report data) is expected to bound the transients experienced by Unit 3.

The 25% accumulation assumed in 1995 was subtracted from the totals recorded through 2005 in the cycle count procedure to obtain the accumulation from 1996 through 2005 for each transient. This accumulation from 1996 through 2005 was then added to the worst-case APS transient recount from 1985 through 1995 to obtain the composite worst-case unit accumulation of cycles from 1985 to 2005, for each transient.

Transient Projections

A yearly accumulation rate must be calculated in order to accurately project transient accumulation through the period of extended operation. The yearly accumulation rate was calculated by dividing the composite-unit accumulation from 1985 through 2005 by the least

Section 4
TIME-LIMITED AGING ANALYSES

number of years of operation up to 2005 (Unit 3, operating period of 18 years). This resulted in the worst-case accumulation of cycles over the least amount of time. This accumulation rate was then multiplied by 22 ($18+22=40$) and added to the composite-unit 2005 accumulation to calculate the projected accumulation at 40 years of operation. Similarly, the accumulation rate was multiplied by 42 ($18+42=60$) and added to the composite-unit 2005 accumulation to calculate the projected accumulation at 60 years of operation.

Transients not included in the FSAR

Some transients which are required by the fatigue management program to accurately calculate fatigue usage are not required to be monitored by the PVNGS FSAR, and were therefore not separately counted in the procedure through 2005. These transients were therefore included in the cycle count verification. However, there is no accumulation record of these transient events from 1996 through 2005. APS has therefore determined an accumulation rate using the recount accumulation data from 1985 through 1995, then dividing this accumulation by the least number of years of operation up to 1995 (Unit 3, operating time of 8 years). The composite unit 2005 accumulation was then calculated by multiplying the accumulation rate by 10 years (1995 to 2005) and adding this to the 1995 recount accumulation.

Transients with a to date accumulation of zero

The yearly accumulation rate for transients which to date have no accumulation was determined by dividing the design basis number of transient events by 40 years. This resulted in the original expected annual accumulation rate of transients, except that no transients have occurred to date. Therefore, the accumulation rate was determined by multiplying the original expected accumulation rate by the percentage of years left in the design basis ($22/40$).

Transients not expected to occur

No yearly accumulation rate was calculated for transients which are not expected to occur. For these transient events at least one event was assumed to occur during the period of extended operation.

Section 4
TIME-LIMITED AGING ANALYSES

Table 4.3-3 - APS Fatigue Cycle Count Verification (Composite Worst-Case Unit), and Projections^(1, 2)

Transient ⁽³⁾	Limiting Number of Events (Table 4.3-2)	Fatigue Management Program Transient Cycle Count Procedure (73ST-9RC02)		Worst-Case APS Transient Recount (1985-1995)	Composite Worst-Case Unit Accumulation (1985-2005) ⁽⁴⁾	Accumulation Rate (per year) ⁽⁵⁾	Projected to 40 years ⁽⁶⁾	Projected to 60 years ⁽⁷⁾
		(1985-1995) 25% Assumed ⁽⁸⁾	Worst-Case (1985-2005) Incl. 25% Assumed					
Normal Events								
1. Plant Heatup, 100°F/hr	500	21	64	NC ⁽⁹⁾	64 ⁽¹⁰⁾	3.56	143	214
2. Plant Cooledown, 100°F/hr	500	20	63	NC	63 ⁽¹⁰⁾	3.50	140	210
3. Plant Loading, 5%/min	15,000	NR ⁽¹¹⁾	NR	NC	NC	NC	NC	NC
4. Plant Unloading, 5%/min	15,000	NR	NR	NC	NC	NC	NC	NC
5. 10% Step Load Increase ⁽¹²⁾	2,000	500	521	132	297 ⁽¹³⁾	16.50	660	990
6. 10% Step Load Decrease ⁽¹²⁾	2,000	NR	NR	72	162 ⁽¹³⁾	9.00	360	540
7. Normal Plant Variation	10 ⁶	NR	NR	NC	NC	NC	NC	NC
8. RC Pump Starting	1,000	250	281	NC	281 ⁽¹⁴⁾	15.61	625	937
9. RC Pump Stopping	1,000	250	275	NC	275 ⁽¹⁴⁾	15.28	612	917
10. Cold Feedwater Following Hot Standby (AFW)	15,000	3750	3752	NC	3752 ⁽¹⁴⁾	208.44	8,338	12,507

Section 4
TIME-LIMITED AGING ANALYSES

Table 4.3-3 - APS Fatigue Cycle Count Verification (Composite Worst-Case Unit), and Projections^(1, 2)

Transient ⁽³⁾	Limiting Number of Events (Table 4.3-2)	Fatigue Management Program Transient Cycle Count Procedure (73ST-9RC02)		Worst-Case APS Transient Recount (1985-1995)	Composite Worst-Case Unit Accumulation (1985-2005) ⁽⁴⁾	Accumulation Rate (per year) ⁽⁵⁾	Projected to 40 years ⁽⁶⁾	Projected to 60 years ⁽⁷⁾
		(1985-1995) 25% Assumed ⁽⁸⁾	Worst-Case (1985-2005) Incl. 25% Assumed					
11. Pressurizer Heatup, 200°F/hr	500	NR	86	NC	86 ⁽¹⁰⁾	4.78	192	287
12. Pressurizer Cooldown, 200°F/hr	500	NR	85	NC	85 ⁽¹⁰⁾	4.72	189	284
13. Shift from Normal to Maximum Purification Flow at 100% Power	1,000	250	250	NC	250 ⁽¹⁴⁾	13.89	556	834
14. Low-Low Volume Control Tank/Charging Pump Suction Diversion to RWT	80	20	20	NC	20 ⁽¹⁴⁾	1.11	45	67
15. Pressure Level Control, Failure to Open	100	25	25	NC	25 ⁽¹⁴⁾	1.39	56	84
16. Unbolting/ Bolting of RC Pump Casing Studs	25	NR	NR	19	19 ⁽¹⁵⁾	1.06	43 ⁽¹⁶⁾	64 ⁽¹⁶⁾
17. Tensioning/ Detensioning of RV Head Studs	50	NR	NR	9	21 ⁽¹³⁾	1.13	45	68 ⁽¹⁶⁾

Section 4
TIME-LIMITED AGING ANALYSES

Table 4.3-3 - APS Fatigue Cycle Count Verification (Composite Worst-Case Unit), and Projections^(1, 2)

Transient ⁽³⁾	Limiting Number of Events (Table 4.3-2)	Fatigue Management Program Transient Cycle Count Procedure (73ST-9RC02)		Worst-Case APS Transient Recount (1985-1995)	Composite Worst-Case Unit Accumulation (1985-2005) ⁽⁴⁾	Accumulation Rate (per year) ⁽⁵⁾	Projected to 40 years ⁽⁶⁾	Projected to 60 years ⁽⁷⁾
		(1985-1995) 25% Assumed ⁽⁸⁾	Worst-Case (1985-2005) Incl. 25% Assumed					
18. Safety Injection Check Valve Test ⁽¹⁷⁾	160	NR	NR	0	0	⁽¹⁸⁾	1	1
19. High Pressure Safety Injection Header Check Valve Test	40	NR	NR	1	3 ⁽¹³⁾	0.13	5	8
20. Turbine Roll Test at Hot Standby	10	NR	NR	3	3	⁽¹⁸⁾	4	4
21. Auxiliary Spray During Cooldown	500	NR	NR	NC	63	6.88	215	352
22. Initiation of Shutdown Cooling	500	125	148	NC	148 ⁽¹⁴⁾	8.22	329	494
Upset Events								
23. RCP Coastdown at 100% Power	10	NR	NR	NC	NC	0.14 ⁽¹⁹⁾	4	6
24. Reactor Trip	50	13	19	28	34	1.89	76 ⁽¹⁶⁾	114 ⁽¹⁶⁾
25. Loss of Reactor Coolant Flow	40	10	12	2	4	0.22	9	14
26. Loss of Load (Load Reduction from 100 to 15% Power)	40	10	11	13	14	0.78	32	47 ⁽¹⁶⁾

Section 4
TIME-LIMITED AGING ANALYSES

Table 4.3-3 - APS Fatigue Cycle Count Verification (Composite Worst-Case Unit), and Projections^(1, 2)

Transient ⁽³⁾	Limiting Number of Events (Table 4.3-2)	Fatigue Management Program Transient Cycle Count Procedure (73ST-9RC02)		Worst-Case APS Transient Recount (1985-1995)	Composite Worst-Case Unit Accumulation (1985-2005) ⁽⁴⁾	Accumulation Rate (per year) ⁽⁵⁾	Projected to 40 years ⁽⁶⁾	Projected to 60 years ⁽⁷⁾
		(1985-1995) 25% Assumed ⁽⁸⁾	Worst-Case (1985-2005) Incl. 25% Assumed					
27. Operational Basis Earthquake	200	NR	0	NC	0 ⁽¹⁰⁾	⁽¹⁸⁾	20 ⁽²⁰⁾	20 ⁽²⁰⁾
28. Inadvertent CEA Drop	40	10	11	5	6	0.33	14	20
29. Inadvertent CEA Withdrawal	40	10	11	0	1	0.06	3	4
30. Loss of Charging and Recovery	200	25	27	5	7	0.39	16	24
31. Loss of Letdown and Recovery	300	210	213	17	20	1.11	45	67
32. Extended Loss of Letdown	800	NR	200	34	234	13.00	520	780
33. Depressurization by Spurious Actuation of Pressurizer Spray Control Valve at 100% Power (Main & Aux. Spray)	40	10	11	0	1	0.06	3	4
34. Partial Loss of Condenser Cooling at 100% Power	40	10	11	NC	11 ⁽¹⁴⁾	0.61	25	37

Section 4
TIME-LIMITED AGING ANALYSES

Table 4.3-3 - APS Fatigue Cycle Count Verification (Composite Worst-Case Unit), and Projections^(1, 2)

Transient ⁽³⁾	Limiting Number of Events (Table 4.3-2)	Fatigue Management Program Transient Cycle Count Procedure (73ST-9RC02)		Worst-Case APS Transient Recount (1985-1995)	Composite Worst-Case Unit Accumulation (1985-2005) ⁽⁴⁾	Accumulation Rate (per year) ⁽⁵⁾	Projected to 40 years ⁽⁶⁾	Projected to 60 years ⁽⁷⁾
		(1985-1995) 25% Assumed ⁽⁸⁾	Worst-Case (1985-2005) Incl. 25% Assumed					
35. Excess Feedwater at 100% Power	40	10	10	2	2	0.11	5	7
36. Turbine Trip Without Reactor Trip	40	10	15	13	18	1.00	40 ⁽¹⁶⁾	60 ⁽¹⁶⁾
37. Inadvertent Actuation of Main Steam Line Isolation Valve	5/40 ⁽²¹⁾	2	3	1/5	1/5	0.06/0.28	3/12	4/17
38. Opening One ADV or Steam Bypass Valve, at 100% Power	40	10	11	1	2	0.11	5	7
39. Seismic Event up to and Including One-Half of the Safe Shutdown Earthquake, at 100% Power	2	NR	NR	NC	NC	⁽²²⁾	NC	NC
40. Initiation of Safety Injection	10	NR	7	4	7 ⁽¹⁰⁾	0.39	16 ⁽¹⁶⁾	24 ⁽¹⁶⁾

Section 4
TIME-LIMITED AGING ANALYSES

Table 4.3-3 - APS Fatigue Cycle Count Verification (Composite Worst-Case Unit), and Projections^(1, 2)

Transient ⁽³⁾	Limiting Number of Events (Table 4.3-2)	Fatigue Management Program Transient Cycle Count Procedure (73ST-9RC02)		Worst-Case APS Transient Recount (1985-1995)	Composite Worst-Case Unit Accumulation (1985-2005) ⁽⁴⁾	Accumulation Rate (per year) ⁽⁵⁾	Projected to 40 years ⁽⁶⁾	Projected to 60 years ⁽⁷⁾
		(1985-1995) 25% Assumed ⁽⁸⁾	Worst-Case (1985-2005) Incl. 25% Assumed					
41. Inadvertent Isolation of FW Heater	5	1	1	0	0	0.07 ⁽¹⁹⁾	2	3
42. Loss of Feedwater Flow to Steam Generators	85	21	22	NC	NC	⁽²³⁾	NC	NC
43. Loss of RCP Seal Coolant	40	NR	NR	NC	NC	NC	NC	NC
44. Loss of RCP Seal Injection	40	NR	NR	NC	NC	NC	NC	NC
45. Inadvertent Auxiliary Spray at 100% Power	5	1	2	0	1	0.06	3	4
46. System Leak due to Rupture of Instrument Line or Sampling Connection	40	10	10	0	0	0.55 ⁽¹⁹⁾	13	24
47. Inadvertent MFIV Closure at 100% Power (One MFIV)	40	10	10	1	1	0.06	3	4

Section 4
TIME-LIMITED AGING ANALYSES

Table 4.3-3 - APS Fatigue Cycle Count Verification (Composite Worst-Case Unit), and Projections^(1, 2)

Transient ⁽³⁾	Limiting Number of Events (Table 4.3-2)	Fatigue Management Program Transient Cycle Count Procedure (73ST-9RC02)		Worst-Case APS Transient Recount (1985-1995)	Composite Worst-Case Unit Accumulation (1985-2005) ⁽⁴⁾	Accumulation Rate (per year) ⁽⁵⁾	Projected to 40 years ⁽⁶⁾	Projected to 60 years ⁽⁷⁾
		(1985-1995) 25% Assumed ⁽⁸⁾	Worst-Case (1985-2005) Incl. 25% Assumed					
48. Inadvertent FW or Condensate Pump Trip at 100% Power	40	10	11	10	11	0.61	25	37
49. MFIV closures due to Loss of Air at 100% Power	5	1	1	1	1	0.06	3	4
50. Depressurization by MSSV at 100% Power	10	2	2	5	5	0.28	12 ⁽¹⁶⁾	17 ⁽¹⁶⁾
51. Startup of one Reactor Coolant Pump at 50% Power	10	NR	NR	NC	NC	0.14 ⁽¹⁹⁾	4	6
52. Loss of Electrical Bus Supplying two RCPS at 100% Power	40	10	14	2	6	0.33	14	20
53. Inadvertent Closure of all MFIVs at 100% Power	5	NR	NR	NC	NC	⁽²⁴⁾	NC	NC

Section 4
TIME-LIMITED AGING ANALYSES

Table 4.3-3 - APS Fatigue Cycle Count Verification (Composite Worst-Case Unit), and Projections^(1, 2)

Transient ⁽³⁾	Limiting Number of Events (Table 4.3-2)	Fatigue Management Program Transient Cycle Count Procedure (73ST-9RC02)		Worst-Case APS Transient Recount (1985-1995)	Composite Worst-Case Unit Accumulation (1985-2005) ⁽⁴⁾	Accumulation Rate (per year) ⁽⁵⁾	Projected to 40 years ⁽⁶⁾	Projected to 60 years ⁽⁷⁾
		(1985-1995) 25% Assumed ⁽⁸⁾	Worst-Case (1985-2005) Incl. 25% Assumed					
54. Spurious Startup/Shutdown of SI Pump or Spurious Opening/ Closing of SI Isolation Valve	40	10	10	1	1	0.06	3	4
Test Events								
55. Primary side Hydrostatic Test, 3125 psia, 100-400F	10	NR	1	NC	1 ⁽¹⁰⁾	(18)	2	2
56. Secondary Side Hydrostatic Test	10	3	3	1	1	(18)	2	2
57. Primary Side Leak Test, 2250 psia, 100-400F	200	NR	5	NC	5 ⁽¹⁰⁾	(18)	6	6
58. Secondary Side Leak Test, 820 psia to design pressure	200	50	50	1	1	(18)	2	2
59. CVCS System Hydrostatic Test	40	10	10	1	1	(18)	2	2
60. LPSI Pump Test	500	125	239	44	84	4.00 ⁽²⁵⁾	172	252

Table 4.3-3 - APS Fatigue Cycle Count Verification (Composite Worst-Case Unit), and Projections^(1, 2)

Transient ⁽³⁾	Limiting Number of Events (Table 4.3-2)	Fatigue Management Program Transient Cycle Count Procedure (73ST-9RC02)		Worst-Case APS Transient Recount (1985-1995)	Composite Worst-Case Unit Accumulation (1985-2005) ⁽⁴⁾	Accumulation Rate (per year) ⁽⁵⁾	Projected to 40 years ⁽⁶⁾	Projected to 60 years ⁽⁷⁾
		(1985-1995) 25% Assumed ⁽⁸⁾	Worst-Case (1985-2005) Incl. 25% Assumed					
61. HPSI Pump Test	500	125	246	44	84	4.00 ⁽²⁵⁾	172	252

¹ The FSAR and design specifications also include Faulted and Emergency transient events. These events are not included here because they are not used in ASME III Class 1 fatigue analyses.

² Results of all calculated transient cycles were rounded up to the next integer (i.e., 11.3=12 or 26.7=27). Projections are correct but may appear low, because the calculated accumulation rates were rounded to two decimals.

³ Un-bolded transients do not contribute significantly to fatigue and therefore are not necessary for calculation of fatigue by the fatigue management program.

⁴ The "Composite Worst-Case Unit Accumulation" column was determined by review of the 2005 record of the cycle count procedure, unless otherwise noted. The highest transient totals recorded in the 1995 record were deleted from the highest totals in the 2005 record to remove the 25% accumulation assumed in 1995. Then the APS recount from 1985 through 1995 was added to the result to obtain the best estimate of the worst-case number of events experienced.

⁵ The "Accumulation Rate," for all transients counted in the cycle count procedure that have an accumulation through 2005, was calculated by dividing the "Composite Worst-Case Unit Accumulation" by the least number of years in operation up to 2005 (Unit 3 operating period of 18 years) to determine the worst case number of events experienced per year.

⁶ The "Projected to 40 years" column was calculated by multiplying the "Accumulation Rate" value by 22 years (18+22=40) and adding the result to the "Composite Worst-Case Unit Accumulation."

⁷ The "Projected to 60 years" column was calculated by multiplying the "Accumulation Rate" value by 42 years (18+42=60) and adding the result to the "Composite Worst-Case Unit Accumulation."

⁸ The "(1985-1995) 25% Assumed" column lists the 25% assumed accumulations initially recorded in Appendix K of the 1995 record of the cycle count procedure.

⁹ Transients not counted in the APS fatigue cycle count verification are marked as "NC."

¹⁰ Transient was counted by the cycle count procedure since initial plant startup, therefore no cycles were assumed. The "Composite Worst-Case Unit Accumulation" is the same as the "(1985-2005)" procedure count.

¹¹ Transients not recorded in the 73ST-9RC02 procedure are marked as "NR."

¹² Transients 5 and 6 were not counted separately in the cycle count procedure; only 10% power increases were recorded in the procedure. Due to an incomplete transient description, the procedure only included power changes between 90% and 100% power.

¹³ Transient was not separately counted in the cycle count procedure, therefore the "Accumulation Rate" was calculated by taking the APS recount number and dividing by the least number of years in operation up to 1995 (Unit 3 operating period of 8 years) to determine the worst-case number of events experienced per year. The "Composite Worst-Case Unit Accumulation" was calculated by multiplying the calculated "Accumulation Rate" by 10 years (1995 to 2005) and adding the result to the APS recount.

¹⁴ Transient event does not contribute significantly to fatigue and is not counted by the Fatigue Management Program. The "Composite Worst-Case Unit Accumulation" includes the 25% accumulation assumed in 1995.

¹⁵ The "Composite Worst-Case Unit Accumulation" for Transient 16, "Unbolting/Bolting of RC Pump Casing Studs," is a conservative estimate for a worst-case stud, extracted by review of maintenance work orders, for the APS fatigue cycle count verification.

¹⁶ The APS fatigue cycle count verification resulted in higher than expected projected values for Transients 16, 17, 24, 26, 36, 40, and 50. These transients will require re-evaluation or other corrective actions when action limits are reached.

¹⁷ Transient 18, "Safety Injection Check Valve Test" is not counted specifically because the check valve test is performed during a stage of startup at normal heatup pressure and temperature, resulting in no significant fatigue accumulation.

¹⁸ Transient is not expected to occur; therefore no "Accumulation Rate" value calculated for this transient. However, at least one occurrence was assumed to occur during the period of extended operation.

¹⁹ Transient has no to-date accumulation through 2005. The "Accumulation Rate" was determined by dividing the design basis number of transient events by 40 years and multiplying the result by the percentage of years left in the design basis (22/40).

²⁰ One Operational Basis Earthquake is equal to 20 transient cycles.

²¹ UFSAR numbers of 5 events from 100% power; 40 events from an unspecified power level.

²² Transient 39, "Seismic Event up to and including One-Half of the Safe Shutdown Earthquake, at 100% Power" is not counted specifically because it is included in the count for transient 27, "Operating Basis Earthquake."

²³ Transient 42, "Loss of Feedwater Flow (to S/G)" is not counted specifically because it is included in the counts for transients 47, 48, and 49.

²⁴ Transient 53, "Inadvertent Closure of all MFIVs at 100% Power" is not counted specifically because it is a duplicate of transient 49, "MFIV Closures due to Loss of Air at 100% Power".

²⁵ Transients 60 and 61, "LPSI and HPSI Pump Tests" are not listed as Licensing and Design Basis Transients. These are quarterly tests that add significant fatigue to the pumps and components upstream of the isolation valves.

Basis for Reduced Cycle Counts

Transient 18, “Safety Injection Check Valve Test”: The limiting number of 160 events in the UFSAR originated from the Combustion Engineering general specification. Combustion Engineering plants subsequently petitioned the NRC (in the early 1980’s) for permission to not perform this quarterly test because of the significant fatigue which would result from inserting cold Safety Injection water. The quarterly test was never performed and never incorporated in the procedure. The check valve test is performed during a stage of startup at normal heatup pressure and temperature, resulting in no significant fatigue accumulation. This transient event is therefore not performed as originally characterized and analyzed and need not be tracked.

Transient 26, “Loss of Load”: The projected number of events may not be reached because the loss of load transient is only significant to fatigue when it causes a turbine trip. This is avoided by performing turbine runback. If corrective actions to reanalyze components become necessary, they may include a revision of the definition of this transient event.

Transient 37, “Inadvertent Actuation of MSIV”: Limiting numbers in the UFSAR are 5 events from 100% power and 40 events from an unspecified power level. Only one event for each unit has been recorded at 100% power.

4.3.1.5 Program Scope, Action Limits, and Corrective Actions

Scope

The scope of the Metal Fatigue of Reactor Coolant Pressure Boundary program will include a bounding set of locations within existing ASME Section III Class 1 vessel and piping fatigue analyses. This set includes the NUREG/CR-6260 sample locations. The scope of the bounding set of monitored locations is sufficient to ensure that fatigue in any other locations of concern, not included in the set, is within the same system and subject to the same transients, or within a system affected by the same transients.

[Table 4.3-4](#) reflects the scope of the enhanced PVNGS fatigue management program. The enhanced program will include (1) Class 1 locations with high calculated cumulative usage factors, (2) components listed in NUREG/CR-6260, (3) Class 1 components for which partial-cycle equations have been developed for stress-based monitoring, and (4) Class 2 portions of the steam generators with a Class 1 analysis and high calculated cumulative usage factors.

The “Fatigue Management Method” column of [Table 4.3-4](#) indicates the method FatiguePro[®] will use to track fatigue usage for each component. These are stress-based fatigue (SBF), cycle-based fatigue (CBF-C - per cycle, CBF-PC - per cycle with partial cycles, or CBF-EP - event pairing), and “global.” The “global” method will only be used for components with low calculated design basis fatigue usage values, for which the fatigue management program does not periodically calculate accumulated fatigue usage to date. However,

transient event cycles that have significant fatigue effects will be counted and tracked to ensure that the numbers of transient events assumed by the design basis calculations will not be exceeded. This “global” coverage will therefore suffice to demonstrate design basis compliance. See [Table 4.3-3](#) for the list of tracked transients.

Corrective Action Limits and Corrective Actions

The PVNGS fatigue management program currently incorporates action limits that provide for evaluation of fatigue usage and cycle count tracking of critical thermal and pressure transients to verify that the ASME Code CUF limit of 1.0 and other CUF design limits will not be exceeded. The program requires this evaluation at least once per fuel cycle. Action limits are based on a fixed percentage of allowed cycles for components monitored by a maximum number of defined transients, while components whose CUF is monitored have specific CUF values for action limits. The current action limits are established to prevent exceeding the maximum number of allowed cycles or a CUF of 1.0, as applicable, and should provide at least one fuel cycle of warning.

The enhanced program specifies corrective actions to be implemented to ensure that appropriate reevaluation or other corrective action is initiated if an action limit is reached.

Action Limit Margins

Corrective action limits must ensure that corrective actions are taken before the design limits are exceeded. Corrective action limits must therefore ensure that appropriate reevaluation or other corrective actions are initiated while sufficient margin remains to allow at least one occurrence of the worst case (highest fatigue usage per cycle) low probability transient that is included in design specifications, without exceeding the code limit CUF of 1.0. For NUREG/CR-6260 locations, CUF calculation will be done using the appropriate F_{en} environmental factor.

Cycle Count Action Limits and Corrective Actions

For Cycle-Based Fatigue monitoring (CBF), action limits have been established based on the design-specified number of cycles. Usage factors in locations monitored by this method are most affected by transient events which are of low probability, and cycle counting of these events is therefore sufficient to account for the fatigue accumulation in them.

Cycle Count Action Limit Margins: In order to assure sufficient margin to accommodate occurrence of a low probability transient, corrective actions must be taken before the remaining number of allowable occurrences for any specified transient, including the low-probability, higher-usage-factor events, becomes less than one. Other events counted by cycle-based monitoring contribute less per event to usage factor, but occur more frequently. To account for both cases, corrective actions are required when the cycle count for any of the significant contributors to usage factor is projected to reach the action limit defined in the program before the end of the next fuel cycle.

Section 4
TIME-LIMITED AGING ANALYSES

For example, in [Table 4.3-3](#) the specified number of “Inadvertent Auxiliary Spray at 100% Power” transient events is (5) so corrective action would be required when 80% (4) of the specified cycles have occurred.

Cycle Count Corrective Actions: If a cycle count action limit is reached, acceptable corrective actions include:

- 1) Review of fatigue usage calculations.
 - To determine whether the transient in question contributes significantly to CUF.
 - To identify the components and analyses affected by the transient in question.
 - To ensure that the analytical bases of the leak-before-break (LBB) fatigue crack propagation analysis and of the high-energy line break (HELB) locations are maintained.
 - To ensure that the analytical bases of a fatigue crack growth and stability analysis in support of relief from ASME Section XI flaw removal and inspection requirements for hot leg small-bore half nozzle repairs are maintained.
- 2) Evaluation of remaining margins on CUF based on cycle-based or stress-based CUF calculations using the PVNGS fatigue management program software.
- 3) Redefinition of the specified number of cycles (e.g., by reducing specified numbers of cycles for other transients and using the margin to increase the allowed number of cycles for the transient that is approaching its specified number of cycles).
- 4) Redefinition of the transient to remove conservatism in predicting the range of pressure and temperature values for the transient.

Since the CBF action limits are based on a somewhat-arbitrary cycle count that does not accurately indicate approach to the CUF = 1.0 fatigue limit, these preliminary actions are designed to determine how close the approach is to the 1.0 limit, and from those determinations, set new action limits. If the CUF has approached 1.0 then further actions for cumulative fatigue usage action limits may be invoked.

Cumulative Fatigue Usage Action Limits and Corrective Actions

The FatiguePro[®] program will continually monitor cumulative usage factor (CUF) at the stress-based fatigue monitoring locations, and cycle-based CUFs will be calculated periodically. The CUF action limits will be revised to provide two to three fuel cycles of warning prior to exceeding a CUF of 1.0.

CUF Action Limit Margins: To provide adequate time for corrective actions and adequate margin to permit continued operation, corrective actions will be required when calculated CUF (from cycle based or stress based monitoring) for any monitored location is projected to

Section 4 TIME-LIMITED AGING ANALYSES

reach 1.0 within the next 2 or 3 fuel cycles. In order to assure sufficient margin to accommodate occurrence of a low probability transient, corrective actions must also be taken while there is still sufficient margin to accommodate at least one occurrence of the worst case (highest fatigue usage per cycle) design transient event. Action limits will permit completion of corrective actions before either the usage factor limit of 1.0 or the design basis number of events, as applicable, is exceeded.

For PVNGS locations identified in NUREG/CR-6260 and described in [Section 4.3.4](#), "Effects of the Reactor Coolant System Environment on Fatigue Life of Piping and Components (Generic Safety Issue 190)," this action limit is based on accrued fatigue usage calculated with the F_{en} factors required for including effects of the reactor coolant environment.

For example, if inadvertent RCS depressurization, when adjusted for the environmental effects of the reactor coolant system at a NUREG/CR-6260 location, causes 20% of the total allowable fatigue usage, corrective action for that location would be required before calculated usage (including the environmental effects factor, F_{en}) reached 0.8.

CUF Corrective Actions: If a CUF action limit is reached, acceptable corrective actions include:

- 1) Determine whether the scope of the monitoring program must be enlarged to include additional affected reactor coolant pressure boundary locations. This determination will ensure that other locations do not approach design limits without an appropriate action.
- 2) Enhance fatigue monitoring to confirm continued conformance to the code limit.
- 3) Repair the component.
- 4) Replace the component.
- 5) Perform a more rigorous analysis of the component to demonstrate that the design code limit will not be exceeded.
- 6) Modify plant operating practices to reduce the fatigue usage accumulation rate.
- 7) Perform a flaw tolerance evaluation and impose component-specific inspections, under ASME Section XI Appendices A or C (or their successors), and obtain required approvals by the NRC.

Section 4
TIME-LIMITED AGING ANALYSES

Table 4.3-4 - Summary of Fatigue Usage from Class 1 Analyses, and Method of Management by the Metal Fatigue of Reactor Coolant Pressure Boundary Program

Component	Maximum Design Basis CUF⁽¹⁾	Reason for Monitoring	Fatigue Management Method⁽²⁾
1. RPV Inlet Nozzle	0.073080	NUREG/CR-6260	CBF-C
2. RPV Outlet Nozzle	0.309574	NUREG/CR-6260	CBF-C
3. RPV Wall and Bottom Head Juncture	0.0012	NUREG/CR-6260	Global ⁽³⁾
4. RPV Wall Transition	0.0035	Bounding location	Global
5. RPV CEDM Nozzles	U1&2 = 0.0066 U3 = 0.0018	Bounding location	Global
6. RPV Instrument Nozzles	U1 = 0.68 U2&3 = 0.140	High CUF	Global
7. RPV Core Stabilizer Lugs	0.0600	Bounding location	Global
8. RPV Flow Baffle	0.0030	Bounding location	Global
9. RPV Fuel Alignment Plate	U1&2 = 0.7207 U3 = 0.9176 ⁽⁴⁾	High CUF	Global
10. RPV Surveillance Holder Assembly	0.0714	Bounding location	Global
11. RPV Integral Supports	0.2900	Bounding location	Global
12. RPV Support Pad Flange	0.06	Bounding location	Global
13. RPV Head Studs	0.8236	High CUF	CBF-EP
14. RPV Closure Head Flange	0.0258	Bounding location	Global
15. RPV Bottom Head Support Lugs	0.9536 ⁽⁵⁾	Bounding location	Global, Bounded by RPV Head Studs
16. Pressurizer Surge Nozzle	0.9602	High CUF	SBF
17. Pressurizer Spray Nozzle	0.9923	High CUF	SBF
18. Pressurizer Bottom Head and Support Skirt	0.7223	High CUF	CBF-C
19. Pressurizer Heater Sleeve Outside Diameter Weld - Sleeve to Head Juncture J-Weld	0.884 (60-year)	High CUF	SBF
20. Pressurizer Manway Cover Plate Assembly Bolts	U1 = 0.345 U2&3 = 0.3752	Bounding location	Global
21. Pressurizer Safety and Relief Valve Lines	0.0048	Bounding location	Global
22. Pressurizer Spray Piping	0.3788 ⁽⁶⁾	Bounding location	Global
23. Hot Leg Surge Nozzle	0.534	High CUF	SBF
24. Surge Line (Elbow)	0.9370	High CUF/ NUREG/CR-6260	SBF
25. Auxiliary Spray Tee	0.6348 ⁽⁶⁾⁽⁷⁾	High CUF	CBF-EP
26. Auxiliary Spray Line	0.563 ⁽⁶⁾	Bounding location	Global, Bounded by Auxiliary Spray Tee

Section 4
TIME-LIMITED AGING ANALYSES

Table 4.3-4 - Summary of Fatigue Usage from Class 1 Analyses, and Method of Management by the Metal Fatigue of Reactor Coolant Pressure Boundary Program

Component	Maximum Design Basis CUF⁽¹⁾	Reason for Monitoring	Fatigue Management Method⁽²⁾
27. Charging Inlet Nozzle	0.9205	High CUF/ NUREG/CR-6260	CBF-EP
28. CVCS Letdown Line	0.2063	Bounding location	Global
29. CVCS Charging Line	0.3189	Bounding location	Global
30. Hot Leg Elbow	0.0177	Bounding location	Global
31. Shutdown Cooling Outlet Nozzles	U1&3 = 0.8068 U2 U ₆₀ = 0.72 ⁽⁸⁾	Bounding location	Global, Bounded by Shutdown Cooling Lines
32. Shutdown Cooling Lines	0.702 ⁽⁹⁾	High CUF	CBF-C
33. Shutdown Cooling Line Elbow	0.1118	NUREG/CR-6260	CBF-EP
34. Safety Injection Nozzles (Loop 1 and Loop 2)	0.3409	NUREG/CR-6260	CBF-PC
35. Safety Injection Piping	0.5155	High CUF	CBF-EP
36. Safety Injection Piping Whip Restraint Lugs	U1 = 0.6015 U2&3 = 0.628	Bounding location	Global
37. Reactor Coolant Drain Lines	0.2302	Bounding location	Global
38. Reactor Coolant Pump Casing Studs	0.988	High CUF	CBF-EP
39. RCP Motor Stand Shell to Flange Juncture	0.668	Bounding location	Global
40. RCP Seal Housing	0.3830	Bounding location	Global
41. RSG Economizer Feedwater Nozzle	U1&3 = 0.90970 U2 = 0.981	High CUF	SBF
42. RSG Downcomer Feedwater Nozzle	U1&3 = 0.983 U2 = 0.996	High CUF	SBF
43. RSG Support Skirt	U1&3 = 0.08331 U2 = 0.155	Bounding location	Global
44. RSG Support Skirt Access Opening Region (Unit 1 & 3 Only)	U1&3 = 0.75104	Bounding location	Global, Bounded by Economizer/ Downcomer FW Nozzles
45. RSG Primary Head	--	--	--
Hot Side	U1&3 = 0.02895 U2 = 0.0309	Bounding location	Global
Cold Side	U1&3 = 0.08502 U2 = 0.0352	Bounding location	Global
46. RSG Primary Inlet Nozzle	U1&3 = 0.04857 U2 = 0.04634	Bounding location	Global
47. RSG Primary Outlet Nozzle	0.01683	Bounding location	Global
48. RSG Primary Manway (Cover and Pad)	U1&3 = 0.03494 U2 = 0.037	Bounding location	Global

Section 4
TIME-LIMITED AGING ANALYSES

Table 4.3-4 - Summary of Fatigue Usage from Class 1 Analyses, and Method of Management by the Metal Fatigue of Reactor Coolant Pressure Boundary Program

Component	Maximum Design Basis CUF⁽¹⁾	Reason for Monitoring	Fatigue Management Method⁽²⁾
49. RSG Primary Manway Studs	--	--	--
Hot Side	U1&3 = 6.53 U2 = 6.33	Bounding location	Global - Replaceable
Cold Side	U1&3 = 4.011 U2 = 4.67	Bounding location	Global - Replaceable
50. RSG Primary Divider Plate	U1&3 = 0.03 U2 = 0.06	Bounding location	Global
51. RSG Tubes	0	Bounding location	Global
52. RSG Tube-to-Tubesheet Weld	U1&3 = 0.18816 U2 = 0.792	Bounding location	Global, Bounded by Economizer / Downcomer FW Nozzles
53. RSG Tubesheet	--	--	--
Hot Side	U1&3 = 0.06570 U2 = 0.928	Bounding location	Global, Bounded by Economizer / Downcomer FW Nozzles
Cold Side	U1&3 = 0.39410 U2 = 0.507	Bounding location	Global, Bounded by Economizer / Downcomer FW Nozzles
54. RSG Tubesheet to Shell (Stub Barrel) Junction			
Hot Side	U1&3 = 0.10059 U2 = 0.064	Bounding location	Global
Cold Side	U1&3 = 0.99876 U2 = 0.996	High CUF	CBF-EP
55. RSG Economizer Cylinder at Tubesheet Cold Side (Unit 1 & 3 Only)	U1&3 = 0.01075	Bounding location	Global
56. RSG Secondary Shell	U1&3 = 0.00773 U2 = 0.00899	Bounding location	Global
57. RSG Downcomer Blowdown Nozzle	U1&3 = 0.197 U2 = 0.273	Bounding location	Global
58. RSG Recirculation Nozzle	U1&3 = 0.099 U2 = 0.114	Bounding location	Global
59. RSG Steam Outlet Nozzle	U1&3 = 0.169 U2 = 0.1767	Bounding location	Global
60. RSG Secondary Manway Pad	U1&3 = 0.129 U2 = 0.140	Bounding location	Global
61. RSG Secondary Manway Studs	U1&3 = 0.618 U2 = 0.7714	Bounding location	Global - Replaceable

Section 4
TIME-LIMITED AGING ANALYSES

Table 4.3-4 - Summary of Fatigue Usage from Class 1 Analyses, and Method of Management by the Metal Fatigue of Reactor Coolant Pressure Boundary Program

Component	Maximum Design Basis CUF⁽¹⁾	Reason for Monitoring	Fatigue Management Method⁽²⁾
62. RSG Welded Secondary Handholes (Unit 1 & 3 Only)	U1&3 = 0.113	Bounding location	Global
63. RSG Welded Secondary Handhole Studs (Unit 1 & 3 Only)	U1&3 = 0.424	Bounding location	Global - Replaceable
64. RSG Stub Barrel Secondary Handhole	U1&3 = 0.940 U2 = 0.955	High CUF	CBF-EP
65. RSG Stub Barrel Secondary Handhole Studs	U1&3 = 1.35 U2 = 2.15	Bounding location	Global - Replaceable
66. RSG Upper Support Lugs	U1&3 = 0.405 U2 = 0.161	Bounding location	Global
67. RSG Feedwater Distribution Box	U1&3 = 0.99201 U2 = 0.988	Bounding location	Global, Monitored by Economizer Feedwater Nozzle Location

¹ Unless otherwise noted, these usage factors were calculated for the design basis number of loading events applicable to the component, and which were originally intended to encompass a 40-year design life. CUF values are for all three units unless otherwise noted.

² See Section 4.3.1 for a description of these methods.

³ The reactor pressure shell and lower head juncture will be monitored by the global method due to the low CUF value obtained even when the environmental factor has been applied.

⁴ While this location has a high usage factor, the design CUF is less than the fatigue design limit of 1.0 and there are no unaccounted or out-of-limit transients to consider. Therefore the component is adequately monitored by counting cycles to assure design cycles are not exceeded.

⁵ Fatigue in these external lugs is fully bounded by fatigue in the RPV head studs, which is monitored by FatiguePro.

The design CUF for the studs is based on 250 heatup-cooldown cycles and 50 boltup cycles. The design CUF of the support lugs is based on 500 heatup-cooldown cycles, and the lugs are not affected by boltup cycles. The usage factor accumulated per thermal cycle is greater for the studs than for the lugs. Therefore, the head studs will reach a CUF of 1.0 before the support lugs, even without the additional fatigue usage from boltup cycles, and are therefore more limiting than the support lugs.

⁶ APS replaced the entire horizontal length of 4-inch main spray pipe, the entire vertical length of 4-inch main spray pipe down to the pressurizer spray nozzle pipe-to-safe-end weld, and the 2-inch x 4-inch auxiliary spray tee for all three units.

⁷ Calculated fatigue usage at the peak CUF location in the auxiliary spray line is due to the stress intensification factor required for a socket weld, compared to the butt welds normally installed in this piping specification. This location was not replaced by the modification described in Note 6. The auxiliary spray tee location will however accumulate fatigue usage significantly faster, making it the bounding location.

⁸ The Unit 2 value of 0.72 is applicable to the limiting regions of the nozzle following a weld overlay installed in 2R14 to mitigate stress corrosion cracking effects. The analysis is based on a 60-year extended operating life. See Section 4.3.2.4 for further explanation of the weld overlay repair and analysis of this component.

The 0.8068 Unit 1 and 3 value is no longer bounded by the 0.702 of item 32, Shutdown Cooling Lines. However, once the overlays are installed, the 40-year equivalent of the 60-year, 0.72 value, 0.48, will be bounded by the 40-year, 0.702 value applicable to item 32. The Unit 1 and 3 overlays will be installed in 1R14 and 3R14 (fall 2008 and spring 2009), before the period of extended operation. Item 31 will therefore remain bounded by 32 for the period of extended operation in all three units.

⁹ This CUF is less than the maximum reported of 0.8419 for the Unit 1 16" Loop 2 SDC line and a 3/4" branch (node 38). The two analyses were not performed to the same level of detail. When considered on the same basis, the valve location had a CUF > 1.0. Therefore the bounding location for fatigue accumulation is at the connection to the valve.

4.3.2 ASME III Class 1 Fatigue Analysis of Vessels, Piping, and Components

Fatigue analyses are performed for ASME III Division 1 Class 1 piping, vessels, heat exchangers, pumps, and valves; and if applicable, their supports. [Table 4.3-5](#) lists all Class 1 vessels, heat exchangers, pumps, piping and subcomponents subject to Class 1 analyses, and the subsection which addresses them.

The PVNGS reactor vessels were designed and fabricated to Class 1 rules of ASME III, 1971 Edition with Addenda through Winter 1973. The PVNGS reactor vessel internals were designed and fabricated to Subsection NG rules of ASME III, 1974 Edition. The reactor vessel internals are therefore designed and analyzed to ASME III Subsection NG. See [Section 4.3.3](#).

Table 4.3-5 - PVNGS Class 1 Components and Piping

Component	Application Subsection
Reactor Pressure Vessel, Head, Studs, and Supports	4.3.2.1
Control Element Drive Mechanism (CEDM) Housings	4.3.2.2
Reactor Vessel Internals (Subsection NG, not Class 1)	4.3.3
Reactor Coolant Pumps	4.3.2.3
Pressurizer	4.3.2.4

Table 4.3-5 - PVNGS Class 1 Components and Piping

Component	Application Subsection
Steam Generators (Primary or Tube Side and Shell Side) ⁽¹⁾	4.3.2.5
Pressure-Retaining Bolting (Included with the Reactor Vessel, Steam Generators, Reactor Coolant Pumps, Pressurizer, and Valves, as Applicable)	As noted
Valves	4.3.2.6
Piping	4.3.2.7
Main Reactor Coolant Loop Piping Nozzles and Thermowells	4.3.2.7
Supports for Class 1 Piping and Valves (See Section 4.3.2.7)	No TLAA

¹ The shell (steam) side of the PVNGS replacement steam generators is Class 2 but also received a Class 1 analysis. See [Section 4.3.2.5](#).

4.3.2.1 Reactor Pressure Vessel, Nozzles, Head, and Studs

Summary Description

The PVNGS reactor pressure vessels were designed, built, and analyzed by Combustion Engineering to ASME III, Subsection NB (Class 1), 1971 Edition with addenda through Winter 1973.

Pressure-retaining and support components of the reactor pressure vessels are subject to an ASME Boiler and Pressure Vessel Code, Division 1, Section III, fatigue analyses. These analyses have been updated to incorporate redefinitions of loads and design basis events, operating changes, and power uprate with steam generator replacement. The currently-applicable fatigue analyses of these components are TLAAs.

Analysis

The design reports for Units 1, 2, and 3 report identical design basis fatigue analysis results, with a few exceptions. The Unit 3 report is the most current of the three and reports the most limiting values (except as may be noted), and was therefore used as the reference for the original fatigue analysis in this section and in the SIA report for development of the fatigue monitoring program, described in [Section 4.3.1](#). [Table 4.3-6](#) presents the current design basis cumulative usage factors (CUF) for the reactor pressure vessel (RPV) components. This list of components corresponds to each of the detailed analyses reported

Section 4
TIME-LIMITED AGING ANALYSES

in the original reactor vessel design reports. The CEDM pressure housing nozzles are discussed in [Section 4.3.2.2 below](#).

Table 4.3-6 - Fatigue Analysis Results for Reactor Pressure Vessel Components

Component	Maximum Design Basis CUF ⁽¹⁾
Closure Head and Vessel Flange	0.0258
Vessel Wall and Bottom Head Juncture	0.0012
Vessel Wall Transition	0.0035
Inlet Nozzle	0.073080
Outlet Nozzle	0.309574
Instrument Nozzles	U1 = 0.68 ⁽²⁾ U2&3 = 0.14
Core Stabilizer Lugs	0.06
Flow Baffle	0.003
Surveillance Holder	0.0714
Reactor Vessel Support, Integral Attachment	0.29
Reactor Vessel Support Pad Flange	0.060
Bottom Head Support/Shear Lugs	0.9536 ⁽³⁾
Vent Pipe	U1&3 = 0.1654 U2 = 0.9527 ⁽⁴⁾
Reactor Vessel Studs	0.8236 ⁽⁵⁾

¹ Unless otherwise noted, these usage factors were calculated for the design basis number of loading events applicable to the component, and which were originally intended to encompass a 40-year design life. CUF values are for all three units unless otherwise noted.

² The Unit 1 instrument nozzle analysis includes a number of conservative assumptions not included in the Unit 2 and 3 analyses. The design basis of all three units includes 15,000 load-following cycles.

³ Fatigue in these external support/shear lugs is bounded by the RPV head studs, which are monitored. The studs will accumulate a higher fatigue usage factor, although their calculated usage factor is lower. See "Reevaluation of Reactor Vessel Head Stud Fatigue..." in the text.

⁴ The Unit 2 vent pipe will be replaced.

⁵ The studs were reevaluated for a reduced number of heatup-cooldown and boltup transients.

Effects of Power Uprate and Steam Generator Replacement

The analyses performed to incorporate the effects of power uprate (PUR) and replacement steam generators (RSG) into the current design bases demonstrated that the effects on fatigue analyses were limited to the inlet and outlet nozzles. The RSG and PUR report addressed the effects on the current design bases of all components in [Table 4.3-6](#).

Reevaluation of Reactor Vessel Head Stud Fatigue for Revised Heatup and Cooldown Curves and Revised Numbers of Transient Events in response to Combustion Engineering Infobulletin 88-09, “Nonconservative Calculation of Cumulative Fatigue Usage”

The 1991 CE Owner’s Group review of Combustion Engineering Infobulletin 88-09, “Nonconservative Calculation of Cumulative Fatigue Usage,” identified a possible increase in the reactor vessel stud cumulative usage factor.

To accommodate the more-conservative pressure curves, the number of heatup-cooldown transients was reduced from 500 to 250 cycles, and the number of boltup transients was reduced from 100 to 50 cycles.

The new cumulative fatigue usage factor, with the new heatup and cooldown pressures and reduced number of transients, is 0.8236. This CUF is less than the 0.9536 calculated for the bottom head support lugs, but the RPV head studs will be monitored instead, as the more-limiting RPV pressure boundary components. The 250 heatup-cooldown cycles used for the stud fatigue analysis is a conservative estimate, but only half of the 500 from the standard Combustion Engineering design specification used for the lugs, and the lugs are not subject to the bolting cycles. The studs will therefore accumulate significantly more fatigue usage per operating cycle than the support/shear lugs.

Evaluation of Instrument Nozzle Fatigue for Revised Load-Following Transients

The Unit 1 design report for the Reactor Pressure Vessel reports a fatigue usage factor of 0.68 for the instrument nozzles, with conservative assumptions and 15,000 load following cycles. The Unit 2 and 3 design reports also include the 15,000 load following cycles but do not make the Unit 1 conservative assumptions, and report a maximum usage factor in these nozzles of only 0.14. Since none of the PVNGS units operate in load-following mode, nor is load following expected, these cycles are not counted, as described in [Table 4.3-2](#).

Repair of the Unit 2 Reactor Vessel Closure Head Vent Pipe

While performing preplanned inservice inspections during the Unit 2 12th refueling outage, in order to address the concerns of NRC Bulletin 2002-02 and NRC Order EA-03-009 for potential primary water stress corrosion cracking (PWSCC) of the various Alloy 600 penetrations in the reactor vessel head, two axial indications were detected in the vent pipe from the reactor vessel head.

Section 4
TIME-LIMITED AGING ANALYSES

The axial indications were removed by machining and confirmed by eddy current testing (ET) examinations to be removed prior to resuming plant operations. Engineering confirmed that sufficient reactor vessel head vent line (i. e. wall thickness) exists to support plant operations for the remaining 40 year design lifetime.

[LER 2005-001-00, June 20, 2005, Ref. 14]

The calculation of fatigue usage in the repaired vent line assumed a constant fatigue rate over the 14.4 years of operation before the repair, based on the as-as-designed 40-year vent pipe fatigue usage factor. This was added to the fatigue expected to accumulate during the remaining 25.6 years of operation, based on the as-repaired vent pipe geometry with the reduced wall thickness. The combined fatigue usage factor for the as-designed and as-repaired vent pipe for the 40-year plant life is therefore higher than originally calculated.

Similar flaws were discovered during the Unit 2 13th refueling outage, and were similarly repaired and similarly analyzed.

This location is not included in the fatigue management or ISI programs. However, the inspection is not required by ASME Section XI. The vessel head will be replaced and the repaired vent line segment will be replaced and reanalyzed, when the vessel head is replaced, before the period of extended operation. The revised fatigue analysis for the replacement will extend to the end of the period of extended operation, and will therefore not be a TLAA.

Disposition: Revision, 10 CFR 54.21(c)(1)(ii); and Aging Management, 10 CFR 54.21(c)(1)(iii)

Revision: Repair of the Unit 2 Reactor Vessel Closure Head Vent Pipe

The segment of the Unit 2 head vent line with wall thickness reduced by the removal of indications will be replaced when the vessel head is replaced, and its fatigue analysis will be revised. The repair and the revised fatigue analysis will demonstrate an adequate fatigue life, projected to the end of the period of extended operation, in accordance with 10 CFR 54.21(c)(1)(ii). This is a commitment for license renewal.

Aging Management

The Metal Fatigue of Reactor Coolant Pressure Boundary program will track events to ensure that appropriate reevaluation or other corrective action is initiated if an action limit is reached. Fatigue in the reactor vessel studs will be tracked by the cycle-based fatigue method. Action limits will permit completion of corrective actions before the design basis number of events is exceeded, and before the cumulative usage factor exceeds the code limit of 1.0. Effects of fatigue in the reactor pressure vessel pressure boundary and its supports will thereby be managed for the period of extended operation, in accordance with 10 CFR 54.21(c)(1)(iii).

The Metal Fatigue of Reactor Coolant Pressure Boundary program is described in [Section 4.3.1](#); and is summarized in Appendix B, [Section B3.1](#). See [Table 4.3-4](#) for details of the program, and [Section 4.3.1.5](#) for a description of its action limits and corrective actions.

The reactor vessel primary coolant inlet and outlet nozzles and lower-head-to-shell juncture are evaluated for effects of the reactor coolant environment on fatigue behavior of these materials, consistent with NUREG/CR-6260. See [Section 4.3.4](#).

4.3.2.2 Control Element Drive Mechanism (CEDM) Nozzle Pressure Housings

Summary Description

The PVNGS CEDM nozzle pressure housings are designed to ASME III, Subsection NB (Class 1), 1974 Edition with addenda through Winter 1974 [[UFSAR, Table 5.2-1](#)], and are constructed from Alloy 600 material to the requirements of the SB-166 material specification. The reactor vessel design reports include the structural analysis of the CEDM nozzle pressure housings. The analysis was reexamined for the power uprate and steam generator replacement modifications.

Analysis

The only location to be considered in the fatigue analysis is the pressure-housing-to-closure-head weld. The calculated fatigue usage factors in these CEDM pressure housing welds are 0.0066, 0.0066, and 0.0018 for Units 1, 2, and 3 respectively. These fatigue usage factors are significantly less than 1.0.

Effects of Power Uprate and Steam Generator Replacement on the CEDM Nozzle Pressure Housing Analysis

The PVNGS steam generator replacement and power uprate modifications (RSG and PUR) included evaluation of the CEDM nozzle. The revised OBE and faulted loads on the Unit 1, 2 and 3 CEDM nozzles following RSG and PUR are less than the maximum allowed loads which were evaluated in the analyses of record. The evaluation identified no changes to design report fatigue usage in the nozzles.

Effect of Combustion Engineering Infobulletin 88-09 "Nonconservative Calculation of Cumulative Fatigue Usage"

The CE Owner's Group review of Combustion Engineering Infobulletin 88-09, "Nonconservative Calculation of Cumulative Fatigue Usage," did not identify any effects on the fatigue analysis of the CEDMs.

Disposition: Validation, 10 CFR 54.21(c)(1)(i)

The maximum calculated usage factor in the CEDM pressure housings indicates that the design has significant margin to the limit of 1.0, and therefore that the design is adequate for

150 times the number of specified design transients; or for 150 40-year design lifetimes. The evaluation of fatigue effects in the CEDM pressure housings therefore remains valid for the period of extended operation, in accordance with 10 CFR 54.21(c)(1)(i).

4.3.2.3 Reactor Coolant Pump Pressure Boundary Components

Summary Description

The PVNGS System 80 reactor coolant pumps were built by the CE-KSB Pump Company, Inc., Newington, New Hampshire, which was a joint venture of Combustion Engineering (CE) and Klein, Schanzlin & Becker Aktiengesellschaft (KSB). The design analysis of the System 80 Reactor Coolant Pump Assembly has been completed in accordance with the ASME Boiler and Pressure Vessel Code, Section III, 1974 Edition (no addenda) for Class 1 Vessels. The load definitions were updated for Replacement Steam Generators (RSG) with Power Uprate and the code analyses were evaluated to determine the applicability of the fatigue analyses with the new loads.

The pump pressure retaining components are constructed in accordance with Subsection NB of the ASME Boiler and Pressure Vessel Code, Section III, which includes a fatigue analysis. The compliance of the pump components to Subsection NB with respect to the fatigue analysis can be demonstrated by two means. A fatigue analysis can be performed in accordance with Subparagraph NB-3222.4(e), or the requirement for the fatigue analysis can be waived if the provisions of Subparagraph NB-3222.4(d) are met. The fatigue analyses are TLAA's. The fatigue waiver analyses are also TLAA's because they depend in part on the assumed numbers of design basis normal and upset transient cycles.

Analysis

All pump casing components are constructed of SA-508, Class 2 and SA-516, Grade 70 carbon steels, clad with SA-336, F8 stainless steel. Per ASME III Subparagraph NB-3122.1, no credit is taken for cladding thickness in the structural analysis.

A fatigue analysis was performed only for pump casing components. The high pressure cooling system and seal housing adapters invoked the fatigue analysis waiver of NB3222.4(d), or were designed to requirements other than those of Section III Class 1.

The maximum total cumulative usage factor for all components is 0.988 for the pump casing closure bolts. The analysis of the pump casing closure studs initially resulted in usage factors greater than 1.0. To reduce the usage factor below 1.0, the number of heatup and cooldown cycles, the most significant contributors to usage factor in all pump components, was reduced to 475 events. This reduced number of heatup and cooldown cycles is incorporated into the fatigue monitoring program.

The original fatigue analyses of record are still valid with replacement steam generators (RSGs) and Power Uprate loads, or the effects of the RSGs and Power Uprate loads on the analysis of record have been reconciled.

No Effect on Reactor Coolant Pumps of Combustion Engineering Infobulletin 88-09
“Nonconservative Calculation of Cumulative Fatigue Usage”

The 1991 CE Owner’s Group review of Combustion Engineering Infobulletin 88-09, “Nonconservative Calculation of Cumulative Fatigue Usage,” did not identify any effects on the fatigue analysis of the reactor coolant pumps.

Disposition: Aging Management, 10 CFR 54.21(c)(1)(iii)

The evaluation of fatigue effects in the reactor coolant pump pressure boundaries will remain valid for the period of extended operation as long as the number of cycles actually experienced does not exceed the design basis number of cycles specified in the Design Specification, UFSAR Table 3.9-1, or the RCP closure studs’ more-restrictive number of heatup and cooldown events. Fatigue usage factors and the NB-3222.4(d) fatigue waivers for the reactor coolant pumps do not depend on effects that are time-dependent at steady-state conditions, but depend only on effects of operational and upset transient events, principally on heatup and cooldown transients.

The Metal Fatigue of Reactor Coolant Pressure Boundary program will track events to ensure that appropriate reevaluation or other corrective action is initiated if action limits are reached. Action limits will permit completion of corrective actions before the design basis number of events is exceeded. The effects of fatigue in the reactor coolant pump pressure boundaries will thereby be managed for the period of extended operation, in accordance with 10 CFR 54.21(c)(1)(iii).

The Metal Fatigue of Reactor Coolant Pressure Boundary program is described in [Section 4.3.1](#); and is summarized in Appendix B, [Section B3.1](#). See [Table 4.3-4](#) for details of the program, and [Section 4.3.1.5](#) for a description of its action limits and corrective actions.

4.3.2.4 Pressurizer and Pressurizer Nozzles

Summary Description

The PVNGS pressurizers are designed to ASME III, Subsection NB (Class 1), 1971 Edition with addenda through Winter 1973.

The pressurizers are welded vertical cylindrical carbon steel pressure vessels with hemispherical heads, welded interior stainless steel cladding, and a cylindrical support skirt and flange attached to the lower head with a forged knuckle support ring. The central vertical surge nozzle, 2 vertical lower level instrument nozzles, and 36 heater sleeves penetrate the lower head. Four shear lugs, welded to the upper shell, stabilize the vessel against seismic and other overturning loads. The central vertical spray nozzle, the manway, four horizontal upper instrument nozzles, and four horizontal safety valve nozzles penetrate the upper head. The surge, spray, and safety valve nozzles have safe ends for welding to the attached stainless steel piping, and these nozzles, safe ends, and safe end welds have

Section 4 TIME-LIMITED AGING ANALYSES

recent crack growth mitigation compressive weld overlays. All of the Alloy 600 instrument nozzles have been replaced with Alloy 690 materials less susceptible to primary water stress corrosion cracking.

The heater sleeves and heaters have all been replaced. The replacement Alloy 690 heater sleeves are attached to the lower vessel head by half-nozzle repairs, welded to external reinforcing pads. The heater sheaths are attached to the outer ends of the Alloy 690 heater sleeves by fillet seal welds. The sheaths of the electric heaters are also Class 1 pressure boundary components, and the welds between end plug and sheath, and the fillet seal welds to the heater sleeves, are Class 1 pressure boundary welds. Unit 1 heater sleeve B18 and Unit 2 heater sleeves A06 and B18 have been closed with welded 316 stainless plugs.

The PVNGS pressurizers have operated since startup with a continuous spray flow to prevent boron concentration stratification and to mitigate spray line and nozzle fatigue. This continuous flow is achieved via regulating bypass valves around each of the two main spray valves.

Analysis

Pressure-retaining and support components of the pressurizer are subject to an ASME Boiler and Pressure Vessel Code, Division 1, Section III, fatigue analysis. These analyses have been updated from time to time to incorporate redefinitions of loads and design basis events, operating changes, power uprate, and modifications; including:

- Effects of indications in a Unit 2 pressurizer support skirt forging weld
- Effects on the pressurizer of NRC Bulletin 88-11 thermal stratification in the surge line not included in the original analyses
- Effects on the pressurizer of insurge-outsurge transients not included in the original analyses
- Effects on the pressurizer of Combustion Engineering Infobulletin 88-09 "Nonconservative Calculation of Cumulative Fatigue Usage"
- Replacement instrument nozzles
- Crack growth and fracture mechanics stability analyses of postulated defects in original heater sleeve attachment welds remaining in the pressurizer lower heads
- Replacement heaters
- Replacement heater sleeves and their welds to the heaters

- Thermal effects on the Unit 3 pressurizer of incorrectly installed replacement heaters
- Compressive weld overlays of the surge, spray, and safety valve nozzles and their safe ends and welds.

[Table 4.3-7](#) summarizes the currently-applicable results of these analyses.

Effect of Combustion Engineering Infobulletin 88-09 “Nonconservative Calculation of Cumulative Fatigue Usage”

The 1991 CE Owner’s Group review of Combustion Engineering Infobulletin 88-09 “Nonconservative Calculation of Cumulative Fatigue Usage” found that the fatigue usage factor in the worst-affected location (bottom head-support skirt) of the PVNGS Unit 1, 2, and 3 pressurizers might increase 32 percent above the design basis calculated value of 0.8895. PVNGS therefore further evaluated these effects and amended the design reports. The revised worst-location 40-year design basis CUF, including these effects, is 0.7223.

Linear Elastic Fracture Mechanics (LEFM) Fatigue Crack Growth Analysis of Indications in a Unit 2 Pressurizer Support Skirt Forging Weld

An inservice inspection detected two indications in the Unit 2 pressurizer support skirt forging weld, near the lower vessel head. A linear elastic fracture mechanics (LEFM) fatigue crack growth analysis predicted growth of the indications from the as-found 0.59 to 0.6921 inches, or only a 17 percent increase, over the design life. The analysis assumed 2,001,500 normal and upset load cycles, including 500 plant startup and shutdown cycles and 480 plants trips. The predicted 0.6921 inch final size is only 30 percent of the 2.3869 inch stable critical crack size. This fatigue crack growth analysis is a TLAA.

No Effect of Power Uprate and Steam Generator Replacement on the Pressurizer Fatigue Analysis

The Westinghouse design report addendum for the pressurizer, for power uprate and steam generator replacement, confirms that these modifications have no effect on the design reports for any of the three units.

Effects of NRC Bulletin 88-11 Thermal Stratification and Insurge-Outsurge Transients

The surge nozzle stress and fatigue analysis is affected by NRC Bulletin 88-11 thermal stratification effects. The original analysis of the surge nozzle has been superseded by the reanalysis for a compressive overlay, which included the thermal stratification and insurge-outsurge effects.

For related thermal stratification effects in the surge line, see [Section 4.3.2.9 below](#).

Absence of TLAAs in the Analysis of Thermal Fatigue Crack Growth in Original Heater Sleeve Attachment Welds, in Support of MNSA Repairs of Unit 3 Sleeves

There are currently no mechanical nozzle seal assemblies (MNSAs) in use at PVNGS. Three MNSAs were used as a temporary means of sealing unit 3 pressurizer heater sleeves. However the MNSAs were replaced with half-nozzle repairs during unit 3 refueling outage 3R11.

A supporting Westinghouse linear elastic fracture mechanics fatigue crack growth analysis, for postulated cracks in the original sleeve-to-inner-wall attachment welds, was based on a 60-year design life, and was therefore not a TLAAs. Although these MNSAs were replaced, this analysis in support of this temporary modification is still applicable, and is cited by a subsequent report and incorporated by reference in the code design reports, because the area of the postulated initial cracks - at the original attachment J-welds - has not been removed.

Effect of MNSA Anchor Holes on the Pressurizer Fatigue Analysis, in Support of MNSA Repairs of Unit 3 Sleeves

Three MNSAs were used as a temporary means of sealing Unit 3 pressurizer heater sleeves A01, A03, and A15. Each MNSA required drilling and tapping the pressurizer shell for four attachment shoulder bolts. The anchor holes in the pressurizer bottom head wall were analyzed for various load conditions and checked against the ASME code including the effects of the anchor holes on the fatigue analysis of the lower head.

When the heater sleeves were replaced the MNSAs were removed and the attachment holes were plugged with threaded studs, which were ground flush and welded over with the reinforcing weld pads added to support the external J-welds for the sleeve attachments. A large pad had been used for the Unit 2 repairs to provide adequate area for ultrasonic inspection (UT) methods then available. Improved UT permitted use of "Mini/MNSA Pad" repairs in Units 1 and 3.

The analysis of the weld pads does not explicitly supersede the results of the fatigue analysis with the tapped anchor holes. Therefore, both fatigue analysis results apply.

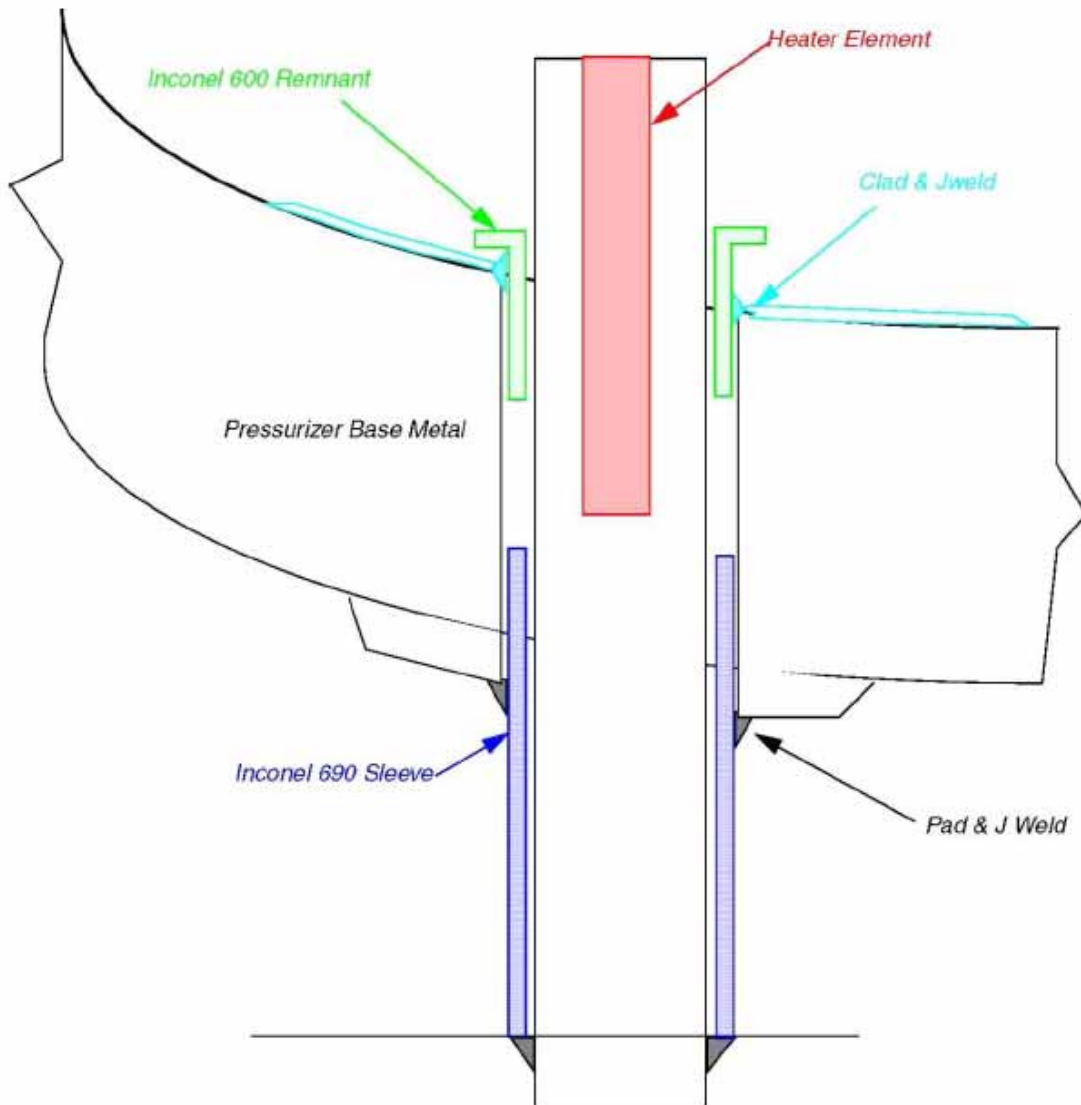

*Figure 4.3-1: Cross Section of Pressurizer Heater Sleeve Penetration
Showing the Half-Nozzle Repair Method,
and the Unit 3 Heater Location Fabrication Error
(Not to Scale)*

Effects on the Fatigue Analyses of the Unit 3 Lower Pressurizer Shell due to Elevated Temperatures, and Absence of a TLAA in the Evaluation of Effects of Creep and Reduced Allowable Design Stress Intensity, ISI Relief Request 33

In 2005, Framatome identified a fabrication error which had installed longer-than-specified replacement heaters in the Unit 3 pressurizer, extending them into the lower region of the heater sleeves, thereby subjecting local regions of the surrounding pressurizer head base metal to temperatures above those for which design stress intensity values are given in the ASME III Appendix I table. All 36 of these Framatome heaters have since been replaced.

The Unit 3 pressurizer is designed to ASME III–1971, W'73 addenda, installed to 1974 W'75. The base metal is SA-533 Grade A Class 1.

SA-533 Grade A is a Table I-1.0, Figure I-9.1 material for which the highest temperature for which design stress intensity values are given is 700°F, the temperature to which NB-1120 also limits the application of Figure I-9.1. The review found that the pressurizer base material surrounding the heater sleeves had been subjected to temperatures up to 779°F for up to 3,700 hours. APS therefore requested approval of an alternative to NB-1120 for these portions of the PVNGS Unit 3 pressurizer base material.

The evaluation applied the elevated temperature rules of Subsection NH, which permit design to specific Subsection NB-3000 rules if creep and relaxation are negligible. The evaluation demonstrated that creep was negligible for the 3,700 hour exposure period, and therefore that Subsection NB rules could be used, with the adjusted design stress intensity factors. This review found no immediate adverse effects on the overheated material, and the NRC granted the relief.

Although this relief was requested “for the remainder of plant life,” as is appropriate for a request supported, in part, by an evaluation of fatigue effects, the supporting evaluation of creep effects was limited to the 3,700-hour exposure to elevated temperature, and the evaluation of the creep effects is therefore not a TLAA.

However, overheating did affect the code fatigue analysis.

Replacement Heater Equivalency Evaluation

The Class 1 pressure boundary of all installed replacement heaters is similar to the original design, and an APS evaluation confirmed that the Class 1 analysis of the original design remains applicable.

Fatigue Analysis Revisions due to Pressurizer Nozzle Overlays

The pressurizer nozzle weld overlays are supported by fracture mechanics analyses and periodic inspections acceptable under ASME Section XI as the means to address aging in the overlaid welds. The fracture mechanics and fatigue crack growth analyses of the materials overlaid by the weld repairs assume 1.5 times the design basis number of events assumed for 40 years, but do not support safety determinations for a defined design lifetime,

and are therefore not TLAAAs. However the revised fatigue analyses of the adjacent materials affected by the overlays are time-dependent, and are TLAAAs unless successfully projected to the end of the period of extended operation. The revised fatigue analyses include the period from initial operation to overlay installation, since these materials were not replaced.

Surge Nozzle: APS evaluated the effects of the weld overlay repairs on the pressurizer surge nozzle. The worst-case projected usage factor for a 60-year lifetime, that is, for 1.5 times 40-year cycles, is 1.4402616 ($U_{40}=0.9602$) at the end of the overlay on the outside surface of the nozzle. However, the surge nozzle is monitored for fatigue usage, and the fatigue CUF will not exceed the code limit of 1.0 so long as the number of applied load cycles does not exceed the number specified by the design specification for this nozzle, and used in the analysis. The analysis includes effects of thermal stratification and insurge-outsurge transients.

Spray Nozzle: APS similarly evaluated the effects of the weld overlay repairs on the pressurizer spray nozzle. The worst-case 60-year projected usage factor is 1.4884243 ($U_{40}=0.9923$) at the inside of the spray pipe. However, the fatigue CUF will not exceed the code limit of 1.0 so long as the number of applied load cycles does not exceed the number specified by the design specification for this nozzle, and used in the analysis.

Safety Valve Nozzles: APS similarly evaluated the effects of the weld overlay repairs on the four pressurizer safety valve nozzles. The worst-case 60-year projected usage factor is 0.0424652 at the end of the overlay on the outside surface of the underside of the nozzle. The design of the safety valve overlay for fatigue is therefore not a TLAA, and is valid for the period of extended operation.

Summary of Analyses

With the design basis set of transients, including power uprate, steam generator replacement, and other effects described above, worst-case calculated 40-year fatigue usage factors exceed 0.9 in a few pressurizer components. Other fracture mechanics or fatigue analyses depend on the limiting number of occurrences assumed for a 40-year design life.

Some of the revised time-dependent component evaluations were based on a 60-year extended licensed operating period, and if valid for the period of extended operation, are therefore not TLAAAs. Others were for shorter periods than 40 years and did not extend to the end of the current 40-year licensed operating period, and were therefore also not TLAAAs.

The fatigue analyses for materials adjacent to the surge and spray nozzle overlay repairs extend their fatigue analyses to a period of extended operation, but were able to meet the 1.0 usage factor acceptance criterion only for a 40-year life and are therefore TLAAAs.

Section 4
TIME-LIMITED AGING ANALYSES

Table 4.3-7 - Summary of PVNGS Pressurizer ASME III Class 1 Analyses and Fatigue Usage Factors

Component Analysis (Date Replacement or Reanalysis Initiated)	TLAA? Basis if not.	Maximum CUF (U ₄₀ , Unless Noted Otherwise) ¹		
		Unit 1	Unit 2	Unit 3
1. Bottom Head and Support Skirt - Worst Location, Inside the Support Knuckle (1993 reanalysis in response to CE Infobulletin 88-09) See also item 17 below for a reanalysis of the Unit 3 bottom head.	Yes	0.7223	0.7223	0.7223
2. LEM Fatigue Crack Growth Analysis of Indications in a Unit 2 Pressurizer Support Skirt Forging Weld (1993) Crack growth to less than critical size for the assumed number of lifetime cycles.	Yes	NA	Crack growth, no CUF	NA
3. Manway-Cover Plate Assembly - Worst Location	Yes	0.013	0.028	0.028
4. Manway Studs	Yes	0.345	0.375	0.375
5. Water Level Boundary	Yes	0.0028	0.0028	0.0028
6. Heaters, Support Plate, and Surge Screen - Natural Frequency Analysis	Yes	200 cycles OBE, <endurance limit otherwise	200 cycles OBE, <endurance limit otherwise	200 cycles OBE, <endurance limit otherwise
7. Shear Lugs - Worst Location	Yes	0.0067	0.0067	0.0067

Section 4
TIME-LIMITED AGING ANALYSES

Table 4.3-7 - Summary of PVNGS Pressurizer ASME III Class 1 Analyses and Fatigue Usage Factors

Component Analysis (Date Replacement or Reanalysis Initiated)	TLAA? Basis if not.	Maximum CUF (U ₄₀ , Unless Noted Otherwise) ¹		
		Unit 1	Unit 2	Unit 3
8. Replacement Lower Horizontal Temperature Nozzle - Worst Location, Outer Sleeve and Clad Weld (1992 Unit 1, 1995 Units 2 and 3)	No. No safety determination ⁽²⁾	1.967 with design specification heatup rate, 0.688 with Plant Technical Specification heatup rate		
9. Replacement Lower Horizontal Temperature Nozzle - Nozzle to Pad (1992 Unit 1, 1995 Units 2 and 3)	Yes	0.029	0.029	0.029
10. Replacement Upper Horizontal Instrument Nozzles (In Upper Head) - Worst Location (1992)	Yes	<0.02	<0.02	<0.02
11. Replacement Lower Vertical Instrument Nozzles (In Lower Head) - Worst Location (1992 U1, 1995 Units 2 and 3)	Yes	0.990	0.990	0.990
12. Effect of MNSA Attachment Holes on Fatigue in the Unit 3 Lower Head (1994)	Yes	NA	NA	0.443
13. Replacement Heaters (Heater Sheath Class 1 Pressure Boundary Sheath Plug Weld) ⁽³⁾	Yes	0.0748	0.0017	0.002
14. Replacement Alloy 690 Heater Sheath to Heater Sleeve Weld	No , 60 years. ⁽⁴⁾	0.54 for 316SS sheaths 0.05 for Alloy 600 sheaths		

Section 4
TIME-LIMITED AGING ANALYSES

Table 4.3-7 - Summary of PVNGS Pressurizer ASME III Class 1 Analyses and Fatigue Usage Factors

Component Analysis (Date Replacement or Reanalysis Initiated)	TLAA? Basis if not.	Maximum CUF (U_{40} , Unless Noted Otherwise) ¹		
		Unit 1	Unit 2	Unit 3
15. Short Heater Sleeve Plugs (for use with stuck heaters)	Yes , qualified life comparable to 40 years.	1.0 for 560 Heatup + Reactor Trip/Loss of Flow + Leak Test cycles		NA
16. Replacement Heater Sleeve OD J-Welds - Worst Location (2003)	No , Evaluated for 60 years. ⁽⁴⁾	$U_{60} = 0.884$	$U_{60} = 0.884$	$U_{60} = 0.884$
17. Unit 1 and 3 Heater Sleeve Mini/MNSA Pad OD Repair ⁽⁵⁾ (2004)	No , Evaluated for 60 years. ⁽⁴⁾	$U_{60} = 0.551$	NA	$U_{60} = 0.551$
18. Unit 3 Lower Head, Including Effects of Overheating from Mislocated Heaters (“Failed Heater Event”) (2005)	No , Evaluated for 60 years. ⁽⁴⁾	NA	NA	$U_{60} = 0.287$
19. Surge Nozzle and Safe End with Overlay Repair	Yes	$0.9602^{(6)}$	$0.9602^{(6)}$	$0.9602^{(6)}$
20. Spray Nozzle and Safe End with Overlay Repair	Yes	$0.9923^{(6)}$	$0.9923^{(6)}$	$0.9923^{(6)}$
21. Safety Nozzles and Safe Ends with Overlay Repair	No , Evaluated for 60 years. ⁽⁴⁾	$U_{60} = 0.04247$	$U_{60} = 0.04247$	$U_{60} = 0.04247$

¹ Unless otherwise noted, the usage factors are U_{40} , calculated for the design basis number of loading events applicable to the component that were originally intended to encompass a 40-year design life.

Unless otherwise noted, the U_{60} usage factors were calculated for 1.5 times the 40-year design basis number of loading events applicable to the component.

² With the specified 200 °F/hr heatup rate the usage factor for the outer sleeve and clad weld is 1.967. However (1) a code analysis is not required for these locations by the design specification, hence the safety determination does not depend on this usage factor; and (2) although the design specification lists 200 °F/hr for the heatup transient, the PVNGS Technical Specifications limit the normal operating heatup rate to 75 °F/hr, and the normal operating cooldown rate to 100 °F/hr [Technical Specification 3.4.3 and Table 3.4.3-1]. With a more realistic but still conservative 100 °F/hr heatup rate the usage factor at these locations is 0.688.

³ The original analyses also included results for the sleeve-to-head junction and the sheath-to-sleeve weld, now superseded by the results summarized on Lines 14 and 15.

⁴ Analyses that are successfully projected to the end of the period of extended operation are not TLAAAs. See [Section 4.1.1](#), "Identification of TLAAAs."

⁵ The design report for the mini-OD pad repair states that it is a conservative result for the MNSA OD pad repair; and therefore that the conclusions are equally valid for the MNSA OD Pad Repair.

⁶ U_{40} is 2/3 of the 60-year value reported by the calculation.

Disposition: Aging Management, 10 CFR 54.21(c)(1)(iii)

Linear Elastic Fracture Mechanics (LEFM) Fatigue Crack Growth Analysis of Indications in a Unit 2 Pressurizer Support Skirt Forging Weld

The LEFM fatigue crack growth analysis of indications in the Unit 2 pressurizer support skirt forging weld is valid for up to 500 plant startup and shutdown cycles, 480 plant trips, and 2,000,000 normal plant maneuvers. The Metal Fatigue of Reactor Coolant Pressure Boundary program will track these events and action limits will ensure that appropriate corrective actions are completed before the design basis number of these events is exceeded. Appropriate corrective actions may include repair, replacement, or reanalysis. Growth of these Unit 2 pressurizer skirt indications will thereby be managed for the period of extended operation in accordance with 10 CFR 54.21(c)(1)(iii).

Fatigue Analyses

All other TLAAAs supporting the pressurizer design either exhibit an acceptable fatigue usage factor, or depend on an effect found to be acceptable for a limiting number of transient events. The Metal Fatigue of Reactor Coolant Pressure Boundary program will ensure that the fatigue usage factors based on those transient events will remain within the code limit of 1.0 for the period of extended operation, or will ensure that appropriate reevaluation or other corrective action is initiated if an action limit is reached. Action limits will permit completion of corrective actions before the design basis number of these events is exceeded, and before the cumulative usage factor exceeds the code limit of 1.0. Fatigue in the pressurizer will therefore be managed by the PVNGS fatigue monitoring program, in accordance with 10 CFR 54.21(c)(1)(iii).

The Metal Fatigue of Reactor Coolant Pressure Boundary program is described in [Section 4.3.1](#); and is summarized in Appendix B, [Section B3.1](#). See [Table 4.3-4](#) for details

of the program, and [Section 4.3.1.5](#) for a description of its action limits and corrective actions.

4.3.2.5 Steam Generator ASME III Class 1, Class 2 Secondary Side, and Feedwater Nozzle Fatigue Analyses

Summary

The PVNGS replacement steam generators (RSGs) are designed to ASME III, Subsection NB (Class 1) and NC (Class 2), 1989 Edition with no addendum. The design reports included design for a concurrent power uprate. The results of the fatigue analyses from these design reports are presented in [Table 4.3-8](#).

Analysis

Pressure-retaining and support components of the primary coolant side of the steam generators are subject to an ASME Boiler and Pressure Vessel Code, Division 1, Section III fatigue analysis. Although the secondary side is Class 2, all pressure retaining parts of the steam generators satisfy the Class 1 criteria, including a Division 1, Section III fatigue analysis.

The replacement steam generators were evaluated for a spectrum of design basis transients sufficient for a 40-year operating life, from date of installation.

Effect of Combustion Engineering Infobulletin 88-09 “Nonconservative Calculation of Cumulative Fatigue Usage”

The CE Owner’s Group review of Combustion Engineering Infobulletin 88-09 did not identify any effects on the fatigue analysis of the original steam generators, and all of the PVNGS steam generators have been replaced.

Steam Generator Tube Code Fatigue Analysis Not a TLAA

The design of the PVNGS steam generators includes a code fatigue analysis of the steam generator tubes, as indicated in [Table 4.3-8](#). This analysis would be a TLAA if the safety determination depended upon it. However the design report indicates a zero fatigue usage factor, and a code fatigue analysis has historically not proved sufficient to support the safety determination for steam generator tubes, which depends on a separate tube inspection program.

The various tube degradation mechanisms not anticipated in the original design have required stringent periodic inspection programs in order to ensure adequate steam generator tube integrity. The steam generator tubes are, in effect, (1) no longer qualified for a licensed design life (10 CFR 54.3(a) Criterion 3), and the (2) the fatigue analysis is therefore no longer the basis of the safety determination; in this case that the tubes will maintain their pressure boundary function between primary and secondary systems (Criterion 5).

Section 4
TIME-LIMITED AGING ANALYSES

Therefore, even in installations (such as PVNGS) with excellent material and chemistry control, or in this case, new steam generators, the safety determination for integrity of steam generator tubes now depends on managing aging effects by a periodic inspection program rather than on the fatigue analysis, and the code fatigue analysis of the tubes is therefore not a TLAA.

Table 4.3-8 - PVNGS Steam Generator Uprated Fatigue Comparison

Component	Maximum Design Basis CUF ⁽¹⁾ (RSGs, Uprated)	
	Current Design, U1/3	Current Design, U2
Support Skirt	0.08331	0.155
Support Skirt Access Opening Region	0.75104	NR ⁽²⁾⁽³⁾
Primary Head		
Hot Side	0.02895	0.0309
Cold Side	0.08502	0.0352
Primary Inlet Nozzle	0.04857	0.04634
Primary Outlet Nozzle	0.01683	0.01683
Primary Nozzle Dam Retaining Rings, Inlet and Outlet	0.0	0.0
Primary Manway		
Pad	0.02747	0.037
Cover	0.03494	0.019
Primary Manway Studs		
Hot Side (No TLAA, replaced every six years)	6.53	6.33
Cold Side (No TLAA, replaced every six years ⁴ in Unit 2, nine years in Unit 1 and 3)	4.011	4.67
Primary Divider Plate	0.03	0.06
Tubes	0	0
Tube to Tubesheet Weld	0.18816	0.792
Tubesheet		
Hot Side	0.06570	0.928
Cold Side	0.39410	0.507
Tubesheet to Shell (Stub Barrel) Junction		
Hot Side	0.10059	0.064
Cold Side	0.99876	0.996
Economizer Cylinder (at the Tubesheet Cold Side)	0.01075	NR
Secondary Shell	0.00773	0.00899
Secondary Shell Instrument Nozzle Holes and Nozzles	NB-3222.4(d) Exemption	NB-3222.4(d) Exemption

Section 4
TIME-LIMITED AGING ANALYSES

Table 4.3-8 - PVNGS Steam Generator Uprated Fatigue Comparison

Component	Maximum Design Basis CUF ⁽¹⁾ (RSGs, Uprated)	
	Current Design, U1/3	Current Design, U2
Small Nozzles	NB-3222.4(d) Exemption	NB-3222.4(d) Exemption
Economizer Feedwater Nozzle	0.90970	0.981
Downcomer Blowdown Nozzle	0.197	0.273
Downcomer Feedwater Nozzle	0.983	0.996
Downcomer Feedwater Piping Assembly	0.106	0.125
Recirculation Nozzle	0.099	0.114
Steam Nozzle	0.169	0.1767
Secondary Manway Pad	0.129	0.140
Secondary Manway Studs	0.618	0.7714
Secondary Handholes Welded on Lower Shell	0.113	NR
Studs for Secondary Handhole Welded on Lower Shell	0.424	NR
Secondary Stub Barrel Handhole	0.940	0.955
Secondary Stub Barrel Handhole Studs (No TLAA, replaced every 29 years in Units 1 and 3, every 18 years in Unit 2)	1.35	2.15
Upper Support Lugs	0.405	0.161
Feedwater Distribution Box	0.99201	0.988

¹ The analyses are for a 40-year component life. The Unit 2 replacement steam generators were installed at about operating year 18, the Unit 1 and 3 replacements at or after operating year 20. The analyses therefore qualify the replacement steam generators for a nominal 60-year plant life in Units 1 and 3, and 58 years in Unit 2.

² Effects of the opening on the stress analysis were evaluated by evaluating stress concentration factors but no fatigue usage was calculated for the Unit 2 opening.

³ Not reported.

⁴ The Unit 2 design report does not distinguish between the hot- and cold-side studs, does not state the separate, lower 4.67 CUF for the cold side, and states a six-year replacement interval for both. However the supporting design analysis reports the 4.67 CUF for the cold side, and therefore states a Unit 2 cold-side stud replacement interval of eight years.

The high usage factors calculated for the primary manway and secondary handhole studs require that these studs be periodically replaced. The fatigue analysis determines the replacement interval but is not otherwise the basis for a safety determination that depends on the licensed life, and the fatigue analysis is therefore not a TLAA for these studs.

Section 4 TIME-LIMITED AGING ANALYSES

Although the replacement steam generator designs are essentially identical, the Unit 2 code analysis was performed first, under separate contract. The calculated CUFs therefore differ to some extent. The results are identical or comparable where comparable methods were used. However:

- The code requires only that the calculated CUF be less than 1.0. In some cases a simple analysis achieved this, and no finer analysis was applied to further reduce the result; though this may have been done for the other unit or units. Compare, for example, the CUFs for the tube sheet hot side and for the tube-to-tube sheet welds.
- The code does not specify all locations which must be analyzed, leaving many of the detailed choices to the experience and skill of the analyst. For example, the Unit 2 analyst did not elect to perform a fatigue analysis at the support skirt opening or in the economizer cylinder near the tubesheet; the Unit 1 and 3 analyst did so.

With power uprate and replacement steam generators the worst-case usage factors calculated for the specified set of design basis transients exceed 0.9 in several other steam generator components. However, except for the steam generator tubes (which are subject to periodic inspection), fatigue usage factors in the steam generator components do not depend on flow-induced vibration or other effects that are time-dependent at steady-state conditions, but depend only on effects of operational and upset transient events. The Metal Fatigue of Reactor Coolant Pressure Boundary program will track these events to ensure that appropriate reevaluation or other corrective action is initiated if an action limit is reached. Action limits will permit completion of corrective actions before the design basis number of events is exceeded.

The Unit 1 and 3 replacement steam generators are also analyzed for a period sufficient to cover their installed life, to the end of the extended period of operation, and the Unit 2 replacement steam generators are analyzed for a period sufficient to cover all but two years of their installed life, including the period of extended operation.

The Unit 2 RSG tube-to-tubesheet welds and the hot sides of the tubesheets; and the cold side of the tubesheets and the feedwater distribution boxes in all three units, have high calculated CUFs but will be monitored using the global cycle counting method as shown in [Table 4.3-4](#). This will prompt actions that address the high-CUF locations when a cycle count action limit is approached. This method is sufficient because the economizer and downcomer feedwater nozzles, which are monitored using stress based fatigue, are more sensitive to plant operational behavior, and their monitored fatigue usage factors will therefore bound those in these other locations.

Disposition: Validation, 10 CFR 54.21(c)(1)(i); and Aging Management, 10 CFR 54.21(c)(1)(iii)

Validation, Units 1 and 3

The fatigue analyses of the Unit 1 and 3 replacement steam generators are for a period sufficient to cover their installed life, to the end of the period of extended operation, and therefore will remain valid for the period of extended operation in accordance with 10 CFR 54.21(c)(1)(i).

Aging Management, Unit 2

The fatigue analyses of the Unit 2 replacement steam generators are for a period sufficient to cover all but about two years of their expected 42-year installed life, including the period of extended operation. The Metal Fatigue of Reactor Coolant Pressure Boundary program will track events to ensure that appropriate reevaluation or other corrective action is initiated if an action limit is reached. Action limits will permit completion of corrective actions before the design basis number of events is exceeded, and before the cumulative usage factor exceeds the code limit of 1.0. Effects of fatigue in the Unit 2 replacement steam generator pressure boundaries with Class 1 analyses will thereby be managed for the period of extended operation, in accordance with 10 CFR 54.21(c)(1)(iii).

The Metal Fatigue of Reactor Coolant Pressure Boundary program is described in [Section 4.3.1](#); and is summarized in Appendix B, [Section B3.1](#). See [Table 4.3-4](#) for details of the program, and [Section 4.3.1.5](#) for a description of its action limits and corrective actions.

4.3.2.6 ASME III Class 1 Valves

Summary Description

PVNGS Class 1 valves (power-operated relief, pressurizer safety, control, motor- and air-operated, manual, check, and solenoid) are designed to ASME III, Subsection NB, 1974 Edition with multiple addenda, the 1977 Edition with Winter 1977 addendum, and the 1989 Edition no addenda [[UFSAR Table 5.2-1](#)]. ASME Section III requires a fatigue analysis only for Class 1 valves with inlets greater than four inches nominal. At PVNGS, specifications for some Class 1 valves with inlets four inches or less also require a fatigue analysis.

Analysis

Code Fatigue Analyses

Fatigue analyses or evaluations were performed for the valves listed in the following table:

Table 4.3-9- Summary of PVNGS Class 1 Valve Fatigue Analyses

Valve, Specification, and Analysis Descriptions	Calculated Design Basis Ops N_A for NB-3545.3 Normal Duty ⁽¹⁾	Maximum Design Basis CUF I_t for NB-3550 Cyclic Loads ⁽¹⁾
<p>1/2/3JSIAUV0651 and 1/2/3JSIBUV0652 Borg-Warner Model 77850/77850-1, 16" Shutdown Cooling Suction Isolation Valve Reanalysis Valve UV-651 was relocated closer to the RCS hot leg in all three Units because of line vibration issues in Unit 1, and reanalyzed. See Section 4.3.2.13. The reanalysis included the UV-652 valves.</p> <p>1/2/3JSICUV0653 and 1/2/3JSIDUV0654 Borg-Warner Model 77850/77850-1, 16" Shutdown Cooling Containment Isolation Valves Since these valves are the same model and experience similar numbers of operating events as the UV-651 and -652 valves, and similar or less-severe transients per event, monitoring fatigue in the UV-651 and -652 valves will ensure that the design basis of the UV-653 and -654 valves also remains valid.</p>	NA ⁽²⁾	0.702 (Crotch) ⁽³⁾
3JCHAHV0205 and 3JCHBHV0203 Valcor Model V526-5631-9, 2" Isolation Valves between the Unit 3 Regenerative Heat Exchanger and Auxiliary Spray Line	10,000	0.151 (Crotch)
1/2/3JRCEPSV0200/201/202/203 Dresser Model 6-31709NAX-1-XNC045 Pressurizer Pressure Safety Valves (6" Inlet)	$>10^6$	0.002 ⁽⁴⁾
1/2/3JCHEPDV0240 Fisher Model 667-DBQ/ 50B0617/ 54A6460, 2" Isolation Valves for the Charging Line	6,000	0.7656 (Valve Body)

¹ N_A and I_t were calculated for the design basis number of loading events applicable to the component that were originally intended to encompass a 40-year design life.

² The fatigue evaluations of the valve components are performed in accordance with ASME Code, Section III, Subparagraph NB-3222.4, hence a calculated N_A for NB-3545.3 normal duty operations is not applicable.

³ “Crotch” is the minimum radius in the valve body between the body and the neck, a stress concentration region and a required analysis location under ASME III Subarticle NB-3500 design rules for Class 1 valves, Subparagraph NB-3545.1.

⁴ The CUF is not explicitly calculated in the Design Report, but the CUF presented here is derived from the statement in the Design Report that the allowable number of cycles from the ASME Code analysis is greater than 10^6 , compared to the specification allowable value of 2,000 cycles ($CUF = 2,000 / >10^6 < 0.002$).

For the three valves modeled with an NB-3545.3 normal duty operating cycle evaluation, the allowed NB-3545.3 N_A normal duty operations far exceed those expected to occur. The calculated cumulative usage factors I_t for NB-3550 cyclic loads are less than the code limit of 1.0.

Fatigue Analyses to be Recovered

Table 4.3-9 does not include all ASME III Class 1 valves. APS has not yet been able to recover a fatigue analysis, or to confirm that none is required, for every ASME III Class 1 valve greater than four inches nominal inlet whose specification or purchase date indicates a design code edition and addendum that might require a fatigue analysis.

APS will recover and evaluate a fatigue analysis for each remaining ASME III Class 1 valve greater than four inches nominal inlet, for which a fatigue analysis is also otherwise required, before the end of the current licensed operating period.

Effect of Combustion Engineering Infobulletin 88-09 “Nonconservative Calculation of Cumulative Fatigue Usage”

The CE Owner’s Group review of Combustion Engineering Infobulletin 88-09 did not identify any effects on the fatigue analyses of Class 1 valves.

Disposition: Validation, 10 CFR 54.21(c)(1)(i); Possible Revision, 10 CFR 54.21(c)(1)(ii); and Aging Management, 10 CFR 54.21(c)(1)(iii)

Validation - Pressure Safety and Auxiliary Spray Isolation Valves

The calculated worst-case usage factors for the Class 1 pressurizer safety valves and the 2” isolation valves for the auxiliary spray line indicate that the designs have large margins, and therefore that the pressure boundaries would withstand fatigue effects for at least two of the original design lifetimes. The design of these valves for fatigue effects is therefore valid for the period of extended operation, in accordance with 10 CFR 54.21(c)(1)(i).

Aging Management - Shutdown Cooling Suction Isolation Valve, and Charging Line Isolation Valves

The calculated worst-case usage factor in these Class 1 valves is 0.7656. However, fatigue usage factors in these valves do not depend on effects that are time-dependent at steady-state conditions, but depend only on effects of operational, abnormal, and upset transient events. The Metal Fatigue of Reactor Coolant Pressure Boundary program will track events to ensure that appropriate reevaluation or other corrective action is initiated if an action limit is reached. Action limits will permit completion of corrective actions before the design basis number of events is exceeded. The charging line isolation valves are subject to similar but less-severe cyclic effects than the charging nozzles, whose fatigue usage is tracked by the stress-based method. The shutdown cooling suction isolation valve is the limiting location on the shutdown cooling line, and will be tracked by the cycle-based fatigue method. Effects of fatigue in Class 1 valve pressure boundaries will thereby be managed for the period of extended operation, in accordance with 10 CFR 54.21(c)(1)(iii).

Validation, Revision, or Aging Management - Valves whose Fatigue Analyses have not been Recovered

APS will recover and evaluate the fatigue analysis for each of the remaining ASME III Class 1 valves greater than four inches nominal inlet, for which a fatigue analysis is also otherwise required, before the end of the current licensed operating period. Each evaluation will either confirm that the analysis remains valid for the period of extended operation, in accordance with 10 CFR 54.21(c)(1)(i); or will revise the analysis for the period of extended operation, in accordance with 10 CFR 54.21(c)(1)(ii); or will include the valve in the Metal Fatigue of Reactor Coolant Pressure Boundary program in accordance with 10 CFR 54.21(c)(1)(iii).

Fatigue in valves added to the program may be managed by individual monitoring; or by monitoring a component with greater projected usage factor, subject to the same or an enveloping set of transient events and valve operations.

The Metal Fatigue of Reactor Coolant Pressure Boundary program is described in [Section 4.3.1](#); and is summarized in Appendix B, [Section B3.1](#). See [Table 4.3-4](#) for details of the program, and [Section 4.3.1.5](#) for a description of its action limits and corrective actions.

4.3.2.7 ASME III Class 1 Piping and Piping Nozzles

Summary Description

Class 1 reactor coolant main loop piping designed and supplied by Combustion Engineering is designed to ASME III, Subsection NB, 1974 edition with addenda through Summer 1974. The main loop piping fatigue analysis was performed to the 1974 edition with addenda through Summer 1974. The fatigue analyses of piping outside the main loop used the 1974

edition with addenda through Winter 1975 or the 1977 edition with addenda through Summer 1979.

These analyses have been updated from time to time to incorporate redefinitions of loads and design basis events, operating changes, power uprate, steam generator replacement, and minor modifications. The currently-applicable fatigue analyses of these components are TLAAs.

For fatigue in the pressurizer surge line see [Section 4.3.2.9 below](#).

Analysis

In the primary coolant system, the most limiting calculated design basis usage factor occurs in the charging nozzle and approaches the limit of 1.0. The high usage factors are primarily due to transient thermal stresses from normal operating and upset injection events.

However, with the exception of the charging line nozzles, and possibly the pressurizer surge line discussed in [Section 4.3.2.9](#) (if thermal stratification has not been completely mitigated); fatigue usage factors in these components do not depend on effects that are time-dependent at steady-state conditions, but depend only on effects of operational, abnormal, and upset transient events. Since the Metal Fatigue of Reactor Coolant Pressure Boundary program will track these events, the design basis fatigue usage factor limit (1.0) will not be exceeded in these locations without an appropriate evaluation and any necessary mitigating actions.

No Cycle-Basis Stress Limit for Supports

The original codes of record (1974 S'74, W'75 to 1977 S'79) did not invoke this requirement, and as permitted by code rules, later editions were not invoked for any support reanalysis.

Effects of Power Uprate and Steam Generator Replacement on the Piping Fatigue Analyses

The effects of power uprate and steam generator replacement were addressed in an addendum to the design report for the RCS piping, nozzles, and RTD thermowells and in the Class 1 analyses for other Class 1 piping systems. The evaluations demonstrated the acceptability of the Class 1 piping system under the current licensing basis design number of transients.

Charging Lines and Nozzles

The nozzle is the critical component in each charging path. The Metal Fatigue of Reactor Coolant Pressure Boundary program will calculate stress-based fatigue in the CVCS charging nozzle.

Reduced Wall Thicknesses in the Reactor Coolant System

The fatigue analysis for the RCS hot leg and cold leg piping was reviewed for the RSG and PUR project. The review produced an addendum to the design reports, which accounts for two piping configurations.

The first is the intended design configuration, assuming full carbon steel field welds. These results continue to remain applicable to the actual pipe runs; except the field welds. This configuration results in a maximum calculated usage factor for the Hot Leg and for the Hot Leg Elbow far below 1.0. This fatigue analysis assumes the design basis transients for a 40-year plant life, and is therefore a TLAA that will be managed through the fatigue management program described in [Section 4.3.1.5](#).

The second configuration assumed reduced piping wall thicknesses at both “postulated” and “acceptable” minimum wall thicknesses. The “postulated” minimum wall thickness values were the bounding values derived from shop records for all three PVNGS Units. The “acceptable” minimum wall thickness values were based on design condition stress limits. This evaluation also assumes a full complement of design basis transients for a 40-year plant life. More importantly, all of the fatigue calculations utilize conservative bending stress intensification factors that are specifically applicable only to the crotch region of elbows. This evaluation also assumed that the entire pipe runs are of reduced wall thickness, rather than only the welds. This evaluation concluded that the “acceptable” minimum wall thickness values in all field weld locations meet all ASME Code requirements.

This evaluation for reduced wall thicknesses calculated fatigue usage factors approaching 1.0. Fatigue in RCS piping can be adequately managed during the period of extended operation using the cycle count method. Cycle count monitoring will ensure that appropriate reevaluation or other corrective action is initiated if cycle count action limit is reached and is therefore adequate to manage the fatigue in the welds, since the revised calculated fatigue usage in the welds has the same transient event cycle count basis. Action limits will permit completion of corrective actions before the design basis number of events is exceeded.

Alloy 600 Hot Leg Small-Bore Nozzle Repairs

All the Alloy 600 instrumentation nozzles have been replaced in the hot legs and pressurizer for all three units in an effort to reduce the potential for Primary Water Stress Corrosion Cracking (PWSCC). Three methods of repairs have been used, “full nozzle,” welded plugs, and “half-nozzle,” also known as “three-quarter” nozzle repairs for the inservice RTDs. The methods and new design basis for the repairs used in the RCS hot leg small-bore nozzles are discussed below. The pressurizer nozzle repairs are discussed in [Section 4.3.2.4](#).

Unit 2 Alloy 600 Hot Leg Partial Penetration Weld Full-Nozzle Repairs

The original RCS hot legs contained a total of 27 Alloy 600 small-bore nozzles with partial penetration welds, in each unit. During 1992, PVNGS replaced seven pressure differential transmitter (PDT) nozzles and one sample nozzle in Unit 2 with full nozzles. The full-nozzle

repair consists of the total removal of all Alloy 600 nozzle and Alloy 82/182 weld material. An Alloy 690 nozzle is installed which penetrates through the whole thickness of the RCS piping and replaces the entire Alloy 600 nozzle. The qualification of this repair method to Class 1 requirements included a fatigue analysis.

The fatigue analyses for the designed and as-built conditions of the repairs results in high CUFs. However the higher CUF associated with the PDT and sampling nozzle will not affect the fatigue monitoring of the RCS piping, which will be monitored using the cycle counting method. The PDT and sampling nozzle do not experience significant thermal transients. The CUF is driven by the operating basis earthquake (OBE) event. This event is tracked by in the monitoring program, which will prompt actions to address the Unit 2 unique high CUF when the cycle count action limit is approached.

Alloy 600 Hot Leg Small-Bore Half-Nozzle Repairs

The remaining hot leg small-bore nozzles were replaced under the PVNGS Alloy 600 replacement program. Alloy 600 nozzles were replaced with the Alloy 690 half-nozzle design. In the half-nozzle design the Alloy 600 nozzle is cut or bored out to just outboard of the partial-penetration weld on the inner surface of the RCS piping. The remainder of the Alloy 600 nozzle, including the partial penetration weld, remains in place. A short Alloy 690 nozzle section is inserted into the bored-out region and is welded to the RCS piping outer surface.

The PDT and sampling half-nozzle repairs were designed to Class 1 requirements of the ASME BPV Code, Section III, and invoked the fatigue waiver of subparagraph NB-32224(d) of the ASME Code, Section III.

The “three-quarter” nozzle repairs were used for the inservice RTDs, and were designed to Class 1 requirements. The analysis was incorporated in the RCS piping design reports with the RSG and PUR addendum. The crack propagation analysis, which ensures that an existing worst case crack in the remaining Alloy 600 nozzle or weld will not propagate far enough to threaten the pressure boundary, is discussed in [Section 4.7.4](#).

All spare RTD nozzles were plugged with Alloy 690 material to prevent PWSCC. The RTD plug is inserted into the nozzle and is welded to the outside diameter of the hot leg. The length of the plug is then field cut to be flush with the inner diameter of the hot leg in order to prevent any flow-induced vibration. After installation, the welded plug constitutes part of the RCS primary boundary, thus they were designed to the Class 1 requirements of ASME BPV Code, Section III which includes a fatigue analysis per NB-3222.4(e).

Effect of Unit 3 MNSA Holes on Reactor Coolant Piping

A mechanical nozzle seal assembly (MNSA) had been installed at a leaking thermowell in Unit 3. This MNSA was replaced with a three-quarter nozzle repair during the U3R10 Alloy 600 replacement program. The tapped holes in the hot leg for the MNSA attachment were not repaired after the nozzle replacement. Consequentially, this portion of this Unit 3

hot leg has a higher CUF at the tapped hole location, as identified in the MNSA design report. The CUF was confirmed in the RSG and PUR design report. The higher CUF associated with the MNSA tapped holes will not affect the fatigue monitoring of the RCS piping. The Metal Fatigue of Reactor Coolant Pressure Boundary program cycle count action limit for the RCS will initiate reevaluation or other corrective actions to address this Unit 3-unique location. Action limits will permit completion of corrective actions before the design basis number of events is exceeded.

Redesigned Reactor Coolant System Thermowells

SER Supplement 7 Chapter 14, "Initial Test Program," describes failure and redesign of the primary loop thermowells:

After evaluating the analytical results and test data submitted by the applicant on this subject, the staff concurs that thermowell failures were caused by the resonance of vortex shedding frequencies and the thermowell natural frequency which resulted in wear and high-cycle fatigue. The staff concludes that analyses conducted by the applicant, supplemented by test data from the CE-Windsor TF-2 flow loop, the CE-KSB pump test loop and the full-scale demonstration tests satisfactorily demonstrated that the new thermowell design is structurally adequate.

This issue was re-addressed during the replacement steam generator and power uprate projects. The evaluation concluded that the current fatigue analysis is still valid and applicable to all three units. The evaluation concluded that the modification did not affect the previous conclusion concerning fatigue of the thermowells. These evaluations indicate no safety determination based on the plant life for these high-cycle loads, and therefore no TLAAs.

Removal of Reactor Coolant System Safety Injection Nozzle Thermal Sleeves

SER Supplement 7 Chapter 14, "Initial Test Program," describes failure and removal of the primary loop safety injection nozzle thermal sleeves (thermal liners).

Ultimately, in order to avoid debris, PVNGS decided to remove all thermal liners from the safety injection nozzles. Any damage done to the nozzle cladding was repaired and operational suitability was verified by non-destructive examination.

The applicant has removed all thermal liners from the safety-injection nozzle areas together with the expansion ridges and repaired all the damages. The staff has reviewed this matter, including the applicant's report regarding resolution of the issue submitted by letter dated December 30, 1983. Since the cumulative usage factor in the area that was behind the liner is a maximum of 0.34 compared with the usage factor of 0.6 at the safe-end portion of the nozzle, the staff concludes that the modification eliminated the

potential problem and will not affect the operability of the nozzles. The staff agrees to this modification and finds it acceptable.

[SER, [Ref. 5](#)]

This issue was re-addressed during the replacement steam generator and power uprate project. The evaluation for replacement steam generator and power uprate concluded that the current fatigue analysis is still valid and applicable to all three units. The evaluation concluded that the modification did not affect the previous conclusion concerning fatigue of the safety injection nozzles.

Flow Stratification Thermal Gradient in the Auxiliary Spray Line and Tee

Possible flow stratification in the auxiliary spray line and tee was first evaluated during hot functional testing, then re-evaluated in response to NRC Bulletin 88-08 concerns, as described in [Section 4.3.2.8](#).

CE recommended assessing the pressurizer spray piping system based on actual operating conditions that may result in more severe thermal loading than those originally defined by CE. This assessment was based on actual operating conditions from the precore, postcore, and natural circulation tests, and the flow evaluation during initial startup testing. The assessment included an evaluation of fatigue effects, but was superseded by the subsequent thermal gradient analysis prompted by the Bulletin 88-08 review.

NRC Bulletin 88-08 was concerned with possible thermal cycling in non-isolatable lines caused by cyclical valve leakage. To investigate the concern, PVNGS implemented a temporary temperature monitoring program in the Unit 3 auxiliary spray line and tee during operating Cycles 3 and 5, as described in [Section 4.3.2.8](#). While the temperature monitoring did not identify any thermal cycling anticipated by Bulletin 88-08, it did identify an unanalyzed thermal gradient in the Auxiliary Spray Line due to inleakage through the auxiliary spray isolation valve. The analysis of the thermal gradient demonstrated that the cumulative fatigue usage factor, including the effects of this thermal gradient, meets ASME Section III Subsection NB-3600 for a 40-year plant life.

Hot Leg Surge and Shutdown Cooling Nozzle Weld Overlays

Primary Water Stress Corrosion Cracking (PWSCC) has been identified as a degradation mechanism for Alloy 82/182 welds and weld butters. While no PWSCC flaws have been detected in PVNGS piping, APS has decided to preemptively perform full structural weld overlays (FSWOL) over pressurizer surge, spray, and safety and relief valve nozzles, and over the hot leg surge and shutdown cooling (SDC) nozzle Alloy 82/182 welds, as the most appropriate course of action to ensure the integrity of the reactor coolant pressure boundary. The pressurizer nozzle overlays are described in [Section 4.3.2.4](#).

All of these components are considered piping components subject to ASME III Subarticle NB-3200. The weld overlay repairs meet requirements for Class 1 components.

Section 4
TIME-LIMITED AGING ANALYSES

The weld overlays are also supported by fracture mechanics analyses and periodic inspections acceptable under ASME Section XI as the means to address aging in the overlaid welds. The fracture mechanics analyses of the materials overlaid by the weld repair are not TLAAs. The LFM and inspections are now the basis for the safety determination. ASME Section XI requires a fatigue crack growth analysis and an LFM analysis to calculate the propagation rate of a flaw in order to determine the inspection interval, but these do not support a safety determination for the entire plant life. However, the revised fatigue analyses of the adjacent materials affected by the overlays are time-dependent, and are TLAAs unless successfully projected to the end of the period of extended operation.

The basis of the fatigue analysis was increased to 60 years by increasing the 40-year number of cycles of each event by a factor of 1.5. The detailed fatigue analyses showed that the usage factors at all evaluated locations are below the allowable value of 1.0. Because the fatigue analyses of materials adjacent to the hot leg and shutdown cooling nozzle weld overlay repairs have been projected to the end of the period of extended operation, these fatigue analyses are not TLAAs. Because the Section XI inspections will be the basis for the safety determination of the overlaid materials, and because the supporting crack growth and LFM analyses are not time-limited to the current operating term, these analyses are not TLAAs.

No Effect on Class 1 Piping and Nozzles of Combustion Engineering Infobulletin 88-09, "Nonconservative Calculation of Cumulative Fatigue Usage"

The 1991 CE Owner's Group review of Combustion Engineering Infobulletin 88-09 did not identify any effects on the fatigue analysis of the reactor coolant piping and other Class 1 system piping or piping nozzles.

Disposition: Aging Management, 10 CFR 54.21(c)(1)(iii)

With the exception of the CVCS charging line nozzle and possibly the pressurizer surge line discussed in [Section 4.3.2.9](#), usage factors and the NB-3222.4(d) fatigue waiver for Class 1 piping pressure boundaries do not depend on effects that are time-dependent at steady-state conditions, but depend only on effects of operational, abnormal, and upset transient events.

The Metal Fatigue of Reactor Coolant Pressure Boundary program will continue to confirm that this is so, or that appropriate reevaluation or other corrective action is initiated if an action limit is reached.

Cycle-Count Monitoring and Cycle-Based Fatigue Monitoring: The Metal Fatigue of Reactor Coolant Pressure Boundary program will count significant transient events and thermal cycles and tracks usage factors in the bounding set of sample locations listed in [Table 4.3-4](#). The program tracks events to ensure either that appropriate reevaluation or other corrective action is initiated if an action limit is reached. Action limits will permit completion of corrective actions before the design basis number of events is exceeded.

Stress-Based Fatigue Monitoring: The CVCS charging nozzles are the limiting components for fatigue in the Class 1 charging paths. These and the hot leg surge line nozzle and limiting surge line elbow are subject to stress-based fatigue monitoring under the Metal Fatigue of Reactor Coolant Pressure Boundary program. The program records the critical parameters of each operating event cycle that affects these nozzles. From that data the program determines the contribution to the usage factor in these nozzles for each event, and maintains a current record of the worst-case cumulative usage factor for each location. This record will be reviewed and evaluated at intervals specified by the program, at a frequency sufficient to ensure that appropriate corrective action is initiated if an action limit is reached. Action limits will permit completion of corrective actions before the cumulative usage factor exceeds the code limit of 1.0.

Effects of fatigue in the Class 1 piping pressure boundary will thereby be managed for the period of extended operation, in accordance with 10 CFR 54.21(c)(1)(iii).

The Metal Fatigue of Reactor Coolant Pressure Boundary program is described in [Section 4.3.1](#); and is summarized in Appendix B, [Section B3.1](#). See [Table 4.3-4](#) for details of the program, and [Section 4.3.1.5](#) for a description of its action limits and corrective actions.

See also [Section 4.3.4](#) for effects of the reactor coolant environment on NUREG/CR-6260 sample locations in the surge line, charging nozzles, safety injection nozzles, and shutdown cooling suction line.

4.3.2.8 Absence of Supplemental Fatigue Analysis TLAAs in Response to Bulletin 88-08 for Intermittent Thermal Cycles due to Thermal-Cycle-Driven Interface Valve Leaks and Similar Cyclic Phenomena

NRC Bulletin 88-08 requested that licensees review the primary coolant pressure boundary and connected interfaces for possible effects of thermal cycles in normally-isolated dead-end branches, due to leaking interface valves.

Summary Description

By letter dated October 3, 1988, Arizona Public Service ... responded to Bulletin 88-08 and identified the auxiliary pressurizer spray system (APSS) as the only system with unisolable piping potentially susceptible to the thermal stratification cycling phenomena described in the Bulletin.

[\[Ref. 15\]](#)

Analysis

In order to satisfy the requirements of Action 3 of the Bulletin, PVGNS implemented a temporary temperature monitoring program of the Unit 3 auxiliary spray line and tee during operating Cycles 3 and 5. The objective of this program was to determine the source of the

Section 4
TIME-LIMITED AGING ANALYSES

stratification in the APSS line, including potential valve leakage, and to verify that the limiting temperature conditions used in the fatigue analysis were valid. This program would also indicate the necessity for the installation of thermocouples in Units 1 and 2. The results of the traces from Cycle 3

...identified the charging system as the potential source of in-leakage into the APSS. The monitored temperature data indicated that thermal stratification (60°F to 115°F) occurred under heatup and cooldown operation. Thermal stratification (up to 90°F) during normal operation was also observed. However, there was no evidence of large temperature fluctuations reflecting in-leakage through the isolation valves into the APSS line from the charging system.

Conclusion

Based on the evaluation of the monitored temperature traces provided by APS during operating cycles 3 and 5 of Unit 3, the staff concludes that APS has demonstrated that no high cycle thermal fatigue will result in the auxiliary spray line from the interaction of in-leakage flow through the isolation valves of the APSS line and turbulent penetration from the main spray line. Since APS has stated that the APSS in PVNGS Units 1 and 2 are identical to Unit 3, the same conclusion also applies to Units 1 and 2.

[\[Ref. 15\]](#)

The form of stratification identified in the auxiliary spray pipe run, up to its first valve, suggests that there is no "high cycle" mixing zone at the temperature interface boundary. Rather there will be a stable low cycle axial and tangential stress condition due only to the temperature differences between the top and bottom of the pipe, and their values will depend on the interface level, with an insignificant mixing zone. Since the observed temperature differences exceeded the 50 °F criterion set by the NRC, APS performed a supplemental bounding thermal gradient stress analysis to determine the effect of low cycle fatigue.

Although investigation of Bulletin 88-08 stratification phenomena prompted this supplemental analysis, the analysis did not analyze effects of the Bulletin 88-08 high-cycle thermal fatigue phenomena, which the testing program had demonstrated to be of no concern. It instead analyzed effects of low-cycle thermal stresses from differential temperature gradients not anticipated in the original code analysis. It therefore affects the original code analysis, as described under "Flow Stratification Thermal Gradient in the Auxiliary Spray Line and Tee" in [Section 4.3.2.7](#).

Absence of a TLAA

The investigations demonstrated that PVNGS is not susceptible to the Bulletin 88-08 phenomena. The supporting evidence is measured data not dependent on time, and prompted no time-dependent analyses of the Bulletin 88-08 phenomena.

4.3.2.9 Bulletin 88-11 Revised Fatigue Analysis of the Pressurizer Surge Line for Thermal Cycling and Stratification

The purpose of this bulletin is to (1) request that addressees establish and implement a program to confirm pressurizer surge line integrity in view of the occurrence of thermal stratification and (2) require addressees to inform the staff of the actions taken to resolve this issue.

[NRC Bulletin 88-11]

Summary Description

The surge lines are designed to ASME III, Subsection NB, 1977 edition with addenda through Summer 1979. The surge line design was re-evaluated in 1991 through the Combustion Engineering Owners Group in response to the NRC Bulletin 88-11 thermal stratification concerns.

Analysis

Effects of Thermal Stratification on the Surge Line Piping Fatigue Analysis

Combustion Engineering (CE) performed a fatigue evaluation of surge lines in various CE Owners Group (CEOG) plants, with thermal stratification loading. The analysis assumed the design basis number of 500 heatup transients. The CEOG analysis is based on a limiting set of thermal stratification transients defined from data collected from several Combustion Engineering units, not including PVNGS, but used the PVNGS surge line for the limiting analysis because its geometry produced the most-limiting stresses. Insurge-outsurge and thermal stratification effects doubled the 40-year CUF of the original analysis of record, at the limiting location in the surge line elbow at the pressurizer.

The elastic analysis produced a cumulative usage factor of 1.65 in the elbow. To decrease the CUF below the ASME fatigue limit of 1.0, CE therefore performed a plastic analysis, resulting in a limiting CUF of 0.937 in the pressurizer elbow. This CEOG limiting-case analysis is conservative because it did not include any credit for mitigating actions, or the actual severity of transients, experienced during operation. A reanalysis for more realistic transients should therefore be able to demonstrate considerable margin. PVNGS collected and reduced their data independently from the other plants; hence, there is no specific thermal transient information from PVNGS within the CEOG report. However, in the absence of any analysis more specific to PVNGS, APS confirmed this bounding analysis as the fatigue analysis of record for this component at PVNGS.

See [Section 4.3.4](#) for effects of the reactor coolant environment on fatigue in this location.

Effect of NRC Bulletin 88-11 on Risk Informed Inservice Inspection (RI-ISI) Program, Relief Request 32.

PVNGS augmented its ASME Section XI, ISI program to include inspections of the surge line elbow, which were performed to address NRC Bulletin 88-11 concerns. PVNGS subsequently proposed the alternative RI-ISI in Relief Request 32 [Ref. 23]. The RI-ISI application is based on the EPRI RI-ISI program, which explicitly considered NRC Bulletin 88-11 concerns in its application. The NRC Bulletin 88-11 concerns are therefore addressed by the PVNGS RI-ISI program.

Effects of Power Uprate and Steam Generator Replacement on the Surge Line Piping Fatigue Analysis

The evaluation of these modifications found that the resulting changes in temperature ranges have no effect on the surge line analysis.

Disposition: Aging Management, 10 CFR 54.21(c)(1)(iii)

The surge line is subject to stress-based fatigue monitoring under the Metal Fatigue of Reactor Coolant Pressure Boundary program. The program maintains a record of the worst-case cumulative usage factors. This record will be reviewed and evaluated at intervals specified by the program, at a frequency sufficient to ensure that appropriate corrective action is initiated if an action limit is reached. Action limits will permit completion of corrective actions before the code limit is exceeded. The effects of fatigue in the Class 1 surge line will thereby be managed for the period of extended operation, in accordance with 10 CFR 54.21(c)(1)(iii).

The Metal Fatigue of Reactor Coolant Pressure Boundary aging management program is described in [Section 4.3.1](#); and is summarized in Appendix B, [Section B3.1](#). See [Table 4.3-4](#) for details of the program, and [Section 4.3.1.5](#) for a description of its action limits and corrective actions.

4.3.2.10 Class 1 Fatigue Analyses of Class 2 Regenerative and Letdown Heat Exchangers

Summary Description

The regenerative heat exchangers were designed and constructed to Class 2 rules on both shell and tube sides. The letdown heat exchangers were designed and constructed to Class 2 rules on the tube side, Class 3 on the shell side. However, although these are Class 2 and 3 heat exchangers, the specifications require a Class 1, NB-3222 analysis, including a fatigue evaluation for a specified set of events, each for a specified number of occurrences, for a 40 year design life.

The current licensing basis reference to these analyses is [UFSAR 9.3.4.1.2](#), [CVCS] Design Criteria:

- F. Letdown and charging portions of the CVCS are designed to withstand the design transients defined in [Table 9.3.4-1](#) without any adverse effects.

Although the Class 1 fatigue analyses are not directly described or cited by this UFSAR statement, the actual qualification for these effects includes the Class 1 analyses, which are therefore TLAAs.

Analysis

Regenerative Heat Exchangers

The regenerative and letdown heat exchanger fatigue analyses were performed with transients specified in the CE general specification for System 80 plants. The numbers of events required by these specifications are consistent with or are greater than the number of transients used as action limits in the fatigue management program with enhancements, described in [Section 4.3.1.5](#).

The original assessment that fatigue in the regenerative and letdown heat exchangers was bounded by the fatigue of the charging nozzle is still valid. The most severe transients for the letdown and regenerative heat exchangers also affect the charging nozzle. The charging nozzle has a higher calculated design basis usage factor (over 0.9) and is monitored by stress-based fatigue. The monitored fatigue usage in the charging nozzle is therefore an appropriate and conservative indication that these heat exchangers may be approaching the code design limit of 1.0.

Letdown Heat Exchangers

The fatigue analysis for standard System 80 letdown heat was performed using the original System 80 transients. The letdown heat exchanger for PVNGS was built to Revision 4 of the CE general letdown heat exchanger specification for System 80 plants, which combined multiple transients from the previous revision of the specification. The new transients were found to bound those used in the standard System 80 letdown heat exchanger fatigue analysis.

Disposition: Aging Management, 10 CFR 54.21(c)(1)(iii)

The Metal Fatigue of Reactor Coolant Pressure Boundary program will track events to ensure that appropriate reevaluation or other corrective action is initiated if an action limit is reached. Action limits will permit completion of corrective actions before the design basis number of events is exceeded, and before the cumulative usage factor exceeds the code limit of 1.0. The combination of cycle counting and stress-based fatigue monitoring of the charging nozzles will assure that the effects of aging in the regenerative and letdown heat

exchangers are managed for the period of extended operation, in accordance with 10 CFR 54.21(c)(1)(iii).

The Metal Fatigue of Reactor Coolant Pressure Boundary program is described in [Section 4.3.1](#); and is summarized in Appendix B, [Section B3.1](#). See [Table 4.3-4](#) for details of the program, and [Section 4.3.1.5](#) for a description of its action limits and corrective actions.

4.3.2.11 Class 1 Fatigue Analyses of Class 2 HPSI and LPSI Safety Injection Safeguard Pumps for Design Thermal Cycles

The HPSI and LPSI safety injection safeguard pumps were designed to ASME III Class 2, for which the code requires no fatigue analysis. However [UFSAR 3.9.3.5.3.3](#) describes design for a stated number of thermal transient cycles.

The structural integrity and operability analyses for both the HPSI and LPSI pumps cite the Class 1 methods of ASME III Subparagraph NB-3222.4 when addressing these thermal transients.

Analysis

40°F to 300°F Transient – 10 Cycles

This thermal transient corresponds to the initiation of safety injection, which is classified as an upset condition. Both the HPSI and LPSI pumps are designed for this transient, therefore the analysis for this thermal transient is a TLAA for both pumps.

The HPSI structural integrity and operability analysis compares the temperature difference caused by this transient with the temperature difference calculated using the maximum thermal stress from ASME III Appendix I Figure I-9.2 for 10 cycles. (The pump casings are Type 304 stainless). The calculation found the maximum equivalent temperature difference for the Figure I-9.2 10-cycle stress range S_a to be 1250.58 °F, which is much greater than the design temperature difference of 260 °F. Using the 260 °F design temperature difference, the calculated fatigue stress range S_a is approximately one-fifth of the Figure I-9.2 allowable fatigue stress range S_a for 10 cycles, 640,000 psi:

$$S_{alt} = \Delta T \times 2 \times \alpha \times E = 260 \text{ °F} \times 2 \times (9.53 \times 10^{-6} / \text{°F}) \times (26.85 \times 10^6 \text{ lbf/in}^2)$$

$$S_{alt} = 133,058 \text{ psi}$$

Where α is the thermal coefficient of expansion and E is the elastic (Young's) modulus. Applying the NB-3222.4(e)(4) rule for the effect of the elastic modulus,

$$S_a = S_{alt} \times E_{I-9.2} / E = 133058 \text{ psi} \times 26.0 / 26.85 = 128,846 \text{ psi}$$

For this alternating stress range, ASME III Appendix I Figure I-9.2 allows approximately 550 operating cycles, compared to the 10 assumed to be required by the HPSI pump design

basis. Therefore sufficient margin exists to support the period of extended licensed operation.

The LPSI pump structural integrity and operability analysis analyzed this transient and found 23,500 allowable cycles and a usage factor of 0.000426 for 10 cycles. Therefore sufficient margin exists to support the period of extended operation.

70°F to 350°F Transient – 500 Cycles

This thermal transient corresponds to the initiation of shutdown cooling. Analysis of the LPSI pump for this transient is cycle based, and is therefore supported by a TLAA.

The LPSI pump structural integrity and operability analysis analyzed this transient and found 18,000 allowable cycles and a usage factor of 0.0278 for the design basis 500 cycles. Therefore sufficient margin exists to support the period of extended operation.

Disposition: Validation, 10 CFR 54.21(c)(1)(i)

There is sufficient margin in the design of these pumps for any possible increase in operating cycles above the original estimate. The design of the HPSI and LPSI pumps is therefore valid for the period of extended operation, in accordance with 10 CFR 54.21(c)(1)(i).

4.3.2.12 Class 1 Analysis of Class 2 Main Steam Safety Valves

Summary Description

The Main Steam Safety Valves (MSSVs) are Dresser Model 3707R, 6 inch inlet by 10 inch outlet, ASME III Class 2 (1974 S '75). However, the design of these Class 2 valves includes a Class 1 fatigue analysis to Subsubarticle NB-3550, "Cyclic Loads for Valves." The cyclic design basis is described in the UFSAR. The fatigue analysis is therefore a TLAA.

Analysis

The MSSVs were specified for a stated number of design transients without failure or malfunction [UFSAR 5.2.2.4.3.2]:

Table 4.3-10 - PVNGS Main Steam Safety Valve Cyclic Design Criteria

Type	Description	Design Basis Number of Cycles
Loss of secondary pressure	Temperature falls from 565 to 75 °F in 60 seconds	5
Secondary side leak test	Pressure rises from 0 to 1375 psig, Temperature rises from 100 to 200 °F	200

Table 4.3-10 - PVNGS Main Steam Safety Valve Cyclic Design Criteria

Type	Description	Design Basis Number of Cycles
Normal plant variations	Step change ± 10 °F from 553 °F	10^6
Plant heatup and cooldown ¹	Temperature rises from 75 to 565 °F and returns to 75 °F at 100 °F/hr with pressures at saturation	500
Hydrostatic test	System is pressurized to 1.5 times the set pressure at 100 °F to 200 °F	10, plus number of hydros before shipment
Turbine trip test	Opening and closing cycles with full-range stem movement	480

¹ Heatup and cooldown are separate transients, each beginning at steady state conditions.

The analysis was performed on two critical areas of the valves, the inlet crotch and the disc, with these results:

$$\text{Inlet Crotch: } I_t = 205/2000 \approx 0.11 < 1.0$$

$$\text{Disc: } U = 745/9500 \approx 0.08 < 1.0$$

Disposition: Validation, 10 CFR 54.21(c)(1)(i)

The existing analysis demonstrates that the design is suitable for at least nine of the original 40-year design lifetimes. The analysis is therefore valid for the period of extended operation, in accordance with 10 CFR 54.21(c)(1)(i).

4.3.2.13 Absence of TLAA's in Evaluations of Effects of Vibration on the Unit 1 Train A Shutdown Cooling System Suction Line Fatigue Analysis, and of Vibration Limits Established for its Isolation Valve Actuator

This section describes evaluations of high vibration of the Unit 1 Train A shutdown cooling (SDC) suction line and of the actuator of its UV651 motor-operated isolation valve. See [Section 4.3.2.7](#) for fatigue effects of design basis thermal and pressure transients in this piping.

Vibration can cause high-cycle fatigue failures if the resulting alternating stresses exceed the endurance limit, or the limits established by test or by other analyses for affected components. Fatigue in the affected piping, and effects on the SDC isolation valve actuator of vibration in excess of levels to which it had been tested and analyzed, were therefore

Section 4
TIME-LIMITED AGING ANALYSES

principal concerns in the evaluation of this problem. These evaluations were therefore examined to confirm that they include no TLAAs.

On March 18, 2006, PVNGS conducted a test to diagnose causes of high vibration in the Unit 1 Train A SDC suction line. The Train A SDC suction line is connected to the Loop 1 hot leg. This test operated both Loop 1 reactor coolant pumps but only one Loop 2 pump. This condition produced high Loop 1 flow, which caused brief excursions of an SDC Train A vibration monitor beyond both the administrative and analytical limits. A trip of a Loop 2 pump, under normal, four-pump operating conditions, could produce the same flow conditions and the same elevated vibration levels in the SDC line; and at these vibration levels, the time required for operator action to shut down the unit might result in unacceptable fatigue usage and eventual failure of the piping or isolation valve motor operator. Loop 1 was therefore restricted to single-pump operation, and the unit was maintained in a shutdown condition for evaluation and correction of the vibration condition.

The correction included moving the Unit 1 UV651 valve inboard, to increase the acoustic response above the line and valve resonance. Unit 1 has since operated at 100 percent power with acceptable vibration levels. APS has since moved the corresponding valves in Units 2 and 3 to prevent similar problems.

Absence of TLAAs

The evaluation of affected piping, supports, and piping components determined that maintaining vibration below the administrative limit would maintain alternating stresses below the endurance limit at the most limiting location. The evaluation of the UV651 valve actuator determined that maintaining vibration below the administrative limit would maintain accelerations below the revised vibration limits established for the actuator for indefinite, continuous operation. These evaluations are therefore not time-limited and are therefore not TLAAs. The evaluations of the piping and valve operator for effects of having exceeded the vibration administrative limit during the test determined that this single event did not produce unacceptable damage. Since these evaluations did not qualify either piping or valve for any similar excursions during the remaining life of the plant, these evaluations are not time-limited and are therefore not TLAAs.

4.3.2.14 High Energy Line Break Postulation Based on Fatigue Cumulative Usage Factor

Summary Description

Break locations are determined in accordance with Branch Technical Position MEB 3-1. However, a leak-before-break analysis (LBB) eliminated the large breaks in the main reactor coolant loops. See [Section 4.3.2.15 below](#).

Analysis

Breaks in piping with ASME III Class 1 fatigue analyses are identified based on cumulative usage factor (with the stated exception of the reactor coolant system primary loops), and these determinations are therefore TLAAs.

PVNGS has containment penetration break exclusion regions (no break zones). However these contain no ASME III Class 1 piping with fatigue analyses, and their qualification is therefore based only on calculated stress. The break locations in these no break zones are therefore independent of time and are not supported by a TLAA.

Disposition: Aging Management, 10 CFR 54.21(c)(1)(iii)

Break locations which depend on usage factor will remain valid as long as the calculated usage factors are not exceeded. The Metal Fatigue of Reactor Coolant Pressure Boundary program ensures that appropriate reevaluation or other corrective actions are initiated if an action limit is reached. Action limits for the HELB design basis permit completion of corrective actions before the calculated design basis usage factors in Class 1 lines (outside the reactor coolant system primary loops) is exceeded. Effects of fatigue on the HELB analysis will thereby be managed for the period of extended operation, in accordance with 10 CFR 54.21(c)(1)(iii).

The Metal Fatigue of Reactor Coolant Pressure Boundary program is described in [Section 4.3.1](#); and is summarized in Appendix B, [Section B3.1](#). See [Section 4.3.1.5](#) for details of the program, and [Table 4.3-4](#) for details of its action limits and corrective actions.

4.3.2.15 Absence of TLAAs in Fatigue Crack Growth Assessments and Fracture Mechanics Stability Analyses for the Leak-Before-Break (LBB) Elimination of Dynamic Effects of Primary Loop Piping Failures

Summary Description

A leak-before-break analysis eliminated the large breaks in the main reactor coolant loops, which permitted omission of evaluations of their jet and pipe whip effects. This permitted omission of large jet barriers and whip restraints. The containment pressurization and equipment qualification analyses retained the large-break assumptions.

The NRC approval of this use of leak-before-break at PVNGS was granted with the original SER, Ref. 5, Supplement 11, §3.6.2.

Analysis

The PVNGS LBB analysis is based on the CESSAR LBB analysis, which is based on the Combustion Engineering Report *Basis for Design of Plant Without Pipe Whip Restraints*, which provided the technical basis for eliminating ruptures of the large reactor coolant piping as a design basis for CE System-80 plants. PVNGS was the prototype, and PVNGS material test data support this study.

Fatigue Crack Growth Analysis (not a TLAA)

The supporting fatigue crack growth analyses are not TLAA's. The principal basis for the safety determination is a fatigue crack growth analysis that confirms that even large postulated cracks grow slowly, even beyond the point at which they become through-wall and begin to leak fast enough that the leak will be detected, and before which catastrophic failure can occur. This evaluation does not depend on the design life.

Fracture Mechanics Stability Analyses (not a TLAA)

LBB at PVNGS is supported by both linear elastic fracture mechanics (LEFM) analyses and elastic-plastic fracture mechanics (EPFM) stability analyses. Neither of them is a TLAA.

An LEFM analysis compares a crack stress intensity K_I calculated for the applied load to the K_{IC} fracture toughness stress intensity factor of the material. If K_I is less than K_{IC} the crack is stable and will not propagate.

If that does not suffice, an EPFM stability analysis compares the crack tip extension energy integral J_{app} calculated for the applied load to the material crack resistance parameter J_{IC} (in the Combustion Engineering documents, J_{IN} in later usage elsewhere). If the calculated J -integral for an applied load is less than J_{IN} ($J_{app} < J_{IC}$), the crack is stable.

If that does not suffice, the crack is still stable if load distribution and shedding cause J_{app} to increase less rapidly than J_{IC} with crack extension. That is, if

$$\frac{\partial J_{app}}{\partial a} < \frac{\partial J_{IC}}{\partial a}$$

—where a is the crack extension, the crack is stable. This is described in terms of a dimensionless tearing modulus

$$T \equiv \frac{\partial J}{\partial a} \frac{E}{\sigma_y^2}$$

—where E is Young's modulus and σ_y is the yield strength. If the tearing modulus T_{app} calculated for the applied load is less than the material tearing modulus T_{mat} the crack is stable.

The only phenomena that have significant effects on the results of these stability analyses are those that produce changes in (1) material properties, or (2) to the expected and assumed state of stress due to (2a) piping and component geometry, or (2b) changes in pressure, thermal, dynamic, or applied loads. Changes in the state of stress have been evaluated, as appropriate, for power uprate and steam generator replacement, but are not themselves time dependent. Changes in primary loop geometry (i.e., due to erosion or corrosion, in the absence of modifications) are insignificant.

The only phenomena that produce significant changes in the K_{IC} , J_{IC} , and T_{mat} material properties of primary loop materials during a normal operating life are neutron embrittlement, which does not affect these materials remote from the reactor vessel beltline, and thermal embrittlement, which is significant only in cast austenitic stainless steel with certain compositions. There is no cast reactor coolant piping at PVNGS. PVNGS primary loops are SA 516 Grade 70 (low-alloy carbon steel), and are therefore not subject to significant thermal embrittlement.

Therefore neither K_{IC} , J_{IC} , nor T_{mat} depend on the design life. Similarly, K_I , J_{app} , and T_I all depend only on the assumed set of applied loads, independent of fatigue effects, and are not time-dependent. Therefore neither of the CESSAR LEFM or EPFM analyses is a TLAA.

Effects of Power Uprate and Steam Generator Replacement on the LBB Analysis

Effects of Power Uprate and Steam Generator Replacement have been evaluated and resulted in no change to the conclusion of the LBB analysis.

4.3.3 Fatigue and Cycle-Based TLAAs of ASME III Subsection NG Reactor Pressure Vessel Internals

Summary Description

The PVNGS reactor vessel internals were designed and fabricated to Subsection NG rules of ASME III, 1974 Edition. The design reports indicate use of some later addenda for some parts.

Reactor Internals Design Bases

The reactor internals design bases are to maintain a coolable geometry that also allows control element assembly (CEA) function. For this purpose, deflections which would influence CEA movement are limited to less than 80% of that which might cause loss of function under design basis loading conditions.

The licensing basis descriptions of the design evaluations and analyses indicate that “fatigue limits” in some contexts are endurance limits, therefore do not depend on the number of applied cycles, and are therefore not TLAAs. However the ASME Subsection NG fatigue analyses of elements of the reactor internals are TLAAs.

Analysis

Evaluations and Analyses Described in the CESSAR and UFSAR

The CESSAR and UFSAR describe several evaluations and analyses that have been performed to ensure that the reactor vessel internals will withstand forces resulting from design loading conditions.

Section 4
TIME-LIMITED AGING ANALYSES

Dynamic Response Analysis of Reactor Internals Under Operational Flow Transients and Steady-State Conditions (UFSAR § 3.9.2.3)

Flow-induced vibration of the reactor internals components during normal operation can be characterized as a forced response to both deterministic (periodic and transient) and random pressure fluctuations in the coolant. This section of the UFSAR describes types of internals, the forces they are subjected to, and the mathematical models used to predict the response of the reactor internals to these forces. However, this section does not describe an analysis of fatigue or other time-limited effects for a licensed operating period, and therefore does not indicate the existence of a TLAA.

Preoperational Flow-Induced Vibration Testing of Reactor Internals (UFSAR § 3.9.2.4)

This section of the UFSAR describes the program phases which satisfy the guidelines of Regulatory Guide 1.20. However, this section does not describe an analysis of fatigue or other time-limited effects for a licensed operating period, and therefore does not indicate the existence of a TLAA.

Dynamic System Analysis of the Reactor Internals Under Faulted Conditions (CESSAR § 3.9.2.5 and UFSAR § 3.9.2.5)

CESSAR Section 3.9.2.5 (NUREG-0852) describes the dynamic analysis methods for reactor internals.

UFSAR Section 3.9.2.5 describes how the stresses of the reactor internals were calculated, and states that the stresses are below the allowable stresses for faulted conditions of the ASME B&PV Code, Section III, Appendix F. However, this section does not describe an analysis of fatigue or other time-limited effects for a licensed operating period, and therefore does not indicate the existence of a TLAA.

Evaluation of High-Cycle Hydraulic Loads with Reduced Cold Leg Temperature

An evaluation of reduction in the reactor coolant cold leg temperature from 500 °F to 450 °F (with four reactor coolant pumps in operation) demonstrated that the resulting hydraulic high-cycle loads on internals are acceptable and within the limits of the existing design. The acceptability of high-cycle loads is not based on time-dependent criteria.

Effects and Analyses Described in Power Uprate and Steam Generator Replacement Licensing Documents

The power uprate and steam generator replacement reports state that the fatigue evaluations of the RVI components were based on the fatigue curve provided in the ASME Code, and provide acceptable results in all cases. These fatigue evaluations are included in design report addenda.

The reports also state that uprate did not increase flow-induced vibration loads on vessel internals, because RCS flow remains within the original design range, but also state that

“Vibration evaluations demonstrate that the new RCS conditions will not adversely affect the response of the RVIs systems and components to flow induced vibrations.” However, a search for these vibration evaluations has only located references describing the methods of analysis, not the evaluations themselves. The subsequent license amendment shows that the final form of the commitments for these “vibration evaluations” are to continue cooperation with joint industry efforts, and therefore that the safety determination depends on no new or additional vibration evaluations.

Summary of Vibration and Other High-Cycle Effects

The evaluations of internals designs to stress and deflection limits, and tests to confirm that vibration endurance limits are not exceeded, do not depend on the design life and are therefore not TLAAs. The final licensing basis safety determination for the effect of power uprate and steam generator replacement on these evaluations relies on no analyses that depend on the design life, and therefore on no TLAAs, but on the licensee’s commitment to continue support and cooperation with industry initiatives to manage effects of vibration and other possible age-related degradation mechanisms in internals.

ASME Subsection NG Fatigue Analyses

The ASME Subsection NG design reports and addenda include calculated usage factors for the reactor internal components. The report addenda for power uprate and steam generator replacement concluded that all code and specification requirements were satisfied.

Absence of TLAAs for Ductility Reduction of Fracture Toughness for the Reactor Vessel Internals

Table 4.1 3 of the NUREG 1800 *Standard Review Plan for License Renewal* identifies “ductility reduction of fracture toughness for the reactor vessel internals” as a potential plant-specific TLAAs. However, a review of the PVNGS licensing basis found no explicit 40-year embrittlement analysis for reactor vessel internals.

Disposition: Aging Management, 10 CFR 54.21(c)(1)(iii)

Since the Subsection NG fatigue usage factors do not depend on flow-induced vibration or other high-cycle effects that are time-dependent at steady-state conditions, but depend more strongly on effects of operational, upset, and emergency transient events, the increase in operating life to 60 years will not have a significant effect on these fatigue usage factors so long as the number of design basis transient cycles remains within the number assumed by the original analysis. Transient cycle counting under the Metal Fatigue of Reactor Coolant Pressure Boundary program will ensure that appropriate reevaluation or other corrective action is initiated if an action limit is reached in any analyzed location in the reactor internals. Action limits will permit completion of corrective actions before the design basis number of events is exceeded. Subsection NG fatigue in the reactor vessel internals will therefore be adequately managed for the period of extended operation, in accordance with 10 CFR 54.21(c)(1)(iii).

The Metal Fatigue of Reactor Coolant Pressure Boundary program is described in [Section 4.3.1](#); and is summarized in Appendix B, [Section B3.1](#). See [Table 4.3-4](#) for details of the program, and [Section 4.3.1.5](#) for a description of its action limits and corrective actions.

4.3.4 Effects of the Reactor Coolant System Environment on Fatigue Life of Piping and Components (Generic Safety Issue 190)

Summary Description

The fatigue data upon which the ASME Section III fatigue curves are based are the result of tests in air at room temperature and constant strain rate. Concerns with possible effects of elevated temperature, reactor coolant chemistry environments, and different strain rates prompted NRC-sponsored research to assess these effects, first presented in the 1993 NUREG/CR-5999 Interim Fatigue Curves.

The NRC concluded that effects of the reactor coolant environment might need to be included in the calculated fatigue life of components, and opened three generic safety issues to address this question, all finally closed to a single Generic Safety Issue 190. Subsequent research and studies refined the methods, which no longer use the interim fatigue curves of NUREG/CR-5999 but calculate an environmental fatigue effect multiplier F_{en} , which depends on material type, temperature, strain rate, and dissolved oxygen; and for carbon and low-alloy steel, sulfur content.

NUREG-1800 Section 4.3.1.2 states that "The applicant's consideration of the effects of coolant environment on component fatigue life for license renewal is an area of review," noting the staff recommendation "that the samples in NUREG/CR-6260 should be evaluated considering environmental effects for license renewal."

The GSI-190 review requirements are therefore imposed by the Standard Review Plan and do not depend on the individual plant licensing basis.

Analysis

NUREG/CR-6260 identifies seven sample locations for newer Combustion Engineering plants:

- Reactor vessel shell and lower head
- Reactor vessel inlet nozzles
- Reactor vessel outlet nozzles
- Surge line
- Charging system nozzle

- Safety injection system nozzle
- Shutdown cooling line.

The thermal sleeves were removed from the PVNGS Loop 1 and Loop 2 safety injection nozzles, potentially increasing the cumulative usage factor (CUF) for the entire interior surface of the nozzle. Therefore two values were calculated for the safety injection nozzles, at the knuckle location and at the safe end. [Table 4.3-11](#) therefore includes both of these locations.

[Table 4.3-11](#) also includes results for the pressurizer heater penetrations. Although NUREG/CR-6260 does not identify the heater penetrations as locations of concern, they may be subject to effects of thermal stratification and insurge-outsurge, have been subject to significant repair, modification, and reanalysis, and accumulation of fatigue usage in them is therefore of concern for the period of extended operation. APS has therefore elected to include them in locations monitored for effects of environmentally-assisted fatigue. The calculated CUF at the heater penetrations is acceptable using the maximum F_{en} . However, the analysis does not specifically account for loads due to insurge-outsurge transients. This loading will be monitored by the Fatigue Management Program using the stress-based fatigue (SBF) method described in [Section 4.3.1](#).

APS therefore evaluated a total of nine NUREG/CR-6260 locations for effects of the reactor coolant system environment on fatigue life (or “environmental effects on fatigue,” EAF). See [Table 4.3-11](#) for the resulting environmentally-assisted fatigue CUFs at these EAF locations.

Removing Conservatism

Section 6.4 of NUREG/CR-6260 advises that conservative assumptions remain which could be removed to reduce the CUF values. The best method to lower the CUF for the few worst locations is fatigue monitoring. By using actual numbers of cycles and severity of transients, the calculated CUF can be reduced sufficient to meet the 1.0 allowable, with EAF, without resorting to more detailed analysis methods. However, in some cases, a combination of fatigue monitoring and revised analyses may be needed.

Locations with EAF $U_{40} < 1.0$ Based on Max F_{en}

Five of the locations (1) RPV Shell and Lower Head, (2) RPV Inlet Nozzle, (3) RPV Outlet Nozzle, (6) Safety Injection Nozzle (Forging Knuckle), and (9) Pressurizer Heater Penetrations, have environmentally-assisted fatigue CUF values below 1.0 when the 40-year design CUF is multiplied by the maximum applicable F_{en} for the material, from NUREG/CR-6583 for carbon and low-alloy steels and from NUREG/CR-5704 for stainless steels.

The environmentally-assisted CUF at Location 1, RPV shell and lower head, projected for 60 years, is much lower than the ASME fatigue limit of 1.0, will therefore remain valid for the period of extended operation, and no monitoring will be required. The remaining eight

NUREG/CR-6260 locations will be monitored for either transient cycles or fatigue. See [Table 4.3-4](#) for monitoring methods.

Locations Re-evaluated with NB-3200 Methods

The remaining four EAF locations have been evaluated using NB-3200 methods to reduce the CUF values. Three of these evaluations also used reduced estimates of the number of design basis transient events, based on plant-specific cycle accumulation data:

Shutdown Cooling Line (Long Radius Elbow, Location 8): The shutdown cooling line long-radius elbow has been re-evaluated using plant-specific transient data. The revised analysis reduced the CUF by reducing the assumed number of transient cycles for 40 years and 60 years based on plant-specific cycle accumulation data. The reduced number of transient cycles will be used to set action limits in the Fatigue Management Program. See [Section 4.3.1.5](#) for a discussion of corrective action limits and corrective actions.

The maximum F_{en} from NUREG/CR-5704 for stainless steels was used. The resulting 40-year and 60-year environmentally-assisted fatigue CUFs are less than the ASME code allowable fatigue limit of 1.0.

This location will be monitored using the cycle-based fatigue, event pairing (CBF-EP) method described in [Section 4.3.1](#).

Charging System Nozzle (Safe End, Location 5): In order to demonstrate that fatigue usage, including environmental effects, can be maintained less than 1.0, the charging nozzle safe end has been evaluated for a plant-specific reduced number of cycles for transient pairs with a significant contribution to fatigue. The reduced number of transient cycles is based on plant-specific cycle accumulation data and will be used to set action limits in the Fatigue Management Program. See [Section 4.3.1.5](#) for a discussion of corrective action limits and corrective actions.

The method uses 6-component stress tensors and plant-specific transient data, consistent with ASME III subarticle NB-3200, for all fatigue-significant design transients. These stress intensities were used to calculate a revised CUF value.

Strain-rate-dependent F_{en} values were then calculated for the significant load set pairs in the fatigue analysis. Load set pairs that produce no significant stress range or fatigue contribution were assigned the maximum F_{en} from NUREG/CR-5704 for stainless steels. The integrated strain rate method described in MRP-47 was used to calculate F_{en} values for individual load pairs that produce significant stress ranges. Each of these significant load pair transients was divided into appropriate time steps, and the stress intensity was used to calculate strain amplitude for each time step. This strain amplitude was then used to determine the strain rate over each time step. The strain rate is used to calculate the F_{en} for the time step; and from these, an integrated weighted F_{en} for the entire load pair transient was calculated. These significant-stress-range F_{en} were then combined with the maximum F_{en} assumed for the less-significant events to produce a weighted average F_{en} for the

Section 4 TIME-LIMITED AGING ANALYSES

component. Multiplying the revised design CUF by the weighted average F_{en} value resulted in a 40-year environmentally-assisted fatigue CUF less than the ASME code allowable fatigue limit of 1.0.

This location will also be monitored using the cycle-based fatigue, event pairing (CBF-EP) method described in [Section 4.3.1](#).

Safety Injection Nozzle (Safe End, Location 7): Fatigue usage at the safety injection nozzle safe end, including environmental effects, has been re-evaluated using the design basis number of transient cycles.

The method is the same as described above for the charging nozzle safe end. It uses 6-component stress tensors and plant-specific transient data, consistent with ASME III Subarticle NB-3200, for all fatigue-significant design transients. These stress intensities were used to calculate a revised CUF value.

Strain-rate-dependent F_{en} values, calculated by the MRP-47 integrated strain rate method for the significant load set pairs, were combined with the assigned maximum F_{en} from NUREG/CR-5704 for stainless steels, for the less significant load set pairs, to produce a weighted average F_{en} for the component. Multiplying the revised design CUF by the weighted average F_{en} resulted in a 40-year environmentally-assisted fatigue CUF above the ASME code allowable fatigue limit of 1.0.

This location will be monitored using the cycle-based fatigue, partial cycle (CBF-PC) method described in [Section 4.3.1](#).

Pressurizer Surge Line (Hot Leg) Elbow (Location 4): Combustion Engineering (CE) performed a fatigue evaluation of surge lines in various CE Owners Group (CEOG) plants, with thermal stratification loading. The analysis assumed the design basis number of 500 heatup transients. The elastic analysis produced a cumulative usage factor of 1.65 in the comparable (and more limiting) surge line pressurizer elbow. To decrease the CUF below the ASME fatigue limit of 1.0, CE then performed a plastic analysis resulting in a limiting CUF of 0.937 in the pressurizer elbow. APS confirmed this bounding analysis as the fatigue analysis of record for this component at PVNGS. See [Section 4.3.2.9](#).

To evaluate effects of the reactor coolant environment, APS re-evaluated the CUF in the pressurizer surge line hot leg elbow using design basis transient cycles and ASME Subsection NB-3200 6-component stress tensors. The elastic analysis produced a CUF of 1.9396, which is above the ASME code allowable fatigue limit of 1.0. This result is consistent with the CUF of 1.65 in the pressurizer elbow from the CE elastic analysis. The CE plastic analysis is more precise than the APS reevaluation; however, the APS hot leg elbow reevaluation will not be refined further because (1) fatigue will be monitored by the Fatigue Management Program, and (2) actual fatigue usage (without F_{en}) should be less than calculated, for the following reason:

Section 4 TIME-LIMITED AGING ANALYSES

The design basis transient events that contribute most to fatigue usage are plant heatup and plant cooldown (startup and shutdown). The design basis assumes 500 of these events; but the composite worst-case unit 2005 accumulation of the heatup-cooldown transient recorded in 73ST-9RC02 is only 64 cycles, projected to reach about 213 cycles in 60 years. Therefore, based on the actual cycle accumulation rate, the projected 60-year CUF without environmental effects is expected to be only about 0.83, based on the 1.9396 elastic reanalysis result.

The maximum F_{en} from NUREG/CR-5704 for stainless steels was used in lieu of the more detailed integrated strain rate approach, because the stratification loads which govern the fatigue calculation do not occur over transient periods that permit calculation of integrated F_{en} values. Multiplying the re-evaluated CUF by the maximum F_{en} resulted in an environmentally-assisted CUF above the ASME code allowable fatigue limit of 1.0, as shown in [Table 4.3-11](#).

Fatigue usage at this location will be monitored using the stress-based fatigue (SBF) method described in [Section 4.3.1](#). This method more closely approximates the actual severity of events as they occur. Therefore, fatigue usage at this location will be adequately monitored and appropriate corrective action limits will permit completion of corrective actions before the cumulative usage factor, including environmental effects, exceeds the ASME fatigue limit of 1.0.

The pressurizer surge line pressurizer elbow will be monitored in lieu of the pressurizer surge line hot leg elbow specified in NUREG/CR-6260. The Combustion Engineering pressurizer surge line flow stratification analysis has shown that the pressurizer elbow has the limiting fatigue usage in the surge line, when calculated on a common basis. The hot leg elbow location experiences the same transients, has essentially the same geometry, and is made of the same material as the pressurizer elbow. Because fatigue is more severe in the pressurizer elbow and because of the similarities to the hot leg elbow, monitoring the pressurizer elbow using the SBF method will accurately indicate the fatigue usage in both locations.

If the monitored pressurizer elbow location reaches the corrective action limit set by the Fatigue Management Program, it will be assumed that the hot leg elbow location has also reached the same action limit. The same corrective actions will be performed for both elbows. See [Section 4.3.1.5](#) for a discussion of corrective action limits and corrective actions.

Section 4
TIME-LIMITED AGING ANALYSES

Table 4.3-11 - Summary of Fatigue Usage Factors at NUREG/CR-6260 Sample Locations, Adapted to PVMNGS

Location	Material	CUF Basis	CUF, U ₄₀	F _{en}	EAF U ₄₀ with F _{en}	EAF U ₆₀ with F _{en}
1. RPV Shell and Lower Head	SA-533, Grade B, Class 1, Low Alloy Steel	40-year design cycles and maximum F _{en}	0.0012	2.455	0.003	0.0045 ⁽¹⁾
2. RPV Inlet Nozzle	SA-508, Class 2, Low Alloy Steel	40-year design cycles and maximum F _{en}	0.072	2.455	0.177	0.177 ⁽²⁾
3. RPV Outlet Nozzle	SA-508, Class 2, Low Alloy Steel	40-year design cycles and maximum F _{en}	0.289	2.455	0.710	0.710 ⁽²⁾
4. Surge Line (Hot Leg) Elbow	SA-376, Type 316, Stainless Steel	Plant-specific cycle projections and maximum F _{en}	1.9396 ⁽³⁾	15.35	29.77	29.77 ^(2,4,5)
5. Charging System Nozzle (Safe End)	SA-182, Type 316, Stainless Steel	Plant-specific cycle projections and strain-rate-dependent F _{en}	0.15534 ⁽⁶⁾	6.391 ⁽⁷⁾	0.9927	0.9927 ⁽²⁾
6. Safety Injection Nozzle (Forging Knuckle)	SA-182, Grade F1, Stainless Steel	40-year design cycles and maximum F _{en}	0.0287	2.455	0.070	0.070 ⁽²⁾
7. Safety Injection Nozzle (Safe End)	SA-182, Type 316, Stainless Steel	40-year design cycles and strain-rate-dependent F _{en}	0.6930 ⁽⁸⁾	3.042 ⁽⁹⁾	2.108	2.108 ^(2,5)
8. Shutdown Cooling Line (Long Radius Elbow)	SA-182, Type 316, Stainless Steel	Plant-specific cycle projections and maximum F _{en}	0.0344	15.35	0.529 ⁽¹⁰⁾	0.789 ⁽¹⁰⁾
9. Pressurizer Heater Penetrations (Not NUREG/CR-6260 locations)	Alloy 600/690 Inconel	40-year design cycles and maximum F _{en}	0.633	1.49	0.943	0.943 ⁽²⁾

¹ The 40-year CUF is sufficiently low to permit validation of the 60-year CUF by multiplying by 1.5.

² The 40-year design basis number of transient cycles is not expected to be exceeded in 60 years; therefore the 40-year environmentally-assisted fatigue CUF is sufficient for 60 years.

- ³ The pressurizer surge line hot leg elbow re-analysis determined stress intensity ranges using 6-component stress tensors and the design basis number of transient cycles to produce this CUF value.
- ⁴ This EAF U_{40} and U_{60} value is very conservative. See the discussion on page 4.3-80.
- ⁵ Action limits will prompt corrective actions before the limit of 1.0 is reached at this location.
- ⁶ The charging nozzle safe end re-analysis determined stress intensity ranges using 6-component stress tensors and an assumed number of cycles based on the current accumulation rate to produce this CUF value.
- ⁷ The charging nozzle safe end re-analysis computed F_{en} values for load set pairs with a significant fatigue contribution; all remaining load set pairs were assigned the maximum F_{en} values for the appropriate material.
- ⁸ The safety injection nozzle safe end re-analysis determined stress intensity ranges using 6-component stress tensors and the design basis number of cycles to produce this CUF value.
- ⁹ The safety injection nozzle safe end re-analysis computed F_{en} values for load set pairs with a significant fatigue contribution, all remaining load set pairs were assigned the maximum F_{en} values for the appropriate material.
- ¹⁰ The shutdown cooling line elbow re-analysis determined that, based on the current rate of cycle accumulation, the 40-year projection of cycles is 31% of the design assumption. Therefore, the design CUF of 0.1118 was reduced to 31% then multiplied by the F_{en} value to determine the 40-year environmentally-assisted fatigue CUF. Similarly, the 60-year projection of cycles is 46% of the design assumption. Therefore, the design CUF of 0.1118 was reduced to 46% then multiplied by the F_{en} value to determine the 60-year environmentally-assisted fatigue CUF.

Disposition: Validation, 10 CFR 54.21(c)(1)(i); and Aging Management, 10 CFR 54.21(c)(1)(iii)

APS performed plant-specific calculations for the seven sample locations applicable to PVNGS identified in NUREG/CR-6260 for newer Combustion Engineering plants. APS has also performed calculations for the safety injection nozzle forging knuckle and the pressurizer heater penetrations, as identified in [Table 4.3-11](#).

Validation

The evaluation of environmental fatigue effects in the RPV shell and lower head location found that the CUF will remain below the ASME code allowable fatigue limit of 1.0 using the maximum applicable F_{en} , when extended to 60 years. The evaluation of fatigue effects in this location has thereby been validated for the period of extended operation, in accordance with 10 CFR 54.21(c)(1)(i), including effects of the reactor coolant environment.

Aging Management

The remainder of these locations will be monitored for fatigue usage including environmental effects by the Metal Fatigue of Reactor Coolant Pressure Boundary program. Appropriate action limits will permit reevaluation or completion of other corrective actions before the cumulative usage factor, including F_{en} , exceeds the ASME fatigue limit of 1.0.

Therefore, the effects of the reactor coolant environment on fatigue usage factors in the RPV inlet nozzle, RPV outlet nozzle, shutdown cooling line long radius elbow, charging nozzle safe end, safety injection nozzle forging knuckle, safety injection nozzle safe end, and the pressurizer heater penetrations will be managed for the period of extended operation in accordance with 10 CFR 54.21(c)(1)(iii).

The pressurizer surge line pressurizer elbow will be used to monitor fatigue in both this location and in the pressurizer surge line hot leg elbow. The same corrective action limits and corrective actions will be applied to both locations. Fatigue in both elbows, including effects of the reactor coolant environment, will thereby be adequately managed for the period of extended operation in accordance with 10 CFR 54.21(c)(1)(iii).

The Metal Fatigue of Reactor Coolant Pressure Boundary program is described in [Section 4.3.1](#); and is summarized in Appendix B, [Section B3.1](#). See [Table 4.3-4](#) for details of the program, and [Section 4.3.1.5](#) for a description of its action limits and corrective actions.

4.3.5 Assumed Thermal Cycle Count for Allowable Secondary Stress Range Reduction Factor in ANSI B31.1 and ASME III Class 2 and 3 Piping

Summary Description

None of ANSI B31.1 or the ASME III Subsections NC and ND for Class 2 and 3 piping invokes fatigue analyses. However, piping in the scope of license renewal that is designed to these codes requires the application of a stress range reduction factor (SRRF) to the allowable stress range for secondary stresses (expansion and displacement) to account for thermal cycling. The allowable secondary stress range is $1.0 S_A$ for 7000 equivalent full-range temperature cycles or less, and is reduced in steps to $0.5 S_A$ for greater than 100,000 cycles. Partial cycles are counted proportional to their temperature range.

These piping analyses are TLAAAs because they are part of the current licensing basis, are used to support safety determinations, and depend on an assumed number of thermal cycles that can be linked to plant life.

Analysis

PVNGS Piping

The EPRI license renewal *Non-Class 1 Mechanical Implementation Guideline and Mechanical Tools* [Ref. 16] includes temperature screening criteria to identify components that might be subject to significant thermal fatigue effects. Normal and upset operating temperatures less than 220 °F in carbon steel components, or 270 °F in stainless steel, will not produce significant thermal stresses, and will not therefore produce significant fatigue effects. A systematic survey of all plant piping systems found that with the exception of reactor coolant sampling lines and the steam generator downcomer and feedwater recirculation lines described in this section, the piping and components within the scope of license renewal:

- Do not meet the operating temperature screening criteria of the EPRI *Mechanical Tools*, and therefore do not experience significant thermal cycle stresses; or
- Clearly do not operate in a cycling mode that would expose the piping to more than three thermal cycles per week, i.e. to more than 7,000 cycles in 60 years; or
- The assumed thermal cycle count for the analyses depends closely on reactor operating cycles, and can therefore conservatively be approximated by the thermal cycles used in the ASME III Class 1 vessel and piping fatigue analyses.

For this last case, see the reactor coolant system thermal cycles listed in [Table 4.3-3](#). Of these, those likely to produce full-range thermal cycles in balance-of-plant Class 2, 3, and B31.1 piping, in a 40-year plant lifetime, are the 500 heatup-cooldown cycles plus 240 reactor trips. Other events may contribute a few full-range cycles or a number of part-range cycles, but the total count of expected full-range thermal cycles is under 1000 for a 40-year

plant life. This is true for in-scope balance-of-plant support systems, as well as the CVCS and ECCS piping more directly connected to the reactor system. For a 60-year life the number of thermal cycles for piping analyses would be proportionally increased to less than 1500, which is only a fraction of the 7000-cycle threshold for which a stress range reduction factor is required in the applicable piping codes.

Reactor Coolant Hot Leg Sample Lines

The survey of all plant piping systems found that the reactor coolant sample line used for periodic hot leg samples may be subject to more than 7,000 thermal cycles. APS therefore revised the design analyses for these lines to increase the design basis estimates of the number of sampling events for a 60-year life and to revise the stress analysis for the revised SRRF. The revised analyses estimate 8,273 sampling operations (and therefore the same number of full-range thermal cycles) in a 60-year operating life. The estimate is for the worst of the three units and accounts for actual plant operating time, sampling rates to date, and the sampling rate expected through the period of extended operation. Hot legs were sampled daily into early 2003, weekly thereafter, and weekly sampling is expected to continue for the remainder of plant life. This estimate exceeds 7,000 and therefore required a revision to the stress analyses for a reduction in the SRRF from 1.0 to 0.9. The revised analyses found that stresses in the limiting locations are less than allowable stresses.

Other nuclear sampling lines have been used less frequently than the hot leg sample lines, are therefore not expected to exceed 7,000 cycles in 60 years, and were therefore not reanalyzed.

Steam Generator Downcomer and Feedwater Recirculation Lines

The downcomer and feedwater recirculation line to each steam generator is unique to Combustion Engineering System 80 plants. These lines were designed with an SRRF of 0.9 for 10,224 thermal cycles. The design analysis was therefore revised for a proportional increase in the number of cycles to $1.5 \times 10,224 = 15,336$, for a 60-year design life, requiring an SRRF of 0.8. The revised analysis found that stresses met allowables, and that break locations and break types of the pipe break analysis were unaffected by the reduced allowable stresses.

Disposition: Validation, 10 CFR 54.21(c)(1)(i); and Revision, 10 CFR 54.21(c)(1)(ii)

For less than 7000 equivalent full-temperature thermal cycles the stress range reduction factor is 1. Therefore, so long as the estimated number of cycles remains less than 7000 for a 60-year life, the stress range reduction factor remains at 1 and the stress range reduction factor used in the piping analysis will not be affected by extending the operation period to 60 years.

Validation for Piping Other than Reactor Coolant Hot Leg Sample and Steam Generator Downcomer and Feedwater Recirculation Lines

The number of equivalent full-range thermal cycles for other than the reactor coolant hot leg sample lines and the steam generator downcomer and feedwater recirculation lines will only be about 1500 or less in 60 years, which is only a fraction of the 7000-cycle threshold for which a stress range reduction factor is required in the applicable piping codes. Therefore the existing analyses of piping for which the allowable range of secondary stresses depends on the number of assumed thermal cycles and that are within the scope of license renewal, other than ASME Class 1 analyses, the hot leg sample lines, and the steam generator downcomer and feedwater recirculation lines, are valid for the period of extended operation, in accordance with 10 CFR 54.21(c)(1)(i).

Revision for Reactor Coolant Hot Leg Sample and Steam Generator Downcomer and Feedwater Recirculation Lines

APS revised the design analyses of these lines for appropriate increases in design estimates of expected full-range thermal cycles and for corresponding reductions in SRRF, as described above. The revised analyses demonstrate that stresses remain within allowables, and that pipe break locations and break types determined by the pipe break analysis of the steam generator downcomer and feedwater recirculation lines are unchanged. These analyses have therefore been extended to the end of the period of extended operation, in accordance with 10 CFR 54.21(c)(1)(ii).

4.4 ENVIRONMENTAL QUALIFICATION (EQ) OF ELECTRIC EQUIPMENT

10 CFR 50.49, "Environmental Qualification of Electric Equipment Important to Safety for Nuclear Power Plants," requires that certain electrical and instrument and control equipment located in harsh environments be qualified to perform their safety-related functions in those harsh environments after the effects of inservice aging.

Aging evaluations that qualify components to at least the end of the current licensed operating period are TLAAs. The PVNGS EQ program is described in [UFSAR 3.11](#).

Summary Description

10 CFR 50.49(e)(5) contains provisions for aging that require, in part, consideration of all significant types of aging degradation that can affect component functional capability. 10 CFR 50.49(e)(5) also requires component replacement or maintenance prior to the end of designated life, unless additional life is established through ongoing qualification. 10 CFR 50.49(k) and (l) permit different qualification criteria to apply based on plant vintage. Supplemental Environmental Qualification regulatory guidance for compliance with these different qualification criteria is provided in Regulatory Guide 1.89 Revision 1, *Environmental Qualification of Certain Electric Equipment Important to Safety for Nuclear Power Plants*, and in NUREG-0588, *Interim Staff Position on Environmental Qualification of Safety Related Electrical Equipment*.

All operating plants must meet the requirements of 10 CFR 50.49 for certain electrical and I&C components important to safety. Compliance with 10 CFR 50.49 provides evidence that the component will perform its intended functions during and after a design basis accident after experiencing the effects of inservice aging.

The PVNGS EQ licensing commitments are outlined in [UFSAR Section 3.11.2.2](#). Electrical equipment within the scope of the PVNGS EQ Program is environmentally qualified in accordance with NUREG-0588, Category I as supplemented by 10 CFR 50.49. The NRC evaluated PVNGS electrical equipment qualification based on Regulatory Guide 1.89 Revision 0, which endorses IEEE Standard 323-1974. This is the guidance applicable to NUREG-0588 Category I plants, such as PVNGS, with construction permits after June 30, 1974. At PVNGS the recommendations of Revision 1 to Reg Guide 1.89 are also met, for harsh environments; with some interpretations of and exceptions to the Reg Guide Revision 1 and IEEE 323-1974 guidance, as described in [UFSAR Section 1.8](#).

Analysis

The *Equipment Qualification Program Manual* (EQ-PM) describes history, licensing basis and other requirements, scope, environments, qualification and analysis methods, and program elements.

Section 4
TIME-LIMITED AGING ANALYSES

The list of qualified components or *Equipment Qualification List* (EQL) is a subset of the plant Site Work Management System (SWMS) data base. Components and commodities requiring electrical environmental qualification are identified by controlled EQ category fields. SWMS lists special maintenance requirements; and lists the environmental zones for components, from which environmental limits can be retrieved from the EQ Program Manual.

The qualification evaluation records for specific component types are maintained as *Electrical Equipment Qualification Data Files* (EEQDFs).

Vibration and Seismic Fatigue Considerations

Vibration aging is a required consideration of electrical component qualification and depends on the design life, and is therefore an element of TLAAs managed by the EQ program. Seismic qualification of PVNGS electrical components also assumes a given number of seismic events and stress cycles in a design life, and the seismic qualifications are therefore TLAAs, but the number of seismic events assumed need not be increased for an increase in the licensed operating period.

Seismic qualification of PVNGS electrical equipment addresses the need to model seismic effects for the design basis number of stress cycles, and to test or analyze components for possible low-cycle fatigue in accordance with IEEE 344-1975 Section 5. The qualification method models the entire set of seismic events expected over the design lifetime.

For balance-of-plant equipment, required vibration and seismic fatigue aging for EQ, and evaluation of fatigue under other design codes and standards, both include two operating-basis earthquake (OBE) events followed by one safe shutdown earthquake (SSE).

For NSSS equipment, required fatigue aging for EQ, and evaluation of fatigue under other design codes and standards, both include 200 maximum-range OBE stress cycles. The SSE is not included in the NSSS-scope fatigue analysis.

The PVNGS requirement for two OBE events instead of the five events required by NUREG-0800 Standard Review Plan (SRP) Section 3.7.3 Criterion 2 is justified because:

- a) PVNGS is in an area with a low probability of a significant earthquake.

The SRP requirement is in fact less conservative. The SRP model assumed only 10 maximum stress cycles per event, or 50 cycles for 5 OBEs; but the PVNGS model assumed a 20 Hz response for 24 seconds per event, or 960 cycles for two OBEs. For code fatigue analyses these 960 cycles are also assumed to be at the maximum stress range.

Equipment qualified by test is subject to at least two events of 30 seconds duration, or a total of 1200 full-range cycles, the majority for five events or 3000 cycles.

Since no significant seismic loads have occurred to date, the original seismic qualifications of electrical equipment will be sufficient for the extended licensed operating period.

Effects of Power Uprate and Steam Generator Replacement

Effects of power uprate (PUR) and steam generator replacement have been evaluated and equipment has been requalified as required.

Environmental Qualification Reanalysis Attributes

The EQ program manages applicable component thermal, radiation, and cyclic aging effects through the aging evaluations based on 10 CFR 50.49 for the current operating license using methods of demonstrating qualification for aging and accident conditions established by 10 CFR 50.49(f). Under 10 CFR 54.21(c)(1)(iii), plant EQ programs, which implement the requirements of 10 CFR 50.49 (as further defined and clarified by NUREG-0588 and RG 1.89, Rev. 1), are an aging management program for license renewal. Maintaining qualification through the extended license renewal period requires that existing EQ evaluations (EEQDFs) be re-evaluated. The important attributes of reanalysis include analytical methods, data collection and reduction methods, underlying assumptions, acceptance criteria, and corrective actions (if acceptance criteria are not met).

Analytical Methods: The analytical models used in the reanalysis of an aging evaluation are the same as those previously applied during the prior evaluation. The Arrhenius methodology is an acceptable model for a thermal aging evaluation. The PVNGS program uses the Arrhenius model or an Arrhenius-based equivalent temperature method. Temperature data used in an aging evaluation are conservative based on plant design temperatures, or are revised when actual plant temperature data indicate they are not conservative. For license renewal radiation aging evaluations, 60-year normal radiation dose is established by extrapolating the 40-year normal dose (40-year dose times 1.5) plus accident radiation dose. Cyclical aging is extended to 60 years in a similar manner. Other models may be justified on a case-by-case basis. Seismic aging need not be extended at PVNGS for reasons described above.

Data Collection and Reduction Methods: Reducing excess conservatism in the component service conditions (for example, temperature, radiation, and cycles) used in the prior aging evaluation is the chief method used for a reanalysis. Actual monitored service conditions such as temperature are generally lower than the design service conditions used in the prior aging evaluation and therefore can support extended thermal life of the equipment. The PVNGS Temperature Monitoring Program provides

...actual plant ambient temperature data to validate existing equipment aging analysis assumption[s] and provide the basis for refining qualified life.... This monitoring program [also identifies] any plant areas experiencing elevated temperatures (i.e., hot spots) in response to NRC Information Notice 89-30....

Underlying Assumptions: EQ component aging evaluations contain sufficient conservatism to account for most environmental changes occurring due to plant modifications and events. When unexpected adverse conditions are identified during operational or maintenance activities that affect the normal operating environment of a qualified component, the affected

Section 4
TIME-LIMITED AGING ANALYSES

EQ component is evaluated and appropriate corrective actions are taken, which may include changes to the qualification bases and conclusions.

Excess conservatism in thermal life analysis may be reduced by reevaluating material activation energy, to justify a higher value that would support extended life at elevated temperature. Similar methods of reducing excess conservatism in the component service conditions and material properties used in prior aging evaluations may be used for radiation and cyclical aging. The PVNGS EQ-PM provides detailed directions for use of these Arrhenius and Arrhenius-based methods, including the basis for activation energies, examples of specific cases, and activation energies for specific materials.

Acceptance Criteria and Corrective Actions: If qualification cannot be extended by reanalysis, the component is refurbished or replaced prior to exceeding the period for which the current qualification remains valid. A reanalysis is to be performed in a timely manner (that is, sufficient time is available to refurbish, replace or requalify the component if reanalysis is unsuccessful).

Disposition: Aging Management, 10 CFR 54.21(c)(1)(iii)

The existing EQ program will be continued for the period of extended operation. Continuing the existing EQ program ensures that the aging effects will be managed and that the EQ components will continue to perform their intended functions for the period of extended operation. Aging effects addressed by the EQ program will thereby be managed for the period of extended operation, in accordance with 10 CFR 54.21(c)(1)(iii).

The Environmental Qualification (EQ) of Electrical Components program is summarized in Appendix B, [Section B3.2](#).

4.5 CONCRETE CONTAINMENT TENDON PRESTRESS

Summary Description

The PVNGS containment is a prestressed concrete, hemispherical-dome-on-a-cylinder structure with a steel membrane liner. Post-tensioned tendons compress the concrete and permit the structure to withstand design basis accident internal pressures.

The steel tendons, in tension, relax with time; and the concrete structure, which the tendons hold in compression, both creeps and shrinks with time. Therefore, to ensure the integrity of the containment pressure boundary under design basis accident loads, an inspection program confirms that the tendon prestress remains within design limits throughout the life of the plant.

The original design predictions of loss of prestress are TLAAAs. Regression analyses of surveillance data that predict the future performance of the post-tensioning system to the end of design life support validation of the tendon design per 10 CFR 54.21(c)(1)(i), as described in NUREG-1800 and NUREG-1801.

Post-Tensioning System

The PVNGS post-tensioning system consists of two tendon groups in each unit:

- 90 vertical, inverted-U-shaped tendons, extending up through the basemat, through the full height of the cylindrical walls, in two subgroups that cross at right angles over the dome.
- 150 horizontal circumferential (hoop) tendons, in two subgroups, at intervals from the basemat to about the 45-degree elevation of the dome. There are 120 cylinder (wall) tendons and 30 dome hoop tendons.

The vertical inverted-U tendons are anchored through the bottom of the basemat. The basemat is conventionally-reinforced concrete. The horizontal hoop tendons are anchored at three exterior buttresses, 120 degrees apart. Each hoop tendon extends 240 degrees around the containment building, passing under an intervening buttress. The tendons are not bonded to the concrete but were inserted in tendon ducts, after concrete cure, and tensioned in the prescribed sequence.

Each tendon consists of up to 186, ¼ - inch high-strength steel wires with cold-formed button heads on each end bearing on a stressing anchorhead. The total tendon load is then carried by a shim stack to steel bearing plates embedded in the structure. The tendons are twisted approximately 1 turn every 20 feet.

Tendon Surveillance Program

Prior to September of 1996, the tendon examinations were governed by Regulatory Guide 1.35, *Inspection of UngROUTED Tendons in Prestressed Concrete Containments*. Under License Amendment 151 [Ref. 19] the program has been governed by ASME XI Subsection IWL - 1992, instead of Regulatory Guide 1.35. The beginning of the second interval will be August 1, 2011 for all three units. The program will be updated for subsequent intervals as required by 10 CFR 50.55a(b)(2)(vi) and (viii), and by 10 CFR 50.55a(g)(4)(ii).

The Concrete Containment Tendon Prestress program is summarized in Appendix B, [Section B3.3](#).

Tendon Samples and Inspection Schedule

The program inspects a random sample of tendons from each group (vertical and hoop), selected for each inspection interval, to confirm that acceptance criteria, calculated from surveillance program predicted prestress force lines, are met, and therefore that tendon prestresses will remain above minimum required values (MRVs)² for the succeeding inspection interval. With enhancements the program will also recalculate the regression analysis trend lines of these two groups, at each inspection, to confirm that average prestresses are expected to remain above their MRVs for the remainder of the licensed operating period. The trend lines of data to date confirm this to at least the end of the period of extended operation. [Figures 4.5-1](#) through [4.5-6](#) summarize the results of these regressions.

ASME XI IWL - 1992 required tendon lift-off tests every five years. At PVNGS, the original licensing basis examined Unit 1 and 3 tendons every five years. The approval of Relief Request RR-4 revised the examination schedule, from examination of Units 1 and 3 only, every 5 years, to examination of each of the 3 units every 10 years.

With the second 10-year IWL inspection interval beginning August 1, 2011, the program will conform to a later edition of ASME Section XI, Subsection IWL, as required by 10 CFR 50.55a. IWL-2421(b) of recent editions (e.g., 2001 with 2002 and 2003 Addenda) permits a 10-year interval between tendon prestress surveillance tests, for each unit of a multi-unit plant, as presently permitted by PVNGS Relief Request RR-L4. This provision is expected to remain for the foreseeable future, and therefore to be available for the second 10-year PVNGS IWL interval.

² The MRV is the minimum prestress, per tendon within a group or subgroup, assumed for design of the containment building, for limiting loads, as a pressure vessel. Also called minimum required prestress, minimum design prestress, and cognates.

Analysis

The program includes randomly-selected surveillance tendons for a 40-year license (through the year 35 surveillance). The tendon selection was random within each of the vertical and horizontal groups. Separate random samples were selected for each of Units 1 and 3 but not Unit 2, since Unit 2 tendon lift-off surveillance was covered under the Unit 1 results under the previous Reg Guide program. Unit 2 was subject only to visual inspection under that program. The tendon sample selection is by calculation and is shown, together with the mean, high-loss, and low-loss predicted values for each tendon to be inspected, in the Tendon Integrity test procedure. The Tendon Integrity test procedure will be revised to extend the list of surveillance tendons to include random samples for the year 45 and 55 surveillances.

The first Unit 2 tendons were examined at the Unit 2, 20th-year inspection, under a new commitment to ASME XI Subsection IWL and under the revised schedule of Relief Request RR-L4, under which lift-off tests are now conducted on each of the 3 units every 10 years, instead of on only Units 1 and 3 every 5 years. Procedures currently include predictions for only the 20th-year tendons for Unit 2, and will be revised again for the Unit 2, 25th-year tendons to be examined in 2010. The Unit 1, 20th-year sample tendon numbers were used to determine the 20th-year Unit 2 surveillance sample, with one adjustment for accessibility.

Minimum Required Values, MRVs

The design acceptance criteria for the prestressing system (upon which the examination acceptance criteria are based) are a minimum average meridional prestressing force of 388 kips/foot in both the dome and cylinder (provided by the vertical tendons), a minimum average dome hoop force of 393 kips/foot, and a minimum cylinder hoop force of 772 kips/foot; including effects of all losses over the design and operating life.

For surveillance purposes these criteria reduce to tendon load minimum required values (MRVs) which the tendons must meet at any time up to the end of design life, including effects of prestress loss.

Tendons were post-tensioned to higher values to ensure adequate tendon force at end of life, including effects of loss of prestress.

Tendon Liftoff Test Acceptance Criteria

The acceptance criteria are based on (1) minimum required average design prestress lift-off forces (minimum required values, MRVs) for each of the three vertical, dome hoop, and cylinder wall hoop tendon subgroups; and (2) prestress reduction predicted mean lift-off force (predicted force) values for each tendon of the two vertical and hoop tendon groups.

The MRVs and the predicted relaxations of the tendon lift-off forces (predicted force and predicted upper and lower limit values) were developed during the original design to confirm the adequacy for the original 40-year licensed operating term.

The tendon liftoff acceptance criteria of the tendon inspection procedures are consistent with those of IWL-3221.1, 1992 Edition.

Surveillance Results

A regression analysis was performed on Unit 1 and 3 horizontal and vertical tendon data including the 15-year surveillances for Units 1 and 3, and on the 20 year surveillance data for Unit 2. The Unit 1, 25-year surveillance was not complete in time to be included in this analysis.

The average value between the shop and field end liftoffs of each tendon was used to obtain a trend line indicating loss of prestress. This trend line was projected to 60 years. The loss curves were compared to the predicted loss of force. The projected loss lines were recalculated using Reg Guide 1.35.1 methods to determine loss of prestress as a percent of the original prestress value for high-loss, median-loss, and low-loss cases. The projected loss lines are consistent with the original design calculation, which calculated loss of prestress for each tendon in the surveillance sample, using methods consistent with Proposed Reg Guide 1.35.1, Rev. 0, April 1979.

The regression analysis trend lines indicate that tendon prestress will remain above the minimum required value (MRV) through the end of the period of extended operation.

[Table 4.5-1](#) summarizes input data. In the table, common tendons (those surveyed at each inspection) are marked in boldface. [Figures 4.5-1](#) through [4.5-6](#) summarize the results of these regressions.

Disposition: Revision, 10 CFR 54.21(c)(1)(ii); and Aging Management, 10 CFR 54.21(c)(1)(iii)

Revision

The condition of the PVNGS containment prestressing system meets criteria for revision of the predicted loss of prestress for the period of extended operation as described in NUREG-1800, Section 4.5.3.1.2. (1) The lift-off trend lines were calculated by regression of individual tendon lift-off data, including results of the 2005, Unit 2 20-year surveillance. These calculations are therefore consistent with NRC Information Notice 99-10, Attachment 3. (2) The regression analysis of surveillance lift-off data extends the trend lines for both the vertical and horizontal cylinder tendons to 60 years. (3) The trend lines for all tendon groups remain above their minimum required values for the period of extended operation.

The current regression analysis of the vertical and horizontal cylinder tendons therefore revises the predicted loss of prestress for the period of extended operation, and demonstrates that loss of prestress is expected to remain within acceptable values for the period of extended operation, in accordance with 10 CFR 54.21(c)(1)(ii).

Aging Management

The existing Concrete Containment Tendon Prestress program (Section B3.3) will be continued for the period of extended operation. The average tendon prestress in each of the vertical and hoop tendon groups will thereby be maintained above its design basis minimum required value (MRV) for the period of extended operation, in accordance with 10 CFR 54.21(c)(1)(iii).

*Table 4.5-1 Tendon Regression Analysis Input Data For PVNGS
Units 1, 2, and 3*

Unit	Year (1)	Tendon (2)	End	Force, Kips	Date	Tension Date	Time at Tension (Years)
Horizontal Cylinder Wall and Dome (Hoop) Tendons							
1	1	H13-07	Field	1393	01/27/84	02/16/82	1.94
1	1	H13-07	Shop	1366	01/27/84	02/16/82	1.94
1	1	H13-21	Field	1497	03/08/84	01/15/82	2.14
1	1	H13-21	Shop	1446	03/01/84	01/15/82	2.12
1	1	H21-37	Field	1471	02/13/84	01/11/82	2.09
1	1	H21-37	Shop	1453	02/28/84	01/11/82	2.13
1	1	H32-16	Field	1387	02/10/84	06/01/81	2.69
1	1	H32-16	Shop	1370	03/07/84	06/01/81	2.77
1	1	H32-30	Field	1502	02/13/84	05/27/81	2.72
1	1	H32-30	Shop	1492	03/07/84	05/27/81	2.78
1	1	H21-44	Field	1508	02/14/84	05/18/81	2.74
1	1	H21-44	Shop	1517	02/28/84	05/18/81	2.78
1	3	H13-25	Field	1486	01/02/86	01/14/82	3.97
1	3	H13-25	Shop	1410	01/03/86	01/14/82	3.97
1	3	H21-11	Field	1451	01/12/86	02/12/82	3.92
1	3	H21-11	Shop	1440	01/06/86	02/12/82	3.90
1	3	H32-09	Field	1464	01/05/86	02/16/82	3.89
1	3	H32-09	Shop	1483	01/02/86	02/16/82	3.88
1	3	H32-30	Field	1516	01/09/86	05/27/81	4.62
1	3	H32-30	Shop	1487	01/02/86	05/27/81	4.60
1	3	H32-33	Field	1505	01/09/86	01/12/82	4.04
1	3	H32-33	Shop	1402	01/02/86	01/12/82	4.04
1	3	H21-42	Field	1645	01/13/86	05/19/81	4.65
1	3	H21-42	Shop	1468	01/03/86	05/19/81	4.63
1	5	H13-19	Shop	1364	04/26/88	02/11/82	6.20
1	5	H21-03	Field	1419	04/19/88	02/17/82	6.17
1	5	H21-03	Shop	1507	04/26/88	02/17/82	6.19

Section 4
TIME-LIMITED AGING ANALYSES

Table 4.5-1 Tendon Regression Analysis Input Data For PVNGS
Units 1, 2, and 3

Unit	Year (1)	Tendon (2)	End	Force, Kips	Date	Tension Date	Time at Tension (Years)
1	5	H21-28	Field	1419	04/15/88	05/27/81	6.89
1	5	H21-28	Shop	1468	04/15/88	05/27/81	6.89
1	5	H32-23	Field	1458	04/19/88	01/15/82	6.26
1	5	H32-23	Shop	1442	03/26/88	01/15/82	6.19
1	5	H32-30	Field	1493	04/19/88	05/27/81	6.90
1	5	H32-30	Shop	1479	03/25/88	05/27/81	6.83
1	5	H32-44	Field	1557	04/18/88	05/19/81	6.92
1	5	H32-44	Shop	1486	03/26/88	05/19/81	6.85
1	10	H13-08	Field	1389	08/27/92	06/30/81	11.16
1	10	H13-08	Shop	1380	08/25/92	06/30/81	11.15
1	10	H32-30	Field	1483	08/12/92	05/27/81	11.21
1	10	H32-30	Shop	1465	08/14/92	05/27/81	11.22
1	10	H32-41	Field	1466	08/11/92	01/11/82	10.58
1	10	H32-41	Shop	1413	08/14/92	01/11/82	10.59
1	15	H21-06	Field	1483	05/15/98	06/30/81	16.87
1	15	H21-06	Shop	1303	06/11/98	06/30/81	16.95
1	15	H32-15	Field	1442	06/02/98	02/12/82	16.30
1	15	H32-15	Shop	1367	06/02/98	02/12/82	16.30
1	15	H32-30	Field	1463	05/15/98	05/27/81	16.97
1	15	H32-30	Shop	1463	06/02/98	05/27/81	17.02
2	20	H21-40	Field	1368	07/08/05	05/03/82	23.18
2	20	H21-40	Shop	1402	07/07/05	05/03/82	23.18
2	20	H32-12	Field	1301	08/17/05	05/03/82	23.29
2	20	H32-12	Shop	1351	07/01/05	06/15/82	23.04
2	20	H32-30	Field	1358	08/17/05	06/15/82	23.17
2	20	H32-30	Shop	1297	07/01/05	05/20/82	23.12
3	1	H13-10	Field	1471	10/17/87	03/28/84	3.55
3	1	H13-10	Shop	1415	10/13/87	03/28/84	3.54
3	1	H13-36	Field	1401	10/17/87	10/21/83	3.99
3	1	H13-36	Shop	1392	10/13/87	10/21/83	3.98
3	1	H13-44	Field	1490	10/15/97	08/12/83	4.18
3	1	H13-44	Shop	1457	10/17/97	08/12/83	4.18
3	1	H21-07	Field	1422	10/19/87	04/09/84	3.53
3	1	H21-07	Shop	1414	10/14/87	04/09/84	3.51
3	1	H32-13	Field	1433	10/19/87	04/05/84	3.53
3	1	H32-13	Shop	1466	10/16/87	04/05/84	3.53
3	1	H32-21	Field	1453	10/19/87	04/03/84	3.54

Section 4
TIME-LIMITED AGING ANALYSES

Table 4.5-1 Tendon Regression Analysis Input Data For PVNGS
Units 1, 2, and 3

Unit	Year (1)	Tendon (2)	End	Force, Kips	Date	Tension Date	Time at Tension (Years)
3	1	H32-21	Shop	1448	10/16/87	04/03/84	3.53
3	3	H13-36	Field	1375	12/20/89	10/21/83	6.17
3	3	H13-36	Shop	1363	01/22/90	10/21/83	6.26
3	3	H13-45	Field	1504	12/20/89	10/27/83	6.15
3	3	H13-45	Shop	1498	01/22/90	10/27/83	6.24
3	3	H21-04	Shop	1403	01/24/90	03/30/84	5.82
3	3	H21-05	Field	1392	12/14/89	04/10/84	5.68
3	3	H21-05	Shop	1349	01/22/90	04/10/84	5.79
3	3	H21-06	Field	1434	03/23/90	03/29/84	5.98
3	3	H21-06	Shop	1352	01/24/90	03/29/84	5.82
3	3	H21-09	Field	1431	12/14/89	04/09/84	5.68
3	3	H21-09	Shop	1387	01/22/90	04/09/84	5.79
3	3	H32-18	Field	1453	12/13/89	03/11/84	5.76
3	3	H32-18	Shop	1483	12/19/89	03/11/84	5.77
3	3	H32-29	Field	1410	12/14/89	11/01/83	6.12
3	3	H32-29	Shop	1444	12/19/89	11/01/83	6.13
3	5	H13-09	Field	1469	08/08/91	04/09/84	7.33
3	5	H13-09	Shop	1361	08/09/91	04/09/84	7.33
3	5	H13-16	Field	1479	08/20/91	03/27/84	7.40
3	5	H13-16	Shop	1354	08/19/91	03/27/84	7.39
3	5	H13-36	Field	1394	08/05/91	10/21/83	7.79
3	5	H13-36	Shop	1368	08/09/91	10/21/83	7.80
3	5	H21-04	Field	1314	07/19/91	03/30/84	7.30
3	5	H21-04	Shop	1394	08/09/91	03/30/84	7.36
3	5	H21-25	Field	1396	07/19/91	03/30/84	7.30
3	5	H21-25	Shop	1370	08/14/91	03/30/84	7.37
3	5	H32-42	Field	1500	07/22/91	10/20/83	7.75
3	5	H32-42	Shop	1468	08/05/91	10/20/83	7.79
3	10	H13-24	Field	1458	12/06/96	03/26/84	12.70
3	10	H13-24	Shop	1314	12/06/96	03/26/84	12.70
3	10	H13-36	Field	1371	12/11/96	10/21/83	13.14
3	10	H13-36	Shop	1342	12/11/96	10/21/83	13.14
3	10	H21-10	Field	1313	11/13/96	03/28/84	12.63
3	10	H21-10	Shop	1324	12/11/96	03/28/84	12.71
3	15	H13-36	Field	1315	08/19/02	10/21/83	18.83
3	15	H13-36	Shop	1330	08/16/02	10/21/83	18.82
3	15	H21-22	Field	1345	08/16/02	03/26/84	18.39

Section 4
TIME-LIMITED AGING ANALYSES

*Table 4.5-1 Tendon Regression Analysis Input Data For PVNGS
Units 1, 2, and 3*

Unit	Year (1)	Tendon (2)	End	Force, Kips	Date	Tension Date	Time at Tension (Years)
3	15	H21-22	Shop	1317	08/16/02	03/26/84	18.39
3	15	H21-43	Field	1456	08/16/02	10/27/83	18.80
3	15	H21-43	Shop	1408	08/16/02	10/27/83	18.80
Inverted-U Vertical Tendons							
1	1	V32	Field	1462	01/09/84	12/1/1981	2.11
1	1	V32	Shop	1338	01/09/84	12/1/1981	2.11
1	1	V43	Field	1517	01/16/84	10/2/1981	2.29
1	1	V43	Shop	1391	01/17/84	10/2/1981	2.29
1	1	V62	Field	1468	01/12/84	11/25/1981	2.13
1	1	V62	Shop	1453	01/12/84	11/25/1981	2.13
1	1	V75	Field	1468	01/10/84	11/24/1981	2.13
1	1	V75	Shop	1438	01/10/84	11/24/1981	2.13
1	3	V02	Field	1440	02/16/86	10/19/1981	4.33
1	3	V02	Shop	1495	02/15/86	10/19/1981	4.33
1	3	V18	Field	1355	02/12/86	10/7/1981	4.35
1	3	V18	Shop	1473	02/09/86	10/7/1981	4.34
1	3	V55	Field	1462	02/13/86	10/9/1981	4.35
1	3	V55	Shop	1445	02/10/86	10/9/1981	4.34
1	3	V75	Field	1471	02/13/86	11/24/1981	4.22
1	3	V75	Shop	1474	02/07/86	11/24/1981	4.21
1	5	V11	Field	1477	02/26/88	10/14/1981	6.37
1	5	V11	Shop	1452	02/26/88	10/14/1981	6.37
1	5	V36	Field	1515	02/26/88	12/1/1981	6.24
1	5	V36	Shop	1363	02/29/88	12/1/1981	6.25
1	5	V75	Field	1454	02/26/88	11/24/1981	6.26
1	5	V75	Shop	1468	02/29/88	11/24/1981	6.26
1	5	V86	Field	1474	02/29/88	7/10/1981	6.64
1	5	V86	Shop	1492	03/01/88	7/10/1981	6.64
1	10	V40	Field	1533	09/18/92	11/23/1981	10.82
1	10	V40	Shop	1538	09/18/92	11/23/1981	10.82
1	10	V53	Field	1416	09/15/92	11/5/1981	10.86
1	10	V53	Shop	1390	09/17/92	11/5/1981	10.87
1	10	V75	Field	1442	09/02/92	11/24/1981	10.77
1	10	V75	Shop	1461	09/14/92	11/24/1981	10.81
1	15	V37	Field	1434	07/24/98	11/30/1981	16.65
1	15	V37	Shop	1376	07/24/98	11/30/1981	16.65
1	15	V72	Field	1402	07/17/98	12/2/1981	16.62

Section 4
TIME-LIMITED AGING ANALYSES

*Table 4.5-1 Tendon Regression Analysis Input Data For PVNGS
Units 1, 2, and 3*

Unit	Year (1)	Tendon (2)	End	Force, Kips	Date	Tension Date	Time at Tension (Years)
1	15	V72	Shop	1390	07/22/98	12/2/1981	16.64
1	15	V75	Field	1448	07/21/98	11/24/1981	16.65
1	15	V75	Shop	1409	07/16/98	11/24/1981	16.64
2	20	V26	Field	1380	09/08/05	8/13/1982	23.07
2	20	V26	Shop	1298	09/08/05	8/13/1982	23.07
2	20	V67	Field	1338	08/31/05	8/16/1982	23.04
2	20	V67	Shop	1479	08/30/05	8/16/1982	23.04
2	20	V75	Field	1430	09/01/05	8/16/1982	23.02
2	20	V75	Shop	1400	09/15/05	8/24/1982	23.06
3	1	V07	Shop	1520	11/03/87	12/19/1983	3.87
3	1	V15	Shop	1491	11/03/87	1/17/1984	3.79
3	1	V16	Field	1558	10/29/87	2/3/1984	3.73
3	1	V16	Shop	1404	10/26/87	2/3/1984	3.73
3	1	V20	Field	1486	12/10/87	2/3/1984	3.85
3	1	V20	Shop	1574	12/10/87	2/3/1984	3.85
3	1	V28	Field	1485	12/03/87	2/9/1984	3.81
3	1	V28	Shop	1421	12/03/87	2/9/1984	3.81
3	1	V49	Field	1527	12/04/87	1/20/1984	3.87
3	1	V49	Shop	1353	10/24/87	1/20/1984	3.76
3	3	V16	Field	1550	11/01/89	2/3/1984	5.74
3	3	V16	Shop	1379	10/30/89	2/3/1984	5.74
3	3	V39	Field	1471	11/01/89	12/20/1983	5.87
3	3	V39	Shop	1398	11/01/89	12/20/1983	5.87
3	3	V59	Field	1485	10/31/89	1/16/1984	5.79
3	3	V59	Shop	1387	11/01/89	1/16/1984	5.79
3	3	V66	Field	1481	10/31/89	2/7/1984	5.73
3	3	V66	Shop	1435	11/02/89	2/7/1984	5.74
3	5	V16	Field	1543	09/11/91	2/3/1984	7.60
3	5	V16	Shop	1410	09/13/91	2/3/1984	7.61
3	5	V33	Field	1598	09/18/91	2/16/1984	7.59
3	5	V33	Shop	1456	09/18/91	2/16/1984	7.59
3	5	V48	Field	1445	09/11/91	12/22/1983	7.72
3	5	V48	Shop	1293	09/12/91	12/22/1983	7.72
3	5	V71	Field	1558	09/10/91	2/9/1984	7.58
3	5	V71	Shop	1468	09/12/91	2/9/1984	7.59
3	10	V13	Field	1507	08/01/96	2/6/1984	12.48
3	10	V13	Shop	1405	08/14/96	2/6/1984	12.52

Section 4
TIME-LIMITED AGING ANALYSES

Table 4.5-1 Tendon Regression Analysis Input Data For PVNGS
Units 1, 2, and 3

Unit	Year (1)	Tendon (2)	End	Force, Kips	Date	Tension Date	Time at Tension (Years)
3	10	V16	Field	1524	08/02/96	2/3/1984	12.50
3	10	V16	Shop	1366	07/31/96	2/3/1984	12.49
3	10	V82	Field	1478	08/02/96	12/22/1983	12.61
3	10	V82	Shop	1394	08/02/96	12/22/1983	12.61
3	15	V16	Field	1517	07/11/02	2/3/1984	18.43
3	15	V16	Shop	1367	07/11/02	2/3/1984	18.43
3	15	V41	Field	1542	07/11/02	1/24/1984	18.46
3	15	V41	Shop	1419	07/16/02	1/24/1984	18.48
3	15	V57	Field	1520	07/16/02	2/7/1984	18.44
3	15	V57	Shop	1378	07/10/02	2/7/1984	18.42

¹ Nominal, post- SIT (Structural Integrity Test).

² Boldface numbers are "common" tendons, examined at each tendon prestress surveillance.

Section 4
TIME-LIMITED AGING ANALYSES

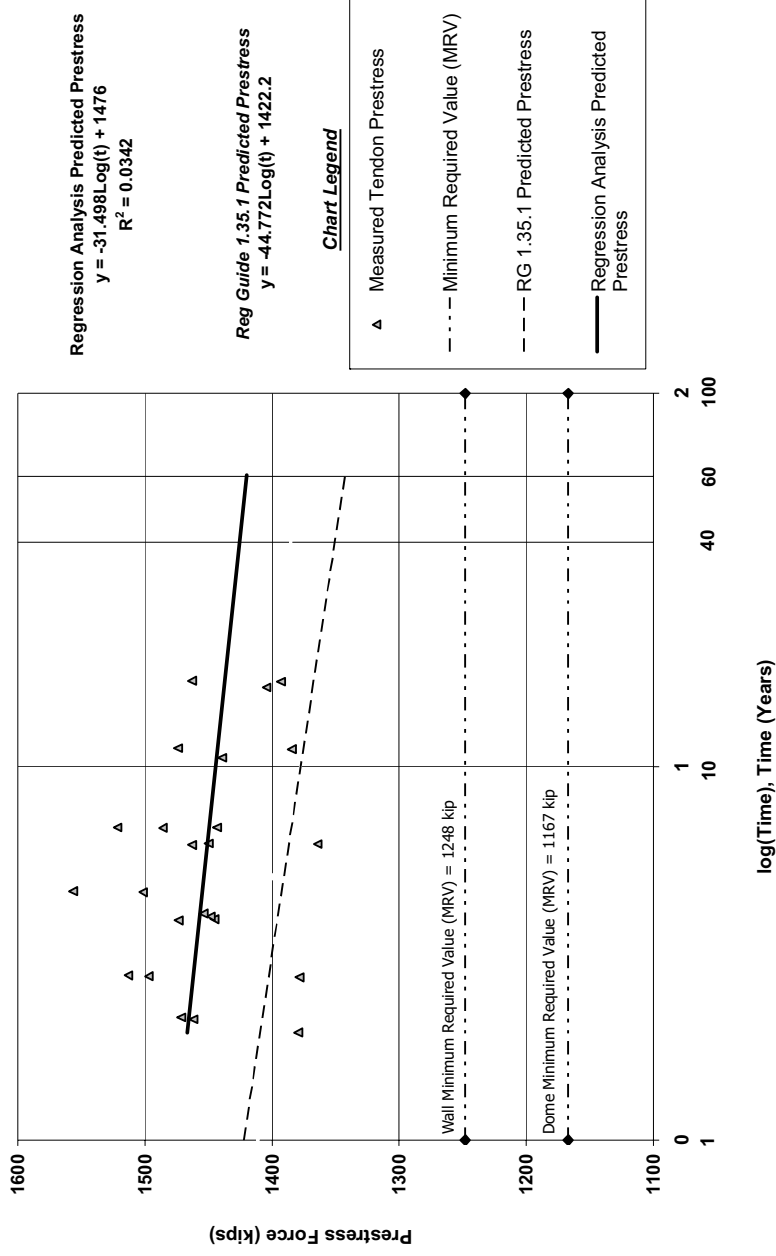

Figure 4.5-1: Regression Analysis of Unit 1 Horizontal Tendon Lift-off Data Through the 15-Year Surveillance; With Reg Guide 1.35.1 Predicted Prestress (See Notes)

Section 4
TIME-LIMITED AGING ANALYSES

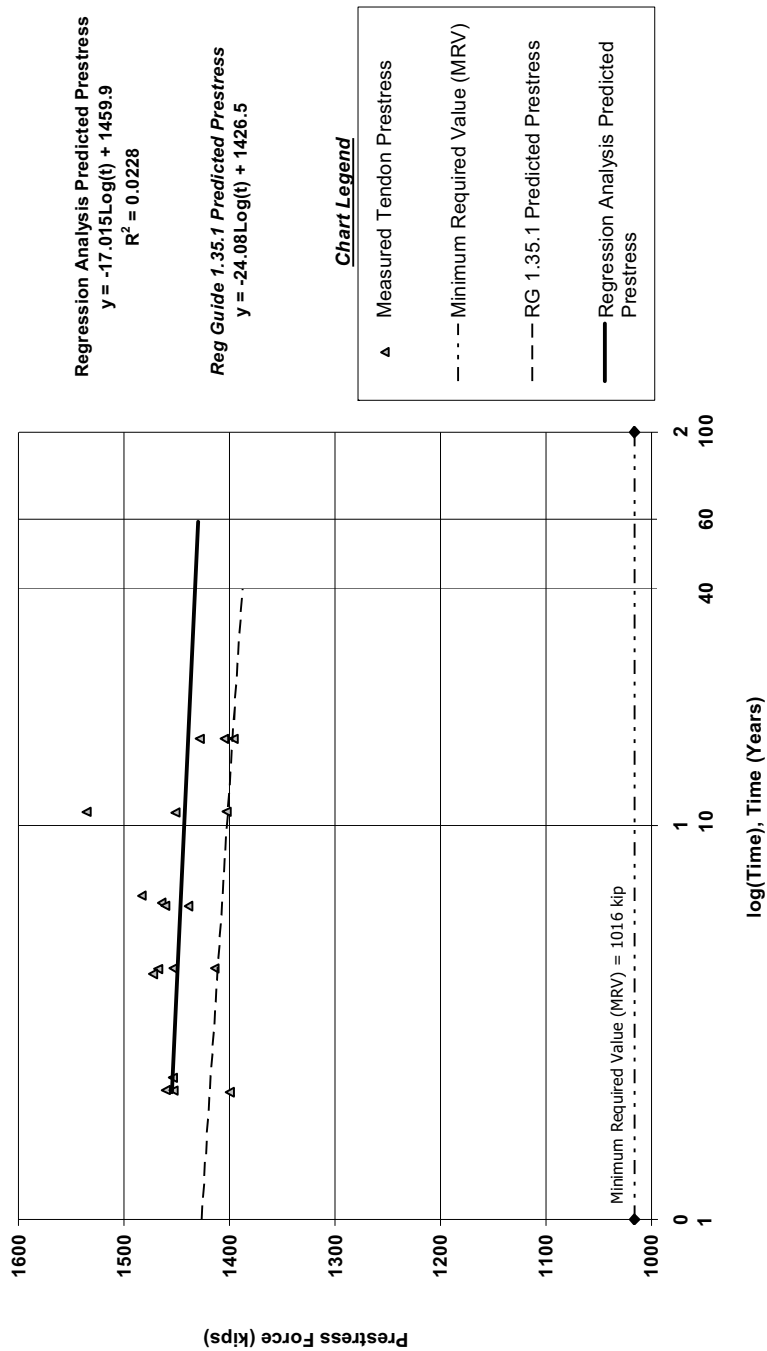

Figure 4.5-2: Regression Analysis of Unit 1 Vertical Tendon Lift-off Data Through the 15-Year Surveillance; With Reg Guide 1.35.1 Predicted Prestress (See Notes)

Section 4
TIME-LIMITED AGING ANALYSES

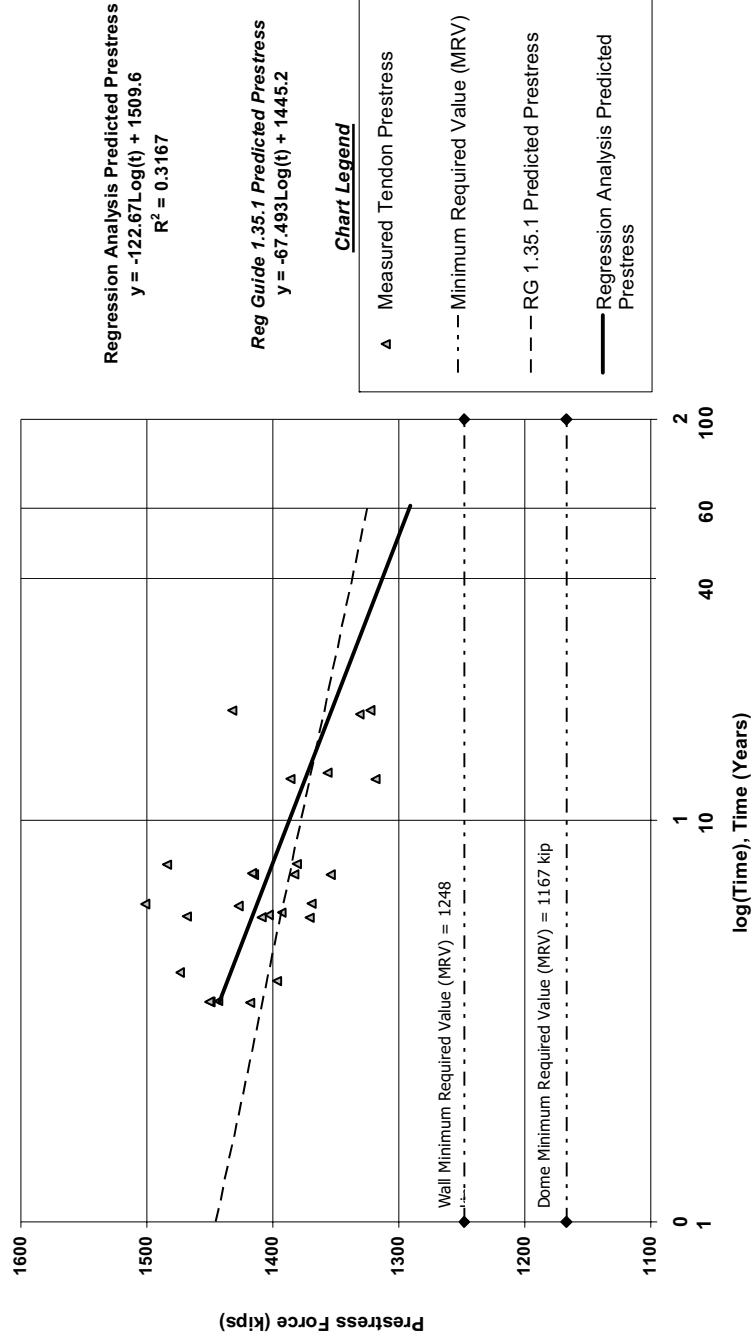

Figure 4.5-3: Regression Analysis of Unit 3 Horizontal Tendon Lift-off Data Through the 15-Year Surveillance; With Reg Guide 1.35.1 Predicted Prestress (See Notes)

Section 4
TIME-LIMITED AGING ANALYSES

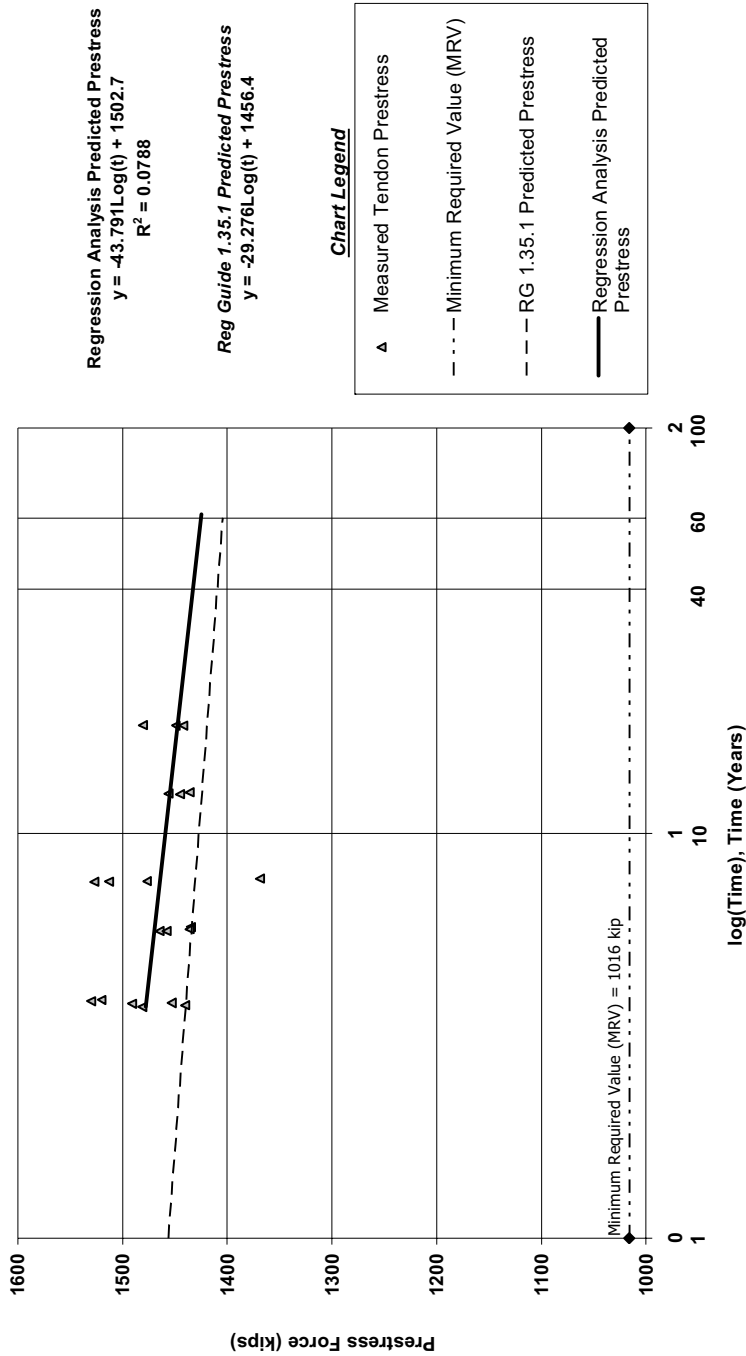

Figure 4.5-4: Regression Analysis of Unit 3 Vertical Tendon Lift-off Data Through the 15-Year Surveillance; With Reg Guide 1.35.1 Predicted Prestress (See Notes)

Section 4
TIME-LIMITED AGING ANALYSES

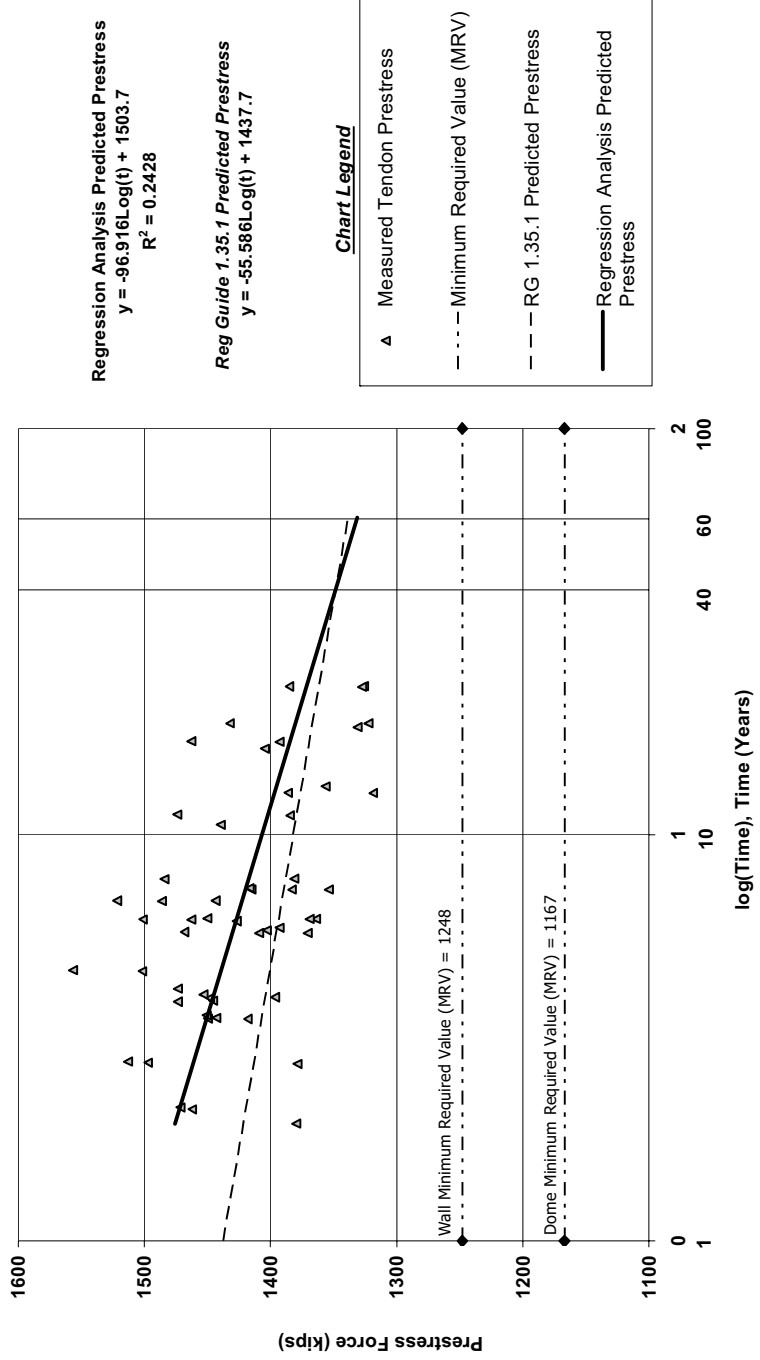

Figure 4.5-5: Joint Regression Analysis of Unit 1, 2, and 3 Horizontal Tendon Lift-off Data Through the Unit 2 20-Year Surveillance; With Reg Guide 1.35.1 Predicted Prestress (See Notes)

Section 4
TIME-LIMITED AGING ANALYSES

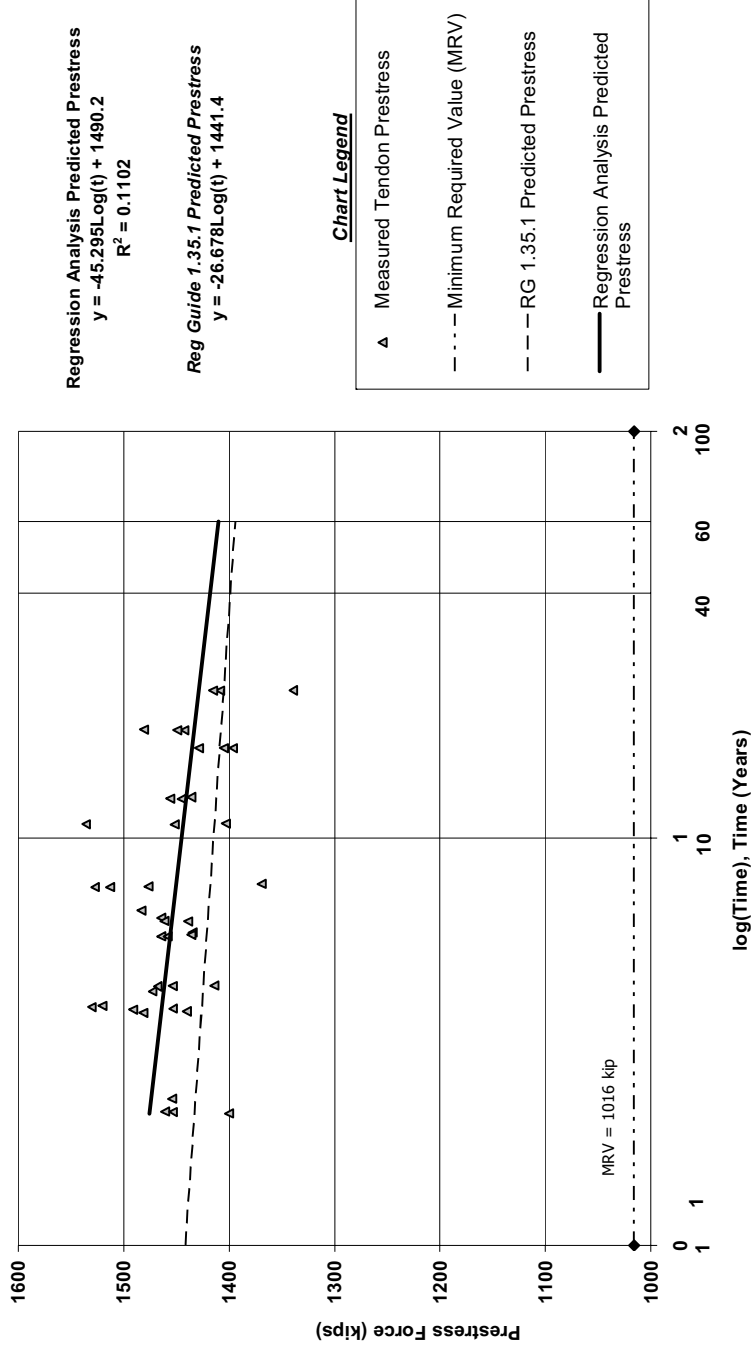

Figure 4.5-6: Joint Regression Analysis of Unit 1, 2, and 3 Vertical Tendon Lift-off Data Through the Unit 2 20-Year Surveillance; With Reg Guide 1.35.1 Predicted Prestress (See Notes)

Notes to Figures:

- a) Since only a single, 20-year inspection has been performed on the Unit 2 tendons, insufficient data were available for a regression analysis of Unit 2 tendons alone. The Unit 2 20-year data were included in the joint regression analysis of all three units.
- b) "Trend line" and "minimum required value" (MRV) are equivalent to the same terms in NUREG-1800 and NUREG-1801 Chapter 4, and X.S1.
- c) The time scale and variable t are actual years from original tensioning date.
- d) The original predicted loss of prestress values used by the surveillance program were calculated separately for each tendon in the surveillance sample, using methods consistent with Proposed Reg Guide 1.35.1 Rev. 0. These lines were calculated "per wire" because they are used to calculate a predicted force per tendon, based on the actual number of wires, in order to compare the predicted force with the surveillance lift-off force. The new predicted force lines ("predicted losses") shown on these plots are average values, recalculated using Reg Guide 1.35.1 methods. The values plotted here assume 186 wires per tendon. Some tendons have fewer due to failure to meet acceptance criteria at installation, or due to removal for surveillance testing.
- e) The dome and cylinder horizontal hoop tendons are sampled and tested as a single group. The predicted force lines were developed from data for the entire horizontal population. The regression lines were similarly developed from surveillance data of a sample that includes both dome and hoop tendons. However the dome tendons have a lower MRV. Both MRVs are shown on the horizontal tendon plots.
- f) The Unit 1, 25-year surveillance was not complete in time to be included in this analysis.
- g) Each of the trend lines is a regression analysis of the entire set (or stated subset) of individual tendon lift-off data for each of the tendon groups. The trend lines were calculated from the actual tendon lift-off forces, regardless of the number of effective wires per tendon.

4.6 CONTAINMENT LINER PLATE, EQUIPMENT HATCH AND PERSONNEL AIR LOCKS, PENETRATIONS, AND POLAR CRANE BRACKETS

The NUREG-1800 *Standard Review Plan for License Renewal* observes that some designs of containment liners, their anchors to the concrete pressure vessel, and their penetrations may be based on an assumed number of loading cycles for the current operating term [NUREG-1800 §4.6].

However, examination of the controlling Bechtel Topical Reports BC-TOP-1 and BC-TOP-5-A, the design specification, the design report, and design calculations, found that the application of cyclic limits to the design is time-dependent only for design of the main steam, main feedwater, and recirculation sump suction penetrations. See [Sections 4.6.2](#) and [4.6.3](#).

Design Criteria and Design Codes

The post-tensioned concrete containment vessels are designed to Bechtel Topical Report BC-TOP-5-A Revision 3. They are poured against steel membrane liners designed to BC-TOP-1 Revision 1. No credit is taken for the liner for the pressure design of the containment vessel, but the liner and penetrations ensure the vessel is leak-tight, and its electrical, process, personnel air lock, and equipment hatch penetrations are part of the containment pressure boundary.

Revision 3 of the BC-TOP-5-A topical is dated February 1975, and lists ASME Section III, Division 1, “1971 ... including applicable addenda” [Ref. 22 § 4.1.2]. This code edition preceded the Summer 1972 Division 1 addendum that added specific criteria for Class MC metal containment components (other than by citation of Section VIII), and preceded the 1975 issue of Division 2, Code for Concrete Reactor Vessels and Containments. However BC-TOP-5-A Revision 3 includes a draft version of Division 2 Article CC-3000, “Design” [Ref. 22 App. C]. The PVNGS containment elements were designed to slightly later editions and addenda, up through the 1975 issue of Division 2.

ASME Section III Division 1, Subsection NE, 1974 and later, Subparagraph NE-3222.4, provides rules for a fatigue analysis of MC components “...for specified operating conditions involving cyclic application of loads and thermal conditions...,” that is, *if cyclic loads are specified* (see also NE-3110).

The design of the recirculation sump suction penetrations is supported by a fatigue analysis waiver under NE-3222.4(d). However, this NE-3222.4(d) waiver is itself a TLAA, because some of the exemption criteria depend on the number of cycles for which loads are applied. See [Section 4.6.3](#).

The guidance of ASME III Division 2 for design of liners for fatigue, of which a draft is also included in BC-TOP-5-A, is limited, referring to Division 1 for specifics.

Containment Liner and its Anchors, Penetration Assemblies, and Attachments and Brackets (including Polar Crane Brackets)

The UFSAR and containment design report states that these elements were designed to ASME III Division 2, *Code for Concrete Reactor Vessels and Containments*, 1975 Edition "...supplemented by the methods in BC-TOP-1 and BC-TOP-5-A."

However neither the containment design specification nor BC-TOP-5-A impose an analysis for cyclic loading on the containment liner to other than quasi-static stress criteria (except possibly by reference, through ASME III Division 2, CC-3570).

Equipment Hatch and Personnel Air Locks

The equipment hatch and personnel airlocks were specified to ASME III Division 1, Subsection NE - *Class MC Components*, 1974 'W74.

Effects of Power Uprate and Steam Generator Replacement

The containment design report has been revised to address effects of power uprate and steam generator replacement. The evaluation concluded that design parameters remain bounded by those assumed for the analyses.

4.6.1 *Absence of a TLAA for Containment Liner Plate, Polar Crane Bracket, Equipment Hatch, Air Lock, and Containment Penetration Design (Except Main Steam, Main Feedwater, and Recirculation Sump Suction Penetrations)*

Liner Plate

The containment liner and penetrations were designed to BC-TOP-1 Revision 1 and BC-TOP-5-A Revision 3.

Bechtel containment design topical reports BC-TOP-1 and BC-TOP-5-A are invoked by the PVNGS containment design specification and design report.

Neither the BC-TOP-1 topical report for the liner plate [Ref. 20 Part I] nor the PVNGS containment design report include results of a fatigue analysis, or of any other design for a stated number of cyclic loads or events, for the liner, or for its anchors or embedments. BC-TOP-1 Part II does include cyclic design of the main steam penetrations.

The UFSAR contains no description of cyclic loads or design cycles for the entire containment building. However, [UFSAR Section 3.8.1.5.4.B](#) describes design cycles that are to be included in the design of the liner plate and penetrations.

Section 4 TIME-LIMITED AGING ANALYSES

Review of the design specification, design report, and design calculations found time-dependent aspects of some penetration designs, but none for liner plate design, and therefore the liner plate design is not supported by a TLAA.

Examination of the controlling BC-TOP-1 and BC-TOP-5-A topical reports, the design specification, and the design report found no evidence that heatup and cooldown or seasonal temperature variations were considered to be cyclical loads on the containment building and liner. Seasonal temperature variations were used to determine thermal stress only for comparison with stress criteria when combined with other loads. The design report uses an incremental-iterative analysis to determine the extent of concrete cracking based on various loading conditions. This cracking was determined to be minor and the report shows that sufficient reinforcement exists to ensure that the containment pressure boundary alone has sufficient strength to resist all loading combinations.

Polar Crane Brackets

The polar crane is supported on a system of girders which are supported by a series of brackets that are attached to the containment shell. BC-TOP-1 Revision 1 reviews design of the polar crane brackets [Ref. 20 Part III], but neither reports nor specifies a fatigue analysis, nor any other design for a stated number of crane lifts, cyclic loads, or other cyclic events. Therefore, design of the polar crane brackets for a finite number of loads is not supported by a TLAA at PVNGS.

See [Section 4.7.1 below](#) for design of the polar crane itself.

Equipment Hatch and Personnel Air Locks

The equipment hatch and personnel air locks were designed to ASME III Division 1, Subsection NE - *Class MC Components*, 1974 'W74. Subparagraph NE-3222.4 provides rules for a fatigue analysis of MC components for cyclic loads *if specified*. However, review of licensing basis documents, specifications, and the design report identified no time-dependent analyses. Designs of the equipment hatch and personnel air locks are therefore not supported by TLAA's.

Penetrations

A search of the licensing basis and review of the design documents for the containment liner and polar crane brackets, found no evidence of any TLAA's applicable to containment penetrations, except for the main steam and main feedwater penetration design in BC-TOP 1 Part II and supporting design calculations, described in [Section 4.6.2 below](#) and the recirculation sump suction penetration design, described in [Section 4.6.3 below](#).

The containment penetrations include no bellows or expansion joints whose design is supported by a TLAA.

4.6.2 Design Cycles for the Main Steam and Main Feedwater Penetrations

Summary Description

The main steam penetrations are designed for cyclic loads. The BC-TOP-1 *Containment Building Liner Plate Design Report* [Ref. 20, Part II §1.1] includes:

- 100 lifetime steady state operating thermal gradient plus normal operating cyclic loads (BC-TOP-1 Part II “Loading Condition V”), and
- 10 steady state operating thermal gradient plus steam pipe rupture cyclic loads (BC-TOP-1 Part II “Loading Condition IV”).

Although neither BC-TOP-1 nor the main steam penetration design calculation explicitly include the main feedwater penetrations, the design calculation for “remaining penetrations” refers to the main steam penetration design calculation for both main steam and main feedwater penetrations.

The elastic-plastic evaluation of BC-TOP-1 Condition IV pipe rupture events can also apply to the main feedwater lines despite the dimensional differences, because the limiting BC-TOP-1 condition IV rupture stress is taken as the plastic limit, which is the same in both cases, since the materials are the same.

Analysis

The BC-TOP-1 analysis of effects of Loading Condition IV and V cyclic loads does not calculate a usage factor, but uses a simplified ASME III Subparagraph NB-3228.3 elastic-plastic analysis to compare the maximum allowed alternating stress range S_a for the assumed number of cycles to the calculated maximum alternating stress intensity for this load combination, $S'_a = S_a K_e$, where K_e is a simplified elastic-plastic multiplier (or fatigue stress intensity multiplier). S_a for the number of event cycles is taken from the applicable ASME III S-N fatigue diagram [Ref. 6 Fig. I-9-1]. The line for material with ultimate tensile strength $\leq 80,000$ psi on the S-N diagram applies to this SA 516 Grade 70 or A 516 Grade 70, 70,000 psi ultimate tensile material [Ref. 20 Part II §§4.1 and 5.1.1, strength from Ref. 6 Table I-7.1].

Evaluation of the main steam penetration calculation for effects of steam generator replacement and power uprate on pipe rupture loads identified no changes to the design calculation.

BC-TOP-1 Loading Condition IV - Normal Plus Pipe Rupture - 10 Cycles

Design for this combination is not a TLAA, since it, in fact, represents a single end-of-design-life event which is not affected by the design lifetime. It is however the subject of a simplified elastic-plastic analysis of the fatigue effects.

Section 4
TIME-LIMITED AGING ANALYSES

For BC-TOP-1 Part II Loading Condition IV (normal thermal gradient plus pipe rupture), the analysis compares the allowed value of S_a from the S-N diagram for 10 cycles, 600,000 psi, to the calculated maximum alternating stress intensity for this load combination,

$$S'_a = S_a K_e = 322,000 \text{ psi}$$

—which is acceptable, since S'_a is less than S_a [Ref. 20 Part II §5.3.4.(d)].

The analysis used 10 cycles instead of 1 for this load combination because 10 is the lowest number of cycles on the S-N diagram. This loading condition meets the definition of a “faulted event,” and therefore, if addressed within an ASME III Class 1 fatigue analysis, would not contribute to the predicted fatigue cumulative usage factor. However, although the main steam and main feedwater penetrations are not ASME III Class 1 components, they must function for faulted events in other components, such as a main steam or main feedwater line break inside containment, which concurrently imposes the worst load on the penetration.

For license renewal purposes, the following estimate of usage factor due to these Condition IV faulted events permits an assessment of the possible additive effect of this event when combined with the effect of Loading Condition V. Referring to the S-N diagram, about 37 cycles are allowed for the 322,000 psi applied stress range S'_a , for an equivalent usage factor of

$$10/37 = 0.270$$

—for the 10 cycles assumed, or

$$1/37 = 0.027$$

—for a single design basis pipe rupture event.

BC-TOP-1 Loading Condition V - Normal Penetration Thermal Gradient Plus Startup-Shutdown - 100 Cycles

For BC-TOP-1 Loading Condition V (normal thermal gradient plus operating cycle), the analysis compares the allowed value of S_a from the S-N diagram for 100 cycles, 200,000 psi, to the calculated maximum alternating stress intensity for this load combination,

$$S'_a = S_a K_e = 52,800 \text{ psi}$$

—which is acceptable, since S'_a is less than S_a [Ref. 20 Part II §5.3.5.(c)].

Section 4
TIME-LIMITED AGING ANALYSES

BC-TOP-1 assumed a set of normal-condition operating loads, “for illustration,” noting that they “vary for each piping system:”

Axial Force	$N_0 = 50$ kips
Bending Moment	$M_0 = 17,800$ in-kips
Shear Force	$V_0 = 0$
Torsion	$T_0 = 0$

[BC-TOP-1, Part II §3.1.5]

BC-TOP-1 did not calculate a usage factor for this case, but referring to the ASME III-1971 Figure I-9-1 S-N diagram, about 3,600 cycles are allowed for the 52,800 psi applied stress range S'_a , for an equivalent usage factor of

$$100/3,600 = 0.028$$

—for the 100 cycles assumed.

The main steam penetration calculation reviewed the limiting pipe rupture loads on the penetration for the plant-specific case. It did not re-evaluate the BC-TOP-1 typical illustrative analysis for plant-specific loads or plant-specific fatigue results, but accepted them without change.

Estimated Number of BC-TOP-1 Loading Condition V Events in 60 Years

The operating history to date indicates that the original design basis 100 operating cycles assumed by the topical report for main steam penetrations (and applicable to main feedwater penetrations) will be exceeded during the 60-year period. However, the Condition V events do not contribute significantly to usage factor, and examination of possible changes to the BC-TOP-1 analysis for any reasonably-expected increase in the number of these events demonstrates adequate margin to the stress limit determined by the elastic-plastic analysis.

PVNGS refuels on 18-month cycles, about 40 refuelings in 60 years. The number of plant heatups to date, from [Table 4.3-3](#), “APS Fatigue Cycle Count Verification (Composite Worst-Case Unit), and Projections”, if projected to 60 years, is 214. Since there are no inboard MSIVs in this PWR design, main steam penetration thermal cycles do not occur separately from reactor coolant system heatup-down cycles. Therefore the same number of main steam penetration full-range thermal cycles (BC-TOP-1 Part II “Condition V” events), perhaps 250, is expected in 60 years. Main feedwater lines have inboard check valves, but for operational reasons their penetrations should experience a similar number of thermal cycles, or even fewer: An interrupted primary system heatup is possible without initiating feedwater heating (or with flow through only the economizer feedwater lines); but a main feedwater penetration heatup is unlikely without a primary system heatup.

Combined Effect of BC-TOP-1 Loading Conditions IV and V with a Large Increase in the Number of Condition V Events

The faulted Loading Condition IV event would not affect the fatigue calculation for an ASME III Class 1 pressure boundary component. Since only one faulted event is assumed at the end of life, the number of faulted events that might be included in a fatigue evaluation, such as this, is also not time-dependent and is therefore not a TLAA. The main steam and main feedwater penetrations are not ASME III Class 1 components; however, they must function following this faulted event. To assess the combined effect, the effect of the increased number of Condition V normal operating loads is therefore combined with the effect of the unchanged number of Condition IV faulted events.

Even if the main steam penetrations experience a very large number of BC-TOP-1 Part II Condition V events, an examination of the analysis basis demonstrates that the design is adequate. The Condition V events do not contribute significantly to usage factor, and a revised BC-TOP-1 analysis for any reasonably expected increase in the number of these events demonstrates adequate margin to the stress limit determined by the elastic-plastic analysis.

ASME III-1971 Figure I-9-1 indicates that about 3,600 cycles could be accommodated by the BC-TOP-1 simplified elastic-plastic analysis at $S_a' = 52,800$ psi, as calculated for the worst-case Condition V event.

Alternatively, adding the usage factor estimated above for 10 Loading Condition IV events to 10 times the 250 startup-shutdown cycles expected in 60 years, or 2500 Condition V events, would still result in a usage factor estimate less than 1.0, and therefore would not affect the conclusion of the analysis:

$$0.270 + 25.0 \times 0.028 = 0.970.$$

The main feedwater penetration calculation does not specifically apply the typical, illustrative BC-TOP-1 main steam penetration fatigue evaluation for the combined Condition IV and V events to the main feedwater penetrations. The applicability of the BC-TOP-1 main steam penetration evaluation to the feedwater penetrations depends on the citation of the separate main steam penetration calculation by the main feedwater penetration calculation, and from the similarity of operating conditions, geometry, and size of these penetrations and lines. (The main steam lines are 28-inch in 56-inch penetrations, the main feedwater lines are 24-inch in 52-inch penetrations, and the penetration design is similar.) The applicability of the main steam penetration evaluation for the period of extended operation to the main feedwater penetrations follows on the same basis.

Disposition: Validation, 10 CFR 54.21(c)(1)(i)

There is sufficient margin in the design for any possible increase in operating cycles above the original estimate. The design of the main steam and main feedwater penetrations is

therefore valid for the period of extended operation, in accordance with 10 CFR 54.21(c)(1)(i).

4.6.3 Design Cycles for the Recirculation Sump Suction Line Penetrations

Summary Description

Recirculation sump suction line containment penetrations were evaluated for an NE-3222.4(d) exemption from fatigue analysis. The exemption criteria depend on the number of cycles for which loads are applied; therefore the exemption is supported by a TLAA.

Analysis

The analysis of these penetrations was based on the alternating stress range for pressure cycles, and demonstrated that the allowable number of cycles is 1×10^4 . This is far greater than the number expected for the period of extended operation.

Disposition: Validation, 10 CFR 54.21(c)(1)(i)

There is sufficient margin in the design for any possible increase in operating cycles above the original estimate. The design of the recirculation penetrations is therefore valid for the period of extended operation, in accordance with 10 CFR 54.21(c)(1)(i).

4.7 PLANT-SPECIFIC TIME-LIMITED AGING ANALYSIS

4.7.1 Load Cycle Limits of Cranes, Lifts, and Fuel Handling Equipment Designed to CMAA-70

Summary Description

The licensing basis describes design of the following lifting machines to Crane Manufacturers Association of America standard CMAA-70:

Cranes

- Containment Polar Crane
- Cask Handling Crane
- SAFLIFT™ Strongback Canister Hoist
- New Fuel Handling Crane

Fuel- and CEA Handling Machines

- Spent Fuel Handling Machine
- Refueling Machine
- Control Element Assembly (CEA) Change Platform
- Fuel Transfer System (Upenders, Trolley, etc.)
- New Fuel Elevator
- CEA Elevator

[UFSAR 9.1.4.1.4]³

The CMAA-70 crane service classification (hereinafter “class” or “service level”) for each machine depends, in part, on the assumption that the number of stress cycles at or near the maximum allowable stress will not exceed the number assumed for that design class. In operation, this means the number of lifts which approach or equal the design load (significant lifts) will not exceed the number of stress cycles assumed for that design class. The designs of these machines for these standard numbers of lifts for the plant lifetime are therefore TLAAs.

³ UFSAR Section 9.1.4.1 describes the design basis of the fuel handling equipment and the “...equipment used for assembly, disassembly and storage of the reactor closure head and internals.” The codes and standards listed in UFSAR Section 9.1.4.1.4 therefore apply to all these machines. CMAA-70 design is more explicit in the crane specifications, and in UFSAR 9.1.4.1.2.A for the fuel- and CEA handling machines.

Cranes

Containment Building Polar Crane: The polar crane is designed to CMAA-70, Class A, with 225 ton main and 35 ton auxiliary hoists [UFSAR 9.1.4.1]. The main hoist is used to remove the reactor vessel head, the reactor vessel upper internals, and the lower internals. The auxiliary hoist is used for routine maintenance and inservice inspection. The crane has three operational requirements: steam generator erection (SGE), plant operation, and steam generator removal (SGR).

Cask Handling Crane: The cask handling crane is an indoor electrical overhead traveling bridge crane with a single failure proof trolley [UFSAR 9.1.4.2.2.16]. The main hoist is rated at 150 tons and the auxiliary hoist is rated at 15 tons. The cask handling crane currently meets CMAA-70, Service Level A standards [UFSAR 9.1.4.1.4].

SAFLIFT Strongback Canister Hoist: The SAFLIFT™ strongback canister hoist is a combined 125 ton lift beam plus 50 ton single-failure-proof canister hoist. It is suspended from the cask handling crane main hook and trolley in order to provide single-failure-proof lifts of spent fuel casks and fuel canisters. It is designed to CMAA-70 Class C (2000), NUREG-0554 (1979), and to NUREG-0612 Appendix C (1980) [UFSAR 9.1.4.2.2.16].

New Fuel Handling Crane: The new fuel handling crane is a CMAA-70 Service Level C, 10 ton bridge crane. It is also used to perform activities associated with spent fuel reconstitution and recaging [UFSAR 9.1.4.2.2.17].

Fuel- and CEA Handling Machines

The original specification for the refueling machines invokes CMAA-70 but does not include a CMAA-70 service level. For each of these machines the specification also requires design for a stated number of lifetime operations that is less than the limiting number contemplated by the lowest CMAA-70 classification (Class A, 100,000 lifts). The specification does not permit a reduction in the CMAA-70 allowable design stresses, and these lower numbers must therefore be estimates of the expected lifetime operations rather than design criteria.

Spent Fuel Handling Machine: The spent fuel handling machine transfers fuel between the new fuel elevator, the transfer system, the spent fuel storage racks, and the spent fuel storage canister in the cask loading pit [UFSAR 9.1.4.2.1]. The specification requires design for 60,000 cycles of full speed hoist operation and 30,000 cycles of bridge and trolley operation. The hook capacity is 2000 lbf.

Refueling Machine: “The refueling machine moves fuel assemblies into and out of the core and between the core and the transfer system” [UFSAR 9.1.4.2.1]. The specification requires design for 60,000 cycles of full speed hoist operation and 30,000 cycles of bridge and trolley operation. The hook load is limited to 2600 lbf over “fuel only regions” and 1600 lbf over “fuel plus hoistbox regions.”

Section 4
TIME-LIMITED AGING ANALYSES

Control Element Assembly (CEA) Change Platform: “The CEA change platform is used to move the CEAs within the Upper Guide Structure or between the UGS and the CEA elevator” [UFSAR 9.1.4.2.1]. The specification requires design for 30,000 cycles of full speed operation. The hook capacity is 2000 lbf. The CEA change platform is not expected to perform any over-capacity lifts during its lifetime.

Fuel Transfer System (Upenders, Trolley, etc.): “The fuel transfer system moves the fuel between the containment building to the fuel building through the transfer tube” [UFSAR 9.1.4.2.1]. The specification requires design for 10,000 cycles of operation, where one cycle consists of the transport and handling operations associated with the exchange of fuel assemblies between the fuel handling and containment buildings. The fuel transfer components are not expected to perform any over-capacity transfers during their lifetime.

New Fuel Elevator: “The new fuel elevator is used to introduce new fuel into the spent fuel pool so that it can be moved to the transfer system by the spent fuel-handling machine” [UFSAR 9.1.4.2.1]. The specification requires design for 20,000 cycles of operation, where one cycle is defined as one complete up and down movement of the elevator. The capacity is 2000 lbf. The new fuel elevator is not expected to perform any over-capacity lifts during its lifetime.

CEA Elevator: “The CEA elevator is used to introduce new CEAs into the refueling pool and may be used to hold the spent CEAs while they are being disassembled for disposal” [UFSAR 9.1.4.2.1]. The specification requires design for 10,000 cycles of operation. The capacity is 2000 lbf. The CEA elevator is not expected to perform any over-capacity lifts during its lifetime.

Analysis

During construction and steam generator replacement, the Polar Crane bridge was used to support a temporary lift rig. None of these lifts exceeded the capacity of the bridge and the polar crane trolley was not used for these lifts. Therefore these activities had no effect on the trolley, and added only a very few full-capacity lifts to the bridge loading history.

The number of significant lifts for each machine per refueling outage is estimated from the UFSAR Section 9.1.4.2.3.3 description of refueling operations. This number is then multiplied by a factor of 1.5 to account for non-refueling lifts. Based on an 18-month refuel cycle, approximately 27 refuel cycles are expected over a 40-year plant design life, or about 40 in a 60-year design life.

Section 4
TIME-LIMITED AGING ANALYSES

Table 4.7-1 - Estimated Maximum Number of Significant Crane Lifts

Lifting Machine	Per Refuel (Pr)	Per Refuel Estimate (Pr x 1.5)	40 year Cycles (27 x Est.)	60 year Cycles (1.5 x 40 yr)	Design Lifts (CMAA Class)
Polar Crane	6 ⁽¹⁾	9	243	390	100,000(A)
Cask Handling Crane	21 ⁽²⁾	32	864	1,296	100,000(A)
SAFLIFT™	63 ⁽²⁾	95	2,565	3,848	500,000(C)
New Fuel Handling Crane	340 ⁽³⁾	510	13,770	20,655	500,000(C)
Spent Fuel Handling Machine	1,071 ⁽⁴⁾	1,607	43,389	65,084	100,000 (A) [30,000] ⁽⁵⁾
Refueling Machine	532 ⁽⁶⁾	798	21,546	32,319	100,000 (A) [30,000]
CEA Change Platform	36 ⁽⁷⁾	54	1458	2187	100,000 (A) [30,000]
Fuel Transfer System	482 ⁽⁸⁾	723	19,521	29,282	100,000 (A) [10,000]
New Fuel Elevator	108 ⁽⁹⁾	162	4,374	6,561	100,000 (A) [20,000]
CEA Elevator	18 ⁽¹⁰⁾	27	729	1,094	100,000 (A) [10,000]

¹ Based on 2 cycles each for missile shield, head, and CEA guide structure per refuel (plus 25 total construction, steam generator replacement, core, and core internal lifts, included in the Pr x 1.5 allowance).

² Based on hypothetical transfer to dry storage of all spent fuel for each refuel (3 cycles per cask, 7 casks per unit, and times 3 units for the common SAFLIFT™).

³ Based on 3 cycles each for 108 new fuel assemblies each refuel and 16 gate lifts per operating cycle.

⁴ Based on core offload/reload, 241 (x2 lifts each) fuel assemblies each refuel, 108 new fuel assemblies to pool each refuel, 168 (x2 lifts each) operating cycles for dry coolant sipping and

ultrasonic inspection, 108 assembly moves for pool optimization, and 37 for fuel assembly inspection each refuel.

⁵ Equipment specification lifetime lifts are in brackets.

⁶ Based on core offload/reload, 241 (x2 lifts each) fuel assemblies each refuel, plus 50 miscellaneous lifts per cycle.

⁷ Based on 89 x 2 cycles every 5 refuelings (36 every refuel).

⁸ Based on core offload/reload, 241 (x2 lifts each) fuel assemblies each refuel.

⁹ Based on 108 new fuel assemblies per refuel.

¹⁰ Based on 89 CEAs every 5 refuels (18 each refuel).

The polar crane, cask handling crane, new fuel handling crane, SAFLIFT™, CEA change platform, CEA elevator, and new fuel elevator will experience only a fraction of their rated lifetime number of lifts over 60 years. Their designs are therefore valid for a 60-year design life.

The estimated operations of the spent fuel handling machine, refueling machine, and fuel transfer system for a 60-year design life exceed the number of operations expected by their original specification. However, these machines were designed to the minimum Service Level A standards of CMAA-70 and are therefore qualified for up to 100,000 lifts. The designs of the spent fuel handling machine, refueling machine, and fuel transfer system are therefore also valid for a 60-year design life.

Therefore, the designs of all of these lifting machines remain valid for the period of extended operation.

Disposition: Validation, 10 CFR 54.21(c)(1)(i)

The CMAA-70 design standard full-capacity lifts for each machine exceeds the number expected of the machine for a 60-year period of operation. The designs of these machines therefore remain valid for the period of extended operation, in accordance with 10 CFR 54.21(c)(1)(i).

4.7.2 Absence of TLAAs for Metal Corrosion Allowances and Corrosion Effects

Summary

Nuclear plant components are commonly designed with corrosion allowances, and TLAAs of corrosion effects for the 40-year design life sometimes occur. However, a review of the PVNGS licensing basis found no description of time-dependant corrosion allowances, rates, or corrosion-dependent design lives of pressure vessels, system components, piping, or metal containment components; other than some *pro forma* statements for which further examination found no time-dependent analytical basis, and those described in [Sections 4.7.4](#) and [4.7.5](#).

4.7.3 Inservice Flaw Growth Analyses that Demonstrate Structural Stability for 40 Years

Summary

Defects discovered by inservice inspection or component failures may be repaired or replaced to restore the basis of the original design analysis; may be repaired or replaced to a different configuration, or may be analyzed to confirm that the as-found condition is acceptable. For ASME components these activities are controlled by Section XI, *Rules for Inservice Inspection of Nuclear Power Plant Components*. A flaw analysis of a Class 1 component usually requires a fatigue crack growth analysis, which is a TLAA if it qualifies the component for the plant design life. A thorough review of the PVNGS licensing basis, supported by interviews with plant staff familiar with the history of Class 1 components, found the following TLAA evaluation of indications discovered during inservice inspections:

- A linear elastic fracture mechanics (LEFM) fatigue crack growth analysis of indications in a Unit 2 pressurizer support skirt forging weld. See [Section 4.3.2.4](#).

The review also found the following similar evaluations of postulated (rather than actual) initial defects:

- Crack growth and fracture mechanics stability analyses of postulated defects in original heater sleeve attachment welds remaining in the pressurizer lower heads following heater sleeve replacements. See [Section 4.3.2.4](#).
- Fatigue crack growth and fracture mechanics stability analyses in support of pressurizer nozzle overlays. See [Section 4.3.2.4](#).
- Fatigue crack growth and fracture mechanics stability analyses in support of hot leg surge and shutdown cooling nozzle weld overlays. See [Section 4.3.2.7](#).
- Fatigue crack growth assessments and fracture mechanics stability analyses in support of the leak-before-break (LBB) evaluation, but no TLAA's. See [Section 4.3.2.15](#).
- Fatigue crack growth and fracture mechanics stability analyses of half-nozzle repairs to alloy 600 material in reactor coolant hot legs. See [Section 4.7.4](#).

4.7.4 Fatigue Crack Growth and Fracture Mechanics Stability Analyses of Half- Nozzle Repairs to Alloy 600 Material in Reactor Coolant Hot Legs; Absence of a TLAA for Supporting Corrosion Analyses

Summary

PVNGS obtained exemptions from the flaw removal and successive inspection requirements of ASME XI (1992) sections IWA-3300 and IWB-2420, for the alternative half-nozzle method used to repair Alloy 600 small bore, hot leg nozzles.

Analysis of corrosion in the hot leg piping walls, exposed by the repairs, depends on time at cold shutdown. This analysis was extended beyond 60 years and is therefore not a TLAA. However the code exemption permitting these repairs was granted only through the fourth 10-year inspection interval, and must therefore be extended for the period of extended operation. The safety determination supporting this code exemption is also supported by a commitment to track time at cold shutdown conditions, which must also be continued for the period of extended operation.

Fatigue crack growth and stability analyses of nozzle remnants and welds left in the hot legs depend on the number of heatup-cooldown and operating basis earthquake (OBE) cycles assumed for a 40-year life, and are therefore TLAAs.

Analysis

Absence of TLAAs in Corrosion Analyses in Support of Hot Leg Half-Nozzle Repairs

In March, 2004, Westinghouse Electric released topical report WCAP-15973-P, approved as WCAP-15973-P-A, *Low-Alloy Steel Component Corrosion Analysis Supporting Small-Diameter Alloy 600/690 Nozzle Repair/Replacement Programs* [Ref. 24]; and calculation CN-CI-02-71, *Summary of Fatigue Crack Growth Evaluation Associated with Small Diameter Nozzles in CEOG Plants* [Ref. 25]. These reports support half nozzle and mechanical nozzle seal assembly (MNSA) repairs in Combustion Engineering plants.

On March 25, 2005, PVNGS submitted APS letter 102-05237 to the NRC [Ref. 26]. This request uses CN-CI-02-71 and WCAP-15973-P in support of a request for exemption from the flaw removal and successive inspection requirements of ASME XI (1992) sections IWA-3300 and IWB-2420, for the alternative half-nozzle method used for the 10 PVNGS Unit 2 small bore, hot leg nozzles to be repaired during the Spring 2005 refueling outage. WCAP-15973-P calculated corrosion rates of 1.53 mils per year (mpy) for Alloy 600 nozzles. In response to the conditions of the final safety evaluation for the Westinghouse topical report, APS calculated that a limiting corrosion rate of 1.377 mpy for Unit 3 would not exceed the allowable diameter until 2058, 60 years after the repair and 10 years after the end of the period of extended operation. This calculation is therefore not a TLAA, and is valid for the period of extended operation.

Section 4 TIME-LIMITED AGING ANALYSES

However, in the relief request submittal, APS made an ongoing commitment to track the time at cold shutdown conditions:

APS commits to continue to track the time at cold shutdown conditions against the assumptions made in the corrosion analysis to assure that the allowable bore diameter is not exceeded over the life of the plant. If the analysis assumptions are exceeded, APS shall provide a revised analysis to the NRC and provide a discussion on whether volumetric inspection of the area is required.

[Ref. 26]

This commitment was made because the corrosion rate at cold shutdown conditions is significantly higher than at operating conditions. This request was authorized by the NRC, consistent with the APS commitment, and is valid for the second, third, and fourth 10 year inspection intervals. Therefore, an extension of this authorization will be required for continued relief from the ASME code sections.

Fatigue Crack Growth and Stability Analysis in Support of Hot Leg Half-Nozzle Repairs

Westinghouse calculation CN-CI-02-71 found that postulated defects left in unremoved portions of the hot leg nozzles would not grow beyond an acceptable or unstable size, assuming 500 heatup/cooldown cycles and 200 OBE cycles, which are the design basis for PVNGS for a 40-year life. The CN-CI-02-71 fatigue crack growth and stability analysis is therefore a TLAA.

Extension to All Hot Leg Small-Bore Nozzles

After reconciling the WCAP 15973-P topical report with the non-Westinghouse documentation which it had originally used as a basis, APS issued Revision 1 to Relief Request 31 in APS Letter 102-05324 [Ref. 27], which adds the 63 previously-repaired small bore hot leg nozzles in all three units to those already covered in the initial request. This request was also granted by the NRC.

All of PVNGS's small diameter hot leg nozzles have been replaced. PVNGS has a total of 27 small diameter hot leg penetrations per unit, as described in section IV of Relief Request 31, Rev. 1, which is enclosed in APS letter 102-05324.

See [Section 4.3.2.7](#) for a description of the half-nozzle repairs and their effects on the RCS fatigue analyses.

Disposition: Aging Management, 10 CFR 54.21(c)(1)(iii)

Corrosion Analysis - No TLAA, but Supporting Program and Exemption Require Extension

The WCAP-15973-P analysis of corrosion in the hot leg pipe wall due to exposure to reactor coolant by small-bore half-nozzle repairs was extended by APS for a period in excess of the period of extended operation, and is therefore not a TLAA. However the relief from the ASME Section XI requirements is supported by an APS commitment to continue to track the time at cold shutdown conditions against the assumptions made in the corrosion analysis, to assure that the allowable bore diameter is not exceeded over the life of the plant. This program is a condition of Revision 1 to Relief Request 31 of APS Letter 102-05324, granted by the NRC, and is applicable to all three units for the second, third, and fourth 10 year inspection intervals. An extension of this authorization will be requested for the period of extended operation, supported by a continuation of the cold shutdown time monitoring program. The effect of corrosion in the half-nozzle hot leg piping bores will thereby be managed for the period of extended operation.

Fatigue Crack Growth and Stability Analysis

The CN-CI-02-71 fatigue crack growth and stability analysis will remain valid for the period of extended operation if the assumed cycle count is not exceeded. The Metal Fatigue of Reactor Coolant Pressure Boundary program will track events to ensure that appropriate reevaluation or other corrective action is initiated if an action limit is reached. Action limits will permit completion of corrective actions before the design basis number of events is exceeded.

Effects of fatigue crack growth originating from postulated defects nozzle and weld remnants in the primary coolant hot leg small-bore nozzle penetrations will thereby be managed for the period of extended operation, in accordance with 10 CFR 54.21(c)(1)(iii).

The Metal Fatigue of Reactor Coolant Pressure Boundary program is summarized in Appendix B, [Section B3.1](#). See [Table 4.3-4](#) for details of the program, and [Section 4.3.1.5](#) for a description of its action limits and corrective actions.

4.7.5 Absence of a TLAA in Corrosion Analyses of Pressurizer Ferritic Materials Exposed to Reactor Coolant by Half-Nozzle Repairs of Pressurizer Heater Sleeve Alloy 600 Nozzles

[Section 4.3.2.4](#), "Pressurizer and Pressurizer Nozzles," describes the half-nozzle repairs that were performed on the pressurizer heater sleeves for Units 1, 2, and 3. The repairs resulted in unclad base metal being exposed to reactor coolant, and therefore to corrosion not considered in the original design. This departure from the original design basis was evaluated and determined to be acceptable. Even though the results were time dependent, they are not TLAAs because the time period is beyond the end of the extended operating period of 60 years.

The bounding case for general corrosion in pressurizer heater sleeves in WCAP-15973-P gives an estimated repair life of 194 years; therefore the analysis is not a TLAA, and is valid for the period of extended operation.

4.7.6 Absence of a TLAA for Reactor Vessel Underclad Cracking Analyses

The NUREG-1800 *Standard Review Plan for License Renewal*, Table 4.1-3, identifies “Intergranular separation in the heat-affected zone (HAZ) of reactor vessel low-alloy steel under austenitic SS cladding” as a potential TLAA. This phenomenon has been addressed in the PVNGS vessel by the choice of material and weld cladding processes that are designed to avoid these defects, consistent with Regulatory Guide 1.43. No cracks have been discovered at PVNGS.

The vessel shell and head plates are constructed of SA-533, Grade B, Class 1 Steel. SA-533 is immune to underclad cracking. The only reactor vessel components susceptible to underclad cracking are constructed of SA-508, i.e. the reactor vessel nozzles and flange. These components were clad with low-heat-input processes, which are not known to cause underclad cracking.

The determination that the reactor vessel material is not susceptible to underclad cracking is not based on time dependent analyses and is therefore not supported by a TLAA. The determination is instead based on material properties and welding processes that eliminated or reduced the potential for underclad cracking.

4.7.7 Absence of a TLAA for a Reactor Coolant Pump Flywheel Fatigue Crack Growth Analysis

The NUREG-1800 *Standard Review Plan for License Renewal* identifies “Fatigue analysis of the reactor coolant pump flywheel” as a potential TLAA [Table 4.1-3].

A reactor coolant pump flywheel could conceivably burst because of centrifugal stresses, which could produce missiles inside containment and could also damage pump seals or other pressure boundary components. This concern is the subject of Regulatory Guide 1.14 and its predecessor Safety Guide 14.

The current PVNGS licensing basis commits to the 10-year-interval inspections of Safety Guide 14 (Rev. 0) Position c.4.b.

PVNGS relies on flywheel design, material, fabrication, and the periodic inspections in accordance with Safety Guide 14 Position c.4.b. No crack growth analysis or time-dependent probabilistic failure assessment has been performed for the PVNGS flywheels, either to extend the inspection interval for less than the design life, or to support a safety determination for the design life, and therefore no TLAA exists.

4.7.8 Building Absolute or Differential Heave or Settlement, including Possible Effects of Changes in a Perched Groundwater Lens

Summary Description

The review of site soil mechanics and hydrogeology for the original PVNGS license application identified two additional related areas: (1) possible effects of heave and settlement on building foundation levels and stability, and (2) possible effects of changes in level of a perched groundwater lens⁴ on heave, settlement, and foundation stability.

Changes in groundwater elevation can affect heave and settlement. Wetting can affect soil compressibility; and in some soil types, the soil hydrostatic pressure, since some soil types swell when wet and shrink when dry. Some others may liquefy under stress when wet, a significant concern for foundation stability.

Concerns for the effects of heave and settlement, and of effects of changes in the perched groundwater level on heave and settlement, prompted interrelated calculations and estimates of these effects by APS and by NRC reviewers. The licensing bases, particularly the PSAR, UFSAR, and SER contain extensive discussions of heave and settlement, and perched groundwater, including references to the plant life.

Because of these references to the plant life, APS has elected to classify these original evaluations and analyses as TLAAs, although (1) the analyses show asymptotic results that might be understood to apply to a considerable period beyond the original 40-year licensed operating period, (2) the anticipated rise in perched near-surface groundwater has instead been a decline, and (3) the Structures Monitoring Program has so far recorded no adverse, or even significant, long-term heave or settlement effects.

The SER and the UFSAR document the licensing commitment to continue the post-construction settlement surveillance program for the life of the license. This surveillance is performed as part of the Structures Monitoring Program ([B2.1.32](#)).

Analysis

Analyses of Post-construction Heave and Settlement

The geology of the PVNGS site area was investigated in detail prior to construction. The results of these investigations were described in the Preliminary Safety Analysis Report (PSAR) and Final Safety Analysis Report (now the updated FSAR or UFSAR). These

⁴ A locally-elevated region of groundwater above an impermeable layer (i.e., perched above an aquitard), charged by some local source, in this case by irrigation prior to construction.

investigations were also reviewed and summarized by the NRC in the SER. APS reported the projected groundwater levels near the power block.

Pre-Construction Heave and Settlement Analyses

Results of the heave and settlement predictions are shown in [UFSAR Section 2.5.4.10.2](#) and [Figures 2.5-87, 2.5-88, and 2.5-89](#). The figures show predicted amounts of heave, total recompression settlements, and post construction settlements, respectively.

- Heave estimates range to a maximum of approximately 7 inches.
- Estimates of total recompression settlements range from approximately 0.2 inch to about 7 inches.
- Estimates of post-construction total settlements are less than 1-½ inches for any structure, and less than ½ inch for most structures. Calculated post-construction differential settlements are less than 0.1 inch.
- Settlements are expected to occur soon after load application and to be well within tolerable limits for the structures involved.

Post-Construction Heave and Settlement Survey Results

A post-construction survey evaluated the prompt post-construction conditions, as of 1984, and concluded that the effects were acceptable.

- Post construction differential settlements for power block structures were within ½ inch. Movements experienced by piping is considerably less, since piping welds between buildings were made at a later date.
- Piping between buildings is inherently flexible to accommodate seismic anchor motion between buildings.
- The pipe supports are designed with 1/16 inch clearance which will accommodate some pipe movement.
- Building settlement in the future is negligible as can be extrapolated from the building settlement curves.
- Settlement calculations demonstrate that piping conditions are acceptable.

Effects of the Perched Groundwater Lens on Building Foundation Heave, Settlement, and Stability

The licensing basis documents describe the site hydrogeology, including the perched groundwater lens. The existence of a perched groundwater lens under the PVNGS site was of concern for three reasons: (1) an increase in the water level of this lens above the

Section 4 TIME-LIMITED AGING ANALYSES

foundation elevations could affect their stability, on the other hand (2) if the level of this lens declined, settlement could conceivably exceed expectations. Also, (3) if recharge from installed ponds increased the groundwater elevation, heave could be greater than contemplated in the design.

Perched Groundwater Level Increase and Foundation Stability

The SER summarized concerns that seepage from the onsite storage reservoir and evaporation pond could raise the perched groundwater levels. APS, however, provided an analysis showing that this seepage would not increase the perched groundwater levels higher than the hydrostatic design basis water levels during the life of the station. The SER results shown in SER Table 2.3 agree with the results of the original groundwater level analysis described in [UFSAR Section 2.4.13.2.4.D](#) that the predicted groundwater levels might increase but would asymptotically level out below the design groundwater levels of the three units.

The [UFSAR Section 2.4.13.2.4.D](#) discussion of this analysis does not directly indicate a dependence of the safety determination on a specific period of time, but rather discusses predictions that the water levels under each unit will stay below design groundwater levels.

The asymptotic characteristic of these predictions and the fact that the post-construction survey results found that the perched groundwater level has actually decreased, validate the safety determination based on these predictions for the period of extended operation. That is, the perched groundwater levels will not exceed the levels assumed for the building foundation designs and will therefore not affect building stability.

Perched Groundwater Level Decrease and Settlement

Rather than rising, the level of the perched groundwater lens has continued to fall. The UFSAR therefore also discusses a potential for subsidence due to decline in the perched groundwater level. However, based on a realistic groundwater model, dewatering of this perched zone can be expected to cause a slight reduction in effective stresses within and below the aquitard resulting in a slight amount of heave, not subsidence.

Observations from the Structures Monitoring Program, confirmed that there is no potential for settlement due to dewatering. The continuing settlement monitoring, which is conducted as part of the Structures Monitoring Program, will ensure that these conclusions remain valid.

Possible Sources of Recharge

The groundwater model assumed that the water storage reservoir was not lined. The conclusion was that seepage from the reservoir would not affect the units. Observations have confirmed that groundwater levels in monitoring wells have declined, some to the point that the wells are dry. These data confirm that recharge to the perched groundwater lens

has decreased significantly since irrigated agriculture ceased in 1975, and the decline in the shallow groundwater levels beneath the units is therefore expected to continue.

Damage to the liner in the 80-acre reservoir was discovered in 2004. The date of the damage is unknown. After discovery of the liner damage, PVNGS designed, and in 2006 constructed, a new double-lined 45-acre reservoir. The 80-acre reservoir was also drained, expanded to 85 acres, and repaired by installation of a new double liner system. The new liners should prevent any future recharge of the shallow aquifer from the reservoirs, which are the only potential source of significant recharge in the vicinity of the units. The wells in the vicinity of the reservoirs have not yet shown any effects of increased leakage to the groundwater. Therefore there is little likelihood of groundwater levels rising high enough to threaten foundation stability in the future.

Current Settlement Monitoring Activities

The PVNGS licensing basis includes a commitment to monitor settlement of structures for the life of the plant. The current Structures Monitoring Program monitors foundation responses and ground movement of the major structures. Settlement monitoring, which is part of the Structures Monitoring Program, is performed at five year intervals and demonstrates compliance with settlement design criteria for each major structure.

Settlement Monitoring Acceptance Criteria

The structures monitoring procedures invoke the following acceptance criteria for post-construction settlement, differential settlement, and post-construction tilt.

- Post-construction settlement for each individual structure: Less than 1.5 inches.
- Post-construction differential settlement at a common point between any two adjacent structures having critical connections: Less than 0.5 inch.
- Post-construction containment tilt angle: Less than 0.057 degrees.

The first action limit is 90 percent of each acceptance criterion and requires an increase in survey frequency, and if necessary, a remedial action plan.

Settlement Monitoring Surveillance Results

Short-term post construction differential settlement (as of 1984) was acceptable. The largest differential settlement was believed to be due to changes in the construction schedule (changes in adjacent loading), and backfill which proved more compressible than originally thought. The largest short-term post-construction differential settlement between any two Category I structures was 0.3 inches.

The settlement monitoring surveillance is performed in accordance with the Structures Monitoring Program procedures with a frequency of 5 years; review of the 2003 settlement monitoring surveillance results concludes that the accumulated total settlement, differential

Section 4
TIME-LIMITED AGING ANALYSES

settlement, and tilt indicate no significant trends. The to-date total settlement, differential settlement, and tilt values are shown [Table 4.7-2](#):

Table 4.7-2 - Settlement Monitoring Surveillance Results: Total Settlement, Differential Settlement, and Containment Tilt⁽¹⁾

	Appendix D Criteria		Unit 1	Unit 2	Unit 3
	Max	90%			
Post-Construction Settlement	1.5 in	1.35 in	1.3092 in	1.1784 in	0.9132 in
Post-Construction Differential Settlement	0.5 in	0.45 in	0.4476 in ⁽²⁾	0.8748 in ⁽³⁾	0.4356 in ⁽²⁾
Containment Building Tilt	0.057°	0.0513°	0.0039°	0.0064°	0.0121°

¹ Values and results were obtained from the 2003 surveillance tests.

² Increased monitoring frequency verified that a significant trend of settlement or differential settlement was not occurring. The frequency has since been reduced to 5 years.

³ The differential settlement values for the 2003 surveillance test between the Auxiliary and Radwaste buildings are larger than the maximum allowable. The reason for the large differential settlement value is the relative large post-construction settlement at the Radwaste building marker (SM-31). The post-construction settlement at SM-31 is within the maximum allowable (1.50 in). The next highest differential settlement value for Unit 2 is between the Radwaste and Control buildings at 0.4332 in, which is close to the 90% action limit. Increased monitoring frequency at both of these locations has verified that a significant trend of settlement or differential settlement was not occurring. The frequency has since been reduced to 5 years.

The foundations therefore are and will remain stable. The settlement monitoring surveillances are included in the Structures Monitoring Program described in [Appendix B2.1.32](#), and fall under the scope of the maintenance rule. The Structures Monitoring Program will continue through the period of extended operation, and will continue to ensure that foundations remain stable.

Disposition: Validation, 10 CFR 54.21(c)(1)(i); and Aging Management, 10 CFR 54.21(c)(1)(iii)

Aging Management - Structures Monitoring Program

The settlement monitoring data, which are collected under the Structures Monitoring Program described in [Appendix B2.1.32](#), indicate that the foundations are and will remain stable. The Structures Monitoring Program will continue through the period of extended operation to ensure that settlement remains below the limits set in the UFSAR and the SER, and therefore that building foundations remain stable, in accordance with 10 CFR 54.21(c)(1)(iii).

Validation - Analysis of Groundwater Effects

Data from the Structures Monitoring Program confirm that there have been no adverse effects of heave or settlement on building foundations to date from any cause. The groundwater monitoring data indicate no potential for settlement due to changes in groundwater level. These results confirm that the assumptions of the original projections of increases in groundwater levels were very conservative and that the conclusions of their safety determination - that there will be no effect on building foundation stability - apply to the foreseeable future and at least to the end of the period of extended operation. The conclusion of the predictions of groundwater level, and the safety determination based on them, therefore remain valid for the period of extended operation, in accordance with 10 CFR 54.21(c)(1)(i).

4.8 ABSENCE OF TLAAS SUPPORTING 10 CFR 50.12 EXEMPTIONS

PVNGS [UFSAR Table 1.10-1](#) lists two 10C FR 50.12 exemptions currently in effect, none of which “involve time-limited assumptions defined by the current operating term” (10 CFR 54.3(a) Criterion 3). Therefore no 10 CFR 50.12 exemptions are supported by TLAAs. A search of licensing correspondence identified all 10 CFR 50.12 exemptions and requests for exemptions and confirmed that no others remain in effect.

4.9 REFERENCES

1. US NRC NUREG-1800. *Standard Review Plan for the Review of License Renewal Applications for Nuclear Power Plants*. Rev. 1. Washington: US NRC, Office of Nuclear Reactor Regulation, September 2005.
2. US NRC NUREG-1801. *Generic Aging Lessons Learned (GALL) Report*. Rev. 1. Washington: USNRC, Office of Nuclear Reactor Regulation, September 2005.
3. US NRC Regulatory Guide 1.190. *Calculational and Dosimetry Methods for Determining Pressure Vessel Neutron Fluence*. Washington: USNRC, March 2001.
4. US NRC Regulatory Guide 1.35. *Inspection of Ungouted Tendons in Prestressed Concrete Containments*. Rev. 3. Washington: USNRC. Revision [blank], February 1973. Revision 1, June 1974. Revision 2 [ADAMS ML003740001], January 1976. Revision 3, July 1990 [ADAMS ML003740007].
5. US NRC NUREG-0857. *Safety Evaluation Report Related to the Operation of PVNGS Units 1, 2, and 3, Docket Nos. STN 50-528, STN 50-529, and STN 50-530, Arizona Public Service Company, et al.*. Washington: USNRC, Office of Nuclear Reactor Regulation, November 1981, with Supplements 1 (February 1982) through 12 (November 1987).
6. *ASME Boiler and Pressure Vessel Code, Section III, Rules for Construction of Nuclear Power Plant Components*. 1971 Edition. New York: ASME.
7. ASTM E 693. *Standard Practice for Characterizing Neutron Exposures in Iron and Low Alloy Steels in Terms of Displacements Per Atom (DPA)*. Philadelphia: American Society for Testing and Materials, Revision 1, 1 January 1994. Revision 2, 10 January 2001.
8. ASTM E 853. *Standard Practice for Analysis and Interpretation of Light-Water Reactor Surveillance Results*. Philadelphia: American Society for Testing and Materials, Revision 1, 1 January 1987. Revision 2, 10 June 2001.
9. APS Letter 161-01657-DBK/PGN. D. B. Karner, Executive Vice President, APS; to US NRC Document Control Desk. "Palo Verde Nuclear Generating Station (PVNGS) Units 1, 2, and 3, Generic Letter 88-11, Radiation Embrittlement of Reactor Vessel Materials." 31 January 1989.

With attached Final Report on Pressure-Temperature Limits for the Palo Verde Nuclear Generating Stations.
10. US NRC *Reactor Vessel Integrity Database Version 2.0.1*. 6 July 2000.

Section 4
TIME-LIMITED AGING ANALYSES

11. Westinghouse Report WCAP-14040-NP-A, *Methodology Used to Develop Cold Overpressure Mitigating System Setpoints and RCS Heatup and Cooldown Limit Curves*. Rev. 4. May 2004.
12. ANPP Letter ANPP-34670-EEVB/PGN. E. E. Van Brunt, Jr., Executive Vice President [and] Project Director; to Director of Nuclear Reactor Regulation, US NRC, Attention: Mr. George W. Knighton, Deputy Director, PWR Project Directorate #7, Division of Pressurized Water Reactor Licensing – B. “Palo Verde Nuclear Generating Station (PVNGS) Units 1, 2, and 3, Docket Nos. STN 50-528 (License NPF-41), STN 50-529 (License NPF-46), STN 50-530, Pressurized Thermal Shock”. 17 January 1986.
13. CE InfoBulletin 88-09. “Nonconservative Calculation of Cumulative Fatigue Usage.”
14. APS Letter 102-05299-DMS/CKS/DJS. David M. Smith, Plant Manager, Nuclear Production; to Document Control Desk, US NRC. “Palo Verde Nuclear Generating Station (PVNGS) Unit 2, Docket No. STN 50-529, License No. NPF-51, Licensee Event Report 2005-001-00.” 20 June 2005.
15. US NRC Letter. Mel B. Fields, Project Manager, Project Directorate IV-2, Division of Reactor Projects - III/IV, Office of Nuclear Reactor Regulation; to James M. Levine, Senior Vice President, Nuclear, APS. “Bounding Thermal Stratification Stresses in the Pressurizer Auxiliary Spray Line for the Palo Verde Nuclear Generating Station (TAC Nos. M88682, M88683 and M88684).” 2 June 1998.

With attached SER in response to the PVNGS response to IEB 88-08, *Safety Evaluation by the Office of Nuclear Reactor Regulation, Bounding Thermal Stratification Stresses in the Pressurizer Auxiliary Spray Line, Arizona Public Service Company, Palo Verde Nuclear Generating Station, Units 1, 2 and 3, Docket Nos. STN 50-528, STN 50-529 and STN 50-530.*
16. EPRI Report 1003056. *Non-Class 1 Mechanical Implementation Guideline and Mechanical Tools*. Rev. 3, Final Report. Palo Alto, CA: Electric Power Research Institute, November 2001.
17. Regulatory Guide 1.89. *Environmental Qualification of Certain Electrical Equipment Important to Safety for Nuclear Power Plants*. Washington: USNRC, Rev. 0 November 1974, Rev. 1 June 1984.
18. NUREG-0588. *Interim Staff Position on Environmental Qualification of Safety Related Electrical Equipment*. Washington: USNRC, July 1981.

Section 4
TIME-LIMITED AGING ANALYSES

19. Amendment 151 to License Numbers NPF-41, NFP-51, and NPF-74. US NRC Letter. Meena Khanna, Project Manager, Section 2, Project Directorate IV, Division of Licensing Project Management Office of Nuclear Reactor Regulation; to Gregg R. Overbeck, Senior Vice President, Nuclear, APS. "Palo Verde Nuclear Generating Station, Units 1, 2, and 3 - Issuance of Amendment on Containment Tendon Surveillance Program and Containment Leakage Rate Testing Program (TAC Nos. MC1069, MC1070, and MC1071)." 19 March 2004 [PVNGS LBI].

With Enclosed Amendment 151 to each license, and Attached Safety Evaluation by the Office of Nuclear Reactor Regulation, Related to Amendment No. 151 to facility Operating License No. NPF-41, Amendment No. 151 to Facility Operating License No. NPF-51, and Amendment No. 151 to Facility Operating License No. NPF-74, Arizona Public Service Company, et al., Palo Verde Nuclear Generating Station, Units 1, 2, and 3, Docket Nos. STN 50-528, STN 50-529, and STN 50-530.

20. Johnson, T. E, and B.W. Weddelsborg. Bechtel Topical Report BC-TOP-1. *Containment Building Liner Plate Design Report*. Rev. 1. Bechtel Corporation, December 1972. Supplemented by Ref. 21. Copy attached to Ref. 21.
21. Chang-Lo, P., and B.W. Weddelsborg. Supplement to BC-TOP-1 Revision 1 [Ref. 20]. *Additional Information Requested by the Atomic Energy Commission on BC-TOP-1 Revision 1 Containment Building Liner Plate Design Report*. San Francisco: Bechtel Power Corporation, September 1973.
22. Reuter, H. R. *et al.* Bechtel Topical Report BC-TOP-5-A. *Prestressed Concrete Nuclear Reactor Containment Structures*. Rev. 3. San Francisco: Bechtel Power Corporation, February 1975.
23. APS Letter 102-05398-CDM/SAB/RJR. David Mauldin, Vice President, Nuclear Engineering and Support; to Document Control Desk, US NRC. "Palo Verde Nuclear Generating Station (PVNGS) Units 1, 2 and 3, Docket Nos. STN 50-528/529/530, Proposed Alternative to PVNGS' ASME Section XI Inservice Inspection Program for ASME Code Category B-F, B-J, C-F-1, and C-F-2 Piping (Relief Request 32)." 16 January 2006 [PVNGS LBI].
24. Westinghouse Topical Report WCAP-15973-P-A. *Low-Alloy Steel Component Corrosion Analysis Supporting Small-Diameter Alloy 600/690 Nozzle Repair/Replacement Programs*. Rev. 0. Westinghouse Proprietary Class 2. Windsor, CT: Westinghouse Electric Company LLC, February 2005.
25. Westinghouse Calculation Note CN-CI-02-71. "Summary of Fatigue Crack Growth Evaluation Associated with Small Diameter Nozzles in CEOG Plants." Rev. 1. Westinghouse Proprietary Class 2. Windsor, CT: Westinghouse Electric Company LLC, 10 May 2000.

Section 4
TIME-LIMITED AGING ANALYSES

26. APS Letter 102-05237-CDM/SAB/RJR. David Mauldin, APS; to US NRC Document Control Desk. "Palo Verde Nuclear Generating Station (PVNGS), Unit 2, Docket No. STN 50-529, 10 CFR 50.55a(a)(3)(i) Alternative Repair Request for Reactor Coolant System Hot Leg Alloy 600 Small-Bore Nozzles (Relief Request 31)." 25 March 2005.

27. APS Letter 102-05324-CDM/SAB/RJR. David Mauldin, APS; to US NRC Document Control Desk. "Palo Verde Nuclear Generating Station (PVNGS), Units 1, 2, 3, Docket No. STN 50-528/529/530, 10 CFR 50.55a(a)(3)(i) Alternative Repair Request for Reactor Coolant System Hot Leg Alloy 600 Small-Bore Nozzles (Relief Request 31, Revision 1)." 16 August 2005.

This Page Intentionally Left Blank

APPENDIX A

UPDATED FINAL SAFETY ANALYSIS REPORT SUPPLEMENT

This Page Intentionally Left Blank

APPENDIX A - TABLE OF CONTENTS

A0	APPENDIX A INTRODUCTION	A-1
A1	SUMMARY DESCRIPTIONS OF AGING MANAGEMENT PROGRAMS	A-2
A1.1	ASME Section XI Inservice Inspection, Subsections IWB, IWC, and IWD	A-2
A1.2	Water Chemistry	A-2
A1.3	Reactor Head Closure Studs	A-3
A1.4	Boric Acid Corrosion	A-3
A1.5	Nickel-Alloy Penetration Nozzles Welded To The Upper Reactor Vessel Closure Heads of Pressurized Water Reactors	A-3
A1.6	Flow-Accelerated Corrosion	A-4
A1.7	Bolting Integrity	A-4
A1.8	Steam Generator Tube Integrity	A-5
A1.9	Open-Cycle Cooling Water System	A-5
A1.10	Closed-Cycle Cooling Water System	A-6
A1.11	Inspection of Overhead Heavy Load and Light Load (Related to Refueling) Handling Systems	A-6
A1.12	Fire Protection	A-6
A1.13	Fire Water System	A-7
A1.14	Fuel Oil Chemistry	A-8
A1.15	Reactor Vessel Surveillance	A-9
A1.16	One-Time Inspection	A-9
A1.17	Selective Leaching of Materials	A-10
A1.18	Buried Piping and Tanks Inspection	A-11
A1.19	One-Time Inspection of ASME Code Class 1 Small-Bore Piping	A-11
A1.20	External Surfaces Monitoring Program	A-12
A1.21	Reactor Coolant System Supplement	A-12
A1.22	Inspection of Internal Surfaces in Miscellaneous Piping and Ducting Components	A-13
A1.23	Lubricating Oil Analysis	A-13
A1.24	Electrical Cables and Connections Not Subject to 10 CFR 50.49 Environmental Qualification Requirements	A-14
A1.25	Electrical Cables and Connections Not Subject to 10 CFR 50.49 Environmental Qualification Requirements Used in Instrumentation Circuits	A-15
A1.26	Inaccessible Medium Voltage Cables Not Subject to 10 CFR 50.49 Environmental Qualification Requirements	A-15
A1.27	ASME Section XI, Subsection IWE	A-16
A1.28	ASME Section XI, Subsection IWL	A-16
A1.29	ASME Section XI, Subsection IWF	A-17
A1.30	10 CFR 50, Appendix J	A-17
A1.31	Masonry Wall Program	A-17
A1.32	Structures Monitoring Program	A-18
A1.33	RG 1.127, Inspection of Water-Control Structures Associated with Nuclear Power Plants	A-18
A1.34	Nickel Alloy Aging Management Program	A-19
A1.35	Electrical Cable Connections Not Subject to 10 CFR 50.49 Environmental Qualification Requirements	A-19

Appendix A
Updated Final Safety Analysis Report Supplement

A1.36	Metal Enclosed Bus	A-20
A2	SUMMARY DESCRIPTIONS OF TIME-LIMITED AGING ANALYSIS AGING MANAGEMENT PROGRAMS	A-21
A2.1	Metal Fatigue of Reactor Coolant Pressure Boundary	A-21
A2.2	Environmental Qualification (EQ) of Electrical Components	A-23
A2.3	Concrete Containment Tendon Prestress.....	A-23
A3	EVALUATION SUMMARIES OF TIME-LIMITED AGING ANALYSES	A-25
A3.1	Reactor Vessel Neutron Embrittlement	A-25
A3.1.1	Neutron Fluence, Upper Shelf Energy and Adjusted Reference Temperature (Fluence, USE, and ART)	A-25
A3.1.2	Pressurized Thermal Shock (PTS).....	A-26
A3.1.3	Pressure-Temperature (P-T) Limits.....	A-26
A3.1.4	Low Temperature Overpressure Protection (LTOP)	A-26
A3.2	Metal Fatigue Analysis.....	A-27
A3.2.1	ASME Section III Class 1 Fatigue Analysis of Vessels, Piping, and Components.....	A-28
A3.2.2	Fatigue and Cycle-Based TLAAAs of ASME III Subsection NG Reactor Pressure Vessel Internals.....	A-35
A3.2.3	Effects of the Reactor Coolant System Environment on Fatigue Life of Piping and Components (Generic Safety Issue 190)	A-35
A3.2.4	Assumed Thermal Cycle Count for Allowable Secondary Stress Range Reduction Factor in ANSI B31.1 and ASME Section III Class 2 and 3 Piping.....	A-37
A3.3	Environmental Qualification (EQ) of Electrical Components	A-37
A3.4	Concrete Containment Tendon Prestress.....	A-38
A3.5	Containment Liner Plate, Equipment Hatches, Personnel Air Locks, Penetrations, and Polar Crane Brackets	A-38
A3.5.1	Design Cycles for the Main Steam and Main Feedwater Penetrations	A-39
A3.5.2	Design Cycles for the Recirculation Sump Suction Line Penetrations	A-39
A3.6	Plant-Specific Time-Limited Aging Analyses	A-40
A3.6.1	Load Cycle Limits of Cranes, Lifts, and Fuel Handling Equipment to CMAA-70.....	A-40
A3.6.2	Fatigue Crack Growth and Fracture Mechanics Stability Analyses of Half-Nozzle Repairs to Alloy 600 Material in Reactor Coolant Hot Legs.....	A-40
A3.6.3	Building Absolute or Differential Heave or Settlement. Including Possible Effects of Changes in a Perched Groundwater Lens	A-40
A4	LICENSE RENEWAL COMMITMENTS	A-42

A0 APPENDIX A INTRODUCTION

Introduction

This appendix provides the information to be submitted in an Updated Final Safety Analysis Report Supplement as required by 10 CFR 54.21(d) for the PVNGS License Renewal Application. [Section A1](#) of this appendix contains summary descriptions of the programs used to manage the effects of aging during the period of extended operation. [Section A2](#) contains summary descriptions of programs used for management of time-limited aging analyses during the period of extended operation. [Section A3](#) contains evaluation summaries of TLAAAs for the period of extended operation. [Section A4](#) contains summary descriptions of license renewal commitments. These summary descriptions of aging management program programs, time-limited aging analyses, and license renewal commitments will be incorporated in the Updated Final Safety Analysis Report for PVNGS following issuance of the renewed operating license in accordance with 10 CFR 50.71(e).

A1 SUMMARY DESCRIPTIONS OF AGING MANAGEMENT PROGRAMS

The integrated plant assessment and evaluation of time-limited aging analyses (TLAA) identified existing and new aging management programs necessary to provide reasonable assurance that components within the scope of License Renewal will continue to perform their intended functions consistent with the current licensing basis (CLB) for the period of extended operation. [Sections A1](#) and [A2](#) describe the programs and their implementation activities.

Three elements common to all aging management programs discussed in [Sections A1](#) and [A2](#) are corrective actions, confirmation process, and administrative controls. These elements are included in the PVNGS Quality Assurance (QA) Program, which implements the requirements of 10 CFR 50, Appendix B. The PVNGS Quality Assurance Program is applicable to all safety-related and, after enhancement, will also be applicable to the nonsafety-related systems, structures and components that are subject to aging management review activities.

Procedures will be enhanced to include those nonsafety-related SSCs requiring aging management within the scope of the PVNGS Quality Assurance Program to address the elements of corrective actions, confirmation process, and administrative controls.

A1.1 ASME SECTION XI INSERVICE INSPECTION, SUBSECTIONS IWB, IWC, AND IWD

ASME Section XI Inservice Inspection, Subsections IWB, IWC, and IWD program manages cracking, loss of fracture toughness, and loss of material in Class 1, 2, and 3 piping and components within the scope of license renewal. The program includes periodic visual, surface, volumetric examinations and leakage tests of Class 1, 2 and 3 pressure-retaining components, including welds, pump casings, valve bodies, integral attachments, and pressure-retaining bolting. PVNGS inspections meet ASME Section XI requirements. The PVNGS third interval ISI Program is in accordance with 10 CFR 50.55a and ASME Section XI, 2001 Edition, through 2003 Addenda. PVNGS will use the ASME Code Edition consistent with the provisions of 10 CFR 50.55a during the period of extended operation.

A1.2 WATER CHEMISTRY

The Water Chemistry program includes maintenance of the chemical environment in the reactor coolant system and related auxiliary systems containing treated boric acid water and includes maintenance of the chemical environment in the steam generator secondary side and the secondary cycle systems to manage cracking, denting, hardening and loss of strength, loss of material, reduction of heat transfer, and wall thinning in primary and

secondary water systems. The Water Chemistry program is based upon the guidelines of EPRI 1002884, "*PWR Primary Water Chemistry Guidelines*", Volumes 1 and 2, and EPRI 1008224, "*PWR Secondary Water Chemistry Guidelines*".

The effectiveness of the program is verified under the One-Time Inspection program (A1.16).

Prior to the period of extended operation, plant procedures will be enhanced to address sampling of effluents from new secondary system cation resins for purgeable and non-purgeable Organic Carbon.

A1.3 REACTOR HEAD CLOSURE STUDS

The Reactor Head Closure Studs program manages reactor vessel stud, nut and washer cracking and loss of material. The Reactor Head Closure Studs program includes periodic visual, surface, and volumetric examinations of reactor vessel flange stud hole threads, reactor head closure studs, nuts, and washers and performs visual inspection of the reactor vessel flange closure during primary system leakage tests. The program implements ASME Section XI code, Subsection IWB, 2001 Edition through the 2003 addenda.

A1.4 BORIC ACID CORROSION

The Boric Acid Corrosion program manages loss of material due to boric acid corrosion. The program includes provisions to identify, inspect, examine and evaluate leakage, and initiate corrective actions. The program relies in part on implementation of recommendations of NRC Generic Letter 88-05, "*Boric Acid Corrosion of Carbon Steel Reactor Pressure Boundary Components in PWR Plants*". Additionally, the program includes examinations conducted during ISI pressure tests performed in accordance with ASME Section XI requirements. The program addresses recent operating experience noted in NRC Regulatory Issue Summary 2003-13, "*NRC Review of Responses to Bulletin 2002-01, Reactor Pressure Vessel Head Degradation and Reactor Coolant Pressure Boundary Integrity*" (which includes NRC Bulletin 2002-01, 2002-02, and NRC Order EA-03-009) and NRC Bulletin 2003-02, "*Leakage from Reactor Pressure Vessel Lower Head Penetrations and Reactor Coolant Pressure Boundary Integrity*".

A1.5 NICKEL-ALLOY PENETRATION NOZZLES WELDED TO THE UPPER REACTOR VESSEL CLOSURE HEADS OF PRESSURIZED WATER REACTORS

The Nickel-Alloy Penetration Nozzles Welded to the Upper Reactor Vessel Closure Heads of Pressurized Water Reactors program manages cracking due to primary water stress corrosion cracking (PWSCC) and loss of material due to boric acid wastage in nickel-alloy

pressure vessel head penetration nozzles and includes the reactor vessel closure head, upper vessel head penetration nozzles and associated welds. The term "primary water stress corrosion cracking" applies to the nozzles and J-welds and "Wastage" applies to the reactor closure head. The aging management for the aging effect of wastage is addressed in Boric Acid Corrosion program (A1.4). This program is consistent with NRC Order EA-03-009. Detection of cracking is accomplished through implementation of a combination of bare metal visual examination (external surface of head) and volumetric examination (underside of head) techniques. Reactor vessel head bare metal inspections and a calculation of the susceptibility ranking of the plant are performed. Examinations are performed by certified personnel. The calculation for all three units verifies a susceptibility ranking of "High" per EA-03-009, as amended. Plants in the "High" category require bare metal visual inspections every refueling outage and ultrasonic, eddy current, or dye penetrant testing every refueling outage per NRC Order EA-03-009, as amended.

Prior to December 31, 2008, the PVNGS Alloy 600 Management Program Plan will be revised to incorporate the applicable examination requirements of ASME Code Case N-729-1 (Reactor Vessel Head Inspections), subject to the conditions specified in 10 CFR 50.55a(g)(6)(ii)(D)(2) through(6).

A1.6 FLOW-ACCELERATED CORROSION

The Flow-Accelerated Corrosion (FAC) program manages wall thinning due to FAC on the internal surfaces of carbon or low alloy steel piping, elbows, reducers, expanders, and valve bodies which contain high energy fluids (both single phase and two phases).

The objectives of the FAC program are achieved by (a) identifying system components susceptible to FAC, (b) an analysis using a predictive code such as CHECWORKS to determine critical locations for inspection and evaluation, (c) providing guidance of follow-up inspections, (d) repairing or replacing components, as determined by the guidance provided by the program, and (e) continual evaluation and incorporation of the latest technologies, industry and plant in-house operating experience.

Procedures and methods used by the FAC program are consistent with APS commitments to NRC Bulletin 87-01, "*Thinning of Pipe Wall in Nuclear Power Plants*", and NRC Generic Letter 89-08, "*Erosion/Corrosion-Induced Pipe Wall Thinning*".

Prior to the period of extended operation, the program procedure will be enhanced to clarify the guidance for susceptible small-bore piping components and to verify the trace chromium content of the carbon steel pipe replacement.

A1.7 BOLTING INTEGRITY

The Bolting Integrity program manages cracking, loss of material, and loss of preload for pressure retaining bolting and ASME component support bolting. The program includes

preload control, selection of bolting material, use of lubricants/sealants consistent with EPRI good bolting practices, and performance of periodic inspections for indication of aging effects. The program is supplemented by Inservice Inspection requirements established in accordance with ASME Section XI, Subsections IWB, IWC, IWD, and IWF for ASME Class bolting.

PVNGS good bolting practices are established in accordance with plant procedures. These procedures include requirements for proper disassembling, inspecting, and assembling of connections with threaded fasteners. The general practices that are established in this program are consistent with EPRI NP-5067, *“Good Bolting Practices, Volume 1 and Volume 2”* and the recommendations of NUREG-1339, *“Resolution of Generic Safety Issue 29: Bolting Degradation or Failure in Nuclear Power Plants”*.

A1.8 STEAM GENERATOR TUBE INTEGRITY

The Steam Generator Tube Integrity program includes the preventive measures, condition monitoring inspections, degradation assessment, repair and leakage monitoring activities necessary to manage cracking, denting, wall thinning, and loss of material. The aging management measures employed include: non-destructive examination, visual inspection, sludge removal, tube plugging, in-situ pressure testing, maintaining the chemistry environment by removal of impurities, and addition of chemicals to control pH and oxygen.

NDE inspection scope and frequency, and primary to secondary leak rate monitoring are conducted consistent with the requirements of the PVNGS Units 1, 2, and 3 Technical Specifications. PVNGS evaluates tube integrity in accordance with the structural integrity performance criteria specified in Technical Specifications which encompasses and exceeds the requirements of Regulatory Guide 1.121. In addition, Technical Specifications include accident induced leakage performance criterion and operational leakage performance criterion. The PVNGS steam generator management practices are consistent with NEI 97-06, *“Steam Generator Program Guidelines”*.

A1.9 OPEN-CYCLE COOLING WATER SYSTEM

The Open-Cycle Cooling Water System program manages loss of material and reduction of heat transfer for components exposed to the raw water of the open-cycle cooling water system. The program includes surveillance techniques and control techniques to manage aging effects caused by biofouling, corrosion, erosion and silting in the open-cycle cooling water system and in structures and components cooled by the open-cycle cooling water system for the period of extended operation. The program is consistent with commitments as established in PVNGS responses to Generic Letter 89-13 *“Service Water System Problems Affecting Safety-Related Components”*.

The Open-Cycle Cooling Water System program provides the general requirements of implementation and maintenance of programs and activities which mitigate aging of the

open-cycle cooling water system and components. The various aspects of the PVNGS program (control, monitoring, maintenance and inspection) are implemented in plant procedures.

Prior to the period of extended operation, the program will be enhanced to clarify guidance in the conduct of heat exchanger and piping inspections using NDE techniques and related acceptance criteria.

A1.10 CLOSED-CYCLE COOLING WATER SYSTEM

The Closed-Cycle Cooling Water System program manages loss of material, cracking, and reduction in heat transfer for components in closed cycle cooling water systems. The program includes maintenance of system corrosion inhibitor concentrations and chemistry parameters following the guidance of EPRI TR-107396 to minimize aging, and periodic testing and inspections to evaluate system and component performance. Inspection methods include visual, ultrasonic testing and eddy current testing.

Prior to the period of extended operation, procedures will be enhanced to incorporate the guidance of EPRI TR-107396 with respect to water chemistry control for frequency of sampling and analysis, normal operating limits, action level concentrations, and times for implementing corrective actions upon attainment of action levels.

A1.11 INSPECTION OF OVERHEAD HEAVY LOAD AND LIGHT LOAD (RELATED TO REFUELING) HANDLING SYSTEMS

The Inspection of Overhead Heavy Load and Light Load (Related to Refueling) Handling Systems program manages loss of material for all cranes, trolley and hoist structural components, fuel handling equipment and applicable rails within the scope of license renewal. Program inspection activities verify the structural integrity of the components required to maintain their intended function. The inspection requirements are consistent with the guidance provided by NUREG-0612, "*Control of Heavy Loads at Nuclear Power Plants*" for load handling systems that handle heavy loads which can directly or indirectly cause a release of radioactive material, applicable industry standards (such as CMAA Spec 70) for other components within the scope of license renewal in this program, and applicable OSHA regulations (such as 29 CFR Volume XVII, Part 1910 and Section 1910.179).

Prior to the period of extended operation, procedures will be enhanced to inspect for loss of material due to corrosion or rail wear.

A1.12 FIRE PROTECTION

The Fire Protection program manages loss of material for fire rated doors, fire dampers, diesel-driven fire pumps, and the halon/CO₂ fire suppression systems, cracking, spalling,

and loss of material for fire barrier walls, ceilings, and floors, and hardness and shrinkage due to weathering of fire barrier penetration seals. Periodic visual inspections of fire barrier penetration seals, fire dampers, fire barrier walls, ceilings and floors, and periodic visual inspections and functional tests of fire-rated doors manage aging. Periodic testing of the diesel-driven fire pumps ensures that there is no loss of function due to aging of diesel fuel supply lines. Drop tests are performed on 10 percent of fire dampers on an 18 month basis to manage aging. Visual inspections manage aging of fire-rated doors every 18 months to verify the integrity of door surfaces and for clearances to detect aging of the fire doors. A visual inspection and function test of the halon and CO₂ fire suppression systems every 18 months manages aging. Ten percent of each type of penetration seal is visually inspected at least once every 18 months. Fire barrier walls, ceilings, and floors including coatings and wraps are visually inspected at least once every 18 months.

Prior to the period of extended operation, the following enhancements will be implemented:

- Procedures will be enhanced to state trending requirements for the diesel-driven fire pump and to include visual inspection of the fuel supply line to detect degradation.
- Procedures will be enhanced to inspect for mechanical damage, corrosion and loss of material of the halon discharge pipe header and the CO₂ system discharge nozzles.
- Procedures will be enhanced to state the qualification requirements for inspecting penetration seals, fire rated doors, fire barrier walls, ceilings and floors.

A1.13 FIRE WATER SYSTEM

The Fire Water System program manages loss of material for water-based fire protection systems. Periodic hydrant inspections, fire main flushing, sprinkler inspections, and flow tests are performed considering applicable National Fire Protection Association (NFPA) codes and standards. The fire water system pressure is continuously monitored such that loss of system pressure is immediately detected and corrective actions are initiated. The Fire Water System program conducts an air or water flow test through each open head spray/sprinkler head to verify that each open head spray/sprinkler nozzle is unobstructed. Visual inspections of the fire protection system exposed to water, evaluating wall thickness to identify evidence of loss of material due to corrosion, are covered by the Inspection of Internal Surfaces in Miscellaneous Piping and Ducting Components program ([A1.22](#)). The Buried Piping and Tanks Inspection program ([A1.18](#)) is credited with the management of aging effects on the external surface of buried fire water system piping.

Prior to the period of extended operation, the following enhancements will be implemented:

- Specific procedures will be enhanced to include review and approval requirements under the Nuclear Administrative Technical Manual (NATM).

- Procedures will be enhanced to be consistent with the current code of record or NFPA 25 2002 Edition.
- Procedures will be enhanced to field service test a representative sample or replace sprinklers prior to 50 years in service and test thereafter every 10 years to ensure that signs of degradation are detected in a timely manner.
- Procedures will be enhanced to be consistent with NFPA 25 Section 7.3.2.1, 7.3.2.2, 7.3.2.3, and 7.3.2.4.
- Procedures will be enhanced to state trending requirements.
- Procedures will be enhanced so that the PVNGS Quality Assurance programs will apply to Fire Protection SSCs that are within the scope of license renewal that are also part of the boundary of the WRF (Water Reclamation Facility).

A1.14 FUEL OIL CHEMISTRY

The Fuel Oil Chemistry program manages loss of material on the internal surface of components in the emergency diesel generator (EDG) fuel oil storage and transfer system, diesel fire pump fuel oil system, and station blackout generator (SBOG) system. The program includes (a) surveillance and monitoring procedures for maintaining fuel oil quality by controlling contaminants in accordance with applicable ASTM Standards, (b) periodic draining of water from fuel oil tanks, (c) visual inspection of internal surfaces during periodic draining and cleaning, (d) ultrasonic wall thickness measurements from external surfaces of fuel oil tanks if there are indications of reduced cross sectional thickness found during the visual inspection, (e) inspection of new fuel oil before it is introduced into the storage tanks, and (f) one-time inspections of a representative sample of components in systems that contain fuel oil by the One-Time Inspection program.

The effectiveness of the program is verified under the One-Time Inspection program ([A1.16](#)).

Prior to the period of extended operation:

Procedures will be enhanced to extend the scope of the program to include the SBOG fuel oil storage tank and SBOG skid fuel tanks.

Procedures will be enhanced to include ten-year periodic draining, cleaning, and inspections on the diesel-driven fire pump day tanks, the SBOG fuel oil storage tanks, and SBOG skid fuel tanks.

Ultrasonic testing (UT) or pulsed eddy current (PEC) thickness examination will be conducted to detect corrosion-related wall thinning if degradation is found during the visual inspections and once on the tank bottoms for the EDG fuel oil storage tanks, EDG fuel oil

day tanks, diesel-driven fire pump day tanks, and SBOG fuel oil storage tanks. The one-time UT or PEC examination on the tank bottoms will be performed before the period of extended operation.

A1.15 REACTOR VESSEL SURVEILLANCE

The Reactor Vessel Surveillance program manages loss of fracture toughness and is consistent with ASTM E 185. Actual reactor vessel plate coupons are used. Weld and heat-affected-zone coupons are made from sections of the same plate welded together with identical weld material heats and weld parameters. The surveillance coupons are tested by a qualified offsite vendor, to its procedures. The testing program and reporting conform to requirements of 10 CFR 50, Appendix H, "*Reactor Vessel Material Surveillance Program Requirements*".

Prior to the period of extended operation:

The schedule will be revised to withdraw the next capsule at the equivalent clad-base metal exposure of approximately 54 EFPY expected for the 60-year period of operation, and to withdraw remaining standby capsules at equivalent clad-base metal exposures not exceeding the 72 EFPY expected for a possible 80-year second period of extended operation. This withdrawal schedule is in accordance with NUREG-1801, Section XI.M31, item 6, and with the ASTM E 185-82 criterion which states that capsules may be removed when the capsule neutron fluence is between one and two times the limiting fluence calculated for the vessel at the end of expected life. This schedule change must be approved by the NRC, as required by 10 CFR 50 Appendix H.

If left in the reactor beyond the presently-scheduled withdrawal, the next scheduled surveillance capsule in each unit will reach a clad-base metal 54 EFPY equivalent at about 40 actual operating EFPY (40, 39, and 42 actual EFPY in Units 1, 2, and 3, respectively).

Procedures will be enhanced to identify the withdrawal of the remaining standby capsules at 72 EFPY, at about 50 to 54 actual operating EFPY, near the end of the extended licensed operating period. The need to monitor vessel fluence following removal of the remaining standby capsules, and ex-vessel or in-vessel methods, will be addressed prior to removing the remaining capsules.

A1.16 ONE-TIME INSPECTION

The One-Time Inspection program conducts one-time inspections of plant system piping and components to verify the effectiveness of the Water Chemistry program (A1.2), Fuel Oil Chemistry program (A1.14), and Lubricating Oil Analysis program (A1.23). The aging effects to be evaluated by the One-Time Inspection program are loss of material, cracking, and reduction of heat transfer. The One-Time Inspection program will include the specific

attributes for the components crediting this program for aging management in the license renewal application.

Plant system piping and components will be subject to one-time inspection on a sampling basis using qualified inspection personnel following established ASME, "*Boiler and Pressure Vessel Code*", Section V, "Nondestructive Examination", (NDE) techniques appropriate to each inspection. Inspection sample sizes will be determined using a methodology that is based on 90% confidence that 90% of the population of components will not experience aging effects in the period of extended operation. The One-Time Inspection program specifies corrective actions and increased sampling of piping/components if aging effects are found during material/environment combination inspections. The one-time inspections will be performed no earlier than 10 years prior to the period of extended operation. All one-time inspections will be completed prior to the period of extended operation. Completion of the One-Time Inspection program in this time period will assure that potential aging effects will be manifested based on at least 30 years of PVNGS operation. Industry and plant-specific operating experience will be evaluated in the development and implementation of this program.

Major elements of the PVNGS One-Time Inspection program include:

- a) Identifying piping and component populations subject to one-time inspection based on common materials and environments,
- b) Determining the sample size of components to inspect using established statistical methods based on the population size of the material-environment groups,
- c) Selecting piping and components within the material-environment groups for inspection based on criteria provided in the One-Time Inspection procedure,
- d) Conducting one-time inspections of the selected components within the sample using ASME Code Section V NDE techniques and acceptance criteria consistent with the design codes/standards or ASME Section XI as applicable to the component.

A1.17 SELECTIVE LEACHING OF MATERIALS

The Selective Leaching of Materials program manages the loss of material due to selective leaching for brass (copper alloy >15% zinc), aluminum-bronze (copper alloy >8% aluminum), and gray cast iron components exposed to closed-cycle cooling water demineralized water, secondary water, and raw water within the scope of license renewal. The Selective Leaching of Materials program is in addition to the Open-Cycle Cooling Water program (A1.9) and the Closed-Cycle Cooling Water program (A1.10) in these cases.

The program includes a one-time inspection (visual and/or mechanical methods) of a selected sample of components internal surfaces to determine whether loss of material due

to selective leaching is occurring. If indications of selective leaching are confirmed, follow up examinations or evaluations are performed.

The Selective Leaching of Materials program is a new program that will be implemented prior to the period of extended operation. Industry and plant-specific operating experience will be evaluated in the development and implementation of this program.

A1.18 BURIED PIPING AND TANKS INSPECTION

The Buried Piping and Tanks Inspection program manages loss of material of buried components in the chemical and volume control, diesel fuel storage and transfer, domestic water, fire protection, WRF fuel system, and essential spray ponds systems. Visual inspections monitor the condition of protective coatings and wrappings found on carbon steel, gray cast iron or ductile iron components and assess the condition of stainless steel components with no protective coatings or wraps. The program includes opportunistic inspection of buried piping and tanks as they are excavated or on a planned basis if opportunistic inspections have not occurred.

The Buried Piping and Tanks Inspection program is a new program that will be implemented prior to the period of extended of operation. Within the ten year period prior to entering the period of extended operation, an opportunistic or planned inspection will be performed. Upon entering the period of extended operation a planned inspection within ten years will be required unless an opportunistic inspection has occurred within this ten year period. Industry and plant-specific operating experience will be evaluated in the development and implementation of this program.

A1.19 ONE-TIME INSPECTION OF ASME CODE CLASS 1 SMALL-BORE PIPING

The One-Time Inspection of ASME Code Class 1 Small-Bore Piping program manages cracking of stainless steel ASME Code Class 1 piping less than or equal to 4 inches. This program is a part of the Risk-Informed Inservice Inspection (RI-ISI) program.

For ASME Code Class 1 small-bore piping, the RI-ISI program requires volumetric examinations on selected weld locations to detect cracking. Weld locations are selected based on the guidelines provided in EPRI TR-112657. Volumetric examinations are conducted in accordance with ASME Section XI with acceptance criteria from Paragraph IWB-3000 and IWB-2430. The fourth interval of the ISI program for each unit at PVNGS will provide the results for the one time inspection of ASME Code Class 1 small-bore piping.

A1.20 EXTERNAL SURFACES MONITORING PROGRAM

The External Surfaces Monitoring Program manages loss of material for steel, aluminum, and copper alloy components and hardening and loss of strength for elastomer components. The program includes those systems and components within the scope of license renewal that require external surface monitoring. Visual inspections conducted during engineering walkdowns will be used to identify aging effects and leakage. Physical manipulation during the visual inspections may also be used to verify absence of hardening or loss of strength for elastomers.

Loss of material for external surfaces is managed by the Boric Acid Corrosion program (A1.4) for components in a system with treated borated water or reactor coolant environment on which boric acid corrosion may occur, Buried Piping and Tanks Inspection program (A1.18) for buried components, and Structures Monitoring Program (A1.32) for civil structures, and other structural items which support and contain mechanical and electrical components.

The External Surfaces Monitoring Program is a new program that will be implemented prior to the period of extended operation. Industry and plant-specific operating experience will be evaluated in the development and implementation of this program.

A1.21 REACTOR COOLANT SYSTEM SUPPLEMENT

Section 3.1 of NUREG-1800, “*Standard Review Plan for the Review of License Renewal Applications for Nuclear Power Plants*”, supplements the aging management programs for the reactor coolant system components with the following additional requirements.

APS will:

A. Reactor Coolant System Nickel Alloy Pressure Boundary Components

Implement applicable (1) NRC Orders, Bulletins and Generic Letters associated with nickel alloys and (2) staff-accepted industry guidelines, (3) participate in the industry initiatives, such as owners group programs and the EPRI Materials Reliability Program, for managing aging effects associated with nickel alloys, (4) upon completion of these programs, but not less than 24 months before entering the period of extended operation, APS will submit an inspection plan for reactor coolant system nickel alloy pressure boundary components to the NRC for review and approval, and

B. Reactor Vessel Internals

(1) Participate in the industry programs for investigating and managing aging effects on reactor internals; (2) evaluate and implement the results of the industry programs as applicable to the reactor internals; and (3) upon completion of these programs, but not less

than 24 months before entering the period of extended operation, APS will submit an inspection plan for reactor internals to the NRC for review and approval.

A1.22 INSPECTION OF INTERNAL SURFACES IN MISCELLANEOUS PIPING AND DUCTING COMPONENTS

The Inspection of Internal Surfaces in Miscellaneous Piping and Ducting Components program manages cracking, loss of material, and hardening and loss of strength. The internal surfaces of piping, piping components, ducting and other components that are not covered by other aging management programs are included in this program.

The Inspection of Internal Surfaces in Miscellaneous Piping and Ducting Components program uses the work control process to conduct and document inspections. The program will perform visual inspections to detect aging effects that could result in a loss of component intended function. The visual inspections will be conducted during periodic maintenance, predictive maintenance, surveillance testing and corrective maintenance.

Within 10 years before entering the period of extended operation, a review will be conducted to determine the number of inspection opportunities afforded by the work control process for all systems within the scope of this program. In the vast majority of cases, it is expected that the number of work opportunities existing will be sufficient to detect aging and provide reasonable assurance that intended functions are maintained. For those systems or components where inspections of opportunity are insufficient, an inspection will be conducted prior to the period of extended operation to provide reasonable assurance that the intended functions are maintained. Additionally, visual inspections may be augmented by physical manipulation to detect hardening and loss of strength of both internal and external surfaces of elastomers. The program also includes volumetric evaluation to detect stress corrosion cracking of the internal surfaces of stainless steel components exposed to diesel exhaust.

The Inspection of Internal Surfaces in Miscellaneous Piping and Ducting Components program is a new program that will be implemented prior to the period of extended operation. Industry and plant-specific operating experience will be evaluated in the development and implementation of this program.

A1.23 LUBRICATING OIL ANALYSIS

The Lubricating Oil Analysis program manages loss of material and reduction of heat transfer for components within the scope of license renewal that are exposed to lubricating and hydraulic oil. The program monitors and maintains lubricating and hydraulic oil properties within acceptance criteria, thereby preserving an environment that is not conducive to aging effects. Acceptance criteria are based upon vendor and industry guidelines for oil chemical and physical properties and for foreign material such as water contamination. Increased contamination and degradation of oil properties provide an

indication of aging of the lubricating oil. Monitoring and trending of lubricating and hydraulic oil properties and particles found within the oil identifies risk to components due to aging prior to loss of intended function.

The effectiveness of the program is verified under the One-Time Inspection program (A1.16).

A1.24 ELECTRICAL CABLES AND CONNECTIONS NOT SUBJECT TO 10 CFR 50.49 ENVIRONMENTAL QUALIFICATION REQUIREMENTS

The Electrical Cables and Connections Not Subject to 10 CFR 50.49 Environmental Qualification Requirements program manages the aging effects of embrittlement, melting, cracking, swelling, surface contamination, or discoloration to ensure that electrical cables, connections and terminal blocks not subject to the environmental qualification (EQ) requirements of 10 CFR 50.49 and within the scope of license renewal are capable of performing their intended functions.

Non-EQ cables, connections and terminal blocks within the scope of license renewal in accessible areas with an adverse localized environment are inspected. The inspections of Non-EQ cables, connectors and terminal blocks in accessible areas are representative, with reasonable assurance, of cables, connections and terminal blocks in inaccessible areas with an adverse localized environment. At least once every ten years, the Non-EQ cables, connections and terminal blocks within the scope of license renewal in accessible areas are visually inspected for embrittlement, melting, cracking, swelling, surface contamination, or discoloration.

The acceptance criterion for visual inspection of accessible Non-EQ cable jacket, connection and terminal blocks insulating material is the absence of anomalous indications that are signs of degradation. Corrective actions for conditions that are adverse to quality are performed in accordance with the corrective action program as part of the QA program.

The Electrical Cables and Connections Not Subject to 10 CFR 50.49 Environmental Qualification Requirements program is a new program that will be implemented prior to the period of extended operation. Industry and plant-specific operating experience will be evaluated in the development and implementation of this program.

A1.25 ELECTRICAL CABLES AND CONNECTIONS NOT SUBJECT TO 10 CFR 50.49 ENVIRONMENTAL QUALIFICATION REQUIREMENTS USED IN INSTRUMENTATION CIRCUITS

The scope of this program includes the cables and connections used in sensitive instrumentation circuits with sensitive, high voltage low-level signals within the Ex-core Neutron Monitoring System including the source range, intermediate range, and power range monitors. The Electrical Cables and Connections Not Subject to 10 CFR 50.49 Environmental Qualification Requirements Used in Instrumentation Circuits program manages embrittlement, cracking, melting, discoloration, swelling, or loss of dielectric strength leading to reduced insulation resistance.

This program provides reasonable assurance that the intended function of cables and connections used in instrumentation circuits with sensitive, low-level signals that are not subject to the environmental qualification requirements of 10 CFR 50.49 and are exposed to adverse localized environments caused by heat, radiation, or moisture are maintained consistent with the current licensing basis through the period of extended operation. In most areas, the actual ambient environments (e.g., temperature, radiation, or moisture) are less severe than the plant design environment for those areas.

Calibration surveillance tests are used to manage the aging of the cable insulation and connections so that instrumentation circuits perform their intended functions. When an instrumentation channel is found to be out of calibration during routine surveillance testing, troubleshooting is performed on the loop, including the instrumentation cable and connections. A review of calibration results will be completed prior to the period of extended operation and every 10 years thereafter.

Prior to the period of extended operation, procedures will be enhanced to identify license renewal scope and require an engineering evaluation of the calibration results and to require that an action request be written when the loop cannot be calibrated to meet acceptance criteria.

A1.26 INACCESSIBLE MEDIUM VOLTAGE CABLES NOT SUBJECT TO 10 CFR 50.49 ENVIRONMENTAL QUALIFICATION REQUIREMENTS

The Inaccessible Medium Voltage Cables Not Subject to 10 CFR 50.49 EQ Requirements program manages localized damage and breakdown of insulation leading to electrical failure in inaccessible medium voltage cables exposed to adverse localized environments caused by significant moisture simultaneously with significant voltage to ensure that inaccessible medium voltage cables not subject to the environmental qualification (EQ) requirements of

10 CFR 50.49 and within the scope of license renewal are capable of performing their intended function.

All cable manholes that contain in-scope non-EQ inaccessible medium voltage cables will be inspected for water collection. Collected water will be removed as required. This inspection and water removal will be performed based on actual plant experience.

The program provides for testing of in-scope non-EQ inaccessible medium voltage cables to provide an indication of the conductor insulation condition. At least once every ten years, a polarization index test as described in EPRI TR-103834-P1-2 or other testing that is state-of-the-art at the time of the testing is performed.

The Inaccessible Medium Voltage Cables Not Subject to 10 CFR 50.49 EQ Requirements program is a new program that will be implemented prior to the period of extended operation. Industry and plant-specific operating experience will be evaluated in the development and implementation of this program.

A1.27 ASME SECTION XI, SUBSECTION IWE

The ASME Section XI, Subsection IWE containment inservice inspection program manages loss of material and loss of sealing of the steel liner of the concrete containment building, including the containment liner plate, piping and electrical penetrations, access hatches, and the fuel transfer tube. Inspections are performed to identify and manage any containment liner aging effects that could result in loss of intended function. Acceptance criteria for components subject to Subsection IWE exam requirements are specified in Article IWE-3000. In conformance with 10 CFR 50.55a(g)(4)(ii), the PVNGS CISI Program is updated during each successive 120-month inspection interval to comply with the requirements of the latest edition and addenda of the Code specified twelve months before the start of the inspection interval.

A1.28 ASME SECTION XI, SUBSECTION IWL

The ASME Section XI, Subsection IWL program manages cracking, loss of material, and increase in porosity and permeability of the concrete containment building and post-tensioned system. Inspections are performed to identify and manage any aging effects of the containment concrete, post-tensioned tendons, tendon anchorages, and concrete surface around the anchorage that could result in loss of intended function. In conformance with 10 CFR 50.55a(g)(4)(ii), the ASME Section XI, Subsection IWL Program is updated during each successive 120-month inspection interval to comply with the requirements of the latest edition and addenda of the Code specified twelve months before the start of the inspection interval.

A1.29 ASME SECTION XI, SUBSECTION IWF

The ASME Section XI, Subsection IWF program manages loss of material, cracking, and loss of mechanical function that could result in loss of intended function for Class 1, 2 and 3 component supports. There are no Class MC supports at PVNGS. In conformance with 10 CFR 50.55a(g)(4)(ii), the PVNGS ISI Program is updated during each successive 120-month inspection interval to comply with the requirements of the latest edition and addenda of the Code specified twelve months before the start of the inspection interval.

A1.30 10 CFR 50, APPENDIX J

The 10 CFR 50, Appendix J program manages loss of material, loss of leak tightness, and loss of sealing. The program monitors leakage rates through the containment pressure boundary, including the penetrations and access openings, in order to detect degradation of containment pressure boundary. Seals, gaskets, and bolted connections are also monitored under the program.

Containment leak rate tests are performed in accordance with 10 CFR 50 Appendix J, "*Primary Reactor Containment Leakage Testing for Water-Cooled Power Reactors*" Option B; Regulatory Guide 1.163, "*Performance-Based Containment Leak-Testing Program*", NEI 94-01, "*Industry Guideline for Implementing Performance-Based Option of 10 CFR Part 50 Appendix J*"; and ANSI/ANS 56.8, "*Containment System Leakage Testing Requirements*".

Containment leak rate tests are performed to assure that leakage through the primary containment, and systems and components penetrating primary containment does not exceed allowable leakage limits specified in the Technical Specifications. Corrective actions are taken if leakage rates exceed established administrative limits for individual penetrations or the overall containment pressure boundary.

A1.31 MASONRY WALL PROGRAM

The Masonry Wall Program, which is part of the Structures Monitoring Program, manages cracking of masonry walls, and structural steel restraint systems of the masonry walls, within scope of license renewal based on guidance provided in IE Bulletin 80-11, "*Masonry Wall Design*" and NRC Information Notice 87-67, "*Lessons Learned from Regional Inspections of Licensee Actions in Response to NRC IE Bulletin 80-11*". The Masonry Wall Program contains inspection guidelines and lists attributes that cause aging of masonry walls, which are to be monitored during structural monitoring inspections, as well as establishes examination criteria, evaluation requirements, and acceptance criteria.

Prior to the period of extended operation, procedures will be enhanced to specify ACI 349.3R-96 as the reference for qualification of personnel to inspect structures under the Masonry Wall Program, which is part of the Structures Monitoring Program.

A1.32 STRUCTURES MONITORING PROGRAM

The Structures Monitoring Program manages the cracking, loss of material, and change in material properties by monitoring the condition of structures and structural supports that are within the scope of license renewal. The Structures Monitoring Program implements the requirements of 10 CFR 50.65 and is consistent with the guidance of NUMARC 93-01, Revision 2 and Regulatory Guide 1.160, Revision 2.

The Structures Monitoring Program provides inspection guidelines for concrete elements, structural steel, masonry walls, structural features (e.g., caulking, sealants, roofs, etc.), structural supports, and miscellaneous components such as doors. The Structures Monitoring Program includes all masonry walls and water-control structures within the scope of license renewal. The Structures Monitoring Program also monitors settlement for each major structure and inspects supports for equipment, piping, conduit, cable tray, HVAC, and instrument components.

Prior to the period of extended operation:

The Structures Monitoring Program will be enhanced to specify ACI 349.3R-96 as the reference for qualification of personnel to inspect structures under the Structures Monitoring Program.

A1.33 RG 1.127, INSPECTION OF WATER-CONTROL STRUCTURES ASSOCIATED WITH NUCLEAR POWER PLANTS

The PVNGS Structures Monitoring Program, which includes all water-control structural components within the scope of RG 1.127, Inspection of Water Control Structures Associated with Nuclear Power Plants, manages cracking, loss of material, loss of bond, loss of strength, and increase in porosity and permeability due to extreme environmental conditions. PVNGS meets the recommendations of Regulatory Guide 1.127, Revision 1.

This program includes inspection and surveillance activities for water-control structures associated with emergency cooling water systems and includes periodic inspections and monitoring of the in-scope water-control structures; i.e., the Ultimate Heat Sink and associated structures.

Prior to the period of extended operation, procedures will be enhanced to specify that the essential spray ponds inspections include concrete below the water level.

A1.34 NICKEL ALLOY AGING MANAGEMENT PROGRAM

The Nickel Alloy Aging Management Program manages cracking due to primary water stress corrosion cracking in all plant locations that contain Alloy 600, with the exception of steam generator tubing (aging management of steam generator tubing is performed by the Steam Generator Tubing Integrity program (A1.8)) and reactor vessel internals (aging management of reactor vessel internals is addressed in Reactor Coolant System Supplement (A1.21)). Aging management requirements for nickel alloy penetration nozzles welded to the upper reactor vessel closure head noted in the Nickel-Alloy Penetration Nozzles Welded to the Upper Reactor Vessel Closure Heads of Pressurized Water Reactors program (A1.5) are included in this program. This program includes reactor coolant system (RCS) and ESF locations. The Alloy 600 aging management program uses inspections, mitigation techniques, repair/replace activities and monitoring of operating experience to manage the aging of Alloy 600 at PVNGS. Detection of indications is accomplished through a variety of examinations consistent with NRC Order EA-03-009, ASME Section XI Subsections IWB and IWC, EPRI Report 1010087 (MRP-139) issued under NEI 03-08 protocol, and commitments made in response to NRC Bulletin 2004-01. Mitigation techniques are implemented when appropriate to preemptively remove conditions that contribute to primary water stress corrosion cracking. Repair/replacement activities are performed to proactively remove or overlay Alloy 600 material, or as a corrective measure in response to an unacceptable flaw in the material. Mitigation and repair/replace activities are consistent with those detailed in MRP-139. The inspection plan of Alloy 690 replacement is also included in this program.

Prior to the period of extended operation, the PVNGS Alloy 600 Management Program Plan will be enhanced to add Alloy 600 steam generator components, including tube sheet cladding and portions of the primary nozzle cladding. In addition, prior to December 31, 2008, the PVNGS Alloy 600 Management Program Plan will be revised to incorporate the applicable examination requirements of ASME Code Case N-729-1 (Reactor Vessel Head Inspections), subject to the conditions specified in 10 CFR 50.55a(g)(6)(ii)(D)(2) through(6) and ASME Code Case N-722 (RCPB Visual Inspections) subject to the conditions listed in 10 CFR 50.55a(g)(6)(ii)(E)(2) through(4).

A1.35 ELECTRICAL CABLE CONNECTIONS NOT SUBJECT TO 10 CFR 50.49 ENVIRONMENTAL QUALIFICATION REQUIREMENTS

The Electrical Cable Connections Not Subject to 10 CFR 50.49 Environmental Qualification Requirements program manages the effects of loosening of bolted external connections due to thermal cycling, ohmic heating, electrical transients, vibration, chemical contamination, corrosion, and oxidation. As part of the PVNGS predictive maintenance program, infrared thermography testing is being performed on non-EQ electrical cable connections, associated with active and passive components within the scope of license renewal. A representative sample will be tested at least once prior to the period of extended operation

using infrared thermography to confirm that there are no aging effects requiring management during the period of extended operation. The selected sample is based upon application (medium and low voltage), circuit loading, and environment.

The Electrical Cable Connections Not Subject to 10 CFR 50.49 Environmental Qualification Requirements program is a new program that will be implemented prior to the period of extended operation. Industry and plant-specific operating experience will be evaluated in the development and implementation of this program.

A1.36 METAL ENCLOSED BUS

The Metal Enclosed Bus (MEB) program manages the effects of loose connections, embrittlement, cracking, melting, swelling, or discoloration of insulation, loss of material of bus enclosure assemblies, hardening of boots and gaskets, and cracking of internal bus supports to ensure that metal-enclosed buses within the scope of license renewal. Internal portions of MEBs are visually inspected for cracks, corrosion, foreign debris, excessive dust buildup, and evidence of water intrusion. The bus insulation is inspected for signs of embrittlement, cracking, melting, swelling, hardening or discoloration, which may indicate overheating or aging degradation. The internal bus supports are inspected for structural integrity and signs of cracks. The bus enclosure assemblies are inspected for loss of material due to corrosion and hardening of boots and gaskets. Samples of the accessible bolted connections on the internal bus work are checked for loose connections by measuring connection resistance.

The Metal Enclosed Bus program is a new program and will be completed before the period of extended operation and once every 10 years thereafter. Industry and plant-specific operating experience will be evaluated in the development and implementation of this program.

A2 SUMMARY DESCRIPTIONS OF TIME-LIMITED AGING ANALYSIS AGING MANAGEMENT PROGRAMS

A2.1 METAL FATIGUE OF REACTOR COOLANT PRESSURE BOUNDARY

The Metal Fatigue of Reactor Coolant Pressure Boundary program will ensure that actual plant experience remains bounded by the assumptions used in the design calculations, or that appropriate corrective measures maintain the design and licensing basis by other acceptable means. Most Class 1 location cumulative usage factor (CUF) estimates support the supposition that the number of transient cycles expected in a 60-year life will not produce fatigue usage factors significantly in excess of those calculated by the analyses that assumed a 40-year life; and should produce none exceeding the code limit of 1.0. Estimates of the effects of the reactor coolant environment as described by NUREG/CR-6260 indicate that CUF in some of these affected locations may however, exceed 1.0. The Metal Fatigue of Reactor Coolant Pressure Boundary program will track the number of transient cycles and cumulative fatigue. If cycle counts or CUF values increase to the program action limits, corrective actions will be initiated to evaluate the design limits and determine appropriate specific corrective actions. Action limits permit completion of corrective actions before the design basis number of events is exceeded.

Prior to the period of extended operation, the following enhancements will be implemented:

The Metal Fatigue of Reactor Coolant Pressure Boundary program will be enhanced to include: (1) additional Class 1 locations with high calculated CUFs, (2) Class 1 components for which transfer functions have been developed for stress-based monitoring, and (3) Class 2 portions of the steam generators with a Class 1 analysis and high calculated CUFs.

The Metal Fatigue of Reactor Coolant Pressure Boundary program will be enhanced with additional cycle count and fatigue usage action limits, and with appropriate corrective actions to be invoked if a component approaches a cycle count action limit or a fatigue usage action limit. Action limits permit completion of corrective actions before the design limits are exceeded.

Cycle Count Action Limit and Corrective Actions

An action limit will require corrective action when the cycle count for any of the critical thermal and pressure transients is projected to reach the action limit defined in the program before the end of the next operating cycle. In order to ensure sufficient margin to accommodate occurrence of a low-probability transient, corrective actions must be taken before the remaining number of allowable occurrences for any specified transient becomes less than 1.

If a cycle count action limit is reached, acceptable corrective actions include:

- 1) Review of fatigue usage calculations
 - a. To determine whether the transient in question contributes significantly to CUF.
 - b. To identify the components and analyses affected by the transient in question.
 - c. To ensure that the analytical bases of the leak-before-break (LBB) fatigue crack propagation analysis and of the high-energy line break (HELB) locations are maintained.
 - d. To ensure that the analytical bases of a fatigue crack growth and stability analysis in support of relief from ASME Section XI flaw removal and inspection requirements for hot leg small-bore half nozzle repairs are maintained.
- 2) Evaluation of remaining margins on CUF based on cycle-based or stress-based CUF calculations using the PVNGS fatigue management program software.
- 3) Redefinition of the specified number of cycles (e.g., by reducing specified numbers of cycles for other transients and using the margin to increase the allowed number of cycles for the transient that is approaching its specified number of cycles).
- 4) Redefinition of the transient to remove conservatism in predicting the range of pressure and temperature values for the transient.

Cumulative Fatigue Usage Action Limit and Corrective Actions

An action limit will require corrective action when calculated CUF (from cycle based or stress based monitoring) for any monitored location is projected to reach 1.0 within the next 2 or 3 operating cycles. In order to ensure sufficient margin to accommodate occurrence of a low-probability transient, corrective actions must be taken while there is still sufficient margin to accommodate at least one occurrence of the worst-case design basis event (i.e., with the highest fatigue usage per event cycle).

If a CUF action limit is reached acceptable corrective actions include:

- 1) Determine whether the scope of the monitoring program must be enlarged to include additional affected reactor coolant pressure boundary locations. This determination will ensure that other locations do not approach design limits without an appropriate action.
- 2) Enhance fatigue monitoring to confirm continued conformance to the code limit.
- 3) Repair the component.
- 4) Replace the component.

- 5) Perform a more rigorous analysis of the component to demonstrate that the design code limit will not be exceeded.
- 6) Modify plant operating practices to reduce the fatigue usage accumulation rate.
- 7) Perform a flaw tolerance evaluation and impose component-specific inspections, under ASME Section XI Appendices A or C (or their successors) and obtain required approvals from the regulatory agency.

For PVNGS locations identified in NUREG/CR-6260, fatigue usage factor action limits will be based on accrued fatigue usage calculated with the F(en) environmental fatigue factors determined by NUREG/CR-5704 and NURGE/CR-6583 methods required for including effects of the reactor coolant environment.

The scope of the Metal Fatigue of Reactor Coolant Pressure Boundary program will be enhanced with a revised list of monitored plant transients that contribute to high usage factor, and with a revised list of monitored locations in Class 1 piping and vessels and in parts of the Class 2 steam generators that have a Class 1 analysis.

A2.2 ENVIRONMENTAL QUALIFICATION (EQ) OF ELECTRICAL COMPONENTS

The Environmental Qualification (EQ) of Electrical Components program manages component thermal, radiation, and cyclic aging effects, using 10 CFR 50.49(f) methods. As required by 10 CFR 50.49, EQ components are to be refurbished or replaced, or have their qualification extended prior to reaching the aging limits established in the evaluation. Maintaining qualification through the extended license renewal period requires that existing EQ evaluations (EEQDFs) be re-evaluated. The Environmental Qualification (EQ) of Electrical Components program is consistent with the guidance of 10 CFR 50.49, NUREG-0588, and Regulatory Guide 1.89, *“Environmental Qualification of Certain Electric Equipment Important to Safety for Nuclear Power Plants”*, Revision 1 for maintaining qualifications of equipment.

A2.3 CONCRETE CONTAINMENT TENDON PRESTRESS

The Concrete Containment Tendon Prestress program, within the PVNGS ASME Section XI Subsection IWL Program, manages the loss of tendon prestress in the post-tensioning system.

The PVNGS post-tensioning system consists of inverted-U-shaped tendons, extending up through the basemat, through the full height of the cylindrical walls and over the dome; and horizontal circumferential (hoop) tendons, at intervals from the basemat to about the 45-degree elevation of the dome. The basemat is conventionally-reinforced concrete. The tendons are ungrouted, in grease-filled glands.

Appendix A
Updated Final Safety Analysis Report Supplement

The beginning of the first IWL tendon examination interval was August 1, 2001 for all three units. The beginning of the second interval will be August 1, 2011 for all three units. As required by 10 CFR 50.55a, beginning August 1, 2011, the program will conform to a later edition of ASME Section XI, Subsection IWL which permits a 10-year interval between tendon prestress surveillance tests, for each unit of a multi-unit plant. The entire scope of IWL-2500, including prestress liftoff measurements, will be required only every 10-years in each unit; except that the visual inspections and anti-corrosion medium surveillances of IWL-2524 and IWL-2525 must be repeated at the intervening 5-year intervals.

The program includes randomly-selected surveillance tendons for a 40-year license (through the year 35 surveillance).

Prior to the period of extended operation, procedures will be enhanced to require an update of the regression analysis for each tendon group of each unit, and of the joint regression of data from all three units, after every tendon surveillance. The documents will invoke and describe regression analysis methods used to construct the lift-off trend lines, including the use of individual tendon data in accordance with Information Notice (IN) 99-10, "*Degradation of Prestressing Tendon Systems in Prestressed Concrete Containments*".

A3 EVALUATION SUMMARIES OF TIME-LIMITED AGING ANALYSES

10 CFR 54.21(c) requires that an applicant for a renewed license identify time-limited aging analyses (TLAAs) and evaluate them for the period of extended operation. The following TLAAs have been identified and evaluated for PVNGS.

A3.1 REACTOR VESSEL NEUTRON EMBRITTLEMENT

Ferritic materials of the reactor vessel are subject to embrittlement (loss of fracture toughness) due to high-energy neutron exposure. The following predictions of neutron fluence and of its embrittlement effects are TLAAs:

- Neutron Fluence, Upper Shelf Energy, Adjusted Reference Temperature (Fluence, USE, and ART)
- Pressurized Thermal Shock (PTS)
- Reactor Vessel Thermal Limit Analysis and Pressure-Temperature (P-T) Limits
- Low Temperature Overpressure Protection (LTOP)

The Reactor Vessel Surveillance program is described in [Section A1.15](#).

A3.1.1 Neutron Fluence, Upper Shelf Energy and Adjusted Reference Temperature (Fluence, USE, and ART)

The critical time-dependent parameter for determining radiation embrittlement effects is lifetime fluence of neutrons with energies greater than 1 MeV. The original design basis fluence predictions for a 32 EFPY life were the standard Combustion Engineering estimates for the CESSAR-80 plants. Power uprate (PUR) had no effect on these fluence projections because this original analysis of record used a power level of 4200 MW_t, which is higher than the PUR level of 3990 MW_t.

Increased plant capacity factors prompted the increase in the lifetime capacity factor assumed for fluence estimates from 80 to 90 percent, and hence increased the assumed EFPY for the period of extended operation to 54 EFPY. With continued use of low-leakage cores, the current Unit 1, 2, and 3 projections of the clad-base metal interface neutron fluence at 54 EFPY are less than the original 32 EFPY projection used to determine the EOL ART and USE reported in the NRE Reactor Vessel Integrity Database. Therefore the original projections remain valid for the period of extended operation.

Fluence, USE, and ART will be managed for the extended licensed operating period by continuing the Reactor Vessel Surveillance program (Section A1.15), with adjustments to the coupon examination schedule to withdraw the next capsule at an equivalent clad-base metal exposure of approximately 54 EFPY, and to withdraw remaining standby capsules at equivalent clad-base metal exposures not exceeding 72 EFPY. The validity of these parameters and the analyses that depend upon them will therefore be adequately managed for the period of extended operation.

A3.1.2 Pressurized Thermal Shock (PTS)

If the reference temperature for pressurized thermal shock (RT_{PTS}) for each heat of material of the reactor pressure vessel does not exceed the applicable screening criterion, only the reactor pressure vessel is “relied on to demonstrate compliance” with the 10 CFR 50.61 PTS rule.

The original PTS evaluation of the PVNGS vessels demonstrated low values of the RT_{PTS} screening parameter. The originally-assumed 32 EFPY neutron fluence is not expected to be exceeded in a 54 EFPY period of extended operation, and no changes to the material composition information or to embrittlement assessment methods have significantly affected the RT_{PTS} screening values. Therefore the conclusions of the original evaluation are unaffected. The original evaluation of the PTS screening parameters, and the conclusion of the evaluation, is therefore valid for the period of extended operation.

A3.1.3 Pressure-Temperature (P-T) Limits

The P-T limit curves are operating limits, based on material embrittlement effects that are valid up to the vessel fluence for which these embrittlement effects are calculated.

The current P-T limit curves permit operation up to 32 EFPY. However, the P-T limit curves were based on an assumed 32 EFPY beltline neutron fluence that is in excess of the maximum fluence now projected for 54 EFPY. Therefore the P-T limit curves are valid for the period of extended operation. New P-T limits will not be required. APS will confirm the basis for 54 EFPY prior to operation beyond 32 EFPY and will update documents in accordance with the provisions of 10 CFR 50.59.

A3.1.4 Low Temperature Overpressure Protection (LTOP)

LTOP is required by Technical Specifications and is provided by relief valves in the two suction lines of the shutdown cooling system (SCS), or by operating with the reactor coolant system (RCS) depressurized and with an open RCS vent of sufficient size.

The LTOP setpoints depend on the P-T limit curves and the ART, both of which will remain valid for the period of extended operation. Therefore the LTOP licensing and design basis analyses will remain valid for the period of extended operation.

A3.2 METAL FATIGUE ANALYSIS

This section describes:

- ASME Section III Class 1 Fatigue Analysis of Vessels, Piping, and Components
- ASME Section III Subsection NG Fatigue Analysis of Reactor Pressure Vessel Internals
- Effects of the Reactor Coolant System Environment on Fatigue Life of Piping and Components (Generic Safety Issue 190)
- Assumed Thermal Cycle Count for Allowable Secondary Stress Range Reduction Factor in B31.1 and ASME Section III Class 2 and 3 Piping

ASME III requires no fatigue analysis for Class 2 components. However, design of the following PVNGS Class 2 components is supported by Class 1 fatigue analyses:

- Secondary sides of the replacement steam generators
- Regenerative and letdown heat exchangers
- HPSI and LPSI pumps
- Main steam safety valves

Basis of Fatigue Analysis

ASME Section III Class 1 design specifications define a design basis set of static and transient load conditions. The design number of each transient specified was selected to be larger than expected to occur during the 40-year licensed life of the plant, based on operating experience, and on projections of future operation based on innovations in the system designs. Although original design specifications commonly state that the transients are for a 40-year design life, the fatigue analyses themselves are based on the specified number of occurrences of each transient rather than on this lifetime.

Fatigue Management Program

The Metal Fatigue of Reactor Coolant Pressure Boundary program described in [Section A2.1](#) ensures that actual plant experience remains bounded by the assumptions used in the design calculations, or that appropriate reevaluation or other corrective action is initiated if an action limit is reached. Action limits permit completion of corrective actions before the design basis number of events is exceeded and before the ASME Section III limit of 1.0 for the fatigue cumulative usage factor is reached.

The PVNGS fatigue management program was implemented in response to industry experience that indicated that the design basis set of transients used for Class 1 analyses of the reactor coolant pressure boundary did not include some significant transients, and therefore might not be limiting for components affected by them.

A3.2.1 ASME Section III Class 1 Fatigue Analysis of Vessels, Piping, and Components

Fatigue analyses exist for ASME III Division 1 Class 1 piping, vessels, heat exchangers, pumps, and valves; and if applicable, their supports.

Class 1 fatigue analyses also support design of the following Class 2 components:

- Secondary sides of the replacement steam generators
- Regenerative and letdown heat exchangers
- HPSI and LPSI pumps
- Main steam safety valves

The Class 1 analyses have been updated to incorporate redefinitions of loads and design basis events, operating changes, and power uprate with steam generator replacement.

The PVNGS reactor vessel internals were analyzed to ASME Section III Subsection NG. See [Subsection A3.2.2](#).

A3.2.1.1 Reactor Pressure Vessel, Nozzles, Head, and Studs

The PVNGS reactor pressure vessels were designed, built, and analyzed by Combustion Engineering to ASME Section III, Subsection NB (Class 1), 1971 Edition with addenda through Winter 1973. The reactor vessel primary coolant inlet and outlet nozzles and lower-head-to-shell juncture are evaluated for effects of the reactor coolant environment on fatigue behavior of these materials, consistent with NUREG/CR-6260. See [Section A3.2.3](#).

The analyses performed to incorporate the effects of power uprate (PUR) and replacement steam generators (RSG) into the current design bases demonstrated that the effects on fatigue analyses were limited to the inlet and outlet nozzles. The modification increased the CUF of the inlet nozzles and the outlet nozzles.

The 1991 CE Owner's Group review of Combustion Engineering Infobulletin 88-09, "*Nonconservative Calculation of Cumulative Fatigue Usage*" identified a possible increase in the reactor vessel stud cumulative usage factor. The Owner's Group review found that the usage factor of reactor vessel studs at PVNGS could increase to greater than 1.0, if the more-conservative pressure curves were used. To accommodate the more-conservative

pressure curves, the number of heatup-cooldown transients was reduced and the number of bolt-up transients was reduced.

The segment of the Unit 2 head vent line with wall thickness reduced by the removal of indications will be replaced, and its fatigue analysis will be revised. The repair and the revised fatigue analysis will demonstrate an adequate fatigue life, projected to the end of the period of extended operation.

The PVNGS fatigue management program will track events to ensure that appropriate reevaluation or other corrective action is initiated if an action limit is reached. Action limits permit completion of corrective actions before the design basis number of events is exceeded, and before the ASME code cumulative fatigue usage limit of 1.0 is reached. The reactor vessel studs will be tracked by the cycle-based fatigue method. The effects of fatigue in the reactor pressure vessel pressure boundary and its supports will thereby be managed for the period of extended operation.

A3.2.1.2 Control Element Drive Mechanism (CEDM) Nozzle Pressure Housings

The PVNGS CEDM nozzle pressure housings are designed to ASME III, Subsection NB (Class 1), 1974 Edition with addenda through Winter 1974. The reactor vessel design reports include the structural analysis of the CEDM nozzle pressure housings. The analysis was re-examined for the power uprate and steam generator replacement modifications.

The maximum calculated usage factor in the CEDM pressure housings indicates that the design has significant margin to the limit of 1.0 and therefore remains valid for the period of extended operation.

A3.2.1.3 Reactor Coolant Pump Pressure Boundary Components

The CE System 80 reactor coolant pumps are designed to ASME III, 1974 Edition (no addenda) for Class 1 Vessels. The load definitions were updated for replacement steam generators (RSG) with power uprate and the code analyses were evaluated to determine the applicability of the analyses of record fatigue analyses with the new loads.

Fatigue usage factors in the reactor coolant pumps do not depend on effects that are time-dependent at steady-state conditions, but depend only on effects of operational and upset transient events, principally on heatup and cooldown transients. The PVNGS fatigue management program tracks events to ensure that appropriate reevaluation or other corrective action is initiated if an action limit is reached. Action limits permit completion of corrective actions before the design basis number of events is exceeded and ensure that fatigue will be adequately managed for the period of extended operation.

A3.2.1.4 Pressurizer and Pressurizer Nozzles

The PVNGS pressurizers are designed to ASME III, Subsection NB (Class 1), 1971 Edition with addenda through Winter 1973. The analyses have been updated from time to time to incorporate redefinitions of loads and design basis events, operating changes, power uprate, and modifications including; effects of NRC Bulletin 88-11 thermal stratification in the surge line, effects of Combustion Engineering Infobulletin 88-09 “*Nonconservative Calculation of Cumulative Fatigue Usage*”, crack growth and fracture mechanics stability of postulated defects in heater sleeve attachment welds, thermal effects of replaced heater sleeves and their welds, and effects of nozzle weld overlays of the surge, spray, and relief nozzles and their safe ends and welds.

The pressurizer heater penetrations are evaluated for effects of the reactor coolant environment on fatigue behavior of these materials, consistent with NUREG/CR-6260. See [Section A3.2.3](#).

The PVNGS pressurizers have operated since startup with a continuous spray flow to prevent boron concentration stratification, and to mitigate spray line and spray nozzle fatigue.

The Liquid Elastic Fracture Mechanics fatigue crack growth analysis of indications in a Unit 2 pressurizer support skirt forging weld will remain valid as long as the number of cyclic events assumed by the analysis is not exceeded. The PVNGS fatigue management program described in [Section A2.1](#) will track these events to ensure that appropriate corrective actions are completed before the design basis number of events is exceeded.

All other fatigue analyses supporting the pressurizer design either exhibit an acceptable fatigue usage factor and remain valid for the period of extended operation, or depend on an effect found to be acceptable for a limiting number of transient events. The PVNGS fatigue management program described in [Section A2.1](#) will ensure that the fatigue usage factors based on those transient events will remain within the code limit of 1.0 for the period of extended operation, or that appropriate reevaluation or other corrective action is initiated if an action limit is reached. Action limits permit completion of corrective actions before the design basis number of events is exceeded and before the cumulative usage factor exceeds the code limit of 1.0.

A3.2.1.5 Steam Generator ASME Section III Class 1, Class 2 Secondary Side, and Feedwater Nozzle Fatigue Analyses

The replacement steam generators (RSGs) are designed to ASME III, Subsection NB (Class 1) and NC (Class 2), 1989 Edition with no addendum. The design reports included design for a concurrent power uprate. Although the secondary side is Class 2, all pressure retaining parts of the steam generator satisfy the Class 1 criteria, including a Division 1, Section III fatigue analysis.

Although the steam generator tubes have a Class 1 fatigue analysis, the calculated usage factor is zero, and the safety determination for integrity of steam generator tubes now depends on managing aging effects by a periodic inspection program rather than on the fatigue analysis. The code fatigue analysis of the tubes is therefore not a TLAA.

The fatigue analyses of the Unit 1 and 3 replacement steam generators are for a period sufficient to cover their installed life, and remain valid for the period of extended operation.

The fatigue analyses of the Unit 2 replacement steam generators are for a period sufficient to cover all but about two years of their expected 42-year installed life, including the period of extended operation. The Metal Fatigue of Reactor Coolant Pressure Boundary program described in [Section A2.1](#) will track events to ensure that appropriate reevaluation or other corrective action is initiated if an action limit is reached. Action limits permit completion of corrective actions before the design basis number of events is exceeded, and before the ASME code cumulative fatigue usage limit of 1.0 is reached.

A3.2.1.6 ASME Section III Class 1 Valves

PVNGS Class 1 valves are designed to ASME Section III, Subsection NB, 1974 Edition with multiple addenda, the 1977 Edition with Winter 1977 addendum, and the 1989 Edition no addendum. ASME Section III requires a fatigue analysis only for Class 1 valves with inlets greater than four inches nominal. At PVNGS, specifications for some Class 1 valves with inlets four inches or less also require a fatigue analysis.

For the valve models with an NB-3545.3 normal duty operating cycle evaluation, the allowed NB-3545.3 N_A normal duty operations far exceed those expected to occur.

The calculated worst-case usage factors for the Class 1 pressurizer relief valves and the 2" isolation valves for the auxiliary spray line indicate that the designs have large margins, and therefore that the pressure boundaries would withstand fatigue effects for at least two of the original design lifetimes. The design of these valves for fatigue effects is therefore valid for the period of extended operation.

The calculated worst-case usage factors for the Unit 1, Class 1 Shutdown Cooling Suction Isolation Valve, and Charging Line Isolation Valves exceed 0.7. However, fatigue usage factors in these valves do not depend on effects that are time-dependent at steady-state conditions, but depend only on effects of operational, abnormal, and upset transient events. The Metal Fatigue of Reactor Coolant Pressure Boundary program described in [Section A2.1](#) tracks events to ensure that appropriate reevaluation or other corrective action is initiated if an action limit is reached. Action limits permit completion of corrective actions before the design basis number of events is exceeded. The charging line isolation valves are subject to similar but less-severe cyclic events than the charging nozzles, whose fatigue usage is tracked by the stress-based method. The shutdown cooling suction isolation valve is the limiting location on the shutdown cooling line which will be tracked by the cycle-based fatigue method.

During the review process APS identified a number of ASME III Class 1 valves greater than four inches nominal inlet that might require a fatigue analysis, but for which the analysis was not immediately retrievable. Efforts are ongoing to confirm the need for and if necessary to obtain these analyses. APS will recover and evaluate the fatigue analysis for each of the remaining ASME III Class 1 valves greater than four inches nominal inlet, for which a fatigue analysis is also otherwise required, before the end of the current licensed operating period. Each of these analyses will be validated or revised for the period of extended operation, or fatigue in the valve will be managed by the Metal Fatigue of Reactor Coolant Pressure Boundary Program described in [Section A2.1](#).

A3.2.1.7 ASME Section III Class 1 Piping and Piping Nozzles

Class 1 reactor coolant main-loop piping supplied by Combustion Engineering is designed to ASME Section III, Subsection NB, 1974 edition with addenda through Summer 1974. The main loop piping fatigue analysis was performed to the 1974 edition with addenda through Summer 1974. The fatigue analyses of piping outside the main loop used the 1974 edition with addenda through Winter 1975 or the 1977 edition with addenda through Summer 1979. These analyses have been updated from time to time to incorporate redefinitions of loads and design basis events, operating changes, power rerate, steam generator replacement, and minor modifications.

See [Section A3.2.1.8](#) for fatigue in the pressurizer surge lines.

The CVCS charging nozzles, the pressurizer surge line hot leg nozzle, and the surge line elbows are the limiting components for fatigue in the Class 1 charging lines and surge line. These locations are subject to stress-based fatigue monitoring under the PVNGS fatigue management program.

The charging nozzle safe ends, the safety injection nozzle forging knuckle and safe ends, and the shutdown cooling line long-radius elbow are evaluated for effects of the reactor coolant environment on fatigue behavior of these materials, consistent with NUREG/CR-6260. See [Section A3.2.3](#).

With the exception of the CVCS charging lines and nozzles and the pressurizer surge lines and nozzles; fatigue usage factors in Class 1 piping and nozzles do not depend on effects that are time-dependent at steady-state conditions, but depend only on effects of operational, abnormal, and upset transient events.

The Metal Fatigue of Reactor Coolant Pressure Boundary program described in [Section A2.1](#) counts significant transient events and thermal cycles, and tracks usage factors in the bounding set of sample locations to ensure that appropriate reevaluation or other corrective action is initiated if an action limit is reached. Action limits permit completion of corrective actions before the design basis number of events is exceeded and before the ASME code cumulative fatigue usage limit of 1.0 is reached.

A3.2.1.8 Bulletin 88-11 Revised Fatigue Analysis of the Pressurizer Surge Line for Thermal Cycling and Stratification

NRC Bulletin 88-11 requested that licensees establish and implement a program to confirm pressurizer surge line integrity in view of the occurrence of thermal stratification and required them to inform the staff of the actions taken to resolve this issue.

The surge line hot leg elbow is evaluated for effects of the reactor coolant environment on fatigue behavior of these materials, consistent with NUREG/CR-6260. See [Section A3.2.3](#).

The surge lines are designed to ASME III, Subsection NB, 1977 edition with addenda through Summer 1979. The surge line design was reevaluated in 1991 through the Combustion Engineering Owners Group (CEOG) in response to the NRC Bulletin 88-11 thermal stratification concerns. The maximum calculated design basis (nominal 40-year) CUF at any location in the surge lines, including thermal stratification effects, is less than 1.0. The surge line is subject to stress-based fatigue monitoring under the Metal Fatigue of Reactor Coolant Pressure Boundary program described in [Section A2.1](#), which will ensure that appropriate reevaluation or other corrective action is initiated if an action limit is reached. Action limits permit completion of corrective actions before the design basis number of events is exceeded, and before the ASME code cumulative fatigue usage limit of 1.0 is reached.

A3.2.1.9 Class 1 Fatigue Analyses of Class 2 Regenerative and Letdown Heat Exchangers

The regenerative heat exchangers were designed and constructed to Class 2 rules on both shell and tube sides. The applicable code version date is 1974 with addenda through the Winter of 1975. The letdown heat exchangers were designed and constructed to Class 2 rules on the tube side, Class 3 on the shell side. However, although these are Class 2 and 3 heat exchangers, the specifications require a Class 1, NB-3222 fatigue analyses.

The regenerative and letdown heat exchanger fatigue analyses were performed with transients specified in the original CE general specification for System 80 plants. The numbers of transient events required by these specifications are consistent with or are greater than the numbers of transient events used in the PVNGS fatigue management program.

Fatigue in the regenerative and letdown heat exchangers was originally determined to be bounded by the fatigue of the charging nozzle. Fatigue usage in the charging nozzles is affected by the same transients that have significant effects on fatigue in these heat exchangers. The charging nozzles are monitored by stress-based fatigue monitoring under the Metal Fatigue of Reactor Coolant Pressure Boundary program described in [Section A2.1](#). The combination of cycle counting and stress-based fatigue monitoring of the charging nozzles will assure that the effects of aging in the regenerative and letdown heat exchangers are managed for the period of extended operation. The program will track

events to ensure that appropriate reevaluation or other corrective action is initiated if an action limit is reached. Action limits permit completion of corrective actions before the design basis number of events is exceeded, and before the ASME code cumulative fatigue usage limit of 1.0 is reached.

A3.2.1.10 Class 1 Fatigue Analyses of Class 2 HPSI and LPSI Safety Injection Safeguard Pumps for Design Thermal Cycles

The HPSI and LPSI safety injection safeguard pumps were designed to ASME III Class 2, for which the code requires no fatigue analysis. However [UFSAR 3.9.3.5.3.3](#) describes design for a stated number of thermal transient cycles, and the Structural Integrity & Operability Analysis design reports for both the HPSI and LPSI pumps cite the Class 1 methods of ASME III Subparagraph NB-3222.4 when addressing these thermal transients.

Both the HPSI and LPSI pumps are designed for initiation of safety injection, which is classified as an upset condition. The LPSI pumps are also designed for shutdown cooling, which is a normal operating condition. The structural integrity and operability analyses for these pumps analyzed these transients and demonstrate sufficient margin for any possible increase in operating cycles above the original estimate. The design of the HPSI and LPSI pumps is therefore valid for the period of extended operation.

A3.2.1.11 Class 1 Analysis of Class 2 Main Steam Safety Valves

The main steam safety valves are ASME III Class 2. However [UFSAR 5.2.2.4.3.2](#) describes a stated number of design transients, and the design includes a Class 1 fatigue analysis to Subarticle NB-3550, "Cyclic Loads for Valves".

The existing analysis demonstrates that the design is suitable for at least nine of the original 40-year design lifetimes and therefore remains valid for the period of extended operation.

A3.2.1.12 High Energy Line Break Postulation Based on Fatigue Cumulative Usage Factor

A leak-before-break analysis (LBB) eliminated large breaks in the main reactor coolant loops. Outside the main loop breaks are selected in accordance with Regulatory Guide 1.46 and Standard Review Plan Branch Technical Position MEB 3-1.

The citation of MEB 3-1 means that "intermediate breaks", between terminal ends in piping with ASME Section III Class 1 fatigue analyses are identified at any location where cumulative usage factor is equal to or greater than 0.1, with the stated exception of the reactor coolant system primary loops, to which the LBB analysis applies.

Break locations that depend on usage factor will remain valid as long as the calculated usage factors are not exceeded. The Metal Fatigue of Reactor Coolant Pressure Boundary program described in [Section A2.1](#) will track events to ensure that the originally-calculated

maximum usage factors are not exceeded, or that appropriate reevaluation or other corrective action is initiated if an action limit is reached. Action limits for the HELB design basis permit completion of corrective actions before the calculated design basis usage factors in Class 1 lines (outside the reactor coolant system loops) is exceeded.

A3.2.2 Fatigue and Cycle-Based TLAAs of ASME III Subsection NG Reactor Pressure Vessel Internals

The reactor vessel internals were designed and fabricated to Subsection NG rules of ASME III, 1974 Edition. The design reports indicate use of some later addenda for some parts.

The ASME Subsection NG design reports and addenda include calculated usage factors for the components. The report addenda for power uprate and steam generator replacement concluded that all code and specification requirements were satisfied.

The Subsection NG fatigue usage factors do not depend on flow-induced vibration or other high-cycle effects that are time-dependent at steady-state conditions, but depend more strongly on effects of operational, upset, and emergency transient events. Therefore, the increase in operating life to 60 years will not have a significant effect on these fatigue usage factors so long as the number of design basis transient cycles remains within the number assumed by the original analysis. The Metal Fatigue of Reactor Coolant Pressure Boundary program described in [Section A2.1](#) will track events to ensure that appropriate reevaluation or other corrective action is initiated if an action limit is reached. Action limits permit completion of corrective actions before the design basis number of events is exceeded.

A3.2.3 Effects of the Reactor Coolant System Environment on Fatigue Life of Piping and Components (Generic Safety Issue 190)

Concerns with possible effects of elevated temperature, reactor coolant chemistry environments, and different strain rates prompted NRC-sponsored research to assess these effects, culminating in the guidance of NUREG/CR-6260, *Application of NUREG/CR-5999 Interim Fatigue Curves to Selected Nuclear Power Plant Components*. Although GSI 190 has been closed for plants with 40-year initial licenses, NUREG-1800 states that "The applicant's consideration of the effects of coolant environment on component fatigue life for license renewal is an area of review", noting the staff recommendation "...that the samples in NUREG/CR-6260 should be evaluated considering environmental effects for license renewal".

NUREG/CR-6260 identifies seven sample locations for newer Combustion Engineering plants such as PVNGS:

- Reactor vessel shell and lower head
- Reactor vessel inlet nozzles
- Reactor vessel outlet nozzles

- Surge line
- Charging system nozzle
- Safety injection system nozzle
- Shutdown cooling line.

The thermal sleeves were removed from both the Loop 1 and Loop 2 safety injection nozzles, potentially increasing the CUF for the entire interior surface of the nozzle, including the knuckle location and safe end, because they were no longer protected by the thermal sleeves. Therefore two values were calculated for the safety injection nozzles, at the knuckle location and at the safe end. The safe ends were found to be limiting in the charging nozzles.

The pressurizer heater penetrations may be subject to effects of thermal stratification and insurge-outsurge transients, have been subject to significant repair, modification, and reanalysis. Accumulation of fatigue usage in them is therefore of concern for the period of extended operation. APS has therefore elected to include them in locations monitored for effects of environmentally-assisted fatigue.

APS therefore evaluated a total of nine locations for effects of the reactor coolant system environment on fatigue life.

PVNGS performed plant-specific calculations for the NUREG/CR-6260 sample locations. The analyses used F_{en} relationships as appropriate for the material at each of the locations. F_{en} values for carbon and low-alloy steels are taken from NUREG/CR-6583. F_{en} values for stainless steels are from NUREG/CR-5704. F_{en} values for the charging nozzle safe ends and safety injection nozzle safe ends were developed using EPRI MRP-47 integrated strain rate methods and the NUREG/CR-5704 values. F_{en} values for the pressurizer surge line and shutdown cooling line were developed using plant-specific transient data. The analyses found that usage factors in two of the NUREG/CR-6260 locations, when projected to the end of a 60-year design life, may exceed 1.0.

NUREG/CR-6260 advises that conservative assumptions remain which could be removed to reduce the CUF values below the 1.0 allowable. The best method to lower the CUF for the few worst locations is fatigue monitoring, using realistic numbers of cycles, realistic severity of transients, and more refined analyses. However, in some cases, a combination of fatigue monitoring and revised analyses may be needed.

All of the NUREG/CR-6260 locations except the first, the vessel lower head to shell juncture, are included in the Metal Fatigue of Reactor Coolant Pressure Boundary program described in [Section A2.1](#). The first location is not monitored because the low projected usage factor, when multiplied by the applicable F_{en} , remains negligible. For the remaining locations the Metal Fatigue of Reactor Coolant Pressure Boundary program will track events and usage factors to ensure that appropriate reevaluation or other corrective action is initiated if an action limit is reached. Action limits permit completion of corrective actions before the design basis number of events is exceeded, and before the ASME code cumulative fatigue usage limit of 1.0 is reached.

A3.2.4 Assumed Thermal Cycle Count for Allowable Secondary Stress Range Reduction Factor in ANSI B31.1 and ASME Section III Class 2 and 3 Piping

PVNGS ASME III Class 2 and 3 piping is designed to the 1974 edition, Summer 1975 addenda; plus later editions and addenda for certain requirements. None of ANSI B31.1 or ASME Section III Subsections NC and ND invokes fatigue analyses. However, if the number of full-range thermal cycles is expected to exceed 7,000, these codes require the application of a stress range reduction factor (SRRF) to the allowable stress range for expansion stresses (secondary stresses). The allowable secondary stress range is $1.0 S_A$ for 7000 equivalent full-temperature thermal cycles or less and is reduced in steps to $0.5 S_A$ for greater than 100,000 cycles. Partial cycles are counted proportional to their temperature range. Therefore, so long as the estimated number of cycles remains less than 7000 for a 60-year life, the stress range reduction factor remains at 1 and the stress range reduction factor used in the piping analysis will not be affected by extending the operation period to 60 years.

The survey of all plant piping systems found that the reactor coolant hot leg sample lines may be subject to more than 7000 significant thermal cycles in 60 years, requiring a reduction in SRRF to 0.9; and that the steam generator downcomer and feedwater recirculation lines may be subject to more than 15,000, requiring a reduction in SRRF to 0.8. The applicable PVNGS design analyses were revised, and found that the secondary stress ranges are within the limits imposed by these reduced SRRFs. The pipe break analysis included in the revised analysis of the steam generator downcomer and feedwater recirculation lines required no change to break locations or break types. These analyses have therefore been extended to the end of the period of extended operation.

The number of equivalent full-range thermal cycles for all other B31.1 and ASME III Class 2 and 3 lines within the scope of license renewal is expected to be only about 1500 or less in 60 years, which is only a fraction of the 7000-cycle threshold for which a stress range reduction factor is required in the applicable piping codes. The piping analyses for these remaining lines therefore require no change to the SRRF of 1.0 and remain valid for the period of extended operation.

A3.3 ENVIRONMENTAL QUALIFICATION (EQ) OF ELECTRICAL COMPONENTS

Aging evaluations that qualify electrical and I&C components required to meet the requirements of 10 CFR 50.49 are evaluated to demonstrate qualification for the 40 year plant life are TLAAs. The existing PVNGS Environmental Qualification program will adequately manage component thermal, radiation, and cyclical aging through the use of aging evaluations based on 10 CFR 50.49(f) qualification methods. As required by 10 CFR 50.49, EQ components not qualified for the current license term are to be

refurbished or replaced, or have their qualification extended prior to reaching the aging limits established in the evaluation.

Continuing the existing 10 CFR 50.49 EQ program ensures that the aging effects will be managed and that the EQ components will continue to perform their intended functions for the period of extended operation. The Environmental Qualification of Electrical Components program is described in [Section A2.2](#).

A3.4 CONCRETE CONTAINMENT TENDON PRESTRESS

The PVNGS containment is a prestressed concrete, hemispherical-dome-on-a-cylinder structure, with a steel membrane liner. Post-tensioned tendons compress the concrete and permit the structure to withstand design basis accident internal pressures. The reinforced concrete basemat is conventionally reinforced.

To ensure the integrity of the containment pressure boundary under design basis accident loads, design predictions of loss of prestress demonstrate that prestress will remain adequate for the design life. An inspection program confirms that the tendon prestress remains within design limits throughout the life of the plant [[UFSAR Section 3.8.1](#), Technical Specification Surveillance Requirement 3.6.200.1].

Original design predictions of prestress force were projected to the end of the period of extended operation. The extended predicted force lines remain above minimum required values (MRVs) for the period of extended operation. Trend lines calculated by regression analyses of tendon surveillance data to date predict that the future performance of the post-tensioning system will remain above the minimum required values (MRV), and therefore that the assumptions of the containment vessel design will remain valid through the end of the period of extended operation.

Continuing the existing Concrete Containment Tendon Prestress program ([A2.3](#)) ensures that loss of prestress aging effects will be managed and that the containment tendons will continue to perform their intended functions for the period of extended operation.

A3.5 CONTAINMENT LINER PLATE, EQUIPMENT HATCHES, PERSONNEL AIR LOCKS, PENETRATIONS, AND POLAR CRANE BRACKETS

NUREG-1800 Section 4.6.1 notes that in some designs “Fatigue of the liner plates or metal containments may be considered in the design based on an assumed number of loading cycles for the current operating term”.

The PVNGS post-tensioned concrete containment vessels are designed to Bechtel Topical Report BC-TOP-5-A Revision 3. The containment design report has been revised to address effects of power uprate and steam generator replacement.

At PVNGS the only metallic components of the containment pressure boundary that are designed for a specific number of load cycles in a design lifetime are the main steam, main feedwater, and recirculation sump suction penetrations (See [Sections A3.5.1](#) and [A3.5.2](#)). The remaining penetrations were designed to stress limit criteria, independent of the number of load cycles, and with no fatigue analyses.

A3.5.1 Design Cycles for the Main Steam and Main Feedwater Penetrations

The BC-TOP-1, "Containment Building Liner Plate Design Report", Part II Section 1.1, describes the main steam penetration design for cyclic loads. The design basis includes

- 100 lifetime steady state operating thermal gradient plus normal operating cyclic loads (Loading Condition V), and
- 10 steady state operating thermal gradient plus steam pipe rupture cyclic loads (Loading Condition IV).

The operating history to date indicates that the original design basis 100 operating cycles assumed for main steam penetrations will be exceeded during the extended operating period. However the number of Condition IV events assumed for design does not change with an increase in the design life, and Condition V events do not contribute significantly to usage factor. Examination of possible changes to the BC-TOP-1 analysis for any reasonably-expected increase in the number of Condition V events demonstrates adequate margin to the stress limit determined by the elastic-plastic analysis. Design of the main feedwater penetrations is bounded by that of the main steam penetrations due to their smaller size, similar geometry and similar operating conditions. The design of the main steam and main feedwater penetrations is therefore valid for the period of extended operation..

A3.5.2 Design Cycles for the Recirculation Sump Suction Line Penetrations

Recirculation sump suction line containment penetrations were evaluated for an NE-3222.4(d) exemption from fatigue analysis. The exemption criteria depend on the number of cycles for which loads are applied; therefore the exemption is supported by a TLAA.

The analysis of these penetrations was based on the alternating stress range for pressure cycles, and demonstrated that the allowable number of cycles is far greater than the number expected for the period of extended operation. There is sufficient margin in the design for any possible increase in operating cycles above the original estimate. The design of the recirculation penetrations is therefore valid for the period of extended operation.

A3.6 PLANT-SPECIFIC TIME-LIMITED AGING ANALYSES

A3.6.1 Load Cycle Limits of Cranes, Lifts, and Fuel Handling Equipment to CMAA-70

[UFSAR Section 9.1.4](#) describes design of lifting machines to Crane Manufacturers Association of America Specification No. 70 (CMAA-70, 1975). The CMAA-70 crane service classification (“class” or “service level”) for each machine depends, in part, on the assumption that the number of stress cycles at or near the maximum allowable stress will not exceed the number assumed for that design class. In operation, this means the number of significant lifts (i.e. those which approach or equal the design load) will not exceed the number of stress cycles assumed for that design class.

In all cases, the design standard full-capacity lifts exceed the number expected of the machine for a 60-year life. The lifting machine designs therefore remain valid for the period of extended operation.

A3.6.2 Fatigue Crack Growth and Fracture Mechanics Stability Analyses of Half-Nozzle Repairs to Alloy 600 Material in Reactor Coolant Hot Legs

PVNGS obtained exemptions from the flaw removal and successive inspection requirements of ASME XI (1992), Sections IWA-3300 and IWB-2420, for the alternative half-nozzle method used to repair Alloy 600 small bore, hot leg nozzles.

Fatigue crack growth and stability analyses of nozzle remnants and welds left in the hot legs depend on the number of heatup-cooldown and operating basis earthquake (OBE) cycles assumed for a 40-year life, and are therefore TLAAs.

The fatigue crack growth and stability analysis will remain valid for the period of extended operation if the assumed cycle count is not exceeded. The Metal Fatigue of Reactor Coolant Pressure Boundary program described in [Section A2.1](#) will track events to ensure that appropriate reevaluation or other corrective action is initiated if an action limit is reached. Action limits permit completion of corrective actions before the design basis number of either of these events is exceeded.

A3.6.3 Building Absolute or Differential Heave or Settlement. Including Possible Effects of Changes in a Perched Groundwater Lens

The review of site soil mechanics and hydrogeology for the original PVNGS license application identified two related areas: (1) possible effects of heave and settlement on building foundation levels and stability, and (2) possible effects of changes in level of a perched groundwater lens on heave, settlement, and foundation stability.

Appendix A
Updated Final Safety Analysis Report Supplement

Evaluations for the effects on heave and settlement prompted interrelated calculations and estimates of these effects by APS and by NRC reviewers. The licensing bases, particularly the PSAR, UFSAR, and SER contain discussions of heave and settlement, and perched groundwater, including references to the plant life. Because of these references to the plant life, APS has elected to classify these original evaluations and analyses as TLAAs.

The PVNGS licensing basis includes a commitment to monitor settlement of structures for the life of the plant. This surveillance is performed as part of the Structures Monitoring Program ([A1.32](#)).

The settlement monitoring data indicate that the post-construction settlement for individual structures, differential settlement between adjacent structures having critical connections, and post-construction containment tilt indicate no significant trends and will remain stable. The settlement monitoring, which is conducted as part of the Structures Monitoring Program ([A1.32](#)), will continue through the period of extended operation to ensure that settlement remains below the limits.

The groundwater monitoring data indicate no potential for settlement due to changes in groundwater level. These results confirm that the assumptions of the original projections of increases in groundwater levels were very conservative and that the conclusions of their safety determination - that there will be no effect on building foundation stability - apply to the foreseeable future and at least to the end of the period of extended operation. The conclusion of the predictions of groundwater level, and the safety determination based on them, therefore remain valid for the period of extended operation.

Table A4-1 License Renewal Commitments

Item No.	Commitment	LRA Section	Implementation Schedule
1	<p>Section A3 [of the LRA] contains evaluation summaries of TLAA's for the period of extended operation. These summary descriptions of aging management program programs and time-limited aging analyses will be incorporated in the Updated Final Safety Analysis Report for PVNGS following issuance of the renewed operating license in accordance with 10 CFR 50.71(e). (RCTSAI 3247244)</p>	A0	The next 10 CFR 50.71(e) UFSAR update following issuance of the renewed operating license. (Estimated June 30, 2011)
2	<p>Procedures will be enhanced to include those nonsafety-related SSCs requiring aging management within the scope of the PVNGS Quality Assurance Program to address the elements of corrective actions, confirmation process, and administrative controls. (RCTSAI 3246887)</p>	A1 B1.3 Summary Descriptions Of Aging Management	Prior to the period of extended operation ¹ .
3	<p>Existing ASME Section XI Inservice Inspection, Subsections IWB, IWC, and IWD program is credited for license renewal. (RCTSAI 3246890)</p>	A1.1 B2.1.1 ASME Section XI Inservice Inspection, Subsections IWB, IWC, AND IWD	Ongoing
4	<p>Existing Water Chemistry program is credited for license renewal, AND Prior to the period of extended operation, plant procedures will be enhanced to address sampling of effluents from new secondary system cation resins for purgeable and nonpurgeable Organic Carbon. (RCTSAI 3246891)</p>	A1.2 B2.1.2 Water Chemistry	Prior to the period of extended operation ¹ .
5	<p>Existing Reactor Head Closure Studs program is credited for license renewal. (RCTSAI 3246892)</p>	A1.3 B2.1.3 Reactor Head Closure Studs	Ongoing
6	<p>Existing Boric Acid Corrosion program is credited for license renewal. (RCTSAI 3246893)</p>	A1.4 B2.1.4 Boric Acid Corrosion	Ongoing

Table A4-1 License Renewal Commitments

Item No.	Commitment	LRA Section	Implementation Schedule
7	<p>Existing Nickel-Alloy Penetration Nozzles Welded to The Upper Reactor Vessel Closure Heads of Pressurized Water Reactors program is credited for license renewal, AND</p> <p>Prior to December 31, 2008, the PVNGS Alloy 600 Management Program Plan will be revised to incorporate the applicable examination requirements of ASME Code Case N-729-1 (Reactor Vessel Head Inspections), subject to the conditions specified in 10 CFR 50.55a(g)(6)(ii)(D)(2) through(6). (RCTSAI 3246894)</p>	<p>A1.5 B2.1.5 Nickel-Alloy Penetration Nozzles Welded to The Upper Reactor Vessel Closure Heads of Pressurized Water Reactors</p>	<p>Prior to December 31, 2008</p>
8	<p>Existing Flow-Accelerated Corrosion program is credited for license renewal, AND</p> <p>Prior to the period of extended operation, the program procedure will be enhanced to clarify the guidance for susceptible small-bore piping components and to verify the trace chromium content of the carbon steel pipe replacement. (RCTSAI 3246895)</p>	<p>A1.6 B2.1.6 Flow-Accelerated Corrosion</p>	<p>Prior to the period of extended operation¹.</p>
9	<p>Existing Bolting Integrity program is credited for license renewal. (RCTSAI 3246896)</p>	<p>A1.7 B2.1.7 Bolting Integrity</p>	<p>Ongoing</p>
10	<p>Existing Steam Generator Tube Integrity program is credited for license renewal. (RCTSAI 3246897)</p>	<p>A1.8 B2.1.8 Steam Generator Tube Integrity</p>	<p>Ongoing</p>
11	<p>Existing Open-Cycle Cooling Water System program is credited for license renewal, AND</p> <p>Prior to the period of extended operation, the program will be enhanced to clarify guidance in the conduct of heat exchanger and piping inspections using NDE techniques and related acceptance criteria. (RCTSAI 3246898)</p>	<p>A1.9 B2.1.9 Open-Cycle Cooling Water System</p>	<p>Prior to the period of extended operation¹.</p>

Table A4-1 License Renewal Commitments

Item No.	Commitment	LRA Section	Implementation Schedule
12	<p>Existing Closed-Cycle Cooling Water System program is credited for license renewal, AND</p> <p>Prior to the period of extended operation, procedures will be enhanced to incorporate the guidance of EPRI TR-107396 with respect to water chemistry control for frequency of sampling and analysis, normal operating limits, action level concentrations, and times for implementing corrective actions upon attainment of action levels. (RCTSAI 3246899)</p>	<p>A1.10 B2.1.10 Closed-Cycle Cooling Water System</p>	<p>Prior to the period of extended operation¹.</p>
13	<p>Existing Inspection Of Overhead Heavy Load And Light Load (Related To Refueling) Handling Systems program is credited for license renewal, AND</p> <p>Prior to the period of extended operation, procedures will be enhanced to inspect for loss of material due to corrosion or rail wear. (RCTSAI 3246900)</p>	<p>A1.11 B2.1.11 Inspection Of Overhead Heavy Load And Light Load (Related To Refueling) Handling Systems</p>	<p>Prior to the period of extended operation¹.</p>
14	<p>Existing Fire Protection program is credited for license renewal, AND</p> <p>Prior to the period of extended operation, the following enhancements will be implemented:</p> <ul style="list-style-type: none"> • Procedures will be enhanced to state trending requirements for the diesel-driven fire pump and to include visual inspection of the fuel supply line to detect degradation. • Procedures will be enhanced to inspect for mechanical damage, corrosion and loss of material of the halon discharge pipe header and the CO₂ system discharge nozzles. • Procedures will be enhanced to state the qualification requirements for inspecting penetration seals, fire rated doors, fire barrier walls, ceilings and floors. (RCTSAI 3246901) 	<p>A1.12 B2.1.12 Fire Protection</p>	<p>Prior to the period of extended operation¹.</p>

Table A4-1 License Renewal Commitments

Item No.	Commitment	LRA Section	Implementation Schedule
15	<p>Existing Fire Water System program is credited for license renewal, AND Prior to the period of extended operation, the following enhancements will be implemented:</p> <ul style="list-style-type: none"> • Specific procedures will be enhanced to include review and approval requirements under the Nuclear Administrative Technical Manual (NATM). • Procedures will be enhanced to be consistent with the current code of record or NFPA 25 2002 Edition. • Procedures will be enhanced to field service test a representative sample or replace sprinklers prior to 50 years in service and test thereafter every 10 years to ensure that signs of degradation are detected in a timely manner. • Procedures will be enhanced to be consistent with NFPA 25 Section 7.3.2.1, 7.3.2.2, 7.3.2.3, and 7.3.2.4. • Procedures will be enhanced to state trending requirements. • Procedures will be enhanced so that the PVNGS Quality Assurance programs will apply to Fire Protection SSCs that are within the scope of license renewal that are also part of the boundary of the WRF (Water Reclamation Facility). <p>(RCTSAI 3246902)</p>	<p>A1.13 B2.1.13 Fire Water System</p>	<p>Prior to the period of extended operation¹.</p>

Table A4-1 License Renewal Commitments

Item No.	Commitment	LRA Section	Implementation Schedule
16	<p>Existing Fuel Oil Chemistry program is credited for license renewal, AND Prior to the period of extended operation:</p> <ul style="list-style-type: none"> • Procedures will be enhanced to extend the scope of the program to include the SBOG fuel oil storage tank and SBOG skid fuel tanks. • Procedures will be enhanced to include ten-year periodic draining, cleaning, and inspections on the diesel-driven fire pump day tanks, the SBOG fuel oil storage tanks, and SBOG skid fuel tanks. • Ultrasonic testing (UT) or pulsed eddy current (PEC) thickness examination will be conducted to detect corrosion-related wall thinning if degradation is found during the visual inspections and once on the tank bottoms for the EDG fuel oil storage tanks, EDG fuel oil day tanks, diesel-driven fire pump day tanks, and SBOG fuel oil storage tanks. The onetime UT or PEC examination on the tank bottoms will be performed before the period of extended operation. <p>(RCTSAI 3246903)</p>	<p>A1.14 B2.1.14 Fuel Oil Chemistry</p>	<p>Prior to the period of extended operation¹.</p>

Table A4-1 License Renewal Commitments

Item No.	Commitment	LRA Section	Implementation Schedule
17	<p>Existing Reactor Vessel Surveillance program is credited for license renewal, AND</p> <p>Prior to the period of extended operation:</p> <ul style="list-style-type: none"> • The schedule will be revised to withdraw the next capsule at the equivalent clad-base metal exposure of approximately 54 EFPY expected for the 60-year period of operation, and to withdraw remaining standby capsules at equivalent clad-base metal exposures not exceeding the 72 EFPY expected for a possible 80-year second period of extended operation. This withdrawal schedule is in accordance with NUREG-1801, Section XI.M31, item 6, and with the ASTM E 185-82 criterion which states that capsules may be removed when the capsule neutron fluence is between one and two times the limiting fluence calculated for the vessel at the end of expected life. This schedule change must be approved by the NRC, as required by 10 CFR 50 Appendix H. • If left in the reactor beyond the presently-scheduled withdrawal, the next scheduled surveillance capsule in each unit will reach a clad-base metal 54 EFPY equivalent at about 40 actual operating EFPY (40, 39, and 42 actual EFPY in Units 1, 2, and 3, respectively). • Procedures will be enhanced to identify the withdrawal of the remaining standby capsules at 72 EFPY, at about 50 to 54 actual operating EFPY, near the end of the extended licensed operating period. The need to monitor vessel fluence following removal of the remaining standby capsules, and ex-vessel or in-vessel methods, will be addressed prior to removing the remaining capsules. <p>(RCTSAI 3246904)</p>	<p>A1.15 B2.1.15 Reactor Vessel Surveillance</p>	<p>Prior to the period of extended operation¹.</p>

Table A4-1 License Renewal Commitments

Item No.	Commitment	LRA Section	Implementation Schedule
18	<p>The One-Time Inspection program conducts one-time inspections of plant system piping and components to verify the effectiveness of the Water Chemistry program (A1.2), Fuel Oil Chemistry program (A1.14), and Lubricating Oil Analysis program (A1.23). The aging effects to be evaluated by the One-Time Inspection program are loss of material, cracking, and reduction of heat transfer. (RCTSAIs 3246906 [U1]; 3247258 [U2]; 3247259 [U3])</p>	<p>A1.16 B2.1.16 One-Time Inspection</p>	<p>Prior to the period of extended operation¹.</p>
19	<p>The Selective Leaching of Materials program is a new program that will be implemented prior to the period of extended operation. Industry and plant-specific operating experience will be evaluated in the development and implementation of this program. (RCTSAIs 3246908 [U1]; 3247260 [U2]; 3247261 [U3])</p>	<p>A1.17 B2.1.17 Selective Leaching Of Materials</p>	<p>Prior to the period of extended operation¹.</p>
20	<p>The Buried Piping and Tanks Inspection program is a new program that will be implemented prior to the period of extended of operation. Within the ten year period prior to entering the period of extended operation, an opportunistic or planned inspection will be performed. Upon entering the period of extended operation a planned inspection within ten years will be required unless an opportunistic inspection has occurred within this ten year period. Industry and plant-specific operating experience will be evaluated in the development and implementation of this program. (RCTSAIs 3246909 [U1]; 3247263 [U2]; 3247264 [U3])</p>	<p>A1.18 B2.1.18 Buried Piping And Tanks Inspection</p>	<p>Prior to the period of extended operation¹.</p>

Table A4-1 License Renewal Commitments

Item No.	Commitment	LRA Section	Implementation Schedule
21	<p>The One-Time Inspection of ASME Code Class 1 Small-Bore Piping program manages cracking of stainless steel ASME Code Class 1 piping less than or equal to 4 inches. This program is a part of the Risk-Informed Inservice Inspection (RI-ISI) program.</p> <p>For ASME Code Class 1 small-bore piping, the RI-ISI program requires volumetric examinations on selected weld locations to detect cracking. Weld locations are selected based on the guidelines provided in EPRI TR-112657. Volumetric examinations are conducted in accordance with ASME Section XI with acceptance criteria from Paragraph IWB-3000 and IWB-2430. The fourth interval of the ISI program for each unit at PVNGS will provide the results for the one time inspection of ASME Code Class 1 small-bore piping. (RCTSAs 3246910 [U1]; 3247265 [U2]; 3247266 [U3])</p>	<p>A1.19 B2.1.19 One-Time Inspection of ASME Code Class 1 Small-Bore Piping</p>	<p>Prior to the period of extended operation¹.</p>
22	<p>The External Surfaces Monitoring Program is a new program that will be implemented prior to the period of extended operation. Industry and plant-specific operating experience will be evaluated in the development and implementation of this program. (RCTSAs 3246911 [U1]; 3247272 [U2]; 3247273 [U3])</p>	<p>A1.20 B2.1.20 External Surfaces Monitoring Program</p>	<p>Prior to the period of extended operation¹.</p>

Table A4-1 License Renewal Commitments

Item No.	Commitment	LRA Section	Implementation Schedule
23	<p>APS will:</p> <p>A. Reactor Coolant System Nickel Alloy Pressure Boundary Components Implement applicable (1) NRC Orders, Bulletins and Generic Letters associated with nickel alloys and (2) staff-accepted industry guidelines, (3) participate in the industry initiatives, such as owners group programs and the EPRI Materials Reliability Program, for managing aging effects associated with nickel alloys, (4) upon completion of these programs, but not less than 24 months before entering the period of extended operation, APS will submit an inspection plan for reactor coolant system nickel alloy pressure boundary components to the NRC for review and approval, and</p> <p>B. Reactor Vessel Internals</p> <p>(1) Participate in the industry programs for investigating and managing aging effects on reactor internals; (2) evaluate and implement the results of the industry programs as applicable to the reactor internals; and (3) upon completion of these programs, but not less than 24 months before entering the period of extended operation, APS will submit an inspection plan for reactor internals to the NRC for review and approval. (RCTSAIs 3246912 [U1]; 3247274 [U2]; 3247276 [U3])</p>	<p>A1.21 B2.1.21 Reactor Coolant System Supplement</p>	<p>Not less than 24 months prior to the period of extended operation¹.</p>
24	<p>The Inspection of Internal Surfaces in Miscellaneous Piping and Ducting Components program is a new program that will be implemented prior to the period of extended operation. Industry and plant-specific operating experience will be evaluated in the development and implementation of this program. (RCTSAIs 3246914 [U1]; 3247277 [U2]; 3247278 [U3])</p>	<p>A1.22 B2.1.22 Inspection Of Internal Surfaces In Miscellaneous Piping And Ducting Components</p>	<p>Prior to the period of extended operation¹.</p>
25	<p>Existing Lubricating Oil Analysis program is credited for license renewal. (RCTSAI 3246915)</p>	<p>A1.23 B2.1.23 Lubricating Oil Analysis</p>	<p>Ongoing</p>

Table A4-1 License Renewal Commitments

Item No.	Commitment	LRA Section	Implementation Schedule
26	The Electrical Cables and Connections Not Subject to 10 CFR 50.49 Environmental Qualification Requirements program is a new program that will be implemented prior to the period of extended operation. Industry and plant-specific operating experience will be evaluated in the development and implementation of this program. (RCTSAI 3246917)	<p>A1.24 B2.1.24 Electrical Cables And Connections Not Subject to 10 CFR 50.49 Environmental Qualification Requirements</p>	Prior to the period of extended operation ¹ .
27	Existing Electrical Cables And Connections Not Subject To 10 CFR 50.49 Environmental Qualification Requirements Used In Instrumentation Circuits program is credited for license renewal , AND Prior to the period of extended operation, procedures will be enhanced to identify license renewal scope and require an engineering evaluation of the calibration results and to require that an action request be written when the loop cannot be calibrated to meet acceptance criteria. (RCTSAI 3246919)	<p>A1.25 B2.1.25 Electrical Cables And Connections Not Subject To 10 CFR 50.49 Environmental Qualification Requirements Used In Instrumentation Circuits</p>	Prior to the period of extended operation ¹ .
28	The Inaccessible Medium Voltage Cables Not Subject to 10 CFR 50.49 EQ Requirements program is a new program that will be implemented prior to the period of extended operation. Industry and plant-specific operating experience will be evaluated in the development and implementation of this program. (RCTSAI 3246920)	<p>A1.26 B2.1.26 Inaccessible Medium Voltage Cables Not Subject To 10 CFR 50.49 Environmental Qualification Requirements</p>	Prior to the period of extended operation ¹ .
29	Existing ASME Section XI, Subsection IWE program is credited for license renewal. (RCTSAI 3246921)	<p>A1.27 B2.1.27 ASME Section XI, Subsection IWE</p>	Ongoing

Table A4-1 License Renewal Commitments

Item No.	Commitment	LRA Section	Implementation Schedule
30	Existing ASME Section XI, Subsection IWL program is credited for license renewal. (RCTSAI 3246922)	A1.28 B2.1.28 ASME Section XI, Subsection IWL	Ongoing
31	Existing ASME Section XI, Subsection IWF program is credited for license renewal. (RCTSAI 3246923)	A1.29 B2.1.29 ASME Section XI, Subsection IWF	Ongoing
32	Existing 10 CFR 50, Appendix J program is credited for license renewal. (RCTSAI 3246924)	A1.30 B2.1.30 10 CFR 50, Appendix J	Ongoing
33	Existing Masonry Wall Program is credited for license renewal, AND Prior to the period of extended operation, procedures will be enhanced to specify ACI 349.3R-96 as the reference for qualification of personnel to inspect structures under the Masonry Wall Program, which is part of the Structures Monitoring Program. (RCTSAI 3246926)	A1.31 B2.1.31 Masonry Wall Program	Prior to the period of extended operation ¹ .
34	Existing Structures Monitoring Program is credited for license renewal, AND Prior to the period of extended operation: <ul style="list-style-type: none"> The Structures Monitoring Program will be enhanced to specify ACI 349.3R-96 as the reference for qualification of personnel to inspect structures under the Structures Monitoring Program. (RCTSAI 3246927)	A1.32 B2.1.32 Structures Monitoring Program	Prior to the period of extended operation ¹ .

Table A4-1 License Renewal Commitments

Item No.	Commitment	LRA Section	Implementation Schedule
38	<p>The Metal Enclosed Bus program is a new program and will be completed before the period of extended operation and once every 10 years thereafter. Industry and plant-specific operating experience will be evaluated in the development and implementation of this program. (RCTSAIs 3246932 [U1]; 3247220 [U2]; 3247221 [U3])</p>	<p>A1.36 B2.1.36 Metal Enclosed Bus</p>	<p>Prior to the period of extended operation and once every 10 years thereafter.</p>
39	<p>(1) The existing Metal Fatigue of Reactor Coolant Pressure Boundary program will be enhanced to provide guidelines and requirements for tracking both transient cycle counts and fatigue usage of fatigue-sensitive, safety related components, using the FatiguePro® software, to maintain the fatigue usage of components within the cumulative usage factor limit of 1.0 established by Section III Subsection NB of the ASME Boiler and Pressure Vessel Code. The enhanced program will include tracking of cumulative usage, counting of transient cycles, manual recording of selected transients, and review of FatiguePro® data.</p> <p>(2) Prior to the period of extended operation, the following enhancements will be implemented:</p> <ul style="list-style-type: none"> • The Metal Fatigue of Reactor Coolant Pressure Boundary program will be enhanced to include (1) additional Class 1 locations with high calculated cumulative usage factors, (2) Class 1 components for which transfer functions have been developed for stress-based monitoring, and (3) Class 2 portions of the steam generators with a Class 1 analysis and high calculated cumulative usage factors. • The Metal Fatigue of Reactor Coolant Pressure Boundary program will be enhanced with additional cycle count and fatigue usage action limits, and with appropriate corrective actions to be invoked if a component approaches a cycle count action limit or a fatigue usage action limit. Action limits permit completion of corrective actions before the design limits are exceeded. <p>(RCTSAI 3246934)</p>	<p>A2.1 B3.1 Metal Fatigue of Reactor Coolant Pressure Boundary A3.2 Metal Fatigue Analysis</p>	<p>Prior to the period of extended operation¹.</p>

Table A4-1 License Renewal Commitments

Item No.	Commitment	LRA Section	Implementation Schedule
40	Maintaining qualification through the extended license renewal period requires that existing EQ evaluations (EEQDFs) be re-evaluated. (RCTSAI 3246935)	A2.2 B3.2 Environmental Qualification (EQ) Of Electrical Components	Prior to the period of extended operation ¹ .
41	<p>Existing Concrete Containment Tendon Prestress program is credited for license renewal, AND</p> <p>The program will be enhanced to continue to compare regression analysis trend lines of the individual lift-off values of tendons surveyed to date, in each of the vertical and hoop tendon groups, with the MRV and PLL for each tendon group, to the end of the licensed operating period, and to take appropriate corrective actions if future values indicated by the regression analysis trend line drop below the PLL or MRV. The regression analyses will be updated for tendons of the affected unit and for a combined data set of all three units following each inspection of an individual unit.</p> <p>Prior to the period of extended operation, procedures will be enhanced to require an update of the regression analysis for each tendon group of each unit, and of the joint regression of data from all three units, after every tendon surveillance. The documents will invoke and describe regression analysis methods used to construct the lift-off trend lines, including the use of individual tendon data in accordance with Information Notice (IN) 99-10, "Degradation of Prestressing Tendon Systems in Prestressed Concrete Containments."</p> <p>The Tendon Integrity test procedure will be revised to extend the list of surveillance tendons to include random samples for the year 45 and 55 surveillances. (RCTSAI 3246937)</p>	<p>A2.3 B3.3 Concrete Containment Tendon Prestress</p> <p>4.5 Concrete Containment Tendon Prestress</p>	Prior to the period of extended operation ¹ .

Table A4-1 License Renewal Commitments

Item No.	Commitment	LRA Section	Implementation Schedule
42	<p>APS will confirm the RCS Pressure-Temperature limits basis for 54 EFPY prior to operation beyond 32 EFPY and will update documents in accordance with the provisions of 10 CFR 50.59. (RCTSAI 3246939)</p>	<p>A3.1.3 Pressure-Temperature Limits</p>	<p>Prior to operation beyond 32 EFPY¹.</p>
43	<p>The segment of the Unit 2 head vent line with wall thickness reduced by the removal of indications will be replaced when the vessel head is replaced, and its fatigue analysis will be revised. The repair and the revised fatigue analysis will demonstrate an adequate fatigue life, projected to the end of the period of extended operation, in accordance with 10 CFR 54.21(c)(1)(ii). This is a commitment for license renewal. (RCTSAI 3246941)</p>	<p>4.3.2.1 A3.2.1.1 Reactor Pressure Vessel, Nozzles, Head, and Studs</p>	<p>Prior to the period of extended operation¹.</p>
44	<p>During the review process APS identified a number of ASME III Class 1 valves greater than four inches nominal inlet that might require a fatigue analysis, but for which the analysis was not immediately retrievable. Efforts are ongoing to confirm the need for and if necessary to obtain these analyses. APS will recover and evaluate the fatigue analysis for each of the remaining ASME III Class 1 valves greater than four inches nominal inlet, for which a fatigue analysis is also otherwise required, before the end of the current licensed operating period. Each of these analyses will be validated or revised for the period of extended operation, or fatigue in the valve will be managed by the Metal Fatigue of Reactor Coolant Pressure Boundary Program. (RCTSAI 3253459)</p>	<p>4.3.2.6 A3.2.1.6 ASME Section III Class 1 Valves</p>	<p>Prior to the end of the current licensed operating period¹.</p>

Table A4-1 License Renewal Commitments

Item No.	Commitment	LRA Section	Implementation Schedule
45	<p>On March 25, 2005, PVNGS submitted APS letter 102-05237 to the NRC. This request uses CN-CI-02-71 and WCAP-15973-P in support of a request for exemption from the flaw removal and successive inspection requirements of ASME XI (1992) sections IWA-3300 and IWB-2420, for the alternative half-nozzle method used for the 10 PVNGS Unit 2 small bore, hot leg nozzles to be repaired during the Spring 2005 refueling outage. WCAP-15973-P calculated corrosion rates of 1.53 mils per year (mpy) for Alloy 600 nozzles. In response to the conditions of the final safety evaluation for the Westinghouse topical report, APS calculated that a limiting corrosion rate of 1.377 mpy for Unit 3 would not exceed the allowable diameter until 2058, 60 years after the repair and 10 years after the end of the period of extended operation. This calculation is therefore not a TLAA, and is valid for the period of extended operation. However, in the relief request submittal, APS made an ongoing commitment to track the time at cold shutdown conditions:</p> <p>APS commits to continue to track the time at cold shutdown conditions against the assumptions made in the corrosion analysis to assure that the allowable bore diameter is not exceeded over the life of the plant. If the analysis assumptions are exceeded, APS shall provide a revised analysis to the NRC and provide a discussion on whether volumetric inspection of the area is required.</p> <p>This commitment was made because the corrosion rate at cold shutdown conditions is significantly higher than at operating conditions. This request was authorized by the NRC, consistent with the APS commitment and is valid for the second, third, and fourth 10 year inspection intervals. Therefore, an extension of this authorization will be required for continued relief from the ASME code sections. (RCTSAI 3246943)</p>	<p>4.7.4 Fatigue Crack Growth and Fracture Mechanics Stability Analyses of Half- Nozzle Repairs to Alloy 600 Material in Reactor Coolant Hot Legs; Absence of a TLAA for Supporting Corrosion Analyses</p>	<p>Prior to the period of extended operation¹.</p>

Table A4-1 License Renewal Commitments

Item No.	Commitment	LRA Section	Implementation Schedule
46	<p>The WCAP-15973-P analysis of corrosion in the hot leg pipe wall due to exposure to reactor coolant by small-bore half-nozzle repairs was extended by APS for a period in excess of the period of extended operation, and is therefore not a TLAA. However the relief from the ASME Section XI requirements is supported by an APS commitment to continue to track the time at cold shutdown conditions against the assumptions made in the corrosion analysis, to assure that the allowable bore diameter is not exceeded over the life of the plant. This program is a condition of Revision 1 to Relief Request 31 of APS Letter 102-05324, granted by the NRC, and is applicable to all three units for the second, third, and fourth 10 year inspection intervals. An extension of this authorization will be requested for the period of extended operation, supported by a continuation of the cold shutdown time monitoring program. (RCTSAI 3246945)</p>	<p>4.7.4 Fatigue Crack Growth and Fracture Mechanics Stability Analyses of Half-Nozzle Repairs to Alloy 600 Material in Reactor Coolant Hot Legs; Absence of a TLAA for Supporting Corrosion Analyses</p>	<p>Prior to the period of extended operation¹.</p>
47	<p>Once the ground surface is made less permeable and ambient monitoring is sufficient to characterize subsurface water quality, a [tritiated water] remediation plan will be implemented. (RCTSAI 3246946)</p>	<p>Environmental Report 2.3</p>	<p>12/31/10</p>
48	<p>New Evaporation Pond No. 3 is currently under construction and is being built using a Best Available Demonstrated Control Technology (BADCT), a geosynthetic clay liner, with two overlaying HDPE liners, including a leachate collection and recovery system, plus soil cement side armoring, including a leak detection system. Following that, the existing liner in Evaporation Pond No. 2 will be replaced with the same BADCT liner system. This liner is approaching the end of its useful life. Following that, the existing liner in Evaporation Pond Number 1 will be replaced with the same BADCT liner system. (RCTSAI: 3246947)</p>	<p>Environmental Report 3.1.2</p>	<p>12/31/15</p>
49	<p>APS will consider the three SAMAs (6, 17 and 23) identified in the analysis using the appropriate PVNGS design process. (RCTSAI 3246952)</p>	<p>Environmental Report D.8</p>	<p>12/31/09</p>

Table A4-1 License Renewal Commitments

- (1) "Prior to period of extended operation," "prior to operation beyond 32 EFPY," and "prior to the end of the current licensed operating period," is prior to the following PVNGS Operating License expiration dates: Unit 1: June 1, 2025; Unit 2: April 24, 2026; Unit 3: November 25, 2027.

This Page Intentionally Left Blank

APPENDIX B

AGING MANAGEMENT PROGRAMS

This Page Intentionally Left Blank

APPENDIX B - TABLE OF CONTENTS

B1	APPENDIX B INTRODUCTION	B-1
B1.1	Overview	B-1
B1.2	Method Of Discussion.....	B-1
B1.3	Quality Assurance Program And Administrative Controls	B-2
B1.4	Operating Experience	B-3
B1.5	Aging Management Programs	B-4
B1.6	Time-Limited Aging Analysis Programs.....	B-5
B2	AGING MANAGEMENT PROGRAMS	B-7
B2.1	Aging Management Program Details.....	B-12
B2.1.1	ASME Section XI Inservice Inspection, Subsections IWB, IWC, And IWD	B-12
B2.1.2	Water Chemistry.....	B-14
B2.1.3	Reactor Head Closure Studs	B-17
B2.1.4	Boric Acid Corrosion.....	B-19
B2.1.5	Nickel-Alloy Penetration Nozzles Welded To The Upper Reactor Vessel Closure Heads Of Pressurized Water Reactors.....	B-21
B2.1.6	Flow-Accelerated Corrosion.....	B-24
B2.1.7	Bolting Integrity.....	B-27
B2.1.8	Steam Generator Tube Integrity.....	B-30
B2.1.9	Open-Cycle Cooling Water System.....	B-34
B2.1.10	Closed-Cycle Cooling Water System	B-37
B2.1.11	Inspection Of Overhead Heavy Load And Light Load (Related To Refueling) Handling Systems.....	B-43
B2.1.12	Fire Protection.....	B-45
B2.1.13	Fire Water System.....	B-48
B2.1.14	Fuel Oil Chemistry	B-51
B2.1.15	Reactor Vessel Surveillance	B-54
B2.1.16	One-Time Inspection	B-56
B2.1.17	Selective Leaching Of Materials.....	B-58
B2.1.18	Buried Piping And Tanks Inspection.....	B-60
B2.1.19	One-Time Inspection Of ASME Code Class 1 Small-Bore Piping	B-62
B2.1.20	External Surfaces Monitoring Program.....	B-64
B2.1.21	Reactor Coolant System Supplement	B-66
B2.1.22	Inspection Of Internal Surfaces In Miscellaneous Piping And Ducting Components....	B-67
B2.1.23	Lubricating Oil Analysis	B-69
B2.1.24	Electrical Cables And Connections Not Subject To 10 CFR 50.49 Environmental Qualification Requirements.....	B-72
B2.1.25	Electrical Cables And Connections Not Subject To 10 CFR 50.49 Environmental Qualification Requirements Used In Instrumentation Circuits	B-74
B2.1.26	Inaccessible Medium Voltage Cables Not Subject To 10 CFR 50.49 Environmental Qualification Requirements.....	B-76
B2.1.27	ASME Section XI, Subsection IWE	B-78
B2.1.28	ASME Section XI, Subsection IWL.....	B-82
B2.1.29	ASME Section XI, Subsection IWF	B-84
B2.1.30	10 CFR 50, Appendix J.....	B-86
B2.1.31	Masonry Wall Program	B-89

Appendix B
AGING MANAGEMENT PROGRAMS

B2.1.32	Structures Monitoring Program	B-92
B2.1.33	RG 1.127, Inspection Of Water-Control Structures Associated With Nuclear Power Plants	B-95
B2.1.34	Nickel Alloy Aging Management Program	B-97
B2.1.35	Electrical Cable Connections Not Subject To 10 CFR 50.49 Environmental Qualification Requirements.....	B-110
B2.1.36	Metal Enclosed Bus	B-112
B3	TLAA SUPPORT ACTIVITIES	B-114
B3.1	Metal Fatigue of Reactor Coolant Pressure Boundary	B-114
B3.2	Environmental Qualification (EQ) of Electrical Components	B-120
B3.3	Concrete Containment Tendon Prestress	B-123

B1 APPENDIX B INTRODUCTION

B1.1 OVERVIEW

License renewal aging management program descriptions are provided in this appendix for each program credited for managing aging effects based upon the aging management review results provided in [Sections 3.1](#) through [3.6](#) of this application. Each aging management program described in this section has ten elements that are consistent with the definitions in Section A.1, "Aging Management Review - Generic", Table A.1-1, "Elements of an Aging Management Program for License Renewal", of the NUREG-1800, *Standard Review Plan for Review of License Renewal Applications for Nuclear Power Plants*. The 10 element detail is only provided when the program is plant specific.

B1.2 METHOD OF DISCUSSION

For those aging management programs that are consistent with the assumptions made in Sections X and XI of NUREG-1801, or are consistent with exceptions, each program discussion is presented in the following format:

- A program description abstract of the overall program form and function is provided.
- A NUREG-1801 consistency statement is made about the program.
- Exceptions to the NUREG-1801 program are outlined and a justification is provided.
- Enhancements to ensure consistency with NUREG-1801 or additions to the NUREG-1801 program to manage aging for additional components with aging effects not assumed in NUREG-1801 for the NUREG-1801 program. A proposed schedule for completion is discussed.
- Operating experience information specific to the program is provided.
- A conclusion section provides a statement of reasonable assurance that the program is effective, or will be effective, once enhanced.

For those programs that are plant-specific, the above form is followed with the additional discussion of all ten elements.

B1.3 QUALITY ASSURANCE PROGRAM AND ADMINISTRATIVE CONTROLS

The PVNGS Quality Assurance Program implements the requirements of 10 CFR 50, Appendix B, “*Quality Assurance Criteria for Nuclear Power Plants and Fuel Processing Plants*,” and will be consistent with the summary provided in Appendix A.2 of NUREG-1800 and the Appendix, “*Quality Assurance for Aging Management Programs*” of NUREG-1801. The PVNGS Quality Assurance Program includes the elements of corrective action, confirmation process, and administrative controls. The PVNGS Quality Assurance Program is applicable to all safety-related and, after enhancement, will also be applicable to all nonsafety-related systems, structures, and components (SSCs) that are subject to aging management activities. Each of these three elements is applicable as follows:

Corrective Action

PVNGS applies its corrective action process to safety-related and, after enhancement, nonsafety-related systems, structures, and components that are subject to aging management. Corrective action process procedures, review and approval processes, and administrative controls are implemented in accordance with the requirements of 10 CFR 50, Appendix B, *Quality Assurance Criteria for Nuclear Power Plants and Fuel Processing Plants*. Conditions adverse to quality (such as failures, malfunctions, deviations, defective material and equipment, and nonconformances) are promptly identified and corrected. Significant conditions adverse to quality (such as failures, malfunctions, deviations, defective material and equipment, and nonconformances) are promptly identified and corrected. In the case of significant conditions adverse to quality, measures are implemented to ensure that the cause is determined and that corrective action is taken to preclude repetition. In addition, the root cause of the significant condition adverse to quality and the corrective actions implemented are documented and reported to appropriate levels of management.

Confirmation Process

The PVNGS Quality Assurance Program requires that measures be taken to preclude repetition of significant conditions adverse to quality. These measures include actions to verify effective implementation of corrective actions.

Plant procedures include provisions for timely evaluation of adverse conditions and implementation of any corrective actions required, including root cause determinations and prevention of recurrence where appropriate (e.g., significant conditions adverse to quality). These procedures provide for tracking, coordinating, monitoring, reviewing, verifying, validating, and approving corrective actions, and to ensure corrective actions have been effectively implemented.

The corrective action process is also monitored for potentially adverse trends. Identification of a potentially adverse trend due to recurring or repetitive unacceptable conditions will result in the initiation of a corrective action document.

Follow-up inspections required by the confirmation process are documented in accordance with the corrective action process. The corrective action process constitutes the confirmation process for aging management programs and activities. The same 10 CFR 50 Appendix B corrective actions and confirmation process applies to nonconforming systems, structures, and components subject to aging management review.

Administrative Controls

PVNGS administrative controls require formal procedures and other forms of written instruction for the activities performed under the programs credited for managing aging. These PVNGS procedures contain objectives, program scope, responsibilities, methods for implementation, and acceptance criteria.

Enhancements

Procedures will be enhanced to include those nonsafety-related SSCs requiring aging management within the scope of the PVNGS Quality Assurance Program to address the elements of corrective actions, confirmation process, and administrative controls.

B1.4 OPERATING EXPERIENCE

Plant-specific and industry-wide operating experience data was reviewed during the aging management review process in order to assure that plant-specific aging effects were consistent with documented industry operating experience and to demonstrate that the identified aging effects are being adequately managed by existing programs.

Review of plant-specific operating experience was performed to identify aging effects experienced. PVNGS Condition Reporting/Disposition Requests (CDRDs) generated since 1996 and Corrective Maintenance Work Orders (SWMS database) generated since 1996 were identified based on key words associated with aging effects and reviewed during the aging management review process.

Industry operating experience reflected in NRC Bulletins, Generic Letters, and Information Notices was screened for aging effect and aging management program applicability and has been included in the operating experience portion of the aging management review process.

The operating experience applicable to each aging management program is discussed in this section as a part of each aging management program discussion.

B1.5 AGING MANAGEMENT PROGRAMS

The following aging management programs are described in the sections listed in this appendix. The programs are either discussed in NUREG -1801 or are plant-specific. Plant-specific programs are listed at the end of the table in [Section B2.0](#).

- ASME Section XI In-service Inspection, Subsections IWB, IWC, and IWD ([Section B2.1.1](#))
- Water Chemistry ([Section B2.1.2](#))
- Reactor Head Closure Studs ([Section B2.1.3](#))
- Boric Acid Corrosion ([Section B2.1.4](#))
- Nickel-Alloy Penetration Nozzles Welded To The Upper Reactor Vessel Closure Heads of Pressurized Water Reactors ([Section B2.1.5](#))
- Flow-Accelerated Corrosion ([Section B2.1.6](#))
- Bolting Integrity ([Section B2.1.7](#))
- Steam Generator Tube Integrity ([Section B2.1.8](#))
- Open-Cycle Cooling Water System ([Section B2.1.9](#))
- Closed-Cycle Cooling Water System ([Section B2.1.10](#))
- Inspection of Overhead Heavy Load and Light Load (Related to Refueling) Handling Systems ([Section B2.1.11](#))
- Fire Protection ([Section B2.1.12](#))
- Fire Water System ([Section B2.1.13](#))
- Fuel Oil Chemistry ([Section B2.1.14](#))
- Reactor Vessel Surveillance ([Section B2.1.15](#))
- One-Time Inspection ([Section B2.1.16](#))
- Selective Leaching of Materials ([Section B2.1.17](#))
- Buried Piping and Tanks Inspection ([Section B2.1.18](#))
- One-Time Inspection of ASME Code Class 1 Small-Bore Piping ([Section B2.1.19](#))

- External Surfaces Monitoring Program ([Section B2.1.20](#))
- Reactor Coolant System Supplement ([Section B2.1.21](#))
- Inspection of Internal Surfaces in Miscellaneous Piping and Ducting Components ([Section B2.1.22](#))
- Lubricating Oil Analysis ([Section B2.1.23](#))
- Electrical Cables and Connections Not Subject to 10 CFR 50.49 Environmental Qualification Requirements ([Section B2.1.24](#))
- Electrical Cables and Connections Not Subject to 10 CFR 50.49 Environmental Qualification Requirements Used in Instrumentation Circuits ([Section B2.1.25](#))
- Inaccessible Medium Voltage Cables Not Subject to 10 CFR 50.49 Environmental Qualification Requirements ([Section B2.1.26](#))
- ASME Section XI, Subsection IWE ([Section B2.1.27](#))
- ASME Section XI, Subsection IWL ([Section B2.1.28](#))
- ASME Section XI, Subsection IWF ([Section B2.1.29](#))
- 10 CFR 50, Appendix J ([Section B2.1.30](#))
- Masonry Wall Program ([Section B2.1.31](#))
- Structures Monitoring Program ([Section B2.1.32](#))
- RG 1.127, Inspection of Water-Control Structures Associated with Nuclear Power Plants ([Section B2.1.33](#))
- Nickel Alloy Aging Management Program ([Section B2.1.34](#))
- Electrical Cable Connections Not Subject to 10 CFR 50.49 Environmental Qualification Requirements ([Section B2.1.35](#))
- Metal Enclosed Bus ([Section B2.1.36](#))

B1.6 TIME-LIMITED AGING ANALYSIS PROGRAMS

The following time-limited aging analysis aging management programs are described in this section. These programs are discussed in NUREG -1801. All programs discussed in this section are existing plant programs.

Appendix B
AGING MANAGEMENT PROGRAMS

- Metal Fatigue of Reactor Coolant Pressure Boundary ([Section B3.1](#))
- Environmental Qualification (EQ) of Electrical Components ([Section B3.2](#))
- Concrete Containment Tendon Prestress ([Section B3.3](#))

B2 AGING MANAGEMENT PROGRAMS

The correlation between NUREG-1801, Generic Aging Lessons Learned (GALL) programs and PVNGS programs is shown below. For PVNGS programs, links to appropriate sections of this appendix are provided.

NUREG-1801 NUMBER	NUREG-1801 PROGRAM	PLANT PROGRAM	EXISTING OR NEW	APPENDIX B REFERENCE
XI.M1	ASME Section XI Inservice Inspection, Subsections IWB, IWC, and IWD	ASME Section XI Inservice Inspection, Subsections IWB, IWC, and IWD	Existing	B2.1.1
XI.M2	Water Chemistry	Water Chemistry	Existing	B2.1.2
XI.M3	Reactor Head Closure Studs	Reactor Head Closure Studs	Existing	B2.1.3
XI.M4	BWR Vessel ID Attachment Welds	Not Applicable to a PWR	N/A	N/A
XI.M5	BWR Feedwater Nozzle	Not Applicable to a PWR	N/A	N/A
XI.M6	BWR Control Rod Drive Return Line Nozzle	Not Applicable to a PWR	N/A	N/A
XI.M7	BWR Stress Corrosion Cracking.	Not Applicable to a PWR	N/A	N/A
XI.M8	BWR Penetrations	Not Applicable to a PWR	N/A	N/A
XI.M9	BWR Vessel Internals	Not Applicable to a PWR	N/A	N/A
XI.M10	Boric Acid Corrosion	Boric Acid Corrosion	Existing	B2.1.4
XI.M11A	Nickel-Alloy Penetration Nozzles Welded To The Upper Reactor Vessel Closure Heads of Pressurized Water Reactors	Nickel-Alloy Penetration Nozzles Welded To The Upper Reactor Vessel Closure Heads of Pressurized Water Reactors	Existing	B2.1.5

**Appendix B
AGING MANAGEMENT PROGRAMS**

NUREG-1801 NUMBER	NUREG-1801 PROGRAM	PLANT PROGRAM	EXISTING OR NEW	APPENDIX B REFERENCE
XI.M12	Thermal Aging Embrittlement of Cast Austenitic Stainless Steel (CASS)	Not Credited	N/A	N/A
XI.M13	Thermal Aging and Neutron Irradiation Embrittlement of Cast Austenitic Stainless Steel (CASS)	Not Credited	N/A	N/A
XI.M14	Loose Parts Monitoring	Not Credited	N/A	N/A
XI.M15	Neutron Noise Monitoring	Not Credited	N/A	N/A
XI.M16	PWR Vessel Internals	Not Credited	N/A	N/A
XI.M17	Flow-Accelerated Corrosion	Flow-Accelerated Corrosion	Existing	B2.1.6
XI.M18	Bolting Integrity	Bolting Integrity	Existing	B2.1.7
XI.M19	Steam Generator Tube Integrity	Steam Generator Tube Integrity	Existing	B2.1.8
XI.M20	Open-Cycle Cooling Water System	Open-Cycle Cooling Water System	Existing	B2.1.9
XI.M21	Closed-Cycle Cooling Water System	Closed-Cycle Cooling Water System	Existing	B2.1.10
XI.M22	Boraflex Monitoring	Not Applicable to PVNGS	N/A	N/A
XI.M23	Inspection of Overhead Heavy Load and Light Load (Related to Refueling) Handling Systems	Inspection of Overhead Heavy Load and Light Load (Related to Refueling) Handling Systems	Existing	B2.1.11
XI.M24	Compressed Air Monitoring	Not Credited	N/A	N/A
XI.M25	BWR Reactor Water Cleanup System	Not Applicable for a PWR	N/A	N/A
XI.M26	Fire Protection	Fire Protection	Existing	B2.1.12

**Appendix B
AGING MANAGEMENT PROGRAMS**

NUREG-1801 NUMBER	NUREG-1801 PROGRAM	PLANT PROGRAM	EXISTING OR NEW	APPENDIX B REFERENCE
XI.M27	Fire Water System	Fire Water System	Existing	B2.1.13
XI.M28	Buried Piping and Tanks Surveillance	Not Credited	N/A	N/A
XI.M29	Aboveground Steel Tanks	Not Credited	N/A	N/A
XI.M30	Fuel Oil Chemistry	Fuel Oil Chemistry	Existing	B2.1.14
XI.M31	Reactor Vessel Surveillance	Reactor Vessel Surveillance	Existing	B2.1.15
XI.M32	One-Time Inspection	One-Time Inspection	New	B2.1.16
XI.M33	Selective Leaching of Materials	Selective Leaching of Materials	New	B2.1.17
XI.M34	Buried Piping and Tanks Inspection	Buried Piping and Tanks Inspection	New	B2.1.18
XI.M35	One-Time Inspection of ASME Code Class 1 Small-Bore Piping	One-Time Inspection of ASME Code Class 1 Small-Bore Piping	Existing	B2.1.19
XI.M36	External Surfaces Monitoring Program	External Surfaces Monitoring Program	New	B2.1.20
XI.M37	Flux Thimble Tube Inspection	Not Credited	N/A	N/A
XI.M38	Inspection of Internal Surfaces in Miscellaneous Piping and Ducting Components	Inspection of Internal Surfaces in Miscellaneous Piping and Ducting Components	New	B2.1.22
XI.M39	Lubricating Oil Analysis	Lubricating Oil Analysis	Existing	B2.1.23
XI.E1	Electrical Cables and Connections Not Subject to 10 CFR 50.49 Environmental Qualification Requirements	Electrical Cables and Connections Not Subject to 10 CFR 50.49 Environmental Qualification Requirements	New	B2.1.24

**Appendix B
AGING MANAGEMENT PROGRAMS**

NUREG-1801 NUMBER	NUREG-1801 PROGRAM	PLANT PROGRAM	EXISTING OR NEW	APPENDIX B REFERENCE
XI.E2	Electrical Cables and Connections Not Subject to 10 CFR 50.49 Environmental Qualification Requirements Used in Instrumentation Circuits	Electrical Cables and Connections Not Subject to 10 CFR 50.49 Environmental Qualification Requirements Used in Instrumentation Circuits	Existing	B2.1.25
XI.E3	Inaccessible Medium Voltage Cables Not Subject to 10 CFR 50.49 Environmental Qualification Requirements	Inaccessible Medium Voltage Cables Not Subject to 10 CFR 50.49 Environmental Qualification Requirements	New	B2.1.26
XI.E4	Metal Enclosed Bus	Metal Enclosed Bus	New	B2.1.36
XI.E5	Fuse Holders	Not Credited	N/A	N/A
XI.E6	Electrical Connections Not Subject to 10 CFR 50.49 Environmental Qualification Requirements	Electrical Connections Not Subject to 10 CFR 50.49 Environmental Qualification Requirements	New	B2.1.35
XI.S1	ASME Section XI, Subsection IWE	ASME Section XI, Subsection IWE	Existing	B2.1.27
XI.S2	ASME Section XI, Subsection IWL	ASME Section XI, Subsection IWL	Existing	B2.1.28
XI.S3	ASME Section XI, Subsection IWF	ASME Section XI, Subsection IWF	Existing	B2.1.29
XI.S4	10 CFR 50, Appendix J	10 CFR 50, Appendix J	Existing	B2.1.30
XI.S5	Masonry Wall Program	Masonry Wall Program	Existing	B2.1.31
XI.S6	Structures Monitoring Program	Structures Monitoring Program	Existing	B2.1.32
XI.S7	RG 1.127, Inspection of Water-Control Structures Associated with Nuclear Power Plants	RG 1.127, Inspection of Water-Control Structures Associated with Nuclear Power Plants	Existing	B2.1.33

**Appendix B
AGING MANAGEMENT PROGRAMS**

NUREG-1801 NUMBER	NUREG-1801 PROGRAM	PLANT PROGRAM	EXISTING OR NEW	APPENDIX B REFERENCE
XI.S.8	Protective Coating Monitoring and Maintenance Program	Not Credited	N/A	N/A
X.M1	Metal Fatigue of Reactor Coolant Pressure Boundary	Metal Fatigue of Reactor Coolant Pressure Boundary	Existing	B3.1
X.E1	Environmental Qualification (EQ) of Electrical Components	Environmental Qualification (EQ) of Electrical Components	Existing	B3.2
X.S1	Concrete Containment Tendon Prestress	Concrete Containment Tendon Prestress	Existing	B3.3
N/A	Plant-Specific	Nickel Alloy Aging Management Program	Existing	B2.1.34
N/A	N/A	Reactor Coolant System Supplement	N/A	B2.1.21

B2.1 AGING MANAGEMENT PROGRAM DETAILS

B2.1.1 ASME Section XI Inservice Inspection, Subsections IWB, IWC, and IWD

Program Description

ASME Section XI Inservice Inspection, Subsections IWB, IWC, and IWD program manages cracking, loss of fracture toughness, and loss of material in Class 1, 2, and 3 piping and components within the scope of license renewal. The program includes periodic visual, surface, volumetric examinations and leakage tests of Class 1, 2 and 3 pressure-retaining components, including welds, pump casings, valve bodies, integral attachments, and pressure-retaining bolting. These components are identified in ASME Section XI Tables IWB-2500-1, IWC-2500-1, and IWD-2500-1 for Class 1, 2, and 3 components, respectively. The ASME Section XI ISI Program has proven within the industry to maintain component structural integrity and ensure that aging effects are discovered and repaired before the loss of component intended function. The PVNGS ISI Program is consistent with ASME Section XI 2001 edition with addenda 2002 and 2003. PVNGS will use the ASME Code Edition consistent with the provisions of 10 CFR 50.55a during the period of extended operation.

In conformance with 10 CFR 50.55a(g)(4)(ii), the PVNGS ISI Program is updated during each successive 120-month inspection interval to comply with the requirements of the latest edition of the Code specified twelve months before the start of the inspection interval.

PVNGS Units 1, 2, and 3 are in the third ISI interval which began July 18, 2008, March 18, 2007, and January 11, 2008, respectively. The program is being conducted in accordance with ASME Section XI, 2001 edition with addenda 2002 and 2003 which is consistent with provisions in 10 CFR 50.55a to use the ASME Code in effect 12 months prior to the start of the inspection interval. PVNGS is following Inspection Program B as allowed by the ASME Code. Requirements are included for scheduling of examinations and tests for Class 1, 2, and 3 components. The program requires periodic visual, surface, volumetric examinations and leakage tests of Class 1, 2 and 3 pressure-retaining components. The PVNGS ASME Section XI ISI program provides measures for monitoring to detect aging effects prior to loss of intended function and provides measures for repair and replacement of components with aging effects.

Inservice inspection of reactor vessel flange stud holes, closure studs, nuts, and washers is evaluated in the Reactor Head Closure Studs program ([B2.1.3](#)).

Inservice inspection of Class 1, 2, and 3 component supports is evaluated in the ASME Section XI, Subsection IWF program ([B2.1.29](#)).

NUREG-1801 Consistency

The ASME Section XI Inservice Inspection, Subsections IWB, IWC, and IWD program is an existing program that is consistent with NUREG-1801, Section XI.M1, "ASME Section XI Inservice Inspection, Subsections IWB, IWC, and IWD".

Exceptions to NUREG-1801

None

Enhancements

None

Operating Experience

Review of PVNGS plant-specific operating experience for the PVNGS ISI Program has not revealed any program adequacy issues or implementation issues with the PVNGS ASME Section XI ISI Program. Industry operating experience is evaluated by PVNGS for relevancy to PVNGS and appropriate actions are taken and documented. Based on these results the PVNGS ISI Program is effective in monitoring ASME Class 1, 2 and 3 components and detecting aging effects prior to loss of intended function.

Review of the Second 10-year ISI Interval Summary Reports for Units 1, 2 and 3 indicate there were no code repairs or code replacements required for continued service of ASME IWB, IWC, and IWD Code components during the 10 year period. The Second 10-year ISI Interval Summary Reports did not indicate any implementation issues with the PVNGS ASME Section XI Program for ASME IWB, IWC, and IWD Code components.

The ISI Program at PVNGS is updated to account for industry operating experience. ASME Section XI is revised every three years and addenda issued in the interim, which allows the code to be updated to reflect operating experience. The requirement to update the ISI Program to reference more recent editions of ASME Section XI at the end of each inspection interval ensures the ISI Program reflects enhancements due to operating experience that have been incorporated into ASME Section XI.

Conclusion

The continued implementation of the ASME Section XI Inservice Inspection, Subsections IWB, IWC, and IWD aging management program provides reasonable assurance that aging effects will be managed such that the systems and components within the scope of this program will continue to perform their intended functions consistent with the current licensing basis for the period of extended operation.

B2.1.2 Water Chemistry

Program Description

The Water Chemistry program manages cracking, denting, hardening and loss of strength, loss of material, reduction of heat transfer, and wall thinning in primary and secondary water systems. The scope of the Primary Water Chemistry Control Program includes maintenance of the chemical environment in the reactor coolant system and related auxiliary systems containing treated borated water. The scope of the Secondary Water Chemistry Control Program includes maintenance of the chemical environment in the Steam Generator secondary side and the secondary cycle systems to limit aging effects associated with corrosion mechanisms and stress corrosion cracking. The Primary Water Chemistry Control Program is consistent with the guidelines of EPRI 1002884 "*PWR Primary Water Chemistry Guidelines*", Volumes 1 and 2, Revision 5, and specific actions for exceeding the Technical Requirements Manual limits of fluorides, chlorides and dissolved oxygen. The Secondary Water Chemistry Control Program is consistent with EPRI 1008224, "*PWR Secondary Water Chemistry Guidelines*", Revision 6.

The water chemistry control strategies are set forth in station strategic plans and these strategies are implemented in station procedures. The programmatic control of the chemical environment ensures that the aging effects due to contaminants are limited. The methods used to manage both the primary and secondary chemical environments rely on the principles of; (1) limiting the concentration of chemical species known to cause corrosion, and (2) addition of chemical species known to inhibit degradation by their influence on pH and dissolved oxygen levels. Water chemistry control is effective in areas of intermediate and high flow where thorough mixing takes place and the monitoring samples are representative of actual conditions. For low flow areas and stagnant portions of the systems sampling may not be as effective in determining local environmental conditions, and a one-time inspection ([B2.1.16](#)) of a representative group of components will provide verification of the effectiveness of the Water Chemistry program in these low flow areas.

NUREG-1801 states that the Water Chemistry program is based on guidelines in EPRI report TR-105714, Revision 3, for primary water chemistry, and TR-102134, Revision 3, for secondary water chemistry. PVNGS has adopted EPRI 1002884, Volumes 1 and 2, Revision 5, for primary water chemistry and EPRI 1008224, Revision 6, for secondary water chemistry. The Revision 5 changes to EPRI 1002884 consider the most recent operating experience and laboratory data. These guideline revisions reflect increased emphasis on plant-specific optimization of primary water chemistry to address individual plant circumstances and the impact of the NEI steam generator initiative, NEI 97-06, which requires utilities to be consistent with the EPRI Guidelines. EPRI 1002884, Volumes 1 and 2, Revision 5, distinguishes between prescriptive requirements and non-prescriptive guidance. Revision 4 of TR-102134 provided an increased depth of detail regarding the corrosion mechanisms affecting steam generators and the balance of plant, and it provided additional guidance on how to integrate these and other concerns into the plant-specific

optimization process. Revision 5 of TR-102134 provided additional details regarding plant-specific optimization and clarified which portions of the EPRI Guidelines are mandatory under NEI 97-06. EPRI 1008224, Revision 6, made minor changes including revised action level 3 requirements, establishing hydrazine action levels and making several control parameter limits more restrictive. Future revisions of the EPRI Primary and Secondary Water Chemistry Guidelines will be adopted as required, commensurate with industry standards.

The One-Time Inspection program ([Section B2.1.16](#)) will be used to verify the effectiveness of the Water Chemistry program.

NUREG-1801 Consistency

The Water Chemistry program is an existing program that, following enhancement, will be consistent with NUREG-1801, Section XI.M2, "Water Chemistry".

Exceptions to NUREG-1801

None

Enhancements

Prior to the period of extended operation, the following enhancements will be implemented in the following program elements:

Scope of Program - Element 1 and Preventative Actions – Element 2

Plant procedures will be enhanced to address sampling of effluents from new secondary system cation resins for purgeable and non-purgeable Organic Carbon.

Operating Experience

The Water Chemistry program is consistent with the EPRI Primary and Secondary Water Chemistry Control Guidelines, Revisions 5 and 6, respectively and therefore benefit from the industry operating experience available when the EPRI guidelines were issued. The Water Chemistry program will continue to evolve in response to ongoing plant operating experience and industry operating experience as conveyed in future revisions to EPRI Guidelines.

PVNGS Primary Chemistry Control:

The station optimization report for primary chemistry control incorporates PVNGS primary chemistry operating history regarding such topics as; RCS pH control program, minimization of Axial Offset Anomaly (AOA), high RCS fluoride, RCS zinc injection, RCS peroxidation, and corrosion product transport control.

High RCS fluoride has been experienced by all three PVNGS units following six refueling outages (U3R6; U2R7; U1R7; U3R7; U2R8 and U1R8). The maximum concentration observed during these outages was 260 ppb during the U3R6 startup. The cause of the fluoride ingress was the degradation of eddy current probe conduit. The conduit liner is composed of Teflon, which deposits small scrapings in the steam generator tubes as a result of eddy current testing. During plant startup, the Teflon is transported throughout the RCS and decomposes as a function of reactor power. A new improved eddy current conduit has been used since U3R8 and has corrected the condition. The highest startup fluoride since using the improved conduit has been 22 ppb through U3R10. There have been no discernable releases of fluoride to the RCS since December 2003.

PVNGS Secondary Chemistry Control:

The station optimization report for secondary chemistry control incorporates PVNGS secondary chemistry operating history regarding iron transport reduction, condenser integrity and dissolved oxygen control. There have been no major primary chemistry excursions during PVNGS' operating history and no major secondary chemistry excursions since the replacement of the steam generators.

In November 2004 Unit 3 was completing 3R11 in which condenser tube plugs were replaced. During the plug replacement there were two tube plugs, one each in the 2A and 2C hotwells that were not installed in the correct locations. Because of a modification that had occurred several years ago, a 1/8-inch hole was drilled in all plugged tubes and a leak path therefore existed in the two tubes with the plugs missing, which allowed circ water to enter the hotwells. Maximum condensate impurities were 567 ppm chloride, 335 ppm sodium and 385 ppm sulfate. This condition lasted for several days before the tubes were located and plugged.

Prior to startup a decision was made to drain and refill the system at least once to help expedite the cleanup. The impurities following the first drain and refill went from 509 ppm chloride to 86 ppm chloride, or 83% cleanup. The above was repeated and the second drain and refill lowered chloride to approximately 6 ppm, or a 93% cleanup. Condensate polishing and steam generator blowdown were used after startup to further reduce impurities. Corrective actions included the development of official tubesheet maps to be used and updated as appropriate, following the addition of new plugs and additional administrative controls for personnel installing and verifying tube plugs.

Conclusion

The continued implementation of the Water Chemistry program, supplemented by the One-Time Inspection program (B2.1.16), provides reasonable assurance that aging effects will be managed such that the systems and components within the scope of this program will continue to perform their intended functions consistent with the current licensing basis for the period of extended operation.

B2.1.3 Reactor Head Closure Studs

Program Description

The Reactor Head Closure Studs program conducts ASME Section XI inspections of reactor vessel flange stud hole threads, reactor head closure studs, nuts, and washers to manage cracking and loss of material. The program includes periodic visual and volumetric examinations of reactor vessel flange stud hole threads, reactor head closure studs, nuts, and washers and performs visual inspection of the reactor vessel flange closure during primary system leakage tests. The PVNGS program implements ASME Section XI code, Subsection IWB, 2001 Edition through the 2003 addenda. Reactor vessel flange stud hole threads, reactor head closure studs, nuts, and washers are identified in ASME Section XI Tables IWB-2500-1 and are within the scope of license renewal. PVNGS follows the preventive measures in RG 1.65. PVNGS uses a lubricant on reactor vessel flange stud hole threads, reactor head closure stud and nut threads, and washer faces after reactor head closure stud, nut, and washer cleaning, and examinations are complete.

In conformance with 10 CFR 50.55a(g)(4)(ii), the PVNGS ISI Program is updated during each successive 120-month inspection interval to comply with the requirements of the latest edition of the Code specified twelve months before the start of the inspection interval. PVNGS will use the ASME Code Edition consistent with the provisions of 10 CFR 50.55a during the period of extended operation.

Potential cracking and loss of material conditions in reactor vessel flange stud hole threads, reactor head closure studs, nuts, and washers are detected through visual or volumetric examinations in accordance with ASME Section XI requirements in PVNGS procedures every ten years. These inspections are conducted during refueling outages. Reactor vessel studs are removed from the reactor vessel flange each refueling outage. Studs, nuts, and washers are stored in protective racks after removal. Reactor vessel flange holes are plugged with water tight plugs during cavity flooding. These methods assure the holes, studs, nuts, and washers are protected from borated water during cavity flooding. Reactor vessel flange leakage is detected prior to reactor startup during reactor coolant system pressure testing each refueling outage.

NUREG-1801 Consistency

The Reactor Head Closure Studs program is an existing program that is consistent with NUREG-1801, Section XI.M3, "Reactor Head Closure Studs".

Exceptions to NUREG-1801

None

Enhancements

None

Operating Experience

Review of plant-specific operating experience has not revealed any implementation issues with the Reactor Head Closure Studs program for reactor vessel closure studs, nuts, washer, and flange thread holes. No cases of cracking due to SCC or IGSCC have been identified with PVNGS reactor vessel studs, nuts, flange stud holes, or washers.

Review of the Refueling Outage Inservice Inspection Summary Reports for Interval 2 indicates there were no repair/replacement items identified with reactor vessel closure studs, nuts washers or flange thread holes. None of the repair/replacement items indicate any implementation issues with the PVNGS ASME Section XI Program for reactor closure studs, nuts washers or flange thread holes.

The ISI Program at PVNGS is updated to account for industry operating experience. ASME Section XI is also revised every three years and addenda issued in the interim, which allows the code to be updated to reflect operating experience. The requirement to update the ISI Program to reference more recent editions of ASME Section XI at the end of each inspection interval ensures the ISI Program reflects enhancements due to operating experience that have been incorporated into ASME Section XI.

Conclusion

The continued implementation of the Reactor Head Closure Studs program provides reasonable assurance that aging effects will be managed such that the systems and components within the scope of this program will continue to perform their intended functions consistent with the current licensing basis for the period of extended operation.

B2.1.4 Boric Acid Corrosion

Program Description

The Boric Acid Corrosion Control program manages loss of material due to boric acid leakage. The program monitors mechanical, electrical and structural components within the scope of license renewal that are susceptible to boric acid corrosion from systems that contain reactor coolant or boric acid. The principal industry guidance document used is WCAP-15988-NP, "*Generic Guidance for an effective Boric Acid Inspection Program for Pressurized Water Reactors*". The program relies in part on implementation of recommendations contained in NRC Generic Letter 88-05, "*Boric Acid Corrosion of Carbon Steel Reactor Pressure Boundary Components in PWR Plants*". Additionally, the program includes examinations conducted during ISI pressure tests performed in accordance with ASME Section XI requirements. The program addresses recent operating experience noted in NRC Regulatory Issue Summary 2003-13, "*NRC Review of Responses to Bulletin 2002-01, Reactor Pressure Vessel Head Degradation and Reactor Coolant Pressure Boundary Integrity*", (which includes NRC Bulletin 2002-01, 2002-02, and NRC Order EA-03-009) and NRC Bulletin 2003-02, "*Leakage from Reactor Pressure Vessel Lower Head Penetrations and Reactor Coolant Pressure Boundary Integrity*".

The Boric Acid Corrosion program includes provisions to identify leakage, inspect and examine for evidence of leakage, evaluate leakage, and initiate corrective actions. The program maintains a tracking and trending program for boric acid leakage from plant components and establishment of a component-based visual history of boric acid leakage/seepage.

NUREG-1801 Consistency

The Boric Acid Corrosion program is an existing program that is consistent with NUREG-1801, Section XI.M10, "Boric Acid Corrosion".

Exceptions to NUREG-1801

None

Enhancements

None

Operating Experience

Industry operating experience indicates that boric acid leakage can cause significant corrosion damage to susceptible plant components. In response to recent NRC generic communications, the reactor coolant system pressure boundary integrity walkdowns have been revised to perform periodic visual inspection of the reactor coolant system

Appendix B
AGING MANAGEMENT PROGRAMS

components, the reactor pressure vessel upper head and bottom head, and document any indication of leakage.

A review of the corrective action program and the work order process both show that boric acid leakage is being identified, evaluated and the resulting component damage is being repaired for the three Units. A review of plant operating experience indicates instances of boric acid concerns identified either on the components from which it leaked and/or on the surrounding equipment. Several occurrences were documented where increased reactor coolant system leakage prompted a containment entry where boric acid leakage was identified from various components within the containment. Both active leakage and crystal buildup have been identified and the effects mitigated without resulting in a loss of intended functions.

Conclusion

The continued implementation of the Boric Acid Corrosion program provides reasonable assurance that aging effects will be managed such that the systems and components within the scope of this program will continue to perform their intended functions consistent with the current licensing basis for the period of extended operation.

B2.1.5 Nickel-Alloy Penetration Nozzles Welded to the Upper Reactor Vessel Closure Heads of Pressurized Water Reactors

Program Description

The Nickel-Alloy Penetration Nozzles Welded to the Upper Reactor Vessel Closure Heads of Pressurized Water Reactors program manages cracking due to primary water stress corrosion cracking (PWSCC) and loss of material due to boric acid wastage in nickel-alloy pressure vessel head penetration nozzles and includes the reactor vessel closure head, upper vessel head penetration nozzles and associated welds. The Nickel-Alloy Penetration Nozzles Welded to the Upper Reactor Vessel Closure Heads of Pressurized Water Reactors program is consistent with NRC Order EA-03-009. The term "PWSCC" applies to the nozzles and J-welds and "Wastage" applies to the Reactor Closure Head. The aging management for the aging effect of loss of material of the upper vessel head due to wastage is addressed in the Boric Acid Corrosion program (B2.1.4).

Detection of cracking (including cracking induced by PWSCC) is accomplished through implementation of a combination of bare metal visual examination on the external surface of the RPV closure head and volumetric examinations on the control element drive mechanism penetration tube walls, eddy current testing of the inner diameter of the penetrations, and supplemental ultrasonic and eddy current testing of the control element drive mechanism penetration ID/OD surfaces and J-groove weld surfaces as required. Eddy current testing of the ID and j-weld is performed on the vent line penetration. Visual examinations are performed by VT-2 certified personnel.

The Alloy 600 Management Program Plan maintains the integrity and operability for all nickel alloy components at PVNGS and the susceptibility ranking of the plant is calculated. The accumulative EDY (Effective Degradation Years) values for the PVNGS units correspond to a susceptibility ranking of "High" per NRC Order EA-03-009, as amended, for all three units. Plants in the "High" category require bare metal visual inspections every refueling outage and ultrasonic, eddy current, or dye penetrant testing every refueling outage per the Order, as amended. Reactor Vessel Head replacements for all three PVNGS Units are scheduled from year 2009 to year 2010.

NUREG-1801 Consistency

The Nickel-Alloy Penetration Nozzles Welded to the Upper Reactor Vessel Closure Heads of Pressurized Water Reactors program is an existing program that, following enhancement, will be consistent with NUREG-1801, Section XI.M11A, "Nickel-Alloy Penetration Nozzles Welded to the Upper Reactor Vessel Closure Heads of Pressurized Water Reactors".

Exceptions to NUREG-1801

None

Enhancements

The following enhancement will be implemented in the following program elements:

Detection of Aging Effects – Element 4, Monitoring and Trending – Element 5, Acceptance Criteria – Element 6, and Corrective Actions – Element 7

Prior to December 31, 2008, the PVNGS Alloy 600 Management Program Plan will be revised to incorporate the applicable examination requirements of ASME Code Case N-729-1 (Reactor Vessel Head Inspections), subject to the conditions specified in 10 CFR 50.55a(g)(6)(ii)(D)(2) through(6).

Operating Experience

Inspections completed to date have indicated no evidence of PWSCC in the vessel head penetration nozzles with the exception of vent line indications on Unit 2 which were repaired by machining and subsequently weld overlayed during refueling outage U2R13. Reactor vessel head replacements for all three PVNGS Units are scheduled from year 2009 to year 2010.

The following is a summary of information that has been provided to the NRC concerning inspections per the requirements of NRC Order EA-03-009:

PVNGS UNIT 1 - REFUELING 12 (U1R12) ending in December, 2005

A visual examination of the bare-metal surface of the reactor head found no evidence of boron or corrosion. No cleaning of the RPV head was necessary during U1R12. Additionally, a boric acid walkdown was performed for the U1R12 refueling outage. Potential boric acid leak sites from pressure retaining components above the RPV head were examined. No leaks or evidence of leakage was found.

Ninety seven control element drive mechanism penetrations had nondestructive exams performed. Eighty four were acceptable with no detectable defects and thirteen had additional examinations performed as a result of the initial examinations. The additional examinations performed on the thirteen penetrations were acceptable with no detectable defects found.

In preparation for modifying the head vent nozzle in Unit 1 to remove the flow-restricting orifice, the vent penetration J-weld and orifice J-weld were examined with manual eddy current testing techniques. Upon removal of the orifice, a surface examination (eddy current) of the J-groove weld and inside nozzle surface was performed as required. The head vent nozzles at PVNGS do not protrude below the surface of the RPV head and, as a result, there is no material below the J-groove weld to be examined. Although two areas of reduced wall dimension were noted, the results of the examinations were acceptable with no detectable defects. The head vent orifice was relocated to a downstream flange.

PVNGS UNIT 2 - REFUELING 13 (U2R13) ending in November, 2006

The visual examination of the bare-metal surface of the reactor head found no evidence of boron or corrosion. Additionally, a Boric Acid Walkdown was performed for the U2R13 refueling outage. Potential boric acid leak sites from pressure retaining components above the RPV head were examined. No indications of previously unreported leakage were identified. The two sites with boric acid deposit at CEDM vents were cleaned and reworked during U2R13. No cleaning of the RPV head was necessary during U2R13.

Non-visual NDE was performed for the reactor head vent nozzle. The two locations of axial indications, which were previously confirmed on the reactor head vent nozzle ID surface and repaired by grinding the indications to an acceptable condition during U2R12 refueling outage, were re-examined during U2R13. Unacceptable indications at or near the same area as those repaired in U2R12 were found. The vent line was repaired with weld overlay using Inconel 52 weld material. These indications were characterized as axial, were not through-wall and there was no evidence of RCS pressure boundary leakage.

The minimum required inspection coverage was obtained for all control element drive mechanism nozzles using ultrasonic and eddy current examination. No flaws were identified.

PVNGS UNIT 3 - REFUELING 10 (U3R10) ending in April, 2003

The examinations performed in Unit 3 yielded no detectable defects, no visual indications of leakage on the reactor vessel vent line and no detection of leakage into the interference fit zone of the ninety seven control element drive mechanism nozzles. As a result, no repairs were required.

PVNGS UNIT 3 - REFUELING 11 (U3R11) ending in December, 2004

The visual examination of the bare-metal surface of the reactor head found no evidence of boron or corrosion. No cleaning of the RPV head was necessary during U3R11. Potential boric acid leak sites from pressure retaining components above the RPV head were examined. Two leak sites at CEDM vents were identified. No active leak was identified. The dry boric acid deposit stayed in the area of the vents and no carbon steel was affected.

The non-visual NDE was performed for the head vent nozzle inspection following the modification of the head vent nozzle to permanently relocate the internal orifice. Upon removal of the orifice a surface examination (eddy current) of the J-groove weld and inside nozzle surface was performed as required. No flaws were found during this examination.

Conclusion

The continued implementation of the Nickel-Alloy Penetration Nozzles Welded to the Upper Reactor Vessel Closure Heads of Pressurized Water Reactors program provides reasonable assurance that aging effects will be managed such that the systems and components within the scope of this program will continue to perform their intended functions consistent with the current licensing basis for the period of extended operation.

B2.1.6 Flow-Accelerated Corrosion

Program Description

The Flow-Accelerated Corrosion (FAC) program manages wall thinning due to flow-accelerated corrosion on the internal surfaces of carbon or low alloy steel piping, elbows, reducers, expanders, and valve bodies which contain high energy fluids (both single phase and two phases). The program implements the EPRI guidelines in NSAC-202L-R3 to detect, measure, monitor, predict and mitigate component wall thinning. To aid in the planning of inspections and choosing inspection locations, PVNGS utilizes the EPRI predictive computer program CHECWORKS that uses the implementation guidance of NSAC-202L-R3.

The objectives of the FAC program are achieved by (a) identifying system components susceptible to FAC, (b) performing analysis using the predictive code CHECWORKS to determine critical locations for inspection and evaluation, (c) providing guidance for follow-up inspection, (d) repairing, replacing, or performing evaluation for components not acceptable for continued service, based on the wear rates and minimum acceptable thickness, and (e) evaluating and incorporating the latest technologies, industry and plant in-house operating experience.

Procedures and methods used by PVNGS FAC program are consistent with APS commitments to NRC Bulletin 87-01, "*Thinning of Pipe Wall in Nuclear Power Plants*", and NRC Generic Letter 89-08, "*Erosion/Corrosion-Induced Pipe Wall Thinning*".

NUREG-1801 Consistency

The Flow-Accelerated Corrosion program is an existing program that, following enhancement, will be consistent with exception to NUREG-1801, Section XI.M17, "Flow-Accelerated Corrosion".

Exceptions to NUREG-1801

Program Elements Affected

Scope of Program – Element 1 and Detection of Aging Effects – Element 4

NUREG-1801, Section XI.M17 indicates the FAC Program relies on implementation of EPRI guidelines in NSAC-202L-R2. However, the guidelines provided in the governing procedure 81DP-0RA02 were developed based on the recommendations provided in the EPRI Guideline NSAC-202L-R3.

The new revision of EPRI guidelines incorporates lessons learned and improvements to detection, modeling, and mitigation technologies that became available since Revision 2

was published. The updated recommendations are intended to refine and enhance those of previous revisions without contradictions to ensure continuity of existing plant FAC programs

Enhancements

Prior to the period of extended operation, the following enhancements will be implemented in the following program elements:

Scope of Program – Element 1, Detection of Aging Effects – Element 4, Monitoring and Trending – Element 5, and Acceptance Criteria – Element 6

The program procedure will be enhanced to clarify the guidance for susceptible small-bore piping components.

Acceptance Criteria – Element 6 and Corrective Actions – Element 7

The program procedure will be enhanced to verify the trace chromium content of the carbon steel pipe replacement.

Operating Experience

Review of the work orders (from May 1996 through present) showed that there has been no reported FAC-related leak or rupture at PVNGS for the components within the scope of license renewal. Most of the work orders identified the effect of wall thinning during the FAC program inspections. There were cases where the allowable thickness determined in accordance with the program guidelines were reached and more rigorous stress analyses were performed to justify continued service and to postpone the replacement. Problems identified during implementation of the program activities were not significant to the safe operation of the plant, and adequate corrective actions were taken to prevent recurrence. Industry and plant operating experience were reviewed for applicability and adjustment of the outage inspection list was determined in accordance with program guidelines.

For previous refueling outages from R9 through R12 of all three units, 80 to 160 locations of large-bore systems were originally selected for inspection before the outage. The scope was expanded if necessary based on UT findings. An inspection location included the subject component (such as an elbow) and its adjacent area (such as upstream and downstream piping). For small-bore systems, 16 to 65 inspections were selected before the outage. The scope was also expanded if necessary based on UT findings. The replacements for each outage are scheduled on proactive basis, determined by the projected remaining service life based on FAC analyses and by programmatic strategy based on industry experience and cost comparison to further inspections. The selections of FAC-resistance materials are stainless steel, chrome-moly alloy, or carbon steel with trace chromium content > 0.1%. Baseline inspections were performed for selected replacement locations of chrome-moly alloy and carbon steel with trace chromium content > 0.1%.

Conclusion

The continued implementation of Flow-Accelerated Corrosion program provides reasonable assurance that the aging effect of wall thinning due to FAC wear will be managed such that the systems and components within the scope of this program will continue to perform their intended functions consistent with the current licensing basis for the period of extended operation.

B2.1.7 Bolting Integrity

Program Description

The Bolting Integrity program manages cracking, loss of material, and loss of preload for pressure retaining bolting and ASME component support bolting. The program includes preload control, selection of bolting material, use of lubricants/sealants consistent with EPRI good bolting practices, and performance of periodic inspections for indication of aging effects. The program is supplemented by Inservice Inspection requirements established in accordance with ASME Section XI, Subsections IWB, IWC, IWD, and IWF for ASME Class bolting.

PVNGS good bolting practices are established in accordance with plant procedures. These procedures include requirements for proper disassembling, inspecting, and assembling of connections with threaded fasteners. The general practices that are established in this program are consistent with EPRI NP-5067, *“Good Bolting Practices, Volume 1 and Volume 2”*, and the recommendations delineated in NUREG-1339.

Following the review of the recommendations provided in NRC Generic Letter 91-17, NUREG-1339 and the EPRI reports, NP-5769 and NP5067, PVNGS had identified and implemented the action items related to bolting degradation or failure. The guidance provided in EPRI NP-5067 and NUREG-1339, together with other industrial experience regarding bolting issues was later consolidated in EPRI TR-104213, *“Bolted Joint Maintenance and Applications Guide”*. Although the procedures for ensuring bolting integrity do not directly reference EPRI reports NP-5769 and TR-104213 or NUREG-1339 as applicable source documents for these recommendations, these procedures do incorporate the action items to ensure the integrity of the subject bolting connections.

The following PVNGS aging management programs supplement the Bolting Integrity program for management of loss of preload, cracking, and loss of material:

- (a) ASME Section XI Inservice Inspection, Subsections IWB, IWC and IWD program (B2.1.1), provides the requirements for inservice inspection of ASME Class 1, 2, and 3 safety-related pressure retaining bolting.
- (b) ASME Section XI, Subsection IWF program (B2.1.29), provides the requirements for inservice inspection of safety-related component support bolting.
- (c) External Surfaces Monitoring Program (B2.1.20) provides the requirements for inspection of pressure retaining closure bolting within the scope of license renewal.

NUREG-1801 Consistency

The Bolting Integrity program is an existing program that is consistent, with exception to NUREG-1801, Section XI.M18, “Bolting Integrity”.

Exceptions to NUREG-1801

Program Elements Affected

Scope of Program – Element 1

NUREG 1801, Section XI.M18 specifies the use of ASME Section XI 1995 edition with addenda 1996. PVNGS third interval ISI Program is using ASME Section XI 2001 edition with addenda 2002 and 2003 which is consistent with provisions in 10 CFR 50.55a to use the ASME Code in effect 12 months prior to the start of the inspection interval. PVNGS will use the ASME Code Edition consistent with the provisions of 10 CFR 50.55a during the period of extended operation.

Parameters Monitored or Inspected – Element 3

The discussion of bolt preload in EPRI NP-5769, Vol. 2, Section 10, indicates that job inspection torque is non-conservative since for a given fastener tension more torque is required to restart the installed bolts. The techniques for measuring the amount of bolt tension in an assembled joint are both difficult and unreliable. EPRI NP-5769, Vol. 2, Section 10 suggests that inspection of preload is usually unnecessary if the installation method has been carefully followed. Torque values are provided in procedures, if not provided by the vendor instructions, design documents or specifications. The torque values provided in procedures are based on the industrial experience that includes the consideration of the expected relaxation of the fasteners over the life of the joint and gasket stress in the application of pressure closure bolting.

Monitoring and Trending –Element 5

NUREG 1801, Section XI.M18 specifies that if bolting connections for pressure retaining components (not covered by ASME Section XI) are reported to be leaking, then they may be inspected daily. If the leak rate does not increase, the inspection frequency may be decreased to biweekly or weekly. For pressure retaining components reported to be leaking, the corrective action program will be initiated. The corrective actions, including adjustment of the inspection frequency for closer monitoring of the condition if necessary, will be identified based on the analysis of the trending data to ensure there is not a loss of intended function of the subject components. For the components that are deemed necessary, preventive maintenance activities, such as gasket replacement or bolting tightness check, can be created.

Enhancements

None

Operating Experience

Both the industry and NRC have revealed a number of instances of bolting concerns from material control and certification (e.g. NRC IE Bulletin 87-02) to bolting practices, use of

Appendix B
AGING MANAGEMENT PROGRAMS

lubrication and injection sealants and its effect on stress corrosion cracking (SCC) (e.g., NRC IE Bulletin 82-02, and INPO SOER 84-05). The Bolting Integrity program incorporates the applicable industry experience on bolting issues into the program. Actions taken include confirmatory testing/analysis or inspections. Also included are the addition of procedures of inspection, material procurement and verification processes. NRC Information Notices, Bulletins, Circulars, and Generic Letters listed in Section 3 of NUREG-1339 were evaluated for applicability to PVNGS Bolting Integrity program to ensure conformance with the recommendations of NUREG-1339.

A review of plant operating experience identified issues with corrosion, missing or loose bolts, inadequate thread engagement, and improper bolt applications. There is no reported case of cracking of the bolts due to stress corrosion cracking. In all cases, the identified concern was corrected or evaluated to be accepted as-is. No significant safety events were identified. Additional actions, such as procedural enhancements, were implemented as needed to prevent recurrence.

Conclusion

The continued implementation of Bolting Integrity program provides reasonable assurance that aging effects will be managed such that the systems and components within the scope of this program will continue to perform their intended functions consistent with the current licensing basis for the period of extended operation.

B2.1.8 Steam Generator Tube Integrity

Program Description

The scope of the Steam Generator Tube Integrity program includes the preventive measures, degradation assessment, steam generator inspection, integrity assessment, primary and secondary chemistry controls, leakage monitoring, and required maintenance and repair activities necessary to manage cracking, denting, wall thinning, and loss of material. The aging management measures employed include, non-destructive examination, visual inspection, sludge removal, tube plugging, in-situ pressure testing and maintaining the chemistry environment by removal of impurities and addition of chemicals to control pH and oxygen. Non-destructive Examination (NDE) inspection scope and frequency, and primary to secondary leak rate monitoring are conducted consistent with the requirements of PVNGS Technical Specifications. PVNGS evaluates tube integrity in accordance with the structural integrity performance criteria specified in Technical Specifications which encompasses and exceeds the requirements of Regulatory Guide 1.121. In addition, Technical Specifications include accident induced leakage performance criterion and operational leakage performance criterion. The steam generator management practices are consistent with NEI 97-06, "*Steam Generator Program Guidelines*".

Guidance for steam generator management is specified in station procedures. This guidance is consistent with the PVNGS Technical Specification requirements for steam generator tube integrity and primary to secondary leakage limits. The PVNGS steam generator inspection frequency is evaluated as part of the Degradation Assessment performed prior to each inservice inspection consistent with the Technical Specification requirements for the observed degradation mechanism. Plugging criteria for removing tubes from service are consistent with Technical Specifications.

Tube support degradation is monitored by the presence of normal support signals at expected tube locations and by visual inspection of the secondary side. The PVNGS steam generator management procedure specifies that steam generators will be visually inspected, as required, on the secondary side at the accessible portions of the following locations: tube sheet region, both hot and cold leg, tube supports, flow distribution plate, and upper steam drum internals.

Aging management activities for steam generator tubing integrity are controlled by station procedures. The steam generators are also monitored under the Maintenance Rule (10 CFR 50.65) as implemented by station procedures. The Steam Generator Tube Integrity program was developed from and is consistent with NEI 97-06, "*Steam Generator Program Guidelines*". PVNGS procedural guidance includes performance criteria for tube structural integrity, operational leakage and accident induced leakage that are consistent with NEI 97-06 and the PVNGS Technical Specifications. Procedural guidelines are also provided for monitoring and maintenance including plugging criteria, plug inspection requirements and inspection requirements for tube supports. The training and qualification standards for personnel engaged in the acquisition and/or evaluation of steam generator

NDE activities are specified in a station administrative procedure, and inspection practices are consistent with EPRI 1003138, "*PWR Steam Generator Examination Guidelines*". PVNGS programmatic guidance also requires that each inspection be based on a degradation assessment that considers active, relevant and potential damage mechanisms.

NUREG-1801 Consistency

The Steam Generator Tube Integrity program is an existing program that is consistent with NUREG-1801, Section XI.M19, "Steam Generator Tube Integrity".

Exceptions to NUREG-1801

None

Enhancements

None

Operating Experience

The Steam Generator Tube Integrity program has been developed to be consistent with NEI 97-06, and it benefits from the industry operating experience available when the initiative was issued as well as the EPRI guidelines it endorses. Station procedural guidance requires that the Steam Generator Degradation Assessment for PVNGS be updated every operating cycle to incorporate the latest industry and plant-specific experience regarding steam generator degradation mechanisms.

NRC Information Notice 97-88 addressed the importance of recognizing the potential for degradation in areas that have not previously experienced tube degradation and the importance of licensees to assess the significance of indications with respect to the qualification of the inspection techniques and the manner in which the indications were detected. The PVNGS Steam Generator Degradation Assessment evaluates industry experience as well as PVNGS experience to identify active, relevant and potential tube damage mechanisms. The inspection sample size, location and method are developed to fully address active mechanisms and provide assurance that relevant and potential mechanisms will be identified if they become active at PVNGS. The inspection expansion criteria take into account both increasing the area inspected when degradation is found and changing the technology used to accurately examine ambiguous or unexpected degradation.

PVNGS Units 1, 2 and 3 are two loop Combustion Engineering (CE) plants with two identical replacement steam generators designed by ABB/CE which are considered a modified CE System 80 design. The original steam generators were replaced in Units 1, 2, and 3 during the fall of 2005, 2003, and 2007, respectively. Each steam generator has a total of 12,580 Alloy 690 thermally treated tubes. The tubes are hydraulically expanded into the tubesheet for the entire tubesheet thickness. The tube support system is similar to the original design, and like the original design is fabricated from 409 ferritic stainless steel. To minimize the

potential for stress corrosion cracking, in addition to the tubing material change, the U-bend region in the first 17 rows were stress relieved after bending.

Industry experience has shown that tube damage in replacement steam generators typically occurs from loose parts and support wear.

Wear is the only active damage mechanism in the PVNGS Replacement Steam Generators (RSGs) as of U1R13 and U2R13, and specifically wear as the result of interaction of tubing with the tube supports. Most of the wear indications were observed in a region around the stay cylinder and at either of the Batwings or Vertical Strap (VS3).

As of the end of the U1R13 and U2R13 outages no corrosion degradation has been detected in any of the PVNGS replacement steam generator tubes.

Due to certain historically observed wear phenomenon, PVNGS has employed conservative administrative plugging criteria related to support wear mechanisms. For example, support wear indications are removed for wear rate greater than or equal to 35% for a normal operating cycle if no previous wear is identified. This plugging criterion is designed to ensure that the structural and accident leakage performance criteria specified in the PVNGS Technical Specifications are not exceeded in the subsequent operating cycle. It was expected, based on RSG redesign, that the conditions necessary to generate high wear rates in the Batwing Stay Cylinder (BWSC) and Cold Leg Corner (CLC) regions were eliminated. While this was clearly the case for CLC wear, the RSG inspection results in Unit 2 during U2R12 and U2R13 indicated that, for at least Unit 2, the RSGs continued to exhibit similar wear conditions within the BWSC region. However a similar result was not observed in Unit 1. There are several possible explanations for these results. These include:

A decision was made prior to Unit 1 RSG installation to plug and stake all the "frontline" BWSC tubes. These are the tubes most likely to be affected by BWSC wear. As these tubes were plugged, no NDE data could be collected to confirm the presence of BWSC wear. However, it should be noted that in Unit 2, BWSC wear was observed randomly throughout the affected region (with the largest wear observed in the frontline tubes). No BWSC wear was observed, at all, in the Unit 1 RSGs.

During discussions with Westinghouse, following U2R12, it was suggested that fabrication issues resulting in less than expected tube to tube support interaction may be a reason for the unexpected observed wear. It is possible that in Unit 1, improved alignment may be resulting in less wear.

On February 19, 2004 Unit 2 was operating at full power when radiation monitors displayed indications of a low level primary to secondary leak. Shortly thereafter the leak rate was calculated to be 11.8 gallons per day, even though grab samples indicated 3 gallons per day, and the decision was made to shut the unit down to find and repair the leak.

After cooling the plant down and performing tests, one SG tube was found to be leaking and was plugged. Further analysis showed that the cause of the leak was from a puncture

Appendix B
AGING MANAGEMENT PROGRAMS

received from a wood screw that was used in the construction of the shipping crates for the tubes when the steam generators were being manufactured. The tubes were placed in the crate and the crate assembled around them. One screw that was used near the outer diameter of the top of the tube bend protruded through the wood and began to puncture the tube material. The screw did not completely penetrate the tube and the unit was operated from its post-outage startup to this date when the tube finally began leaking. Contamination to the secondary plant was minimal and the unit entered Mode 1 on March 9, 2004. Corrective actions put in place after the event prevented recurrence in the Unit 1 and 3 replacement steam generators.

Conclusion

The continued implementation of the Steam Generator Tube Integrity program provides reasonable assurance that aging effects will be managed such that the systems and components within the scope of this program will continue to perform their intended functions consistent with the current licensing basis for the period of extended operation.

B2.1.9 Open-Cycle Cooling Water System

Program Description

The Open-Cycle Cooling Water System program manages loss of material and reduction of heat transfer for components exposed to the raw water of the open-cycle cooling water system. The program includes surveillance techniques and control techniques to manage aging effects caused by biofouling, corrosion, erosion and silting in the open-cycle cooling water system and in structures and components cooled by the open-cycle cooling water system. The only safety-related open-cycle service water system is the essential spray pond system. Essential spray ponds serve as the ultimate heat sink. In addition to the essential spray pond system, the open-cycle cooling water program also addresses the essential cooling water system heat exchangers that are administratively located within the essential cooling water system license renewal boundary and the emergency diesel generator jacket water, emergency diesel generator fuel oil, emergency diesel generator lube oil and emergency diesel generator turbo air intercooler heat exchangers that are administratively located with the emergency diesel generator system license renewal boundary together with their associated components that are exposed to raw water supplied by the essential spray ponds system. The program is consistent with PVNGS commitments as established in responses to Generic Letter 89-13.

The surveillance techniques utilized in the Open-Cycle Cooling Water program include visual inspection and Non-Destructive Examination (NDE) of selected components together with thermal and hydraulic performance monitoring of heat exchangers and of the essential spray pond system as an integrated whole. The control techniques utilized in the Open-Cycle Cooling Water program include (1) water chemistry controls to mitigate the potential for the development of aggressive cooling water conditions, (2) flushes and (3) physical and/or chemical cleaning of heat exchangers and of the Essential Spray Ponds to remove fouling and to reduce the potential sources of fouling.

NUREG-1801 Consistency

The Open-Cycle Cooling Water System program is an existing program that, following enhancement, will be consistent with NUREG-1801, Section XI, M20, "Open-Cycle Cooling Water System".

Exceptions to NUREG-1801

None

Enhancements

Prior to the period of extended operation, the following enhancements will be implemented in the following program elements:

Detection of Aging Effects – Element 4 and Acceptance Criteria – Element 6

Clarify guidance in the conduct of heat exchanger and piping inspections using NDE techniques and related acceptance criteria.

Operating Experience

PVNGS has experienced fouling of safety related coolers and heat exchangers due to inadequate chemistry control. In 1994, PVNGS implemented a new chemistry control program for the emergency spray pond system to control corrosion and prevent fouling of the safety-related components. Throughout the period of 1994 through May 2006, PVNGS made a series of changes to this program which created a chemical environment that was progressively more conducive to fouling of the heat exchangers which were relied upon to transfer heat from the reactor, containment, diesel generators, and safety-related equipment rooms to the ultimate heat sink. The foulant was determined to be a buildup of excess chemicals which were added as part of the chemistry control program. Years of test results showed degraded heat exchanger performance, numerous heat exchanger inspections which documented chemical buildup, and an increasing need to clean the heat exchangers more frequently. In May 2006 degraded performance was observed in all trains in all three units. Because of design margins, only Unit 2 Train B essential cooling water system heat exchanger was identified where fouling may have been sufficient to cause a loss of safety function.

As a result of an NRC inspection related to this operating history, the NRC concluded that there were five violations of NRC requirements, characterized as performance deficiencies. Upon final evaluation, the NRC determined that because these violations were of very low safety significance, had been entered into the corrective action program, the root-cause had been identified, and appropriate corrective actions had been taken, they were considered non-cited violations.

The following immediate corrective actions were taken to return the effected systems to full operability:

- The essential spray ponds system chemistry was corrected.
- Essential cooling water system heat exchangers were cleaned in all three units.
- Diesel generator intercoolers were cleaned in all three units and diesel generator test frequency was increased until it was determined that the immediate corrective actions were effective.
- Procedures were revised to require a work order to be generated to clean any emergency diesel generator intercooler if temperature exceeds 120° F.
- The spray ponds were cleaned in all three units.

Appendix B
AGING MANAGEMENT PROGRAMS

- Additional cleaning and inspections of the diesel generator and essential cooling water heat exchangers were scheduled.

The following corrective actions were taken to ensure root-cause issues were corrected:

- Chemistry control program was revised to establish appropriate limits and to increase sampling frequencies.
- Revised essential cooling water heat exchanger procedures to ensure thermal performance was adequately evaluated
- Established controls that required changes to the chemistry control program to undergo 10 CFR 59 reviews
- Actions were taken to reinforce the need to maintain a “low threshold” with respect to corrective action initiation.
- Corrected the use of computer models that predicted calcium phosphate scale

Conclusion

The continued implementation of the Open-Cycle Cooling Water System program provides reasonable assurance that aging effects will be managed such that the systems and components within the scope of this program will continue to perform their intended functions consistent with the current licensing basis for the period of extended operation.

B2.1.10 Closed-Cycle Cooling Water System

Program Description

The Closed-Cycle Cooling Water (CCCW) System program manages loss of material, cracking, and reduction in heat transfer for components in the following closed-cycle cooling water systems:

- Diesel Generator Jacket Water System
- Essential Chilled Water System
- Essential Cooling Water System
- Normal Chilled Water System
- Nuclear Cooling Water System

The CCCW systems serve heat exchangers and related components that are within the scope of license renewal in the following interfacing systems:

- Auxiliary Steam System
- Chemical and Volume Control System
- Spent Fuel Pool Cooling and Clean Up System
- Reactor Coolant System
- Secondary Chemical Control System
- Safety Injection and Shutdown Cooling System
- Nuclear Sampling System
- Auxiliary Building HVAC
- Containment Building HVAC
- Control Building HVAC

The program includes (a) maintenance of system corrosion inhibitor concentrations to minimize aging effects and (b) periodic testing and inspections to evaluate system and component performance. The water chemistry aspect of the program maintains an environment within CCCW systems that is consistent with the parameters specified in EPRI TR-107396 for CCCW system. Water chemistry is maintained through the addition of an

iron corrosion inhibitor (nitrite), a copper corrosion inhibitor (tolyltriazole - TTA), pH control and biocide (glutaraldehyde). System corrosion inhibitor concentrations are maintained at levels described in EPRI TR-107396 to minimize aging effects. Testing and inspections are performed in accordance with guidance in EPRI TR 107396 for closed-cycle cooling water (CCCW) systems as appropriate for their license renewal intended functions; for example, components in scope of license renewal for criterion a(2) considerations only are not subject to internal inspection or performance testing. Inspection processes include visual, eddy-current and ultrasonic methods. Testing methods include functional demonstrations and monitoring, thermal and hydraulic performance testing.

NUREG-1801 Consistency

The Closed-Cycle Cooling Water System program is an existing program that, following enhancement, will be consistent with exception to NUREG-1801, Section XI.M21, "Closed-Cycle Cooling Water".

Exceptions to NUREG-1801

Program Elements Affected

Preventive Actions - Element 2

NUREG-1801, Section XI.M21, Element 2, requires materials used in CCCW systems to be appropriate to the type of service. The essential cooling water system for each unit is provided with two radiation monitors (one per train) that employ an aluminum "window" as a pressure boundary between the CCCW and the ionization detector within the flow-through sample chambers. The chemical treatment program at PVNGS does not include controls described in EPRI TR-107396 as appropriate for aluminum. Exception is taken to employ the NUREG 1801 AMP XI.M38 Internal Surfaces Monitoring Program to manage the aging of the aluminum "windows" of the radiation monitors. A review of plant operating experience reveals no instances where aging effects have led to the loss of the intended function of the subject components.

Parameters Monitored or Inspected - Element 3 and Monitoring and Trending – Element 5

NUREG-1801, Section XI.M21, Element 3 requires testing and inspection as described in EPRI TR-107396 and further states "For pumps, the parameters monitored include flow, discharge pressures, and suction pressures and for heat exchangers, the parameters monitored include flow, inlet and outlet temperatures, and differential pressure" and Element 5 states "visual inspections and performance/functional tests are to be performed to confirm the effectiveness of the program". PVNGS monitors system parameters and performs a combination of visual inspections, non-destructive examinations, performance and functional tests as well as thermal performance tests as described in EPRI TR-107396 Section 8.4 to confirm the effectiveness of the CCCW program in managing the aging of components and systems exposed to CCCW. Plant configuration constraints and consideration of components in-scope of license renewal for 10 CFR 54.4 criterion a(2) considerations only

have led to several exceptions with respect to some measures set forth in NUREG-1801 with respect to testing and inspection specifics that together do not compromise the ability to monitor program effectiveness to ensure the component intended functions are maintained. Specific exceptions taken include:

a.) The essential cooling water, spent fuel cooling and cleanup, and shutdown cooling heat exchangers are not monitored for differential pressure. The program of periodic sampling and maintenance of system chemistry together with thermal performance testing in conformance with EPRI NR-7552, and, in the case of the essential cooling water heat exchanger, periodic ECT of the heat exchanger tubes and, in the case of the spent fuel cooling and cleanup heat exchanger, periodic NDE of the heat exchanger shell are adequate to ensure that component intended functions of pressure boundary and heat transfer are maintained.

b.) The essential chilled water and essential cooling water system circulating water pumps are not subject to periodic internal visual inspection or casing NDE. These pumps are monitored for flow, suction pressure and discharge pressure in accordance with the approved ASME Pump and Valve In-Service Testing Program. The performance monitoring of these pumps together with periodic sampling and control of water chemistry is adequate to ensure component intended function is maintained.

c.) The essential chilled water system chiller condenser, water cooler and lube oil cooler are not individually monitored for flow, inlet and outlet temperatures, and differential pressure. During periodic surveillance testing, the heat load on the essential chilled water system is not reproducible from test-to-test. Plant procedures require that these components are subject to visual inspection when their respective chiller is rebuilt. Visual inspection together with the periodic sampling and control of system water chemistry is adequate to ensure the component intended functions are maintained.

d.) The individual ventilation cooling coils served by the essential chilled water system are not monitored for differential pressure and, additionally are not subject to visual inspection of their internal surfaces or NDE because the internal diameter and geometry of the coils preclude effective internal inspection. The combination of chemistry control, preventive maintenance, air side inspection, and testing of a control room air filtration unit in each train provides reasonable assurance that essential auxiliary building HVAC and control building HVAC system cooling coil performance has not degraded. A review of plant operating experience reveals no instances where aging effects have led to the loss of the intended function of the subject components.

e.) The diesel generator jacket water engine-driven circulating water pump, the motor-driven circulating water pump, the jacket water heat exchanger, turbo air intercooler, turbocharger and governor lube oil cooler are not individually monitored for flow, inlet and outlet temperatures, and differential pressure and internal visual inspections are not performed on each component. At PVNGS, diesel generator performance parameters are monitored through periodic Technical Specification surveillance tests. Plant procedures require temperature and pressure parameters be compared to pre-established limiting values. From

the comparison, overall heat exchanger and pump performance can be inferred collectively for the diesel generator under test. With respect to the motor-driven circulating water pump, the pump operates cyclically together with a heater to maintain jacket water temperature when the diesel generator is in standby; its functional performance is continuously monitored by measuring jacket water temperature. The diesel generator governor oil cooler, the engine-driven and motor-driven circulating water pumps and the turbocharger are not individually subject to periodic visual inspection. The jacket water heat exchanger and the turbo air intercooler are periodically inspected visually as an indication of interior surface conditions throughout the diesel generator jacket water system. The surveillance tests together with periodic visual inspections and the periodic sampling and control of system water chemistry are adequate to ensure the component intended functions are maintained within the diesel generator jacket water system.

f.) The RC hot leg sample cooler is within scope of license renewal for 10 CFR 54.4 criteria a(3) fire protection considerations that identify the capability to obtain a RC hot leg sample for boron concentration as a means of reactivity control. Exception is taken for regular, periodic inspection and testing of this heat exchanger based on its variable heat load and on its frequent use in normal operations that would permit identification of any abnormality in obtaining a sample. The periodic sampling and maintenance of system chemistry together with operator observation of component performance in service is adequate to ensure the component intended function of pressure boundary and heat transfer are maintained for the RC hot leg sample cooler.

g.) Several heat exchangers are provided which do not have a license renewal heat transfer intended function and are not monitored for parameters pertaining to heat transfer nor subject to periodic performance monitoring and inspection to manage the aging effect of reduction in heat transfer. These heat exchangers include the letdown heat exchanger, which has the intended function of pressure boundary, and the following heat exchangers, which have the intended function of leakage barrier - spatial:

- auxiliary steam vent condenser
- cooler for auxiliary steam radiation monitor
- cooling coils for normal HVAC Units (containment, auxiliary, and control building HVAC)
- steam generator hot leg, cold leg and downcomer blowdown sample coolers
- pressurizer steam space and surge line sample coolers
- safety injection sample coolers

For these heat exchangers, the periodic sampling and maintenance of system chemistry is adequate to ensure the component intended function is maintained.

Appendix B AGING MANAGEMENT PROGRAMS

Preventative Actions – Element 2, Parameters Monitored or Inspected - Element 3, Detection of Aging Effects – Element 4, Monitoring and Trending – Element 5 and Acceptance Criteria – Element 6.

The program described in NUREG-1801, Section XI.M21, is based on the 1997 version of the EPRI Closed Cooling Water Chemistry Guidelines, TR-107396 Rev. 0. The PVNGS program currently uses the 2004 version of the EPRI Closed Cooling Water Chemistry Guidelines Rev. 1. This difference is considered to be an exception. This exception is acceptable because the EPRI Closed Cooling Water Chemistry guidelines are a consensus document that is updated based on new operating experience, research data, and expert opinion. Incorporation of later versions of the guidance document ensures that the program addresses new information.

Enhancements

Prior to the period of extended operation, the following enhancements will be implemented in the following program elements:

Preventive Actions - Element 2, Acceptance Criteria – Element 6, and Acceptance Criteria – Element 7

Procedures will be enhanced to incorporate the guidance of EPRI TR-107396 with respect to water chemistry control for frequency of sampling and analysis, normal operating limits, action level concentrations, and times for implementing corrective actions upon attainment of action levels.

Operating Experience

A review of the PVNGS plant-specific operating experience indicates that there has been no evidence of significant fouling or loss of material that has resulted in a loss of intended function observed in the following closed cycle cooling systems:

- Diesel Generator Jacket Water System
- Essential Chilled Water System
- Essential Cooling Water System
- Normal Chilled Water System
- Nuclear Cooling Water System

During the second half of 2001, water chemistry monitoring identified an elevated levels of chlorides and sulfates characteristic of leakage from the essential spray pond system into the essential cooling water system of Unit 3. Diagnostic water chemistry testing further localized the source of the leak to the B-train essential cooling water heat exchanger. Visual inspection and NDE (eddy current testing) were performed and localized the leak to a heat

Appendix B
AGING MANAGEMENT PROGRAMS

exchanger tube which was subsequently plugged. The cause was evaluated as a pit resulting from corrosion from the open-cycle cooling side of the heat exchanger into the closed-cycle side of the heat exchanger. An expanded testing program encompassing 100% of the essential cooling water heat exchanger tubes in all three units revealed no further degradation. This event demonstrates the effectiveness of managing the aging of the closed-cycle cooling water systems.

Conclusion

The continued implementation of the Closed-Cycle Cooling Water program provides reasonable assurance that aging effects will be managed such that the systems and components within the scope of this program will continue to perform their intended functions consistent with the current licensing basis for the period of extended operation.

B2.1.11 Inspection of Overhead Heavy Load and Light Load (Related to Refueling) Handling Systems

Program Description

The Inspection of Overhead Heavy Load and Light Load (Related to Refueling) Handling Systems program manages loss of material for all cranes, trolley and hoist structural components, fuel handling equipment and applicable rails within the scope of license renewal. Visual inspections will assess conditions such as loss of material due to corrosion of structural members and visible signs of rail wear.

The inspections for the Inspection of Overhead Heavy Load and Light Load (Related to Refueling) Handling Systems program are performed using various preventive maintenance work orders. The inspection requirements are consistent with:

- (1) The guidance provided by NUREG-0612, “*Control of Heavy Loads at Nuclear Power Plants*” for load handling systems that handle heavy loads which can directly or indirectly cause a release of radioactive material.
- (2) Applicable industry standards (such as CMAA Spec 70) for other cranes within the scope of license renewal.
- (3) Applicable OSHA regulations (29 CFR Volume XVII, Part 1910 and Section 1910.179).

NUREG-1801 Consistency

The Inspection of Overhead Heavy Load and Light Load (Related to Refueling) Handling Systems program is an existing program that, following enhancement, will be consistent with NUREG-1801, Section XI.M23, “Inspection of Overhead Heavy Load and Light Load (Related to Refueling) Handling Systems”.

Exceptions to NUREG-1801

None

Enhancements

Prior to the period of extended operation, the following enhancement will be implemented in the following program element:

Detection of Aging Effects – Element 4

Procedures will be enhanced to inspect for loss of material due to corrosion or rail wear.

Operating Experience

No occurrences of unacceptable corrosion for components within the scope of the Inspection of Overhead Heavy Load and Light Load (Related to Refueling) Handling Systems program have been identified. Additionally, since PVNGS cranes, hoists, trolleys and fuel handling equipment have not been operated outside their design limits nor beyond their design lifetime, no fatigue related structural failures have occurred.

Conclusion

The continued implementation of the Inspection of Overhead Heavy Load and Light Load (Related to Refueling) Handling Systems program provides reasonable assurance that aging effects will be managed such that the systems and components within the scope of this program will continue to perform their intended functions consistent with the current licensing basis for the period of extended operation.

B2.1.12 Fire Protection

Program Description

The Fire Protection program manages loss of material for fire rated doors, fire dampers, diesel-driven fire pumps, and the CO₂ and halon fire suppression systems, cracking, spalling, and loss of material for fire barrier walls, ceilings, and floors, and hardness and shrinkage due to weathering of fire barrier penetration seals. Periodic visual inspections of fire barrier penetration seals, fire dampers, fire barrier walls, ceilings and floors, and periodic visual inspections and functional tests of fire-rated floors are performed to ensure that they can perform their intended function.

The Fire Protection program manages aging by a visual inspection on ten percent of each type of penetration seal at least once every 18 months. This sample set method ensures that each penetration seal is inspected at least once every 15 years.

The Fire Protection program manages aging by a visual inspection every 18 months of the fire barrier walls, ceilings, and floors, including coating and wraps of Thermo-lag enclosures, examining for any signs of aging such as cracking, spalling, and loss of material.

The Fire Protection program manages aging by drop testing on ten percent of all accessible fire dampers on an 18 month basis.

The Fire Protection program manages aging by performing visual inspections every 18 months on fire-rated doors to verify the integrity of door surfaces and for clearances to detect aging of the fire doors prior to the loss of intended function.

The diesel-driven fire pumps are under observation during performance tests such as flow tests, start/run tests for detecting any aging of the fuel supply line. The fuel oil supply line is also managed by the Fuel Oil Chemistry program ([B2.1.14](#)) and External Surface Monitoring Program ([B2.1.20](#)).

A visual inspection and function test of the halon and CO₂ fire suppression systems is performed every 18 months.

NUREG-1801 Consistency

The Fire Protection program is an existing program that, following enhancement, will be consistent with exception to NUREG-1801, Section XI.M26, "Fire Protection".

Exceptions to NUREG-1801

Program Elements Affected

Parameters Monitored or Inspected - Element 3 and Detection of Aging Effects – Element 4

NUREG-1801 recommends a visual inspection and function test of the halon and CO₂ systems every six months. The PVNGS procedures for visual inspections and function testing of the halon and CO₂ fire suppression systems are performed every 18 months per Technical Requirements Manual Surveillance Requirement (TSR) 3.11.106.4 and 3.11.103.4, respectively. This procedural function test would identify any mechanical damage of the halon and CO₂ fire suppression system that prevents the system from performing its intended function. The 18 month frequency is considered sufficient to ensure system availability and operability based on station operating history that indicates no loss of intended function due to aging. A review of the past ten years of operating experience and corrective action documentation has shown no degradation or loss of intended function between test intervals.

Enhancements

Prior to the period of extended operation, the following enhancements will be implemented in the following program elements:

Parameters Monitored or Inspected – Element 3, Detection of Aging Effects – Element 4, Monitoring and Trending –Element 5, and Acceptance Criteria – Element 6

Procedures will be enhanced to state trending requirements for the diesel-driven fire pump and to include visual inspection of the fuel supply line to detect degradation.

Procedures will be enhanced to inspect for mechanical damage, corrosion and loss of material of the halon discharge pipe header and the CO₂ system discharge nozzles.

Procedures will be enhanced to state the qualification requirements for inspecting penetration seals, fire rated doors, fire barrier walls, ceilings and floors.

Operating Experience

Plant operating experience indicates that there have been instances of Thermo-Lag degradation and cracking. These portions of affected Thermo-Lag envelopes have been reworked according to PVNGS specification. PVNGS has also experienced door skin cracks. These have been weld repaired according to specification.

During May of 2005, a fire protection audit was performed by members of APS and other industry representatives. The audit team observed current conditions and installations of the CO₂ and halon suppression systems during walk-downs of selected fire zones. All systems were found in good condition. Multiple walkdowns per unit were conducted to examine the current condition of existing fire barriers in the Unit 1 control building, the Unit 2

Appendix B
AGING MANAGEMENT PROGRAMS

turbine building, and the Unit 3 auxiliary building. There was one adverse condition identified in the Unit 3 auxiliary building where copper piping was penetrating the floor barriers. The audit team found no degraded conditions (e.g., cracks, gouges, holes in material, joint/seal gaps) of installed electrical raceway fire barriers.

In September of 2006, it was discovered that a carbon steel pipe nipple was in need of replacement due to galvanic corrosion and was subsequently replaced. The nipple was located between a galvanized tee and a brass valve. This event is representative of the PVNGS experience of detecting degradations and leakage in time to take corrective action prior to the loss of intended function.

During the 2007 fire protection audit, a concern was raised for the need of a plan to identify fire protection equipment obsolescence issues. Design modifications have been identified to address these issues.

Conclusion

The continued implementation of the Fire Protection program provides reasonable assurance that aging effects will be managed such that the systems and components within the scope of this program will continue to perform their intended functions consistent with the current licensing basis for the period of extended operation.

B2.1.13 Fire Water System

Program Description

The Fire Water System program manages loss of material for water-based fire protection systems. Periodic hydrant inspections, fire main flushing, sprinkler inspections, and flow tests in accordance with National Fire Protection Association (NFPA) codes and standards ensure that the water-based fire protection systems are capable of performing their intended function. The fire water system pressure is continuously monitored such that loss of system pressure is immediately detected and corrective actions initiated.

The Fire Water System program conducts an air or water flow test through each open head spray/sprinkler nozzle to verify that each open head spray/sprinkler nozzle is unobstructed. The Fire Water System program tests a representative sample of fire protection sprinkler heads or replaces those that have been in service for over 50 years, using the guidance of the current code of record or NFPA 25, 2002 Edition, and will test at 10-year intervals thereafter during the period of extended operation to ensure that signs of degradation, such as corrosion, are detected in a timely manner.

Visual inspections evaluating wall thickness to identify evidence of loss of material due to corrosion will be done through the Inspection of Internal Surfaces in Miscellaneous Piping and Ducting Components program (B2.1.22). Buried Piping and Tanks Inspection program (B2.1.18) is credited with the management of aging effects on the external surface of buried fire water system piping.

NUREG-1801 Consistency

The Fire Water System program is an existing program that, following enhancement, will be consistent with exception to NUREG-1801, Section XI.27, "Fire Water System".

Exceptions to NUREG-1801

Program Elements Affected

Detection of Aging Effects – Element 4

PVNGS performs power block hose station gasket inspections once per 18 months as opposed to once per 12 months. Technical Requirements Manual Surveillance Requirement (TSR) 3.11.104.4 states the inspection frequency to be 18 months.

PVNGS performs hydrostatic testing on fire hoses once per three years. Replacement fire hoses that have been hydrostatically tested are available if needed in lieu of performing a hydrostatic test. TSR 3.11.104.6 states the inspection frequency to be 3 years.

Enhancements

Prior to the period of extended operation, the following enhancements will be implemented in the following program elements:

Preventive Actions - Element 2 and Acceptance Criteria – Element 6

Specific procedures will be enhanced to include review and approval requirements under the Nuclear Administrative Technical Manual (NATM).

Parameters Monitored or Inspected – Element 3

Procedures will be enhanced to be consistent with the current code of record or NFPA 25, 2002 Edition.

Detection of Aging Effects – Element 4

Procedures will be enhanced to field service test a representative sample or replace sprinklers prior to 50 years in service and test thereafter every 10 years to ensure that signs of degradation are detected in a timely manner.

Procedures will be enhanced to be consistent with NFPA 25 Section 7.3.2.1, 7.3.2.2, 7.3.2.3, and 7.3.2.4.

Monitoring and Trending –Element 5

Procedures will be enhanced to state trending requirements.

Corrective Actions – Element 7

Procedures will be enhanced so that the PVNGS Quality Assurance programs will apply to Fire Protection SSCs that are within the scope of license renewal that are also part of the boundary of the WRF (Water Reclamation Facility).

Operating Experience

NaOH and NaSO₃ are added to the fire water system and sampled periodically. Based on analyses of corrosion coupons, the corrosion rate has been 0.3 mils/yr thus indicating successful corrosion control measures.

There has been some at-grade evidence of buried piping leakage observed. Remote field eddy current testing was performed on about 7,721 feet of 12-inch pipe covering the fire water main loop. Test results indicated that there were several sections of pipe that had localized degradation in excess of the minimum wall thickness of 40% of nominal wall thickness. Validation was then performed by excavating and removing two spools, and corrosion related pitting was confirmed. PVNGS replaced portions of the North and South Loop piping with epoxy lined reinforced fiberglass. Replacement of approximately 6,000

Appendix B
AGING MANAGEMENT PROGRAMS

feet of pipe on the North Loop was completed during September of 2001. Approximately 4,500 feet of pipe on the South Loop was completed during July of 2006. Some of this degradation was attributed to coating holidays caused by improper backfilling and lack of cathodic protection attention during early plant operation.

The flushes of the deluge system, fire hydrants, and underground fire water loops have identified little or no debris in the lines, and there have been no indications that the SSCs would not be able to perform their intended function.

A review of the past ten years of corrective action documents showed no signs of gasket degradation or fire hose degradation due to inspection intervals of 18 months and three years, respectively.

Conclusion

The continued implementation of the Fire Water System program provides reasonable assurance that aging effects will be managed such that the systems and components within the scope of this program will continue to perform their intended functions consistent with the current licensing basis for the period of extended operation.

B2.1.14 Fuel Oil Chemistry

Program Description

The Fuel Oil Chemistry program manages loss of material on the internal surface of components in the emergency diesel generator (EDG) fuel oil storage and transfer system, diesel fire pump fuel oil system, and station blackout generator (SBOG) system. The program includes (a) surveillance and monitoring procedures for maintaining fuel oil quality by controlling contaminants in accordance with applicable ASTM Standards, (b) periodic draining of water from fuel oil tanks, (c) visual inspection of internal surfaces during periodic draining and cleaning, (d) ultrasonic wall thickness measurements of fuel oil tanks if there are indications of reduced cross sectional thickness found during the visual inspection, (e) inspection of new fuel oil before it is introduced in the fuel oil tanks, and (f) one-time inspections of a representative sample of components in systems that contain fuel oil by the One-Time Inspection Program.

Fuel oil quality is maintained by monitoring and controlling fuel oil contaminants in accordance with applicable ASTM Standards. This is accomplished by periodic sampling and chemical analysis of the fuel oil inventory at the plant and sampling, testing, and analysis of new fuel oil prior to introduction into the fuel oil storage tanks. Initial samples of new fuel oil are inspected for entrained foreign material and water as precautions during the delivery process to avoid introducing contaminants. If a sample appears to be unsatisfactory, delivery is discontinued or not allowed.

The One-Time Inspection program ([Section B2.1.16](#)) will be used to verify the effectiveness of the Fuel Oil Chemistry program.

NUREG-1801 Consistency

The Fuel Oil Chemistry program is an existing program that, following enhancement, will be consistent with exception to NUREG-1801, Section XI.M30, "Fuel Oil Chemistry".

Exceptions to NUREG-1801

Program Elements Affected

Preventive Actions - Element 2

Stabilizers and corrosion inhibitors are not added to the diesel fuel based on the plant operation experience with negligible underground temperature swings, an arid outdoor environment, and operating experience showing the historical absence of water in the EDG fuel oil. Fuel oil quality is maintained through periodic sampling.

Parameters Monitored or Inspected - Element 3 and Acceptance Criteria -Element 6

NUREG-1801 states within Element 3, in part, the ASTM Standards D1796 and D2709 are used for determination of water and sediment contamination in diesel fuel. PVNGS Technical Specification 5.5.13 requires use of ASTM Standard D1796-83 only.

Monitoring and Trending –Element 5

Water has never been discovered within the EDG fuel oil system, and therefore biological activity is not monitored. PVNGS Technical Specification Bases for Surveillance Requirement 3.8.1.5 state that removal of water is the most effective means of controlling microbiological fouling.

Enhancements

Prior to the period of extended operation, the following enhancements will be implemented in the following program elements:

Scope of Program – Element 1, Parameters Monitored or Inspected – Element 3, and Monitoring and Trending –Element 5

Procedures will be enhanced to extend the scope of the program to include SBOG fuel oil storage tank and SBOG skid fuel tanks.

Preventive Actions - Element 2 and Detection of Aging Effects – Element 4

Procedures will be enhanced to include ten-year periodic draining, cleaning, and inspections on the diesel-driven fire pump day tanks, SBOG fuel oil storage tanks, and SBOG skid fuel tanks.

Detection of Aging Effects – Element 4

Ultrasonic testing (UT) or pulsed eddy current (PEC) thickness examination will be conducted to detect corrosion-related wall thinning if degradation is found during the visual inspections and once on the tank bottoms for the EDG fuel oil storage tanks, EDG fuel oil day tanks, diesel-driven fire pump day tanks, and SBOG fuel oil storage tanks. The one-time UT or PEC examination on the tank bottoms will be performed before the period of extended operation.

Operating Experience

PVNGS has no operating experience resulting in MIC in EDG fuel oil. Also, operating experience has shown negligible underground temperature swings and absence of water in the EDG fuel oil.

In 2005, during the U2R12 refueling outage, strainers downstream of the EDG fuel oil day tank were found to be clogged. The cause was determined to be a buildup of sediment in

Appendix B
AGING MANAGEMENT PROGRAMS

the fuel oil day tank. The day tank was re-filled from empty following inspection, and the sediment on the tank bottom was stirred and flowed in down into the strainers. The day tank had never been filled from empty since startup. Resulting from the observed sediment buildup, one-time corrective maintenance work orders were written to clean, inspect, and flush the remaining fuel oil day tanks. In one of the five tanks inspected, a film of fuel sediment was removed. Other corrective actions include establishing a ten-year periodic preventive maintenance task to inspect, clean and flush the diesel fuel oil storage and day tanks.

Conclusion

The continued implementation of the Fuel Oil Chemistry program, supplemented by the One-Time Inspection program (B2.1.16), provides reasonable assurance that aging effects will be managed such that the systems and components within the scope of this program will continue to perform their intended functions consistent with the current licensing basis for the period of extended operation.

B2.1.15 Reactor Vessel Surveillance

Program Description

The Reactor Vessel Surveillance program manages loss of fracture toughness and consists of scheduled withdrawal and testing of vessel material surveillance coupons, consistent with 10 CFR 50 Appendix H and with ASTM E185-82.

Since peak neutron fluence at the end of the design life may exceed 10^{17} n/cm² (E > 1 MeV) and since vessel material coupons were installed, PVNGS determined neutron embrittlement effects, consistent with Regulatory Guide 1.99, Rev. 2, by option 1[b], "Neutron Embrittlement Using Surveillance Data". Actual reactor vessel coupons are used. Limiting heat-affected-zone (HAZ) materials were selected from limiting plate materials.

The original surveillance program documents prescribed coupon material sources, types, and numbers; neutron dosimetry; temperature monitors; capsule number, design and location; and the original examination schedule and methods, including unirradiated baseline and irradiated coupon examinations. Current examination methods and report requirements are also controlled by commitment to 10 CFR 50 Appendix H and to ASTM E 185-82.

Fragments of surveillance specimens are retained for possible future use.

The last-tested 230-degree azimuth capsule specimens from each of the three reactor vessels were withdrawn at about 14 effective full-power years and exposed to fluences equivalent to about 18 to 20 effective full-power years.

NUREG-1801 Consistency

The Reactor Vessel Surveillance program is an existing program that, following enhancement, will be consistent with NUREG-1801, Section XI.M31 "Reactor Vessel Surveillance".

Exceptions to NUREG-1801

None

Enhancements

Prior to the period of extended operation, the following enhancements will be implemented:

The schedule will be revised to withdraw the next capsule at the equivalent clad-base metal exposure of approximately 54 EFPY expected for the 60-year period of extended operation, and to withdraw remaining standby capsules at equivalent clad-base metal exposures not exceeding the 72 EFPY expected for a possible 80-year second period of extended operation. This withdrawal schedule is in accordance with NUREG-1801, Section XI.M31,

item 6, and with the ASTM E 185-82 criterion which states that capsules may be removed when the capsule neutron fluence is between one and two times the limiting fluence calculated for the vessel at the end of expected life. This schedule change must be approved by the NRC, as required by 10 CFR 50 Appendix H.

If left in the reactor beyond the presently-scheduled withdrawal, the next scheduled surveillance capsule in each unit will reach a clad-base metal 54 EFPY equivalent at about 40 actual operating EFPY (40, 39, and 42 actual EFPY in Units 1, 2, and 3, respectively).

Procedures will be enhanced to identify the withdrawal of the remaining standby capsules at 72 EFPY, at about 50 to 54 actual operating EFPY, near the end of the extended licensed operating period. The need to monitor vessel fluence following removal of the remaining standby capsules, and ex-vessel or in-vessel methods, will be addressed prior to removing the remaining capsules.

Operating Experience

The recent examination results indicate that the reactor vessel has been accumulating fluence at a rate less than that originally assumed. The recent examination results also show that decreases in USE and increases in RT_{NDT} are less than projected, thereby demonstrating generous operating margins to pressure-temperature limits; in the limiting materials. The minor exception was the Unit 3 weld coupons, which experienced a larger than expected ΔRT_{NDT} , however this is not the limiting material. The continuation of the reactor vessel surveillance program for the period of extended operation will be revised to extend the coupon withdrawal and examination schedule in order to provide surveillance coupons exposed to fluences sufficient to monitor the effects of neutron irradiation on the reactor vessel throughout its operating lifetime, in accordance with 10 CFR 50 Appendix H and ASTM E 185-82.

Conclusion

The continued implementation of the Reactor Vessel Surveillance program provides reasonable assurance that aging effects will be managed such that the systems and components within the scope of this program will continue to perform their intended functions consistent with the current licensing basis for the period of extended operation.

B2.1.16 One-Time Inspection

Program Description

The One-Time Inspection program conducts one-time inspections of plant system piping and components to verify the effectiveness of the Water Chemistry program (B2.1.2), Fuel Oil Chemistry program (B2.1.14), and Lubricating Oil Analysis program (B2.1.23). The aging effects to be evaluated by the One-Time Inspection program are loss of material, cracking, and reduction of heat transfer. The One-Time Inspection program will include the specific attributes for the components crediting this program for aging management in the license renewal application.

Plant system piping and components will be subject to one-time inspection on a sampling basis using qualified inspection personnel following established ASME, "*Boiler and Pressure Vessel Code*", Section V, "Nondestructive Examination", (NDE) techniques appropriate to each inspection. Inspection sample sizes will be determined using a methodology that is based on 90% confidence that 90% of the population of components will not experience aging effects in the period of extended operation. The One-Time Inspection program specifies corrective actions and increased sampling of piping/components if aging effects are found during material/environment combination inspections. The one-time inspections will be performed no earlier than 10 years prior to the period of extended operation. All one-time inspections will be completed prior to the period of extended operation. Completion of the One-Time Inspection program in this time period will assure that potential aging effects will be manifested based on at least 30 years of PVNGS operation.

Major elements of the PVNGS One-Time Inspection program include:

- a) Identifying piping and component populations subject to one-time inspection based on common materials and environments,
- b) Determining the sample size of components to inspect using established statistical methods based on the population size of the material-environment groups,
- c) Selecting piping and components within the material/environment groups for inspection based on criteria provided in the One-Time Inspection procedure,
- d) Conducting one-time inspections of the selected components within the sample using ASME Code Section V NDE techniques and acceptance criteria consistent with the design codes/standards or ASME Section XI as applicable to the component.

NUREG-1801 Consistency

The One-Time Inspection program is a new program that, when implemented, will be consistent with NUREG-1801, Section XI.M32, "One Time Inspection".

Exceptions to NUREG-1801

None

Enhancements

None

Operating Experience

During the 10 year period prior to the period of extended operation, one-time inspections will be accomplished at PVNGS using ASME NDE techniques to identify possible aging effects. ASME code techniques in the ASME Section XI ISI Program have proven to be effective in detecting aging effects prior to loss of intended function. Review of PVNGS plant-specific operating experience associated with the ISI Program has not revealed any ISI program adequacy issues or implementation issues with the PVNGS ASME Section XI ISI Program. The same NDE techniques used in the ASME Section XI ISI Program will be used in the PVNGS One-Time Inspection program. Using ASME code NDE techniques will be effective in identifying aging effects if present.

Based on reviews of available operating experience and the strength of ASME code NDE techniques, the PVNGS One-Time Inspection program provides reasonable assurance that aging effects will be effective in identifying loss of material, cracking, or reduction of heat transfer aging effects in the systems and components included in the One-Time Inspection Program in the 10 year period prior to the period of extended operation. Industry and plant-specific operating experience will be evaluated in the development and implementation of this program.

Conclusion

The implementation of the One-Time Inspection program will provide reasonable assurance that aging effects will be managed such that the systems and components within the scope of this program will continue to perform their intended functions consistent with the current licensing basis for the period of extended operation.

B2.1.17 Selective Leaching of Materials

Program Description

The Selective Leaching of Materials program manages the loss of material due to selective leaching for copper alloy >15% zinc (brass), copper alloy >8% aluminum (aluminum-bronze), and gray cast iron components exposed to closed-cycle cooling water, demineralized water, secondary water, and raw water within the scope of license renewal. Components susceptible to selective leaching are in the auxiliary steam, essential chilled water, essential cooling water, essential spray ponds, and fire protection systems.

A one-time inspection of a selected sample of components internal surfaces will be performed. Visual and/or mechanical methods will determine whether loss of material due to selective leaching is occurring. If these inspections detect dezincification, de-alloying, or graphitization, which are indications of selective leaching, then a follow-up examination/evaluation will be performed. The examination/evaluation may require confirmation of selective leaching with a metallurgical evaluation which may include microstructure examination. The sample size of the system/material/environment combination may be expanded based on the results of the evaluation and testing. If indications of selective leaching are confirmed, follow up examinations/evaluations will be performed.

A station procedure will implement the Selective Leaching of Materials program. The initial visual inspections and evaluations will be completed prior to the period of extended operation.

NUREG-1801 Consistency

The Selective Leaching of Materials program is a new program that, when implemented, will be consistent with exception to NUREG-1801, Section XI.M33, "Selective Leaching of Materials".

Exceptions to NUREG-1801

Program Elements Affected

Scope of Program – Element 1, Preventive Actions – Element 2, Parameters Monitored or Inspected – Element 3, and Detection of Aging Effects – Element 4

NUREG-1801, Section XI.M33 recommends hardness testing of sample components in addition to visual inspections. However, a qualitative determination of selective leaching will be used in lieu of Brinell hardness testing for components within the scope of the PVNGS Selective Leaching of Materials program. The exception involves the use of examinations, other than Brinell hardness testing identified in NUREG-1801 to identify the presence of selective leaching of materials. The exception is justified, because (1) hardness testing may

not be feasible for most components due to form and configuration (e.g., heat exchanger tubes) and (2) other mechanical means, e.g., scraping, or chipping, provide an equally valid means of identification.

Additionally, hardness testing will only provide definitive results if baseline values are available for comparison purposes. Specific material contents for copper alloys may not be known and gray cast irons may not have published hardness numbers. Without specific numbers for comparison, hardness testing would yield unusable results. In lieu of hardness testing, visual and mechanical inspections will be performed on a sampling of components constructed of copper alloys (>15% zinc and >8% aluminum) and gray cast iron from various station system environments. Follow-up examinations or evaluations will be performed on component material samples where indications of dezincification, de-alloying, or graphitization are visually detected and additional analysis as part of the engineering evaluation is required. The engineering evaluation may require confirmation with a metallurgical evaluation (which may include a microstructure examination).

Enhancements

None

Operating Experience

The Selective Leaching of Materials program is a new program that is a one-time inspection with no plant-specific program operating experience history.

The accelerated de-alloying of aluminum-bronze (copper alloy >8% aluminum), caused by Microbiologically Induced Corrosion (MIC), which was the subject of Information Notice 94-59 regarding selective leaching, is documented. The PVNGS open-cycle cooling water systems are chemically treated with biocides to prevent the growth of MIC causing bacteria and systems, not in continuous use, are recirculated periodically to ensure adequate chemical mixing is maintained. Industry and plant-specific operating experience will be evaluated in the development and implementation of this program.

Conclusion

The implementation of the Selective Leaching of Materials program will provide reasonable assurance that aging effects will be managed such that the systems and components within the scope of this program will continue to perform their intended functions consistent with the current licensing basis for the period of extended operation.

B2.1.18 Buried Piping and Tanks Inspection

Program Description

The Buried Piping and Tanks Inspection program manages loss of material on external surfaces of buried components in the following systems: chemical and volume control, diesel fuel storage and transfer, domestic water, fire protection, WRF fuel system, and essential spray ponds. Opportunistic visual inspections will monitor the condition of protective coatings and wrappings found on carbon steel, gray cast iron or ductile iron components and assess the condition of stainless steel components with no protective coatings or wraps. Any evidence of damaged wrapping or coating defects is an indicator of possible corrosion damage to the external surface of the components.

The Buried Piping and Tanks Inspection program is a new program that will be implemented prior to the period of extended operation. Within the ten year period prior to entering the period of extended operation an opportunistic or planned inspection will be performed. The Buried Piping and Tanks Inspection program requires a planned inspection within the first ten years of the period of extended operation if an opportunistic inspection has not been performed within this ten year period.

NUREG-1801 Consistency

The Buried Piping and Tanks Inspection program is a new program that, when implemented, will be consistent with exception to NUREG-1801, Section XI.M34, "Buried Piping and Tanks Inspection".

Exceptions to NUREG-1801

Program Elements Affected

Scope of Program – Element 1 and Acceptance Criteria- Element 6

NUREG-1801, Section XI.M34 scope only includes buried steel piping and components. However, PVNGS also includes stainless steel in their buried piping program that will be managed as part of this aging management program.

Scope of Program – Element 1, Preventive Actions – Element 2, and Acceptance Criteria- Element 6

NUREG-1801, Section XI.M34 relies on preventive measures such as coatings and wrappings. However, portions of buried stainless steel piping may not be coated or wrapped. Inspections of buried piping that is not wrapped will inspect for loss of material due to general, pitting, crevice, and microbiologically influenced corrosion.

Enhancements

None

Operating Experience

The Buried Piping and Tanks Inspection program is a new program. Degradation of buried components was addressed at PVNGS during an inspection program in September 2002. Observations of this inspection program include:

During the past several years, leaks developed in various buried piping segments, which potentially threaten the continuous operation of PVNGS. These leaks collectively indicated a negative trend in the overall integrity of the buried pipe.

Inspection and maintenance activities were implemented in order to address overall integrity of the buried pipe. Determination of system priorities and development of a draft inspection plan for each of the evaluated systems was developed.

The applicable systems with piping installed below grade were evaluated and assigned ranking based on priority. The majority of these evaluated buried piping systems have very little or no identified potential for degradation.

The majority of the systems evaluated in the inspection program are not within the scope of license renewal. The PVNGS corrective action documentation to date has shown that, for the systems within the scope of license renewal, degradation has been found primarily in the fire protection system. Fire protection system has had localized degradation in excess of the minimum wall requirement of 40% nominal wall thickness. The designated segments of the degraded ductile iron piping have been replaced by fiberglass reinforced plastic piping. The fire protection system has not experienced a failure that affected the ability of the plant to achieve and maintain safe shutdown in the event of a fire. To date, the actual pipe failures of the underground fire protection system have been isolated and repaired without adversely affecting any fire protection water suppression system.

Industry and plant-specific operating experience will be evaluated in the development and implementation of this program.

Conclusion

The implementation of the Buried Piping and Tanks Inspection program will provide reasonable assurance that aging effects will be managed such that the systems and components within the scope of this program will continue to perform their intended functions consistent with the current licensing basis for the period of extended operation.

B2.1.19 One-Time Inspection of ASME Code Class 1 Small-Bore Piping

Program Description

The One-Time Inspection of ASME Code Class 1 Small-Bore Piping program manages cracking of stainless steel ASME Code Class 1 piping less than or equal to 4 inches. This program is a part of the Risk-Informed Inservice Inspection (RI-ISI) program.

For ASME Code Class 1 small-bore piping, the RI-ISI program requires volumetric examinations (by ultrasonic testing) on selected weld locations to detect cracking. Weld locations are selected based on the guidelines provided in EPRI TR-112657. Volumetric examinations are conducted in accordance with ASME Section XI with acceptance criteria from Paragraph IWB-3131 and IWB-2430. The fourth interval of the ISI program will provide the results for the one time inspection of ASME Code Class 1 small-bore piping.

In conformance with 10 CFR 50.55a(g)(4)(ii), the ISI Program is updated each successive 120 month inspection interval to comply with the requirements of the latest edition of the ASME Code specified twelve months before the start of the inspection interval.

NUREG-1801 Consistency

The One-Time Inspection of ASME Code Class 1 Small-Bore Piping program is an existing program that is consistent, with exception to NUREG-1801, Section XI.M35, "One-Time Inspection of ASME Code Class 1 Small-Bore Piping".

Exceptions to NUREG-1801

Program Elements Affected

Scope of Program - Element 1

The PVNGS risk-informed process, examination requirements are performed consistent with EPRI TR-112657, "*Revised Risk-Informed Inservice Inspection Evaluation Procedure*", Rev. B-A, instead of EPRI Report 1000701, "*Interim Thermal Fatigue Management Guideline*" (MRP-24). Guidelines for identifying piping susceptible to potential effects of thermal stratification or turbulent penetration that are provided in EPRI Report 1000701 are also provided in EPRI TR-112657. The recommended inspection volume for welds in EPRI Report 1000701 are identical to those for inspection of thermal fatigue in RI-ISI programs; thus, the PVNGS risk-informed process examination requirements meet the requirements of NUREG-1801 and no enhancements are required.

Enhancements

None

Operating Experience

PVNGS has experienced cracking of stainless steel ASME Code Class 1 piping less than or equal to NPS 4. A hair-line weld failure was caused by cyclic fatigue due to vibration combined with being improperly supported on a shutdown cooling suction line. Piping modifications have reduced the excessive vibration. A review of the second 10-year ISI Interval Summary Reports for Units 1, 2 and 3 indicate there were no code repairs or code replacements required for continued service of ASME IWB Code components during the second 10-year ISI Interval.

Conclusion

The implementation of the One-Time Inspection of ASME Code Class 1 Small-Bore Piping program during the 4th Inservice Inspection Interval will provide reasonable assurance that aging effects will be managed such that the systems and components within the scope of this program will continue to perform their intended functions consistent with the current licensing basis for the period of extended operation.

B2.1.20 External Surfaces Monitoring Program

Program Description

The External Surfaces Monitoring Program manages loss of material for steel, aluminum, and copper alloy components, and hardening and loss of strength for elastomer components. The program includes those systems and components within the scope of license renewal that require external surface monitoring. Visual inspections of external surfaces conducted during engineering walkdowns will be used to identify aging effects and leakage. Physical manipulation during the visual inspections may also be used to verify absence of hardening or loss of strength for elastomers.

The following aging management programs are used to manage aging for external surfaces that are not in the scope of the external surfaces monitoring program.

1. Boric Acid Corrosion ([B2.1.4](#)) for components in a system with treated borated water or reactor coolant environment in which boric acid corrosion may occur.
2. Buried Piping and Tanks Inspection ([B2.1.18](#)) for buried components.
3. Structures Monitoring Program ([B2.1.32](#)) for civil structures, and other structural items which support and contain mechanical and electrical components.

NUREG-1801 Consistency

The External Surfaces Monitoring Program is a new program that, when implemented, will be consistent with exception to NUREG-1801, Section XI.M36, "External Surfaces Monitoring Program".

Exceptions to NUREG-1801

Program Elements Affected

Scope of Program – Element 1, Preventive Actions – Element 2, Detection of Aging Effects – Element 4 Monitoring and Trending - Element 5, and Acceptance Criteria- Element 6

The exceptions to NUREG-1801, XI.M36 are an increase to the scope of the materials inspected to include aluminum, copper alloy and elastomers and an increase to the scope of aging effects to include hardening and loss of strength for elastomers. Additionally, visual inspections may be augmented by physical manipulation to detect hardening and loss of strength of elastomers.

Enhancements

None

Operating Experience

The External Surfaces Monitoring Program is a new program, however, external surfaces inspections via system inspections and walkdowns have been in effect at PVNGS and have proven effective in maintaining the material condition of plant systems. The elements that comprise these inspections (e.g., the scope of the inspections and inspection techniques) are consistent with industry practice.

System engineering walkdowns require that aging effects are documented and that a corrective action be initiated for any deficiencies or adverse trends. A review of plant-specific operating experiences indicates that any documented aging has not caused the failure of component's intended functions.

Industry and plant-specific operating experience will be evaluated in the development and implementation of this program.

Conclusion

The implementation of the External Surfaces Monitoring Program will provide reasonable assurance that aging effects will be managed such that the systems and components within the scope of this program will continue to perform their intended functions consistent with the current licensing basis for the period of extended operation.

B2.1.21 Reactor Coolant System Supplement

Section 3.1 of NUREG-1800, "*Standard Review Plan for the Review of License Renewal Applications for Nuclear Power Plants*" supplements the aging management programs for the reactor coolant system components with the following additional requirements.

APS will:

A. Reactor Coolant System Nickel Alloy Pressure Boundary Components

Implement applicable (1) NRC Orders, Bulletins and Generic Letters associated with nickel alloys and (2) staff-accepted industry guidelines, (3) participate in the industry initiatives, such as owners group programs and the EPRI Materials Reliability Program, for managing aging effects associated with nickel alloys, (4) upon completion of these programs, but not less than 24 months before entering the period of extended operation, APS will submit an inspection plan for reactor coolant system nickel alloy pressure boundary components to the NRC for review and approval, and

B. Reactor Vessel Internals

(1) Participate in the industry programs for investigating and managing aging effects on reactor internals; (2) evaluate and implement the results of the industry programs as applicable to the reactor internals; and (3) upon completion of these programs, but not less than 24 months before entering the period of extended operation, APS will submit an inspection plan for reactor internals to the NRC for review and approval.

B2.1.22 Inspection of Internal Surfaces in Miscellaneous Piping and Ducting Components

Program Description

The Inspection of Internal Surfaces in Miscellaneous Piping and Ducting Components program manages cracking, loss of material, and hardening and loss of strength. The internal surfaces of piping, piping components, ducting and other components that are not covered by other aging management programs are included in this program.

The Inspection of Internal Surfaces in Miscellaneous Piping and Ducting Components program uses the work control process to conduct and document inspections. The program will perform visual inspections to detect aging effects that could result in a loss of component intended function. The visual inspections will be conducted during periodic maintenance, predictive maintenance, surveillance testing and corrective maintenance. Additionally, visual inspections may be augmented by physical manipulation to detect hardening and loss of strength of both internal and external surfaces of elastomers. The program also includes volumetric evaluation to detect stress corrosion cracking of the internal surfaces of stainless steel components exposed to diesel exhaust.

Within 10 years before entering the period of extended operation, a review will be conducted to determine the number of inspection opportunities afforded by the work control process for all systems within the scope of this program. In the vast majority of cases, it is expected that the number of work opportunities existing will be sufficient to detect aging and provide reasonable assurance that intended functions are maintained. For those systems or components where inspections of opportunity are insufficient, an inspection will be conducted prior to the period of extended operation to provide reasonable assurance that the intended functions are maintained.

The Inspection of Internal Surfaces in Miscellaneous Piping and Ducting Components program is a new program that will be implemented prior to the period of extended operation.

NUREG-1801 Consistency

The Inspection of Internal Surfaces in Miscellaneous Piping and Ducting Components program is a new program that, when implemented, will be consistent with exception to NUREG-1801, Section XI.M38, "Inspection of Internal Surfaces in Miscellaneous Piping and Ducting Components".

Exceptions to NUREG-1801

Program Elements Affected:

Scope of Program – Element 1; Parameters Monitored or Inspected – Element 3; Detection of Aging Effects – Element 4; and Monitoring and Trending – Element 5.

NUREG-1801 XI.M38 provides for a program of visual inspections of the internal surfaces of miscellaneous steel piping and ducting components to ensure that existing environmental conditions are not causing material degradation that could result in a loss of component intended functions. The exceptions to NUREG-1801, XI.M38 are an increase to the scope of the materials inspected to include stainless steel, aluminum, copper alloy and elastomers in addition to steel and an increase to the scope of aging effects to include hardening and loss of strength for elastomers. Additionally, visual inspections may be augmented (1) by physical manipulation to detect hardening and loss of strength of elastomers and (2) by volumetric evaluation to detect stress corrosion cracking of the internal surfaces of stainless steel components exposed to diesel exhaust.

Enhancements

None

Operating Experience

Inspection of Internal Surfaces in Miscellaneous Piping and Ducting Components program is a new program. Therefore no programmatic operating experience has been gained. Industry and plant-specific operating experience will be evaluated in the development and implementation of this program.

Conclusion

The implementation of the Inspection of Internal Surfaces in Miscellaneous Piping and Ducting Components program will provide reasonable assurance that aging effects will be managed such that the systems and components within the scope of this program will continue to perform their intended functions consistent with the current licensing basis for the period of extended operation.

B2.1.23 Lubricating Oil Analysis

Program Description

The Lubricating Oil Analysis program manages loss of material and reduction of heat transfer for components within the scope of license renewal that have surfaces exposed to lubricating and hydraulic oils. The program will ensure the lubricating and hydraulic oil environment in mechanical systems is maintained to the required quality. The program monitors and controls oil contaminants, primarily water and particulates, within acceptable limits, thereby preserving an environment that is not conducive to aging effects. Monitoring and trending of oil analysis results identifies the potential for component aging before loss of component intended function occurs. The program includes acceptance criteria based on vendor and industry guidelines.

Plant procedures implement sampling methods, lubricant test methods and lubricant test data evaluation requirements. Sample schedules are established and managed within the plant Reliability Centered Maintenance and Preventative Maintenance Program.

The One-Time Inspection program ([Section B2.1.16](#)) will be used to verify the effectiveness of the Lubricating Oil Analysis program.

NUREG-1801 Consistency

The Lubricating Oil Analysis program is an existing program that is consistent with exception to NUREG-1801, Section XI.M39, "Lubricating Oil Analysis".

Exceptions to NUREG-1801

Program Elements Affected

Parameters Monitored or Inspected – Element 3; Acceptance Criteria- Element 6

NUREG-1801 recommends that lubricating oil in components subject to periodic oil changes be tested using particle-counting test methods to detect evidence of abnormal wear rates or excessive corrosion. At PVNGS, the Lubricating Oil Analysis program conducts particle-counting on turbine oils but not on diesel engine oils due to the potential for interference by soot. The Lubricating Oil Analysis program relies upon elemental analysis techniques as described in ASTM D6595 "*Determination of Wear Metals and Contaminants in Used Lubricating Oils or Used Hydraulic Fluids by Rotating Disc Electrode Atomic Emission Spectroscopy*". Elemental analysis techniques are considered to be a form of particle-counting that also provides information about the metallurgy of the particles. The use of elemental analysis in lieu of particle counting techniques is deemed to provide a greater degree of insight into lubricant condition for the purpose of managing aging.

Appendix B AGING MANAGEMENT PROGRAMS

NUREG-1801 recommends that lubricating oil in components that are not subject to periodic oil changes be tested additionally for flash point in order to verify suitability for continued use. At PVNGS, the Lubricating Oil Analysis program considers flash point testing to provide indication of lubricating oil contamination by fuel oils. The Lubricating Oil Analysis program therefore requires flash point testing only for lubricating oils in components where the potential exists for contamination of the lubricating oil by fuel oil.

NUREG-1801 recommends that lubricating oil in components that are not subject to periodic oil changes be tested additionally for neutralization number. At PVNGS, the Lubricating Oil Analysis program tests diesel engine lubrication oils using the Total Base Number (BN) parameter for lubricant evaluations performed to assess the suitability of oil for continued use; Total Acid Number (AN) has been found to be of limited utility in evaluating engine oils for continued use, however, this test is used for evaluating the oils in other components for continued use.

Enhancements

None

Operating Experience

PVNGS site specific operating experience revealed no pattern of events involving loss of intended function as a result of aging effects related to lubricating oil contamination or degradation.

Reactor coolant pump bearing systems which includes the pump thrust bearing and the oil overflow storage tank - During the 1994-1997 time frame, abnormal water levels were measured in oil samples of 4 of the 12 pump bearings. Three of these were from Unit 2. When the water was discovered, corrective action was taken to remove the water and oil. Testing was performed until acceptable oil dryness could be established. The cause was determined to be an outage related cleaning practice that resulted in placing water in the oil. All 12 reactor coolant pump bearing systems have been dry since the cleaning practice was changed.

Emergency diesel generator particulate (wear metal) condition - In July of 1999, abnormal wear metal levels were measured in the 2MDGAH01 engine oil. The test measurement indicated a step change in chrome. The cylinder liners were believed to be the most likely source of the wear metal. Boroscope inspection isolated the liner which was removed and replaced. Visual inspection post maintenance indicated axial wear in the form of scratches which caused narrow cuts through the chrome. The cause was determined to be a random event that occurred where the gaps in the rings were aligned.

Conclusion

The continued implementation of the Lubricating Oil Analysis program, supplemented by the One-Time Inspection program ([B2.1.16](#)), provides reasonable assurance that aging effects

Appendix B
AGING MANAGEMENT PROGRAMS

will be managed such that the systems and components within the scope of this program will continue to perform their intended functions consistent with the current licensing basis for the period of extended operation.

B2.1.24 Electrical Cables and Connections Not Subject to 10 CFR 50.49 Environmental Qualification Requirements

Program Description

The Electrical Cables and Connections Not Subject to 10 CFR 50.49 Environmental Qualification Requirements program manages embrittlement, melting, cracking, swelling, surface contamination, or discoloration to ensure that electrical cables, connections and terminal blocks not subject to the environmental qualification (EQ) requirements of 10 CFR 50.49 and within the scope of license renewal are capable of performing their intended functions.

Technical information contained within SAND96-0344 and EPRI TR-1003057 was used to determine the service limitations of the cable, connection and terminal block insulating materials. SAND96-0344 and EPRI TR-109619 provided guidance on techniques for visually inspecting cables, connections and terminal blocks for aging.

Non-EQ cables, connections and terminal blocks within the scope of license renewal in accessible areas with an adverse localized environment are inspected. The inspections of Non-EQ cables, connectors and terminal blocks in accessible areas are representative, with reasonable assurance, of cables, connections and terminal blocks in inaccessible areas with an adverse localized environment. At least once every ten years, the Non-EQ cables, connections and terminal blocks within the scope of license renewal in accessible areas are visually inspected for embrittlement, melting, cracking, swelling, surface contamination, or discoloration.

The acceptance criterion for visual inspection of accessible Non-EQ cable jacket, connection terminal block insulating material is the absence of anomalous indications that are signs of degradation. Corrective actions for conditions that are adverse to quality are performed in accordance with the corrective action program as part of the QA program. The corrective action program provides reasonable assurance that deficiencies adverse to quality are either promptly corrected or are evaluated to be acceptable.

A new procedure will implement the aging management program and provide for the identification of adverse localized environments.

NUREG-1801 Consistency

The Electrical Cables and Connections Not Subject to 10 CFR 50.49 Environmental Qualification Requirements program is a new program that, when implemented, will be consistent with NUREG-1801, Section XI.E1, "Electrical Cables and Connections Not Subject to 10 CFR 50.49 Environmental Qualification Requirements".

Exceptions to NUREG-1801

None

Enhancements

None

Operating Experience

The Electrical Cables and Connections Not Subject to 10 CFR 50.49 Environmental Qualification Requirements program is a new program.

Industry operating experience has shown that adverse localized environments caused by heat or radiation for electrical cables and connections may exist next to or above steam generators, pressurizers or hot process pipes, such as feedwater lines. These adverse localized environments have been found to cause degradation of the insulating materials on electrical cables and connections that is visually observable, such as color changes or surface cracking. These visual indications can be used as indications of degradation.

A review of the plant operating history found three minor cases of cable aging due to adverse environments.

A lighting power cable with degraded insulation was found. The cause was indeterminate and cable was replaced. In the second case, conduits were run too close to a steam line. The conduits were relocated and the cables meggered. No cable degradation was found. In the third case, water was found leaking from a pull box. The cable was abandoned and conduit was sealed.

Industry and plant-specific operating experience will be evaluated in the development and implementation of this program.

Conclusion

The implementation of the Electrical Cables and Connections Not Subject to 10 CFR 50.49 Environmental Qualification Requirements program will provide reasonable assurance that adverse localized environments are identified and aging effects will be managed such that the systems and components within the scope of this program will continue to perform their intended functions consistent with the current licensing basis for the period of extended operation.

**B2.1.25 Electrical Cables and Connections Not Subject to 10 CFR 50.49
Environmental Qualification Requirements Used in
Instrumentation Circuits**

Program Description

The scope of the Electrical Cables and Connections Not Subject to 10 CFR 50.49 Environmental Qualification Requirements Used in Instrumentation Circuits program includes the cables and connections used in sensitive instrumentation circuits with sensitive, high voltage low-level signals within the ex-core neutron monitoring system. The Electrical Cables and Connections Not Subject to 10 CFR 50.49 Environmental Qualification Requirements Used in Instrumentation Circuits program manages embrittlement, cracking, melting, discoloration, swelling, or loss of dielectric strength leading to reduced insulation resistance.

The purpose of this program is to provide reasonable assurance that the intended function of cables and connections used in instrumentation circuits with sensitive, low-level signals that are not subject to the environmental qualification requirements of 10 CFR 50.49 and are exposed to adverse localized environments caused by heat, radiation, or moisture are maintained consistent with the current licensing basis through the period of extended operation. In most areas, the actual ambient environments (e.g., temperature, radiation, or moisture) are less severe than the plant design environment for those areas.

Calibration surveillance tests will be used to manage the aging of the cable insulation and connections so that instrumentation circuits perform their intended functions. When an instrumentation channel is found to be out of calibration during routine surveillance testing, troubleshooting is performed on the loop, including the instrumentation cable and connections. A review of the calibration results will be completed before the period of extended operation and every 10 years thereafter.

NUREG-1801 Consistency

The Electrical Cables and Connections Not Subject to 10 CFR 50.49 Environmental Qualification Requirements Used in Instrumentation Circuits program is an existing program, that following enhancement, will be consistent with NUREG-1801, Section XI.E2, "Electrical Cables and Connections Not Subject to 10 CFR 50.49 Environmental Qualification Requirements Used in Instrumentation Circuits".

Exceptions to NUREG-1801

None

Enhancements

Prior to the period of extended operation, the following enhancement will be implemented in the following program elements:

Scope of Program – Element 1, Detection of Aging Effects - Element 4, and Corrective Actions – Element 7

Procedures will be enhanced to identify license renewal scope and require an engineering evaluation of the calibration results and to require that an action request be written when the loop cannot be calibrated to meet acceptance criteria.

Operating Experience

Industry operating experience has identified occurrences of cable and connection insulation degradation in high voltage, low level instrumentation circuits performing radiation monitoring and nuclear instrumentation functions. The majority of occurrences are related to cable and connection insulation degradation inside of containment near the reactor vessel or to a change in an instrument readout associated with a proximate change in temperature inside the containment.

A review of plant operating experience identified issues with ex-core noise and spiking. A root cause analysis was performed and corrective actions included system walkdowns and testing which identified cable and connection characterization. Continued coaxial connector replacements, utilization of ferrite beads, and improved grounding have been effective in improving overall performance.

Conclusion

The continued implementation of the Electrical Cables and Connections Not Subject to 10 CFR 50.49 Environmental Qualification Requirements Used in Instrumentation Circuits program provides reasonable assurance that aging effects will be managed such that the systems and components within the scope of this program will continue to perform their intended functions consistent with the current licensing basis for the period of extended operation.

B2.1.26 Inaccessible Medium Voltage Cables Not Subject to 10 CFR 50.49 Environmental Qualification Requirements

Program Description

The Inaccessible Medium Voltage Cables Not Subject to 10 CFR 50.49 EQ Requirements program manages localized damage and breakdown of insulation leading to electrical failure in inaccessible medium voltage cables exposed to adverse localized environments caused by significant moisture simultaneously with significant voltage to ensure that inaccessible medium voltage cables not subject to the environmental qualification (EQ) requirements of 10 CFR 50.49 and within the scope of license renewal are capable of performing their intended function.

All cable manholes that contain in-scope non-EQ inaccessible medium voltage cables will be inspected for water collection. The collected water will be removed as required. This inspection and water removal will be performed based on actual plant experience but at least every two years.

All in-scope non-EQ inaccessible medium voltage cables routed through manholes will be tested to provide an indication of the conductor insulation condition. A polarization index test as described in EPRI TR-103834-P1-2 or other testing that is state-of-the-art at the time the testing will be performed at least once every ten years. The first test will be completed before the period of extended operation.

The acceptance criteria for each test will be defined for the specific type of test performed and the specific cable tested. Periodic inspections of cable manholes, for the accumulation of water will minimize cable exposure to water. Corrective actions for conditions that are adverse to quality are performed in accordance with the corrective action program as part of the QA program. The corrective action program provides reasonable assurance that deficiencies adverse to quality are either promptly corrected or are evaluated to be acceptable.

Procedures will implement the aging management program for testing of the medium voltage cables not subject to 10 CFR 50.49 EQ requirements and the periodic inspections and removal of water from the cable manholes containing in-scope medium voltage cables not subject to 10 CFR 50.49 EQ requirements.

NUREG-1801 Consistency

The Inaccessible Medium Voltage Cables Not Subject to 10 CFR 50.49 EQ Requirements program is a new program that, when implemented, will be consistent with NUREG-1801, Section XI.E3, "Inaccessible Medium Voltage Cables Not Subject to 10 CFR 50.49 Environmental Qualification Requirements".

Exceptions to NUREG-1801

None

Enhancements

None

Operating Experience

Industry operating experience has shown that cross linked polyethylene or high molecular weight polyethylene insulation materials, exposed to significant moisture and voltage, are most susceptible to water tree formation. Formation and growth of water trees varies directly with operating voltage.

PVNGS has not experienced a failure of any inaccessible medium voltage cables. PVNGS has experienced cases where medium voltage cable splices have been subjected to water intrusion resulting in low megger readings. PVNGS is in the process of implementing corrective actions to minimize the intrusion of water into manholes by identifying sources of water, elevating the top of a manhole, and increasing the inspection frequency of manholes found to have water to once every year.

Industry and plant-specific operating experience will be evaluated in the development and implementation of this program.

Conclusion

The implementation of Inaccessible Medium Voltage Cables Not Subject to 10 CFR 50.49 EQ Requirements program will provide reasonable assurance that aging effects will be managed so that the intended functions of the inaccessible medium voltage cables within the scope of license renewal are maintained during the period of extended operation.

B2.1.27 ASME Section XI, Subsection IWE

Program Description

The ASME Section XI, Subsection IWE program manages loss of material and loss of sealing of the steel liner of the concrete containment building. For the inspection interval from 07/18/2008 to 07/17/2018, for Unit 1, from 03/18/2007 to 03/17/2017, for Unit 2, from 01/11/2008 to 01/10/2018, for Unit 3, PVNGS performs Containment Inservice Inspections (CISIs) in accordance with the 2001 Edition of ASME Section XI, Subsection IWE (with the 2002 and 2003 addenda), supplemented with the applicable requirements of 10 CFR 50.55a(b)(2)(ix). Inspections are performed to identify and manage any containment liner degradation due to loss of material that could result in loss of intended function. Included in this inspection program are the containment liner plate and its integral attachments, such as piping and electrical penetrations, access hatches, the fuel transfer tube, and pressure-retaining bolting. Acceptance criteria for components subject to IWE exam requirements are specified in Article IWE-3000.

The ASME Section XI, Subsection IWE program is implemented in accordance with 2INT-IWE-1, 2, and 3, Inservice Inspection (ISI) Examination Program Plan for ASME Section XI, Subsection IWE. A general visual examination is used to identify indications of degradation. All areas requiring augmented examination per criteria IWE-1240 and IWE-2420 receive a detailed visual inspection. ASME Table 2500-1, Note (1)(d), states that pressure retaining bolted connections shall be considered for examination, and bolted connections need not be disassembled for performance of examinations.

NUREG-1801 Consistency

The ASME Section XI, Subsection IWE program is an existing program that is consistent with exception to NUREG-1801, Section XI.S1, ASME Section XI, Subsection IWE.

Exceptions to NUREG-1801

Program Elements Affected

Scope of Program – Element 1

Pressure retaining containment seals and gaskets are not addressed by the 2001 edition of ASME Section XI, Subsection IWE (with the 2002 and 2003 addenda). These components are evaluated per 10 CFR 50, Appendix J program ([B2.1.30](#)).

Parameters Monitored or Inspected - Element 3

The ASME Section XI, Subsection IWE program is in accordance with the 2001 Edition of the ASME Section XI, Subsection IWE (with the 2002 and 2003 addenda). This edition of the code does not specify seven categories of examination in Table IWE 2500-1.

Monitoring and Trending - Element 5

According to ASME Section XI, Paragraphs IWE-2420(b) and (c), flaws or areas of degradation that have been accepted by engineering evaluation shall be reexamined during the next inspection period, and if they are found to remain essentially unchanged for this inspection period, these areas no longer require augmented examination. This is not consistent with Element 5, which requires that they remain essentially unchanged for three consecutive inspection periods.

IWE 2430 was deleted prior to the issuance of the 2001 Edition of ASME Section XI, (with the 2002 and 2003 addenda). The changes to Table IWE 2500-1 eliminate several examination categories. The categories that remain all require 100% examination. Therefore no items are available for additional examinations.

Acceptance Criteria – Element 6, Corrective Actions – Element 7, and Confirmation Process – Element 8

Table IWE-3410-1 was deleted prior to the issuance of the 2001 Edition of ASME Section XI, (with the 2002 and 2003 addenda). The acceptance standards previously specified in Table IWE-3410-1 are now given in Section IWE 3500.

Enhancements

None

Operating Experience

The latest IWE Inservice Inspection results (ISI) are documented as follows:

Unit 1 ISI Report

The Unit 1 IWE Inservice Inspection examinations were performed during the twelfth refueling outage (U1R12) at the Unit 1. This was the first refueling for Interval 1, Period 3 and it was conducted October 8, 2005 through December 24, 2005. The results of these examinations are documented in accordance with 1INT-IWE-1, Inservice Inspection (ISI) Examination Program Plan for ASME Section XI, Subsection IWE.

An evaluation of the results from the ISI examination indicated the integrity of the systems has been maintained. All discrepancies were corrected or determined “use-as-is” in accordance with PVNGS work control practices and ASME Section XI.

Unit 2 ISI Report

The Unit 2 IWE Inservice Inspection examinations were performed during the twelfth refueling outage (U2R12) at Unit 2. This was the first refueling for Interval 1, Period 3 and it was conducted April 2, 2005 through May 20, 2005. The results of these examinations are

Appendix B
AGING MANAGEMENT PROGRAMS

documented in accordance with 1INT-IWE-2, Inservice Inspection (ISI) Examination Program Plan for ASME Section XI, Subsection IWE.

An evaluation of the results from the ISI examinations indicated the integrity of the systems has been maintained. All discrepancies were corrected or determined "use-as-is" in accordance with PVNGS work control practices and ASME Section XI.

Unit 3 ISI Report

The Unit 3 IWE examinations were performed during the twelfth refueling outage (U3RI2) at the Unit 3. This was the first refueling for Interval 1, Period 3 and it was conducted from April 1, 2006 through May 12, 2006. The results of these examinations are documented in accordance with 1INT-IWE-3, Inservice Inspection (ISI) Examination Program Plan for ASME Section XI, Subsection IWE.

An evaluation of the results from the ISI examinations indicated the integrity of the systems has been maintained. There were no rejectable or abnormal indications found during this ISI inspection activity.

General Visual Examinations for Period 2 of the 1st Interval of the IWE Inservice Inspection Program were performed for Unit 3. Special attention was given to the areas at the floor level mentioned in NRC Information Notice IN 04-09, "*Corrosion of Steel Containment and Containment Liner*". No abnormal conditions or signs of degradation were observed. There were no areas that had evidence of water/moisture contacting the liner plate or penetrating the joint between the liner plate and the floor. Several areas at different elevations were also examined after the coating had been removed. These areas had scratches or blisters in the coating that needed the coating replaced. No signs of degradation were detected in the base metal of the liner prior to re-coating. Before the outage, EPRI performed a Self Assessment of the IWE/IWL Programs for all three Units and had no concerns. The Programs are addressing all issues that are listed in NRC Information Notice IN 04-09, "*Corrosion of Steel Containment and Containment Liner*".

Visual examination of Containment liner plate found no degradation and minor coating touchups were performed. ISI updated ASME Section XI code year to implement IWE and IWL with a five year grace period.

PVNGS does not use steel expansion bellows in the design of mechanical penetrations and is not subject to the failure modes described in NRC Information Notice IN 92-20, "*Inadequate Local Leak Rate Testing*". These concerns are addressed through PVNGS Technical Specifications and the associated leak rate testing requirements of 10 CFR 50 Appendix J.

Conclusion

The continued implementation of the ASME Section XI, Subsection IWE program provides reasonable assurance that aging effects will be managed such that the systems and

Appendix B
AGING MANAGEMENT PROGRAMS

components within the scope of this program will continue to perform their intended functions consistent with the current licensing basis for the period of extended operation.

B2.1.28 ASME Section XI, Subsection IWL

Program Description

The ASME Section XI, Subsection IWL program manages cracking, loss of material, and increase in porosity and permeability of the concrete containment building and post-tensioned system. Included in this inspection program are the concrete containment structure (includes all accessible areas of the concrete dome, cylinder walls, and buttresses), and the post-tensioning system (includes tendons, end anchorages, and concrete surfaces around the end anchorages). Concrete surface areas are visually examined for indications of distress or deterioration such as those defined in ACI201.1R-92. Tendon prestress forces are measured by lift-off, and tendon wires are examined for corrosion or mechanical damage. The yield strength, ultimate tensile strength, and elongation are recorded. Grease caps are examined for grease leakage or grease cap deformation. Grease samples are analyzed in accordance with Table IWL-2525-1. For the inspection interval from August 1, 2001 to July 31, 2011, PVNGS performs IWL Inservice Inspections in accordance with the 1992 Edition of ASME Section XI (with 1992 Addendum), Subsection IWL, supplemented with the applicable requirements of 10 CFR 50.55a(b)(2) and additional commitments. The PVNGS IWL ISI program is consistent with the 2001 edition of ASME Section XI, Subsection IWL, including the 2002 and 2003 Addenda.

In conformance with 10 CFR 50.55a(g)(4)(ii), the PVNGS IWL ISI program is updated during each successive 120-month inspection interval to comply with the requirements of the latest edition of the Code specified twelve months before the start of the inspection interval.

The ASME Section XI, Subsection IWL program addresses the requirements for the containment inservice inspection intervals for the concrete and the post-tensioning system for each of the containment structures. Plant surveillance tests verify the structural integrity of the containment tendon system and specify the work necessary for the verification of containment tendon integrity.

NUREG-1801 Consistency

The ASME Section XI, Subsection IWL program is an existing program that is consistent with NUREG-1801, Section XI.S2, ASME Section XI, Subsection IWL.

Exceptions to NUREG-1801

None

Enhancements

None

Operating Experience

The ASME Section XI, Subsection IWL program inspects the post-tensioned concrete containment in accordance with 10 CFR 50.55a(b)(2)(viii)(A through E). When observed degradation could indicate the presence of degradation in inaccessible areas, or the conditions described in 10 CFR 50.55a(b)(2)(viii)(C or D) are detected, the ISI Program Engineer shall be notified, and the conditions shall be included in the ISI Summary report. A copy of the ISI Summary Report shall be transmitted to the NRC within 90 days after the completion of the refueling outage. In addition to ISI Summary report requirements, a special report shall be prepared and submitted to the NRC within 30 days after the detection of any abnormal degradation of the containment concrete and/or post-tensioning system, in accordance with Technical Specifications.

A review of PVNGS operating experience has identified only two instances where observed degradation was significant enough to warrant inclusion in a Summary Report. The grease spots identified in these cases are located on the containment exterior concrete surface. An engineering evaluation determined that these are cosmetic conditions, and there are no detrimental affects to the structure.

NRC Information Notice IN 99-10, "*Degradation of Prestressing Tendon Systems in Prestressed Concrete Containments*" was issued to notify licensees of the types of degradation observed on the prestressed tendon systems. APS reviewed the information documented in the Information Notice for applicability. The existing PVNGS Tendon Integrity Surveillance procedures are based on the guidance of Regulatory Guide 1.35. The degradation and conditions discussed in the Information Notice are monitored and evaluated per Tendon Integrity surveillance procedures. A trend of degradation described in IN 99-10 has not occurred at PVNGS.

Conclusion

The continued implementation of the ASME Section XI, Subsection IWL program provides reasonable assurance that aging effects will be managed such that the systems and components within the scope of this program will continue to perform their intended functions consistent with the current licensing basis for the period of extended operation.

B2.1.29 ASME Section XI, Subsection IWF

Program Description

The ASME Section XI, Subsection IWF program provides a systematic method for periodic nondestructive examination (NDE), visual examination and testing of systems, structures and components to ensure the integrity of component pressure boundaries and supports. The ASME Section XI, Subsection IWF program manages loss of material, cracking, and loss of mechanical function that could result in loss of intended function for Class 1, 2 and 3 component supports. There are no Class MC supports at PVNGS.

In conformance with 10 CFR 50.55a(g)(4)(ii), the PVNGS ISI Program is updated during each successive 120-month inspection interval to comply with the requirements of the latest edition of the Code specified twelve months before the start of the inspection interval.

PVNGS Units 1, 2, and 3 are in the third ISI interval which began July 18, 2008, March 18, 2007, and January 11, 2008, respectively. The program is being conducted in accordance with ASME Section XI 2001 Edition with 2002 and 2003 Addenda. PVNGS Inservice Inspection Program performs inspections as defined by Program B of ASME Section XI.

NUREG-1801 Consistency

The ASME Section XI, Subsection IWF program is an existing program that is consistent with NUREG-1801, Section XI.S3 ASME Section XI, Subsection IWF.

Exceptions to NUREG-1801

None

Enhancements

None

Operating Experience

Review of plant-specific operating experience for the PVNGS ISI Program has not revealed any implementation issues with the PVNGS ASME Section XI, Subsection IWF program.

The ASME Section XI, Subsection IWF program at PVNGS is updated to account for industry operating experience. ASME Section XI is also periodically revised to reflect operating experience. The requirement to update the ASME Section XI, Subsection IWF program to reference more recent editions of ASME Section XI at the end of each inspection interval ensures the program reflects enhancements due to operating experience that have been incorporated into ASME Section XI.

The latest IWF Inservice inspections (ISI) are documented as follows:

Unit 1 ISI Report

The Unit 1 Inservice Inspection Report Thirteenth Refueling Outage (October 2007) is a summary of the examinations performed during the thirteenth refueling outage (U1R13) at the PVNGS Unit 1. This report also includes all applicable examinations conducted since the last refueling outage. This was the second refueling for Interval 2, Period 3, which was conducted from May 19, 2007 through July 19, 2007.

An evaluation of the results from the ISI examination indicated the integrity of the systems has been maintained. All discrepancies were corrected or determined "use-as-is" in accordance with PVNGS work control practices and ASME Section XI.

Unit 2 ISI Report

The Unit 2 Inservice Inspection Report Thirteenth Refueling Outage (February 2007) is a summary of the examinations performed during the thirteenth refueling outage (U2R13) at the Palo Verde Nuclear Generating (PVNGS) Unit 2. This report also includes all applicable examinations conducted since the last refueling outage. This was the second refueling for Interval 2, Period 3 and it was conducted September 30, 2006 through November 14, 2006.

An evaluation of the results from the ISI examinations indicated the integrity of the systems has been maintained. All discrepancies were corrected or determined "use-as-is" in accordance with PVNGS work control practices and ASME Section XI.

Unit 3 ISI Report

The Unit 3 Inservice Inspection Report Twelfth Refueling Outage (August 2006) is a summary of the examinations performed during the twelfth refueling outage (U3R12) at the PVNGS Unit 3. This report also includes all applicable examinations conducted since the last refueling outage. This was the first refueling for Interval 2, Period 3 and it was conducted from April 1, 2006 through May 12, 2006.

An evaluation of the results from the ISI examinations indicated the integrity of the systems has been maintained. There were no rejectable or abnormal indications found during this ISI inspection activity.

Conclusion

The continued implementation of the ASME Section XI, Subsection IWF program provides reasonable assurance that aging effects will be managed such that the systems and components within the scope of this program will continue to perform their intended functions consistent with the current licensing basis for the period of extended operation.

B2.1.30 10 CFR 50, Appendix J

Program Description

The 10 CFR 50, Appendix J program manages loss of material, loss of leak tightness, and loss of sealing. The program assures leakage through the primary containment and systems and components penetrating the primary containment do not exceed allowable leakage rate limits specified in the Technical Specifications. The 10 CFR 50 Appendix J program does not prevent degradation due to aging effects but provides measures for monitoring to detect the degradation prior to the loss of intended function. Periodic monitoring of leakage from the containment, containment isolation valves, and containment penetrations assures proper maintenance and repairs can be performed prior to the loss of intended function. The 10 CFR 50 Appendix J program establishes compliance with the regulations and guidance provided in 10 CFR 50 Appendix J, "*Primary Reactor Containment Leakage Testing for Water-Cooled Power Reactors*" (Option B); Regulatory Guide 1.163, "*Performance-Based Containment Leak-Testing Program*"; NEI 94-01, *Industry Guideline for Implementing Performance-Based Option of 10 CFR Part 50 Appendix J*; and ANSI/ANS 56.8, "*Containment System Leakage Testing Requirements*".

The 10 CFR 50 Appendix J program is implemented in accordance with station procedures which establish the bases for leakage rate testing, establishment of performance-based intervals for Type A, B, and C leakage rate testing, record keeping requirements, assignment of administrative leakage rate limits, retest requirements and corrective actions.

NUREG-1801 Consistency

The 10 CFR 50, Appendix J program is an existing program that is consistent with NUREG-1801, Section XI.S.4, "10 CFR 50, Appendix J".

Exceptions to NUREG-1801

None

Enhancements

None

Operating Experience

An industry review of leak rate testing experience indicates that only a small percentage of Type A tests have experienced excessive leakage. Furthermore, the observed leakage in these cases was only marginally above the allowable limits. These observations led to the conclusion that Type A test frequency could be established based upon ILRT performance. The Integrated Leakage Rate Test acceptance criteria are 1.0 La (as-found), and 0.75 La (as-left). The most recent Type A tests for each unit are as follows:

Unit 1

Date of last Type A test: November 1999 (U1 R8)

As-Found Leakage: 0.58 La

As-Left Leakage: 0.55 La

Unit 2

Date of last Type A test: November 2000 (U2 R9)

As-Found Leakage: 0.42 La

As-Left Leakage: 0.42 La

Unit 3

Date of last Type A test: April 2000 (U3 R8)

As-Found Leakage: 0.51 La

As-Left Leakage: 0.51 La

Type B and C tests are conducted at various intervals for the many different penetrations tested. The results of the individual Type B and Type C tests are combined and the total combined leakage is updated after each test. The Type B and C combined leakage rate acceptance criteria is 0.6 La. Data from the most recent Type B and C tests are as follows:

Unit 1

Date of testing: Cycle 13 (June 2007)

Minimum Path: 0.0208 La

Maximum Path: 0.0675 La

Unit 2

Date of testing: Cycle 14 (May 2008)

Minimum Path: 0.0218 La

Maximum Path: 0.0480 La

Unit 3

Date of testing: Cycle 13 (December 2007)

Minimum Path: 0.0240 La

Maximum Path: 0.0429 La

Type B and C test failures have been noted in the past due to debris, corrosion products, and general degradation of valve seating surfaces. The issues were corrected by cleaning the seating surface or adjusting the connecting components.

Condition reports address the failure of a Type A test due to excessive leakage through a containment isolation valve that passed a Type C test both before and after the Type A test failure. Among the causes identified for this condition was the procedure that tested this valve in the opposite direction from accident conditions. The extensive evaluations associated with these condition reports resulted in both hardware modifications and

Appendix B
AGING MANAGEMENT PROGRAMS

procedural changes. Blind flanges were installed to eliminate several valves as part of the containment pressure boundary, and preventative maintenance tasks were developed to ensure proper soft seat adjustments. New leak rate tests were added that require personnel to use a special test apparatus inside the containment during power. Since these corrective actions have been implemented, no further problems have been identified for this or similar valves at PVNGS.

Conclusion

The continued implementation of the 10 CFR 50 Appendix J program provides reasonable assurance that aging effects will be managed such that the systems and components within the scope of this program will continue to perform their intended functions consistent with the current licensing basis for the period of extended operation.

B2.1.31 Masonry Wall Program

Program Description

The Masonry Wall Program is part of the Structures Monitoring Program that implements structures monitoring requirements as specified by 10 CFR 50.65. In seismic Category I structures, the Masonry Wall Program manages cracking of masonry walls and structural steel restraint systems of the masonry walls, within scope of license renewal based on guidance provided in IE Bulletin 80-11, "*Masonry Wall Design*" and NRC Information Notice 87-67, "*Lessons Learned from Regional Inspections of Licensee Actions in Response to NRC IE Bulletin 80-11*". Some masonry walls in non-Category I structures are in-scope for license renewal based on UFSAR commitments to satisfy fire protection requirements. The guidance of IE Bulletin 80-11 does not apply to these walls. Aging management of masonry walls with fire barrier intended functions is evaluated in [Section B2.1.12](#), "Fire Protection".

The Masonry Wall Program contains inspection guidelines and lists attributes that cause aging of masonry walls, which are to be monitored during structural monitoring inspections. It establishes examination criteria, evaluation requirements, and acceptance criteria. The provisions of the program are consistent with the guidance provided in NRC Information Notice 87-67, "*Lessons Learned from Regional Inspections of Licensee Actions in Response to IE Bulletin 80-11*" for inspections and evaluation of masonry wall cracking in Category I structures not addressed in the evaluation basis in response to NRC IE Bulletin 80-11.

There are concrete masonry walls in only two seismic Category I structures; the control building and the auxiliary building. Project procedural requirements prohibit the attachment of seismic Category I piping to masonry walls. The masonry walls in seismic Category I structures were designed in accordance with NUREG 75/087 and the 1974 masonry codes and specifications by the Masonry Industry Advancement Committee. These masonry walls are classified as non-Category I, however they are designed to retain their structural integrity in the event of an operating basis earthquake (OBE) or a safe shutdown earthquake (SSE).

Two non-seismic Category I structures; the turbine building and the fire pump house contain masonry walls that are within the scope of license renewal. These walls are identified as fire barriers. IE Bulletin 80-11 does not apply to these walls in Non-seismic Category I structures.

NUREG-1801 Consistency

The Masonry Wall Program is an existing program that, following enhancement, will be consistent with NUREG-1801, Section XI.S.5, "Masonry Wall Program".

Exceptions to NUREG-1801

None

Enhancements

Prior to the period of extended operation, the following enhancement will be implemented in the following program element:

Detection of Aging Effects – Element 4

Procedures will be enhanced to specify ACI 349.3R-96 as the reference for qualification of personnel to inspect structures under the Masonry Wall Program, which is part of the Structures Monitoring Program.

Operating Experience

The Structures Monitoring Program, which includes the Masonry Wall Program, has been effective in controlling cracking and various types of aging effects that could invalidate the evaluation basis. The walkdowns conducted as part of the Structures Monitoring Program inspect and monitor a number of attributes to masonry walls that are consistent with recommendations delineated in NRC Information Notice IN 87-67, "*Lessons Learned from Regional Inspections of Licensee Actions in Response to IE Bulletin 80-11*" that ensure the intended functions of all masonry walls within scope of license renewal are maintained for the period of extended operation.

The masonry walls have been inspected as part of the Structures Monitoring Program beginning with a walkdown as each unit was turned over to operations from the construction organization. A baseline condition was established based on the as-built condition of the structures, the results of the first two years of the Structural Monitoring Program (June 1994 through June 1996), and information obtained from other preexisting structural monitoring programs. All masonry walls were found to be in good condition with their structural integrity and functional intent in compliance with their design criteria. One area was found to be acceptable but requiring additional monitoring. At Unit 1 on the 100 ft elevation of the control building, cracks were discovered on the masonry block walls in the switch gear, equipment, and battery rooms. It was determined by engineering evaluation that the structural integrity of the masonry block walls has not been compromised. To determine whether the cracks were original shrinkage cracks or current progressive cracks, and to facilitate additional monitoring, inscribed referenced marks were placed on the cracks. These cracks will be monitored during the next structures monitoring inspection to determine if further corrective action is required. The corresponding walls in Units 2 and 3 were inspected and no cracks were found.

All areas of degradation identified during the Structures Monitoring inspections are documented on Component Observations Reports (COR's).

The most recent inspection is documented in the Periodic Assessment of Maintenance Rule Program PVNGS January 2004 through June 2005.

Appendix B
AGING MANAGEMENT PROGRAMS

A review of all of the COR's generated to date shows that masonry walls have been subject to relatively few aging effects. Some cracks that are no larger than 1/8" width have been identified. All cracks have been evaluated by engineering and determined to be acceptable without repair. No cases of degradation of external steel bracing have been identified.

Conclusion

The continued implementation of the Masonry Wall Program provides reasonable assurance that aging effects will be managed such that the systems and components within the scope of this program will continue to perform their intended functions consistent with the current licensing basis for the period of extended operation.

B2.1.32 Structures Monitoring Program

Program Description

The Structures Monitoring Program manages cracking, loss of material, and change in material properties by monitoring the condition of structures and structural supports that are within the scope of license renewal. The program implements the requirements of 10 CFR 50.65 (Maintenance Rule) and is consistent with the guidance of NUMARC 93-01, Rev 2 and Regulatory Guide 1.160, Rev. 2. The Structures Monitoring Program provides inspection guidelines and walkdown checklists for concrete elements, structural steel, masonry walls, structural features (e.g. caulking, sealants, roofs, etc.), structural supports, and miscellaneous components such as doors. The scope of the Structures Monitoring Program includes all masonry walls and water-control structures within the scope of license renewal. The program also monitors settlement for each major structure and inspects supports for equipment, piping, conduit, cable tray, HVAC, and instrument components. The scope of the Structures Monitoring Program does not include the inspection of the supports specifically inspected per the requirements of the ASME Section XI In-Service Inspection Program. Though coatings may have been applied to the external surfaces of structural members, no credit was taken for these coatings in the determination of aging effects for the underlying materials. The Structures Monitoring Program evaluates the condition of the coatings as an indication of the condition of the underlying materials.

Periodic inspections required by the Structures Monitoring Program are performed and documented per plant procedures. Initial baseline inspections under the Structures Monitoring Program were performed from June 1994 to June 1996. Each of the spray ponds is inspected every five years, and settlement monitoring surveillance is performed for each major structure every five years. For other inspections, representative SSCs are monitored at each of the three units, such that the equivalent of one complete unit is inspected every 10 years. All three units will be 100% inspected (with the possible exception of inaccessible areas) within a 30-year period.

NUREG-1801 Consistency

The Structures Monitoring Program is an existing program that, following enhancement, will be consistent with NUREG-1801, Section XI.S6, "Structures Monitoring Program".

Exceptions to NUREG-1801

None

Enhancements

Prior to the period of extended operation, the following enhancements will be implemented in the following program element:

Detection of Aging Effects – Element 4

The Structures Monitoring Program will be enhanced to specify ACI 349.3R-96 as the reference for qualification of personnel to inspect structures under the Structures Monitoring Program.

Operating Experience

Miscellaneous openings and gaps in barriers that may impact the environmental equipment qualifications at PVNGS were reviewed and all identified deficiencies were corrected in accordance with NRC Information Notice IN 95-52 "*Barrier and Seals between Harsh Environments*".

NRC Information Notice IN 2002-12 "*Submerged Safety-Related Electrical Cables*" identified several failures and weaknesses associated with protracted submergence in water of electrical cables that feed safety-related equipment. Significant amounts of water have been found in various manholes and the entry is from an unknown source. The intrusion of water into the manholes is being effectively controlled through a pumping program.

NRC Information Notice IN 2003-08 "*Potential Flooding through Unsealed Concrete Floor Cracks*" identified failures involving flooding of rooms containing safety-related panels and equipment as a result of fire water seepage through unsealed concrete floor cracks. No through cracking has been identified at PVNGS and the program has been revised to provide guidance for the identification of through wall cracks in flood barriers in the future.

NRC Information Notice IN 2005-11, "*Internal Flooding/Spray-Down of Safety-Related Equipment Due to Unsealed Equipment Hatch Floor Plugs and/or Blocked Floor Drains*" identified the possibility of flooding safety-related equipment as a result of (1) equipment hatch floor plugs that are not water tight and (2) blockage of equipment floor drain systems that are credited to mitigate the effects of flooding. All hatches/plugs that are credited as flood barriers are water tight. Instructions were developed to provide removal and reinstallation instructions for hatches and plugs to maintain the required seals.

Adverse and critical conditions were found on the roof of Unit 1's Turbine Building. These conditions included punctured membrane and rigid insulation, deteriorated tar patches with mesh reinforcement exposed, damaged flashing exposing the roof membrane seal, raised blisters/raised areas in the membrane, several long areas of damaged flashing, and large cracks through the roof membrane into the rigid insulation. The large cracks and large blister/raised areas in the roof membrane are significant leakage paths and classify the condition of the roof at Elevation 240' as critical. A previously issued CRDR addressed the concern that in inclement weather the Turbine building had experienced consistent and dependable flooding, which had caused equipment failure. To address these concerns Unit 1's Turbine Building roof was replaced. Unit 2 and 3's Turbine Building roofs have been previously replaced.

Conclusion

The continued implementation of the Structures Monitoring Program provides reasonable assurance that aging effects will be managed such that the systems and components within the scope of this program will continue to perform their intended functions consistent with the current licensing basis for the period of extended operation.

B2.1.33 RG 1.127, Inspection of Water-Control Structures Associated with Nuclear Power Plants

Program Description

The PVNGS Structures Monitoring Program, which includes all water-control structural components within the scope of RG 1.127, *Inspection of Water Control Structures Associated with Nuclear Power Plants*, manages cracking, loss of material, loss of bond, loss of strength, and increase in porosity and permeability due to extreme environmental conditions. PVNGS is not committed to Regulatory Guide 1.127 but has a Structures Monitoring Program in place. The existing PVNGS Structures Monitoring Program is consistent with the recommendations of RG 1.127 as evaluated in NUREG-1801. The program is in compliance with the requirements of 10 CFR 50.65 and includes inspection and surveillance activities for the water-control structures associated with emergency cooling water systems. The inspections are currently performed on a frequency of at least once every five years based on the acceptable inspection results from previous inspections. This is consistent with RG 1.127 Position C4. The Structures Monitoring Program includes:

- Periodic visual inspections of in-scope concrete structures using techniques identified in industry standards and codes.
- Periodic monitoring of the hydraulic and structural condition of the Ultimate Heat Sink as described in [UFSAR section 1.2.10.3.3.3](#), as well as associated structures.

NUREG-1801 Consistency

The RG 1.127, Inspection of Water-Control Structures Associated with Nuclear Power Plants program is an existing program that, following enhancement, will be consistent with NUREG-1801, Section XI.S7, “RG 1.127, Inspection of Water-Control Structures Associated with Nuclear Power Plants”.

Exceptions to NUREG-1801

None

Enhancements

Prior to the period of extended operation, the following enhancement will be implemented in the following program element:

Detection of Aging Effects – Element 4

Procedures will be enhanced to specify that the essential spray ponds inspections include concrete below the water level.

Operating Experience

A review of the Structures Monitoring inspection documents shows that the essential spray ponds have been subject to relatively few aging effects. These inspections include diving inspections performed for each unit to exam the internals of the essential spray pond structures. Unit's 1, 2, and 3 Spray Pond's "A" and "B" are in acceptable condition and meet all engineering functional requirements including performance, maintainability, and safety.

In 2007, evidence of a leak was discovered on the south end of the west wall of Unit 1 Spray Pond A. The source of the leak was determined to be a damaged expansion joint in the spray pond wall. The joint was repaired per plant procedures. The joints in the same location for Units 2 and 3 were examined and no other evidence of leakage was found.

The essential spray ponds in all three Units have developed small cracks that are visible on the outer surface of the sidewalls. An accumulation of water outside the essential spray ponds at these crack locations has been identified on several occasions over a period of years. There are no visual indications, such as rust stains on the exterior surface of the walls or significant cracking along the height of the walls, to indicate that the structural integrity of the walls is compromised. The type and level of cracking for Unit 1 walls is slightly greater than that for Unit 2 walls, while Unit 3 walls show no cracking or spalling of this kind. There are no visual indications that the structural integrity of any of the walls is compromised and the cracks are most likely a result of thermal contraction/expansions. Therefore, since there is no impact on structural integrity, the requirements to provide sufficient cooling capacity are not affected.

Conclusion

The continued implementation of the Structures Monitoring Program, which includes all water-control structural components within the scope of RG 1.127, Inspection of Water-Control Structures Associated with Nuclear Power Plants provides reasonable assurance that aging effects will be managed such that the systems and components within the scope of this program will continue to perform their intended functions consistent with the current licensing basis for the period of extended operation.

B2.1.34 Nickel Alloy Aging Management Program

Program Description

The plant-specific Nickel Alloy Aging Management Program manages cracking due to primary water stress corrosion cracking in all plant locations that contain Alloy 600, with the exception of steam generator tubing and reactor vessel internals. Aging management of steam generator tubing is performed by the Steam Generator Tubing Integrity program (B2.1.8). Aging management of reactor vessel internals is addressed in Reactor Coolant System Supplement (B2.1.21). Aging management requirements for nickel alloy penetration nozzles welded to the upper reactor vessel closure head noted in the Nickel-Alloy Penetration Nozzles Welded to the Upper Reactor Vessel Closure Heads of Pressurized Water Reactors program (B2.1.5) are included in this program. This program includes reactor coolant system (RCS) and ESF locations. The term Alloy 600 is used throughout this program to represent Nickel Alloy 600 material and Nickel Alloy 82/182 weld metal. Non-Alloy 600 nickel components (e.g., welds made of Alloy 52/152) are subject to the ASME Section XI Inservice Inspection program (B2.1.1) requirements as indicated in the Program Plan.

The plant-specific Nickel Alloy Aging Management Program uses inspections, mitigation techniques, repair/replace activities and monitoring of operating experience to manage the aging of Alloy 600 at PVNGS. Detection of indications is accomplished through a variety of examinations consistent with NRC Order EA-03-009, ASME Section XI Subsections IWB and IWC, EPRI Report 1010087 (MRP-139) issued under NEI 03-08 protocol, and NRC Bulletin 2004-01. The official review and incorporation of practices of MRP-139 is not currently complete and the implementation schedule, per MRP-139, is defined in the Program Plan. Mitigation techniques are implemented when appropriate to preemptively remove conditions that contribute to PWSCC. Repair/replacement activities are performed to proactively remove or overlay Alloy 600 material, or as a corrective measure in response to an unacceptable flaw in the material. Mitigation and repair/replace activities are partially complete with those detailed in MRP-139. Historical Operating experience was reviewed and Operating experience is continually monitored to provide improvements and modifications to the Alloy 600 Program as needed.

Aging Management Program Elements

The results of an evaluation of each element against the 10 elements described in Appendix A of NUREG-1800, “*Standard Review Plan for Review of License Renewal Applications for Nuclear Power Plants*” are provided below.

Scope of Program – Element 1

With the exception of steam generator tubing, which is managed by the Steam Generator Tube Integrity Aging Management program (B2.1.8), and reactor vessel internals, all Alloy 600 locations in plant systems are included in the scope of this program. This program

includes reactor coolant system (RCS) and ESF locations. Aging management requirements for nickel alloy penetration nozzles welded to the upper reactor vessel closure head noted in the Nickel-Alloy Penetration Nozzles Welded to the Upper Reactor Vessel Closure Heads of Pressurized Water Reactors Aging Management program (B2.1.5) are included in this program.. The term Alloy 600 will be used throughout this program to represent Nickel Alloy 600 material and Nickel Alloy 82/182 weld metal. The inspection plan of Alloy 690 replacement is also included in this program.

The PVNGS Alloy 600 aging management program identifies the following Alloy 600 locations including dissimilar metal (DM) welds:

- RPV Upper Head Penetrations / 97 CEDMs', 1 Head Vent
- Bottom Mounted Instrument Nozzles (BMI) / 61 Incore Instrumentation Penetrations
- RCS Piping / 12 Cold Leg instrument nozzles, 8 RCP instrument nozzles

The pressurizer (PZR) instrument nozzles and heater sleeves have been replaced with Alloy 690 material.

The RCS Hot Leg instrument nozzles also have been replaced with Alloy 690 material.

The dissimilar metal butt-welds which are addressed in this program are those greater than or equal to 1" NPS in locations operating at cold leg temperature or higher. The Alloy 600 material locations at lower than cold leg temperatures are not subject to increased augmented inspections/replacements at this time because of the lower PWSCC susceptibility at lower service temperatures.

The PVNGS Alloy 600 aging management program identifies the following RCS dissimilar metal butt welds:

- PZR Surge (PZR Side) 12" dia
- PZR Surge (HL Side) 12" dia
- Shutdown Cooling 1 16" dia
- Shutdown Cooling 2 16" dia
- Safety Injection 1A 14" dia
- Safety Injection 1B 14" dia
- Safety Injection 2A 14" dia
- Safety Injection 2B 14" dia

Appendix B
AGING MANAGEMENT PROGRAMS

- Bottom Mounted Instrument Nozzles (BMI) / Cold leg zinc injection, half-nozzle repair to be developed / None planned

Pressurizer Nozzles

- Pressurizer instrument nozzles (7 each unit) / None / Complete (replaced with Alloy 690 material)
- Pressurizer heater sleeves / None / Complete (replaced with Alloy 690 material)

Dissimilar Metal Welds

- PZR Spray / Structural Weld Overlay / weld overlays implemented
- PZR Safeties / Structural Weld Overlay / weld overlays implemented
Surge Line (HL and PZR Side) / Structural weld Overlay or MSIP / weld overlays implemented
- PZR Spray 1A and 1B / Structural weld Overlay or MSIP / None
- Shutdown Cooling 1 and 2 / Structural weld, Overlay or MSIP / weld overlays planned for Unit 2 Spring 2008, Unit 1 Fall 2008, Unit 3 Spring 2009
- Safety Injection lines / None / None
- Drain Line 1A and 1B / None / None
- Drain Line 2A / None / None
- Letdown Line / None / None
- Charging Line / None / None

RCS Piping Instrument Nozzles

- 27 Hot Legs (each unit) / None / Complete (replaced or plugged with Alloy 690 material)
- 12 Cold Legs (each unit) / Cold leg zinc injection, half-nozzle repair to be developed / None planned
- RCP Instrument Taps / None / None planned

The Water Chemistry program ([B2.1.2](#)) provides preventive actions for monitoring and control of the supporting environment for PWSCC. Primary water chemistry changes such as zinc addition is being evaluated to improve resistance to PWSCC for locations that are not being replaced or mitigated by other means.

Parameters Monitored/Inspected – Element 3

The Nickel Alloy Aging Management Program utilizes various inspection and examination techniques for early detection of PWSCC in Alloy 600 components. Visual exams are used to detect evidence of leakage from pressure retaining components due to cracking and/or discontinuities and imperfections on the surface of the component. Surface examinations indicate the presence of surface discontinuities. Volumetric examination indicates the presence of cracking/discontinuities throughout the volume of material. All alloy 600 locations receive a bare metal inspection every outage, including the dissimilar metal welds.

Detection of Aging Effects – Element 4

The Nickel Alloy Aging Management Program utilizes various visual, surface and volumetric inspection and examination techniques for early detection of PWSCC in Alloy 600 components.

Three types of visual exams are used:

- 1) VT-2 Exams which are conducted to detect evidence of leakage from pressure retaining components,
- 2) Bare Metal Visual (BMV) Exams which are similar to VT-2 exams but require removal of insulation to allow direct access to the metal surface,
- 3) Visual Exams which are conducted to assess the general condition of non-pressure boundary components.

Surface Exams are used to indicate the presence of surface discontinuities and are conducted by liquid penetrant or eddy current methods. Volumetric Exams indicate the presence of discontinuities throughout the volume of material and are conducted by radiographic, ultrasonic, or eddy current methods, or a combination.

The following examinations are identified by the Nickel Alloy Aging Management Program for Alloy 600 locations:

Component / Current Examinations

Reactor Pressure Vessel (RPV)

- RPV Upper Head Penetrations / UT, ET per NRC Order EA-03-009. Bare metal visual examinations are also performed
- Bottom Mounted Instrument Nozzles (BMI) / Bare metal visual examination

Pressurizer Nozzles

- Pressurizer instrument nozzles (7 each unit) / Bare metal visual examinations

- Pressurizer heater sleeves / Bare metal visual examinations

Dissimilar Metal Welds

- PZR Spray / Bare metal visual examinations, UT, RT,PT
- PZR Safeties / Bare metal visual examinations, UT, RT, PT
- Surge Line (HL and PZR Side) / Bare metal visual examinations, UT
- PZR Spray 1A and 1B / Bare metal visual examinations
- Shutdown Cooling 1 and 2 / Bare metal visual examinations, UT
- Safety Injection lines / Bare metal visual examinations, UT
- Drain Line 1A and 1B / Bare metal visual examinations
- Drain Line 2A / Bare metal visual examinations
- Letdown Line / Bare metal visual examinations
- Charging Line / Bare metal visual examinations

RCS Piping Instrument Nozzles

- 27 Hot Legs (each unit) / Bare metal visual examinations
- 12 Cold Legs (each unit) / Bare metal visual examinations
- 8 RCP instrument taps (4 per pump each unit) / Bare metal visual examinations

Note: Examination frequencies are identified in Element 5.

Monitoring and Trending – Element 5

The following examination frequencies are identified by the Nickel Alloy Aging Management Program for Alloy 600 locations:

a) Reactor Pressure Vessel (RPV) Upper Head Penetrations:

- 1) An Above Head Bare Metal Visual Examination of each RPVH every refueling outage
- 2) Under Head NDE Examination of each RPVH penetration every refueling outage.

Reactor Vessel Head replacements for all three PVNGS Units are scheduled from year 2009 to year 2010.

NDE inspections consists of volumetric ultrasonic examination of the CEDM penetration tube wall and Eddy current testing of the ID of the penetrations, and supplemental ultrasonic and eddy current testing of the CEDM penetration ID/OD surface and J-groove weld surfaces as required. Eddy current testing of the ID and j-weld is performed on the vent line penetration.

b) Bottom Mounted Instrumentation (BMI) Nozzles:

- 1) PVNGS performs bare metal examinations of 100% of the nozzles every outage. PVNGS will evaluate an inspection done every other outage based on future industry guidance.

c) Pressurizer:

- 1) All of the steam space nozzles have been replaced with Alloy 690 nozzles with an internal attachment weld in all three units (12 nozzles total). These nozzles are visually inspected on a refueling outage interval.
- 2) The water space nozzle in the lower shell and two water space nozzles in the lower head have been replaced with 690 nozzles in all three units (9 nozzles total). The replacement nozzles are attached using an external temper bead pad weld. These nozzles are visually inspected every refueling outage.
- 3) The replacement heater sleeves are also visually inspected every refueling outage.

d) RCS Dissimilar Metal Butt-Welds:

(Note that the implementation schedule for each unit is defined in the Program Plan)

100% volumetric every 5 yrs and bare metal visuals every refueling when volumetric exams are not performed (MRP-139 Exam Category D and Category H):

- PZR Surge (PZR)
- PZR Surge (HL)
- Shutdown Cooling 1
- Shutdown Cooling 2
- PZR Spray Nozzle Safe Ends
- PZR Safety Nozzle Safe Ends

Appendix B
AGING MANAGEMENT PROGRAMS

100% volumetric every 6 years and bare visual examination once every three (3) refuelings when volumetric exams are not performed (MRP-139 Exam Category E):

- Safety Injection 1A
- Safety Injection 1B
- Safety Injection 2A
- Safety Injection 2B

Visual examination once every three (3) refuelings (MRP-139 Exam Category K):

- PZR Spray 1A
- PZR Spray 1B
- Drain Line 1A
- Drain Line 1B
- Drain Line 2A
- Letdown Line
- Charging Line

e) Hot Leg Instrument Nozzles: Bare metal inspections of the Hot Leg Instrument Nozzles are performed every outage.

f) Cold Leg Instrument Nozzles: Bare metal inspections of the Cold Leg Instrument Nozzles are performed every outage. Insulation around each nozzle has been modified to allow bare metal visual inspections.

g) Reactor Coolant Pump instrument taps: Bare metal inspections are performed every outage.

Acceptance Criteria – Element 6

Acceptance criteria are specified in procedures. Procedures specify examination requirements and acceptance criteria in accordance with the applicable regulatory (NRC Order EA-03-009 or ASME Section XI) or industry guideline. For components included in MRP-139, it requires that all indications found during inspections must be evaluated per ASME Section XI requirements and indications that do not satisfy IWB-3500 acceptance criteria must be dispositioned by analysis (such as IWB-3600), repaired or replaced.

Corrective Actions – Element 7

Relevant indications failing to meet applicable acceptance criteria are repaired or evaluated in accordance with the plant corrective action program.

PVNGS site QA procedures, review and approval processes, and administrative controls are implemented in accordance with the requirements of 10 CFR 50, Appendix B that are acceptable for addressing corrective actions.

Confirmation Process – Element 8

PVNGS QA procedures, review and approval processes and administrative controls are implemented in accordance with the requirements of 10 CFR 50, Appendix B, which are acceptable in addressing confirmation processes.

Administrative Controls – Element 9

PVNGS QA procedures, review and approval processes and administrative controls are implemented in accordance with the requirements of 10 CFR 50, Appendix B, which are acceptable in addressing administrative controls.

Operating Experience – Element 10

PVNGS has proactively replaced:

- all of the Alloy 600 pressurizer instrument nozzles (seven pressurizer nozzles in Unit 1 were welded using 82/182 weld material since the equivalent Alloy 690 weld material (52/152) was not commercially available at the time of the repair) and hot leg instrument nozzles in each Unit
- all pressurizer heater sleeves (36 per Unit)
- instrument nozzles in the steam generator cold leg plenum as part of the steam generator replacements on Units 1, 2 and 3.

A failure history, including repair or replacement information, search shows the following :

Component / Failure History / Repair or Replacements

a) Reactor Pressures Vessel (RPV)

- RPV Upper Head Penetrations / No CEDM indications. U2 vent line indications 2R12 / U2 vent line indications repaired by machining
- Bottom Mounted Instrument Nozzles (BMI) / No failures / None.

b) Pressurizer Nozzles

- Pressurizer instrument nozzles (7 each unit) / U1 1991 / Replaced with Alloy 690 material
- Pressurizer heater sleeves / Leaking nozzles, 6 circ and 6 axial indications (not leaking) / Preventively replaced all PZR sleeves in 3 units using external pad and partial nozzle replacement

c) Dissimilar Metal Welds

- PZR Spray / No Failures / None
- PZR Safeties / No failures / None
- Surge Line (HL and PZR Side) / No failures / None
- PZR Spray 1A and 1B / No failures / None
- Shutdown Cooling 1 and 2 / No Failures / None
- Safety Injection lines / No failures / None
- Drain Line 1A and 1B / No failures / None
- Drain Line 2A / No failures / None
- Letdown Line / No failures / None
- Charging Line / No failures / None

d) RCS Piping Instrument Nozzles

- 27 Hot Legs (each unit) / 5 cracked nozzles, suspect PWSCC / Preventively replaced all 27 nozzles in 3 units using partial nozzle replacement with OD j-weld
- 12 Cold Legs (each unit) / No failures / None
- RCP instrument taps / No failures / None

NRC Bulletin 2003-02 - Lower Head Penetrations

In response to NRC Bulletin 2003-02, "*Leakage from Reactor Pressure Vessel Lower Head Penetrations and Reactor Coolant Pressure Boundary Integrity*", PVNGS performed visual examinations during refueling outages U1-R12 - ending Dec. 2005, U2-R12 - ending May 2005, U3-R11 - ending Dec. 2004, U3-R12 - ending May 2006 of all 61 bottom mounted instrumentation (BMI) nozzles by a PVNGS Level III VT-2 qualified examiner. No boric acid

deposits were noted in the area of the nozzle annulus during the "as-found" inspections. The 61 nozzles showed no evidence of leakage.

NRC Bulletin 2004-01 - Pressurizer Penetrations

In response to NRC Bulletin 2004-01, PVNGS performed pressurizer heater sleeve visual inspections and did not identify any leakage.

On June 7, 2004, PVNGS Unit 3 went off-line and PVNGS personnel performed a bare metal, 360 degree, visual inspection of 100 percent of all pressurizer heater sleeves. The inspection did not identify any leakage.

On June 14, 2004, all three PVNGS units went off-line and PVNGS personnel performed a bare metal, 360 degree, visual inspection of 100 percent of all pressurizer heater sleeves in all three units. The inspection did not identify any leakage.

On July 13, 2004, Unit 2 went off-line and PVNGS personnel performed a bare metal, 360 degree, visual inspection of 100 percent of all pressurizer heater sleeves. The inspection did not identify any leakage.

The pressurizer instrument nozzles in all three units have been replaced with Alloy 690 nozzles. Also, during the 11th refueling outage, from Sept. 2003 through Dec. 2003, for Unit 2, 34 of 36 pressurizer heater sleeves (Alloy 600) were replaced with thermally treated SB-167, Alloy 690, sleeves using the half-nozzle repair technique. The two sleeves that were not replaced were plugged during a previous outage using Alloy 690 material.

UNIT 1

In response to NRC Bulletin 2004-01 during Unit 1 refueling outage 12 ending December 2005, pressurizer bare metal visual inspections were performed and found no evidence of leakage. No relevant indications of through-wall leakage were identified during these inspections. No additional follow-up NDE was required. No relevant indications were observed. No boric acid residue was identified during the inspection of the pressurizer.

All 36 pressurizer heater sleeves were modified using the half-nozzle repair technique. The original heater sleeve was cut at a location within the pressurizer lower shell. A weld pad of Alloy 690 was overlaid on the exterior surface of the shell. New Alloy 690 sleeves were inserted and attached to the weld pad. This repair resulted in the relocation of the ASME pressure boundary weld from the inside surface to the outside surface of the pressurizer shell. The repairs were made using Alloy 690 material.

UNIT 2

In response to NRC Bulletin 2004-01 during Unit 2 refueling outage ending May 2005, pressurizer bare metal visual inspections were performed and found no evidence of leakage. No relevant indications of through-wall leakage were identified during this

inspection. No additional follow-up NDE was required. No boric acid residue was identified during the inspection of the Unit 2 pressurizer. No corrective actions were required.

UNIT 3

In response to NRC Bulletin 2004-01 during Unit 3 refueling outage 11 ending December 2004, PVNGS normally visually examines the pressurizer shell exposed by the gap between the insulation and the heater sleeves and other nozzles. However, during the heater sleeve modification project performed in Unit 3, the bottom shell insulation was removed and no corrosion was seen.

The Unit 3 pressurizer had three heater sleeves that were repaired during previous outages. These were repaired using a mechanical nozzle seal assembly (MNSA).

There were no relevant indications of through-wall leakage during the inspection of the Unit 3 pressurizer heater sleeves including the 3 sleeves previously repaired. No additional follow-up NDE was required based on the initial eddy current results.

No boric acid residue was identified during the inspection of the Unit 3 pressurizer.

Although there was no visual evidence of boron leakage identified at the start of the outage, APS had previously decided to permanently modify the heater sleeves during 3R11. All 36 heater sleeves, including the three previously repaired using a MNSA, were modified using the half-nozzle repair technique. The original heater sleeve was cut at a location within the pressurizer lower shell. A weld pad of Alloy 690 was overlaid on the exterior surface of the shell. New Alloy 690 half sleeves were inserted and attached to the weld pad. This repair resulted in the relocation of the ASME Pressure boundary weld from the inside surface to the outside surface of the pressurizer shell. The repairs were made using Alloy 690 material.

For Unit 3, refueling outage 12, by letter dated June 15, 2006, the NRC staff notified APS that the staff had closed their efforts with regard to the review of APS' Bulletin 2004-01 responses for PVNGS Units 1, 2, and 3.

Enhancements

Prior to the period of extended operation, the following enhancement will be implemented in the following program element:

Scope of Program – Element 1

The PVNGS Alloy 600 Management Program Plan will be enhanced to add Alloy 600 steam generator components, including tube sheet cladding and portions of the primary nozzle cladding.

Appendix B
AGING MANAGEMENT PROGRAMS

In addition, the following enhancement will be implemented in the following program elements:

Detection of Aging Effects – Element 4, Monitoring and Trending – Element 5, Acceptance Criteria – Element 6, and Corrective Actions – Element 7

Prior to December 31, 2008, the PVNGS Alloy 600 Management Program Plan will be revised to incorporate the applicable examination requirements of ASME Code Case N-729-1 (Reactor Vessel Head Inspections), subject to the conditions specified in 10 CFR 50.55a(g)(6)(ii)(D)(2) through(6) and ASME Code Case N-722 (RCPB Visual Inspections) subject to the conditions listed in 10 CFR 50.55a(g)(6)(ii)(E)(2) through(4).

Conclusion

The continued implementation of the Nickel Alloy Aging Management Program provides reasonable assurance that aging effects will be managed such that the systems and components within the scope of this program will continue to perform their intended functions consistent with the current licensing basis for the period of extended operation.

B2.1.35 Electrical Cable Connections Not Subject to 10 CFR 50.49 Environmental Qualification Requirements

Program Description

The Electrical Cable Connections Not Subject to 10 CFR 50.49 Environmental Qualification Requirements program manages the effects of loosening of bolted external connections due to thermal cycling, ohmic heating, electrical transients, vibration, chemical contamination, corrosion, and oxidation to ensure that electrical cable connections not subject to the environmental qualification (EQ) requirements of 10 CFR 50.49 and within the scope of license renewal are capable of performing their intended function.

As part of the predictive maintenance program, infrared thermography testing is performed on Non-EQ electrical cable connections, associated with active and passive components within the scope of license renewal. A representative sample of external connections will be tested at least once prior to the period of extended operation using infrared thermography to confirm that there are no aging effects requiring management. The infrared thermography will detect loosening of bolted connections or high resistance of cable connections due to thermal cycling, ohmic heating, electrical transients, vibration, chemical contamination, corrosion, and oxidation. The selected sample to be tested is based upon application (medium and low voltage), circuit loading, and environment. The technical basis for the sample selection is documented. The acceptance criteria for thermography testing will be based on the temperature rise above the reference temperature. The reference temperature will be ambient temperatures or the baseline temperature data from the same type of connections being tested. The one-time testing of a sample of Non-EQ electrical cable connectors is representative, with reasonable assurance, that Non-EQ electrical cable connections within similar application, circuit loading conditions, and environments are bounded by the testing.

Corrective actions for conditions that are adverse to quality will be performed in accordance with the corrective action program as part of the QA program. The corrective action program provides reasonable assurance that deficiencies adverse to quality are either promptly corrected or are evaluated to be acceptable.

The Electrical Cable Connections Not Subject to 10 CFR 50.49 Environmental Qualification Requirements program is a new program that will be implemented prior to the period of extended operation.

NUREG-1801 Consistency

The Electrical Cable Connections Not Subject to 10 CFR 50.49 Environmental Qualification Requirements program is a new program that, when implemented, will be consistent with Proposed License Renewal Interim Staff Guidance LR-ISG-2007-02 and NUREG-1801, Section XI.E6, "Electrical Cable Connections Not Subject to 10 CFR 50.49 Environmental Qualification Requirements".

Exceptions to NUREG-1801

None

Enhancements

None

Operating Experience

PVNGS routinely performs infrared thermography on electrical components and connections. A review of the plant operating experience identified scans where electrical cable connections showed thermal anomalies. The connections associated with these thermal anomalies were cleaned and re-tighten. No loss of equipment intended function has occurred due to these thermal anomalies. There is sufficient confidence that the implementation of the Electrical Cable Connections Not Subject to 10 CFR 50.49 Environmental Qualification Requirements program will provide confirmation that supports industry operating experience that electrical connections have not experienced a high degree of failures.

PVNGS has experienced corrosion of battery connections. An engineering evaluation was performed and corrective action taken. No loss of equipment intended function occurred due the corrosion.

Industry and plant-specific operating experience will be evaluated in the development and implementation of this program.

Conclusion

The implementation of the Electrical Cable Connections Not Subject to 10 CFR 50.49 Environmental Qualification Requirements program will provide reasonable assurance that adverse localized environments are identified and aging effects will be managed such that the systems and components within the scope of this program will continue to perform their intended functions consistent with the current licensing basis for the period of extended operation.

B2.1.36 Metal Enclosed Bus

Program Description

The Metal Enclosed Bus program manages the effects of loose connections, embrittlement, cracking, melting, swelling, or discoloration of insulation, loss of material of bus enclosure assemblies, hardening of boots and gaskets, and cracking of internal bus supports to ensure that metal-enclosed buses within the scope of license renewal are capable of performing their intended function. The metal enclosed buses (MEBs) within the scope of this program are the MEBs that are used during station blackout recovery.

A sample of the MEB accessible bolted connections will be inspected for evidence of over heating. Contact resistance testing will be performed on a sample of accessible splice plates to check for loose connections.

Each bus section will be inspected for cracks, corrosion, foreign debris, excessive dust buildup, and evidence of water intrusion. The bus insulation will be inspected for signs of embrittlement, cracking, melting, swelling, or discoloration, which may indicate overheating or aging degradation. The internal bus supports will be inspected for structural integrity and signs of cracks. The bus enclosure assemblies will be inspected for loss of material due to corrosion and hardening of boots and gaskets. The Metal Enclosed Bus program will be completed prior to the period of extended operation and once every 10 years thereafter.

NUREG-1801 Consistency

The Metal Enclosed Bus program is a new program that, when implemented, will be consistent with NUREG-1801, Section XI.E4, "Metal Enclosed Bus".

Exceptions to NUREG-1801

None

Enhancements

None

Operating Experience

Industry experience has shown that failures have occurred on Metal Enclosed Buses caused by cracked insulation and moisture or debris buildup internal to the Metal Enclosed Bus. Experience has shown that bus connections in the Metal Enclosed Buses exposed to appreciable ohmic heating during operation may experience loosening due to repeated cycling of connected loads. NRC Information Notice IN 2000-14: "*Non Vital Bus Fault Leads to Fire and Loss of Offsite Power*" and IN 89-64: "*Electrical Bus Bar Failures*" are examples of non-segregated bus duct failures.

Appendix B
AGING MANAGEMENT PROGRAMS

A review of the operating experience has determined that there have been no problems that resulted in the loss of intended function of the MEBs at PVNGS. Sections of the MEBs are inspected every other outage and thermography is being performed on the bus at the transformer connections once every 6 months. The inspection results for the MEB during the last 10 years have revealed only one splice plate required rework and repairs to cracked Noryl sleeving have been made. No occurrences of corrosion, loss of material, hardening, foreign debris, excessive dust buildup, water intrusion or overheating have been found.

Industry and plant-specific operating experience will be evaluated in the development and implementation of this program.

Conclusion

The implementation of the Metal Enclosed Bus program provides reasonable assurance that aging effects will be managed such that the systems and components within the scope of this program will continue to perform their intended functions consistent with the current licensing basis for the period of extended operation.

B3 TLAA SUPPORT ACTIVITIES

B3.1 METAL FATIGUE OF REACTOR COOLANT PRESSURE BOUNDARY

Program Description

The calculated design lifetime cumulative usage factor U for fatigue is defined by Subparagraph NB 3222.4 of the Section III of the ASME Boiler and Pressure Vessel Code. An equivalent term $I(t)$ is defined for valves in Paragraph NB 3552. The acceptance criterion for systems and components designed to these requirements is that U or $I(t)$ not exceed 1.0. These terms, and current values estimated or calculated for monitoring purposes, are also rendered as CUF, usage factor, fatigue usage, fatigue usage factor, cumulative usage, or cumulative fatigue usage factor.

The Metal Fatigue of Reactor Coolant Pressure Boundary program uses cycle counting and usage factor tracking to ensure that actual plant experience remains bounded by design assumptions and calculations reflected in the PVNGS UFSAR.

The existing Metal Fatigue of Reactor Coolant Pressure Boundary program requires manual review of the Control Room Logs and Post Trip Reviews; and any event transients or trips are recorded and added to those previously determined. A simplified cycle-based cumulative usage factor (CUF) is calculated for the pressurizer spray nozzle in each unit. The existing program requires corrective actions if the recorded numbers of cycles exceed the limits stated by the UFSAR, or if the pressurizer spray nozzle CUF exceeds 0.65. This 0.65 CUF action limit for the spray nozzle, and the monitoring method for it, will be superseded by the enhanced PVNGS fatigue management program.

The enhanced Metal Fatigue of Reactor Coolant Pressure Boundary program will use a computerized, EPRI-licensed software program, FatiguePro®, which manages cumulative fatigue damage in metal components of the reactor coolant pressure boundary and the Class 2 portions of the steam generators with a Class 1 analysis. The FatiguePro® program will track fatigue usage for each of the selected components by either (1) stress-based fatigue (SBF) calculations, using a Green's transfer function to calculate the fatigue effects of transient cycles based on indicated severity, (2) cycle-based fatigue (CBF) calculations, which count transient cycles and assign the maximum design basis stress range per event pair in order to calculate fatigue effects, or (3) a simple comparison of the number of occurrences of transient cycles to the number assumed for design. The locations in which fatigue effects are controlled by counting alone (method 3) are those with relatively low design fatigue usage values, and therefore, for which cycle counting will suffice to demonstrate design basis compliance.

The results of the above methods for cycle count and fatigue monitoring will be summarized and reviewed at least once per fuel cycle. This review will identify the need for any corrective actions, including any necessary revisions to the fatigue analyses.

The scope of the existing Metal Fatigue of Reactor Coolant Pressure Boundary program includes transient cycle counting that encompasses all of the PVNGS NUREG/CR-6260 locations. The usage factors calculated by the enhanced program for limiting NUREG/CR-6260 locations will include environmental effects of the reactor coolant environment as determined by NUREG/CR-6583 and NUREG/CR-5704.

The Metal Fatigue of Reactor Coolant Pressure Boundary program is implemented via procedure. The existing procedure provides guidelines and requirements for manual fatigue management.

The existing procedure will be enhanced to provide guidelines and requirements for tracking both transient cycle counts and fatigue usage of fatigue-sensitive, safety related components, using the FatiguePro® software, to maintain the fatigue usage of components within the cumulative usage factor limit of 1.0 established by Section III Subsection NB of the ASME Boiler and Pressure Vessel Code. The enhanced program will include tracking of cumulative usage, counting of transient cycles, manual recording of selected transients, and review of FatiguePro® data.

NUREG-1801 Consistency

The Metal Fatigue of Reactor Coolant Pressure Boundary program is an existing program that, following enhancement, will be consistent with NUREG 1801, Section X.M1, "Metal Fatigue of Reactor Coolant Pressure Boundary".

Exceptions to NUREG-1801

None

Enhancements

Prior to the period of extended operation, the following enhancements will be implemented in the following program elements:

Scope of Program, Element 1

The Metal Fatigue of Reactor Coolant Pressure Boundary program will be enhanced to include (1) additional Class 1 locations with high calculated cumulative usage factors, (2) Class 1 components for which transfer functions have been developed for stress-based monitoring, and (3) Class 2 portions of the steam generators with a Class 1 analysis and high calculated cumulative usage factors

Preventive Actions - Element 2, Acceptance Criteria – Element 6, and Corrective Actions – Element 7

The Metal Fatigue of Reactor Coolant Pressure Boundary program will be enhanced with additional cycle count and fatigue usage action limits, and with appropriate corrective actions to be invoked if a component approaches a cycle count action limit or a fatigue usage action limit. Action limits permit completion of corrective actions before the design limits are exceeded.

Cycle Count Action Limit and Corrective Actions

An action limit will require corrective action when the cycle count for any of the critical thermal and pressure transients is projected to reach the action limit defined in the program before the end of the next operating cycle. In order to ensure sufficient margin to accommodate occurrence of a low-probability transient, corrective actions must be taken before the remaining number of allowable occurrences for any specified transient becomes less than 1.

If a cycle count action limit is reached, acceptable corrective actions include:

- 1) Review of fatigue usage calculations
 - a. To determine whether the transient in question contributes significantly to CUF.
 - b. To identify the components and analyses affected by the transient in question.
 - c. To ensure that the analytical bases of the leak-before-break (LBB) fatigue crack propagation analysis and of the high-energy line break (HELB) locations are maintained.
 - d. To ensure that the analytical bases of a fatigue crack growth and stability analysis in support of relief from ASME Section XI flaw removal and inspection requirements for hot leg small-bore half nozzle repairs are maintained.
- 2) Evaluation of remaining margins on CUF based on cycle-based or stress-based CUF calculations using the PVNGS fatigue management program software.
- 3) Redefinition of the specified number of cycles (e.g., by reducing specified numbers of cycles for other transients and using the margin to increase the allowed number of cycles for the transient that is approaching its specified number of cycles).
- 4) Redefinition of the transient to remove conservatism in predicting the range of pressure and temperature values for the transient.

Cumulative Fatigue Usage Action Limit and Corrective Actions

An action limit will require corrective action when calculated CUF (from cycle-based or stress-based monitoring) for any monitored location is projected to reach 1.0 within the next

2 or 3 operating cycles. In order to ensure sufficient margin to accommodate occurrence of a low-probability transient, corrective actions must be taken while there is still sufficient margin to accommodate at least one occurrence of the worst-case design basis event (i.e., with the highest fatigue usage per event cycle).

If a CUF action limit is reached acceptable corrective actions include:

- 1) Determine whether the scope of the monitoring program must be enlarged to include additional affected reactor coolant pressure boundary locations. This determination will ensure that other locations do not approach design limits without an appropriate action.
- 2) Enhance fatigue monitoring to confirm continued conformance to the code limit.
- 3) Repair the component.
- 4) Replace the component.
- 5) Perform a more rigorous analysis of the component to demonstrate that the design code limit will not be exceeded.
- 6) Modify plant operating practices to reduce the fatigue usage accumulation rate.
- 7) Perform a flaw tolerance evaluation and impose component-specific inspections, under ASME Section XI Appendices A or C (or their successors) and obtain required approvals from the regulatory agency.

For PVNGS locations identified in NUREG/CR-6260, fatigue usage factor action limits will be based on accrued fatigue usage calculated with the F(en) environmental fatigue factors determined by NUREG/CR-5704 and NURGE/CR-6583 methods required for including effects of the reactor coolant environment.

Parameters Monitored or Inspected – Element 3 and Monitoring and Trending - Element 5

The scope of the Metal Fatigue of Reactor Coolant Pressure Boundary program will be enhanced with a revised list of monitored plant transients that contribute to high usage factor, and with a revised list of monitored locations in Class 1 piping and vessels and in parts of the Class 2 steam generators that have a Class 1 analysis

Operating Experience

The methods of the FatiguePro® software, used by the Metal Fatigue of Reactor Coolant Pressure Boundary program, were developed by EPRI for the industry, in response to NRC concerns that early-life operating cycles at some units had caused fatigue usage factors to accumulate faster than anticipated in the design analyses. This fatigue management program was therefore designed to ensure that the code limit will not be exceeded in the remainder of the licensed life. The industry operating experience program reviews industry experience, including experience that may affect fatigue management, to ensure that

applicable experience is evaluated and incorporated in plant analyses and procedures. Any necessary evaluations are conducted under the plant corrective action program.

The Metal Fatigue of Reactor Coolant Pressure Boundary program was implemented in response to industry experience that indicated that the design basis set of transients used for Class 1 analyses of the reactor coolant pressure boundary did not include some significant transients, and therefore might not be limiting for components affected by them. The program has remained responsive to both industry and plant-specific emerging issues and concerns. Examples:

Pressurizer surge and spray nozzle, hot leg surge nozzle, and surge line transients:

Flow stratification, boron concentration, and spray line and nozzle fatigue concerns prompted operation with continuous spray from initial startup in all three units. The thermal stratification concerns were later documented in NRC Bulletin 88-11. The pressurizer nozzle weld overlays are supported by fracture mechanics analyses and periodic inspections acceptable under ASME Section XI as the means to address aging in the overlaid welds. These locations are included in the PVNGS fatigue management program, and these nozzles now have full-strength weld overlays with reanalyses including the thermal stratification and insurge-outsurge effects.

Auxiliary spray line and tee and partial main spray line and main spray check valve replacement:

The concerns raised by NRC Bulletin 88-08 prompted a series of evaluations, eventually prompting replacement of the main spray line from and including the main spray check valve to the nozzle, and the auxiliary spray line and tee inboard of the auxiliary spray check valve.

Linear elastic fracture mechanics analysis (LEFM) of indications in the Unit 2 pressurizer support skirt forging weld:

An inservice inspection detected two indications in the Unit 2 pressurizer support skirt forging weld, near the lower vessel head, which were evaluated by an LEFM fatigue crack growth analysis.

Unit 1 shutdown cooling suction line 1A excessive vibration:

Brief vibration excursions of the Unit 1 shutdown cooling suction line 1A prompted extensive investigation of causal mechanisms; and remedial actions, including evaluation of possible fatigue effects on piping, appending a revised isolation valve code analysis and valve operator dynamic qualification to the analysis of record, relocation of the line 1A inboard isolation valve for all three units.

CE Owner's Group initiative on surge line micro cracking:

Recent concerns with possible micro cracking in the surge line nozzles are being addressed by a Combustion Engineering Owner's Group initiative, in which PVNGS is participating.

The fatigue usage factors at locations affected by these events depend not only on these salient events, but on many others. Therefore, even if a cycle limit is approached, an examination of the usage factors at these critical locations which takes credit for the fact that cycles are not being accumulated as rapidly for other events as assumed by the analysis, will in most cases demonstrate that usage factors will remain below the allowable limit of 1.0.

Results of fatigue monitoring at PVNGS to date also indicate that in most cases the number of design transient events assumed by the original design analysis should be sufficient for the period of extended operation, and that the design basis fatigue cumulative usage factor limit of 1.0 should not be exceeded at the monitored locations for the period of extended operation. See [Section 4.3](#), which also addresses possible exceptions.

Conclusion

The continued implementation of the Metal Fatigue of Reactor Coolant Pressure Boundary program provides reasonable assurance that aging effects will be managed such that the systems and components within the scope of this program will continue to perform their intended functions consistent with the current licensing basis for the period of extended operation.

B3.2 ENVIRONMENTAL QUALIFICATION (EQ) OF ELECTRICAL COMPONENTS

Program Description

The Environmental Qualification (EQ) of Electrical Components program manages component thermal, radiation, and cyclic aging effects, using 10 CFR 50.49(f) methods. PVNGS is a NUREG-0588 Category I plant. Electrical equipment within the scope of the PVNGS EQ Program is environmentally qualified in accordance with NUREG-0588, Category I requirements as supplemented by 10 CFR 50.49. The NRC evaluated PVNGS electrical equipment qualification based on Regulatory Guide 1.89 Revision 0, which endorses IEEE Standard 323-1974. The recommendations of Revision 1 to Regulatory Guide 1.89 are also met, for harsh environments; with some interpretations of and exceptions to the Regulatory Guide Revision 1 and IEEE 323-1974 guidance. As required by 10 CFR 50.49, EQ components not qualified for the current license term are to be refurbished or replaced, or have their qualification extended prior to reaching the aging limits established in the evaluation. Aging evaluations for EQ components that specify a qualification of at least 40 years are considered time-limited aging analyses (TLAAs) for License Renewal.

The PVNGS EQ Program complies with the requirements 10 CFR 50.49 and NUREG-0588, and is consistent with the guidance of Regulatory Guide 1.89, Rev. 1 for maintaining qualification of EQ equipment.

Qualified components are identified in a controlled Equipment Qualification List (EQL) maintained within the Site Work Management System (SWMS) data base. The SWMS EQL lists special maintenance requirements; and lists the environmental zones for components, from which environmental limits can be retrieved from the EQ Program Manual. Changes to the EQL are controlled by Equipment Qualification Control Forms.

The qualification evaluation records for specific component types are maintained in Electrical Equipment Qualification Data Files. Required maintenance activities are also described by EQ Maintenance Data Sheets in the EQ Data File.

Analytical Methods:

Reanalysis may refine previously-conservative methods or conservative environmental condition assumptions; may invoke local environmental data collected for that purpose; and may change underlying assumptions, acceptance criteria, and corrective actions (if acceptance criteria are not met). Thermal effects are estimated by Arrhenius methods or an Arrhenius-based equivalent temperature. Normal operating radiation and non-seismic cyclic effects are assumed linear with time unless adjustments are possible or necessary because of operating, configuration, shielding, power, or measured dose changes. The original seismic qualifications of electrical equipment will be sufficient for the extended licensed

operating period, particularly since no significant seismic loads have occurred to date. Vibration aging and other cyclic effects may require reevaluation.

Data Collection and Reduction Methods:

The PVNGS EQ Program does not apply condition or performance monitoring programs for purposes of confirming qualified life. Reanalysis may, however, invoke local environmental data collected for that purpose. The PVNGS Temperature Monitoring Program determines actual area temperatures and evaluates potential hot spots. These data have been and may be used to revise thermal qualified life by Arrhenius methods or by an Arrhenius-based equivalent temperature method. The PVNGS EQ PM provides detailed directions for use of these Arrhenius and Arrhenius-based methods, including the basis for activation energies, examples of specific cases, and activation energies for specific materials.

Underlying Assumptions:

EQ component aging evaluations contain sufficient conservatism to account for most environmental changes occurring due to plant modifications and events. When unexpected adverse conditions are identified during operational or maintenance activities that affect the normal operating environment of a qualified component, the affected EQ component is evaluated and appropriate corrective actions are taken, which may include changes to the qualification bases and conclusions. The reanalysis of an aging evaluation is documented according to the station's quality assurance program, which requires the verification of assumptions and conclusions.

Acceptance Criteria and Corrective Actions:

If the qualification cannot be extended by reanalysis, the component will be refurbished, replaced, or requalified to maintain qualification for the period of extended operation. A reanalysis is to be performed in a timely manner (that is, sufficient time is available to refurbish, replace, or requalify the component if reanalysis is unsuccessful).

NUREG-1801 Consistency

The Environmental Qualification (EQ) of Electrical Components program is an existing program that is consistent with NUREG-1801, Section X.E1, "Environmental Qualification (EQ) of Electrical Components".

Exceptions to NUREG-1801

None

Enhancements

None

Operating Experience

The PVNGS EQ Program complies with 10 CFR 50.49, and includes consideration of PVNGS operating experience and NRC generic communications for determining qualification bases and conclusions, including qualified life.

Operating experiences, system, equipment or component related information, as reported through NRC Bulletins, Notices, Circulars, Generic Letters and Part 21 Notifications are evaluated for applicability to the PVNGS EQ Program under the PVNGS Regulatory Interaction and Correspondence Control procedure. When an emerging industry aging issue is identified that affects the qualification of an EQ component, the affected component is evaluated and appropriate corrective actions are taken. Any change to the qualification evaluations are documented in the affected EEQDF, and any applicable corrective actions are identified. Issues addressing equipment qualification are reconciled in EEQDF sections that specifically document thermal, radiation, and cyclic qualified lives, or in the EQ-PM for generic issues.

Conclusion

The continued implementation of the Environmental Qualification (EQ) of Electrical Components program provides reasonable assurance that aging will be managed such that the systems and components within the scope of this program will continue to perform their intended functions consistent with the current licensing basis for the period of extended operation.

B3.3 CONCRETE CONTAINMENT TENDON PRESTRESS

Program Description

The Concrete Containment Tendon Prestress program, within the ASME Section XI Subsection IWL Program, manages the loss of tendon prestress aging effect in the post-tensioning system, and is consistent with supplemental requirements of 10 CFR 50.55a. Prior to September of 1996 the tendon examinations were governed by Regulatory Guide 1.35. Beginning with License Amendment 151 the program was governed by ASME XI Subsection IWL, 1992 Edition with 1992 Addenda. The beginning of the second 10-year inspection interval will be August 1, 2011 for all three units. The program will be updated for subsequent intervals as required by 10 CFR 50.55a(b)(2)(vi) and (viii), and by 10 CFR 50.55a(g)(4)(ii).

In conformance with 10 CFR 50.55a(b)(2)(vi) and (viii), and with 10 CFR 50.55a(g)(4)(ii), the PVNGS ISI Program is updated during each successive 120-month inspection interval to comply with the requirements of the latest edition of the Code specified twelve months before the start of the inspection interval. PVNGS will use the ASME Code Edition consistent with the provisions of 10 CFR 50.55a during the period of extended operation.

Under the original program, tendon lift-off surveillances were performed for Units 1 and 3 at 1, 3, and 5 years post-structural-integrity test, and at each succeeding 5-year interval. Unit 2 tendons were examined visually and in other ways, but their lift-off test surveillances were encompassed within the Unit 1 tests, under rules then applicable to 2-unit plants with virtually-identical containments. A licensing change under approved Relief Request RR 4 imposed similar lift-offs on Unit 2, beginning with its 20th year, but also extended the surveillance interval to ten years. Therefore, lift-offs are now surveyed in each unit every 10 years.

The PVNGS post-tensioning system consists of inverted-U-shaped vertical tendons, extending up through the basemat, through the full height of the cylindrical walls and over the dome; and horizontal circumferential (hoop) tendons, at intervals from the basemat to about the 45-degree elevation of the dome. The basemat is conventionally reinforced. The tendons are ungrouted, in grease-filled glands.

The design basis of the containment system requires that the average prestresses of the tendons in the horizontal dome and cylinder hoop tendon subgroups, and in the vertical tendon group, remain above their respective minimum required values (MRVs). The MRVs are from the original design bases and assumptions.

In order to ensure that the design basis continues to be met, the acceptance criteria require that the prestress in each tendon remain above, or within a stated tolerance below, the predicted force. At PVNGS, predicted forces are calculated for each individual tendon. The program also defines specific action levels for additional inspections and corrective actions,

and specifies acceptance criteria for the additional inspections and corrected conditions. The predicted lower limit (PLL) described in NUREG-1801 is functionally equivalent to the first action level of the PVNGS and IWL 3221.1 acceptance criteria, at 95 percent of the predicted force line.

The surveillance program predicted mean prestress force lines and their tolerance-band upper and lower limit lines, and the predicted forces for each surveillance tendon, were developed from the loss of prestress model used for the original design, and are consistent with Regulatory Guide 1.35.1, Proposed Revision 0.

Following each 10-year tendon surveillance on each unit, the PVNGS tendon surveillance program confirms tendon prestress by comparing individual tendon lift-off values from the current surveillance with the action levels derived from the predicted lift-off force for each surveyed tendon, as described above.

The first set of regression analyses of tendon lift-off data were performed in support of the PVNGS LRA. The regression analyses of surveillance data are consistent with Information Notice (IN) 99-10, *"Degradation of Prestressing Tendon Systems in Prestressed Concrete Containments, Attachment 3"*. The program will be enhanced to continue to compare regression analysis trend lines of the individual lift-off values of tendons surveyed to date, in each of the vertical and hoop tendon groups, with the MRV and PLL for each tendon group, to the end of the licensed operating period, and to take appropriate corrective actions if future values indicated by the regression analysis trend line drop below the PLL or MRV. The regression analyses will be updated for tendons of the affected unit and for a combined data set of all three units following each inspection of an individual unit.

NUREG-1801 Consistency

The Concrete Containment Tendon Prestress program is an existing program that, following enhancement, will be consistent with NUREG-1801, Section X.S1, "Concrete Containment Tendon Prestress".

Exceptions to NUREG-1801

None

Enhancements

Prior to the period of extended operation, the following enhancement will be implemented in the following program element:

Monitoring and Trending - Element 5 and Acceptance Criteria – Element 6

Procedures will be enhanced to require an update of the regression analysis for each tendon group of each unit, and of the joint regression of data from all three units, after every tendon surveillance. The documents will invoke and describe regression analysis methods used to construct the lift-off trend lines, including the use of individual tendon data in

accordance with Information Notice (IN) 99-10, "*Degradation of Prestressing Tendon Systems in Prestressed Concrete Containments*".

Operating Experience

Tendon surveillance and lift-off tests are conducted by qualified staff familiar with the tendon performance history and with current issues and practices. The program employs examination procedures which invoke and are developed from the PVNGS design criteria (MRVs), inspection acceptance criteria (predicted force lines and their tolerance band upper and lower limit lines; and their application to action levels and corrective actions), inspection schedule, sample selection, and effective stress calculation methods.

The PVNGS tendon inspections to date have shown no evidence of significant corrosion or other effects that might damage wires, minimum wire breakage (after initial installation), and no accelerated loss of prestress due to high temperatures or other causes. The only significant findings were pin hole grease leaks in Units 2 and 3, which were evaluated as having no detrimental effects on the containment structure.

The most recent results of the Concrete Containment Tendon Prestress program are documented. A regression analysis of the lift-off data to date was extended to 60 years, and demonstrated that average prestress in both the vertical tendon group and the horizontal cylinder and horizontal dome tendon subgroups should remain above the applicable MRVs for at least 60 years of operation; and that all tendons should therefore maintain their design basis function for the extended period of operation. The material condition of other components (concrete, bearing surfaces, grease, buttonheads, etc.) showed only minor degradation in a few areas; none indicating a need for significant corrective action.

The program is consistent with current standards, practices, and experience of the industry.

Conclusion

The continued implementation of the Concrete Containment Tendon Prestress program provides reasonable assurance that loss of prestress will be managed such that the systems and components within the scope of this program will continue to perform their intended functions consistent with the current licensing basis for the period of extended operation.

This Page Intentionally Left Blank

APPENDIX C

(NOT USED)

This Page Intentionally Left Blank

APPENDIX D

TECHNICAL SPECIFICATION CHANGES

(No Changes Requested)

This Page Intentionally Left Blank