

**DISTRIBUTED ENERGY PROGRAM REPORT**

# Combined Heat and Power Market Potential for Opportunity Fuels

August 2004

By

Resource Dynamics Corporation



**U.S. Department of Energy**  
**Energy Efficiency**  
**and Renewable Energy**

Bringing you a prosperous future where energy  
is clean, abundant, reliable, and affordable





# Table of Contents

<b>Introduction.....</b>	<b>1-1</b>
Project Objectives.....	1-1
Approach.....	1-1
Report Organization.....	1-2
<b>The Opportunity Fuels.....</b>	<b>2-1</b>
The Biomass Fuels.....	2-4
Anaerobic Digester Gas.....	2-5
Biomass Gas.....	2-9
Black Liquor.....	2-12
Crop Residues.....	2-13
Ethanol.....	2-15
Food Processing Waste.....	2-16
Landfill Gas.....	2-18
Municipal Solid Waste and Refuse Derived Fuel.....	2-19
Sludge Waste.....	2-21
Wood and Wood Waste.....	2-22
Industrial Process Waste and Byproducts.....	2-25
Blast Furnace Gas.....	2-25
Coke.....	2-26
Coke Oven Gas.....	2-28
Industrial VOC's.....	2-29
Textile Waste.....	2-31
Fossil Fuel Derivatives.....	2-32
Coalbed Methane.....	2-32
Wellhead Gas.....	2-34
Processed Opportunity Fuels.....	2-36
Orimulsion.....	2-36
Tire-Derived Fuel.....	2-38
Summary of Fuel Attributes and Performance.....	2-41
Chapter 2 Summary.....	2-45
<b>DER Technologies for Opportunity Fuels.....</b>	<b>3-1</b>
Steam Turbines.....	3-1
Combustion Turbines.....	3-6
Reciprocating Engines.....	3-9
Microturbines.....	3-12
Fuel Cells.....	3-15
Chapter 3 Summary.....	3-17
<b>Availability and Technical Potential.....</b>	<b>4-1</b>
Anaerobic Digester Gas.....	4-1
Biomass Gas.....	4-6
Coalbed Methane.....	4-8
Landfill Gas.....	4-11
Tire-Derived Fuel.....	4-13
Wellhead Gas.....	4-15
Wood (Forest Residues / Harvested Wood).....	4-17
Wood (Urban Wood Waste).....	4-19
Chapter 4 Summary.....	4-22
<b>Current Projects and Future Prospects.....</b>	<b>5-1</b>

Anaerobic Digester Gas.....	5-1
Biomass Gas.....	5-3
Coalbed Methane.....	5-5
Landfill Gas.....	5-6
Tire-Derived Fuel.....	5-7
Wellhead Gas.....	5-8
Wood and Wood Waste.....	5-9
Chapter 5 Summary.....	5-10

## List of Tables

Table 2-1. Coal and TDF: Fuel Analysis by Weight Percent.....	2-38
Table 2-2. Opportunity Fuel Performance Matrix.....	2-42
Table 3-1. Equipment and Maintenance Average Costs.....	3-18
Table 4-1. WWTPs Capable of ADG Projects with Technical Potential.....	4-2
Table 4-2. Potential MW Production from Cow and Pig Farms Large Enough for DER Projects.....	4-4
Table 4-3. Biomass Availability and Technical Potential by State.....	4-6
Table 4-4. Underground Mines and Coal Production by State.....	4-9
Table 4-5. Number of Landfills, Waste in Place, and Potential Capacity for New LFG Projects.....	4-11
Table 4-6. United States Oil and Gas Wells, by State.....	4-14
Table 4-7. Harvested Wood Availability and Technical Potential.....	4-17
Table 4-8. Urban Wood Waste Availability and Technical Potential.....	4-19
Table 4-9. Estimated Potential Thermal and Electric Capacity for the Opportunity Fuels.....	4-22

## List of Figures

Figure 2-1. Flowchart of Biomass Fuels for DER/CHP Applications.....	2-2
Figure 2-2. The Biomass Fuels.....	2-4
Figure 2-3. The Anaerobic Digestion Process: Converting Waste to Energy.....	2-5
Figure 2-4. A Combined Cycle Gasification System.....	2-9
Figure 2-5. Crops - almost any type of crop produces residues that can be used as a fuel.....	2-13
Figure 2-6. Municipal Solid Waste - the source of MSW and LFG fuels.....	2-19
Figure 2-7. Wood Waste Recycling Yard.....	2-22
Figure 2-8. Coalbed Methane Collection Process.....	2-32
Figure 2-9. The Orinoco Belt - the world's largest reserve of bitumen, used to make Orimulsion.....	2-36
Figure 2-10. Tire Piles - The Main Source of Tire-Derived Fuel.....	2-39
Figure 3-1. The Steam Turbine Cycle.....	3-2
Figure 3-2. Combustion Turbine System (with intercooler).....	3-7
Figure 3-3. Schematic of an Otto (spark-ignition) Reciprocating Engine with Heat Recovery.....	3-10
Figure 3-4. Microturbine System with Recuperator.....	3-12
Figure 3-5. Fuel Cell Schematic.....	3-16
Figure 4-1. Potential MW for WWTP ADG Projects by State.....	4-4
Figure 4-2. Potential MW for Animal Farm ADG Projects by State.....	4-6
Figure 4-3. Estimated Biomass Reserves by State.....	4-8
Figure 4-4. Estimated CBM MW Potential, by State.....	4-10
Figure 4-5. Estimated Potential Electric Capacity for New LFG Projects, By State.....	4-12
Figure 4-6. United States Distribution of Scrap Tires.....	4-14
Figure 4-7. Number of Oil and Gas Wells By State.....	4-16
Figure 4-8. Harvested Wood Fuel Availability By State.....	4-18
Figure 4-9. Urban Wood Waste Availability By State.....	4-20
Figure 5-1. 200 kW ADG Fuel Cell in Portland, Oregon.....	5-2
Figure 5-2. The Different Types of Gasifiers.....	5-4
Figure 5-3. The Exeter Energy Facility burns 100 percent tire-derived fuel.....	5-7
Figure 5-4. Microturbines can even provide power to offshore wells.....	5-9



## Abstract

The purpose of this report is to determine the best opportunity fuel(s) for distributed energy resources and combined heat and power (DER/CHP) applications, examine the DER/CHP technologies that can use them, and assess the potential market impacts of opportunity fueled DER/CHP applications. Opportunity fuels can be a cheap and reliable alternative to fossil fuels, and are likely to gain in market share as there is an increase in the price of fossil fuels and the need for environment-friendly energy sources. The first section of this report is an introduction explaining project objectives and approach.

The second section of this report introduces the various opportunity fuels. Current status, technology, economics, market condition, and environmental issues associated with each fuel are discussed. Availability, cost, and installed capacity data are also included where available. After each fuel is analyzed, the eight opportunity fuels with the most DER/CHP potential are chosen for further evaluation. These eight fuels are anaerobic digester gas, biomass gas, coalbed methane, landfill gas, tire-derived fuel, wellhead gas, wood (forest residue), and wood (urban wood waste).

The third section of this report discusses the prime mover technologies required to utilize these fuels. The CHP/DG technologies considered in this report include reciprocating engines, microturbines, combustion turbines, steam turbines (and associated boiler systems) and fuel cells. The technologies that are required when using opportunity fuels, such as gasifiers, are also considered. For each technology, the following information is collected and analyzed: history and status in the marketplace, operation, emissions controls, efficiency, equipment costs and modifications for each opportunity fuel, maintenance costs and issues with opportunity fuels, and common applications. From the information gathered, a set of cost, performance, efficiency, and emissions data is developed for each generator type consuming a particular opportunity fuel.

The fourth section of this report analyzes availability and technical market potential of each fuel in detail, and the fifth section discusses the current status and future outlook for each fuel. From this, the top 5-6 opportunity fuels for DER/CHP applications are selected. These fuels are anaerobic digester gas, biomass gas, landfill gas, and wood waste.





# 1

## **Introduction**

An opportunity fuel is any type of fuel that is not widely used, but has the potential to be an economically viable source of power generation. Opportunity fuels are typically unconventional, and usually derived from some sort of waste or byproduct. Most of the time, opportunity fuels are inferior in one way or another to conventional fossil fuels, but this is to be expected. After all, the widespread use of coal, petroleum, and natural gas as fuel sources is not a random coincidence – they are plentiful resources with high heating values and easy combustibility (i.e. they make good fuels). However, natural resources are limited, emission controls are getting stricter, and the price of many fossil fuels is extremely volatile. Opportunity fuels can provide a cheap and reliable alternative. With the increasing and unstable prices of fossil fuels, and the need for more environment-friendly energy sources, opportunity fuels are likely to gain in market share. Not every opportunity fuel is well suited for DER/CHP applications – this report determines the best opportunity fuel(s) and examines their potential market impacts.

### **Project Objectives**

The objectives of this project are to:

- Identify potential DER/CHP opportunity fuels,
- Research their availability and ability to be used in DER/CHP applications,
- Examine DER/CHP technologies that can use these opportunity fuels, and
- Perform a market assessment to determine the potential market for opportunity fueled DER/CHP applications.

### **Approach**

#### **Task 1 – Collect Opportunity Fuels Information**

This task collects and summarizes key opportunity fuel information. Existing relevant studies were collected. DER equipment manufacturers and other stakeholders were contacted and interviewed for their experience with the use of opportunity fuels. Information on the quality characteristics of the available opportunity fuel sources, their potential suitability as a DER/CHP fuel, and their potential environmental implications was examined. Rough supply availability and cost estimates for each reasonably suitable and available opportunity fuel were also developed. The eight opportunity fuels most suitable for DER/CHP applications were chosen for further analysis.

#### **Task 2 – Evaluate CHP Technology Options**

This task examines the set of CHP/ DG technologies that can use opportunity fuels. The technologies considered include reciprocating engines, microturbines, combustion turbines, steam turbines (and associated boiler systems) and fuel cells. Other technologies that are required when using opportunity fuels, such as gasifiers, were also researched. From these, a set of cost, performance, efficiency and emissions data was developed for each generator type consuming a particular opportunity fuel.

**For each CHP/DG technology, the following information was collected and analyzed:**

- **History and Status.** The history of the technology is reviewed, and its current status in the marketplace is detailed.
- **Operation.** The operational methodology of the technology is described, along with a schematic diagram.

- **Emissions Controls.** Emissions and emissions control technologies are reviewed.
- **Efficiency.** Electric and overall efficiency are listed.
- **Equipment Costs and Modifications for each Opportunity Fuel.** For each DG equipment/opportunity fuel combination, equipment capital costs, installation costs, and modification costs (new and retrofit) are estimated.
- **Maintenance Costs and Issues with Opportunity Fuels.** Maintenance costs are discussed, maintenance issues for each opportunity fuel are identified, and associated costs are estimated.
- **Applications.** Common applications (e.g., baseload power, CHP, peak shaving) are listed.

### **Task 3 – Analyze Potential Market Impacts and Develop Recommendations**

In this task, the long-term potential for DER/CHP technologies is modeled by examining the technology, economic, and regulatory frameworks to determine where economically feasible applications have potential. The availability and potential for each opportunity fuel was thoroughly analyzed to determine the 4 to 6 most promising opportunity fuels, and to determine inputs for The Distributed Power Economic Rationale Selection (DISPERSE) model, a proven tool that accurately projects the potential for different DER and CHP technologies, by market sector, application type, power size range, and state, will be used. This model takes into account the price and performance of emerging technologies, electricity deregulation, and emissions regulations. RDC's proprietary approach uses a four-step process to estimate the potential market for an on-site power generation technology. After the market potential for each opportunity fuel was estimated, the results were analyzed, interpreted and presented, so that conclusions could be drawn.

### **Report Organization**

The first section of this report is an introduction to the various opportunity fuels. The current status, technology, economics, market conditions and environmental issues associated with each fuel are discussed. Availability, cost, and installed capacity data are also included where available. After each fuel has been analyzed, the eight opportunity fuels with the most DER/CHP potential are chosen for further evaluation. Next, the prime mover technologies required to utilize these fuels are discussed, and cost estimates for both equipment and maintenance are made. Following that, the availability and technical market potential of each fuel is analyzed in detail, and the current status and future outlook for each fuel is discussed. From this, the top 5-6 opportunity fuels for DER/CHP applications are selected.

Next, the DISPERSE market potential analysis model is then used to perform a detailed market assessment of the most promising fuels (this step is underway and not included in this draft). The fuels will be further evaluated, potential market impacts to be developed and analyzed, and recommendations will be made.

## 2 *The Opportunity Fuels*

An opportunity fuel is any type of fuel that is not widely used, but has the potential to be an economically viable source of power generation. To assemble a list of potential opportunity fuels, an extensive literature search was conducted. Biomass fuels, coalbed methane, petroleum coke and tire-derived fuel have been the subjects of various research studies, so these fuels topped the list of potential candidates. A review of the most relevant literature on opportunity fuels can be found in Appendix A. As a result of this effort, over twenty opportunity fuels were identified as potential candidates for DER/CHP:

- Anaerobic Digester Gas
- Biomass Gas
- Black Liquor
- Blast Furnace Gas
- Coalbed Methane
- Coke (Coal and Petroleum)
- Coke Oven Gas
- Crop Residues
- Ethanol
- Food Processing Waste
- Industrial VOC's
- Landfill Gas
- Municipal Solid Waste / Refuse Derived Fuel
- Orimulsion
- Sludge Waste
- Textile Waste
- Tire Derived Fuel
- Wellhead Gas
- Wood and Wood Waste

Most of the opportunity fuels can be divided into two categories: biomass fuels and industrial process waste or byproducts. Biomass fuels can take on many different forms, but all of them are derived from the carbon-based materials contained in living organisms. There are six main types of solid biomass fuels: crop residues, farm waste, food processing waste, municipal solid waste, sludge waste, and wood/wood waste. All of these fuels can be processed and combusted in a boiler/steam turbine configuration, some more easily than others. Most of these potential fuels are found in dry form, with the exception of farm waste, sludge waste, and some types of food processing waste, which are moist fuels ideal for anaerobic digestion. Black liquor, a byproduct of the pulping process, is also a moist biomass fuel, but it is usually directly burned in boilers or gasified due to its high heat content.

From the six solid waste fuels, several liquid and gaseous biomass fuels can be formed, such as ethanol, biomass gas, landfill gas, and anaerobic digester gas. Figure 2-1 illustrates the relationship between the different waste fuels, and how they can be used with DER/CHP technologies.

The second largest group of opportunity fuels consists of waste and byproducts from industrial processes. Iron and steel mills, petroleum refineries, textile mills, and various industrial facilities produce waste and byproduct solids and gases that can be used as fuels. There are six different opportunity fuels that can be obtained from industrial processes, and they are reviewed in the first chapter:

- Blast Furnace Gas
- Coal Coke
- Coke Oven Gas
- Industrial VOC's
- Petroleum Coke
- Textile Waste

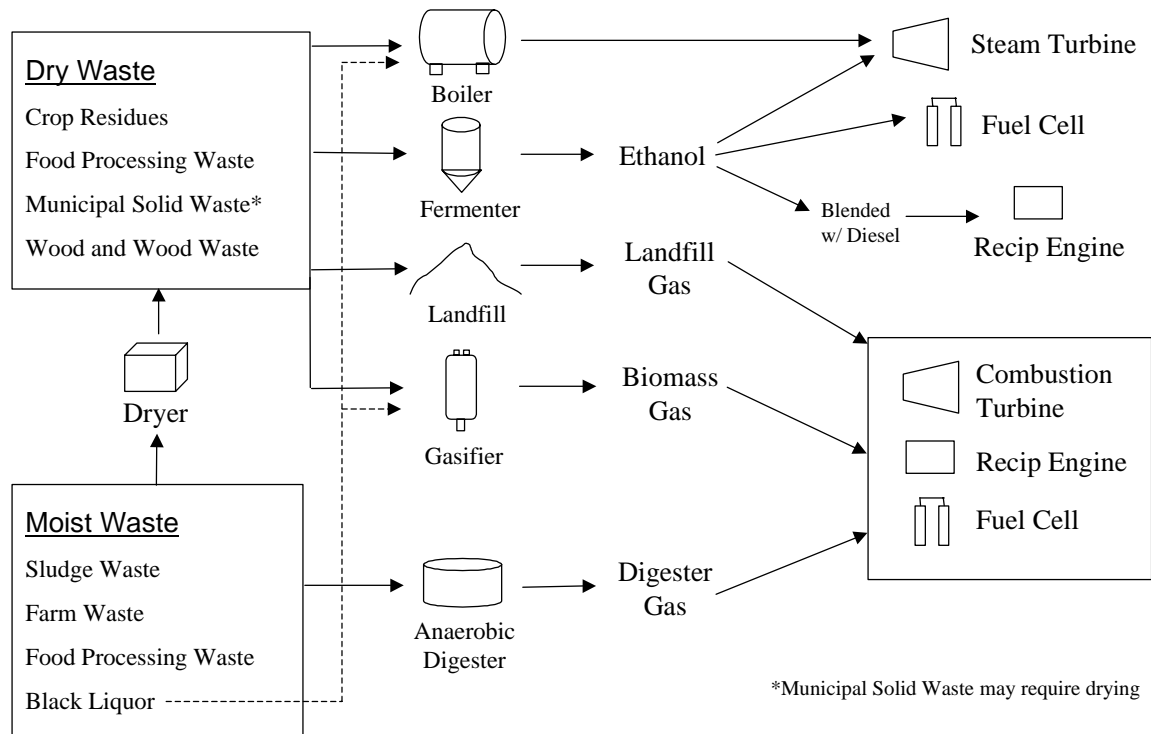

**Figure 2-1. Flowchart of Biomass Fuels for DER/CHP Applications**

The third category of opportunity fuels is fossil fuel derivatives. These fuels are byproducts derived from traditional fossil fuels, such as coal and natural gas. While some of the industrial process fuels like petroleum coke may fall in this category as well, only coalbed methane and wellhead gas are derived directly from fossil fuel mining and drilling operations. Both fuels have high heating values and are most commonly flared on-site when DER/CHP is not used.

Finally, there are two opportunity fuels that are already being produced and sold, but for a very limited market. Tire derived fuel is made from shredding and processing scrap tires, and it works nearly as well as coal for boiler fuel. Still, tire derived fuel has only found acceptance in certain niche markets. Orimulsion is made from natural bitumen reserves found in Venezuela’s Orinoco Belt. The tar-like substance is emulsified in water and sold as a boiler fuel. So far, however, the U.S. market for Orimulsion has been non-existent.

Overall, there are 19 opportunity fuels to evaluate, when some of the similar fuels are combined. The fuels will be examined in the following order:

**The Biomass Fuels**

1. Anaerobic Digester Gas
2. Biomass Gas
3. Black Liquor
4. Crop Residues
5. Ethanol
6. Food Processing Waste
7. Landfill Gas

8. Municipal Solid Waste (and Refuse Derived Fuel)
9. Sludge Waste
10. Wood and Wood Waste

### **Industrial Process Waste and Byproducts**

1. Blast Furnace Gas
2. Coke (Coal and Petroleum)
3. Coke Oven Gas
4. Industrial VOC's
5. Textile Waste

### **Fossil Fuel Derivatives**

1. Coalbed Methane
2. Wellhead Gas

### **Processed Opportunity Fuels**

1. Orimulsion
2. Tire Derived Fuel

In this chapter, the current status, technologies, economics, market conditions and environmental issues associated with each fuel are discussed, and availability, cost and installed capacity data is provided when available. After all of these fuels have been analyzed, the eight opportunity fuels with the strongest potential for DER/CHP projects are chosen for further evaluation.

## **The Biomass Fuels**

Biomass fuels, or biofuels, are defined as fuels made of organic material from a biological origin. They consist of residues, waste, or byproducts derived from living (or once-living) organisms. For this reason, biomass is considered a renewable source of energy. It can be used as a solid fuel, converted into a liquid, or gasified. Crop residues, food processing waste, and wood fuels are all considered biomass, as are farm waste, municipal solid waste and sludge waste. Although farm wastes are not typically used as a solid fuel, they can be converted into ethanol or anaerobic digester gas. The various paths that the six main solid biomass fuels can take are depicted in Figure 2-2 on the following page.

In the United States, there is over 9 GW of installed electric capacity from biomass fuels.<sup>1</sup> It is the second most utilized renewable power resource next to hydroelectric. Each year in the United States, 37 billion kilowatt-hours of electricity are produced from 60 million tons of biomass.<sup>2</sup> Still, biomass may be the most underutilized energy resource. Biofuels provide only four percent of the energy produced in the U.S., but could provide as much as twenty percent.<sup>3</sup>

---

<sup>1</sup> *Biopower: Biomass Gasification – Commercialization and Development: The Combined Heat and Power Option.* World Wide Web. February 2004. <http://www.eere.energy.gov/biopower/bplib/library/ligascd.htm>

<sup>2</sup> *Biopower: Renewable Electricity from Plant Material.* World Wide Web. February 2003. <http://www.eere.energy.gov/biopower/basics/index.htm>

<sup>3</sup> *Biomass: Clean Energy For America's Future.* World Wide Web. February 2003. [http://www.biomass.org/fact\\_sheet\\_2.htm](http://www.biomass.org/fact_sheet_2.htm)

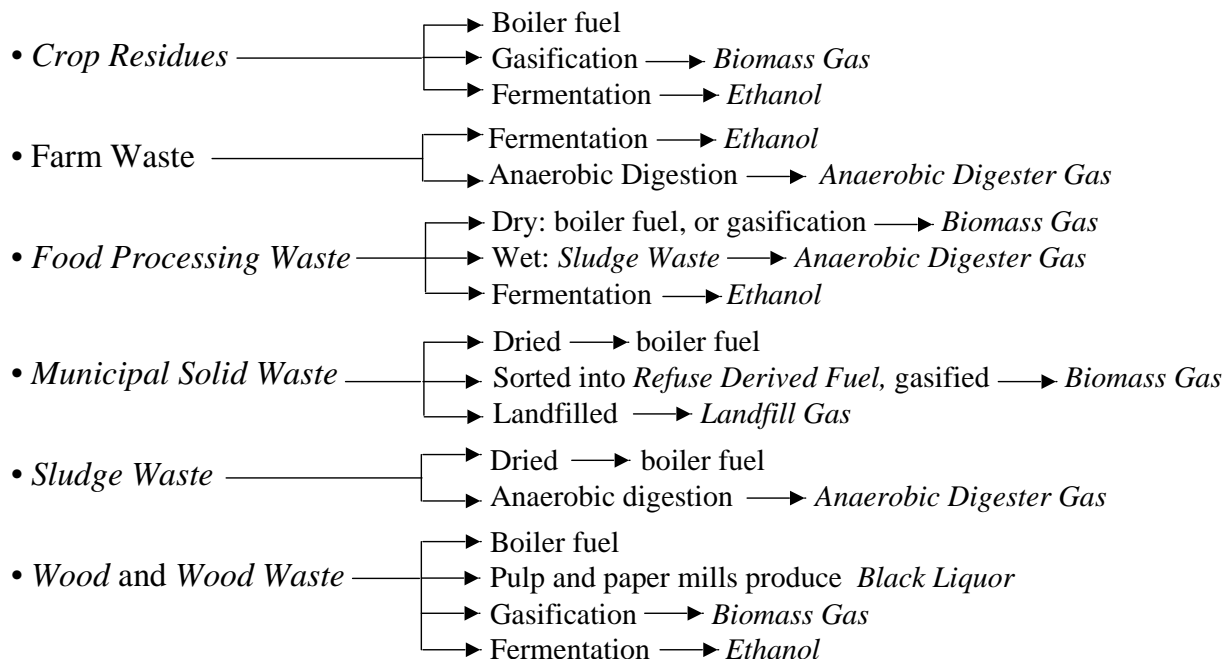

**Figure 2-2. The Biomass Fuels – Individual fuel types are italicized.**

According to the EIA’s study, “Biomass for Electricity Generation”, there are an estimated 590 million wet tons (equivalent to 413 dry tons) of excess biomass available in the United States annually (not including MSW or sludge waste). According to the report, only 20 million wet tons (equivalent to 14 dry tons, enough to supply 3 GW of electric capacity) would be available at a delivered price of \$1.25 per million Btu (the average price of delivered coal) or lower.<sup>4</sup> However, small (non-utility) users such as industrial facilities typically pay more than \$1.25 (up to \$2.50) per MMBtu for coal. Thus, it is likely that more biomass would be available at cost-effective levels for non-utility users than the EIA figures show.

For all biomass power producers, the national Renewable Energy Production Incentive (REPI), stemmed from the Energy Policy Act of 1992, may apply. The incentive provides a credit of 1.5 cents per kWh for biomass power producers, with the exception of municipal solid waste, but it is subject to annual congressional appropriations. For gaseous biomass fuels, the IRS Section 29 Tax Credit for unconventional fuels offers users a credit of about \$1.00 per MMBtu of energy produced, but the stipulations are loaded with fine print so only a select few facilities would apply. Many state governments also offer loans, grants, credits, or tax exemptions of some sort for those utilizing biomass power. Nearly all biomass power production projects are covered under the Public Utility Regulatory Act (PURPA) as qualifying facilities and small power producers. The act requires utilities to purchase any excess power generation from facilities using renewable fuels or combined heat and power.

The continued need for on-site industrial power, waste reduction, stricter environmental regulations, new government incentives, and consumer demand for renewable energy can help fuel the biomass industry’s growth. Cofiring solid biofuels with coal reduces emissions, and is an attractive option for coal plant operators in non-attainment areas. Modifying boilers to burn 100 percent solid biomass fuel is also an option, as is ethanol production from solid biomass feedstocks. Biomass gas, whether obtained from an anaerobic digester, landfill or gasifier, is more likely to be used in DER/CHP applications than solid

<sup>4</sup> Haq, Zia. *Biomass for Electricity Generation*. World Wide Web. March 2003. <http://www.eia.doe.gov/oiaf/analysispaper/biomass/>

biomass fuels, and the implementation of biogas technologies is on the rise. Overall, worldwide biomass power generation is expected to grow to at least 30 GW by 2020, more than double the current figure.<sup>5</sup>

### Anaerobic Digester Gas

Anaerobic digester gas (ADG) is a gas recovered from the decomposition of organic material by bacteria in the absence of oxygen. An anaerobic digester is a sealed, heated enclosure that provides a suitable environment for naturally occurring anaerobic bacteria to convert waste into methane gas. The source material can be wastewater (public sewage or industrial), animal manure, or other organic waste sludge. The bacteria consume the waste and break it down into a methane-based gas, in the process removing harmful constituents. The gas produced by the bacteria, about 50 percent methane and 30 percent carbon dioxide, is usually flared and/or used as a heat source for the digester tank. However, it has the potential to be a steady and reliable source of fuel, essentially free to those that produce it.

Anaerobic digester gas has a Btu content of about 600 MMBtu/ft<sup>3</sup> (60 percent that of natural gas). Any DER/CHP technology normally powered by natural gas can be modified to run on anaerobic digester gas. The most ideal ADG-fueled DER/CHP technologies are reciprocating engines, microturbines and fuel cells. Combustion turbines require too many modifications. Boilers feeding steam turbines can be used with little modifications, but are usually used for larger applications. No matter what the technology, however, the anaerobic digester gas is produced and treated in the same manner. First, the organic sludge is stored, thickened and heated before it enters the digester tank. In the tank, anaerobic bacteria consume the sludge and release a methane gas that is collected and treated to remove contaminants. The treated gas can be fed to a prime mover to produce heat and electricity. Some of the heat produced can be used to preheat the sludge. This process is illustrated in Figure 2-3.

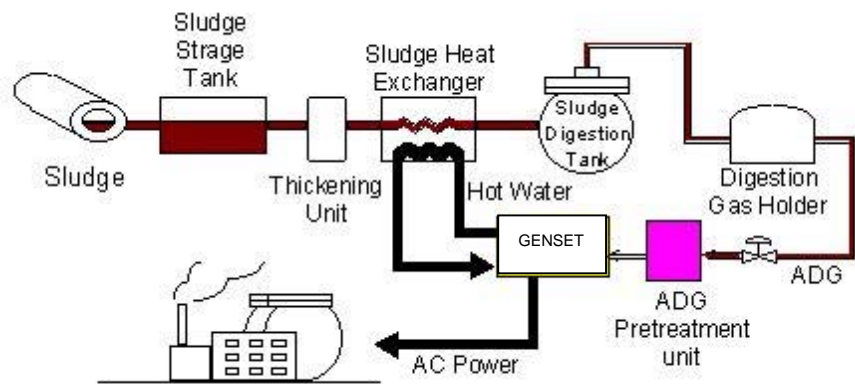

Figure 2-3. The Anaerobic Digestion Process: Converting Waste to Energy

Source: [www.toshiba.co.jp/product/fc/fce/adg.htm](http://www.toshiba.co.jp/product/fc/fce/adg.htm)

### Current Status

There are over 75,000 wastewater treatment plants (industrial and municipal) in the United States, although only about 5,000 currently contain anaerobic digesters. Most industrial treatment plants use *aerobic* digestion, since it is the traditional method of treating organic wastewater streams, and most facilities already have these digesters in place. Many smaller industrial plants simply send their wastewater to local municipal facilities, which also mostly utilize aerobic digestion. While aerobic digesters are well established, anaerobic digesters offer many potential benefits to plant operators. With anaerobic digestion, less solid waste is left over, no power is required to aerate the wastewater, and recoverable energy is produced in the form of methane gas. However, the startup time for an anaerobic system is much greater, especially when the organic waste volume is low, so a steady, non-dilute stream

<sup>5</sup> Ibid.

of wastewater sludge is required for continuous operation. Because of this, anaerobic digesters are best suited for large facilities with a constant, high-volume organic waste stream.<sup>6</sup>

The most common industries for anaerobic wastewater treatment are food and beverage processing, pulp and paper, and petrochemicals. However, only a small fraction of these treatment plants utilize their digester gas for energy. Fuel cells operating on digester gas are a promising new application, having been successfully implemented at municipal treatment plants in Yonkers, NY, Boston Harbor, MA, and Portland, OR. At least 35 more ADG fuel cell sites are being planned in New York and California alone.<sup>7</sup>

Aside from wastewater treatment plants, some large animal farms in the United States utilize anaerobic digestion to treat waste manure. Farms using anaerobic digesters to treat cow and pig waste produce less emissions and odors than conventional treatment methods, which usually let the waste decompose naturally and use the remains for fertilizer. The aerobic digesters commonly used by wastewater treatment plants require energy to operate and are generally not used at farms. Several farms have recently turned to anaerobic digestion to treat their waste, and many of these farms benefit from on-site power production. Currently, there are over 30 commercially successful animal waste methane biogas generators in the United States, and many more are in the planning processes.<sup>8</sup>

### **Economics and Market Considerations**

Anaerobic digester gas could conceivably be sold at the same rate as natural gas on a Btu-basis (currently about \$5.00-\$6.00 per MMBtu), but facilities are much more likely to use the gas for their own heat and power needs. When a digester is already in place, ADG is a free fuel source to plant operators, and when one is not in place, many benefits other than power production can be seen. Installing an anaerobic digester typically costs between \$900 and \$1,500 per kW, depending on various factors, and about \$0.001 to \$0.003 per kWh to maintain. ADG performs better than landfill gas, coke oven gas, and the other low-Btu gases, and can replace natural gas in almost any prime mover technology, although some equipment modifications may be required. This section examines the economics and market considerations for wastewater treatment plants and farms that could produce heat and power from anaerobic digester gas.

### **Wastewater Treatment Plants**

There are at least 60,000 industrial and 16,000 publicly owned wastewater treatment plants in the United States.<sup>9</sup> Municipal treatment plants can be found in almost every county and industrial plants are located throughout the U.S. in both rural and urban areas. These industrial plants include breweries, distilleries, food and beverage processing facilities, pulp and paper mills, as well as other industries. Other large facilities, such as parks, prisons and schools, may treat their own wastewater instead of sending it to the municipal treatment plant. Many wastewater treatment plants already utilize anaerobic digesters, even if they do not produce electricity, since they are required by the EPA to at least collect and flare the methane gas emitted from their sludge waste. These plants would only need to install a genset where the gas is normally flared in order to begin producing power.

For wastewater treatment plants with aerobic digesters, installing an anaerobic digester can provide many economic benefits. Less sludge waste is leftover from the anaerobic process, meaning less will have to be

---

<sup>6</sup> Kleerebezem, Robbert and Herve Macarie. "Process Wastewaters: Anaerobic's Bigger Bite". *Chemical Engineering*. April 2003.

<sup>7</sup> Spiegel, R.J. *Fuel Cell Operation on Anaerobic Digester Gas*. Presentation Notes. World Wide Web. March 2003. <http://www.netl.doe.gov/publications/proceedings/01/hybrids/spiegel.pdf>

<sup>8</sup> *Methane Generators Turn Agricultural Waste into Energy*. California Agriculture, Volume 55, Number 5. September/October 2001.

<sup>9</sup> MagnaDrive News Releases. *New Technology from MagnaDrive Corp. Offers Dramatic Energy Savings to Water/Wastewater Treatment Industry*. World Wide Web. May 2003. <http://www.magnadrive.com/news/news-121200.shtml>



hauled to a landfill if it cannot be used as a soil amendment (farmers, gardeners and nurseries will often take sludge waste from treatment plants and use it as an organic amendment for their soil). In addition, no power is required to aerate the wastewater sludge, so all of the power produced from ADG can be used for the treatment plant's needs. Furthermore, plants producing their own power almost always pay less than they would to purchase power from a utility. For wastewater treatment plants that do not currently utilize anaerobic digestion, installing a digester-generator combination will often produce positive economic results.

### **Animal Farms**

Anaerobic digesters are sometimes used to treat manure and other organic waste from animal farms. Compared to other treatment methods, fewer emissions and odors are produced and less waste is left behind, but the cost of an anaerobic digester is often prohibitive for small and struggling farms. This makes anaerobic digesters most attractive to large farms with heavy waste streams – in addition, these farms are the ones with the highest power demand. Each ton of animal waste yields substantial amounts of gas per digestion cycle, which lasts about one month when operating at 95°F. Most large commercial farms produce hundreds of tons of animal waste each year, and could generate much more power than what is demanded on-site.

Recently, Environmental Power Corporation, through its subsidiary Microgy Cogeneration Systems, reached an agreement with Dairyland Power Cooperative to create a strategic alliance deploying animal waste to energy systems in Dairyland's Midwest service territory. The proposed systems will produce up to 25 MW of electric capacity using Microgy's proprietary anaerobic digestion technology. The biogas produced will be purchased by Dairyland for energy production, but most generators will be installed on-site at the farms. This agreement is the first of its kind - most farms are not so lucky in finding a partner to purchase their excess gas and/or electricity.

For many farms, the cost to obtain, operate and maintain a digester-generator system is not matched by the benefits they would gain using the electric and thermal output onsite. Thermal demand is usually too low to warrant a CHP unit, and electric demand on most farms is also fairly low. If a farm qualified with the Public Utilities Regulatory Policy Act of 1978 as a small power-producing facility, it could sell excess electricity to the local utility. Third party ownership agreements can sometimes be reached, similar to Microgy and Dairyland, although finding an interested third party may prove difficult. Overall, the additional expenses of installation, the remote location of most farms, issues with grid interconnection and qualifying status, and difficulty in obtaining third party ownership keep all but a select few farms from being good candidates for DER/CHP projects.

### **Environmental Issues**

Anaerobic digester gas can be considered a renewable source of energy, since waste is always being created. Anaerobic digesters reduce the odor, pathogens, water and air pollution associated with waste sludge. During combustion, carbon monoxide, nitrous oxides, organic compounds, and some dioxins are produced, but the formation of these pollutants can be minimized with a well-designed combustion process and emission control technologies. Anaerobic digesters do present a safety risk, as they can pose an immediate threat to any human life that enters the container due to the high levels of hydrogen sulfide and ammonia, especially since all oxygen is sealed out. The container must be thoroughly cleaned and vented prior to entry.

### **Availability, Cost, and Installed Capacity Data**

**Availability:** Anaerobic digester gas is only available from sources that utilize anaerobic digestion – currently only some farms and wastewater treatment plants. There are not many ADG-generator systems currently in operation; however, there is a strong potential for market growth. There are over 75,000 wastewater treatment plants in the United States, and while only a small fraction contain anaerobic digesters, many more of them could potentially benefit from ADG as a fuel.<sup>10</sup>

**Costs:** An anaerobic digester consists of storage devices, a sealed concrete tank, and gas collection and transportation equipment, and installation costs typically range from \$900 to \$1,500 per kW depending on the system. The digester does require occasional cleaning and maintenance, costing about \$0.001 to \$0.003 per kWh. However, many treatment plants and some farms already contain digesters because they are required to collect and flare the gas contained in their waste. These facilities only need to install a genset to convert the flared gas into heat and electricity. Almost any natural gas DER/CHP technology can be used, and usually only slight modifications are required. In addition, government incentives may apply.

**Installed Capacity (Non-Utility):** Biomass gas (or biogas), which includes anaerobic digester gas, was accountable for 113 MW of electricity and 641,000 MMBtu of thermal output in the year 2000.<sup>11</sup>

### **The Bottom Line**

Anaerobic digester gas is a promising opportunity fuel. It is a good energy source for on-site power generation using reciprocating engines, fuel cells, or microturbines, and excess electricity can often be sold. Most farms do not demand enough power to warrant a DER/CHP project based solely on their own consumption, unless partnership with a utility or third party is an option. However, industrial and municipal wastewater treatment plants are very strong candidates for DER and CHP applications using ADG.

## **Biomass Gas**

Biomass gas is the gaseous fuel obtained when any type of solid biomass is run through a gasifier. Depending on the carbon and hydrogen content of the biomass and the gasifier's properties, the heating value of the gas can range anywhere from 150 to 800 Btu/ft<sup>3</sup> (15 to 80 percent that of natural gas) Low-Btu biomass gas is usually burned in boilers for steam and heat, although it is sometimes used for small on-site CHP operations. These projects are only ideal for those producing low-quality biomass as waste, who otherwise might have to pay for its disposal. This analysis will focus primarily on high-quality biomass gas that can be burned more efficiently in DER/CHP applications.

One characteristic that separates biomass gas from the other opportunity fuels (and the one thing that could potentially hinder its progress) is the required purchase of a gasifier. A gasifier is a special piece of equipment that extracts volatile fuel vapors from biomass and leaves only ash and small particulates behind. Biomass gas can come from any of the biomass fuels – crop residues, food processing waste, wood and wood waste are the main types that are used.

Gasifiers make use of a process called pyrolysis, which releases the volatile components of a fuel at around 600 °C via a series of complex reactions. Biomass fuels are an ideal choice for pyrolysis, since

---

<sup>10</sup> MagnaDrive News Releases. *New Technology from MagnaDrive Corp. Offers Dramatic Energy Savings to Water/Wastewater Treatment Industry*. World Wide Web. May 2003. <http://www.magnadrive.com/news/news-121200.shtml>

<sup>11</sup> U.S. Energy Information Administration Form 860 B - Database of Non-Utility Generators, 2000.

they have so many volatile components (70-86%, on a dry basis, compared to coal's 30%).<sup>12</sup> In addition to pyrolysis, a second gasification process is often employed, converting the leftover char into a carbon gas using steam and/or combustion. Because of this efficient conversion process, high quality biomass gas usually has a higher heat content than ADG, and can be used in existing gas engines and turbines. With most gasifiers, about 80 percent of the volatile contents of a fuel are recovered, but new gasification systems have reached higher conversion efficiencies.

The most efficient method of utilizing biomass gas is a combined cycle gasification system. Steam from the secondary turbine is used in the gasification process to produce biomass gas for the primary combustion turbine (see Figure 2-4). Generally, these systems are only cost-effective in large power applications because with smaller DER units, the relatively low power output would not justify the gasifier's high capital cost (which could reach \$1,000/kW). More simple (but less efficient) gasifier systems have been developed for smaller DER/CHP applications with low-quality wood waste fuels, but their track record has not been nearly as impressive as their large industrial counterparts.

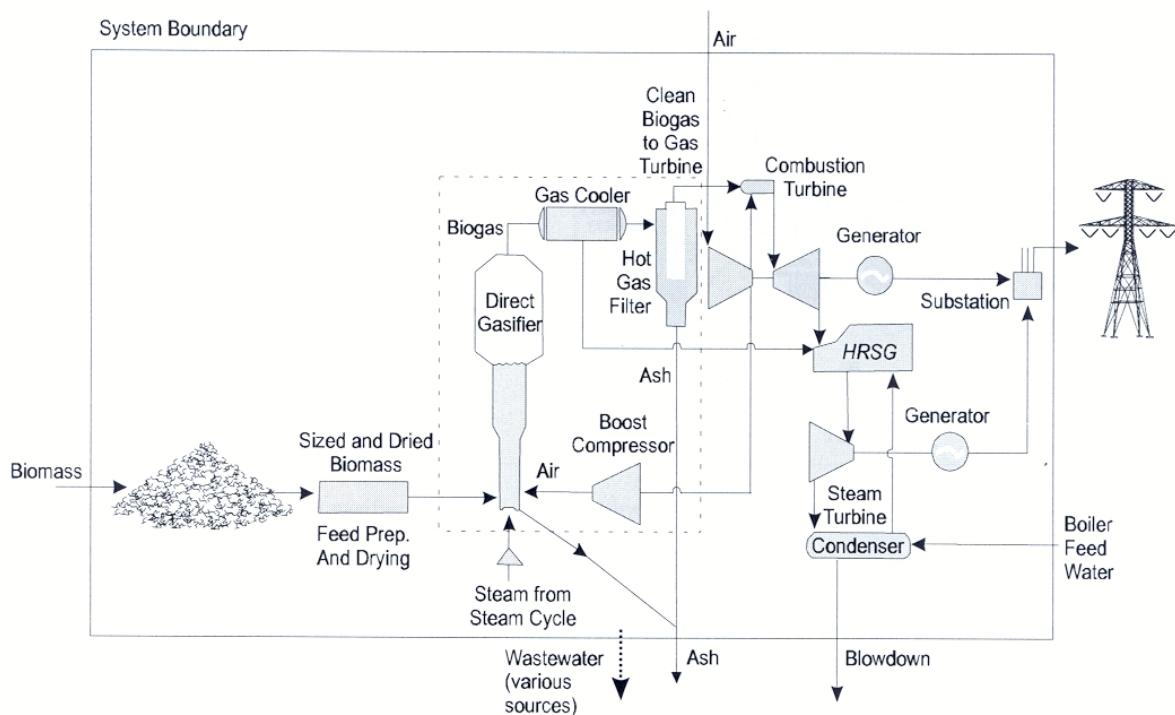

**Figure 2-4. A Combined Cycle Gasification System**

Source: [www.eren.doe.gov/power/pdfs/bio\\_gasification.pdf](http://www.eren.doe.gov/power/pdfs/bio_gasification.pdf)

### **Current Status**

Biomass gas is not yet widely used as an energy source, but it is becoming more common now that people are realizing its potential benefits. Although burning solid biomass fuels directly requires less capital expenses, the increased efficiency and energy output of a gasification system can offset the additional costs. Also, biomass gas units produce much less NO<sub>x</sub>, CO<sub>2</sub> and particulate matter than directly combusting the solid fuel.

<sup>12</sup> U.S. Department of Energy. Biopower – Projects – Technologies – Gasification. World Wide Web. February 2003. [http://www.eere.energy.gov/biopower/projects/ia\\_tech\\_gas1.htm](http://www.eere.energy.gov/biopower/projects/ia_tech_gas1.htm)

To date, biomass gasification systems have been used primarily with mill residue and crop residues, where plant owners have a free fuel source that would otherwise have to be disposed of. Most of these applications consist of either large combined cycle turbines, or small heating applications with crude gasification systems. While large applications have had some success with combined cycle units producing over 50 MW, their gasification systems are generally too expensive for DER/CHP. Smaller units that produce low quality biomass gas (150-300 Btu/ft<sup>3</sup>) have proven successful in third world countries lacking fossil fuel resources, as well as some small heating applications with wood waste fuels, but the potential for DER/CHP with such low quality gas is limited. However, there are many ongoing projects developing and testing various biomass gasification systems for DER/CHP applications, particularly in Europe, and some promising results are being found.

Currently the capital costs of gasifier systems are the biggest hindrance to their implementation, but as new gasification systems are developed, the efficiencies will continue to increase and the costs will be driven down. Government initiatives will also help the biomass gasification industry in certain countries, and installations will contribute towards the objectives of the Kyoto Agreement in reducing greenhouse gas emissions.

### **Economics and Market Considerations**

A gasifier is an expensive piece of equipment. In a combined cycle setup, a gasifier can be even more expensive than both turbines combined. When all of the gas cleaning equipment and installation costs are considered, gasifiers cost about \$800 per kW to obtain in the 5-50 MW range. In the near future, the cost is expected to lower to \$400-\$600 per kW, but this is still a significant hurdle.<sup>13</sup> Usually a gasifier can only justify its cost if a large amount of power is produced – small biomass gasification systems are typically not economical. While CHP systems under 20 MW can be beneficial in applications with a free fuel source, larger systems have proven themselves to be more cost-effective.

The main market for biomass gas at its current state is large industrial applications, utilities, and facilities with a free fuel source. The cost to obtain solid biomass is often high compared to coal and other fossil fuels. To help facilitate this problem, the Federal government has programs such as REPI that provide financial incentives and operating cost reductions to crop residue users. State loans, grants, credits and tax exemptions are also available in some areas. Still, the combined capital cost of a gasifier and recurring cost of fuel purchases will stop many potential biomass gas projects from getting off the ground.

In order for biomass gas to become a serious contender in the DER/CHP market, either the cost of gasification systems must fall, or there will need to be a dramatic decline in the cost of biomass fuels (via collecting and trading infrastructures). Until then, DER/CHP applications will only be suitable for niche applications in industries where biomass is either produced as a waste product or can be obtained for a very cheap price.

### **Environmental Issues**

Biomass gas is just as clean, and sometimes cleaner than natural gas, so emission controls are less of an issue. The particulates and contaminants of the gas will change depending on the quality and type of gasifier used, and the feedstock utilized – some types of biomass produce a great deal of tar that must be removed. In the turbine, filters will usually suffice for gas cleaning, but control technologies may be required for NO<sub>x</sub> emissions in non-attainment areas.

---

<sup>13</sup> U.S. Department of Energy. *Gasification-Based Biomass*. World Wide Web. April 2003. [www.eren.doe.gov/power/pdfs/bio\\_gasification.pdf](http://www.eren.doe.gov/power/pdfs/bio_gasification.pdf)

### **Availability, Cost, and Installed Capacity Data**

Availability: There is an estimated 400 million dry tons of biomass available for fuel in the United States.<sup>14</sup> Only a small fraction of this biomass can be obtained at a market-clearing price.

Costs: Biomass generally costs about \$30-35 per dry ton to obtain (transportation included), which translates to about \$2.00 per million Btu for the solid fuel.<sup>15</sup> At certain facilities, biomass waste can be obtained for free. Gasifiers are expensive, on the order of \$650 per kW, plus another \$100-\$200 per kW for installation (and additional maintenance costs of 0.001-0.003 cents/kWh).<sup>16</sup>

Installed Capacity (Non-Utility): Biomass gas was accountable for 113 MW of U.S. installed capacity and 641,000 MMBtu of thermal output in the year 2000, although that figure also includes anaerobic digester gas.<sup>17</sup>

### **The Bottom Line**

While high-efficiency combined cycle gasification systems have proven themselves cost-effective, biomass gas is not very suitable for small CHP applications. Because the cost of a gasifier is so high, the power output and efficiency must be high enough to cover that cost; either that or the biomass fuel must be obtained at a very cheap price. However, the available resources and corresponding technical potential for biomass gas is unparalleled, since it can use nearly any type of biomass (crop residues, food processing waste, MSW, wood and wood waste) for fuel. This study will consider Biomass gas for further analysis, to see how it competes with other opportunity fuels in the sub-50 MW range, and to see what cost parameters are required for biomass gas to break into the market.

### **Black Liquor**

Black liquor is a byproduct of the pulping process. During pulping, wood fibers are separated and treated to produce a pulp, which is then converted into paper. With chemical pulping, the lignin in wood is dissolved in a digester, which separates the fibers and creates black liquor, a tar-like substance, as a waste product. Black liquor is an organic material consisting mainly of carbon, oxygen and sodium, and can be collected and used as a fuel to generate heat and power.

Black liquor is usually incinerated in special recovery boilers that recover any remaining chemicals and generate heat, steam, and electricity for the pulp or paper mill. Boilers designed for fuel oil and coal can be modified to accommodate black liquor. Gasification is another option, which produces a fuel gas that can power a gas turbine with a relatively high efficiency. Although gasification-systems burn cleaner and achieve higher efficiencies, their capital cost is also much higher.

### **Current Status**

For CHP gensets larger than 1 MW in size, black liquor accounts for more thermal output than any fuel besides natural gas.<sup>18</sup> This is due to the widespread use of black liquor for generating heat and power at

---

<sup>14</sup> Haq, Zia. *Biomass for Electricity Generation*. World Wide Web. March 2003.

<sup>15</sup> *Biomass Feedstock Availability in the United States: 1999 State Level Analysis*. Oak Ridge National Laboratory. World Wide Web. March 2003. <http://bioenergy.ornl.gov/resourcedata/index.html>

<sup>16</sup> *Biopower: Biomass Gasification – Commercialization and Development: The Combined Heat and Power Option*. World Wide Web. February 2004. <http://www.eere.energy.gov/biopower/bplib/library/ligascd.htm>

<sup>17</sup> U.S. Energy Information Administration Form 860 B - Database of Non-Utility Generators, 2000.

<sup>18</sup> Ibid.

paper mills. Most pulp and paper mills utilize their black liquor to generate additional heat for the plant. Some mills also produce electricity, and sell excess power to a local company or power utility. Excess black liquor can be sold as a fuel if there is a market for it nearby.

### **Economics and Market Considerations**

Most pulp and paper mills use all of their black liquor to provide for onsite heat and power needs. While excess black liquor is available, its scarcity and the lack of a supporting distribution infrastructure, keep the fuel from being a serious candidate for outside markets. In general, black liquor energy is limited to pulp and paper mills, and possibly their surrounding facilities.

### **Environmental Issues**

Black liquor, which comes from the pulp and paper derived from trees, can be considered a renewable resource. Black liquor contains some sulfur and small amounts of nitrogen, so SO<sub>x</sub> and NO<sub>x</sub> production are potential problems. Emission control technologies may be needed in some areas.

### **Availability, Cost, and Installed Capacity Data**

Availability: Black liquor is produced at paper mills with pulping operations, but the majority is already used as an energy source by the mills themselves. The amount of excess black liquor produced at these mills is inconsequential. It is rarely sold for outside consumption.

Costs: Black liquor is a free fuel supply for pulp and paper mills. The boilers and gasifiers they use are specifically designed for black liquor.

Installed Capacity (Non-Utility): Black liquor account for 3.4 GW of electric capacity and 432 million MMBtu thermal output in the year 2000. These number show the fuel was mostly for thermal applications.<sup>19</sup>

### **The Bottom Line**

Black liquor is a proven opportunity fuel, already extensively used by pulp and paper mills, especially for steam generation. If a market were to develop, it could potentially be sold as an alternative boiler fuel. However, pulp and paper mills benefit greatly from using black liquor as a fuel, so there is not much leftover, and the cost of collecting and transporting the fuel would likely eliminate any benefits.

### **Crop Residues**

Crop residues are materials that remain after crops have been harvested and/or processed. Bagasse (sugar cane residue), rice hulls, rice straw, wheat straw, nutshells, and prunings from orchards and vineyards are all considered crop residues. They all have the potential to generate power, with an energy content ranging from 2,500 to 4,000 Btu per pound when the crop is wet (6,000-9,000 Btu per pound, dry). Crop residues are produced in abundance on nearly every United States farm.

When used as a fuel, crop residues are most often burned in boilers to create steam, although sometimes the residues are gasified. Existing coal boilers can be converted to burn solid crop-residue fuel in cofiring blends with few necessary modifications. Cofiring with coal is a common practice that increases the plant's net heat rate and decreases SO<sub>x</sub> and NO<sub>x</sub> emissions. Crop residues can also be burned on their

---

<sup>19</sup> Ibid.

own, but a coal-fired boiler would require many modifications and adjustments. As with most steam turbine applications, crop residues are better suited for large industrial or utility operations, and as with most solid biomass fuels, cofiring with coal is usually the most attractive option.

### **Current Status**

Due to high moisture content, varying ability, and relatively high costs, crop residues are not a viable fuel alternative for most DG/CHP applications. They provide only five percent (575 MW) of all biomass electricity generated in the United States. Bagasse accounts for nearly half of this number (255 MW).<sup>20</sup> Crop residue fuels are generally only favorable is when the prime mover is located reasonably close to the site of crop production, and when the collection of residues can be incorporated into farm operation. Otherwise, the cost of collecting and transporting the residues can be too high.



**Figure 2-5. Crops - almost any type of crop produces residues that can be used as a fuel**

### **Economics and Market Considerations**

Due to the high costs associated with collecting and transporting crop residues, their market price is often considerably higher than fossil fuels. There are large variations in price depending on crop availability and region. Most areas do not have an infrastructure for gathering, brokering and shipping crop residues. However, the Federal government has programs such as REPI that provide financial incentives and operating cost reductions to crop residue users. State loans, grants, credits and tax exemptions are also available in some areas.

At the present time, there is no market for trading crop residues for use as a fuel. The availability and quality of the residues are highly regional, and depend on which crops are grown locally and the quantities produced. Some contractual relationships exist to purchase crop wastes for power, but they are very limited. Seasonality, including possible floods and droughts, is another issue that can affect availability and quality. In order for a market to exist, there must be an efficient and established system of gathering, brokering and transporting the crop residue fuels. Dedicated energy crops (crops grown specifically for the production of crop residue as a fuel) would be required. Currently, no such infrastructure exists.

### **Environmental Issues**

Using crop residues as a fuel is beneficial to the environment. The controlled burning of crop residues for power generation removes up to 98 percent of emissions that occur in an uncontrolled, open burn (many farmers burn their crop residues as waste). Like most biomass fuels, utilizing crop residues recycles carbon in a closed loop. The sulfur and nitrogen content in crop residues is much lower than in coal, so coal-fired plants would benefit from cofiring, and the ash content for most crop residues is very low.

<sup>20</sup> U.S. Department of Energy National Renewable Energy Laboratory. Profiles in Renewable Energy – Case Studies of Successful Utility-Sector Projects. Washington, D.C., August 1994. [www.nrelinfo.nrel.gov/documents/profiles.html](http://www.nrelinfo.nrel.gov/documents/profiles.html)

### **Availability, Cost, and Installed Capacity Data**

Availability: An estimated 150,651,000 dry tons of crop residues are available for fuel use in the United States each year.<sup>21</sup>

Costs: Usually crop residues cost between \$30 and \$45 per dry ton to obtain (averaging about \$2.25 per MMBtu, delivered), and modifications to existing equipment may be required.<sup>22</sup> According to EIA, coal costs between \$1.25 and \$2.50 per MMBtu for manufacturing facilities to obtain, so some crop residues may be competitive with coal when comparing the delivered price.

Installed Capacity (Non-Utility): Crop residue accounted for 296,000 kW of electric capacity and 13.9 million MMBtu of thermal output in the year 2000.<sup>23</sup>

### **The Bottom Line**

The lack of a market infrastructure along with high collection and transportation costs limit the use of crop residues to cofiring applications and regional use.

## **Ethanol**

Ethanol is a liquid fuel produced from the fermentation of wood waste, crop residues, farm wastes, and other biomass fuels. While ethanol's most common use is in alcoholic beverages and cleaning solutions, it has also been used to power various vehicles, modified diesel gensets, and steam turbine systems. In addition, it has recently been used extensively as an additive for gasoline in vehicles, making them burn at a higher octane with fewer emissions. Ethanol is also being considered for powering fuel cells in future designs and applications. Because it is a liquid fuel, it is easily transported, and power generation with ethanol is more environment-friendly than combusting solid biomass fuels.

### **Current Status**

Ethanol is not widely used for stationary power production. Its largest use as a fuel comes from being blended with gasoline and diesel fuels for vehicle engines. Some vehicles have been designed to run on 100 percent ethanol, and some diesel engines have been converted to run on the fuel, but its use as a stand-alone fuel has been very limited so far. Ethanol is believed by many to be the best present choice to provide energy to fuel cells, as it has demonstrated fewer emissions, higher efficiencies and better performance than any other fuel besides pure hydrogen. And unlike hydrogen, ethanol is readily available and much of the required infrastructure is already set in place (gasoline pumps and pipelines can easily be converted to ethanol). While most of the present research is focused on mixed fuels and vehicular applications, ethanol would also make an ideal fuel for certain DER and CHP operations.

### **Economics and Market Considerations**

Ethanol is mostly produced from corn crop residues in the Midwest, but it can come from a number of different sources. The overall cost to produce ethanol is not very high, since fermentation is a relatively simple process and feedstocks are abundant, although a good amount of energy is required. The cost to

---

<sup>21</sup> *Biomass Feedstock Availability in the United States: 1999 State Level Analysis*. Oak Ridge National Laboratory. World Wide Web. March 2003. <http://bioenergy.ornl.gov/resourcedata/index.html>

<sup>22</sup> Ibid.

<sup>23</sup> U.S. Energy Information Administration Form 860 B - Database of Non-Utility Generators, 2000.



transport ethanol is much lower than solid fuels, but pipelines may have to be constructed or modified. Compared to solid biomass fuels, emissions are lower and efficiency is higher, and both of these are money-saving characteristics. Major equipment modifications may be required, however, for existing prime movers to run on liquid ethanol fuels. Maintenance costs, on the other hand, should not significantly increase.

The largest market for ethanol power production is likely farms and wood processing facilities that could produce the fuel for free (minus the cost of fermentation equipment and operation). If ethanol-powered fuel cells take off, they could provide a great market for the opportunity fuel, with potential government incentives and financial backing. However, currently the market for ethanol fuels is highly focused on the transportation industry, and this is the only area for which the government has provided support. Most of the work going into ethanol comes from fuel blends where ethanol is mixed with gasoline or diesel fuel, so that it may work in existing vehicle engines without necessary modifications. In addition, the work going into ethanol-powered fuel cells (where 100 percent ethanol is used) is also primarily focused on vehicular applications. Until more attention is focused on ethanol as a stand-alone fuel for stationary power generators, its market potential as an opportunity fuel will be limited.

### **Environmental Issues**

Ethanol is a renewable source of energy. When burned for fuel, ethanol produces fewer emissions than fossil fuels in every significant category (NO<sub>x</sub>, SO<sub>x</sub>, CO<sub>2</sub>, CO, VOCs, particulates). Some SO<sub>x</sub> compounds are created when blending ethanol with gasoline, but this is not an issue for stationary power production. No emission controls should be required for ethanol-powered gensets.

### **Availability, Cost, and Installed Capacity Data**

Availability: While ethanol fuel is not readily available for immediate use, almost any type of biomass can be converted into the liquid fuel through fermentation. There are over 500 million wet tons of biomass available each year, although only a fraction can be obtained at a market-clearing price.

Cost: Biomass fuels can be expensive to obtain (typically ranging from \$20-\$50 per ton and \$1.25-\$4.00 per MMBtu), so ethanol is best produced on-site or nearby farms and processing facilities, where biomass can be obtained at a relatively cheap price. The cost to obtain and maintain fermentation equipment can also be high.

Installed Capacity: Liquid wood waste fuels (ethanol) accounted for 48 MW of electric capacity and 7.8 million MMBtu of thermal output in the year 2000 – it is mostly used in thermal applications.<sup>24</sup>

### **The Bottom Line**

Ethanol could have potential as an opportunity fuel, but there are three things holding it back: 1) The cost of biomass fuels, 2) The energy and costs associated with fermentation, and 3) The focus on mixed ethanol-gasoline and ethanol-diesel blends for automotive purposes. Aside from these drawbacks, ethanol makes a promising opportunity fuel for fuel cells and certain steam turbine and reciprocating engine applications. However, the cost to obtain ethanol varies greatly depending on application and location, and not much research has been accomplished using 100 percent ethanol fuel for stationary power generation. Its future as an opportunity fuel for DER/CHP remains uncertain, but it will likely have more success in the transportation industry, where most of its current research efforts lie.

---

<sup>24</sup> U.S. Energy Information Administration Form 860 B - Database of Non-Utility Generators, 2000.

## **Food Processing Waste**

Food processing waste (FPW) consists of any wastes generated in the food processing industry that can be used for fuel. Potato waste, cheese whey wastes, fruit pits, leftover sludge, and other energy-rich wastes can all be converted into a solid biomass fuel. The waste can be dried and cut into chips to be fired in a boiler (similar to coal). Cofiring is usually preferred, as it reduces the emissions in a coal-fired plant and no boiler modifications are necessary. To create a gaseous fuel, anaerobic digestion can be used – the food waste is stored in an oxygen-deprived tank, where anaerobic bacteria consume it and release a methane gas. Gasification can also be utilized, but only with dry FPW. To create a liquid fuel, certain food wastes can be fermented and turned into ethanol. Some new technologies are capable of extracting the ethanol from the waste and using the liquid fuel to generate power. Different types of wastes will produce different types of fuel, and even the same food waste can be used in very different ways, which makes it hard to categorize certain characteristics of food processing waste. In this section, only solid food processing waste is considered (see ADG, Biomass Gas, and Ethanol for information on its gaseous and liquid forms).

### **Current Status**

Aside from a handful of food processing facilities and certain research projects, food processing waste is not currently used as a fuel for DER/CHP projects. Despite its many potential benefits, FPW has yet to gain widespread acceptance or appeal. One problem is that currently most FPW is disposed as industrial wastewater and discharged to the local treatment plant. Another problem is the varying characteristics and properties of different types of FPW, making it hard to consolidate into a consistent source of fuel. Still, certain waste streams would make ideal fuel sources for the plants that produce them, and there could be a good amount of potential in the large industry of food processing.

### **Economics and Market Considerations**

Food processing waste utilization can significantly reduce fuel costs for food processing facilities. While some processing costs may be incurred in drying and cutting the waste into chips, FPW is essentially a free fuel source for the food processing industry. Federal and state government incentives may be offered to users of the fuel, and cofiring is a cost-saving option for those already utilizing a coal-fired boiler.

There is virtually no market for food processing wastes as a fuel, except for in the food processing industry. It is environment-friendly and performs fairly well when processed, but due to the large variations in the types of waste and fuels produced, and the lack of a distribution infrastructure, it would be difficult to produce a consistent quality product on a large scale. It is possible that nearby plants may want to purchase the waste for cofiring in a coal-fired boiler or some other application. If so, the waste would sell for about the same rate as coal on a Btu-basis.

### **Environmental Issues**

Food processing waste is a renewable energy source. The fuel usually burns cleaner than fossil fuels and can perform nearly as well as coal in its solid state. When ethanol is produced, it burns cleaner than natural gas or diesel and performs just as well in reciprocating engines. When FPW is gasified, the release of methane gas is prevented, and the waste left behind makes an excellent fertilizer. There are few negative impacts of using food processing waste as a fuel.

### **Availability, Cost, and Installed Capacity Data**

Availability: There is large surplus of food processing waste created every year. Fruit pits, nutshells, oat hulls, and other forms of food waste are produced in abundance, but they are rarely used as a fuel, so there is a large market among food producers.

Costs: If the fuel is sold as a solid, the price would be competitive with coal on a Btu basis (\$1.25 to \$2.50 per MMBtu, delivered). Transportation costs would add about \$10.00 per ton, per 50 miles. Some minor boiler equipment modifications may be necessary.

Installed Capacity: Unknown. The current installed capacity is minimal, and hard to pinpoint.

### **The Bottom Line**

Food processing wastes can produce a high quality and clean-burning fuel for a relatively low price, but the wide variety in the waste and fuel types and the lack of a market infrastructure prevents its widespread use. Food processing waste can come from a variety of sources, and utilize a number of different generation technologies. Potential candidates are hard to generalize and must be evaluated on a case-by-case basis.

### **Landfill Gas**

Landfill gas (LFG) is gas created by the decomposition of landfill waste, which is essentially an anaerobic digestion process. Accordingly, the gas is similar to ADG, containing about 50 percent methane and just under 50 percent carbon dioxide. In the past, LFG was simply collected and flared, but now many landfills are taking advantage of their waste gas, using it to produce heat and power. This cuts down on methane emissions and can potentially generate revenue for the landfill. In general, 1 million tons of municipal solid waste produces 300 cubic foot per minute of landfill gas that could generate 7,000,000 kWh of electricity per year, enough to power 700 homes.<sup>25</sup> Most of the candidates for LFG projects have more than 1 million tons of waste in place.

Developers such as INGENCO and Granger Electric/Energy typically purchase the rights a landfill's gas, transport it to a spot where a genset can interconnect with the power grid, and sell the electricity to a third party or utility for 4-6 cents per kWh. Sometimes landfills will act as developers themselves, and sometimes the gas is directly pipelined to the facility where it will be used.

Landfill gas is similar to natural gas, but with a smaller percentage of methane and much more carbon dioxide. The Btu content of landfill gas (500 MMBtu/ft<sup>3</sup>) is about half that of natural gas, but it can still generate a substantial amount of power, and only minor modifications and increased maintenance are required for existing equipment. Microturbines are among the best choices for LFG applications because they function reliably with low-Btu content gases, and produce very few emissions. In addition, the low flow rate of LFG favors smaller gensets. LFG can also power fuel cells if the gas is cleaned of sulfur and halides, but this adds additional costs.

### **Current Status**

Of the estimated 6,000 landfills in the United States, of which at least 2,500 are active, only about 340 currently utilize their landfill gas for power. Many more landfills are in the planning process for LFG-to-

---

<sup>25</sup> U.S. Environmental Protection Agency – Landfill Methane Outreach Program. World Wide Web. April 2004.  
<http://www.epa.gov/lmop/index.htm>

energy projects, and at least 600 have been identified to have strong project potential.<sup>26</sup> The EPA is encouraging the use of LFG to generate power through the Landfill Methane Outreach Program, which provides assistance and incentives to LFG-to-energy projects. With many of these projects, a third party developer pays for the rights to the landfill gas. They have the choice of maintaining a genset at the landfill site (and transporting the electricity to their facility) or pipelining the gas to their facility and using it in a DER/CHP application. For facilities within a 2-mile radius of the landfill site, the latter option is usually chosen.

### **Economics and Market Considerations**

When it is sold, LFG sells for roughly the same price as natural gas on a per Btu basis (\$5-\$6 per MMBtu), although the Federal government (through REPI) sometimes offers a tax credit of approximately \$1.00 for every MMBtu of energy produced, and will help finance nearly any LFG-to-energy project. State governments often provide financial incentives as well. However, the market for LFG is generally limited to either the areas immediately surrounding landfills, or facilities that are interconnected to the power grid. Landfills are typically built far from commercial and residential locations. In addition, when the gas is pipelined, odor can be a concern. As such, landfill gas CHP units are usually limited to nearby industrial operations. Despite the high initial cost, some LFG-to-energy projects with pipelines as long as ten miles have become profitable DER/CHP operations, thanks mostly to government incentives and financing.

Sometimes, a third party developer may want to produce electricity at the landfill and transport it to their site. When this happens, the developer would be responsible for operating and maintaining the power generator at the landfill site. Electricity generated is sold for 4-6 cents per kWh, enough to give the developers a small profit margin. Landfills can also use their gas to meet their own heat and power needs, selling any excess electricity to the local utility, and many landfills have benefited from this practice.

### **Environmental Issues**

Using landfill gas as a fuel is beneficial to the environment since it prevents the release of methane and carbon dioxide into the atmosphere. According to the EPA, utilizing 1 million tons of waste for landfill gas energy has the same greenhouse gas impact as planting 8,300 acres of trees.<sup>27</sup> It also reduces unpleasant odors and explosion threats from landfills. Although not renewable in the classic sense of the word, LFG can be considered a renewable energy source since garbage is always being created. Burning landfill gas for energy does produce some harmful emissions, but they can be treated with proper emission control technologies.

### **Availability, Cost, and Installed Capacity Data**

Availability: Out of the 5,000-plus landfills in the United States, there are only about 340 sites using LFG for energy, and about 600 more have been identified as strong candidates for LFG projects.<sup>28</sup>

Costs: When landfill gas is sold, it is usually the same price as natural gas on a per Btu basis (about \$5.50 per MMBtu). Gas collection and transport to the genset is almost always already in place since large landfills are required to collect and flare their gas. The only costs for onsite use, then, are associated with the genset and its maintenance. Pipelines and/or electric distribution lines would add to the cost.

---

<sup>26</sup> Ibid.

<sup>27</sup> Ibid.

<sup>28</sup> Ibid.

Installed Capacity (Non-Utility): Landfill gas accounted for 716 MW of electric capacity, and 2 million MMBtu of thermal output in 2000.<sup>29</sup>

### **The Bottom Line**

Landfill gas is a good energy source for landfills and the facilities immediately surrounding them. While the quality is not as high as natural gas, using it conserves natural resources and is beneficial to the environment.

### **Municipal Solid Waste and Refuse Derived Fuel**

Municipal solid waste (MSW) is commonly referred to as trash or garbage. It is collected at landfills and can consist of any type of refuse. The section on landfill gas describes how MSW is naturally converted into a gaseous fuel. In some areas, however, MSW is dried and burned in high temperature boilers to generate steam and electricity. However, a great deal of drying, cleaning, and emission controls must be applied to the waste before it is ready to incinerate. Recently, some collection sites have begun producing Refuse derived fuel (RDF), which has been thoroughly sorted so that only energy-producing components remain. This fuel can either be burned in boilers or gasified, and it performs better than MSW, but it costs money to produce.



**Figure 2-6. Municipal Solid Waste - the source of MSW and LFG fuels.**

Major modifications must be made to existing coal-fired boilers if MSW is to be used as a substitute. The heating value of MSW averages less than 5,000 Btu/lb so much more ash and residue are left behind than coal, whose heating value is more than three times as high. Using a stoker-type boiler to incinerate the waste is usually the best choice, since they can burn MSW with the fewest modifications. Pollution control technologies, such as scrubbers, reduce toxic waste in the combustion smoke by neutralizing acid gases. Filters are also employed to remove certain objects and magnets are used to remove metal from the waste. Refuse derived fuel is handled more easily since most of the undesirable components have been removed.

Recently, United Technologies Research Center compiled a report on biomass gasification using RDF. Overall, the findings were very positive, and the researchers were able to employ a low-cost garbage collection, preparation, and gasification system that powered an advanced 85 MW combined cycle gas turbine.<sup>30</sup> This type of installation, however, would fall under the category of biomass gas, which is considered a separate opportunity fuel (see Biomass Gas).

### **Current Status**

In the United States, over 200 million tons of municipal solid waste is produced each year. MSW is the second largest biomass fuel source in the United States, behind wood-based fuels, producing 2.6 GW of

<sup>29</sup> U.S. Energy Information Administration Form 860 B - Database of Non-Utility Generators, 2000.

<sup>30</sup> Biomass Gasification and Power Generation Using Advanced Gas Turbine Systems

power each year. Most of this energy comes from projects started in the 1970's, because of the oil embargo and worries about environmental pollutants from dumps and landfills. Baltimore and Montgomery County's 60 MW waste-to-energy facilities in Maryland are an examples of MSW projects still going strong. However, recently many MSW power projects have been losing steam and shutting down. Large new landfills and the EPA's backing of LFG have slowed down new solid waste to energy projects. The use of MSW as a fuel will likely decrease in the near future, as RDF gasification and LFG provide cleaner and more efficient alternatives for turning waste to energy.

### **Economics and Market Considerations**

Because MSW is a solid fuel, it cannot be transported through pipelines or stored in pressure vessels. The heat content of the fuel is extremely low, so transportation can be very expensive. Because of this, MSW and RDF projects are best implemented at garbage collection sites, or at nearby facilities. Emission control technologies can be costly, but Federal and state government agencies offer various incentives for using MSW as a fuel. Excess electricity generated from MSW and RDF can be sold to nearby utilities or consumers. However, LFG projects are generally more efficient and profitable.

Municipal solid waste is not an ideal fuel source. The quality is unpredictable, and emissions can be high because of various components found in the waste. In general, municipal solid waste is an inferior fuel to landfill gas, which has become the preferred method of burning waste methane. Refuse derived fuel may be cleaner and offer better combustibility, but new gasification systems being developed would outperform the fuel in its solid form. The future for solid MSW and RDF projects does not look so bright from an economic and marketing standpoint.

### **Environmental Issues**

Although not renewable in the traditional sense of the word, municipal solid waste can be considered a renewable energy source since trash is always being created. Incinerating MSW reduces the amount of waste by up to 90 percent in volume and 75 percent in weight.<sup>31</sup> While many pollutants may be produced during combustion, scrubbers and other pollution control technologies reduce the toxic materials that are emitted.

### **Availability, Cost, and Installed Capacity Data**

Availability: Over 200 million tons of municipal solid waste is produced each year in the United States alone.<sup>32</sup> Municipal solid waste is available at any of the thousands of landfills located in the U.S., but it is rarely used as a fuel. Landfill gas utilization is usually a more attractive option, but for many landfills this is not a possibility, and MSW is a viable option

Costs: MSW is a "free" fuel, but collecting, drying, and transporting the waste can be costly. In addition, major equipment modifications and emission control technologies will likely be required.

Installed Capacity (Non-Utility): MSW accounted for 2.6 GW of electric capacity and 20.4 million Btu of thermal output in 2000. These numbers illustrate that the fuel was mostly used for heat production.<sup>33</sup>

---

<sup>31</sup> Ibid.

<sup>32</sup> Ibid.

<sup>33</sup> U.S. Energy Information Administration Form 860 B - Database of Non-Utility Generators, 2000.

### **The Bottom Line**

MSW and RDF are not ideal fuels for a number of reasons. Their quality varies, they are not easily transported, and large emission control technologies and cleaning devices must be implemented when burning the solid fuels. In addition, landfill gas-to-energy projects are usually more attractive, and new RDF gasification systems may make burning solid waste obsolete. MSW and RDF are not recommended as solid fuels, but biomass gas from RDF is potentially promising, and warrants further investigation.

### **Sludge Waste**

Sludge waste is sewage sludge from wastewater treatment plants. The sludge can be dried and burned as a fuel to generate steam and power. This same wastewater sludge is often converted into anaerobic digester gas for waste treatment and fuel use. Burning the solid sludge, however, is another power-producing alternative that eliminates most of the harmful constituents.

For solid-firing, the sludge must be dried thoroughly prior to combustion. Once this occurs, it can be used in existing boilers in place of coal, or it can be co-fired. Some modifications to existing boilers will be necessary to accommodate the low combustibility of the fuel and increased cleaning and maintenance will be required. Stokers are preferred for firing the sludge waste since fewer modifications are necessary.

### **Current Status**

Not many wastewater treatment plants use their sludge to generate electricity, but the technology exists and solid sludge waste can be used as a source of power. It is generally more effective to use an anaerobic digester to convert the organic portion of the waste to a more flexible, gaseous fuel. However, burning sludge waste directly is also an option.

### **Economics and Market Considerations**

The heat content of sludge waste is only about 3,500 Btu/lb (25-30 percent that of coal), its moisture content is very high, and sludge-fired boilers require additional maintenance. As a result, sludge waste is not a strong potential energy source for outside markets. However, it is a free source of fuel that can be used by wastewater treatment plants in combined heat and power applications. If excess power is produced, it may be sold to local utilities or consumers. Anaerobic digester gas is almost invariably a more efficient and smarter choice for CHP projects at wastewater treatment plants.

### **Environmental Issues**

The use of sludge waste as a fuel promotes conservation of resources and takes care of hazardous wastewater sludge, but burning the waste creates its own emissions, which must be controlled properly with emission control technologies. Using an anaerobic digester to extract the methane from organic sludge waste and burning the digester gas as a fuel is a more environment-friendly option.

### **Availability, Cost, and Installed Capacity Data**

Availability: There are over 75,000 wastewater treatment plants in the United States. Sludge waste is treated at every one of these plants, but it is rarely used as an energy source due to its poor combustibility and low fuel quality. In addition, anaerobic digester gas is usually a more attractive option.

Costs: The sludge waste is free to treatment plants, except for the costs associated with collection, drying, and transportation. It is not sold as a fuel – it is used by the plants themselves to generate electricity.

Installed Capacity (Non-Utility): Sludge waste accounted for 5 MW of electricity, and no thermal output in the year 2000.<sup>34</sup>

### **The Bottom Line**

Sludge waste is not a particularly good fuel. It can be useful to waste water treatment plants, but even then its usefulness as a solid fuel is questionable. Except for small treatment facilities with boilers where no digester is installed, anaerobic digester gas is generally a better option.



Courtesy NREL

**Figure 2-7. Wood Waste Recycling Yard**

### **Wood and Wood Waste**

Wood or wood waste, as an opportunity fuel, is defined as any type of wood or wood-based product that can be burned to generate power. There are four categories that wood and wood waste fall into: dedicated energy crops (not yet produced in the United States), harvested wood (wood chips), mill residue (bark, sawdust and planer shavings), and urban wood waste (treated/painted wood, yard trimmings, etc.).

In most wood and wood waste applications, the wood is dried, cut into chips, and transported to a boiler, where it is burned to produce steam that powers a steam turbine/generator. Cofiring with coal is sometimes used to increase the net heat rate of a coal-fired plant, but its effectiveness is limited due to wood's poor grindability. Pulverizers for coal are unable to handle high quantities of wood. Stokers and cyclone boilers are the most suited to cofiring wood and wood waste fuels as they require the least modifications. In some cases, wood is liquefied into an

ethanol fuel (see Ethanol) or gasified (see Biomass Gas). For best results with solid wood fuels, a boiler system made specifically for wood fuels should be used.

### **Current Status**

Burning wood is one of the oldest methods of generating both thermal and electric energy. Wood fuels account for over two-thirds of all biomass electric generation capacity.<sup>35</sup> Nearly 1,000 wood-fired plants exist in the U.S., generally ranging from 10 to 25 MW.<sup>36</sup> There are at least 75 wood-fueled CHP units that qualify as distributed energy resources<sup>37</sup>. The most common form of wood fuel consumption is lumber processing, pulp, and paper mills using their residues to provide heat and power for the plant. Many of these wood fuel installations utilize gasification systems, especially mill residues (see Biomass Gas), but when discussing wood and wood waste in this report, the fuels are understood to be in solid form.

---

<sup>34</sup> Ibid.

<sup>35</sup> U.S. Department of Energy National Renewable Energy Laboratory. Profiles in Renewable Energy – Case Studies of Successful Utility-Sector Projects. Washington, D.C., August 1994. [www.nrelinfo.nrel.gov/documents/profiles.html](http://www.nrelinfo.nrel.gov/documents/profiles.html)

<sup>36</sup> R.L. Brain, R.P. Overend and K.R. Craig, *Biomass-Fired Power Generation*. NREL, 1996.

<sup>37</sup> U.S. Energy Information Administration Form 860 B - Database of Non-Utility Generators, 2000.



### **Economics and Market Considerations**

Wood collection and transportation can be labor intensive and expensive, although wood can usually be hauled up to 75 miles for \$8 to \$15 per ton.<sup>38</sup> In the end, the cost of delivered wood fuel ranges from \$15 to \$45 per dry ton. Forest residues, or harvested wood, average about \$30 per dry ton to obtain (\$2.00 per MMBtu, more expensive than most coals), while urban wood wastes average about \$18 per dry ton of fuel (\$1.20 per MMBtu, cheaper than most coals).<sup>39</sup> In addition, through the REPI, the Federal government may offer a 1.5 cents per kWh incentive to users of wood fuels, and most states offer some type of incentive.

The availability of wood and wood waste is highly regional – users must be close to the source. Over 65 percent of wood energy consumption currently takes place in on-site cogeneration applications, primarily in the lumber processing, pulp and paper industries. These industries have a “free” fuel source, no transportation costs, a secure fuel supply, and can meet on-site thermal and electric power demands with their wood waste. Like black liquor, the mill residues produced by these industries are almost always used to provide additional heat and power for their plants. For this reason, the market for mill residues is slight, and the fuel source is not considered any further in this report (except as a possible precursor to biomass gas). With wood fuels produced from forest residues, or urban wood waste, the consumer must pay for the fuel, and usually the cost is only beneficial when the user is close to the source, since transportation costs can quickly make wood fuels uneconomical. In general, transportation of 25-50 miles produces marginal results, and any transportation over 50 miles will not be economical.

One potential source of wood fuel that has drawn some interest recently is forest thinnings. Due to the wildfires that destroyed parts of Arizona, California and other states, forests with dangerous potential are now being thinned out so that fires won't start or spread as easily. Normally the wood waste from forest thinning is burned, but it could potentially be used as a cheap fuel for boilers and gasification systems. McNeil Technologies recently conducted a study for Colorado's Office of Energy Management and Conservation on the subject. According to the study, nearly 36,000 dry tons of biomass would be available from Summit and Eagle County's forest thinnings each year – enough fuel to produce over 3 MW of electricity. However, the study concluded that delivered forest thinnings would cost nearly \$100 per dry ton to obtain – much too expensive to compete with other fuels.<sup>40</sup> If a more efficient collection and transportation system were developed, the prices may go down, but it appears that forest thinnings do not offer any benefits over other wood waste fuels.

### **Environmental Issues**

Wood and wood waste are considered renewable resources. Although carbon dioxide is produced in burning wood fuels, if new trees are planted, the net carbon dioxide emissions will approach zero. Urban wood waste may contain components and pollutants that need to be removed prior to burning, or else hazardous emissions and increased fouling will occur. SO<sub>x</sub> and NO<sub>x</sub> emissions, as well as the ash content, are much less than coal so co-firing will help reduce emissions. Wood ash is non-toxic and does not contain pollutants or heavy metals, but some states still consider it hazardous waste.

---

<sup>38</sup> *Study of Processing and Utilizing Urban Wood Waste and Pallets for Fuel in the State of Minnesota*. M.L. Smith Environmental, Tinley Park, IL: Januaray 1995.

<sup>39</sup> *Biomass Feedstock Availability in the United States: 1999 State Level Analysis*. Oak Ridge National Laboratory. World Wide Web. March 2003. <http://bioenergy.ornl.gov/resourcedata/index.html>

<sup>40</sup> *From Forest Thinnings to Boiler Fuel*. Western Regional Biomass Energy Program. World Wide Web, August 2004. <http://www.westbioenergy.org/dec2003/06.htm>

### **Availability, Cost, and Installed Capacity Data**

Availability: There is an abundance of wood and wood waste suitable for use as a fuel, and the estimated amounts of harvested wood, mill residues, and urban wood waste available are provided below:

Harvested wood – Estimated 45 million dry tons available annually.

Urban wood waste – Estimated 37 million dry tons available annually.<sup>41</sup>

Costs: Estimated costs include transportation. Modifications to existing equipment may also be required when using wood or wood waste as a fuel.

Harvested wood – Between \$20 and \$40 per dry ton of fuel (delivered price).

Urban Wood Waste – Between \$10 and \$30 per dry ton of fuel (delivered price).<sup>42</sup>

Urban wood waste boilers may require additional emission control and filtration devices because the fuel has a higher level of contaminants and impurities.

Installed Capacity (Non-Utility): Solid wood waste: 2.4 GW of capacity, 81.5 million MMBtu of thermal output. Liquid wood waste (ethanol): 48 MW of capacity, 7.9 million MMBtu of thermal output.<sup>43</sup>

### **The Bottom Line**

Wood and wood waste are promising biomass-based opportunity fuels. Although the cost for these fuels is usually greater than coal, they burn cleaner and can easily be co-fired. While solid wood fuels are best suited for industrial applications, they can also be a fuel source for steam-powered DER and CHP, especially coal-fired units in the 10-50 MW range.

## **Industrial Process Waste and Byproducts**

The second category of opportunity fuels, Industrial Process Waste and Byproducts, consists of non-biomass fuels created as a waste or byproduct of an industrial process. Blast furnace gas, coke, coke oven gas, industrial VOC's, and textile waste all fall into this category. All of these opportunity fuels are produced at industrial facilities, and would otherwise be considered a waste or byproduct (although many may already be used by the facilities for additional heat and/or power).

Blast furnace gas, coke, and coke oven gas are produced at iron/steel mills and petroleum refineries. The gaseous fuels are often recirculated for additional heat, but many facilities could potentially see more benefits from a DER/CHP installation. Solid cokes (coal and petroleum) are often mixed with coal in the facility's boilers and furnaces, although most petroleum coke is simply disposed of since more is produced than can be used. Textile waste and industrial VOC's are not used extensively by the facilities that produce them, with the exception of some textile waste being cofired in coal boilers.

In this section, the industrial waste and byproduct fuels will be examined to see if there is any potential for DER/CHP. If so, the fuels may be chosen for further evaluation in this report.

---

<sup>41</sup> Ibid.

<sup>42</sup> Ibid.

<sup>43</sup> U.S. Energy Information Administration Form 860 B - Database of Non-Utility Generators, 2000.

## **Blast Furnace Gas**

Blast furnace gas (BFG) is the gas discharged from blast furnaces in iron and steel mills. The gas can be sent to a coke oven for additional heat, recirculated to supply additional heat to the furnace, or it may be used to produce heat and power. BFG gas has a high carbon content, an extremely low heating value, and variable quality. The gas can be burned in a boiler, and exhibits properties similar to natural gas, but its quality and heat content are abysmally low. Blast furnace gas deposits adhere very firmly to boiler surfaces so special provisions and extra effort must be made when cleaning the boiler. The blast furnace gas supply is prone to sudden fluctuations, so special safety precautions are required and an alternative fuel must be available if steam or electricity production is to be steadily maintained. Because of all of these drawbacks, BFG is rarely burned as a fuel – it is most often recirculated in the furnace or coke oven for additional heat.

### **Current Status**

Currently, blast furnace gas is only utilized in the iron and steel mills where blast furnaces are used. Its low heating value (typically 90 Btu/ft<sup>3</sup>) seriously limits its effectiveness and potential as a fuel.

### **Economics and Market Considerations**

Blast furnace gas could be transported and sold to nearby facilities for heat and power operations, but there is neither an abundant supply of the gas nor a foreseeable demand. The fuel is inferior to natural gas in every category, and is best utilized immediately after collection while it is still hot. It is more economically feasible for steel mills to use BFG for their own heat and power needs than to sell it to an outside power producer.

The market for blast furnace gas is limited to iron and steel mills. Most mills that produce the gas already use it for recirculation and additional heat. New steel making technologies may soon render the blast furnace obsolete, and there is already a downward trend in production and demand for BFG. For example, in 2001, BFG production and demand fell 16 percent from the previous year in the United Kingdom across all areas of use.<sup>44</sup> This trend is being observed throughout the world and is likely to continue.

### **Environmental Issues**

Blast furnace gas has a high carbon content, and an extremely high nitrogen content. When burned, large amounts of carbon dioxide and nitrogen oxides will be produced, and emission control technologies must be applied.

### **Availability, Cost, and Installed Capacity Data**

Availability: Availability is determined by the usage of blast furnaces, primarily in iron and steel mills. Almost all blast furnace gas is recirculated or used in some other way by the mill itself, so the gas is generally unavailable for outside purchase.

Costs: BFG is free to iron and steel mills. Its quality is too low to be sold to outside markets.

---

<sup>44</sup> United Kingdom Department of Trade and Industry [www.dti.gov.uk](http://www.dti.gov.uk); The Iron and Steel Statistics Bureau.

Installed Capacity (Non-Utility): Blast furnace gas accounted for an estimated 1.3 GW of electric capacity and 94.5 million MMBtu of thermal output, the high T/E ratio indicating that the fuel is almost always used for heat.<sup>45</sup>

### **The Bottom Line**

Blast furnace gas has several disadvantages as an opportunity fuel. Production of BFG is on the decline and quality of the fuel is extremely low. It is beneficial to the iron and steel mills that produce it, but its utility in DG/CHP applications is limited.

### **Coke**

Petroleum coke (pet coke), a carbon-rich black solid, is the byproduct of coking conversion processes, which separate light and heavy crude oil products. Coke is also produced when heating coal, but its supply is low and the price of coal coke is actually greater than that of coal. Petroleum coke, on the other hand, is in abundant supply and its price is always less than that of coal. There are three types of pet coke produced in the coking process – sponge, shot, and needle. Only sponge and shot coke are used as a fuel. Some drawbacks of petroleum coke include a low volatility, a high sulfur content, and high nickel and vanadium contents in the ash. However, the fuel offers a high heat content (14,000 Btu/lb), a low ash content and easy grindability at a very low cost.

Coke can be used in place of coal or fuel oil in conventional boilers, with only a few modifications. However, the fuel contains many harmful contaminants and a high sulfur content so extensive emission controls are required. For this reason, pet coke is often blended and co-fired with sub-bituminous coal in large-scale industrial applications. If not, several cleaning devices and emission control technologies must be put in place.

### **Current Status**

The world production of petroleum coke in 1995 totaled over 50 million tons (Mt), with 80 percent coming from U.S. refineries.<sup>46</sup> Accordingly, the majority of petroleum coke produced in the U.S. is exported to foreign markets, where it is used primarily as a fuel. In the United States, the Department of Energy (DOE) estimates that the largest users of pet coke (other than refineries) are independent power producers, who often fire 100 percent coke, not a coke-coal blend, in boiler/steam turbine systems over 50 MW in size. Coal coke is also produced in large amounts, although it is rarely used outside of iron and steel mills so the outside supply is low.

### **Economics and Market Considerations**

According to an IEA Coal Research study, worldwide petroleum coke production grew by 50 percent between 1987 and 1998, to 50 Mt a year. Production is expected to reach 100 Mt by 2010.<sup>47</sup> This increase in production of pet coke is driven by the demand for light crude oil products (for which petroleum coke is the by-product), not by the demand for coke itself. The demand for light petroleum products like butane and jet fuel has been on the rise, so the production and sale of petroleum coke has been increasing. With such an excess of supply, the price for petroleum coke is usually much less than that of coal, although it contains higher amounts of sulfur, as well as some heavy metals. Customers are

---

<sup>45</sup> U.S. Energy Information Administration Form 860 B - Database of Non-Utility Generators, 2000.

<sup>46</sup> 1996 Update Petroleum Coke and Coal Markets. KvH Carbon.

<sup>47</sup> IEA Coal Research Profiles: *The Use of Petroleum Coke In Coal-Fired Plants*. World Wide Web. April 2003. <http://www.iea-coal.org.uk/pdf/files/pf01-10.pdf>

generally not willing to purchase pet coke if they can get coal for the same price. Recently, the price has fallen to as low as \$15 a ton.<sup>48</sup> The high Btu content of petroleum coke makes it attractive from a cost-benefit standpoint, however it has a low volatility and more emission control technologies are required.

Conversely, the production of coal coke has been on the decline, and it is almost always used up by iron and steel mills for additional heat. The remaining coal coke that is on the market sells for a much higher price than coal, so purchasing it for DER/CHP applications would not make any sense when coal (which produces fewer emissions and makes a better boiler fuel) could be used for cheaper.

Very few mills and refineries market coke themselves. Most coal coke is used by steel mills, and leftover pet coke is contracted out to resellers by refineries for market distribution. In the United States, large independent power producers and refineries are the main users of pet coke – utilities only use it sparingly as an alternative boiler fuel. Worldwide, petroleum coke is most often used in cement kilns and calcining operations. The foreign market for petroleum coke is larger than the domestic market, mainly due to a lower price than coal and the United States' strict environmental regulations. The best markets for pet coke are places where coal is less readily available and/or more expensive, such as Japan. When international coal prices go up, the worldwide demand for petroleum coke increases.

### **Environmental Issues**

Coke typically has a very high sulfur content (up to 8 percent), which causes significant sulfur oxide emissions. Therefore, coke is not a good choice for areas with stringent SO<sub>x</sub> emission standards. The nitrogen content of coke is also higher than coal. This, along with higher flame temperatures, leads to increased NO<sub>x</sub> emissions. The ash of petroleum coke contains high nickel and vanadium contents, and it is prone to produce more dust than most coals. Coke boilers require more emission controls than coal-fired boilers, as well as more frequent cleaning and maintenance.

### **Availability, Cost, and Installed Capacity Data**

Availability: The availability of coal coke depends on the use of coal at iron and steel mills, which has been on the decline. The availability of pet coke depends on the production of light petroleum products, which has been on the rise. Over 50 million tons of petroleum coke is produced worldwide each year – 40 million of which comes from U.S. refineries.<sup>49</sup>

Costs: Coal coke is not widely available for sale, and is usually more expensive than coal. Petroleum coke prices have recently fallen to around \$15 a ton due to the increasing supply.

Installed Capacity (Non-Utility): Petroleum coke accounted for 1.1 GW of electric capacity and 29.4 million MMBtu thermal output in the year 2000.<sup>50</sup> The figures for coal coke are unknown.

### **The Bottom Line**

While coal coke is expensive and hard to find, petroleum coke is a cheap and readily available energy source. Although it contains many contaminants and more emission controls are required than for coal, pet coke's lower price can make it economically beneficial for consumers. However, because of its impurities and contaminants, pet coke is only suitable for large-scale, high temperature industrial

---

<sup>48</sup> Energy Argus Monthly – Petroleum Coke. Monday September 3, 2001. Report No. 01s-001.

<http://www.energyargus.com/coke>

<sup>49</sup> 1996 Update Petroleum Coke and Coal Markets. KvH Carbon

<sup>50</sup> U.S. Energy Information Administration Form 860 B - Database of Non-Utility Generators, 2000.

applications. Although petroleum coke could potentially power 25-50 MW steam turbines, DER and CHP petroleum coke-fired units likely will not become popular until a cleaner, more efficient method of burning the fuel is developed.

### **Coke Oven Gas**

Coke oven gas refers to the gas and vapors generated during the production of coal and petroleum coke. It can be collected and burned as a fuel similar to natural gas, although the quality is not nearly as high (coke oven gas is only 35 percent methane and almost 50 percent hydrogen). Coke oven gas burns readily because of its high free-hydrogen content, which also makes it an ideal candidate for fuel cells. Its Btu content is around 550 Btu/ft<sup>3</sup> (about half that of natural gas) so most gensets will require some modifications and additional maintenance to accommodate the lower heating value. The fuel can be used in place of natural gas in boilers, but larger burner-gas port openings may be required due to the higher flow rate, impurities, and the resulting deposit build-up. Coke oven gas can also be used to power modified engines and gas turbines, but the fuel's variable supply and low methane content limit its energy producing capabilities.

### **Current Status**

Coke oven gas is currently used only in mills and refineries as an additional source of heat, and sometimes electricity. It is not produced in great quantities, and its production is limited by the use of petroleum and coal. Its inferiority to natural gas and its limited availability prevent it from being a serious contender in outside markets.

### **Economics and Market Considerations**

In 2001 in the United Kingdom, coke oven gas production from coal fell 11.5 percent and demand fell 14.5 percent.<sup>51</sup> Similar trends occurred for solid coke, and a general decline in all coal coke products can be observed worldwide. Coal coke oven gas production is dependant on the use of coal as an energy source, particularly in manufacturing iron and steel. Coke oven gas from petroleum production is more abundant, since light petroleum products are in high demand.

At steel mills and petroleum refineries, using coke oven gas to produce heat or electricity can be a good economic decision. The gas could also be sold to nearby power producers, transported through a pipeline and sold for roughly the same price as natural gas (\$5-\$6 per MMBtu). However, pipeline construction costs can be high, and it is generally more beneficial for a plant to use coke oven gas for its own power needs, so this has never been done in practice. Most mills and refineries that produce coke oven gas already burn it as a fuel or recirculate it for additional heat, so the remaining market for coke oven gas is limited to plants that do not already benefit from its utilization.

### **Environmental Issues**

The cokemaking process creates some environmental concerns. Air emissions and the use of quench water cause major environmental problems in the just the manufacturing process. Harmful sulfur and nitrous oxide emissions are also produced when burning coke oven gas for energy. Control technologies must be applied in both cases, and they can be costly.

---

<sup>51</sup> United Kingdom Department of Trade and Industry [www.dti.gov.uk](http://www.dti.gov.uk); The Iron and Steel Statistics Bureau.

### **Availability, Cost, and Installed Capacity Data**

Availability: Unknown. Coke oven gas is rarely sold as a fuel. It is generally used by the iron and steel mills or petroleum refineries that produce it.

Costs: Coke oven gas is free to mills and refineries. If it were sold, it would likely cost about the same as natural gas on a Btu-basis (\$5.50 per MMBtu).

Installed Capacity (Non-Utility): For petroleum coke oven gas, an estimated 184 MW of installed electric capacity and 16,126 MMBtu of thermal output.<sup>52</sup> For coal coke oven gas, the installed capacity is unknown.

### **The Bottom Line**

Coke oven gas generally is not a practical fuel for outside markets since its quality is significantly lower than natural gas and its supply depends on the use of coal and petroleum. For the mills and refineries that have a free gas supply, however, it is a practical and cost-effective source of heat and power. As with black liquor, most of the mills and refineries that can make use of their coke oven gas already do so, so the market that is leftover is relatively small.

### **Industrial VOC's**

Volatile organic compounds (VOC's) evaporate easily during many industrial processes, and they are an ever-increasing threat to the environment. Industrial VOC's must be collected and eliminated from the atmosphere. This is usually accomplished through oxidation, using thermal or catalytic oxidizers. However, the VOC's can instead be used as a fuel to help supply power for the industrial operation, while at the same time eliminating environmental threats.

Thus far, the only technology that has been successfully applied to industrial VOC's is cofiring in a natural gas combustion turbine. High-temperature combustion is preferred in order to eliminate all of the dangerous compounds, and this can only be achieved with a secondary fuel. In addition, the VOC-air mixture is simply too dilute to be used on its own. The VOC fuel is treated like an air injection into the gas combustor, and it is essentially just that, since the concentration of VOC's is so low. However, the highly reactive VOC's will provide additional energy to the natural gas stream as it enters the turbine, which can be used as a DER/CHP unit to power the entire facility.

### **Current Status**

Currently, the use of industrial VOC's is limited to cofiring with natural gas turbines. Advanced in gas turbine technology that increase efficiency and reduce energy costs will help bolster utilization of this technology.

### **Economics and Market Considerations**

While the fuel efficiency of the gas turbine is enhanced by a limited amount of VOC-air injection, the concentration of VOC's is so low that there is no noticeable degradation in performance, and no additional maintenance is required. The market for industrial VOC's as a fuel is limited to industrial plants that produces the volatile compounds. Many of these plants already use oxidizers to eliminate their VOC's, and are unlikely to abandon them and switch to this gas turbine technology, unless a significant

---

<sup>52</sup> U.S. Energy Information Administration Form 860 B - Database of Non-Utility Generators, 2000.

decrease in operating costs is incurred. The main market for the fuel is new or expanding industrial facilities, or plants located in areas with increasingly strict emissions regulations. As with most DER/CHP projects, the market also depends on the local price of electricity and natural gas. Areas with high electricity prices are more likely to benefit from distributed power, though in the case of VOC's, high natural gas prices have a negative effect on the market for Industrial VOC's, since they must be cofired with the fuel.

### **Environmental Issues**

The elimination of volatile organic compounds from the atmosphere is positive for the environment. However, some VOC's may survive the combustion process and leak out into the atmosphere. To prevent this, a high-temperature but slow-moving combustion process is preferred, and this is possible when using a natural gas combustion turbine.

### **Availability, Cost, and Installed Capacity Data**

Availability: Industrial VOC's are produced in many industrial facilities throughout the country. Most of these facilities already have oxidizers in place to cut down on VOC emissions, but they still may benefit from VOC utilization and on-site power generation. The exact availability numbers are unknown.

Costs: Industrial VOC's are free to industrial plants, and the facility must treat these wastes properly. Thus, the cost of using VOC's for fuel can be equated to the cost of the competing treatment option. The cost to install a natural gas turbine and the necessary VOC collection and transportation equipment at a facility is only slightly higher than a normal gas turbine, and the maintenance required is about the same.

Installed Capacity: Unknown, and hard to measure since most of the power comes from natural gas.

### **The Bottom Line**

Using industrial VOCs to produce power is an innovative and efficient way of eliminating VOC's from the air while producing heat and electricity for an industrial plant. However, the fuel's use is limited to VOC-laden air injection into a natural gas combustion stream. Most of the energy produced by the turbine comes from the natural gas, not from the dilute VOC-air mixture. While this practice is certainly worthy of consideration as a competitive treatment option, industrial VOC's do not qualify as a stand-alone fuel.

## **Textile Waste**

Textile waste can consist of excess yarn, thread, cloth, carpet, or any other fabric. The excess material is either recycled or thrown away as garbage. However, the waste can be utilized as an energy source with about the same heat content as biomass. Although the waste contains many more pollutants and contaminants than biomass fuels, it can still be cofired with coal to produce heat and power for textile mills.

Although gasification systems exist for textile waste (to be cofired with natural gas instead of coal), these systems' high capital cost-to-benefit ratio make them impractical for most textile mills. The fuel's quality is generally too low to be fired by itself, so cofiring with coal is the only practical option. Most coal-fired boilers can handle a 5-10 percent blend of textile waste with little, if any, modifications required.



### **Current Status**

Currently, most textile waste is recycled, although some textile mills utilize their waste in cofiring applications to produce their own heat and power. The quality of textile waste as a fuel is extremely poor compared to coal, so cofiring is usually the only feasible option.

### **Economics and Market Considerations**

For most textile mills, the benefit of utilizing their waste comes from saving on coal costs. Usually, textile waste is only a practical fuel for mills that already contain a coal-fired boiler. However, in cases where on-site power generation could seriously reduce electricity costs (i.e. locations where the cost of electricity is high), installing a coal-fired boiler and using textile waste as a blended fuel is an option.

The market for textile waste as a fuel is generally limited to textile mills, due to its low value, and even then it is limited to coal cofiring applications. Mills already using coal-fired boilers are the best potential market. At present there is no other identifiable place in the DER/CHP market for textile waste as a fuel.

### **Environmental Concerns**

Although textile wastes contain some harmful constituents, burning a 5 to 10 percent blend will not contribute significantly to regulated emissions. Typically, the same emission controls for coal-fired boilers will also apply to coal-textile waste blends.

### **Availability, Cost, and Installed Capacity Data**

Availability: Textile waste is available at every textile mill, although not all mills will benefit from its utilization – most are better off recycling their waste.

Costs: For a plant that already contains a coal-fired boiler, adding textile waste to form a 5-10 percent blend is usually beneficial. Few, if any, modifications are necessary, and the plant will save on fuel costs. For plants without a coal-fired boiler, a cost-benefit analysis must be performed.

Installed Capacity: Unavailable. Installed capacity is minimal.

### **The Bottom Line**

Textile waste is not promising as an opportunity fuel. Its heating value is lower than biomass, it contains more pollutants, and it must be cofired with coal to be effective. Furthermore, the market for textile waste as a fuel is generally limited to textile mills.

## **Fossil Fuel Derivatives**

The third category of opportunity fuels are fossil fuel derivatives. These fuels are derived from fossil fuel mining and drilling operations, where excess gas is created and must be treated and disposed of. Most mines and wells flare their excess gas to prevent the release of methane into the atmosphere. This gas, however, can be used for power production in DER/CHP applications.

At coalmines, the mining process produces a methane gas whose properties and heat content are very similar to natural gas. The gas is called coalbed methane, and it is often injected into natural gas pipelines, but it can also be used as a fuel for DER/CHP projects.

At oil and gas wells, excess gas escapes to the top of the well, building up pressure. In order to release this pressure, the wells release and flare the untreated gas. However, this wellhead gas can be used for small-scale power generation at the oil and gas wells' facilities.

This section examines these two fuels derived from fossil fuels, and determines if there is enough potential for DER/CHP to warrant further evaluation in the chapters to come.

### Coalbed Methane

Coalbed methane (CBM) is a methane gas released from coalmines. It can be collected before, during, and after mining, and condensed into a fuel similar to natural gas. The highest quality gas comes from drainage holes made before mining. In this situation, methane has not had a chance to interact with air. CBM can also be collected from coalmine ventilation air, but the quality and percentage of methane is much lower. After mining, high quality CBM can be collected from gob wells. See Figure 2-8 for a diagram of a typical coal mining operation.

Coalbed methane can replace natural gas in any power generating technology – gas turbines, steam turbines, microturbines, reciprocating engines, and fuel cells. The gas collected from drainage holes before and after mining is usually around 90 percent methane, so once cleaned, it can be used in natural gas applications with no degradation in quality. In fact, drainage methane is so similar to natural gas and so high in quality that is often injected directly into natural gas pipelines. Ventilation air emissions, which account for the majority of coalmine methane emissions, are low quality methane-air mixtures. New technologies, however, can oxidize the ventilation air to make it suitable for thermal energy applications. The thermal demand at coalmines is limited, so combined heat and power operations are rare.

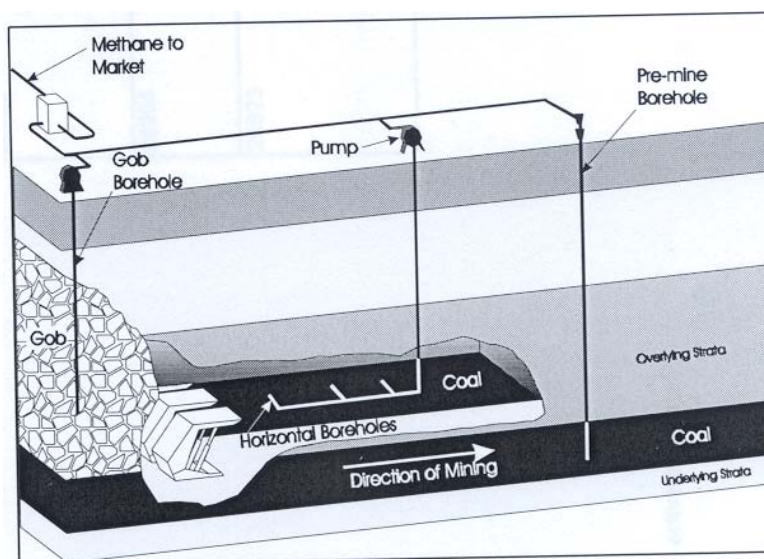

**Figure 2-8. Coalbed Methane Collection Process – CBM can be collected before, during and after mining**

Source: EPA CMOP website: <http://www.epa.gov/cmop/pdf/inf002.pdf>

### Current Status

The total volume of CBM liberated in the United States in 2000 was estimated to be 196 billion cubic feet, 141 billion of which came from underground mining operations.<sup>53</sup> However, much of this liberated CBM consists of low-Btu ventilation air. In 2001, 48 billion cubic feet of high-quality coalbed methane was recovered from horizontal and vertical gob wells, with about 80 percent being injected into natural gas pipelines.<sup>54</sup> The rest (about 8 billion cubic feet) was flared into the atmosphere, although some was utilized in on-site DER operations. Still, more high-quality CBM is

<sup>53</sup> U.S. Environmental Protection Agency – Coalbed Methane Outreach Program. World Wide Web. February 2003. <http://www.epa.gov/cmop/index.htm>

<sup>54</sup> “Evaluating CMM Power Generation Projects in the U.S.” *Coalbed Methane Extra*, July 2003 Edition. U.S. Environmental Protection Agency – Coalbed Methane Outreach Program. World Wide Web. May 2004. <http://www.epa.gov/coalbed/clibrary/extra/07-2003.pdf>

produced from drainage holes before mining operations, and even more could be obtained after mining operations if additional gob wells are drilled.

The Coalbed Methane Outreach Program (CMOP) is an EPA program encouraging the use of coalbed methane as an energy source. In addition to providing resources and promoting the use of CBM, the program helps plan and finance CBM projects, including both DER and pipeline sales.

Currently, the most popular application for CBM is pipeline sales, where the gas is cleaned and injected directly into natural gas pipelines. About 7-8% of the natural gas in United States pipelines comes from coalbed methane. The National Petroleum Council is considering utilizing coalbed methane even further, to make it a more significant source of domestic natural gas. With their 2003 report, *Balancing Natural Gas Policy: Fueling the Demands of a Growing Economy*, the Council showed interest in obtaining CBM from coal reserves, specifically those located beneath the Rocky Mountains. Most of these reserves are not being mined, and are currently inaccessible, but there is still great potential for future use. However, the utilization of these reserves for natural gas should not have any significant impact on the potential for CBM DER.

### **Economics and Market Considerations**

Coalbed methane can be used in many ways to produce revenue. Drainage methane is usually of high enough quality to be injected into natural gas pipelines or used in natural gas units without any modifications to existing equipment. Many smaller mines do not currently have drainage systems installed, although the cost to install a drainage system is not very high considering the many benefits that can be obtained from the high quality gas. Methane from ventilation air, which accounts for most of the methane emissions from coalmines, is a mixture so its quality is not nearly as high. Even so, the ventilation air, which is normally flared, can be used to provide thermal energy at the coalmines, since their thermal demand is typically low. The process of collecting methane from the mine, both drainage or ventilation air, is not expensive and most of the necessary steps (i.e. the drainage holes and collection devices) are already set in place. The gas only needs to be stored and transported to a DER/CHP unit for power production. The main issue then, is the coalmine's demand for electricity and heat. Most facilities have a high electric demand, and excess electricity can almost always be sold to a local utility, although issues with grid interconnection could arise. Excess thermal energy, on the other hand, requires a nearby facility with a thermal demand, so most CBM gensets are not built for CHP. As an extra incentive, coalmines utilizing coalbed methane may qualify for the IRS Section 29 Tax Credit for unconventional fuels, which provides users with about \$1.00 per MMBtu of energy produced, but only certain facilities (those opened between 1979 and 1993) apply. Coalbed methane DER projects do not qualify as PURPA qualifying facilities or small power producers, but most facilities do not require utility sales so this is not an issue.

### **Environmental Issues**

Coalbed methane emissions account for 10 percent of the United States' total methane emissions.<sup>55</sup> Using this methane as an energy source would cut down on emissions and conserve natural resources. CBM holds the same environmental hazards as natural gas, and must be treated accordingly, with the same emission control technologies.

---

<sup>55</sup> U.S. Environmental Protection Agency – Coalbed Methane Outreach Program. World Wide Web. February 2003. <http://www.epa.gov/cmop/index.htm>

### **Availability, Cost, and Installed Capacity Data**

Availability: In 2000, 196 billion cubic feet of coalbed methane was released, and 141 billion came from mining operations. At least 140 billion cubic feet of CBM could potentially be collected for fuel use annually.<sup>56</sup> However, much of the CBM included here is ventilation air – 48 billion cubic feet of high quality CBM was collected from gob wells in 2001, although about 80 percent goes to natural gas pipeline sales.<sup>57</sup>

Costs: High quality CBM is interchangeable with natural gas, and is sold at the same rate, currently about \$5.50 per MMBtu. For coal mining operators, however, the gas is free and can be used for on-site or nearby power generation. The lower quality ventilation air/methane mixture can be used for thermal energy applications, and could presumably be sold for about half the price of natural gas.

Installed Capacity (Non-Utility): Information on the electric capacity and thermal output from coalbed methane is unavailable, and hard to define since the gas is often injected into the natural gas pipeline, and used in place of natural gas.

### **The Bottom Line**

Coalbed methane is a viable alternative to natural gas for most markets. The methane collected through drainage holes is of a very high quality, and can replace natural gas in any application with no necessary modifications. In addition, its use is beneficial to the environment. Onsite demand for electricity at coalmines is usually very high, but the thermal demand is usually too low to warrant CHP. While excess electricity can potentially be sold to the local utility, excess heat utilization requires a nearby facility with a thermal demand.

### **Wellhead Gas**

Oil and natural gas wells produce a methane gas that leaks and collects at the cap of the well. The gas is normally flared to prevent pressure buildup and explosions. The flare gas, however, is capable of producing heat and power for the well. It is not nearly as clean as the natural gas that is injected in pipelines, but its heating value averages around 1,100 Btu/ft<sup>3</sup>. Wellhead gas (also called casinghead gas) contains a great many impurities, so it must be thoroughly cleaned prior to use. Exactly how thorough depends on the technology. Reciprocating engines and large turbines require much cleaner fuel than microturbines. Also, for onsite utilization applications, wells usually do not require much electric power to operate, and microturbines are better suited for small power production applications.

### **Current Status**

Although some oil and gas wells use microturbines to turn their wellhead gas into a power source for the plant, most simply flare their gas into the atmosphere. The Rocky Mountain Oilfield Testing Center (part of the U.S. Department of Energy) conducted a project in 1998 running microturbines on wellhead gas.<sup>58</sup> Capstone has since provided microturbines for over 200 wellhead gas projects in the United States and

---

<sup>56</sup> Ibid.

<sup>57</sup> "Evaluating CMM Power Generation Projects in the U.S." *Coalbed Methane Extra*, July 2003 Edition. U.S. Environmental Protection Agency – Coalbed Methane Outreach Program. World Wide Web. May 2004.  
<http://www.epa.gov/coalbed/clibrary/extra/07-2003.pdf>

<sup>58</sup> Rocky Mountain Oilfield Testing Center Microturbine Project. Stacy & Stacy Consulting, LLC. Prepared by: Michael J. Taylor, Project Manager. Available at: [http://www.globalmicroturbine.com/pdf/gas\\_oil\\_flaring/96ec2.pdf](http://www.globalmicroturbine.com/pdf/gas_oil_flaring/96ec2.pdf)

throughout the world. The wells utilizing this technology can supply all of their power, including nearby compressor stations. For this application, the demand for heat is almost always too low to justify CHP.

### **Economics and Market Considerations**

The nature of wellhead gas limits its use to oil and gas wells and surrounding facilities. The gas at the cap of the well must be collected and flared (or utilized) on-site. Wells are required to flare their gas to reduce methane emissions, so they already have the collection and flaring of the gas in place and only need to install a DER/CHP unit where the gas is flared. The only users of the electricity produced are the well itself and nearby compressor stations, which can usually be powered by a single 30 kW microturbine. However, it is likely that the well will produce more gas (large oil wells produce 300-400 million cubic feet of wellhead gas each day). Instead of flaring the remaining gas, it could be used to power secondary microturbines, as long as a utility or third party agrees to purchase the electricity produced. In addition, wellhead gas may qualify for the IRS Section 29 Tax Credit, and Federal and state governments may offer further incentives to users.

### **Environmental Issues**

When wellhead gas is flared, many harmful byproducts are released into the atmosphere. When the gas is used as a power source for microturbines, not as much harmful gas is released. In addition to this environmental benefit, using wellhead gas conserves natural resources by extracting more power from oil and natural gas reserves. Although some emissions are produced in the process of turning wellhead gas into power, these are negligible when compared to the emissions that would be produced from flaring.

### **Availability, Cost, and Installed Capacity Data**

Availability: Wellhead gas is available at any oil or gas well, but it must be utilized on-site. There are over 1,000 oil and gas wells in the United States alone that could potentially benefit from wellhead gas utilization.<sup>59</sup>

Cost: Wellhead gas is free to the owners and operators of oil and gas wells. Chances are slight that it would ever be sold as a fuel, but if it were thoroughly cleaned of its impurities, it could potentially be sold as natural gas.

Installed Capacity: There are many (over 100) wellhead gas microturbine projects underway in the United States, with over 3 MW of total capacity. Few, if any, capture their waste heat so the thermal output is negligible.

### **The Bottom Line**

Using wellhead gas for power production at oil and gas wells allows them to benefit and potentially profit from this practice. There is little or no thermal demand at the well itself, so CHP is unlikely to be implemented unless an arrangement is made with a nearby facility. Any excess electricity produced can potentially be sold to the local utility.

---

<sup>59</sup> RIGDATA, Fort Worth Texas. <http://www.rigdata.com/locnts.pdf>

## **Processed Opportunity Fuels**

The final category of opportunity fuels are those that are already being processed and sold for fuel, but have so far only been used in niche applications. Orimulsion and tire-derived fuel are the two opportunity fuels that fall in this category.

Orimulsion is a fuel produced from emulsifying bitumen, found in Venezuela, in water. The product is sold by the barrel to foreign markets, but in the United States a market for Orimulsion does not currently exist.

Tire-derived fuel is either processed at dedicated facilities and by the users of the fuel themselves. The processing costs vary depending on the degree of quality required for the given application. So far, tire-derived fuel has been used in cement kilns and some industrial applications, but the fuel has not quite caught on in the DER/CHP market.

This section takes a look at Orimulsion and tire-derived fuel to see what (if any) potential these processed opportunity fuels have in DER/CHP applications.

### **Orimulsion**

Orimulsion is a naturally occurring bitumen (a high density petroleum-based tar), emulsified into water. Its name is derived from the Orinoco Belt in Venezuela, which contains the world's largest natural reserve of bitumen. Orimulsion can be burned in place of coal and residual fuel oil in nearly any application.

A recently constructed 36-foot, 188 mile pipeline connects the Orinoco Belt with the Jose Terminal in the Caribbean Sea. The terminal, whose storage capacity was recently doubled to 320,000 tons, is where Orimulsion is transported onto ships.<sup>60</sup>

Transportation from this point is achieved in the same manner as fuel oil. Orimulsion is most often fired in boilers, and magnesium is usually added to the fuel to prevent boiler tube corrosion. Orimulsion has a high combustion efficiency and ignition stability, along with high carbon conversion efficiencies. Its Btu content, about 13,000 Btu per ton, is on par with coal but not as high as fuel oil. The fuel delivery system for existing fuel oil boilers requires new burner guns and atomizers to accommodate the higher flow rates necessary maintain the same boiler heat input.

### **Current Status**

Orimulsion is currently used as a fuel in parts of Europe, Canada, South America and Japan. It is not yet commercially available in the United States. Petroleos de Venezuela, S.A., a worldwide energy corporation, estimates that there are 267 billion barrels of recoverable bitumen reserves in the Orinoco



**Figure 2-9. The Orinoco Belt - the world's largest reserve of bitumen, used to make Orimulsion**

<sup>60</sup> Petroleos de Venezuela, S.A. World Wide Web. February 2003. <http://www.pdvsa.com/orimulsion/english/>

Belt. Since the construction of a new horizontal-drilling emulsification facility in 1993, Orimulsion production has remained steady at around 100,000 barrels a day.<sup>61</sup>

Recently, however, the Venezuelan government has discovered that it is more profitable to sell Orinoco crude as a blend or synthetic grade, rather than using it to produce Orimulsion. The nation is now phasing out Orimulsion production by not renewing supply contracts, so things appear bleak for this once promising opportunity fuel. However, Orimulsion can still be produced by emulsifying the crude in water, so there may still be project potential.

### **Economics and Market Considerations**

Compared to fuel oil boilers, the thermal efficiency is 2.5 percent less for Orimulsion (due to its lower Btu content). There is also increased fouling of the boiler tubes and usually more emission controls are required. However, there is a substantial difference in the fuel costs – Orimulsion can be obtained at a lesser price. The lower fuel costs typically offset any losses due to the thermal efficiency, fouling and emissions issues. The cost of collecting, transporting and storing Orimulsion is similar to residual fuel oils.

Orimulsion can be used in most coal and residual fuel oil boilers with only a few necessary modifications. The lower fuel costs are the fuel's main selling point. However, transportation costs are likely to limit the use of Orimulsion to coastal plants that can receive tanker shipments directly or via pipeline. Orimulsion has been primarily used as an alternative fuel for existing oil and coal-fired units. Some Japanese companies have developed units designed specifically for Orimulsion fuel. Increased production of these units may help allow Orimulsion to be more widely utilized.

### **Environmental Issues**

An Orimulsion tanker spill would be similar to an oil tanker spill, but with fewer adverse environmental effects. Orimulsion disperses when added to water, but it is not as toxic as most fuel oils. Safety measures must be taken to prevent these kind of spills from ever happening. Like other fossil fuels, the combustion of Orimulsion produces SO<sub>x</sub>, NO<sub>x</sub>, and particulates that must be treated with emission control technologies. The sulfur emissions are especially high, and more emission controls are required than for coal or fuel oil. Some NO<sub>x</sub> control technologies, such as flue gas recirculation, may not work as well with Orimulsion, although its NO<sub>x</sub> levels are generally lower than coal. Considerable amounts of solid waste will most likely be generated in combustion and emission controls, so disposal or utilization must be considered.

### **Availability, Cost, and Installed Capacity Data**

Availability: There are over 250 billion barrels worth of Orimulsion reserves in the Orinoco Belt. Production averages about 100,000 barrels a day.<sup>62</sup>

Costs: Orimulsion costs about the same as coal and less than most fossil fuels. The delivered fuel cost is around \$1.70 per MMBtu, so it is competitive with coal and fuel oil.<sup>63</sup> However, modifications to existing boilers are a necessity, and increased emission controls are usually required.

Installed Capacity: There are currently no Orimulsion-fired gensets in the United States.

---

<sup>61</sup> Bitor – Orimulsion. World Wide Web. February 2003. <http://www.orimulsionfuel.com>

<sup>62</sup> Bitor – Orimulsion. World Wide Web. February 2003. <http://www.orimulsionfuel.com>

<sup>63</sup> Petroleos de Venezuela, S.A. World Wide Web. February 2003. <http://www.pdvsa.com/orimulsion/english/>

**The Bottom Line**

Orimulsion has potential as an opportunity fuel for large power plants. It is of similar quality to fuel oil, and can be obtained at a lower price. If more Orimulsion-fueled gensets are produced, it could become a competitor with today’s fossil fuels. However, there is currently no market for Orimulsion in the United States, and the recent phasing out of Orimulsion production by the Venezuelan government will likely render the fuel obsolete.

**Tire-Derived Fuel**

Tire-derived fuel (TDF) is a solid fuel derived from scrap rubber tires. The fuel’s properties are similar to coal and it can be burned in most coal-fired boilers without modifications. Although the majority of coal-fired gensets do not qualify as DER or CHP, according to the EIA 860-B database, there are over 300 coal-fired CHP units in the United States under 50 MW in size (totaling over 4 GW) that could potentially utilize tire-derived fuel.<sup>64</sup>

There are 20 different grades of ground and shredded rubber from discarded tires, based on the size and consistency of the rubber chips. Typical TDF grades are 0.25 to 3 inches in size with varying degrees of wire removal. An average tire contains 280,000 Btu – the equivalent of 2.5 gallons of oil or 20 pounds of coal.<sup>65</sup> TDF-coal cofiring blends are common. TDF performs similarly to coal, and has a heating value of about 16,000 Btu per pound. Provided below in Table 2-1 is a side-by-side comparison of the properties of coal and TDF, as obtained from an EPA study.<sup>66</sup>

**Table 2-1. Coal and TDF: Fuel Analysis by Weight Percent (%)**

<b>Fuel</b>	<b>Carbon</b>	<b>Hydrogen</b>	<b>Oxygen</b>	<b>Nitrogen</b>	<b>Sulfur</b>	<b>Ash</b>	<b>Moisture</b>	<b>Heating Value (Btu/lb)</b>
Coal	73.92	4.85	6.41	1.76	1.59	6.23	5.24	13,346
TDF	83.87	7.09	2.17	0.24	1.23	4.78	0.62	15,500

While TDF contains more carbon than coal, it contains less nitrogen, sulfur and oxygen, which will result in fewer SO<sub>x</sub> and NO<sub>x</sub> emissions. Tire-derived fuel also has less ash, less moisture, and a higher heating value than coal.

There are four steps that go into processing TDF:

1. Primary Shred – Double rotor shear shredder – strips 2 to 4 inches wide
2. Secondary Shred – Second shredder/granulator makes the finished size chips
3. Screening – Chips are screened with trommel or disc screens – oversize chips returned to #2
4. Metal Removal – Metal bead and wire is removed with magnets

Once all of these steps have been performed, the tire chips are ready to be used as fuel. TDF is most often burned in boilers designed for coal. Minimal modifications are necessary, with only a slight increase in maintenance costs. When TDF is burned independently or in a high-percent blend, higher boiler temperatures are preferred in order to completely burn the fuel. Although the high flame temperature will slightly increase NO<sub>x</sub> emissions, the emissions from coal are higher and control technologies are already

<sup>64</sup> U.S. Energy Information Administration Form 860 B - Database of Non-Utility Generators, 2000.

<sup>65</sup> *Tire Derived Fuel*. World Wide Web. February 2003. <http://www.scraptire.com/2/TDF2.html>

<sup>66</sup> Joel I. Reisman, Paul M. Lemieux, Air Emissions from Scrap Tire Combustion, EPA, Oct. 1997/



in place. With lower temperature boilers, the fuel is not always completely burned, more particulates are produced, and more maintenance is required. Still, cofiring tire-derived fuel almost always enhances boiler performance due to its high heating value and lower emissions. Fluidized bed, cyclone, and stoker-fed boilers are all options for TDF combustion. While tire-derived fuel is a good candidate for many coal-fired CHP and DER applications, so far it has only been utilized in large industrial operations.

### **Current Status**

In the United States, between 250 and 350 million tires are discarded each year.<sup>67</sup> Several hundred million tires are currently in landfills or tire piles. Tires are now banned from most landfills and must be disposed of at dedicated sites. This makes it easier to collect the tires for tire-derived fuel. The producers of TDF use specialized machinery to shred, screen, and remove metal from the tires before they sell the fuel to local consumers. Two dedicated TDF-to-energy facilities have been established, using specially designed boilers and producing 50 MW of electric power combined. Projects like these, however, are few and far between – cement kilns, utilities, and industrial facilities have been the primary users of tire-derived fuel.



**Figure 2-10. Tire Piles - The Main Source of Tire-Derived Fuel**

TDF has not yet caught on in the DER and CHP industries, but it can replace or supplement coal in nearly any application. In the year 2000, over 4 GW of electricity and 300 trillion Btu's of thermal output were produced by coal-fired CHP units under 50 MW.<sup>68</sup> In many of these cases, cofiring with or switching to tire-derived fuel could be beneficial.

### **Economics and Market Considerations**

The processing costs for tire-derived fuel generally fall between \$15 and \$19 per ton, and the fuel sells for about 5 dollars more (\$20-\$24 per ton). Transportation for solid fuels is typically around \$10 per ton, per fifty miles. Assuming these prices and a fifty-mile trip, TDF would cost about \$1.00 per MMBtu to obtain. Cofiring with coal is the most popular method of TDF energy production because coal-fired boilers already exist and TDF can be easily co-fired with no modifications. Cofiring saves money since TDF is less expensive and contains less sulfur than coal. When attempting to fire 100 percent TDF in existing coal-fired boilers, heavily processed TDF is required, sometimes costing more than coal. As a result, there is little incentive for coal users to make a complete switch. For 100 percent tire-derived fuel, boilers specifically designed for TDF are recommended.

The growing demand for TDF has begun to create a supply infrastructure with manufacturers and brokers. For the entire United States, the current users are: Cement Kilns (30%), Pulp & Paper Mills (23%), Utility

<sup>67</sup> Electric Power Research Institute. *Strategic Analysis of Biomass and Waste Fuels for Electric Power Generation*. Palo Alto, CA: December 1993. Report TR-102773, p. 2-46.

<sup>68</sup> U.S. Energy Information Administration Form 860 B - Database of Non-Utility Generators, 2000.

Boilers (19%), Industrial Boilers (13%), and Dedicated Tire to Energy (10%).<sup>69</sup> Most of these facilities utilize TDF strictly for heat. Tire-derived fuel has not yet broken into the DER/CHP market. The vast majority of TDF operations are industrial applications larger than 50 MW.

TDF does not require any special handling, and since the Btu content is so high, transportation is not as costly as for biomass and other opportunity fuels. Still, transportation accounts for a good portion of the delivered cost, which varies greatly depending on distance, volume and transport mode. Because of this, it is preferable to obtain TDF from a nearby location. Most TDF processing plants are located close to large tire piles, which are common throughout the country, most prominently in the Midwest and Northeast regions. Government subsidies for waste tires are available in many states, and this can significantly reduce the cost of the fuel. In certain cases, states without subsidies will purchase tires from nearby subsidized states because it is actually less costly than obtaining the tires at home. For example, TDF users and producers in California often purchase tires from Utah, Oregon, and Arizona, since they all have subsidies on waste tires. Once the tires are obtained, they are ground, shredded, and processed for use. With average market conditions, the price of TDF is slightly less than the price of coal on a Btu basis, and it performs nearly as well.

### **Environmental Issues**

The sulfur content of tire-derived fuel, while less than coal, is still considerable and usually ranges from 0.98 to 1.66 percent.<sup>70</sup> The nitrogen content is extremely low, so NO<sub>x</sub> emissions are low. TDF ash has a greater carbon content than coal ash, but TDF produces less ash than coal. Although tire-derived fuel is not renewable in the classic sense of the word, tires are always being produced and the stockpile of waste tires in the United States grows each year. The utilization of TDF reduces waste and promotes the conservation of natural resources.

### **Availability, Cost, and Installed Capacity Data**

**Availability:** In the United States, between 250 and 350 million tires are discarded each year and several hundred million tires are currently in landfills or tire piles.<sup>71</sup> Only a small fraction of this number is used for TDF. Currently, the fuel is not produced in abundance, only enough to supply the current demand. If the market grows, production will likely increase.

**Costs:** TDF costs about \$22.00 a ton (\$0.69 cents per MMBtu) not including transportation costs (about \$10 a ton per 50 miles). According to EIA, coal costs \$30-\$60 a ton at manufacturing plants, which means TDF could be still be economical when transported over 100 miles. Most coal-fired boilers do not require any modifications to switch to TDF, which has similar characteristics to coal. More maintenance may be required, however, due to incomplete burning at low boiler temperatures, as well as removing metal scraps and wires often embedded in the tires.

**Installed Capacity:** In 2000, the installed capacity of TDF units was 69 MW, and the installed thermal output 18,000 MMBtu.<sup>72</sup> Most of the electric capacity comes from the two dedicated TDF-to-energy facilities.

---

<sup>69</sup> *Markets for Tires as Fuel*. World Wide Web. May 2003. [http://geocities.com/watchdogs\\_99/ca\\_research.html](http://geocities.com/watchdogs_99/ca_research.html)

<sup>70</sup> U.S. Energy Information Administration, FERC Form 423, 1991-1996.

<sup>71</sup> Electric Power Research Institute. *Strategic Analysis of Biomass and Waste Fuels for Electric Power Generation*. Palo Alto, CA: December 1993. Report TR-102773, p. 2-46.

<sup>72</sup> U.S. Energy Information Administration Form 860 B - Database of Non-Utility Generators, 2000.

### **The Bottom Line**

Tire-derived fuel is an ideal opportunity fuel that can replace or be cofired with coal in nearly any application. A supply infrastructure has already been created, the fuel is usually available at a lower price (or at least competitive with coal), and fewer emissions are produced. Although many DER/CHP opportunities are available, TDF is best suited for large utility or industrial applications, and the market so far has consisted of cement kilns, utilities, dedicated facilities, industrial cofiring operations, or any sizeable energy user with coal generation on-site.

### **Summary of Fuel Attributes and Performance**

There are a large number of alternative fuels with an opportunity to break into the DER and CHP marketplace. Each fuel has its advantages and disadvantages, but they all have the potential to generate power for certain markets. For many opportunity fuels, the market is limited to those who produce the fuel as a byproduct. Sometimes the fuel is marketable to areas immediately surrounding the production facilities, but transportation costs are a limiting factor. Even with these limitations, some of these fuels still have a great deal of potential in their own niche markets. Some other fuels look promising enough to become serious players in the distributed power industry. Table 2-2 summarizes the attributes and performance (availability, heating value, costs, emissions, DER/CHP potential, and limitations) of each opportunity fuel. Then, a score is derived for each fuel, the results are summarized, and the eight most promising fuels are chosen for further evaluation.

Combined Heat and Power Market Potential for Opportunity Fuels

Table 2-2. Opportunity Fuel Performance Matrix

Opportunity Fuel	Availability	Heating Value	Fuel Cost	Equipment Cost	Emissions / Environment	DER/CHP Potential	Rating	Limitations
Anaerobic Digester Gas	●	●	●	●	●	●	5.0	Need anaerobic digester
Biomass Gas	●	●	●	○	●	●	4.0	Gasifiers extremely expensive
Black Liquor	○	●	●	●	●	●	3.0	Most BL already used up by mills
Blast Furnace Gas	○	○	●	●	●	○	2.0	Limited availability, low Btu
Coalbed Methane	●	●	●	●	●	●	5.0	Coal mines - lack CHP demand
Coke Oven Gas	○	●	●	●	●	●	3.0	Availability - most already used
Crop Residues	●	●	○	●	●	●	3.0	Difficulty in gathering/transport
Food Processing Waste	●	●	●	●	●	●	4.0	Limited market, broad category
Ethanol	●	●	●	●	●	●	4.0	Currently only used for vehicles
Industrial VOC's	○	○	●	●	●	●	2.0	Must be used w/ NG turbine
Landfill Gas	●	●	●	●	●	●	4.5	Landfills – little demand for CHP
MSW / RDF	●	○	●	○	●	●	3.0	Low heating value, contaminants
Orimulsion	○	●	●	●	●	●	2.5	Orimulsion not available in U.S.
Petroleum Coke	●	●	●	●	○	○	3.5	Many contaminants; large apps
Sludge Waste	●	○	●	○	●	○	2.5	Low heating value, contaminants
Textile Waste	●	●	●	●	●	○	3.0	Must be cofired; larger apps
Tire-Derived Fuel	●	●	●	●	●	●	4.0	Best suited for large apps
Wellhead Gas	●	●	●	●	●	●	4.5	Oil / gas wells – no CHP demand
Wood (Forest Residues)	●	●	●	●	●	●	4.0	Fuel can be expensive
Wood Waste	●	●	●	●	●	●	4.5	Waste may have contaminants

Key: ● = excellent / not an issue, ○ = average / could become an issue, ○ = poor / major issue

Each fuel's positive and negative attributes are discussed below, and the most promising fuels are chosen for further evaluation in this report.

**\*Anaerobic Digester Gas (5.0)** – Very promising opportunity fuel for wastewater treatment plants (municipal and industrial), and to a lesser extent, animal farms. The fuel is especially beneficial in cases where a digester has already been installed, and is an ideal choice for DER/CHP applications. *Anaerobic Digester Gas is a promising opportunity fuel and will be examined further in the following sections.*

**\*Biomass Gas (4.0)** – The only thing possibly preventing biomass gas from becoming a serious contender in the DER/CHP market is the cost of the gasification system. However, biomass gas could be a promising fuel for CHP operations in the 5-50 MW range if a free source of biomass is found or the cost of biomass fuels is decreased. *Biomass Gas could be a promising opportunity fuel for larger projects, and will be examined further in the following sections.*

**Black Liquor (3.0)** – Black liquor is a strong opportunity fuel for the pulp and paper mills that produce it. However, these mills already utilize black liquor to their benefit, and there is little to no market left for the fuel. *Black Liquor will not be considered for further evaluation in this report.*

**Blast Furnace Gas (2.0)** – An extremely low heating value and limited availability make this fuel inadequate for outside markets. Iron and steel mills utilize it for additional heat, but that is the extent of its usefulness. *Blast Furnace Gas will not be considered for further evaluation in this report.*

**\*Coalbed Methane (5.0)** – Coalbed methane is a high-quality fuel, and is essentially free to coal mine owners and operators. However, the demand for heat and power at a coal mine is minor compared to the potential energy produced, so CHP can only be applied when nearby facilities agree to pick up the load. Or, the gas can be transported through natural gas pipelines to its destination. *Although not ideal for combined heat and power applications, coalbed methane is a promising fuel and will be examined further in the following sections.*

**Coke Oven Gas (3.0)** – This fuel is utilized by iron/steel mills and petroleum refineries to provide additional heat and power. Although some facilities do not utilize coke oven gas to its full extent, the remaining market is thin, and the fuel is only beneficial to those that produce it. *Coke Oven Gas will not be considered for further evaluation in this report.*

**Crop Residues (3.0)** – The labor involved with gathering and transporting crop residues causes their cost to be the highest among the biomass fuels. Until a better infrastructure is created, or dedicated energy crops are introduced, crop residues will remain too expensive for economic energy production. *Crop Residues will not be considered for further evaluation in this report.*

**Food Processing Waste (4.0)** – While food processing waste is a strong fuel choice for certain food processing facilities, the category is too broad to make generalizations. The availability and cost data for this fuel category is lacking, and decisions must be made on a case-by-case basis. *Although somewhat promising, Food Processing Waste will not be considered for further evaluation in this report.*

**Ethanol (4.0)** – If ethanol-powered fuel cells catch on, ethanol could become the fuel of choice for this technology. Currently, however, ethanol is only being used in gasoline and diesel fuel blends, for automotive applications. There is potential for stationary power production with ethanol in the future, but so far, even with fuel cell power, all focus has been on the transportation industry. *Even though there could be potential in the future, right now CHP/DER potential is limited, so Ethanol will not be considered for further evaluation in this report*

**Industrial VOC's (2.0)** – Since the VOC-air mixture collected from industrial facilities is too dilute to be an effective stand-alone fuel, it must be cofired in natural gas turbines. For this reason, it is not a very promising opportunity fuel. *Industrial VOC's will not be considered for further evaluation in this report.*

**\*Landfill Gas (4.5)** – Although it is an essentially free and plentiful fuel source, landfill gas must be utilized either on-site or within a 10-15 miles of a landfill. When utilized on-site, excess electricity can be sold to the power grid, but the thermal demand for landfills is too low to warrant CHP applications, unless it is utilized by a nearby facility. Even so, landfill gas is one of the most promising opportunity fuels. The market is strong, it is being heavily backed by the EPA, and it can provide a sizeable revenue for landfill operators. *Landfill Gas is a promising fuel and will be examined further in the following sections.*

**Municipal Solid Waste and Refuse Derived Fuel (3.0)** – Aside from its cost, MSW and RDF are inferior fuel. It has a low heating value, high moisture content, and many impurities. Gasification of waste is almost always preferred, and new technologies are making this possible. MSW does not have a very promising future. *Municipal Solid Waste and Refuse Derived Fuel will not be considered for further evaluation in this report.*

**Orimulsion (2.5)** – Despite the fact that Orimulsion is a low-cost fuel that performs fairly well, there is currently no market for the fuel in the United States. Until the U.S. market barrier is broken, Orimulsion can only be considered for overseas projects. *Orimulsion will not be considered for further evaluation in this report.*

**Petroleum Coke (3.5)** – While there is a plentiful supply of Petroleum Coke, and the price is lower than coal, it is a dangerous substance and contains a great deal of contaminants. So far, it has only been applied to large-scale operations, and it is not well suited for small DER/CHP projects. *Petroleum Coke will not be considered for further evaluation in this report.*

**Sludge Waste (2.5)** – Like MSW, the most positive aspect of Sludge Waste is its cost. The heating value is even lower than MSW, and the moisture content higher. It does not make a very good fuel, and anaerobic digestion is almost always preferred. *Sludge Waste will not be considered for further evaluation in this report.*

**Textile Waste (3.0)** – As a stand-alone fuel, the quality of textile waste is poor. It must be cofired with coal in large-scale applications to become effective. Even then, its usefulness is limited to reducing fuel costs for textile mills. *Textile Waste will not be considered for further evaluation in this report.*

**\*Tire-Derived Fuel (4.0)** – While tire-derived fuel performs similarly to coal, like coal, it is best suited for large-scale industrial operations. However, it could be a potential fuel source for steam turbines in the 25-50 MW range, and it is an excellent candidate for CHP. The availability is plentiful, and its price is about the same as or less than coal. *Tire-Derived Fuel is a promising fuel and will be examined further in the following sections.*

**\*Wellhead Gas (4.5)** – The gas collected from oil and gas well caps is full of contaminants, but high in heating value. The market is currently limited to oil and gas wells and their surrounding areas, and as the demand for energy at oil and gas wells is small, CHP is only beneficial when a nearby facility can utilize the heat. However, this technology is in its infancy, and there are hundreds of oil and gas wells simply flaring their wellhead gas that could potentially benefit from on-site power production. *Although not ideal for combined heat and power applications, wellhead gas is a promising opportunity fuel and will be examined further in the following sections.*

**\*Wood (Forest Residues) (4.0)** – Forest residues, or harvested wood, is the most utilized solid biomass fuel in the country. The price is relatively high, but the fuel performs well and resources are plentiful. While best suited for large-scale applications, it is also ideal for steam turbines in the 25-50 MW range. *Forest Residues are a promising fuel and will be examined further in the following sections.*

**\*Wood (Urban Wood Waste) (4.5)** – Urban wood waste can come from a variety of sources, and the price is always less expensive than forest residues or harvested wood. However, depending on the source, the wood waste may contain some contaminants and impurities that raise emission levels and must be removed prior to burning. *Urban Wood Waste is a promising fuel and will be examined further in the following sections.*

## **Chapter 2 Summary**

After summarizing the attributes, benefits, and drawbacks of each opportunity fuel, black liquor, blast furnace gas, coke oven gas, crop residues, food processing waste, industrial VOC's, MSW, Orimulsion, petroleum coke, sludge waste, and textile waste were eliminated from further evaluation. For most of these fuels, the quality is too low, the price is too high, or the market is not strong enough. Other fuels are only suitable for cofiring or large-scale industrial applications. For the remaining opportunity fuels (listed on the next page) a more in-depth analysis is performed, starting with a description of the prime mover technologies, and followed by an examination of each fuel's availability, current status, and future outlook.

### **Opportunity Fuels Considered for Further Evaluation:**

- Anaerobic Digester Gas
- Biomass Gas
- Coalbed Methane
- Landfill Gas
- Tire-Derived Fuel
- Wellhead Gas
- Wood (Forest Residues)
- Wood Waste





### 3

## ***DER Technologies for Opportunity Fuels***

Distributed energy resources (DER) are typically defined as small power generation sited at or close to the facility that uses the output. Most DER technologies can be used with opportunity fuels, including steam turbines, combustion turbines, reciprocating engines, microturbines and fuel cells. Each of these technologies can be configured to capture waste heat and produce useful thermal output, typically referred to as combined heat and power (CHP). For solid fuels that are not gasified (TDF and wood fuels), a steam turbine and boiler unit is the only practical technology option, since solids can only be efficiently burned in a boiler. Gaseous fuels can also be burned in a boiler to produce steam, but reciprocating engines, combustion turbines, microturbines, and fuel cells are also options for gaseous opportunity fuels. Each technology has its advantages and disadvantages, depending primarily on fuel characteristics and site electrical and thermal loads.

This chapter examines the various technologies used for producing power with opportunity fuels. An introduction and brief overview of the leading DER technologies (steam turbine, combustion turbine, reciprocating engine, microturbine, and fuel cell) is given, discussing the history, operation, emissions, efficiency and costs associated with each technology. Then, equipment modifications and specializations required for opportunity fuels are discussed, and the associated costs are estimated. Maintenance issues are also identified for each technology and fuel, with estimated cost increases for each case. Finally, potential applications for the prime mover technologies are discussed. At the end of the chapter, the equipment and maintenance costs for each fuel are summarized in table form.

### **Steam Turbines**

Steam turbines were invented in 1884 by Englishman Charles Parsons as an alternative to the reciprocating steam engines that dominated the era. They were first brought to America in the early 1900's for industrial operations and power generating applications. The steam turbines produced electricity much more efficiently than reciprocating steam engines, and quickly became the American standard.

Throughout the 1900's, new developments in steam turbines were made, making them more efficient and capable of producing electricity at an extremely low cost. Improving the metallurgy of the turbines allowed for higher temperature and pressure steam, which improved the turbine performance. Electric efficiencies were improved to about 33 percent. However, the advent of combustion turbines slowed down the progress of the steam turbine, as combustion turbines can be sited more quickly. Still, steam turbines remain a consistent and reliable source of power. Although traditionally used for large-scale power applications, steam turbines have proven themselves successful in many DER/CHP operations in the 5-50 MW range, particularly with solid waste and byproduct fuels.

### **Operation**

A high-pressure boiler is used by steam turbine systems to generate steam. Water enters the boiler and is heated to a high temperature and pressure, creating steam that enters the turbine. The steam causes the turbine blades to rotate, creating power that is converted into electricity with a generator. A condenser and pump are used to collect the leftover steam and water, feeding it into the boiler and completing the cycle. This cycle is illustrated in Figure 3-1.

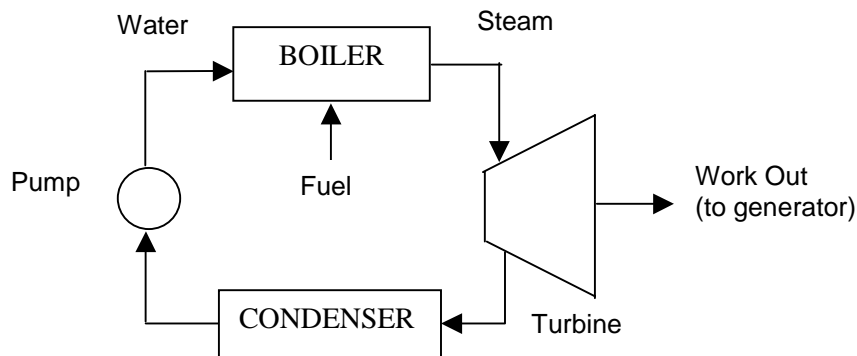

**Figure 3-1. The Steam Turbine Cycle**

Emissions created in the operation of steam turbines are generated in the boiler, where the fuel is combusted. Because the working fluid in the turbine is steam, and not gas, there is no harmful exhaust from the turbine. For CHP applications, the steam is often used for process heating, and this can be done in two ways. With a topping cycle, the steam is first used in the turbine for electricity generation, and the lower-pressure steam is then used for heating. With a bottoming cycle, the steam is used first for process heat, and is then sent to the turbine to generate electricity. The electric and thermal demands of a facility help dictate which method is chosen.

### **Emission Controls**

Boilers using coal or other solid fuels usually produce more emissions than those using oil or gas because it is easier to control the combustion of liquids and gases.

NO<sub>x</sub> is one of the greatest environmental concerns, and emission regulations can be strict in certain areas. Selective catalytic or non-catalytic reduction can be employed after the fuel is combusted to reduce NO<sub>x</sub> emissions. In addition, low excess air firing, low nitrogen fuel oil, water or steam injection, and flue gas recirculation can all work to bring down the boiler NO<sub>x</sub> levels. The best choice will depend on local air pollution statutes, the boiler's characteristics, and the fuel that is used.

Sulfur compounds, or SO<sub>x</sub>, are also a major concern. Reduction methods include using low sulfur fuel (tire-derived fuel and wood fuels produce less sulfur than coal) and desulfurizing the fuel and/or flue gas. Dispersion methods, which use a tall stack to release the exhaust gas higher into the atmosphere, also help to reduce the harmful effects of sulfur emissions.

Carbon monoxide (CO) is another concern, but modern boilers are designed to limit the amount of CO produced in the combustion process. Proper burner maintenance should prevent CO from reaching undesirable levels. Volatile organic compounds (VOCs), hydrocarbons, and particulate matter are also potential emission problems. Like carbon monoxide, proper burner and boiler maintenance should keep these emissions at acceptable levels.

### **Efficiency**

Modern steam turbine power plants have electric efficiencies of around 35 percent. Smaller turbines have a harder time reaching this number, and low-Btu opportunity fuels lead to even lower efficiencies. For CHP projects in the 5-50 MW range, electrical efficiencies of 20 to 35 percent are typical, depending on the turbine size and opportunity fuel used (a 5 MW turbine running on LFG might have an efficiency of

20 percent, while a 50 MW turbine running on CBM could have an efficiency of about 35 percent). Chemical deposits and corrosion in the boiler will bring the efficiency down over time, but this can be countered with regular cleaning and maintenance.

## **Equipment Costs**

Compared to combustion turbines and reciprocating engines, steam turbine-based DER is more expensive to obtain and operate. The cost per kilowatt decreases as the turbines get larger, making large facilities the most ideal locations. However, when working with a free or relatively cheap fuel source, smaller steam turbines can still be economical. Also, unless gasifiers are used, steam turbine boiler systems are the only technology that can utilize solid fuels.

The cost per kW to obtain a steam turbine boiler system ranges from \$400 to \$1,200 per kW, with between \$200 and \$400 per kW for installation. The boiler usually makes up about 20-25 percent of the overall price for a new steam turbine system.

## **Equipment Modifications for Opportunity Fuels**

In a typical steam turbine setup, the only equipment that may require modification to use opportunity fuels is the boiler system. Boilers are available that run on either solid or gaseous fuels, but only solid (coal) boilers are modified to run on solid opportunity fuels, and only gaseous (natural gas) boilers are retrofit to run on other gaseous fuels. The base costs for solid and gaseous boilers are comparable, but some fuels will require more modifications than others. Most opportunity fuels require higher flow rates and leave many deposits behind, so the boiler must be modified to accommodate the increased gas volume and resulting deposit buildup.

### **Solid Fuels**

For solid-fueled boilers, the fuel is dried, pulverized (if necessary), and incinerated to generate heat and produce steam. Coal-fired boilers are specifically designed to burn pulverized coal, so modifications will be required if the fuel's characteristics are different. Usually the opportunity fuel is broken down into chips so that it does not need to be pulverized. Stokers are often the best choice for incinerating opportunity fuels since they will work with almost any solid fuel and require no modifications, but fluidized bed boilers are sometimes required due to emissions. The amount of changes that are necessary, and how much the boiler would cost, depends on the boiler design and the fuel that is used, but some generalizations can be made.

Solid biomass fuels (wood and wood waste) have relatively low Btu content and contain some impurities (especially urban wood waste). Typically, circulating fluidized bed or moving grate boilers are used. A boiler built for biomass fuels would cost between 50 and 100 percent more than a normal boiler, and some additional cleaning/filtration devices may be required. Because of these changes, the overall cost for a steam turbine system would increase by around 25 percent. Wood wastes typically contain more contaminants, so additional impurity removal equipment is usually required, adding on about 5 percent to the total cost.

Tire-derived fuel, unlike wood fuels, has about the same heat content and combustion characteristics as coal. If shredded and pulverized adequately, TDF should be able to power any coal-fired boiler with little to no necessary modifications. It is assumed that no modifications will be required, and that the equipment will cost about the same as for coal. However, most TDF grades have metal wires embedded in the tires, which can cause problems in the boiler and will likely increase maintenance costs.

### **Boiler Modification/Replacement**

If a steam turbine system is already in place with a coal-fired boiler, the boiler may be replaced without any necessary changes to the turbine. Although most boilers can be customized to run on any suitable fuel, the modifications required can become expensive, and more maintenance is usually required. In these cases, it may make more sense to simply replace the boiler in the steam turbine system. If a new boiler were built for an existing system, it could be custom-designed for a specific opportunity fuel and the existing steam turbine. Since a boiler makes up about 20-30 percent of the price of the steam turbine system, replacing it would cost about 20-30 percent of the price of a new boiler-steam turbine system. Of course, cofiring with coal in an existing boiler would not require any modifications or equipment costs as long as the fuel is thoroughly processed and kept below a maximum percent. However, even though cofiring can be advantageous, the market analysis presented later in this report focuses on applications using 100 percent opportunity fuels.

### **Gaseous Fuels**

Gaseous opportunity fuels can also be combusted in a boiler in order to operate steam turbines. Anaerobic digester gas and landfill gas can be classified as low-Btu gases (gases with heat contents between 400 and 600 Btu/ft<sup>3</sup>). A boiler designed to run on a low-Btu fuel, however, costs only slightly more than natural gas boiler. There is a slight decline in efficiency and power output, and more maintenance is required, but the boiler itself costs nearly the same as one designed to operate with natural gas. With everything considered, a steam turbine designed to run on low-Btu fuels would only cost about 10-15 percent more than the natural gas alternative. If an anaerobic digester is required to produce ADG, the capital cost is approximately \$900-\$1,500 per kW, depending on various factors.

Unlike solid-fueled boilers, natural gas boilers can easily be modified to operate on low-Btu fuels. With a few changes to the burner and manifolds, boilers can use these fuels with only a small decrease in efficiency and power output. The resulting cost per kW to modify existing equipment would not exceed 10 percent the price of a new boiler-steam turbine system. Coalbed methane, when it is of high enough quality, can replace natural gas in boilers without any noticeable degradation in quality, so no modifications are required and no additional costs are incurred. Biomass gas can also replace natural gas, with only about a 10 percent decline in power output (assuming a heat content of 600-800 Btu/ft<sup>3</sup>), although the purchase of a gasifier (approximately \$800 per kW, installed) would be required.

### **Maintenance Costs and Issues with Opportunity Fuels**

For steam turbines with coal or natural gas-fired boilers, maintenance typically costs \$0.005 to \$0.011 per kWh. With most opportunity fuels, impurities and deposit accumulations in the boiler and boiler tubes increase, so more maintenance is usually required. As with equipment costs, maintenance costs per kWh tend to decrease as the system size grows.

### **Solid Fuels**

For a steam turbine system running on wood fuels, the variable maintenance required for the boiler typically doubles. Since about half of the maintenance associated with a steam turbine system is required by the boiler, variable maintenance for the system costs about 50 percent more than normal. With urban wood waste and mill residues, more impurities are present, so more cleaning and maintenance is necessary – an additional 10 percent is estimated. When boilers are designed specifically for wood fuels (as opposed to modified), the maintenance costs may not be as high.

Tire-derived fuel, however, burns somewhat cleaner than coal and does not require as much maintenance as the wood fuels. TDF requires varying levels of maintenance, depending on the level of wire removal, the size of the chips, and the incineration temperature. In general, variable maintenance costs are expected to increase by about 50 percent compared to coal, mainly because of the more frequent cleaning caused by metal scraps and other impurities embedded in the tires. Since the boiler represents about half of the overall system in terms of maintenance, the variable costs for TDF are increased by 25 percent.

### **Gaseous Fuels**

For gaseous low-Btu fuels, a boiler's variable maintenance costs will increase by about 50 percent as well (corresponding to 25 percent for the entire steam turbine system). The low-Btu fuels produce more deposits and increase fouling of the tubes, requiring additional and more frequent cleaning and maintenance. For ADG, if an anaerobic digester is not already installed, an additional \$0.001 to \$0.003 per kWh is required for maintenance. Biomass gas, a medium-Btu fuel, usually does not require additional maintenance costs except for the \$0.001 to \$0.003 per kWh required to operate and maintain the gasifier. Coalbed methane, a high-Btu and relatively clean fuel, should not require any additional maintenance costs.

### **Overall Maintenance Costs**

The overall maintenance costs are calculated for a 6,000 hour year of continuous operation. The variable maintenance costs for a natural gas or coal-fired system are multiplied by a percentage factor dependant on the opportunity fuel, and the fixed maintenance costs remain the same. Overall, the cost to maintain a steam turbine-boiler system running on low-Btu gas is about \$0.006 to \$0.013 per kWh. For biomass gas and tire-derived fuel, the cost increases slightly to \$0.006-\$0.014. For wood and wood waste, the total maintenance costs are higher at \$0.007 to \$0.016, and \$0.008-\$0.017, respectively. With coalbed methane, the annual maintenance costs are comparable to natural gas, in the range of \$0.005-\$0.011 per kWh.

### **Applications for Steam Turbines**

Steam turbines are suitable for a number of CHP applications, but they are not common in the DER market, except in the paper, chemical and petroleum industries. Their efficiencies are higher with large industrial units, and they are believed by many to be outdated, expensive, and maintenance-prone. This is true to an extent, as they are generally more expensive than reciprocating engines and combustion turbines. Also, licensed boiler operators are sometimes required to maintain the boiler system, and a constant clean source of water is needed. However, maintenance costs are often lower than reciprocating engines and combustion turbines, and steam turbines tend to make a good choice for DER and CHP when waste fuels are utilized and leftover steam is used for heating. For solid waste fuels without gasification, steam turbine systems are often the only choice available, and for gaseous opportunity fuels they tend to require less modifications than combustion turbines. Furthermore, the emissions from boilers can be less than combustion turbines or reciprocating engines when using gaseous fuels. Still, the cost of a steam turbine-boiler system is more expensive than competing technologies and it is most likely to be used only with solid opportunity fuels.

### **Combustion Turbines**

Combustion turbines have been used for power generation for decades, and range in size from simple cycle units starting at about 1 MW up to several hundred MW when configured as a combined cycle power plant. Units from 1-15 MW are generally referred to as industrial turbines, differentiating them

from larger utility grade turbines and smaller microturbines. Units smaller than 1 MW exist, but very few have been installed in the U.S. since their price is high and electrical efficiencies are relatively low. Traditionally, turbine applications have been limited by lower electrical efficiencies to combined heat and power uses at industrial and institutional settings and peaking units for electric utilities. However, improvements in electrical efficiency have been made and combustion turbines are now being used for intermediate and baseload power.

### Operation

Historically, industrial turbines have been developed as aero derivatives using jet propulsion engines as a design base. Some, however, have been designed specifically for stationary power generation or for compression applications in the oil and gas industries. In a combustion turbine, air is compressed, mixed with a gaseous or liquid fuel and ignited. The combustion products are expanded directly through the blades in a turbine to drive an electric generator. The compressor and turbine usually have multiple stages and axial blading. This differentiates them from smaller microturbines that have radial blades and are single staged.

Unfortunately, the intricacy of blade design and spacing with combustion turbines means that most existing units cannot be feasibly retrofit to run on low-Btu gases. However, coalbed methane can always be used, and new units can be specially designed to run on low-Btu fuels. For an illustration of the combustion turbine cycle, see Figure 3-2. The intercooler shown in the figure is generally reserved for larger units that can economically incorporate this improvement.

Combined heat and power is easily achieved with combustion turbines, since their exhaust gas is extremely hot (about 1000°F). The gas can be used to produce steam in a heat recovery steam generator (HRSG). An HRSG is essentially a large heat exchanger that transfers the exhaust gas' heat to water and produces steam. The exhaust gas is cooled to about 300°F – lower temperatures could cause condensation of the exhaust gases that could lead to corrosion, and the steam is heated to a high temperature and pressure. Combined cycle units (where steam from the HRSG is used to power a steam turbine) are commonly used by utilities and large industrial operations due to their high efficiency and power output. In DER sized units, the steam produced in the HRSG can be used for industrial processes or other heating applications.

### Emission Controls

Given that combustion takes place outside of the turbine area (unlike reciprocating engines, where combustion takes place inside the cylinder), turbines have more flexibility in reducing NO<sub>x</sub> emissions. NO<sub>x</sub> emissions from uncontrolled natural gas turbines range from 75 to over 150 ppm, due to high combustion temperatures. Emissions control of combustion turbines can be accomplished by injecting water or steam to reduce the combustion temperature and reduce NO<sub>x</sub> levels down to 25-45 ppm. In addition, these methods increase power production and can increase the system efficiency. While these means have proven effective in limiting NO<sub>x</sub> emissions, the availability of water supply and space for storage tanks are constraints for some applications. Some turbines use diffusion flame combustors, which inject small amounts of air into the fuel prior to combustion, mixing the gases with turbulent diffusion. In many states, these measures are deemed adequate to meet NO<sub>x</sub> regulations.

Dry Low NO<sub>x</sub> (DLN), conceptually similar to lean burn technology for reciprocating engines, creates a lean, homogeneous mixture of air and fuel that then enters the combustor. This minimizes hot spots and reduces the combustion temperature, which leads to lower NO<sub>x</sub> levels. DLN has become the standard for NO<sub>x</sub> control in natural gas combustion turbines, but it is not easily used with low-Btu fuels.

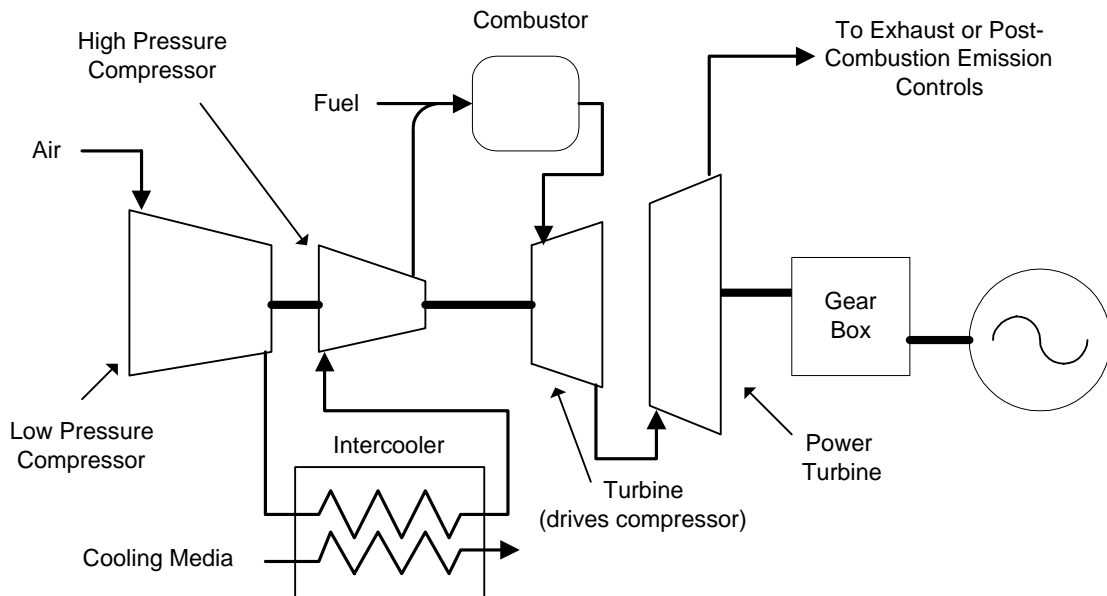

**Figure 3-2. Combustion Turbine System (with intercooler)**

Although combustion turbines tend to generate lower emissions than reciprocating engines, in many U.S. states units must be installed with additional control technologies to further reduce  $\text{NO}_x$  emissions. Selective catalytic reduction is the primary option for further reduction of  $\text{NO}_x$ . Catalytic combustors, one emerging  $\text{NO}_x$  control option, fully convert the input fuel and air without the use of a flame. Since in a traditional combustor the majority of  $\text{NO}_x$  is produced in the high-temperature region near the flame, catalytic systems substantially reduce these emissions. This system is currently under demonstration and is not yet commercially available.  $\text{SCONO}_x$ , another emissions control development, uses a proprietary oxidation/adsorption/regeneration process to reduce  $\text{NO}_x$ , CO, and total hydrocarbons to levels below U.S. standards. This technology is currently being developed, and may allow for economic installations of industrial turbines with single digit  $\text{NO}_x$  emissions.

## Efficiency

Electrical efficiencies of simple cycle combustion turbines in the 1-50 MW range fall between 25 and 40 percent. For combined cycle turbines, electric efficiencies are more on the order of 30 to 45 percent. Low-Btu fuels and smaller applications will stay on the lower side of these ranges. More durable and temperature resistant materials (ceramics, single-crystal superalloys, and directionally solidified material) or advanced cooling schemes (transpiration and vortex) are needed for first stage turbine blades and combustors in order to increase the operating temperature/compression ratio and, therefore, efficiencies of turbines. Such developments will also result in less down-time and lower-cost maintenance.

Efficiency may be improved through the use of recuperators (air-to-air heat exchangers that use exhaust gases to preheat the compressed combustor inlet air). Although recuperation is not commonly employed for turbines in the  $>1$  MW size range, Solar Turbines now offers its Mercury 50, a 4 MW recuperated unit with an electric efficiency of 38.5 %. Intercooling (cooling air between 2 or more compression stages) can increase efficiency by reducing air compression power requirements, and produces lower temperature

air for better cooling of turbine parts, but this is unlikely for DER units. Ambient effects on efficiency are also important since peak turbine use is normally during high temperature periods when turbine maximum output is lowest. Current methods to lessen the effects of ambient temperature include evaporative, mechanical, or adsorption inlet air chillers, steam injection into the combustor for higher mass flow or NO<sub>x</sub> control, and compressed air storage/injection.

### **Equipment Costs and Modifications for Opportunity Fuels**

Combustion turbines cost significantly less than most steam turbine systems on a per kilowatt-basis. The combustion unit is not as expensive as a boiler, and costs less to maintain. However, combustion turbines require a high pressure gas as the working fluid, so a fuel compressor is necessary for ADG, LFG and CBM which are collected at around atmospheric pressure. The fuel compressor will use up approximately 10 percent of the power generated, so the cost per kW increases by about 10 percent. The cost to obtain a natural gas combustion turbine ranges from \$300 to \$900 per kW, depending on the unit's size and design, with between \$200 and \$300 per kW for installation. Smaller facilities will fall on the higher end of the price spectrum. Combined cycle units typically cost a few hundred dollars more per kW.

Combustion turbines can run on low-Btu gases, but it is not very practical and major modifications are almost always required. Gases with low heat contents require higher flow rates, and usually contain more impurities than natural gas. To accommodate this, modified nozzles, large combustion areas, heavy-duty compressors, large intake manifolds, and more cleaning devices are required. Since the gas must be compressed heavily, much of the power generated from the turbine would have to be used on the compressor. In addition, the gas collected from landfills and digesters does not always flow in a continuous stream, which could cause blade stalling and other issues for the turbine. Finally, most combustion turbines are designed for large-scale industrial applications, but most landfills and treatment plants do not produce enough gas for this, and are limited to small power production.

Because of all the modifications required, existing natural gas turbines cannot easily be retrofitted to run on low-Btu fuels. Combustion turbines designed for low-Btu gases generally cost 50 percent more than natural gas turbines on a per kW basis, but sometimes the cost can be doubled, depending on the turbine's size and design. If an anaerobic digester is to be installed, additional capital costs of \$900- \$1,500 per kW are incurred. Operation and maintenance costs for ADG and LFG also increase significantly when compared to natural gas. For these reasons, combustion turbines are usually not the most attractive option for low-Btu fuels. However, many turbines utilizing ADG and LFG have been installed successfully using a natural gas blend. Existing natural gas turbine designs require very few modifications when using blended fuel, and adding natural gas to low-Btu fuels increases their performance. However, this report is focusing on applications solely using opportunity fuels, so the market analysis presented later focuses on higher cost, more capable technology designed to use 100 percent opportunity fuels.

Biomass gas typically produces a medium-Btu fuel that is much cleaner than ADG and LFG. It can be used in most combustion turbines with little to no modifications. Coalbed methane can also be used in combustion turbines, since its properties are so similar to natural gas. The equipment and maintenance costs for biomass gas and coalbed methane are assumed to be the same as when using natural gas as a fuel, although for biomass gas the power output is decreased by about 10 percent (causing a 10 percent increase in equipment cost per kW), and a gasifier (\$500-\$700 per kW plus \$100-\$300 per kW for installation) must be added to the capital costs.

Wellhead gas is a special case, in that it is a high-Btu fuel, but it contains so many impurities that it must be thoroughly cleaned and scrubbed before used in any application besides a microturbine. So much



cleaning is required for gas turbines and engines that microturbines are usually the most attractive option, and the only technology that is used for these projects.

### **Maintenance Costs and Issues with Opportunity Fuels**

Overall maintenance for combustion turbines typically costs between \$0.004 and \$0.008 per kWh for natural gas units. When a gas turbine is operating on a low-Btu gas, only increased cleaning and more frequent maintenance check-ups are required. The increases are significant, however, and variable maintenance costs for low-Btu gas turbines increase by 50 to 100 percent. Variations in gas composition, turbine design, and other factors make the exact number hard to predict, so an additional 75 percent for turbines running on low-Btu gases is estimated. For a 6000-hour year, the total maintenance costs for a low-Btu gas combined cycle turbine would be on the order of \$0.08-\$0.0018 per kWh. An anaerobic digester can add up to \$0.003 per kWh for maintenance. For coalbed methane and biomass gas, the low price of \$0.004-\$0.008 per kWh is maintained, although for biomass gas, gasifier maintenance (\$0.001-\$0.003 per kWh) must be added. With combined cycle turbines, the base-case price rises to \$0.005-\$0.011 per kW, and the same multipliers and adders are used for each fuel.

### **Applications for Combustion Turbines**

Combustion turbines are typically used for industrial and large commercial facilities for CHP applications. Large industrial applications often use combustion turbines in combined-cycle configurations, where the exhaust gas is used to produce steam for a secondary steam turbine. Even in combined cycle configurations, considerable waste heat can be produced for CHP applications. Coalbed methane performs just as well as natural gas, so it is the best opportunity fuel for combustion turbines. Biomass gas also performs well, although its methane content is not quite as high. Low-Btu gases like ADG and LFG are not suited well for combustion turbine applications, and too many modifications on natural gas turbines would be required to accommodate the low-Btu fuels. Furthermore, the size of most ADG and LFG applications is less than 5 MW, so prices will be on the high end of the spectrum. Still, combustion turbines are one of the most prominent DER/CHP technologies, and will be considered for all of the gaseous opportunity fuels.

### **Reciprocating Engines**

Of all the electricity-generating technologies, reciprocating engines have been around the longest. Both Otto (spark ignition) and Diesel cycle (compression ignition) engines have gained widespread acceptance in almost every sector of the economy. For reciprocating engines to operate with gaseous opportunity fuels, Otto cycle engines are usually required. Reciprocating engines have been utilized worldwide for applications ranging from fractional horsepower units to large 60 MW baseload electric power plants. They have become common at landfills and wastewater treatment plants, burning low-Btu waste gases for combined heat and power applications. Reciprocating engines are also commonly used in coalbed methane projects.

### **Operation**

Most engines used for power generation are four-stroke and operate in four cycles (intake, compression, combustion, and exhaust). The four-stroke process begins with fuel and air being mixed, usually before introduction into the combustion cylinder for spark ignited units (see Figure 3-3). In turbocharged applications, the air is compressed before mixing with fuel. The fuel/air mixture is introduced into a combustion cylinder that is closed at one end and contains a moveable piston. The mixture is then compressed as the piston moves toward the top of the cylinder. The pressure of the hot, combusted

gases drives the piston down the cylinder. Energy in the moving piston is translated to rotational energy by a crankshaft. As the piston reaches the bottom of its stroke, the exhaust valve opens and the exhaust is expelled from the cylinder by the rising piston.

Reciprocating engine CHP systems can be designed to produce steam, hot water, or hot air. There are many different possible configurations for heat recovery, and all have their advantages and disadvantages. Standard heat exchangers are typically used to produce hot water and steam. Sometimes, however, ebullient cooling systems are used to produce steam and cool the engine in the process. With ebullient systems, a boiling coolant is circulated through the engine jacket and fed through an air-to-water heat exchanger along with the engine's exhaust. Forced circulation systems, which utilize higher temperature and pressure water in the engine jacket, are sometimes used to produce pressurized steam.

On certain occasions, exhaust gas from the reciprocating engine is used to directly dry certain products such as bricks and ceramics. This is referred to as "dirty drying" because of particulates and other contaminants in the engine's exhaust. The most common method of heat recovery from reciprocating engines, however, remains to be conventional heat exchangers that utilize the engine's hot exhaust gas, jacket water and lube oil to produce hot water and steam. This method is shown in the Figure 3-3 schematic.

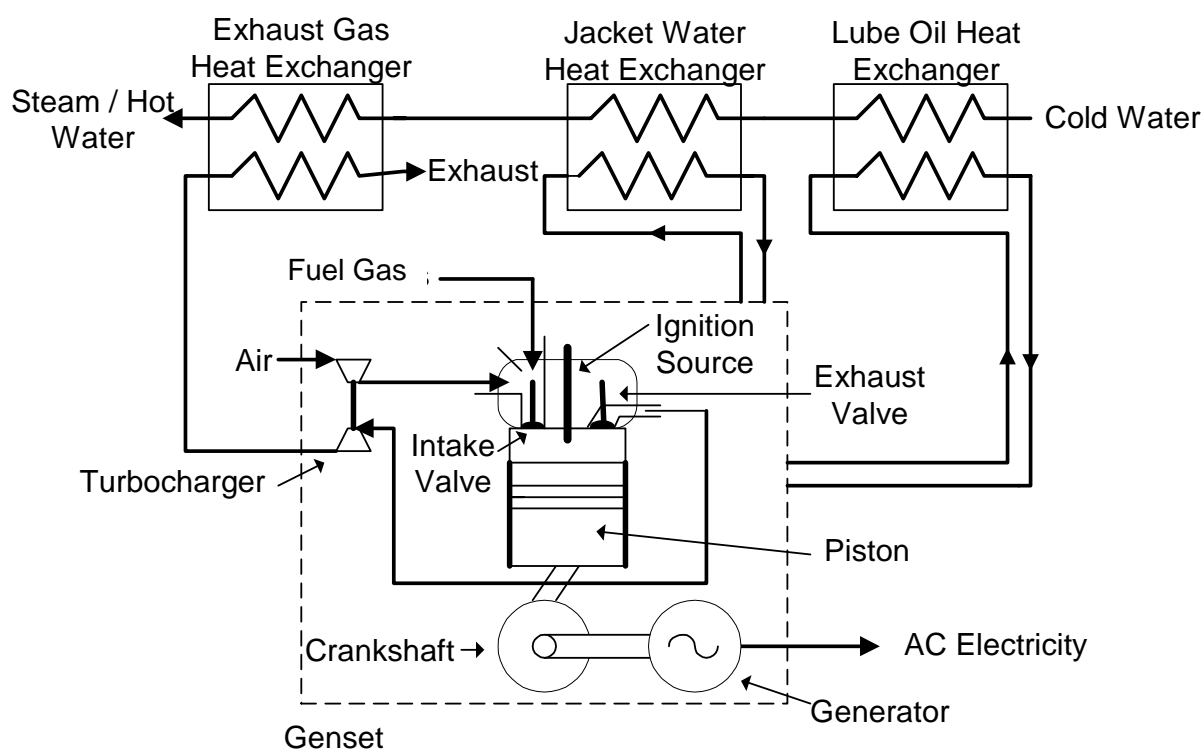

Figure 3-3. Schematic of an Otto (spark-ignition) Reciprocating Engine with Heat Recovery

## Emission Controls

The combustion process produces  $\text{NO}_x$  and, as a result of improper fuel/air mixtures and excessive cylinder cooling, carbon monoxide, hydrocarbon, and particulate emissions. Because reciprocating engines combust gas under high pressure, emission control technologies are harder to apply compared to

turbines, and in general, more NO<sub>x</sub> is produced. Frequent and thorough maintenance helps reduce emissions, and this is needed even more so for most opportunity fuels. Control technologies like Selective Catalytic Reduction (SCR) and other post-combustion methods are complicated and expensive to implement and maintain. In certain areas with strict environmental regulations, SCR is required for reciprocating engines, even when using biogas. This can make it difficult to site units for certain DER/CHP applications.

New emission control methods focus on lean-burn technologies that use a higher ratio of air to fuel than traditional units. Lean-burn combustion improves efficiencies and lowers NO<sub>x</sub> emissions, but also lowers power output. This can be compensated for by the incorporation of turbocharging, which increases the power density. Lean-burn technology, however, is not as effective for low-Btu fuels, which already bring down the engine's power output by as much as 15 percent. The amount of excess air that can be used with low-Btu fuels is limited, as the fuel-air mixture can easily become too dilute. Still, lean-burn technologies are almost always used with LFG and ADG to reduce NO<sub>x</sub> emissions to acceptable levels. Effective turbocharging is necessary when using lean-burn engines with low-Btu fuels.

## Efficiency

Electric efficiencies for reciprocating engines typically fall between 30 and 40 percent, with an overall efficiency of about 80 percent when CHP is utilized. Small engines running on low-Btu fuels will have a harder time reaching these numbers. Combustion chamber design is important not only to the efficient and complete combustion of fuels but also for the reduction of NO<sub>x</sub> emissions. How and when fuel is injected in the cycle plays an important role in how the fuel is combusted, and thus influences power, efficiency, and emissions. High efficiency engines will operate at higher-pressure levels that will require high-energy spark ignition systems with durable components. Effective turbocharging is key to increasing Brake Mean Effective Pressure, which in turn leads to increased efficiency. Turbocharged engines can achieve greater power density, allowing units to be placed in a smaller area and/or lessen foundation reinforcement requirements.

## Equipment Costs and Modifications for Opportunity Fuels

While reciprocating engines have a lower capital cost than most other small power generating technologies, environmental siting, permitting, and other issues can make them expensive to install. Reciprocating engines are most common in the 500 kW to 5 MW size range, but single units as large as 20 MW do exist. The cost to obtain a natural gas-fueled reciprocating engine typically ranges from \$300 to \$800 per kW, with between \$200 and \$500 per kW for installation. Once again, smaller units will fall on the high end of the price spectrum.

Reciprocating engines have the same problems with low-Btu fuels as gas turbines, namely they must be modified to accommodate a higher flow rate and more impurities. However, these modifications are achieved much more easily. More filtration devices and new manifolds are all that is required to accommodate these low-Btu constraints, typically adding on about 5 percent to the cost of a natural gas engine. In addition, the lower heating values of landfill gas and anaerobic digester gas cause about a 15 percent decrease in power output compared to a natural gas engine, which increases the overall cost per kilowatt.

With these factors considered, reciprocating engines designed to run on low-Btu fuels cost about 15 to 20 percent more per kW to obtain than their natural gas counterparts, increasing the price by about \$150-\$200 per kW. Installation costs remain roughly the same. To modify an existing natural gas engine to run on a low Btu gas, it would generally cost around 25 percent of a new engine's installed cost (about \$250

per kW). For facilities installing an anaerobic digester, additional capital costs of \$900-\$1,500 per kW can be expected.

Biomass gas can be used to power reciprocating engines, although combined cycle turbines are almost always used for efficiency purposes. For engines fueled by biomass gas, no equipment modifications are required when the gas is of high enough quality, and only a 10 percent decrease in power output is seen. A gasifier (about \$800 per kW, installed) also must be added to the capital costs.

Coalbed methane can also power reciprocating engines, with no modifications required and only a slight decrease in power output. The installed cost would typically range from \$800 to \$1,200 per kW. As with the other power generating technologies, the performance difference between natural gas and coalbed methane is negligible.

### Maintenance Costs and Issues with Opportunity Fuels

The maintenance problems associated with reciprocating engines are increased wear and tear, more cleaning, and up to 8 times more frequent oil changes for low-Btu fuels. Typically, variable maintenance for a low-Btu gas engine costs about 80 percent more than required for running on natural gas. Normally, the overall maintenance costs for reciprocating engines are about \$0.008-\$0.023 per kWh, when operating on a continuous basis. For low-Btu gases, the variable costs are increased by roughly 80 percent, which brings the total operation and maintenance costs to \$0.013-\$0.039 per kWh for a 6,000 hour year (plus \$0.001-\$0.003 per kWh if an anaerobic digester is installed). For coalbed methane and biomass gas, no additional maintenance is required except for gasifier maintenance (\$0.001-\$0.003 per kWh), so same costs required for natural gas engines can be assumed.

### Applications for Reciprocating Engines

Reciprocating engines are used in a wide variety of applications, and are most often used for backup power (diesel engines). Natural gas models are most commonly used for small DER/CHP operations, particularly in areas with lenient emissions requirements. As for opportunity fuels, reciprocating engines are much better suited for low-Btu gases than combustion turbines. They have been used successfully in many ADG, LFG and coalbed methane power-generating applications, and arguably make the best overall choice in areas where emissions are not an issue.

### Microturbines

The technology used in microturbines is derived from aircraft auxiliary power systems, diesel engine turbochargers, and automotive designs. A number of companies have developed units for small-scale distributed power generation in the 30-500 kW size range. Capstone Turbines are currently offering a line of microturbines capable of operating on a number of different fuels, including anaerobic digester gas, coalbed methane, landfill gas, and wellhead gas. Their two commercial units, at 30 and 60 kW, have been installed in hundreds of successful

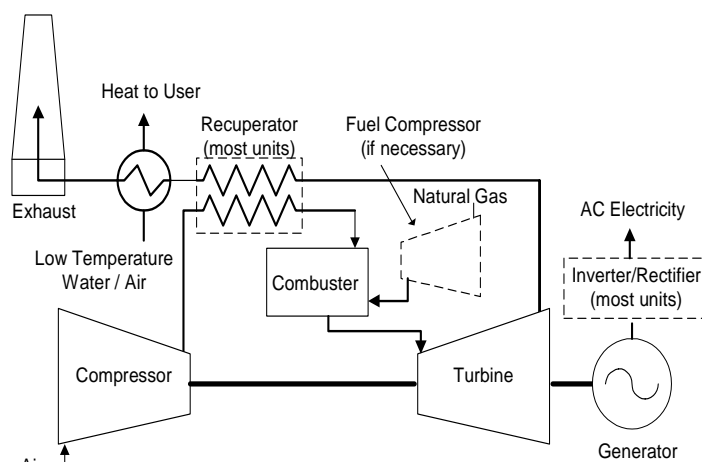

Figure 3-4. Microturbine System with Recuperator

projects, and many more projects are currently in the planning process.

## Operation

Simple microturbines consist of a compressor, combustor, turbine, and generator. The compressors and turbines are typically radial-flow designs, and resemble automotive engine turbochargers with only one moving part. Most designs are single-shaft and use a high-speed permanent magnet generator producing variable voltage, variable frequency alternating current (AC) power. An inverter is employed to produce 60 Hz AC power. Most microturbine units are currently designed for continuous-duty operation and are recuperated to obtain competitive electric efficiencies. A typical microturbine system with a recuperator is depicted in Figure 3-4.

Microturbines rotate at high-speeds (40,000+ rpm) and therefore require high-reliability bearing systems. Two configurations are currently being used: air bearings with a compliant foil system, and a pressurized lube-oil system with a pump. Systems with air bearings eliminate the oil system and are simpler, require less maintenance, and have no parasitic oil pump load. However, oil bearings generally last longer.

Microturbines do not produce as much heat as combustion turbines, but they can still be used to produce hot water and steam for CHP applications. Unrecuperated models have a much higher exhaust temperature than recuperated models, but at the sacrifice of electric efficiency and power output. If the microturbine is going to be used extensively for heating applications, the choice between recuperated and unrecuperated can be difficult. Ultimately, it depends on the facility's power needs, and in either case a simple heat exchanger is used.

## Emission Controls

In general, microturbine emissions are lower than steam turbines, combustion turbines and reciprocating engines. NO<sub>x</sub> levels are reported as less than 9 ppm for the Capstone microturbine (30 kW) running on natural gas, without the use of any emission control technologies. Achieving less than 9 ppm is also the goal for microturbine projects using LFG and ADG, but this can be difficult to obtain if the methane percentage falls below 40 percent. Still, NO<sub>x</sub> emissions of less than 9 ppm can almost always be achieved as long as a 15% oxygen mix is used. Some field tests show that when operating at part-load, NO<sub>x</sub> emissions for microturbines are significantly higher than 9 ppm, but the units' small size usually exempts them from emissions regulations.

Emission control technologies in microturbines tend to focus on combustor design and flame control rather than techniques used in larger industrial turbines like water/steam injection. However, because of their small size, these units can fall below most compliance requirement triggers. As a result, some microturbine installations have been exempt from emission regulations, and they are a popular choice for government-assisted ADG and LFG projects.

## Efficiency

Recuperators (air-to-air heat exchangers that use exhaust gases to preheat the combustor inlet air) can improve microturbine electric efficiency to between 20-30% versus the 14-20% efficiency rates of typical non-recuperated units. Microturbines running on low-Btu gases are somewhat less efficient. Obtaining a higher efficiency may require higher engine temperatures necessitating improvements in recuperator materials (such as ceramics). Microturbine efficiency is impacted by the available fuel's pressure level. Units that are supplied high-pressure gas (50-60 psig) are 1-4% more efficient than those using low-pressure gas because of the parasitic requirements of the fuel compressor.

## Equipment Costs and Modifications for Opportunity Fuels

Although microturbines are more expensive than the traditional prime movers, they do not produce as many emissions. The cost to obtain a microturbine ranges from \$700 to \$1,300 per kW, with between \$300 and \$700 per kW for installation.

Microturbines are a promising new power generating technology for DER and CHP applications. They only have one rotating part, so wear and tear and deposit accumulation are minimal. Microturbines were designed to work well with a variety of gases, and can handle methane contents as low as 35 percent, making them ideal for low-Btu gases like landfill gas and ADG. However, with low-Btu biogases, a fuel compressor may be required to compress the gas to 55 psig. The capital cost of the fuel compressor is not very significant compared to the capital cost of installing a microturbine system, but it does require a good deal of power to operate. The power consumption of the fuel compressor is about 10 percent of the microturbine's power output, so a Capstone microturbine rated at 30 kW is only capable of producing 27 kW of power when running on biogas.<sup>1</sup>

Microturbines can handle low-Btu gases better than most engines and turbines because of their simple design. No modifications are required, but in addition to the power required by the fuel compressor, there is a small decline in power output (5-10 percent) when running on landfill or digester gas. With both factors considered, a 15-20 percent increase in price per kilowatt is seen for microturbines utilizing low-Btu gases. The only other drawback is slightly increased maintenance, discussed in the next section. With ADG, the purchase of a digester (\$900-\$1500 per kW) may be required. Coalbed methane and biomass gas can also be used to fuel microturbines, with relatively no decrease in power output and no necessary modifications (although a fuel compressor will likely be required, and in the case of biomass gas, a gasifier must be added).

Unlike the other power generating technologies, microturbines are perfectly capable of using dirty wellhead gas as a fuel, and their small size makes them ideal for oil and gas well applications. The wells are already required to flare excess wellhead gas to prevent pressure buildup, but it is difficult and costly to clean the gas of impurities before it is flared. Unless the high-impurity gas is extensively cleaned prior to combustion, microturbines are the only technology that can handle it. Wellhead gas has an extremely high heat content (1,100 Btu/ft<sup>3</sup>), and a high pressure, so there is no decrease in power output. No modifications are necessary for microturbines to run on wellhead gas, although more maintenance will be required.

## Maintenance Costs and Issues with Opportunity Fuels

Microturbines are different from normal steam and gas turbines in that they contain only one rotating part, and do not require liquids for cooling or lubrication. For a microturbine running on natural gas, overall maintenance typically costs between \$0.006 and \$0.012 per kWh. Microturbines are designed so that they can run on nearly any methane-based gas, including the low-Btu waste gases, with only a slight decrease in power output. More variable maintenance is required, however, usually about 50 to 60 percent more than normal. Wellhead gas contains even more impurities than low-Btu gases, but it does have a much higher heating value. It is assumed that the maintenance for wellhead gas microturbines would be about the same for ones running on low-Btu gas on a per kWh basis. For microturbines running on these opportunity fuels, overall maintenance costs between \$0.008 and \$0.017 per kWh, when operating at 6,000 hours a year. With ADG, a digester's maintenance costs between \$0.001 and \$0.003

---

<sup>1</sup> At temperatures above 65°F, the Capstone C30's maximum power output drops below 30 kW (25 kW at 90°F), and using a low-Btu fuel will further bring it down.

per kWh. With coalbed methane, no additional maintenance is required so costs should stay in the \$0.006-\$0.012 per kWh range, and with biomass gas, an additional \$0.001-\$0.003 per kWh for the gasifier is added.

### **Applications for Microturbines**

Perhaps the greatest advantage of microturbines is their ability to accept a wide range of fuel types. While most turbines and reciprocating engines must be redesigned to accommodate low-Btu or high-impurity fuels, microturbines can easily operate on these lower-quality fuels with no necessary modifications. This is due mainly to the microturbine's simple design. Microturbines also have a very small footprint, which makes them ideal for DER applications, and their design allows for easy CHP implementation. Microturbines produce low emissions, so they have become popular in New York and other areas with strict environmental regulations. They are often chosen for anaerobic digester gas and landfill gas power generation, and they are the only technology capable of producing power from untreated wellhead gas. As time goes by and costs go down, microturbines may become an increasingly common technology for DER/CHP applications, especially with gaseous opportunity fuels.

### **Fuel Cells**

Fuel cells are an emerging small-scale power generation technology, mostly under 1 MW, although larger applications do exist. The first fuel cell was developed in 1839 by Sir William Grove. However, they were not used as practical generators of electricity until the 1960's when they were installed in NASA's Gemini and Apollo spacecraft. One company, UTC Fuel Cells, currently manufactures a 200 kW phosphoric acid fuel cell that is being used in commercial and industrial applications. These fuel cells have been used successfully in ADG and LFG power applications, and many more projects are currently being planned. A number of other fuel cell companies are field-testing demonstration units, and commercial deliveries are expected in 2004-2005.

### **Operation**

There are many types of fuel cells, but each uses the same basic principle to generate power. A fuel cell consists of two electrodes (an anode and a cathode) separated by an electrolyte. Hydrogen fuel is fed into the anode, while oxygen (or air) enters the fuel cell through the cathode. With the aid of a catalyst, the hydrogen atom splits into a proton (H<sup>+</sup>) and an electron. The proton passes through the electrolyte to the cathode, and the electrons travel through an external circuit connected as a load, creating a DC current. The electrons continue on to the cathode, where they combine with hydrogen and oxygen, producing water and heat. A typical fuel cell is illustrated in Figure 3-5.

The main differences between fuel cell types are in their electrolytic material. Each different electrolyte has both benefits and disadvantages, based on materials and manufacturing costs, operating temperature, achievable efficiency, power to volume (or weight) ratio, and other operational considerations. Currently only Phosphoric Acid fuel cells are being produced commercially for power generation. Other types, such as solid oxide, proton exchange membrane, and molten carbonate fuel cells, have entered the testing and demonstration phases. The part of a fuel cell that contains the electrodes and electrolytic material is called the "stack," and is a major component of the cost of the total system. Stack replacement is very costly but becomes necessary when efficiency degrades as operating hours accumulate.

Fuel cells require hydrogen for operation. However, it is generally impractical to use hydrogen directly as a fuel source; instead, it is extracted from hydrocarbon fuels using a reformer. Cost effective, efficient fuel reformers that can convert various fuels to hydrogen are necessary to allow fuel cells increased

flexibility and commercial feasibility. Fuel reformers have been built to extract hydrogen from almost any type of fuel, including anaerobic digester gas and landfill gas.

UTC's phosphoric acid fuel cells can easily be used in two different types of industrial cogeneration applications: to produce hot water at around 140° F, or to produce hot water at around 140° F and low temperature steam at 250° F. Overall CHP efficiency for both is around 80%.

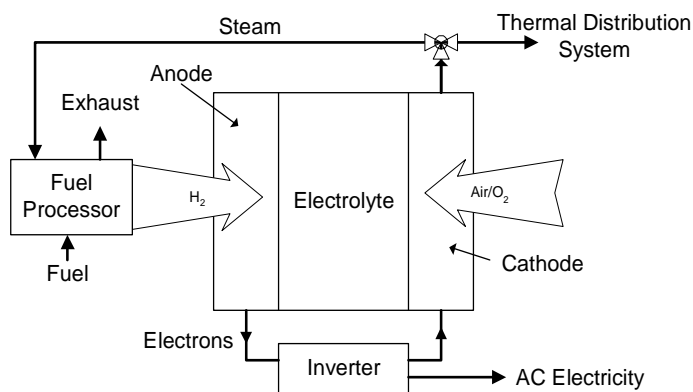

**Figure 3-5. Fuel Cell Schematic**

Proton exchange membrane and alkaline fuel cells operate at lower temperatures, so only hot water and space heating applications are possible. Solid oxide and molten carbonate fuel cells, however, operate at extremely high temperatures (over 1000°F) so they can be used in a number of cogeneration applications, as well as fuel cell-turbine hybrid systems.

### Emission Controls

Fuel cells have very low levels of NO<sub>x</sub> and CO emissions because the power conversion process is electrochemical rather than combustion-based. For this reason, as emission standards become increasingly stringent, fuel cells will offer a clear advantage, especially in non-attainment zones. To date, fuel cells have been exempt from environmental regulations in most parts of the United States.

### Efficiency

Fuel cells are the most consistently efficient power generating technology. PAFC's generate electricity at about 35-40 % efficiency, with an overall efficiency of 70-80% if the by-product thermal energy produced by the fuel cell is used for cogeneration. Most of the other fuel cell designs have higher electric efficiencies, but still achieve an overall efficiency of about 80% when cogeneration is utilized. Operating temperatures for phosphoric acid fuel cells are in the range of 350-400°F.

### Equipment Costs and Modifications for Opportunity Fuels

Fuel cells are very expensive to obtain at this time since they are a new technology, but their installation costs are average and maintenance costs are very low. As time goes by, the price of fuel cells may go down, and they may become more competitive with the other power generating technologies. The cost to obtain a fuel cell system is typically \$4,000-\$5,000 per kW, with about \$300-\$500 per kW for installation.

Fuel cells normally run on natural gas, using a fuel reformer to extract the free hydrogen. Fuel cells can also run on anaerobic digester gas or landfill gas, but they require a slightly different fuel reformer, with a larger fuel injector and larger piping. For landfill gas, extensive scrubbing is sometimes necessary to neutralize the sulfur and halides. While fuel cells running on natural gas cost close to \$4,000 per kW, units operating on low-Btu fuels would cost slightly more to obtain, with a small decline in power output. For the purposes of this project, it is assumed that low-Btu fuels will add about 10 percent to the equipment cost. If the purchase of an anaerobic digester is required, an additional capital cost of \$900-



\$1,500 per kW can be expected. Of course, coalbed methane and high-quality biomass gas could also be used to power fuel cells with minimal modifications (although with biomass gas, an installed gasifier will add around \$800 per kW on to the total cost).

### **Maintenance Costs and Issues with Opportunity Fuels**

Today's fuel cells (phosphoric acid) cost about \$0.011 to \$0.017 per kWh to maintain. Because no combustion occurs in a fuel cell system, there is not as much deposit buildup, and the purity of the fuel used is not as much of an issue. Most of the maintenance issues stem from the fuel reformer, which converts fuels into hydrogen. Using a lower Btu fuel with more impurities may require increased cleaning and maintenance of the fuel reformer. For the purposes of this analysis, the assumption is that maintenance costs will increase about 10 percent with ADG, LFG and biomass gas (for a total of \$0.012-\$0.018 per kWh). For biomass gas, the maintenance costs of a gasifier are also added, and for ADG, digester maintenance may be required.

### **Applications for Fuel Cells**

Since fuel cells are the newest DER/CHP technology, their availability is minimal, and they have not been utilized in many non-demonstration projects. Phosphoric acid and PEM units are less than 500 kW in size, but much larger units are possible in the future with solid oxide and molten carbonate fuel cell systems. Phosphoric acid fuel cells have been used in anaerobic digester gas projects at wastewater treatment centers, with special government funding, and the results have been mixed. Regardless, more ADG fuel cell projects are planned. Recently a fuel reformer has been designed to work with landfill gas, and projects are currently in the planning phases. As environmental regulations become stricter, and the price of fuel cells comes down, they may become more common for DER/CHP applications.

## **Chapter 3 Summary**

The equipment and maintenance costs for the eight chosen opportunity fuels are summarized in Table 3-1 on the following page. The data was obtained by taking the low and high costs for coal/natural gas systems (estimated using DOE technology characterizations and various data sources), and multiplying them by the percentage factors for opportunity fuels, obtained from equipment manufacturers. While the price ranges are often large, they give an idea to how much an average opportunity fuels project would cost in comparison with the different prime mover technologies. For anaerobic digester gas, it is assumed that the facility already has an anaerobic digester installed. If not, an additional capital cost of \$900-\$1,500 and an additional maintenance cost of \$0.001-\$0.003 should be added. CHP equipment is not included, but the cost to install, operate and maintain a heat exchanger remains constant across the board.

In the following chapters, the availability and potential capacity of all eight opportunity fuels are examined, and the current status and future outlook of each fuel is discussed.

Combined Heat and Power Market Potential for Opportunity Fuels

Table 3-1. Equipment and Maintenance Average Costs (not including CHP equipment)

Fuel	Cost	Steam Turbine*	Gas Turbine	Combined Cycle	Recip. Engine	Microturbine	Fuel Cell
Anaerobic Digester Gas**	Modify Existing Equip. (\$/kW)	\$70 - \$180	n/a	n/a	\$140 - \$360	\$0	n/a
	New Equipment (\$/kW)	\$650 - \$1,750	\$650 - \$1,650	\$950 - \$2,100	\$550 - \$1,440	\$1,120 - \$2,230	\$4,700 - \$6,000
	Maintenance (\$/kW/h)	\$0.006 - \$0.013	\$0.006 - \$0.011	\$0.007 - \$0.016	\$0.013 - \$0.039	\$0.008 - \$0.017	\$0.012 - \$0.018
Biomass Gas***	Modify Existing Equip. (\$/kW)	\$600 - \$1,000	\$600 - \$1,000	\$600 - \$1,000	\$600 - \$1,000	\$600 - \$1,000	n/a
	New Equipment (\$/kW)	\$1,240 - \$2,720	\$1,130 - \$2,290	\$1,350 - \$2,620	\$1,130 - \$2,380	\$1,670 - \$3,130	\$5,300 - \$7,000
	Maintenance (\$/kW/h)	\$0.006 - \$0.014	\$0.005 - \$0.011	\$0.006 - \$0.014	\$0.009 - \$0.026	\$0.007 - \$0.015	\$0.013 - \$0.021
Coalbed Methane	Modify Existing Equip. (\$/kW)	\$0	\$0	\$0	\$0	\$0	n/a
	New Equipment (\$/kW)	\$600 - \$1,600	\$530 - \$1,290	\$700 - \$1,500	\$500 - \$1,300	\$1,070 - \$2,130	\$4,300 - \$5,500
	Maintenance (\$/kW/h)	\$0.005 - \$0.011	\$0.004 - \$0.008	\$0.005 - \$0.011	0.008 - \$0.023	\$0.006 - \$0.012	\$0.011 - \$0.017
Landfill Gas	Modify Existing Equip. (\$/kW)	\$70 - \$170	n/a	n/a	\$140 - \$360	\$0	n/a
	New Equipment (\$/kW)	\$650 - \$1,750	\$650 - \$1,650	\$1,075 - \$2,400	\$550 - \$1,440	\$1,120 - \$2,230	\$4,700 - \$6,000
	Maintenance (\$/kW/h)	\$0.006 - \$0.013	\$0.006 - \$0.011	\$0.007 - \$0.016	\$0.013 - \$0.039	\$0.008 - \$0.017	\$0.012 - \$0.018
Tire-Derived Fuel	Modify Existing Equip. (\$/kW)	\$0	n/a	n/a	n/a	n/a	n/a
	New Equipment (\$/kW)	\$700 - \$1,900	n/a	n/a	n/a	n/a	n/a
	Maintenance (\$/kW/h)	\$0.006 - \$0.014	n/a	n/a	n/a	\$0	n/a
Wellhead Gas	Modify Existing Equip. (\$/kW)	n/a	n/a	n/a	n/a	\$1,000 - \$2,000	n/a
	New Equipment (\$/kW)	n/a	n/a	n/a	n/a	\$0.008 - \$0.017	n/a
	Maintenance (\$/kW/h)	n/a	n/a	n/a	n/a	n/a	n/a
Wood (Forest Residues)	Modify Existing Equip. (\$/kW)	\$140 - \$420	n/a	n/a	n/a	n/a	n/a
	New Equipment (\$/kW)	\$700 - \$1,900	n/a	n/a	n/a	n/a	n/a
	Maintenance (\$/kW/h)	\$0.006 - \$0.014	n/a	n/a	n/a	n/a	n/a
Urban Wood Waste	Modify Existing Equip. (\$/kW)	\$150 - \$440	n/a	n/a	n/a	n/a	n/a
	New Equipment (\$/kW)	\$740 - \$2,000	n/a	n/a	n/a	n/a	n/a
	Maintenance (\$/kW/h)	\$0.007 - \$0.015	n/a	n/a	n/a	n/a	n/a

\*including boiler costs  
 \*\*not including digester costs  
 \*\*\*including gasifier costs

## 4

### ***Availability and Technical Potential***

This chapter thoroughly investigates the availability of each fuel's resources, and estimates their potential thermal and electric capacity in the United States. Availability is broken down on a state-by-state basis to predict the best potential markets for each fuel, and then the data is used to estimate the technical potential capacities.

The availability of opportunity fuels depends on a number of factors, including local resources, processing plants, and market infrastructures. For anaerobic digester gas and landfill gas, facilities are located ubiquitously throughout the country. Biomass gas can utilize any type of biomass as a fuel, and the highest concentration of biomass reserves lies in the South and Midwest. The availability of coalbed methane and wellhead gas, on the other hand, is highly regional, depending on the prevalence of underground reserves and the locations of mines and wells. Tire piles for tire-derived fuel are located throughout the country, generally more prevalent around high-population areas. Harvested wood fuels are most readily available in heavily forested areas, while the availability of wood waste is more population-based.

For each fuel type, the available data is explained and presented in tabular and graphic form, when applicable. After the data is discussed, rough estimates for the potential thermal and electric capacity of each fuel are made. For the purposes of this project, only the continental United States is considered.

#### **Anaerobic Digester Gas**

The two largest markets for anaerobic digester gas are wastewater treatment plants (WWTPs) and animal farms. These energy sources could provide at least 3 GW of electricity in the United States if utilized to their current potential, and much more if they are fully realized.<sup>1</sup> While animal farms are usually not ideal for DER/CHP applications because of their rural location and limited demand, they have been successful in collaborations with third parties and utilities that can utilize the energy produced. Municipal and industrial wastewater treatment plants make up the rest of the potential market. While food processing waste and other biomass waste streams are potential sources for the gas, it is usually in the form of wastewater sludge from industrial WWTPs, which are included in this analysis.

#### **Availability: Wastewater Treatment Plants**

Wastewater treatment plants are located ubiquitously throughout the United States. There are approximately 60,000 industrial and 16,000 municipal WWTPs in the country,<sup>2</sup> although the majority of plants are not large enough to support anaerobic digester gas to energy projects. For municipal plants, mainly used for treating sewage water, location and size is directly related to population. Industrial WWTPs however, are more regional, depending on the type of plant and the location of resources. Food and beverage processing are by far the most common industries for anaerobic wastewater treatment, followed by pulp, paper, and petrochemicals.<sup>3</sup> Publicly owned municipal treatment plants, although outnumbered by industrial plants, are often the best choices for ADG projects because of government incentives and financial backing.

---

<sup>1</sup> Spiegel, R.J. *Fuel Cell Operation on Anaerobic Digester Gas*. Presentation Notes. World Wide Web. March 2003.

<http://www.netl.doe.gov/publications/proceedings/01/hybrids/spiegel.pdf>

<sup>2</sup> MagnaDrive News Releases – *New Technology from MagnaDrive Corp. Offers Dramatic Energy Savings to Water/Wastewater Treatment Industry*. World Wide Web. May 2003. <http://www.magnadrive.com/news/news-121200.shtml>

<sup>3</sup> Kleerebezem, Robbert and Herve Macarie. "Process Wastewaters: Anaerobic's Bigger Bite". *Chemical Engineering*. April 2003.

While not all wastewater treatment plants are suited for ADG projects (many do not produce enough waste), most plants that are capable of utilizing ADG require a Water Discharge Permit, issued by the EPA. The EPA Envirofacts Warehouse website contains a database of Water Discharge Permits issued to various facilities throughout the United States. Facility information, including the wastewater flow rate, is included in the data when available. The goal then, is to come up with a correlation between the wastewater flow rate, the amount of gas produced, and the amount of electricity that could be generated.

A Focus on Energy study assessing digester gas to energy projects in Wisconsin profiled 60 different municipal wastewater treatment plants, giving the daily wastewater flow rate and digester gas production for each facility.<sup>4</sup> The results were averaged for facilities producing more than 1 million gallons per day (MGD) of wastewater, and it was found that a facility that producing 1 MGD generates about 8.4 million cubic feet of biogas each day. At 600 Btu/ft<sup>3</sup> and with an electric efficiency of 30%, a total of about 27 kW could be produced from this gas, enough to warrant a 30 kW microturbine installation. Facilities producing less than 1 MGD are usually not good candidates for DER/CHP, so this is where the cutoff was made. The EPA Envirofacts database was queried for facilities with Water Discharge Permits producing at least 1 MGD of wastewater. Facilities of all types were included in the query, but it turns out the majority of potential sites are municipal WWTPs. It should be noted, however, that this database is not all-inclusive. Not all facilities in the database contained flow rate data, so they could not be included in the analysis. In addition, certain SIC codes that do not produce organic-laden wastewater were not included since they are not good candidates for ADG. For some states (Arizona, Iowa, New Jersey, Rhode Island, South Carolina and Vermont), the majority of treatment plants were not accounted for since their flow rate data was missing, so municipal treatment plant data from EPA's 2000 Clean Water Needs Survey was used. Still, any industrial plants lacking flow rate data are not accounted for, and the technical potential for ADG from wastewater treatment plants should be taken as a lower estimate. The data for each state is summarized in the following table and map.

**Table 4-1. WWTPs Capable of ADG Projects with Technical Potential**

State	Potential Projects	Potential MW
Alabama	168	40
Arizona	89	25
Arkansas	116	40
California	273	222
Colorado	114	28
Connecticut	65	14
Delaware	8	6
Florida	288	80
Georgia	163	30
Idaho	31	5
Illinois	467	175
Indiana	283	66
Iowa	70	12
Kansas	80	18
Kentucky	120	203
Louisiana	294	98
Maine	71	721

---

<sup>4</sup> Vik, Thomas E. *Anaerobic Digester Methane to Energy – A Wisconsin Statewide Assessment*. Prepared for Focus On Energy by McMahon Associates, Inc. January 23, 2003.

Combined Heat and Power Market Potential for Opportunity Fuels

---

Maryland	87	26
Massachusetts	95	65
Michigan	633	439
Minnesota	168	43
Mississippi	110	52
Missouri	187	111
Montana	27	4
Nebraska	54	16
Nevada	11	12
New Hampshire	32	4
New Jersey	102	40
New Mexico	27	6
New York	257	114
North Carolina	194	38
North Dakota	16	69
Ohio	301	101
Oklahoma	64	11
Oregon	62*	18
Pennsylvania	425	174
Rhode Island	14	6
South Carolina	107	22
South Dakota	32	3
Tennessee	134	32
Texas	454	152
Utah	51	19
Vermont	17	1
Virginia	171	361
Washington	88	32
West Virginia	84	258
Wisconsin	177	34
Wyoming	31	229
<b>U.S. Total</b>	<b>6,850</b>	<b>4,275</b>

Source: EPA: Envirofacts Water Discharge Permits Database and 2000 Clean Water Needs Survey

Overall, there are at least 6,580 potential ADG projects for wastewater treatment plants, with 4.3 GW of technical potential. Assuming a 4/3 thermal to electric ratio and a 6,000-hour operating year, a total of 116 trillion Btu of thermal energy could be recovered. Since flow rate information is missing for many of the facilities in the Envirofacts database, the actual technical potential could be much greater – this should be considered a lower estimate for WWTPs.

Figure 4-1. Potential MW for WWTP ADG Projects by State

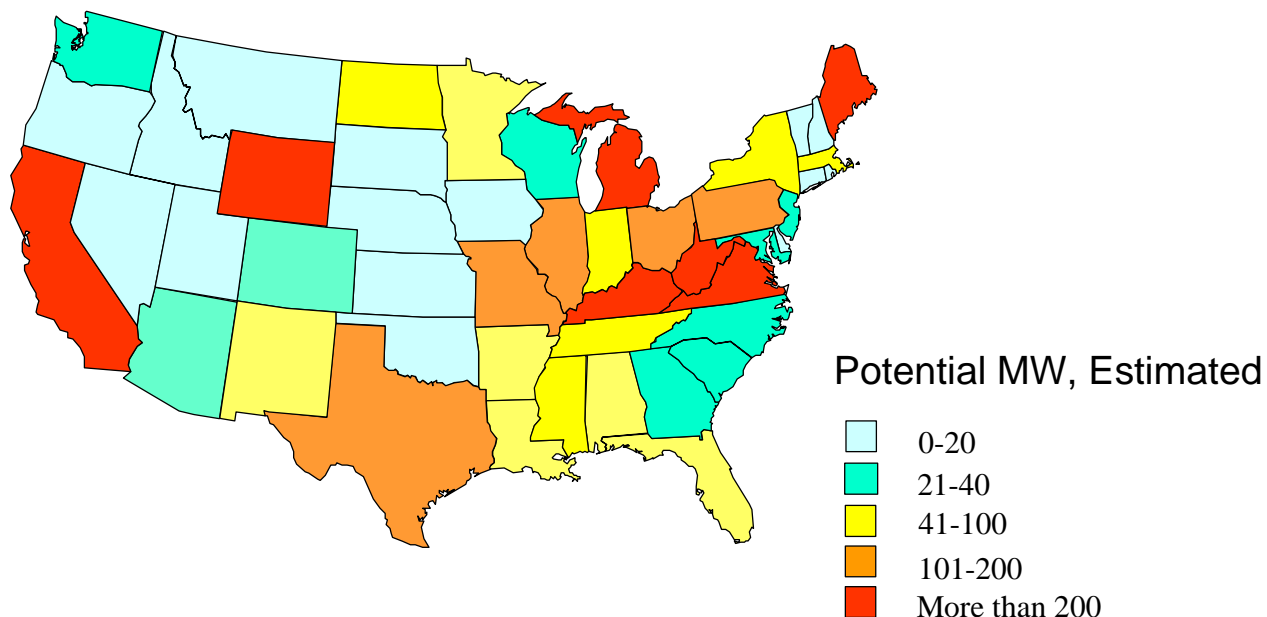

**Availability: Animal Farms**

Most animal farms are not suitable for DER/CHP, but there are over 100,000 animal farms in the United States and many of them are capable of benefiting from ADG power. Cow and pig manure are the most common components in animal farm wastewater sludge, and their properties make them well suited for anaerobic digestion. Poultry waste can also be used to produce ADG, but it is produced in smaller quantities, its moisture content is lower and its volatile contents evaporate rapidly, so it is not as good of a choice. According to various sources, a single cow produces enough waste to generate 0.1 to 0.2 kW of power from ADG, but this number can vary depending on the type of cow (beef/dairy) and the living conditions (close quarters or free range). Pigs generally produce about one-fifth to one-fourth the amount of waste that a cow produces (0.02 to 0.06 kW per pig), although this number varies as well. Overall, the smallest farms capable of powering a 30 kW microturbine would contain about 200 cows or 800-1,000 pigs. The 2002 Census of Agriculture gives information on the number of farms, and the number of animals contained in each state, broken down by size. Farms with over 200 cows or over 1,000 pigs were counted, and the potential MW production estimated. In some cases census data on the number of cows/pigs was withheld to avoid releasing data on individual farms, but the size range was still given. In these cases the lowest number in the range was used, and a plus sign was placed next to the total, showing that there may be more cows/pigs than indicated. As expected, the highest concentration of farm manure ADG projects lies in the Midwest, although North Carolina and California have the second and fourth highest potential, respectively. The results are summarized in the table and map below.

Table 4-2. Potential MW Production from Cow and Pig Farms Large Enough for DER Projects

State	Farms w/ over 200 Beef Cows	# of Beef Cows	Farms w/ over 200 Dairy Cows	# of Dairy Cows	Farms w/ over 1,000 Hogs/Pigs	# of Hogs/Pigs	Potential MW
Alabama	453	148,322	25	9,867	33	145,632	30
Arizona	197	109,539	92	154,027	1	1,000+	40
Arkansas	510	160,023	25	6,033+	70	247,951	35

Combined Heat and Power Market Potential for Opportunity Fuels

California	927	444,799	1,580	1,605,801	10	126,594	313
Colorado	883	352,201	103	90,882	25	720,279	95
Connecticut	0	0	31	11,192	0	0	2
Delaware	1	200+	13	3,921+	5	7,388	1
Florida	981	630,488	139	133,727	2	2,000+	115
Georgia	302	93,555	102	55,867	59	271,607	33
Idaho	631	275,156	319	359,273	3	8,591	96
Illinois	126	36,989	85	30,134	970	3,352,399	144
Indiana	48	12,364	80	55,505	788	2,820,959	123
Iowa	431	132,246	140	64,675	3,876	13,263,736	560
Kansas	1,356	448,063	44	76,781	197	1,374,702	134
Kentucky	398	118,775	57	14,624+	81	304,354	32
Louisiana	386	144,406	42	12,504	4	5,268	24
Maine	2	400+	42	14,629	0	0	2
Maryland	14	4,673	51	20,907	11	11,000+	4
Massachusetts	0	0	18	5,199+	2	2,000+	1
Michigan	15	3,986+	295	146,521	220	780,267	54
Minnesota	154	45,157	287	115,108	1,624	5,534,015	245
Mississippi	298	96,592	39	12,047	39	285,858	28
Missouri	1,075	347,360	55	18,986	404	2,493,691	155
Montana	2,337	987,895	21	6,319+	40	149,671	155
Nebraska	2,303	976,640	48	30,423	574	2,329,322	244
Nevada	317	213,375	23	27,945	1	1,000+	36
New Hampshire	0	0	15	3,900+	0	0	1
New Jersey	3	620	8	2,632+	3	5,952	1
New Mexico	690	332,581	153	313504	0	0	97
New York	6	1,291	576	274,265	17	51,194	43
North Carolina	131	41,153	75	27,692	1,404	9,803,370	402
North Dakota	1,257	379,631	19	7,589	22	92,530	62
Ohio	47	14,156	165	65,377	413	1,024,696	53
Oklahoma	1,459	503,136	48	35,937	102	2,183,182	168
Oregon	713	355,559	136	87,829	2	2,000+	67
Pennsylvania	13	3,108	325	111,345	315	971,354	56
Rhode Island	0	0	1	200+	0	0	0
South Carolina	87	27,886	35	11,429	55	251,158	16
South Dakota	2,503	889,935	55	32,180	257	1,123,301	183
Tennessee	329	95,316	86	26,211	44	160,466	25
Texas	4,716	1,926,067	409	256,745	20	856,624	362
Utah	419	181,484	124	63,822	14	659,169	63
Vermont	2	400+	163	65,335	0	0	10
Virginia	314	102,236	110	35,180	42	387,054	36
Washington	228	97,473	323	208,338	8	13,564	46
West Virginia	29	8,723	14	4,277+	2	2,000+	2
Wisconsin	45	14,239	839	346,576	119	278,781	65
Wyoming	1,193	546,525	5	1,000+	3	104,635	86
<b>U.S. Total</b>	<b>28,329</b>	<b>11,304,723</b>	<b>7,440</b>	<b>5,064,260</b>	<b>11,881</b>	<b>52,210,314</b>	<b>4,544</b>

Source: 2002 United States Census of Agriculture: <http://www.nass.usda.gov/census/census02/volume1/index2.htm>

**Figure 4-2. Potential MW for Animal Farm ADG Projects by State**

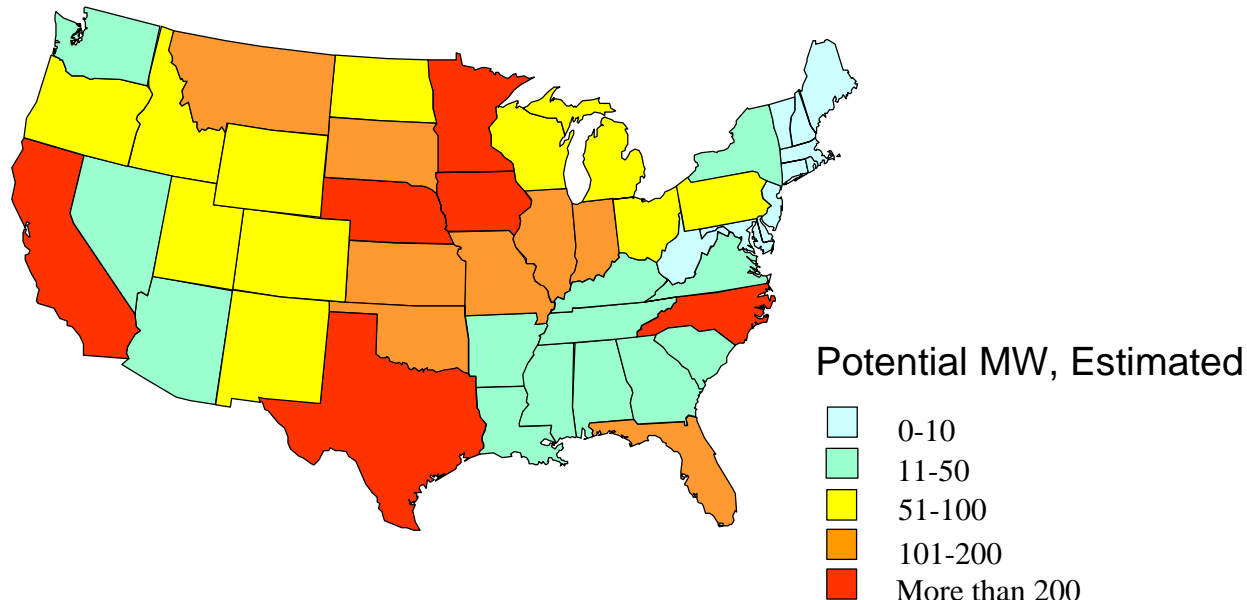

If all of the manure from all of the cows and pigs on United States farms capable of DER projects was utilized for ADG, approximately 4.5 GW of electricity could be produced. If there nearby facilities could accept the thermal load in all of these cases, a thermal output of 124 trillion Btu/year could be obtained, assuming a 4/3 thermal to electric ratio and 6,000 hours of operation.

With both WWTPs and animal farms considered, the total technical potential for ADG is about 8.8 GW of electricity and 240 trillion Btu/year of thermal output.

### Biomass Gas

Biomass gas can be obtained from any type of biomass fuel so its availability is somewhat hard to pinpoint. Crop residues, food processing waste, wood fuels, dedicated energy crops, mill residues, and other types of biomass can all be converted into a gaseous fuel with roughly the same properties. Oak Ridge National Laboratory conducted a Biomass Feedstock Availability study that estimates the availability of biomass resources for harvested wood, crop residues, mill residues, dedicated energy crops, and wood wastes. These would be the primary sources of biomass gas, and the total availability of all of these resources was estimated on a state-by-state basis in this report. Most of the biomass reserves in this country are located in the Midwest and the South. The results are summarized in the table and map below. The technical potential for biomass gas in each state was also calculated in the table, assuming a 30 percent electric efficiency, a 6,000-hour operating year, and an 80 percent conversion efficiency for the gasifier.

**Table 4-3. Biomass Availability and Technical Potential by State**

State	Availability (tons)	Potential MW
Alabama	17,681,689	3,077
Arizona	1,100,491	191
Arkansas	13,604,348	2,367
California	11,298,705	1,966



Combined Heat and Power Market Potential for Opportunity Fuels

Colorado	3,581,889	623
Connecticut	906,309	158
Delaware	461,521	80
Florida	9,533,398	1,659
Georgia	16,111,675	2,803
Idaho	7,165,782	1,247
Illinois	33,359,162	5,804
Indiana	18,606,863	3,238
Iowa	32,786,037	5,705
Kansas	21,343,522	3,714
Kentucky	10,809,048	1,881
Louisiana	11,834,427	2,059
Maine	2,213,697	385
Maryland	1,959,222	341
Massachusetts	1,435,895	250
Michigan	12,163,103	2,116
Minnesota	21,247,327	3,697
Mississippi	17,930,978	3,120
Missouri	19,522,892	3,397
Montana	6,761,444	1,176
Nebraska	21,773,296	3,789
Nevada	336,603	59
New Hampshire	2,016,455	351
New Jersey	975,806	170
New Mexico	1,081,589	188
New York	8,438,083	1,468
North Carolina	10,855,777	1,889
North Dakota	21,043,177	3,662
Ohio	18,962,520	3,299
Oklahoma	12,699,956	2,210
Oregon	9,809,975	1,707
Pennsylvania	7,427,043	1,292
Rhode Island	115,514	20
South Carolina	9,368,065	1,630
South Dakota	16,005,411	2,785
Tennessee	15,232,952	2,651
Texas	20,747,118	3,610
Utah	722,821	126
Vermont	1,022,669	178
Virginia	8,714,941	1,516
Washington	9,920,241	1,726
West Virginia	3,736,487	650
Wisconsin	14,963,398	2,604
Wyoming	1,465,684	255
<b>U.S. Total</b>	<b>510,855,005</b>	<b>88,889</b>

Source: Oak Ridge National Laboratory – Biomass Feedstock Availability Analysis  
<http://bioenergy.ornl.gov/resourcedata/index.html>

On average, solid biomass fuels cost about \$30-\$35 per dry ton to obtain unless one produces biomass as a waste product or is very close to the source. For facilities very far from a biomass source, a price of \$50 per dry ton is typical.<sup>5</sup> For the purposes of this project, a price of \$30 per dry ton for delivered biomass is assumed. At about 7,500 Btu/lb, assuming a gasifier conversion efficiency of 80 percent, this translates to \$2.50 per MMBtu, much less than the cost of natural gas.

With all of the biomass available in the United States, biomass gas has the potential to produce 89 GW of electricity and 2,450 trillion Btu of thermal output, assuming a 4/3 thermal to electric ratio. While the actual potential is much less due to various inhibiting factors, biomass gas' technical potential is the highest of all the opportunity fuels.

**Figure 4-3. Estimated Biomass Reserves by State**

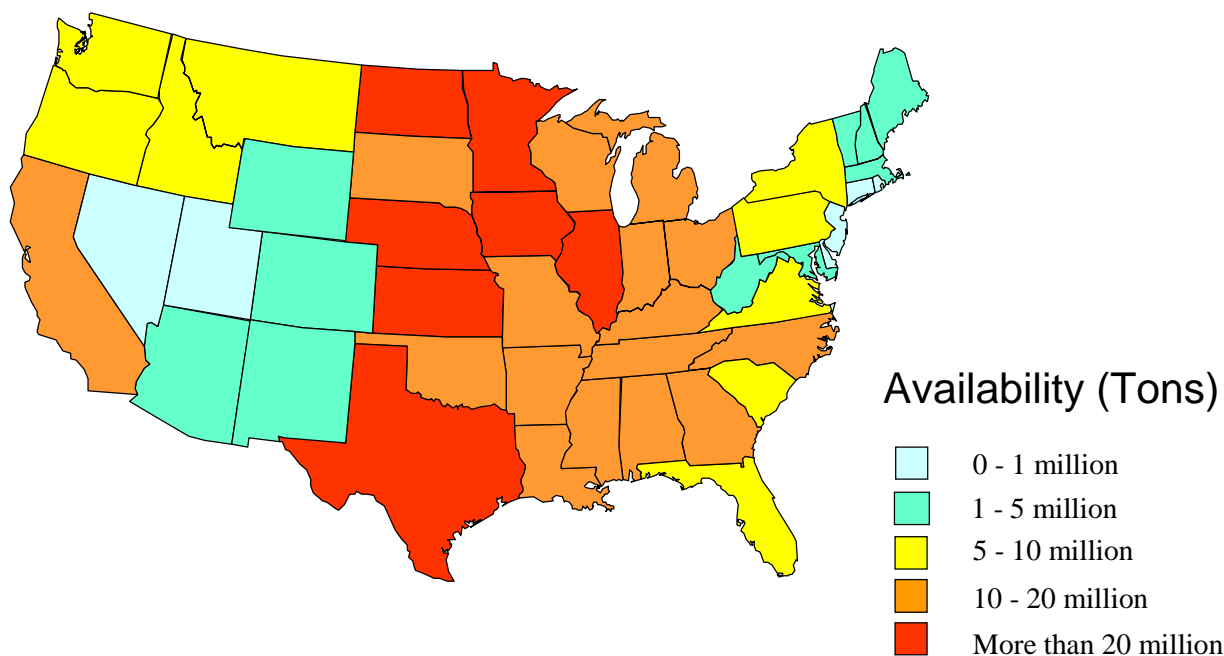

### Coalbed Methane

The location of coal reserves in the United States is highly regional, so the market for coalbed methane is regional as well. Many of the nation's coal reserves remain untapped and could be drilled for methane gas, but coalbed methane for DER is only considered at operational underground coalmines that can utilize their gas as an energy source. Surface mines produce some methane, but much higher quantities are available at underground mines, as methane concentrations typically increase with depth. To illustrate this point, while only 40 percent of U.S. coal is produced at underground mines, these mines account for over 70 percent of estimated coalmine methane emissions.<sup>6</sup> The states with the greatest number of underground mines are near the middle of the Appalachian Mountains: Virginia, West Virginia and Kentucky all have over 100 underground mines, and Pennsylvania is not far behind with 82. Overall, only 15 states have underground coalmines, and most of them contain less than 10 mines.

---

<sup>5</sup> *Biomass Feedstock Availability in the United States: 1999 State Level Analysis*. Oak Ridge National Laboratory. World Wide Web. March 2003. <http://bioenergy.ornl.gov/resourcedata/index.html>

<sup>6</sup> *Identifying Opportunities for Methane Recovery at U.S. Coal Mines*. U.S. Environmental Protection Agency Atmospheric Pollution Prevention Division. September 1997.

In the EPA's September 1997 Report, *Identifying Opportunities for Methane Recovery at U.S. Coal Mines*, profiles of selected gassy underground coal mines were presented, which included information on coal and methane production, as well as electric demand and potential capacity for certain mines. Using this data, it was found that on average, about 1 million cubic feet per day of methane is produced for every million tons of coal per year, and this much methane could produce about 1.5 MW of electricity. Using these numbers, the estimated potential capacity for each state was calculated. This data, along with the number of coalmines and coal production, is presented in the table below, and illustrated in the following map.

**Table 4-4. Underground Mines and Coal Production by State**

State	Underground Mines	Coal Production (1000 tons/yr)	Potential MW (Estimated)
Alabama	9	15,895	24
Arizona	0	0	0
Arkansas	0	0	0
California	0	0	0
Colorado	8	19,982	30
Connecticut	0	0	0
Delaware	0	0	0
Florida	0	0	0
Georgia	0	0	0
Idaho	0	0	0
Illinois	12	29,642	44
Indiana	5	3,688	6
Iowa	0	0	0
Kansas	0	0	0
Kentucky	246	80,177	120
Louisiana	0	0	0
Maine	0	0	0
Maryland	2	3,196	5
Massachusetts	0	0	0
Michigan	0	0	0
Minnesota	0	0	0
Mississippi	0	0	0
Missouri	0	0	0
Montana	0	0	0
Nebraska	0	0	0
Nevada	0	0	0
New Hampshire	0	0	0
New Jersey	0	0	0
New Mexico	1	4	0
New York	0	0	0
North Carolina	0	0	0
North Dakota	0	0	0
Ohio	9	11,933	18
Oklahoma	1	241	0
Oregon	0	0	0
Pennsylvania	82	57,959	87
Rhode Island	0	0	0
South Carolina	0	0	0
South Dakota	0	0	0
Tennessee	11	1,456	2
Texas	0	0	0
Utah	13	26,656	40
Vermont	0	0	0
Virginia	107	23,181	35
Washington	0	0	0
West Virginia	200	98,439	148
Wisconsin	0	0	0
Wyoming	1	1,210	2
<b>U.S. Total</b>	<b>707</b>	<b>372,449</b>	<b>559</b>

**Figure 4-4. Estimated CBM MW Potential, by State**

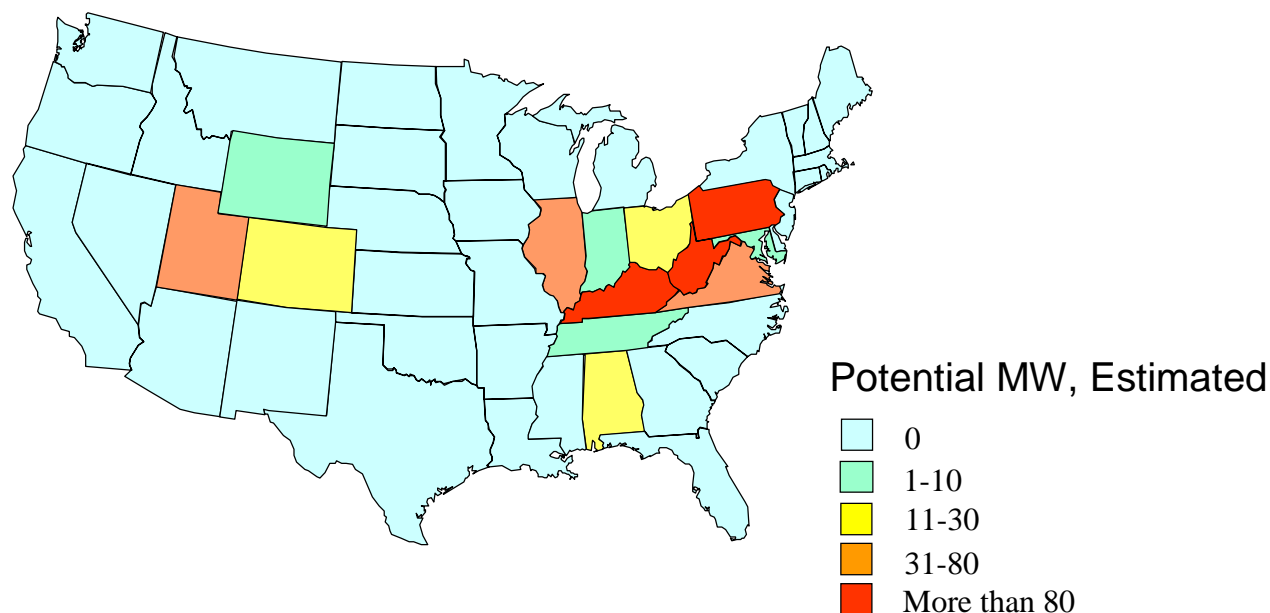

Using the estimates discussed above, only about 560 MW of electricity could be produced from underground coalmines participating in CBM energy projects. Assuming a 4/3 thermal to electric efficiency ratio and a 6,000 hour operating year, about 15.2 trillion Btu of thermal output could be produced with CHP. While the number is not exact since the methane produced per ton of coal varies drastically from mine to mine, it is inconceivable that the current selection of underground coalmines could produce over 1 GW of electricity. Furthermore, thermal demand is usually too low at coalmines to warrant CHP, so the market potential is not very high.

### Landfill Gas

Like municipal wastewater treatment plants, the presence of landfills is generally population-based. However, for sanitation purposes, landfills are usually located far away from major cities. Most estimates of recoverable methane indicate that landfills are capable of at least 3 GW of total electric power production.

The Environmental Protection Agency maintains a database that documents landfills in the United States, along with their landfill gas project status (Operational, Construction, Shut Down, Potential, or Unknown). Sites with LFG projects that are operational, under construction, or those that have been shut down are not considered candidates for new DER/CHP applications. To get an idea of how much potential there is for new projects, all of the remaining landfill sites (those not participating in LFG projects) were analyzed. Most sites contained a value for “waste in place”, which shows how many tons of waste are currently stored at the landfill. For sites missing this information, the average waste in place for landfills not participating in LFG projects (about 2,000,000 tons) was used. Using an estimated ratio given by the EPA that correlates waste in place to LFG flow rate, and converting that flow rate into an electric capacity (assuming 30% efficiency), an estimated potential MW for each state was calculated. The numbers were tallied for each state, and it turns out California by far has the most potential (about 500 MW) for new LFG projects. New York, Illinois, Ohio, Pennsylvania and Texas make up the next tier, all with well over 100 MW of potential. For a breakdown of each state’s estimated potential capacity, see the map and table provided below.

**Table 4-5. Number of Landfills, Waste in Place, and Potential Capacity for New LFG Projects**

<b>State</b>	<b>Number of Landfills not participating in LFG Projects</b>	<b>Estimated Waste In Place (tons)</b>	<b>Estimated Potential MW</b>
Alabama	43	91,300,000	72
Arizona	18	54,800,000	43
Arkansas	7	13,300,000	11
California	270	616,800,000	489
Colorado	27	127,800,000	101
Connecticut	23	36,100,000	29
Delaware	3	10,700,000	8
Florida	51	134,900,000	107
Georgia	45	90,900,000	72
Idaho	30	60,000,000	48
Illinois	43	188,600,000	149
Indiana	79	107,100,000	85
Iowa	21	28,600,000	23
Kansas	31	33,600,000	27
Kentucky	31	62,900,000	50
Louisiana	34	82,900,000	66
Maine	11	9,100,000	7
Maryland	37	62,700,000	50
Massachusetts	22	40,100,000	32
Michigan	18	30,200,000	24
Minnesota	26	36,500,000	29
Mississippi	27	47,800,000	38
Missouri	101	127,400,000	101
Montana	5	14,500,000	11
Nebraska	23	21,200,000	17
Nevada	10	55,700,000	44
New Hampshire	21	46,800,000	37
New Jersey	13	23,200,000	18
New Mexico	5	15,500,000	12
New York	66	240,700,000	191
North Carolina	116	111,900,000	89
North Dakota	1	2,600,000	2
Ohio	59	163,000,000	129
Oklahoma	19	44,500,000	35
Oregon	9	30,800,000	24
Pennsylvania	55	155,200,000	123
Rhode Island	3	4,400,000	3
South Carolina	48	90,700,000	72
South Dakota	1	6,600,000	5
Tennessee	127	130,000,000	103
Texas	76	220,300,000	174
Utah	50	51,100,000	40
Vermont	7	13,700,000	11

Virginia	31	53,800,000	43
Washington	48	119,800,000	95
West Virginia	23	40,300,000	32
Wisconsin	42	40,900,000	32
Wyoming	1	4,200,000	3
<b>U.S. Total</b>	<b>1,857</b>	<b>3,795,500,000</b>	<b>3,006</b>

Source: EPA LMOP Database, April 2004: <http://www.epa.gov/lmop/proj/index.htm#1>

**Figure 4-5. Estimated Potential Electric Capacity for New LFG Projects, By State**

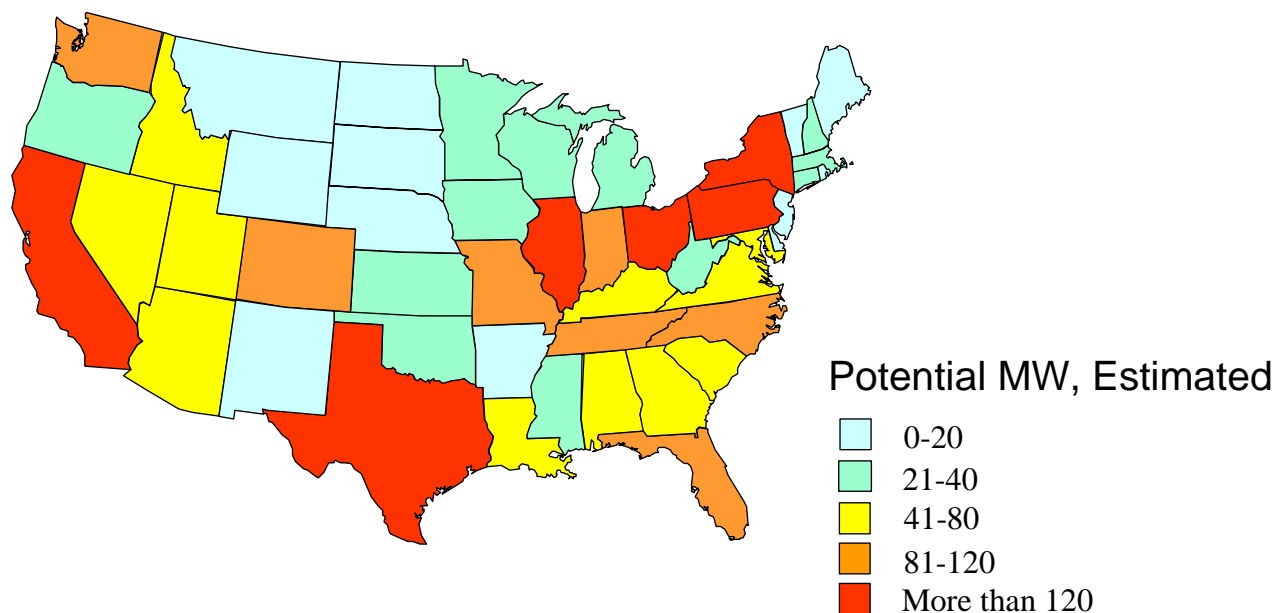

According to the EPA’s latest Landfill Methane Outreach Program Database, there are 382 operational LFG projects and 22 projects currently under construction, although some of these projects are for direct use or thermal applications (not producing electricity). It is estimated that the 404 current projects could produce a total of 2.5 GW at full capacity – landfills generating electricity constitute 2.2 GW of this number, so an estimated 0.3 GW could be obtained from landfills only producing thermal output. Using the same estimates, the potential capacity for the remaining 1,857 landfills (those not undergoing projects) is approximately 3 GW. So, in addition to the 1.8 GW currently being produced, there is a potential for 3.3 GW of electricity from new LFG projects, as well as 82 trillion Btu of additional thermal output (assuming a 4/3 thermal to electric ratio and a 6,000 hour year). While the technical potential for landfill gas is fairly high, it pales in comparison to ADG and biomass gas, especially considering that many of the largest and most ideal sites for LFG projects are already being utilized.

### Tire-Derived Fuel

Although the exact number of tires available for tire-derived fuel available in each state is undetermined, there are some regional differences that can be seen. States with higher populations tend to produce more waste tires, but they are not always stockpiled or stored in-state. Some smaller states like Indiana and Ohio contain large stockpiles of tires from various states in the general vicinity. Of the estimated 800 million tires stockpiled, over 60 percent are stored in just 11 states: Michigan, Indiana, Illinois, New

York, Rhode Island, Pennsylvania, Louisiana, California, Maine, Texas, and Ohio. The remainder is divided among the other 39 states, which average 1 percent a piece.<sup>7</sup>

One would think that the best markets for tire-derived fuel are the top 11 states that were mentioned, especially since the cost to obtain the fuel depends so much on transportation. However, certain states (Virginia, Florida, Mississippi, Illinois, Utah, Arizona, Oregon and Washington) have government subsidies that encourage scrap tire utilization. This results in increased TDF utilization for these states. It also results in nearby states importing scrap tires at the subsidized rate for their own tire-derived fuel projects. For example, the majority of scrap tires utilized by TDF projects in California are imported from nearby states with subsidies. As a consequence, ninety percent of California's scrap tires are stockpiled instead of utilized, and the tires used for TDF projects come mostly from Arizona, Oregon, and Washington.<sup>8</sup> States with TDF subsidies are listed below.

**Known States with TDF Subsidies:**

- Arizona
- Florida
- Illinois
- Mississippi
- Oregon
- Utah
- Virginia
- Washington

Aside from state subsidies, however, the number of tires stockpiled is the determining factor in a state's tire-derived fuel availability and market. Below is a pie chart that illustrates the availability of scrap tires in each of the top states. Ohio is the largest stockpile holder, with even more scrap tires than Texas and California, two states much greater than Ohio in size and population. Maine, Louisiana, and Rhode Island are three more small states with incredibly large stockpiles, making them excellent candidates for TDF projects. The distribution of scrap tires among the top states is illustrated on the next page.

It is estimated that 250-350 million tires are discarded in the United States each year. Each tire is equivalent to about 2.5 barrels of fuel oil according to heat content (each tire contains about 340,000 Btu). If the 300 million tires discarded each year were used for fuel, the total heat capacity would be about 40 million MMBtu per year, and about 1.5 GW of electricity could be produced. However, the actual potential for tire-derived fuel DER/CHP projects is much lower due to limited demand and lack of market infrastructure. Plus, there are many useful products that are now being manufactured from recycled tires, so only about half of the scrap tires in the U.S. are truly going to waste. Still, if the right market infrastructure was implemented, all of the waste tires could potentially be used for TDF – however, its technical potential (1.5 GW) still remains less than most of the other opportunity fuels.

---

<sup>7</sup> *Scrap Tire Use/Disposal Study*. Scrap Tire Management Council, Washington, DC. April 1997.

<sup>8</sup> *Ibid.*

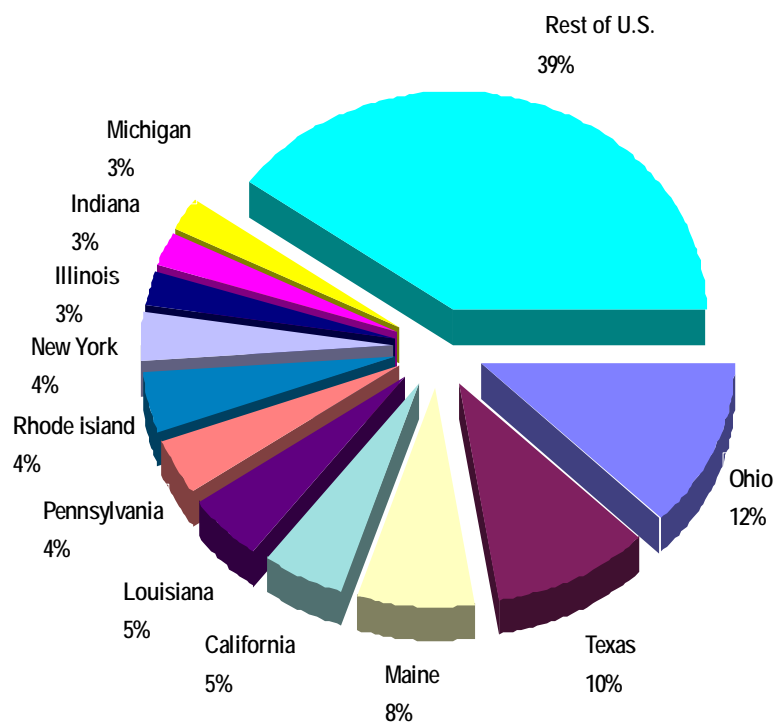

**Figure 4-6. United States Distribution of Scrap Tires**

Source: *Scrap Tire Use/Disposal Study*. Scrap Tire Management Council, Washington, D.C. 1997.

## Wellhead Gas

As with coal reserves, the number of states that have access to oil and natural gas reserves is limited. This is even more important for wellhead gas, since the fuel is always utilized on-site. The vast majority of oil and gas wells are located in states just to the north and west of the Gulf of Mexico. Texas is by far the biggest oil and gas producer, with over 500 wells, followed by Louisiana and Oklahoma, with over 100 a piece. New Mexico and Wyoming also contain numerous oil and gas reserves, with over 50 wells located in both states. Other states that contain over 10 wells include Alabama, Arkansas, California, Colorado, Kansas, Mississippi, Montana, North Dakota, Pennsylvania, Utah, and West Virginia. The other states all have less than 10 wells, with 24 of them containing no wells at all.<sup>9</sup> While land-based oil wells are much better candidates for DG/CHP applications, the wells on inland waters and offshore locations are noted as well and included in each state’s total. However, these types of wells are only prominent in Louisiana and Texas. See the map and table provided for a visual and statistical breakdown of this information.

**Table 4-6. United States Oil and Gas Wells, by State**

State	Land-based	Inland Waters	Offshore	Total
Alabama	9	0	1	10
Arizona	0	0	0	0
Arkansas	10	0	0	10
California	42	0	0	42
Colorado	38	0	0	38

<sup>9</sup> RIGDATA, Fort Worth Texas. World Wide Web. May 2003. <http://www.rigdata.com/locnts.pdf>



Combined Heat and Power Market Potential for Opportunity Fuels

Connecticut	0	0	0	0
Delaware	0	0	0	0
Florida	1	0	0	1
Georgia	0	0	0	0
Idaho	0	0	0	0
Illinois	1	0	0	1
Indiana	1	0	0	1
Iowa	0	0	0	0
Kansas	33	0	0	33
Kentucky	8	0	0	8
Louisiana	64	31	81	176
Maine	0	0	0	0
Maryland	0	0	0	0
Massachusetts	0	0	0	0
Michigan	4	0	0	4
Minnesota	0	0	0	0
Mississippi	12	0	0	12
Missouri	0	0	0	0
Montana	13	0	0	13
Nebraska	0	0	0	0
Nevada	0	0	0	0
New Hampshire	0	0	0	0
New Jersey	0	0	0	0
New Mexico	81	0	0	81
New York	2	0	0	2
North Carolina	0	0	0	0
North Dakota	16	0	0	16
Ohio	5	0	0	5
Oklahoma	148	0	0	148
Oregon	0	0	0	0
Pennsylvania	17	0	0	17
Rhode Island	0	0	0	0
South Carolina	0	0	0	0
South Dakota	0	0	0	0
Tennessee	0	0	0	0
Texas	521	5	20	546
Utah	14	0	0	14
Vermont	0	0	0	0
Virginia	5	0	0	5
Washington	0	0	0	0
West Virginia	26	0	0	26
Wisconsin	0	0	0	0
Wyoming	51	0	0	51
<b>U.S. Total</b>	<b>1122</b>	<b>36</b>	<b>102</b>	<b>1260</b>

Source: RIGDATA, Fort Worth Texas  
<http://www.rigdata.com/locnts.pdf>

**Figure 4-7. Number of Oil and Gas Wells By State**

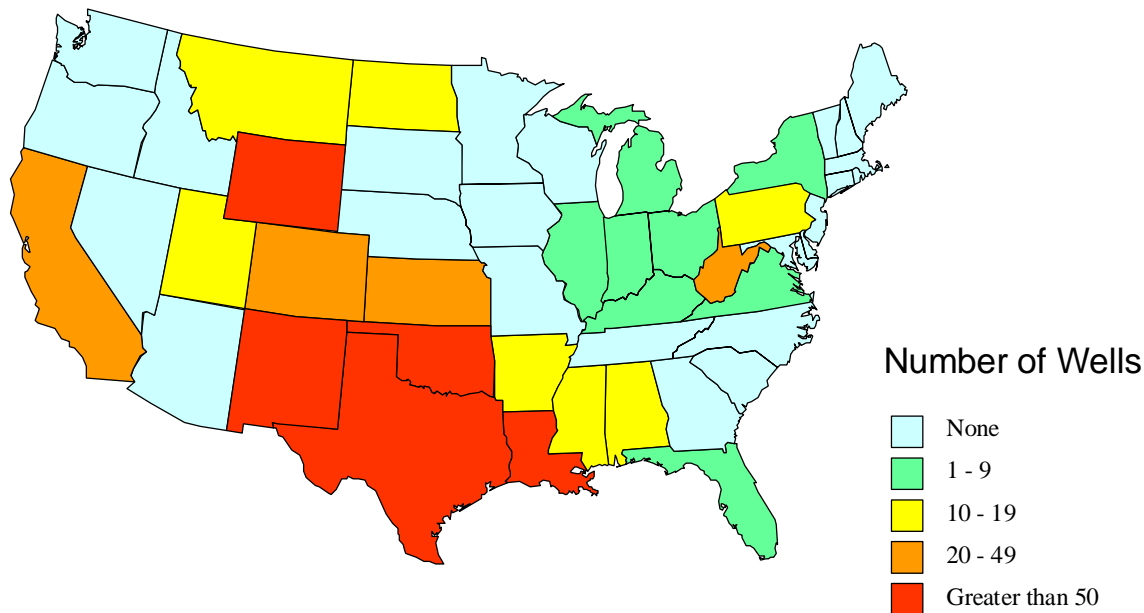

When considering resources alone, the potential thermal capacity for wellhead gas is very high – each well produces about 5 million cubic feet of high-energy casehead gas per hour, making the total potential capacity over 40 trillion MMBtu per year. However, installations are usually microturbines only large enough to meet the well and nearby facilities’ power needs, meaning most of the gas is still flared. The most common installations at oil and gas wells are 30 kW Capstone microturbines. Sometimes more than one microturbine is installed, but it is rare that the power needs of an oil or gas well and its surrounding facilities exceed 100 kW, and it is difficult to obtain third party ownership or utility interest because of their remote locations. Capstone has supplied microturbines to between 100 and 200 facilities already, and more are in the planning process. Assuming that 1,000 more facilities have 100 kW project potential, the total capacity is about 100 MW. If a thermal demand is met at these installations, then wellhead gas has a technical thermal potential of about 2.7 million MMBtu (assuming a 4/3 thermal to electric ratio).

### **Wood (Forest Residues / Harvested Wood)**

The 1999 Biomass Availability study by Oak Ridge National Laboratory estimates the amount of biomass available for each state, within certain price ranges. The available resources data provided an availability estimate, and the price ranges gave an idea to how much the fuel would cost in different regions. For harvested wood, the average price remained between \$29 and \$30 per dry ton for nearly every state. While the average price to obtain the fuel does not change significantly from state to state, the amount of biomass fuel available does.

The west coast is by far the largest reservoir for forest residues and harvested wood fuels. California, Oregon, and Washington all produce over 2 million dry tons of harvested wood biomass each year that could be used as a fuel. The second largest region for this fuel is the southeast. North Carolina produces over 2 million dry tons, and most of the other states in the region produce over 1.5 million dry tons each year. New York, Pennsylvania, and Maine also produce over 1.5 million dry tons. These states are all prime candidates for marketing harvested wood as a biomass fuel. For a breakdown of harvested wood availability for every state, see the table and map provided. Included in the table is an estimated potential

MW capacity for each state, assuming a heat content of 7,500 Btu/lb, a 6,000-hour operating year, and a 30 percent electric efficiency.

**Table 4-7. Harvested Wood Availability and Technical Potential**

<b>State</b>	<b>Tons Available</b>	<b>Potential MW</b>
Alabama	1,899,000	413
Arizona	261,400	57
Arkansas	1,737,800	378
California	2,364,400	514
Colorado	720,300	157
Connecticut	204,100	44
Delaware	48,400	11
Florida	975,700	212
Georgia	1,967,800	428
Idaho	1,179,500	257
Illinois	423,300	92
Indiana	470,100	102
Iowa	135,000	29
Kansas	88,100	19
Kentucky	883,500	192
Louisiana	1,641,800	357
Maine	1,529,100	333
Maryland	351,200	76
Massachusetts	366,200	80
Michigan	1,327,900	289
Minnesota	874,900	190
Mississippi	1,774,600	386
Missouri	938,700	204
Montana	1,316,700	286
Nebraska	34,400	7
Nevada	14,400	3
New Hampshire	564,400	123
New Jersey	130,700	28
New Mexico	241,900	53
New York	1,746,400	380
North Carolina	2,004,900	436
North Dakota	21,700	5
Ohio	430,100	94
Oklahoma	292,200	64
Oregon	2,515,900	547
Pennsylvania	1,763,000	383
Rhode Island	35,900	8
South Carolina	1,158,400	252
South Dakota	64,300	14
Tennessee	1,732,600	377
Texas	1,050,700	229
Utah	173,000	38

Vermont	497,200	108
Virginia	1,793,600	390
Washington	2,379,600	518
West Virginia	1,352,500	294
Wisconsin	1,138,400	248
Wyoming	256,100	56
<b>U.S. Total</b>	<b>44,871,800</b>	<b>9,760</b>

Source: Oak Ridge National Laboratory – Biomass Feedstock Availability Analysis  
<http://bioenergy.ornl.gov/resourcedata/index.html>

With 44,871,800 tons of harvested wood reserves available each year, there is the potential for 10 GW of electric capacity and 270 million MMBtu of thermal energy from forest residues (assuming a 4/3 thermal to electric efficiency ratio and a 6,000 hour year). However, there needs to be more incentives for the use of harvested wood fuels – at the current rate, the delivered cost averages about \$30.00 per ton (\$2.00 per MMBtu, significantly more expensive than coal in most locations). The lack of a market infrastructure and expensive transportation costs hinder this potentially promising fuel, and keep it limited to niche applications. It should be noted that the data used to calculate the potential for harvested wood was also included in calculating the potential for biomass gas.

**Figure 4-8. Harvested Wood Fuel Availability By State**

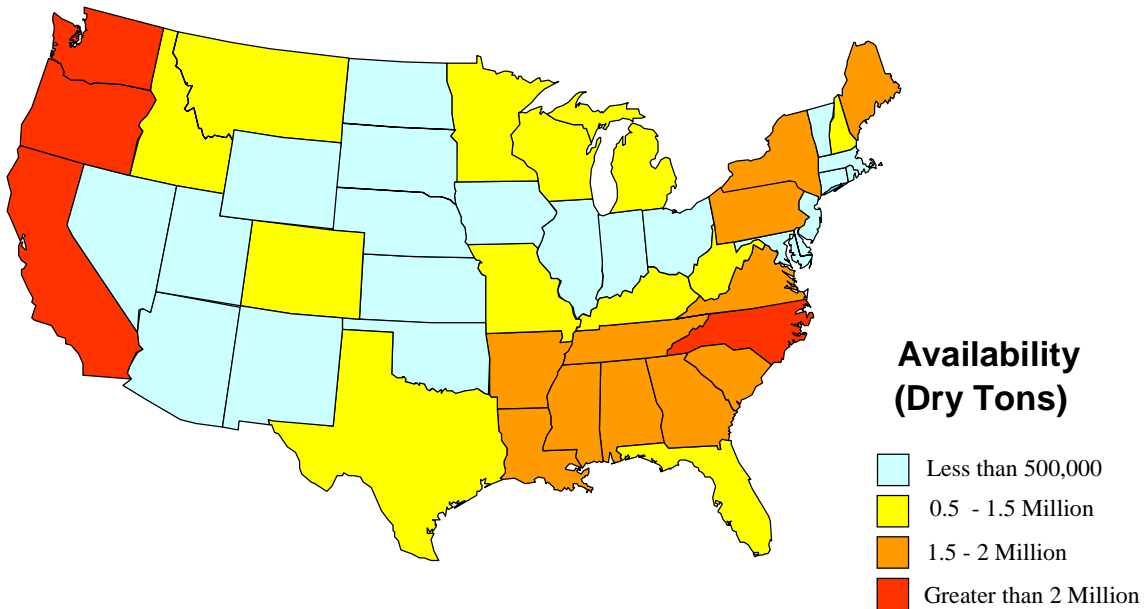

**Wood (Urban Wood Waste)**

Although the name *urban wood waste* may cause one to believe that the source of the fuel is trash from large cities, that is far from the case. The fuel category is very broad and can consist of yard trimmings, wood pallets, construction and demolition waste, and other wood wastes not necessarily found in urban areas. The 1999 Biomass Availability study provides the amount of urban wood waste available for each state, from wood recycling yards and municipal yard waste processing sites, within certain price ranges.

The average price remained consistent from state to state, at about 18 dollars per dry ton. The availability of the fuel, however, changes drastically with each state and region.

Another type of wood waste is mill residue, which is produced at mills and wood processing facilities. This waste is free to the producer, and is usually utilized by these facilities in one way or another. DER/CHP applications are becoming more common, and there is certainly a market among these facilities. However, most often the mill waste is already used for process heating or cofiring in large-scale applications. Urban wood waste has the potential to be a marketable fuel source for DER/CHP projects, since its price is usually less than coal, it is not an industrial byproduct, and it is available for consumption in every state.

The largest markets for urban wood waste exist in California, Texas, Florida, and South Carolina, followed closely by New York and Minnesota. All of these states produce over 1.5 million dry tons of urban wood waste each year. Ohio, Kansas, and many southeastern states produce over 1 million tons each year, and would also make great markets for the fuel. For a breakdown of urban wood waste availability for every state, see the table and map provided. Included in the table is an estimated MW potential for each state, assuming 7,500 Btu/lb, 30 percent efficiency, and a 6,000-hour year.

**Table 4-8. Urban Wood Waste Availability and Technical Potential**

<b>State</b>	<b>Tons Available</b>	<b>Potential MW</b>
Alabama	1,372,610	299
Arizona	366,227	80
Arkansas	667,273	145
California	2,633,022	573
Colorado	157,769	34
Connecticut	411,563	90
Delaware	64,931	14
Florida	4,596,584	1,000
Georgia	1,436,823	313
Idaho	338,162	74
Illinois	693,411	151
Indiana	527,684	115
Iowa	286,337	62
Kansas	1,227,148	267
Kentucky	576,165	125
Louisiana	753,870	164
Maine	180,597	39
Maryland	341,071	74
Massachusetts	698,787	152
Michigan	826,224	180
Minnesota	1,532,529	333
Mississippi	784,719	171
Missouri	525,911	114
Montana	86,766	19
Nebraska	170,121	37
Nevada	306,853	67
New Hampshire	184,298	40

New Jersey	648,481	141
New Mexico	238,160	52
New York	1,900,133	413
North Carolina	1,060,056	231
North Dakota	544,184	118
Ohio	1,240,864	270
Oklahoma	185,289	40
Oregon	304,220	66
Pennsylvania	666,605	145
Rhode Island	49,671	11
South Carolina	2,149,833	468
South Dakota	206,637	45
Tennessee	1,126,715	245
Texas	2,015,749	438
Utah	231,275	50
Vermont	68,004	15
Virginia	865,757	188
Washington	487,387	106
West Virginia	175,393	38
Wisconsin	639,110	139
Wyoming	295,638	64
<b>U.S. Total</b>	<b>36,846,616</b>	<b>8,014</b>

Source: Oak Ridge National Laboratory – Biomass Feedstock Availability Analysis  
<http://bioenergy.ornl.gov/resourcedata/index.html>

Figure 4-9. Urban Wood Waste Availability By State

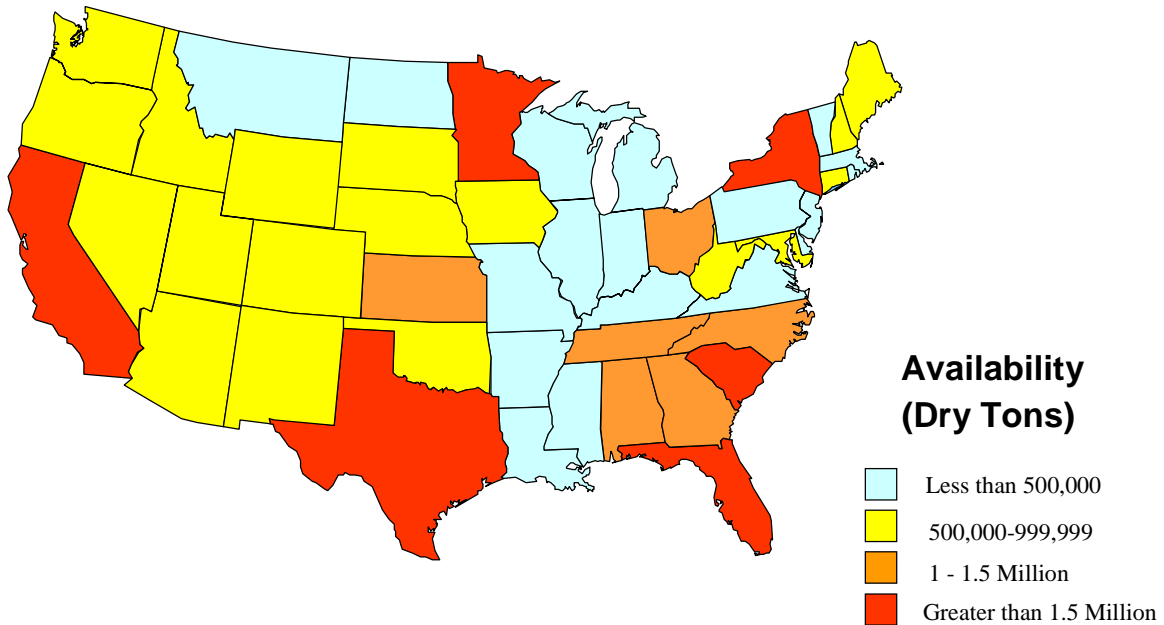

Although physical properties are similar, wood waste is very different than harvested wood fuel. The processing costs are less, and it is much cheaper to purchase. On the negative side, it usually contains more impurities so equipment and maintenance costs can be affected. There are a number of industrial plants already utilizing their wood wastes, and many more with the potential to do so, although these wastes usually fall under the mill residue category, and gasification (biomass gas) is usually a better option for industrial applications. Urban wood waste, however, would require a market infrastructure for gathering, processing and selling the fuel. Currently waste is stockpiled in recycling yards, and some facilities do produce wood waste boiler fuel, but the market would need to drastically expand for urban wood waste to become a major player in the industry.

The total annual United States urban wood waste reserves are estimated to be 36,846,616 tons. At 7,500 Btu/lb, this could provide about 8 GW of electricity and 220 million MMBtu of thermal energy each year. And at a price of about \$1.20 per MMBtu, urban wood waste could be very competitive with coal as a solid boiler fuel. It should be noted that the data used to calculate the potential for urban wood waste was also included in calculating the potential of biomass gas.

## **Chapter 4 Summary**

The availability of the eight fuels in each state has been analyzed, but there are certain things one must keep in mind with this analysis. The states' size and population were not taken into account, and this can skew the perception of market potential. While a state may have a large amount of reserves, the market potential is limited if the population is scarce, as is the case in the Midwest. Also, larger states can appear to have a great amount of reserves compared to smaller states, but they could really have the same amount per unit area. These things should always be considered when analyzing the market potential of a state from the given availability data. Regardless, the data is a good indicator to where the best resources and markets are for each of opportunity fuels.

In examining each fuel's availability and technical potential, it is apparent that each of the chosen opportunity fuels has a very strong potential for use. While coalbed methane, wellhead gas, and to a lesser extent, harvested wood are only available in certain regions, the amount available in these regions is plentiful and abundant. Anaerobic digester gas, biomass gas, landfill gas, tire-derived fuel, and wood waste, although sometimes concentrated in certain regions, are more or less ubiquitous throughout the continental U.S., so regional availability for these fuels is not an issue. Although in some cases the actual potential capacity is probably much less than the technical, all of the opportunity fuels in this section are capable of producing a good deal of power.

The estimated thermal and electric capacities, in annual trillion Btu and GW, are given for each fuel in Table 3-8. These are technical potentials, meaning the maximum possible potential if all available resources are utilized.

**Table 4-9. Estimated Potential Thermal and Electric Capacity for the Opportunity Fuels**

<b>Fuel</b>	<b>Potential Thermal Output (Estimated, Trillion Btu/yr)</b>	<b>Potential Electric Capacity (Estimated, GW)</b>
Anaerobic Digester Gas	240	9
Biomass Gas	2,450	89
Coalbed Methane	15	0.5
Landfill Gas	82	3
Tire-Derived Fuel	40	1.5
Wellhead Gas	3	0.1
Wood (Harvested)	270	10
Urban Wood Waste	220	8

If all potential resources were utilized for these 8 fuels, the total technical capacity would be over 2.8 quadrillion Btu of thermal output and over 105 GW of electricity. However, only a small fraction of the technical potential is likely to be realized. In the next chapter, the current status and future outlook of each fuel is thoroughly examined to paint a more realistic picture of the actual project potential for the fuels. Then, the most promising fuels are chosen for detailed market analyses using the DISPERSE model.



## 5

### ***Current Projects and Future Prospects***

While the availability of a fuel's resources is important, it means nothing if the fuel is not utilized. In this section, current and future opportunity fuel projects are examined to find out exactly how each fuel is being implemented and if there are any barriers, limitations, and/or drawbacks to their use. Some of the chosen opportunity fuels, such as anaerobic digester gas, landfill gas, biomass and wood waste are widely used with growing acceptance in the DER/CHP marketplace. Other fuels like coalbed methane and wellhead gas are gaining momentum for DER projects, but CHP is rarely ever implemented because of low facility thermal demand. Tire-derived fuel and harvested wood, on the other hand, have not caught on in the DER or CHP markets and have been mostly limited to large industrial heating applications. This section examines these issues to further define the potential market and determine which fuels are the most promising.

#### **Anaerobic Digester Gas**

Wastewater treatment plants have been utilizing anaerobic digester gas for energy for nearly thirty years. However, only recently has it become a widespread phenomenon. In the past, modified natural gas internal combustion engines were primarily used, although some ADG-powered gas turbines and boiler-steam turbine systems did exist. Installations, however, were few and far between. With the recent advent of microturbines and fuel cells, anaerobic digester gas has been receiving more attention as an alternative energy source. These technologies can utilize the fuel in small-scale power operations while producing very few emissions. In areas where emission regulations are strict, microturbines and fuel cells operating on ADG provide an environmentally sound power source, and state governments often provide crucial funding and project assistance.

Anaerobic digester gas performs very well when thoroughly cleaned of contaminants and impurities, although there is a noticeable degradation in power output compared to natural gas. The main problems facilities face are the condensation of water inside transport tubes, and the occasional dip in digester gas flow rate. The water problem can be easily solved with thorough drying and well-placed water traps. For plants that experience lags in their digester gas flow rate, natural gas is often used as a secondary fuel, triggered by a mechanism that senses when the flow rate is too low. Another potential problem is the formation of silicon dioxide from siloxane, a chemical found in shampoo and cosmetics. The silicon dioxide special carbon filter upstream, however, can easily solve this problem. Applied Filter Technology ([www.appliedfiltertechnology.com](http://www.appliedfiltertechnology.com)) specializes in producing these filters.

Despite these minor setbacks, anaerobic digester gas is one of the most promising opportunity fuels, and almost all wastewater treatment plant projects have seen positive results. In addition, ADG projects always take advantage of CHP, since treatment plants tend to have a high thermal demand. Some facilities that currently utilize ADG in DER/CHP applications are described below.

#### **Internal Combustion Engines and Turbines**

Several wastewater treatment plants installed internal combustion engines for CHP applications in the late 1970's and 1980's, and most are still in operation. The earliest known plant is the Village Creek Wastewater Treatment Center in Arlington, Texas. They installed two 1.15 MW IC engines in 1977 that run on anaerobic digester gas. Overhauls have been necessary every 28,000 hours, which is more frequent than most natural gas engines. The two IC engines were not utilizing all of the site's potential power, so a gas turbine was installed in 2001 to put the rest of the gas to use. As with most ADG operations, moisture condensation and dips in flow rate have been the only two problems encountered

with the fuel. In an interesting twist, instead of using natural gas as a secondary fuel when the flow rate drops too low, gas from a local landfill (LFG) is used for backup.

The Papillion Creek Wastewater Treatment Center in Bellevue, Nebraska also installed two small IC engines in 1977. The engines worked so well that three more were installed in the mid-80's. Recently, a new engine has been installed to keep up with the increased waste flow. All of the engines are designed for CHP and allow for dual-fuel flow so that natural gas can be used when necessary. Typically, only 4 of the 6 engines are running at a given time, so there is no downtime for maintenance or repairs. While water condensation can be a problem when the weather changes, this occurs rarely and is only a minor setback. The plant operations manager stated that significant savings are achieved from utilizing digester gas, and that the facility's power costs would double if the fuel was not used.

The Oxnard Wastewater Treatment Plant in Oxnard, California installed three 500 kW IC engines for CHP in 1981. With this plant, H<sub>2</sub>S formation in the gas was a particular problem. To combat this issue, ferric chloride is added to the waste sludge, effectively preventing the hazardous compound's formation. This treatment works well and is relatively cheap, so other wastewater plants have since followed suit. The Oxnard plant uses natural gas as a secondary fuel when the ADG flow rate dips too low, but this is infrequent and hasn't occurred for several years.

While other treatment plants using IC engines and gas turbines exist, the three plants discussed offer a good view of the overall picture. Combustion engines are more popular than turbines, since plants typically produce less than 5 MW of power. Sometimes ADG is used as a boiler fuel, but this is rare. The only problems plants experience are moisture and flow-rate related, and both problems are easily solved.



**Figure 5-1. 200 kW ADG Fuel Cell in Portland, Oregon**

### **Fuel Cells and Microturbines**

Fuel cells and microturbines are relatively new technologies, and only recently have they been applied to anaerobic digester gas projects. While more expensive than traditional engines and turbines, they produce very few emissions and are much more environmentally sound. Because of this, some states are willing to provide extra funding for fuel cell and microturbine projects, eliminating the cost advantage of the more conventional technologies. The best markets for fuel cells and microturbines are states like New York and California with strict emissions regulations, since their governments are more likely to provide funding.

The first ADG fuel cell project occurred at the Yonkers Wastewater Treatment Plant in Yonkers, New York. In 1997, a 200 kW fuel cell was installed, and for the most part it has been a resounding success. Similar projects were soon underway in Portland, Oregon and Boston, Massachusetts. The state governments helped fund the projects on a five-year trial period, in an effort to promote this environment-friendly technology. The main problem experienced at these plants, besides excess moisture and occasional dips in flow rate, was the lack of knowledge and experience regarding fuel cell operation and maintenance. Rather than hiring fuel cell experts, the plants opted to train their own workers on how to operate and maintain the machinery. This resulted in a number of errors and problems that could have

easily been avoided. Although the lesson has been learned, the Deer Island Wastewater Treatment plant in Boston chose to discontinue fuel cell operations in 2002, after the initial five-year trial period. The other two plants have kept their fuel cells and continue operation, although the plant in Portland has decided to add two microturbines for additional power production. Many more fuel cell projects are planned, and with the lessons learned from the three initial projects, they should be even more successful.

Microturbines are less expensive than fuel cells, but they produce slightly more emissions. Still, microturbines are much more environment-friendly than conventional engines and turbines, and like fuel cells, governments often provide critical funding for microturbine projects at municipal wastewater treatment plants. One of the first successful CHP microturbine projects was at the Lewiston Wastewater Treatment Plant in Lewiston, New York. The two 30 kW microturbines are dual fuel, to allow for natural gas injection during periods of high demand, or when the ADG flow rate is low. The microturbines were installed in 2000, and have remained in steady operation for two years. As with the other technologies, moisture can be a problem, so the gas is thoroughly dried before it is transported to the microturbine. Another problem occurred when siloxane chemicals formed silicon dioxide deposits in the turbine known as “white ash”. When the operators noticed this problem, a carbon filter was placed upstream and the white ash has not returned since. The recently installed microturbines at the Columbia Boulevard Wastewater Treatment Plant in Portland (where a fuel cell is already in operation) have experienced some problems with water getting into the combustion area, but this is in the process of being solved, and no more problems are anticipated. Many other microturbine projects are planned throughout the country, including the Owl’s Head Wastewater Treatment Plant in Brooklyn, and several more in the state of New York. As with fuel cells, the best markets for microturbine CHP projects are places like New York where emission regulations are strict and the government is willing to help with funding.

Overall, anaerobic digester gas appears to be the most promising opportunity fuel for DER/CHP applications, and it will be evaluated thoroughly in the following section. The actual potential for ADG projects in the United States will be estimated using RDC’s DISPERSE model.

### **Biomass Gas**

Biomass gasification has been used since World War II, when over a million gasifiers were built for the civilian sector to produce “woodgas” while the troops used up all of the fossil fuels. After the war, woodgas was soon forgotten, as it is inferior in almost every way to natural gas. However, now that fossil fuel resources are being depleted and costs are rising, biomass gasification systems are becoming more attractive to power consumers, and installations are beginning to pop up around the world.

There are many different types of gasifiers, and they all have their drawbacks and benefits. Moving and fluid bed gasifiers are the most common, but fluid beds are most often utilized in biomass gas applications, because they can handle a wide variety of feedstocks. Entrained bed gasifiers are not used in DER/CHP applications, only large 100+ MW installations where the feedstock consists of very fine particles. The different gasifier types are depicted in Figure 5-2, along with a summary of their characteristics. In the diagrams, “B” refers to the biomass feedstock, and “P” represents the pyrolysis gas (the gas used to power the genset).

While large industrial gasification systems are the most energy efficient, smaller CHP systems are also being developed, tested, and installed. As part of a major Department of Energy (DOE) initiative, two current projects are underway. The Hawaii Biomass Gasifier Project is an effort to demonstrate high-efficiency gasification systems for converting biomass resources into electricity, and the project so far has seen much success with many different types of fuels. The Vermont Gasification Project uses an

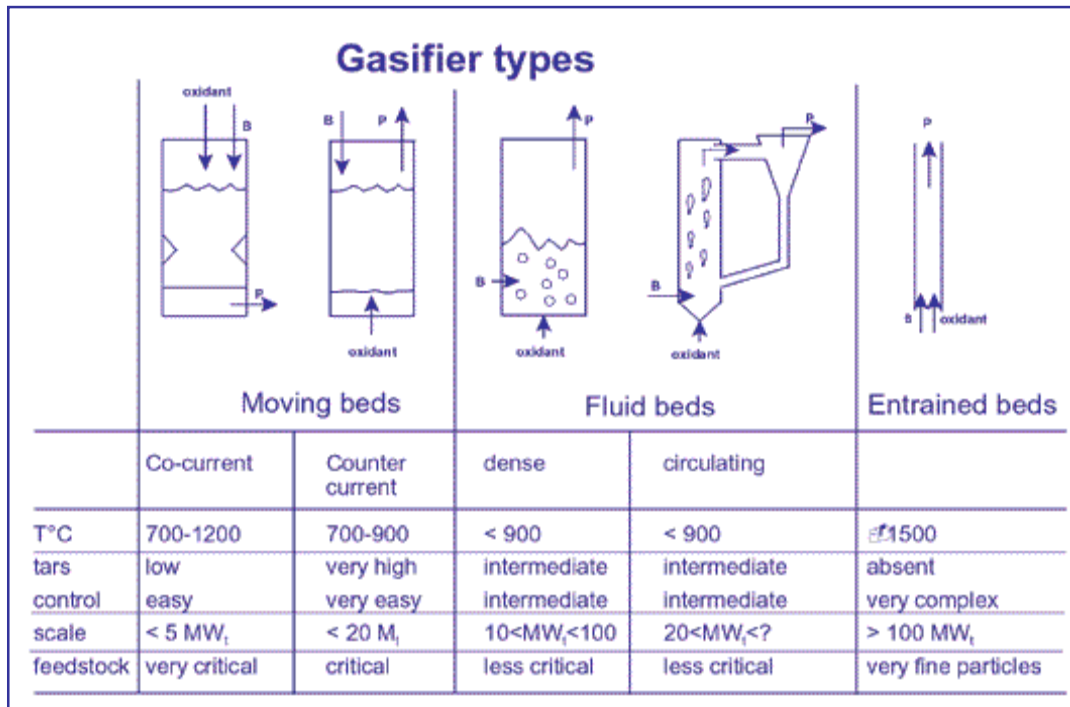

Figure 5-2. The Different Types of Gasifiers

alternative, indirect gasification process (not depicted in Figure 5-2). This project was initiated by the Future Energy Resources Company (FERCO) and it demonstrates the integration of the Battelle Columbus Laboratories indirectly-heated gasifier that produces a medium-heating value gas, used to power a combined cycle turbine. The Battelle gasifiers are a less expensive alternative to conventional combined cycle gasification systems.

A new type of gasifier genset is being developed by Recovered Energy Resources, LLC using an updraft gasification system, a ceramic heat exchanger, and air turbines. The company is producing modular 1.5 MW gasifier/turbine systems that can handle a wide variety of biomass or coal-based fuels. Recovered Energy Resources does not sell the units to customers – their strategy is to install their gasifier/turbine systems close to an interested party and sell the electricity and/or heat produced. Usually the gasifier will operate on waste fuels produced by the nearby facility, creating a mutually beneficial relationship. The company’s pitch is that there is no capital cost, no operational responsibility and no fuel purchasing for the interested party – Recovered Energy Resources will take care of all these things, only charging the customer a flat rate for the electricity and/or heat produced by the system. If Recovered Energy Resources’ business model is successful, this would be an attractive option for many producers of biomass waste.

Sometimes biomass gas with a very low Btu content (either due to low-quality feedstock or a crude gasification system) is produced and utilized, mainly for heating applications. A new system, however, is being created by Cratech to burn low-quality agricultural residues for CHP. Cratech has developed a gasification process that creates clean and particulate-free biomass gas that can be run through a combustion turbine. The company has been developing their gasification system for many years, with the help of government funding, and the final turbine modifications are now being made. Even with a low heat content of 200 Btu/ft<sup>3</sup>, a representative at Cratech claimed they are able to run the 225 kW CHP combustion turbine with no serious problems. If cost-effective, this new gasification method could provide CHP to a number of farms, mills and processing plants that aren’t suited for large-scale power production.

Another type of gasification system is being studied by the United Technologies Research Center in East Hartford, Connecticut. This system is specifically designed to handle refuse-derived fuel (RDF – municipal solid waste that has been sorted) or wood waste. Using an 85 MW advanced gas turbine system (combined cycle), the gasified garbage performed exceptionally well in simulated computer testing. The gasifier used was an advanced transport gasifier, a new type of circulating fluid-bed gasifier that allows a high fuel throughput with a small gasifier diameter, and minimal feedstock processing. Using the advanced combined cycle turbine with the advanced transport gasifier, a 45 percent efficient, low-cost, low-emission system was simulated. However, while this 85 MW gasifier/turbine system may work well in computer simulations, it has not been tested in the real world, and smaller (less than 50 MW) gasifier/turbine systems would not be capable of such high performance standards. Still, the results of the study are promising, and an RDF gasification system would eliminate some of the fuel cost concerns associated with most biomass fuels.

Outside of the United States, many biomass gasification projects have been implemented, especially in Europe. The Skydraft combined cycle plant in Varnamo, Sweden produces about 6 MW of electricity to the grid as well as 9 MW of thermal power to the district heating system. The gas turbine runs on biomass gas – wood, bark, forest residues, willow, straw, and refuse-derived fuel have all been used without any major operating problems. The ARBRE biomass gasification plant, located in North Yorkshire, UK, operates a combined cycle turbine with a net electrical output of 8 MW and an electric efficiency of over 30 percent. The plant operates on chopped up coppice shrubs and sells its electricity to the local grid. At the University of Brussels, the Binagas project is underway. The gasification system utilizes the indirect firing of gas turbines. The fuel gas produced by the gasifier is combusted directly in a heat exchanger, where clean air from the compressor is heated up and fed into the gas turbine. While this configuration eliminates tar build-up in the turbine, it creates other problems such as fouling and corrosion of the heat exchanger. All of these plants utilize high-quality biomass feedstocks and generate electricity at fairly high efficiencies.

Many biomass gas CHP systems are being used in India and third world countries where agricultural and forest residues are abundant. They are being implemented with international funding to provide a cheap and clean power source with a never-ending fuel supply for the third-world countries. While the systems would probably not be cost-effective in the United States, they are being implemented successfully in other countries. The experience, along with future technological advancements, could help bring down the price of gasification systems so that they can be economically viable in the States.

Although biomass gas is not quite ready for widespread implementation, it does have a niche in certain markets and there is an abundance of resources available for fuel. Biomass gas could potentially replace fossil fuels in applications where biomass resources can be easily obtained. Biomass gas is examined thoroughly in the following sections – estimating the potential capacity, identifying the potential market, and determining the cost parameters for market entry.

### **Coalbed Methane**

Coalbed methane is a very high quality fuel source, but the technical potential for DER projects is not very high, and coalmines generally have little to no thermal demand, so CHP is usually not an option. Facilities and equipment manufacturers were contacted to examine these problems, and to see if there were any other issues with the fuel.

Most of the time, the high quality methane collected from mine drainage holes is cleaned and injected into a natural gas pipeline. Many coalmines have a pipeline running through their site, and pipeline sales are an easy money-making alternative to on-site power production. When CBM has been utilized on-site, it is always exclusively for electricity. Some electricity-producing facilities were contacted, and there are

no apparent problems with the fuel. It is easily collected through drainage holes, and only a slight cleaning and scrubbing is required before it is ready to use. Gas turbines and reciprocating engines have traditionally been used as prime movers in CBM projects, and they perform just as well as they do with natural gas. Recently microturbines have become popular for CBM, with Capstone reporting about 60 microturbine projects currently underway. Most coalmines have high electric demands, so they utilize all of the electricity that they produce. Although waste heat is sometimes recirculated or otherwise distributed, the thermal demand at coalmines is generally too low to warrant combined heat and power.

However, there is still some hope for coalbed methane-fired CHP. If a nearby facility is willing to accept the thermal load, then a combined heat and power project could be implemented. The generator could either be located on-site, or the gas could be pipelined to the facility. In either case, the facility would have to be located fairly close to the coalmine. For most coalmines, however, there are no nearby facilities to be found and pipeline sales are an easy and economical option. While many coalmines have chosen to utilize their methane on-site instead of pipeline injection, they are all strictly producing electricity. No CHP projects have been documented, and it appears that none are currently being planned.

While the chance of numerous coalbed methane CHP projects being implemented is slim to none, the fuel makes an excellent choice for DER projects at coalmines and there is still a fairly large market there. Although many coalmines prefer pipeline sales, DER projects can be even more profitable, and most coalmines could benefit from on-site power production. The coalmines with the best potential for DER projects are those without nearby access to natural gas pipelines, but with close grid access so that some of the electricity can be sold. However, the number of underground coalmines is limited, and many of the best potential candidates are already benefiting from pipeline sales. While coalbed methane could easily provide 500 MW of electric capacity, there just isn't any more potential unless unused coalbeds were drilled for the gas – and even then, it would likely just be used as natural gas. Due to coalbed methane's low technical potential and limited CHP capabilities, it will not be considered for further evaluation in this report.

## Landfill Gas

Landfill gas is gaining acceptance as a fuel for DER/CHP projects, and there are many facilities that could potentially benefit from its use. While landfills themselves rarely utilize the energy produced (the thermal and electric demand is too low) nearby facilities can purchase the rights to the gas and/or electricity. The fuel usually sells for cheaper than natural gas, and unlike anaerobic digester gas, the flow rate remains constant. Most of the time, a developer such as INGENCO, Granger Electric/Energy, or Waste Management Inc. purchases rights to the gas, and generates electricity on-site. Then the electricity is sold to a third party or utility at a rate of about 4-6 cents per kWh. The EPA is strongly encouraging the use of landfill gas as a fuel, so they will offer tax refunds and other government incentives to facility operators. The EPA and state governments will also assist in project planning and financing, making landfill gas an attractive option for DER/CHP project seekers.



**Figure 5-2: Landfill Gas Microturbine**

Landfill gas project operators find there are no real issues with the fuel itself, besides its sometimes-unpleasant odor and the occasional buildup of silicon dioxide. Every generator that is being used in LFG projects has either been custom-designed for landfill gas, or can handle the gas without any serious issues. Reciprocating engines are the most common, but microturbines are becoming more popular, especially in areas with strict environmental regulations.

While moisture condensation was a serious problem for anaerobic digester gas at wastewater treatment plants, it is not much of an issue with landfill gas, since the source material is relatively dry. Silicon dioxide deposits can form when siloxane is present, but this problem is more prevalent in ADG installations. Special filters should be used whenever high amounts of siloxane are found in the LFG project's waste stream (see Applied Filter Technologies, [www.appliedfiltertechnologies.com](http://www.appliedfiltertechnologies.com)). Because LFG is a low-Btu gas, Dry-low NO<sub>x</sub> control technologies cannot be used and maintenance is increased when compared to natural gas-fired units.

At most landfills, the gas collection equipment is already in place since they are required to flare their waste gas. Only some pipes need to be built and a genset installed. Grid interconnection is often an issue, and sometimes pipelines need to be built in order to transport the gas to a spot that the generator can interconnect. Other projects within 2 miles of the landfill may want to have the gas transported via pipeline directly to their facility.

Sometimes additional gas wells need to be drilled at the landfill, as was the case with the Avery County Landfill in Newland, North Carolina. The LFG flow rate at this landfill was too low, so more gas wells were drilled, and the extra costs nearly crippled the project. Most of the time, however, the flow rate is adequate and extra gas wells are not necessary. As long as all of the equipment is designed and installed correctly, and the genset properly maintained, there are no problems with landfill gas as a fuel.

The main issue with landfill gas is its limited market. A landfill, a project developer and a third party or utility must agree on a contract that is mutually beneficial, and sometimes it is just not possible. Of the thousands of landfills across the U.S., about 340 are currently utilizing their gas for electricity, and the EPA has pinpointed about 600 more potential projects. However, many more landfills are likely capable of LFG projects. While this market is fairly strong, it is not nearly as prevalent as anaerobic digester gas, which has thousands of potential installations. Still, landfill gas is one of the most promising opportunity fuels and it will be evaluated thoroughly in the following section.

### Tire-Derived Fuel

Tire-derived fuel has been around for quite some time, but has not yet made an impact on the DER/CHP market. The fuel is primarily used as a supplement to coal in cofiring applications. Its heating value is often higher than coal, and unprocessed TDF can be purchased for a much cheaper price, so cofiring is advantageous to most facility operators. While highly processed TDF can be burned exclusively in coal-fired boilers with no necessary modifications, maintenance costs will increase, and processed TDF can be more expensive than coal. For this reason, lower-grade TDF is usually purchased for a cheap price and cofired at 10-20 percent, with only a slight possible increase in maintenance costs for the unit.



**Figure 5-3. The Exeter Energy Facility burns 100 percent tire-derived fuel**

Other TDF operations have been found in cement kilns, paper mills, and other industrial facilities, but it is either burned just for heat, or as a supplementary boiler fuel. Scrap tires are chosen by cement mills and other industrial facilities because of their cheap price and high Btu content. The facilities burn whole tires

at high temperatures to melt the embedded metal wires and extract all of the available thermal energy. Although this produces a considerable amount of emissions, controls can be put in place and these facilities often have lower standards than normal. Other facilities, such as paper mills, purchase tire-derived fuel as a supplementary boiler fuel, but never use it for a primary fuel source. While tire-derived fuel has found a niche in these two types of facilities, there is still an abundance of scrap tires in the United States that could potentially be used for combined heat and power applications.

There are only two known facilities in the United States that burn 100 percent tire-derived fuel for electricity. The Exeter Energy facility in Sterling, Connecticut (pictured in Figure 5-3) is owned by CMS Energy and was completed in 1991. It burns TDF in two inclined reciprocating grate boilers specifically designed for the fuel. The boilers reach temperatures of over 3,000 degrees Fahrenheit so that unprocessed tires can be used. The waste heat is used to preheat the feedwater for the boilers, and the steam is used to power a 30 MW turbine. The boilers have had no reported problems so far in over ten years of operation.

The other facility is a 20 MW plant located in Ford Heights, Illinois that is capable of burning 17,000 lbs of tire-derived fuel per hour. The plant was completed in 1996, but shortly after completion, Illinois modified its Retail Rate Act and repealed certain rate incentives, forcing the original owners into bankruptcy. In 1998, the plant was purchased by KTI, Inc. and Casella Waste Systems and put back into operation. The incentives were reinstated in 2002. Like the Exeter plant, the boiler was designed specifically for tire-derived fuel, so there have been no problems thus far.

If tire-derived fuel is to become successful in the DER/CHP market, more facilities like these must be established and publicized. Currently, however, the main markets for TDF are cement kilns, industrial facilities, and cofiring applications, where the fuel is primarily used for heat. When using 100 percent TDF in existing coal-fired boilers, the fuel must be heavily processed, costing about the same as coal (sometimes more), so there is no incentive for coal-users to switch to TDF. However, there is plenty of incentive for current coal-users to cofire TDF, since cheaper, low-grade TDF can be used. Furthermore, TDF contains less sulfur and nitrogen than coal, so less SO<sub>x</sub> and NO<sub>x</sub> emissions are produced in cofiring operations. Cofiring is a primary market for tire-derived fuel projects, but most coal-fired plants are not considered DER/CHP. As a further hindrance, the technical potential for TDF is not very high compared with most of the other opportunity fuels, and it is very doubtful that even 1 GW of electric capacity will ever be realized. It is unclear what lies in the future for tire-derived fuel, but as of this moment, it is not considered a prime contender for DER/CHP applications.

## **Wellhead Gas**

Wellhead gas, or casehead gas, is an ideal source of power for oil and gas wells who could benefit from on-site electricity generation. Until recently, the gas was considered too “dirty” to be used as a fuel, since extensive cleaning and scrubbing would need to be performed prior to combustion. With the advent of the microturbine, however, wellhead gas energy projects are becoming much more common.

The Rocky Mountain Oilfield Testing Center Microturbine Project proved that microturbines are perfectly capable of running on dirty wellhead gas. The project showed that the Capstone 30 kW microturbines do not require any modifications or special cleaning devices to utilize the gas. Compared to natural gas, more maintenance is required – about the same as for the low-Btu gases. However, this was expected and the project was a complete success. After this, many oil and gas wells began microturbine projects with Capstone Turbines.

To date, Capstone has provided microturbines for over 100 wellhead gas projects in the United States. Ten offshore projects have been implemented, and 30-40 offshore projects are expected by the end of



2003. Of the 100+ projects, however, only two utilize combined heat and power since the thermal demand at oil and gas wells is so low. Sometimes nearby facilities can utilize the thermal energy, but most wells are found in remote locations, making this a very rare occurrence. The electric demand at oil and gas wells is also quite small, but a 30 kW microturbine is usually about the right size.

For small DER microturbine applications at oil and gas wells, wellhead gas makes an excellent fuel choice. There are over 1,000 oil and gas wells in the United States, so only a tenth of the potential market has been reached. Although not ideal for CHP, wellhead gas is free to oil and gas wells, and is highly recommended as an opportunity fuel at these installations. However, the potential capacity for wellhead gas is very low compared to the other opportunity fuels, so it will not be considered for further analysis in this report.



**Figure 5-4. Microturbines can even provide power to offshore wells**

### Wood and Wood Waste

While wood waste is often used for CHP projects in the wood and paper industries, harvested wood is rarely used as a fuel for DER/CHP. Harvested wood fuels are more expensive than wood waste, although they tend to burn cleaner and require less maintenance. Even so, every single wood-burning DER/CHP project encountered uses wood waste for fuel. Every facility contacted produces the waste themselves, meaning the only costs come from processing it into burnable chips. While this is obviously the best option for those in the wood and paper industries, outside customers can purchase other wood waste fuels from recycling yards and processing centers. Including transportation and processing costs, urban wood waste sells for roughly \$18.00 per dry ton (\$1.20 per MMBtu), while harvested wood sells for about \$30.00 a ton (\$2.00 per MMBtu).

In Vermont, where the forestry industry is large, the Future Energy Resources Company (FERCO) runs a 50 MW wood-fired power generation plant. They use wood and wood waste as fuels, fired in boilers that power specially designed steam turbines. The plant has been running for years without any major problems. FERCO is now experimenting with wood gasification systems for powering combined cycle turbines (see the Biomass Gas section), but their power plant remains up and running.

When a boiler is designed to run on wood or wood waste, it performs nearly as well as a coal-fired boiler. Even though there is an obvious decrease in the fuel's heating value and the boiler may require more maintenance, burning wood for fuel does not create any additional problems. Of the many wood-processing facilities contacted, none reported any significant drawbacks or shortcomings with using their wood waste as a fuel. Some types of wood waste require more preparation and cleaning than others, but they all seem to perform well in a boiler.

Although wood waste is an ideal fuel for those in the wood and paper processing industries, finding outside markets for the fuel could prove a challenge. For those without a free supply of wood waste, wood fuels are only beneficial when their price is drastically less than coal. A wood-fired boiler costs more than a coal-fired boiler, and usually more maintenance is required. On top of that, coal is simply a superior fuel. Therefore, the only way wood fuels can be successful is if they cost significantly less than coal on a Btu-basis, or if government incentives were offered. Although some facilities may qualify for biomass tax reductions, the price for wood wastes is about the same as coal, and harvested wood is usually much more expensive. Because of this, the market for wood fuels is virtually nonexistent outside of the wood and paper processing industries.

The use of harvested wood for fuel will not become a reality unless government incentives are offered. The collection, processing and transportation costs are just too high. However, wood waste can be purchased much cheaper than coal in some areas, and there is still a large potential market in the wood and paper industries. While many facilities already utilize their waste for fuel, there are also many that do not, and there is always an excess of wood waste available for use. If the right incentives were offered, and an infrastructure was developed, wood wastes could potentially replace coal in many DER/CHP applications. While the future for harvested wood fuels appears somewhat bleak, wood wastes could still become a strong player in the DER/CHP market.

## **Chapter 5 Summary**

Now that the current projects and the future outlook for each fuel has been examined, the final screening has been conducted, and only the most promising opportunity fuels were chosen for further evaluation. A summary is provided below.

### **Fuels Considered for Further Evaluation:**

- Anaerobic Digester Gas
- Biomass Gas
- Landfill Gas
- Wood Waste

### **Fuels Eliminated from Further Evaluation:**

- Coalbed Methane – Limited potential, coalmines not good candidates for CHP
- Harvested Wood – Fuel is too expensive, limited market
- Tire-Derived Fuel – Processed TDF can cost more than coal, limited market, limited potential
- Wellhead Gas – Only suitable for small DER installations at oil/gas wells (very limited potential)

The next phase of this project will discuss and present Resource Dynamics Corporation's DISPERSE model for opportunity fuels. This model will calculate the approximate cost to generate electricity with the five fuels, and compare it with electricity prices throughout the country. The model, based on fuel, equipment and maintenance costs, as well as local electricity rates, chooses the best locations for potential opportunity fuel projects and calculates the overall cost to generate electricity, as well as equipment payback periods.

The Distributed Energy Program would like to acknowledge Oak Ridge National Laboratory for its Technical Project Input of this Report.

## OAK RIDGE NATIONAL LABORATORY

MANAGED BY UT-BATTELLE FOR THE DEPARTMENT OF ENERGY

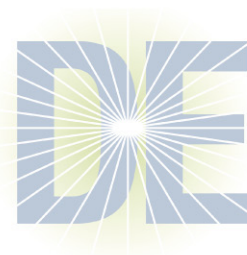

### **A Strong Energy Portfolio for a Strong America**

Energy efficiency and clean, renewable energy will mean a stronger economy, a cleaner environment, and greater energy independence for America. Working with a wide array of state, community, industry, and university partners, the U.S. Department of Energy's Office of Energy Efficiency and Renewable Energy invests in a diverse portfolio of energy technologies.

#### **For more information contact:**

EERE Information Center

1-877-EERE-INF (1-877-337-3463)

[www.eere.energy.gov](http://www.eere.energy.gov)