

# **MICROTURBINE POWER CONVERSION TECHNOLOGY REVIEW**

**R. H. Staunton  
B. Ozpineci  
Oak Ridge National Laboratory**

## DOCUMENT AVAILABILITY

Reports produced after January 1, 1996, are generally available free via the U.S. Department of Energy (DOE) Information Bridge.

**Web site** <http://www.osti.gov/bridge>

Not available externally.

Reports are available to DOE employees, DOE contractors, Energy Technology Data Exchange (ETDE) representatives, and International Nuclear Information System (INIS) representatives from the following source.

Office of Scientific and Technical Information

P.O. Box 62

Oak Ridge, TN 37831

**Telephone** 865-576-8401

**Fax** 865-576-5728

**E-mail** [reports@adonis.osti.gov](mailto:reports@adonis.osti.gov)

**Web site** <http://www.osti.gov/contact.html>

This report was prepared as an account of work sponsored by an agency of the United States Government. Neither the United States Government nor any agency thereof, nor any of their employees, makes any warranty, express or implied, or assumes any legal liability or responsibility for the accuracy, completeness, or usefulness of any information, apparatus, product, or process disclosed, or represents that its use would not infringe privately owned rights. Reference herein to any specific commercial product, process, or service by trade name, trademark, manufacturer, or otherwise, does not necessarily constitute or imply its endorsement, recommendation, or favoring by the United States Government or any agency thereof. The views and opinions of authors expressed herein do not necessarily state or reflect those of the United States Government or any agency thereof.



ORNL/TM-2003/74

# Microturbine Power Conversion Technology Review

April 8, 2003

R. H. Staunton  
B. Ozpineci

OAK RIDGE NATIONAL LABORATORY  
Oak Ridge, Tennessee 37831  
managed by  
UT-BATTELLE, LLC  
for the  
U.S. DEPARTMENT OF ENERGY  
under contract No. DE-AC05-00OR22725

# CONTENTS

1. INTRODUCTION .....	1
2. POWER CONVERSION DESIGNS .....	2
2.1 Microturbine Generators .....	2
2.2 Power Converter Design .....	3
2.2.1 DC link converter.....	3
2.2.2 High frequency link converter .....	4
2.2.3 Cycloconverter .....	5
3. INFORMATION OBTAINED FROM INDUSTRY AND TECHNOLOGY REVIEW .....	6
3.1 Information Needs .....	6
3.2 Manufacturers of Power Converters .....	7
3.3 Data Provided by Manufacturers .....	11
3.3.1 Primary manufacturers .....	11
3.3.2 Alternative design approaches of interest .....	17
3.4 Notes on Other Connection Technology.....	18
4. CONVERTER TECHNOLOGY AND RELIABILITY .....	20
4.1 Status of Power Converter Technology .....	20
4.1.1 Operating modes and transitions.....	20
4.1.2 Software used in the programmable digital controllers .....	20
4.1.3 Universal interface/communications.....	21
4.1.4 Proposed requirements for ancillary services .....	21
4.2 System Reliability in an Emerging Industry .....	22
4.2.1 Reliability issues .....	22
4.2.2 Operating environment .....	23
5. SUMMARY AND RECOMMENDATIONS FOR FUTURE WORK .....	25
ACKNOWLEDGMENTS .....	28
APPENDIX A – POWER CONVERTER INFORMATION FORM .....	A-1

## 1. INTRODUCTION

In this study, the Oak Ridge National Laboratory (ORNL) is performing a technology review to assess the market for commercially available power electronic converters that can be used to connect microturbines to either the electric grid or local loads. The intent of the review is to facilitate an assessment of the present status of marketed power conversion technology to determine how versatile the designs are for potentially providing different services to the grid based on changes in market direction, new industry standards, and the critical needs of the local service provider. The project includes data gathering efforts and documentation of the state-of-the-art design approaches that are being used by microturbine manufacturers in their power conversion electronics development and refinement. This project task entails a review of power converters used in microturbines sized between 20 kW and 1 MW.

The power converters permit microturbine generators, with their non-synchronous, high frequency output, to interface with the grid or local loads. The power converters produce 50- to 60-Hz power that can be used for local loads or, using interface electronics, synchronized for connection to the local feeder and/or microgrid. The power electronics enable operation in a stand-alone mode as a voltage source or in grid-connect mode as a current source. Some microturbines are designed to automatically switch between the two modes.

The information obtained in this data gathering effort will provide a basis for determining how close the microturbine industry is to providing services such as voltage regulation, combined control of both voltage and current, fast/seamless mode transfers, enhanced reliability, reduced cost converters, reactive power supply, power quality, and other ancillary services. Some power quality improvements will require the addition of storage devices; therefore, the task should also determine what must be done to enable the power conversion circuits to accept a varying dc voltage source. The study will also look at technical issues pertaining to the interconnection and coordinated/compatible operation of multiple microturbines.

It is important to know today if modifications to provide improved operation and additional services will entail complete redesign, selected component changes, software modifications, or the addition of power storage devices. This project is designed to provide a strong technical foundation for determining present technical needs and identifying recommendations for future work.

## 2. POWER CONVERSION DESIGNS

This section considers the high-speed generator designs that are used in microturbine systems and the power electronics (i.e., power converter) that generally interface with the generators to develop the necessary 3-phase, line-frequency voltages.

### 2.1 Microturbine Generators

The highest efficiency operating speeds of microturbines tend to be quite high, often exceeding 100,000 rpm. The speeds are generally variable over a wide range (i.e., from 50,000 rpm to 120,000 rpm) to accommodate varying loads while maintaining both high efficiency and optimum long-term reliability. The microturbine drives a high-frequency generator that may be either synchronous or asynchronous (or non-synchronous). The caged rotor design in asynchronous (or induction) generators tends to make it a less-costly alternative to synchronous generators. Synchronous generators contain a magnetic rotor that is designed to use either rare earth permanent magnets or coils with additional hardware for delivering current (e.g., slip rings, brushes). Although asynchronous generators are somewhat rare in the industry, they are the generator of choice in wind and hydro generation applications.

Power requirements to the generator vary depending on the design. A synchronous generator with a wound rotor assembly will require dc power for energizing the rotor poles. An asynchronous generator in most microturbine applications will require a 3-phase current to the stator at a frequency correlated well to the rotational speed so that power is produced.



Ingersoll Rand's microturbine makes use of a high-speed gearbox instead of a high-frequency power converter

In conventional applications, synchronous generators have an advantage where they can be connected directly to the grid if speed is properly regulated. This is generally<sup>1</sup> not the case in high-speed microturbine applications. For all generator types, a 3-phase, high frequency voltage, typically in the range of 1,000 Hz to 3,000 Hz, will be developed that must be converted to line frequency before the generated power becomes usable.

---

<sup>1</sup> An exception will be seen later where one manufacturer chose to use a conventional low speed generator after gearing down the turbine speed.

## 2.2 Power Converter Design

Figure 2.1 shows a general diagram for a microturbine generator system followed by a power converter and a filter. The ac/ac power converter essentially converts high frequency ac to 50 or 60 Hz ac.

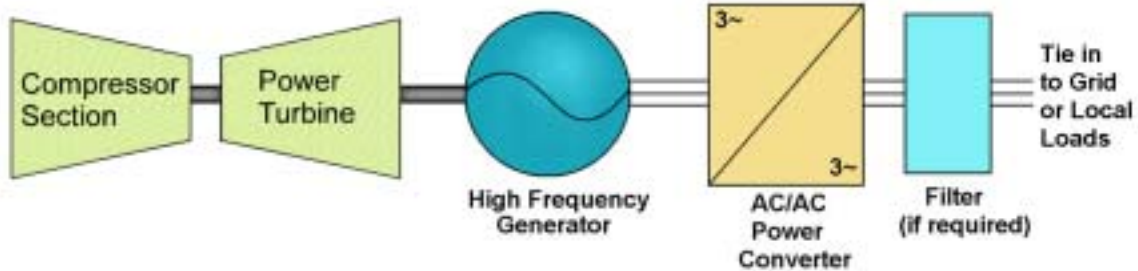

Fig. 2.1. General microturbine diagram.

The power converter can also be designed to provide valuable ancillary services to the power grid or microgrid. These services may include voltage support, sag support, static volt-amp-reactive (VAR) compensation, load following, operating reserve (e.g., spinning or non-spinning), backup supply, and/or start-up power for the microturbine or other local microturbines. Voltage support is common for grid-independent operation while load following is used for grid-connected operation. Operating reserve capability may or may not be recognized by the local electricity provider depending on their current tariffs and the capabilities of the microturbine installation. The availability of backup supply and start-up power varies not only by microturbine manufacturer but also by what options may be purchased with the microturbine. For this reason, it will become a topic of discussion in contacts with manufacturers (see Sect. 3.3).

### 2.2.1 DC link converter

The most common power converter topology that is used for connecting microturbines to the grid is the dc link converter. Figure 2.2 shows a microturbine generator feeding power to an active rectifier circuit (or, alternatively, a passive rectifier) followed by a dc link and inverter circuit.

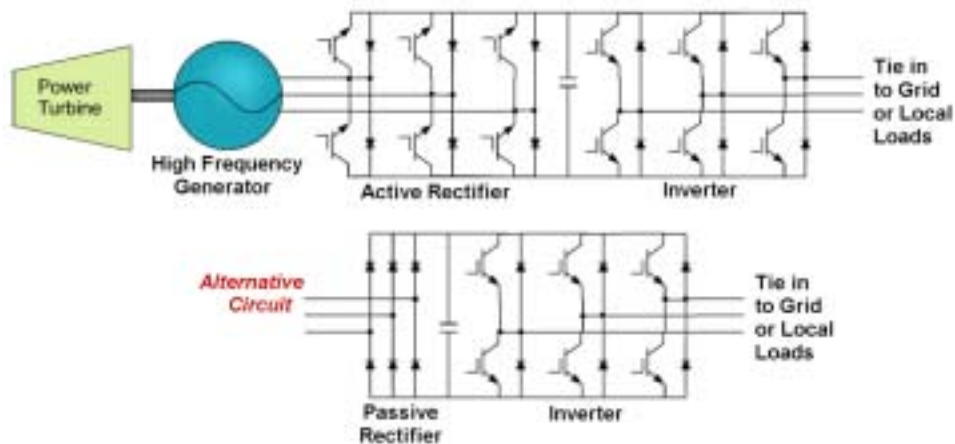

Fig. 2.2. Simplified diagram of a dc link converter .

The high frequency power from the generator must be converted to dc before the inverter can reconstruct a three-phase voltage supply at lower frequency required for grid connection. A controller manages the operation of the active rectifier and inverter circuitry by ensuring that functions such as voltage following, current following, phase matching, harmonic suppression, etc. are performed reliably and at high efficiency. The controller may be mostly on-board, pc-based, a processor linked to a pc, etc., depending on constraints and factors such as desired microturbine packaging, desired versatility, type of available features, and the sophistication/maturity of the system design.

## 2.2.2 High frequency link converter

Another type of power conversion circuit that is of high interest is the high frequency link converter (HFLC). Figure 2.3 shows a microturbine generator feeding 3-phase power to a rectifier and the dc is then fed to a high frequency, single-phase inverter so that a compact, high frequency transformer can be used. The secondary of the transformer feeds an ac/ac converter that takes the single phase, high frequency voltage to produce a 3-phase voltage at a frequency and phase needed to make a direct connection to the grid.

Although the HFLC requires a higher part count, the circuit provides several advantages including:

- The use of a transformer for robust isolation
- The high frequency inverter permits the use of compact, high-frequency transformers
- The use of a transformer permits the easy addition of other isolated loads and supplies via additional windings and taps
- The circuit eliminates the need for static transfer switches
- Ancillary services can be provided with control software changes and additional hardware
- Adding additional hardware is easier

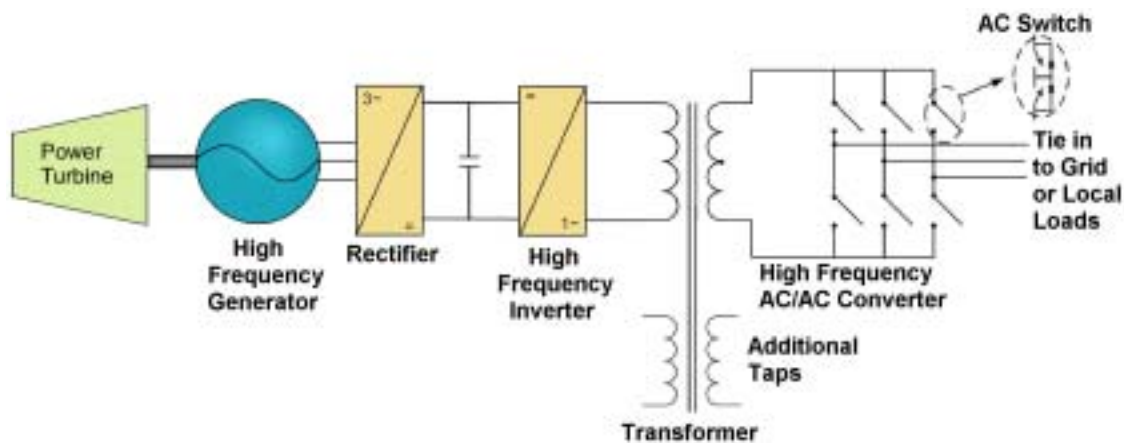

**Fig. 2.3. Simplified diagram of a high frequency link converter .**

Thus, a well-designed HFLC that is controlled by software could potentially provide unique characteristics (e.g., additional voltages, isolation/protection) to the microturbine owner. The system may offer certain advantages for growing with the needs of the owner. No microturbine manufacturer is presently marketing generation systems using an HFLC.

The data gathering effort will try to identify any development efforts or other experimental programs involving HFLC or any other unique or innovative power converter topologies.



### 2.2.3 Cycloconverter

A cycloconverter or a matrix converter could be used to connect the microturbine generator to the grid instead of using a rectifier and an inverter. These converters, as shown in Figure 2.4, directly convert ac voltages at one frequency to ac voltages at another frequency with variable magnitude. For this reason, they are also called frequency changers. The disadvantages of these converters are that they have double the number of switches compared to the dc link approach and they do not have a dc or ac link to store energy. Without energy storage in the converter, any fluctuations at either side of the converter will directly influence the other side. In addition to this, it is not possible to connect a battery or any other power source to these converters unlike the dc link converter or the HFLLC.

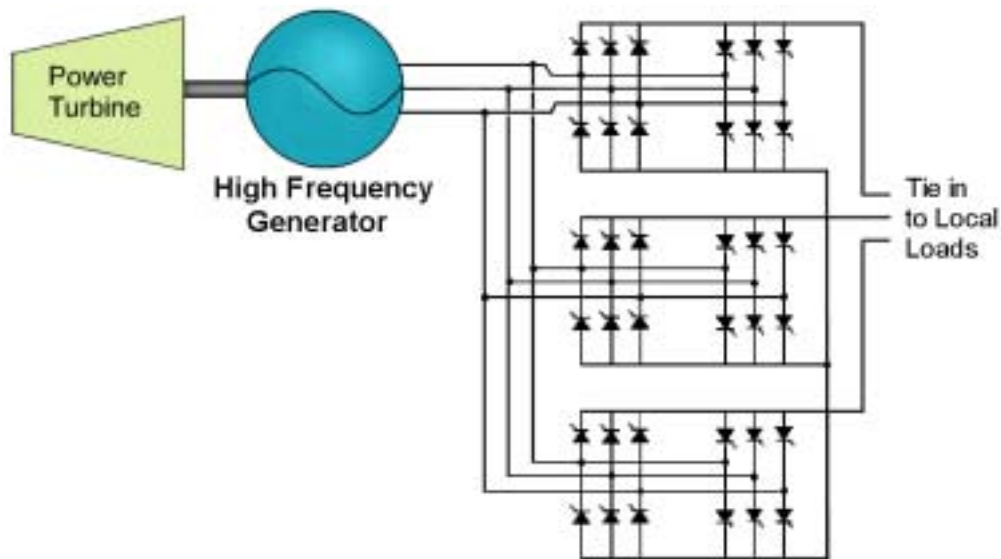

Fig. 2.4. Simplified diagram of a cycloconverter.

A cycloconverter can still be used for microturbines with the high frequency link inverter. Instead of converting the generator voltage to dc and then to high frequency ac, a cycloconverter can directly convert the three-phase ac voltage to single-phase high frequency ac voltage.

### 3. INFORMATION OBTAINED FROM INDUSTRY AND TECHNOLOGY REVIEW

The data gathering effort performed in this study was conducted from December 2002 through March of 2003. Information was obtained through a variety of means including Internet searches, inspections of microturbines, review of microturbine manuals, and conversations with company engineers.

#### 3.1 Information Needs

Questions were sent to microturbine power converter manufacturers and developers from several companies. Examples of the questions are provided in Appendix A along with descriptive text explaining precisely what information was being sought. This section lists the types of information the data gathering effort was designed to obtain.

The types of information that were sought during the data gathering effort include the following:

##### Generator Type and General Description

- Asynchronous vs. synchronous
- Packaging – power converter location
- Turbine speed range
- Modes of operation (e.g., stand alone, grid connect)
- Power rating
- Cost of power converters
- Manufacturer/supplier identification

##### Power Conversion (technical)

- Determine if the converters are pulse-width-modulated or if they use a commutated-pulse architecture (i.e., line commutated inverter)
- Identify type of circuit topology
- Determine the switching frequency
- Determine internal circuit control (onboard microprocessor or a computer with software)
- Determine if there are concerns with electromagnetic interference (EMI) and harmonic distortion
- Types of ancillary services/special features provided by power converter
- Required accessories
- Other features

##### Component issues

- Determine if the architecture uses MOSFETs vs. IGBTs or pn diodes vs. Schottky Diodes
- Determine how close the switching devices operate to their maximum ratings
- Identify the operating/maximum temperatures
- Identify the heat removal method
- Determine how much fault current may be developed and for how long

Analysis – Determine whether hardware changes would be needed to expand the ability of the system to provide grid support (i.e., ancillary services) or if they can be accomplished with just a change to the processor or software.

As with many inquiries sent to industry, a rapid and enthusiastic response is a rare exception. Engineers, marketing, and sales personnel are generally overworked and unable to devote time to preparing

responses, even if they see some potential benefit in doing so. However, this data gathering effort had an additional challenge in that the industry it sought to query is young, struggling for survival, addressing numerous urgent problems, and very sensitive to releasing technical design-related information. In addition, the early production microturbines now in service, including mechanical systems and power converters, have experienced reliability problems. Although the contacts made with manufacturers were not designed to probe for such information, responders may somehow feel that full admission of such matters was expected. One power converter manufacturer, after considering the information request, simply declined to respond without offering any explanation. In spite of these challenges, reasonably complete results were eventually obtained by perseverance, seeking out alternate contacts from companies, inspecting local production microturbines, and reviewing literature (i.e., including owner's manuals and training manuals).

### 3.2 Manufacturers of Power Converters

This section presents basic information relating to domestic and foreign power converter manufacturers whose products are, or can be, used in microturbines in the size category from 20 kW and 1 MW. This study will, in later sections, focus primarily on domestic manufacturers; this is necessitated by the fact that detailed design data, which is quite difficult to obtain from U.S. manufacturers, will be more difficult (i.e., essentially impossible) to obtain from foreign manufacturers.

It becomes very evident just how *new* the microturbine industry is when one considers all of the manufacturers that are either marketing their products as of the last few years, are taking orders for soon-to-be introduced products, or are strictly in the development of products. Even the “oldest” manufacturers are just beginning to see their products arrive at the first major overhaul point. At best, the reliability calculations for microturbines and the associated power converters are now becoming less theoretical and more based on actual in-service data.



Capstone microturbine - 60 KW

Table 3.1 provides a list of all known power converter manufacturers and/or microturbine manufacturers. It indicates their relevant product or development activity, whether their power converters are an in-house design and production effort, and additional notes or comments. The table indicates that a number of microturbine manufacturers do not produce their own power converters for a number of reasons. For instance, Elliot Energy Systems purchases all of the power converters used in their microturbines from Bowman Power Systems, and Ingersoll Rand Energy Systems uses a gearbox that enables them to use conventional induction and synchronous generators that connect to the grid/loads without the use of a power converter (see Sect. 3.3.2). Although the parent company of Elliott Energy Systems, Ebara Corporation of Japan, is reportedly becoming a new supplier of power converters to Elliott, it is too early to report on how these power converters might differ from those supplied by Bowman.

**Table 3.1. Power converter and/or microturbine manufacturers whose products are in production and available on the market**

<b>Manufacturer</b>	<b>Product or Development Activity</b>	<b>Producer of power converters<sup>a</sup></b>	<b>Notes</b>
Ballard	Ecostar™ power converters from 10 kW to 1 MW	Yes, for other generation applications	Fuel cells are Ballard's main product line
Bowman Power Systems	Turbogen™ family of microturbines ranging from 25 kWe to 80 kWe	Yes	Supplies converters to Elliot Energy Systems, Inc.
Capstone Turbine Corporation	30 kW and 60 kW microturbines (200 kW microturbine under development)	Yes	Integral module; DOE-AMP <sup>b</sup> participant
Cummins	30 kW and 60 kW microturbines	No	Basic microturbine systems are obtained from Capstone
Elliott Energy Systems, Inc. owned by the Ebara Corporation (Japan)	35 kW, 60 kW, and 80 kW microturbines, products have used Bowman power converters; however, the Ebara Corp. is an emerging supplier	No	Supplies mechanical microturbine systems to Bowman Power Systems
Ingersoll Rand Energy Systems	70 kW PowerWorks microturbine (no power converter used), larger units planned.	NA (see text)	DOE-AMP <sup>b</sup> participant, gearbox is used to reduce rpm and to facilitate use of low speed generator.
Turbec AB (owned by ABB & Volvo)	Model T100 is a 100 kW microturbine marketed almost exclusively to Europe	Yes	Modest sales in U.S.; not fully included in the present study
Xantrex	A wide range of power converters are available for any type of generator.	For other generation applications	No present microturbine applications

(a) Indicates whether the power converters are an in-house product.

(b) DOE-AMP = Department of Energy's Advanced Microturbine Program, not all participants are involved in development of power electronics and therefore not all are listed.

Turbec produces a Model T100 105 kW combined heat and power (CHP) microturbine that uses a dc link power converter to convert the generator's high frequency output to useful power. Turbec markets primarily to Europe with distributors in Italy, Switzerland, France, UK, Ireland, Denmark, and Germany; therefore, this study's consideration of Model T100 is somewhat limited. However, several unique features/characteristics that merit consideration are briefly summarized in Sect. 3.3.



Capstone (30kW) opened to show major assemblies

Table 3.1 also lists some manufacturers, such as Ballard and Xantrex, who market versatile power converters designed for use with renewable energy generators (e.g., wind, solar) and other types of distributed generation applications. These applications are distinct primarily because they need not accept a high-frequency output from generators such as used in microturbines. Although Ballard and Xantrex have also developed products capable of converting power from high-speed microturbine generators, they are not currently marketed.

Table 3.2 lists the companies that are currently developing a microturbine and/or power converter(s). In some cases, the companies are pursuing almost 100% product development research activity with technology demonstrations planned within a year. Although the companies listed in this table do not presently market specifically microturbine power converters, most appear to be quite notable for the high degree of innovation they are using to attain versatile, new products.

Table 3.3 provides the Internet addresses for the full list of vendors presented in this section.

**Table 3.2. Potential power converter and/or microturbine manufacturers who are now in the R&D phase of product development**

<b>Manufacturer</b>	<b>Development Activity</b>	<b>Producer of power converters<sup>a</sup></b>	<b>Notes</b>
AeroVironment	No firm microturbine project yet, has Power Electronics Module (PEM)	Yes	Solar products, iPower Technologies
DTE Energy Technologies	ENT 400 kW microturbine to be added to internal combustion generator line	No	Power converter will be purchased from Turbo Genset
General Electric, Global Research Center & GE Industrial	Developing microturbine for 175 kW (ultimately, 175-350 kW) and power electronics	Yes	DOE-AMP <sup>b</sup> participant
Northern Power Systems	Research into development of advanced algorithms and modular circuit designs; may enable seamless transitions	Plans to produce power converters	Nothing announced yet to industry prior to completing work on patents.
SatCon Power Systems	Developing a wide range of power conversion systems for all types of distributed generation	Unknown	Storage systems also in development.
Turbo Genset	Developing a 50 kW microturbine and power converter system	Yes	Microturbine will be sold to DTE Energy

(a) Indicates whether the power converters are a product of their in-house design efforts.

(b) DOE-AMP = Department of Energy's Advanced Microturbine Program, not all participants are involved in development of power electronics and therefore not all are listed.

**Table 3.3. Manufacturers and internet URLs**

<b>Manufacturer</b>	<b>Internet URL</b>
Ballard	<a href="http://www.ballard.com/">http://www.ballard.com/</a>
Bowman Power Systems	<a href="http://www.bowmanpower.com/">http://www.bowmanpower.com/</a>
Capstone Turbine Corporation	<a href="http://www.microturbine.com/">http://www.microturbine.com/</a>
Cummins Northwest Inc.	<a href="http://www.cumminsnorthwest.com/PowerGen/Microturbine.asp">http://www.cumminsnorthwest.com/PowerGen/Microturbine.asp</a>
DTE Energy Technologies	<a href="http://www.dtetech.com/">http://www.dtetech.com/</a>
Elliott Energy Systems, Inc./ Ebara Corp.	<a href="http://www.elliott-turbo.com/new/products_microturbines.html">http://www.elliott-turbo.com/new/products_microturbines.html</a>
General Electric (GE)	<a href="http://www.eren.doe.gov/der/microturbines/pdfs/geslide.pdf">http://www.eren.doe.gov/der/microturbines/pdfs/geslide.pdf</a>
Ingersoll Rand Energy Systems	<a href="http://205.147.212.185/">http://205.147.212.185/</a>
Northern Power Systems	<a href="http://www.northernpower.com/">http://www.northernpower.com/</a>
SatCon Power Systems	<a href="http://www.inverpower.com/products/alten/alten.html">http://www.inverpower.com/products/alten/alten.html</a>
Turbec AB (owned by ABB & Volvo)	<a href="http://www.turbec.com/">http://www.turbec.com/</a>
Turbo Genset	<a href="http://www.turbogenset.com/">http://www.turbogenset.com/</a>
Xantrex	<a href="http://www.xantrex.com/Products/index.asp">http://www.xantrex.com/Products/index.asp</a>

### 3.3 Data Provided by Manufacturers

This section provides information on power converters provided by five primary manufacturers of power converters. The information will include a summary of general features, operating parameters, ancillary services, special features, power quality, circuit topology, and other circuit details including component types and thermal specifications. A short summary of industry needs is also provided.

The second subsection will consider important companies also meriting special consideration because of the unique features of their design and/or because they offer an alternative design approach.

#### 3.3.1 Primary manufacturers

Based on the information presented in Section 3.2, the final list of companies in the U.S. market who are presently producing and marketing power converters suitable for distributed generation (i.e., not *just* microturbines) is quite small. It includes the following:

- Ballard (provided power converters for Honeywell microturbines in 1998)
- Bowman Power Systems
- Capstone Turbine Corporation
- Xantrex (no presently marketed microturbine application)

General Electric (GE), which is well along in their development of a relatively large microturbine, was also helpful in providing information and is included in this data summary. Ballard has developed a 110 kVA “microturbine system” (i.e., power converter system) that the company says is capable of operating in grid and stand-alone mode with all the grid connect and retry strategies in accordance with IEEE 1547.<sup>2</sup> Xantrex, which has developed a wide range of power converters that can be used in microturbine applications, has also provided information.

The investigation of Capstone power converters was performed using (1) responses from the company, (2) information obtained through visits to three research sites<sup>3</sup> where Capstones are used, and (3) a review of Capstone documentation. All of the above companies were asked in a series of questions to provide details pertaining to (1) their microturbines (or the microturbines from other manufacturers that make use of their power converter), (2) technical aspects of the power converters, (3) technical issues (e.g., power quality), and (4) electronic component details.

Table 3.4 provides information on the microturbine generator type, packaging, power converter switching frequency, features and manufacturer. The most detailed information is listed under the two current manufacturers of microturbine power converters, Bowman and Capstone. Detailed information for GE’s product was also obtained because they are well along in developing a specific microturbine product. Clearly among the manufacturers, power converter designs are being directed for use with synchronous generators although Xantrex indicates that they are also willing to adapt designs to non-synchronous machines. Current power converter products are modular and integrated into the microturbine; however, for GE’s 175 kW design, external packaging of the converter is planned. Power converter switching

---

<sup>2</sup> IEEE 1547 is the *Standard for Interconnecting Distributed Resources with Electric Power Systems* (See Sect. 4.1.2.)

<sup>3</sup> Project staff inspected a 30 kW Capstone microturbine at the CHP Integration Laboratory – A National User Facility at ORNL, a 60 kW Capstone at the High Temperature Material Laboratory (HTML) at ORNL, and a 30 kW unit at the EPRI PEAC Corporation in Knoxville, Tennessee.

frequency is generally up to 8 kHz for the different manufacturers, although Xantrex designs may use much higher frequencies.<sup>4</sup>

A key feature indicated in Table 3.4 is that all of the manufacturers use some type of reprogrammable digital control system for the power converters. This provides a potentially needed level of versatility that may become critical in the future (see Sect. 4.1). The modes of operation generally include stand alone (i.e., for supplying power to local loads only) and grid connect, which must be synchronized to the grid. The GE microturbine is planned for grid-connect operation only. Switching between modes is a major issue. The quality or speed of the transitions from one mode to another varies from manufacturer to manufacturer and also depends on the mode to which the unit is being switched (see Sect. 4.1). The transitions generally cause a voltage interruption. This can be a significant problem in many of today's applications in industry and in the commercial sector. Only Ballard claims to have completely seamless transitions; however, this must be demonstrated in a microturbine system and made available in the commercial market.

The Capstone microturbine has stand-alone and grid connect modes with automatic switching between them. Transferring from grid connect to stand alone takes 2 to 4 minutes while returning to grid connect takes only 5 seconds.

---

<sup>4</sup> Higher switching frequencies generally come with a power de-rating penalty.



**Table 3.4. Microturbine manufacturer, operating parameters, and general features**

<b>Subject</b>	<b>Ballard</b>	<b>Bowman and Elliott<sup>1</sup></b>	<b>Capstone Turbine Corporation</b>	<b>General Electric</b>	<b>Xantrex</b>
<b>Type of generator used in microturbine</b>	Synchronous	Synchronous	Synchronous permanent magnet generator	Synchronous permanent magnet	May be used with synchronous or non-synchronous
<b>Packaging of overall unit</b>	Modular circuit	Integral packaging	Integral packaging	Power converter in nearby cabinet	Not currently integrated in package
<b>Turbine speed range</b>	Customer dependent	68,000 rpm (normal)	45K-96K rpm	12K -50K rpm	NA
<b>Power converter switching frequency</b>	4-8 kHz	8 kHz	Unknown	≤8 kHz rectifier, ≤5 kHz inverter	2-18 kHz depending on power level
<b>Modes of Operation and seamlessness of transfer</b>	Stand-alone & grid-connect (seamless switching possible)	Stand-alone & grid-connect with sub-second switchover	Stand-alone & grid-connect with auto-switching (see text)	Grid connect only	Stand-alone & grid-connect (interruption only when grid V drops)
<b>Type of digital control</b>	Microprocessor (reprogrammable)	Microprocessor (reprogrammable)	Digital signal processor	Flash-based microprocessor	Digital signal processor by Texas Instruments
<b>Accessories for operation in different modes</b>	Unknown	Optional dual-mode switch required for grid independent mode	Battery required for stand-alone mode and black start (see text for other accessories)	NA	Uninterruptible power supply required for black start of microturbine
<b>Power rating of power converter</b>	10 kW to 110 kW	60 kW and 80 kW	30 kW and 60 kW (200 kW future)	175 kW @ 40°C	Power converters from 5 kW to 1 MW
<b>Manufacturer of mechanical portion</b>	No microturbine product or application at present	Elliot Energy Systems	Capstone	General Electric	No microturbine product or application at present
<b>Manufacturer of power converter</b>	Ballard Power Systems	Bowman Power Systems	Capstone	General Electric	Xantrex
<b>Cost of power converter and/or microturbine</b>	Depends on application	---	~\$30,000 for the 30kW model microturbine	TBD when product is introduced into market	\$70/kW to \$1,000/kW for power converters depending on application

<sup>1</sup>Power converters supplied by Bowman Power Systems

The Capstone can be used with other accessories than the battery listed in the table. For instance, Capstone's Dual Mode Controller contains a utility disconnect and will allow automatic switching between grid connect and stand alone modes. Up to 20 units can be MultiPacked (paralleled) as a standard feature, and up to 100 can be MutiPacked using the optional Capstone Power Server. The purchase of an external power meter will facilitate operation with reverse power protection and load following.

Table 3.5 lists the various types of ancillary services that the power converters are capable of supplying to the grid. The listing also includes a few special features of interest such as operation by remote control and monitoring device and communications that support operation of multiple microturbines in a parallel configuration. A review of Table 3.5 shows that, with the exception of Bowman/Elliott and GE, the power converter manufacturers claimed an extensive list of ancillary services and special features. The analysts strongly suspect that in some cases, claims may have been made on a more theoretical basis (i.e., making claims of *potential* capabilities). Therefore, some level of caution is advised in considering the implicit claims indicated by the table. However, this is essentially a moot point for the purposes of this study, since the primary goal of the study is to determine exactly this – the *potential* features of the microturbine power converters.

As indicated above, the Capstone load following service and reverse power protection feature require the use of an accessory (i.e., an external power meter called the “pulse issuing power meter”).

Table 3.6 shows a summary of the microturbine power converter topology, the type of switching components used, key thermal specifications, cooling method, and power quality concerns (if any). For all manufacturers, the table indicates many similarities including a dc link topology, pulse width modulation (PWM) waveforms in the inverter output, and some type of forced air heat sink arrangement (except for Ballard, which uses liquid cooling). Certain topics, such as how close the switching devices operate to their maximum ratings, proved to be too sensitive to result in any significant response from the companies. The filtering referred to in the bottom two rows of the table has proved effective for all manufacturers in producing an output waveform that does not produce EMI, sinusoidal in shape, and often with lower harmonic distortion than found on the local grid.

Regarding the type of circuit topology, GE provided additional details regarding their 175 kW power converter. The 3-phase, two-level active IGBT power electronic bridge converts the 3-phase, high-frequency generator voltage to dc. The voltage on the dc link is regulated by the active rectifier and it feeds a 480V, 3-phase, IGBT inverter. The dc link voltage is also monitored so that turbine loading/speed can be adjusted according to the apparent inverter loading of the dc link.

**Table 3.5. Microturbine ancillary services and special features**

<b>Subject</b>	<b>Ballard</b>	<b>Bowman and Elliott<sup>1</sup></b>	<b>Capstone Turbine Corporation</b>	<b>General Electric</b>	<b>Xantrex</b>
<b>Voltage sag support</b>	Yes		Possible		Yes
<b>Static VAR compensation</b>	Yes	Can select 1.0 to 0.6 leading/lagging power factors (Elliot)	Possible	Yes – power factor control only	Yes
<b>Load following</b>	Yes	Yes	Yes		Yes
<b>Operating reserve (spinning or non-spinning)</b>			Yes		Yes
<b>Backup supply</b>	Yes		Yes		Yes
<b>Blackstart capability (without external grid)</b>	Yes	Greystart available provided gas is present and oil is warm	Yes		Yes
<b>Remote controllability</b>	Yes	Yes	Yes		Yes
<b>Communication (operation in parallel with other units)</b>	Yes – has multi-unit capability for up to 10 units in parallel.	Yes	Yes, using the standard MultiPac RS485 communications port		Yes
<b>Others</b>		Reverse power protection (in Elliot microturbine therefore an assumed feature of Bowman)	Peak shaving, Reverse power protection, and auto-restart (following a fault)		

<sup>1</sup>Power converters supplied by Bowman Power Systems

**Table 3.6. Microturbine circuit topology, components, thermal specifications, and power quality concerns**

<b>Subject</b>	<b>Ballard</b>	<b>Bowman and Elliott<sup>1</sup></b>	<b>Capstone Turbine Corporation</b>	<b>General Electric</b>	<b>Xantrex</b>
<b>Identify circuit topology</b>	DC link converter	DC link converter	DC link converter (current regulated)	DC link converter (see details in text)	Voltage source dc link converter
<b>Identify type of waveform generated</b>	Pulse width modulation (PWM)	PWM	PWM	PWM	High frequency sine-triangle PWM
<b>Identify type of power devices in inverter</b>	IGBTs	IGBTs or intelligent power modules (IPM) by Semikron/IR	IPM using IGBTs	IGBTs manufactured by Powerex	IGBTs or IPM by Eupec, Powerex
<b>Switching devices operate how close to maximum ratings?</b>	No information provided	Confidential	No information provided	Dependent on factors such as load and speed (see text)	No information provided
<b>Maximum ambient T</b>	40°C	45°C	50°C	40°C without derating	45°C (min. is -20°C)
<b>Maximum device junction temperature</b>	Unknown	150°C	115°C	125°C	150°C (not operated above 110°C)
<b>Method of cooling of power switching components</b>	Water/liquid cooling	Force air cooling with heatsink	Force air cooling with heatsink	Force air cooling with heatpipe heatsink	Force air cooling with heatsink <i>or</i> water cooled
<b>Permissible overload current</b>	No information provided	300% of peak rated for 2 cycles	200% for 1s, 150% for 10s, 125% for 30s, and 110% for 60s	This design parameter is TBD	Depends on application
<b>Filtering and shielding</b>	Both are used	Both are used	Both are used	Filtering included for harmonics and EMI	Both may be used
<b>Power quality considerations</b>	No EMI or harmonic distortion problems	No EMI or harmonic distortion problems	No EMI or harmonic distortion problems. Harmonics well below IEEE 519 limits.	Harmonic levels will meet IEEE 519	No EMI or harmonic distortion problems

<sup>1</sup>Power converters supplied by Bowman Power Systems

GE also supplied additional details regarding how close the switching devices operate to their maximum ratings. Obviously, this depends on the output voltage of the generator and other factors such as load and speed. GE follows general design rules of 10% voltage margin for the main power electronics. This may seem to be a tight margin but, in reality, how appropriate it is can be determined only from the design details.<sup>5</sup> GE is still developing the overall circuit control strategy and will be operating the power conversion electronics for the first time in the spring of 2003. GE will be assessing device stress as well as other system operating points, and their test results will determine whether the bridge is correctly used and rated. GE states that sophisticated junction temperature techniques are used to maintain device temperatures within published limits.

The final question asked of manufacturers was what they would like to see from the Government or industry (e.g., product, component) that would be of help to them. The responses shown in Table 3.7 were obtained from Ballard, GE, Capstone, and Bowman Power Systems.

**Table 3.7. Present industry needs from the perspective of power converter manufacturers**

<b>Manufacturer</b>	<b>Needs from the government and/or industry</b>
<b>Ballard</b>	Ballard states that they would like to see funding for high-voltage/current silicon carbide diode development.
<b>Bowman and Elliott</b>	Bowman Power Systems indicated that it is desirable to have a sustained incentive, either by way of a fund or a geographic-supported region, which developers could rely upon over a number of years to provide a proving ground for the technology.
<b>Capstone Turbine Corporation</b>	Capstone indicated that they would like to see continued development and adoption of interconnection standards.
<b>General Electric</b>	GE stated that they would like to see the implementation of codes and standards to improve and accelerate technology acceptance.
<b>Xantrex</b>	No response

### 3.3.2 Alternative design approaches of interest

Turbec AB's mostly European product has a number of interesting features worth reviewing. Their T100 microturbine is rated at 105 ( $\pm 3$ ) kW, has a nominal speed of 70,000 rpm, and is designed for operation indoors only. The unit provides CHP with a gas-water, counter-current flow heat exchanger providing a 122°F to 158°F temperature rise. The net electrical efficiency is 30% while the net total efficiency is 78% (assuming full use of the heated water). A two-pole permanent magnet high-speed generator feeds 500 VAC, 2333 Hz to a dc link converter that produces 400 VAC, 3-phase, 50 Hz or alternatively 480 VAC, 60 Hz. The converter can be operated in reverse to use the generator as a starter motor for the microturbine. A power module controller (PMC) controls and operates the entire electrical system. The

---

<sup>5</sup> GE is currently using 1400V parts with about a 900V dc Link. GE attempts to apply 10% extra margin after all worst case control and transient effects have been accounted for. Hence, device switching transients will be added to the 900V link voltage before the margin is applied. The switching transients can be controlled by altering the gate drive characteristics and stray bus inductance.

It is possible to require less margin if higher performance bridge topologies (buswork) and controls are used. Manufacturers apply margin based on their experiences, control complexity and response (i.e., ability to control the dc Link Voltage during input/output transients) and power electronic bridge design. It is very advantageous for an equipment manufacturer to achieve a higher rating or extra performance over a competitor's product by developing their own philosophy for rating and application capability.

T100 features a communications connection that permits the operator to monitor and control the microturbine from a remote location.

It would be unfair to consider the “challenge” of power converters seamlessly transitioning before and after grid outages without also considering how one alternative microturbine approach already performs this function with relative ease. Ingersoll Rand’s synchronous generator, which uses a high-speed gear box instead of a power converter, features a switchgear package that includes two motorized breakers that act to isolate segmented loads from either the microturbine or the facility distribution system. One breaker is used to connect the microturbine when it is synchronized. The other, upstream breaker acts to isolate the microturbine/segmented load combination in an intentional island. When the electrical protection system detects a grid failure, the upstream breaker is automatically opened and the microturbine assumes all power management to the loads. This transition occurs without any loss of power to the loads. When the protection system detects that the grid is back to normal, another seamless transition is made to return to grid parallel operation.



Front control panels of Capstone and Elliott microturbines

### 3.4 Notes on Other Connection Technology

Microturbines produced by companies such as Bowman, Elliott, and Capstone, can be operated in a stand-alone mode to supply local loads or connected directly to the grid. The internal circuitry provides effective filtering for EMI and harmonic distortion and ensures that the microturbine’s 3-phase power is fed into the grid synchronously. There are various options for interfacing small power sources to the utility. This section describes one such solution, called the GridGateway.

This 240V (up to 7kW) residential interconnection system, which consists of two DSP-controlled double pole relays, acts as a transfer switch by connecting and disconnecting a distributed generation system to the grid and/or load. It senses the three-phase grid and generator voltages and disconnects the distributed generator in cases of under/over-frequency, under/over-voltage, and over-voltage THD. The fault limits

for voltage and frequency can be set by the user through a graphical user interface on a computer, which communicates with the unit through a serial port.

The power to the control circuitry of the GridGateway system comes from both the generator and the grid; therefore, if either of them fails, the unit will continue to function. The system can operate in four states, utility only, no connection, distributed generator only, or parallel operation. When it is turned on, the distributed generator switch is open, isolating the generator from the load and the grid. However, the grid switch starts in the state it was last in, before power was turned off.

According to the manufacturer, EPRI-PEAC, this interconnection system can be connected to the power meter and will be ready to operate in half an hour because of its plug-and-play capability.

The GridGateway technology uses relays instead of solid state devices. A concern with relays is that they could potentially get stuck, which may cause undesirable problems to the generator, the load, or the grid. Tests need to be done in order to evaluate system performance and whether the reliability of the relays is adequate without additional protection in case of failures. If this system passes the tests fundamentally intact, it could be used as a transfer switch complementing the utility interface converter.



Elliott microturbine (80kW) opened for servicing



View inside front cover of Elliott

## 4. CONVERTER TECHNOLOGY AND RELIABILITY

This section summarizes findings from Section 3, discusses the present status of microturbine technology, describes various technical needs, and discusses aspects of system reliability from the perspective of a fledgling industry.

### 4.1 Status of Power Converter Technology

This section discusses microturbine operating modes and the voltage interruptions that accompany switching between modes, the present status of software used in the digital controllers, and the need for universal interfaces and standard communications. The final discussion focuses on the full range of ancillary services that microturbines can be made to provide. The section states how manufacturers should be *encouraged* to make various services available and how certain ones might be standardized.

#### 4.1.1 Operating modes and transitions

The present, conventional microturbine designs, when in the stand-alone mode, act as a voltage source to local loads. That is, the digitally controlled power converters regulate voltage and frequency while supplying current as needed by the load. However, the designs do not regulate voltage well enough to share reactive power flow. The microturbines are all operated at essentially the same voltage. When the microturbines are in the grid-connect mode, they act as a current sources, that is, they follow the voltage and frequency of the grid, and regulate the current, or power output, to a preset value. That value can either be constant, or it can load follow if desired.

None of the microturbines that are presently available in the market provide seamless switching between operating modes. This may be acceptable early-on in this emerging industry, but it will not be acceptable in the long term if greater market penetration is to occur. At a minimum, adaptations should be made to the system designs so brief voltage drops during switching can be bridged reliably.

#### 4.1.2 Software used in the programmable digital controllers

The digital control schemes for the controllers were found to be versatile in all cases. This was an encouraging finding since, given the necessary sensors and controls, the controllers can be reprogrammed to provide a number of new features and services to both the user and the grid. Given this situation, the study considered the present status of the software now in place.

Capstone, as an example, provides two systems that aggregates their microturbines and provides services. With both systems, the microturbine is either operated in the stand alone mode as a voltage source or in the grid connect mode as a current source. The power electronics hardware is capable of regulating both current and voltage simultaneously, but the control system is not presently programmed to perform this task. This is because the Capstone philosophy is to supply a product that meets IEEE 1547. IEEE 1547 states that the microturbine, or other distributed generation device, is not allowed to impact voltage. In reality, this may only limit a *group* of several microturbines operating in parallel assuming a reasonably “stiff” voltage in the feeder. Therefore, this standard requires that, in the grid connect mode, microturbines do not regulate voltage, they only follow the grid voltage. Thus, the microturbines cannot be used for distribution system voltage regulation at this time.<sup>6</sup>

---

<sup>6</sup> For the same reason, the several microturbines operating together cannot be used for voltage support at the end of long feeders. The microturbines are also capable of supporting voltage by reducing load, but this also is would not be allowed.



Bowman's power converters operate not only with permanent-magnet, high-speed alternators (microturbines), but also with wind generators and fuel cells. The Bowman units presently provide voltage regulation and power factor control. However, when the units are in the grid connect mode, the inverters acts as a current source only, similar to the Capstone Unit.

#### **4.1.3 Universal interface/communications**

In researching the ability of microturbines to operate in parallel, it was found that there is generally some level of capability in this area without purchasing special interface or communications accessories. It was also apparent that, as the number of units that a customer wishes to operate in parallel increases, one or perhaps two different controllers are necessary. The question of compatibility of microturbines from different manufacturers working together in large numbers is, at best, uncertain due to the lack of any type of universal interface. An example of two necessary interconnection accessories from one manufacturer is provided below.

The first Capstone control system is the Capstone Remote Monitoring System (CRMS). The CRMS allows you to communicate locally with up to 40 microturbines. The microturbines are "daisy chained" together using their serial ports and an RS 232 ethernet connection. One turbine is the master and the rest are in the "slave" mode. Data provided from each microturbine includes control panels, strip charts, trend graphs, event alarms and automation panels. The load cycle and scheduler automatically starts, stops, and commands power to the micro turbines locally or remotely. The event monitor logs starts, stops, and faults. The turbines can be controlled to provide a set power level or to load follow. If they are load following, a compatible power meter must be purchased which provides a pulse count. The CRMS will load the turbines for the maximum fuel efficiency point. If a site has several Capstone turbines, the only additional need is for the software to run them with the CRMS.

The second system offered by Capstone is the Power Server CPS 100. The CPS 100 integrates up to 100 turbines into a single generation system with one point of control. The CPS100 contains a microprocessor which provides high speed networking via one RS-232 connection or a modem. There is also internet command via TCP/IP. There is an interface to the power meter so that control can be load following/peak shaving and dual mode (grid connect/stand alone). The CPS100 will load the turbines for the maximum fuel efficiency point. The CPS100 will also balance runtime so that all turbines are run at the same number of hours over time. There are also analog and discrete inputs for communications from other plant equipment.

#### **4.1.4 Proposed requirements for ancillary services**

As can be observed from the vendor data summarized in this report, there is not a standard on what electrical services the manufacturers provide. The analysts of this study believe that some of these services should be provided without extra accessories and others made available as options. Initially, manufacturers should be *encouraged* to make various services available. This may quickly lead to those same services being expected by potential customers.

#### **Recommended or required services:**

1. Stand-alone and grid-connect operation modes and seamless switching between them in sub-cycles without voltage interruption.
2. Blackstart capability to start the microturbine without the external grid and whenever needed.
3. Remote controllability, so that the microturbine system can be controlled and monitored by a computer or a control panel without the need of actually being physically next to the system. This also brings the possibility of internet monitoring and control. It can also give access to the utility

to control the system to prevent anti-islanding and to de-energize it remotely for maintenance and repair.

4. Onboard, reprogrammable microprocessors, so that the firmware can be upgraded easily, maybe even by the user, remotely.
5. Communication or the ability to operate with others so that numerous microturbines from the same or different manufacturers can be connected to each other and controlled by the master unit (one of the microturbines). As an extension to this point, with the cooperation of the converter manufacturers for other alternate energy sources, microturbine systems should be able to communicate with the other alternate energy systems.
6. Modularity or flexibility to add any additional hardware for optional services without taking everything apart.

#### **Optional Services:**

1. Voltage sag support
2. Static VAR compensation
3. Load following
4. Backup supply
5. Operating reserve (spinning or nonspinning)

The reason for including voltage sag support and static VAR compensation at an option level is that not all applications need these services; however, it is strongly recommended that these services be included since they can be implemented with just some additional software code and, if needed, they could contribute even with the microturbine off. Especially, considering the predicted possible increased importance of non-active power in the near future, static VAR compensation would be crucial option to have.

## **4.2 System Reliability in an Emerging Industry**

This section provides an early assessment of reliability in domestic microturbines. This assessment cannot yet be based on any type of quantitative evaluation, but rather, based loosely on certain industry events and product operating conditions that seem to be creating clear signals that are relevant to reliability.

### **4.2.1 Reliability issues**

The microturbine industry is essentially new, where manufacturers are either marketing their products as of the last few years, are taking orders for soon-to-be introduced products, or are strictly in the development stage of new products. Even the “oldest” manufacturers are just beginning to see their products arrive at the first major overhaul point.

At best, the reliability calculations for microturbines and the associated power converters are now becoming less theoretical and more based on actual in-service data. However, a more realistic perspective shows subassembly designs that have been corrected for design weaknesses, often more than once, and field upgrades that alter any attempts at accurately tracking performance of the affected subassemblies.

Although this study was not intended to explore failures, multiple reports were heard concerning failures of power converters, EMI filters, and other systems. There are also many reports of aggressive actions taken by the manufacturers to correct problems in the field to maintain the highest degree of customer satisfaction and keep company reputation untarnished. The failures, the redesign process, and aggressive

implementation of upgrades are all typical processes that take place when technologically complex products are introduced into the market.

Section 4.2.2 will explore some possible root causes for some of the failures that have been experienced in the microturbine industry to date.

#### **4.2.2 Operating environment**

In the course of this study, it was observed that the present microturbine manufacturers and vendors market their product to be located in outdoor locations where the microturbine cabinet and internal packaging (if any) are the only type of protection that the electronics have from the outside weather conditions.

The power converter electronics in the Capstone microturbines are packaged in a ventilated metal box located under the mechanical portion of the microturbine. The metal box is enclosed in the main cabinet of the microturbine. Air enters through a filter at the lower portion of the cabinet front through horizontal slits and travels a short distance before entering into the power converter box. The air is forced through the box with fans and exits at the opposite end. Some air flow can occur through these openings even when the microturbine is shut down. Such air flow would be partially impeded only by one or more air filters depending on the microturbine design. The Elliott microturbine design does not include the box located internal to the cabinet thus providing even less protection to the converter circuit.

The power converter electronics and digital control circuitry used for microturbines are both quite elaborate and sophisticated. It is unusual to see this type of electronics located in a semi-open cabinet located outdoors in the open because of how this might impact reliability. It is always a significant design challenge to have complex circuitry located in an uncontrolled, outdoor environment operate reliably. Looking throughout industry, examples of electronics routinely used in outdoor ambient conditions protected only by a cabinet/enclosure are few:

- Electronics used in vehicles
- Traffic light controls
- A portion of the electronics operated by electric utilities
- Portable electronics such as for communications

Although the above electronics are specifically designed to operate in severe ambient conditions, they are not fully valid comparisons. Many of these are better protected than in the microturbine example given above. For instance, a computer in an automobile may be enclosed in a nearly air-tight enclosure that would reduce the potential for condensation. Similarly, traffic control electronics may be enclosed in a box designed with a rubber seal. In these cases, the potential for condensation due to daily environmental cycles is significantly reduced.

In situations where microturbines are frequently shut down, left idle for hours or longer, and started up, there could be a potential for condensation inside the cabinet depending on changes in the ambient temperatures and humidity levels (e.g., daytime conditions vs. night conditions). Long idle periods during humid weather could cause moisture to be absorbed in certain components degrading insulating materials. In addition, some components (e.g., screw-down wire terminals) or cabinet surfaces may experience corrosion or become tarnished due to moisture.

The microturbine industry is not oblivious to these concerns. As indicated in Section 3.3, Turbec AB's T100 microturbine is designed for indoor installations only. Although it takes its air from an outdoor

intake, that occurs only when the unit is operating (i.e., the power electronics would be warm precluding condensation). Additional design work and careful testing over time would be required to permit outdoor installations with greater exposure to the elements.

The fact that the microturbines are generally operated continuously outdoors is *helpful* from a reliability standpoint since component heating tends to keep surfaces dry and the ventilation prevents excess heat. The main concern during operating periods may be unusually hot, humid summer days; however, the use of conservative design margins and built-in thermal protection should prevent failures from occurring.

## 5. SUMMARY AND RECOMMENDATIONS FOR FUTURE WORK

In the future, several ancillary services will be provided by a local, automated response, as opposed to system operator dispatch. The primary services that will be provided on a local basis include: reactive power supply and voltage control, black start, regulation, energy imbalance, network stability, spinning reserve, and load following. Each of these services requires that power be exported to the grid.

Gaining the ability to export power to the grid will require that the power electronics converter and interface control both voltage magnitude and phase angle. It would be necessary to control the electronics quite rapidly, in response to sensed local conditions. In addition, the capability to synchronize quickly will be needed. Finally, the power electronics would have to be capable of accepting power from a storage device such as a battery or ultra-capacitor because a microturbine is not capable of responding quickly.

Other microturbine technology needs, both present and future, are the standardization of interconnection and communications so that many units, even from different manufacturers, can be operated together in parallel. Power converters could benefit immediately from the introduction of silicon carbide (SiC) switching devices into the market due to their ability to operate at higher temperatures and other attractive characteristics discussed below.

The following topical discussions provide examples of useful research and critically needed tests that ORNL strongly recommends in support of the emerging microturbine industry. The following discussions offer strong technical justification for believing that these projects, if pursued, would provide significant cost savings and benefits to the manufacturers of power electronics.

### 1. *Control of real and reactive power in grid connect or stand alone mode.*

At the present time, power electronic converters used on microturbines operate in either voltage mode or current mode. Voltage mode is used when the microturbine is in stand alone, not grid connected, and the voltage level is set by the user. Current mode is used when the microturbine is grid connected. The current level and the power factor (for some manufacturers) are set by the user. As discussed above, it is desirable that the power electronics be capable of controlling both the real and reactive power. Voltage regulation cannot be provided without this capability, and reactive power will circulate among generators in a small-stand alone grid unless the reactive power is controlled.

One approach to resolving this issue would be to develop an enhancement to an existing power converter system so that it is capable of controlling voltage magnitude and phase angle (real and reactive power) in both the stand-alone mode and the grid connected mode. A project could be designed to evaluate the ability of the power-conditioning unit to enable real and reactive power sharing and to perform voltage regulation. The goal would be for voltage regulation to be provided in both the stand-alone and grid-connected modes. A project could be designed to test a power conditioning unit installed on a microturbine that has connections to both a local load and the distribution system. The work would evaluate, verify, and characterize the ability to perform voltage regulation under both operating modes.

### 2. *Seamless transition from grid-connect to stand-alone mode in subcycles*

In grid-connect mode, the utility interface works in current control, but in stand-alone mode it works in voltage control. To switch from one mode to the other, the microturbine and the interface could be shut down and then started in the other mode. This causes an undesirable voltage outage or brief fluctuation. A better alternative is a seamless transition without interrupting voltage production. Many manufacturers

offer “seamless” transition in their products but, in reality, it occurs in a few cycles causing voltage fluctuations. In some products, the transitions range from a few seconds to a few minutes.

The goal should be that the seamless transition from grid-connect to stand-alone modes and vice versa occur in a short, sub-cycle time. For this reason, research is required to come up with an algorithm to decrease the seamless transition time with minimum voltage distortion.

One approach would be to develop an enhancement to the existing Bowman power-conditioning unit so that it is capable of synchronizing frequency with the distribution system and changing control modes seamlessly. A project could be designed to test the device on a group of power sources and loads with a distribution system connection. The work would evaluate, verify, and characterize the ability to do a seamless transfer.

### 3. *Ganging microturbines with other microturbines and different energy sources:*

In many applications, microturbines in the field will be required to work in parallel with other microturbines or different energy sources such as fuel cells, diesel generators, photovoltaic systems, batteries, etc. Presently, only a few commercially available utility interfaces for microturbines, such as Capstone units, have a feature for connecting several microturbines together (other energy sources not included), and these mostly require extra accessories. However, this feature should be a standard built-in function of a general utility interface, and it should also include the ability to be ganged with other energy sources.

Three approaches are possible for the ganging of different energy sources. In the first approach, the output voltage of each energy source is converted to dc or high frequency ac. Then, these outputs are connected in series or parallel as required and converted to 60Hz with a dc link converter to be connected with the grid and/or to feed loads.

In the second approach, the output voltages of each energy sources are converted to dc and are connected to a multilevel inverter again to be connected to feed loads or directly to the utility grid.

In the third approach, each microturbine connects to the grid separately from the others relying wholly on their grid- or load-connect interface electronics. However, this is inconsistent with the approach we envision to enable the supply of ancillary services. Further enhancements are desirable where grid and/or load connection is coordinated instead of relying on multiple independent connections.

More research is required to evaluate the pros and cons of these approaches and to investigate the possibility of alternative solutions for ganging microturbines and other distributed energy resources.

Additional insight into solutions for the above issues can be gained by leveraging on other research being performed at ORNL on several different power electronics applications. The results of the following projects can be directly or indirectly applied to the microturbine power converters:

1. *Integrating numerous solid oxide fuel cell modules:* This project focuses on ways to connect fuel cell modules for higher power generation.
2. *Military generator sets:* This project is for the analysis, design, and building of mobile military generator sets for the Army.
3. *Hybrid electric vehicles (HEV):* Several projects are ongoing in the research and development of new power converter topologies, novel electrical machines, and their control. This also includes a system-level study of the benefits of SiC-based power devices on hybrid electric vehicle applications.

The experience gained from all these projects will be useful in microturbine applications. For example, the first project will provide answers to the similar problem of paralleling microturbines with each other and with other distributed generators. Additionally, experience from military generator sets and HEV power converters and electrical machines will be directly applicable to microturbine systems.

#### 4. *Ability to interface with energy storage devices.*

The existing power converters from various manufacturers are capable of accepting a constant dc input. However, the voltage from many dc sources is variable such as from a fuel cell or an energy storage device (e.g., battery or ultra-capacitor). A dc-to-dc converter is needed. If the energy storage capability was available, the power converter could provide very high, short-duration power to start motors and supply fault current. This would make small systems much more viable and practical when operating in a stand-alone mode.

One approach to developing a dc interface would be to enhance an existing power converter so that it is capable of accepting a *variable* dc voltage input. A project could be designed to test the device on a group of power sources and loads to evaluate the ability to start motors, provide fault current, and regulate voltage during normal system operation.

#### 5. *Silicon Carbide switching devices*

Recently, silicon carbide- (SiC-) based power devices have been drawing increasing attention because of their superior characteristics compared with silicon- (Si-) based power devices. SiC-based power devices possess the features of high voltage, high power, high frequency, and high temperature operation in a smaller package. A SiC-based power converter would have the benefits of reduced losses, higher efficiency, up to 2/3 reduction in the heatsink size, smaller passive components, and less susceptibility to extreme ambient heat. Microturbine power converters would certainly benefit from utilizing SiC-power devices. The response from Ballard regarding what they would like to see from the Government or industry that would be of help to them was, "*Funding for High-voltage/Current Silicon Carbide diodes.*" This response provides strong confirmation of the importance of SiC in this industry.

Further work is required to demonstrate the system-level benefits of SiC devices on microturbine power converter applications.

## **ACKNOWLEDGEMENTS**

Our sincere thanks to the companies who have responded to our request for information and for the excellent technical reviews provided by Leon Tolbert (ORNL and University of Tennessee – Knoxville) and John Kueck (ORNL).



## DISTRIBUTION

### Internal

1. J. D. Kueck
2. M. Olszewski
3. B. Ozpineci
4. R. H. Staunton
5. L. M. Tolbert
- 6–7. Laboratory Records

### External

8. D. A. Haught, U.S. Department of Energy, EE-2D/Forrestal Building, 1000 Independence Avenue, S.W., Washington, D.C. 20585.
9. R. A. Kost, U.S. Department of Energy, EE-2G/Forrestal Building, 1000 Independence Avenue, S.W., Washington, D.C. 20585.
10. S. A. Rogers, U.S. Department of Energy, EE-2G/Forrestal Building, 1000 Independence Avenue, S.W., Washington, D.C. 20585.
11. E. J. Wall, U.S. Department of Energy, EE-2G/Forrestal Building, 1000 Independence Avenue, S.W., Washington, D.C. 20585.

## APPENDIX A POWER CONVERTER INFORMATION FORM

The following standardized form was used to query the microturbine industry primarily regarding power converters that are (or can be) used for connecting microturbines to the grid and/or local loads. After each question in the form, text is added to describe what information is being sought from the company.

---

### DER Power Conversion Circuit Information Request

A. Indicate the applicable generator type and packaging.

**1. Type of generator:**

Asynchronous (induction) generator

Synchronous generator (synchronous machine, pm machine, etc)

**Description: Both asynchronous (induction) and synchronous (or permanent magnet) generators can be used in microturbine applications. If synchronous generators are run at a constant speed, the voltage they generate would be at constant frequency; therefore, they can be connected to the grid directly. While connected to the grid, they can feed capacitive and reactive power to the grid. These two points are what makes them attractive for industry applications. Synchronous generators require an external field coil excitation; therefore, they contain brushes which require frequent maintenance. Permanent magnet (PM) generators, which are also synchronous machines, however, do not need brushes. The problem with PM generators is that they are expensive.**

**Induction generators are low cost and they have a robust construction. Squirrel-cage induction generators do not require external excitation; therefore, they have a simpler control and they do not need brushes. Without any brushes, they are virtually maintenance-free. Induction generators are not used much in the industry because their speed depends on the load and unlike a synchronous machine, they cannot be connected to the grid directly without a power converter, which increases system cost.**

**For microturbine systems, either generator can be used, but the induction generator would be preferred because of its low cost, simpler control, and maintenance free nature.**

**2. Is the inverter an integral part of a microturbine package? Is the circuit modular and in what respect?**

**Description: Some manufacturers produce just the microturbine, some the power converter, and others produce both. It is important to know if the manufacturers prefer selling the microturbine and the power converter in one package or letting the consumers to buy each component from different manufacturers as modules.**

B. Indicate the types of circuits/components used in the power conversion circuit.

**3. Identify the type of circuit topology**

DC link converter used?

High-frequency ac link converter in development?      Marketed?

Other?

**Description:** Section 2.2 explains the differences between these two types of circuit topologies.

**4. Identify the type of waveform generation used in the converter.**

Pulse-width-modulated (PWM)?

Line commutated?

Other?

**Description:** PWM is used in dc-link converters with self-controlled power devices such as IGBTs, MOSFETs, gate turn off (GTO) thyristors, etc. because these can be turned on and off with a gate signal.

**On the other hand, conventional thyristors (also known as Silicon Controlled Rectifiers or SCRs), can be turned on using a gate signal but they can be turned off only using auxiliary commutation circuits or by line commutation.**

**Line commutation waits for the input line voltage to cross zero, so that the thyristors see zero anode cathode voltage and zero current and they turn off.**

**5. Identify the kind of power devices that are being used (+ device manufacturers).**

MOSFETs?

Manufacturer?

Schottky Diodes?

Manufacturer?

IGBTs or IPM?

Manufacturer?

pn diodes?

Manufacturer?

Other switching devices?

Manufacturer?

**Description:** MOSFETs and IGBTs are the two most popular controlled power devices in the present power converter technology. MOSFETs are preferred for their high frequency capability and low losses; however, they are only available for low power applications. For high power applications IGBTs are used.

**The same reasoning goes for the Schottky diodes and the pn diodes. Schottky diodes are low power low loss diodes while the pn diodes have higher losses but they can be used in a wider power range.**

**The difference between an intelligent power module (IPM) and a discrete IGBT is that an IPM has the gate drivers, current, voltage, and temperature protection embedded in the package.**

**Other semiconductors the manufacturers might be using are thyristors, GTOs, Integrated Gate Commutated Thyristors (IGCTs), etc.**

As the silicon carbide (SiC) technology matures, it is expected that the SiC MOSFET+ SiC Schottky diode pair will take over the Si IGBT+Si pn diode pair in the medium-to-high power range.

**6. How close do the switching devices operate to their maximum ratings (device stress)?**

**Description:** Extreme voltage, current, and temperature stress on power devices can cause early failure; therefore, they have to be operated well below their maximum ratings. For the reliability of the power converters, device stress is an important factor.

**7. Thermal performance and limits.**

What are the rated and max operating ambient temperatures?

What is the rated (max) device (e.g., MOSFET) temperature?

**Description:** As explained earlier, temperature stress could cause device failure. To decrease the device temperature below the maximum value, heatsinks are required. The higher the ambient temperature, the more space the heatsink will occupy.

Another reason for requesting the ambient temperature values is to find out what extreme temperatures these microturbine systems can withstand. This can limit or increase the range of microturbine application environment.

**8. What kind of cooling (heat removal method) is being used?**

Forced-air cooling with heatsink?

Water/liquid cooling?

**Description:** These heat removal methods can be used both at high or low power levels; however, usually for low power applications forced-air cooling and for high power applications water/liquid cooling is preferred. This is because the former is a simpler method while the latter can remove more heat, faster.

Forced-air cooling requires a considerable size finned heatsink with fans forcing air through the fins to cool the power converters. For water/liquid cooling, there is no need for fins; instead the coolant goes through pipes inside a thinner heatsink.

The water/liquid cooling requires approximately one-third the heatsink size compared to forced-air cooling but it also requires an additional pump to force the liquid through the pipes.

**9. Describe the fault tolerant capabilities of the converter.**

How much overload current can be tolerated and for how long?

**Description:** As with any other electronic system, reliability of the power converter is crucial. All power converters can handle a certain amount of overload current for a certain period of time. The more overload current is tolerable and the more the overload time is, the more reliable the

inverter will be; however, it should also be remembered that if the devices are derated for better overloading capability, then the efficiency will be sacrificed during the normal operation.

Some converters use advanced controls for fault tolerant operation of the system. With this fault tolerant control, either the system continues operation with the help of some kind of redundancy in the converter or the fault is managed so that the converter and the other components connected to it suffer the least damage.

#### **10. Power quality considerations or issues**

Are there any significant EMI problems?

Are there any significant harmonic distortion problems?

What kind of solutions have been used?

- filtering?
- shielding?

**Description:** Electromagnetic interference (EMI) is always an important concern for power converter applications. If the EMI is not filtered and/or shielded properly, it would affect all the nearby electronics circuits including the controls of the microturbine.

Harmonic distortion depends on the converter topology, switching frequency, and the control principle. The utility interface should produce a waveform as close to a sine wave as possible. If not, the harmonics will pollute the utility. For this reason, harmonic optimum converters and well-designed filters are required.

C. Indicate the following converter/microturbine system capabilities:

#### **11. What is the range of speed for the turbine?**

**Description:** The speed of the microturbine determines the frequency of the generator output voltage or the power converter input voltage. The frequency of the converter voltage input is important for timing and harmonic issues. If there is a controlled rectifier in the front end of the converter then the switching times of the controlled switches will depend on the input frequency. If, on the other hand, there is an uncontrolled (diode) rectifier, then timing is not a problem. However, in both cases the converter harmonics and consequently filter design will depend on this frequency, thus, the microturbine speed.

#### **12. What is the switching frequency used in the converter?**

**Description:** A switching frequency greater than 20 kHz (i.e., unusually high) is preferred for power converters because this frequency is above the audible range and it is easier to filter the harmonics if they are at higher frequencies. Switching frequency depends on the power device and the converter topology being used.

#### **13. What modes of operation can the microturbine provide to the user?**

Stand-alone?

Grid connect?

Is there seamless switching between these modes (without voltage interruption)?

**Description:** In grid-connect mode, utility interface works in current control, but in stand-alone mode it works in voltage control. To switch from one mode to the other, the microturbine and the interface could be shut down and then started in the other mode. This causes an undesirable voltage fluctuation. A better alternative is a seamless transition without interrupting voltage production. Some manufacturers offer *near* seamless transition in their products but it is done in several cycles causing voltage fluctuations.

The goal should be that the seamless transition from grid-connect to stand-alone modes and vice versa occur in a short, sub-cycle time.

#### 14. What type of internal circuit control is used?

Onboard microprocessor?

Is the device reprogrammable?

**Description:** Microturbine system can be controlled locally by an onboard microprocessor or remotely through another computer. It would be preferred to have the onboard microprocessor for local controls and the option for remote control.

If reprogrammable devices are available then firmware upgrade might be possible or third-party software could be used to reprogram the microprocessor for additional controls or ancillary services.

#### 15. Are there any required accessories for operating the microturbine in a grid dependent mode, grid independent mode, or for microturbine startup?

**Description:** Some microturbine systems might be using additional circuitry to start the microturbine and/or to switch from grid-connect to stand-alone mode. Ideally, the converter should be able to do both of these without the need for additional power circuits just using advanced controls.

#### 16. What types of ancillary services or special features can the power converter provide?

Voltage Sag support?

**Description:** A service in which the generator provides voltage compensation for momentary voltage drops in the grid.

Static VAR compensation?

**Description:** Control of the reactive power by adjusting the phase of the generated current relative to the grid voltage.

Load following?

**Description:** The use of online generation equipment to track the intra- and inter-hour changes in local loads. Load following differs from regulation in three important respects, (1) it occurs over longer time intervals than regulation (i.e., 10 minutes or more rather than minute to minute), (2)

the load following patterns of individual customers are highly correlated with each other, and (3) load following changes are often predictable (e.g., because of the weather dependence of many loads) and have similar day-to-day patterns.

Operating reserve (spinning or nonspinning)?

**Description:** Spinning reserve is an immediate (10-second), frequency-responsive supply of power when contingencies and frequency deviations occur. Nonspinning reserve, or supplemental reserve, does not have to be on-line when initially called and may have 10 minutes to fully respond.

Backup supply?

**Description:** Customer plan to restore system contingency reserves within 30 to 60 minutes if the customer's primary supply is disabled.

Blackstart capability (without external grid)?

**Description:** Blackstart is the capability to start generation without outside power and restore all or a major portion of the power system to service without support from outside after a total system collapse. Blackstart appears to be a service that microgrids are qualified to sell since many microgrids are inherently capable of operating independently of the power system. To be useful to the power system, however, the blackstart units have to be located where they can be used and capable of re-starting other generators. Some microgrids may not be large enough or located properly to be useful.

A variation on this service is "greystart," which requires that certain conditions exist such as the oil being warm and natural gas being available.

Remote controllability?

**Description:** Ability to start, stop, adjust loading on a microturbine, and perform other basic functions from a computer or keypad at a remote location. Some monitoring information is essential to support making control decisions.

Communication (ability to operate in parallel with others)?

**Description:** Ability of the microturbines to operate with others in a parallel configuration where each is able to load follow in a measured and stable fashion (i.e., to control both real and reactive power flow). Communication between the microturbines is considered essential in many control schemes.

Others?

**17. Power ratings of the microturbines and/or power converters?**

**Self explanatory.**

**18. Identification of systems for instances where different manufacturers produce the microturbine and converter.**

Manufacturer of the power converter?

Manufacturer of the microturbine?

**Self explanatory.**

**19. Costs of the power converters for each power range?**

**Self explanatory.**

**20. What would you like to see from the Government or industry (e.g., product, component) that would be of help to your company?**

**Self explanatory.**