

# EASEP Press Backgrounder

**Early  
Apollo  
Scientific  
Experiments  
Package**

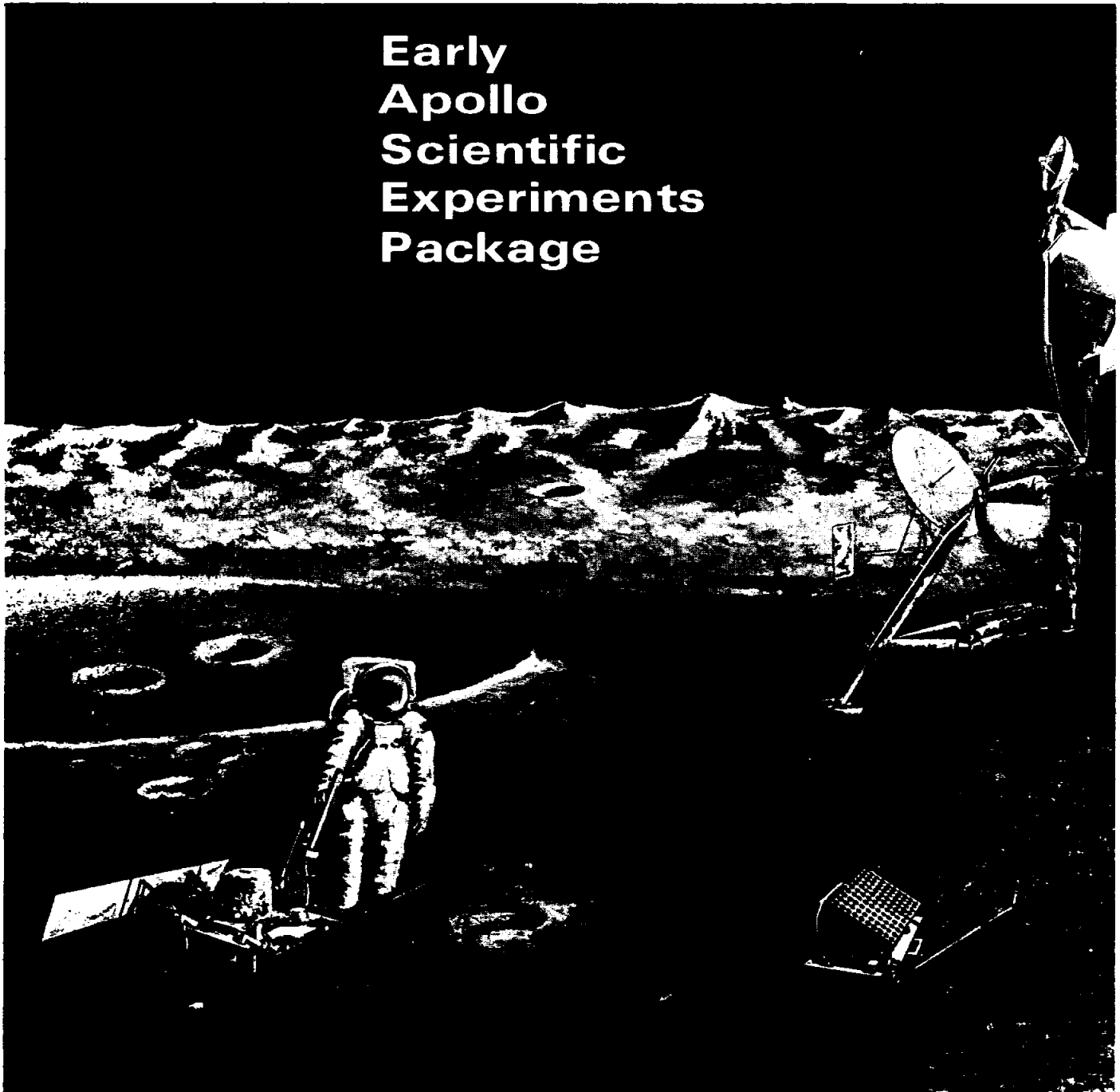

**Aerospace  
Systems Division**

Property of:  
Michigan Space & Science Center

Donor: Lisa Neal  
Donation Date: 1 Aug 1997

From Daniel H. Schurz  
Director of Public Relations  
The Bendix Corporation  
Aerospace Systems Division  
Ann Arbor, Michigan 48107  
  
April 1969



## COVER ILLUSTRATION

The Astronaut on the cover is adjusting a helical antenna on the Passive Seismic Experiment Package. A passive seismometer contained in the large vertical cylinder below the antenna sends information through a data system contained in the base of the package before transmission to earth.

To the Astronaut's left is the Laser Ranging Retro-Reflector, already deployed and pointing toward the Earth. Scientists will use the reflector as a target for laser beams to develop a variety of accurate scientific data regarding distances and dynamic interactions between the earth and the moon.

## ACKNOWLEDGMENTS

The design, integration and test of the Early Apollo Scientific Experiments Package is being performed for the National Aeronautics and Space Administration by the Aerospace Systems Division of The Bendix Corporation.

Subcontractors to Bendix for the Passive Seismic Experiment Package are: Dynatronics (multiplexer); Ling-Temco-Vought (PSE mounting plate and solar panel substrate); Lockheed (second surface mirrors); Philco (transmitters), and Spectro Labs (solar cells). Teledyne supplied the Passive Seismometer which was modified by Bendix for the Passive Seismic Experiment.

The Laser Ranging Retro-Reflector array subcontractor is Arthur D. Little, Inc. The Retro-Reflectors were supplied to Arthur D. Little, Inc. by Perkin-Elmer.

## INTRODUCTION

This Backgrounder is published by the Aerospace Systems Division of The Bendix Corporation to familiarize the reader with the Early Apollo Scientific Experiments Package (EASEP), its origins, objectives and operation. This booklet is designed to be a quick reference source and the reader will find a general statement of the EASEP design followed by a more detailed examination of the component systems.

Additional copies of this publication and further information about EASEP may be obtained by contacting Mr. Daniel H. Schurz, Director of Public Relations and Advertising, Bendix Aerospace Systems Division, Ann Arbor, Michigan 48107.

## MISSION BACKGROUND AND OBJECTIVES

The problem of deciding what man will do once he gets to the moon is as exacting as getting him there. While the primary purpose of the first mission will be to demonstrate the capabilities for a lunar landing and return, the astronaut will gather maximum scientific information within the limited mobility and time he is allowed on his first lunar landing.

In the summer of 1965, the National Academy of Sciences Space Science Board met at Woods Hole, Massachusetts to consider the most desirable areas of space study. This board proposed 15 major questions which would guide lunar exploration:

1. What is the internal structure of the moon?
2. What is the geometric shape of the moon?
3. What is the present internal energy regime of the moon?
4. What is the composition of the lunar surface?
5. What principal processes are responsible for the present structure of the lunar surface?
6. What is the present tectonic pattern and distribution of tectonic activity on the moon?
7. What are the dominant processes of erosion, transport and deposition of material on the lunar surface?
8. What volatile substances are present on or near the lunar surface?
9. Are there organic and/or proto-organic molecules on the moon?
10. What is the age of the moon and the age range of stratigraphic units on the lunar surface?
11. What is the history of dynamic interaction between the earth and the moon?

12. What is the thermal, the tectonic, and possible volcanic history of the moon?
13. What has been the rate of solid objects striking the moon and how has that flux varied with time?
14. What is the history of cosmic and solar radiation flux acting on the moon?
15. What magnetic fields are retained in rocks on the lunar surface?

In addition to these specific scientific questions regarding the moon, there are questions pertaining to space travel in general which may be answered during lunar voyages. Man's ability to do meaningful extra-terrestrial work is still an open question and the goals of early lunar operations must be constrained by this uncertainty. As our experience with men in space grows, these constraints become more defined and our ability to predict success for involved missions increases.

From the list of questions from the Woods Hole meeting, it was possible to design a complete geophysical station which would give the desired information about the moon and its environment. This station would be housed in a bay of the Lunar Module and be deployed by the astronauts on the moon. The Bendix design for this station was proposed as the Apollo Lunar Surface Experiments Package (ALSEP), a contract awarded to The Bendix Corporation in 1966.

ALSEP is a sophisticated geophysical station which is designed to return information about the moon's physical properties and the electromagnetic characteristics of the moon and deep space. Powered by a radioisotope thermoelectric generator, it is designed to return scientific data from the moon for up to two years. Its central station receives information from the various experiments and transmits it to the earth. The central station also receives earth commands and relays them to the individual experiments. This ambitious scientific lunar station requires approximately one-half hour for deployment by two astronauts. They carry the two experiment packages away from the Lunar Module, set up the central station and power source,

align four experiments, take photographs and collect soil samples.

While it appears these tasks are all well within the astronauts' capabilities, it now seems more desirable to set more conservative tasks for man's initial landing on the moon. The collection of soil samples and deployment of a simple scientific experiment package will be most in keeping with the purpose of the first mission, which is to prove that man can, indeed, land on the moon and return to earth safely. Initially, plans were made for the astronauts to leave the Lunar Module, collect soil samples, take photographs and then return to the module for an eight-hour sleep, after which they would deploy ALSEP. To keep the mission simple, the second trip outside the Lunar Module was cancelled. ALSEP deployment, then, will await the successful completion of the first lunar mission, and is scheduled for deployment on the second lunar landing, with two similar packages to be deployed on the following two missions.

For the new mission requirements, Bendix designed a package which draws upon its broad ALSEP experience. Since the new experiment package would occupy the same place in the Lunar Module as ALSEP, it was decided to utilize the basic ALSEP pallets. Because one of the ALSEP pallets housed the ALSEP central station electronics, it was logical to use the existing electronics package. This has the additional virtue of having been already fully integrated into the NASA communications and data processing facilities. The ALSEP experiment which would provide the most significant information traded off against ease of deployment is the Passive Seismic Experiment (PSE) which, in the new design, is mounted permanently on the central station.

The use of ALSEP-proved components allows the rapid delivery of a very reliable product at minimum cost. This design, the Early Apollo Scientific Experiments Package (EASEP), was approved by NASA on November 5, 1968.

The two EASEP packages can be removed and deployed by one astronaut within ten minutes during the astronauts' lunar excursion. They do not require deployment far from the Lunar Module and will operate satisfactorily with minimal emplacement and alignment. The PSE returns significant scientific data about



the interior of the moon by measuring seismic activity. The solar cell power supply is attached directly to the same pallet which carries the PSE and electronics equipment. The other pallet, which carries the Laser Ranging Retro-Reflector Experiment, or LRRR, will become a target for earth-based lasers. Because both pallets are completely independent, either or both may be deployed by the astronauts, depending on the progress of the mission.

EASEP, then, consists of two scientific experiment packages which emphasize simplicity and ease of deployment, proved acceptability to the Lunar Module and NASA communication requirements, and the return of maximum scientific information for effort expended.

The principal investigator for the Passive Seismic Experiment is Dr. Gary Latham of Lamont Geological Observatory. Dr. George Sutton of the University of Hawaii, Dr. Frank Press of the Massachusetts Institute of Technology, and Dr. Maurice Ewing of Columbia University are the co-investigators for the experiment. Mr. Ludo VanHemelrijck is Dr. Latham's Project Engineer.

The principal investigator for the LRRR is Professor C.O. Alley of the University of Maryland. The co-investigators are: Professor P.L. Bender, National Bureau of Standards, University of Colorado; Professor R.H. Dicke, Princeton University; Professor J.E. Fallor, Wesleyan University, Middletown, Connecticut; Professor W.M. Kaula, University of California at Los Angeles; Professor G.J.F. MacDonald, University of California at Santa Barbara; Dr. H.H. Plotkin, Goddard Space Flight Center and Professor D.T. Wilkinson, Princeton University. Participating scientists at the University of Maryland include Professor D.G. Currie and Professor S.K. Poultney. Members of the technical staff at the University of Maryland are Dr. S.K. Chang and Mr. H. Kriemelmeir.

## EASEP SYSTEM DESCRIPTION

### PASSIVE SEISMIC EXPERIMENT PACKAGE

The purpose of the Passive Seismic Experiment Package (PSEP) is to measure lunar seismic activity. These measurements will indicate the structure, strain regime and physical properties of the interior of the moon as well as record meteoroid impacts and tectonic disturbances.

The basic unit of operation of the experiment is a suspended weight which will tend to remain immobile as the experiment package moves with the motions of the moon. This relative motion between the weight and the rest of the experiment causes an electrical change which becomes a reading of amount and frequency of motion. These measurements are taken by three units which, between them, report long- and short-period vibrations along vertical and horizontal axes.

### DATA SUBSYSTEM

The PSEP measurements are sent to the earth by a transmitter which shares the PSEP helical antenna with the command receiver. An earth command is selected and transmitted to the PSEP as a phase modulated signal in digital form. The message is received, decoded, and directed to the experiment as a discrete command. The information, or science, from the experiment is sent to the data processing unit and combined with other PSEP data in a special format which is transmitted, in digital form, through the helical antenna back to earth.

## LASER RANGING RETRO-REFLECTOR EXPERIMENT

The other section of EASEP, the Laser Ranging Retro-Reflector Experiment, is wholly passive and has no electronics nor is it connected in any way to the first EASEP Package. The retro-reflector unit will be a target for earth-based laser beams. The LRRR experiment will precisely measure earth-moon distance over a period of several years from which fluctuations in the earth's rotation rate, measurements of gravity influences on the moon and other astronomical information can be derived. The unit is functionally a reflecting surface. A flat reflecting surface on the moon, however, would be useless because with a flat mirror the angle of incidence equals the angle of reflection; a laser beam would be reflected depending on the alignment of the mirror relative to the earth-moon direction, and could fall anywhere on the earth or even in space. The reflector array used for the EASEP experiment uses retro-reflectors manufactured with extreme precision from selected high-quality fused silica. These reflectors have the property that the angles of incidence and reflection coincide independent of the reflector's position, and for this reason have been used here on earth in such things as bicycle and highway reflectors. A corner reflector on the moon will permit a laser ray to be reflected along the same path with which it strikes the reflector: a laser ray from Hawaii is reflected to Hawaii; a ray from Washington, D.C. is reflected to Washington, D.C.

# PASSIVE SEISMIC EXPERIMENT SUBSYSTEM DETAILS

## PASSIVE SEISMIC EXPERIMENT PACKAGE

The Passive Seismic Experiment Package carries the Passive Seismic Experiment (PSE) and data system. Figures 1 and 2 show the PSEP in its stowed and deployed configurations.

The PSEP also includes the solar panels, which power the experiment during the lunar day and isotope heaters which will help it survive the cold (-300 degree F) lunar night.

The solar panels convert the energy of sunlight to electricity and have an output of 33 to 43 watts. The panels operate only during the lunar day; during the lunar night, PSEP is inoperative. The output of the solar panels is fed to the power conditioning unit and supplies all the electrical requirements of the PSEP; excess current is dissipated by resistors.

The isotope survival heaters produce 15 watts each and are fueled with a small amount of Pu 238 which emits a very low level of radiation. They are completely shielded so that no stray radioactivity escapes to the lunar environment. There are no controls for the heaters and they operate both during the lunar day and night.

## DUST DETECTOR

Also mounted on the PSEP is a dust detector which reports through the Data System the buildup of dust particles on the surfaces of the PSEP. The detector measures in two planes and consists of photocells which will sense dust as an apparent decrease in the intensity of the sun. The unit measures one and three-quarters inches square by two and two-thirds inches high.

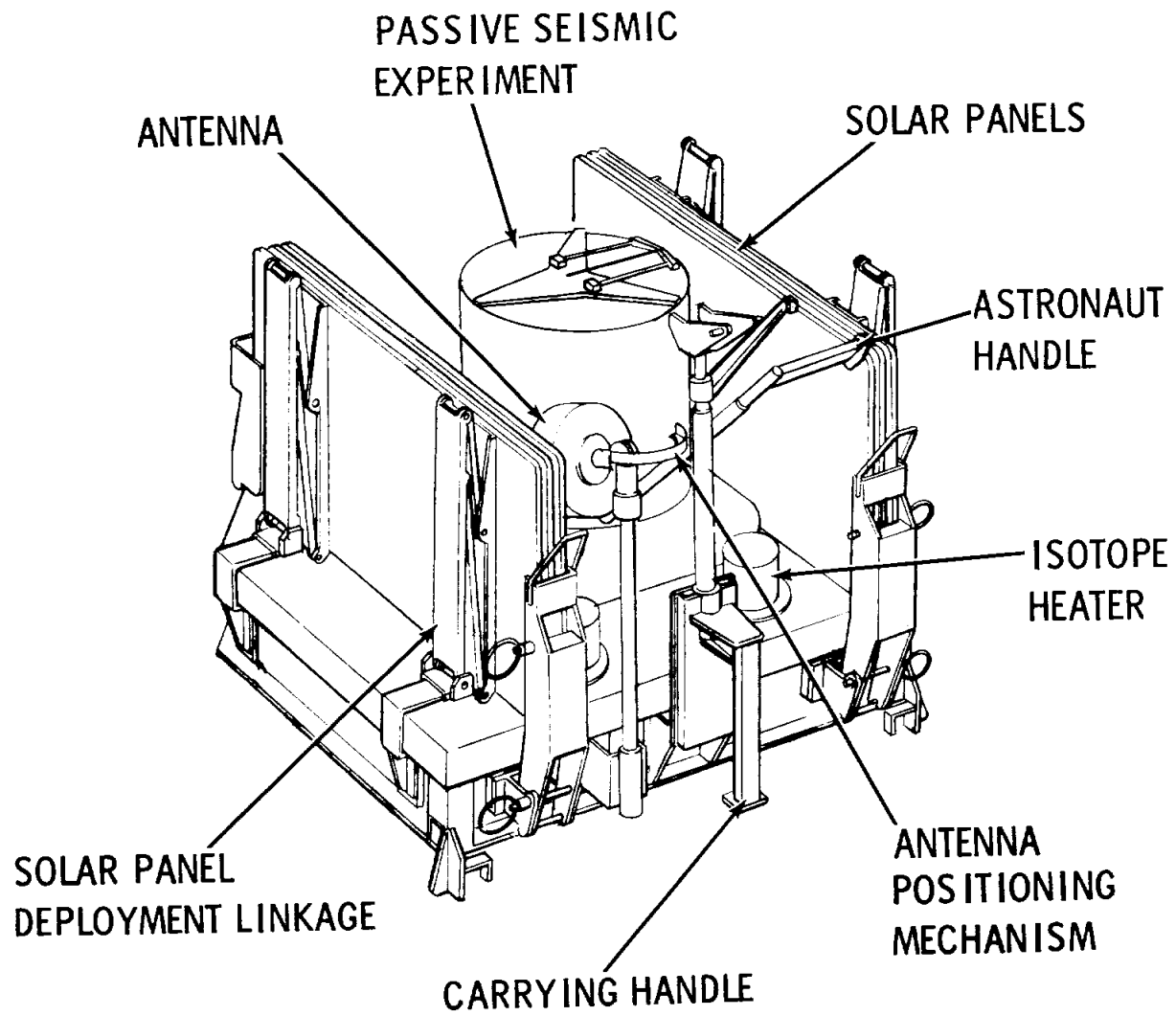

Figure 1 Passive Seismic Experiment Package Stowed Configuration

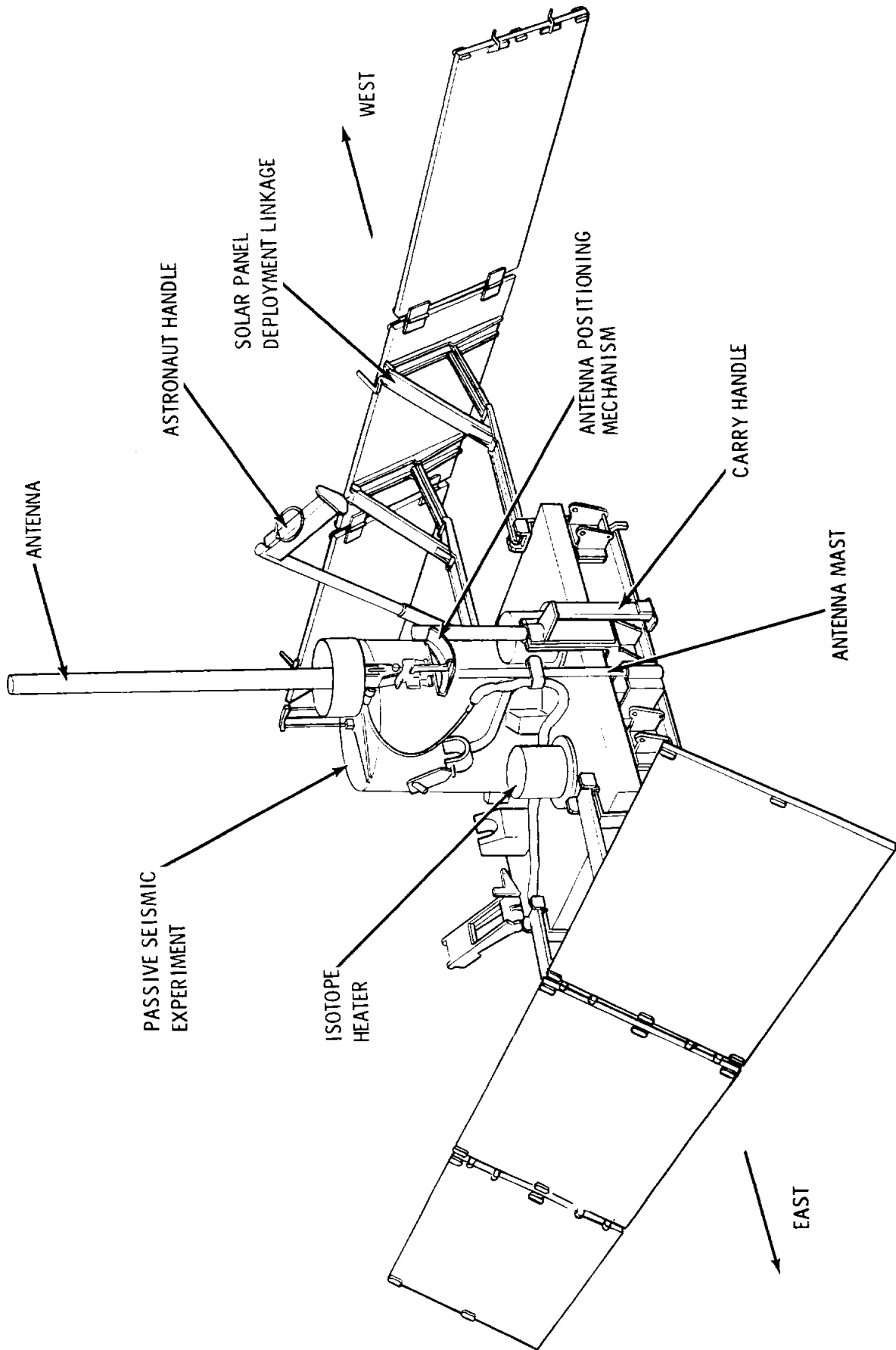

Figure 2 Passive Seismic Experiment Package Deployed Configuration

## PASSIVE SEISMIC EXPERIMENT DETAILS

The PSE exterior is a cylindrical beryllium container which measures 11 inches in diameter by 15 inches high and weighs 25 pounds. It is secured to subpallet No. 1 at four points and it is covered with a highly reflective surface for thermal control during the lunar day. This cylinder contains four seismic sensors and associated electronics; three long-period (LP) sensors are mounted on a leveling assembly with a short-period (SP) sensor attached beneath. (Figure 3).

The LP sensors measure frequencies from approximately one to 0.004 cycle per second and contain 1.65-pound masses mounted on the ends of three booms which allow two masses to swing in horizontal arcs and the remaining mass to swing vertically. The moving masses are electrically part of a capacitance circuit which produces an output proportional to their displacement. The vertical measuring mass swings on a boom suspended from its frame by a Lacoste spring, which compensates for the weight of the boom/mass assembly.

The SP sensor is a single-axis device which detects vertical motions of approximately 20 to 0.05 cycles per second. It consists of a magnet suspended in a coil. For high frequency seismic activity, the magnet behaves as the mass in the LP sensor and the coil moves in relation to it, cutting its magnetic field and inducing a voltage which is proportional to the velocity of the relative motion.

The electronics associated with each sensor amplify and filter the outputs and convert them to 10 bit digital words which are stored until the PSE receives a signal from the Data System that it is ready to accept the information for transmission to the Earth. The digital data is then fed to the Data System where it is placed in the data format and transmitted to earth as eight distinct measurements: six signals for the three LP seismic outputs; the SP output; and a measurement of the temperature of the sensor.

Fifteen commands may be addressed to the PSE from the earth. These commands are sequential (take the next step) as well as "on-off" commands, so that more than fifteen functions may be

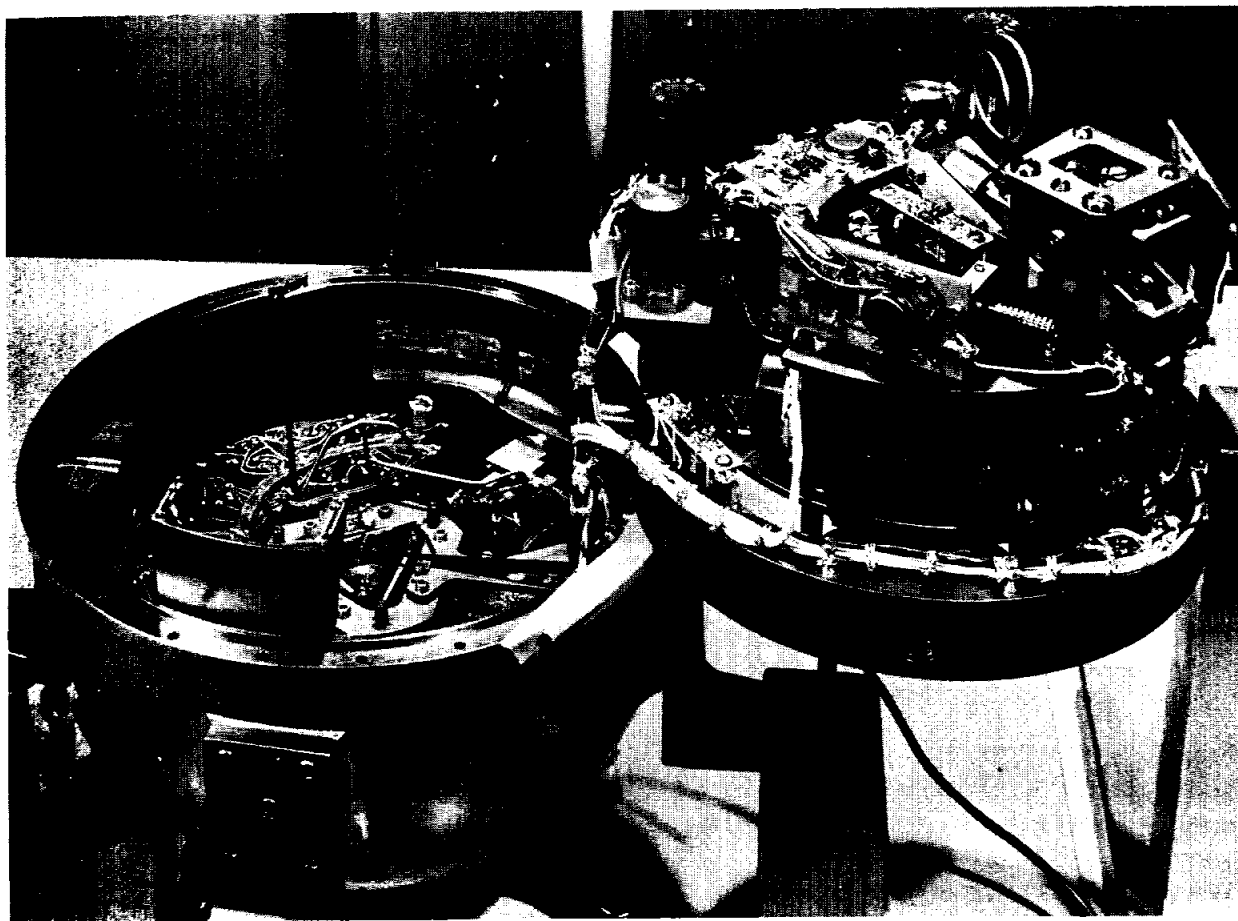
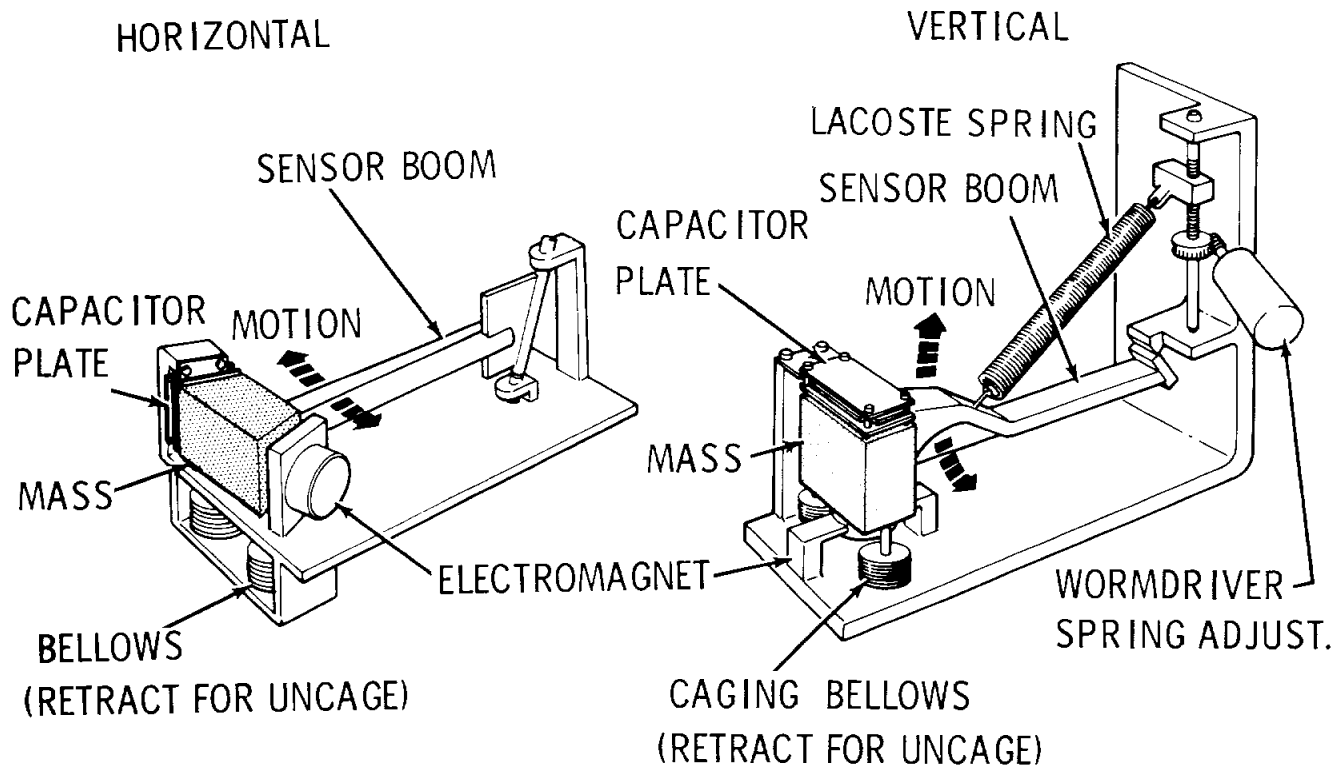

Figure 3 Passive Seismic Experiment Details



commanded from earth. Additionally, there are automatic leveling modes which control the leveling motors without specific earth commands. Three commands control the gain of the sensors, two provide calibration, five are directed to leveling the experiment and one command each controls the heater and the uncage function. These commands are selected, converted to digital form and placed in the command data format which is transmitted to the PSEP.

The PSE sensor masses are held immobile during their trip to the moon by pins. These pins are mounted on bellows which are inflated to hold the pins in the masses. After the experiment is placed on the moon, an earth command fires a squib venting the bellows, collapsing it and retracting the pins so the masses are free.

### **DATA SUBSYSTEM DETAILS**

Mounted on the same pallet as the PSE, the Data Subsystem is the PSEP central control unit. The system is responsible for: reception and decoding of uplink (earth to moon) commands; timing and control of the PSEP; collection and transmission of downlink (moon to earth) scientific and engineering data. The Data Subsystem (DSS), Figure 4, is composed of the following parts:

(1) the antenna, a ribbon wound helically around a fiberglass cylinder 23 inches long by 1 1/2 inches in diameter. This gives a directional (35 degree beam width) and highly sensitive unit (15.2 db gain) which must be aimed at the earth by the astronaut. It operates for both reception and transmission

(2) the diplexer switch, which may connect either of two transmitters to the antenna

(3) the diplexer filter, which selects whether the antenna operates to receive or transmit information and connects receiver input and transmitter output to the antenna

(4) the transmitter, a 1-watt phase modulated unit

(5) the command receiver, which detects uplink signals

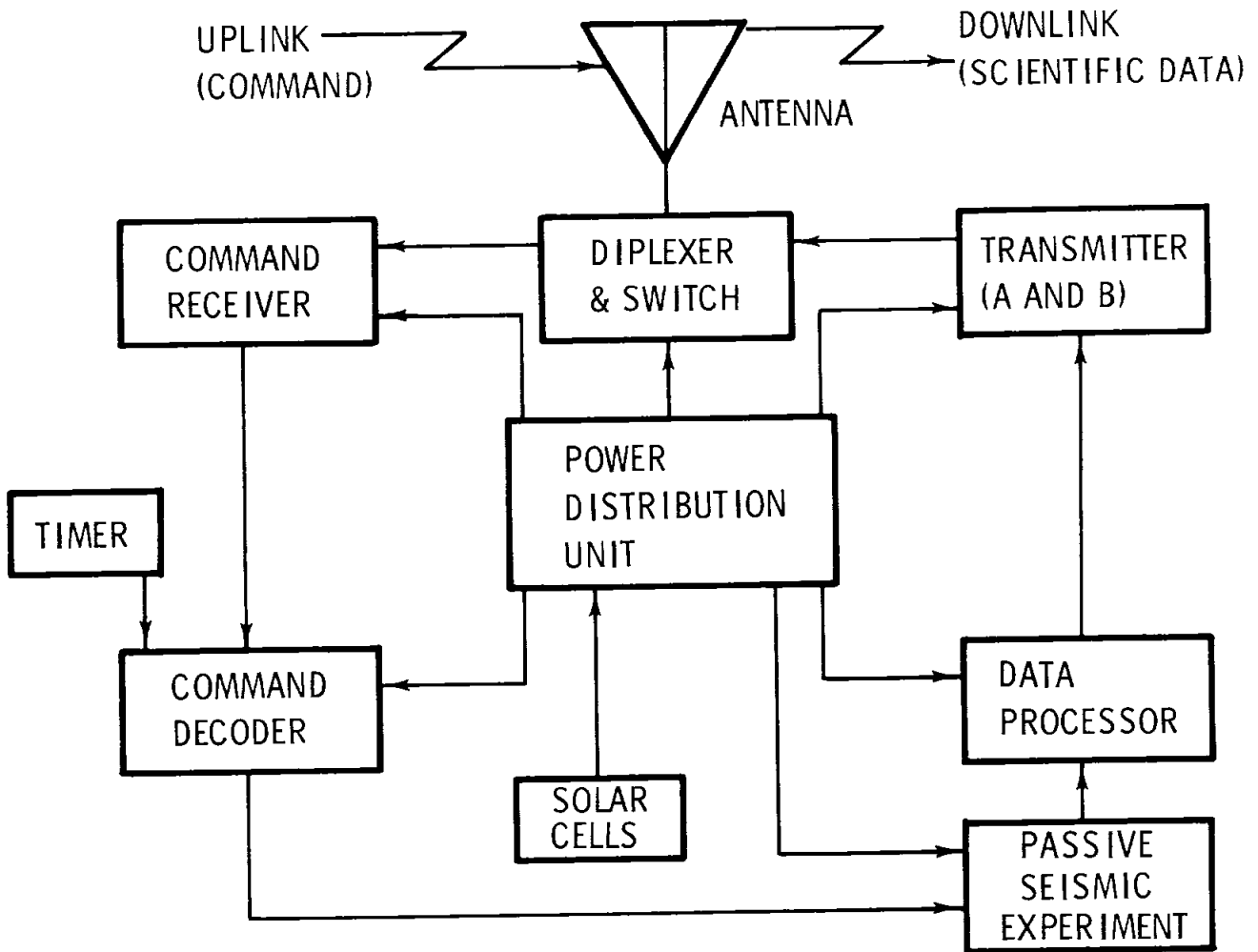

Figure 4 Data Subsystem Block Diagram

- (6) the command decoder, which processes information from the command receiver and issues commands to the PSEP. This is the "executive" on board PSEP, and is constructed using multilayer printed circuit boards. It can understand 128 different commands and issue 100 commands. Immediately after deployment and before the astronauts leave, it issues the "UNCAGE" command to the PSE
- (7) the timer, a clock which provides backup timing signals
- (8) the data processor is a combination digital data processor and analog multiplexer converter which collects information from the PSEP and places it in the EASEP format for downlink transmission
- (9) the power distribution unit (PDU), which controls power to the units of the PSEP.

Physically, the DSS is contained in the pallet on which the PSE and solar panels are mounted. Each component is boxed, and is interconnected by a wire harness ending in multi-pin connectors which make removal and replacement of individual components a relatively simple operation.

### **PSEP DEPLOYMENT**

The astronaut opens the SEQ bay door on the Lunar Module and grasps a deployment lanyard which is attached to a boom and the PSEP; pulling the lanyard extends the boom and then allows the PSEP to be drawn from the scientific equipment bay and lowered to the Lunar surface in a continuous motion. The lanyard is restowed, and the astronaut picks up the PSEP and walks about 30 feet from the Lunar Module (Figure 5). He lowers the PSEP to the lunar surface on an East-West axis, walks around the package and extends deployment handle to its working height. Using this handle to steady himself, he removes a series of retainer pins and lanyards. He then grasps the carrying handle and, rotating the unit, aligns it using the shadow cast by an indicator on top of the PSE. When he is satisfied with the alignment, the astronaut pulls a lanyard attached to the deployment handle and the spring loaded solar panels pivot to their deployed position (Figure 6). The astronaut then adjusts the antenna to correspond to the landing site, completing the deployment (Figure 7). The total time required is approximately six minutes.

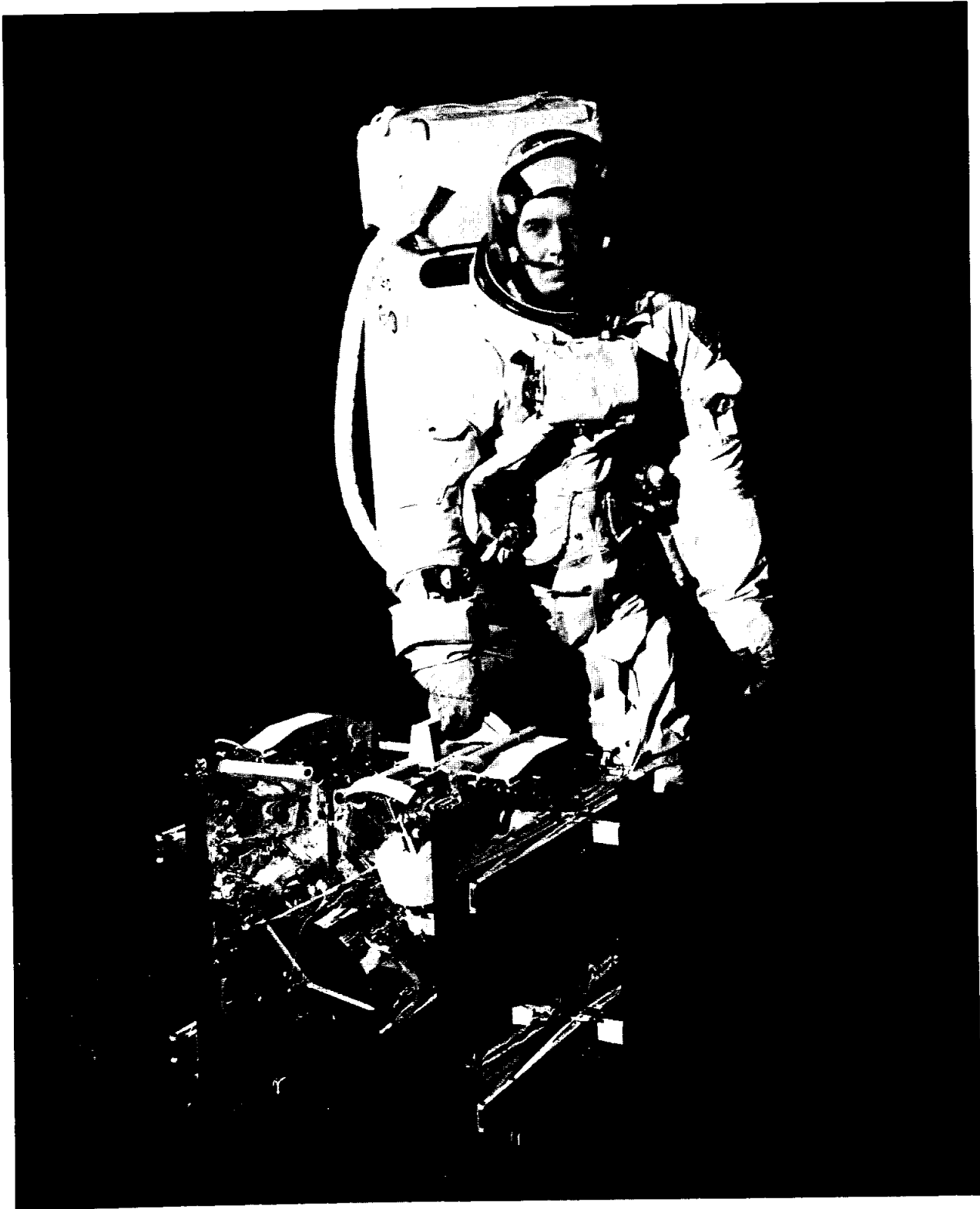

Figure 5 Astronaut Carrying the PSEP



Figure 6 Astronaut Deploying the PSEP

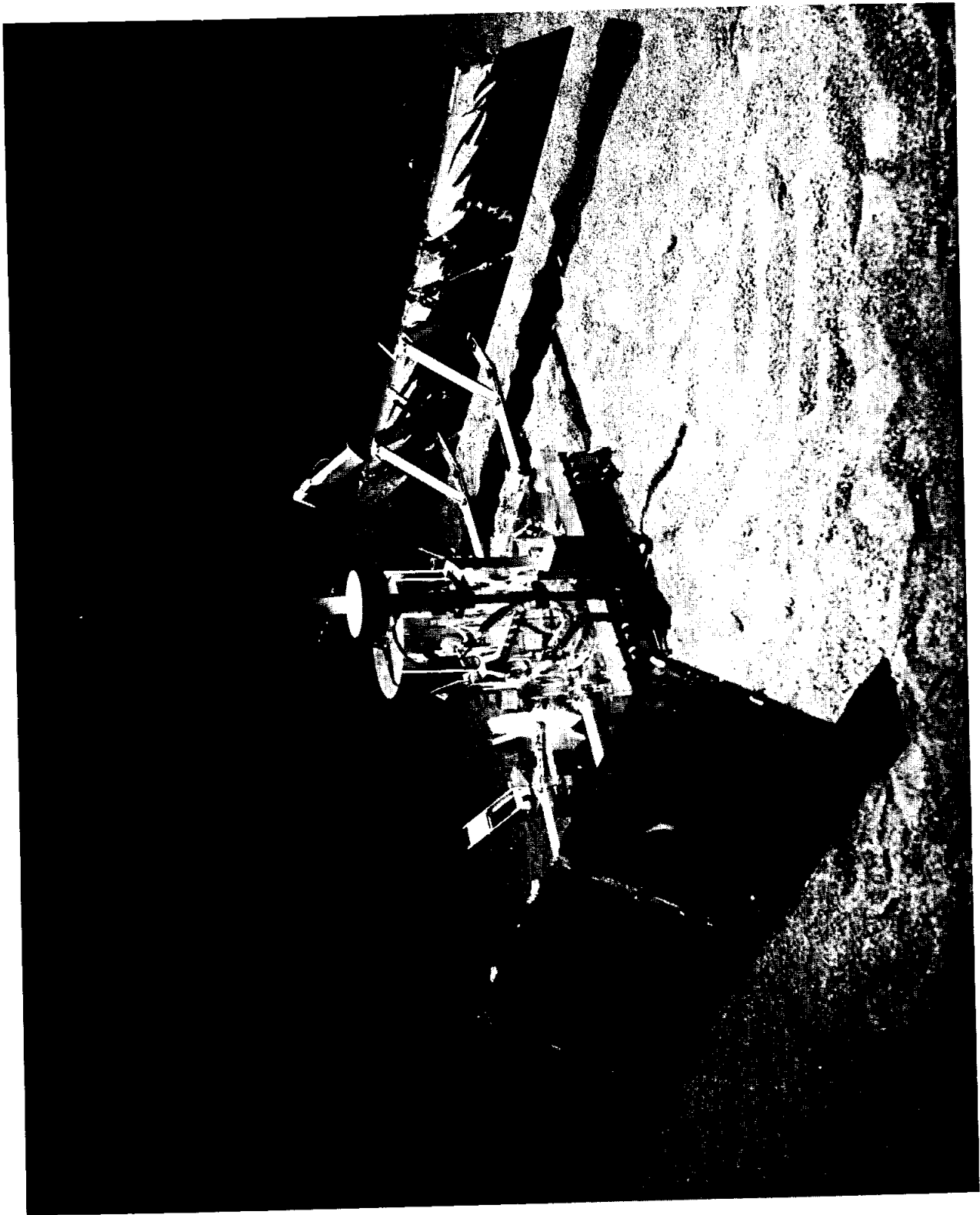

Figure 7 Passive Seismic Experiment Package

# LASER RANGING RETRO-REFLECTOR SUBSYSTEM DETAILS

## LASER RANGING RETRO-REFLECTOR

The Laser Ranging Retro-Reflector is mounted on its own pallet and has provisions for alignment  $\pm 5$  degrees or better by the astronaut when it is placed on the lunar surface (Figure 8).

The reflector unit is an array of 100 cylindrical cavities each containing a fused silica retro-reflecting prism. The retro-reflecting prism is a corner cut from a perfect cube of synthetic fused silica. A corner has the unique property that light shining into the corner will be sequentially reflected from the three faces of the corner and come out in a path that is parallel to the incident light.

The array structure, designed and fabricated by Arthur D. Little, Inc., supports and aligns the retro-reflectors. This structure provides passive thermal control by means of appropriate selection of cavity geometry, surface properties, and insulation, to minimize temperature gradients in the retro-reflectors and thereby assure satisfactory optical performance.

The retro-reflectors are mounted in the array with Teflon rings as shown in Figure 9. They are installed with the apex of the finished prism pointing down the cylinder and secured in the cylinder by a retaining ring. Total weight of the experiment assembly is about 65 (11 lunar) pounds and its structure and thermal design will permit survival and functional utility for up to ten years.

## LASER RANGING RETRO-REFLECTOR DEPLOYMENT

To deploy the reflector array, the astronaut removes the unit from the SEQ bay of the Lunar Module using a boom and lanyard as in removing the PSEP. The astronaut then walks about 30 feet from the lunar module and sets the array on the lunar surface approximately 10 feet from the PSEP and rough aligns it on an E-W axis. Using both the array tilting handle and the deployment handle, he aligns the unit to suit the particular lunar landing site, lowers the package to the surface, and aligns the experiment. Total deployment time for the reflector is approximately four minutes.

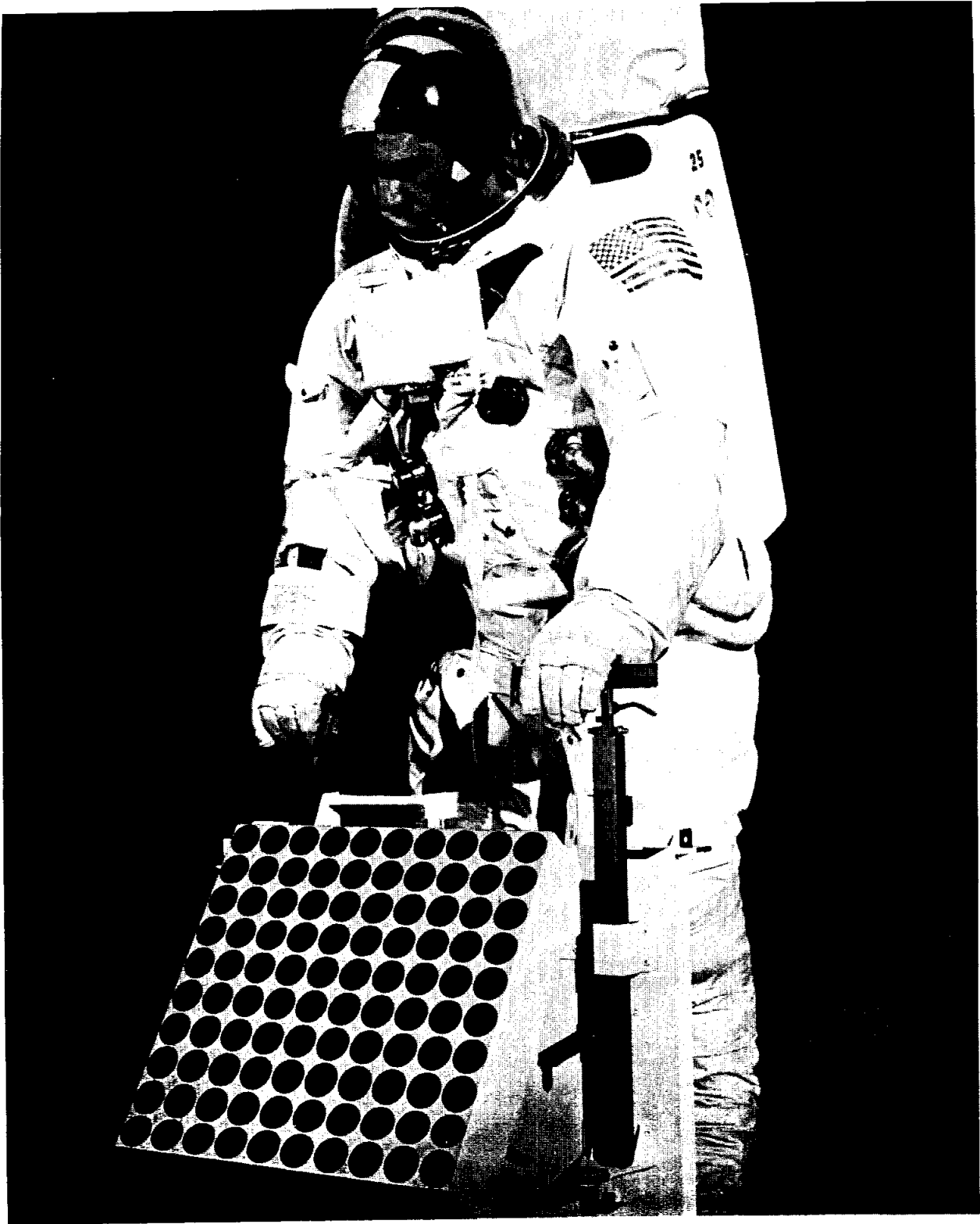

Figure 8 Astronaut Deploying and Aligning LRRR



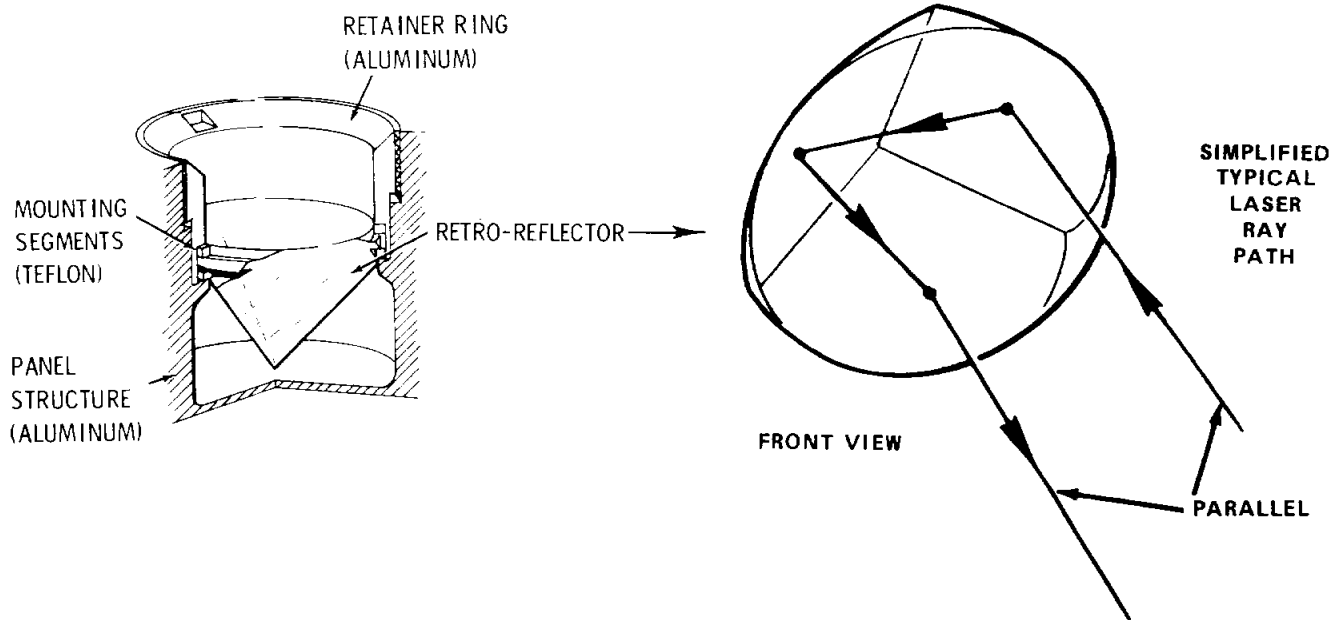
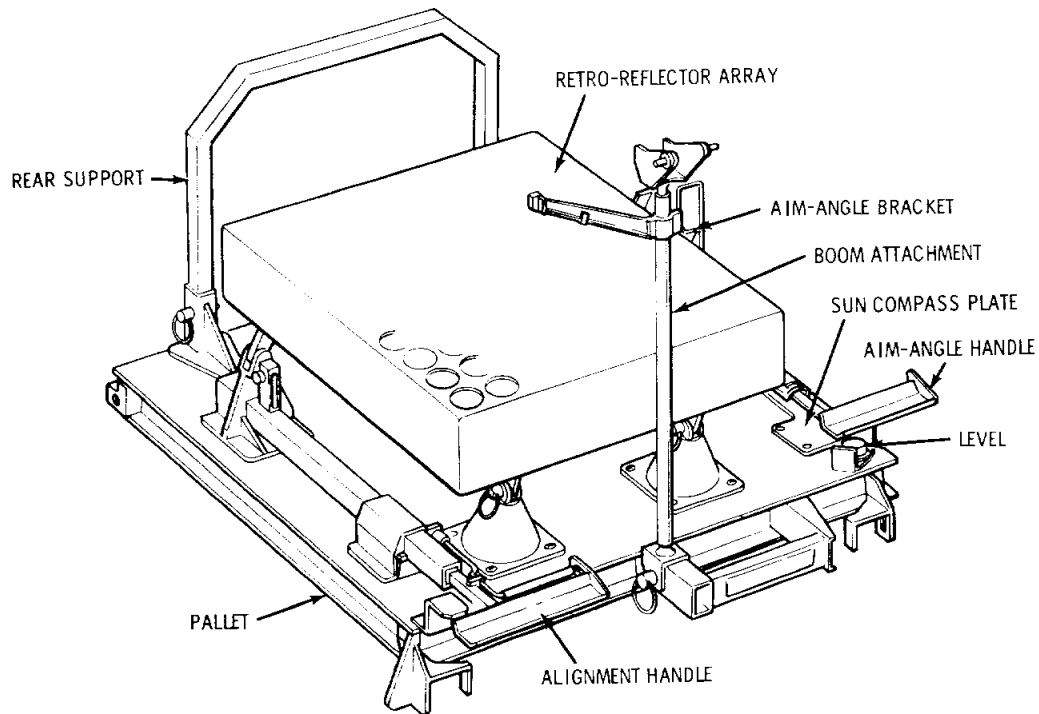

Figure 9 LRRR Details

## UTILIZATION OF THE LASER RANGING RETRO-REFLECTOR

The prospect of reflecting a laser beam from the moon does not carry with it a clear suggestion of the value of such an undertaking.

The most obvious value of the reflector array is that, in providing a specific reflective surface on the moon it will allow very precise measurements of the point-to-point distance from the earth to the moon. Since we know the speed of light and can measure in nanoseconds (one billionth of a second), it is possible to measure the time required for a beam of light to go to the moon and return and from it find the earth-moon distance with an uncertainty of 15 centimeters.

Such precision will also give much more accurate measurements of earth distances between two transmitting laser stations, and from this type of information scientists will be able to develop a large body of new information about the earth as well.

Primarily, scientists will be looking for previously unmeasurable variations in the orbit and rotation of the earth and moon.

Variations in the orbit of the moon reveal the gravitational interactions of the earth, moon and sun. This study will allow a greater understanding of the nature of gravity and will help to clarify whether or not the force of gravity is slowly diminishing, a theory which may be proved if, using the Laser Ranging Retro-Reflector, the moon's orbit is discovered to increase by an extremely small ratio ( $2-6 \times 10^{-11}$ ) each year.

Using the moon as a reference point, the wobbling of the earth on its axis may be studied; this motion is called Chandler's Wobble. Scientists have observed that Chandler's Wobble is not constant, but seems to be caused by some unknown circumstance. The earth's rotation gradually returns to a stable axis only to be excited again by this unknown force. Of great significance is the fact that earthquakes seem to relate to Chandler's Wobble, and it may be that an understanding of the Wobble may allow scientists to predict earthquakes much as they now predict the weather.

The measurement of Chandler's Wobble is similar to another measurement to track any continental drift. This theory of continental drift holds that Africa, South America and Antarctica were once a single continent that "drifted" apart. Over a period of about ten years, scientists, using the reflector, may discover that points on the continents are slowly drifting apart.

Again, because of the ability to make precision measurements using a laser reflector on the moon, very accurate information about the lunar orbit will be made available. Similarly, the wobbling motion of the moon about its center of gravity may be accurately measured, and this information will give a much greater understanding of the internal structure of the moon. The answer to the moon's origin may be found in whether it is an homogenous mass (formed in outer space and caught in the earth's gravity) or, like the earth, composed of various concentrations of masses caused by large scale differentiation from thermal heating and volcanic activity.

Thus, the ability to make extremely precise measurements about earth-moon distances will produce a great body of new knowledge about the size of the earth, the structure and origin of the moon and even our understanding of gravity.