

faces include three flight separable structural attachments as well as electrical, propellant and pressurization umbilicals. A launch facility umbilical interface located at the intertank provides ground services to purge the intertank and to actuate vent valves for pre-launch operations. A more detailed description of the interfaces can be found in Figure 9-1.

#### 9.1.7 Range Safety

Because of incompatibilities between the Shuttle baseline range safety system and the Air Force Eastern Test Range safety requirements a decision has been made to implement a new baseline Flight Termination System, which includes an External Tank propellant dispersal system. It will be carried on operational flights as long as required. The system will be "triplex" in that charges will be placed in the External Tank and one in each of the SRB's. The details of the exact system design are still under consideration. Trade studies are now underway regarding: ET electronics redundancy versus cross-strapping; intertank ordnance versus linear tank length charges; SRB charge; and redundant open-loop versus closed-loop dual initiator.

#### 9.1.8 Schedules

A brief look at the Level I (NASA Headquarters) controlled milestones for the ET identifies the program's accomplishments and the

work ahead.

- Completed Preliminary Design Review (PDR) Sept. 1974
- Completed Critical Design Review (CDR) Nov. 1975
- Complete delivery of Main Propulsion Test Tank to NSTL May 1977
- Complete delivery of ET Ground Vibration Test Article to MSFC March 1978
- Deliver first flight tank to KSC for FMOFT Sept. 1978

## 9.2 Observations

A general overview of the ET program indicates that the program's management systems have been in place and working well for some time now. The basic detail engineering design/drawings are about 75% complete with full assembly and installation release due sometime in the third quarter of 1976. A study has been in progress for some time to determine if the Structural Test Article test requirements can be simplified and reduced. This, of course, is a cost/schedule saving procedure which involves an analysis of what each test returns for the money and time invested. Many of the actions (RID's) from the CDR are still being worked, while all those from prior milestone reviews have been closed. Manufacturing facilities (plant, tooling, etc.) and procurements of materials and effort appear to be supporting the ET program at this time. Specific areas of concern and efforts to resolve them are discussed in the following segments of

this section of the report.

### 9.2.1 Review System

With the completion of the External Tank Critical Design Review in November 1975, the ET program is considered sufficiently mature to allow fabrication of the deliverable tanks for flight. The review established a baseline configuration. Almost all changes will need to be approved by MSFC. In addition to the day-to-day activities normally conducted at both MSFC and at Martin Marietta, regular reviews and Shuttle Panels dealing with the External Tank continue to be the major technical management control exerted on the program. Reviews include the ET Quarterly Technical Management Review conducted at MSFC or the Michoud Assembly Facility (MAF), weekly teleconference meetings to examine problems and expectations, and the Configuration Control Board operations. Further discussion of what transpired at the CDR will be helpful in understanding the depth of the reviews conducted on the ET.

The CDR was conducted at the NASA Michoud Assembly Facility, in New Orleans, Louisiana, between November 10 and 21, 1975. There were a total of 363 Review Item Discrepancies (RID's) submitted.

These were distributed as follows:

Structures	129
Propulsion	77

Total = 363

Electrical	98
TPS	59

Of these RID's 81 were withdrawn, combined with others or disapproved, leaving 282 "working" items. More than half of these have been closed out since the CDR by completion of the work or that the activity is fully in process. The remainder are being worked with expected completion before mid-year 1976.

The CRD may then be summarized as follows:

(a) Structures and propulsion system design has been thoroughly reviewed and found to be technically adequate. Production can proceed with baseline design.

(b) The TPS baseline concept has been found to be technically sound. Development can continue on that baseline.

(c) The electrical system components review has highlighted three hardware problems - (1) Cryogenic Connectors (Low Temperature Limitations), (2) Ullage Transducers (High Temperature Limitations), and (3) Instrumentation Sample Rates (MUX Impact).

(d) MPTA (Main Propulsion Test Article) requirements require further iteration to match the requirement to vehicle capability.

The action items resulting from the CDR included such things as:

(a) The contractor (MMC) is to perform a cost trade study

on the use of Inconel 718 for the aft SRB thrust fitting. They are to consider the procurement schedule to determine if it would be less costly to change out the material than to continue with the development cost of a titanium fitting.

(b) JSC is to assure that adequate handling and logistic plans exist in support of the MGVT.

(c) Rockwell International, Space Division, is to investigate the problem of overheating of the ullage pressure sensors. MMC is to evaluate other components for compatibility with the predicted gaseous oxygen temperatures. This will apply to both the flight vehicle and the MPTA.

(d) MSFC will review Volume X of the Level II requirements documents and SN-C-005 (contractual specification) and initiate the appropriate change request to make the External Tank contamination requirements compatible with the system contamination control requirements.

There are a number of major Level II working Panels that deal with the External Tank as it relates to (1) the integrated propulsion system (SSPM Directive #24), (2) Range Safety (SSPM #42), and (3) thermal design (SSPM Directive #46) and so on. Since these Panels meet and discuss technical and management problems on a continuous basis, they support the day-to-day operations as well as the major

reviews such as the CDR.

### 9.2.2 Design Progress

This section will focus on two areas of interest - (1) those design areas that are significant to the operation of the Space Shuttle System as a whole but which have received a minimum of attention from the Panel before, and (2) significant concerns regarding design requirements, design implementation, redesign due to test. The test program and its status is covered in another section of this chapter.

#### 9.2.2.1 ET Venting and Tumbling

A liquid oxygen venting system is incorporated into the ET. Along with its associated tumbling system, it is designed to enhance the separation safety between the Orbiter and the ET. The vent system relieves the liquid oxygen tank pressure if it increases to 23-25 psig. The nearly nonpropulsive design limits thrust to less than 50 pounds. The liquid hydrogen tank may vent after separation if the tank reaches a pressure of 20-22 psig, but its direction of thrust will not affect the tumbling motion. The tumbling system associated with the liquid oxygen venting system operates by opening a pyro-operated valve in the nose cap. This allows the oxygen gas to escape through a single port located such that its thrust moves the nose of the External Tank

away from the Orbiter at a slightly greater rate than the rear tank movement to create an increasing rate of tumbling. This energy is not related to the function of separation. The tumbling motion contributes to a more predictable trajectory by preventing atmospheric skip, and helps cause the External Tank to break up into fragments at about 185,000 feet altitude. This technique of entry results in a smaller, more predictable ocean impact area of about 100 x 600 n. mi. for tank pieces.

#### 9.2.2.2 Flight Test Configuration

The first six External Tanks to be used in the Space Shuttle Orbital Flight Test Program (OFT) have additional development flight instrumentation (DFI) over and above that to be used on the operational vehicles. These are installed to confirm the External Tank design, provide for diagnostic analysis to analyze flight anomalies and support operational planning. The instrumentation has been added with a minimum of changes being made to the base vehicle. The changes involved segments of the structure, the propulsion, electronic conditioning and thermal protection systems. An additional Orbiter/ET interface has, however, been added. The DFI electrical system, supplied by Orbiter power, consists of 342 measurements including bus-voltage monitoring and PCM multiplexer BITE monitoring as well as hardware for signal conditioning to assure a compatible data interface with

the Orbiter. The DFI measurements interface with the Orbiter Frequency Division Multiplexer. Measurements associated with POGO, acoustic and other vibration measurements interface with the Orbiter through the ET frequency modulation multiplexer to tape recorders.

#### 9.2.2.3 SRB Thrust Panel

The intertank cylindrical structure consists of two machined thrust panels and six stringer stiffened panels joined mechanically. No weldments are used. The two thrust panels distribute the concentrated axial SRB thrust loads to the LOX and liquid hydrogen tanks and to adjacent intertank skin panels. The panels are selectively machined with tapered skin thicknesses, and 26 external parallel ribs are integral with each panel. The panels are machined from aluminum plate, 2219-T87, to a finished size of 2.06" x 130" x 271" height. This panel must then be formed into the 165" radius after machining. It contains thicknesses ranging from 2" around the SRB Beam to 0.135" in the web sections. AVCO, the subcontractor, planned to hot-form these panel at about 375° in their "Bump Press." Because these panels are already in the so-called "T87" condition no temperature higher than 325° is actually allowed. Given their experience on another contract, AVCO indicates that if the hot-forming is to take place at 325° F. the panel will break. The options under consideration are: (a) ship the job to Denver Martin Marietta where there is a "Break Press" of suffi-



cient size, or (b) consider changing the material to the T37 condition for the fabrication process and then age it to the T87 condition. A decision has not been made and the Panel will follow this item.

#### 9.2.2.4 Range Safety Implementation for the ET

The following tentative agreements have been reached regarding that portion of the range safety flight termination system that is to be designed for the External Tank:

(a) The range safety system will be triplex (one per SRB, one on ET).

(b) ET electronics for this system are to be on the ET.

(c) It is assumed that the External Tank termination system may not be required on all launches, and will be designed for easy installation and removal at the launch site.

(d) MSFC is determining the desirability of locating the ordnance in the intertank area versus running a charge the length of the ET.

(e) Studies are being made on the best way to achieve system redundancy. Redundancy is not required if the system is "cross-strapped" from the SRB system. So far these studies indicate there is inadequate antenna coverage during the early part of the ascent flight to support redundancy requirements.

(f) Requirements in Volume X of the Level II Shuttle documents will be changed to meet the "triplex" requirement. These actions and their implementation will be followed by continuing Panel attention.

#### 9.2.2.5 Structural Loads Updating

In November 1975 the Orbiter/Integration Contractor generated new structural loads indicating that there will be significantly higher liquid hydrogen tank body loads as a result of time phasing of the moment and lateral load combinations. In addition when newer High-Q cases are examined it would appear that High-Q loads will increase the interface loads. As a result it would appear that either a higher pre-pressure or structural beef-up may be required. This area is under study at this time and will also be followed by the Panel in future examinations of the ET.

#### 9.2.2.6 Pulse Code Modulation (PCM) Multiplexer (MUX) Capability

Current data requirements are close to the limits of the hardware to accommodate the data bits. The PCM MUX capability is 16,000 BITS with current usage at about 15,500 BITS. The potential for overload is obvious. Such a problem is not uncommon at this stage of the program. Scrub-down of the requirements for measurements and sampling rates is currently underway. This area will be examined

at future reviews by the Panel.

#### 9.2.2.7 Weight Status

The ET current inert weight is calculated or estimated to be 73,756 pounds. The specification weight at this time is 73,999 pounds. The margin is obviously small and will continue to require stringent management attention. The weight status is based principally on calculations and less than 15% is estimated.

#### 9.2.2.8 Thermal Protection (TPS)

A number of significant issues have surfaced and are in various stages of resolution at this time. Some of these are of particular interest to various Panel members and therefore are discussed here.

(a) Rockwell indicates that revised ascent heating loads are somewhat higher than used by the ET designers in their design of the TPS. RI is currently evaluating their latest calculations of ascent conditions. These calculations, along with further high energy plasma arc/wind tunnel testing, should provide a more accurate picture of the thermal and structural load provisions to be made for the ET. The greatest effect appears to be on the forward section of the liquid oxygen tank and on the intertank. There is less impact on the liquid hydrogen tank. If the loads are higher there will be substantial increase in the amount of insulation required and a

corresponding growth in weight. Both the trajectory parameters and the analysis methodology using lower altitude trajectory, wind tunnel data recovery factors, and roughness effects are under review.

(b) There is possibility of the lift-off of the CPR-421 insulation at the interface between the CPR insulation and the so-called "super light ablator" material. This would be due to the heat of reaction from CPR in liquid phase expanding the volume of air in the ablator material. The pressure increase forms voids at the interface of the two materials which then bubble out. There is also a possibility that the CPR-421 interacts with the adhesive and primer used to hold the insulations to the tank. Finally, the angle at which the two materials interface may result in aerodynamic lift-off. All of these areas are being studied and appropriate tests are underway.

(c) Material development and installation methods are still causing some problems. The low strength of thick SLA-561s at the substrate is under intensive study and test to resolve this material problem.

(d) Minimization of damage to the Orbiter TPS tiles from ice on ET protuberances is receiving intensive study. There are more than 70 that can collect ice. Studies focus on reducing ice formation to a minimum by further protection of the ET areas of concern and

understanding the tolerance of the Orbiter tiles to damage from ice impact including the extent of tile thermal degradation.

#### 9.2.2.9 Lightning Protection

The ET design incorporates features to protect the structure and subsystems from the direct and indirect effects of triggered atmospheric electrical discharges during flight operations. The ET is designed to function after an initial strike of 200,000 amperes peak at the ET lightning rod and a second lightning strike of 50,000 ampere peak across the ET body while it is in motion. Lightning protection criteria for the Space Shuttle Program are found in detail in the document JSC-07636 with changes 1 and 2 updating it to March 1976. Lightning protection is provided by the launch site until liftoff. Thereafter, the bare 20 inch long, 20 degree nose cone at the tip of the ET nose cap serves as a lightning rod. Preliminary lightning tests indicate that a 0.03 inch wall-gauge gaseous oxygen line running along the outside of the tank can accommodate restrike currents with a forward motion as low as one foot per second. Further lightning tests are being conducted to confirm the design. Simulated lightning tests indicate the minimum (0.08 inches) the skin gauge on the liquid oxygen tank will withstand expected strike currents.

#### 9.2.3 Major Ground Tests

There are three major ET ground test programs, or better still, three programs using the ET as a major test item: (1) Structural Tests, (2) Main Propulsion Test, and (3) Ground Vibration Test.

Structural tests will be performed at the MSFC facilities to confirm structural analyses and to verify the design. The general objectives of this program are:

- (a) Verify structural integrity of the ET for critical internal and external design limits, yield and ultimate loads.
- (b) Obtain data to substantiate dynamic and stress analyses.
- (c) Verify the structural integrity of the interface hardware.
- (d) Obtain influence coefficients (stress and deflection) for structural and functional characteristics.
- (e) Verify the structural integrity of the substructure and of primary structure bracketry.
- (f) Determine growth capability for future missions.
- (g) Determine weight savings candidates for the production article.

The hardware used for these tests has been designated the STA or Structural Test Article. It consists of the following major test assemblies: Intertank Static, LOX Modal, LOX Static, Liquid Hydrogen Static. One LOX tank and one LH<sub>2</sub> tank simulator section

are used in conjunction with the STA elements.

The Main Propulsion Test (MPT) program is to be performed at the National Space Technology Laboratory (NSTL) in Mississippi. It will assess and verify the integrated Space Shuttle main propulsion system performance. The MPT External Tank will be mated to a simulated Orbiter midbody made of boiler-plate, and a flight weight aft fuselage with the main engine cluster. The ET MPT article is flight configured with modifications to meet the needs of the test. A total of fifteen test firings are planned with eleven being either full duration or approaching full duration.

The ground vibration test (GVT) program at the Advanced Dynamic Test Stand at MSFC will measure frequency, mode shapes, and damping characteristics of the mated Space Shuttle vehicle. The GVT External Tank is a flight configured structural article that will be returned to MAF at the completion of the GVT for refurbishment and recycling into a production ET. The experimental results will provide a basis for updating the math model so that follow-on analytical studies will yield refined and more accurate data. Substantiated or updated coupled dynamic math models will provide more confidence in the Orbiter guidance and control system design, POGO analyses, structural load predictions, and flutter analyses in support of the first Space Shuttle flights. It is understood that a 1/4-scale test program is also in the plans.

9.3 Hazard Analyses and Safety Concerns

Both NASA and its contractors have developed a hazard analyses and safety program on the External Tank program that is working well. Typical products are the "Space Shuttle External Tank Critical Design Review Hazards Analysis Report" (MMC-ET-RA01-A dated October 17, 1975) and the "Space Shuttle Safety Concerns Summary Report" (JSC 90090) which includes the ET as a part of the total picture. The elements of the process used by Martin Marietta in arriving at risk assessments include:

- (a) Process of hazard identification, analysis and corrective action.
- (b) Review and evaluation of changes for hazards.
- (c) Trade studies.
- (d) Safety assessment summary
- (e) Catalogue of hazard and then resolution.

The ET Critical Design Review summarized the hazards at that time and most of them are now resolved.

<u>SYSTEM</u>	<u>HAZARDS</u>
Structures and TPS	19
Propulsion and Mechanical	27
Electrical	10
Transportation and Support Equipment	<u>2</u>
TOTAL .....	58 (Most of these have been resolved)



To provide the reader an understanding of these hazards, the following were selected from the Summary Safety Concerns report:

(a) The impact of ice forming and breaking away from the ET and impacting the Orbiter TPS. This was mentioned in previous sections of the report.

(b) There is no provision for draining the LOX and hydrogen from the ET except through the Orbiter feedlines and the propellant lines in the aft fuselage. The concern is that detanking during an emergency must be accomplished through a system which may be involved in the emergency. An emergency drain system is under consideration.

(c) There may be post separation contact between the ET and Orbiter because of undesirable motions caused by post-separation venting. This is under study.

(d) The flammability of the ET tank insulation and adequacy of the wire insulation are both under further review.

#### 9.4 Material to Update the Basic Information

To assure the reader the most current information, this section has been established to include new, pertinent information developed by the Panel since the prior sections were written. This update adds, modifies or deletes previous data contained in this report.

#### 9.4.1 Boundary Layer Tripping

Analysis of the "yoke" fitting on the forward Orbiter-to-ET attachment indicates that the fitting will cause the boundary layer to be tripped on the Orbiter (laminary to turbulent flow) earlier than desired. This will result in an increased heat transfer resulting in increased material temperatures of perhaps 80 to 100 degrees F. The extent of this problem is still under study along with possible redesigns of the yoke explosive bolt hardware.

#### 9.4.2 Implementation Of Range Safety Requirements

The current design approach is to mount two conical shaped charges in the intertank between the LOX and LH<sub>2</sub> tanks, along with the two antennas, two batteries and associated electronics. The development of a cost/effective method of implementing range safety is under study with the objective of establishing an acceptable level of hazard from Space Transportation System operations and determining criteria for employment of a full or partial flight termination system. Total system definition and ET design requirements are expected to be established by August 1976.

#### 9.4.3 Thermal and Structural Loads

Since thermal analysis data will not be available to support the design of the TPS for the External Tank the TPS design must include margins for any surprises. This may result in excessive weights and additional expense for TPS development now and further changes may be required a year from now when the revised heating data becomes available. The latest structural loads data (April 1976) may cause serious impacts on

the current ET hardware, in the intertank, hydrogen tank and interface hardware. If load relief trajectories now under investigation do not reduce the loads, the weight impact may exceed some 300 pounds and affect many pieces of hardware already designed.

#### 9.4.4 Ice Protection

There are more than 70 ET protuberances which can collect ice. Steps have been and are being taken to alleviate this problem. The application of spray-on insulation (SOFI) has been examined and can provide ice control for about 85% of the surface area ( $=584 \text{ ft}^2$ ) with about  $83 \text{ ft}^2$  remaining to be covered. The application of the insulation in these areas is somewhat more complicated than that for the remainder of the External Tank. Tolerance of the Orbiter and tank to the ice/frost accumulations during pad operations and ascent portion of the mission are still under assessment.

#### 9.4.5 Thermal Protection System (TPS)

CPR 488 which is a reformulated CPR 421 deleting the cobalt is currently being evaluated. Preliminary results indicate that either may be used to provide the needed thermal protection.

#### 9.4.6 LOX Anti-Geysering System

The test setup at Martin Marietta Corporation division at Denver, CO, to test the efficacy of the anti-geysering system is now in the final stages of installation and checkout. Baseline flow testing is scheduled to start soon after July 1, 1976.

The major challenges on the External Tank of safety significance are thermal insulation, ice formation, the use of teflon electrical wire insulation in the liquid oxygen tank, and provisions for control of reentry.

Response:

Thermal Insulation

(a) The nose of the LOX tank has been revised from a hemispherical to a double cone configuration to avoid bow shock reattachment on the ogive and thereby reduce the heating. Wind tunnel testing, analysis of thermal data and development testing of TPS materials on coupons and subscale tanks are continuing to characterize the TPS properties.

Ice Formation

(b) Tests have been run in the Eglin AFB environmental chamber using a 10-foot diameter tank insulated with CPR-421 of several different configurations. The specific objective of these tests is to determine for selected worst environmental conditions the thickness and density of ice/frost. Other objectives were: (a) to verify the searchlight concept as a method to prevent ice/frost formation on TPS surfaces and (b) to demonstrate the feasibility of using conductive paints to prevent ice/frost formation. Test data are being analyzed.

Teflon Electrical Wire Insulation

(c) During the Apollo 13 investigation, a test program was run (according to procedures outlined in NHB 8060.1A, Test 4) on the teflon insulated instrumentation wiring used in the Saturn vehicles. The results of this program showed: (a) that the Saturn harness insulation immersed in LOX could not be ignited by any electrical overload; (b) in gaseous oxygen, the Saturn harness could be ignited when overloaded by approximately 800 percent electrically; (c) in the unlikely event of ignition, fire would not propagate through the feedthrough connector at the tank wall because the connector pins, rated at 7 amps, would fail open preventing propagation to the other side. As a result, no changes were made in the Saturn stages LOX tank instrumentation wiring.

The smallest wire in the ET will be No. 22 (except for 1/2-mil platinum wire in loading and liquid level sensors). Maximum design current for the No. 22 wire is 2 amperes. The maximum current into the tank under any single failure in sensor or signal conditioner is 1.5 amps. The duration of current will only be long enough for the 1/2 mil wire in the tank or circuit components in the signal conditioner to fuse (open).

The ET Project plans to conduct configuration tests using ET hardware and worst case conditions to assure no hazard exists.

Control of Reentry

(d) The adoption of non-propulsive venting will ensure against premature breakup due to LOX and hydrogen tank ruptures. The baselining of a tumbling system utilizing a pyro valve with initiation at ET/Orbiter separation will provide the necessary controlled reentry.

TPS CONFIGURATION TABULATION

	TPS MATERIAL	THICKNESS-INCHES
<u>Acreage</u>		
Nose Fairing	SLA-561	0.35
LO <sub>2</sub> Vent Louvers	SLA-561	TBD
Conduit Fairing	SLA-561	0.4
LO <sub>2</sub> Tank Ogive	CPR-421	Taper
LO <sub>2</sub> Tank Barrel	CPR-421	1.0
LO <sub>2</sub> Tank Fwd Bulkhead	CPR-421	0.5
LO <sub>2</sub> Tank Aft Dome	None Req.	-----
Intertank	CPR-421 / SLA-561	0.5
LH <sub>2</sub> Tank Fwd Dome	CPR-421	0.5
LH <sub>2</sub> Tank Aft Dome	CPR-421	2.0
LH <sub>2</sub> Tank Barrel	CPR-421 / SLA-561	1.0
<u>Penetrations</u>		
LO <sub>2</sub> Feedline	CPR-421	1.0
LO <sub>2</sub> Antigeysers Line	CPR-421	1.0
GO <sub>2</sub> Pressurization Line	None Req.	-----
LH <sub>2</sub> Feedline	SLA-561/CPR	0.4/1.0
LH <sub>2</sub> Recirculation Line	SLA-561/CPR	0.4/1.0
GH <sub>2</sub> Pressurization Line	None Req.	-----
Electrical Cable Tray	SLA-561	0.05-0.35
LH <sub>2</sub> Vent Line	CPR-421	0.5
LO <sub>2</sub> A/G Line Fairing	SLA-561	0.4
LO <sub>2</sub> Feedline Fairing	SLA-561	0.4
GH <sub>2</sub> Press Line Fairing	SLA-561	0.4
IT Conduit Fairing	SLA-561	0.4
<u>Structural Attachments</u>		
LO <sub>2</sub> Feedline (5)	None Req.	-----
LO <sub>2</sub> Antigeysers Line (14)	SLA-561	0.4
LO <sub>2</sub> Press Line/Cable Tray-LO Tank (17)	Req. TBD	
GH <sub>2</sub> Press Line (15)	SLA-561	0.2
<u>Instrumentation</u>		
	TBD	
<u>Interface Structure</u>		
Fwd ET/ORB Attachment Strut	SLA-561(Fwd Face)	0.25
Aft ET/ORB Thrust Strut	SLA-561(Fwd Face)	0.10
Aft ET/ORB Vertical Strut	SLA-561	0.15
Aft ET/ORB Diagonal Strut	SLA-561	0.15
Aft ET/ORB Crossbeam Fairing	SLA-561	0.30 Fwd/Aft Face 0.20 Top/Bottom
Fwd ET/SRB Attachment	None Req.	-----
LO <sub>2</sub> Line Aft Interface Attachment	Req. TBD	
LH <sub>2</sub> Line Aft Interface Attachment	Req. TBD	
<u>Isolator Requirements</u>		
ET/SRB Aft Attachment (4)	Glass Phenolic	0.4
ET/ORB Fwd Attachment (2)	"	0.5
ET/ORB Aft Vertical Attachment (2)	"	0.4
ET/ORB Aft Sway Attachment (1)	"	0.4
LO <sub>2</sub> Feedline Attachment (8)	"	0.4
LO <sub>2</sub> Pressurization Line/Cable Tray Antigeysers Line Attachment (14)	Glass Phenolic	0.5
LH <sub>2</sub> Pressurization Line Attachment (15)	"	0.5
<u>Miscellaneous Areas</u>		
Intertank Forward of SRB Attachment	CPR-421	1.0
Intertank Forward of ORB Attachment	CPR-421/SLA-561	0.5/0.1
Intertank Umbilical Plate	None Req.	-----
Intertank Umbilical Plate Cutout	SLA-561	0.2
LH <sub>2</sub> Tank Aft of Fwd ORB Attachments	CPR-421/SLA-561	1.0/0.2
Acreage Around Structural Attachment	SLA/CPR	0.1/ Variable
I/T Vent & Surrounding Area	SLA/CPR	TBD

FIGURE 9-1

EXTERNAL TANK ATTACHMENT HARDWARE

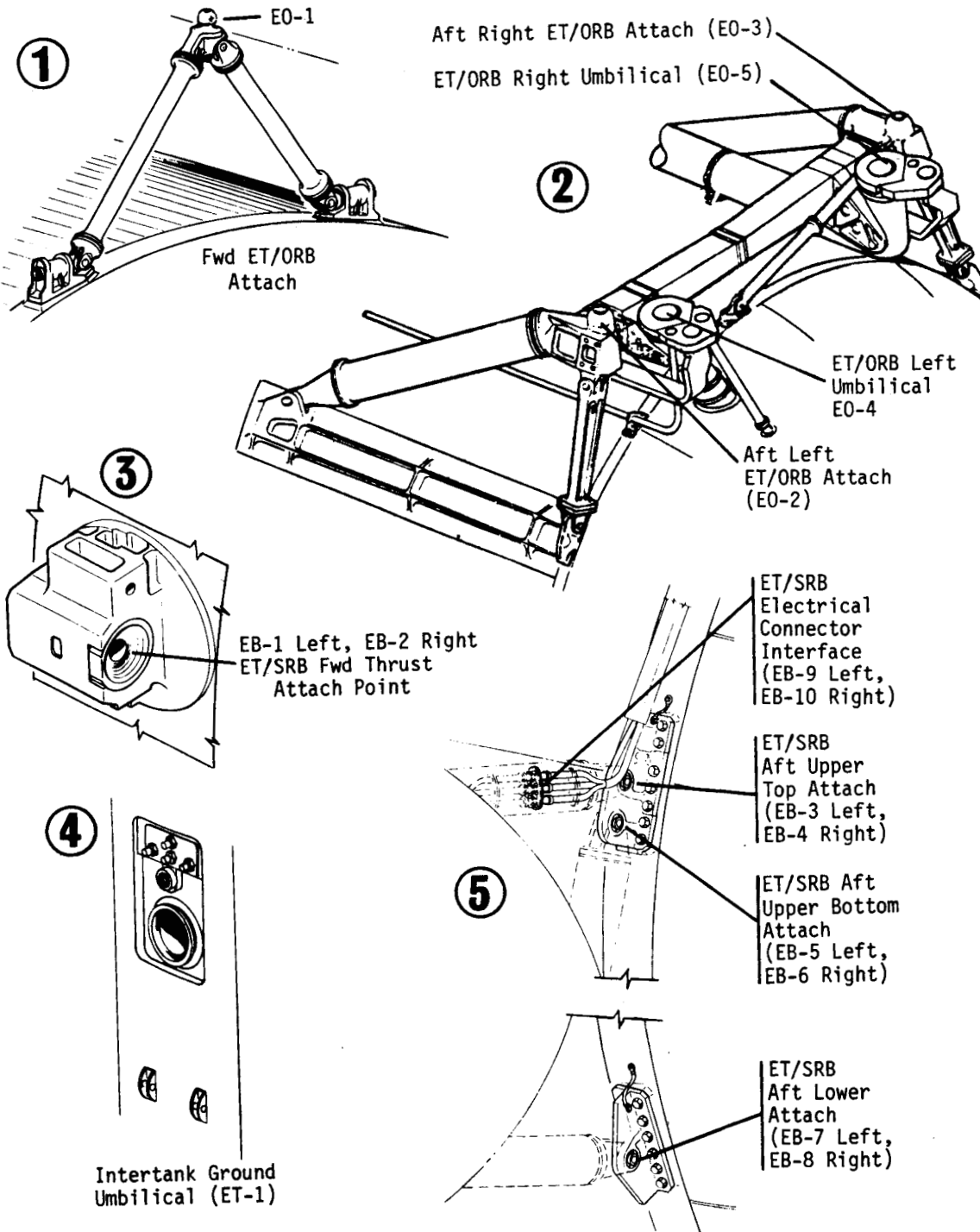

## 10.0 SOLID ROCKET BOOSTER

### 10.1 Introduction

Two solid rocket boosters (SRB's) burn in parallel with the Orbiter main propulsion system to provide initial ascent thrust. Primary elements of the booster are the solid rocket motor, forward and aft structures, the thrust vector control (TVC), operational flight instrumentation and recovery avionics, separation motors and pyrotechnics and recovery parachutes. Each SRB will weigh in excess of one and a quarter million pounds.

The major milestones for the SRB project provide a perspective on the current status of the program and the work ahead:

- a. Delivery of the first machine finished case segment to Thiokol for filling is scheduled for September 1976.
- b. The firing of the first solid rocket motor as part of the development test program is to be completed in July 1977.
- c. The SRB Critical Design Review (CDR) is to be held in May 1977.

As further background the response from the Shuttle organization to the Panel's last Annual Report on the SRB is included as Attachment 10-1.

For the purposes of both description and data reporting, the SRB section of the report is divided as follows: Project Management, Solid Rocket Motor, Booster Separation Motors, Structures, Thrust



Vector Control, Electrical/Electronics/Instrumentation, Recovery Equipment, Range Safety/Flight Termination, Ground Support Equipment, Major Ground Tests, and Development Tests.

## 10.2 Project Management

The SRB overall design and control is currently being done by MSFC. The project management system utilized by NASA and its major SRB contractors is similar to that used on other elements of the Shuttle program. There are quarterly reviews conducted for NASA management and technical personnel, with the most recent one held on April 1-2, 1976 at the MSFC. Periodic design reviews for the major components of the SRB are conducted about once a month. Telecons and special meetings are a normal part of the technical management and working engineer system. The review system also includes integration reviews and program level reviews as required.

Recent additions to the list of major contractors working on the SRB include:

- a. McDonnell Douglas Astronautics Company will provide the structures subsystem.
- b. United Technologies, Chemical Systems Division, will provide the Booster Separation Motors.
- c. Moog, Inc., Controls Division, will provide the Thrust Vector Control Actuator.

(d) Bendix Company of Teterboro, New Jersey, will provide the Integrated Electronic Assembly.

The Martin Marietta Co. has been selected as the recovery system contractor. Plans are underway to acquire the Booster Assembly Contractor (BAC). The intent of MSFC is to phaseover the logistics and operations planning as well as other assembly integration tasks to this contractor starting in the last half of 1976. The RFP has been issued and a contractor will be selected around mid-year.

### 10.3 Observations

#### 10.3.1 Weight

The SRB weights are of course important. Since there are two units weight increases on the SRB have to be doubled to appreciate their impact on the total Shuttle. The table below shows the weight statistics:

SRB x 2 = 365,454 pounds inert specification control weight  
= 357,738 pounds is the current inert weight  
= 7,716 pounds margin  
= 2,586,034 pounds total control weight  
= 2,220,580 pounds solid propellant weight

The available margin for the SRB's is roughly 2.2% on the inert weight. This is a somewhat tight figure at this time considering the

possible growth due to design additions and modifications resulting from the development test program.

#### 10.3.2 Solid Rocket Motor (SRM)

The solid rocket motor is more than 125 feet long and 12 feet in diameter. The solid propellant is cast and cured in four casting segments which are transported by rail to the launch site where they are to be assembled into the finished motor. The SRM propellant is the same type as that used in the Poseidon and the First Stage Minuteman motors. The nozzle is nearly 13 feet long and is also 12 feet in diameter at the exit. It weighs nearly 11 tons. A key feature of this nozzle is a flexible bearing constructed of alternate layers of elastomeric rubber and steel which permits the nozzle to be gimbaled and deflected for attitude control of the Shuttle System during ascent portion of the mission. The SRM igniter mounted in the head of the motor weighs about 660 pounds and is larger than many tactical rocket motors. The igniter consists of a safe and arm device, a pyrogen initiator, and the main pyrogen igniter. The SRM's are designed to burn for about two minutes carrying the Shuttle cluster to about 25 miles altitude after which the SRB will separate, parachute to the ocean for recovery and reuse.

The SRM is deep in the phase of component design, development,

and testing. The SRM Critical Design Review (CDR) is set for mid-1977. The ground tests of interest include the following:

- |  |                        |
|--|------------------------|
| (a) Subscale Flexible Bearing (Nozzle) | Completed Successfully |
| (b) Prototype Flex Bearing Tests       | December 1976          |
| (c) Ignition System Development & Qual | February 1977          |
| (d) Ignition Safeing and Arming D & Q  | Mid-1977               |
| (e) Case Hydroburst                    | September 1977         |
| (f) Nozzle/TVC Confirmation            | December 1977          |
| (g) Railroad "Hump" Test               | Mid-1978               |

To accomplish the program the following types and quantities of motors are being produced: four development motors, three qualification motors, and five ground test motors. Two of the ground test motors are inert - two are empty and one is for structural test. In addition, the present schedule includes six flight motors.

The motors will be used in the following test schedule:

- |                         |          |                |
|-------------------------|----------|----------------|
| (a) Development firings | Number 1 | July 1977      |
|                         | Number 2 | September 1977 |
|                         | Number 3 | February 1978  |
|                         | Number 4 | April 1978     |

On the Number 2 and 3 firings the same refurbished case will be used. A refurbished nozzle and flexible bearing will be used on the Number 4

development firing while the number 3 firing will use a non-refurbished or used flexible bearing.

(b) Qualification Firings	Number 1	July 1978
	Number 2	August 1978
	Number 3	December 1978

On the Number 1 and 3 qualification firings the same refurbished case will be used.

#### 10.3.2.1 Design Loads

The magnitude of the flight and water impact loads and the resultant attrition rate or loss of the SRB's during recovery is of concern because of the effect such losses have on the cost per flight figures for the Shuttle mission. The design load considerations for reuse of the SRB directly affect the SRM. The SRM case is designed for the maximum expected operating pressure. The nozzle and aft skirt are subjected to support loads from the launch pad, reentry acoustic (organ pipe effect). The aft end of the SRM is designed for water impact and the water cavity collapse loads after the rocket strikes the water.

The major concern regarding design loads has centered on the water impact loads. Originally, the project anticipated a water impact load based on 100 ft/sec vertical velocity. As a result of analysis and model tests by MSFC, their contractors, and other federal agencies,

the project has determined that a vertical velocity of 85 ft/sec is more realistic. This means a reduction in total program cost, reduced risk of losing an entire SRB during entry, and a more acceptable weight margin. The change in expected attrition rates is shown in the following table:

Water Impact Attrition For 85 ft/sec

	<u>85 ft/sec</u>	<u>100 ft/sec</u>
Aft Skirt	7.2%	20.0%
Aft SRM Segments	1.3	9.5
Forward SRM Segments	1.9	1.3
SRM Nozzle	3.6	7.0
TVC Actuators	8.3	12.5
TVC Power Supply	3.6	10.0

No attrition analyses have been done on a configuration using less than three (3) parachutes.

10.3.2.2 Case Heat Treat

Shuttle SRM components are unique in that they will be recovered and reused again and again. This requirement involves complex strength requirements in both material fracture toughness and tensile properties. Considerable effort is being expended in baselining a heat treat process to achieve the proper mechanical properties. The work so far shows that the heat treat profile used

produces acceptable tensile properties in all materials tested to date and the heat treat has produced acceptable toughness properties with the exception of one questionable sample. As a result the baseline heat treat profile appears acceptable for meeting the SRM case material mechanical requirements.

#### 10.3.2.3 Corrosion of the SRM Case

Essentially, the SRM is a segmented stack of large cylindrical shells made from D6AC steel, joined together by a clevis arrangement, and fastened with MP35N pins. The SRM case design is such that it should prevent corrosive attack, accelerated galvanic corrosion, crevice corrosion, and stress corrosion. The optimum scheme for joint protection will be determined based on results from tests where parts are immersed in flowing seawater. The majority of the case is to be coated with organic films of proven protective capability and the joints will use a sealant and an organic barrier combination.

It has been recognized that the female portions of the clevis joints present the greatest uncertainty regarding protection. This uncertainty has been taken into account as far as possible and such joints will receive special attention during assembly and be subjected to non-destructive test techniques.

#### 10.3.2.4 Thrust-Time Shaping

Thiokol Chemical was directed by MSFC to provide a support study on SRM thrust-time (performance) shaping to the Rockwell International, Space Division. This thrust-time study involved grain design and inhibitors. The studies indicated that through the performance-shaping it would be possible to desensitize key ascent flight parameters and reduce flight load problems. These requirement changes occurred after the base-lining of the SRM design and therefore will have an effect on the SRM schedule, cost and facilities. The changes to the SRM propellant will have only a minimum impact on the SRM program.

#### 10.3.2.5 Nozzle Flexible Bearing

The SRM nozzle design is shown in Figure 10-1. The flex bearing is a nozzle subassembly which gives a  $\pm 8$  degree omnidirectional thrust vector control capability to the SRM. Sub-scale testing of this flex bearing indicated material problems that would have to be resolved prior to the fabrication of the full-scale unit scheduled for testing at a later date.

The problem appears to be in the use of the elastomers (rubber material) and their stability during processing of the bearing itself in the hot-mold process. Studies to date have identified four candidate elastomers that appear suitable for SRM flex bearing use so that there should be no real difficulty in building and success-



fully testing a prototype bearing.

#### 10.3.2.6 Ignition System

The ignition system is large and somewhat sophisticated. Figure 10-2 shows both the igniter assembly which has a large quantity of propellant and the safe and arm unit which is a motorized assembly to open and close the ports used to ignite the system. Testing and development of this component is currently in full swing and will be monitored by the Panel.

#### 10.3.3 Booster Separation Motor

To meet the SRB separation requirements listed below it was decided that small rocket motors would be best in translating the SRB away from the Orbiter and External Tank at the desired time in the Space Shuttle ascent trajectory.

These requirements include the following:

- (a) Separation of the SRB should preclude damage to or recontact with other Shuttle elements during or after separation.
- (b) Exhaust gases from the rocket motor's separation systems should not cause damage to the remaining Shuttle elements which would require repair or replacement of the Orbiter TPS.
- (c) Installation of the separation motors shall be in the SRB nose frustum and SRB aft skirt.

(d) Release of all structural attachments shall occur within 30 milliseconds and the thrust of each set of BSM's shall reach 55,500 pounds of thrust in each set within 30 to 135 milliseconds of the separation command.

(e) The design should provide for safe separation for angles of attack and sideslip over a range of  $\pm 15$  degrees including the rates and dynamic pressures which follow. The maximum dynamic pressure shall be 75 psf and the maximum rates shall be  $\pm 2$  degrees per second in pitch and yaw. These rates and dynamic pressures will be sensed or computed by the Orbiter and when exceeded shall inhibit the separation of the SRB's.

The status of motor development indicates that there are no major concerns on this project. The propellant has been baselined and characterized. Detailed design drawings and preliminary analysis reports have been completed. The PDR was conducted in February 1976 and motor case fabrication has been initiated. Further definition of the interface between the Booster Separation Motors and the SRB/ET/Orbiter are required. The exact nature of this definition is not known at this time.

By mid-1976 testing of the igniters should be completed. The first four test motors should be completed by mid-January 1977. Qualification is set for 1977 and the delivery of the flight hardware is set for 1978.

#### 10.3.4 Integrated Electronic Assembly (IEA)

The IEA system utilizes orbiter power for the Orbiter data bus.

It provides support to the following SRB functions:

- (a) Thrust Vector Control (TVC) Subsystem
- (b) Development Flight Instrumentation
- (c) Range Safety System
- (d) Recovery System
- (e) Shuttle Flight Control System (through the Orbiter)
- (f) Separation System
- (g) SRM

Figure 10-3 shows the IEA unit in simple detail. There are actually two types, one mounted in the forward skirt and one mounted with the aft External Tank attach ring. Both are watertight. They weigh about 190 pounds ready-to-go and are about 12" x 13" x 45" in size. The PDR was completed in December 1975. Mockup vibration testing is underway, and stress corrosion susceptibility studies have been completed. The only concern is the lead time required for the procurement of the watertight connectors for the units.

#### 10.3.5 Structures

This area includes all of those structural items that tie the various subsystems together - the aft skirt, ET struts and attachments, systems tunnels, forward skirt, forward ordnance ring, tow-

ing pendant, altitude sensor assembly, frustum assembly, nose cap assembly, and flotation installation. This program is in a very early stage and will be reviewed by the Panel as it evolves in the future.

#### 10.4 Range Safety System

This has been partially discussed in the section devoted to the External Tank. Therefore only that portion of the Range Safety Flight Termination system dealing with the SRB is covered here. It was determined that a conical shaped charge was no longer needed in the nose cone of the SRB, and that the SRB would use a linear-shaped charge along 10% of the SRM portion of the SRB. Such a charge would be placed on either side of the SRM. This system is to be applied to both the SRB's. The specified requirement in Volume X, JSC 07700 will now state: "The SRB's shall be provided with ground-commanded systems to destruct the SRB's. System components shall be reusable where cost savings will result."

Trade studies are currently being conducted with regard to the use of a redundant open-loop initiator versus a closed-loop dual initiator. Closed-loop refers to the initiation of the charge from both ends, while open-loop means setting the train off from only one end. The Panel will follow the evolving system to assure that the decisions being made receive appropriate management attention.

## 10.5 SRB Reuse

The reuse requirements "drive" the design of the SRB and its components.

The total number of times the components are used is as follows:

(a) Structures (excluding nose cap and thermal shield) .....	40
(b) Thrust Vector Control .....	20
(c) Electrical and Instrumentation (excluding batteries, lights, exposed cables) .....	20
(d) Recovery System (parachutes, et.al.) .....	10
(e) Solid Rocket Motor (except as below) .....	20
Flex Bearing Materials (elastomers) .....	10
Nozzle Ablator Material .....	1
O-Ring Seals .....	1
(f) Pyrotechnic Devices .....	1
(g) Booster Separation Motors .....	1

Specific design features to assure reusability include the use of protective coatings over a relatively small percentage of the SRB, a weld-free SRM case, watertight compartments for electrical/electronic/instrumentation installations, stiffening rings for water impact loads, flexible aft-skirt heat shield, and similar design items. To achieve the design requirements a good deal of effort continues to be expended on the case heat-treat process, Thermal Protection Subsystem materials, the paints and sealants, and flotation materials. The status of these areas is to be monitored during the Panel's future reviews.

Decisions on the reuseability of a piece of hardware will, of

course, depend on what wears out and what causes an item to be considered worn-out. The point at which a piece of hardware is considered worn out is not a discretely defined point but will result from the cumulative effects of exposure to environments and handling. Loss from water impact damage is the most significant attrition factor. Retrieval operations once the SRB is in the water poses the next major possibility for losing it since there can be problems locating the vehicle or towing it; also, there is the possibility of storms severe enough to preclude retrieval or damage the vehicle while in the water. Other factors that would preclude reuse of specific items include:

- (a) Structures - wearout or damage due to accumulated dings, dents, and corrosion.
- (b) Recovery - excessive parachute ribbon damage from inflation and retrieval.
- (c) Electrical and Instrumentation - Mechanical failures, e.g., cracked solder joints, broken wires, "drift" of piece parts.
- (d) TVC - Failures in the actuator rod end bearing; the power supply flex hoses, valving, exhaust ducting, pumps; as well as general corrosion.
- (e) SRM - Accumulated abnormal loss of metal from grit blast

preparation during refurbishment.

#### 10.6 Test Program

The SRB will be qualified at the motor level (SRM) in addition to the normal qualification of components. Because it is a recoverable and reuseable item there are special tests not required on other elements of the Shuttle program.

The common structural tests conducted on all segments of the Shuttle vehicle are a part of the SRB test program as well. These include static structural tests to verify material selection, validate stress analyses and design margins, etc. Dynamic model surveys will provide data on dynamic model analysis. Separation tests, including full-scale tests of the separation motors, will verify design and performance. The SRB component environmental certification test requirements and methods are included in the MSFC report "SRB Component Environmental Certification Test Requirements and Methods" SE-019-067-2H. Rather than discuss the details of this program in this report the reader should examine the MSFC test document itself.

Finally, requirements for retest of the refurbished hardware is **crucial** to this program.

The test area will be a subject for further examination to assure that the confidence level achieved through the test program is of sufficient degree to support the first Orbital Flight Test

as well as subsequent missions.

#### 10.7 Fracture Control

There is a very detailed fracture control program now in full operation. It is understood that fracture control requirements have been included in all procurement packages along with a requirement for fracture control boards. On October 8, 1975 the first formal meeting of the MSFC/SRB Fracture Control Board (FCB) was held. The SRB/FCB staffed by MSFC is responsible for the overall SRB program. In addition there is an SRM Fracture Control Board established and staffed by Thiokol which has been in operation for some time.

To illustrate the work of the MSFC Board the meeting on December 10, 1975 reviewed the Booster Separation Motor (BSM) Fracture Control Plan. This review covered the FCB's organization and responsibilities and the implementation of the fracture control plan at the contractor with particular attention to part selection logic and the design/analysis, fabrication and test procedures.

An example of the hardware placed under fracture control is seen in the Thiokol FCB activities. Thiokol has reviewed the various parts which make up the SRM and, based on fracture control selection logic, has made a determination of the fracture critical items. The items which have been identified for fracture control are the case segments, igniter chamber and adapter, and the nozzle



stationary shell and flex shims. These items, in most cases, have high tensile stresses. However, the selection process gave particular attention to the impact on mission success and program schedule if the hardware should fail and have to be replaced. The clevis joint and the basic-part membranes are the most significant items on this list. More detailed fracture mechanics analyses have been performed on such parts to determine the expected flaw growth, critical number of cycles, stresses, and test proof factor. In particular, testing has been completed for the clevis joint to determine its mode of failure. The testing and analysis completed to date have shown that these parts can withstand significantly more cycles and higher stresses than expected during the actual mission.

In addition to the fracture mechanics analysis, some stress corrosion work has been completed. Areas of investigation include effects of material exposure to sea water, coatings, heat treating effects, and fracture toughness determinations considering temperature effects. This work is to be supplemented with testing on forging sections, hydroburst testing, etc.

A point brought up during MSFC FRB discussions with Thiokol is important. They were asked what they would do differently in testing, traceability, inspection, etc., if a part was not under fracture control. The answer was that all parts of the SRM would be

subjected to the same rigor regardless of fracture control disposition. The primary difference is the level of review for any item that is out of specification or is considered to have a discrepancy. The MSFC/FCB is in the process of evaluating the need to place the SRM propellants under fracture control. Thiokol has not considered this necessary at this time.

#### 10.8 SRM "Burn Through"

Burn-through relates to the loss of case integrity because the propellant burns a hole in the case. Previous solid rocket experience, particularly on military rockets, has been examined and applied to the design of the Shuttle SRM. Potential "burn-through" failure modes identified during the Panel's review were:

- (a) Propellant grain defects.
- (b) Nozzle ablatives.
- (c) O-ring seals and clevis joints.
- (d) Internal case insulation.
- (e) Propellant inhibitor.
- (f) Forward case segment igniter bolt holes.
- (g) Propellant-liner-insulation-case bonds.

The design appears to be based on demonstrated concepts to preclude case burn-through and there are adequate safety factors of 2:1 or higher to accommodate uncertainties. Extensive component

testing will be performed to validate this design approach.

#### 10.9 SRB Hazards

The following listing is provided to indicate the types and numbers of hazards on the SRB. Many of these hazards have been eliminated; others have been accepted by management based on a thorough review of the problem. Some are still being worked.

SRB ignition overpressure

Late ignition of one of the SRB's

Failure of fore or aft BSM's

Public hazard from impact of SRB (in work)

Contingency abort capability with SRB (in work)

Emergency escape in flight

SRB mechanical safe-arm device to be enabled in the VAB (in work)

Excessive q-alpha and/or q-beta on Shuttle ascent

#### 10.10 Lightning Protection

SRB equipment requiring protection includes the pyrotechnics, TVC sensors and switching circuits, integrated electronics assembly plus all exposed electrical cables. The governing design document is the JSC-07636 Rev. A, dated November 4, 1975, "Space Shuttle Program Lightning Protection Criteria Document." Briefly the SRB nozzle

lightning design measures being taken include: single point ground on power circuits, use of twisted wire pairs,  $2 \pm 1$ /millisecond delays for switching functions, cable tunnel protection, multi-grounded overall shields on ordnance cables, and tests. This area will continue to be monitored by the Panel.

#### 10.11 Addendum

This is the period in the SRB development when requirements are still in evolution. A revised SRB Verification Plan (Volume IV, SE-019-019-2H) has been released since the earlier sections were written. Some of the latest updates are to assure complete records on test programs, procedures and results.

The "SRB Component Environmental Test Requirements and Methods" was issued in December 1975 as SE-019-067-2H. It establishes the detailed environmental test requirements, test methods, and test criteria to be utilized in the environmental acceptance and certification testing.

The SRB safe and arm device critical design review was conducted at the subcontractor's site in June 1976. Final closeout for the resulting actions is scheduled for July/August 1976.

## ATTACHMENT 10-1

The Solid Rocket Booster is in an early stage of development. Critical areas must be monitored closely for the earliest possible detection and resolution of problems to assure that trade-offs provide for the maximum Space Shuttle system safety. Such areas include recovery and re-use of the booster.

RESPONSE: Space Shuttle Program Management and especially the SRB Project Manager are sensitive to the areas affected by the reusability concept. Special analyses are continuing to maintain high reliability of the components and subsystems which are affected by planned reuse. In addition to the activities within the SRB project at MSFC, a special SRB review function was established within the JSC Space Shuttle Systems Engineering Office to provide an independent assessment of the SRB design and development activities. This function includes review of subsystem designs (structures, avionics, recovery, TVC, etc.) as well as the refurbishment planning. This review group is involved in source selections for these subsystems all the way from design through RFP preparation to participation in SEB's. They are currently assessing the design criteria for recovery system parachutes and the planning for the parachute drop test programs.

It is important to note that hazards to personnel involved in the water retrieval of the booster and parachutes are no longer a major concern, since divers are not now planned for the nozzle plugging operation. The Naval Undersea Center is developing an underwater remote controlled device to accomplish this without diver participation.

In addition to these independent review activities, study teams have been formed to establish refurbishment operations requirements for returning the SRB reusable components to a flight acceptable condition.

**FIGURE 10-1**

**SRM Nozzle Design**

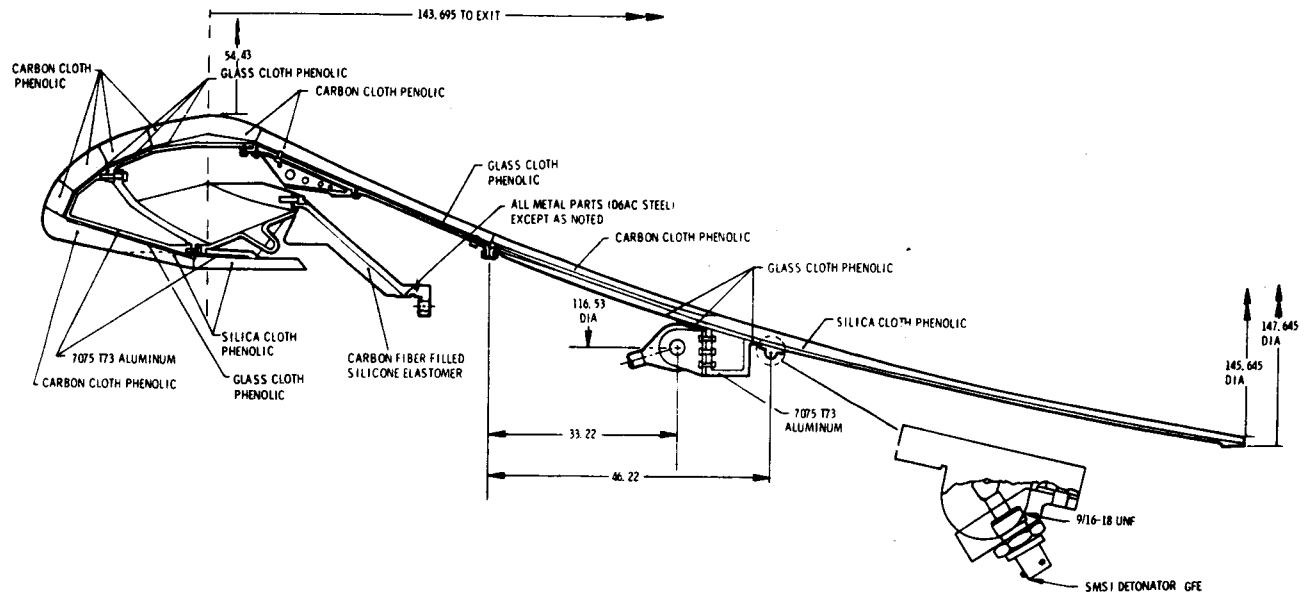

**FIGURE 10-2**  
**IGNITER ASSEMBLY**

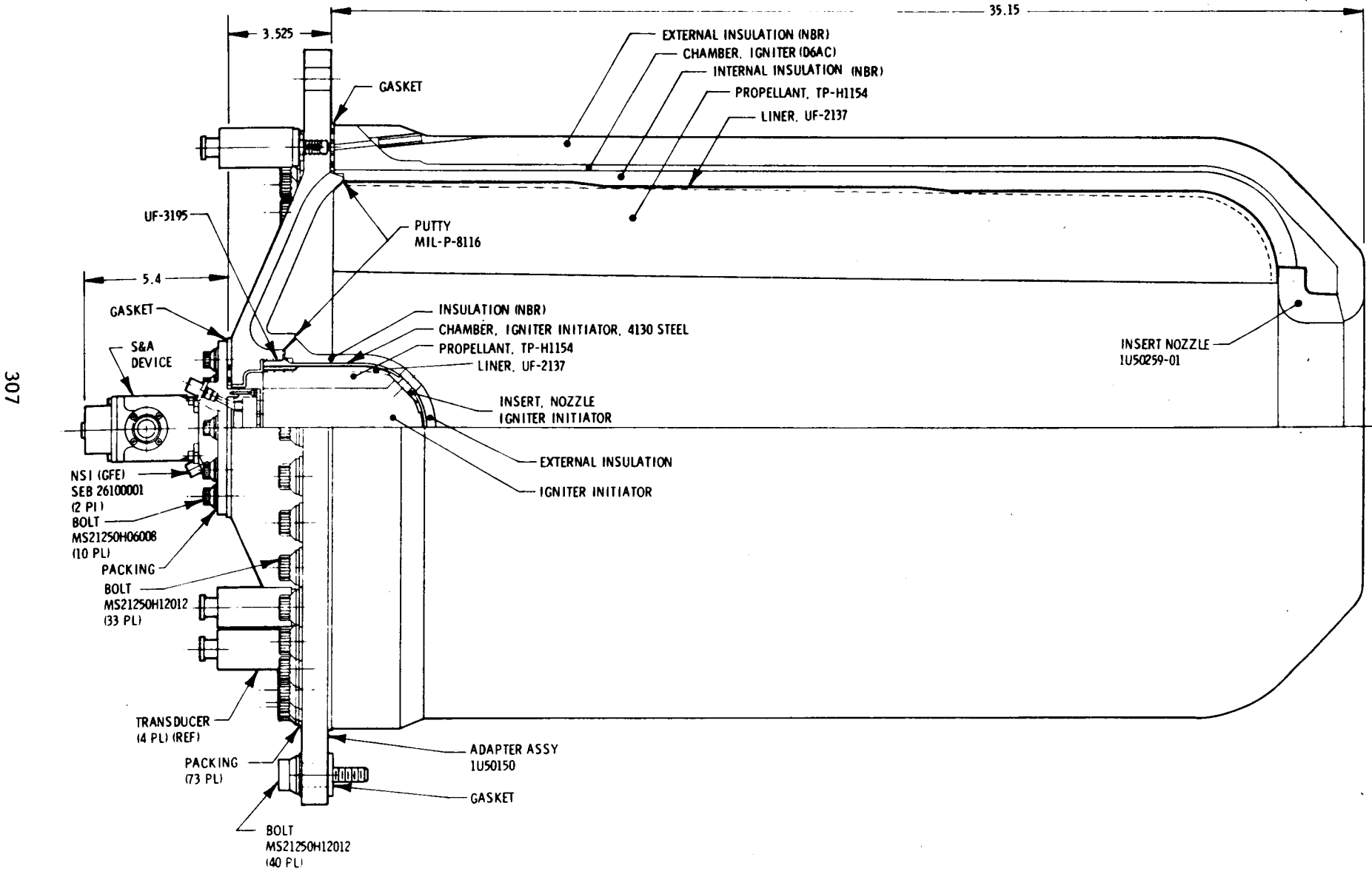

FIGURE 10-3

INTEGRATED ELECTRONIC ASSEMBLY ISOMETRIC

