

RECEIVING AND DISTRIBUTION MANAGER

J-253

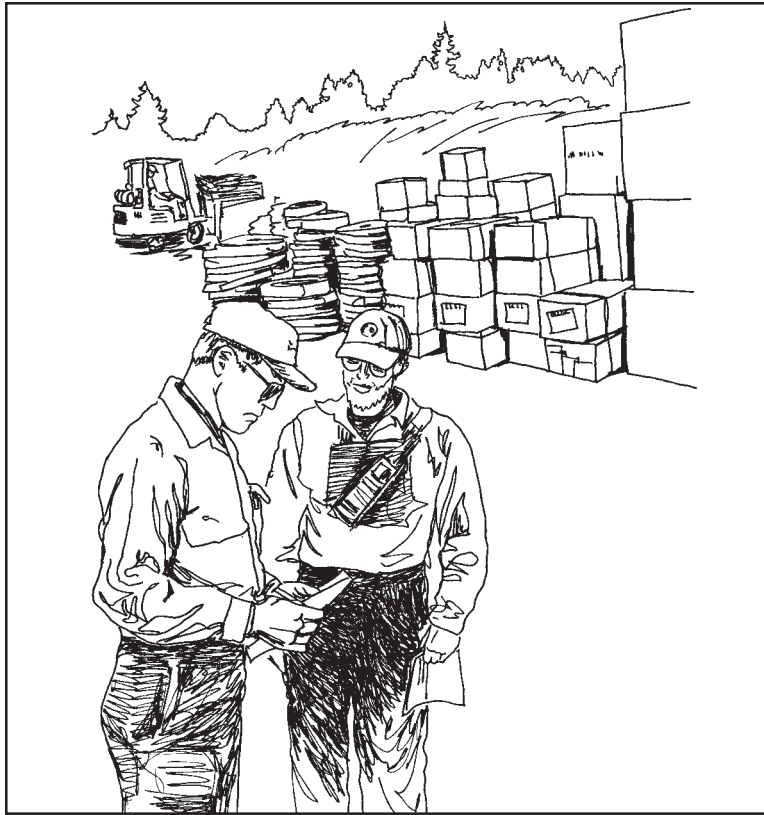

Job Aid
October, 2003
NFES 1244



CERTIFICATION STATEMENT

on behalf of the

NATIONAL WILDFIRE COORDINATING GROUP

The following training material attains the standards prescribed for courses developed under the interagency curriculum established and coordinated by the National Wildfire Coordinating Group. The instruction is certified for interagency use and is known as:

Receiving and Distribution Manager, J-253
Certified at Level I

This product is part of an established NWCWG curriculum. It meets the COURSE DEVELOPMENT AND FORMAT STANDARDS – Fifth Edition, 2001 and has received a technical review and a professional edit.

Member NWCWG and Training Working Team Liaison

Date

10/23/03

Chairperson, Training Working Team

Date

10/16/03

Description of the Performance Based System

The NWCG Wildland and Prescribed Fire Qualifications System is a "performance-based" qualifications system. In this system, the primary criterion for qualification is individual performance as observed by an evaluator using approved standards. This system differs from previous wildland fire qualifications systems which have been "training based." Training based systems use the completion of training courses or a passing score on an examination as a primary criteria for qualification.

A performance-based system has two advantages over a training based system:

- Qualification is based upon real performance, as measured on the job, versus perceived performance, as measured by an examination or classroom activities.
- Personnel who have learned skills from sources outside wildland fire suppression, such as agency specific training programs or training and work in prescribed fire, structural fire, law enforcement, search and rescue, etc., may not be required to complete specific courses in order to qualify in a wildfire position.

1. The components of the wildland fire qualifications system are as follows:

- a. Position Task Books (PTB) contain all critical tasks which are required to perform the job. PTBs have been designed in a format which will allow documentation of a trainee's ability to perform each task. Successful completion of all tasks required of the position, as determined by an evaluator, will be the basis for recommending certification.

IMPORTANT NOTE: Training requirements include completion of all required training courses prior to obtaining a PTB. Use of the suggested training courses or job aids is recommended to prepare the employee to perform in the position.

- b. Training courses and job aids provide the specific skills and knowledge required to perform tasks as prescribed in the PTB.
- c. Agency Certification is issued in the form of an incident qualification card certifying that the individual is qualified to perform in a specified position.

2. Responsibilities

The local office is responsible for selecting trainees, proper use of task books, and certification of trainees, see appendix A of the NWCG Wildland and Prescribed Fire Qualification System Guide, PMS 310-1, for further information.

RECEIVING AND DISTRIBUTION MANAGER J-253

Job Aid
October, 2003
NFES 1244

Sponsored for NWCG publication by the NWCG Training Working Team

Comments regarding the content of this publication should be directed to:
National Interagency Fire Center, National Fire Training Support Group, 3833
S. Development Ave., Boise, Idaho 83705. Email:
nwcg_standards@nifc.blm.gov.

Additional copies of this publication may be ordered from National Interagency
Fire Center, ATTN: Great Basin Cache Supply Office, 3833 South Develop-
ment Avenue, Boise, Idaho 83705. Order NFES 1244.

TABLE OF CONTENTS

INTRODUCTION	4
I. GENERAL	
Obtain and Assemble Materials Needed for Kit	7
Documentation Forms	7
Miscellaneous Items	8
II. MOBILIZATION	
A. Information from Local Dispatch Upon Initial Activation	8
B. Gather Information	10
III. INCIDENT ACTIVITIES	
A. Incident and Check-in	10
B. Briefing from Supply Unit Leader(SUPL) ...	11
C. Personnel to Operate Supply Area	13
D. Organize Supply Area	13
E. Procedures for Receiving Supplies and Equipment.....	17

TABLE OF CONTENTS (continued)

F. Procedures for Issuance and Tracking of Supplies	17
G. Notification to Ordering Manager (ORDM) of Supplies Received	18
H. Maintain Inventory	19
I. Supervise the Receiving and Distribution Unit	21
J. Brief Subordinate(s) and Relief Personnel	31
K. Coordinate with Appropriate Incident Personnel	32
L. Reports Required by the Supply Unit Leader	32
M. Evaluate Performance of Subordinates	33
N. Excesss Resources and Supplies	33
IV. DEMOBILIZATION	
Demobilization and Check-out	34

APPENDICES

Appendix A, Check-out Authority, Example	37
Appendix B, ICS 213, General Message, Example	39
Appendix C, Mix Ratio Chart	41
Appendix D, ICS 214, Unit Log, Example	43
Appendix E, 24-Hour Clock	45
Appendix F, Glossary of Terms and Acronyms ...	47

RECEIVING AND DISTRIBUTION MANAGER
(RCDM)
JOB AID, J-253 INTRODUCTION

The Receiving and Distribution Manager has been identified as a position within the Incident Command System (ICS). The J-253 job aid, which supports this position, is part of the National Wildfire Coordination Group's (NWCG), Wildland Fire Suppression Curriculum. The subjects within the performance based curriculum may be administered by either an instructor led formal training course or by the use of job aids. It is highly suggested that the trainee have previous incident experience. *Forklift certification may be required per agency policy.*

Job aids are "how to" books that assist an individual in performing specific tasks associated with a position. They may be used by an individual, in a trainee position, who has met all of the prerequisites, but has not completed the position task book for that position. They are also used after the individual has become qualified, as an aid or refresher in doing the job.

Note: Additional logistics information can be obtained from the National Logistics website at www.fs.fed.us/logistics.

The performance based qualification system stipulates that an individual must complete a Position Task Book prior to becoming qualified for that position. Refer to the "Wildland and Prescribed Fire Qualification System Guide, PMS 310-1" for the established standards for this position. *It is recommended that this job aid be issued when the position task book is initiated.*

This job aid has been developed by an interagency development group with guidance from the National Interagency Fire Center, Fire Training under authority of the NWCG, with coordination and assistance of personnel from the following agencies:

UNITED STATES DEPARTMENT OF THE
INTERIOR
Bureau of Land Management
Trenna Butler
Ed Ryan
Marianne Schappek

UNITED STATES DEPARTMENT OF
AGRICULTURE
Forest Service
Lynn Burton

DEPARTMENT OF NATURAL RESOURCES
State of Wisconsin, Division of Forestry
Ken Terrill

NATIONAL INTERAGENCY FIRE CENTER
Fire Training, NWCG Development Unit
Karin Nichols
Jan Hendrick

We appreciate the efforts of those people associated with the development and review of this package.

Sponsored for NWCG publication by the NWCG Training Working Team, October, 2003.

Comments regarding the content of this publication should be directed to: National Interagency Fire Center, Fire Training, 3833 South Development Avenue, Boise, Idaho 83705.
Email: nwcg_standards@nifc.blm.gov

Additional copies of this publication may be ordered from: National Interagency Fire Center, ATTN: Great Basin Cache Supply Office, 3833 S. Development Avenue, Boise, Idaho 83705. Order NFES #1244.

I. GENERAL

Obtain and Assemble Materials Needed for Kit.

Kit will be assembled and prepared prior to receiving an assignment. Kit will contain critical items needed for functioning during the first 48 hours. Kit will be easily transportable and within agency weight limitation. Web gear or briefcase (not both) should not exceed 20 pounds.

- Proof of Incident qualifications (Red Card)
- Position Task book, NFES 2354
- Fireline Handbook, PMS 410-1, NFES 0065
- National Fire Equipment System Catalog, NFES 0362

Documentation Forms:

- ICS 213, General Message, NFES 1336
- ICS 214, Unit Log, NFES 1337
- ICS 219, Resource Status Card (T-Card), NFES 1342 and holder (optional)
- ICS 226, Individual Performance Rating, NFES 2074
- SF-261, Crew Time Report, NFES 0891 and/or OF-288 Emergency Firefighter Time Report, NFES 0866
- OF-316 Interagency Incident Waybill, NFES 1472

- Agency specific forms

Miscellaneous Items (optional):

- Assorted pens, pencils, felt tip markers, highlighters, thumb tacks, string tags, pads of paper, clipboard, masking/strapping tape, duct tape, envelopes, surveyor flagging, file system supplies, hole punch, scissors, box cutter, etc.
- Calculator
- Flashlight (extra batteries)
- Alarm clock
- Camera
- Calendar
- Tape measure
- Insect repellent
- Local area maps
- Road atlas
- Self locking metal seal, NFES 1938

II. MOBILIZATION

A. Obtain Complete Information From Local Dispatch Upon Initial Activation.

1. Obtain a copy of the order form which contains:
 - Incident/Project name
 - Incident/Project order number

- Office reference number (cost code)
- Descriptive location/response area
- Legal location (township, range, section)
- Incident frequencies (if available)
- Incident base/phone number (contact)
- Request number
- Reporting date/time and location, e.g., Incident Command Post (ICP)
- Transportation arrangements and routes
- Special instructions

Retain a copy of this order form for your personal fire experience record.

2. The individual will have:

- Frameless soft pack containing personal gear, not to exceed 45 lb.
- RCDM kit, not to exceed 20 lb.
- Proper Personal Protective Equipment (PPE) for the job.

B. Gather Information

Gather all available information necessary to accurately assess incident; make appropriate decisions about immediate needs and actions including:

- Type of incident
 - Planned operations, e.g., multiple remote camps, burnout operations, water handling operations.
- Current situation status
- Expected duration of incident
- Terrain
- Weather (current and expected)

III. INCIDENT ACTIVITIES

A. Arrive at Incident and Check In

- Locate supervisor (supply unit leader; SUPL.)
- Report to status check-in recorder and complete ICS 211, Check-in List.
- Report to the finance/administration section for time keeping procedures.

B. Obtain Initial Briefing from the SUPL.

You are responsible for asking adequate questions that will allow satisfactory completion of all job aspects. *There are no stupid questions.* Briefing should include as a minimum:

- Sleeping and eating arrangements.
- Location of your work area(s).
 - Cache/distribution area
 - Fueling and fuel storage area
 - Hazardous material area
 - Tool and equipment areas
 - Delivery areas
- Copies of supplies and resources that have been ordered and received.
- Personnel ordered for your function, work schedule, policy and operating procedures, and chain of command in your unit.
- Projections for additional personnel and equipment, approximate time and numbers and expected duration of incident.
- List of personnel authorized to check out supplies and materials.

- Obtain a current listing of the contractors and a summary of contract specifications on filling supply requests from the finance section chief or procurement unit leader.
Request daily updates from the logistics section chief of new contractors.
- Type of communications available:
 - Command net and channel
 - Logistics net and channel
 - Phones and numbers
Cell/Hardline
 - Other
- People you will interface with on the incident:
 - Unit leaders and staff
- Established/needed security procedures.
- Recycling requirements and availability of recycle units.
- Local cache availability
- Return procedures for surplus resources.
- Established briefing procedures within the supply unit.
- Request a current copy of the Incident Action Plan (IAP) and incident map.

Supply Unit Leader

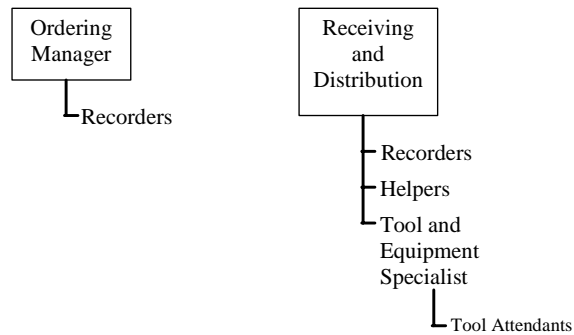

C. Order Required Personnel to Support the Receiving and Distribution Area.

- Camp crew/helpers
- Tool and equipment specialists
- Cache demobilization specialist
- Certified forklift operator (OSHA requirement)

D. Organize Physical Layout of a Secure and Safe Receiving and Distribution Area.

- Ensure sufficient space for receiving, storage and issuance of equipment and supplies for projected incident size. This area needs to be large and flat to accommodate forklift operations. When possible store items on pallets for easy access and transporting. *Remember: OSHA certification is required for all forklift operators.*

- Provide for protection from environmental hazards.
- Due to noise, lighting, dust, etc., ensure that the area does not conflict with sleep areas, mess areas, etc.
- Provide for the safety of incident personnel and security of the unit with barricades, lighting, signing and security personnel.
- Develop security procedures and maintain contact with SUPL and security manager (SECM) concerning all present and anticipated security problems.
- Ensure adequate area for hazardous materials. Know location of Material Safety Data Sheets (MSDS) and the Hazardous Material Spill Plan.
- Ensure adequate ingress/egress for delivery vehicles.
- Separate tool area from supply storage.
- Ensure the supply area is safe from hazards. At a minimum check for the following:
 - Flag all trip hazards and hanging ropes.
 - Place electrical cords in a safe area away from foot traffic areas and ensure water tight connections.

- Ensure boxes are stable when stacking (heavy boxes on the bottom)
- Ensure personal protective equipment (PPE) has been issued to and is utilized by all unit personnel.

PPE must be utilized to protect personnel from blood born pathogens, biological hazards, puncture wounds, eye injuries and other identified hazards. Contact the medical unit leader for assistance in this area.

- Place fire extinguisher strategically in fuel storage, hazardous materials, tool storage, and cache areas.

The following page depicts a sample layout of a supply area. No two layouts are ever the same, but all need to include the basic elements shown.

Sample Receiving and Distribution Area Layout

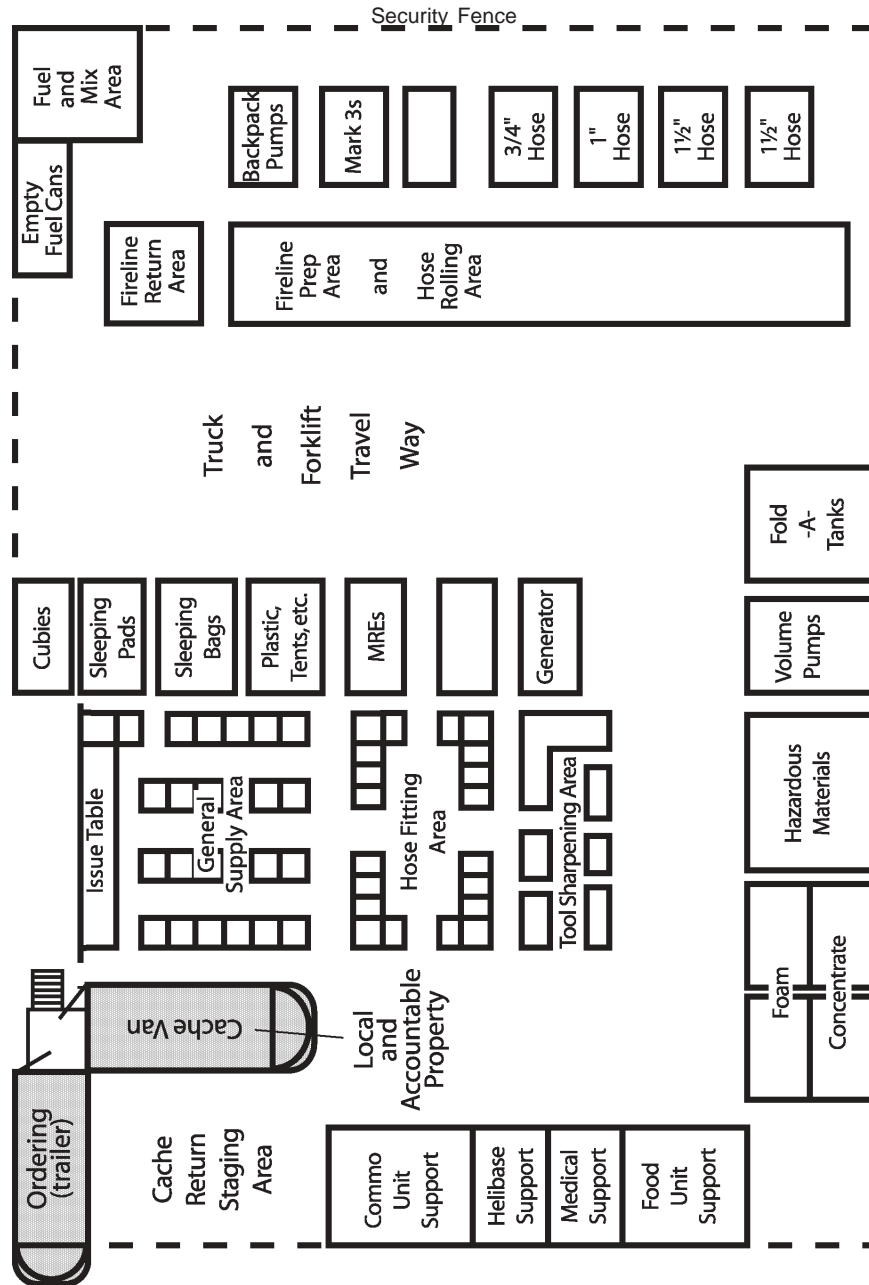

E. Establish Procedures for Receiving Supplies and Equipment.

- Designate and sign areas for loading and off-loading of supplies.
- Supplies and equipment are to be stored within the secure supply area.
- Prepare procedures for receiving filled orders
- Check off on waybill/receipt item(s) received.
- Prepare procedures for supply/ equipment storage, rehabilitation, and/or return to cache.
- Utilize integrated electronic resource tracking system if available.

F. Establish Procedures for Issuance and Tracking of Supplies and Equipment.

- Instruct subordinates on maintaining the list of personnel authorized to check out supplies and materials.

See example of Check-Out Authority checklist, Appendix A.

- Set up and maintain a file system for receiving and distribution of supplies and equipment.

Whether the system is a series of boxes, a piece of canvas with pockets, or a filing cabinet does not matter as long as it is functional and works as a status keeping system.

- Maintain a separate file for contractors. Some contractors, e.g., national contractors, are to provide their own supplies. Establish an accountability system for checking out supplies that allows for billing of non-returned items.
- Ensure issue receipts to contractors are routed to finance/administration section.
- Ensure that the issue table is adequately identified and provide clear ingress/egress for personnel.
- Ensure that special orders for materials and supplies are delivered or issued to the requester in a timely manner. These orders need to be verified for accuracy.
- Ensure that receipts for accounts payable get to the buying unit or finance/administration section.

G. Notify ORDM of Supplies and Equipment Received.

Proper notification should include:

- Receipts of supply and equipment (record date and time.)

- Turning all delivery documents/waybills over to the ordering manager.
- Noting discrepancies between what is listed on the delivery document and what was actually received.
- Critical cancellations
- Inform the SUPL of supplies and equipment received.

H. Maintain Inventory of Supplies and Equipment.

- Through an established filing system, maintain inventories of all supplies and equipment on the incident.
- Display, at all times, the status and location of accountable property by using T-cards or other visible means. Items checked out to crew or individuals should be accounted for in the file system.

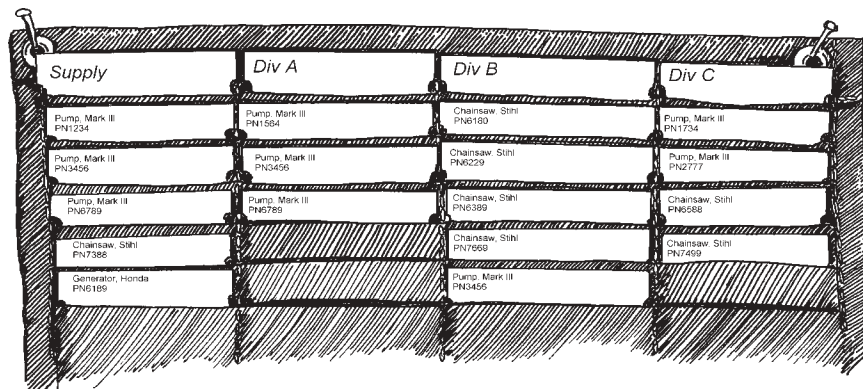

- Update written inventory of supplies and equipment in the cache as requested by the SUPL. The Outstanding/Surplus Item report, from the cache, will help identify those property items still assigned to the incident.
- Order materials to maintain specified cache stock levels.
- Receive written request for supplies and resources directly from incident personnel or through the incident communication system.
- Document requests on a ICS 213, General Message, legibly, and containing the following information:
 - Request date/time and date/time needed
 - Catalog number (if available)
 - Description of item(s)
 - Number desired, units of issue
 - Any special billing requirements
 - Whom to notify when the item is delivered.
 - Delivery point(s)
 - Name of requesting party and agency
 - Authorized approval

See Appendix B, ICS 213, General Message example.

- Plan to maintain at least one operational period additional inventory in stock at all times. If orders are placed during the afternoon and are filled the afternoon of the following day, plan adequate supplies for two operational periods.
- All fuel should be labeled, e.g., date and fuel only or mix ratio.

See Appendix C, Mix Ratio Chart.

I. Supervise and Manage the Receiving and Distribution Function.

- Provide for proper shipping, storage and handling of hazardous materials assigned to the supply cache.
- Comply with and enforce known and identified health and safety regulations.
- Ensure that materials are on hand for unexpected problems, e.g., weather, no air support, food shortage, equipment shortage.
- Excess supplies that are not needed in the next week should be returned to the cache. Complete return waybill documents and remove associated T-cards.
- Ensure adequate staffing levels for peak times (operational period change and demobilization).

- Identify and support individual strengths of the receiving and distribution crew by delegating, e.g., issuing of supplies, restocking of supplies, filling line orders, fuel depot, hose rolling.
- Supervise tool and equipment function, to provide safety and security for the tool and equipment area.
- On major incidents this function may include:
 - Changing the layout of the tool and equipment work area.
 - Moving the tool and equipment work area away from the receiving and distribution function to a nearby building or warehouse to provide better lighting, power, and protection from the elements.
 - Locating the work area away from foot traffic for safety reasons.
 - Locating issuing and receiving points separate from the tool sharpening or equipment handling section, and providing ready access to a parking area for easy loading and unloading.
 - Clearing combustible growth and materials from tool sharpening sites.
 - Providing an ABC Class fire extinguisher.

- Establishing a security barrier around your work area to prevent theft.
- Ensuring tool grinding and other noisy activities are kept away from the check-out point and sleeping area.
- Ensuring that personnel have been issued and use the additional personal protective equipment dealing with this function, e.g., aprons, face shield, goggles, gloves.

Tool and Equipment Specialists (TESP)

The job of the tool and equipment specialist is to maintain a supply of tools and equipment, store the tools and equipment that are used on the incident and recondition these items as necessary. The tool and equipment specialist needs to be able to make a quick evaluation of these returned tools to determine which can and can not be reconditioned. Do not waste time on tools and equipment that should be sent back to the fire cache for repair or disposal.

Laying Out the Tool and Equipment Work Area.

The location of the tool and equipment work area already may have been decided when you are assigned to the incident. Otherwise your job upon arrival will be to determine and lay out your work area in cooperation with other functions of the logistics section.

Safety is of primary importance. Personnel who are working with power tools need sufficient lighting to eliminate potential accidents. Commercial power, if available, is preferable. Otherwise portable generators are needed to operate maintenance tools and provide adequate lighting.

Establish a security barrier around your work area to prevent theft. Stack sleeping bag cartons or other large storage containers around the perimeter, with the smaller, more sensitive tools and equipment placed inside. Fences, tape and rope may also be used.

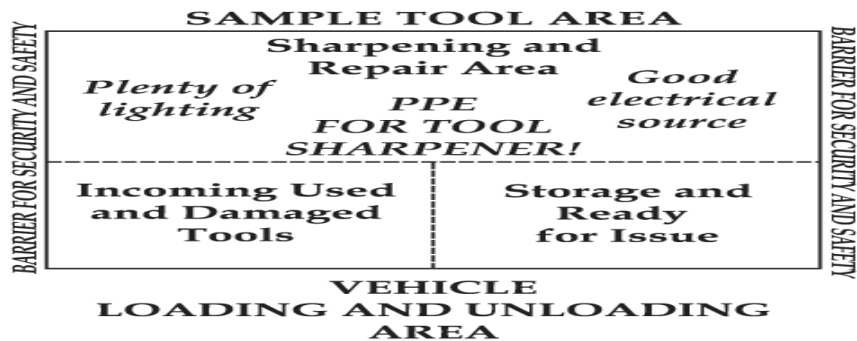

Maintaining Tools and Equipment

Hand tools and equipment must be maintained and any unserviceable tools must be repaired or returned to the cache.

Inspection of tools by the tool and equipment specialist is of utmost importance in providing worker safety and accomplishing the objectives of the incident. You must carefully look at the following indicators when inspecting for serviceability:

Cutting (Pulaskis, Axes, and Brush Hooks)

Handles:

- looseness
- wedges
- cracks
- splinters
- smoothness

Heads:

- cracks
- wear
- sharpness

Scraping (Shovels, McLeods, Cal Barron
Tool, Hazel-Hoe)

Handles:

- looseness
- wedges
- cracks
- splinters
- smoothness

Heads:

- cracks
- wear
- sharpness
- rivets

SHOVEL

Each edge of the shovel is sharpened from the point to approximately 1 1/2 inches from the top of the blade, the bevel being on the inner face of the blade.

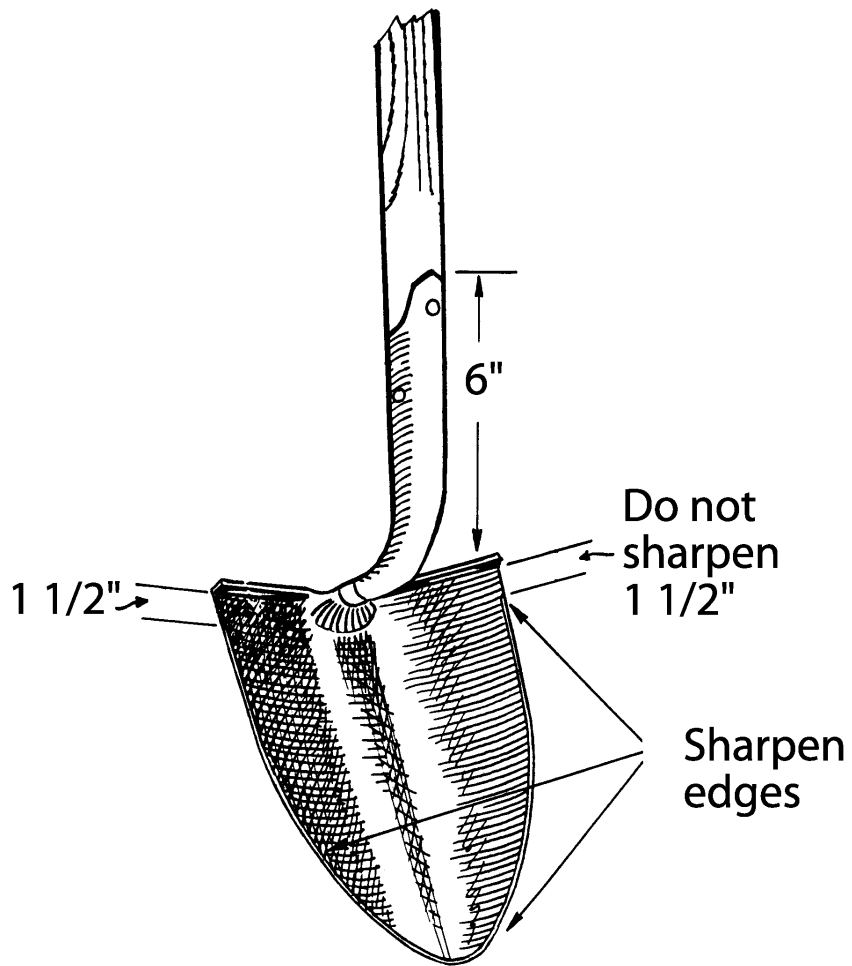

MCLEOD

Grind the hoe so there is a good cutting edge on the inside face. Bevel is on the outside of the blade, away from the handle.

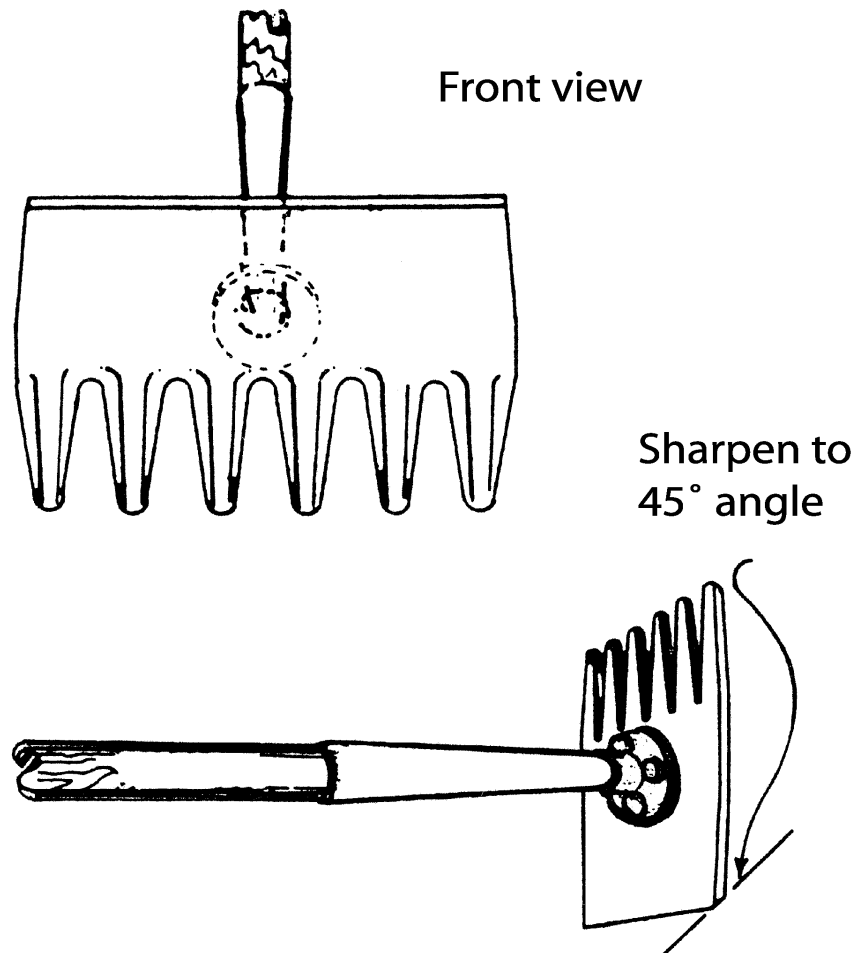

PULASKI

Ax bit to be ground with an even taper back from the cutting edge at least 2 1/2 inches. Hoe side ground to a good cutting edge, the bevel to be approximately 3/8 inch deep on the inside of the blade; that is, on the side facing the handle.

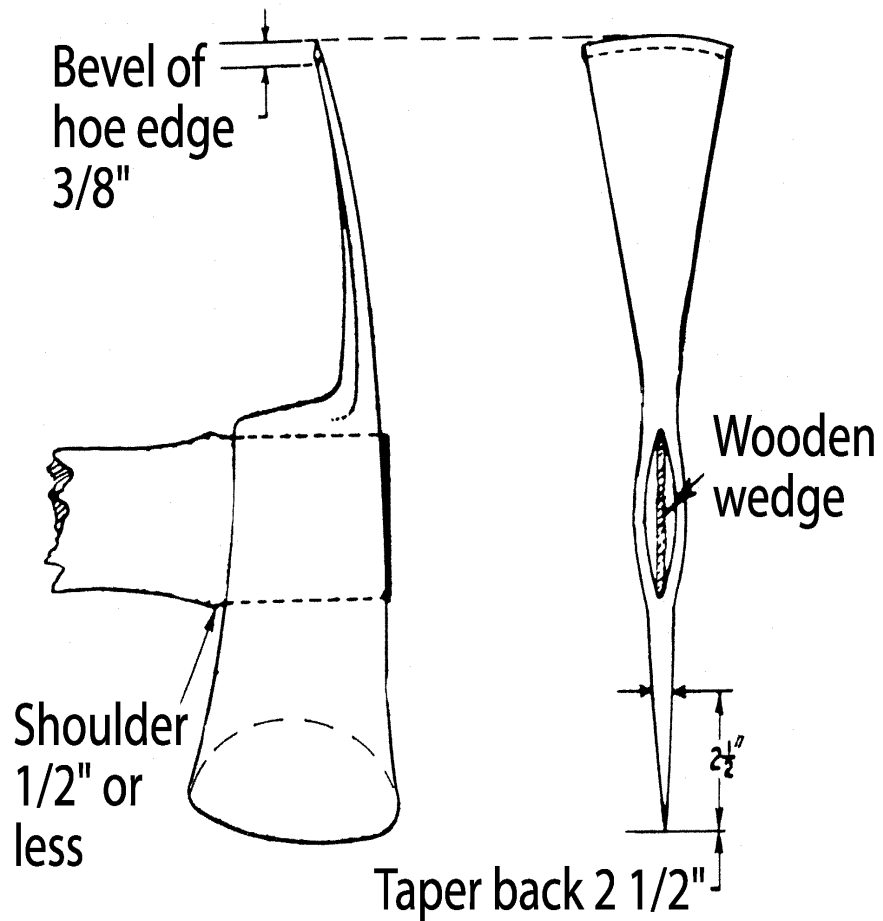

Tools not meeting standards during the incident will be separated from other tools. They will be clearly marked unserviceable so they will not be inadvertently reissued. Serviceable tools will be reconditioned for each operational period. You may need to help your tool attendants assemble the tools for issuance.

All tool sharpening, servicing and repair must be done to insure that appropriate safety measures are taken while tools are being reconditioned. This includes the following practices:

- Power grinder
 - Place power cords in safe location.
 - Ground power tools.
 - Wear goggles and other face protection.
 - Wear hearing protection.
 - Wear gloves.
 - Wear special aprons.
- Use proper tool jigs.
- Hand sharpening
 - Wear gloves.
 - Clamp tools firmly.
 - Use file handles and guards.
- All tools ready for issue should have sheaths/guards attached (taping sharp edges is adequate).

Other types of tools used in wildland fire fighting and other types of incidents, e.g., hazardous materials spills, earthquakes, and floods, can place different demands on the tool and equipment specialist. The tool and equipment specialist may have to have training to deal with the specialized tools and equipment required for abating those incidents.

These specialized equipment operations can fall under the tool and equipment specialist's responsibility and they should be prepared to deal with those needs based on their local requirements.

J. Brief Subordinate(s) and Relief Personnel.

- Initial staff briefing
- Daily briefing(s)
 - New personnel
 - Special problems, e.g., injuries.
 - Changes of policy and operating procedures.
 - Upcoming operational needs, e.g., burnout, base/camps.
 - Outstanding orders
 - Canceled orders
 - Schedule changes
 - Safety concerns, e.g., work/rest compliance, nutrition, work environment.
 - Current situation and outlook

- K. Interact and Coordinate with Appropriate Incident Personnel.
- Establish and maintain positive interpersonal and interagency working relationships.
 - Establish and maintain communication with other unit leaders and staff.
 - Recognize conflict early and take appropriate action, e.g., seek the advice of the logistics section chief (LSC), SUPL, or human resource specialist (HRSP).
 - Recognize cultural language difficulties that impact work output and expectations.
 - Integrate cultural resource considerations into all activities.
- L. Prepare and Submit Reports as Required by the SUPL.
- Submit Crew Time Reports daily
 - Prepare ICS 214, Unit Log.
 - Events that occur in the receiving/distribution unit.
 - List of the RCDM's staff.
 - Difficulties meeting time frames.
 - Policy guideline changes
 - Problems encountered and the actions taken.

- Submit documents in a timely manner to meet deadlines and/or incident requirements.

See Appendix D, ICS 214, Unit Log example.

M. Evaluate Performance of Subordinate(s) as Required by Agency Policy.

Performance evaluations are done for all unit personnel/crews prior to their release from the incident. Performance evaluations are discussed with the individual(s).

N. Identify and Release Excess Resources and Supplies.

- Return excess or used supplies to the cache whenever possible, utilizing backhaul in delivery vehicles.
 - Prepare waybills or shipping invoices (include NFES number and correct unit of issue) for all supplies returned.
 - Utilize original packing boxes whenever possible.
 - Avoid direct contact with filament tape on items to be shipped.
 - All hose should be returned rolled up.

- Utilize cargo sealed tags on load when waybills are completed. Place tag numbers on waybill.
- Advise supply unit leader of excess material for return to vendor (retrograde).

IV. DEMOBILIZATION

Demobilization and Check-out.

Keep in mind that demobilization starts when the incident starts.

- Final demobilization process
 - A Cache Demobilization Specialist (CDSP) and a 5 ton cache van is recommended to assist/expedite the return of supplies and equipment to the National Interagency Support Cache (NISC).
 - Assure the return of all issued supplies and equipment before signing the ICS 221, Demobilization Checkout for incident personnel.
 - Coordinate with ORDM on cancellations of unfilled orders no longer needed.
 - Identify excess assigned personnel for inclusion in the demobilization plan.

- Contact NISC (or receiving unit) regarding critical shortages to determine if these shortages can be accommodated through your unit demobilization.
- Accountable property is generally in short supply and should be returned to NISC (or agency) as soon as the incident is over. Provide “property numbers” of accountable property on shipping and return documents (use separate waybill for accountable property).
- Notify receiving agency and give estimated time of arrival (ETA) of items that will be returned to their destination (assure that this is done for every load returned).
- Ensure all fuel cans, containers and fuel tanks are emptied and purged prior to shipping.
- Assure hazardous materials are properly documented and are shipped in accordance with Department of Transportation Regulations (49 CFR part 172). If you don’t know how this is accomplished ask either the SUPL or NISC.

- Load hazardous material last so that it is easily inspected at Department of Transportation check stations.
- Turn all receiving and distribution records over to the SUPL.
- Return all work materials to the originating supplier.
- Return your area to its pre-incident condition.
- Demobilization of receiving and distribution personnel
 - Submit all required information to the SUPL.
 - Receive demobilization instructions from SUPL.
 - Brief replacement RCDM.
 - Obtain ICS 221, Demobilization Checkout from the planning section.
 - Check out with each section indicated on the ICS 221.
 - Submit completed ICS 221 to the documentation unit in the planning section.

APPENDIX A

Check-out Authority, Example

Item:	Check-out Authority									
	Crew Boss	Individual	Saw Team or Sawyers	EMT/Medical	Safety Officer	Division Group Supervisor	Air Ops Helibase Mgr.	Unit Leaders		
Sleeping Bag, Grey Pad, Headlamp, Hard Hat, Fire Shelter, Goggles, Canteen, Pants, Shirts, Gloves, Tools	X	Replacement Only	~	~	~	~	~	~	~	~
Tents, Lanterns, Heaters, Propane	~	~	~	~	~	~	~	~	~	Facilities Setup
Flashlight, Batteries, Ribbon, 1 Person First Aid Kits	~	X	~	~	~	~	~	~	~	~
10 Person First Aid kit	X	~	~	X	~	~	~	~	~	~
Chainsaw Items	~	~	X	~	~	~	~	~	~	~
Wrap Around Safety Glasses	~	~	~	~	X	~	~	~	~	~
Fireline Equipment- 1 1/2" Hose, Mark III pumps, Fuses, Fuel, Light Sticks, MREs, etc.	~	~	~	~	~	X	~	~	~	~
Air Support Items	~	~	~	~	~	~	X	~	~	~
Support Items	~	~	~	~	~	~	~	~	~	X

APPENDIX B
ICS 213, GENERAL MESSAGE

*U.S.GPO:1992-0-790-001

GENERAL MESSAGE

TO: Chamber	POSITION Ordering Manager
FROM: Smith	POSITION Division B Supervisor
SUBJECT: Order of supplies	DATE: 8/20 1945
MESSAGE: I need the following items for the day operational period, by 0600, 8/20 <i>I will pickup order</i>	
1 ea. pump kit, NFES 0670	
5 ea. reducers 1" x 3/4", NFES 0733	
5 ea. wye 3/4", NFES 0739	
5 ea. reducer 1 1/2" x 1", NFES 0010	
5 ea. nozzle 3/4" NFES 0136	
10 LG Hose, garden, NFES 1016	
5 LG Hose, 1", NFES 0966	
5 LG Hose, 1 1/2" , NFES 0114	
SIGNATURE/POSITION <i>Smith, DIVS</i>	

REPLY

DATE	TIME	SIGNATURE/POSITION
-------------	-------------	---------------------------

213 ICS 179
NFES 1336

PERSON RECEIVING GENERAL MESSAGE KEEP THIS COPY

(SENDER:) REMOVE THIS COPY. FOR YOUR FILES

APPENDIX C Mix Ratio Chart

2 Cycle Oil to gas for chainsaws and pumps

Chainsaw			Mark III Pump
<i>Ratio</i>	<i>2-Cycle Oil</i>	<i>Gas</i>	<i>Ratio</i>
16:1	1 QT. (32 oz.)	4 Gal	16:1
32:1	1/2 QT. (16 oz.)	4 Gal	
32:1 Instruction on can	Example: 1 Can 1 Gal		
40:1 Instruction on can			
50:1 Instruction on can			
Read the can, instructions differ according to brand of oil			
Drip Torch			
<i>Ratio</i>	<i>Diesel</i>	<i>Gas</i>	
3:1	3 parts	1 part	
Example: 3 gallons diesel, 1 gallon gas			

Note: Label and date all fuel containers

APPENDIX E 24-HOUR CLOCK

<i>12 Hour</i>	<i>24 Hour</i>	<i>Pronounced</i>
1 AM	0100	Zero-one hundred
2 AM	0200	Zero-two hundred
3 AM	0300	Zero-three hundred
4 AM	0400	Zero-four hundred
5 AM	0500	Zero-five hundred
6 AM	0600	Zero-six hundred
7 AM	0700	Zero-seven hundred
8 AM	0800	Zero-eight hundred
9 AM	0900	Zero-nine hundred
10 AM	1000	ten hundred
11 AM	1100	eleven hundred
12 NOON	1200	twelve hundred
1 PM	1300	thirteen hundred
2 PM	1400	fourteen hundred
3 PM	1500	fifteen hundred
4 PM	1600	sixteen hundred
5 PM	1700	seventeen hundred
6 PM	1800	eighteen hundred
7 PM	1900	nineteen hundred
8 PM	2000	twenty hundred
9 PM	2100	twenty-one hundred
10 PM	2200	twenty-two hundred
11 PM	2300	twenty-three hundred
12 Midnight	2400	twenty-four hundred

To get 24 hour time, notice that you add 12 to the PM time to get the first two numbers of the hour, i.e., 8 PM is twenty hundred ($8 + 12 = 20$).

APPENDIX F

GLOSSARY OF TERMS AND ACRONYMS

For additional fireline terms, refer to Wildland Fire Terminology, PMS 205, NFES 1832

Accountable Property	Items with a purchase price of \$5,000.00 or more or items that the agency considers sensitive (cameras, chainsaws, items with property numbers).
A/C	Aircraft, fixed or rotor wing.
AD	Administratively Determined (rates and pay plan for emergency workers.)
AGL	Above Ground Level, altitude expressed in feet above the ground.
AIDS	Aerial Ignition Devices - usually refers to a ping pong ball machine or a helitorch.
Air Contact	Particular aviation resource to contact when reporting to a fire.
Air Show	Multiple aircraft over a fire, usually including air tankers.

APPENDIX F (continued)

Air Tactical	ICS position within the operations section. Air Tactical Group Supervisor (ATGS), synonymous with air attack.
Air Transportable Modular Unit (ATMU)	A weather data collection and forecasting facility consisting of seven modules, weighing a total of 355 pounds and occupying 34.2 cubic feet of space when transported. Requires a supplemental order of helium, procured locally.
Alumigel®	Jelly like substance produced by mixing gasoline and Alumigel® powder. It is then applied with an ignition device such as a helitorch to ignite fires.
ALS	Advanced Life Support
ATA	Actual Time of Arrival
Air Tanker	Fixed wing aircraft capable of delivering fire retardant (liquid and foam).
ATD	Actual Time of Departure

APPENDIX F (continued)

Av Gas	Fuel for aircraft with internal combustion engines (reciprocating engines).
Azimuth	The horizontal distance in angular degrees in a clockwise direction from the north point.
Back Haul	Excess supplies, equipment or trash returned from a location on an incident.
Base	The location at which primary logistical functions for an incident are coordinated and administered. There is only one base per incident, e.g., incident command post (ICP).
Bearing	Position of an object with reference to a point on a compass.
Backpack Pump	A collapsible backpack made of neoprene or high strength nylon fabric that carries approximately five gallons of water fitted with a hand pump. (bladder bag)
BDU	Battle Dress Uniform; Fire resistant pants

APPENDIX F (continued)

Black Water/ Sewage Truck	Vehicle capable of pumping and hauling raw sewage (black water) to certified sewage treatment facility.
Booster Pump	An intermediary pump for supplying additional lift in pumping water uphill past the capacity of the first pump.
Casual(EFF)	An employee who is picked up temporarily for a fire emergency, see AD. Also referred to as Emergency Fire Fighter (EFF)
Chief of Party	Person in charge of passengers while traveling.
Clamshell	Reusable battery holder for King® radios. Holds 9 AA batteries. Listed as Holder, Battery, King, NFES 1034.
Compressed Air Foam System (CAFS)	A generic term used to describe foam systems consisting of an air compressor (air source), water pump and foam solution.
Commo	Communications

APPENDIX F (continued)

Consumable Property	Items that are expected to be consumed on the incident (batteries, MREs, canteens).
Coordination Center	Regional/Zone/State level center for mobilization of resources to incidents, etc. (dispatch)
Coupling, hose	A fitting on the end of a hose that connects the ends of adjacent hoses or other components of hose, e.g., male, female, quick connect, pin lug.
Coyote Tactics	A progressive line construction technique involving self-sufficient crews which build fire line until the end of the operational period, remain at or near that point while in an unavailable status and begin building fireline at that point at the start of the next operational period.
CSJRL	Cotton-Synthetic Jacketed, Rubber Lined hose.
Cubie	Cubitainer: a five gallon container used for transporting drinking water.

APPENDIX F (continued)

Demob	Demobilization, process of removing resources, usually off incidents.
DHS	Department of Homeland Security
Dispatch	Dispatch center; a facility from which resources are assigned to an incident.
Division	Incident division, usually designated by a letter, e.g., Division A.
DJRL	Double Jacketed Rubber Lined hose.
Dozer	A tracked vehicle with a front mounted blade used for building fireline; bulldozer.
Dozer tender	Bulldozer service unit
Drum Lifter	A device used to transport a 55 gallon drum via a sling on a helicopter.
Durable Property	Non-accountable items, with useful life expectancy longer than one incident.

APPENDIX F (continued)

Engine	A truck mounted with a pump and tank (water), used in fire suppression.
EMS	Emergency Medical Service
EMT	Emergency Medical Technician
ETA	Estimated Time of Arrival
ETD	Estimated Time of Departure
ETE	Estimated Time En Route.
Expanded Dispatch	The organization in dispatch that is activated when the complexity of logistics coordination approaches a level the initial attack dispatch organization can no longer support.
FAA	Federal Aviation Administration
FBO	Fixed Base Operator; usually the local airport.

APPENDIX F (continued)

Fill or Kill	Policy designed to indicate ability to fill an order or if it can not be filled within a reasonable amount of time (1 hour is standard), then “kill” it. Determine whether to reorder at a later time or cancel the order. This policy is referenced in the National Interagency Mobilization Guide.
Fire Cache	A supply of fire tools and equipment assembled in planned quantities or standard units at a strategic point for exclusive use in fire suppression.
Fixed Wing	Aircraft with stationary wings; an airplane.
FLE	Fire Line Explosives, used for rapid construction of fire line with a small number of specially trained personnel.
FMO	Fire Management Officer

APPENDIX F (continued)

Foam	An extinguishing agent, chemically and/or mechanically produced, that blankets and adheres to the fuels to reduce combustion. When foam products are mixed at 1% or less, the foam will remain effective at preventing ignition for 12 hours. Works with current class A foam delivery systems.
Fol-da-tank®	A portable, collapsible water tank with a tubular frame; varies in capacity from 500-1500 gallons.
FTS	Federal Telephone System
Gated Wye	A gated valve used in hose lays to allow connection of other hoses within the trunk line, e.g., 1" lateral hose with nozzle.
GHT	Garden Hose Thread, 3/4 inch hose fittings
Gorman Rupp	Small, portable water pump.
Gray Water (Grey)	Used water from the kitchen and shower units.
Greenwich Mean Time	The time at "0" longitude, Greenwich, England (Zulu time).

APPENDIX F (continued)

Hazardous Material	Substances that are identified, classified and regulated in the Code of Federal Regulations, Title 49 and Hazardous Materials Regulation 175. A hazardous material is a substance or material which has been determined by the Department of Transportation to be capable of posing an unreasonable risk to health, safety and property when transported in commerce and which has been so designated.
Head (water pressure)	Pressure due to elevation of water. Equals 0.433 pounds per square inch per foot of elevation.
Helibucket	Specially designed bucket carried by a helicopter like a sling load and used for aerial delivery of water or fire retardants.
Helitorch	An aerial ignition device slung beneath a helicopter to disperse ignited lumps of jelled gasoline (Alumigel®).
Hot Food/ Drink Cans	Nonreusable cans that are used to ship hot or cold drinks and food to remote locations.

APPENDIX F (continued)

Hot Shots, IHC	Specially trained seasonal hand crew (type 1).
Hoverfill Tank	Large, portable tank from which helitankers can hoverfill.
IA	Initial Attack, first effort to suppress a fire
IC	Incident Commander
Impeller	Rotating part of a centrifugal pump which imparts energy to the liquid to be moved. For shearing purposes, the impeller is on a rotating shaft within the body of liquid.
IMSR	Incident Management Situation Report (Sit Report). Daily report giving the current fire situation in the United States.
Incident	An event (fire, flood, earthquake, other disasters)

APPENDIX F (continued)

Incident Command System (ICS)	An organization used to manage an emergency incident or a non-emergency event. It can be used equally well for both small and large situations. The system has considerable internal flexibility. It can grow or shrink to meet differing needs. This makes it a very cost-effective and efficient management system. The system can be applied to a wide variety of emergency and non-emergency situations.
Incident Action Plan (IAP)	Contains objectives reflecting the overall incident strategy and specific control actions for the next operational period. The plan may be oral or written.
Incident Overhead	All supervisory positions described in the incident command system.
Increaser	Increasing coupling used on hose, pump or nozzles to permit connection of a larger size of hose.

APPENDIX F (continued)

Inductor	A control mechanism that allows a regulated quantity of foam concentrate to be introduced into the main hose line.
Infrared	A heat detection system used for fire detection, mapping and heat source identification.
Inside Diameter	The internal diameter of a tube, conductor or coupling as distinguished from the outside diameter. Fire hose sizes are classified by a nominal internal diameter.
IR Scan	Infrared survey of a fire
Iron Pipe Standard Thread	Standard system of thread for connecting various types of rigid piping. These threads are much finer and more difficult to connect in the field than National Standard threads.
Kamlock	Type of fitting that provides quick connecting/disconnecting hose.

APPENDIX F (continued)

Lead Line	Line or set of lines made of rope, webbing or cable and used in helicopter external load operations. Placed between a swivel or the cargo hook and the load.
Lead Plane	Aircraft with pilot used to make trial runs over the target area to check wind, smoke conditions, topography and lead air tankers to the target.
Lined Fire Hose	Fire hose with a smooth inner coating of rubber or plastic to reduce friction loss.
Liquid Concentrate	Liquid phosphate fertilizers used as fire retardants, usually diluted three to five times prior to application.
Live Line or Reel	Hose line or reel on a fire engine, carried connected to the pump, ready for use without making connection to pump or attaching nozzle.

APPENDIX F (continued)

Load Calculation Form	An agency form used to calculate helicopter load weight.
Local Agency	An agency having jurisdictional responsibility for all or part of an incident.
Longline	A line or set of lines, usually in 50 feet increments, used in external load operations that allow the helicopter to place loads in areas which the helicopter can not land.
MAC	Multi-Agency Coordinating Group
MAFFS	Modular Airborne Fire Fighting System, the military's air tanker program (used when more tankers are needed than there are available on contract).
Mark III	Small, portable water pump
Mark 26	Portable water pump (smaller than a Mark III)
Medevac	Emergency medical evacuation

APPENDIX F (continued)

Misery Whip	Crosscut saw
MIST	Minimum impact suppression tactics
Mix Ratio	The ratio of liquid foam concentrate to water, usually expressed as a percent.
Monitor	Turret type nozzle usually mounted on an engine.
Mob Guides	Reference used to facilitate the mobilization of resources. Includes policies, procedures, and where to find the resources.
Mopup	Extinguish or remove burning material near control lines after an area has burned to secure the fire or to reduce residual smoke.
MRE	Meals Ready to Eat, light weight, packaged food used on fires
Multicom	A VHF/AM aircraft radio frequency (122.9 MHz) assigned by the FAA for use in air-to-air communications.
Mud	Fire retardant

APPENDIX F (continued)

NH	National Fire Hose, coupling threads used for fire hose 1½" and larger.
NFES Catalog	Referred to as the National Fire Equipment System Catalog. This catalog is used to order equipment and supplies from fire caches.
NICC	National Interagency Coordination Center at Boise, ID.
NIFC	National Interagency Fire Center at Boise, ID
Nomex®	A fire resistant synthetic material used in the manufacturing of flight suits, pants and shirts for firefighters.
Nozzle Aspirated Foam System	A foam generating device that mixes air at atmospheric pressure with foam solution in a nozzle chamber.
Nozzle, Forester	Twin-tip combination nozzle for 1" hose. Combination fog/straight stream nozzle tip; low volume.

APPENDIX F (continued)

Nozzle, KK	Combination barrel nozzle. Higher volume than the Forester nozzle.
NPSH	National Pipe Straight Hose coupling threads (straight pipe threads for hose couplings and nipple).
NPT	National Pipe Threads/American Standard Taper pipe threads
NTE	Not to exceed; a personnel term used for positions that have a limited duration due to funding or project length.
Payload	Weight of passengers and/or cargo being carried by an aircraft.
PAX	Passengers
PC	Paracargo, cargo delivered by means of fixed wing aircraft and parachutes specialty packed and rigged, usually by smokejumper paracargo specialists.
PG	Personal gear bag
Phoschek®	Long term red colored fire retardant

APPENDIX F (continued)

PIC	Pilot in Command
Piston Pump	Positive displacement pump with 2, 4, and 6 reciprocating pistons to force water from the pump chamber in conjunction with appropriate action of inlet and discharge valves.
Probeye®	Infrared scanning device that picks up hotspots on fires.
Proportioner	A device that adds a predetermined amount of foam concentrate to water to form a foam solution.
PSD	Plastic Sphere Dispenser - refers to a machine installed in a helicopter that dispenses plastic spheres (ping pong balls) filled with potassium permanganate. The machine injects a small amount of ethylene glycol into each sphere and then dispenses them out of the helicopter. The exothermal reaction of the two chemicals creates enough heat to ignite the plastic sphere, in 25 to 30 seconds, which in turn ignites the fuel bed. Aerial Sphere Dispenser Kit, NFES 3410

APPENDIX F (continued)

PTO	Power Take-Off, a supplementary mechanism enabling the engine power to be used to operate non-automotive apparatus (such as a pump).
Pumpkin	Collapsible, soft-sided, freestanding portable water tank.
Ramp	Parking area for aircraft adjacent to a runway.
Red Card	Fire qualification card issued to personnel showing their qualifications to fill specific fire positions.
Reel	A frame on which hose is wound (3/4 to 1 inch hose) supplied by a water tank on the apparatus.
Resource	Any person, aircraft, supply or equipment available for assignment to an incident. Described by kind and type, e.g., T2 Crew, ICT1, T6 Engine.

APPENDIX F (continued)

Resource Order	Form used by dispatchers, service personnel and logistics coordinators to document the request, ordering or release of resources and the tracking of those resources on an incident.
Respirator	A simple filter mask for individual protection against smoke and fumes for use on wildland fires.
Retardant	A chemical having a retarding action on fire, usually applied with an air tanker.
Retrograde	Reversal of an order; shipping supply items from the incident back to the cache or to another incident.
Requisition	A form/procedure for purchasing supplies.
RH	Relative Humidity, a measure of moisture in the air.
Rocker Lug Coupling	Hose coupling in which the lugs used for tightening or loosening are semicircular in shape and designed to pass over obstructions.

APPENDIX F (continued)

Rotor Wash	The air turbulence caused by the movement of the rotor blades of a helicopter.
Rotorwing	Aircraft with a rotor system that rotates about an axis to provide lift and/or thrust for a helicopter.
RX	Prescribed fire
SIPT	Straight Iron Pipe Thread
Slurry	Fire retardant
SMJ or SJ	Smokejumper; fire suppression personnel who parachute to fires via fixed wing aircraft.
SOP	Standard Operating Procedures
Spotter	Smokejumper supervisor in charge of a jumper load; performs navigation, communication and paracargo duties.
Stocking Levels	Minimum levels of supplies kept on hand at a fire cache.

APPENDIX F (continued)

Strainer	A wire or metal guard used to keep debris from clogging pipe or other openings made for pumping water. Placed on suction hose it will protect pumps from foreign materials.
Surfactant	A surface active agent. A formulation which, when added to water in proper amounts, will reduce the surface tension and increase penetration capabilities of the water, e.g., wet water, class A foam, soap.
Swamper	Assistant to an equipment operator
T&A	Time and Attendance
Tail Number	FAA number used to identify aircraft, located on the tail of the ship. American aircraft tail numbers begin with the letter N, e.g., N543TY, N67344.
Tanker	Air tanker

APPENDIX F (continued)

TFR	Temporary Flight Restriction. This airspace restriction is obtained through the FAA. It is an area of airspace over an incident that is defined both laterally and vertically, which has been temporarily or partially closed to nonessential aircraft for a specific period of time.
Thread	The specific dimensions of screw thread employed to couple fire hose and equipment. American National Standard Hose Thread has been adopted for fire hose couplings.
Torch, Drip	A hand-held device for igniting fires by dripping flaming liquid fuel on the materials to be burned. Fuel used is generally a mixture of diesel and gasoline.
Trash Pump	Medium sized pump used for moving large amounts of liquids, e.g., grey water, retardant. These pumps are ordered as volume pumps.
UTF	Unable to fill; pertaining to resource orders.

APPENDIX F (continued)

Water Buffalo	Liquid storage unit
Water Tender	Ground vehicle capable of transporting specified quantities of water, e.g., Type 1 water tender; 5000 gallon capacity, 300 gallon per minute pumping capability.
WFSA	Wildland Fire Situation Analysis. An analysis tool used to determine the most appropriate management strategy for a wildfire that has escaped initial attack.
WX	Weather
Xedar®	Type of heat seeking video display unit that identifies hot spots during mopup.
100 hour	Mandatory maintenance done to aircraft every 100 hours (there is also a 50 hour, 1000 hour, etc.)

NOTES