

Environmental control.- No anomalies were noted in the environmental control system operation.

Thermal control.- The thermal control system of the CSM performed normally until the incident.

Cryogenic system.- Both the liquid hydrogen and the liquid oxygen systems operated satisfactorily up to the time of the accident as far as the fuel cells and environmental control systems were concerned. Because of the unbalance in hydrogen quantities during loading, and unequal usage during launch pad operation, several hydrogen low-pressure master alarms were detected on the caution and warning system. (A description of the caution and warning system is contained in Appendix A, Part A2.10.) At 46:40:08 the oxygen tank no. 2 quantity measurement indicated 100 percent quantity and remained at this value until the pressure rise at 55:53:35. With the exception of the above, system operations were normal to the time of the accident.

The following sections will describe the low hydrogen pressure master alarm and supercritical liquid hydrogen and oxygen destratification up to the time of the accident.

Hydrogen Low Pressure Master Alarm

The caution and warning system, upon receipt of a malfunction or out-of-tolerance signal, simultaneously identifies the abnormal condition and alerts the crew to its existence. Each signal (both oxygen and hydrogen pressure are on one indicator) will activate the system status indicator, light the master alarm light, and place an audio tone in the crew's headsets. The crew can turn off or reset the master alarm; however, the particular system status malfunction indicators remain lit, blocking further master alarms on this indication, until the malfunction is cleared.

At lift-off, the quantity readings for the hydrogen tanks no. 1 and no. 2 were 91 percent and 93.4 percent, respectively. This was due to initial loading values (98.7 percent for tank no. 1 and 99.4 percent for tank no. 2) and the difference in usage during countdown.

At approximately 32:00 g.e.t., a quantity unbalance of 2.38 percent existed between the hydrogen tanks, and a quantity balancing procedure was conducted to prevent tank no. 1 low-pressure master alarms during the sleep period. In the "auto" mode the tank heaters are turned on and off by pressure switches connected in series. When the pressure in either tank reaches about 260 psi, the heaters in both tanks are switched off. The heaters remain off until the opened pressure switch closes at

approximately 225 psi. Since one tank pressure switch normally remains closed, the tank that controls the upper pressure will also control at the lower pressure. During the flight, tank no. 2 was controlling. Tank no. 1 pressure was almost reaching the caution and warning low pressure point (224.2 psia) prior to tank no. 2 reaching its pressure switch activation point of 233.6 psia to turn on the heaters.

Since tank no. 2 had the greater quantity, at 32:00 the tank no. 1 heaters were manually turned off by the crew while tank no. 2 remained in auto. This condition would allow the fuel cells to obtain hydrogen from tank no. 2 because of its higher pressure and in turn reduce its quantity of hydrogen. Several master alarms occurred immediately after this change (33:10, 33:41, 34:01, and 34:32).

At 36:48 the hydrogen tank no. 1 heater was placed back to auto for the sleep period. On the first "down" pressure cycle a master alarm occurred (38:00) due to hydrogen tank no. 1 pressure dropping lower than 224.24 psia, awaking the crew. The crew reset the alarm, and no master alarms occurred through the sleep period although the heaters cycled several times. To obtain a balanced condition for the next sleep period, the ground controllers devised the following plan for the next day's operation:

1. After crew wakeup, turn hydrogen tank no. 2 heater to off and leave hydrogen tank no. 1 in auto for two to three pressure cycles to determine if this will transfer heater control to tank no. 1 in anticipation of using this configuration for sleep.

2. If successful, tank no. 1 heaters will be turned off during the day and tank no. 2 heaters left in auto to create a quantity unbalance in favor of tank no. 1.

3. During the next sleep period, the tanks will be balanced by placing tank no. 1 heaters in auto and tank no. 2 heaters to off.

This plan was executed when the crew awoke the next day. At the time of the accident, tank no. 1 was in off and tank no. 2 was in auto, and the caution and warning master alarm was reset with a low hydrogen pressure indication present at 55:52:30. This hydrogen low pressure indication locked out the master alarm during the time of the increasing pressure in oxygen tank no. 2.

Cryogenic Tank Destratification

To prevent stratification in the oxygen and hydrogen tanks, two fans are located in each tank. A diagram of the oxygen tank showing

the two fans and quantity gaging probe is shown in figure B4-11. The flight plan called for the fans to be operated in both the hydrogen and oxygen tanks at the following times: 3:40, 12:09, 23:12, 29:40, 37:30, and 46:39 g.e.t. The ground controllers requested the oxygen tank no. 2 fans to be operated at 47:54 and both the oxygen and hydrogen fans be operated at 51:07.

Review of cryogenic and electrical instrumentation data does not indicate that the fans were switched on at 3:40 and at 29:40. No changes in cryogenic pressures and quantities, and no indications of an increase in spacecraft current were noted. The operation of the fans during the other destratification periods were normal; however, three oxygen tank no. 2 differences were noted: (1) transients on pitch and yaw thrust vector control gimbal command parameters at fan turnon and turnoff, (2) quantity gaging probe malfunctioned just after or at the time the fans came on, and (3) ac main bus 2 indicated a 1.8-volt negative transient when the fans were turned on at 47:54.

The pitch and yaw thrust vector control gimbal command (TVC command) parameters are an excellent transient detector on ac main bus 2 when the stabilization and control system is turned off because of its sensitivity and high sampling rate (100 samples per second). The sensitivity of the system is determined by the position of the rate high/low switch and the attitude deadband maximum/minimum switch. The TVC command signals are not transmitted to the ground when the instrumentation system is in low bit rate mode.

The system was in the low sensitivity mode during two destratification periods. When oxygen tank no. 2 fans were turned on during tank destratification periods, a negative initial transient was detected and when the fans were turned off, a positive initial transient was detected on the TVC command parameters. These transients are readily detectable in the high sensitivity mode and barely detectable in the low sensitivity mode. Examination of the Apollo 11 records indicates that the system was in the high sensitivity mode once during the fan destratification periods and a similar transient occurred when the fans were turned on. The data indicate that the transients are normal for fan turnon and turnoff, and only indicate a relatively large current change on ac main bus 2.

At 47:40:08 the oxygen quantity changed from approximately 82 percent to 100 percent, or full-scale high. This change in reading or quantity system malfunction occurred just after or at the time the oxygen tank no. 2 fans were turned on. Because of the way the system recovered at the time of the accident, the data indicate that the probe or its associated wiring shorted. Since the instrumentation system was in low bit rate, it is possible to determine exactly when the oxygen

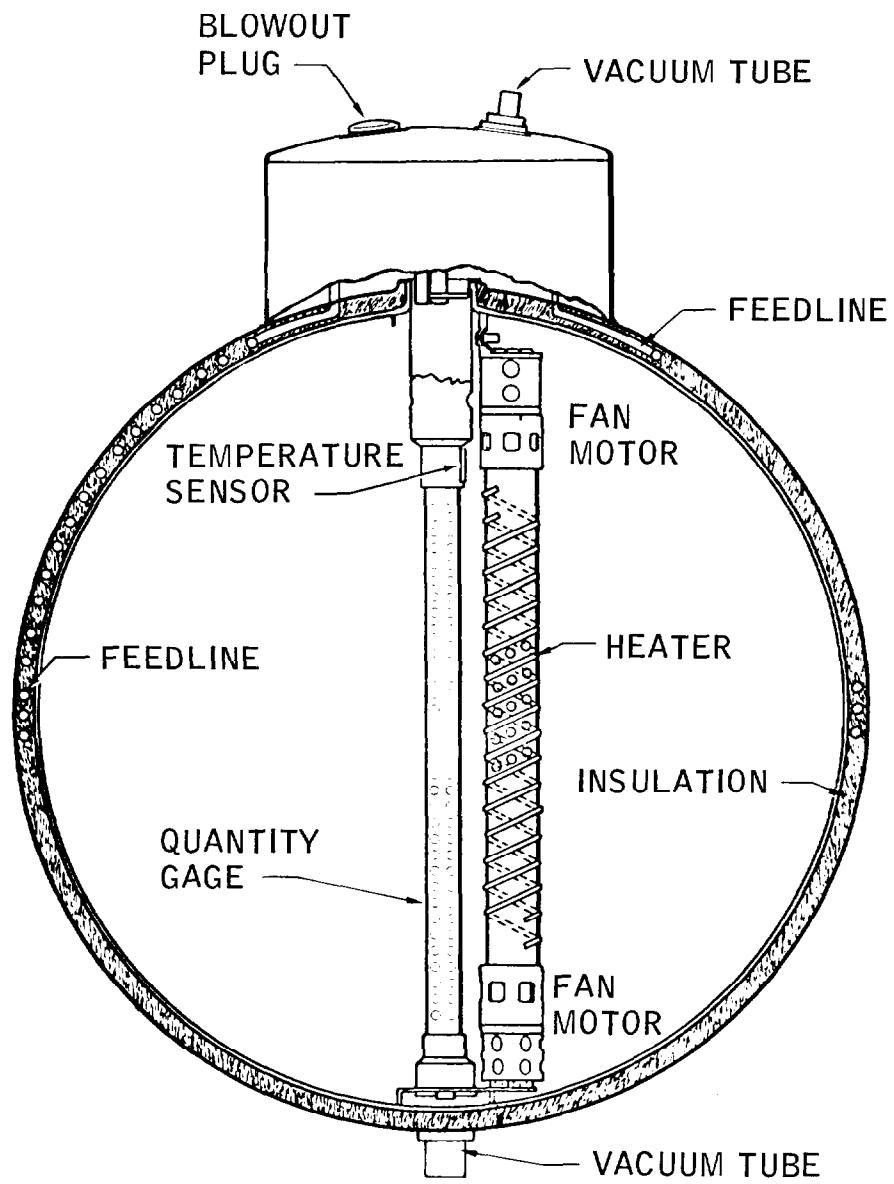

Figure B4-11.- Arrangement of components within oxygen tank.

tank no. 1 and no. 2 fans were turned on. The electrical data indicate that the oxygen tank no. 1 and no. 2 fans were turned on between the times of 47:40:05 and 47:40:08. A plot of cryogenic pressures, quantities, total CSM current, and ac main bus 2 is shown in figure B4-12. Therefore, the oxygen tank no. 1 and no. 2 fans were turned on in a period of time between 3 seconds prior to the probe malfunction and the time that the probe malfunctioned.

When the oxygen tank no. 2 fans were turned on the next time at 47:54:50, the ac main bus 2 decreased 1.8 volts for one sample (0.1 second). At the same time the TVC command parameters indicated a negative initial transient. Because of the sampling rate (10 samples per second) of the instrumentation system and the small number of fan cycles examined in the high bit rate mode, it cannot be determined if this negative initial transient is characteristic of other fan turnon's or is an indication of a deteriorating fan or wiring.

The complete oxygen and hydrogen tank destratification history prior to the accident is shown in table B4-I. Changes in oxygen and hydrogen pressures and quantities indicate normal destratification of the tanks during all fan cycles. The next destratification period occurred at 55:53:18, or when the events started leading to the accident.

References 1 through 6 and instrumentation records were used as a source of information and data in the preparation of this part of the report.

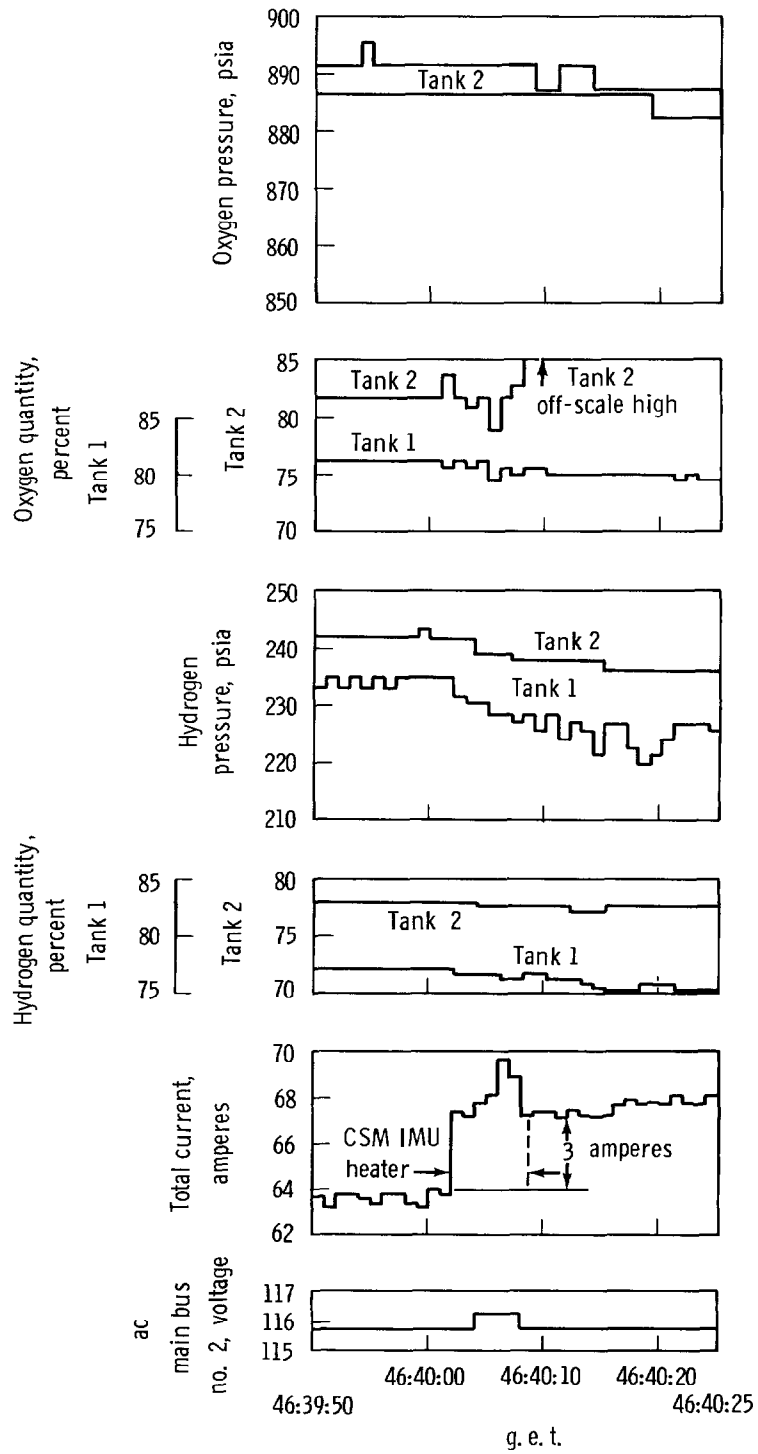

Figure B4-12.- Fan cycle at 46:40.

TABLE B4-I.- CRYOGENIC TANK DESTRATIFICATION

Planned destratification	Actual start of destratification	Verified air-to-ground	SCS transients	Remarks
3:40:00	No indications	Not verified	No indications	No indications
12:09:00 Presleep checklist	12:08:58 to 12:09:04	Not verified	12:09:03.6	Normal destratification
23:12:00 Postsleep checklist	23:10:53 to 23:11:01.5	Verified	23:11:01	Normal destratification
29:40:00	No indications	Not verified	Low bit rate	No indications
37:30:00 Presleep checklist	36:46:19 to 36:46:21	Partial verification	36:46:20.5	Normal destratification
46:39:00 Postsleep checklist	46:40:02 to 46:40:05-08	Verified	Low bit rate	Normal destratification quantity gaging system malfunctioned
Ground control request (O ₂ tank no. 2 only)	47:54:50	Verified	47:54:50	Normal destratification - fans ran for approximately 11.5 minutes
Ground control request	51:07:43 to 51:07:47	Verified	Low bit rate	Normal destratification

PART B5

INCIDENT EVENTS

INTRODUCTION

This part of the report covers the significant events which took place at the time of the accident. The period covered is 55:52:00 g.e.t. to 56:00:05 g.e.t. Prior to this period, spacecraft operation had been essentially according to plan and neither the ground controllers nor the crew had any warning of the events about to occur. The first indication of a problem was a loud bang heard by all three crew members which was followed by a master caution and warning. The immediate indications in the spacecraft were that this warning had been triggered by an electrical transient. Several minutes later two fuel cells failed in the power system, and the crew became fully occupied trying to reconfigure the spacecraft electrical system. Fourteen minutes later they noticed venting and began to understand what had actually happened in the cryogenic oxygen system.

On the ground, the flight controllers first noticed that the spacecraft computer had been automatically restarted. Shortly afterwards, indication of a master caution and warning caused the flight controllers to scan their data for a problem. Since many telemetry measurements had by this time departed from their nominal values, the ground controllers' immediate reaction was to suspect an instrumentation failure. Steps were undertaken to sort the false telemetry readings from the true ones; and, simultaneously, instructions were given to help the crew handle new problems. About an hour later the ground personnel had sorted out the facts sufficiently to know that it would only be a short time before the cryogenic oxygen system would fail completely.

Reconstruction of the mission events in the detail presented in the following pages has required several hundred man-days of data analysis. Consequently, the crew and mission controllers could not possibly have understood the situation in the same depth at the time the events were actually happening. The primary sources of data for the analysis have been telemetry records, transcripts of voice communications, crew debriefings, and interviews with personnel on duty in Mission Control.

Table B5-I is a detailed chronology of the events during this time period, and figure B5-1 shows the sequence of events grouped according to spacecraft systems. For events obtained from telemetry data, where time is shown to a fraction of a second, this refers to the time at which the parameter in question was actually sampled by the telemetry system. As discussed in Part B7 of this Appendix, the characteristics of the

telemetry system place an uncertainty on the time of an event. The uncertainty is a function of the telemetry system sampling rate.

The remainder of this section is a discussion of the events at the time of the accident, grouped according to the spacecraft systems involved.

TABLE B5-1.- DETAILED CHRONOLOGY FROM
2.5 MINUTES BEFORE THE ACCIDENT TO 5 MINUTES AFTER THE ACCIDENT

<u>Time, g.e.t.</u>	<u>Event</u>
Events During 52 Seconds Prior to First Observed Abnormality	
55:52:31	Master caution and warning triggered by low hydrogen pressure in tank no. 1. Alarm is turned off after 4 seconds.
55:52:58	Ground requests tank stir.
55:53:06	Crew acknowledges tank stir.
55:53:18	Oxygen tank no. 1 fans on.
55:53:19	Oxygen tank no. 1 pressure decreases 8 psi.
55:53:20	Oxygen tank no. 2 fans turned on.
55:53:20	Stabilization control system electrical disturbance indicates a power transient.
55:53:21	Oxygen tank no. 2 pressure decreases 4 psi.
Abnormal Events During 90 Seconds Preceding the Accident	
55:53:22.718	Stabilization control system electrical disturbance indicates a power transient.
55:53:22.757	1.2-volt decrease in ac bus 2 voltage.
55:53:22.772	11.1-amp rise in fuel cell 3 current for one sample.
55:53:36	Oxygen tank no. 2 pressure begins rise lasting for 24 seconds.
55:53:38.057	11-volt decrease in ac bus 2 voltage for one sample.
55:53:38.085	Stabilization control system electrical disturbance indicates a power transient.

TABLE B5-I.- DETAILED CHRONOLOGY FROM
 2.5 MINUTES BEFORE THE ACCIDENT TO 5 MINUTES AFTER THE ACCIDENT - Continued

<u>Time, g.e.t.</u>	<u>Event</u>
55:53:41.172	22.9-amp rise in fuel cell 3 current for one sample.
55:53:41.192	Stabilization control system electrical disturbance indicates a power transient.
55:54:00	Oxygen tank no. 2 pressure rise ends at a pressure of 953.8 psia.
55:54:15	Oxygen tank no. 2 pressure begins to rise.
55:54:30	Oxygen tank no. 2 quantity drops from full scale for 2 seconds and then reads 75.3 percent.
55:54:31	Oxygen tank no. 2 temperature begins to rise rapidly.
55:54:43	Flow rate of oxygen to all three fuel cells begins to decrease.
55:54:45	Oxygen tank no. 2 pressure reaches maximum value of 1008.3 psia.
55:54:48	Oxygen tank no. 2 temperature rises 40° F for one sample.
55:54:51	Oxygen tank no. 2 quantity jumps to off-scale high and then begins to drop until the time of telemetry loss.
55:54:52	Oxygen tank no. 2 temperature reads -151.3° F.
55:54:52.703	Oxygen tank no. 2 temperature suddenly goes off-scale low.
55:54:52.763	Last telemetered pressure from oxygen tank no. 2 before telemetry loss is 995.7 psia.
55:54:53.182	Sudden accelerometer activity on X, Y, and Z axes.
55:54:53.220	Stabilization control system body rate changes begin.

TABLE B5-I.- DETAILED CHRONOLOGY FROM
 2.5 MINUTES BEFORE THE ACCIDENT TO 5 MINUTES AFTER THE ACCIDENT - Continued

<u>Time, g.e.t.</u>	<u>Event</u>
55:54:53.323	Oxygen tank no. 1 pressure drops 4.2 psi.
55:54:53.5	2.8-amp rise in total fuel cell current.
55:54:53.542	X, Y, and Z accelerations in CM indicate 1.17g, 0.65g and 0.65g, respectively.
	1.8-Second Data Loss
55:54:53.555	Loss of telemetry begins.
55:54:53.555+	Master caution and warning triggered by dc main bus B undervoltage. Alarm is turned off in 6 seconds. All indications are that the cryogenic oxygen tank no. 2 lost pressure in this time period and the panel separated.
55:54:54.741	Nitrogen pressure in fuel cell 1 is off-scale low indicating failed sensor.
55:54:55.35	Recovery of telemetry data.

Events During 5 Minutes Following the Accident

55:54:56	Service propulsion system engine valve body temperature begins a rise of 1.65° F in 7 seconds.
55:54:56	Dc main bus A decreases 0.9 volt to 28.5 volts and dc main bus B decreases 0.9 volt to 29.0 volts.
55:54:56	Total fuel cell current is 15 amps higher than the final value before telemetry loss. High current continues for 19 seconds.
55:54:56	Oxygen tank no. 2 temperature reads off-scale high after telemetry recovery.
55:54:56	Oxygen tank no. 2 pressure reads off-scale low following telemetry recovery.

TABLE B5-I.- DETAILED CHRONOLOGY FROM
 2.5 MINUTES BEFORE THE ACCIDENT TO 5 MINUTES AFTER THE ACCIDENT - Continued

<u>Time, g.e.t.</u>	<u>Event</u>
55:54:56	Oxygen tank no. 1 pressure reads 781.9 psia and begins to drop steadily.
55:54:57	Oxygen tank no. 2 quantity reads off-scale high following telemetry recovery.
55:54:59	The reaction control system helium tank C temperature begins a 1.66° F increase in 36 seconds.
55:55:01	Oxygen flow rates to fuel cells 1 and 3 level off after steadily decreasing.
55:55:02	The surface temperature of the service module oxidizer tank in bay 3 begins a 3.8° F increase in a 15-second period.
55:55:02	The service propulsion system helium tank temperature begins a 3.8° F increase in a 32-second period.
55:55:09	Dc main bus A voltage recovers to 29.0 volts; dc main bus B recovers to 28.8 volts.
55:55:20	Crew reports, "I believe we've had a problem here."
55:55:35	Crew reports, "We've had a main B bus undervolt."
55:55:49	Oxygen tank no. 2 temperature begins steady drop lasting 59 seconds.
55:56:10	Crew reports, "Okay right now, Houston. The voltage is looking good, and we had a pretty large bang associated with the caution and warning there. And as I recall, main B was the one that had had an amp spike on it once before."
55:56:38	Oxygen tank no. 2 quantity becomes erratic for 69 seconds before assuming an off-scale-low state.

TABLE B5-I.- DETAILED CHRONOLOGY FROM
2.5 MINUTES BEFORE THE ACCIDENT TO 5 MINUTES AFTER THE ACCIDENT - Concluded

<u>Time, g.e.t.</u>	<u>Event</u>
55:57:04	Crew reports, "That jolt must have rocked the sensor on--see now--oxygen quantity 2. It was oscillating down around 20 to 60 percent. Now it's full-scale high again."
55:57:39	Master caution and warning triggered by dc main bus B undervoltage. Alarm is turned off in 6 seconds.
55:57:40	Dc main bus B drops below 26.25 volts and continues to fall rapidly.
55:57:44	Ac bus 2 fails within 2 seconds.
55:57:45	Fuel cell 3 fails.
55:57:59	Fuel cell 1 current begins to decrease.
55:58:02	Master caution and warning caused by ac bus 2 being reset. Alarm is turned off after 2 seconds.
55:58:06	Master caution and warning triggered by dc main bus A undervoltage. Alarm is turned off in 13 seconds.
55:58:07	Dc main bus A drops below 26.25 volts and in the next few seconds levels off at 25.5 volts.
55:58:07	Crew reports, "ac 2 is showing zip."
55:58:25	Crew reports, "Yes, we got a main bus A undervolt now, too, showing. It's reading about 25-1/2. Main B is reading zip right now."
56:00:06	Master caution and warning triggered by high hydrogen flow rate to fuel cell 2. Alarm is turned off in 2 seconds.

B-444

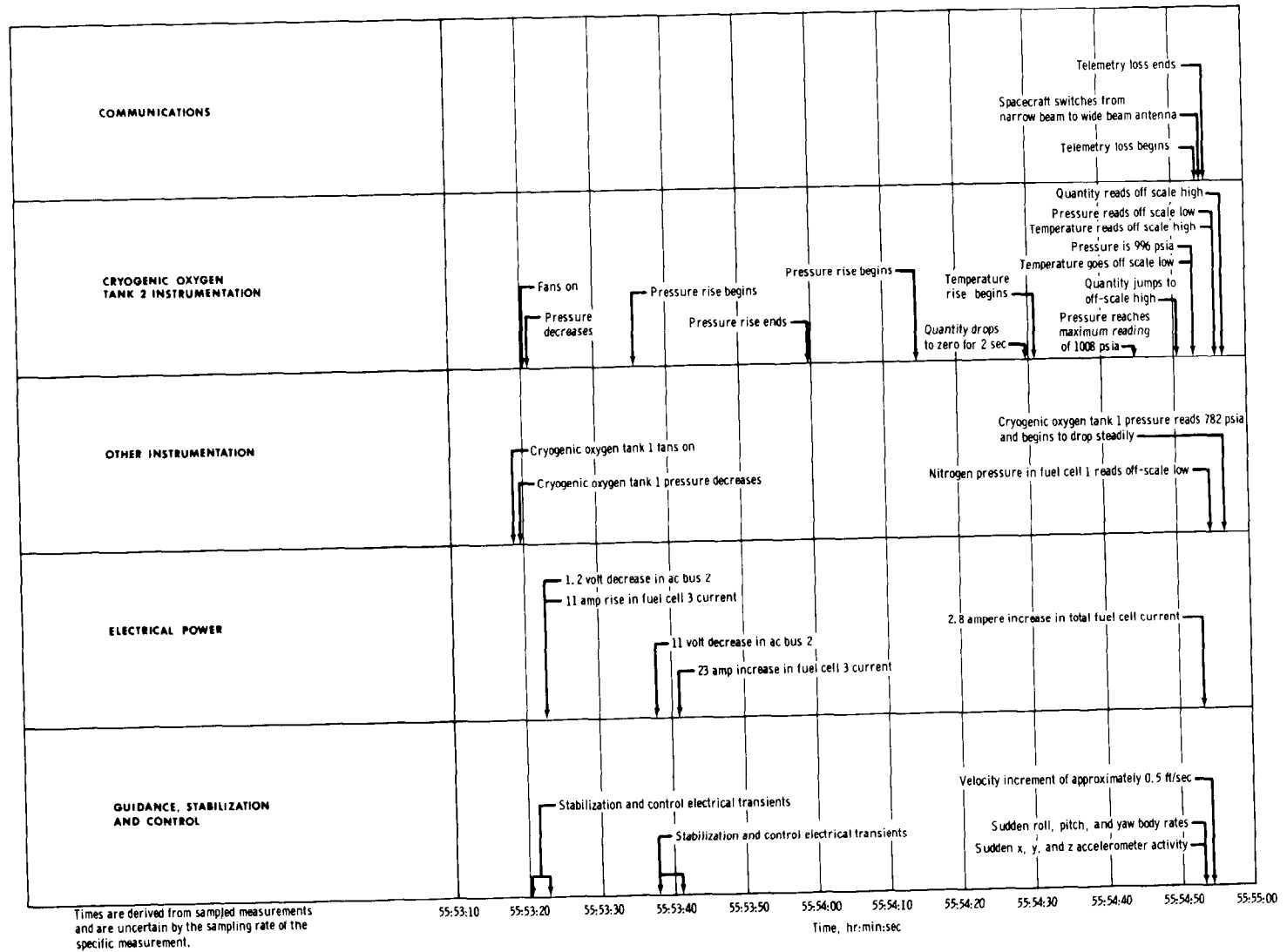

Figure B5-1.- Sequence of events immediately preceding the accident.

STATUS OF THE SPACECRAFT PRIOR TO THE ACCIDENT

At 55:52:00, just prior to the accident, the electrical system was configured as shown in figure B5-2. Fuel cells 1 and 2 were supplying main bus A; fuel cell 3 was supplying main bus B. The power for the fans in cryogenic oxygen tank no. 2 was being supplied by ac bus 2, as was power for the quantity sensor in that tank. The stabilization control system thruster vector control system was receiving its power from ac bus 2. Two quantities in this system, the pitch and yaw thrust vector control gimbal commands, though not intended for measurement of electrical system currents and voltages, are sensitive indicators of electrical transients on ac bus 2. These quantities are telemetered to the ground with a sampling rate of 100 samples per second. At 55:52:00 the telemetry system was operating in the high-bit-rate mode and the narrow beam antenna was in use.

The cryogenic oxygen tank no. 2 quantity gage had failed to a 100-percent reading in the 46th hour of the flight. (See Part B4, the subsection entitled "Spacecraft Systems Operation.") All other cryogenic oxygen instrumentation was operating normally.

The cryogenic hydrogen tank 1 pressure decreased sufficiently to trigger the master caution and warning at 55:52:31. (For a description of the master caution and warning system, see Part 2.10 of Appendix A.) The ground then requested a fan cycle, and the crew acknowledged the request. A fan cycle consists of the crew turning on the stirring fans located in both the cryogenic oxygen and hydrogen tanks and allowing them to run for approximately 1 minute. Normally, the hydrogen fans are turned on first, followed by the fans in oxygen tank no. 1 and a few seconds later by the fans in oxygen tank no. 2.

FAN TURNON AND ASSOCIATED ELECTRICAL ANOMALIES

At 55:53:18 when the two fans in cryogenic oxygen tank no. 1 were turned on by the crew, a drop in ac bus 1 voltage (fig. B5-3) and an increase of 1 ampere in total command module current indicated that the fans had been electrically energized. (Total command module current, plotted in figure B5-4, is obtained by adding the current outputs of all three fuel cells and subtracting the current drain of the lunar module.) A subsequent decrease in tank pressure and oscillations in the fuel cell flowmeters indicated that the fans had begun to stir the oxygen (fig. B5-3).

At 55:53:20 the crew turned on the cryogenic oxygen tank no. 2 fans. An increase in fuel cell current of 1-1/2 amperes, a drop in ac bus 2

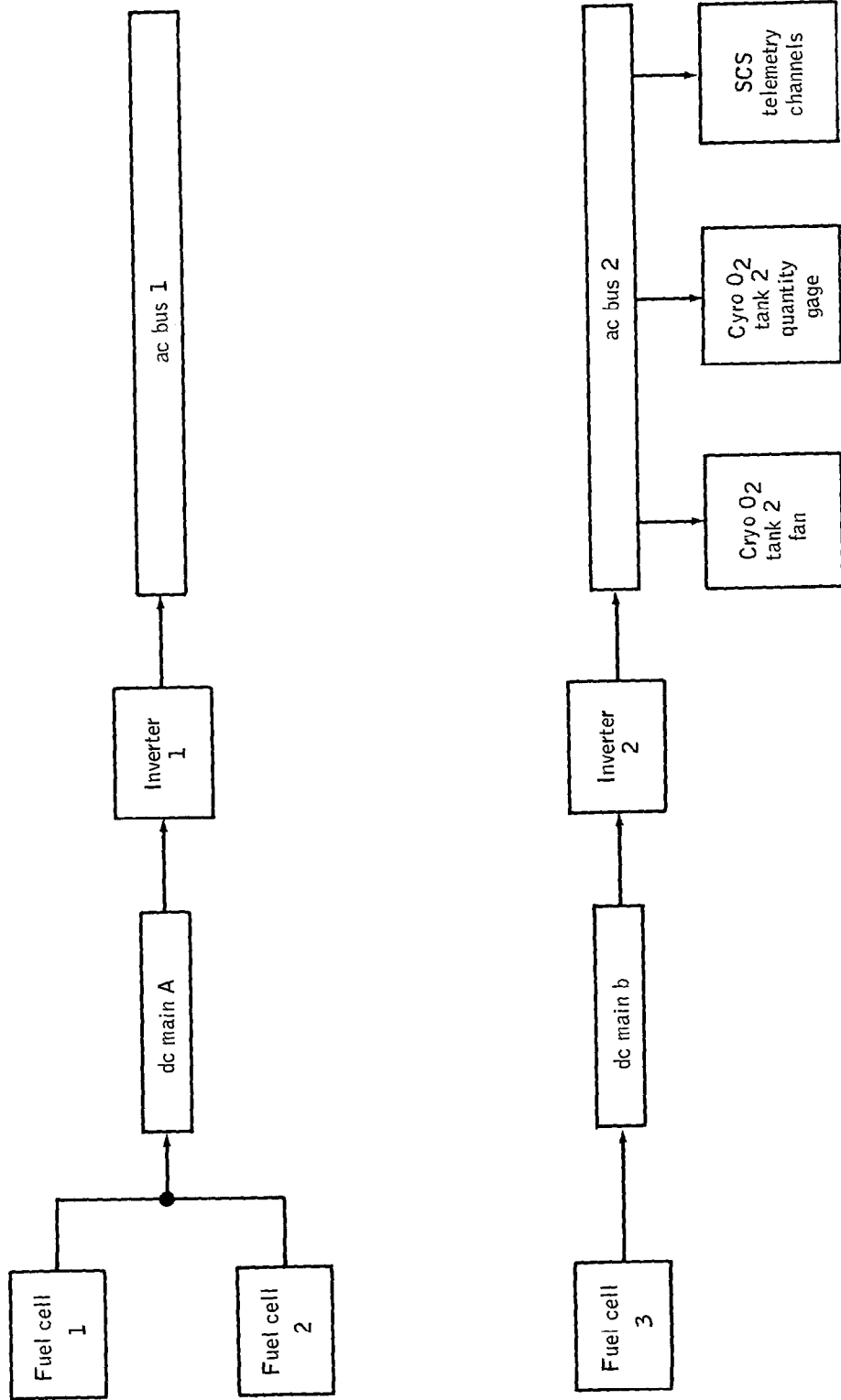

Figure B5-2.- Configuration of electrical power system at 55:53:20.

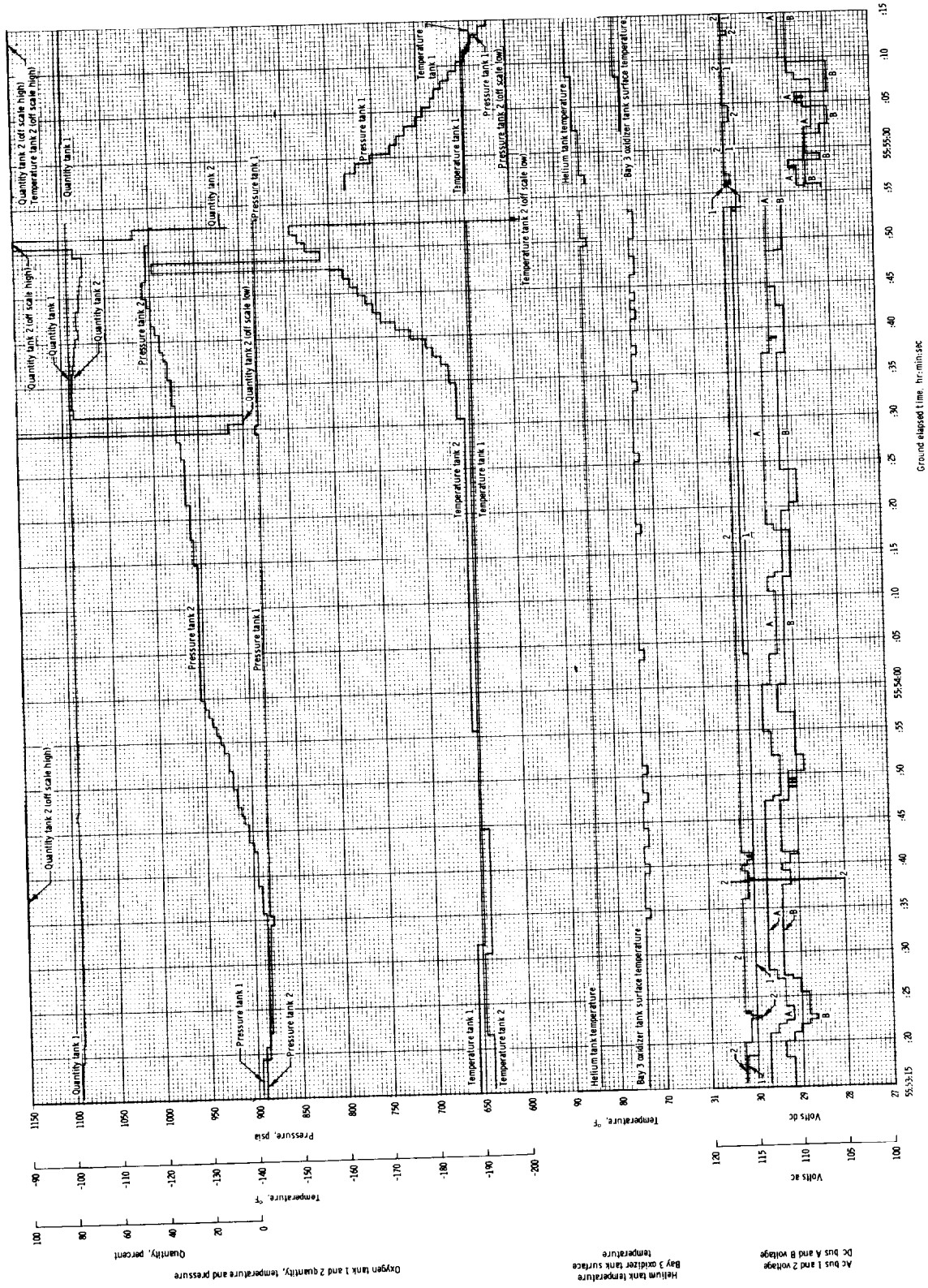

Figure B5-3(a).- Telemetered parameters during anomaly.

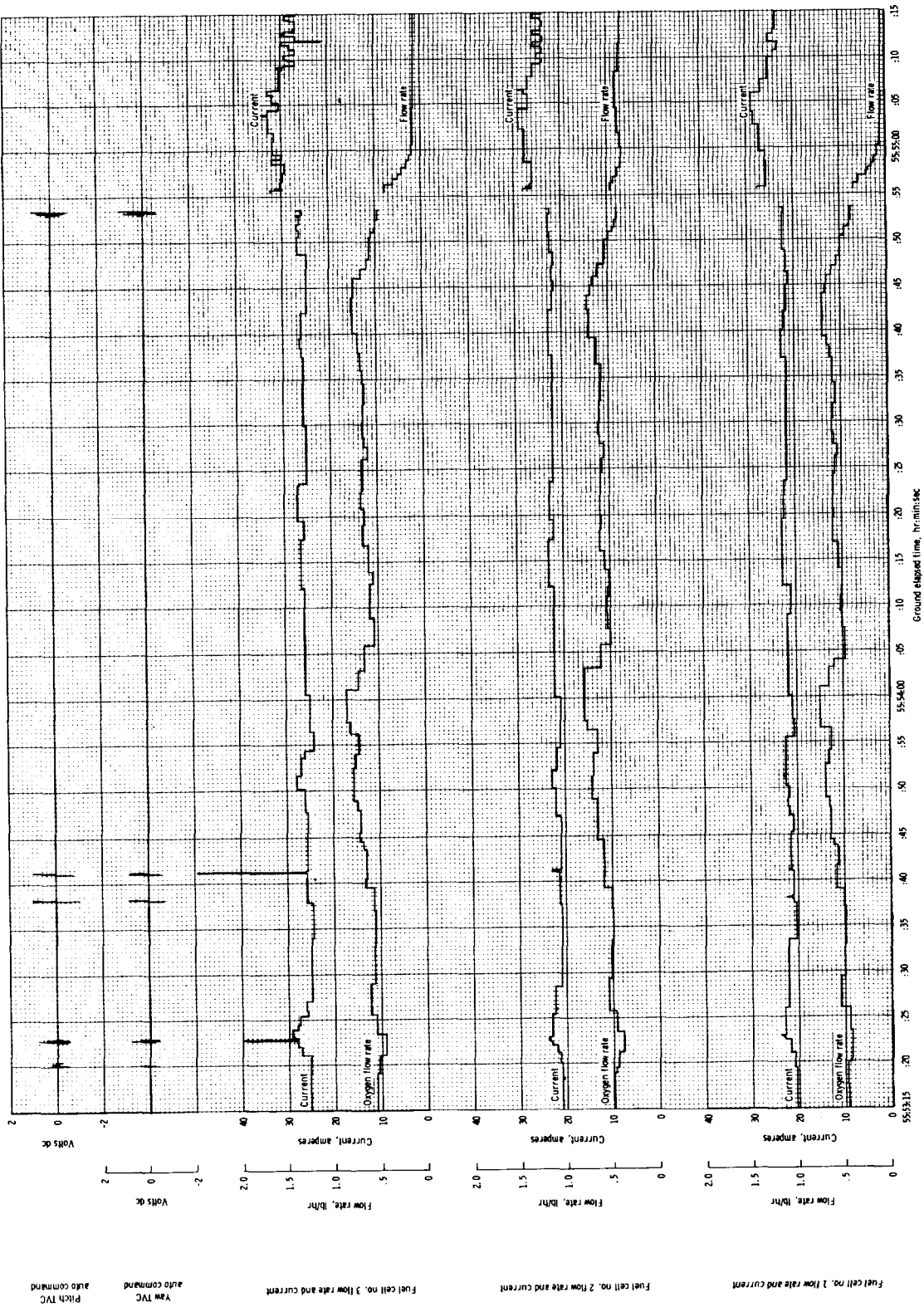

Figure B5-3(b).-- Telemetered parameters, concluded.

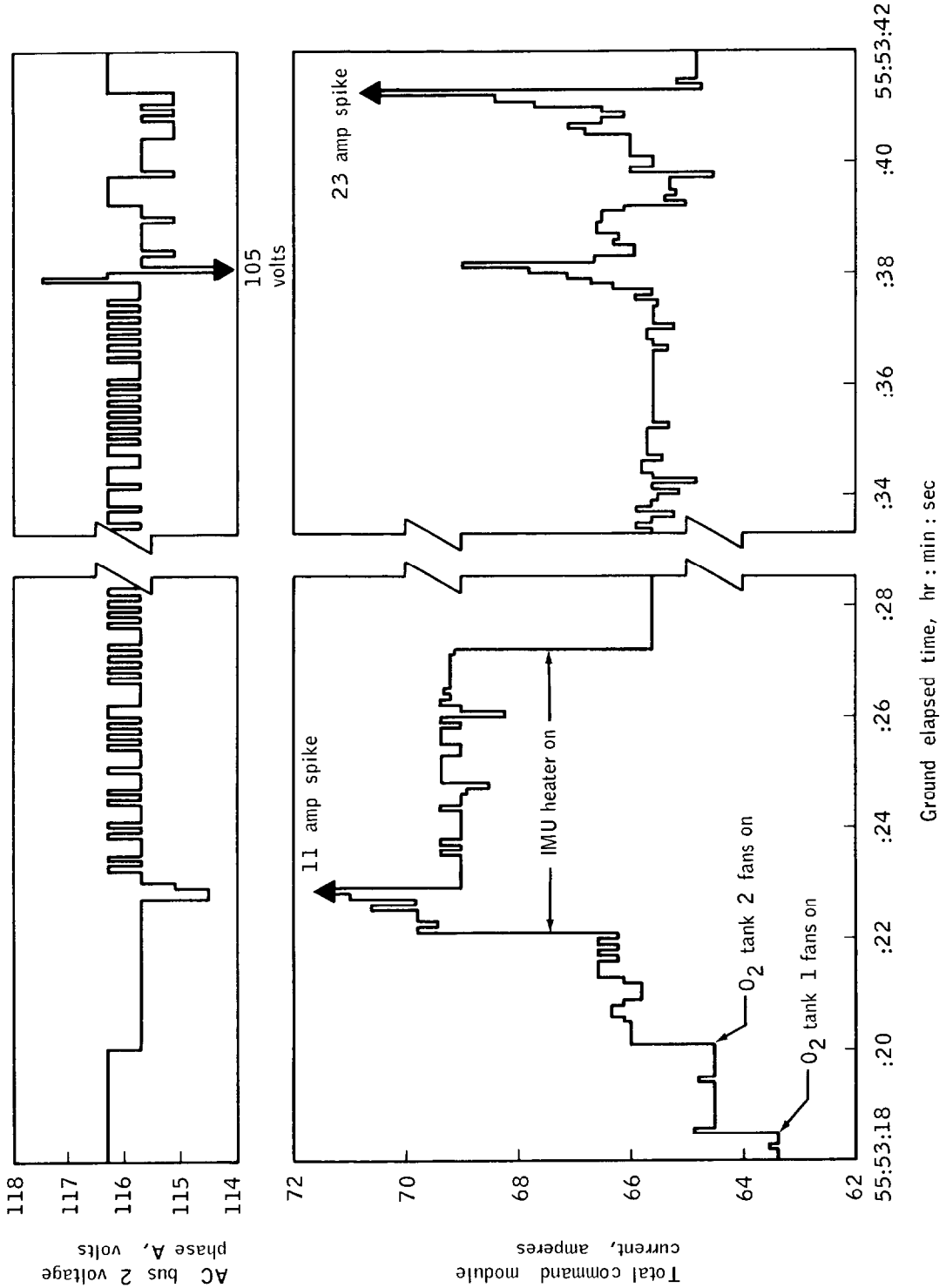

Figure B5-4.- Electrical anomalies.

voltage of 0.6 volt, and a glitch in the stabilization control system telemetry indicated that the fans had been electrically energized. These events are shown in figures B5-4 and B5-5. However, it is not certain that the fans began rotating at this time, since the tank no. 2 pressure showed a minimum observable drop and the fan motor stall current does not significantly differ from the running current. The quantity gage in tank no. 2 was already in a failed condition, and the fuel cell flowmeters were already being affected by the fan operation in tank no. 1 so that neither of these instruments could positively verify rotation of the fans in tank no. 2. During the next 20 seconds a series of electrical anomalies occurred which cannot be explained as a result of known loads in the spacecraft. These anomalies are shown in figure B5-4. The first, at 55:53:23 was an 11-amp positive spike in the output current of fuel cell 3. Several events were associated with this spike:

(a) The command module current decreased approximately 1/2 ampere immediately afterward.

(b) The ac bus 2 voltage had a transient decrease and then began to alternate between 115.7 and 116.3 volts, whereas it had been maintaining a steady value of 115.7 volts since fan turnon.

These events indicate that at the time of the 11-amp spike, a load may have been disconnected from ac bus 2. This could have been one of the fan motors in cryogenic oxygen tank no. 2.

At 55:53:38 another abnormal electrical disturbance occurred, a 3-amp spike of current and variations in ac bus 2 voltage. The ac bus 2 voltage first increased 2 volts and then dropped suddenly from 116 to 105 volts. The ac bus 2 is a three-phase electrical system, although the only voltage telemetered is phase A. The operation of the inverter which generates ac bus 2 is such that it attempts to maintain a constant average voltage among the three phases; if one phase becomes heavily loaded, the inverter will increase the voltages of the other two phases. Consequently, it is possible that the voltage rise in ac bus 2 at 55:53:37.8 was caused by a heavy load applied to phase B or phase C. The decrease in voltage immediately afterward was probably caused by loading of phase A.

At 55:53:41 a 23-amp spike occurred on fuel cell 3 output current, after which the total command module current returned to a steady value within 0.3 ampere of the value prior to turnon of cryogenic oxygen tank no. 2 fans. Also, the voltage of ac bus 2 returned to the value it had shown prior to fan turnon. At the same time transients appeared in the stabilization control system, as shown in figure B5-5.

The most probable cause of the electrical disturbances between 55:53:22 and 55:53:42 is that a short circuit occurred in the electrical

system of the cryogenic oxygen tank no. 2 fans. The short circuit was sufficiently severe to result in loss of part of the fan load at 55:53:22 and the remainder at 55:53:41. Reduction of the load could have been caused by fuses blowing or by wires opening.

It should be noted that the nature of the telemetry records makes it difficult to define the exact parameters of the electrical disturbances. Since the value of fuel cell 3 current is sampled by the telemetry system at 10 times per second, the duration of the observed current spikes is in question by 0.2 second. Also, the peak values of the spikes may well have exceeded the maximum recorded values. For similar reasons a large current spike could possibly have occurred at 55:53:38 simultaneous with the 11-volt decrease of ac bus 2. If the spike were very short, less than 0.1 second duration, it could have occurred between the times of successive telemetry samples and thus not have been recorded.

The electrical anomalies ended by 55:53:42 and no further electrical disturbances were observed for the next minute.

OXYGEN TANK PARAMETERS FROM 55:53:30 UNTIL LOSS OF TELEMETRY

Thirteen seconds after the 11-amp spike and 6 seconds before the 23-amp spike, the pressure in cryogenic oxygen tank no. 2 began a steady increase at an abnormally rapid rate. The increase began at 55:53:35 and lasted 19 seconds before the pressure reached a plateau of 954 psia for 21 seconds. At 55:54:15 the pressure rise resumed, reaching a maximum value of 1008 psia 9 seconds before loss of telemetry. During this rise the master caution and warning trip level of 975 psia was exceeded, but a master alarm was not generated because of the existing cryogenic pressure warning occasioned by low hydrogen pressure. After reaching 1008 psia, the pressure decreased to 996 psia just before loss of telemetry. The oxygen flow rate for all three fuel cells declined for about 10 seconds and then began to rise just before loss of telemetry.

The pressure transducer for cryogenic oxygen tank no. 2 is not located in the tank but is connected to the tank along with a pressure relief valve through 19 feet of tubing. The relief valve is set to open fully at 1008 psia. (See figure B7-4 for a diagram of this portion of the cryogenic oxygen system and Part B7 of this Appendix for a more complete description of the cryogenic oxygen pressure sensing system). The remote location of the oxygen pressure transducer causes some time lag in the telemetered pressure data but unless there are unknown restrictions, such as clogging of the filter at the tank end of the line, this lag will not cause serious errors in the pressure reading under the conditions observed.

This page left blank intentionally.

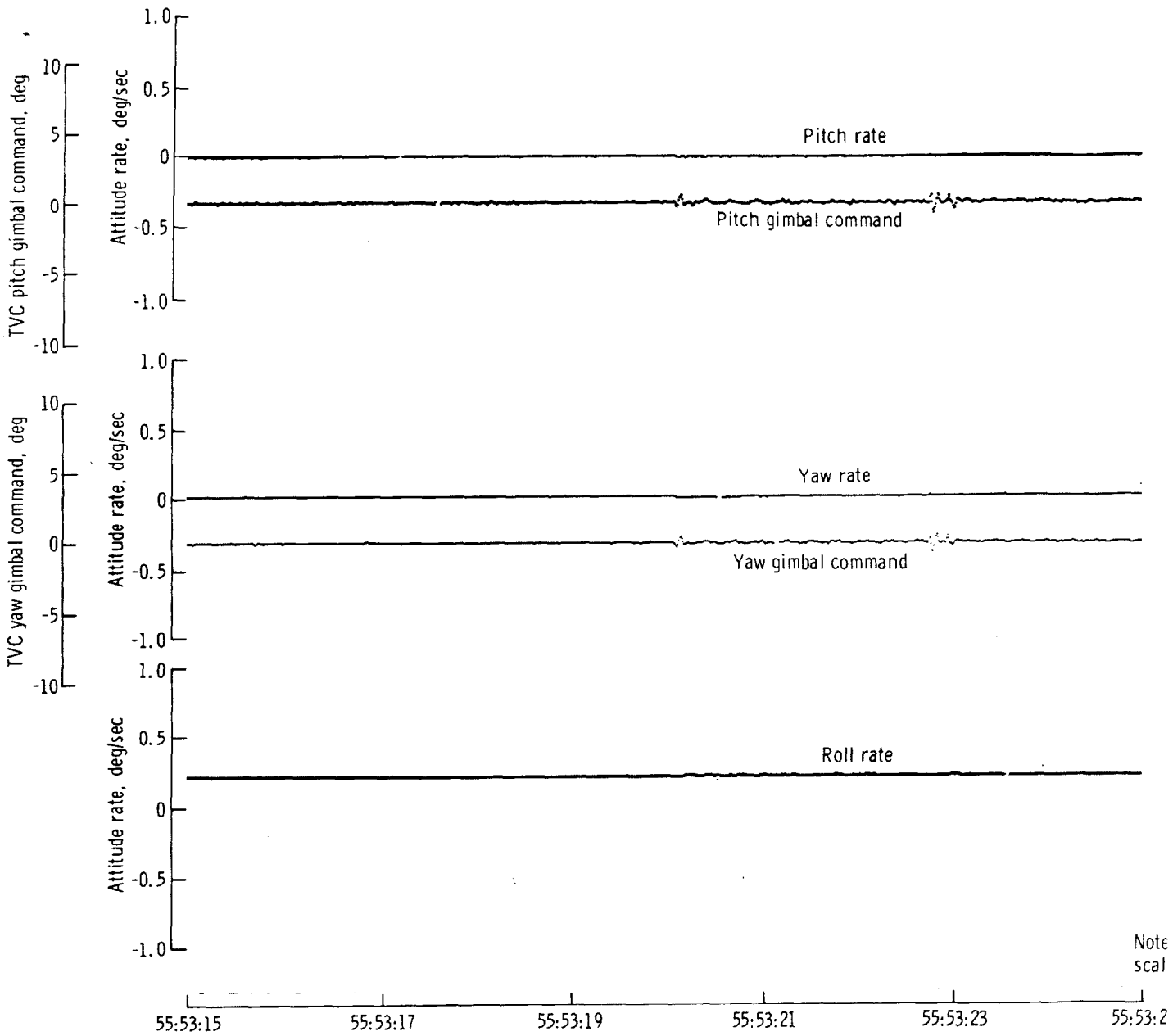

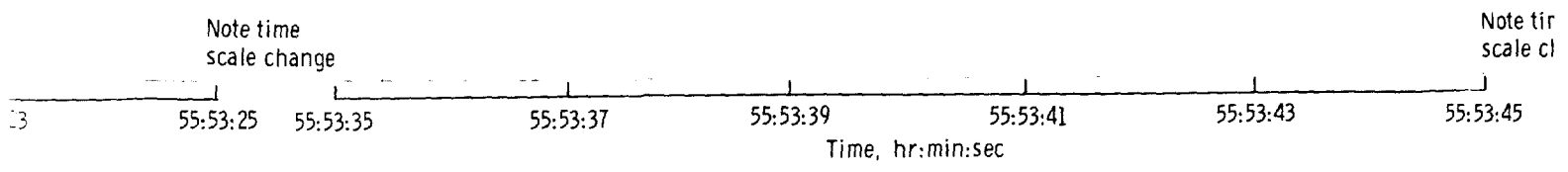
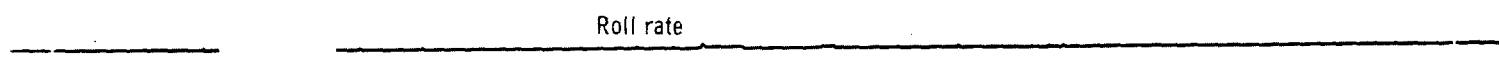
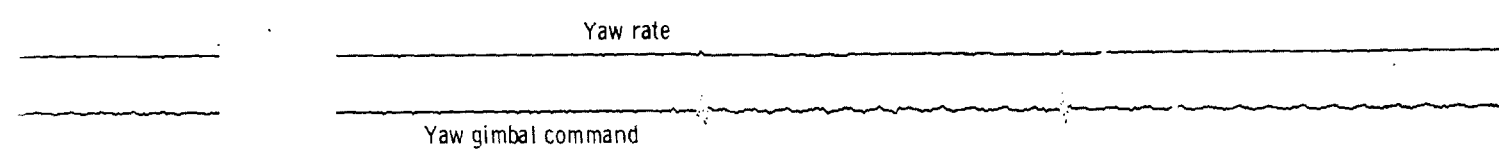
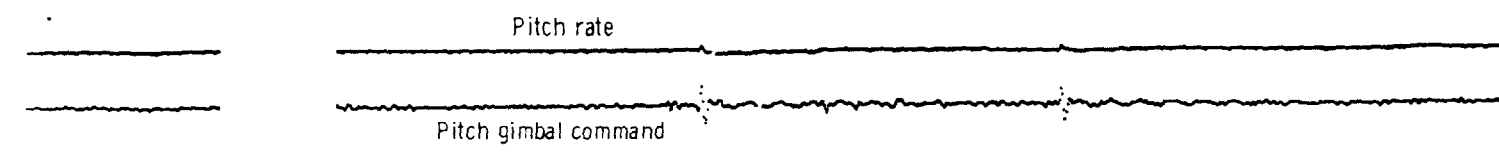

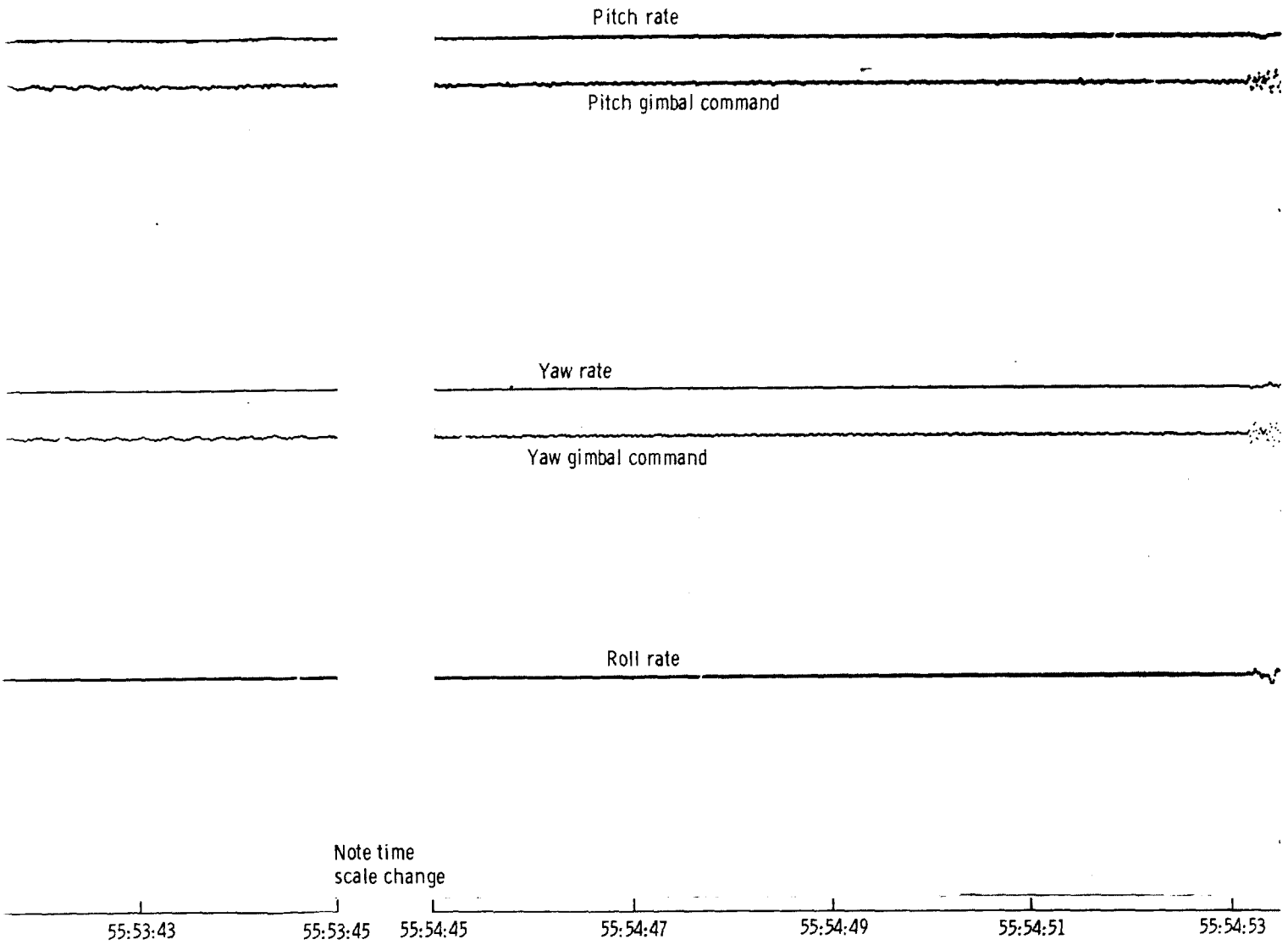

Figure B5-5.- Disturbances observed on thrust vector control gimbal command signals.

The quantity gage for oxygen tank no. 2, which had been in a failed state ever since the 46th hour, suddenly dropped to 6.6 percent and then to off-scale low at 55:54:30. These readings do not correlate with other telemetered data and are, consequently, thought to be erroneous. The gage then jumped to a 75-percent reading, which may be reliable data since it is about the value to be expected. Afterwards the quantity decreased gradually for 19 seconds until 3 seconds before telemetry loss, at which time an erratic gage output occurred. The behavior of this type of gage when a short across the capacitor probe is removed is to drop to zero for several seconds and then return to a correct reading. However, the gage has other failure modes which result in a wandering false indication. See Part B7 of this Appendix for a discussion of the quantity gage. Because of the gage's erratic behavior, it cannot be stated with complete confidence that the 75-percent reading obtained at 55:54:32 is reliable.

The temperature in cryogenic oxygen tank no. 2 remained at -190° F $\pm 2^{\circ}$ until 55:54:31 when a steady rise in temperature commenced. At 55:54:48 a single data sample indicated a reading 40 degrees higher than the adjacent readings. The last data sample before loss of telemetry was off-scale low, probably indicating a short circuit in the gage or wiring. As discussed in Part B7 of this Appendix, the time constant of the temperature sensor is in the order of at least tens of seconds, which means that the 40-degree jump in reading at 55:54:48 and the final off-scale reading were both due to sensor failure or telemetry system errors. Also, because of the slow gage response, the indicated rate at which the temperature rose between 55:54:31 and 55:54:52 could have been caused by an actual temperature rise of greater magnitude.

The temperature and quantity of cryogenic oxygen tank no. 1 remained steady until telemetry loss. The pressure remained nominal until 0.2 second prior to telemetry loss, when a slight drop was observed.

LOSS OF TELEMETRY

At the time of the accident the spacecraft telemetry signal was being received on both a 210-ft-diameter and an 85-ft-diameter antenna at the Deep Space Instrumentation Facility in Goldstone, California. The carrier level on the Goldstone 85-ft antenna was -100 dBm. At 55:54:53 the signal strength dropped abruptly below -160 dBm, the lower limit of the signal strength recorder, and began an erratic increase. Figure B5-6 is a plot of the carrier strength received at the 85-ft antenna, corrected by 8 dB to show the carrier strength received at the 210-ft antenna. The 210-ft antenna was not equipped with a signal strength recorder.

_____ Yaw

_____ Yaw

Figure

B-55

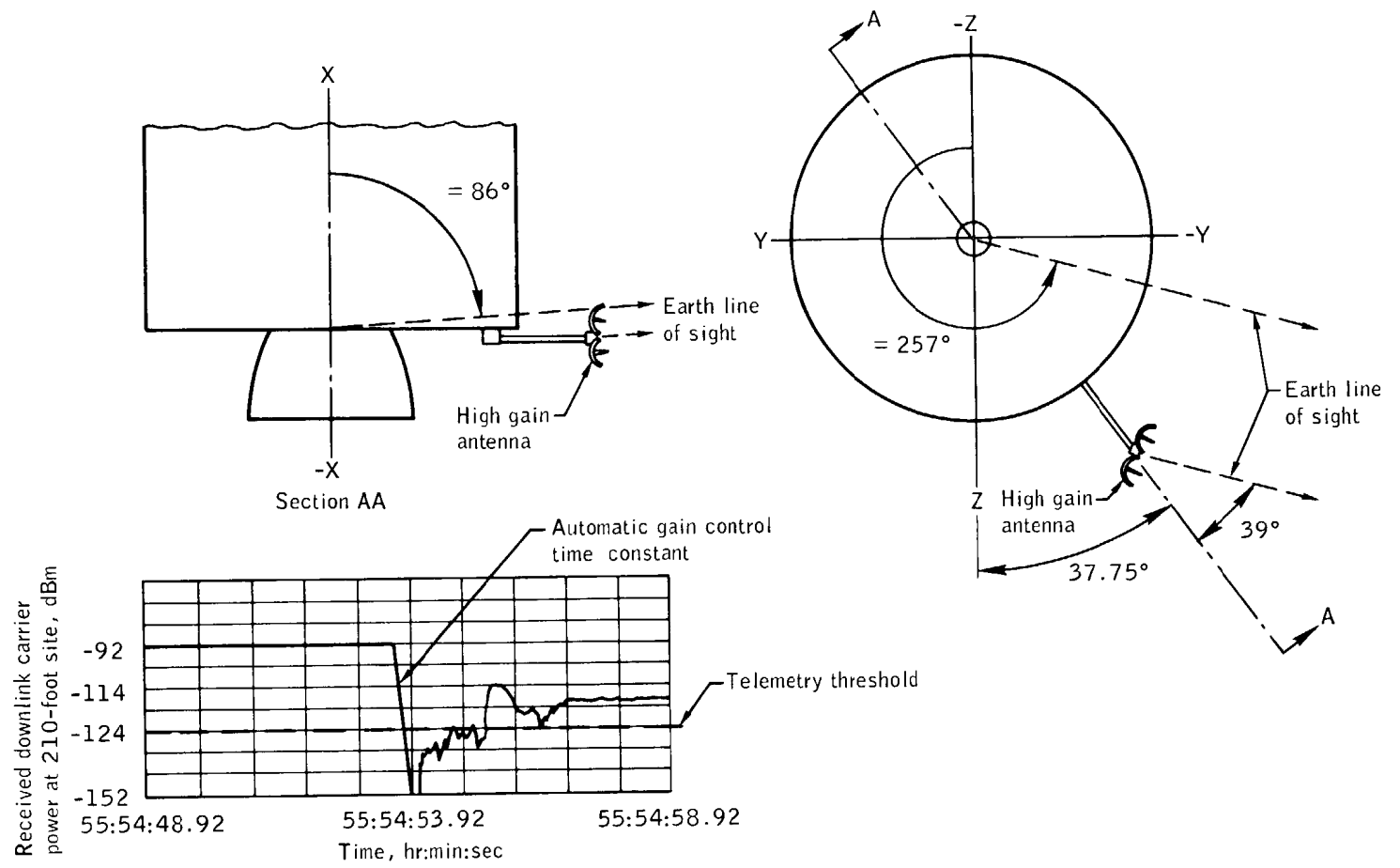

Figure B5-6.- Received S-band downlink power.

Telemetry data recovered completely 1.8 seconds after the loss of carrier power. Sporadic telemetry data are available within the 1.8-second period.

The recorded input signal to the PCM bit detector provides an indication of the rapidity with which the telemetry signal was lost. There appears to be some degradation in signal-to-noise ratio in the time period from 55:54:53.51 to 55:54:53.555. This may have been the result of attitude changes of the spacecraft causing mispointing of the high-gain antenna. At 55:54:53:555 an abrupt change in the character of the signal occurred, and the signal-to-noise ratio rapidly decreased in a period of 1 millisecond. The limitations in the available records make it impossible to definitely determine the speed with which the loss occurred, but an estimate is 1 millisecond.

Although figure B5-6 indicates that the signal required 0.3 second to decrease 60 dB, the actual time was probably much shorter. The decrease of 60 dB in 0.3 second is the same as that obtained when the input signal is abruptly removed from the receiver. This slow response is caused by long time constant circuitry in the automatic gain control.

When the telemetry signal was reacquired, the spacecraft had switched from the narrow-beam antenna to the wide-beam antenna. This has been verified by signal-strength calculations and comparisons of antenna patterns with spacecraft attitude. The spacecraft is designed to automatically switch to the wide-beam antenna if the pointing error of the narrow-beam antenna exceeds 3 degrees.

If a power supply interruption larger than 0.4 second occurs in the communication system, the system design is such that the power output will automatically drop 19 dB for a 90-second period. This power reduction cannot be observed in the received signal strength after recovery of telemetry.

SPACECRAFT EVENTS AT THE TIME OF TELEMETRY LOSS

A large number of spacecraft events took place approximately at the time of telemetry loss. These events are discussed in detail in the following sections as they relate to the various spacecraft systems. This section describes the events as an aid in understanding their interrelationship.

Within the last second prior to telemetry loss, several indications of spacecraft motion appeared on the telemetry records of body accelerometers, and roll, pitch, and yaw rate. The total fuel cell current increased by 3 amperes at the last data sample.

When telemetry data were restored at 55:54:55.35, a large number of channels associated with the electrical system, stabilization control system, and cryogenic system showed marked changes (fig. B5-3). Both dc main A and main B had dropped 0.9 volt and the master caution and warning had been triggered because of an undervoltage on main bus B. The undervoltage triggering level is 26.25 volts and the initial voltage on main B registered 28.1 volts. All three fuel cell currents had increased by 5 amperes over the values before telemetry loss. Both ac bus voltages had maintained their previous values. All telemetry readings from cryogenic oxygen tank no. 2 showed off-scale readings. The temperature was off-scale in the high temperature direction, the quantity gage read 100 percent, and the pressure gage read off-scale low. The capability of the gage is to read pressures as low as 19 psia. Cryogenic oxygen tank no. 1 had not changed temperature or quantity. However, the pressure had decreased from 879 psia to 782 psia. The regulated nitrogen pressure in fuel cell 1 dropped to zero during telemetry loss and remained at zero. The continued operation of this fuel cell indicates a sensor malfunction. As shown in figure B5-7, the wires from the nitrogen pressure sensor to the telemetry system pass along the front of the shelf which supports the fuel cells, in close proximity to the panel covering bay 4. It is quite possible that damage to these wires caused the change observed in the nitrogen pressure reading.

Approximately at the time of telemetry loss all three crew members heard a single loud bang. One or two seconds later they noted the master caution and warning caused by main bus B undervoltage and at 55:55:00 turned off the alarm. They also verified that fuel cell currents were normal at this time. Figure B5-8 is a photograph of the command module control panel showing the type of displays provided the crew. At 55:55:20 the crew reported, "I believe we've had a problem here," and at 55:55:35, "We've had a main B bus undervolt." Later they reported that a computer restart had occurred at the time of the bang, which had already been noted in Mission Control.

Photographs later taken by the crew show the panel covering bay 4, the bay containing the cryogenic oxygen tanks, cryogenic hydrogen tanks, and fuel cells, to be missing. One of these photographs is reproduced in figure B5-9 and a photograph prior to launch is shown in figure B5-10. The high-gain antenna located adjacent to bay 4 shows a misalignment of one of the four dishes. The photographs also show that the axes of fuel cells 1 and 3 have shifted 7 degrees in such a way that the tops of the fuel cells point outward. It is not possible to determine conclusively from the photographs whether or not cryogenic oxygen tank no. 2 is present, partially missing, or totally missing. It is probable that the loud bang heard by the crew was caused by the separation of the panel from the spacecraft approximately at the time of telemetry loss.

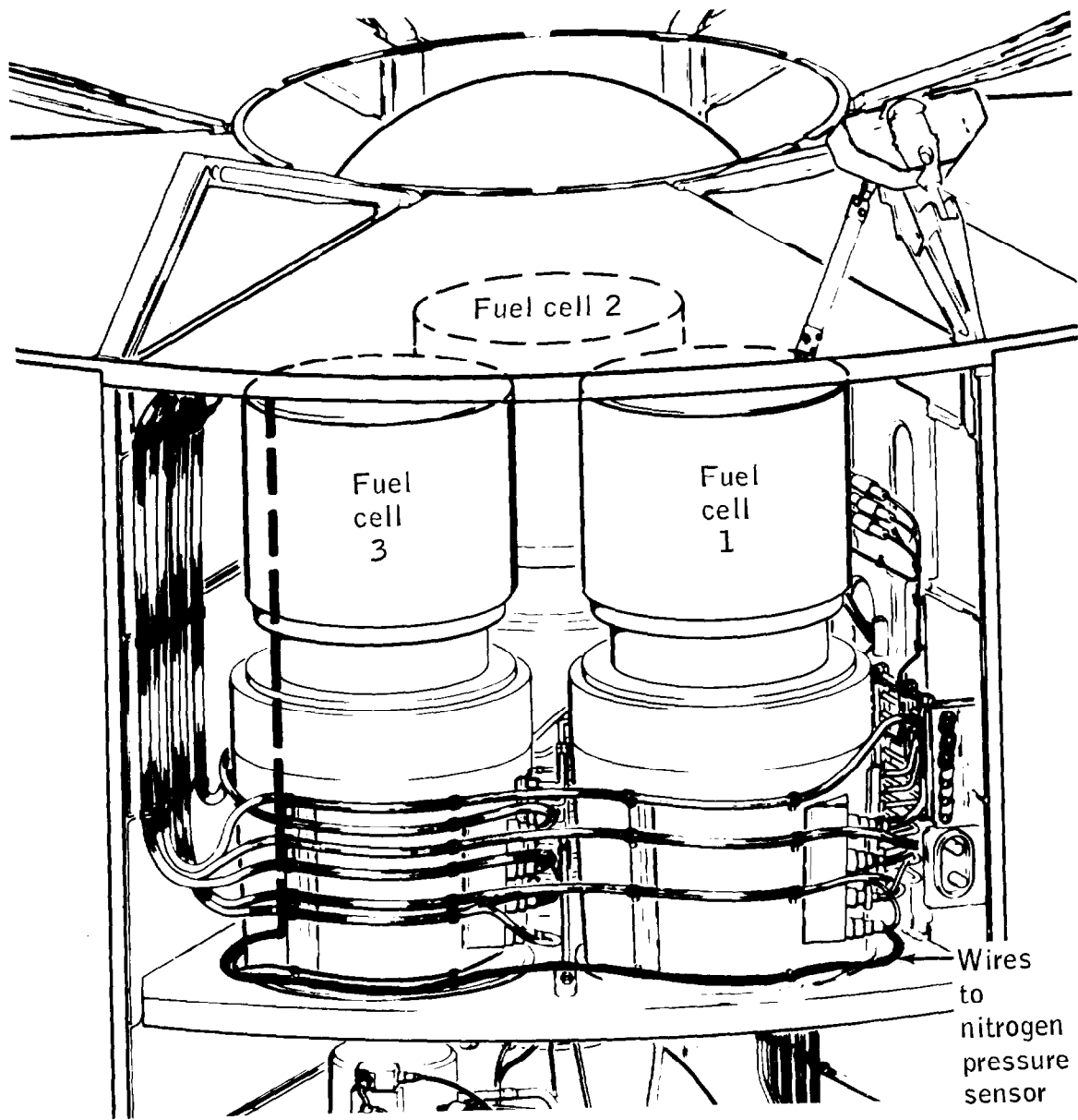

Figure B5-7.- Location of wiring to nitrogen pressure sensor in fuel cell 1.

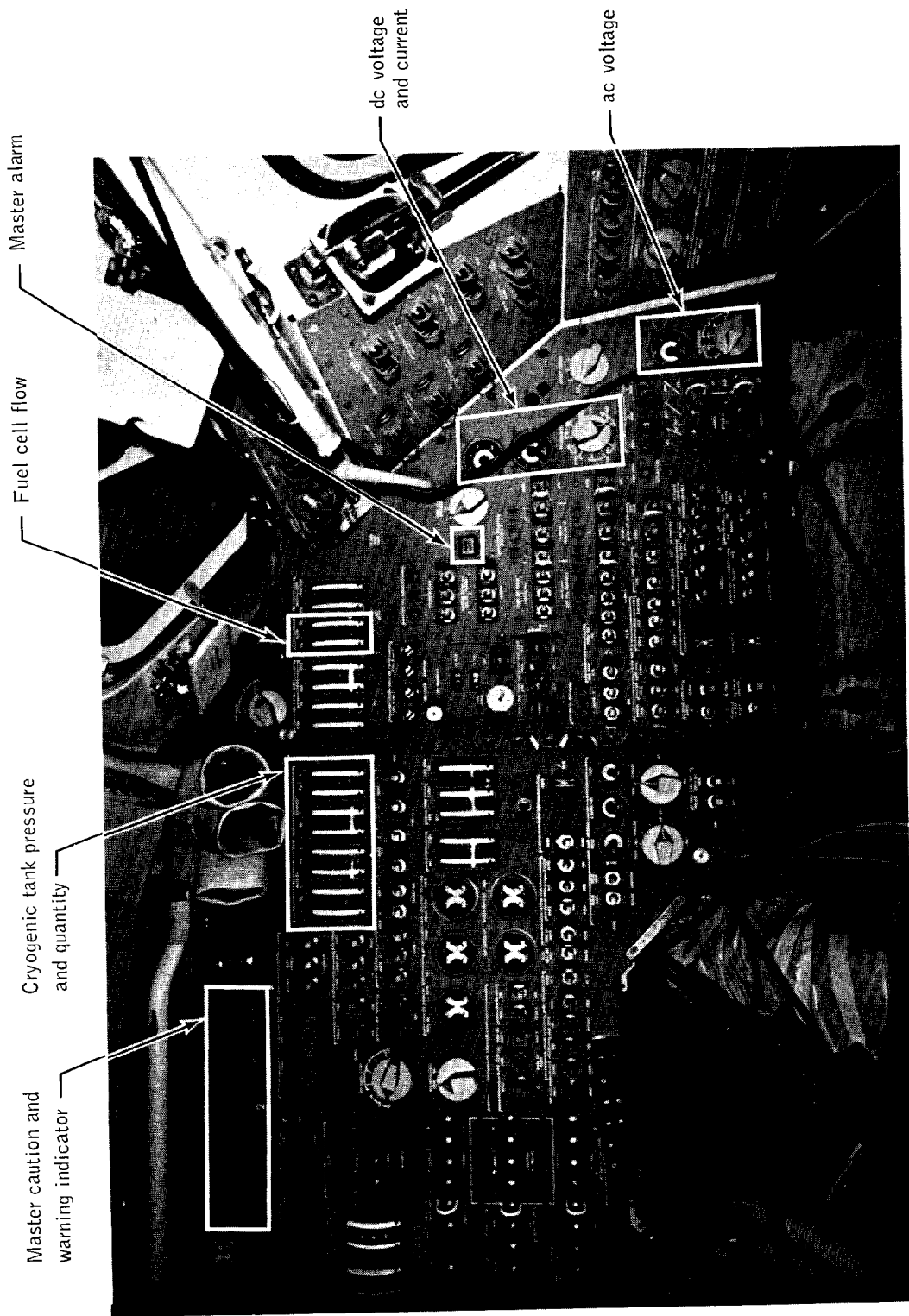

Figure B5-8.- Command module instrument panel.



Figure B5-9.- Photograph of service module taken by crew.

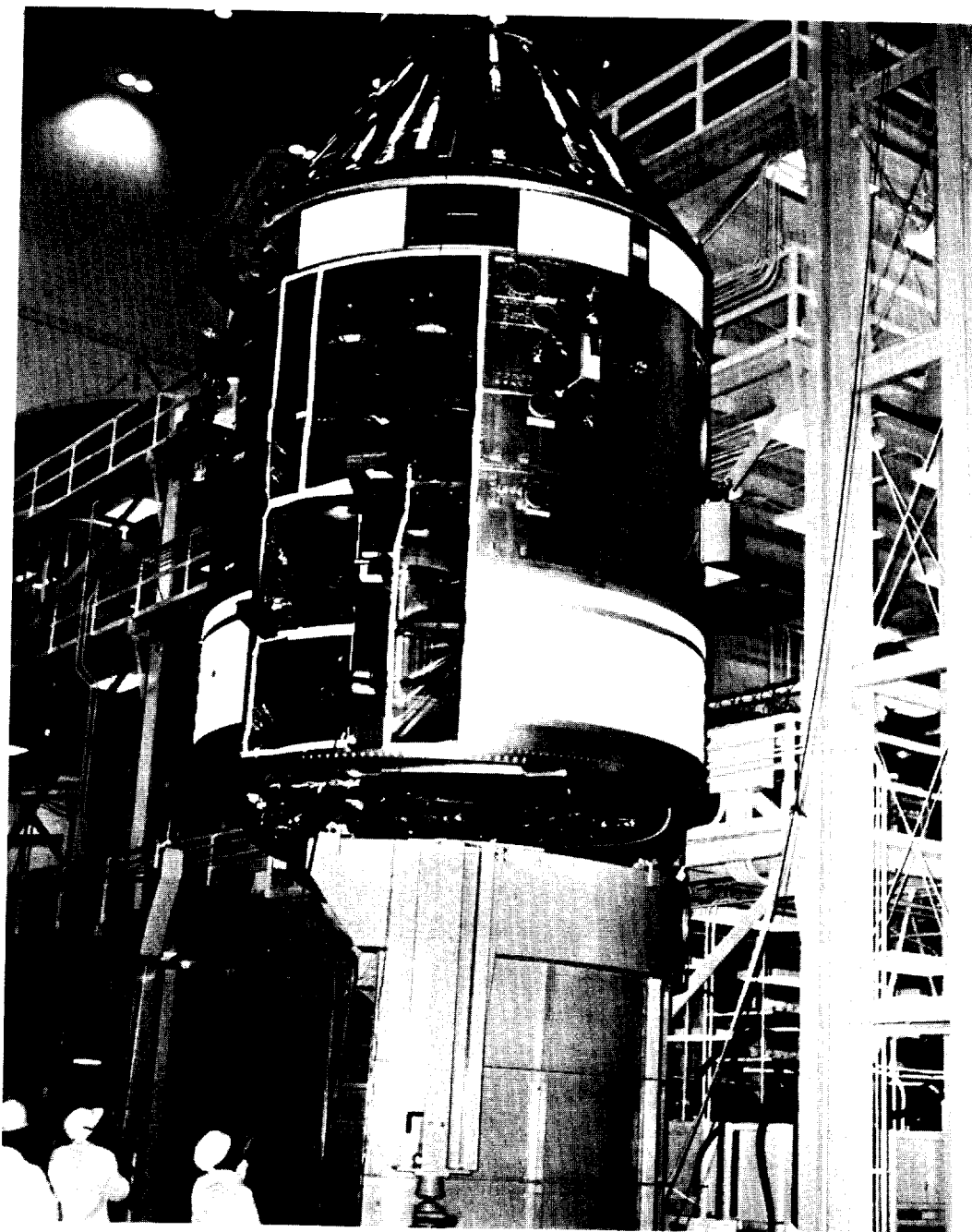

Figure B5-10.- Bay 4 of service module.

CHANGES IN SPACECRAFT DYNAMICS

At 55:54:53.182, less than half a second before telemetry loss, the body-mounted linear accelerometers in the command module, which are sampled at 100 times per second, began indicating spacecraft motions. These disturbances were erratic but reached peak values of 1.17g, 0.65g, and 0.65g in the X, Y, and Z directions, respectively, about 13 milliseconds before data loss.

At 55:54:53.220 the pitch, roll, and yaw rate gyros indicated low-amplitude variations in output. These gyros are body mounted in the command module, have a full-scale range of ± 1 degree per second, are sampled 100 times per second, and provide a fairly sensitive indication of spacecraft motions. They are also sensitive to electrical disturbances not necessarily associated with the gyros; however, the characteristics of the output at 55:54:53.220 are believed to have resulted from low-amplitude dynamic forces acting on the spacecraft. These channels were, of course, lost at 55:54:53.555, along with all other telemetered data. Figure B5-11 is a record of all three rate gyro outputs.

When telemetry was recovered at 55:54:55.35, these channels definitely indicated that moments had been applied to the spacecraft. The total change in angular moment was:

Roll	-1535 ft-lb-sec
Pitch	-6482 ft-lb-sec
Yaw	-5919 ft-lb-sec

The roll, pitch, and yaw rates were automatically compensated for by the attitude control system, as shown in figure B5-11.

The inertial platform on the command module contains three mutually orthogonal integrating accelerometers, whose outputs are telemetered with an increment value of 0.2 fps. After telemetry was recovered, a change of two increments was observed in one axis, one increment in the second axis, and zero increments in the third axis.