



THE INTERAGENCY GPS EXECUTIVE BOARD

STEWARDSHIP PROJECT #204

GPS L1 Civil Signal Modernization (L1C)

JULY 30, 2004



Kenneth W. Hudnut, Ph.D.
L1C Project Civil Co-Leader
Department of the Interior
United States Geological Survey
(626)583-7232
hudnut@usgs.gov



U.S. AIR FORCE

Bryan Titus, Captain, USAF
L1C Project Military Co-Leader
Navstar Global Positioning System
Space and Missile Systems Center
(310)363-6899
bryan.titus@losangeles.af.mil

This report represents an input to the U.S. Government based on a study sponsored and funded by the Interagency GPS Executive Board. The findings and recommendations in the report do not represent an official policy of the U.S. Government or programmatic decision of any acquisition executive of the U.S. Government.

Table of Contents

1.0	EXECUTIVE SUMMARY	1
2.0	INTRODUCTION.....	3
3.0	PROJECT OBJECTIVES.....	4
4.0	PROCESS DESCRIPTION	5
4.1	Overview	5
4.2	Technical Feasibility Determination	7
4.3	Expert Presentations and Questionnaires	8
4.4	User Group Interviews	10
5.0	EXPERT INTERVIEW RESULTS AND ANALYSIS	10
5.1	Technical Feasibility Results.....	10
5.2	Expert Interview Results.....	13
5.2.1	Response Statistics and Summary	13
5.2.2	Should L1C be Implemented?	16
5.2.3	Modulation Preferences	17
5.2.4	The Message Data Rate Dilemma.....	18
5.2.5	Data Rate Analysis and Recommendation.....	21
5.3	Expert Interview Signal Recommendations	24
6.0	MARKET SEGMENT SIGNAL NEEDS AND USER FEEDBACK	25
6.1	Single-Frequency Applications Dominate	26
6.2	Which will be the Single Frequency of Choice?.....	27
6.3	Market Segments	29
6.3.1	Consumer Product Needs for a New Signal	29
6.3.2	Aviation Signal Requirements	30
6.3.3	Professional and Scientific Signal Requirements	31
6.4	User Interviews.....	32
7.0	CONCLUSIONS AND RECOMMENDATIONS.....	33
8.0	ACKNOWLEDGEMENTS:	34

L1C FINAL REPORT

TABLE OF ATTACHMENTS

<u>A-1.0</u> : L1C Initial Presentation at CGSIC; Portland, Oregon; September 8, 2003	A 2
<u>A-1.1</u> : Presentation and Questionnaire Provided at NAVCEN Booth during ION GPS-2003.....	A 13
<u>A-1.2</u> : <u>GPS World</u> article on L1C Project (October 2003 issue)	A 18
<u>A-2.0</u> : L1C Presentation at GPS System Engineering Forum (GSEF); Los Angeles, California; October 28-29, 2003	A 19
<u>A-3.0</u> : L1C Paper presented at International Civil Aviation Organization (ICAO) - Air Navigation Conference (ANC), Navigation Systems Panel (NSP); Canberra, Australia; November 11, 2003	A 44
<u>A-3.1</u> : L1C ‘flimsy’ for ICAO ANC NSP feedback	A 48
<u>A-3.2</u> : ICAO Contracting States listing	A 54
<u>A-4.0</u> : L1C Presentation at International GPS Service (IGS) 10 th Annual Meeting; Berne, Switzerland; March 3, 2004	A 59
<u>A-4.1</u> : L1C Poster – presented at IGS Meeting.....	A 74
<u>A-5.0</u> : L1C Presentation (Parts I & II) at IEEE PLANS; Monterey, California; April 28, 2004	A 75
<u>A-6.0</u> : Annotated L1C Technical Interview Presentation	A 108
<u>A-6.1</u> : Questionnaire Used for Experts Survey	A 134
<u>A-7.0</u> : L1C Technical Questionnaire Responses (55 responses included).....	A 136
<u>A-8.0</u> : Civil User Benefits	A 347
<u>A-8.1</u> : User Group Guidelines.....	A 392
<u>A-9.0</u> : Economic Benefits.....	A 395

1.0 Executive Summary

The objective of this document is to report the findings of the L1 Civil Signal Modernization (L1C) Stewardship Project (Technical Project #204) to the Interagency GPS Executive Board (IGEB) in support of policy decisions about whether or not to endorse a 4th civil signal on the Navstar Global Positioning System (GPS). The report also provides support for decisions about what characteristics are most important for this potential new civil GPS signal.

The IGEB funded this project in August of 2003 to provide recommendations (based both on technical work and stakeholder feedback) on whether or not a modernized civil signal (L1C) could and should be added at L1. Because of funding restrictions, the objectives and the results were limited to:

1. Determine if it would be possible, technically, to insert a new civil GPS navigation signal at the L1 frequency in addition to the C/A code, P(Y) code, M code, and Interplex code.
 - **Our technical team evaluated this issue and concluded it is possible to add L1C while maintaining a constant transmitted signal amplitude and preserving “flex” power control options.**
2. Determine if a broad and representative range of civil GPS experts and users want L1C in addition to the current C/A code.
 - **Based on small group presentations followed by questionnaires to centers of GPS expertise, including U.S. government agencies, GPS equipment manufacturers, and university departments specializing in GPS applications, 55 responses were received from around the world. The survey result is unambiguous that L1C is desired, even at the expense of a slight reduction in the C/A signal power.**
3. Determine what L1C signal characteristics would be most desirable for the widest range of user applications. In particular, two key characteristics were evaluated:
 - a. Modulation waveform, with the options being BOC(1,1) and BOC(5,1).
(Note: BOC(1,1) was accepted as the modulation template through EU/US negotiations during the course of this project. At one time the Galileo team was evaluating subtle alternatives to BOC(1,1). If a better modulation is found which meets the EU/US agreements on signal compatibility, the U.S. should be prepared to implement it instead of BOC(1,1). However, such a replacement would have to be studied very carefully, justified thoroughly, and is very unlikely.)
 - **The survey result is clear that most experts prefer BOC(1,1) for all L1C potential applications.**
 - b. Message data rate and content, with the options being 25, 50, and 100+ bits per second (bps)

- **The answer is clear, although with less unanimity, that L1C should provide a data rate of 25 bps with no additional messages. This optimizes signal robustness for all applications. An equal number of requests were made for a higher data rate, although for at least three different and conflicting requirements, not all of which could be accommodated concurrently. This recommendation leaves differential GPS signals, integrity messages, long duration orbit and clock parameters, or simply faster orbit and clock parameters to other communication services, which either exist now or are rapidly developing, and which are better suited to these specialized tasks.**

Had the originally requested funding been available, this project would have next addressed specific technical design issues in order to prepare high-level L1C signal recommendations to guide development and documentation of L1C signal details, including:

- A proposed specific method of adding L1C to the existing suite of L1 signals
- Details of the recommended modulation waveform, e.g., BOC(1,1)
- A recommended code generation method, and recommended code lengths, for each of the two L1C signal components
- A recommended forward error correction algorithm and additional message content if needed

Should additional funding be made available, we recommend these follow-on actions and would be pleased to continue our work:

- Contact all the survey respondents and additional interested parties, asking them to review this report in order to fully validate or, if necessary, slightly modify its conclusions
- Perform technical studies to determine how best to incorporate the L1C signal
- Review forward error correction (FEC) options to determine if changing from the current L2C and L5 standard would be worth the potential improvement in error rate
- Propose specific code generation methods and code lengths for each L1C signal component
- Prepare a top level signal description to enable the Interface Control Working Group (ICWG) to develop detailed specifications
- Interact with the GPS/Galileo interoperability working groups to optimize the worldwide civil user benefits while protecting allied military effectiveness

This IGEB Stewardship Project has been successful in establishing the feasibility, desirability, and some of the key characteristics of an L1C signal. The processes used to reach these conclusions included (a) assembly of a technical team to conduct analyses and then reach conclusions during a two-day meeting at the GPS Joint Program Office (JPO), (b) public presentations and papers that supported the overall goals of the project, answered questions, and elicited feedback, (c) individual technical presentations to GPS experts in government agencies, GPS companies, and at universities to obtain specific recommendations on an L1C questionnaire, and (d) interviews with user groups to determine the benefits GPS now provides and what improvements would be most helpful to their applications. This report documents the processes,

the materials created, the results obtained, and the conclusions and recommendations reached, as delineated at the beginning of this Executive Summary.

The L1C team wishes to express its thanks to the IGEB Senior Steering Group (SSG) and the Director's office of the IGEB Executive Secretariat for enabling this study and for guidance during this nearly year-long effort. We also are particularly grateful for the time and effort of the many organizations and their staff who participated in the expert group briefings and responded with meaningful answers, comments, and suggestions. Without this volunteer work, from around the world, the project could not have succeeded. Through it all, it was gratifying to find clear answers to important questions about the future of GPS.

Finally, it is important to highlight the splendid working relationship between the GPS JPO and the USGS. Both parties worked cooperatively to fully protect national security interests while providing civil users the best possible service. This project has been an excellent example of dual-use GPS stewardship.

2.0 Introduction

GPS is in the midst of a radical, albeit gradual, transformation. From launch of the first GPS satellite in 1978 through all of 2003 there have been only three navigation signals on only two frequencies. With these signals, GPS has completely changed how the world navigates. However, over the next several years the number of navigation signals will increase from three to seven and the number of frequencies from two to three. In addition, the new signals will have substantially better characteristics, including a pilot carrier, much longer codes, the use of forward error correction, and a more flexible message structure with much better resolution. New and modern civil signals will be on L2 and on the new L5 frequency. The current GPS modernization plan, however, leaves the L1 frequency with only the outdated C/A signal for civil applications. With the addition of L1C, all three GPS frequencies would then provide a modernized civil signal, completing the GPS modernization process.

There is good reason to concentrate attention on L1. Today it carries C/A, the only civil GPS signal. In the future, even with new and modern L2 and L5 signals, L1 is expected to remain the most important civil frequency. This is primarily because it is less affected by ionospheric refraction error than L2 or L5. (L1 has only 61% of the L2 error and 56% of the L5 error.) This inherent advantage relative to L2 and L5 helps motivate the basic goal of this project.

The L1C project was initiated to determine whether it would be technically possible to add L1C to an already crowded suite of L1 signals, to determine whether GPS users could use and would welcome L1C, and to determine what L1C characteristics would be most valuable for the broadest range of GPS users. This report documents the activities, the presentation materials, the processes used, the results we have obtained, and the conclusions we have reached.

Section 3.0, immediately below, reviews the Project Objectives. It recognizes that the objectives had to be narrowed because of funding restrictions, and it defines the steps that would have been taken next without these restrictions (or that can be taken next if funds become available).

Section 4.0 then provides a description of the processes used to achieve these objectives. The overview in Section 4.1 includes a review of supporting activities, including multiple presentations, literally around the world. Section 4.2 then describes the evaluation process used to determine whether L1C technically can be added to the other L1 signals. Section 4.3 defines the process of reaching out to a wide range of worldwide GPS experts, defining the L1C issues through multiple presentations to small government, industry, and academic centers, and obtaining valuable answers and comments from the overwhelming majority. Section 4.4 describes the parallel process of interviewing many GPS users to determine how GPS is valuable and what improvements they would most appreciate.

Section 5.0 presents and evaluates the expert interview results. Included in Section 5.1 is a discussion of the technical evaluation of the GPS L1 signal structure to determine whether one more signal can be added, while retaining the required characteristics of a constant amplitude composite signal and the ability to control the allocation of power to each individual signal. Section 5.2 reports the results from the expert surveys, statistically evaluating the source of the responses, whether the experts support the addition of L1C, which modulation is preferred by the experts, the apparent data rate dilemma, and how the dilemma was resolved. Section 5.3 summarizes the signal recommendations based on the expert interviews.

Section 6.0 provides an overview of user signal requirements by market segment. It then summarizes results from informal user group interviews. Users were asked why and how GPS is useful and important now and what improvements would be most appreciated.

Section 7.0 presents the Project Conclusions and Recommendations, and Section 8.0 offers acknowledgements to the key participants.

This report also includes a large number of attachments. These include most of the presentation materials used during the project. Of particular importance are:

- Attachment 6.0 Presentation given to most of the GPS experts, explains the issues and the options
- Attachment 6.1 Questionnaire the experts were asked to return with answers and comments
- Attachment 7.0 The 55 individual responses to the questionnaires
- Attachment 8.0 Review of user group needs and perspectives

3.0 Project Objectives

The objectives have been narrowed since this project was first proposed in August 2003. There are two reasons for this. First, the funding was about half what had been requested, so we de-scoped accordingly, reducing our planned level of effort on both the technical work and stakeholder feedback work. Second, the U.S. and the European Union (EU) commenced and recently completed negotiations about the compatibility of Galileo L1 signals with both military and civil GPS signals. As part of these negotiations, the U.S. Department of State offered that the U.S. would implement a new signal on L1 with BOC(1,1) modulation if Europe would do the same on Galileo. Although there is room for both sides to deviate somewhat from this particular

modulation, as long as the compatibility requirements are met, the specific modulation question was no longer as important a question for this project to resolve.

Therefore, the narrowed L1C project objectives have been to:

1. Determine technical feasibility of adding another civil GPS navigation signal at the L1 frequency in addition to the C/A code, P(Y) code, M code, and Interplex code signals.
2. Determine, by means of presentations and interviews, if a broad and representative range of civil GPS experts and users want an L1C in addition to the current C/A code.
3. Determine what L1C signal characteristics would be most desirable for the widest range of user applications. In particular, two key characteristics were evaluated:
 - a. Modulation waveform, with the options being BOC(1,1) and BOC(5,1) (Note: BOC(1,1) was chosen as the preferred modulation template through US/EU negotiations during the course of this project, although there is room for further evaluation and a different agreement by both parties.)
 - b. Message data rate and content, with the options being 25, 50, and 100+ bps
4. Prepare a high-level L1C signal specification to guide development of the signal details, including:
 - c. A proposed method of adding L1C to the existing suite of L1 signals
 - d. A recommended modulation waveform, e.g., BOC(1,1)
 - e. Recommended code generation and code lengths for the two L1C signal components
 - f. Recommended data rate, forward error correction, and additional message content if needed

Objectives 1, 2 and 3 have been accomplished to the extent possible with resources available, on time and on budget. The 4th objective has not been realized due to limited resources. The following section describes the methods we used to achieve the first three objectives.

4.0 Process Description

4.1 Overview

Three main activities were used to achieve the project objectives. The first was to determine the feasibility of adding another signal to the already crowded L1 signal structure. Ever since the start of GPS there have been two signals at L1, the C/A code and the P(Y) code, which are transmitted in phase quadrature. A key objective has always been for the composite signal to have a constant amplitude in order to maximize transmitter efficiency. Thus, to add the two components of the new military M code required some clever engineering. Chip by chip multiplexing of the M code is used to provide both a data signal component and a data-less, or pilot carrier, signal component in a single bi-phase composite signal. To achieve a constant transmitted signal amplitude, a fourth “Interplex” signal was then introduced. Therefore, to add the two components of an L1C signal while maintaining a constant amplitude was seen as quite a challenge. This activity also assessed the potential interference of L1C to legacy C/A receivers, recognizing that full backward compatibility is essential. After considerable preliminary work, a

two-day technical meeting was held early in the project to address L1C feasibility as well as other issues related to design and implementation of the L1C signal (see Section 4.2).

The second activity was to obtain feedback from GPS experts around the world on whether or not, and – if so – how *best* to configure an L1 modernized signal. Based on this expert input, recommendations would be made on what specific L1C characteristics would best serve the worldwide user base. Section 4.3 describes this process and Section 5 describes the results.

The third activity was to obtain feedback from GPS user communities about the benefits GPS now provides and what improvements would be most helpful to their applications. We did not expect technical guidance from these interviews, but it was important to get an overall impression of what applications were being served, what was working well, and what type of improvements would be most beneficial.

The following sections explain these three activities in more detail, but before that it also is important to characterize the scope of related meetings, presentations, and papers which supported the overall goals of this project. For example, multiple presentations were made to inform stakeholders about the L1C Project, to answer their questions, and to elicit their feedback. This effort began at the 42nd CGSIC meeting forum on 8 September 2003 in Portland, Oregon (Attachment 1.0). Immediately after the CGSIC meeting the presentation was continuously shown at the USCG NAVCEN booth throughout ION GPS-2003 and a document which combined the presentation with a questionnaire (Attachment 1.1) was made available. Subsequently, *GPS World* published an article introducing the L1C Project to the global GPS user community (Attachment 1.2).

Additional major L1C presentations included the following, all of which are documented in attachments to this report:

- (A) The L1C Project group technical meeting, held at the GPS JPO on 8-9 October, 2003. Material developed for and presented at this meeting led to the GPS System Engineering Forum (GSEF) technical review presentation on 28-29 October, 2003 in Los Angeles, California (Attachment 2.0). See Section 4.2 of this report.
- (B) International Civil Aviation Organization (ICAO) - Air Navigation Conference (ANC), Navigation Systems Panel (NSP); Canberra, Australia Nov. 11, 2003 (Attachments 3.0, 3.1 and 3.2). Presentations and user feedback by Taylor and Dorfler.
- (C) Meeting with the Japan GPS Council (JGPSC) stakeholder group in Tokyo, Japan on 23 January 2004 using the expert group presentation and questionnaire (Attachments 6.0 and 6.1). Presentations and user feedback by Titus and Stansell.
- (D) The International GPS Service (IGS) 10th annual symposium; invited presentation and poster on 3-4 March 2004 in Berne, Switzerland (Attachments 4.0 & 4.1) by Stansell.
- (E) The L1C Project presentations and stakeholder feedback sessions formed a prominent part of the IEEE PLANS conference special session on GPS Modernization on 28 April 2004 at Monterey, California (Attachments 5.1 & 5.2). Presentations and user feedback by Hudnut and Stansell.

We also expect to present our findings at upcoming meetings of the CGSIC, the ION, and other groups during the upcoming year, as requested and as opportunities arise.

A summary and chronology of L1C project presentations and meetings is given in Table 4.1.

Table 4.1 - Chronology of L1C Project Presentations and Meetings:

Date	Event
7 August 2003	Joint L1C team planning meeting (at GPS JPO)
28 August	Joint L1C team planning meeting (at GPS JPO) w/ D. Turner
3 September	Joint meeting with Aerospace for GPS III briefing (at GPS JPO)
5 September	Meeting re. L1C Project with Mr. Mike Shaw (at GPS JPO)
5 Sept. (late a.m.)	Meeting with Aerospace experts on worst case aggregate global interference calculations (at GPS JPO)
8 September	CGSIC 42 nd Meeting: L1C presentation and participation in panel open forum; Mr. Hank Skalski, chairman (Portland) http://www.navcen.uscg.gov/cgsic/meetings/default.htm
10-12 September	ION Meeting L1C display at USCG NAVCEN booth
23 September	Civil IFOR meeting; Mr. Hank Skalski, chairman (DC)
24 September	L1C core group strategy & planning meeting (at GPS JPO)
8-9 October	L1C Project – Initial Technical Meeting (at GPS JPO)
20 October	L1C user meeting with Larry Young, NASA/JPL (at USGS)
28-29 October	GSEF Meeting presentation (at ARINC)
11 November	ICAO ANC NSP, Canberra, Australia
23 January	L1C Meeting with JGPSC, Tokyo, Japan
3-4 March	L1C Presentation & Poster at International GPS Service (IGS) 10 th Annual Meeting, Berne, Switzerland
10 March	CGSIC 43 rd Mtg.: L1C Presentation (Hothem); Arlington, VA http://www.navcen.uscg.gov/cgsic/meetings/default.htm
20 April	Joint team progress review meeting (at GPS JPO)
22 April	L1C Presentation at ION Southern California Section http://www.ion.org/sections/southcalifornia.cfm
28 April	L1C Presentation and Group Interview at IEEE PLANS, session and forum on GPS Modernization, Monterey, California --- all presentations available at http://www.igeb.gov/outreach/
29 June	Joint team progress review meeting (at GPS JPO)
20-21 Sept.	CGSIC Long Beach, CA --- Invited --- L1C Project Final Report (will speak and be an open forum panel participant)

4.2 Technical Feasibility Determination

The L1 frequency now carries two GPS signals, C/A and P(Y). Beginning in 2005, IIR-M satellites will be launched with two additional signals on L1, M code and the Interplex code which is there only to maintain a constant transmitter signal amplitude. Another important requirement on all new satellites is “flex power”, the ability to command a relative power increase or decrease on any of the signal components. With the existing signals and the constraints of constant amplitude and flex power, adding yet another L1 signal could be difficult at best. Therefore, the initial question was whether adding L1C technically was feasible.

To address this question, a team of GPS signal experts was engaged. The technical team included: Dr. John Betz of MITRE; Dr. Charles Cahn, consultant to Aerospace; Dr. Phil Dafesh of Aerospace; Dr. Chris Hegarty of MITRE; Karl Kovach of ARINC; Rich Keegan, GPS industry consultant; and Tom Stansell of Stansell Consulting. After a period of analytical work, preparation of documents, exchange of information, preliminary meetings, etc., a two-day meeting was held on October 8-9, 2003 at the GPS JPO. The L1C Project co-leaders Dr. Ken Hudnut of USGS and 1Lt Bryan Titus of the GPS JPO chaired the meeting and 2Lt Jason Taylor also participated. The meeting was focused on whether or not L1C could be added and if so how best to do so.

4.3 Expert Presentations and Questionnaires

As stated in Section 4.1, the second key activity was to obtain feedback from GPS experts around the world on whether or not, and, if so, how best to configure an L1 modernized signal. Table 4.2 summarizes these technical presentations and shows whether a response was received or not. Both the number (54) and the percent of questionnaire responses to the presentations was very high, although some invitations to receive a presentation were not accepted. The individual questionnaire responses (Attachment 7.0) are worth reviewing.

Table 4.2 - Technical Presentations and Responses

Date	Location	Type	Group & Contact Person	Resp.
09/08/03	Portland, OR	Personal	CGSIC	Y
09/10/03	Portland, OR	Personal	NAVCEN Booth at ION	Y
09/11/03	Portland, OR	Personal	NAVCEN Booth at ION	Y
09/12/03	Portland, OR	Personal	NAVCEN Booth at ION	Y
10/20/03	Pasadena, CA	Personal	JPL	Y
12/15/03	Washington, DC	Personal	US GPS Industry Council	N
12/15/03	Washington, DC	Personal	NASA	N
12/16/03	Washington, DC	Personal	NGS/NOAA (Milbert)	Y
12/19/03	Virginia (2) & California	WEB	U.S. Coast Guard	Y
12/23/03	Moscow, Russia	WEB	Thales (Lyusin)	Y
01/23/04	Tokyo, Japan	Personal	Japan GPS Council Members	Y
02/06/04	New Brunswick, CA	WEB	University of New Brunswick (Langley)	Y
02/10/04	Clifton, NJ	WEB	ITT Aerospace Communications	Y
02/11/04	Sydney, Australia	WEB	University of New South Wales (Rizos)	Y
02/12/04	Dallas, Texas	WEB	NavWard (Ward)	Y
02/27/04	Calgary, Canada	WEB	University of Calgary (Lachapelle)	Y
02/27/04	Stanford, CA	WEB	Stanford University (Enge)	Y
02/27/04	Sunnyvale, CA	WEB	Trimble Navigation	Y
03/03/04	Bern, Switzerland	Personal	Talk & Poster Presentation at IGS Mtg.	N
03/04/04	Bern, Switzerland	Personal	Poster Presentation at IGS Meeting	N
03/10/04	Arlington, VA	Personal	Talk at CGSIC Meeting	N
03/22/04	Olathe, KS	WEB	Garmin (Pemble, Kao)	Y
03/31/04	Calgary, CA, Heerbrugg, CH	WEB	NovAtel (Fenton) & Leica (Euler)	Y
04/08/04	Newport Beach, CA	WEB	RFMD (Warloe, Keegan)	Y
04/09/04	San Jose, CA (+ 2 other sites)	WEB	SiRF (Garin)	Y
04/12/04	Cedar Rapids, IA	WEB	Rockwell Collins (McGraw)	Y

04/22/04	El Segundo, CA	Personal	Southern California ION Section Meeting	N
04/28/04	Monterey, CA	Personal	PLANS Conference	Y
05/14/04	Columbus, OH	WEB	Ohio State University (Brzezinska)	Y
06/29/04	Campbell, CA	WEB	Qualcomm (Krasner)	Y
06/29/04	Lexington, MA	WEB	MIT Lincoln Laboratory	Y
07/02/04	Frederick, MD	WEB	AOPA	Y
07/09/04	Athens, OH	WEB	Ohio University (Braasch)	Y

Almost immediately after the L1C project was approved there were important opportunities to begin technical outreach. Therefore, a technical presentation and a questionnaire (Attachments 1.0 and 1.1) were prepared quickly and taken to the September 2003 CGSIC and ION GPS meetings in Portland, Oregon. Dr. Ken Hudnut participated on a CGSIC GPS Modernization panel and gave the L1C presentation on September 8. During the ION meeting the presentation was continuously shown at the NAVCEN exhibit booth, a stack of questionnaires was available, and Tom Stansell was present to answer questions.

The initial questionnaire was intended to be self-explanatory, showing the presentation material in the left column and questions on the right. These early efforts resulted in a gratifying number of useful responses. The same questionnaire also was used in a technical discussion at the Jet Propulsion Laboratory on October 20, 2003.

By December of 2003 the issues were in better focus and both a new presentation and a simplified questionnaire were created. Minor improvements were made to these documents in the months to follow. The final version of the presentation, with a written explanation for each chart, and the final questionnaire are included as Attachments 6.0 and 6.1. Reading this material will help you interpret the individual questionnaire responses included as Attachment 7.0 and evaluated below.

Table 4.2, above, lists the date of each presentation or other outreach effort, the audience, and whether or not there was a response. It is always difficult to obtain meaningful feedback from a questionnaire, but we are pleased with both the quantity and the quality of responses received.

It should be noted that although many of the presentations were made in person by one of the team members, a large number were presented remotely over the Internet. Some of these were to several sites simultaneously. Each site projected a web browser page on a conference room screen. The presenter controlled which slide was being shown, could move a pointer on the screen, and verbally communicated by speakerphone. For example, on December 19, 2003, a presentation was made simultaneously to U.S. Coast Guard facilities at Alexandria, VA, Portsmouth, VA, and Petaluma, CA. Using the web permitted worldwide participation, including presentations in Australia, Canada, Russia, and Switzerland.

The technical presentations were intended for GPS experts who could provide guidance in what signal characteristics would most benefit their constituents. This included Government agencies and laboratories, GPS companies, and University professors and graduate students. These experts provided valuable feedback from most GPS application perspectives, including land, sea, air, and space, and with requirements ranging from the highest possible precision to the lowest possible cost.

4.4 User Group Interviews

As described in Section 4.1, the third activity was to conduct interviews with user groups in order to gain non-technical feedback on L1C design considerations. Making use of the User Group Guidelines (Attachment 8.1), members of the L1C Project team were asked to identify users and speak with them about the project. Furthermore, additional information was gleaned from reports that had been developed previously for related purposes. The interviews were intended to evoke responses that might either confirm or refute previously understood user interests in the range of possible capabilities of L1C, depending on which signal design parameter is used. For example, users who would benefit most from a low data rate would be those wishing to have better performance in wooded, urban, or even indoor environments. The interviews also were used to capture new considerations about ways in which L1C could better meet the navigation requirements of user groups.

5.0 Expert Interview Results and Analysis

5.1 Technical Feasibility Results

Section 4.2 is a review of the process used to determine whether an additional signal could be added to the already-planned suite of L1 signals. The challenge was not simply to add a new signal but at the same time to maintain a constant total signal amplitude. This is needed to maximize satellite power efficiency. Also, it is important to be able to adjust the relative power level of each signal component (flex power). Several ways were found to achieve these objectives, so the question of technical feasibility was answered in the affirmative.

Another aspect of the study was to evaluate the compatibility of L1C with the existing C/A signal, with the military M code signal, and with potential Galileo signals. Every signal in the L1 band interferes to some degree with all the others. Current civil users do not want L1C to adversely affect performance by significantly raising the noise floor of C/A receivers. National security interests require sufficient spectral separation of L1C from the M code signal, and it also limits the total power of both L1 civil signals combined. As with C/A signals, L1C signals interfere with each other. Therefore, it is important to set power levels with all these parameters in mind. The technical meeting confirmed ways to evaluate these factors and made preliminary assessments. Figure 5.1 illustrates that spectral separation of signals in the L1 band was a very important consideration. Figure 5.2 illustrates that an important part of the analysis was to consider signal “hot spots”, i.e., places on earth where the total power received from all satellites in view reaches a maximum during some part of the day. These are areas where interference between signals is at its worst during part of each day. These calculations not only depend on the satellite orbits but, importantly, they depend on assumptions about the gain of receiver antennas.

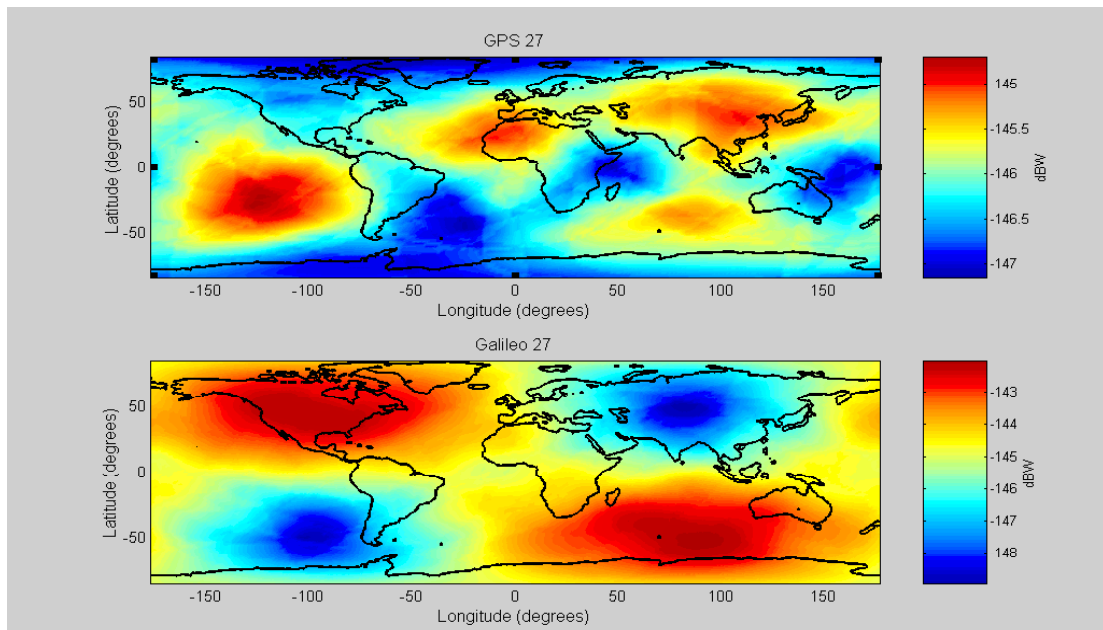
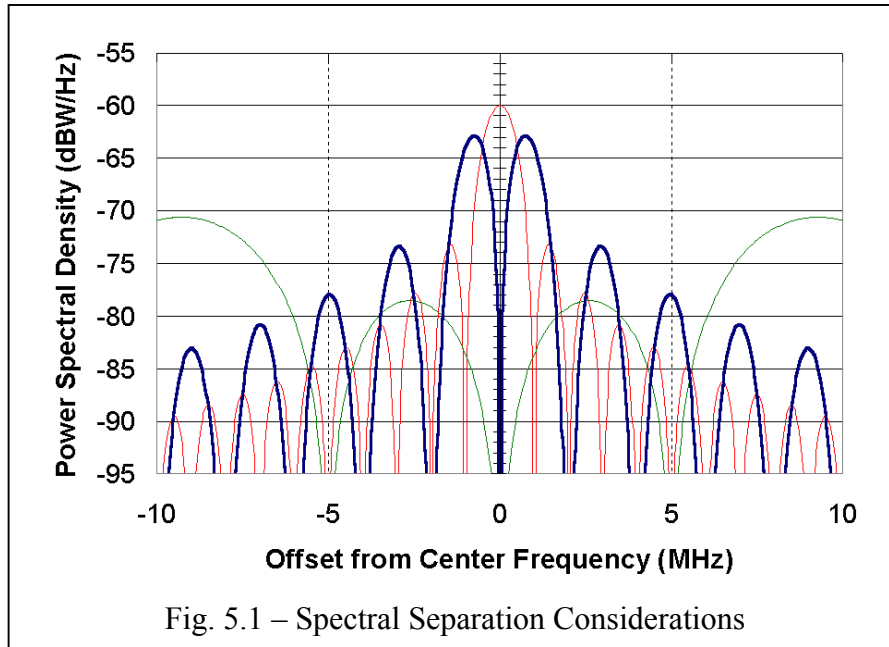

Combined constellation (GPS & Galileo) results for global aggregate power. (Raghavan and Cooper, The Aerospace Corp.)

Fig. 5.2 – Illustration of Signal Hot Spot Analysis

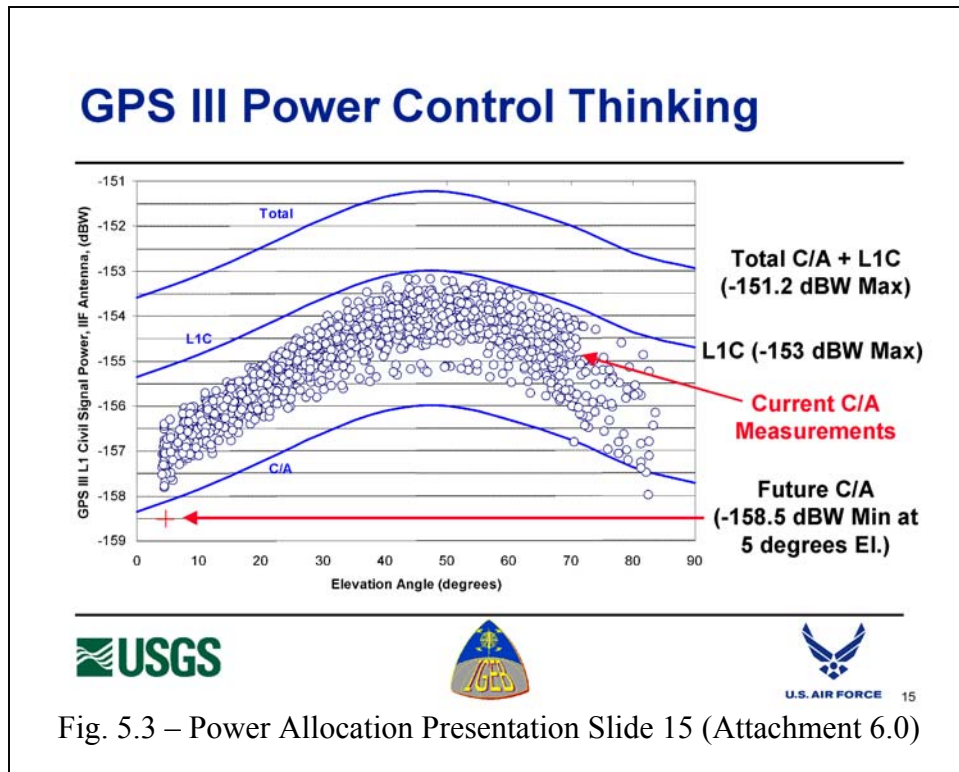

As a result of these efforts, decisions were reached about which signals and what power levels would best fit the constraints. A summary of these results was presented soon afterwards by Hudnut and Titus, at the invitation of the GPS Systems Engineering Forum (GSEF), at their meeting on October 28-29, 2003 (see Attachment 2.0). Also, Figure 5.3 was developed and has been a key part of the presentation to GPS experts (Slide 15 of Attachment 6.0).

The following paragraphs are a brief summary of the October 8-9, 2003 meeting and its key decisions.

An initial classified session, led by Titus and including nearly all of the participants in the following main meeting, identified the power level and signal modulation options considered acceptable to the U.S. Government. A range of several possible signal modulations was reviewed, and trade-offs were carefully considered. The BOC(1,1) signal modulation arose as being both acceptable and also preferred by most participants as the best overall solution. Signal aggregate power was discussed and reviewed. The evaluation approach and algorithms which had been used by Titus and Betz during negotiations with the EU Galileo team were applied to this analysis as well. It was agreed that L1C would carry at least the same messages that will be carried by L2C and L5.

Discussion of signal structure and modulation options, as well as multiplexing and coding techniques, led to the conclusion that design and implementation of L1C is feasible. Partly because of the 1.5 dB increase in specified minimum C/A signal power, L1C can be added without negative impact on C/A receivers. It was decided that the C/A signal will be continued indefinitely. The promise of a data-less channel and increased power, as well as enhanced GNSS interoperability, were agreed to be main user benefits from a technical standpoint.

It was agreed that user feedback, primarily from technical experts throughout the GPS manufacturing and international community, would be gathered as a next step. Now that a limited and concrete number of questions could be asked, this greatly simplified the questionnaire. That is, the form distributed after our initial presentation (Attachment 1.1) asked for user feedback on a wider range of issues, some of which were decided on at our technical meeting. Following that, we were able to identify just those key few questions upon which user feedback would be most critical to L1C design. So, the interview process was modified and a new questionnaire developed to accompany the technical interview process from this point forward. The new technical presentation (annotated slide set in Attachment 6.0) and questionnaire (Attachment 6.1) became highly effective tools for gaining technical stakeholder input on those questions where a range of options remained open.

After the technical sessions were completed, the meeting participants then discussed and agreed to help with a process of eliciting stakeholder feedback using an approach suggested by Joe Dorfler. The approach is based on his prior experience with similar efforts determining user requirements for WAAS and GPS III. The approach is to gain input from non-technical GPS users, and the results have been developed into the material described in Section 4.4.

5.2 Expert Interview Results

A key element of the L1C project was to interview GPS experts around the world to determine:

- If a broad and representative range of civil GPS experts and users wanted an L1C signal in addition to the present C/A code, although with slightly reduced C/A signal power
- What L1C signal characteristics would be most desirable for the widest range of user applications. In particular, two key characteristics were evaluated:
 - Modulation waveform, with the options being BOC(1,1) and BOC(5,1)
 - Message data rate and content, with the options being 25, 50, and 100+ bps

Attachment 6.0 is an annotated version of the presentation, and Attachment 6.1 is the expert's questionnaire form. This Section 5.2 of the report is an evaluation and analysis of the expert responses, which are individually included in Attachment 7.0. Subsection 5.2.5 of this section offers conclusions and recommendations based on the expert responses.

5.2.1 Response Statistics and Summary

In many cases an organization would create one consolidated response after a presentation. In other cases several people from an organization would respond separately, often with different recommendations. Therefore, it isn't straightforward to imply an organizational response from differing personal responses. In the opposite sense, an organizational response may actually represent the opinion of just one person or, at most, a very few people. Recognizing these difficulties and accepting the potential distortion caused by mixing personal and presumed organizational responses, the following statistics are based simply on the number of responses received. Answers to key questions are summarized in Table 5.1. The headings, from left to

right, are: (1) a reference number, (2) the organization name, (3) the contact person's name, (4) whether attribution is permitted, (5) whether the response favors L1C, (6) which of the two modulation waveforms is favored, and (7) what message bit rate is preferred. A blank cell under Organization or Name shows that the respondent chose no attribution for that information. A blank cell under Modulation or Rate shows that no preference was indicated.

Table 5.1 – Summary of Responses Received

Ref.	Organization	Name	Att.	Favor L1C?	Mod.	Rate (bps)
1	ACRT, Inc.	Godfrey, Cathy Genest	Y	Y		25
2	Air Force Research Laboratory	Sampson, Steven J.	Y	N		
3	AOPA		Y/N	Y		25
4	Rockwell Collins	McGraw, Gary	Y	Y	BOC(1,1)	50 to 100
5	Comm. Research Labs	Hama, Shin'ichi	Y	Y		100
6	ENRI	Ito, Ken	Y	Y		100
7	ENRI	Sakai, Takeyasu	Y	Y		100
8	Evolution Robotics	Schell, Steve	Y	Y		25
9		Kakutani, Kazuaki	N/Y	Y		25
10	Furuno Electric Company	Kawai, Masato	Y	Y	BOC(1,1)	100
11	Furuno Electric Company	Okada, Tsutomu	Y	Y	BOC(1,1)	100
12	Garmin International	Seymour, Jarrod	Y	Y	BOC(1,1)	50
13	ITT Aerospace/Communications	Cangiani, Gene	Y	Y	BOC(1,1)	100
14			N	Y		25
15			N	Y	BOC(1,1)	50
16	JAXA	Kogure, Satoshi	Y	Y	BOC(1,1)	25
17			N	Y	BOC(1,1)	25
18			N	Y	BOC(5,1)	100
19	Leica Geosystems	Euler, Hans-Jurgen	Y	Y	BOC(5,1)	25
20			N	Y	BOC(1,1)	100
21	NASA/JPL		N	Y		250
22	NASA/Shuttle		N	N		100
23	NavCom Technology, Inc.	Hatch, Ron	Y	Y	1,1 or 5,1	100
24	NavCom Technology, Inc.	Knight, Jerry	Y	Y	1,1 or 5,1	100 or ?
25	Navward GPS Consulting	Ward, Phillip W.	Y	Y	BOC(5,1)	25
26	NEC Toshiba Space	Maeda, Hiroaki	Y	Y		100
27	NEC Toshiba Space	Ono, Takeshi	Y	Y	BOC(1,1)	100
28	NEC Toshiba Space	Sagawa, Kazumi	Y	Y	BOC(1,1)	50
29	National Geodetic Survey	Milbert, Dennis	Y	Y	N/A	N/A
30		Iwata, Toshiaki	N/Y	Y	BOC(5,1)	100
31	Nikon-Trimble Co.	Izawa, Mitsuma	Y	?		25
32	NovAtel, Inc.	Fenton, Pat	Y	Y	BOC(5,1)	25
33	Ohio State University	Brzezinska, Dorota	Y	Y	BOC(5,1)	100
34	Ohio University	Braasch, Michael	Y	Y	BOC(5,1)	25

35	Panasonic Automotive Systems	Ishigaki, Toshihiro	Y	Y		100
36	pcisys (?)	Lee, Ron	Y	N		
37	Pioneer Corporation	Ando, Hitoshi	Y	Y		50
38	Pioneer Corporation	Kigure, Yoshiyuki	Y	Y	BOC(1,1)	
39	Qualcomm	Krasner, Norman	Y	Y	BOC(1,1)	100
40	RF Micro Devices (RFMD)	Warloe, Andreas	Y	Y	BOC(1,1)	25
41	SiRF Technology, Inc	Garin, Lionel	Y	Y	BOC(1,1)	25
42	Stanford University	Enge, Per	Y	Y	BOC(1,1)	25
43	Thales Navigation	Lyusin, Sergey	Y	Y	BOC(1,1)	100
44	Thales Navigation	Snow, Robert	Y	Y	BOC(1,1)	50
45	University of New Brunswick	Beran, Tomas	Y	Y	BOC(1,1)	25
46	University of New Brunswick	Wang, Chaochao	Y	Y	BOC(1,1)	25
47	University of New South Wales	Babu, Ravindra	Y	Y	BOC(1,1)	100
48	University of New South Wales	Jia, Xiaodong	Y	Y	BOC(1,1)	25
49	University of New South Wales	Mumford, Peter	Y	Y		25
50	University of New South Wales	Rizos, Chris	Y	Y	BOC(1,1)	100
51	University of Calgary	Lachapelle & Team	Y	Y	BOC(1,1)	50
52	University of Sydney	Quigley, Aaron	Y	Y	BOC(1,1)	25
53	US Coast Guard, C2CEN	Wolfe, Parsons, Cleveland	Y	Y	BOC(1,1)	25
54	US Coast Guard, NAVCEN	Schutzenhofer, John	Y	Y	BOC(1,1)	25
55	Trimble		Y/N			

Note: The last input (Ref. # 55) was received after the following analyses were completed. Therefore, because this input also did not address the specific questions, it was not included in the statistics.

Of the first 54 total responses to the survey, it is interesting to see where in the world they originated. Figure 5.1 shows the distribution. The largest number, but less than half, were from the U.S. The second largest number were from Japan. A number of these were the result of our activities at the September 2003 CGSIC and ION GPS meetings in Portland, OR. A larger number were stimulated by one presentation to multiple companies at the Japan GPS Council (JGPSC) meeting in Tokyo on January 23, 2004. Together the U.S. and Japan produced 80% of all responses. Primarily because of academic interest and a response from NovAtel, Australia and Canada produced the third and fourth largest number of responses. Finally, there was one response from Russia on behalf of Thales Navigation and one from Switzerland for Leica Geosystems.

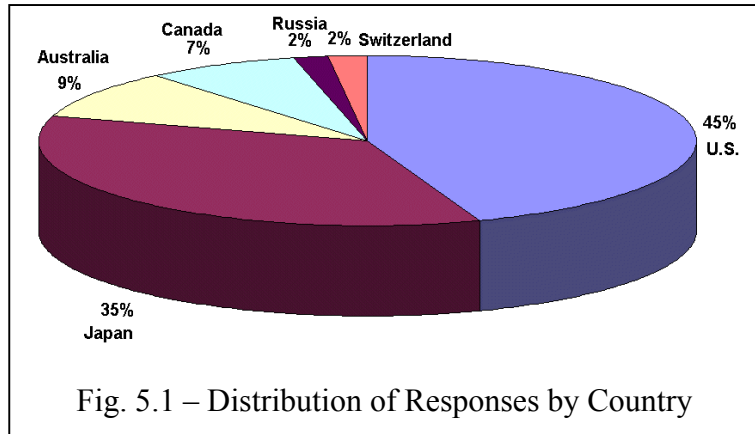

Fig. 5.1 – Distribution of Responses by Country

The lack of response from Europe was not for lack of trying. There were as many, if not more, European companies and delegates at the September ION meeting as Japanese delegates. A number of European companies and universities were invited directly, but there was no response. A paper and a poster display were presented in Bern Switzerland at an IGS meeting during March, 2004 with no results. Perhaps some Europeans considered interest in L1C to be controversial with respect to the Galileo program.

5.2.2 Should L1C be Implemented?

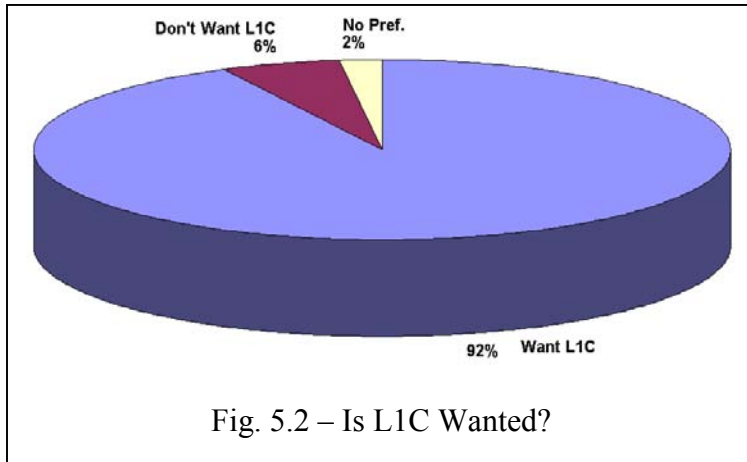

Figure 5.2 shows the distribution of responses to the question of whether a new civil GPS signal should be added at the L1 frequency, even at the expense of reduced C/A signal power, or conversely whether a more powerful C/A signal should be the only civil signal on L1.

The results are overwhelming and unambiguous that Government agencies, GPS manufacturers, and University researchers agree that

L1C is desirable. This is true for all realms of use: Land, Sea, Air, and even Space. (Note there were two different responses from NASA, one from JPL and the other from the Shuttle program. The first wanted L1C and the second didn't, even though the Shuttle response asked for a 100 bps data rate which would be possible only if L1C were implemented.) The full spectrum of user equipment requirements, from the highest precision products to products requiring the lowest possible cost, were favorable to having L1C. The advantages of having a data-less pilot carrier, of having longer codes to reduce or eliminate cross-correlation and narrowband interference problems, of a higher precision and more flexible message structure, and of forward error correction and other message improvements clearly are recognized as desirable improvements for essentially all applications.

The nearly unanimous desire to add L1C is tempered by the insistence that C/A code remain for the indefinite future in order to support many millions of legacy receivers. It would not be acceptable to substitute L1C for C/A, it must be an additional signal. (However, the signal designers must define a way for L1C to continue if, several decades from now, it does become feasible to discontinue the C/A signal. In other words, turning C/A off is not planned but if it were to happen it must not affect what then perhaps could be a billion or more L1C receivers.)

5.2.3 Modulation Preferences

Figure 5.3 shows the distribution of responses to the question of which modulation waveform is preferred for L1C, i.e., BOC(1,1) or BOC(5,1). Fifty percent of the respondents selected BOC(1,1) and 33% had no preference. A relatively small 13% preferred BOC(5,1), and the remaining 4% would be satisfied with either waveform. From a purely statistical perspective, BOC(1,1) is the “winner”. Although this preference may have been greatly influenced by the US/EU agreement to use BOC(1,1) on both GPS and Galileo, a number of the respondents had solid reasons for preferring one waveform over the other, and it is instructive to review some of these comments. Of the seven responses which preferred BOC(5,1), three had supporting comments, which were:

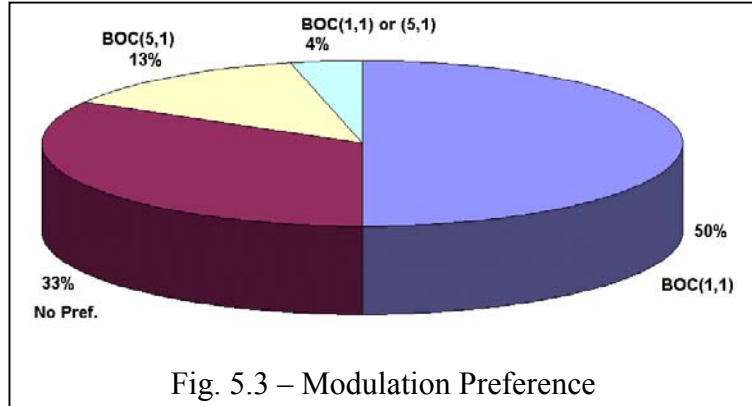

Fig. 5.3 – Modulation Preference

- a) The reason of BOC(5,1), we chose it because it will be able to minimize the interference with present L1 C/A. (Leica Geosystems, Ref. # 19)
- b) Expecting advances in signal processing to continue at the current pace, the implementation of BOC(5,1) will be feasible in the planned time frame for modernization. (Ohio State University, Ref. # 33)
- c) Both the BOC (1,1) and the BOC (5,1) are acceptable. The BOC (5,1) is preferred since it provides less interference both to M-code and the C/A-code and it can offer better code-loop tracking accuracy. (Ohio University, Ref. # 34)

Of the 27 respondents who preferred BOC(1,1), some of the key comments were:

- d) We have concerns that the wider bandwidth of the BOC(5,1) signal would make it extremely difficult to design and produce a practical Navwar prevent notch filter. For this reason, the BOC(1,1) is preferred. (Rockwell Collins, Ref. # 4)
- e) BOC (1,1) appears to be a safe choice at this time based on both technical and political grounds. (Ref. # 20)
- f) BOC(1,1) with 2X Minimum C/A power is a good compromise to improvement in sensitivity in both autonomous and wireless assisted modes. (Qualcomm, Ref. # 39)
- g) Select BOC(1,1) signal since the full bandwidth can be supported by consumer chipsets. The BOC(5,1) has a much wider bandwidth [therefore] requiring a wider Rx bandwidth and higher sampling rate. The BOC(1,1) signal can improve code tracking since there are twice as many code edges than a normal C/A code without the wider bandwidth penalties. (RF Micro Devices, Ref. # 40)
- h) We believe BOC(1,1) is the best modulation scheme for the modern signal because of its lower bandwidth, and therefore lower power consumption. Combined with the longer code

suggested below, it will also support our cross-correlation requirements. (SiRF Technology, Ref. # 41)

- i) On balance, I would expect that BOC(1,1) would be more readily useable by aviation, because of correlation subpeak ambiguities. To my recollection, BOC(1,1) has subpeaks every 150 meters, whereas BOC(5,1) would have subpeaks every 30 meters. Failure to correctly resolve the BOC(1,1) subpeak would be readily detectable by RAIM, but the 30 meter ambiguity may be difficult to detect using RAIM. Hence, it has a greater prospect of hazardously misleading information (HMI). This risk can be offset by using multiple correlation samples per satellite, but this practice increases the cost of the avionics. In addition, the precision advantage of BOC(5,1) is not that important to aviation, because we use carrier smoothing. (Stanford University, Ref. # 42)
- j) BOC(5,1) is undesirable, because wide bandwidth will lead to the following disadvantages for consumer products: a) high sampling frequency and as result bigger power consumption; b) problems with harmonics and digital noise because of wideband RF. (Thales Navigation, Ref. # 43)
- k) In order to have more robust position solutions, the BOC(1,1) signal appears to have better characteristics than the BOC(5,1) because of its more isolated and lower autocorrelation secondary peaks (relative to the main peak), even if this implies a slightly higher multipath impact. It is however likely that in the coming years, new techniques will reduce this impact of multipath to a smaller scale. (University of Calgary, Ref. # 51)

Overall, it seems BOC(1,1) is a safe and effective choice. To choose BOC(5,1) would require much more study and a very convincing rationale. It also would require revision of the current EU/US agreement to use BOC(1,1) as the template for the new L1 signal. Although this is very unlikely, it is not impossible, because BOC(5,1) meets the EU/US negotiated compatibility criteria somewhat better than BOC(1,1).

5.2.4 The Message Data Rate Dilemma

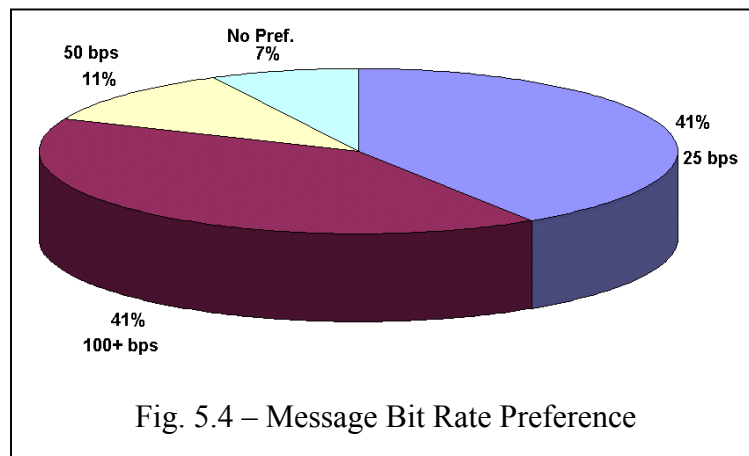

Whereas there is near universal agreement that a modernized L1C signal would be desirable, there seems to be a complete stalemate on the question of message bit rate. As shown by Figure 5.4, 41% of the total responses support a 25 bps data rate and another 41% support 100 bps or higher. Only 11% support retaining the traditional 50 bps rate, and 7% have no preference.

Those who support 25 bps are unified on a single goal, which is to receive the GPS messages under marginal signal conditions, whether those conditions are due to foliage attenuation, weak indoor signals, or if operating in a high interference environment. That the supporters of 25 bps are unified is an important observation and it affects the interpretation of results. Pertinent comments from supporters of 25 bps include:

- 1) L1 C/A is great, but we still have trouble - lots of trouble - under tree canopy, coverage is spotty. Improved use in wooded area important to us. We often work under trees and in urban areas. Indoor use would open up a whole new industry. (ACRT Inc., Ref. # 1)
- 2) Based on the discussions during the briefing, it appears that the new L-1C should focus on the 25bps option. (AOPA, Ref. # 3)
- 3) Improved performance indoors and under foliage would be most desirable. (Evolution Robotics, Ref. # 8)
- 4) The lower data rate (25 bps) is preferred since it extends system performance in low signal-strength environments. The TTFF concerns can easily be eliminated simply by placing a day's worth of ephemeris messages onto the web and other media. (Rockwell Collins, Ref. # 34)
- 5) The 25bps choice is my choice since it makes decoding bits possible at phase lock threshold of the un-modulated carrier component. The downside is that it will take twice as long to get the ephemeris. That is somewhat mitigated by the new message structure being proposed. (RF Micro Devices, Ref. # 40)
- 6) For sensitivity improvement, we would like to go as low as possible in bit rate, 25bits per second. (SiRF Technology, Ref. # 41)
- 7) On balance, I prefer the low data rate alternative, since the highest available data rate of 100 bps would have a hard time supporting aviation time to alarm requirements. Our time to alarm requirement for Category I precision approach is 6 seconds, which probably allows one second for message duration. At 100 bps, this dictates a maximum message length of 100 bits. Of these, 24-32 bits must be used for error detection (parity), and so the messaging efficiency would be at between 68% and 76%, which is low compared to today's systems like WAAS. (Stanford University, Ref. # 42)
- 8) It will be useful to maintain lock in foliated areas. The users who may benefit from that could be land surveyors, automobile navigation users and GPS-equipped cell phone users. (University of New Brunswick, Ref. # 45)
- 9) High speed of data is not the objective of GPS. It can be addressed with satellite communication. (etc.) (University of New South Wales, Ref. # 48)
- 10) I need signals under trees (University of New South Wales, Ref. # 49)
- 11) I chose 25 bps over 50 bps since I feel it is more important to be able to acquire a message in poor signal conditions than having a faster TTFF. (Rockwell Collins, Ref. # 54)

In contrast, supporters of 100+ bps have three completely different and mutually exclusive objectives. The first group wants GPS to provide integrity and/or differential correction messages, much like an SBAS system. Galileo signal designers presumably intend to use their L1 OS signal for this purpose, transmitting messages at 125 bps. Note that comment (6) above from Professor Per Enge of Stanford University suggests that 100 bps may not be adequate for that purpose. Comments from this group include:

- 12) Correction for ionospheric delay and integrity information (new messages) (ENRI, Ref. # 6)

- 13) Ionospheric corrections; Integrity for public transportation; Messaging space allowing regional governments to broadcast serious disaster/weather information to their nations (ENRI, Ref. # 7)
- 14) Forecast of signal outage (similar to NANU); Troposphere delay map like WAAS Iono-Delay Map, but with smaller grid intervals (Furuno Electric Company, Ref. # 10)
- 15) Integrity, more accurate ephemeris data, search and rescue information (new msg's) (ITT Aerospace/Communications, Ref. # 13)
- 16) I believe it wouldn't be a challenge for GPS III to exceed the performance offered by GPS-WAAS. In fact, exceeding the performance of GPS-WAAS would be a good criterion for GPS III to meet. The navigation data rate of 50 bps is adequate for aviation. It may take 100 bps data rate from GPS satellites to match the performance of GPS-WAAS. (Ref. # 20)
- 17) Could add real time differential correction to data to greatly improve user accuracy and integrity. Should the GPS data rate be increased to provide additional messages? Integrity: No DGPS: Yes mainly for added accuracy. With GPS+Galileo, would RAIM be sufficient for integrity? Yes. My applications benefit most from transmitting DGPS corrections via the data message. (NASA JPL, Ref. # 21)
- 18) Self 'differential' corrections, e.g., clock & orbit (new msg's) (NavCom Technology, Ref. # 24)
- 19) Wants integrity and DGPS data in message (NEC Toshiba Space, Ref. # 26)
- 20) Precise ionosphere correction message; integrity message; satellite anomaly should be broadcast immediately via message (NEC Toshiba Space, Ref. # 27)
- 21) Differential corrections, ionosphere in particular (it would make sense if the user receives all the relevant information from one source), integrity information (Ohio State University, Ref. # 33)

The second “group” of 100+ bps supporters is Qualcomm and a Japanese company (without attribution). We believe Qualcomm currently embeds more GPS receivers in cell phones than any other company. Therefore, when Qualcomm speaks we should pay close attention. The Japanese company is a leader in GPS for car navigation. Both would like GPS to send clock and ephemeris parameters which last much longer than 2 hours. The problem is that getting any message at all in urban and indoor environments is extremely difficult. Their thought is that if a user could acquire clock and ephemeris messages which last 8 to 12 hours, then at subsequent times of the day a position fix could be computed even if only code measurements are available. Relevant comments from each response are:

- 22) We have the intention to prolong the period that the ephemeris data are valid for the hot start operation of GPS receivers. We think that this period is about 4 hours from the power off. But we hope that this period will be prolonged 8 or 12 hours later from power off. (Ref. # 18)
- 23) Desire . . . to permit ephemeris period of validity to greatly exceed the approximate 4 hours currently provided. Graceful degradation is O.K. but desire is to at least double the validity period. Extension to well beyond 8 hours is highly desirable. This allows receivers to use the same ephemeris information under weak signal conditions for extended periods of time (ephemeris perhaps received from a land based server). (Qualcomm, Ref. # 39)

The third group of 100+ bps supporters wants no additional messages at all. They want a higher data rate to minimize the time to first fix (TTFF) and also to minimize the time from first acquiring a “fresh” satellite (one for which there is no valid, stored clock and ephemeris data) before it can be used for navigation or for a snapshot position fix. Comments from this group include:

- 24) Faster TTFF will be desirable (Furuno Electric Company, Ref. # 11)
- 25) It would be useful to transmit ephemeris at a faster rate so the TTFF could be reduced (Garmin, Ref. # 12)
- 26) Quick-repeating ephemeris (ex. less than 15 seconds) and almanac (ex. less than 6.25 minutes). (*Note contradictory input in comment 21, although with a similar objective.*) (Ref. # 18.)
- 27) I hope no additional messages. I want to get ephemeris faster. My expectations for new L1C signal are as follows: (1) Reduce effect of interference (2) Improve TTFF. (Panasonic Automotive Systems, Ref. # 35)
- 28) I have placed fast messaging as my preference to help with fast TTFF. (University of New South Wales, Ref. # 50)

Therefore, in contrast to the 41% of respondents who all want a 25 bps data rate to improve system performance in difficult signal conditions, the 41% who want 100+ bps are divided, some wanting extra integrity and accuracy messages, some wanting extra messages to extend the validity interval of the clock and ephemeris parameters, and some wanting no extra messages but a higher data rate to minimize TTFF and time to use a fresh satellite signal. Not to be left out, 11% of the respondents want to continue with the traditional rate of 50 bps. These respondents in general had no strong reason for selecting 50 bps.

5.2.5 Data Rate Analysis and Recommendation

The previous section makes it clear there is a major conflict of interests about how best to enhance the messaging performance of L1C. We believe a simple assessment of these conflicts actually is the best assessment. Figure 5.4 shows that if we consider only those who expressed a preference and then arbitrarily split the group wanting 100+ bps into three equal subgroups: 15% for accuracy and integrity messages, 15% for longer lasting orbit and clock messages, and 15% for faster transmission with no additional messages, then note that 12% would be happy with 50 bps, we see there is no way to reconcile these minority positions. In contrast, 43% of those who expressed an opinion want 25 bps to make the signal more robust and to enhance system

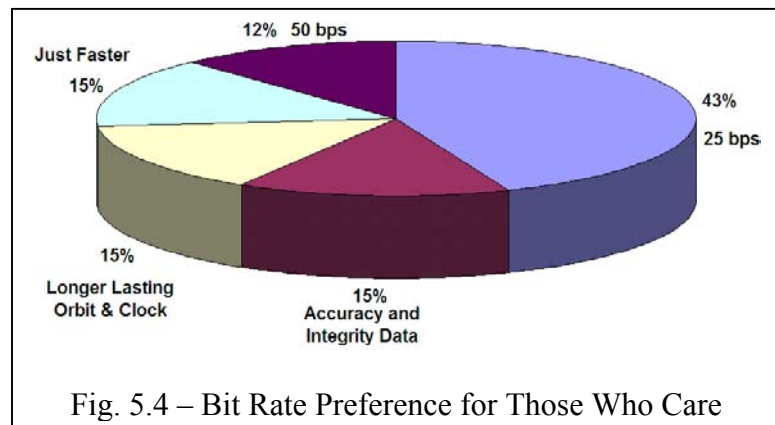

Fig. 5.4 – Bit Rate Preference for Those Who Care

performance under difficult signal conditions. Based on “winner take all”, 25 bps would be the obvious selection. More careful analysis shows this is to be a reasonable outcome.

Take the case of flying toward an area for which the FAA has issued a NOTAM alerting aviators that GPS performance may be unreliable in that region. Let’s assume the GPS receiver will drop lock and stop providing navigation information 50 miles from the center of this region. With a bit rate of 25 bps, loss of message data and loss of lock will occur at about the same 50 mile radius. However, at 100 bps the message data would become unreliable over a 100 mile radius. It is unlikely a certified receiver would be allowed to continue giving navigation information without message reception even if the receiver were locked to the GPS signals and continued to provide pseudorange measurements. At 25 bps the area affected by message loss and by signal drop lock is about the same. At 100 bps the radius affected by message loss is twice as large and the area affected is four times as large. Although for different reasons, the same relative performance issues apply to navigation in forests, along tree-lined roads, and inside buildings.

The penalty for this more robust message performance is that the time required to obtain clock and ephemeris parameters from each satellite is from 36 to 48 seconds as compared with 18 to 48 seconds with C/A today. The quickest time is worse but the longest time is the same. Because certified aircraft receivers now require receipt of two identical messages from a satellite before its signal can be used, the minimum time needed by an aviation receiver to obtain C/A ephemeris and clock data actually is 48 to 78 seconds. Because the modernized message on L1C will have a strong cyclic redundancy check (CRC) and will identify the specific satellite it describes, crosscorrelation problems are eliminated and we expect certified receivers will be allowed to begin using a satellite signal after receiving only one CRC-validated message. Therefore, for aviation, we compare 36 to 48 seconds using L1C at 25 bps with 48 to 78 seconds with C/A today. Not only are the message and drop lock thresholds approximately the same at 25 bps in areas with high levels of interference, the aviation TTFF would be faster with L1C than today.

Integrity and DGPS Messaging

One of our team members is Karl Kovach of ARINC who probably has more experience with GPS messaging issues than any other professional in the field. He was asked to comment on using GPS messaging for some of the desired high rate features. His responses are quoted in the following discussions.

There are problems trying to use GPS messages for integrity and/or for differential GPS (DGPS). With respect to integrity messages, Karl stated: “the sense I have is that most folks are starting to realize that trying to turn GPS III into a clone of WAAS for integrity and DGPS is not such a smart idea. Really, if you think about it - - since WAAS can't meet the 5.2 second [time to alert] requirement with a real-time data link at 250 bps (500 sps), then why would anyone think GPS III can meet it with a real-time data link at 100 bps (200 sps)?” This same perspective is expressed by Professor Per Enge of Stanford University in response # 42 of Attachment 7.0.

SBAS employs a ground station to uplink integrity and DGPS messages to a communication satellite which then re-broadcasts these messages at the GPS L1 frequency to users within its antenna coverage “footprint”. However, there are jurisdictional problems, at least for aviation

navigation. No sovereign nation (or in the case of the EU, group of nations) is willing to relinquish control of aviation in its territory to another sovereign entity. It is unlikely other nations would allow GPS, under U.S. control, to define integrity within their territory. It also seems clear the U.S. Government will not allow other nations to control the signals GPS broadcasts over their sovereign territory. This would be a jurisdictional and logistics nightmare. It is far better for individual nations to use local means to provide integrity and DGPS messages.

Karl Kovach continues: “For integrity, the idea that is starting to take hold is simply to prevent integrity failures right at the source. For satellites, that means a fail-safe clock system like [that] on the IIR birds. For the OCS, that means pre-validating the upload data before uplink. There is an old saying which is appropriate here: ‘An ounce of prevention is worth a pound of cure.’”

Regarding DGPS messages, there are other problems. For example, the DGPS message structure is different for different applications. Single frequency DGPS has different requirements than dual frequency DGPS. Even if these differences can be bridged, local monitor stations would have to forward correction messages to the satellites, which requires either a much larger, worldwide, GPS ground monitor network or for the U.S. to accept and use measurements from international stations. Compared with local means of providing DGPS signals, this seems more cumbersome than it is worth. Furthermore, such a service would directly compete with commercial systems already in place.

It also appears that in the GPS III era, dual frequency autonomous GPS navigation may approach one decimeter accuracy. For most applications, external DGPS will not be necessary. Therefore, it will be used only for quite specialized applications to achieve even better accuracy, and such very high accuracy and specialized applications are not logically supported by a global system.

We conclude that not only is there disagreement about how to use a 100+ bps GPS data rate, it is cumbersome and impractical to use GPS for integrity and differential messages.

Faster TTFF

Two competing methods were proposed to improve TTFF. One was to transmit longer lasting orbit and clock data, and the other was to not transmit additional data but to transmit the required minimum orbit and clock data at a faster bit rate. The groups who wanted this capability were focused on GPS embedded in cell phones or on car navigation applications. The problem is real. Drive out of a city parking lot after a few hours and it often takes many blocks of driving before GPS begins to provide navigation. In some cases it is necessary to stop in an open area for awhile. Driving in obstructed areas can briefly interrupt the signal and thus prevent whole messages from being acquired.

Even if the data were provided at a faster rate, that does not prevent brief outages which prevent reception of whole messages. Furthermore, some satellite signals may not be visible except when passing through an intersection, and this brief time is not adequate to receive a whole message.

It would seem the best solution is to provide users in urban environments with an alternate way to obtain GPS orbit and clock parameters. We agree that orbit and clock information which is valid for 8 to 12 hours or more also would be very beneficial. However, urban environments are where other technologies are emerging which can provide alternate communication links. For example, wireless wideband Internet access is becoming more readily available. By the time L1C could be available on most GPS satellites (perhaps by 2020), such access will be common on cell phones. Automobiles are likely to be equipped with wireless Internet access as well, which could be used not only to provide long duration GPS orbit and clock parameters but also local traffic congestion reports and routing support. A commuter also could use a home Internet connection with a wireless link to the car in the garage to obtain traffic and orbit information in the morning before leaving for work. Long term orbits would still be valid on the commute home that evening. With the vast increase in number of users, there will be commercial incentives to make such navigation and traffic support functions readily available at very low marginal cost.

Karl Kovach suggests there will be no objection for the GPS Control Segment to make long term orbit and clock parameters available over the Internet. The equivalent already is available from the Jet Propulsion Laboratory (JPL) and other computational centers associated with the International GPS Service (IGS).

We conclude that not only is it impossible to agree that the best way to use a 100+ bps data rate is to enhance TTFF, we believe it is functionally better to solve this problem in a more elegant and effective way by using local communication services. Cell phones are communication devices, and the bandwidth of these links is getting faster. Wireless Internet access is proliferating rapidly, and this application could further increase the incentive. Not only will an external solution work better, it can provide other useful information as well, such as warnings about local traffic congestion and suggestions for alternate routing.

5.3 Expert Interview Signal Recommendations

Based on analysis of responses from GPS experts in a wide range of specialties, this L1C project concludes:

1. It is technically feasible to add a modernized civil signal on the GPS L1 frequency.
2. There is a nearly universal desire for an additional, modernized L1 civil signal.
3. The modulation preference clearly is BOC(1,1) rather than BOC(5,1).
4. Although with less unanimity, the best choice of data rate is 25 bps. This optimizes signal robustness for all applications but leaves DGPS, integrity messaging, long duration orbit and clock parameters, and faster orbit and clock parameters to local communication services that are inherently better suited to this task.
5. The following additional tasks are recommended:

- Review this report and its conclusions with the respondents and other interested parties to fully validate or, if necessary, slightly modify the conclusions
- Perform technical studies to determine how best to incorporate the L1C signal
- Review forward error correction options to determine if changing from the current L2C and L5 standards would be worth the potential improvement in error rate
- Propose specific code generators and code lengths for each L1C signal component
- Review waveforms similar to BOC(1,1) which may give slightly better performance
- Prepare a top level signal description to enable the Interface Control Working Group (ICWG) process to develop detailed specifications
- Interact with the GPS/Galileo interoperability working groups to optimize benefits for the worldwide civil user population while protecting national security interests

6.0 Market Segment Signal Needs and User Feedback

This section examines several key segments of the GPS market from the perspective of signal needs. At this time every market segment depends on the GPS C/A code, so in that sense the C/A code has proven to be adequate for all existing applications. However, when companies developed today's products there were no signal options; they could use only the one available signal. GPS modernization will provide two other civil signals, L2C and L5, and GPS III now offers the opportunity to design a new civil signal at L1. Therefore, the present question is what new L1 signal characteristics will best serve the full spectrum of existing and future applications.

Some have suggested that all civil signals should be considered as a package when developing a new L1 signal. In other words, GPS will provide a civil service consisting of at least three signals: C/A at 1575.46 MHz (L1), L2C at 1227.6 MHz (L2), and L5 at 1176.45 MHz (L5). Each of these not only are at different frequencies, they have three different modulation waveforms, two different data rates, and two different message formats. In addition, Galileo is expected to provide similar Open Service (OS) signals at L1 and at L5 (E5a). (Galileo also intends to provide other signals as well, but none of the others shares a frequency with GPS, and access to most could require a user fee. The U.S. Government has made it clear that all civil GPS signals will be provided free of charge to all users, worldwide. Therefore, when developing a new GPS signal it would be inappropriate to take into account anything but the free Galileo OS signals which overlay GPS.) Should L1C, therefore, be developed to enhance the overall package of already-planned GPS and the common OS Galileo signals?

Our answer to the previous question is "no". This is because the largest number of users, by a vast margin, is expected to use only one of the common GPS and Galileo frequencies. In most cases we think this will be L1, although L5 also may be selected for many single-frequency applications. The following section examines the reasons for this conclusion. In either case, if L1C is likely to be used widely for single-frequency navigation, such receivers must rely on that one signal for all its navigation information. It can't take some data from one frequency, other information from a second frequency, etc. Therefore, L1C must be designed to support single frequency navigation applications and, in that sense, be able to function independently of all other GPS signals.

On the other hand, it might be helpful for L1C to have somewhat different characteristics than L5 to give companies a broader range of choices when considering which signal to use for single frequency applications.

6.1 Single-Frequency Applications Dominate

Some will find this assertion troubling. After all, won't technology make dual-frequency receivers practical for all applications, and isn't dual-frequency removal of ionospheric refraction error of vital interest to most users? We believe the answers are "no" and "no".

Until recently car navigation has been the largest GPS application. In the near future, if not already, embedded GPS in cell phones will be the largest application. Consider that, worldwide, between 400 and 500 million cell phones are sold annually. Expected trends are for cell phone sales to climb and for inclusion of GPS to increase. As a result, industry experts believe GPS will be available to a billion worldwide users within the next 15 years. Although the original impetus for GPS was to support the wireless E-911 service, other market forces are pushing the market toward greater use of GPS. For example, recent Nextel ads read: "*WHERE TO TURN FOR DIRECTION. Nextel's GPS-enabled phones get you there with audible turn-by-turn directions.*" GPS offers wireless providers another competitive feature and another source of revenue. It offers subscribers additional safety, directions to and advice about services, a way to remember the way back to favorite places or to record the location of a photograph, and perhaps customers will allow merchants to alert them when near certain stores on an approved list. All of these require more continuous use of GPS.

Car navigation is expected to be the second largest GPS application. There are many millions of car navigators in use today, and the number will grow dramatically over the next decade or two.

When annual production quantities are numbered in the millions, or the hundreds of millions, the dominant consideration is minimum product cost to meet performance requirements. The pressure on embedded GPS makers is to lower the chip cost to well under a dollar, perhaps reaching 25 cents. A large fraction of the overall GPS cost, therefore, is the antenna and the RF bandpass filter, which are substantially less expensive for single frequency reception. In cell phones, the most important antenna function is revenue-producing communication, and communication performance is not being sacrificed to add today's single frequency GPS much less to incorporate a more elaborate two-frequency antenna. When fractions of a penny count and when consumers don't demand it, it's almost inconceivable that dual frequency receivers will ever be used in high volume cell phones. The same cost pressures exist for car navigation, although with less emphasis, so far, to combine a GPS antenna with a cell phone antenna.

If consumers demanded ionospheric refraction correction and were willing to pay for better GPS accuracy, manufacturers would be happy to supply the products. However, unless the improvement is free, as with SBAS (Satellite Based Augmentation System), this isn't happening. SBAS provides differential and ionospheric correction signals at the L1 frequency, so the added cost to have this service in the GPS receiver is practically negligible. Other differential correction signals also are available, but they require an extra receiver, which consumers have shown no interest in buying. Better antennas and wider bandwidth receivers with improved

signal processing can minimize multipath error, but suppliers continue to stress low cost rather than better accuracy. Japan has a network of differential correction stations which provide signals via sidetones on FM broadcast stations. Reception is included in the car radio at negligible extra expense, so the service is in wide use. Such systems also may provide traffic alerts to help navigation routing adapt to local traffic conditions. For the user, this is a low cost way not only to achieve better accuracy but also to obtain a potentially important routing benefit.

The conclusion seems to be that although better accuracy may be desirable, manufacturers and consumers don't perceive it as worth increasing GPS cost or complexity, especially if even better accuracy is available for free, such as with an SBAS signal. (The Wide Area Augmentation System, or WAAS, is the U.S. SBAS, and SBAS is automatically included in almost all current consumer products.) If traffic information plus differential GPS corrections can be broadcast locally, there also would be both a public and a private incentive to incorporate such signals in GPS car navigation products, especially because the consumer also obtains these benefits essentially for free.

Therefore, we conclude that the vast majority of GPS applications will be for consumers and that consumers predominantly will use single frequency GPS receivers. Single frequency GPS receivers thus will vastly outnumber more complex receivers, and the resulting difference in production volume will further increase the cost differential. As a result, the L1C signal must be designed for stand-alone navigation service, providing all necessary information to its users.

6.2 Which will be the Single Frequency of Choice?

Current plans limit the choice of which signal to use for single frequency applications to L1 and L5. This is because improved satellite geometry (more satellites) is an extremely valuable asset, especially in environments where signal blockage by terrain, trees, or buildings is a problem, and these are common problems for most consumer applications. Therefore the ability to use both Galileo and GPS satellites offers a benefit to the user which can't be ignored. Previous paragraphs have established that the vast majority of consumer products will use only one frequency, and the EU is designing Galileo to transmit only two signals which overlap GPS frequencies, namely L1 and L5 (E5a). Therefore, these are the only two signals which will allow use of all GPS and Galileo satellites while retaining the simplicity of a single-frequency design.

There are two key advantages to L5. It is expected to be the most powerful civil GPS and Galileo signal. The minimum received L5 power specification for GPS is between -154 and -154.9 dBW into a circularly polarized antenna. The equivalent L1 C/A code specification today is -158.5 dBW, or from 3.6 to 4.5 dB weaker. (Measurements show that transmitted C/A signals are 1 to 2 dB stronger than the specification, so the practical difference may be only 1.6 to 3.5 dB.) The proposed L1C signal could be specified to have a minimum signal of -155.5 dBW, or only 0.6 to 1.5 dB weaker than the L5 specification. Even so, signal power is extremely important and may drive the signal selection toward L5 for single frequency use.

The second key L5 advantage is signal bandwidth, because it has a 10 MHz (actually 10.23 MHz) code clock rate. This provides 10 dB better rejection of narrowband in-band interference than the 1 MHz C/A code and 5.2 dB better rejection than the BOC(1,1) signal. These can be

important for some applications and, along with more signal power, may drive design decisions toward L5.

The case for L1 rests on three points. The first is the effect of the ionosphere on received signals. At certain latitudes, and especially during times of peak solar storms, scintillation causes signal fading and can cause loss of lock. The problem is more severe at lower frequencies, e.g., L5 versus L1. Probably more important, ionospheric refraction error is inversely proportional to the square of the signal center frequency. Therefore, L5 ionospheric errors always are 1.8 times worse than L1 errors. If the ionospheric error at L1 is 3 meters, at L5 it will be 5.4 meters. L1 provides better single frequency accuracy than L5, even when SBAS ionospheric corrections are applied.

The second key point is the inverse of the L5 bandwidth advantage. The 10 MHz L5 code practically fills the allotted signal bandwidth. Therefore, it is important for the RF filter to be wide enough to accept most of the L5 signal energy but with sharp bandpass skirts to reject out of band interference. This type of filter requires more “poles” and thus is more expensive to manufacture. (Remember that we are talking about a penny of cost being important for consumer applications.) In contrast, the main spectral lobes of a BOC(1,1) signal occupy only the central ± 2 MHz of the ± 10 MHz allotted signal bandwidth. This gives designers the choice to use a wide bandwidth filter with sharp skirts for applications requiring maximum accuracy or, to minimize cost for consumer applications, to use a relatively narrow bandwidth filter with fewer poles and wider skirts. Current consumer GPS products typically use a narrow bandwidth filter to save cost even though better accuracy could be obtained with a wider filter and faster processing circuitry.

Another result of the bandwidth difference between L1 and L5 is that by using a narrower bandwidth RF filter the consumer product can digitally process the signal with a lower clock rate. This may be an important difference for battery powered products such as cell phones. (Today, cell phone power is saved by shutting down the GPS receiver when not in use. Because the initial objective was only for E-911 positioning, GPS is used very seldom. In the future, however, people will begin to expect and to use more continuous navigation services, so concern for battery consumption will increase.) Consider also the wrist watch navigator, where power is even more limited.

Better narrowband interference protection from the 10 MHz L5 code is countered at L1 in two ways. First, it is known that the L5 band contains more interference than the remarkably quiet L1 band. Narrowband interference of current L1 receivers is practically unknown. Second, by using a narrowband RF filter there is less bandwidth exposed to interference. In other words, the filter attenuates many interfering signals that otherwise would affect an equivalent signal in the L5 band.

The final L1 advantage is experience. Many millions of L1 C/A receivers are in use around the world. Receiver companies and end users have vast experience with the L1 band. It will be many years before enough L5 and E5a signals are available to support a robust navigation service. During this time L1 use will continue to expand rapidly. Experience will favor the continued selection of L1 as the single-frequency signal of choice.

Ultimately the market will determine whether L1 or L5 becomes the dominant single-frequency signal. We believe it will be L1. However, even if L5 becomes the ultimate signal of choice, it would be unacceptable to design L1C without the ability to optimally support single-frequency GPS navigation.

6.3 Market Segments

In order to characterize market needs, we characterize the market segments as follows:

Table 6.1 – Primary Market Segments

	Professional & Scientific	Commercial	Consumer
Land			
Marine			
Aviation			

The “professional and scientific” column is intended to stress applications where very high accuracy is required. This includes GIS data collection, land survey, machine control, earthquake, volcano, and structure monitoring, and weather prediction. Although GIS data collection products typically require sub-meter accuracy, the others require accuracy of a centimeter or better. The “commercial” category represents products which are used by companies as a business tool. Such products include truck and taxicab tracking and routing systems, navigation systems for small commercial vessels to supertankers, and aircraft navigation systems for business aircraft to jetliners. By “consumer” products we mean items which are sold to individuals rather than companies. Such products range from GPS embedded in a cell phone to navigation systems for cars, boats, and airplanes.

The following paragraphs discuss likely signal requirements for each major column of the table as well as for some of the rows, e.g., aviation.

6.3.1 Consumer Product Needs for a New Signal

The most important driver for consumer products tends to be achieving the lowest possible cost to achieve competitive performance requirements. For navigation applications, better map displays and routing software are more important differentiators than improved GPS receiver characteristics. For embedded GPS, low power as well as low cost are the drivers. For these reasons, we expect most, although not all, consumer applications will use single-frequency receivers. Because satellite geometry and visibility are so vital to adequate performance, we also expect most consumer products to use both GPS and Galileo on a common frequency. The key exception to single frequency consumer products is likely to be navigation equipment for general aviation, where WAAS support of dual-frequency receivers will significantly improve available accuracy with integrity, availability, continuity, and coverage. These improvements will allow general aviation aircraft to make precision approaches to all approved airports without needing other equipment.

Although the L1C waveform will be chosen by the Government, it seems likely that consumer companies would prefer BOC(1,1) over BOC(5,1). With its narrower bandwidth, BOC(1,1) gives companies the opportunity to choose between L5 for the advantages of a wide bandwidth signal or L1C for the reciprocal advantages of a narrower bandwidth signal. This is an important consideration for very low cost applications, but even general aviation companies probably would prefer BOC(1,1) to avoid any concern about tracking a sub-peak of the BOC(5,1) correlation function.

The most contentious issue is data rate. Four nearly orthogonal needs have been defined. These are: (1) for a high data rate to provide additional accuracy and integrity messages, (2) for a high data rate to minimize the time needed to collect the clock and ephemeris messages and begin using a fresh satellite signal or to begin navigating (TTFF), (3) for a high data rate to provide messages with longer-lasting orbit and clock parameters, such as 8 to 12 hours, so subsequent position fixes don't require reception of a new message, and (4) for a low data rate to maximize the chance of receiving any message at all in challenged signal environments.

These clearly are conflicting requirements, and there is no way to favor one without hurting the others. We must seek a solution which provides the best possible performance to all users, and the key to this may be through other ways to deliver messages.

The data-less or pilot carrier component of L1C is an advantage for all users. This permits receivers in challenged conditions to acquire and track signals at lower S/N levels than would be possible without a pilot carrier. This is an advantage for all applications, but especially for indoor use.

6.3.2 Aviation Signal Requirements

Aviation users are facing a major transition and therefore a dilemma. Unlike other users, certification requirements for aircraft and equipment make it more expensive to upgrade a navigation receiver than simply buying a new product and plugging it in. Every certified aviation receiver today employs the single frequency C/A code. In the future there will be at least three and possibly four civil GPS signals. Galileo will provide signals at L1 and at L5 (E5a), so these two signals will give access both to GPS and to Galileo, practically doubling the number of visible satellites. Galileo also intends to have an E5b signal not only for navigation but also to send integrity data to aviators. Although of limited interest within the U.S., E5b may be mandated in Europe and could require a user charge.

The aviation community recognizes that these major changes are coming, and it is understood that performance will be improved significantly. However, there is very little incentive to make any change until the new options and their advantages are clearly defined, the signals are specified, the services are nearly available, and certified equipment is available at a reasonable price. For example, although WAAS already has been commissioned for use in the U.S., very few certified receivers are available and very few are being installed. Owners don't want to invest in a new receiver just to add single frequency WAAS when another replacement may be desired or required in a few years because of all the new options on the way.

The FAA urged and sponsored development of the L5 signal. The main advantage of L5 for aviation is to permit dual-frequency navigation with both signals (L1 and L5) in Aeronautical Radio-Navigation Service (ARNS) bands. (L2C will be available several years sooner than L5, but it is not in an ARNS band.) Although L5 alone must support navigation if L1 is not available, its 80% larger ionospheric error makes it a significantly less desirable single-frequency signal than L1, even with SBAS corrections. When combined with L1 to eliminate ionospheric refraction errors, aviation performance, especially with SBAS, is greatly improved. (Dual frequency receivers with SBAS support are expected to provide the equivalent of Category I precision guidance.) Therefore, L1 will continue to be the most important signal for aviation, and development of L1C offers a chance to further improve performance.

Some aviation experts have recommended a higher data rate on L1C so GPS can provide integrity and differential correction messages directly, thus eliminating the need for a separate SBAS signal. In contrast, other aviation experts want a very low data rate so L1C remains usable as close to areas for which the FAA has issued a NOTAM alerting aviators that GPS performance may be unreliable in that region. It is important to seek an answer which provides benefit to both points of view. Once again, resolving this conflict of objectives may have to rely on other data sources.

6.3.3 Professional and Scientific Signal Requirements

High precision applications include Geographical Information System (GIS) data collection where half meter accuracy is needed, land survey where centimeter accuracy is required, and machine control where centimeter accuracy under harsh dynamic conditions is needed. Also included is monitoring of structures such as bridges and dams where sub-centimeter accuracy is desired. Finally, this same type of equipment is used for a variety of scientific applications such as volcano and earthquake monitoring, determination of polar motion and continental drift, and atmospheric observations for weather prediction.

With the exception of GIS data collection, all of these applications require dual frequency carrier phase measurements. These are available today using C/A measurements on L1 with codeless or semi-codeless measurements of L2, aided by L1 tracking. A major improvement for these applications is on the way because, for the first time in GPS history, a civil code on L2 (L2C) will be provided. With this code, L2 measurements will be far more robust, and eventually the complex and expensive codeless and semi-codeless circuits no longer will be needed. When L5 becomes available from most satellites, it also will be incorporated. Three frequency receivers are expected to extend the range over which high precision measurements can be made and provide quicker results over conventional distances. These improvements also will be enhanced by access to both GPS and Galileo signals.

Because Professional and Scientific receivers have access to all signals and all messages, and because the primary measurement is of carrier phase, there are no major concerns with any L1C signal option. The primary benefit will be the pilot carrier. Otherwise, there are no problems using BOC(1,1) or BOC(5,1), and with access to all messages there is no particular benefit to a higher or a lower data rate on L1C. The one exception is that accuracy is the most important

consideration for this group. Anything that could be added to the message to further improve accuracy would be welcome.

6.4 User Interviews

Section 4.4 outlined the process whereby user groups would be surveyed to determine their current use of and dependence on GPS and what improvements they would appreciate the most. The approach is documented in Attachment 8.0 and the results are documented in Attachment 8.0. The approach was to identify a potential benefit to users from each main technical improvement expected from L1C. Major established GPS user groups were identified by discipline or interest (see User Benefits Matrix in Table 6.2 below), and *a priori* assessments made of how L1C parameter choices might impact each user group positively. For these cases, an ‘X’ was assigned in this matrix, and an explanation of user potential benefits was created. During the interview process with users, these potential benefits were discussed and validated, and additional comments were elicited by the process.

Table 6.2 – Benefit of Each L1C Improvement to User Applications

L1C Improvement ⇒ Application ↓	Lower Signal Thresholds for Navigation (Power & Dataless Channel)	More Robust Autonomous Navigation (Power, FEC & Data Rate)	Less Susceptible to Interference (Power & Code Structure)	Higher Dynamics Tracking (Power and Dataless Channel)	Reduced Cross- correlation (Longer Spreading Codes)
Location Based Services/Recreation	X	X	X		X
Scientific	X		X		X
Aviation			X		X
Agriculture	X	X		X	X
Surface Transportation	X	X	X		X
Mining & Construction	X	X	X	X	X
Surveying/Civil Engineering	X		X	X	X
Public Safety/Security	X	X	X		X
Timing			X		X
Rail	X	X			X
Space	X				X
Environment	X	X			X
Maritime and Waterways		X	X		X

In Section A of Attachment 8.0, the potential user benefits for each L1C performance enhancement are explained for the non-technical GPS user. Section B is the matrix above, and Section C contains an explanation and user response information for each of the major application areas given in the matrix. For each ‘X’ in the matrix, a description of the potential benefit for that user group is given in Attachment 8.0. In all cases, the users who were

interviewed believed that modernizing L1C would be of positive benefit to them in their GPS applications.

For example, all user groups clearly would benefit from reduced susceptibility to self-interference by adding L1C instead of simply boosting L1 C/A power levels. These user survey data also make it clear that, in particular, a more robust and powerful GPS L1C signal would be very welcome.

The user interviews verified and strengthened our conclusion that L1C would be a valuable asset to GPS and should be implemented.

7.0 Conclusions and Recommendations

We conclude that:

1. L1C is technically feasible,
2. The need for L1C is strongly supported by stakeholders, and
3. Experts prefer the following signal characteristics:
 - a. BOC(1,1) signal modulation
 - b. 25 bps data rate

These three points reflect our primary findings on the first three L1C Project objectives, which were achieved on schedule and on budget, as described in detail within this report (including the documentation provided in the attachments).

Recommendations to the IGEB are as follows:

- 1) Implement L1C as soon as feasible (it makes sense to complete GPS modernization across all three GPS frequency bands)
- 2) Retain C/A indefinitely, but implement L1C such that C/A can be discontinued in the distant future without a negative impact on L1C users
- 3) Implement BOC(1,1) as the L1C modulation. *(At one time the Galileo team was evaluating subtle alternatives to BOC(1,1). If a better modulation is found which meets the EU/US agreements on signal compatibility, the U.S. should be prepared to implement it instead of BOC(1,1). However, such a replacement would have to be studied very carefully, justified thoroughly, and is very unlikely.)*
- 4) Implement L1C with a data rate of 25 bps and with no additional messages. This yields the greatest global benefit by making the signal more robust for all users without sacrificing robustness for the sake of a particular set of users. Therefore, DGPS signals, integrity messages, long duration orbit and clock parameters, and faster orbit and clock parameters should be provided by local or regional communication services which are inherently better suited to these tasks and also may include added value information.

The fourth L1C Project objective, to define the detailed signal specification for L1C, has not been achieved. This work should be done soon, however, in preparation for GPS III acquisition

(e.g., CDD and ICWG processes) and for the next steps in international GNSS cooperation on system interoperability with Galileo and QZSS. We consider this forthcoming technical work to be best addressed by the technical team that has molded L1C up to this point, and this report contains our recommendations for that future work (in the Executive Summary and Section 5.3). We stand ready to continue, resources permitting, and of course pending decisions of the IGEB.

8.0 Acknowledgements:

We greatly appreciate the ideas and time contributed by all questionnaire respondents, and the major in-kind support of all corporations and agencies whose employees participated. We especially acknowledge the JGPSC in Japan and the DOTARS group in Australia for their assistance in distributing and encouraging feedback throughout the duration of the L1C Project.

GPS JPO officers serving under Col Rick Reaser, former Chief GPS Engineer, have guided and provided their input and ideas to the L1C Project. Initially, Maj Pat Harrington and Capt Reginald Victoria were involved in framing and successfully proposing the project. Capt Bryan Titus then brought the L1C Project through its main phases of technical development, while simultaneously working with the international GNSS community to ensure interoperability between GPS and Galileo. Lt Jason Taylor assisted by effectively presenting the L1C Project at the ANC Navigation Systems Panel in Canberra, Australia. During final stages of the project, Col(S) Mark Crews, LtCol Douglas Brown and Capt Dominic Alcocer have seen everything through to completion.

This project was made possible through the devoted and talented engineers and GPS experts working as contractors for the government. In particular, Mr. Tom Stansell played a crucial role in all aspects of design and strategy, as well as technical interviewing, throughout the duration of the project, and he wrote major sections of this report. Along with Mr. Stansell, Charlie Cahn, Rich Keegan, Karl Kovach, Chris Hegarty, Phil Dafesh, and John Betz also participated significantly in technical deliberations over signal design considerations. Joe Dorfler led the collection of information from the GPS user community through the user benefits feedback approach and by accessing previously conducted reports and information.

Members of the Aerospace GPS III group helped in various capacities (Clark, Yowell, Jamison, Raghavan, Cooper and others), and we appreciate their support and the information they provided.

We appreciate the reviews provided by Bill Leith and Nancy King of USGS, as well as the support of Lucy Jones and Bill Ellsworth of the USGS National Earthquake Program.

Finally, last but certainly not least, we are also especially grateful for the support of Larry Hothem (IGEB SSG member for DOI) and Dave Turner (Director, IGEB Executive Secretariat), whose guidance at many points along the way, from initiation to completion, made this project possible.

L1C FINAL REPORT

TABLE OF ATTACHMENTS

<u>A-1.0</u> : L1C Initial Presentation at CGSIC; Portland, Oregon; September 8, 2003	A 2
<u>A-1.1</u> : Presentation and Questionnaire Provided at NAVCEN Booth during ION GPS-2003.....	A 13
<u>A-1.2</u> : <u>GPS World</u> article on L1C Project (October 2003 issue)	A 18
<u>A-2.0</u> : L1C Presentation at GPS System Engineering Forum (GSEF); Los Angeles, California; October 28-29, 2003	A 19
<u>A-3.0</u> : L1C Paper presented at International Civil Aviation Organization (ICAO) - Air Navigation Conference (ANC), Navigation Systems Panel (NSP); Canberra, Australia; November 11, 2003	A 44
<u>A-3.1</u> : L1C ‘flimsy’ for ICAO ANC NSP feedback	A 48
<u>A-3.2</u> : ICAO Contracting States listing	A 54
<u>A-4.0</u> : L1C Presentation at International GPS Service (IGS) 10 th Annual Meeting; Berne, Switzerland; March 3, 2004	A 59
<u>A-4.1</u> : L1C Poster – presented at IGS Meeting.....	A 74
<u>A-5.0</u> : L1C Presentation (Parts I & II) at IEEE PLANS; Monterey, California; April 28, 2004	A 75
<u>A-6.0</u> : Annotated L1C Technical Interview Presentation	A 108
<u>A-6.1</u> : Questionnaire Used for Experts Survey	A 134
<u>A-7.0</u> : L1C Technical Questionnaire Responses (55 responses included).....	A 136
<u>A-8.0</u> : Civil User Benefits	A 347
<u>A-8.1</u> : User Group Guidelines.....	A 392
<u>A-9.0</u> : Economic Benefits.....	A 395



L1 Modernization Project (L1C)

Ken Hudnut, Ph.D.
Project Manager
Geophysicist, USGS

Lt Bryan Titus
Navstar GPS JPO, Co-Lead
Sat. Nav. Engineer, USAF

CGSIC 42nd Meeting
Portland, Oregon; September 8, 2003

Purpose

- **To solicit comments from civil and other GPS stakeholders about:**
 - **whether or not a modernized GPS L1 civil signal should be added - and, if so -**
 - **what types of modernization would be most valuable, and why**
- **The U.S. Government has not yet determined whether a modernized GPS L1 civil signal should be added**



Why Modernize? L1 C/A is Excellent

- L1 C/A works well; it supports millions of users
 - Accuracy is astounding
 - Absolute accuracy is a few meters (good for most users)
 - Differential navigation can give sub-meter accuracy
 - Surveyors and scientists rely upon sub-centimeter differential results
 - Interference is minimal
 - It's being used for safety-of-life navigation
- Why consider changing anything so successful?
 - *"If it isn't broken, why fix it"... there's room for improvement*



What are Opportunities for Improvement?

- Any of the longer-coded L1C options would be less susceptible to narrowband interference than L1 (C/A)
 - Could improve cross-correlation properties:
 - Improve indoor or wooded area use
 - Increase number of satellites and code signal power without causing unacceptable self-interference
 - Improve receiver signal acquisition threshold
 - Navigation message could contain more:
 - Precision, flexibility, and forward error correction (FEC)
 - Signal tracking and data demodulation thresholds (robustness) would be better with a modernized signal
 - GPS III schedule presents an opportunity - requirements need to go into a CDD by Aug. 2004
-



Proposed Objectives

- **Compatible signal for legacy C/A receivers**
 - Continue to provide the C/A code
 - Minimize added noise for C/A receivers
- **New signals with better performance than C/A**
 - Better correlation properties (longer codes)
 - More signal power and better threshold tracking
 - Improved performance indoors and under foliage
 - Improved message structure, precision, etc.
 - Improved narrowband interference protection

L1C Data Rate Tradeoff

- L1C modernized data presumably will be similar to or the same as for L2C and L5
 - Forward error correction (FEC) also will be used
- Some data rate options:
 - 25 bps (L2C) provides data in challenged situations
 - Urban canyons, indoors, in wooded areas
 - 50 bps (L5) same as C/A now
 - 100 bps would allow additional messages (e.g., integrity warnings)
- What is best for your applications?



L1C Signal Power Tradeoff

- Higher power signals generally are better
 - Better operation in challenged circumstances (interference, wooded areas, indoors, etc.)
 - More precise measurements (higher SNR)
- However, higher power L1C signals could slightly increase L1 C/A noise
 - Less than 0.5 dB, depending on the signal choice
- What is best for your applications?

L1C Code Length Tradeoff

- The C/A code length is 1,023 chips (short)
- Modernized codes are at least 10 times longer
- Longer codes have major advantages:
 - Eliminate cross-satellite interference
 - Reduce effect of narrowband interference
 - Enable more and more powerful satellite signals
- But, acquisition time (per correlator) is longer
 - Technology now permits thousands of correlators
- What is best for your applications?



Adding L1C Messages - Which Ones?

- **GPS messages are only for navigation**
- **Added value messages might provide:**
 - **Integrity warnings of “bad” satellite signals or weather, rescue, or other NAV-related messages**
- **What is the best integrity source ?**
 - **Ground signals, GEO satellites, RAIM, or GPS ?**
 - **With GPS plus other GNSS, is RAIM sufficient ?**
- **What is best for your applications?**



L1C Almanac & Ephemeris Precision

- C/A ephemeris precision is about 1 meter
- L1C ephemeris may have 1 cm precision
- Is this of any benefit for your applications?
- L1C “compact almanac” may be less precise than C/A to cover more satellites faster
- Is this change desirable or not?

Note: almanac contains coarse orbit data, broadcast by each SV for all SV's, whereas ephemeris contains precise data broadcast by each SV for only its own orbit & clock parameters



Your Reaction to L1C Modernization

- Do you favor L1 civil signal modernization?
- What are your concerns?
- What are your desires?
- Why? *Please fill out the questionnaire*

USCG NAVCEN Booth @ ION
<http://L1C.gps.gov/>
L1C_GPS@usgs.gov



L1 Modernization Project (L1C)
ION GPS/GNSS 2003
 Portland, Oregon; September 10-12, 2003

<p style="text-align: center;"><u>Purpose</u></p> <ul style="list-style-type: none"> ▪ To solicit comments from civil and other GPS stakeholders about: <ul style="list-style-type: none"> ▪ Whether or not a modernized GPS L1 civil signal should be added - and, if so - ▪ What types of modernization would be most valuable, and why ▪ The U.S. Government has not yet determined whether a modernized GPS L1 civil signal should be added 	
<p style="text-align: center;"><u>Why Modernize? L1 C/A is Excellent</u></p> <ul style="list-style-type: none"> ▪ L1 C/A works well; it supports millions of users ▪ Accuracy is astounding <ul style="list-style-type: none"> ▪ Absolute accuracy is a few meters (good for most users) ▪ Differential navigation can give sub-meter accuracy ▪ Surveyors and scientists rely upon sub-centimeter differential results ▪ Interference is minimal ▪ It's being used for safety-of-life navigation ▪ Why consider changing anything so successful? <ul style="list-style-type: none"> ▪ "If it isn't broken, why fix it" (there's room for improvement) 	<p style="text-align: center;"><u>Comments</u></p>

<p><u>What are Opportunities for Improvement?</u></p> <ul style="list-style-type: none"> ▪ Any of the longer-coded L1C options would be less susceptible to narrowband interference than L1 (C/A) ▪ Could improve cross-correlation properties: <ul style="list-style-type: none"> ▪ Improve indoor or wooded area use ▪ Increase number of satellites and code signal power without causing unacceptable self-interference ▪ Improve receiver signal acquisition threshold ▪ Navigation message could contain more: <ul style="list-style-type: none"> ▪ Precision, flexibility, with forward error correction (FEC) ▪ Signal tracking and data demodulation thresholds (robustness) would be better with a modernized signal ▪ GPS III schedule presents an opportunity - requirements need to go into a CDD by Aug. 2004 	<p><u>Comments</u></p>
<p><u>Proposed Objectives</u></p> <ul style="list-style-type: none"> ▪ Compatible signal for legacy C/A receivers <ul style="list-style-type: none"> ▪ Continue to provide the C/A code ▪ Minimize added noise for C/A receivers ▪ New signals with better performance than C/A <ul style="list-style-type: none"> ▪ Better correlation properties (longer codes) ▪ More signal power and better threshold tracking <ul style="list-style-type: none"> ▪ <i>Improved performance indoors and under foliage</i> ▪ Improved message structure, precision, etc. ▪ Improved narrowband interference protection 	<p><u>Comments</u></p>

L1C Data Rate Tradeoff

- L1C modernized data presumably will be similar to or the same as for L2C and L5
 - Forward error correction (FEC) also will be used
- Some data rate options:
 - 25 bps (L2C) provides data in challenged situations
 - *Urban canyons, indoors, in wooded areas*
 - 50 bps (L5) same as C/A now
 - 100 bps would allow additional messages (e.g., integrity warnings)
- What is best for your applications?

Response

Rank: 1 = best

Importance:

10 = very important

5 = moderate

0 = not important

Data Rate	Your Rank	Import
25 bps		
50 bps		
100 bps		

L1C Signal Power Tradeoff

- Higher power signals generally are better
 - Better operation in challenged circumstances (interference, wooded areas, indoors, etc..)
 - More precise measurements (higher SNR)
- However, higher power L1C signals could slightly increase L1 C/A noise
 - Less than 0.5 dB, depending on the signal choice
- What is best for your applications?

Response

Increase Signal Power:

Yes or No

Comment:

L1C Code Length Tradeoff

- The C/A code length is 1,023 chips (short)
- Modernized codes are at least 10 times longer
- Longer codes have major advantages:
 - Eliminate cross-satellite interference
 - Reduce effect of narrowband interference
 - Enable more and more powerful satellite signals
- But, acquisition time (per correlator) is longer
 - Technology now permits thousands of correlators
- What is best for your applications?

Response

The L1C code normally used for signal acquisition should be:

10,230 chips

20,460 chips

Longer

Comment:

<p><u>Adding L1C Messages – Which Ones?</u></p> <ul style="list-style-type: none"> ▪ GPS messages are only for navigation ▪ Added value messages might provide: <ul style="list-style-type: none"> ▪ Integrity warnings of “bad” satellite signals or weather, rescue, or other NAV-related messages ▪ What is the best integrity source ? <ul style="list-style-type: none"> ▪ Ground signals, GEO satellites, RAIM, or GPS ? ▪ With GPS plus Galileo, is RAIM sufficient ? ▪ What is best for your applications? 	<p><u>Response</u></p> <p>Should the GPS data rate be increased to provide additional messages?</p> <p>Integrity: Yes No</p> <p>DGPS: Yes No</p> <p>Other: Yes No</p> <p>With GPS+Galileo, would RAIM be sufficient for integrity?</p> <p style="text-align: right;">Yes No</p>
<p><u>L1C Almanac & Ephemeris Precision</u></p> <ul style="list-style-type: none"> ▪ C/A ephemeris precision is about 1 meter ▪ L1C ephemeris may have 1 cm precision ▪ Is this of any benefit for your applications? ▪ L1C “compact almanac” may be less precise than C/A to cover more satellites faster ▪ Is this change desirable or not? 	<p><u>Response</u></p> <p>Would increased precision of the GPS ephemeris be valuable?</p> <p style="text-align: center;">Yes No</p> <p>Would decreased precision of the almanac to provide more satellites quicker be valuable?</p> <p style="text-align: center;">Yes No</p>
<p><u>Your Reaction to L1C Modernization</u></p> <ul style="list-style-type: none"> ▪ Do you favor L1 civil signal modernization? ▪ What are your concerns? ▪ What are your desires? ▪ Why? 	<p><u>Reaction</u></p> <p>Favor L1 Modernization?</p> <p style="text-align: center;">Yes No</p>

Respond to one of the following:

E-mail: L1C_GPS@USGS.gov

FAX: 626-583-7827

Mail: L1C GPS, 525 South Wilson Ave., Pasadena, CA 91106-3212

Your Printed Name: _____

Title or Position: _____

Organization: _____

Contact Information: _____

Additional Comments:

Attachment 1.2: GPS World article on L1C Project (October 2003)

GLOBAL VIEW

Civil Signals, Galileo Focus of CGSIC Event

Monitoring of GPS civil signals, investigation of a "modernized" civil signal at L1, and GPS's relationship with Europe's Galileo system drew the attention of attendees at the Civil GPS Service Interface Committee (CGSIC) meeting held September 8 and 9 in Portland, Oregon.

Tom Nagle, the U.S. Department of Transportation representative at the GPS Joint Program Office (JPO), told the CGSIC audience that JPO has decided to exercise an option for monitoring current and future civil signals as part of its contract with Boeing Corporation to modernize the GPS ground control segment. Currently, the U.S. Air Force operators of GPS only monitor the P(Y)-code signals, which has generally reflected the health of C/A-code signals as well.

However, Nagle pointed out, "As new civil signals come on line on new generations of satellites, there are more parts on the satellite that are uniquely associated with the civil signal. As a result, we could get a signal failure that doesn't show up in the P/Y signal."

Under the current schedule, a system for civil monitoring would be in place by 2007. (An article in September 2003 *GPS World* discusses the issue of civil GPS monitoring.)

GPS/Galileo Talks. Ralph Braibanti, director of the State Department's Office of Space and Advanced Technology, described the negotiations with the European Commission (EC) to ensure the compatible and interoperable coexistence

of GPS and Galileo. In recent months, a European proposal to overlay the Galileo Public Regulated Service (PRS) on a part of the L1 band where the United States plans to put its new military M-code has created considerable concern among some U.S. officials.

A two-day meeting on a classified basis with the EC team in London in early September reviewed the U.S. navigation warfare plans in greater detail than past discussions. "I think we've made a lot of progress in at least convincing them that there's a serious problem [with a PRS overlay] that we need to solve together," Braibanti said. He added that the negotiators hope to reach agreement by the end of the year on most major issues, which would coincide with Europe's deadline for finishing the design of Galileo satellites. The next meeting of the two sides was scheduled for October 2-3 in Washington, D.C.

The agreement presently being discussed would only extend through the design and validation phase that concludes with the deployment of Galileo's 30 satellites (with a current target date of 2008), according to Braibanti. Meanwhile, the two sides are discussing a process to shape an agreement for cooperative activities between GPS and a fully operational Galileo.

Jason Kim, a senior policy analyst in the U.S. Commerce Department's Office of Space Commercialization and a member of the Interagency

GPS Executive Board (IGEB) executive secretariat, described the reorganized interagency (civil/military) requirements process for GPS modernization. Kim also enumerated the projects that the IGEB will finance with its GPS "stewardship" funds, including a study on the possibility of a new civil signal at L1 and a GNSS market analysis.

A Better Civil L1 Signal? Ken Hudnut, a U.S. Geological Survey geophysicist, described the IGEB-funded investigation into modernizing the L1 civil signal along the line of planned improvements at the L2 and L5 frequencies that will be available in the coming years. The signals would be compatible with legacy L1 C/A-code receivers, Hudnut said.

A longer code and faster data rate are two of the most important enhancements under consideration, but L1C modernization could also incorporate forward error correction (FEC) techniques, higher signal power, and broadcast of precise satellite ephemerides (orbital location of each spacecraft). The overall objectives of such improvements would be to increase positioning accuracy and receivers' sensitivity for signal acquisition and tracking in adverse environments (indoors, wooded areas, and so forth), as well as reduce the effect of narrowband interference.

The L1 Modernization Project, co-led by Hudnut and Lt. Bryan Titus at GPS JPO, developed a questionnaire for civil users, available by email, L1C_GPS@USGS.gov, fax 626-583-7827, or by mail, L1C GPS, 525 South Wilson Ave., Pasadena, California 91106-3212.

The U.S. government has not yet decided whether to add an L1C signal to GPS transmissions. If approved, the proposal for a modernized L1C could feed into the GPS III requirements process, scheduled for completion in August 2004.

China, EU, & Galileo

Negotiators for the European Union (EU) and the People's Republic of China agreed on provisions for China's participation in the Galileo program.

According to EU officials, this opens the way for China to take a substantial financial part in the program through a stakeholding in the Galileo Joint Undertaking, the body that will manage the program, and in European Space Agency (ESA) activities to build space and ground infrastructure. According to reports, China may invest up to €230 million (\$263 million) in the estimated €3-4 billion project. India and Israel have also indicated interest in similar participation.

The agreement was initiated in Beijing on September 18 by François Lamoureux, director-general of Energy and Transport (DG-TREN) at the European Commission (EC), and Shi Dinghuan, secretary general of China's Ministry of Science and Technology. The proposal was scheduled for submission to the EU Transport Council meeting on October 9 for formal approval by EU member states. Any agreement would also have to gain approval from China's State Council. If approved, the text would then be submitted for signature at the forthcoming

Continued on page 54

www.gpsworld.com



IGEB L1C Stewardship Project

GSEF – October 28-29, 2003

Program Considerations

Dr. Ken Hudnut, USGS



1Lt. Bryan Titus, GPS JPO

U.S. Department of the Interior
U.S. Geological Survey

IGEB L1C Stewardship Project

- **Project funded at \$355K** (IGEB memo July, 2003)
- **Co-chaired**
 - 1Lt. Bryan Titus, GPS JPO
 - Dr. Ken Hudnut, USGS, Pasadena
- **Funding split \$120K to JPO; \$235K to USGS**
(MIPR dated 8/15/03; performance period 8/19/03-8/19/04)
- **Coordinated and cooperative activities**



CGSIC/ION in Portland and IFOR

- **Hudnut presentation at CGSIC, Portland (9/8/03)**
 - ‘Civil Input on Future GNSS Signals’ issues panel, chaired by Hank Skalski (on CGSIC www)
 - Feedback and discussion during panel Q&A
 - Covered in October issue of GPS World (pg. 14)
- **NAVCEN booth at ION conference (9/10-12/03)**
 - Slide presentation on laptop, one-on-one discussions, and ~ 60 questionnaires distributed
- **Civil IFOR presentation (9/23/03)**
 - Larry Hothem, DOI/USGS



Feedback and Lessons Learned

- **Feedback**
 - Four completed forms and three ‘free-form’ e-mail comments (most responses from technically inclined NASA and FAA employees/contractors)
- **Lessons have been learned – we are now redirecting our survey efforts**
 - Low response rate from general questionnaire
 - There is definite interest in the GPS community
 - Outreach must be more direct and “personal”



L1C Technical and Strategy Meeting

- **Four sessions on 8-9 October at the JPO**
 1. Navwar issues (classified)
 2. Code structure and interference issues
 3. Message structure discussions
 4. Application advantages and outreach planning
 - **Participants**
 - Chaired by Titus and Hudnut
 - Included Betz, Cahn, Dafesh, Dorfler, Hegarty, Keegan, Kovach, Stansell, and Taylor
 - **L1C benefits by user group being compiled**
-



Next Steps

- **Prepare two types of survey**
- **Conduct surveys, domestic and international**
- **Consolidate the survey results**
- **Update the technical approach details**
- **Prepare final IGEB report, including:**
 - **Process description**
 - **Survey results and cost estimates**
 - **Policy recommendations**
 - **Signal design recommendations**
 - **If a new signal is proposed**



IGEB L1C Stewardship Project

GSEF – October 28-29, 2003

Program Considerations

Dr. Ken Hudnut, USGS

1Lt. Bryan Titus, GPS JPO



U.S. Department of the Interior
U.S. Geological Survey

Technical Considerations

- **L1C technical meeting at JPO on Oct. 8 – 9**
 - **Compatibility with US/Allied security**
 - **Backward compatibility with legacy C/A receivers**
 - **Signal design**
 - **Message options**
 - **Technical trade-offs for user benefits**



US/Allied Security Compatibility

- **Classified session on 8 Oct.**
 - Navwar scenario and impacts were presented to technical experts
- **Group agreed there are three viable modulations**
 - BPSK-R(2)
 - BOC(1,1)
 - BOC(5,1)
- **Other modulations will not be considered**

C/A Legacy Compatibility

- Any new GPS L1 signal must be RF compatible with legacy C/A receivers
- Previous experience with M code and Galileo produced useful analysis tools
 - US/EU agreed Assumptions Document
 - US agreed Methodology for Analysis of GNSS Interference Effects
- Considered scenarios with and without Galileo OS



Increased C/A Headroom

- **Prior to January of 2003, the minimum specified C/A signal power was -160 dBW**
 - **Worst case calculations show YMCA interference degrades received C/N_0 to 31.2 dB-Hz**
 - **Minimum C/A signal power specification increased to -158.5 dBW to give headroom for new GPS and Galileo signals**
 - **Releasing JPO margin raises C/N_0 to 32.7 dB-Hz**
 - **The effect of new GPS and Galileo signals is dependent on modulation and signal power**
-



C/A Legacy Compatibility Analysis

- Analysis assumes GPS L1C and Galileo OS use the same BOC(1,1) modulation
- Three scenarios are considered
 - YMCA only
 - (a) Today, (b) Better power control, (c) Triple the min. C/A power
 - L1C or OS (At 3 dB more min power than min C/A)
 - L1C and OS (Each 3 dB more min power than min C/A)
- Power control in satellites limits the max interfering C/A, L1C, and OS power levels

C/A Compatibility Analysis Results

Scenario	Min C/A	Max C/A	Min L1C/OS	Max L1C/OS	Eff. C/A Min. C/N ₀	Note
YMCA Only	-158.5	-153.0			32.7	Today
	-158.5	-156.0			33.6	Power Control
	-153.7	-151.2			36.7	Triple C/A
L1C or OS	-158.5	-156.0	-155.5	-153.0	33.3	L1C or OS
L1C & OS	-158.5	-156.0	-155.5	-153.0	33.0	L1C & OS

- YMCA is with C/A signals only, no L1C, no Galileo
- L1C and OS results assume BOC(1,1)
- Increasing C/A power x3 yields only x2 result
- BOC(1,1) w/ power control is better for C/A than now
- The BOC(1,1) signal power is twice the C/A power

L1C Signal Design

- **Minimum L1C Signal Power = -155.5 dBW**
 - Twice the minimum C/A power
- **Center frequency = 1575.42 MHz**
- **Modulation: BPSK(2), BOC(1,1), or BOC(5,1)**
- **Components: data and data-less channels**
 - Tracking sensitivity 6 dB better than C/A channel
 - FEC gives 5 dB of data threshold improvement



L1C Signal Design

- **Spreading code length**
 - No shorter than 10,230 chips
- **Data rate**
 - 25, 50, or 100 bps data rates are being considered
- **Message structure**
 - Same as L2C and L5
 - Others under consideration (e.g., integrity, precision)
- **Multiplexing**
 - Majority voting and TDM are being considered
 - Invisible to the user



Requirements Surveys

- **Review of prior studies conducted for GPS III**
 - **Two survey methods will be used**
 - **User surveys based on L1C benefits**
 - 15 user groups identified (next slide)
 - **Expert surveys based on L1C design choices**
 - Government agencies
 - GPS manufacturers
 - GPS service providers
 - University GPS faculty
 - GPS industry experts
 - ION section meetings
-



User Trade-offs and Benefits

- **Fifteen user groups have been identified**
 - **Location based services**
 - **Scientific**
 - **Aviation**
 - **Agriculture**
 - **Surface transportation**
 - **Mining and Construction**
 - **Surveying/Civil engineering**
 - **Public safety**
 - **Timing**
 - **Rail**
 - **Recreation**
 - **Space**
 - **Environment**
 - **Maritime**
 - **Security**



User Technical Trade-offs and Benefits

- Each user group is assigned a team member
 - Face to face meetings/interviews with representatives from each user group
 - A “checklist” of items will be covered
 - L1C user benefits will be explained
 - e.g.: Increased robustness to interference
 - e.g.: Improved ability to acquire and track indoors
 - Requirements and preferences will be gathered from the user community
-



Compilation of User Requirements

- Information gathered in the meeting/interview phase will be compiled and compared
- Plan to have statistically significant input from the GPS user community
- Signal recommendation will be the result of the users' input



Expert Survey Technique

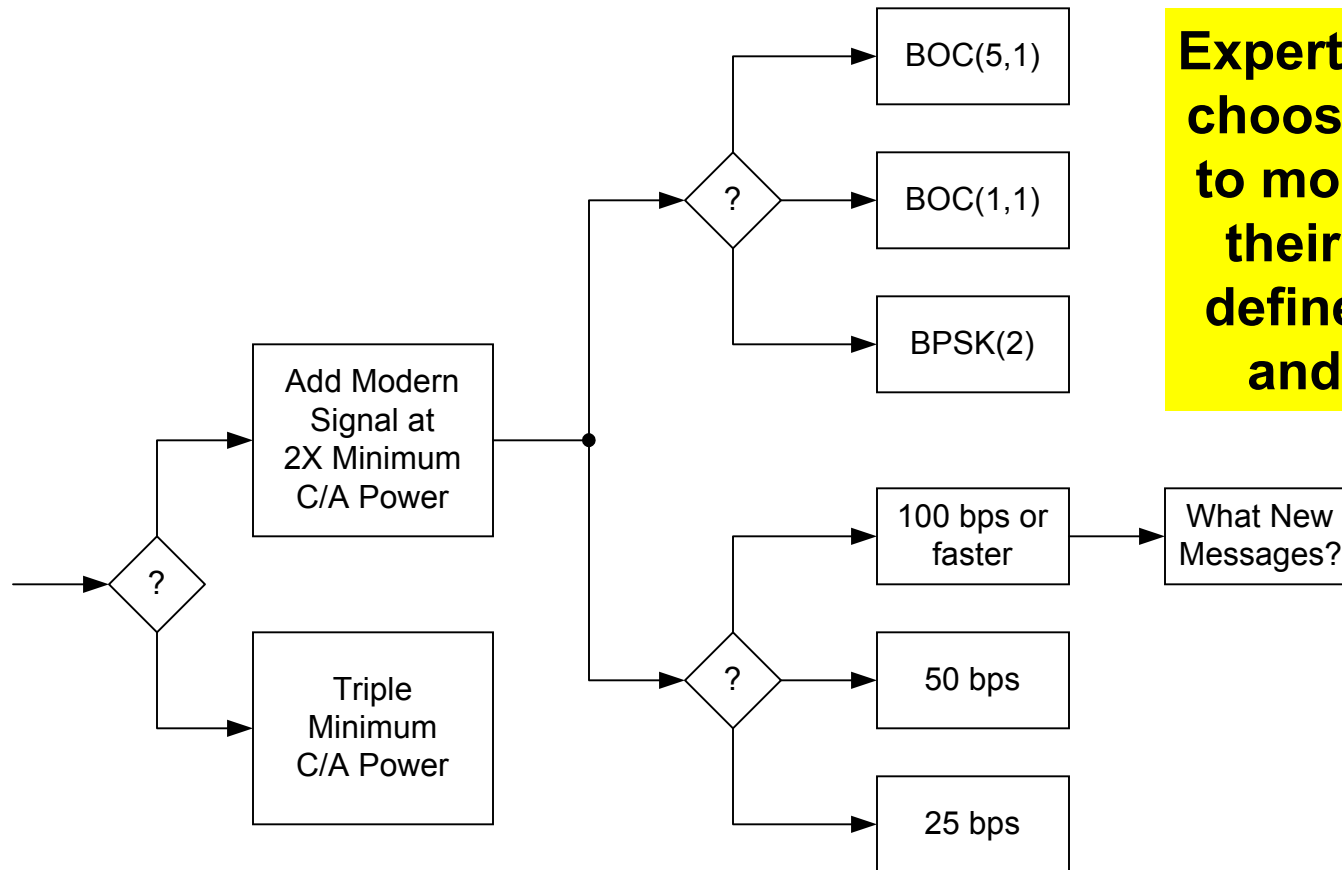

Experts asked to help choose the best path to modernization for their applications, define applications, and explain why

Conclusions

- Preparation is well underway
- Expect to submit final report by Sept., '04
- Budget should be sufficient

Backup Slides



C/A Signal Power Measurements

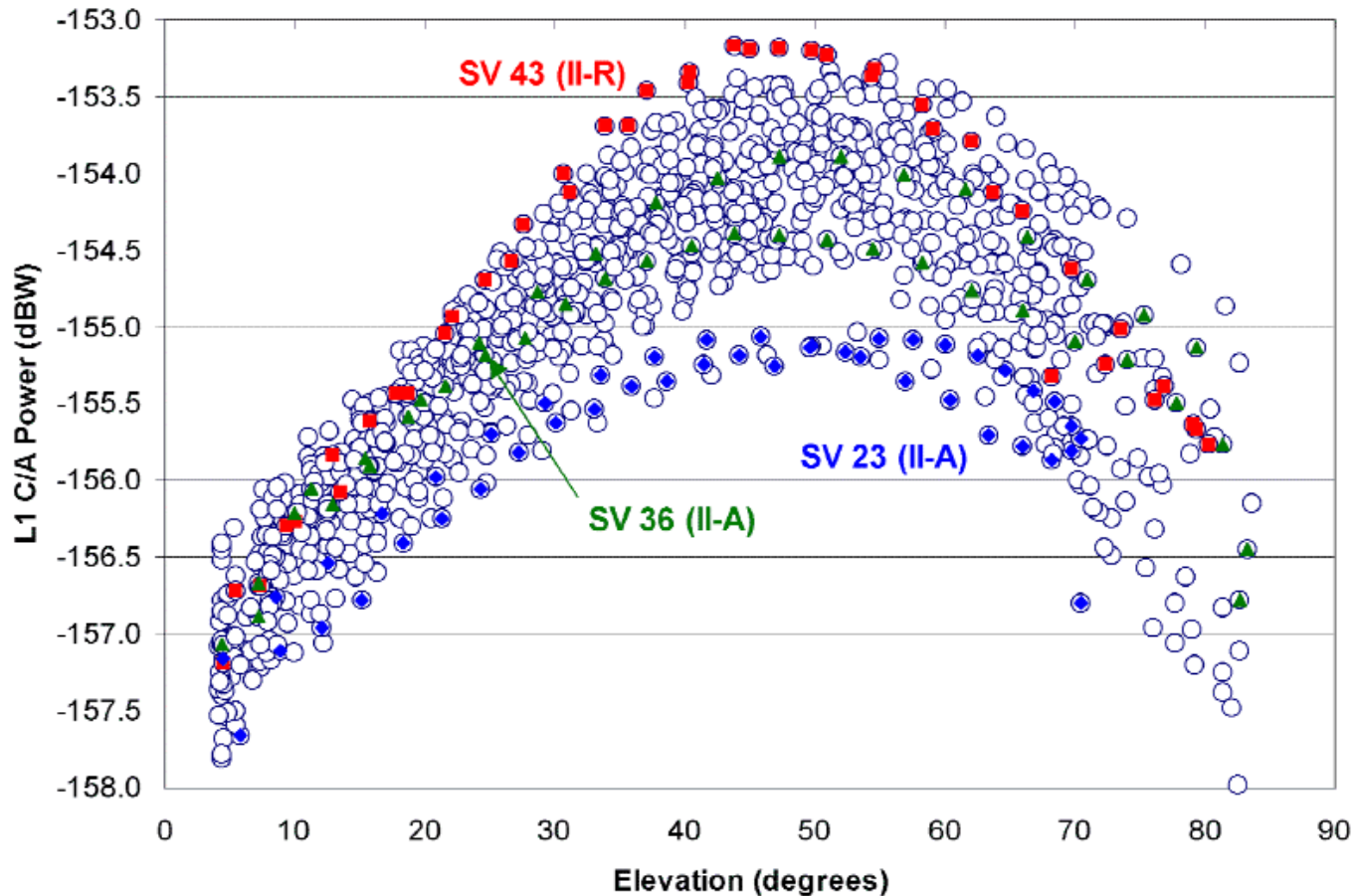

**1.5 dB of
JPO margin
was released**

**Raising the
minimum
specified
C/N₀ from
31.2 dB-Hz
to
32.7 dB-Hz**

GPS III with IIF Antenna Pattern

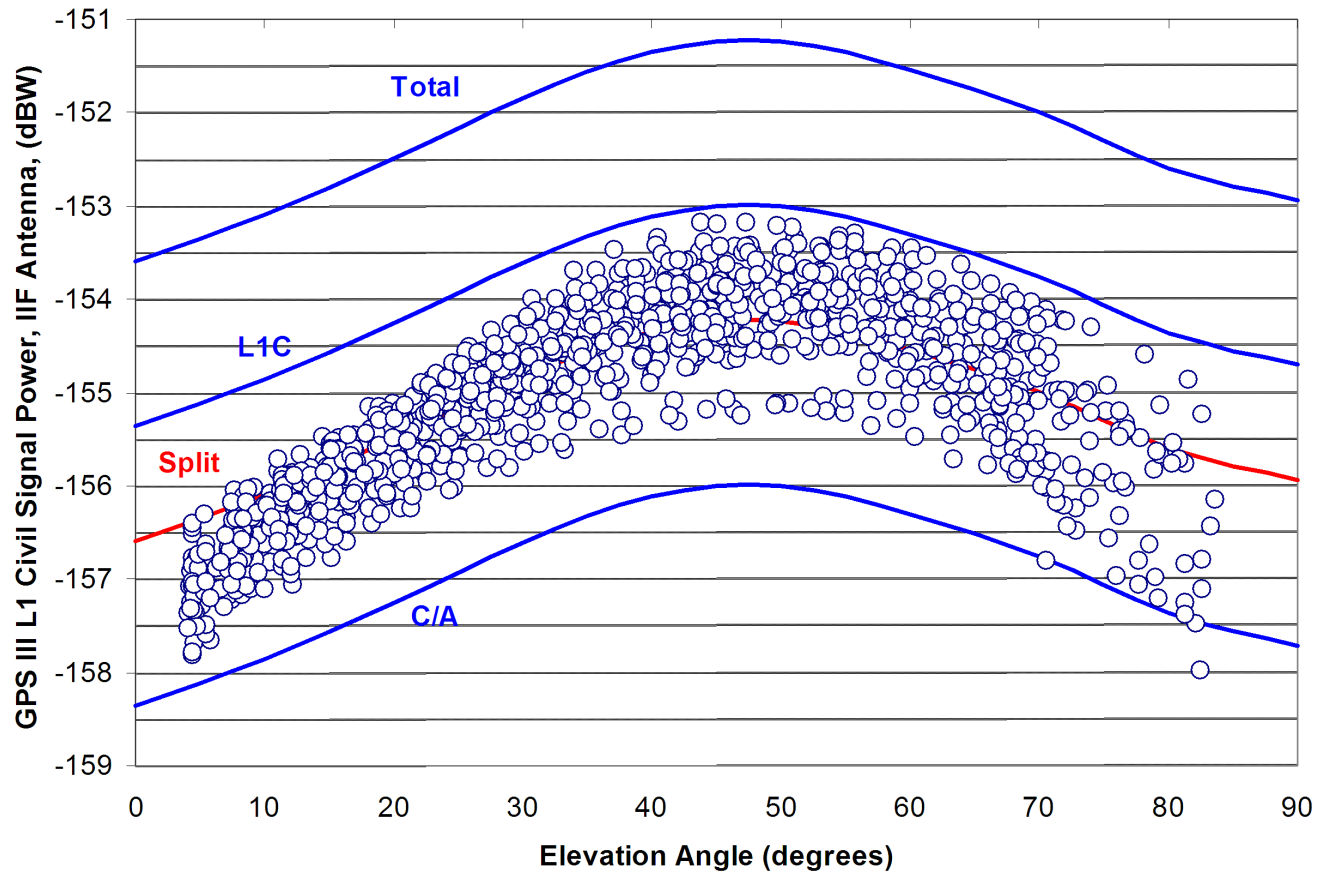

GPS III with IIR-M Antenna Pattern

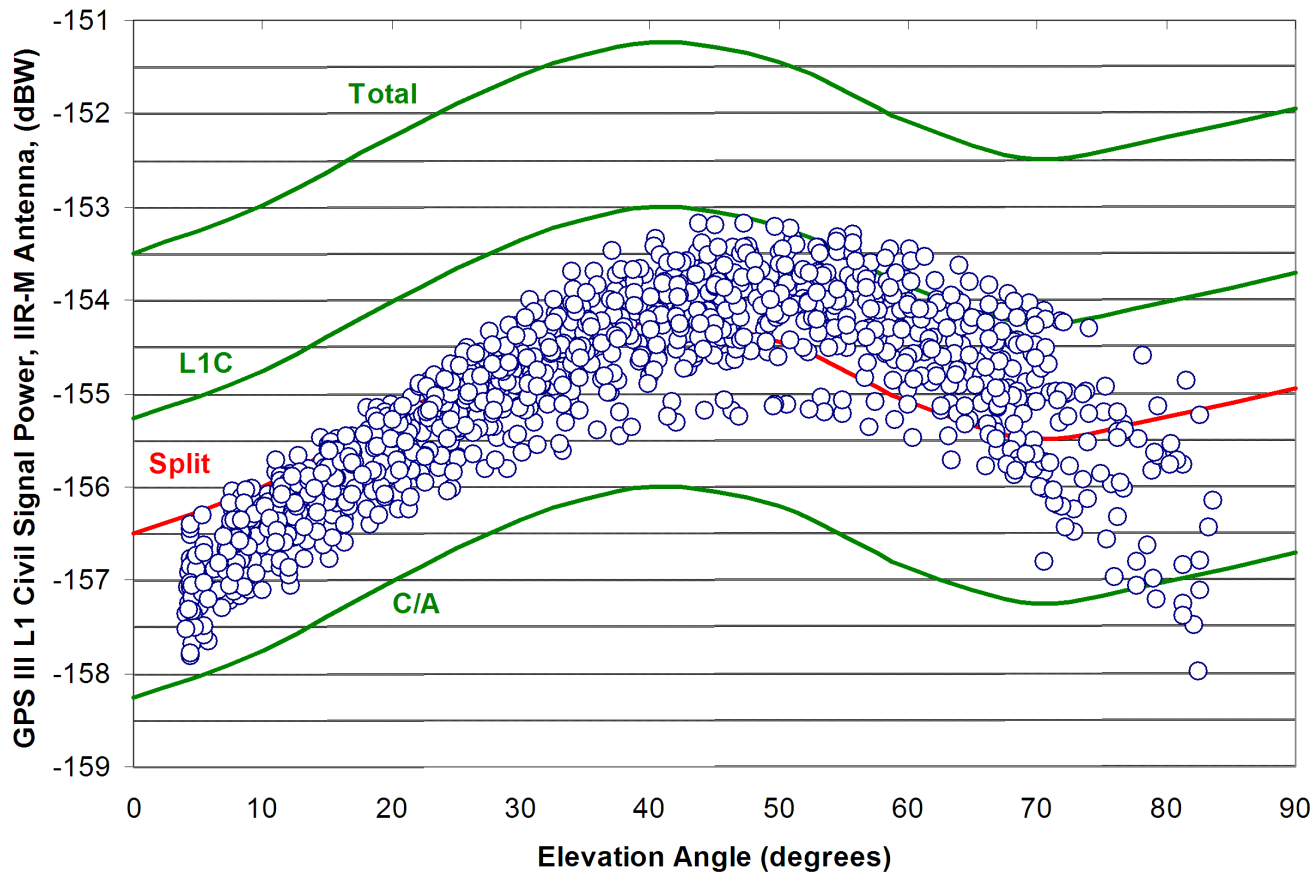

Attachment 3.0: L1C Paper: ANC Canberra – ICAO Navigation Systems Panel

NSP/WP/

NAVIGATION SYSTEMS PANEL WORKING GROUP MEETING

Canberra, Australia

Agenda Item XX

**GLOBAL POSITIONING SYSTEM CIVIL FREQUENCY (L1)
MODERNIZATION OPPORTUNITY**

(Presented by the United States of America)

SUMMARY

The Global Positioning System (GPS) provides a solid foundation for enhancing CNS/ATM systems and services. Programs are underway to add additional GPS civil frequencies (L2C and L5) and upgrade the ground control network. There is a unique and exciting opportunity to add a modernized civil signal to the L1 frequency to further improve GPS civil services.

This paper provides a brief overview of the L1 modernization opportunity, technical examples/benefits of modernization, and a specific point of contact for Meeting attendees and other user representatives to enable them to provide direct information to the personnel responsible for L1 modernization.

1. INTRODUCTION

1.1 Global Navigation Satellite Systems (GNSS) signals and services are progressively becoming a critical element for the modernization of global communications, navigation, surveillance and air traffic management (CNS/ATM) infrastructures.

Assessments in recent years, such as those made at the 1995 Special Communications/Operations Divisional Meeting, have suggested that GNSS-based operations may not reach their full potential until additional civil signals or core satellite constellations are available.

1.2 The United States is aggressively pursuing a Global Positioning System (GPS) modernization program. This program will result in several civil improvements to include the addition of new civil signals at 1227.6 MHz and 1176.45 MHz (L2C and L5 respectively). These new civil signals will complement the GPS civil signal currently being broadcast at 1575.42 MHz (L1 C/A).

2. L1 MODERNIZATION OPPORTUNITY

2.1 The L1 C/A civil signal structure has performed well over the years. It currently supports millions of users on a global basis--from cell phones to transportation operations. Recognizing that the L1 signal structure was designed in the 1970s, this real-world success reflects highly upon the vision and insight of those early GPS engineers. However, the fact remains that modern signal design alternatives are available today to add an improved GPS civil signal to L1.

2.2 The issue is what to do--continue broadcasting only the 1970's vintage L1 civil signal or take advantage of the significant civil performance improvements that can be obtained by adding a modernized L1 signal. Some of the available L1 modernization options will definitely open new doors for civil users.

On a technical level, these options can reduce interference susceptibility, improve cross-correlation properties and enhance signal acquisition, tracking, and data demodulation thresholds (robustness). The doors that will be opened include higher accuracy GPS position determination using only the satellite signals (potentially obviating the need for some types of differential systems) and expanded satellite signal availability in confined areas thereby increasing the utility of GPS signals in wooded areas and indoors.

2.3 There are several possible L1 modernization options. The key will be to select one or more options that will assure/support:

- a) Full and complete backward compatibility for current L1 users;
- b) Harmonization with all current and planned augmentation and core satellite systems--such as Satellite-based Augmentation Systems (SBAS), Ground-based Augmentation Systems (GBAS), Ground-based Regional Augmentation Systems (GRAS), GLONASS, QZSS and Galileo;
- c) Maximum real-world benefit for L1 user groups;
- d) The development of a realistic L1 modernization plan that can be executed in a timely fashion, be affordable, minimize risk and provide a path for future growth and development opportunities.

Examples of some the possible modernization options and their subsequent benefits include:

- a) A different data rate for this new L1 civil signal from the current 50 bps rate. Benefits from a slower data rate (25 bps) include an improved ability to obtain the satellite message inside and under cover, resulting in better signal acquisition in environments such as heavily forested areas. Benefits from an upward adjustment (100 bps) could include an opportunity to add additional information, such as an integrity message.
- b) Signal Waveform modernization (e.g. BOC (1,1), (5,1), BPSK (2)) will significantly improve performance in interference environments and improve receiver accuracy.
- c) Increased power levels (-158.5 to -155.5 dbW) will provide better signal acquisition and tracking, and better coverage as a result of greater signal availability.
- d) Longer code length (recognizing that 10230 will be the minimum length) will reduce self-interference and increase resistance to both intentional and unintentional narrow band interference and jamming (e.g. VHF transmitters).
- e) The addition of error corrections (FEC Rate $\frac{1}{2}$, k=7 or better) will enable the user to obtain navigation data at much lower power levels; $\frac{1}{2}$ or less compared to the current C/A performance.
- f) Modernization of the message content (e.g. similar to L5 and L2C with the possible addition of integrity, authentication, over the air NANUS, additional ionosphere correction terms, etc.) will provide better navigation performance in terms of position accuracy, integrity and timing.

2.4 One of the first challenges will be to document service improvements that are desired by the myriad of domestic and international L1 users. The planned approach will be to obtain inputs from a cross-section of L1 users, such as government organizations, manufacturers, and end-state users.

After compiling the data, it will be analyzed and categorized according to desired end-state improvements and the user group/direct benefit of the improvement, such as: Rail Transportation--better signal acquisition and tracking in heavily forested areas.

The second challenge will be to estimate the real-world value of the end-state improvement. Given there is a clear understanding of the direct user benefit, it seems reasonable to assume that the benefit will be of some value.

Current thinking is that there are fundamentally two broad classes for determining "value". The first and most important is the inherent safety related value. Measuring the value of safety is difficult if not impossible to reasonably determine for some user groups. For others, there reportedly are methods for measuring the "value" of safety improvements.

The second class of benefits are those that likely can be estimated by a majority of the user groups in terms of tangible resources. For instance, if L1 were modernized to enable

the production of GNSS receivers at a lower cost, then one should be able to reasonably determine the cost savings, or the potential value of this L1 modernization option.

For these reasons, the US Interagency GPS Executive Board (IGEB) has approved and funded an effort led by the United States Geological Survey and Department of Defense Global Positioning System Joint Program Office to interact with domestic and international user groups for the purpose of assuring the broadest range of information is obtained to support the best L1 modernization decisions.

3. CONCLUSION

3.1 The Panel members and meeting attendees are encouraged to participate in the L1 modernization opportunity by contacting Lt. Jason Taylor, Chief International GPS Signal Requirements, Telephone: (310) 363-3259, E-mail: jason.taylor1@losangeles.af.mil and providing information regarding desired L1 service improvements and subsequent benefits. Inquiries may also be addressed to the project email address at L1C_GPS@USGS.gov. Additionally, all are invited to widely distribute this paper to colleagues and user groups with a recommendation to make contact and be involved in shaping the L1 future.

**NAVIGATION SYSTEMS PANEL WORKING GROUP MEETING
Canberra, Australia
November 10-21, 2003**

Questionnaire to provide a common point of reference for Panel input for L1C modernization.

The US has an opportunity to provide a modernized signal at L1 improving civil performance. It is also technically possible to improve the signal without jeopardizing current L1 C/A civil uses--assuring full backward compatibility.

Attached are the range of potential L1C modernization improvements under consideration, possible benefits, and explanations as to why this L1C improvement can provide a benefit.

Before making a decision whether or not/how to proceed with L1C modernization, we would like to determine and document if Aviation would actually obtain real-world benefits from a modernized L1C signal.

Hence, we would appreciate receiving your responses to the following points/questions:

1. Based on your knowledge and personal experience could you highlight some of the ways GPS is being used today by Aviation other than those already listed in the SARPs.
2. One L1C modernization option, which may benefit the Aviation community, is greater resistance to radio frequency interference (both intentional and unintentional) thereby improving the overall navigation performance and reliability for both manned and unmanned aircraft/vehicles.
 - Do you believe such a modernization will benefit the Aviation community?
 - If it is a benefit, what do you think the benefit is "worth", in terms of money, time saved, degree of safety improvement, operational savings—would appreciate any type of measure we can use to establish the benefit value.
 - Approximately how many Aviation community users do you think will benefit from these suggested L1C modernization improvements?
3. What other L1C modernization options—based on the attached list—do you think will benefit Aviation users? For each option, please provide the specific

benefit, the “worth” of the benefit, and how many Aviation users will realize the benefit.

4. An alternative option may be to simply increase the transmitted power of the L1 C/A-code power (e.g., by 4 dB or 5 dB). What do you think of this option?

5. Finally, based on your knowledge and Aviation experience, how rapidly do you think GPS use will grow over the next 5-10 years?

Thank You!!

L1C Improvement ⇒ Application ↓	Lower Signal Thresholds for Navigation (Power & Dataless Channel)	More Robust Autonomous Navigation (Power, FEC & Data Rate)	Less Susceptible to Interference (Power & Code Structure)	Higher Dynamics Tracking (Power and Dataless Channel)	Reduced Cross-correlation (Longer Spreading Codes)	Improved Accuracy (Increased signal bandwidth)
Location Based Services	X	X	X		X	X
Scientific	X		X		X	
Aviation			X		X	
Agriculture	X	X		X	X	
Surface Transportation	X	X	X		X	X
Mining & Construction	X	X	X	X	X	
Surveying/Civil Engineering	X		X	X	X	
Public Safety	X	X	X		X	X
Timing			X		X	
Rail	X	X			X	X
Recreation	X	X	X		X	X
Space	X				X	
Environment	X	X			X	
Maritime		X	X		X	X
Security	X	X	X		X	X

L1C Improvement	User Benefit	Explanation
<p>Lower Signal Thresholds for Navigation (Power & Dataless Channel)</p>	<p>The user will be more likely to navigate (a) in difficult signal conditions, such as in a forest, in a city, inside a building, on a tree lined road, etc., i.e., where GPS signals are attenuated, as well as (b) in the presence of GPS radio interference.</p>	<p>A stronger signal and the dataless channel allow the receiver to track and make navigation measurements in more difficult signal conditions than now. The improvement is at least 6 dB.</p>
<p>More Robust Autonomous Navigation (Power, FEC, & Data Rate)</p>	<p>The user will be more likely to obtain the satellite messages needed to <u>begin</u> navigation (a) in difficult signal conditions, such as in a forest, in a city, inside a building, on a tree lined road, etc., i.e., where GPS signals are attenuated, as well as (b) in the presence of GPS radio interference.</p> <p>The “time to first fix” after the GPS receiver is turned on depends on receiving an “ephemeris” message from each available satellite.</p>	<p>A stronger signal and Forward Error Correction (FEC) will permit message recovery with weaker signals or with more radio noise. The improvement is 5 dB at 50 bps and 8 dB at 25 bps. The 8 dB improvement makes it possible to obtain messages even with the weakest GPS signal the receiver can track.</p> <p>Note that once the ephemeris message is received, it lasts for one to three hours, so continuous reception of messages is not required, but time to first fix depends on receiving messages quickly after the receiver is turned on.</p> <p>This benefit relates to “autonomous” navigation, meaning that ephemeris messages are received from the satellites and <u>not</u> provided by a network, as is often done for E-911 use.</p>

L1C Improvement	User Benefit	Explanation
Less Susceptible to Interference (Power & Code Structure)	The user will be more likely to navigate in the presence of GPS radio interference.	Interference protection is part of the improvements noted above (higher signal power, the dataless channel, FEC, and a lower data rate). However, it is repeated here to point out that although code structure does <u>not</u> help with weaker signals, it <u>does</u> help in the face of certain types of RF interference. (It does not help against wideband UWB interference.)
Higher Dynamics Tracking (Power and Dataless Channel)	Precise measurements will be more dependable in physically difficult situations, such as GPS guidance of an earthmover blade as it hits rocks and concrete – transmitting intense shock and vibration to the GPS antenna.	Some of the most demanding accuracy requirements are in severe physical conditions, such as GPS guidance of construction and earthmoving machinery. These environments are subject to high levels of shock and vibration (jerk and acceleration). A stronger signal and a dataless channel permits the tracking loop to remain locked with 64 times higher levels of jerk and 16 times higher levels of acceleration at the antenna.
Reduced Cross-correlation (Longer Spreading Codes)	Reduces the possibility of tracking an incorrect satellite without needing verification algorithms in the receiver. Improves performance in challenged environments when there are weak and strong signals visible.	Using long codes will reduce cross-correlation between satellite signals, reduce the self-interference experienced by C/A code, and increase the amount of dynamic range possible between satellites.

Improved Accuracy (Increased signal bandwidth)	More accurate position locations are possible in the same challenged environments.	All of the modulations under consideration have at least 3 dB more bandwidth than C/A code. This will improve accuracy for the same level of receiver complexity, and is primarily beneficial for lower cost receivers.
---	--	---

ICAO Contracting States

ÉTATS CONTRACTANTS / CONTRACTING STATES / ESTADOS CONTRATANTES /

(English / [French](#) / [Spanish](#) / [Russian](#))

Afghanistan / Afghanistan / Afganistán / _____
Albania / Albanie / Albania / _____
Algeria / Algérie / Argelia / _____
Andorra / Andorre / Andorra / _____
Angola / Angola / Angola / _____
Antigua and Barbuda / Antigua-et-Barbuda / Antigua y Barbuda / _____ - _____
Argentina / Argentine / Argentina / _____
Armenia / Arménie / Armenia / _____
Australia / Australie / Australia / _____
Austria / Autriche / Austria / _____
Azerbaijan / Azerbaïdjan / Azerbaiyán / _____

Bahamas / Bahamas / Bahamas / _____
Bahrain / Bahreïn / Bahrein / _____
Bangladesh / Bangladesh / Bangladesh / _____
Barbados / Barbade / Barbados / _____
Belarus / Bélarus / Belarús / _____
Belgium / Belgique / Bélgica / _____
Belize / Belize / Belice / _____
Benin / Bénin / Benin / _____
Bhutan / Bhoutan / Bhután / _____
Bolivia / Bolivie / Bolivia / _____
Bosnia and Herzegovina / Bosnie-Herzégovine / Bosnia y Herzegovina / _____ - _____
Botswana / Botswana / Botswana / _____
Brazil / Brésil / Brasil / _____
Brunei Darussalam / Brunéi Darussalam / Brunei Darussalam / _____ - _____
Bulgaria / Bulgarie / Bulgaria / _____
Burkina Faso / Burkina Faso / Burkina Faso / _____ - _____
Burundi / Burundi / Burundi / _____

Cambodia / Cambodge / Camboya / _____
Cameroon / Cameroun / Camerún / _____
Canada / Canada / Canadá / _____
Cape Verde / Cap-Vert / Cabo Verde / _____ - _____
Central African Republic / République centrafricaine / República Centroafricana / _____

Chad / Tchad / Chad / _____
Chile / Chili / Chile / _____
China / Chine / China / _____
Colombia / Colombie / Colombia / _____
Comoros / Comores / Comoras / _____
Congo / Congo / Congo / _____
Cook Islands / Îles Cook / Islas Cook / _____
Costa Rica / Costa Rica / Costa Rica / _____ - _____
Côte d'Ivoire / Côte d'Ivoire / Côte d'Ivoire / _____ - _____
Croatia / Croatie / Croacia / _____

Cuba / Cuba / Cuba / _____
Cyprus / Chypre / Chipre / _____
Czech Republic / République tchèque / República Checa / _____

Democratic People's Republic of Korea / République populaire démocratique de Corée / República Popular Democrática de Corea / _____
Democratic Republic of the Congo / République démocratique du Congo / República Democrática del Congo / _____
Denmark / Danemark / Dinamarca / _____
Djibouti / Djibouti / Djibouti / _____
Dominican Republic / République dominicaine / República Dominicana / _____

Ecuador / Équateur / Ecuador / _____
Egypt / Égypte / Egipto / _____
El Salvador / El Salvador / El Salvador / _____
Equatorial Guinea / Guinée équatoriale / Guinea Ecuatorial / _____
Eritrea / Érythrée / Eritrea / _____
Estonia / Estonie / Estonia / _____
Ethiopia / Éthiopie / Etiopía / _____

Fiji / Fidji / Fiji / _____
Finland / Finlande / Finlandia / _____
France / France / Francia / _____

Gabon / Gabon / Gabón / _____
Gambia / Gambie / Gambia / _____
Georgia / Géorgie / Georgia / _____
Germany / Allemagne / Alemania / _____
Ghana / Ghana / Ghana / _____
Greece / Grèce / Grecia / _____
Grenada / Grenade / Granada / _____
Guatemala / Guatemala / Guatemala / _____
Guinea / Guinée / Guinea / _____
Guinea-Bissau / Guinée-Bissau / Guinea-Bissau / _____
Guyana / Guyana / Guyana / _____

Haiti / Haïti / Haití / _____
Honduras / Honduras / Honduras / _____
Hungary / Hongrie / Hungría / _____

Iceland / Islande / Islandia / _____
India / Inde / India / _____
Indonesia / Indonésie / Indonesia / _____
Iran (Islamic Republic of) / Iran (République islamique d') / Irán (República Islámica del) / _____
 (_____
Iraq / Iraq / Iraq / _____
Ireland / Irlande / Irlanda / _____
Israel / Israël / Israel / _____
Italy / Italie / Italia / _____

Jamaica / Jamaïque / Jamaica / _____
Japan / Japon / Japón / _____
Jordan / Jordanie / Jordania / _____

Kazakhstan / Kazakhstan / Kazajstán / _____

Kenya / Kenya / Kenya / _____

Kiribati / Kiribati / Kiribati / _____

Kuwait / Koweït / Kuwait / _____

Kyrgyzstan / Kirghizistan / Kirguistán / _____

Lao People's Democratic Republic / République démocratique populaire lao / República Democrática Popular Lao / _____ - _____

Latvia / Lettonie / Letonia / _____

Lebanon / Liban / Líbano / _____

Lesotho / Lesotho / Lesotho / _____

Liberia / Libéria / Liberia / _____

Libyan Arab Jamahiriya / Jamahiriya arabe libyenne / Jamahiriya Árabe Libia / _____

Lithuania / Lituanie / Lituania / _____

Luxembourg / Luxembourg / Luxemburgo / _____

Madagascar / Madagascar / Madagascar / _____

Malawi / Malawi / Malawi / _____

Malaysia / Malaisie / Malasia / _____

Maldives / Maldives / Maldivas / _____

Mali / Mali / Malí / _____

Malta / Malte / Malta / _____

Marshall Islands / Îles Marshall / Islas Marshall / _____

Mauritania / Mauritanie / Mauritania / _____

Mauritius / Maurice / Mauricio / _____

Mexico / Mexique / México / _____

Micronesia (Federated States of) / Micronésie (États fédérés de) / Micronesia (Estados Federados de) / _____ (_____)

Monaco / Monaco / Mónaco / _____

Mongolia / Mongolie / Mongolia / _____

Morocco / Maroc / Marruecos / _____

Mozambique / Mozambique / Mozambique / _____

Myanmar / Myanmar / Myanmar / _____

Namibia / Namibie / Namibia / _____

Nauru / Nauru / Nauru / _____

Nepal / Népal / Nepal / _____

Netherlands / Pays-Bas / Países Bajos / _____

New Zealand / Nouvelle-Zélande / Nueva Zelandia / _____

Nicaragua / Nicaragua / Nicaragua / _____

Niger / Niger / Níger / _____

Nigeria / Nigéria / Nigeria / _____

Norway / Norvège / Noruega / _____

Oman / Oman / Omán / _____

Pakistan / Pakistan / Pakistán / _____

Palau / Palaos / Palau / _____

Panama / Panama / Panamá / _____

Papua New Guinea / Papouasie-Nouvelle-Guinée / Papua Nueva Guinea / _____ - _____

Paraguay / Paraguay / Paraguay / _____

Peru / Pérou / Perú / _____

Philippines / Philippines / Filipinas / _____

Poland / Pologne / Polonia / _____
Portugal / Portugal / Portugal / _____

Qatar / Qatar / Qatar / _____

Republic of Korea / République de Corée / República de Corea / _____
Republic of Moldova / République de Moldova / República de Moldova / _____
Romania / Roumanie / Rumania / _____
Russian Federation / Fédération de Russie / Federación de Rusia / _____
Rwanda / Rwanda / Rwanda / _____

Saint Kitts and Nevis / Saint-Kitts-et-Nevis / Saint Kitts y Nevis / ____ - ____ - ____
Saint Lucia / Sainte-Lucie / Santa Lucía / ____ - ____
Saint Vincent and the Grenadines / Saint-Vincent-et-les Grenadines / San Vicente y las Granadinas /

Samoa / Samoa / Samoa / _____
San Marino / Saint-Marin / San Marino / ____ - ____
Sao Tome and Principe / Sao Tomé-et-Príncipe / Santo Tomé y Príncipe / ____ - ____ - ____
Saudi Arabia / Arabie saoudite / Arabia Saudita / _____
Senegal / Sénégal / Senegal / _____
Seychelles / Seychelles / Seychelles / _____
Sierra Leone / Sierra Leone / Sierra Leona / ____ - ____
Singapore / Singapour / Singapur / _____
Slovakia / Slovaquie / Eslovaquia / _____
Slovenia / Slovénie / Eslovenia / _____
Solomon Islands / Îles Salomon / Islas Salomón / _____
Somalia / Somalie / Somalia / _____
South Africa / Afrique du Sud / Sudáfrica / _____
Spain / Espagne / España / _____
Sri Lanka / Sri Lanka / Sri Lanka / ____ - ____
Sudan / Soudan / Sudán / _____
Suriname / Suriname / Suriname / _____
Swaziland / Swaziland / Swazilandia / _____
Sweden / Suède / Suecia / _____
Switzerland / Suisse / Suiza / _____
Syrian Arab Republic / République arabe syrienne / República Árabe Siria / _____

Tajikistan / Tadjikistan / Tayikistán / _____
Thailand / Thaïlande / Tailandia / _____
The former Yugoslav Republic of Macedonia / L'ex-République yougoslave de Macédoine / La ex República Yugoslava de Macedonia / _____
Togo / Togo / Togo / _____
Tonga / Tonga / Tonga / _____
Trinidad and Tobago / Trinité-et-Tobago / Trinidad y Tabago / _____
Tunisia / Tunisie / Túnez / _____
Turkey / Turquie / Turquía / _____
Turkmenistan / Turkménistan / Turkmenistán / _____

Uganda / Ouganda / Uganda / _____
Ukraine / Ukraine / Ucrania / _____
United Arab Emirates / Émirats arabes unis / Emiratos Árabes Unidos / _____

United Kingdom / Royaume-Uni / Reino Unido / _____
United Republic of Tanzania / République-Unie de Tanzanie / República Unida de Tanzania /

United States / États-Unis / Estados Unidos / _____

Uruguay / Uruguay / Uruguay / _____

Uzbekistan / Ouzbékistan / Uzbekistán / _____

Vanuatu / Vanuatu / Vanuatu / _____

Venezuela / Venezuela / Venezuela / _____

Viet Nam / Viet Nam / Viet Nam / _____

Yemen / Yémen / Yemen / _____

Yugoslavia / Yougoslavie / Yugoslavia / _____

Zambia / Zambie / Zambia / _____

Zimbabwe / Zimbabwe / Zimbabwe / _____

Total: 188



Improving the GPS L1 Signal

GPS III Offers the Opportunity

Tom Stansell

Tom@Stansell.com

IGS Symposium, Bern

3 March 2004

Introducing L1C Project Leadership



Dr. Ken Hudnut
Co-Chair, USGS



1Lt. Bryan Titus
Co-Chair,
JPO

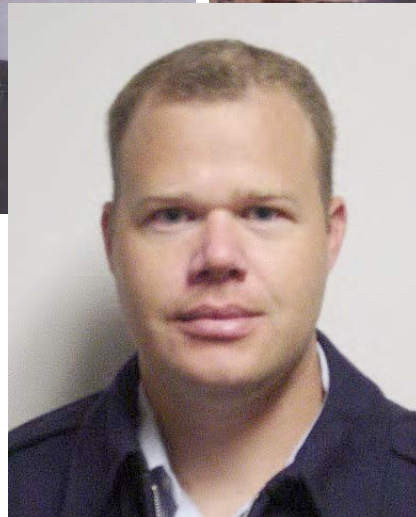

2Lt. Jason Taylor



Tom
Stansell



An Invitation: Contact Information

E-mail: L1C_GPS@USGS.gov

FAX: 626-583-7827

Mail: L1C GPS

Attn: Ken Hudnut

525 South Wilson Ave.

Pasadena, CA 91106-3212



Historic Changes and New Initiative

- **GPS has had only 3 navigation signals**
 - L1 C/A, L1 P/Y, L2 P/Y
- **GPS modernization will add at least 4 more**
 - L1 M, L2 M, L2C, and L5
- **All were designed without asking preferences**
 - Even L5, designed by an RTCA committee
- **Historic initiative:**
 - The IGEB has funded the L1C Project to seek input on the best approach for a new L1 civil signal



First L1C Modernization Question

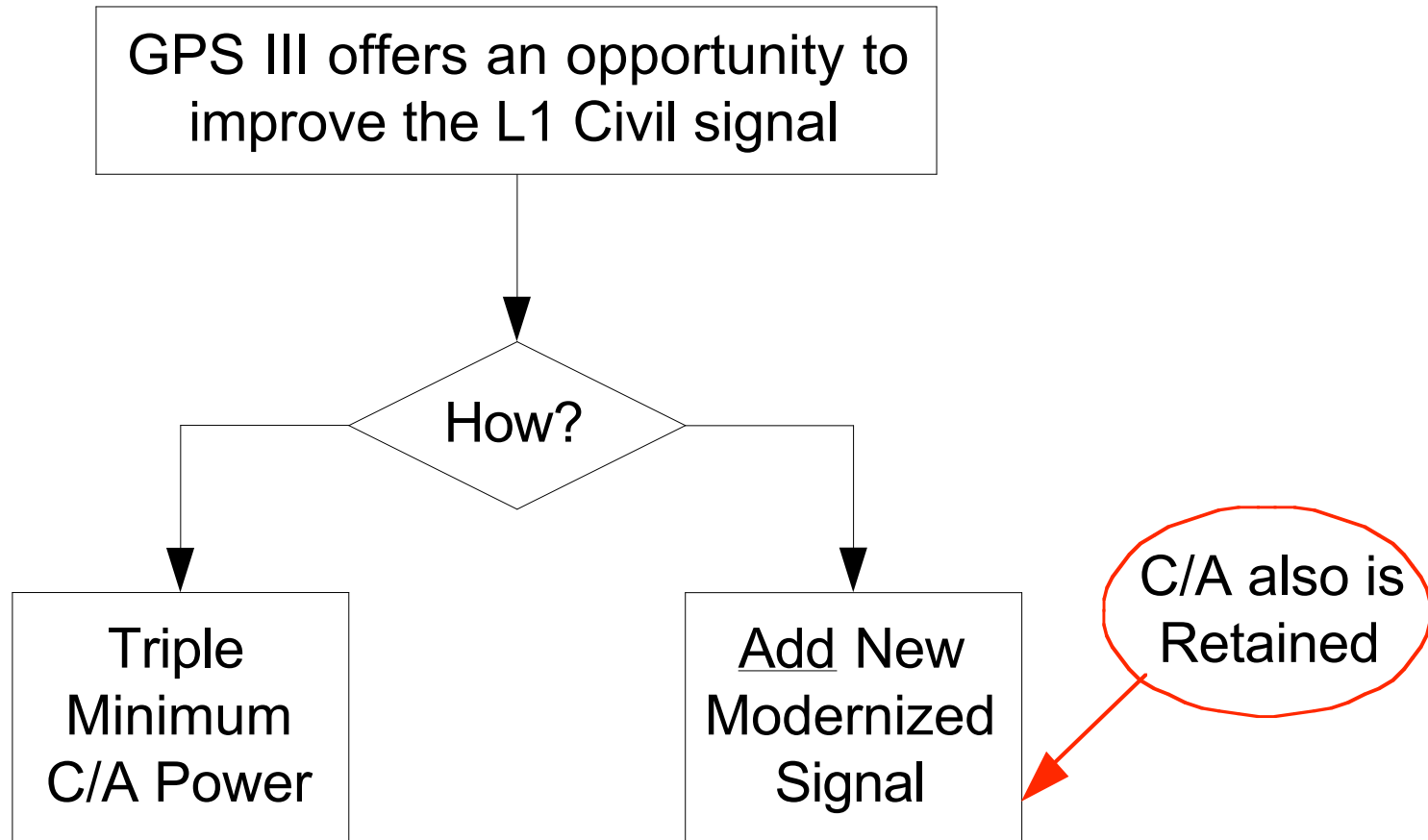

Constrained to Fit Between M & C/A

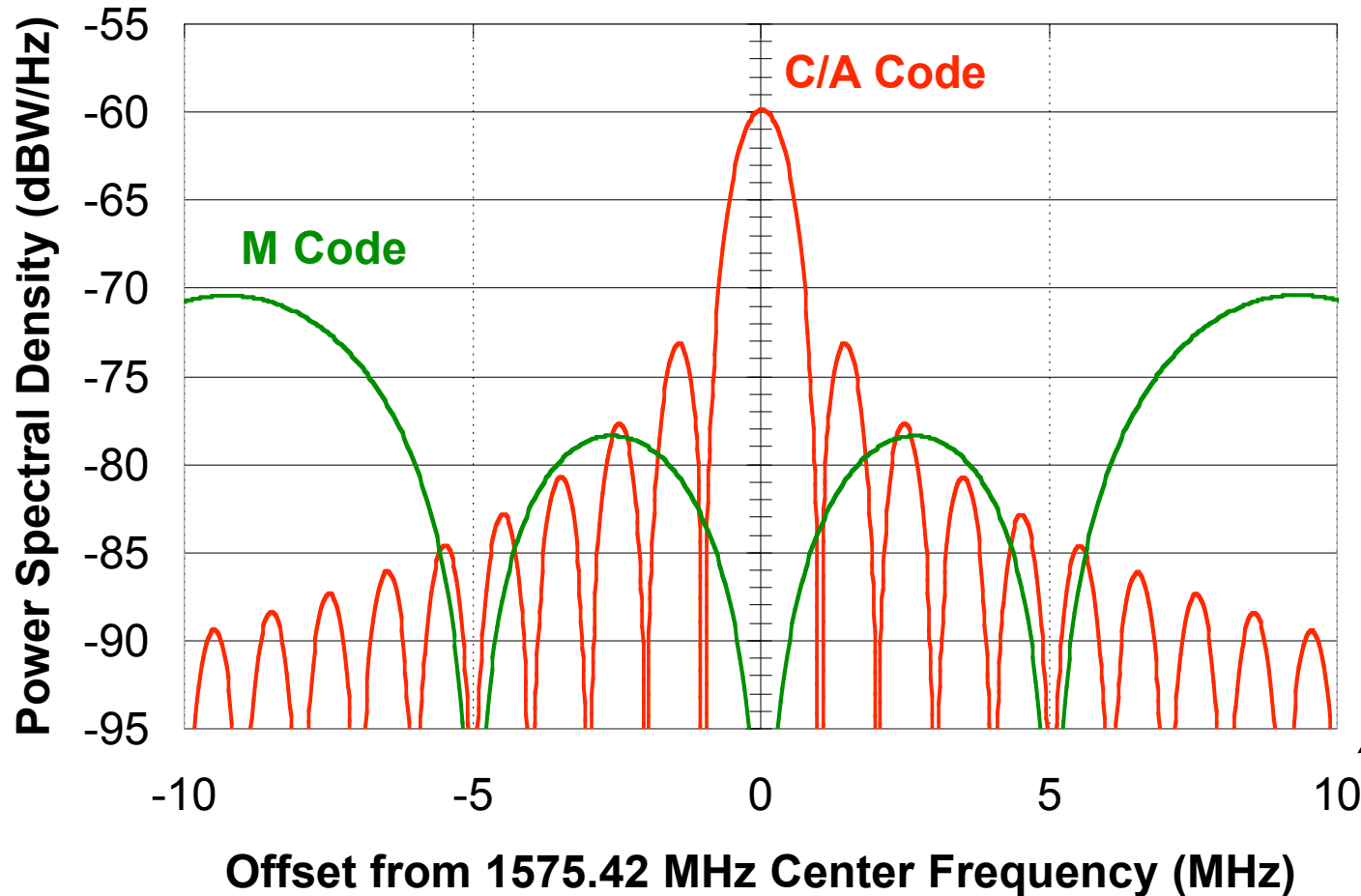

P(Y) is the
“old” military
signal

So, fitting
between C/A
and M codes
is the focus

*Note change
in frequency
scale*

Such As BOC(1,1) (OK for M and for C/A)

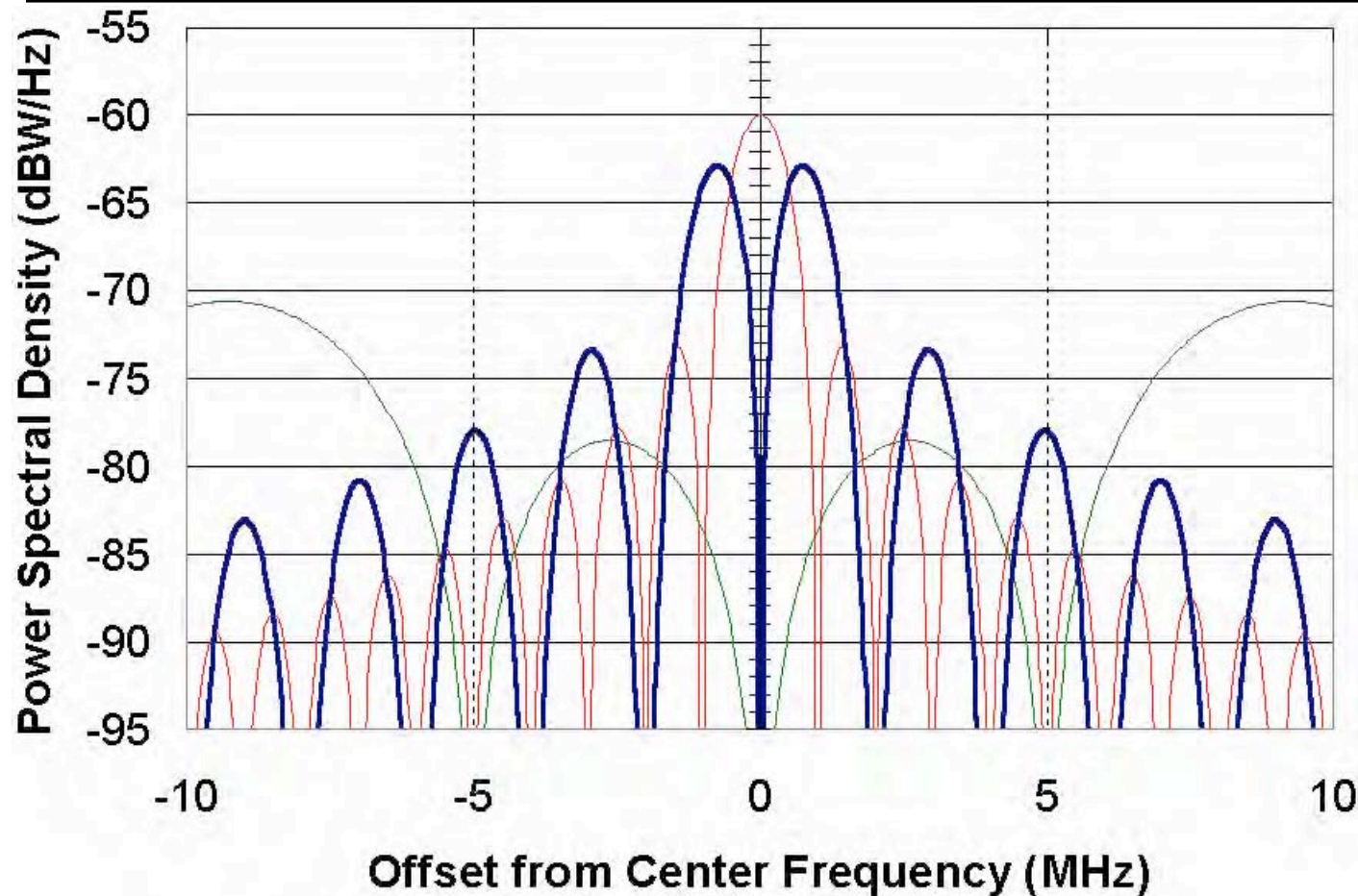

**BOC(1,1)
Spectral
Separation
Coefficient
(SSC)**

**For C/A =
-67.8 dB/Hz**

**For M =
-82.4 dB/Hz**

News: Galileo Signal Decision

http://europa.eu.int/rapid/start/cgi/guestfr.ksh?p_action.gettxt=gt&doc=IP/04/264|0|RAPID&lg=EN&display=

Loyola de Palacio welcomes the outcome of EU/US discussions on GALILEO

The United States and the European Commission, joined by the European Union Member States, held a successful round of negotiations in Brussels on 24-25 February 2004. The delegations built upon progress made in The Hague and in Washington and were able to reach agreement on most of the overall principles of GPS/Galileo cooperation.

- Adoption of a common baseline signal structure for their respective open services (the future GPS intends to use a BOC 1,1 signal whereas the Galileo open service intends to use a fully compatible optimized version of the same signal which guarantees an high-level of performance).



GPS III Power Control Thinking

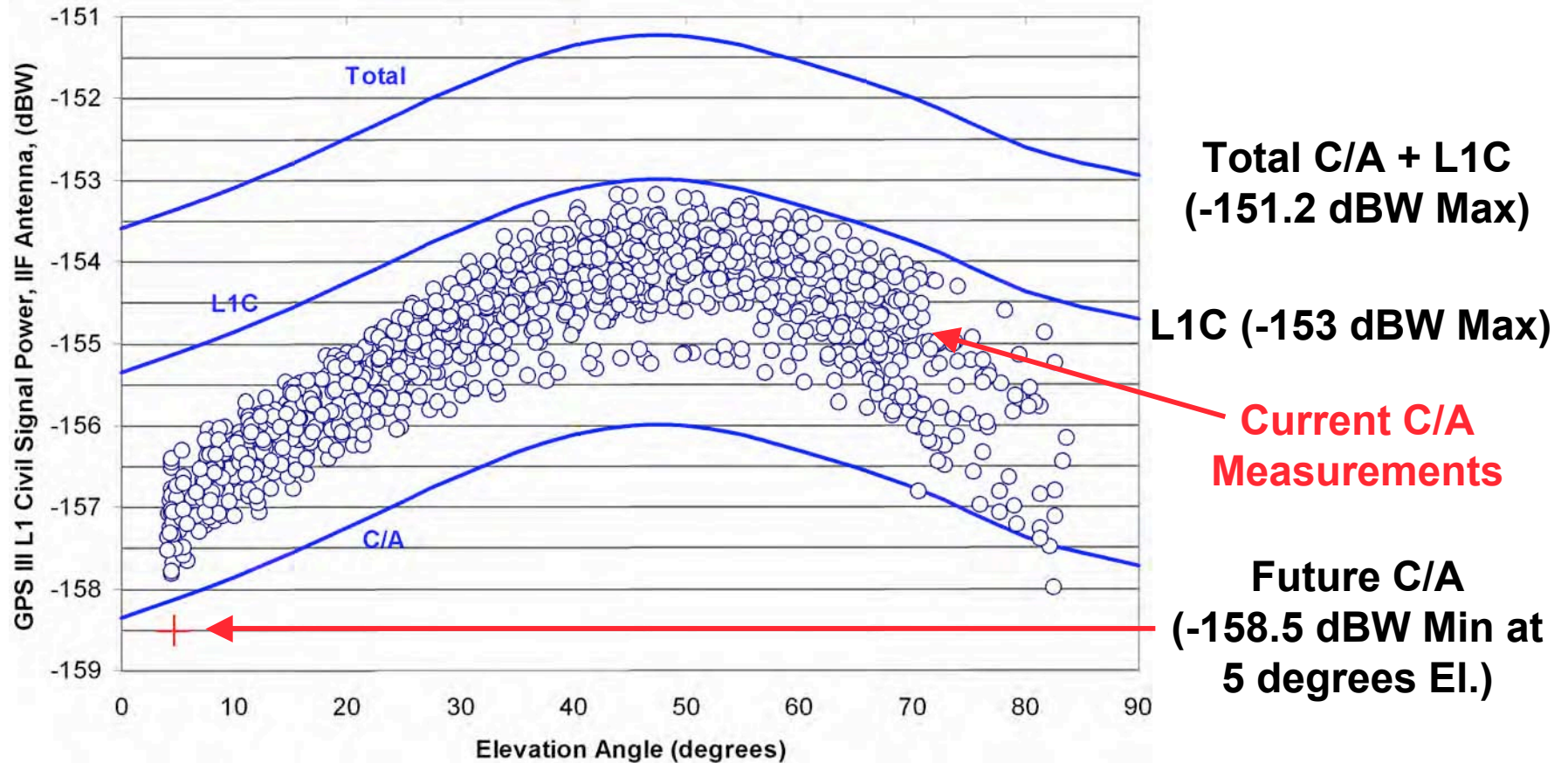

First L1C Modernization Question

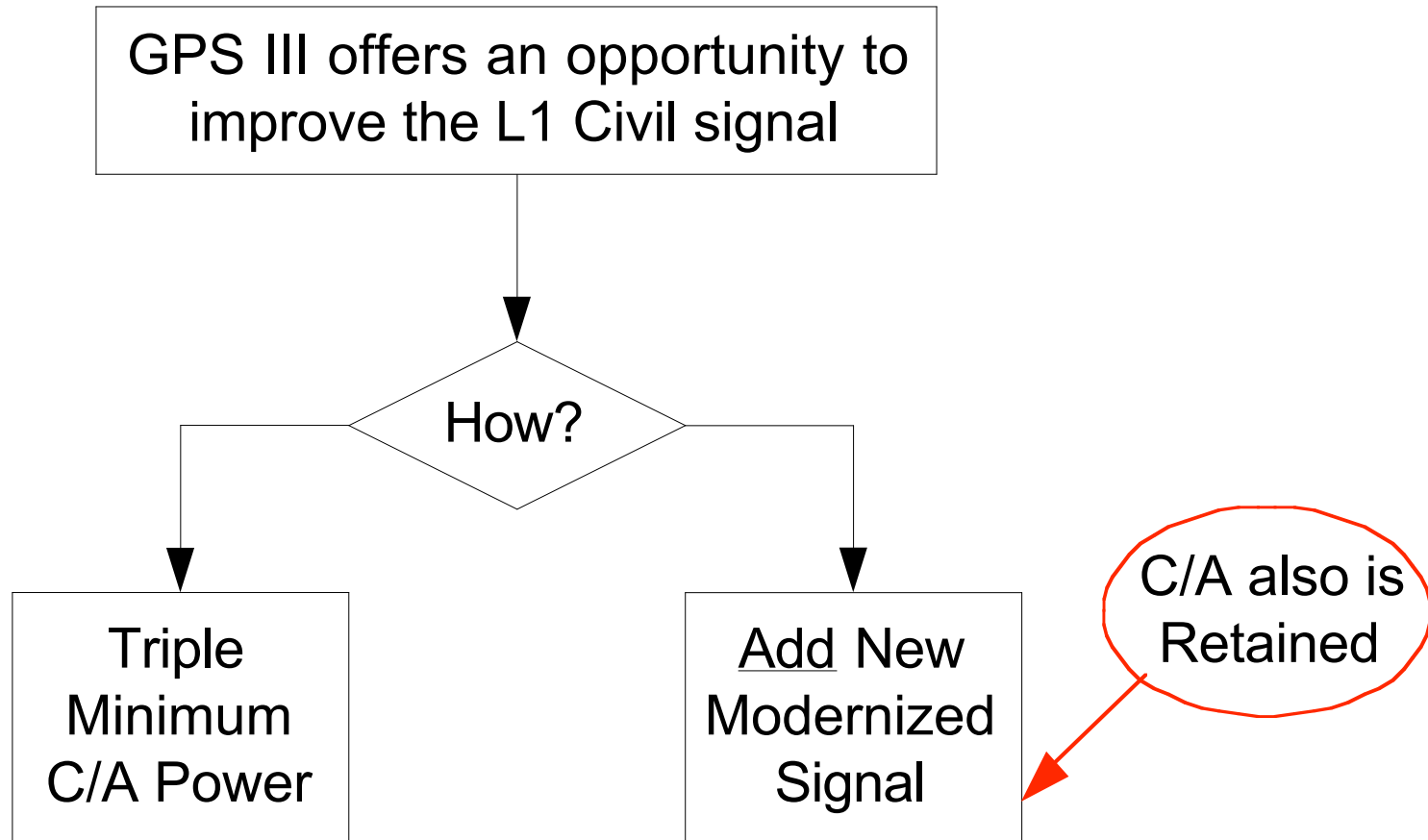

Next L1C Modernization Questions

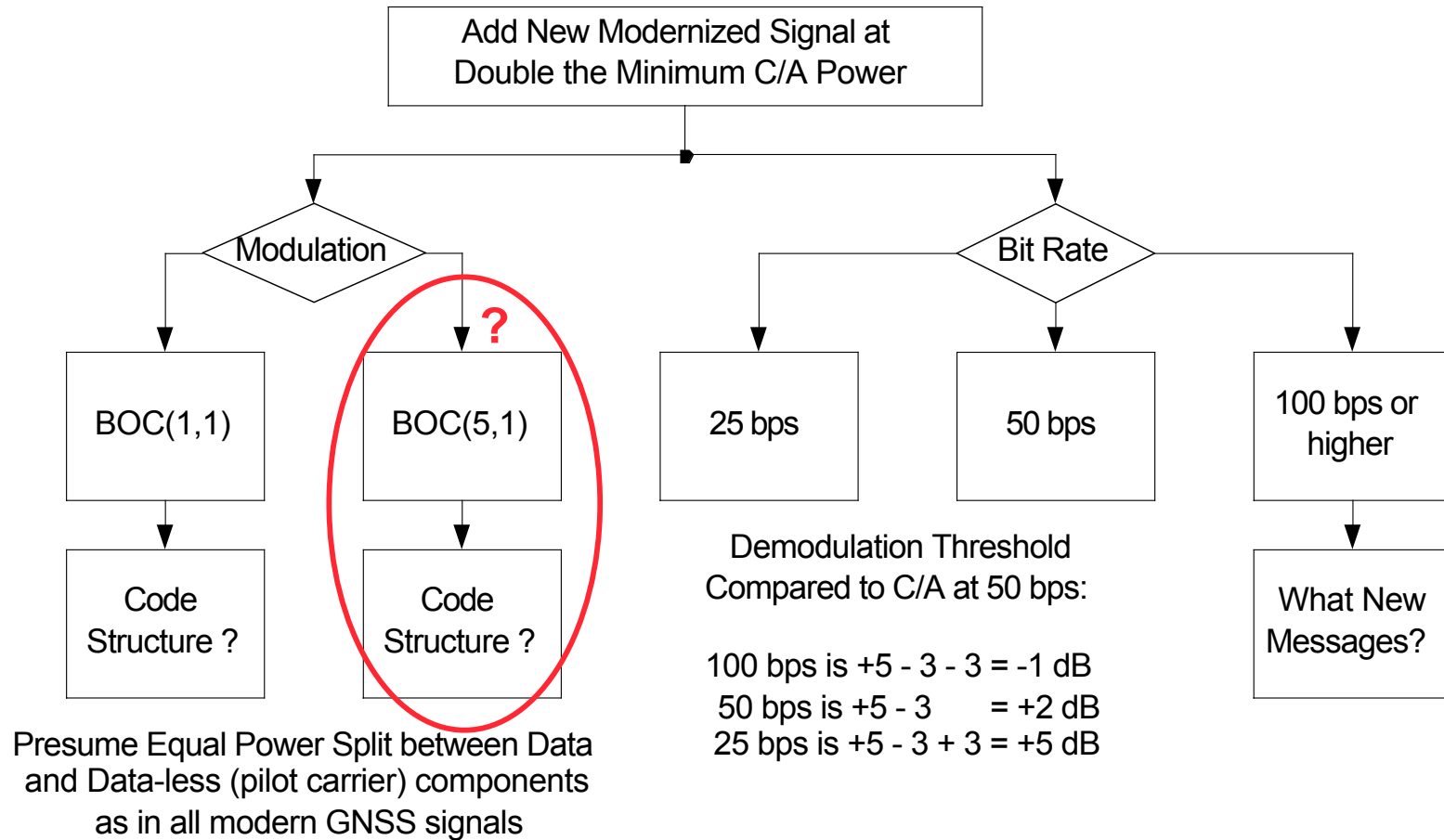

Choose One After Each Diamond

What is best for your applications?

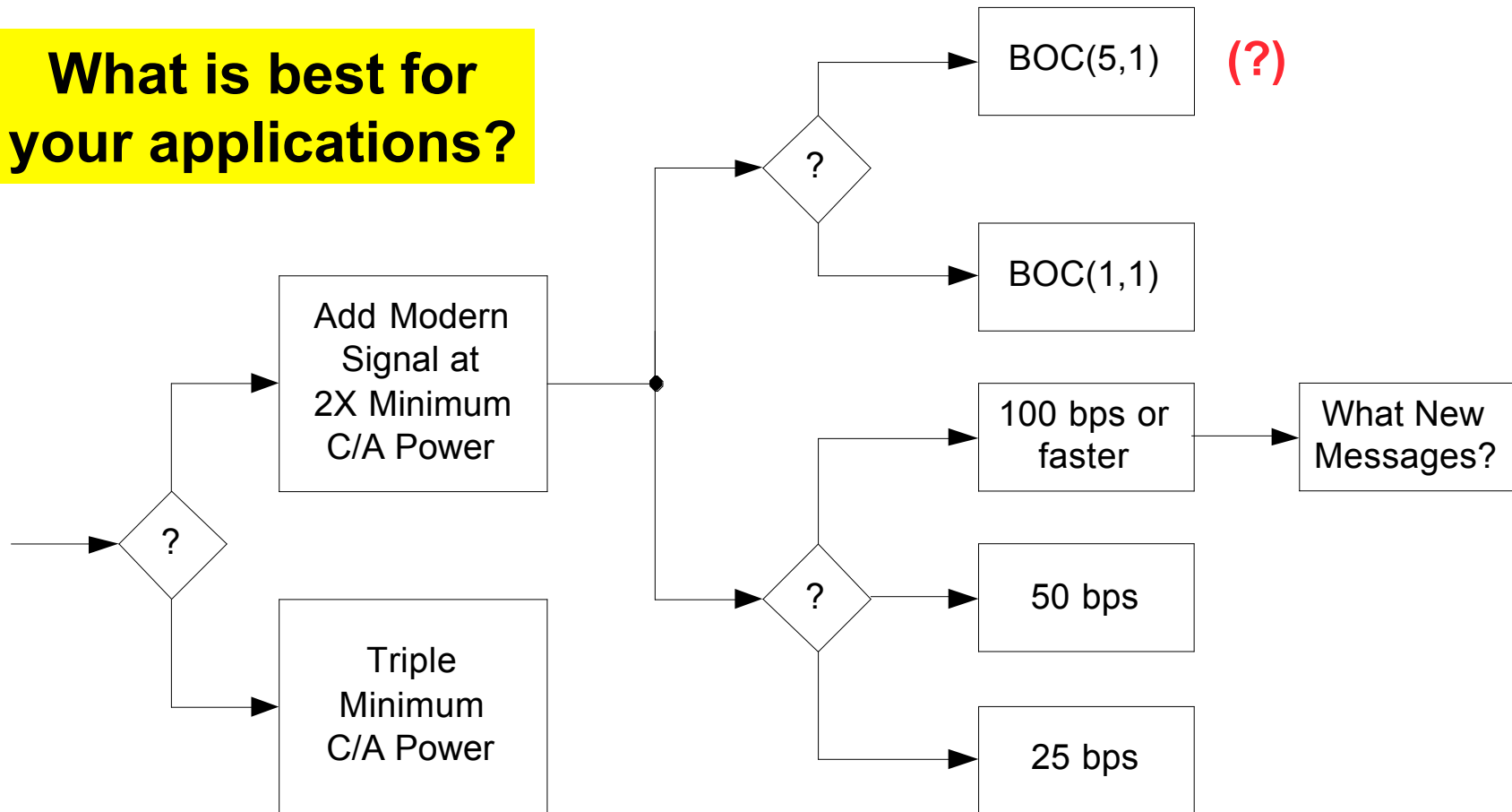

Questionnaire Page 1

L1C Questionnaire

Name: _____ Date: _____

Title/Position _____

Organization _____

Address _____

Phone: _____ E-Mail: _____

Circle Preferences:

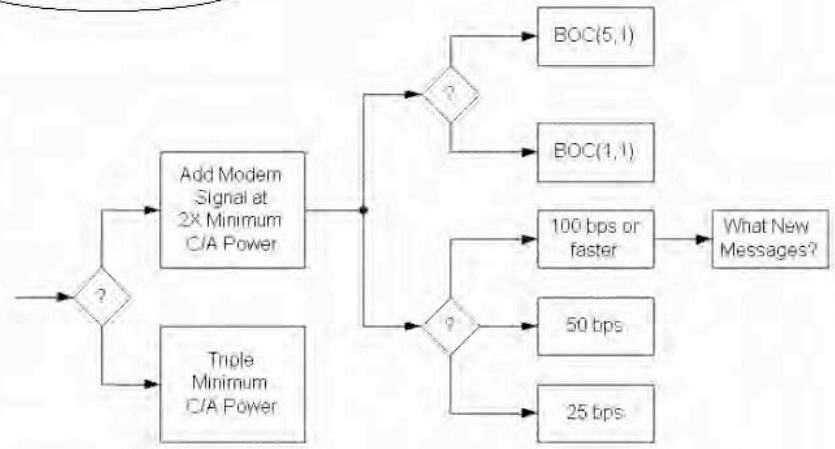

What new messages:

Comments:



Questionnaire Page 2

Application Specific Questions

Name: _____ Date: _____

Title/Position: _____

Organization: _____

Your Primary Expertise			
	Professional & Scientific	Commercial	Consumer
Land			
Sea			
Air			
Space			

Applications	
1	

Expected Number of Users in 2005			
	Professional & Scientific	Commercial	Consumer
Land			
Sea			
Air			
Space			

Expected Number of Users in 2020			
	Professional & Scientific	Commercial	Consumer
Land			
Sea			
Air			
Space			

Importance			
Parameter	Best Desired	Worst Acceptable	Importance
Accuracy			
TIFF			
Availability			
Continuity			
Integrity			
Robustness			



Schedule a Web-Based Interview

E-mail: L1C_GPS@USGS.gov

FAX: 626-583-7827

Mail: L1C GPS

Attn: Ken Hudnut

525 South Wilson Ave.

Pasadena, CA 91106-3212

See Tom Stansell at the L1C Poster

Tom@Stansell.com





U.S. AIR FORCE

IGEB L1C Project

The U.S. Government is seeking your input on how best to design a new L1 civil signal to be implemented on Block III GPS Satellites

Learn the signal options and respond to the questionnaire

Schedule a 60 to 90 minute web-based presentation at your facility

E-mail: L1C_GPS@USGS.gov

FAX: 626-583-7827

Mail: L1C GPS

Attn: Ken Hudnut

525 South Wilson Ave.

Pasadena, CA 91106-3212

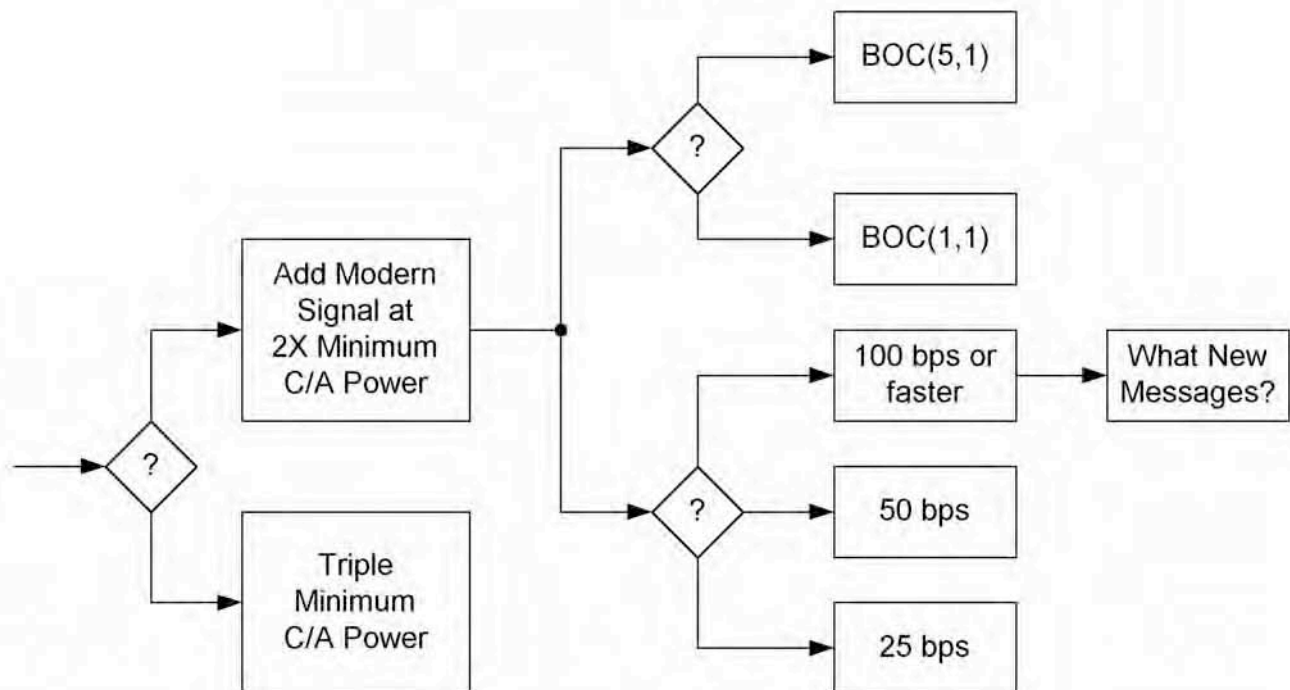

Talk with Tom Stansell about L1C on Wednesday and Thursday



L1 Modernization Project (L1C)

Ken Hudnut, Ph.D.
Project Manager
Geophysicist, USGS

Lt Bryan Titus
Navstar GPS JPO, Co-Lead
Sat. Nav. Engineer, USAF

IEEE PLANS Meeting
Monterey, California; April 28, 2004

Project Objectives

- **Obtain feedback from all GPS stakeholders on whether or not, and – if so – how *best* to add, a modernized signal on L1.**
 - **Assess interference to legacy L1 C/A receivers, recognizing that full backwards compatibility is essential.**

- **Form recommendations to the IGEB on whether or not, and how, the GPS L1 civil signal should be modernized.**

- **The U.S. Government has not yet determined whether a modernized GPS L1 civil signal should be added.**



Technical Considerations

- **Compatibility with US/Allied security**
- **Backward compatibility with legacy C/A receivers**
- **Signal design**
- **Message options**
- **Technical trade-offs for user benefits**
 - e.g., data rate

Stakeholder Interviews

- **Conducting surveys with domestic and international users**
 - **Technical - interview to be conducted next here**
 - **Non-technical - conducted user interviews**

- **Consolidating the survey results**
 - **First interim report recently submitted to IGEB**
 - **Assessing which user groups remain - please contact us at L1C_GPS@USGS.gov to arrange for a full interview with your organization**



L1C Project Interviews Conducted

CGSIC

NAVCEN Booth Activities at ION

JPL

US GPS Industry Council

NASA

NGS/NOAA

U.S. Coast Guard

Thales Navigation

Japan GPS Council Members

University of New Brunswick

Lincoln Laboratory

ITT Aerospace Communications

University of New South Wales

NavWard

University of Calgary

Stanford University

Trimble Navigation

Talk and Poster at IGS Meeting

Talk at CGSIC Meeting

Garmin

NovAtel

Leica

RFMD

SiRF

Rockwell-Collins

IEEE - PLANS 2004 Meeting



Final Steps

- **Will conduct second technical meeting**

- **Will prepare final IGEB report, including:**
 - **Process descriptions**
 - **Survey results**
 - **Cost-benefit analysis**
 - **Policy recommendations**
 - **Signal design recommendations**



Improving the GPS L1 Signal

GPS III Offers the Opportunity

Introducing



Dr. Ken Hudnut
Co-Chair, USGS



1Lt. Bryan Titus
Co-Chair,
JPO

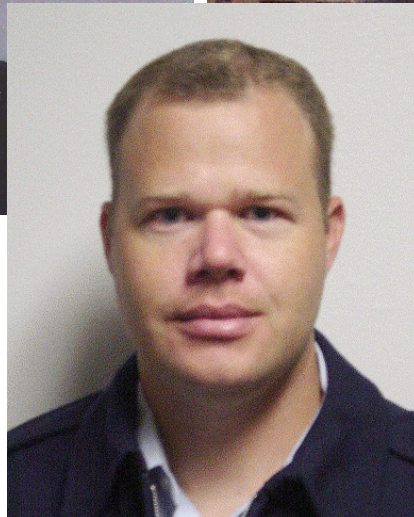

2Lt. Jason Taylor

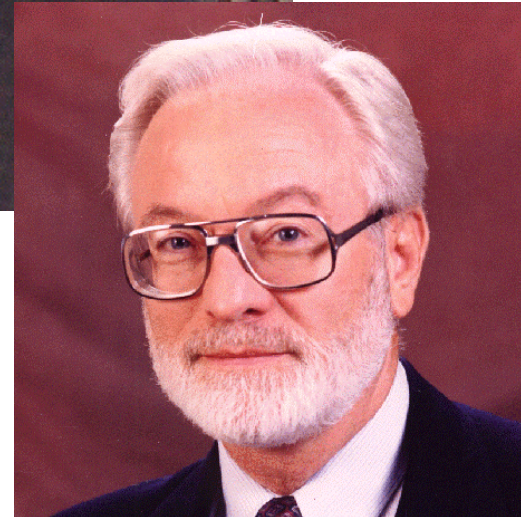

Tom Stansell



Estimated Signal Availability

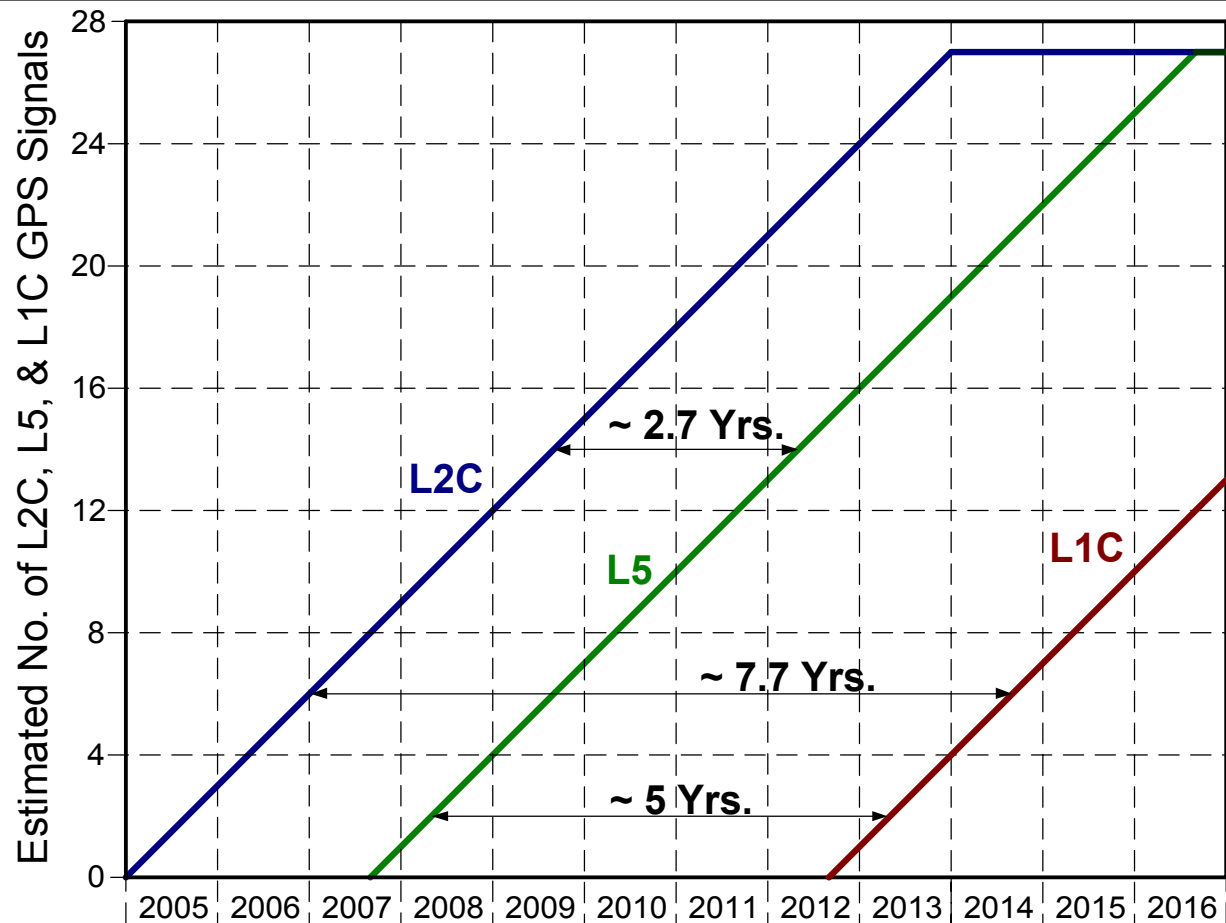

Assumes eight IIR-M satellites and average of three successful launches per year

Not Official

First L1C Modernization Question

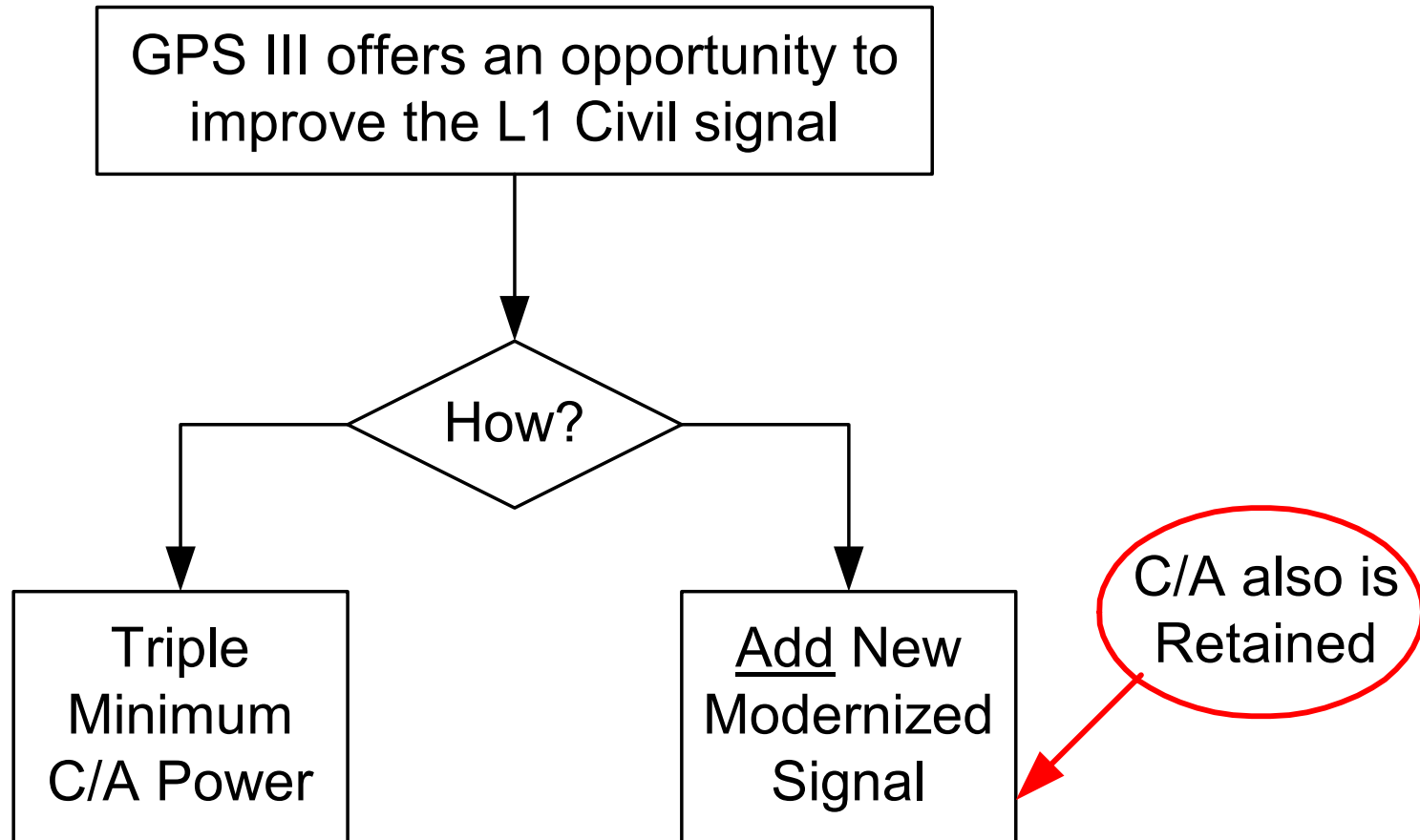

Where To Fit a New L1 Signal ?

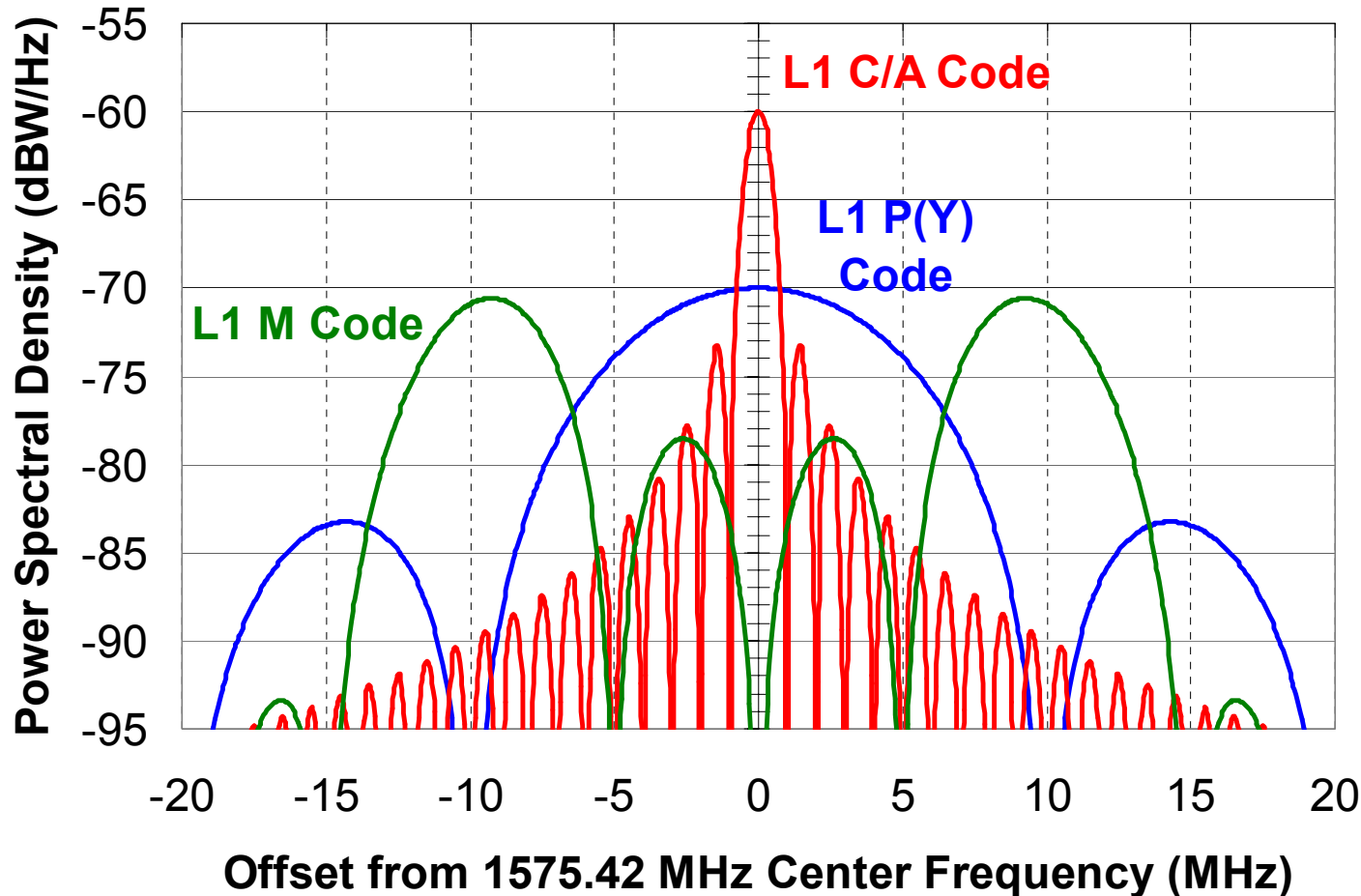

L1 Spectrum

L1 already will have C/A, P(Y), and M code signals

Finding space for a new signal is a challenge

Compromise is required

Must “Fit” Between M and C/A Codes

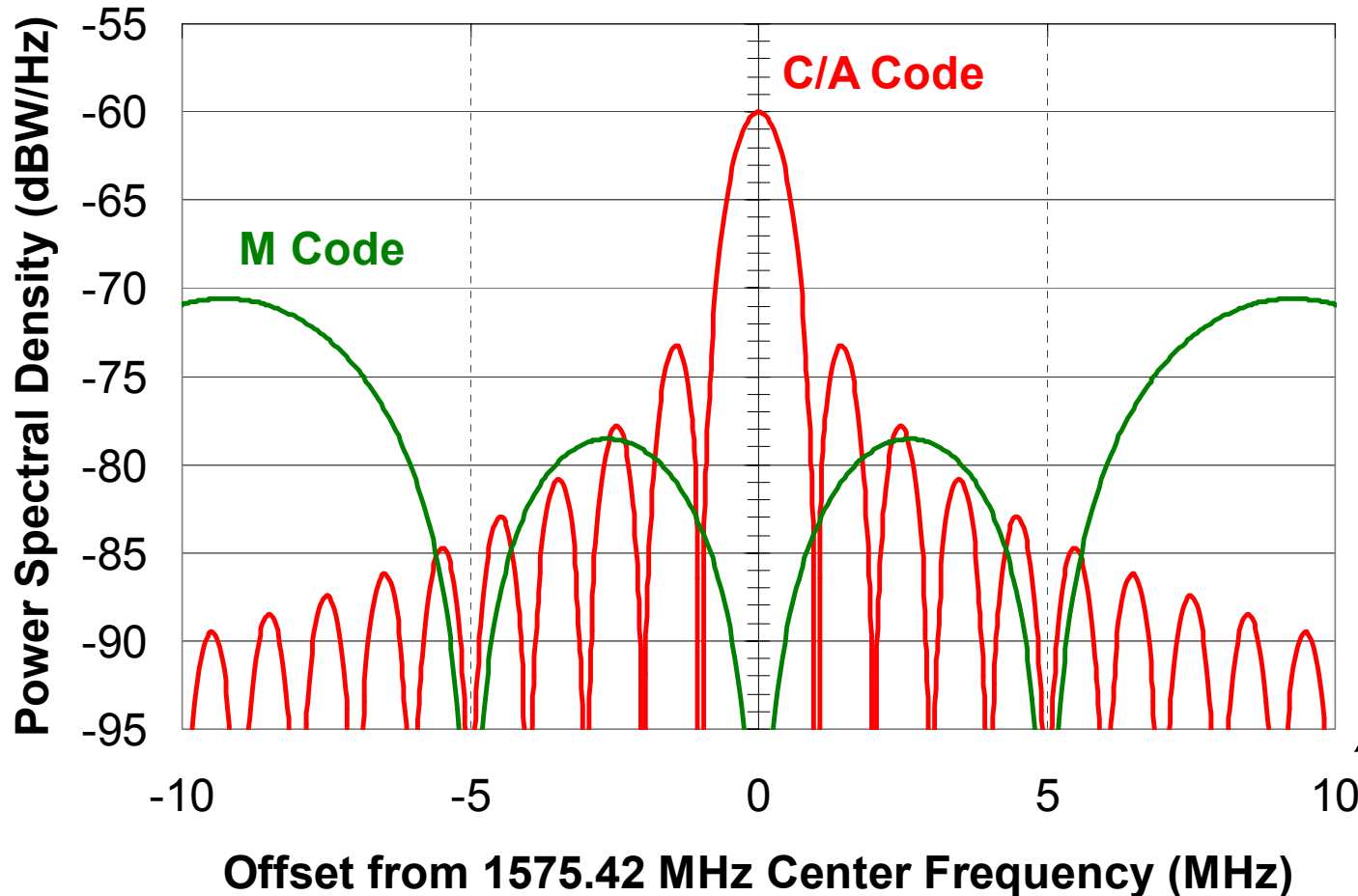

**P(Y) is the
“old” military
signal**

**So, fitting
between C/A
and M codes
is the focus**

***Note change
in frequency
scale***

Such As BOC(1,1) (OK for M and for C/A)

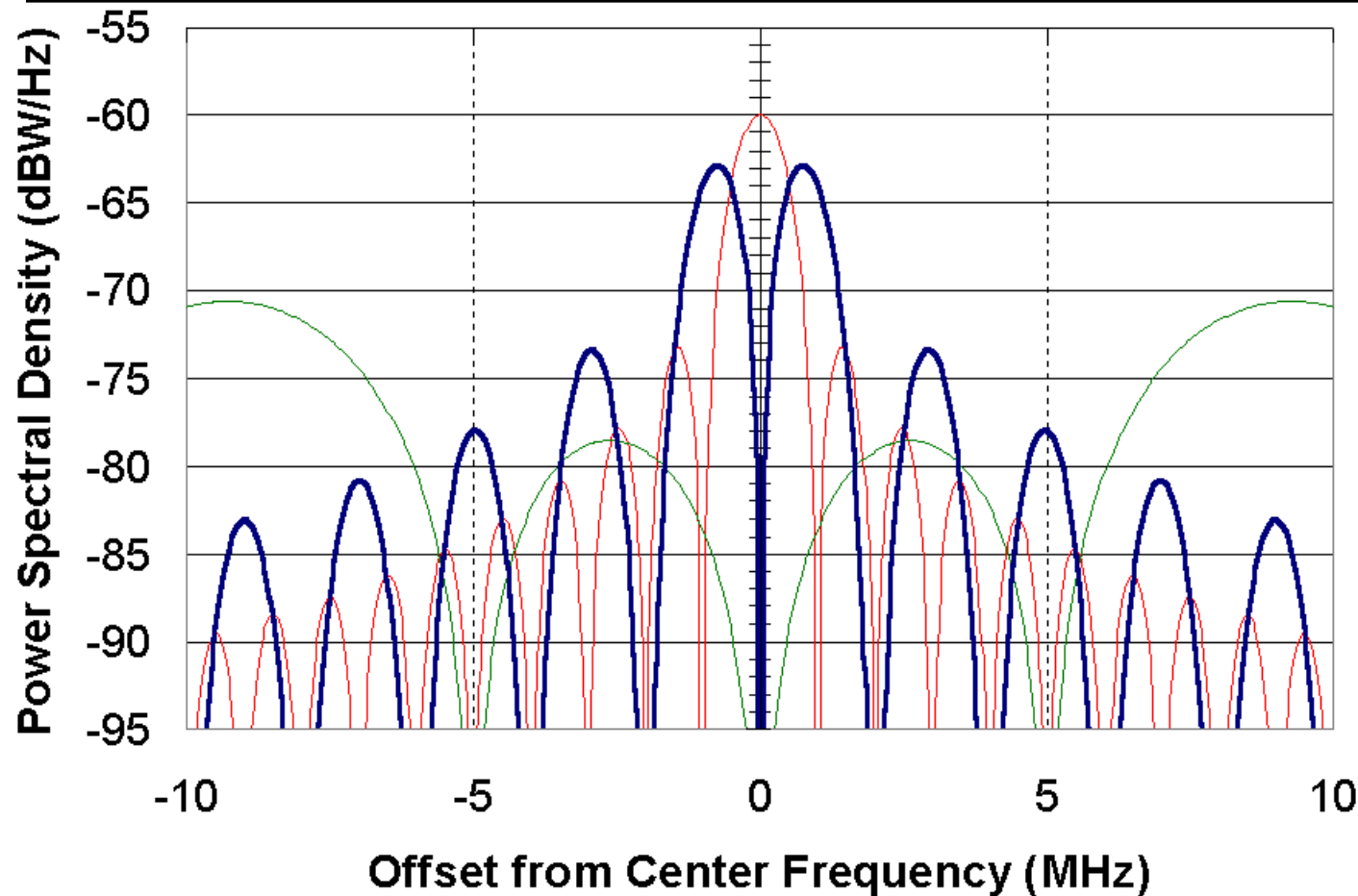

**BOC(1,1)
Spectral
Separation
Coefficient
(SSC)**

**For C/A =
-67.8 dB/Hz**

**For M =
-82.4 dB/Hz**

What's a BOC ?

- **BOC = Binary Offset Carrier**
- **The code is modulated by a square wave**
- **M code is a BOC(10,5)**
 - **5 MHz code modulated with a 10 MHz square wave**
- **BOC(1,1)**
 - **1 MHz code modulated with a 1 MHz square wave**



Code Chips 1, 0



Square Wave

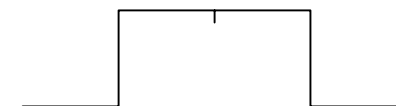

Transmit Signal

Two U.S. Signal Spectrum Candidates

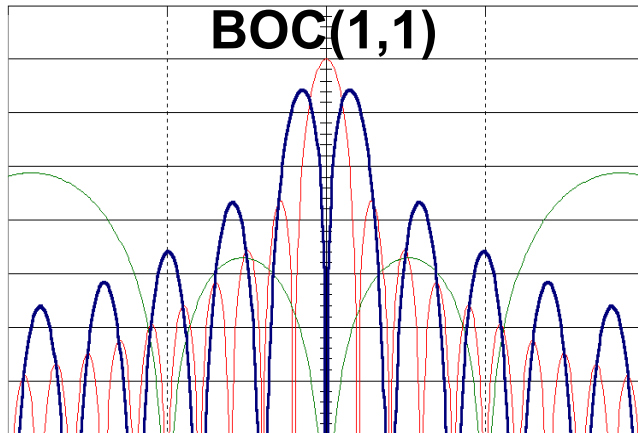

Government will decide

BOC(1,1)

**OK C/A and M Compatibility
Permits 4 MHz receiver bandwidth
The Leading Candidate**

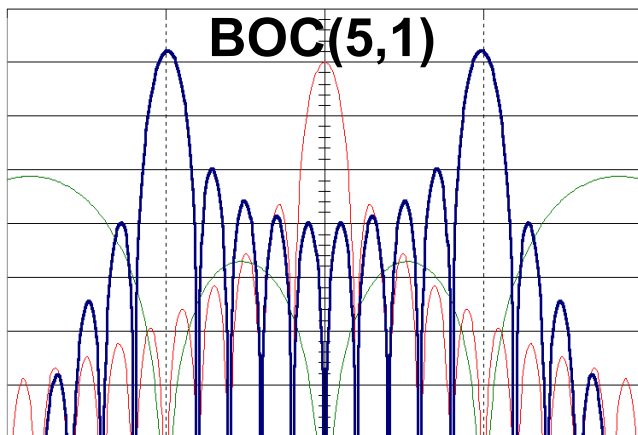

BOC(5,1) (?)

**Better C/A and M Compatibility
8 dB better code loop S/N
Concern about correlation sub-peaks
Requires ≥ 12 MHz receiver bandwidth**

Galileo Signal Decision

http://europa.eu.int/rapid/start/cgi/guestfr.ksh?p_action.gettxt=gt&doc=IP/04/264|0|RAPID&lg=EN&display=

Loyola de Palacio welcomes the outcome of EU/US discussions on GALILEO

The United States and the European Commission, joined by the European Union Member States, held a successful round of negotiations in Brussels on 24-25 February 2004. The delegations built upon progress made in The Hague and in Washington and were able to reach agreement on most of the overall principles of GPS/Galileo cooperation.

- Adoption of a common baseline signal structure for their respective open services (the future GPS intends to use a BOC 1,1 signal whereas the Galileo open service intends to use a fully compatible optimized version of the same signal which guarantees an high-level of performance).



Autocorrelation Functions (Absolute Value)

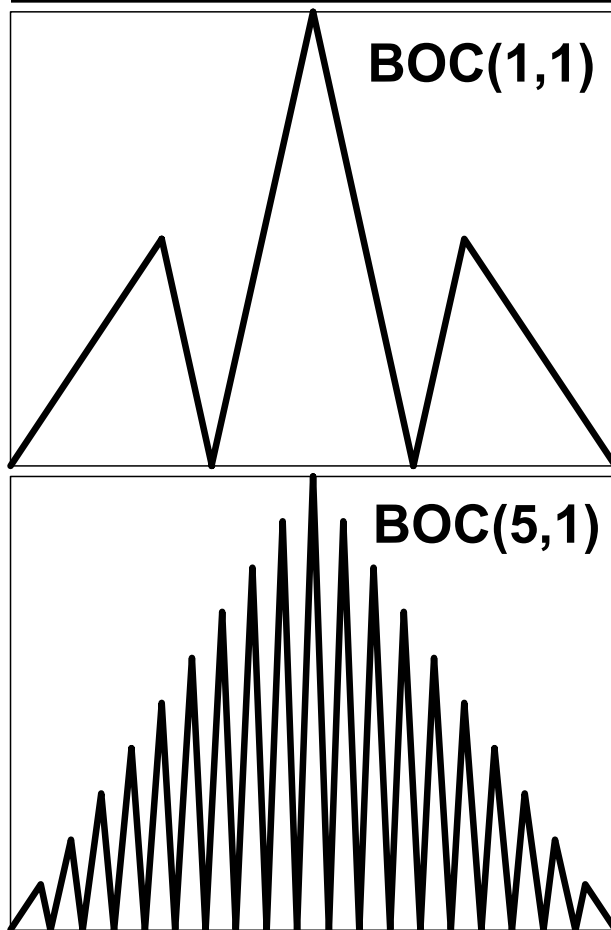

Government will decide

BOC(1,1)

OK C/A and M Compatibility
Permits 4 MHz receiver bandwidth
The Leading Candidate

BOC(5,1) (?)

Better C/A and M Compatibility
8 dB better code loop S/N
Concern about correlation sub-peaks
Requires ≥ 12 MHz receiver bandwidth

Multipath Defined

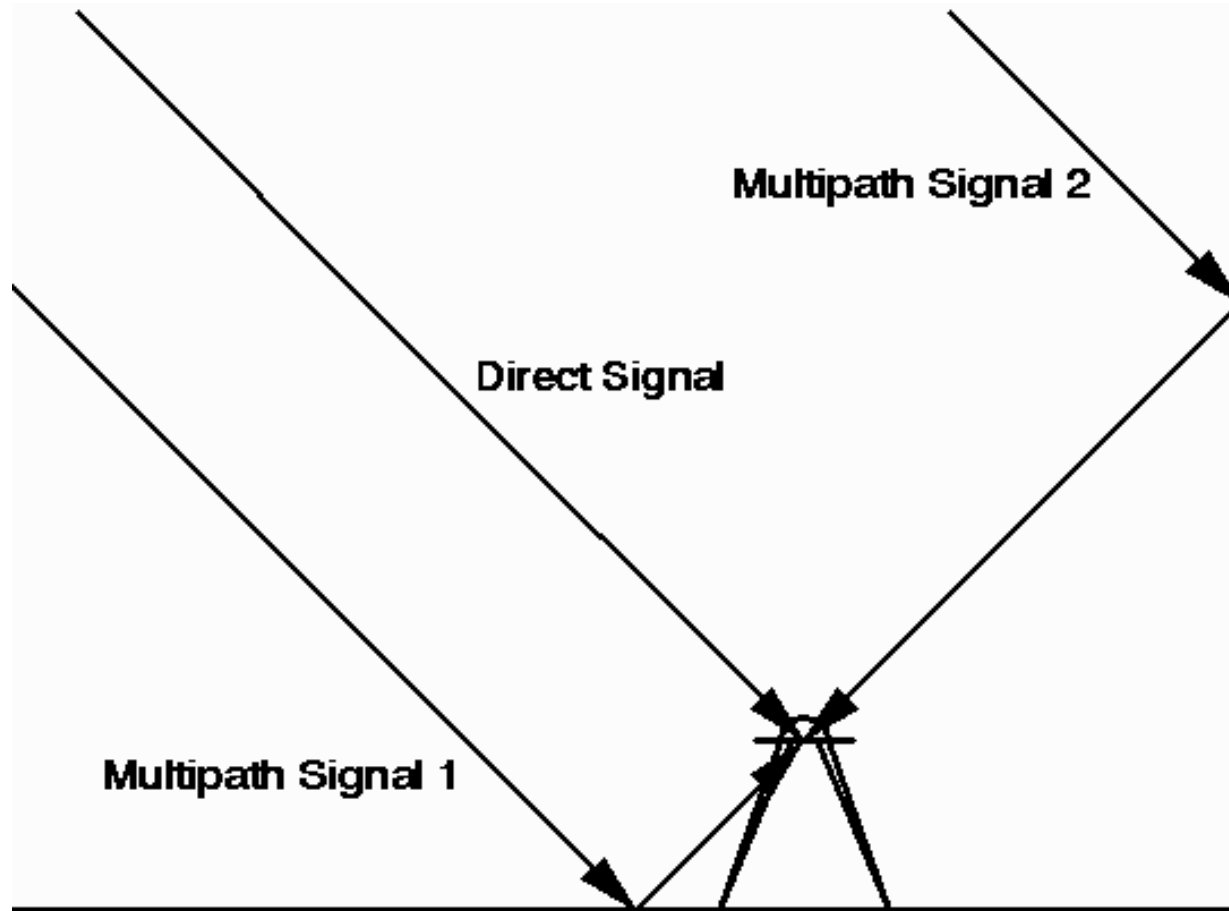

Narrow Correlator Multipath Error

Not intended
to be precise

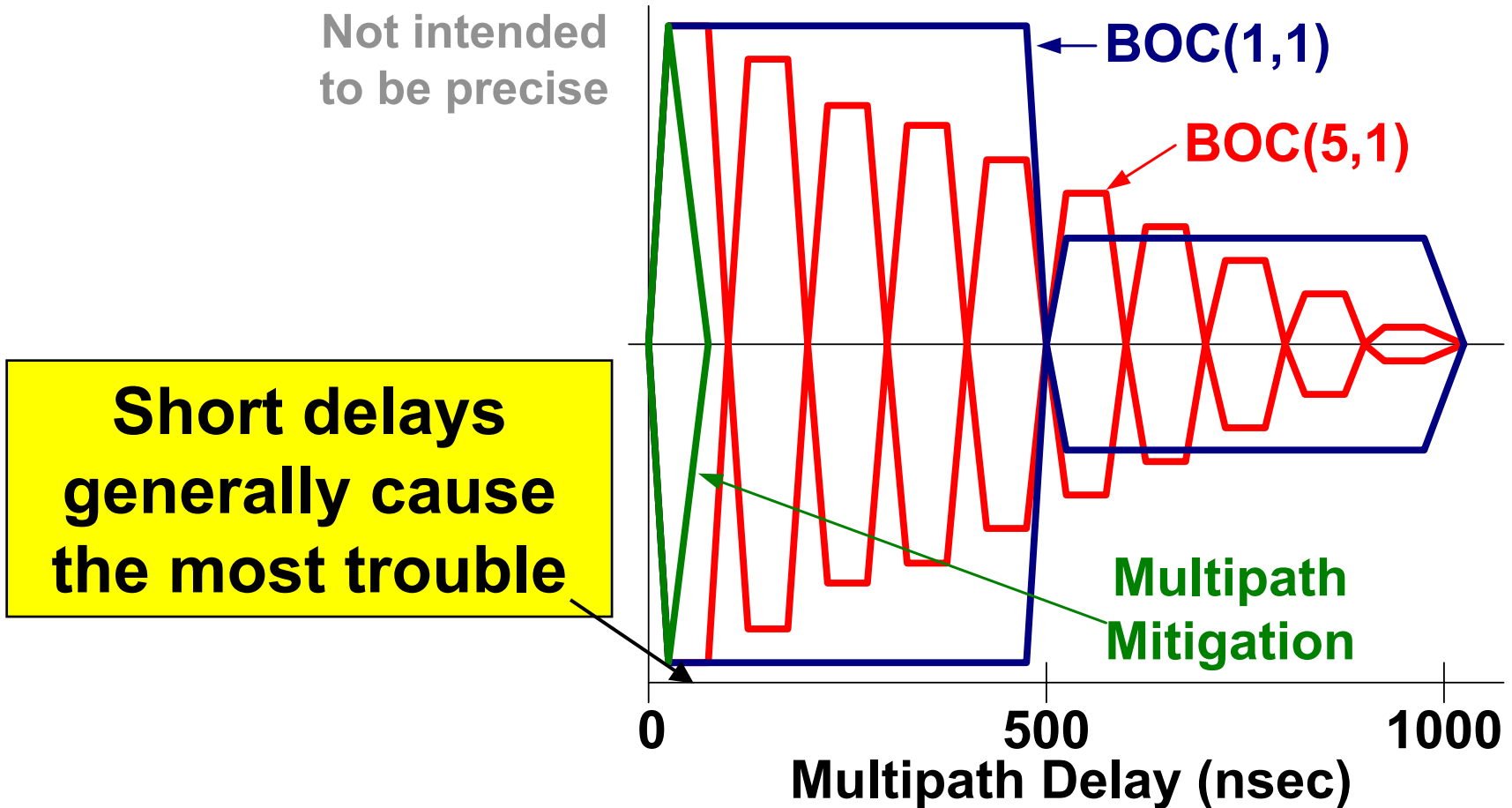

Multipath Performance

- **With multipath mitigation, there is no effective difference in multipath error**
 - Requires wide bandwidth receiver processing
- **Without multipath mitigation, higher code clock rates do reduce multipath error**
 - However, short delay multipath generally causes more trouble and affects all signal options
 - Local reflections tend to be stronger
 - Phase change tends to be much slower, so filtering is less effective (carrier-aided code smoothing)

GPS III Power Control Thinking

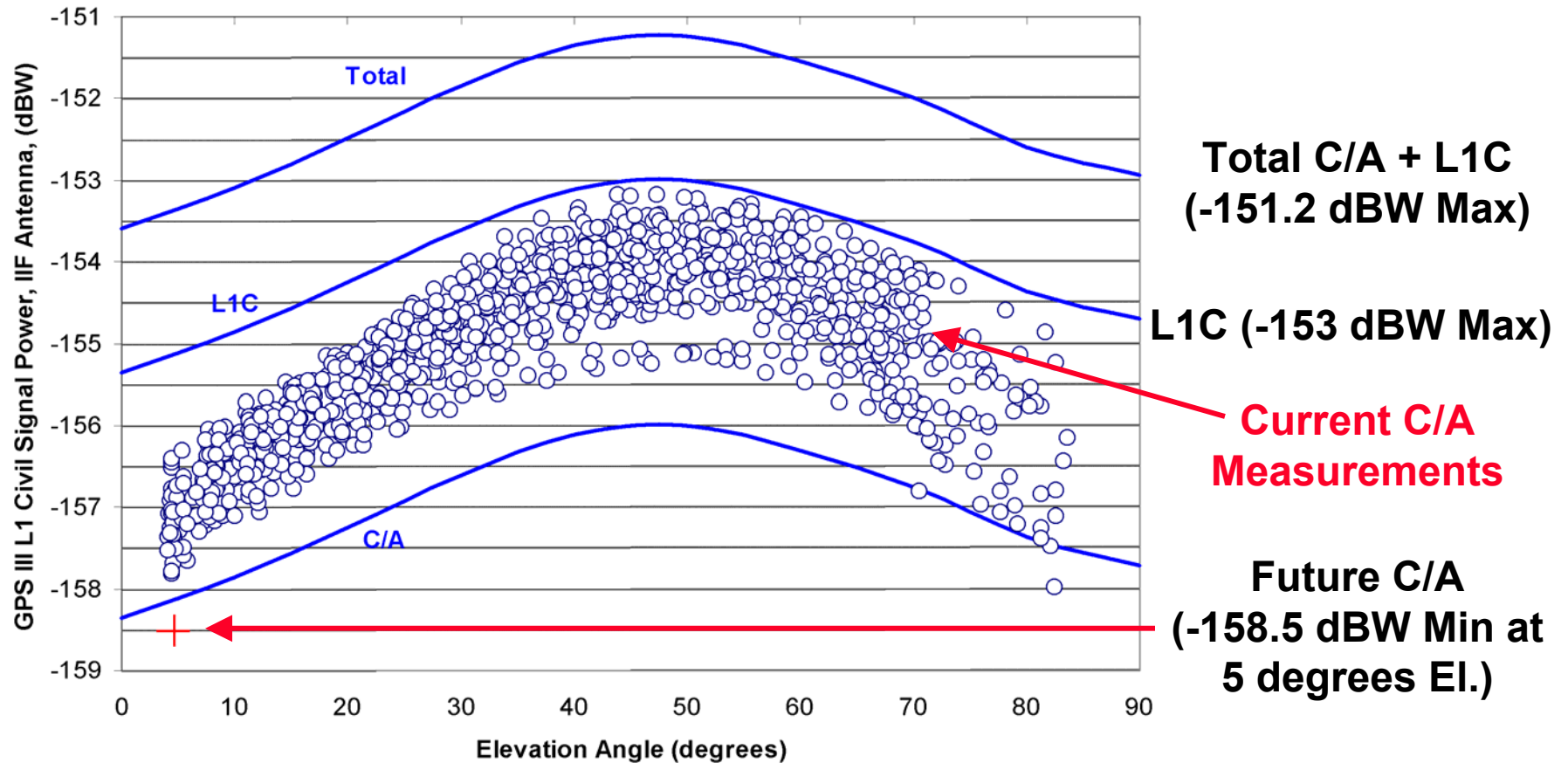

First L1C Modernization Question

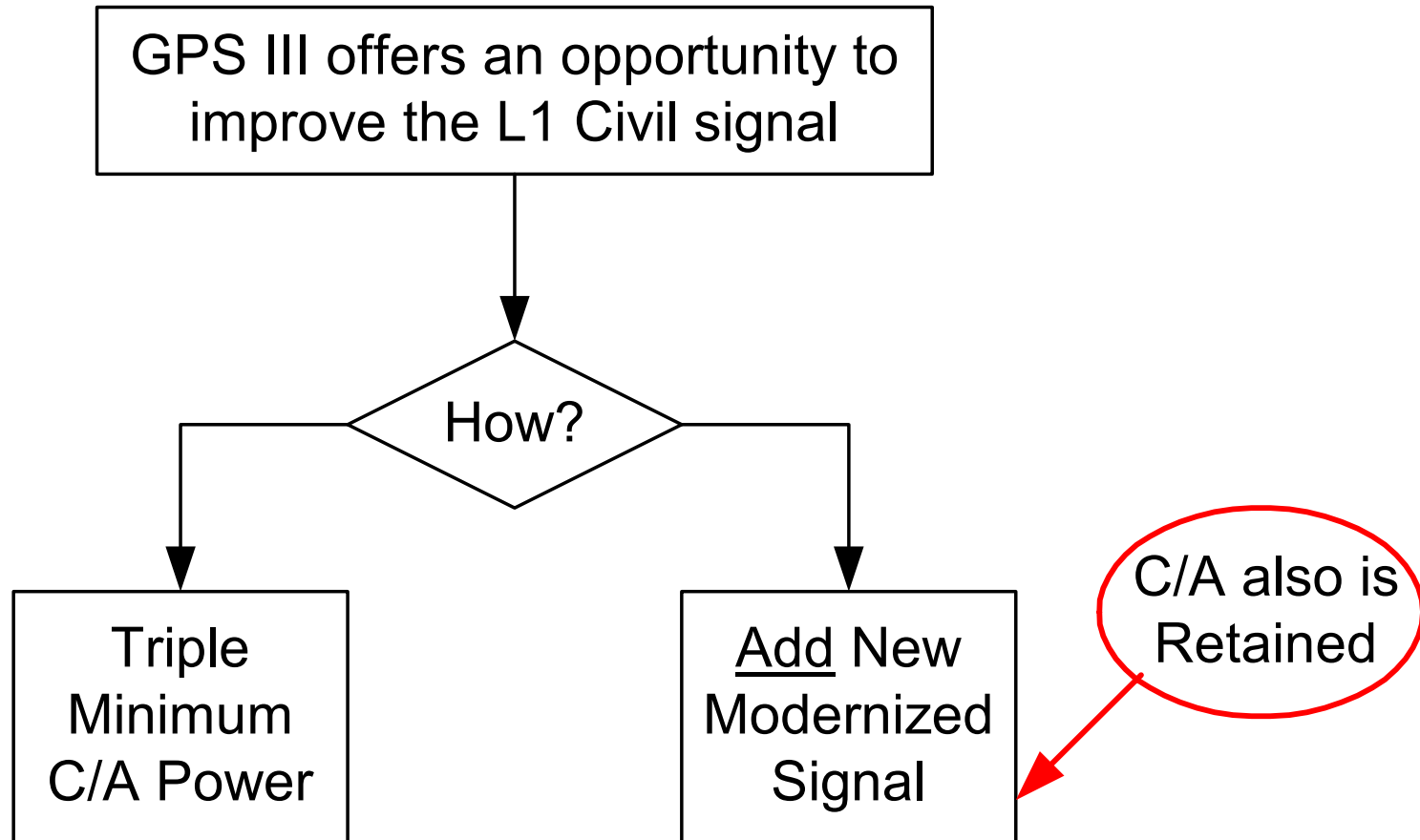

Triple Minimum C/A Power (4.77 dB)

Advantages

- Simple improvement
- Increase minimum C/A power by 4.77 dB
- No receiver change to benefit
- Helps all C/A users, one launch at a time

(Also could hurt) →

Disadvantages

- Raises C/A noise floor 1.8 dB
- Net is $4.8 - 1.8 = 3.0$ dB (x3 yields x2 effectiveness)
- Data also only 3 dB better
- Retains fixed data format
- Unimproved crosscorrelation (Increased strong-to-weak signal correlation may force receiver software updates if not a receiver replacement)
- Not a “competitive” signal

New L1C Signal Improvements

- **Twice the minimum C/A signal power**
 - **Longer codes (10,230 chips minimum)**
 - **Eliminate cross-satellite correlation interference**
 - **Reduce effect of narrowband interference**
 - **Message improvements**
 - **Higher resolution, reduced error rate, more flexible**
 - **Data-less signal component**
 - **Pilot carrier improves tracking threshold**
 - **Better for high precision phase measurements**
 - **Increase signal bandwidth (code clock rate)**
 - **Added interference protection, less code noise**
-



Next L1C Modernization Questions

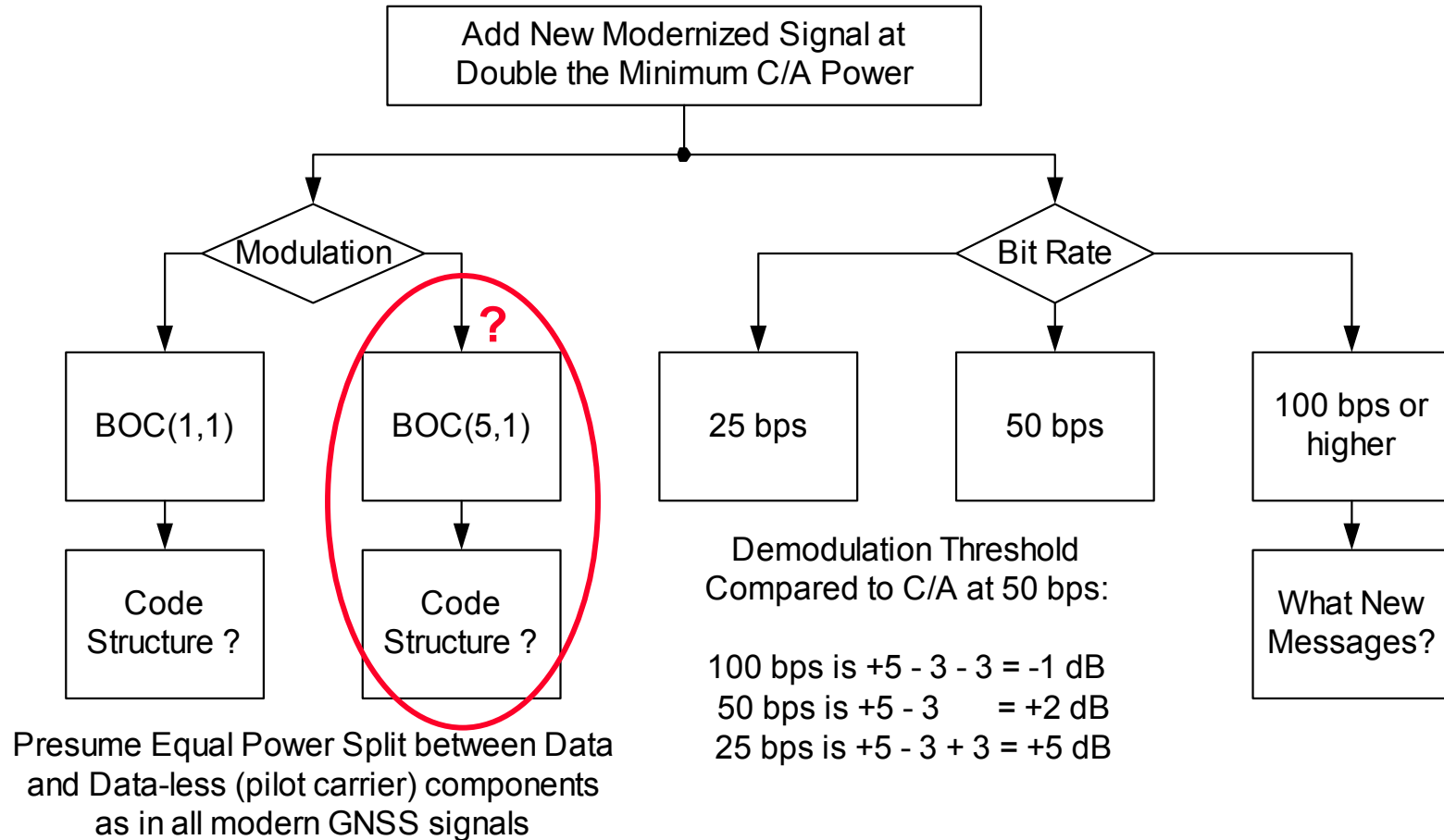

L1C Modulation Choices

- **Choice will be made by the Government and must balance between interference to legacy C/A users and national security**
- **BOC(1,1) seems to be the best compromise**
- **BOC(5,1) is better for interference but risks tracking the wrong autocorrelation peak and forces a wide receiver bandwidth**
- **Longer codes solve the C/A crosscorrelation problem (strong signal interference with weak signals)**



BOC(5,1) Considerations

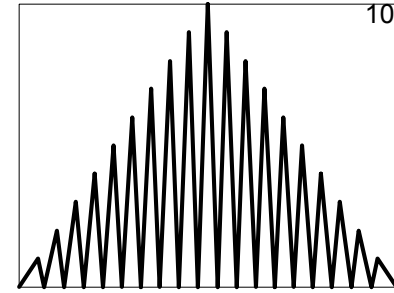

- **Adjacent correlation peaks only 0.9 dB down**
 - What is the risk of tracking the wrong peak?
- **But, the peaks are 30 meters apart**
- **Methods exist to convert signal to BPSK(1)**
 - Techniques defined by C. Cahn and by P. Ward
 - Convert double sidebands to center frequency
 - No ambiguity in tracking BPSK(1) result
 - If <15 m error, can then track BOC(5,1) center peak
 - Steeper autocorrelation function, more code transitions
- **Requires 3x bandwidth of BOC(1,1) receiver**
- **Multipath mitigation also is less effective**

Data Structure Improvements

- A modern signal would share message structure improvements with L2C and L5
- Forward Error Correction (FEC) improves data threshold by 5 dB
- High resolution ephemeris (1 cm)
- Compact almanac (7 satellites in one message block)
- Staggered almanac timing speeds collection
- Message will define the satellite



100 bps Data Rate or Faster

Advantages

- **Permits additional messages**
 - Integrity data?
 - Differential corrections?
- **What new messages would you want?**

Disadvantages

- **Requires more signal power to receive any message**
- **100 bps requires 4 times more signal power than 25 bps (6 dB)**
- **Signal must be 6 dB above tracking threshold to obtain messages**
 - **Autonomous, not assisted, tracking threshold**

25 bps Data Rate

Advantages

- Messages can be acquired at the autonomous signal tracking threshold (not Assisted GPS threshold)
- Especially helps in poor signal conditions such as in a forest, on a tree-lined road, indoors, or with interference
- In a tough environment can be the difference between working and not working

Disadvantages

- Requires twice as long to obtain messages compared with 50 bps
 - Clock & Ephemeris in:
 - 18 to 24 sec at 50 bps
 - 36 to 48 sec at 25 bps
- Time To First Fix (TTFF) can be 24 seconds longer than with 50 bps (traditional rate)



Choose One After Each Diamond

What is best for your applications?

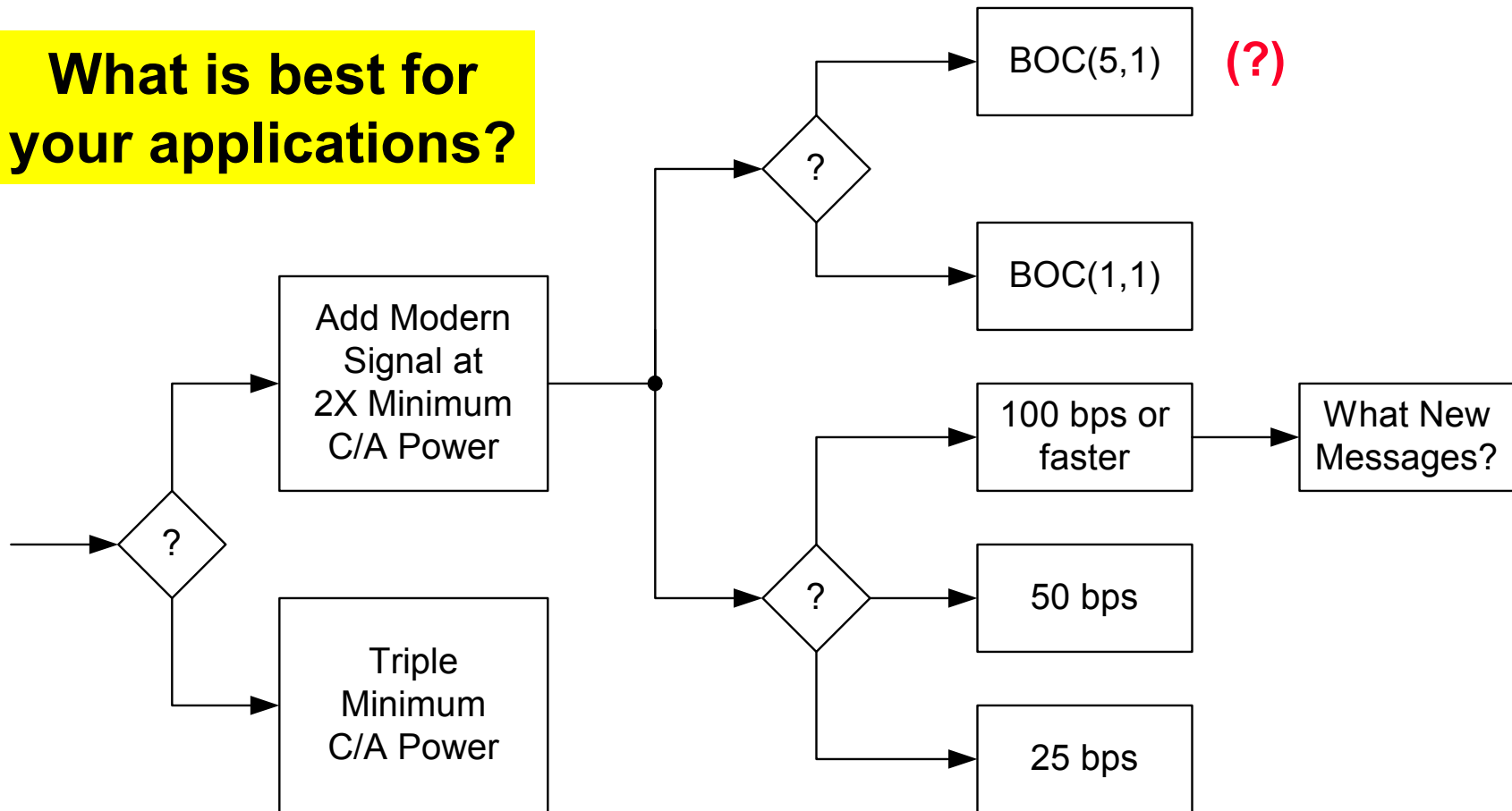

Questionnaire Page 1

L1C Questionnaire

Name: _____ Date: _____

Title/Position _____

Organization _____

Address _____

Phone: _____ E-Mail: _____

Circle Preferences:

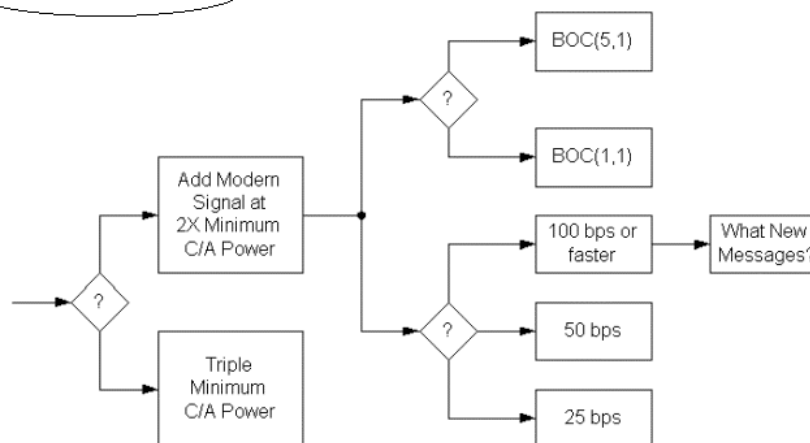

What new messages:

Comments:



Questionnaire Page 2

Application Specific Questions

Name: _____ Date: _____

Title/Position _____

Organization _____

Your Primary Expertise			
	Professional & Scientific	Commercial	Consumer
Land			
Sea			
Air			
Space			

Expected Number of Users in 2005			
	Professional & Scientific	Commercial	Consumer
Land			
Sea			
Air			
Space			

Expected Number of Users in 2020			
	Professional & Scientific	Commercial	Consumer
Land			
Sea			
Air			
Space			

Applications

1. _____

Parameter	Importance		Importance
	Best Desired	Worst Acceptable	
Accuracy			
TTF			
Availability			
Continuity			
Integrity			
Robustness			



L1C Technical Presentation

These pages present the slides used in the technical presentation. Some of the presentations were made in a conference room setting, but most were presented over the WEB to one or more locations at a time. After the presentation, participants were asked to fill in and submit a questionnaire to express their L1C preferences. Below is the title slide.



The title slide is used to explain that this is an Interagency GPS Executive Board (IGEB) Stewardship Project with two sponsors: the U.S. Geological Survey (USGS) and the U.S. Air Force GPS Joint Program Office. It also points out that the subject is whether and how to improve the GPS civil signal on the L1 frequency and that the GPS III program offers an opportunity to introduce signal changes.

Introducing

1Lt. Bryan Titus
Co-Chair,
JPO

Dr. Ken Hudnut
Co-Chair, USGS

2Lt. Jason Taylor

Tom Stansell

USGS

JPO

U.S. AIR FORCE 2

Because not everyone could be involved in each discussion, Slide 2 introduces the key participants in these technical presentations. The co-chairs are Dr. Ken Hudnut of the USGS earthquake research office in Pasadena, CA. Bryan Titus, now Capt. Titus, has been the co-chair from the GPS Joint Program Office. It was anticipated that Capt. Titus would transfer out of the JPO before this project ended, and his anticipated replacement was to have been Lt. Jason Taylor, shown above. However, plans change, and Bryan’s replacement on this project is Capt. Dominic (Dom) Alcocer.

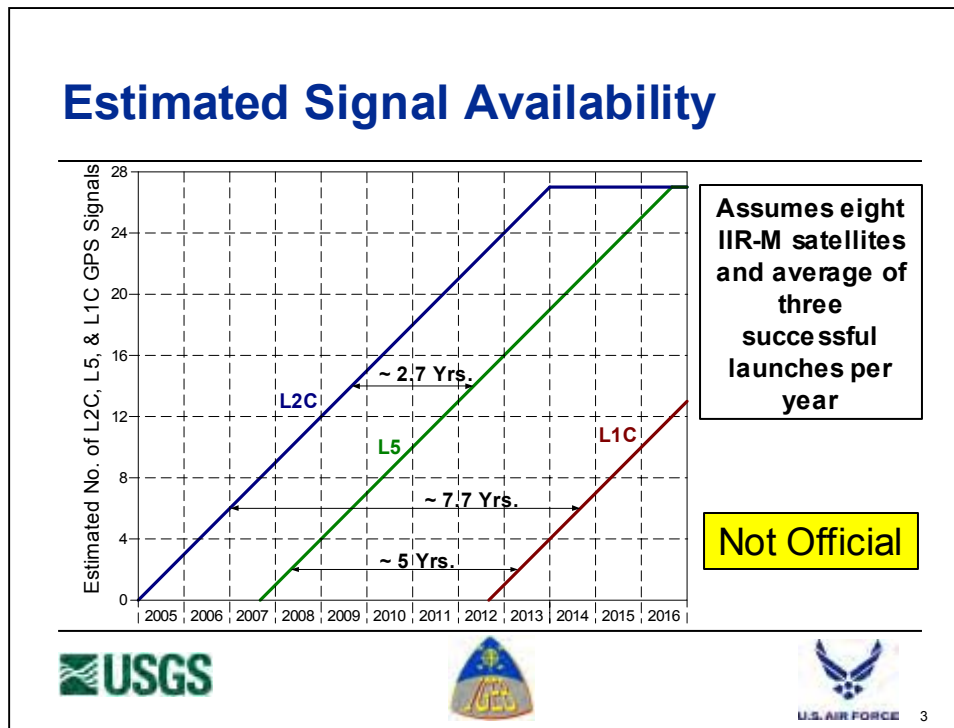

Slide 3 was a late addition to the presentation to give a sense of the L1C schedule relative to other new GPS civil signals. The plot is NOT official and DOES NOT reflect a plan or a promise by the U.S. Government. The plot assumes that on average there will be three successful GPS satellite launches per year for the indefinite future. Some will say that GPS III satellites may be launched two or more at a time and pressure to improve civil and military performance will fund a faster launch rate. Others will argue that IIR, IIR-M, and IIF satellites may last longer than IIA satellites and budget constraints will continue the policy of launching only when a replacement satellite is needed. Therefore, it is reasonable to assume 3 per year.

The chart shows the estimated number of new civil signals being transmitted in 2005 and beyond. The first IIR-M probably will be launched early in 2005 with L2C, the first modernized civil signal. Only 8 IIR-M satellites will be launched. After that the IIF series will commence, providing both L2C and L5. (Note that the first IIF may be launched before 2007. However, this will not accelerate the availability of L5, because all of the IIR-M satellites eventually will be launched, delaying availability of L5 relative to L2C by 8 launches. At 3 per year, this is approximately 2.7 years, as shown on the plot.

Current plans call for the first GPS III to be launched by 2012. Presumably this would be the first time an improved L1 signal (L1C) could be available. The plot assumes that starting in late 2005 only GPS III satellites will be launched. This is extremely optimistic, so a delay of more than 7.7 years relative to L2C is likely, unless later versions of the IIF are modified to carry L1C.

Note that L2C and L1C share the characteristic that they are adding capability to existing signals. Thus, the first signals are valuable, because they will be used in conjunction with the existing signals. In contrast, L5 does not exist today, so many launches are required to provide a service.

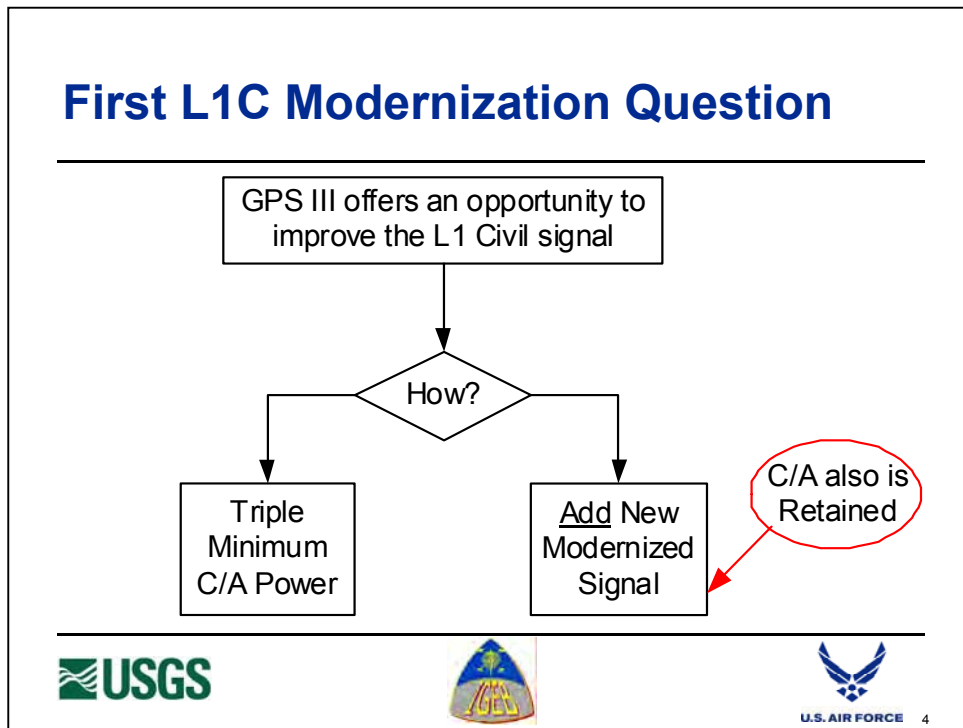

Slide 4 asks the primary question of whether a new L1 signal is wanted or needed. On the left is the alternative of “simply” increasing the power of the existing C/A signal. Presumably that would improve performance for all current users and avoid the difficulties of providing a new signal. On the right is the other approach of adding a new, modernized civil signal at the L1 frequency. This idea has raised much concern that C/A would be discontinued and replaced with a new signal. To address this concern, it was a ground-rule of this study that the C/A signal would be retained indefinitely. A new signal would be an addition not a substitution.

On the other hand, there are those who can envision a time, many decades from now, when the number of legacy users dependant on C/A will have all but disappeared. This will occur naturally as all new receiver designs become compatible with the modernized signals. A new generation of GPS experts will then have to decide whether to discontinue C/A and transfer it’s power to the modernized signal. This is of no concern for today’s users, because C/A will be retained indefinitely. However, it is important for signal designers to assure that a path exists so C/A could be discontinued in the distant future without then disrupting legacy L1C use.

Where To Fit a New L1 Signal ?

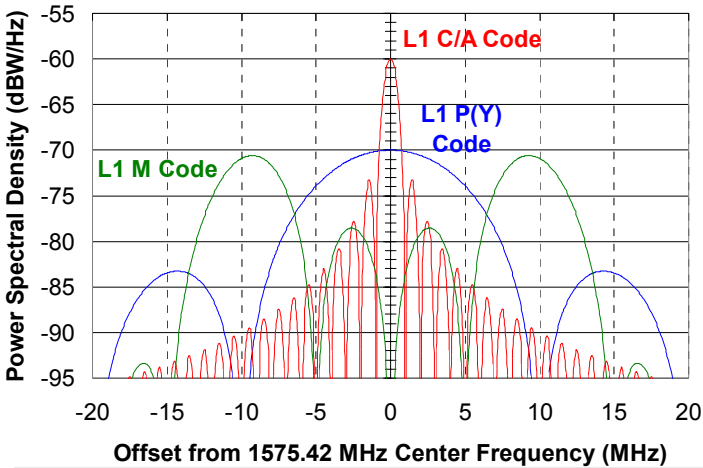

L1 Spectrum

L1 already will have C/A, P(Y), and M code signals

Finding space for a new signal is a challenge

Compromise is required



Slide 5 shows the challenge of fitting a new signal in the GPS L1 Spectrum which seems full with the two existing C/A and P/Y signals plus the future M Code military signal. This and the next plot show power spectral density in dBW/Hz, which allows us to see very weak signal components throughout the GPS L1 band. The challenge is to insert a new signal which doesn't add significant noise to existing C/A code receivers and which can be locally denied, along with the C/A code, by an allied military force while preserving use of the new M code military signal.

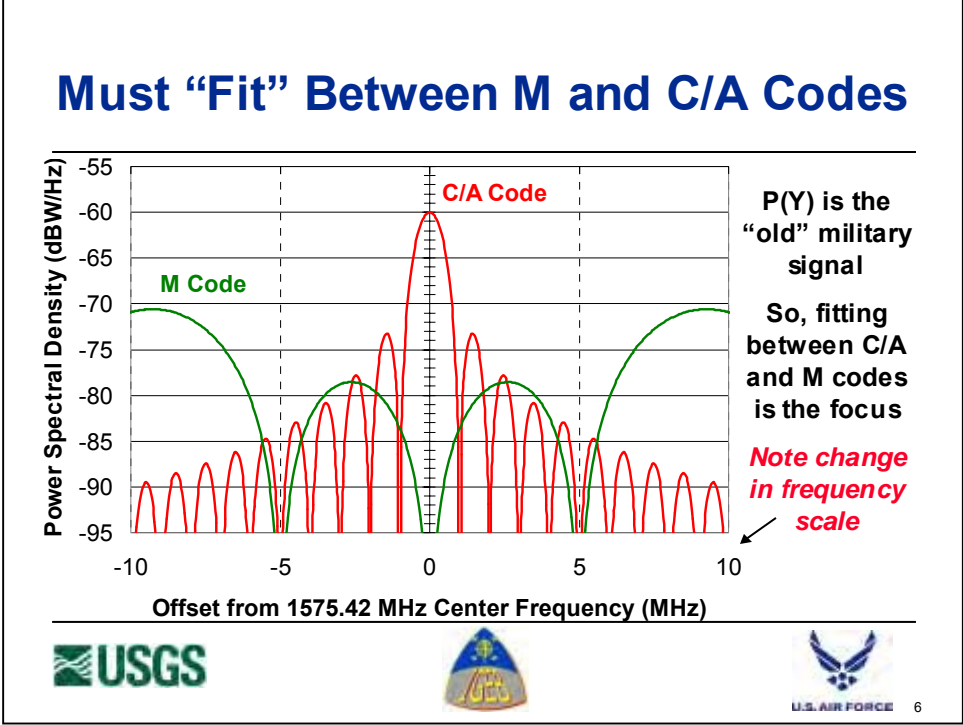

Slide 6 emphasizes that the main requirement of a new signal is to fit between the new M code and the C/A code signals. M code was developed specifically to provide spectral separation between civil and military signals, so there must be significant separation between any new civil signal and the M code. In addition, a new civil signal must not interfere with legacy C/A code users.

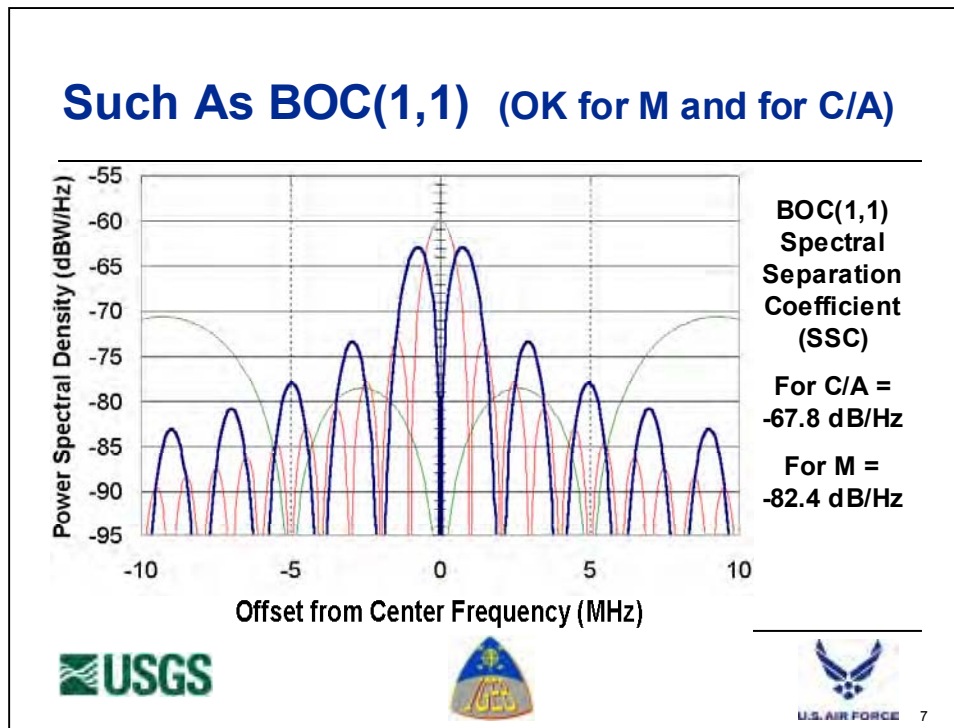

Slide 7 shows the spectrum of a BOC(1,1) signal, which is the leading candidate for a new civil signal. The main lobes of the signal are close enough to the spectrum center that there is “OK” separation from M code, and with a null at the center there is sufficient separation from the C/A code. The measure of separation is the Spectral Separation Coefficient (SSC) which is obtained from convolving the spectra of the two signals. The SSC quantifies the effect of the interference from one signal to a linear receiver of the other signal. For example, the SSC between a BOC(1,1) signal and the C/A code is -67.8 dB/Hz. To determine the interference caused by the aggregate power of all incident BOC(1,1) signals to a C/A code receiver, the aggregate power at a worst case time and position (the “hot spot”) is transformed by the SSC into the noise power density affecting a C/A code receiver. From other evaluations, the hot spot power is about 11.5 dB higher than the peak power transmitted by each satellite, depending on the user equipment antenna pattern. The peak L1C power from each satellite is taken from Slide 15 to be -153 dBW. Therefore, the hot spot power is about -141.5 dBW. Based on the BOC(1,1) SSC value, the resultant interference to a C/A receiver is -209.3 dBW/Hz, which is well under the -201 dBW/Hz noise floor of a C/A receiver with a 3 dB noise figure. Even so, at the hot spot this would cause a 0.6 dB increase in the C/A receiver noise floor, which is one reason the GPS Joint Program Office recently revised the minimum C/A power specification from -160 to -158.5 dBW. This 1.5 dB increase in specified minimum power more than compensates for all the new signals expected in the L1 frequency band.

This discussion included assumptions which may be different in other evaluation scenarios. For example, the maximum power transmitted by the satellites and the user equipment antenna pattern are assumptions. Whether or not Galileo or other L1 signals are included makes a difference. In fact, the results also depend on whether C/A to C/A mutual interference is included or not. The purpose here is to show the concept, not to draw definitive conclusions.

What's a BOC ?

- **BOC = Binary Offset Carrier**
- **The code is modulated by a square wave**
- **M code is a BOC(10,5)**
 - 5 MHz code modulated with a 10 MHz square wave
- **BOC(1,1)**
 - 1 MHz code modulated with a 1 MHz square wave

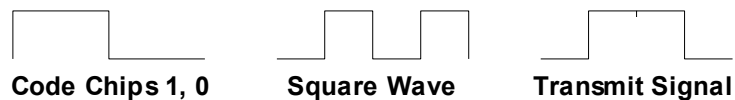

Slide 8 describes the BOC waveform. For BOC(1,1), the diagram at the bottom shows two code chips, the modulating square wave, and the resulting transmitted signal.

Two U.S. Signal Spectrum Candidates

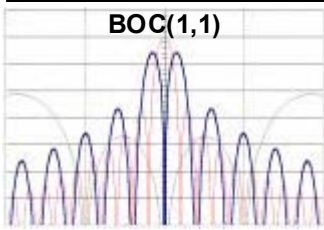

BOC(1,1)

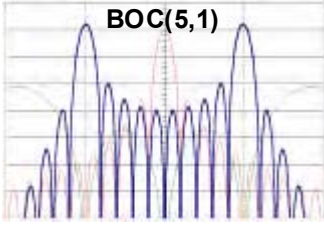

Government will decide

BOC(1,1)
 OK C/A and M Compatibility
 Permits 4 MHz receiver bandwidth
 The Leading Candidate



BOC(5,1)

BOC(5,1) (?)
 Better C/A and M Compatibility
 8 dB better code loop S/N
 Concern about correlation sub-peaks
 Requires ≥ 12 MHz receiver bandwidth

Slide 9 shows the spectrum of the two waveform candidates being offered for consideration: BOC(1,1) and BOC(5,1). The red question mark was added after the U.S. and the European Union (EU) announced tentative agreement on BOC(1,1) as the prototype civil signal that both GPS and Galileo would transmit in the L1 band. Although it would seem that BOC(1,1) has been anointed, the actual agreement was that the waveform must meet a specific set of compatibility criteria relative to the C/A and M codes. In this regard, BOC(5,1) is better than BOC(1,1) on both counts. It is likely the US and the EU will use identically the same waveform on L1, but it can be any waveform which meets the criteria. Some have proposed that BOC(5,1) would give better performance than BOC(1,1). If BOC(5,1) receives significant industry support, it remains possible for the US and EU negotiators to select BOC(5,1).

The main performance advantage of BOC(5,1) is that it has 9.5 “transitions” per microsecond versus 1.5 for BOC(1,1). As a result, with adequate receiver bandwidth the code tracking loop S/N is 8 dB better than with BOC(1,1). Opponents would argue that this is of little significance because with carrier aided code smoothing the C/A code, which has only 0.5 transitions per microsecond, achieves code tracking performance of a few centimeters and that ionospheric and multipath errors, not the loop S/N, are the dominant sources of code noise.

A key difference in the waveforms is that BOC(1,1) can be processed with a receiver bandwidth as little as 4 MHz whereas BOC(5,1) requires a minimum bandwidth of 12 MHz. Proponents of BOC(1,1) say that very low cost, low power, embedded receivers benefit from a narrow bandwidth signal rather than having to increase clock rates and employ a more complex filter for a wider bandwidth signal. Proponents of BOC(5,1) counter that the advance of technology should solve both these problems.

Galileo Signal Decision

http://europa.eu.int/rapid/start/cgi/guestfr.ksh?p_action.gettxt=gt&doc=IP/04/264|0|R APID&lg=EN&display=

Loyola de Palacio welcomes the outcome of EU/US discussions on GALILEO

The United States and the European Commission, joined by the European Union Member States, held a successful round of negotiations in Brussels on 24-25 February 2004. The delegations built upon progress made in The Hague and in Washington and were able to reach agreement on most of the overall principles of GPS/Galileo cooperation.

- Adoption of a common baseline signal structure for their respective open services (the future GPS intends to use a BOC 1,1 signal whereas the Galileo open service intends to use a fully compatible optimized version of the same signal which guarantees an high-level of performance).



10

Slide 10 highlights a key part of the agreement reached between the US and the EU. As quoted from a press release by Loyola de Palacio, the US and the EU adopted a “common baseline signal structure” on L1 for both GPS and Galileo. The phrase “optimized version of the same signal” shows that EU experts are evaluating other waveforms which meet the agreed compatibility criteria. These could include BOC(5,1) or minor variations of BOC(1,1). Because proposed launch schedules require the EU to commit to a waveform before the US, it is very unlikely the US would select a waveform which does not perform as well as the Galileo signal. In fact, it is likely the waveforms provided by GPS and by Galileo will be identical. The main point is that the US and the EU have agreed on compatibility criteria for selecting a waveform and BOC(1,1) is the initial choice but other variants are being considered.

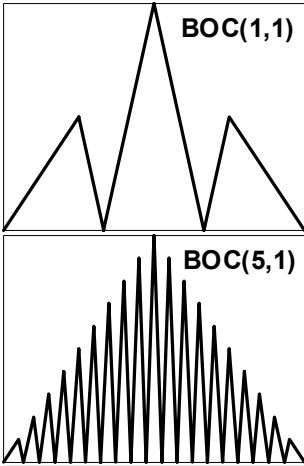

Autocorrelation Functions (Absolute Value)



Government will decide

BOC(1,1)
 OK C/A and M Compatibility
 Permits 4 MHz receiver bandwidth
 The Leading Candidate

BOC(5,1) (?)
 Better C/A and M Compatibility
 8 dB better code loop S/N
 Concern about correlation sub-peaks
 Requires >= 12 MHz receiver bandwidth

Slide 11 compares the absolute value of the BOC(1,1) and the BOC(5,1) autocorrelation functions. As you recall, the C/A code, BPSK(1) autocorrelation function has the same width but only one peak at the center. BOC(1,1) has three peaks, but the sub-peaks are at half (voltage) amplitude relative to the correct center peak. This 6 dB power difference is considered easy to detect, so if receivers are designed to avoid a false lock, the probability of tracking the wrong peak is considered negligible. The slope of the center of the BOC(1,1) autocorrelation function is 3 times steeper than the slope of a BPSK(1) autocorrelation function because there are 1.5 signal transitions per microsecond for BOC(1,1) and 0.5 transitions for BPSK(1).

The central peak slope of the BOC(5,1) autocorrelation function is 6.33 times that of the BOC(1,1) slope because the BOC(5,1) waveform has 9.5 transitions per microsecond. This characteristic improves code loop S/N, but as shown in the figure it introduces concern a receiver could falsely lock to and track a sub-peak. The concern is heightened because the sub-peaks on either side of the central peak are only 0.9 dB below the central peak.

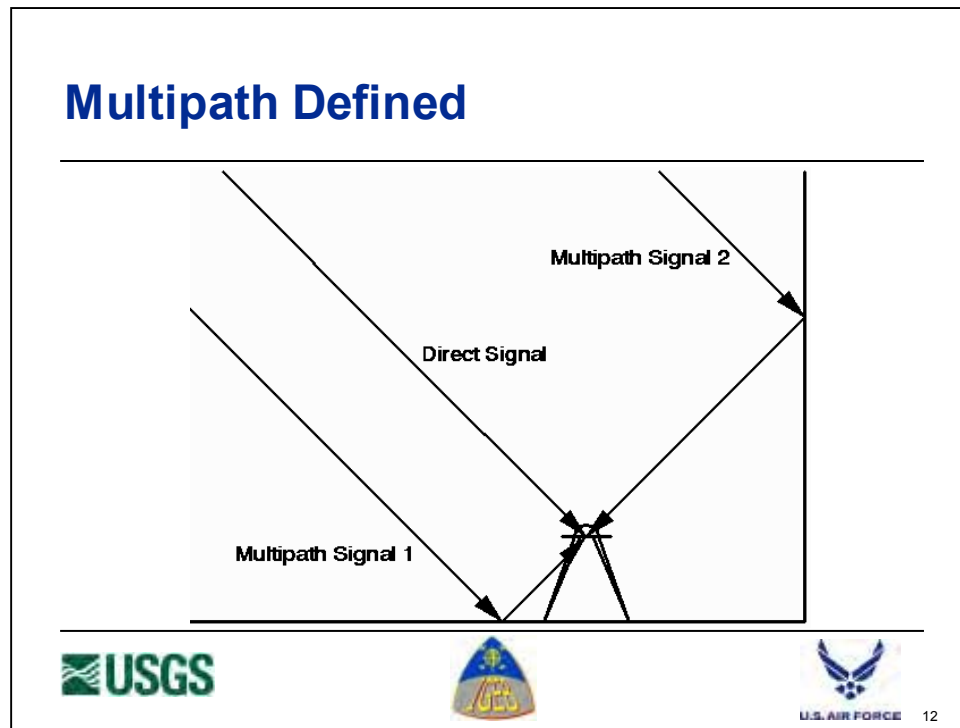

Slide 12 is in case a respondent doesn't understand the physical nature of multipath. The desired signal is the direct signal from the satellite to the receiver antenna. However, the antenna also receives the same signal when reflected from any surface in view. The only valuable signal is the direct signal. All reflected signals introduce distortions and noise which hurt accuracy and can cause significant signal fading.

Several methods are used to reduce the amplitude and minimize the effect of these multipath signals. The satellite signals are transmitted with left hand circular polarization, and good user antennas match that polarization because the polarization of one-bounce multipath signals are reversed to right hand circular. Thus, good circular polarization of user antennas helps attenuate multipath signals. Antennas which can be hard mounted often are designed to minimize the reception of signals near or below the horizon because most multipath signals arrive at a low or negative elevation angle.

Within the receiver there are two main ways to minimize the impact of multipath. The first is carrier aided code tracking. Because the L1 carrier wavelength is 19 centimeters, the multipath effect is measured in centimeters. On the other hand, the multipath effect on code tracking is measured in meters. The carrier signal very precisely measures the change in range between the satellite and the user, but unlike the code signal it doesn't provide an absolute measure of the total pseudorange. Carrier aided code smoothing combines the precision of carrier measurements with unambiguous code measurements to provide information with far less multipath noise.

The second receiver technique is to employ a multipath mitigation code correlator. The earliest version of this is the "narrow correlator" which significantly reduces the impact of multipath signals. More effective techniques also have been developed and are in use.

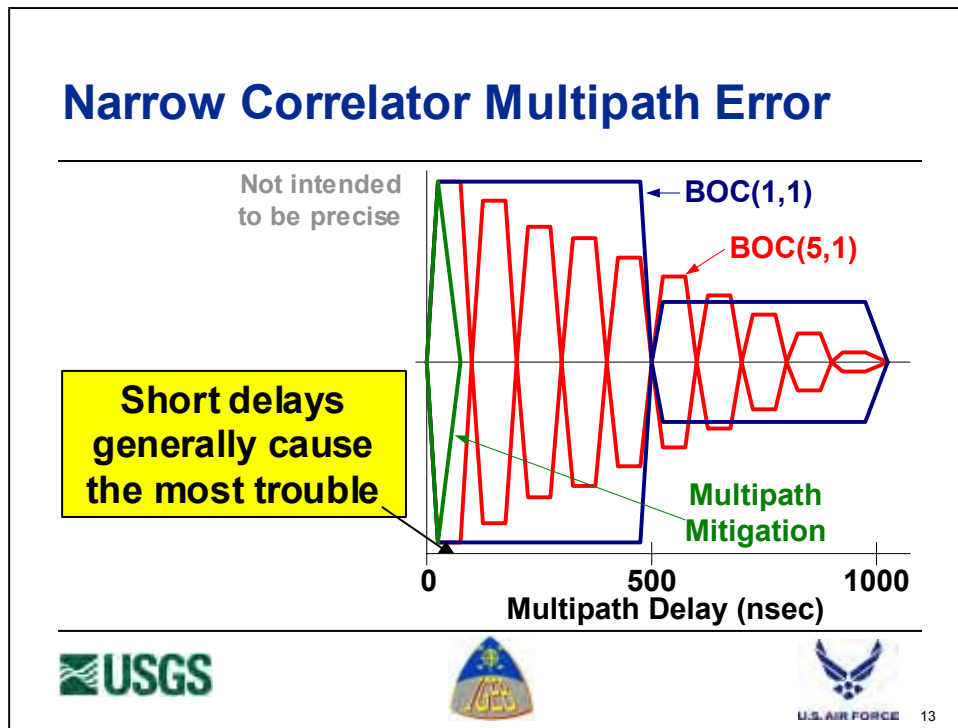

Slide 13 addresses the issue of whether the choice of signal waveform will affect receiver multipath performance. The graphic is not intended to be precise but to illustrate the issues. The plot shows the error caused by a single multipath signal, when tracking with a narrow correlator, as a function of its arrival time relative to the direct signal. Delays beyond just over 1000 nanoseconds (ns) have no effect because the reflected signal is completely de-correlated by the pseudorandom code which has a chip period of 1000 ns. As the carrier phase of the multipath signal changes relative to the carrier phase of the direct signal the code error slowly oscillates between the limits defined by the figure. A BPSK(1) signal like the C/A code has an error profile which rises from zero to the two maxima and remains there until just beyond 1000 ns. The BOC(1,1) profile (shown in blue) is the same except that at the half way point the polarity of the error limits is reversed and the amplitude becomes one third that during the first half. This, of course, is due to the 1 MHz square wave modulating the 1 MHz code. The BOC(5,1) signal (shown in red) has nine reversals of polarity and the error amplitude is reduced after each one.

On the surface it would seem that either of these would be better than the BPSK(1) C/A code, but the reality is more complicated. In particular, most multipath signals, especially those which do the most harm, have a short delay. Studies have shown that in most circumstances there is little or no multipath energy beyond a delay of 300 ns, and the amplitude falls off rapidly over this range. In addition, use of a multipath mitigation correlator, as illustrated in green, means to first order that there is no difference in performance with either of the signal waveforms. Performance is determined by the receiver design. Although this is true with one of the several types of multipath mitigation correlator, the most often used such correlator, such as the double delta or Strobe correlator, suffers another “secondary” multipath response at each polarity change. From this perspective, it would be better to use the double delta or Strobe type correlator with the BOC(1,1) waveform than with the BOC(5,1) correlator.

Multipath Performance

- **With multipath mitigation, there is no effective difference in multipath error**
 - Requires wide bandwidth receiver processing
- **Without multipath mitigation, higher code clock rates do reduce multipath error**
 - However, short delay multipath generally causes more trouble and affects all signal options
 - Local reflections tend to be stronger
 - Phase change tends to be much slower, so filtering is less effective (carrier-aided code smoothing)



14

Slide 14 summarizes the points made with the previous slide. If multipath mitigation is used, there is no effective difference regardless of which waveform is chosen, except that with a double delta or Strobe type of correlator the secondary multipath responses with a BOC(5,1) waveform are closer to the origin where most of the multipath energy is found. All multipath mitigation correlators require a wide bandwidth receiver to function effectively.

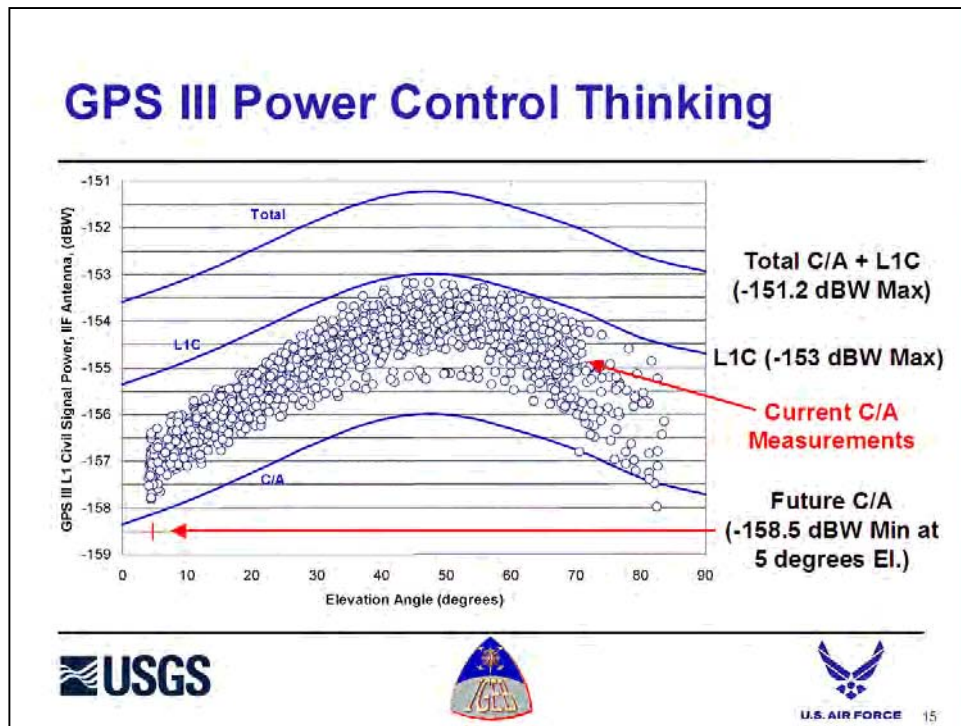

Slide 15 shows the proposed L1C and C/A power sharing ideas. It is based on the premise that GPS III will be able to precisely control the power of each of its signal components. Note first that the specified minimum C/A signal power received by a +3 dBi linearly polarized antenna, oriented to receive the minimum signal power, is -158.5 dBW at 5 degrees of elevation and above. Although the critical elevation angle is 5 degrees, the specified minimum power is the same at all elevation angles above 5 degrees. The fact that signal power does increase at higher elevation angles is an artifact of satellite antenna design limitations. The ideal satellite antenna would deliver constant power at every elevation angle. The small circles represent actual C/A signal power measurements from many GPS satellites as a function of elevation angle. Clearly there is more C/A signal power than the specified minimum.

Although not official, and still under evaluation, the GPS JPO suggested that it would be acceptable for the maximum total civil signal power on L1 to be -151 dBW. This may have to be reduced somewhat not only for national security reasons but also to limit inter-signal interference, especially when the total GPS plus Galileo signal power is considered. However, working with these numbers it would be possible to increase the current C/A signal to the total power curve at the top of the figure. On the other hand, to provide the best new L1C performance, C/A power would be reduced to the lower curve, leaving room for L1C to be more powerful than any of the current C/A signals. The reduced C/A power would more than meet the current signal specification, and there would be seven or more years before the first GPS III launch, in 2012 or beyond, for a large fraction of current receivers to be replaced by L1C-enabled versions. Legacy C/A-only receivers still in use would receive signals closer to the specification level than now from the new satellites. In this way, legacy signals are preserved while encouraging users to upgrade to receivers compatible not only with L1C but also the expected new Galileo signals. For a smooth transition it is important for US and EU authorities to publish complete signal specifications as soon as possible.

Triple Minimum C/A Power (4.77 dB)

Advantages

- Simple improvement
- Increase minimum C/A power by 4.77 dB
- No receiver change to benefit
- Helps all C/A users, one launch at a time

(Also could hurt)

Disadvantages

- Raises C/A noise floor 1.8 dB
- Net is $4.8 - 1.8 = 3.0$ dB (x3 yields x2 effectiveness)
- Data also only 3 dB better
- Retains fixed data format
- Unimproved crosscorrelation (Increased strong-to-weak signal correlation may force receiver software updates if not a receiver replacement)
- Not a “competitive” signal



17

Slide 16 is not reproduced here. Having covered the background material, Slide 16 was a repeat of Slide 4 to return to the basic question of whether simply to increase the C/A signal power or to add a new signal, such as a BOC(1,1) L1C signal, while also retaining the C/A code.

Slide 17 examines the advantages and disadvantages of simply increasing the C/A signal power. The suggested increase of 4.8 dB would be with respect to the specified minimum signal power of -158.5 dBW. Presumably this option would be relatively simple, and every legacy C/A user could benefit. Unfortunately, there are disadvantages as well. The SSC of one C/A signal with respect to another is 6 dB worse than the effect of BOC(1,1) signals on C/A. With the suggested power increase, as shown in Slide 15, the maximum power of each C/A signal would be -151.2 dBW, so the hot spot discussed with Slide 7 would be at -139.7 dBW. The resultant interference to a C/A receiver is -201.3 dBW/Hz, which is barely under the -201 dBW/Hz noise floor of a C/A receiver with a 3 dB noise figure. At the hot spot this would cause a 2.8 dB increase in the C/A receiver noise floor, based on the same assumptions used with Slide 7 for a BOC(1,1) signal. Most important, both analyses ignore all other interference sources. Regardless of the assumptions, however, it is clear that simply increasing C/A power is not an effective way to improve the L1 civil signal.

New L1C Signal Improvements

- **Twice the minimum C/A signal power**
- **Longer codes** (10,230 chips minimum)
 - Eliminate cross-satellite correlation interference
 - Reduce effect of narrowband interference
- **Message improvements**
 - Higher resolution, reduced error rate, more flexible
- **Data-less signal component**
 - Pilot carrier improves tracking threshold
 - Better for high precision phase measurements
- **Increase signal bandwidth (code clock rate)**
 - Added interference protection, less code noise



18

Slide 18 lists a number of L1C improvements relative to C/A in addition to more signal power (“twice the minimum C/A signal power”). Every modernized GPS signal (L2C, L5, and M code) employs a much longer code than the 1023 chip C/A code. The minimum code length for L2C and for L5 is 10,230 chips, and undoubtedly this would be the same for L1C. This will greatly reduce and practically eliminate cross-satellite interference which is a significant problem with C/A code. (A powerful GPS signal can be acquired by a C/A receiver looking for a different satellite because the code provides as little as 21 to 23 dB of crosscorrelation protection.) A longer code also reduces the impact of narrowband interference. L1C naturally would provide the modernized message structure which will be implemented on L2C and L5. This includes higher resolution (a few centimeters rather than ~40 cm), use of forward error correction (FEC), a strong cyclic redundancy check (CRC) to validate individual messages, and a more flexible message structure. Very importantly, L1C also will provide two signal components, one with data and one without data, i.e., a pilot carrier, which improves tracking threshold by a minimum of 3 dB. Finally, L1C will have a broader spectrum (more waveform transitions) than C/A code, which adds some interference protection and improves code loop S/N.

The strong CRC alone can be an important improvement. For example, certified aviation receivers today are required to receive two identical copies of the ephemeris message before it can be used for navigation. This is because the check sum error detection employed today is not strong enough to guarantee no errors after receiving just one message. The modern CRC is sufficient to guarantee no errors with just one message. This by itself can accelerate time to first fix (TTFF) or time to first use of a newly acquired signal.

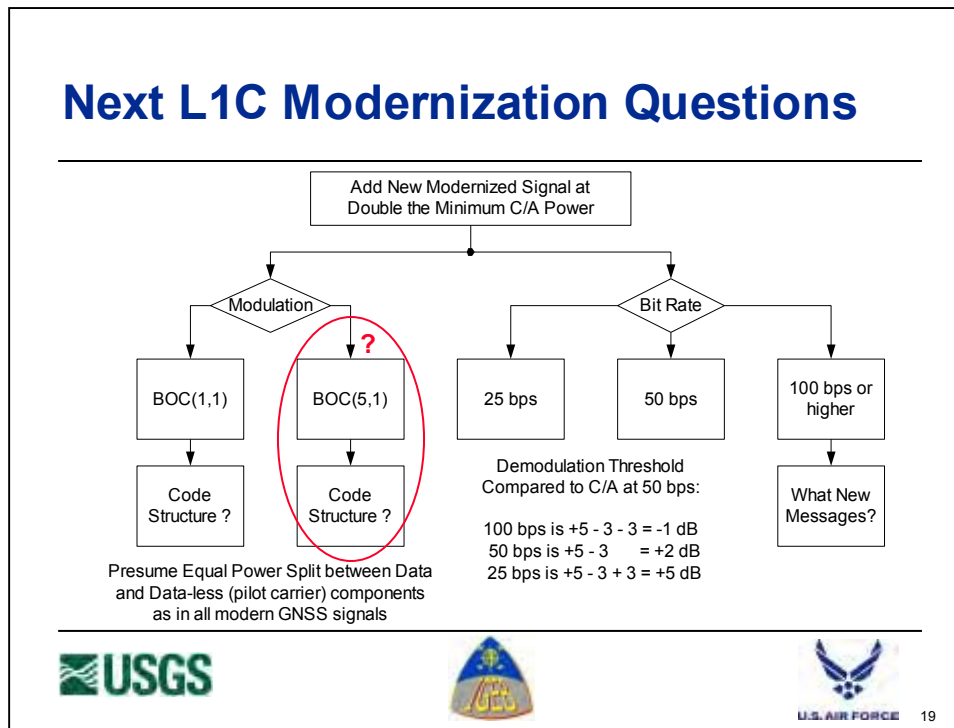

Slide 19 asks the next key questions. If you prefer having a modernized signal, which modulation waveform do you recommend, BOC(1,1) or BOC(5,1)? Also, what message bit rate do you prefer? The advantages and disadvantages of the two modulation waveforms have been covered adequately in previous slides.

To help make the bit rate decision, a small table is included on the slide. If we compare the L1C signal to a C/A signal of equal power, the L1C signal will have a 2 dB better data demodulation threshold than the C/A signal. This is mostly because forward error correction (FEC) will be used. The FEC algorithm adopted for L2C and L5 yields a 5 dB improvement in threshold. (An improved algorithm may be considered for GPS III.) This is reduced by 3 dB because the power of modern signals is divided equally between data and data-less components. The net at 50 bps is an improvement of 2 dB. If a 100 bps data rate is chosen there is another reduction of 3 dB because only half the energy is available per bit. The result is a 1 dB performance penalty relative to a 50 bps C/A signal. Conversely, choosing a 25 bps rather than 50 bps gains 3 dB, giving a 5 dB advantage over C/A code. The advantage of higher data rates is having more data in the same time or the same amount of data quicker. The advantage of 25 bps is that the message recovery threshold is approximately the same as the signal acquisition and tracking threshold. If a user can barely acquire and track the signal in a challenged environment, 25 bps also allows the message to be acquired so navigation can begin. At higher data rates a stronger signal is required to demodulate the message.

Responses occur in three general groups. One wants a faster data rate so additional integrity or differential correction messages can be provided. The second group wants a faster rate so necessary messages can be acquired sooner to improve TTFF or to use a fresh satellite quicker. The third group is concerned about using GPS in challenged environments, such as in a forest, inside a building, or when subject to interference, so they want a slower rate to assure navigation.

L1C Modulation Choices

- **Choice will be made by the Government and must balance between interference to legacy C/A users and national security**
 - **BOC(1,1) seems to be the best compromise**
 - **BOC(5,1) is better for interference but risks tracking the wrong autocorrelation peak and forces a wide receiver bandwidth**
 - **Longer codes solve the C/A crosscorrelation problem** (strong signal interference with weak signals)
-



20

Slide 20 summarizes the L1C modulation choices. The choice will be made by the Government, and it will be greatly influenced by the US/EU negotiations regarding compatibility and interoperability of GPS and Galileo signals.

BOC(5,1) Considerations

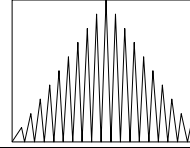

- **Adjacent correlation peaks only 0.9 dB down**
 - What is the risk of tracking the wrong peak?
- **But, the peaks are 30 meters apart**
- **Methods exist to convert signal to BPSK(1)**
 - Techniques defined by C. Cahn and by P. Ward
 - Convert double sidebands to center frequency
 - No ambiguity in tracking BPSK(1) result
 - If <15 m error, can then track BOC(5,1) center peak
 - Steeper autocorrelation function, more code transitions
- **Requires 3x bandwidth of BOC(1,1) receiver**
- **Multipath mitigation also is less effective**



21

Slide 21 addresses a major concern with the BOC(5,1) waveform, which is how to guarantee that a receiver won't falsely track one of the autocorrelation sub-peaks. Resolving which peak is being tracked is difficult using only amplitude data in the face of significant noise because the peaks immediately adjacent to the central peak are only 0.9 dB below the central peak. Sufficient integrity cannot be guaranteed using amplitude alone. However, it has been noted that the peaks are 30 meters apart. It should be clear that tracking the wrong peak on one or several satellites would be detected immediately by Receiver Autonomous Integrity Monitoring (RAIM) algorithms. If a problem is detected it can be corrected without causing an integrity failure. Another approach is to convert the BOC(5,1) signal to the equivalent of a BPSK(1) signal as suggested by Dr. Charlie Cahn and Mr. Phil Ward. If the unambiguous result can be tracked with an assured accuracy of better than 15 meters, the receiver can then begin to track the center peak of the native BOC(5,1) autocorrelation function.

For some applications the requirement to have a minimum receiver bandwidth three times wider than with BOC(1,1) is a disadvantage.

Also, for receivers using a double delta or Strobe type of multipath mitigation correlator, the secondary multipath responses which occur at each location the waveform in Slide 13 crosses zero means that these responses with BOC(5,1) are closer to the small-delay region with the greatest multipath energy than with BOC(1,1). This can be a disadvantage for such receivers.

Data Structure Improvements

- **A modern signal would share message structure improvements with L2C and L5**
- **Forward Error Correction (FEC) improves data threshold by 5 dB**
- **High resolution ephemeris (1 cm)**
- **Compact almanac (7 satellites in one message block)**
- **Staggered almanac timing speeds collection**
- **Message will define the satellite**



22

Slide 22 summarizes data structure improvements with a modernized signal. Presumably would use the same message structure already designed for L2C and for L5. These include FEC yielding at least 5 dB. Given the steady advance of chip technology (Moore's Law), it may be appropriate to employ an FEC for L1C which exceeds the performance of the currently selected FEC. This would require the receiver chip to have somewhat more data storage and processing power, but Moore's Law should make this possible at little or no meaningful cost.

The new message provides a slant range (pseudorange) orbit and clock resolution (not necessarily accuracy) on the order of one centimeter. The resolution of today's message is about 40 centimeters. Because orbit and clock accuracy is rapidly approaching 10 centimeters, better resolution is needed to prevent the message structure from limiting ultimate GPS accuracy.

The potential for a "compact almanac" is being studied. The idea is to pack as many satellites into an almanac message as possible by assuming each orbit is perfectly circular. This approximation allows one message to provide up to seven satellite orbits. The penalty is that unknown orbit ellipticity can cause 300 to 500 Hz of signal frequency uncertainty which could increase acquisition time. Because almanac data also can be obtained in other ways, the decision may be to transmit a more accurate orbit description at a lower rate. Almanac acquisition also can be accelerated by having satellites transmit different almanac messages at the same time, taking maximum advantage of multi-channel receivers.

The final point is more significant than it would seem. Certified aviation receivers now must compare every received ephemeris to a recent almanac to verify that the orbit is correct for the assumed satellite being tracked. This is because the poor crosscorrelation performance of the C/A code allows one strong signal to be mistaken for another satellite. Longer codes will eliminate this problem, but to make absolutely sure the message will identify the source satellite.

100 bps Data Rate or Faster

Advantages

- **Permits additional messages**
 - Integrity data?
 - Differential corrections?
- **What new messages would you want?**

Disadvantages

- **Requires more signal power to receive any message**
- **100 bps requires 4 times more signal power than 25 bps (6 dB)**
- **Signal must be 6 dB above tracking threshold to obtain messages**
 - **Autonomous, not assisted, tracking threshold**



23

Slide 23 presents advantages and disadvantages of a higher data rate such as 100 bps or faster. The slide assumed there was only one reason for a faster rate, which would be to transmit additional information. Therefore it asks the respondent to identify what new messages would be desired, such as integrity or differential correction data. Late in the interview process it became clear that another group of users wanted a faster data rate in order to reduce time to first fix or time to use a fresh satellite signal. These users would not want additional messages which, from their perspective, would defeat the purpose for a faster data rate.

The disadvantage is that a stronger signal is required to demodulate the message than is required to acquire and track the signal. One example of this disadvantage is that aircraft flying toward an area for which the FAA has issued a NOTAM to alert aviators that GPS will be unreliable in that region will be affected first by message loss before the receiver actually stops making reliable pseudorange measurements. At 25 bps, message demodulation and pseudorange measurements would be lost at about the same location. At 100 bps, message loss would occur about twice as far from the center of this region than loss of pseudorange tracking.

25 bps Data Rate

Advantages

- Messages can be acquired at the autonomous signal tracking threshold (not Assisted GPS threshold)
- Especially helps in poor signal conditions such as in a forest, on a tree-lined road, indoors, or with interference
- In a tough environment can be the difference between working and not working

Disadvantages

- Requires twice as long to obtain messages compared with 50 bps
- Clock & Ephemeris in:
- 18 to 24 sec at 50 bps
 - 36 to 48 sec at 25 bps
- Time To First Fix (TTFF) can be 24 seconds longer than with 50 bps (traditional rate)



24

Slide 24 compares the advantages and disadvantages of a 25 bps data rate. The key advantage is that the message demodulation threshold is almost exactly the same as the signal tracking threshold. (Note that this statement assumes unassisted GPS operation with the potential for modest dynamics. Assisted GPS, e.g., for E-911 applications, has been shown to permit use with signals so weak the message could not possibly be demodulated.) For example, receivers operating under forest cover or aviation receivers operating near an area for which the FAA has issued a NOTAM alerting aviators that GPS in that region will be unreliable, can still obtain the satellite message with signals as weak as the receiver tracking threshold. In difficult environments this can mean the difference between having GPS navigation or not.

The key disadvantage of 25 bps is that the data comes slower. The new message structure provides clock and ephemeris data in 18 to 24 seconds at 50 bps. That would be 9 to 12 seconds at 100 bps if additional messages are not added. At 25 bps the clock and ephemeris data requires 36 to 48 seconds. Therefore, time to first fix at 25 bps would be 24 seconds longer than at 50 bps and could be as much as 36 seconds longer than at 100 bps.

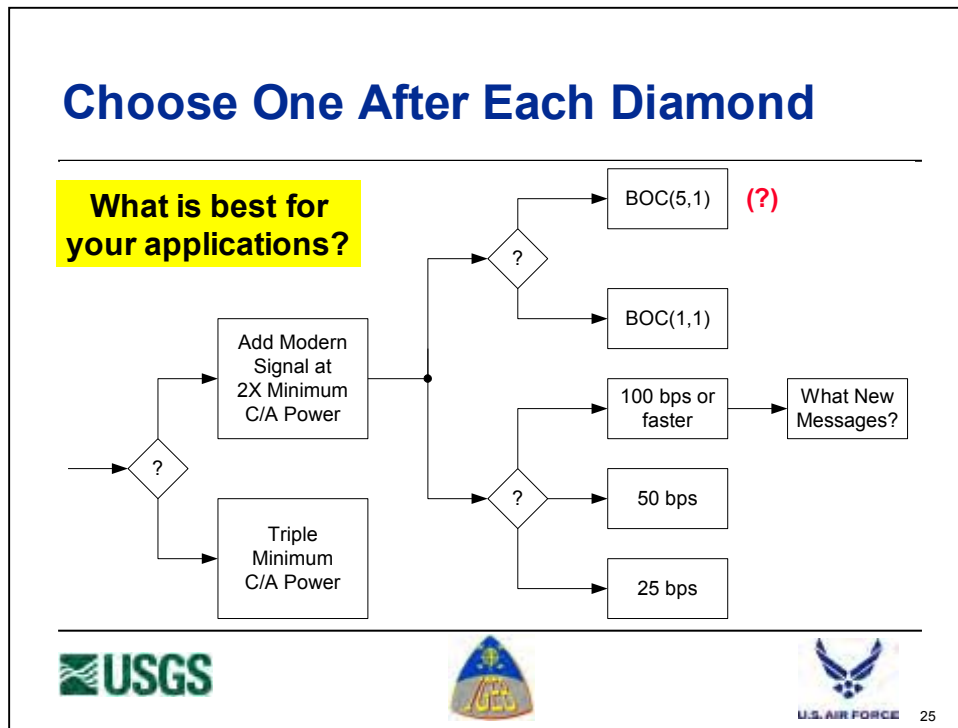

Slide 25 summarizes the questions being asked of the GPS experts. Starting at the left, the first question is whether simply to increase the C/A code power or to reduce the C/A power somewhat in order to add a modern L1C signal. If the respondent prefers the new signal, the next pair of questions address which waveform and which data rate is preferred. Two waveforms are offered, BOC(5,1) and BOC(1,1). The red question mark next to BOC(5,1) was added to signify that the US and the EU have agreed to have the same basic type of signal on L1, with the initial template being BOC(1,1). However, if respondents strongly support BOC(5,1) it would be possible for the US and the EU to change the template.

The most difficult issue is data rate. As stated before, many want a higher data rate in order to transmit more information such as integrity messages and/or differential correction data. Others want a higher rate without additional messages in order to shorten time to first fix (TTFF). A third group is concerned about operation in challenged environments. They want a lower data rate in order to receive GPS messages any place the signal can be acquired and tracked. (Note that this does not apply to low dynamic, assisted GPS applications, such as E-911, where measurements can be made with even weaker signals.)

Questionnaire Page 1

L1C Questionnaire

Name: _____ Date: _____

Title/Position: _____

Organization: _____

Address: _____

Phone: _____ E Mail: _____

Circle Preferences:

What new messages:

Comments:

26

Slide 26 shows the top of the questionnaire form. Each respondent is asked to circle his or her choice, to list any additional messages they want GPS to transmit, and to provide comments as extensive as possible.

Not shown, at the bottom of the page each respondent has the opportunity to designate whether his or her name and/or organization is for attribution or not. All responses are included in the final report. The name and/or organization, as well as other identifying information, for those requested non-attribution are deleted. However, the technical response and comments are retained.

Questionnaire Page 2

Application Specific Questions

Name: _____ Date: _____
Title/Position: _____
Organization: _____

Your Primary Expertise		
Professional & Scientific	Commercial	Consumer
Land		
Sea		
Air		
Space		

Applications
1.

Expected Number of Users in 2005		
Professional & Scientific	Commercial	Consumer
Land		
Sea		
Air		
Space		

Expected Number of Users in 2020		
Professional & Scientific	Commercial	Consumer
Land		
Sea		
Air		
Space		

Parameter	Importance		Importance
	Best Desired	Worst Acceptable	
Accuracy			
TTFF			
Availability			
Continuity			
Integrity			
Robustness			



Slide 27 is the last in the presentation. It asks respondents to indicate their area(s) of greatest expertise, to list the applications of most interest to them, and to predict for these areas what number of GPS receivers will be in use in the years 2005 and 2020. It also asks respondents to rank order the importance of GPS characteristics such as accuracy, TTFF, availability, etc., and to indicate the range of performance from the best that could be used to the worst that would be acceptable.

L1C Questionnaire

Name: _____ Date: _____

Title/Position _____

Organization _____

Address _____

Phone: _____ E-Mail: _____

Circle Preferences:

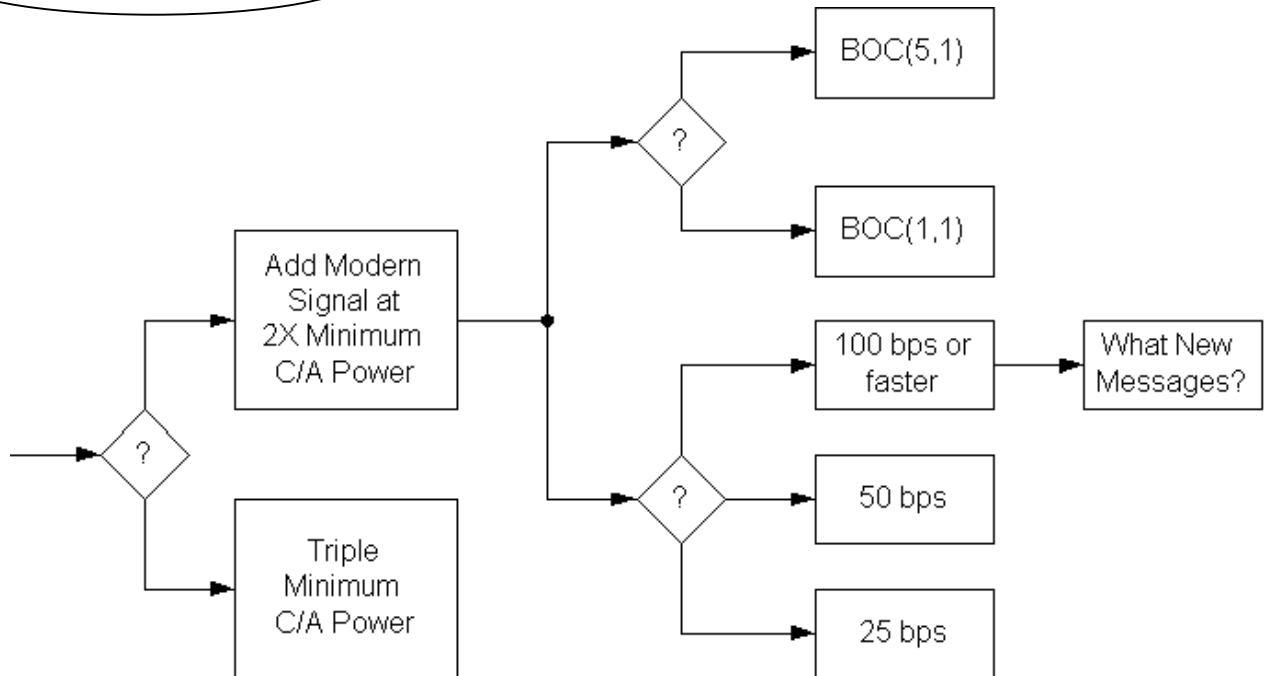

What new messages:

Comments:

Signature: _____

For Attribution?: Your Name: Yes No Your Organization: Yes No

Application Specific Questions

Name: _____ Date: _____

Title/Position _____

Organization _____

Your Primary Expertise			
	Professional & Scientific	Commercial	Consumer
Land			
Sea			
Air			
Space			

Expected Number of Users in 2005			
	Professional & Scientific	Commercial	Consumer
Land			
Sea			
Air			
Space			

Expected Number of Users in 2020			
	Professional & Scientific	Commercial	Consumer
Land			
Sea			
Air			
Space			

<u>Applications</u>
1.

Value			
Parameter	Best Desired	Worst Acceptable	Importance
Accuracy			
TTF			
Availability			
Continuity			
Integrity			
Robustness			

Importance: 1 = Very, 3 = Moderate, 5 = Not Significant

L1C Questionnaire Responses

The Following is Reference # 1

Respond to one of the following:

E-mail: L1C_GPS@USGS.gov

FAX: 626-583-7827

Mail: L1C GPS, 525 South Wilson Ave., Pasadena, CA 91106-3212

Your Printed Name: Cathy Genest Godfrey

Title or Position: GIS/GPS Coordinator

Organization: ACRT, INC

Contact Information: 2545 Bailey Rd, Kent OH 44221

cgodfrey@acrtinc.com

Additional Comments: 330 945 6122 ext 308

Exciting opportunity!

L1 Modernization Project (L1C)
ION GPS/GNSS 2003
 Portland, Oregon; September 10-12, 2003

<p align="center"><u>Purpose</u></p> <ul style="list-style-type: none"> ▪ To solicit comments from civil and other GPS stakeholders about: <ul style="list-style-type: none"> ▪ Whether or not a modernized GPS L1 civil signal should be added - and, if so - ▪ What types of modernization would be most valuable, and why ▪ The U.S. Government has not yet determined whether a modernized GPS L1 civil signal should be added 	
<p align="center"><u>Why Modernize? L1 C/A is Excellent</u></p> <ul style="list-style-type: none"> ▪ L1 C/A works well; it supports millions of users ▪ Accuracy is astounding <ul style="list-style-type: none"> ▪ Absolute accuracy is a few meters (good for most users) ▪ Differential navigation can give sub-meter accuracy ▪ Surveyors and scientists rely upon sub-centimeter differential results ▪ Interference is minimal ▪ It's being used for safety-of-life navigation ▪ Why consider changing anything so successful? <ul style="list-style-type: none"> ▪ "If it isn't broken, why fix it" (there's room for improvement) 	<p align="center"><u>Comments</u></p> <p><i>It is great, but we still have trouble - lots of trouble - under tree canopy, coverage is spotty</i></p>

<p><u>What are Opportunities for Improvement?</u></p> <ul style="list-style-type: none"> ▪ Any of the longer-coded L1C options would be less susceptible to narrowband interference than L1 (C/A) ▪ Could improve cross-correlation properties: <ul style="list-style-type: none"> ▪ <u>Improve indoor or wooded area use</u> ▪ Increase number of satellites and code signal power without causing unacceptable self-interference ▪ Improve receiver signal acquisition threshold ▪ Navigation message could contain more: <ul style="list-style-type: none"> ▪ Precision, flexibility, with forward error correction (FEC) ▪ Signal tracking and data demodulation thresholds (robustness) would be better with a modernized signal ▪ GPS III schedule presents an opportunity - requirements need to go into a CDD by Aug. 2004 	<p><u>Comments</u></p> <p>Improved use in wooded area important to us.</p> <hr/> <p>I believe indoor use improvement would open up a whole new industry.</p>
<p><u>Proposed Objectives</u></p> <ul style="list-style-type: none"> ▪ Compatible signal for legacy C/A receivers <ul style="list-style-type: none"> ▪ Continue to provide the C/A code ▪ Minimize added noise for C/A receivers ▪ New signals with better performance than C/A <ul style="list-style-type: none"> ▪ Better correlation properties (longer codes) ▪ More signal power and better threshold tracking <ul style="list-style-type: none"> ▪ <i>Improved performance indoors and under foliage</i> ▪ Improved message structure, precision, etc. ▪ Improved narrowband interference protection 	<p><u>Comments</u></p> <p>Yes!</p>

<p style="text-align: center;"><u>L1C Data Rate Tradeoff</u></p> <ul style="list-style-type: none"> ▪ L1C modernized data presumably will be similar to or the same as for L2C and L5 <ul style="list-style-type: none"> ▪ Forward error correction (FEC) also will be used ▪ Some data rate options: <ul style="list-style-type: none"> ▪ 25 bps (L2C) provides data in challenged situations <ul style="list-style-type: none"> ▪ <i>Urban canyons, indoors, in wooded areas</i> ▪ 50 bps (L5) same as C/A now ▪ 100 bps would allow additional messages (e.g., integrity warnings) ▪ What is best for your applications? <p style="margin-left: 40px;"><i>We often work under trees & in urban situations</i></p> 	<p style="text-align: center;"><u>Response</u></p> <p>Rank: 1 = best Importance: 10 = very important 5 = moderate 0 = not important</p> <p style="text-align: center;">Data Rate Your Rank</p> <p style="text-align: center;">Import</p> <p style="text-align: center;"><u>25 bps</u></p> <p style="text-align: center;">50 bps</p> <p style="text-align: center;">100 bps</p>
<p style="text-align: center;"><u>L1C Signal Power Tradeoff</u></p> <ul style="list-style-type: none"> ▪ Higher power signals generally are better <ul style="list-style-type: none"> ▪ Better operation in challenged circumstances (interference, wooded areas, indoors, etc..) ▪ More precise measurements (higher SNR) ▪ However, higher power L1C signals could slightly increase L1 C/A noise <ul style="list-style-type: none"> ▪ Less than 0.5 dB, depending on the signal choice ▪ What is best for your applications? 	<p style="text-align: center;"><u>Response</u></p> <p>Increase Signal Power:</p> <p style="text-align: center;"><u>Yes</u> or No</p> <p>Comment: <i>I believe the noise issue can be dealt with & is worth the tradeoff.</i></p>
<p style="text-align: center;"><u>L1C Code Length Tradeoff</u></p> <ul style="list-style-type: none"> ▪ The C/A code length is 1,023 chips (short) 	<p style="text-align: center;"><u>Response</u></p> <p>The L1C code normally used for signal acquisition should be:</p>

<ul style="list-style-type: none">▪ Modernized codes are at least 10 times longer▪ Longer codes have major advantages:<ul style="list-style-type: none">▪ Eliminate cross-satellite interference▪ Reduce effect of narrowband interference▪ Enable more and more powerful satellite signals▪ But, acquisition time (per correlator) is longer<ul style="list-style-type: none">▪ Technology now permits thousands of correlators▪ What is best for your applications?	<p>10,230 chips</p> <p>20,460 chips</p> <p>Longer</p> <p>Comment: How much longer? Probably worth trade off</p>
--	---

<p><u>Adding L1C Messages – Which Ones?</u></p> <ul style="list-style-type: none"> GPS messages are only for navigation Added value messages might provide: <ul style="list-style-type: none"> Integrity warnings of "bad" satellite signals or weather, rescue, or other NAV-related messages What is the best integrity source ? <ul style="list-style-type: none"> Ground signals, GEO satellites, RAIM, or GPS ? With GPS plus Galileo, is RAIM sufficient ? What is best for your applications? <p><i>Not familiar enough with RAIM</i></p>	<p><u>Response</u></p> <p>Should the GPS data rate be increased to provide additional messages?</p> <p>Integrity: <input checked="" type="radio"/> Yes No</p> <p>DGPS: <input checked="" type="radio"/> Yes No</p> <p>Other: Yes No</p> <p>With GPS+Galileo, would RAIM be sufficient for integrity?</p> <p><i>n/a</i> Yes No</p>
<p><u>L1C Almanac & Ephemeris Precision</u></p> <ul style="list-style-type: none"> C/A ephemeris precision is about 1 meter L1C ephemeris may have 1 cm precision Is this of any benefit for your applications? L1C "compact almanac" may be less precise than C/A to cover more satellites faster Is this change desirable or not? <p><i>cm precision nice but not necessary</i></p>	<p><u>Response</u></p> <p>Would increased precision of the GPS ephemeris be valuable?</p> <p><input checked="" type="radio"/> Yes No</p> <p>Would decreased precision of the almanac to provide more satellites quicker be valuable?</p> <p><input checked="" type="radio"/> Yes No</p>
<p><u>Your Reaction to L1C Modernization</u></p> <ul style="list-style-type: none"> Do you favor L1 civil signal modernization? What are your concerns? What are your desires? Why? 	<p><u>Reaction</u></p> <p>Favor L1 Modernization?</p> <p><input checked="" type="radio"/> Yes No</p>

As a private, For-profit company, providing GPS services is an added value factor for what we do (vegetation management). I have had field users filled with frustration over PDP & weak/attenuated signal issues. As the data coordinator, I have pulled my hair over post-processing issues & just plain skewed data. Anything that would make this process more efficient & more ACCURATE will be greatly welcomed.

Intentionally Left Blank to Separate Responses

The Following is Reference # 2

Name: Steven J Sampson Date: 28 Apr 04

Title/Position Senior Electronics Engineer

Organization Air Force Research Laboratory/VSSSE
3550 Aberdeen Avenue SE, Kirtland AFB NM 87117-5776

Address [Redacted]

Phone: 505 846 5816

E-Mail: steven.sampson@kirtland.af.mil

Circle Preferences:

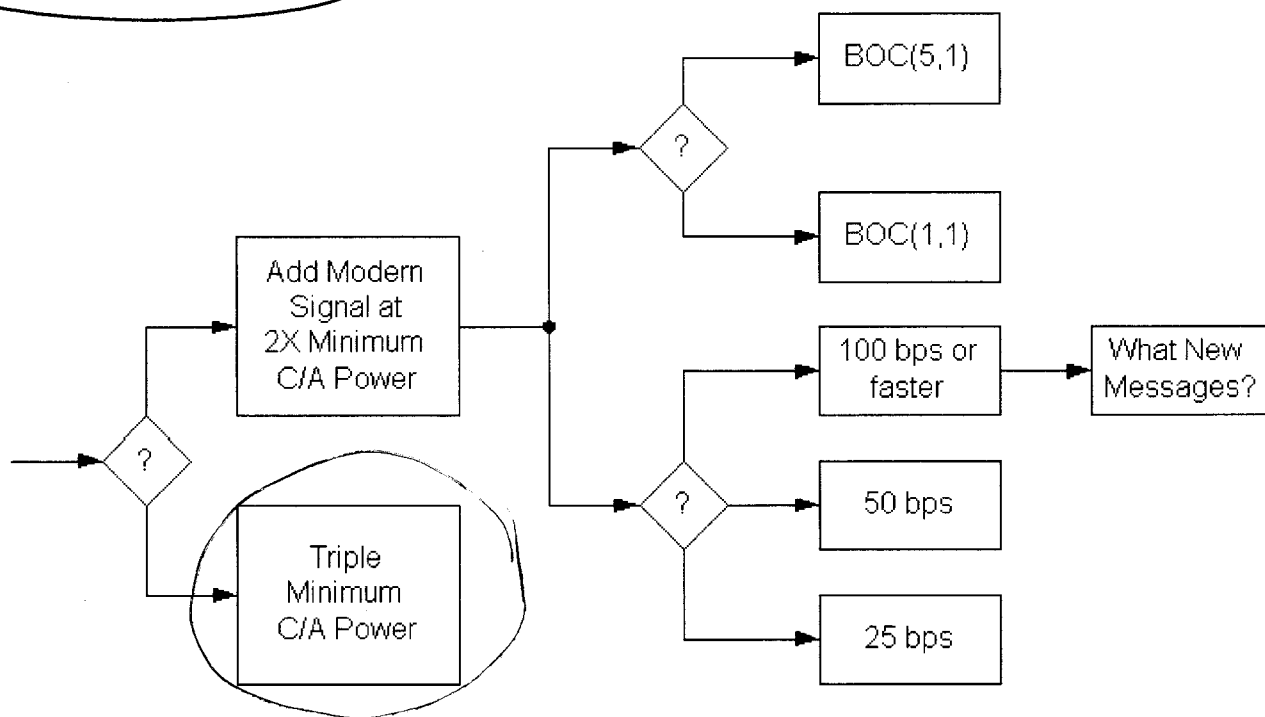

What new messages: Secure signal for JPALS use.

Comments: Antispoof leverage from P or M-code in case of coastal source of interference from navigation warfare.

Signature: Steven J Sampson

For Attribution?: Your Name: Yes No

Your Organization: Yes No

Application Specific Questions

Name: Steven J. Sampson Date: 28 Apr 09

Title/Position Senior Electronics Engineer

Organization Air Force Research Laboratory / VSSLE

Your Primary Expertise			
	Professional & Scientific	Commercial	Consumer
Land			
Sea			
Air			
Space	X		

Applications

1. Flight Control for satellites and missile interceptor
2. Tracking System for launch vehicles and range safety
3. Terminal guidance for manned space-flight rendezvous and reentry.

Expected Number of Users in 2005			
	Professional & Scientific	Commercial	Consumer
Land			
Sea			
Air			
Space	dozen		

Expected Number of Users in 2020			
	Professional & Scientific	Commercial	Consumer
Land			
Sea			
Air			
Space	hundreds		

Value			
Parameter	Best Desired	Worst Acceptable	Importance
Accuracy			3
TTF		X	4
Availability			1
Continuity			5
Integrity	X		2
Robustness			3

Importance: 1 = Very, 3 = Moderate, 5 = Not Significant

Intentionally Left Blank to Separate Responses

The Following is Reference # 3

L1C Questionnaire

Name: _____ Date: Tuesday, July 06, 2004

Title/Position _____

Organization Aircraft Owners and Pilots Association

Address 421 Aviation Way, Frederick, MD 21701

Phone: 301-695-2211 E-Mail: _____

Circle Preferences:

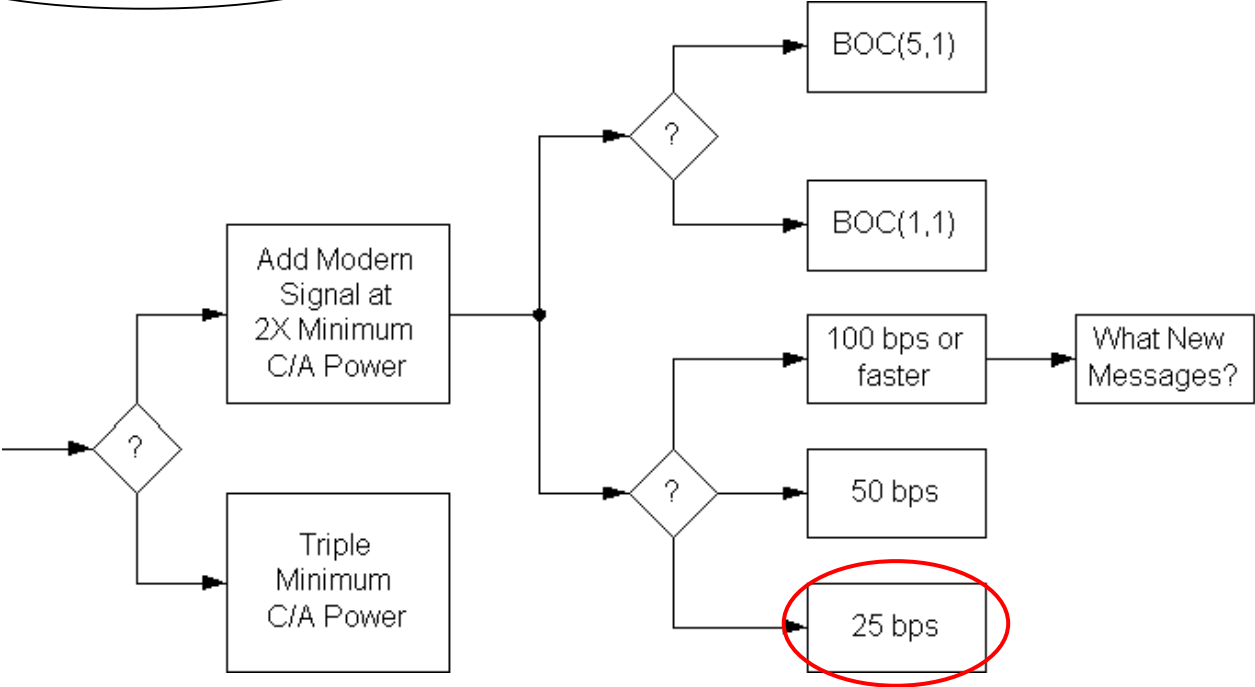

What new messages:

Intentionally left blank.

Comments:

It is our observation that the future improvements to space based positioning, navigation, and timing (PNT) are in a state of flux. Both the United States and European Union are planning to offer high performance systems in the future. General aviation pilots use PNT services for thousands of flights daily. Space based PNT is often the pilots' only electronic navigation system onboard the aircraft. Pilots also use these systems for other onboard features such as terrain awareness, traffic avoidance,

weather in the cockpit, electronic charting of airspace boundaries and temporary flight restriction airspace depiction. Pilots increasingly rely on PNT for all weather access to general aviation airports. Because general aviation is increasingly using space based PNT for daily operations, we offer the following comments:

- The general aviation community should not be expected to upgrade their aircraft navigation systems frequently.
- General aviation requires space-based PNT to be available constantly, without degradation. Intentional or accidental interference is increasingly difficult to tolerate.
- Other performance parameters of importance to general aviation include accuracy and integrity. Providing aircraft with three-dimensional flight guidance to every runway improves safety. Ensuring that the positioning information is valid is extremely crucial when relying on the information for aeronautical purposes.
- AOPA views these changes to space based PNT as an opportunity to dramatically improve the quality of navigation globally. Therefore, a strategy needs to be in place to ensure that each improvement is complementary of the one before.

Based on the discussions during the briefing, it appears that the new L-1C should focus on the 25bps option. This determination was made without the benefit of consultation from other elements of the decision making process. The FAA should also be consulted to validate assumptions that went into reaching this decision.

- As a result of the recent developments in the United States and around the world, AOPA believes that dialogue should commence to ensure that there is a coordinated strategic vision for the evolution of PNT. The vision should include demarcation where new equipment will be required to receive the benefits, or where existing services will be altered or eliminated. The correct modification to the L-1C signal will then be easier to identify by end-user organizations such as AOPA.

Signature: _____

For Attribution?: Your Name: Yes No Your Organization: Yes No

Application Specific Questions

Name: _____ Date: Tuesday, July 06, 2004

Title/Position _____

Organization Aircraft Owners and Pilots Association

Your Primary Expertise			
	Professional & Scientific	Commercial	Consumer
Land			
Sea			
Air			X
Space			

- Applications**
1. Electronic aeronautical navigation.
 2. Terrain and traffic awareness applications, used avoid unplanned impact with terrain and mid-air collisions.

Expected Number of Users in 2005			
	Professional & Scientific	Commercial	Consumer
Land			
Sea			
Air			400,000-600,000
Space			

Expected Number of Users in 2020			
	Professional & Scientific	Commercial	Consumer
Land			
Sea			
Air			100%
Space			

Value			
Parameter	Best Desired	Worst Acceptable	Importance
Accuracy	X		1
TTF		X	3
Availability	X		1
Continuity		X	3
Integrity	X		1
Robustness	X		1

Importance: 1 = Very, 3 = Moderate, 5 = Not Significant

Intentionally Left Blank to Separate Responses

The Following is Reference # 4

L1C Questionnaire

Name: Gary A. McGraw Date: 4/28/2004

Title/Position Principal Systems Engineer, Advanced Technology Center

Organization Rockwell Collins

Address 400 Collins Rd. NE, Cedar Rapids, IA 52498

Phone: 319-295-4578

E-Mail: gamcgraw@rockwellcollins.com

Circle Preferences:

Note: This is a consolidation of Rockwell Collins comments.

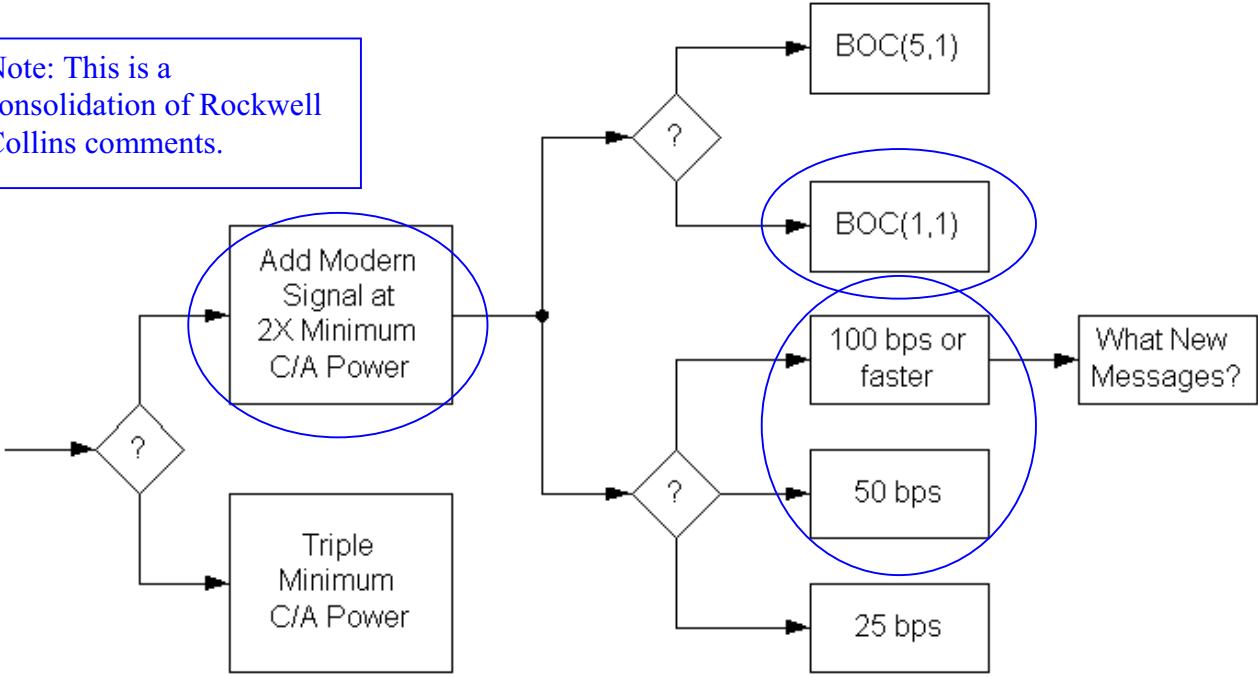

What new messages:

If GPS-III/Galileo will have built-in integrity channels, then higher data rate would make sense.

Comments:

- Tripling minimum C/A power fails to address potential co-channel interference issues with L1-C/A, so a modernized design makes the most sense. Commonality with Galileo is also desirable.
- We have concerns that the wider bandwidth of the BOC(5,1) signal would make it extremely difficult to design and produce a practical Navwar prevent notch filter. For this reason, the BOC(1,1) is preferred.

- Given that only a handful of satellites will have been launched with the L2C signal, is there an opportunity to make the L2C signal design common with L1C? The actual receiver development impact may not be that large with having three or more signal designs, but the overall program costs of maintaining separate standards, etc., should not be discounted.
- The increased power and the availability of a data-free signal component, makes lowering the data rate to 25 bps unnecessary. A higher data rate than 50 bps would be useful if integrity data is to be broadcast. For example, the six seconds required for a message on L5 could be shortened to three seconds if the data rate were increased to 100 bps. Of course the impact on tracking thresholds of a 200 sps rate would have to be assessed.

Signature: _____

For Attribution?: Your Name: Yes No Your Organization: Yes No

Application Specific Questions

Name: _____ Date: _____

Title/Position _____

Organization _____

Your Primary Expertise			
	Professional & Scientific	Commercial	Consumer
Land			
Sea			
Air		x	
Space			

<u>Applications</u>
<ol style="list-style-type: none"> 1. Civil aviation 2. Military

Expected Number of Users in 2005			
	Professional & Scientific	Commercial	Consumer
Land			
Sea			
Air			
Space			

Expected Number of Users in 2020			
	Professional & Scientific	Commercial	Consumer
Land			
Sea			
Air			
Space			

Value			
Parameter	Best Desired	Worst Acceptable	Importance
Accuracy			
TTF			
Availability			
Continuity			
Integrity			
Robustness			

Importance: 1 = Very, 3 = Moderate, 5 = Not Significant

Intentionally Left Blank to Separate Responses

The Following is Reference # 5

L1C Questionnaire

Name: Shin'ichi Hama Date: Feb. 12, 2004

Title/Position Group leader of the Quasi-zenith satellite system

Organization Communications Research Laboratory (Japan)

Address 4-2 Nukuikita-machi, Koganei, Tokyo, 184-8795 Japan

Phone: +81 42 327 5690 E-Mail: hama@crl.go.jp

Circle Preferences:

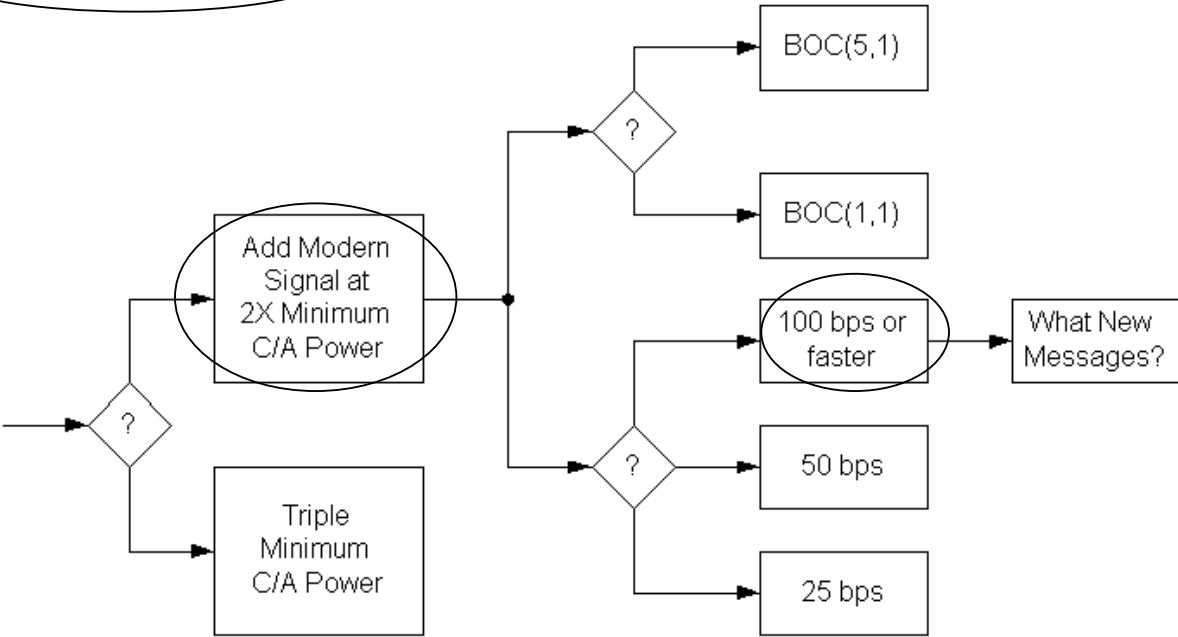

What new messages:
e.g. GGTO (GPS to Galileo Time Offset)

Comments:

The undefined part of the new message may be used by a local system for future use.

Signature: 

For Attribution?: Your Name: Yes No Your Organization: Yes No

Intentionally Left Blank to Separate Responses

The Following is Reference # 6

L1C Questionnaire

Name: Ken ITO Date: 12/Feb/2004

Title/Position Principal Researcher

Organization ENRI (Electronic Navigation Research Institute)

Address 7-42-23, Jndaiji-Higashi, Chofu, Tokyo

Phone: +81-422-41-3194 E-Mail: itoken@enri.go.jp

Circle Preferences:

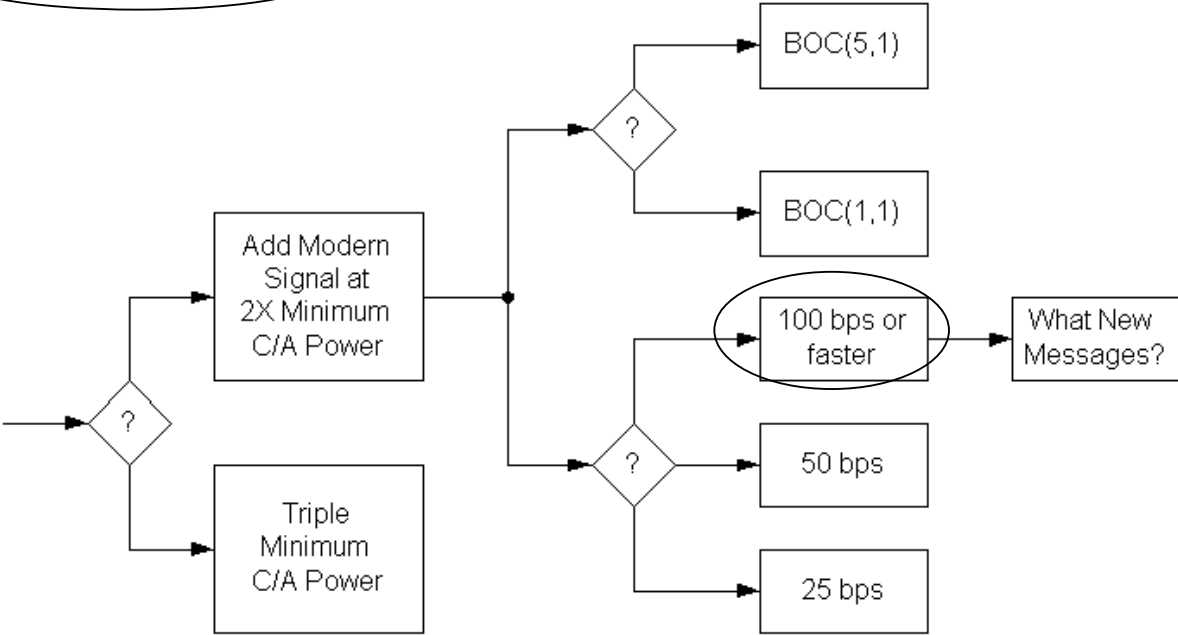

What new messages:
Correction for ionospheric delay and integrity information

Comments:

Signature: Ken Ito

For Attribution?: Your Name: Yes No

Your Organization: Yes No

Application Specific Questions

Name: Ken ITO Date: 12/Feb/2004

Title/Position Principal Researcher

Organization ENRI (Electronic Navigation Research Institute)

Your Primary Expertise			
	Professional & Scientific	Commercial	Consumer
Land			
Sea			
Air	X		
Space			

<u>Applications</u>
1. Civil aviation

Expected Number of Users in 2005			
	Professional & Scientific	Commercial	Consumer
Land			
Sea			
Air			
Space			

Expected Number of Users in 2020			
	Professional & Scientific	Commercial	Consumer
Land			
Sea			
Air			
Space			

Value			
Parameter	Best Desired	Worst Acceptable	Importance
Accuracy	16 m (horizontal) 4.0 to 6.0 m (vertical)	0.4 nmi	
TTFF		30 sec	
Availability	0.99 to 0.99999	0.99 to 0.99999	
Continuity	1-8x(10-6)/15 sec	1-(10-5)/hr	
Integrity	1-(10-7)/hr	1-(10-7)/hr	
Robustness			1

Importance: 1 = Very. 3 = Moderate. 5 = Not Significant

Intentionally Left Blank to Separate Responses

The Following is Reference # 7

L1C Questionnaire

Name: Takeyasu Sakai Date: 2/12/04

Title/Position Researcher

Organization Electronic Navigation Research Institute

Address 7-42-23 Jindaiji-Higashi, Chofu-shi, Tokyo 182-0012

Phone: +81-422-41-3194 E-Mail: sakai@enri.go.jp

Circle Preferences:

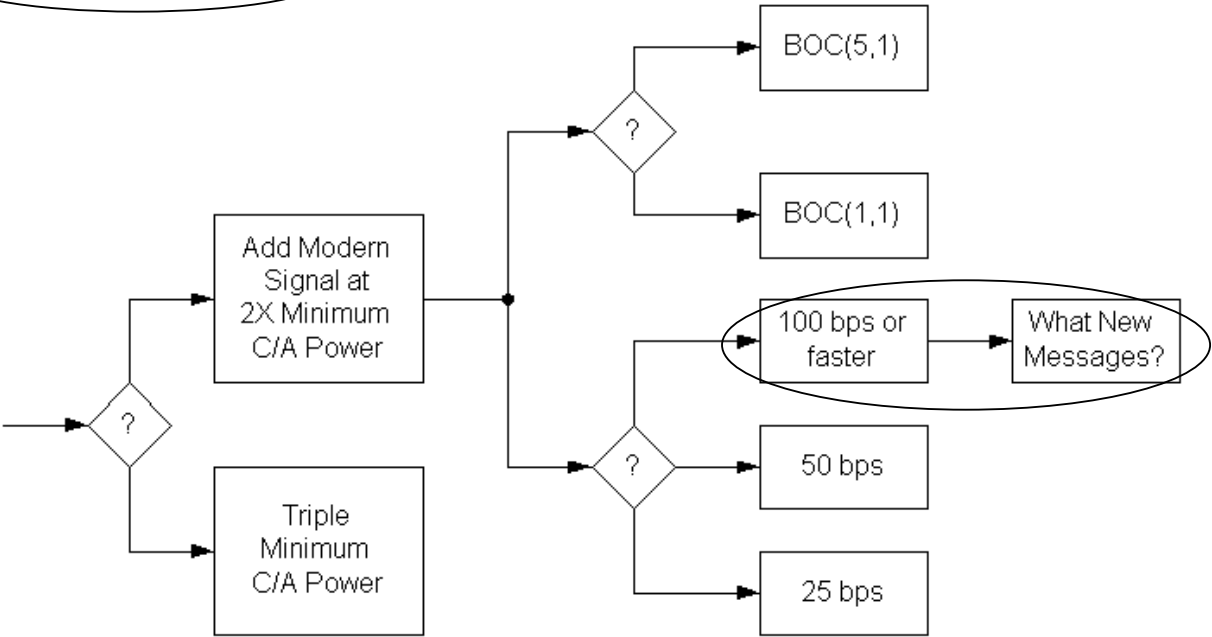

What new messages: Ionospheric Corrections.
Integrity Information for Public Transportation.
Messaging space allowing regional governments to broadcast serious disaster/weather information to their nations.

Comments:

Signature: *f. Sakai*

For Attribution?: Your Name: Yes No

Your Organization: Yes No

Intentionally Left Blank to Separate Responses

The Following is Reference # 8

L1 Modernization Project (L1C)
ION GPS/GNSS 2003
Portland, Oregon; September 10-12, 2003

<p style="text-align: center;"><u>Purpose</u></p> <ul style="list-style-type: none">▪ To solicit comments from civil and other GPS stakeholders about:<ul style="list-style-type: none">▪ Whether or not a modernized GPS L1 civil signal should be added - and, if so -▪ What types of modernization would be most valuable, and why▪ The U.S. Government has not yet determined whether a modernized GPS L1 civil signal should be added	
<p style="text-align: center;"><u>Why Modernize? L1 C/A is Excellent</u></p> <ul style="list-style-type: none">▪ L1 C/A works well; it supports millions of users▪ Accuracy is astounding<ul style="list-style-type: none">▪ Absolute accuracy is a few meters (good for most users)▪ Differential navigation can give sub-meter accuracy▪ Surveyors and scientists rely upon sub-centimeter differential results▪ Interference is minimal▪ It's being used for safety-of-life navigation▪ Why consider changing anything so successful?<ul style="list-style-type: none">▪ "If it isn't broken, why fix it" (there's room for improvement)	<p style="text-align: center;"><u>Comments</u></p>

<p><u>What are Opportunities for Improvement?</u></p> <ul style="list-style-type: none"> ▪ Any of the longer-coded L1C options would be less susceptible to narrowband interference than L1 (C/A) ▪ Could improve cross-correlation properties: <ul style="list-style-type: none"> ▪ Improve indoor or wooded area use ▪ Increase number of satellites and code signal power without causing unacceptable self-interference ▪ Improve receiver signal acquisition threshold ▪ Navigation message could contain more: <ul style="list-style-type: none"> ▪ Precision, flexibility, with forward error correction (FEC) ▪ Signal tracking and data demodulation thresholds (robustness) would be better with a modernized signal ▪ GPS III schedule presents an opportunity - requirements need to go into a CDD by Aug. 2004 	<p><u>Comments</u></p>
<p><u>Proposed Objectives</u></p> <ul style="list-style-type: none"> ▪ Compatible signal for legacy C/A receivers <ul style="list-style-type: none"> ▪ Continue to provide the C/A code ▪ Minimize added noise for C/A receivers ▪ New signals with better performance than C/A <ul style="list-style-type: none"> ▪ Better correlation properties (longer codes) ▪ More signal power and better threshold tracking <ul style="list-style-type: none"> ▪ <i>Improved performance indoors and under foliage</i> ▪ Improved message structure, precision, etc. ▪ Improved narrowband interference protection 	<p><u>Comments</u></p> <p>Improved performance indoors and under foliage would be most desirable.</p>

L1C Data Rate Tradeoff

- L1C modernized data presumably will be similar to or the same as for L2C and L5
 - Forward error correction (FEC) also will be used
- Some data rate options:
 - 25 bps (L2C) provides data in challenged situations
 - *Urban canyons, indoors, in wooded areas*
 - 50 bps (L5) same as C/A now
 - 100 bps would allow additional messages (e.g., integrity warnings)
- What is best for your applications?

Response

Rank: 1 = best
 Importance:
 10 = very important
 5 = moderate
 0 = not important

Data Rate	Your Rank	Import
25 bps	1	10
50 bps	2	
100 bps	3	

L1C Signal Power Tradeoff

- Higher power signals generally are better
 - Better operation in challenged circumstances (interference, wooded areas, indoors, etc..)
 - More precise measurements (higher SNR)
- However, higher power L1C signals could slightly increase L1 C/A noise
 - Less than 0.5 dB, depending on the signal choice
- What is best for your applications?

Response

Increase Signal Power:
 Yes
 Comment:
 Again, for indoors and other challenging situations

L1C Code Length Tradeoff

- The C/A code length is 1,023 chips (short)
- Modernized codes are at least 10 times longer
- Longer codes have major advantages:
 - Eliminate cross-satellite interference
 - Reduce effect of narrowband interference
 - Enable more and more powerful satellite signals
- But, acquisition time (per correlator) is longer
 - Technology now permits thousands of correlators
- What is best for your applications?

Response

The L1C code normally used for signal acquisition should be:
 10,230 chips
 20,460 chips
 Longer
 Comment:

<p><u>Adding L1C Messages – Which Ones?</u></p> <ul style="list-style-type: none"> ▪ GPS messages are only for navigation ▪ Added value messages might provide: <ul style="list-style-type: none"> ▪ Integrity warnings of “bad” satellite signals or weather, rescue, or other NAV-related messages ▪ What is the best integrity source ? <ul style="list-style-type: none"> ▪ Ground signals, GEO satellites, RAIM, or GPS ? ▪ With GPS plus Galileo, is RAIM sufficient ? ▪ What is best for your applications? 	<p><u>Response</u></p> <p>Should the GPS data rate be increased to provide additional messages?</p> <p>Integrity: No</p> <p>DGPS: No</p> <p>Other: No</p> <p>With GPS+Galileo, would RAIM be sufficient for integrity?</p> <p style="text-align: center;">Yes</p>
<p><u>L1C Almanac & Ephemeris Precision</u></p> <ul style="list-style-type: none"> ▪ C/A ephemeris precision is about 1 meter ▪ L1C ephemeris may have 1 cm precision ▪ Is this of any benefit for your applications? ▪ L1C “compact almanac” may be less precise than C/A to cover more satellites faster ▪ Is this change desirable or not? 	<p><u>Response</u></p> <p>Would increased precision of the GPS ephemeris be valuable?</p> <p style="text-align: center;">Yes No</p> <p>Would decreased precision of the almanac to provide more satellites quicker be valuable?</p> <p style="text-align: center;">Yes No</p>
<p><u>Your Reaction to L1C Modernization</u></p> <ul style="list-style-type: none"> ▪ Do you favor L1 civil signal modernization? ▪ What are your concerns? ▪ What are your desires? ▪ Why? 	<p><u>Reaction</u></p> <p>Favor L1 Modernization?</p> <p style="text-align: center;">Yes</p>

Respond to one of the following:

E-mail: L1C_GPS@USGS.gov

FAX: 626-583-7827

Mail: L1C GPS, 525 South Wilson Ave., Pasadena, CA 91106-3212

Your Printed Name: Steve Schell_____

Title or Position: Mechanical Engineer_____

Organization: Evolution Robotics_____

Contact Information: 130 W. Union St. Pasadena, CA 91103_____

626-535-2715_____

Additional Comments:

Intentionally Left Blank to Separate Responses

The Following is Reference # 9

L1C Questionnaire

Name: KAZUAKI KAKUTANI Date: 3 FEB 2004

Title/Position _____

Organization _____

Address _____ JAPAN

Phone: _____ E-Mail: _____

Circle Preferences:

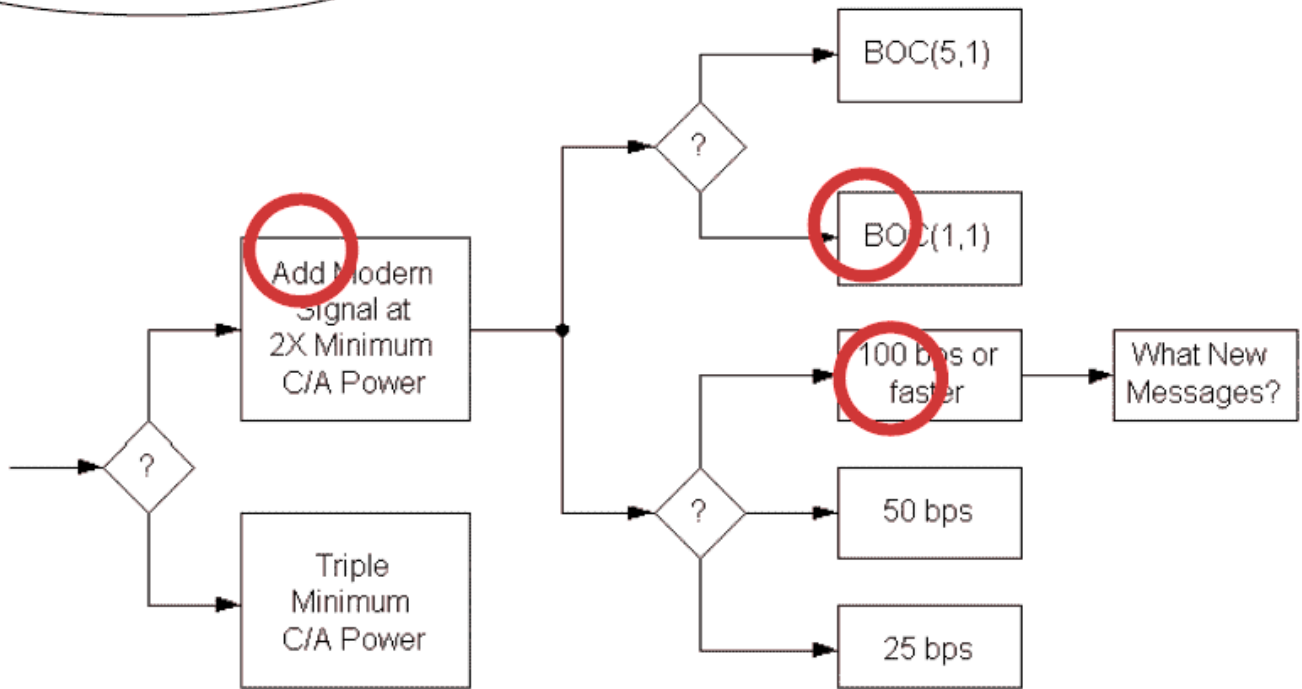

What new messages:
To Attached

Comments:
To Attached

Signature: _____

For Attribution?: Your Name: Yes No

Your Organization: Yes No

The request of the signal form is thought to vary in the application.

Our company holds the business that OEM supplies a GPS receiver to a GPS receiver to build in our company product, and other company.

Therefore goods request client's receiver develop necessity.

From now on, the use field of GPS will spread out all the more, and furthermore a GPS use stage will expand.

Therefore, it is expected to increase from now on, and there is a good requirement toward low electric current on the circuit scale/gate number/channel several prizes of the correlation vessel that accumulates it on the IC at the same time with the cost complying with, too.

1. Signal form.

It is about to hope because demand for the new machine happens if a new signal form is decided when it thinks from the position of us receiver manufacturer.

But, when it thinks with the client's position, it will reply it "It is fully satisfied in positioning place precision being used with the present goods."

Hesitation is born with the satisfied position for the new movement.

So, let's think from the position that advantage convenience is more found, and see it.

There are many places where it was surrounded in geographical features by a mountain, and there are many electric wires, street trees, obstacles such as a crossing overpass sidewalk, a high layer building in Japan.

Furthermore, it is the environment which a satellite to see in the view in arrangement of the satellite is scarce in.

A L1 wave is used in Japan, and there are many cases that Fix isn't made in positioning place operation very much about RTK in the city area that does positioning place of the high precision a little more as a result.

(I want the number of the satellite increased under the present condition "that it can be hardly used").

From now on, the use field of GPS spreads out all the more, and furthermore a GPS use stage will expand, too.

Then, there is much skill law that the poor function of the GPS system is made up for with, and it is thought the thing that comes out to the market to extend a use range.

For example, they are combination with other GNSS systems and the use of the false satellite system.

Though a conclusion is hard to give to this question, an idea becomes necessary very much with the code system of present L1 in the employment side.

Modernization is thought necessity when it thinks from such an aspect, too.

It thinks that you had better put a new signal on GPS III from such a thing.

2. Modulation form.

BOC (5,1) has the danger that it locks in the wrong mountain which many correlation peaks existed in.

It may think about the algorithm of the signal search • Lock • Tracking newly to avoid this danger.

If it is BOC (1,1), even present algorithm is wrong, and the danger that Lock & Tracking is very small.

Therefore, you must make the receiver of the extreme power low cost, and L1 signal treatment is thought the form of the signal of BOC (1,1) to be favorable.

3. Data rate.

L1 is thought that you had better provide advantage convenience because the correspondence of 25 bps is being taken into consideration with the L2 plan. Therefore, it agrees with the one that a rate is increased.

For example, it wants the information that the extreme power hastens TTFF, and DGPS information.

And, it wants the satellite number information that a laser reflex mirror board is carried, too.

Application Specific Questions

172 of 406

Name: _____ Date: _____

Title/Position _____

Organization _____

Your Primary Expertise			
	Professional & Scientific	Commercial	Consumer
Land		1000000	
Sea			
Air			
Space			

<u>Applications</u>
2. OEM

Expected Number of Users in 2005			
	Professional & Scientific	Commercial	Consumer
Land		1500000	
Sea			
Air			
Space			

Expected Number of Users in 2020			
	Professional & Scientific	Commercial	Consumer
Land		2000000	
Sea			
Air			
Space			

Value			
Parameter	Best Desired	Worst Acceptable	Importance
Accuracy			
TTF	≅ 0	20sec	1
Availability			
Continuity			
Integrity			
Robustness			

Importance: 1 = Very, 3 = Moderate, 5 = Not Significant

Application Specific Questions

173 of 406

Name: _____ Date: _____

Title/Position _____

Organization _____

Your Primary Expertise

	Professional & Scientific	Commercial	Consumer
Land		500	
Sea	100	200	
Air			
Space			

Applications

3. Measurement System

Expected Number of Users in 2005

	Professional & Scientific	Commercial	Consumer
Land		500	
Sea	100	300	
Air			
Space			

Expected Number of Users in 2020

	Professional & Scientific	Commercial	Consumer
Land		20000	
Sea	100	2000	
Air			
Space			

Value

Parameter	Best Desired	Worst Acceptable	Importance
Accuracy			1
TTF			3
Availability			1
Continuity			
Integrity			
Robustness			

Importance: 1 = Very, 3 = Moderate, 5 = Not Significant

L1 Modernization Project (L1C)

ION GPS/GNSS 2003

Purpose

- The US Government has not yet determined whether a modernized GPS L1 civil signal should be added.
- To solicit comments from civil and other GPS stakeholders about;
 - Whether or not a modernized GPS L1 civil signal should be added – and, if so
 - What types of modernization would be most valuable., and why ?

XX

Why Modernize ? L1 C/A is Excellent

- L1 C/A works well; It supports millions of users.
- Accuracy is astounding
 - Absolute accuracy is a few meters (good for most users)
 - Differential navigation can give sub-meter accuracy
 - Surveyors and scientists rely upon sub-centimeter differential results
- Interference is minimal
- Its being used for safety-of-life navigation
- Why consider changing anything so successful ?
 - “If it is not broken, why fix it” (there is room for improvement)

Your comment

(1) GPS is an excellent system and is now a part and parcel of infrastructures. Utilization of GPS in multiple new application fields has already been commenced. The problem areas of the present system have come to be noticed in such moves of the market.

For example, it would be necessary to solve the urban canyon issues, where a number of satellites are not visible due to tall buildings, in order to improve serviceability in urban areas. Some measures to solve this issue by modernization of GPS should be outreached more actively.

(2) L1 C/A is a useful signal, and it should be provided continuously throughout all phases of GPS modernization. It should not be terminated, as almost all present civil receivers are dependent on it. Implementation of another L1C without any impact on L1 C/A is welcome, should the present L1 C/A be provided continuously.

(3) Improvement of Integrity, Accuracy and Availability are the permanent themes to be addressed.

L1C may be useful, should sufficient improvements (in terms of cross-correlation resistance, multi-path resistance, higher signal level, etc.) be realized with L1C.

L1C will be used and propagated, if good. Couldn't it be compatible with Galileo? Merits to users might be greater, if L1C would be used for positioning in common with the signal provided by Galileo, where more than 20 satellites of GPS and Galileo are visible all the time.

XX

What are Opportunities for Improvement ?

- Any of the longer-coded L1C options would be less susceptible to narrowband interference than L1(C/A)
- Could improve cross-correlation properties
 - Improve indoor or wooded area use
 - Increase number of satellites and code signal power without causing unacceptable self-interference
 - Improve receiver signal acquisition threshold
- Navigation message could contain more
 - Precision, flexibility, with forward error correction (FEC)
- Signal tracking and data demodulation thresholds (robustness) would be better with a modernized signal
- GPS III schedule presents an opportunity - requirements need to go into a CDD by Aug. 2004

Your comment

Emphasis should not be placed on the merits too much. Instead, merits and demerits should be weighed more on, say, longer code.

XX

Proposed Objectives

- Compatible signal for legacy C/A receivers
 - Continue to provide the C/A code
 - Minimize added noise for C/A receivers
- New signals with better performance than C/A
 - Better correlation properties (longer codes)
 - More signal power and better threshold tracking
 - Improved performance indoors and under foliage
 - Improved message structure, precision, etc
 - Improved narrowband interference protection

Your comment

The target values should not cause one-sided pressure on other infrastructures, including portable phone systems.

XX

L1C Data Rate Tradeoff

- L1C modernized data presumably will be similar to or the same as for L2C and L5
Forward error correction (FEC) also will be used
- Some data rate options::
25 bps (L2C) provides data in challenged situations (such as urban canyons, indoors, in wooded areas)
50 bps (L5) same as C/A now
100 bps would allow additional messages (e.g.. Integrity warnings)
- What is best for your applications ?

Response

Rank 1 = best
Importance
: 10 = very important
5 = moderate
0 = not important

Data Rate	Your Rank	Importance
25bps	1	10
50bps		
100bps	1	5

XX

L1C Signal Power Tradeoff

- Higher power signals generally are better
Better operation in challenged circumstances (interference, wooded areas, indoors, etc.)
More precise measurements (higher SNR)
- However, higher power L1C signals could slightly increase L1 C/A noise
Less than 0.5 dB, depending on the signal choice
- What is best for your applications ?

Response

Increase Signal Power Yes

Comment

- (1) The signal level must be enhanced. However, multi-channel receivers will become common- place, when GLONASS, Galileo and other GNSS become available. Such issue should also be discussed.**
- (2) The signal power of L1 C/A should not be made higher than that of Block IIR, to avoid negative impacts on the conventional receivers.
L1C should promote utilization of GPS in situations where use of present GPS is difficult.**

Adding L1C Messages – Which Ones ?

- GPS messages are only for navigation
- Added value messages might provide Integrity warnings of “bad” satellite signals or weather, rescue, or other NAV-related messages
- What is the best integrity source ?
Ground signals, GEO satellites, RAIM, or GPS ?
With GPS plus Galileo, is RAIM sufficient ?
- What is best for your applications?

Response

Should the GPS data rate be increased to provide additional messages

- Integrity **Yes**
- DGPS **Yes**
- Others

With GPS + Galileo, would RAIM be sufficient for integrity

Yes

From the user stand point, rules should be established, as combines systems are likely increased in the future.

XX

L1C Almanac & Ephemeris Precision

- C/A ephemeris precision is about 1 meter
- L1C ephemeris may have 1 cm precision
- Is this of any benefit for your applications ?
- L1C “compact almanac” may be less precise than C/A to cover more satellites faster
- Is this change desirable or not?

Response

Would increased precision of the GPS ephemeris be valuable

Yes

Would decrease precision of the almanac to provide more satellite quicker be valuable

No

XX

Your Reaction to L1C Modernization~

- Do you favor L1 civil signal modernization ?

Yes

- What are your concerns ?

Enormous number of receivers with the present specification is placed in the market, and they will be used for a prolonged period of time.

They will be used in the same environment with the receivers of new specification.

How are you going to decide the baseline standards of compatibility under such conditions?

- What are your desires ?

- Why ?

Respond to one of the following :

E-Mail: L1C_GPS@USGS.gov

Fax: +1-626-583-7827

Mail: L1C GPS, 525 South Wilson Ave., Pasadena, CA 91106-3212

Your Printed Name: Kazuaki Kakutani

Title of Position :

Organization :

Contact Information :

Intentionally Left Blank to Separate Responses

The Following is Reference # 10

L1C Questionnaire

Name: Masato Kawai Date: 2004/02/12
 Title/Position Advising Research Engineer
 Organization Furuno Electric Co., Ltd.
 Address 9-52, Ashihara-cho, Nishinomiya-city, Hyogo, 662-8580, Japan
 Phone: +81-798-63-1144 E-Mail: masato.kawai@furuno.co.jp

Circle Preferences:

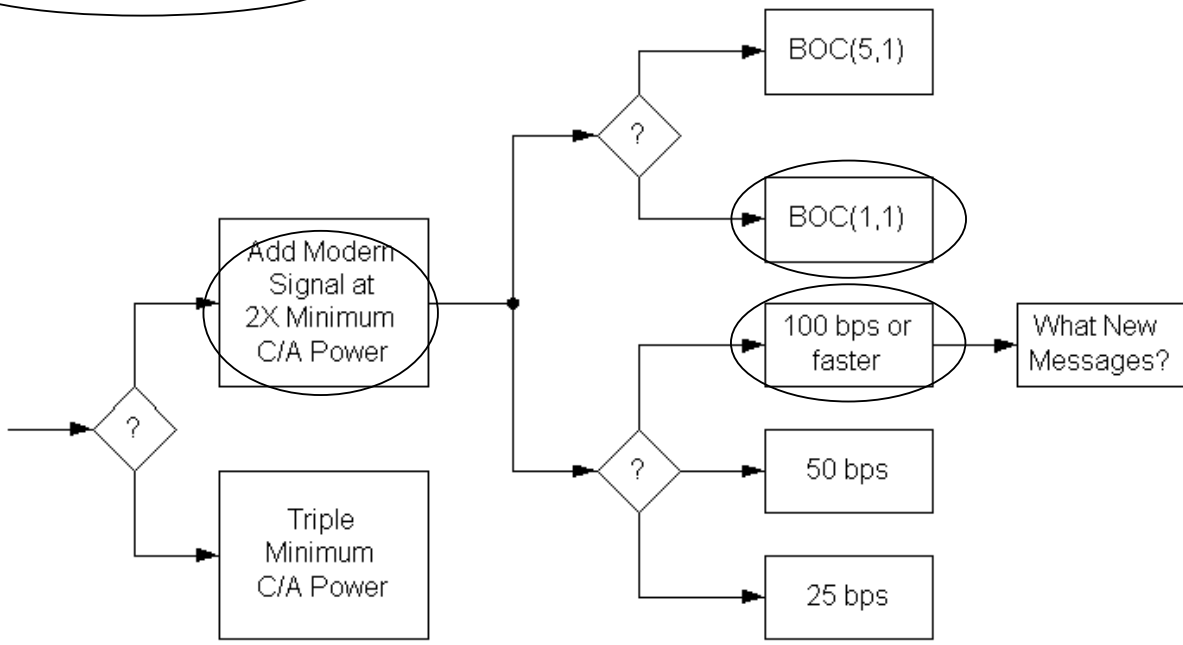

What new messages:

- (1) Forecast of signal outage on new message. (Similar to NANU information email)
- (2) Toropsheric delay map like WAAS Iono-Delay Map, but with smaller grid intervals (if possible) -> This may be done by future augmentation system.

Comments:

Nothing in particular

Masato Kawai

Signature: _____

For Attribution?: Your Name: Yes No Your Organization: Yes No

Intentionally Left Blank to Separate Responses

The Following is Reference # 11

L1C Questionnaire

Name: Tsutomu OKADA Date: 2004/02/19

Title/Position Assistant Chief

Organization Furuno Electric Co., Ltd.

Address 9-52 Ashihara-cho, Nishinomiya-shi, Hyogo 662-8580, Japan

Phone: +81-798-63-1144 E-Mail: tsutomu.okada@furuno.co.jp

Circle Preferences:

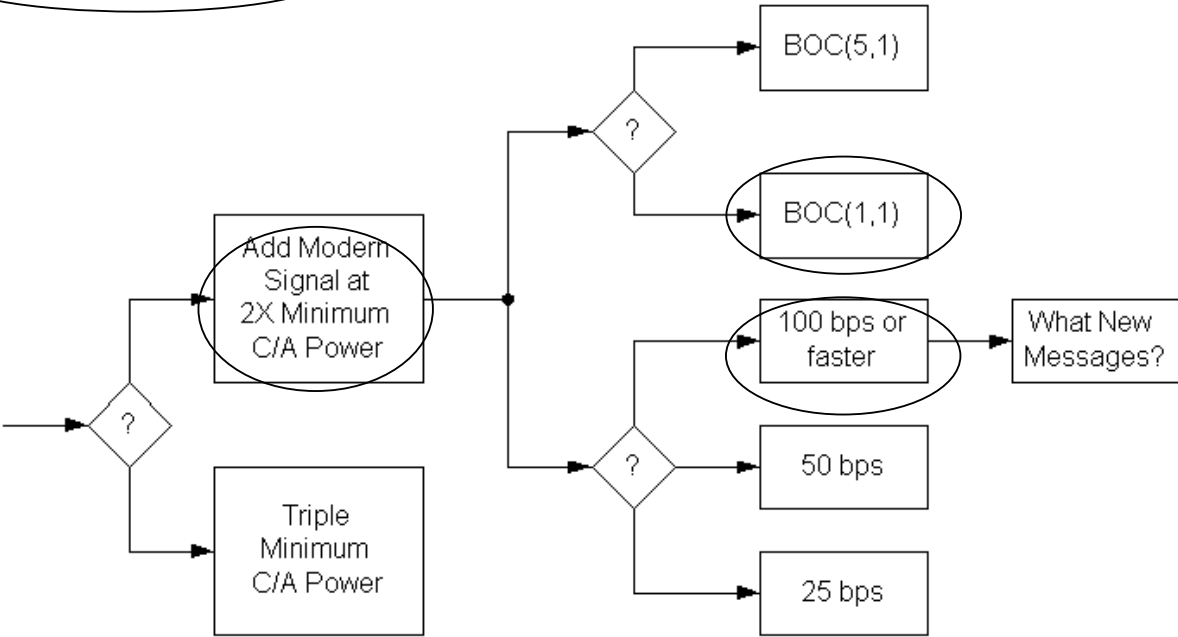

What new messages:
Interoperable messages with Galileo L1 OS signal

Comments:
I think L1C code and data rate should have interoperability with Galileo L1 OS signal. Also, faster TTFB will be desirable. I give low priority for 25 bps because I cast GPS/IMU will displace Assisted GPS.

Signature: *Tsutomu Okada*

For Attribution?: Your Name: Yes No Your Organization: Yes No

Intentionally Left Blank to Separate Responses

The Following is Reference # 12

L1C Questionnaire

185 of 406

Name: JARROD SEYMOUR Date: 4-12-04

Title/Position DESIGN ENGINEER

Organization GARMIN

Address 1200 E 151st St.

Phone: 913-397-8200

E-Mail: jarrad.seymour@garmin.com

Circle Preferences:

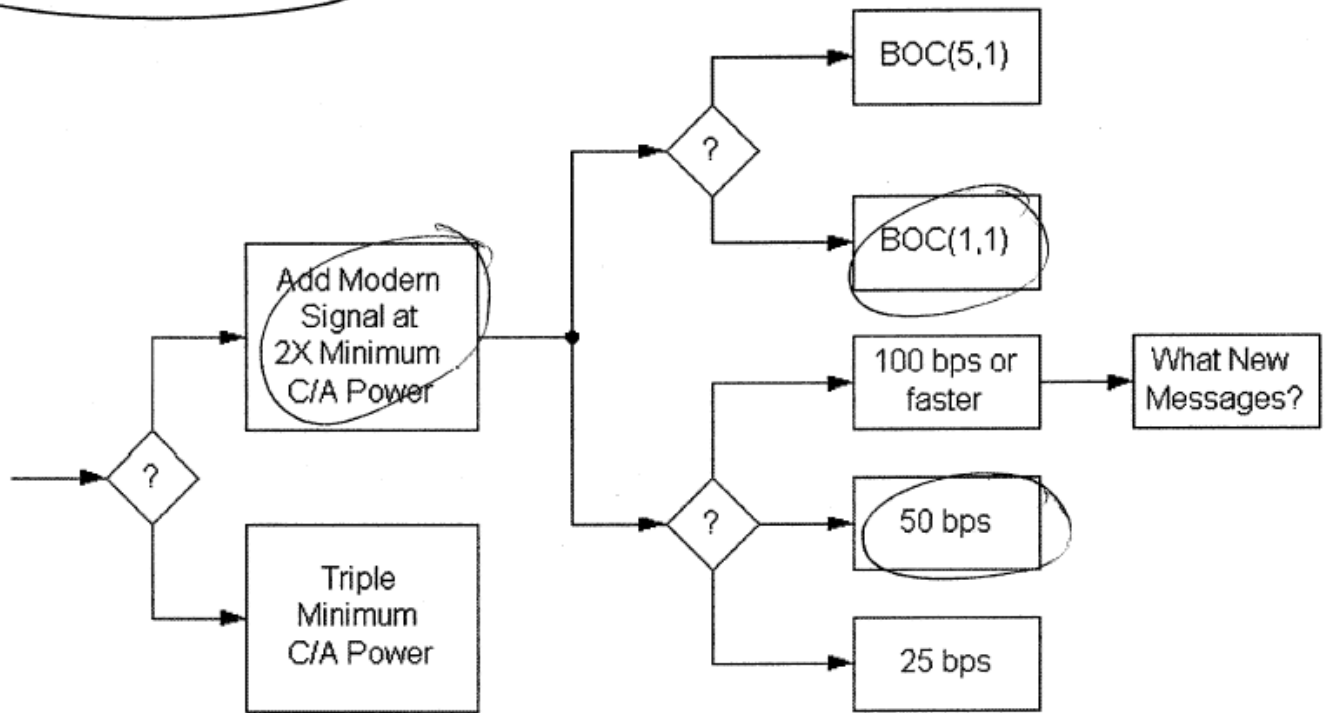

What new messages:

Comments:

SEE ATTACHED DOCUMENT

Signature: 

For Attribution?: Your Name: Yes No

Your Organization: Yes No

Comments:

We chose the 50bps mode to specify the effective data rate with forward error correction. This would give us an actual bit rate of 100bps and that corresponds to 1 bit per code length. This way we can have a better demodulation threshold and integrate over the whole code length.

If there is an advantage to go to the 100bps(effective) rate that outweighs the ability to integrate over the whole code length we don't see it and would welcome any responses on this issue.

Another possibility with the 50bps(effective) rate is not using FEC on the whole message. What if just part of the message is FEC encoded and the other part is transmitted at 100bps. We would need some way to frame sync on the whole message, but it would be useful to transmit ephemeris at a faster rate so the TTFF could be reduced if we have a strong signal. In cases where the signal is weak, the ephemeris could be decoded and verified with error correction bits. We could download multiple copies of ephemeris, compare them, and along with the error correction bits determine where the bit errors are. It is unclear if this would result in better thresholds but it is an idea. The advantage is that in areas of good signal the TTFF is fast and just takes a little longer when the signal is weak.

Thanks!

Jarrold Seymour
Garmin International

Application Specific Questions

187 of 406

Name: JARROD SEYMOUR Date: 4-12-04

Title/Position: ~~DESIGN~~ DESIGN ENGINEER

Organization: GARMIN

Your Primary Expertise			Applications 1.
	Professional & Scientific	Commercial	
Land			
Sea			
Air			
Space			

Expected Number of Users in 2005			
	Professional & Scientific	Commercial	Consumer
Land			8 million
Sea			1 million
Air			200,000
Space			

Expected Number of Users in 2020			
	Professional & Scientific	Commercial	Consumer
Land			
Sea			
Air			
Space			

Value			
Parameter	Best Desired	Worst Acceptable	Importance
Accuracy		CURRENT	1
TTF		CURRENT	1
Availability			3
Continuity			3
Integrity			3
Robustness			3

Importance: 1 = Very, 3 = Moderate, 5 = Not Significant

Intentionally Left Blank to Separate Responses

The Following is Reference # 13

L1C Questionnaire

Name: Gene Cangiani Date: 2/16/04

Title/Position Staff Scientist

Organization ITT Aerospace/Communications Division

Address 100 Kingsland Rd Clifton, NJ 07014

Phone: 973 284-2722

E-Mail: gene.cangiani@itt.com

Circle Preferences:

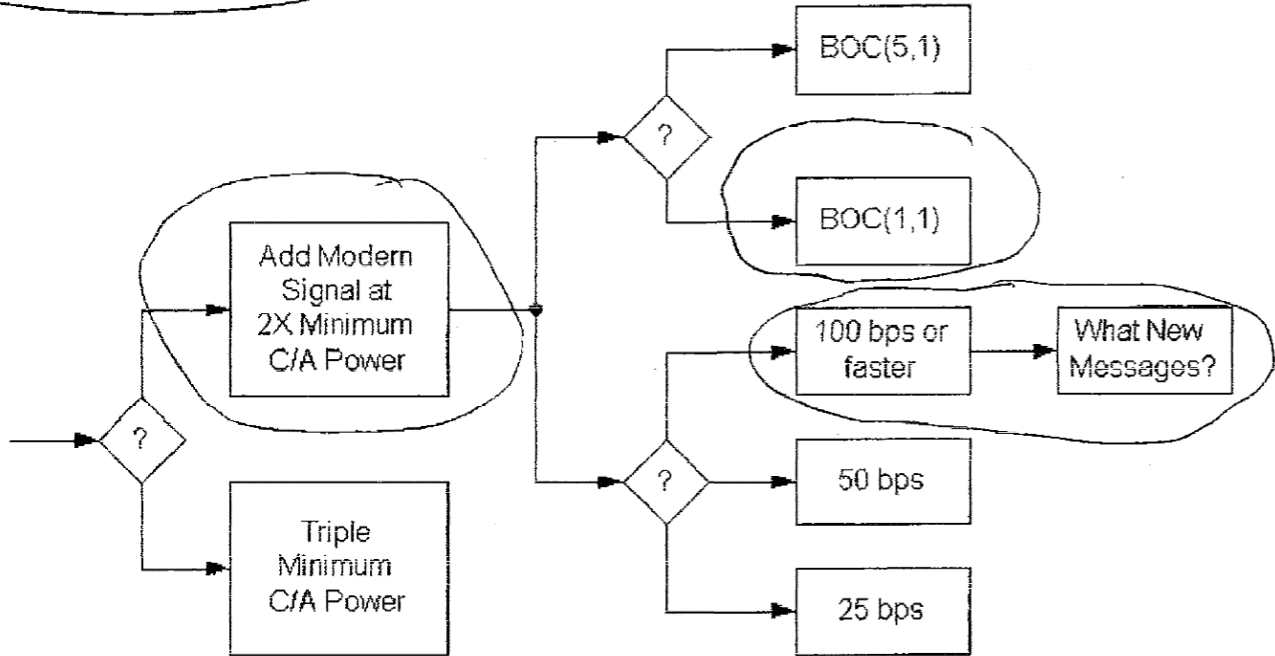

What new messages:

*Integrity, more accurate ephemeris data,
Search + ~~rescue~~ rescue information*

Comments:

We have been developing new modulation techniques to add more signals to the L Band downlinks. They may be more power efficient than the techniques you have in mind. We would like to be involved in the process of selecting the modulation type.

Signature: Gene Cangiani

For Attribution?: Your Name: Yes No

Your Organization: Yes No

Intentionally Left Blank to Separate Responses

The Following is Reference # 14

L1C Questionnaire

Name: _____ Date: _____ 2004/02/12 _____

Title/Position Associate Senior Engineer

Organization _____

Address _____

Phone: _____

E-Mail: _____

Circle Preferences:

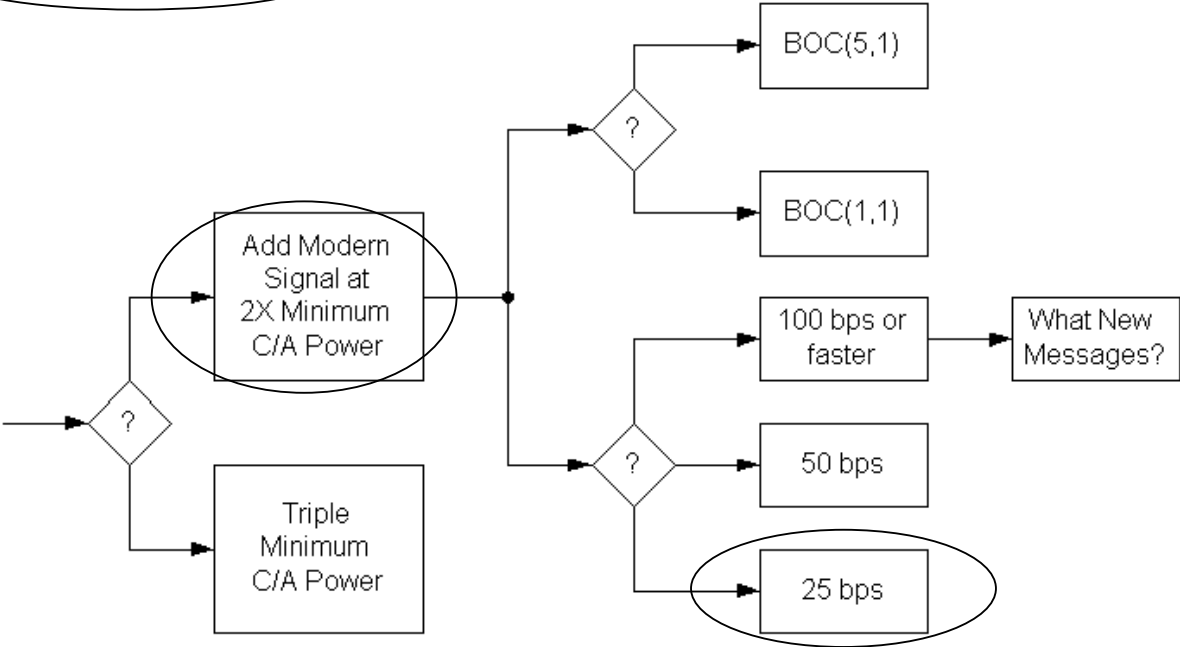

What new messages:

Comments:

Applications for indoor use will be expected to develop, so I think low data rate and more powerful signal will be more useful in Japan.

Signature: _____

For Attribution?: Your Name: Yes No Your Organization: Yes No

Intentionally Left Blank to Separate Responses

The Following is Reference # 15

L1C Questionnaire

Name: _____ Date: _____ 2004/02/12 _____

Title/Position Engineer

Organization _____

Address _____

Phone: _____ E-Mail: _____

Circle Preferences:

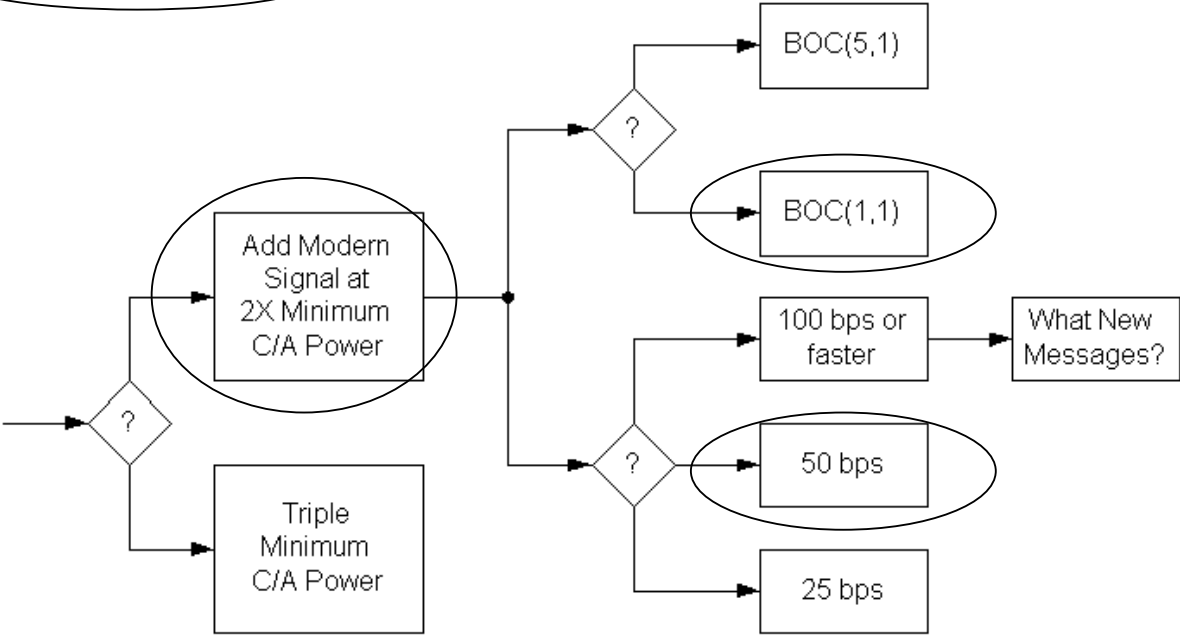

What new messages:

Comments:
 I think most GPS users like car navigation users are satisfied with present positioning accuracy.
 So I want to continue the current data rate.

Signature: _____

For Attribution?: Your Name: Yes No Your Organization: Yes No

Intentionally Left Blank to Separate Responses

The Following is Reference # 16

L1C Questionnaire

Name: Satoshi Kogure Date: 2004.02.12

Title/Position Associate Senior Engineer

Organization Satellite Applications Center, Office of Space Applications, JAXA

Address 2-1-1 Sengen, Tsukuba, Ibaraki, 305-8505 JAPAN

Phone: +81-298-68-5511

E-Mail: kogure.satoshi@jaxa.jp

Circle Preferences:

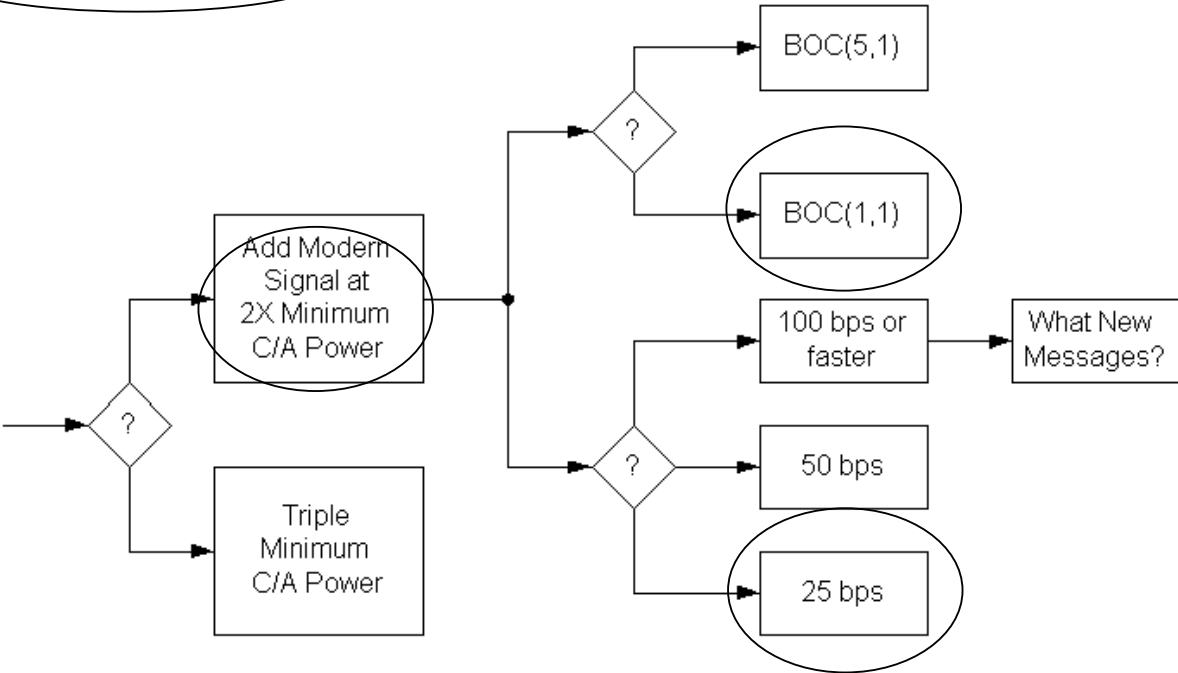

What new messages:

It is desired that L1C has enough rooms in its data message for local or regional augmentation systems using same data message format. Integrity, disaster alarm etc. are to be added by local operators through their own augmentation systems or L1C new NAV message.

Comments:

QZSS has a strong benefit for the users in bad circumstances such as in urban canyon and wooden forest. If GPS L1C will enhance this characteristic, I believe that we will have great performance for navigation by using L1C and QZSS correction data broadcasting. As for modulation method, I hope Galileo will employ same signal structure as GPS L1C so as to facilitate to have interoperability with GPS and QZSS.

Signature: 

For Attribution?: Your Name: Yes No Your Organization: Yes No

Application Specific Questions

Name: Satoshi Kogure Date: 2004.02.12

Title/Position Associate Senior Engineer

Organization Satellite Applications Center, Office of Space Applications, JAXA

Your Primary Expertise			
	Professional & Scientific	Commercial	Consumer
Land			
Sea			
Air			
Space	X		

Expected Number of Users in 2005			
	Professional & Scientific	Commercial	Consumer
Land		8 Millions	
Sea			
Air			
Space			

Expected Number of Users in 2020			
	Professional & Scientific	Commercial	Consumer
Land		80 Millions	
Sea			
Air			
Space			

Applications

1. Navigation and LBS for mobile users with cellular phone
2. Car navigation
3. Land and maritime traffic control

Value			
Parameter	Best Desired	Worst Acceptable	Importance
Accuracy	0.5 - 1m*	1 - 3m*	2
TTF			3
Availability	99.999%	99.99%	1
Continuity	$1 \cdot 10^{-5} / h$	$1 \cdot 10^{-4} / h$	2
Integrity	$10^{-7} / h^*$	$10^{-6} / h^*$	1
Robustness			1

Importance: 1 = Very, 3 = Moderate, 5 = Not Significant
* with correction data through QZSS signal

Intentionally Left Blank to Separate Responses

The Following is Reference # 17

L1C Questionnaire

Name: _____ Date: 02/12/04

Title/Position Associate Senior Engineer

Organization _____

Address _____

Phone: _____ E-Mail: _____

Circle Preferences:

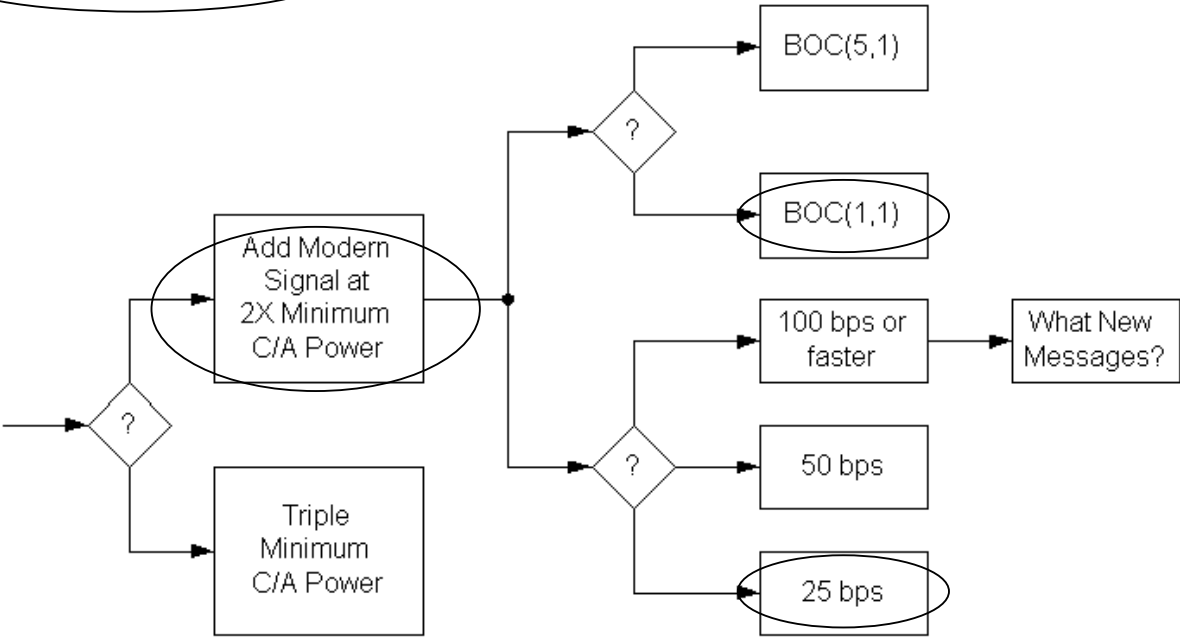

What new messages:

Comments:

Signature: _____

For Attribution?: Your Name: Yes No

Your Organization: Yes No

Intentionally Left Blank to Separate Responses

The Following is Reference # 18

L1C Questionnaire

Name: _____ Date: 06 Feb. '04

Title/Position Deputy General Manager

Organization _____

Address _____

Phone: _____

Circle Preferences:

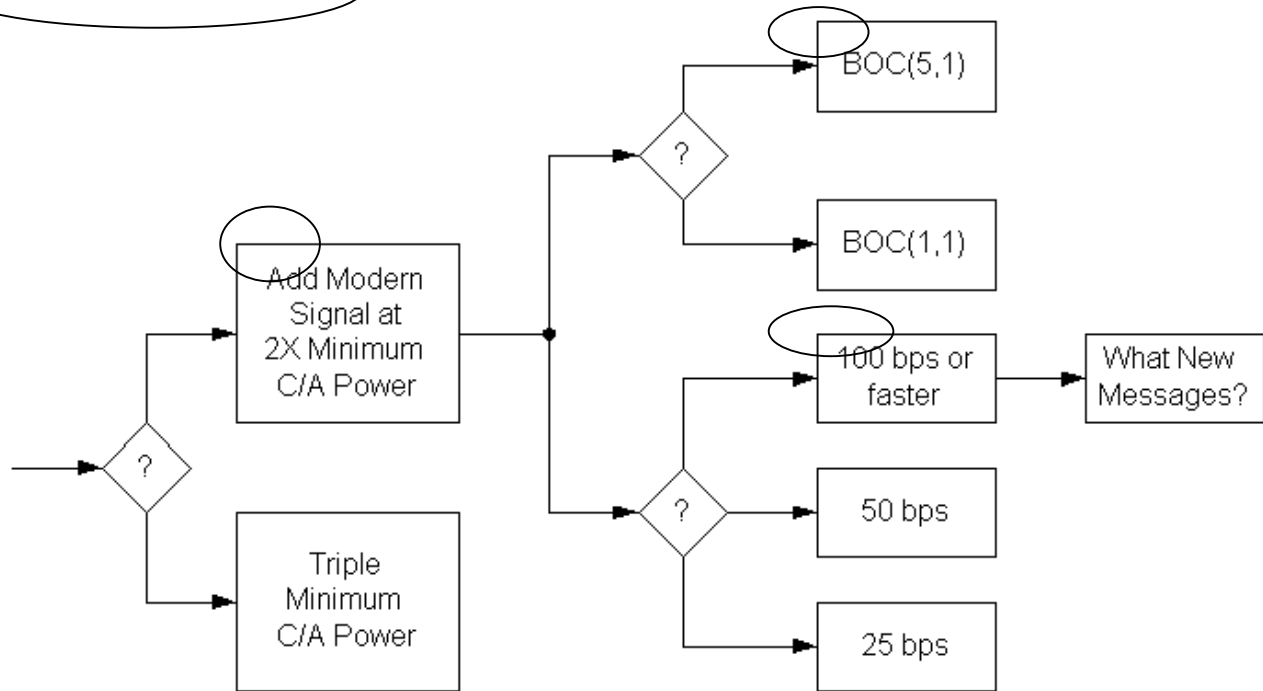

What new messages:

1. Quick-repeating ephemeris (ex. less than 15 seconds) and almanac (ex. less than 6.25 minutes)
2. Other satellite's Ephemeris. Predicted ephemeris up to 12 hours later. (I will discuss this issue later.)

Comments:

1. The interference with present L1 C/A should be minimized.
2. The interference between GPS and Galileo should be minimized.
3. The items in "New L1C Signal Improvements" (P16) in the document "Improving the GPS L1 Signal (GPS III offers the Opportunity)" that is presented by Mr. Stansell on Jan. 23rd at Tokyo should be realized.

Signature: _____

For Attribution?: Your Name: Yes No

Your Organization: Yes No

Application Specific Questions

Name: _____ Date: _____ 06 Feb. '04

Title/Position _____

Organization _____

Your Primary Expertise			
	Professional & Scientific	Commercial	Consumer
Land	-	-	X
Sea	-	-	X
Air	-	-	-
Space	-	-	-

Applications

1. Car Navigation
2. Marine Navigation

Expected Number of Users in 2005(annualy)			
	Professional & Scientific	Commercial	Consumer
Land	-	-	2,500,000 ^(**1)
Sea	-	-	-
Air	-	-	-
Space	-	-	-

Expected Number of Users in 2020(annualy)			
	Professional & Scientific	Commercial	Consumer
Land	-	-	-
Sea	-	-	-
Air	-	-	-
Space	-	-	-

*1: This Number shows for Car Navigation only in Japan

Value			
Parameter	Best Desired	Worst Acceptable	Importance
Accuracy	X		1
TTF			2
Availability			2
Continuity			2
Integrity		X	3
Robustness			3

Importance: 1 = Very, 3 = Moderate, 5 = Not Significant

Additional Comment

1. The issue of cross-correlation

There is an idea to change present C/A power to "Triple Minimum C/A Power" for L1C modernization, we need to consider cross-correlation problem about this idea.

The GPS receivers manufactured by us are almost installed for car navigation units. This cross-correlation issue is going to influence the acquisition threshold level and the reacquisition threshold level of our GPS receivers.

If "Triple Minimum C/A Power" is adopted in the future, cross-correlation level may exceed the acquisition threshold level or the reacquisition threshold level.

The acquisition and the reacquisition threshold levels are determined to consider the experimental result of receiving the satellites' signals at the fixed point.

We describe the diagram of receiving the satellites' signals at the open sky fixed point in Figure 1.

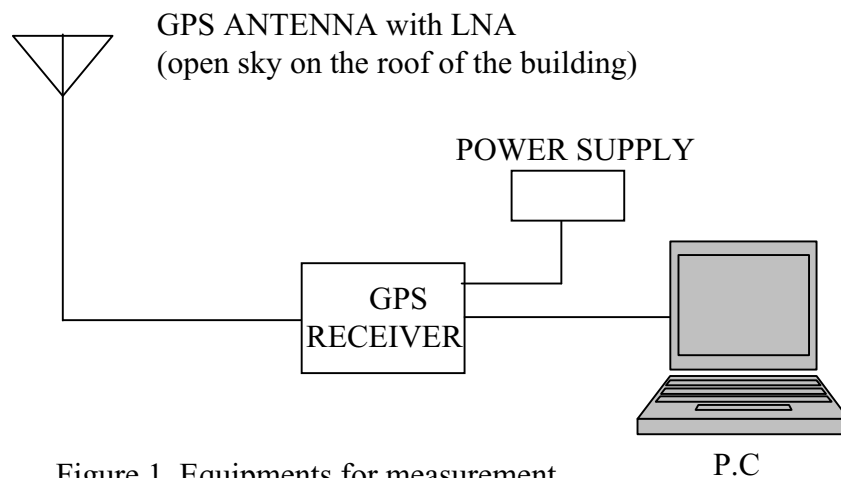

Figure 1 Equipments for measurement

If the radiation power of L1 C/A triples, the receiving power will increase by 4.77dB, then the cross-correlation power of strong signals will exceed our acquisition and reacquisition threshold. Our GPS receivers may occur the positioning error often in such situation. We have produced GPS receivers for car navigation over six million at January, 2004. So, if the idea of "Triple C/A power" is put into operation, a lot of GPS users may be thrown into serious confusion.

Therefore, we wish to be adopted the other idea instead of "Triple C/A power."

*2: J.J.Spilker, GPS Signal Structure and Performance Characteristics, Global Positioning System Volume I, Institute of Navigation, p46

2. The issue of transmitting ephemeris data

In case of adopting the method of over 100 bps transmitting rate of navigation data, we hope that the other satellite's ephemeris data will be transmitted from some satellite.

The purpose are described as follows.

- 1) We have the intention to prolong the period that the ephemeris data are valid for the hot start operation of GPS receivers. We think that this period is about 4 hours from the power off. But we hope that this period will be prolonged 8 or 12 hours later from power off.
- 2) If GPS receiver acquires the other satellites' ephemeris data(These ephemeris data haven't necessarily 2 cm accuracy to be aimed about L1C) and these ephemeris data are available in the future for example the data are available 8 hours or 12 hours later, there will be high possibility to get hot start operation at the time when GPS receivers are powered on 8 or 12 hours later because already acquired ephemeris data will be available at this moment.

According to this reason, GPS receivers are going to make progress about the availability and usefulness for car navigation application.

3. The reason of BOC(5,1) we chose

We chose it because it will be able to minimize the interference with present L1 C/A.

L1 Modernization Project (L1C)

ION GPS/GNSS 2003

Purpose

- The US Government has not yet determined whether a modernized GPS L1 civil signal should be added.
- To solicit comments from civil and other GPS stakeholders about;
 - Whether or not a modernized GPS L1 civil signal should be added – and, if so
 - What types of modernization would be most valuable., and why ?

XX

Why Modernize ? L1 C/A is Excellent

- L1 C/A works well; It supports millions of users.
- Accuracy is astounding
 - Absolute accuracy is a few meters (good for most users)
 - Differential navigation can give sub-meter accuracy
 - Surveyors and scientists rely upon sub-centimeter differential results
- Interference is minimal
- Its being used for safety-of-life navigation
- Why consider changing anything so successful ?
 - “If it is not broken, why fix it” (there is room for improvement)

Your comment

L1 C/A signal has a number of application fields where it is used with full satisfaction in terms of accuracy. Accordingly, continued utilization in the future should be guaranteed by warranting the presently functional system.

In addition, L1 C/A dependant receiver is suitable for low priced, compact sized and low power consuming products due to its attributes including comparatively easy signal acquisition and simple structures.

It is anticipated that the receiver will be utilized readily in the current application fields and future fields where L1 C/A accuracy will fully meet the requirements. For instance, L1 C/A signal is now just like Real Time Clock (RTC) incorporated in almost all home electric appliances.

Thus, the new signal structure should ensure continued use of L1 C/A, even upon realization of L1C signal under new GPS due to the reasons as explained above. Besides, higher accuracy and sensitivity than those with the conventional L1 C/A signal are looked for with L1C.

L1C Code Length Tradeoff

- The C/A code length is 1.023 chips (short)
- Modernized codes are at least 10 times longer
- Longer codes have major advantages:
 - Eliminate cross-satellite interference
 - Reduce effect of narrowband interference
 - Enable more and more powerful satellite signals
- But, acquisition time (per correlator) is longer
 - Technology now permits thousands of correlators
- What is best for your applications ?

Response

The L1C code normally used for signal acquisition should be **10,230 chip**

Comment

A longer signal acquisition time would be required for enhanced code length, and deterioration of TTFF becomes a matter of concern. On the other hand, a significant number of correlator might be required to shorten TTFF.

For such reasons, about 10,230 of code length will be enough to eliminate cross correlation among the signals-in space. Unnecessary enhancement of code length may result in complication with the receiver.

Besides, incorporation of some subtle measures (e.g., measure for an easy handover from L1 C/A code) is requested.

XX

Adding L1C Messages – Which Ones ?

- GPS messages are only for navigation
- Added value messages might provide
 - Integrity warnings of “bad” satellite signals or weather, rescue, or other NAV-related messages
- What is the best integrity source ?
 - Ground signals, GEO satellites, RAIM, or GPS ?
 - With GPS plus Galileo, is RAIM sufficient ?
- What is best for your applications?

Response

Should the GPS data rate be increased to provide additional messages

Integrity **Yes**

DGPS **Yes**

Others **Yes**

With GPS + Galileo, would RAIM be sufficient for integrity

Yes

XX

L1C Almanac & Ephemeris Precision

- C/A ephemeris precision is about 1 meter
- L1C ephemeris may have 1 cm precision
- Is this of any benefit for your applications ?

- L1C “compact almanac” may be less precise than C/A to cover more satellites faster
- Is this change desirable or not?

Response

Would increased precision of the GPS ephemeris be valuable

Yes

Would decrease precision of the almanac to provide more satellite quicker be valuable

Yes

XX

Your Reaction to L1C Modernization

- Do you favor L1 civil signal modernization ?

Yes

- What are your concerns ?

It is necessary to minimize adverse effects on L1 C/A code.

TTFB delay should be avoided as the result of enhanced code length..

- **What are your desires ?**
Signal structure that can co-exist with L1 C/A code is wanted.
- **Why ?**
Many users are already using L1 C/A signal in the world.

Respond to one of the following :

E-Mail: L1C_GPS@USGS.gov

Fax: +1-626-583-7827

Mail: L1C GPS, 525 South Wilson Ave., Pasadena, CA 91106-3212

Your Printed Name: _____

Title of Position : GM Communications Equipment Division_____

Organization : _____

Contact Information : _____

Additional Cmments :

Intentionally Left Blank to Separate Responses

The Following is Reference # 19

L1C Questionnaire

Name: Dr. Hans-Jürgen Euler _____ Date: April 7, 2004 _____

Title/Position Leica Fellow in Research, Corporate Technology Center _____

Organization Leica Geosystems AG, Switzerland _____

Address CH-9435 Heerbrugg _____

Phone: +41 71 727 3388 _____

E-Mail: Hans-J.uergen.Euler@Leica-Geosystems.com

Circle Preferences:

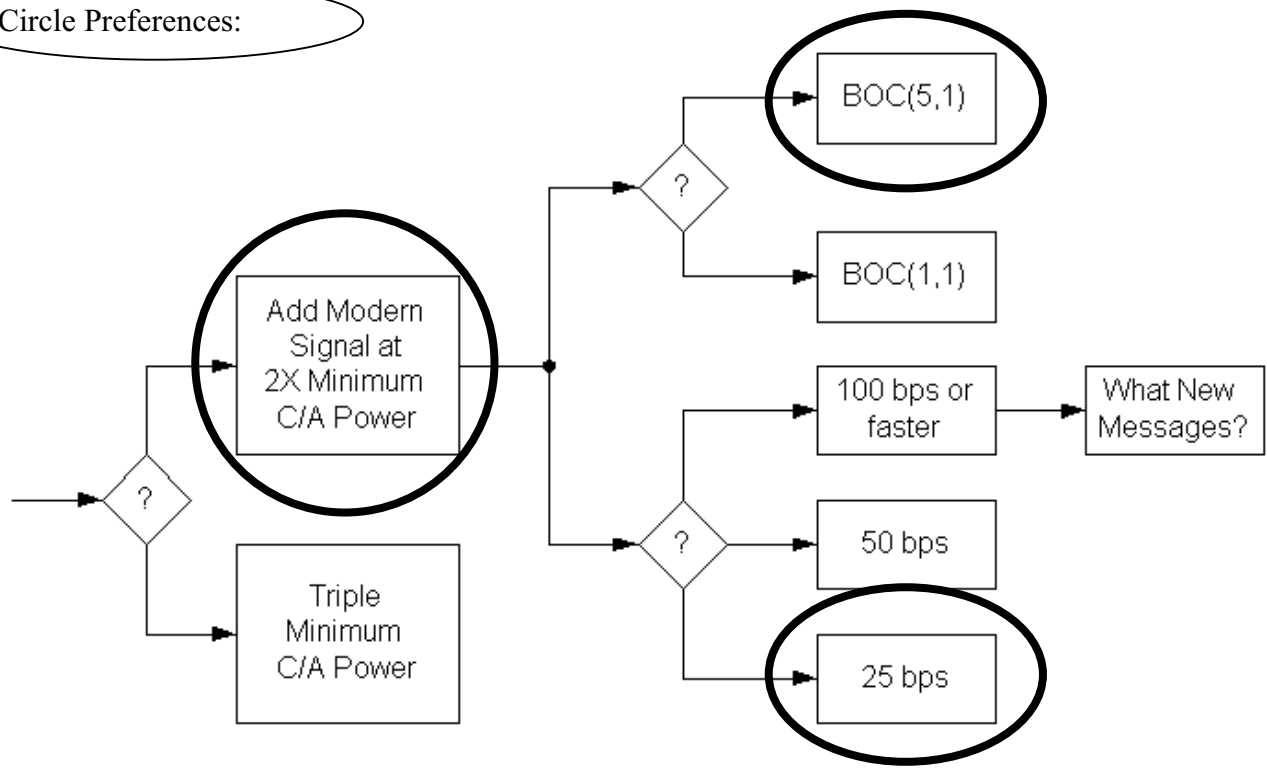

What new messages:

Comments:

Signature: _____

For Attribution?: Your Name: Yes No

Your Organization: Yes No

Application Specific Questions

Name: Dr. Hans-Jürgen Euler _____ Date: April 7, 2004 _____

Title/Position Leica Fellow in Research, Corporate Technology Center _____

Organization Leica Geosystems AG, Switzerland _____

Your Primary Expertise			
	Professional & Scientific	Commercial	Consumer
Land	X	X	
Sea			
Air			
Space			

Expected Number of Users in 2005			
	Professional & Scientific	Commercial	Consumer
Land			
Sea			
Air			
Space			

Expected Number of Users in 2020			
	Professional & Scientific	Commercial	Consumer
Land			
Sea			
Air			
Space			

Applications

1. Surveying / Geodetic applications
2. Kinematic for precise vehicle tracking (1 cm) or better
3. Structural monitoring
4. Reference network applications

Value			
Parameter	Best Desired	Worst Acceptable	Importance
Accuracy	X		1
TTF		X	3
Availability	X		2
Continuity			3
Integrity	X		2
Robustness	X		2

Importance: 1 = Very, 3 = Moderate, 5 = Not Significant

Intentionally Left Blank to Separate Responses

The Following is Reference # 20

L1C Questionnaire

Name: _____ Date: 07/03/04_____

Title/Position Senior Staff Member

Organization _____

Address _____

Phone: _____ E-Mail: _____

Circle Preferences:

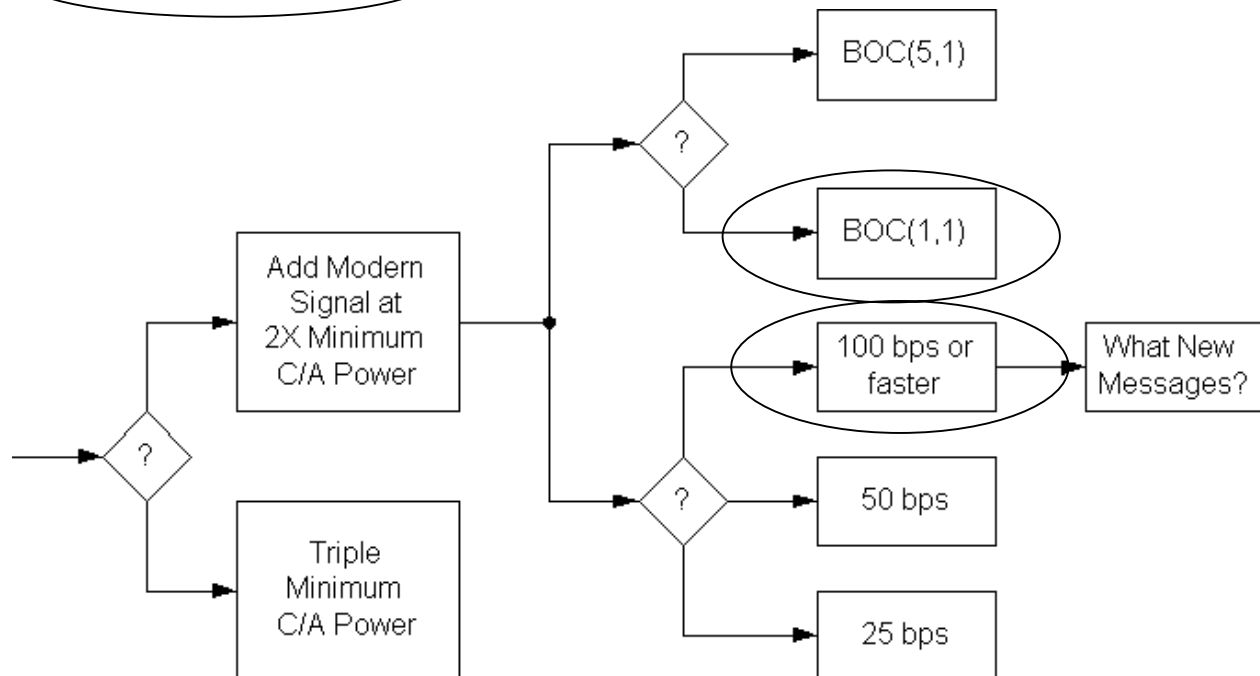

What new messages:
Satellite signal integrity

Comments:
Preferences:

- Add modern signal at 2 x minimum C/A power
- BOC (1, 1) appears to be a safe choice at this time based on both technical and political grounds.
- I expect 100 bps would be required.

The comments below pertain specifically to civil aviation navigation, a very specialized application of GPS with stringent requirements. The number of receiver units sold may be small, but the number of users is vast: all air travelers (that's all of us).

In my view, the main requirements of aviation are:

- assured positioning accuracy to each user (based on integrity monitoring implemented in each receiver), and
- robustness (which includes availability and continuity)

It's a challenge to meet these requirements for precision approaches with GPS of today, even with a dedicated and vastly expensive augmentation like WAAS. I believe it wouldn't be a challenge for GPS III to exceed the performance offered by GPS-WAAS. In fact, exceeding the performance of GPS-WAAS would be a good criterion for GPS III to meet.

In order to meet the requirements stated above for precision approaches, GPS III would have an advantage over the current system: It'd be in a position to exploit additional redundancies.

- redundant systems (GPS and Galileo),
- redundant satellites in each system,
- redundant measurements from each satellite (at different frequencies), and
- redundant differential corrections from multiple sources not required to be maintained specifically for aviation (e.g., CORS sites and NDGPS).

With these options, it wouldn't be a challenge for GPS III to exceed the performance of GPS-WAAS.

RFI would continue to be a source of concern, and additional signal power and longer/faster codes would help.

The navigation data rate of 50 bps is adequate for aviation. TTFF is not an issue, but time-to-alarm (TTA) is, and TTA for category I precision approaches is 6 seconds. It may take 100 bps data rate from GPS satellites to match the performance of GPS-WAAS. The current fixed format, however, must change to include different message types, FEC, and other features of L2C and L5.

Signature: _____

For Attribution?: Your Name: No Your Organization: No

Application Specific Questions

Name: _____ Date: 07/-3/04

Title/Position Senior Staff Member

Organization _____

Your Primary Expertise			
	Professional & Scientific	Commercial	Consumer
Land			
Sea			
Air		x	
Space			

Expected Number of Users in 2005			
	Professional & Scientific	Commercial	Consumer
Land			
Sea			
Air		3000	
Space			

Expected Number of Users in 2020			
	Professional & Scientific	Commercial	Consumer
Land			
Sea			
Air		10000	
Space			

<u>Applications</u>
1.

Value			
Parameter	Best Desired	Worst Acceptable	Importance
Accuracy	~ 1 m		1
TTF	30 s	3 min	5
Availability	0.99999	0.9999	1
Continuity	0.99999999	0.999999	1
Integrity	0.99999999	0.999999	1
Robustness	1	1	1

Importance: 1 = Very, 3 = Moderate, 5 = Not Significant

Intentionally Left Blank to Separate Responses

The Following is Reference # 21

L1 Modernization Project (L1C)
ION GPS/GNSS 2003
 Portland, Oregon; September 10-12, 2003

<p style="text-align: center;"><u>Purpose</u></p> <ul style="list-style-type: none"> ▪ To solicit comments from civil and other GPS stakeholders about: <ul style="list-style-type: none"> ▪ Whether or not a modernized GPS L1 civil signal should be added - and, if so - ▪ What types of modernization would be most valuable, and why ▪ The U.S. Government has not yet determined whether a modernized GPS L1 civil signal should be added 	
<p style="text-align: center;"><u>Why Modernize? L1 C/A is Excellent</u></p> <ul style="list-style-type: none"> ▪ L1 C/A works well; it supports millions of users ▪ Accuracy is astounding <ul style="list-style-type: none"> ▪ Absolute accuracy is a few meters (good for most users) ▪ Differential navigation can give sub-meter accuracy ▪ Surveyors and scientists rely upon sub-centimeter differential results ▪ Interference is minimal ▪ It's being used for safety-of-life navigation ▪ Why consider changing anything so successful? <ul style="list-style-type: none"> ▪ "If it isn't broken, why fix it" (there's room for improvement) 	<p style="text-align: center;"><u>Comments</u></p> <p>CA code spectral lines, combined with other factors, have caused a major failure of GPS equipment in orbit. All four GPS receivers on the Navy's GFO ocean altimetry mission were severely affected (not used operationally) by the interplay of the CA code and bias in the A/D sampler.</p> <p>A longer code would not have exhibited the same problem.</p>

<p><u>What are Opportunities for Improvement?</u></p> <ul style="list-style-type: none"> ▪ Any of the longer-coded L1C options would be less susceptible to narrowband interference than L1 (C/A) ▪ Could improve cross-correlation properties: <ul style="list-style-type: none"> ▪ Improve indoor or wooded area use ▪ Increase number of satellites and code signal power without causing unacceptable self-interference ▪ Improve receiver signal acquisition threshold ▪ Navigation message could contain more: <ul style="list-style-type: none"> ▪ Precision, flexibility, with forward error correction (FEC) ▪ Signal tracking and data demodulation thresholds (robustness) would be better with a modernized signal ▪ GPS III schedule presents an opportunity - requirements need to go into a CDD by Aug. 2004 	<p><u>Comments</u></p> <p>Improved cross-correlation properties is especially important when using pseudolites. It helps to avoid an effect of the “near-far problem”.</p> <p>Could add realtime differential correction to data to greatly improve user accuracy and integrity.</p> <p>“Signal tracking and data demodulation thresholds (robustness) would be better with a modernized signal” Change “would be” to “could be”.Reason: We may trade off better accuracy, etc., for less robustness.</p>
<p><u>Proposed Objectives</u></p> <ul style="list-style-type: none"> ▪ Compatible signal for legacy C/A receivers <ul style="list-style-type: none"> ▪ Continue to provide the C/A code ▪ Minimize added noise for C/A receivers ▪ New signals with better performance than C/A <ul style="list-style-type: none"> ▪ Better correlation properties (longer codes) ▪ More signal power and better threshold tracking <ul style="list-style-type: none"> ▪ <i>Improved performance indoors and under foliage</i> ▪ Improved message structure, precision, etc. ▪ Improved narrowband interference protection 	<p><u>Comments</u></p> <p>Add better pseudorange precision and lower multipath error, both from higher chip rate or use of BOC signals, to objectives for new signals.</p>

L1C Data Rate Tradeoff

- L1C modernized data presumably will be similar to or the same as for L2C and L5
 - Forward error correction (FEC) also will be used
- Some data rate options:
 - 25 bps (L2C) provides data in challenged situations
 - *Urban canyons, indoors, in wooded areas*
 - 50 bps (L5) same as C/A now
 - 100 bps would allow additional messages (e.g., integrity warnings)
- What is best for your applications?

Response

Rank: 1 = best

Importance:

10 = very important

5 = moderate

0 = not important

Data Rate	Your Rank	Import
25 bps	5	
50 bps	0	Redundant to current data
100 bps	5	
0 bps	5	acquire low-level signals
250 bps	10	realtime science users

L1C Signal Power Tradeoff

- Higher power signals generally are better
 - Better operation in challenged circumstances (interference, wooded areas, indoors, etc..)
 - More precise measurements (higher SNR)
- However, higher power L1C signals could slightly increase L1 C/A noise
 - Less than 0.5 dB, depending on the signal choice
- What is best for your applications?

Response

Increase Signal Power:

Yes

Comment:

Since I plan to exploit the new signal, some more power is better. There is a logical limit to signal power. If the power becomes much higher than today's CA power, further increases will not help, as the system noise will then be dominated by jamming from other L1C signals, which will also increase.

L1C Code Length Tradeoff

- The C/A code length is 1,023 chips (short)

Response

The L1C code normally used for

- Modernized codes are at least 10 times longer
- Longer codes have major advantages:
 - Eliminate cross-satellite interference
 - Reduce effect of narrowband interference
 - Enable more and more powerful satellite signals
- But, acquisition time (per correlator) is longer
 - Technology now permits thousands of correlators
- What is best for your applications?

signal acquisition should be:

10,230 chips

20,460 chips

Longer

Comment:

We need to specify the code repetition interval, which is the period divided by the chipping rate. One requirement I have is that this interval be longer than 0.01 second.

<p><u>Adding L1C Messages – Which Ones?</u></p> <ul style="list-style-type: none"> ▪ GPS messages are only for navigation ▪ Added value messages might provide: <ul style="list-style-type: none"> ▪ Integrity warnings of “bad” satellite signals or weather, rescue, or other NAV-related messages ▪ What is the best integrity source ? <ul style="list-style-type: none"> ▪ Ground signals, GEO satellites, RAIM, or GPS ? <p>I suggest GPS receivers on a few LEOs for 24 hr global integrity monitor.</p> <ul style="list-style-type: none"> ▪ With GPS plus Galileo, is RAIM sufficient ? ▪ What is best for your applications? 	<p><u>Response</u></p> <p>Should the GPS data rate be increased to provide additional messages?</p> <p>Integrity: No</p> <p>DGPS: Yes mainly for added accuracy</p> <p>Other: Yes No</p> <p>With GPS+Galileo, would RAIM be sufficient for integrity?</p> <p style="text-align: center;">Yes</p> <p>My applications benefit most from transmitting DGPS corrections via the data message</p>
<p><u>L1C Almanac & Ephemeris Precision</u></p> <ul style="list-style-type: none"> ▪ C/A ephemeris precision is about 1 meter ▪ L1C ephemeris may have 1 cm precision ▪ Is this of any benefit for your applications? ▪ L1C “compact almanac” may be less precise than C/A to cover more satellites faster ▪ Is this change desirable or not? 	<p><u>Response</u></p> <p>Would increased precision of the GPS ephemeris be valuable?</p> <p style="text-align: center;">Yes</p> <p>Would decreased precision of the almanac to provide more satellites quicker be valuable?</p> <p style="text-align: center;">No</p>
<p><u>Your Reaction to L1C Modernization</u></p> <ul style="list-style-type: none"> ▪ Do you favor L1 civil signal modernization? ▪ What are your concerns? ▪ What are your desires? High chip rate, ▪ Why? 	<p><u>Reaction</u></p> <p>Favor L1 Modernization? Yes concerns? Inaction could freeze GPS into the current sub-optimal civil signal on L1. desires? High chip rate, high data rate Why? More precision, lower multipath, improved realtime accuracy.</p>

Intentionally Left Blank to Separate Responses

The Following is Reference # 22

L1 Modernization Project (L1C)
ION GPS/GNSS 2003
 Portland, Oregon; September 10-12, 2003

<p style="text-align: center;"><u>Purpose</u></p> <ul style="list-style-type: none"> ▪ To solicit comments from civil and other GPS stakeholders about: <ul style="list-style-type: none"> ▪ Whether or not a modernized GPS L1 civil signal should be added - and, if so - ▪ What types of modernization would be most valuable, and why ▪ The U.S. Government has not yet determined whether a modernized GPS L1 civil signal should be added 	
<p style="text-align: center;"><u>Why Modernize? L1 C/A is Excellent</u></p> <ul style="list-style-type: none"> ▪ L1 C/A works well; it supports millions of users ▪ Accuracy is astounding <ul style="list-style-type: none"> ▪ Absolute accuracy is a few meters (good for most users) ▪ Differential navigation can give sub-meter accuracy ▪ Surveyors and scientists rely upon sub-centimeter differential results ▪ Interference is minimal ▪ It's being used for safety-of-life navigation ▪ Why consider changing anything so successful? <ul style="list-style-type: none"> ▪ "If it isn't broken, why fix it" (there's room for improvement) 	<p style="text-align: center;"><u>Comments</u></p> <p>Current implementation is adequate for Shuttle.</p>

<u>What are Opportunities for Improvement?</u>	<u>Comments</u>
<ul style="list-style-type: none"> ▪ Any of the longer-coded L1C options would be less susceptible to narrowband interference than L1 (C/A) ▪ Could improve cross-correlation properties: <ul style="list-style-type: none"> ▪ Improve indoor or wooded area use ▪ Increase number of satellites and code signal power without causing unacceptable self-interference ▪ Improve receiver signal acquisition threshold ▪ Navigation message could contain more: <ul style="list-style-type: none"> ▪ Precision, flexibility, with forward error correction (FEC) ▪ Signal tracking and data demodulation thresholds (robustness) would be better with a modernized signal ▪ GPS III schedule presents an opportunity - requirements need to go into a CDD by Aug. 2004 	<p>Slight benefit</p> <p>Slight benefit</p> <p>Slight benefit</p> <p>Slight benefit</p>
<u>Proposed Objectives</u>	<u>Comments</u>
<ul style="list-style-type: none"> ▪ Compatible signal for legacy C/A receivers <ul style="list-style-type: none"> ▪ Continue to provide the C/A code ▪ Minimize added noise for C/A receivers ▪ New signals with better performance than C/A <ul style="list-style-type: none"> ▪ Better correlation properties (longer codes) ▪ More signal power and better threshold tracking <ul style="list-style-type: none"> ▪ <i>Improved performance indoors and under foliage</i> ▪ Improved message structure, precision, etc. ▪ Improved narrowband interference protection 	<p>Would degrade current MAGR-S C/A signal by ~ 0.5 dB</p> <p>Slight benefit</p>

L1C Data Rate Tradeoff

- L1C modernized data presumably will be similar to or the same as for L2C and L5
 - Forward error correction (FEC) also will be used
- Some data rate options:
 - 25 bps (L2C) provides data in challenged situations
 - *Urban canyons, indoors, in wooded areas*
 - 50 bps (L5) same as C/A now
 - 100 bps would allow additional messages (e.g., integrity warnings)
- What is best for your applications?

Response

Rank: 1 = best

Importance:

10 = very important

5 = moderate

0 = not important

Data Rate	Your Rank	Import
25 bps		0
50 bps		5
100 bps	1	10

L1C Signal Power Tradeoff

- Higher power signals generally are better
 - Better operation in challenged circumstances (interference, wooded areas, indoors, etc..)
 - More precise measurements (higher SNR)
- However, higher power L1C signals could slightly increase L1 C/A noise
 - Less than 0.5 dB, depending on the signal choice
- What is best for your applications?

Response

Increase Signal Power:

Yes or No

Comment: Shuttle MAGR currently has good signal reception; don't really need to improve. Would cause 0.5 dB degradation to current.

L1C Code Length Tradeoff

- The C/A code length is 1,023 chips (short)
- Modernized codes are at least 10 times longer
- Longer codes have major advantages:
 - Eliminate cross-satellite interference
 - Reduce effect of narrowband interference
 - Enable more and more powerful satellite signals
- But, acquisition time (per correlator) is longer
 - Technology now permits thousands of correlators
- What is best for your applications?

Response

The L1C code normally used for signal acquisition should be:

10,230 chips

20,460 chips

Longer

Comment:

Quick acquisition is important for Shuttle; more difficult at orbital speeds.

<p><u>Adding L1C Messages – Which Ones?</u></p> <ul style="list-style-type: none"> ▪ GPS messages are only for navigation ▪ Added value messages might provide: <ul style="list-style-type: none"> ▪ Integrity warnings of “bad” satellite signals or weather, rescue, or other NAV-related messages ▪ What is the best integrity source ? <ul style="list-style-type: none"> ▪ Ground signals, GEO satellites, RAIM, or GPS ? ▪ With GPS plus Galileo, is RAIM sufficient ? ▪ What is best for your applications? 	<p><u>Response</u></p> <p>Should the GPS data rate be increased to provide additional messages?</p> <p>Integrity: <u>Yes</u> No</p> <p>DGPS: Yes No</p> <p>Other: Yes No</p> <p>With GPS+Galileo, would RAIM be sufficient for integrity?</p> <p style="text-align: right;"><u>Yes</u> No</p>
<p><u>L1C Almanac & Ephemeris Precision</u></p> <ul style="list-style-type: none"> ▪ C/A ephemeris precision is about 1 meter ▪ L1C ephemeris may have 1 cm precision ▪ Is this of any benefit for your applications? ▪ L1C “compact almanac” may be less precise than C/A to cover more satellites faster ▪ Is this change desirable or not? 	<p><u>Response</u></p> <p>Would increased precision of the GPS ephemeris be valuable?</p> <p style="text-align: center;"><u>Yes</u> No</p> <p>Possibly would allow precision landings w/o MSBLS?</p> <p>Would decreased precision of the almanac to provide more satellites quicker be valuable?</p> <p style="text-align: center;">Yes <u>No</u></p> <p>Probably not due to difficulty acquiring SV’ s at orbital speeds</p>
<p><u>Your Reaction to L1C Modernization</u></p> <ul style="list-style-type: none"> ▪ Do you favor L1 civil signal modernization? ▪ What are your concerns? ▪ What are your desires? ▪ Why? 	<p><u>Reaction</u></p> <p>Favor L1 Modernization?</p> <p style="text-align: center;">Yes <u>No</u></p> <p>Probably not much benefit for Shuttle, because would require new receiver in order to take advantage of.</p>

Intentionally Left Blank to Separate Responses

The Following is Reference # 23

L1C Questionnaire

Name: Ron Hatch

Title/Position Director Navigation Systems

Organization NavCom Technology, Inc.

Address 20780 Madrona Ave, Torrance, CA 90503

Phone: 310-381-2603

E-Mail: rhatch@navcomtech.com

Circle Preferences:

1) Triple C/A Minimum Power or Add modernized signal

2) BPSK(2) BOC(1,1) BOC(5,1)

3) 25 bps 50 bps 100 bps or higher

4) What new messages:

High rate clock & Orbit corrections.

Comments:

Signature: Ronald B. Hatch

For Attribution?: Your Name: Yes No

Your Organization: Yes No

Intentionally Left Blank to Separate Responses

The Following is Reference # 24

L1C Questionnaire

Name: Jerry Knight
 Title/Position: Manager of Advanced GPS Development
 Organization: NavCom Technology / John Deere
 Address: 20780 Madonna Ave
 Phone: (310) 381-2609 E-Mail: jknight@navcomtech.com

Circle Preferences:

- 1) Triple C/A Minimum Power or Add modernized signal
- 2) ~~No~~ BPSK(2) BOC(1,1) BOC(5,1) *either*
- 3) 25 bps 50 bps 100 bps or higher *or don't care*
- 4) What new messages: Self "differential" corrections eg. clock drift

Comments:

Signature: Jerry Knight

For Attribution?: Your Name: Yes No Your Organization: Yes No

Intentionally Left Blank to Separate Responses

The Following is Reference # 25

L1C Questionnaire

Name: Phillip W. Ward Date: 2/12/2004

Title/Position President

Organization Navward GPS Consulting

Address 4024 Stone Haven Dr., Garland, TX 75043-7290

Phone: 972-240-5419 E-Mail: navward@comcast.net

Circle Preferences:

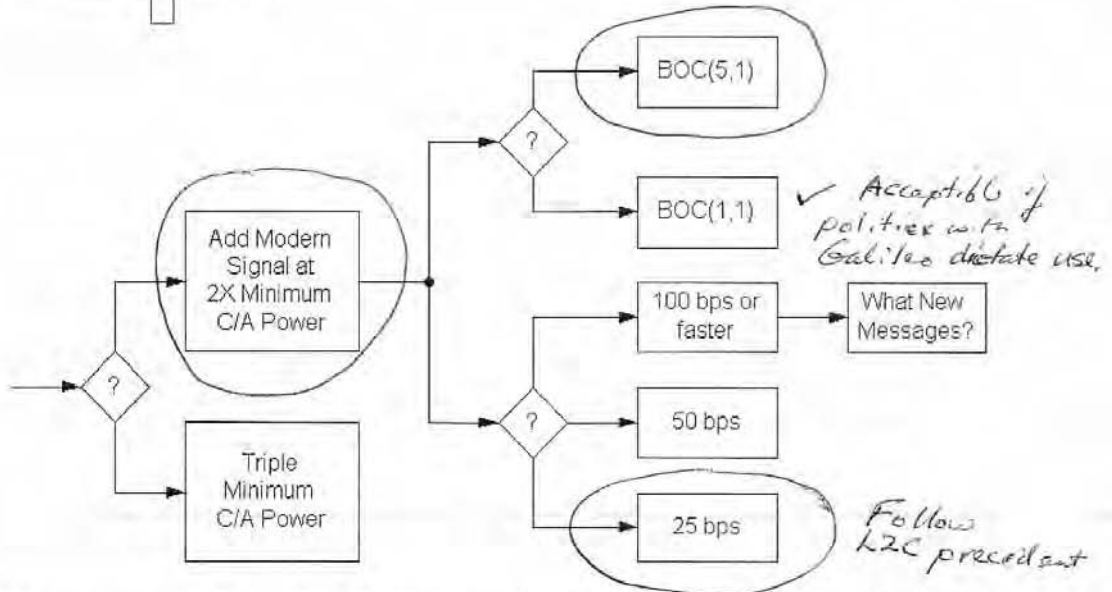

What new messages: The satellite's health (integrity) as part of ephemeris/clock correction data.

Comments: Excellent modernization plan for GPS III.

Signature: *Phillip W. Ward*

For Attribution?: Your Name: Yes No Your Organization: Yes No

Application Specific Questions

Name: Phillip W. Ward Date: 02/12/04

Title/Position President

Organization Navward GPS Consulting

Your Primary Expertise			<u>Applications</u>
	Professional & Scientific	Commercial	<p>1. I am a User Equipment (UE) design specialist with both Military & Commercial UE background. If I filled in the "Expected Number" and "Value" tables, I would use numbers from a source other than my own. <i>PWW</i></p>
Land			
Sea			
Air			
Space			

Expected Number of Users in 2005			
	Professional & Scientific	Commercial	Consumer
Land			
Sea			
Air			
Space			

Expected Number of Users in 2020			
	Professional & Scientific	Commercial	Consumer
Land			
Sea			
Air			
Space			

Value			
Parameter	Best Desired	Worst Acceptable	Importance
Accuracy			
TTFF			
Availability			
Continuity			
Integrity			
Robustness			

Importance: 1 = Very, 3 = Moderate, 5 = Not Significant

Intentionally Left Blank to Separate Responses

The Following is Reference # 26

L1 Modernization Project (L1C)

ION GPS/GNSS 2003

Purpose

- The US Government has not yet determined whether a modernized GPS L1 civil signal should be added.
- To solicit comments from civil and other GPS stakeholders about;
 - Whether or not a modernized GPS L1 civil signal should be added – and, if so

To be added

What types of modernization would be most valuable., and why ?

As to the coding of GPS messages, please make the deletion of ambiguity from the repeated use of 1 ms PRN code easier by using Hoffman Code, etc. Also, please make arrangements so that necessary data would be provided to users quickly through, for instance, adoption of CRC in the message code, or by making the message structure more flexible..

XX

Why Modernize ? L1 C/A is Excellent

- L1 C/A works well; It supports millions of users.
- Accuracy is astounding
 - Absolute accuracy is a few meters (good for most users)
 - Differential navigation can give sub-meter accuracy
 - Surveyors and scientists rely upon sub-centimeter differential results
- Interference is minimal
- Its being used for safety-of-life navigation
- Why consider changing anything so successful ?
 - “If it is not broken, why fix it” (there is room for improvement)

Your comment

L1 signal is sufficiently useful, but there remains a room for improvement.

XX

What are Opportunities for Improvement ?

- Any of the longer-coded L1C options would be less susceptible to narrowband interference than L1(C/A)
- Could improve cross-correlation properties
 - Improve indoor or wooded area use
 - Increase number of satellites and code signal power without causing unacceptable self-interference
 - Improve receiver signal acquisition threshold

- Navigation message could contain more Precision, flexibility, with forward error correction (FEC)
- Signal tracking and data demodulation thresholds (robustness) would be better with a modernized signal
- GPS III schedule presents an opportunity - requirements need to go into a CDD by Aug. 2004

Your comment

L5 is longer-coded, and L2 is planned in a longer-code. So, no more longer-code is required. Instead, the same level with the present L1 will be enough in view of quick initial acquisition. Much is expected of the flexibility of navigation message format.

Besides, message code with CRC, etc. is also looked for. Transmission of modernized L1 signal from GPS- is looked for..

XX

Proposed Objectives

- Compatible signal for legacy C/A receivers
 - Continue to provide the C/A code
 - Minimize added noise for C/A receivers
- New signals with better performance than C/A
 - Better correlation properties (longer codes)
 - More signal power and better threshold tracking
 - Improved performance indoors and under foliage
 - Improved message structure, precision, etc
 - Improved narrowband interference protection

Your comment

Signal and message structure compatible with the conventional C/A code receivers and improvement of accuracy are looked for. .

XX

L1C Data Rate Tradeoff

- L1C modernized data presumably will be similar to or the same as for L2C and L5
 - Forward error correction (FEC) also will be used
- Some data rate options::
 - 25 bps (L2C) provides data in challenged situations (such as urban canyons, indoors, in wooded areas)
 - 50 bps (L5) same as C/A now

100 bps would allow additional messages (e.g., Integrity warnings)

- What is best for your applications ?

Response

Rank 1 = best

Importance

: 10 = very important

5 = moderate

0 = not important

Data Rate	Your Rank	Importance
25bps	3	0
50bps	2	5
100bps	1	10

XX

L1C Signal Power Tradeoff

- Higher power signals generally are better
 - Better operation in challenged circumstances (interference, wooded areas, indoors, etc.)
 - More precise measurements (higher SNR)
- However, higher power L1C signals could slightly increase L1 C/A noise
 - Less than 0.5 dB, depending on the signal choice
- What is best for your applications ?

Response

Increase Signal Power Yes

Comment

Slightly stronger signal would be preferable

XX

L1C Code Length Tradeoff

- The C/A code length is 1.023 chips (short)
- Modernized codes are at least 10 times longer
- Longer codes have major advantages:
 - Eliminate cross-satellite interference
 - Reduce effect of narrowband interference
 - Enable more and more powerful satellite signals
- But, acquisition time (per correlator) is longer
 - Technology now permits thousands of correlators
- What is best for your applications ?

Response

The L1C code normally used for signal acquisition should be **10,230 chip**

Comment

We are developing GPS receivers for use in space. The signal acquisition in the vast space is a subject requiring intensive studies. Besides, the receiver being for space applications, thousands of correlator cannot be incorporated. For this reason, merits of modernized L1 signal may not be available to us, should the chip length be made longer..

XX

Adding L1C Messages – Which Ones ?

- GPS messages are only for navigation
- Added value messages might provide
 - Integrity warnings of “bad” satellite signals or weather, rescue, or other NAV-related messages
- What is the best integrity source ?
 - Ground signals, GEO satellites, RAIM, or GPS ?
 - With GPS plus Galileo, is RAIM sufficient ?
- What is best for your applications?

Response

Should the GPS data rate be increased to provide additional messages

Integrity **Yes**

DGPS **Yes**

Others

With GPS + Galileo, would RAIM be sufficient for integrity

No

GPS signal only may be received. In such event, it is preferable to have integrity data incorporated in GPS signal

XX

L1C Almanac & Ephemeris Precision

- C/A ephemeris precision is about 1 meter
- L1C ephemeris may have 1 cm precision
- Is this of any benefit for your applications ?

- L1C “compact almanac” may be less precise than C/A to cover more satellites faster
- Is this change desirable or not?

Response

Would increased precision of the GPS ephemeris be valuable

No

Would decrease precision of the almanac to provide more satellite quicker be valuable

No

Instead, please study the method of quicker Almanac broadcasting in the efforts for flexible message format structure.

XX

Your Reaction to L1C Modernization

- Do you favor L1 civil signal modernization ?

Yes

- What are your concerns ?

Emphasis on the usefulness of long code is enough to cause concerns for possible termination of short code.

- What are your desires ?

Modernization of message is specifically looked for, while maintaining the conventional short code.

- Why ?

Short signal acquisition time is to be maintained by continued use of short code.

Error of 1 ms code cycle is to be eliminated by Hoffman coding of messages (in the same manner with the L5C messages).

Information such as Almanac is to be acquired quickly by flexible message format.

Inclusion of Integrity data and DGPS data in messages is expected.

Respond to one of the following :

E-Mail: L1C_GPS@USGS.gov

Fax: +1-626-583-7827

Mail: L1C GPS, 525 South Wilson Ave., Pasadena, CA 91106-3212

Your Printed Name: Hiroaki Maeda

Title of Position : Assistant Manager, Satellite Solutions Planning Group

Organization : NEC Toshiba Space

Contact Information : maeda.hiroaki@ntspace.jp

Additional Cmmnts :

Intentionally Left Blank to Separate Responses

The Following is Reference # 27

L1C Questionnaire

Name: Takeshi Ono Date: Feb.10th.2004

Title/Position Engineering Manager

Organization NEC Toshiba Space Systems Ltd.

Address 4035 Ikebe-cho Tsuzuki-ku Yokohama Japan

Phone: +81-45-938-8345

E-Mail: ono.takeshi@ntspace.jp

Circle Preferences:

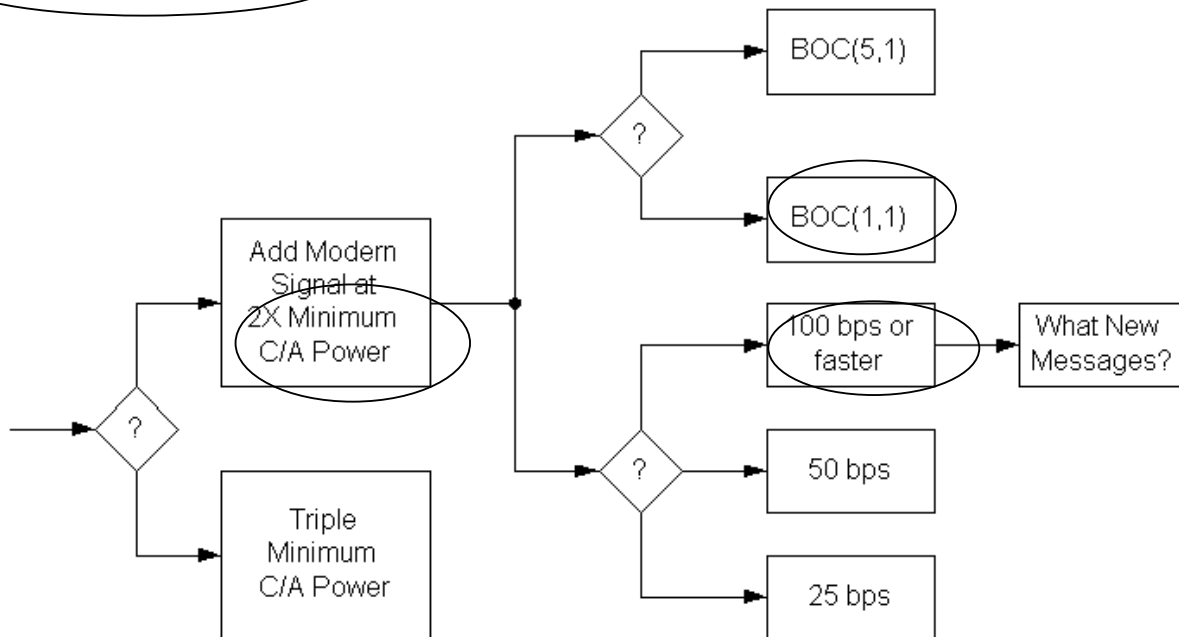

What new messages:
 Precise Ionosphere Correction Message
 Integrity message

Comments:
 Satellite anomaly should be broadcast immediately via message.

小野 岡

Signature: _____

For Attribution?: Your Name: Yes No

Your Organization: Yes No

Application Specific Questions

Name: Takeshi Ono Date: Feb.10th.2004

Title/Position Engineering Manager

Organization NEC Toshiba Space Systems Ltd.

Your Primary Expertise			
	Professional & Scientific	Commercial	Consumer
Land	X		
Sea			
Air			
Space		X	

Applications

1. Time transfer Receiver
2. Satellite Orbit Determination
3. Ionosphere and troposphere observation receiver

Expected Number of Users in 2005			
	Professional & Scientific	Commercial	Consumer
Land	2000000		
Sea			
Air			
Space		50	

Expected Number of Users in 2020			
	Professional & Scientific	Commercial	Consumer
Land	10000000		
Sea			
Air			
Space		100	

Value			
Parameter	Best Desired	Worst Acceptable	Importance
Accuracy	1m	10m	1
TTFF	180sec	60sec	2
Availability	99.999%	99.99%	2
Continuity	$1 \cdot 10^{-5} / h$	$1 \cdot 10^{-4} / h$	2
Integrity	$10^{-7} / h$	$10^{-6} / h$	1
Robustness			2

Importance: 1 = Very, 3 = Moderate, 5 = Not Significant

Intentionally Left Blank to Separate Responses

The Following is Reference # 28

L1C Questionnaire

Name: Kazumi Sagawa Date: Feb.18th.2004
 Title/Position Engineering Manager
 Organization NEC Toshiba Space Systems Ltd.
 Address 4035 Ikebe-cho Tsuzuki-ku Yokohama Japan
 Phone: +81-45-938-8242 E-Mail: sagawa.kazumi@ntspace.jp

Circle Preferences:

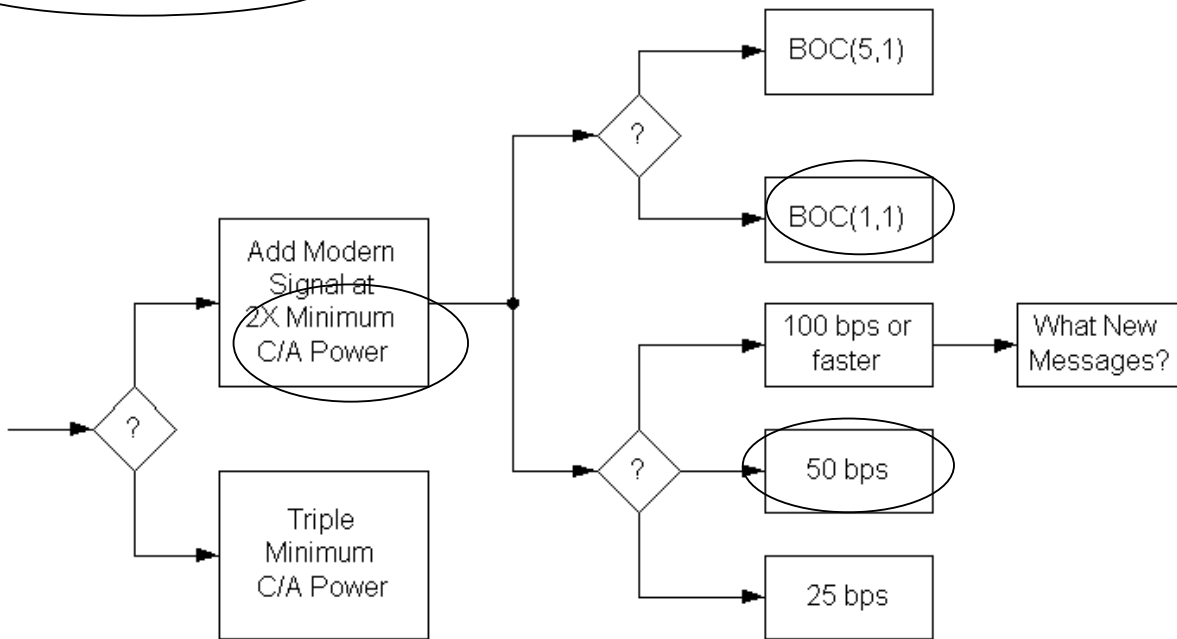

What new messages:

Comments:

A necessary data rate may be sufficient for the GPS in 25bps.
 But, the EIRP had better be big so that it will be able to expand it like SBAS.

Handwritten signature: 佐川 一美

Signature: _____

For Attribution?: Your Name: Yes No Your Organization: Yes No

Intentionally Left Blank to Separate Responses

The Following is Reference # 29

Date: Fri, 19 Dec 2003 14:23:45 -0500
From: "Dennis Milbert" <Dennis.Milbert@noaa.gov>
To: Tom@Stansell.com
CC: hudnut@gps.caltech.edu,
Dennis Milbert <Dennis.Milbert@noaa.gov>,
Charlie Challstrom <Charlie.Challstrom@noaa.gov>,
David.Turner@ta.doc.gov
Subject: NGS comments on L1 Modernization

Dear Tom,

Thanks again for the briefing. Here are our comments

=====

Responses to L1C Questionnaire:

Based on the the collected comments and discussion at the meeting, the following is the National Geodetic Survey, NOS, NOAA response. We note that other elements in NOS and in NOAA may have similar or differing viewpoints.

We prefer a modernized L1C signal. This would give the opportunity to provide a data-less signal component that would have useful carrier phase tracking properties.

We have no preference regarding BOC(1,1) vs. BOC(5,1). We are primarily interested in accurate carrier phase and ambiguity resolution. Pseudorange (PR) accuracy is a secondary, albeit, important item. Neither signal type has a major PR difference, particularly if narrow correlator multipath suppression technology is utilized.

We have no preference regarding message bit rate.

We have no preference regarding new messages. We will be operating in a multifrequency mode, so L2C and L5 messaging will be available. We will have access to the messages on those channels.

The general comments from our group:

More robustness against cycle slips would be welcome.

Current signal options show no improvement to ambiguity resolution -- makes discussion less interesting.

Calibration of satellite antenna phase centers to center of mass of the satellite is crucial.

Calibration of signals, possibly permitting undifferenced ambiguity resolution would be very interesting.

Respectfully submitted,

Dr. Dennis G. Milbert
Chief Geodesist
NOAA, National Geodetic Survey, N/NGS
1315 East-West Hwy., SSMC3, Room 8635
Silver Spring, MD 20910-3282

phone: 301-713-3222 x144
fax: 301-713-4315
internet: Dennis.Milbert@noaa.gov

Intentionally Left Blank to Separate Responses

The Following is Reference # 30

L1C Questionnaire

Name: Toshiaki Iwata Date: 2004/02/12

Title/Position Senior Research Scientist

Organization _____

Address _____

Phone: +81-29-861-5706 E-Mail: _____

Circle Preferences:

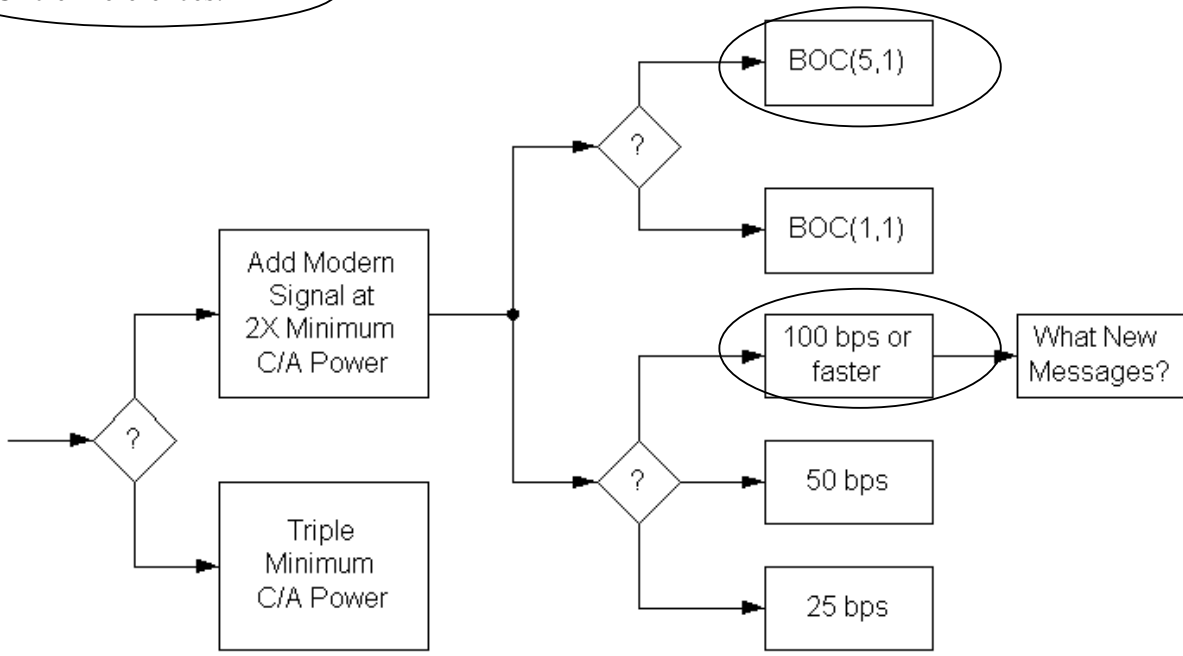

What new messages: the difference among GPS time, UTC(CRL) and UTC(NMIJ)

Comments:

Signature: _____

For Attribution?: Your Name: Yes No Your Organization: Yes No

Application Specific Questions

Name: Toshiaki Iwata Date: 2004/02/12

Title/Position Senior Research Scientist

Organization _____

Your Primary Expertise			
	Professional & Scientific	Commercial	Consumer
Land			✓
Sea			
Air			
Space	✓		

Applications

1. Synchronization of distributed power supply.
2. Locational identification of distributed power supply.

Expected Number of Users in 2005			
	Professional & Scientific	Commercial	Consumer
Land			10
Sea			
Air			
Space			

Expected Number of Users in 2020			
	Professional & Scientific	Commercial	Consumer
Land			10000
Sea			
Air			
Space			

Value			
Parameter	Best Desired	Worst Acceptable	Importance
Accuracy			
TTF			
Availability			
Continuity			
Integrity			
Robustness			

Importance: 1 = Very, 3 = Moderate, 5 = Not Significant

Intentionally Left Blank to Separate Responses

The Following is Reference # 31

L1 Modernization Project (L1C)

ION GPS/GNSS 2003

Purpose

- The US Government has not yet determined whether a modernized GPS L1 civil signal should be added.
- To solicit comments from civil and other GPS stakeholders about;
 - Whether or not a modernized GPS L1 civil signal should be added – and, if so
 - What types of modernization would be most valuable., and why ?

XX

Why Modernize ? L1 C/A is Excellent

- L1 C/A works well; It supports millions of users.
- Accuracy is astounding
 - Absolute accuracy is a few meters (good for most users)
 - Differential navigation can give sub-meter accuracy
 - Surveyors and scientists rely upon sub-centimeter differential results
- Interference is minimal
- Its being used for safety-of-life navigation
- Why consider changing anything so successful ?
 - “If it is not broken, why fix it” (there is room for improvement)

Your comment

My personal basic conception is such that the full compatibility with the conventional C/A code (meaning that the present code can be used without any change) should be the major premise of the proposed change. If it is not feasible, the signal change should be abandoned regardless of the development expenditures, because the impact on the end users is infinite..

XX

What are Opportunities for Improvement ?

- Any of the longer-coded L1C options would be less susceptible to narrowband interference than L1(C/A)
- Could improve cross-correlation properties
 - Improve indoor or wooded area use
 - Increase number of satellites and code signal power without causing unacceptable self-interference
 - Improve receiver signal acquisition threshold
- Navigation message could contain more
 - Precision, flexibility, with forward error correction (FEC)

L1C Data Rate Tradeoff

- L1C modernized data presumably will be similar to or the same as for L2C and L5
Forward error correction (FEC) also will be used
- Some data rate options::
25 bps (L2C) provides data in challenged situations (such as urban canyons, indoors, in wooded areas)
50 bps (L5) same as C/A now
100 bps would allow additional messages (e.g.. Integrity warnings)
- What is best for your applications ?

Response

Rank 1 = best

Importance

: 10 = very important

5 = moderate

0 = not important

Data Rate	Your Rank	Importance
25bps	1	10
50bps	2	5
100bps	3	0

XX

L1C Signal Power Tradeoff

- Higher power signals generally are better
Better operation in challenged circumstances (interference, wooded areas, indoors, etc.)
More precise measurements (higher SNR)
- However, higher power L1C signals could slightly increase L1 C/A noise
Less than 0.5 dB, depending on the signal choice
- What is best for your applications ?

Response

Increase Signal Power No

Comment

A higher priority on the existing C/A code users.

There will not be any problem, even if it is not specifically high, as it has to be left to manufacturers' efforts.

XX

L1C Code Length Tradeoff

- The C/A code length is 1.023 chips (short)
- Modernized codes are at least 10 times longer

L1C Almanac & Ephemeris Precision

- C/A ephemeris precision is about 1 meter
- L1C ephemeris may have 1 cm precision
- Is this of any benefit for your applications ?
- L1C “compact almanac” may be less precise than C/A to cover more satellites faster
- Is this change desirable or not?

Response

Would increased precision of the GPS ephemeris be valuable

No

Would decrease precision of the almanac to provide more satellite quicker be valuable

Yes

XX

Your Reaction to L1C Modernization

- **Do you favor L1 civil signal modernization ?**

It is difficult to say Yes or No at present.

- **What are your concerns ?**

Coordination with the present C/A code users is the prerequisite.

GPS modernization project itself may be delayed by too hefty ideal.

Isn't it possible to cope with L2C that is already close at hand?

- **What are your desires ?**

Our desires as below:

Support of multi-path removal through improved correlation performance.

Short Ephemeris acquisition time through reduced length of navigation message (less than 10 seconds).

With improvement of the present 1 ms C/A code chip rate. SS frequency diffusion is increased. Thus, development of compact-size equipment as well as development of technology to reduce positioning interval are made easier.

However, the foregoing may be realized by L2C as well.

- **Why ?**

As per the above .

Respond to one of the following :

E-Mail: L1C_GPS@USGS.gov

Fax: +1-626-583-7827

Mail: L1C GPS, 525 South Wilson Ave., Pasadena, CA 91106-3212

Your Printed Name: Mitsuma C. Izawa

Title of Position : Senior Manager

Organization : Nikon-Trimble Co Ltd

Contact Information : mitsuma_izawa@trimble.co

Additional Cmmnts :

Intentionally Left Blank to Separate Responses

The Following is Reference # 32

L1C Questionnaire

Name: Pat Fenton on behalf of NovAtel Inc. _____ Date: April 2, 2004

Title/Position Chief Technology Officer _____

Organization NovAtel Inc. _____

Address 1120 68th Avenue N.E., Calgary Alberta Canada

Phone: (403) 295-4539 _____

E-Mail: pfenton@novatel.ca

Circle Preferences:

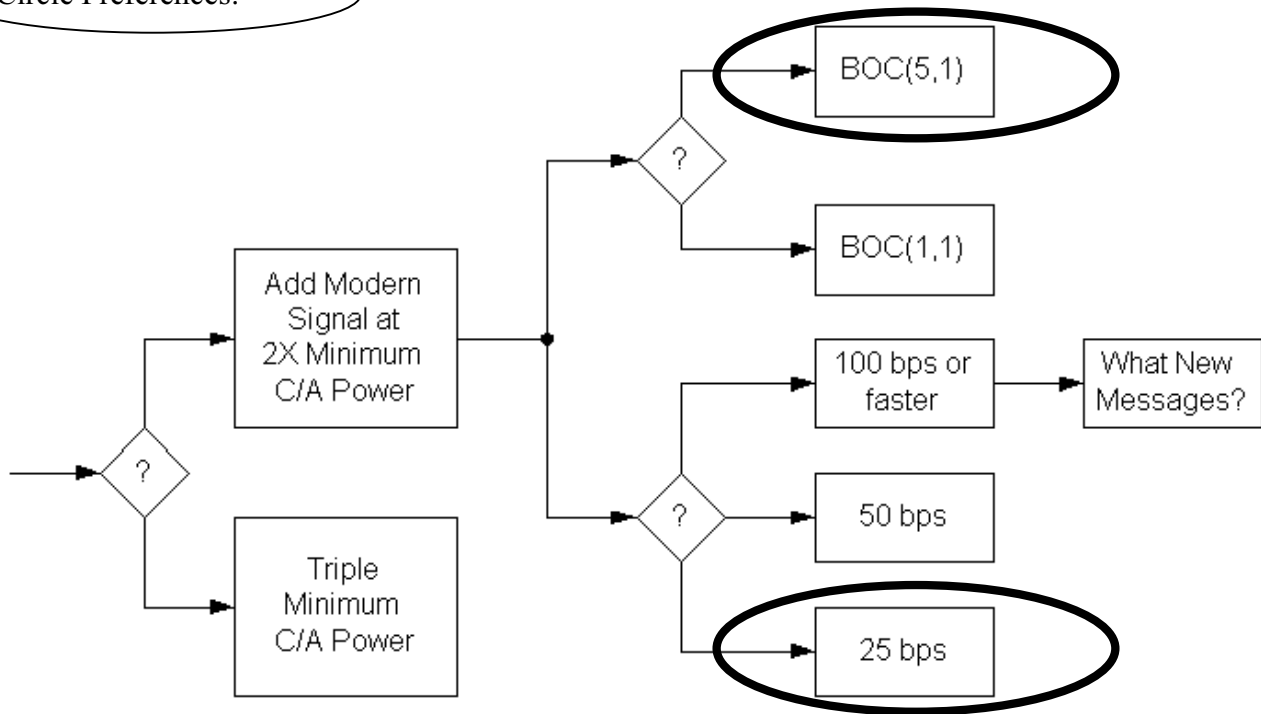

What new messages:

Comments:

Signature: Pat F. _____

For Attribution?: Your Name: Yes No

Your Organization: Yes No

Application Specific Questions

Name: Pat Fenton Date: April 2,2004

Title/Position Chief Technology Officer

Organization NovAtel Inc.

Your Primary Expertise			
	Professional & Scientific	Commercial	Consumer
Land	X	X	
Sea	X	X	
Air	X	X	
Space			

Expected Number of Users in 2005			
	Professional & Scientific	Commercial	Consumer
Land	X000	X0,000	
Sea	X0	X00	
Air	X0	X00	
Space	X		

Expected Number of Users in 2020			
	Professional & Scientific	Commercial	Consumer
Land	X0,000	X,000,000	
Sea	X00	X0,000	
Air	X00	X0,000	
Space	X0		

Applications

1. We sell cards into most application areas; air, land, sea, cars, trains, UAVs, survey instruments, seismic, Jet trainers, Aircraft landing, takeoff, in-route, deformation monitoring, Asset tracking, Timing, Ground reference networks,

Value			
Parameter	Best Desired	Worst Acceptable	Importance
Accuracy	0.1m	1m	1 (OEM) 2 (Aviation)
TTFF	60	120	3
Availability	100	99%	2
Continuity	100	99%	2
Integrity	Yes		1(Aviation), 3 (OEM)
Robustness	Yes		1

Importance: 1 = Very, 2 = Moderate, 5 = Not Significant

Intentionally Left Blank to Separate Responses

The Following is Reference # 33

L1C Questionnaire

Name: _____ Dorota Brzezinska, Charles Toth _____ Date: May 21, 2004

Title/Position _____ Associate Professor, Sr. Research Scientist _____

Organization _____ The Ohio State University _____

Address _____ 470 Hitchcock Hall, 2070 Neil Avenue, Columbus, OH 43210-1275 _____

Phone: _____ 614 292-8787 _____ E-Mail: _____ dbrzezinska@osu.edu, toth.2@osu.edu _____

Circle Preferences:

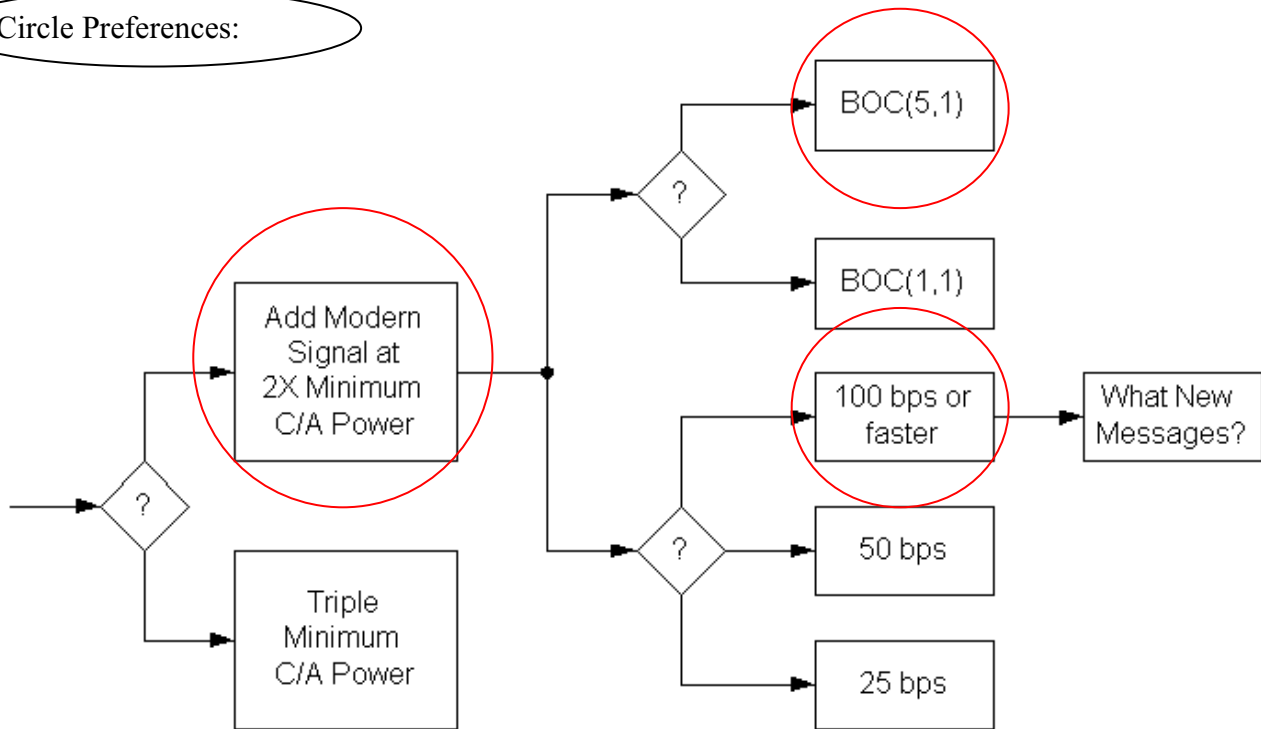

What new messages:

Differential corrections, ionosphere in particular (it would make sense if the user receives all the relevant information from one source), integrity information

Comments:

Expecting advances in signal processing to continue at the current pace, the implementation of BOC(5,1) will be feasible in the planned time frame for modernization.

Signature: _____

For Attribution?: Your Name: Yes No

Your Organization: Yes No

Application Specific Questions

Name: _____ Dorota Brzezinska, Charles Toth _____ Date: May 21, 2004

Title/Position _____ Associate Professor, Sr. Research Scientist _____

Organization _____ The Ohio State University _____

Your Primary Expertise			
	Professional & Scientific	Commercial	Consumer
Land	X		
Sea			
Air	X		
Space			

Applications

1. Land-based mobile mapping
2. Airborne mapping
3. RTK
4. Airborne and land-based gravimetry

Expected Number of Users in 2005			
	Professional & Scientific	Commercial	Consumer
Land	No change	Growing	Growing
Sea			
Air	No change	Growing	Growing
Space			

Expected Number of Users in 2020			
	Professional & Scientific	Commercial	Consumer
Land	Growing	10x	10x
Sea			
Air	Growing	2x	2x
Space			

Value			
Parameter	Best Desired	Worst Acceptable	Importance
Accuracy	cm-level	dm-level	1
TTF			5
Availability			1
Continuity			3
Integrity			3
Robustness			3

Importance: 1 = Very, 3 = Moderate, 5 = Not Significant

Intentionally Left Blank to Separate Responses

The Following is Reference # 34

L1C Questionnaire

Name: Michael S. Braasch Date: July 9, 2004

Title/Position: Professor of Electrical Engineering

Organization: Ohio University / Avionics Engineering Center

Address 322D Stocker Center, Ohio University, Athens, OH 45701-2979

Phone: 740-593-0105 E-Mail: braaschm@ohio.edu

Circle Preferences:

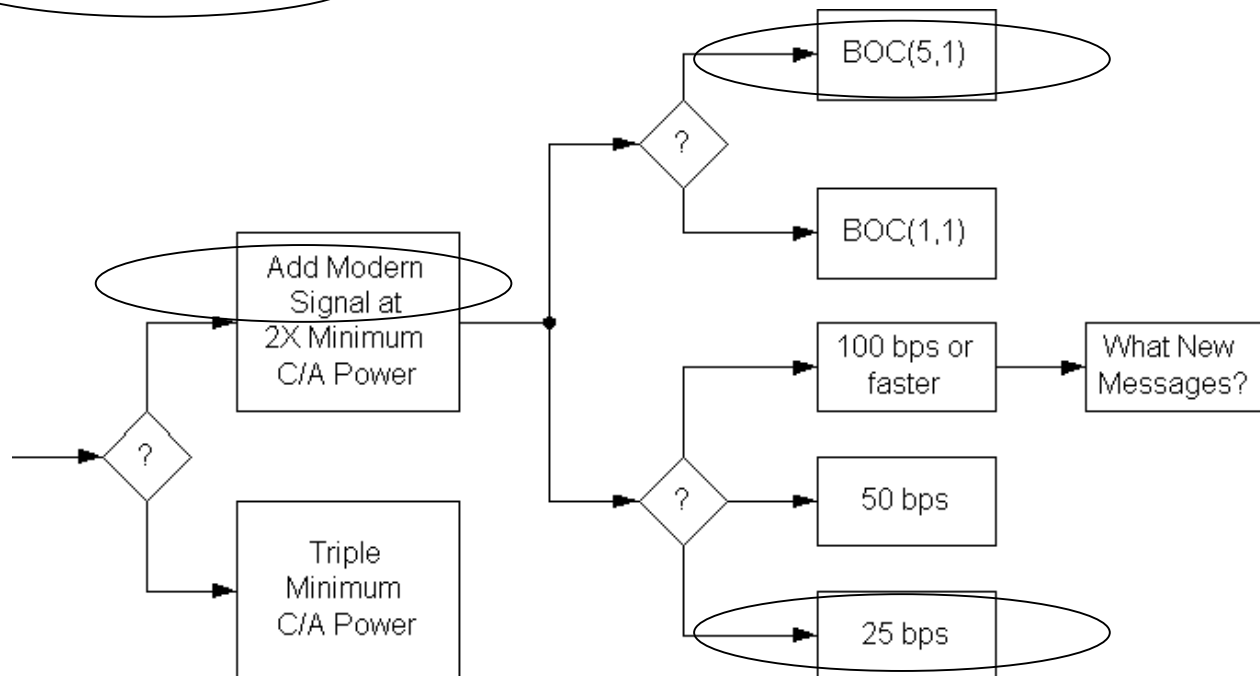

What new messages: NONE

Comments: A new modernized signal is highly desirable. It allows us to take advantage of many if not all of the improvements which have been identified or implemented elsewhere. These improvements include longer codes (which reduce various forms of interference), message improvements and a data-free signal component. Although there are both advantages and disadvantages associated with increased and decreased message data rates, the lower data rate (25 bps) is preferred since it extends system performance in low signal-strength environments. The TTFF concerns can easily be eliminated simply by placing a day's worth of ephemeris messages onto the web and other media. Both the BOC (1,1) and the BOC (5,1) are acceptable. The BOC (5,1) is preferred since it provides less interference both to M-code and the C/A-code and it can offer better code-loop tracking accuracy.

Signature: Michael S. Braasch

For Attribution?: Your Name: Yes Your Organization: Yes

Application Specific Questions

Name: Michael S. Braasch Date: July 9, 2004

Title/Position Professor of Electrical Engineering

Organization Ohio University / Avionics Engineering Center

Your Primary Expertise

	Professional & Scientific	Commercial	Consumer
Land			
Sea			
Air	X	x	x
Space			

Expected Number of Users in 2005

	Professional & Scientific	Commercial	Consumer
Land			
Sea			
Air	20,000	10,000	50,000
Space			

Expected Number of Users in 2020

	Professional & Scientific	Commercial	Consumer
Land			
Sea			
Air	50,000	30,000	150,000
Space			

Applications

1. Guidance, navigation, and surveillance of civilian aircraft (both unmanned and manned).

Value

Parameter	Best Desired	Worst Acceptable	Importance
Accuracy	Centimeter-level	20 meters (horizontal)	3
TTF	Instantaneous	2 minutes	3
Availability	100%	5 minutes per day of unavailability	1
Continuity	100%	Probability of loss of continuity less than 1e-5 per 120 seconds	1
Integrity	100%	Probability of loss of integrity less than 1e-7 per hour	1
Robustness	'bulletproof'	Needs to be no worse than the existing C/A code	1

Importance: 1 = Very, 3 = Moderate, 5 = Not Significant

Intentionally Left Blank to Separate Responses

The Following is Reference # 35

L1C Questionnaire

Name: Toshihiro Ishigaki Date: 26 J anuary 2004

Title/Position Staff Engineer

Organization Matsushita Electric Industrial Co.,Ltd. Panasonic Automotive Systems Company

Address 600 Saedo-cho Tsuzuki-ku Yokohama J apan

Phone: +81 45 939 1249

E-Mail: ishigaki.toshihiro@jp.panasonic.com

Circle Preferences:

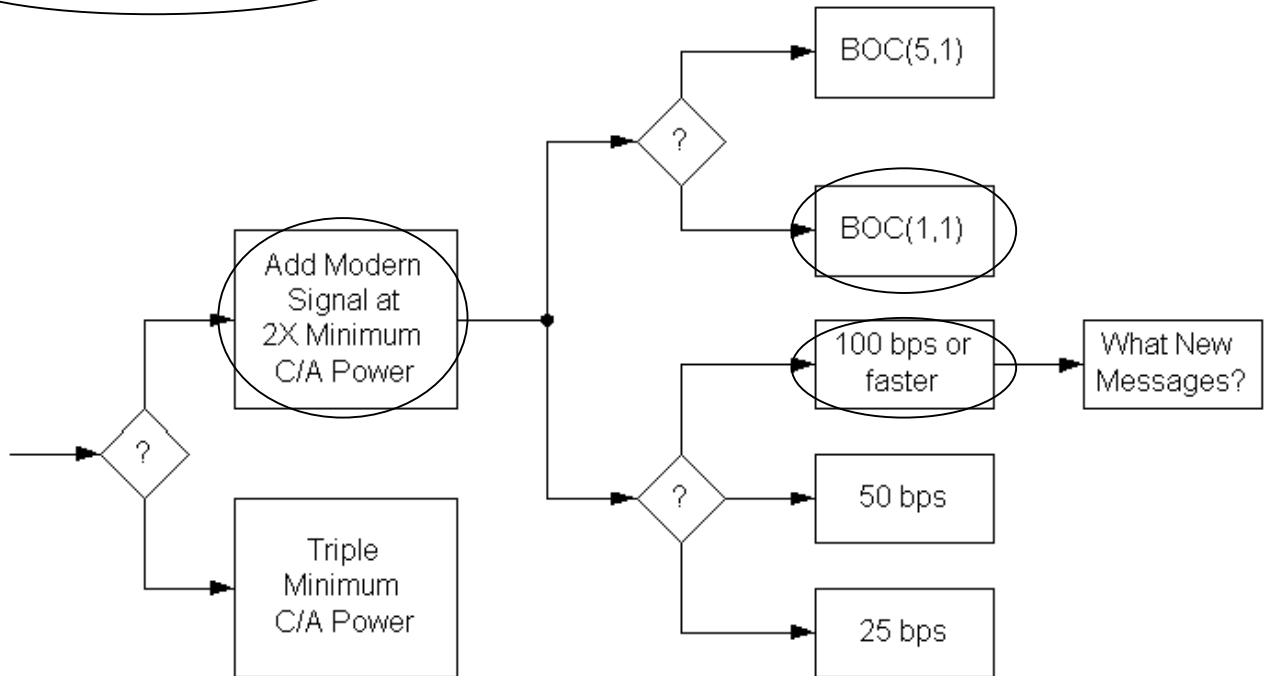

What new messages:

I hope no additional messages. I want to get ephemeris faster.

Comments:

I request strongly that the impact on existing C/A receivers is negligible.

My expectations for new L1C signal are as follows.

- (1) Reduce effect of interference
- (2) Improve TTFF

Signature: _____

For Attribution?: Your Name: Yes No Your Organization: Yes No

Application Specific Questions

Name: Toshihiro Ishigaki Date: 26 January 2004

Title/Position Staff Engineer

Organization Matsushita Electric Industrial Co.,Ltd. Panasonic Automotive Systems Company

Your Primary Expertise			
	Professional & Scientific	Commercial	Consumer
Land			○
Sea			
Air			
Space			

Expected Number of Users in 2005			
	Professional & Scientific	Commercial	Consumer
Land			?
Sea			
Air			
Space			

Expected Number of Users in 2020			
	Professional & Scientific	Commercial	Consumer
Land			?
Sea			
Air			
Space			

Applications

1. Car Navigation System

Value			
Parameter	Best Desired	Worst Acceptable	Importance
Accuracy			3
TTF			1
Availability		○	3
Continuity			1
Integrity			1
Robustness	○		1

Importance: 1 = Very, 3 = Moderate, 5 = Not Significant

L1 Modernization Project (L1C)

ION GPS/GNSS 2003

Purpose

- The US Government has not yet determined whether a modernized GPS L1 civil signal should be added.
- To solicit comments from civil and other GPS stakeholders about;
Whether or not a modernized GPS L1 civil signal should be added – and, if so –

To be added

What types of modernization would be most valuable, and why ?

The same signal structure as with L2C or L5 is preferable.

Reasons It is not desirable to have more number of signals with different structures .

XX

Why Modernize ? L1 C/A is Excellent

- L1 C/A works well; It supports millions of users.
- Accuracy is astounding
Absolute accuracy is a few meters (good for most users)
Differential navigation can give sub-meter accuracy
Surveyors and scientists rely upon sub-centimeter differential results
- Interference is minimal
- Its being used for safety-of-life navigation
- Why consider changing anything so successful ?
“If it is not broken, why fix it” (there is room for improvement)

Your comment

Certainly, L1 signal is sufficiently useful at present. However, it might be felt to be outdated, when L2C and L5 have come to be provided, especially when Galileo services have come to be commenced.

XX

What are Opportunities for Improvement ?

- Any of the longer-coded L1C options would be less susceptible to narrowband interference than L1(C/A)
- Could improve cross-correlation properties
Improve indoor or wooded area use
Increase number of satellites and code signal power without causing unacceptable self-interference
Improve receiver signal acquisition threshold
- Navigation message could contain more
Precision, flexibility, with forward error correction (FEC)
- Signal tracking and data demodulation thresholds (robustness) would be better with a modernized signal
- GPS III schedule presents an opportunity - requirements need to go into a CDD by Aug. 2004

L1C Signal Power Tradeoff

- Higher power signals generally are better
 - Better operation in challenged circumstances (interference, wooded areas, indoors, etc.)
 - More precise measurements (higher SNR)
- However, higher power L1C signals could slightly increase L1 C/A noise
 - Less than 0.5 dB, depending on the signal choice
- What is best for your applications ?

Response

Increase Signal Power Yes

Comment

It is necessary to minimize the L1 C/A noise, but greater resistance against other noise sources is looked for

XX

L1C Code Length Tradeoff

- The C/A code length is 1.023 chips (short)
- Modernized codes are at least 10 times longer
- Longer codes have major advantages:
 - Eliminate cross-satellite interference
 - Reduce effect of narrowband interference
 - Enable more and more powerful satellite signals
- But, acquisition time (per correlator) is longer
 - Technology now permits thousands of correlators
- What is best for your applications ?

Response

The L1C code normally used for signal acquisition should be 10,230 chip

Comment

About this level would be appropriate in consideration of the signal acquisition time.

XX

Adding L1C Messages – Which Ones ?

- GPS messages are only for navigation
- Added value messages might provide
 - Integrity warnings of “bad” satellite signals or weather, rescue, or other NAV-related messages
- What is the best integrity source ?
 - Ground signals, GEO satellites, RAIM, or GPS ?
 - With GPS plus Galileo, is RAIM sufficient ?

- What is best for your applications?

Response

Should the GPS data rate be increased to provide additional messages

Integrity **Yes**
 DGPS **Yes**
 Others **Yes**

With GPS + Galileo, would RAIM be sufficient for integrity

No

XX

L1C Almanac & Ephemeris Precision

- C/A ephemeris precision is about 1 meter
- L1C ephemeris may have 1 cm precision
- Is this of any benefit for your applications ?
- L1C “compact almanac” may be less precise than C/A to cover more satellites faster
- Is this change desirable or not?

Response

Would increased precision of the GPS ephemeris be viable

Yes

Would decrease precision of the almanac to provide more satellite quicker be viable

Yes

XX

Your Reaction to L1C Modernization

- **Do you favor L1 civil signal modernization ?**
Yes
- **What are your concerns ?**
Interference with the present C/A code and the issue of signal acquisition time
- **What are your desires ?**
Establishment of compatibility and inter-operability with Galileo and QZSS

- **Why ?**

Upon commencement of Galileo or QZSS services, they will be used side by side with GPS services in general

Respond to one of the following :

E-Mail: L1C_GPS@USGS.gov

Fax: +1-626-583-7827

Mail: L1C GPS, 525 South Wilson Ave., Pasadena, CA 91106-3212

Your Printed Name: Toshihiro Ishigaki

Title of Position : Chief Engineer, R&D Center

Organization : Matsushita, Panasonic Automotive Systems

Contact Information : ishigaki.toshihiro@jp.panasonic.com

Additional Cmmnts :

Intentionally Left Blank to Separate Responses

The Following is Reference # 36

To: L1C_gps@usgs.gov
From: ronlee@pcisys.net
Subject: L1C modernization input
Date: Thu, 9 Oct 2003 20:53:07 GMT

The overall survey is fundamentally flawed. It acts as though L1 C/A is the only signal. Well before any L1C signal could be implemented L2C and L5 signals will be on-orbit. Thus the overall improvement needs to be evaluated in terms of three signals. Many of the assumed "shortfall" of L1 C/A should have been addressed in the design of L2C and L5.

The other major concern is the likelihood that current and future L1 C/A receivers in millions of UE will be rendered obsolete by the proposed L1C signal when ultimately the power used to transmit L1 C/A is diverted to other civil signals.

If there is ANY possibility that L1 C/A will be shut off then I am opposed to any minimal overall benefits in transitioning from a L1 C/A, L2C, L5 nav signal architecture to a L1C, L2C, L5 architecture.

I am a daily user of GPS (aviation) with three receivers worth over \$ 11,000. Under no circumstance could I justify changing them out to even use L2C/L5 much less an " improved" L1 signal.

Intentionally Left Blank to Separate Responses

The Following is Reference # 37

L1 Modernization Project (L1C)

ION GPS/GNSS 2003

Purpose :

- The US Government has not yet determined whether a modernized GPS L1 civil signal should be added.
- To solicit comments from civil and other GPS stakeholders about;
 - Whether or not a modernized GPS L1 civil signal should be added – and, if so
 - What types of modernization would be most valuable., and why ?

XX

Why Modernize ? L1 C/A is Excellent

- L1 C/A works well; It supports millions of users.
- Accuracy is astounding
 - Absolute accuracy is a few meters (good for most users)
 - Differential navigation can give sub-meter accuracy
 - Surveyors and scientists rely upon sub-centimeter differential results
- Interference is minimal
- Its being used for safety-of-life navigation
- Why consider changing anything so successful ?
 - “If it is not broken, why fix it” (there is room for improvement)

<Your comment ? >

There is no problem with the present level of accuracy, when car navigation only is taken into thought. What is required is the system being maintained stably and continuously in the foreseeable future as well..

XX

What are Opportunities for Improvement ?

- Any of the longer-coded L1C options would be less susceptible to narrowband interference than L1(C/A)
- Could improve cross-correlation properties
 - Improve indoor or wooded area use
 - Increase number of satellites and code signal power without causing unacceptable self-interference
 - Improve receiver signal acquisition threshold
- Navigation message could contain more
 - Precision, flexibility, with forward error correction (FEC)
- Signal tracking and data demodulation thresholds (robustness) would be better with a modernized signal
- GPS III schedule presents an opportunity - requirements need to go into a CDD by Aug. 2004

<Your comment ? >

Present GPS is used for car navigation by augmenting its shortfalls by map-matching and inertial navigation with gyro and car velocity pulse detection. Present GPS is satisfactory to that extent.

XX

Proposed Objectives

- Compatible signal for legacy C/A receivers
 - Continue to provide the C/A code
 - Minimize added noise for C/A receivers
- New signals with better performance than C/A
 - Better correlation properties (longer codes)
 - More signal power and better threshold tracking
 - Improved performance indoors and under foliage
 - Improved message structure, precision, etc
 - Improved narrowband interference protection

<Your comment ? >

Compatibility with the present system and continued provision of C/A code are indispensable. Nothing more is required at present.

XX

L1C Data Rate Tradeoff :

- L1C modernized data presumably will be similar to or the same as for L2C and L5
 - Forward error correction (FEC) also will be used
- Some data rate options::
 - 25 bps (L2C) provides data in challenged situations (such as urban canyons, indoors, in wooded areas)
 - 50 bps (L5) same as C/A now
 - 100 bps would allow additional messages (e.g.. Integrity warnings)
- What is best for your applications ?

Response

Rank : 1 = best

Importance :

: 10 = very important

5 = moderate

0 = not important

Data Rate	Your Rank	Importance
25bps	3	0
50bps	1	10
100bps	2	0

XX

L1C Signal Power Tradeoff :

- Higher power signals generally are better
 - Better operation in challenged circumstances (interference, wooded areas, indoors, etc.)
 - More precise measurements (higher SNR)
- However, higher power L1C signals could slightly increase L1 C/A noise
 - Less than 0.5 dB, depending on the signal choice
- What is best for your applications ?

Response :

Increase Signal Power : Yes

Comment :

Better resistance against interference is necessary for stable operation, but there is no specific problem with the current level. It would become necessary upon identification of new interference sources that have negative effects on GPS in the future.

XX

L1C Code Length Tradeoff :

- The C/A code length is 1.023 chips (short)
- Modernized codes are at least 10 times longer
- Longer codes have major advantages:
 - Eliminate cross-satellite interference
 - Reduce effect of narrowband interference
 - Enable more and more powerful satellite signals
- But, acquisition time (per correlator) is longer
 - Technology now permits thousands of correlators
- What is best for your applications ?

Response :

The L1C code normally used for signal acquisition should be :

Comment :

1023 is a minimum requirement, as present 1023 chip is usable. The shorter the better for mobile applications, as the signal acquisition time is prolonged with longer chips.

XX

Adding L1C Messages – Which Ones ?

- GPS messages are only for navigation
- Added value messages might provide
 - Integrity warnings of “bad” satellite signals or weather, rescue, or other NAV-related messages
- What is the best integrity source ?
 - Ground signals, GEO satellites, RAIM, or GPS ?
 - With GPS plus Galileo, is RAIM sufficient ?
- What is best for your applications?

Response :

Should the GPS data rate be increased to provide additional messages ?

Integrity : **No**

DGPS : **No**

Others : **No**

With GPS + Galileo, would RAIM be sufficient for integrity ?

Reply is reserved, as it is not examined yet.

XX

L1C Almanac & Ephemeris Precision

- C/A ephemeris precision is about 1 meter
- L1C ephemeris may have 1 cm precision
- Is this of any benefit for your applications ?
- L1C “compact almanac” may be less precise than C/A to cover more satellites faster
- Is this change desirable or not?

Response :

Would increased precision of the GPS ephemeris be valuable ?

Yes (Talking about which is better)

Would decrease precision of the almanac to provide more satellite quicker be valuable ?

No

XX

Your Reaction to L1C Modernization :

- Do you favor L1 civil signal modernization ?
 - Yes**
 - Welcome, if compatible.**
- What are your concerns ?
 - Continuation of present compatibility and present system operation.**
- What are your desires ?

Continued availability of free-of-charge services.

- **Why ?**
Continued provision of present services is wanted.

Respond to one of the following :

E-Mail: L1C_GPS@USGS.gov

Fax: +1-626-583-7827

Mail: L1C GPS, 525 South Wilson Ave., Pasadena, CA 91106-3212

Your Printed Name: Hitoshi Ando

Title of Position : Manager Engineering Department IV

Organization : Pioneer Corporation, Mobile Entertainment Company

Contact Information : hitoshi_ando@post.pioneer.co.jp

Additional Cmmnts :

Intentionally Left Blank to Separate Responses

The Following is Reference # 38

Questionnaire

Name: YOSHIYUKI KIGURE Date: 2004/2/6

Title/Position General Manajer Planing&Coordination Division
Mobile Entertainment Company

Organization PIONEER CORPORATION

Address 1-4-1 MEGURO, MEGURO-KU TOKYO 135-8654 J APAN

Phone: +81-3-3495-4564
 -Mail: yoshiyuki_kigure@post.pioneer.co.jp

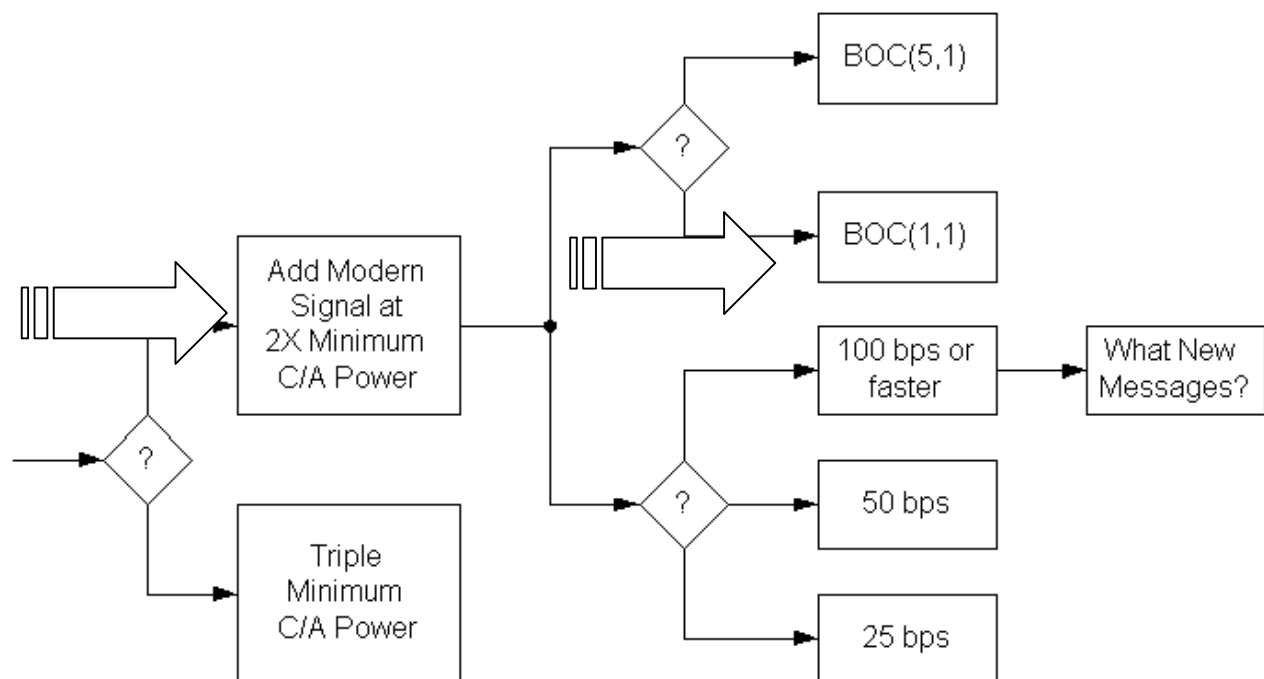

Comments:

First, I choose the upper plan ,and next BOC(1.1) method pointed out by arrows.

Because, I'm afraid the first lower plan, that is Triple Minimum C/A power, would have the wrong influences to the weak signal and forces a wide receiver bandwidth that are big disadvantages..

On the contrary, New LC1 Signal have much merits as written in documents .

On the next question, I think BOC(1.1) method seem to be fit for the date structure improvements in many ways, such as less effective multi path mitigation, lead to compact almanac, and so on.

I do BOC(1.1) .

Signature: YOSHIYUKI KIGURE

Intentionally Left Blank to Separate Responses

The Following is Reference # 39

L1C Questionnaire

Name: Dr. Norman F. Krasner Date: July 7, 2004

Title/Position Vice President, Technology

Organization Qualcomm

Address 675 Campbell Technology Parkway, Suite 200, Campbell, CA. 95008

Phone: 408-626-0502 E-Mail: nkrasner@qualcomm.com

Circle Preferences:

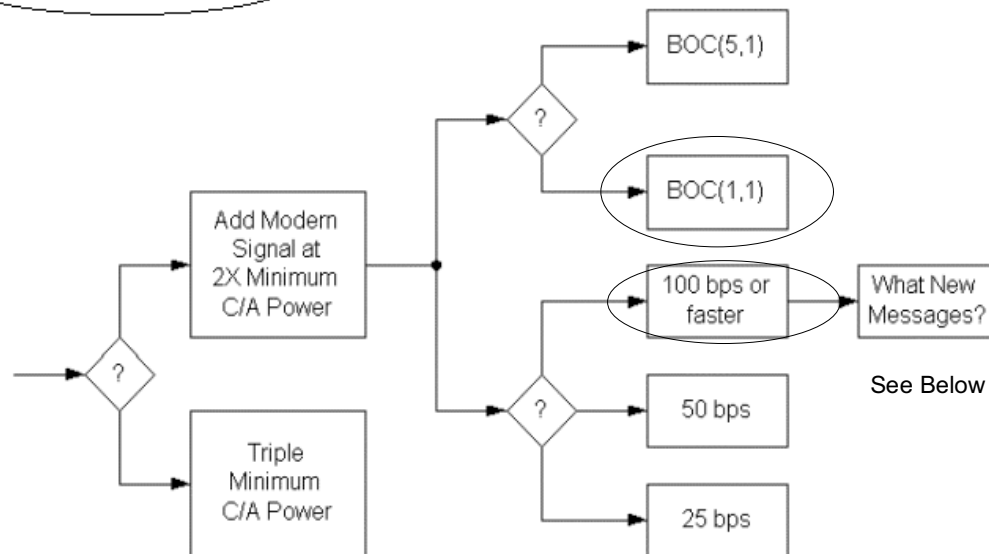

What New Messages: Desire for improvement in messaging to permit ephemeris period of validity to greatly exceed the approximate 4 hours currently provided. Graceful degradation is O.K. but desire is to at least double the validity period.

Comments: Below are general comments gotten from discussion with multiple parties at Qualcomm. Qualcomm focuses upon use of GPS and assisted GPS in wireless applications in which the signal received power is typically too weak to allow demodulation with conventional GPS receivers—often 20 to 30 dB below typical open sky conditions.

1. The BOC(1,1) with 2X Minimum C/A power is a good compromise to improvement in sensitivity in both autonomous and wireless assisted modes.
2. We assume the L1C consists of equal power pilot and signaling components as described in the presentation. Some additional comments are provided below.

3. The data message at 100 bps allows more rapid transmission of information and also allows incorporation of new message information. We would like to see ephemeris (including clock modeling) that has an *extended time of applicability capability* in excess of the current 4 hours.

Discussion:

Extension beyond 4 hours can incur some loss of accuracy, but the degradation should be gradual rather than severe, at the boundaries. Extension to well beyond 8 hours is highly desirable. This allows receivers to use the same ephemeris information under weak signal conditions for extended periods of time (ephemeris perhaps received from a land based server).

4. We suggest *considering* encoding the message data with a rate $\frac{1}{2}$ turbo code rather than a simple short convolutional code.

Discussion:

Such a code, with interleaver length on the order of 300 bits, can provide performance improvement of 2 dB or more over that of a convolutional code and in excess of 7 dB improvement beyond an uncoded PSK signal, assuming coherent demodulation. A CRC should be included for error detection. A downside of this approach is, assuming 100 Hz data rate, the block length is around 3 seconds. This long decoding latency should be weighed against the improved sensitivity.

5. The PN codes for the pilot channel should be designed to permit rapid acquisition at very low SNR with practical hardware.

Discussion

The approach of using a product type PN code like that of L5 (or Galileo E5A) or Galileo L1 is a good one—e.g. use a first PN code of length 10230 (10 msec) which is phase reversed according to a second code, e.g. of length say 16 (in this case producing code length 160 msec). This allows acquisition to be possible (but still somewhat complex) at low SNR using the L1c pilot, which would probably be otherwise prohibitive.

6. The pilot channel and data channel of the L1c should have different orthogonal PN codes.

Discussion

Under these situations the data channel would not affect the ability to acquire the pilot channel. This will also enable the data channel symbols to be encoded as QPSK data, advantageously, as discussed below in 7.

7. The L1c data channel if rate $\frac{1}{2}$ encoded with an FEC can be advantageously be encoded as a QPSK signal.

Discussion

The I component could be data bits (if a turbo code is used) and the Q component could be parity bits. This will keep the symbol rate to a lower value (as compared to encoding all data with BPSK) and perhaps improve bit and symbols synchronization performance.

8. We suggest that time of week information be encoded at a slow rate on the pilot channel—e.g. at a rate of 1 bit every 160 msec or every 320 msec, for example.

Discussion

Providing time-of-week helps assisted GPS receivers set their time at very low received levels, without requiring demodulation of SV data at these low levels (which may be impossible). This still allows *coherent* integration of the pilot channel (for acquisition), for example, over a period of 160 msec, or perhaps 320 msec, which is the practical limit for most applications. Additional sensitivity is gotten by then performing incoherent integration.

This suggestion may be combined advantageously with item 5 above in the following way. Choose to transmit (time of week) data via code multiplexing. For example, send bit 0 by sending PN code A and choose to send bit 1 by sending PN code B. PN codes A and B can be constructed as a product type code from a first PN code, say F (e.g. of length 10230 chips), but with two different low rate codes, H1 and H2, say each of length 16. H1 and H2 can be chosen, for example to be Walsh codes with low cross correlation properties for small lags.

The above method of encoding this time data was suggested as orthogonal signals rather than, say binary phase shift keying. Since the pilot channel may be used as a phase reference for the data channel one would like to avoid phase modulation which can reduce the effectiveness of the pilot channel as a carrier phase reference, particularly under fading conditions. A negative effect of the orthogonal signaling is that when used for acquisition of very weak signals, the detection sensitivity is slightly worse than if antipodal (BPSK) signaling were used.

A short time-of-week word, e.g. 10 bits, would suffice for the purposes of time setting. For example a 10 bit word, with bit periods 160 msec, corresponds to a time word sent every 1.6 seconds, and hence an ambiguity of $2^{10} \times 1.6 = 1600$ seconds (26.7 minutes), which should be adequate for most purposes. Synchronizing to the time-of-week word could be done by decoding enough symbols to determine that successive time-of-week words differed from one another (arithmetically) by one.

Application Specific Questions

Name: Dr. Norman F. Krasner Date: July 7, 2004

Title/Position Vice President, Technology

Organization Qualcomm

Your Primary Expertise			
	Professional & Scientific	Commercial	Consumer
Land			X
Sea			
Air			
Space			

Expected Number of Users in 2005			
	Professional & Scientific	Commercial	Consumer
Land			100 Million
Sea			
Air			
Space			

Expected Number of Users in 2020			
	Professional & Scientific	Commercial	Consumer
Land			>1 Billion
Sea			
Air			
Space			

Applications

1. GPS Cell phones for emergency response and value added services

Uses wireless assisted primarily-server provides assistance data to aid GPS set-improves sensitivity and TTFF

2. Some Commercial Use for Fleet Tracking

Importance			
Parameter	Best Desired	Worst Acceptable	Importance
Accuracy	5 M	10 M	M
TTFF	1 sec	10 sec	H
Availability			H
Continuity			H
Integrity			L
Robustness			H

H=high
M=moderate
L=low

Notes:

Number of Users Indicates Number of Cellphones equipped with GPS receiving capability. Not all users will choose to utilize the GPS capability.

Estimates for year 2020 based upon half the cellphones equipped with GPS capability.

By continuity, we assume this means continuity with current C/A code method. Very large installed base at time of implementation makes continuity essential.

Accuracy is that associated with typical clear view of sky.

TTFF assumes message read from satellites and clear view of sky.

Intentionally Left Blank to Separate Responses

The Following is Reference # 40

L1C Questionnaire

Name: Andreas Warloe Date: July 9, 2004

Title/Position Engineering Manager, Mobile Applications

Organization RF Micro Devices

Address 2 Executive Circle Suite 175, Irvine CA 92614

Phone: 949-863-3562 E-Mail: awarloe@rfmd.com

Circle Preferences:

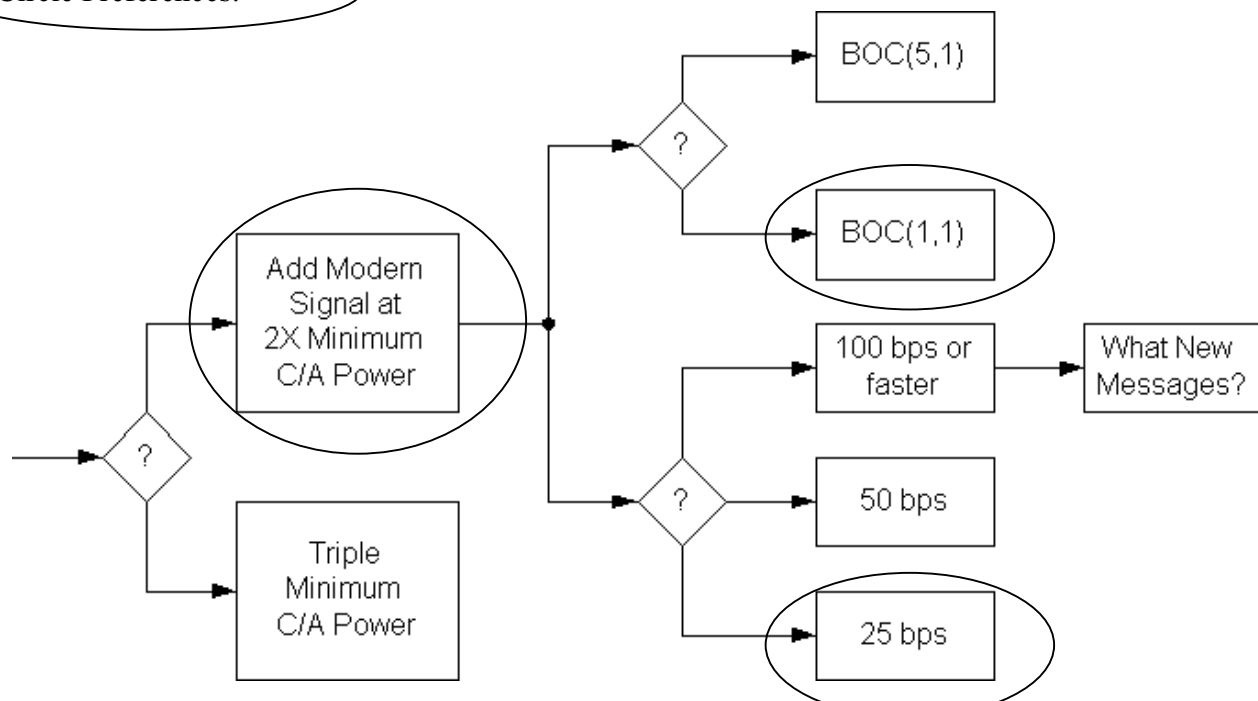

What new messages:

Comments:

1. Add a modern L1 signal at twice the power. Just adding more power to the C/A does not solve the basic problems of the signal structure. Those being the cross correlation problem - actually makes it worse with higher power, and the Bit Sync process that is the least robust process of acquisition. The new signal structure significantly reduces the cross correlation and Bits are unambiguously synchronized to code epochs. Additionally, there is a no-data component that permits much longer coherent integrations for lower signal acquisition, and lowers the tracking threshold.
2. Select BOC(1,1) signal since the full bandwidth can be supported by consumer chipsets. The BOC(5,1) has a much wider bandwidth if the advantages of such a signal are exploited, requiring a

wider Rx bandwidth and higher sampling rate. The BOC(1,1) signal can improve code tracking since there are twice as many code edges than a normal C/A code without the wider bandwidth penalties.

3. The 25bps choice (which is actually a 50sps signal with a rate 1/2 FEC code) is my choice since it makes decoding bits possible at phase lock threshold of the un-modulated carrier component, something that is not possible with the current C/A code. The downside is that it will take twice as long to get the ephemeris that is somewhat mitigated by the new message structure that is being proposed. If this "threshold" feature is not important than I would vote for the fastest data rate possible to permit much quicker ephemeris gathering.

Signature: _____

For Attribution?: Your Name: Yes No Your Organization: Yes No

Intentionally Left Blank to Separate Responses

The Following is Reference # 41

L1C Questionnaire

Name: Lionel GARIN Date: 4/13/04

Title/Position Director System Architecture and Technology

Organization SiRF Technology, Inc.

Address 148 E Brokaw Road San Jose, CA95112

Phone: (408)467-0410 E-Mail: lionelg@sirf.com

Circle Preferences:

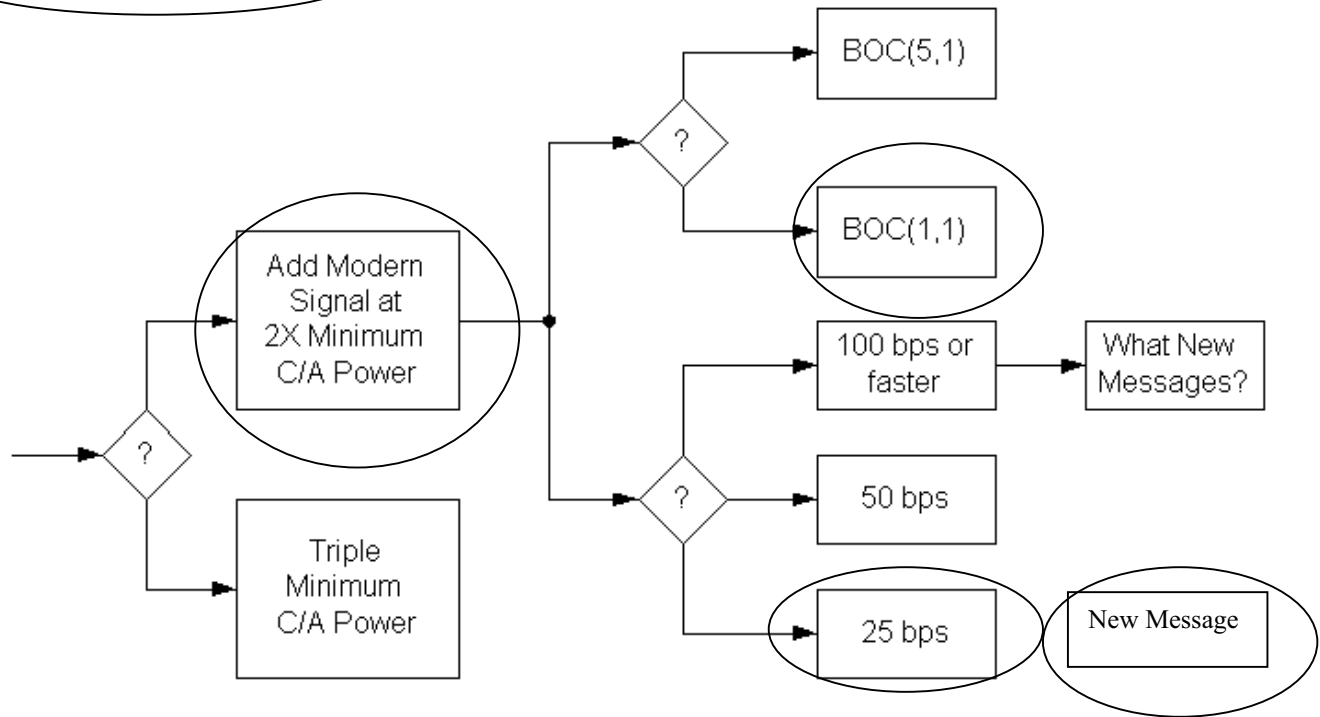

What new messages:

- Ephemeris corrections to apply to the Ephemeris already broadcast on L1 C/A, to get the 1cm resolution level. Only for the Broadcasting satellite
- PRN of the broadcasting satellite should be part of the message (for direct identification of the SAT from the message only, not the PRN sequence on which it was acquired)

Comments:

Our main concerns are sensitivity, MP mitigation and cross correlation improvements, at a reasonable complexity, and power consumption. The capability to receive broadcast data is secondary, especially if the L1 C/A is still broadcast.

Modulation characteristics:

- We believe BOC(1,1) is the best modulation scheme for the modern signal because of its lower bandwidth, and therefore lower power consumption. Combined with the longer code suggested below, it will also support our cross-correlation requirements.
- The modulation should be a split signal (PRN-code and data modulated on I, PRN-code modulated on Q)

Bit rate/PRN sequence rate:

- For sensitivity improvement, we would like to go as low as possible in bit rate, 25bits per second

Error correction/Bit-Symbol Duration/Bit transition Synchronization

- The Message would be FEC encoded at half rate, identical to L2C solution. Symbol period: 20ms.
- PRN sequence period: 10ms (2 PRN sequences per symbol).
- The L1C PRN sequence has to be synchronized onto the L1-C/A bit sequence
- The 2 bit half rate of the FEC (20ms) has to be synchronized onto the L1 C/A code nav bit transitions.
- The L1C frame rate has to be a multiple of the L1 C/A frame, and synchronized with it

Broadcast message contents:

- As the broadcast message is still available in L1 C/A, we don' t see the necessity to transmit the same message content on this new signal. This is even compounded by the very low data rate, which would force an unacceptable master frame update rate.

- We suggest ephemeris extension for the broadcasting satellite ONLY, to reach the 1cm resolution, to apply to the Ephemeris already broadcast on L1 C/A.
- We would strongly recommend to add the PRN number of the broadcasting satellite as a separate explicit field in the broadcast message.

Other General Comments:

In the case our suggestion is not retained, there is another approach we would recommend: to reduce the size of the master frame, and improve the repetition rate, a subset of the neighboring satellites(Ephemeris or almanacs) could be transmitted(4 to 6), instead of the full constellation. Neighboring satellites are defined as the ones with the smallest angular distance with the satellite of interest, form a center of earth vantage point of view.

We are definitely not interested in having a ASCII message capability in the broadcast message. The data rate would be much too slow, and this information would not reach our end user anyway.

We would like to reiterate another comment we made during the presentation. It would be a bad idea to have all commercially available signals optimized for the same type of application. It makes much better sense to have L2C and L5 optimized for surveying or handheld applications, and keep L1 and all the derivatives optimized for low cost, single frequency, very high volume applications

Signature:



For Attribution?:

Your Name: Yes No

Your Organization: Yes No

Intentionally Left Blank to Separate Responses

The Following is Reference # 42

L1C Questionnaire

Name: Per Enge Date: June 30, 2004

Title/Position Professor of Aeronautics & Astronautics, Director of the GPS Laboratory at Stanford University

Organization Stanford University

Address 496 Lomita Mall, Durand Building, Room 250, Stanford University, Stanford CA 94304-4035

Phone: (650) 723 2853 E-Mail: per@relgyro.stanford.edu

Circle Preferences:

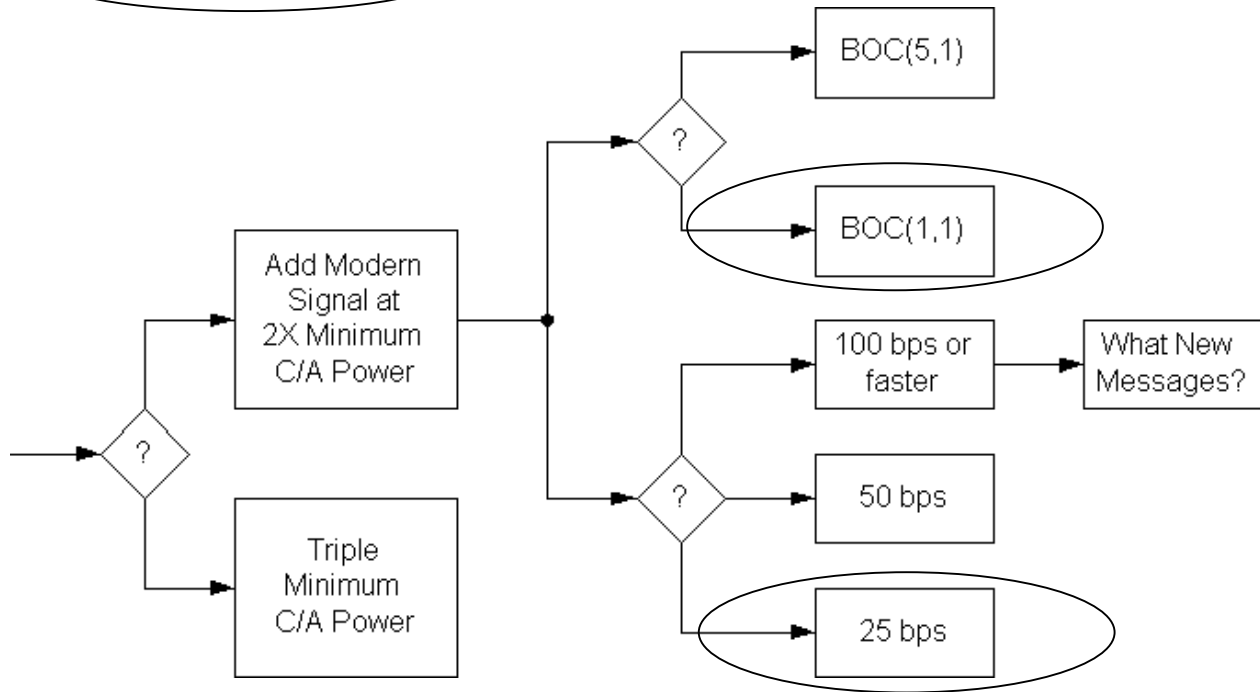

Comments: All three issues are tough and difficult to resolve without more study.

On balance, I would expect that BOC(1,1) would be more readily useable by aviation, because of correlation subpeak ambiguities. To my recollection, BOC(1,1) has subpeaks every 150 meters, whereas BOC(5,1) would have subpeaks every 30 meters. Failure to correctly resolve the BOC(1,1) subpeak would be readily detectable by RAIM, but the 30 meter ambiguity may be difficult to detect using RAIM. Hence, it has a greater prospect of hazardously misleading information (HMI). This risk can be offset by using multiple correlation samples per satellite, but this practice increases the cost of

the avionics. In addition, the precision advantage of BOC(5,1) is not that important to aviation, because we use carrier smoothing.

On balance, I prefer the low data rate alternative, since the highest available data rate of 100 bps would have a hard time supporting aviation time to alarm requirements. Our time to alarm requirement for Category I precision approach is 6 seconds, which probably allows one second for message duration. At 100 bps, this dictates a maximum message length of 100 bits. Of these 24-32 bits must be used for error detection (parity), and so the messaging efficiency would be at between 68% and 76%, which is low compared to today's systems like WAAS.

Signature: Per Enge

For Attribution?: Your Name: Yes Your Organization: Yes

Application Specific Questions

Name: _____ Per Enge _____ Date: June 30, 2004 _____

Title/Position _____ Professor of Aeronautics & Astronautics _____

Organization _____ Stanford University _____

Your Primary Expertise			
	Professional & Scientific	Commercial	Consumer
Land			some
Sea			some
Air	most		
Space			

Expected Number of Users in 2005			
	Professional & Scientific	Commercial	Consumer
Land			
Sea			
Air	prototype only at SU		
Space			

Expected Number of Users in 2020			
	Professional & Scientific	Commercial	Consumer
Land			
Sea			
Air	prototype only at SU		
Space			

Applications	
1.	

Value			
Parameter	Best Desired	Worst Acceptable	Importance
Accuracy	3		
TTF	3		
Availability	1		
Continuity	1		
Integrity	1		
Robustness			

Importance: 1 = Very, 3 = Moderate, 5 = Not Significant

Intentionally Left Blank to Separate Responses

The Following is Reference # 43

L1C Questionnaire

Name: Sergey Lyusin Date: January 29, 2004

Title/Position Technology Manager

Organization Thales Navigation, Inc.

Address Leninski Prospect 113/1, Moscow, Russia

Phone: 7 (09 5)9 56 59 6 4 E-Mail: lsv@ashtech.ru

Circle Preferences:

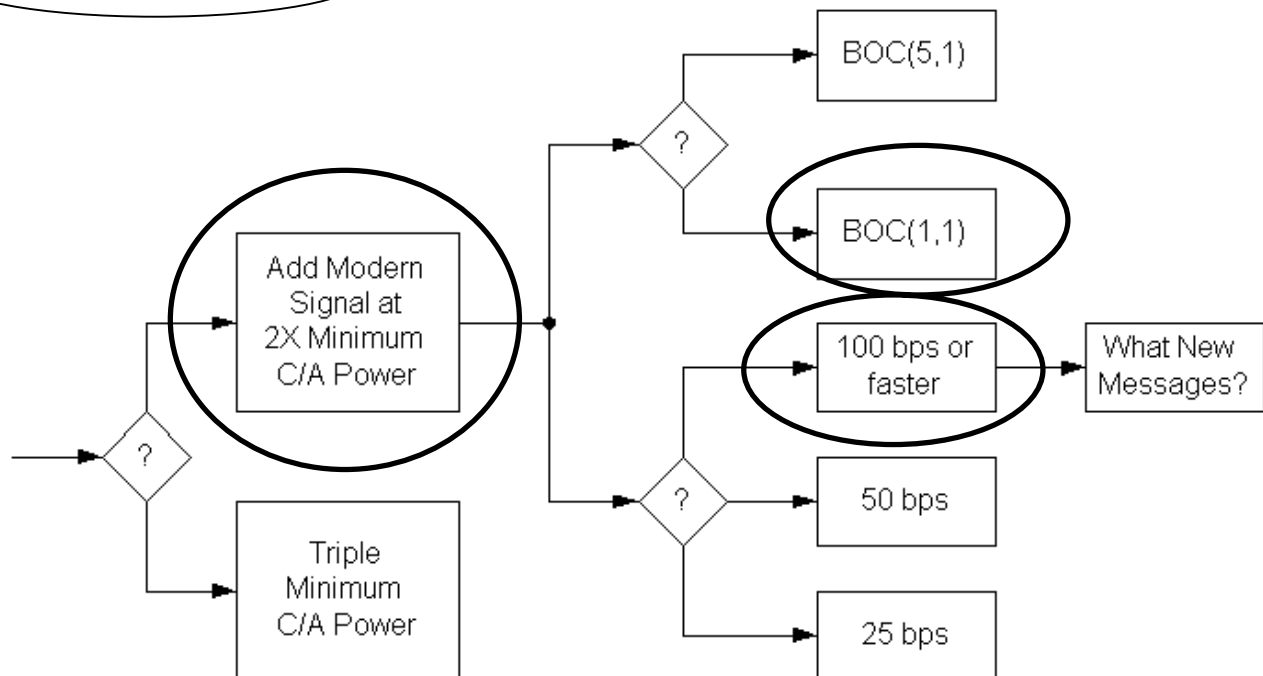

What new messages:

Long term ephemeris (24 hours or more) for in-door tracking.

May be it would be possible to combine advantages of 25 bps and 100 bps, for example: use 100 bps as base data rate, spent 50% of all bits for fast data transfer and other 50% for slow data transfer by means of combining of four sequential bits into one slow bit (may be with some internal modulation).

Comments:

1. **BOC(5,1) is undesirable, because wide bandwidth will lead to the following disadvantages for consumer products: a) high sampling frequency and as result bigger**

power consumption; b) problems with harmonics and digital noise because of wideband RF.

- 2. 10,230 code period is questionable, because this case code delay search will be 10 times longer. It may be critical for in-door application.**

Signature: _____

A handwritten signature in cursive script, appearing to read "Henry", is written over a horizontal line.

For Attribution?:

Your Name: Yes

Your Organization: Yes

Application Specific Questions

Name: Sergey Lyusin Date: **J anuary 29 , 2004**

Title/Position Technology Manager

Organization Thales Navigation, Inc.

Your Primary Expertise			
	Professional & Scientific	Commercial	Consumer
Land	+		+
Sea			
Air			
Space			

Applications

1. Car navigation
2. Cell phones
3. Land survey
4. GIS

Expected Number of Users in 2005			
	Professional & Scientific	Commercial	Consumer
Land			
Sea			
Air			
Space			

Expected Number of Users in 2020			
	Professional & Scientific	Commercial	Consumer
Land			
Sea			
Air			
Space			

Land Survey

Value			
Parameter	Best Desired	Worst Acceptable	Importance
Accuracy	1 cm	2 cm	1
TTF	20 sec	500 sec	3
Availability	95%	70%	1
Continuity			3
Integrity			3
Robustness			5

Importance: 1 = Very, 3 = Moderate, 5 = Not Significant

Cell phones

Value			
Parameter	Best Desired	Worst Acceptable	Importance
Accuracy	1 m	50 m	3
TTF	5 sec	50 sec	3
Availability	100 %	70 %	1
Continuity			1
Integrity			3
Robustness			3

Importance: 1 = Very, 3 = Moderate, 5 = Not Significant

Intentionally Left Blank to Separate Responses

The Following is Reference # 44

L1C Questionnaire

Name: Dr. Robert Snow Date: November 13, 2003

Title/Position Director of Reference Station Marketing and L1 C/A Survey Product

Organization Thales Navigation

Address 471 El Camino Real, Santa Clara, CA 95050

Phone: 408-615-5246 E-Mail: Rsnow@thalesnavigation.com

Circle Preferences:

- 1) Triple C/A Minimum Power or Add modernized signal (L1C)
- 2) BPSK(2) BOC(1,1) BOC(5,1)
- 3) 25 bps 50 bps 100 bps or higher
- 4) What new messages:
-

Comments:

- Yes, modernization is worth doing and it's very important.
- This process has been effective

Signature: Verbal OK Received

For Attribution?: Your Name: Yes No Your Organization: Yes No

Intentionally Left Blank to Separate Responses

The Following is Reference # 45

L1C Questionnaire

Name: Tomas Beran

Date: February 16, 2004

Title/Position Ph.D. Student /Research Assistant

Organization GRL GPS Research Group, Dept. of GGE, UNB

Address P.O. Box 4400, Fredericton, NB, E3B 5A3

Phone: (506) 453-5088

E-Mail: s48c6@unb.ca

Circle Preferences:

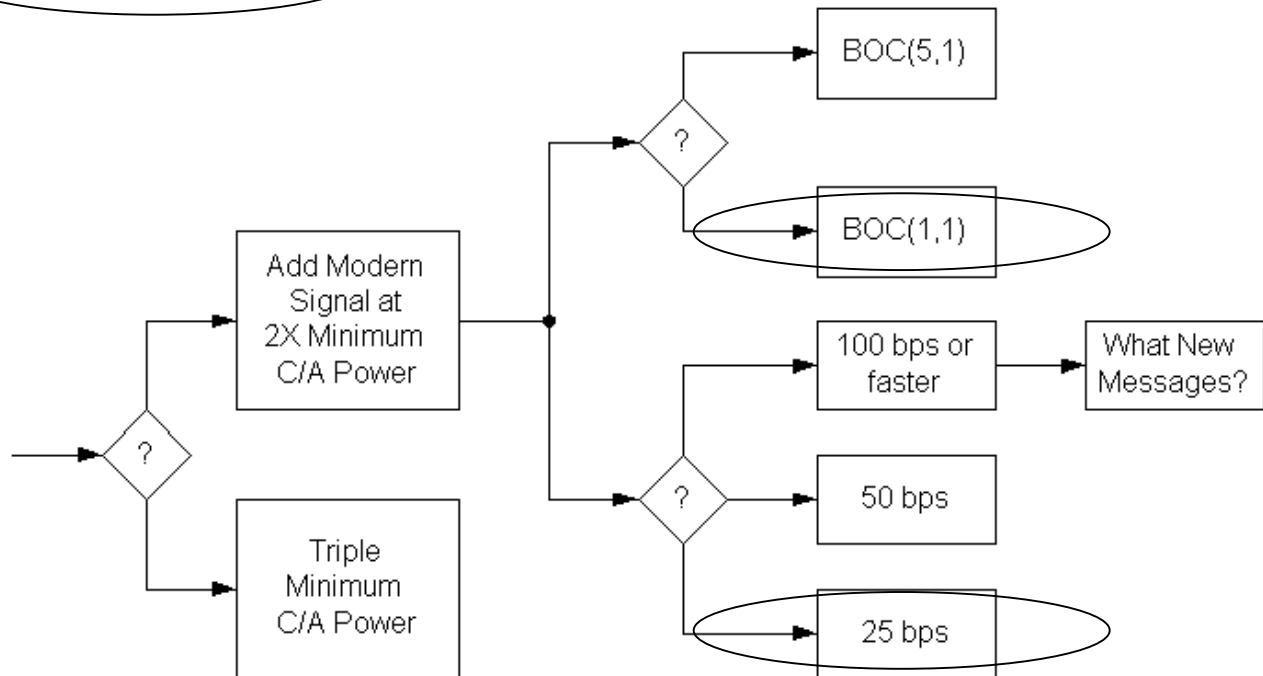

What new messages:

Comments:

It will be useful to maintain lock in foliated areas. The users who may benefit from that could be land surveyors, automobile navigation users and GPS-equipped cell phone users.

Signature: _____

For Attribution?: Your Name: Yes No

Your Organization: Yes No

Application Specific Questions

Name: Tomas Beran

Date: February 16, 2004

Title/Position Ph.D. Student /Research Assistant

Organization GRL GPS Research Group, Dept. of GGE, UNB

Your Primary Expertise

	Professional & Scientific	Commercial	Consumer
Land	x		
Sea			
Air	x		
Space	x		

Applications

1. automobile navigation
2. cell-phone navigation
3. agricultural apps.
4. land surveying apps.

Expected Number of Users in 2005

	Professional & Scientific	Commercial	Consumer
Land			
Sea			
Air			
Space			

Expected Number of Users in 2020

	Professional & Scientific	Commercial	Consumer
Land			
Sea			
Air			
Space			

Value

Parameter	Best Desired	Worst Acceptable	Importance
Accuracy	5 cm	1 m	1
TTF	5 sec	30 sec	2
Availability	100%	90%	1
Continuity	100%	99%	1
Integrity			2
Robustness			3

Importance: 1 = Very, 3 = Moderate, 5 = Not Significant

Intentionally Left Blank to Separate Responses

The Following is Reference # 46

L1C Questionnaire

Name: Chaochao Wang Date: Feb-06-2004

Title/Position Ph.D. Student

Organization University of New Brunswick, Canada

Address P.O. Pox 4400 Fredericton

Phone: 506-451-6855

E-Mail: chaochao.wang@unb.ca

Circle Preferences:

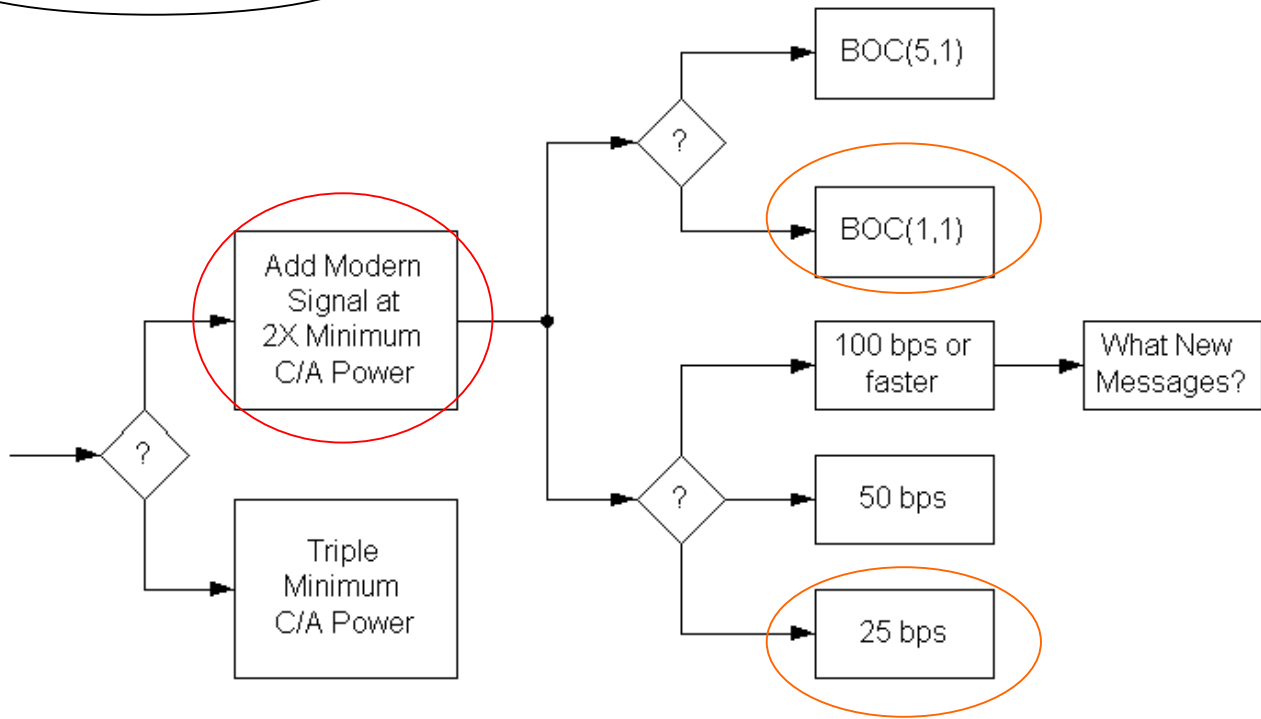

What new messages:

Comments:

The high accuracy ephemeris (1cm) will be very beneficial for the GPS meteorological research, esp. in real time or near real time mode

Signature: _____

For Attribution?: Your Name: Yes No

Your Organization: Yes No

Intentionally Left Blank to Separate Responses

The Following is Reference # 47

L1C Questionnaire

Name: Ravindra Babu Date: 20th Feb 2004

Title/Position PhD Student

Organization University of New South Wales

Address Sydney , New South Wales – 2052, Australia

Phone: (02) 9385-4206 E-Mail: s.ravi@unsw.edu.au

Circle Preferences:

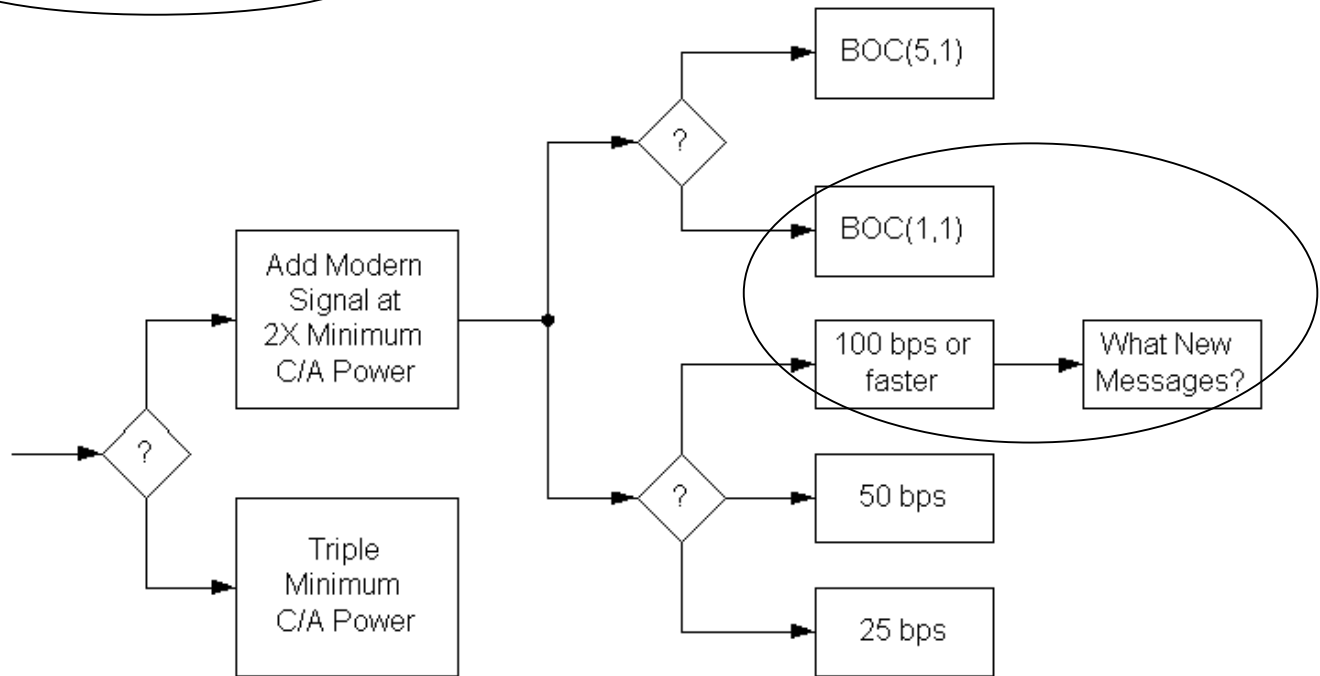

What new messages: Integrity Data

Comments:

Signature: Ravindra Babu

For Attribution?: Your Name: Yes No Your Organization: Yes No

Application Specific Questions

Name: Ravindra Babu Date: 20th Feb 2004

Title/Position PhD Student

Organization University of New South Wales

Your Primary Expertise			
	Professional & Scientific	Commercial	Consumer
Land	GPS/INS integrated systems		
Sea			
Air			
Space			

Applications

1. Automobile
2. Wireless
3. Georeferencing

Expected Number of Users in 2005			
	Professional & Scientific	Commercial	Consumer
Land	>10000	>1 million	>1 million
Sea			
Air			
Space			

Expected Number of Users in 2020			
	Professional & Scientific	Commercial	Consumer
Land	>10000	>100 million	>100 million
Sea			
Air			
Space			

Value			
Parameter	Best Desired	Worst Acceptable	Importance
Accuracy	3	5	1
TTF	3	1	3
Availability	3	5	1
Continuity	1	3	1
Integrity	1	3	1
Robustness	1	3	1

Importance: 1 = Very, 3 = Moderate, 5 = Not Significant

Intentionally Left Blank to Separate Responses

The Following is Reference # 48

L1C Questionnaire

325 of 406

Name: XIAODONG JIA Date: 23/02/2004

Title/Position S

Organization SNAP UNSW

Address _____

Phone: 61-2-93854208

E-Mail: xiaodong@student.unsw.edu.au

Circle Preferences:

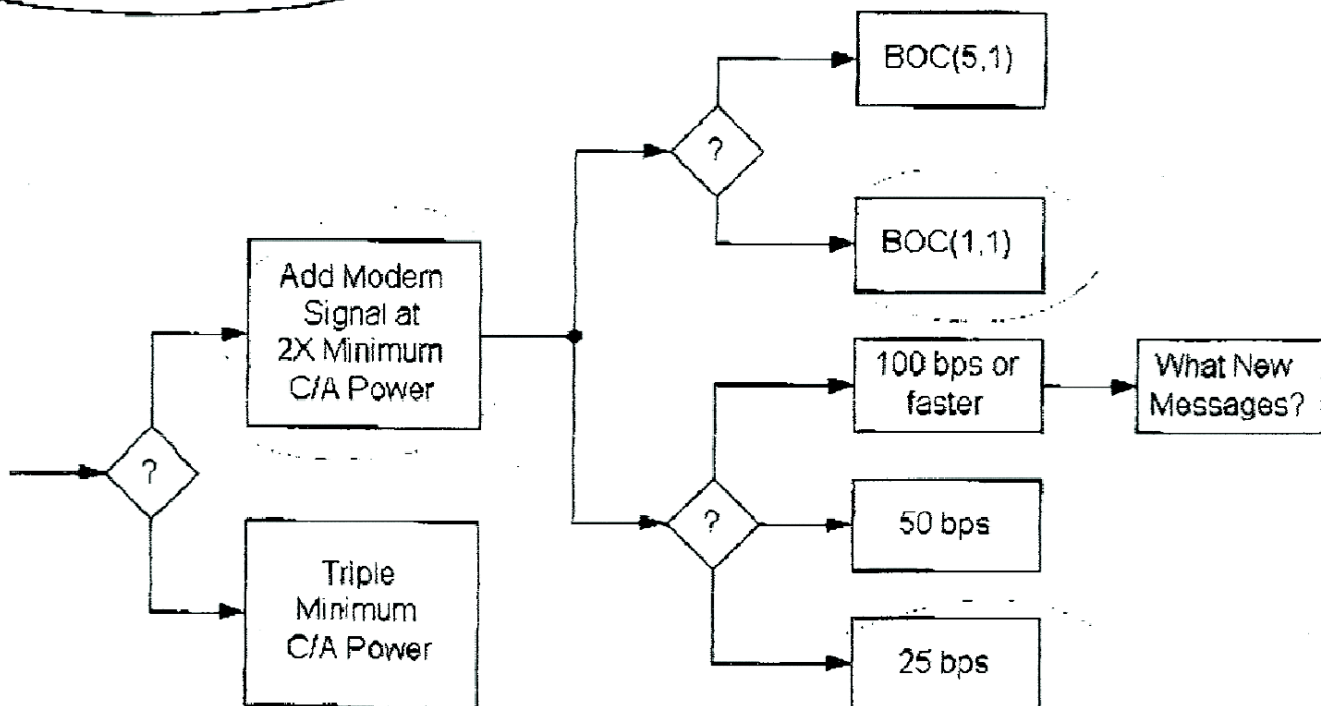

What new messages: *why do we need new messages? what would be the requirements and applications?*

Comments: *High speed of data rate is not the objective of GPS, it can be addressed with satellite communication. If we do need GPS system transfer information in high speed, then this issue should be looked at in the integration of GPS & satellite communications. Precise measurement under difficult environment should be considered in this kind*

Signature: _____ *under difficult environment should be considered in this kind*

For Attribution?: Your Name: Yes No

Your Organization: Yes No *improvement.*

Intentionally Left Blank to Separate Responses

The Following is Reference # 49

Signature: peter mumford

For Attribution?: Your Name: Yes No Your Organization: Yes No

Intentionally Left Blank to Separate Responses

The Following is Reference # 50

L1C Questionnaire

Name: Chris Rizos Date: 12 February 2004

Title/Position Professor of Geodesy & Navigation

Organization School of Surveying & Spatial Information Systems

Address University of New South Wales, Sydney NSW 2052, Australia

Phone: +61-2-93854205 E-Mail: c.rizos@unsw.edu.au

Circle Preferences:

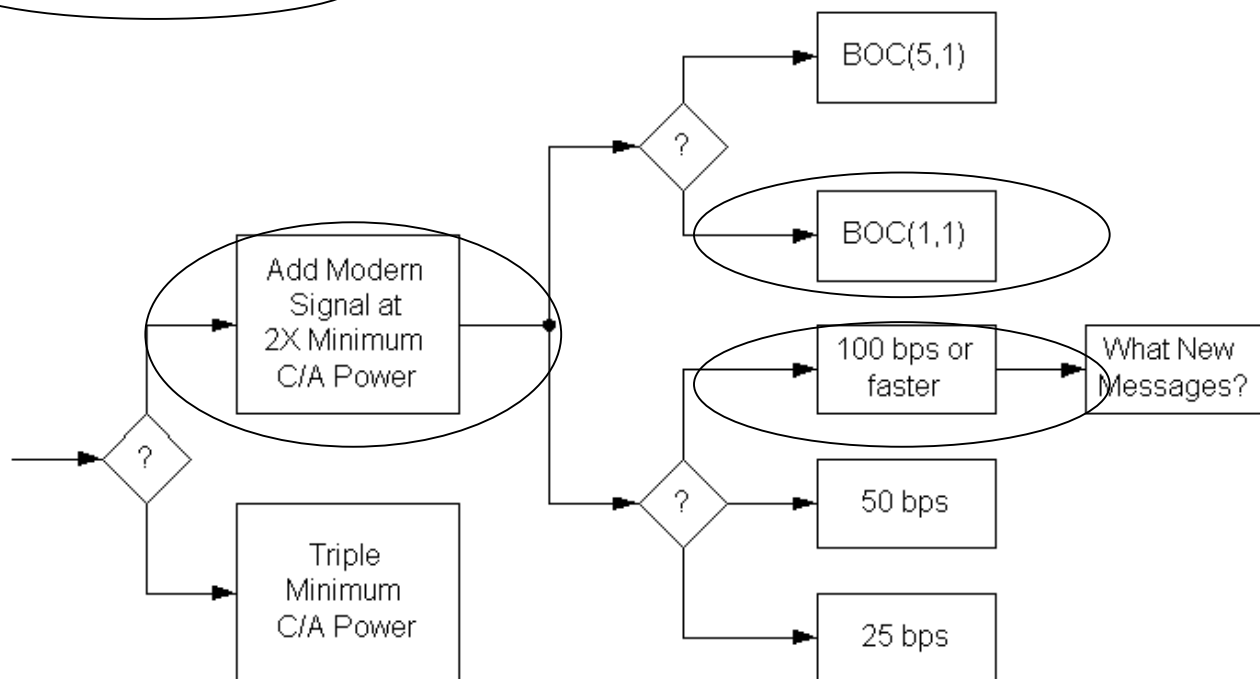

What new messages:

Can't think of any at the moment! ~~But~~ we have years to think about this!

Comments:

I have placed fast messaging as my preference to help with fast TTFF. As a person interested in surveying, and wants the gear to work in weak signal environments, I know this is not the optimal choice. However I believe that we can use assisted-GPS to aid the receiver, so I'm not concerned about the possibility of not always being able to extract the data message under such (exceptional) circumstances.

Signature: Chris Rizos

For Attribution?: Your Name: **Yes** No Your Organization: **Yes** No

Application Specific Questions

Name: Chris Rizos Date: 12 February 2004

Title/Position Professor of Geodesy & Navigation

Organization School of Surveying & Spatial Information Systems, UNSW

Your Primary Expertise			
	Professional & Scientific	Commercial	Consumer
Land	Y		
Sea			
Air			
Space			

Expected Number of Users in 2005			
	Professional & Scientific	Commercial	Consumer
Land	?		
Sea			
Air			
Space			

Expected Number of Users in 2020			
	Professional & Scientific	Commercial	Consumer
Land	?		
Sea			
Air			
Space			

Applications

1. Land surveying
2. Machine guidance/control
3. Mobile mapping (land & airborne)
4. Geodesy
5. Deformation monitoring
6. High precision kinematic positioning

Value			
Parameter	Best Desired	Worst Acceptable	Importance
Accuracy	<1cm	10cm	1
TTF	<10sec	2min	3
Availability	100%	90%	3
Continuity	?		
Integrity	?		
Robustness	?		

Importance: 1 = Very, 3 = Moderate, 5 = Not Significant

Intentionally Left Blank to Separate Responses

The Following is Reference # 51

L1C Questionnaire

Names: Drs. G. Lachapelle, S. Skone, M.G. Petovello, and Mr. O. J ulien

Date: March 9, 2004

Organization Position Location and Navigation Group, Department of Geomatics Engineering,
The University of Calgary

Address 2500 University Drive NW, Calgary, AB, Canada, T2N 1N4

Phone: 403-220-5834

E-Mail: Lachapelle@geomatics.ucalgary.ca

Circle Preferences:

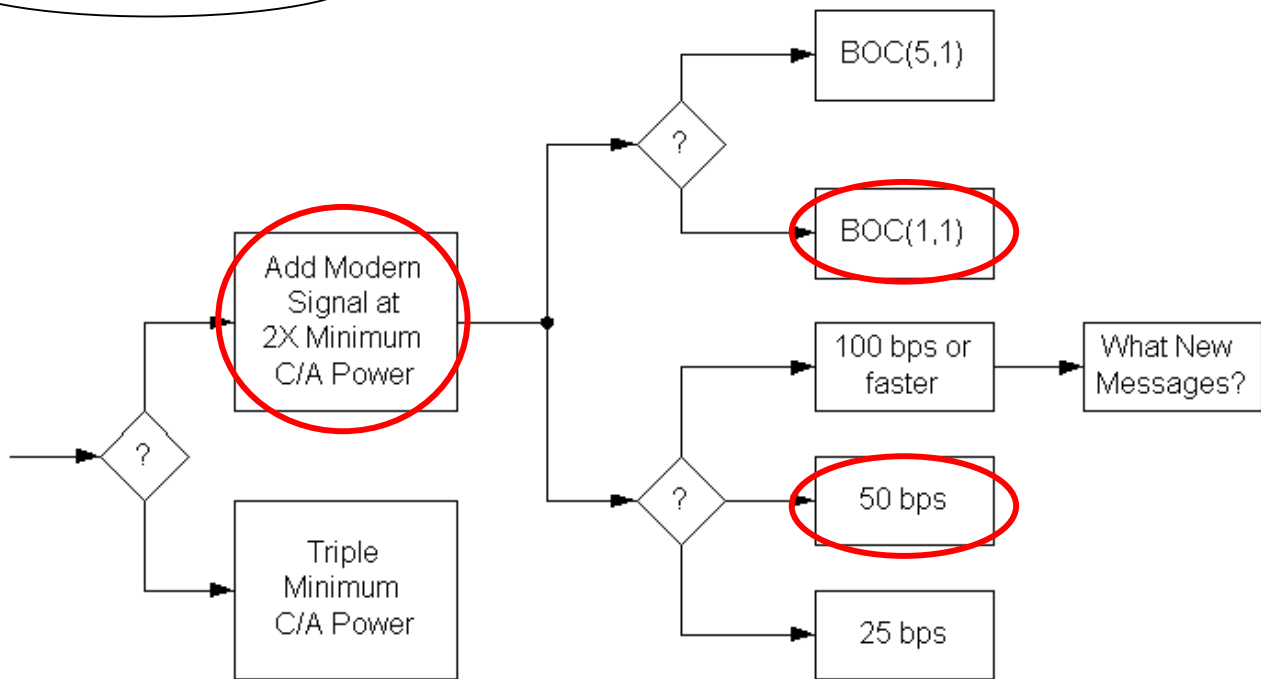

What new messages:

Comments: See attached sheet

Signature: _____

For Attribution?: Your Name: Yes No

Your Organization: Yes No

Application Specific Questions

Names: Drs. G. Lachapelle, S. Skone, M.G. Petovello, and Mr. O. J ulien

Date: March 9, 2004

Organization Department of Geomatics Engineering, The University of Calgary

Your Primary Expertise			
	Professional & Scientific	Commercial	Consumer
Land	X		
Sea	X		
Air	X		
Space			

Expected Number of Users in 2005			
	Professional & Scientific	Commercial	Consumer
Land			
Sea			
Air			
Space			

Expected Number of Users in 2020			
	Professional & Scientific	Commercial	Consumer
Land			
Sea			
Air			
Space			

Applications

1.

Value			
Parameter	Best Desired	Worst Acceptable	Importance
Accuracy	<1 cm	20 m	1
TTF	0 s	30 s	3
Availability	100 %	100 %	1
Continuity	Very High		3
Integrity	Very High		3
Robustness	Very High		3

Importance: 1 = Very, 3 = Moderate, 5 = Not Significant

Answer to the L1C Questionnaire

From Gérard Lachapelle, Susan Skone, Mark Petovello and Olivier Julien, Department of Geomatics Engineering, University of Calgary, Canada

The main fields of studies of the Department of Geomatics Engineering at the University of Calgary related to GPS are (1) high accuracy positioning, (2) indoor or urban positioning and (3) Use of GPS for atmospheric studies. Hereafter is a description of what would be expected from a new GPS signal to improve the current performance of positioning and navigation in these two areas. This description discusses only the signal itself and not the whole system.

For high accuracy positioning, there are two main sources of errors that limit the position accuracy: multipath and atmospheric errors. To minimize multipath errors, a signal with low inherent multipath-induced errors using a high chip rate and having a multipath-resistant correlation function (essentially a narrow main peak) would be preferable. Atmospheric delay is the main problem when medium to long baselines are considered. For this reason, atmospheric estimation (that can include ionospheric first and second order delays as well as tropospheric bias) is necessary. A strong signal power, reducing the impact of noise and the occurrence of cycle slips would allow an easier and more robust atmospheric estimation process. The use of a signal implementing these two propositions would provide a significant enhancement in the large numbers of applications linked to high precision positioning such as RTK or meteorology.

For indoor and urban positioning, the main concern is the power loss when signals go through materials. It often implies loss of lock, but also strong multipath environment as well as possible cross-correlation problems. In order to improve navigation in such circumstances, a strong signal with low cross-correlation peaks (long code) would be of tremendous benefit. Of course, a signal with a high inherent resistance to multipath would be important as well. Finally, in order to have more efficient acquisition and tracking in degraded environment, the presence of a data-less channel is also needed to avoid squaring loss due to non-coherent integration.

For atmospheric studies, in particular for water vapour estimation, very precise broadcast orbits are highly desirable. Thus a relatively high data rate for the navigation message would allow the more frequent transmission of information which, with the proper structure, could lead to more precise orbits. The latter would also improve single point positioning in real-time.

To summarize, although the idea of a very strong C/A code is seducing, the opportunity to have a new signal that would better fit critical criteria such as the existence of a data-less channel or better cross-correlation properties is more interesting. Moreover, the increase of the signal to noise ratio through longer coherent integration decreases the problem of having a lower signal power. In order to have more robust position solutions, the BOC(1,1) signal appears to have better characteristics than the BOC(5,1) because of its more isolated and lower autocorrelation secondary peaks (relative to the main peak), even if this implies a slightly higher multipath impact. It is however likely that in the coming years, new techniques will reduce this impact of multipath to a smaller scale. A 50 Hz data rate similar to the one currently used also seems appropriate.

Intentionally Left Blank to Separate Responses

The Following is Reference # 52

L1C Questionnaire

Name: Aaron Quigley Date: 28/1/04

Title/Position Senior Research Fellow

Organization University of Sydney

Address School of Information Technologies, Sydney, NSW Australia

Phone: +61 2 9351 4156

E-Mail: aquigley@it.usyd.edu.au

Circle Preferences:

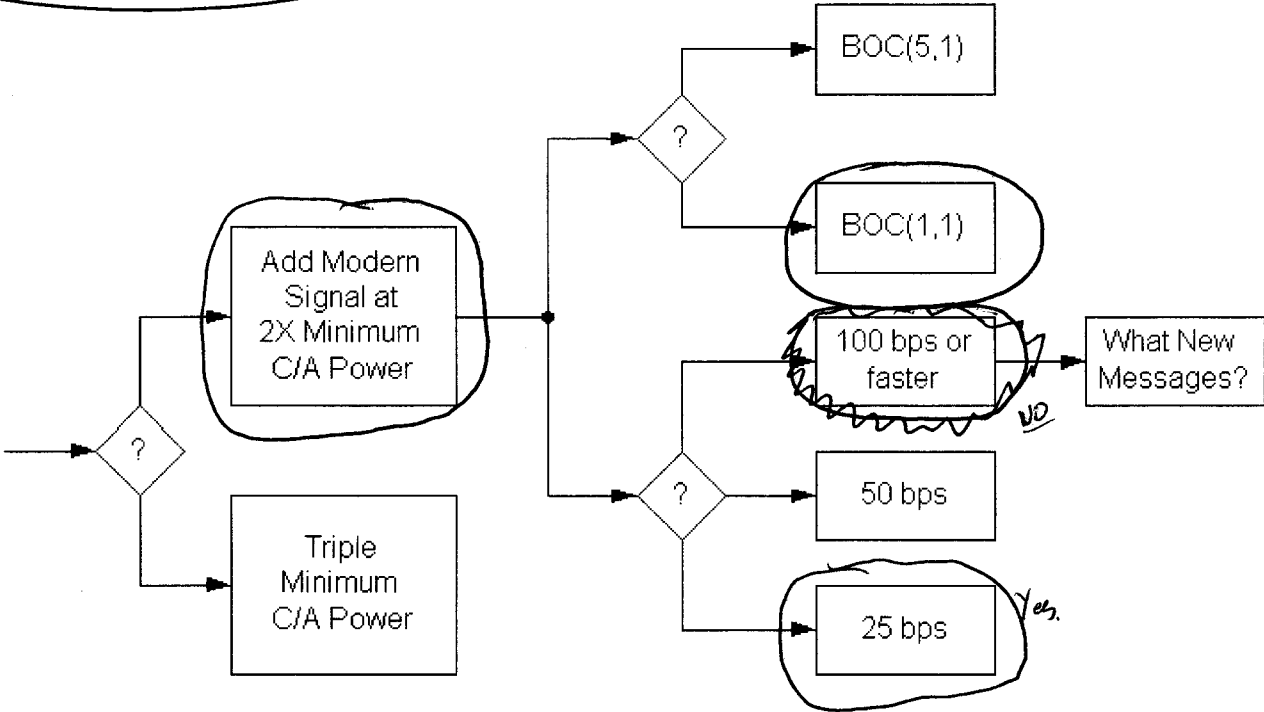

What new messages:

Comments: *New signal supports phased in receiver generation. Triple power may affect too many critical GPS systems already in operation. (power reduction to accommodate new signal can be managed by improved receiver fabrication techniques (gain, power....)).*

Signature: Aaron Quigley

For Attribution?: Your Name: Yes No Your Organization: Yes No

Application Specific Questions

Name: Dr Aaron Quigley Date: 28/4/4
 Title/Position Senior Research Fellow
 Organization University of Sydney, Australia.

Your Primary Expertise			
	Professional & Scientific	Commercial	Consumer
Land	7yrs	3yrs	1yr
Sea			
Air			
Space			

Expected Number of Users in 2005			
	Professional & Scientific	Commercial	Consumer
Land	500		5000
Sea			
Air			
Space			

Expected Number of Users in 2020			
	Professional & Scientific	Commercial	Consumer
Land	0	100,000	1-5 million (3)
Sea			
Air			
Space			

Applications

- In-door Location System. (Information Marketing)
 - Based on handset (ETOA + Bluetooth)
 - Future GPS based system in mobile handset (phone).

Parameter	Value		
	Best Desired	Worst Acceptable	Importance
Accuracy	3	4	3
TTF	4	4	4
Availability	2	2	1
Continuity	4	5	4
Integrity	2	3	4
Robustness	3	4	3

Importance: 1 = Very, 3 = Moderate, 5 = Not Significant

Intentionally Left Blank to Separate Responses

The Following is Reference # 53

L1C Questionnaire

Name: [LT Parsons, Mr. Wolfe, Mr. Cleveland](#)

Date: [1/7/04](#)

Title/Position: [DGPS Project Engineering Staff](#)

Organization: [US Coast Guard Command and Control Engineering Center](#)

Address [4000 Coast Guard Blvd, Portsmouth, VA 23435](#)

Phone: [\(757\) 686-4015](#) E-Mail: dwolfe@C2CEN.uscg.mil

Circle Preferences:

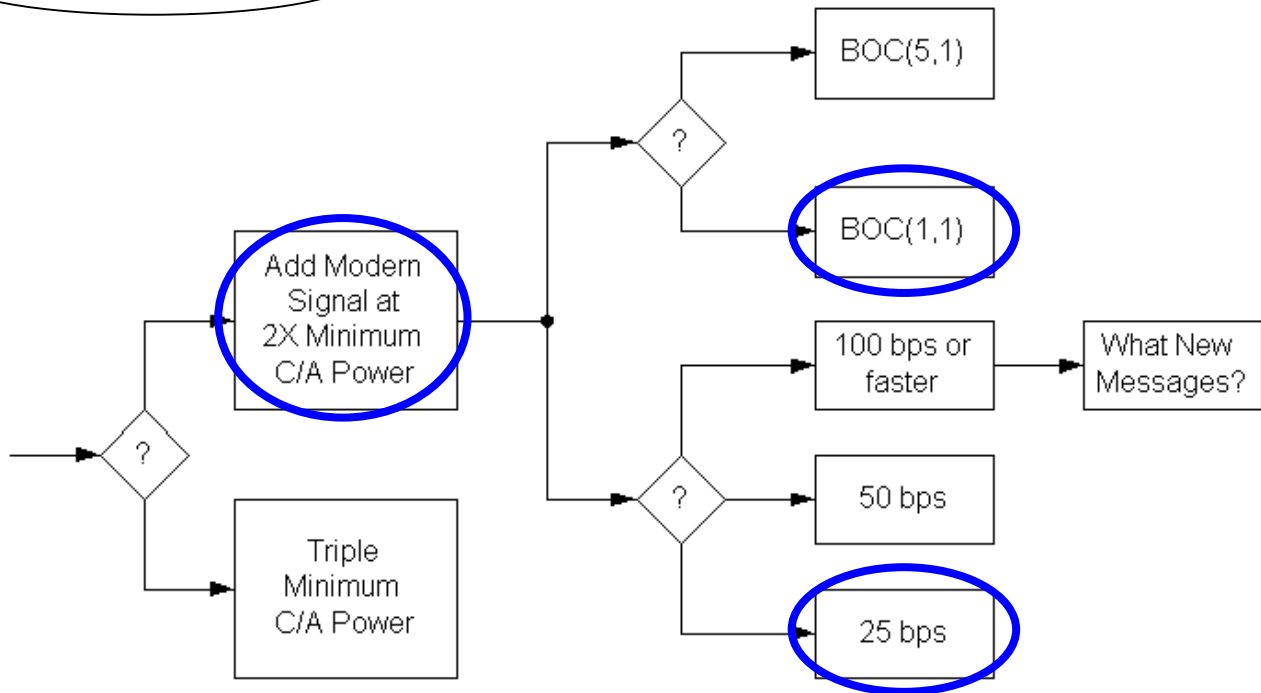

What new messages: [None](#)

Comments: [C2CEN would support a higher baud rate than 25 baud, if there were sufficient benefit to justify it. For maritime applications, assuming that the receiver is tracking the legacy signal to obtain clock and ephemeris data, it would be best if the 25 baud data stream on the BOC-1-1 signal provided a means of enhancing user equipment integrity monitoring.](#)

Signature: [LT Parsons, Mr. Wolfe, Mr. Cleveland](#)

For Attribution?: Your Name: Yes No Your Organization: Yes No

Application Specific Questions

Name: [LT Parsons, Mr. Wolfe, Mr. Cleveland](#) Date: [1/7/04](#)

Title/Position [DGPS Project Engineering Staff](#)

Organization [US Coast Guard Command and Control Engineering Center](#)

Your Primary Expertise			
	Professional & Scientific	Commercial	Consumer
Land		X	
Sea		X	
Air			
Space			

Expected Number of Users in 2005			
	Professional & Scientific	Commercial	Consumer
Land		Nationwide	
Sea		Nationwide	
Air			
Space			

Expected Number of Users in 2020			
	Professional & Scientific	Commercial	Consumer
Land		Nationwide	
Sea		Nationwide	
Air			
Space			

Applications

1. The US Coast Guard uses GPS to place and maintain aids to navigation.
2. The US Coast Guard uses GPS as a navigational tool aboard afloat platforms.
3. The US Coast Guard augments GPS with the N/DGPS system to provide users with better than 10 meter 2DRMS position accuracy and system integrity not inherent to GPS.

Value			
Parameter	Best Desired	Worst Acceptable	Importance
Accuracy	10cm	30cm	1
TTF	2min	15min	2
Availability	99.999%	99.9%	1
Continuity	Not yet Defined	Not yet Defined	3
Integrity	Integral & Monitored	Via Augmentation	1
Robustness	<10events/1Mhrs	<10events/1Mhrs	2

Importance: 1 = Very, 3 = Moderate, 5 = Not Significant

Intentionally Left Blank to Separate Responses

The Following is Reference # 54

L1C Questionnaire

Name: John Schutzenhofer Date: 1/13/04

Title/Position LT / Chief, DGPS Management Section

Organization USCG Navigation Center

Address 7323 Telegraph Rd. Alexandria, VA 22315

Phone: (703) 313-5939

E-Mail: jschutzenhofer@navcen.uscg.mil

Circle Preferences:

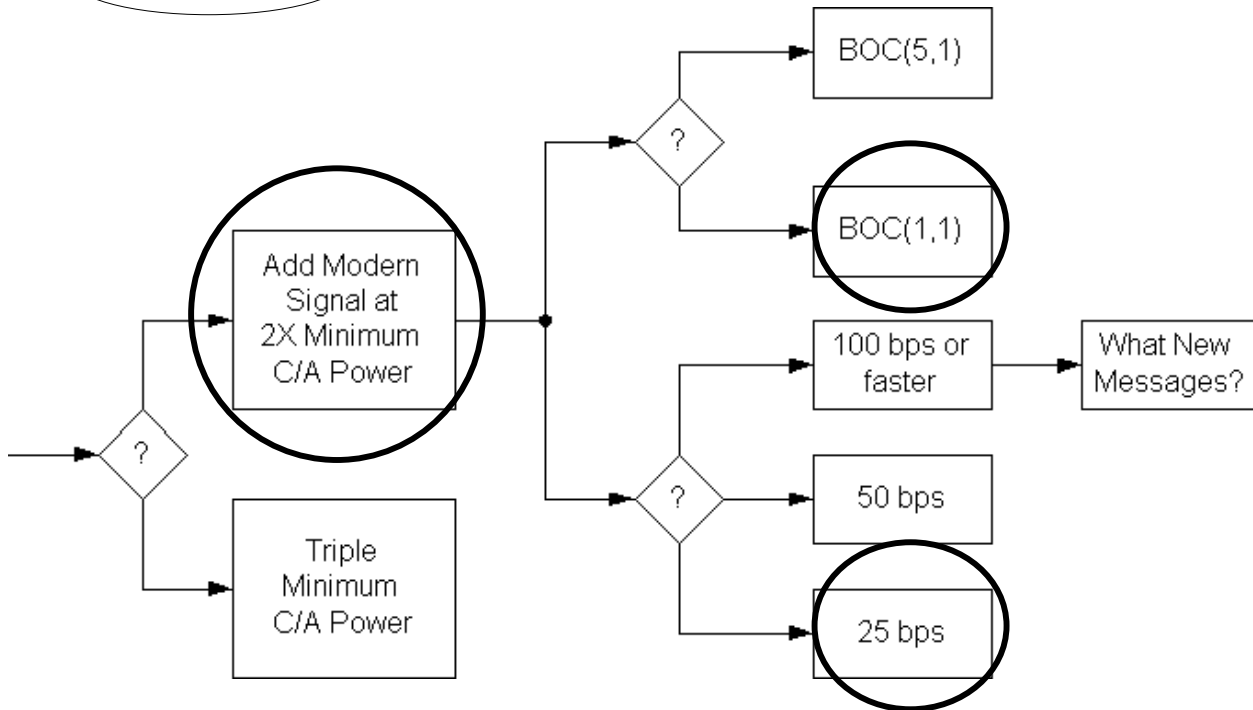

What new messages:

Comments:

I chose 25 bps over 50 bps since I feel it is more important to be able to acquire a message in poor signal conditions than having a faster TTFF.

Signature: John Schutzenhofer

For Attribution?: Your Name: Yes

Your Organization: Yes

Application Specific Questions

Name: John Schutzenhofer Date: 1/13/04

Title/Position LT / Chief, DGPS Management Section

Organization USCG Navigation Center

Your Primary Expertise

	Professional & Scientific	Commercial	Consumer
Land			
Sea		X	
Air			
Space			

Expected Number of Users in 2005

	Professional & Scientific	Commercial	Consumer
Land			
Sea			
Air			
Space			

Expected Number of Users in 2020

	Professional & Scientific	Commercial	Consumer
Land			
Sea			
Air			
Space			

Applications

1. The Coast Guard uses GPS (DGPS) to accurately place Aids to Navigation.
2. The Coast Guard used GPS in the development of the differential correction signal (DGPS).

Value

Parameter	Best Desired	Worst Acceptable	Importance
Accuracy	10 cm	3 m	3
TTF	1 min	15 min	5
Availability	99.999%	99.7%	1
Continuity			
Integrity	Alarm <5 sec	Alarm >10 sec	3
Robustness			1

Importance: 1 = Very, 3 = Moderate, 5 = Not Significant

Intentionally Left Blank to Separate Responses

The Following is Reference # 55

L1C Questionnaire

Name: _____ Date: July 26, 2004

Title/Position _____

Organization Trimble

Address 749 North Mary Avenue, Sunnyvale, CA 94085

Phone: _____ E-Mail: _____

Circle Preferences: * **Will depend on actual circumstances; please refer to comments below:**

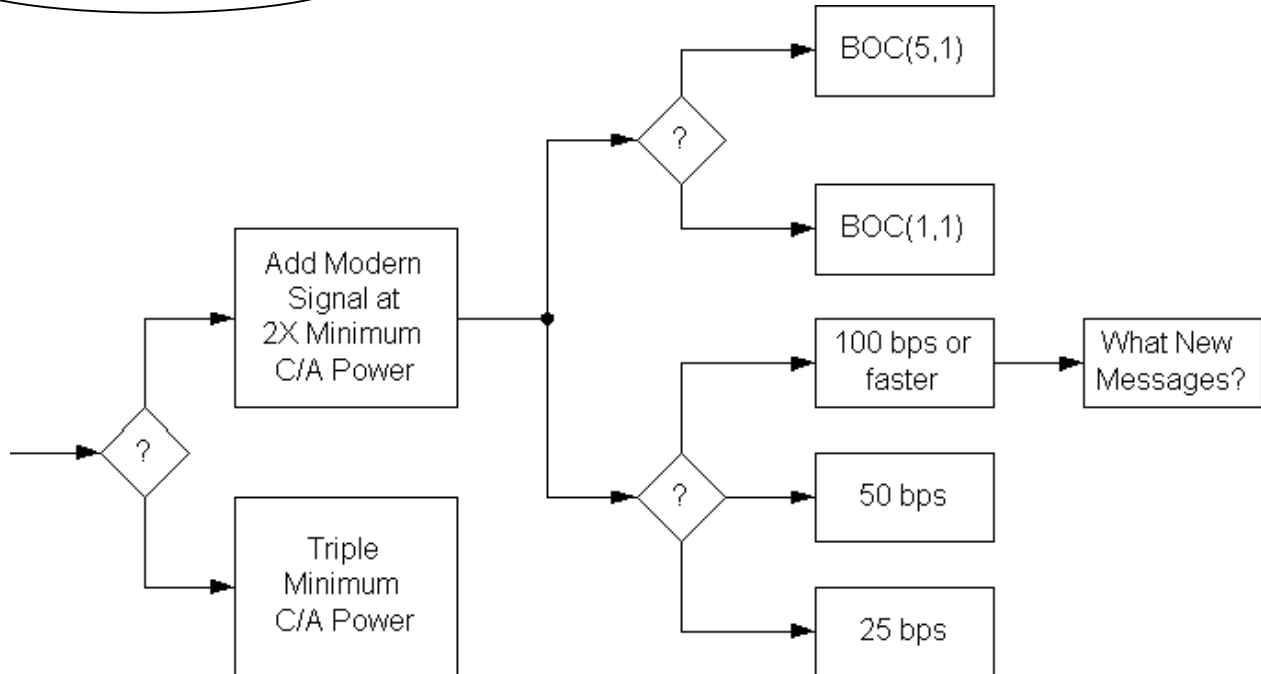

What new messages:

Comments:

*** As of this date, we have insufficient information regarding the source of power that allows a code to be added. Bit rates and code lengths become meaningful after power trade-offs and sources are better defined. L1C may be beneficial, or may not, depending on how much power is truly available after preserving military and civilian agency requirements and the present C/A power levels to serve the installed user base. While we understand the benefits of longer codes, our preference is for the implementation of such codes on L2C first.**

Signature: Deleted

For Attribution?: Your Name: Yes No Your Organization: Yes No

CIVIL USER GROUP BENEFITS

The following attachment presents the benefits of the 4th civil signal, L1C. The first section, (A) Benefits, will provide the reader with a short understanding of each of the six categories that this paper considers as the benefits of L1C. Section (B), Benefits Matrix, is a quick reference guide (first seen on page XX) that enables the reader to easily associate the benefits described with those portions of the GPS civil user community (studied for this paper) that can reap the greatest reward from L1C's introduction. Section (C), Benefits Explained, will show in great detail the understanding of how each studied user group us currently uses GPS and how the 4th civil signal will enhance that particular groups productivity and effectiveness in the future. Specific examples (that explain each "X" in the Matrix) are also provided in each user group's section. Finally, section (D) Team Member POCs, provides a list of the personnel responsible for research on each user group.

Section A: Benefits

L1C Improvement	User Benefit	Explanation
<p>Lower Signal Thresholds for Navigation (Power & Dataless Channel)</p>	<p>The user will be more likely to navigate (a) in difficult signal conditions, such as in a forest, in a city, inside a building, on a tree lined road, etc., i.e., where GPS signals are attenuated, as well as (b) in the presence of radio frequency interference (RFI) to GPS.</p>	<p>A stronger signal and the dataless channel allow the receiver to track and make navigation measurements in more challenged signal conditions than now. The improvement is at least 6 dB.</p>
<p>More Robust Autonomous Navigation (Power, Forward Error Correction (FEC), & Data Rate)</p>	<p>The user will be more likely to obtain the satellite messages needed to <u>begin</u> navigation (a) in difficult signal conditions, such as in a forest, in a city, inside a building, on a tree lined road, etc., i.e., where GPS signals are attenuated, as well as (b) in the presence of RFI to GPS.</p> <p>The “time to first fix” (TTFF) after the GPS receiver is turned on depends on receiving an “ephemeris” message from each available satellite. As a result, the user will get a faster TTFF.</p>	<p>A stronger signal and FEC will permit message recovery with weaker signals or with more radio frequency noise. The improvement is 5 dB at 50 bps and 8 dB at 25 bps. The 8 dB improvement makes it possible to obtain messages even with the weakest GPS signal the receiver can track.</p> <p>Note that once the ephemeris message is received, it lasts for one to three hours, so continuous reception of messages is not required, but time to first fix depends on receiving messages quickly after the receiver is turned on.</p> <p>This benefit relates to “autonomous” navigation, meaning that ephemeris messages are received from the satellites and <u>not</u> provided by a network, as is often done for E-911 use.</p>

L1C Improvement	User Benefit	Explanation
Less Susceptible to Interference (Power & Code Structure)	The user will be more likely to navigate in the presence of RFI to GPS.	Interference protection is part of the improvements noted above (higher signal power, the dataless channel, FEC, and a lower data rate). However, it is repeated here to point out that although code structure does <u>not</u> help with weaker signals, it <u>does</u> help in the face of certain types of RF interference. (It does not help against Ultrawide Band (UWB) interference.)
Higher Dynamics Tracking (Power and Dataless Channel)	Precise measurements will be more dependable in physically difficult situations, such as GPS guidance of an earthmover blade as it hits rocks and concrete – transmitting intense shock and vibration to the GPS antenna.	Some of the most demanding accuracy requirements are in severe physical conditions, such as GPS guidance of construction and earthmoving machinery. These environments are subject to high levels of shock and vibration (jerk and acceleration). A stronger signal and a dataless channel permit the tracking loop to remain locked with 64 times higher levels of jerk and 16 times higher levels of acceleration at the antenna.
Reduced Cross-correlation (Longer Spreading Codes)	Reduces the possibility of tracking an incorrect satellite without needing verification algorithms in the receiver. Improves performance in challenged environments when there are weak and strong signals visible.	Using long codes will reduce cross-correlation between satellites signals, reduce the self-interference experienced by C/A code, and increase the amount of dynamic range possible between satellites.
Improved Accuracy (Increased signal bandwidth)	More accurate position locations are possible in the same challenged environments.	All of the modulations under consideration have at least 3 dB more bandwidth than C/A code. This will improve accuracy for the same level of receiver complexity, and is primarily beneficial for lower cost receivers.

Section B: Benefits Matrix

L1C Improvement → Application ↓	Lower Signal Thresholds for Navigation (Power & Dataless Channel)	More Robust Autonomous Navigation (Power, FEC & Data Rate)	Less Susceptible to Interference (Power & Code Structure)	Higher Dynamics Tracking (Power and Dataless Channel)	Reduced Cross- correlation (Longer Spreading Codes)	Improved Accuracy (Increased signal bandwidth)
Location Based Services/Recreation	X	X	X		X	X
Scientific	X		X		X	
Aviation			X		X	
Agriculture	X	X		X	X	
Surface Transportation	X	X	X		X	X
Mining & Construction	X	X	X	X	X	
Surveying/Civil Engineering	X		X	X	X	
Public Safety/Security	X	X	X		X	X
Timing			X		X	
Rail	X	X			X	X
Space	X				X	
Environment	X	X			X	
Maritime and Waterways		X	X		X	X

Note: The last column “Improved Accuracy (Increased signal bandwidth)” greatly depends on the particular receiver used in each instance. While improved accuracy is an added benefit of L1C in roughly half of the studied cases, it is largely dependent on the combination of the improved signal and improved receivers.

SECTION C: Benefits Explained

L1C Modernization Civil Outreach Program

LOCATION BASED SERVICES/RECREATION

- **APPLICATIONS**

- Personal Productivity
 - Increased time efficiencies
 - Ease of use
 - Portability
 - Flexibility/Utility
- Resource/Management
 - Asset tracking/monitoring
 - Situational Awareness
 - Personal security
 - Location determination

- **REQUIREMENTS**

- Accuracy: 1 meter or less
- Availability/Coverage: Challenged Environments/Inside
- Power Consumption
- Jamming/Interference
- Timing: 10 nanoseconds

References

Location-based services information was obtained from literature reviews, interviews, discussions with manufacturers and data obtained from documents submitted in support of the GPS-III program.

Location-based services can be viewed as a non-critical navigation and position determination category pertaining to the personal/individual use of low cost GPS receivers for a broad range of applications. Consequently, the number of users will likely be the largest of all the categories under consideration particularly when GPS navigation and position determination capabilities are combined with a communications capability in a low cost/affordable, and practical receiver/transmitter.

Hand-held GPS devices, coupled with data base flexibility and communications capabilities, will likely be as prevalent in the future, as cell phones are today. Users will want these hand held devices to be smaller and inexpensive, longer-lasting and flexible.

As with the cell phone, use of future GPS equipment will not be tied to a specific platform application such as personal automobile navigation, rather, consumers will want to use a single device for multiple applications. For instance: recreation (e.g. boating, hiking, sightseeing); avoiding being lost (either outside or inside a building) tracking and/or monitoring resources (employees, vehicles, pets and family members) and emergency assistance (such as the current E911 initiative).

The goals of the user will likely be focused on improving personal productivity by better time management and reducing “down” time, managing and/or tracking resources, and situational awareness.

To achieve these goals, the user will want GPS to be available everywhere—inside buildings, in urban canyons, parking garages, remote locations and challenged, high jamming/interference environments, etc. In addition, there will be a desire to use the receiver continuously resulting in power consumption becoming increasingly critical, as will the size and functionality of the display, ease of use (user friendliness), data base flexibility and completeness, operational reliability, and overall cost—both initial purchase and user charges.

One vision of a fully functional personal unit satisfying these user requirements is a low-cost wrist watch sized unit, similar to today’s digital watch but with a magnified display, capable of remotely downloading a required data base on an as-needed basis.

The envisioned unit will be fully programmable (i.e. voice/command entry) to satisfy multiple functions (e.g. navigation, resource tracking etc.) The initial cost of the wrist watch unit will likely be nominal, but will require a guaranteed subscription contract for data base and communications services for a minimum number of months/years.

Regardless, whether the individual unit be a wrist watch device or some other configuration, the motivation for purchasing the equipment will likely be driven by a desire to increase personal productivity, manage resources and assure reliable situational awareness. User equipment flexibility and subsequent personal utility will be the key factors in the decision to buy. Investment in GPS-based equipment for personal use will likely be evaluated on an individual level based on the cost of the unit, user equipment flexibility, immediate personal utility (solving an immediate problem/concern), potential/future productivity improvements, and quality of life benefits associated with owning one or more units.

Data base availability and two-way data link (other enabling technologies) will likely dominate the growth curve for development and sales of mobile personal units. Miniaturization, display advancements and power-cell improvements will be important, but they are not critical path “utility” enablers.

Utility will be optimized by having accurate, functionally supportive data readily available, on-demand, as conditions dictate. Preprogramming of a personal unit, advanced knowledge of all the information required and sufficient personal unit storage capability will likely not be possible in one unit. Hence the need for data link and on-demand database services.

Examples (Note: reference numbers (e.g. (1,1)... (3,5)...) correspond to the Xs in Section B: Benefits Matrix)

(1,1) A stronger signal and data-less channel thereby improving the ability to rely on GPS services in challenged environments, such as under forest cover, beside tree-lined roads, in urban canyons and inside buildings (e.g., 911 applications).

(1,1) A stronger signal and data-less channel thereby expanding recreational uses in challenged environments, such as forested areas.

(1,2) Improved signal acquisition and tracking thereby expanding the utility of GPS for establishing position location and monitoring movements in regions where the satellite signals are weakest, such as high-rise buildings and city environments.

(1,2) Improved signal acquisition and tracking thereby increasing the utility of GPS to determine an initial position location and reducing the probability of loss of signal enabling continuous navigation without disruption. Potential applications include improving the ability to find/relocate trails, campsites, water accesses, wells, fishing locations, etc.

(1,3) Greater resistance to radio frequency interference (both intentional and unintentional) thereby increasing the reliability of GPS receivers for determining and maintaining position information in locations susceptible to such radio interference.

(1,5) Longer spreading codes and reduced cross-correlation between satellite signals (i.e. self interference) thereby improving receiver performance in challenged environments where both weak and strong satellite signals are available, such as inside buildings or under forest cover.

(1,6) Improved accuracy and position determination capability due to increased signal bandwidth thereby improving the location accuracy and identification of objects (e.g. fire hydrants; water/gas meters, control valves utility poles, etc.) and people in challenging environments.

(1,6) Improved accuracy and position determination capability due to increased signal bandwidth thereby improving overall receiver utility (e.g. finding/relocating trails, campsites, water accesses, wells, fishing locations/nets, etc.).

L1C Modernization Civil Outreach Program

SCIENTIFIC

- **APPLICATIONS**
 - Resource Management
 - Manpower reduction
 - Time efficiency
 - Equipment placement
 - Off-site preparation
 - Improved Geodetic Database
 - Frequency of updates
 - Densification of network
 - Unification of Datum

- **REQUIREMENTS**
 - Accuracy
 - Timing
 - Availability/Coverage

References

Scientific information was obtained from literature reviews, interviews, discussions with manufacturers and data extracted from documents submitted in support of the GPS-III program.

Scientific uses of GPS span a broad range of applications; from space, atmospheric, oceanic, and earth research to the tracking and monitoring of migratory herds.

Some of the most demanding scientific requirements are found in the Geodetic Survey community. Geodetic survey is a vital element for Geodesy. In turn, Geodesy is at the heart of many scientific applications because it is the science that specializes in determining the shape and size of the Earth and its gravity field in three-dimensional space and time.

These three dimensional position coordinates and precise time on a unique terrestrial reference frame are directly derived by using GPS services. Use of this information can be essential for orienting space/satellite sensor data to the location of points on the earth for: communication systems, weather systems, GIS systems that identify topography, land use, and ocean conditions.

Over the years GPS based methodologies have set the record in achieving highest position accuracy in near real-time by complementing creative observational methods, ground/space augmentation and innovative data processing techniques. Geodetic surveyors would like a simple low-cost, low-power, light-weight GPS receiver which can deliver 1 cm accuracy in real time any where in the world at all times.

The improved accuracy, integrity and availability of service are important for various geophysical measurements. In many instances these measurements are taken in “challenged environments” and reliable signal availability can be a problem. For instance: data collected to entrap geophysical activity across the plate boundaries or in an earthquake zone are of great importance to forecast crustal movements.

The precise position coordinates and time on a unified global reference frame would provide a seamlessly interoperable global system with no loss of accuracy and integrity to the geodesists, geophysicists and navigators. The future vision of geodetic survey is to be able to complete a survey project (which used to take days to weeks) almost in real time with 1000 times more accuracy. It is believed that worldwide capability of real time accurate 3D positioning (1 cm) at any given time is going to make the greatest impact on “our collective economic development.”

Improved real-time and post-processing algorithms are going to provide the power to extract every bit of the possible accuracy from the measurements. Precise satellite calibration and satellite body modeling are going to aid precise orbit determination, thereby improving the position and timing accuracy.

Clearly GPS signal performance—in terms of reliability and availability—are a definite must for the geodetic community. Reliability and availability are also critical for other scientific applications, particularly those that involve tracking and monitoring the movement of objects. For instance: migratory herds, natural and manmade objects (e.g., ice flows, oil spills, buildings, bridges, etc.), precise placement of equipment for “building” data collection networks—sensors, monitors, etc.

Examples (Note: reference numbers (e.g. (1,1)... (3,5)...) correspond to the Xs in Section B: Benefits Matrix)

(2,1) A stronger signal and data-less channel thereby improving positioning support for geological mapping, tracking migratory wildlife, etc. in presence of foliage. Could expand the large range of uses of GPS services for recording the movements of tectonic plates, and documenting volcanic, earthquake and landslide activity.

(2,3) Greater resistance to radio frequency interference (both intentional and unintentional) thereby increasing the reliability of GPS services in places subject to such radio interference.

(2,5) Longer spreading codes and reduced cross-correlation between satellite signals (i.e., self-interference) thereby improving receiver performance in challenged environments where weak and strong satellite signals are available, such as areas with dense surrounding vegetation.

L1C Modernization Civil Outreach Program

AVIATION

- **APPLICATIONS**
 - Airspace System Efficiencies
 - Increased Capacity/Access
 - Reduced Separation
 - Lower Emissions/Noise
 - Safety Enhancement
 - Operational Improvements
 - Optimized Scheduling
 - Delay Reduction
 - Fuel Savings
 - Situational Awareness

- **REQUIREMENTS (Application Dependent)**
 - Accuracy
 - Integrity
 - Continuity of Service
 - Availability/Coverage

References

Aviation services information was obtained from, literature reviews, interviews, discussions with manufacturers and data obtained from documents submitted in support of the GPS-III program.

The current GPS civil signals do not provide adequate levels of integrity, availability, and continuity of service to permit GPS to replace ground-based navigation aids for manned safety-of-life applications.

Augmentation systems such as the wide area augmentation system (WAAS) and local area augmentation system (LAAS) are being developed to address some aspects of current GPS civil signal services, but there are many aspects of the current GPS that make it difficult to achieve required performance levels, even with augmentations.

There are a number of key, underlying assumptions being made by the civil aviation community in its use of GPS for high integrity applications and in the deployment of augmentations that may not be widely recognized. Future GPS signal improvements need to consider these civil

assumptions to preserve the investments being made for augmentation systems and GPS equipment. These include:

- **Single Satellite Fault Assumption.** A key assumption made in the use of receiver autonomous integrity monitoring (RAIM) fault detection error (FDE) algorithms in the civil airspace is that probability of multiple satellite failures is so small that it can be ignored.

Proposed operational changes to provide navigation data uploads simultaneously to all satellites creates the risk of multiple satellite failures, since an incorrect ephemeris/clock load could be propagated to all satellites at once. Even if monitoring could catch this quickly, this still presents a problem for overall constellation availability and continuity.

- **Signal Quality Monitoring Assumptions (SQM).** Due to lack of detailed knowledge of satellite signal fault modes, the civil community has had to make assumptions about the form and magnitude of signal anomalies. Thus, there are limited assurances that current SQM designs will catch the most likely civil signal distortions. Consequently, there is some risk that the investments being made in WAAS and LAAS ground equipment will not yield target levels of safety.

Other improvements that are desired by the aviation community include service guarantees in the following areas:

- Reduction in satellite failure rate and improvement in constellation monitoring could remove the need to do fault detection and exclusion.
- Increased numbers of satellites and more robust civil signals for improved coverage, availability and continuity, particularly in challenged environments.
- Increased guaranteed minimum signal power to improve interference margins.
- Velocity performance guarantees for GPS heads up display guidance, inertial alignment, and paired operations.

From a signal design perspective, ranging precision including multipath effects is not a dominant error component for en route through precision approach (APV or LPV) using GPS/WAAS, but is a significant error source for LAAS Category II-III precision approaches (particularly when the provision of integrity is considered). For present-day WAAS, residual ionospheric errors are dominant. If, as planned, WAAS users migrate to using L1 and L5 for direct ionospheric measurements, then ranging precision may become a more significant factor. Improving ranging precision over that provided by the C/A-code may also be important if GPS III is to provide integrity from GPS without augmentation.

Examples (Note: reference numbers (e.g. (1,1)... (3,5)...) correspond to the Xs in Section B: Benefits Matrix)

(3,3) Greater resistance to radio frequency interference (both intentional and unintentional) thereby improving the overall navigation performance and reliability for both manned and unmanned aircraft/vehicles.

(3,5) Longer spreading codes and reduced cross-correlation between satellite signals (i.e. self interference) and a data message which identifies the satellite, thereby improving receiver performance, especially in challenging operational conditions where weak and strong satellite signals are available.

L1C Modernization Civil Outreach Program

AGRICULTURE

- **APPLICATIONS**
 - Yield mapping
 - Soil Sampling, Soil Preparation
 - Irrigation
 - Precise, Real Time Surveying
 - Vehicle/equipment control
 - Harvesting/Product tracking
 - Government subsidizes/incentives

- **REQUIREMENTS**
 - Accuracy: one meter or less
 - Availability: 99.9% or better
 - Integrity: 5 seconds or better
 - Repeatability

References

Agriculture information was obtained during interviews with US Department of Agriculture (USDA) representatives; discussions with equipment manufacturers, literature reviews and data obtained from documents submitted in support of the GPS-III program.

Yield Mapping

GPS use has the potential of providing site-specific optimization of land use—Yield Mapping. Yield Mapping is a process of determining exactly what is needed to increase crop production while reducing environmental impacts. Fertilizer application and insecticides/pesticides are primary concerns. Nitrogen use/application is a dominant issue and application of nitrogen needs to be site specific. One meter level accuracy or better is required and repeatability is critical. Repeatability is the ability to return to the exact same spot at different times throughout the year.

Yield Mapping, made possible by improved GPS performance, is not a sole function of GPS. It relies on a total system/process properly integrated to achieve the desired result. Specifically, those systems/processes include a mechanism for accurate soil sampling, the application medium (e.g. farm equipment), and precise control of the application.

Soil Sampling/Soil Preparation

Soil sampling, or mapping of the soil, requires sub-meter accuracy to determine the variations of soil content and composition. Variations of soil content and composition will establish a baseline for initial soil preparation and soil maintenance. Currently, differential GPS augmentations are available to achieve these accuracy levels. However, they are not in widespread use and are relatively expensive.

Irrigation

Irrigation is another agricultural necessity that will benefit from GPS. Several mechanized systems are used to irrigate fields, such as large rotating arms with multiple rotating sprinkler heads and fixed irrigation pipe with rotating sprinklers. Precise irrigation will both increase per acre yield and reduce the amount of water used to achieve crop optimization. Increased, repeatable GPS accuracy will be needed to achieve improved irrigation, less than 10 meters, both horizontal and vertical.

Precise, Real Time Surveying

Real-time, precise surveys, (centimeter level accuracy) such as the ones needed for irrigation, could provide significant economic benefit to the farmer as well as improve environmental conditions. An example of the benefits of real-time, precise surveys coupled with precise vehicle control is as follows:

Harvesting/Product Tracking

Accurate, repeatable planting, cultivation, insecticides/pesticides applications, and harvesting are essential for per acre product optimization. In preparation for planting, farmers fertilize in the Fall. When it is time to plant, they attempt to plant exactly where they fertilized, but this is obviously difficult to do. As a result, planting may not occur at the optimum fertilized location. To ensure this does not occur, farmers generally apply large amounts of fertilizer, both costly to them and harmful to the environment (nitrogen). Cultivation requires sub-centimeter accuracy. A large machine moving between rows of crops must remain properly oriented and controlled, otherwise crop destruction will occur. The same conditions apply for harvesting. In addition, a twenty-four hour harvesting capability would theoretically double the value of a harvesting machine and cut harvesting time by 50%. Centimeter level control would be needed, as well as high system availability/integrity (99.9%+/5 seconds or better), with an automatic equipment shutdown feature in the event of a signal failure or loss.

Recording of product. As we move more towards genetically engineered crops, there will be a need to trace the history of the end state product. For instance, aerial application of chemicals must be precisely known (e.g. path flown, type of chemical, etc.), methods used to engineer crops—this information will likely be needed for the Federal regulators, the people purchasing the crop (Note: today's regulations to qualify for an organically grown product), and the end state consumer. Preservation of crop identity (Pharming) from soil preparation to the supermarket will benefit from improved GPS and affordable equipment.

Vehicle/Equipment Control

Farm size and efficiencies are another area that could benefit from better GPS performance. To remain in the farming business, farmers have had to expand. For example, the price of a bushel of wheat has not significantly increased in the past two decades, but the cost to produce that bushel of wheat has gone up dramatically. To stay in business, the farmer has to produce more bushels of wheat. Small farms have gone by the wayside and farms are generally getting larger. Big farms require either more or bigger equipment to work the fields. Equipment has been getting bigger to accommodate this need. Main reason is productivity. One person operating a large machine can produce more than one person operating a small machine. But machine size and related expenses are not linear, in terms of both initial purchase price and cost of operations/maintenance. A machine capable of twice the output may cost ten times the price. Several small machines may be economically attractive, but their practical use in today's world, is not viable. However, if an improved GPS-L1C, with reliable, sub-meter performance could be used to automatically control a fleet of small machines, day or night, the move to bigger machines may end. Integrity will be an important enabler of fleet farming—as a guide: 5 seconds or better.

Government Subsidizes/Incentives

Farming is generally not a business. Survival is the key, keeping everything running from year-to-year. The Farm Bill is a major factor. This Bill keeps farmers alive, and it is taken very seriously. If the Farm Bill levies a requirement to do something—like use a GPS based system—to qualify for a subsidy, use of the GPS based system will likely occur.

The Environmental Protection Agency (EPA) is an extremely powerful motivator. Currently, nitrogen and pesticides are big issues in the EPA. If the EPA issued a regulation or gave a farmer relief from a regulation if a GPS-based system were used, then the GPS-based system would likely be used as soon as possible.

Examples (Note: reference numbers (e.g. (1,1)... (3,5)...) correspond to the Xs in Section B: Benefits Matrix)

(4,1) A stronger signal and data-less channel thereby increasing the utility of relying on GPS services in orchards and under tree canopies to enable an accurate assessment of crop conditions and more reliable control of both field/soil maintenance and harvesting equipment.

(4,2) Improved signal acquisition and tracking thereby improving the ability to determine site-specific optimization of land production in places where satellite signals are weakest, e.g., under a tree canopy. Optimization of land production includes yield mapping—determining exactly what is required for improved crop production (e.g. insecticides, pesticides, fertilizers).

(4,4) Higher dynamics tracking of GPS signals enabling the ability to retain signal lock with 64 times higher levels of “jerk” and 16 times higher levels of antenna acceleration thereby

improving the performance of earthmoving and land preparation machinery subject to strong shock and vibration.

(4,5) Longer spreading codes and reduced cross-correlation between satellite signals (i.e. self interference) thereby improving receiver performance in challenged environments where weak and strong satellite signals are available, such as in orchards/tree farms.

L1C Modernization Civil Outreach Program

SURFACE TRANSPORTATION

- **APPLICATIONS**
 - Command and Control
 - Optimized Scheduling
 - Lower operating costs
 - Asset/Resource Tracking
 - Reduced Congestion
 - Fuel Savings
 - Lower Emissions
 - Increased road capacities
 - Increased Operator efficiencies/safety
 - Accident investigation
 - Collision avoidance

- **REQUIREMENTS**
 - Accuracy: 10 cm
 - Integrity: 10 seconds or less
 - Availability/Coverage: 99.9%
 - Fix Interval: 1-2 seconds

References

Surface Transportation information was obtained during discussions with Federal Highways Administration (FHWA) personnel, literature reviews, discussions with equipment manufacturers, and data obtained from documents submitted in support of the GPS-III program.

The following summary of highway statistics and scenarios provide a relative framework for assessing the potential benefits of using GPS-based systems and services in the vehicular transportation area:

More than 6,000,000 accidents happen on US highways every year, resulting in more than 5,200,000 injuries and more than 41,000 fatalities every year.

The total cost of these mishaps are in excess of \$150 Billion per year. It has been estimated that as much as three-quarters of these accidents could be prevented if the driver's attention were not diverted in the moments before the collision. The National Highway Safety Administration estimates that 1.1 million (17%) of all crashes could be prevented if all vehicles had three devices installed, (1) rear end notification, (2) roadway departure and (3) lane/change merge warning.

GPS is an enabling technology for these devices. The estimated benefit of these devices would be the saving of thousands of lives and at least \$23 Billion per year.

An Automatic Collision notification device (like the Cadillac On-Star System) that sends out a signal giving time, location and notice that an air bag has deployed would help dispatch emergency services with reduced arrival times, which saves lives. Forty percent of all traveled miles are on rural roads, but they account for 60% of all traffic fatalities because of slow emergency response, greater distances, and lack of precise accident location information in real time. GPS use can provide precise accident location information regardless of the location, assuming adequate coverage and availability of signal services.

The use of GPS based technologies to exercise positive control and management of manned and unmanned fleet operations as well as real time asset and resource tracking is a growing business. Current uses include tracking and monitoring of platforms in real-time; logging/recording vehicle location and issuing status/progress reports; initiating and/or commanding actions based upon platform status, such as dispatching maintenance crews, changing delivery schedules, rerouting vehicle, and providing real time notification to end state users.

Use of GPS to further improve Fleet Management operations and provide bottom line dollar benefits are expected to continue to expand based upon the availability and performance levels of GPS services. Signal availability and coverage are critical path items for Fleet Management growth, followed closely by user equipment cost and size. Coverage in the city canyons is needed with availability at 99.9% or higher.

Fleet Management operations for companies that have drivers out in the field benefit by using GPS coupled with communication capabilities. Typical users include electrical, plumbing, telecommunications, couriers, etc. A dispatcher collects vehicle data, such as maximum speed, vehicle location, length of time at specific location, and activation of specific events associated with vehicle operations. The information is then used to measure vehicle and driver productivity. Management reports provide data in a variety of formats, including number of stops, average stop length, and percentage of total time spent on service calls.

GPS supported Traffic/Highway Movement improvements are beginning to enter the inventory and growth is anticipated in the following areas:

- Intersection collision avoidance. GPS is being considered as one potential sensor (along with onboard radars and road sensors) for this application.
- Automatic Vehicle Location (AVL) – This is a general category of systems that are geared at determining vehicle position for fleet tracking, etc. Public safety users (e.g., police cars, fire trucks) are leveraging research funded by the Department of Justice (DOJ) for Federal vehicle tracking. In larger metropolitan regions of the U.S. most buses are equipped with GPS for AVL. This is occurring mostly for driver/passenger protection. An example was cited of a hijacked bus being quickly recovered because of GPS-based AVL. Bus AVL equipage is growing, even in suburban/rural areas.

- Road construction/grading, surveys of roadside infrastructure – similar to most surveying applications, cm-level accuracy is required. Better surveying results in longer road-life. Caterpillar has been very involved in applying GPS technology in road construction equipment.
- Road quality monitoring – Some vehicles are equipped with photographic equipment to detect road surface faults (cracks, potholes). GPS is used to locate the faults so that road crews can be sent for repairs. The accuracy required from GPS for these photo-logging systems is on the order of 1 m, 2-sigma.
- Traffic monitoring – several studies have placed GPS receivers on a number of private citizen automobiles in order to better understand typical driving habits. These studies have concluded that questionnaires to determine driving habits are not very accurate – it was found that in the questionnaires most respondents left out many trips
- Intelligent Transportation Systems (ITS): ITS involves the use of technology to improve highway efficiency/safety. Cameras and magnetic loop sensors embedded in roads provide situational awareness to traffic operation centers (TOCs). Employees at the TOCs monitor traffic and post alerts as necessary on roadside variable message signs. Traffic information is also provided to the public via websites. Atlanta has perhaps the most sophisticated TOC, which was compared in appearance to something from “Star Trek.” One current trend is to increase the level of communication among various TOCs, so that travelers have advance notice of traffic at far-away destinations.
- Autonomous vehicle operations are a driver for both accuracy and integrity performance. An accuracy of 10 cm, to maintain lane orientation and a 10 second integrity threshold or better has been suggested as a performance requirement.

Examples (Note: reference numbers (e.g. (1,1)... (3,5)...) correspond to the Xs in Section B: Benefits Matrix)

(5,1) A stronger signal and data-less channel thereby improving the ability to continuously navigate in challenged environments, such as beside tree-lined roads and in urban canyons.

(5,2) Improved signal acquisition and tracking thereby increasing the utility of GPS to determine an initial position location and reducing the probability of loss of signal enabling continuous navigation without disruption.

(5,3) Greater resistance to radio frequency interference (both intentional and unintentional) thereby improving the efficiency and effectiveness of resource/asset monitoring, dispatch and control—such as fleet operations.

(5,5) Longer spreading codes and reduced cross-correlation between satellite signals (i.e. self interference) thereby improving receiver performance in challenged environments where both weak and strong satellite signals are available, such as in cities and along tree lined roads.

(5,6) Improved accuracy and position determination capability due to increased signal bandwidth thereby improving the efficiency and effectiveness of resource/asset monitoring, dispatch and control—such as fleet operations.

L1C Modernization Civil Outreach Program

MINING/CONSTRUCTION

- **APPLICATIONS**
 - Centralized Precision Command and Control of Equipment
 - Remote Operations
 - Lower operating costs
 - Asset/Resource Tracking
 - Survey/Assessment
 - Material Placement
 - Resource/Equip Location
 - Personnel Assignments

- **REQUIREMENTS**
 - Accuracy: 5-10 cm
 - Integrity: unspecified
 - Availability: continuous (open pit mine, construction site mask angle problems)

References

Mining/Construction information was obtained during discussions with equipment manufacturers, literature reviews and data obtained from documents submitted in support of the GPS-III program.

Mining and Construction activities are site specific operations. Consequently, the utility of GPS is a function of site characteristics, localized conditions and the subsequent availability of GPS signals at the site location.

An initial requirement is to build, using GPS survey equipment, a precise Geographical Information System (GIS). For instance, mining operations depend upon a GIS reference data base for information such as:

- Physical characteristics (Height, Spatial Location, etc.)
- Micro Soil / Rock / Mineral Types
- Record of Previous Excavations

Mining equipment, and to a certain extent construction equipment, can be autonomously controlled through an integration of the GIS reference data base, equipment specific position information and the desired task to be performed. Advanced computer vision applications can also be applied thereby reducing and, in some instances, deleting the need for manual/labor-

intensive physical equipment operation. In particular, surface mining equipment may be outfitted to perform in this fashion.

Planning and resource management of mining operations are commonly governed by a resource planning system that uses the GIS reference data base as one of its main inputs for performing mining decision analyses. The decision analyses function of the resource planning system determines the optimum use of available resources for completing specific tasks. In turn, a task plan is developed, a schedule is produced, specific equipments functions are determined, etc. and this information is provided to the decision maker(s) for execution.

Following equipment programming, the equipment autonomously navigates the entire area performing the activities in accordance with the plan. Typical activities include scraping, excavating/digging, leveling, loading of ore/surface debris into trucks for transport, reporting of on-board sensors on the condition of the soil/minerals and plants (if any) by time and location for future evaluation/analysis, etc.

This typical scenario ends successfully when the task plan has been completed and all gathered information has been provided to the resource planning system and/or the GIS reference database has been updated--as appropriate. The scenario ends unsuccessfully if the equipment is unable to complete the plan (e.g. due to an obstacle not in the plan, equipment failure, loss of position data, etc).

Specific benefits of evolving to this type of GPS based system for mining and construction operations include:

- *Increased Automation of Mines/Construction Sites.* Fewer required human heavy equipment operators onboard the actual equipment.
- *Increased Safety.* It may be the case that mining and construction operations can take place in areas where it may be too dangerous to send human operated equipment.
- *Environment Mitigation.* In many areas land reclamation is required after the mining operations cease. Tracking of large topographic features can minimize and automate the reclamation effort
- *Size and Cost of Mining/Construction Equipment.* It is believed that the unit size of a piece of mining equipment may become smaller, as it is believed equipment size has been driven to maximize operator efficiency and productivity. Typically the cost of a larger version of a piece of equipment is substantially greater than the cost of a smaller variant.

Examples (Note: reference numbers (e.g. (1,1)... (3,5)...) correspond to the Xs in Section B: Benefits Matrix)

(6,1) A stronger signal and data-less channel thereby improving the ability to continuously navigate and operate machinery in challenged environments, such as open pit mines or under foliage.

(6,2) Improved signal acquisition and tracking thereby increasing the utility of GPS to determine an initial position location and reducing the probability of loss of signal enabling continuous navigation without disruption.

(6,3) Greater resistance to radio frequency interference (both intentional and unintentional) thereby improving the performance of GPS receivers in locations subject to such radio interference.

(6,4) Higher dynamics tracking of GPS signals enabling the ability to retain signal lock with 64 times higher levels of “jerk” and 16 times higher levels of antenna acceleration thereby improving the performance and guidance of earthmoving and construction equipment (e.g. graders, loaders, shovels, trucks, etc.).

(6,5) Longer spreading codes and reduced cross-correlation between satellite signals (i.e., self interference) thereby improving receiver performance in challenged environments where both weak and strong satellite signals are available.

L1C Modernization Civil Outreach Program

SURVEYING/CIVIL ENGINEERING

- **APPLICATIONS**
 - Static and Dynamic Survey
 - Movement/Motion Detection
 - Site Preparation
 - Material/Equipment Location-Placement
 - Lower operating costs

- **REQUIREMENTS**
 - Accuracy
 - Integrity
 - Availability
 - Repeatability
 - Reliability

References

Surveying/Civil Engineering information was obtained during discussions with equipment manufacturers, literature reviews and data obtained from documents submitted in support of the GPS-III program.

Surveying operations have been made more cost effective and efficient by relying on GPS signals to augment and/or replace traditional methods. There are several manufacturers and systems from which to choose, ranging from modular Bluetooth-enabled equipment for topography, construction and boundary-survey applications to multiple frequency GPS augmented systems (e.g. camera, inertial measurement units) for installation on land vehicles to collect digital geo-referenced imagery in real time. Equipment is also available for hydrographic surveying and other marine applications. In all instances, signal reliability, repeatability and availability are paramount.

Precision GPS equipment has been integrated into bridge monitoring programs worldwide and has produced positive results. A similar application is currently under consideration for tall buildings in urban environments. Specifically, GPS-based building monitoring in Chicago is being examined to validate commercial wind tunnel testing. Generally scaled models of tall buildings are tested in commercial wind tunnels during the design phase to determine the likely loads under both service-level and extreme wind conditions. “Engineers must know how accurately they are predicting building displacements and accelerations in the design phase, particularly when using wind tunnel studies, and how these responses affect daily performance and operation of tall buildings from the habitability and serviceability”.

Urban GPS-based applications raise a number of issues/concerns, such as potential RF interference and multipath interference. These “challenged environments” will have to be evaluated on an individual basis to assure GPS services can provide the desired level of performance.

Similar “challenged environment” concerns have also been expressed regarding GPS use in mobile mapping systems. For instance, “conventional road centerline surveys provide high accuracy, sometimes to the sub-centimeter level, but present several difficulties such as survey crew safety, disruptions to traffic flow, inaccessibility of some highways to survey, cost, slow production rate, and re-surveys”.

The Ohio Department of Transportation has responded to these real-world problems by supporting the development of a mobile survey system based on a tightly integrated GPS/inertial reference system combined with a fast, down looking, color digital camera. Overall accuracy is in the centimeter range at speeds up to 35 miles per hour, and can support 65 mile per hour “surveys” if lower accuracy is acceptable. This capability results in an ability to survey approximately 60 lane miles of highway per day, as compared to traditional methods which can survey approximately 2 lane miles of highway per day.

GPS-based mobile surveying is also being used for other modes of transportation, such as detecting situations where railroad tracks become shifted or buckled in order to fix them before railroad derailments are triggered. GPS receivers are put on locomotives and data is collected during each trip. This data is processed to determine the location of tracks relative to the distance from a common point. The distances between consecutive tracks are computed to measure misalignments. When the distance exceeds a certain threshold, the track is repaired. In addition to signal availability, repeatability and robustness, accuracy is also critical. A variation of 10 cm can be significant and cause potential problems. Accuracy is important to avoid accidents as well as prevent unnecessary repairs.

Examples (Note: reference numbers (e.g. (1,1)... (3,5)...) correspond to the Xs in Section B: Benefits Matrix)

(7,1) A stronger signal and data-less channel thereby improving the ability to conduct surveys and engineering operations in challenged environments, such as under forest cover or in urban environments.

(7,3) Greater resistance to radio frequency interference (both intentional and unintentional) thereby increasing the reliability of GPS receivers for determining and maintaining position information in locations susceptible to such radio interference.

(7,4) Higher dynamics tracking of GPS signals enabling the ability to retain signal lock with 64 times higher levels of “jerk” and 16 times higher levels of antenna acceleration thereby permitting continuous signal tracking even if the antenna is being jerked around or even dropped.

(7,5) Longer spreading codes and reduced cross-correlation between satellite signals (i.e. self interference) thereby improving receiver performance in challenged environments where weak and strong satellite signals are available, such as under forest cover.

L1C Modernization Civil Outreach Program

PUBLIC SAFETY/SECURITY

- **APPLICATIONS**
 - Personnel Productivity
 - Manpower Reduction
 - Improved time efficiencies
 - Situational Awareness
 - Location determination
 - Navigation
 - Resource Management
 - Public Service/Emergency Vehicle Dispatch
 - Fleet Operations and Management
 - Asset Tracking and Monitoring
 - People/Equipment Tracking and Monitoring

- **REQUIREMENTS**
 - Availability
 - Coverage
 - Accuracy
 - Repeatability

References

Public Safety and security information was obtained during discussions with Federal Bureau of Investigation Engineering and Research representatives, literature reviews, discussions with equipment manufacturers, and data obtained from documents submitted in support of the GPS-III program.

Summary

This set of applications involves a particularly wide range of uses for GPS, with different uses requiring different capabilities. One overriding interest is use of GPS in challenging environments that incur limited visibility and significant attenuation of signals. Another important interest is for battery-operated receivers with very low power consumption. Some types of augmentations, as well as external assistance and aiding, might help contribute to meeting these challenges.

Details

GPS services are currently being used for Public Safety and security purposes, such as dispatch and monitoring of emergency service vehicles and in the law enforcement area. Public Safety applications extend beyond the common notion of identifying and directing an emergency response vehicle to the shortest path to the scene of an accident, to applications in the Fleet Management area to ensure resource optimization as well as record documentation.

Fleet Management in the Public Safety mission area is viewed as being able to coordinate multiple emergency response vehicles to the scene of a critical accident/incident. This coordination can involve several vehicle types (e.g. fire, police, rescue) and be over large distances and long periods of time.

In such occasions it is also necessary to accurately record the actions and responses of each vehicle for subsequent court actions, insurance purposes, training, etc. The GPS capability to provide a common time reference and precise location information has simplified the incident/accident documentation process.

Improved personnel productivity, reduced errors and increased efficiencies have all been identified with introducing GPS technology in the Public Safety/Security areas area.

GPS in Law Enforcement/Security has a broad range of potential uses that include both highly accurate and less accurate requirements. Some uses would entail the location of a suspect using GPS. In this specific use, accuracy in the 10-meter range would be adequate in order to locate the suspect without running the risk of public revelation of highly sophisticated police tools resulting from a subpoena of methods and techniques. Other uses, such as crime scene reconstruction, could pin an entire investigation on the precise location of a bullet hole or resting place of a piece of evidence in the aftermath of an incident. For these uses, centimeter accuracy is of greater value.

In either case, a real concern and where improvements are definitely needed are: coverage, signal availability, and service/signal protection. Public safety and security representatives have indicated a definite need for more signal availability in city canyons and being able to easily acquire the signal without worrying about equipment placement and antenna patterns.

A perfect scenario would be the ability to “slap-on” a GPS receiver under a bumper and be assured that the signal would be received regardless of where the vehicle traveled.

There is also some difficulty acquiring GPS signals at high speeds—200-300 knots. Being able to remotely activate a GPS receiver on an aircraft while in flight in lieu of having to initialize the receiver while the aircraft is on the ground is a desirable feature. Modification to the waveform might render this high speed acquisition more possible.

Another user equipment feature of interest is intentional user equipment crippling and/or shut down particularly when GPS is integrated into a vehicle control system. Remotely crippling and/or shutting down a vehicle control system would benefit FBI field operations.

User equipment should be small, lightweight and power efficient. In addition, it should have the capability of retrieving and storing data based upon specific operational requirements. Wristwatch size GPS, combined with a communications device, a tracking capability and a “help” feature is desirable.

User equipment power requirements limit operational utility. Power efficient systems are a must, as well as being able to remotely turn the equipment on or off and preprogram its operation.

Examples (Note: reference numbers (e.g. (1,1)... (3,5)...) correspond to the Xs in Section B: Benefits Matrix)

(8,1) A stronger signal and data-less channel thereby improving the ability for emergency response vehicles and personnel to continuously navigate in challenged environments, such as beside tree lined roads, urban canyons and inside of buildings.

(8,1) A stronger signal and data-less channel thereby improving the ability to rely on GPS services in challenged environments, such as foliage, under cover, inside of buildings. Potential applications include the monitoring, tracking and control of personnel and objects.

(8,2) Improved signal acquisition and tracking thereby increasing the utility and reliability for multiple vehicles and emergency personnel to coordinate efforts in response to critical accidents/incidents, such as highway accidents, fires and natural disasters in challenged signal environments such as beside tree lined roads, urban canyons and inside of buildings.

(8,2) Improved signal acquisition and tracking thereby expanding the utility of GPS for establishing position location and monitoring movements in regions where the satellite signals are weakest, such as inside buildings, city environments, and within/under vehicles.

(8,3) Greater resistance to radio frequency interference (both intentional and unintentional) thereby increasing the reliability of emergency response vehicles and personnel to effectively operate in locations susceptible to such radio interference.

(8,3) Greater resistance to radio frequency interference (both intentional and unintentional) thereby increasing the security uses of GPS receivers in locations which might experience such radio interference. Potential applications include coordinating, recording/documenting the actions of multiple security resources (e.g. people, vehicles) in response to a security threat. Note: accurate documentation facilitates follow-on activities such as court actions, investigations and insurance claims.

(8,5) Longer spreading codes and reduced cross-correlation between satellite signals (i.e. self interference) thereby improving receiver performance in challenged environments where both

weak and strong satellite signals are available, such as in forest areas, city environments, within/under vehicles and inside buildings.

(8,6) Improved accuracy and position determination capability due to increased signal bandwidth thereby being better able to coordinate multiple emergency response vehicles to the scene of a critical incident/accident.

(8,6) Improved accuracy and position determination capability due to increased signal bandwidth thereby improving the accuracy and repeatability of coordinating and recording/documenting the actions of multiple security resources (e.g. people, vehicles) in response to a security threat. (Note: accurate documentation facilitates follow-on activities, such as court actions, investigations and insurance claims).

L1C Modernization Civil Outreach Program

TIMING

- **APPLICATIONS**
 - Systems Efficiencies
 - Data Transfer Rates
 - Lower deployment costs
 - Lower operating costs
 - Infrastructure Optimization
 - Distributed synchronization
 - Increased robustness

- **REQUIREMENTS**
 - Time Accuracy
 - Time Transfer Accuracy
 - Frequency Accuracy
 - Coverage/Availability: 99.7%
 - Protection

References

Timing information was obtained from literature reviews, interviews, discussions with manufacturers and data extracted from documents submitted in support of the GPS-III program.

The majority of “timing” users reside in the telecommunications community. Although scientific applications have a more stringent requirement for frequency and time accuracy, the sheer volume and criticality of the telecommunication applications make this area a driving concern for GPS services.

As noted by P. Mann and E. Butterfield in an Institute of Navigation Paper: *“Global Positioning System Use in Telecommunications:*

“Synchronization is essential to the effective operation of telecommunication networks. The digital switching and transmission systems implemented in telecommunications networks today require synchronization to realize the design efficiencies and prevent impairments. In fact, the quality of a telecommunication carrier’s services is based, in part, on the quality of the synchronization.”

As the nation's (if not the world's) telecommunication infrastructure becomes increasingly dependent on GPS, the issue of the integrity and reliability of the synchronization will become extremely critical – perhaps exceeding those imposed by safety of life missions.

Time and frequency synchronization can be achieved by either common-view time transfer or by using GPS or UTC time directly. Common-view time transfer, wherein two remote stations observe the same satellite(s) at the same time and then compare data to synchronize their clocks, yields the highest accuracy. Sub-nanosecond synchronization is routinely achieved. However, this requires additional communications infrastructure.

Conversely, users can synchronize their time or frequency standards independently with GPS, but this has relatively limited accuracy – on the order of 100 nanoseconds or so depending on the type of receiving equipment used. Fortunately, this easily meets the Stratum-1 needs of most commercial and industrial users (≤ 1 microsecond).

Specific applications include the Public Switched Telephone Network (PSTN), Synchronous Optical Network (SONET), wireless, and internet. Wireless applications can be subdivided into those that require both precise time and frequency references, such as CDMA, and those that only require precise frequency, such as GSM and TDMA.

Beyond telecommunications, power companies are using GPS for measuring phase differences between power transmission stations, for event recording, for post disturbance analysis and for measuring the relative frequency of power stations. GPS is being used for worldwide time transfer synchronization of clocks for supporting astronomical observations such as Very Long Baseline Interferometry (VLBI)/Pulsar observations.

The current specification for frequency accuracy is 1 part in 10^{10} . Relating this back to timing performance, this can be supported by a 10 nano-second (ns) level accuracy, assuming a long enough observation interval (e.g., greater than 100 sec). Since the short-term stability of the GPS signal-in-space (SIS) interface is on the order of 1 part in 10^{12} for observation intervals of 100 sec, the dominant error source is the user's receiving equipment.

ANSI and ITU standards dictate that telecom carriers operate T1 line synchronization at a frequency accuracy of 1 part in 10^{11} . This is currently done with Rubidium or Cesium atomic frequency standards slaved to a GPS receiver to allow long observation intervals (e.g. 10,000 seconds or more) where the mid-term stability of the GPS SIS interface is on the order of 1 part in 10^{13} . To support this with just a GPS receiver implies high-end receiving equipment with (on the order of) 1 ns performance.

Due to the criticality of timing for telecommunication applications, the requirements for a robust, distributed infrastructure leads to protection against loss of GPS signals (due to RFI or environmental conditions) as an important factor. Atomic frequency standards are currently employed for “flywheel” time keeping to guard against temporary loss of GPS signals.

To reduce the need for multiple sites and high operating costs to support telecommunications requirements, the enhanced availability of GPS in restricted urban areas, challenged environments, and indoor environments are important pacing factors.

It should be noted that the timing performance demanded by telecommunications also would benefit other applications, such as meteorology and electric power systems.

Examples (Note: reference numbers (e.g. (1,1)... (3,5)...) correspond to the Xs in Section B: Benefits Matrix)

(9,3) Greater resistance to radio frequency interference (both intentional and unintentional) thereby expanding the location options for installing GPS antennas in support of time/time transfer applications.

(9,5) Longer spreading codes and reduced cross-correlation between satellite signals (i.e. self interference) thereby improving receiver performance in challenged environments where both weak and strong satellite signals are available, such as on inside buildings.

L1C Modernization Civil Outreach Program

RAIL TRANSPORTATION

- **APPLICATIONS**
 - Command and Control
 - Optimized Scheduling/Capacity Increase
 - Lower operating costs
 - Asset/Resource Tracking
 - Maintenance Efficiencies
 - - Infrastructure (e.g. track, bridge)
 - - Equipment (e.g. locomotive, cars)

- **REQUIREMENTS**
 - Accuracy: 1-2 meters
 - Integrity: 99.999 for Positive Train Control (PTC)
 - Availability: 99.9

References

Rail transportation information was obtained during discussions with the Federal Railroad Administration (FRA), literature reviews, discussions with equipment manufacturers and data obtained from documents submitted in support of the GPS-III program.

Operating and controlling passenger and freight traffic, tracking and scheduling shipments and containers, monitoring systems and health of equipment, providing arrival and departure estimates, and issuing warnings (e.g. railroad crossings) are day-to-day rail activities that will potentially benefit from GPS services.

Numerous research and development programs are currently underway to determine the near and long term benefits of incorporating GPS based technology into routine rail operations.

With respect to specific safety of life research, the September 8, 1999 *Report of the Railroad Safety Advisory Committee to the Federal Railroad Administrator on Implementation of Positive Train Control*, PTC initiative to: (1) prevent train-to-train collisions via positive train separation, (2) enforce speed restrictions, (3) provide protection for roadway workers and their equipment, describes the status of efforts to develop, test, demonstrate and deploy PTC systems. The Federal Railroad Administrator (FRA) believes tragedies, such as the life ending collision in Flagstaff Arizona, are completely avoidable with today's technology, and that the railroads would find economic benefits with the same PTC systems. FRA cited a Draper Lab study that predicted PTC would reduce the probability of train-to-train collisions by a factor of 100.

An error by a single human can cause a fatal train accident (e.g. engineer falling asleep, dispatcher error). FRA estimates that it would cost \$3B for the railroads to fully implement PTC (60% for equipment on locomotives, 20% for track-side equipment, and 20% for control centers). Once the investments were made, little further investment would be needed even if additional tracks were laid (in contrast to conventional track signaling, for which costs accrue by the track mile).

FRA believes that the benefits of PTC would be greater than this \$3B investment. It was speculated that the railroads understand that PTC is cost-benefit justified, but do not want to publicly admit it because then they would be forced to implement PTC by regulation. The railroads do not want to be forced into PTC – mostly because of the financial burden.

The accuracy required for PTC is approximately 1 m. One of the more demanding PTC scenarios that results in this accuracy requirement is the avoidance of switch fouling. For train position determination, GPS is only needed to periodically update the primary location system consisting of an odometer/tachometer (one demonstration system also included a ring laser gyro – FRA believes this is overkill). Even after passing through long tunnels (e.g., the 8-9 mile Cascade tunnel in Washington or the 6-7 mile Moffett tunnel in Colorado), along-track errors of the odometer are only on the order of less than 10 feet. Odometer outputs plus switch position sensors can provide very accurate train location inputs to PTC systems.

Desired improvements to GPS:

- If GPS could provide 1-2 m accuracy with integrity, then PTC could rely on stand-alone GPS vice a differential system.
- Additional signal availability would improve odometer calibration.

Several of the railroad companies (e.g. Burlington Northern) and local Transportation Departments have been investing in programs that have produced positive results.

Examples of such programs include: the “Burlington Northern Santa Fe GPS Survey Project,” S. Sauer, *Bulletin 758 – American Railway Engineering Association* – This paper describes a Burlington Northern Railroad GPS surveying project to precisely record the locations of the railroad’s physical assets (e.g., tracks, grade, stations, mileposts, etc.); and the integration of communications and GPS in the Oregon Department of Transportation’s APCO Project 25—where GPS is being used to (1) control radio equipment based on location, (2) as part of the instrumentation monitoring performance of the radio equipment under test, and (3) as part of an asset management application.

Examples (Note: reference numbers (e.g. (1,1)... (3,5)...) correspond to the Xs in Section B: Benefits Matrix)

(10,1) A stronger signal and data-less channel thereby improving train operations and control in challenged environments, such as along tree lined tracks.

(10,2) Improved signal acquisition and tracking thereby increasing the utility of GPS to determine an initial position location and reducing the probability of loss of signal enabling

continuous service without disruption. Applications include the operation, control and monitoring of engines/cars, as well as the construction, maintenance and repair of rails and rail foundations.

(10,5) Longer spreading codes and reduced cross-correlation between satellite signals (i.e. self interference) thereby improving receiver performance in challenged environments where both weak and strong satellite signals are available, such as along tree lined tracks.

L1C Modernization Civil Outreach Program

SPACE

- **APPLICATIONS**
 - Space Platform Efficiencies
 - Reduced Weight
 - Fewer payload requirements
 - Lower production costs
 - Increased capabilities
 - Lower Launch & Operational Costs
 - Reduced ground Control
 - Less ground infrastructure
 - Autonomous operations

- **REQUIREMENTS**
 - Attitude and Velocity Accuracy
 - Coverage/availability
 - Availability of low cost, space-qualified receivers.

References

Space information was obtained from, literature reviews, discussions with manufacturers/NASA and data obtained from documents submitted in support of the GPS-III program.

GPS use in space can generally be categorized as either improving space platform efficiencies or improving space platform operations for both low orbiting platforms and satellites/vehicles operating outside of the GPS orbit altitude.

Due to the nature of varied space operations and demands placed on satellite performance, key requirements include coverage/signal availability and ultra-high attitude ($0.1 - < 0.01$ deg) and velocity (1 mm/s - 0.1 mm/s) accuracy needs. The availability of low-cost, space-qualified GPS receivers has also been a major impediment for the space user community.

In the near term, the major customer for GPS is NASA. However, this trend is projected to evolve as more civil and commercial groups develop sound business cases for developing space-based programs.

The commercial investment in space will likely be accelerated by a reduction in the overall cost of developing, deploying and maintaining space based systems, and the bottom line profitability of the investment.

GPS will likely influence commercial growth as the insertion and integration of GPS technology are relied on to reduce both production and operating costs.

GPS based space equipment will also be key in future scientific applications such as synthetic aperture radar and hyper-spectral imaging. The desired end-state is to develop and deploy a platform in a cost-effective manner and have it autonomously operate for extended periods of time.

Autonomous satellite “formation flying” for assuring relative platform positioning (in order to increase constellation/system performance) has also been identified as a real-world benefit for equipping platforms with accurate GPS receivers.

Examples (Note: reference numbers (e.g. (1,1)... (3,5)...) correspond to the Xs in Section B: Benefits Matrix)

(11,1) A stronger signal and data-less channel thereby improving the ability for tracking GPS signals and making navigation measurements in difficult signal conditions.

(11,5) Longer spreading codes and reduced cross-correlation between satellite signals (i.e. self interference) thereby improving receiver performance in challenged environments where both weak and strong satellite signals are available.

L1C Modernization Civil Outreach Program

ENVIRONMENT

- **APPLICATIONS**
 - Resource Management
 - Manpower reduction
 - Time efficiency
 - Equipment placement
 - Off-site preparation
 - Improved Environment
 - Land erosion
 - Noise Abatement
 - Natural and manmade events
 - Water management
 - Conservation
 - Land management
- **REQUIREMENTS**
 - Accuracy
 - Timing
 - Availability/Coverage

References

Environmental information was obtained from literature reviews, interviews, discussions with manufacturers and data extracted from documents submitted in support of the GPS-III program.

Environmental uses of GPS span a broad range of applications. Land erosion; noise abatement; natural and manmade event monitoring, control and management; conservation; water management; land management, etc. are but a few of the real-world environmental applications and areas benefiting from GPS.

GPS civil signal performance desires are also as varied as the range of applications. Examples of these applications are offered to clarify this point:

1. Oil exploration and tracking/containing an oil spill: It is not unusual for untapped oil reserves to be located near an environmentally sensitive area, whether that reserve be

below ground or on the ocean floor. The point is that very precise and stable platforms are needed to perform drilling operations and to extract the oil reserve. Accurate platform positioning and drilling—as specified by seismologists (hence a need for repeatability)—saves time, resources and minimizes the overall impact to the environment. Civil signal performance requirements for this function are 5 meter accuracy and 99% availability. These are the same civil signal requirements needed to clean-up/track/control and oil spill—except for the addition of a velocity requirement of .05m/sec.

An oil spill event can be a bit more difficult and certainly more environmentally significant than a drilling operation. When a spill occurs, emergency crews, oil company representatives and FEMA personnel are typically rushed to the site to begin immediate clean-up activities. This initial movement and location of equipment and personnel must be fully coordinated and accurately placed in all weather conditions and at night. Should conditions worsen and the spill perimeter expand, spill management personnel must have immediate and accurate notification and have sufficiently precise information to reallocate resources and/or request additional resources. GPS equipment satisfies these and other oil spill recovery operations.

2. A more routine event—as compared to an oil spill—is the application of chemicals to manage and control the land. Most often associated with the application of pesticides and herbicides, the inaccurate use of these chemicals can have disastrous and long lasting effects—even more severe than an oil spill.

GPS provides several services in support of crop dusting/aerial spraying. For instance: GPS is used to initially survey the field. Based on the needs of the area to be sprayed, the survey data is used to map the area with respect to the type, level and intensity of the spraying. This survey information, the needs of the area to be sprayed, the chemical allocations and flight path obstacles/local features are given to the pilot/loaded into the aircraft. GPS equipment on-board the aircraft is then relied upon—with pilot control—to apply the chemicals. GPS requirements for this function are 0.01 meters of accuracy

Following application, measures are taken to record spraying activities to maintain a complete record of the location, type, and extent of the process. In general, accuracy requirements are 25 meters and repeatability and availability are a must for the accurate construction of a useable database.

Examples (Note: reference numbers (e.g. (1,1)... (3,5)...) correspond to the Xs in Section B: Benefits Matrix)

(12,1) A stronger signal and data-less channel thereby enhancing the ability for a receiver to track and navigate in challenged environments, such as under forest cover and inside of buildings. Potential applications include real-time mapping of wildfire perimeters during fire crisis and determining surface effects during severe weather conditions, such as tornados and hurricanes.

(12,2) Improved signal acquisition and tracking thereby increasing the utility of a GPS receiver to determine an initial position location and reducing the probability of loss of signal enabling continuous navigation without disruption. Potential applications include improving the ability to monitor and track wildlife and migratory birds.

(12,5) Longer spreading codes and reduced cross-correlation between satellite signals (i.e. self interference) thereby improving receiver performance in challenged environments where both weak and strong satellite signals are available, such as in a forest or along tree-lined roads.

L1C Modernization Civil Outreach Program

MARITIME AND WATERWAYS

- **APPLICATIONS**

- Waterway/Harbor preparation, construction and marking
- Navigation efficiencies
- Vessel management, tracking and control
- Shipment/Cargo management, tracking and control
- Equipment management, tracking and control

- **REQUIREMENTS**

- Accuracy: 5-10 cm
- Integrity
- Velocity: 1/10 knot
- Availability/Coverage: 99.9% (Waterway, Harbor)
- Fix Interval: 1-2 seconds

References

Maritime and Waterways information was provided by the USCG Navigation Center, literature reviews, discussions with equipment manufacturers and data obtained from documents submitted in support of the GPS-III program.

The following three organizations provide international standards for maritime GPS equipment and services:

1. International Electrotechnical Commission (IEC) – The IEC (see www.iec.ch) is “...the international standards and conformity assessment body for all fields of electrotechnology.” IEC Technical Committee No. 80 (IECTC 80) is chartered for standards related to maritime navigation and radiocommunication equipment and systems.
2. International Association of Marine Aids to Navigation and Lighthouse Authorities (IALA) – IALA (see www.beta.ialahq.org) is a non-profit international technical association, focused on marine nav aids, established in 1957.
3. International Maritime Organization (IMO) – The IMO (see www.imo.org) is “...the United Nations' specialized agency responsible for improving maritime safety and preventing pollution from ships.”

The *Federal Radionavigation Plan* (FRP) provides marine requirements for various phases of operations. The most demanding requirement is 10-cm vertical accuracy for engineering and construction vessels. However, for dredging and construction purposes it was suggested that the 10 cm figure was inadequate and 5-10 cm vertical accuracy was actually needed.

The stringent dredging and construction requirements are being met with private differential GPS systems employing carrier-phase ambiguity resolution.

The USCG nationwide differential GPS (NDGPS) service specifications indicate a 10 meter, 95% accuracy, but in reality, the performance is closer to 1-3 meters with the understanding that end state accuracy is a function of the distance from the transmitter.

The inland waterway navigation requirement is 2-5 meters and in some locations, the NDGPS does not satisfy the requirement. After the additional civil signals are available, the belief is that NDGPS accuracies will be closer to 0.5-1 meter, thereby satisfying the inland waterway requirement. NDGPS integrity is an issue since the current integrity monitors are only single frequency. Changes will be made as more frequencies are made available to the civil users. Neither multipath nor terrain masking are problems since most large ships have the GPS antennas as much as fifty feet or more above mean sea level. In addition, signal quality monitoring was not deemed an issue for marine navigation.

Velocity requirements can be as stringent as 1/10 knot for special maneuvering such as horseshoe turns.

The USCG's aid-to-navigation fleet is almost totally dependent on DGPS at present. These vessels place buoys and need an accurate position for accurate placement. An anecdote was given about a veteran ship captain, who upon receiving a USCG demo of DGPS services, exclaimed "[I've been traveling up and down this river for years – [DGPS] explains why I'm seeing the buoys, for the first time, in a straight line!]"

Desired enhancements for Maritime and Waterways include:

- Increased accuracies provided by standalone GPS (i.e., reduced broadcast clock and ephemeris errors)
- Reduction in maximum range and range rate errors
- Signal structure features to facilitate ambiguity resolution
- Sufficient number of satellites to: (1) prevent occurrences of dilution of precision (DOP) holes (2) allow greater availability for Receiver Autonomous Integrity Monitoring (RAIM) algorithms in user equipment.
- Higher inclination orbits for better DOPs
- Flexibility to allow the system to more rapidly adapt to changing user needs (e.g., reprogrammable codes)

Examples (Note: reference numbers (e.g. (1,1)... (3,5)...) correspond to the Xs in Section B: Benefits Matrix)

(13,2) Improved signal acquisition and tracking thereby increasing the utility of a GPS receiver to determine an initial position location and reducing the probability of loss of signal enabling continuous navigation without disruption. Potential applications include improved navigation while operating in lakes and inland waterways masked by foliage.

(13,3) Greater resistance to radio frequency interference (both intentional and unintentional) thereby increasing the maritime uses of GPS receivers in locations susceptible to such radio interference sources, including onboard radio equipment and similar equipment in harbor and harbor approach areas and congested coastal environments.

(13,5) Longer spreading codes and reduced cross-correlation between satellite signals (i.e. self interference) thereby improving receiver performance in challenged environments where both weak and strong satellite signals are available, such as lakes and inland waterways masked by foliage.

(13,6) Improved accuracy and position determination capability due to increased signal bandwidth thereby increasing the utility of standalone GPS for all weather inland waterway, harbor and harbor approach navigation, dredging, and placement/maintenance of buoys and channel markers.

Section D: Team Member POCs

<u>Group</u>	<u>POC</u>
Location Based Services/Recreation	(Stansell)
Scientific	(Hudnut)
Aviation	(Hegarty)
Agriculture	(Hudnut)
Surface Transportation	(Titus)
Mining & Construction	(Stansell)
Surveying/Civil Engineering	(Stansell)
Public Safety/Security	(Betz)
Timing	(Kovach)
Rail	(Taylor)
Space	(Titus)
Environment	(Hudnut)
Maritime and Waterways	(Dorfler)

User Group Guidelines

User Group Contact Methodology and Information Checklist

Background: The intent of the following User Group Contact Methodology and Information Checklist is to standardize an approach for obtaining the requisite information/data to support the L1C modernization decision making process.

This document should be viewed as a tool for the interviewer and a template for recording the information obtained during the interview. The recorded information obtained from all interviews will be consolidated, hence the reason for a standardized approach and reporting format.

Each of the 10 Steps begins with the Objective of the Step followed by a suggested approach and in some cases, a method for completing the Step and obtaining the information/data.

1. **Set the Stage:** Introduce yourself and briefly describe the purpose of the meeting.

Consider the following: The GPS Joint Program Office has an opportunity to modernize the L1C signal to improve civil performance. And, they have determined it would be technically possible to improve the signal without jeopardizing the current L1 civil uses--assuring full backward compatibility.

The range of potential improvements includes:

- Improved accuracy for some applications
- Better performance in interference environments
- Better signal acquisition and tracking

But, before making a decision whether or not to modernize the signal and make the investment, they have been asked to contact Civil User groups to determine and document if they would actually obtain real-world benefits from a modernized signal.

I appreciate you taking the time to meet. Everything that is discussed will be “non-attribution” unless you have no objection to referencing your name/company with the information provided. Also, if you have time, I would like you to review my notes for accuracy and completeness before I submit them to the JPO.

2. **Document those Attending:** Exchange business cards. If this is not possible then obtain the following for each person:

- Name
- Title
- Business/Address
- Phone Number
- Fax Number

- E-mail address
- User Group the person is "representing". Note: one person may be able to provide information about more than one User Group--such as a manufacturer

3. **Baseline Current User Group Uses:** Get the person talking, provide an opportunity for them to transmit, and determine their level of GPS user group knowledge.

Consider the following question as a lead in: Based on your knowledge and personal experience could you highlight some of the ways GPS is being used today by (User Group, e.g. Aviation).

As indicated in the Objective of this Step **Baseline Current User Group Uses**, as the people talk, suggest taking notes to assure you capture as many of the uses as possible. Based on previous experience, this typically goes one of two ways--either there is a "flood" of information or "pregnant silence"--the former is more common.

4. **Validate Examples:** As appropriate, based on the previous response, offer the examples and determine if they are "valid". The examples for each User Group are contained in the attached matrix and bullet list.

Consider the following: Based on our preliminary review of (User Group) uses, we thought that they may benefit from a modernized L1C, for instance:

Example 1, 2, 3...

What do you think--do you think these are valid "benefit" examples to support modernizing L1C?

Possible answers, yes, no, I don't know. If there is an "I don't know", then ask them if they can suggest a person that may know.

If there is a yes or no, then likely they will provide additional information to support this response. Again, it is important to take notes to capture this response rationale.

Comment: To prepare a "complete" report we will need to have some idea of how many people will benefit, the "value" of the benefit and how many people will not benefit from a modernized L1C. The objectives of Steps 5-7 are to obtain this information.

5. **Number of Users Benefiting** (if the answer in Step 4 is yes):

Consider the following: Approximately how many (User Group) users do you think will benefit from these suggested L1C modernization improvements?

6. **Number of Users Not Benefiting** (if the answer in Step 4 is either yes or no):

Consider the following: Approximately how many (User Group) users do you think will not benefit from these suggested L1C modernization improvements?

7. **Value of the Benefit** (if the answer in Step 4 is yes):

Consider the following: Any idea or opinion on the value of these benefits, in terms of dollar value, time and effort saved, safety benefits, expanded demand for GPS receivers or anything else that could be used to determine the value of the L1C modernization benefits for the (User Group).

8. **Other Potential Benefits of L1C Modernization** (if the answer in Step 4 is either yes or no)

Consider the following: In light of the fact that a modernized L1C signal may improve accuracy, provide better performance in interference environments and be easier to acquire and track, can you think of any other benefits that (User Group) may derive from a modernized L1C?

Likely answers to this question will either be yes or no. If yes, repeat Steps 5,6,7.

Comment: L1C modernization will take several years to be an end-state user reality. GPS user growth projections are available in various government and private reports, such as the DOC report and Frost and Sullivan. But, believe it is reasonable to also get a growth projection for the person(s) being interviewed.

9. **Growth Projection:**

Consider the following: Based on your knowledge and experience with (User Group) GPS users, how rapidly do you think GPS use will grow over the next 5-10 years?

10. **Follow on Contact:** It is not uncommon for an interviewee or interviewer to "think of something else" or have follow-on questions.

Consider the following: Tell the interviewee that you are going to go back to the office and type up a record of the discussion. Before submitting the record of discussion to the JPO, you would like to send it to him/her for his review and comment--just to make certain you got the information right and in case he/she thinks of "something else". Also, mention—as in Step 1-- Everything that has been discussed will be “non-attribution” unless you have no objection to referencing your name/company with the information provided. Ask him/her if there is no objection.

Economic Benefits

Determine a methodology for estimating the potential monetary benefits of L1 modernization for the manufacturers and GPS user groups.

Quantification of the benefits for GPS civil applications is a complex task. Ultimately, the benefits to the civil community are measured in dollars. Improvements in safety are often an important motivation for using GPS. In all cases, at a minimum, safety is preserved (i.e. safety is never traded for increased profitability). However, in virtually most situations, the major motivation for implementing GPS applications is some economic benefit.

The economic benefit of a civil GPS/L1 modernization application is typically a function of one or more of the practical uses that have been outlined in the individual user group reports (attachment 2). The economic benefit may also be a function of other factors that have nothing to do with GPS/L1. For example, regulatory and institutional factors can impact the profitability of a GPS application irrespective of the actual real-world requirement. Also, the economic benefit of a civil GPS/L1 modernization application may be a function of other enabling technologies, such as data communications (e.g. Public Safety/Security) and database capabilities (e.g. Surface Transportation).

Consequently, the assessment of the benefit of a civil application is often confounded by dependence on non-technical factors (such as regulatory and institutional issues) as well as requirements for non-GPS enabling technologies.

The Team concluded that the ideal situation would be to obtain an estimate of the economic benefits associated with an L1 modernization option from each manufacturer and user group. In turn, this information could be used to develop a “business case” for investment in L1 modernization.

However, the Team recognized that the likelihood of this ideal situation was small and a more realistic methodology would be required. In light of the inter- and intra-dependencies discussed above, the likelihood of obtaining useful data from all of those contacted and completing such an effort from zero initial data would likely exceed the available time and resources.

Hence, the Team developed the following methodology for estimating economic benefits of L1 modernization:

1. Obtain publicly available information from a cross-section of civil GPS market analyses, surveys and reports. Note: There are several commercial products currently available. However, the cost of obtaining these products is outside the allocated budget (e.g. Frost and Sullivan, Ovum, Allied Business Intelligence, Price Waterhouse Coopers, etc.).

2. Obtain publicly available information used to justify the investment and planned development of Galileo.
3. Determine “high level” civil categories of use that will be in-line with the information obtained from the publicly available market analyses, surveys and reports and the civil user group categories studied in attachment 2 (e.g. Location Based Services, Aviation, Agriculture, Timing, etc.)
4. As appropriate, place each of the civil user groups under the appropriate “high level” category. For instance: High Level Category—Telematics; possible Civil User groups under this category could be: Aviation, Surface Transportation, Rail, Mining and Construction, Maritime and Waterways.
5. Using information obtained from interviews, literature searches, and JPO supplied GPS-III data estimate the percent of increased GPS utility resulting from L1 modernization for each of the civil user groups.
6. Estimate the overall percent of increased GPS utility for each of the High Level Categories based on the estimated user group improvements.
7. Summarize the High Level Category estimates to determine the overall projected economic benefit of an L1 modernization.

The Team recognized that this methodology would produce a rough order of magnitude estimate of the civil economic benefit. However, resource and time constraints limited other alternatives.

It was determined that a rigorous assessment to determine the civil economic benefits of GPS would be a valuable tool for guiding future GPS modernization strategies and investments.

The remaining sections of this Attachment will address the specific steps taken to determine a rough order of magnitude estimate of the civil economic benefits of L1 modernization.

Step 1: Obtain publicly available information from a cross-section of civil GPS market analyses, surveys and reports. Note: There are several commercial products currently available. However, the cost of obtaining these products is outside the allocated budget (e.g. Frost and Sullivan, Ovum, Allied Business Intelligence, Price Waterhouse Coopers, etc.).

Although there are several commercial products, obtaining specific information regarding the findings and conclusions of these market analyses, surveys and reports proved to be a definite challenge. Fortunately, many of the companies “selling” their reports offered snapshot views of the findings in their sales literature and issued public statements/press

releases regarding the content of their reports. Based on these sources, and relying on publicly available information, the following data was compiled:

Projections for Location Technologies and Associated Markets

Source	Mkt Proj (\$)	Year	Market
OnStar	\$2.3B	2005	Telematics
Strategis Group	\$5.3B	2005	Telematics
Frost & Sullivan	\$7.2B	2005	Telematics
Ovum	\$20B	2006	Mobile Location Services
Ovum	\$4.7B	2004	Information Services
The Kelsey Group	\$11B	2005	Location Services
Dain Rauscher Wessels Report	\$19B	2005	Telematics
UBS Warburg	\$24B	2005	Wireless Vehicles
Allied Business Intelligence	\$14B	2005	Commercial GPS
Allied Business Intelligence	\$8B	2005	Telematics
Roland Berger Strategy Consultants	\$11B	2004	Telematics
UBS Warburg LLC	\$47.2B	2010	Telematics - All
UBS Warburg LLC	\$7B	2010	Telematics Service Providers
Strategis Group	\$32B	2005	Wireless Location Services
Dataquest	\$3B	2003	Data Subscribers
ABI	\$8B	2005	IVIS - In-Vehicle Information, Navigation, Communications and Roadside Technology
Allied Business Intelligence	\$60B	2005	Global GPS equipment shipment market value
Allied Business Intelligence	\$10B	2005	GPS equipment shipments for communications
Allied Business Intelligence	\$22B	2005	GPS equipment shipments for in-vehicle navigation systems
Strategis Group	\$81B	2005	European Wireless Location Services
Allied Business Intelligence	\$40.7B	2006	Covers the US, Europe, Japan, Latin America and the rest of the world markets for LBS and wireless subscribers, service revenues, GPS equipment and components, mcommerce, vcommerce and Bluetooth.
Bear Stearns	\$3 trillion	2005	iAppliances -- intelligent, internet-enabled devices and services - Mobile/Personal Information Solutions, Consumer Electronics/Entertainment Devices

Note: Lately, "telematics" has mainly been used to describe "automotive telematics," the use of computers and telecommunications to enhance the functionality of motor vehicles; for example, wireless data applications in cars, trucks, and buses. However, the original definition of telematics is the blending of computers and telecommunications.

An example of the type of available public information providing a GPS economic insight is well illustrated in this January 5, 2004 Press Release from ABIresearch:

“As consumer awareness of global position systems (GPS) increases, so has product innovation and total market revenue. While roughly half of the market today consists of sales of automotive and asset-tracking equipment, these segments will still continue to grow at rates faster than that of the broader market for GPS equipment. Despite the strength of these markets, new segments are constantly emerging for GPS applications, driving demand for gear as diverse as people-tracking devices and GPS golf systems. The net result will be a market worth over \$22 billion by 2008, according to technology market research firm ABI.

Companies like Garmin, Wherify Wireless and Navman are synonymous with integrating GPS receivers into innovative form factors. Advances in GPS integrated circuits (ICs) will fuel this trend across the entire industry. Sony's recent announcement unveiling a miniature, single-chip IC provides further evidence that more of these novel applications are likely in an ever-increasing range of devices.

According to a recent study from ABI, unit growth in ICs, the brains behind the devices' positioning capabilities, will likely be at about 35% compounded annually over the next five years. Revenue growth will be strong, but not as spectacular as unit growth, due mainly to pricing pressure.

The study, ["GPS World Markets: Opportunities for Equipment and IC Suppliers,"](#) examines the current status and trends of the global positioning systems industry. Covered areas include wireless and in-vehicle navigation, as well as growing segments such as recreation, communication, people tracking, marine and surveying, among others. For each segment, total market value is forecasted to 2008 in addition to regional totals. An analysis of key market drivers and barriers for each segment is presented. The report also quantifies the market for GPS IC shipments, ASP and revenue to 2008.

Step 2: Obtain publicly available information used to justify the investment and planned development of Galileo.

On 20 November 2001 PriceWaterhouseCoopers, with the support of Ovum, Willis, Denton Wilde Sapte, and Deutsche Bank, publicly released a report to support the development of a business plan for Galileo. This report provided the following cost-benefit information to justify a Galileo investment:

1. The estimated cost of Galileo was Euro 3.6 billion. The EC and ESA have budgeted Euro 1.25 billion for the Development phase and application development. This leaves a balance of Euro 2.35 billion to be spent on deploying the system. This will need to be met by a combination of public sector support and private sector funding.
2. It is very important that Galileo should commence service by 2008. The market will be in a rapid growth phase by then, and GPS III (a more sophisticated version) is expected to commence operations 1 or 2 years thereafter. Galileo will only become established if it is in the market in time to gain acceptance in the launch of new equipment and services which will accompany this change. If that is achieved we estimate that the annual sale of Galileo receivers will increase from 100 [million] in 2010 to some 875 [million] by 2020; which represents market penetration rising from 13% to 52%.
3. Estimated Galileo Revenues in millions of Euros:

Table 2 Estimated revenues by application (Euro m 2001 prices)

Application	2010	2015	2020
Personal communications and location	48	276	288
Commercial Aviation	-	20	100
Police and Fire (Pedestrian resource management)	1	10	20
Oil and Gas – Rig Positioning	1	8	15
Oil and Gas – Land and transition zone seismic exploration	2	9	10
Others	14	47	82
Total	66	370	515

Figure 3 Revenue scenarios (2001 prices)

Blue line reflects a 5% chipset royalty; red line is a 2% chipset royalty

4. The benefits principally arise from air traffic control, marine navigation, and route guidance for motor vehicles. The largest and most robust are generated from the aviation and maritime industries.

Table 4 Value of Main Benefits (Euro m 2000 prices)

Description of Benefit	Annual values		NPV 2008-
	201	2020	
Improvements in air traffic control			
cost savings for airlines	166	3,38	7,476
Time savings for passengers	82	1,66	5,447
Marine navigation	81	2,63	4,864
Total	329	7,68	17,787

The previous study for the Commission implied higher total benefits of Euro 27.2 billion NPV (using our discount rates) largely because it estimated greater benefits from route guidance.

Even with these more conservative assumptions on user benefits and the exclusion of producer benefits we estimate total benefits at Euro 17.8 billion in NPV terms and costs at Euro 3.9 billion, implying a benefit:cost ratio of 4.6. This should be regarded as a strongly positive ratio. For example public sector transport projects in the UK, on the underground railway and on roads, often proceed with ratios of about 3.0.

Steps 3 & 4: Determine “high level” civil categories of use that will be in-line with the information obtained from the publicly available market analyses, surveys and reports and the civil user group categories listed in attachment 2 (e.g. Location Based Services, Aviation, Agriculture, Timing, etc.)

As appropriate, place each of the civil user groups under the appropriate “high level” category. For instance: High Level Category—Telematics; Civil User groups under this category: Aviation, Surface Transportation, Rail, Mining and Construction, Maritime and Waterways.

The Team developed the following set of user groups as a basis for assessing the real world value of modernizing L1:

- Location Based Services/Recreation
- Scientific
- Aviation
- Agriculture
- Surface Transportation
- Mining & Construction
- Surveying/Civil Engineering
- Public Safety/Security
- Timing
- Rail
- Space
- Environment
- Maritime and Waterways

The individual reports for each of these user groups are contained in Attachment 2.

Steps 3 and 4 of the Team methodology proved to be closely linked with each other. Information obtained during Step 1 actually defined the “high level” civil categories for which there was publicly available information. Those categories are:

- Mobile and Wireless Location Services
- Information/Data Services
- Commercial GPS
- In Vehicle Information and navigation services—“telematics”

The next task was to map the user groups into the “high level” civil categories. This mapping was subjective. It was based upon a review of the user group responses regarding how they actually use GPS and the perceived “population” that formed the basis of the individual market analyses. The exact population is not known because the Team did not have access to the actual market analyses.

The final Team mapping of the 13 user groups into the 4 “high level” civil categories is as follows:

Mobile and Wireless Location Services
 Location Based Services/Recreation

Information/Data Services
 Environment
 Scientific
 Public Safety/Security

Commercial GPS
 Mining & Construction
 Agriculture
 Timing
 Maritime and Waterways
 Surveying/Civil Engineering

In Vehicle Information and navigation services—“telematics”
 Surface Transportation
 Aviation
 Rail
 Space

One “high level” civil category referenced in the market analyses completed by Allied Business Intelligence but did not correlate with the user group categories surveyed by the Team was “GPS Equipment Shipments”. It was concluded that this category represented the aggregate projected market value of equipment sales across the spectrum of all user groups, both domestic and international. The Team agreed that these projected dollar values should be considered when estimating the projected dollar value of each of the 4 high level civil categories.

The next task was to estimate the projected dollar value of each of the high level civil categories. This estimate was based on the GPS market analyses information obtained in Step 1 and the Galileo investment information obtained in Step 2. The overall objective of this task was to approximate a “rough order of magnitude” dollar value, recognizing that the approximation would be a Team consensus based on the publicly available information.

The Team determined that the following figures for each of the high level civil categories represented a reasonable rough order of magnitude estimate of their 2005 projected dollar values:

- Mobile and Wireless Location Services: \$16B
- Information/Data Services : \$2.5B
- Commercial GPS : \$11B
- In Vehicle Information and navigation services—“telematics”: \$7B

Step 5: Using information obtained from the interviews, literature searches, and JPO supplied GPS-III data estimate the percent of increased GPS utility resulting from L1 modernization for each of the civil user groups.

This task required a thorough review of the data/information provided in the attachments, discussion, and consensus on a reasonable estimate of the potential increase in GPS utility resulting from L1 modernization.

The degree of potential increase is clearly dependent upon the type of improvements that would be made to L1. For instance, if an L1 modernization decision was made to Lower Signal Thresholds for Navigation (Power & Dataless Channel) then there would be a definite benefit for some user groups. Specifically, for the Location Based Services/Recreation user group, a stronger signal and data-less channel improves the ability to rely on GPS services in challenged environments, such as under forest cover, beside tree-lined roads, in urban canyons and inside buildings (e.g., 911 applications).

Recognizing that the extent and options for L1 modernization have not been determined, an attempt was made to estimate the range of potential increased GPS utility for each individual user group. For instance, continuing with the example in the preceding paragraph—if a positive decision was made to Lower Signal Thresholds for Navigation (Power & Dataless Channel), the percent of increased GPS utility for the Location Based Services/Recreation user group would be greater as compared to the percent of increased GPS utility if a decision was made not to Lower Signal Thresholds for Navigation (Power & Dataless Channel).

The Team decided to adopt a pessimistic/optimistic approach for determining the range of potential increased GPS utility for each user group. Clearly, the lower bound for increased utility would be zero—assuming a worse possible case scenario. To estimate an upper bound, the information in Attachment 2 was carefully reviewed and analyzed. The upper bound for each of the user groups was estimated as follows:

- Location Based Services/Recreation: 4%
- Scientific: 2%
- Aviation: 0.5%
- Agriculture: 3%
- Surface Transportation: 4%
- Mining & Construction: 3.5%
- Surveying/Civil Engineering: 1%
- Public Safety/Security: 3%
- Timing: 0.5%
- Rail: 2%
- Space: 0.5%
- Environment: 0.5%
- Maritime and Waterways: 1%

Step 6: Estimate the overall percent of increased GPS utility for each of the High Level Categories based on the estimated user group improvements.

Given the 13 user groups mapping into the 4 “high level” civil categories—Step 3/4 and the estimated upper bound percent of increased GPS utility—Step 5—the percent of potential benefit for each of the high level civil categories is as follows:

Mobile and Wireless Location Services: 4%
 Location Based Services/Recreation: 4%

Information/Data Services: 5.5%
 Environment 0.5%
 Scientific: 2%
 Public Safety/Security: 3%

Commercial GPS: 9%
 Mining & Construction: 3.5%
 Agriculture: 3%
 Timing: 0.5%
 Maritime and Waterways: 1%
 Surveying/Civil Engineering: 1%

In Vehicle Information and navigation services—“telematics”: 7%
 Surface Transportation: 4%
 Aviation: 0.5%
 Rail: 2%
 Space: 0.5%

Step 7: Summarize the High Level Category estimates to determine the overall projected economic benefit of an L1 modernization.

If it is assumed that the estimated percent of increased GPS utility for each of the high level categories (resulting from L1 modernization) is directly proportional to an increase in the projected dollar values for each category (Step 3/4) then the potential monetary benefits of L1 modernization can be estimated as follows:

- Mobile and Wireless Location Services: 4% of \$16B = \$640M
- Information/Data Services : 5.5 % of \$2.5B = \$62.5M
- Commercial GPS : 9% of \$11B = \$990M
- In Vehicle Information and navigation services—“telematics”:
7% of \$7B = \$490M

Total “Upper Bound” Potential Monetary Benefits of L1 Modernization: \$2.1825B

Conclusion:

An implied objective of these efforts was to determine a rough order of magnitude estimate of the civil economic benefit of L1 modernization that would be a conservative indication of the real-world effect of modernization. Critics of this economic assessment will likely be quick to point out many weaknesses of the adopted Team methodology, such as:

- a. The baseline GPS market projection data (Steps 1/2) obviously contained many assumptions that the Team could not access.
- b. The selection of the 4 high level civil categories and the mapping of the 13 user groups into those categories may not be accurate.
- c. The consensus process—used to estimate the individual user group benefits of modernization—produced consensus figures that may not be accurate.
- d. The estimated percent of increased GPS utility may not be directly proportional to an increase in projected dollar value.

The Team participants were fully aware of the weaknesses of the adopted methodology. They also recognized the practical need to address the economic issue and attempt to quantify the real-world monetary benefits resulting from modernization.

In light of the need to be both real-world and conservative and based on the available data, the Team concluded that the “upper bound” of potential monetary benefits of L1 modernization would likely be in the \$1-1.5B range.