

Proposed Rules

Federal Register

Vol. 73, No. 189

Monday, September 29, 2008

This section of the FEDERAL REGISTER contains notices to the public of the proposed issuance of rules and regulations. The purpose of these notices is to give interested persons an opportunity to participate in the rule making prior to the adoption of the final rules.

DEPARTMENT OF AGRICULTURE

Rural Utilities Service

7 CFR Parts 1728 and 1755

Standards and Specifications for Timber Products Acceptable for Use by Rural Development Utilities Programs' Electric and Telecommunications Borrowers

AGENCY: Rural Utilities Service, USDA.

ACTION: Proposed rule.

SUMMARY: The Rural Utilities Service, an agency delivering the United States Department of Agriculture's (USDA) Rural Development Utilities Programs, hereinafter referred to as USDA Rural Development or Agency, proposes to revise its regulations on Electric and Telecommunications Standards and Specifications for Materials, Equipment and Construction, by codifying specifications for wood poles, stubs and anchor logs, wood crossarms (solid and laminated), transmission timbers and pole keys, and for quality control and inspection of timber products. The Agency is proposing to update these specifications to conform with revisions in the industry and to follow Agency policy on insurance requirements.

DATES: Written comments must be received by the agency or bear a postmark or equivalent no later than November 28, 2008.

ADDRESSES: Submit comments by either of the following methods:

- *Federal eRulemaking Portal:* Go to <http://www.regulations.gov> and, in the lower "Search Regulations and Federal Actions" box, select "Rural Utilities Service" from the agency drop-down menu, then click on "Submit." In the Docket ID column, select RUS-07-Electric-0010 to submit or view public comments and to view supporting and related materials available electronically. Information on using [Regulations.gov](http://www.regulations.gov), including instructions for accessing documents, submitting comments, and viewing the docket after the close of the comment period, is

available through the site's "User Tips" link.

- *Postal Mail/Commercial Delivery:* Please send your comment addressed to Michele Brooks, Director, Program Development and Regulatory Analysis, USDA Rural Development, 1400 Independence Avenue, STOP 1522, Room 5818-S, Washington, DC 20250-1522. Please state that your comment refers to Docket No. RUS-07-Electric-0010.

Other Information: Additional information about USDA Rural Development and its programs is available on the Internet at <http://www.rurdev.usda.gov/index.html>.

Submit written comments to Michele L. Brooks, Director, Program Development and Regulatory Analysis, USDA Rural Development, 1400 Independence Ave., SW., Stop 1522, Room 5818-S South Building, Washington, DC 20250-1522.

An original and three copies of all comments (7 CFR 1700.4) are required. All comments received will be made available for inspection at room 1246-S, during regular business hours (7 CFR 1.27(b)).

FOR FURTHER INFORMATION CONTACT: Mr. H. Robert Lash, Transmission Branch, Electric Staff Division, USDA Rural Development, Room 1246 S.T.O.P 1569, 1400 Independence Ave., SW., Washington, DC 20250-1569, or telephone (202) 720-0486.

SUPPLEMENTARY INFORMATION:

Executive Order 12866

This proposed rule is exempted from the Office of Management and Budget (OMB) review for purposes of Executive Order 12866 and, therefore, has not been reviewed by OMB.

Executive Order 12988

This proposed rule has been reviewed in accordance with Executive Order 12988, Civil Justice Reform. The Agency has determined that this proposed rule meets the applicable standards provided in section 3 of the Executive Order. In addition, all state and local laws and regulations that are in conflict with this rule will be preempted; no retroactive effect will be given to this rule; and, in accordance with section 212(e) of the Department of Agriculture Reorganization Act of 1994 (7 U.S.C. 6912(e)) administrative appeal procedures, if any are required, must be

exhausted before an action against the Department or its agencies.

Executive Order 12372

This proposed rule is excluded from the scope of Executive Order 12372, Intergovernmental Consultation, which may require consultation with State and local officials. See the final rule related notice entitled "Department Programs and Activities Excluded from Executive Order 12372," (50 FR 47034) advising that agency loans, loan guarantees, and RTB bank loans were not covered by Executive Order 12372.

Regulatory Flexibility Act Certification

It has been determined that the Regulatory Flexibility Act is not applicable to this proposed rule since the USDA Rural Development Programs is not required by 5 U.S.C. 601 *et seq.*) or any other provision of law to publish a notice of proposed rulemaking with respect to the subject matter of this proposed rule.

Paperwork Reduction Act and E-Government Act

In accordance with the Paperwork Reduction Act of 1995 (44 U.S.C. Chapter 35, as amended), USDA Rural Development invites comments on this information collection for which approval from the Office of Management and Budget (OMB) will be requested.

Comments on this proposal must be received by November 28, 2008.

Comments are invited on (a) whether the collection of information is necessary for the proper performance of the functions of the agency, including whether the information will have practical utility; (b) the accuracy of the agency's estimate of burden including the validity of the methodology and assumption used; (c) ways to enhance the quality, utility and clarity of the information to be collected; and (d) ways to minimize the burden of the collection of information on those who are to respond, including through the use of appropriate automated, electronic, mechanical, or other technological collection techniques on other forms of information technology.

Comments may be sent to Michele L. Brooks, Director, Program Development and Regulatory Analysis, USDA Rural Development, 1400 Independence Ave., SW., Stop 1522, Room 5818-S South Building, Washington, DC 20250-1522.

Title: 7 CFR Parts 1728 and 1755.

OMB Control Number: 0572-0076.

Type of Request: Revision of a currently approved information collection package.

Abstract: The Agency has a tremendous amount of interest in loan security and protection of the Government's interest over the long term life of a loan, which is generally secured by a first mortgage security instrument and amortized over a period of up to 35 years. Therefore, the Agency necessarily has a strong interest in the business, financial, and operating aspects of its borrowers.

The Agency proposes to revise its regulations on Electric and Telecommunications Standards and Specifications for Materials, Equipment and Construction, by codifying specifications for wood poles, stubs and anchor logs, wood crossarms (solid and laminated), transmission timbers and pole keys, and for quality control and inspection of timber products. The Agency is proposing to update these specifications to conform with revisions in the industry and to follow Agency policy on insurance requirements.

Respondents: Businesses and Not-for-profit institutions.

Estimated Number of Respondents: 25.

Estimated Number of Responses per Respondent: 1,600.

Estimated Total Annual Burden on Respondents: 40,000.

This estimated total annual burden is a decrease of 363 due to the changes in the requirement that borrowers submit an annual summary report and reserve stock notices on timber specifications.

Copies of this information collection can be obtained from MaryPat Daskal, Program Development and Regulatory Analysis, at (202) 720-7853.

All responses to this information collection and recordkeeping notice will be summarized and included in the request for OMB approval. All comments will also become a matter of public record. USDA Rural Development is committed to the E-Government Act, which requires Government agencies in general to provide the public the option of submitting information or transacting business electronically to the maximum extent possible.

Send questions or comments regarding this burden or any other aspect of these collections of information, including suggestions for reducing the burden to Director, Program Development and Regulatory Analysis, USDA Rural Development Programs, 1400 Independence Ave., SW., Room 5818-S Bldg., STOP 1522, Washington, DC 20250-1522.

National Environmental Policy Act Certification

The Administrator of the Agency has determined that this proposed rule will not significantly affect the quality of the human environment as defined by the National Environmental Policy Act of 1969 (42 U.S.C. 4321 *et seq.*). Therefore, this action does not require an environmental impact statement or assessment.

Catalog of Federal Domestic Assistance

The program described by this proposed rule is listed in the Catalog of Federal Domestic Assistance Programs under No. 10.850, Rural Electrification Loans and Loan Guarantees, No. 10.851, Rural Telephone Loans and Loan Guarantees, and No. 10.852, Rural Telephone Bank Loans. This catalog is available on a subscription basis from the Superintendent of Documents, the United States Government Printing Office, Washington, DC 20402-9325, telephone number (202) 512-1800.

Unfunded Mandates

This proposed rule contains no Federal mandates (under the regulatory provision of Title II of the Unfunded Mandates Reform Act) for State, local, and tribal governments or the private sector. This rule is not subject to the requirements of section 202 and 205 of the Unfunded Mandates Reform Act.

Background

The Agency maintains bulletins that contain construction standards and specifications for materials and equipment. These standards and specifications apply to systems constructed by electric and telecommunications borrowers in accordance with the loan contract, and contain standard construction units, materials, and equipment units used on electric and telecommunications borrowers' systems. Bulletins 1728F-700, "Specification for Wood Poles, Stubs and Anchor Logs"; 1728H-701, "Specification for Wood Crossarms (Solid and Laminated), Transmission Timbers and Pole Keys"; and 1728H-702, "Specification for Quality Control and Inspection of Timber Products", establish standards for the manufacture and inspection of wood utility poles, crossarms and poles keys.

The summary of the proposed major changes to these three bulletins are as follows:

1. All references cited in these bulletins would be updated to the latest edition.

2. The definition "pole broker" would be added to the list of definitions to include as many organizations as

possible to provide borrowers a source from which they might purchase wood products.

3. Proposing to allow borrowers six months to notify treating plants about poles not meeting the required preservative retention.

4. In accordance with Agency policy on insurance requirements for contractors working for borrowers, the specification would be revised to require manufacturers and inspection agencies to maintain certain limits of liability and errors and omission insurance.

5. All poles would be required to be sterilized during the conditioning or treating cycle. This sterilization should reduce the number of poles with pre-treatment decay.

6. The independent inspection agency's identification on the face of the pole would be branded.

7. The Agency would revise the qualifications for inspectors and quality control personnel and would return to prior qualifications of the specifications.

8. Provisions would be added to further clarify that wood products, producers and inspection agencies maintain the greatest degree of separation and eliminate any appearance of conflict of interest.

List of Subjects

7 CFR Part 1728

Electric power, Loan programs—energy, Reporting and recordkeeping requirements, Rural areas.

7 CFR Part 1755

Loan programs—communications, Reporting and recordkeeping requirements, Rural areas, Telephone.

For reasons set forth in the preamble, the Agency proposes to amend 7 CFR chapter XVII as follows:

PART 1728—ELECTRIC STANDARDS AND SPECIFICATIONS FOR MATERIALS AND CONSTRUCTION

1. The authority citation for part 1728 continues to read as follows:

Authority: 7 U.S.C. 901 *et seq.*; 1921 *et seq.*, 6941 *et seq.*

2. Section 1728.97(b) is amended by revising the revision date of Bulletin 1728F-700.

§ 1728.97 Incorporation by reference of electric standards and specifications.

(b) *List of Bulletins.*

* * * * *

Bulletin 1728F-700, Specification for Wood Poles, Stubs and Anchor Logs [INSERT DATE OF PUBLICATION OF

THE FINAL RULE IN THE FEDERAL REGISTER]

* * * * *

3. Section 1728.201 is revised to read as follows:

§ 1728.201 Bulletin 1728H-701, Specification for Wood Crossarms (Solid and Laminated), Transmission Timbers and Pole Keys.

(a) *General Provisions.* (1) This section implements contractual provisions between the Agency and borrowers receiving financial assistance. The contractual agreement between the Agency and its borrowers requires the borrower's system to be constructed in accordance with Agency accepted plans and specifications. Each electric borrower must purchase only wood crossarms produced in accordance with the specification in this section.

(2) Each electric borrower shall require each contractor to agree in writing to furnish only materials produced in accordance with the specification in this section.

(3) This specification describes the minimum acceptable quality of wood distribution crossarms and transmission crossarms (hereinafter called crossarms) that are purchased by or for borrowers. Where there is conflict between this specification and any other specification referred to in this section, this specification shall govern.

(4) Various requirements relating to quality control and inspection are contained in § 1728.202 of this part, Specification for Quality Control and Inspection of Timber Products. Section 1728.201 of this part and the American National Standards Institute (ANSI) O5.2, 1996, (R2001) American National Standard for Wood Products—Structural Glued Laminated Timber for Utility Structures, ANSI O5.3, 2002, American National Standard for wood products Solid Saw—Wood Crossarms and Braces—Specification and Dimensions shall be followed exactly and shall not be interpreted or subjected to judgment by the quality control person or an independent inspector.

(5) The purchaser shall purchase from producers only material that meets the requirements of this specification. Each purchaser shall use a written purchase order to purchase material for use in financed systems in order to ensure compliance with the standards and specifications of this part. The written purchase order shall contain a provision that specifically requires the producer to comply with the provisions of this part. The purchase order shall contain a provision that specifically requires the producer to make the treating plant and storage areas available, during normal

business hours, in order for representatives of either the purchaser or this agency to inspect such to determine compliance with the standards and specifications of this part.

(6) The producer shall provide the inspectors with full information (drawings, etc.) relating to the requirements contained in the purchase order which is supplementary to this specification.

(7) The producer shall maintain, or have access to, adequate laboratory facilities at or near the treating plant, and all chemical tests, assays or analyses associated with the treatment shall be independently performed in the laboratory by both the quality control designee and the borrower's inspector. The producer may use a central laboratory as accepted on a case-by-case basis.

(8) Inspection and treatment of all timber products produced under this specification shall be performed after receipt of the order from the purchaser, except as provided for reserve treated stock.

(9) The testing and inspection of the lamination process shall be in accordance with American Institute of Timber Construction (AITC) 200-2004, Inspection Manual.

(10) With the exception of reserve treated stock, all invoices for treated timber products shall be accompanied, in duplicate, by a copy of the producer's Certificate of Compliance and a copy of either the Independent Inspection Report or a Quality Assurance Plan Certificate. The certificate shall be presented to the purchaser with the invoice. For reserve treated stock, inspection reports shall be available from the inspection agency. When shipped from reserve stock, the invoice shall bear an endorsement and a further certification by the producer that the material meets the requirements of this specification and any supplementary requirements cited in the purchase order under which it is purchased.

(11) Crossarms shall be warranted to conform to this specification. If any crossarm is determined to be defective or does not conform to this specification within 1 year after delivery to the borrower, it shall be replaced as promptly as possible by the producer. In the event of failure to do so, the purchaser may make such replacement and the cost of the crossarm, at destination, shall be recoverable from the producer.

(12) Crossarm producers shall take out and maintain liability insurance and a bond or miscellaneous errors and omissions insurance for not less than \$1 million and \$500,000, respectively.

Upon request, evidence of compliance shall be provided. The evidence shall be in the form of a certificate of insurance signed by a representative of the insurance company and include a provision that no changes in, or cancellation of, will be made without the prior written notice to the Director, Electric Staff Division, USDA Rural Development.

(b) *Definitions.*

Agency refers to Rural Utilities Service.

Arm is the structural wood member used to support electrical conductors and equipment. Arm is used interchangeably with crossarm.

Certificate of compliance is a certification by an authorized employee of the producer that the material shipped meets the requirements of this specification and any supplementary requirements specified in a purchase order from a borrower or the borrower's contractor.

Crossarm is a structural wood member used to support electrical conductors and equipment and is a term used interchangeably with arm.

Independent inspection is the examination of material by an independent inspector employed by a commercial inspection agency.

Inspection is the examination of material in sufficient detail to ensure conformity to all phases of the specification under which it was purchased.

Lot is a quantity of crossarms of like size, conditioning, and fabrication, usually making up one treating charge.

Producer is used to describe the party who manufactures and/or treats crossarms.

Purchaser is the borrower or contractors acting as the borrower's agent, except where a part of the specification specifically refers only to the borrower or the contractor.

Quality control designee is an individual designated by the producer to oversee proper operation of the manufacturer's internal quality control system.

Reserve treated stock are timber products treated in accordance with this specification, prior to and in anticipation of the receipt of specific orders, and held in storage ready for immediate shipment.

Supplier is the producer, or in some cases, the distributor selling crossarms to the borrower.

Treating plant is the organization that applies the preservative treatment to the crossarms.

(c) *Related specifications and standards incorporated by reference.* The following specifications and

standards are pending approval of incorporation by reference by the Office of the Federal Register in accordance with 5 U.S.C. 552(a) and 1 CFR part 51. Copies of each reference are available for inspection during normal business hours, room 1246-S, U.S. Department of Agriculture, Washington, DC or, at the Office of the Federal Register, 800 North Capitol Street, NW., suite 700, Washington, DC. Copies of these standards and specifications may be purchased from the addresses shown below.

(1) West Coast Lumber Inspection Bureau, Standard No. 17, Grading Rules for West Coast Lumber, January 1, 2004, available from West Coast Lumber Inspection Bureau, P.O. Box 23145, Portland, Oregon 97281, telephone (503) 639-0651, Fax (503) 684-8928. The Web address for West Coast Lumber Inspection Bureau is <http://www.wclib.org/>.

(2) The following Southern Pine Inspection Bureau Standards, available from Southern Pine Inspection Bureau, 4709 Scenic Highway, Pensacola, Florida 32504-9094, telephone (850) 434-2611. The Web address for the Southern Pine Inspection Bureau is <http://www.spib.org/>.

(i) Standard Grading Rules for Southern Pine Lumber, available from Southern Pine Inspection Bureau, 4709 Scenic Highway, Pensacola, Florida 32504, telephone (850) 434-2611.

(ii) Special Product Rules for Structural, Industrial, and Railroad-Freight Car Lumber.

(3) American Wood-Protection Association (AWPA), Book of Standards, 2007 edition, available from AWPA, P.O. Box 361784, Birmingham, AL 35236-1784, telephone 205 733-4077, <http://www.awpa.com/>, include the following standards:

(i) A1-98, Standard Methods for Analysis of Creosote and Oil-Type Preservatives.

(ii) A2-07, Standard Methods for Analysis of Waterborne Preservatives and Fire-Retardant Formulations.

(iii) A3-05, Standard Methods for Determining Penetration of Preservatives and Fire Retardants.

(iv) A5-05, Standard Methods for Analysis of Oil-Borne Preservatives.

(v) A6-01, Method for the Determination of Oil-Type Preservatives and Water in Wood.

(vi) A7-04, Standard Wet Washing Procedure for Preparing Wood for Chemical Analysis.

(vii) A9-01, Standard Method for Analysis of Treated Wood and Treating Solutions by X-Ray Spectroscopy.

(viii) A11-93, Standard Method for Analysis of Treated Wood and Treating

Solutions by Atomic Absorption Spectroscopy.

(ix) U1-07, Use Category System: User Specification for Treated Wood.

(x) T1-07, Use Category System: Processing and Treatment Standard.

(xi) M1-07, Standard for the Purchase of Treated Wood Products.

(xii) M2-07, Standard for Inspection of Treated Timber Products.

(xiii) M3-05, Standard Quality Control Procedures for Wood Preserving Plants.

(xiv) M4-06, Standard for the Care of Preservative-Treated Wood Products.

(xv) P1/P13-06, Standards for Creosote Preservatives.

(xvi) P5-07, Standards for Waterborne Preservatives.

(xvii) P8-06, Standards for Oil-Borne Preservatives, and

(xviii) P9-06, Standards for Solvents and Formulations for Organic Preservative Systems.

(4) American Institute of Timber Construction (AITC) 200-2004, Inspection Manual, 2004 edition, available from AITC, 7012 S. Revere Park Way, Englewood, Colorado 80112, telephone (303) 792-9559, Web address: <https://www.aitc-glulam.org/index.asp>.

(5) American National Standards Institute (ANSI) O5.2-1996 (R2001), American National Standard for Wood Products—Structural Glued Laminated Timber for Utility Structures, available from ANSI, 25 West 43rd Street, New York, New York 10036, telephone (212) 642-4900, Web address: <http://www.ansi.org/>.

(6) American Society for Testing and Materials (ASTM) D9-05, Standard Terminology Relating to Wood, available from ASTM, 100 Barr Harbor Dr. West, PO Box C700, Conshohocken, PA 19428-2959, telephone number (610) 832-9585, Web address: <http://www.astm.org>.

(d) *Independent Inspection Plan*. This plan or a Quality Assurance Plan, as described in paragraph (e) of this section, is acceptable for supplying crossarms. All crossarms purchased under the Independent Inspection Plan, for use on an Agency financed system shall be inspected by a qualified independent inspector in accordance with § 1728.202 of this part.

(1) The borrower has the prerogative to contract directly with the inspection agency for service. The borrower should, where practical, select the inspection agency so that continual employment is dependent only on performance acceptable to the borrower and in accordance with this specification. The selected inspection agency shall not be allowed to

subcontract the service to any other inspection agency.

(2) The producer shall not be permitted to be a party to the selection of the inspection agency by the borrower and shall not interfere with the work of the inspector, except to provide notification of the readiness of material for inspection. To obtain inspection services for reserve stock, the producer may deal directly with the inspection agency. Under the Independent Inspection Plan, the producer shall not be permitted to treat material before it has been properly inspected in the white, as evidenced by the inspector's hammer mark.

(3) The methods of inspection described in this section and in § 1728.202 of this part shall be used no matter which plan crossarms are produced under, i.e., Independent Inspection Plan, or Quality Assurance Plans, as described in this section.

(e) *Quality Assurance Plans*. The producer shall furnish crossarms conforming to this specification as monitored by an acceptable Quality Assurance Plan. Borrower groups or agents for borrower groups endeavoring to operate Quality Assurance Plans shall submit their plan for assuring quality control to the Chairman, Technical Standards Committee "A", Electric Staff Division, USDA Rural Development, Stop 1569, Washington, DC 20250-1569.

(f) *Material requirements*—(1) *Material and grade*. All crossarms furnished under this specification shall be free of brashy wood, decay, and insect holes larger than $\frac{3}{32}$ of an inch and shall meet additional requirements as shown on specific drawings. Crossarms shall be made of one of the following:

(i) Douglas-fir which conforms to the applicable crossarm provisions of paragraphs 170 and 170a, or the applicable transmission arm provisions of paragraphs 169 and 169a of the 2004 Standard Grading Rules for West Coast Lumber No. 17. Only coastal origin Douglas-fir shall be used for Douglas-fir crossarms manufactured under this specification;

(ii) Southern Yellow Pine which conforms to the provisions of Dense Industrial Crossarm 65, as described in paragraph 31.2 in Southern Pine Inspection Bureau 1991 Special Product Rules for Southern Pine; or

(iii) Laminated wood crossarms shall conform to ANSI O5.2, and have at least the same load carrying capacity as the solid sawn arm it replaces. The load carrying capacity of the laminated arms shall be determined by one of the procedures outlined in ANSI O5.2.

(2) Borrowers may use alternative crossarms that are listed in Informational Publication 202-1, List of Materials Acceptable for Use on Systems of the Agency Electrification Borrowers.

(3) *Knots*. Sound, firm, and tight knots, if well spaced, are allowed.

(i) Slightly decayed knots are permitted, except on the top face,

provided the decay extends no more than $\frac{3}{4}$ of an inch into the knot and provided the cavities will drain water when the arm is installed. For knots to be considered well spaced, the sum of the sizes of all knots in any 6 inches of length of a piece shall not exceed twice the size of the largest knot permitted. More than one knot of maximum

permissible size shall not be in the same 6 inches of length. Slightly decayed, firm, or sound "pin knots" ($\frac{3}{8}$ of an inch or less) are not considered in size, spacing, or zone considerations.'

(ii) Knots are subject to limits on size and location as detailed in Tables I and II, as follows:

BILLING CODE 3410-P

**TABLE I – KNOT LIMITS FOR DISTRIBUTION ARMS
DRAWING W2.1G (SEE FIGURE 1, APPENDIX A)
All Dimensions in Inches**

Class of Knot and Location	MAXIMUM KNOT DIAMETER	
	<u>CLOSE GRAIN</u>	<u>DENSE GRAIN</u>
Round Knots		
Single Knot: Maximum Diameter		
Center Section*		
Upper Half	3/4	1
Lower Half	1	1-1/4
Elsewhere	1-1/4	1-1/2
Sum of Diameters in a 6-Inch Length: Maximum		
Center Section		
Upper Half	1-1/2	2
Lower Half	2	2-1/2
Elsewhere	2-1/2	3

* No knot shall be closer than its diameter to the pole mounting hole.

**TABLE II – KNOT LIMITS FOR TRANSMISSION ARMS
(SEE FIGURE 2, APPENDIX A)
All Dimensions in Inches**

POLE MOUNTING HOLE ZONE*	MAXIMUM DIAMETER FOR SINGLE KNOT		
	UPPER HALF (inner zone) UPPER HALF (outer zone)	3/4 1 for close grain 1-1/4 dense grain	
OTHER LOCATIONS <u>TRANSMISSION ARM SIZE**</u>	<u>NARROW FACE</u>	<u>WIDE FACE (TWO SIDES)</u>	
		<u>EDGE</u>	<u>ALONG CENTERLINE</u>
4-5/8 x 5-5/8 or less	1	1-1/4	1-1/4
5-5/8 x 7-3/8	1-1/4	1-3/8	1-7/8
3-5/8 x 9-3/8	3/4	1-3/4	2-1/4

*No knot will be closer than its diameter to the pole mounting hole.

**For cross sections not shown, refer to grading rules.

the round knot allowed at the specific location.

(iv) Spike knots shall be prohibited in deadend arms. Any spike knot across the top face shall be limited to the equivalent displacement of a knot $\frac{3}{8}$ of an inch deep on one face and the maximum round knot for its particular location on the worst face, with a maximum width of 1 inch measured at the midpoint of the spiked section. Elsewhere across the bottom or side faces, spike knots shall not exceed $\frac{1}{2}$ the equivalent displacement of a round knot permitted at that location, provided that the depth of the knot on the worst face shall not exceed the maximum round knot allowed at that location.

(v) Loose knots and knot holes shall be such that they can drain water when the arm is installed in its normal position. In the center section, upper half, loose knots shall not be greater than $\frac{1}{2}$ the dimensions of round knots. Elsewhere, loose knots shall not be greater than the round knot dimension. Loose knots shall be prohibited in deadend arms.

(vi) All knots except those "spike" knots intersecting a corner shall be measured on the least diameter of the knot.

(vii) A knot shall be considered to occupy a specific zone or section if the center of the knot (i.e., pith of knot) is within the zone or on the zone's boundary.

(viii) If a round or oval knot appears on two faces and is in two zones, each face shall be judged independently. When this does not occur, average the least dimension showing on both faces. Knots which occur on only one face of a free of heart center (FOHC) arm shall be permitted to be 25 percent larger than the stated size.

(ix) *Knot spacing.* Two or more knots opposite each other on any face shall be limited by a sum not to exceed the size of a maximum single knot permitted for the location. On all four faces, all knots shall be well spaced.

(x) Knots which have a maximum of $\frac{5}{8}$ inch diameter may intersect pin holes in the center section. One inch diameter knots may intersect insulator pin holes elsewhere.

(4) *Miscellaneous characteristics, features, and requirements.* (i) The top face of distribution crossarms shall not have more than four medium pitch and bark pockets in 8-foot arms, and not more than five pitch and bark pockets in 10-foot arms. Elsewhere a maximum of six medium pockets in 8-foot arms and eight in 10-foot arms shall be permitted. Equivalent smaller pockets

shall be permissible. An occasional large pocket is permissible.

(ii) Shakes shall be prohibited.

(iii) *Checks.* Prior to treatment on properly seasoned arms, single face checks shall not exceed an average penetration of $\frac{1}{4}$ the depth from any face and shall be limited to 10 inches long on the top face, and $\frac{1}{3}$ the arm length on the other faces. Checks shall not be repeated in the same line of grain in adjacent pin holes. The sum of the average depths of checks occurring in the same plane on opposite faces shall be limited to $\frac{1}{4}$ the face depth.

(iv) Compression wood shall be prohibited on any face. Compression wood is permitted if wholly enclosed in the arm, more than six annual rings from the surface, and not over $\frac{3}{8}$ of an inch in width.

(v) Insect holes $\frac{3}{32}$ of an inch and larger shall be prohibited. Insect pin holes (i.e. holes not over $\frac{1}{16}$ of an inch diameter) shall be allowed if scattered and not exceeding 10 percent of the arm girth.

(vi) Wane shall be allowed on one edge, limited to approximately 1 inch measured across the corner. Outside of the top center section, an aggregate length not to exceed 2 feet may have wane up to $1\frac{1}{2}$ inches on an occasional piece on one or both edges. Bark shall be removed.

(vii) Prior to preservative treatment, and after treatment, crook, bow, or twist shall not exceed $\frac{1}{2}$ of an inch in 8-foot arms and $\frac{5}{8}$ of an inch in 10-foot arms.

(g) *Manufacture.* (1) All dimensions and tolerances shall conform to those shown on the drawings in this section or drawings supplied with the purchase order. Drawings supplied shall meet or exceed minimum dimensions and tolerances shown on the drawings in this section. Cross-sectional dimensions shall be measured and judged at about $\frac{1}{4}$ the arm length, except when the defects of "skip dressing" or "machine bite or offset" are involved.

(2) Lamination techniques shall comply with ANSI O5.2-1996.

(3) Pin and bolt holes shall be smoothly bored without undue splintering where drill bits break through the surface. The center of any hole shall be within $\frac{1}{8}$ of an inch of the center-line locations on the face in which it appears. Holes shall be perpendicular to the starting and finishing faces.

(4) *Shape.* The shape of the arms at any cross section, except for permissible wane, shall be as shown on the respective drawings in this section or supplied with the order. The two top edges may be either chamfered or rounded $\frac{3}{8}$ of an inch radius. The two

bottom edges shall be slightly eased $\frac{1}{8}$ of an inch radius for the entire length.

(5) *Incising.* The lengthwise surfaces of Douglas-fir crossarms shall be incised approximately $\frac{1}{4}$ of an inch deep. The incision shall be reasonably clean cut with a spacing pattern that ensures uniform penetration of preservative.

(6) *Quality of Work.* All crossarms shall be of the highest quality production. Crossarms shall be dressed on four sides, although "hit and miss skips" may occur on two adjacent faces on occasional pieces.

(h) *Conditioning prior to treatment.*

(1) All solid sawn crossarms shall be made of lumber which has been kiln-dried. Douglas-fir arms shall have an average moisture content of 19 percent or less, with a maximum not to exceed 22 percent. Southern Yellow Pine arms shall have an average moisture content of 22 percent or less, with a maximum not to exceed 30 percent.

(2) Moisture content levels shall be measured at about $\frac{1}{4}$ the length and at a depth of about $\frac{1}{5}$ the crossarm's thickness. Additionally, the moisture content gradient between the shell (i.e. $\frac{1}{4}$ of an inch deep) and the core (i.e. about 1 inch deep) shall not exceed 5 percentage points.

(3) A minimum of at least 20 solid sawn crossarms per treating charge shall be measured to verify moisture content and shall be duly recorded by the quality control designee.

(4) The moisture content of lumber used in laminating shall, at the time of gluing, be within the range of 8 to 12 percent, inclusive.

(i) *Preservatives.* (1) The preservatives shall be:

(i) Creosote which conforms to the requirements of AWP Standard P1 when analyzed in accordance with the methods in AWP Standard A1, sections 2, 3, 4, either 5 or 9, and 6;

(ii) Pentachlorophenol which contains not less than 95 percent chlorinated phenols and conforms to AWP Standard P8 when analyzed in accordance with AWP Standard A5 or A9. The hydrocarbon solvents for introducing the preservative into the wood shall meet the requirements of AWP Standard P9 Type A;

(iii) Waterborne Preservatives, shall be any of the following:

(A) Ammoniacal Copper Arsenates (ACA) and Ammoniacal Copper Zinc Arsenate (ACZA) which shall meet the requirements of AWP Standard P5, when analyzed in accordance with methods in AWP Standards A2, A9, or A11; and

(B) Chromated Copper Arsenates (CCA) which shall meet the requirements of one of the formulations

given in AWP Standard P5, sections 4, 5 or 6, and 10. Tests to establish conformity shall be made in accordance with AWP Standards A2, A9, or A11.

(1) *The pH of treating solutions of the waterborne preservatives shown in AWP Standard P5, section 10, shall be determined in accordance with AWP Standard A2, section 8.*

(2) Waterborne preservatives are available either as oxides, which form non-ionizing chemical compounds in the wood, or as salts, which leave ionizing compounds as well as non-ionizing compounds in the wood. Unless otherwise specified in the purchase order, the oxide formulations of waterborne preservatives shall be supplied.

(3) Douglas-fir crossarms shall not be treated with CCA preservatives.

(4) Materials treated with waterborne preservatives shall be free of visible surface deposits.

(iv) Copper Naphthenate (CuN) concentrate used to prepare wood preserving solutions shall contain not less than 6 percent nor more than 8 percent copper in the form of CuN and shall conform to AWP Standard P8 when analyzed in accordance with AWP Standard A5. The hydrocarbon

solvents for introducing the preservative into the wood shall meet the requirements of AWP Standard P9 Type A.

(2) [Reserved]

(j) *Preservative treatment.* (1) All timber products treated under this specification shall be treated by either a pressure or a thermal (non-pressure) process.

(2) These materials may be further conditioned by steaming, or by heating in hot oil (Douglas-fir), within the following limits:

	Time hours (max.)	Temperature
Steam	3	220° F
Heating in Preservation.	3	210° F

(3) A final steam or hot oil bath may be used only to meet cleanliness requirements of paragraph (k) of this section. Total duration of the final steam bath shall not exceed 2 hours and the temperature shall not exceed 240 degrees Fahrenheit.

(k) *Results of treatments.* (1) The quality control designee shall test or supervise the testing of each treated charge for penetration and retention.

(2) *Method of Sampling.* When testing penetration and retention, a borer core shall be taken from not less than 20 crossarms in each treating charge. The borings shall be taken from any face except the top face at a point as close to the end as possible, being at least 3 inches from the end of the arm and no closer than 3 inches from the edge of the holes. The bored holes shall be plugged with preservative-treated plugs driven into the arm. Borings from laminated arms shall not be taken from the same laminate unless there is an end joint separation.

(3) As determined in accordance with AWP A3, all sapwood present in Douglas-fir or Southern Yellow Pine crossarms shall be completely penetrated with preservative. In the heartwood of Douglas-fir crossarms, the penetration shall be not less than 3 inches longitudinally from the edge of holes and ends, and at least 3/16 inch from the surface of any face.

(4) Retention of preservative in the outer 9/10 of an inch for Douglas-fir and one inch for Southern Yellow Pine assay zones at the treating plant shall be not less than:

Preservation	Retention (pcf)	AWPA analysis method
Creosote	8	A6
Pentachlorophenol	*0.4	A5
ACA, ACZA, or CCA	0.4	A2, A7, A9, or A11
Copper Naphthenate	0.04	A5, A9, or A11

* The pentachlorophenol retention is for the lime ignition method. The copper pyridine method, retention 0.36 pcf is required when timbers may have been in contact with salt water, and for all species native to the Pacific coast region. It is not required when it specifically states on the rough sawn material invoice that this material has not been in contact with salt water or is shown by analysis to have no additional chlorides present in the wood before treating.

(5) Cleanliness of lengthwise surfaces of all crossarms shall be free from tarry, greasy, or sticky material, and from oil exudation and pentachlorophenol crystallization (blooming).

(6) Re-treatment of materials which do not meet the penetration and retention requirements of this specification may be done only twice. Initial treatment steaming time plus re-treatment steaming time, combined, shall not exceed time allowed in paragraph (i) of this section.

(1) *Marks and brands.* (1) All crossarms shall be legibly branded (hot brand) or die-stamped and to a depth of approximately 1/16 of an inch before treatment.

(2) The letters and figures shall be not less than 1/2 of an inch in height. The top of the brand shall be oriented to the top of the arm.

(3) The brand or die-stamp shall include:

(i) The manufacturer's identification symbol;

(ii) Month and year of manufacture;

(iii) Species of timber such as DF for Douglas-fir and SP for Southern Yellow Pine; and

(iv) The preservative notated with a C for creosote, P for penta, S for waterbornes, or N for Copper Naphthenate.

(4) An example is:

M-6-06 Manufacturer—Month—Year
DF-P Douglas-fir—penta treated

(5) The brand or stamp shall be placed on either of the wide surfaces of the arms, oriented with letters right side up towards the top of the arm and preferably about 1 foot from the midpoint of the arm.

(6) The mark should be approximately the same location on each type of crossarm of each producer.

(7) Brands, inspection marks, or quality assurance marks shall be

removed from arms that do not meet these specifications.

(m) *Storage.* (1) Producers may treat crossarms for reserve stock under any of the Rural Development approved plans.

(2) Crossarms treated with oil-borne preservatives which have been held in storage for more than 1 year before shipment to the borrower, shall be re-assayed before shipment and shall be re-treated if found nonconforming for retention on orders placed in accordance with this section.

(3) Crossarms shall meet the assay after re-treatment in accordance with paragraph (k) of this section.

(4) Crossarms which are held in storage after final acceptance shall be stacked in piles or on skids in such a manner as to assure good ventilation. The stacks shall be covered or stored indoors for protection from the sun and weather to reduce checking, bending, and loss of preservative.

(n) *Drawings.* (1) The drawings of Appendix B of this section, Crossarm Drilling Guide, have a type number and show in detail the hole size, shape, and pattern desired for crossarms ordered under this specification.

(2) Purchase orders shall indicate the type or size and length crossarm required. For orders of arms where no drawings are included, the dimension tolerance of $+ \frac{1}{8}'' - 0''$ shall be used. For

example, a $3\frac{3}{4} \times 4\frac{3}{4}$ cross section shall actually be $3\frac{3}{4}'' \times 4\frac{3}{4}'' + \frac{1}{8}''$.

(3) Crossarms shall be furnished in accordance with the details of these drawings or in accordance with drawings attached to the purchase order.

(4) Appropriate drawings for transmission arms are to be specified and included with purchase orders. Technical drawings for transmission crossarms are published in Bulletin 1728F-811, "Electric Transmission

Specifications and Drawings, 115kV through 230kV", and Bulletin 1728F-810, "Electric Transmission Specification and Drawings, 34.5kV through 69kV".

(o) *Destination inspection.* All crossarms shall meet or exceed their minimum dimensions for at least 1 year after date of delivery. Borrowers have the right to reject crossarms that do not meet minimum dimensions.

BILLING CODE 3410-P

Appendix A to § 1728.201—Distribution
and Transmission Arms

DISTRIBUTION ARMS

Figure 1

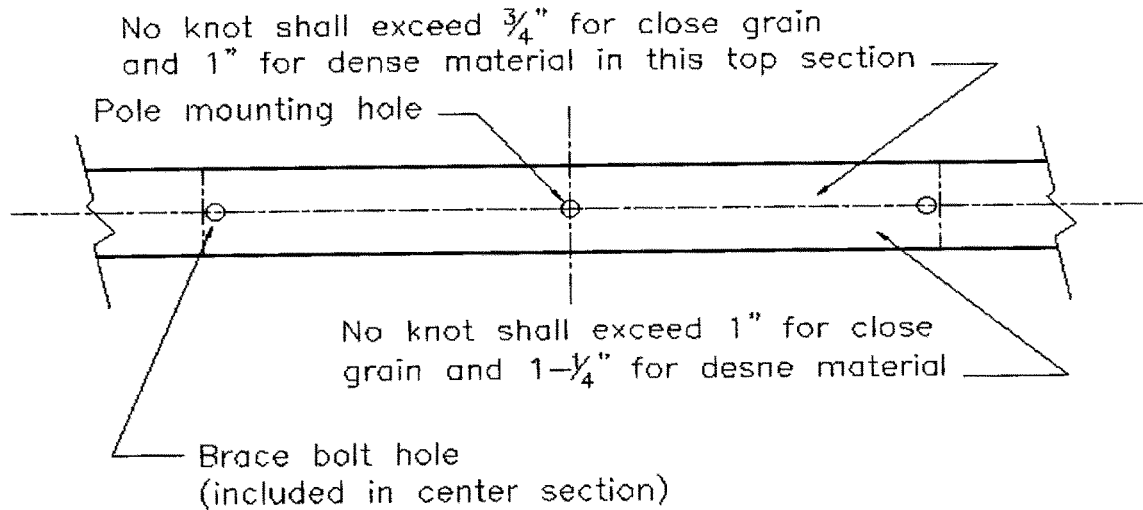

TRANSMISSION ARMS POLE MOUNTING HOLE ZONE

Figure 2

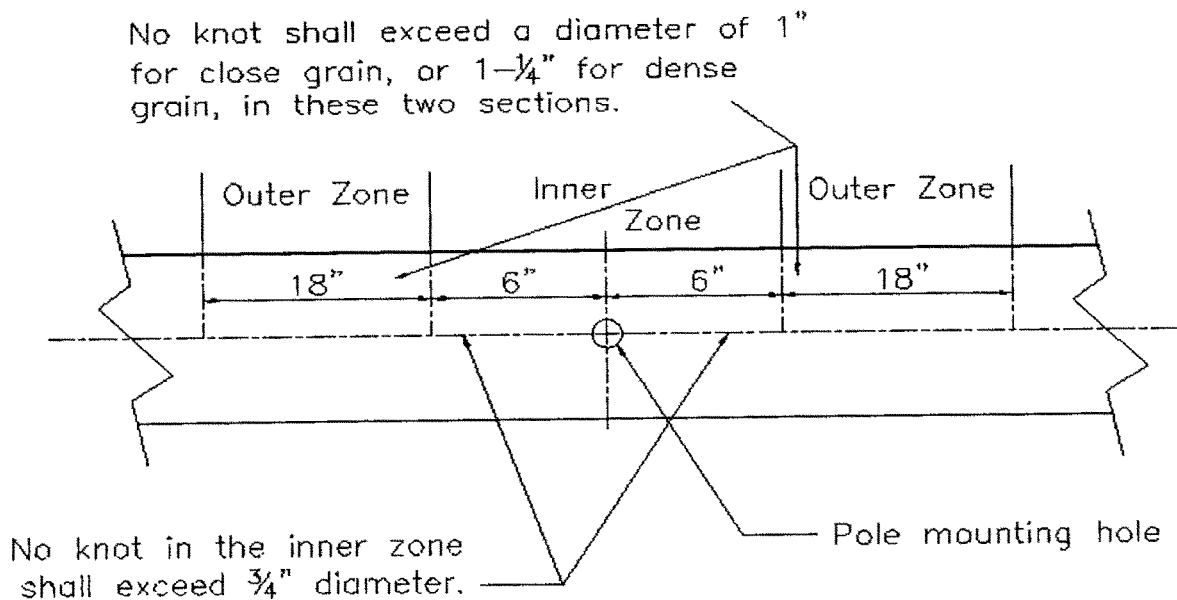

Appendix B to § 1728.201—Crossarm Drilling Guide

TOLERANCES AND SIZES OF HOLES			
	NOMINAL	GO	NO GO
(A)	11/16"	5/8"	3/4"
(B)	7/16"	3/8"	1/2"
(C)	9/16"	1/2"	5/8"

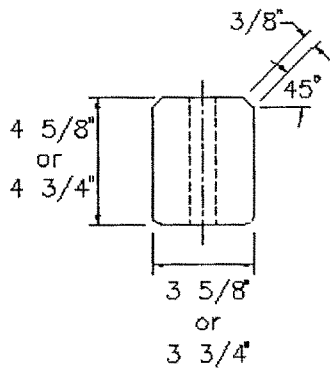
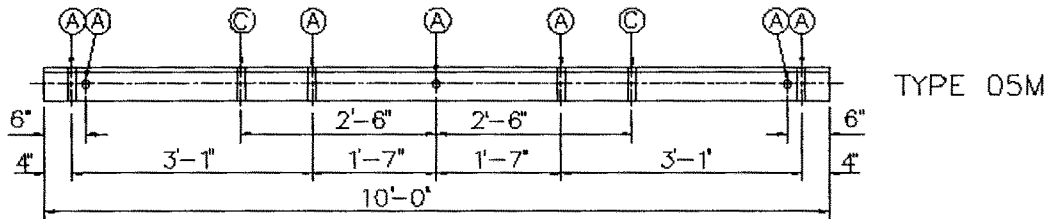
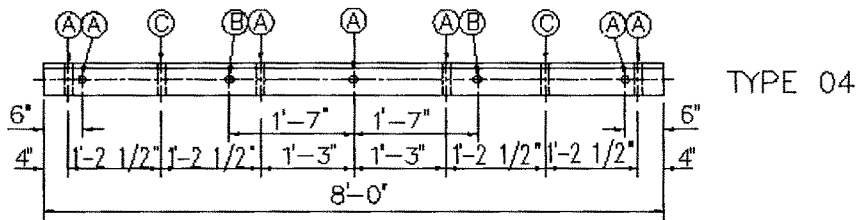

NOTES:

1. Holes are to be located within $\pm 1/8"$
2. Length of the crossarm is to be within $\pm 1/4"$
3. The tolerance of any cross section is $+1/8"$ and $-0"$ at time of manufacture.
4. All holes are to be drilled on centerlines of crossarm faces.

DISTRIBUTION CROSSARM DRILLING GUIDE

--	--	--

BILLING CODE 3410-C

**Appendix C to § 1728.201—Metric
Conversion Factors**

To convert from	To	Multiply by
Foot (ft)	Meter (m)	0.3048
Inch (in)	Centimeter	2.54
Pound per cubic foot (pcf) (lb/ft ³)	Kilogram per cubic meter (kg/m ³)	1.601846
Pound per square inch (psi) (lb/in ²)	Kilogram per square meter (kg/m ²)	703.0696
Degrees Fahrenheit (X °F)	Degrees Celsius (°C)	$\frac{5}{9}(X - 32)$

4. Section 1728.202 is amended by revising paragraphs (a) through (k) and by revising Appendix A to § 1728.202 to read as follows.

**§ 1728.202 Bulletin 1728H-702,
Specification for Quality Control and
Inspection of Timber Products.**

(a) *Scope.* This specification describes in more detail the responsibilities and procedures pertaining to quality control for crossarms, as specified in section 1728.201 of this part, and poles, covered in Bulletin 1728F-700, Specification for Wood Poles, Stubs and Anchor Logs," incorporated by reference in § 1728.97 of this part and in § 1755.97 of 7 CFR part 1755.

(b) Related specifications and standards incorporated by reference. The following specifications and standards referenced throughout this section are pending approval of incorporation by reference in accordance with 5 U.S.C. 552(a) and 1 CFR part 51. Copies of each are available for inspection during normal business hours, room 1246-S, U.S. Department of Agriculture, Washington, DC or at the Office of the Federal Register, 800 North Capitol Street, NW., suite 700, Washington, DC. Copies of these standards and specifications may be purchased from the addresses shown below.

(1) American Wood-Protection Association (AWPA), Book of Standards, 2005 edition, available from AWPA, P.O. Box 361784, Birmingham, AL 35236-1784, telephone 205 733-4077, <http://www.awpa.com/>, include the following standards:

(i) A1-06, Standard for Coal Tar Creosote for Land and Fresh Water Use.

(ii) A2-05, Standard Methods for Analysis of Waterborne Preservatives and Fire-Retardant Formulations.

(iii) A3-05, Standard Methods for Determining Penetration of Preservatives and Fire Retardants.

(iv) A5-05, Standard Methods for Analysis of Oil-Borne Preservatives.

(v) A6-01, Method for the Determination of Water and Oil-Type Preservatives in Wood.

(vi) A7-04, Wet Ashing Procedure for Preparing Wood for Chemical Analysis.

(vii) A9-01, Standard Method for Analysis of Treated Wood and Treating Solutions by X-Ray Emission Spectroscopy.

(viii) A11-93, Analysis of Treated Wood and Treating Solutions by Atomic Absorption Spectroscopy.

(ix) U1-07, Use Category System: User Specification for Treated Wood.

(x) T1-07, Use Category System Processing and Treatment Standard.

(xi) M1-07, Standard for the Purchase and Preservation of Forest Products.

(xii) M2-05, Standard Instructions for the Inspection of Preservative Treatment of Wood.

(xiii) M3-05, Standard Quality Control Procedures for Wood Preserving Plants.

(xiv) M4-06, Standard for the Care of Preservative-Treated Wood Products.

(xv) P1/P13-06, Standard for Coal Tar Creosote for Land and, Fresh Water and Marine (Coastal Water Use).

(xvi) P5-07, Standards for Water-Borne Preservatives.

(xvii) P8-06, Standards for Oil-Borne Preservatives.

(xviii) P9-03, Standards for Solvents for Organic Preservative Systems.

(2) American Institute of Timber Construction (AITC) 200-92, Inspection Manual, 1992 edition, available from AITC, 7012 S. Revere Parkway, Suite 140, Englewood, Colorado 80110, telephone number (303) 792-9559.

(3) American National Standards Institute (ANSI) O5.2-1996 (R2001), American National Standard for Wood Products—Structural Glued Laminated Timber for Utility Structures, available from ANSI, 25 West 43rd Street, New York, New York 10036, telephone (212) 642-4900, Web address: <http://www.ansi.org/>.

(4) American Society for Testing and Materials (ASTM) D9-05, Standard Terminology Relating to Wood, available from ASTM, 100 Barr Harbor Dr. West, PO Box C700, Conshohocken, PA 19428-2959, telephone number (610) 832-9585, Web address: <http://www.astm.org>.

(c) *General stipulations.* (1) Conformance of poles and crossarms to agency specifications for the most part is the responsibility of the producer's

management. A member of the producer's staff shall be designated quality control designee and charged with the responsibility for the exercise of proper quality control procedures. Failure of a selected third-party inspection agency to properly perform their required overview responsibilities may subject said agency to subsequent liability claims for unsatisfactory or inadequate product performance.

(2) The requirements in American Wood Protection Association (AWPA) Standard M3, covering records, adequate laboratory, plant gauges, and other plant facilities including proper storage, shall be followed.

(3) The methods of inspection described in this section shall be used no matter which plan timber products are purchased under, i.e., Insured Warranty Plan, Independent Inspection Plan, or Quality Assurance Plans, as described in § 1728.201 of this part or Bulletin 1728F-700. The number of poles and crossarms actually inspected by monitors for quality control under a Quality Assurance Plan or the Insured Warranty Plan may vary from the number of poles and crossarms inspected under the Independent Inspection Plan. Under the Independent Inspection Plan, each pole and a sample number of crossarms shall be inspected.

(4) Under the Independent Inspection Plan, the borrower should designate in the purchase order which inspection agency it has selected. This service shall not be subcontracted to another agency. Unless the borrower contracts for inspection as a separate transaction, the treating company shall obtain the services of the borrower's designated inspection agency. For reserve treated stock for purchase under the Independent Inspection Plan, the treating company shall obtain the services of an inspection agency.

(5) Individual inspectors in the employ of Independent Inspection Agencies shall be experienced, competent and employed by only a single inspection Agency. The inspector shall perform all phases of the inspection personally and in the proper sequence. The primary responsibility of the inspector is to determine, for the

borrower, by careful inspection and verification, that the timber products, preservative, and treatment meet the requirements of Bulletins 1728F-700 and 1728H-701 and that the methods, storage facilities, and production equipment conform to applicable specifications. For details of the inspector's qualifications see Appendix A of this section.

(6) Independent inspection agencies and inspectors shall maintain their impartiality. To do so, inspection agencies, inspectors, producers and brokers must maintain the greatest degree of separation and eliminate even the appearance of a conflict of interest. Inspection agencies shall not receive gratuities from or enter into financial agreements, other than for inspection services, with suppliers for which they perform inspection. Inspection agencies shall not provide gratuities or free services to suppliers. Inspection agencies shall not offer product warranties on inspected material.

(7) Failure of an individual inspector to follow proper procedures or failure of an inspection agency to properly supervise inspectors or follow the appropriate specifications are grounds for debarment of inspection of agency financed material.

(8) Inspection agencies shall have and maintain liability insurance in the amount of \$500,000 and a surety bond or miscellaneous errors and omission insurance for consequential damages for not less than \$250,000. Upon request, evidence of compliance to this requirement shall be forwarded to the agency. The evidence shall be in the form of a certificate of insurance or a Bond signed by a representative of the insurance or Surety Bonding company and include a provision that no change in, or cancellation of, will be made without the prior written notice to Chairman, Technical Standards Committee "A" (Electric).

(9) Inspection agencies shall maintain their own laboratory that is properly equipped according to AWPA standards, capable of completely analyzing the respective preservatives treatments, and at a minimum to run referee methods. This laboratory shall be independent from any treating plant laboratory. Independent Inspection Agencies may use one central laboratory.

(10) Laminated materials manufactured for use on borrower systems shall comply with manufacturing and quality control requirements specified in ANSI O5.2-1996 (R2001), American National Standard for Wood Products—Structural Glued Laminated Timber for Utility

Structures. The product shall be marked and certified.

(i) Laminated material shall be inspected in accordance with ANSI O5.2-1996 (R2001).

(ii) Quality control of material shall be performed to determine conformance with § 1728.201 of this part and AITC 200-2004, Inspection Manual.

(d) *Quality control and inspection procedures for product acceptance.* It is the responsibility of the plant quality control designee to perform the following procedures to ensure that a particular lot of material conforms to the requirements of the applicable agency specification prior to treatment. After the plant quality control designee has performed these procedures, a particular lot of material shall be released to the inspector for verification of conformance.

(1) Poles can be purchased under any of the three purchase plans. These plans are Insured Warranty Plan, Independent Inspection Plan, or a Quality Assurance Plan. Under all of these plans, all poles in a lot shall be inspected by the plant quality control designee. Under the Insured Warranty Plan and a Quality Assurance Plan, the number of poles in a lot actually inspected by a third party inspector may be less than every pole, depending on the terms of the plans.

(i) Ample space and assistance shall be provided by the treating plant for handling and turning to ensure that the surfaces of all items can be adequately inspected.

(ii) Under the Independent Inspection Plan, all poles shall be inspected by the Independent Inspector for conformance to the requirements of Bulletin 1728F-700. If a pole is rejected and the cause of rejection is corrected, the rejected pole may be offered again for inspection as new material.

(iii) Dimensions, length, and circumference shall be measured by a standard steel tape to determine that they are in agreement with the details for class and length in the brand and butt stamp. If it is obvious by visual comparison with a measured pole that the brand information is correct, individual poles need not be measured. Pole circumference dimensions made prior to treatment shall govern acceptance. Reduction in dimension due to treatment and shipping shall be not more than 2 percent below the minimum for the pole class.

(iv) If 15 percent of the poles in a lot offered for inspection are defective, the inspector shall terminate the inspection. Re-examination of an entire lot by plant quality control shall be required when the number of rejected poles equals or exceeds 15 percent of the lot inspected.

All defective or nonconforming poles either shall be removed from the lot or have their brands marked out.

(v) Poles in a lot shall be inspected for decay and all poles shall be of the same seasoning condition. If the plant quality control designee suspects that decay has occurred, a slice from both ends shall be cut for closer examination. If 5 percent of the inspected poles in a lot shows evidence of decay, the entire lot shall be unconditionally rejected without further sorting.

(vi) Moisture content, when limited by the purchaser, as stated on the purchaser's purchase order, shall be measured by calibrated electronic moisture meter. Calibration of the meter shall include not only the zero settings for the X and Y readings, but also two resistance standards for 12 and 22 percent moisture content.

(vii) Material failing to conform for moisture content may be retested upon request after a recalibration of the instrument. The results of the second test shall govern disposition of the lot.

(viii) Re-examination for any mechanical damage or deterioration and for original acceptance shall be conducted on timber products not treated within 10 days after original inspection.

(2) Crossarms can be purchased only under either of two purchase plans. These plans are the Independent Inspection Plan or Quality Assurance Plans. Under the Independent Inspection Plan, crossarms are to be inspected prior to manufacture, during manufacture, and after treatment. Under a Quality Assurance Plan, crossarms are monitored according to the terms of the quality assurance program acceptable to Rural Development Utilities Programs.

(i) Inspection prior to treatment shall include:

(A) Surface inspection of all ends of all arms. This is usually done on the stacks of arms prior to manufacture. Particular attention shall be paid to defects commonly found in the ends, such as compression wood, red heart and other forms of decay, shakes, splits, through checks, scantiness, honeycomb, and low density, determined by rings per inch and percent of summerwood. Whenever the number of nonconforming arms is found to exceed 0.5 percent of the lot or one arm, whichever is greater, the entire lot shall be rejected for excess number of defective ends. After the producer has removed or marked out the defective material, the arms may be resubmitted for inspection.

(B) Surface inspection of the lengthwise sides performed on a random representative sample. The

sample size shall equal 20 percent of a lot size or 200 arms, whichever is smaller. The inspector shall examine side surfaces as they are slowly rotated. When necessary, the rotation may be stopped for closer inspection. Whenever the number of nonconforming arms is found to exceed 2 percent of the sample size, the entire lot shall be rejected. After the producer has removed or marked out the defective material, the arms may be resubmitted for inspection.

(C) Check of moisture content of the random sample by a calibrated moisture meter.

(D) Check of crossarm dimensions of the random sample measured after surfacing.

(ii) Inspection during manufacture shall consist of:

(A) Checking bolt and insulator pin holes for squareness and excessive splintering;

(B) Checking brands for completeness, location, and legibility; and

(C) Checking arms for conformance.

(iii) Under the Independent Inspection Plan, there shall be a final inspection after treatment for preservative retention and penetration and for damage.

(3) Structural glued laminated timber shall be tested and inspected in accordance with AITC 200, Inspection Manual. Grade of lumber shall be inspected by a qualified grader for specified quality, and so marked, in accordance with grading rules of the American Lumber Standards. Adhesives used for all structural arms shall meet requirements of ANSI O5.2-1996 (R2001) paragraph 5.2. Melamine urea adhesives shall not be used. End joint spacing and limitations shall be in accordance with ANSI O5.2-1996 (R2001).

(e) *Preservatives.* (1) Creosote shall conform to the requirements of AWWA Standard P1 when analyzed by AWWA Standard A1, sections 2, 3, 4, either 5 or 9, and 6, as follows:

(i) Each occasional charge; and
 (ii) The first charge and one of every five charges randomly selected in consecutive charges shall be analyzed.

(2) Solutions of waterborne preservatives shall be analyzed for components in accordance with AWWA Standards A2, A9, or A11, and shall meet the requirements of P5 for

composition. AWWA A2 shall be used as a referee method.

(3) Pentachlorophenol shall contain not less than 95 percent chlorinated phenols and should conform to AWWA Standard P8 in hydrocarbon solvent AWWA P9 Type A.

(4) Copper Naphthenate in hydrocarbon solvent (AWWA P9 Type A) shall contain not less than 6 percent nor more than 8 percent copper in the form of Copper Naphthenate and shall conform to AWWA Standard P8 when analyzed in accordance with AWWA Standard A5.

(f) *Plant facilities and inspection during treatment.* (1) Manufacturing and treating plant facilities shall conform to AWWA Standard M3, paragraph 3. Pressure plants shall be equipped with recording instruments to register time, pressure, temperature and vacuum during each cycle of treatment. Pressure plants shall also be equipped with indicating thermometers and pressure and vacuum gauges to check the accuracy of the recorders. Work tanks shall be equipped with a thermometer. Thermal treating vats shall be equipped with a time and temperature recorder and with an indicating thermometer. Temperature recording devices are not mandatory for plants treating exclusively with waterborne preservatives.

(2) Temperature and humidity readings throughout the kiln shall be recorded on a recording chart and verified by observation of direct reading equipment. Gauges and recording equipment shall be calibrated annually.

(3) Under the Independent Inspection Plan, the inspector shall be present during the treatment procedure, except at times when it may be impractical, such as during late night or early morning treatments. At such times of absence, temperature, pressure, and vacuum data shall be taken from the recording charts.

(4) Recording instruments shall be checked with calibrated indicating gauges and thermometers, per AWWA standard M3. Inaccuracies shall be referred to the treating plant for prompt correction. If an inaccuracy which indicates error resulting in non-compliance with this specification indicating possible damage to the

material, the inspector shall reject the charge.

(g) *Results of treatment.* (1) Poles shall be tested for retention and penetration by means of a calibrated increment borer 0.2 inches ± 0.02 inches in diameter in accordance with procedures in AWWA Standard M2. Under the Independent Inspection Plan, all treating charges shall be tested for retention and penetration. Plant quality control and independent inspection shall do their analyses separately. Under the Insured Warranty Plan and Quality Assurance Plans, the frequency of testing retention and penetration may vary according to the Agency approved plan.

(i) Unless otherwise specified, borings shall be taken approximately 1 foot above the face brand to 1 foot below the face brand. For pressure treated Western Red Cedar and all butt treated poles, borings shall be taken approximately 1 foot below groundline.

(ii) Penetration compliance shall be determined in accordance with AWWA Standard A3. Chrome Azurol S and Penta-Check shall be used to determine penetration of copper containing preservatives and penta, respectively.

(iii) *Retention sampling.* (A) When there are 20 or more poles in the treating charge, the retention sample for creosote shall consist of 20 assay zones from southern pine and Douglas-fir poles. All poles in charges with fewer than 20 poles shall be bored once. Charges with less than 15 poles shall be bored once and bored again on a random basis to obtain a minimum of 15 assay zones.

(B) Retention samples shall be taken from 20 poles in charges of 20 or more poles.

(C) Retention samples for Alaska yellow, western red, and northern white cedars shall consist of a minimum of 30 assay zones for creosote and waterborne preservatives. For penta charges of fewer than 30 poles, the sample shall contain the assay zone from each pole in the lot.

(D) Retention samples shall consist of borings, representative of pole volumes for each class and length in the charge. Further selection and marking of poles of mixed seasoning, volume, and location on the tram shall be made as illustrated in the following table:

Number of poles	Class/length	Vol. in cu. ft.	% of total volume	Number of borings
27	7/30	232	15	3
26	4/35	447	29	6
11	5/35	163	10	2
* 55	6/35	704	46	9

Number of poles	Class/length	Vol. in cu. ft.	% of total volume	Number of borings
Total	1,546

* If a portion of these poles were green and some partially seasoned, then the number of borings should reflect the approximate percentage of each.

(iv) When material in a lot consists of fewer pieces than the designated minimum number of samples for assay, additional borings shall be taken so as to make up at least the minimum sample, and in such manner that the sample is representative of the lot of material with respect to any variations in size, seasoning condition, or other features that might affect the results of treatment.

(v) Analyses for preservative retention shall be performed as follows:

(A) Creosote retention shall be analyzed by AWPAs Standard A6;

(B) Penta retention shall be analyzed by AWPAs Standard A5 or A9. Copper pyridine method is required when timber may have been in contact with salt water and for all species native to the Pacific coast region, unless the raw material invoice specifically states that the material either has not been in contact with salt water or has been shown by analysis to have contained no additional chlorides before treating;

(C) Copper Naphthenate retention shall be analyzed by tests in accordance with AWPAs Standards A5 or A9;

(D) Waterborne preservatives retention shall be analyzed by tests in accordance with AWPAs Standards A2, A7, A9, or A11; and

(E) Prior to unloading a tram, the inspectors may take their own samples and analyze them concurrently with the quality control designee, but each shall work independently, and quality control data shall be presented before acceptance of the charge.

(vi) *Penetration sampling of poles.* (A) Group A poles consist of poles with a circumference of 37.5 inches or less at 6 feet from butt.

(1) Bore 20 Group A poles or 20 percent of the poles, whichever is greater. Accept if 100 percent of the sample conform; otherwise, bore all poles.

(2) Re-treat the charge if more than 15 percent of the borings are found to be nonconforming.

(3) Re-treat all nonconforming poles if 15 percent or fewer fail the requirement.

(B) Group B poles consist of poles with circumference greater than 37.5 inches at 6 feet from the butt.

(1) For Group B poles 50 feet and shorter, bore each pole and re-treat only those found to be nonconforming,

unless more than 15 percent fail; in that case, re-treat the entire lot.

(2) For Group B poles longer than 50 feet, bore each pole twice at 90 degrees apart around the pole and accept only those poles conforming to the penetration requirement in both borings. All nonconforming poles may be re-treated only twice.

(vii) All holes (nominal 0.2 of an inch diam. bit) shall be promptly filled with treated, tight-fitting wood plugs.

(2) Under the Independent Inspection Plan, all treating charges of crossarms shall be tested for retention and penetration. Plant quality control inspectors and independent inspectors shall do their analyses independently. Under the Quality Assurance Plans, the frequency of testing retention and penetration may vary according to the plan.

(i) The penetration and retention sample shall consist of 20 (48 for creosote) outer $\frac{6}{10}$ of an inch for Douglas-fir and 1 inch for Southern Yellow Pine zones from borings taken from any face except the top face at a location as close to the end as possible being at least 3 inches from the end of the arm and no closer than 3 inches from the edge of any holes. For laminated material, borings shall be taken from laminates on a random basis.

(ii) Preservative penetration shall be tested by taking not less than 20 borings from 20 crossarms in each charge, determined in accordance with AWPAs Standard A3. Chrome Azurol S and Penta-Check shall be used to determine penetration of copper containing preservatives and penta, respectively.

(3) Laminated material shall be checked for any evidence of delamination due to treatment and for the identifying quality stamp of AITC or American Plywood Association (APA).

(4) If used for analysis, x-ray fluorescence instruments (XRF) shall be accurate and reliable, and they shall generate reproducible results. Instruments shall have thorough instructions which should include recommendations on drying techniques, equipment, and density calculations. These drying recommendations shall be followed when using XRF instruments.

(5) To check the precision of the x-ray fluorescence instrument (XRF) at plants where it is used, once weekly the independent inspector shall rerun a

sample at the inspection agency's laboratory. The independent inspector's laboratory shall use XRF or the referee method, maintain a log showing the plant's analysis value and the inspector's laboratory result. If the values are within the AWPAs precision statement for each respective analysis method, the plant instrument needs no further calibration. Inspection agency XRF instruments shall be calibrated quarterly by the referee method for each preservative treatment that is being analyzed by the XRF.

(6) Each independent inspector and plant quality control personnel that use XRF instruments, shall be trained and certified competent by the instrument manufacturer.

(h) *Product acceptance.* Under the Independent Inspection Plan, the inspector shall signify acceptance by marking each piece of accepted material with a clear, legible hammer stamp in one end prior to treatment and in the other end after treatment. The inspector shall personally mark each piece, and shall not delegate this responsibility to another person.

(i) Charge Inspection Reports.

(1) Inspection Reports shall have the following matters:

(i) Total pieces in the lot, number of pieces, and causes for rejection;

(ii) Conditioning details of the material prior to treatment;

(iii) Analyses of preservatives identified by the analyst's signature or certification;

(iv) The details of treatment; and

(v) The results of treatment. Results shall include the following:

(A) The depth of penetration for retention samples and a summary of all poles rejected for insufficient penetration;

(B) Separate worksheets for retention analyses, prepared by quality control designee and independent inspector;

(2) On each inspection report the independent inspector and the plant quality control designee shall certify, in writing, that the material listed on the report has been inspected before, during, and after treatment, and that the preservative used was analyzed in accordance with the requirements of this section.

(3) Each inspector or inspection agency shall permanently retain for a period of 1 year a copy or transcript of

each report of inspection, together with laboratory worksheets covering retention by assay and preservative analyses for the purchaser, and on request shall furnish a copy or transcript of any of these reports to the Chairman, Technical Standards Committee "A", Electric Staff Division, USDA Rural Development Utilities Programs, Washington, DC 20250-1569.

(j) *Charge numbers on re-treat poles.* The letter "R" shall be added to the original charge number in the butts of all poles that are re-treated for insufficient penetration or retention of preservative.

All poles that fail to meet treatment requirements after two re-treatments shall be permanently rejected.

(k) *Safety provisions.* Poles intended for agency borrowers shall not be inspected when, in the opinion of the inspector, unsafe conditions are present.

Appendix A to § 1728.202—Inspector's Qualifications

Inspection agencies should see that inspectors assigned to the inspection of timber products and treatment for borrowers are competent and experienced.

In general, any of the following examples are considered as minimum qualifying

experience before a new inspector may be permitted to inspect timber products for borrowers:

(a) Three years' experience as an inspector of timber and the preservative treatment of timber; or

(b) Three years' experience in timber treating plant quality control work; or

(c) Under the direct, on site, supervision of an experienced, well-qualified inspector, the prospective inspector shall have performed the following:

(1) Inspected at least 10,000 poles and/or crossarms "in the white."

(2) Checked preservative penetration results on at least 10,000 poles and crossarms;

(3) Made at least 100 wood assays for preservative retention;

(4) Made at least 25 analyses of each type of preservative used on material the person is assigned to inspect; and

(5) Certified competent by the XRF instrument manufacturer.

(d) In both (a) and (b) of this Appendix A, the experience should be not less than that required in (c).

(e) Inspectors experienced in the inspections of one product, such as poles, should not be qualified to inspect another product, such as crossarms, until the above experience is gained for each respective product.

(f) The inspector should be especially well informed in wood preservation and the

operation of a timber treating plant, and be competent in preservative analysis and other laboratory work.

(g) In all cases, an inspector should be thoroughly instructed in the application of the specifications and the standards pertaining thereto before being permitted to independently inspect timber products and the treatments applied to them. Knowledge of these specifications and standards, as well as the inspector's proficiency, may be checked routinely by members of the agency staff.

* * * * *

PART 1755—TELECOMMUNICATIONS STANDARDS AND SPECIFICATIONS FOR MATERIALS, EQUIPMENT AND CONSTRUCTION

4. The authority citation continues to read as follows:

Authority: 7 U.S.C. 901 *et seq.*, 1921 *et seq.*, 6941 *et seq.*

5. Section 1755.97 is amended in the table by revising the entry for Bulletin 1728F-700 to read as follows:

§ 1755.97 Incorporation by reference of telephone standards and specifications.

* * * * *

Bulletin No.	Specification No.	Date last issued	Title of standard or specification
* * * * *	* * * * *	* * * * *	* * * * *
1728F-700		[Effective date of final rule]	Specification for Wood Poles, Stubs and Anchor Logs.

Dated: September 8, 2008.

James M. Andrew,

Administrator, Rural Utilities Service.

[FR Doc. E8-21798 Filed 9-26-08; 8:45 am]

BILLING CODE 3410-15-P

DEPARTMENT OF TRANSPORTATION

Federal Aviation Administration

14 CFR Part 71

[Docket No. FAA-2008-0757; Airspace Docket No. 08-ASW-13]

Proposed Amendment of Class E Airspace; Big Spring, TX

AGENCY: Federal Aviation Administration (FAA), DOT.

ACTION: Notice of proposed rulemaking.

SUMMARY: This action proposes to amend Class E airspace at Big Spring McMahon Wrinkle Airport, Big Spring, TX. Additional controlled airspace is necessary to accommodate changes to the VOR/DME RWY 17 Standard Instrument Approach Procedure (SIAP)

at Big Spring McMahon-Wrinkle Airport, Big Spring, TX. The FAA is taking this action to enhance the safety and management of Instrument Flight Rules (IFR) aircraft operations at Big Spring McMahon-Wrinkle Airport.

DATES: Comments must be received on or before November 13, 2008.

ADDRESSES: Send comments on this proposal to the U.S. Department of Transportation, Docket Operations, 1200 New Jersey Avenue, SE., West Building Ground Floor, Room W12-140, Washington, DC 20590-0001. You must identify the docket number FAA-2008-0757/Airspace Docket No. 08-AS-W-13, at the beginning of your comments. You may also submit comments on the Internet at <http://www.regulations.gov>. You may review the public docket containing the proposal, any comments received, and any final disposition in person in the Dockets Office between 9 a.m. and 5 p.m., Monday through Friday, except Federal holidays. The Docket Office (telephone 1-800-647-5527), is on the ground floor of the building at the above address.

FOR FURTHER INFORMATION CONTACT: Scott Enander, Central Service Center, Operations Support Group, Federal Aviation Administration, Southwest Region, 2601 Meacham Blvd., Fort Worth, TX 76193-0530; telephone: (817) 222-5582.

SUPPLEMENTARY INFORMATION:

Comments Invited

Interested parties are invited to participate in this proposed rulemaking by submitting such written data, views, or arguments, as they may desire. Comments that provide the factual basis supporting the views and suggestions presented are particularly helpful in developing reasoned regulatory decisions on the proposal. Comments are specifically invited on the overall regulatory, aeronautical, economic, environmental, and energy-related aspects of the proposal. Communications should identify both docket numbers and be submitted in triplicate to the address listed above. Commenters wishing the FAA to acknowledge receipt of their comments on this notice must submit with those