

Technical Guidelines for Voluntary Reporting of Greenhouse Gas Program

Chapter 1, Emission Inventories

Part I: Appendix

	<u>Page</u>
Section 1: Methods for Calculating Forest Ecosystem and Harvested Carbon, with Standard Estimates for Forest Types of the United States	2
APPENDIX A - Forest Ecosystem Yield Tables for Reforestation	58
APPENDIX B - Forest Ecosystem Yield Tables for Afforestation	110
APPENDIX C - Scenarios of Harvest and Carbon Accumulation in Harvested Wood Products	162
APPENDIX D - Summary of Data and Methods Contributing to Calculation of the Disposition of Carbon in Harvested Wood Products	204
Section 2: Guidelines for Using Models	228
Section 3: Measurement Protocols for Forest Carbon Sequestration	233

Chapter 1, GHG Inventories: Part I

Appendix Section 1: Methods for Calculating Forest Ecosystem and Harvested Carbon, with Standard Estimates for Forest Types of the United States

The material presented in Appendix Section 1 (this section) is adapted from a USDA Forest Service General Technical Report (Smith et al. 2006).

1.1 Introduction

International agreements recognize forestry activities as one way to sequester carbon, and thus mitigate the increase of carbon dioxide in the atmosphere; this may slow possible climate change effects. The United States initiated a voluntary reporting program in the early 1990's (U.S. Dep. Energy 2005). A system for developing estimates of the quantity of carbon sequestered in forest stands and harvested wood products¹ throughout the United States is a vital part of the voluntary program. This system must be relatively easy to use, transparent, economical, and accurate. In this publication, we present methods and regional average tables that meet these criteria.

Carbon is sequestered in growing trees, principally as wood in the tree bole. However, accrual in forest ecosystems also depends on the accumulation of carbon in dead wood, litter, and soil organic matter. When wood is harvested and removed from the forest, not all of the carbon flows immediately to the atmosphere. In fact, the portion of harvested carbon sequestered in long-lasting wood products may not be released to the atmosphere for years or even decades. If carbon remaining in harvested wood products is not part of the accounting system, calculation of the change in carbon stock for the forest area that is harvested will incorrectly indicate that all the harvested carbon is released to the atmosphere immediately. Failing to account for carbon in wood products significantly overestimates emissions to the atmosphere in the year in which the harvest occurs.

We adopted the approach of Birdsey (1996), who developed tables of forest carbon stocks and carbon in harvested wood to provide basic information on average carbon change per area. The tables are commonly referred to as "look-up tables" because users can identify the appropriate table for their forest, and look up the average regional carbon values for that type of forest. We have updated the tables by using new inventory surveys, forest carbon and timber projection models, and a more precise definition of carbon pools. We also include additional forest types and background information for customizing the tables for a user's specific needs.

The look-up tables are categorized by region, forest type, previous land use, and, in some cases, productivity class and management intensity. Users must identify the categories for their forest, estimate the area of forestland, and, if needed, characterize the amount of wood harvested from

¹ Traditionally, the phrase "forest products" includes paper, but the phrase "wood products" does not. The literature for forest carbon has not recognized this distinction. To be consistent with the literature, documentation relating to the 1605b program defines "wood products" as, products derived from the harvested wood from a forest, including fuel-wood and logs and the products derived from them such as cut timber, plywood, wood pulp, paper, etc. Included are both products in use and in disposal systems such as landfills (but which have not yet decayed, releasing carbon to the atmosphere as CO₂ and/or CH₄).

the area in a way that is compatible with the format of the look-up tables. The average carbon estimates per area in the look-up tables must be multiplied by the area or, as appropriate, harvested volumes, to obtain estimates in total carbon stock or change in carbon stock.

The estimates in the look-up tables are called “average estimates,” indicating that they should be used when it is impractical to use more resource-intensive methods to characterize forest carbon, that is, particularly when more specific information is not available. Because these tables represent averages over large areas, the actual carbon stocks and flows for specific forests, or projects, may differ. The look-up tables should not be used when conditions for a project or site differ greatly from the classifications specified for the tables. Some users may require an alternative to an “all-or-nothing” use of the tables because they may have some information and need to use the tables to supplement, or fill in gaps, in carbon stocks. Alternatively, users may require slight alterations to the tabular data provided. Therefore, we also include the underlying assumptions and appropriate citations so that the tables can be adjusted to data availability and information requirements of individual activities.

The accuracy of estimates from look-up tables will depend on how well the estimates in the tables represent the specific conditions of the land area or stratum for which estimates are required. In general, application of a regional estimate from a look-up table to a specific tract of land will get a rating of “C” to reflect the level of uncertainty inherent in this approach. However, a close match between the characteristics of the specific land area and the land characteristics defined by a look-up table could result in a higher rating. The following tabulation illustrates how look-up tables may be rated under the 1605(b) reporting system. This is intended as a guide to rating – individual circumstances must be carefully considered before conducting such an accuracy assessment.

<i>Rating</i>	<i>Characterization</i>	<i>Application of look-up tables</i>
A	Most accurate (within 10 % of true value)	Estimates in look-up tables validated with independent data for the specific site and management conditions.
B	Adequate accuracy (within 20 % of true value)	Estimates in look-up tables modified or adjusted to match the specific site and management conditions. For example, estimates of carbon in live and standing dead trees are recalculated using local biomass equations for a narrowly defined productivity class.
C	Marginal accuracy (within 30 % of true value)	Typical application of regional look-up tables that generally match the site and management conditions. Sites are defined by region, forest type, and productivity class. Management includes regeneration after harvest, afforestation, and in some cases, “low” or “high” intensity.
D	Inadequate accuracy	Use of look-up tables for sites or management conditions that are not represented by the tables. For example, using the Northeast, White-red-jack pine table for an intensively managed, thinned red pine plantation.

The focus of this document is to explain the methodology in a transparent way and present sets of look-up tables for quantifying forest carbon when site-specific information is limited. In the sections that follow, we introduce the tables and provide general guidance for their use. First, tables of forest ecosystem carbon are presented; these are followed by tables to calculate the disposition of carbon in harvested wood products. Additional information on methods and data sources follows these tables. This organization was adopted so that readers interested in using the tables can do so quickly. Both metric and English units are used for measures of area and volume.² However, all values for carbon mass are expressed in metric units—tonnes (t)—unless specified otherwise. English units are included because most of the necessary input quantities are commonly expressed in units such as cubic feet/acre (for stand-level growing-stock volume) or thousand square feet of $\frac{3}{8}$ -inch plywood (a primary wood product), for example. Carbon stocks and stock changes are usually discussed and reported in metric units of carbon mass; this can lead to carbon in forests expressed as tonnes/hectare or in the United States as metric tons/acre. The forest ecosystem carbon tables are in Appendices A, B, and C; ancillary information on carbon in harvested wood is in Appendix D.

1.2 Forest Ecosystem Carbon Tables

Tables of estimates of forest carbon stock are provided for common forest types within each of 10 U.S. regions (Fig. 1.1). Six distinct forest ecosystem carbon pools are listed: live trees, standing dead trees, understory vegetation, down dead wood, forest floor, and soil organic carbon. These pools are defined in Table 1.1. As an example, the table for reforested maple-beech-birch stands in the northeast is shown in Table 1.2. The complete set of tables are in Appendices A and B. The first two columns in each table are age and growing-stock volume; the remaining columns represent carbon stocks for the various carbon pools and are dependent on age or growing-stock volume. Pools are quantified as carbon densities, that is, tonnes per unit area (acres or hectares).

The use of the tables can be summarized in three steps: 1) identify the most appropriate table for the particular carbon sequestration project; 2) extract the tabular information required for estimating carbon sequestration by the project; and 3) complete any necessary custom modifications or post-processing needed to suit data requirements. The information in the tables is based on a national-level, forest carbon accounting model (FORCARB2; Heath and others 2003, Smith and others 2004a), a timber projection model (ATLAS; Mills and Zhou 2003, Mills and Kincaid 1992, updated for Haynes 2003), and the USDA Forest Service, Forest Inventory and Analysis (FIA) Program's database of forest surveys (FIADB; USDA For. Serv. 2005, Alerich and others 2005). Details are provided in the methods section.

The two basic sets of tables in Appendices A and B differ only with respect to assumptions associated with previous land use. The first set displays carbon stocks on forest land remaining forest land, also called “reforestation” or “regrowth” of a stand following a clearcut harvest (Table 1.2, for example, and Appendix A). The second set displays accumulation of carbon stocks for a stand established on land that was not forest, called “afforestation” (Appendix B).

² A tonne (t) is defined as 10^6 grams, or 2,204.62 pounds (lb). Other metric and English equivalents include 0.404686 hectare (ha) = 1 acre (ac), 2.54 centimeter (cm) = 1 inch (in), 0.0283168 cubic meter (m^3) = 1 cubic foot (ft^3), and 0.907185 tonne = 1 short ton = 2,000 pounds.

The separate set of afforestation tables accounts for lower carbon densities of down dead wood, forest floor, and soil carbon in the initial years after forest establishment on nonforest land. However, as stands mature, the level of carbon stocks in these pools approaches the regional averages represented in the reforestation tables.

The tables in Appendices A and B provide estimates of carbon stock. The net change in carbon stock (sometimes called flux) associated with a growing forest can be determined by dividing the difference between two carbon stocks by the time interval between them. (See Examples 1.1 and 1.2 for information on using these tables.)

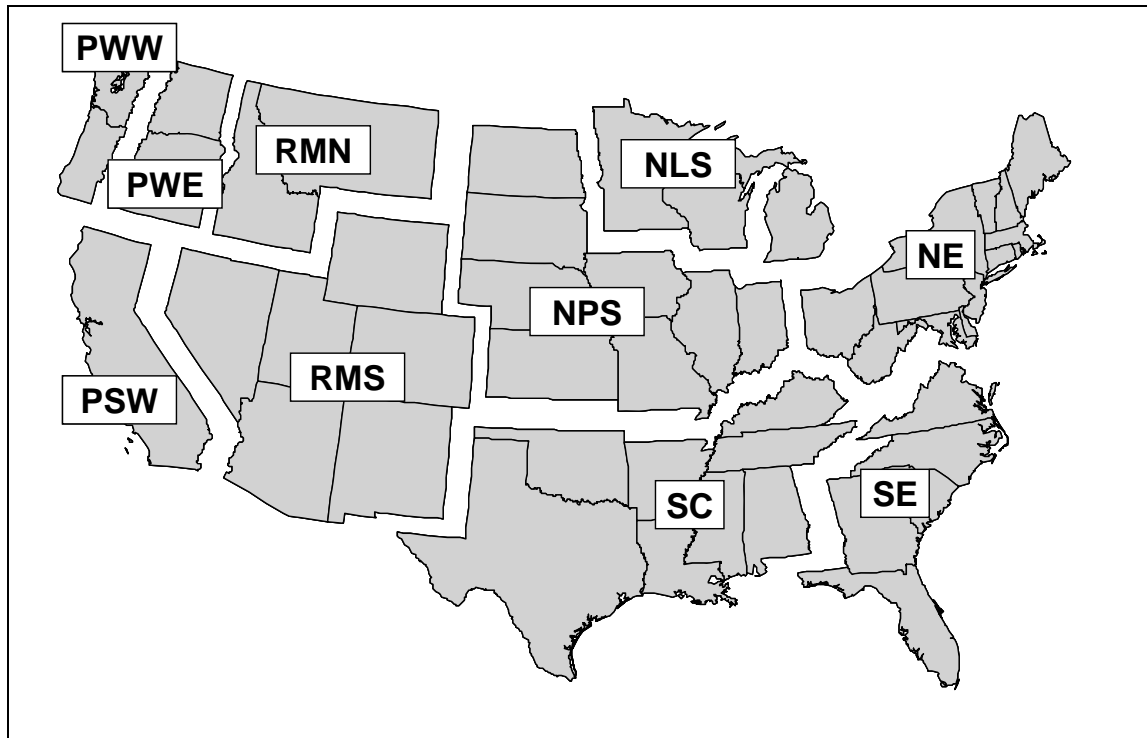

Figure 1.1—Definition of regions: Pacific Northwest, West (PWW); Pacific Northwest, East (PWE); Pacific Southwest (PSW); Rocky Mountain, North (RMN); Rocky Mountain, South (RMS); Northern Prairie States (NPS); Northern Lake States (NLS); Northeast (NE); South Central (SC); and Southeast (SE). Note that regions are merged for some tables, these combinations include: NLS and NPS as North Central; PWW, PWE, and PSW as Pacific Coast; RMN and RMS as Rocky Mountain; SC and SE as South; and RMN, RMS, PWE, and PSW as West (except where stated otherwise).

1.2.1 Modifications to Forest Ecosystem Tables

The forest ecosystem tables provide regional averages as scenarios of forest growth and carbon accumulation, but they need not be used as the sole source of information on forest yield or carbon. For instance, a landowner may independently acquire estimates of growth or carbon accumulation that are specific to a particular carbon sequestration project. In this case, an appropriate use of the tables is to combine available data and to selectively use columns of carbon stocks to fill gaps in information.

Users must have a general understanding of the relationships between the columns of the table to most appropriately substitute site-specific information for a carbon pool. Some columns can be viewed as independent or dependent variables, depending on the carbon pool of interest. If new data are incorporated in a table, any dependent columns (carbon pools) probably will require minor adjustments (recalculations). Figure 1.2 illustrates the basic relationships underlying calculations of carbon stock. Stand age and growing-stock volume are from the ATLAS model and based on FIA data such that they reflect region, forest type, and typical forest management regimes. Pools of live and standing-dead tree carbon are estimated directly from growing-stock volume. Carbon stocks of understory or down dead wood are estimated directly from live tree carbon and are only indirectly affected by growing-stock volume.

Growing-stock volume (stand volume in Figure 1.2) is the merchantable volume of wood in live trees as defined by FIA (Smith and others 2004c, Alerich and others 2005). Briefly, trees contributing volume to this stand-level summary value are commercial species that meet specified standards of size and quality or vigor. Users with other volume estimates for their stands must consider how to translate the volumes to be consistent with growing-stock volume. Thus, a landowner interested in applying these carbon estimates to another growth table should link tree carbon from the tables presented here to the new (separately obtained) estimates of growing-stock volume rather than to stand age (see Example 1.3). The methods section further explains how to use selected carbon pools from the table.

1.3 Tables for Harvested Wood Products Carbon

Harvested wood products serve as reservoirs of carbon that are not immediately emitted to the atmosphere at the time of harvest. The amount of carbon sequestered in products depends on how much wood is harvested and removed from the forest, to what products the harvested wood is allocated, and the half-life of wood in these products (Row and Phelps 1996, Skog and others 2004). The central focus of the carbon in harvested wood products estimates is the carbon change from two pools: carbon in products in use and carbon in landfills. Carbon in harvested wood is initially processed or manufactured into primary wood products, such as lumber and paper. These are then incorporated into end-use products, such as houses and newspapers. Intact primary and end-use products are considered “in use” until they are discarded, and a portion of these discarded products go to landfills. Additionally, a portion of carbon initially sequestered as products is eventually returned to the atmosphere through mechanisms such as combustion and decay. This emitted carbon is classified according to whether it occurred through a process of combustion with some concomitant energy recapture. This distinction between the two paths for carbon emitted to the atmosphere is included to assess potential displacement of other fuel sources. The four categories for the disposition of carbon in harvested wood are defined in Table 1.1. Note that the carbon in the four categories sum to 100 percent of the carbon harvested and removed from the forest.

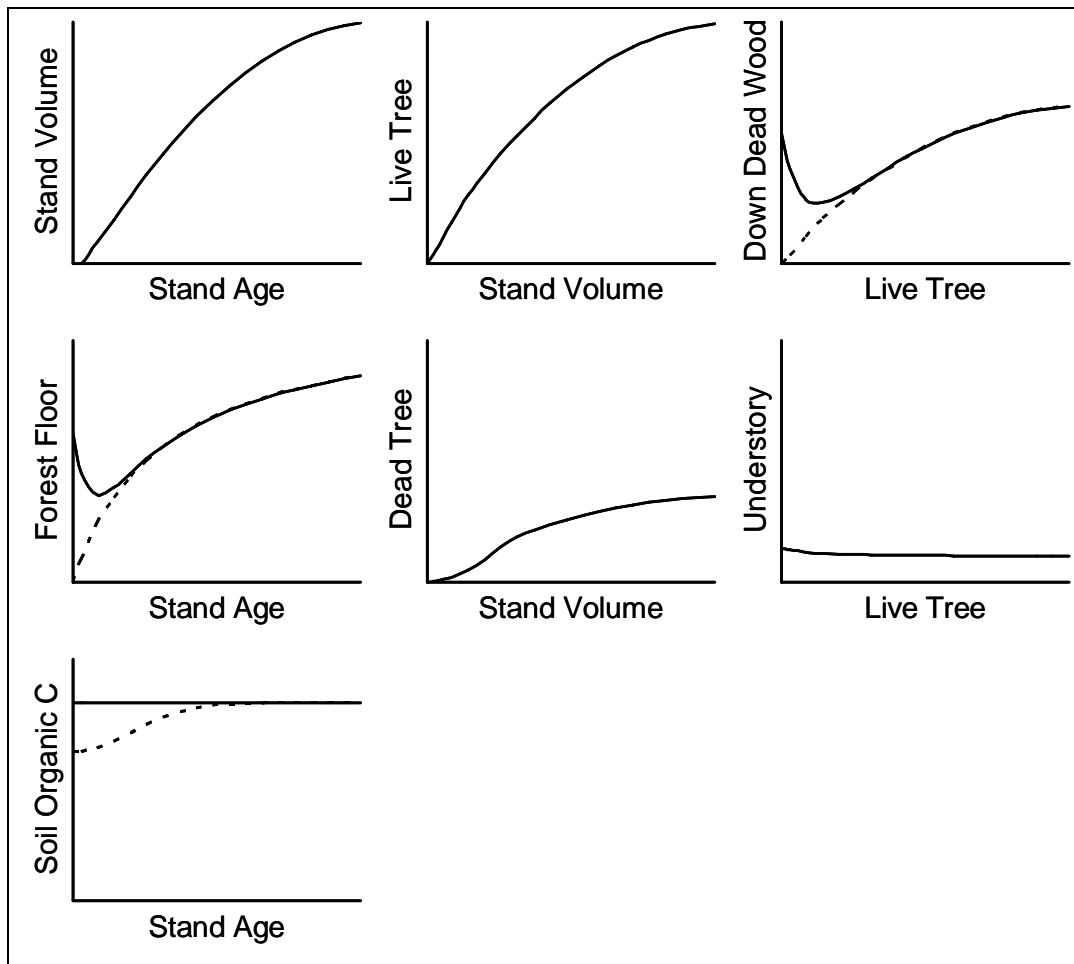

Figure 1.2—Graphs indicating the basic relationships between the components of the forest ecosystem carbon tables. Figures are not drawn to scale; numerical representation for each graph is available from the tables. Dashed lines are qualitative representation of where afforestation tables (Appendix B) differ from the reforestation tables (Appendix A). Note that stand volume refers to growing-stock volume of live trees.

The path that transforms trees-in-forests to wood-in-products can be described by the diagram in Figure 1.3. Quantities defined for the first three boxes in the diagram can serve as starting points, or data sources, for determining the disposition of carbon in wood products. Consistent with this, we provide factors for starting calculations of carbon in harvested wood products on the bases of forestland, the amount of industrial roundwood harvested, or the quantity of primary wood products produced by mills, depending on the data available (see definitions and details in the methods section). The forestland, or land-based, estimates are an extension of the forest ecosystem tables presented above. The other two starting points can be classified as product-based calculations, which are based on harvested logs or the output of mills. It is important to note that calculations from all three starting points (Fig. 1.3) focus on the same quantities of products in use or in landfills, and they all rely on the same model of allocation and longevity of end uses. They differ only in the level of detail available as the principal source of information on harvested wood – the path from input data to final disposition (Fig. 1.3). In the methods section, we provide the interrelated methods for calculating carbon in harvested wood for each of

these starting points. Additionally, Appendix D provides background data and details on these calculations for wood products.

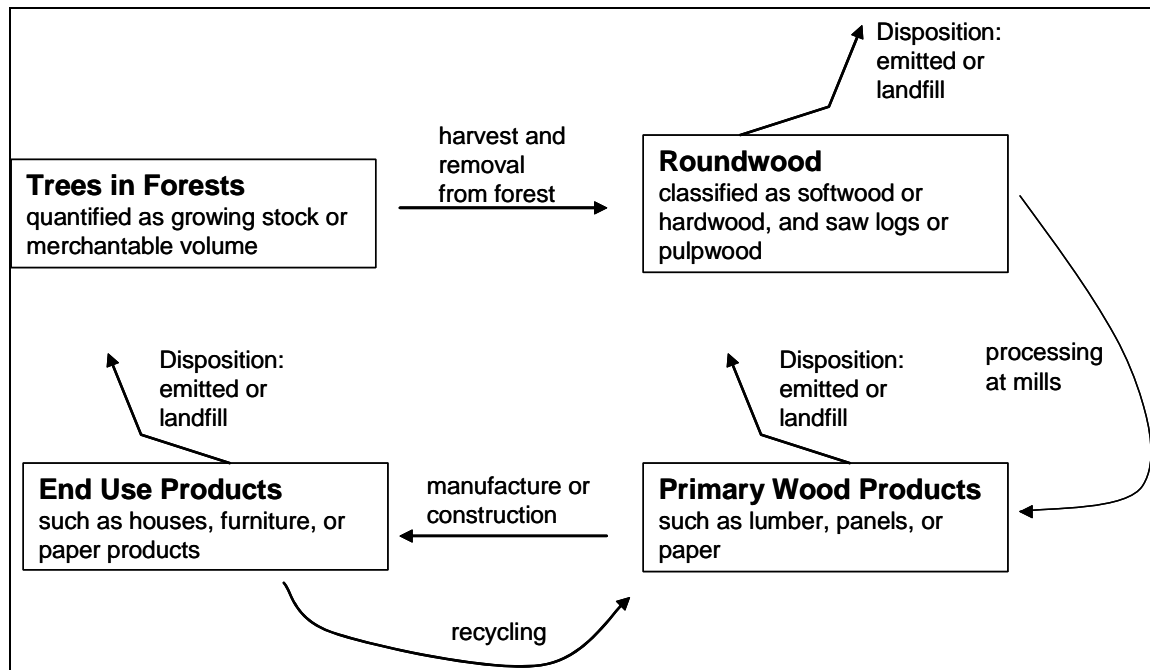

Figure 1.3—The transition of carbon in forest trees to end-use products represented by a sequence of distinct pools separated by processes that move carbon between pools. Calculations of carbon in harvested wood products may start with any of the first three pools: trees in forests, roundwood, or primary wood products.

1.3.1 Land-based Estimates

The land-based estimates are provided as an additional set of forest ecosystem tables with harvest scenarios, which provide carbon estimates for harvested wood products over an interval after harvest (see Table 1.3 and Appendix C). At harvest, a large portion of carbon in tree biomass is allocated to the harvested wood pools, a second portion is assumed to decay rapidly after harvest (emitted at harvest), and the remainder stays on site in the forest as down dead wood or forest floor. The “emitted at harvest” carbon is assumed emitted at site soon after harvest; this is included to distinguish it from the two products emissions categories, which are emissions associated with processing, use, or disposal of harvested wood after removal from the site. Tree biomass allocated to harvested wood is removed from the site for processing, and it is allocated to the four disposition categories defined in Table 1.1. Changes in the allocation of this pool of harvested carbon among the categories are tracked over an interval of stand growth following harvest (see columns 10, 11, 12, and 13 of Table 1.3). Note that the harvested products carbon pools are also quantified as carbon densities, that is, tonnes per unit area (acres or hectares), because they are derived from land-based carbon densities.

These land-based estimates of carbon in harvested wood need not be limited to the examples in Table 1.3 or Appendix C. Similar calculations are possible for other harvest quantities, stand ages, or forest types. Factors for estimating and allocating harvested carbon from the forest ecosystem tables are included in Tables 1.4, 1.5, and 1.6. These are used to calculate the

disposition of carbon in harvested wood products (see Example 1.4). The stand-level volume of growing stock in live trees, such as 172.1 m³/ha in Table 1.3, is used to predict total carbon in harvested wood. Growing-stock volume from the ecosystem table is converted to categories of roundwood carbon mass according to factors in Tables 1.4 and 1.5. The disposition of this carbon in wood products is then allocated according to Table 1.6. Additional information on the use or adaptation of the harvest scenario tables can be found in the methods section that follows, Example 1.4, and Appendix D.

1.3.2 Product-based Estimates

Harvest information is often available in the form of wood delivered to mills or the output of mills. As such, the product-based estimates of carbon in harvested wood products focus on quantities of wood as the starting point for calculating the disposition of carbon. Specifically, these starting points are industrial roundwood logs or primary wood products (such as lumber, panels, or paper) as indicated in Figure 1.3. Thus, quantities are of total carbon and not directly linked to forest area. The disposition of carbon in products based on an initial quantity, or carbon mass, of roundwood is allocated according to Table 1.6. The specific carbon content of primary wood products is calculated from factors in Table 1.7. The disposition of carbon over time for these primary products is according to factors in Tables 1.8 and 1.9, which provide the fractions of carbon from original primary products that remain in use or in landfills, respectively. Again, additional information on the use or adaptation of the tables for product-based calculations can be found in the section that follows, Examples 1.5 and 1.6, and Appendix D.

1.4 Methods and Data Sources for Tables

The purpose of this section is to provide detailed information on data sources, models, and assumptions used in developing the tables or calculations described earlier. Also, we outline linkages between the carbon calculations. These further illustrate how the tables were developed and updated, how the methods were applied, and provide information needed to further modify or customize the tabular carbon summaries.

In these tables, we provide estimates for as many as ten carbon pools. Forest structure provides a convenient modeling framework for assigning carbon to one of six distinct forest ecosystem pools: live trees, standing dead trees, understory vegetation, down dead wood, forest floor, and soil organic carbon (Table 1.1). These pools are consistent with guidelines of the Intergovernmental Panel on Climate Change (Penman and others 2003). The disposition of carbon in harvested wood is summarized in four categories that describe the end-fate of the harvested wood: products in use, landfills, emitted with energy capture, and emitted without energy capture (see definitions in Table 1.1).

1.4.1 Forest Ecosystem Carbon

Forest ecosystem carbon is significantly affected by the following factors: region of the United States, forest type, previous land use, management, and productivity. The development and

format of the tables are based on Birdsey (1996): current stand-level carbon and growth-and-yield models were compiled as forest carbon yield tables. Forest types correspond to definitions in the FIADB and represent common productive forests within each region.

The first two columns in each forest ecosystem table represent an age-volume relationship (also known as a yield curve) based on information from the timber projection model ATLAS (Mills and Kincaid 1992 with updates for Haynes 2003). ATLAS uses data on timber growth and yield and FIA data to develop a set of tables of growing-stock volume for projecting large-scale forest inventories representing U.S. forests for various policy scenarios. The yields (age-volume) represented in Appendices A, B, and C are broad averages; the basic set is from the appendix tables in Mills and Zhou (2003). Stand ages included in the tables are from the ATLAS yields, and these were limited to 90 years in the South and 125 years elsewhere. We assume all age-volume relationships are based on an average level of planting or stand establishment, that is, after clearcut harvest (reforestation) or as a part of stand establishment (afforestation). Additional tables are included for Southern pines and some Pacific Northwest forests to reflect stands with relatively higher productivity or more intensive management practices (see specific tables in Appendices A through C). These yields are based on ATLAS and timber projections prepared for Haynes (2003).

Carbon estimates are derived from the individual carbon-pool estimators in FORCARB2 (Heath and others 2003, Smith and others 2004a, Smith and Heath 2005). FORCARB2 is essentially a national empirical simulation and carbon-accounting model that produces stand-level, inventory-based estimates of carbon stocks for forest ecosystems and regional estimates of carbon in harvested wood. Estimates of carbon in live and standing dead trees are based on the methods of Jenkins and others (2003) and Smith and others (2003). A new set of stand level volume-to-biomass equations was calibrated to the FIADB available on the Internet as of July 29, 2005 (USDA For. Serv. 2005). These are the bases for the carbon values for live and standing dead trees provided here. However the volume-based estimates of tree carbon from FORCARB2 required minor modification for the tables because many yield curves specify zero volume at both 0 and 5 years. This produced discontinuities over time in the estimates of tree carbon, usually in the second and third age classes. Carbon in tree biomass is accruing even if sapling trees remain below the threshold for classification of growing-stock volume³ but above the classification size where trees are considered part of the understory. Therefore, tree carbon at the first row of the table is set to zero, and carbon for year 5 (and occasionally the third age class) is based on a modification of the volume-based estimates. Briefly, a subset of the FIADB with younger stands was used to develop age-based regressions with biomass from tree data (Jenkins and others 2003); these regressions converged with the volume-based estimates, usually by age 10 to 15. We used a ratio of the two estimates to smooth estimates between the second and third age classes.

Estimates in carbon density in understory vegetation are based on Birdsey (1996); estimates of carbon density in down dead wood were developed by FORCARB2 simulations. Estimates of these two pools are based on region, forest type, and live-tree biomass. (For additional

³ The minimum tree size for growing stock is 5 inches d.b.h.; significant tree carbon can accumulate in a stand before trees reach this threshold.

discussion or example values, see Smith and others (2004b) and Smith and Heath (2005)). The carbon density of forest floor is a function of region, forest type, and stand age (Smith and Heath 2002). Estimates of soil organic carbon are based on the national STATSGO spatial database (USDA Soil Conserv. Serv. 1991) and the general approach described by Amichev and Galbraith (2004). These represent average soil organic carbon by region and forest type in the Forest Service's Renewable Resources Planning Act (RPA) 2002 Forest Resource Assessment database. For additional information, see USDA For. Serv. (2005) and Smith and others (2004c).

Slight modifications to the direct application of FORCARB2 estimators were incorporated to develop the reforestation (Table 1.2 and Appendix A) and afforestation (Appendix B) tables. The reforestation tables are based on the assumption that at harvest, a portion of slash becomes down dead wood or forest floor at the start of the next rotation; these additional components then decay with time in the new stand (Smith and Heath 2002). The initial carbon densities for down dead wood and forest floor are listed in the first row of the Appendix A tables. Values for down dead wood are proportional to levels at the time of harvest and added logging residue (based on Johnson (2001)). Decay rates for down dead wood and forest floor are calculated from Turner and others (1995) and Smith and Heath (2002). The afforestation tables are based on the reforestation tables with the assumption that the residual carbon of down dead wood and forest-floor material remaining after harvest does not exist at the start of the afforested stands. Thus, these pools are set to zero at the first row of the table. Accumulation of soil organic carbon in previously nonforest land (the afforestation tables) is based on the accumulation function described in West and others (2004) with the assumption that soil carbon density is initially at 75 percent of the average forest value, which is within the range of values associated with soil organic carbon after deforestation (Lal 2005). Users with more specific data about soil organic carbon or effects of previous land use can easily modify the tables to reflect this information.

The tables are designed to accommodate modification or replacement of selected data. Estimates for years or stand volumes not defined explicitly can be determined with linear interpolation (Example 1.2). The separate carbon pools, according to column, allow the user to extract or substitute values as needed to complement separately obtained site-specific information. However, users should be aware of the relationships between the parts as described in Figure 1.2 to substitute columns.

Figure 1.2 can be used as a guide in customizing tables. As an example, a user with a model of stand growth for a particular project but still wishing to use the carbon estimates from a table should: 1) choose an appropriate carbon table by matching forest type, 2) make the appropriate substitutions of new data, and 3) then recalculate the carbon columns affected by the substitution. After the age and volume columns are replaced, recalculations based on interpolation are required for carbon pools of live and standing dead trees, understory vegetation, and down dead wood. Forest floor is determined by stand age, and values of soil carbon depend on assumptions that apply to reforestation or afforestation (Fig. 1.2). The substitutions and recalculations can be made by using a spreadsheet. Example 1.3 expands on this discussion and provides a numerical example.

As illustrated in Figure 1.2, most of the relationships between columns of the tables are nonlinear. As a consequence, small errors are possible when interpolating between two points, such as in the volume to tree carbon pairs. However, these errors likely will be minimal. The nonlinearity can produce more significant errors if the tables are applied to aggregate summaries of large forest areas, that is, substantially greater than 10,000 ha (Smith and others 2003). As a result, it is best to apply the tables to relatively smaller forest areas versus calculating large aggregate volume and area.

1.4.2 Harvested Wood Carbon

The basic information required for calculating the disposition of carbon in harvested wood products based on each of the three starting points (Fig. 1.3) are in Tables 1.4 through 1.9. The purpose of this section is to provide sufficient background so that a user can apply these tables. However, some users may want to modify the estimates to incorporate alternate data or assumptions, so we also provide background data and detailed explanations in Appendix D of how these tables are generated.

Methods for calculating the disposition of carbon in harvested wood and the starting points for making such calculations are organized according to the diagram in Figure 1.3. These starting points, which correspond to possible sources of data (independent variables) are: 1) the volume of wood in a forest available for harvest and subsequent processing (for example, growing-stock volumes in Tables 1.2 and 1.3); 2) roundwood harvest from a forest in the form of saw logs and pulpwood, which is a measure of wood available for processing at mills; and 3) primary wood products, that is products produced at mills, such as lumber, panels, or paper. We discuss methods and application of each of these, beginning with estimates based on primary wood products as inputs.

The model that allocates carbon over time since harvest is the same for all three starting points, and this model is based on primary wood products (see Appendix D for details). Thus, the disposition is a function of primary wood product and time. Any of the additional calculations necessary for the “upstream” (on Figure 1.3) starting points are essentially required to translate input carbon stocks to primary wood product equivalents. Conversely, calculations at “downstream” starting points do not quantify all pools of harvested carbon. For example, a portion of the wood harvested from a forest ecosystem is processed into primary wood products, but carbon in other biomass remains on site as logging residue or is removed from site as fuelwood or what ultimately becomes waste in the production of primary products. Thus, identifying pools such as fuelwood is necessary for starting from the forest ecosystem to partition carbon and obtain the quantity going to primary products. Quantifying fuelwood is not possible, and unnecessary, for starting from data on a quantity of primary wood products.

Before applying the forest ecosystem tables, users should identify: 1) the approach most appropriate for the data available, and 2) the type of summary values or results that are appropriate to the carbon accounting method and the forest carbon project. Each starting point requires slightly different input data and each accounts for somewhat different pools of carbon. Compatibility between available data and the appropriate starting point depends on identifying these differences. In addition to having different starting points to compute carbon stocks or

stock change, there may be differences in information needs, such as for carbon reporting. Carbon accounting requirements may specify tracking carbon harvested in one or more years and reporting carbon sequestered at one or more later years. For example, one may be interested in tracking products associated with a particular year or may be interested in the cumulative effects of successive harvests. Alternatively, an accounting method that focuses on the long-term effects of current rates of harvest and processing on future stocks of carbon in harvested wood products requires estimates of carbon in use or in landfills at 100 years after harvest (Miner, in press). Thus, all of our projection tables extend through 100 years.

Consideration of imports or exports of harvested wood can complicate the calculations. The effect of considering the movement of harvested wood or wood products over boundaries depends on the approach used to account for carbon. Basic carbon accounting approaches, as presented by the Intergovernmental Panel on Climate Change (Penman and others 2003) are: stock-change, atmospheric-flow, and production. The accounting method presented here is a production approach: the disposition of carbon is estimated for all wood produced, including exports. Imports are excluded from accounting under the production approach. Currently, the IPCC does not provide guidelines on accounting methods for trade in harvested carbon. However, the additional information required to account for imports or exports is essentially the disposition, as described in this document, for the specific quantities of carbon imported or exported. A possible default assumption is that the disposition of carbon in exported wood is identical to that of carbon in products retained in the United States.

Primary wood products. Primary wood products such as lumber, plywood, panels, and paper are the products of mills; they provide a product-based starting point for calculating the disposition of carbon in harvested wood products (Fig. 1.3). Specific primary products are identified in Table 1.7. Manufacturing or construction incorporates these primary products into end-use products such as houses, furniture, and paper. Each end-use product has an expected lifespan, and after use the primary products may be recovered for additional use, burned, or otherwise disposed of. After disposal, carbon in products is allocated to disposal pools, which ultimately leads to long-term storage in landfills or to emission to the atmosphere. Thus, the disposition of primary wood products are modeled through partitioning and residence times of a succession of intermediate pools to the final disposition categories as defined in Table 1.1.

Table 1.7 includes factors for converting primary wood products into total mass of carbon. For example, 1000 ft² of 3/8-inch softwood plywood averages 0.236 tonne of carbon. Tables 1.8 and 1.9 indicate the fraction of each primary product that remains in use or in landfills, respectively, for a given number of years after harvest and production, with the assumption that harvest and production are at time zero. The tables represent national averages. Table 1.8 lists the fraction of each primary product remaining in an end use product for up to 100 years after harvest and processing. For example, column 2 of Table 1.8 indicates that after 10 years, 77.7 percent of softwood lumber remains in an end-use product; end uses include residential or other construction, furniture, and wood containers. The change in carbon between the initial quantity of primary products and the amount specified in later years in Table 1.8 represents products taken out of use; these are then either sequestered in landfills or emitted to the atmosphere. Table 1.9 includes an estimate of carbon sequestered in landfills. In the example of softwood

lumber at 10 years, the fraction is 14.1 percent (column 2 of Table 1.9). Thus, the remaining carbon (8.2 percent), in softwood lumber has been emitted to the atmosphere by year 10.

Recycling of paper products is an assumption built into Tables 1.8 and 1.9. (See Appendix D for details on paper recycling.) The value of including the effect of recycling on the disposition of carbon in harvested wood products can depend on the carbon accounting information needed. For example, recycling can affect quantities in use or in landfills if calculations are focused on a single cohort of carbon such as paper originally produced in a specific year. That is, accounting for effects of recycling can matter if tracking carbon from a single year or owner is important. We include recycling of paper because recycling is relatively common, its effects may be important, and statistics are available to include recycling in the calculations.

Tables 1.8 and 1.9 can be used to calculate net change of carbon in harvested wood products, the cumulative effect of successive annual harvests, and carbon remaining at 100 years. The change in carbon stocks between successive years is net annual flux. The tables are based on the assumption that harvest and processing occur in the same year (year set to zero); they provide annual steps for 50 years. Values can be interpolated for annualized estimates between years 50 and 100. Cumulative effects of annual harvests are obtained by repeating calculations for each harvest and summing stock or stock change estimates for each year of interest. A numerical application for calculating the disposition of carbon in primary wood products is provided in Example 1.6, in which the cumulative effect of annual production at a mill is calculated. See Appendix D for additional information on model assumptions, values used to describe allocation and longevity, and calculations of the factors in Tables 1.7 through 1.9.

Roundwood. Roundwood⁴ is logs, bolts or other round sections cut from trees for industrial manufacture or consumer use (Johnson 2001). Most roundwood is processed by mills, and it is this quantity of harvested wood that provides the roundwood starting point in Figure 1.3. Classification of harvested wood as roundwood is commonly a part of regional or State-wide statistics on timber harvesting or processing (Johnson 2001, Smith and others 2004c). A regional linkage between roundwood and the primary wood products model (discussed earlier) is the basis for establishing the disposition of carbon from roundwood. The allocation of roundwood to domestically produced primary wood products was constructed from Adams and others (2006). The resulting model of the allocation of carbon in roundwood according to region and roundwood category is represented as Table 1.6.

Table 1.6 was developed in the style of similar tables in Birdsey (1996), which are based on Row and Phelps (1996). Inputs are carbon mass in roundwood according to region and roundwood category. Total roundwood is allocated to the four disposition categories (see definitions in Table 1.1), and changes in allocation are tracked as fractions over years 1 through 100 after

⁴ The definition and classification of roundwood as it is used here is important to quantifying and allocating carbon in harvested wood products. The calculations in this document use roundwood as essentially logs for industrial manufacture. Roundwood comes from both growing stock and other sources, and not all growing stock becomes roundwood. The definition of roundwood can also include fuelwood, but fuelwood and bark on roundwood are specifically excluded from “roundwood” as used in this document. Roundwood can be classified as sawtimber versus pulpwood (for example, Birdsey 1996, Row and Phelps 1996) but the more common usage is sawtimber versus poletimber (for example, Johnson 2001) or saw logs versus pulpwood.

manufacture or processing. Roundwood is classified by region (Fig. 1.1) and category: softwood saw logs, softwood pulpwood, hardwood saw logs, and hardwood pulpwood. Saw logs come from larger diameter trees and generally are utilized for solid wood products; pulpwood comes from smaller diameter trees and usually is used for pulpwood products. Some roundwood classifications are pooled across regions for Table 1.6; this is done where production of a particular type is relatively low. Roundwood, as classified for Table 1.6, excludes bark on logs and wood used as fuelwood. The allocation of emitted carbon to the fraction associated with energy capture is based on the allocation patterns in Birdsey (1996). A numerical application of Table 1.6 is provided in Example 1.5. See Appendix D for additional background information and sample calculations used to generate Table 1.6.

Scenarios for Forest Ecosystem Harvest. The land-based starting point for calculating the disposition of carbon in harvested wood products is from the forest ecosystem carbon tables (for example, Table 1.3), as described in Figure 1.3 (trees in forests). Calculations starting with wood in forests are distinctly different from starting with products in two respects: 1) inputs are land-based measures of merchantable wood in a forest, such as growing-stock volume, and 2) estimates of carbon in harvested wood also include fuelwood as well as bark on all logs (roundwood and fuelwood). The bases for linking forest ecosystems to roundwood, and thus the disposition of carbon in products, are compilations of summary values from harvest statistics (Johnson 2001) and estimates of tree biomass (Jenkins and others 2004) applied to current FIADB survey data.

Converting growing-stock volume to carbon mass in roundwood is based on factors in Tables 1.4 and 1.5. Table 1.4 is used to partition growing-stock volume according to species type (softwood or hardwood) and size of logs. This is followed by converting volume to carbon mass according to the carbon content of wood. These values for carbon in growing-stock volume are extended to estimates of carbon in roundwood according to factors in Table 1.5. The disposition of carbon is then based on Table 1.6.

The harvest scenario tables were constructed from the ecosystem tables by appending a reforestation table (from Appendix B) to an afforestation table (from Appendix A) at a stand age designated as a clearcut harvest. Carbon in harvested wood products was added by applying factors in Tables 1.4 through 1.6. The Appendix C tables are examples of how forest carbon stocks can include carbon in harvested wood; these are not recommendations for rotation length or timing of harvest. Assumptions and background data for compiling Tables 1.4, 1.5, and 1.6 (as well as the other starting points for calculating carbon in harvested wood products) are included in Appendix D. Despite differences in input data and extent of harvested carbon included, all three starting points rely on the same model of allocation and longevity of end uses. They differ only in the level of detail available as the principal source of information on harvested wood (Fig. 1.3).

1.5 Uncertainty

Estimates of carbon stocks and stock changes are based on regional averages and reflect the current best available data for developing regional estimates. Quantitative expressions of uncertainty are not available for most data summaries, coefficients, or model results presented in the tables. However, uncertainty analyses were developed for previous similar estimates of carbon, from which our tables were developed (Heath and Smith 2000, Skog and others 2004, Smith and Heath 2005). Similar quantitative uncertainty analyses are being developed for these estimates of carbon stocks and stock changes in forests and harvested wood products.

Precision is partly dependent on the scale of the forest carbon sequestration project of interest. Overall, precision is expected to be lower as these methods are applied to smaller scale projects versus with regional summaries. That is, precision depends on the degree of specificity in information about a particular forest or project. It may be useful to distinguish between two basic components of uncertainty in the application of these tables. Uncertainty about the regional averages, which are based on data summaries or models, can influence estimates for specific projects, which generally are small subsets of a region. However, variability within region likely will have a much greater influence on uncertainty than regional values. This is shown in Figure 1.4, which is an example of the volume-to-biomass relationships used to estimate tree carbon from merchantable volume (columns 2 and 3 in Table 1.2). Each point represents an individual permanent FIA inventory plot where the 95-percent confidence interval about the mean of carbon in live trees is generally less than 5 percent of the mean. The regression line represents the regional average; the 95-percent confidence intervals about this mean are indicated in Table 1.10. These two relative intervals reflect regional variability in biomass relative to volume. For example, the 99th percentile of stand growing-stock volumes for this forest in the FIADB is 361 m³/ha and the mean carbon density for these plots is likely between 192 and 197 t/ha (Figure 1.4, ±1.4 percent of the expected 194 t/ha). The distinction between uncertainty about coefficients and regional or temporal variability may also apply to calculating the disposition of carbon in harvested wood products as well. Uncertainty about the actual allocation of roundwood to primary products may not be as important as year-to-year change or how activity at a single mill compares with the region as a whole.

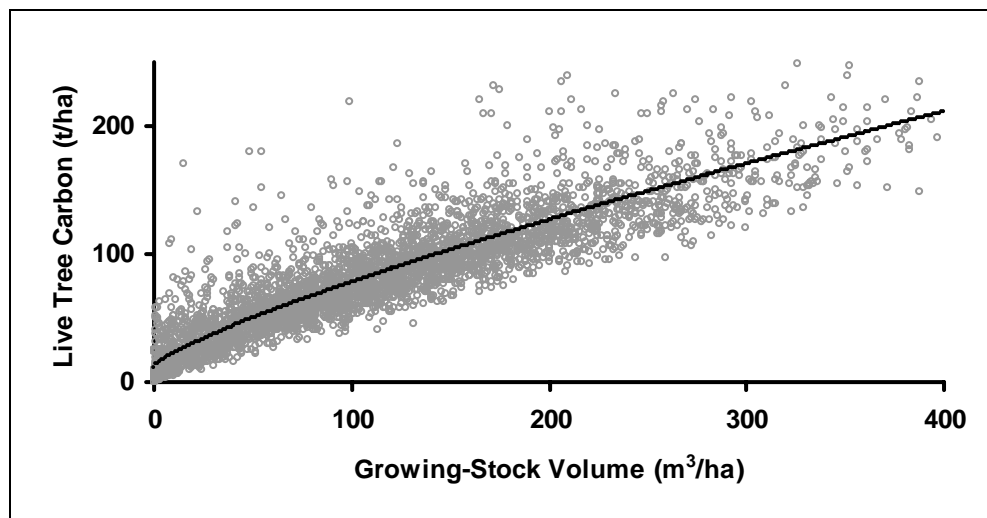

Figure 1.4—A component of uncertainty associated with representing an average forest stand in the ecosystem tables. Individual points represent live tree carbon density for FIA permanent inventory plots for maple-beech-birch forests for the Northeast; the line represents carbon in tree biomass as predicted by growing-stock volume as used in Tables 1.2 and 1.3.

1.6 Conclusions

Summing the two estimates, forest ecosystem carbon and carbon in harvested wood products, gives the total effect of forest carbon sequestration for an activity. To assure accuracy, conducting modest inventories will help show the adequacy of the tables in characterizing carbon sequestration.

Carbon estimates depend on available data. Tables of average values cannot perfectly replicate each individual stand. Growth and yield information applicable to a particular stand can provide greater precision than regional averages. Similarly, carbon stocks in wood products that are calculated from quantities of primary wood products are likely to be more precise than products calculations starting simply from area of forest. However, the link between forest and sequestration in products may be less clear when starting from primary wood products. Forest composition, site conditions, and climate differ by regions, and climate, timber markets, and forest management priorities are subject to change from year to year. The methods described in this publication are most useful in identifying a general expected magnitude of carbon in forests, and to help plan carbon sequestration projects to achieve a certain goal.

1.7 Literature Cited

- Adams, D.A.; Haynes, R.W.; Daigneault, A.J. 2006. **Estimated timber harvest by U.S. region and ownership, 1950-2002**. Gen. Tech. Rep. PNW-659. Portland, OR: U.S. Department of Agriculture, Forest Service, Pacific Northwest Research Station. 64 p.
- Alerich, C.L.; Klevgard, L.; Liff, C.; Miles, P.D.; Knight, B. 2005. **The forest inventory and analysis database: database description and users guide version 2.0**. USDA Forest Service. June 1, 2005. http://ncrs2.fs.fed.us/4801/fiadb/fiadb_documentation/FIADB_DOCUMENTATION.htm (2 December 2005).
- Amichev, B.Y.; Galbraith, J.M. 2004. **A revised methodology for estimation of forest soil carbon from spatial soils and forest inventory data sets**. Environmental Management. 33(Suppl. 1): S74-S86.
- Birdsey, R.A. 1996. **Carbon storage for major forest types and regions in the coterminous United States**. In: Sampson, N.; Hair, D., eds. Forests and global change. Volume 2: Forest management opportunities for mitigating carbon emissions. Washington, DC: American Forests: 1-25, Appendixes 2-4.
- de Silva Alves, J.W.; Boeckx, P.; Brown, K. [and others]. 2000. **Chapter 5 – Waste**. In: Penman, J.; Kruger, D.; Galbally, I. [and others], eds. Good practice guidance and uncertainty management in national greenhouse gas inventories. Hayama, Kanagawa, Japan: Institute for Global Environmental Strategies for the Intergovernmental Panel on Climate Change: 5.1-5.32.
- Haynes, R.W., coord. 2003. **An analysis of the timber situation in the United States: 1952-2050**. Gen. Tech. Rep. PNW-560. Portland, OR: U.S. Department of Agriculture, Forest Service, Pacific Northwest Research Station. 254 p.
- Heath, L.S.; Smith, J.E. 2000. **An assessment of uncertainty in forest carbon budget projections**. Environmental Science and Policy. 3: 73-82.
- Heath, L.S.; Smith, J.E.; Birdsey, R.A. 2003. **Carbon trends in U. S. forest lands: a context for the role of soils in forest carbon sequestration**. In: Kimble, J.M.; Heath, L.S.; Birdsey, R.A.; Lal, R., eds. The potential of US forest soils to sequester carbon and mitigate the greenhouse effect. New York: CRC Press: 35-45.
- Jenkins, J.C.; Chojnacky, D.C.; Heath, L.S.; Birdsey, R.A. 2003. **National-scale biomass estimators for United States tree species**. Forest Science. 49: 12-35.
- Jenkins, J.C.; Chojnacky, D.C.; Heath, L.S.; Birdsey, R.A. 2004. **A comprehensive database of biomass regressions for North American tree species**. Gen. Tech. Rep. NE-319. Newtown Square, PA: U.S. Department of Agriculture, Forest Service, Northeastern Research Station. 45 p. [1 CD-ROM].

- Johnson, T.G., ed. 2001. **United States timber industry—an assessment of timber product output and use, 1996**. Gen. Tech. Rep. SRS-45. Asheville, NC: U.S. Department of Agriculture, Forest Service, Southern Research Station. 145 p.
- Lal, R. 2005. **Forest soils and carbon sequestration**. *Forest Ecology and Management*. 220: 242-258.
- McKeever, D.B. 2002. **Domestic market activity in solidwood products in the United States, 1950 – 1998**. Gen. Tech. Rep. PNW-524. Portland, OR: U.S. Department of Agriculture, Forest Service, Pacific Northwest Research Station. 76 p.
- Mills, J.; Kincaid, J. 1992. **The aggregate timberland analysis system—ATLAS: a comprehensive timber projection model**. Gen. Tech. Rep. PNW-281. Portland, OR: U.S. Department of Agriculture, Forest Service, Pacific Northwest Research Station. 160 p.
- Mills, J.; Zhou, X. 2003. **Projecting national forest inventories for the 2000 RPA timber assessment**. Gen. Tech. Rep. PNW-568. Portland, OR: U.S. Department of Agriculture, Forest Service, Pacific Northwest Research Station. 58 p.
- Miner, R. [In press.] **The 100-year method for forecasting carbon sequestration in forest products in use**. *Mitigation and Adaptation Strategies for Global Change*.
- Penman, J.; Gytarsky, M.; Hiraishi, T. [and others], eds. 2003. **Good practice guidance for land use, land use change, and forestry**. Hayama, Kanagawa, Japan: Institute for Global Environmental Strategies for the Intergovernmental Panel on Climate Change. 502 p.
- Row, C.; Phelps, R.B. 1996. **Wood carbon flows and storage after timber harvest**. In: Sampson, N.; Hair, D., eds. *Forests and global change. Volume 2: Forest management opportunities for mitigating carbon emissions*. Washington, DC: American Forests: 27-58.
- Skog, K.E.; Nicholson, G.A. 1998. **Carbon cycling through wood products: the role of wood and paper products in carbon sequestration**. *Forest Products Journal*. 48(7/8): 75-83.
- Skog, K.E.; Pingoud, K.; Smith, J.E. 2004. **A method countries can use to estimate changes in carbon stored in harvested wood products and the uncertainty of such estimates**. *Environmental Management*. 33(Suppl. 1): S65-S73.
- Smith, J.E.; Heath, L.S. 2002. **A model of forest floor carbon mass for United States forest types**. Res. Pap. NE-722. Newtown Square, PA: U.S. Department of Agriculture, Forest Service, Northeastern Research Station. 37 p.
- Smith, J.E.; Heath, L.S. 2005. **Land use change and forestry and related sections**. In: *Inventory of U.S. greenhouse gas emissions and sinks: 1990-2003*. Washington, DC: U.S. Environmental Protection Agency: 231-239, Appendix 3.12.

- Smith, J.E.; Heath, L.S.; Jenkins, J.C. 2003. **Forest volume-to-biomass models and estimates of mass for live and standing dead trees of U.S. forests.** Gen. Tech. Rep. NE-298. Newtown Square, PA: U.S. Department of Agriculture, Forest Service, Northeastern Research Station. 57 p.
- Smith, J.E.; Heath, L.S.; Woodbury, P.B. 2004a. **Forest carbon sequestration and products storage.** In: Bickel, Kathryn, ed. U.S. agriculture and forestry greenhouse gas inventory: 1990-2001. Tech. Bull. No. 1907. Washington, DC: U.S. Department of Agriculture, Office of Chief Economist: 80-93, Appendix C.
- Smith, J.E.; Heath, L.S.; Woodbury, P.B. 2004b. **How to estimate forest carbon for large areas from inventory data.** Journal of Forestry. 102: 25-31.
- Smith, James E.; Heath, Linda S.; Skog, Kenneth E.; Birdsey, Richard A. 2006. **Methods for calculating forest ecosystem and harvested carbon, with standard estimates for forest types of the United States.** Gen. Tech. Rep. NE-XXX. Newtown Square, PA: U.S. Department of Agriculture, Forest Service, Northeastern Research Station. xx p.
- Smith, W.B.; Miles, P.D.; Vissage, J.S.; Pugh, S.A. 2004c. **Forest resources of the United States, 2002.** Gen. Tech. Rep. NC-241. St. Paul, MN: U.S. Department of Agriculture, Forest Service, North Central Research Station. 137 p.
- Turner, D.P.; Koerper, G.J.; Harmon, M.E.; Lee, J.J. 1995. **A carbon budget for forests of the conterminous United States.** Ecological Applications. 5: 421-436.
- U.S. Department of Agriculture, Forest Service. 2005. **Forest inventory mapmaker, RPA tabler, and FIADB download files.** <http://ncrs2.fs.fed.us/4801/fiadb/index.htm>. (2 December 2005).
- U.S. Department of Agriculture, Soil Conservation Service. 1991. State soil geographic (STATSGO) data base data use information. Misc. Publication Number 1492, USDA, Natural Resources Conservation Service, National Soil Survey Center, Fort Worth, TX.
- U.S. Department of Energy, Energy Information Administration. 2005. **Voluntary reporting of greenhouse gases program.** <http://www.eia.doe.gov/oiaf/1605/frntvrgg.html>. (2 December 2005).
- Wenger, K.F., ed. 1984. **Forestry handbook, 2nd edition.** New York: Society of American Foresters, John Wiley & Sons. 1335 p.
- West, T.O.; Marland, G.; King, A.; Post, W.M.; Jain, A.K.; Andrasko, K. 2004. **Carbon management response curves: estimates of temporal soil carbon dynamics.** Environmental Management. 33(4): 507-518.

1.8 Examples

Example 1.1 – Obtain values for carbon stock and net stock change for stands of maple-beech-birch in the Northeast.

Use Table 1.2 to determine values for live tree carbon stock at years 25 and 45 and calculate net stock change over the interval.

Reading directly from the table, live tree carbon stocks are 53.2 and 87.8 t/ha for years 25 and 45, respectively.

Net annual stock change in live tree carbon between year 25 and 45, which is from the difference in stocks divided by the length of the interval between stocks:

$$\text{Net annual stock change} = (87.8 - 53.2) / 20 = 1.7 \text{ t/ha/yr}$$

The positive value for stock change indicates a net increase in carbon over the interval; this is consistent with the sign convention used for net stock change in this document. This tabular approach is applicable to all carbon pools in Appendices A, B, and C. Users must first classify the forest of interest and choose the most appropriate table.

Example 1.2 – Obtain an estimate of carbon stock when the value is not explicitly provided on a table, for stands of maple-beech-birch in the Northeast.

Use Table 1.2 to calculate live tree carbon stock of a stand with volume of wood (growing-stock volume) of 150 m³/ha. This value is obtained by linearly interpolating between rows 7 and 8 of Table 1.2. The estimate of live tree carbon is between rows 7 and 8 because 150 m³/ha is also between those two rows, and live tree carbon is a function of volume (Fig. 1.2).

Linear interpolation identifies a value for carbon stock between 101.1 and 113.1 t/ha that is linearly proportional to the position of 150 between 146.6 and 172.1 (from rows 7 and 8 of Table 1.2).

$$\begin{aligned} & \text{Live tree carbon (if volume is 150 m}^3\text{/ha)} \\ &= (150.0 - 146.6) / (172.1 - 146.6) \times (113.1 - 101.1) + 101.1 \\ &= 0.133 \times 12.0 + 101.1 = 102.7 \text{ t/ha} \end{aligned}$$

The value 0.133 means the carbon stock is 13.3 percent of the distance between the two stocks listed on the table, 101.1 and 113.1 t/ha.

Example 1.3 – Modify a table to include independently obtained information about a forest carbon project

In this example, assume you have a project with loblolly pine established after clearcut harvest on existing forest land in the South Central region. The volume yields (Wenger, 1984) are:

Age	Mean volume
<i>years</i>	<i>m³/ha</i>
0	0.0
10	30.6
15	122.6
20	187.9
25	238.9
30	277.9

The appropriate carbon table is Table A47, which is duplicated for this example. The goal is to construct a hybrid table from the new growth and yield estimates (columns 1-2) and the appropriate estimates for each of the carbon pools (columns 3-8).

A47.— Regional estimates of timber volume and carbon stocks for loblolly and shortleaf pine stands on forest land after clearcut harvest in the South Central

Age	Mean Volume	Mean carbon density						
		Live tree	Standing dead tree	Under-story	Down dead wood	Forest floor	Soil organic	Total nonsoil
<i>years</i>	<i>m³/hectare</i>	<i>tonnes carbon/hectare</i>						
0	0.0	0.0	0.0	4.2	9.2	12.2	41.9	25.6
5	0.0	10.8	0.7	4.7	7.7	6.5	41.9	30.3
10	19.1	23.1	1.3	3.9	6.8	6.4	41.9	41.5
15	36.7	32.4	1.6	3.5	6.2	7.5	41.9	51.2
20	60.4	42.2	1.8	3.3	5.9	8.7	41.9	61.9
25	85.5	52.0	2.0	3.1	5.8	9.8	41.9	72.8
30	108.7	59.6	2.1	3.0	5.8	10.7	41.9	81.2
35	131.2	66.6	2.3	2.9	5.9	11.5	41.9	89.1
40	152.3	73.1	2.3	2.9	6.0	12.2	41.9	96.4
45	172.3	79.0	2.4	2.8	6.1	12.7	41.9	103.1
50	191.4	84.7	2.5	2.8	6.4	13.2	41.9	109.5
55	208.4	89.6	2.6	2.7	6.5	13.7	41.9	115.1
60	223.9	94.0	2.6	2.7	6.7	14.1	41.9	120.1
65	238.4	98.1	2.7	2.6	7.0	14.4	41.9	124.8
70	252.9	102.2	2.7	2.6	7.2	14.7	41.9	129.4
75	264.6	105.5	2.7	2.6	7.3	15.0	41.9	133.1
80	277.1	108.9	2.8	2.6	7.6	15.2	41.9	137.0

To construct the modified table, copy the first two columns directly from the new yield table and then interpolate some of the carbon pool densities from Table A47. Estimates for live- and standing dead trees are dependent on growing-stock volume (as indicated in Fig. 1.2). These values can be determined by linear interpolation as described in Example 1.2. Similarly, understory and down dead wood stocks, which are dependent on the updated live tree carbon stocks (Fig. 1.2), can be determined by interpolation. For example, the value of down dead wood carbon stock in row two is based on linearly interpolating between rows three and four of Table A47, that is, down dead wood = $(29.2 - 23.1) / (32.4 - 23.1) \times (6.2 - 6.8) + 6.8 = 6.4$ t/ha. Interpolation is not necessary for estimates of forest floor or soil organic carbon. Forest floor is a function of stand age, and soil organic carbon is 41.9 t/ha.

The resulting modified defaults for South Central loblolly pine based on separately obtained growth and yield:

Age	Mean volume	Mean carbon density						
		Live tree	Standing dead tree	Under-story	Down dead wood	Forest floor	Soil organic	Total nonsoil
<i>years</i>	<i>m³/ha</i>	<i>tonnes carbon/hectare</i>						
0	0.0	0.0	0.0	4.2	9.2	12.2	41.9	25.6
10	30.6	29.2	1.5	3.6	6.4	6.4	41.9	47.1
15	122.6	63.9	2.2	2.9	5.8	7.5	41.9	82.3
20	187.9	83.7	2.5	2.8	6.3	8.7	41.9	104.0
25	238.9	98.2	2.7	2.6	7.0	9.8	41.9	120.3
30	277.9	109.1	2.8	2.6	7.6	10.7	41.9	132.8

Example 1.4 – Calculate carbon in harvested wood products remaining in use at 15 years after harvest based on volume of growing stock at time of harvest

Starting with an example from the Pacific Northwest, we will calculate the disposition of carbon in harvested wood products that are still in use at 15 years after harvest from the Douglas-fir forest described in Table C12. More specifically, we will show the steps involved to calculate that 53.3 t/ha of harvested carbon are in use at 15 years after harvest, starting from a harvested growing-stock volume of 718.8 m³/ha (Table C12). We use factors from Tables 1.4, 1.5, and 1.6. These calculations are land-based estimates of carbon in harvested wood products based on the “trees in forests” starting point identified in Figure 1.3. Additional details on expanding these calculations to other harvested wood categories within the table or to other forest types are in Appendix D.

The sequence of steps required to determine carbon in use at year 15 are: 1) convert growing-stock volume to carbon mass according to four categories; 2) convert carbon in growing stock to carbon in roundwood; and 3) determine carbon remaining in products at the appropriate year.

Step 1: We assume that an average harvest for a forest type group produces roundwood logs that can be classified as softwood or hardwood as well as saw logs and pulpwood. The conversion from volume of wood to carbon mass depends on the specific carbon content of wood. Factors in Table 1.4 are used to allocate the 718.8 m³/ha of growing-stock volume to four pools of carbon. For example, carbon in the softwood saw log part of growing-stock volume is the product of: growing-stock volume, the softwood fraction of growing-stock volume, the saw log fraction of softwood, softwood specific gravity, and the carbon fraction of wood fiber (0.5). The calculations from Table 1.4 are:

$$\begin{aligned} &\text{Softwood saw log carbon in growing-stock volume} \\ &= 718.8 \times 0.959 \times 0.914 \times 0.440 \times 0.5 = 138.61 \text{ t/ha} \\ &\text{Softwood pulpwood carbon in growing-stock volume} \\ &= 718.8 \times 0.959 \times (1 - 0.914) \times 0.440 \times 0.5 = 13.04 \text{ t/ha} \\ &\text{Hardwood saw log carbon in growing-stock volume} \\ &= 718.8 \times (1 - 0.959) \times 0.415 \times 0.426 \times 0.5 = 2.61 \text{ t/ha} \\ &\text{Hardwood pulpwood carbon in growing-stock volume} \\ &= 718.8 \times (1 - 0.959) \times (1 - 0.415) \times 0.426 \times 0.5 = 3.67 \text{ t/ha} \end{aligned}$$

Thus, total carbon stock in 718.8 m³/ha of growing-stock volume is 183.60 t/ha.

Step 2: We need to represent carbon in these four categories in terms of carbon in roundwood, which excludes bark and fuelwood. However, not all growing-stock volume becomes roundwood, and some roundwood is from non-growing stock sources. Factors in Table 1.5 are used to obtain carbon in roundwood. For example, carbon in roundwood is the product of: carbon in growing-stock volume, the fraction of growing-stock volume that is roundwood, and the ratio of roundwood to growing-stock volume that is roundwood. The calculations from Table 1.5 are:

$$\begin{aligned} &\text{Softwood saw log carbon in roundwood} = 138.61 \times 0.929 \times 0.965 = 124.26 \text{ t/ha} \\ &\text{Softwood pulpwood carbon in roundwood} = 13.04 \times 0.929 \times 1.099 = 13.31 \text{ t/ha} \\ &\text{Hardwood saw log carbon in roundwood} = 2.61 \times 0.947 \times 0.721 = 1.78 \text{ t/ha} \\ &\text{Hardwood pulpwood carbon in roundwood} = 3.67 \times 0.947 \times 0.324 = 1.13 \text{ t/ha} \end{aligned}$$

Thus, total carbon stock in roundwood is 148.36 t/ha.

Step 3: The disposition of carbon in harvested wood products is described by Table 1.6, which allocates carbon according to region, roundwood category, and years since harvest and processing. The allocation factors for product in use at year 15 for Pacific Northwest, West apply here. The two hardwood categories are pooled in this region. The calculation for carbon density of products in use is the sum of the products of roundwood carbon and the corresponding allocation factor, these are:

$$\begin{aligned} &\text{Carbon in products in use at year 15} \\ &= (124.26 \times 0.423) + (13.31 \times 0.020) + ((1.78 + 1.03) \times 0.174) = 53.33 \text{ t/ha.} \end{aligned}$$

Example 1.5 – Calculate the disposition of carbon in harvested wood products at 100 years after harvest and processing from roundwood data

Using Table 1.6, assume that a harvest in the Northeast produced 2,000 t dry weight of roundwood. This represents 1,000 t of carbon because wood is assumed to be 50 percent carbon. The roundwood was harvested in the following proportions: 79 t carbon as softwood sawtimber, 51 t as softwood pulpwood, 465 t of hardwood sawtimber, and 405 t of hardwood pulpwood. Also assume that these quantities represent roundwood without bark and exclude fuelwood; thus Table 1.6 is the correct choice to calculate the disposition of carbon.

The four roundwood categories are allocated to the classifications for the disposition of carbon in wood products by the appropriate factors for 100 years after production from the Northeast portion of Table 1.6.

$$\begin{aligned} \text{Total carbon in use} &= \text{sum of four fractions} \\ &= (79 \times 0.095) + (51 \times 0.006) + (465 \times 0.035) + (405 \times 0.103) = 65.80 \text{ t} \\ \text{Total carbon in landfills} &= \text{sum of four fractions} \\ &= (79 \times 0.223) + (51 \times 0.084) + (465 \times 0.281) + (405 \times 0.158) = 216.56 \text{ t} \\ \text{Total carbon emitted with energy recapture} &= \text{sum of four fractions} \\ &= (79 \times 0.338) + (51 \times 0.510) + (465 \times 0.387) + (405 \times 0.336) = 368.75 \text{ t} \\ \text{Total carbon emitted without energy recapture} &= \text{sum of four fractions} \\ &= (79 \times 0.344) + (51 \times 0.400) + (465 \times 0.296) + (405 \times 0.403) = 348.43 \text{ t} \end{aligned}$$

Total carbon in roundwood after 100 years is the sum of the four pools. Note that the total in this example is 999.5 t and not the 1,000 t we started with; this is due to rounding.

Example 1.6 – Calculate stocks of carbon in harvested wood products based on having primary wood products data such as products from a mill

Given the information on softwood lumber and softwood plywood produced from 2000 to 2003 (in the following tabulation) we use Tables 1.7, 1.8, and 1.9 to calculate: 1) carbon in the primary products, 2) the accumulation of carbon stocks over a period of 4 years, and 3) total carbon stocks after 100 years. Note that Tables 1.8 and 1.9 provide the fraction of primary product remaining for a given number of years after processing; this example assumes that harvest and processing are at the beginning of each year (2000-2003) and estimates for the amount remaining apply to the end of each year. This is an application of calculating the disposition of carbon in harvested wood based on quantities of primary wood products, as described in Figure 1.3.

Step 1: Determine initial carbon stocks for two primary products based on given quantities produced each year over the 4-year period by using factors from Table 1.7. For example, 93,000 MBF softwood lumber \times 0.443 = 41,199 t carbon.

The initial carbon stocks for two primary products, softwood lumber and softwood plywood:

Year	Quantity of primary product		Carbon stock	
	Softwood lumber	Softwood plywood	Softwood lumber	Softwood plywood
	<i>thousand board feet</i>	<i>thousand square feet, 3/8-inch basis</i>	<i>tonnes carbon</i>	<i>tonnes carbon</i>
2000	93,000	183,000	41,199	43,188
2001	85,000	175,000	37,655	41,300
2002	95,000	170,000	42,085	40,120
2003	100,000	173,000	44,300	40,828

Step 2: Calculate carbon stocks in end uses and landfills for each product for each year after production for the period 2000-2003 based on inputs of wood harvested and processed in each year. Use Tables 1.8 and 1.9 to determine stocks for each year since processing. Note that each of the 20 intermediate values in the following tabulation is based on the sum of carbon contributed from softwood lumber and softwood plywood. For example, the carbon stocks of primary products produced in 2001 are 37,655 t of softwood lumber and 41,300 t of softwood plywood. From this, a total of **3,820 t** are in landfills at the end of 2003 (after 3 years). The quantity is calculated as: 3,820 t = (37,655 \times 0.051) + (41,300 \times 0.046).

Disposition of carbon in primary wood products over four years:

Year of production	Carbon in end uses at end of:				Carbon in landfills at end of:			
	2000	2001	2002	2003	2000	2001	2002	2003
2000	82,238	80,130	78,150	76,255	1,433	2,824	4,088	5,352
2001		76,947	74,977	73,127		1,339	2,640	3,820
2002			80,106	78,049			1,399	2,757
2003				82,952				1,451
Total	82,238	157,078	233,233	310,382	1,433	4,163	8,127	13,379

Thus, total carbon stocks for the end of 2002 are 241,360 t, with 233,233 t in end uses and 8,127 t in landfills. The balance of the cumulative total carbon in products from 2000 through 2002 has been emitted to the atmosphere, that is, 245,547 t initially in primary products minus the 241,360 t sequestered equals 4,187 t emitted from the primary products by 2002.

Step 3: Calculate carbon remaining in end uses or in landfills at 100 years after each of the harvest years. The estimates are based on initial stocks of carbon in each primary product multiplied by the respective fraction remaining as obtained from Tables 1.8 and 1.9. For example, carbon in primary product from harvest and processing in 2000 and in use at 100 years is **20,222 t** = $(41,199 \times 0.234) + (43,188 \times 0.245)$.

Year of production	Carbon in:	
	End uses	Landfills
	-----tonnes carbon-----	
2000	20,222	33,961
2001	18,930	31,770
2002	19,677	33,092
2003	20,369	34,273
Total	79,198	133,096

Thus, of the 245,547 t of carbon in primary products produced from 2000 through 2002, 24 percent remain sequestered in products in use, 40 percent in landfills, and 36 percent emitted to the atmosphere.

1.9 Tables

Table 1.1.—Classification of carbon in forest ecosystems and in harvested wood

Forest ecosystem carbon pools	
Live trees	Live trees with diameter at breast height (d.b.h.) of at least 2.5 cm (1 inch), including carbon mass of coarse roots (greater than 0.2 to 0.5 cm, published distinctions between fine and coarse roots are not always clear), stems, branches, and foliage.
Standing dead trees	Standing dead trees with d.b.h. of at least 2.5 cm, including carbon mass of coarse roots, stems, and branches.
Understory vegetation	Live vegetation that includes the roots, stems, branches, and foliage of seedlings (trees less than 2.5 cm d.b.h.), shrubs, and bushes.
Down dead wood	Woody material that includes logging residue and other coarse dead wood on the ground and larger than 7.5 cm in diameter, and stumps and coarse roots of stumps.
Forest floor	Organic material on the floor of the forest that includes fine woody debris up to 7.5 cm in diameter, tree litter, humus, and fine roots in the organic forest floor layer above mineral soil.
Soil organic carbon	Belowground carbon without coarse roots, but including fine roots and all other organic carbon not included in other pools, to a depth of 1 meter.
Categories for disposition of carbon in harvested wood	
Products in use	End-use products that have not been discarded or otherwise destroyed, examples include residential and nonresidential construction, wooden containers, and paper products.
Landfills	Discarded wood and paper placed in landfills where most carbon is stored long-term and only a small portion of the material is assumed to degrade, at a slow rate.
Emitted with energy capture	Combustion of wood products with concomitant energy capture as carbon is emitted to the atmosphere.
Emitted without energy capture	Carbon in harvested wood emitted to the atmosphere through combustion or decay without concomitant energy recapture.

Table 1.2.—Example reforestation table with regional estimates of timber volume and carbon stocks on forest land after clearcut harvest for maple-beech-birch stands in the Northeast

Age	Mean volume	Mean carbon density						
		Live tree	Standing dead tree	Under-story	Down dead wood	Forest floor	Soil organic	Total nonsoil
<i>years</i>	<i>m³/hectare</i>	<i>tonnes carbon/ hectare</i>						
0	0.0	0.0	0.0	2.1	32.0	27.7	69.6	61.8
5	0.0	7.4	0.7	2.1	21.7	20.3	69.6	52.2
15	28.0	31.8	3.2	1.9	11.5	16.3	69.6	64.7
25	58.1	53.2	5.3	1.8	7.8	17.6	69.6	85.7
35	89.6	72.8	6.0	1.7	6.9	20.3	69.6	107.8
45	119.1	87.8	6.6	1.7	7.0	23.0	69.6	126.0
55	146.6	101.1	7.0	1.7	7.5	25.3	69.6	142.7
65	172.1	113.1	7.4	1.7	8.2	27.4	69.6	157.7
75	195.6	123.8	7.7	1.7	8.8	29.2	69.6	171.2
85	217.1	133.5	7.9	1.7	9.5	30.7	69.6	183.2
95	236.6	142.1	8.1	1.7	10.1	32.0	69.6	193.9
105	254.1	149.7	8.3	1.6	10.6	33.1	69.6	203.4
115	269.7	156.3	8.5	1.6	11.1	34.2	69.6	211.7
125	283.2	162.1	8.6	1.6	11.5	35.1	69.6	218.8

Table 1.3.—Example harvest scenario table with regional estimates of timber volume, carbon stocks, and carbon in harvested wood products on forest land after clearcut harvest for maple-beech-birch stands in the Northeast

Mean volume			Mean carbon density										
Age	Inventory	Harvested	Live tree	Standing dead tree	Under-story	Down dead wood	Forest floor	Soil organic	Products in use	In landfills	Emitted with energy capture	Emitted without energy capture	Emitted at harvest
<i>years</i>	<i>m³/hectare</i>		<i>tonnes carbon/hectare</i>										
0	0.0		0.0	0.0	2.1	0.0	0.0	52.2					
5	0.0		7.4	0.7	2.1	0.5	4.2	52.3					
15	28.0		31.8	3.2	1.9	2.3	10.8	53.7					
25	58.1		53.2	5.3	1.8	3.8	15.8	56.0					
35	89.6		72.8	6.0	1.7	5.2	19.7	58.9					
45	119.1		87.8	6.6	1.7	6.2	22.7	61.8					
55	146.6		101.1	7.0	1.7	7.2	25.3	64.4					
65	0.0	172.1	0.0	0.0	2.1	32.0	27.7	66.3	34.5	0.0	39.7	14.1	7.5
5	0.0		7.4	0.7	2.1	21.7	20.3	67.1	22.9	4.7	43.1	17.5	
15	28.0		31.8	3.2	1.9	11.5	16.3	68.2	13.2	8.1	46.2	20.7	
25	58.1		53.2	5.3	1.8	7.8	17.6	68.9	10.3	8.8	47.1	22.0	
35	89.6		72.8	6.0	1.7	6.9	20.3	69.2	8.7	9.1	47.5	22.9	
45	119.1		87.8	6.6	1.7	7.0	23.0	69.4	7.6	9.4	47.8	23.5	
55	146.6		101.1	7.0	1.7	7.5	25.3	69.5	6.7	9.6	47.9	24.0	
65	0.0	172.1	0.0	0.0	2.1	32.0	27.7	69.5	40.4	9.8	87.8	38.5	7.7

NOTE: Emitted column is shown as positive values so that all nonsoil columns can be summed to check totals.

Table 1.4.—Factors to calculate carbon in growing stock volume: softwood fraction, sawtimber-size fraction, and specific gravity by region and forest type group^a

Region	Forest type	Fraction of growing-stock volume that is softwood ^b	Fraction of softwood growing-stock volume that is sawtimber-size ^c	Fraction of hardwood growing-stock volume that is sawtimber-size ^c	Specific gravity ^d of softwoods	Specific gravity ^d of hardwoods
Northeast	Aspen-birch	0.247	0.439	0.330	0.353	0.428
	Elm-ash-cottonwood	0.047	0.471	0.586	0.358	0.470
	Maple-beech-birch	0.132	0.604	0.526	0.369	0.518
	Oak-hickory	0.039	0.706	0.667	0.388	0.534
	Oak-pine	0.511	0.777	0.545	0.371	0.516
	Spruce-fir	0.870	0.508	0.301	0.353	0.481
	White-red-jack pine	0.794	0.720	0.429	0.361	0.510
Northern Lake States	Aspen-birch	0.157	0.514	0.336	0.351	0.397
	Elm-ash-cottonwood	0.107	0.468	0.405	0.335	0.460
	Maple-beech-birch	0.094	0.669	0.422	0.356	0.496
	Oak-hickory	0.042	0.605	0.473	0.369	0.534
	Spruce-fir	0.876	0.425	0.276	0.344	0.444
	White-red-jack pine	0.902	0.646	0.296	0.389	0.473
Northern Prairie States	Elm-ash-cottonwood	0.004	0.443	0.563	0.424	0.453
	Loblolly-shortleaf pine	0.843	0.686	0.352	0.468	0.544
	Maple-beech-birch	0.010	0.470	0.538	0.437	0.508
	Oak-hickory	0.020	0.497	0.501	0.448	0.565
	Oak-pine	0.463	0.605	0.314	0.451	0.566
	Ponderosa pine	0.982	0.715	0.169	0.381	0.473
Pacific Northwest, East	Douglas-fir	0.989	0.896	0.494	0.429	0.391
	Fir-spruce-m.hemlock	0.994	0.864	0.605	0.370	0.361
	Lodgepole pine	0.992	0.642	0.537	0.380	0.345
	Ponderosa pine	0.996	0.906	0.254	0.385	0.513
Pacific Northwest, West	Alder-maple	0.365	0.895	0.635	0.402	0.385
	Douglas-fir	0.959	0.914	0.415	0.440	0.426
	Fir-spruce-m.hemlock	0.992	0.905	0.296	0.399	0.417
	Hemlock-Sitka spruce	0.956	0.909	0.628	0.405	0.380
Pacific Southwest	Mixed conifer	0.943	0.924	0.252	0.394	0.521
	Douglas-fir	0.857	0.919	0.320	0.429	0.483
	Fir-spruce-m.hemlock	1.000	0.946	0.000	0.372	0.510
	Ponderosa Pine	0.997	0.895	0.169	0.380	0.510
	Redwood	0.925	0.964	0.468	0.376	0.449
Rocky Mountain, North	Douglas-fir	0.993	0.785	0.353	0.428	0.370
	Fir-spruce-m.hemlock	0.999	0.753	0.000	0.355	0.457
	Hemlock-Sitka spruce	0.972	0.735	0.596	0.375	0.441
	Lodgepole pine	0.999	0.540	0.219	0.383	0.391
	Ponderosa pine	0.999	0.816	0.000	0.391	0.374

Continued

Table 1.4.—continued

Region	Forest type	Fraction of growing-stock volume that is softwood ^b	Fraction of softwood growing-stock volume that is sawtimber-size ^c	Fraction of hardwood growing-stock volume that is sawtimber-size ^c	Specific gravity ^d of softwoods	Specific gravity ^d of hardwoods
Rocky Mountain, South	Aspen-birch	0.297	0.766	0.349	0.355	0.350
	Douglas-fir	0.962	0.758	0.230	0.431	0.350
	Fir-spruce-m.hemlock	0.958	0.770	0.367	0.342	0.350
	Lodgepole pine	0.981	0.607	0.121	0.377	0.350
	Ponderosa pine	0.993	0.773	0.071	0.383	0.386
Southeast	Elm-ash-cottonwood	0.030	0.817	0.551	0.433	0.499
	Loblolly-shortleaf pine	0.889	0.556	0.326	0.469	0.494
	Longleaf-slash pine	0.963	0.557	0.209	0.536	0.503
	Oak-gum-cypress	0.184	0.789	0.500	0.441	0.484
	Oak-hickory	0.070	0.721	0.551	0.438	0.524
	Oak-pine	0.508	0.746	0.425	0.462	0.516
South Central	Elm-ash-cottonwood	0.044	0.787	0.532	0.427	0.494
	Loblolly-shortleaf pine	0.880	0.653	0.358	0.470	0.516
	Longleaf-slash pine	0.929	0.723	0.269	0.531	0.504
	Oak-gum-cypress	0.179	0.830	0.589	0.440	0.513
	Oak-hickory	0.057	0.706	0.534	0.451	0.544
West ^e	Oak-pine	0.512	0.767	0.432	0.467	0.537
	Pinyon-juniper	0.986	0.783	0.042	0.422	0.620
	Tanoak-laurel	0.484	0.909	0.468	0.430	0.459
	Western larch	0.989	0.781	0.401	0.433	0.430
	Western oak	0.419	0.899	0.206	0.416	0.590
	Western white pine	1.000	0.838	0.000	0.376	--

-- = no hardwood trees in this type in this region.

^aEstimates based on survey data for the conterminous United States from USDA Forest Service, Forest Inventory and Analysis Program's database of forest surveys (FIADB; USDA For. Serv. 2005) and include growing stock on timberland stands classified as medium- or large-diameter stands. Proportions are based on volume of growing-stock trees.

^bTo calculate fraction in hardwood, subtract fraction in softwood from 1.

^cSoftwood sawtimber are trees at least 22.9 cm (9 in) d.b.h., hardwood sawtimber is at least 27.9 cm (11 in) d.b.h. To calculate fraction in less-than-sawtimber-size trees, subtract fraction in sawtimber from 1. Trees less than sawtimber-size are at least 12.7 cm (5 in) d.b.h.

^dAverage wood specific gravity is the density of wood divided by the density of water based on wood dry mass associated with green tree volume.

^eWest represents an average over all western regions for these forest types.

Table 1.5.—Regional factors to estimate carbon in roundwood logs, bark on logs, and fuelwood

Region ^a	Timber type	Roundwood category	Ratio of roundwood to growing-stock volume that is roundwood ^b	Ratio of carbon in bark to carbon in wood ^c	Fraction of growing-stock volume that is roundwood ^d	Ratio of fuelwood to growing-stock volume that is roundwood ^b
Northeast	SW	Saw log	0.991	0.182	0.948	0.136
		Pulpwood	3.079	0.185		
	HW	Saw log	0.927	0.199	0.879	0.547
		Pulpwood	2.177	0.218		
North Central	SW	Saw log	0.985	0.182	0.931	0.066
		Pulpwood	1.285	0.185		
	HW	Saw log	0.960	0.199	0.831	0.348
		Pulpwood	1.387	0.218		
Pacific Coast	SW	Saw log	0.965	0.181	0.929	0.096
		Pulpwood	1.099	0.185		
	HW	Saw log	0.721	0.197	0.947	0.957
		Pulpwood	0.324	0.219		
Rocky Mountain	SW	Saw log	0.994	0.181	0.907	0.217
		Pulpwood	2.413	0.185		
	HW	Saw log	0.832	0.201	0.755	3.165
		Pulpwood	1.336	0.219		
South	SW	Saw log	0.990	0.182	0.891	0.019
		Pulpwood	1.246	0.185		
	HW	Saw log	0.832	0.198	0.752	0.301
		Pulpwood	1.191	0.218		

SW=Softwood, HW=Hardwood.

^aNorth Central includes the Northern Prairie States and the Northern Lake States; Pacific Coast includes the Pacific Northwest (West and East) and the Pacific Southwest; Rocky Mountain includes Rocky Mountain, North and South; and South includes the Southeast and South Central.

^bValues and classifications are based on data in Tables 2.2, 3.2, 4.2, 5.2, and 6.2 of Johnson (2001).

^cRatios are calculated from carbon mass based on biomass component equations in Jenkins and others (2003) applied to all live trees identified as growing stock on timberland stands classified as medium- or large-diameter stands in the survey data for the conterminous United States from USDA Forest Service, Forest Inventory and Analysis Program's database of forest surveys (FIADB; USDA For. Serv. 2005, Alerich and others 2005). Carbon mass is calculated for boles from stump to 4-inch top, outside diameter.

^dValues and classifications are based on data in Tables 2.9, 3.9, 4.9, 5.9, and 6.9 of Johnson (2001).

Table 1.6.—Average disposition patterns of carbon as fractions in roundwood by region and roundwood category; factors assume no bark on roundwood and exclude fuelwood

Year after production	Northeast, Softwood							
	Saw log				Pulpwood			
	In use	Landfill	Energy	Emitted without energy	In use	Landfill	Energy	Emitted without energy
0	0.569	0.000	0.240	0.190	0.513	0.000	0.306	0.181
1	0.542	0.014	0.246	0.197	0.436	0.025	0.334	0.204
2	0.517	0.027	0.252	0.203	0.372	0.046	0.359	0.223
3	0.495	0.039	0.257	0.209	0.317	0.063	0.381	0.239
4	0.474	0.050	0.262	0.214	0.271	0.077	0.399	0.253
5	0.455	0.060	0.266	0.219	0.232	0.088	0.415	0.265
6	0.438	0.069	0.270	0.223	0.197	0.098	0.429	0.276
7	0.422	0.078	0.274	0.227	0.167	0.106	0.441	0.286
8	0.406	0.085	0.277	0.231	0.139	0.113	0.452	0.296
9	0.392	0.093	0.281	0.235	0.114	0.118	0.463	0.305
10	0.379	0.099	0.284	0.238	0.093	0.123	0.472	0.313
15	0.326	0.126	0.296	0.252	0.037	0.128	0.497	0.338
20	0.288	0.144	0.304	0.264	0.021	0.122	0.505	0.352
25	0.259	0.158	0.311	0.273	0.016	0.114	0.509	0.362
30	0.234	0.168	0.316	0.281	0.014	0.107	0.510	0.369
35	0.214	0.176	0.321	0.289	0.013	0.102	0.510	0.376
40	0.197	0.183	0.324	0.296	0.012	0.098	0.510	0.381
45	0.182	0.189	0.327	0.302	0.011	0.094	0.510	0.385
50	0.169	0.194	0.330	0.307	0.010	0.092	0.510	0.388
55	0.158	0.198	0.332	0.312	0.009	0.090	0.510	0.391
60	0.148	0.202	0.333	0.317	0.009	0.088	0.510	0.393
65	0.139	0.205	0.335	0.321	0.008	0.087	0.510	0.395
70	0.131	0.208	0.336	0.325	0.008	0.086	0.510	0.396
75	0.124	0.211	0.337	0.328	0.007	0.086	0.510	0.397
80	0.117	0.214	0.337	0.332	0.007	0.085	0.510	0.398
85	0.111	0.216	0.338	0.335	0.007	0.085	0.510	0.399
90	0.106	0.219	0.338	0.338	0.006	0.085	0.510	0.399
95	0.100	0.221	0.338	0.341	0.006	0.084	0.510	0.400
100	0.095	0.223	0.338	0.344	0.006	0.084	0.510	0.400

Continued

Table 1.6.—continued

Year after production	Northeast, Hardwood							
	Saw log				Pulpwood			
	In use	Landfill	Energy	Emitted without energy	In use	Landfill	Energy	Emitted without energy
0	0.614	0.000	0.237	0.149	0.650	0.000	0.185	0.166
1	0.572	0.025	0.246	0.157	0.590	0.021	0.202	0.186
2	0.534	0.048	0.255	0.163	0.539	0.039	0.218	0.203
3	0.500	0.067	0.263	0.170	0.496	0.054	0.232	0.218
4	0.469	0.085	0.271	0.175	0.459	0.067	0.244	0.231
5	0.440	0.102	0.278	0.180	0.426	0.078	0.254	0.242
6	0.415	0.116	0.284	0.185	0.398	0.087	0.263	0.253
7	0.391	0.129	0.290	0.190	0.372	0.095	0.271	0.262
8	0.369	0.141	0.295	0.194	0.349	0.102	0.279	0.271
9	0.349	0.152	0.300	0.198	0.327	0.108	0.286	0.279
10	0.331	0.162	0.305	0.202	0.308	0.114	0.292	0.286
15	0.260	0.198	0.324	0.218	0.252	0.127	0.310	0.311
20	0.212	0.221	0.338	0.229	0.226	0.130	0.319	0.325
25	0.178	0.235	0.348	0.239	0.211	0.131	0.323	0.335
30	0.152	0.245	0.356	0.247	0.198	0.132	0.327	0.343
35	0.131	0.253	0.362	0.254	0.187	0.133	0.329	0.351
40	0.115	0.258	0.368	0.260	0.178	0.134	0.331	0.357
45	0.102	0.262	0.372	0.265	0.169	0.136	0.333	0.363
50	0.090	0.265	0.375	0.269	0.160	0.138	0.334	0.368
55	0.081	0.268	0.378	0.273	0.153	0.140	0.335	0.373
60	0.073	0.270	0.380	0.277	0.146	0.142	0.335	0.377
65	0.066	0.272	0.382	0.280	0.139	0.144	0.336	0.381
70	0.059	0.274	0.384	0.283	0.133	0.146	0.336	0.385
75	0.054	0.275	0.385	0.286	0.127	0.148	0.336	0.388
80	0.049	0.277	0.386	0.288	0.122	0.150	0.336	0.392
85	0.045	0.278	0.386	0.290	0.117	0.152	0.336	0.395
90	0.041	0.279	0.387	0.293	0.112	0.154	0.336	0.398
95	0.038	0.280	0.387	0.294	0.108	0.156	0.336	0.400
100	0.035	0.281	0.387	0.296	0.103	0.158	0.336	0.403

Continued

Table 1.6.—continued

Year after production	North Central, Softwood							
	Saw log				Pulpwood			
	In use	Landfill	Energy	Emitted without energy	In use	Landfill	Energy	Emitted without energy
0	0.630	0.000	0.249	0.121	0.514	0.000	0.305	0.180
1	0.599	0.016	0.257	0.127	0.438	0.025	0.332	0.204
2	0.570	0.032	0.265	0.133	0.374	0.046	0.356	0.223
3	0.544	0.045	0.272	0.138	0.320	0.063	0.377	0.240
4	0.520	0.058	0.279	0.143	0.274	0.077	0.396	0.254
5	0.499	0.069	0.285	0.147	0.235	0.088	0.411	0.266
6	0.478	0.080	0.291	0.151	0.200	0.097	0.425	0.278
7	0.459	0.090	0.296	0.154	0.170	0.105	0.437	0.288
8	0.442	0.099	0.301	0.158	0.143	0.112	0.448	0.297
9	0.425	0.107	0.306	0.162	0.118	0.118	0.458	0.306
10	0.410	0.115	0.310	0.165	0.096	0.122	0.467	0.314
15	0.349	0.145	0.327	0.178	0.041	0.127	0.491	0.340
20	0.306	0.166	0.339	0.189	0.024	0.121	0.500	0.354
25	0.272	0.181	0.348	0.198	0.020	0.113	0.503	0.364
30	0.245	0.193	0.356	0.206	0.018	0.107	0.504	0.372
35	0.222	0.202	0.362	0.213	0.016	0.101	0.504	0.378
40	0.203	0.210	0.367	0.220	0.015	0.097	0.504	0.383
45	0.187	0.216	0.371	0.226	0.014	0.094	0.504	0.387
50	0.173	0.221	0.374	0.231	0.014	0.091	0.504	0.391
55	0.161	0.225	0.377	0.236	0.013	0.089	0.504	0.393
60	0.151	0.229	0.379	0.241	0.012	0.088	0.504	0.395
65	0.141	0.233	0.381	0.245	0.012	0.087	0.504	0.397
70	0.133	0.236	0.382	0.249	0.011	0.086	0.504	0.399
75	0.125	0.239	0.383	0.253	0.010	0.086	0.504	0.400
80	0.118	0.241	0.384	0.257	0.010	0.085	0.504	0.401
85	0.112	0.244	0.385	0.260	0.009	0.085	0.504	0.401
90	0.106	0.246	0.385	0.263	0.009	0.085	0.504	0.402
95	0.101	0.248	0.385	0.266	0.009	0.085	0.504	0.402
100	0.096	0.250	0.385	0.269	0.008	0.084	0.504	0.403

Continued

Table 1.6.—continued

Year after production	North Central, Hardwood							
	Saw log				Pulpwood			
	In use	Landfill	Energy	Emitted without energy	In use	Landfill	Energy	Emitted without energy
0	0.585	0.000	0.253	0.162	0.685	0.000	0.165	0.150
1	0.544	0.024	0.262	0.170	0.630	0.020	0.181	0.169
2	0.507	0.046	0.271	0.177	0.582	0.038	0.196	0.184
3	0.473	0.065	0.279	0.183	0.541	0.052	0.209	0.198
4	0.443	0.082	0.286	0.189	0.506	0.064	0.219	0.210
5	0.416	0.097	0.293	0.194	0.476	0.075	0.229	0.220
6	0.391	0.111	0.299	0.199	0.448	0.084	0.237	0.230
7	0.368	0.124	0.305	0.203	0.424	0.092	0.245	0.239
8	0.347	0.135	0.310	0.208	0.401	0.099	0.252	0.247
9	0.328	0.146	0.315	0.212	0.381	0.106	0.259	0.255
10	0.310	0.155	0.320	0.216	0.362	0.111	0.265	0.262
15	0.242	0.189	0.338	0.231	0.306	0.127	0.282	0.285
20	0.197	0.210	0.350	0.243	0.278	0.132	0.291	0.299
25	0.165	0.224	0.360	0.252	0.259	0.136	0.296	0.309
30	0.140	0.233	0.367	0.260	0.244	0.138	0.300	0.317
35	0.121	0.239	0.373	0.267	0.231	0.141	0.303	0.325
40	0.106	0.244	0.378	0.272	0.219	0.144	0.306	0.331
45	0.093	0.248	0.381	0.278	0.208	0.147	0.308	0.337
50	0.083	0.251	0.384	0.282	0.198	0.150	0.309	0.343
55	0.074	0.253	0.387	0.286	0.189	0.153	0.311	0.348
60	0.066	0.255	0.389	0.290	0.180	0.156	0.312	0.353
65	0.060	0.257	0.390	0.293	0.172	0.159	0.313	0.357
70	0.054	0.259	0.391	0.296	0.164	0.161	0.313	0.361
75	0.049	0.260	0.392	0.299	0.157	0.164	0.314	0.365
80	0.045	0.261	0.393	0.301	0.150	0.167	0.314	0.368
85	0.041	0.262	0.393	0.304	0.144	0.170	0.315	0.372
90	0.038	0.263	0.393	0.306	0.138	0.172	0.315	0.375
95	0.035	0.264	0.393	0.308	0.133	0.175	0.315	0.378
100	0.032	0.265	0.393	0.309	0.127	0.177	0.315	0.381

Continued

Table 1.6.—continued

Year after production	Pacific Northwest, East, Softwood			
	All			
	In use	Landfill	Energy	Emitted without energy
0	0.637	0.000	0.197	0.166
1	0.601	0.016	0.207	0.176
2	0.569	0.031	0.215	0.185
3	0.541	0.043	0.223	0.192
4	0.516	0.055	0.230	0.199
5	0.494	0.065	0.236	0.205
6	0.473	0.074	0.242	0.211
7	0.454	0.083	0.247	0.216
8	0.437	0.090	0.251	0.221
9	0.420	0.098	0.256	0.226
10	0.405	0.104	0.260	0.231
15	0.351	0.127	0.274	0.248
20	0.315	0.143	0.283	0.260
25	0.287	0.154	0.289	0.270
30	0.264	0.163	0.294	0.279
35	0.245	0.170	0.298	0.287
40	0.228	0.177	0.301	0.294
45	0.213	0.182	0.304	0.301
50	0.199	0.188	0.306	0.307
55	0.187	0.192	0.308	0.313
60	0.176	0.196	0.309	0.318
65	0.166	0.200	0.310	0.323
70	0.157	0.204	0.311	0.328
75	0.149	0.207	0.311	0.333
80	0.141	0.210	0.312	0.337
85	0.134	0.213	0.312	0.341
90	0.128	0.216	0.312	0.345
95	0.121	0.219	0.312	0.348
100	0.116	0.221	0.312	0.351

Continued

Table 1.6.—continued

Year after production	Pacific Northwest, West, Softwoods							
	Saw log				Pulpwood			
	In use	Landfill	Energy	Emitted without energy	In use	Landfill	Energy	Emitted without energy
0	0.740	0.000	0.125	0.135	0.500	0.000	0.352	0.148
1	0.703	0.018	0.134	0.144	0.422	0.026	0.382	0.170
2	0.670	0.035	0.141	0.153	0.357	0.047	0.409	0.187
3	0.640	0.050	0.148	0.161	0.301	0.064	0.433	0.202
4	0.613	0.064	0.154	0.169	0.254	0.078	0.453	0.215
5	0.589	0.076	0.160	0.176	0.215	0.089	0.471	0.226
6	0.566	0.088	0.165	0.182	0.180	0.098	0.486	0.236
7	0.545	0.098	0.169	0.188	0.150	0.106	0.499	0.245
8	0.525	0.108	0.174	0.194	0.121	0.112	0.512	0.254
9	0.506	0.117	0.178	0.199	0.096	0.118	0.523	0.262
10	0.489	0.125	0.182	0.204	0.075	0.122	0.533	0.270
15	0.423	0.157	0.196	0.224	0.020	0.127	0.559	0.295
20	0.376	0.179	0.206	0.239	0.004	0.119	0.567	0.309
25	0.340	0.195	0.213	0.252	0.001	0.110	0.569	0.319
30	0.310	0.208	0.219	0.263	0.000	0.103	0.569	0.327
35	0.284	0.218	0.224	0.273	0.000	0.097	0.569	0.334
40	0.263	0.227	0.228	0.282	0.000	0.092	0.569	0.339
45	0.244	0.234	0.232	0.290	0.000	0.088	0.569	0.342
50	0.228	0.240	0.234	0.298	0.000	0.085	0.569	0.345
55	0.213	0.246	0.237	0.305	0.000	0.083	0.569	0.348
60	0.200	0.251	0.238	0.311	0.000	0.081	0.569	0.349
65	0.188	0.255	0.240	0.317	0.000	0.080	0.569	0.351
70	0.178	0.259	0.240	0.322	0.000	0.079	0.569	0.352
75	0.168	0.263	0.241	0.328	0.000	0.078	0.569	0.353
80	0.159	0.267	0.242	0.332	0.000	0.077	0.569	0.353
85	0.151	0.270	0.242	0.337	0.000	0.077	0.569	0.354
90	0.143	0.273	0.242	0.341	0.000	0.076	0.569	0.354
95	0.136	0.276	0.242	0.345	0.000	0.076	0.569	0.355
100	0.130	0.279	0.242	0.349	0.000	0.076	0.569	0.355

Continued

Table 1.6.—continued

Year after production	Pacific Northwest, West, Hardwood				Pacific Southwest, Softwood			
	All				All			
	In use	Landfill	Energy	Emitted without energy	In use	Landfill	Energy	Emitted without energy
0	0.531	0.000	0.288	0.181	0.675	0.000	0.170	0.156
1	0.481	0.021	0.305	0.193	0.637	0.018	0.180	0.166
2	0.438	0.040	0.319	0.204	0.602	0.034	0.189	0.175
3	0.400	0.055	0.332	0.213	0.572	0.048	0.197	0.183
4	0.367	0.069	0.343	0.221	0.545	0.061	0.204	0.191
5	0.338	0.081	0.352	0.229	0.521	0.072	0.210	0.197
6	0.312	0.091	0.361	0.235	0.498	0.082	0.216	0.204
7	0.289	0.100	0.369	0.241	0.478	0.092	0.221	0.209
8	0.268	0.109	0.377	0.247	0.458	0.101	0.226	0.215
9	0.248	0.116	0.383	0.252	0.440	0.109	0.231	0.220
10	0.231	0.122	0.390	0.257	0.424	0.116	0.235	0.225
15	0.174	0.142	0.409	0.275	0.363	0.143	0.250	0.243
20	0.143	0.152	0.420	0.285	0.323	0.161	0.260	0.257
25	0.122	0.157	0.427	0.294	0.292	0.173	0.268	0.267
30	0.107	0.160	0.432	0.301	0.266	0.183	0.273	0.277
35	0.095	0.162	0.436	0.306	0.245	0.192	0.278	0.285
40	0.085	0.164	0.440	0.312	0.226	0.198	0.282	0.293
45	0.076	0.166	0.442	0.316	0.210	0.204	0.285	0.300
50	0.069	0.167	0.444	0.320	0.196	0.210	0.288	0.306
55	0.062	0.169	0.445	0.324	0.184	0.214	0.290	0.312
60	0.057	0.170	0.446	0.327	0.173	0.218	0.292	0.317
65	0.052	0.171	0.447	0.330	0.162	0.222	0.293	0.322
70	0.048	0.172	0.447	0.333	0.153	0.226	0.294	0.327
75	0.044	0.173	0.447	0.336	0.145	0.229	0.295	0.331
80	0.040	0.174	0.448	0.338	0.137	0.232	0.296	0.335
85	0.037	0.175	0.448	0.340	0.130	0.235	0.296	0.339
90	0.035	0.176	0.448	0.342	0.124	0.238	0.296	0.343
95	0.032	0.177	0.448	0.344	0.117	0.240	0.296	0.346
100	0.030	0.177	0.448	0.345	0.112	0.243	0.296	0.349

Continued

Table 1.6.—continued

Year after production	Rocky Mountain, Softwood			
	All			
	In use	Landfill	Energy	Emitted without energy
0	0.704	0.000	0.209	0.087
1	0.664	0.019	0.223	0.094
2	0.628	0.036	0.235	0.101
3	0.595	0.051	0.247	0.107
4	0.567	0.065	0.256	0.112
5	0.541	0.077	0.265	0.118
6	0.517	0.088	0.273	0.122
7	0.495	0.098	0.280	0.127
8	0.474	0.107	0.287	0.131
9	0.455	0.116	0.294	0.135
10	0.438	0.124	0.300	0.139
15	0.373	0.152	0.320	0.154
20	0.330	0.171	0.333	0.165
25	0.297	0.185	0.343	0.175
30	0.271	0.195	0.350	0.184
35	0.248	0.204	0.356	0.192
40	0.229	0.211	0.360	0.200
45	0.213	0.217	0.364	0.207
50	0.198	0.222	0.367	0.213
55	0.185	0.227	0.369	0.219
60	0.174	0.231	0.371	0.225
65	0.163	0.235	0.372	0.230
70	0.154	0.238	0.373	0.235
75	0.146	0.241	0.373	0.240
80	0.138	0.244	0.373	0.244
85	0.131	0.247	0.373	0.249
90	0.124	0.250	0.373	0.253
95	0.118	0.253	0.373	0.256
100	0.112	0.255	0.373	0.260

Continued

Table 1.6.—continued

Year after production	Southeast, Softwood							
	Saw log				Pulpwood			
	In use	Landfill	Energy	Emitted without energy	In use	Landfill	Energy	Emitted without energy
0	0.636	0.000	0.260	0.104	0.553	0.000	0.276	0.171
1	0.601	0.017	0.270	0.112	0.482	0.024	0.300	0.193
2	0.570	0.032	0.279	0.119	0.422	0.044	0.323	0.211
3	0.541	0.045	0.288	0.125	0.370	0.061	0.342	0.227
4	0.516	0.057	0.296	0.131	0.327	0.074	0.359	0.241
5	0.493	0.068	0.303	0.136	0.290	0.085	0.373	0.252
6	0.472	0.078	0.310	0.140	0.257	0.094	0.385	0.263
7	0.453	0.087	0.315	0.145	0.229	0.102	0.396	0.273
8	0.435	0.095	0.321	0.149	0.202	0.109	0.407	0.282
9	0.418	0.103	0.326	0.153	0.178	0.115	0.416	0.291
10	0.402	0.110	0.331	0.157	0.158	0.119	0.425	0.298
15	0.345	0.136	0.347	0.172	0.102	0.127	0.448	0.323
20	0.306	0.153	0.357	0.184	0.083	0.123	0.456	0.337
25	0.276	0.166	0.364	0.194	0.075	0.118	0.460	0.347
30	0.251	0.176	0.370	0.203	0.070	0.113	0.462	0.355
35	0.231	0.184	0.374	0.211	0.066	0.110	0.463	0.361
40	0.213	0.190	0.378	0.219	0.063	0.107	0.463	0.367
45	0.198	0.196	0.381	0.226	0.060	0.105	0.463	0.372
50	0.184	0.201	0.383	0.232	0.057	0.104	0.463	0.376
55	0.172	0.206	0.384	0.238	0.054	0.103	0.463	0.380
60	0.162	0.209	0.385	0.244	0.052	0.103	0.463	0.383
65	0.152	0.213	0.386	0.249	0.049	0.103	0.463	0.385
70	0.144	0.216	0.386	0.254	0.047	0.103	0.463	0.387
75	0.136	0.219	0.386	0.259	0.045	0.103	0.463	0.389
80	0.128	0.222	0.386	0.263	0.043	0.103	0.463	0.391
85	0.122	0.225	0.386	0.267	0.041	0.104	0.463	0.392
90	0.116	0.227	0.386	0.271	0.040	0.104	0.463	0.393
95	0.110	0.230	0.386	0.274	0.038	0.105	0.463	0.395
100	0.104	0.232	0.386	0.277	0.036	0.105	0.463	0.396

Continued

Table 1.6.—continued

Year after production	Southeast, Hardwood							
	Saw log				Pulpwood			
	In use	Landfill	Energy	Emitted without energy	In use	Landfill	Energy	Emitted without energy
0	0.609	0.000	0.225	0.166	0.591	0.000	0.225	0.185
1	0.565	0.025	0.234	0.176	0.524	0.023	0.245	0.208
2	0.526	0.047	0.243	0.184	0.467	0.042	0.263	0.227
3	0.491	0.066	0.252	0.192	0.419	0.058	0.279	0.244
4	0.459	0.083	0.259	0.198	0.378	0.071	0.293	0.258
5	0.431	0.099	0.266	0.205	0.343	0.082	0.305	0.271
6	0.405	0.113	0.272	0.210	0.312	0.091	0.315	0.282
7	0.381	0.126	0.278	0.216	0.285	0.099	0.324	0.292
8	0.359	0.137	0.283	0.221	0.259	0.106	0.333	0.302
9	0.339	0.147	0.288	0.225	0.236	0.112	0.341	0.311
10	0.321	0.157	0.293	0.230	0.216	0.117	0.348	0.319
15	0.252	0.190	0.310	0.248	0.161	0.126	0.368	0.345
20	0.207	0.211	0.322	0.261	0.139	0.125	0.376	0.360
25	0.175	0.224	0.331	0.271	0.128	0.123	0.379	0.370
30	0.150	0.233	0.337	0.280	0.121	0.120	0.382	0.378
35	0.131	0.239	0.343	0.287	0.114	0.118	0.383	0.385
40	0.115	0.244	0.347	0.294	0.108	0.117	0.384	0.391
45	0.102	0.248	0.351	0.299	0.103	0.117	0.384	0.396
50	0.091	0.251	0.353	0.304	0.098	0.117	0.385	0.401
55	0.082	0.254	0.355	0.309	0.093	0.117	0.385	0.405
60	0.074	0.256	0.357	0.313	0.089	0.117	0.385	0.409
65	0.067	0.258	0.358	0.317	0.085	0.118	0.385	0.412
70	0.061	0.260	0.359	0.320	0.081	0.119	0.385	0.415
75	0.056	0.261	0.360	0.323	0.078	0.120	0.385	0.418
80	0.051	0.263	0.361	0.326	0.074	0.121	0.385	0.420
85	0.047	0.264	0.361	0.328	0.071	0.122	0.385	0.422
90	0.043	0.265	0.361	0.331	0.068	0.123	0.385	0.424
95	0.040	0.266	0.361	0.333	0.066	0.124	0.385	0.426
100	0.037	0.267	0.361	0.335	0.063	0.125	0.385	0.427

Continued

Table 1.6.—continued

Year after production	South Central, Softwood							
	Saw log				Pulpwood			
	In use	Landfill	Energy	Emitted without energy	In use	Landfill	Energy	Emitted without energy
0	0.629	0.000	0.228	0.143	0.570	0.000	0.266	0.164
1	0.594	0.016	0.237	0.153	0.501	0.024	0.290	0.185
2	0.563	0.030	0.246	0.160	0.442	0.043	0.312	0.203
3	0.536	0.043	0.254	0.167	0.393	0.059	0.330	0.218
4	0.511	0.055	0.261	0.174	0.350	0.073	0.346	0.231
5	0.489	0.065	0.267	0.179	0.314	0.084	0.360	0.242
6	0.469	0.074	0.272	0.184	0.282	0.093	0.373	0.253
7	0.451	0.083	0.277	0.189	0.254	0.101	0.383	0.262
8	0.433	0.090	0.282	0.194	0.228	0.108	0.394	0.271
9	0.417	0.098	0.287	0.199	0.204	0.114	0.403	0.279
10	0.402	0.104	0.291	0.203	0.184	0.118	0.411	0.287
15	0.347	0.129	0.305	0.219	0.129	0.127	0.434	0.311
20	0.310	0.145	0.314	0.231	0.108	0.125	0.443	0.325
25	0.282	0.156	0.320	0.242	0.099	0.120	0.447	0.334
30	0.258	0.166	0.325	0.251	0.093	0.117	0.449	0.342
35	0.238	0.173	0.329	0.259	0.087	0.114	0.450	0.349
40	0.221	0.180	0.332	0.267	0.083	0.112	0.451	0.354
45	0.206	0.186	0.334	0.274	0.079	0.111	0.451	0.360
50	0.193	0.191	0.336	0.280	0.075	0.110	0.451	0.364
55	0.181	0.195	0.338	0.286	0.071	0.110	0.451	0.368
60	0.170	0.200	0.339	0.292	0.068	0.110	0.451	0.371
65	0.160	0.203	0.340	0.297	0.065	0.110	0.451	0.374
70	0.151	0.207	0.340	0.302	0.062	0.110	0.451	0.377
75	0.143	0.210	0.340	0.307	0.059	0.111	0.451	0.379
80	0.135	0.213	0.340	0.311	0.057	0.112	0.451	0.381
85	0.128	0.216	0.340	0.315	0.054	0.112	0.451	0.383
90	0.122	0.219	0.340	0.319	0.052	0.113	0.451	0.384
95	0.116	0.221	0.340	0.322	0.050	0.114	0.451	0.386
100	0.110	0.224	0.340	0.325	0.048	0.114	0.451	0.387

Continued

Table 1.6.—continued

Year after production	South Central, Hardwood							
	Saw log				Pulpwood			
	In use	Landfill	Energy	Emitted without energy	In use	Landfill	Energy	Emitted without energy
0	0.587	0.000	0.237	0.176	0.581	0.000	0.228	0.191
1	0.543	0.024	0.247	0.186	0.513	0.023	0.249	0.214
2	0.503	0.046	0.257	0.194	0.455	0.043	0.268	0.234
3	0.468	0.064	0.265	0.202	0.406	0.059	0.285	0.250
4	0.437	0.081	0.273	0.209	0.365	0.072	0.298	0.265
5	0.409	0.096	0.280	0.215	0.329	0.083	0.310	0.278
6	0.383	0.109	0.286	0.221	0.298	0.092	0.321	0.289
7	0.360	0.121	0.292	0.227	0.270	0.100	0.331	0.300
8	0.338	0.132	0.298	0.232	0.244	0.107	0.340	0.310
9	0.319	0.142	0.303	0.237	0.221	0.113	0.348	0.319
10	0.301	0.151	0.307	0.241	0.201	0.117	0.355	0.327
15	0.235	0.182	0.325	0.258	0.146	0.126	0.375	0.353
20	0.192	0.201	0.336	0.271	0.125	0.125	0.383	0.368
25	0.162	0.213	0.344	0.281	0.115	0.121	0.386	0.378
30	0.140	0.221	0.351	0.289	0.108	0.118	0.388	0.386
35	0.122	0.226	0.356	0.297	0.102	0.116	0.390	0.393
40	0.107	0.230	0.360	0.303	0.096	0.114	0.391	0.399
45	0.095	0.234	0.363	0.308	0.092	0.114	0.391	0.404
50	0.085	0.237	0.365	0.313	0.087	0.113	0.391	0.409
55	0.077	0.239	0.367	0.317	0.083	0.113	0.391	0.413
60	0.069	0.241	0.369	0.321	0.079	0.113	0.391	0.416
65	0.063	0.243	0.370	0.325	0.076	0.114	0.391	0.419
70	0.057	0.244	0.371	0.328	0.072	0.115	0.391	0.422
75	0.052	0.246	0.371	0.331	0.069	0.115	0.391	0.424
80	0.048	0.247	0.372	0.334	0.066	0.116	0.391	0.427
85	0.044	0.248	0.372	0.336	0.064	0.117	0.391	0.428
90	0.040	0.249	0.372	0.338	0.061	0.118	0.391	0.430
95	0.037	0.250	0.372	0.341	0.059	0.119	0.391	0.432
100	0.034	0.251	0.372	0.342	0.056	0.120	0.391	0.433

Continued

Table 1.6.—continued

Year after production	West, Hardwood			
	All			
	In use	Landfill	Energy	Emitted without energy
0	0.568	0.000	0.256	0.177
1	0.529	0.018	0.267	0.186
2	0.494	0.034	0.277	0.195
3	0.464	0.048	0.286	0.202
4	0.437	0.061	0.294	0.208
5	0.412	0.073	0.301	0.214
6	0.390	0.083	0.308	0.220
7	0.369	0.092	0.314	0.225
8	0.350	0.101	0.319	0.230
9	0.332	0.109	0.325	0.234
10	0.316	0.116	0.330	0.239
15	0.256	0.143	0.347	0.255
20	0.217	0.159	0.358	0.266
25	0.188	0.171	0.367	0.275
30	0.165	0.179	0.373	0.283
35	0.146	0.186	0.379	0.289
40	0.130	0.192	0.383	0.295
45	0.116	0.196	0.387	0.300
50	0.105	0.200	0.390	0.305
55	0.095	0.203	0.393	0.309
60	0.087	0.205	0.395	0.313
65	0.079	0.208	0.396	0.316
70	0.073	0.210	0.398	0.319
75	0.067	0.212	0.399	0.322
80	0.062	0.213	0.400	0.325
85	0.058	0.215	0.400	0.327
90	0.053	0.216	0.401	0.330
95	0.050	0.218	0.401	0.332
100	0.046	0.219	0.401	0.334

Table 1.7.—Factors to convert primary wood products to carbon mass from the units characteristic of each product

Solidwood product or paper	Unit	Factor to convert units to tons (2000 lb) carbon	Factor to convert units to tonnes carbon
Softwood lumber / laminated veneer lumber/ glulam lumber/ I-joists	thousand board feet	0.488	0.443
Hardwood lumber	thousand board feet	0.844	0.765
Softwood plywood	thousand square feet, 3/8-inch basis	0.260	0.236
Oriented strandboard	thousand square feet, 3/8-inch basis	0.303	0.275
Non structural panels (average)	thousand square feet, 3/8-inch basis	0.319	0.289
Hardwood veneer/ plywood	thousand square feet, 3/8-inch basis	0.315	0.286
Particleboard / medium density fiberboard	thousand square feet, 3/4-inch basis	0.647	0.587
Hardboard	thousand square feet, 1/8-inch basis	0.152	0.138
Insulation board	thousand square feet, 1/2-inch basis	0.242	0.220
Other industrial products	thousand cubic feet	8.250	7.484
Paper	tons, air dry	0.450	0.496

Table 1.8.—Fraction of carbon in primary wood products remaining in end uses up to 100 years after production (year 0 indicates fraction at time of production, with fraction for year 1 the allocation after 1 year)

Year after production	Softwood lumber	Hardwood lumber	Softwood plywood	Oriented strandboard	Non-structural panels	Miscellaneous products	Paper
0	1	1	1	1	1	1	1
1	0.973	0.938	0.976	0.983	0.969	0.944	0.845
2	0.947	0.882	0.952	0.967	0.939	0.891	0.713
3	0.922	0.831	0.930	0.952	0.911	0.841	0.603
4	0.898	0.784	0.909	0.937	0.883	0.794	0.509
5	0.875	0.741	0.888	0.922	0.857	0.749	0.430
6	0.854	0.701	0.869	0.908	0.832	0.707	0.360
7	0.833	0.665	0.850	0.895	0.808	0.667	0.299
8	0.813	0.631	0.832	0.881	0.785	0.630	0.243
9	0.795	0.600	0.815	0.869	0.763	0.595	0.192
10	0.777	0.571	0.798	0.856	0.741	0.561	0.149
11	0.760	0.545	0.782	0.844	0.721	0.530	0.115
12	0.743	0.520	0.767	0.832	0.701	0.500	0.088
13	0.728	0.497	0.752	0.821	0.683	0.472	0.068
14	0.712	0.476	0.738	0.810	0.665	0.445	0.052
15	0.698	0.456	0.724	0.799	0.647	0.420	0.040
16	0.684	0.438	0.711	0.789	0.630	0.397	0.030
17	0.671	0.421	0.698	0.778	0.614	0.375	0.023
18	0.658	0.405	0.685	0.768	0.599	0.354	0.018
19	0.645	0.389	0.673	0.759	0.584	0.334	0.013
20	0.633	0.375	0.662	0.749	0.569	0.315	0.009
21	0.622	0.362	0.650	0.740	0.555	0.297	0.006
22	0.611	0.349	0.639	0.731	0.542	0.281	0.005
23	0.600	0.337	0.629	0.722	0.529	0.265	0.004
24	0.589	0.326	0.619	0.713	0.517	0.250	0.003
25	0.579	0.316	0.609	0.705	0.505	0.236	0.002
26	0.569	0.306	0.599	0.697	0.493	0.223	0.002
27	0.560	0.296	0.589	0.689	0.482	0.210	0.001
28	0.551	0.287	0.580	0.681	0.471	0.198	0.001
29	0.542	0.278	0.571	0.673	0.460	0.187	0.001
30	0.533	0.270	0.563	0.666	0.450	0.177	0.001
31	0.525	0.263	0.554	0.658	0.440	0.167	0.000
32	0.517	0.255	0.546	0.651	0.431	0.157	0.000
33	0.509	0.248	0.538	0.644	0.421	0.149	0.000
34	0.501	0.241	0.530	0.637	0.412	0.140	0.000
35	0.494	0.235	0.522	0.630	0.404	0.132	0.000
36	0.487	0.229	0.515	0.623	0.395	0.125	0.000
37	0.480	0.223	0.508	0.617	0.387	0.118	0.000
38	0.473	0.217	0.500	0.610	0.379	0.111	0.000
39	0.466	0.211	0.493	0.604	0.372	0.105	0.000
40	0.459	0.206	0.487	0.598	0.364	0.099	0.000

Continued

Table 1.8.—continued

Year after production	Softwood lumber	Hardwood lumber	Softwood plywood	Oriented strandboard	Non-structural panels	Miscellaneous products	Paper
41	0.453	0.201	0.480	0.592	0.357	0.094	0.000
42	0.447	0.196	0.474	0.586	0.350	0.088	0.000
43	0.441	0.191	0.467	0.580	0.343	0.083	0.000
44	0.435	0.187	0.461	0.574	0.337	0.079	0.000
45	0.429	0.183	0.455	0.568	0.330	0.074	0.000
46	0.423	0.178	0.449	0.563	0.324	0.070	0.000
47	0.418	0.174	0.443	0.557	0.318	0.066	0.000
48	0.413	0.170	0.437	0.552	0.312	0.063	0.000
49	0.407	0.166	0.432	0.546	0.306	0.059	0.000
50	0.402	0.163	0.426	0.541	0.301	0.056	0.000
55	0.378	0.146	0.401	0.516	0.275	0.042	0.000
60	0.356	0.131	0.377	0.493	0.252	0.031	0.000
65	0.336	0.119	0.356	0.471	0.232	0.023	0.000
70	0.318	0.108	0.336	0.450	0.214	0.018	0.000
75	0.301	0.098	0.318	0.431	0.198	0.013	0.000
80	0.286	0.090	0.301	0.413	0.183	0.010	0.000
85	0.271	0.082	0.286	0.395	0.170	0.007	0.000
90	0.258	0.075	0.271	0.379	0.159	0.006	0.000
95	0.246	0.069	0.258	0.364	0.148	0.004	0.000
100	0.234	0.064	0.245	0.349	0.138	0.003	0.000

Table 1.9.—Fraction of carbon in primary wood products remaining in landfills up to 100 years after production (year 0 indicates fraction at time of production, with fraction for year 1 the allocation after 1 year)

Year after production	Softwood lumber	Hardwood lumber	Softwood plywood	Oriented strandboard	Non-structural panels	Miscellaneous products	Paper
0	0	0	0	0	0	0	0
1	0.018	0.041	0.016	0.011	0.021	0.037	0.051
2	0.035	0.078	0.032	0.021	0.040	0.072	0.093
3	0.051	0.111	0.046	0.032	0.059	0.104	0.128
4	0.067	0.141	0.060	0.041	0.076	0.134	0.155
5	0.081	0.168	0.073	0.050	0.093	0.163	0.178
6	0.094	0.193	0.085	0.059	0.108	0.189	0.196
7	0.107	0.215	0.096	0.068	0.123	0.213	0.211
8	0.119	0.235	0.107	0.076	0.137	0.236	0.225
9	0.130	0.254	0.118	0.084	0.151	0.257	0.236
10	0.141	0.270	0.128	0.091	0.163	0.277	0.245
11	0.151	0.285	0.137	0.098	0.176	0.296	0.251
12	0.161	0.299	0.146	0.105	0.187	0.313	0.254
13	0.170	0.312	0.155	0.112	0.198	0.329	0.255
14	0.178	0.323	0.163	0.118	0.208	0.344	0.255
15	0.187	0.334	0.171	0.124	0.218	0.357	0.253
16	0.194	0.344	0.178	0.130	0.227	0.370	0.251
17	0.202	0.352	0.185	0.136	0.236	0.382	0.248
18	0.209	0.361	0.192	0.142	0.245	0.393	0.245
19	0.215	0.368	0.199	0.147	0.253	0.403	0.242
20	0.222	0.375	0.205	0.152	0.261	0.413	0.239
21	0.228	0.381	0.211	0.157	0.268	0.422	0.235
22	0.234	0.387	0.217	0.162	0.275	0.430	0.232
23	0.239	0.392	0.222	0.167	0.282	0.438	0.228
24	0.245	0.397	0.227	0.171	0.288	0.445	0.224
25	0.250	0.402	0.233	0.176	0.294	0.451	0.221
26	0.255	0.406	0.238	0.180	0.300	0.457	0.218
27	0.259	0.410	0.242	0.184	0.306	0.463	0.214
28	0.264	0.414	0.247	0.188	0.311	0.468	0.211
29	0.268	0.417	0.251	0.192	0.316	0.473	0.209
30	0.272	0.421	0.256	0.196	0.321	0.477	0.206
31	0.276	0.424	0.260	0.200	0.326	0.481	0.203
32	0.280	0.426	0.264	0.204	0.330	0.485	0.200
33	0.284	0.429	0.268	0.207	0.335	0.488	0.198
34	0.287	0.432	0.272	0.211	0.339	0.491	0.196
35	0.291	0.434	0.275	0.214	0.343	0.494	0.194
36	0.294	0.436	0.279	0.217	0.347	0.497	0.191
37	0.298	0.438	0.282	0.221	0.350	0.499	0.189
38	0.301	0.440	0.286	0.224	0.354	0.502	0.187
39	0.304	0.442	0.289	0.227	0.357	0.504	0.186
40	0.307	0.444	0.292	0.230	0.361	0.506	0.184

Continued

Table 1.9.—continued

Year after production	Softwood lumber	Hardwood lumber	Softwood plywood	Oriented strandboard	Non-structural panels	Miscellaneous products	Paper
41	0.310	0.446	0.295	0.233	0.364	0.507	0.182
42	0.312	0.447	0.298	0.236	0.367	0.509	0.181
43	0.315	0.449	0.301	0.239	0.370	0.510	0.179
44	0.318	0.450	0.304	0.241	0.373	0.512	0.178
45	0.320	0.452	0.307	0.244	0.376	0.513	0.176
46	0.323	0.453	0.309	0.247	0.378	0.514	0.175
47	0.325	0.454	0.312	0.249	0.381	0.515	0.174
48	0.328	0.456	0.315	0.252	0.384	0.516	0.173
49	0.330	0.457	0.317	0.255	0.386	0.516	0.172
50	0.332	0.458	0.320	0.257	0.388	0.517	0.171
55	0.343	0.463	0.331	0.269	0.399	0.520	0.166
60	0.352	0.468	0.342	0.280	0.408	0.521	0.162
65	0.361	0.472	0.351	0.290	0.417	0.521	0.160
70	0.369	0.475	0.360	0.300	0.424	0.521	0.157
75	0.376	0.478	0.368	0.309	0.430	0.521	0.156
80	0.382	0.481	0.375	0.317	0.436	0.521	0.154
85	0.389	0.483	0.382	0.325	0.441	0.520	0.153
90	0.395	0.486	0.388	0.333	0.446	0.519	0.152
95	0.400	0.488	0.394	0.340	0.450	0.519	0.152
100	0.405	0.490	0.400	0.347	0.454	0.518	0.151

Table 1.10.—Confidence intervals for the estimates of carbon density for live and standing dead trees at the 50th and 99th percentiles of volume. The percentiles reflect the distribution of stand-level volume in survey data for the conterminous United States.^a The 95-percent intervals about the expected carbon density are represented as the percentage of the carbon density; thus, the interval is \pm the percentage.

Forest type-region ^b	Volume at the 50 th percentile					Volume at the 99 th percentile				
	Growing stock volume	Live tree carbon density	Live tree confidence interval	Standing dead tree carbon density	Standing dead tree confidence interval	Growing stock volume	Live tree carbon density	Live tree confidence interval	Standing dead tree carbon density	Standing dead tree confidence interval
	<i>m³/ha</i>	<i>t C/ha</i>	\pm percent	<i>t C/ha</i>	\pm percent	<i>m³/ha</i>	<i>t C/ha</i>	\pm percent	<i>t C/ha</i>	\pm percent
Aspen-birch, Northeast	52	47	3.3	7	7.7	279	140	3.0	17	11.0
Maple-beech-birch, Northeast	118	87	1.0	13	4.3	361	194	1.4	18	7.6
Oak-hickory, Northeast	120	90	1.0	8	5.7	392	226	1.3	10	10.6
Oak-pine, Northeast	124	85	3.1	8	15.8	430	216	3.5	11	29.5
Spruce-balsam fir, Northeast	82	60	2.0	14	6.4	374	170	2.5	18	11.3
White-red-jack pine, Northeast	182	103	2.0	11	12.6	572	241	3.2	14	25.5
Aspen-birch, Northern Lake States	54	44	1.2	10	5.6	311	153	1.2	20	7.7
Elm-ash-cottonwood, Northern Lake States	60	54	2.3	11	9.2	514	270	2.2	18	16.3
Maple-beech-birch, Northern Lake States	108	84	0.8	10	4.8	348	207	1.0	12	9.1
Oak-hickory, Northern Lake States	84	80	1.0	8	5.4	343	230	1.3	12	10.4
Spruce-balsam fir, Northern Lake States	54	44	1.8	9	8.5	329	163	1.7	20	9.8
White-red-jack pine, Northern Lake States	101	61	2.4	10	12.0	725	267	2.6	16	24.2
Elm-ash-cottonwood, Northern Prairie States	76	66	3.7	9	17.5	514	271	2.2	18	16.3
Maple-beech-birch, Northern Prairie States	93	75	1.1	12	4.8	348	194	1.4	18	7.6
Oak-hickory, Northern Prairie States	77	76	1.0	8	5.5	343	202	1.1	10	9.7
Oak-pine, Northern Prairie States	59	52	3.4	7	15.3	355	159	2.8	10	22.6

Continued

Table 1.10 - Continued

Forest type-region ^b	Volume at the 50 th percentile					Volume at the 99 th percentile				
	Growing stock volume	Live tree carbon density	Live tree confidence interval	Standing dead tree carbon density	Standing dead tree confidence interval	Growing stock volume	Live tree carbon density	Live tree confidence interval	Standing dead tree carbon density	Standing dead tree confidence interval
	<i>m³/ha</i>	<i>t C/ha</i>	<i>± percent</i>	<i>t C/ha</i>	<i>± percent</i>	<i>m³/ha</i>	<i>t C/ha</i>	<i>± percent</i>	<i>t C/ha</i>	<i>± percent</i>
Douglas-fir, Pacific Northwest, East	138	84	1.5	18	8.8	627	264	1.9	29	16.1
Fir-spruce-mountain hemlock, Pacific Northwest, East	216	98	1.5	31	6.3	746	268	1.4	48	11.1
Lodgepole pine, Pacific Northwest, East	65	36	4.1	10	22.6	528	123	2.3	23	15.9
Ponderosa pine, Pacific Northwest, East	100	51	1.9	8	13.8	508	187	1.7	17	18.7
Alder-maple, Pacific Northwest, West	190	88	4.4	25	25.5	1,005	352	4.2	55	38.3
Douglas-fir, Pacific Northwest, West	308	150	1.3	30	17.1	1,876	727	1.7	84	18.5
Douglas-fir, high productivity and high management intensity, Pacific Northwest, West	147	79	3.4	18	24.3	822	319	2.2	21	38.4
Fir-spruce-mountain hemlock, Pacific Northwest, West	360	179	3.1	49	12.6	1,342	527	3.2	84	20.4
Hemlock-Sitka spruce, Pacific Northwest, West	503	203	2.7	51	17.2	1,795	602	3.2	104	27.4
Hemlock-Sitka spruce, high productivity, Pacific Northwest, West	420	174	2.6	46	20.1	1,795	602	3.2	104	27.4
California mixed conifer, Pacific Southwest	241	121	1.9	28	7.5	983	397	1.8	66	9.4

Continued

Table 1.10 – Continued

Forest type-region ^b	Volume at the 50 th percentile					Volume at the 99 th percentile				
	Growing stock volume	Live tree carbon density	Live tree confidence interval	Standing dead tree carbon density	Standing dead tree confidence interval	Growing stock volume	Live tree carbon density	Live tree confidence interval	Standing dead tree carbon density	Standing dead tree confidence interval
	<i>m³/ha</i>	<i>t C/ha</i>	<i>± percent</i>	<i>t C/ha</i>	<i>± percent</i>	<i>m³/ha</i>	<i>t C/ha</i>	<i>± percent</i>	<i>t C/ha</i>	<i>± percent</i>
Fir-spruce-mountain hemlock, Pacific Southwest	352	175	3.1	48	12.7	1,342	475	2.7	80	18.8
Western oak, Pacific Southwest	66	61	3.9	9	21.8	570	310	3.5	18	33.5
Douglas-fir, Rocky Mountain, North	128	79	1.6	18	9.1	627	264	1.9	29	16.1
Fir-spruce-mountain hemlock, Rocky Mountain, North	170	81	1.5	29	6.9	746	271	1.4	49	11.2
Lodgepole pine, Rocky Mountain, North	135	58	2.4	14	12.9	528	152	3.2	27	20.1
Ponderosa pine, Rocky Mountain, North	51	30	3.7	6	11.8	508	183	1.7	17	18.6
Aspen-birch, Rocky Mountain, South	89	61	2.9	17	10.1	498	202	3.2	32	16.2
Douglas-fir, Rocky Mountain, South	115	83	2.9	20	13.2	546	270	3.6	40	21.0
Fir-spruce-mountain hemlock, Rocky Mountain, South	188	96	1.7	32	7.0	736	265	2.3	48	13.4
Lodgepole pine, Rocky Mountain, South	150	63	2.5	20	10.6	521	153	3.2	20	10.6
Ponderosa pine, Rocky Mountain, South	83	53	1.7	7	13.7	353	141	2.3	11	26.9
Loblolly-shortleaf pine, Southeast	75	47	2.1	4	10.5	636	210	1.6	8	15.7

Continued

Table 1.10 – Continued

Forest type-region ^b	Volume at the 50 th percentile					Volume at the 99 th percentile				
	Growing stock volume	Live tree carbon density	Live tree confidence interval	Standing dead tree carbon density	Standing dead tree confidence interval	Growing stock volume	Live tree carbon density	Live tree confidence interval	Standing dead tree carbon density	Standing dead tree confidence interval
	<i>m³/ha</i>	<i>t C/ha</i>	<i>± percent</i>	<i>t C/ha</i>	<i>± percent</i>	<i>m³/ha</i>	<i>t C/ha</i>	<i>± percent</i>	<i>t C/ha</i>	<i>± percent</i>
Loblolly-shortleaf pine, high productivity and management intensity, Southeast	91	53	1.8	3	13.8	385	144	1.8	5	18.3
Longleaf-slash pine, Southeast	46	25	3.6	2	13.7	429	145	2.0	3	21.7
Longleaf-slash pine, high productivity and management intensity, Southeast	82	44	1.5	2	16.4	249	91	2.3	2	20.5
Oak-gum-cypress, Southeast	98	75	2.1	8	10.2	527	237	2.0	14	14.8
Oak-hickory, Southeast	104	81	1.3	7	7.5	536	263	1.4	11	13.1
Oak- pine, Southeast	61	48	2.5	4	9.3	462	201	2.0	9	13.9
Elm-ash-cottonwood, South Central	69	64	3.4	8	17.2	461	245	3.8	14	32.5
Loblolly-shortleaf pine, South Central	71	47	2.3	4	16.0	506	167	2.2	6	24.5
Loblolly-shortleaf pine, high productivity and management intensity, South Central	61	42	1.8	2	17.4	309	116	2.3	2	24.2
Oak-gum-cypress, South Central	100	81	2.0	7	10.9	534	244	2.5	9	21.4
Oak-hickory, South Central	79	69	1.0	5	6.5	390	206	1.2	7	11.9
Oak-pine, South Central	64	53	2.2	5	11.6	436	190	2.5	9	19.2

^a Data from USDA Forest Service, Forest Inventory and Analysis Program's database of forest surveys (FIADB; USDA For. Serv. 2005).

^b These correspond to the table identifiers in Appendix A, B, and C.

APPENDIX A

Forest Ecosystem Yield Tables for Reforestation⁵

A1.	Aspen-birch, Northeast	A26.	Hemlock-Sitka spruce, high productivity, Pacific Northwest, West
A2.	Maple-beech-birch, Northeast	A27.	Mixed conifer, Pacific Southwest
A3.	Oak-hickory, Northeast	A28.	Fir-spruce-mountain hemlock, Pacific Southwest
A4.	Oak-pine, Northeast	A29.	Western oak, Pacific Southwest
A5.	Spruce-balsam fir, Northeast	A30.	Douglas-fir, Rocky Mountain, North
A6.	White-red-jack pine, Northeast	A31.	Fir-spruce-mountain hemlock, Rocky Mountain, North
A7.	Aspen-birch, Northern Lake States	A32.	Lodgepole pine, Rocky Mountain, North
A8.	Elm-ash-cottonwood, Northern Lake States	A33.	Ponderosa pine, Rocky Mountain, North
A9.	Maple-beech-birch, Northern Lake States	A34.	Aspen-birch, Rocky Mountain, South
A10.	Oak-hickory, Northern Lake States	A35.	Douglas-fir, Rocky Mountain, South
A11.	Spruce-balsam fir, Northern Lake States	A36.	Fir-spruce-mountain hemlock, Rocky Mountain, South
A12.	White-red-jack pine, Northern Lake States	A37.	Lodgepole pine, Rocky Mountain, South
A13.	Elm-ash-cottonwood, Northern Prairie States	A38.	Ponderosa pine, Rocky Mountain, South
A14.	Maple-beech-birch, Northern Prairie States	A39.	Loblolly-shortleaf pine, Southeast
A15.	Oak-hickory, Northern Prairie States	A40.	Loblolly-shortleaf pine, high productivity and management intensity, Southeast
A16.	Oak-pine, Northern Prairie States	A41.	Longleaf-slash pine, Southeast
A17.	Douglas-fir, Pacific Northwest, East	A42.	Longleaf-slash pine, high productivity and management intensity, Southeast
A18.	Fir-spruce-mountain hemlock, Pacific Northwest, East	A43.	Oak-gum-cypress, Southeast
A19.	Lodgepole pine, Pacific Northwest, East	A44.	Oak-hickory, Southeast
A20.	Ponderosa pine, Pacific Northwest, East	A45.	Oak-pine, Southeast
A21.	Alder-maple, Pacific Northwest, West	A46.	Elm-ash-cottonwood, South Central
A22.	Douglas-fir, Pacific Northwest, West	A47.	Loblolly-shortleaf pine, South Central
A23.	Douglas-fir, high productivity and high management intensity, Pacific Northwest, West	A48.	Loblolly-shortleaf pine, high productivity and management intensity, South Central
A24.	Fir-spruce-mountain hemlock, Pacific Northwest, West	A49.	Oak-gum-cypress, South Central
A25.	Hemlock-Sitka spruce, Pacific Northwest, West	A50.	Oak-hickory, South Central
		A51.	Oak-pine, South Central

⁵ Note tonnes are metric tonnes in all tables.

A1.— Regional estimates of timber volume and carbon stocks for aspen-birch stands on forest land after clearcut harvest in the Northeast

Age	Mean volume	Mean carbon density						
		Live tree	Standing dead tree	Under-story	Down dead wood	Forest floor	Soil organic	Total nonsoil
<i>years</i>	<i>m³/hectare</i>	<i>tonnes carbon/hectare</i>						
0	0.0	0.0	0.0	2.0	18.7	10.2	87.4	31.0
5	0.0	6.6	0.6	2.2	12.9	7.5	87.4	29.8
15	12.9	21.3	1.8	2.1	7.1	6.0	87.4	38.4
25	33.8	36.0	2.9	2.1	5.2	6.5	87.4	52.7
35	58.4	50.1	3.8	2.1	4.9	7.5	87.4	68.4
45	84.7	62.7	4.6	2.1	5.3	8.5	87.4	83.1
55	112.4	75.1	5.3	2.0	6.0	9.3	87.4	97.8
65	141.7	87.5	5.9	2.0	6.9	10.1	87.4	112.4
75	172.6	100.0	6.5	2.0	7.8	10.7	87.4	127.1
85	205.0	112.7	7.1	2.0	8.8	11.3	87.4	141.9
95	238.9	125.5	7.7	2.0	9.8	11.8	87.4	156.7
105	274.4	138.5	8.2	2.0	10.8	12.2	87.4	171.7
115	311.4	151.7	8.8	2.0	11.8	12.5	87.4	186.8
125	349.9	165.0	9.3	2.0	12.8	12.9	87.4	202.0
<i>years</i>	<i>ft³/acre</i>	<i>tonnes carbon/acre</i>						
0	0	0.0	0.0	0.8	7.6	4.1	35.4	12.5
5	0	2.7	0.2	0.9	5.2	3.0	35.4	12.1
15	184	8.6	0.7	0.9	2.9	2.4	35.4	15.5
25	483	14.6	1.2	0.8	2.1	2.6	35.4	21.3
35	835	20.3	1.5	0.8	2.0	3.0	35.4	27.7
45	1,210	25.4	1.9	0.8	2.2	3.4	35.4	33.6
55	1,607	30.4	2.1	0.8	2.4	3.8	35.4	39.6
65	2,025	35.4	2.4	0.8	2.8	4.1	35.4	45.5
75	2,466	40.5	2.6	0.8	3.2	4.3	35.4	51.4
85	2,929	45.6	2.9	0.8	3.6	4.6	35.4	57.4
95	3,414	50.8	3.1	0.8	4.0	4.8	35.4	63.4
105	3,921	56.0	3.3	0.8	4.4	4.9	35.4	69.5
115	4,450	61.4	3.5	0.8	4.8	5.1	35.4	75.6
125	5,001	66.8	3.8	0.8	5.2	5.2	35.4	81.8

A2.— Regional estimates of timber volume and carbon stocks for maple-beech-birch stands on forest land after clearcut harvest in the Northeast

Age	Mean Volume	Mean carbon density						
		Live Tree	Standing dead tree	Under-story	Down dead wood	Forest floor	Soil organic	Total nonsoil
<i>years</i>	<i>m³/hectare</i>	<i>tonnes carbon/hectare</i>						
0	0.0	0.0	0.0	2.1	32.0	27.7	69.6	61.8
5	0.0	7.4	0.7	2.1	21.7	20.3	69.6	52.2
15	28.0	31.8	3.2	1.9	11.5	16.3	69.6	64.7
25	58.1	53.2	5.3	1.8	7.8	17.6	69.6	85.7
35	89.6	72.8	6.0	1.7	6.9	20.3	69.6	107.8
45	119.1	87.8	6.6	1.7	7.0	23.0	69.6	126.0
55	146.6	101.1	7.0	1.7	7.5	25.3	69.6	142.7
65	172.1	113.1	7.4	1.7	8.2	27.4	69.6	157.7
75	195.6	123.8	7.7	1.7	8.8	29.2	69.6	171.2
85	217.1	133.5	7.9	1.7	9.5	30.7	69.6	183.2
95	236.6	142.1	8.1	1.7	10.1	32.0	69.6	193.9
105	254.1	149.7	8.3	1.6	10.6	33.1	69.6	203.4
115	269.7	156.3	8.5	1.6	11.1	34.2	69.6	211.7
125	283.2	162.1	8.6	1.6	11.5	35.1	69.6	218.8
<i>years</i>	<i>ft³/acre</i>	<i>tonnes carbon/acre</i>						
0	0	0.0	0.0	0.8	13.0	11.2	28.1	25.0
5	0	3.0	0.3	0.8	8.8	8.2	28.1	21.1
15	400	12.9	1.3	0.8	4.7	6.6	28.1	26.2
25	830	21.5	2.1	0.7	3.2	7.1	28.1	34.7
35	1,280	29.5	2.4	0.7	2.8	8.2	28.1	43.6
45	1,702	35.5	2.7	0.7	2.8	9.3	28.1	51.0
55	2,095	40.9	2.8	0.7	3.0	10.3	28.1	57.7
65	2,460	45.8	3.0	0.7	3.3	11.1	28.1	63.8
75	2,796	50.1	3.1	0.7	3.6	11.8	28.1	69.3
85	3,103	54.0	3.2	0.7	3.8	12.4	28.1	74.1
95	3,382	57.5	3.3	0.7	4.1	12.9	28.1	78.5
105	3,632	60.6	3.4	0.7	4.3	13.4	28.1	82.3
115	3,854	63.3	3.4	0.7	4.5	13.8	28.1	85.7
125	4,047	65.6	3.5	0.7	4.6	14.2	28.1	88.6

A3.— Regional estimates of timber volume and carbon stocks for oak-hickory stands on forest land after clearcut harvest in the Northeast

Age	Mean volume	Mean carbon density						
		Live tree	Standing dead tree	Under-story	Down dead wood	Forest floor	Soil organic	Total nonsoil
<i>years</i>	<i>m³/hectare</i>	<i>tonnes carbon/hectare</i>						
0	0.0	0.0	0.0	2.1	46.7	8.2	53.1	56.9
5	0.0	6.9	0.7	2.1	31.4	5.7	53.1	46.7
15	54.5	43.0	3.6	1.9	16.5	4.1	53.1	69.1
25	95.7	71.9	4.0	1.9	10.8	4.5	53.1	93.0
35	135.3	96.2	4.2	1.8	9.2	5.3	53.1	116.8
45	173.3	118.2	4.5	1.8	9.2	6.3	53.1	139.9
55	209.6	136.8	4.6	1.8	9.9	7.3	53.1	160.3
65	244.3	154.3	4.8	1.8	10.8	8.1	53.1	179.7
75	277.4	170.6	4.9	1.8	11.8	8.9	53.1	198.0
85	308.9	186.0	5.0	1.8	12.8	9.7	53.1	215.2
95	338.8	200.4	5.1	1.8	13.7	10.3	53.1	231.3
105	367.1	213.9	5.1	1.7	14.6	10.9	53.1	246.4
115	393.7	226.5	5.2	1.7	15.5	11.5	53.1	260.5
125	418.6	238.2	5.3	1.7	16.3	12.0	53.1	273.6
<i>years</i>	<i>ft³/acre</i>	<i>tonnes carbon/acre</i>						
0	0	0.0	0.0	0.8	18.9	3.3	21.5	23.0
5	0	2.8	0.3	0.8	12.7	2.3	21.5	18.9
15	779	17.4	1.4	0.8	6.7	1.7	21.5	28.0
25	1,368	29.1	1.6	0.7	4.4	1.8	21.5	37.7
35	1,934	38.9	1.7	0.7	3.7	2.2	21.5	47.3
45	2,477	47.8	1.8	0.7	3.7	2.6	21.5	56.6
55	2,996	55.4	1.9	0.7	4.0	2.9	21.5	64.9
65	3,492	62.4	1.9	0.7	4.4	3.3	21.5	72.7
75	3,965	69.1	2.0	0.7	4.8	3.6	21.5	80.1
85	4,415	75.3	2.0	0.7	5.2	3.9	21.5	87.1
95	4,842	81.1	2.0	0.7	5.6	4.2	21.5	93.6
105	5,246	86.6	2.1	0.7	5.9	4.4	21.5	99.7
115	5,626	91.7	2.1	0.7	6.3	4.7	21.5	105.4
125	5,983	96.4	2.1	0.7	6.6	4.9	21.5	110.7

A4.— Regional estimates of timber volume and carbon stocks for oak-pine stands on forest land after clearcut harvest in the Northeast

Age	Mean volume	Mean carbon density						
		Live tree	Standing dead tree	Under-story	Down dead wood	Forest floor	Soil organic	Total nonsoil
<i>years</i>	<i>m³/hectare</i>	<i>tonnes carbon/hectare</i>						
0	0.0	0.0	0.0	4.2	30.0	29.7	66.9	63.9
5	0.0	6.2	0.6	4.2	23.0	20.2	66.9	54.3
15	36.5	27.0	2.6	3.3	14.6	15.3	66.9	62.9
25	70.9	48.6	3.2	2.9	10.4	17.1	66.9	82.2
35	103.1	67.9	3.7	2.6	8.4	20.3	66.9	102.9
45	133.1	84.7	4.0	2.5	7.6	23.6	66.9	122.3
55	160.9	99.1	4.2	2.4	7.4	26.6	66.9	139.8
65	186.7	113.0	4.4	2.3	7.7	29.3	66.9	156.6
75	210.2	123.6	4.6	2.3	8.0	31.6	66.9	170.0
85	231.5	133.1	4.7	2.3	8.4	33.6	66.9	182.1
95	250.8	141.7	4.8	2.2	8.8	35.4	66.9	192.9
105	267.9	149.2	4.9	2.2	9.2	37.0	66.9	202.5
115	282.7	155.7	5.0	2.2	9.6	38.4	66.9	210.9
125	295.4	161.3	5.1	2.2	9.9	39.7	66.9	218.2
<i>years</i>	<i>ft³/acre</i>	<i>tonnes carbon/acre</i>						
0	0	0.0	0.0	1.7	12.1	12.0	27.1	25.9
5	0	2.5	0.3	1.7	9.3	8.2	27.1	22.0
15	522	10.9	1.1	1.3	5.9	6.2	27.1	25.4
25	1,013	19.7	1.3	1.2	4.2	6.9	27.1	33.3
35	1,473	27.5	1.5	1.1	3.4	8.2	27.1	41.7
45	1,902	34.3	1.6	1.0	3.1	9.6	27.1	49.5
55	2,300	40.1	1.7	1.0	3.0	10.8	27.1	56.6
65	2,668	45.7	1.8	0.9	3.1	11.8	27.1	63.4
75	3,004	50.0	1.8	0.9	3.2	12.8	27.1	68.8
85	3,309	53.9	1.9	0.9	3.4	13.6	27.1	73.7
95	3,584	57.3	1.9	0.9	3.6	14.3	27.1	78.1
105	3,828	60.4	2.0	0.9	3.7	15.0	27.1	82.0
115	4,040	63.0	2.0	0.9	3.9	15.6	27.1	85.4
125	4,222	65.3	2.1	0.9	4.0	16.1	27.1	88.3

A5.— Regional estimates of timber volume and carbon stocks for spruce-balsam fir stands on forest land after clearcut harvest in the Northeast

Age	Mean volume	Mean carbon density						
		Live tree	Standing dead tree	Under-story	Down dead wood	Forest floor	Soil organic	Total nonsoil
<i>years</i>	<i>m³/hectare</i>	<i>tonnes carbon/hectare</i>						
0	0.0	0.0	0.0	2.1	20.3	33.7	98.0	56.2
5	0.0	7.0	0.7	1.8	16.0	23.6	98.0	49.1
15	11.5	20.1	2.0	1.6	10.6	18.6	98.0	53.0
25	29.1	32.5	3.3	1.5	8.0	20.7	98.0	66.0
35	51.6	45.7	4.6	1.4	7.1	24.2	98.0	83.1
45	76.9	57.4	5.7	1.4	6.9	27.7	98.0	99.2
55	102.6	68.7	6.9	1.4	7.3	30.7	98.0	114.9
65	126.4	78.6	7.4	1.3	7.8	33.3	98.0	128.5
75	149.3	87.9	7.6	1.3	8.4	35.5	98.0	140.8
85	170.9	96.5	7.8	1.3	9.1	37.4	98.0	152.2
95	191.6	104.5	8.0	1.3	9.7	39.1	98.0	162.6
105	211.1	111.9	8.2	1.3	10.4	40.6	98.0	172.3
115	229.6	118.8	8.3	1.3	11.0	41.9	98.0	181.2
125	247.1	125.3	8.4	1.3	11.6	43.0	98.0	189.6
<i>years</i>	<i>ft³/acre</i>	<i>tonnes carbon/acre</i>						
0	0	0.0	0.0	0.9	8.2	13.6	39.7	22.7
5	0	2.8	0.3	0.7	6.5	9.5	39.7	19.9
15	164	8.1	0.8	0.6	4.3	7.5	39.7	21.4
25	416	13.2	1.3	0.6	3.2	8.4	39.7	26.7
35	738	18.5	1.9	0.6	2.9	9.8	39.7	33.6
45	1,099	23.2	2.3	0.6	2.8	11.2	39.7	40.1
55	1,466	27.8	2.8	0.6	2.9	12.4	39.7	46.5
65	1,807	31.8	3.0	0.5	3.2	13.5	39.7	52.0
75	2,133	35.6	3.1	0.5	3.4	14.4	39.7	57.0
85	2,443	39.0	3.2	0.5	3.7	15.2	39.7	61.6
95	2,738	42.3	3.2	0.5	3.9	15.8	39.7	65.8
105	3,017	45.3	3.3	0.5	4.2	16.4	39.7	69.7
115	3,281	48.1	3.4	0.5	4.4	16.9	39.7	73.3
125	3,532	50.7	3.4	0.5	4.7	17.4	39.7	76.7

A6.— Regional estimates of timber volume and carbon stocks for white-red-jack pine stands on forest land after clearcut harvest in the Northeast

Age	Mean volume	Mean carbon density						
		Live tree	Standing dead tree	Under-story	Down dead wood	Forest floor	Soil organic	Total nonsoil
<i>years</i>	<i>m³/hectare</i>	<i>tonnes carbon/hectare</i>						
0	0.0	0.0	0.0	2.1	20.4	13.8	78.1	36.3
5	0.0	7.3	0.7	2.2	15.8	10.7	78.1	36.8
15	30.0	28.6	2.9	1.8	10.4	9.4	78.1	53.1
25	54.4	44.7	3.9	1.8	7.5	10.1	78.1	68.1
35	77.9	57.7	4.3	1.7	6.1	11.2	78.1	81.0
45	100.6	69.4	4.6	1.7	5.5	12.2	78.1	93.4
55	122.5	78.7	4.8	1.6	5.3	13.1	78.1	103.4
65	142.3	86.8	5.0	1.6	5.3	13.7	78.1	112.5
75	160.9	94.3	5.2	1.6	5.5	14.2	78.1	120.8
85	178.4	101.2	5.3	1.6	5.8	14.7	78.1	128.6
95	194.7	107.6	5.4	1.6	6.0	15.0	78.1	135.7
105	210.0	113.5	5.5	1.6	6.3	15.4	78.1	142.3
115	224.1	118.9	5.6	1.6	6.6	15.6	78.1	148.3
125	237.1	123.8	5.7	1.6	6.8	15.9	78.1	153.8
<i>years</i>	<i>ft³/acre</i>	<i>tonnes carbon/acre</i>						
0	0	0.0	0.0	0.8	8.3	5.6	31.6	14.7
5	0	3.0	0.3	0.9	6.4	4.3	31.6	14.9
15	429	11.6	1.2	0.7	4.2	3.8	31.6	21.5
25	777	18.1	1.6	0.7	3.0	4.1	31.6	27.5
35	1,113	23.3	1.7	0.7	2.5	4.6	31.6	32.8
45	1,438	28.1	1.9	0.7	2.2	5.0	31.6	37.8
55	1,751	31.8	2.0	0.7	2.1	5.3	31.6	41.9
65	2,034	35.1	2.0	0.7	2.2	5.5	31.6	45.5
75	2,300	38.2	2.1	0.7	2.2	5.8	31.6	48.9
85	2,550	41.0	2.1	0.6	2.3	5.9	31.6	52.0
95	2,783	43.5	2.2	0.6	2.4	6.1	31.6	54.9
105	3,001	45.9	2.2	0.6	2.6	6.2	31.6	57.6
115	3,202	48.1	2.3	0.6	2.7	6.3	31.6	60.0
125	3,389	50.1	2.3	0.6	2.8	6.4	31.6	62.2

A7.— Regional estimates of timber volume and carbon stocks for aspen-birch stands on forest land after clearcut harvest in the Northern Lake States

Age	Mean volume	Mean carbon density						
		Live tree	Standing dead tree	Under-story	Down dead wood	Forest floor	Soil organic	Total nonsoil
<i>years</i>	<i>m³/hectare</i>	<i>tonnes carbon/hectare</i>						
0	0.0	0.0	0.0	2.0	13.4	10.2	146.1	25.6
5	0.0	7.3	0.5	2.1	9.5	7.5	146.1	26.8
15	2.9	13.9	1.4	2.1	5.0	6.0	146.1	28.4
25	21.5	26.8	2.7	2.1	3.9	6.5	146.1	42.0
35	47.2	40.8	4.1	2.0	4.0	7.5	146.1	58.4
45	72.8	53.5	5.3	2.0	4.6	8.5	146.1	74.0
55	97.1	64.9	6.1	2.0	5.4	9.3	146.1	87.7
65	119.5	75.0	6.7	2.0	6.1	10.1	146.1	99.8
75	139.7	83.8	7.1	2.0	6.8	10.7	146.1	110.4
85	157.5	91.5	7.4	2.0	7.4	11.3	146.1	119.6
95	173.0	98.0	7.7	2.0	7.9	11.8	146.1	127.4
105	186.0	103.4	7.9	2.0	8.4	12.2	146.1	133.9
115	196.4	107.7	8.1	2.0	8.7	12.5	146.1	139.1
125	204.3	110.9	8.3	2.0	9.0	12.9	146.1	143.0
<i>years</i>	<i>ft³/acre</i>	<i>tonnes carbon/acre</i>						
0	0	0.0	0.0	0.8	5.4	4.1	59.1	10.4
5	0	3.0	0.2	0.8	3.8	3.0	59.1	10.9
15	42	5.6	0.6	0.8	2.0	2.4	59.1	11.5
25	307	10.9	1.1	0.8	1.6	2.6	59.1	17.0
35	674	16.5	1.6	0.8	1.6	3.0	59.1	23.6
45	1,041	21.6	2.2	0.8	1.9	3.4	59.1	29.9
55	1,388	26.2	2.5	0.8	2.2	3.8	59.1	35.5
65	1,708	30.3	2.7	0.8	2.5	4.1	59.1	40.4
75	1,996	33.9	2.9	0.8	2.8	4.3	59.1	44.7
85	2,251	37.0	3.0	0.8	3.0	4.6	59.1	48.4
95	2,472	39.7	3.1	0.8	3.2	4.8	59.1	51.6
105	2,658	41.8	3.2	0.8	3.4	4.9	59.1	54.2
115	2,807	43.6	3.3	0.8	3.5	5.1	59.1	56.3
125	2,920	44.9	3.3	0.8	3.6	5.2	59.1	57.9

A8.— Regional estimates of timber volume and carbon stocks for elm-ash-cottonwood stands on forest land after clearcut harvest in the Northern Lake States

Age	Mean volume	Mean carbon density						
		Live tree	Standing dead tree	Under-story	Down dead wood	Forest floor	Soil organic	Total nonsoil
<i>years</i>	<i>m³/hectare</i>	<i>tonnes carbon/hectare</i>						
0	0.0	0.0	0.0	2.0	9.4	27.7	179.9	39.2
5	0.0	3.9	0.4	1.9	6.5	20.3	179.9	33.0
15	2.4	10.3	1.0	1.9	3.4	16.3	179.9	32.9
25	13.2	20.1	2.0	1.9	2.4	17.6	179.9	44.1
35	25.2	29.8	3.0	1.9	2.4	20.3	179.9	57.3
45	37.4	38.7	3.9	1.9	2.6	23.0	179.9	70.1
55	49.8	47.1	4.7	1.9	3.0	25.3	179.9	82.1
65	62.3	55.6	5.3	1.9	3.5	27.4	179.9	93.8
75	74.9	62.8	5.6	1.9	3.9	29.2	179.9	103.4
85	87.5	69.9	5.8	1.9	4.3	30.7	179.9	112.6
95	100.1	76.8	6.0	1.9	4.7	32.0	179.9	121.4
105	112.9	83.6	6.2	1.9	5.1	33.1	179.9	130.0
115	125.8	90.4	6.4	1.9	5.6	34.2	179.9	138.5
125	139.2	97.4	6.5	1.9	6.0	35.1	179.9	147.0
<i>years</i>	<i>ft³/acre</i>	<i>tonnes carbon/acre</i>						
0	0	0.0	0.0	0.8	3.8	11.2	72.8	15.8
5	0	1.6	0.2	0.8	2.6	8.2	72.8	13.3
15	35	4.2	0.4	0.8	1.4	6.6	72.8	13.3
25	189	8.1	0.8	0.8	1.0	7.1	72.8	17.8
35	360	12.0	1.2	0.8	1.0	8.2	72.8	23.2
45	535	15.7	1.6	0.8	1.1	9.3	72.8	28.4
55	712	19.1	1.9	0.8	1.2	10.3	72.8	33.2
65	890	22.5	2.2	0.8	1.4	11.1	72.8	38.0
75	1,070	25.4	2.3	0.8	1.6	11.8	72.8	41.8
85	1,250	28.3	2.4	0.8	1.7	12.4	72.8	45.6
95	1,431	31.1	2.4	0.8	1.9	12.9	72.8	49.1
105	1,613	33.8	2.5	0.8	2.1	13.4	72.8	52.6
115	1,798	36.6	2.6	0.8	2.2	13.8	72.8	56.0
125	1,990	39.4	2.7	0.8	2.4	14.2	72.8	59.5

A9.— Regional estimates of timber volume and carbon stocks for maple-beech-birch stands on forest land after clearcut harvest in the Northern Lake States

Age	Mean volume	Mean carbon density						Total nonsoil
		Live tree	Standing dead tree	Under-story	Down dead wood	Forest floor	Soil organic	
<i>years</i>	<i>m³/hectare</i>	<i>tonnes carbon/hectare</i>						
0	0.0	0.0	0.0	2.1	19.5	27.7	134.3	49.4
5	0.0	5.1	0.5	2.0	13.3	20.3	134.3	41.2
15	4.3	13.4	1.3	1.7	6.7	16.3	134.3	39.4
25	24.6	30.3	3.0	1.6	4.8	17.6	134.3	57.3
35	48.1	47.7	4.0	1.5	4.7	20.3	134.3	78.2
45	72.5	62.9	4.4	1.4	5.2	23.0	134.3	96.9
55	96.9	77.3	4.7	1.4	6.1	25.3	134.3	114.8
65	121.3	91.1	4.9	1.4	7.0	27.4	134.3	131.8
75	145.3	104.4	5.1	1.4	8.0	29.2	134.3	148.0
85	168.9	117.1	5.3	1.3	8.9	30.7	134.3	163.3
95	191.9	129.3	5.4	1.3	9.8	32.0	134.3	177.8
105	214.4	140.9	5.6	1.3	10.7	33.1	134.3	191.6
115	236.0	151.9	5.7	1.3	11.5	34.2	134.3	204.6
125	256.9	162.4	5.8	1.3	12.3	35.1	134.3	216.9
<i>years</i>	<i>ft³/acre</i>	<i>tonnes carbon/acre</i>						
0	0	0.0	0.0	0.9	7.9	11.2	54.3	20.0
5	0	2.1	0.2	0.8	5.4	8.2	54.3	16.7
15	62	5.4	0.5	0.7	2.7	6.6	54.3	16.0
25	351	12.2	1.2	0.6	1.9	7.1	54.3	23.2
35	688	19.3	1.6	0.6	1.9	8.2	54.3	31.7
45	1,036	25.4	1.8	0.6	2.1	9.3	54.3	39.2
55	1,385	31.3	1.9	0.6	2.5	10.3	54.3	46.5
65	1,733	36.9	2.0	0.6	2.8	11.1	54.3	53.4
75	2,076	42.2	2.1	0.6	3.2	11.8	54.3	59.9
85	2,414	47.4	2.1	0.5	3.6	12.4	54.3	66.1
95	2,743	52.3	2.2	0.5	4.0	12.9	54.3	72.0
105	3,064	57.0	2.3	0.5	4.3	13.4	54.3	77.5
115	3,373	61.5	2.3	0.5	4.7	13.8	54.3	82.8
125	3,671	65.7	2.3	0.5	5.0	14.2	54.3	87.8

A10.— Regional estimates of timber volume and carbon stocks for oak-hickory stands on forest land after clearcut harvest in the Northern Lake States

Age	Mean volume	Mean carbon density						
		Live tree	Standing dead tree	Under-story	Down dead wood	Forest floor	Soil organic	Total nonsoil
<i>years</i>	<i>m³/hectare</i>	<i>tonnes carbon/hectare</i>						
0	0.0	0.0	0.0	2.1	20.5	8.2	97.1	30.8
5	0.0	6.7	0.7	2.2	14.1	5.7	97.1	29.3
15	4.1	17.0	1.7	2.0	7.3	4.1	97.1	32.1
25	21.9	33.6	3.1	1.9	5.2	4.5	97.1	48.2
35	42.5	50.3	3.6	1.8	5.0	5.3	97.1	66.1
45	64.9	66.7	3.9	1.8	5.7	6.3	97.1	84.4
55	88.7	83.6	4.2	1.8	6.7	7.3	97.1	103.5
65	113.4	99.1	4.5	1.7	7.8	8.1	97.1	121.2
75	139.0	114.7	4.7	1.7	8.9	8.9	97.1	139.0
85	165.2	130.3	4.9	1.7	10.1	9.7	97.1	156.7
95	192.1	146.0	5.1	1.7	11.3	10.3	97.1	174.4
105	219.2	161.6	5.3	1.7	12.5	10.9	97.1	192.0
115	246.4	177.0	5.4	1.6	13.7	11.5	97.1	209.2
125	272.5	191.6	5.5	1.6	14.8	12.0	97.1	225.6
<i>years</i>	<i>ft³/acre</i>	<i>tonnes carbon/acre</i>						
0	0	0.0	0.0	0.8	8.3	3.3	39.3	12.5
5	0	2.7	0.3	0.9	5.7	2.3	39.3	11.9
15	58	6.9	0.7	0.8	2.9	1.7	39.3	13.0
25	313	13.6	1.2	0.8	2.1	1.8	39.3	19.5
35	608	20.4	1.4	0.7	2.0	2.2	39.3	26.7
45	928	27.0	1.6	0.7	2.3	2.6	39.3	34.2
55	1,267	33.8	1.7	0.7	2.7	2.9	39.3	41.9
65	1,620	40.1	1.8	0.7	3.1	3.3	39.3	49.0
75	1,986	46.4	1.9	0.7	3.6	3.6	39.3	56.2
85	2,361	52.7	2.0	0.7	4.1	3.9	39.3	63.4
95	2,745	59.1	2.1	0.7	4.6	4.2	39.3	70.6
105	3,133	65.4	2.1	0.7	5.1	4.4	39.3	77.7
115	3,521	71.6	2.2	0.7	5.5	4.7	39.3	84.7
125	3,895	77.5	2.2	0.7	6.0	4.9	39.3	91.3

A11.— Regional estimates of timber volume and carbon stocks for spruce-balsam fir stands on forest land after clearcut harvest in the Northern Lake States

Age	Mean volume	Mean carbon density						
		Live tree	Standing dead tree	Under-story	Down dead wood	Forest floor	Soil organic	Total nonsoil
<i>years</i>	<i>m³/hectare</i>	<i>tonnes carbon/hectare</i>						
0	0.0	0.0	0.0	2.1	16.0	33.7	261.8	51.9
5	0.0	3.4	0.3	2.1	12.4	23.6	261.8	41.8
15	3.0	9.3	0.9	2.6	7.7	18.6	261.8	39.1
25	23.2	24.3	2.4	1.9	6.1	20.7	261.8	55.3
35	51.1	41.2	4.1	1.6	5.8	24.2	261.8	77.0
45	77.2	56.0	5.1	1.5	6.1	27.7	261.8	96.4
55	100.7	67.4	5.8	1.4	6.6	30.7	261.8	111.9
65	121.6	77.2	6.4	1.3	7.1	33.3	261.8	125.2
75	140.2	85.5	6.8	1.3	7.6	35.5	261.8	136.8
85	156.5	92.8	7.2	1.2	8.2	37.4	261.8	146.8
95	170.9	99.0	7.5	1.2	8.6	39.1	261.8	155.4
105	183.5	104.3	7.7	1.2	9.1	40.6	261.8	162.9
115	194.4	109.0	7.9	1.2	9.5	41.9	261.8	169.4
125	203.8	112.9	8.1	1.2	9.8	43.0	261.8	174.9
<i>years</i>	<i>ft³/acre</i>	<i>tonnes carbon/acre</i>						
0	0	0.0	0.0	0.9	6.5	13.6	105.9	21.0
5	0	1.4	0.1	0.9	5.0	9.5	105.9	16.9
15	43	3.7	0.4	1.0	3.1	7.5	105.9	15.8
25	332	9.8	1.0	0.8	2.5	8.4	105.9	22.4
35	730	16.7	1.7	0.7	2.4	9.8	105.9	31.2
45	1,103	22.7	2.1	0.6	2.5	11.2	105.9	39.0
55	1,439	27.3	2.4	0.6	2.7	12.4	105.9	45.3
65	1,738	31.2	2.6	0.5	2.9	13.5	105.9	50.7
75	2,003	34.6	2.7	0.5	3.1	14.4	105.9	55.4
85	2,237	37.5	2.9	0.5	3.3	15.2	105.9	59.4
95	2,442	40.1	3.0	0.5	3.5	15.8	105.9	62.9
105	2,622	42.2	3.1	0.5	3.7	16.4	105.9	65.9
115	2,778	44.1	3.2	0.5	3.8	16.9	105.9	68.5
125	2,912	45.7	3.3	0.5	4.0	17.4	105.9	70.8

A12.— Regional estimates of timber volume and carbon stocks for white-red-jack pine stands on forest land after clearcut harvest in the Northern Lake States

Age	Mean volume	Mean carbon density						
		Live tree	Standing dead tree	Under-story	Down dead wood	Forest floor	Soil organic	Total nonsoil
<i>years</i>	<i>m³/hectare</i>	<i>tonnes carbon/hectare</i>						
0	0.0	0.0	0.0	2.0	25.5	13.8	120.8	41.3
5	0.0	0.4	0.0	2.0	19.3	10.7	120.8	32.5
15	6.6	8.0	0.8	2.0	11.6	9.4	120.8	31.8
25	48.1	35.4	3.5	2.0	8.8	10.1	120.8	59.9
35	104.7	62.9	4.9	2.0	8.1	11.2	120.8	89.1
45	158.9	85.8	5.5	2.0	8.2	12.2	120.8	113.7
55	209.1	105.3	5.9	2.0	8.8	13.1	120.8	135.0
65	255.1	122.2	6.2	2.0	9.5	13.7	120.8	153.6
75	297.4	137.1	6.5	2.0	10.3	14.2	120.8	170.0
85	336.1	150.3	6.7	2.0	11.0	14.7	120.8	184.6
95	371.7	162.0	6.9	2.0	11.8	15.0	120.8	197.7
105	404.2	172.5	7.0	2.0	12.5	15.4	120.8	209.3
115	434.0	182.0	7.2	2.0	13.1	15.6	120.8	219.8
125	461.3	190.5	7.3	1.9	13.7	15.9	120.8	229.3
<i>years</i>	<i>ft³/acre</i>	<i>tonnes carbon/acre</i>						
0	0	0.0	0.0	0.8	10.3	5.6	48.9	16.7
5	0	0.2	0.0	0.8	7.8	4.3	48.9	13.2
15	94	3.3	0.3	0.8	4.7	3.8	48.9	12.9
25	688	14.3	1.4	0.8	3.6	4.1	48.9	24.2
35	1,496	25.5	2.0	0.8	3.3	4.6	48.9	36.1
45	2,271	34.7	2.2	0.8	3.3	5.0	48.9	46.0
55	2,988	42.6	2.4	0.8	3.5	5.3	48.9	54.6
65	3,646	49.5	2.5	0.8	3.8	5.5	48.9	62.2
75	4,250	55.5	2.6	0.8	4.1	5.8	48.9	68.8
85	4,804	60.8	2.7	0.8	4.5	5.9	48.9	74.7
95	5,312	65.6	2.8	0.8	4.8	6.1	48.9	80.0
105	5,777	69.8	2.8	0.8	5.1	6.2	48.9	84.7
115	6,203	73.6	2.9	0.8	5.3	6.3	48.9	89.0
125	6,593	77.1	2.9	0.8	5.6	6.4	48.9	92.8

A13.— Regional estimates of timber volume and carbon stocks for elm-ash-cottonwood stands on forest land after clearcut harvest in the Northern Prairie States

Age	Mean volume	Mean carbon density						
		Live tree	Standing dead tree	Under-story	Down dead wood	Forest floor	Soil organic	Total nonsoil
<i>years</i>	<i>m³/hectare</i>	<i>tonnes carbon/hectare</i>						
0	0.0	0.0	0.0	2.1	11.3	27.7	84.8	41.0
5	0.0	3.9	0.4	2.1	7.7	20.3	84.8	34.4
15	0.0	8.7	0.9	2.7	3.9	16.3	84.8	32.4
25	5.8	15.5	1.6	2.4	2.5	17.6	84.8	39.7
35	21.8	27.7	2.8	2.2	2.5	20.3	84.8	55.5
45	45.1	43.2	4.3	2.0	3.3	23.0	84.8	75.7
55	73.0	60.2	5.6	1.9	4.3	25.3	84.8	97.2
65	104.1	78.9	6.1	1.8	5.5	27.4	84.8	119.7
75	137.4	96.5	6.5	1.8	6.7	29.2	84.8	140.6
85	171.9	114.0	6.9	1.7	7.9	30.7	84.8	161.2
95	206.8	131.3	7.2	1.7	9.1	32.0	84.8	181.3
105	241.7	148.2	7.5	1.6	10.3	33.1	84.8	200.7
115	275.8	164.3	7.8	1.6	11.4	34.2	84.8	219.2
125	308.6	179.6	8.0	1.6	12.4	35.1	84.8	236.6
<i>years</i>	<i>ft³/acre</i>	<i>tonnes carbon/acre</i>						
0	0	0.0	0.0	0.8	4.6	11.2	34.3	16.6
5	0	1.6	0.2	0.8	3.1	8.2	34.3	13.9
15	0	3.5	0.4	1.1	1.6	6.6	34.3	13.1
25	83	6.3	0.6	1.0	1.0	7.1	34.3	16.1
35	312	11.2	1.1	0.9	1.0	8.2	34.3	22.5
45	644	17.5	1.7	0.8	1.3	9.3	34.3	30.6
55	1,043	24.3	2.3	0.8	1.7	10.3	34.3	39.4
65	1,488	31.9	2.5	0.7	2.2	11.1	34.3	48.5
75	1,964	39.0	2.6	0.7	2.7	11.8	34.3	56.9
85	2,456	46.1	2.8	0.7	3.2	12.4	34.3	65.2
95	2,956	53.1	2.9	0.7	3.7	12.9	34.3	73.4
105	3,454	60.0	3.0	0.7	4.2	13.4	34.3	81.2
115	3,941	66.5	3.2	0.6	4.6	13.8	34.3	88.7
125	4,410	72.7	3.2	0.6	5.0	14.2	34.3	95.8

A14.— Regional estimates of timber volume and carbon stocks for maple-beech-birch stands on forest land after clearcut harvest in the Northern Prairie States

Age	Mean volume	Mean carbon density						
		Live tree	Standing dead tree	Under-story	Down dead wood	Forest floor	Soil organic	Total nonsoil
<i>years</i>	<i>m³/hectare</i>	<i>tonnes carbon/hectare</i>						
0	0.0	0.0	0.0	2.1	12.8	27.7	64.9	42.6
5	0.0	5.1	0.5	2.2	8.8	20.3	64.9	37.0
15	0.9	10.5	1.1	1.9	4.4	16.3	64.9	34.2
25	8.2	18.5	1.8	1.7	2.8	17.6	64.9	42.5
35	21.4	29.7	3.0	1.6	2.6	20.3	64.9	57.1
45	38.2	41.3	3.8	1.5	2.9	23.0	64.9	72.4
55	57.4	53.6	4.2	1.4	3.5	25.3	64.9	88.1
65	78.6	66.5	4.5	1.3	4.3	27.4	64.9	104.0
75	101.0	79.6	4.7	1.3	5.1	29.2	64.9	119.9
85	124.4	92.9	4.9	1.2	5.9	30.7	64.9	135.7
95	148.6	106.2	5.1	1.2	6.7	32.0	64.9	151.3
105	173.1	119.4	5.3	1.2	7.6	33.1	64.9	166.6
115	197.4	132.1	5.5	1.2	8.4	34.2	64.9	181.3
125	220.5	144.0	5.6	1.1	9.1	35.1	64.9	195.0
<i>years</i>	<i>ft³/acre</i>	<i>tonnes carbon/acre</i>						
0	0	0.0	0.0	0.9	5.2	11.2	26.2	17.3
5	0	2.1	0.2	0.9	3.6	8.2	26.2	15.0
15	13	4.3	0.4	0.8	1.8	6.6	26.2	13.8
25	117	7.5	0.7	0.7	1.1	7.1	26.2	17.2
35	306	12.0	1.2	0.6	1.0	8.2	26.2	23.1
45	546	16.7	1.5	0.6	1.2	9.3	26.2	29.3
55	821	21.7	1.7	0.6	1.4	10.3	26.2	35.6
65	1,123	26.9	1.8	0.5	1.7	11.1	26.2	42.1
75	1,443	32.2	1.9	0.5	2.1	11.8	26.2	48.5
85	1,778	37.6	2.0	0.5	2.4	12.4	26.2	54.9
95	2,123	43.0	2.1	0.5	2.7	12.9	26.2	61.2
105	2,474	48.3	2.2	0.5	3.1	13.4	26.2	67.4
115	2,821	53.5	2.2	0.5	3.4	13.8	26.2	73.4
125	3,151	58.3	2.3	0.5	3.7	14.2	26.2	78.9

A15.— Regional estimates of timber volume and carbon stocks for oak-hickory stands on forest land after clearcut harvest in the Northern Prairie States

Age	Mean volume	Mean carbon density						Total nonsoil
		Live tree	Standing dead tree	Under-story	Down dead wood	Forest floor	Soil organic	
<i>years</i>	<i>m³/hectare</i>	<i>tonnes carbon/hectare</i>						
0	0.0	0.0	0.0	2.1	14.1	8.2	45.9	24.4
5	0.0	6.7	0.6	2.4	9.8	5.7	45.9	25.1
15	2.1	15.6	1.6	2.1	5.2	4.1	45.9	28.6
25	13.0	27.5	2.7	2.0	3.7	4.5	45.9	40.3
35	27.4	40.0	3.2	1.9	3.5	5.3	45.9	53.9
45	43.0	52.2	3.6	1.8	3.9	6.3	45.9	67.8
55	59.1	64.3	3.9	1.8	4.5	7.3	45.9	81.7
65	74.9	74.7	4.1	1.7	5.1	8.1	45.9	93.8
75	90.2	84.6	4.3	1.7	5.7	8.9	45.9	105.2
85	104.7	93.7	4.4	1.7	6.3	9.7	45.9	115.8
95	118.3	102.1	4.5	1.6	6.9	10.3	45.9	125.6
105	130.8	109.7	4.7	1.6	7.4	10.9	45.9	134.4
115	142.0	116.5	4.7	1.6	7.9	11.5	45.9	142.3
125	151.9	122.5	4.8	1.6	8.3	12.0	45.9	149.2
<i>years</i>	<i>ft³/acre</i>	<i>tonnes carbon/acre</i>						
0	0	0.0	0.0	0.8	5.7	3.3	18.6	9.9
5	0	2.7	0.2	1.0	4.0	2.3	18.6	10.2
15	30	6.3	0.6	0.9	2.1	1.7	18.6	11.6
25	186	11.1	1.1	0.8	1.5	1.8	18.6	16.3
35	391	16.2	1.3	0.8	1.4	2.2	18.6	21.8
45	615	21.1	1.4	0.7	1.6	2.6	18.6	27.4
55	844	26.0	1.6	0.7	1.8	2.9	18.6	33.0
65	1,070	30.2	1.7	0.7	2.1	3.3	18.6	37.9
75	1,289	34.2	1.7	0.7	2.3	3.6	18.6	42.6
85	1,497	37.9	1.8	0.7	2.6	3.9	18.6	46.9
95	1,691	41.3	1.8	0.7	2.8	4.2	18.6	50.8
105	1,869	44.4	1.9	0.7	3.0	4.4	18.6	54.4
115	2,030	47.2	1.9	0.7	3.2	4.7	18.6	57.6
125	2,171	49.6	2.0	0.7	3.3	4.9	18.6	60.4

A16.— Regional estimates of timber volume and carbon stocks for oak-pine stands on forest land after clearcut harvest in the Northern Prairie States

Age	Mean volume	Mean carbon density						
		Live tree	Standing dead tree	Under-story	Down dead wood	Forest floor	Soil organic	Total nonsoil
<i>years</i>	<i>m³/hectare</i>	<i>tonnes carbon/hectare</i>						
0	0.0	0.0	0.0	4.2	17.8	29.7	36.2	51.7
5	0.0	5.1	0.4	4.2	13.8	20.2	36.2	43.8
15	4.5	13.8	1.2	4.3	8.7	15.3	36.2	43.2
25	28.4	29.8	2.6	3.6	6.5	17.1	36.2	59.5
35	57.9	47.4	3.4	3.3	5.8	20.3	36.2	80.2
45	86.7	63.3	4.0	3.1	5.8	23.6	36.2	99.8
55	113.2	77.0	4.4	2.9	6.2	26.6	36.2	117.1
65	137.1	89.4	4.7	2.9	6.7	29.3	36.2	132.9
75	158.1	98.9	5.0	2.8	7.1	31.6	36.2	145.4
85	176.0	106.8	5.2	2.7	7.5	33.6	36.2	155.9
95	190.8	113.3	5.4	2.7	7.9	35.4	36.2	164.7
105	202.4	118.3	5.5	2.7	8.2	37.0	36.2	171.7
115	210.9	121.9	5.6	2.7	8.5	38.4	36.2	177.1
125	216.1	124.1	5.7	2.7	8.6	39.7	36.2	180.8
<i>years</i>	<i>ft³/acre</i>	<i>tonnes carbon/acre</i>						
0	0	0.0	0.0	1.7	7.2	12.0	14.6	20.9
5	0	2.1	0.2	1.7	5.6	8.2	14.6	17.7
15	65	5.6	0.5	1.7	3.5	6.2	14.6	17.5
25	406	12.1	1.0	1.5	2.6	6.9	14.6	24.1
35	828	19.2	1.4	1.3	2.3	8.2	14.6	32.5
45	1,239	25.6	1.6	1.2	2.4	9.6	14.6	40.4
55	1,618	31.2	1.8	1.2	2.5	10.8	14.6	47.4
65	1,959	36.2	1.9	1.2	2.7	11.8	14.6	53.8
75	2,259	40.0	2.0	1.1	2.9	12.8	14.6	58.8
85	2,515	43.2	2.1	1.1	3.1	13.6	14.6	63.1
95	2,727	45.8	2.2	1.1	3.2	14.3	14.6	66.6
105	2,893	47.9	2.2	1.1	3.3	15.0	14.6	69.5
115	3,014	49.3	2.3	1.1	3.4	15.6	14.6	71.7
125	3,088	50.2	2.3	1.1	3.5	16.1	14.6	73.2

A17.— Regional estimates of timber volume and carbon stocks for Douglas-fir stands on forest land after clearcut harvest in the Pacific Northwest, East

Age	Mean volume	Mean carbon density						Total nonsoil
		Live tree	Standing dead tree	Under-story	Down dead wood	Forest floor	Soil organic	
<i>years</i>	<i>m³/hectare</i>	<i>tonnes carbon/hectare</i>						
0	0.0	0.0	0.0	4.6	26.0	37.2	94.8	67.8
5	0.0	2.7	0.3	4.4	22.5	35.4	94.8	65.2
15	3.8	8.7	0.9	4.1	17.2	32.9	94.8	63.7
25	47.7	38.3	3.8	3.7	15.9	31.8	94.8	93.5
35	119.0	75.1	7.5	3.6	16.5	31.6	94.8	134.2
45	184.7	104.0	10.0	3.5	17.1	32.0	94.8	166.5
55	241.8	127.3	10.9	3.4	17.8	32.7	94.8	192.1
65	290.9	146.4	11.5	3.4	18.5	33.6	94.8	213.5
75	332.7	162.2	12.0	3.4	19.2	34.6	94.8	231.4
85	368.3	175.3	12.4	3.4	19.8	35.6	94.8	246.5
95	398.6	186.2	12.7	3.4	20.5	36.6	94.8	259.3
105	424.4	195.4	13.0	3.3	21.0	37.5	94.8	270.2
115	446.4	203.1	13.2	3.3	21.6	38.4	94.8	279.5
125	465.2	209.6	13.3	3.3	22.0	39.2	94.8	287.5
<i>years</i>	<i>ft³/acre</i>	<i>tonnes carbon/acre</i>						
0	0	0.0	0.0	1.9	10.5	15.1	38.3	27.4
5	0	1.1	0.1	1.8	9.1	14.3	38.3	26.4
15	54	3.5	0.4	1.7	7.0	13.3	38.3	25.8
25	682	15.5	1.5	1.5	6.4	12.9	38.3	37.8
35	1,701	30.4	3.0	1.4	6.7	12.8	38.3	54.3
45	2,639	42.1	4.1	1.4	6.9	12.9	38.3	67.4
55	3,456	51.5	4.4	1.4	7.2	13.2	38.3	77.8
65	4,157	59.3	4.7	1.4	7.5	13.6	38.3	86.4
75	4,755	65.6	4.9	1.4	7.8	14.0	38.3	93.6
85	5,264	70.9	5.0	1.4	8.0	14.4	38.3	99.8
95	5,697	75.4	5.1	1.4	8.3	14.8	38.3	104.9
105	6,065	79.1	5.2	1.4	8.5	15.2	38.3	109.4
115	6,379	82.2	5.3	1.4	8.7	15.5	38.3	113.1
125	6,648	84.8	5.4	1.3	8.9	15.8	38.3	116.3

A18.— Regional estimates of timber volume and carbon stocks for fir-spruce-mountain hemlock stands on forest land after clearcut harvest in the Pacific Northwest, East

Age	Mean volume	Mean carbon density						
		Live tree	Standing dead tree	Under-story	Down dead wood	Forest floor	Soil organic	Total nonsoil
<i>years</i>	<i>m³/hectare</i>	<i>tonnes carbon/hectare</i>						
0	0.0	0.0	0.0	4.8	16.6	37.2	62.1	58.6
5	0.0	3.1	0.3	4.1	14.5	35.4	62.1	57.4
15	0.0	5.8	0.6	3.7	11.0	32.9	62.1	54.0
25	15.2	15.5	1.6	3.2	9.3	31.8	62.1	61.3
35	52.1	33.9	3.4	2.8	9.2	31.6	62.1	80.9
45	97.4	53.0	5.3	2.6	9.7	32.0	62.1	102.6
55	144.4	71.3	7.1	2.5	10.6	32.7	62.1	124.3
65	189.7	88.3	8.8	2.4	11.6	33.6	62.1	144.7
75	231.5	103.3	10.3	2.4	12.6	34.6	62.1	163.2
85	268.7	116.4	11.6	2.3	13.6	35.6	62.1	179.6
95	301.0	127.6	12.8	2.3	14.4	36.6	62.1	193.6
105	328.2	136.9	13.7	2.3	15.2	37.5	62.1	205.5
115	350.6	144.4	14.4	2.2	15.8	38.4	62.1	215.2
125	368.3	150.3	15.0	2.2	16.3	39.2	62.1	223.0
<i>years</i>	<i>ft³/acre</i>	<i>tonnes carbon/acre</i>						
0	0	0.0	0.0	1.9	6.7	15.1	25.1	23.7
5	0	1.3	0.1	1.7	5.9	14.3	25.1	23.2
15	0	2.3	0.2	1.5	4.5	13.3	25.1	21.9
25	217	6.3	0.6	1.3	3.8	12.9	25.1	24.8
35	745	13.7	1.4	1.1	3.7	12.8	25.1	32.8
45	1,392	21.4	2.1	1.1	3.9	12.9	25.1	41.5
55	2,063	28.9	2.9	1.0	4.3	13.2	25.1	50.3
65	2,711	35.7	3.6	1.0	4.7	13.6	25.1	58.6
75	3,308	41.8	4.2	1.0	5.1	14.0	25.1	66.1
85	3,840	47.1	4.7	0.9	5.5	14.4	25.1	72.7
95	4,302	51.6	5.2	0.9	5.8	14.8	25.1	78.4
105	4,691	55.4	5.5	0.9	6.1	15.2	25.1	83.2
115	5,010	58.4	5.8	0.9	6.4	15.5	25.1	87.1
125	5,264	60.8	6.1	0.9	6.6	15.8	25.1	90.3

A19.— Regional estimates of timber volume and carbon stocks for lodgepole pine stands on forest land after clearcut harvest in the Pacific Northwest, East

Age	Mean volume	Mean carbon density						
		Live tree	Standing dead tree	Under-story	Down dead wood	Forest floor	Soil organic	Total nonsoil
<i>years</i>	<i>m³/hectare</i>	<i>tonnes carbon/hectare</i>						
0	0.0	0.0	0.0	4.8	13.1	24.1	52.0	42.0
5	0.0	1.9	0.2	4.8	11.4	22.0	52.0	40.2
15	6.6	8.1	0.8	3.5	9.0	19.4	52.0	40.7
25	40.8	24.3	2.4	2.6	8.3	18.3	52.0	56.0
35	81.7	40.1	4.0	2.3	8.2	18.2	52.0	72.8
45	120.5	54.0	5.4	2.2	8.3	18.7	52.0	88.5
55	156.3	64.5	6.4	2.1	8.4	19.4	52.0	100.8
65	189.3	73.6	7.4	2.0	8.6	20.4	52.0	111.9
75	219.9	81.7	8.2	1.9	8.9	21.4	52.0	122.0
85	248.0	88.9	8.9	1.9	9.2	22.4	52.0	131.2
95	274.0	95.4	9.5	1.9	9.6	23.3	52.0	139.7
105	298.2	101.2	10.1	1.8	9.9	24.3	52.0	147.4
115	320.5	106.5	10.6	1.8	10.3	25.2	52.0	154.4
125	341.2	111.4	10.9	1.8	10.6	26.0	52.0	160.7
<i>years</i>	<i>ft³/acre</i>	<i>tonnes carbon/acre</i>						
0	0	0.0	0.0	2.0	5.3	9.8	21.1	17.0
5	0	0.8	0.1	2.0	4.6	8.9	21.1	16.3
15	95	3.3	0.3	1.4	3.6	7.8	21.1	16.5
25	583	9.8	1.0	1.1	3.4	7.4	21.1	22.7
35	1,168	16.2	1.6	0.9	3.3	7.4	21.1	29.5
45	1,722	21.8	2.2	0.9	3.3	7.6	21.1	35.8
55	2,234	26.1	2.6	0.8	3.4	7.9	21.1	40.8
65	2,706	29.8	3.0	0.8	3.5	8.2	21.1	45.3
75	3,142	33.1	3.3	0.8	3.6	8.6	21.1	49.4
85	3,544	36.0	3.6	0.8	3.7	9.1	21.1	53.1
95	3,916	38.6	3.9	0.8	3.9	9.4	21.1	56.5
105	4,261	41.0	4.1	0.7	4.0	9.8	21.1	59.6
115	4,580	43.1	4.3	0.7	4.2	10.2	21.1	62.5
125	4,876	45.1	4.4	0.7	4.3	10.5	21.1	65.0

A20.— Regional estimates of timber volume and carbon stocks for ponderosa pine stands on forest land after clearcut harvest in the Pacific Northwest, East

Age	Mean volume	Mean carbon density						
		Live tree	Standing dead tree	Under-story	Down dead wood	Forest floor	Soil organic	Total nonsoil
<i>years</i>	<i>m³/hectare</i>	<i>tonnes carbon/hectare</i>						
0	0.0	0.0	0.0	4.8	9.6	24.1	50.7	38.5
5	0.0	3.3	0.3	4.6	8.5	22.0	50.7	38.6
15	4.1	7.9	0.8	3.8	6.8	19.4	50.7	38.7
25	21.6	17.3	1.7	3.2	6.2	18.3	50.7	46.7
35	40.8	26.2	2.6	2.9	5.9	18.2	50.7	55.9
45	61.4	34.9	3.3	2.8	6.0	18.7	50.7	65.5
55	83.3	43.6	3.7	2.6	6.3	19.4	50.7	75.7
65	106.0	52.5	4.2	2.5	6.7	20.4	50.7	86.2
75	129.3	61.3	4.6	2.4	7.3	21.4	50.7	96.9
85	153.0	70.0	4.9	2.4	7.9	22.4	50.7	107.6
95	176.8	78.6	5.3	2.3	8.6	23.3	50.7	118.1
105	200.4	87.0	5.6	2.3	9.4	24.3	50.7	128.4
115	223.6	95.1	5.9	2.2	10.1	25.2	50.7	138.4
125	246.0	102.8	6.1	2.2	10.8	26.0	50.7	147.9
<i>years</i>	<i>ft³/acre</i>	<i>tonnes carbon/acre</i>						
0	0	0.0	0.0	1.9	3.9	9.8	20.5	15.6
5	0	1.3	0.1	1.8	3.5	8.9	20.5	15.6
15	59	3.2	0.3	1.5	2.8	7.8	20.5	15.6
25	309	7.0	0.7	1.3	2.5	7.4	20.5	18.9
35	583	10.6	1.1	1.2	2.4	7.4	20.5	22.6
45	878	14.1	1.3	1.1	2.4	7.6	20.5	26.5
55	1,190	17.7	1.5	1.1	2.5	7.9	20.5	30.6
65	1,515	21.2	1.7	1.0	2.7	8.2	20.5	34.9
75	1,848	24.8	1.8	1.0	2.9	8.6	20.5	39.2
85	2,187	28.3	2.0	1.0	3.2	9.1	20.5	43.5
95	2,527	31.8	2.1	0.9	3.5	9.4	20.5	47.8
105	2,864	35.2	2.3	0.9	3.8	9.8	20.5	52.0
115	3,195	38.5	2.4	0.9	4.1	10.2	20.5	56.0
125	3,515	41.6	2.5	0.9	4.4	10.5	20.5	59.8

A21.— Regional estimates of timber volume and carbon stocks for alder-maple stands on forest land after clearcut harvest in the Pacific Northwest, West

Age	Mean volume	Mean carbon density						
		Live tree	Standing dead tree	Under-story	Down dead wood	Forest floor	Soil organic	Total nonsoil
<i>years</i>	<i>m³/hectare</i>	<i>tonnes carbon/hectare</i>						
0	0.0	0.0	0.0	4.7	32.2	9.3	115.2	46.2
5	0.0	8.0	0.8	4.7	22.0	3.9	115.2	39.5
15	49.5	31.0	3.1	3.7	12.3	4.5	115.2	54.6
25	229.7	99.4	9.9	2.8	13.5	6.2	115.2	131.9
35	380.8	153.8	15.4	2.5	16.4	7.6	115.2	195.7
45	513.7	200.8	20.1	2.4	19.8	8.6	115.2	251.7
55	633.3	242.5	22.2	2.3	23.3	9.4	115.2	299.7
65	742.1	280.1	23.9	2.2	26.7	10.1	115.2	343.0
75	842.1	314.4	25.3	2.2	29.9	10.7	115.2	382.4
85	934.5	346.0	26.6	2.1	32.8	11.1	115.2	418.6
95	1,020.3	375.2	27.7	2.1	35.6	11.5	115.2	452.0
105	1,100.3	402.2	28.7	2.0	38.1	11.9	115.2	483.0
115	1,175.0	427.4	29.6	2.1	40.5	12.2	115.2	511.8
125	1,244.9	450.9	30.4	2.3	42.7	12.4	115.2	538.7
<i>years</i>	<i>ft³/acre</i>	<i>tonnes carbon/acre</i>						
0	0	0.0	0.0	1.9	13.0	3.8	46.6	18.7
5	0	3.2	0.3	1.9	8.9	1.6	46.6	16.0
15	708	12.6	1.3	1.5	5.0	1.8	46.6	22.1
25	3,282	40.2	4.0	1.1	5.5	2.5	46.6	53.4
35	5,442	62.3	6.2	1.0	6.6	3.1	46.6	79.2
45	7,342	81.3	8.1	1.0	8.0	3.5	46.6	101.9
55	9,050	98.1	9.0	0.9	9.4	3.8	46.6	121.3
65	10,605	113.3	9.7	0.9	10.8	4.1	46.6	138.8
75	12,034	127.2	10.3	0.9	12.1	4.3	46.6	154.8
85	13,355	140.0	10.8	0.9	13.3	4.5	46.6	169.4
95	14,582	151.8	11.2	0.8	14.4	4.7	46.6	182.9
105	15,725	162.8	11.6	0.8	15.4	4.8	46.6	195.4
115	16,792	173.0	12.0	0.9	16.4	4.9	46.6	207.1
125	17,791	182.5	12.3	0.9	17.3	5.0	46.6	218.0

A22.— Regional estimates of timber volume and carbon stocks for Douglas-fir stands on forest land after clearcut harvest in the Pacific Northwest, West

Age	Mean volume	Mean carbon density						
		Live tree	Standing dead tree	Under-story	Down dead wood	Forest floor	Soil organic	Total nonsoil
<i>years</i>	<i>m³/hectare</i>	<i>tonnes carbon/hectare</i>						
0	0.0	0.0	0.0	4.6	50.3	27.5	94.8	82.4
5	0.0	8.4	0.8	4.5	43.9	23.7	94.8	81.3
15	37.4	30.3	3.0	3.9	34.6	20.7	94.8	92.6
25	208.9	107.1	10.7	3.4	33.9	21.2	94.8	176.3
35	391.8	181.6	17.4	3.2	35.2	23.3	94.8	260.7
45	554.7	246.1	21.2	3.1	37.1	26.0	94.8	333.5
55	698.4	302.2	24.1	3.0	39.4	28.9	94.8	397.6
65	826.0	351.4	26.4	3.0	41.8	31.8	94.8	454.4
75	939.9	394.9	28.4	2.9	44.4	34.5	94.8	505.1
85	1,042.1	433.7	30.1	2.9	47.0	37.0	94.8	550.7
95	1,134.5	468.6	31.6	2.9	49.5	39.3	94.8	591.9
105	1,218.3	500.1	32.9	2.9	51.9	41.5	94.8	629.2
115	1,294.7	528.7	34.0	2.9	54.3	43.4	94.8	663.3
125	1,364.7	554.8	35.0	2.8	56.5	45.3	94.8	694.4
<i>years</i>	<i>ft³/acre</i>	<i>tonnes carbon/acre</i>						
0	0	0.0	0.0	1.9	20.3	11.1	38.3	33.3
5	0	3.4	0.3	1.8	17.8	9.6	38.3	32.9
15	535	12.3	1.2	1.6	14.0	8.4	38.3	37.5
25	2,985	43.3	4.3	1.4	13.7	8.6	38.3	71.3
35	5,600	73.5	7.1	1.3	14.2	9.4	38.3	105.5
45	7,927	99.6	8.6	1.3	15.0	10.5	38.3	135.0
55	9,981	122.3	9.7	1.2	15.9	11.7	38.3	160.9
65	11,804	142.2	10.7	1.2	16.9	12.9	38.3	183.9
75	13,432	159.8	11.5	1.2	18.0	14.0	38.3	204.4
85	14,893	175.5	12.2	1.2	19.0	15.0	38.3	222.9
95	16,213	189.6	12.8	1.2	20.0	15.9	38.3	239.5
105	17,411	202.4	13.3	1.2	21.0	16.8	38.3	254.6
115	18,503	213.9	13.8	1.2	22.0	17.6	38.3	268.4
125	19,503	224.5	14.2	1.1	22.9	18.3	38.3	281.0

A23.— Regional estimates of timber volume and carbon stocks for Douglas-fir stands on forest land after clearcut harvest in the Pacific Northwest, West; volumes are for high-productivity sites (growth rate greater than 165 cubic feet wood per acre per year) with high-intensity management (replanting with genetically improved stock, fertilization, and precommercial thinning)

Age	Mean volume	Mean carbon density						
		Live tree	Standing dead tree	Under-story	Down dead wood	Forest floor	Soil organic	Total nonsoil
<i>years</i>	<i>m³/hectare</i>	<i>tonnes carbon/hectare</i>						
0	0.0	0.0	0.0	4.6	49.3	27.5	94.8	81.4
5	0.0	9.5	0.9	4.4	43.1	23.7	94.8	81.7
15	19.8	23.4	2.3	4.0	33.3	20.7	94.8	83.8
25	169.7	84.6	8.5	3.5	31.2	21.2	94.8	148.9
35	445.7	187.4	10.0	3.2	35.4	23.3	94.8	259.3
45	718.8	286.2	10.6	3.0	40.8	26.0	94.8	366.7
55	924.1	359.4	10.9	3.0	44.9	28.9	94.8	447.0
65	1,086.5	416.7	11.1	2.9	48.2	31.8	94.8	510.7
75	1,225.8	465.6	11.2	2.9	51.4	34.5	94.8	565.5
85	1,346.8	507.8	11.3	2.9	54.3	37.0	94.8	613.4
95	1,452.4	544.6	11.4	2.8	57.0	39.3	94.8	655.2
105	1,544.4	576.5	11.5	2.9	59.6	41.5	94.8	691.9
115	1,544.4	576.5	11.5	2.9	59.0	43.4	94.8	693.4
125	1,544.4	576.5	11.5	2.9	58.7	45.3	94.8	694.8
<i>years</i>	<i>ft³/acre</i>	<i>tonnes carbon/acre</i>						
0	0	0.0	0.0	1.9	19.9	11.1	38.3	32.9
5	0	3.8	0.4	1.8	17.5	9.6	38.3	33.0
15	283	9.5	0.9	1.6	13.5	8.4	38.3	33.9
25	2,425	34.2	3.4	1.4	12.6	8.6	38.3	60.3
35	6,370	75.9	4.1	1.3	14.3	9.4	38.3	104.9
45	10,272	115.8	4.3	1.2	16.5	10.5	38.3	148.4
55	13,207	145.4	4.4	1.2	18.2	11.7	38.3	180.9
65	15,527	168.6	4.5	1.2	19.5	12.9	38.3	206.7
75	17,518	188.4	4.5	1.2	20.8	14.0	38.3	228.9
85	19,248	205.5	4.6	1.2	22.0	15.0	38.3	248.2
95	20,756	220.4	4.6	1.2	23.1	15.9	38.3	265.2
105	22,072	233.3	4.7	1.2	24.1	16.8	38.3	280.0
115	22,072	233.3	4.7	1.2	23.9	17.6	38.3	280.6
125	22,072	233.3	4.7	1.2	23.7	18.3	38.3	281.2

A24.— Regional estimates of timber volume and carbon stocks for fir-spruce-mountain hemlock stands on forest land after clearcut harvest in the Pacific Northwest, West

Age	Mean volume	Mean carbon density						
		Live tree	Standing dead tree	Under-story	Down dead wood	Forest floor	Soil organic	Total nonsoil
<i>years</i>	<i>m³/hectare</i>	<i>tonnes carbon/hectare</i>						
0	0.0	0.0	0.0	4.8	23.8	29.5	62.1	58.1
5	0.0	3.2	0.3	4.8	20.7	27.0	62.1	56.0
15	8.2	11.6	1.2	3.9	16.0	25.2	62.1	57.9
25	62.3	42.5	4.3	3.2	14.8	25.6	62.1	90.3
35	145.5	84.3	8.4	2.8	15.6	27.1	62.1	138.2
45	238.7	128.7	12.9	2.6	17.4	28.9	62.1	190.6
55	333.9	168.2	16.8	2.5	19.4	30.8	62.1	237.8
65	427.0	205.1	20.5	2.5	21.6	32.6	62.1	282.2
75	515.8	239.2	23.9	2.4	23.8	34.2	62.1	323.4
85	599.0	270.3	27.0	2.3	25.9	35.6	62.1	361.2
95	676.0	298.5	29.8	2.3	28.0	36.8	62.1	395.5
105	746.6	323.9	32.4	2.3	29.9	37.9	62.1	426.5
115	810.8	346.7	34.1	2.3	31.7	38.9	62.1	453.7
125	869.1	367.2	35.1	2.2	33.4	39.8	62.1	477.7
<i>years</i>	<i>ft³/acre</i>	<i>tonnes carbon/acre</i>						
0	0	0.0	0.0	1.9	9.6	11.9	25.1	23.5
5	0	1.3	0.1	1.9	8.4	10.9	25.1	22.7
15	117	4.7	0.5	1.6	6.5	10.2	25.1	23.4
25	890	17.2	1.7	1.3	6.0	10.4	25.1	36.6
35	2,080	34.1	3.4	1.1	6.3	11.0	25.1	55.9
45	3,412	52.1	5.2	1.1	7.1	11.7	25.1	77.1
55	4,772	68.1	6.8	1.0	7.9	12.5	25.1	96.2
65	6,103	83.0	8.3	1.0	8.7	13.2	25.1	114.2
75	7,371	96.8	9.7	1.0	9.6	13.8	25.1	130.9
85	8,560	109.4	10.9	0.9	10.5	14.4	25.1	146.2
95	9,661	120.8	12.1	0.9	11.3	14.9	25.1	160.0
105	10,670	131.1	13.1	0.9	12.1	15.4	25.1	172.6
115	11,588	140.3	13.8	0.9	12.8	15.8	25.1	183.6
125	12,421	148.6	14.2	0.9	13.5	16.1	25.1	193.3

A25.— Regional estimates of timber volume and carbon stocks for hemlock-Sitka spruce stands on forest land after clearcut harvest in the Pacific Northwest, West

Age	Mean volume	Mean carbon density						
		Live tree	Standing dead tree	Under-story	Down dead wood	Forest floor	Soil organic	Total nonsoil
<i>years</i>	<i>m³/hectare</i>	<i>tonnes carbon/hectare</i>						
0	0.0	0.0	0.0	4.7	43.2	27.5	116.3	75.4
5	0.0	5.9	0.6	4.7	37.6	23.7	116.3	72.5
15	33.7	22.5	2.2	4.1	29.4	20.7	116.3	78.9
25	184.1	78.0	7.8	3.1	27.6	21.2	116.3	137.7
35	350.8	139.8	14.0	2.7	28.4	23.3	116.3	208.2
45	516.7	201.6	20.2	2.5	30.6	26.0	116.3	280.9
55	678.7	256.6	25.7	2.4	33.2	28.9	116.3	346.8
65	835.1	309.1	30.9	2.3	36.2	31.8	116.3	410.4
75	985.6	359.2	35.9	2.2	39.6	34.5	116.3	471.5
85	1,129.8	406.7	40.1	2.2	43.2	37.0	116.3	529.2
95	1,267.4	451.8	42.8	2.3	46.8	39.3	116.3	583.0
105	1,398.3	494.4	45.2	2.5	50.4	41.5	116.3	634.0
115	1,522.4	534.7	47.4	2.7	53.9	43.4	116.3	682.2
125	1,639.6	572.6	49.4	2.9	57.3	45.3	116.3	727.5
<i>years</i>	<i>ft³/acre</i>	<i>tonnes carbon/acre</i>						
0	0	0.0	0.0	1.9	17.5	11.1	47.1	30.5
5	0	2.4	0.2	1.9	15.2	9.6	47.1	29.3
15	482	9.1	0.9	1.6	11.9	8.4	47.1	31.9
25	2,631	31.6	3.2	1.3	11.2	8.6	47.1	55.7
35	5,013	56.6	5.7	1.1	11.5	9.4	47.1	84.2
45	7,385	81.6	8.2	1.0	12.4	10.5	47.1	113.7
55	9,699	103.9	10.4	1.0	13.4	11.7	47.1	140.3
65	11,935	125.1	12.5	0.9	14.7	12.9	47.1	166.1
75	14,086	145.4	14.5	0.9	16.0	14.0	47.1	190.8
85	16,146	164.6	16.2	0.9	17.5	15.0	47.1	214.2
95	18,113	182.8	17.3	0.9	18.9	15.9	47.1	235.9
105	19,983	200.1	18.3	1.0	20.4	16.8	47.1	256.6
115	21,757	216.4	19.2	1.1	21.8	17.6	47.1	276.1
125	23,432	231.7	20.0	1.2	23.2	18.3	47.1	294.4

A26.— Regional estimates of timber volume and carbon stocks for hemlock-Sitka spruce stands on forest land after clearcut harvest in the Pacific Northwest, West; volumes are for high-productivity sites (growth rate greater than 225 cubic feet wood/acre/year)

Age	Mean volume	Mean carbon density						
		Live tree	Standing dead tree	Under-story	Down dead wood	Forest floor	Soil organic	Total nonsoil
<i>years</i>	<i>m³/hectare</i>	<i>tonnes carbon/hectare</i>						
0	0.0	0.0	0.0	4.7	42.7	27.5	116.3	74.9
5	0.0	5.9	0.6	4.7	37.1	23.7	116.3	72.0
15	80.3	36.4	3.6	3.7	30.4	20.7	116.3	94.8
25	221.7	90.4	9.0	3.0	28.6	21.2	116.3	152.3
35	413.7	161.0	16.1	2.7	30.3	23.3	116.3	233.3
45	669.6	253.6	25.4	2.4	35.6	26.0	116.3	342.9
55	903.9	332.1	33.2	2.3	40.5	28.9	116.3	437.0
65	1,119.3	403.3	39.9	2.2	45.5	31.8	116.3	522.6
75	1,318.1	468.3	43.7	2.3	50.4	34.5	116.3	599.3
85	1,502.0	528.1	47.1	2.6	55.1	37.0	116.3	669.9
95	1,672.1	583.0	50.0	2.9	59.7	39.3	116.3	735.0
105	1,829.1	633.5	52.6	3.2	64.1	41.5	116.3	794.8
115	1,973.0	679.5	54.9	3.4	68.2	43.4	116.3	849.4
125	2,103.3	721.0	56.9	3.6	72.0	45.3	116.3	898.7
<i>years</i>	<i>ft³/acre</i>	<i>tonnes carbon/acre</i>						
0	0	0.0	0.0	1.9	17.3	11.1	47.1	30.3
5	0	2.4	0.2	1.9	15.0	9.6	47.1	29.1
15	1,148	14.7	1.5	1.5	12.3	8.4	47.1	38.4
25	3,169	36.6	3.7	1.2	11.6	8.6	47.1	61.6
35	5,912	65.1	6.5	1.1	12.3	9.4	47.1	94.4
45	9,570	102.6	10.3	1.0	14.4	10.5	47.1	138.8
55	12,918	134.4	13.4	0.9	16.4	11.7	47.1	176.8
65	15,996	163.2	16.1	0.9	18.4	12.9	47.1	211.5
75	18,837	189.5	17.7	0.9	20.4	14.0	47.1	242.5
85	21,465	213.7	19.0	1.1	22.3	15.0	47.1	271.1
95	23,896	235.9	20.2	1.2	24.2	15.9	47.1	297.4
105	26,140	256.4	21.3	1.3	25.9	16.8	47.1	321.6
115	28,197	275.0	22.2	1.4	27.6	17.6	47.1	343.7
125	30,059	291.8	23.0	1.5	29.1	18.3	47.1	363.7

A27.— Regional estimates of timber volume and carbon stocks for mixed conifer stands on forest land after clearcut harvest in the Pacific Southwest

Age	Mean volume	Mean carbon density						
		Live tree	Standing dead tree	Under-story	Down dead wood	Forest floor	Soil organic	Total nonsoil
<i>years</i>	<i>m³/hectare</i>	<i>tonnes carbon/hectare</i>						
0	0.0	0.0	0.0	4.8	12.0	37.2	49.8	54.0
5	0.0	4.2	0.3	4.8	10.7	35.4	49.8	55.4
15	2.0	8.1	0.8	4.8	8.4	32.9	49.8	54.9
25	11.1	14.6	1.5	6.9	7.0	31.8	49.8	61.7
35	24.4	22.3	2.2	4.9	6.3	31.6	49.8	67.3
45	44.5	32.9	3.3	3.6	6.3	32.0	49.8	78.1
55	71.9	46.5	4.7	2.8	6.9	32.7	49.8	93.5
65	106.6	62.8	6.3	2.2	7.9	33.6	49.8	112.8
75	147.9	81.4	8.1	1.8	9.3	34.6	49.8	135.3
85	195.4	102.0	10.2	1.5	11.1	35.6	49.8	160.4
95	248.3	124.2	12.4	1.3	13.1	36.6	49.8	187.5
105	305.6	147.5	14.8	1.1	15.3	37.5	49.8	216.2
115	366.7	171.8	17.2	1.0	17.6	38.4	49.8	245.9
125	430.5	196.6	19.7	1.0	20.0	39.2	49.8	276.4
<i>years</i>	<i>ft³/acre</i>	<i>tonnes carbon/acre</i>						
0	0	0.0	0.0	1.9	4.9	15.1	20.2	21.9
5	0	1.7	0.1	1.9	4.3	14.3	20.2	22.4
15	29	3.3	0.3	1.9	3.4	13.3	20.2	22.2
25	159	5.9	0.6	2.8	2.8	12.9	20.2	25.0
35	349	9.0	0.9	2.0	2.6	12.8	20.2	27.2
45	636	13.3	1.3	1.5	2.5	12.9	20.2	31.6
55	1,028	18.8	1.9	1.1	2.8	13.2	20.2	37.9
65	1,523	25.4	2.5	0.9	3.2	13.6	20.2	45.7
75	2,114	33.0	3.3	0.7	3.8	14.0	20.2	54.8
85	2,793	41.3	4.1	0.6	4.5	14.4	20.2	64.9
95	3,548	50.2	5.0	0.5	5.3	14.8	20.2	75.9
105	4,368	59.7	6.0	0.5	6.2	15.2	20.2	87.5
115	5,240	69.5	7.0	0.4	7.1	15.5	20.2	99.5
125	6,152	79.6	8.0	0.4	8.1	15.8	20.2	111.9

A28.— Regional estimates of timber volume and carbon stocks for fir-spruce-mountain hemlock stands on forest land after clearcut harvest in the Pacific Southwest

Age	Mean volume	Mean carbon density						
		Live tree	Standing dead tree	Under-story	Down dead wood	Forest floor	Soil organic	Total nonsoil
<i>years</i>	<i>m³/hectare</i>	<i>tonnes carbon/hectare</i>						
0	0.0	0.0	0.0	4.8	16.0	37.2	51.9	58.0
5	0.0	3.2	0.3	4.8	14.0	35.4	51.9	57.7
15	2.0	7.9	0.8	4.2	10.9	32.9	51.9	56.8
25	13.7	17.3	1.7	3.4	9.3	31.8	51.9	63.5
35	32.4	29.5	3.0	2.9	8.6	31.6	51.9	75.6
45	58.8	45.2	4.5	2.6	8.9	32.0	51.9	93.2
55	94.0	63.1	6.3	2.4	9.8	32.7	51.9	114.3
65	136.7	83.5	8.4	2.2	11.2	33.6	51.9	138.9
75	185.6	105.7	10.6	2.1	13.1	34.6	51.9	166.0
85	239.2	128.9	12.9	2.0	15.2	35.6	51.9	194.6
95	296.6	153.0	15.3	1.9	17.5	36.6	51.9	224.2
105	356.8	177.4	17.7	1.8	19.9	37.5	51.9	254.4
115	419.1	202.0	20.2	1.8	22.4	38.4	51.9	284.8
125	482.7	226.6	22.7	1.7	25.0	39.2	51.9	315.1
<i>years</i>	<i>ft³/acre</i>	<i>tonnes carbon/acre</i>						
0	0	0.0	0.0	1.9	6.5	15.1	21.0	23.5
5	0	1.3	0.1	1.9	5.7	14.3	21.0	23.4
15	28	3.2	0.3	1.7	4.4	13.3	21.0	23.0
25	196	7.0	0.7	1.4	3.7	12.9	21.0	25.7
35	463	11.9	1.2	1.2	3.5	12.8	21.0	30.6
45	840	18.3	1.8	1.1	3.6	12.9	21.0	37.7
55	1,343	25.5	2.6	1.0	4.0	13.2	21.0	46.3
65	1,954	33.8	3.4	0.9	4.5	13.6	21.0	56.2
75	2,652	42.8	4.3	0.8	5.3	14.0	21.0	67.2
85	3,419	52.2	5.2	0.8	6.1	14.4	21.0	78.8
95	4,239	61.9	6.2	0.8	7.1	14.8	21.0	90.7
105	5,099	71.8	7.2	0.7	8.1	15.2	21.0	102.9
115	5,989	81.8	8.2	0.7	9.1	15.5	21.0	115.2
125	6,899	91.7	9.2	0.7	10.1	15.8	21.0	127.5

A29.— Regional estimates of timber volume and carbon stocks for western oak stands on forest land after clearcut harvest in the Pacific Southwest

Age	Mean volume	Mean carbon density						
		Live tree	Standing dead tree	Under-story	Down dead wood	Forest floor	Soil organic	Total nonsoil
<i>years</i>	<i>m³/hectare</i>	<i>tonnes carbon/hectare</i>						
0	0.0	0.0	0.0	4.7	13.3	31.7	27.6	49.7
5	0.0	2.6	0.2	4.6	8.9	28.4	27.6	44.8
15	0.0	5.7	0.6	4.5	4.1	24.6	27.6	39.5
25	1.0	8.8	0.9	4.4	2.1	23.4	27.6	39.5
35	25.9	30.6	3.1	4.2	2.0	23.5	27.6	63.4
45	76.3	65.1	4.5	4.1	3.0	24.3	27.6	101.1
55	127.8	98.3	5.4	4.0	4.2	25.5	27.6	137.5
65	174.4	124.0	6.0	4.0	5.2	26.8	27.6	166.1
75	215.0	145.3	6.5	4.0	6.1	28.1	27.6	189.9
85	249.4	162.7	6.8	4.0	6.8	29.4	27.6	209.7
95	278.4	177.1	7.1	4.0	7.4	30.6	27.6	226.1
105	302.8	189.0	7.3	3.9	7.9	31.7	27.6	239.7
115	323.3	198.8	7.4	3.9	8.3	32.6	27.6	251.1
125	340.6	207.0	7.6	3.9	8.6	33.5	27.6	260.7
<i>years</i>	<i>ft³/acre</i>	<i>tonnes carbon/acre</i>						
0	0	0.0	0.0	1.9	5.4	12.8	11.2	20.1
5	0	1.1	0.1	1.9	3.6	11.5	11.2	18.1
15	0	2.3	0.2	1.8	1.7	10.0	11.2	16.0
25	15	3.6	0.4	1.8	0.8	9.5	11.2	16.0
35	370	12.4	1.2	1.7	0.8	9.5	11.2	25.7
45	1,090	26.3	1.8	1.7	1.2	9.8	11.2	40.9
55	1,826	39.8	2.2	1.6	1.7	10.3	11.2	55.6
65	2,493	50.2	2.4	1.6	2.1	10.9	11.2	67.2
75	3,072	58.8	2.6	1.6	2.5	11.4	11.2	76.9
85	3,564	65.9	2.8	1.6	2.7	11.9	11.2	84.9
95	3,979	71.7	2.9	1.6	3.0	12.4	11.2	91.5
105	4,328	76.5	2.9	1.6	3.2	12.8	11.2	97.0
115	4,620	80.5	3.0	1.6	3.3	13.2	11.2	101.6
125	4,868	83.8	3.1	1.6	3.5	13.6	11.2	105.5

A30.— Regional estimates of timber volume and carbon stocks for Douglas-fir stands on forest land after clearcut harvest in the Rocky Mountain, North

Age	Mean volume	Mean carbon density						
		Live tree	Standing dead tree	Under-story	Down dead wood	Forest floor	Soil organic	Total nonsoil
<i>years</i>	<i>m³/hectare</i>	<i>tonnes carbon/hectare</i>						
0	0.0	0.0	0.0	4.7	22.4	37.2	38.8	64.4
5	0.0	2.7	0.3	4.7	20.2	35.4	38.8	63.2
15	1.1	6.1	0.6	4.7	16.3	32.9	38.8	60.6
25	19.7	21.5	2.2	3.4	14.0	31.8	38.8	72.8
35	57.1	44.3	4.4	2.7	12.8	31.6	38.8	95.8
45	100.9	66.5	6.7	2.3	12.1	32.0	38.8	119.5
55	145.9	87.2	8.7	2.1	11.8	32.7	38.8	142.5
65	189.3	105.9	10.1	1.9	11.6	33.6	38.8	163.1
75	229.7	122.5	10.7	1.8	11.6	34.6	38.8	181.3
85	266.3	137.0	11.2	1.8	11.7	35.6	38.8	197.3
95	298.6	149.4	11.6	1.7	11.8	36.6	38.8	211.1
105	326.6	159.9	12.0	1.7	12.0	37.5	38.8	223.0
115	350.1	168.6	12.2	1.6	12.1	38.4	38.8	232.9
125	369.5	175.7	12.4	1.6	12.2	39.2	38.8	241.1
<i>years</i>	<i>ft³/acre</i>	<i>tonnes carbon/acre</i>						
0	0	0.0	0.0	1.9	9.1	15.1	15.7	26.0
5	0	1.1	0.1	1.9	8.2	14.3	15.7	25.6
15	16	2.5	0.2	1.9	6.6	13.3	15.7	24.5
25	281	8.7	0.9	1.4	5.6	12.9	15.7	29.5
35	816	17.9	1.8	1.1	5.2	12.8	15.7	38.8
45	1,442	26.9	2.7	0.9	4.9	12.9	15.7	48.4
55	2,085	35.3	3.5	0.8	4.8	13.2	15.7	57.7
65	2,705	42.9	4.1	0.8	4.7	13.6	15.7	66.0
75	3,283	49.6	4.3	0.7	4.7	14.0	15.7	73.4
85	3,806	55.4	4.5	0.7	4.7	14.4	15.7	79.8
95	4,268	60.5	4.7	0.7	4.8	14.8	15.7	85.4
105	4,667	64.7	4.8	0.7	4.8	15.2	15.7	90.2
115	5,003	68.2	4.9	0.7	4.9	15.5	15.7	94.3
125	5,280	71.1	5.0	0.7	4.9	15.8	15.7	97.6

A31.— Regional estimates of timber volume and carbon stocks for fir-spruce-mountain hemlock stands on forest land after clearcut harvest in the Rocky Mountain, North

Age	Mean volume	Mean carbon density						Total nonsoil
		Live tree	Standing dead tree	Under-story	Down dead wood	Forest floor	Soil organic	
<i>years</i>	<i>m³/hectare</i>	<i>tonnes carbon/hectare</i>						
0	0.0	0.0	0.0	4.7	25.7	37.2	44.1	67.7
5	0.0	3.1	0.3	4.7	23.2	35.4	44.1	66.8
15	0.0	5.8	0.6	4.7	18.8	32.9	44.1	62.8
25	18.2	17.0	1.7	3.4	16.2	31.8	44.1	70.1
35	61.6	38.1	3.8	2.7	15.3	31.6	44.1	91.4
45	113.8	59.5	5.9	2.3	15.1	32.0	44.1	114.8
55	167.2	80.0	8.0	2.1	15.3	32.7	44.1	138.1
65	218.2	98.6	9.9	2.0	15.7	33.6	44.1	159.7
75	264.6	115.0	11.5	1.9	16.1	34.6	44.1	179.1
85	305.4	129.1	12.9	1.8	16.6	35.6	44.1	196.0
95	340.2	140.9	14.1	1.8	17.0	36.6	44.1	210.4
105	368.8	150.5	15.0	1.7	17.4	37.5	44.1	222.2
115	391.6	158.0	15.8	1.7	17.7	38.4	44.1	231.6
125	408.8	163.7	16.4	1.7	17.9	39.2	44.1	238.8
<i>years</i>	<i>ft³/acre</i>	<i>tonnes carbon/acre</i>						
0	0	0.0	0.0	1.9	10.4	15.1	17.9	27.4
5	0	1.3	0.1	1.9	9.4	14.3	17.9	27.0
15	0	2.3	0.2	1.9	7.6	13.3	17.9	25.4
25	260	6.9	0.7	1.4	6.5	12.9	17.9	28.4
35	880	15.4	1.5	1.1	6.2	12.8	17.9	37.0
45	1,626	24.1	2.4	0.9	6.1	12.9	17.9	46.5
55	2,390	32.4	3.2	0.9	6.2	13.2	17.9	55.9
65	3,118	39.9	4.0	0.8	6.3	13.6	17.9	64.6
75	3,782	46.5	4.7	0.8	6.5	14.0	17.9	72.5
85	4,365	52.2	5.2	0.7	6.7	14.4	17.9	79.3
95	4,862	57.0	5.7	0.7	6.9	14.8	17.9	85.1
105	5,271	60.9	6.1	0.7	7.0	15.2	17.9	89.9
115	5,596	63.9	6.4	0.7	7.2	15.5	17.9	93.7
125	5,842	66.2	6.6	0.7	7.2	15.8	17.9	96.6

A32.— Regional estimates of timber volume and carbon stocks for lodgepole pine stands on forest land after clearcut harvest in the Rocky Mountain, North

Age	Mean volume	Mean carbon density						
		Live tree	Standing dead tree	Under-story	Down dead wood	Forest floor	Soil organic	Total nonsoil
<i>years</i>	<i>m³/hectare</i>	<i>tonnes carbon/hectare</i>						
0	0.0	0.0	0.0	4.8	17.7	24.1	37.2	46.5
5	0.0	1.9	0.1	4.8	15.9	22.0	37.2	44.6
15	0.2	4.1	0.3	4.8	12.8	19.4	37.2	41.3
25	15.9	14.3	1.4	3.5	10.8	18.3	37.2	48.3
35	51.6	29.9	3.0	2.4	9.6	18.2	37.2	63.1
45	94.3	45.8	4.6	1.9	8.9	18.7	37.2	79.9
55	138.8	59.4	5.9	1.7	8.4	19.4	37.2	94.9
65	182.1	71.6	7.2	1.5	8.1	20.4	37.2	108.8
75	223.1	82.5	8.3	1.4	7.9	21.4	37.2	121.5
85	261.0	92.1	9.2	1.4	7.8	22.4	37.2	132.9
95	295.3	100.5	10.1	1.3	7.8	23.3	37.2	143.1
105	325.9	107.8	10.7	1.3	7.8	24.3	37.2	151.9
115	353.2	114.2	11.1	1.2	7.9	25.2	37.2	159.6
125	377.3	119.7	11.5	1.2	7.9	26.0	37.2	166.3
<i>years</i>	<i>ft³/acre</i>	<i>tonnes carbon/acre</i>						
0	0	0.0	0.0	1.9	7.2	9.8	15.0	18.8
5	0	0.8	0.0	1.9	6.4	8.9	15.0	18.0
15	3	1.7	0.1	1.9	5.2	7.8	15.0	16.7
25	227	5.8	0.6	1.4	4.4	7.4	15.0	19.6
35	737	12.1	1.2	1.0	3.9	7.4	15.0	25.5
45	1,348	18.5	1.9	0.8	3.6	7.6	15.0	32.3
55	1,983	24.0	2.4	0.7	3.4	7.9	15.0	38.4
65	2,603	29.0	2.9	0.6	3.3	8.2	15.0	44.0
75	3,189	33.4	3.3	0.6	3.2	8.6	15.0	49.2
85	3,730	37.3	3.7	0.6	3.2	9.1	15.0	53.8
95	4,220	40.7	4.1	0.5	3.2	9.4	15.0	57.9
105	4,658	43.6	4.3	0.5	3.2	9.8	15.0	61.5
115	5,048	46.2	4.5	0.5	3.2	10.2	15.0	64.6
125	5,392	48.4	4.6	0.5	3.2	10.5	15.0	67.3

A33.— Regional estimates of timber volume and carbon stocks for ponderosa pine stands on forest land after clearcut harvest in the Rocky Mountain, North

Age	Mean volume	Mean carbon density						
		Live tree	Standing dead tree	Under-story	Down dead wood	Forest floor	Soil organic	Total nonsoil
<i>years</i>	<i>m³/hectare</i>	<i>tonnes carbon/hectare</i>						
0	0.0	0.0	0.0	4.8	18.8	24.1	34.3	47.7
5	0.0	3.3	0.2	4.8	17.0	22.0	34.3	47.2
15	1.3	6.3	0.6	4.3	13.9	19.4	34.3	44.5
25	18.6	15.9	1.6	3.2	12.0	18.3	34.3	50.9
35	51.8	30.9	3.0	2.5	11.1	18.2	34.3	65.7
45	89.4	46.1	3.9	2.2	10.7	18.7	34.3	81.5
55	127.1	60.4	4.5	2.0	10.6	19.4	34.3	96.9
65	162.2	73.3	5.1	1.9	10.6	20.4	34.3	111.2
75	193.8	84.6	5.5	1.8	10.7	21.4	34.3	124.0
85	221.0	94.2	5.8	1.7	10.9	22.4	34.3	135.0
95	243.7	102.0	6.1	1.7	11.0	23.3	34.3	144.1
105	261.8	108.2	6.3	1.6	11.1	24.3	34.3	151.6
115	275.6	112.9	6.4	1.6	11.2	25.2	34.3	157.3
125	285.1	116.1	6.5	1.6	11.2	26.0	34.3	161.4
<i>years</i>	<i>ft³/acre</i>	<i>tonnes carbon/acre</i>						
0	0	0.0	0.0	1.9	7.6	9.8	13.9	19.3
5	0	1.3	0.1	1.9	6.9	8.9	13.9	19.1
15	19	2.6	0.2	1.8	5.6	7.8	13.9	18.0
25	266	6.4	0.6	1.3	4.8	7.4	13.9	20.6
35	740	12.5	1.2	1.0	4.5	7.4	13.9	26.6
45	1,278	18.6	1.6	0.9	4.3	7.6	13.9	33.0
55	1,816	24.5	1.8	0.8	4.3	7.9	13.9	39.2
65	2,318	29.7	2.0	0.8	4.3	8.2	13.9	45.0
75	2,769	34.2	2.2	0.7	4.3	8.6	13.9	50.2
85	3,159	38.1	2.4	0.7	4.4	9.1	13.9	54.6
95	3,483	41.3	2.5	0.7	4.5	9.4	13.9	58.3
105	3,742	43.8	2.5	0.7	4.5	9.8	13.9	61.3
115	3,938	45.7	2.6	0.6	4.5	10.2	13.9	63.6
125	4,075	47.0	2.6	0.6	4.5	10.5	13.9	65.3

A34.— Regional estimates of timber volume and carbon stocks for aspen-birch stands on forest land after clearcut harvest in the Rocky Mountain, South

Age	Mean volume	Mean carbon density						Total nonsoil
		Live tree	Standing dead tree	Under-story	Down dead wood	Forest floor	Soil organic	
<i>years</i>	<i>m³/hectare</i>	<i>tonnes carbon/hectare</i>						
0	0.0	0.0	0.0	4.7	11.6	31.7	58.8	48.1
5	0.0	3.1	0.3	4.7	9.0	28.4	58.8	45.5
15	0.0	6.4	0.6	4.7	5.5	24.6	58.8	41.9
25	6.3	13.9	1.4	4.8	3.8	23.4	58.8	47.2
35	22.7	25.7	2.6	4.5	3.3	23.5	58.8	59.6
45	45.0	38.8	3.9	4.3	3.5	24.3	58.8	74.7
55	70.7	52.3	5.2	4.2	3.9	25.5	58.8	91.1
65	98.1	64.7	6.5	4.1	4.5	26.8	58.8	106.5
75	126.5	76.6	7.7	4.0	5.1	28.1	58.8	121.5
85	155.0	88.0	8.8	3.9	5.8	29.4	58.8	135.9
95	183.1	98.8	9.9	3.9	6.4	30.6	58.8	149.5
105	210.5	108.8	10.9	3.8	7.0	31.7	58.8	162.2
115	236.8	118.3	11.8	3.8	7.6	32.6	58.8	174.1
125	261.8	127.0	12.4	3.8	8.2	33.5	58.8	184.9
<i>years</i>	<i>ft³/acre</i>	<i>tonnes carbon/acre</i>						
0	0	0.0	0.0	1.9	4.7	12.8	23.8	19.5
5	0	1.2	0.1	1.9	3.6	11.5	23.8	18.4
15	0	2.6	0.3	1.9	2.2	10.0	23.8	17.0
25	90	5.6	0.6	1.9	1.5	9.5	23.8	19.1
35	324	10.4	1.0	1.8	1.4	9.5	23.8	24.1
45	643	15.7	1.6	1.7	1.4	9.8	23.8	30.2
55	1,010	21.2	2.1	1.7	1.6	10.3	23.8	36.9
65	1,402	26.2	2.6	1.6	1.8	10.9	23.8	43.1
75	1,808	31.0	3.1	1.6	2.1	11.4	23.8	49.2
85	2,215	35.6	3.6	1.6	2.3	11.9	23.8	55.0
95	2,617	40.0	4.0	1.6	2.6	12.4	23.8	60.5
105	3,008	44.0	4.4	1.6	2.8	12.8	23.8	65.7
115	3,384	47.9	4.8	1.5	3.1	13.2	23.8	70.5
125	3,741	51.4	5.0	1.5	3.3	13.6	23.8	74.8

A35.— Regional estimates of timber volume and carbon stocks for Douglas-fir stands on forest land after clearcut harvest in the Rocky Mountain, South

Age	Mean volume	Mean carbon density						Total nonsoil
		Live tree	Standing dead tree	Under-story	Down dead wood	Forest floor	Soil organic	
<i>years</i>	<i>m³/hectare</i>	<i>tonnes carbon/hectare</i>						
0	0.0	0.0	0.0	4.8	17.0	37.2	30.9	59.0
5	0.0	2.6	0.3	4.8	15.3	35.4	30.9	58.4
15	1.6	7.2	0.7	4.8	12.6	32.9	30.9	58.3
25	15.3	19.8	2.0	4.4	11.1	31.8	30.9	68.9
35	39.1	37.2	3.7	2.0	10.4	31.6	30.9	84.9
45	66.2	54.6	5.5	1.2	10.2	32.0	30.9	103.5
55	93.9	71.6	7.2	0.9	10.3	32.7	30.9	122.7
65	120.8	85.9	8.6	0.7	10.4	33.6	30.9	139.2
75	146.1	98.8	9.9	0.6	10.6	34.6	30.9	154.5
85	169.5	110.3	11.0	0.6	10.9	35.6	30.9	168.4
95	190.7	120.6	12.1	0.6	11.1	36.6	30.9	180.9
105	209.8	129.5	12.9	0.6	11.4	37.5	30.9	192.0
115	227.0	137.5	13.3	0.7	11.7	38.4	30.9	201.6
125	242.3	144.4	13.8	0.7	12.0	39.2	30.9	210.1
<i>years</i>	<i>ft³/acre</i>	<i>tonnes carbon/acre</i>						
0	0	0.0	0.0	2.0	6.9	15.1	12.5	23.9
5	0	1.1	0.1	2.0	6.2	14.3	12.5	23.6
15	23	2.9	0.3	2.0	5.1	13.3	12.5	23.6
25	219	8.0	0.8	1.8	4.5	12.9	12.5	27.9
35	559	15.0	1.5	0.8	4.2	12.8	12.5	34.4
45	946	22.1	2.2	0.5	4.1	12.9	12.5	41.9
55	1,342	29.0	2.9	0.4	4.2	13.2	12.5	49.6
65	1,726	34.8	3.5	0.3	4.2	13.6	12.5	56.3
75	2,088	40.0	4.0	0.2	4.3	14.0	12.5	62.5
85	2,422	44.7	4.5	0.2	4.4	14.4	12.5	68.1
95	2,726	48.8	4.9	0.2	4.5	14.8	12.5	73.2
105	2,999	52.4	5.2	0.3	4.6	15.2	12.5	77.7
115	3,244	55.6	5.4	0.3	4.7	15.5	12.5	81.6
125	3,463	58.5	5.6	0.3	4.9	15.8	12.5	85.0

A36.— Regional estimates of timber volume and carbon stocks for fir-spruce-mountain hemlock stands on forest land after clearcut harvest in the Rocky Mountain, South

Age	Mean volume	Mean carbon density						
		Live tree	Standing dead tree	Under-story	Down dead wood	Forest floor	Soil organic	Total nonsoil
<i>years</i>	<i>m³/hectare</i>	<i>tonnes carbon/hectare</i>						
0	0.0	0.0	0.0	4.8	11.3	37.2	31.5	53.3
5	0.0	1.8	0.2	4.8	10.2	35.4	31.5	52.4
15	0.0	4.0	0.4	4.8	8.3	32.9	31.5	50.4
25	8.5	12.0	1.2	4.3	7.3	31.8	31.5	56.5
35	27.7	24.4	2.4	2.8	7.0	31.6	31.5	68.3
45	49.5	36.7	3.7	2.3	6.9	32.0	31.5	81.5
55	71.9	48.7	4.9	1.9	7.0	32.7	31.5	95.2
65	94.1	58.6	5.9	1.7	7.1	33.6	31.5	107.0
75	115.7	67.8	6.8	1.6	7.3	34.6	31.5	118.1
85	136.5	76.2	7.6	1.5	7.6	35.6	31.5	128.5
95	156.4	84.0	8.4	1.4	7.9	36.6	31.5	138.2
105	175.2	91.2	9.1	1.3	8.2	37.5	31.5	147.3
115	193.0	97.8	9.8	1.3	8.5	38.4	31.5	155.7
125	209.6	103.8	10.4	1.2	8.8	39.2	31.5	163.4
<i>years</i>	<i>ft³/acre</i>	<i>tonnes carbon/acre</i>						
0	0	0.0	0.0	2.0	4.6	15.1	12.7	21.6
5	0	0.7	0.1	2.0	4.1	14.3	12.7	21.2
15	0	1.6	0.2	2.0	3.4	13.3	12.7	20.4
25	122	4.8	0.5	1.7	3.0	12.9	12.7	22.9
35	396	9.9	1.0	1.1	2.8	12.8	12.7	27.6
45	708	14.8	1.5	0.9	2.8	12.9	12.7	33.0
55	1,028	19.7	2.0	0.8	2.8	13.2	12.7	38.5
65	1,345	23.7	2.4	0.7	2.9	13.6	12.7	43.3
75	1,654	27.4	2.7	0.6	3.0	14.0	12.7	47.8
85	1,951	30.8	3.1	0.6	3.1	14.4	12.7	52.0
95	2,235	34.0	3.4	0.6	3.2	14.8	12.7	55.9
105	2,504	36.9	3.7	0.5	3.3	15.2	12.7	59.6
115	2,758	39.6	4.0	0.5	3.4	15.5	12.7	63.0
125	2,995	42.0	4.2	0.5	3.6	15.8	12.7	66.1

A37.— Regional estimates of timber volume and carbon stocks for lodgepole pine stands on forest land after clearcut harvest in the Rocky Mountain, South

Age	Mean volume	Mean carbon density						
		Live tree	Standing dead tree	Under-story	Down dead wood	Forest floor	Soil organic	Total nonsoil
<i>years</i>	<i>m³/hectare</i>	<i>tonnes carbon/hectare</i>						
0	0.0	0.0	0.0	4.8	10.8	24.1	27.0	39.7
5	0.0	2.1	0.2	4.8	9.8	22.0	27.0	38.9
15	0.0	4.3	0.4	4.8	8.1	19.4	27.0	37.0
25	5.0	9.2	0.9	4.8	7.0	18.3	27.0	40.1
35	18.3	16.9	1.7	3.4	6.5	18.2	27.0	46.6
45	37.0	25.9	2.6	2.5	6.4	18.7	27.0	56.0
55	58.5	34.1	3.4	2.0	6.4	19.4	27.0	65.4
65	81.2	42.0	4.2	1.7	6.6	20.4	27.0	74.9
75	104.1	49.5	4.9	1.5	6.8	21.4	27.0	84.1
85	126.7	56.4	5.6	1.4	7.1	22.4	27.0	92.9
95	148.3	62.8	6.3	1.3	7.4	23.3	27.0	101.1
105	168.6	68.6	6.9	1.2	7.7	24.3	27.0	108.6
115	187.3	73.8	7.4	1.1	8.0	25.2	27.0	115.5
125	204.1	78.3	7.8	1.1	8.3	26.0	27.0	121.5
<i>years</i>	<i>ft³/acre</i>	<i>tonnes carbon/acre</i>						
0	0	0.0	0.0	1.9	4.4	9.8	10.9	16.1
5	0	0.9	0.1	1.9	4.0	8.9	10.9	15.7
15	0	1.7	0.2	1.9	3.3	7.8	10.9	15.0
25	71	3.7	0.4	1.9	2.8	7.4	10.9	16.2
35	262	6.8	0.7	1.4	2.6	7.4	10.9	18.9
45	529	10.5	1.0	1.0	2.6	7.6	10.9	22.7
55	836	13.8	1.4	0.8	2.6	7.9	10.9	26.5
65	1,160	17.0	1.7	0.7	2.7	8.2	10.9	30.3
75	1,488	20.0	2.0	0.6	2.7	8.6	10.9	34.0
85	1,810	22.8	2.3	0.6	2.9	9.1	10.9	37.6
95	2,120	25.4	2.5	0.5	3.0	9.4	10.9	40.9
105	2,410	27.8	2.8	0.5	3.1	9.8	10.9	44.0
115	2,677	29.8	3.0	0.5	3.2	10.2	10.9	46.7
125	2,917	31.7	3.2	0.4	3.4	10.5	10.9	49.2

A38.— Regional estimates of timber volume and carbon stocks for ponderosa pine stands on forest land after clearcut harvest in the Rocky Mountain, South

Age	Mean volume	Mean carbon density						
		Live tree	Standing dead tree	Under-story	Down dead wood	Forest floor	Soil organic	Total nonsoil
<i>years</i>	<i>m³/hectare</i>	<i>tonnes carbon/hectare</i>						
0	0.0	0.0	0.0	4.8	9.7	24.1	24.1	38.6
5	0.0	1.8	0.2	4.8	8.8	22.0	24.1	37.6
15	0.0	3.7	0.4	4.8	7.1	19.4	24.1	35.4
25	4.4	9.4	0.9	4.8	6.2	18.3	24.1	39.7
35	16.2	18.6	1.9	2.9	5.8	18.2	24.1	47.4
45	32.2	28.8	2.7	2.1	5.8	18.7	24.1	58.1
55	50.3	38.2	3.0	1.7	5.9	19.4	24.1	68.3
65	69.3	47.1	3.3	1.5	6.0	20.4	24.1	78.3
75	88.4	55.5	3.6	1.3	6.3	21.4	24.1	88.0
85	107.2	63.2	3.8	1.2	6.6	22.4	24.1	97.1
95	125.5	70.4	4.0	1.1	6.9	23.3	24.1	105.7
105	143.0	77.1	4.1	1.0	7.2	24.3	24.1	113.7
115	159.5	83.2	4.3	1.0	7.5	25.2	24.1	121.1
125	175.1	88.8	4.4	0.9	7.8	26.0	24.1	127.9
<i>years</i>	<i>ft³/acre</i>	<i>tonnes carbon/acre</i>						
0	0	0.0	0.0	2.0	3.9	9.8	9.8	15.6
5	0	0.7	0.1	2.0	3.5	8.9	9.8	15.2
15	0	1.5	0.1	2.0	2.9	7.8	9.8	14.3
25	63	3.8	0.4	2.0	2.5	7.4	9.8	16.1
35	231	7.5	0.8	1.2	2.4	7.4	9.8	19.2
45	460	11.7	1.1	0.9	2.3	7.6	9.8	23.5
55	719	15.5	1.2	0.7	2.4	7.9	9.8	27.6
65	990	19.1	1.4	0.6	2.4	8.2	9.8	31.7
75	1,263	22.4	1.5	0.5	2.5	8.6	9.8	35.6
85	1,532	25.6	1.5	0.5	2.7	9.1	9.8	39.3
95	1,793	28.5	1.6	0.4	2.8	9.4	9.8	42.8
105	2,043	31.2	1.7	0.4	2.9	9.8	9.8	46.0
115	2,280	33.7	1.7	0.4	3.0	10.2	9.8	49.0
125	2,503	35.9	1.8	0.4	3.2	10.5	9.8	51.8

A39.— Regional estimates of timber volume and carbon stocks for loblolly-shortleaf pine stands on forest land after clearcut harvest in the Southeast

Age	Mean volume	Mean carbon density						
		Live tree	Standing dead tree	Under-story	Down dead wood	Forest floor	Soil organic	Total nonsoil
<i>years</i>	<i>m³/hectare</i>	<i>tonnes carbon/hectare</i>						
0	0.0	0.0	0.0	4.2	9.9	12.2	72.9	26.3
5	0.0	11.1	0.7	4.0	8.4	6.5	72.9	30.6
10	19.1	22.6	1.3	3.6	7.5	6.4	72.9	41.4
15	36.7	31.3	1.6	3.4	6.8	7.5	72.9	50.7
20	60.4	40.8	1.9	3.2	6.6	8.7	72.9	61.2
25	85.5	50.3	2.1	3.1	6.5	9.8	72.9	71.9
30	108.7	58.2	2.3	3.1	6.6	10.7	72.9	80.8
35	131.2	65.6	2.4	3.0	6.7	11.5	72.9	89.3
40	152.3	72.5	2.5	3.0	6.9	12.2	72.9	97.1
45	172.3	78.9	2.7	2.9	7.2	12.7	72.9	104.4
50	191.4	85.0	2.7	2.9	7.5	13.2	72.9	111.3
55	208.4	90.3	2.8	2.9	7.8	13.7	72.9	117.4
60	223.9	95.1	2.9	2.8	8.1	14.1	72.9	122.9
65	238.4	99.6	2.9	2.8	8.3	14.4	72.9	128.1
70	252.9	104.0	3.0	2.8	8.6	14.7	72.9	133.2
75	264.6	107.6	3.0	2.8	8.9	15.0	72.9	137.3
80	277.1	111.4	3.1	2.8	9.1	15.2	72.9	141.6
85	289.5	115.1	3.1	2.8	9.4	15.5	72.9	145.9
90	299.6	118.2	3.2	2.7	9.6	15.7	72.9	149.4
<i>years</i>	<i>ft³/acre</i>	<i>tonnes carbon/acre</i>						
0	0	0.0	0.0	1.7	4.0	4.9	29.5	10.7
5	0	4.5	0.3	1.6	3.4	2.6	29.5	12.4
10	273	9.2	0.5	1.4	3.0	2.6	29.5	16.8
15	525	12.7	0.7	1.4	2.8	3.0	29.5	20.5
20	863	16.5	0.8	1.3	2.7	3.5	29.5	24.8
25	1,222	20.4	0.9	1.3	2.6	4.0	29.5	29.1
30	1,554	23.5	0.9	1.2	2.7	4.3	29.5	32.7
35	1,875	26.6	1.0	1.2	2.7	4.7	29.5	36.1
40	2,177	29.3	1.0	1.2	2.8	4.9	29.5	39.3
45	2,462	31.9	1.1	1.2	2.9	5.2	29.5	42.3
50	2,736	34.4	1.1	1.2	3.0	5.4	29.5	45.1
55	2,978	36.5	1.1	1.2	3.1	5.5	29.5	47.5
60	3,200	38.5	1.2	1.1	3.3	5.7	29.5	49.8
65	3,407	40.3	1.2	1.1	3.4	5.8	29.5	51.8
70	3,614	42.1	1.2	1.1	3.5	6.0	29.5	53.9
75	3,782	43.5	1.2	1.1	3.6	6.1	29.5	55.6
80	3,960	45.1	1.3	1.1	3.7	6.2	29.5	57.3
85	4,138	46.6	1.3	1.1	3.8	6.3	29.5	59.1
90	4,281	47.8	1.3	1.1	3.9	6.3	29.5	60.5

A40.— Regional estimates of timber volume and carbon stocks for loblolly-shortleaf pine stands on forest land after clearcut harvest in the Southeast; volumes are for high-productivity sites (growth rate greater than 85 cubic feet wood/acre/year) with high-intensity management (replanting with genetically improved stock)

Age	Mean volume	Mean carbon density						
		Live tree	Standing dead tree	Under-story	Down dead wood	Forest floor	Soil organic	Total nonsoil
<i>years</i>	<i>m³/hectare</i>	<i>tonnes carbon/hectare</i>						
0	0.0	0.0	0.0	4.1	20.4	12.2	72.9	36.8
5	0.0	11.0	0.7	4.0	15.9	6.5	72.9	38.0
10	47.7	31.9	1.4	3.8	12.9	6.4	72.9	56.3
15	146.5	67.4	1.9	3.7	11.4	7.5	72.9	91.9
20	244.8	102.3	2.1	3.7	10.5	8.7	72.9	127.3
25	315.2	124.2	2.3	3.7	9.7	9.8	72.9	149.7
30	347.3	134.1	2.4	3.7	8.8	10.7	72.9	159.7
35	351.5	135.4	2.4	3.7	8.0	11.5	72.9	160.9
40	355.0	136.5	2.4	3.7	7.3	12.2	72.9	161.9
45	358.5	137.5	2.4	3.6	6.8	12.7	72.9	163.1
50	362.0	138.6	2.4	3.6	6.4	13.2	72.9	164.3
55	362.0	138.6	2.4	3.6	6.1	13.7	72.9	164.4
60	362.0	138.6	2.4	3.6	5.9	14.1	72.9	164.6
65	362.0	138.6	2.4	3.6	5.7	14.4	72.9	164.8
70	362.0	138.6	2.4	3.6	5.6	14.7	72.9	164.9
75	362.0	138.6	2.4	3.6	5.5	15.0	72.9	165.1
80	362.0	138.6	2.4	3.6	5.4	15.2	72.9	165.3
85	362.0	138.6	2.4	3.6	5.4	15.5	72.9	165.5
90	362.0	138.6	2.4	3.6	5.3	15.7	72.9	165.6
<i>years</i>	<i>ft³/acre</i>	<i>tonnes carbon/acre</i>						
0	0	0.0	0.0	1.7	8.3	4.9	29.5	14.9
5	0	4.5	0.3	1.6	6.4	2.6	29.5	15.4
10	682	12.9	0.6	1.6	5.2	2.6	29.5	22.8
15	2,094	27.3	0.8	1.5	4.6	3.0	29.5	37.2
20	3,498	41.4	0.9	1.5	4.3	3.5	29.5	51.5
25	4,504	50.3	0.9	1.5	3.9	4.0	29.5	60.6
30	4,963	54.3	1.0	1.5	3.6	4.3	29.5	64.6
35	5,024	54.8	1.0	1.5	3.2	4.7	29.5	65.1
40	5,074	55.2	1.0	1.5	3.0	4.9	29.5	65.5
45	5,124	55.7	1.0	1.5	2.8	5.2	29.5	66.0
50	5,174	56.1	1.0	1.5	2.6	5.4	29.5	66.5
55	5,174	56.1	1.0	1.5	2.5	5.5	29.5	66.5
60	5,174	56.1	1.0	1.5	2.4	5.7	29.5	66.6
65	5,174	56.1	1.0	1.5	2.3	5.8	29.5	66.7
70	5,174	56.1	1.0	1.5	2.3	6.0	29.5	66.8
75	5,174	56.1	1.0	1.5	2.2	6.1	29.5	66.8
80	5,174	56.1	1.0	1.5	2.2	6.2	29.5	66.9
85	5,174	56.1	1.0	1.5	2.2	6.3	29.5	67.0
90	5,174	56.1	1.0	1.5	2.2	6.3	29.5	67.0

A41.— Regional estimates of timber volume and carbon stocks for longleaf-slash pine stands on forest land after clearcut harvest in the Southeast

Age	Mean volume	Mean carbon density						
		Live tree	Standing dead tree	Under-story	Down dead wood	Forest floor	Soil organic	Total nonsoil
<i>years</i>	<i>m³/hectare</i>	<i>tonnes carbon/hectare</i>						
0	0.0	0.0	0.0	4.2	9.7	12.2	110.0	26.1
5	0.0	5.3	0.4	4.2	7.8	6.5	110.0	24.1
10	19.1	14.1	0.9	3.8	6.7	6.4	110.0	31.8
15	36.7	21.4	1.0	3.6	5.9	7.5	110.0	39.4
20	60.4	30.4	1.1	3.4	5.6	8.7	110.0	49.2
25	85.5	39.2	1.1	3.3	5.6	9.8	110.0	59.0
30	108.7	47.2	1.2	3.2	5.6	10.7	110.0	67.9
35	131.2	54.8	1.2	3.1	5.8	11.5	110.0	76.4
40	152.3	61.9	1.3	3.0	6.0	12.2	110.0	84.4
45	172.3	68.5	1.3	3.0	6.3	12.7	110.0	91.9
50	191.4	74.8	1.3	2.9	6.7	13.2	110.0	99.0
55	208.4	80.4	1.3	2.9	7.0	13.7	110.0	105.2
60	223.9	85.4	1.3	2.9	7.3	14.1	110.0	111.0
65	238.4	90.1	1.4	2.9	7.6	14.4	110.0	116.3
70	252.9	94.8	1.4	2.8	7.9	14.7	110.0	121.6
75	264.6	98.6	1.4	2.8	8.1	15.0	110.0	125.9
80	277.1	102.6	1.4	2.8	8.4	15.2	110.0	130.5
85	289.5	106.6	1.4	2.8	8.7	15.5	110.0	135.0
90	299.6	109.8	1.4	2.8	9.0	15.7	110.0	138.6
<i>years</i>	<i>ft³/acre</i>	<i>tonnes carbon/acre</i>						
0	0	0.0	0.0	1.7	3.9	4.9	44.5	10.5
5	0	2.2	0.2	1.7	3.1	2.6	44.5	9.8
10	273	5.7	0.3	1.5	2.7	2.6	44.5	12.9
15	525	8.7	0.4	1.4	2.4	3.0	44.5	15.9
20	863	12.3	0.4	1.4	2.3	3.5	44.5	19.9
25	1,222	15.9	0.5	1.3	2.3	4.0	44.5	23.9
30	1,554	19.1	0.5	1.3	2.3	4.3	44.5	27.5
35	1,875	22.2	0.5	1.3	2.4	4.7	44.5	30.9
40	2,177	25.0	0.5	1.2	2.4	4.9	44.5	34.2
45	2,462	27.7	0.5	1.2	2.6	5.2	44.5	37.2
50	2,736	30.3	0.5	1.2	2.7	5.4	44.5	40.1
55	2,978	32.5	0.5	1.2	2.8	5.5	44.5	42.6
60	3,200	34.6	0.5	1.2	2.9	5.7	44.5	44.9
65	3,407	36.5	0.6	1.2	3.1	5.8	44.5	47.1
70	3,614	38.4	0.6	1.1	3.2	6.0	44.5	49.2
75	3,782	39.9	0.6	1.1	3.3	6.1	44.5	51.0
80	3,960	41.5	0.6	1.1	3.4	6.2	44.5	52.8
85	4,138	43.1	0.6	1.1	3.5	6.3	44.5	54.6
90	4,281	44.4	0.6	1.1	3.6	6.3	44.5	56.1

A42.— Regional estimates of timber volume and carbon stocks for longleaf-slash pine stands on forest land after clearcut harvest in the Southeast; volumes are for high-productivity sites (growth rate greater than 85 cubic feet wood/acre/year) with high-intensity management (replanting with genetically improved stock)

Age	Mean volume	Mean carbon density						
		Live tree	Standing dead tree	Under-story	Down dead wood	Forest floor	Soil organic	Total nonsoil
<i>years</i>	<i>m³/hectare</i>	<i>tonnes carbon/hectare</i>						
0	0.0	0.0	0.0	4.1	21.1	12.2	110.0	37.4
5	0.0	8.8	0.4	4.0	16.3	6.5	110.0	36.0
10	47.7	27.2	0.8	3.9	13.1	6.4	110.0	51.3
15	146.5	60.1	0.8	3.8	11.4	7.5	110.0	83.5
20	244.8	91.2	0.9	3.7	10.3	8.7	110.0	114.8
25	315.2	113.5	0.9	3.7	9.5	9.8	110.0	137.3
30	347.3	122.8	0.9	3.7	8.5	10.7	110.0	146.6
35	351.5	124.0	0.9	3.7	7.6	11.5	110.0	147.7
40	355.0	125.0	0.9	3.7	6.9	12.2	110.0	148.7
45	358.5	126.0	0.9	3.7	6.4	12.7	110.0	149.8
50	362.0	127.0	0.9	3.7	6.0	13.2	110.0	150.9
55	362.0	127.0	0.9	3.7	5.7	13.7	110.0	151.0
60	362.0	127.0	0.9	3.7	5.5	14.1	110.0	151.2
65	362.0	127.0	0.9	3.7	5.3	14.4	110.0	151.3
70	362.0	127.0	0.9	3.7	5.2	14.7	110.0	151.5
75	362.0	127.0	0.9	3.7	5.1	15.0	110.0	151.7
80	362.0	127.0	0.9	3.7	5.0	15.2	110.0	151.9
85	362.0	127.0	0.9	3.7	4.9	15.5	110.0	152.0
90	362.0	127.0	0.9	3.7	4.9	15.7	110.0	152.2
<i>years</i>	<i>ft³/acre</i>	<i>tonnes carbon/acre</i>						
0	0	0.0	0.0	1.7	8.5	4.9	44.5	15.2
5	0	3.6	0.2	1.6	6.6	2.6	44.5	14.6
10	682	11.0	0.3	1.6	5.3	2.6	44.5	20.8
15	2,094	24.3	0.3	1.5	4.6	3.0	44.5	33.8
20	3,498	36.9	0.4	1.5	4.2	3.5	44.5	46.5
25	4,504	45.9	0.4	1.5	3.8	4.0	44.5	55.6
30	4,963	49.7	0.4	1.5	3.5	4.3	44.5	59.3
35	5,024	50.2	0.4	1.5	3.1	4.7	44.5	59.8
40	5,074	50.6	0.4	1.5	2.8	4.9	44.5	60.2
45	5,124	51.0	0.4	1.5	2.6	5.2	44.5	60.6
50	5,174	51.4	0.4	1.5	2.4	5.4	44.5	61.1
55	5,174	51.4	0.4	1.5	2.3	5.5	44.5	61.1
60	5,174	51.4	0.4	1.5	2.2	5.7	44.5	61.2
65	5,174	51.4	0.4	1.5	2.2	5.8	44.5	61.2
70	5,174	51.4	0.4	1.5	2.1	6.0	44.5	61.3
75	5,174	51.4	0.4	1.5	2.1	6.1	44.5	61.4
80	5,174	51.4	0.4	1.5	2.0	6.2	44.5	61.5
85	5,174	51.4	0.4	1.5	2.0	6.3	44.5	61.5
90	5,174	51.4	0.4	1.5	2.0	6.3	44.5	61.6

A43.— Regional estimates of timber volume and carbon stocks for oak-gum-cypress stands on forest land after clearcut harvest in the Southeast

Age	Mean volume	Mean carbon density						
		Live tree	Standing dead tree	Under-story	Down dead wood	Forest floor	Soil organic	Total nonsoil
<i>years</i>	<i>m³/hectare</i>	<i>tonnes carbon/hectare</i>						
0	0.0	0.0	0.0	1.8	10.2	6.0	158.0	18.1
5	0.0	6.7	0.7	1.9	6.2	2.4	158.0	17.9
10	9.8	18.8	1.9	1.8	4.5	2.4	158.0	29.3
15	19.9	28.3	2.4	1.7	3.7	3.0	158.0	39.1
20	32.7	38.0	2.8	1.7	3.5	3.8	158.0	49.7
25	45.4	46.8	3.1	1.6	3.6	4.4	158.0	59.5
30	58.1	54.0	3.4	1.6	3.8	5.0	158.0	67.8
35	73.4	62.3	3.6	1.6	4.2	5.5	158.0	77.2
40	92.2	71.9	3.9	1.6	4.7	6.0	158.0	88.1
45	110.7	80.9	4.2	1.6	5.2	6.4	158.0	98.3
50	128.1	89.0	4.4	1.5	5.7	6.8	158.0	107.5
55	146.3	97.3	4.6	1.5	6.2	7.2	158.0	116.7
60	166.1	105.9	4.7	1.5	6.7	7.5	158.0	126.5
65	186.4	114.5	4.9	1.5	7.3	7.8	158.0	136.1
70	205.7	122.5	5.1	1.5	7.8	8.1	158.0	145.0
75	222.5	129.3	5.2	1.5	8.2	8.4	158.0	152.6
80	237.9	135.4	5.3	1.5	8.6	8.6	158.0	159.4
85	257.3	142.9	5.5	1.5	9.1	8.9	158.0	167.8
90	278.9	151.2	5.6	1.5	9.6	9.1	158.0	177.0
<i>years</i>	<i>ft³/acre</i>	<i>tonnes carbon/acre</i>						
0	0	0.0	0.0	0.7	4.1	2.4	63.9	7.3
5	0	2.7	0.3	0.8	2.5	1.0	63.9	7.3
10	140	7.6	0.8	0.7	1.8	1.0	63.9	11.9
15	284	11.5	1.0	0.7	1.5	1.2	63.9	15.8
20	467	15.4	1.1	0.7	1.4	1.5	63.9	20.1
25	649	18.9	1.3	0.7	1.5	1.8	63.9	24.1
30	830	21.9	1.4	0.7	1.5	2.0	63.9	27.4
35	1,049	25.2	1.5	0.6	1.7	2.2	63.9	31.3
40	1,318	29.1	1.6	0.6	1.9	2.4	63.9	35.7
45	1,582	32.7	1.7	0.6	2.1	2.6	63.9	39.8
50	1,830	36.0	1.8	0.6	2.3	2.8	63.9	43.5
55	2,091	39.4	1.8	0.6	2.5	2.9	63.9	47.2
60	2,374	42.9	1.9	0.6	2.7	3.1	63.9	51.2
65	2,664	46.3	2.0	0.6	2.9	3.2	63.9	55.1
70	2,940	49.6	2.1	0.6	3.2	3.3	63.9	58.7
75	3,180	52.3	2.1	0.6	3.3	3.4	63.9	61.8
80	3,400	54.8	2.2	0.6	3.5	3.5	63.9	64.5
85	3,677	57.8	2.2	0.6	3.7	3.6	63.9	67.9
90	3,986	61.2	2.3	0.6	3.9	3.7	63.9	71.6

A44.— Regional estimates of timber volume and carbon stocks for oak-hickory stands on forest land after clearcut harvest in the Southeast

Age	Mean volume	Mean carbon density						
		Live tree	Standing dead tree	Under-story	Down dead wood	Forest floor	Soil organic	Total nonsoil
<i>years</i>	<i>m³/hectare</i>	<i>tonnes carbon/hectare</i>						
0	0.0	0.0	0.0	4.2	10.8	6.0	45.3	21.0
5	0.0	8.1	0.8	4.2	6.7	2.4	45.3	22.1
10	11.7	21.0	2.1	3.8	4.8	2.4	45.3	34.0
15	21.2	30.3	2.5	3.5	3.8	3.0	45.3	43.1
20	33.8	40.0	2.8	3.3	3.5	3.8	45.3	53.4
25	46.6	49.5	3.0	3.2	3.6	4.4	45.3	63.8
30	60.2	57.5	3.2	3.1	3.8	5.0	45.3	72.6
35	76.3	66.6	3.4	3.0	4.2	5.5	45.3	82.7
40	94.3	76.2	3.6	2.9	4.6	6.0	45.3	93.5
45	114.1	86.4	3.8	2.9	5.2	6.4	45.3	104.7
50	133.0	95.8	4.0	2.8	5.7	6.8	45.3	115.2
55	151.4	104.8	4.1	2.8	6.2	7.2	45.3	125.1
60	168.9	113.0	4.2	2.7	6.7	7.5	45.3	134.2
65	185.6	120.8	4.3	2.7	7.2	7.8	45.3	142.8
70	201.5	128.0	4.4	2.7	7.6	8.1	45.3	150.8
75	215.7	134.4	4.5	2.6	8.0	8.4	45.3	157.9
80	229.4	140.5	4.6	2.6	8.3	8.6	45.3	164.6
85	242.5	146.2	4.6	2.6	8.7	8.9	45.3	171.0
90	254.1	151.3	4.7	2.6	9.0	9.1	45.3	176.6
<i>years</i>	<i>ft³/acre</i>	<i>tonnes carbon/acre</i>						
0	0	0.0	0.0	1.7	4.4	2.4	18.3	8.5
5	0	3.3	0.3	1.7	2.7	1.0	18.3	9.0
10	167	8.5	0.8	1.5	1.9	1.0	18.3	13.8
15	303	12.3	1.0	1.4	1.5	1.2	18.3	17.4
20	483	16.2	1.1	1.3	1.4	1.5	18.3	21.6
25	666	20.1	1.2	1.3	1.5	1.8	18.3	25.8
30	860	23.3	1.3	1.3	1.5	2.0	18.3	29.4
35	1,091	26.9	1.4	1.2	1.7	2.2	18.3	33.5
40	1,348	30.8	1.5	1.2	1.9	2.4	18.3	37.8
45	1,630	35.0	1.5	1.2	2.1	2.6	18.3	42.4
50	1,901	38.8	1.6	1.1	2.3	2.8	18.3	46.6
55	2,164	42.4	1.7	1.1	2.5	2.9	18.3	50.6
60	2,414	45.7	1.7	1.1	2.7	3.1	18.3	54.3
65	2,652	48.9	1.7	1.1	2.9	3.2	18.3	57.8
70	2,880	51.8	1.8	1.1	3.1	3.3	18.3	61.0
75	3,082	54.4	1.8	1.1	3.2	3.4	18.3	63.9
80	3,278	56.8	1.8	1.1	3.4	3.5	18.3	66.6
85	3,465	59.2	1.9	1.0	3.5	3.6	18.3	69.2
90	3,632	61.2	1.9	1.0	3.6	3.7	18.3	71.5

A45.— Regional estimates of timber volume and carbon stocks for oak-pine stands on forest land after clearcut harvest in the Southeast

Age	Mean volume	Mean carbon density						
		Live tree	Standing dead tree	Under-story	Down dead wood	Forest floor	Soil organic	Total nonsoil
<i>years</i>	<i>m³/hectare</i>	<i>tonnes carbon/hectare</i>						
0	0.0	0.0	0.0	4.2	11.3	10.3	61.4	25.8
5	0.0	7.4	0.6	4.1	9.0	5.8	61.4	26.9
10	13.6	19.6	1.2	3.6	7.7	5.9	61.4	38.0
15	27.8	29.3	1.6	3.5	6.7	6.8	61.4	47.9
20	43.9	39.0	1.9	3.4	6.2	7.7	61.4	58.2
25	59.3	46.8	2.1	3.3	5.8	8.6	61.4	66.5
30	77.2	55.4	2.3	3.2	5.6	9.2	61.4	75.8
35	96.8	64.4	2.5	3.2	5.7	9.8	61.4	85.5
40	117.2	73.4	2.7	3.1	5.9	10.2	61.4	95.3
45	136.4	81.6	2.8	3.1	6.1	10.6	61.4	104.2
50	154.1	88.9	2.9	3.1	6.3	11.0	61.4	112.2
55	171.4	96.0	3.0	3.0	6.6	11.3	61.4	119.9
60	189.6	103.2	3.1	3.0	6.9	11.5	61.4	127.8
65	204.5	109.1	3.2	3.0	7.2	11.8	61.4	134.3
70	218.8	114.6	3.3	3.0	7.5	12.0	61.4	140.3
75	234.5	120.6	3.4	2.9	7.8	12.1	61.4	146.9
80	247.6	125.5	3.5	2.9	8.1	12.3	61.4	152.3
85	259.4	129.9	3.5	2.9	8.3	12.5	61.4	157.2
90	272.3	134.7	3.6	2.9	8.6	12.6	61.4	162.4
<i>years</i>	<i>ft³/acre</i>	<i>tonnes carbon/acre</i>						
0	0	0.0	0.0	1.7	4.6	4.2	24.9	10.4
5	0	3.0	0.3	1.7	3.6	2.4	24.9	10.9
10	195	7.9	0.5	1.5	3.1	2.4	24.9	15.4
15	397	11.9	0.6	1.4	2.7	2.7	24.9	19.4
20	628	15.8	0.8	1.4	2.5	3.1	24.9	23.5
25	848	19.0	0.8	1.3	2.3	3.5	24.9	26.9
30	1,104	22.4	0.9	1.3	2.3	3.7	24.9	30.7
35	1,384	26.1	1.0	1.3	2.3	4.0	24.9	34.6
40	1,675	29.7	1.1	1.3	2.4	4.1	24.9	38.5
45	1,950	33.0	1.1	1.2	2.5	4.3	24.9	42.2
50	2,202	36.0	1.2	1.2	2.6	4.4	24.9	45.4
55	2,450	38.8	1.2	1.2	2.7	4.6	24.9	48.5
60	2,710	41.8	1.3	1.2	2.8	4.7	24.9	51.7
65	2,923	44.1	1.3	1.2	2.9	4.8	24.9	54.3
70	3,127	46.4	1.3	1.2	3.0	4.8	24.9	56.8
75	3,352	48.8	1.4	1.2	3.2	4.9	24.9	59.5
80	3,539	50.8	1.4	1.2	3.3	5.0	24.9	61.6
85	3,707	52.6	1.4	1.2	3.4	5.0	24.9	63.6
90	3,891	54.5	1.4	1.2	3.5	5.1	24.9	65.7

A46.— Regional estimates of timber volume and carbon stocks for elm-ash-cottonwood stands on forest land after clearcut harvest in the South Central

Age	Mean volume	Mean carbon density						
		Live tree	Standing dead tree	Under-story	Down dead wood	Forest floor	Soil organic	Total nonsoil
<i>years</i>	<i>m³/hectare</i>	<i>tonnes carbon/hectare</i>						
0	0.0	0.0	0.0	4.2	11.2	6.0	49.9	21.4
5	0.0	8.6	0.9	4.9	7.0	2.4	49.9	23.7
10	11.7	18.3	1.8	4.1	4.9	2.4	49.9	31.5
15	21.2	27.0	2.7	3.7	3.9	3.0	49.9	40.3
20	33.8	36.3	3.3	3.5	3.6	3.8	49.9	50.3
25	46.6	45.1	3.6	3.3	3.7	4.4	49.9	60.0
30	60.2	53.8	3.8	3.2	4.0	5.0	49.9	69.7
35	76.3	63.3	4.1	3.1	4.4	5.5	49.9	80.4
40	94.3	73.3	4.4	2.9	5.0	6.0	49.9	91.6
45	114.1	83.8	4.6	2.9	5.6	6.4	49.9	103.4
50	133.0	95.1	4.8	2.8	6.4	6.8	49.9	115.9
55	151.4	104.2	5.0	2.7	7.0	7.2	49.9	126.0
60	168.9	112.7	5.1	2.7	7.5	7.5	49.9	135.5
65	185.6	120.7	5.3	2.6	8.0	7.8	49.9	144.5
70	201.5	128.4	5.4	2.6	8.5	8.1	49.9	153.0
75	215.7	135.1	5.5	2.6	9.0	8.4	49.9	160.6
80	229.4	141.6	5.6	2.5	9.4	8.6	49.9	167.8
85	242.5	147.8	5.7	2.5	9.8	8.9	49.9	174.7
90	254.1	153.4	5.8	2.5	10.2	9.1	49.9	180.9
<i>years</i>	<i>ft³/acre</i>	<i>tonnes carbon/acre</i>						
0	0	0.0	0.0	1.7	4.5	2.4	20.2	8.7
5	0	3.5	0.3	2.0	2.8	1.0	20.2	9.6
10	167	7.4	0.7	1.7	2.0	1.0	20.2	12.7
15	303	10.9	1.1	1.5	1.6	1.2	20.2	16.3
20	483	14.7	1.3	1.4	1.5	1.5	20.2	20.4
25	666	18.3	1.4	1.3	1.5	1.8	20.2	24.3
30	860	21.8	1.6	1.3	1.6	2.0	20.2	28.2
35	1,091	25.6	1.7	1.2	1.8	2.2	20.2	32.5
40	1,348	29.7	1.8	1.2	2.0	2.4	20.2	37.1
45	1,630	33.9	1.9	1.2	2.3	2.6	20.2	41.8
50	1,901	38.5	1.9	1.1	2.6	2.8	20.2	46.9
55	2,164	42.2	2.0	1.1	2.8	2.9	20.2	51.0
60	2,414	45.6	2.1	1.1	3.0	3.1	20.2	54.8
65	2,652	48.9	2.1	1.1	3.3	3.2	20.2	58.5
70	2,880	52.0	2.2	1.0	3.5	3.3	20.2	61.9
75	3,082	54.7	2.2	1.0	3.6	3.4	20.2	65.0
80	3,278	57.3	2.3	1.0	3.8	3.5	20.2	67.9
85	3,465	59.8	2.3	1.0	4.0	3.6	20.2	70.7
90	3,632	62.1	2.3	1.0	4.1	3.7	20.2	73.2

A47.— Regional estimates of timber volume and carbon stocks for loblolly-shortleaf pine stands on forest land after clearcut harvest in the South Central

Age	Mean volume	Mean carbon density						
		Live tree	Standing dead tree	Under-story	Down dead wood	Forest floor	Soil organic	Total nonsoil
<i>years</i>	<i>m³/hectare</i>	<i>tonnes carbon/hectare</i>						
0	0.0	0.0	0.0	4.2	9.2	12.2	41.9	25.6
5	0.0	10.8	0.7	4.7	7.7	6.5	41.9	30.3
10	19.1	23.1	1.3	3.9	6.8	6.4	41.9	41.5
15	36.7	32.4	1.6	3.5	6.2	7.5	41.9	51.2
20	60.4	42.2	1.8	3.3	5.9	8.7	41.9	61.9
25	85.5	52.0	2.0	3.1	5.8	9.8	41.9	72.8
30	108.7	59.6	2.1	3.0	5.8	10.7	41.9	81.2
35	131.2	66.6	2.3	2.9	5.9	11.5	41.9	89.1
40	152.3	73.1	2.3	2.9	6.0	12.2	41.9	96.4
45	172.3	79.0	2.4	2.8	6.1	12.7	41.9	103.1
50	191.4	84.7	2.5	2.8	6.4	13.2	41.9	109.5
55	208.4	89.6	2.6	2.7	6.5	13.7	41.9	115.1
60	223.9	94.0	2.6	2.7	6.7	14.1	41.9	120.1
65	238.4	98.1	2.7	2.6	7.0	14.4	41.9	124.8
70	252.9	102.2	2.7	2.6	7.2	14.7	41.9	129.4
75	264.6	105.5	2.7	2.6	7.3	15.0	41.9	133.1
80	277.1	108.9	2.8	2.6	7.6	15.2	41.9	137.0
85	289.5	112.3	2.8	2.6	7.8	15.5	41.9	140.9
90	299.6	115.1	2.8	2.5	7.9	15.7	41.9	144.0
<i>years</i>	<i>ft³/acre</i>	<i>tonnes carbon/acre</i>						
0	0	0.0	0.0	1.7	3.7	4.9	17.0	10.4
5	0	4.4	0.3	1.9	3.1	2.6	17.0	12.3
10	273	9.4	0.5	1.6	2.8	2.6	17.0	16.8
15	525	13.1	0.6	1.4	2.5	3.0	17.0	20.7
20	863	17.1	0.7	1.3	2.4	3.5	17.0	25.1
25	1,222	21.1	0.8	1.3	2.4	4.0	17.0	29.5
30	1,554	24.1	0.9	1.2	2.3	4.3	17.0	32.9
35	1,875	27.0	0.9	1.2	2.4	4.7	17.0	36.1
40	2,177	29.6	0.9	1.2	2.4	4.9	17.0	39.0
45	2,462	32.0	1.0	1.1	2.5	5.2	17.0	41.7
50	2,736	34.3	1.0	1.1	2.6	5.4	17.0	44.3
55	2,978	36.3	1.0	1.1	2.7	5.5	17.0	46.6
60	3,200	38.1	1.1	1.1	2.7	5.7	17.0	48.6
65	3,407	39.7	1.1	1.1	2.8	5.8	17.0	50.5
70	3,614	41.4	1.1	1.1	2.9	6.0	17.0	52.4
75	3,782	42.7	1.1	1.1	3.0	6.1	17.0	53.9
80	3,960	44.1	1.1	1.0	3.1	6.2	17.0	55.5
85	4,138	45.5	1.1	1.0	3.1	6.3	17.0	57.0
90	4,281	46.6	1.1	1.0	3.2	6.3	17.0	58.3

A48.— Regional estimates of timber volume and carbon stocks for loblolly-shortleaf pine stands on forest land after clearcut harvest in the South Central; volumes are for high-productivity sites (growth rate greater than 120 cubic feet wood/acre/year) with high-intensity management (replanting with genetically improved stock)

Age	Mean volume	Mean carbon density						
		Live tree	Standing dead tree	Under-story	Down dead wood	Forest floor	Soil organic	Total nonsoil
<i>years</i>	<i>m³/hectare</i>	<i>tonnes carbon/hectare</i>						
0	0.0	0.0	0.0	4.1	20.4	12.2	41.9	36.7
5	0.0	10.8	0.4	4.1	15.8	6.5	41.9	37.6
10	47.7	34.2	0.9	3.9	13.0	6.4	41.9	58.3
15	146.5	68.7	1.0	3.8	11.5	7.5	41.9	92.5
20	244.8	99.2	1.1	3.7	10.5	8.7	41.9	123.2
25	315.2	118.3	1.1	3.7	9.6	9.8	41.9	142.6
30	347.3	126.8	1.1	3.7	8.7	10.7	41.9	151.1
35	351.5	127.9	1.1	3.7	7.8	11.5	41.9	152.1
40	355.0	128.8	1.1	3.7	7.2	12.2	41.9	153.0
45	358.5	129.8	1.1	3.7	6.7	12.7	41.9	154.0
50	362.0	130.7	1.1	3.7	6.3	13.2	41.9	155.0
55	362.0	130.7	1.1	3.7	6.0	13.7	41.9	155.2
60	362.0	130.7	1.1	3.7	5.8	14.1	41.9	155.3
65	362.0	130.7	1.1	3.7	5.6	14.4	41.9	155.5
70	362.0	130.7	1.1	3.7	5.5	14.7	41.9	155.7
75	362.0	130.7	1.1	3.7	5.4	15.0	41.9	155.9
80	362.0	130.7	1.1	3.7	5.3	15.2	41.9	156.0
85	362.0	130.7	1.1	3.7	5.2	15.5	41.9	156.2
90	362.0	130.7	1.1	3.7	5.2	15.7	41.9	156.4
<i>years</i>	<i>ft³/acre</i>	<i>tonnes carbon/acre</i>						
0	0	0.0	0.0	1.7	8.2	4.9	17.0	14.9
5	0	4.4	0.2	1.6	6.4	2.6	17.0	15.2
10	682	13.8	0.3	1.6	5.2	2.6	17.0	23.6
15	2,094	27.8	0.4	1.5	4.6	3.0	17.0	37.4
20	3,498	40.1	0.4	1.5	4.2	3.5	17.0	49.9
25	4,504	47.9	0.4	1.5	3.9	4.0	17.0	57.7
30	4,963	51.3	0.5	1.5	3.5	4.3	17.0	61.1
35	5,024	51.8	0.5	1.5	3.2	4.7	17.0	61.6
40	5,074	52.1	0.5	1.5	2.9	4.9	17.0	61.9
45	5,124	52.5	0.5	1.5	2.7	5.2	17.0	62.3
50	5,174	52.9	0.5	1.5	2.6	5.4	17.0	62.7
55	5,174	52.9	0.5	1.5	2.4	5.5	17.0	62.8
60	5,174	52.9	0.5	1.5	2.3	5.7	17.0	62.9
65	5,174	52.9	0.5	1.5	2.3	5.8	17.0	62.9
70	5,174	52.9	0.5	1.5	2.2	6.0	17.0	63.0
75	5,174	52.9	0.5	1.5	2.2	6.1	17.0	63.1
80	5,174	52.9	0.5	1.5	2.1	6.2	17.0	63.1
85	5,174	52.9	0.5	1.5	2.1	6.3	17.0	63.2
90	5,174	52.9	0.5	1.5	2.1	6.3	17.0	63.3

A49.— Regional estimates of timber volume and carbon stocks for oak-gum-cypress stands on forest land after clearcut harvest in the South Central

Age	Mean volume	Mean carbon density						
		Live tree	Standing dead tree	Under-story	Down dead wood	Forest floor	Soil organic	Total nonsoil
<i>years</i>	<i>m³/hectare</i>	<i>tonnes carbon/hectare</i>						
0	0.0	0.0	0.0	1.8	10.8	6.0	52.8	18.6
5	0.0	5.4	0.5	2.1	6.5	2.4	52.8	16.9
10	9.8	17.8	1.8	1.8	4.6	2.4	52.8	28.4
15	19.9	28.4	2.8	1.7	3.8	3.0	52.8	39.8
20	32.7	39.3	3.2	1.7	3.6	3.8	52.8	51.6
25	45.4	48.8	3.4	1.6	3.7	4.4	52.8	61.9
30	58.1	57.2	3.5	1.6	4.0	5.0	52.8	71.2
35	73.4	66.9	3.6	1.6	4.4	5.5	52.8	82.1
40	92.2	76.9	3.7	1.6	5.0	6.0	52.8	93.1
45	110.7	86.1	3.7	1.5	5.5	6.4	52.8	103.4
50	128.1	94.4	3.8	1.5	6.0	6.8	52.8	112.6
55	146.3	102.8	3.9	1.5	6.5	7.2	52.8	121.9
60	166.1	111.6	3.9	1.5	7.1	7.5	52.8	131.6
65	186.4	120.3	4.0	1.5	7.6	7.8	52.8	141.2
70	205.7	128.3	4.0	1.5	8.1	8.1	52.8	150.1
75	222.5	135.1	4.1	1.5	8.5	8.4	52.8	157.6
80	237.9	141.2	4.1	1.5	8.9	8.6	52.8	164.4
85	257.3	148.8	4.1	1.5	9.4	8.9	52.8	172.6
90	278.9	157.0	4.2	1.4	9.9	9.1	52.8	181.6
<i>years</i>	<i>ft³/acre</i>	<i>tonnes carbon/acre</i>						
0	0	0.0	0.0	0.7	4.4	2.4	21.4	7.5
5	0	2.2	0.2	0.8	2.6	1.0	21.4	6.9
10	140	7.2	0.7	0.7	1.9	1.0	21.4	11.5
15	284	11.5	1.1	0.7	1.5	1.2	21.4	16.1
20	467	15.9	1.3	0.7	1.5	1.5	21.4	20.9
25	649	19.7	1.4	0.7	1.5	1.8	21.4	25.1
30	830	23.1	1.4	0.7	1.6	2.0	21.4	28.8
35	1,049	27.1	1.4	0.6	1.8	2.2	21.4	33.2
40	1,318	31.1	1.5	0.6	2.0	2.4	21.4	37.7
45	1,582	34.9	1.5	0.6	2.2	2.6	21.4	41.8
50	1,830	38.2	1.5	0.6	2.4	2.8	21.4	45.6
55	2,091	41.6	1.6	0.6	2.6	2.9	21.4	49.3
60	2,374	45.2	1.6	0.6	2.9	3.1	21.4	53.3
65	2,664	48.7	1.6	0.6	3.1	3.2	21.4	57.1
70	2,940	51.9	1.6	0.6	3.3	3.3	21.4	60.7
75	3,180	54.7	1.6	0.6	3.5	3.4	21.4	63.8
80	3,400	57.2	1.7	0.6	3.6	3.5	21.4	66.5
85	3,677	60.2	1.7	0.6	3.8	3.6	21.4	69.9
90	3,986	63.5	1.7	0.6	4.0	3.7	21.4	73.5

A50.— Regional estimates of timber volume and carbon stocks for oak-hickory stands on forest land after clearcut harvest in the South Central

Age	Mean volume	Mean carbon density						
		Live tree	Standing dead tree	Under-story	Down dead wood	Forest floor	Soil organic	Total nonsoil
<i>years</i>	<i>m³/hectare</i>	<i>tonnes carbon/hectare</i>						
0	0.0	0.0	0.0	4.2	11.7	6.0	38.6	21.8
5	0.0	9.7	0.9	4.7	7.3	2.4	38.6	25.0
10	11.7	20.9	1.9	4.0	5.2	2.4	38.6	34.3
15	21.2	30.1	2.1	3.6	4.2	3.0	38.6	43.0
20	33.8	39.5	2.3	3.4	3.9	3.8	38.6	52.9
25	46.6	48.2	2.4	3.3	3.9	4.4	38.6	62.2
30	60.2	56.6	2.6	3.1	4.2	5.0	38.6	71.4
35	76.3	65.6	2.7	3.0	4.6	5.5	38.6	81.4
40	94.3	76.2	2.8	2.9	5.2	6.0	38.6	93.1
45	114.1	85.7	2.9	2.8	5.8	6.4	38.6	103.7
50	133.0	94.7	3.0	2.8	6.3	6.8	38.6	113.6
55	151.4	103.3	3.0	2.7	6.9	7.2	38.6	123.1
60	168.9	111.3	3.1	2.7	7.4	7.5	38.6	132.0
65	185.6	118.8	3.2	2.6	7.9	7.8	38.6	140.4
70	201.5	126.0	3.2	2.6	8.4	8.1	38.6	148.3
75	215.7	132.3	3.2	2.6	8.8	8.4	38.6	155.3
80	229.4	138.3	3.3	2.5	9.2	8.6	38.6	162.0
85	242.5	144.0	3.3	2.5	9.6	8.9	38.6	168.3
90	254.1	149.1	3.3	2.5	9.9	9.1	38.6	174.0
<i>years</i>	<i>ft³/acre</i>	<i>tonnes carbon/acre</i>						
0	0	0.0	0.0	1.7	4.7	2.4	15.6	8.8
5	0	3.9	0.4	1.9	2.9	1.0	15.6	10.1
10	167	8.5	0.8	1.6	2.1	1.0	15.6	13.9
15	303	12.2	0.9	1.5	1.7	1.2	15.6	17.4
20	483	16.0	0.9	1.4	1.6	1.5	15.6	21.4
25	666	19.5	1.0	1.3	1.6	1.8	15.6	25.2
30	860	22.9	1.0	1.3	1.7	2.0	15.6	28.9
35	1,091	26.6	1.1	1.2	1.9	2.2	15.6	33.0
40	1,348	30.8	1.1	1.2	2.1	2.4	15.6	37.7
45	1,630	34.7	1.2	1.2	2.3	2.6	15.6	41.9
50	1,901	38.3	1.2	1.1	2.6	2.8	15.6	46.0
55	2,164	41.8	1.2	1.1	2.8	2.9	15.6	49.8
60	2,414	45.0	1.3	1.1	3.0	3.1	15.6	53.4
65	2,652	48.1	1.3	1.1	3.2	3.2	15.6	56.8
70	2,880	51.0	1.3	1.1	3.4	3.3	15.6	60.0
75	3,082	53.5	1.3	1.0	3.6	3.4	15.6	62.8
80	3,278	56.0	1.3	1.0	3.7	3.5	15.6	65.6
85	3,465	58.3	1.3	1.0	3.9	3.6	15.6	68.1
90	3,632	60.3	1.4	1.0	4.0	3.7	15.6	70.4

A51.— Regional estimates of timber volume and carbon stocks for oak-pine stands on forest land after clearcut harvest in the South Central

Age	Mean volume	Mean carbon density						
		Live tree	Standing dead tree	Under-story	Down dead wood	Forest floor	Soil organic	Total nonsoil
<i>years</i>	<i>m³/hectare</i>	<i>tonnes carbon/hectare</i>						
0	0.0	0.0	0.0	4.2	12.4	10.3	41.7	26.9
5	0.0	8.7	0.7	4.4	10.0	5.8	41.7	29.6
10	13.6	21.4	1.4	3.7	8.6	5.9	41.7	41.0
15	27.8	31.9	1.7	3.5	7.7	6.8	41.7	51.5
20	43.9	41.8	2.0	3.3	7.1	7.7	41.7	61.9
25	59.3	50.9	2.2	3.2	6.7	8.6	41.7	71.6
30	77.2	59.2	2.5	3.1	6.6	9.2	41.7	80.6
35	96.8	67.9	2.6	3.0	6.7	9.8	41.7	90.0
40	117.2	76.5	2.8	2.9	6.9	10.2	41.7	99.4
45	136.4	84.4	3.0	2.9	7.1	10.6	41.7	108.0
50	154.1	91.4	3.1	2.8	7.4	11.0	41.7	115.7
55	171.4	98.2	3.2	2.8	7.7	11.3	41.7	123.2
60	189.6	105.2	3.3	2.8	8.0	11.5	41.7	130.8
65	204.5	110.7	3.4	2.7	8.3	11.8	41.7	137.0
70	218.8	116.0	3.5	2.7	8.6	12.0	41.7	142.8
75	234.5	121.8	3.6	2.7	9.0	12.1	41.7	149.2
80	247.6	126.5	3.6	2.7	9.3	12.3	41.7	154.4
85	259.4	130.7	3.7	2.7	9.6	12.5	41.7	159.0
90	272.3	135.2	3.8	2.6	9.9	12.6	41.7	164.1
<i>years</i>	<i>ft³/acre</i>	<i>tonnes carbon/acre</i>						
0	0	0.0	0.0	1.7	5.0	4.2	16.9	10.9
5	0	3.5	0.3	1.8	4.0	2.4	16.9	12.0
10	195	8.6	0.6	1.5	3.5	2.4	16.9	16.6
15	397	12.9	0.7	1.4	3.1	2.7	16.9	20.9
20	628	16.9	0.8	1.3	2.9	3.1	16.9	25.0
25	848	20.6	0.9	1.3	2.7	3.5	16.9	29.0
30	1,104	24.0	1.0	1.2	2.7	3.7	16.9	32.6
35	1,384	27.5	1.1	1.2	2.7	4.0	16.9	36.4
40	1,675	31.0	1.1	1.2	2.8	4.1	16.9	40.2
45	1,950	34.2	1.2	1.2	2.9	4.3	16.9	43.7
50	2,202	37.0	1.3	1.2	3.0	4.4	16.9	46.8
55	2,450	39.7	1.3	1.1	3.1	4.6	16.9	49.9
60	2,710	42.6	1.3	1.1	3.3	4.7	16.9	52.9
65	2,923	44.8	1.4	1.1	3.4	4.8	16.9	55.4
70	3,127	47.0	1.4	1.1	3.5	4.8	16.9	57.8
75	3,352	49.3	1.4	1.1	3.6	4.9	16.9	60.4
80	3,539	51.2	1.5	1.1	3.8	5.0	16.9	62.5
85	3,707	52.9	1.5	1.1	3.9	5.0	16.9	64.4
90	3,891	54.7	1.5	1.1	4.0	5.1	16.9	66.4

APPENDIX B

Forest Ecosystem Yield Tables for Afforestation (Establishment on Nonforest Land)⁶

Carbon Stocks with Afforestation of Land

B1.	Aspen-birch, Northeast	B26.	Hemlock-Sitka spruce, high productivity and management intensity, Pacific Northwest, West
B2.	Maple-beech-birch, Northeast	B27.	Mixed conifer, Pacific Southwest
B3.	Oak-hickory, Northeast	B28.	Fir-spruce-mountain hemlock, Pacific Southwest
B4.	Oak-pine, Northeast	B29.	Western oak, Pacific Southwest
B5.	Spruce-balsam fir, Northeast	B30.	Douglas-fir, Rocky Mountain, North
B6.	White-red-jack pine, Northeast	B31.	Fir-spruce-mountain hemlock, Rocky Mountain, North
B7.	Aspen-birch, Northern Lake States	B32.	Lodgepole pine, Rocky Mountain, North
B8.	Elm-ash-cottonwood, Northern Lake States	B33.	Ponderosa pine, Rocky Mountain, North
B9.	Maple-beech-birch, Northern Lake States	B34.	Aspen-birch, Rocky Mountain, South
B10.	Oak-hickory, Northern Lake States	B35.	Douglas-fir, Rocky Mountain, South
B11.	Spruce-balsam fir, Northern Lake States	B36.	Fir-spruce-mountain hemlock, Rocky Mountain, South
B12.	White-red-jack pine, Northern Lake States	B37.	Lodgepole pine, Rocky Mountain, South
B13.	Elm-ash-cottonwood, Northern Prairie States	B38.	Ponderosa pine, Rocky Mountain, South
B14.	Maple-beech-birch, Northern Prairie States	B39.	Loblolly-shortleaf pine, Southeast
B15.	Oak-hickory, Northern Prairie States	B40.	Loblolly-shortleaf pine, high productivity and management intensity, Southeast
B16.	Oak-pine, Northern Prairie States	B41.	Longleaf-slash pine, Southeast
B17.	Douglas-fir, Pacific Northwest, East	B42.	Longleaf-slash pine, high productivity and management intensity, Southeast
B18.	Fir-spruce-mountain hemlock, Pacific Northwest, East	B43.	Oak-gum-cypress, Southeast
B19.	Lodgepole pine, Pacific Northwest, East	B44.	Oak-hickory, Southeast
B20.	Ponderosa pine, Pacific Northwest, East	B45.	Oak-pine, Southeast
B21.	Alder-maple, Pacific Northwest, West	B46.	Elm-ash-cottonwood, South Central
B22.	Douglas-fir, Pacific Northwest, West	B47.	Loblolly-shortleaf pine, South Central
B23.	Douglas-fir, high productivity and management intensity, Pacific Northwest, West	B48.	Loblolly-shortleaf pine, high productivity and management intensity, South Central
B24.	Fir-spruce-mountain hemlock, Pacific Northwest, West	B49.	Oak-gum-cypress, South Central
B25.	Hemlock-Sitka spruce, Pacific Northwest, West	B50.	Oak-hickory, South Central
		B51.	Oak-pine, South Central

⁶ Note tonnes are metric tonnes in all tables.

B1.— Regional estimates of timber volume and carbon stocks for aspen-birch stands with afforestation of land in the Northeast

Age	Mean volume	Mean carbon density						
		Live tree	Standing dead tree	Under-story	Down dead wood	Forest floor	Soil organic	Total nonsoil
<i>years</i>	<i>m³/hectare</i>	<i>tonnes carbon/hectare</i>						
0	0.0	0.0	0.0	2.0	0.0	0.0	65.6	2.0
5	0.0	6.6	0.6	2.2	0.5	1.6	65.8	11.5
15	12.9	21.3	1.8	2.1	1.7	4.0	67.4	30.9
25	33.8	36.0	2.9	2.1	2.8	5.8	70.4	49.6
35	58.4	50.1	3.8	2.1	3.9	7.3	74.0	67.1
45	84.7	62.7	4.6	2.1	4.9	8.4	77.7	82.6
55	112.4	75.1	5.3	2.0	5.8	9.3	80.9	97.6
65	141.7	87.5	5.9	2.0	6.8	10.1	83.4	112.3
75	172.6	100.0	6.5	2.0	7.8	10.7	85.1	127.1
85	205.0	112.7	7.1	2.0	8.8	11.3	86.2	141.9
95	238.9	125.5	7.7	2.0	9.8	11.8	86.8	156.7
105	274.4	138.5	8.2	2.0	10.8	12.2	87.1	171.7
115	311.4	151.7	8.8	2.0	11.8	12.5	87.3	186.8
125	349.9	165.0	9.3	2.0	12.8	12.9	87.4	202.0
<i>years</i>	<i>ft³/acre</i>	<i>tonnes carbon/acre</i>						
0	0	0.0	0.0	0.8	0.0	0.0	26.5	0.8
5	0	2.7	0.2	0.9	0.2	0.6	26.6	4.7
15	184	8.6	0.7	0.9	0.7	1.6	27.3	12.5
25	483	14.6	1.2	0.8	1.1	2.4	28.5	20.1
35	835	20.3	1.5	0.8	1.6	2.9	30.0	27.2
45	1,210	25.4	1.9	0.8	2.0	3.4	31.4	33.4
55	1,607	30.4	2.1	0.8	2.4	3.8	32.7	39.5
65	2,025	35.4	2.4	0.8	2.8	4.1	33.7	45.5
75	2,466	40.5	2.6	0.8	3.1	4.3	34.4	51.4
85	2,929	45.6	2.9	0.8	3.5	4.6	34.9	57.4
95	3,414	50.8	3.1	0.8	3.9	4.8	35.1	63.4
105	3,921	56.0	3.3	0.8	4.4	4.9	35.3	69.5
115	4,450	61.4	3.5	0.8	4.8	5.1	35.3	75.6
125	5,001	66.8	3.8	0.8	5.2	5.2	35.4	81.8

B2.— Regional estimates of timber volume and carbon stocks for maple-beech-birch stands with afforestation of land in the Northeast

Age	Mean volume	Mean carbon density						
		Live tree	Standing dead tree	Under-story	Down dead wood	Forest floor	Soil organic	Total nonsoil
<i>years</i>	<i>m³/hectare</i>	<i>tonnes carbon/hectare</i>						
0	0.0	0.0	0.0	2.1	0.0	0.0	52.2	2.1
5	0.0	7.4	0.7	2.1	0.5	4.2	52.3	15.0
15	28.0	31.8	3.2	1.9	2.3	10.8	53.7	50.0
25	58.1	53.2	5.3	1.8	3.8	15.8	56.0	79.8
35	89.6	72.8	6.0	1.7	5.2	19.7	58.9	105.4
45	119.1	87.8	6.6	1.7	6.2	22.7	61.8	125.0
55	146.6	101.1	7.0	1.7	7.2	25.3	64.4	142.3
65	172.1	113.1	7.4	1.7	8.0	27.4	66.3	157.5
75	195.6	123.8	7.7	1.7	8.8	29.1	67.7	171.1
85	217.1	133.5	7.9	1.7	9.5	30.7	68.6	183.2
95	236.6	142.1	8.1	1.7	10.1	32.0	69.1	193.9
105	254.1	149.7	8.3	1.6	10.6	33.1	69.3	203.4
115	269.7	156.3	8.5	1.6	11.1	34.2	69.5	211.7
125	283.2	162.1	8.6	1.6	11.5	35.1	69.5	218.8
<i>years</i>	<i>ft³/acre</i>	<i>tonnes carbon/acre</i>						
0	0	0.0	0.0	0.8	0.0	0.0	21.1	0.8
5	0	3.0	0.3	0.8	0.2	1.7	21.2	6.1
15	400	12.9	1.3	0.8	0.9	4.4	21.7	20.2
25	830	21.5	2.1	0.7	1.5	6.4	22.7	32.3
35	1,280	29.5	2.4	0.7	2.1	8.0	23.8	42.7
45	1,702	35.5	2.7	0.7	2.5	9.2	25.0	50.6
55	2,095	40.9	2.8	0.7	2.9	10.2	26.0	57.6
65	2,460	45.8	3.0	0.7	3.2	11.1	26.8	63.7
75	2,796	50.1	3.1	0.7	3.5	11.8	27.4	69.2
85	3,103	54.0	3.2	0.7	3.8	12.4	27.8	74.1
95	3,382	57.5	3.3	0.7	4.1	12.9	28.0	78.5
105	3,632	60.6	3.4	0.7	4.3	13.4	28.1	82.3
115	3,854	63.3	3.4	0.7	4.5	13.8	28.1	85.7
125	4,047	65.6	3.5	0.7	4.6	14.2	28.1	88.6

B3.— Regional estimates of timber volume and carbon stocks for oak-hickory stands with afforestation of land in the Northeast

Age	Mean volume	Mean carbon density						
		Live tree	Standing dead tree	Under-story	Down dead wood	Forest floor	Soil organic	Total nonsoil
<i>years</i>	<i>m³/hectare</i>	<i>tonnes carbon/hectare</i>						
0	0.0	0.0	0.0	2.1	0.0	0.0	39.8	2.1
5	0.0	6.9	0.7	2.1	0.5	0.9	39.9	11.0
15	54.5	43.0	3.6	1.9	2.9	2.5	40.9	54.0
25	95.7	71.9	4.0	1.9	4.9	3.9	42.7	86.6
35	135.3	96.2	4.2	1.8	6.6	5.2	44.9	114.0
45	173.3	118.2	4.5	1.8	8.1	6.3	47.2	138.8
55	209.6	136.8	4.6	1.8	9.4	7.2	49.1	159.8
65	244.3	154.3	4.8	1.8	10.6	8.1	50.6	179.5
75	277.4	170.6	4.9	1.8	11.7	8.9	51.7	197.9
85	308.9	186.0	5.0	1.8	12.7	9.7	52.3	215.1
95	338.8	200.4	5.1	1.8	13.7	10.3	52.7	231.3
105	367.1	213.9	5.1	1.7	14.6	10.9	52.9	246.4
115	393.7	226.5	5.2	1.7	15.5	11.5	53.0	260.5
125	418.6	238.2	5.3	1.7	16.3	12.0	53.1	273.6
<i>years</i>	<i>ft³/acre</i>	<i>tonnes carbon/acre</i>						
0	0	0.0	0.0	0.8	0.0	0.0	16.1	0.8
5	0	2.8	0.3	0.8	0.2	0.4	16.2	4.5
15	779	17.4	1.4	0.8	1.2	1.0	16.6	21.8
25	1,904	29.1	1.6	0.7	2.0	1.6	17.3	35.0
35	1,934	38.9	1.7	0.7	2.7	2.1	18.2	46.1
45	2,477	47.8	1.8	0.7	3.3	2.5	19.1	56.2
55	2,996	55.4	1.9	0.7	3.8	2.9	19.9	64.7
65	3,492	62.4	1.9	0.7	4.3	3.3	20.5	72.6
75	3,965	69.1	2.0	0.7	4.7	3.6	20.9	80.1
85	4,415	75.3	2.0	0.7	5.1	3.9	21.2	87.1
95	4,842	81.1	2.0	0.7	5.5	4.2	21.3	93.6
105	5,246	86.6	2.1	0.7	5.9	4.4	21.4	99.7
115	5,626	91.7	2.1	0.7	6.3	4.7	21.5	105.4
125	5,983	96.4	2.1	0.7	6.6	4.9	21.5	110.7

B4.— Regional estimates of timber volume and carbon stocks for oak-pine stands with afforestation of land in the Northeast

Age	Mean volume	Mean carbon density						
		Live tree	Standing dead tree	Under-story	Down dead wood	Forest floor	Soil organic	Total nonsoil
<i>years</i>	<i>m³/hectare</i>	<i>tonnes carbon/hectare</i>						
0	0.0	0.0	0.0	4.2	0.0	0.0	50.2	4.2
5	0.0	6.2	0.6	4.2	0.4	3.8	50.3	15.2
15	36.5	27.0	2.6	3.3	1.7	10.3	51.6	44.9
25	70.9	48.6	3.2	2.9	3.0	15.6	53.9	73.3
35	103.1	67.9	3.7	2.6	4.2	19.9	56.6	98.3
45	133.1	84.7	4.0	2.5	5.2	23.5	59.5	119.8
55	160.9	99.1	4.2	2.4	6.1	26.6	61.9	138.4
65	186.7	113.0	4.4	2.3	6.9	29.2	63.8	155.8
75	210.2	123.6	4.6	2.3	7.6	31.6	65.1	169.5
85	231.5	133.1	4.7	2.3	8.1	33.6	66.0	181.8
95	250.8	141.7	4.8	2.2	8.7	35.4	66.4	192.8
105	267.9	149.2	4.9	2.2	9.1	37.0	66.7	202.4
115	282.7	155.7	5.0	2.2	9.5	38.4	66.8	210.9
125	295.4	161.3	5.1	2.2	9.9	39.7	66.9	218.1
<i>years</i>	<i>ft³/acre</i>	<i>tonnes carbon/acre</i>						
0	0	0.0	0.0	1.7	0.0	0.0	20.3	1.7
5	0	2.5	0.3	1.7	0.2	1.6	20.4	6.2
15	522	10.9	1.1	1.3	0.7	4.2	20.9	18.2
25	1,013	19.7	1.3	1.2	1.2	6.3	21.8	29.6
35	1,473	27.5	1.5	1.1	1.7	8.0	22.9	39.8
45	1,902	34.3	1.6	1.0	2.1	9.5	24.1	48.5
55	2,300	40.1	1.7	1.0	2.5	10.8	25.1	56.0
65	2,668	45.7	1.8	0.9	2.8	11.8	25.8	63.1
75	3,004	50.0	1.8	0.9	3.1	12.8	26.4	68.6
85	3,309	53.9	1.9	0.9	3.3	13.6	26.7	73.6
95	3,584	57.3	1.9	0.9	3.5	14.3	26.9	78.0
105	3,828	60.4	2.0	0.9	3.7	15.0	27.0	81.9
115	4,040	63.0	2.0	0.9	3.9	15.6	27.0	85.3
125	4,222	65.3	2.1	0.9	4.0	16.1	27.1	88.3

B5.— Regional estimates of timber volume and carbon stocks for spruce-balsam fir stands with afforestation of land in the Northeast

Age	Mean volume	Mean carbon density						
		Live tree	Standing dead tree	Under-story	Down dead wood	Forest floor	Soil organic	Total nonsoil
<i>years</i>	<i>m³/hectare</i>	----- <i>tonnes carbon/hectare</i> -----						
0	0.0	0.0	0.0	2.1	0.0	0.0	73.5	2.1
5	0.0	7.0	0.7	1.8	0.6	5.0	73.7	15.1
15	11.5	20.1	2.0	1.6	1.9	13.0	75.6	38.5
25	29.1	32.5	3.3	1.5	3.0	19.0	78.9	59.3
35	51.6	45.7	4.6	1.4	4.2	23.7	83.0	79.7
45	76.9	57.4	5.7	1.4	5.3	27.5	87.1	97.4
55	102.6	68.7	6.9	1.4	6.3	30.7	90.7	113.9
65	126.4	78.6	7.4	1.3	7.3	33.3	93.5	127.9
75	149.3	87.9	7.6	1.3	8.1	35.5	95.4	140.5
85	170.9	96.5	7.8	1.3	8.9	37.4	96.6	152.0
95	191.6	104.5	8.0	1.3	9.6	39.1	97.3	162.5
105	211.1	111.9	8.2	1.3	10.3	40.6	97.7	172.2
115	229.6	118.8	8.3	1.3	11.0	41.9	97.9	181.2
125	247.1	125.3	8.4	1.3	11.6	43.0	97.9	189.6
<i>years</i>	<i>ft³/acre</i>	----- <i>tonnes carbon/acre</i> -----						
0	0	0.0	0.0	0.9	0.0	0.0	29.7	0.9
5	0	2.8	0.3	0.7	0.3	2.0	29.8	6.1
15	164	8.1	0.8	0.6	0.8	5.2	30.6	15.6
25	416	13.2	1.3	0.6	1.2	7.7	31.9	24.0
35	738	18.5	1.9	0.6	1.7	9.6	33.6	32.2
45	1,099	23.2	2.3	0.6	2.1	11.1	35.2	39.4
55	1,466	27.8	2.8	0.6	2.6	12.4	36.7	46.1
65	1,807	31.8	3.0	0.5	2.9	13.5	37.8	51.8
75	2,133	35.6	3.1	0.5	3.3	14.4	38.6	56.9
85	2,443	39.0	3.2	0.5	3.6	15.2	39.1	61.5
95	2,738	42.3	3.2	0.5	3.9	15.8	39.4	65.8
105	3,017	45.3	3.3	0.5	4.2	16.4	39.5	69.7
115	3,281	48.1	3.4	0.5	4.4	16.9	39.6	73.3
125	3,532	50.7	3.4	0.5	4.7	17.4	39.6	76.7

B6.— Regional estimates of timber volume and carbon stocks for white-red-jack pine stands with afforestation of land in the Northeast

Age	Mean volume	Mean carbon density						
		Live tree	Standing dead tree	Under-story	Down dead wood	Forest floor	Soil organic	Total nonsoil
<i>years</i>	<i>m³/hectare</i>	<i>tonnes carbon/hectare</i>						
0	0.0	0.0	0.0	2.1	0.0	0.0	58.6	2.1
5	0.0	7.3	0.7	2.2	0.4	3.1	58.8	13.8
15	30.0	28.6	2.9	1.8	1.6	7.1	60.3	41.9
25	54.4	44.7	3.9	1.8	2.5	9.4	62.9	62.3
35	77.9	57.7	4.3	1.7	3.2	11.0	66.2	77.9
45	100.6	69.4	4.6	1.7	3.8	12.2	69.4	91.7
55	122.5	78.7	4.8	1.6	4.3	13.0	72.3	102.5
65	142.3	86.8	5.0	1.6	4.8	13.7	74.5	111.9
75	160.9	94.3	5.2	1.6	5.2	14.2	76.1	120.5
85	178.4	101.2	5.3	1.6	5.6	14.7	77.0	128.4
95	194.7	107.6	5.4	1.6	5.9	15.0	77.6	135.6
105	210.0	113.5	5.5	1.6	6.3	15.4	77.9	142.2
115	224.1	118.9	5.6	1.6	6.6	15.6	78.0	148.2
125	237.1	123.8	5.7	1.6	6.8	15.9	78.1	153.8
<i>years</i>	<i>ft³/acre</i>	<i>tonnes carbon/acre</i>						
0	0	0.0	0.0	0.8	0.0	0.0	23.7	0.8
5	0	3.0	0.3	0.9	0.2	1.3	23.8	5.6
15	429	11.6	1.2	0.7	0.6	2.9	24.4	17.0
25	777	18.1	1.6	0.7	1.0	3.8	25.5	25.2
35	1,113	23.3	1.7	0.7	1.3	4.5	26.8	31.5
45	1,438	28.1	1.9	0.7	1.5	4.9	28.1	37.1
55	1,751	31.8	2.0	0.7	1.8	5.3	29.3	41.5
65	2,034	35.1	2.0	0.7	1.9	5.5	30.2	45.3
75	2,300	38.2	2.1	0.7	2.1	5.8	30.8	48.8
85	2,550	41.0	2.1	0.6	2.3	5.9	31.2	52.0
95	2,783	43.5	2.2	0.6	2.4	6.1	31.4	54.9
105	3,001	45.9	2.2	0.6	2.5	6.2	31.5	57.6
115	3,202	48.1	2.3	0.6	2.7	6.3	31.6	60.0
125	3,389	50.1	2.3	0.6	2.8	6.4	31.6	62.2

B7.— Regional estimates of timber volume and carbon stocks for aspen-birch stands with afforestation of land in the Northern Lake States

Age	Mean volume	Mean carbon density						
		Live tree	Standing dead tree	Under-story	Down dead wood	Forest floor	Soil organic	Total nonsoil
<i>years</i>	<i>m³/hectare</i>	<i>tonnes carbon/hectare</i>						
0	0.0	0.0	0.0	2.0	0.0	0.0	109.6	2.0
5	0.0	7.3	0.5	2.1	0.6	1.6	109.9	12.1
15	2.9	13.9	1.4	2.1	1.1	4.0	112.7	22.5
25	21.5	26.8	2.7	2.1	2.2	5.8	117.6	39.6
35	47.2	40.8	4.1	2.0	3.3	7.3	123.7	57.4
45	72.8	53.5	5.3	2.0	4.3	8.4	129.8	73.6
55	97.1	64.9	6.1	2.0	5.2	9.3	135.2	87.6
65	119.5	75.0	6.7	2.0	6.1	10.1	139.4	99.8
75	139.7	83.8	7.1	2.0	6.8	10.7	142.2	110.4
85	157.5	91.5	7.4	2.0	7.4	11.3	144.1	119.6
95	173.0	98.0	7.7	2.0	7.9	11.8	145.1	127.4
105	186.0	103.4	7.9	2.0	8.4	12.2	145.6	133.9
115	196.4	107.7	8.1	2.0	8.7	12.5	145.9	139.1
125	204.3	110.9	8.3	2.0	9.0	12.9	146.0	143.0
<i>years</i>	<i>ft³/acre</i>	<i>tonnes carbon/acre</i>						
0	0	0.0	0.0	0.8	0.0	0.0	44.3	0.8
5	0	3.0	0.2	0.8	0.2	0.6	44.5	4.9
15	42	5.6	0.6	0.8	0.5	1.6	45.6	9.1
25	307	10.9	1.1	0.8	0.9	2.4	47.6	16.0
35	674	16.5	1.6	0.8	1.3	2.9	50.1	23.2
45	1,041	21.6	2.2	0.8	1.7	3.4	52.5	29.8
55	1,388	26.2	2.5	0.8	2.1	3.8	54.7	35.4
65	1,708	30.3	2.7	0.8	2.5	4.1	56.4	40.4
75	1,996	33.9	2.9	0.8	2.7	4.3	57.6	44.7
85	2,251	37.0	3.0	0.8	3.0	4.6	58.3	48.4
95	2,472	39.7	3.1	0.8	3.2	4.8	58.7	51.5
105	2,658	41.8	3.2	0.8	3.4	4.9	58.9	54.2
115	2,807	43.6	3.3	0.8	3.5	5.1	59.0	56.3
125	2,920	44.9	3.3	0.8	3.6	5.2	59.1	57.9

B8.— Regional estimates of timber volume and carbon stocks for elm-ash-cottonwood stands with afforestation of land in the Northern Lake States

Age	Mean volume	Mean carbon density						
		Live tree	Standing dead tree	Under-story	Down dead wood	Forest floor	Soil organic	Total nonsoil
<i>years</i>	<i>m³/hectare</i>	----- tonnes carbon/hectare -----						
0	0.0	0.0	0.0	2.0	0.0	0.0	134.9	2.0
5	0.0	3.9	0.4	1.9	0.2	4.2	135.4	10.7
15	2.4	10.3	1.0	1.9	0.6	10.8	138.8	24.7
25	13.2	20.1	2.0	1.9	1.2	15.8	144.9	41.1
35	25.2	29.8	3.0	1.9	1.8	19.7	152.4	56.2
45	37.4	38.7	3.9	1.9	2.4	22.7	159.9	69.7
55	49.8	47.1	4.7	1.9	2.9	25.3	166.5	81.9
65	62.3	55.6	5.3	1.9	3.4	27.4	171.6	93.7
75	74.9	62.8	5.6	1.9	3.9	29.1	175.2	103.4
85	87.5	69.9	5.8	1.9	4.3	30.7	177.4	112.6
95	100.1	76.8	6.0	1.9	4.7	32.0	178.7	121.4
105	112.9	83.6	6.2	1.9	5.1	33.1	179.4	130.0
115	125.8	90.4	6.4	1.9	5.6	34.2	179.7	138.5
125	139.2	97.4	6.5	1.9	6.0	35.1	179.8	147.0
<i>years</i>	<i>ft³/acre</i>	----- tonnes carbon/acre -----						
0	0	0.0	0.0	0.8	0.0	0.0	54.6	0.8
5	0	1.6	0.2	0.8	0.1	1.7	54.8	4.3
15	35	4.2	0.4	0.8	0.3	4.4	56.2	10.0
25	189	8.1	0.8	0.8	0.5	6.4	58.6	16.6
35	360	12.0	1.2	0.8	0.7	8.0	61.7	22.7
45	535	15.7	1.6	0.8	1.0	9.2	64.7	28.2
55	712	19.1	1.9	0.8	1.2	10.2	67.4	33.1
65	890	22.5	2.2	0.8	1.4	11.1	69.5	37.9
75	1,070	25.4	2.3	0.8	1.6	11.8	70.9	41.8
85	1,250	28.3	2.4	0.8	1.7	12.4	71.8	45.6
95	1,431	31.1	2.4	0.8	1.9	12.9	72.3	49.1
105	1,613	33.8	2.5	0.8	2.1	13.4	72.6	52.6
115	1,798	36.6	2.6	0.8	2.2	13.8	72.7	56.0
125	1,990	39.4	2.7	0.8	2.4	14.2	72.8	59.5

B9.— Regional estimates of timber volume and carbon stocks for maple-beech-birch stands with afforestation of land in the Northern Lake States

Age	Mean volume	Mean carbon density						
		Live tree	Standing dead tree	Under-story	Down dead wood	Forest floor	Soil organic	Total nonsoil
<i>years</i>	<i>m³/hectare</i>	----- <i>tonnes carbon/hectare</i> -----						
0	0.0	0.0	0.0	2.1	0.0	0.0	100.7	2.1
5	0.0	5.1	0.5	2.0	0.4	4.2	101.0	12.2
15	4.3	13.4	1.3	1.7	1.0	10.8	103.6	28.3
25	24.6	30.3	3.0	1.6	2.3	15.8	108.1	53.0
35	48.1	47.7	4.0	1.5	3.6	19.7	113.7	76.5
45	72.5	62.9	4.4	1.4	4.8	22.7	119.3	96.2
55	96.9	77.3	4.7	1.4	5.9	25.3	124.3	114.5
65	121.3	91.1	4.9	1.4	6.9	27.4	128.1	131.7
75	145.3	104.4	5.1	1.4	7.9	29.1	130.7	147.9
85	168.9	117.1	5.3	1.3	8.9	30.7	132.4	163.3
95	191.9	129.3	5.4	1.3	9.8	32.0	133.4	177.8
105	214.4	140.9	5.6	1.3	10.7	33.1	133.9	191.6
115	236.0	151.9	5.7	1.3	11.5	34.2	134.1	204.6
125	256.9	162.4	5.8	1.3	12.3	35.1	134.2	216.9
<i>years</i>	<i>ft³/acre</i>	----- <i>tonnes carbon/acre</i> -----						
0	0	0.0	0.0	0.9	0.0	0.0	40.8	0.9
5	0	2.1	0.2	0.8	0.2	1.7	40.9	4.9
15	62	5.4	0.5	0.7	0.4	4.4	41.9	11.5
25	351	12.2	1.2	0.6	0.9	6.4	43.8	21.4
35	688	19.3	1.6	0.6	1.5	8.0	46.0	31.0
45	1,036	25.4	1.8	0.6	1.9	9.2	48.3	38.9
55	1,385	31.3	1.9	0.6	2.4	10.2	50.3	46.3
65	1,733	36.9	2.0	0.6	2.8	11.1	51.8	53.3
75	2,076	42.2	2.1	0.6	3.2	11.8	52.9	59.9
85	2,414	47.4	2.1	0.5	3.6	12.4	53.6	66.1
95	2,743	52.3	2.2	0.5	4.0	12.9	54.0	72.0
105	3,064	57.0	2.3	0.5	4.3	13.4	54.2	77.5
115	3,373	61.5	2.3	0.5	4.7	13.8	54.3	82.8
125	3,671	65.7	2.3	0.5	5.0	14.2	54.3	87.8

B10.— Regional estimates of timber volume and carbon stocks for oak-hickory stands with afforestation of land in the Northern Lake States

Age	Mean volume	Mean carbon density						
		Live tree	Standing dead tree	Under-story	Down dead wood	Forest floor	Soil organic	Total nonsoil
<i>years</i>	<i>m³/hectare</i>	----- <i>tonnes carbon/hectare</i> -----						
0	0.0	0.0	0.0	2.1	0.0	0.0	72.8	2.1
5	0.0	6.7	0.7	2.2	0.5	0.9	73.1	11.0
15	4.1	17.0	1.7	2.0	1.3	2.5	74.9	24.5
25	21.9	33.6	3.1	1.9	2.6	3.9	78.2	45.0
35	42.5	50.3	3.6	1.8	3.9	5.2	82.2	64.8
45	64.9	66.7	3.9	1.8	5.2	6.3	86.3	83.9
55	88.7	83.6	4.2	1.8	6.5	7.2	89.9	103.3
65	113.4	99.1	4.5	1.7	7.7	8.1	92.6	121.1
75	139.0	114.7	4.7	1.7	8.9	8.9	94.5	138.9
85	165.2	130.3	4.9	1.7	10.1	9.7	95.8	156.7
95	192.1	146.0	5.1	1.7	11.3	10.3	96.4	174.4
105	219.2	161.6	5.3	1.7	12.5	10.9	96.8	192.0
115	246.4	177.0	5.4	1.6	13.7	11.5	97.0	209.2
125	272.5	191.6	5.5	1.6	14.8	12.0	97.1	225.6
<i>years</i>	<i>ft³/acre</i>	----- <i>tonnes carbon/acre</i> -----						
0	0	0.0	0.0	0.8	0.0	0.0	29.5	0.8
5	0	2.7	0.3	0.9	0.2	0.4	29.6	4.4
15	58	6.9	0.7	0.8	0.5	1.0	30.3	9.9
25	313	13.6	1.2	0.8	1.0	1.6	31.6	18.2
35	608	20.4	1.4	0.7	1.6	2.1	33.3	26.2
45	928	27.0	1.6	0.7	2.1	2.5	34.9	33.9
55	1,267	33.8	1.7	0.7	2.6	2.9	36.4	41.8
65	1,620	40.1	1.8	0.7	3.1	3.3	37.5	49.0
75	1,986	46.4	1.9	0.7	3.6	3.6	38.3	56.2
85	2,361	52.7	2.0	0.7	4.1	3.9	38.7	63.4
95	2,745	59.1	2.1	0.7	4.6	4.2	39.0	70.6
105	3,133	65.4	2.1	0.7	5.1	4.4	39.2	77.7
115	3,521	71.6	2.2	0.7	5.5	4.7	39.2	84.7
125	3,895	77.5	2.2	0.7	6.0	4.9	39.3	91.3

B11.— Regional estimates of timber volume and carbon stocks for spruce-balsam fir stands with afforestation of land in the Northern Lake States

Age	Mean volume	Mean carbon density						
		Live tree	Standing dead tree	Under-story	Down dead wood	Forest floor	Soil organic	Total nonsoil
<i>years</i>	<i>m³/hectare</i>	<i>tonnes carbon/hectare</i>						
0	0.0	0.0	0.0	2.1	0.0	0.0	196.4	2.1
5	0.0	3.4	0.3	2.1	0.3	5.0	197.0	11.1
15	3.0	9.3	0.9	2.6	0.8	13.0	202.0	26.5
25	23.2	24.3	2.4	1.9	2.1	19.0	210.8	49.7
35	51.1	41.2	4.1	1.6	3.6	23.7	221.7	74.2
45	77.2	56.0	5.1	1.5	4.8	27.5	232.7	94.9
55	100.7	67.4	5.8	1.4	5.8	30.7	242.3	111.1
65	121.6	77.2	6.4	1.3	6.7	33.3	249.7	124.8
75	140.2	85.5	6.8	1.3	7.4	35.5	254.9	136.5
85	156.5	92.8	7.2	1.2	8.0	37.4	258.2	146.6
95	170.9	99.0	7.5	1.2	8.6	39.1	260.0	155.3
105	183.5	104.3	7.7	1.2	9.0	40.6	261.0	162.9
115	194.4	109.0	7.9	1.2	9.4	41.9	261.5	169.3
125	203.8	112.9	8.1	1.2	9.8	43.0	261.7	174.9
<i>years</i>	<i>ft³/acre</i>	<i>tonnes carbon/acre</i>						
0	0	0.0	0.0	0.9	0.0	0.0	79.5	0.9
5	0	1.4	0.1	0.9	0.1	2.0	79.7	4.5
15	43	3.7	0.4	1.0	0.3	5.2	81.7	10.7
25	332	9.8	1.0	0.8	0.8	7.7	85.3	20.1
35	730	16.7	1.7	0.7	1.4	9.6	89.7	30.0
45	1,103	22.7	2.1	0.6	2.0	11.1	94.2	38.4
55	1,439	27.3	2.4	0.6	2.4	12.4	98.0	45.0
65	1,738	31.2	2.6	0.5	2.7	13.5	101.1	50.5
75	2,003	34.6	2.7	0.5	3.0	14.4	103.2	55.3
85	2,237	37.5	2.9	0.5	3.2	15.2	104.5	59.3
95	2,442	40.1	3.0	0.5	3.5	15.8	105.2	62.9
105	2,622	42.2	3.1	0.5	3.7	16.4	105.6	65.9
115	2,778	44.1	3.2	0.5	3.8	16.9	105.8	68.5
125	2,912	45.7	3.3	0.5	4.0	17.4	105.9	70.8

B12.— Regional estimates of timber volume and carbon stocks for white-red-jack pine stands with afforestation of land in the Northern Lake States

Age	Mean volume	Mean carbon density						
		Live tree	Standing dead tree	Under-story	Down dead wood	Forest floor	Soil organic	Total nonsoil
<i>years</i>	<i>m³/hectare</i>	<i>tonnes carbon/hectare</i>						
0	0.0	0.0	0.0	2.0	0.0	0.0	90.6	2.0
5	0.0	0.4	0.0	2.0	0.0	3.1	90.9	5.7
15	6.6	8.0	0.8	2.0	0.6	7.1	93.2	18.5
25	48.1	35.4	3.5	2.0	2.5	9.4	97.3	52.9
35	104.7	62.9	4.9	2.0	4.5	11.0	102.3	85.3
45	158.9	85.8	5.5	2.0	6.2	12.2	107.4	111.6
55	209.1	105.3	5.9	2.0	7.6	13.0	111.8	133.8
65	255.1	122.2	6.2	2.0	8.8	13.7	115.2	152.9
75	297.4	137.1	6.5	2.0	9.9	14.2	117.6	169.6
85	336.1	150.3	6.7	2.0	10.8	14.7	119.1	184.4
95	371.7	162.0	6.9	2.0	11.7	15.0	120.0	197.5
105	404.2	172.5	7.0	2.0	12.4	15.4	120.5	209.3
115	434.0	182.0	7.2	2.0	13.1	15.6	120.7	219.8
125	461.3	190.5	7.3	1.9	13.7	15.9	120.8	229.2
<i>years</i>	<i>ft³/acre</i>	<i>tonnes carbon/acre</i>						
0	0	0.0	0.0	0.8	0.0	0.0	36.7	0.8
5	0	0.2	0.0	0.8	0.0	1.3	36.8	2.3
15	94	3.3	0.3	0.8	0.2	2.9	37.7	7.5
25	688	14.3	1.4	0.8	1.0	3.8	39.4	21.4
35	1,496	25.5	2.0	0.8	1.8	4.5	41.4	34.5
45	2,271	34.7	2.2	0.8	2.5	4.9	43.5	45.2
55	2,988	42.6	2.4	0.8	3.1	5.3	45.3	54.2
65	3,646	49.5	2.5	0.8	3.6	5.5	46.6	61.9
75	4,250	55.5	2.6	0.8	4.0	5.8	47.6	68.6
85	4,804	60.8	2.7	0.8	4.4	5.9	48.2	74.6
95	5,312	65.6	2.8	0.8	4.7	6.1	48.6	79.9
105	5,777	69.8	2.8	0.8	5.0	6.2	48.7	84.7
115	6,203	73.6	2.9	0.8	5.3	6.3	48.8	88.9
125	6,593	77.1	2.9	0.8	5.5	6.4	48.9	92.8

B13.— Regional estimates of timber volume and carbon stocks for elm-ash-cottonwood stands with afforestation of land in the Northern Prairie States

Age	Mean volume	Mean carbon density						
		Live tree	Standing dead tree	Under-story	Down dead wood	Forest floor	Soil organic	Total nonsoil
<i>years</i>	<i>m³/hectare</i>	<i>tonnes carbon/hectare</i>						
0	0.0	0.0	0.0	2.1	0.0	0.0	63.6	2.1
5	0.0	3.9	0.4	2.1	0.3	4.2	63.8	10.8
15	0.0	8.7	0.9	2.7	0.6	10.8	65.4	23.7
25	5.8	15.5	1.6	2.4	1.1	15.8	68.3	36.4
35	21.8	27.7	2.8	2.2	1.9	19.7	71.8	54.3
45	45.1	43.2	4.3	2.0	3.0	22.7	75.4	75.3
55	73.0	60.2	5.6	1.9	4.2	25.3	78.5	97.1
65	104.1	78.9	6.1	1.8	5.5	27.4	80.9	119.7
75	137.4	96.5	6.5	1.8	6.7	29.1	82.6	140.6
85	171.9	114.0	6.9	1.7	7.9	30.7	83.6	161.2
95	206.8	131.3	7.2	1.7	9.1	32.0	84.2	181.3
105	241.7	148.2	7.5	1.6	10.3	33.1	84.5	200.7
115	275.8	164.3	7.8	1.6	11.4	34.2	84.7	219.2
125	308.6	179.6	8.0	1.6	12.4	35.1	84.7	236.6
<i>years</i>	<i>ft³/acre</i>	<i>tonnes carbon/acre</i>						
0	0	0.0	0.0	0.8	0.0	0.0	25.7	0.8
5	0	1.6	0.2	0.8	0.1	1.7	25.8	4.4
15	0	3.5	0.4	1.1	0.2	4.4	26.5	9.6
25	83	6.3	0.6	1.0	0.4	6.4	27.6	14.7
35	312	11.2	1.1	0.9	0.8	8.0	29.1	22.0
45	644	17.5	1.7	0.8	1.2	9.2	30.5	30.5
55	1,043	24.3	2.3	0.8	1.7	10.2	31.8	39.3
65	1,488	31.9	2.5	0.7	2.2	11.1	32.7	48.4
75	1,964	39.0	2.6	0.7	2.7	11.8	33.4	56.9
85	2,456	46.1	2.8	0.7	3.2	12.4	33.8	65.2
95	2,956	53.1	2.9	0.7	3.7	12.9	34.1	73.4
105	3,454	60.0	3.0	0.7	4.2	13.4	34.2	81.2
115	3,941	66.5	3.2	0.6	4.6	13.8	34.3	88.7
125	4,410	72.7	3.2	0.6	5.0	14.2	34.3	95.8

B14.— Regional estimates of timber volume and carbon stocks for maple-beech-birch stands with afforestation of land in the Northern Prairie States

Age	Mean volume	Mean carbon density						
		Live tree	Standing dead tree	Under-story	Down dead wood	Forest floor	Soil organic	Total nonsoil
<i>years</i>	<i>m³/hectare</i>	----- <i>tonnes carbon/hectare</i> -----						
0	0.0	0.0	0.0	2.1	0.0	0.0	48.6	2.1
5	0.0	5.1	0.5	2.2	0.3	4.2	48.8	12.4
15	0.9	10.5	1.1	1.9	0.7	10.8	50.0	25.0
25	8.2	18.5	1.8	1.7	1.2	15.8	52.2	39.0
35	21.4	29.7	3.0	1.6	1.9	19.7	54.9	55.7
45	38.2	41.3	3.8	1.5	2.6	22.7	57.7	71.9
55	57.4	53.6	4.2	1.4	3.4	25.3	60.0	87.9
65	78.6	66.5	4.5	1.3	4.2	27.4	61.9	103.9
75	101.0	79.6	4.7	1.3	5.1	29.1	63.2	119.8
85	124.4	92.9	4.9	1.2	5.9	30.7	64.0	135.7
95	148.6	106.2	5.1	1.2	6.7	32.0	64.4	151.2
105	173.1	119.4	5.3	1.2	7.6	33.1	64.7	166.6
115	197.4	132.1	5.5	1.2	8.4	34.2	64.8	181.3
125	220.5	144.0	5.6	1.1	9.1	35.1	64.8	195.0
<i>years</i>	<i>ft³/acre</i>	----- <i>tonnes carbon/acre</i> -----						
0	0	0.0	0.0	0.9	0.0	0.0	19.7	0.9
5	0	2.1	0.2	0.9	0.1	1.7	19.8	5.0
15	13	4.3	0.4	0.8	0.3	4.4	20.3	10.1
25	117	7.5	0.7	0.7	0.5	6.4	21.1	15.8
35	306	12.0	1.2	0.6	0.8	8.0	22.2	22.6
45	546	16.7	1.5	0.6	1.1	9.2	23.3	29.1
55	821	21.7	1.7	0.6	1.4	10.2	24.3	35.6
65	1,123	26.9	1.8	0.5	1.7	11.1	25.0	42.1
75	1,443	32.2	1.9	0.5	2.0	11.8	25.6	48.5
85	1,778	37.6	2.0	0.5	2.4	12.4	25.9	54.9
95	2,123	43.0	2.1	0.5	2.7	12.9	26.1	61.2
105	2,474	48.3	2.2	0.5	3.1	13.4	26.2	67.4
115	2,821	53.5	2.2	0.5	3.4	13.8	26.2	73.4
125	3,151	58.3	2.3	0.5	3.7	14.2	26.2	78.9

B15.— Regional estimates of timber volume and carbon stocks for oak-hickory stands with afforestation of land in the Northern Prairie States

Age	Mean volume	Mean carbon density						
		Live tree	Standing dead tree	Under-story	Down dead wood	Forest floor	Soil organic	Total nonsoil
<i>years</i>	<i>m³/hectare</i>	<i>tonnes carbon/hectare</i>						
0	0.0	0.0	0.0	2.1	0.0	0.0	34.5	2.1
5	0.0	6.7	0.6	2.4	0.5	0.9	34.6	11.0
15	2.1	15.6	1.6	2.1	1.1	2.5	35.4	22.9
25	13.0	27.5	2.7	2.0	1.9	3.9	37.0	37.9
35	27.4	40.0	3.2	1.9	2.7	5.2	38.9	53.0
45	43.0	52.2	3.6	1.8	3.5	6.3	40.8	67.4
55	59.1	64.3	3.9	1.8	4.3	7.2	42.5	81.5
65	74.9	74.7	4.1	1.7	5.0	8.1	43.8	93.7
75	90.2	84.6	4.3	1.7	5.7	8.9	44.7	105.2
85	104.7	93.7	4.4	1.7	6.3	9.7	45.3	115.8
95	118.3	102.1	4.5	1.6	6.9	10.3	45.6	125.5
105	130.8	109.7	4.7	1.6	7.4	10.9	45.8	134.4
115	142.0	116.5	4.7	1.6	7.9	11.5	45.9	142.3
125	151.9	122.5	4.8	1.6	8.3	12.0	45.9	149.2
<i>years</i>	<i>ft³/acre</i>	<i>tonnes carbon/acre</i>						
0	0	0.0	0.0	0.8	0.0	0.0	13.9	0.8
5	0	2.7	0.2	1.0	0.2	0.4	14.0	4.5
15	30	6.3	0.6	0.9	0.4	1.0	14.3	9.3
25	186	11.1	1.1	0.8	0.8	1.6	15.0	15.3
35	391	16.2	1.3	0.8	1.1	2.1	15.7	21.4
45	615	21.1	1.4	0.7	1.4	2.5	16.5	27.3
55	844	26.0	1.6	0.7	1.8	2.9	17.2	33.0
65	1,070	30.2	1.7	0.7	2.0	3.3	17.7	37.9
75	1,289	34.2	1.7	0.7	2.3	3.6	18.1	42.6
85	1,497	37.9	1.8	0.7	2.6	3.9	18.3	46.9
95	1,691	41.3	1.8	0.7	2.8	4.2	18.5	50.8
105	1,869	44.4	1.9	0.7	3.0	4.4	18.5	54.4
115	2,030	47.2	1.9	0.7	3.2	4.7	18.6	57.6
125	2,171	49.6	2.0	0.7	3.3	4.9	18.6	60.4

B16.— Regional estimates of timber volume and carbon stocks for oak-pine stands with afforestation of land in the Northern Prairie States

Age	Mean volume	Mean carbon density						
		Live tree	Standing dead tree	Under-story	Down dead wood	Forest floor	Soil organic	Total nonsoil
<i>years</i>	<i>m³/hectare</i>	<i>tonnes carbon/hectare</i>						
0	0.0	0.0	0.0	4.2	0.0	0.0	27.1	4.2
5	0.0	5.1	0.4	4.2	0.4	3.8	27.2	13.9
15	4.5	13.8	1.2	4.3	1.0	10.3	27.9	30.6
25	28.4	29.8	2.6	3.6	2.1	15.6	29.1	53.6
35	57.9	47.4	3.4	3.3	3.3	19.9	30.6	77.2
45	86.7	63.3	4.0	3.1	4.4	23.5	32.1	98.2
55	113.2	77.0	4.4	2.9	5.3	26.6	33.5	116.2
65	137.1	89.4	4.7	2.9	6.2	29.2	34.5	132.5
75	158.1	98.9	5.0	2.8	6.8	31.6	35.2	145.1
85	176.0	106.8	5.2	2.7	7.4	33.6	35.7	155.7
95	190.8	113.3	5.4	2.7	7.8	35.4	35.9	164.6
105	202.4	118.3	5.5	2.7	8.2	37.0	36.0	171.7
115	210.9	121.9	5.6	2.7	8.4	38.4	36.1	177.1
125	216.1	124.1	5.7	2.7	8.6	39.7	36.1	180.8
<i>years</i>	<i>ft³/acre</i>	<i>tonnes carbon/acre</i>						
0	0	0.0	0.0	1.7	0.0	0.0	11.0	1.7
5	0	2.1	0.2	1.7	0.1	1.6	11.0	5.6
15	65	5.6	0.5	1.7	0.4	4.2	11.3	12.4
25	406	12.1	1.0	1.5	0.8	6.3	11.8	21.7
35	828	19.2	1.4	1.3	1.3	8.0	12.4	31.3
45	1,239	25.6	1.6	1.2	1.8	9.5	13.0	39.7
55	1,618	31.2	1.8	1.2	2.2	10.8	13.5	47.0
65	1,959	36.2	1.9	1.2	2.5	11.8	14.0	53.6
75	2,259	40.0	2.0	1.1	2.8	12.8	14.2	58.7
85	2,515	43.2	2.1	1.1	3.0	13.6	14.4	63.0
95	2,727	45.8	2.2	1.1	3.2	14.3	14.5	66.6
105	2,893	47.9	2.2	1.1	3.3	15.0	14.6	69.5
115	3,014	49.3	2.3	1.1	3.4	15.6	14.6	71.7
125	3,088	50.2	2.3	1.1	3.5	16.1	14.6	73.2

B17.— Regional estimates of timber volume and carbon stocks for Douglas-fir stands with afforestation of land in the Pacific Northwest, East

Age	Mean volume	Mean carbon density						
		Live tree	Standing dead tree	Under-story	Down dead wood	Forest floor	Soil organic	Total nonsoil
<i>years</i>	<i>m³/hectare</i>	<i>tonnes carbon/hectare</i>						
0	0.0	0.0	0.0	4.6	0.0	0.0	71.1	4.6
5	0.0	2.7	0.3	4.4	0.3	5.2	71.3	12.7
15	3.8	8.7	0.9	4.1	0.9	13.0	73.1	27.5
25	47.7	38.3	3.8	3.7	3.9	18.6	76.3	68.3
35	119.0	75.1	7.5	3.6	7.7	22.9	80.2	116.7
45	184.7	104.0	10.0	3.5	10.7	26.2	84.2	154.3
55	241.8	127.3	10.9	3.4	13.1	28.9	87.7	183.6
65	290.9	146.4	11.5	3.4	15.0	31.1	90.4	207.5
75	332.7	162.2	12.0	3.4	16.6	33.0	92.3	227.2
85	368.3	175.3	12.4	3.4	18.0	34.5	93.4	243.6
95	398.6	186.2	12.7	3.4	19.1	35.9	94.1	257.2
105	424.4	195.4	13.0	3.3	20.0	37.0	94.5	268.7
115	446.4	203.1	13.2	3.3	20.8	38.0	94.6	278.4
125	465.2	209.6	13.3	3.3	21.5	39.0	94.7	286.7
<i>years</i>	<i>ft³/acre</i>	<i>tonnes carbon/acre</i>						
0	0	0.0	0.0	1.9	0.0	0.0	28.8	1.9
5	0	1.1	0.1	1.8	0.1	2.1	28.9	5.2
15	54	3.5	0.4	1.7	0.4	5.2	29.6	11.1
25	682	15.5	1.5	1.5	1.6	7.5	30.9	27.7
35	1,701	30.4	3.0	1.4	3.1	9.3	32.5	47.2
45	2,639	42.1	4.1	1.4	4.3	10.6	34.1	62.5
55	3,456	51.5	4.4	1.4	5.3	11.7	35.5	74.3
65	4,157	59.3	4.7	1.4	6.1	12.6	36.6	84.0
75	4,755	65.6	4.9	1.4	6.7	13.3	37.3	91.9
85	5,264	70.9	5.0	1.4	7.3	14.0	37.8	98.6
95	5,697	75.4	5.1	1.4	7.7	14.5	38.1	104.1
105	6,065	79.1	5.2	1.4	8.1	15.0	38.2	108.8
115	6,379	82.2	5.3	1.4	8.4	15.4	38.3	112.7
125	6,648	84.8	5.4	1.3	8.7	15.8	38.3	116.0

B18.— Regional estimates of timber volume and carbon stocks for fir-spruce-mountain hemlock stands with afforestation of land in the Pacific Northwest, East

Age	Mean volume	Mean carbon density						
		Live tree	Standing dead tree	Under-story	Down dead wood	Forest floor	Soil organic	Total nonsoil
<i>years</i>	<i>m³/hectare</i>	<i>tonnes carbon/hectare</i>						
0	0.0	0.0	0.0	4.8	0.0	0.0	46.6	4.8
5	0.0	3.1	0.3	4.1	0.3	5.2	46.8	13.0
15	0.0	5.8	0.6	3.7	0.6	13.0	47.9	23.7
25	15.2	15.5	1.6	3.2	1.6	18.6	50.0	40.5
35	52.1	33.9	3.4	2.8	3.6	22.9	52.6	66.6
45	97.4	53.0	5.3	2.6	5.6	26.2	55.2	92.7
55	144.4	71.3	7.1	2.5	7.6	28.9	57.5	117.5
65	189.7	88.3	8.8	2.4	9.4	31.1	59.3	140.0
75	231.5	103.3	10.3	2.4	11.0	33.0	60.5	160.0
85	268.7	116.4	11.6	2.3	12.4	34.5	61.3	177.3
95	301.0	127.6	12.8	2.3	13.6	35.9	61.7	192.0
105	328.2	136.9	13.7	2.3	14.5	37.0	62.0	204.4
115	350.6	144.4	14.4	2.2	15.3	38.0	62.1	214.4
125	368.3	150.3	15.0	2.2	16.0	39.0	62.1	222.5
<i>years</i>	<i>ft³/acre</i>	<i>tonnes carbon/acre</i>						
0	0	0.0	0.0	1.9	0.0	0.0	18.9	1.9
5	0	1.3	0.1	1.7	0.1	2.1	18.9	5.3
15	0	2.3	0.2	1.5	0.2	5.2	19.4	9.6
25	217	6.3	0.6	1.3	0.7	7.5	20.3	16.4
35	745	13.7	1.4	1.1	1.5	9.3	21.3	27.0
45	1,392	21.4	2.1	1.1	2.3	10.6	22.4	37.5
55	2,063	28.9	2.9	1.0	3.1	11.7	23.3	47.5
65	2,711	35.7	3.6	1.0	3.8	12.6	24.0	56.7
75	3,308	41.8	4.2	1.0	4.4	13.3	24.5	64.7
85	3,840	47.1	4.7	0.9	5.0	14.0	24.8	71.7
95	4,302	51.6	5.2	0.9	5.5	14.5	25.0	77.7
105	4,691	55.4	5.5	0.9	5.9	15.0	25.1	82.7
115	5,010	58.4	5.8	0.9	6.2	15.4	25.1	86.8
125	5,264	60.8	6.1	0.9	6.5	15.8	25.1	90.0

B19.— Regional estimates of timber volume and carbon stocks for lodgepole pine stands with afforestation of land in the Pacific Northwest, East

Age	Mean volume	Mean carbon density						
		Live tree	Standing dead tree	Under-story	Down dead wood	Forest floor	Soil organic	Total nonsoil
<i>years</i>	<i>m³/hectare</i>	----- <i>tonnes carbon/hectare</i> -----						
0	0.0	0.0	0.0	4.8	0.0	0.0	39.0	4.8
5	0.0	1.9	0.2	4.8	0.2	2.4	39.1	9.5
15	6.6	8.1	0.8	3.5	0.8	6.4	40.1	19.6
25	40.8	24.3	2.4	2.6	2.3	9.8	41.9	41.4
35	81.7	40.1	4.0	2.3	3.7	12.6	44.1	62.8
45	120.5	54.0	5.4	2.2	5.0	14.9	46.2	81.5
55	156.3	64.5	6.4	2.1	6.0	17.0	48.1	95.9
65	189.3	73.6	7.4	2.0	6.9	18.7	49.6	108.5
75	219.9	81.7	8.2	1.9	7.6	20.3	50.7	119.7
85	248.0	88.9	8.9	1.9	8.3	21.7	51.3	129.6
95	274.0	95.4	9.5	1.9	8.9	22.9	51.7	138.5
105	298.2	101.2	10.1	1.8	9.4	24.0	51.9	146.6
115	320.5	106.5	10.6	1.8	9.9	25.0	52.0	153.8
125	341.2	111.4	10.9	1.8	10.4	25.8	52.0	160.3
<i>years</i>	<i>ft³/acre</i>	----- <i>tonnes carbon/acre</i> -----						
0	0	0.0	0.0	2.0	0.0	0.0	15.8	2.0
5	0	0.8	0.1	2.0	0.1	1.0	15.8	3.8
15	95	3.3	0.3	1.4	0.3	2.6	16.2	7.9
25	583	9.8	1.0	1.1	0.9	4.0	17.0	16.8
35	1,168	16.2	1.6	0.9	1.5	5.1	17.8	25.4
45	1,722	21.8	2.2	0.9	2.0	6.0	18.7	33.0
55	2,234	26.1	2.6	0.8	2.4	6.9	19.5	38.8
65	2,706	29.8	3.0	0.8	2.8	7.6	20.1	43.9
75	3,142	33.1	3.3	0.8	3.1	8.2	20.5	48.4
85	3,544	36.0	3.6	0.8	3.3	8.8	20.8	52.4
95	3,916	38.6	3.9	0.8	3.6	9.3	20.9	56.1
105	4,261	41.0	4.1	0.7	3.8	9.7	21.0	59.3
115	4,580	43.1	4.3	0.7	4.0	10.1	21.0	62.2
125	4,876	45.1	4.4	0.7	4.2	10.5	21.0	64.9

B20.— Regional estimates of timber volume and carbon stocks for ponderosa pine stands with afforestation of land in the Pacific Northwest, East

Age	Mean volume	Mean carbon density						
		Live Tree	Standing dead tree	Under-story	Down dead wood	Forest floor	Soil organic	Total nonsoil
<i>years</i>	<i>m³/hectare</i>	----- <i>tonnes carbon/hectare</i> -----						
0	0.0	0.0	0.0	4.8	0.0	0.0	38.0	4.8
5	0.0	3.3	0.3	4.6	0.3	2.4	38.1	10.8
15	4.1	7.9	0.8	3.8	0.8	6.4	39.1	19.7
25	21.6	17.3	1.7	3.2	1.8	9.8	40.8	33.7
35	40.8	26.2	2.6	2.9	2.7	12.6	42.9	47.0
45	61.4	34.9	3.3	2.8	3.6	14.9	45.1	59.4
55	83.3	43.6	3.7	2.6	4.5	17.0	46.9	71.5
65	106.0	52.5	4.2	2.5	5.4	18.7	48.4	83.3
75	129.3	61.3	4.6	2.4	6.3	20.3	49.4	94.9
85	153.0	70.0	4.9	2.4	7.2	21.7	50.0	106.2
95	176.8	78.6	5.3	2.3	8.1	22.9	50.3	117.2
105	200.4	87.0	5.6	2.3	9.0	24.0	50.5	127.7
115	223.6	95.1	5.9	2.2	9.8	25.0	50.6	137.9
125	246.0	102.8	6.1	2.2	10.6	25.8	50.7	147.6
<i>years</i>	<i>ft³/acre</i>	----- <i>tonnes carbon/acre</i> -----						
0	0	0.0	0.0	1.9	0.0	0.0	15.4	1.9
5	0	1.3	0.1	1.8	0.1	1.0	15.4	4.4
15	59	3.2	0.3	1.5	0.3	2.6	15.8	8.0
25	309	7.0	0.7	1.3	0.7	4.0	16.5	13.7
35	583	10.6	1.1	1.2	1.1	5.1	17.4	19.0
45	878	14.1	1.3	1.1	1.5	6.0	18.2	24.0
55	1,190	17.7	1.5	1.1	1.8	6.9	19.0	28.9
65	1,515	21.2	1.7	1.0	2.2	7.6	19.6	33.7
75	1,848	24.8	1.8	1.0	2.6	8.2	20.0	38.4
85	2,187	28.3	2.0	1.0	2.9	8.8	20.2	43.0
95	2,527	31.8	2.1	0.9	3.3	9.3	20.4	47.4
105	2,864	35.2	2.3	0.9	3.6	9.7	20.5	51.7
115	3,195	38.5	2.4	0.9	4.0	10.1	20.5	55.8
125	3,515	41.6	2.5	0.9	4.3	10.5	20.5	59.7

B21.— Regional estimates of timber volume and carbon stocks for alder-maple stands with afforestation of land in the Pacific Northwest, West

Age	Mean volume	Mean carbon density						
		Live tree	Standing dead tree	Under-story	Down dead wood	Forest floor	Soil organic	Total nonsoil
<i>years</i>	<i>m³/hectare</i>	----- <i>tonnes carbon/hectare</i> -----						
0	0.0	0.0	0.0	4.7	0.0	0.0	86.4	4.7
5	0.0	8.0	0.8	4.7	0.8	1.8	86.7	16.1
15	49.5	31.0	3.1	3.7	2.9	4.4	88.9	45.2
25	229.7	99.4	9.9	2.8	9.4	6.2	92.8	127.8
35	380.8	153.8	15.4	2.5	14.6	7.6	97.6	193.9
45	513.7	200.8	20.1	2.4	19.0	8.6	102.4	250.9
55	633.3	242.5	22.2	2.3	23.0	9.4	106.7	299.4
65	742.1	280.1	23.9	2.2	26.5	10.1	109.9	342.8
75	842.1	314.4	25.3	2.2	29.8	10.7	112.2	382.4
85	934.5	346.0	26.6	2.1	32.8	11.1	113.6	418.6
95	1,020.3	375.2	27.7	2.1	35.5	11.5	114.5	452.0
105	1,100.3	402.2	28.7	2.0	38.1	11.9	114.9	483.0
115	1,175.0	427.4	29.6	2.1	40.5	12.2	115.1	511.8
125	1,244.9	450.9	30.4	2.3	42.7	12.4	115.2	538.7
<i>years</i>	<i>ft³/acre</i>	----- <i>tonnes carbon/acre</i> -----						
0	0	0.0	0.0	1.9	0.0	0.0	35.0	1.9
5	0	3.2	0.3	1.9	0.3	0.7	35.1	6.5
15	708	12.6	1.3	1.5	1.2	1.8	36.0	18.3
25	3,282	40.2	4.0	1.1	3.8	2.5	37.6	51.7
35	5,442	62.3	6.2	1.0	5.9	3.1	39.5	78.5
45	7,342	81.3	8.1	1.0	7.7	3.5	41.5	101.5
55	9,050	98.1	9.0	0.9	9.3	3.8	43.2	121.1
65	10,605	113.3	9.7	0.9	10.7	4.1	44.5	138.7
75	12,034	127.2	10.3	0.9	12.1	4.3	45.4	154.7
85	13,355	140.0	10.8	0.9	13.3	4.5	46.0	169.4
95	14,582	151.8	11.2	0.8	14.4	4.7	46.3	182.9
105	15,725	162.8	11.6	0.8	15.4	4.8	46.5	195.4
115	16,792	173.0	12.0	0.9	16.4	4.9	46.6	207.1
125	17,791	182.5	12.3	0.9	17.3	5.0	46.6	218.0

B22.— Regional estimates of timber volume and carbon stocks for Douglas-fir stands with afforestation of land in the Pacific Northwest, West

Age	Mean volume	Mean carbon density						
		Live tree	Standing dead tree	Under-story	Down dead wood	Forest floor	Soil organic	Total nonsoil
<i>years</i>	<i>m³/hectare</i>	<i>tonnes carbon/hectare</i>						
0	0.0	0.0	0.0	4.6	0.0	0.0	71.1	4.6
5	0.0	8.4	0.8	4.5	0.8	3.6	71.3	18.1
15	37.4	30.3	3.0	3.9	3.0	10.0	73.1	50.3
25	208.9	107.1	10.7	3.4	10.7	15.4	76.3	147.3
35	391.8	181.6	17.4	3.2	18.2	20.2	80.2	240.6
45	554.7	246.1	21.2	3.1	24.6	24.4	84.2	319.4
55	698.4	302.2	24.1	3.0	30.2	28.0	87.7	387.5
65	826.0	351.4	26.4	3.0	35.1	31.3	90.4	447.2
75	939.9	394.9	28.4	2.9	39.5	34.2	92.3	500.0
85	1,042.1	433.7	30.1	2.9	43.4	36.9	93.4	547.0
95	1,134.5	468.6	31.6	2.9	46.9	39.3	94.1	589.1
105	1,218.3	500.1	32.9	2.9	50.0	41.4	94.5	627.2
115	1,294.7	528.7	34.0	2.9	52.9	43.4	94.6	661.8
125	1,364.7	554.8	35.0	2.8	55.5	45.3	94.7	693.4
<i>years</i>	<i>ft³/acre</i>	<i>tonnes carbon/acre</i>						
0	0	0.0	0.0	1.9	0.0	0.0	28.8	1.9
5	0	3.4	0.3	1.8	0.3	1.5	28.9	7.3
15	535	12.3	1.2	1.6	1.2	4.0	29.6	20.3
25	2,985	43.3	4.3	1.4	4.3	6.2	30.9	59.6
35	5,600	73.5	7.1	1.3	7.3	8.2	32.5	97.4
45	7,927	99.6	8.6	1.3	10.0	9.9	34.1	129.2
55	9,981	122.3	9.7	1.2	12.2	11.3	35.5	156.8
65	11,804	142.2	10.7	1.2	14.2	12.7	36.6	181.0
75	13,432	159.8	11.5	1.2	16.0	13.9	37.3	202.3
85	14,893	175.5	12.2	1.2	17.6	14.9	37.8	221.3
95	16,213	189.6	12.8	1.2	19.0	15.9	38.1	238.4
105	17,411	202.4	13.3	1.2	20.2	16.8	38.2	253.8
115	18,503	213.9	13.8	1.2	21.4	17.6	38.3	267.8
125	19,503	224.5	14.2	1.1	22.5	18.3	38.3	280.6

B23.— Regional estimates of timber volume and carbon stocks for Douglas-fir stands with afforestation of land in the Pacific Northwest, West; volumes are for high-productivity sites (growth rate greater than 165 cubic feet wood/acre/year) with high-intensity management (replanting with genetically improved stock, fertilization, and precommercial thinning)

Age	Mean volume	Mean carbon density						
		Live tree	Standing dead tree	Under-story	Down dead wood	Forest floor	Soil organic	Total nonsoil
<i>years</i>	<i>m³/hectare</i>	----- <i>tonnes carbon/hectare</i> -----						
0	0.0	0.0	0.0	4.6	0.0	0.0	71.1	4.6
5	0.0	9.5	0.9	4.4	0.9	3.6	71.3	19.3
15	19.8	23.4	2.3	4.0	2.3	10.0	73.1	42.0
25	169.7	84.6	8.5	3.5	8.5	15.4	76.3	120.5
35	445.7	187.4	10.0	3.2	18.7	20.2	80.2	239.6
45	718.8	286.2	10.6	3.0	28.6	24.4	84.2	352.8
55	924.1	359.4	10.9	3.0	35.9	28.0	87.7	437.2
65	1,086.5	416.7	11.1	2.9	41.7	31.3	90.4	503.6
75	1,225.8	465.6	11.2	2.9	46.6	34.2	92.3	560.5
85	1,346.8	507.8	11.3	2.9	50.8	36.9	93.4	609.7
95	1,452.4	544.6	11.4	2.8	54.5	39.3	94.1	652.5
105	1,544.4	576.5	11.5	2.9	57.6	41.4	94.5	690.0
115	1,544.4	576.5	11.5	2.9	57.6	43.4	94.6	692.0
125	1,544.4	576.5	11.5	2.9	57.6	45.3	94.7	693.8
<i>years</i>	<i>ft³/acre</i>	----- <i>tonnes carbon/acre</i> -----						
0	0	0.0	0.0	1.9	0.0	0.0	28.8	1.9
5	0	3.8	0.4	1.8	0.4	1.5	28.9	7.8
15	283	9.5	0.9	1.6	0.9	4.0	29.6	17.0
25	2,425	34.2	3.4	1.4	3.4	6.2	30.9	48.8
35	6,370	75.9	4.1	1.3	7.6	8.2	32.5	97.0
45	10,272	115.8	4.3	1.2	11.6	9.9	34.1	142.8
55	13,207	145.4	4.4	1.2	14.5	11.3	35.5	176.9
65	15,527	168.6	4.5	1.2	16.9	12.7	36.6	203.8
75	17,518	188.4	4.5	1.2	18.8	13.9	37.3	226.8
85	19,248	205.5	4.6	1.2	20.6	14.9	37.8	246.7
95	20,756	220.4	4.6	1.2	22.0	15.9	38.1	264.1
105	22,072	233.3	4.7	1.2	23.3	16.8	38.2	279.2
115	22,072	233.3	4.7	1.2	23.3	17.6	38.3	280.0
125	22,072	233.3	4.7	1.2	23.3	18.3	38.3	280.8

B24.— Regional estimates of timber volume, and carbon stocks for fir-spruce-mountain hemlock stands with afforestation of land in the Pacific Northwest, West

Age	Mean volume	Mean carbon density						
		Live tree	Standing dead tree	Under-story	Down dead wood	Forest floor	Soil organic	Total nonsoil
<i>years</i>	<i>m³/hectare</i>	----- <i>tonnes carbon/hectare</i> -----						
0	0.0	0.0	0.0	4.8	0.0	0.0	46.6	4.8
5	0.0	3.2	0.3	4.8	0.3	5.5	46.8	14.0
15	8.2	11.6	1.2	3.9	1.0	13.6	47.9	31.4
25	62.3	42.5	4.3	3.2	3.8	19.4	50.0	73.2
35	145.5	84.3	8.4	2.8	7.6	23.8	52.6	126.9
45	238.7	128.7	12.9	2.6	11.5	27.2	55.2	183.0
55	333.9	168.2	16.8	2.5	15.1	29.9	57.5	232.5
65	427.0	205.1	20.5	2.5	18.4	32.1	59.3	278.5
75	515.8	239.2	23.9	2.4	21.4	33.9	60.5	320.8
85	599.0	270.3	27.0	2.3	24.2	35.4	61.3	359.3
95	676.0	298.5	29.8	2.3	26.8	36.8	61.7	394.2
105	746.6	323.9	32.4	2.3	29.0	37.9	62.0	425.5
115	810.8	346.7	34.1	2.3	31.1	38.9	62.1	453.0
125	869.1	367.2	35.1	2.2	32.9	39.8	62.1	477.2
<i>years</i>	<i>ft³/acre</i>	----- <i>tonnes carbon/acre</i> -----						
0	0	0.0	0.0	1.9	0.0	0.0	18.9	1.9
5	0	1.3	0.1	1.9	0.1	2.2	18.9	5.7
15	117	4.7	0.5	1.6	0.4	5.5	19.4	12.7
25	890	17.2	1.7	1.3	1.5	7.9	20.3	29.6
35	2,080	34.1	3.4	1.1	3.1	9.6	21.3	51.3
45	3,412	52.1	5.2	1.1	4.7	11.0	22.4	74.0
55	4,772	68.1	6.8	1.0	6.1	12.1	23.3	94.1
65	6,103	83.0	8.3	1.0	7.4	13.0	24.0	112.7
75	7,371	96.8	9.7	1.0	8.7	13.7	24.5	129.8
85	8,560	109.4	10.9	0.9	9.8	14.3	24.8	145.4
95	9,661	120.8	12.1	0.9	10.8	14.9	25.0	159.5
105	10,670	131.1	13.1	0.9	11.7	15.3	25.1	172.2
115	11,588	140.3	13.8	0.9	12.6	15.7	25.1	183.3
125	12,421	148.6	14.2	0.9	13.3	16.1	25.1	193.1

B25.— Regional estimates of timber volume and carbon stocks for hemlock-Sitka spruce stands with afforestation of land in the Pacific Northwest, West

Age	Mean volume	Mean carbon density						
		Live tree	Standing dead tree	Under-story	Down dead wood	Forest floor	Soil organic	Total nonsoil
<i>years</i>	<i>m³/hectare</i>	<i>tonnes carbon/hectare</i>						
0	0.0	0.0	0.0	4.7	0.0	0.0	87.3	4.7
5	0.0	5.9	0.6	4.7	0.6	3.6	87.6	15.3
15	33.7	22.5	2.2	4.1	2.2	10.0	89.8	41.0
25	184.1	78.0	7.8	3.1	7.7	15.4	93.7	112.1
35	350.8	139.8	14.0	2.7	13.8	20.2	98.5	190.5
45	516.7	201.6	20.2	2.5	19.9	24.4	103.4	268.5
55	678.7	256.6	25.7	2.4	25.3	28.0	107.7	338.0
65	835.1	309.1	30.9	2.3	30.5	31.3	111.0	404.1
75	985.6	359.2	35.9	2.2	35.4	34.2	113.3	467.0
85	1,129.8	406.7	40.1	2.2	40.1	36.9	114.7	526.0
95	1,267.4	451.8	42.8	2.3	44.5	39.3	115.6	580.7
105	1,398.3	494.4	45.2	2.5	48.7	41.4	116.0	632.3
115	1,522.4	534.7	47.4	2.7	52.7	43.4	116.2	680.9
125	1,639.6	572.6	49.4	2.9	56.4	45.3	116.3	726.6
<i>years</i>	<i>ft³/acre</i>	<i>tonnes carbon/acre</i>						
0	0	0.0	0.0	1.9	0.0	0.0	35.3	1.9
5	0	2.4	0.2	1.9	0.2	1.5	35.4	6.2
15	482	9.1	0.9	1.6	0.9	4.0	36.3	16.6
25	2,631	31.6	3.2	1.3	3.1	6.2	37.9	45.3
35	5,013	56.6	5.7	1.1	5.6	8.2	39.9	77.1
45	7,385	81.6	8.2	1.0	8.0	9.9	41.8	108.7
55	9,699	103.9	10.4	1.0	10.2	11.3	43.6	136.8
65	11,935	125.1	12.5	0.9	12.3	12.7	44.9	163.6
75	14,086	145.4	14.5	0.9	14.3	13.9	45.8	189.0
85	16,146	164.6	16.2	0.9	16.2	14.9	46.4	212.8
95	18,113	182.8	17.3	0.9	18.0	15.9	46.8	235.0
105	19,983	200.1	18.3	1.0	19.7	16.8	46.9	255.9
115	21,757	216.4	19.2	1.1	21.3	17.6	47.0	275.6
125	23,432	231.7	20.0	1.2	22.8	18.3	47.1	294.0

B26.— Regional estimates of timber volume and carbon stocks for hemlock-Sitka spruce stands with afforestation of land in the Pacific Northwest, West; volumes are for high productivity sites (growth rate greater than 225 cubic feet wood/acre/year)

Age	Mean volume	Mean carbon density						
		Live tree	Standing dead tree	Under-story	Down dead wood	Forest floor	Soil organic	Total nonsoil
<i>years</i>	<i>m³/hectare</i>	<i>tonnes carbon/hectare</i>						
0	0.0	0.0	0.0	4.7	0.0	0.0	87.3	4.7
5	0.0	5.9	0.6	4.7	0.6	3.6	87.6	15.3
15	80.3	36.4	3.6	3.7	3.6	10.0	89.8	57.2
25	221.7	90.4	9.0	3.0	8.9	15.4	93.7	126.8
35	413.7	161.0	16.1	2.7	15.9	20.2	98.5	215.8
45	669.6	253.6	25.4	2.4	25.0	24.4	103.4	330.7
55	903.9	332.1	33.2	2.3	32.7	28.0	107.7	428.3
65	1,119.3	403.3	39.9	2.2	39.8	31.3	111.0	516.4
75	1,318.1	468.3	43.7	2.3	46.2	34.2	113.3	594.8
85	1,502.0	528.1	47.1	2.6	52.1	36.9	114.7	666.7
95	1,672.1	583.0	50.0	2.9	57.5	39.3	115.6	732.7
105	1,829.1	633.5	52.6	3.2	62.5	41.4	116.0	793.1
115	1,973.0	679.5	54.9	3.4	67.0	43.4	116.2	848.2
125	2,103.3	721.0	56.9	3.6	71.1	45.3	116.3	897.8
<i>years</i>	<i>ft³/acre</i>	<i>tonnes carbon/acre</i>						
0	0	0.0	0.0	1.9	0.0	0.0	35.3	1.9
5	0	2.4	0.2	1.9	0.2	1.5	35.4	6.2
15	1,148	14.7	1.5	1.5	1.5	4.0	36.3	23.2
25	3,169	36.6	3.7	1.2	3.6	6.2	37.9	51.3
35	5,912	65.1	6.5	1.1	6.4	8.2	39.9	87.3
45	9,570	102.6	10.3	1.0	10.1	9.9	41.8	133.8
55	12,918	134.4	13.4	0.9	13.2	11.3	43.6	173.3
65	15,996	163.2	16.1	0.9	16.1	12.7	44.9	209.0
75	18,837	189.5	17.7	0.9	18.7	13.9	45.8	240.7
85	21,465	213.7	19.0	1.1	21.1	14.9	46.4	269.8
95	23,896	235.9	20.2	1.2	23.3	15.9	46.8	296.5
105	26,140	256.4	21.3	1.3	25.3	16.8	46.9	321.0
115	28,197	275.0	22.2	1.4	27.1	17.6	47.0	343.2
125	30,059	291.8	23.0	1.5	28.8	18.3	47.1	363.3

B27.— Regional estimates of timber volume and carbon stocks for mixed conifer stands with afforestation of land in the Pacific Southwest

Age	Mean volume	Mean carbon density						
		Live Tree	Standing dead tree	Under-story	Down dead wood	Forest floor	Soil organic	Total nonsoil
<i>years</i>	<i>m³/hectare</i>	----- <i>tonnes carbon/hectare</i> -----						
0	0.0	0.0	0.0	4.8	0.0	0.0	37.4	4.8
5	0.0	4.2	0.3	4.8	0.4	5.2	37.5	14.8
15	2.0	8.1	0.8	4.8	0.8	13.0	38.4	27.4
25	11.1	14.6	1.5	6.9	1.5	18.6	40.1	43.0
35	24.4	22.3	2.2	4.9	2.2	22.9	42.2	54.5
45	44.5	32.9	3.3	3.6	3.3	26.2	44.3	69.4
55	71.9	46.5	4.7	2.8	4.7	28.9	46.1	87.5
65	106.6	62.8	6.3	2.2	6.3	31.1	47.5	108.7
75	147.9	81.4	8.1	1.8	8.2	33.0	48.5	132.5
85	195.4	102.0	10.2	1.5	10.2	34.5	49.1	158.5
95	248.3	124.2	12.4	1.3	12.4	35.9	49.5	186.2
105	305.6	147.5	14.8	1.1	14.8	37.0	49.7	215.2
115	366.7	171.8	17.2	1.0	17.2	38.0	49.7	245.2
125	430.5	196.6	19.7	1.0	19.7	39.0	49.8	275.9
<i>years</i>	<i>ft³/acre</i>	----- <i>tonnes carbon/acre</i> -----						
0	0	0.0	0.0	1.9	0.0	0.0	15.1	1.9
5	0	1.7	0.1	1.9	0.2	2.1	15.2	6.0
15	29	3.3	0.3	1.9	0.3	5.2	15.5	11.1
25	159	5.9	0.6	2.8	0.6	7.5	16.2	17.4
35	349	9.0	0.9	2.0	0.9	9.3	17.1	22.1
45	636	13.3	1.3	1.5	1.3	10.6	17.9	28.1
55	1,028	18.8	1.9	1.1	1.9	11.7	18.7	35.4
65	1,523	25.4	2.5	0.9	2.6	12.6	19.2	44.0
75	2,114	33.0	3.3	0.7	3.3	13.3	19.6	53.6
85	2,793	41.3	4.1	0.6	4.1	14.0	19.9	64.1
95	3,548	50.2	5.0	0.5	5.0	14.5	20.0	75.3
105	4,368	59.7	6.0	0.5	6.0	15.0	20.1	87.1
115	5,240	69.5	7.0	0.4	7.0	15.4	20.1	99.2
125	6,152	79.6	8.0	0.4	8.0	15.8	20.1	111.7

B28.— Regional estimates of timber volume and carbon stocks for fir-spruce-mountain hemlock stands with afforestation of land in the Pacific Southwest

Age	Mean volume	Mean carbon density						
		Live Tree	Standing dead tree	Under-story	Down dead wood	Forest floor	Soil organic	Total nonsoil
<i>years</i>	<i>m³/hectare</i>	----- <i>tonnes carbon/hectare</i> -----						
0	0.0	0.0	0.0	4.8	0.0	0.0	38.9	4.8
5	0.0	3.2	0.3	4.8	0.3	5.2	39.1	13.8
15	2.0	7.9	0.8	4.2	0.9	13.0	40.0	26.7
25	13.7	17.3	1.7	3.4	1.9	18.6	41.8	43.0
35	32.4	29.5	3.0	2.9	3.2	22.9	43.9	61.5
45	58.8	45.2	4.5	2.6	4.9	26.2	46.1	83.5
55	94.0	63.1	6.3	2.4	6.9	28.9	48.0	107.6
65	136.7	83.5	8.4	2.2	9.1	31.1	49.5	134.3
75	185.6	105.7	10.6	2.1	11.5	33.0	50.5	162.7
85	239.2	128.9	12.9	2.0	14.0	34.5	51.2	192.4
95	296.6	153.0	15.3	1.9	16.6	35.9	51.5	222.6
105	356.8	177.4	17.7	1.8	19.3	37.0	51.7	253.3
115	419.1	202.0	20.2	1.8	22.0	38.0	51.8	284.0
125	482.7	226.6	22.7	1.7	24.6	39.0	51.9	314.6
<i>years</i>	<i>ft³/acre</i>	----- <i>tonnes carbon/acre</i> -----						
0	0	0.0	0.0	1.9	0.0	0.0	15.8	1.9
5	0	1.3	0.1	1.9	0.1	2.1	15.8	5.6
15	28	3.2	0.3	1.7	0.3	5.2	16.2	10.8
25	196	7.0	0.7	1.4	0.8	7.5	16.9	17.4
35	463	11.9	1.2	1.2	1.3	9.3	17.8	24.9
45	840	18.3	1.8	1.1	2.0	10.6	18.7	33.8
55	1,343	25.5	2.6	1.0	2.8	11.7	19.4	43.5
65	1,954	33.8	3.4	0.9	3.7	12.6	20.0	54.3
75	2,652	42.8	4.3	0.8	4.6	13.3	20.4	65.9
85	3,419	52.2	5.2	0.8	5.7	14.0	20.7	77.8
95	4,239	61.9	6.2	0.8	6.7	14.5	20.9	90.1
105	5,099	71.8	7.2	0.7	7.8	15.0	20.9	102.5
115	5,989	81.8	8.2	0.7	8.9	15.4	21.0	114.9
125	6,899	91.7	9.2	0.7	10.0	15.8	21.0	127.3

B29.— Regional estimates of timber volume and carbon stocks for western oak stands with afforestation of land in the Pacific Southwest

Age	Mean volume	Mean carbon density						
		Live tree	Standing dead tree	Under-story	Down dead wood	Forest floor	Soil organic	Total nonsoil
<i>years</i>	<i>m³/hectare</i>	----- <i>tonnes carbon/hectare</i> -----						
0	0.0	0.0	0.0	4.7	0.0	0.0	20.7	4.7
5	0.0	2.6	0.2	4.6	0.1	3.7	20.8	11.3
15	0.0	5.7	0.6	4.5	0.2	9.8	21.3	20.8
25	1.0	8.8	0.9	4.4	0.4	14.4	22.2	28.8
35	25.9	30.6	3.1	4.2	1.3	18.1	23.4	57.3
45	76.3	65.1	4.5	4.1	2.7	21.1	24.5	97.5
55	127.8	98.3	5.4	4.0	4.1	23.6	25.5	135.3
65	174.4	124.0	6.0	4.0	5.1	25.6	26.3	164.8
75	215.0	145.3	6.5	4.0	6.0	27.4	26.9	189.2
85	249.4	162.7	6.8	4.0	6.8	29.0	27.2	209.2
95	278.4	177.1	7.1	4.0	7.4	30.3	27.4	225.8
105	302.8	189.0	7.3	3.9	7.8	31.5	27.5	239.6
115	323.3	198.8	7.4	3.9	8.3	32.6	27.5	251.0
125	340.6	207.0	7.6	3.9	8.6	33.5	27.6	260.6
<i>years</i>	<i>ft³/acre</i>	----- <i>tonnes carbon/acre</i> -----						
0	0	0.0	0.0	1.9	0.0	0.0	8.4	1.9
5	0	1.1	0.1	1.9	0.0	1.5	8.4	4.6
15	0	2.3	0.2	1.8	0.1	3.9	8.6	8.4
25	15	3.6	0.4	1.8	0.1	5.8	9.0	11.7
35	370	12.4	1.2	1.7	0.5	7.3	9.5	23.2
45	1,090	26.3	1.8	1.7	1.1	8.5	9.9	39.4
55	1,826	39.8	2.2	1.6	1.7	9.5	10.3	54.8
65	2,493	50.2	2.4	1.6	2.1	10.4	10.6	66.7
75	3,072	58.8	2.6	1.6	2.4	11.1	10.9	76.6
85	3,564	65.9	2.8	1.6	2.7	11.7	11.0	84.7
95	3,979	71.7	2.9	1.6	3.0	12.3	11.1	91.4
105	4,328	76.5	2.9	1.6	3.2	12.7	11.1	97.0
115	4,620	80.5	3.0	1.6	3.3	13.2	11.1	101.6
125	4,868	83.8	3.1	1.6	3.5	13.6	11.2	105.5

B30.— Regional estimates of timber volume and carbon stocks for Douglas-fir stands with afforestation of land in the Rocky Mountain, North

Age	Mean volume	Mean carbon density						
		Live tree	Standing dead tree	Under-story	Down dead wood	Forest floor	Soil organic	Total nonsoil
<i>years</i>	<i>m³/hectare</i>	----- <i>tonnes carbon/hectare</i> -----						
0	0.0	0.0	0.0	4.7	0.0	0.0	29.1	4.7
5	0.0	2.7	0.3	4.7	0.2	5.2	29.2	13.0
15	1.1	6.1	0.6	4.7	0.4	13.0	30.0	24.8
25	19.7	21.5	2.2	3.4	1.3	18.6	31.3	47.0
35	57.1	44.3	4.4	2.7	2.8	22.9	32.9	77.0
45	100.9	66.5	6.7	2.3	4.1	26.2	34.5	105.8
55	145.9	87.2	8.7	2.1	5.4	28.9	35.9	132.3
65	189.3	105.9	10.1	1.9	6.6	31.1	37.1	155.6
75	229.7	122.5	10.7	1.8	7.6	33.0	37.8	175.6
85	266.3	137.0	11.2	1.8	8.5	34.5	38.3	193.0
95	298.6	149.4	11.6	1.7	9.3	35.9	38.6	207.9
105	326.6	159.9	12.0	1.7	9.9	37.0	38.7	220.5
115	350.1	168.6	12.2	1.6	10.5	38.0	38.8	231.0
125	369.5	175.7	12.4	1.6	10.9	39.0	38.8	239.6
<i>years</i>	<i>ft³/acre</i>	----- <i>tonnes carbon/acre</i> -----						
0	0	0.0	0.0	1.9	0.0	0.0	11.8	1.9
5	0	1.1	0.1	1.9	0.1	2.1	11.8	5.2
15	16	2.5	0.2	1.9	0.2	5.2	12.1	10.0
25	281	8.7	0.9	1.4	0.5	7.5	12.7	19.0
35	816	17.9	1.8	1.1	1.1	9.3	13.3	31.2
45	1,442	26.9	2.7	0.9	1.7	10.6	14.0	42.8
55	2,085	35.3	3.5	0.8	2.2	11.7	14.5	53.6
65	2,705	42.9	4.1	0.8	2.7	12.6	15.0	63.0
75	3,283	49.6	4.3	0.7	3.1	13.3	15.3	71.1
85	3,806	55.4	4.5	0.7	3.4	14.0	15.5	78.1
95	4,268	60.5	4.7	0.7	3.8	14.5	15.6	84.1
105	4,667	64.7	4.8	0.7	4.0	15.0	15.7	89.2
115	5,003	68.2	4.9	0.7	4.2	15.4	15.7	93.5
125	5,280	71.1	5.0	0.7	4.4	15.8	15.7	97.0

B31.— Regional estimates of timber volume and carbon stocks for fir-spruce-mountain hemlock stands with afforestation of land in the Rocky Mountain, North

Age	Mean volume	Mean carbon density						
		Live tree	Standing dead tree	Under-story	Down dead wood	Forest floor	Soil organic	Total nonsoil
<i>years</i>	<i>m³/hectare</i>	----- <i>tonnes carbon/hectare</i> -----						
0	0.0	0.0	0.0	4.7	0.0	0.0	33.1	4.7
5	0.0	3.1	0.3	4.7	0.3	5.2	33.2	13.6
15	0.0	5.8	0.6	4.7	0.6	13.0	34.0	24.7
25	18.2	17.0	1.7	3.4	1.7	18.6	35.5	42.4
35	61.6	38.1	3.8	2.7	3.8	22.9	37.4	71.2
45	113.8	59.5	5.9	2.3	6.0	26.2	39.2	100.0
55	167.2	80.0	8.0	2.1	8.0	28.9	40.8	127.0
65	218.2	98.6	9.9	2.0	9.9	31.1	42.1	151.4
75	264.6	115.0	11.5	1.9	11.6	33.0	43.0	172.9
85	305.4	129.1	12.9	1.8	13.0	34.5	43.5	191.3
95	340.2	140.9	14.1	1.8	14.2	35.9	43.8	206.8
105	368.8	150.5	15.0	1.7	15.1	37.0	44.0	219.4
115	391.6	158.0	15.8	1.7	15.9	38.0	44.1	229.4
125	408.8	163.7	16.4	1.7	16.4	39.0	44.1	237.1
<i>years</i>	<i>ft³/acre</i>	----- <i>tonnes carbon/acre</i> -----						
0	0	0.0	0.0	1.9	0.0	0.0	13.4	1.9
5	0	1.3	0.1	1.9	0.1	2.1	13.4	5.5
15	0	2.3	0.2	1.9	0.2	5.2	13.8	10.0
25	260	6.9	0.7	1.4	0.7	7.5	14.4	17.2
35	880	15.4	1.5	1.1	1.5	9.3	15.1	28.8
45	1,626	24.1	2.4	0.9	2.4	10.6	15.9	40.4
55	2,390	32.4	3.2	0.9	3.3	11.7	16.5	51.4
65	3,118	39.9	4.0	0.8	4.0	12.6	17.0	61.3
75	3,782	46.5	4.7	0.8	4.7	13.3	17.4	70.0
85	4,365	52.2	5.2	0.7	5.2	14.0	17.6	77.4
95	4,862	57.0	5.7	0.7	5.7	14.5	17.7	83.7
105	5,271	60.9	6.1	0.7	6.1	15.0	17.8	88.8
115	5,596	63.9	6.4	0.7	6.4	15.4	17.8	92.8
125	5,842	66.2	6.6	0.7	6.7	15.8	17.8	95.9

B32.— Regional estimates of timber volume and carbon stocks for lodgepole pine stands with afforestation of land in the Rocky Mountain, North

Age	Mean volume	Mean carbon density						
		Live tree	Standing dead tree	Under-story	Down dead wood	Forest floor	Soil organic	Total nonsoil
<i>years</i>	<i>m³/hectare</i>	<i>tonnes carbon/hectare</i>						
0	0.0	0.0	0.0	4.8	0.0	0.0	27.9	4.8
5	0.0	1.9	0.1	4.8	0.1	2.4	28.0	9.2
15	0.2	4.1	0.3	4.8	0.2	6.4	28.7	15.9
25	15.9	14.3	1.4	3.5	0.8	9.8	29.9	29.8
35	51.6	29.9	3.0	2.4	1.7	12.6	31.5	49.6
45	94.3	45.8	4.6	1.9	2.7	14.9	33.0	69.9
55	138.8	59.4	5.9	1.7	3.4	17.0	34.4	87.5
65	182.1	71.6	7.2	1.5	4.2	18.7	35.5	103.2
75	223.1	82.5	8.3	1.4	4.8	20.3	36.2	117.3
85	261.0	92.1	9.2	1.4	5.3	21.7	36.7	129.7
95	295.3	100.5	10.1	1.3	5.8	22.9	36.9	140.6
105	325.9	107.8	10.7	1.3	6.3	24.0	37.1	150.0
115	353.2	114.2	11.1	1.2	6.6	25.0	37.1	158.1
125	377.3	119.7	11.5	1.2	6.9	25.8	37.2	165.2
<i>years</i>	<i>ft³/acre</i>	<i>tonnes carbon/acre</i>						
0	0	0.0	0.0	1.9	0.0	0.0	11.3	1.9
5	0	0.8	0.0	1.9	0.0	1.0	11.3	3.7
15	3	1.7	0.1	1.9	0.1	2.6	11.6	6.4
25	227	5.8	0.6	1.4	0.3	4.0	12.1	12.1
35	737	12.1	1.2	1.0	0.7	5.1	12.7	20.1
45	1,348	18.5	1.9	0.8	1.1	6.0	13.4	28.3
55	1,983	24.0	2.4	0.7	1.4	6.9	13.9	35.4
65	2,603	29.0	2.9	0.6	1.7	7.6	14.4	41.8
75	3,189	33.4	3.3	0.6	1.9	8.2	14.6	47.5
85	3,730	37.3	3.7	0.6	2.2	8.8	14.8	52.5
95	4,220	40.7	4.1	0.5	2.4	9.3	14.9	56.9
105	4,658	43.6	4.3	0.5	2.5	9.7	15.0	60.7
115	5,048	46.2	4.5	0.5	2.7	10.1	15.0	64.0
125	5,392	48.4	4.6	0.5	2.8	10.5	15.0	66.8

B33.— Regional estimates of timber volume and carbon stocks for ponderosa pine stands with afforestation of land in the Rocky Mountain, North

Age	Mean volume	Mean carbon density						
		Live tree	Standing dead tree	Under-story	Down dead wood	Forest floor	Soil organic	Total nonsoil
<i>years</i>	<i>m³/hectare</i>	----- <i>tonnes carbon/hectare</i> -----						
0	0.0	0.0	0.0	4.8	0.0	0.0	25.7	4.8
5	0.0	3.3	0.2	4.8	0.3	2.4	25.8	10.9
15	1.3	6.3	0.6	4.3	0.6	6.4	26.5	18.2
25	18.6	15.9	1.6	3.2	1.4	9.8	27.6	31.8
35	51.8	30.9	3.0	2.5	2.7	12.6	29.0	51.6
45	89.4	46.1	3.9	2.2	4.0	14.9	30.5	71.1
55	127.1	60.4	4.5	2.0	5.3	17.0	31.7	89.2
65	162.2	73.3	5.1	1.9	6.4	18.7	32.7	105.4
75	193.8	84.6	5.5	1.8	7.4	20.3	33.4	119.6
85	221.0	94.2	5.8	1.7	8.2	21.7	33.8	131.6
95	243.7	102.0	6.1	1.7	8.9	22.9	34.1	141.6
105	261.8	108.2	6.3	1.6	9.5	24.0	34.2	149.6
115	275.6	112.9	6.4	1.6	9.9	25.0	34.3	155.7
125	285.1	116.1	6.5	1.6	10.1	25.8	34.3	160.2
<i>years</i>	<i>ft³/acre</i>	----- <i>tonnes carbon/acre</i> -----						
0	0	0.0	0.0	1.9	0.0	0.0	10.4	1.9
5	0	1.3	0.1	1.9	0.1	1.0	10.4	4.4
15	19	2.6	0.2	1.8	0.2	2.6	10.7	7.4
25	266	6.4	0.6	1.3	0.6	4.0	11.2	12.9
35	740	12.5	1.2	1.0	1.1	5.1	11.8	20.9
45	1,278	18.6	1.6	0.9	1.6	6.0	12.3	28.8
55	1,816	24.5	1.8	0.8	2.1	6.9	12.8	36.1
65	2,318	29.7	2.0	0.8	2.6	7.6	13.2	42.7
75	2,769	34.2	2.2	0.7	3.0	8.2	13.5	48.4
85	3,159	38.1	2.4	0.7	3.3	8.8	13.7	53.3
95	3,483	41.3	2.5	0.7	3.6	9.3	13.8	57.3
105	3,742	43.8	2.5	0.7	3.8	9.7	13.8	60.5
115	3,938	45.7	2.6	0.6	4.0	10.1	13.9	63.0
125	4,075	47.0	2.6	0.6	4.1	10.5	13.9	64.8

B34.— Regional estimates of timber volume and carbon stocks for aspen-birch stands with afforestation of land in the Rocky Mountain, South

Age	Mean volume	Mean carbon density						
		Live tree	Standing dead tree	Under-story	Down dead wood	Forest floor	Soil organic	Total nonsoil
<i>years</i>	<i>m³/hectare</i>	<i>tonnes carbon/hectare</i>						
0	0.0	0.0	0.0	4.7	0.0	0.0	44.1	4.7
5	0.0	3.1	0.3	4.7	0.2	3.7	44.2	12.1
15	0.0	6.4	0.6	4.7	0.4	9.8	45.4	22.0
25	6.3	13.9	1.4	4.8	0.9	14.4	47.4	35.3
35	22.7	25.7	2.6	4.5	1.7	18.1	49.8	52.5
45	45.0	38.8	3.9	4.3	2.5	21.1	52.3	70.5
55	70.7	52.3	5.2	4.2	3.4	23.6	54.4	88.6
65	98.1	64.7	6.5	4.1	4.2	25.6	56.1	105.0
75	126.5	76.6	7.7	4.0	4.9	27.4	57.3	120.6
85	155.0	88.0	8.8	3.9	5.7	29.0	58.0	135.3
95	183.1	98.8	9.9	3.9	6.3	30.3	58.4	149.2
105	210.5	108.8	10.9	3.8	7.0	31.5	58.6	162.1
115	236.8	118.3	11.8	3.8	7.6	32.6	58.7	174.0
125	261.8	127.0	12.4	3.8	8.2	33.5	58.8	184.8
<i>years</i>	<i>ft³/acre</i>	<i>tonnes carbon/acre</i>						
0	0	0.0	0.0	1.9	0.0	0.0	17.8	1.9
5	0	1.2	0.1	1.9	0.1	1.5	17.9	4.9
15	0	2.6	0.3	1.9	0.2	3.9	18.4	8.9
25	90	5.6	0.6	1.9	0.4	5.8	19.2	14.3
35	324	10.4	1.0	1.8	0.7	7.3	20.2	21.3
45	643	15.7	1.6	1.7	1.0	8.5	21.1	28.5
55	1,010	21.2	2.1	1.7	1.4	9.5	22.0	35.9
65	1,402	26.2	2.6	1.6	1.7	10.4	22.7	42.5
75	1,808	31.0	3.1	1.6	2.0	11.1	23.2	48.8
85	2,215	35.6	3.6	1.6	2.3	11.7	23.5	54.8
95	2,617	40.0	4.0	1.6	2.6	12.3	23.6	60.4
105	3,008	44.0	4.4	1.6	2.8	12.7	23.7	65.6
115	3,384	47.9	4.8	1.5	3.1	13.2	23.8	70.4
125	3,741	51.4	5.0	1.5	3.3	13.6	23.8	74.8

B35.— Regional estimates of timber volume and carbon stocks for Douglas-fir stands with afforestation of land in the Rocky Mountain, South

Age	Mean volume	Mean carbon density						
		Live tree	Standing dead tree	Under-story	Down dead wood	Forest floor	Soil organic	Total nonsoil
<i>years</i>	<i>m³/hectare</i>	----- <i>tonnes carbon/hectare</i> -----						
0	0.0	0.0	0.0	4.8	0.0	0.0	23.2	4.8
5	0.0	2.6	0.3	4.8	0.2	5.2	23.3	13.1
15	1.6	7.2	0.7	4.8	0.6	13.0	23.8	26.3
25	15.3	19.8	2.0	4.4	1.5	18.6	24.9	46.2
35	39.1	37.2	3.7	2.0	2.8	22.9	26.2	68.6
45	66.2	54.6	5.5	1.2	4.2	26.2	27.5	91.7
55	93.9	71.6	7.2	0.9	5.5	28.9	28.6	114.1
65	120.8	85.9	8.6	0.7	6.6	31.1	29.5	132.9
75	146.1	98.8	9.9	0.6	7.6	33.0	30.1	149.8
85	169.5	110.3	11.0	0.6	8.5	34.5	30.5	164.9
95	190.7	120.6	12.1	0.6	9.2	35.9	30.7	178.3
105	209.8	129.5	12.9	0.6	9.9	37.0	30.8	190.0
115	227.0	137.5	13.3	0.7	10.5	38.0	30.9	200.1
125	242.3	144.4	13.8	0.7	11.1	39.0	30.9	208.9
<i>years</i>	<i>ft³/acre</i>	----- <i>tonnes carbon/acre</i> -----						
0	0	0.0	0.0	2.0	0.0	0.0	9.4	2.0
5	0	1.1	0.1	2.0	0.1	2.1	9.4	5.3
15	23	2.9	0.3	2.0	0.2	5.2	9.7	10.6
25	219	8.0	0.8	1.8	0.6	7.5	10.1	18.7
35	559	15.0	1.5	0.8	1.2	9.3	10.6	27.8
45	946	22.1	2.2	0.5	1.7	10.6	11.1	37.1
55	1,342	29.0	2.9	0.4	2.2	11.7	11.6	46.2
65	1,726	34.8	3.5	0.3	2.7	12.6	11.9	53.8
75	2,088	40.0	4.0	0.2	3.1	13.3	12.2	60.6
85	2,422	44.7	4.5	0.2	3.4	14.0	12.3	66.7
95	2,726	48.8	4.9	0.2	3.7	14.5	12.4	72.2
105	2,999	52.4	5.2	0.3	4.0	15.0	12.5	76.9
115	3,244	55.6	5.4	0.3	4.3	15.4	12.5	81.0
125	3,463	58.5	5.6	0.3	4.5	15.8	12.5	84.6

B36.— Regional estimates of timber volume and carbon stocks for fir-spruce-mountain hemlock stands with afforestation of land in the Rocky Mountain, South

Age	Mean volume	Mean carbon density						
		Live tree	Standing dead tree	Under-story	Down dead wood	Forest floor	Soil organic	Total nonsoil
<i>years</i>	<i>m³/hectare</i>	----- <i>tonnes carbon/hectare</i> -----						
0	0.0	0.0	0.0	4.8	0.0	0.0	23.6	4.8
5	0.0	1.8	0.2	4.8	0.1	5.2	23.7	12.1
15	0.0	4.0	0.4	4.8	0.3	13.0	24.3	22.5
25	8.5	12.0	1.2	4.3	0.9	18.6	25.3	37.0
35	27.7	24.4	2.4	2.8	1.9	22.9	26.7	54.5
45	49.5	36.7	3.7	2.3	2.9	26.2	28.0	71.7
55	71.9	48.7	4.9	1.9	3.8	28.9	29.1	88.2
65	94.1	58.6	5.9	1.7	4.6	31.1	30.0	101.9
75	115.7	67.8	6.8	1.6	5.3	33.0	30.6	114.4
85	136.5	76.2	7.6	1.5	6.0	34.5	31.0	125.8
95	156.4	84.0	8.4	1.4	6.6	35.9	31.3	136.3
105	175.2	91.2	9.1	1.3	7.2	37.0	31.4	145.8
115	193.0	97.8	9.8	1.3	7.7	38.0	31.4	154.6
125	209.6	103.8	10.4	1.2	8.2	39.0	31.5	162.6
<i>years</i>	<i>ft³/acre</i>	----- <i>tonnes carbon/acre</i> -----						
0	0	0.0	0.0	2.0	0.0	0.0	9.6	2.0
5	0	0.7	0.1	2.0	0.1	2.1	9.6	4.9
15	0	1.6	0.2	2.0	0.1	5.2	9.8	9.1
25	122	4.8	0.5	1.7	0.4	7.5	10.3	15.0
35	396	9.9	1.0	1.1	0.8	9.3	10.8	22.1
45	708	14.8	1.5	0.9	1.2	10.6	11.3	29.0
55	1,028	19.7	2.0	0.8	1.6	11.7	11.8	35.7
65	1,345	23.7	2.4	0.7	1.9	12.6	12.1	41.2
75	1,654	27.4	2.7	0.6	2.2	13.3	12.4	46.3
85	1,951	30.8	3.1	0.6	2.4	14.0	12.6	50.9
95	2,235	34.0	3.4	0.6	2.7	14.5	12.7	55.1
105	2,504	36.9	3.7	0.5	2.9	15.0	12.7	59.0
115	2,758	39.6	4.0	0.5	3.1	15.4	12.7	62.6
125	2,995	42.0	4.2	0.5	3.3	15.8	12.7	65.8

B37.— Regional estimates of timber volume and carbon stocks for lodgepole pine stands with afforestation of land in the Rocky Mountain, South

Age	Mean volume	Mean carbon density						
		Live tree	Standing dead tree	Under-story	Down dead wood	Forest floor	Soil organic	Total nonsoil
<i>years</i>	<i>m³/hectare</i>	----- <i>tonnes carbon/hectare</i> -----						
0	0.0	0.0	0.0	4.8	0.0	0.0	20.2	4.8
5	0.0	2.1	0.2	4.8	0.2	2.4	20.3	9.7
15	0.0	4.3	0.4	4.8	0.4	6.4	20.8	16.4
25	5.0	9.2	0.9	4.8	0.9	9.8	21.7	25.5
35	18.3	16.9	1.7	3.4	1.7	12.6	22.8	36.2
45	37.0	25.9	2.6	2.5	2.5	14.9	24.0	48.4
55	58.5	34.1	3.4	2.0	3.4	17.0	25.0	59.9
65	81.2	42.0	4.2	1.7	4.1	18.7	25.7	70.8
75	104.1	49.5	4.9	1.5	4.9	20.3	26.3	81.1
85	126.7	56.4	5.6	1.4	5.6	21.7	26.6	90.7
95	148.3	62.8	6.3	1.3	6.2	22.9	26.8	99.4
105	168.6	68.6	6.9	1.2	6.8	24.0	26.9	107.4
115	187.3	73.8	7.4	1.1	7.3	25.0	26.9	114.5
125	204.1	78.3	7.8	1.1	7.7	25.8	27.0	120.8
<i>years</i>	<i>ft³/acre</i>	----- <i>tonnes carbon/acre</i> -----						
0	0	0.0	0.0	1.9	0.0	0.0	8.2	1.9
5	0	0.9	0.1	1.9	0.1	1.0	8.2	3.9
15	0	1.7	0.2	1.9	0.2	2.6	8.4	6.6
25	71	3.7	0.4	1.9	0.4	4.0	8.8	10.3
35	262	6.8	0.7	1.4	0.7	5.1	9.2	14.6
45	529	10.5	1.0	1.0	1.0	6.0	9.7	19.6
55	836	13.8	1.4	0.8	1.4	6.9	10.1	24.2
65	1,160	17.0	1.7	0.7	1.7	7.6	10.4	28.7
75	1,488	20.0	2.0	0.6	2.0	8.2	10.6	32.8
85	1,810	22.8	2.3	0.6	2.2	8.8	10.8	36.7
95	2,120	25.4	2.5	0.5	2.5	9.3	10.8	40.2
105	2,410	27.8	2.8	0.5	2.7	9.7	10.9	43.5
115	2,677	29.8	3.0	0.5	2.9	10.1	10.9	46.3
125	2,917	31.7	3.2	0.4	3.1	10.5	10.9	48.9

B38.— Regional estimates of timber volume and carbon stocks for ponderosa pine stands with afforestation of land in the Rocky Mountain, South

Age	Mean volume	Mean carbon density						
		Live Tree	Standing dead tree	Under-story	Down dead wood	Forest floor	Soil organic	Total nonsoil
<i>years</i>	<i>m³/hectare</i>	----- <i>tonnes carbon/hectare</i> -----						
0	0.0	0.0	0.0	4.8	0.0	0.0	18.1	4.8
5	0.0	1.8	0.2	4.8	0.2	2.4	18.1	9.4
15	0.0	3.7	0.4	4.8	0.3	6.4	18.6	15.6
25	4.4	9.4	0.9	4.8	0.8	9.8	19.4	25.7
35	16.2	18.6	1.9	2.9	1.5	12.6	20.4	37.5
45	32.2	28.8	2.7	2.1	2.4	14.9	21.4	50.9
55	50.3	38.2	3.0	1.7	3.1	17.0	22.3	63.1
65	69.3	47.1	3.3	1.5	3.9	18.7	23.0	74.5
75	88.4	55.5	3.6	1.3	4.6	20.3	23.5	85.2
85	107.2	63.2	3.8	1.2	5.2	21.7	23.8	95.1
95	125.5	70.4	4.0	1.1	5.8	22.9	24.0	104.2
105	143.0	77.1	4.1	1.0	6.3	24.0	24.0	112.5
115	159.5	83.2	4.3	1.0	6.8	25.0	24.1	120.2
125	175.1	88.8	4.4	0.9	7.3	25.8	24.1	127.2
<i>years</i>	<i>ft³/acre</i>	----- <i>tonnes carbon/acre</i> -----						
0	0	0.0	0.0	2.0	0.0	0.0	7.3	2.0
5	0	0.7	0.1	2.0	0.1	1.0	7.3	3.8
15	0	1.5	0.1	2.0	0.1	2.6	7.5	6.3
25	63	3.8	0.4	2.0	0.3	4.0	7.9	10.4
35	231	7.5	0.8	1.2	0.6	5.1	8.3	15.2
45	460	11.7	1.1	0.9	1.0	6.0	8.7	20.6
55	719	15.5	1.2	0.7	1.3	6.9	9.0	25.5
65	990	19.1	1.4	0.6	1.6	7.6	9.3	30.2
75	1,263	22.4	1.5	0.5	1.8	8.2	9.5	34.5
85	1,532	25.6	1.5	0.5	2.1	8.8	9.6	38.5
95	1,793	28.5	1.6	0.4	2.3	9.3	9.7	42.2
105	2,043	31.2	1.7	0.4	2.6	9.7	9.7	45.5
115	2,280	33.7	1.7	0.4	2.8	10.1	9.7	48.6
125	2,503	35.9	1.8	0.4	3.0	10.5	9.8	51.5

B39.— Regional estimates of timber volume and carbon stocks for loblolly-shortleaf pine stands with afforestation of land in the Southeast

Age	Mean volume	Mean carbon density						
		Live tree	Standing dead tree	Under-story	Down dead wood	Forest floor	Soil organic	Total nonsoil
<i>years</i>	<i>m³/hectare</i>	<i>tonnes carbon/hectare</i>						
0	0.0	0.0	0.0	4.2	0.0	0.0	54.7	4.2
5	0.0	11.1	0.7	4.0	0.9	3.2	54.9	19.8
10	19.1	22.6	1.3	3.6	1.8	5.5	55.4	34.8
15	36.7	31.3	1.6	3.4	2.5	7.3	56.3	46.1
20	60.4	40.8	1.9	3.2	3.3	8.7	57.4	57.9
25	85.5	50.3	2.1	3.1	4.1	9.8	58.7	69.4
30	108.7	58.2	2.3	3.1	4.7	10.7	60.2	79.0
35	131.2	65.6	2.4	3.0	5.3	11.5	61.8	87.9
40	152.3	72.5	2.5	3.0	5.9	12.2	63.3	96.1
45	172.3	78.9	2.7	2.9	6.4	12.7	64.8	103.6
50	191.4	85.0	2.7	2.9	6.9	13.2	66.2	110.7
55	208.4	90.3	2.8	2.9	7.3	13.7	67.5	116.9
60	223.9	95.1	2.9	2.8	7.7	14.1	68.6	122.6
65	238.4	99.6	2.9	2.8	8.1	14.4	69.6	127.8
70	252.9	104.0	3.0	2.8	8.4	14.7	70.4	133.0
75	264.6	107.6	3.0	2.8	8.7	15.0	71.0	137.1
80	277.1	111.4	3.1	2.8	9.0	15.2	71.5	141.5
85	289.5	115.1	3.1	2.8	9.3	15.5	71.9	145.8
90	299.6	118.2	3.2	2.7	9.6	15.7	72.2	149.3
<i>years</i>	<i>ft³/acre</i>	<i>tonnes carbon/acre</i>						
0	0	0.0	0.0	1.7	0.0	0.0	22.1	1.7
5	0	4.5	0.3	1.6	0.4	1.3	22.2	8.0
10	273	9.2	0.5	1.4	0.7	2.2	22.4	14.1
15	525	12.7	0.7	1.4	1.0	2.9	22.8	18.7
20	863	16.5	0.8	1.3	1.3	3.5	23.2	23.4
25	1,222	20.4	0.9	1.3	1.6	4.0	23.8	28.1
30	1,554	23.5	0.9	1.2	1.9	4.3	24.4	32.0
35	1,875	26.6	1.0	1.2	2.2	4.7	25.0	35.6
40	2,177	29.3	1.0	1.2	2.4	4.9	25.6	38.9
45	2,462	31.9	1.1	1.2	2.6	5.2	26.2	41.9
50	2,736	34.4	1.1	1.2	2.8	5.4	26.8	44.8
55	2,978	36.5	1.1	1.2	3.0	5.5	27.3	47.3
60	3,200	38.5	1.2	1.1	3.1	5.7	27.8	49.6
65	3,407	40.3	1.2	1.1	3.3	5.8	28.2	51.7
70	3,614	42.1	1.2	1.1	3.4	6.0	28.5	53.8
75	3,782	43.5	1.2	1.1	3.5	6.1	28.7	55.5
80	3,960	45.1	1.3	1.1	3.7	6.2	28.9	57.3
85	4,138	46.6	1.3	1.1	3.8	6.3	29.1	59.0
90	4,281	47.8	1.3	1.1	3.9	6.3	29.2	60.4

B40.— Regional estimates of timber volume and carbon stocks for loblolly-shortleaf pine stands with afforestation of land in the Southeast; volumes are for high productivity sites (growth rate greater than 85 cubic feet wood/acre/year) with high intensity management (replanting with genetically improved stock)

Age	Mean volume	Mean carbon density						
		Live tree	Standing dead tree	Under-story	Down dead wood	Forest floor	Soil organic	Total nonsoil
<i>years</i>	<i>m³/hectare</i>	----- tonnes carbon/hectare -----						
0	0.0	0.0	0.0	4.1	0.0	0.0	54.7	4.1
5	0.0	11.0	0.7	4.0	0.4	3.2	54.9	19.3
10	47.7	31.9	1.4	3.8	1.2	5.5	55.4	43.8
15	146.5	67.4	1.9	3.7	2.5	7.3	56.3	82.9
20	244.8	102.3	2.1	3.7	3.8	8.7	57.4	120.6
25	315.2	124.2	2.3	3.7	4.7	9.8	58.7	144.6
30	347.3	134.1	2.4	3.7	5.0	10.7	60.2	155.8
35	351.5	135.4	2.4	3.7	5.1	11.5	61.8	158.0
40	355.0	136.5	2.4	3.7	5.1	12.2	63.3	159.8
45	358.5	137.5	2.4	3.6	5.2	12.7	64.8	161.4
50	362.0	138.6	2.4	3.6	5.2	13.2	66.2	163.1
55	362.0	138.6	2.4	3.6	5.2	13.7	67.5	163.5
60	362.0	138.6	2.4	3.6	5.2	14.1	68.6	163.9
65	362.0	138.6	2.4	3.6	5.2	14.4	69.6	164.2
70	362.0	138.6	2.4	3.6	5.2	14.7	70.4	164.5
75	362.0	138.6	2.4	3.6	5.2	15.0	71.0	164.8
80	362.0	138.6	2.4	3.6	5.2	15.2	71.5	165.1
85	362.0	138.6	2.4	3.6	5.2	15.5	71.9	165.3
90	362.0	138.6	2.4	3.6	5.2	15.7	72.2	165.5
<i>years</i>	<i>ft³/acre</i>	----- tonnes carbon/acre -----						
0	0	0.0	0.0	1.7	0.0	0.0	22.1	1.7
5	0	4.5	0.3	1.6	0.2	1.3	22.2	7.8
10	682	12.9	0.6	1.6	0.5	2.2	22.4	17.7
15	2,094	27.3	0.8	1.5	1.0	2.9	22.8	33.5
20	3,498	41.4	0.9	1.5	1.5	3.5	23.2	48.8
25	4,504	50.3	0.9	1.5	1.9	4.0	23.8	58.5
30	4,963	54.3	1.0	1.5	2.0	4.3	24.4	63.1
35	5,024	54.8	1.0	1.5	2.1	4.7	25.0	63.9
40	5,074	55.2	1.0	1.5	2.1	4.9	25.6	64.7
45	5,124	55.7	1.0	1.5	2.1	5.2	26.2	65.3
50	5,174	56.1	1.0	1.5	2.1	5.4	26.8	66.0
55	5,174	56.1	1.0	1.5	2.1	5.5	27.3	66.2
60	5,174	56.1	1.0	1.5	2.1	5.7	27.8	66.3
65	5,174	56.1	1.0	1.5	2.1	5.8	28.2	66.5
70	5,174	56.1	1.0	1.5	2.1	6.0	28.5	66.6
75	5,174	56.1	1.0	1.5	2.1	6.1	28.7	66.7
80	5,174	56.1	1.0	1.5	2.1	6.2	28.9	66.8
85	5,174	56.1	1.0	1.5	2.1	6.3	29.1	66.9
90	5,174	56.1	1.0	1.5	2.1	6.3	29.2	67.0

B41.— Regional estimates of timber volume and carbon stocks for longleaf-slash pine stands with afforestation of land in the Southeast

Age	Mean volume	Mean carbon density						
		Live tree	Standing dead tree	Under-story	Down dead wood	Forest floor	Soil organic	Total nonsoil
<i>years</i>	<i>m³/hectare</i>	<i>tonnes carbon/hectare</i>						
0	0.0	0.0	0.0	4.2	0.0	0.0	82.5	4.2
5	0.0	5.3	0.4	4.2	0.4	3.2	82.8	13.6
10	19.1	14.1	0.9	3.8	1.1	5.5	83.6	25.4
15	36.7	21.4	1.0	3.6	1.7	7.3	84.9	34.9
20	60.4	30.4	1.1	3.4	2.5	8.7	86.6	46.0
25	85.5	39.2	1.1	3.3	3.2	9.8	88.6	56.6
30	108.7	47.2	1.2	3.2	3.8	10.7	90.9	66.1
35	131.2	54.8	1.2	3.1	4.4	11.5	93.2	75.1
40	152.3	61.9	1.3	3.0	5.0	12.2	95.5	83.4
45	172.3	68.5	1.3	3.0	5.6	12.7	97.8	91.1
50	191.4	74.8	1.3	2.9	6.1	13.2	99.9	98.4
55	208.4	80.4	1.3	2.9	6.5	13.7	101.8	104.8
60	223.9	85.4	1.3	2.9	6.9	14.1	103.5	110.6
65	238.4	90.1	1.4	2.9	7.3	14.4	105.0	116.1
70	252.9	94.8	1.4	2.8	7.7	14.7	106.2	121.4
75	264.6	98.6	1.4	2.8	8.0	15.0	107.1	125.8
80	277.1	102.6	1.4	2.8	8.3	15.2	107.9	130.3
85	289.5	106.6	1.4	2.8	8.6	15.5	108.5	134.9
90	299.6	109.8	1.4	2.8	8.9	15.7	109.0	138.5
<i>years</i>	<i>ft³/acre</i>	<i>tonnes carbon/acre</i>						
0	0	0.0	0.0	1.7	0.0	0.0	33.4	1.7
5	0	2.2	0.2	1.7	0.2	1.3	33.5	5.5
10	273	5.7	0.3	1.5	0.5	2.2	33.8	10.3
15	525	8.7	0.4	1.4	0.7	2.9	34.4	14.1
20	863	12.3	0.4	1.4	1.0	3.5	35.0	18.6
25	1,222	15.9	0.5	1.3	1.3	4.0	35.9	22.9
30	1,554	19.1	0.5	1.3	1.5	4.3	36.8	26.7
35	1,875	22.2	0.5	1.3	1.8	4.7	37.7	30.4
40	2,177	25.0	0.5	1.2	2.0	4.9	38.7	33.7
45	2,462	27.7	0.5	1.2	2.2	5.2	39.6	36.9
50	2,736	30.3	0.5	1.2	2.5	5.4	40.4	39.8
55	2,978	32.5	0.5	1.2	2.6	5.5	41.2	42.4
60	3,200	34.6	0.5	1.2	2.8	5.7	41.9	44.8
65	3,407	36.5	0.6	1.2	3.0	5.8	42.5	47.0
70	3,614	38.4	0.6	1.1	3.1	6.0	43.0	49.1
75	3,782	39.9	0.6	1.1	3.2	6.1	43.4	50.9
80	3,960	41.5	0.6	1.1	3.4	6.2	43.7	52.7
85	4,138	43.1	0.6	1.1	3.5	6.3	43.9	54.6
90	4,281	44.4	0.6	1.1	3.6	6.3	44.1	56.1

B42.— Regional estimates of timber volume and carbon stocks for longleaf-slash pine stands with afforestation of land in the Southeast; volumes are for high productivity sites (growth rate greater than 85 cubic feet wood/acre/year) with high intensity management (replanting with genetically improved stock)

Age	Mean volume	Mean carbon density						
		Live tree	Standing dead tree	Under-story	Down dead wood	Forest floor	Soil organic	Total nonsoil
<i>years</i>	<i>m³/hectare</i>	<i>tonnes carbon/hectare</i>						
0	0.0	0.0	0.0	4.1	0.0	0.0	82.5	4.1
5	0.0	8.8	0.4	4.0	0.3	3.2	82.8	16.7
10	47.7	27.2	0.8	3.9	1.0	5.5	83.6	38.4
15	146.5	60.1	0.8	3.8	2.2	7.3	84.9	74.2
20	244.8	91.2	0.9	3.7	3.4	8.7	86.6	107.9
25	315.2	113.5	0.9	3.7	4.2	9.8	88.6	132.1
30	347.3	122.8	0.9	3.7	4.6	10.7	90.9	142.7
35	351.5	124.0	0.9	3.7	4.6	11.5	93.2	144.8
40	355.0	125.0	0.9	3.7	4.7	12.2	95.5	146.5
45	358.5	126.0	0.9	3.7	4.7	12.7	97.8	148.1
50	362.0	127.0	0.9	3.7	4.8	13.2	99.9	149.6
55	362.0	127.0	0.9	3.7	4.8	13.7	101.8	150.1
60	362.0	127.0	0.9	3.7	4.8	14.1	103.5	150.4
65	362.0	127.0	0.9	3.7	4.8	14.4	105.0	150.8
70	362.0	127.0	0.9	3.7	4.8	14.7	106.2	151.1
75	362.0	127.0	0.9	3.7	4.8	15.0	107.1	151.4
80	362.0	127.0	0.9	3.7	4.8	15.2	107.9	151.6
85	362.0	127.0	0.9	3.7	4.8	15.5	108.5	151.9
90	362.0	127.0	0.9	3.7	4.8	15.7	109.0	152.1
<i>years</i>	<i>ft³/acre</i>	<i>tonnes carbon/acre</i>						
0	0	0.0	0.0	1.7	0.0	0.0	33.4	1.7
5	0	3.6	0.2	1.6	0.1	1.3	33.5	6.8
10	682	11.0	0.3	1.6	0.4	2.2	33.8	15.5
15	2,094	24.3	0.3	1.5	0.9	2.9	34.4	30.0
20	3,498	36.9	0.4	1.5	1.4	3.5	35.0	43.6
25	4,504	45.9	0.4	1.5	1.7	4.0	35.9	53.5
30	4,963	49.7	0.4	1.5	1.9	4.3	36.8	57.7
35	5,024	50.2	0.4	1.5	1.9	4.7	37.7	58.6
40	5,074	50.6	0.4	1.5	1.9	4.9	38.7	59.3
45	5,124	51.0	0.4	1.5	1.9	5.2	39.6	59.9
50	5,174	51.4	0.4	1.5	1.9	5.4	40.4	60.6
55	5,174	51.4	0.4	1.5	1.9	5.5	41.2	60.7
60	5,174	51.4	0.4	1.5	1.9	5.7	41.9	60.9
65	5,174	51.4	0.4	1.5	1.9	5.8	42.5	61.0
70	5,174	51.4	0.4	1.5	1.9	6.0	43.0	61.1
75	5,174	51.4	0.4	1.5	1.9	6.1	43.4	61.3
80	5,174	51.4	0.4	1.5	1.9	6.2	43.7	61.4
85	5,174	51.4	0.4	1.5	1.9	6.3	43.9	61.5
90	5,174	51.4	0.4	1.5	1.9	6.3	44.1	61.5

B43.— Regional estimates of timber volume and carbon stocks for oak-gum-cypress stands with afforestation of land in the Southeast

Age	Mean volume	Mean carbon density						
		Live tree	Standing dead tree	Under-story	Down dead wood	Forest floor	Soil organic	Total nonsoil
<i>years</i>	<i>m³/hectare</i>	----- <i>tonnes carbon/hectare</i> -----						
0	0.0	0.0	0.0	1.8	0.0	0.0	118.5	1.8
5	0.0	6.7	0.7	1.9	0.4	1.1	118.9	10.9
10	9.8	18.8	1.9	1.8	1.2	2.1	120.1	25.8
15	19.9	28.3	2.4	1.7	1.8	3.0	121.9	37.2
20	32.7	38.0	2.8	1.7	2.4	3.7	124.4	48.6
25	45.4	46.8	3.1	1.6	3.0	4.4	127.2	58.9
30	58.1	54.0	3.4	1.6	3.4	5.0	130.5	67.5
35	73.4	62.3	3.6	1.6	4.0	5.5	133.8	77.0
40	92.2	71.9	3.9	1.6	4.6	6.0	137.2	88.0
45	110.7	80.9	4.2	1.6	5.1	6.4	140.4	98.2
50	128.1	89.0	4.4	1.5	5.7	6.8	143.5	107.4
55	146.3	97.3	4.6	1.5	6.2	7.2	146.2	116.7
60	166.1	105.9	4.7	1.5	6.7	7.5	148.7	126.4
65	186.4	114.5	4.9	1.5	7.3	7.8	150.7	136.1
70	205.7	122.5	5.1	1.5	7.8	8.1	152.4	145.0
75	222.5	129.3	5.2	1.5	8.2	8.4	153.8	152.6
80	237.9	135.4	5.3	1.5	8.6	8.6	155.0	159.4
85	257.3	142.9	5.5	1.5	9.1	8.9	155.8	167.8
90	278.9	151.2	5.6	1.5	9.6	9.1	156.5	177.0
<i>years</i>	<i>ft³/acre</i>	----- <i>tonnes carbon/acre</i> -----						
0	0	0.0	0.0	0.7	0.0	0.0	48.0	0.7
5	0	2.7	0.3	0.8	0.2	0.5	48.1	4.4
10	140	7.6	0.8	0.7	0.5	0.9	48.6	10.4
15	284	11.5	1.0	0.7	0.7	1.2	49.3	15.1
20	467	15.4	1.1	0.7	1.0	1.5	50.3	19.7
25	649	18.9	1.3	0.7	1.2	1.8	51.5	23.8
30	830	21.9	1.4	0.7	1.4	2.0	52.8	27.3
35	1,049	25.2	1.5	0.6	1.6	2.2	54.2	31.2
40	1,318	29.1	1.6	0.6	1.9	2.4	55.5	35.6
45	1,582	32.7	1.7	0.6	2.1	2.6	56.8	39.7
50	1,830	36.0	1.8	0.6	2.3	2.8	58.1	43.5
55	2,091	39.4	1.8	0.6	2.5	2.9	59.2	47.2
60	2,374	42.9	1.9	0.6	2.7	3.1	60.2	51.2
65	2,664	46.3	2.0	0.6	2.9	3.2	61.0	55.1
70	2,940	49.6	2.1	0.6	3.2	3.3	61.7	58.7
75	3,180	52.3	2.1	0.6	3.3	3.4	62.3	61.8
80	3,400	54.8	2.2	0.6	3.5	3.5	62.7	64.5
85	3,677	57.8	2.2	0.6	3.7	3.6	63.1	67.9
90	3,986	61.2	2.3	0.6	3.9	3.7	63.3	71.6

B44.—Regional estimates of timber volume and carbon stocks for oak-hickory stands with afforestation of land in the Southeast

Age	Mean volume	Mean carbon density						
		Live tree	Standing dead tree	Under-story	Down dead wood	Forest floor	Soil organic	Total nonsoil
<i>years</i>	<i>m³/hectare</i>	----- tonnes carbon/hectare -----						
0	0.0	0.0	0.0	4.2	0.0	0.0	33.9	4.2
5	0.0	8.1	0.8	4.2	0.5	1.1	34.1	14.7
10	11.7	21.0	2.1	3.8	1.2	2.1	34.4	30.2
15	21.2	30.3	2.5	3.5	1.8	3.0	34.9	41.0
20	33.8	40.0	2.8	3.3	2.4	3.7	35.6	52.2
25	46.6	49.5	3.0	3.2	2.9	4.4	36.4	63.1
30	60.2	57.5	3.2	3.1	3.4	5.0	37.4	72.3
35	76.3	66.6	3.4	3.0	4.0	5.5	38.3	82.5
40	94.3	76.2	3.6	2.9	4.5	6.0	39.3	93.3
45	114.1	86.4	3.8	2.9	5.1	6.4	40.2	104.6
50	133.0	95.8	4.0	2.8	5.7	6.8	41.1	115.1
55	151.4	104.8	4.1	2.8	6.2	7.2	41.9	125.0
60	168.9	113.0	4.2	2.7	6.7	7.5	42.6	134.2
65	185.6	120.8	4.3	2.7	7.2	7.8	43.2	142.8
70	201.5	128.0	4.4	2.7	7.6	8.1	43.7	150.8
75	215.7	134.4	4.5	2.6	8.0	8.4	44.1	157.9
80	229.4	140.5	4.6	2.6	8.3	8.6	44.4	164.6
85	242.5	146.2	4.6	2.6	8.7	8.9	44.6	171.0
90	254.1	151.3	4.7	2.6	9.0	9.1	44.8	176.6
<i>years</i>	<i>ft³/acre</i>	----- tonnes carbon/acre -----						
0	0	0.0	0.0	1.7	0.0	0.0	13.7	1.7
5	0	3.3	0.3	1.7	0.2	0.5	13.8	6.0
10	167	8.5	0.8	1.5	0.5	0.9	13.9	12.2
15	303	12.3	1.0	1.4	0.7	1.2	14.1	16.6
20	483	16.2	1.1	1.3	1.0	1.5	14.4	21.1
25	666	20.1	1.2	1.3	1.2	1.8	14.7	25.5
30	860	23.3	1.3	1.3	1.4	2.0	15.1	29.3
35	1,091	26.9	1.4	1.2	1.6	2.2	15.5	33.4
40	1,348	30.8	1.5	1.2	1.8	2.4	15.9	37.8
45	1,630	35.0	1.5	1.2	2.1	2.6	16.3	42.4
50	1,901	38.8	1.6	1.1	2.3	2.8	16.6	46.6
55	2,164	42.4	1.7	1.1	2.5	2.9	16.9	50.6
60	2,414	45.7	1.7	1.1	2.7	3.1	17.2	54.3
65	2,652	48.9	1.7	1.1	2.9	3.2	17.5	57.8
70	2,880	51.8	1.8	1.1	3.1	3.3	17.7	61.0
75	3,082	54.4	1.8	1.1	3.2	3.4	17.8	63.9
80	3,278	56.8	1.8	1.1	3.4	3.5	18.0	66.6
85	3,465	59.2	1.9	1.0	3.5	3.6	18.1	69.2
90	3,632	61.2	1.9	1.0	3.6	3.7	18.1	71.5

B45.— Regional estimates of timber volume and carbon stocks for oak-pine stands with afforestation of land in the Southeast

Age	Mean volume	Mean carbon density						
		Live tree	Standing dead tree	Under-story	Down dead wood	Forest floor	Soil organic	Total nonsoil
<i>years</i>	<i>m³/hectare</i>	<i>tonnes carbon/hectare</i>						
0	0.0	0.0	0.0	4.2	0.0	0.0	46.1	4.2
5	0.0	7.4	0.6	4.1	0.5	3.1	46.2	15.6
10	13.6	19.6	1.2	3.6	1.2	5.1	46.7	30.8
15	27.8	29.3	1.6	3.5	1.9	6.6	47.4	42.8
20	43.9	39.0	1.9	3.4	2.5	7.7	48.3	54.5
25	59.3	46.8	2.1	3.3	3.0	8.5	49.5	63.7
30	77.2	55.4	2.3	3.2	3.5	9.2	50.7	73.7
35	96.8	64.4	2.5	3.2	4.1	9.8	52.0	83.9
40	117.2	73.4	2.7	3.1	4.7	10.2	53.3	94.1
45	136.4	81.6	2.8	3.1	5.2	10.6	54.6	103.3
50	154.1	88.9	2.9	3.1	5.6	11.0	55.8	111.5
55	171.4	96.0	3.0	3.0	6.1	11.3	56.8	119.4
60	189.6	103.2	3.1	3.0	6.6	11.5	57.8	127.4
65	204.5	109.1	3.2	3.0	6.9	11.8	58.6	134.0
70	218.8	114.6	3.3	3.0	7.3	12.0	59.2	140.1
75	234.5	120.6	3.4	2.9	7.7	12.1	59.8	146.7
80	247.6	125.5	3.5	2.9	8.0	12.3	60.2	152.2
85	259.4	129.9	3.5	2.9	8.2	12.5	60.6	157.1
90	272.3	134.7	3.6	2.9	8.5	12.6	60.8	162.3
<i>years</i>	<i>ft³/acre</i>	<i>tonnes carbon/acre</i>						
0	0	0.0	0.0	1.7	0.0	0.0	18.6	1.7
5	0	3.0	0.3	1.7	0.2	1.2	18.7	6.3
10	195	7.9	0.5	1.5	0.5	2.1	18.9	12.5
15	397	11.9	0.6	1.4	0.8	2.7	19.2	17.3
20	628	15.8	0.8	1.4	1.0	3.1	19.6	22.0
25	848	19.0	0.8	1.3	1.2	3.5	20.0	25.8
30	1,104	22.4	0.9	1.3	1.4	3.7	20.5	29.8
35	1,384	26.1	1.0	1.3	1.7	4.0	21.0	34.0
40	1,675	29.7	1.1	1.3	1.9	4.1	21.6	38.1
45	1,950	33.0	1.1	1.2	2.1	4.3	22.1	41.8
50	2,202	36.0	1.2	1.2	2.3	4.4	22.6	45.1
55	2,450	38.8	1.2	1.2	2.5	4.6	23.0	48.3
60	2,710	41.8	1.3	1.2	2.7	4.7	23.4	51.6
65	2,923	44.1	1.3	1.2	2.8	4.8	23.7	54.2
70	3,127	46.4	1.3	1.2	2.9	4.8	24.0	56.7
75	3,352	48.8	1.4	1.2	3.1	4.9	24.2	59.4
80	3,539	50.8	1.4	1.2	3.2	5.0	24.4	61.6
85	3,707	52.6	1.4	1.2	3.3	5.0	24.5	63.6
90	3,891	54.5	1.4	1.2	3.5	5.1	24.6	65.7

B46.— Regional estimates of timber volume and carbon stocks for elm-ash-cottonwood stands with afforestation of land in the South Central

Age	Mean volume	Mean carbon density						
		Live tree	Standing dead tree	Under-story	Down dead wood	Forest floor	Soil organic	Total nonsoil
<i>years</i>	<i>m³/hectare</i>	<i>tonnes carbon/hectare</i>						
0	0.0	0.0	0.0	4.2	0.0	0.0	37.4	4.2
5	0.0	8.6	0.9	4.9	0.6	1.1	37.5	16.0
10	11.7	18.3	1.8	4.1	1.2	2.1	37.9	27.6
15	21.2	27.0	2.7	3.7	1.8	3.0	38.5	38.2
20	33.8	36.3	3.3	3.5	2.4	3.7	39.2	49.1
25	46.6	45.1	3.6	3.3	3.0	4.4	40.2	59.4
30	60.2	53.8	3.8	3.2	3.6	5.0	41.2	69.4
35	76.3	63.3	4.1	3.1	4.2	5.5	42.2	80.2
40	94.3	73.3	4.4	2.9	4.9	6.0	43.3	91.5
45	114.1	83.8	4.6	2.9	5.6	6.4	44.3	103.3
50	133.0	95.1	4.8	2.8	6.3	6.8	45.3	115.9
55	151.4	104.2	5.0	2.7	6.9	7.2	46.2	126.0
60	168.9	112.7	5.1	2.7	7.5	7.5	46.9	135.5
65	185.6	120.7	5.3	2.6	8.0	7.8	47.6	144.5
70	201.5	128.4	5.4	2.6	8.5	8.1	48.1	153.0
75	215.7	135.1	5.5	2.6	9.0	8.4	48.6	160.6
80	229.4	141.6	5.6	2.5	9.4	8.6	48.9	167.8
85	242.5	147.8	5.7	2.5	9.8	8.9	49.2	174.7
90	254.1	153.4	5.8	2.5	10.2	9.1	49.4	180.9
<i>years</i>	<i>ft³/acre</i>	<i>tonnes carbon/acre</i>						
0	0	0.0	0.0	1.7	0.0	0.0	15.1	1.7
5	0	3.5	0.3	2.0	0.2	0.5	15.2	6.5
10	167	7.4	0.7	1.7	0.5	0.9	15.3	11.2
15	303	10.9	1.1	1.5	0.7	1.2	15.6	15.5
20	483	14.7	1.3	1.4	1.0	1.5	15.9	19.9
25	666	18.3	1.4	1.3	1.2	1.8	16.3	24.0
30	860	21.8	1.6	1.3	1.4	2.0	16.7	28.1
35	1,091	25.6	1.7	1.2	1.7	2.2	17.1	32.4
40	1,348	29.7	1.8	1.2	2.0	2.4	17.5	37.0
45	1,630	33.9	1.9	1.2	2.3	2.6	17.9	41.8
50	1,901	38.5	1.9	1.1	2.6	2.8	18.3	46.9
55	2,164	42.2	2.0	1.1	2.8	2.9	18.7	51.0
60	2,414	45.6	2.1	1.1	3.0	3.1	19.0	54.8
65	2,652	48.9	2.1	1.1	3.2	3.2	19.3	58.5
70	2,880	52.0	2.2	1.0	3.5	3.3	19.5	61.9
75	3,082	54.7	2.2	1.0	3.6	3.4	19.7	65.0
80	3,278	57.3	2.3	1.0	3.8	3.5	19.8	67.9
85	3,465	59.8	2.3	1.0	4.0	3.6	19.9	70.7
90	3,632	62.1	2.3	1.0	4.1	3.7	20.0	73.2

B47.— Regional estimates of timber volume and carbon stocks for loblolly-shortleaf pine stands with afforestation of land in the South Central

Age	Mean volume	Mean carbon density						
		Live tree	Standing dead tree	Under-story	Down dead wood	Forest floor	Soil organic	Total nonsoil
<i>years</i>	<i>m³/hectare</i>	<i>tonnes carbon/hectare</i>						
0	0.0	0.0	0.0	4.2	0.0	0.0	31.4	4.2
5	0.0	10.8	0.7	4.7	0.7	3.2	31.5	20.1
10	19.1	23.1	1.3	3.9	1.6	5.5	31.8	35.4
15	36.7	32.4	1.6	3.5	2.2	7.3	32.3	47.0
20	60.4	42.2	1.8	3.3	2.9	8.7	33.0	58.9
25	85.5	52.0	2.0	3.1	3.6	9.8	33.7	70.5
30	108.7	59.6	2.1	3.0	4.1	10.7	34.6	79.5
35	131.2	66.6	2.3	2.9	4.6	11.5	35.5	87.8
40	152.3	73.1	2.3	2.9	5.0	12.2	36.4	95.4
45	172.3	79.0	2.4	2.8	5.4	12.7	37.2	102.4
50	191.4	84.7	2.5	2.8	5.8	13.2	38.0	108.9
55	208.4	89.6	2.6	2.7	6.1	13.7	38.8	114.6
60	223.9	94.0	2.6	2.7	6.4	14.1	39.4	119.8
65	238.4	98.1	2.7	2.6	6.7	14.4	40.0	124.5
70	252.9	102.2	2.7	2.6	7.0	14.7	40.4	129.2
75	264.6	105.5	2.7	2.6	7.2	15.0	40.8	133.0
80	277.1	108.9	2.8	2.6	7.4	15.2	41.1	136.9
85	289.5	112.3	2.8	2.6	7.7	15.5	41.3	140.8
90	299.6	115.1	2.8	2.5	7.9	15.7	41.5	144.0
<i>years</i>	<i>ft³/acre</i>	<i>tonnes carbon/acre</i>						
0	0	0.0	0.0	1.7	0.0	0.0	12.7	1.7
5	0	4.4	0.3	1.9	0.3	1.3	12.8	8.1
10	273	9.4	0.5	1.6	0.6	2.2	12.9	14.3
15	525	13.1	0.6	1.4	0.9	2.9	13.1	19.0
20	863	17.1	0.7	1.3	1.2	3.5	13.3	23.8
25	1,222	21.1	0.8	1.3	1.4	4.0	13.7	28.5
30	1,554	24.1	0.9	1.2	1.6	4.3	14.0	32.2
35	1,875	27.0	0.9	1.2	1.8	4.7	14.4	35.5
40	2,177	29.6	0.9	1.2	2.0	4.9	14.7	38.6
45	2,462	32.0	1.0	1.1	2.2	5.2	15.1	41.4
50	2,736	34.3	1.0	1.1	2.3	5.4	15.4	44.1
55	2,978	36.3	1.0	1.1	2.5	5.5	15.7	46.4
60	3,200	38.1	1.1	1.1	2.6	5.7	16.0	48.5
65	3,407	39.7	1.1	1.1	2.7	5.8	16.2	50.4
70	3,614	41.4	1.1	1.1	2.8	6.0	16.4	52.3
75	3,782	42.7	1.1	1.1	2.9	6.1	16.5	53.8
80	3,960	44.1	1.1	1.0	3.0	6.2	16.6	55.4
85	4,138	45.5	1.1	1.0	3.1	6.3	16.7	57.0
90	4,281	46.6	1.1	1.0	3.2	6.3	16.8	58.3

B48.— Regional estimates of timber volume and carbon stocks for loblolly-shortleaf pine stands with afforestation of land in the South Central; volumes are for high-productivity sites (growth rate greater than 120 cubic feet wood/acre/year) with high-intensity management (replanting with genetically improved stock)

Age	Mean volume	Mean carbon density						
		Live tree	Standing dead tree	Under-story	Down dead wood	Forest floor	Soil organic	Total nonsoil
<i>years</i>	<i>m³/hectare</i>	<i>tonnes carbon/hectare</i>						
0	0.0	0.0	0.0	4.1	0.0	0.0	31.4	4.1
5	0.0	10.8	0.4	4.1	0.4	3.2	31.5	18.9
10	47.7	34.2	0.9	3.9	1.3	5.5	31.8	45.7
15	146.5	68.7	1.0	3.8	2.7	7.3	32.3	83.4
20	244.8	99.2	1.1	3.7	3.8	8.7	33.0	116.5
25	315.2	118.3	1.1	3.7	4.6	9.8	33.7	137.6
30	347.3	126.8	1.1	3.7	4.9	10.7	34.6	147.3
35	351.5	127.9	1.1	3.7	5.0	11.5	35.5	149.2
40	355.0	128.8	1.1	3.7	5.0	12.2	36.4	150.8
45	358.5	129.8	1.1	3.7	5.0	12.7	37.2	152.4
50	362.0	130.7	1.1	3.7	5.1	13.2	38.0	153.8
55	362.0	130.7	1.1	3.7	5.1	13.7	38.8	154.2
60	362.0	130.7	1.1	3.7	5.1	14.1	39.4	154.6
65	362.0	130.7	1.1	3.7	5.1	14.4	40.0	155.0
70	362.0	130.7	1.1	3.7	5.1	14.7	40.4	155.3
75	362.0	130.7	1.1	3.7	5.1	15.0	40.8	155.6
80	362.0	130.7	1.1	3.7	5.1	15.2	41.1	155.8
85	362.0	130.7	1.1	3.7	5.1	15.5	41.3	156.0
90	362.0	130.7	1.1	3.7	5.1	15.7	41.5	156.2
<i>years</i>	<i>ft³/acre</i>	<i>tonnes carbon/acre</i>						
0	0	0.0	0.0	1.7	0.0	0.0	12.7	1.7
5	0	4.4	0.2	1.6	0.2	1.3	12.8	7.6
10	682	13.8	0.3	1.6	0.5	2.2	12.9	18.5
15	2,094	27.8	0.4	1.5	1.1	2.9	13.1	33.8
20	3,498	40.1	0.4	1.5	1.6	3.5	13.3	47.1
25	4,504	47.9	0.4	1.5	1.9	4.0	13.7	55.7
30	4,963	51.3	0.5	1.5	2.0	4.3	14.0	59.6
35	5,024	51.8	0.5	1.5	2.0	4.7	14.4	60.4
40	5,074	52.1	0.5	1.5	2.0	4.9	14.7	61.0
45	5,124	52.5	0.5	1.5	2.0	5.2	15.1	61.7
50	5,174	52.9	0.5	1.5	2.0	5.4	15.4	62.2
55	5,174	52.9	0.5	1.5	2.0	5.5	15.7	62.4
60	5,174	52.9	0.5	1.5	2.0	5.7	16.0	62.6
65	5,174	52.9	0.5	1.5	2.0	5.8	16.2	62.7
70	5,174	52.9	0.5	1.5	2.0	6.0	16.4	62.8
75	5,174	52.9	0.5	1.5	2.0	6.1	16.5	63.0
80	5,174	52.9	0.5	1.5	2.0	6.2	16.6	63.1
85	5,174	52.9	0.5	1.5	2.0	6.3	16.7	63.1
90	5,174	52.9	0.5	1.5	2.0	6.3	16.8	63.2

B49.— Regional estimates of timber volume and carbon stocks for oak-gum-cypress stands with afforestation of land in the South Central

Age	Mean volume	Mean carbon density						
		Live tree	Standing dead tree	Under-story	Down dead wood	Forest floor	Soil organic	Total nonsoil
<i>years</i>	<i>m³/hectare</i>	----- tonnes carbon/hectare -----						
0	0.0	0.0	0.0	1.8	0.0	0.0	39.6	1.8
5	0.0	5.4	0.5	2.1	0.3	1.1	39.7	9.5
10	9.8	17.8	1.8	1.8	1.1	2.1	40.1	24.7
15	19.9	28.4	2.8	1.7	1.8	3.0	40.7	37.8
20	32.7	39.3	3.2	1.7	2.5	3.7	41.5	50.4
25	45.4	48.8	3.4	1.6	3.1	4.4	42.5	61.3
30	58.1	57.2	3.5	1.6	3.6	5.0	43.6	70.9
35	73.4	66.9	3.6	1.6	4.2	5.5	44.7	81.8
40	92.2	76.9	3.7	1.6	4.9	6.0	45.8	93.0
45	110.7	86.1	3.7	1.5	5.4	6.4	46.9	103.3
50	128.1	94.4	3.8	1.5	6.0	6.8	47.9	112.6
55	146.3	102.8	3.9	1.5	6.5	7.2	48.8	121.9
60	166.1	111.6	3.9	1.5	7.0	7.5	49.7	131.6
65	186.4	120.3	4.0	1.5	7.6	7.8	50.3	141.2
70	205.7	128.3	4.0	1.5	8.1	8.1	50.9	150.0
75	222.5	135.1	4.1	1.5	8.5	8.4	51.4	157.6
80	237.9	141.2	4.1	1.5	8.9	8.6	51.8	164.4
85	257.3	148.8	4.1	1.5	9.4	8.9	52.0	172.6
90	278.9	157.0	4.2	1.4	9.9	9.1	52.3	181.6
<i>years</i>	<i>ft³/acre</i>	----- tonnes carbon/acre -----						
0	0	0.0	0.0	0.7	0.0	0.0	16.0	0.7
5	0	2.2	0.2	0.8	0.1	0.5	16.1	3.9
10	140	7.2	0.7	0.7	0.5	0.9	16.2	10.0
15	284	11.5	1.1	0.7	0.7	1.2	16.5	15.3
20	467	15.9	1.3	0.7	1.0	1.5	16.8	20.4
25	649	19.7	1.4	0.7	1.2	1.8	17.2	24.8
30	830	23.1	1.4	0.7	1.5	2.0	17.6	28.7
35	1,049	27.1	1.4	0.6	1.7	2.2	18.1	33.1
40	1,318	31.1	1.5	0.6	2.0	2.4	18.5	37.6
45	1,582	34.9	1.5	0.6	2.2	2.6	19.0	41.8
50	1,830	38.2	1.5	0.6	2.4	2.8	19.4	45.6
55	2,091	41.6	1.6	0.6	2.6	2.9	19.8	49.3
60	2,374	45.2	1.6	0.6	2.9	3.1	20.1	53.3
65	2,664	48.7	1.6	0.6	3.1	3.2	20.4	57.1
70	2,940	51.9	1.6	0.6	3.3	3.3	20.6	60.7
75	3,180	54.7	1.6	0.6	3.5	3.4	20.8	63.8
80	3,400	57.2	1.7	0.6	3.6	3.5	20.9	66.5
85	3,677	60.2	1.7	0.6	3.8	3.6	21.1	69.9
90	3,986	63.5	1.7	0.6	4.0	3.7	21.1	73.5

B50.— Regional estimates of timber volume and carbon stocks for oak-hickory stands with afforestation of land in the South Central

Age	Mean volume	Mean carbon density						
		Live tree	Standing dead tree	Under-story	Down dead wood	Forest floor	Soil organic	Total nonsoil
<i>years</i>	<i>m³/hectare</i>	<i>tonnes carbon/hectare</i>						
0	0.0	0.0	0.0	4.2	0.0	0.0	29.0	4.2
5	0.0	9.7	0.9	4.7	0.6	1.1	29.1	17.1
10	11.7	20.9	1.9	4.0	1.4	2.1	29.4	30.3
15	21.2	30.1	2.1	3.6	2.0	3.0	29.8	40.8
20	33.8	39.5	2.3	3.4	2.6	3.7	30.4	51.6
25	46.6	48.2	2.4	3.3	3.2	4.4	31.1	61.5
30	60.2	56.6	2.6	3.1	3.8	5.0	31.9	71.0
35	76.3	65.6	2.7	3.0	4.4	5.5	32.7	81.2
40	94.3	76.2	2.8	2.9	5.1	6.0	33.5	92.9
45	114.1	85.7	2.9	2.8	5.7	6.4	34.3	103.6
50	133.0	94.7	3.0	2.8	6.3	6.8	35.1	113.6
55	151.4	103.3	3.0	2.7	6.9	7.2	35.8	123.1
60	168.9	111.3	3.1	2.7	7.4	7.5	36.4	132.0
65	185.6	118.8	3.2	2.6	7.9	7.8	36.9	140.4
70	201.5	126.0	3.2	2.6	8.4	8.1	37.3	148.3
75	215.7	132.3	3.2	2.6	8.8	8.4	37.6	155.3
80	229.4	138.3	3.3	2.5	9.2	8.6	37.9	162.0
85	242.5	144.0	3.3	2.5	9.6	8.9	38.1	168.3
90	254.1	149.1	3.3	2.5	9.9	9.1	38.3	174.0
<i>years</i>	<i>ft³/acre</i>	<i>tonnes carbon/acre</i>						
0	0	0.0	0.0	1.7	0.0	0.0	11.7	1.7
5	0	3.9	0.4	1.9	0.3	0.5	11.8	6.9
10	167	8.5	0.8	1.6	0.6	0.9	11.9	12.2
15	303	12.2	0.9	1.5	0.8	1.2	12.1	16.5
20	483	16.0	0.9	1.4	1.1	1.5	12.3	20.9
25	666	19.5	1.0	1.3	1.3	1.8	12.6	24.9
30	860	22.9	1.0	1.3	1.5	2.0	12.9	28.7
35	1,091	26.6	1.1	1.2	1.8	2.2	13.2	32.9
40	1,348	30.8	1.1	1.2	2.0	2.4	13.6	37.6
45	1,630	34.7	1.2	1.2	2.3	2.6	13.9	41.9
50	1,901	38.3	1.2	1.1	2.5	2.8	14.2	46.0
55	2,164	41.8	1.2	1.1	2.8	2.9	14.5	49.8
60	2,414	45.0	1.3	1.1	3.0	3.1	14.7	53.4
65	2,652	48.1	1.3	1.1	3.2	3.2	14.9	56.8
70	2,880	51.0	1.3	1.1	3.4	3.3	15.1	60.0
75	3,082	53.5	1.3	1.0	3.6	3.4	15.2	62.8
80	3,278	56.0	1.3	1.0	3.7	3.5	15.3	65.5
85	3,465	58.3	1.3	1.0	3.9	3.6	15.4	68.1
90	3,632	60.3	1.4	1.0	4.0	3.7	15.5	70.4

B51.— Regional estimates of timber volume and carbon stocks for oak-pine stands with afforestation of land in the South Central

Age	Mean volume	Mean carbon density						
		Live tree	Standing dead tree	Under-story	Down dead wood	Forest floor	Soil organic	Total nonsoil
<i>years</i>	<i>m³/hectare</i>	<i>tonnes carbon/hectare</i>						
0	0.0	0.0	0.0	4.2	0.0	0.0	31.3	4.2
5	0.0	8.7	0.7	4.4	0.6	3.1	31.4	17.5
10	13.6	21.4	1.4	3.7	1.5	5.1	31.7	33.1
15	27.8	31.9	1.7	3.5	2.3	6.6	32.2	46.0
20	43.9	41.8	2.0	3.3	3.0	7.7	32.8	57.8
25	59.3	50.9	2.2	3.2	3.7	8.5	33.6	68.5
30	77.2	59.2	2.5	3.1	4.3	9.2	34.4	78.2
35	96.8	67.9	2.6	3.0	4.9	9.8	35.3	88.2
40	117.2	76.5	2.8	2.9	5.5	10.2	36.2	98.1
45	136.4	84.4	3.0	2.9	6.1	10.6	37.0	107.0
50	154.1	91.4	3.1	2.8	6.6	11.0	37.9	115.0
55	171.4	98.2	3.2	2.8	7.1	11.3	38.6	122.6
60	189.6	105.2	3.3	2.8	7.6	11.5	39.2	130.4
65	204.5	110.7	3.4	2.7	8.0	11.8	39.8	136.7
70	218.8	116.0	3.5	2.7	8.4	12.0	40.2	142.6
75	234.5	121.8	3.6	2.7	8.8	12.1	40.6	149.0
80	247.6	126.5	3.6	2.7	9.2	12.3	40.9	154.2
85	259.4	130.7	3.7	2.7	9.5	12.5	41.1	158.9
90	272.3	135.2	3.8	2.6	9.8	12.6	41.3	164.0
<i>years</i>	<i>ft³/acre</i>	<i>tonnes carbon/acre</i>						
0	0	0.0	0.0	1.7	0.0	0.0	12.7	1.7
5	0	3.5	0.3	1.8	0.3	1.2	12.7	7.1
10	195	8.6	0.6	1.5	0.6	2.1	12.8	13.4
15	397	12.9	0.7	1.4	0.9	2.7	13.0	18.6
20	628	16.9	0.8	1.3	1.2	3.1	13.3	23.4
25	848	20.6	0.9	1.3	1.5	3.5	13.6	27.7
30	1,104	24.0	1.0	1.2	1.7	3.7	13.9	31.7
35	1,384	27.5	1.1	1.2	2.0	4.0	14.3	35.7
40	1,675	31.0	1.1	1.2	2.2	4.1	14.6	39.7
45	1,950	34.2	1.2	1.2	2.5	4.3	15.0	43.3
50	2,202	37.0	1.3	1.2	2.7	4.4	15.3	46.5
55	2,450	39.7	1.3	1.1	2.9	4.6	15.6	49.6
60	2,710	42.6	1.3	1.1	3.1	4.7	15.9	52.8
65	2,923	44.8	1.4	1.1	3.2	4.8	16.1	55.3
70	3,127	47.0	1.4	1.1	3.4	4.8	16.3	57.7
75	3,352	49.3	1.4	1.1	3.6	4.9	16.4	60.3
80	3,539	51.2	1.5	1.1	3.7	5.0	16.5	62.4
85	3,707	52.9	1.5	1.1	3.8	5.0	16.6	64.3
90	3,891	54.7	1.5	1.1	4.0	5.1	16.7	66.4

APPENDIX C

Scenarios of Harvest and Carbon Accumulation in Harvested Wood Products^{7,8}

Carbon Stocks on Forest Land and in Harvested Wood Products After Clearcut Harvest

C1.	Maple-beech-birch, Northeast	C14.	Mixed conifer, Pacific Southwest
C2.	Oak-hickory, Northeast	C15.	Western oak, Pacific Southwest
C3.	Spruce-balsam fir, Northeast	C16.	Douglas-fir, Rocky Mountain, North
C4.	Aspen-birch, Northern Lake States	C17.	Lodgepole pine, Rocky Mountain, North
C5.	Maple-beech-birch, Northern Lake States	C18.	Fir-spruce-mountain hemlock, Rocky Mountain, South
C6.	White-red-jack pine, Northern Lake States	C19.	Ponderosa pine, Rocky Mountain, South
C7.	Elm-ash-cottonwood, Northern Prairie States	C20.	Loblolly-shortleaf pine, high productivity and management intensity, Southeast
C8.	Oak-hickory, Northern Prairie States	C21.	Oak-gum-cypress, Southeast
C9.	Douglas-fir, Pacific Northwest, East	C22.	Oak-hickory, Southeast
C10.	Ponderosa pine, Pacific Northwest, East	C23.	Oak-pine, Southeast
C11.	Alder-maple, Pacific Northwest, West	C24.	Loblolly-shortleaf pine, high productivity and management intensity, South Central
C12.	Douglas-fir, high productivity and management intensity, Pacific Northwest, West	C25.	Oak-gum-cypress, South Central
C13.	Hemlock-Sitka spruce, high productivity, Pacific Northwest, West	C26.	Oak-hickory, South Central
		C27.	Oak-pine, South Central

⁷ Note carbon mass is in metric tons (tonnes) in all tables, and age refers to stand age.

⁸ These tables are example harvest scenarios; they are not recommendations for timing of harvest.

C1.— Regional estimates of timber volume, carbon stocks, and carbon in harvested wood products on forest land after clearcut harvest for maple-beech-birch stands in the Northeast

Mean volume			Mean carbon density										
Age	Inventory	Harvested	Live tree	Standing dead tree	Under-story	Down dead wood	Forest floor	Soil organic	Products in use	In landfills	Emitted with energy capture	Emitted without energy capture	Emitted at harvest
years	----- m^3 /hectare -----		----- tonnes carbon/hectare -----										
0	0.0		0.0	0.0	2.1	0.0	0.0	52.2					
5	0.0		7.4	0.7	2.1	0.5	4.2	52.3					
15	28.0		31.8	3.2	1.9	2.3	10.8	53.7					
25	58.1		53.2	5.3	1.8	3.8	15.8	56.0					
35	89.6		72.8	6.0	1.7	5.2	19.7	58.9					
45	119.1		87.8	6.6	1.7	6.2	22.7	61.8					
55	146.6		101.1	7.0	1.7	7.2	25.3	64.4					
65	0.0	172.1	0.0	0.0	2.1	32.0	27.7	66.3	34.5	0.0	39.7	14.1	7.5
5	0.0		7.4	0.7	2.1	21.7	20.3	67.1	22.9	4.7	43.1	17.5	
15	28.0		31.8	3.2	1.9	11.5	16.3	68.2	13.2	8.1	46.2	20.7	
25	58.1		53.2	5.3	1.8	7.8	17.6	68.9	10.3	8.8	47.1	22.0	
35	89.6		72.8	6.0	1.7	6.9	20.3	69.2	8.7	9.1	47.5	22.9	
45	119.1		87.8	6.6	1.7	7.0	23.0	69.4	7.6	9.4	47.8	23.5	
55	146.6		101.1	7.0	1.7	7.5	25.3	69.5	6.7	9.6	47.9	24.0	
65	0.0	172.1	0.0	0.0	2.1	32.0	27.7	69.5	40.4	9.8	87.8	38.5	7.7
years	----- ft^3 /acre -----		----- tonnes carbon/acre -----										
0	0		0.0	0.0	0.8	0.0	0.0	21.1					
5	0		3.0	0.3	0.8	0.2	1.7	21.2					
15	400		12.9	1.3	0.8	0.9	4.4	21.7					
25	830		21.5	2.1	0.7	1.5	6.4	22.7					
35	1,280		29.5	2.4	0.7	2.1	8.0	23.8					
45	1,702		35.5	2.7	0.7	2.5	9.2	25.0					
55	2,095		40.9	2.8	0.7	2.9	10.2	26.0					
65	0	2,460	0.0	0.0	0.8	13.0	11.2	26.8	13.9	0.0	16.1	5.7	3.0
5	0		3.0	0.3	0.8	8.8	8.2	27.2	9.3	1.9	17.5	7.1	
15	400		12.9	1.3	0.8	4.7	6.6	27.6	5.3	3.3	18.7	8.4	
25	830		21.5	2.1	0.7	3.2	7.1	27.9	4.2	3.6	19.0	8.9	
35	1,280		29.5	2.4	0.7	2.8	8.2	28.0	3.5	3.7	19.2	9.3	
45	1,702		35.5	2.7	0.7	2.8	9.3	28.1	3.1	3.8	19.3	9.5	
55	2,095		40.9	2.8	0.7	3.0	10.3	28.1	2.7	3.9	19.4	9.7	
65	0	2,460	0.0	0.0	0.8	13.0	11.2	28.1	16.4	4.0	35.5	15.6	3.1

C2.— Regional estimates of timber volume, carbon stocks, and carbon in harvested wood products on forest land after clearcut harvest for oak-hickory stands in the Northeast

Mean volume			Mean carbon density										
Age	Inventory	Harvested	Live tree	Standing dead tree	Under-story	Down dead wood	Forest floor	Soil organic	Products in use	In landfills	Emitted with energy capture	Emitted without energy capture	Emitted at harvest
years	----- m^3 /hectare -----		----- tonnes carbon/hectare -----										
0	0.0		0.0	0.0	2.1	0.0	0.0	39.8					
5	0.0		6.9	0.7	2.1	0.5	0.9	39.9					
15	54.5		43.0	3.6	1.9	2.9	2.5	40.9					
25	95.7		71.9	4.0	1.9	4.9	3.9	42.7					
35	135.3		96.2	4.2	1.8	6.6	5.2	44.9					
45	173.3		118.2	4.5	1.8	8.1	6.3	47.2					
55	209.6		136.8	4.6	1.8	9.4	7.2	49.1					
65	0.0	244.3	0.0	0.0	2.1	46.7	8.2	50.6	45.0	0.0	57.5	17.8	2.2
5	0.0		6.9	0.7	2.1	31.4	5.7	51.2	30.6	6.3	61.6	21.8	
15	54.5		43.0	3.6	1.9	16.5	4.1	52.1	18.0	11.3	65.3	25.7	
25	95.7		71.9	4.0	1.9	10.8	4.5	52.6	13.8	12.7	66.6	27.3	
35	135.3		96.2	4.2	1.8	9.2	5.3	52.8	11.4	13.3	67.3	28.4	
45	173.3		118.2	4.5	1.8	9.2	6.3	53.0	9.7	13.7	67.7	29.2	
55	209.6		136.8	4.6	1.8	9.9	7.3	53.0	8.4	14.0	68.0	29.9	
65	0.0	244.3	0.0	0.0	2.1	46.7	8.2	53.1	52.4	14.3	125.7	48.2	2.4
years	----- ft^3 /acre -----		----- tonnes carbon/acre -----										
0	0		0.0	0.0	0.8	0.0	0.0	16.1					
5	0		2.8	0.3	0.8	0.2	0.4	16.2					
15	779		17.4	1.4	0.8	1.2	1.0	16.6					
25	1,368		29.1	1.6	0.7	2.0	1.6	17.3					
35	1,934		38.9	1.7	0.7	2.7	2.1	18.2					
45	2,477		47.8	1.8	0.7	3.3	2.5	19.1					
55	2,996		55.4	1.9	0.7	3.8	2.9	19.9					
65	0	3,492	0.0	0.0	0.8	18.9	3.3	20.5	18.2	0.0	23.3	7.2	0.9
5	0		2.8	0.3	0.8	12.7	2.3	20.7	12.4	2.5	24.9	8.8	
15	779		17.4	1.4	0.8	6.7	1.7	21.1	7.3	4.6	26.4	10.4	
25	1,368		29.1	1.6	0.7	4.4	1.8	21.3	5.6	5.1	26.9	11.0	
35	1,934		38.9	1.7	0.7	3.7	2.2	21.4	4.6	5.4	27.2	11.5	
45	2,477		47.8	1.8	0.7	3.7	2.6	21.4	3.9	5.5	27.4	11.8	
55	2,996		55.4	1.9	0.7	4.0	2.9	21.5	3.4	5.7	27.5	12.1	
65	0	3,492	0.0	0.0	0.8	18.9	3.3	21.5	21.2	5.8	50.9	19.5	1.0

C3.— Regional estimates of timber volume, carbon stocks, and carbon in harvested wood products on forest land after clearcut harvest for spruce-balsam fir stands in the Northeast

Mean volume			Mean carbon density										
Age	Inventory	Harvested	Live tree	Standing dead tree	Under-story	Down dead wood	Forest floor	Soil organic	Products in use	In landfills	Emitted with energy capture	Emitted without energy capture	Emitted at harvest
years	----- m^3/ha -----		----- tonnes carbon/hectare -----										
0	0.0		0.0	0.0	2.1	0.0	0.0	73.5					
5	0.0		7.0	0.7	1.8	0.6	5.0	73.7					
15	11.5		20.1	2.0	1.6	1.9	13.0	75.6					
25	29.1		32.5	3.3	1.5	3.0	19.0	78.9					
35	51.6		45.7	4.6	1.4	4.2	23.7	83.0					
45	76.9		57.4	5.7	1.4	5.3	27.5	87.1					
55	102.6		68.7	6.9	1.4	6.3	30.7	90.7					
65	0.0	126.4	0.0	0.0	2.1	20.3	33.7	93.5	23.6	0.0	22.2	11.1	14.8
5	0.0		7.0	0.7	1.8	16.0	23.6	94.5	13.4	3.5	25.8	14.2	
15	11.5		20.1	2.0	1.6	10.6	18.6	96.1	5.7	5.6	28.8	16.9	
25	29.1		32.5	3.3	1.5	8.0	20.7	97.0	4.1	5.6	29.3	17.9	
35	51.6		45.7	4.6	1.4	7.1	24.2	97.5	3.5	5.4	29.5	18.6	
45	76.9		57.4	5.7	1.4	6.9	27.7	97.8	3.0	5.4	29.6	19.0	
55	102.6		68.7	6.9	1.4	7.3	30.7	97.9	2.6	5.3	29.6	19.3	
65	0.0	126.4	0.0	0.0	2.1	20.3	33.7	98.0	26.0	5.4	51.9	30.7	15.4
years	----- $ft^3/acre$ -----		----- tonnes carbon/acre -----										
0	0		0.0	0.0	0.9	0.0	0.0	29.7					
5	0		2.8	0.3	0.7	0.3	2.0	29.8					
15	164		8.1	0.8	0.6	0.8	5.2	30.6					
25	416		13.2	1.3	0.6	1.2	7.7	31.9					
35	738		18.5	1.9	0.6	1.7	9.6	33.6					
45	1,099		23.2	2.3	0.6	2.1	11.1	35.2					
55	1,466		27.8	2.8	0.6	2.6	12.4	36.7					
65	0	1,807	0.0	0.0	0.9	8.2	13.6	37.8	9.6	0.0	9.0	4.5	6.0
5	0		2.8	0.3	0.7	6.5	9.5	38.3	5.4	1.4	10.5	5.7	
15	164		8.1	0.8	0.6	4.3	7.5	38.9	2.3	2.3	11.6	6.8	
25	416		13.2	1.3	0.6	3.2	8.4	39.3	1.7	2.3	11.9	7.3	
35	738		18.5	1.9	0.6	2.9	9.8	39.5	1.4	2.2	11.9	7.5	
45	1,099		23.2	2.3	0.6	2.8	11.2	39.6	1.2	2.2	12.0	7.7	
55	1,466		27.8	2.8	0.6	2.9	12.4	39.6	1.1	2.2	12.0	7.8	
65	0	1,807	0.0	0.0	0.9	8.2	13.6	39.6	10.5	2.2	21.0	12.4	6.2

C4.— Regional estimates of timber volume, carbon stocks, and carbon in harvested wood products on forest land after clearcut harvest for aspen-birch stands in the Northern Lake States

Mean volume			Mean carbon density										
Age	Inventory	Harvested	Live tree	Standing dead tree	Under-story	Down dead wood	Forest floor	Soil organic	Products in use	In landfills	Emitted with energy capture	Emitted without energy capture	Emitted at harvest
years	----- m^3 /hectare -----		----- tonnes carbon/hectare -----										
0	0.0		0.0	0.0	2.0	0.0	0.0	109.6					
5	0.0		7.3	0.5	2.1	0.6	1.6	109.9					
15	2.9		13.9	1.4	2.1	1.1	4.0	112.7					
25	21.5		26.8	2.7	2.1	2.2	5.8	117.6					
35	47.2		40.8	4.1	2.0	3.3	7.3	123.7					
45	72.8		53.5	5.3	2.0	4.3	8.4	129.8					
55	0.0	97.1	0.0	0.0	2.0	13.4	10.2	135.2	12.7	0.0	12.1	4.8	32.4
5	0.0		7.3	0.5	2.1	9.5	7.5	137.4	8.7	1.6	13.3	6.0	
15	2.9		13.9	1.4	2.1	5.0	6.0	140.9	5.4	2.8	14.3	7.1	
25	21.5		26.8	2.7	2.1	3.9	6.5	143.3	4.3	3.1	14.6	7.6	
35	47.2		40.8	4.1	2.0	4.0	7.5	144.7	3.7	3.2	14.8	7.9	
45	72.8		53.5	5.3	2.0	4.6	8.5	145.4	3.2	3.3	14.9	8.1	
55	0.0	97.1	0.0	0.0	2.0	13.4	10.2	145.8	15.5	3.4	27.1	13.1	32.5
years	----- ft^3 /acre -----		----- tonnes carbon/acre -----										
0	0		0.0	0.0	0.8	0.0	0.0	44.3					
5	0		3.0	0.2	0.8	0.2	0.6	44.5					
15	42		5.6	0.6	0.8	0.5	1.6	45.6					
25	307		10.9	1.1	0.8	0.9	2.4	47.6					
35	674		16.5	1.6	0.8	1.3	2.9	50.1					
45	1,041		21.6	2.2	0.8	1.7	3.4	52.5					
55	0	1,388	0.0	0.0	0.8	5.4	4.1	54.7	5.1	0.0	4.9	1.9	13.1
5	0		3.0	0.2	0.8	3.8	3.0	55.6	3.5	0.6	5.4	2.4	
15	42		5.6	0.6	0.8	2.0	2.4	57.0	2.2	1.1	5.8	2.9	
25	307		10.9	1.1	0.8	1.6	2.6	58.0	1.7	1.2	5.9	3.1	
35	674		16.5	1.6	0.8	1.6	3.0	58.5	1.5	1.3	6.0	3.2	
45	1,041		21.6	2.2	0.8	1.9	3.4	58.8	1.3	1.3	6.0	3.3	
55	0	1,388	0.0	0.0	0.8	5.4	4.1	59.0	6.3	1.4	11.0	5.3	13.2

C5.— Regional estimates of timber volume, carbon stocks, and carbon in harvested wood products on forest land after clearcut harvest for maple-beech-birch stands in the Northern Lake States

Mean volume			Mean carbon density										
Age	Inventory	Harvested	Live tree	Standing dead tree	Under-story	Down dead wood	Forest floor	Soil organic	Products in use	In landfills	Emitted with energy capture	Emitted without energy capture	Emitted at harvest
years	----- m^3 /hectare -----		----- tonnes carbon/hectare -----										
0	0.0		0.0	0.0	2.1	0.0	0.0	100.7					
5	0.0		5.1	0.5	2.0	0.4	4.2	101.0					
15	4.3		13.4	1.3	1.7	1.0	10.8	103.6					
25	24.6		30.3	3.0	1.6	2.3	15.8	108.1					
35	48.1		47.7	4.0	1.5	3.6	19.7	113.7					
45	72.5		62.9	4.4	1.4	4.8	22.7	119.3					
55	96.9		77.3	4.7	1.4	5.9	25.3	124.3					
65	0.0	121.3	0.0	0.0	2.1	19.5	27.7	128.1	19.0	0.0	19.0	7.2	37.1
5	0.0		5.1	0.5	2.0	13.3	20.3	129.5	13.3	2.4	20.7	8.9	
15	4.3		13.4	1.3	1.7	6.7	16.3	131.7	8.3	4.3	22.2	10.5	
25	24.6		30.3	3.0	1.6	4.8	17.6	132.9	6.6	4.8	22.6	11.2	
35	48.1		47.7	4.0	1.5	4.7	20.3	133.6	5.6	5.1	22.9	11.6	
45	72.5		62.9	4.4	1.4	5.2	23.0	134.0	4.9	5.3	23.1	12.0	
55	96.9		77.3	4.7	1.4	6.1	25.3	134.2	4.3	5.5	23.2	12.3	
65	0.0	121.3	0.0	0.0	2.1	19.5	27.7	134.2	22.9	5.6	42.3	19.8	37.2
years	----- ft^3 /acre -----		----- tonnes carbon/acre -----										
0	0		0.0	0.0	0.9	0.0	0.0	40.8					
5	0		2.1	0.2	0.8	0.2	1.7	40.9					
15	62		5.4	0.5	0.7	0.4	4.4	41.9					
25	351		12.2	1.2	0.6	0.9	6.4	43.8					
35	688		19.3	1.6	0.6	1.5	8.0	46.0					
45	1,036		25.4	1.8	0.6	1.9	9.2	48.3					
55	1,385		31.3	1.9	0.6	2.4	10.2	50.3					
65	0	1,733	0.0	0.0	0.9	7.9	11.2	51.8	7.7	0.0	7.7	2.9	15.0
5	0		2.1	0.2	0.8	5.4	8.2	52.4	5.4	1.0	8.4	3.6	
15	62		5.4	0.5	0.7	2.7	6.6	53.3	3.3	1.7	9.0	4.3	
25	351		12.2	1.2	0.6	1.9	7.1	53.8	2.7	2.0	9.2	4.5	
35	688		19.3	1.6	0.6	1.9	8.2	54.1	2.3	2.1	9.3	4.7	
45	1,036		25.4	1.8	0.6	2.1	9.3	54.2	2.0	2.1	9.3	4.9	
55	1,385		31.3	1.9	0.6	2.5	10.3	54.3	1.7	2.2	9.4	5.0	
65	0	1,733	0.0	0.0	0.9	7.9	11.2	54.3	9.3	2.3	17.1	8.0	15.1

C6.— Regional estimates of timber volume, carbon stocks, and carbon in harvested wood products on forest land after clearcut harvest for white-red-jack pine stands in the Northern Lake States

Mean volume			Mean carbon density										
Age	Inventory	Harvested	Live tree	Standing dead tree	Under-story	Down dead wood	Forest floor	Soil organic	Products in use	In landfills	Emitted with energy capture	Emitted without energy capture	Emitted at harvest
years	----- $m^3/\text{hectare}$ -----		----- $\text{tonnes carbon/hectare}$ -----										
0	0.0		0.0	0.0	2.0	0.0	0.0	90.6					
5	0.0		0.4	0.0	2.0	0.0	3.1	90.9					
15	6.6		8.0	0.8	2.0	0.6	7.1	93.2					
25	48.1		35.4	3.5	2.0	2.5	9.4	97.3					
35	104.7		62.9	4.9	2.0	4.5	11.0	102.3					
45	158.9		85.8	5.5	2.0	6.2	12.2	107.4					
55	0.0	209.1	0.0	0.0	2.0	25.5	13.8	111.8	25.0	0.0	20.5	9.1	37.9
5	0.0		0.4	0.0	2.0	19.3	10.7	113.7	16.8	3.3	23.2	11.3	
15	6.6		8.0	0.8	2.0	11.6	9.4	116.6	9.7	5.8	25.7	13.4	
25	48.1		35.4	3.5	2.0	8.8	10.1	118.5	7.4	6.5	26.4	14.3	
35	104.7		62.9	4.9	2.0	8.1	11.2	119.6	6.1	6.8	26.7	14.9	
45	158.9		85.8	5.5	2.0	8.2	12.2	120.3	5.2	7.0	27.0	15.4	
55	0.0	209.1	0.0	0.0	2.0	25.5	13.8	120.6	29.5	7.2	47.6	24.8	39.1
years	----- ft^3/acre -----		----- $\text{tonnes carbon/acre}$ -----										
0	0		0.0	0.0	0.8	0.0	0.0	36.7					
5	0		0.2	0.0	0.8	0.0	1.3	36.8					
15	94		3.3	0.3	0.8	0.2	2.9	37.7					
25	688		14.3	1.4	0.8	1.0	3.8	39.4					
35	1,496		25.5	2.0	0.8	1.8	4.5	41.4					
45	2,271		34.7	2.2	0.8	2.5	4.9	43.5					
55	0	2,988	0.0	0.0	0.8	10.3	5.6	45.3	10.1	0.0	8.3	3.7	15.3
5	0		0.2	0.0	0.8	7.8	4.3	46.0	6.8	1.3	9.4	4.6	
15	94		3.3	0.3	0.8	4.7	3.8	47.2	3.9	2.4	10.4	5.4	
25	688		14.3	1.4	0.8	3.6	4.1	48.0	3.0	2.6	10.7	5.8	
35	1,496		25.5	2.0	0.8	3.3	4.6	48.4	2.5	2.7	10.8	6.0	
45	2,271		34.7	2.2	0.8	3.3	5.0	48.7	2.1	2.8	10.9	6.2	
55	0	2,988	0.0	0.0	0.8	10.3	5.6	48.8	12.0	2.9	19.3	10.1	15.8

C7.— Regional estimates of timber volume, carbon stocks, and carbon in harvested wood products on forest land after clearcut harvest for elm-ash-cottonwood stands in the Northern Prairie States

Mean volume			Mean carbon density										
Age	Inventory	Harvested	Live tree	Standing dead tree	Under-story	Down dead wood	Forest floor	Soil organic	Products in use	In landfills	Emitted with energy capture	Emitted without energy capture	Emitted at harvest
years	----- m ³ /hectare -----		----- tonnes carbon/hectare -----										
0	0.0		0.0	0.0	2.1	0.0	0.0	63.6					
5	0.0		3.9	0.4	2.1	0.3	4.2	63.8					
15	0.0		8.7	0.9	2.7	0.6	10.8	65.4					
25	5.8		15.5	1.6	2.4	1.1	15.8	68.3					
35	21.8		27.7	2.8	2.2	1.9	19.7	71.8					
45	45.1		43.2	4.3	2.0	3.0	22.7	75.4					
55	0.0	73.0	0.0	0.0	2.1	11.3	27.7	78.5	10.0	0.0	10.9	3.9	31.2
5	0.0		3.9	0.4	2.1	7.7	20.3	79.8	7.0	1.3	11.7	4.7	
15	0.0		8.7	0.9	2.7	3.9	16.3	81.8	4.3	2.5	12.5	5.5	
25	5.8		15.5	1.6	2.4	2.5	17.6	83.1	3.4	2.8	12.7	5.9	
35	21.8		27.7	2.8	2.2	2.5	20.3	84.0	2.8	2.9	12.9	6.1	
45	45.1		43.2	4.3	2.0	3.3	23.0	84.4	2.4	3.1	13.0	6.3	
55	0.0	73.0	0.0	0.0	2.1	11.3	27.7	84.6	12.2	3.1	23.9	10.4	31.4
years	----- ft ³ /acre -----		----- tonnes carbon/acre -----										
0	0		0.0	0.0	0.8	0.0	0.0	25.7					
5	0		1.6	0.2	0.8	0.1	1.7	25.8					
15	0		3.5	0.4	1.1	0.2	4.4	26.5					
25	83		6.3	0.6	1.0	0.4	6.4	27.6					
35	312		11.2	1.1	0.9	0.8	8.0	29.1					
45	644		17.5	1.7	0.8	1.2	9.2	30.5					
55	0	1,043	0.0	0.0	0.8	4.6	11.2	31.8	4.1	0.0	4.4	1.6	12.6
5	0		1.6	0.2	0.8	3.1	8.2	32.3	2.8	0.5	4.7	1.9	
15	0		3.5	0.4	1.1	1.6	6.6	33.1	1.8	1.0	5.0	2.2	
25	83		6.3	0.6	1.0	1.0	7.1	33.6	1.4	1.1	5.2	2.4	
35	312		11.2	1.1	0.9	1.0	8.2	34.0	1.1	1.2	5.2	2.5	
45	644		17.5	1.7	0.8	1.3	9.3	34.2	1.0	1.2	5.3	2.6	
55	0	1,043	0.0	0.0	0.8	4.6	11.2	34.2	4.9	1.3	9.7	4.2	12.7

C8.— Regional estimates of timber volume, carbon stocks, and carbon in harvested wood products on forest land after clearcut harvest for oak-hickory stands in the Northern Prairie States

Mean volume			Mean carbon density										
Age	Inventory	Harvested	Live tree	Standing dead tree	Under-story	Down dead wood	Forest floor	Soil organic	Products in use	In landfills	Emitted with energy capture	Emitted without energy capture	Emitted at harvest
<i>years</i>	<i>m³/hectare</i>		<i>tonnes carbon/hectare</i>										
0	0.0		0.0	0.0	2.1	0.0	0.0	34.5					
5	0.0		6.7	0.6	2.4	0.5	0.9	34.6					
15	2.1		15.6	1.6	2.1	1.1	2.5	35.4					
25	13.0		27.5	2.7	2.0	1.9	3.9	37.0					
35	27.4		40.0	3.2	1.9	2.7	5.2	38.9					
45	43.0		52.2	3.6	1.8	3.5	6.3	40.8					
55	59.1		64.3	3.9	1.8	4.3	7.2	42.5					
65	0.0	74.9	0.0	0.0	2.1	14.1	8.2	43.8	13.2	0.0	13.9	5.1	37.1
5	0.0		6.7	0.6	2.4	9.8	5.7	44.3	9.2	1.7	15.0	6.2	
15	2.1		15.6	1.6	2.1	5.2	4.1	45.1	5.7	3.1	16.0	7.3	
25	13.0		27.5	2.7	2.0	3.7	4.5	45.5	4.5	3.5	16.4	7.8	
35	27.4		40.0	3.2	1.9	3.5	5.3	45.7	3.8	3.7	16.5	8.1	
45	43.0		52.2	3.6	1.8	3.9	6.3	45.9	3.3	3.9	16.7	8.3	
55	59.1		64.3	3.9	1.8	4.5	7.3	45.9	2.9	4.0	16.8	8.5	
65	0.0	74.9	0.0	0.0	2.1	14.1	8.2	45.9	15.8	4.1	30.7	13.8	37.2
<i>years</i>	<i>ft³/acre</i>		<i>tonnes carbon/acre</i>										
0	0		0.0	0.0	0.8	0.0	0.0	13.9					
5	0		2.7	0.2	1.0	0.2	0.4	14.0					
15	30		6.3	0.6	0.9	0.4	1.0	14.3					
25	186		11.1	1.1	0.8	0.8	1.6	15.0					
35	391		16.2	1.3	0.8	1.1	2.1	15.7					
45	615		21.1	1.4	0.7	1.4	2.5	16.5					
55	844		26.0	1.6	0.7	1.8	2.9	17.2					
65	0	1,070	0.0	0.0	0.8	5.7	3.3	17.7	5.4	0.0	5.6	2.1	15.0
5	0		2.7	0.2	1.0	4.0	2.3	17.9	3.7	0.7	6.1	2.5	
15	30		6.3	0.6	0.9	2.1	1.7	18.2	2.3	1.3	6.5	3.0	
25	186		11.1	1.1	0.8	1.5	1.8	18.4	1.8	1.4	6.6	3.1	
35	391		16.2	1.3	0.8	1.4	2.2	18.5	1.5	1.5	6.7	3.3	
45	615		21.1	1.4	0.7	1.6	2.6	18.6	1.3	1.6	6.7	3.4	
55	844		26.0	1.6	0.7	1.8	2.9	18.6	1.2	1.6	6.8	3.5	
65	0	1,070	0.0	0.0	0.8	5.7	3.3	18.6	6.4	1.6	12.4	5.6	15.1

C9.— Regional estimates of timber volume, carbon stocks, and carbon in harvested wood products on forest land after clearcut harvest for Douglas-fir stands in the Pacific Northwest, East

Age years	Mean volume		Mean carbon density										
	Inventory <i>m</i> ³ /hectare	Harvested	Live tree	Standing dead tree	Under- story	Down dead wood	Forest floor	Soil organic	Products in use	In landfills	Emitted with energy capture	Emitted without energy capture	Emitted at harvest
0	0.0		0.0	0.0	4.6	0.0	0.0	71.1					
5	0.0		2.7	0.3	4.4	0.3	5.2	71.3					
15	3.8		8.7	0.9	4.1	0.9	13.0	73.1					
25	47.7		38.3	3.8	3.7	3.9	18.6	76.3					
35	119.0		75.1	7.5	3.6	7.7	22.9	80.2					
45	184.7		104.0	10.0	3.5	10.7	26.2	84.2					
55	241.8		127.3	10.9	3.4	13.1	28.9	87.7					
65	290.9		146.4	11.5	3.4	15.0	31.1	90.4					
75	0.0	332.7	0.0	0.0	4.6	26.0	37.2	92.3	41.1	0.0	27.3	16.1	74.9
5	0.0		2.7	0.3	4.4	22.5	35.4	92.9	31.8	4.2	29.9	18.6	
15	3.8		8.7	0.9	4.1	17.2	32.9	93.8	22.6	8.2	32.3	21.3	
25	47.7		38.3	3.8	3.7	15.9	31.8	94.3	18.5	9.9	33.3	22.8	
35	119.0		75.1	7.5	3.6	16.5	31.6	94.6	15.8	11.0	33.9	23.9	
45	184.7		104.0	10.0	3.5	17.1	32.0	94.7	13.7	11.8	34.2	24.8	
55	241.8		127.3	10.9	3.4	17.8	32.7	94.7	12.1	12.4	34.5	25.6	
65	290.9		146.4	11.5	3.4	18.5	33.6	94.8	10.7	12.9	34.6	26.2	
75	0.0	332.7	0.0	0.0	4.6	26.0	37.2	94.8	50.7	13.4	62.0	42.9	79.1

Continued

C9.—Continued

Age years	Mean volume		Mean carbon density										
	Inventory <i>ft³/acre</i>	Harvested	Live tree	Standing dead tree	Under- story	Down dead wood	Forest floor	Soil organic	Products in use	In landfills	Emitted with energy capture	Emitted without energy capture	Emitted at harvest
0	0		0.0	0.0	1.9	0.0	0.0	28.8					
5	0		1.1	0.1	1.8	0.1	2.1	28.9					
15	54		3.5	0.4	1.7	0.4	5.2	29.6					
25	682		15.5	1.5	1.5	1.6	7.5	30.9					
35	1,701		30.4	3.0	1.4	3.1	9.3	32.5					
45	2,639		42.1	4.1	1.4	4.3	10.6	34.1					
55	3,456		51.5	4.4	1.4	5.3	11.7	35.5					
65	4,157		59.3	4.7	1.4	6.1	12.6	36.6					
75	0	4,755	0.0	0.0	1.9	10.5	15.1	37.3	16.6	0.0	11.1	6.5	30.3
5	0		1.1	0.1	1.8	9.1	14.3	37.6	12.9	1.7	12.1	7.5	
15	54		3.5	0.4	1.7	7.0	13.3	38.0	9.1	3.3	13.1	8.6	
25	682		15.5	1.5	1.5	6.4	12.9	38.2	7.5	4.0	13.5	9.2	
35	1,701		30.4	3.0	1.4	6.7	12.8	38.3	6.4	4.5	13.7	9.7	
45	2,639		42.1	4.1	1.4	6.9	12.9	38.3	5.5	4.8	13.9	10.0	
55	3,456		51.5	4.4	1.4	7.2	13.2	38.3	4.9	5.0	14.0	10.3	
65	4,157		59.3	4.7	1.4	7.5	13.6	38.3	4.3	5.2	14.0	10.6	
75	0	4,755	0.0	0.0	1.9	10.5	15.1	38.3	20.5	5.4	25.1	17.4	32.0

C10.— Regional estimates of timber volume, carbon stocks, and carbon in harvested wood products on forest land after clearcut harvest for ponderosa pine stands in the Pacific Northwest, East

Age years	Mean volume		Mean carbon density										
	Inventory <i>m</i> ³ /hectare	Harvested	Live tree	Standing dead tree	Under- story	Down dead wood	Forest floor	Soil organic	Products in use	In landfills	Emitted with energy capture	Emitted without energy capture	Emitted at harvest
0	0.0		0.0	0.0	4.8	0.0	0.0	38.0					
5	0.0		3.3	0.3	4.6	0.3	2.4	38.1					
15	4.1		7.9	0.8	3.8	0.8	6.4	39.1					
25	21.6		17.3	1.7	3.2	1.8	9.8	40.8					
35	40.8		26.2	2.6	2.9	2.7	12.6	42.9					
45	61.4		34.9	3.3	2.8	3.6	14.9	45.1					
55	83.3		43.6	3.7	2.6	4.5	17.0	46.9					
65	106.0		52.5	4.2	2.5	5.4	18.7	48.4					
75	0.0	129.3	0.0	0.0	4.8	9.6	24.1	49.4	14.4	0.0	9.4	5.6	27.0
5	0.0		3.3	0.3	4.6	8.5	22.0	49.7	11.1	1.5	10.3	6.5	
15	4.1		7.9	0.8	3.8	6.8	19.4	50.2	7.9	2.9	11.2	7.5	
25	21.6		17.3	1.7	3.2	6.2	18.3	50.5	6.5	3.5	11.5	8.0	
35	40.8		26.2	2.6	2.9	5.9	18.2	50.6	5.5	3.8	11.7	8.3	
45	61.4		34.9	3.3	2.8	6.0	18.7	50.7	4.8	4.1	11.8	8.7	
55	83.3		43.6	3.7	2.6	6.3	19.4	50.7	4.2	4.3	11.9	8.9	
65	106.0		52.5	4.2	2.5	6.7	20.4	50.7	3.8	4.5	12.0	9.2	
75	0.0	129.3	0.0	0.0	4.8	9.6	24.1	50.7	17.7	4.7	21.4	15.0	29.0

Continued

C10.—Continued

Age years	Mean volume		Mean carbon density										
	Inventory	Harvested	Live tree	Standing dead tree	Under- story	Down dead wood	Forest floor	Soil organic	Products in use	In landfills	Emitted with energy capture	Emitted without energy capture	Emitted at harvest
	----- ft ³ /acre -----		----- tonnes carbon/acre -----										
0	0		0.0	0.0	1.9	0.0	0.0	15.4					
5	0		1.3	0.1	1.8	0.1	1.0	15.4					
15	59		3.2	0.3	1.5	0.3	2.6	15.8					
25	309		7.0	0.7	1.3	0.7	4.0	16.5					
35	583		10.6	1.1	1.2	1.1	5.1	17.4					
45	878		14.1	1.3	1.1	1.5	6.0	18.2					
55	1,190		17.7	1.5	1.1	1.8	6.9	19.0					
65	1,515		21.2	1.7	1.0	2.2	7.6	19.6					
75	0	1,848	0.0	0.0	1.9	3.9	9.8	20.0	5.8	0.0	3.8	2.3	10.9
5	0		1.3	0.1	1.8	3.5	8.9	20.1	4.5	0.6	4.2	2.6	
15	59		3.2	0.3	1.5	2.8	7.8	20.3	3.2	1.2	4.5	3.0	
25	309		7.0	0.7	1.3	2.5	7.4	20.4	2.6	1.4	4.7	3.2	
35	583		10.6	1.1	1.2	2.4	7.4	20.5	2.2	1.6	4.7	3.4	
45	878		14.1	1.3	1.1	2.4	7.6	20.5	1.9	1.7	4.8	3.5	
55	1,190		17.7	1.5	1.1	2.5	7.9	20.5	1.7	1.8	4.8	3.6	
65	1,515		21.2	1.7	1.0	2.7	8.2	20.5	1.5	1.8	4.8	3.7	
75	0	1,848	0.0	0.0	1.9	3.9	9.8	20.5	7.2	1.9	8.7	6.1	11.7

C11.— Regional estimates of timber volume, carbon stocks, and carbon in harvested wood products on forest land after clearcut harvest for alder-maple stands in the Pacific Northwest, West

Age	Mean volume		Mean carbon density										
	Inventory	Harvested	Live tree	Standing dead tree	Under-story	Down dead wood	Forest floor	Soil organic	Products in use	In landfills	Emitted with energy capture	Emitted without energy capture	Emitted at harvest
years	----- $m^3/\text{hectare}$ -----		----- $\text{tonnes carbon/hectare}$ -----										
0	0.0		0.0	0.0	4.7	0.0	0.0	86.4					
5	0.0		8.0	0.8	4.7	0.8	1.8	86.7					
15	49.5		31.0	3.1	3.7	2.9	4.4	88.9					
25	229.7		99.4	9.9	2.8	9.4	6.2	92.8					
35	380.8		153.8	15.4	2.5	14.6	7.6	97.6					
45	0.0	513.7	0.0	0.0	4.7	32.2	9.3	102.4	42.6	0.0	95.0	16.6	50.6
5	0.0		8.0	0.8	4.7	22.0	3.9	104.6	30.3	5.4	98.7	19.8	
15	49.5		31.0	3.1	3.7	12.3	4.5	108.4	18.8	10.1	102.1	23.1	
25	229.7		99.4	9.9	2.8	13.5	6.2	111.2	14.5	11.7	103.3	24.7	
35	380.8		153.8	15.4	2.5	16.4	7.6	113.0	11.8	12.5	103.9	25.8	
45	0.0	513.7	0.0	0.0	4.7	32.2	9.3	114.1	52.6	13.1	199.3	43.3	51.4
years	----- ft^3/acre -----		----- $\text{tonnes carbon/acre}$ -----										
0	0		0.0	0.0	1.9	0.0	0.0	35.0					
5	0		3.2	0.3	1.9	0.3	0.7	35.1					
15	708		12.6	1.3	1.5	1.2	1.8	36.0					
25	3,282		40.2	4.0	1.1	3.8	2.5	37.6					
35	5,442		62.3	6.2	1.0	5.9	3.1	39.5					
45	0	7,342	0.0	0.0	1.9	13.0	3.8	41.5	17.2	0.0	38.4	6.7	20.5
5	0		3.2	0.3	1.9	8.9	1.6	42.3	12.2	2.2	39.9	8.0	
15	708		12.6	1.3	1.5	5.0	1.8	43.9	7.6	4.1	41.3	9.3	
25	3,282		40.2	4.0	1.1	5.5	2.5	45.0	5.9	4.7	41.8	10.0	
35	5,442		62.3	6.2	1.0	6.6	3.1	45.7	4.8	5.1	42.1	10.4	
45	0	7,342	0.0	0.0	1.9	13.0	3.8	46.2	21.3	5.3	80.7	17.5	20.8

C12.— Regional estimates of timber volume, carbon stocks, and carbon in harvested wood products on forest land after clearcut harvest for Douglas-fir stands in the Pacific Northwest, West; volumes are for high-productivity sites (growth rate greater than 165 cubic feet wood/acre/year) with high-intensity management (replanting with genetically improved stock, fertilization, and precommercial thinning)

Mean volume			Mean carbon density										
Age	Inventory	Harvested	Live tree	Standing dead tree	Under-story	Down dead wood	Forest floor	Soil organic	Products in use	In landfills	Emitted with energy capture	Emitted without energy capture	Emitted at harvest
years	----- m ³ /hectare -----		----- tonnes carbon/hectare -----										
0	0.0		0.0	0.0	4.6	0.0	0.0	71.1					
5	0.0		9.5	0.9	4.4	0.9	3.6	71.3					
15	19.8		23.4	2.3	4.0	2.3	10.0	73.1					
25	169.7		84.6	8.5	3.5	8.5	15.4	76.3					
35	445.7		187.4	10.0	3.2	18.7	20.2	80.2					
45	0.0	718.8	0.0	0.0	4.6	49.3	27.5	84.2	100.1	0.0	57.0	31.8	82.6
5	0.0		9.5	0.9	4.4	43.1	23.7	86.0	76.9	10.9	63.0	38.0	
15	19.8		23.4	2.3	4.0	33.3	20.7	89.2	53.3	21.6	68.9	45.1	
25	169.7		84.6	8.5	3.5	31.2	21.2	91.4	42.5	26.1	71.2	49.0	
35	445.7		187.4	10.0	3.2	35.4	23.3	92.9	35.6	28.8	72.6	51.8	
45	0.0	718.8	0.0	0.0	4.6	49.3	27.5	93.8	130.6	30.7	130.5	85.9	96.5
years	----- ft ³ /acre -----		----- tonnes carbon/acre -----										
0	0		0.0	0.0	1.9	0.0	0.0	28.8					
5	0		3.8	0.4	1.8	0.4	1.5	28.9					
15	283		9.5	0.9	1.6	0.9	4.0	29.6					
25	2,425		34.2	3.4	1.4	3.4	6.2	30.9					
35	6,370		75.9	4.1	1.3	7.6	8.2	32.5					
45	0	10,272	0.0	0.0	1.9	19.9	11.1	34.1	40.5	0.0	23.1	12.9	33.4
5	0		3.8	0.4	1.8	17.5	9.6	34.8	31.1	4.4	25.5	15.4	
15	283		9.5	0.9	1.6	13.5	8.4	36.1	21.6	8.7	27.9	18.3	
25	2,425		34.2	3.4	1.4	12.6	8.6	37.0	17.2	10.6	28.8	19.8	
35	6,370		75.9	4.1	1.3	14.3	9.4	37.6	14.4	11.7	29.4	21.0	
45	0	10,272	0.0	0.0	1.9	19.9	11.1	38.0	52.9	12.4	52.8	34.8	39.0

C13.— Regional estimates of timber volume, carbon stocks, and carbon in harvested wood products on forest land after clearcut harvest for hemlock-Sitka spruce stands in the Pacific Northwest, West; volumes are for high productivity sites (growth rate greater than 225 cubic feet wood/acre/year)

Mean volume			Mean carbon density										
Age	Inventory	Harvested	Live tree	Standing dead tree	Under-story	Down dead wood	Forest floor	Soil organic	Products in use	In landfills	Emitted with energy capture	Emitted without energy capture	Emitted at harvest
years	----- m^3 /hectare -----		----- tonnes carbon/hectare -----										
0	0.0		0.0	0.0	4.7	0.0	0.0	87.3					
5	0.0		5.9	0.6	4.7	0.6	3.6	87.6					
15	80.3		36.4	3.6	3.7	3.6	10.0	89.8					
25	221.7		90.4	9.0	3.0	8.9	15.4	93.7					
35	413.7		161.0	16.1	2.7	15.9	20.2	98.5					
45	0.0	669.6	0.0	0.0	4.7	42.7	27.5	103.4	85.8	0.0	49.3	27.3	93.4
5	0.0		5.9	0.6	4.7	37.1	23.7	105.6	65.8	9.4	54.5	32.7	
15	80.3		36.4	3.6	3.7	30.4	20.7	109.5	45.5	18.5	59.6	38.8	
25	221.7		90.4	9.0	3.0	28.6	21.2	112.3	36.3	22.4	61.6	42.1	
35	413.7		161.0	16.1	2.7	30.3	23.3	114.1	30.4	24.7	62.8	44.6	
45	0.0	669.6	0.0	0.0	4.7	42.7	27.5	115.2	111.8	26.3	112.9	73.8	105.6
years	----- ft^3 /ac e-----		----- tonnes carbon/acre -----										
0	0		0.0	0.0	1.9	0.0	0.0	35.3					
5	0		2.4	0.2	1.9	0.2	1.5	35.4					
15	1,148		14.7	1.5	1.5	1.5	4.0	36.3					
25	3,169		36.6	3.7	1.2	3.6	6.2	37.9					
35	5,912		65.1	6.5	1.1	6.4	8.2	39.9					
45	0	9,570	0.0	0.0	1.9	17.3	11.1	41.8	34.7	0.0	20.0	11.1	37.8
5	0		2.4	0.2	1.9	15.0	9.6	42.8	26.6	3.8	22.1	13.2	
15	1,148		14.7	1.5	1.5	12.3	8.4	44.3	18.4	7.5	24.1	15.7	
25	3,169		36.6	3.7	1.2	11.6	8.6	45.4	14.7	9.1	24.9	17.0	
35	5,912		65.1	6.5	1.1	12.3	9.4	46.2	12.3	10.0	25.4	18.0	
45	0	9,570	0.0	0.0	1.9	17.3	11.1	46.6	45.3	10.6	45.7	29.9	42.7

C14.— Regional estimates of timber volume, carbon stocks, and carbon in harvested wood products on forest land after clearcut harvest for mixed conifer stands in the Pacific Southwest

Age years	Mean volume		Mean carbon density										
	Inventory <i>m³/hectare</i>	Harvested	Live tree	Standing dead tree	Under- story	Down dead wood	Forest floor	Soil organic	Products in use	In landfills	Emitted with energy capture	Emitted without energy capture	Emitted at harvest
0	0.0		0.0	0.0	4.8	0.0	0.0	37.4					
5	0.0		4.2	0.3	4.8	0.4	5.2	37.5					
15	2.0		8.1	0.8	4.8	0.8	13.0	38.4					
25	11.1		14.6	1.5	6.9	1.5	18.6	40.1					
35	24.4		22.3	2.2	4.9	2.2	22.9	42.2					
45	44.5		32.9	3.3	3.6	3.3	26.2	44.3					
55	71.9		46.5	4.7	2.8	4.7	28.9	46.1					
65	106.6		62.8	6.3	2.2	6.3	31.1	47.5					
75	0.0	147.9	0.0	0.0	4.8	12.0	37.2	48.5	17.3	0.0	12.2	6.3	42.7
5	0.0		4.2	0.3	4.8	10.7	35.4	48.8	13.3	1.9	13.2	7.3	
15	2.0		8.1	0.8	4.8	8.4	32.9	49.3	9.3	3.7	14.3	8.5	
25	11.1		14.6	1.5	6.9	7.0	31.8	49.6	7.4	4.5	14.7	9.1	
35	24.4		22.3	2.2	4.9	6.3	31.6	49.7	6.2	4.9	15.0	9.6	
45	44.5		32.9	3.3	3.6	6.3	32.0	49.8	5.3	5.3	15.2	10.0	
55	71.9		46.5	4.7	2.8	6.9	32.7	49.8	4.7	5.5	15.3	10.3	
65	106.6		62.8	6.3	2.2	7.9	33.6	49.8	4.1	5.7	15.4	10.5	
75	0.0	147.9	0.0	0.0	4.8	12.0	37.2	49.8	20.9	5.9	27.6	17.0	45.6

Continued

C14.—Continued

Age years	Mean volume		Mean carbon density										
	Inventory	Harvested	Live tree	Standing dead tree	Under- story	Down dead wood	Forest floor	Soil organic	Products in use	In landfills	Emitted with energy capture	Emitted without energy capture	Emitted at harvest
	----- ft ³ /acre -----		----- tonnes carbon/acre -----										
0	0		0.0	0.0	1.9	0.0	0.0	15.1					
5	0		1.7	0.1	1.9	0.2	2.1	15.2					
15	29		3.3	0.3	1.9	0.3	5.2	15.5					
25	159		5.9	0.6	2.8	0.6	7.5	16.2					
35	349		9.0	0.9	2.0	0.9	9.3	17.1					
45	636		13.3	1.3	1.5	1.3	10.6	17.9					
55	1,028		18.8	1.9	1.1	1.9	11.7	18.7					
65	1,523		25.4	2.5	0.9	2.6	12.6	19.2					
75	0	2,114	0.0	0.0	1.9	4.9	15.1	19.6	7.0	0.0	4.9	2.5	17.3
5	0		1.7	0.1	1.9	4.3	14.3	19.8	5.4	0.8	5.4	3.0	
15	29		3.3	0.3	1.9	3.4	13.3	20.0	3.7	1.5	5.8	3.4	
25	159		5.9	0.6	2.8	2.8	12.9	20.1	3.0	1.8	6.0	3.7	
35	349		9.0	0.9	2.0	2.6	12.8	20.1	2.5	2.0	6.1	3.9	
45	636		13.3	1.3	1.5	2.5	12.9	20.1	2.2	2.1	6.1	4.0	
55	1,028		18.8	1.9	1.1	2.8	13.2	20.1	1.9	2.2	6.2	4.2	
65	1,523		25.4	2.5	0.9	3.2	13.6	20.2	1.7	2.3	6.2	4.3	
75	0	2,114	0.0	0.0	1.9	4.9	15.1	20.2	8.5	2.4	11.2	6.9	18.4

C15.— Regional estimates of timber volume, carbon stocks, and carbon in harvested wood products on forest land after clearcut harvest for western oak stands in the Pacific Southwest

Age years	Mean volume		Mean carbon density										
	Inventory <i>m³/hectare</i>	Harvested	Live tree	Standing dead tree	Under- story	Down dead wood	Forest floor	Soil organic	Products in use	In landfills	Emitted with energy capture	Emitted without energy capture	Emitted at harvest
0	0.0		0.0	0.0	4.7	0.0	0.0	20.7					
5	0.0		2.6	0.2	4.6	0.1	3.7	20.8					
15	0.0		5.7	0.6	4.5	0.2	9.8	21.3					
25	1.0		8.8	0.9	4.4	0.4	14.4	22.2					
35	25.9		30.6	3.1	4.2	1.3	18.1	23.4					
45	76.3		65.1	4.5	4.1	2.7	21.1	24.5					
55	127.8		98.3	5.4	4.0	4.1	23.6	25.5					
65	174.4		124.0	6.0	4.0	5.1	25.6	26.3					
75	0.0	215.0	0.0	0.0	4.7	13.3	31.7	26.9	19.5	0.0	52.4	7.8	59.7
5	0.0		2.6	0.2	4.6	8.9	28.4	27.1	14.7	2.3	53.7	9.1	
15	0.0		5.7	0.6	4.5	4.1	24.6	27.3	9.8	4.4	55.1	10.4	
25	1.0		8.8	0.9	4.4	2.1	23.4	27.5	7.6	5.4	55.7	11.1	
35	25.9		30.6	3.1	4.2	2.0	23.5	27.5	6.2	5.9	56.0	11.6	
45	76.3		65.1	4.5	4.1	3.0	24.3	27.6	5.2	6.3	56.2	12.0	
55	127.8		98.3	5.4	4.0	4.2	25.5	27.6	4.5	6.5	56.4	12.4	
65	174.4		124.0	6.0	4.0	5.2	26.8	27.6	3.9	6.7	56.5	12.7	
75	0.0	215.0	0.0	0.0	4.7	13.3	31.7	27.6	22.9	6.9	109.0	20.7	60.4

Continued

C15.—Continued

Age years	Mean volume		Mean carbon density										
	Inventory <i>ft³/acre</i>	Harvested	Live tree	Standing dead tree	Under- story	Down dead wood	Forest floor	Soil organic	Products in use	In landfills	Emitted with energy capture	Emitted without energy capture	Emitted at harvest
0	0		0.0	0.0	1.9	0.0	0.0	8.4					
5	0		1.1	0.1	1.9	0.0	1.5	8.4					
15	0		2.3	0.2	1.8	0.1	3.9	8.6					
25	15		3.6	0.4	1.8	0.1	5.8	9.0					
35	370		12.4	1.2	1.7	0.5	7.3	9.5					
45	1,090		26.3	1.8	1.7	1.1	8.5	9.9					
55	1,826		39.8	2.2	1.6	1.7	9.5	10.3					
65	2,493		50.2	2.4	1.6	2.1	10.4	10.6					
75	0	3,072	0.0	0.0	1.9	5.4	12.8	10.9	7.9	0.0	21.2	3.2	24.1
5	0		1.1	0.1	1.9	3.6	11.5	10.9	5.9	0.9	21.7	3.7	
15	0		2.3	0.2	1.8	1.7	10.0	11.1	4.0	1.8	22.3	4.2	
25	15		3.6	0.4	1.8	0.8	9.5	11.1	3.1	2.2	22.5	4.5	
35	370		12.4	1.2	1.7	0.8	9.5	11.1	2.5	2.4	22.7	4.7	
45	1,090		26.3	1.8	1.7	1.2	9.8	11.2	2.1	2.5	22.8	4.9	
55	1,826		39.8	2.2	1.6	1.7	10.3	11.2	1.8	2.6	22.8	5.0	
65	2,493		50.2	2.4	1.6	2.1	10.9	11.2	1.6	2.7	22.9	5.1	
75	0	3,072	0.0	0.0	1.9	5.4	12.8	11.2	9.3	2.8	44.1	8.4	24.4

C16.— Regional estimates of timber volume, carbon stocks, and carbon in harvested wood products on forest land after clearcut harvest for Douglas-fir stands in the Rocky Mountain, North

Age years	Mean volume		Mean carbon density										
	Inventory ----- <i>m</i> ³ /hectare -----	Harvested	Live tree	Standing dead tree	Under- story	Down dead wood	Forest floor	Soil organic	Products in use	In landfills	Emitted with energy capture	Emitted without energy capture	Emitted at harvest
0	0.0		0.0	0.0	4.7	0.0	0.0	29.1					
5	0.0		2.7	0.3	4.7	0.2	5.2	29.2					
15	1.1		6.1	0.6	4.7	0.4	13.0	30.0					
25	19.7		21.5	2.2	3.4	1.3	18.6	31.3					
35	57.1		44.3	4.4	2.7	2.8	22.9	32.9					
45	100.9		66.5	6.7	2.3	4.1	26.2	34.5					
55	145.9		87.2	8.7	2.1	5.4	28.9	35.9					
65	189.3		105.9	10.1	1.9	6.6	31.1	37.1					
75	0.0	229.7	0.0	0.0	4.7	22.4	37.2	37.8	40.7	0.0	31.8	8.1	30.6
5	0.0		2.7	0.3	4.7	20.2	35.4	38.1	31.2	4.4	35.1	9.9	
15	1.1		6.1	0.6	4.7	16.3	32.9	38.5	21.5	8.8	38.3	12.0	
25	19.7		21.5	2.2	3.4	14.0	31.8	38.7	17.2	10.7	39.6	13.3	
35	57.1		44.3	4.4	2.7	12.8	31.6	38.8	14.3	11.8	40.3	14.2	
45	100.9		66.5	6.7	2.3	12.1	32.0	38.8	12.3	12.5	40.8	15.1	
55	145.9		87.2	8.7	2.1	11.8	32.7	38.8	10.7	13.1	41.1	15.8	
65	189.3		105.9	10.1	1.9	11.6	33.6	38.8	9.4	13.6	41.3	16.4	
75	0.0	229.7	0.0	0.0	4.7	22.4	37.2	38.8	49.1	13.9	73.2	25.1	36.3

Continued

C16.—Continued

Age years	Mean volume		Mean carbon density										
	Inventory <i>ft</i> ³ / <i>acre</i>	Harvested	Live tree	Standing dead tree	Under- story	Down dead wood	Forest floor	Soil organic	Products in use	In landfills	Emitted with energy capture	Emitted without energy capture	Emitted at harvest
0	0		0.0	0.0	1.9	0.0	0.0	11.8					
5	0		1.1	0.1	1.9	0.1	2.1	11.8					
15	16		2.5	0.2	1.9	0.2	5.2	12.1					
25	281		8.7	0.9	1.4	0.5	7.5	12.7					
35	816		17.9	1.8	1.1	1.1	9.3	13.3					
45	1,442		26.9	2.7	0.9	1.7	10.6	14.0					
55	2,085		35.3	3.5	0.8	2.2	11.7	14.5					
65	2,705		42.9	4.1	0.8	2.7	12.6	15.0					
75	0	3,283	0.0	0.0	1.9	9.1	15.1	15.3	16.5	0.0	12.9	3.3	12.4
5	0		1.1	0.1	1.9	8.2	14.3	15.4	12.6	1.8	14.2	4.0	
15	16		2.5	0.2	1.9	6.6	13.3	15.6	8.7	3.6	15.5	4.9	
25	281		8.7	0.9	1.4	5.6	12.9	15.6	6.9	4.3	16.0	5.4	
35	816		17.9	1.8	1.1	5.2	12.8	15.7	5.8	4.8	16.3	5.8	
45	1,442		26.9	2.7	0.9	4.9	12.9	15.7	5.0	5.1	16.5	6.1	
55	2,085		35.3	3.5	0.8	4.8	13.2	15.7	4.3	5.3	16.6	6.4	
65	2,705		42.9	4.1	0.8	4.7	13.6	15.7	3.8	5.5	16.7	6.6	
75	0	3,283	0.0	0.0	1.9	9.1	15.1	15.7	19.9	5.6	29.6	10.2	14.7

C17.— Regional estimates of timber volume, carbon stocks, and carbon in harvested wood products on forest land after clearcut harvest for lodgepole pine stands in the Rocky Mountain, North

Age years	Mean volume		Mean carbon density										
	Inventory <i>m³/hectare</i>	Harvested	Live tree	Standing dead tree	Under- story	Down dead wood	Forest floor	Soil organic	Products in use	In landfills	Emitted with energy capture	Emitted without energy capture	Emitted at harvest
0	0.0		0.0	0.0	4.8	0.0	0.0	27.9					
5	0.0		1.9	0.1	4.8	0.1	2.4	28.0					
15	0.2		4.1	0.3	4.8	0.2	6.4	28.7					
25	15.9		14.3	1.4	3.5	0.8	9.8	29.9					
35	51.6		29.9	3.0	2.4	1.7	12.6	31.5					
45	94.3		45.8	4.6	1.9	2.7	14.9	33.0					
55	138.8		59.4	5.9	1.7	3.4	17.0	34.4					
65	182.1		71.6	7.2	1.5	4.2	18.7	35.5					
75	0.0	223.1	0.0	0.0	4.8	17.7	24.1	36.2	32.3	0.0	25.6	6.4	6.4
5	0.0		1.9	0.1	4.8	15.9	22.0	36.5	24.8	3.5	28.2	7.9	
15	0.2		4.1	0.3	4.8	12.8	19.4	36.8	17.1	7.0	30.7	9.5	
25	15.9		14.3	1.4	3.5	10.8	18.3	37.0	13.6	8.5	31.8	10.5	
35	51.6		29.9	3.0	2.4	9.6	18.2	37.1	11.4	9.3	32.4	11.3	
45	94.3		45.8	4.6	1.9	8.9	18.7	37.1	9.8	9.9	32.7	11.9	
55	138.8		59.4	5.9	1.7	8.4	19.4	37.2	8.5	10.4	33.0	12.5	
65	182.1		71.6	7.2	1.5	8.1	20.4	37.2	7.5	10.8	33.1	13.0	
75	0.0	223.1	0.0	0.0	4.8	17.7	24.1	37.2	39.0	11.1	58.8	19.9	10.6

Continued

C17.—Continued

Age years	Mean volume		Mean carbon density										
	Inventory	Harvested	Live tree	Standing dead tree	Under- story	Down dead wood	Forest floor	Soil organic	Products in use	In landfills	Emitted with energy capture	Emitted without energy capture	Emitted at harvest
	----- ft ³ /acre -----		----- tonnes carbon/acre -----										
0	0		0.0	0.0	1.9	0.0	0.0	11.3					
5	0		0.8	0.0	1.9	0.0	1.0	11.3					
15	3		1.7	0.1	1.9	0.1	2.6	11.6					
25	227		5.8	0.6	1.4	0.3	4.0	12.1					
35	737		12.1	1.2	1.0	0.7	5.1	12.7					
45	1,348		18.5	1.9	0.8	1.1	6.0	13.4					
55	1,983		24.0	2.4	0.7	1.4	6.9	13.9					
65	2,603		29.0	2.9	0.6	1.7	7.6	14.4					
75	0	3,189	0.0	0.0	1.9	7.2	9.8	14.6	13.1	0.0	10.4	2.6	2.6
5	0		0.8	0.0	1.9	6.4	8.9	14.8	10.0	1.4	11.4	3.2	
15	3		1.7	0.1	1.9	5.2	7.8	14.9	6.9	2.8	12.4	3.9	
25	227		5.8	0.6	1.4	4.4	7.4	15.0	5.5	3.4	12.8	4.3	
35	737		12.1	1.2	1.0	3.9	7.4	15.0	4.6	3.8	13.1	4.6	
45	1,348		18.5	1.9	0.8	3.6	7.6	15.0	3.9	4.0	13.2	4.8	
55	1,983		24.0	2.4	0.7	3.4	7.9	15.0	3.4	4.2	13.3	5.1	
65	2,603		29.0	2.9	0.6	3.3	8.2	15.0	3.0	4.4	13.4	5.3	
75	0	3,189	0.0	0.0	1.9	7.2	9.8	15.0	15.8	4.5	23.8	8.1	4.3

C18.— Regional estimates of timber volume, carbon stocks, and carbon in harvested wood products on forest land after clearcut harvest for fir-spruce-mountain hemlock stands in the Rocky Mountain, South

Age years	Mean volume		Mean carbon density										
	Inventory <i>m</i> ³ /hectare	Harvested	Live tree	Standing dead tree	Under- story	Down dead wood	Forest floor	Soil organic	Products in use	In landfills	Emitted with energy capture	Emitted without energy capture	Emitted at harvest
0	0.0		0.0	0.0	4.8	0.0	0.0	23.6					
5	0.0		1.8	0.2	4.8	0.1	5.2	23.7					
15	0.0		4.0	0.4	4.8	0.3	13.0	24.3					
25	8.5		12.0	1.2	4.3	0.9	18.6	25.3					
35	27.7		24.4	2.4	2.8	1.9	22.9	26.7					
45	49.5		36.7	3.7	2.3	2.9	26.2	28.0					
55	71.9		48.7	4.9	1.9	3.8	28.9	29.1					
65	94.1		58.6	5.9	1.7	4.6	31.1	30.0					
75	0.0	115.7	0.0	0.0	4.8	11.3	37.2	30.6	16.4	0.0	14.8	3.4	26.5
5	0.0		1.8	0.2	4.8	10.2	35.4	30.9	12.6	1.8	16.1	4.1	
15	0.0		4.0	0.4	4.8	8.3	32.9	31.2	8.7	3.6	17.4	5.0	
25	8.5		12.0	1.2	4.3	7.3	31.8	31.3	6.9	4.3	17.9	5.5	
35	27.7		24.4	2.4	2.8	7.0	31.6	31.4	5.7	4.8	18.2	5.9	
45	49.5		36.7	3.7	2.3	6.9	32.0	31.4	4.9	5.1	18.4	6.2	
55	71.9		48.7	4.9	1.9	7.0	32.7	31.5	4.3	5.3	18.6	6.5	
65	94.1		58.6	5.9	1.7	7.1	33.6	31.5	3.8	5.5	18.6	6.7	
75	0.0	115.7	0.0	0.0	4.8	11.3	37.2	31.5	19.8	5.6	33.5	10.3	30.2

Continued

C18.—Continued

Age years	Mean volume		Mean carbon density										
	Inventory	Harvested	Live tree	Standing dead tree	Under- story	Down dead wood	Forest floor	Soil organic	Products in use	In landfills	Emitted with energy capture	Emitted without energy capture	Emitted at harvest
	----- ft ³ /acre -----		----- tonnes carbon/acre -----										
0	0		0.0	0.0	2.0	0.0	0.0	9.6					
5	0		0.7	0.1	2.0	0.1	2.1	9.6					
15	0		1.6	0.2	2.0	0.1	5.2	9.8					
25	122		4.8	0.5	1.7	0.4	7.5	10.3					
35	396		9.9	1.0	1.1	0.8	9.3	10.8					
45	708		14.8	1.5	0.9	1.2	10.6	11.3					
55	1,028		19.7	2.0	0.8	1.6	11.7	11.8					
65	1,345		23.7	2.4	0.7	1.9	12.6	12.1					
75	0	1,654	0.0	0.0	2.0	4.6	15.1	12.4	6.6	0.0	6.0	1.4	10.7
5	0		0.7	0.1	2.0	4.1	14.3	12.5	5.1	0.7	6.5	1.7	
15	0		1.6	0.2	2.0	3.4	13.3	12.6	3.5	1.4	7.0	2.0	
25	122		4.8	0.5	1.7	3.0	12.9	12.7	2.8	1.7	7.3	2.2	
35	396		9.9	1.0	1.1	2.8	12.8	12.7	2.3	1.9	7.4	2.4	
45	708		14.8	1.5	0.9	2.8	12.9	12.7	2.0	2.0	7.5	2.5	
55	1,028		19.7	2.0	0.8	2.8	13.2	12.7	1.7	2.1	7.5	2.6	
65	1,345		23.7	2.4	0.7	2.9	13.6	12.7	1.5	2.2	7.5	2.7	
75	0	1,654	0.0	0.0	2.0	4.6	15.1	12.7	8.0	2.3	13.5	4.2	12.2

C19.— Regional estimates of timber volume, carbon stocks, and carbon in harvested wood products on forest land after clearcut harvest for ponderosa pine stands in the Rocky Mountain, South

Age years	Mean volume		Mean carbon density										
	Inventory <i>m³/hectare</i>	Harvested	Live tree	Standing dead tree	Under- story	Down dead wood	Forest floor	Soil organic	Products in use	In landfills	Emitted with energy capture	Emitted without energy capture	Emitted at harvest
0	0.0		0.0	0.0	4.8	0.0	0.0	18.1					
5	0.0		1.8	0.2	4.8	0.2	2.4	18.1					
15	0.0		3.7	0.4	4.8	0.3	6.4	18.6					
25	4.4		9.4	0.9	4.8	0.8	9.8	19.4					
35	16.2		18.6	1.9	2.9	1.5	12.6	20.4					
45	32.2		28.8	2.7	2.1	2.4	14.9	21.4					
55	50.3		38.2	3.0	1.7	3.1	17.0	22.3					
65	69.3		47.1	3.3	1.5	3.9	18.7	23.0					
75	0.0	88.4	0.0	0.0	4.8	9.7	24.1	23.5	14.2	0.0	11.1	2.8	18.5
5	0.0		1.8	0.2	4.8	8.8	22.0	23.6	10.9	1.6	12.2	3.5	
15	0.0		3.7	0.4	4.8	7.1	19.4	23.9	7.5	3.1	13.3	4.2	
25	4.4		9.4	0.9	4.8	6.2	18.3	24.0	6.0	3.7	13.8	4.6	
35	16.2		18.6	1.9	2.9	5.8	18.2	24.1	5.0	4.1	14.1	5.0	
45	32.2		28.8	2.7	2.1	5.8	18.7	24.1	4.3	4.4	14.2	5.3	
55	50.3		38.2	3.0	1.7	5.9	19.4	24.1	3.7	4.6	14.3	5.5	
65	69.3		47.1	3.3	1.5	6.0	20.4	24.1	3.3	4.7	14.4	5.7	
75	0.0	88.4	0.0	0.0	4.8	9.7	24.1	24.1	17.1	4.9	25.5	8.8	21.3

Continued

C19.—Continued

Age years	Mean volume		Mean carbon density										
	Inventory	Harvested	Live tree	Standing dead tree	Under- story	Down dead wood	Forest floor	Soil organic	Products in use	In landfills	Emitted with energy capture	Emitted without energy capture	Emitted at harvest
	----- ft ³ /acre -----		----- tonnes carbon/acre -----										
0	0		0.0	0.0	2.0	0.0	0.0	7.3					
5	0		0.7	0.1	2.0	0.1	1.0	7.3					
15	0		1.5	0.1	2.0	0.1	2.6	7.5					
25	63		3.8	0.4	2.0	0.3	4.0	7.9					
35	231		7.5	0.8	1.2	0.6	5.1	8.3					
45	460		11.7	1.1	0.9	1.0	6.0	8.7					
55	719		15.5	1.2	0.7	1.3	6.9	9.0					
65	990		19.1	1.4	0.6	1.6	7.6	9.3					
75	0	1,263	0.0	0.0	2.0	3.9	9.8	9.5	5.8	0.0	4.5	1.2	7.5
5	0		0.7	0.1	2.0	3.5	8.9	9.6	4.4	0.6	4.9	1.4	
15	0		1.5	0.1	2.0	2.9	7.8	9.7	3.0	1.2	5.4	1.7	
25	63		3.8	0.4	2.0	2.5	7.4	9.7	2.4	1.5	5.6	1.9	
35	231		7.5	0.8	1.2	2.4	7.4	9.7	2.0	1.7	5.7	2.0	
45	460		11.7	1.1	0.9	2.3	7.6	9.8	1.7	1.8	5.8	2.1	
55	719		15.5	1.2	0.7	2.4	7.9	9.8	1.5	1.9	5.8	2.2	
65	990		19.1	1.4	0.6	2.4	8.2	9.8	1.3	1.9	5.8	2.3	
75	0	1,263	0.0	0.0	2.0	3.9	9.8	9.8	6.9	2.0	10.3	3.6	8.6

C20.— Regional estimates of timber volume, carbon stocks, and carbon in harvested wood products on forest land after clearcut harvest for loblolly-shortleaf pine stands in the Southeast; volumes are for high productivity sites (growth rate greater than 85 cubic feet wood/acre/year) with high intensity management (replanting with genetically improved stock)

Age	Mean volume		Mean carbon density										
	Inventory	Harvested	Live tree	Standing dead tree	Under-story	Down dead wood	Forest floor	Soil organic	Products in use	In landfills	Emitted with energy capture	Emitted without energy capture	Emitted at harvest
years	----- m^3 /hectare -----		----- tonnes carbon/hectare -----										
0	0.0		0.0	0.0	4.1	0.0	0.0	54.7					
5	0.0		11.0	0.7	4.0	0.4	3.2	54.9					
10	47.7		31.9	1.4	3.8	1.2	5.5	55.4					
15	146.5		67.4	1.9	3.7	2.5	7.3	56.3					
20	244.8		102.3	2.1	3.7	3.8	8.7	57.4					
25	0.0	315.2	0.0	0.0	4.1	20.4	12.2	58.7	41.1	0.0	30.3	14.2	22.2
5	0.0		11.0	0.7	4.0	15.9	6.5	60.2	26.9	5.4	35.2	18.3	
10	47.7		31.9	1.4	3.8	12.9	6.4	61.8	19.1	8.0	37.9	20.7	
15	146.5		67.4	1.9	3.7	11.4	7.5	63.3	15.2	9.2	39.3	22.1	
20	244.8		102.3	2.1	3.7	10.5	8.7	64.8	13.2	9.6	39.9	23.0	
25	0.0	315.2	0.0	0.0	4.1	20.4	12.2	66.2	53.0	9.9	70.6	37.9	27.3
years	----- ft^3 /acre -----		----- tonnes carbon/acre -----										
0	0		0.0	0.0	1.7	0.0	0.0	22.1					
5	0		4.5	0.3	1.6	0.2	1.3	22.2					
10	682		12.9	0.6	1.6	0.5	2.2	22.4					
15	2,094		27.3	0.8	1.5	1.0	2.9	22.8					
20	3,498		41.4	0.9	1.5	1.5	3.5	23.2					
25	0	4,504	0.0	0.0	1.7	8.3	4.9	23.8	16.6	0.0	12.3	5.8	9.0
5	0		4.5	0.3	1.6	6.4	2.6	24.4	10.9	2.2	14.2	7.4	
10	682		12.9	0.6	1.6	5.2	2.6	25.0	7.7	3.2	15.3	8.4	
15	2,094		27.3	0.8	1.5	4.6	3.0	25.6	6.1	3.7	15.9	8.9	
20	3,498		41.4	0.9	1.5	4.3	3.5	26.2	5.3	3.9	16.2	9.3	
25	0	4,504	0.0	0.0	1.7	8.3	4.9	26.8	21.4	4.0	28.6	15.3	11.0

C21.— Regional estimates of timber volume, carbon stocks, and carbon in harvested wood products on forest land after clearcut harvest for oak-gum-cypress stands in the Southeast

Age years	Mean volume		Mean carbon density										
	Inventory <i>m³/hectare</i>	Harvested	Live tree	Standing dead tree	Under- story	Down dead wood	Forest floor	Soil organic	Products in use	In landfills	Emitted with energy capture	Emitted without energy capture	Emitted at harvest
0	0.0		0.0	0.0	1.8	0.0	0.0	118.5					
5	0.0		6.7	0.7	1.9	0.4	1.1	118.9					
10	9.8		18.8	1.9	1.8	1.2	2.1	120.1					
15	19.9		28.3	2.4	1.7	1.8	3.0	121.9					
20	32.7		38.0	2.8	1.7	2.4	3.7	124.4					
25	45.4		46.8	3.1	1.6	3.0	4.4	127.2					
30	58.1		54.0	3.4	1.6	3.4	5.0	130.5					
35	73.4		62.3	3.6	1.6	4.0	5.5	133.8					
40	92.2		71.9	3.9	1.6	4.6	6.0	137.2					
45	110.7		80.9	4.2	1.6	5.1	6.4	140.4					
50	0.0	128.1	0.0	0.0	1.8	10.2	6.0	143.5	14.5	0.0	15.5	6.0	53.4
5	0.0		6.7	0.7	1.9	6.2	2.4	146.2	9.4	2.1	17.0	7.5	
10	9.8		18.8	1.9	1.8	4.5	2.4	148.7	6.6	3.1	17.8	8.4	
15	19.9		28.3	2.4	1.7	3.7	3.0	150.7	5.2	3.6	18.3	8.9	
20	32.7		38.0	2.8	1.7	3.5	3.8	152.4	4.4	3.8	18.5	9.3	
25	45.4		46.8	3.1	1.6	3.6	4.4	153.8	3.9	3.9	18.7	9.5	
30	58.1		54.0	3.4	1.6	3.8	5.0	155.0	3.5	4.0	18.8	9.7	
35	73.4		62.3	3.6	1.6	4.2	5.5	155.8	3.2	4.0	18.8	9.9	
40	92.2		71.9	3.9	1.6	4.7	6.0	156.5	3.0	4.1	18.9	10.0	
45	110.7		80.9	4.2	1.6	5.2	6.4	156.9	2.8	4.1	18.9	10.2	
50	0.0	128.1	0.0	0.0	1.8	10.2	6.0	157.3	17.0	4.2	34.4	16.3	53.4

Continued

C21.—Continued

Age years	Mean volume		Mean carbon density										
	Inventory	Harvested	Live tree	Standing dead tree	Under- story	Down dead wood	Forest floor	Soil organic	Products in use	In landfills	Emitted with energy capture	Emitted without energy capture	Emitted at harvest
	----- ft ³ /acre -----		----- tonnes carbon/acre -----										
0	0		0.0	0.0	0.7	0.0	0.0	48.0					
5	0		2.7	0.3	0.8	0.2	0.5	48.1					
10	140		7.6	0.8	0.7	0.5	0.9	48.6					
15	284		11.5	1.0	0.7	0.7	1.2	49.3					
20	467		15.4	1.1	0.7	1.0	1.5	50.3					
25	649		18.9	1.3	0.7	1.2	1.8	51.5					
30	830		21.9	1.4	0.7	1.4	2.0	52.8					
35	1,049		25.2	1.5	0.6	1.6	2.2	54.2					
40	1,318		29.1	1.6	0.6	1.9	2.4	55.5					
45	1,582		32.7	1.7	0.6	2.1	2.6	56.8					
50	0	1,830	0.0	0.0	0.7	4.1	2.4	58.1	5.9	0.0	6.3	2.4	21.6
5	0		2.7	0.3	0.8	2.5	1.0	59.2	3.8	0.8	6.9	3.0	
10	140		7.6	0.8	0.7	1.8	1.0	60.2	2.7	1.3	7.2	3.4	
15	284		11.5	1.0	0.7	1.5	1.2	61.0	2.1	1.4	7.4	3.6	
20	467		15.4	1.1	0.7	1.4	1.5	61.7	1.8	1.5	7.5	3.7	
25	649		18.9	1.3	0.7	1.5	1.8	62.3	1.6	1.6	7.6	3.8	
30	830		21.9	1.4	0.7	1.5	2.0	62.7	1.4	1.6	7.6	3.9	
35	1,049		25.2	1.5	0.6	1.7	2.2	63.1	1.3	1.6	7.6	4.0	
40	1,318		29.1	1.6	0.6	1.9	2.4	63.3	1.2	1.6	7.6	4.1	
45	1,582		32.7	1.7	0.6	2.1	2.6	63.5	1.1	1.7	7.7	4.1	
50	0	1,830	0.0	0.0	0.7	4.1	2.4	63.7	6.9	1.7	13.9	6.6	21.6

C22.— Regional estimates of timber volume, carbon stocks, and carbon in harvested wood products on forest land after clearcut harvest for oak-hickory stands in the Southeast

Age years	Mean volume		Mean carbon density										
	Inventory <i>m³/hectare</i>	Harvested	Live tree	Standing dead tree	Under- story	Down dead wood	Forest floor	Soil organic	Products in use	In landfills	Emitted with energy capture	Emitted without energy capture	Emitted at harvest
0	0.0		0.0	0.0	4.2	0.0	0.0	33.9					
5	0.0		8.1	0.8	4.2	0.5	1.1	34.1					
10	11.7		21.0	2.1	3.8	1.2	2.1	34.4					
15	21.2		30.3	2.5	3.5	1.8	3.0	34.9					
20	33.8		40.0	2.8	3.3	2.4	3.7	35.6					
25	46.6		49.5	3.0	3.2	2.9	4.4	36.4					
30	60.2		57.5	3.2	3.1	3.4	5.0	37.4					
35	76.3		66.6	3.4	3.0	4.0	5.5	38.3					
40	94.3		76.2	3.6	2.9	4.5	6.0	39.3					
45	114.1		86.4	3.8	2.9	5.1	6.4	40.2					
50	0.0	133.0	0.0	0.0	4.2	10.8	6.0	41.1	15.7	0.0	17.9	6.8	53.7
5	0.0		8.1	0.8	4.2	6.7	2.4	41.9	10.1	2.3	19.5	8.5	
10	11.7		21.0	2.1	3.8	4.8	2.4	42.6	7.0	3.5	20.5	9.4	
15	21.2		30.3	2.5	3.5	3.8	3.0	43.2	5.4	4.0	21.0	10.0	
20	33.8		40.0	2.8	3.3	3.5	3.8	43.7	4.6	4.3	21.2	10.4	
25	46.6		49.5	3.0	3.2	3.6	4.4	44.1	4.0	4.4	21.4	10.6	
30	60.2		57.5	3.2	3.1	3.8	5.0	44.4	3.6	4.5	21.5	10.9	
35	76.3		66.6	3.4	3.0	4.2	5.5	44.6	3.3	4.5	21.6	11.1	
40	94.3		76.2	3.6	2.9	4.6	6.0	44.8	3.0	4.6	21.6	11.2	
45	114.1		86.4	3.8	2.9	5.2	6.4	44.9	2.8	4.6	21.7	11.4	
50	0.0	133.0	0.0	0.0	4.2	10.8	6.0	45.0	18.2	4.6	39.6	18.3	53.7

Continued

C22.—Continued

Age	Mean volume		Mean carbon density								Emitted with energy capture	Emitted without energy capture	Emitted at harvest	
	Inventory	Harvested	Live tree	Standing dead tree	Under-story	Down dead wood	Forest floor	Soil organic	Products in use	In landfills				
<i>years</i>	<i>ft³/acre</i>		<i>tonnes carbon/acre</i>											
0	0		0.0	0.0	1.7	0.0	0.0	13.7						
5	0		3.3	0.3	1.7	0.2	0.5	13.8						
10	167		8.5	0.8	1.5	0.5	0.9	13.9						
15	303		12.3	1.0	1.4	0.7	1.2	14.1						
20	483		16.2	1.1	1.3	1.0	1.5	14.4						
25	666		20.1	1.2	1.3	1.2	1.8	14.7						
30	860		23.3	1.3	1.3	1.4	2.0	15.1						
35	1,091		26.9	1.4	1.2	1.6	2.2	15.5						
40	1,348		30.8	1.5	1.2	1.8	2.4	15.9						
45	1,630		35.0	1.5	1.2	2.1	2.6	16.3						
50	0	1,901	0.0	0.0	1.7	4.4	2.4	16.6	6.3	0.0	7.3	2.8	21.7	
5	0		3.3	0.3	1.7	2.7	1.0	16.9	4.1	0.9	7.9	3.4		
10	167		8.5	0.8	1.5	1.9	1.0	17.2	2.8	1.4	8.3	3.8		
15	303		12.3	1.0	1.4	1.5	1.2	17.5	2.2	1.6	8.5	4.1		
20	483		16.2	1.1	1.3	1.4	1.5	17.7	1.9	1.7	8.6	4.2		
25	666		20.1	1.2	1.3	1.5	1.8	17.8	1.6	1.8	8.6	4.3		
30	860		23.3	1.3	1.3	1.5	2.0	18.0	1.5	1.8	8.7	4.4		
35	1,091		26.9	1.4	1.2	1.7	2.2	18.1	1.3	1.8	8.7	4.5		
40	1,348		30.8	1.5	1.2	1.9	2.4	18.1	1.2	1.8	8.8	4.5		
45	1,630		35.0	1.5	1.2	2.1	2.6	18.2	1.1	1.9	8.8	4.6		
50	0	1,901	0.0	0.0	1.7	4.4	2.4	18.2	7.4	1.9	16.0	7.4	21.7	

C23.— Regional estimates of timber volume, carbon stocks, and carbon in harvested wood products on forest land after clearcut harvest for oak-pine stands in the Southeast

Age years	Mean volume		Mean carbon density										
	Inventory ----- m^3 /hectare -----	Harvested	Live tree	Standing dead tree	Under- story	Down dead wood	Forest floor	Soil organic	Products in use	In landfills	Emitted with energy capture	Emitted without energy capture	Emitted at harvest
0	0.0		0.0	0.0	4.2	0.0	0.0	46.1					
5	0.0		7.4	0.6	4.1	0.5	3.1	46.2					
10	13.6		19.6	1.2	3.6	1.2	5.1	46.7					
15	27.8		29.3	1.6	3.5	1.9	6.6	47.4					
20	43.9		39.0	1.9	3.4	2.5	7.7	48.3					
25	59.3		46.8	2.1	3.3	3.0	8.5	49.5					
30	77.2		55.4	2.3	3.2	3.5	9.2	50.7					
35	96.8		64.4	2.5	3.2	4.1	9.8	52.0					
40	117.2		73.4	2.7	3.1	4.7	10.2	53.3					
45	136.4		81.6	2.8	3.1	5.2	10.6	54.6					
50	0.0	154.1	0.0	0.0	4.2	11.3	10.3	55.8	19.5	0.0	17.6	7.2	41.4
5	0.0		7.4	0.6	4.1	9.0	5.8	56.8	13.0	2.6	19.6	9.1	
10	13.6		19.6	1.2	3.6	7.7	5.9	57.8	9.4	3.9	20.8	10.2	
15	27.8		29.3	1.6	3.5	6.7	6.8	58.6	7.6	4.5	21.4	10.9	
20	43.9		39.0	1.9	3.4	6.2	7.7	59.2	6.5	4.8	21.7	11.3	
25	59.3		46.8	2.1	3.3	5.8	8.6	59.8	5.9	5.0	21.9	11.6	
30	77.2		55.4	2.3	3.2	5.6	9.2	60.2	5.3	5.1	22.0	11.9	
35	96.8		64.4	2.5	3.2	5.7	9.8	60.6	4.9	5.2	22.1	12.1	
40	117.2		73.4	2.7	3.1	5.9	10.2	60.8	4.5	5.3	22.2	12.3	
45	136.4		81.6	2.8	3.1	6.1	10.6	61.0	4.2	5.3	22.2	12.5	
50	0.0	154.1	0.0	0.0	4.2	11.3	10.3	61.1	23.5	5.4	39.9	19.9	42.1

Continued

C23.—Continued

Mean volume			Mean carbon density										
Age	Inventory	Harvested	Live tree	Standing dead tree	Under-story	Down dead wood	Forest floor	Soil organic	Products in use	In landfills	Emitted with energy capture	Emitted without energy capture	Emitted at harvest
<i>years</i>	<i>ft³/acre</i>		<i>tonnes carbon/acre</i>										
0	0		0.0	0.0	1.7	0.0	0.0	18.6					
5	0		3.0	0.3	1.7	0.2	1.2	18.7					
10	195		7.9	0.5	1.5	0.5	2.1	18.9					
15	397		11.9	0.6	1.4	0.8	2.7	19.2					
20	628		15.8	0.8	1.4	1.0	3.1	19.6					
25	848		19.0	0.8	1.3	1.2	3.5	20.0					
30	1,104		22.4	0.9	1.3	1.4	3.7	20.5					
35	1,384		26.1	1.0	1.3	1.7	4.0	21.0					
40	1,675		29.7	1.1	1.3	1.9	4.1	21.6					
45	1,950		33.0	1.1	1.2	2.1	4.3	22.1					
50	0	2,202	0.0	0.0	1.7	4.6	4.2	22.6	7.9	0.0	7.1	2.9	16.8
5	0		3.0	0.3	1.7	3.6	2.4	23.0	5.3	1.0	7.9	3.7	
10	195		7.9	0.5	1.5	3.1	2.4	23.4	3.8	1.6	8.4	4.1	
15	397		11.9	0.6	1.4	2.7	2.7	23.7	3.1	1.8	8.7	4.4	
20	628		15.8	0.8	1.4	2.5	3.1	24.0	2.6	1.9	8.8	4.6	
25	848		19.0	0.8	1.3	2.3	3.5	24.2	2.4	2.0	8.9	4.7	
30	1,104		22.4	0.9	1.3	2.3	3.7	24.4	2.2	2.1	8.9	4.8	
35	1,384		26.1	1.0	1.3	2.3	4.0	24.5	2.0	2.1	8.9	4.9	
40	1,675		29.7	1.1	1.3	2.4	4.1	24.6	1.8	2.1	9.0	5.0	
45	1,950		33.0	1.1	1.2	2.5	4.3	24.7	1.7	2.2	9.0	5.1	
50	0	2,202	0.0	0.0	1.7	4.6	4.2	24.7	9.5	2.2	16.1	8.1	17.0

C24.— Regional estimates of timber volume, carbon stocks, and carbon in harvested wood products on forest land after clearcut harvest for loblolly-shortleaf pine stands in the South Central; volumes are for high-productivity sites (growth rate greater than 120 cubic feet wood/acre/year) with high-intensity management (replanting with genetically improved stock)

Age	Mean volume		Mean carbon density										
	Inventory	Harvested	Live tree	Standing dead tree	Under-story	Down dead wood	Forest floor	Soil organic	Products in use	In landfills	Emitted with energy capture	Emitted without energy capture	Emitted at harvest
<i>years</i>	<i>m³/hectare</i>		<i>tonnes carbon/hectare</i>										
0	0.0		0.0	0.0	4.1	0.0	0.0	31.4					
5	0.0		10.8	0.4	4.1	0.4	3.2	31.5					
10	47.7		34.2	0.9	3.9	1.3	5.5	31.8					
15	146.5		68.7	1.0	3.8	2.7	7.3	32.3					
20	244.8		99.2	1.1	3.7	3.8	8.7	33.0					
25	0.0	315.2	0.0	0.0	4.1	20.4	12.2	33.7	39.7	0.0	27.3	15.0	18.8
5	0.0		10.8	0.4	4.1	15.8	6.5	34.6	27.1	4.9	31.4	18.7	
10	47.7		34.2	0.9	3.9	13.0	6.4	35.5	20.1	7.4	33.8	20.9	
15	146.5		68.7	1.0	3.8	11.5	7.5	36.4	16.4	8.5	34.9	22.2	
20	244.8		99.2	1.1	3.7	10.5	8.7	37.2	14.5	9.1	35.5	23.0	
25	0.0	315.2	0.0	0.0	4.1	20.4	12.2	38.0	52.8	9.4	63.2	38.7	23.8
<i>years</i>	<i>ft³/acre</i>		<i>tonnes carbon/acre</i>										
0	0		0.0	0.0	1.7	0.0	0.0	12.7					
5	0		4.4	0.2	1.6	0.2	1.3	12.8					
10	682		13.8	0.3	1.6	0.5	2.2	12.9					
15	2,094		27.8	0.4	1.5	1.1	2.9	13.1					
20	3,498		40.1	0.4	1.5	1.6	3.5	13.3					
25	0	4,504	0.0	0.0	1.7	8.2	4.9	13.7	16.1	0.0	11.1	6.1	7.6
5	0		4.4	0.2	1.6	6.4	2.6	14.0	11.0	2.0	12.7	7.6	
10	682		13.8	0.3	1.6	5.2	2.6	14.4	8.1	3.0	13.7	8.4	
15	2,094		27.8	0.4	1.5	4.6	3.0	14.7	6.7	3.4	14.1	9.0	
20	3,498		40.1	0.4	1.5	4.2	3.5	15.1	5.9	3.7	14.4	9.3	
25	0	4,504	0.0	0.0	1.7	8.2	4.9	15.4	21.4	3.8	25.6	15.7	9.6

C25.— Regional estimates of timber volume, carbon stocks, and carbon in harvested wood products on forest land after clearcut harvest for oak-gum-cypress stands in the South Central

Age years	Mean volume		Mean carbon density										
	Inventory <i>m³/hectare</i>	Harvested	Live tree	Standing dead tree	Under- story	Down dead wood	Forest floor	Soil organic	Products in use	In landfills	Emitted with energy capture	Emitted without energy capture	Emitted at harvest
0	0.0		0.0	0.0	1.8	0.0	0.0	39.6					
5	0.0		5.4	0.5	2.1	0.3	1.1	39.7					
10	9.8		17.8	1.8	1.8	1.1	2.1	40.1					
15	19.9		28.4	2.8	1.7	1.8	3.0	40.7					
20	32.7		39.3	3.2	1.7	2.5	3.7	41.5					
25	45.4		48.8	3.4	1.6	3.1	4.4	42.5					
30	58.1		57.2	3.5	1.6	3.6	5.0	43.6					
35	73.4		66.9	3.6	1.6	4.2	5.5	44.7					
40	92.2		76.9	3.7	1.6	4.9	6.0	45.8					
45	110.7		86.1	3.7	1.5	5.4	6.4	46.9					
50	0.0	128.1	0.0	0.0	1.8	10.8	6.0	47.9	14.5	0.0	16.0	6.5	57.0
5	0.0		5.4	0.5	2.1	6.5	2.4	48.8	9.4	2.1	17.5	7.9	
10	9.8		17.8	1.8	1.8	4.6	2.4	49.7	6.6	3.2	18.3	8.8	
15	19.9		28.4	2.8	1.7	3.8	3.0	50.3	5.2	3.7	18.8	9.3	
20	32.7		39.3	3.2	1.7	3.6	3.8	50.9	4.4	3.9	19.0	9.7	
25	45.4		48.8	3.4	1.6	3.7	4.4	51.4	3.9	4.0	19.2	9.9	
30	58.1		57.2	3.5	1.6	4.0	5.0	51.8	3.5	4.1	19.3	10.1	
35	73.4		66.9	3.6	1.6	4.4	5.5	52.0	3.2	4.1	19.3	10.3	
40	92.2		76.9	3.7	1.6	5.0	6.0	52.3	2.9	4.2	19.4	10.4	
45	110.7		86.1	3.7	1.5	5.5	6.4	52.4	2.7	4.2	19.4	10.6	
50	0.0	128.1	0.0	0.0	1.8	10.8	6.0	52.5	17.0	4.3	35.5	17.2	57.0

Continued

C25.—Continued

Mean volume			Mean carbon density										
Age	Inventory	Harvested	Live tree	Standing dead tree	Under-story	Down dead wood	Forest floor	Soil organic	Products in use	In landfills	Emitted with energy capture	Emitted without energy capture	Emitted at harvest
<i>years</i>	<i>ft³/acre</i>		<i>tonnes carbon/acre</i>										
0	0		0.0	0.0	0.7	0.0	0.0	16.0					
5	0		2.2	0.2	0.8	0.1	0.5	16.1					
10	140		7.2	0.7	0.7	0.5	0.9	16.2					
15	284		11.5	1.1	0.7	0.7	1.2	16.5					
20	467		15.9	1.3	0.7	1.0	1.5	16.8					
25	649		19.7	1.4	0.7	1.2	1.8	17.2					
30	830		23.1	1.4	0.7	1.5	2.0	17.6					
35	1,049		27.1	1.4	0.6	1.7	2.2	18.1					
40	1,318		31.1	1.5	0.6	2.0	2.4	18.5					
45	1,582		34.9	1.5	0.6	2.2	2.6	19.0					
50	0	1,830	0.0	0.0	0.7	4.4	2.4	19.4	5.9	0.0	6.5	2.6	23.1
5	0		2.2	0.2	0.8	2.6	1.0	19.8	3.8	0.8	7.1	3.2	
10	140		7.2	0.7	0.7	1.9	1.0	20.1	2.7	1.3	7.4	3.6	
15	284		11.5	1.1	0.7	1.5	1.2	20.4	2.1	1.5	7.6	3.8	
20	467		15.9	1.3	0.7	1.5	1.5	20.6	1.8	1.6	7.7	3.9	
25	649		19.7	1.4	0.7	1.5	1.8	20.8	1.6	1.6	7.8	4.0	
30	830		23.1	1.4	0.7	1.6	2.0	20.9	1.4	1.7	7.8	4.1	
35	1,049		27.1	1.4	0.6	1.8	2.2	21.1	1.3	1.7	7.8	4.2	
40	1,318		31.1	1.5	0.6	2.0	2.4	21.1	1.2	1.7	7.9	4.2	
45	1,582		34.9	1.5	0.6	2.2	2.6	21.2	1.1	1.7	7.9	4.3	
50	0	1,830	0.0	0.0	0.7	4.4	2.4	21.3	6.9	1.7	14.4	7.0	23.1

C26.— Regional estimates of timber volume, carbon stocks, and carbon in harvested wood products on forest land after clearcut harvest for oak-hickory stands in the South Central

Age years	Mean volume		Mean carbon density										
	Inventory <i>m</i> ³ / <i>hectare</i>	Harvested	Live tree	Standing dead tree	Under- story	Down dead wood	Forest floor	Soil organic	Products in use	In landfills	Emitted with energy capture	Emitted without energy capture	Emitted at harvest
0	0.0		0.0	0.0	4.2	0.0	0.0	29.0					
5	0.0		9.7	0.9	4.7	0.6	1.1	29.1					
10	11.7		20.9	1.9	4.0	1.4	2.1	29.4					
15	21.2		30.1	2.1	3.6	2.0	3.0	29.8					
20	33.8		39.5	2.3	3.4	2.6	3.7	30.4					
25	46.6		48.2	2.4	3.3	3.2	4.4	31.1					
30	60.2		56.6	2.6	3.1	3.8	5.0	31.9					
35	76.3		65.6	2.7	3.0	4.4	5.5	32.7					
40	94.3		76.2	2.8	2.9	5.1	6.0	33.5					
45	114.1		85.7	2.9	2.8	5.7	6.4	34.3					
50	0.0	133.0	0.0	0.0	4.2	11.7	6.0	35.1	16.0	0.0	18.9	7.5	49.5
5	0.0		9.7	0.9	4.7	7.3	2.4	35.8	10.0	2.4	20.6	9.2	
10	11.7		20.9	1.9	4.0	5.2	2.4	36.4	6.8	3.6	21.6	10.3	
15	21.2		30.1	2.1	3.6	4.2	3.0	36.9	5.2	4.1	22.1	10.9	
20	33.8		39.5	2.3	3.4	3.9	3.8	37.3	4.4	4.3	22.4	11.2	
25	46.6		48.2	2.4	3.3	3.9	4.4	37.6	3.8	4.4	22.5	11.5	
30	60.2		56.6	2.6	3.1	4.2	5.0	37.9	3.4	4.4	22.7	11.7	
35	76.3		65.6	2.7	3.0	4.6	5.5	38.1	3.1	4.5	22.7	11.9	
40	94.3		76.2	2.8	2.9	5.2	6.0	38.3	2.9	4.5	22.8	12.1	
45	114.1		85.7	2.9	2.8	5.8	6.4	38.4	2.7	4.5	22.8	12.3	
50	0.0	133.0	0.0	0.0	4.2	11.7	6.0	38.5	18.4	4.6	41.8	19.8	49.5

Continued

C26.—Continued

Age	Mean volume		Mean carbon density										
	Inventory	Harvested	Live tree	Standing dead tree	Under-story	Down dead wood	Forest floor	Soil organic	Products in use	In landfills	Emitted with energy capture	Emitted without energy capture	Emitted at harvest
<i>years</i>	<i>ft³/acre</i>		<i>tonnes carbon/acre</i>										
0	0		0.0	0.0	1.7	0.0	0.0	11.7					
5	0		3.9	0.4	1.9	0.3	0.5	11.8					
10	167		8.5	0.8	1.6	0.6	0.9	11.9					
15	303		12.2	0.9	1.5	0.8	1.2	12.1					
20	483		16.0	0.9	1.4	1.1	1.5	12.3					
25	666		19.5	1.0	1.3	1.3	1.8	12.6					
30	860		22.9	1.0	1.3	1.5	2.0	12.9					
35	1,091		26.6	1.1	1.2	1.8	2.2	13.2					
40	1,348		30.8	1.1	1.2	2.0	2.4	13.6					
45	1,630		34.7	1.2	1.2	2.3	2.6	13.9					
50	0	1,901	0.0	0.0	1.7	4.7	2.4	14.2	6.5	0.0	7.6	3.0	20.0
5	0		3.9	0.4	1.9	2.9	1.0	14.5	4.1	1.0	8.3	3.7	
10	167		8.5	0.8	1.6	2.1	1.0	14.7	2.8	1.4	8.8	4.2	
15	303		12.2	0.9	1.5	1.7	1.2	14.9	2.1	1.7	9.0	4.4	
20	483		16.0	0.9	1.4	1.6	1.5	15.1	1.8	1.7	9.1	4.6	
25	666		19.5	1.0	1.3	1.6	1.8	15.2	1.6	1.8	9.1	4.7	
30	860		22.9	1.0	1.3	1.7	2.0	15.3	1.4	1.8	9.2	4.8	
35	1,091		26.6	1.1	1.2	1.9	2.2	15.4	1.3	1.8	9.2	4.8	
40	1,348		30.8	1.1	1.2	2.1	2.4	15.5	1.2	1.8	9.2	4.9	
45	1,630		34.7	1.2	1.2	2.3	2.6	15.5	1.1	1.8	9.2	5.0	
50	0	1,901	0.0	0.0	1.7	4.7	2.4	15.6	7.5	1.9	16.9	8.0	20.0

C27.— Regional estimates of timber volume, carbon stocks, and carbon in harvested wood products on forest land after clearcut harvest for oak-pine stands in the South Central

Age years	Mean volume		Mean carbon density										
	Inventory ----- m^3 /hectare -----	Harvested	Live tree	Standing dead tree	Under- story	Down dead wood	Forest floor	Soil organic	Products in use	In landfills	Emitted with energy capture	Emitted without energy capture	Emitted at harvest
0	0.0		0.0	0.0	4.2	0.0	0.0	31.3					
5	0.0		8.7	0.7	4.4	0.6	3.1	31.4					
10	13.6		21.4	1.4	3.7	1.5	5.1	31.7					
15	27.8		31.9	1.7	3.5	2.3	6.6	32.2					
20	43.9		41.8	2.0	3.3	3.0	7.7	32.8					
25	59.3		50.9	2.2	3.2	3.7	8.5	33.6					
30	77.2		59.2	2.5	3.1	4.3	9.2	34.4					
35	96.8		67.9	2.6	3.0	4.9	9.8	35.3					
40	117.2		76.5	2.8	2.9	5.5	10.2	36.2					
45	136.4		84.4	3.0	2.9	6.1	10.6	37.0					
50	0.0	154.1	0.0	0.0	4.2	12.4	10.3	37.9	19.7	0.0	17.4	8.2	42.8
5	0.0		8.7	0.7	4.4	10.0	5.8	38.6	13.2	2.6	19.4	10.1	
10	13.6		21.4	1.4	3.7	8.6	5.9	39.2	9.6	3.9	20.6	11.3	
15	27.8		31.9	1.7	3.5	7.7	6.8	39.8	7.7	4.5	21.2	11.9	
20	43.9		41.8	2.0	3.3	7.1	7.7	40.2	6.7	4.8	21.5	12.4	
25	59.3		50.9	2.2	3.2	6.7	8.6	40.6	6.0	4.9	21.6	12.7	
30	77.2		59.2	2.5	3.1	6.6	9.2	40.9	5.5	5.0	21.8	13.0	
35	96.8		67.9	2.6	3.0	6.7	9.8	41.1	5.1	5.1	21.9	13.2	
40	117.2		76.5	2.8	2.9	6.9	10.2	41.3	4.7	5.2	21.9	13.4	
45	136.4		84.4	3.0	2.9	7.1	10.6	41.4	4.4	5.3	22.0	13.6	
50	0.0	154.1	0.0	0.0	4.2	12.4	10.3	41.5	23.8	5.4	39.4	22.0	43.6

Continued

C27.—Continued

Mean volume			Mean carbon density										
Age	Inventory	Harvested	Live tree	Standing dead tree	Under-story	Down dead wood	Forest floor	Soil organic	Products in use	In landfills	Emitted with energy capture	Emitted without energy capture	Emitted at harvest
<i>years</i>	<i>ft³/acre</i>		<i>tonnes carbon/acre</i>										
0	0		0.0	0.0	1.7	0.0	0.0	12.7					
5	0		3.5	0.3	1.8	0.3	1.2	12.7					
10	195		8.6	0.6	1.5	0.6	2.1	12.8					
15	397		12.9	0.7	1.4	0.9	2.7	13.0					
20	628		16.9	0.8	1.3	1.2	3.1	13.3					
25	848		20.6	0.9	1.3	1.5	3.5	13.6					
30	1,104		24.0	1.0	1.2	1.7	3.7	13.9					
35	1,384		27.5	1.1	1.2	2.0	4.0	14.3					
40	1,675		31.0	1.1	1.2	2.2	4.1	14.6					
45	1,950		34.2	1.2	1.2	2.5	4.3	15.0					
50	0	2,202	0.0	0.0	1.7	5.0	4.2	15.3	8.0	0.0	7.0	3.3	17.3
5	0		3.5	0.3	1.8	4.0	2.4	15.6	5.3	1.0	7.9	4.1	
10	195		8.6	0.6	1.5	3.5	2.4	15.9	3.9	1.6	8.3	4.6	
15	397		12.9	0.7	1.4	3.1	2.7	16.1	3.1	1.8	8.6	4.8	
20	628		16.9	0.8	1.3	2.9	3.1	16.3	2.7	1.9	8.7	5.0	
25	848		20.6	0.9	1.3	2.7	3.5	16.4	2.4	2.0	8.8	5.1	
30	1,104		24.0	1.0	1.2	2.7	3.7	16.5	2.2	2.0	8.8	5.3	
35	1,384		27.5	1.1	1.2	2.7	4.0	16.6	2.1	2.1	8.8	5.4	
40	1,675		31.0	1.1	1.2	2.8	4.1	16.7	1.9	2.1	8.9	5.4	
45	1,950		34.2	1.2	1.2	2.9	4.3	16.8	1.8	2.1	8.9	5.5	
50	0	2,202	0.0	0.0	1.7	5.0	4.2	16.8	9.6	2.2	16.0	8.9	17.6

Appendix D

Detailed Information on Development and Use of Tables for Calculating Carbon in Harvested Wood Products (Tables 1.4 through 1.9)

This appendix features detailed information on the source of coefficients for Tables 1.4 through 1.9. This will help users in adapting carbon calculations to specific needs. Information is organized by the three starting points: primary wood products (Tables D1 through D5), roundwood (principally Tables D6 and D7), and forest ecosystems (principally Tables D8 through D12).

The choice of starting points depends on the available wood products information. For example, a landowner may want to know potential carbon sequestration for a given area of forest. This is addressed by the principally land-based estimate that starts from a measure of trees in a forest, specifically growing-stock volume. Alternatively, a measure of wood removed at harvest, such as logs transported to mills for processing, volume or mass of industrial roundwood, is another starting point. Finally, a starting point with relatively precise information is based on quantities of primary wood products. These latter two starting points can be considered product-based. Data on roundwood and primary products are often available as State-level or regional statistics.

The methods for these three starting points will result in identical core results, if consistent data are available corresponding to the starting points. This is because estimates of the disposition—or fate—of carbon in products over time are based on likely uses and longevity of primary wood products. Thus, the data and assumptions on primary wood products serve as the model for the disposition of carbon over time. These data and assumptions are discussed below in the section on primary wood products. All additional calculations associated with the other two starting points (roundwood or forest ecosystem) are based on linking inputs to the disposition of these primary wood products. If roundwood is the starting point, or input quantity, then the disposition of carbon is calculated by linking carbon in roundwood to the separate primary wood product classifications. Similarly, volume of merchantable wood in forests is linked to quantities of roundwood before calculating the disposition of carbon over time. These links can include some additional output estimates which are not associated with all three starting points, such as the fraction of emitted carbon associated with energy recapture. Data and assumptions used to link the different inputs to a common quantity of harvested wood are presented below in the section on roundwood and the section on forest ecosystem.

Primary Wood Products

Primary wood products are the initial results of processing at mills; examples of primary products include lumber, panels, and paper. These primary products are usually incorporated into end-use products with the long-term disposition of carbon classified as remaining in use, in landfills, or emitted to the atmosphere following burning or decomposition. Calculations are in three parts: 1) converting quantity of primary product to quantity of carbon, 2) determining the fraction of carbon in primary product in use as a function of time since production, and 3) determining the fraction of carbon in primary product in landfills as a function of time since

production. These steps correspond to Tables 1.7, 1.8, and 1.9, respectively. Total carbon emissions to the atmosphere for a given year are the difference between the initial quantity of carbon in primary wood products and the sum of carbon in use or in landfills.

Carbon in primary wood products is based on conversion factors in Table 1.7, which were computed using data in Table D1. Specific carbon content of wood fiber in solid wood products (those in Table D1) is 50 percent, and the carbon content of air dry weight paper is 45 percent. Table D1 includes factors to convert the customary units used for each primary product to a standard mass and volume for calculating carbon mass of the wood fibers.

The fractions of primary wood products remaining in use for a given number of years after production in Table 1.8 were developed by first allocating the primary product to a number of end-uses and then determining the fraction remaining in each end use over time. The allocation of primary products to end uses is presented in Table D2. The fraction remaining in use over time is determined using first-order decay functions and the half-lives presented in Table D3. The fraction of primary products (and thus the fraction of carbon) remaining in use can be calculated by the following:

[Equation D1]

$$\begin{aligned}
 & \text{Fraction of carbon in solid wood products remaining in use in year } n \\
 &= (\text{fraction used in single family houses}) \times e^{(-n \times \ln(2) / \text{half-life for sf houses})} \\
 &+ (\text{fraction used in multifamily houses}) \times e^{(-n \times \ln(2) / \text{half-life for mf houses})} \\
 &+ (\text{fraction used in mobile homes}) \times e^{(-n \times \ln(2) / \text{half-life mobile homes})} \\
 &+ (\text{fraction used in repair and alteration}) \times e^{(-n \times \ln(2) / \text{half-life repair})} \\
 &+ (\text{fraction used in nonresidential except railroads}) \times e^{(-n \times \ln(2) / \text{half-life non res ex rr})} \\
 &+ (\text{fraction used in railroad ties}) \times e^{(-n \times \ln(2) / \text{half-life rr ties})} \\
 &+ (\text{fraction used in railroad cars}) \times e^{(-n \times \ln(2) / \text{half-life rr cars})} \\
 &+ (\text{fraction used in household furniture}) \times e^{(-n \times \ln(2) / \text{half-life hh furn})} \\
 &+ (\text{fraction used in commercial furniture}) \times e^{(-n \times \ln(2) / \text{half-life com furn})} \\
 &+ (\text{fraction used in other manufacturing}) \times e^{(-n \times \ln(2) / \text{half-life oth manf})} \\
 &+ (\text{fraction used in wood containers}) \times e^{(-n \times \ln(2) / \text{half-life wood cont})} \\
 &+ (\text{fraction used in pallets}) \times e^{(-n \times \ln(2) / \text{half-life pallets})} \\
 &+ (\text{fraction used in dunnage}) \times e^{(-n \times \ln(2) / \text{half-life dunnage})} \\
 &+ (\text{fraction used in other uses}) \times e^{(-n \times \ln(2) / \text{half-life other uses})} \\
 &+ (\text{fraction used in exports}) \times e^{(-n \times \ln(2) / \text{half-life exports})}
 \end{aligned}$$

[Equation D2]

$$\begin{aligned}
 & \text{Fraction of paper products remaining in use in year } n \\
 &= e^{(-n \times \ln(2) / \text{half-life for paper})}
 \end{aligned}$$

The fractions of paper in use, as provided in Table 1.8, are based on Equation D2 and the assumption that some paper is recycled. To include the effects of recycling in these calculations, the following general assumptions are necessary: an average half-life of paper products, a rate of paper recovery and recycling, and the efficiency of reuse of paper fibers. We use a half-life of

2.6 years, a paper recovery rate of 0.48, and an efficiency of reuse of 0.70⁹ (Skog and Nicholson 1998, Row and Phelps 1996).

The difference between a fraction of paper in use calculated by Equation D2 for a particular year and the fraction from the previous year represents the amount of paper discarded during that year. We assume that 48 percent of the discarded paper is recycled and 70 percent of the fibers in recycled paper are recovered and incorporated into new paper products. This represents a net recovery of 33.6 percent of fibers from discarded paper. The fraction of these recycled fibers remaining in use in subsequent years also is determined according to Equation D2. This sequence of calculations can be repeated for the fraction of paper discarded each year. Thus, the summed remaining fractions of the original paper and all subsequently recycled fractions are included in Table 1.8. All these successive calculations pertain to the original paper fibers produced from wood at the beginning of the first year, yet none of the fiber from the original paper production is expected to remain in paper products beyond five rounds of recycling¹. Therefore, the estimates provided in Table 1.8 are based on five rounds of recycling, because beyond this point the effects of additional rounds are negligible. Thus, each fiber has the potential to be included in the recycling process up to five times. However, if the fiber is in the 66.4 percent (1 - 0.336) of discarded paper that is lost during recycling, there is no potential for additional recycling because it is no longer in the system.

The fractions of primary wood product remaining in landfills for a given number of years after production in Table 1.9 were developed by determining the fraction discarded to landfills each year and then determining the part of those fractions remaining in landfills over subsequent years. Thus, Table 1.9 is based on years since production but accounts for both rate of disposal to landfills and cumulative effect of residence times in landfills. Allocation to landfills occurs in two parts: 1) the fraction discarded at year n after production is the difference in the in-use fractions between two successive years from Table 1.8, that is, fraction at year n minus fraction at year n-1; and 2) the part of the discarded fraction that is placed in landfills is determined by fractions in Table D4 (the fractions for the year 2002). The fraction going to landfills is further divided into nondegradable and degradable pools, which are supplied in Table D5. The nondegradable pool is sequestered permanently. The fraction of the degradable pool remaining in subsequent years is determined by first-order decay, that is, $\text{fraction remaining} = \exp(-\text{years} \times \ln(2)/\text{half-life})$, and the half-life is shown in Table D5.

Example calculations and applications of selected factors in Tables 1.7, 1.8, and 1.9 – disposition from primary wood products

This set of example calculations determines the disposition of carbon in a primary wood product at 3 and 100 years after production. The product for this example is 320,000 ft² of 3/8-inch softwood plywood. These calculations are possible with factors from Tables 1.7, 1.8, and 1.9, but this example illustrates the foundation for those factors by using Tables D1 through D5. Note that some of these calculations are spreadsheet-intensive, so we show only enough work to illustrate the basic process.

Specifically, we calculate:

⁹ Klungness, J. 2005. Personal communication. Chemical Engineer, USDA Forest Service, Forest Products Lab, One Gifford Pinchot Drive, Madison, WI 53726-2398.

- 1) Initial quantity of carbon in the primary wood product (Table D1, used to make Table 1.7)
- 2) Amount of this carbon in single-family houses at years 3 and 100 (Equation D1 and Tables D2 and D3; this is an applications example)
- 3) Amount of this carbon in use in all end-use products at years 3 and 100 (Equation D1 and Tables D2 and D3; resulting fractions presented in Table 1.8)
- 4) Amount of this carbon in landfills from all end-use products at years 3 and 100 (Tables 1.8, D4, and D5; resulting fractions presented in Table 1.9)

Part 1: Initial quantity of carbon, from Table D1:

$$320,000 \text{ ft}^2 \times 31.25 \text{ ft}^3/1,000 \text{ ft}^2 \times 35.0 \text{ lb/ft}^2 \times 0.95 = 332,500 \text{ lb of wood fiber}$$

$$332,500 \text{ lb} \times 0.5 \times (1 \text{ short ton} / 2000 \text{ lb}) = 83.13 \text{ tons of carbon}$$

$$332,500 \text{ lb} \times 0.5 \times (1 \text{ metric ton} / 2204.62 \text{ lb}) = 75.41 \text{ t of carbon}$$

Note this is the only table that includes non-metric units.

Part 2: Amount of softwood plywood carbon in single-family houses at years 3 and 100, from Equation D1 and Tables D2 and D3:

$$\begin{aligned} &\text{In single-family houses at 3 years} \\ &= 75.41 \times 0.334 \times \exp(-3 \times \ln(2)/100) = 24.67 \text{ t} \\ &\text{In single-family houses at 100 years} \\ &= 75.41 \times 0.334 \times \exp(-100 \times \ln(2)/100) = 12.59 \text{ t} \end{aligned}$$

Part 3: Amount of softwood plywood carbon in use in all end-use products at years 3 and 100, from Equation D1 and Tables D2 and D3:

$$\begin{aligned} &\text{Amount of carbon in use at 3 years (showing the 15 terms from Equation D1)} \\ &= 75.41 \times (0.327 + 0.032 + 0.029 + 0.227 + 0.087 + 0.000 + 0.001 + 0.043 + 0.047 + \\ &0.070 + 0.006 + 0.018 + 0.000 + 0.008 + 0.036) = 75.41 \times 0.930 = 70.1 \text{ t} \end{aligned}$$

$$\begin{aligned} &\text{Amount of carbon in use at 100 years (showing the 15 terms from Equation D1)} \\ &= 75.41 \times (0.167 + 0.012 + 0.000 + 0.024 + 0.032 + 0.000 + 0.000 + 0.005 + 0.005 + \\ &0.000 + 0.000 + 0.000 + 0.000 + 0.000 + 0.000) = 75.41 \times 0.245 = 18.5 \text{ t} \end{aligned}$$

Note that the sum of terms from equation D1 is the fraction remaining in use at the end of a given year. These fractions are calculated and provided in Table 1.8, for example the fractions 0.930 and 0.245, which are for years 3 and 100, respectively.

Part 4: Amount of carbon in landfills from all end-use products at years 3 and 100, from Tables 1.8, D4, and D5:

Note that the amount of carbon in landfills at the end of year 3 is a sum from material discarded in each of the years, that is: from year 1, the nondegradable fraction of carbon discarded in year 1 plus the remaining part of the degradable fraction after two years of decay; from year 2, the nondegradable fraction of carbon discarded in year 2 plus the remaining part of the degradable fraction after one year of decay; and from year 3, the carbon discarded to landfills in year 3.

Coefficients from Table 1.8 are necessary because the amount discarded each year is based on the difference between the amounts in use at the start and end of each year. By multiplying 75.41 by the first four softwood plywood coefficients in Table 1.8, we obtain in-use stocks of 75.41, 73.60, 71.79, and 70.13 t carbon, which represent the time of processing (the beginning of year 1) and the ends of years 1, 2, and 3, respectively.

$$\begin{aligned} &\text{Nondegradable fraction from year 1} \\ &= (75.41-73.60) \times 0.67 \times 0.77 = 0.9337 \text{ t} \\ &\text{Degradable fraction from year 1 remaining at year 3} \\ &= (75.41-73.60) \times 0.67 \times (1-0.77) \times \exp(-2 \times \ln(2)/14) = 0.2526 \text{ t} \\ &\text{Nondegradable fraction from year 2} \\ &= (73.60-71.79) \times 0.67 \times 0.77 = 0.9337 \text{ t} \\ &\text{Degradable fraction from year 2 remaining at year 3} \\ &= (73.60-71.79) \times 0.67 \times (1-0.77) \times \exp(-1 \times \ln(2)/14) = 0.2654 \text{ t} \\ &\text{Nondegradable fraction from year 3} \\ &= (71.79-70.13) \times 0.67 \times 0.77 = 0.8559 \text{ t} \\ &\text{Degradable fraction from year 3 remaining at year 3} \\ &= (71.79-70.13) \times 0.67 \times (1-0.77) \times \exp(-0 \times \ln(2)/14) = 0.2557 \text{ t} \end{aligned}$$

Thus, total carbon in landfills at the end of the third year = 3.5 t.

Note that the fraction of softwood plywood in landfills at the end of year 3 in Table 1.9 can be determined from the previous series of calculations by changing the first factor in each line to represent the relative amount discarded each year rather than the absolute amount. The calculations are:

$$\begin{aligned} &\text{Nondegradable fraction from year 1} \\ &= (1-0.976) \times 0.67 \times 0.77 = 0.0124 \\ &\text{Degradable fraction from year 1 remaining at year 3} \\ &= (1-0.976) \times 0.67 \times (1-0.77) \times \exp(-2 \times \ln(2)/14) = 0.0034 \\ &\text{Nondegradable fraction from year 2} \\ &= (0.976-0.952) \times 0.67 \times 0.77 = 0.0124 \\ &\text{Degradable fraction from year 2 remaining at year 3} \\ &= (0.976-0.952) \times 0.67 \times (1-0.77) \times \exp(-1 \times \ln(2)/14) = 0.0035 \\ &\text{Nondegradable fraction from year 3} \\ &= (0.952-0.930) \times 0.67 \times 0.77 = 0.0114 \\ &\text{Degradable fraction from year 3 remaining at year 3} \\ &= (0.952-0.930) \times 0.67 \times (1-0.77) \times \exp(-0 \times \ln(2)/14) = 0.0034 \end{aligned}$$

Thus, total fraction in landfills at year the end of the third year = 0.047. The difference between this value and the 0.046 in Table 1.9 is due to rounding.

Net flux of carbon to landfills at year 3 is the difference between the previous values and similar calculations for year 2, or more simply from Table 1.9:
 $75.41 \times (0.046 - 0.032) = 1.06 \text{ t in year 3}$

A similar series of calculations can be repeated for year 100, or more simply from Tables 1.8 and 1.9: the amount of carbon in landfills at 100 years = $75.41 \times 0.400 = 3.2 \text{ t}$, and the flux of carbon in landfills at 100 years = $75.41 \times (0.400-0.394)/5 = 0.09 \text{ t in year 100}$.

Roundwood

Industrial roundwood is basically harvested logs brought to mills for processing. Roundwood, as used here, refers to wood that is processed to primary wood products; it excludes bark or roundwood that is identified as fuelwood. Input values for calculations from this starting point are carbon mass of roundwood logs grouped by categories defined for Table 1.6. The links between these inputs and the disposition of carbon in primary wood products are the allocation patterns described in Tables D6 and D7.

Carbon mass of roundwood logs is categorized as softwood or hardwood and saw logs or pulpwood. However, if roundwood data are not classified according to type or size of logs, this appendix includes factors for distributing roundwood to appropriate categories according to regional averages. Additionally, roundwood data in the form of volume of wood can be converted to carbon with average values for specific gravity of softwood or hardwood species. These factors are included in Tables 1.4 or D8. See additional discussion of their use in the section on Forest Ecosystem.

Average disposition patterns of roundwood carbon by region and roundwood category are presented in Table 1.6. These values were developed from regional average allocation of roundwood to primary wood products in Table D6. Disposition of carbon allocated to primary wood products then follows the patterns described above by Tables 1.8 and 1.9, which allocate carbon to in-use or landfill classifications. The balance of carbon originally in roundwood but no longer in use or in landfills is emitted to the atmosphere. The fraction emitted to the atmosphere that occurs with energy recapture is calculated using Table D7 (Birdsey 1996). These fractions for primary products are pooled within regions to allocate roundwood carbon for up to four categories per region. These fractional values are displayed in Table 1.6, which is the resulting net effect of linking information in Tables D6, 1.8, 1.9, and D7.

Example calculations related to constructing and applying Table 1.6 – disposition from roundwood

This example calculates the disposition of carbon in roundwood. We calculate the disposition of carbon at 15 years after harvest and the processing of 10,000 m³ of hardwood saw logs from a maple-beech-birch forest in the Northeast. The example demonstrates the basic set of calculations used to develop and apply Table 1.6. It is limited in scope because factorial combinations of year, roundwood categories, and classifications for the disposition of carbon in harvested wood products can require a sequence of many repeated spreadsheet calculations.

We calculate:

- 1) Carbon mass based on volume of saw logs
- 2) The allocation of carbon from saw logs at year 15 – the allocation values in Table 1.6
- 3) The disposition of carbon – apply the allocation factors from Table 1.6 to carbon mass from step 1

Part 1: The carbon mass of roundwood can be determined using the volume. The product of volume of roundwood and specific gravity (from Tables 1.4 or D8) is mass; 50 percent of this is carbon mass. Based on specific gravity from Table 1.4, total carbon for this example is:

$$= 10,000 \times 0.518 \times 0.5 = 2,590 \text{ t}$$

Part 2: The allocation of roundwood logs to primary wood products according to region and category are provided in Table D6. The fractions of primary products remaining in use or in landfills at a given year are provided in Tables 1.8 and 1.9, respectively. The fraction of emitted carbon associated with energy recapture is from Table D7. The calculations for hardwood saw logs from the Northeast at 15 years are:

$$\begin{aligned} & \text{Fraction of carbon in products in use (summed products from Table D6 and Table 1.8)} \\ & = (0 \times 0.698) + (0.492 \times 0.456) + (0 \times 0.724) + (0 \times 0.799) + ((0.005 + 0.022) \times 0.647) \\ & \quad + (0.038 \times 0.420) + (0.058 \times 0.040) \\ & = 0 + 0.224 + 0 + 0 + 0.017 + 0.016 + 0.002 = 0.260 \end{aligned}$$

$$\begin{aligned} & \text{Fraction of carbon in landfills (summed products from Table D6 and Table 1.9)} \\ & = (0 \times 0.187) + (0.492 \times 0.334) + (0 \times 0.171) + (0 \times 0.124) + ((0.005 + 0.022) \times 0.218) \\ & \quad + (0.038 \times 0.357) + (0.058 \times 0.253) \\ & = 0 + 0.164 + 0 + 0 + 0.006 + 0.014 + 0.015 = 0.198 \end{aligned}$$

$$\begin{aligned} & \text{Fraction of carbon emitted by year 15 (one minus the fractions in use or in landfills)} \\ & = 1 - 0.260 - 0.198 = 0.542 \end{aligned}$$

$$\begin{aligned} & \text{Fraction of carbon emitted with energy recapture (from Table D7)} \\ & = 0.542 \times 0.6143 \times \exp(-((15/6812)^{0.5953})) = 0.324 \end{aligned}$$

$$\begin{aligned} & \text{Fraction of carbon emitted without energy recapture} \\ & = 0.542 - 0.324 = 0.218 \end{aligned}$$

These fractions allocate the disposition of carbon at year 15 after harvest for hardwood saw logs in the Northeast (see Table 1.6).

Part 3: The application of the factors from Table 1.6 (calculated in Step 2) to carbon in roundwood (calculated in Step 1) determines the disposition of carbon at year 15, which is:

In use	= 0.260 × 2,590 = 673 t
Landfills	= 0.198 × 2,590 = 513 t
Emitted with energy	= 0.324 × 2,590 = 839 t
Emitted without energy	= 0.218 × 2,590 = 565 t

Forest Ecosystems

Wood in trees in a forest is often characterized according to the total volume of merchantable wood. Merchantable volume can be expressed per unit of forest area; in this case, we use the volume of growing stock of live trees as defined by the USDA Forest Service, Forest Inventory and Analysis Data Base (FIADB; Alerich and others 2005). Merchantable volume must be linked to amount of roundwood carbon to calculate the expected disposition of carbon in harvested wood products (as described above for roundwood and primary wood products).

A set of regional average factors (Tables D8 through D12) is used for the calculations to transform growing-stock volume to carbon in roundwood, which is then allocated to the expected disposition of carbon in primary wood products. This land-based approach for calculating the disposition of carbon in harvested wood products differs from the previously described product-based approaches in two important respects: the disposition of carbon is expressed as mass per area of forest rather than as an absolute mass, and additional carbon pools must be considered such as ecosystem carbon and carbon removed at harvest but not incorporated into wood products. Calculations can include carbon in roundwood removed as fuelwood as well as carbon in bark on roundwood. Furthermore, estimates of forest carbon at the time of harvest place constraints on quantities harvested. For instance, total carbon mass allocated to harvest, as in Table 1.3, is calculated from volume but is limited to a portion of live tree biomass.

The starting variable for the forest ecosystem calculation is volume at harvest (for example, 172.1 m³/ha in Table 1.3). Carbon in growing-stock volume is allocated to the four categories of roundwood using the factors in Table 1.4. The first three factors allocate growing stock based on two separate divisions among trees contributing to stand-level growing-stock volume: first, to hardwood or softwood types, and second, to sawtimber diameter- or less-than-sawtimber diameter trees. These factors were developed from the most recent forest inventory data for each State in the FIADB and are summarized according to region and forest type. Data from the FIADB were compiled to reflect types and sizes of trees in stands that are likely to be harvested; thus, trees are classified as growing stock and stands are identified as medium- or large-diameter (Alerich and others 2005). Finally, volumes of wood are converted to carbon mass according to the specific gravity of wood. Values for specific gravity (Jenkins and others 2004) were summarized from the FIADB with the same criteria as the other factors in Table 1.4. Table D8 contains regional averages for the factors in Table 1.4. Thus, the product of growing-stock volume and the first, second, and fourth columns of factors (in Tables 1.4 or D8) is the average dry weight of softwood sawtimber in that growing-stock volume. To convert dry weight to carbon mass, multiply by 0.5.

The next step in the process is to calculate carbon in roundwood from the previously calculated values of carbon in growing-stock volume. The definition of roundwood is the same as elsewhere in this text; as such, it excludes bark and the portion of roundwood identified as fuelwood. Not all roundwood is from growing-stock volume, and not all of growing-stock volume becomes roundwood. Table 1.5 includes the fraction of growing stock that is roundwood and the ratio of roundwood to growing-stock volume that is roundwood. These factors are from Johnson (2001) and are also in Tables D9 and D10. The product of carbon in growing-stock volume and these two factors from Table 1.5 is the mass of carbon in roundwood for each of the roundwood categories.

Fuelwood and bark on roundwood are also carbon pools removed from site at harvest. These are calculated separately because they are not part of the roundwood carbon pool allocated according to Table 1.6. Fuelwood, as used here, is a portion of total roundwood as defined in Johnson (2001). For the harvest scenario tables (Appendix C), we assume that carbon from these pools is emitted the same year as harvest. Thus, the carbon is added to the two emitted categories at the time of harvest; all of the fuelwood and a portion of the bark on roundwood are emitted with energy capture. Tables 1.5 and D11 provide ratios of carbon in bark to carbon in wood summarized according to region. The ratios apply to roundwood logs and are based on biomass

component equations of Jenkins and others (2003); they are summaries from the FIADB by types and sizes of stem wood and bark in stands that are likely to be harvested (as described above for Table 1.4). The product of carbon in roundwood and the bark ratio (from Tables 1.5 or D11) is carbon in bark on roundwood. Fuelwood is estimated from the ratio of fuelwood to growing-stock volume that is roundwood (Johnson 2001), which is summarized in Tables 1.5 and D12. Thus, carbon in fuelwood is the product of carbon in roundwood and the fuelwood ratio (from Tables 1.5 or D12), and bark on fuelwood is the product of carbon in fuelwood and the bark ratio.

Ecosystem carbon is removed, emitted, or remains on site at harvest. Thus, total non-soil carbon at the time of harvest in the Appendix C tables (the harvest scenarios) equals the non-soil carbon in the corresponding year of the Appendix B tables (afforestation). Similarly, total non-soil forest ecosystem carbon at the time of harvest in the Appendix C tables (the harvest scenarios) equals the non-soil carbon at age zero of the Appendix A tables (reforestation). The pools of carbon in down dead wood and forest floor at the time of harvest reflect logging residue. These decay over time even as new material accumulates in these pools with stand regrowth (Turner and others 1995, Johnson 2001, Smith and Heath 2002, Smith and others 2004b). The pool of carbon removed at harvest is based on regional average values and calculated as described above. The residual carbon—not on-site or removed—is assigned to the “emitted at harvest” column in Appendix C. While site disturbance associated with harvest likely results in carbon emissions, this pool is also likely to include carbon in wood removed but not classified as roundwood. The use of regional averages to allocate ecosystem and harvested carbon also suggests that values in the final column (in Appendix C) may be larger or smaller, depending on actual forests or harvests. The Appendix C tables are examples of how forest carbon stocks can include carbon in harvested wood; these are not recommendations for rotation length or timing of harvest.

The use of regional fractions or ratios to allocate carbon for a number of forest types within the region has potential for occasional extreme or unrealistic values. That is, the sum of carbon in roundwood, fuelwood, and bark is limited by live tree carbon density. To avoid extreme values, some limits are set for the use of these regional averages. The fuelwood ratios used for calculating the fuelwood components of the harvest scenario tables (Appendix C) are averages by type but not size (that is, columns 3 and 6 in Table D12). We also limit the proportion of live tree carbon allocated to roundwood plus bark to 66 percent, and the limit for total carbon removed (roundwood, bark, and fuelwood) is 78 percent of live tree carbon. These limits are based on generalized tree biomass component equations from Jenkins and others (2003). Calculated values for carbon removed at harvest (such as for Appendix C) seldom exceed these limits, but one of the exceptions is included in the example below.

Example calculations of carbon in harvested wood products for Table 1.3 – disposition from forest ecosystems

This example illustrates the calculations to determine the disposition of carbon in wood products for the harvest scenario tables in Appendix C. We calculate the disposition of carbon at 15 years after harvest from a maple-beech-birch forest in the Northeast (see Table 1.3). Most of the following example can be completed with factors in Tables 1.4 through 1.6 (as opposed to tables in this section), but it is included here because it illustrates the above discussion.

We calculate:

- 1) Carbon in growing-stock volume according to the roundwood categories (Table 1.4)
- 2) Carbon in roundwood from carbon in growing-stock volume (Table 1.5)
- 3) The additional pools of carbon in fuelwood and bark on roundwood, which are assumed emitted with or without energy capture soon after harvest
- 4) Modifications to totals for roundwood or fuelwood if necessary
- 5) The disposition of carbon at 15 years after harvest (Table 1.6)

Part 1: Carbon in growing-stock volume is calculated with the factors in Table 1.4, which allocates volume to four categories based on wood type and log size. The example growing-stock volume harvested in Table 1.3 is 172.1 m³/ha. Three steps are needed to calculate total carbon in growing-stock volume: growing stock is allocated to softwood or hardwood; volumes are partitioned to saw logs and pulpwood; and finally, carbon mass is determined from specific gravity of wood, which is 50 percent carbon by dry weight. Thus, the softwood saw log part of growing stock = (growing-stock volume) × (softwood fraction) × (sawtimber-size fraction) × (softwood specific gravity) × (carbon fraction of wood). The calculated values from growing-stock volume are:

$$\begin{aligned} \text{Softwood sawtimber carbon} &= 172.1 \times 0.132 \times 0.604 \times 0.369 \times 0.5 = 2.53 \text{ t/ha} \\ \text{Softwood poletimber carbon} &= 172.1 \times 0.132 \times (1 - 0.604) \times 0.369 \times 0.5 = 1.66 \text{ t/ha} \\ \text{Hardwood sawtimber carbon} &= 172.1 \times (1 - 0.132) \times 0.526 \times 0.518 \times 0.5 = 20.35 \text{ t/ha} \\ \text{Hardwood poletimber carbon} &= 172.1 \times (1 - 0.132) \times (1 - 0.526) \times 0.518 \times 0.5 = 18.34 \text{ t/ha} \end{aligned}$$

Total carbon stock in 172.1 m³/ha of growing-stock volume is 42.88 t/ha.

Part 2: Carbon in roundwood, which excludes bark and fuelwood, is determined from factors in Table 1.5. The two factors determine the fraction of growing-stock volume that is roundwood, and the ratio of total roundwood to growing-stock volume that is roundwood. The calculated values for roundwood are:

$$\begin{aligned} \text{Softwood saw log carbon} &= 2.53 \times 0.948 \times 0.991 = 2.38 \text{ t/ha} \\ \text{Softwood pulpwood carbon} &= 1.66 \times 0.948 \times 3.079 = 4.84 \text{ t/ha} \\ \text{Hardwood saw log carbon} &= 20.35 \times 0.879 \times 0.927 = 16.58 \text{ t/ha} \\ \text{Hardwood pulpwood carbon} &= 18.34 \times 0.879 \times 2.177 = 35.09 \text{ t/ha} \end{aligned}$$

Thus, total carbon in roundwood is 58.90 t/ha.

Part 3: Pools of carbon in bark on roundwood are based on ratios in Table 1.5; these are also applied to calculate bark on fuelwood. The portion of bark on roundwood allocated to emitted with energy capture is according to coefficient A from Table D7. Carbon in fuelwood is calculated from factors in Table 1.5. The calculations are:

Softwood saw log bark carbon = $2.38 \times 0.182 = 0.43$ t/ha
 Softwood pulpwood bark carbon = $4.84 \times 0.185 = 0.90$ t/ha
 Hardwood saw log bark carbon = $16.58 \times 0.199 = 3.30$ t/ha
 Hardwood pulpwood bark carbon = $35.09 \times 0.218 = 7.65$ t/ha

Thus, total carbon in bark on roundwood is 12.28 t/ha.

Part of carbon in bark on roundwood emitted with energy capture is
 = $(0.43 \times 0.5582) + (0.90 \times 0.6289) + (3.30 \times 0.6143) + (7.65 \times 0.5272)$
 = 6.87 t/ha

Part of carbon in bark on roundwood emitted without energy capture is
 = $12.28 - 6.87 = 5.41$ t/ha

Softwood saw log carbon in fuelwood with bark
 = $2.53 \times 0.948 \times 0.136 \times (1 + 0.182) = 0.39$ t/ha
 Softwood pulpwood carbon in fuelwood with bark
 = $1.66 \times 0.948 \times 0.136 \times (1 + 0.185) = 0.25$ t/ha
 Hardwood saw log carbon in fuelwood with bark
 = $20.35 \times 0.879 \times 0.547 \times (1 + 0.199) = 11.73$ t/ha
 Hardwood pulpwood carbon in fuelwood with bark
 = $18.34 \times 0.879 \times 0.547 \times (1 + 0.218) = 10.74$ t/ha

Thus, total carbon in fuelwood with bark is 23.11 t/ha.

Part 4: Limits are placed on values calculated for roundwood and fuelwood where the regional average factors result in extreme values for some forest types (as discussed above). Based on biomass component equations, total carbon in roundwood with bark is limited to 66 percent of live tree carbon density, and the sum of roundwood, fuelwood, and bark is limited to 78 percent. Live tree carbon density at harvest is 113.1 t/ha (from Table B2).

The sum of roundwood and bark is less than 66 percent of live tree carbon
 $(58.90 + 12.28) / 113.1 = 0.629$

However, the sum of roundwood, fuelwood, and bark is greater than 78 percent of live tree carbon
 $(58.90 + 12.28 + 23.11) / 113.1 = 0.834$

Therefore, the seven carbon pools are reduced by the factor $0.78/0.834=0.935$

Roundwood softwood saw log = $2.38 \times 0.935 = 2.22$ t/ha
 Roundwood softwood pulpwood = $4.84 \times 0.935 = 4.53$ t/ha
 Roundwood hardwood saw log = $16.58 \times 0.935 = 15.50$ t/ha
 Roundwood hardwood pulpwood = $35.09 \times 0.935 = 32.81$ t/ha

Roundwood bark emitted with energy capture = $6.87 \times 0.935 = 6.42$ t/ha
 Roundwood bark emitted without energy capture = $5.41 \times 0.935 = 5.06$ t/ha

Fuelwood with bark = $23.11 \times 0.935 = 21.61$ t/ha

These modified values are used in subsequent calculations and are applied to the harvest scenario tables. Such modifications occur infrequently with the tables presented in Appendix C.

Part 5: The four pools of roundwood carbon are each allocated to the four disposition categories for carbon in wood products according to Table 1.6. Totals are the summed products of roundwood carbon and allocation at year 15. Carbon in fuelwood and bark are one-time additions to the emitted columns (in Appendix C). Thus the disposition of carbon at year 15 is calculated as:

$$\begin{aligned} &\text{Total roundwood carbon in use} \\ &= (2.22 \times 0.326) + (4.53 \times 0.037) + (15.50 \times 0.260) + (32.81 \times 0.252) = 13.19 \text{ t/ha} \\ &\text{Total roundwood carbon in landfills} \\ &= (2.22 \times 0.126) + (4.53 \times 0.128) + (15.50 \times 0.198) + (32.81 \times 0.127) = 8.10 \text{ t/ha} \\ &\text{Total roundwood carbon emitted with energy recapture} \\ &= (2.22 \times 0.296) + (4.53 \times 0.497) + (15.50 \times 0.324) + (32.81 \times 0.310) = 18.10 \text{ t/ha} \\ &\text{Total roundwood carbon emitted without energy recapture} \\ &= (2.22 \times 0.252) + (4.53 \times 0.338) + (15.50 \times 0.218) + (32.81 \times 0.311) = 15.67 \text{ t/ha} \end{aligned}$$

$$\begin{aligned} &\text{Total carbon emitted with energy recapture is the sum of roundwood, bark, and fuelwood} \\ &= 18.10 + 6.42 + 21.61 = 46.13 \text{ t/ha} \end{aligned}$$

$$\begin{aligned} &\text{Total carbon emitted without energy recapture is the sum of roundwood and bark} \\ &= 15.67 + 5.06 = 20.73 \text{ t/ha} \end{aligned}$$

These are the carbon density values for the four harvested wood classifications at 15 years after harvest in Table 1.3 (that is, 13.2, 8.1, 46.1, and 20.7). The differences between values in this example and those in the table are due to rounding subtotals in this example.

Table D1.—Factors to convert solid wood products in customary units to carbon^a

Solid wood product	Unit	Cubic feet per unit	Pounds/cubic foot	Fraction of product that is wood fiber	Factor to convert units to tons (2000 lb) carbon	Factor to convert units to tonnes carbon
Softwood lumber/ laminated veneer lumber/ glulam lumber/ I-joists	thousand board feet	59.17	33.0	1.00	0.488	0.443
Hardwood lumber	thousand board feet	83.33	40.5	1.00	0.844	0.765
Softwood plywood	thousand square feet, 3/8-inch basis	31.25	35.0	0.95	0.260	0.236
Oriented strandboard	thousand square feet, 3/8-inch basis	31.25	40.0	0.97	0.303	0.275
Nonstructural panels (average)	thousand square feet, 3/8- inch basis	31.25	--	--	0.319	0.289
Hardwood veneer/ plywood	thousand square feet, 3/8- inch basis	31.25	42.0	0.96	0.315	0.286
Particleboard / Medium density fiberboard	thousand square feet, 3/4- inch basis	62.50	45.0	0.92	0.647	0.587
Hardboard	thousand square feet, 1/8-inch basis	10.42	60.0	0.97	0.152	0.138
Insulation board	thousand square feet, 1/2-inch basis	41.67	23.5	0.99	0.242	0.220
Other industrial products	thousand cubic feet	1.00	33.0	1.00	8.250	7.484

-- = not applicable.

^aFactors in the last two columns are calculated by multiplying the previous three columns to provide the mass of product in pounds, the fraction of carbon in wood (assumed to be 0.5), and converting mass to tons or tonnes.

Table D2.—Fraction of solid wood product production used for various end uses in the United States, and used for export, 1998

End use	Product				
	Lumber ^a		Structural panels ^b		Non-structural panels ^c
	Softwood	Hardwood	Softwood plywood	Oriented strandboard	
New residential construction					
Single family	0.332	0.039	0.334	0.578	0.130
Multifamily	0.031	0.004	0.033	0.047	0.019
Mobile homes	0.039	0.002	0.035	0.060	0.037
Residential upkeep and improvement	0.253	0.039	0.243	0.164	0.112
New nonresidential construction					
All except railroads	0.079	0.028	0.090	0.071	0.053
Railroad ties	0.001	0.047	0.000	0.000	0.000
Railcar repair	0.000	0.008	0.001	0.000	0.000
Manufacturing					
Household furniture	0.023	0.235	0.046	0.002	0.138
Commercial furniture	0.004	0.048	0.050	0.006	0.218
Other products	0.035	0.095	0.083	0.021	0.094
Shipping					
Wooden containers	0.006	0.008	0.008	0.000	0.005
Pallets	0.037	0.349	0.025	0.001	0.001
Dunnage etc	0.002	0.007	0.000	0.000	0.000
Other uses ^d	0.126	0.007	0.009	0.041	0.139
Total domestic use	0.967	0.917	0.957	0.991	0.946
Export	0.033	0.083	0.043	0.009	0.054

^aIncludes hardwood and softwood dimension and boards, glulam, and lumber I-joist flanges.

^bIncludes softwood plywood, OSB, structural composite lumber, and I-joist webs.

^cIncludes hardwood plywood, particleboard, medium-density fiberboard, hardboard, and insulation board.

^dOther uses for lumber and panels include: 1) upkeep and improvement of nonresidential structures, 2) roof supports and other construction in mines, 3) made-at-home projects such as furniture, boats, and picnic tables, 4) made-on-the-job products such as advertising and display structures, and 5) any other uses.

Source: Calculated from tables in McKeever (2002).

Table D3.—Half-life for products by end use

End use or product	Half-life
	<i>years</i>
New residential construction	
Single family	100
Multifamily	70
Mobile homes	12
Residential upkeep and improvement	30
New nonresidential construction	
All except railroads	67
Railroad ties	12
Railcar repair	12
Manufacturing	
Household furniture	30
Commercial furniture	30
Other products	12
Shipping	
Wooden containers	6
Pallets	6
Dunnage etc	6
Other uses for lumber and panels	12
Solid wood exports	12
Paper	2.6

Sources: Skog and Nicholson (1998), Row and Phelps (1996), Klungness, J. 2005. Personal communication. Chemical Engineer, USDA Forest Service, Forest Products Lab, One Gifford Pinchot Drive, Madison, WI 53726-2398.

Table D4.—Fraction of discarded wood and paper placed in landfills

Year	Wood to landfills	Paper to landfills	Year (continued)	Wood to landfills	Paper to landfills
1950	0.05	0.05	1977	0.49	0.38
1951	0.06	0.05	1978	0.55	0.43
1952	0.06	0.06	1979	0.62	0.48
1953	0.07	0.06	1980	0.68	0.52
1954	0.07	0.06	1981	0.69	0.53
1955	0.08	0.06	1982	0.71	0.53
1956	0.08	0.07	1983	0.72	0.53
1957	0.09	0.07	1984	0.73	0.54
1958	0.09	0.07	1985	0.74	0.54
1959	0.10	0.07	1986	0.76	0.54
1960	0.11	0.09	1987	0.77	0.54
1961	0.12	0.09	1988	0.78	0.54
1962	0.13	0.10	1989	0.79	0.54
1963	0.13	0.10	1990	0.74	0.54
1964	0.14	0.11	1991	0.79	0.50
1965	0.15	0.11	1992	0.71	0.48
1966	0.17	0.13	1993	0.70	0.48
1967	0.19	0.15	1994	0.70	0.44
1968	0.22	0.17	1995	0.73	0.39
1969	0.24	0.19	1996	0.71	0.37
1970	0.26	0.21	1997	0.69	0.38
1971	0.29	0.23	1998	0.68	0.39
1972	0.32	0.25	1999	0.68	0.39
1973	0.35	0.27	2000	0.67	0.37
1974	0.37	0.29	2001	0.67	0.35
1975	0.40	0.32	2002	0.67	0.34
1976	0.43	0.34			

Source: Freed, R. 2004. Personal communication. Environmental Scientist, ICF Consulting, 9300 Lee Highway, Fairfax, VA 22031.

Table D5.—Nondegradable fraction of wood and paper in landfills and half-life for degradable fraction

Nondegradable fraction in landfills ^a	
Wood	0.77
Paper	0.44
Half-life of degradable fraction (yr) ^b	
	14

^a Source: Freed, R. and C. Mintz. 2003 (29 Aug). Letter to H Ferland (EPA), K Skog (USDA), T Wirth (EPA) and E Scheehle (EPA). Revised input data for WOODCARB. On file with: Forest Products Laboratory, One Gifford Pinchot Drive, Madison, WI 53726-2398

^b Source: de Silva Alves and others (2000).

Table D6.—Fraction of each classification of roundwood according to category as allocated to primary wood products (based on data from 2002)^a

Region	Category ^b		Softwood lumber	Hardwood lumber	Softwood plywood	Hardwood plywood ^c	Oriented strandboard	Non- structural panels	Other industrial products	Wood pulp	Fuel and other emissions
	SW/HW	SL/PW									
Northeast	SW	SL	0.391	0	0.004	0	0	0.020	0.083	0.072	0.431
		PW	0	0	0	0	0.010	0.016	0	0.487	0.487
	HW	SL	0	0.492	0	0.005	0	0.022	0.038	0.058	0.386
		PW	0	0	0	0	0.293	0.007	0	0.350	0.350
North Central	SW	SL	0.378	0	0	0	0	0.049	0.120	0.084	0.370
		PW	0	0	0	0	0.020	0.009	0	0.486	0.486
	HW	SL	0	0.458	0	0.006	0	0.013	0.044	0.064	0.415
		PW	0	0	0	0	0.361	0.009	0	0.315	0.315
Pacific Northwest, East	SW	All	0.422	0	0.069	0	0	0.001	0.001	0.144	0.363
Pacific Northwest, West	SW	SL	0.455	0	0.089	0	0	0.009	0.073	0.114	0.260
		PW	0	0	0	0	0	0	0	0.500	0.500
	HW	All	0	0.160	0	0.140	0	0.002	0	0.229	0.469
Pacific Southwest	SW	All	0.454	0	0	0	0	0.040	0.036	0.145	0.325
Rocky Mountain	SW	SL	0.402	0	0.054	0	0	0.033	0.062	0.153	0.296
		PW	0.350	0	0.076	0	0	0.027	0.054	0.129	0.364
	Southeast	HW	SL	0	0.455	0	0.006	0	0.049	0.012	0.087
PW			0	0	0	0	0.180	0.002	0	0.409	0.409
South Central		SW	SL	0.324	0	0.130	0	0	0.019	0.023	0.133
	PW		0	0	0	0	0.135	0.006	0	0.430	0.430
	HW	SL	0	0.434	0	0.023	0	0.025	0.003	0.102	0.413
PW		0	0	0	0	0.160	0.001	0	0.419	0.419	
West ^d	HW	All	0	0.039	0	0.301	0	0.015	0.066	0.147	0.432

^aData based on Adams and others (2006).

^bSW/HW=Softwood/Hardwood, SL/PW=Saw log/Pulpwood. Saw log includes veneer logs.

^cHardwood plywood fractions are pooled with nonstructural panels when allocating roundwood to the primary products listed in Tables 1.8 and 1.9.

^dWest includes hardwoods in Pacific Northwest, East; Pacific Southwest; Rocky Mountain, North; and Rocky Mountain, South.

Table D7.—Coefficients for estimating fraction of emitted carbon associated with energy recapture with emission for roundwood

Region	Roundwood category ^a		Coefficients ^b		
	SW/HW	SL/PW	a	b	c
Northeast	SW	SL	0.5582	2594	0.6557
		PW	0.6289	3062	0.5432
	HW	SL	0.6143	6812	0.5953
		PW	0.5272	3483	0.5364
North Central	SW	SL	0.6728	2162	0.6550
		PW	0.6284	3494	0.5117
	HW	SL	0.6097	5144	0.6236
		PW	0.5243	3399	0.5451
Pacific Northwest, East	SW	All	0.5421	1144	0.7958
Pacific Northwest, West	SW	SL	0.4823	823	0.8561
		PW	0.7040	2376	0.5184
Pacific Southwest	HW	All	0.6147	4746	0.6306
		SW	All	0.5216	1278
Rocky Mountain	SW	All	0.7072	992	0.7353
Southeast	SW	SL	0.7149	1313	0.6051
		PW	0.6179	3630	0.5054
	HW	SL	0.5749	4574	0.5954
		PW	0.5490	3731	0.5025
South Central	SW	SL	0.6136	1264	0.6634
		PW	0.6190	3455	0.5148
	HW	SL	0.5744	4541	0.6070
		PW	0.5449	3239	0.5324
West ^c	HW	All	0.5917	6433	0.6054

^aApplicable to roundwood without bark or fuelwood, which is classified as: SW/HW=Softwood/Hardwood, SL/PW=Saw log/Pulpwood.

^bEstimates are calculated according to: $\text{fraction} = a \times \exp(-(\text{year}/b)^c)$, based on proportions in Table 1.7 of Birdsey (1996). We assume that values in the Birdsey (1996) table are that portion of the growing-stock volume harvested and removed from the forest, so that the values are generally accurate when applied to roundwood categories.

^cWest includes hardwoods in Pacific Northwest, East; Pacific Southwest; Rocky Mountain, North; and Rocky Mountain, South.

Table D8—Average regional factors to calculate carbon in growing-stock volume: softwood fraction, sawtimber-size fraction, and specific gravity^{a,b}

Region	Fraction of growing-stock volume that is softwood ^c	Fraction of softwood growing-stock volume that is sawtimber-size ^d	Fraction of hardwood growing-stock volume that is sawtimber-size ^d	Specific gravity ^e of softwoods	Specific gravity ^e of hardwoods
Northeast	0.226	0.647	0.579	0.371	0.518
Northern Lake States	0.292	0.556	0.407	0.360	0.473
Northern Prairie States	0.093	0.622	0.511	0.434	0.537
Pacific Northwest, East	0.980	0.865	0.501	0.396	0.424
Pacific Northwest, West	0.890	0.911	0.538	0.426	0.415
Pacific Southwest	0.829	0.925	0.308	0.399	0.510
Rocky Mountain, North	0.983	0.734	0.442	0.394	0.389
Rocky Mountain, South	0.865	0.742	0.337	0.369	0.353
Southeast	0.423	0.612	0.512	0.462	0.508
South Central	0.358	0.693	0.523	0.463	0.529

^aThese factors correspond to the values in Table 1.4.

^bEstimates based on survey data for the conterminous United States from USDA Forest Service, Forest Inventory and Analysis Program's database of forest surveys (FIADB; USDA For. Serv. 2005) and include growing stock on timberland stands classified as medium- or large-diameter stands. Fractions are based on volumes of growing stock trees.

^cTo calculate fraction in hardwood, subtract fraction in softwood from 1.

^dSoftwood sawtimber are trees at least 22.9 cm (9 in) d.b.h., hardwood sawtimber is at least 27.9 cm (11 in) d.b.h. To calculate fraction in less-than-sawtimber-size trees, subtract fraction in sawtimber from 1. Trees less than sawtimber-size are at least 12.7 cm (5 in) d.b.h.

^eAverage wood specific gravity is the density of wood divided by the density of water based on wood dry mass associated with green tree volume.

Table D9.—Fraction of growing-stock volume that is roundwood and ratio of volume of logging residue to growing-stock volume by region and wood type^a

Region ^b	Fraction of growing-stock volume that is roundwood			Ratio of volume of logging residue to growing-stock volume ^c		
	Softwood	Hardwood	All	Softwood	Hardwood	All
Northeast	0.948	0.879	0.901	0.471	0.602	0.560
North Central	0.931	0.831	0.848	0.384	0.441	0.431
Pacific Coast	0.929	0.947	0.930	0.133	0.081	0.131
Rocky Mountain	0.907	0.755	0.899	0.305	0.246	0.301
South	0.891	0.752	0.840	0.090	0.254	0.149

^aValues and classifications are based on data in Tables 2.9, 3.9, 4.9, 5.9, and 6.9 of Johnson (2001).

^bNorth Central includes the Northern Prairie States and the Northern Lake States; Pacific Coast includes the Pacific Northwest (West and East) and the Pacific Southwest; Rocky Mountain includes Rocky Mountain, North and South; and South includes the Southeast and South Central.

^cRatios used as part of estimates of down dead wood following harvest in Appendix A and C.

Table D10.—Ratios of roundwood (without fuelwood) to growing-stock volume (that is, the growing-stock volume that is roundwood) by category^a

Region ^c	Roundwood:growing-stock volume ^b					
	Softwood			Hardwood		
	Sawtimber-size	Less than sawtimber-size	All	Sawtimber-size	Less than sawtimber-size	All
Northeast	0.991	3.079	1.253	0.927	2.177	1.076
North Central	0.985	1.285	1.077	0.960	1.387	1.071
Pacific Coast	0.965	1.099	1.005	0.721	0.324	0.606
Rocky Mountain	0.994	2.413	1.089	0.832	1.336	0.862
South	0.990	1.246	1.047	0.832	1.191	0.933

^aValues and classifications are based on data in Tables 2.2, 3.2, 4.2, 5.2, and 6.2 of Johnson (2001).

^bRatios are calculated for roundwood after deducting fuelwood and are based on volumes. The denominators are portions of growing-stock volume according to wood type and size. Numerators for “less than sawtimber-size” include poletimber and nongrowing-stock sources. We assume the ratios do not include bark and use these values as a step in determining the allocation of carbon for Table 1.5 and Appendix C, based on growing stock.

^cNorth Central includes the Northern Prairie States and the Northern Lake States; Pacific Coast includes the Pacific Northwest (West and East) and the Pacific Southwest; Rocky Mountain includes Rocky Mountain, North and South; and South includes the Southeast and South Central.

Table D11.—Regional average ratios of carbon in bark to carbon in wood according to wood type and size

Region ^b	Ratio of carbon in bark to carbon in wood ^a					
	Softwood ^c			Hardwood ^d		
	Sawtimber-size ^e	Poletimber-size ^e	All	Sawtimber-size	Poletimber-size	All
Northeast	0.182	0.185	0.183	0.199	0.218	0.205
North Central	0.182	0.185	0.183	0.199	0.218	0.206
Pacific Coast	0.181	0.185	0.181	0.197	0.219	0.203
Rocky Mountain	0.181	0.185	0.182	0.201	0.219	0.210
South	0.182	0.185	0.183	0.198	0.218	0.204

^aRatios are calculated from carbon mass based on biomass component equations in Jenkins and others (2003) applied to all live trees identified as growing stock on timberland stands classified as medium- or large-diameter stands in the survey data for the conterminous United States from USDA Forest Service, Forest Inventory and Analysis Program's database of forest surveys (FIADB; USDA For. Serv. 2005, Alerich and others 2005). Note that "sawtimber trees" and "poletimber trees" are not stand-level classifications as used here; these terms apply to individual trees. Carbon mass is calculated for boles from stump to 4-inch top, outside diameter.

^bNorth Central includes the Northern Prairie States and the Northern Lake States; Pacific Coast includes the Pacific Northwest (West and East) and the Pacific Southwest; Rocky Mountain includes Rocky Mountain, North and South; and South includes the Southeast and South Central.

^cSoftwood sawtimber-size are trees at least 22.9 cm (9 in) d.b.h., and softwood poletimber-size trees are 12.7 to 22.6 cm (5.0 to 8.9 in) d.b.h.

^dHardwood sawtimber-size is at least 27.9 cm (11 in) d.b.h., and hardwood poletimber-size trees are 12.7 to 27.7 cm (5.0 to 10.9 in) d.b.h.

^eWhen applying these ratios to roundwood, we assume that ratios based on sawtimber-size trees and ratios based on poletimber-size trees in the forest apply to saw log roundwood and pulpwood roundwood, respectively.

Table D12.—Ratios of total fuelwood to corresponding portion of growing-stock volume that is roundwood, that is, both growing-stock and nongrowing-stock sources of fuelwood divided by a portion of growing-stock volume that is roundwood^a

Region ^c	Fuelwood:growing-stock volume ^b					
	Softwood			Hardwood		
	Sawtimber- size	Less than sawtimber- size	All	Sawtimber- size	Less than sawtimber- size	All
Northeast	0.009	1.017	0.136	0.073	4.051	0.547
North Central	0.015	0.180	0.066	0.040	1.230	0.348
Pacific Coast	0.035	0.242	0.096	0.279	2.627	0.957
Rocky Mountain	0.006	3.145	0.217	0.168	50.200	3.165
South	0.010	0.049	0.019	0.168	0.644	0.301

^aValues and classifications are based on data in Tables 2.2, 3.2, 4.2, 5.2, and 6.2 of Johnson (2001).

^bRatios are calculated for roundwood after deducting fuelwood and are based on volumes. The denominators are portions of growing-stock volume according to wood type and size. Numerators for “less than sawtimber-size” include poletimber and nongrowing-stock sources. We assume the ratios do not include bark and use these values as a step in determining the allocation of carbon for Table 1.5 and Appendix C, based on growing stock.

^cNorth Central includes the Northern Prairie States and the Northern Lake States; Pacific Coast includes the Pacific Northwest (West and East) and the Pacific Southwest; Rocky Mountain includes Rocky Mountain, North and South; and South includes the Southeast and South Central.

Chapter 1, GHG Inventories: Part I

Appendix Section 2: Guidelines for Using Models

2.1 Introduction

Forest carbon accounting estimates are almost always based, at least in part, on models. Models are a simplification of a complex system, often coded into computer programs. For forestry applications, models usually consist of a series of mathematical equations designed to represent ecological processes of forests. In some cases models may be as simple as an equation based on a multiplier, such as multiplying dry weight biomass by 0.5 for an estimate of carbon.

Models are available for estimating carbon stocks and flows for forests at a variety of scales and for specific conditions and activities. Some models may be more accurate than look-up tables for specific activities or entities, but may require more effort and possibly a higher cost to apply.

Models may be useful tools for estimating both entity-wide carbon flows and activity-level accomplishments, but the estimates should be evaluated to be sure the models are appropriate for each application. The basic elements of model evaluation are described in section 2.3.

Before using a model, it is necessary to determine the area of land to be included in the estimate, and characterize that area in a way that is compatible with the estimates from the model. To achieve the best results, the selected model should be parameterized for the specific conditions of the land area to which the model is applied. Partitioning of the land area into relatively uniform strata may help in matching and parameterizing a model for a specific application.

2.2 Kinds of models

Two general classes of models can be used to estimate changes in carbon stocks. Entities may use either type of model provided the guidance in this section is followed.

Traditional empirical forestry models, developed to predict timber production (estimated in volume units), can be modified to predict carbon stocks or flows. The modification may be as simple as converting the estimated volume to carbon using standard coefficients or ratios from the literature (e.g., Hoover et al., 2000). However, a more complex approach may be required to fully account for changes in all of the ecosystem carbon pools, some of which may not be directly related to volume.

More recently, models that include representation of key ecosystem processes such as photosynthesis and respiration are becoming available. An appealing feature of such models is that they may be applied to conditions and treatments beyond those represented in the data used to develop the models; however, this extrapolation should be done cautiously with appropriate verification to ensure the accuracy of estimates. Ecosystem process models often produce outputs in units of mass (carbon). Many ecosystem process models have been developed for research applications, but this does not limit their use or potential for application to practical forest management issues (e.g., Battaglia and Sands, 1998; Valentine, 1999).

2.3 Model evaluation and documentation

Model evaluation and documentation are important steps in developing an inventory of forest carbon. The accuracy of carbon stock and flux estimates is in part a function of model performance in relation to conditions of the entity. Therefore, the following guidelines are provided for evaluating and documenting models chosen by the entity to estimate carbon stocks and flows.

These guidelines are based on an extensive review of how ecological or forestry-related models are evaluated for public policy (Prisley and Mortimer, 2004). There are published standards for model evaluation for some applications. For example, the American Society for Testing and Materials (ASTM) has guides for groundwater flow models and standards for atmospheric dispersion model performance (ASTM, 2000; 2002).

No standards have yet been established specifically for forest carbon accounting; however, there is general guidance available for Federal agencies providing information. The Data Quality Act (Pub. L. No. 106-554, 114 Stat. 2763A-153 [2000]) requires that nearly all Federal agencies provide guidance to maximize integrity of information disseminated by the agency, and provides a mechanism to request a correction from the agency. As a result of the Data Quality Act, the Department of Agriculture (USDA, 2003; as cited in Prisley and Mortimer, 2004) released guidance that includes the following:

When creating estimates or forecasts that are derived from existing data sources using models or other techniques [emphasis added]:

- *Use sound statistical methods that conform to accepted professional standards.*
- *Document models and other estimation or forecasting techniques to describe the data sources used and the methodologies and assumptions employed.*

Prisley and Mortimer (2004) summarize criteria to be considered in determining appropriate use of a model, including listing model assumptions, limitations, and uncertainties; use of peer-review; and adequate empirical testing. Entities using models should follow these guidelines to receive a higher rating (see section 2.5):

1. *The scope of the model should be clearly defined. This is the model domain, and can be expressed in terms of ecophysiological regions, spatial scale, temporal scale, etc. The model application should then be limited to the domain for which a model has been developed and evaluated.*
2. *Models should be clearly documented. Documentation should include assumptions, known limitations, embedded hypotheses, assessment of uncertainties, and sources (for equations, data sets, factors or parameters, etc).*

3. *Models should be scientifically reviewed. A thorough peer review process would include evaluation of equations, modeling system, software, and calibration data set, for applicability and adequacy. In addition the review should be conducted not only by modeling specialists, but specialists in relevant fields of biology, ecology, physiology, etc.*
4. *When possible, model results should be compared with field observations and results of this comparison should be documented.*
5. *Sensitivity analysis should be conducted to examine model behavior across the range of parameters for which it is to be applied. Sensitivity analysis provides an understanding of model robustness, and helps increase a user's confidence in model results.*
6. *Model should be made available for testing/evaluation.*
7. *Because models are a function of the scientific understanding and data at the point in time at which the model was developed, they should be periodically reviewed in light of new knowledge and data. If necessary, models should be recalibrated based on this evaluation.*
8. *When models are applied for regulatory purposes or in policy development, a public comment period is critical.*

Peer review is an important part of the model evaluation process. Although models used in the private sector may be confidential, the internal evaluation process should also follow standards for peer review. Recommendations for conducting scientific peer review from the Office of Management and Budget (as cited in Prisley and Mortimer, 2004) include:

- *peer reviewers be selected primarily on the basis of necessary technical expertise,*
- *peer reviewers be expected to disclose to agencies prior technical/policy positions they may have taken on the issues at hand,*
- *peer reviewers be expected to disclose to agencies their sources of personal and institutional funding (private or public sector), and*
- *peer reviews be conducted in an open and rigorous manner.*

2.4 Validating models with field data

The data used to test the model results should be independent of the data used to parameterize the model. There are many kinds of statistical tests available for quantifying the conformance of

model output with field data. Selection criteria for an appropriate statistical test should include the ability to quantify the percentage difference between the model output and the data at the 95% confidence level, or the ability to test a hypothesis that the difference between model output and the data is not greater than a specific percentage at the 95% confidence level.

2.5 Rating estimates from models

As discussed in the general forest inventory guidelines, the rating for using a model depends on how well the model represents the specific conditions of the land area, as determined by the model evaluation. If the model is a good fit, it should result in a “B” rating. A model that is developed specifically for the land conditions and management practices of the reporter may achieve a higher rating, especially if the model is validated following guidelines in section 1.4. To achieve an “A” rating from using a model for estimating changes in carbon stocks, comparison with field data from the area of model application is required. Use of an inappropriate model for the land characteristics and practices may result in a lower rating. The following table provides some more specific guidance about rating a model application:

<i>Rating</i>	<i>Characterization</i>	<i>Typical Description for Forestry</i>
A	Most accurate method (within 10 % of true value)	Model is validated with data specific to the site conditions and management practices.
B	Adequate accuracy (within 20 % of true value)	Use of a model that is parameterized specifically for the site conditions and management practices.
C	Marginal accuracy (within 30 % of true value)	Use of a model that generally matches the site and management conditions. For example, a regional model for a forest type that is similar in application to a look-up table.
D	Inadequate accuracy	Use of global estimates.

2.6 References

- American Society for Testing and Materials. 2000. *Standard Guide for Statistical evaluation of Atmospheric Dispersion Model Performance*. Standard D6589-00. West Conshohocken, Pennsylvania.
- American Society for Testing and Materials. 2002. *Standard Guide for Comparing Ground-Water Flow Model Simulations to Site-Specific Information*. Standard D5490-93. ASTM, West Conshohocken, Pennsylvania.
- Battaglia, M. and P.J. Sands. 1998. Process-based forest productivity models and their application in forest management. *Forest Ecology and Management* 102: 13-32.
- Hoover, Coeli M.; Richard A. Birdsey; Linda S. Heath; and Susan L. Stout. 2000. How to estimate carbon sequestration on small forest tracts. *J. Forestry* 98(9): 13-19.
- Prisley, S.P., and M. J. Mortimer. 2004. A synthesis of literature on evaluation of models for policy applications, with implications for carbon accounting. *For. Ecol. And Mgt.*, 198(1-3): 89-103.
- U.S. Department of Agriculture. 2003. *Supplementary Guidelines for the Quality of Regulatory Information Disseminated by USDA Agencies and Offices*. Washington, D.C.: Office of the Chief Information Officer. http://www.ocio.usda.gov/irm/qi_guide/regulatory.htm.
- Valentine, Harry T. 1999. Estimation of the net primary productivity of even-aged stands with a carbon allocation model. *Ecological modeling* 122: 139-149.

Chapter 1, GHG Inventories: Part I

Appendix Section 3: Measurement Protocols for Forest Carbon Sequestration

3.1 Scope of Guidelines

The scope of this section is to provide guidance on protocols for measuring and monitoring carbon emissions or removals from forestry activities at both the entity and sub-entity scales. An entity could be involved in more than one sector, such as a utility company that has both forestry and power production activities. In the context of these guidelines, only the forestry sector part of the entity's greenhouse gas inventory is considered. The section supports the Voluntary Reporting of Greenhouse Gas program of the U.S. government, also known as 1605(b).

Although large entities are required to report their entire inventory of emissions and sequestration in order for the report to be registered, the estimation of the forestry portion of their comprehensive inventory requires specialized inventory methods as described in the forestry technical guidelines. Small entities can register reductions from specific activities without supplying a complete greenhouse gas inventory if certain criteria are met. Entities may use one or a combination of estimation methods: look-up tables, models, or measurement (see section 2.6 in Technical Guidelines for Voluntary Reporting of Greenhouse Gases, Chapter 1, Section I). The goal of this section of the guidelines is to provide more detailed guidance for: defining boundaries; measuring, monitoring, and estimating changes in carbon stocks; implementing plans to measure and monitor carbon; and developing quality assurance and quality control plans.

Forestry activities mainly affect the exchange of carbon dioxide between the land and atmosphere. Techniques and methods for measuring and monitoring (M&M) terrestrial carbon pools that are based on commonly accepted principles of forest inventory, soil sampling, and ecological surveys are well established and will be elaborated on further in the following sections.

Most forestry activities designed to increase carbon stocks have few non-CO₂ greenhouse gas emissions associated with them. Exceptions include: use of fertilizer to enhance tree growth (possible N₂O emissions), forested wetland restoration (possible increase in CH₄ emissions), use of nitrogen-fixing trees (possible increase in N₂O emissions), and biomass burning for instance in site preparation (possible increase in N₂O and CH₄ emissions). It is likely that these are for the most part insignificant in the forest sector and practical and cost-efficient methods for measuring these non-CO₂ greenhouse gases in this sector are less well developed.

For forestry activities, it is not always necessary to measure all pools (Brown et al., 2000)—selective or partial accounting systems may be appropriate as long as all pools for which emissions are likely to increase as a result of the activity (loss in carbon or emission) are included. The selection of which pools to measure and monitor depends on several factors, including expected rate of change, magnitude and direction of the change, availability and accuracy of methods to quantify change, and cost to measure. All pools that are expected to

decrease must be measured and monitored. Pools that are expected to increase by a small amount may not need to be estimated if costs are high relative to the magnitude of the increase. For example, understory herbaceous vegetation in the case of afforestation is rarely a significant factor in the ecosystem carbon budget.

This section focuses on forest ecosystem carbon only, and includes only the carbon pools existing on the land (e.g., live and dead above and below ground biomass and soil; see section 2.1 in Technical Guidelines for Voluntary Reporting of Greenhouse Gases, Chapter 1, Section I); it does not include methods for wood products that are addressed elsewhere in this report. Experience has shown that the following steps are needed in any protocol to produce credible and transparent estimates of net changes in carbon stocks:

- Designing a monitoring plan, including delineation of boundaries, stratification of project area, type and number of sample plots, and frequency of monitoring
- Sampling procedures for the carbon stocks
- Methods of estimating the carbon stocks and techniques to analyse the results
- Methods for estimating the net change in carbon stocks
- Development of a quality assurance and quality control plan

The details of how to implement each of these steps and processes are described next. The focus of these guidelines is on field measurements designed to produce accurate net changes in carbon stocks to known levels of precision. A suggested target for the accuracy and precision for forest carbon accounting is to obtain an estimate that is within 10 percent of the true value, with 95 percent confidence that the estimate lies within these bounds (see section 2.6.4 in Technical Guidelines for Voluntary Reporting of Greenhouse Gases, Chapter 1, Section I). A measurement system with this level of precision will result in a rating of “A” under the reporting guidelines for the 1605(b) program. If the level of precision is within 20 percent of the true value, with 95% confidence, the rating under 1605(b) will be “B”.

Entities involved with the forest sector generally have good records on types of management, timber stock, harvest rates, and other information for their different land areas. Such records could be readily used to develop estimates of net changes in carbon stocks from their forest activities (details of approaches are included in section 3.2 below). For other entities where such data are not available (e.g. for non-industrial forest land owners), there are a variety of national to regional databases, readily downloadable from the internet, that could be used to estimate changes in carbon stocks on their lands (Box 3.1). Although using such data are likely to result in less accurate and less precise changes in carbon stocks than estimates based on field measurements, when such data are used in combination with the methods described in this report they can provide, with a modest effort, estimates superior to those based on default values alone. The sources in Box 3.1 are also useful for verifying that measurements and calculations made by an entity are within the ranges reported at national and regional scales.

Box 3.1. Internet sites potentially useful for carbon estimation.

<i>Internet site:</i>	<i>Organization:</i>	<i>Relevant content:</i>
http://fia.fs.fed.us/	USDA Forest Service Forest Inventory and Analysis	-Forest statistics of the U.S. -Forest statistics by state -Sample plot and tree data -Forest inventory methods and basic definitions
http://fhm.fs.fed.us/	USDA Forest Service Forest Health Monitoring	-Forest health status -Regional data on soils, CWD -Forest health monitoring methods
http://www.fs.fed.us/ne/global/	USDA Forest Service Global Change Research	-State-by-state forest carbon estimates
http://www.fs.fed.us/ne/durham/4104/products/forcarb.shtml	USDA Forest Service, U.S. carbon budget project	-On-line carbon estimation -Forest carbon estimation methods -U.S. and regional forest carbon statistics
http://www.fs.fed.us/pnw/sev/rpa/	USDA Forest Service resources planning act	-Timber resource statistics and projections
http://unfccc.int/ http://www.ipcc.ch/	United Nations Framework Convention on Climate Change and IPCC	-International guidance on carbon accounting and estimation
http://www.safeclimate.net	World Resources Institute	-Greenhouse gas mitigation projects -Accounting, measuring, and reporting procedures
http://nature.org/initiatives/climatechange/	The Nature Conservancy	-Greenhouse gas mitigation projects -Accounting and reporting procedures
http://www.winrock.org/what/ecosystem.cfm	Winrock International	-Greenhouse gas mitigation projects -Developments in baseline and leakage analyses -Accounting, measuring, and reporting procedures

3.2 Monitoring Design

3.2.1 Boundaries

Forestry activities and the land base for an entity can vary in size (from tens of hectares to up to hundreds of thousands of hectares) and can be confined to a single or several geographic areas. The area may be one contiguous block of land having a single owner or many small blocks of land spread over a wide area having a large number of small or a few large landowners. The spatial boundaries of the land need to be clearly defined to facilitate accurate measuring, monitoring, accounting, and verification. The spatial boundaries can be in the form of permanent boundary markers (e.g., fences), clearly defined topographic descriptions (e.g., rivers/creeks, mountain ridges), spatially explicit located boundaries (identified with a Global Positioning system (GPS)), and/or other methods. Ground-based surveys that delineate property boundaries are an accurate means of documenting land boundaries. There are many different methods and tools that can be employed to identify and delineate land boundaries, including remote sensing (e.g., satellite imagery from optical or radar sensor systems, aerial photos), GPS, topographic maps, and land records. Larger areas across the landscape can be defined through specific boundary descriptions using GPS-based coordinates on topographic maps or other suitable means.

Boundaries need to be properly documented from the start (mapped and described) and should preferably not be subject to any changes through the duration of the estimation period. In the event that boundary changes take place, these would need to be reported and inclusions and/or exclusions of physical land area need to be surveyed using the above described methods (this would mean adjusting the estimated net emissions or removals of greenhouse gases attributable to the activity or entity).

3.2.2 Stratification of land area

Once the land area has been delineated, it is useful to collect basic background information such as land-use history and maps of soil, vegetation, and topography. The land for the project or entity can be geo-referenced and mapped onto a base map. A geographic information system (GIS) would be useful for such an activity. Such maps can then be used to stratify the area into more or less homogeneous units to increase the efficiency of sampling.

To facilitate the field work and increase the accuracy and precision of measuring and monitoring, it is useful to divide the area (population of interest) into sub-populations or strata that form relatively homogenous units. Useful tools for defining strata include ground-truthed maps from satellite imagery (Box 3.2), aerial photographs, and maps of vegetation, soils or topography. Many of these products are available as GIS data layers (e.g., STATSGO soil maps, USGS Digital Elevation Model, 1992 National Land Cover map) that can be overlain in a GIS to identify possible strata. The key to useful stratification is to ensure that measurements are more alike within each stratum than in the sample frame as a whole. A geographic information system (GIS) can automatically determine stratum size and the size of exclusions or buffer zones.

The size and spatial distribution of the land area does not influence site stratification – one large contiguous block of land or many small parcels are considered the population of interest and are

stratified in the same manner. In general, stratification also decreases the costs of monitoring because it is expected to diminish the sampling effort necessary, while maintaining the same level of confidence, because of smaller variation in carbon stocks in each stratum than in the whole area. The stratification should be carried out using criteria that are directly related to the variables to be measured and monitored, e.g. the carbon pools in trees for afforestation. For afforestation, the strata may be defined on the basis of variables such as the tree species (if several), age class (as generated by delay in practical planting schedules), initial vegetation (e.g. completely cleared versus cleared with patches or scattered trees), and site factors (soil type, elevation, and slope etc.). There is, however, a trade-off between the number of strata and sampling intensity. The strata should be large enough to enable adequate sampling within each stratum, but not so large as to incur higher costs. There is no hard and fast rule, and forestry analysts need to use their expert judgment in deciding on the number of strata to include.

Site visits to the project or entity area and nearby areas with existing vegetation that will be the target of the activity will aid in the stratification of the area. Field assessments and measurements of key variables such as general soil type, topography, and nearby existing vegetation all greatly aid in the stratification of the area and contribute to a cost efficient monitoring plan.

Box 3.2. Remote sensing data

Remote sensing data are useful for a variety of tasks involved with designing and implementing measuring and monitoring plans for forest-based carbon activities, including: provision of a land-use map for the area, stratification of the area, land-use history, monitoring overall performance, and providing a verifiable record that the carbon pool exists. Below is a table of selected data sets, both public and private, that can gather data for most forestry activities. These sensors have been rigorously calibrated to ensure accurate measurements.

Selected high resolution data sources for monitoring carbon sequestration projects

Sensor/ Satellite	Spatial Resolution	Spectral Resolution	Revisit Time	Owner	Data
Landsat 5 TM	30 m	VNIR/SWIR	16 days	NASA/USGS	http://edc.usgs.gov
Landsat 7 ETM+	30 m	VNIR/SWIR	17 days	NASA/USGS	http://edc.usgs.gov
EO-1 ALI	30 m	VNIR/SWIR	18 days	NASA	http://edc.usgs.gov
EO-1 Hyperion	30 m	VNIR/SWIR	19 days	NASA	http://edc.usgs.gov
IKONOS	1- 4 m	VNIR/SWIR	2 – 5 days	Space Imaging	http://www.spaceimaging.com
Quickbird	0.6 – 3 m	VNIR/SWIR	1 – 4 days	DigitalGlobe	http://www.digitalglobe.com

TM = Thematic Mapper; ETM+ = Enhanced Thematic Mapper Plus; ALI = Advanced Land Imager;
VNIR = Visible to Near Infrared; SWIR = Shortwave Infrared

3.2.3 Type and number of sampling plots

3.2.3.1 Plot type

For forestry activities, permanent or temporary sampling plots could be used for sampling over time to estimate changes in the relevant carbon pools. Both methods have advantages and disadvantages. Permanent sample plots are generally regarded as statistically more efficient for estimating changes in forest carbon stocks compared with temporary plots because there is high covariance between observations at successive sampling events (Avery and Burkhardt, 1983). Moreover, permanent plots permit efficient verification, if needed, at relatively low cost: a verifying organization can find and measure permanent plots at random to verify, in quantitative terms, the design and implementation of the carbon monitoring plan. Disadvantages of permanent plots are that their location could be known and they could be treated differently (such as fertilize, irrigate, etc. to enhance the carbon stocks), and that they could be difficult to re-locate if the area has significant disturbance over the measurement interval. The advantages of temporary plots are that they may be established more cost-efficiently to estimate the carbon stocks of the relevant pools, their location changes at each sampling interval, and they would not be lost by disturbances. The main disadvantage of temporary plots is related to the precision in estimating the change in forest carbon stocks. Because individual trees are not tracked (see Clark et al. 2001 for further discussion), the co-variance term is non-existent and it will be more difficult to attain the targeted precision level without measuring more plots. Thus any time advantage gained by using temporary over permanent forest plots may be lost by the need to install more temporary plots to achieve the targeted precision.

If permanent sample plots are used, marking or mapping the trees to measure the growth of individuals at each time interval is recommended so that growth of survivors, mortality, and ingrowth of new trees can be tracked. Changes in carbon stocks for each tree are then estimated and summed per plot. Statistical analyses are then performed on net carbon accumulation per plot, including ingrowth and losses due to mortality. Because the permanent plots also track mortality, they can be used to track the major changes in dead wood (both lying and standing) after the initial inventory of this component.

3.2.3.2 Number of plots

The level of precision required for a carbon inventory has a direct effect on inventory costs and needs to be carefully chosen by those who will use the inventory results. As mentioned above, from past experience with forest carbon measurement of projects (e.g. Brown 2002), a reasonable estimate of the net change in carbon stocks that can be achieved at a reasonable cost is to within 10% of the true value of the mean at the 95% confidence level.

Once the level of precision has been decided upon, sample sizes must be determined for each stratum in the project area. Each carbon pool may have a different variance (amount of variation around the mean). However, experience has shown that focusing on the variance of the tree component for forestry activities captures most of the variance. Although the variance in other pools may be high, they often are a small contribution to the net change in carbon stocks or can actually decrease the total variance when the net change in all pools is estimated. For example, understory in forests can be quite variable but it is generally a very small component of the net

change, while dead wood, which is also highly variable, can be a large component of the net change and so higher precision of estimating that carbon pool often reduces the overall variability of the estimated net change in carbon.

The sample size for monitoring in each stratum needs to be calculated on the basis of the estimated variance of the carbon stock in each stratum and the proportional area of the stratum. Typically, to estimate the number of plots needed for monitoring, at a given confidence level, it is necessary to first obtain an estimate of the expected variance of the carbon stock in trees in each stratum. This can be accomplished either from existing data of the type of activity to be implemented (e.g., a forest inventory in an area representative of the proposed activity—see e.g. Box 3.3) or by making measurements on an existing area representing the proposed activity. For example, if the activity is to afforest agricultural lands and the activity will last for 20 years, then a measure of the carbon stocks in the trees of about 10-15 plots (for plot dimensions see below) of an existing 20 year forest would suffice. If the project area comprises more than one stratum, then this procedure needs to be repeated for each one. Such measurements will provide estimates of the variance in each stratum and with the area of the stratum, the total number of plots per stratum can be estimated using standard statistical methods (see Users Manual and worksheet at http://www.winrock.org/what/docs/Manual_MM_plot_calculator_Vers_1_July_2005.doc and http://www.winrock.org/what/docs/Plot_calculator_for_multi-strata_land.xls).

As sampling plots cannot always be relocated or reoccupied for a variety of reasons (e.g., plot markers are overgrown or are removed by people, plots are burned or records are lost), it is prudent to increase the number of plots beyond the minimum in the initial sampling design. By increasing the number of plots to some percentage over the calculated minimum number of samples, there is a cushion that helps to meet the minimum precision requirements even though there are missing plots in subsequent inventories. It is recommended that the minimum sample size be increased by 10 to 15% to allow for plots that cannot be relocated.

Entities that contemplate progressive plantings over time must develop an open-ended monitoring framework that can accommodate the progressive addition of plantings to the area over time. This can be done by predicting the eventual size of the area at year X and progressively assigning distinct stand-age cohorts to separate strata within the overall, and growing, population, anticipating a full contingent of permanent sample plots to be installed by year X. It is recommended that no more than two or three age classes be combined into one cohort class.

Unlike sampling for trees as described above, the same soil sample cannot be monitored over time. Instead, on each sample collection, the unit sampled (soil sample) is destroyed for the analysis of its relevant components, and as variability among samples is high even at small spatial scales, the statistical concept of paired samples, even if collected only centimeters apart, cannot be reliably employed. Thus the changes in mean soil carbon between two temporally-separated sample pools are best quantified by comparing means, via the Reliable Minimum Estimate (RME) approach (Dawkins, 1957), or by directly calculating the difference between the means and associated confidence limits (Sokal and Rohlf, 1995). The objective is not to establish that the two means are significantly different, but rather to estimate with 95% confidence the minimum change in mean soil carbon that has taken place from one monitoring

event to the next. For the RME approach (Figure 3.1), the monitoring results from plots are pooled to derive a mean for the sample population at time “two”, then the 95% confidence interval is subtracted to establish a minimum estimate of the population mean. Change in soil carbon is calculated by subtracting the maximum estimate of the population mean at time “one” (mean at time 1 plus 95% C.I.) from the minimum mean estimate at time “two”. The resulting difference represents, with 95% confidence, the minimum change in mean soil carbon from time “one” to time “two” (Figure 3.1).

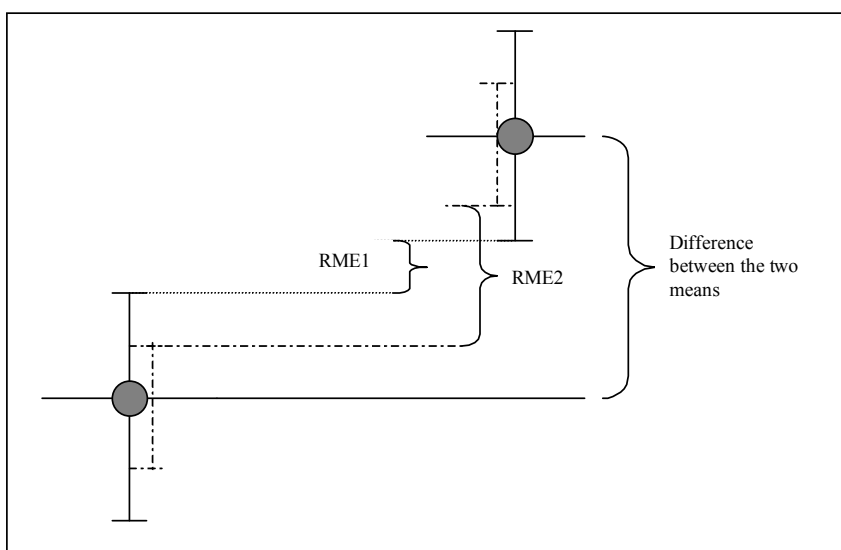

Figure 3.1. Illustration of the relationship between the magnitude of the reliable minimum estimate (RME) between Time 1 and Time 2 sampling periods and the 95% confidence interval (the solid and dashed bars) around the mean soil carbon content (shaded circle). The confidence interval is a function of the standard error, which equals the standard deviation divided by the square root of the sample size. The larger the sample size, the smaller the standard error and the smaller the 95% confidence interval. Thus, RME1 is smaller than RME2 because it is based on fewer samples.

This approach of course assumes normality, and soil carbon values are usually normally distributed. In cases where a data set is shown to be non-normally distributed, for example, where a number of extreme values positively skew the data, data can be transformed (e.g. converting values to logarithms), or alternatively dividing up the non-normally distributed data set *a posteriori* into normally-distributed subsets (i.e. post stratification). Otherwise, a non-parametric test (e.g. Kruskal-Wallis), using the median to represent central tendency, may be applied to quantify differences between sample means.

Box 3.3: Using FIA Data to Estimate Coefficient of Variation and Number of Sampling Plots

- Download data and apply biomass equations and expansion factors (see section 3.4.1) for the specific area and forest type of interest. Sum to give plot level results.
- Take means across the dataset or optionally across strata of interest, then calculate standard deviation and the coefficient of variation.
- The minimum number of plots required for monitoring is calculated by solving for n in the formula for the confidence interval (CI). Target $\pm 7-8\%$ of the mean as a reasonable level of error (this gives the sampling error only; sources of error such as measurement error and model error are likely to account for between 10-20% of total error, thus a target of $\pm 7-8\%$ CI of the mean for sampling will result in a total error for the confidence interval of about 10% of the mean).

$$n = (s \times 1.960) / (\text{mean} \times 0.08)^2 \quad (\text{where } s = \text{standard deviation})$$

The 95 % CI becomes the $\pm 8\%$ error chosen as a reasonable measurement error level—we can be 95 % sure that the true mean is covered by the determined measurement error.

- If the activity is planned to run for 50 – 70 years, use the large FIA size class (one method of sorting the FIA data) where variation and consequently minimum number of plots is low. (Variation is highest in young or small size class plots regardless of whether regeneration was natural or artificial).
- Minimum number of plots may be decreased by stratification of study area according to, for example, slope, soil type, or site index.

Coefficients of variation and minimum number of sampling plots at 95 % confidence level calculated for specific forest types in three regions using FIA data

<i>Region</i>	<i>Forest Type</i>	<i>FIA Size Class</i>	<i>C.V. %</i>	<i>Number of plots 95 %</i>
Ohio	Oak-Hickory	<i>Large</i>	27	45
		<i>Medium</i>	33	65
		<i>Small</i>	63	237
Illinois	Oak-Hickory	<i>Large</i>	41	99
		<i>Medium</i>	35	74
		<i>Small</i>	74	325
Lower Mississippi Valley	Bottomlands	<i>Large</i>	29	50
		<i>Medium</i>	33	66
		<i>Small</i>	80	384

How much of the change in mean soil carbon can be reliably reported will depend on the resolution permitted by the monitoring framework. Sampling intensity (i.e. number of soil samples) and frequency must be taken into consideration when attempting to resolve changes in soil carbon over time. Resolution in quantifying the minimum change between two means with a given level of confidence can be expressed as the percent of the absolute difference between the means. A targeted resolution (e.g. 80% of the absolute difference between the means), or alternatively, a targeted magnitude of change in soil carbon (not to exceed the absolute difference between the mean estimates), can be achieved by adjusting sampling intensity, sampling frequency, or a combination of both.

Increasing sampling intensity serves to reduce standard error around mean estimates separated in time, and better distinguish change that takes place (Figure 3.2). As high levels of variability in carbon among sample units are typical of soils (often ~ 30% C.V.), high sampling intensity is consequently required to discern change.

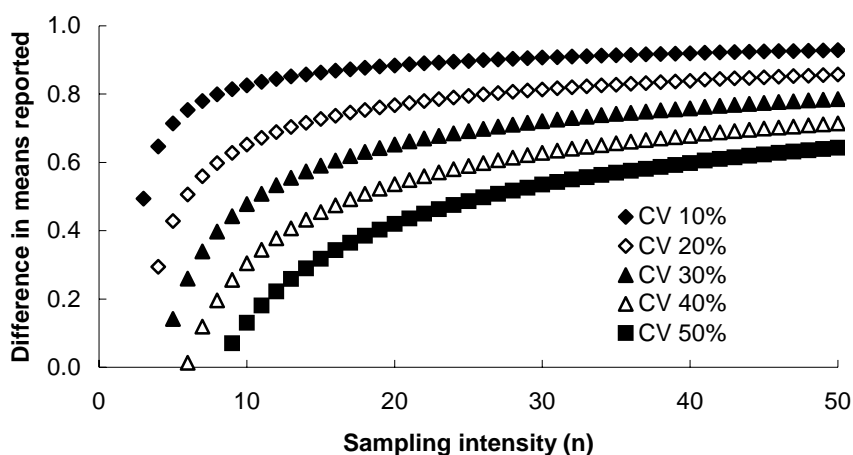

Figure 3.2. Percent difference in means reported as a function of sampling intensity (with 95% confidence).

The resolution of change detection also depends on the magnitude of the change itself, and as this is time dependent, it is appropriate to consider frequency of sampling. Increasing the interval between sampling events should increase the magnitude of the change that takes place, which, where variance around the means is constant, increases the percentage and magnitude of the change resolved (Figure 3.3). This is an important consideration, in that small changes expected with short sampling intervals may be undetectable, even with high sampling intensity.

Required sample size (for a targeted % absolute difference between the means or targeted magnitude of change) is thus a function of (1) inherent variability (which can be mitigated for via stratification or reduced by composite sampling), (2) magnitude of change expected (thus sampling interval and assumed rate of soil C accumulation), and (3) desired confidence level. Sample size can be estimated by adapting the commonly used Minimum Detectable Difference calculation (Zar, 1996) to solve for sample size for a targeted difference in means, once a sample interval has been chosen.

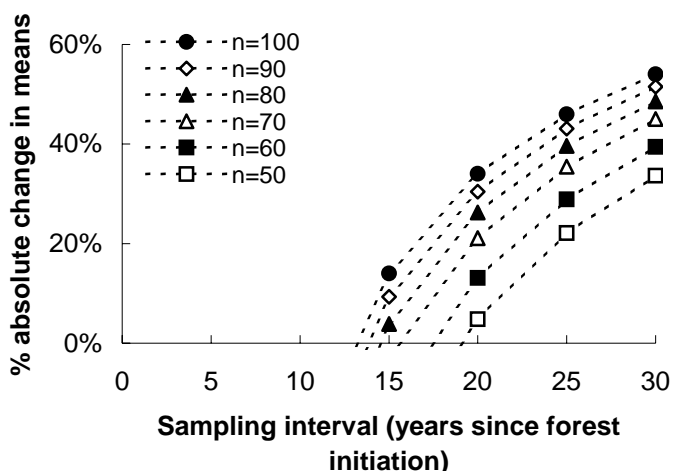

Figure 3.3. An example of how the percent absolute change in mean (with 95% confidence) soil carbon for afforestation activities varies in relation to the sampling interval and sample size (n), assuming constant coefficient of variation (30%), constant rate of soil carbon accumulation of 0.5 t C/ha.yr, and initial soil carbon 50 t/ha.

3.2.4 Frequency of monitoring

The frequency of monitoring is related to the rate and magnitude of change - the smaller the expected change, the greater the potential that frequent monitoring will not detect a significant change. That is, frequency of monitoring should be determined by the magnitude of expected change—less frequent monitoring is applicable if only small changes are expected.

The frequency of monitoring should take into consideration the carbon dynamics of the activity and costs involved. Given the dynamics of forest processes, they are generally measured over periods of 5-year intervals (e.g., the US National Forest Inventory). For carbon pools that respond more slowly such as soil, even longer periods could be used (see section 3.4.4). Thus it is recommended that for carbon accumulating in the trees, the frequency of measuring and monitoring should be defined in accordance with the rate of change of the carbon stock, and in the case of plantations in accordance with the rotation length.

Monitoring only the changes in carbon stocks in the permanent monitoring plots does not necessarily provide information that the project is accomplishing the same changes in carbon stocks across the whole area and that the activity is accomplishing what it set out to do—e.g. plant several thousand hectares of trees. Repeated visits to the carbon monitoring plots will only show that the carbon in those plots (which were randomly located and purportedly represent the population) is accumulating carbon with known accuracy and precision. To give confidence that the overall activity is performing as well as the plots, it is also suggested that, through time, periodic checks are made using an independent approach. This can be accomplished through field checking using indicators of carbon stock changes such as tree height for afforestation activities. Thus entities could produce such indicators that can readily be field-checked across the area. High resolution remote sensing imagery could also be used to accomplish this task, at least with respect to area treated. Periodic acquisition of such imagery or even aerial imagery could be a relatively inexpensive way to monitor overall performance.

3.3 Sampling Design

3.3.1 Plot layout

Permanent plot locations can be selected either randomly or systematically. If stratified random sampling is used, sample units for each stratum can still be selected systematically. If little is known about the population being sampled, random selection of sample units is generally safer than systematic selection; however this would depend on the area and type of activity. If plot values are distributed irregularly in a random pattern, then both approaches are about equally precise. If some parts of the strata have higher carbon content than others, systematic selection will usually result in greater precision than random selection.

For some areas, it may not be possible to pre-stratify because from all the usual characteristics, the site appears to be homogeneous. However, it is possible that after the first monitoring event, for example, the change in carbon stocks is highly variable and that on further analysis the measurements can be grouped into like classes—in other words can be post-stratified.

3.2 Size and shape of sample plots

The size and shape of the sample plots is a trade-off between accuracy, precision, and time (cost) of measurement. Experience has shown that sample plots containing smaller sub-units of various shapes and sizes, depending on the variables to be measured, are cost efficient. For instance, for afforestation, all trees are measured in the entire sample plot, whereas non-tree vegetation, litter and soil data are collected in a smaller area known as a sub-plot. The FIA standard plot is comprised of a cluster of four subplots of relatively small radius. The monitoring system could use this design or a series of nested plots as described next.

Nested plots for recording discrete size classes of stems and/or select forest components are a practical design for sampling and are better suited than fixed-area plots for stands with a wide range of tree diameters or for stands with changing diameters and stem densities that take place over time (Figure 3.4). Optimum area for nested plots can be anticipated by predicting changes in stem density and mean stem diameter over time, or by direct measurements of proxy stands of known age. It is likely that individual trees in even-aged stands will grow at different rates resulting in *uneven size* distribution, and trees will occur in all nested plots in later years of measurements. However, when the forest is likely to remain *evenly sized*, a single plot would suffice.

Nested plots are composed of several (typically 2 to 4, depending upon forest structure) full circular plots and each of the nested circles should be viewed separately. When trees attain the minimum size for one of the nested circles they are measured and included, and when they exceed the maximum size, measurement of that tree in that nest stops and begins in the next larger nest. If ingrowth into a new nest occurs between measurements, the growth up to the maximum size is included with the smaller nest, and growth in excess of this size is accounted in the larger nest (see Box 3.4 in section 3.4.1.1).

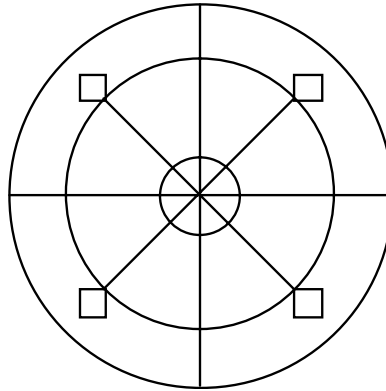

Figure 3.4. Schematic diagram of nested, fixed area circular sample plots. Saplings could be measured in the smallest circular plot (about 1 m radius), trees between 2.5 and 50 cm diameter at breast height (dbh) could be measured in the medium circular plot (about 10 to 14 m radius depending on stem density), trees above 50 cm dbh could be measured in the largest circular plot (about 20 m radius), and understory and fine litter could be measured in the four small plots located in each quadrant of the sample area. The radius and diameter limits for each circular plot would be a function of local conditions and expected size of the trees through time.

Plots are extrapolated to full hectare area to produce carbon stock estimates. Extrapolation by use of expansion factors occurs by calculating the proportion of a hectare that is occupied by a given plot. As an example, if a series of nested circles measuring 4 m, 14 m and 20 m in radius were used, their areas are equal to 50 m², 616 m² and 1,257 m² respectively. The expansion factors for converting the plot data to a hectare basis are 198.9 for the smallest, 16.2 for the intermediate and 8.0 for the largest nested circular plot.

Time and effort spent in field measurement depends both on sample size (number of plots) and plot area. While increasing sample size increases precision, increasing plot area decreases variability between samples roughly following the relationship derived by Freese (1962) (see Table 3.1),

$$CV_2^2 = CV_1^2 * \sqrt{(P_1 / P_2)}$$

where “CV” is the coefficient of variation and “P” is plot area. Thus, by increasing plot area, variation between plots is reduced, which allows for a smaller sample size while achieving the same precision level. For example, pilot studies could provide an estimate of the CV and plot area (e. g. from FIA plots-see Box 3.3.), then a CV could be selected to achieve the desired precision given cost considerations. Substitution of these values into the above equation will provide an estimate of the plot area needed for optimum sampling.

Table 3.1. Effect of plot area on inter-plot variability and range of values (min/max)

Statistics	0.04 ha. plot	1 ha. plot
n=	75	3
Mean (t C/ha)	209	209
Variance	22754	5870
SD	151	77
SE	17	44
C.V. (%)	72	37
95% CI (t C/ha)	34	176
MIN	48	155
MAX	799	297

3.3.3 Selection of carbon pools to measure and monitor

The selection of which pools to measure and monitor depends on several factors, including expected rate of change, magnitude and direction of change, availability and accuracy of methods to quantify change, and cost to measure. All pools that are expected to decrease as a result of activities must be measured and monitored. Pools that are expected to increase by a small amount relative to the overall rate of change need not be measured and monitored, for example, understory herbaceous vegetation in the case of an afforestation project. The decision matrix shown in Table 3.2 presents the main carbon pools for forests and which ones should (Y), maybe (M), or should not (N) be measured for each forestry activity type.

Clearly it makes sense to measure and monitor the carbon pool in live trees and their roots for all activity types. Aboveground non-tree live carbon (or understory) may need measuring if this is a significant component, such as where shrubs are present in large numbers; it may not need measuring if the understory is dominated by herbaceous material as this is likely to account for very small changes over the duration of the activity (less than three percent). It is recommended that forest floor be measured in most activity types, especially where the forest is likely to be dominated by conifers, as this can be a significant component of the total carbon pool. Dead wood is composed of standing dead trees and downed dead wood. For changes in management for timber, this must be measured as this pool often decreases as a result of a project—e.g., a change from more intensive harvesting to less intensive harvesting will cause the dead wood pool to decrease (less timber is removed and less slash is left behind). Soil organic carbon is likely to change significantly for afforestation, forest restoration, and mine land reclamation activities as the initial condition of soil is likely to be low in carbon. However changes in forest management or even forest preservation (from harvesting to preservation) are likely to produce very small to no changes in soil carbon and the cost to measure this pool could exceed the value of the carbon. The decision to monitor wood products depends on whether the project area will ultimately be harvested or not (see section 4.6 in Technical Guidelines for Voluntary Reporting of Greenhouse Gases, Chapter 1, Section I). For short rotation biomass energy plantations this would be necessary as the product is the main purpose of the activity. Activities related to changes in forest management need also to measure and monitor wood products as often this reduces the change in the live carbon pool; likewise for forest preservation if the original activity

was a timber production forest. In other words, all the live biomass “protected” by the activity (either as preservation or reduced logging intensity) cannot be claimed as a savings for the atmosphere because some of the biomass went into long-term wood products.

Table 3.2. A decision matrix to illustrate the selection of pools to measure and monitor in forestry projects (modified from Brown et al. 2000). For explanation of letters and numbers in this table, see below

Activity type	Carbon pools to be measured and monitored						
	Living biomass			Dead Organic Matter		Soil	Wood Products ¹
	Aboveground: trees	Aboveground: non-tree	Below-ground	Forest floor	Dead wood		
Afforestation	Y1	M2	Y3	M4	M5	Y6	M
Forest restoration	Y1	M2	Y3	M4	M5	Y6	N
Forest management	Y1	N	Y3	M4	Y5	N	Y
Agroforestry	Y1	M2	Y3	M4	N	Y6	M
Short rotation biomass energy plantations	Y1	N	Y3	M4	N	Y6	Y
Mineland reclamation	Y1	M2	Y3	M4	M5	Y6	M
Forest preservation	Y1	M2	Y3	M4	M5	M6	Y

¹ No methods are provided for measuring this pool as the focus of this report is on ecosystem carbon; see another technical appendix for methods for estimating change in stocks of wood products

Letters in the above table refer to the need for measuring and monitoring the carbon pools:

- Y= Yes - the change in this pool is likely to be large and should be measured.
 N = No - the change is likely small to none and thus it is not necessary to measure this pool.
 M = Maybe - the change in this pool may need to be measured depending upon the forest type and/or management intensity of the project.

Numbers in the above table refer to different methods for measuring and monitoring the carbon pools:

- 1= See methods of carbon stock measurement for aboveground biomass of trees (Section 4.1.1)
 2 = See methods described for aboveground biomass of non-trees vegetation (Section 4.1.2)
 3 = See methods for measuring/estimating the carbon stock in belowground biomass (Section 4.2).
 4 = See methods for measuring the carbon stock in forest floor (4.3.1)
 5 = See methods for measuring dead wood (Section 4.3.2).
 6 = See methods for measuring the carbon pool in soils (Section 4.4).

3.4 Measurement and Data Analysis Techniques

Measurements of net carbon flows for forests generally lend themselves to the stock-change estimation method—that is the amount of carbon sequestered is estimated as the net change in carbon stocks over a period of time. Much of the discussion in section 3.2 above focuses on the design needed to precisely estimate changes in carbon stocks. Although for most components the stock change method is applicable, for some components the flow method may be appropriate. For example, changes in the dead wood pool are often estimated from the difference between inputs from slash (estimated from the difference between total tree biomass and mass of timber removed) and outputs from decomposition of the dead wood. In the next sections, methods for both the stock and flow approach, when appropriate, are presented for estimating the change in carbon stocks.

Methods are based on measurements and models resulting in estimates of biomass, except for soil, which can be measured in units of carbon directly. Biomass is generally converted to units of carbon by multiplying biomass by 0.5, unless more specific data are available.

3.4.1. Living aboveground biomass

3.4.1.1. Trees

The carbon stocks of trees are most accurately and precisely estimated through the use of direct methods, i.e. through a field inventory, where all the trees in the sample plots above a minimum diameter are measured. The minimum diameter is often 5 cm at dbh, but can vary depending on the expected size of trees—for arid environments where trees grow slowly, the minimum diameter may be as small as 2.5 cm diameter, whereas for humid environments where trees grow rapidly it could be up to 10 cm diameter. Biomass and carbon stock are estimated using appropriate allometric equations applied to the tree measurements. For practical purposes, tree biomass is often estimated from equations that relate biomass to dbh only. Although the combination of dbh and height as the independent variable is often superior to dbh alone, measuring tree height can be time consuming and will increase the expense of any monitoring program. Furthermore, the empirical database of trees in the US shows that highly significant biomass regression equations can be developed with very high r-squares using just dbh (see Tables 3.3 and 3.4).

Often biomass equations are reported for individual species or groups of species, but this literature is sometimes inconsistent and incomplete for all tree species in the United States. However, it has been shown by recent analyses that equations based on multi-species groupings can work well for US forests (Schroeder et al. 1997).

Jenkins et al. (2003) compiled all available diameter-based allometric regression equations for estimating total aboveground and component biomass, defined in dry mass terms, for trees in the United States. A total of 318 biomass equations were assembled for over 100 species from 104 sources (Jenkins et al. 2003). Jenkins et al. used a method to generate “pseudodata” (Pastor et al. 1984) by calculating biomass values for a range of diameters within bounds of raw data for each equation. These pseudodata were used to refit new equations for 10 broad species groups (Table 3.3; details of the species in each of the 10 groups can be found in Jenkins et al. 2003).

When using allometric equations, the given maximum diameter used in the regression should be carefully observed. Using the equations for trees that exceed the maximum diameters should only be done after careful consideration of the functional form of the equation. In particular, caution should be used with equations that are based on an exponential function (e.g. the equations in Table 3.3). Equations using a more sigmoidal form, where biomass is constrained at large diameters, are more stable and can be more safely used even beyond the given maximum bounds (Brown et al. 1989). Table 3.4 lists the general equations of Schroeder et al. (1997) and Brown and Schroeder (1999) which have this sigmoidal/constrained form. Figure 3.4 compares the estimated biomass per tree for a given diameter based on the exponential and sigmoidal models. Up to about 75 cm diameter the models give the same estimated biomass per tree but beyond this point the exponential models result in an increasingly larger and larger estimated biomass whereas the sigmoidal model is more conservative.

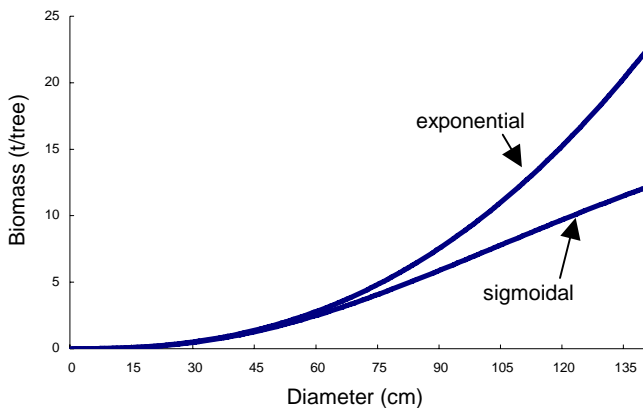

Figure 3.4. A comparison of the relative treatment of large trees by equations with an exponential form (e.g. the hard maple/oak/hickory/beech equation; Table 3.3) and those with a limiting function (e.g. the eastern hardwoods equation; Table 3.4).

In addition the equations of Jenkins et al. (2003), while an exhaustive coverage of the US tree flora, are dominated by western species in the softwood category. Western softwoods are unique with regard to stature and consequently do not well represent southern pines or eastern fir-spruce species. In contrast the equations for pines and fir-spruce of Brown and Schroeder (1999, Table 3.4) are calculated specifically for these groups of species.

Table 3.3. Parameters and equations¹ for estimating total aboveground biomass for hardwood and softwood species, grouped into 10 main classes, in the U.S.

	Species Group	Parameters		Data points ²	Max ³ dbh (cm)	RMSE ⁴ (log units)	R ²
		β_0	β_1				
Hardwood	Aspen/alder/ cottonwood/ willow	-2.2094	2.3867	230	70	0.507441	0.953
	Soft maple/birch	-1.9123	2.3651	316	66	0.491685	0.958
	Mixed hardwood	-2.4800	2.4835	289	56	0.360458	0.980
	Hard maple/oak/ hickory/ beech	-2.0127	2.4342	485	73	0.236483	0.988
Softwood	Cedar/larch	-2.0336	2.2592	196	250	0.294574	0.981
	Douglas-fir	-2.2304	2.4435	165	210	0.218712	0.992
	True fir/hemlock	-2.5384	2.4814	395	230	0.182329	0.992
	Pine	-2.5356	2.4349	331	180	0.253781	0.987
	Spruce	-2.0773	2.3323	212	250	0.250424	0.988
Woodland ⁵	Juniper/oak/mesquite	-0.7152	1.7029	61	78	0.384331	0.938

¹Biomass equation:

$$y = \text{Exp}(\beta_0 + \beta_1 \ln x)$$

where

y = total aboveground biomass (kg) for trees 2.5 - cm dbh and larger

x = diameter at breast height (cm)

Exp = "e" to the power of

ln = natural log base "e" (2.718282)

²Number of data points generated from published equations (generally at 5-cm dbh intervals) for parameter estimation.

³Maximum dbh of trees measured in published equations.

⁴Root mean squared error or estimate of the standard deviation of the regression error term in natural log units.

⁵Woodland group includes both hardwood and softwood species from dryland forests.

Table 3.4. Parameters and equations¹ for estimating aboveground biomass for southern and eastern hardwood and softwood species in the U.S. (from Brown and Schroeder 1999).

Class	Parameters				Data	Max	R ²
	β_0	β_1	β_2	β_3	Points	<i>dbh</i> cm	
Hardwoods	0.5	25000	2.5	246872	454	85.1	0.990
Pines	0.887	10486	2.84	376907	137	56.1	0.980
Fir-spruce	0.357	34185	2.47	425676	83	71.6	0.980

¹Biomass equation:

$$y = \beta_0 + \frac{\beta_1 x^{\beta_2}}{x^{\beta_2} + \beta_3}$$

where

y = aboveground biomass (kg)

x = diameter at breast height (cm)

An example of how to calculate aboveground tree biomass and its change using a nested plot design and using allometric regression equations is given below in Box 3.4.

Box 3.4. Calculating the carbon stock and its change in aboveground trees from allometric regression equations

As a hypothetical example, a single plot from oak/hickory forest will be examined. The plot consists of three nested subplots:

- 5 m radius for trees measuring 2.5 to < 10 cm dbh
- 14 m radius for trees ≥ 10 to < 50 cm dbh
- 20 m radius for trees ≥ 50 cm dbh

The allometric regression equation of Jenkins et al. (2003) is used for hard maple/oak/hickory/beech to convert from diameter at breast height (dbh) to biomass.

The figure and table below show measurements over two time periods. Note the following: at time 2, ingrowth of trees too small to be measured at time 1 (trees 101 and 102 in the small nest and 103 in the intermediate nest) and outgrowth from one plot size and ingrowth into the next size when the max/min thresholds are passed (trees 004, 005 small to intermediate, tree 009 intermediate to large).

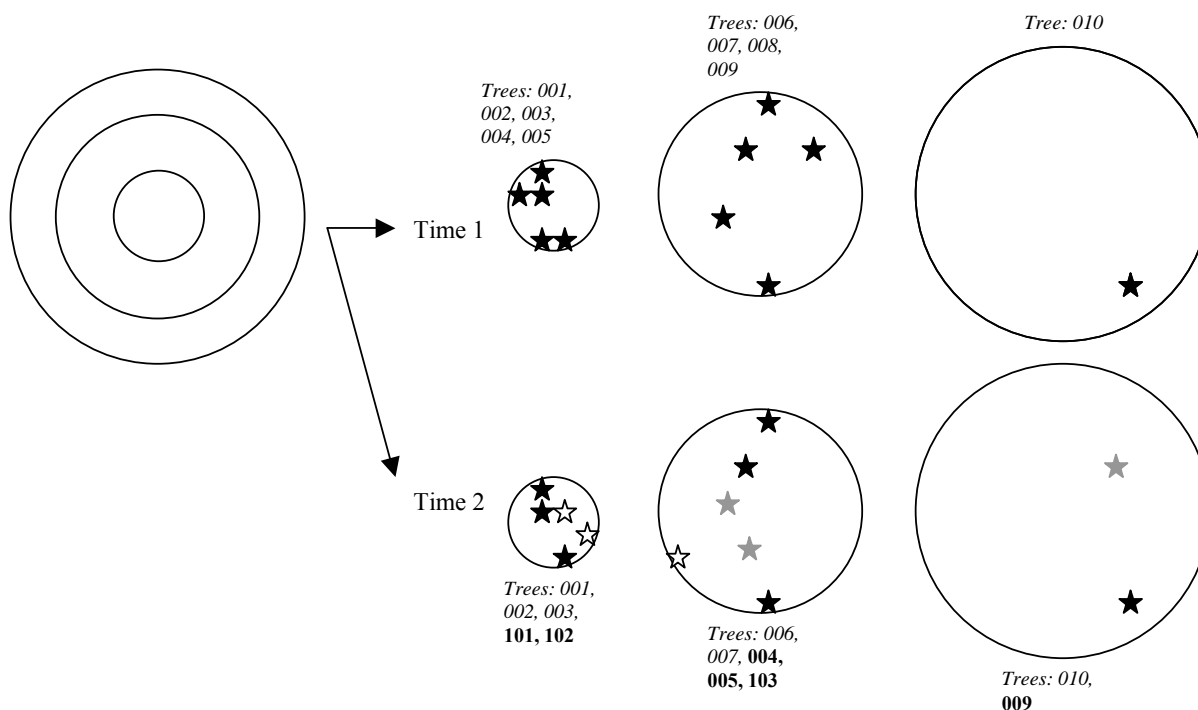

The three nested plots at time 1 and time 2. The stars indicate the position of trees. At time 2, black stars indicate trees that remained in the same size class as at time 1. Grey stars indicate trees that have grown into the next class and white stars are trees that have exceeded the measurement minimum for that plot for the first time.

Time 1				Time 2			
Tag	Nest	dbh (cm)	Biomass (kg)	Tag	Nest	dbh (cm)	Biomass (kg)
001	Small	2.6	1.37	001	Small	3.1	2.10
002	Small	5.3	7.74	002	Small	5.8	9.64
003	Small	6.1	10.90	003	Small	6.8	14.20
004	Small	6.2	11.34	004	Intermediate	10	36.32
005	Small	8.1	21.74	005	Intermediate	12.1	57.76
006	Intermediate	10.2	38.11	006	Intermediate	10.9	44.79
007	Intermediate	12.3	60.11	007	Intermediate	13.3	72.71
008	Intermediate	38.6	972.67	008	DEAD	DEAD	972.67
009	Intermediate	48.2	1670.20	009	Large	51	1916.30
010	Large	57.0	2512.15	010	Large	58	2620.79
				101	Small	2.5	1.24
				102	Small	2.8	1.64
				103	Intermediate	10.3	39.03

Change in biomass stocks in each subplot =

(Σ biom. increments of trees remaining in subplot size class) +

(Σ biom. increments for outgrowth trees [= Σ max biomass for size class – biomass at time 1]) +

(Σ biom. increments for ingrowth trees [= Σ biomass at time 2 – min biomass for size class])

$$\begin{aligned}
 \text{Small subplot} &= [(2.1-1.37) + (9.64-7.74) + (14.20-10.9)] + \\
 & \quad [(36.32-11.74) + (36.32-21.74)] + [(1.24-1.24) + (1.64-1.24)] \\
 &= (0.73 + 1.90 + 3.30) + (24.97 + 14.57) + (0 + 0.39) = 45.87 \text{ kg}
 \end{aligned}$$

$$\begin{aligned}
 \text{Intermediate subplot} &= [(44.79-38.11) + (72.71-60.11)] + [(1826.12-1670.20)] + [(36.32-36.32) \\
 & \quad + (57.76-36.32) + (39.03-36.32)] \\
 &= (6.68 + 12.60) + (155.92) + (0 + 21.44 + 2.71) = 199.35 \text{ kg}
 \end{aligned}$$

$$\begin{aligned}
 \text{Large subplot} &= ((2620.79-2512.15)) + ((-)) + ((1916.30-1826.12)) \\
 &= (108.64) + (-) + (90.18) = 198.82 \text{ kg}
 \end{aligned}$$

Change in biomass = $\Sigma \Delta$ biomass in each subplot x expansion factor for that subplot

$$\begin{aligned}
 \text{Small} &- 45.87 \times 127.32 = 5840.50 \text{ kg/ha} \\
 \text{Int.} &- 199.35 \times 16.24 = 3237.44 \text{ kg/ha} \\
 \text{Large} &- 198.82 \times 7.96 = 1582.13 \text{ kg/ha}
 \end{aligned}$$

Sum = 10660.07 kg/ha = 10.7 t/ha for the time interval

An alternative approach for estimating biomass of forests is to base it on the volume of the commercial component of the tree. The volume of the commercial component is estimated using standard techniques in forestry. This method is commonly used with temporary plots. The estimated volume then needs to be converted to total aboveground biomass, including the other tree components, such as branches, twigs, and leaves. This volume-based method is based on factors developed at the stand level, for closed canopy forests, and cannot be used for estimating biomass of individual trees.

There are two potential methods. The first calculates biomass directly from stand volume for different vegetation types in different regions, and the second has the additional step of calculating a biomass expansion factor (BEF) that can be broadly applied to three vegetation types across the United States. In both cases, growing stock volume (GSV) is defined as the net outside bark volume of growing-stock trees at least 12.5 cm in diameter to a minimum of 10 cm diameter at tree top or at the point where the central stem breaks into limbs (definition used by the USFS forest inventory). Other definitions of volume could be used but the BEFs reported here could *not* be applied—new ones would have to be developed for local conditions.

1. Direct Method – Smith, Heath and Jenkins 2003

Smith et al. (2003) used growing stock volume data from the FIA and the biomass equations of Jenkins et al. (2003) to develop regression equations of the form:

$$\text{Aboveground biomass (t/ha)} = F \times (G + (1 - \exp(-\text{GSV (m}^3/\text{ha)} / H))$$

Where

GSV = growing stock volume
F, G, H = regression coefficients

A total of 57 variants of this equation were developed for a variety of forest types across 10 regions in the continental US. Details of the coefficients for each of the variants of the equation can be found in Smith et al. (2003); the manuscript can be downloaded from the internet: http://www.fs.fed.us/ne/newtown_square/publications/technical_reports/index.shtml).

2. Biomass Expansion Factor Method – Schroeder et al. 1997, Brown and Schroeder 1999.

This method is expressed as (Brown and Schroeder, 1999):

$$\text{Aboveground biomass (t/ha)} = \text{GSV (m}^3/\text{ha)} \times \text{BEF (t/m}^3)$$

Where:

GSV = growing stock volume

BEF = [total aboveground biomass of all living trees to a minimum diameter at breast height of 2.5 cm]/[growing stock volume]

The BEF is significantly related to the GSV for most forest types, generally starting high at low volumes then declining at an exponential rate to a constant low value at high volumes. Thus using one value for the BEF for all values of GSV is incorrect. This general relationship has been found to apply to many forests of the world, including tropical forests (Brown 1997) and forests in China (Fang et al. 1998)

Schroeder et al. (1997) and Brown and Schroeder (1999) provide methods to calculate the BEF (t/m^3) for all forest types and regions across the eastern US.

Hardwoods: $BEF = \exp(1.912 - (0.344 \times \ln GSV))$
If $GSV > 200 \text{ m}^3/\text{ha}$ use a constant BEF of 1.

Spruce-Fir: $BEF = \exp(1.771 - (0.339 \times \ln GSV))$
If $GSV > 160 \text{ m}^3/\text{ha}$ use a constant BEF of 1.

Pines: $GSV < 10 \text{ m}^3/\text{ha}$ $BEF = 1.68 \text{ t/m}^3$
 $GSV 10 - 100 \text{ m}^3/\text{ha}$ $BEF = 0.95 \text{ t/m}^3$
 $GSV > 100 \text{ m}^3/\text{ha}$ $BEF = 0.81 \text{ t/m}^3$

Where $GSV =$ growing stock volume in m^3/ha .

An example of using both the direct and the BEF methods to calculate biomass for two forest types is found in Box 3.5. The two methods differ by less than 5 % for both forest types and thus can be considered as giving equivalent results. Thus, the user may select either method.

Box 3.5. Calculating biomass from stand volume data

Example 1: An oak-hickory forest in Wisconsin with a growing stock volume of 180 m³/ha.

A. Direct Method

Smith et al. (2003) list the following coefficients for calculating aboveground biomass (AGB) of oak-hickory in the Northern Lake States:

$$F = 307.5 \quad G = 0.0748 \quad H = 186.9$$

$$\begin{aligned} \text{Therefore AGB} &= F \times (G + (1 - \exp(-\text{volume}/H))) \\ &= 307.5 \times (0.0748 + (1 - \exp(-180/186.9))) \\ &= 213.1 \text{ t/ha} \end{aligned}$$

B. BEF Method

As growing stock volume is < 200 m³/ha we must calculate the BEF. Oak-hickory is a hardwood forest type.

$$\begin{aligned} \text{Therefore BEF} &= \exp(1.912 - (0.344 \times \ln \text{GSV})) \\ &= \exp(1.912 - (0.344 \times \ln(180))) \\ &= 1.134 \end{aligned}$$

$$\begin{aligned} \text{Therefore AGB} &= \text{GSV} \times \text{BEF} \\ &= 180 \times 1.134 \\ &= 204.1 \text{ t/ha} \end{aligned}$$

Example 2: A loblolly pine plantation in Georgia with a growing stock volume of 120 m³/ha.

A. Direct Method

Smith et al. (2003) list the following coefficients for calculating aboveground biomass (AGB) of planted pine in the South East States:

$$F = 187.3 \quad G = 0.0662 \quad H = 184.9$$

$$\begin{aligned} \text{Therefore AGB} &= F \times (G + (1 - \exp(-\text{volume}/H))) \\ &= 187.3 \times (0.0662 + (1 - \exp(-120/184.9))) \\ &= 101.8 \text{ t/ha} \end{aligned}$$

B. BEF Method

As growing stock volume is > 100 m³/ha and the forest type is pine the BEF is 0.81 t/m³.

$$\begin{aligned} \text{Therefore AGB} &= \text{GSV} \times \text{BEF} \\ &= 120 \times 0.81 \\ &= 97.2 \text{ t/ha} \end{aligned}$$

An important consideration is the accounting of ingrowth and mortality when estimating change in biomass stocks. Not understanding where, when and how to include these components can lead to erroneous estimates of changes in aboveground biomass. The approach taken depends on whether permanent or temporary plots are being used. For permanent plots, the method is based on tracking individual surviving trees (see Box 3.4) while for temporary plots the estimation is of the pool of biomass at time 1 and time 2. For permanent plots there is no requirement to track tree mortality but there must be an estimate of trees growing into the plots (i.e. exceeding the minimum measurement size only at time 2). For an accurate estimate using temporary plots both ingrowth and mortality should be included but due to the nature of temporary plots it is normally not possible to determine the date of a mortality event or which trees had passed the minimum measurement boundary during the census interval.

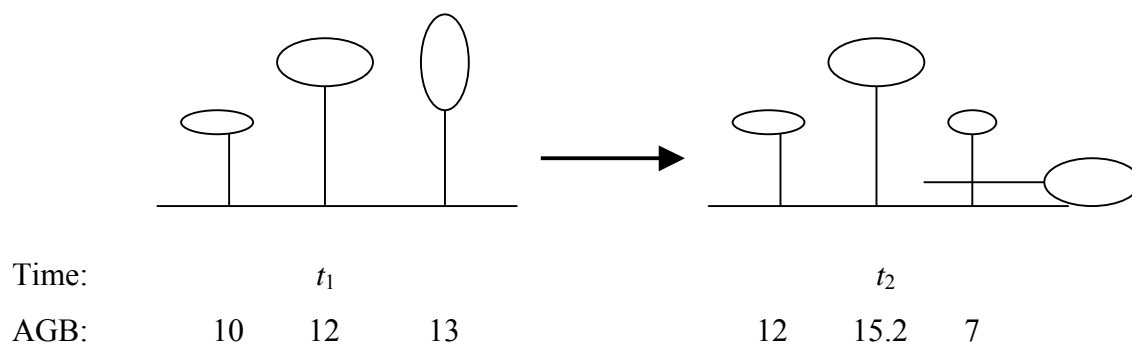

Permanent Plot:

$$\begin{aligned}
 \text{Stand Increment} &= (\Sigma \text{Increments of surviving trees}) + (\Sigma \text{Increment(s) of ingrowth}) \\
 &= ((12 - 10) + (15.2 - 12)) + (7 - 4) \\
 &= (2 + 3.2) + (3) \\
 &= 8.2
 \end{aligned}$$

Temporary Plot:

$$\begin{aligned}
 \text{Stand Increment} &= (\Sigma \text{AGB at } t_2 - \Sigma \text{AGB at } t_1) \\
 &= ((12 + 15.2 + 7) - (10 + 12 + 13)) \\
 &= (34.2 - 35) \\
 &= -0.8
 \end{aligned}$$

Figure 3.5. An illustration of the methods of calculating change in aboveground biomass stocks for permanent plots and temporary plots. AGB = aboveground biomass of live trees; AGB of a minimum-sized tree is set arbitrarily to 4 units (based on Clark et al. 2001).

Figure 3.5 shows a hypothetical example of the same trees being measured with the temporary plot and the permanent plot method (almost invariably temporary plots would be in different locations at time 1 and time 2 but for ease of illustration the exact location is remeasured). The change in biomass stock for ingrowth trees is the biomass of the new tree at time 2 minus the minimum biomass required for a tree to be measured.

It is clear that the two methods give widely different results. Although in this example the temporary plot gives a negative change in stock, it could just as readily give a larger positive change than the permanent plots.

3.4.1.2 Non-tree vegetation

Herbaceous plants in forest understory can be measured by simple harvesting techniques in small subplots (2-4 per plot are recommended) within each sample plot (Figure 3.4). A small frame (either circular or square), usually encompassing about 0.25 m² can be used. The material inside the frame is cut to ground level, pooled by plot, and weighed. Well-mixed sub-samples are then oven-dried to determine dry-to-wet mass ratios. These ratios are then used to convert the entire sample to oven-dry mass.

For shrubs and other large non-tree vegetation it is desirable to measure the biomass by simple destructive harvesting techniques. A small sub-plot (dependent on the size of the vegetation) is established and all the shrub vegetation is harvested and weighed. An alternative approach, if the shrubs are large, is to develop local shrub biomass regression equations based on variables such as crown area and height or diameter at base of plant or some other relevant variable (e.g., number of stems in multi-stemmed shrubs). The equations would then be based on regressions of biomass of the shrub versus some logical combination of the independent variables.

3.4.2 Belowground biomass

The measurement of aboveground biomass is relatively established and simple. Belowground biomass (coarse and fine roots), however, can only be measured with time-consuming methods. Consequently it is more efficient and effective to apply a regression model to determine belowground biomass from knowledge of aboveground biomass. The following regression models can be used to estimate belowground biomass (Cairns et al., 1997):

Boreal:

$$\text{BBD (t/ha)} = \exp(-1.0587 + 0.8836 \times \ln \text{ABD} + 0.1874)$$

Temperate:

$$\text{BBD} = \exp(-1.0587 + 0.8836 \times \ln \text{ABD} + 0.2840)$$

Tropical:

$$\text{BBD} = \exp(-1.0587 + 0.8836 \times \ln \text{ABD})$$

Where BBD = belowground biomass density in tons per hectare (t/ha) and ABD = aboveground biomass density (t/ha)

$$n = 151; r^2 = 0.84$$

Applying these equations allows an accurate assessment of belowground biomass. This is the most practical and cost-effective method of determining biomass of roots.

For the calculation of increment the exact usage of these equations is important. For tagged trees in permanent plots, it is not possible to simply calculate the total aboveground biomass at time 1 and time 2, apply the equations and then divide by the number of years. This approach cannot account for ingrowth or mortality trees (see section 3.4.1). Instead change in belowground biomass stocks should be calculated using the following method:

1. Calculate aboveground biomass at time 1 using allometric equations and the appropriate expansion factors.
2. Calculate increment of biomass accumulation aboveground between time 1 and time 2 (see section 3.4.1), and add to time one to estimate the biomass stock at time 2.
3. Apply appropriate belowground equation (above) to estimate belowground biomass at each time interval.
4. $(\text{Time 2 belowground} - \text{time 1 belowground}) / \text{number of years} = \text{annual change in stock of biomass belowground.}$

3.4.3 Dead organic matter

3.4.3.1 Forest floor

The forest floor can be directly sampled by simple harvesting techniques in small subplots within each permanent plot (Figure 3.4). A small frame (either circular or square), usually encompassing an area of about 0.25 m² (if the forest floor is particularly deep as often found in some of the western US forests, then a smaller frame [0.06 m²] can be used), as described for herbaceous vegetation above, is generally used. If herbaceous material is collected, the forest floor can be collected from the same frames at the same locations. Using a pair of clippers, all live vegetation from the sample area is carefully removed. Living mosses should be clipped at the base of the green, photosynthetic material. Using a sharp knife or a pair of clippers, the forest floor along the inner surface of the frame is carefully cut through to separate it from the surrounding soil. The entire volume of the forest floor must be carefully removed from within the confines of the sampling frame down to the top of the mineral soil layer (to distinguish the bottom of the forest floor from the top of the mineral soil see section below on soil organic carbon). All litter within the frame is collected, all samples pooled and weighed. A well-mixed sub-sample is collected and placed in a marked bag. This sample is used to determine oven dry-to-wet weight ratios to convert the total wet mass to oven-dry mass. For practical purposes when a laboratory is not available, forest floor samples can be sent to professional labs for drying and weighing.

For the forest floor, amounts of C per unit area are given by:

$$(\text{forest floor oven dry weight (g) / sampling frame area (cm}^2\text{)}) \times 100$$

where multiplying by 100 converts the units to metric t/ha.

3.4.2.2 Dead wood

Dead wood, both standing and lying, does not generally correlate well with any index of stand structure (Harmon et al., 1993). Methods have been developed for measuring biomass of dead wood and have been tested in many forest types and generally require no more effort than measuring live trees (Harmon and Sexton, 1996; Delaney et al., 1998). There are two approaches that can be used to estimate the volume of dead wood lying on the ground, depending upon the expected quantity present.

Method 1 –when the quantity is expected to be less than about 10-15% of the aboveground biomass: A time-efficient method is the line-intersect method. Experience has determined that at least 100 m length of line per plot must be used (Harmon and Sexton 1996). For practical field purposes experience has shown that placing two 50 m sections of line at right angles across the plot center is a time efficient approach. However, the line could just as readily be established as one 100 m length through the plot center. To allow remeasurement of the same ‘dead wood plot’ it is important to accurately record where the line was placed. Each piece of dead wood is classified into one of several density classes. The diameters of all pieces of wood that intersect the line are measured, their density class noted, and the volume per unit area calculated for each density class as follows:

Volume of lying dead wood

$$\text{Volume (m}^3/\text{ha)} = \pi^2 * [(d1^2 + d2^2 \dots \dots dn^2)/8L]$$

Where d1, d2, dn = diameter, in cm, of each of the n pieces intersecting the line, and L = the length of the line (100 m recommended) (for more details see Harmon and Sexton, 1996).

Method 2 –when the quantity is expected to be more than 10-15% of the aboveground biomass: When the quantity of dead wood lying on the forest floor is expected to be high and variably distributed, it is more desirable to do a complete inventory of the wood in the permanent plots. In this method all the dead wood in one of the medium circles of the sample plots should be measured (see also Harmon and Sexton 1996 for details on the methods). For a complete census, the volume of each piece of dead wood lying within the circle is calculated based on the diameter measurements taken at 1 m intervals along each piece of dead wood in the plot. The volume of each piece is then estimated as the volume of a truncated cylinder based on the average of the two diameter measurements and the distance between them (usually 1 m). As with method 1, each piece of dead wood is also classified into a density class. The volume is summed for each density class and using the appropriate factor (based on the area of the plot) expressed on a m³/ha basis for each density class.

Density measurements: Experience shows that three density classes are sufficient—sound, intermediate and rotten. An objective and consistent way to distinguish between them is needed. A common practice in the field is to strike the wood with a strong sharp blade--if the blade bounces off it is sound, if it enters slightly it is intermediate, and if it causes the wood to fall apart it is rotten. Samples of dead wood in each density class are then collected to determine their wood density. Mass of dead wood is then the product of volume per density class (from above equation) and the wood density for that class. Thus a key step in this method is

classifying the dead wood into its correct density class and then adequately sampling a sufficient number of logs in each class to represent the wood densities present. It is advisable to sample at least 10 logs or more of each different density class. In forests with unique plant forms, like early successional species and palms as in tropical forests, it is also advisable to treat these as separate groups and sample them the same way as well.

The simplest method to estimate dead wood density would be to have a value for the proportion of undecomposed density that each of the three decomposition classes represents. Estimates of undecomposed wood densities are widely available in the literature (e.g. forestry handbooks). This initial density value multiplied by the decomposition proportion by the volume gives biomass. Heath and Chojnacky (2001) calculated the proportions as 90% (sound), 70% (intermediate) and 40% (rotten) for forests in the northeast USA. These proportions could be used, but test samples to check the validity of these default data would be very important.

For forest areas with few species and where the rate of decomposition of wood is well known for given species or forest types, simple decomposition models could be locally developed for estimating the density of the dead wood at different stages of decomposition (Beets et al. 1999). Volume of wood would still need to be estimated based on either method 1 or 2 above, but the density could be estimated based on the model of decomposition.

Rates of decomposition across regions and forest types are given (Table 3.6). Where the age of a piece of dead wood is known, current density can be calculated from decomposition rate, then the biomass can be calculated from volume.

An example of a dead wood calculation is given in Box 3.6.

Box 3.6. Calculating biomass density of dead wood.

In the following example dead wood is sampled along 100 m of line (line-intersect method) to determine the biomass stock. Diameters and density classes are recorded and a sub-sample collected to determine density in each of the three density classes (sound, intermediate and rotten). The following numbers represent the hypothetical results:

13.8	cm	sound
10.7	cm	sound
18.2	cm	sound
10.2	cm	intermediate
11.9	cm	intermediate
56.0	cm	rotten

Densities of subsamples:	Sound:	0.43 t/m ³
	Intermediate:	0.34 t/m ³
	Rotten:	0.19 t/m ³

Volume of sound wood:	$\pi^2 \times [d1^2 + d2^2 \dots dn^2 / 8L]$
	$\pi^2 \times [13.8^2 + 10.7^2 + 18.2^2 / 800]$
	7.85 m ³ /ha

Volume of intermediate wood:	$\pi^2 \times [10.2^2 + 11.9^2 / 800]$
	3.03 m ³ /ha

Volume of rotten wood:	$\pi^2 \times [56.0^2 / 800]$
	38.7 m ³ /ha

$$\text{Biomass stock} = (7.85 \times 0.43) + (3.03 + 0.34) + (38.7 \times 0.19) = 11.8 \text{ t/ha}$$

Standing dead wood can be measured as part of the tree inventory. Standing dead trees should be measured according to the same criteria as live trees. However, the measurements that are taken and the data that are recorded vary slightly from live trees. For example, if the standing dead tree contains branches and twigs and resembles a live tree (except for leaves) this would be indicated on the field data records. From the measurement of its dbh, its biomass can be estimated using the appropriate biomass regression equation as for live trees, subtracting out the biomass of leaves (about 2-3 % of aboveground biomass). However, a dead tree can contain only small and large branches, or only large branches, or no branches – these conditions need to be recorded in the field measurements. Branches need to be classified in proportion to the size of the standing dead tree so that the total biomass can be reduced accordingly to account for less of the dead tree remaining. When a tree has no branches and is just the bole, then its volume can be estimated from measurements of its basal diameter, height, and an estimate of its top diameter;

and its biomass can be estimated with its density class. Examples of how to estimate the biomass of standing dead wood are given in Box 3.7.

Box 3.7. Calculating biomass of standing dead wood.

1. A tree with no leaves in mixed hardwood forest with a diameter of 25 cm at breast height, density class assumed to be sound.

Use the equation of Jenkins et al. (2003) for mixed hardwood forests, 3 % deduction due to the lack of any leaves.

$$y = \exp(-2.4800 + 2.4835 \times \ln(25)) = 248.16 \text{ kg} \times 0.97 = 240.72 \text{ kg}$$

As this dead tree is the only dead tree measured in a 14 m plot the mass is multiplied by the expansion factor of 16.24 to give a biomass of 3.91 t/ha.

2. A sugar maple tree with missing branches (missing branches estimated as 15 % of aboveground biomass). Diameter at breast height measured as 51 cm; density class assumed to be sound.

Use the equation of Jenkins et al. (2003) for hard maple/oak/hickory/beechn with a 15 % deduction for missing biomass.

$$y = \exp(-2.0127 + 2.4342 \times \ln(51)) = 1,916.3 * 0.85 = 1,628.9 \text{ kg}$$

As this dead tree is the only dead tree measured in a 20 m plot the mass is multiplied by the expansion factor of 7.96 to give a biomass density of 12.97 t/ha.

3. A bole with no branches is measured. The height is 15 m, basal diameter is 40 cm and top diameter is 25 cm. Analysis of a cored sample reveals a wood density of 0.49 g/cm³.

$$\begin{aligned} \text{The volume of a truncated cone} &= 1/3\pi \times h \times (r_1^2 + r_2^2 + r_1 \times r_2) \\ &= 1/3\pi \times 1500 \times (20^2 + 12.5^2 + 20 \times 12.5) \\ \text{Biomass density} &= 1,266,455 \text{ cm}^3 \times 0.49 \text{ g/cm}^3 \\ &= 620,563 \text{ g} = 0.62 \text{ tons} \end{aligned}$$

As this dead tree is the only dead tree measured in a 14 m plot the mass is multiplied by the expansion factor of 16.24 to give a biomass density of 10.08 t/ha.

Table 3.6: Decomposition rate constants and half-lives for down dead wood by region and forest type.

Region	Forest Type	Decomposition Rate ^a	Half Life
		<i>Year⁻¹</i>	<i>Years</i>
Pacific Northwest	Douglas-fir	0.022	31.5
	Spruce-fir	0.028	24.8
	Hemlock-spruce	0.031	22.4
	Lodgepole pine	0.041	16.9
	Hardwoods	0.082	8.5
	Ponderosa pine	0.017	40.8
	Redwoods	0.014	49.5
Rocky Mountains	Douglas-fir	0.022	31.5
	Ponderosa pine	0.017	40.8
	Spruce-fir	0.014	49.5
	Larch	0.022	31.5
	Lodgepole pine	0.023	30.1
South	Oak-hickory	0.075	9.2
	Oak-pine	0.060	11.6
	Bottomland hardwood	0.112	6.2
	Natural pine	0.056	12.4
	Planted pine	0.056	12.4
Northeast	White/red pine	0.042	16.5
	Spruce-fir	0.042	16.5
	Oak-hickory	0.075	9.2
	Maple-beech-birch	0.062	11.2
North Central	White/red pine	0.042	16.5
	Spruce-fir	0.042	16.5
	Maple-beech	0.082	8.5
	Aspen-birch	0.082	8.5
	Bottomland hardwood	0.112	6.2
	Oak-hickory	0.060	11.6

^afrom Turner et al. 1993

3.4.4 Soil organic carbon

To obtain an accurate inventory of organic carbon stocks in the mineral soil or organic soil, three types of variables must be measured: soil depth, soil bulk density (calculated from the oven-dry weight of soil from a known volume of sampled material), and the concentrations of organic

carbon within the sample. General guidance on sampling and analyzing forest and agricultural soils for estimating carbon stocks can be found in Lal et al. (2001) and Robertson et al. (1999).

Tracking changes in soil carbon over time requires that the same *equivalent* mass of soil is measured from one monitoring event to another. Sampling to a fixed depth (equal volumes) can result in underestimation of carbon gains via forestation because as the bulk density generally decreases over time, the same sampled volume contains less of the original soil mass equivalent. Rates of accrual estimated from sampling to a fixed depth should therefore be considered *conservative* estimates of soil carbon accretion.

Sampling to greater depth, in cases where there are no additions of new carbon at greater depth, reduces the detectability of change by diluting additions that take place in the upper layers of the soil column. Richter et al. (1999), monitoring 35 years of forest regrowth of loblolly pine in the Calhoun Experimental Forest in South Carolina, found no significant increase in soil carbon below 7.5 cm depth. Likewise, Markewitz et al. (2002), contrasting formerly cultivated and never-tilled sites under longleaf pine, found the most notable carbon difference in the upper 10 cm of soil. As hardwood leaf litter is likely to break down and become incorporated into the soil more quickly, and hardwood trees typically produce more roots than pines, inputs of soil carbon are expected to a greater depth, to 40 or 50 centimeters (MacDonald, 1999, Winrock, unpublished data, Figure 3.6).

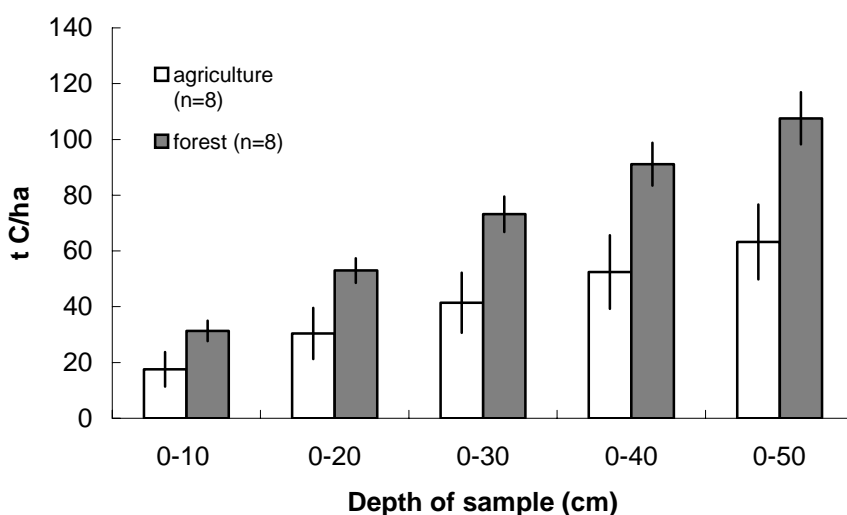

Figure 3.6. Mineral soil carbon, forest = 50-70 year old bottomland hardwoods on clay soil, bars = 95% confidence intervals (data from ongoing projects monitored by Winrock staff—unpublished data).

The forest floor is sampled as described above, exposing the top of the mineral or organic soil. In some soils, telling the difference between the bottom of the forest floor and the top of the mineral soil can be difficult. In those cases, one can refer to standard soil sampling methods (e.g. in Robertson et al. 1999) for tips on how to distinguish the top of mineral soil. Coring tools and liners to hold the soil cores of varying lengths are commercially available, but it is often impractical to use the manually-operated impact-driven soil-coring tool below about 30 cm.

However, simple soil corers have been found to work in many soils, particularly in the deeper soils of the central and southern regions of the US. Shallow soil pits to 30 cm or so also work well and have been shown to be a cost-efficient method. The impact-driven soil coring tool is not very practical for collecting deep cores, and it is not practical nor cost efficient to use a truck or trailer-mounted hydraulically-driven soil coring tool in most forest areas.

Composite sampling is an effective means to reduce inter-sample variability. This is done by aggregating a pre-determined number of samples (2-4 samples) from each collection site in the field, from which one sample is derived for analysis. The resulting *composite* sample captures more of the range of inter-microsite variability in soil carbon.

3.4.4.1 Sampling the mineral soil

Soil chemical concentrations are generally measured in air-dried soils, while bulk density measurements must be made on oven-dried soils. It is often easiest to take separate sets of cores for the bulk density and carbon determination because the sample preparation for each differs somewhat. In addition, fewer cores may be needed to accurately estimate bulk density because it is generally less variable than soil chemical properties.

Using the core sampler method, mineral soil samples are collected from within the area of the sampling frame after the forest floor has been removed. Because the carbon concentration of forest floor materials is much higher than that of the mineral soil, including even a small amount of surface organic material can result in a serious overestimation of soil carbon stocks.

Once the soil corer has been inserted into the soil to the desired depth, it must be removed from the ground by pulling upwards in a smooth vertical motion. The top and bottom (or bottom only depending upon the coring tool used) of the core should be trimmed even with the rims. When taking cores for measurements of bulk density, care should be taken to avoid any loss of soil from the cores; if any material is lost the sample needs to be taken again. All the material in the corer should be placed into an appropriately labeled sample bags.

The excavation method involves digging a small pit, wide enough to collect the soil to the depth desired. A hand shovel can be used to collect material to the desired depth, making sure that sufficient volume of soil from the sides of the pit equal approximately the volume of a soil corer. It is important that material is collected from the entire depth to avoid biasing the sample. Uniform rings can be used to sample sides of the pit for bulk density, making sure not to compress the soil

As with forest floor samples, soil samples can also be sent to a professional lab for analysis. Experience shows that commercial laboratories exist throughout the country and routinely analyze plant and soil samples for a variety of measures using standard techniques. It is recommended that the selected laboratory be checked to make sure that they follow the commonly accepted standard procedures both with respect to sample preparation (sieving etc.), drying temperatures, and method for carbon analysis (dry combustion method).

For bulk density determination, dry the samples in an oven at 105 °C for a minimum of 48 hours. And if the soil contains coarse rocky fragments, retain the coarse fragments, weighed them and record their weights.

For soil carbon determination, the material is sieved through a 2 mm sieve and the material is then thoroughly mixed. The dry combustion method using a controlled-temperature furnace (e.g. LECO CHN-2000 or equivalent) is the recommended method for determining total carbon in the soil (Nelson and Sommers 1996). Where carbonate minerals may be present, a new dry combustion method using the LECO RC-412 multi-carbon analyzer is the preferred method. Both organic and inorganic forms of carbon can be measured on the same mineral soil sample in one analytical run. An alternative is to remove any carbonates through acid treatment before hand.

As an alternative to the multi-carbon analyzer, the dichromate oxidation method with heating is acceptable for measuring organic C (Nelson and Sommers 1996) and the pressure calcimeter method is acceptable for determining soil carbonates (Sherrod et al. 2002). The classic Walkley-Black method is not acceptable for determining organic C in soil because of incomplete wet combustion and other inaccuracies. Additional details about the multi-carbon analyzer and other carbon analysis methods can be found in the FIA Lab Methods Manual (Amacher et al. 2003).

The bulk density of the mineral soil core is calculated by:

$$\rho_b = \frac{ODW}{CV - (RF / PD)}$$

Where:

ρ_b = Bulk density of the < 2mm fraction, in grams per cubic centimeter (g/cm³)
 ODW = Oven dry mass of fine fraction (<2 mm) in grams
 CV = Core volume in cm³
 RF = Mass of coarse fragments (> 2 mm) in grams
 PD = Density of rock fragments in g/cm³. This is often given as 2.65 g/cm³, though the actual value may be determined by submerging a known mass of coarse fragments in a known volume of water; the displacement gives an estimate of rock volume, which can then be used to calculate density.

The bulk density and carbon concentration data are used to compute amounts of carbon per unit area.

For the mineral soil, amounts of C per unit area are given by:

$$C (t / ha) = [(soil\ bulk\ density, (g / cm^3) \times soil\ depth (cm) \times \% C)] \times 100$$

In this equation the %C must be expressed as a decimal fraction; e.g. 2.2 %C is expressed as 0.022 in the equation. An example of how to calculate carbon in organic soil carbon plots is given in Box 3.8.

Box 3.8. Calculating mass of soil carbon per unit area

Mass of carbon per unit volume is calculated by multiplying carbon concentration (reported as percent mass) times bulk density (g/cm^3). Bulk density equals the oven dry weight of the soil core divided by the core volume. For example, a core of volume 94.2 cm^3 (1 cm radius x 30 cm length cylinder) with dry weight 144.06 yields a bulk density of $1.53 \text{ g}/\text{cm}^3$. Referencing the sample depth, mass per unit area is calculated, which represents a corresponding volume of soil. Thus,

$$\text{Volume/hectare} = 100 \text{ m} \times 100 \text{ m} \times 0.3 \text{ m (sample depth)} = 3 \times 10^9 \text{ cm}^3 = 3,000 \text{ m}^3$$

$$\text{Mass/hectare} = 3 \times 10^9 \text{ cm}^3 \times 1.53 \text{ g}/\text{cm}^3 \text{ (bulk density)} = 4.586 \times 10^9 \text{ g} = 4,586 \text{ tons}$$

Part of this volume is of course occupied by tree roots, which are accounted for separately, however, this fraction tends to be insignificant and for practical purposes is ignored here.

From within the same plot, the corresponding aggregate core analyzed for carbon concentration yields 0.8 % mass carbon. Mass per unit area, 4,586 t/ha, calculated previously, multiplied times 0.8 % yields equivalent 36.7 tons of soil carbon per hectare. A series of sample calculations of mass soil carbon are tabulated below.

Sample weight (g)	Volume (cm^3)	Bulk density (g/cm^3)	Volume/ha (m^3)	Mass/ha (tons)	Carbon conc. (% mass)	Mass soil C (t/ha)
144.06	94.2	1.53	3.E+09	4586	0.80	36.7
126.48	94.2	1.34	3.E+09	4026	0.82	33.0
146.95	94.2	1.56	3.E+09	4678	0.72	33.7
132.20	94.2	1.40	3.E+09	4208	0.90	37.9
147.39	94.2	1.56	3.E+09	4692	0.53	24.9
131.96	94.2	1.40	3.E+09	4200	1.39	58.4
115.95	94.2	1.23	3.E+09	3691	1.22	45.0
133.96	94.2	1.42	3.E+09	4264	1.09	46.5
115.59	94.2	1.23	3.E+09	3679	1.20	44.2
139.03	94.2	1.48	3.E+09	4425	0.76	33.6
					<i>Mean</i>	39.4
					<i>95 % CI</i>	6.7

3.4.5 Non-CO₂ gases

Although the primary purpose of forestry activities is to increase carbon stocks, forestry activities may also result in changes in non-CO₂ greenhouse gas emissions and removals. Such activities include biomass burning; application of synthetic and organic fertilizers to soils; cultivation of nitrogen fixing trees; and peat flooding and drainage. In addition, land-use activities that disturb soils, e.g., site preparation during afforestation, may affect non-CO₂ emissions and removals from soils. For many cases, changes in non-CO₂ greenhouse gas emissions or removals caused by these activities will be small relative to net changes in carbon stocks over the lifetime of the activity. No guidelines are provided in this document for monitoring, estimating, or reporting significant fluxes of non-CO₂ gases for forestry.

3.5 Estimation Methods and Uncertainty

3.5.1 Estimating net change for the system

The type of activity influences how each of the carbon stock components are integrated into an estimate of the net change in carbon stock at each monitoring interval. The activities listed in Table 3.2 can be grouped into two main classes. The first class includes those that would typically be implemented on non-forested lands (afforestation, forest restoration, agroforestry, short-rotation biomass energy plantations and mine land reclamations). The other class includes those activities implemented on existing forested land (forest management and forest preservation). This grouping has implications for how measurements and estimations are integrated to arrive at an estimate of the net change in total carbon stocks in the time interval.

3.5.1.1 Activities on non-forested lands

All activities on non-forested lands typically begin on land that initially has very low carbon stocks in vegetation (generally less than a couple of tons/ha) and variable amounts in the soil. In each of these cases a sampling regime would be implemented that monitors each of the carbon stock components indicated in Table 3.2. These methods have already been discussed above in section 3.4. The task is then how to combine all the estimates of the carbon stock for each component to arrive at an estimate of the net change in total carbon.

Using permanent plots, the carbon stock for living and standing dead trees above- and belowground and down dead wood of individual plots can be monitored through time and therefore the change in carbon stocks can be estimated directly at the plot level. In this case the change in carbon stocks for the different components should be summed within plots to give a per plot carbon stock change in t C/ha. The plot level results are then averaged to give mean and 95 % confidence intervals. The mean change in carbon stocks per unit area is then multiplied by the area of the activity to produce an estimate of the total change in carbon. If stratification is used, this approach is repeated for each stratum and then all strata are added together to estimate the total. This total is then converted to t CO₂ equivalent by multiplying by 3.67.

Soils, forest floor and non-tree vegetation are calculated separately as the statistics, number of sampling plots and even the sampling interval may be different than for the other components. The results from these measurements are analyzed to produce an estimate of the mean and the 95% confidence interval. This estimate is then added to create a system level mean and 95% confidence interval. The total confidence interval is calculated as follows:

$$\text{Total 95\% CI} = \sqrt{([95\%CI_{\text{veg}}]^2 + [95\%CI_{\text{soil}}]^2 + [95\%CI_{\text{forest floor}}]^2 + [95\%CI_{\text{non-tree vegetation}}]^2)}$$

Where $[95\%CI_{\text{veg}}]$ = 95% confidence interval for vegetation, $[95\%CI_{\text{soil}}]$ = 95% confidence interval for soil etc.

If part of the afforested area is harvested, the sampling plots would theoretically monitor the change in live and dead biomass. However, they would not monitor the amount going into wood products. As mentioned above, the reason wood products need to be considered is that the decrease in live biomass from harvesting does not mean that the equivalent amount of carbon went into the atmosphere—some of it could go into long-lived wood products. Thus to correctly estimate the effects of harvesting on the net change in carbon stocks, the amount of wood biomass going into long-term wood products is needed. This quantity per unit area and its estimated 95 % confidence interval would then be added to the total change. An example of the integration of all the components from permanent plots is given in Box 3.9, where the initial carbon stocks are of agricultural crop.

If temporary plots are employed to measure changes in carbon stocks, the mean and 95% confidence interval of the carbon stock in each component across all plots is calculated at time 1 and time 2. The total carbon stock at each time interval is then estimated by summing the means for each component and the total error is estimated as follows:

$$\text{Total 95\% CI} = \sqrt{([95\%CI_{c1}]^2 + [95\%CI_{c2}]^2 + \dots + [95\%CI_{cn}]^2)}$$

Where $[95\%CI_{c1}]$ = 95% confidence interval for component 1 (e.g. aboveground biomass), component 2, etc. for all components measured in the plots)

The change in carbon stock is calculated by subtracting the mean carbon stock at time 2 from that at time 1. The confidence interval is calculated as:

$$\text{Total 95\% CI} = \sqrt{([95\%CI_{\text{time1}}]^2 + [95\%CI_{\text{time2}}]^2)}$$

Where $[95\%CI_{\text{time1}}]$ = 95% confidence interval for time 1 and $[95\%CI_{\text{time2}}]$ = 95% confidence interval for time 2.

The net change is calculated as above for permanent plots by subtracting the initial carbon stocks (practically zero if afforestation occurs on former cropland). Finally, the total carbon stock change on a per unit area basis is multiplied by the total area to produce an estimated total change in carbon and confidence interval for the area.

All the discussion in this section has been for an activity with a single stratum. If the activity contained multiple strata then each would be calculated separately as detailed here. Once the area-based carbon dioxide equivalents and confidence were calculated for each strata the numbers could be combined. The new confidence interval for the combined strata would be estimated as follows:

$$\text{Total 95\% CI} = \sqrt{ [95\%CI_{s1}]^2 + [95\%CI_{s2}]^2 + \dots + [95\%CI_{sn}]^2 }$$

Where $[95\%CI_{s1}]$ = 95% confidence interval for strata 1, strata 2, etc. for all strata measured in the project.

The methods presented here for calculating uncertainty in reported values are known as “error propagation”. Error propagation is simple and robust. However, these methods should be used with caution where:

- Correlations exist between datasets – for example between two carbon pools.
- Uncertainties are very large (greater than 100 %)

In these cases it is statistically more appropriate to use a Monte Carlo analysis¹⁰. In practice the difference in results attained through the two methods are small unless correlations and/or uncertainties are very high.

¹⁰ The principle of Monte Carlo analyses is to perform the summing of uncertainties many times each time with the uncertain stocks or increments chosen randomly by the computer software from within the distribution of uncertainties input initially by the user.

These analyses can be carried out using Monte Carlo software such as Simetar, @Risk or Crystal Ball (www.simetar.com, www.palisade.com/html/risk.asp, www.crystalball.com).

Box 3.9. Calculating net change for the system

The hypothetical example is a afforestation activity on 500 ha of former cropland. The baseline for carbon stocks is cropland with an average carbon stock in vegetation of 0.9 t C/ha. The following table reports the change in carbon stock between years 1 and 10.

Plot number	Change in carbon stocks (t C/ha)			SUM t C/ha
	Living biomass		Dead Organic Matter	
	Aboveground: trees	Belowground	Dead wood	
Plot 1	12.1	2.4	0.1	14.6
Plot 2	11.5	2.3	0.0	13.8
....
....
Plot 31	12.6	2.5	0.1	15.1
Plot 32	10.9	2.2	0.1	13.2

	Mean	13.9
	95 % CI	2.4
	+ Non-tree Vegetation	1.8
	<i>N-T V 95 % CI</i>	0.1
	+ Forest Floor	0.2
	<i>F.F. 95 % CI</i>	0.1
	+ Soil	0.5
	<i>Soil 95 % CI</i>	0.1
	- Baseline stock on cropland	0.9
	<i>Baseline 95 % CI</i>	0.1
	NET change in carbon stock	15.5
	95 % CI	2.4
Net change in stocks over area:	15.5 t C/ha x 3.67 t CO ₂ eq/ha / t C/ha x 500 ha	
± the 95 % CI:	2.4 t C/ha x 3.67 t CO ₂ eq/ha / t C/ha x 500 ha	
Therefore the net change is:	28,443 ± 4,419 t CO ₂ eq over 10 years	

3.5.1.2 Activities on forested lands

Forest management involves alternating periods of harvest and regrowth, and as such carbon stocks in forest biomass vary over time (Figure 3.7). In addition, changes in management practices can result in increased carbon storage through a variety of ways, such as: changing the timing or intensity of harvest, reducing damage to the residual stand through more efficient logging practices, switching from clear-cut harvesting to selective-cut harvesting, or by creating or widening riparian buffer zones.

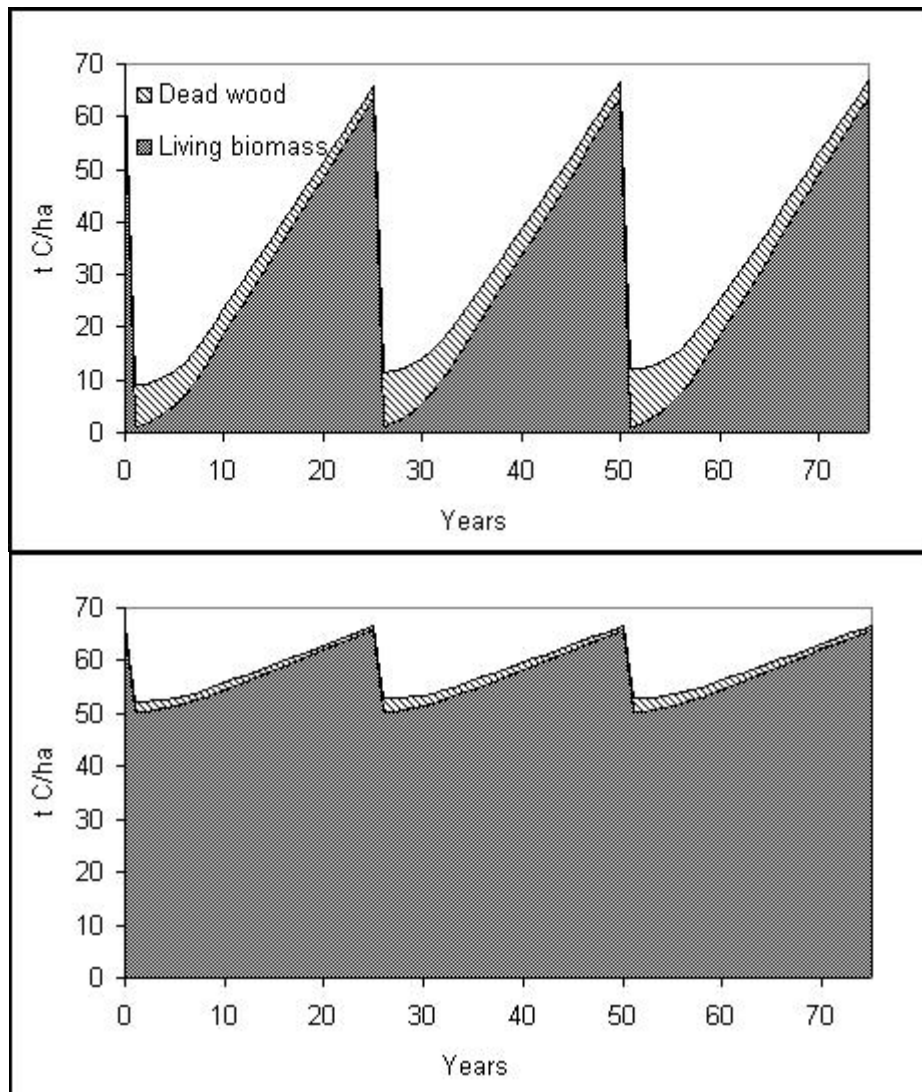

Figure 3.7. Carbon stocks associated with (top) complete harvest of forest followed by 25-year even-aged management and (bottom) selective harvest of a similar forest.

Initially it is important to consider what carbon pools are important in forest management activities. Clearly live vegetation, dead wood, and wood products are central. With the examples in Figure 3.7, the amount of dead wood increases over time with subsequent harvest. The amount of dead wood that accumulates through time is a function of the amount of slash left behind and the rate of decomposition of that slash—the larger the amount of slash and the slower

the rate of decomposition, the larger the amount that accumulates. Measurement of soil organic carbon is, at best, marginally beneficial in forest management activities. Soil carbon may be reduced slightly immediately following harvest (Laiho et al, 2002, Carter et al, 2002), however, any losses will be regained as the succeeding forest regrows with accompanying soil organic matter inputs (Carter et al., 2002). Relative difference in post-harvest effects on soil carbon between varying harvest intensities are slight and often undetectable (Carter et al., 2002). Because differences in soil carbon resulting from changes in management are seldom discernible or long-lived, the significant additional effort of soil sampling on projects on forested lands is not recommended.

The differences in the effects of clear-cut versus selective-cut harvests on forest ecosystem carbon stocks (Figure 3.7) has implications for the accuracy and precision of measuring and monitoring their changes over time. To address this, two alternative methodologies for monitoring changes in carbon stocks are presented here.

Direct Measurement Method

Where the activity includes clear-cut harvesting, the simplest approach is to install sample plots and monitor the changes in carbon stocks as described above (sections 3.2-3.4). As shown in Figure 3.7, there will be periods of carbon accumulation and period of carbon loss resulting in positive and negative changes in carbon stocks. With a well-designed sampling regime, remeasurements will reveal shifts of pre-harvest living biomass to the dead wood pool (i.e. logging slash and collateral mortality), and subsequent decomposition over time, as well as regrowth, resulting after harvest. Mean total carbon stocks and 95% confidence intervals are calculated in the same way as for activities on non-forested lands.

Indirect Measurement Method

In situations of selective-cut harvesting, where harvest intensity per hectare is low, the required number of plots to capture the variation in harvested areas could be so large as to make measurement neither financially nor practically feasible. In this case it is possible to use targeted measurements plus the statistics of the relevant logging activity. It is more appropriate to measure the change in live biomass due to harvesting directly. The change in live biomass caused by logging is a result of the extraction of timber and damage to residual trees. The following information is typically required to calculate carbon gains and losses through the indirect measurement method:

- Total volume removed
- Area damaged per cubic meter removed
- Amount of slash and damage to residual stand per volume removed
- Rate of regrowth in the harvested areas
- Decomposition rates of slash.

The change in carbon stocks using this approach is calculated as:

$$\Delta \text{ live biomass C} + \Delta \text{ dead biomass C}$$

where Δ is the change in carbon of live biomass and dead biomass caused by timber harvesting. The estimates of each term can be made annually or over longer time periods.

Δ live biomass C = (rate of C accumulation over the time interval – [biomass C from logging damage + C in timber extracted])

The change in live biomass caused by logging is a result of the extraction of timber, the slash from the harvested tree, and damage to residual trees, all of which will cause a decrease in live biomass or represent a negative quantity after harvest. On the positive side is the rate of carbon accumulation during regrowth that applies to those areas affected by timber extraction.

Estimating the amount of damaged and dead biomass produced in the logging operations involves establishing field plots around a harvested tree(s) (the plot usually has dimensions equivalent to the distance from the stump to the top of the harvested tree and as wide as the crown diameter of the harvested tree), collecting information about the initial diameter and height of the harvested tree, measuring the amount of volume removed, and measuring the diameter of all trees that were severely damaged and presumed to be dead. The number of such plots to establish and sample would be based on the same procedures described above in section 3.2.3.2. These measurements are then combined to produce a ratio of total amount of live biomass converted to dead biomass per unit mass of timber extracted. The rate of carbon accumulation in the regrowing forest could be obtained from measurements of tagged trees in the sample plot over time as described in section 3.4.1.1, but only applied to the area affected by the logging (area of the gap).

Δ dead biomass C = (dead biomass from logging damage and slash x decomposition rate)

The slash and damaged wood is assumed to enter the dead wood pool, where it starts to decompose. Each year more dead wood is added from harvesting, but each year some is lost because of decomposition and resulting emissions of carbon. Decomposition of dead wood is modeled as a simple exponential function based on mass of dead wood and a decomposition coefficient (proportion decomposed per year). The decomposition coefficients for a variety of forest types are given in Table 3.6. The change in carbon stocks of the slash and damaged wood could be measured in the field but it tends to be time consuming and costly. The range of decomposition rates given in Table 3.6 covers all major forest types in the US. Mean total changes in carbon stocks and 95% confidence intervals could then be calculated in the same way as shown in Box 3.9.

3.6 Quality Assurance and Quality Control (QA/QC)

Measuring and monitoring requires provisions for quality assurance (QA) and quality control (QC) to be implemented via a QA/QC plan to ensure that the reported carbon units are reliable and meet minimum measurement standards. The plan should become part of the documentation and include procedures for: (1) collecting reliable field measurements; (2) verifying laboratory procedures; (3) verifying data entry and analysis techniques and; (4) data maintenance and archiving.

3.6.1. QA/QC for field measurements

Collecting reliable field measurements is an important step in the quality assurance plan. Those responsible for the carbon measurement work should be fully trained in all aspects of field data collection and data analyses. Experience has shown that it is wise for the entity involved with measuring and monitoring prepare Standard Operating Procedures (SOPs) for each step of the field carbon measurements which should be adhered to at all times. These SOPs should detail all phases of the field measurements so that future personnel can repeat the measurements identically to previous times. It is recommended that a document be produced and filed with the project documents that show that QA/QC steps have been followed.

Field crews should receive extensive training and should be fully cognizant of all procedures and the importance of collecting data as accurately as possible. In addition, an audit program for field measurements and sampling should be established to check data collection. A typical audit program consists of three types of checks. During a *hot check*, auditors observe field crew members during data collection on a field plot. *Cold checks* occur where the field crews are not present for the audit. Finally *blind checks* represent the complete remeasurement of a plot by the auditors. Hot checks permit the correction of errors in techniques. Measurement variance can be calculated through blind checks. At the end of the fieldwork 10-20 % of the plots should be checked independently. Field data collected at this stage can be compared with the original data. Any errors found should be corrected and recorded. Any errors discovered could be expressed as a percentage of all plots that have been rechecked to provide an estimate of the measurement error.

3.6.2 QA/QC for laboratory measurements

Standard operating procedures (SOPs) should also be prepared by the operating entity and followed for each part of the analyses. Typical steps for the SOP for laboratory measurements include calibration of combustion instruments for measuring total C or C forms using commercially-available certified C standards. Likewise all balances for measuring dry weights should periodically be calibrated against known weights, for fine scale balances this is most accurately carried out by the manufacturer. Where possible 10-20 % of samples could be reanalyzed/reweighed to produce an error estimate. Professional laboratories typically perform these steps, and if such a lab is used such records need to be obtained by the entity.

3.6.3 QA/QC for data entry

To produce reliable carbon estimates, the proper entry of data into the data analyses spreadsheets is required (this step may be redundant if the field data are collected in an electronic format). It is important that steps are taken to ensure that errors are minimized. Common sense should be used when reviewing the results of the data analysis to make sure that they fit within the realm of reality. Communication between all personnel involved in measuring and analyzing data should be used to resolve any apparent anomalies before final analysis of the monitoring data can be

completed. If there are any problems with the monitoring plot data (that cannot be resolved), the plot should not be used in the analysis. Errors can be reduced if the entered data are reviewed using expert judgment and, if necessary, comparison with independent data.

3.6.4 QA/QC for data archiving

Because of the relatively long-term nature of forestry activities, data archiving (maintenance and storage) will be an important component of the work. Data archiving should take several forms:

- Original copies of the field measurement (either data sheets or electronic files) and laboratory data should be maintained in original form and placed on electronic media, and stored in a secure location, by the carbon measurement implementers.
- Copies of all data analyses and models; the final estimate of the amount of carbon sequestered; any GIS products; and a copy of the measuring and monitoring reports should all be stored in a dedicated and safe place, preferably offsite.

It is recommended that given the time frame for reporting and the pace of production of updated versions of software and new hardware for storing data, that the electronic copies of the data and report be updated periodically or converted to a format that could be accessed by any future software application.

3.7 References

- Amacher, M.C., K.P. O'Neill, R. Dressbach, and C. Palmer. 2003. Forest Inventory and Analysis Manual of Soil Analysis Methods. 2003 edition. Available on-line at <http://socrates.lv-hrc.nevada.edu/fia/ia/IAWeb/Soil.htm>
- Avery T.E. and H.E. Burkhardt (eds.). 1983. Forest Measurements, 3rd edition. McGraw-Hill, New York.
- Beets, P.N., K.A. Robertson, J.B. Ford-Robertson, J. Gordon, J.P. Maclaren, 1999. Description and validation of C change: a model for simulating carbon content in managed *Pinus radiata* stands. New Zealand Journal of Forestry Science 29: 409-427.
- Brown, S. 2002. Measuring carbon in forests: current status and future challenges. Environmental Pollution 116: 363-372.
- Brown, S. 1997. Estimating Biomass and Biomass Change of Tropical Forests: A Primer. UN FAO Forestry Paper 134, Rome. 55 pp.
- Brown, S.L. and P.E. Schroeder. 1999. Spatial patterns of aboveground production and mortality of woody biomass for eastern US forests. Ecological Applications 9: 968-980. (errata: Brown, S.L., Schroder, P.E. 2000. Ecological Applications 10: 937).
- Brown, S., O. Masera, and J. Sathaye. 2000b. Project-based activities. In R. Watson, I. Noble, B. Bolin, N. H. Ravindranath, D. J. Verardo and D. J. Dokken (eds.), Land use, land-use change, and forestry; Special Report to the Intergovernmental Panel on Climate Change, Cambridge University Press, Ch. 5, pp.283-338.
- Brown, S., A.J.R. Gillespie and A.E. Lugo. 1989. Biomass estimation methods for tropical forests with applications to forest inventory data. Forest Science 35: 881-902.
- Cairns, M.A., S. Brown, E.H. Helmer, G.A. Baumgardner. 1997. Root biomass allocation in the world's upland forests. Oecologia 111: 1-11.
- Carter, M.C., T.J. Dean, M. Zhou, M.J. Messina and Z. Wang. 2002. Short-term changes in soil C, N, and biota following harvesting and regeneration of loblolly pine (*Pinus taeda* L.). Forest Ecology and Management 164: 67-88.
- Clark, D. A., S. Brown, D. W. Kicklighter, J. Q. Chambers, J. R. Thomlinson, and Jian Ni, 2001. Measuring net primary production in forests: concepts and field methods. Ecological Applications 11:356-370.
- Dawkins, H.C. 1957. Some results of stratified random sampling of tropical high forest. Seventh British Commonwealth Forestry Conf. 7 (iii) 1-12.
- Delaney, M., S. Brown, A. E. Lugo, A. Torres-Lezama, and N. Bello Quintero. 1998. The quantity and turnover of dead wood in permanent forest plots in six life zones of Venezuela. Biotropica 30:2-11.
- Fang, J.Y., G. Wang, G.H. Liu, and S.L. Xu. 1998. Forest biomass of China: an estimation based on biomass-volume relationships. Ecological Applications 8:1084-1091.

- Fang, J, A. Chen, C. Peng, S. Zhao, and L. Ci. 2001. Changes in forest biomass carbon storage in China between 1949 and 1998. *Science* 292: 2320-2322.
- Freese, F. 1962. *Elementary Forest Sampling*. USDA Handbook 232. GPO Washington, DC. 91 pp.
- Harmon, M.E. and J. Sexton. 1996. Guidelines for measurements of woody detritus in forest ecosystems. U. S. LTER Publication No. 20.
- Harmon, M. E., S. Brown and S.T. Gower. 1993. Consequences of tree mortality to the global carbon cycle. In T. S. Vinson and T. P. Kolchugina (eds.), *Carbon cycling in boreal and subarctic ecosystems, biospheric response and feedbacks to global climate change*. Symposium Proceedings, USEPA, Corvallis, OR, pp. 167-176.
- Heath, L.S. and D.C. Chojnacky. 2001. Down dead wood statistics for Maine timberlands, 1995. USDA-FS Resource Bulletin NE-150.
- Jenkins, J.C., D.C. Chojnacky, L.S. Heath, and R.A. Birdsey. 2003. National-scale biomass estimation for United States tree species. *Forest Science* 49: 12-35.
- Laiho, R., F. Sanchez, A. Tiarks, P.M. Dougherty and C.C. Trettin. 2002. Impacts of intensive forestry on early rotation trends in site carbon pools in the southeastern US. *Forest Ecology and Management* 174: 177-189.
- Lal, R., J.M. Kimble, R.F. Follett, and B.A. Stewart (eds). 2001. *Assessment methods for soil carbon*. Lewis Publishers, Boca Raton, FL.
- MacDicken, K.G. 1997: *A Guide to Monitoring Carbon Storage in Forestry and Agroforestry Projects*. Winrock International, Arlington, VA, USA, 87 pp, available at www.winrock.org/what/ecosystem.cfm
- MacDonald, C. 1999. Dynamics of soil organic carbon content due to reforestation of bottomland hardwood forests on marginal farmland in the Mississippi River Valley. Masters thesis. Stephen F. Austin State University. Texas.
- Markewitz, D., F. Sartori,, and C. Craft. 2002. Soil change and carbon storage in longleaf pine stands planted on marginal agricultural lands. *Ecological Applications* 12: 1276-1285.
- Means, J., H. Hansen, G. Koerper, P. Alaback, AND M. Klopsch. 1994. Software for computing plant biomass -- BIOPAK Users Guide. USDA-FS General Technical Report PNW-GTR-340.
- Nelson, D.W., and L.E. Sommers. 1996. Total carbon, organic carbon, and organic matter. p. 961-1010. In: D.L. Sparks et al. (eds.) *Methods of soil analysis*. Part 3. Chemical methods. SSSA, Madison, WI.
- Pastor, J., J.D. Aber, AND J.M. Melillo. 1984. Biomass prediction using generalized allometric regressions for some northeast tree species. *For. Ecol. Manage.* 7: 265-274.
- Richter, D.R., D. Markewitz,, S.E. Trumbore, and C.G. Wells. 1999. Rapid accumulation and turnover of soil carbon in a reestablishing forest. *Nature* 400: 56-58.
- Robertson, G.P., D.C. Coleman, C.S. Bledsoe and P. Sollins 1999. *Standard methods for long-term ecological research*. Oxford University Press, Oxford, U.K.

- Schroeder, P., S. Brown, J. Mo, R. Birdsey and C. Cieszewski, 1997. Biomass estimation for temperate broadleaf forests of the United States using inventory data. *Forest Science* 43: 424-434.
- Sherrod, L.A., G. Dunn, G.A. Peterson, and R.L. Kolberg. 2002. Inorganic carbon analysis by modified pressure calcimeter method. *Soil Sci. Soc. Am. J.* 66:299-305.
- Smith, J.E., L.S. Heath and J.C. Jenkins. 2003. Forest volume-to-biomass models and estimates of mass for live and standing dead trees of U.S. forests. USDA-FS General Technical Report NE-298.
- Sokal, R. R. and F. J. Rohlf. 1995. *Biometry: the principles and practice of statistics in biological research*. 3rd edition. W. H. Freeman and Co.: New York. 887 pp. ISBN: 0-7167-2411-1.
- Turner, D.P., J.J. Lee, G.J. Koerper, and J.R. Barker. 1993. The forest sector carbon budget of the United States: carbon pools and flux under alternative policy options. Corvallis, OR: US Environmental Protection Agency. 202 p
- USDA Forest Service. 2002. FIA Field Methods for Phase 3 Measurements. Soil measurements and sampling. Available on-line at <http://fia.fs.fed.us/library.htm#Manuals>
- Winjum, J.K., S. Brown, and B. Schlamadinger. 1998. Forest harvests and wood products: sources and sinks of atmospheric carbon dioxide. *Forest Science* 44: 272-284.
- Zar, J.H. 1996. *Biostatistical analysis*. Prentice Hall, Englewood Cliffs, New Jersey.