



# **Determination of the $\delta(^{15}\text{N}/^{14}\text{N})$ and $\delta(^{18}\text{O}/^{16}\text{O})$ of Nitrate in Solids: RSIL Lab Code 2897**

Chapter 14 of  
Book 10, Methods of the Reston Stable Isotope  
Laboratory  
Section C, Stable Isotope-Ratio Methods

Techniques and Methods 10-C14

**U.S. Department of the Interior**  
**U.S. Geological Survey**



# **Determination of the $\delta(^{15}\text{N}/^{14}\text{N})$ and $\delta(^{18}\text{O}/^{16}\text{O})$ of Nitrate in Solids: RSIL Lab Code 2897**

By Kinga Révész and Karen Casciotti

**Chapter 14 of  
Book 10, Methods of the Reston Stable Isotope  
Laboratory  
Section C, Stable Isotope-Ratio Methods**

Edited by Kinga Révész and Tyler B. Coplen

Techniques and Methods 10-C14

**U.S. Department of the Interior  
U.S. Geological Survey**

**U.S. Department of the Interior**  
DIRK KEMPTHORNE, Secretary

**U.S. Geological Survey**  
Mark D. Myers, Director

U.S. Geological Survey, Reston, Virginia 2007

For sale by U.S. Geological Survey, Information Services  
Box 25286, Denver Federal Center  
Denver, CO 80225

For more information about the USGS and its products:  
Telephone: 1-888-ASK-USGS  
World Wide Web: <http://www.usgs.gov/>

Any use of trade, product, or firm names in this publication is for descriptive purposes only and does not imply endorsement by the U.S. Government.

Although this report is in the public domain, permission must be secured from the individual copyright owners to reproduce any copyrighted material contained within this report.

*Suggested citation:*

Révész, Kinga, and Casciotti, Karen, 2007, Determination of the  $\delta^{15}\text{N}/^{14}\text{N}$  and  $\delta^{18}\text{O}/^{16}\text{O}$  of Nitrate in Solids: RSIL Lab Code 2897, chap. C14 of Révész, Kinga, and Coplen, Tyler B., eds., Methods of the Reston Stable Isotope Laboratory: Reston, Virginia, U.S. Geological Survey, Techniques and Methods, book 10, sec. C, chap. 14, 24 p.

## Foreword

The Reston Stable Isotope Laboratory (RSIL) provides stable isotope analyses on a routine basis for a large user community within the U.S. Geological Survey (USGS) and elsewhere. The RSIL also serves the USGS National Research Program (NRP) through its project on Stable Isotope Fractionation in Hydrologic Processes. The NRP conducts basic and problem-oriented hydrologic research in support of the mission of the USGS. The stable isotope project conducts research on the use of isotope-ratio measurements in studies of water resources and environmental quality. One objective of this project is to develop new techniques for isotopic analysis of H, N, O, C, and S in environmental samples. New analytical techniques expand the range of tools available for studying the movement of those elements in hydrologic and biogeochemical systems. Another objective of the project is to test new applications of isotope measurements in specific field settings. Field studies of isotope behavior have contributed to understanding of water-supply sustainability, ground-water/surface-water interactions, paleoclimate history, biologic cycling of nutrients, ground-water contamination, and natural remediation. This project also contributes to the improvement of measurement science and the development of isotope databases.

Book 10 of the Techniques and Methods Series of the USGS contains detailed descriptions of methods of the RSIL, including routine analytical methods called standard operating procedures (SOPs), along with safety guidelines, maintenance procedures, and other information about the operation of the RSIL. Section C of Book 10 contains the SOPs for a variety of methods to measure stable isotope ratios, each of which constitutes a chapter. Each chapter is limited to a narrow field of subject matter to permit flexibility in revision as the need arises.



Pierre Glynn  
Chief, Branch of Regional Research, Eastern Region



# Contents

Forward .....	iii
Conversion Factors .....	vii
Acronyms and Abbreviations .....	vii
Symbols.....	viii
Summary of Procedure.....	1
Reporting Units and Operational Range .....	1
Reference Materials and Documentations.....	2
Reference Materials Used, Storage Requirements, and Shelf Life .....	2
Documentation .....	3
Labware, Instrumentation, and Reagents .....	3
Sample Collection, Preparation, Analysis, Retention Times, and Disposal.....	4
Sample Containers, Preservation, and Handling Requirements .....	4
Sample Preparation and Time Requirements.....	4
Performing the Analysis and Time Requirements .....	5
Problematic Samples.....	7
Interferences .....	7
Troubleshooting and Bench Notes .....	7
Maintenance and Maintenance Records .....	7
Sample Retention Time and Disposal .....	8
Data Acquisition, Processing, Evaluation, Quality Control, and Quality Assurance .....	8
Laboratory Information Management System for Light Stable Isotopes (LIMS-LSI) .....	8
Quality-Control (QC) Samples.....	8
Acceptance Criteria for All QC Samples .....	9
Corrective Action Requirements .....	9
Responsible Parties for All QA/QC Functions for Procedures Covered in RSIL SOPs.....	9
Data Management and Records.....	9
Health, Safety, and Waste-Disposal Information.....	9
Applicable Health and Safety Issues .....	9
Personal Protection .....	9
Electrical Hazards .....	10
Chemical Hazards .....	10
Gas Cylinder Handling .....	10
Biological Hazards .....	10
Specific Waste-Disposal Requirements .....	10
Revision History .....	11
References Cited .....	12
Appendixes.....	13
A. Step-by-Step Procedure to Log-In Samples to LIMS-LSI .....	13
B. Step-by-Step Procedure to Print a Template and a Samples-to-Be-Analyzed List .....	15
C. Step-by-Step Preparation Procedure for N Isotope Analyses of Nitrate by Bacterial Denitrification .....	17
D. Step-by-Step Procedure to Add Sample Information to Sequence Table.....	20
E. Step-by-Step Procedure to Transfer Data to LIMS-LSI, to Transfer Data to Back-Up Computer, and to Reevaluate Old Data .....	21
F. Step-by-Step Procedure to Determine and Apply Correction Factors and Evaluate Data .....	22

G. Daily Check List.....	23
H. Step-by-Step Procedure to Report Data.....	24

## Figures

1. Schematic of Modified Finnigan GasBench Inlet System.....	4
2. Schematic of a continuous flow isotope-ratio mass spectrometer (CF-IRMS). ....	5



## Conversion Factors

Multiply	By	To Obtain
Length		
millimeter (mm)	0.03937	inch
centimeter (cm)	0.3937	inch
meter (m)	3.281	foot
Volume		
microliter ( $\mu\text{L}$ )	$0.0610210^{-3}$	cubic inch
milliliter (mL)	0.06102	cubic inch
cubic centimeter ( $\text{cm}^3$ )	0.06102	cubic inch
Mass		
nanogram (ng) = $10^{-3}$ $\mu\text{g}$	$3.527 \times 10^{-11}$	ounce
microgram ( $\mu\text{g}$ ) = $10^{-3}$ mg	$3.527 \times 10^{-8}$	ounce
milligram (mg) = $10^{-3}$ g	$3.527 \times 10^{-5}$	ounce
gram (g) = $10^{-3}$ (kg)	$3.527 \times 10^{-2}$	ounce
kilogram = $10^3$ g; $10^6$ mg; $10^9$ $\mu\text{g}$ ; $10^{12}$ ng	2.205	pound
Density		
gram per cubic centimeter ( $\text{g}/\text{cm}^3$ )	0.5780	ounce per cubic inch
Temperature		
Celsius ( $^{\circ}\text{C}$ )	$^{\circ}\text{F} = 9/5 (^{\circ}\text{C}) + 32$	Fahrenheit ( $^{\circ}\text{F}$ )
Pressure (force/area)		
kilopascal (kPa)	$9.869 \times 10^{-3}$	atmosphere, standard (atm)
kilopascal (kPa)	$1.450 \times 10^{-1}$	pound-force/square inch (psi)
kilopascal (kPa)	$1.000 \times 10^{-2}$	bar
kilopascal (kPa)	$2.961 \times 10^{-1}$	inches of mercury at $60^{\circ}\text{F}$

## Acronyms and Abbreviations

ANSI	American National Safety Institute
ASR	analytical services request
CF-IRMS	continuous flow isotope-ratio mass spectrometer
DIW	deionized water
GC	gas chromatograph
HDPE	high-density polyethylene
IAEA	International Atomic Energy Agency

IRMS	isotope-ratio mass spectrometer
LIMS-LSI	Laboratory Information Management System for Light Stable Isotopes
mg/L	milligram per liter
MSDS	Material Safety Data Sheets
mM	millimolar
nM	nanomolar
N	normal
NED	N-(1-haphthyl)ethylenediamine dihydrochloride)
NFPA	National Fire Protection Association
NWQL	National Water Quality Laboratory (USGS)
per mill, ‰	1/1000
pF	picofarad
QA	quality assurance
QC	quality control
QC/QA	quality control/quality assurance
RSIL	Reston Stable Isotope Laboratory
SLAP	Standard Light Antarctic Precipitation
SOP	standard operating procedure
TSA	tryptic soy agar
TSB	tryptic soy broth
USGS	U.S. Geological Survey
VSMOW	Vienna Standard Mean Ocean Water
μM	micromolar

## Symbols

Ω	ohm
<	less than
>	greater than
≥	greater than or equal
≤	less than or equal

# Determination of the $\delta(^{15}\text{N}/^{14}\text{N})$ and $\delta(^{18}\text{O}/^{16}\text{O})$ of Nitrate in Solids: RSIL Lab Code 2897

By Kinga Révész and Karen Casciotti

## Summary of Procedure

The purpose of Reston Stable Isotope Laboratory (RSIL) lab code 2897 is to determine the  $\delta(^{15}\text{N}/^{14}\text{N})$ , abbreviated as  $\delta^{15}\text{N}$ , and  $\delta(^{18}\text{O}/^{16}\text{O})$ , abbreviated as  $\delta^{18}\text{O}$ , of nitrate ( $\text{NO}_3^-$ ) in solids. The  $\text{NO}_3^-$  fraction of the nitrogen species is dissolved by water (called leaching) and can be analyzed by the bacterial method covered in RSIL lab code 2900. After leaching, the  $\delta^{15}\text{N}$  and  $\delta^{18}\text{O}$  of dissolved  $\text{NO}_3^-$  is analyzed by conversion of  $\text{NO}_3^-$  to nitrous oxide ( $\text{N}_2\text{O}$ ), which serves as the analyte for mass spectrometry. A culture of denitrifying bacteria is used in the enzymatic conversion of  $\text{NO}_3^-$  to  $\text{N}_2\text{O}$ , which follows the pathway shown in equation 1:



Because the bacteria *Pseudomonas aureofaciens* lacks  $\text{N}_2\text{O}$  reductive activity, the reaction stops at  $\text{N}_2\text{O}$ , unlike the typical denitrification reaction, which goes to  $\text{N}_2$ . After several hours, the conversion is complete, and the  $\text{N}_2\text{O}$  is extracted from the vial, separated from water vapor by Nafion drier and from  $\text{CO}_2$  with a layered  $\text{Mg}(\text{ClO}_4)_2/\text{Ascarite}$  trap, and trapped in a small-volume trap immersed in liquid nitrogen. After the  $\text{N}_2\text{O}$  is released, it is further purified by gas chromatography (GC) before introduction to the isotope-ratio mass spectrometer (IRMS). The IRMS is a Finnigan Delta<sup>Plus</sup> continuous flow IRMS (CF-IRMS). It has a universal triple collector, consisting of two wide cups with a narrow cup in the middle; it is capable of simultaneously measuring mass/charge ( $m/z$ ) of the  $\text{N}_2\text{O}$  molecule 44, 45, and 46. The ion beams from these  $m/z$  values are as follows:  $m/z = 44 = \text{N}_2\text{O} = ^{14}\text{N}^{14}\text{N}^{16}\text{O}$ ;  $m/z = 45 = \text{N}_2\text{O} = ^{14}\text{N}^{15}\text{N}^{16}\text{O}$  or  $^{14}\text{N}^{14}\text{N}^{17}\text{O}$ ;  $m/z = 46 = \text{N}_2\text{O} = ^{14}\text{N}^{14}\text{N}^{18}\text{O}$ . The  $^{17}\text{O}$  contributions to the  $m/z$  44 and  $m/z$  45 ion beams are accounted for before  $\delta^{15}\text{N}$  values are reported.

## Reporting Units and Operational Range

Variations in stable isotope–amount ratios typically are small. Stable isotope–amount ratios commonly are determined as the relative difference in the ratio of the amount of the less abundant isotope (usually the heavy isotope) to the amount of the more abundant isotope (usually the light isotope) of the sample with respect to that of the reference. This relative difference is designated  $\delta^i\text{E}$ , which is a shortened form of  $\delta(^i\text{E}/\text{E})$  or  $\delta(^i\text{E})$  and is defined according to equation 2:

$$\delta^i\text{E} = \delta(^i\text{E}) = \delta(^i\text{E}/^j\text{E}) = \frac{n_{\text{X}}(^i\text{E})/n_{\text{X}}(^j\text{E}) - n_{\text{ref}}(^i\text{E})/n_{\text{ref}}(^j\text{E})}{n_{\text{ref}}(^i\text{E})/n_{\text{ref}}(^j\text{E})} \quad (2)$$

where  $i$  and  $j$  are isotopes of element E and  $n_{\text{X}}(^i\text{E})/n_{\text{X}}(^j\text{E})$  and  $n_{\text{ref}}(^i\text{E})/n_{\text{ref}}(^j\text{E})$  are the ratios of the isotope amounts in the unknown X and a reference ref. A positive  $\delta^i\text{E}$  value indicates that the unknown is more enriched in the amount of the heavy isotope ( $^i\text{E}$ ) than the reference. A negative  $\delta^i\text{E}$  value indicates that the unknown is depleted in the amount of the heavy isotope relative to the reference. Values of  $\delta^i\text{E}$  have been

reported in parts per hundred (‰ or percent), parts per thousand (‰ or per mill), and parts per ten thousand. For stable nitrogen isotope–amount ratios,  $\delta^{15}\text{N}$  is defined as follows:

$$\delta^{15}\text{N} = \delta(^{15}\text{N}) = \delta(^{15}\text{N}/^{14}\text{N}) = \frac{n_{\text{X}}(^{15}\text{N})/n_{\text{X}}(^{14}\text{N}) - n_{\text{ref}}(^{15}\text{N})/n_{\text{ref}}(^{14}\text{N})}{n_{\text{ref}}(^{15}\text{N})/n_{\text{ref}}(^{14}\text{N})} \quad (3)$$

For stable oxygen isotope–amount ratios,  $\delta^{18}\text{O}$  is defined as follows:

$$\delta^{18}\text{O} = \delta(^{18}\text{O}) = \delta(^{18}\text{O}/^{16}\text{O}) = \frac{n_{\text{X}}(^{18}\text{O})/n_{\text{X}}(^{16}\text{O}) - n_{\text{ref}}(^{18}\text{O})/n_{\text{ref}}(^{16}\text{O})}{n_{\text{ref}}(^{18}\text{O})/n_{\text{ref}}(^{16}\text{O})} \quad (4)$$

The primary reference material for relative nitrogen isotope ratio measurements ( $\delta^{15}\text{N}$ ) is atmospheric nitrogen gas ( $\text{N}_2$ ), which is widespread and homogeneous and, by convention, has a  $\delta^{15}\text{N}$  consensus value of 0 ‰ (Mariotti, 1983). The primary reference material for relative oxygen isotope–ratio measurements ( $\delta^{18}\text{O}$ ) is Vienna Standard Mean Ocean Water (VSMOW), which, by convention, has a consensus value of 0 ‰ (Gonfiantini, 1978; Coplen, 1996). By interspersing internationally distributed isotopic reference materials with accepted  $\delta$  values among unknown samples, the  $\delta$  values can be determined on normalized  $\delta^{15}\text{N}$  and  $\delta^{18}\text{O}$  scales. The  $\delta^{15}\text{N}$  scale is determined by analyzing reference materials IAEA-N-1 and USGS32, which have assigned values of +0.43 and +180 ‰, respectively (Böhlke and Coplen, 1995). The  $\delta^{18}\text{O}$  scale is determined by analyzing reference materials VSMOW and Standard Light Artic Precipitation (SLAP), which have consensus values of 0 and –55.5 ‰, respectively. The  $\delta^{15}\text{N}$  and  $\delta^{18}\text{O}$  measurements are made with a CF-IRMS, which alternately measures the isotope–amount ratios of the sample  $\text{N}_2\text{O}$  gas and one or more injections of the “working reference”  $\text{N}_2\text{O}$  gas. Values of  $\delta^{15}\text{N}$  and  $\delta^{18}\text{O}$  typically are reported in parts per thousand (‰).

The system was tested by analyzing pure inorganic samples (potassium and sodium nitrates). The routine analysis requires 0.28  $\mu\text{g N}$ ; however, the system is capable of analyzing samples as small as 0.14  $\mu\text{g N}$  in one sample aliquot. Therefore, the range of nitrogen concentration needed for this analyses is more than 0.03 mg/kg  $\text{NO}_3^-$  as N, compared with less than 1000 mg/kg  $\text{NO}_3^-$  covered in RSIL Lab code 2893 (Révész and Qi, 2006), where  $\delta^{15}\text{N}$  of total nitrogen in solids is determined by elemental analyzer (EA). The  $\delta^{15}\text{N}$  values of reference materials ranged from approximately –1.8 to +180 ‰, which covers much of the range of isotopic composition of natural samples. The  $\delta^{18}\text{O}$  ranged from approximately –29 ‰ to +56 ‰, which covers much of the range of isotopic composition of natural samples. The precision and accuracy of the results were acceptable, and no memory effect was observed. The precision and accuracy were less than  $\pm 0.25$  ‰ and less than  $\pm 0.5$  ‰ for the  $\delta^{15}\text{N}$  and  $\delta^{18}\text{O}$  measurements, respectively.

## Reference Materials and Documentation

### Reference Material Used, Storage Requirements, and Shelf Life

Internationally distributed reference materials used in the RSIL are solid nitrogen-bearing materials, which have wide range of isotopic composition. In the measurement of  $\delta^{15}\text{N}$ , USGS34 potassium nitrate ( $\text{KNO}_3$ ) with a  $\delta^{15}\text{N}$  value of –1.8 ‰ (Böhlke and others, 2003) and a USGS32  $\text{KNO}_3$  with a  $\delta^{15}\text{N}$  value of +180 ‰ (Böhlke and others, 1993) are used. For  $\delta^{18}\text{O}$  measurement, samples are referenced using USGS34 with a  $\delta^{18}\text{O}$  value of –27.9 ‰ and USGS35 sodium nitrate ( $\text{NaNO}_3$ ) with a  $\delta^{18}\text{O}$  value of

+57.5 ‰ (Böhlke and others, 2003). The USGS35 reference has a nonterrestrial  $n(^{18}\text{O})/n(^{17}\text{O})$  ratio; therefore, its  $\delta^{15}\text{N}$  value should not be used as a reference for this method.

All of these reference materials are stored in the RSIL at room temperature in glass bottles capped with Teflon-coated or cone-shaped caps to keep moisture out. Their shelf life is indefinite.

Primary stocks of 20-mmol/L reference nitrates are dissolved and stored frozen and diluted to a 20- $\mu\text{mol/L}$  secondary working stock every 1 to 2 months. This 20- $\mu\text{mol/L}$  stock is also stored frozen between uses and is analyzed along with the samples in amounts similar to that of the samples analyzed in a particular batch.

## Documentation

All calibration results are stored in the Laboratory Information Management System for Light Stable Isotopes (LIMS-LSI) (Coplen, 2000) under sample identifiers N-7, N-34, and N-35.

## Labware, Instrumentation, and Reagents

Preparatory labware and apparatus includes beakers, watch glasses, 160-mL glass serum bottles, Petri dishes, flasks, a torch, sterile plastic test tubes, spreading loop, a laboratory shaker, freezers, a refrigerator, an autoclave, and a tabletop centrifuge.

The analytical apparatus consists of three different units: (1) an automated sample extraction and analysis system, (2) IRMS, and (3) computer software. The automated sample extraction and analysis system is a modified version of the Finnigan GasBench (fig. 1), first described by Casciotti and others (2002) and Sigman and others (2001).

The automated sample extraction and analysis unit is constructed to hold 32 samples and is furnished with a CTC Analytical CombiPAL robotic sampling arm by which the sample ultimately is sent to the IRMS through a water removal unit (Nafion drier), a  $\text{CO}_2$  removal unit [ $\text{Mg}(\text{ClO}_4)_2/\text{Ascarite}$  trap], a cryogenic trap, a GC column, a second water removal unit (Nafion drier), and an open split. The CTC Analytical CombiPAL autosampler houses two needles, side by side, allowing separate He inflow (25 mL/min) to purge the entire vial and a He +  $\text{N}_2\text{O}$  outflow for sample collection. The purged sample flows through a Nafion water removal tube and is collected for 13 min in the cryogenic trap (95  $\times$  0.16 cm-O.D., stainless steel) submerged in liquid  $\text{N}_2$  ( $-192^\circ\text{C}$ ). By removing the trap from liquid  $\text{N}_2$ , the sample warms to room temperature, and the sublimed sample is released to the gas chromatograph (Porapak-Q, held at room temperature) under a He flow rate of 3 mL/min through a Nafion drier, an open split that limits the flow to 0.3 mL/min, and ultimately into the IRMS. The chromatography is necessary for separating traces of  $\text{CO}_2$  from the  $\text{N}_2\text{O}$  sample before determination of the isotope amount ratio.

The IRMS is a Finnigan Delta<sup>plus</sup> CF-IRMS (fig. 2). The fundamental principle of the CF-IRMS technique is that a carrier gas transports the analyte through an initial stage of online chemistry for conversion to a form acceptable by the IRMS (Brenna and others, 1997), in this case  $\text{N}_2\text{O}$  gas. This is an automated system generating online, high-precision  $\delta$  values. In the IRMS, gas molecules are ionized in a source by electrons emitted from a hot filament. The ions are accelerated into an analyzer, forming an ion beam, are separated in a magnetic field, and then collected in Faraday cup collectors. The ion beam intensities are measured with electrometers. This IRMS has a universal triple collector, consisting of two wide cups with a narrow cup in the middle, and is capable of simultaneously measuring  $m/z$  44, 45, and 46. The resistor–capacitor combination on the electrometers used to measure these masses are as follows:  $3 \times 10^8 \Omega$  and 680 pF for cup 1,  $3 \times 10^{10} \Omega$  and 5 pF for cup 2, and  $3 \times 10^{11} \Omega$  and 2 pF for cup 3.

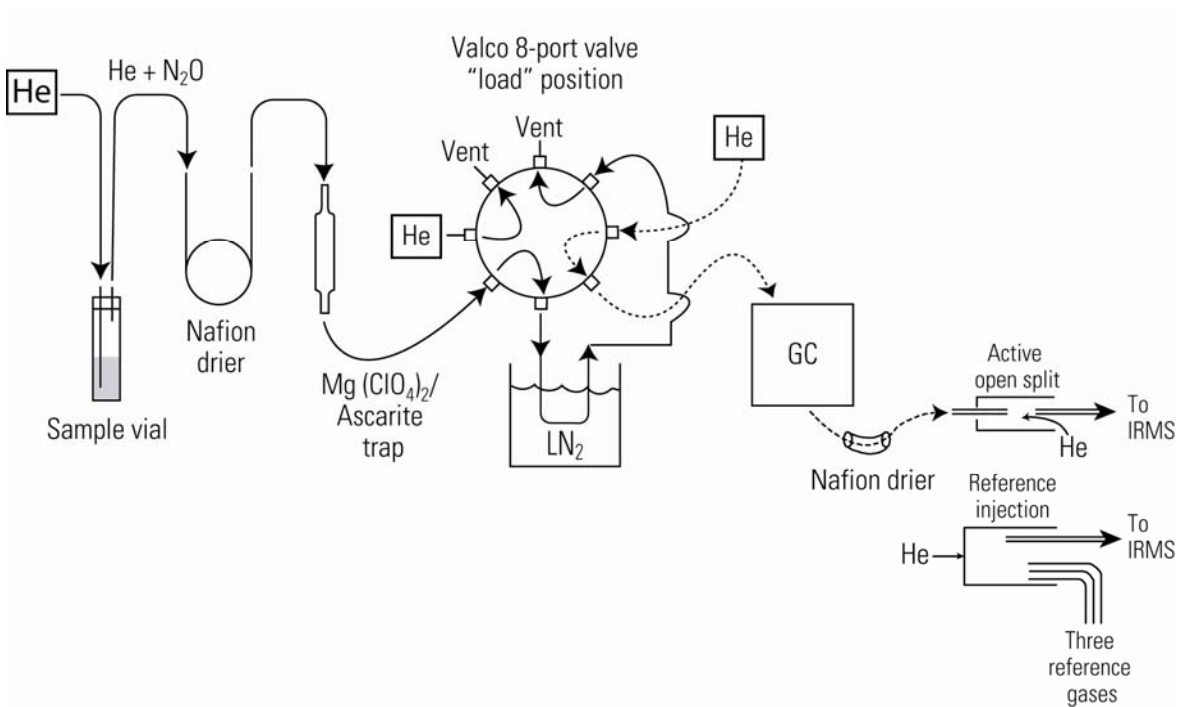

**Figure 1.** Schematic of Modified Finnigan GasBench Inlet System.

The Finnigan ISODAT 2.0 software is designed (1) to control the GasBench preparation system, (2) to operate the IRMS, (3) to acquire data from the IRMS, and (4) to calculate delta values.

## Sample Collection, Preparation, Analysis, Retention Times, and Disposal

### Sample Container, Preservation, and Handling Requirements

Each sample is collected in a high-density polyethylene (HDPE) scintillation vial with a Polyseal cap (Wheaton 986706), available from the RSIL. Sample size should be approximately 30 g, with an N concentration more than 0.03 mg/kg as nitrogen, and should be dried to prevent any biological conversion of nitrogen-bearing material to  $\text{NO}_3^-$  during storage or transportation. The bottles are labeled with isotopes whose concentrations are to be determined along with the respective laboratory code or schedule number. No treatment, preservation, or special shipping is required.

### Sample Preparation and Time Requirements

Sample preparation involves logging in samples to the LIMS-LSI. The logging-in procedure involves logging samples in batches to LIMS-LSI that could contain from 1 to 100 samples per batch (also called a project), printing labels for each sample, and printing a summary project report. Each sample label contains the Field ID (the identifier by which the sample submitter knows each sample) and the unique RSIL Lab ID assigned by the LIMS-LSI. The summary project report is inserted into a three-ring binder titled "Samples in Progress."

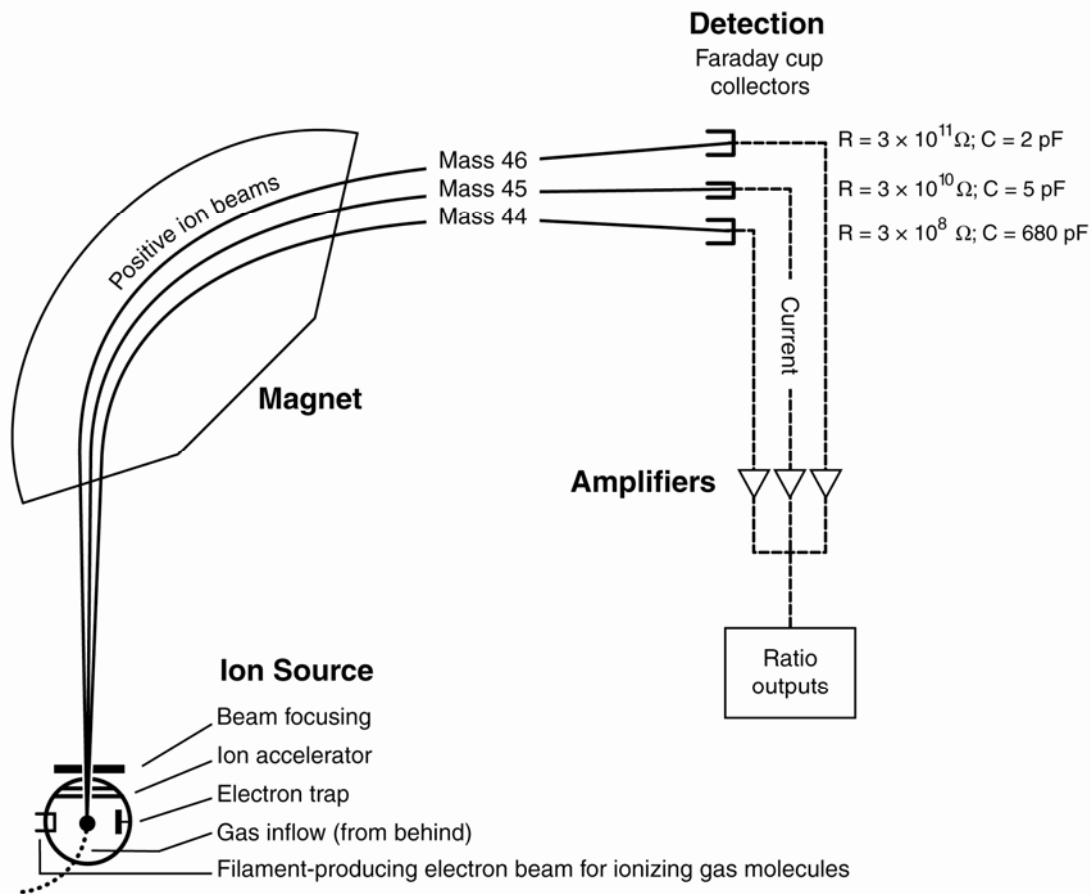

**Figure 2.** Schematic of a continuous flow isotope-ratio mass spectrometer (CF-IRMS) (modified from Clark and Fritz, 1997).

If samples are submitted through the USGS National Water Quality Laboratory (NWQL), the Field ID is a unique number for each sample assigned according to NWQL guidelines; this unique number is written on the analytical services request (ASR) form accompanying a sample, and the ASR information is entered into the LIMS-LSI system. This information is e-mailed to the submitter of the samples for identification of any errors and subsequently e-mailed to the NWQL. Copies of the ASR forms are mailed to the NWQL. Step-by-step procedures are given in Appendix A.

A sample work-order sheet is created by LIMS-LSI by printing a “Template” and a “Samples-To-Be-Analyzed” form; step-by-step procedures are given in Appendix B. The time requirement for this preparation is about 1 to 5 days.

## Performing the Analysis and Time Requirements

Approximately 30 mg of a solid sample is placed in a 150-mL beaker and 80 mL of deionized water (DIW) is added; this mixture needs to be stirred well and allowed to sit covered overnight. The sample is then filtered and rinsed several times with 10-mL aliquots of DIW, not to exceed more than 300 mL of water in total. The  $\text{NO}_3^-$  concentration is determined at this point.

A denitrifier culture is prepared by cultivating the appropriate strain of *P. aureofaciens* for  $\delta^{15}\text{N}$  and  $\delta^{18}\text{O}$  determination. Using tryptic soy broth (TSB) medium amended with 10 mM  $\text{NO}_3^-$  and 15 mM  $\text{NH}_4^+$ ,

the bacteria are first inoculated in a starter tube (5 mL) and then transferred into autoclaved 160-mL serum bottles containing 130 mL of medium.

The bacteria (5- to 10-day-old cultures) are harvested by centrifugation in 40-mL aliquots and resuspended in 4 mL of new medium that does not contain  $\text{NO}_3^-$  to achieve a 10-fold concentration. The concentrated cells are added to 20-mL headspace vials in 3-mL aliquots. The vials are sealed with a Teflon-lined silicone septum and purged with helium for 1 h. At this point, the TSB in the vials should be  $\text{NO}_3^-$  and nitrite ( $\text{NO}_2^-$ ) free and the headspace He should be  $\text{N}_2\text{O}$  free. Several drops of antifoaming agent are added to each vial to reduce foaming during subsequent  $\text{N}_2\text{O}$  extraction.

An amount between 1 and 10 mL of a sample containing dissolved  $\text{NO}_3^-$  is added to the prepared vials to achieve a constant amount of analyte  $\text{N}_2\text{O}$ , typically 10 to 20 nmol. Because of this, the sample submitter must provide the  $\text{NO}_3^-$  concentrations along with each sample. After the samples are injected, the sample vials are stored upside down for at least 2 h to prevent any leaking through the septum while  $\text{NO}_3^-$  is converted to  $\text{N}_2\text{O}$ .

The next day, 0.1 mL of 10 N NaOH is added by syringe to each vial to scavenge the bulk of dissolved  $\text{CO}_2$ , which kills the bacteria as well. The step-by-step procedure is given in Appendix C.

All samples are prepared and analyzed automatically in batches of a maximum of 32 water samples a day. Four to six aliquots of reference materials are analyzed; N-7 (USGS32;  $\text{KNO}_3$ ) and N-34 (USGS34;  $\text{KNO}_3$ ) are used to calibrate  $\delta^{15}\text{N}$  values, and N-34 (USGS34) and N-35 (USGS35) to calibrate  $\delta^{18}\text{O}$  values. The sample vials are loaded into a 32-position aluminum tray that is accessed by the autosampler. The process is automated and controlled by the ISODAT 2.0 mass-spectrometer program; therefore, it requires loading new sample headings into the "Sequence Table" in ISODAT 2.0, choosing appropriate "Methods" (the method that controls the CTC Analytical CombiPAL system and the method that controls the analysis, both of which were set up previously in the system) and starting sequence acquisition. The step-by-step procedure is given in Appendix D.

For each sample analysis, the vial is purged by the autosampler for 13 min using He gas at a flow rate of 30 mL/min. The flow from the exit needle is directed through a Nafion drier, followed by a layered  $\text{Mg}(\text{ClO}_4)_2$ /Ascarite trap to remove water and  $\text{CO}_2$  from the gas stream before trapping  $\text{N}_2\text{O}$  under liquid nitrogen ( $\text{LN}_2$ ). The  $\text{N}_2\text{O}$  is then released from the  $\text{LN}_2$  trap and is passed through a Porapac-Q-coated capillary gas chromatograph and on to the IRMS.

After the analyses are completed, the data are exported from the ISODAT 2.0 database to a removable disc or "memory stick" (see Appendix E), imported to LIMS-LSI, and transferred to a Data Back-Up Computer. Final daily correction factors are determined (see Appendix F) based on the daily analyses of reference materials using equations 5 and 6, which are represented with numerical values:

$$+180 \text{‰} = m \times \delta^{15}\text{N}_{\text{USGS32 - workingref.gas}} + b \quad (5)$$

$$-1.8 \text{‰} = m \times \delta^{15}\text{N}_{\text{USGS34 - workingref.gas}} + b \quad (6)$$

The values +180 ‰ and -1.8 ‰ are the assigned values of the two international reference materials, USGS32 and USGS34, respectively. The  $\delta^{15}\text{N}$  values in equations 5 and 6 are the mean daily delta values of the respective international reference materials relative to the working reference gas;  $b$  is the additive correction factor, and  $m$  is the expansion coefficient correction factor. Oxygen isotopic correction factors are determined in the same way; however, the values of the oxygen isotopic internationally distributed reference materials should be used, and the  $\delta^{18}\text{O}$  values in the equations would be the daily delta values of the respective internationally distributed reference materials relative to the working reference gas. When two or more reference materials with different isotopic compositions are analyzed, the correction for sample blank does not need to be applied if the magnitude of the blank in the samples and reference



materials is identical. However, if only a single reference material is analyzed, only one-point calibration is possible; in that case, a blank correction must be applied.

If replicates do not agree within acceptable tolerances, they are analyzed until acceptable statistics are achieved. The computerized LIMS-LSI will not release data until the statistics are acceptable. The time requirement for performing the analyses described earlier is a minimum of 2 days if the bacterial culture is already prepared.

The systematic procedure is listed in the “Lab Procedures” binder. The supervisor should review suggested changes before they are adopted.

## Problematic Samples

Problematic samples include (1) samples that have concentrations less than 14 µg N/L, (2) samples that have a mixture of  $\text{NO}_3^-$  and  $\text{NO}_2^-$  because this technique does not distinguish between these two forms of nitrogen, and (3) samples that have nonterrestrial  $n(^{17}\text{O})/n(^{16}\text{O})$  isotope-amount ratios. This can be problematic for  $\delta^{15}\text{N}$  analysis because the  $\delta^{15}\text{N}$  calculation assumes that the amount of oxygen isotopes in the  $\text{NO}_3^-$  follow a mass-dependent relation; that is, that  $\delta^{17}\text{O} = 0.52 \times \delta^{18}\text{O}$ . For samples containing atmospheric  $\text{NO}_3^-$  that have excess  $^{17}\text{O}$ , the bacterial method may overestimate the  $\delta^{15}\text{N}$  values by as much as 1 to 2 ‰. Therefore, for samples that are expected to contain more than 20 % atmospheric  $\text{NO}_3^-$ , users should contact the RSIL for methods to quantify  $\delta^{17}\text{O}$  values and determine accurate  $\delta^{15}\text{N}$  values.

## Interferences

Because  $\text{CO}_2$  has the same  $m/z$  values as  $\text{N}_2\text{O}$ , it poses an analytical interference if it is not completely removed from the sample stream. Ammonia ( $\text{NH}_4^+$ ) and dissolved organic nitrogen (DON) do not cause interference.

## Troubleshooting and Bench Notes

Bacterial growth during the initial culture phase is monitored by accumulation of  $\text{NO}_2^-$ . In a healthy culture,  $\text{NO}_2^-$  is completely consumed in 5 to 7 days. If  $\text{NO}_2^-$  is not completely consumed in 7 days, the culture is discarded.

## Maintenance and Maintenance Records

Stocks of bacteria are maintained in 15 % glycerol in a  $-80\text{ }^\circ\text{C}$  freezer. Each week, new plates are streaked from that stock and transferred on agar plates every 2 to 3 days. Single colonies from second- and third-generation plates, but not older, are used to inoculate working cultures. The history of all working cultures is kept in a culture log, with the bacterial strain, date of inoculation, source of inoculum, and date of harvest.

The Nafion driers require replacement every 8 to 10 months. The  $\text{Mg}(\text{ClO}_4)_2$ /Ascarite trap is repacked every 4 to 6 months. The GC is baked out ( $100\text{ }^\circ\text{C}$  overnight) as needed, usually every week.

The IRMS requires a daily check (see Appendix G). A logbook is kept for each IRMS, where notes of maintenance checks, normal settings, problems, and repairs are listed.

Routine maintenance is necessary for the upkeep of the IRMS vacuum system, including (1) checking the pump performance from time to time, (2) changing the pump oil, and (3) changing the oil cartridge in each turbomolecular pump at 6-month intervals. Pump conditions are listed, such as date of oil changes, problems, and repairs in the pump database (file path  $\text{C}:\backslash\text{RSIL}\backslash\text{vacuum pumps}$ ).

Maintenance of ISODAT 2.0 includes importing/transferring results from the ISODAT 2.0 database to the LIMS-LSI computer hard disk and the Data Back-Up computer hard disk (Appendix E).

## **Sample Retention Time and Disposal**

Samples are retained in the RSIL for at least 4 months after reporting data. Samples are then discarded unless the submitter has requested that the samples be returned.

The ISODAT sample files from the IRMS computer are kept indefinitely on two different hard disks of the Data Back-Up computer. Paper reports are kept for a few weeks. Analytical results from the IRMS are exported to LIMS-LSI and kept indefinitely. No data are entered by hand, and no manual calculations are performed on the data.

## **Data Acquisition, Processing, Evaluation, Quality Control, and Quality Assurance**

### **Laboratory Information Management System for Light Stable Isotope (LIMS-LSI)**

In the RSIL, the LIMS-LSI (Coplen, 2000) is used for data processing and evaluation. This system is a database program capable of (1) storing information about samples, (2) storing the results of mass spectrometric delta values of samples after importing from the ISODAT database, (3) calculating analytical results using standardized algorithms stored in a database, (4) normalizing delta values using isotopic reference materials, and (5) generating templates to facilitate loading of samples. With this system, the following can be ensured: (1) quality assurance (QA), (2) laboratory efficiency, (3) reduction of workload and errors owing to the elimination of retyping of data by laboratory personnel, and (4) a decrease in errors in data reported to sample submitters. This database provides a complete record of information on how laboratory reference materials have been analyzed and provides a record of what correction factors have been used. It provides an audit trail for the RSIL.

### **Quality Control (QC) Samples**

Samples are prepared and analyzed in batches—a maximum of 32 daily. Each batch contains approximately four to six reference materials: two are depleted in  $^{15}\text{N}$  and  $^{18}\text{O}$ , and two are enriched in  $^{15}\text{N}$  and  $^{18}\text{O}$ . All of these reference materials serve as QC samples. The preparation and analytical cost of these isotopic reference materials is the responsibility of the RSIL. Both the RSIL and the NWQL monitor these results. Quarterly, the RSIL prepares a summary of results of these internationally distributed isotopic reference materials and makes them available to the NWQL.

Daily, the analyst (1) examines the computer printouts for indications of analytical problems, (2) determines the daily additive and expansion correction factors by the LIMS-LSI, and (3) applies correction factors to isotopic data. The values of these correction factors along with the date and range of analysis numbers are recorded manually in the laboratory “GasBench book” even though the data are already in the LIMS-LSI. After printing the list of isotopic results from the “Table of Samples in Progress,” the analyst reviews the results, determines which samples need to be analyzed a third time to achieve acceptable results (i.e.,  $\Delta\delta \leq 0.25\%$  for  $\delta^{15}\text{N}$  and  $\leq 0.5\%$  for  $\delta^{18}\text{O}$ ) and puts them back to the template. The final average isotopic values for each QC sample, with dates and analysis numbers, are recorded manually in the laboratory “GasBench book” even though the data are already in LIMS-LSI.

## Acceptance Criteria for All QC Samples

Acceptance criteria for QC samples are the same as acceptance criteria for the samples. The rules are as follows:

- If standard deviation is less than or equal to 0.25 ‰ for  $\delta^{15}\text{N}$  and less than or equal to 0.5 ‰ for  $\delta^{18}\text{O}$ , use mean delta.
- If there are three or more analyses, delete the outlier and recalculate.
- If standard deviation of this recalculation is less than or equal to 0.25 ‰ for  $\delta^{15}\text{N}$  and less than or equal to 0.5 ‰ for  $\delta^{18}\text{O}$ , use the mean from this recalculation.
- If none of the above is the case, the result is not accepted and corrective action is required.

## Corrective Action Requirements

If an analyst finds any problem with the daily reference sample data, the analyst contacts the supervisor. The trouble-shooting process will require an evaluation and reanalysis of certain samples to identify the origin of the problem.

If samples do not give satisfactory results after three or more separate analyses, the analyst averages all the data and reports the mean value. Such analytical results are indicated with a comment, and the customer will be advised by e-mail or other means. If the sample was submitted through the NWQL, it is the responsibility of the customer to determine whether the data need to be qualified. If so, the NWQL will mark the result appropriately in USGS databases.

## Responsible Parties for All QA/QC Functions for Procedures Covered in RSIL SOPs

The analyst, with supervisor approval, is responsible for qualifying data and notifying customers.

## Data Management and Records

In addition to evaluating daily sample analyses, every week, an analyst evaluates the data project-by-project, reports results to the customers, and files final project data reports in the laboratory "Correspondence" binder (Appendix H).

## Health, Safety, and Waste-Disposal Information

### Applicable Health and Safety Issues

#### Personal Protection

Safety glasses and protective gloves are recommended whenever samples are handled, especially when the samples are of biological origin. For other precautions and safety procedures, consult the Material Safety Data Sheets (MSDS), which are on file in the laboratory, and <http://www.ilpi.com/msds/#Manufacturers> provides links to MSDSs of most chemical companies.

## Electrical Hazards

Electrical systems must conform to the National Electric Code, the National Fire Protection Association Code (NFPA 70-1971), and the American National Standards Institute (ANSI) Code (C1-1971). Consult the U.S. Geological Survey's Safety and Environmental Health Handbook (U.S. Geological Survey, 2002).

Shock hazards exist inside the instruments. Only an authorized service representative or an individual with training in electronic repair should remove panels or circuit boards where voltages are greater than 20 V. The instruments require a third—wire protective—grounding conductor. Three-to-two wire adapters are unsafe for these instruments.

## Chemical Hazards

The reagent 10 N NaOH is used to stop the bacterial reaction and scavenge CO<sub>2</sub> in the sample vials after NO<sub>3</sub><sup>-</sup> conversion to N<sub>2</sub>O. Gloves should be worn when handling strong bases, and if contact occurs, the affected area should be rinsed thoroughly with water.

## Gas Cylinder Handling

Compressed gas cylinders must be handled and stored according to the Safety and Environmental Health Handbook (U.S. Geological Survey, 2002). Each cylinder must be (1) carefully inspected when received; (2) securely fastened at all times with an approved chain assembly or belt; (3) capped at all times when not in use; (4) capped when transported; (5) transported only by a properly designed vehicle (hand truck); and (6) stored separately with other full, empty, flammable, or oxidizing tanks of gas, as appropriate.

## Biological Hazards

The bacteria used in this method are not a significant health hazard. However, infection may occur if bacterial culture comes in contact with open wounds or if needles that have been used with the bacteria puncture the skin. If contact with bacterial culture occurs, wash the affected area thoroughly with water and use an alcohol swab (70% EtOH) to cleanse the affected area.

Bacterial cultures should be killed by autoclaving or by addition of 0.05 mL 10 N NaOH to the culture before sink disposal.

Needles that have been used with the bacteria should be placed in a "Sharps" container, sealed, and disposed of when the container is full. The container should be labeled "biological hazard" and disposed of in the same manner that hazardous chemicals are disposed of.

## Specific Waste-Disposal Requirements

None.

# Revision History

Publication Series and Series Number: Techniques and Methods 10-C14 (Book 10, Section C, Chapter 14)

Publication Title: Determination of the  $\delta(^{15}\text{N}/^{14}\text{N})$  and  $\delta(^{18}\text{O}/^{16}\text{O})$  of Nitrate in Solids: RSIL Lab Code 2897

Publication Authorship: Révész, Kinga, and Casciotti, Karen.

First Version and Date of First Release: 2007

Current Version and Date of Current Release: 2007

Summary of Product Components

Component	Description	Last Revised In Publication Version	Date of Last Revision

List of Revisions (latest version first):

## References Cited

- Böhlke, J.K., Gwinn, C.J., and Coplen, T.B., 1993, New reference materials for nitrogen-isotope-ratio measurements: *Geostandards Newsletter*, v. 17, p.159–164.
- Böhlke, J.K., and Coplen, T.B., 1995, Interlaboratory comparison of reference materials for nitrogen-isotope-ratio measurements, *in* Reference and Intercomparison Materials for Stable Isotopes of Light Elements: Vienna, Austria, International Atomic Energy Agency, IAEA-TECDOC-825, p. 51–66.
- Böhlke, J.K., Mroczkowski, S.J., and Coplen, T.B., 2003, Oxygen isotopes in nitrate: New reference materials for  $^{18}\text{O}$ : $^{17}\text{O}$ : $^{16}\text{O}$  measurements and observations on nitrate-water equilibration: *Rapid Communications in Mass Spectrometry*, v. 17, p. 1835–1846.
- Brenna, J.T., Corso, T.N., Tobias, H.J., and Caimi, R.J., 1997, High-precision continuous-flow isotope-ratio mass spectrometry: *Mass Spectrometry Reviews*, v. 16, p. 227–258.
- Casciotti, K.L., Sigman, D.M., Galanter Hastings, M., Böhlke, J.K., and Hilkert, A., 2002, Measurement of the oxygen isotopic composition of nitrate in seawater and freshwater using the denitrifier method: *Analytical Chemistry*, v. 74, p. 4905–4912.
- Gonfiantini, R., 1978, The  $\delta$ -notation and the mass-spectrometric measurement techniques, *in* Gat, J.R., and Gonfiantini, R., eds., *Stable isotope hydrology: deuterium and oxygen-18 in the water cycle*. International Atomic Energy Agency, Technical Report Series No 210, chap. 4. p. 35–85.
- Clark, I., and Fritz, P. 1997, *Environmental Isotopes in hydrogeology*: New York, Lewis Publisher, p. 328.
- Coplen, T.B., 2000, A guide for the laboratory information management system (LIMS) for light stable isotopes—Version 7 and 8: U. S. Geological Survey Open-File Report 00-345, p. 121.
- Coplen, T.B., 1996, New guideline for the reporting of stable hydrogen, carbon and oxygen isotope ratio data: *Geochimica Cosmochimica Acta*, v. 60, p. 36–59.
- Mariotti, A., 1983, Atmospheric nitrogen is a reliable standard for natural  $^{15}\text{N}$  abundance measurements: *Nature*, v. 303, p. 685–687.
- Révész, K., and Qi, H., 2006, Determination of the  $\delta(^{15}\text{N}/^{14}\text{N})$  of total nitrogen in solids: RSIL Lab Code 2893, *in* Révész, K., and Coplen, T.B., eds., *Methods of the Reston Stable Isotope Laboratory*: Reston, Va., U.S. Geological Survey, Techniques and Methods, Book 10, Sec. C, Chap. 11, 31 p.
- Sigman, D. M., Casciotti, K. L., Andreani, M., Barford, C., Galanter, M., and Böhlke, J.K., 2001, A bacterial method for the nitrogen isotopic analysis of nitrate in seawater and freshwater: *Analytical Chemistry*, v. 73, p. 4145–4153.
- U.S. Geological Survey, 2002, USGS Handbook 445-3-H, *Safety and Environmental Health Handbook*, 435 p.

## Appendix A. Step-by-Step Procedure to Log-In Samples to LIMS-LSI

1. For samples submitted through the NWQL:
  - a. Match up information on sample bottles with information on ASR forms by spreading out ASR forms and placing each bottle on its respective ASR form. Check for broken bottles.
  - b. Assign the NWQL #s based on the Julian date of the Monday following the submission date. Check note on bulletin board for “Next NWQL #.” Write the NWQL #s on ASR forms, then update “Next NWQL #” on bulletin board.
  - c. Use “New Project Log-In” in LIMS-LSI to assign G-#s; field IDs are the Station IDs. The submission date is the date samples are logged in.
  - d. Enter all ASR information into LIMS-LSI, sample by sample.
  - e. Print out two Project Reports, Labels (two for each sample), and Sample Range forms.
  - f. Put a label on a sample bottle and on the corresponding ASR form; crosscheck Field IDs between bottles and ASR forms.
  - g. Make one photocopy of each ASR form.
  - h. Enter G-# range into the appropriate template.
  - i. Proofread information on Sample Range forms against ASR forms (recruit help if necessary). Make corrections in LIMS-LSI, if necessary and print out corrected Sample Range Forms. Initial and date both Project Reports to indicate that proofreading is complete.
  - j. In LIMS-LSI, save the NWQL Headings to a diskette.
  - k. In ISOTOPEs e-mail on the common-use PC, copy headings into new message from diskette by opening headings-file in Notepad and copying and pasting to new message. Print a copy of headings and e-mail to each project chief for information review and the NWQL [Attn: Jeanne Hatcher (jhatcher@usgs.gov)].
  - l. Mail copies (not originals) of ASR forms and corrected Sample Range forms to the NWQL [National Water Quality Laboratory, Attn: Jeanne Hatcher, U.S. Geological Survey, P.O. Box 25708, MS 407, Building 95, Denver Federal Center, Denver, CO 80225-0608 (Tel: 303-236-3481)]. Envelope should be mailed every Friday.
  - m. Punch holes in original ASRs and put in “Central Lab” binder along with project reports and date on piece of tape. Punch holes in the NWQL headings and other project report and place in “Samples-in-Progress” binder.
  - n. Add samples to the “Table of Samples to Be Analyzed” in LIMS-LSI.
    - i. Click the “Projects” button of LIMS-LSI.
    - ii. Select the project that was logged in.
    - iii. Click the “Templates” button.
    - iv. Select “GB for N and O.”
    - v. Click “Add” and close LIMS-LSI.
  - o. Put samples in freezer for storage until analyzed.
2. For samples submitted directly to the RSIL:
  - a. For sample submitter:
    - i. Download “RSIL Excel Worksheet” from the RSIL website at <http://isotopes.usgs.gov/>.
    - ii. Fill out the requested sample information.
    - iii. Send diskette and a hard copy along with the samples.
  - b. For RSIL personnel:
    - i. Match up information on sample bottles with submitted “Excel Worksheet.”
    - ii. Enter all Excel Worksheet information into LIMS-LSI by loading diskette. Submission date is the date samples are logged in.
    - iii. Use “New Project Log-in” in LIMS-LSI to assign G-#s; field IDs are the Station IDs.
    - iv. Print out one Project Reports and container labels (one for each sample).

- v. Put a label on a sample bottle and crosscheck Field IDs between bottles and Excel Worksheet forms.
- vi. Enter G-# range into the appropriate template.
- vii. Punch holes in original Excel Worksheet and all the information for the project and put in “Samples-in-Progress” binder.
- viii. Add samples to the “Table of Samples to Be Analyzed” in LIMS-LSI.
  - 1. Click the “Projects” button of LIMS-LSI.
  - 2. Select the project that was logged in.
  - 3. Click the “Templates” button.
  - 4. Select “GB for N and O.”
  - 5. Click “Add” and close LIMS-LSI.
- ix. Put samples in freezer for storage until analyzed.



## **Appendix B. Step-by-Step Procedure to Print a Template and a Samples-to-Be-Analyzed List**

### **Template**

1. Use "Print Template" in LIMS-LSI.
2. Select "appropriate template" for GasBench, aureofaciens, N&O, and "Delta Plus" IRMS.
3. Design analysis sequence with 32 ports.
4. Click "New Template."
5. Add any sample information you want in column "Sample/Extraction Info."
6. Click "Print."
7. Insert diskette to receive sample headings.
8. Click "OK."
9. Exit LIMS-LSI.
10. Write sample amount (mL) needed to load into each vial, and the date that samples should be analyzed on the template.

**Samples to be Analyzed List 10/20/2003 3:54:33 PM**

N-7, N-34, and N-35 Are Reference Materials

<b>Port</b>	<b>Sample #</b>	<b>Amount</b>
<b>1</b>	<b>N-7</b>	
<b>2</b>	<b>N-34</b>	
3	G-70	
4	G-71	
5	G-72	
6	G-73	
7	G-74	
8	G-75	
<b>9</b>	<b>N-34</b>	
<b>10</b>	<b>N-7</b>	
11	G-76	
12	G-77	
13	G-78	
14	G-79	
15	G-80	
16	G-81	
17	G-82	
18	G-83	
19	G-84	
<b>20</b>	<b>N-35</b>	
21	G-85	
22	G-86	
23	G-87	
24	G-88	
25	G-89	
26	G-90	
27	G-91	
28	G-92	
29	G-93	
30	G-94	
<b>31</b>	<b>N-35</b>	
<b>32</b>	<b>N-7</b>	

# Appendix C. Step-by-Step Preparation Procedure for N Isotope Analyses of Nitrate by Bacterial Denitrification

## Making the Plates

1. Preparing the plates:
  - a. Mix together:
    - i. 23 g tryptic soy agar (TSA)
    - ii. 0.5 g KNO<sub>3</sub>
    - iii. 500 mL E-pure or Milli-Q water
  - b. AUTOCLAVE 30 MIN.
  - c. Cool ~15 min (until you can handle the flask with a gloved hand).
  - d. Pour into sterile plastic Petri dishes, flaming the lip of the flask every 3 to 4 plates (500 mL should make ~20 plates).
  - e. Allow the plates to solidify overnight.
  - f. Label the bag with a piece of tape; include what kind of plates (TSA, plus NO<sub>3</sub><sup>-</sup>), today's date, and initials of who made the plates.
  - g. Store plates in the refrigerator until use.
2. Streaking the bacteria:
  - a. In the -80 °C-freezer there is a box that contains the freezer stocks of *P. aureofaciens* American Type Culture Collection (ATCC)13985.
  - b. Take bacteria from the freezer stock: Do not wait for the vial to thaw—use a sterile toothpick to scrape some bacterial slush from the tube. CLOSE the tube before doing anything else. The freezer stocks are our most important resource.
  - c. Lightly touch the toothpick to the surface of a plate to transfer the bacterial slush. It should form a small puddle.
  - d. Using a flamed loop, spread the puddle by streaking back and forth through it. Flame the loop. Proceed with streaking by crossing trails twice with tracks of the first streak. Flame the loop. Cross trails twice with the second streak and proceed. This plate will be numbered as #1.
  - e. To streak new plates from earlier plates: Using a single colony from #1 plate, streak, flame, streak, flame, streak (as above from freezer stocks). This plate will be numbered as #2.
  - f. Plate labeling:
    - i. Strain (*P. aureofaciens*)
    - ii. Plate #
    - iii. Today's date
    - iv. Source information in parentheses (“freezer” or date of earlier plate)
  - g. Plates take 2 to 3 days to mature so one will typically go through a round each week.
  - h. Keep plate lineages together for ease of organization. Discard old plate lineages when a new #2 plate has matured and is ready to be used for inoculating. If streaking #3s also streak new #1s on the same day.

## Preparing the Tryptic Soy Broth (TSB)

1. Wash the 580 mL specially made medium bottles (580-mL bottle attaches with 23 × 75.5 mm 20 mL headspace vial neck) used serum bottles (new ones do not have to be cleaned):
  - a. Brush wash inside with Liqui-Nox detergent.
  - b. Rinse with warm water and deionized water (DIW).
  - c. Bake in 200° C oven overnight.

2. Making the medium: (making 7000 mL medium and distribute into 14 × 580 mL bottles):
  - a. Mix together:
    - i. 210 g DIFCO Tryptic soy broth (TSB)
    - ii. 7.0 g KNO<sub>3</sub>
    - iii. 3.5 g (NH<sub>4</sub>)<sub>2</sub>SO<sub>4</sub>
    - iv. 34.3 g potassium phosphate
  - b. Add 7000 mL DIW.
  - c. Distribute the well-homogenized 500 mL mixed medium into a 580-mL bottle by peristaltic pump.
  - d. Seal bottles with blue butyl stoppers and aluminum crimp-seals.
  - e. Autoclave for 60 min, the time starts after the autoclave reached 120 °C.
3. Making the NO<sub>3</sub><sup>-</sup>-free medium: (making 2000 mL medium and distributing into 20 × 100 mL serum bottles)
  - a. Mix together:
    - i. 30 g Tryptic soy broth
    - ii. 0.5 g (NH<sub>4</sub>)<sub>2</sub>SO<sub>4</sub>
    - iii. 4.9 g KH<sub>2</sub>PO<sub>4</sub>
  - b. Add 2000 mL DIW.
  - c. Distribute the well-homogenized 100 mL NO<sub>3</sub><sup>-</sup>-free medium into 160-mL serum bottles by peristaltic pump.
  - d. Autoclave for 60 min, the time starts after the autoclave reaches 120 °C.
4. Incubating the bacteria:
  - a. Measure 5-mL autoclaved medium into a sterile plastic test tube.
  - b. Using a well-flamed loop, pick a colony from a #2 or #3 plate (do not inoculate from a #1 plate unless it is an emergency).
  - c. Open the tube and touch the end of the loop to the inside of the tube or swish the end of the loop in the broth to transfer the colony. Whichever you do, do it quickly. Get in and out of the bottle as quickly as possible.
  - d. Label tube:
    - i. Strain
    - ii. Today's date
    - iii. Source of the inoculum (plate # and date)
  - e. Incubate the tube on a shaker overnight. This is good for 1 day only.
  - f. Add 5 mL starting solution to each 580-mL culture bottle, and enter each inoculated bottle in the Culture Log, one line per bottle.
  - g. Put the bottles on the shaker, and grow bacteria for a week.
5. Generally, inoculations will be done four times a week (Tuesday through Friday) with two to four bottles each day. These cultures will grow for a week before they are harvested so if you need it next week, inoculate it today.

### Testing Bacteria for Incomplete Conversion of Nitrate

1. Withdraw 1 mL from each 580-mL culture to be harvested.
2. Add 40 µL sulfanilamide.
3. Add 40 µL N-(1-haphthyl)ethylenediamine dihydrochloride (NED).
4. If it turns pink, the bacteria did not convert the NO<sub>3</sub><sup>-</sup> to N<sub>2</sub>O completely, it stopped at NO<sub>2</sub><sup>-</sup>. Do not use that bottle. In a good conversion you should see no NO<sub>2</sub><sup>-</sup> and a dense culture after 5 days

## Harvesting the Bacteria—Concentrating Culture by Centrifugation

1. Pour 200 mL culture into 200-mL centrifuge bottles.
2. Put the bottles into centrifuge, making sure they balance out each other.
3. Centrifuge it for 15 min, 18 °C with 73,800 rpm. (Bacteria should be pelleted on the bottom of the bottle).
4. Discard clear medium supernatant, taking care not to disturb the pellet of bacteria.
5. Add 10 mL from a 100-mL,  $\text{NO}_3^-$ -free medium unit into each bottle.
6. Shake it well to resuspend the bacteria.
7. Transfer the resuspended bacteria into a 200-mL beaker.
8. Use remaining  $\text{NO}_3^-$ -free medium for rinsing all four centrifuge bottles.
9. Combine all of them in one 200-mL beaker.
10. Add 10 drops antifoam B.

## Adding Concentrated Cell Culture to Sample Vial and Purging Headspace and Adding Samples

1. Dispense 3 mL concentrated cell culture into sample vial.
2. Seal vial with Teflon-lined silicone septum and aluminum crimps.
3. Insert He vent needle (1.5-in. long, 25 gauge) into vial.
4. Insert each vial upside down into purging rack.
5. Purge vials with 3 to 4 psi He for 1 h.
6. Inject appropriate amount sample water to produce 5 to 20 nmol  $\text{N}_2\text{O}$  (1 to 10 mL) with an airtight syringe equipped with a 25-gauge needle. If the amount of water needed is more than 4 mL, insert a venting needle to avoid over pressurization. Mix well by inverting the vial several times.
7. Turn the vial upside down and incubate it for 2 h.
8. Samples now are ready to be loaded to GasBench for isotope analysis.

## Appendix D. Step-by-Step Procedure to Add Sample Information to Sequence Table

1. Insert the diskette with sample headings generated by LIMS-LSI.
2. Open sequence table in Excel.
3. Open "N<sub>2</sub>O Sample Sequence File" under GB configuration.
4. Copy sequence template from Excel and paste it to sequence table.
5. Select appropriate "method" for each sample.
6. Define reference line and blank line (if you have any).
7. Start.
8. Give Folder Name: Comment.
  - a. Select pre: "Date."
9. Give File Name: leave it empty
  - a. Select pre: "Analyzes #."
  - b. Select post: "Identifier 1."
  - c. Select: "Print Result."
10. Click OK.
11. Wait for first sample to be analyzed.

## Appendix E. Step-by-Step Procedure to Transfer Data to LIMS-LSI, to Transfer Data to Back-Up Computer, and to Reevaluate Old Data

1. Transfer data to LIMS-LSI:
  - a. Start LIMS.
  - b. Choose "Import Analysis."
  - c. Choose IRMS "Delta Plus."
  - d. Click "Import."
  - e. Select the file that will be imported.
  - f. Select columns containing  $\delta^{15}\text{N}$  and  $\delta^{18}\text{O}$  data. Check the boxes to import these two columns.
  - g. Click Import. Note: Sample ID, Peak Area, Analysis # are automatically imported to LIMS-LSI.
2. Transfer data to Data Back-Up computer:
  - a. Go to Windows Explorer in the Data Back-Up computer.
  - b. Find the drive your back ups are stored.
  - c. Choose: "RSIL."
  - d. Choose: "Mass. Spec. Analysis Back Up."
  - e. Choose: "P." (Stands for Delta<sup>Plus</sup> IRMS).
  - f. Under that folder create a new folder. The name of the folder should be the date range when those analyses were done that you want to back up.
  - g. Transfer data to that folder.
  - h. Make back ups every 2 weeks or so, as required.
3. Reevaluate old data:
  - a. Find your samples in the Data Back-Up computer.
  - b. Transfer data by a Zip disk or "memory stick" to the computer where a virtual version of ISODAT 2.0 is installed.
  - c. Reevaluate your data.

## Appendix F. Step-by-Step Procedure to Determine and Apply Correction Factors and Evaluate Data

1. Open “Correction Factors and Normalization Equations” in LIMS-LSI.
2. Select the IRMS and isotope, such as “P (Delta Plus) for 15N or 18O.”
3. Select “Query.”
4. Double click on the last sample analyzed on that day.
5. Evaluate data of the reference materials. (Ignore outliers. There should not be more than 1 or 2 outliers).
6. Choose “Normalize with all References.”
7. Accept “Expansion Correction and Additive Correction factors.”
8. Print out correction factor sheet.
9. Report daily reference values and correction factors along with date and range of analysis number to the “GB” binder.
10. Go back to LIMS-LSI main menu by closing open windows.
11. Choose “Print Samples in Progress,”
  - a. Open “Sample in Progress.”
  - b. Choose appropriate isotope.
  - c. Choose appropriate prefix (W for water, N for nitrogen, S for sulfur, O for oxygen).
  - d. Put in sample ID range from “Samples-to-Be-Analyzed” sheet. Click Print.
12. Review results; determine repeats.
13. Put repeats back to “Table of Samples to Be Analyzed.”
  - a. Go back to LIMS-LSI main menu.
  - b. Open “Print Templates.”
  - c. Select appropriate template name for the IRMS with which the samples are analyzed.
  - d. Find the sample in the “List of Samples.”
  - e. Change “Repeats” from 0 to 1.
  - f. Close windows and exit LIMS-LSI.



## Appendix G. Daily Check List

Analyst in charge: \_\_\_\_\_ Date: \_\_\_\_\_

Weekly:

1. Change working reference gas tank and He gas tank if the pressure is < 500 psi. Order new ones for spares; reference gas is research grade, He carrier gas is zero grade.
2. Change Nafion after every 10 months and water and CO<sub>2</sub> trap after every 6 months.

THESE ITEMS ARE TO BE CHECKED OFF AS YOU CHECK THEM DAILY!

1. Check He and Reference gas flow. [ ]
2. Check background masses. [ ]

Cups	Mass	Intensity (V)	Mass	Intensity (V)	Resistor ( $\Omega$ )	Capacity (pF)
1	<b>28</b>	0.007		0	$3 \times 10^8$	680
2	<b>29</b>	0.003	<b>18</b>	1.256	$3 \times 10^{10}$	5
3	<b>30</b>	0.083	<b>18</b>	6.818	$3 \times 10^{11}$	2

3. Analyze Ref on/off method three times to stabilize IRMS. [ ]
4. Check peak center. If it is off default value (2047) by 50, do mass calibration. [ ]
5. Analyze Ref on/off method 10 times to stabilize IRMS (STD should be < 0.1 ‰). [ ]

ConFlo Pressure Setting N <sub>2</sub> O (bar)	N <sub>2</sub> O signal (V) Mass 45 on Cup 2
0.25	0.638
0.50	1.59
<b>0.75 Optimal setting</b>	<b>2.653</b>
1.00	3.921
1.25	5.315
1.50	7.059
1.75	8.778
2.00	>10.8 (saturated)

6. Check paper in printer. [ ]

## Appendix H. Step-by-Step Procedure to Report Data

1. Open “Store Samples in Progress” in LIMS-LSI.
2. Choose the appropriate isotope.
3. Choose sample ID range from “Sample in Progress” print out.
4. Store data.
5. Go back to the LIMS-LSI main menu.
6. Open “Project” and find the appropriate project in the list.
7. Select “Print Report” and check whether the project report contains all the results. If not, search for the missing results in the database.
8. Select “Results,” transfer data in Excel format or (and) text format to a diskette, and report data to customer through e-mail.
9. Click “Print Report” to print a project report and put it in the “Correspondence” binder along with all other documents in the “Samples In Progress” binder that are related to this project.
10. If the samples were submitted through the NWQL, click “NWQL Export” and transfer data in NWQL format to a disc; report these data to the NWQL by e-mail. Print a copy of the NWQL export file and save in the “Correspondence” binder with the project report printed in the step above.