

FAST
Small Explorer Mission

Project Data Management Plan

August 13, 1996

National Aeronautics and Space Administration
Goddard Space Flight Center
Greenbelt, Md 20771

National Aeronautics and Space Administration
Goddard Space Flight Center
Project Data Management Plan
for the FAST Small Explorer Mission

Prepared by: _____
Ms. Mary E. Baxter (Hughes STX) Date
SMEX Software Systems Engineer

Concurrence: _____
Dr. Charles W. Carlson (UCB) Date
FAST Principal Investigator

Concurrence: _____
Dr. Robert F. Pfaff (696) Date
FAST Project Scientist

Concurrence: _____
Mr. Jim Watzin (740.4) Date
SMEX Project Manager

Concurrence: _____
Mr. Paul J. Pashby (602) Date
Manager, Orbiting Satellites Project

Concurrence: _____
Dr. Joseph H. King (633) Date
Head, NSSDC

Concurrence: _____
Dr. George L. Withbroe (SA) Date
Science Director for Sun-Earth Connection

Table of Contents

1.0	Introduction	1
1.1	Purpose and Scope.....	1
1.2	PDMP Management Responsibility.....	1
1.3	Change Control.....	1
1.4	Relevant Documents.....	2
2.0	Project Overview	3
2.1	Project Objectives.....	3
2.2	Science and Mission Objectives.....	3
2.3	Spacecraft Description.....	3
2.4	Mission Summary.....	5
3.0	Instrument Overview.....	6
3.1	Electrostatic Analyzers (ESAs).....	6
3.2	Time-of-flight Energy Mass Angle Spectrograph (TEAMS).....	7
3.3	Magnetic Field Instrument.....	11
3.4	Electric Field/Langmuir Probe (E-Fields).....	11
3.5	Instrument Data Processing Unit (IDPU)	14
4.0	Project Data Flow	15
4.1	Mission Operations.....	15
4.2	Science Operations.....	19
4.3	Data Accessibility and Archiving	24
5.0	Data Rights and Rules for Data Use	27
6.0	Acronyms and Abbreviations	28
	Appendix A: Data Products.....	31
A.1	Science Data Product Summary	31
A.2	Associated Archive Products.....	33

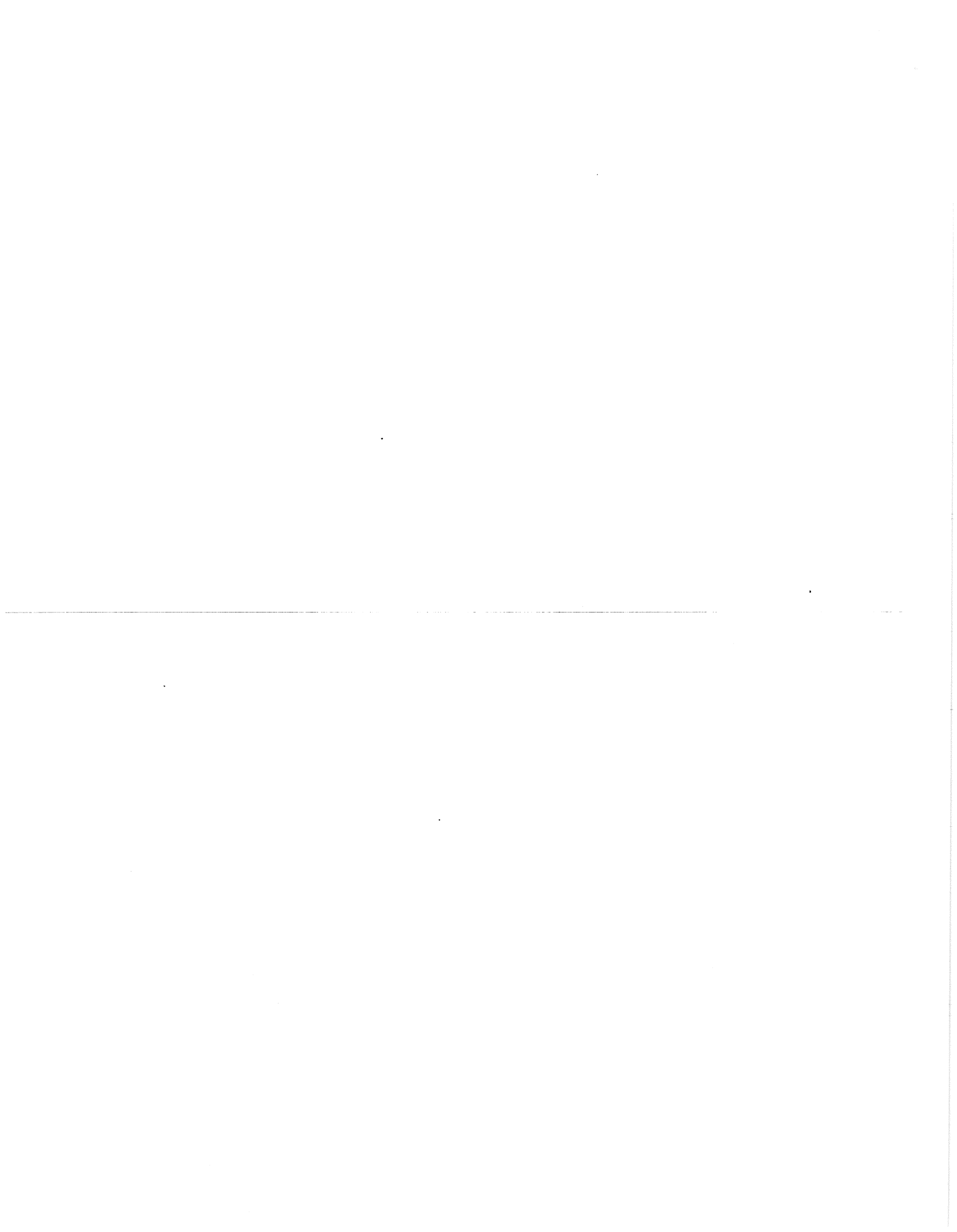

1.0 Introduction

1.1 Purpose and Scope

This document provides the Project Data Management Plan (PDMP) for the Fast Auroral Snapshot (FAST) Explorer mission. This PDMP describes all of the activities associated with the flow of FAST scientific data including the planning and scheduling of observations, the on-board instruments and their data collection characteristics, the operational phases of the mission, and the eventual archiving of data products. While plans for eventual disposition of data products to be located at common facilities are described, this PDMP does not address the disposition of data once they have been delivered to the designated archive.

The purpose of this PDMP is to ensure that FAST data management has been adequately addressed, and to provide a basis for assessing demands on, and capabilities of, data management infrastructure elements. Further, during the FAST mission development and operations phases, the purpose of this PDMP is also:

- to identify data products and explicitly establish the timeline for when they will be made available for wide use;
- to serve as the interface control document between the project and its designated archive; and
- to explicitly identify and specify data products, software, and supporting information to be delivered by the investigators to the project and/or to the designated archives.

1.2 PDMP Management Responsibility

The Small Explorer Project Office at Goddard Space Flight Center (GSFC), Code 740.4, is responsible for the development, maintenance, and management of the PDMP until FAST has transitioned to an operational mission after launch. Responsibility for the plan remains with the SMEX Project Manager, Mr. James Watzin/Code 740.4, (301) 286-7417, until 30 days after launch. At that time, responsibility for the FAST mission, including PDMP updates, will transition to the Orbiting Satellite Project (Code 602) at GSFC.

1.3 Change Control

After signature release and until transition to an operational mission, the FAST PDMP will be modified and updated as required in accordance with the Configuration Management Plan for Small Class Explorer (SMEX) Missions [1]. After launch and transition of responsibility for the FAST mission to Code 600, PDMP change control will be the responsibility of Code 602.

1.4 Relevant Documents

The referenced documents that pertain to the FAST PDMP are listed below. SMEX/FAST project documents are available from the SMEX Configuration Management office, (301) 286-7599.

- [1] "Configuration Management Plan for Small Class Explorer (SMEX) Missions", SMEX-MGMT-002, July 1989.
- [2] "SMEX/FAST Project Plan", SMEX-MGMT-012, July 1992.
- [3] "SMEX/FAST Telemetry and Command Handbook", FAST-ICD-001, Volume I (Version 3.2, June 1993) and Volume II (Version 8.0, March 1994).
- [4] "Space Data Systems Operations with SFDUs: System and Implementation Aspects", CCSDS 610.0-G-5, Green Book, Issue 5, February 1987 or later.
- [5] "Detailed Mission Requirements (DMR) Document for the Small Explorer FAST Mission", 501-215/FAST, March 1993.
- [6] "Data Acquisition Plan for the FAST Small Explorer Mission", 502-DAP/FAST, March 1993.
- [7] "ICD Between the FAST PPS and the UCB FAST Team", 521-ICD-004, April 1993.
- [8] "FAST Flight Operations Plan", FAST-OPS-006, November 1993.
- [9] "FAST Interface Control Document Between the Command Management System and the Science Operations Centers", 514-4ICD/1092, April 1993.
- [10] "NSSDC Common Data Format (CDF) Users Guide", Ver 2.4, NSSDC/WDC-A-R&S, GSFC, January 1994.

2.0 Project Overview

2.1 Project Objectives

The SMEX program at the GSFC was established in 1989 to provide rapid, low cost mission opportunities to the space science community using a single designated Principal Investigator (PI) approach. Three SMEX missions were selected for definition in June, 1989. The first SMEX mission, the Solar Anomalous Magnetospheric Particle Explorer (SAMPEX) was launched in July of 1992. FAST is the second SMEX mission. It is currently scheduled for launch in August 1996 from the Western Test Range. The third SMEX mission, the Submillimeter Wave Astronomy Satellite (SWAS) is scheduled for launch in 1996.

2.2 Science and Mission Objectives

The FAST mission will investigate the plasma physics of auroral phenomena at extremely high time and spatial resolutions. Data from the FAST satellite are expected to reveal the key physical processes responsible for accelerating electrons into the earth's upper atmosphere that produce the visible aurora. The FAST Principal Investigator (PI) is Dr. Charles W. Carlson of the University of California, Berkeley (UCB). He is supported by a team of ten Co-Investigators (see Section 4).

In order to achieve the scientific objectives of the FAST mission, the Spacecraft instruments must repeatedly sample the high altitude fields and charged particle environment over the auroral zones that surround the earth's north and south magnetic poles. In order to capture the auroral phenomena over small time and spatial scales, FAST will utilize high speed data sampling, a large, fast-loading or "burst" memory, and smart, on-board software to trigger on the appearance of various key phenomena. Since both fields and particle data will be collected within the auroral acceleration region, the measurements promise to enable cause and effect to be distinguished among a myriad of auroral physics phenomena. FAST scientific objectives are further described in the FAST Project Plan [2].

A very important aspect of the FAST Small Explorer mission is its linkage to scientific studies planned by several other teams of researchers in the space physics community. For example, campaigns are being formulated in which sounding rockets and dedicated ground-based all-sky cameras, auroral TV, and magnetometers would operate in conjunction with coincident FAST orbits overhead. In addition, FAST provides an important low-altitude complement to the International Solar Terrestrial Physics (ISTP) program.

2.3 Spacecraft Description

The FAST spacecraft is a small, lightweight, orbit-normal spinner with multiple on-orbit deployable booms. The spacecraft provides structure, power, thermal control, telemetry and communication links, attitude control, and health monitoring support for the scientific instruments. An expanded view of the FAST spacecraft is shown in Figure 1. (NOTE: The deployed spacecraft configuration is shown later, in Figure 4).

The FAST primary structure is constructed of aluminum and includes a circular deck on which the instruments and electronic boxes are mounted. There are two magnetometer booms located 180 degrees relative to each other in the spin plane, which are stowed along the spin axis for launch. In addition, there are two axial stacer electric field booms and four radial, equally spaced, wire electric field booms that are deployed after launch. The power subsystem consists of fixed, body-mounted, GaAs solar arrays with shunt regulators, as well as a NiCd battery and an unregulated +28 volt DC bus for power distribution. Temperatures are controlled primarily by passive thermal control elements.

The spacecraft command and data handling (C&DH) system is embedded within the spacecraft electronics module. This module is known as the Mission Unique Electronics (MUE), and uses a pair of 2 MHz 80C85 microprocessors, with 72Kbyte ROM and 320Kbyte RAM. The MUE performs telecommand reception, stored command processing, telemetry data collection and generation, attitude control, power management and battery charge control, and spacecraft health and safety functions. Also within the MUE is an 800Kbyte RAM recorder for capturing spacecraft safing events. The Instrument Data Processing Unit (IDPU) manages and controls the multiple components of the fields and particles instruments, including boom deployment. Within the IDPU is a high density 1 Gbit solid state recorder, which includes a 1-2 Mbyte partition for spacecraft health and safety data.

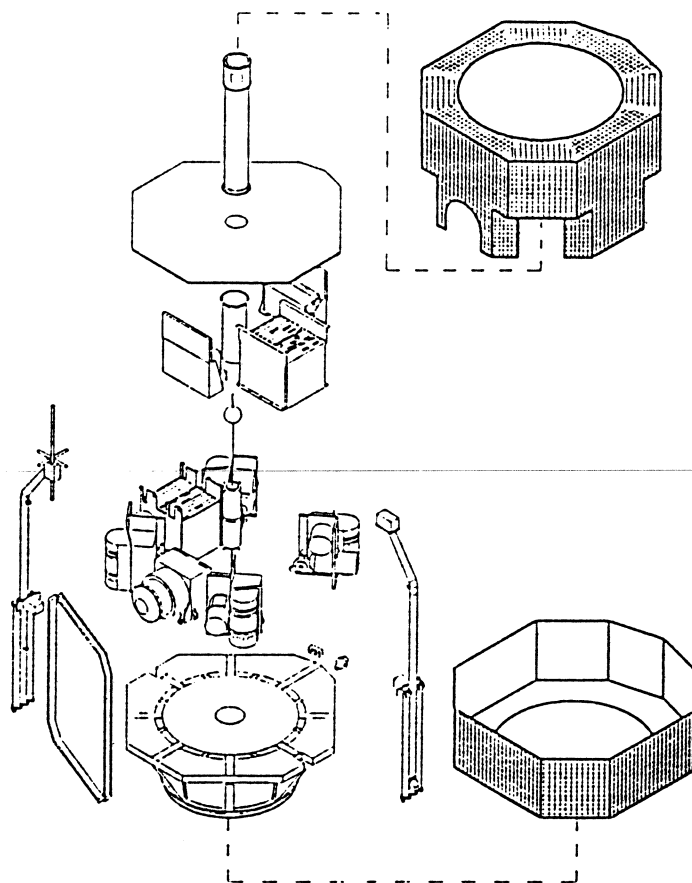

Figure 1: FAST Spacecraft

The Attitude Control System (ACS) for FAST is designed to maintain the spacecraft attitude as a simple spinner with a rotation rate of approximately 12 rpm. Pointing requirements are met by utilizing a complement of sensors, torquers and standard electronics in the MUE. The near orbit-normal spinner will use electromagnets to keep up with the daily orbit precession and to perform sun angle avoidance maneuvers to maintain the sun angle less than 60°.

FAST uses a standard 5-Watt NASA transponder that receives commands at a data rate of 2Kbps that are transmitted as Non-Return to Zero (NRZ) bi-phase modulation on a 16 KHz sub-carrier at 2.03964 GHz. Telemetry data is transmitted at 4 digital data rates (4 Kbps, 900 Kbps, 1.5 Mbps, and 2.25 Mbps) using NRZ phase modulation directly on the carrier.

2.4 Mission Summary

A summary of the nominal FAST mission parameters is listed in Table 1. FAST will be launched on a Pegasus rocket in August, 1996, nominally into a 350 x 4200 km orbit, inclined 83 degrees. The orbit's alignment of perigee changes at -1.75 degrees per day, and its right ascension of ascending node changes at -0.5 degrees per day. Mission life is nominally 1 year, with additional years of operation possible.

Orbit Description	inclination: 83° apogee: 4200 km perigee: 350 km period: 133 min
Launch Date	August 12, 1996
Launch Vehicle	Pegasus
Nominal Mission Duration	1 year
Potential Mission Life	5 years+
Spacecraft Mass	410 lb.
Attitude Control Accuracy	spin: +0, -1% precession: ±1.0°
On-Board Data Storage Capacity	1 Gigabit
Continuous Data Acquisition Rate	variable, up to 8 Mbits/sec

Table 1: FAST Mission Summary

FAST auroral science investigation requirements dictate a campaign style of mission operations while the FAST apogee is in the northern hemisphere during the local winter months. For the first such two month campaign period, one to two passes of telemetry (acquired at Poker Flat, Alaska and Kiruna, Sweden) will be scheduled every orbit (10-11 per day), with commands being sent at least once per day. (Note: Such commanding will be possible every orbit from Poker Flat during the campaign.) For the rest of the FAST mission, non-campaign telemetry contacts will be 10-11 per day in the northern hemisphere and 4-6 contacts in the southern hemisphere.

The SMEX missions do not utilize the NASA Tracking and Data Relay System (TDRS) and instead rely on a network of ground stations. FAST science downlinks can be performed at 900 Kbps, 1.5 Mbps, and 2.25 Mbps. This mission scenario will yield an average data volume ranging from 4-5 Gbytes per day (campaign) to 1-3 Gbytes per day (non-campaign). A multi-mission Payload Operations Control Center (POCC) at GSFC will support all SMEX missions (currently in use by SAMPEX). The FAST Science Operations Center (SOC) will be located at the University of California (Berkeley).

FAST relies heavily on the recommendations of the Consultative Committee for Space Data Systems (CCSDS) to provide a standard approach for implementing spacecraft telemetry and command interfaces. The CCSDS recommendations utilize layered packetization concepts (virtual channels, application-specific telemetry and command data packets), which simplifies the distribution of telemetry between the MUE, the IDPU, ground operational segments, the SOC, and the National Space Science Data Center (NSSDC).

3.0 Instrument Overview

Equipped with an array of sensors to measure fields and particles, FAST will investigate the production of electric fields and plasma waves by electrons and ions and will also investigate the acceleration and heating of electrons and ions by the waves and fields themselves. The instruments in the FAST complement include: a 3-axis, vector set of electric field/Langmuir double probes (extending 60 meters tip-to-tip in the spin plane) which include additional inner sensors for wavelength and phase velocity measurements, vector fluxgate and search coil magnetometers for DC and AC magnetic field measurements, an ion mass spectrograph, an electron spectrograph, and electron and ion spectrometers. These individual instruments are described in more detail below. Control and management of these instrument components (including boom deployment) is performed by the IDPU.

3.1 Electrostatic Analyzers (ESAs)

3.1.1 ESA Instrument Description

Quadr spherical ESAs are used to measure electron and ion distribution functions. As illustrated in Figure 2, particles enter the analyzer over a 360° field of view (FOV), are selected in energy by the electrostatic analyzer, and imaged by micro channel plate (MCP) and discrete anodes. The 360° FOV is in the spacecraft spin plane which is aligned to within 6° of the magnetic field when the spacecraft is in the auroral zones. The out-of-plane FOV is 10° (5.5° at full-width half maximum (FWHM)) and 12° (7° FWHM) for the electron and ion sensors, respectively.

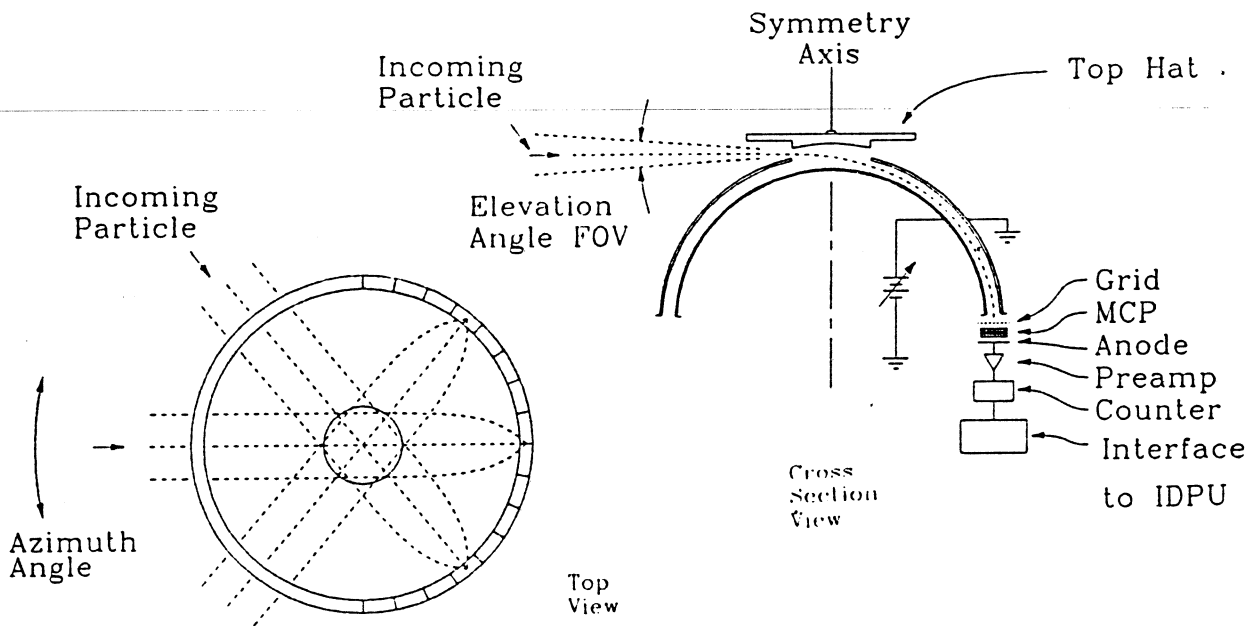

Figure 2: FAST ESA

For the FAST satellite, the sensor head is split into two half analyzers on opposite sides of the spacecraft. Sixteen half analyzers are arranged into four ESA stacks located at 90° intervals around the spacecraft. Each ESA stack contains three Stepped ESA (SESA) analyzers that are used to make the high time resolution electron measurement, and a single ion or electron spectrometer (IESA or EESA) used to make detailed distribution measurements. Each analyzer in the stack can be commanded to operate in numerous combinations of modes and configurations. The ESA stacks also include preamplifier-counter boards, an ESA logic-interface board, and high and low voltage supplies.

ESA capabilities for FAST are summarized in Table 2.

	IESA	EESA	SESA
Measurement Type	Ion	Electron	Electron Stepped
Energy Range	3 eV - 24 keV	4 eV - 30keV	4 eV - 30 keV
$\Delta E/E$	0.20	0.15	0.15
Geometric Factor	.014 CM ² -SR-E	.0047 CM ² -SR-E	6 x .010 CM ² -SR-E
Field of View	360° x 12° *	360° x 10°*	360° x 10°
Angular Resolution	11.2° x 12°	11.2° x 10°	22.5° x 10°
Time Resolution	78 ms	78 ms	1.6 ms
Sample Array (Energy x Angle)	48E x 32A**	48E x 32A**	6E x 16A**

* Field of view can be deflected +/- 10° from the center angle

** A larger energy sample array can be achieved with poorer time resolution

Table 2: ESA Capabilities Summary

The electron and ion spectrometers (EESA & IESA) will step through their energy ranges, collecting 24, 48, or 96 energy samples in 32 pitch angle sectors. The standard mode will measure a pitch angle distribution containing 48 energy samples every 78 ms. The 24 and 96 energy sample modes allow alternate trade-offs between time and energy resolution. The spectrometers also include deflection plates that will tilt the field of view to intersect the Earth's magnetic field.

The SESA sensors operate as spectrographs, whereby each of the six sensor pairs measures separate energy ranges. The individual sensor pairs can be programmed to operate at fixed energy, or cycle over a limited number of steps within their energy window. Depending on their operating mode, the set of SESA sensors will measure a distribution containing 16 pitch angle bins and 6, 12, 24, or 48 energy bins. The minimum sample time for an array of 6 energies is 1.6 ms.

3.1.2 ESA Data Acquisition

The data measured by the ESAs are collected by the IDPU and organized into 11 separate CCSDS packets (also see Section 5, Table 13). Each packet contains ancillary data identifying the specific mode each spectrometer was operating in when the data was collected. The IESA, EESA, and SESA counts are accumulated into 14-bit counters. The counters are read directly by the IDPU to produce the respective IESA, EESA, or SESA Burst Data Packets (SESA burst data spans across 6 packets). The burst data are also averaged (over a selectable number of sweeps) and placed into respective IESA, EESA, or SESA Survey Data Packets. The ESAs also send twelve electron-event signals to the FAST wave-particle correlator (see Section 3.4.2.3.4).

3.2 Time-of-flight Energy Mass Angle Spectrograph (TEAMS)

3.2.1 TEAMS Instrument Description

The TEAMS (Time-of-flight Energy Angle Mass Spectrograph) instrument for the FAST payload is a high sensitivity mass resolving ion spectrometer with an instantaneous 360° x 7° field of view. TEAMS is designed to measure the full 3-dimensional distribution function of the major ion species (including H⁺, He⁺, He⁺⁺ and O⁺) within one half spin period of the spacecraft. The sensor covers the energy range between 1.2 and 12000 eV/charge and thus the core of all important plasma distributions in the auroral region.

A perspective view of the TEAMS sensor showing the basic principles of operations is presented in Figure 3. The instrument is mounted with its axis of symmetry perpendicular to the spacecraft spin axis and perpendicular to the spacecraft surface.

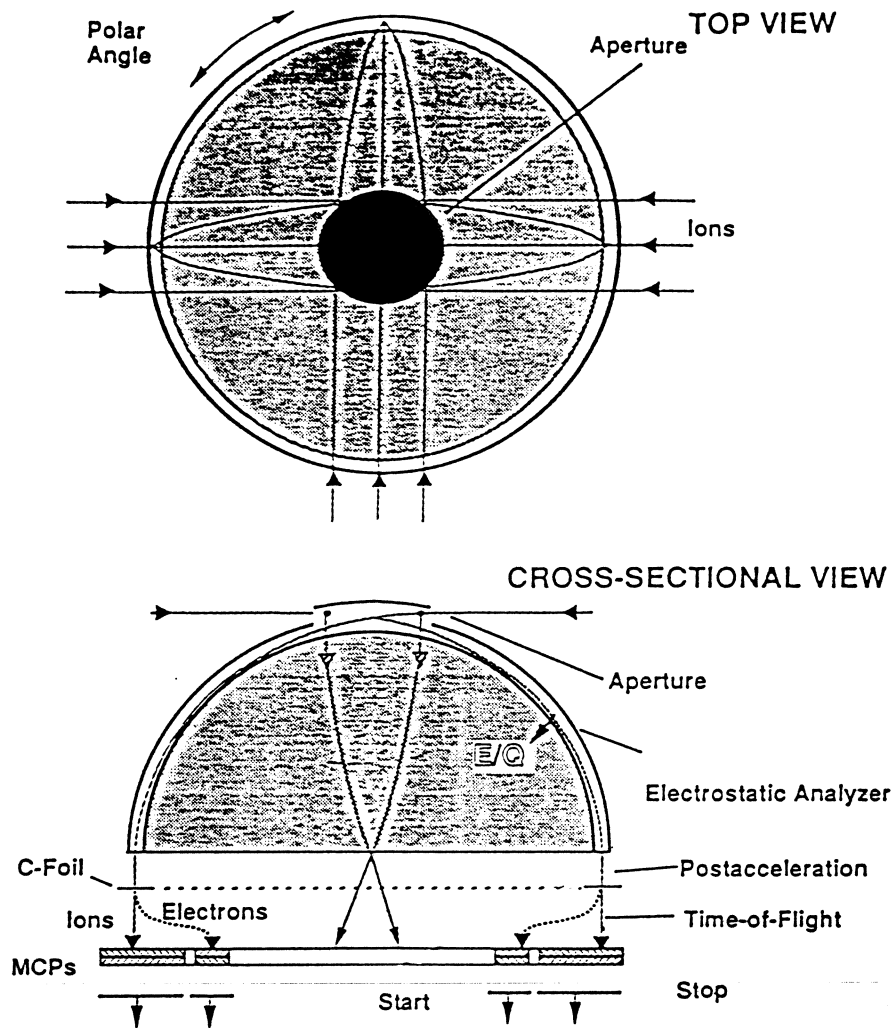

Figure 3: TEAMS Principles of Operation

The TEAMS instrument combines the selection of incoming ions according to their energy per charge by electrostatic deflection in a toroidal section analyzer with post-acceleration of up to 25 keV/e and subsequent time-of-flight analysis. The energy-per-charge analyzer is of the symmetrical quadrispherical type with a uniform response over 360° of polar angle (similar to the IESAs). The full angular range of the analyzer is divided into 16 channels of 22.5° each. With a cross-plate voltage of 0.14 - 1400 V (varied in an exponential sweep), the energy range is 1.2 - 12000 eV/e. Depending on the mode of the instrument, the full energy sweep is performed 32 or 64 times per spin. Behind the analyzer section the ions are accelerated by a post-acceleration voltage before passing through the thin ($\approx 3.5 \mu\text{g}/\text{cm}^2$) carbon foil (C-Foil) at the entrance to the Time-of-Flight (TOF) section. The start signal is provided by secondary electrons, which are emitted from the C-Foil during the passage of the ions, and are accelerated to 1-1.5 keV and deflected onto the start MCP assembly. The stop signal is provided by the ions impinging on the stop MCP assembly, which is 3 cm behind the C-Foil. The MCPs are segmented, such that the secondary electrons from the C-Foil also provide position information for the angular sectoring. The mass per charge of the ions can be derived from the TOF measurement and the data from analyzer section.

The sensor electronics of the instrument record the time-of-flight of each individual ion, the incidence in azimuthal angle (given by the spacecraft spin) and polar angle (given by the start position), and the energy per charge. A summary of the TEAMS capabilities is provided in Table 3.

Measurement Type	Ion Mass Spectrometer
Energy Range	1.2 eV - 12 keV
$\Delta E/E$	0.136
Geometric Factor	.023 CM ² -SR-E
Field of View	360° x 7°
Angular Resolution (3D)	5.6° or 11.2° x 22.5°
Time Resolution	2.5 s (3D) 78 or 156 ms (2D)
Sample Array	4M x 48E x 64 Ω (3D) 4M x 48E x 16 α (2D)

Table 3: TEAMS Instrument Summary

3.2.2 TEAMS Data Acquisition

The data stream of the TEAMS sensor consists of Live Pulse Height Events (raw energy, angle and time-of-flight data from individual events), various monitor rates, housekeeping data and various mass, energy, angle distributions of ions. In order to compress the data stream the digital outputs from the time-of-flight spectrograph are encoded in a look up table and the resulting energy-angle event is accumulated into an incrementing memory, separately for 3-4 different masses, in an angle-energy matrix. The pole channels of the instrument are separately accumulated with the highest time resolution. In addition, a mass spectrum with 64 mass channels is accumulated for longer time. The time resolution of these telemetry products depends on the telemetry rate of the FAST satellite and the instrument mode. These tasks are implemented on a signal processing board inside the TEAMS sensor.

The data acquisition modes of TEAMS are summarized in Table 4. TEAMS will produce science data that is accumulated into 6 separate CCSDS data packets, which are summarized in Table 12 (Section 5). To all data products (except Burst, Pole Channels and PHA Events) a compression from 16 to 8 bits is applied.

3.2.2.1 Full Angle (Survey)

The Full Angle Survey packet contains data for the four major species, H⁺, O⁺, He⁺, and He⁺⁺ with high angle and energy resolution. An angle mapping with 64 solid angle bins has been chosen which gives 16 bins around the equator and 4 at the poles. The full angular range is covered in half a spin, but the actual time resolution of the data product depends on the mode. Note that the angular resolution of this product does not change when the number of sweeps per spin changes - more sweeps just go into each bin.

3.2.2.2 Mass Spectrum

The Hi Mass Distribution packet is designed to give a spectrum in Mass per charge in order to identify minor species such as O₂⁺ or molecular ions. This is done by dividing the mass per charge range covered by the instrument into 64 logarithmically spaced bins, and mapping the time-of-flight channels for each energy step into these bins. We emphasize that each bin does not represent a particular species, but represents a small range in "mass-per-charge space." The different species will be evident as peaks in the mass-per-charge spectrum. There are 16 energies and 16 solid angles for this packet. The 16 energies are achieved by accumulating data for three consecutive energy steps together in the 48 step sweep. A mapping with 16 solid angles has been chosen with 4 bins around the equator and 2 bins at the poles.

3.2.2.3 Pole Channels

Because the instrument opening angles along the spin axis always point in approximately the same direction, regardless of spin phase, a measurement made at these positions for every sweep gives a high time-resolution measurement of how the fluxes in this direction are changing. In the Pole Channel

Packet, data from positions 0 and 15 (+spin axis) are combined in one angle bin, and 7 and 8 (-spin axis) are combined in the other.

					Slow Survey				Fast Survey				Burst	
					SS 1	SS 2	FS 1a	FS 1	FS 2a	FS 2	FS 3a	FS 3	Burst A	Burst B
Data Product	Species	Masses	Angles Pos/SA	Energy Steps					Time Resolution					
									In # of Spins					
Full Angle (Survey)	H+	1	64	48	4	2	2	2	2	1	1	0.5	0.5	
	O+	1	64	48	4	2	2	2	2	1	1	0.5	0.5	
	He+, He2+	2	64	48	8	4	4	4	2	2	1	1		
Mass	all	64	16	16	16	16	16	16	8	8	4	4		
Spectrum														
Pole	H+	1	2	32			0.031	0.016	0.031	0.016	0.031	0.016		
Channels	O+	1	2	32			0.031	0.016	0.031	0.016	0.031	0.016		
	He+, 2+	2	2	32							0.031	0.016		
Burst	H+, He2+	4	16	48									0.031	0.016
	O+, He+													
Monitor		# of Rates												
Rates		32		1	0.031	0.031	0.031	0.016	0.031	0.016	0.031	0.016		
	All	Total Bits *												
PHA Events		32	Events/Spin:		128	256	256	512	512	1024	1024	2048		
Total Bit Rate In kbps					7.8	12.3	18.9	28.7	29.5	41.0	57.5	78.8	157.6	315.2

* PHA Events contain the following Bits: TOF 8, POS 8, Section 1, Stop 2, Energy Step 8, Spin Angle 6, Priority 1;

Table 4: TEAMS Data Acquisition Modes

3.2.2.4 Burst Data

The Burst Data packet gives the highest time/angle/energy resolution data for the four major species, H⁺, O⁺, He⁺, and He⁺⁺. For each step of a sweep, data is collected from all 16 positions.

3.2.2.5 Monitor Rates

The Monitor Rates packet contains the raw data rates from the instrument. They include the Start rates, the Start-Stop Coincidence rates, and the rates from all 16 Start position signals and all 4 Stop position signals. For each spin, these rates are available for one 'major' energy step (16 'major' steps per spin), one set of rates for each sweep. Therefore there are either 32 or 64 sets of rates per spin. The energy step used increments with each spin.

3.2.2.6 PHA Events

The pulse height analyzer (PHA) Data Packet contains detailed information on the individual events measured in the instrument.

3.3 Magnetic Field Instrument

3.3.1 Magnetometer Descriptions

The FAST magnetic field instrumentation includes both a DC Fluxgate magnetometer and an AC search coil magnetometer (see Figure 4). Magnetometer capabilities are summarized in Table 5.

The fluxgate magnetometer is a three-axis instrument using highly stable low noise ring core sensors. The sensors are boom-mounted at two meters from the spacecraft body, in a shielded housing. The sensor electronics provides drive signals for the sensors and amplifies and detects the second harmonic signals that are proportional to the magnetic field. The electronics will provide magnetic field information from DC to 100 Hz to a 16-bit ADC.

The search coil magnetometer uses a three axis sensor system that contains laminated permalloy cores, windings and preamplifiers. The system provides AC magnetic field data over the frequency range 10 Hz to 2.5 kHz on two axes. The third axis extends this response to 500 kHz. The electronics further amplify the signals and provide them to a 16-bit ADC.

Measurement	DC Fluxgate	AC Search Coil
Frequency Range	0 - 50 Hz	10 Hz - 2.5 kHz (2 axes) 10Hz - 500kHz (1 axis)
Sampling Resolution	2 ms	0.1 ms
Measurement Range	10^{-5} to 0.6 G	
Measurement Resolution	(16 bit)	(16 bit)

Table 5: Magnetometer Instrument Summary

3.3.2 Magnetometer Data Acquisition

Data acquisition for the fluxgate and the search-coil magnetometer is performed by the signal processing circuitry of the E-Field instrument (Section 3.4.2).

3.4 Electric Field/Langmuir Probe (E-Fields)

3.4.1 Electric Fields Instrument Description

The FAST E-fields instrument has ten spherical sensors, two each on four 28 m, radial wire booms and one each on two axial stacers (see Figure 5). The spheres on the wire booms are located 28 m and 23 m from the spacecraft. The axial spheres are separated by 8 m tip-to-tip. Each sphere houses a preamplifier circuit. The booms contain wires that carry power, bias voltages, bias currents, and control signals to the sphere and contain two coaxial cables for the sphere output signals. Six of the spheres (numbers 2, 3, 6, 7, 9, and 10) can operate in either voltage mode or current mode. The outer spheres (numbers 1, 4, 5, and 8) operate in voltage mode only.

The electric field is derived from the voltage difference between two spheres that are in voltage mode. In voltage mode, the spheres are biased fixed current and the preamplifier output represents the floating potential. The input impedance of the sphere is $>10^{11}$ ohms and less than 1 pF (for frequencies less than 500 kHz). The sphere preamplifiers have a -20 dB response at 2 MHz with 100 MOhm parallel with 5 pF input impedance. In current mode, the sphere is biased to a fixed voltage and the preamplifier output represents the current in the sphere (as a Langmuir probe). The current mode preamplifier uses a logarithmic amplifier with a 90 dB dynamic range. Spheres 6, 7, 9, and 10 are sensitive to currents between 1 nA and 40 uA with frequencies below 2 kHz. Sphere 2 and 3 measure currents between 25 nA and 1 mA over the same bandwidth.

In order to limit and control the flux of photo-electrons from the booms or spacecraft to the spheres, sections of the outer braid of the wire are biased fixed potentials with respect to the sphere.

These sections are called stubs and guards; each sphere is surrounded by two each. The guard and stub voltage offsets can be set by ground command or calculated on board by the IDPU. The power supply for each boom has a ground which floats with the outer sphere potential. The spheres can measure DC potentials of +/- 45 V, which allows measurement of up to 1.6 V/m electric fields. A summary of E-field and Langmuir probe capabilities is provided in Table 6.

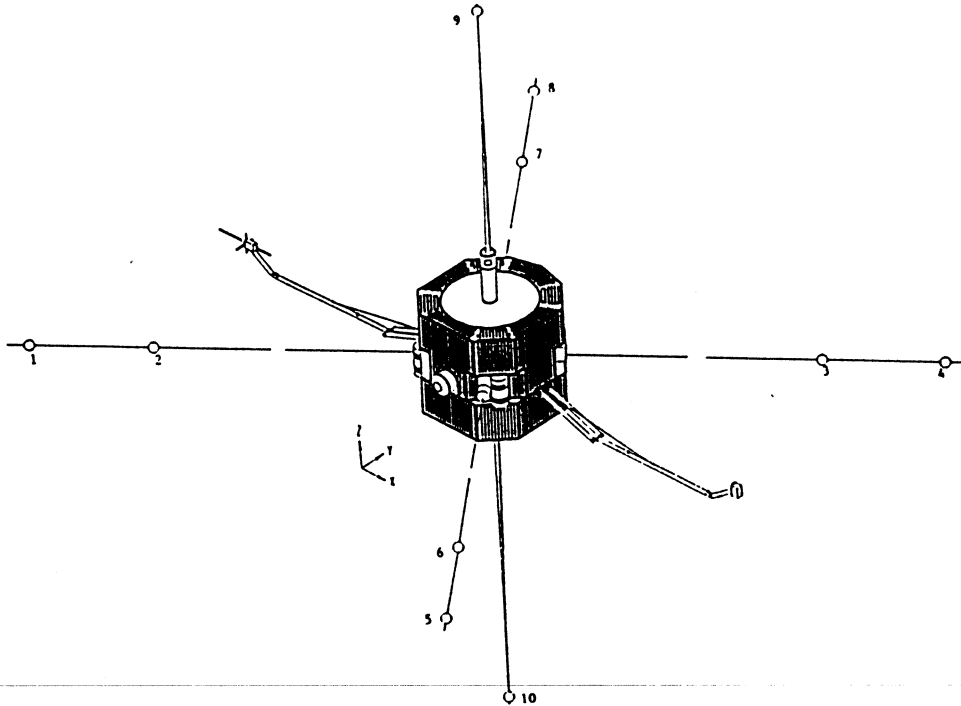

Figure 4: On-Orbit Boom Configuration

Measurement	DC Electric Field	Wave Electric Field	Swept Freq Spectrum Analyzer	E-field Rectifier/ filters	AC E-field Burst Memory	Density	Temp
Frequency Range	0-300 Hz	300 Hz - 16 kHz	0 - 2 MHz	100 kHz - 2 MHz	0 - 1 MHz	2 kHz	n/a
Sampling Resolution	30 μ s	30 μ s	32 ms	30 μ s	0.5 μ s	0.5 ms	1 s
Measurement Range	± 1.6 V/m	± 200 mV/m**	70 dB \ddagger	0.1 mV/m- 1 V/m $\ddagger\ddagger$	selectable inputs	1 - 10 ⁵ cm ⁻³	0.1 eV - 1 keV
Measurement Resolution	0.05 mV/m (16 bit)	0.05 mV/m (16 bit)	(8 bit)	(8 bit)	(10 bit)	(8 bit)	(8 bit)

* Frequency resolution, 15 kHz

** Amplitude range increases (up to 24 V p) for wavelengths less than boom length

\ddagger Gain selectable

$\ddagger\ddagger$ Selectable gain, range varies with antenna length

Table 6: E-Field/L-Probe Instrument Summary

3.4.2 E-Fields Data Acquisition

The FAST fields signal processing system is described in more detail in the following paragraphs. A summary listing of data packets is provided in Table 12 (Section 5).

3.4.2.1 Low-Frequency Signal Processing (Survey Data)

The low-frequency survey (DC to 1 kHz) packets contains electric field signals that are the difference between the potentials of two spheres, as well as magnetometer signals. The differential or voltage signals are filtered at several different Nyquist frequencies (250 Hz, 1 kHz, 4 kHz, and 16 kHz). The 1 kHz Nyquist signals can be sampled at eight different rates from 16 samples/s to 2048 samples/s. The 250 Hz Nyquist signals can be sampled from 4 samples/s to 512 samples/s. The filtered signals are then A/D converted and packetized into three types of survey packets (APIDs 1032-1034).

3.4.2.2 Low-Frequency Signal Processing (Burst Data)

The low-frequency burst (DC to 16 kHz) packets (APIDs 1048 - 1055) are formed from the outputs of eight 16-bit ADCs. There are 33 available signals that can be multiplexed into these ADCs based on ground command or stored instrument mode. These signals include raw data from the spheres (10) and the magnetometer (6), differential signals (12), and outputs (see below) from the BBF (4) and the PWT (1). In addition to signal source, Nyquist filter frequencies, sample rate, and gain can also be selected.

3.4.2.3 High-Frequency Signal Processing

The FAST fields high-frequency signal processing consists of eight wide band (2 MHz) differential amplifiers and a number of analog switches. The eight wide band signals are differential voltages between seven sphere pairs (1-4, 5-8, 1-2, 3-4, 5-6, 7-8) and data from the search coil magnetometer. One to four of the eight available signals are distributed to the following subsystems via analog switches which are configured based on ground command or stored instrument mode.

3.4.2.3.1 Swept Frequency Analyzer (SFA)

The swept-frequency analyzer has four channels. The nominal operating mode measures the spectral power density up to 2 MHz at 256 discrete frequencies spaced at 8.35 kHz. The IF filter band width is 15 kHz. One 256 point sweep is made every 62.5 ms on each of the four channels. The instrument has an 80 dB range from 2×10^{-14} (mV/m)²/Hz to 2×10^{-6} (mV/m)²/Hz or narrow band sensitivity from 20 uV/m to 200 mV/m. The SFA can be configured to operate on 500 kHz, 1MHz, 2MHz, or 4 MHz band width with sweep speeds of 31.25 ms or 62.5 ms. The signal gains can be attenuated by a factor of ten to measure large-amplitude (>200 mV/m) events. The SFA data are collected into Burst (APID 1057) and Average (APID 1036) packets.

3.4.2.3.2 Plasma Wave Tracker (PWT)

The Plasma Wave Tracker uses one of the four SFA channels. Instead of integrating the power in the 15 kHz pass-band, the plasma wave tracker remixes the IF to a 0.5 to 15.5 kHz signal which is fed to a burst ADC. The plasma wave tracker has a low jitter (<100 Hz) VCO with a selectable input frequency that can be updated every 1/8 second or every 1 second. An FFT of the PWT signal gives a very high resolution (in frequency) of a 15 kHz wide band of selectable frequency (for example, the 300 kHz to 315 kHz band could be selected). The selected band can be by ground command, automatic tracking (zero crossing counters), or by microprocessor algorithm (electron cyclotron frequency calculated from magnetic field). The PWT data is in the ADC packets (see Section 3.4.2.2).

3.4.2.3.3 Broad Band Filters (BBF)

The BBF unit has four wide band channels. The signals are high-pass filtered (>200 kHz), rectified, and output in the BBF packet (APID 1035). The resulting DC signal represents the envelope of the wave signal. The BBF data have a range from 0.2 mV/m to 200 mV/m (or ten times for short wave measurements).

3.4.2.3.4 Wave-Particle Correlator (WPC)

The WPC receives two wide-band electric field signals and twelve electron-event signals from the ESA instrument (see Section 3.2.1). Each of the twelve electron-event signals are registered in three counters. One counter gives the total count. The second counter gives the count of the events that occur only when the electric field signal is positive. The third counter registers only the electron events that

occur when the quadrature (90 degree phase shifted) signal is positive. The data are compressed to form the WPC data packet (APID 1056). The electric field signals can be chosen to have a 200 kHz to 4 MHz band (Langmuir / AKR correlator) or a 1 kHz to 20 kHz band (lower- hybrid correlator).

3.4.2.3.5 High Speed Burst Memory (HSBM)

The HSBM has four wide band inputs which are Nyquist filtered at 1 MHz (high pass at 2.5 kHz). Each of the four signals are A/D converted to 10 bits at 2 MSamples/s and read into a 10 MByte RAM. The HSBM divides the RAM into four buffers. One buffer is always accepting data. Two of the buffers are holding the best events as determined by a trigger system. The fourth buffer is outputting data to the IDPU formatter in the HSBM packet (APID 1058) or to the fields DSP. The input buffer is circular and holds only 0.25 seconds of data. The output buffer is read every ~1 second. The trigger system (see Section 4.2.2.2) selects the best 0.25 second event of the 1 second output period. The HSBM data represent +/- 200 mV/m with 0.2 mV/m resolution (or ten times).

3.4.2.3.6 High-Frequency (HFQ) Phase Difference Measurement

The HFQ phase difference measurement measures the relative phase between any of four of the eight wide band signals. The four selected signals yield six phase differences. The phase difference measurement is an eight-bit signed integer giving a +/- 180 degree phase difference. The HFQ packet (APID 1038) also contains zero crossing counters which, with narrow band signals, represent the wave frequency (0 to 8 MHz) with 256 Hz accuracy. The HFQ packet also contains the PWT tracking frequency.

3.4.2.4 Fields Digital Signal Processor (DSP)

The fields DSP receives data from either the eight digital outputs of the low-frequency ADCs, the HSBM or the WPC. The DSP can Fast Fourier Transform (FFT) these data and average over up to 128 spectra. The DSP can also perform cross-spectral analysis on adjacent channels. Up to six FFTs can be performed in real time on the 32768 ksample/s data. The FFT data is output in the DSP packet (APID 1037).

3.5 Instrument Data Processing Unit (IDPU)

The IDPU uses a 10 MHz processor (32C016 derivative), with 16Kbyte ROM, 64Kbyte EEPROM, and 256Kbyte RAM for processor operations. Internal to the IDPU is a Formatter card, implemented using custom gate arrays, which is the primary hub for instrument control, data distribution, and timing. The Formatter provides interfaces to the individual instrument electronics and performs high speed data acquisition, compression, averaging, and packetization of the science data. Also within the IDPU is a high density 1 Gbit (128 Mbyte) mass memory (solid state recorder) used for storage of collected science data. The mass memory includes Error Detection and Correction (EDAC) circuitry to prevent corruption from radiation effects. (The recorder includes a selectable (1-2 Mbyte) partition for spacecraft health and safety data.) The Formatter arbitrates and sequences data into and out of the mass memory, and provides a DMA interface to the processor. Using ground-programmable table loads and commands, the IDPU flight software manages science telemetry data acquisition, and performs necessary instrument control and housekeeping functions. Data acquisition criteria are described further in Section 4.2.3.

4.0 Project Data Flow

4.1 Mission Operations

As shown in Figure 5, The FAST Ground Data System (GDS) is comprised primarily of institutional multi-mission facilities located at GSFC. Each of these systems typically consists of one or more mid-class workstations and requisite software, and are described in the following sections.

FAST adheres to Version 1 CCSDS Recommendations for telemetry and command data services. Specific implementations are described in the FAST T&C Handbook [3]. All command (CMD) and telemetry (TLM) interfaces between data system elements (space-ground, ground-ground) are defined using the Transfer Frame (TF), the Packet (PKT), or the Standard Formatted Data Unit (SFDU) [4].

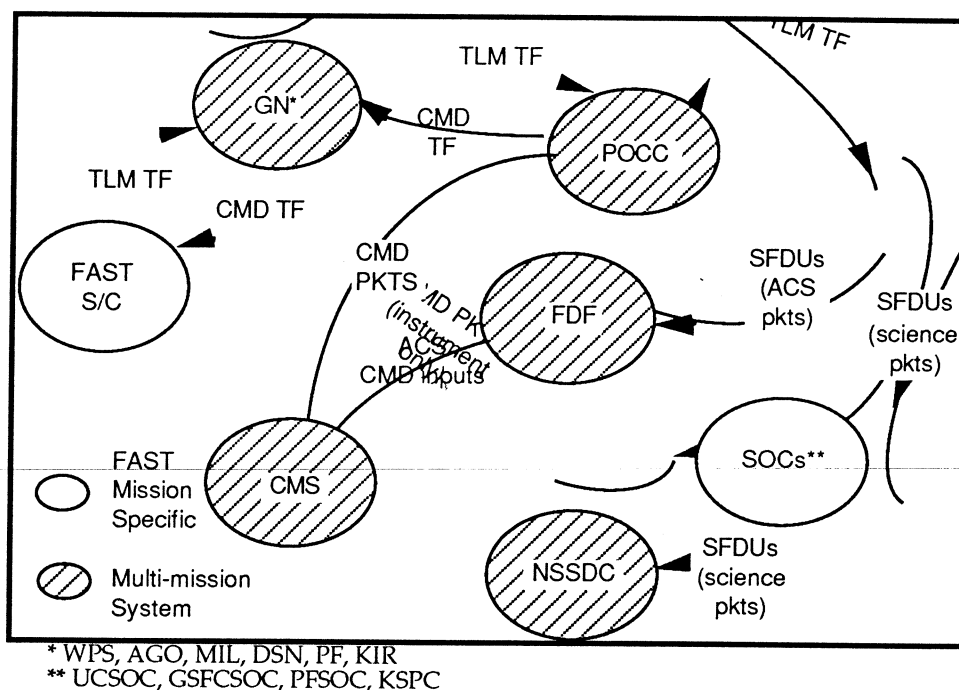

Figure 5: FAST Telemetry and Command Interfaces

An overview of FAST mission operations is provided in the following sections. Complete details of the data processing systems and support services are provided by the Mission Operations and Data Analysis (MO&DA) Directorate are described in the FAST Detailed Mission Requirements (DMR) [5].

4.1.1 Telemetry Services

4.1.1.1 Space to Ground Communications

FAST does not use the TDRS system, and instead relies on six geographically dispersed Ground Network (GN) or Deep Space Network (DSN) stations and the NASA Communications (NASCOM) network. These stations (Table 7) provide relatively transparent telemetry and command connections between the spacecraft and the Ground Data System (GDS) elements. The PF station consists of the Transportable Operations and Tracking Station (TOTS), developed and operated by the Wallops Flight Facility (WFF). The Kiruna station utilizes the facilities of the European Space Agency (ESA) and a project-provided Ground Support Equipment (GSE) for FAST-specific telemetry processing. Downlinks will be done at the highest rate possible for a given contact. Further details of FAST space to ground communications are described in the FAST Data Acquisition Plan [6].

Name	Station Location	Service Mbps	Telemetry				Commanding
			0.004	900	1.5	2.25	
WPS	Wallops Island, VA	X	X	X	X	X	
PF	Poker Flat, AK	X	X	X	X	X	
DSN	Canberra, Australia*	X	X			X	
MIL	Merrit Island, FL	X	X	X		X	
AGO	Santiago, Chile	X	X			X	
KIR	Kiruna, Sweden	X	X	X	X		

* For L&EO and as backup, these services and rates are also available at the DSN Madrid, Spain and Goldstone CA stations.

Table 7: FAST Ground Station Summary

4.1.1.2 Telemetry Channels

At the packet level the MUE samples spacecraft engineering, health, and safety data (currents, voltages, temperatures, attitude measurements) and creates time-tagged housekeeping (H/K) packets. The IDPU creates similar instrument H/K packets. The IDPU also creates science packets, as was described in Section 3. An Application Process Identifier (APID) in each packet header provides a unique label for each packet type.

At the transfer frame level, FAST telemetry is separated into 6 separate Virtual Channels (VCs). Characteristics of each VC are shown in Table 8.

VC	Data Contents	Data Rate (Kbps) Range	Recorder Vol(Mbytes)	
			Range	Typical
VC0	Real-time s/c H/K	1	n/a	n/a
VC1	Playback s/c H/K	0-1	1-2	1
VC2	Burst Data	2600-5900	0-120	54
VC3	Quicklook Survey Data	60-960	0-8	0
VC4	Routine Survey Data		0-120	58
	fast:	290-960		
	slow:	60-120		
VC5	IDPU Engineering	1-25	1	1

Table 8: Virtual Channel Characteristics

VC0 is used to transmit H/K packets collected while in contact with a ground station (real-time data). Stored H/K packets are continuously collected and stored in the IDPU recorder and are played back in VC1. The primary science channels are VC2 (burst event data) and VC4 (continuous Survey Data), both of which can contain either real-time or playback data. VC 3, (quicklook Survey Data), is used to set aside a small amount of Survey Data for DSN contacts, which have a limited (50 Kbps) real-time data throughput. VC5 is used for instrument diagnostics and IDPU flight software downlinks. The process for selecting incoming science data for VCs 2-4 is described in Section 4.2.2.

4.1.1.3 Science Data Telemetry Format

For FAST, all science packets are the same length and fit exactly within a transfer frame, as shown in Figure 6. Within the application data field are three fields. Ancillary data contains data on the instrument mode in effect for each specific packet. This is followed by 1024 bytes of science data specific to each particular packet type (Burst ESA Packets, Survey TEAMS Packets,

etc.). The last 2 bytes of each packet contain statistical information from the Error Detection and Correction (EDAC) circuitry of the IDPU memory.

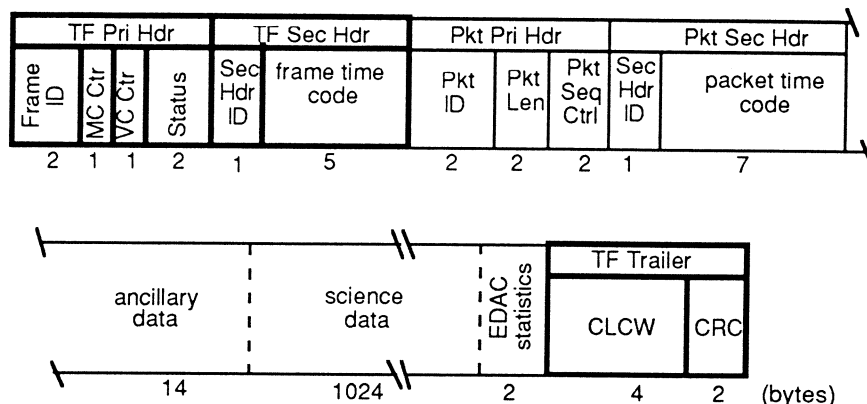

Figure 6: FAST Science Data Telemetry Format

4.1.1.4 Telemetry Processing

The volume of FAST science data received and processed differs significantly between campaign and non-campaign phases of the mission. Data are received by GSFC from all GN and DSN stations (except Kiruna) via NASCOM lines. Data are recorded on Metrum tape at Kiruna (campaign) and additionally at Santiago (southern apogee) and mailed back to GSFC.

	Campaign (60 days)	Non-campaign (300 days)	1 year total
Input	5.3 Gbytes/day	756 Mbytes/day	545 Gbytes
Throughput	Peak Ave	20 Mbps 491 kbps	20 Mbps 76 kbps
Output	5.3 Gbytes/day	756 Mbytes/day	545 Gbytes
Distribution Time	4 hrs post-receipt	4 hrs post-receipt	n/a

Table 9: Level-Zero Telemetry Data Processing

The Packet Processing System (PPS), located at GSFC, ingests and processes all VC data from each ground contact pass that is forwarded by the ground stations (both NASCOM and Metrum tape). Throughout the mission, the PPS will perform Level-Zero-Processing (LZP) on the FAST data. The PPS will extract packets from the VC transfer frames (shown in Figure 6), and reassemble, quality check, and annotate each packet. The PPS will create single-pass Production Data Sets by sorting packets received within each pass by their APID. The PPS will forward-time-order packets and delete redundant packets. Comprehensive data quality information, including errors and gaps, will be generated and provided. The Production Data Sets will be formatted into SFDUs and distributed electronically to the University of California, Berkeley, Science Operations Center (UCSOC). Details of the interface can be found in the PPS to UCSOC ICD [7].

4.1.2 Mission Control

Data flow for FAST mission telemetry and commands was shown in Figure 5. The MUE flight software on-board the FAST spacecraft can receive and act on commands immediately (real-time command processing) or store them on-board for later execution (stored command processing). Stored commands can be activated based on either an Absolute Time Sequence (ATS) or a Relative Time Sequence (RTS); the latter are used primarily for event-driven autonomous spacecraft safing. Details of spacecraft commanding can be found in the T&C Handbook [3].

The Command Management System (CMS) performs off-line generation of CCSDS command packets. These command packets can contain ATS or RTS table loads, flight software or table loads, or sequences of commands to be sent in real-time. The CMS forwards command packets to the Payload Operations and Control Center (POCC) for transmittal to the spacecraft via the GN stations. The POCC receives real-time VCO telemetry back from the spacecraft via the GN stations for spacecraft health and safety monitoring. Additionally the Flight Dynamic Facility (FDF) receives spacecraft ACS data packets, performs orbit calculations and spacecraft attitude determination, and generates precession commands for forwarding to the CMS. The CMS, POCC, and FDF are all multi-mission facilities located at GSFC.

4.1.3 Mission Planning and Scheduling

Mission operations, planning and scheduling are the responsibility of the FAST Flight Operations Team (FOT). The FOT operates primarily out of the SMEX Mission Operations Room (MOR) at GSFC, using the CMS, POCC, and PPS systems previously described. Details of FAST flight operations are described in the FAST Flight Operations Plan [8].

Over the course of 1 year, the FAST mission cycles through six phases as identified in Table 10. For any follow-on years, cycles will repeat (except for L&EO).

Mission Phase	Length (days)	Contacts (per day)	Primary Stations	Backup Stations
Launch & Early Orbit	7	10-11**	all except KIR	-
1st Southern Apogee	92	4-6 min	all except KIR	-
1st Northern Apogee	42*	4-5	PF	DSN, AGO, WPS
Winter Campaign	60	15-16**	PF, KIR	DSN, AGO, WPS
2nd Southern Apogee	103	4-6 min	all except KIR	-
2nd Northern Apogee	65	4-5	PF	DSN, AGO, WPS

* The winter campaign will begin about 20 days into the 1st northern apogee phase.

** Every orbit contact, plus 5 additional at Kiruna.

Table 10: Nominal FAST Mission Phases

FAST is nominally a 1 year mission, with the expectation that additional years of operation may be added, particularly in light of the delays in the POLAR mission. POLAR will take high-temporal-resolution images of the auroral oval from a vantage point of about 8 Earth radii, or 51 200 km. An important scientific objective will be to correlate POLAR's global observations of auroral dynamics and morphology with FAST's detailed particle acceleration observations.

Campaign periods are the times during which data acquisition from the FAST spacecraft and concurrent measurements with other spacecraft and ground based observations are both emphasized. The first Campaign is planned for 8 weeks beginning in January, 1995, when the FAST apogee is over the northern auroral zone. This time period is a subset of the International Auroral Study (IAS) as part of the international Solar Terrestrial Physics Program (STEP), and will be a period when auroral scientists will concentrate on making simultaneous measurements from many different instruments around the world. Several observational campaigns are planned utilizing radars, imagers, and magnetometers on the ground. Some rocket flights are also planned.

During all mission phases, each ground contact may begin with a command session, though nominally only one command session will be planned for each day. The length of each contact will depend on the visibility of the ground station, but in no case will it exceed 30 minutes (limited by spacecraft power constraints). The amount of telemetry data received during each contact will depend on the length of the contact and the downlink data rate. Data on planned contacts will be distributed to all involved parties via the Remote User System Terminal (RUST) system. Further mission planning and scheduling details are described in the FAST Data Acquisition Plan [6].

4.2 Science Operations

All science operations will be under the direction of the Principal Investigator, Dr. Charles W. Carlson. The Co-Investigators on the team are identified in Table 11, along with their associated scientific instruments and institutions.

Instrument	Institution	Co-Investigator
Electric Field/ Langmuir Probes; ESAs; TEAMS	Space Sciences Laboratory, University of California, Berkeley	Dr. Cynthia A. Cattell Dr. Robert E. Ergun Dr. James P. McFadden Dr. Forrest S. Mozer Dr. Michael A. Termerin
TEAMS	Lockheed Palo Alto Research Laboratory	Dr. David M. Klumpar Dr. William K. Peterson Dr. Edward G. Shelley
Magnetometers	University of California - LA	Dr. Richard C. Elphic*
TEAMS	University of New Hampshire	Dr. Eberhard Moebius

* Now at Los Alamos National Laboratory

Table 11: FAST Co-Investigator Team

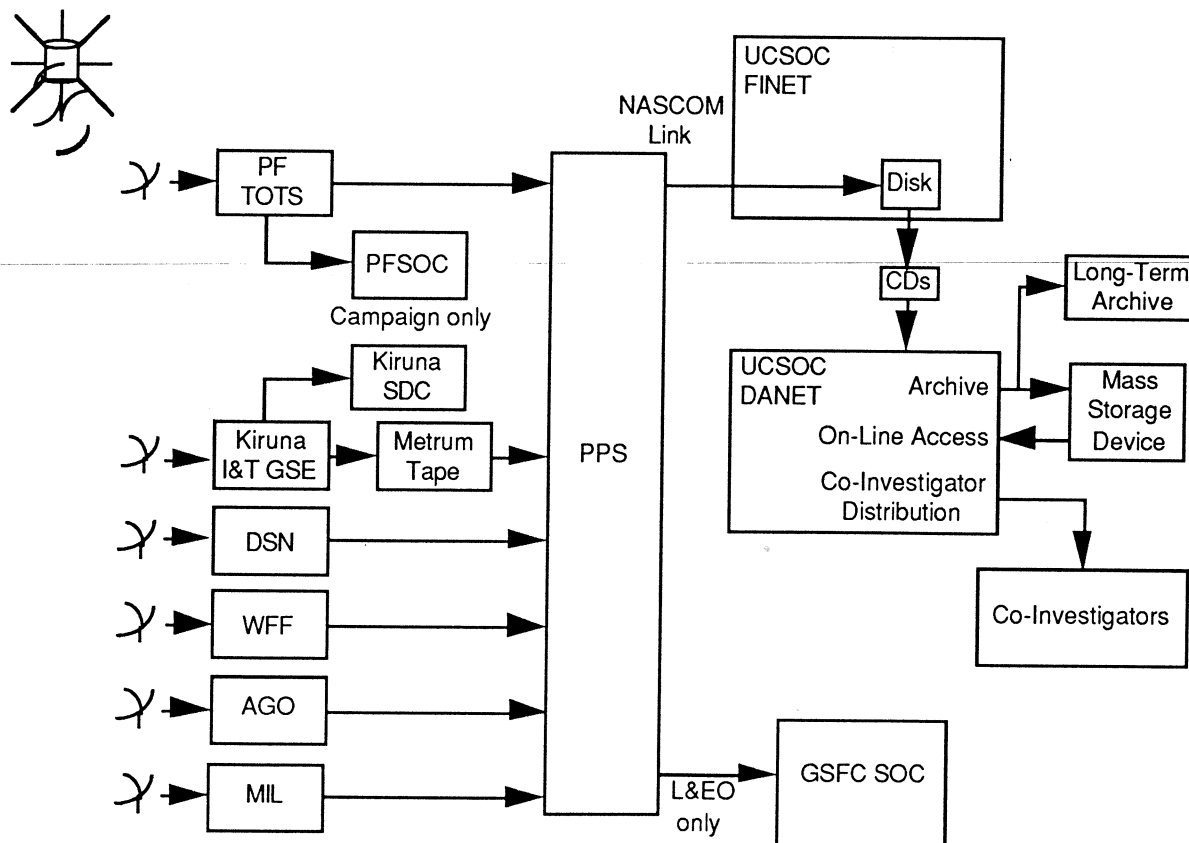

Figure 7: FAST Science Telemetry Data Flow

FAST science telemetry flow is shown in Figure 7.

The UCSOC archives all Level 0 data received from the PPS, provides on-line access and software to perform data processing, and is the source for data sets to be archived by the NSSDC. Additionally, science telemetry also flows to various other SOCs during certain mission phases. These SOCs and other aspects of science operations are described in the following sections.

4.2.1. Science Operations Centers (SOCs)

The FAST mission will have two general types of SOCs; archive and real-time. The archive SOC will be the UCSOC maintained at the Space Sciences Laboratory, University of California, Berkeley. Real-time SOCs will be maintained at three different locations during different phases of the mission.

4.2.1.1 Archive SOC

The UCSOC will be in operation throughout the mission, and will be connected to Mission Operations Directorate Network (MODNET) at GSFC by a T1 data line with a capacity of 1.544 Mbps. The primary function of this SOC will be to receive the files of production data generated by the PPS within several hours of its downlink from the spacecraft. Some initial verification and processing will be done on this data, and it will then be passed on to the archive system to be saved on CD-ROM disks. In addition, the UCSOC will receive planning information from various units on MODNET at GSFC, and will also generate and transmit (to CMS on MODNET at GSFC) the commands required to operate the instruments on the spacecraft. A schematic of the UCSOC is shown in Figure 8.

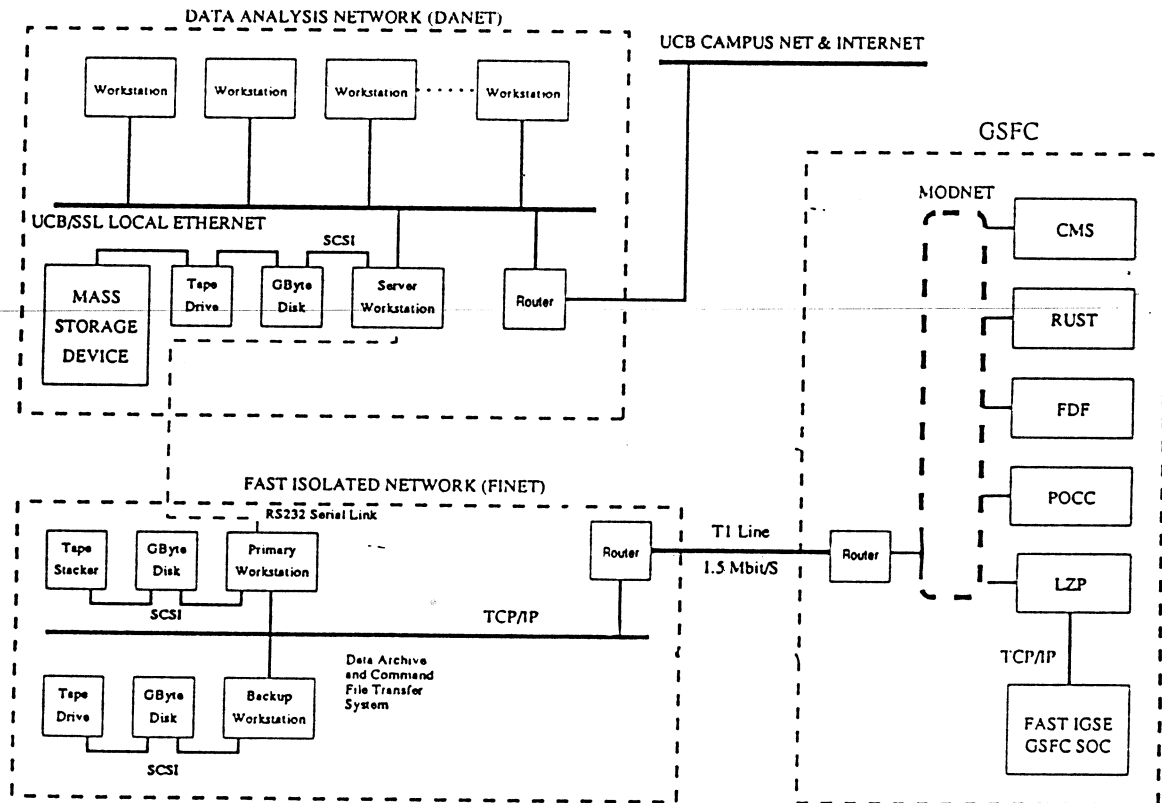

Figure 8: FAST UCSOC Network

The UCSOC will include two networks called FINET and DANET. FINET will be made up of primary and secondary workstations (Sparc10s), and the large amount of disk space which will be required to support the receipt of FAST data. This network will be connected to the T1 line to MODNET and will be functionally isolated from all other networks. The initial verification of FAST data and the commanding activity will take place on FINET. FINET and DANET will be connected by a link that maintains isolation of FINET.

DANET will be made up of a server workstation (Sun SparcServer 1000) and such other workstations (Sparc10s) as will be required to support the analysis of FAST data. Attached to the server workstation will be the equipment required to write CD-ROM disks and the jukeboxes (Phillips CDD521, others) which will hold these disks. The initial analysis of FAST data will be done on DANET, and the database that will maintain information about the FAST data on the jukebox will run on DANET as well (see Section 4.2.4 for more on analysis and database software). DANET will be attached to the building network at the Space Sciences Laboratory, which is connected to the UCB campus network and to the Internet.

4.2.1.2 Real-time SOCs

Each of the real-time SOCs consists of a subset of the systems that comprise the UCSOC. Each real-time SOC will receive and/or send FAST data over network connections specific to its location. The data will be received from the network by a primary or a secondary relay workstation, which will relay it to a network of target workstations for the immediate display of desired aspects of this data using the Core Routine of the Data Analysis Program (see Section 4.2.4). The real-time SOCs will not have the archiving capability of the UCSOC.

The GSFC SOC, co-located with the GDS at GSFC, will be active during L&EO from spacecraft launch through the completion of boom deployment. The PFSOC will receive planning information, generate instrument commands, and provide real-time display and control of the on-board instrument. The GSFC SOC will receive production data sets from the PPS, and will transmit commands to the CMS over MODNET. (The GSFC SOC is also known as the Instrument Ground Support Equipment (IGSE), and serves in that role during spacecraft I&T.)

The Poker Flat SOC (PFSOC), co-located with the PF TOTS station, will be active during the northern apogee campaigns. The GSFC SOC will receive planning information, generate instrument commands, and provide real-time display and control of the on-board instrument. The PFSOC will receive telemetry data on a direct feed from the PF TOTS, and will transmit commands to the CMS on a dedicated 9.6 Kbps line to the MODNET.

The Kiruna Science Processing Facility (KSPC), co-located with the KIR station, will be active during the northern apogee campaigns. The KSPC has no instrument commanding capability, and provides primarily real-time data analysis capability. The KPS receives telemetry data on a direct feed from the KIR ground station (via the FAST GSE).

4.2.2 Science Control

4.2.2.1 Instrument Commanding

The instrument commands generated by the SOCs can consist of daily command loads (including ATS stored loads), or real-time commands. These instrument commands are merged into the spacecraft command load by the CMS, which is then uplinked to the spacecraft. Files sent by the SOCs to CMS are described in the SOC to CMS ICD [9]. Daily command loads to the spacecraft will control instrument data collection times, manage Instrument Operation Modes (IOMs), manage instrument power and mass memory, provide a table of sun-nadir angle information, and load other IDPU memory files as necessary. In addition, the on-board ATS command buffers used for spacecraft control have space allocated for 110 instrument commands per day.

These instrument ATS commands will be the primary means by which the UCB PI team will operate the FAST spacecraft. The ATS commands will primarily be used to select among pre-loaded IOMs at different times in the orbit. The ATS commands will also be used to make specific commands (changes in electric field antenna bias current, instrument calibration, etc.) time tagged to a specific point in the orbit.

Stored onboard FAST are 16 IOMs (8 set parameters for the particle instrument and 8 set parameters for the fields instruments. At any time, one particle IOM and one field IOM are operating). Different IOMs emphasize measurement of different physical parameters on different time scales.

They are activated to emphasize a specific science objective, while remaining within power usage and mass memory constraints. Each IOM defines the following: telemetry data rates (for each packet type), readout order, and burst size; particle detector energy sweeps and accumulation times; fields signal selection, sample rates, and density mode; and instrument power usage, housekeeping, and default mode parameters.

Real-time commanding will also be available, but only during the campaign phase of the mission. Real-time commands are limited to the selection of a prior-loaded IOM, and will have up to a 1-minute delay time. These commands will be used to set optimal instrument modes based on ground and spacecraft observations, and to coordinate with ground, rocket, or other satellite measurements.

4.2.2.2 IDPU Telemetry Selection Criteria

As described in Sections 3 and 4.1.1, science data consists of Burst Data, Slow Survey Data, and Fast Survey Data. The FAST mass memory recorder can be filled up in as little as 100 seconds at the highest onboard data rates. This requires the IDPU to select the best burst or Survey Data for storage and for later transmission to the ground. This is done by a combination of onboard 'triggers' and best data selection-rejection ('goodness') criteria. ATS commands are used by the UCB Team to control those criteria which can change during different portions of the orbit. On-board triggering criteria can also be chosen that will synchronize FAST measurements with related ground operations.

The IDPU mass memory contains 128 Mbytes of data, which is allocated into 7 memory blocks for different data types. Burst Data has its own allocation (VC2) of mass memory. Slow Survey Data and Fast Survey Data are the same data (just with different adjustable readout rates) and go into the same memory allocation (VC4). One or two Fast/Slow Survey packets may be selected to go into the quick look data memory allocation (VC3) for DSN station telemetry contacts. The remaining memory blocks are allocated to VC1, VC5, Headers (where headers for all packets are stored) and High Speed Burst Memory (HSBM). An allocation for HSBM data provides a temporary location for incoming burst data.

Slow Survey Data will be taken throughout auroral regions, while Fast Survey Data will typically be on only during active aurora. 'Trigger algorithms' will enable Slow and/or Fast Survey Data collection. These algorithms will use particle and field data as inputs (e.g., maximum electron count rate in the sweeping EESA), and have programmable parameters, time scales and hysteresis. Collection of Fast Survey Data can also be forced on or off by ATS command.

Burst Data collection will be triggered to select best events. When the IDPU starts collecting Burst Data, it first fills up the allocated space for (max 64 Mbytes) of VC2 storage. After that, burst data is temporarily held in the HSBM allocation, from which the IDPU begins to overwrite VC2 data (on a packet-by-packet basis) according to the defined selection-rejection criteria. If incoming data from the instruments in the HSBM doesn't exceed the 'goodness' of data already in VC2, the incoming data is discarded.

4.2.3 Science Planning and Scheduling

Science planning and scheduling during non-campaign periods will be performed by the PI team at the UCSOC. As described above, the UCSOC provide the PI team the facilities for archiving data delivered from GSFC, monitoring instrument operation, health and safety, and generating instrument commands. The scientists will analyze data from prior passes, predictions of available power and ground station contacts, and possible collaborative ground or spacecraft measurements in order to determine the desired modes of operation.

Science planning and scheduling during the campaign will be performed from the PFSOC, which will be manned 24 hours per day by the PI and Co-I team with the main focus on night-time passes. Science staff will also support the KSPC, which will be operational 8 hours per day. During the campaign, real-time data from FAST will be examined to aid in determining the optimal operation mode for a given pass. In addition, some real-time data from ground based instruments will be available to the scientists at the PFSOC. These include all-sky camera and magnetometer data from the chains

operated by the Geophysical Institute of the University of Alaska. At times, other ground based data may also be examined in real-time (e.g., data from the Greenland radar or the CANOPUS magnetometer chain).

Although actual operational activities may be highly variable, during the campaign a baseline on-board sequence of events is planned:

- 1) The FAST spacecraft enters the hemisphere containing apogee. IDPU is in 'Back-Orbit Mode'.
- 2) IDPU will change to 'Diagnostic Mode' 60 sec prior to reaching 50 degrees (programmable default) magnetic latitude.
- 3) Diagnostic Mode will last about 60 sec and includes ramping up high voltage, pulsing preamplifiers, electronics checkouts, etc. Diagnostic data goes into Survey Data stream.
- 4) After Diagnostic Mode is complete, IDPU changes to 'Data Collection Mode' (above about 50 degrees magnetic latitude).
- 5) When the spacecraft reaches 50 degrees magnetic latitude equator-ward bound, the IDPU will return to Back-Orbit Mode.

ATS commands files will be generated daily by the FAST PI team in order to select the best portions of the orbit for data collection, while remaining within the resource limitations of the spacecraft. Limits in power generated by the solar array restrict the amount of time that the experiments can be on.

The UCSOC and PFSOC will receive planning information from various units on MODNET at GSFC. These inputs include orbit predictions from FDF, ground contact data from the RUST, and power budget information from the CMS and POCC. These data will be used to generate and transmit to the CMS (at GSFC) the ATS and other commands required to operate the instruments on the spacecraft.

4.2.4 Science Data Set Generation

The Production Data Sets distributed electronically to the UCSOC (see Figure 8) will be formatted into SFDUs by the PPS (see Section 4.1.2). Incoming Production Data Sets and other supporting data such as the 24 hour attitude data set, will be archived as the Level_0 Data Product. For further details of Level_0 Data Product generation and archive, see Section 4.3. The FAST data analysis and data set generation software consists of two parts: (1) the Database Program; and (2) the Data Analysis Program.

4.2.4.1 Database Program

The Database Program (which is based on Sybase) will be used by scientists to perform a search of available data and to access the archived data. Searches can be done both locally at the UCSOC and via remote login (see Section 4.3). The Database Program allows scientists to determine what types of data are available under a given set of conditions. The program can search on many criteria (a simple example being date and time). To access the archived data, the Data Base Program takes the requests generated by the scientist and produces a list of the required CD-ROM files for input to the Data Analysis Program.

4.2.4.2 Data Analysis Program

The Data Analysis Program will be used to provide the following capabilities: (1) real-time data displays during L&EO and campaign operations; (2) on-line scientific analysis; (3) batch data processing; and (4) production of Survey Data. The Data Analysis Program is based on the electric and magnetic field data analysis program for the CRRES and Geotail satellites. It consists of a Core Routine (with add-on modules) and a Graphics Package.

4.2.4.2.1 Core Routine Software

The Core Routine assumes that the telemetry data that it receives is time organized. It de-commutates the archived Level_0 Data Product, performs batch data processing (such as de-spinning of the fields or calculating moments of distributions) and converts it into physical units. This data is called Raw_Data. The Core Routine contains a simple interface that allows scientific add-on modules software to obtain Raw_Data from the Core Routine, perform scientific calculations, and pass the resulting Science_Data back to the Core Routine.

4.2.4.2.2 Graphics Package Software

The analysis software contains a general Graphics Package for plotting the Raw_Data or the Science_Data. It also has a user-friendly interface that allows scientists to interact with the data and specify what quantities they want to examine. In real-time mode, it is designed to plot a set of quantities that are specified prior to data acquisition. This set can be optimized for the types of science to be done on a given orbit. The Graphics Package can be set up by the user in a variety of ways, including number of windows, number of plots, scaling, etc. The Graphics Package also makes adjustable gray scale or color coded plots, and can plot any quantity as a function of time (or quantity 1 versus quantity 2 over a time interval).

The Graphics Package can produce output files for storage in the database; one example is the Survey Data Product (see Section 5.1). Files also can be sent to PostScript (and Color PostScript) devices for producing hard-copy of a publishable quality. The Graphics Package can also make ASCII data files, for use by other analysis software, such as IDL-based systems. ASCII output for the Survey Data Product can be provided in the NSSDC Common Data Format (CDF) [10].

4.3 Data Accessibility and Archiving

4.3.1 Data Accessibility Plan

1. Survey data at 5 sec (spin-averaged) time resolution will be provided to the ISTEP CDHF and the NSSDC within 3 months of data receipt. It will also be made available via the WWW to the science community as soon as it is available. The survey data are not intended for publication purposes until certified by the PI. Certification will be completed as soon as possible but within 9 months of receipt of data. The certified survey data generally will be made available to the FAST Mission investigators and the larger scientific community at the same time.
2. Level 0 data, as well as calibration and all ancillary data, will be delivered to the NSSDC as soon as possible. The delivery will be within 3 months of data receipt, starting one year after launch.
3. Software and documentation will be provided by the FAST SWT to make the Level 0 data correctly and independently usable by the scientific community within one year of launch. Software updates will be submitted as available. As indicated in 4.3.2.3 below, the actual executability of the FAST s/w (or the providing of equivalent functionality) in the NSSDC ADP environment will not occur until some future time.

4.3.2 Data Repositories

4.3.2.1 Project Data Repositories

As was shown in Figure 8, LZP science telemetry (in SFDU format) electronically arrives at the UCSOC FINET from GSFC. The archiving hardware is located on the FINET, which is isolated from the main analysis hardware and the mass storage device.

Incoming SFDUs will be stored on write-once CD-ROM media using a UNIX-based mastering system. Multiple copies of each CD-ROM are made for backup, and to provide complete sets of the data for Co-Investigator institutions. The CD-ROM disks are then physically moved to one of several

jukeboxes that make up the mass storage device, which allows the data to be accessed on-line via the DANET. The jukeboxes are controlled by management software running on a fileserver, which provides an index to the files on the CD-ROM media. Files will be accessible by name, but users will typically use the Database Program to request data using scientific-based search criteria. The DANET is tied into a LAN serving analysis workstations as well as the outside world (UCB Campus Net and Internet). Therefore, once a desired file is identified, an authorized user can easily access the data for processing by the Data Analysis Program or for other analysis activity.

In addition to the science telemetry SFDUs, spacecraft ephemeris data (from FDF) and definitive attitude data (from UCLA) will be archived. Together these three data sets constitute the Level 0 Data Product. The volume of SFDUs received during a 1 year mission is identified in Table 8 (volume of ephemeris and attitude data will be inconsequential). Any additional years will produce data at a similar rate.

The UCSOC will act as a project data node providing data to interested investigators. These investigators will use the Database program and Survey Data/Plots to determine periods of interest. The higher resolution data for specific intervals will usually be provided via Internet.

4.3.2.2 Discipline Archives

Not applicable.

4.3.2.3 NSSDC

NSSDC will receive, archive, and provide network and other access to a copy of the 5-sec Survey data. NSSDC will facilitate the inclusion of this data product in the ISTEP CDHF data base.

NSSDC will also receive and archive a copy of the Level 0 data on CD-ROM disks, along with the supporting software, documentation, calibration, and ancillary data. However, because the use of these data presently require a FAST-specific ADP environment, secondary users' access to and use of these Level 0 data and supporting material will be achieved through the FAST Data facility at the University of California at Berkeley until such time as the NSSDC or equivalent organization can assume this responsibility.

4.3.3 Directories and Catalogs

Many of the functions of directories and catalogs are provided by the FAST Database Program which will be available online through the UCSOC and the NSSDC as previously described. Limited amounts of higher level information, such as that needed by the NASA Master Directory, will be provided by UCSOC in consultation with NSSDC.

4.3.4 Standards

Format standards used for data products are described in Section 5.

4.3.5 Networking Requirements

Project-specific networks required for mission operations are described in the FAST DMR [5]. Other than routine use of the Internet (see Section 4.3.1.1), and the UCSOC LANs already described, no other networking resources are required.

5.0 Data Rights and Rules for Data Use

The FAST mission and instruments have an "open" data policy. FAST Survey Data will be non-proprietary and publicly available to identify possible scientifically interesting events or intervals. It will be provided to the ISTEP CDHF and also made available to the community via the WWW. During the data certification period, the publication of the survey data must be endorsed by the P.I. The UCSOC will be pleased to work with any members of the science community who would like to carry out higher level analysis of the Level 0 data. Where applicable, community members may be required to contribute resources to facilitate such data acquisition and processing at the UCSOC.

6.0 Acronyms and Abbreviations

ACS	Attitude Control System
ADC	Analog Digital Converter
ADP	Automated Data Processing
ALT	Altitude
ATS	Absolute Time Sequence
BBF	Broad Band Filters
CCSDS	Consultative Committee for Space Data Systems
CDF	Common Data Format
CDHF	Central Data Handling Facility
CLCW	Command Link Control Word
CMS	Command Management System
Co-I	Co-Investigator
C&DH	Command and Data Handling
DAP	Data Acquisition Plan
DMR	Detailed Mission Requirements
DSN	Deep Space Network
DSP	Data Signal Processor
EDAC	Error Detection and Correction
EESA	Electron ESA
ESA	Electrostatic Analyzers
FAST	Fast Auroral SnapshoT
fce	electron cyclotron frequency
FDF	Flight Dynamics Facility
FFT	Fast Fourier Transform
FOT	Flight Operations Team
FOV	Field of View
fpe	electron plasma frequency
FWHM	Full-Width Half Maximum
GDS	Ground Data System
GN	Ground Network

GSE Ground Support Equipment
 GSFC Goddard Space Flight Center
 GSFC SOC Goddard Space Flight Center Science Operations Center
 HFQ High-Frequency
 H/K Housekeeping
 HSBM High Speed Burst Memory
 IAS International Auroral Study
 ICD Interface Control Document
 IDPU Instrument Data Processing Unit
 IESA Ion ESA
 INVLAT Invariant Latitude
 IOM Instrument Operation Modes
 ISTP International Solar Terrestrial Physics
 KSPF Kiruna Science Processing Facility
 LAN Local Area Network
 LT Local Time
 LZP Level-Zero-Processing
 L&EO Launch and Early Orbit
 MCP Micro Channel Plate
 MLT Magnetic Local Time
 MOR Mission Operations Room
 MO&DA Mission Operations and Data Analysis
 MUE Mission Unique Electronics
 NASA National Aeronautics and Space Administration
 NRZ Non-Return to Zero
 NSSDC National Space Science Data Center
 PDMP Project Data Management Plan
 PFSOC Poker Flat Science Operations Center
 PHA Pulse Height Analyzer
 PI Principal Investigator
 PKT Packet
 POCC Payload Operations Control Center

PPS	Packet Processing System
PWT	Plasma Wave Tracker
RAM	Random Access Memory
ROM	Read Only Memory
RTS	Relative Time Sequence
RUST	Remote User System Terminal
SAMPEX	Solar Anomalous Magnetospheric Particle Explorer
SESA	Stepped ESA
SFA	Swept Frequency Analyzer
SFDU	Standard Formatted Data Unit
SMEX	Small Explorers
SOC	Science Operations Centers
STEP	Solar Terrestrial Physics Program
SWAS	Submillimeter Wave Astronomy Satellite
TEAMS	Time-of-flight Energy Mass Angle Spectrograph
TDRS	Tracking and Data Relay System
TF	Transfer Frame
TOTS	Transportable Operations and Tracking Station
T&C	Telemetry and Command
UCB	University of California at Berkeley
UCLA	University of California at Los Angeles
UCSOC	University of California at Berkeley Science Operations Center
UT	Universal Time
VC	Virtual Channel
WFF	Wallops Flight Facility
WPC	Wave-Particle Correlator

Appendix A: Data Products

A.1 Science Data Product Summary

Table 12 summarizes the science data products that will be produced by the FAST mission, and includes references to PDMP Sections where the generation of each product is described. The Level_0 and Survey Data Products are described in more detail in the following sections.

Data Product	Description (Ref.)	Data Format	Volume per Year	Public Release
Level_0 Data	LZP telemetry, spacecraft ephemeris, definitive attitude (see 4.3.1.1)	SFDU	545 Gbytes	Launch + 2 yrs
Survey Data	see below (also 4.2.4.2.2)	ASCII or CDF	~10 Gbytes	UCSOC receipt + 60 days
Survey Data Plots	see below (also 4.2.4.2.2)	Postscript	~8 Gbytes	UCSOC receipt + 60 days

Table 12: Science Data Product Summary

The Survey Data Products are "non-citable" in the sense that they are of uncertain validity and are intended as indices to the Level_0 Data.

A.1.1 Level_0 Data Product

The Level_0 Data Product consists of time-ordered and level-zero-processed sets of each science packet, organized into sets as received for each ground contact. Also included is spacecraft ephemeris data and definitive attitude data for each. Table 13 provides a summary listing of the FAST science packets; the creation of each science packet and its contents was described in Section 3. Additional packets (not listed) contain instrument status, housekeeping, and other supporting data.

Particle Data Packets		Fields Data Packets	
APID	Description	APID	Description
1024	EESA Survey	1032	Field Survey 0
1025	IESA Survey	1033	Field Survey 1
1026	SESA Survey	1034	Field Survey 2
1039	EESA Burst	1035	BBF
1040	IESA Burst	1036	SFA Average
1041	SESA 1 Burst	1037	DSP
1041	SESA 2 Burst	1038	HFQ
1041	SESA 3 Burst	1048	Field ADC 1
1041	SESA 4 Burst	1049	Field ADC 2
1041	SESA 5 Burst	1050	Field ADC 3
1041	SESA 6 Burst	1051	Field ADC 4
1027	TEAMS Full Angle (Survey)	1052	Field ADC 5
1028	TEAMS Mass Spectrum	1053	Field ADC 6
1029	TEAMS Pole Channels	1054	Field ADC 7
1030	TEAMS Monitor Rates	1055	Field ADC 8
1031	TEAMS PHA Events	1056	WPC
1047	TEAMS Burst Data	1057	SFA Burst
		1058	HSBM

Table 13: Science Data Packet Summary

A.1.2 Survey Data and Data Plots

There will be 5 pages of summary plots: (1) DC fields, (2) AC fields, (3) electrons, (4) ions, and (5) diagnostics. The time period that each page represents is 30 minutes. The plots will start on the even minute (preceeding the actual start of the data). The time resolution will be one spin period (approximately 5s). The horizontal scale will include the following parameters: UT (hr:min), invariant latitude, magnetic local time, altitude, geographic latitude of footpoint and geographic longitude of footpoint. There will also be mode/data history line with mode information and the times when slow and fast survey and burst data are obtained.

The data will be formatted in ASCII and in CDF. The plots will be in Postscript file format.

The Survey Data Products are non-citable and are intended as indices to the Level 0 Data.

The coordinate system is as follows:

- (1) The y-axis is along the spacecraft spin axis, positive in the direction closest to westward;
- (2) The x-axis is given by the Y cross model B direction (positive equatorward in the auroral zone); and
- (3) The z-axis completes the right hand coordinate system (X cross Y) and is mostly parallel to the model magnetic field.

Note that this coordinate system has a discontinuity at the pole.

A time line containing the instrument mode and data history should be at the bottom of every plot page. The data history line has a horizontal axis representing time, with gray shading marking the time the instrument is in fast survey, darker shading for burst, and black for both fast survey and burst. Additionally, the history should include markers for high speed burst memory captures. The instrument mode number should be written at the beginning of the time line.

"Nominal" survey data is as follows:

Page 1 - DC magnetic and electric fields

- A, B and C. The three components of the magnetic field (B_x , B_y , B_z) minus the model magnetic field.
- D. Magnetic ELF. The RMS deviation in the spin fit to the magnetic field.
- E and F. The x and z components of the electric field (obtained by spinfitting over the ~5s spin period) with an amplitude range of +/- 100mV/m. (Note that the $V \times B$ field is not subtracted).
- G. Sigma E, the root mean square deviation in the spin fit of the electric field with scale of 0-100 mV/m.

Page 2 - AC electric and magnetic fields

- A. VLF Electric field spectrum (0-16 kHz, 64 frequency bands)
- B. VLF Magnetic field spectrum (0-16 kHz, 64 frequency bands)
- C. Total VLF electric field power
- D. Total VLF magnetic field power
- E. HF electric field spectrum (0-2MHz, 64 frequency bands)
- F. HF magnetic field spectrum
- G. Total HF electric field power (200 kHz-2 MHz)

- H. Total HF magnetic field power (200 kHz -2 MHz)

Page 3 - Electron plots

- A, B and C. Zero, 90 and 180 degree pitch angle electron energy flux spectrograms
D. Pitch angle electron spectrogram at 1 keV
E. Pitch angle electron spectrogram at 10 keV
F. Integrated energy flux

Page 4 - Ion plots

- A and B. 90 and 180 degree pitch angle ion energy flux spectrogram
C. Mass-energy plots (spectrograms) (HMR)
D and E. H⁺ and O⁺ angle-energy plots (spectrograms) (surv.)
F and G. H⁺ and O⁺ angle-time spectrograms (surv.)

Page 5 - Diagnostics

- A. The spacecraft potential relative to sphere 8
B. The bias current to sphere 1
C. The thermal current (measured from sphere 2, 6, or 9) plotted only when the sphere is in current mode.
D and E. Spin/sun and spin/magnetic field angles. The angles between the spin axis and the sun direction and between the spin axis and the magnetic field.
F, G and H. The three components of the electric field with an amplitude range of +/- 1.6 V/m. (Note that the V X B field is not subtracted)

A.2 Associated Archive Products

In addition to the science data products, software required to access and analyze the datasets will be archived as described in Section 4.3. These include the Database Program, various Data Analysis Programs, the mass storage device management software, and all appropriate documentation.