

FLOWCHART FOR DETERMINATION OF WHICH TEST PROCEDURE TO USE FOR CHEST/SPINAL (CHIROPRACTIC) RADIOGRAPHIC SYSTEMS

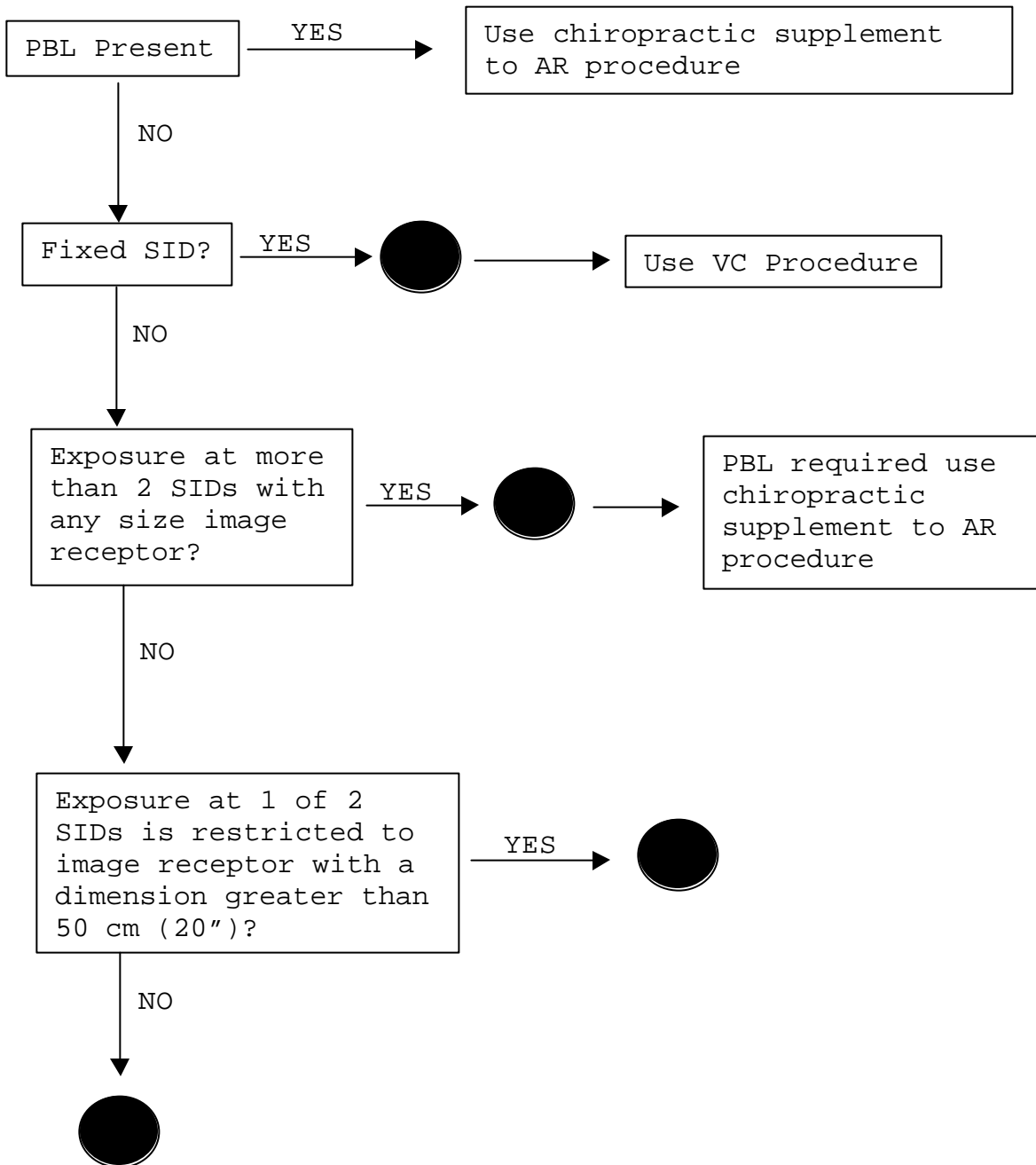

ATTACHMENT 2



DEPARTMENT OF HEALTH, EDUCATION, AND WELFARE  
PUBLIC HEALTH SERVICE  
FOOD AND DRUG ADMINISTRATION  
ROCKVILLE, MARYLAND 20857

SEP 3 1980

MA:BRH:DOC:XPB:353

TO: Manufacturers and Assemblers of Diagnostic X-ray Equipment

SUBJECT: The Numerical Indication of Source to Image Receptor Distance (SID), 21 CFR 1020.31(e)(1)(i)

This letter is intended to clarify the FDA position regarding the numerical indication of SID on stationary general purpose systems as required by 21 CFR 1020.31(e)(1)(i). This regulation states that "means shall be provided to indicate when the axis of the x-ray beam is perpendicular to the plane of the image receptor, to align the center of the x-ray field with respect to the center of the image receptor to within 2 percent, and to indicate the SID to within 2 percent."

Assemblers contend that the underlined requirement is met on certified, PBL-equipped systems by (1) user instructions specifying the position of each microswitch and the corresponding SID to the permanently-mounted image receptor, and (2) installation of an "exposure ready" light on the beam limiting device. This light is only illuminated when the microswitch is activated. The microswitches are frequently used to provide discrete SID's to the wall-mounted image receptor, and are occasionally used to provide discrete SID's to the under-table image receptor. Most stationary general purpose radiographic systems, however, permit exposures to the image receptor(s) at SID's for which PBL is not provided, through use of an override switch.

It is the FDA position that all stationary general purpose radiographic systems must be equipped with means to provide numerical indication of any and all SID's (inches and/or centimeters) at which the system is designed to operate when the useful beam is perpendicular to the plane of the image receptor. This requirement may be satisfied by means of a retractable tape measure on the tube housing assembly, a tape measure mounted on the tubestand track parallel to the beam axis, or by other means which provide the required numerical indication at all operational SID's. A statement in the user instructions relating microswitch locations to SID's is not considered to meet the requirement.

Should there be any questions on this requirement please call X-ray Products Branch at 301-443-3403.

A handwritten signature in cursive script, reading 'Robert G. Britain', is positioned above the typed name and title.

Robert G. Britain  
Director  
Division of Compliance  
Bureau of Radiological Health

X-RAY TUBE FOCAL SPOT LOCATION

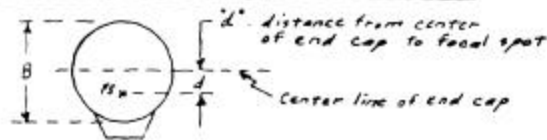

B - diameter of tube endbell  
 d - distance from center of endbell down to focal spot

MANUFACTURER	TYPE HOUSING	DISTANCE "d"	HOUSING CONFIGURATION
CGR	J185	45 mm	
	240	35 mm	
	260	35 mm	
	550	48 mm	
	610 } 620 }	63 mm	
MACHLETT	DYN 50	30.2 mm	
	DYN 60 } DYN 62 }	41.7 mm	
EIMAC	B100	29.4 mm	
	B150	41.6 mm	
	B160	42.4 mm	
	B180	57.2 mm	
EUREKA	Diamond 150TH } Emerald 125-T }	30.2 mm	

Method of locating the focal spot of an x-ray tube if it is not already indicated on the tube:

1. Measure the diameter of the tube end bell in millimeters.
2. Divide the diameter of the endbell by 2 and measure down (or up) from the edge of the endbell to locate the center of the endbell.
3. Measure down from the center of the endbell the distance "d" given in the above chart for the x-ray tube used. Mark the point with a permanent ink pen. This is the location of the focal spot according to data supplied by the manufacturer.
4. If the tube being used is not noted on the above chart, approximate the focal spot location by measuring 1/4 of the endbell diameter up from the bottom of the endbell.

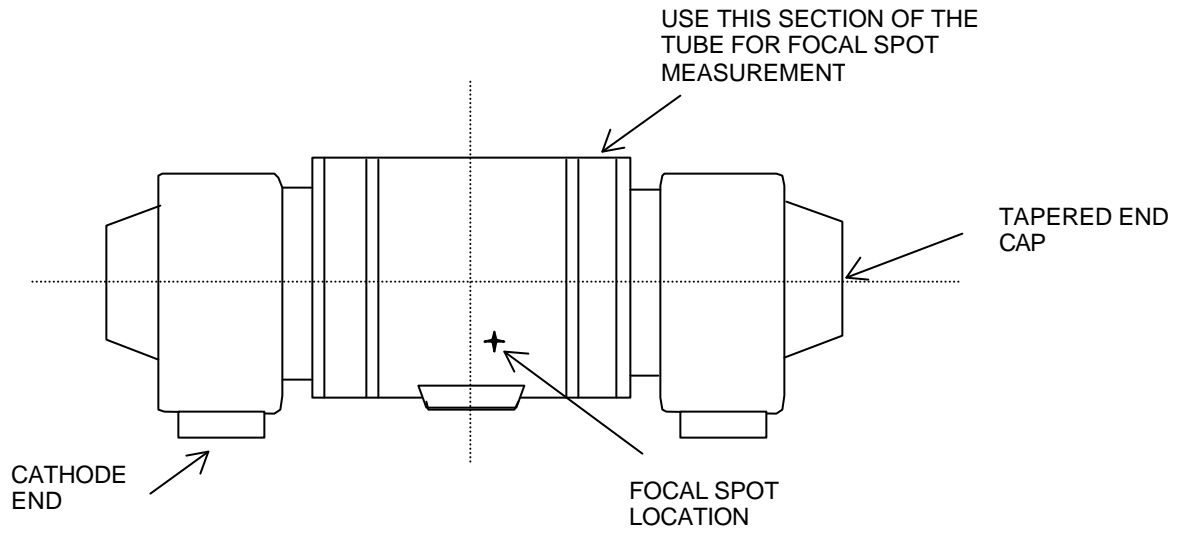

FIGURE 1

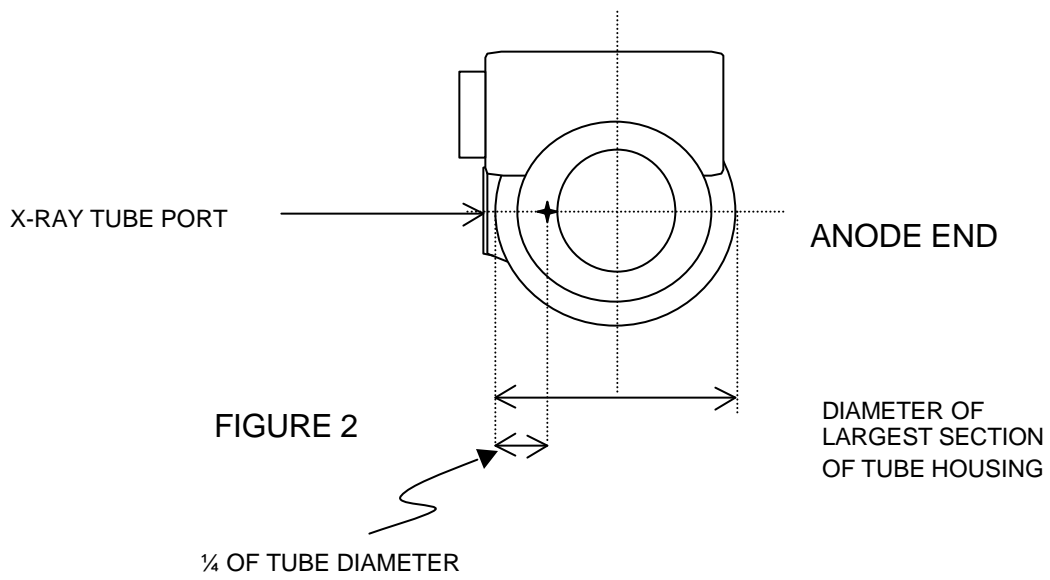

FIGURE 2



Food and Drug Administration  
8757 Georgia Avenue  
Silver Spring MD 20910

MAR 26 1984

Ref:MA:OC:DRP:XPB:380

TO: MANUFACTURERS AND ASSEMBLERS OF DIAGNOSTIC X-RAY EQUIPMENT

SUBJECT: Definitions of "General Purpose X-ray System"  
and "Other Than General Purpose X-ray System"

Questions continue to arise concerning the definitions of "general purpose" and "other than general purpose" as they appear in 21 CFR 1020.31(d), (e), and (f) of the performance standard and the applicability of these sections to an installed x-ray system.

We are writing this letter to the x-ray industry to revise and restate FDA's definitions of "general purpose" and "other than general purpose" for the purposes of 21 CFR 1020.31. Copies of this letter will be sent to all FDA District Offices and FDA field x-ray inspectors. This letter incorporates the original definitions, issued in 1979, and appearing on page 10 of the Assembler's Guide; the contents of our November 24, 1982 letter in which we permitted the limited use of a second SID; and our recent change permitting the limited use of tilting cassette holders.

Definitions: "General Purpose"  
"Other Than General Purpose"

- A. An x-ray system, designed for and limited by its design for diagnostic purposes to only one of the following body regions is classified as "other than general purpose" for the purposes of 21 CFR 1020.31.
- 1 - extremities
  - 2 - head or head and neck
  - 3 - thoracic
  - 4 - abdominal
- B. An x-ray system, designed for and limited by its design for diagnostic purposes to only one of the following specialized applications, is classified as "other than general purpose" for the purposes of 21 CFR 1020.31.
- 1 - System designed for cystographic, urologic, or other specialized exams of the kidney, bladder, and/or urinary tract.
  - 2 - Dental x-ray system designed for use with intraoral and/or extraoral image receptors.

M/A Ltr. 380

2

- 3 - Cephalometric x-ray system or dental x-ray system designed for use with extraoral image receptors whenever special cephalometric devices are attached.
- 4 - An x-ray system designed specifically for chest or spinal radiography when installed:
  - a. with a single fixed source-to-image-receptor distance (SID) along the horizontal axis
  - or
  - b. with two SIDs along the horizontal axis when exposure at one of the two SIDs is restricted to image receptors with a dimension greater than 50 centimeters (20 inches).

Either a or b may be installed with a permanently-mounted vertical cassette holder or Bucky (tilting or non-tilting) but not with a permanent x-ray table. If installed with a tilting vertical cassette holder or Bucky, exposure shall not be possible when the x-ray beam axis is within  $\pm 3$  degrees of the vertical and the image receptor plane is within  $\pm 3$  degrees of perpendicular to the x-ray beam axis. Mobile or hang-on cassette holders or mobile tables may be used without restriction in such systems.

- 5 - Mammographic x-ray system.
  - 6 - Therapy simulation x-ray system.
  - 7 - System designed for and installed in operating rooms.
  - 8 - Pantomographic x-ray system.
  - 9 - Tomographic x-ray system (when used in the tomographic mode of operation).
- C. Any x-ray system, which by its design is not limited to radiographic examination of a specific anatomical region and does not meet the requirements of paragraphs A or B preceding is considered to be "general purpose" for the purposes of 21 CFR 1020.31.

M/A Ltr. 380

3

If we can provide further information about this subject, please contact Mr. Tom Mosely, X-ray Products Branch (HFZ-311), Division of Radiological Products, Office of Compliance, Center for Devices and Radiological Health, 8757 Georgia Avenue, Silver Spring, Maryland 20910, (301-427-7222).

Sincerely yours,

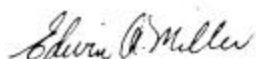

Edwin A. Miller  
Acting Director  
Division of Radiological Products  
Office of Compliance  
Center for Devices  
and Radiological Health

TEST CONFIGURATION

ATTACHMENT 5

FRONT VIEW

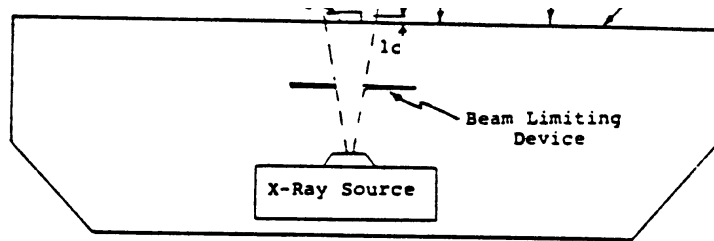

front view

ATTACHMENT 5

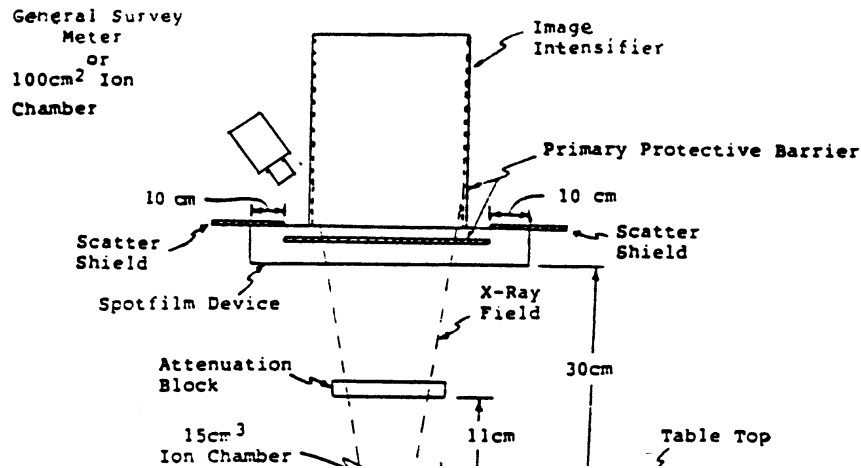

SIDE VIEW

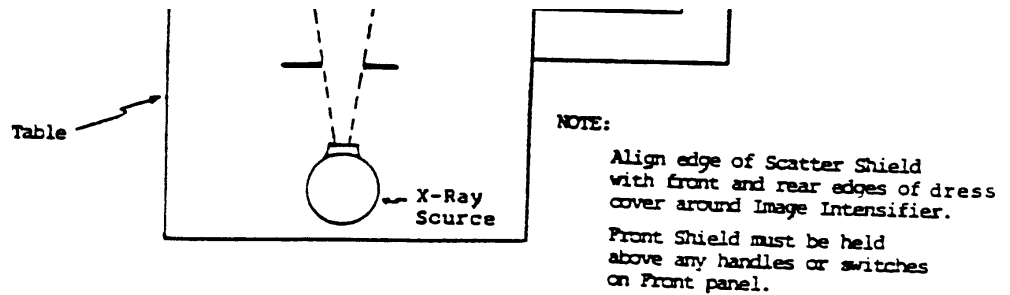

SIDE VIEW

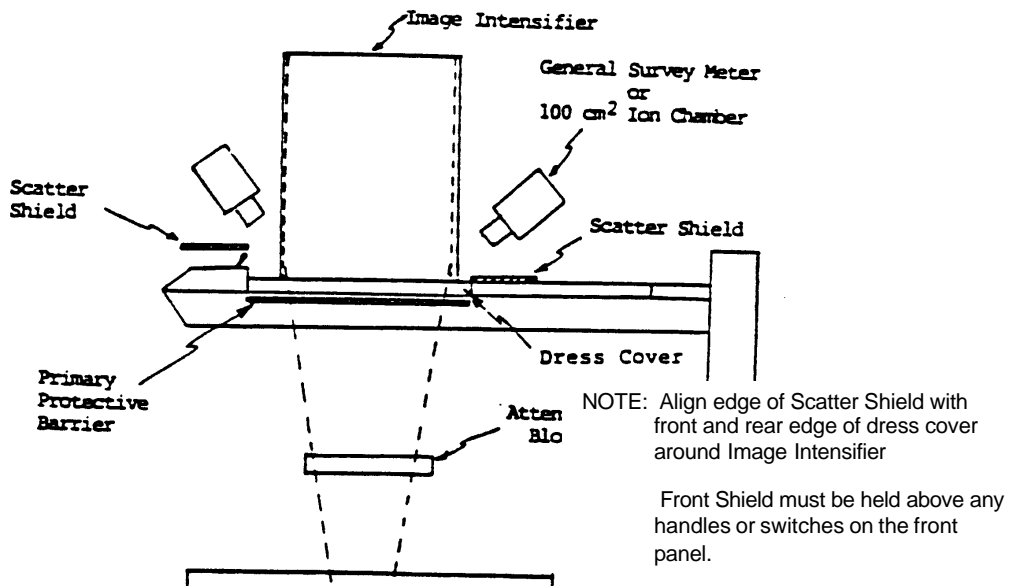



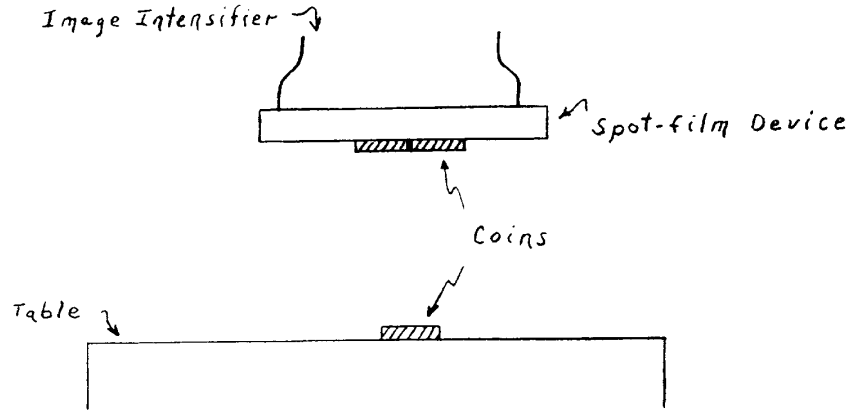

Figure 1

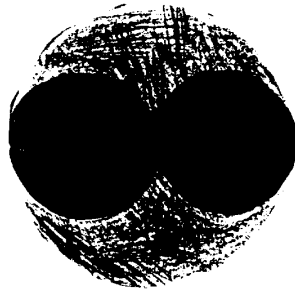
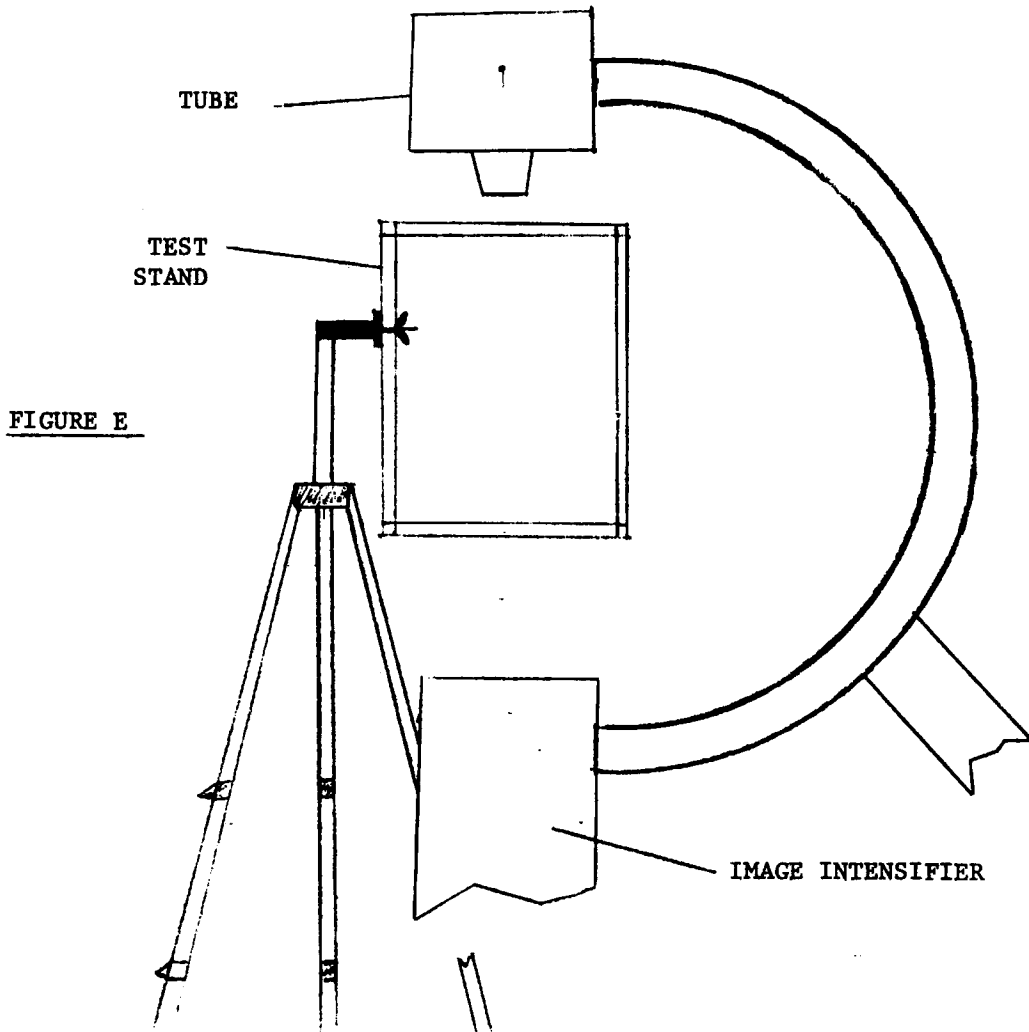
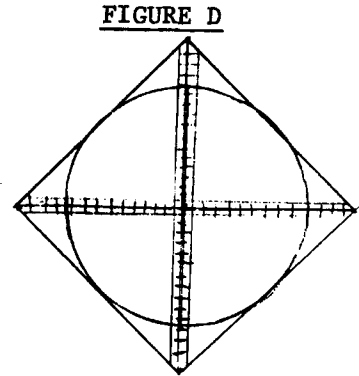
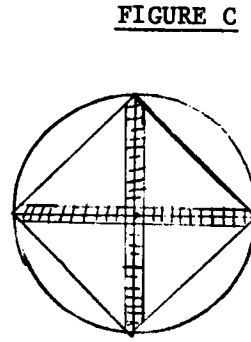
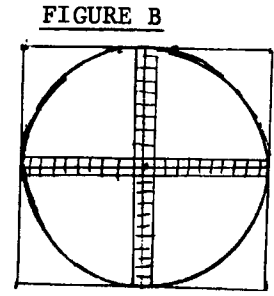
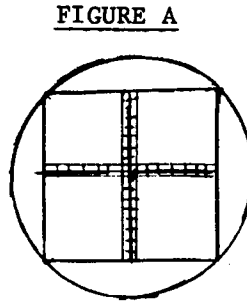
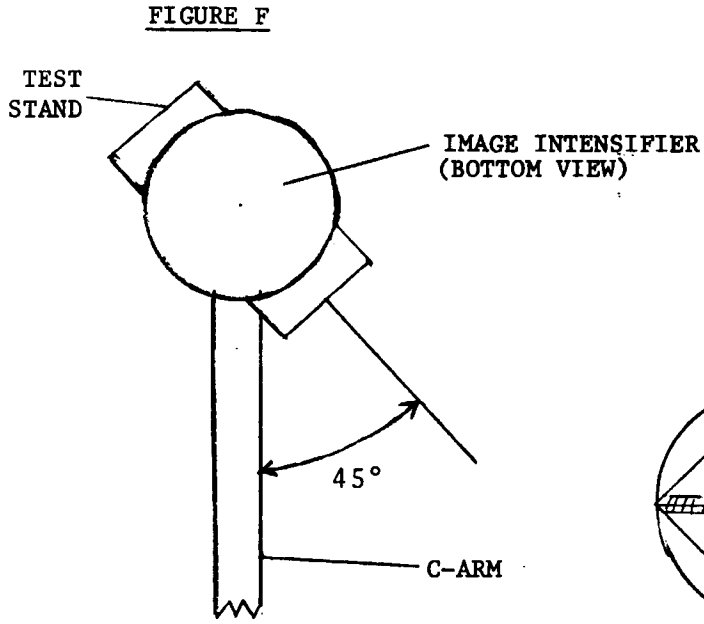
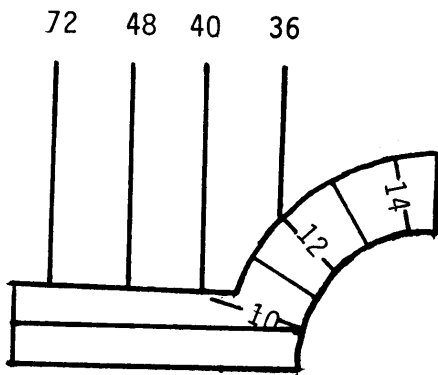
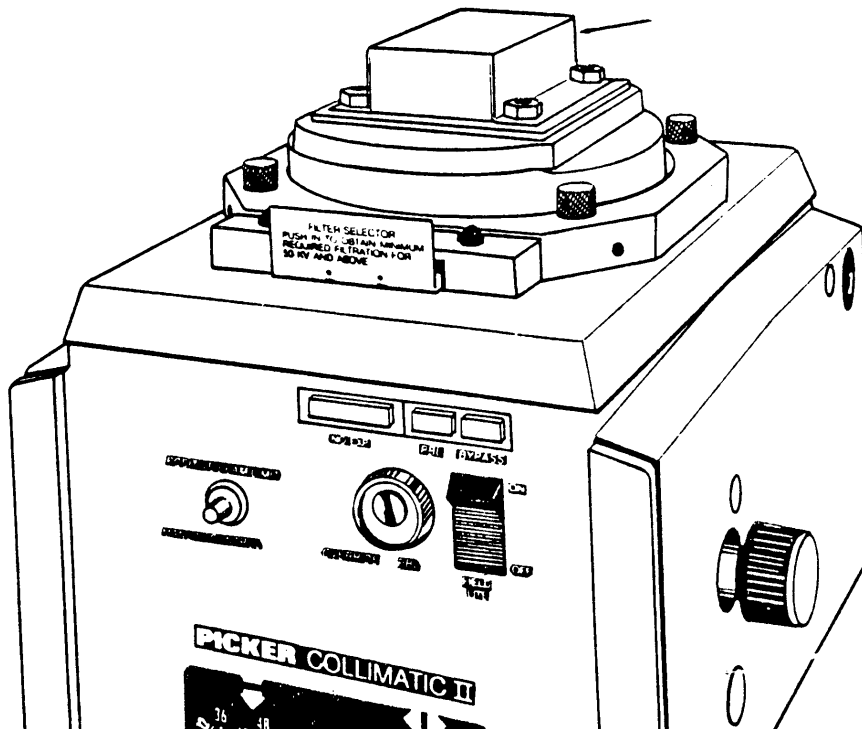
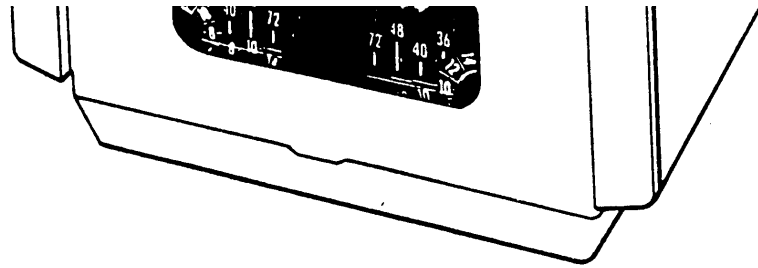

Figure 2

ATTACHMENT 7





Incorrect

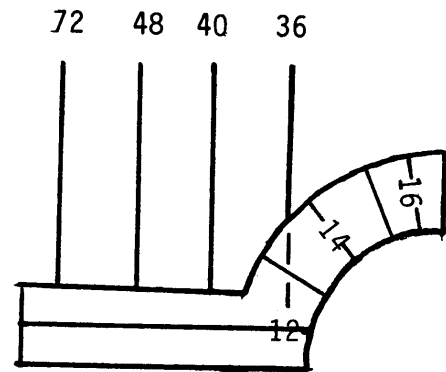

Correct