

## **Appendix C**

### **Oregon Uniform Sign Guidelines for Recreational Boat Launching and Transient Tie-Up Facilities**

# Uniform Sign GUIDELINES for

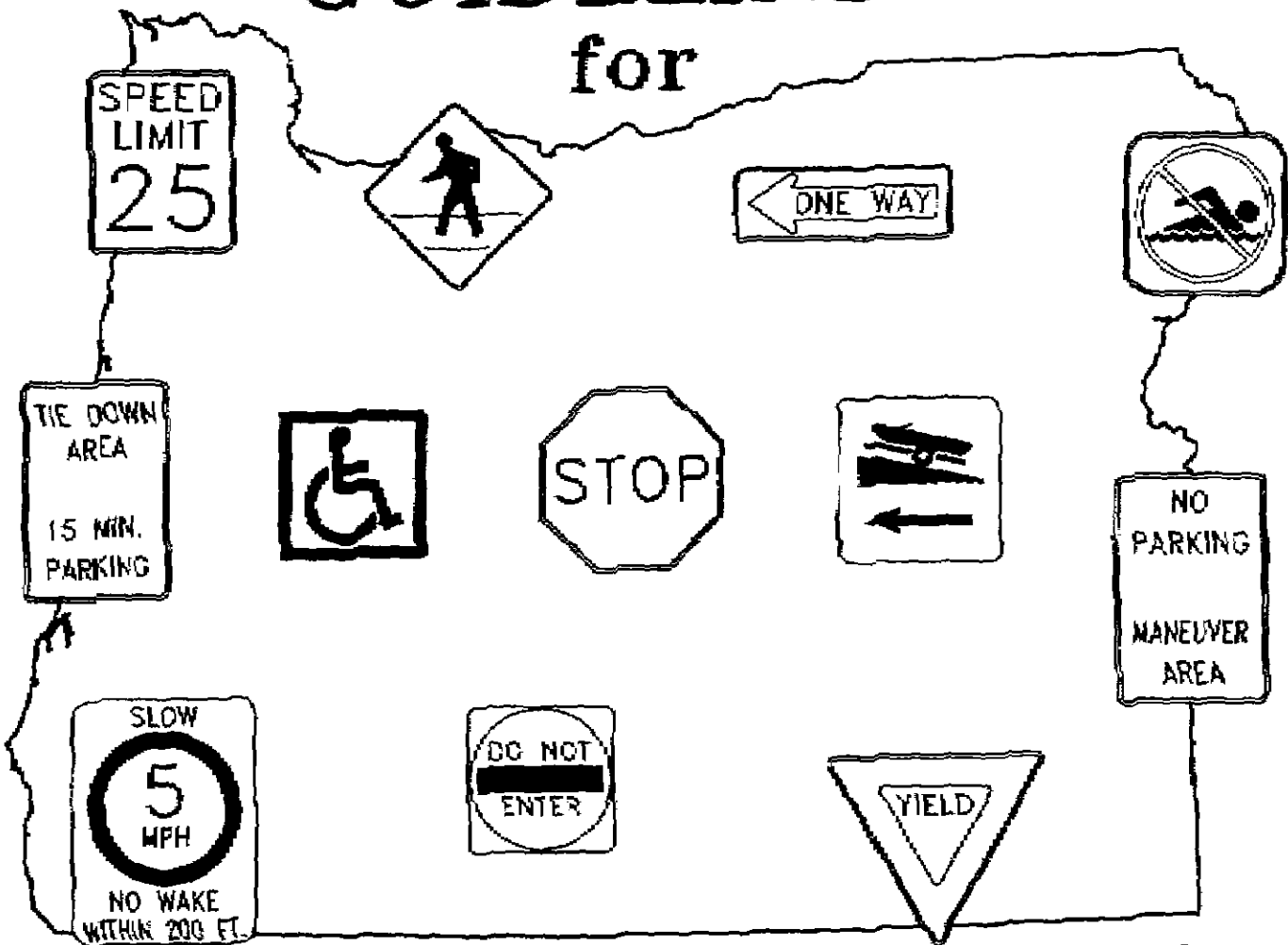

## Recreational Boat Launching and Transient Tie-Up Facilities



September 1997

**UNIFORM SIGN GUIDELINES  
for  
RECREATIONAL BOAT LAUNCHING  
and  
TRANSIENT TIE-UP FACILITIES**

September 1997

Prepared by:

Boating Facilities Program  
Oregon State Marine Board  
P.O. Box 14145  
Salem, OR 97309-5065

Dave Obern, Facilities Program Manager  
Paul Donheffner, Director

Ron Rhodehamel, P.E., Chief Facilities Engineer  
Ray Lanham, P.E., Facilities Engineer  
Jeff Smith, Project Manager  
Ramin Pakdel, Associate Engineer  
Darrell Monk, Engineering Technician

Telephone: (503) 373-1405

FAX: (503) 378-4597

E-Mail: [marine.board@state.or.us](mailto:marine.board@state.or.us)

Internet: [www.marinebd.osmb.state.or.us](http://www.marinebd.osmb.state.or.us)

**Note:** Permission is granted for duplication, copy, use, and reuse of any and all information contained in this document. The Oregon State Marine Board does not consider nor warrant in any manner that the information presented in these guidelines is all inclusive or absolute. It the responsibility of the owner and project engineer to determine the best selection of signage for each site application.

## TABLE OF CONTENTS

	<u>PAGE</u>
<b>INTRODUCTION</b>	
Background .....	1
Purpose .....	1
Goal .....	1
<b>I. GENERAL SIGN INFORMATION</b>	
<b>A. Sign Design</b>	
1. Background .....	2
2. Rules of Capitalization .....	3
3. Text Size .....	3
4. Text Size for Signs Viewed from a Moving Vehicle .....	3
5. Text Size for Signs Viewed from a Stationary Position .....	4
6. Federal Recreation Symbols .....	4
7. Enforcement with Symbols .....	5
8. Arrows .....	5
9. Distance Figures .....	6
10. Abbreviations .....	6
11. Standard Vehicle Sign Shapes .....	6
12. Standard Vehicle Sign Colors .....	7
13. Standard Waterway Sign Colors .....	7
14. Standard Sign Materials .....	8
<b>II. UPLAND SIGN APPLICATIONS</b>	
<b>A. Vehicle Control Devices</b>	
1. Background .....	9
2. Vehicle Control Objectives .....	9
3. Requirements of Vehicle Control Devices .....	10
<b>B. Vehicle Regulatory Signs</b>	
1. Background .....	11
2. Stop Sign .....	11
3. Yield Sign .....	12
4. Do Not Enter Sign .....	12
5. One Way Signs .....	13
6. Speed Limit Sign .....	13
7. No Parking Sign .....	13
8. No Parking/Maneuver Area Sign .....	14

9.	Disabled Parking Sign .....	14
10.	Ready Area Sign .....	14
11.	Tie Down Sign .....	15
<b>C. Vehicle Warning Signs</b>		
1.	Background .....	16
2.	Pedestrian Crossing Sign .....	16
<b>D. Vehicle Information Signs</b>		
1.	Background .....	17
2.	Entrance Signs .....	17
3.	Ramp Directional Sign .....	17
4.	Single Car Parking Area Sign .....	17
5.	Boat Trailer Parking Area Sign .....	17
6.	Other Activity Areas - Day Use, Camping, Swimming .....	18
7.	General Information Board - Cluster Signs .....	18
8.	Credit Signs .....	18
<b>E. Vehicle Pavement Markings</b>		
1.	Background .....	19
2.	Centerline Access Road .....	19
3.	Boat Ramp Lane Stripes .....	19
4.	Parking Spaces .....	20
5.	Stop Lines .....	20
6.	Pedestrian Crosswalks .....	20
7.	Directional Arrows .....	21
8.	Disabled Access Aisle .....	21
9.	Disabled Access Symbol .....	21
<b>III. ACCESS FACILITY SIGN APPLICATIONS</b>		
<b>A. Boat Ramp and Tie-Up Control Devices</b>		
1.	Background .....	22
2.	Boat Ramp and Tie-Up Sign Mounting Location .....	22
3.	Vehicle and Boat Control Objectives .....	22
4.	Requirements of Ramp and Tie-Up Control Devices .....	22
<b>B. Boat Ramp and Tie-Up Regulatory Signs</b>		
1.	Background .....	24
2.	Boarding Float .....	24
3.	Transient Tie-Up Regulations .....	24

<b>C. Boat Ramp and Tie-Up Warning Signs</b>	
1. Background .....	25
2. Danger - No Swimming Sign .....	25
3. Danger - No Diving Sign .....	26

<b>D. Boat Ramp and Tie-Up Information Signs</b>	
1. Background .....	27
2. Name of Facility - Waterbody .....	27
3. Boating Safety Kiosk Signs .....	27

#### **IV. WATERWAY SIGN APPLICATIONS**

<b>A. Boating Control Devices</b>	
1. Background .....	28
2. Boating Control Objectives .....	28
3. Requirements of Boating Control Devices .....	29

<b>B. Boating Regulatory Signs/Buoys</b>	
1. Background .....	30
2. Slow No Wake Sign .....	30

<b>C. Boating Warning Signs/Buoys</b>	
1. Background .....	31
2. Fairway or Channel Marker Signs .....	31
3. Fairway or Channel Marker Buoys .....	31
4. Danger - Rock, Shoal, or Stumps .....	31

<b>E. Waterway Information Signs</b>	
1. Background .....	32
2. Pumpout Sign .....	32
3. Dump Station Sign .....	32

#### **V. APPENDIX**

<b>A. Facility Sign Layout</b>	
1. Typical Facility Sign Layout Example .....	33
2. Typical Sign Post Details .....	34

<b>B. Upland Sign Examples</b>	
1. Regulatory Signs .....	35
2. Warning Signs .....	35
3. Informational Signs .....	36
4. Pavement Markings .....	37
5. Disabled Parking .....	38
<b>C. Boat Ramp and Tie-Up Sign Layout</b>	
1. Typical Boat Ramp Sign Layout Example .....	39
2. Typical Tie-Up Sign Layout Example .....	39
<b>D. Waterway Sign Examples</b>	
1. Regulatory Signs .....	40
2. Warning Signs .....	40
3. Informational Signs .....	41

## INTRODUCTION

### ***Background***

In the absence of any specific and detailed national or state boat access signage guidelines the Oregon State Marine Board (OSMB) has developed a manual for uniform sign guidelines recommended for use at all public boat access sites in Oregon. Any system of signs and pavement markings, must also assess the impacts of a risk management plan and legal liability to the responsible agency.

These guidelines take into account related "roadway and park" signage standards. Warning sign guidelines are based on risk management practices developed by many states and agencies around the country. We recognize that as legal actions will continue to evolve these guidelines will likely be modified periodically.

This manual is intended to be used in conjunction with OSMB published Guidelines on Recreational Boat Launching and Tie-Up Facilities.

Please use these guidelines as they are intended, as a guide. Every effort has been made to provide engineers with the most reliable design parameters that should work in most all locations and conditions. Any deviations should be carefully analyzed. OSMB does not consider nor warrant that these guidelines are all inclusive and/or absolute. It is up to the project engineer and owner to carefully consider each individual site for best design and appropriate selection of signs.

### ***Purpose***

The purpose of the manual is to provide statewide guidance for the effective use and management of vehicle, pedestrian and boat visual aids. This manual provides the basic signing and pavement marking principals for planning or operating public boat access facilities in Oregon.

Compliance with these principals, standards, and guidelines will assist in providing effective and efficient visual aids (sign and pavement markings) that meet minimum user safety objectives at public recreational boating facilities.

### ***Goal***

The most important goal is to provide the user with a clear, concise and uniform system of visual aids for Regulatory, Warning, and Information purposes. Safety is paramount but must be balanced carefully with "Sign Clutter" and the tendency to over inform the user and lose the intent of the principal goal.



## I - GENERAL SIGN INFORMATION

### A. Sign Design

#### 1. Background

- a. Design of signs should assure that such features as size, contrast, color, shape, composition, and lighting or reflectorization are combined to draw attention to the sign; that shape, size, colors, and simplicity of message (text) combine to produce a clear meaning and that legibility and size combine with placement to permit adequate time for viewing and response.
- b. Standard designs have been developed for most signs and should be utilized, whenever provided such as the Manual on Uniform Traffic Control Devices (MUTCD), Universal Access for Outdoor Recreation Symbols, and U.S. Coast Guard Inland Waterway Marking System.
- c. The following rules are presented with the understanding that sign messages are infinitely variable and perfect application of these rules cannot always be achieved.
  1. Maximum of four words per message, except where proper names are used. Proper names that may be several words long will count as one word in a message.
  2. For signs with more than one message the following apply:
    - \* Maximum of three worded messages per sign.
    - \* Maximum of four words per message.
    - \* Total words on sign not to exceed eight, not counting word groups that build proper names.
- d. Where possible limit vehicle guide signs to three messages and three lines of text. Do not exceed four lines of text. Information signs viewed while stationary are the exception and may contain more lines or messages.
- e. The nearest destination lying straight ahead should be the top message line of a guide sign, below it, the next important destination to the left, and to the right in that order. If there is more than one destination shown in any direction, the name of the nearest shall appear above that of any further away.

- f. For signs combining worded and symbol plates per sign, each symbol counts as a separate message. This means a maximum of four symbol plates per sign, each symbol counting as a separate message. More symbol messages are allowed than text messages. Four verses three.
- g. In some instances signs that need to have variable messages will be needed, rate signs and self registration signs are examples of signs that may require different messages during the year.
- h. Generally, left justify all messages and leave the text jagged on the right. This will improve readability.

## **2. Rules of Capitalization**

- a. Generally all sign text shall be upper case text except for the following exceptions.
- b. Proper names for destinations shall be spelled in upper and lower case texts. This includes named destinations within a facility. The name of a facility is considered a proper name, words like launch ramp and day-use area are not considered proper names and should be all upper case texts.
- c. Examples: Chinook Landing and Sand Island Marine Park are proper names, LAUNCH RAMP and PARKING AREA are not proper names.
- d. A sign set in all upper case texts will take 14 percent longer to read and require 40 percent more space.
- e. Direction messages are spelled in upper case texts. Examples: RIGHT TURN ONLY, STOP, ONE WAY, ½ MILE ON THE RIGHT.
- f. Direction words are spelled in upper case texts, if they occur together with destinations on the same sign. Examples: Meldrum Bar Launch Ramp RIGHT, Carver Ramp TURN LEFT.

## **3. Text Size**

- a. Text size is a function of viewing distance, speed and the amount of time available for viewing. Speed and viewing time are interrelated for people in vehicles or boats.

#### 4. Text Size for Signs Viewed from a Moving Vehicle

- a. Roads and bicycle trails within a facility.

<u>Speed</u>	<u>Size</u>
More than 25 MPH	3" Text
25 MPH and Less	2" Text

#### 5. Text Size for Signs Viewed from a Stationary Position

- a. The text of signs for stationary vehicles or pedestrian viewing can be sized based on typical viewing distances. These guidelines are based on the ability to read a sign from a distance rather than the amount of time required to read a message from a moving vehicle.
- b. Unless otherwise governed by other regulations text size can be based upon the distance from which the message is to be viewed.

<u>Distance</u>	<u>Size</u>
Viewed from 4 feet or less	5/8" Text
Viewed from 5 to 7 feet	3/4" Text
Viewed from 8 to 12 feet	1" Text
Viewed from 13 to 20 feet	2" Text
Viewed from over 20 feet	3" text

#### 6. Federal Recreation Symbols

- a. Use symbols in situations where they are more effective than conventional worded message signs. Symbols are particularly effective for non-English users. Use standard symbols without modification.
- b. Symbols provide a common, non-verbal language to transmit visitor information. Federal Recreation Symbols have been developed and approved by a Federal Interagency Committee. Adherence to these adopted symbols is important to achieve and maintain uniformity with other governmental entities who also use these symbols. Symbols are intended for use whenever they can effectively be substituted for a text message.
- c. To determine whether or not a symbol would be appropriate for a specific use, the following criteria should be used:
1. Is the activity, service, or the facility obvious? The obvious should not be symbolized.

2. Is the symbol repetitious of text signs that already exist? Generally, both should not be used together, however see the Enforcement with Symbols Section for an exception. Worded signs or bulletins should continue to be used to explain detailed information which symbols cannot convey.
3. Does the symbol identify the activity, service, or facility to the extent that an explanatory text is not required? If the symbol will not stand on its own merit it should not be used. Symbols should be used to establish distinctions between activities, services, or facilities.

## **7. Enforcement with Symbols**

- a. Using Federal Recreation Symbols with the red prohibitory slash to indicate prohibited activities is a common practice. Be aware though, that citations can not be written based on signs that only have a symbol and do not have text.
- b. The standard prohibitory text used with symbols will generally say the word "NO" followed by the name of the activity. Example: NO PARKING etc... It is best to use the modified symbol sign that includes the symbol and text on one sign plate, rather than add a separate sign below with the prohibitory text.
- c. Text should be black, symbol will be black or brown, on a white background, with a red circle and slash (if no). If the chances of ever writing a citation in that area are slight or that the impact caused by people occasionally violating the rule are slight, a text rider may not be warranted.

## **8. Arrows**

- a. As a general rule directional arrows should be horizontal or vertical. Sometimes, a sloping or oblique arrow will convey a clearer indication of the direction to be followed.
- b. The size of arrows is relative to the text size on the sign. The distance between the barbs of the arrow should be equal to the text size or the size of character used in the symbol sign.
- c. There are a maximum of five different possible arrow directions: straight up, oblique left up (45 degrees), straight left (90 degrees), oblique right up (45 degrees), and straight right (90 degrees).
- d. Arrows pointing to the right shall be on the extreme right of the destination and distance to destination figures, if used.

- e. On roads where site conditions dictate a narrow sign, and an arrow positioned to the left or right of the message would produce an overly wide sign, the arrow may be centered below the message. This is not applicable to direction signs with more than one directional arrow.

## **9. Distance Figures**

- a. The distance figures shall follow after the destination name or directions on all signs.
- b. Show distances to the nearest mile if distance is three miles or greater. If distance is less than three miles, round to the nearest fraction of a quarter mile ( $\frac{1}{4}$ ,  $\frac{1}{2}$ ,  $\frac{3}{4}$ ).
- c. Distances for trail signs are shown different. Trail signs should always show the distance to the nearest fraction.
- d. For distance measurements using feet or yards place the distance in the same location on the sign. Feet and yard measures shall be shown to the nearest unit of 50. Be aware some states are moving to metric measurements.

## **10. Abbreviations**

- a. Use complete words or symbols in sign messages whenever possible. Abbreviate words where length of named destinations or features would cause excessive sign length, and where the abbreviated form has clear meaning to the public. Periods are part of the abbreviation, except for the cardinal directions, N, S, E, W that do not use periods.

## **11. Standard Vehicle Sign Shapes**

- a. The DIAMOND is used for the majority of warning signs.
- b. The RECTANGLE, with the longer dimension vertical is used for the majority of the regulatory signs and some warning signs.
- c. The RECTANGLE, with the longer dimension horizontal is used for the majority of guide signs including recreation guide signs and some warning signs.
- d. The SQUARE shape is used for Federal Recreation Symbols.
- e. The PENTAGON with the point up is used for School and School Crossing signs.

- f. The PENNANT shape with the longer dimension horizontal is used only for No Passing Zone warning sign.
- g. The OCTAGON is used only for the Stop sign.
- h. The EQUILATERAL TRIANGLE with one point down is used only for the Yield sign.
- i. The ROUND shape is used for the railroad advance warning signs and Civil Defense Evacuation route sign.

## 12. Standard Vehicle Sign Colors

- a. The following color code establishes general meanings that have been identified as being appropriate for use in conveying traffic control information, principally on signs.
  - 1. YELLOW: General Warning
  - 2. RED: Stop or Prohibition
  - 3. BLUE: Motorist Services
  - 4. GREEN: Guidance or Informational
  - 5. BROWN: Historic, Cultural, Recreational
  - 6. ORANGE: Construction or Maintenance
  - 7. BLACK: Regulatory
  - 8. WHITE: Regulatory

## 13. Standard Waterway Sign Colors

- a. The following color and symbol code establishes general meanings that have been identified as being appropriate for use in conveying boating control information on signs and buoys:
  - 1. Color        WHITE:       Regulatory, Warning, Information
  - 2. Text         BLACK:       Regulatory, Warning, Information
  - 3. Symbols     DIAMOND:       International Orange
  - DIAMOND WITH CROSS: International Orange
  - CIRCLE:       International Orange
  - RECTANGLE:    International Orange

- 4. Buoy Color RED: Right side of channel returning to port. Even numbers.  
 GREEN: Left side of channel returning to port. Odd numbers.  
 WHITE: Regulatory, Warning.  
 RED/GREEN STRIPED: Preferred channel .  
 BLUE/WHITE STRIPED: Mooring.
  
- 5. Navigational Aid Shape
  - TRIANGLE: Right side of channel returning to port.  
Even numbers.
  - SQUARE: Left side of channel returning to port. Odd  
numbers.

**14. Standard Sign Materials**

- a. Typically there are three different materials used as the plate or backing for the sign message. Those three materials are listed in the order from most commonly used to least commonly used, aluminum, plastic, and wood.
- b. Aluminum is by far the most commonly used sign plate material. It is light weight, corrosion resistant, and comes in a wide variety of sizes and shapes. Sign shall be fabricated from aluminum sheeting with the alloy 6061-T6, 5052-H38, 5154-H38, or approved equal. Aluminum blank plates shall be anodized, alodine, cleaned, degreased, chromated, or otherwise properly prepared to receive paint, as recommended by the paint manufacturer.
- 1. Plate thickness is based on the longest sign dimension, as the sign gets bigger the plate thickness increases. Aluminum plate thickness shall be as follows:

Longest Sign Dimension	Sheet Aluminum Thickness
Less than 20"	0.063"
20" through 30"	0.080"
31" through 48"	0.100"
Over 48"	0.125"

- c. Plastic is generally used for small signs. These signs might be small credit sign that might be attached to another larger sign. Plastic might also be used for an instructional or identification sign located in an area not exposed to the general public where it could be vandalized.
- d. Wood is seldom used at boating facilities due to its weight, chances of delamination, and rot. On occasion, a large facility will construct a decorator facility identification sign, with deep relief carved from wood, stained and/or painted are about the only applications that are used.

## II - UPLAND SIGN APPLICATIONS

### A. Vehicle Control Devices

#### 1. Background

- a. The purpose of vehicle control devices are to help insure safety by providing orderly and predictable movement of motorized, non-motorized vehicle within any facility open to public travel.
- b. Vehicle control devices are all signs, signals, pavement markings, and devices placed on, over or adjacent to a street, road, or highway by authority of a public body having jurisdiction to regulate, warn, or guide vehicle. Nothing in this manual is intended to supersede any specific federal, state, or local requirements that may apply to access roads and parking areas. This manual will cover only those devices that may apply at recreational boating facilities.

#### 2. Vehicle Control Objectives

- a. Boaters typically have four primary objectives when entering a boating facility and must make a number of "decisions" at various "points" both on land and at the waters edge. These generally include information and regulatory visual aids. In addition, there are a number of warning visual aids that should be used to advise the user of various "dangers" that may be encountered and should be marked.
- b. First, as they enter the facility along the park access road, their primary objective is to easily locate the launch ramp and ready the boat for launching. Second, after they launch, their next destination is to locate the boat trailer parking area and restroom. Third, after completion of their boating activity retrieve the boat trailer and tie-down. Fourth, is to exit the facility.
- c. To best assist the user at each "decision point" either signs and/or pavement markings can be used. These visual aids should precede or be located immediately before each turn or action that may be needed. Note it takes at least 1.5 seconds to react to a visual aid and at 10 MPH the perceptible reaction braking distance is 22 ft. In general drivers look for signs first followed by pavement markings. At any area in the facility warning signs may be needed.
- d. These objectives can be facilitated by providing a direct route to the launch area without having to traverse through the boat trailer parking area or other activity areas throughout the park. As vehicles are preparing to launch, access around these vehicles should be provided to create positive traffic flow.



- e. The most serious congestion point is the launch ramp, followed by parking areas then access roads. By design, every effort should be made to place the user in a "one way grid" which will reduce congestion and the need for signs and pavement markings.
- f. Trailered vehicles require large turning areas, therefore proper signage at decision points within the facility is very important to avoid conflict/congestion in day use, single car parking, and other areas not designed to accommodate trailered vehicles.

### **3. Requirements of Vehicle Control Devices**

- a. This section explains the basic principles, and layout for the design and usage of vehicle control devices within public boating facilities throughout Oregon. A broader use of standard symbols in preference to word messages is a desirable and important step toward greater safety and facilitation of vehicle control in view of cultural diversity and accommodates the need of multi lingual users.
- b. Please reference the federal Manual on Uniform Traffic Control Devices (MUTCD) U.S. Dept. of Transportation and adopted for use in every state which outlines standard guidance for streets and highways.
- c. There are three broad categories of signs and pavement markings:
  - 1. Regulatory
  - 2. Warning
  - 3. Information
- d. To be effective, a vehicle control device should meet five basic requirements:
  - 1. Fulfill a need based on safety, direction, or hazards likely to be encountered.
  - 2. Command attention. Proper size and color.
  - 3. Convey a clear, simple meaning. Use standard symbols where possible.
  - 4. Command respect to users. Consider type and frequency of use.
  - 5. Give adequate time for proper response. Location, location, location.
- e. Detailed below are typical signs (Information, regulatory and warning) found at boating facilities. Construction signs are not covered as the MUTCD and state laws specifically detail all minimum requirements needed.

## **B. Vehicle Regulatory Signs**

### **1. Background**

- a. Regulatory signs inform users of vehicle laws or regulations and indicate the applicability of legal requirements that would not otherwise be apparent. These signs shall be erected wherever needed to fulfill this purpose, but unnecessary applications should be avoided.
- b. By design vehicular travel speed within a typical boating facility parking and launch area is generally less than 10 miles per hour. In low speed areas, certain roadway signs are not used as safety is not impaired. Therefore, conformity to the MUTCD may not be applicable in certain applications.

### **2. Stop Sign**

- a. STOP signs should only be used where vehicles are required to come to a complete stop. In most all cases, access "park" roads to boating facilities are considered low volume streets or secondary roads with low approach speeds. A 30" x 30" octagonal sign will be used as a standard.
- b. A STOP sign may be warranted within a boating facility at an intersection where one or more of the following conditions exist:
  1. Intersection of a less important road with a main road where application of the normal right-of-way rule is hazardous.
  2. Road entering a through highway or street.
  3. Intersections where a combination of high speed, restricted view, and serious accident record indicates a need for control by the STOP sign.
- c. At lower speeds typical within parking areas, stop signs are generally not required at the end of each parking row.
- d. Typical locations of STOP signs within boating facilities are where the access road intersects a main arterial road and at the launch ramp prior to traveling across the top of the ramp. A stop bar should be used in combination with a stop sign.

### **3. Yield Sign**

- a. The YIELD sign assigns right-of-way to traffic on certain approaches to an intersection. Vehicles controlled by a YIELD sign need to stop only when necessary to avoid interference with other traffic that is given the right-of-way. The standard size shall be a 36" x 36" x 36" triangular sign.
- b. The YIELD sign may be warranted if one or more of the following conditions exist:
  1. On a minor road at an intersection where it is necessary to assign right-of-way to the major road, but where a stop is not necessary at all times.
  2. Where the safe approach speed on the minor road exceeds 10 miles per hour.
  3. At any intersection where a traffic problem exists and where an engineering study indicates the problem may be corrected by use of a YIELD sign.
- c. YIELD signs should not be erected on more than one of the approaching lanes at an intersection or used at an intersection containing a STOP sign.
- d. Typical location of YIELD signs within boating facilities are where a parking loop road merges with the access road, loop road yields or give right-of-way to the access road, provided there is good visibility.
- e. Generally YIELD signs are not used within the parking or maneuvering areas due to low speeds and efforts to reduce sign clutter.

### **4. Do Not Enter Sign**

- a. To prohibit traffic from entering a restricted (one way) road, the DO NOT ENTER sign should be conspicuously placed in the most appropriate position at the end of a one-way road. Normally the sign is installed on the right-hand side of the roadway facing traffic entering the roadway in the wrong direction. Where traffic is approaching in a curve, a second sign on the left-hand side of the roadway may be justified. The standard size shall be a 30" x 30" square sign.
- b. Typical location of DO NOT ENTER signs within boating facilities are when the park two way access road separates into a one way grid (sign placed on exit lane).

- c. Generally DO NOT ENTER signs are not used within the parking or maneuvering areas as low speeds and strategically placed directional arrows (pavement markings) are more effective and reduce sign clutter.

#### **5. One Way Signs**

- a. The ONE WAY sign shall be used when required to indicate streets or roadways upon which vehicular traffic is allowed to travel in one direction only. The sign size for boating facility/park applications shall be 36" x 12" rectangle.
- b. ONE WAY signs are used they should be placed parallel to the one-way street directly opposite the exits from public roadways at intersections.
- c. Typical location of ONE WAY signs within boating facilities are at larger facilities that may have several parking areas and loop roads and signs may be desirable over pavement directional arrows for enhanced safety.
- d. Generally ONE WAY signs are not used within the parking or maneuvering areas as low speeds and strategically placed directional arrows (pavement markings) are more effective and reduce sign clutter.

#### **6. Speed Limit Sign**

- a. The designated maximum speed determined by state law for public parks is 25 miles per hour unless otherwise governed by local jurisdiction. The standard and minimum size is a 24" x 30" rectangular sign.
- b. Typical location of SPEED signs are at each end of any access road exceeding 500 feet (to the grid, maneuver or parking area). The signs shall be located on the right-hand side of the direction of travel.
- c. Speed Bumps should be avoided as they may cause severe damage to boats with bunk trailers or trailers without springs. If controlling speed is an issue, consider using a series of traffic buttons spiked or epoxied across the roadway to create a "rumble strip" in combination with signs. Also reducing straight travel ways will assist in controlling vehicle speed.

#### **7. No Parking Sign**

- a. The NO PARKING sign prohibits any parking along a given roadway or area. If the restriction applies to a limited area or zone, the limits of the zone should be shown by arrows. The standard size shall be a 12" x 18" rectangular sign. See the subsequent sign section for No Parking - Maneuver Ahead signs.

- b. Generally NO PARKING signs are not used along access roads or within the parking areas. By design travel and maneuver areas should be the minimum size to avoid the need for NO PARKING signs and the apparent opportunity for illegal parking.

#### **8. No Parking/Maneuver Area Sign**

- a. This sign designates No Parking within the area used to maneuver vehicle and trailer to launch and retrieve a vessel. The standard size shall be a 12" x 18" rectangular sign.
- b. Typical location of NO PARKING/ MANEUVER AREA signs are at head of the maneuver area allowing room for vehicles to pull forward without striking the sign post. Multiple lanes may require additional signs and pavement markings.

#### **9. Disabled Parking Sign**

- a. The DISABLED PARKING sign is used to designate disabled parking spaces and is to be used in combination with the disabled pavement marking symbol. A DISABLED PARKING sign is required for every disabled parking space. The standard size shall be a 12" x 18" rectangular sign, text is prescribed according to state law.
- b. The sign shall be located directly in front of each stall (head-in) allowing room for vehicles to pull forward without striking the sign post. If the stall is a pull through, or placement in front of the stall is not an option, locate the sign in the disabled access aisle area located on either side of the disabled parking space. When locating a sign in the access aisle, make sure the placement will not conflict with accessibility standards.

#### **10. Ready Area Sign**

- a. The READY AREA sign designates spaces used to prepare for launch. This sign also stipulates a maximum occupancy time limit of 15 minutes. The standard size shall be a 12" x 18" rectangular sign.
- b. Typical location of READY AREA signs are at defined Ready Areas (prepare to launch areas that do not restrict access or maneuvering into the ramp). The sign shall be located at the midpoint and adjacent to each space as applicable.

- c. If more than three ready area spaces exist, locate one sign at the beginning of the first space and use pavement markings to indicate the spaces designated for ready area use.

## **11. Tie Down Sign**

- a. The TIE DOWN sign designates spaces used to prepare for travel after retrieval. This sign also stipulates a maximum occupancy time limit of 15 minutes. The standard size shall be a 12" x 18" rectangular sign.
- b. Typical location of TIE DOWN signs are at defined Tie Down areas, tie down areas do not restrict egress or maneuvering from the ramp. Signs shall be located at the midpoint and adjacent to each space as applicable.
- c. If more than three Tie Down spaces exist, locate one sign at the beginning of the first space and use pavement markings to indicate the spaces designated for tie down use.

## **C. Vehicle Warning Signs**

### **1. Background**

- a. Generally warning signs are used when it is deemed necessary to warn vehicle of existing or potentially hazardous conditions on or adjacent to a roadway. Adequate warning signs are of great assistance to the vehicle operator and are valuable in safe-guarding and expediting traffic.
- b. The use of warning signs should be kept to a minimum because the unnecessary use of them to warn of conditions which are apparent tends to breed disrespect for all signs.
- c. Follow the federal Manual on Uniform Traffic Control Devices (MUTCD) U.S. Dept. of Transportation, adopted for use in every state which outlines standard guidance for sign colors, black text on a yellow background.

### **2. Pedestrian Crossing Sign**

- a. The PEDESTRIAN CROSSING sign may be used as a means of assisting the vehicle operator in defining the specific point of pedestrian crossing. This sign should only be used at locations that are unusually hazardous or at locations not readily apparent to on coming vehicular traffic. The standard size shall be a 30" x 30" square sign, rotated 45 degrees with a black symbol on a yellow background.
- b. Mount a 24" x 18" text sign with "PED XING" below the PEDESTRIAN CROSSING symbol sign, black text on a yellow background.
- c. Typical location of PEDESTRIAN CROSSING signs are at any defined pedestrian crossing of an access road, except intersections with stop sign or lights. The signs shall be located on the right-hand side of the direction of travel. Normally crosswalk pavement markings are used in combination with the sign.
- d. In general, a crosswalk located within a parking area will not require a Pedestrian Crossing sign. At these locations crosswalk pavement markings may be used.

## **D. Vehicle Information Signs**

### **1. Background**

- a. Assisting users to find a facility and specific activity areas within a boating facility is very important, especially to avoid frustration in not finding an area or being "locked in" a one way grid system.
- b. Up to four area directional signs can be combined into one sign located at or before a decision point. In large facilities Exit, Single Car Parking, Boat Trailer Parking, or other activity areas may be needed.

### **2. Entrance Signs**

- a. FACILITY ENTRANCE or welcome signs vary widely in size, text, and color based on managing agency requirements. Many entrance signs incorporate symbols to aid the user in finding principal activity areas. OSMB has no minimum requirements for these signs.

### **3. Ramp Directional Sign**

- a. The RAMP DIRECTIONAL sign directs users to the boat launch ramp. This sign is generally located at the entrance to the facility and can be used within the facility where there may be confusion on direction of travel to the launch area. The standard size shall be a 18" x 18" square sign.

### **4. Single Car Parking Area Sign**

- a. This SINGLE CAR DIRECTIONAL sign directs vehicles to single car parking areas and helps to avoid conflicts and confusion between boat trailer parking and single car parking areas and keeps the single cars from cycling through the ramp maneuver area. The standard size shall be a 18" x 18" square sign.

### **5. Boat Trailer Parking Area Sign**

- a. This BOAT TRAILER PARKING sign directs vehicles with boat trailers to the designated trailer parking area. The standard size shall be a 18" x 18" square sign.



## **6. Other Activity Areas - Day Use, Camping, Swimming**

- a. Other activity area signs may include DAY USE, CAMPING, PICNIC AREA. Use standard information sign text and/or symbols with directional arrows as required.

## **7. General Information Board - Cluster Signs**

- a. Various types and sizes of GENERAL INFORMATION BOARD or Sign Boards are in use. These boards generally cluster a number of general information, park regulations, safety and interpretive messages in one location. They are normally placed along principal walkways or at the hub of activity areas. OSMB is developing a standard bulletin sign.
- b. CLUSTER SIGNS are being successfully used by State Parks Department and incorporate one central place for information, warning, and regulation signs usually along pedestrian walkways. Individual signs are mounted and clustered on a single wood framework.

## **8. Credit Signs**

- a. Project CREDIT SIGNS are very important and are required for all OSMB facility grant projects to properly identify all sources of grant funds and the cooperating agencies. Individual logo signs are mounted to the credit sign.
- b. Credit Sign is 36" x 30", brown background with cream text with room for two logo signs (cooperating agency and OSMB) at the bottom of the sign. Individual logo signs are 12" x 14" and may include Cooperating Agency, OSMB, Department of Fish and Wildlife, and U. S. Fish and Wildlife - Sportfish and Restoration Fund.
- c. When the number of agencies involved in a project exceeds two, an auxiliary sign blank is fabricated. The sign blank is 36" x 18", brown background with a 1/2" cream border, no text, extra individual logo signs will be attached to it and it will be mounted below the credits sign.

## **E. Pavement Markings**

### **1. Background**

- a. Pavement markings are used to supplement regulations or warnings of other devices such as signs. In other instances, they are used alone and produce results that cannot be obtained by the use of any other device. In such cases they serve as a very effective means of conveying certain regulations and warnings that could not otherwise be made clearly understandable.
- b. Pavement markings do have limitations. They are rendered useless by snow, may not be clearly visible when wet, and may not be very durable when subjected to heavy traffic. Also in heavy traffic the pavement markings may not be visible until the point of decision has past. In spite of these limitations, they have the advantage, under favorable conditions, of conveying warnings or information to the driver without diverting his attention from the roadway.

### **2. Center Line Access Roads**

- a. A center line separates traffic traveling in opposite directions and need not be at the geometrical midpoint of the pavement. Generally, a single dashed yellow center line is used to delineate traffic on a single purpose park access road. Normally these roadways do not allow passing zones. If there are areas where there is poor sight distance, curves, or passing is restricted, a solid line should be use in place of the dashed line. Center line striping shall be 4 inches wide and reflectorized.
- b. The center line is also used as an alignment stripe in the launch ramp maneuver area. Center lines dividing traffic are not required or desired within parking areas as they tend to confuse parking areas with travel ways.

### **3. Boat Ramp Lane Stripes**

- a. A lane stripe separates boaters as they maneuver and back down the launch ramp. The stripe are helpful trailer alignment as the trailer is backed over the vertical curve. A single solid yellow line is used to delineate launch lanes on launch ramps with multiple adjacent lanes.

- b. To assist the boater as the trailer is backed down the ramp and improve visibility of the facility components traffic delineators are typically epoxied to the ramp side of the abutment. The delineators are 36 inches tall and generally red in color with yellow reflective sheet banding around the upper portion. The improved visibility the delineators provide help keep the boaters from backing into the side of the boarding floats or running their trailer up the abutment. Delineators have a flexible base and can be run over without damaging the delineator of the vehicle.

#### **4. Parking Spaces**

- a. Delineation of parking spaces encourages more orderly and efficient use of parking spaces where parking turnover is substantial. Parking space stripes shall be white or yellow in color and 4 inches wide. Parking space stripes need not be reflectorized.

#### **5. Stop Lines**

- a. Stop lines are solid white, 12 inch wide lines, extending across all approach lanes. Stop lines should be used in areas where it is important to indicate the point, behind which vehicles are required to stop.
- b. Where stop lines are used, they should ordinarily be placed 4 feet in advance of and parallel to the nearest crosswalk line. In the absence of a marked crosswalk, the stop line should be placed at the desired stopping point, in no case more than 30 feet or less than 4 feet from the nearest edge of the intersecting roadway.
- c. If a stop line is used in conjunction with a STOP sign, it should ordinarily be placed in line with the STOP sign. However, if the sign cannot be located exactly where vehicles are expected to stop, the stop line should be placed at the stopping point.

#### **6. Pedestrian Crosswalks**

- a. Crosswalk markings are designed to guide pedestrians across a roadway on a certain path. At locations where there are no intersections, these markings legally establish the crosswalk. Crosswalk lines shall be solid white in color and 12 inches wide with an 18 inch gap separating each line.

- b. Crosswalk lines shall be situated perpendicular to the line of vehicle travel and shall be 8 feet wide. Crosswalks located within an access road exceeding 500 feet in length shall be used in combination with a PEDESTRIAN CROSSING sign.

## **7. Directional Arrows**

- a. Directional arrows shall be white in color, located in the center of the traffic lane and used to guide and regulate traffic flow. Arrows should be located at decision points throughout the facility. At the beginning and end of each parking access aisle, arrows should be placed to show direction of travel.
- b. Locate arrows 5 feet back from the nearest edge of the intersecting roadway. If the parking access aisle length exceeds 150 feet, intermittent arrows should be placed at 150 ft intervals. Directional arrows should be placed at intersections to direct desired traffic flow. Avoid excessive and unnecessary placement of arrows throughout the facility.
- c. See the Pavement Marking section in the appendix for the arrow size.

## **8. Disabled Access Aisle**

- a. The disabled access aisle provides an area for persons with disabilities to exit and enter their vehicle. Two aisle widths are used. The first is a standard aisle width of 6 feet, and the second is a van accessible aisle that is 8 feet wide.
- b. One in every eight accessible spaces, but not less than one, shall be served by an access aisle 8 feet wide and shall be designated "van accessible." Both disabled access aisles shall extend the entire length of the disabled parking space. Access aisle striping shall be yellow in color and 4 inches wide.

## **9. Disabled Parking Symbol**

- a. The disabled parking symbol indicates parking spaces reserved for persons with disabilities. The symbol shall be centered in the disabled parking stall 2 feet back from the roadway. If the parking space is a pull through boat trailer space, then there shall be two disabled parking symbols, one located at each end facing the direction of entry. The symbol is 4' x 4' square. The perimeter lines and interior symbol lines are white in color, 4 inches wide, and non-reflectorized. The background color is blue.

### **III - ACCESS FACILITY SIGN APPLICATIONS**

#### **A. Boat Ramp and Tie-Up Control Devices**

##### **1. Background**

- a. A considerable mix of activity (vehicles, boats and pedestrians) occurs at the launch ramp or tie-up dock area. To reduce congestion and improve safety within this transition area a system of regulation, warning, and information signs should be used.

##### **2. Boat Ramp and Tie-Up Sign Mounting Location**

- a. Depending on the text size of the sign to be mounted and the water fluctuation at the facility a sign can be either mounted at the top of a pile or on the float. Use the Text Size subsection in the previous Sign Design section to assist in the decision of the sign mounting location and anticipated viewing distance. Some facilities receive more vertical water fluctuation than the viewing distance of some text size.
- b. An exception to the rule is the large Slow No Wake Signs or Channel Markers where visibility off shore is needed are typically mounted to the top of piles.

##### **3. Vehicle and Boat Control Objectives**

- a. It is important to consider signs visible both from the landside and waterside perspective. Often times boaters have a difficult time "finding" the public dock especially if other private docks (or launch ramps) are located nearby.

##### **4. Requirements of Ramp and Tie-Up Control Devices**

- a. Some signs lend themselves closer to standard MUTCD signs and standard recreation symbols, others to U.S. Coast Guard Inland Waterway Signs/Buoys. Carefully evaluate if you are managing vehicles, people or boats to determine which type of sign to use.
- b. As for Upland - Vehicle and Waterway - Boat Signs, three categories of signs are used:
  1. Regulatory
  2. Warning
  3. Information

- c. To be effective, a vehicle control device should meet five basic requirements:
  - 1. Fulfill a need based on safety, direction, or hazards likely to be encountered.
  - 2. Command attention. Proper size and color.
  - 3. Convey a clear, simple meaning. Use standard symbols where possible.
  - 4. Command respect to users. Consider type and frequency of use.
  - 5. Give adequate time for proper response. Location, location, location.
  
- d. Detailed below are standard signs found at boat launch ramp and Tie-Up Facilities. Construction signs are covered by MUTCD or U.S. Coast Guard requirements.

## **B. Boat Ramp and Tie-Up Regulatory Signs**

### **1. Background**

- a. The purpose of boat ramp and tie-up signs is to inform boaters of boarding float and transient floats restrictions, tie-up time limits, and regulations. These signs shall be used whenever needed to fulfill this purpose, but unnecessary applications should be avoided.

### **2. Boarding Float Regulations**

- a. This sign reads "BOARDING FLOATS MAXIMUM TIE-UP TIME 15 MIN." The sign should be located near the head of the boarding floats facing the launch ramp approach. The standard size shall be a 18" x 24" rectangular sign.

### **3. Transient Tie-Up Regulations**

- a. This sign reads "TRANSIENT MOORAGE MAXIMUM TIE-UP TIME (12, 24, or 72 HOURS)." This sign should be located on the float or piling facing the water body, depending on the amount of water fluctuation the site experiences. See Boat Ramp and Tie-Up Mounting Location in the previous section. The standard size shall be a 18" x 24" rectangular sign.

## C. Boat Ramp and Tie-Up Warning Signs

### 1. Background

- a. Generally warning signs are used when it is deemed necessary to warn users of the facility of existing or potentially hazardous conditions on or adjacent to a facility. Adequate warning signs are of great assistance to the boat operators and are valuable in safe-guarding facility users.
- b. There are variable levels of risk for a dangerous or hazardous situation. The words used on a sign can give an indication of the risk of the hazard. Warning sign, key words are listed in the order of severity.
  1. NOTICE General notice or advisory statements.
  2. CAUTION Notice to be on guard to minimize risk, likely obvious.
  3. WARNING Notice of approaching or possible risk, may be hidden.
  4. HAZARD Notice of risk that may cause or contribute to injury either obvious or hidden.
  5. DANGER Notice of high risk likely to cause or contribute to injury either obvious or hidden.
  6. EXTREME DANGER Notice of high risk, high probability of injury or death even if person uses due care either obvious or hidden.
- c. The variable levels of risk for a dangerous or hazardous situation can be grouped into two levels of risk. The color used on a sign can also give an indication of the risk of the hazard. The two suggested warning sign colors are listed for the grouping of key words and severity. All symbols shall be either black or brown with a red slash, meaning "No" a restricted activity.
  1. Notice, Caution, Warning - Yellow Background Black Text
  2. Hazard, Danger, Extreme Danger - White Background Red Text

### 2. Danger - No Swimming Sign

- a. The NO SWIMMING sign should be used as a means of eliminating swimming activity around boarding and transient floats. This sign should be used at locations where adjacent day use or swim areas tend to attract swimmer to the floats.



- b. **NO SWIMMING** signs will be will have a black or brown symbol on a white background with a red circle and slash. The sign may have some text identifying the restricted activity and a brief reason why, in this case Boats Underway.

### **3. Danger - No Diving Sign**

- a. The **NO DIVING** sign should be used as a means of eliminating swimmers from diving from the boarding and transient floats. This sign should be used at locations where adjacent day use or swim areas tend to attract swimmers to the floats.
- b. **NO DIVING** signs will be will have a black or brown symbol on a white background with a red circle and slash. The sign may have some text identifying the restricted activity and a brief reason why, in this case Shallow Water, Underwater Hazard, or simply Danger.

## **D. Boat Ramp and Tie-Up Information Signs**

### **1. Background**

- a. Boat ramp and tie-up informational signs are provided to as a service to keep the facility users informed of local conditions, facility name and location on a waterway, and other miscellaneous information

### **2. Facility Name Sign**

- a. The facility name sign informs boaters on the waterway, the name of the facility, water body and river mile (where applicable). This sign should be located on the float facing the water body.

### **3. Boat Safety Kiosk Signs**

- a. The kiosk sign is typically located near the top of the boat ramp in an area with high visibility. This kiosk is a cluster of three signs containing information on waterway rules, local regulations and hazards, river charts and/or map of water body, waterskiing safety, and other miscellaneous information.

## **IV - WATERWAY SIGN APPLICATIONS**

### **A. Boating Control Devices**

#### **1. Background**

- a. The purpose of on-water regulatory signage is to inform boaters of waterway speed limits, boarding float and transient float restrictions, and tie-up time limits. Many boating facilities are well signed on-shore but provide minimal information to users on-water.
- b. Boating control devices are all signs and buoys placed on, over or adjacent to boating facility by authority of a public body having jurisdiction to regulate, warn, or guide traffic. Nothing in this manual is intended to supersede any specific federal, state, or local requirements that may apply to boat launch, tie-up or navigational channels. This manual will cover only those devices that may apply at recreational boating facilities.

#### **2. Boating Control Objectives**

- a. The objective of signs and buoys is to inform and regulate activities at the land-water interface. Normally signs are posted on piling, on the boarding floats, or along the ramp and buoys are anchored in the water off-shore.
- b. Boaters typically have four primary objectives when launching or retrieving boats from boating facility and must make a number of "decisions" at various "points" both on land and at the waters edge. These generally include information and regulatory visual aids. In addition, there are a number of warning visual aids that should be used to advise the user of various "dangers" that may be encountered and should be marked.
- c. First, their primary objective is to safely launch the boat and have some means to tie-up while parking the vehicle. Second, after they return from parking, the next destination is maneuvering along a channel or fairway to open water. Third after completion of their boating activity tie-up their boat and retrieve the boat trailer. Fourth, is to load the boat and exit the launch area.
- d. To best assist the user at each "decision point" either signs and/or buoys can be used. These visual aids should precede or be located immediately before each turn or action that may be needed. Note it takes at least 1.5 seconds to react to a visual aid and at 5 MPH the perceptive reaction distance is 11 ft. Boat operators look for signs first followed by buoys.

- e. These objectives can be facilitated by providing a direct route to the launch area from open water without having to traverse through or around designated or non-designated swim areas, shoals or other obstacles. A clear area (no long term mooring) is required at the launch site extending the waters edge outwards to create a positive boat flow.
- f. The most serious congestion point is the boarding floats, followed by the adjacent boat maneuver area then access channel. By design, every effort should be made to facilitate land side vehicle movements which in turn will expedite water side boat movements.
- g. In general, boats require a clear space of 1.5 times the boat length in order to adequately make a turn and are subject to effects of current, wind, and tidal actions especially critical at launch point and low travel speeds.

### **3. Requirements of Boating Control Devices**

- a. This section explains the basic principles, and layout for the design and usage of boating control devices adjacent to public boating facilities throughout Oregon. A broader use of standard symbols in preference to word messages is a desirable and important step toward greater safety and facilitation of traffic control in view of cultural diversity and accommodates the need of multi lingual users.
- b. Please reference state statutes for recreational boating devices OAR 250-10-175 Uniform Waterway Marking Rules which outlines standard guidance for all boating control devices. These rules follow the prescribed U.S. Coast Guard regulations for Inland Waterway Marking System.
- c. There are three broad categories of buoys and signs:
  - 1. Regulatory
  - 2. Warning
  - 3. Information
- d. To be effective, a boating control device should meet five basic requirements:
  - 1. Fulfill a need based on safety, direction, or hazards likely to be countered.
  - 2. Command attention. Proper size and color.
  - 3. Convey a clear, simple meaning. Use standard symbols were possible.
  - 4. Command respect to users. Consider type and frequency of use.
  - 5. Give adequate time for proper response. Location, location, location.

## **B. Boating Regulatory Signs/Buoys**

### **1. Background**

- a. The purpose of regulatory signs/buoys is to inform users of boating laws or regulations and indicate the applicability of legal requirements that would not otherwise be apparent. These signs shall be erected wherever needed to fulfill this purpose, but unnecessary applications should be avoided.

### **2. Slow No Wake Sign/Buoys**

- a. The Slow No Wake sign denotes that boat speed limit within 200 feet of the ramp and/or floats is Slow No Wake - Maximum 5 MPH. This sign should be located on the piling facing the water body. The standard sizes of this sign are 18"x 24", 24"x 36", and 36" x 48" rectangle sign.
- b. By law, boating speed adjacent to launch (within 200 ft - any direction from end of floats or ramp) is Slow No Wake - Maximum 5 MPH.
- c. A buoy may be used (anchored) 200 ft from the end of the boarding floats or boat ramp to denote the Slow No Wake - Maximum 5 MPH area.

## **C. Waterway Warning Signs/Buoys**

### **1. Background**

- a. Use warning signs when needed to alert users to known hazards not readily apparent or normally associated with facility use. Warning signs will have black texts on a yellow reflective background.
- b. Warning signs are used when deemed necessary to warn boat operators of existing or potential hazardous conditions at or near the facility. Warning signs indicate the need for caution on the part of the boat operator. The condition may call for a reduction of speed or maneuver area that is not consistent with operator expectancy.

### **2. Fairway or Channel Marker Signs**

- a. Channel marker signs guide boaters safely in and out of a boat facility. OSMB provides channel markers to aid only in the navigation from the boating facility to the main waterbody. The square 36" x 36" sign is green in color and is labeled with odd numbers. The triangular 48" wide by 48" tall sign is red in color and is labeled with even numbers.

### **3. Fairway or Channel Marker Buoys**

- a. Channel marker buoys guide boaters safely in and out of a boat facility. OSMB provides channel buoys to aid only in the navigation from the boating facility to the main water body.

### **4. Danger - Rock, Shoals or Stumps**

- a. Danger marker buoys warn boater of local hazards in and around a boat facility or main channel. OSMB provides buoys to mark rocks or jetties that may not be readily apparent at low water.

## **D. Waterway Information Signs**

### **1. Background**

- a. The purpose of waterway information signs is to inform the boater of services available at facilities.

### **2. Pumpout Signs**

- a. A PUMPOUT SIGN will be mounted in close proximity to the pumpout to let boaters where and that the service exists. If the pumpout is located where the sign at the pumpout can not be seen from the waterway a second sign should be placed at a location visibility for the water body. The sign will have a black symbol on a white background with a orange border. Text will be added the bottom of the sign identifying which vessel waste service is available.

### **3. Dump Station Signs**

- a. A DUMP STATION SIGN will be mounted in close proximity to the dump station to let boaters where and that the service exists. If the dump station is located where the sign at the pumpout can not be seen from the waterway a second sign should be placed at a location visibility for the water body. The sign will have a black symbol on a white background with a orange border. Text will be added the bottom of the sign identifying which vessel waste service is available.

# TYPICAL FACILITY SIGN LAYOUT

N.T.S.

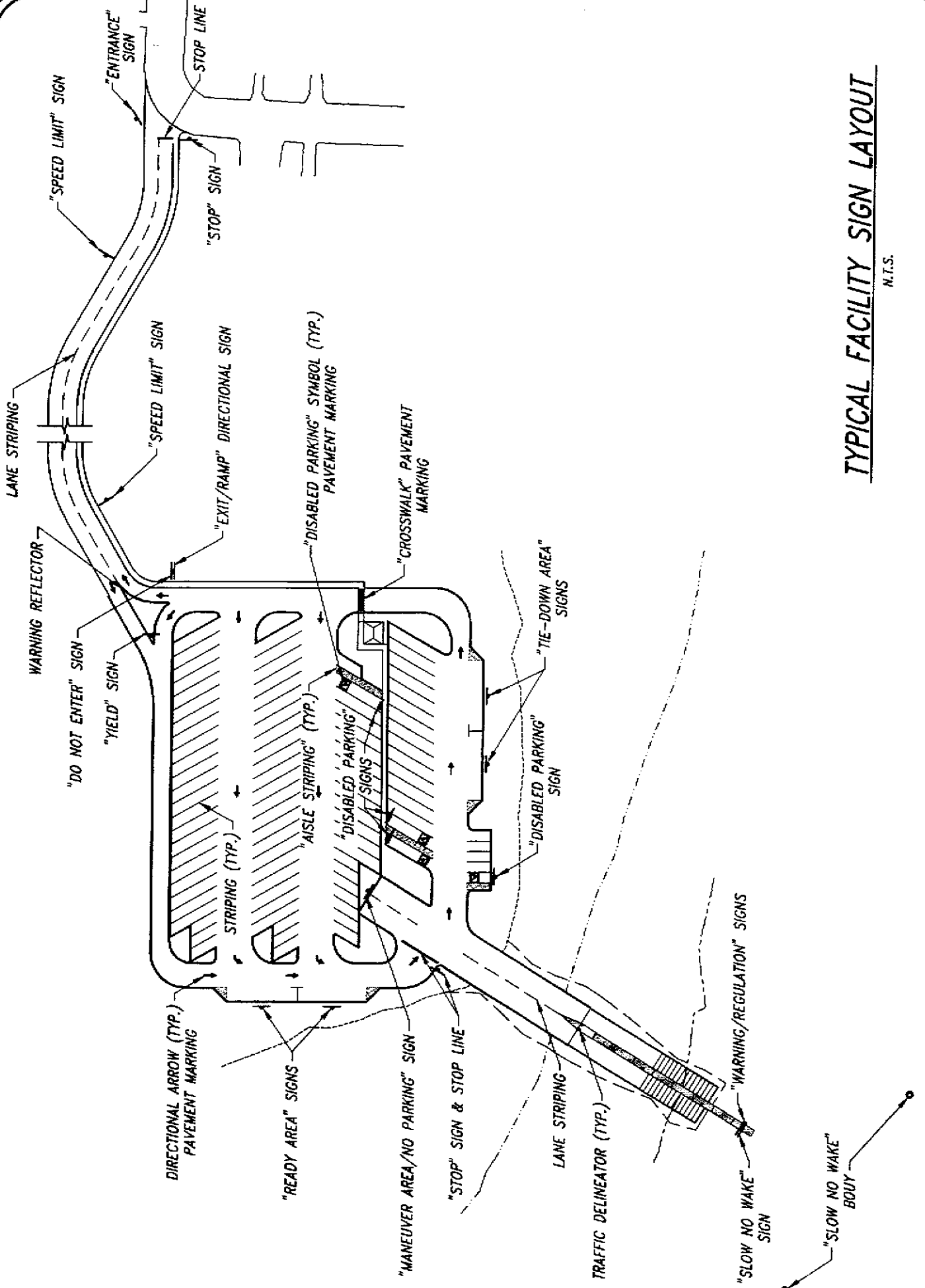



**NOTE:**

HORIZONTAL CLEARANCE SHALL NOT BE LESS THAN 2' FROM THE EDGE OF TRAVEL WAY.

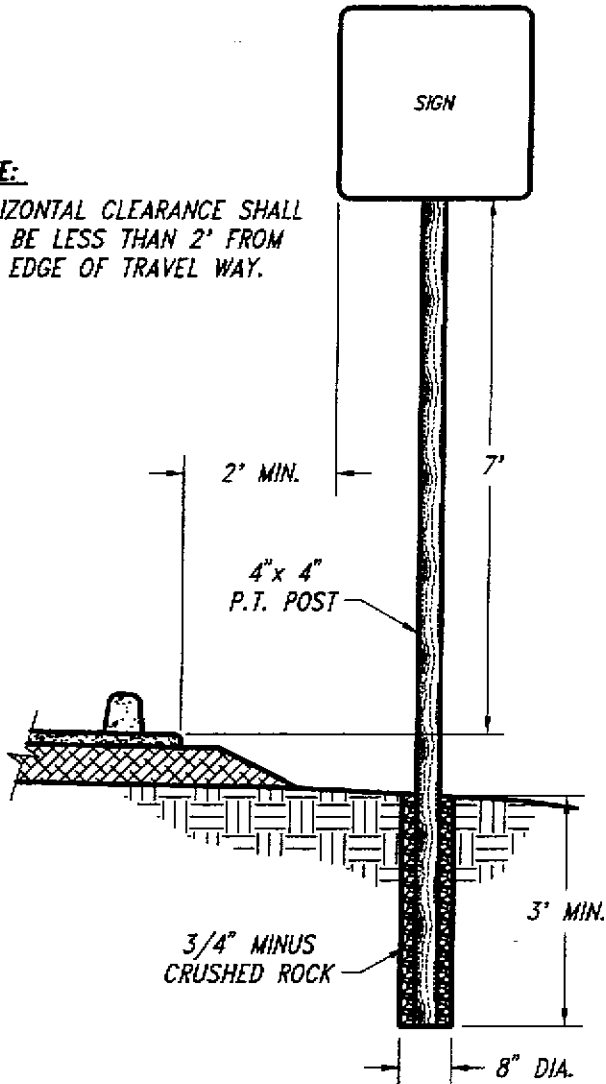

**WOOD SIGN POST**

**NOTE:**

STEEL POST USED ONLY WHEN SIGN IS LOCATED IN ASPHALT.

2" x 2", 12 GAUGE STEEL TUBING W/ 7/16" HOLES ON 1" CENTERS, FULL LENGTH, ON TWO OPPOSITE SIDES

INSERT SIGN POST A MIN. OF 18" INTO 2 1/4" x 2 1/4" GROUND ANCHOR. ANCHOR SHALL BE SET IN CONCRETE A MIN. OF 30" BELOW FINISH GRADE. SIGN POST IS BOLTED TO ANCHOR.

ANCHOR 3" ABOVE FINISH GRADE

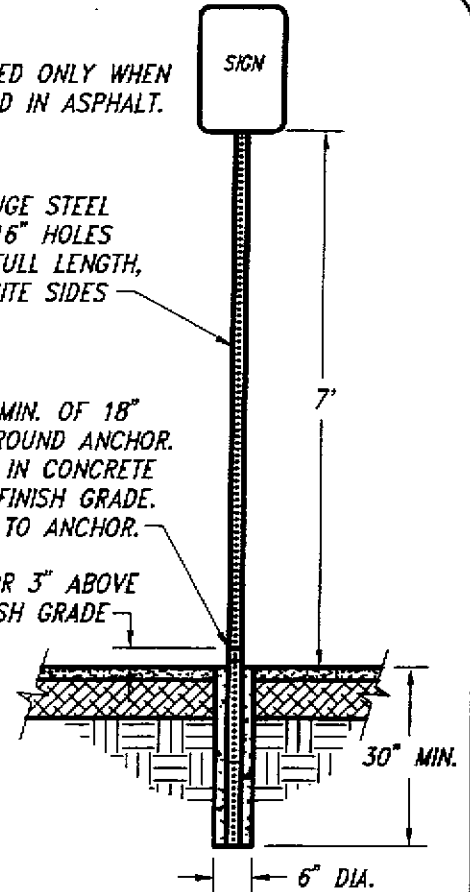

**STEEL SIGN POST**

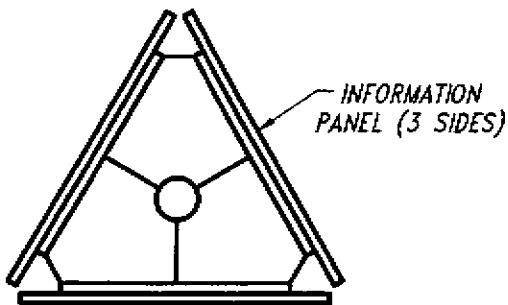

**STEEL KIOSK PLAN VIEW**

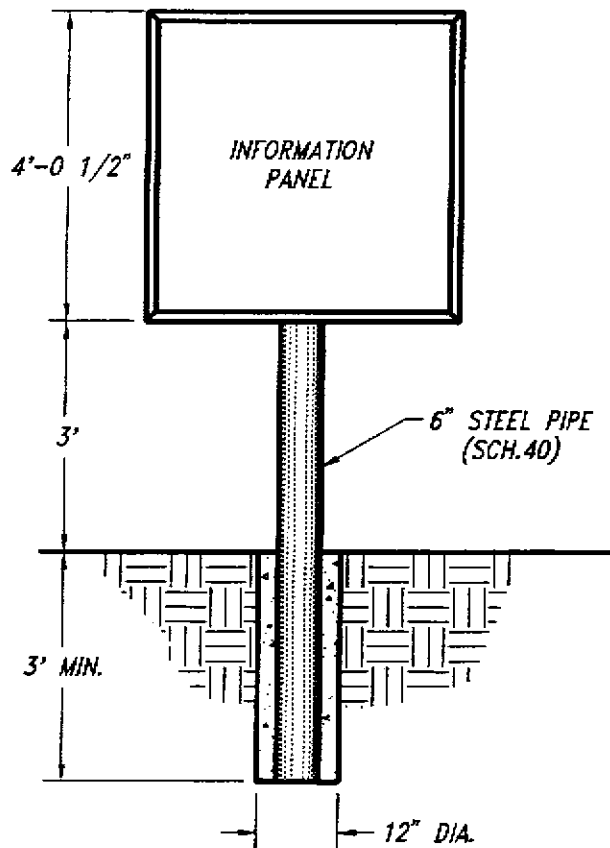

**STEEL KIOSK ELEVATION**

**SIGN POST DETAILS**



SIGN NO: RU-01  
30" x 30"  
WHITE/RED  
MUTCD NO: R1-1

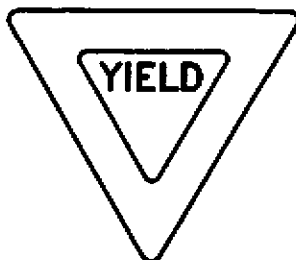

SIGN NO: RU-02  
36" x 36" x 36"  
WHITE/RED  
MUTCD NO: R1-2

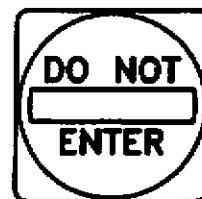

SIGN NO: RU-03  
24" x 24"  
WHITE/RED  
MUTCD NO: R5-1

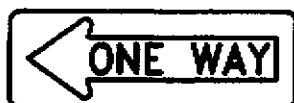

SIGN NO: RU-04  
36" x 12"  
BLACK/WHITE  
MUTCD NO: R6-1



SIGN NO: RU-05  
18" x 24"  
BLACK/WHITE  
MUTCD NO: R6-2



SIGN NO: RU-06  
24" x 30"  
BLACK/WHITE  
MUTCD NO: R2-1

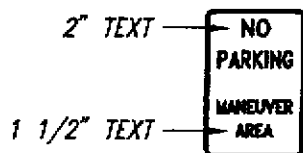

SIGN NO: RU-07  
12" x 18"  
RED/WHITE  
MUTCD NO: N/A



SIGN NO: RU-08  
12" x 18"  
RED/WHITE  
MUTCD NO: R8-3

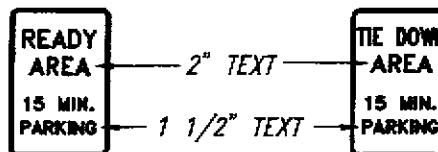

SIGN NO: RU-09  
12" x 18"  
BLACK/WHITE  
MUTCD NO: N/A

SIGN NO: RU-10  
12" x 18"  
BLACK/WHITE  
MUTCD NO: N/A

VEHICLE REGULATORY SIGNS



SIGN NO: 1U-01  
18" x 18"  
WHITE/BROWN  
MUTCD NO: N/A



SIGN NO: 1U-02  
18" x 18"  
WHITE/BROWN  
MUTCD NO: N/A

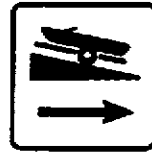

SIGN NO: 1U-03  
18" x 18"  
WHITE/BROWN  
MUTCD NO: N/A

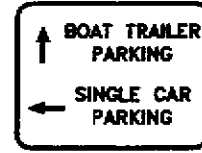

SIGN NO: 1U-04  
18" x 24"  
WHITE/BROWN

2" TEXT

VEHICLE INFORMATIONAL



SIGN NO: WL-01  
30" x 30"  
BLACK/YELLOW  
MUTCD NO: W11-2



SIGN NO: WL-02  
24" x 18"  
BLACK/YELLOW  
MUTCD NO: W11-2P

VEHICLE WARNING

NAME OF FACILITY → 2" TEXT  
NAME OF WATERBODY → 1 1/2" TEXT  
This facility was developed with a grant from the State Marine Board in cooperation with \_\_\_\_\_ The facility is owned and operated by \_\_\_\_\_ 1" TEXT

MARINE BOARD FACILITY GRANT SIGN 12" x 14"

SPONSOR SIGN OR LOGO



SIGN NO: 1U-06  
12" x 14"



SIGN NO: 1U-07  
12" x 14"



SIGN NO: 1U-08  
12" x 14"

**NOTE:**  
CREDITS SIGN: CREAM TEXT ON BROWN BACKGROUND W/ 1/2" CREAM BORDER ON 0.125" ANODIZED ALUMINUM BLANK

SIGN NO: 1U-05  
30" x 36"

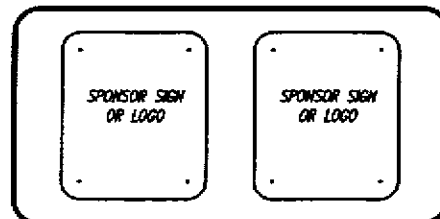

SIGN NO: 1U-09  
18" x 36"

CREDIT SIGNS

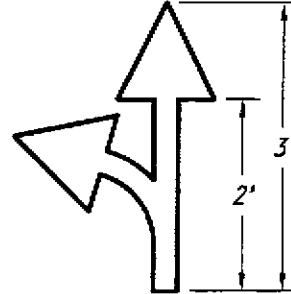
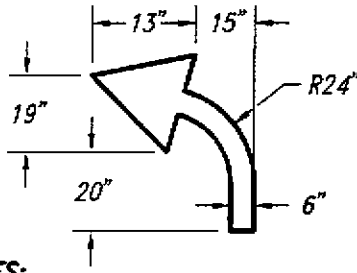
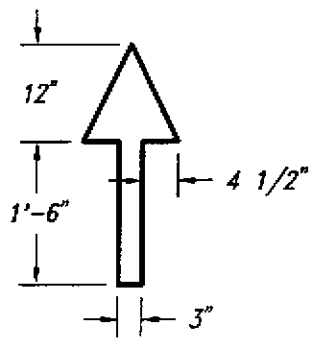
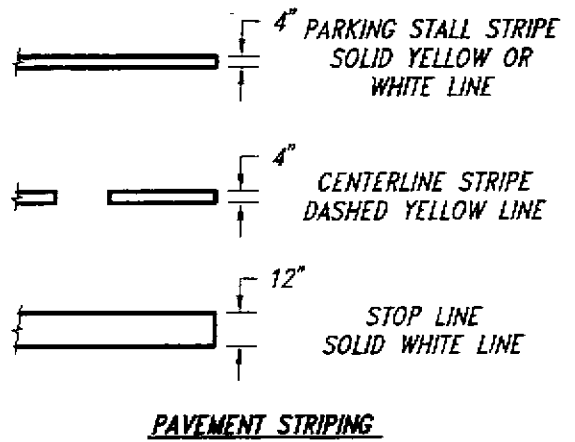
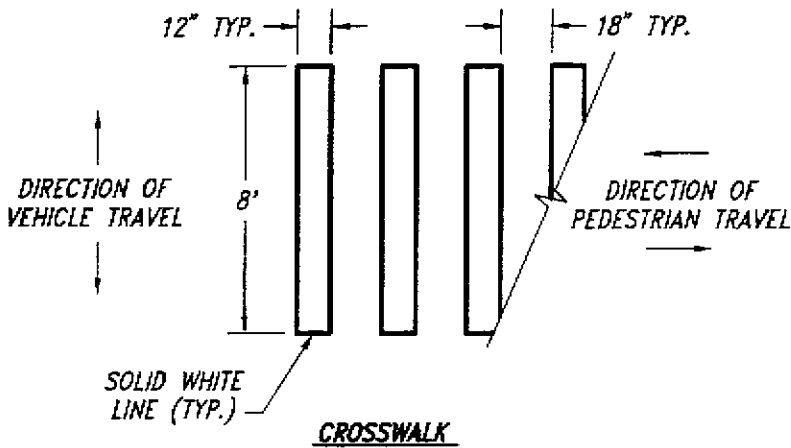

**NOTES:**

1. PAINT ARROWS SOLID WHITE
2. CENTER ARROWS WITHIN TRAFFIC LANE

**DIRECTIONAL ARROWS**

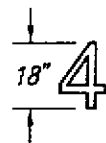

**NOTE:**

NUMBERS USED TO LABEL LAUNCH LANES

**PAVEMENT LETTERING**

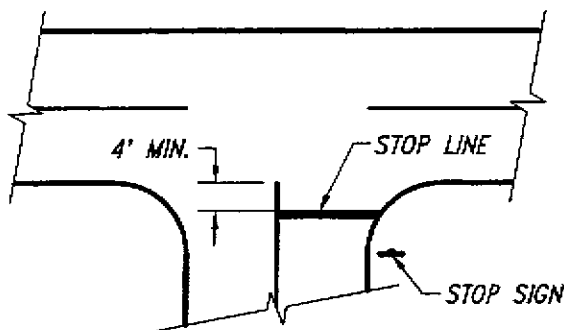

**STOP LINE NOTES:**

1. PAINT STOP LINE SOLID WHITE
2. STOP LINE SHALL EXTEND ACROSS ALL APPROACH LANES
3. IN NO CASE SHALL THE STOP LINE BE PLACED MORE THAN 30 FEET OR LESS THAN 4 FEET FROM THE NEAREST EDGE OF THE INTERSECTION ROADWAY

**STOP LINE LOCATION**

**PAVEMENT MARKINGS**

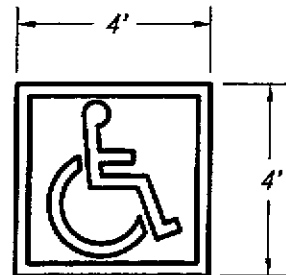
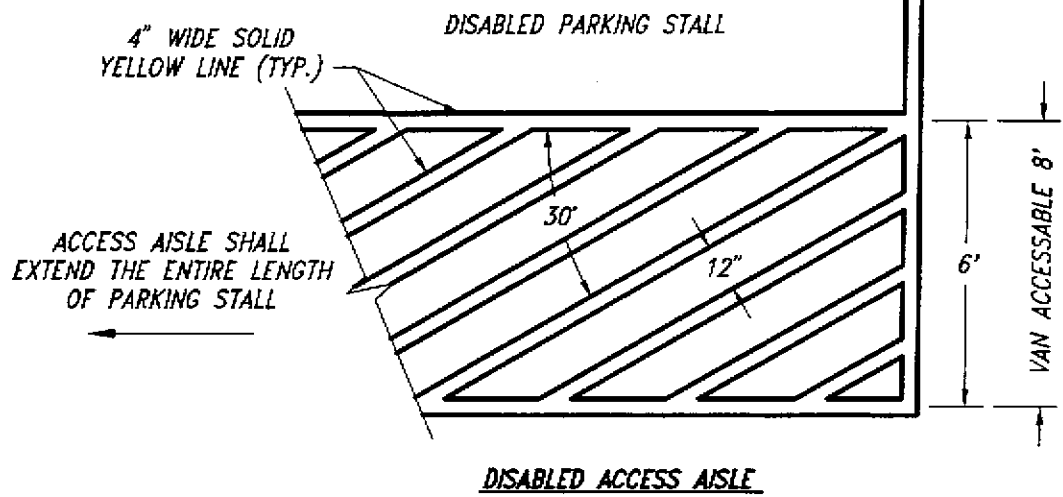

**NOTE:**  
 BORDER & SYMBOL ARE 4" SOLID WHITE LINES. BACKGROUND COLOR IS BLUE

DISABLED PARKING SYMBOL

SIGN NO: RU-11  
 12" x 18"  
 BLUE/WHITE  
 MUTCD NO: N/A



SIGN NO: RL-12  
 3" x 12"  
 BLUE/WHITE  
 MUTCD NO: N/A

DISABLED PARKING SIGN

DISABLED SIGN & PAVEMENT MARKINGS

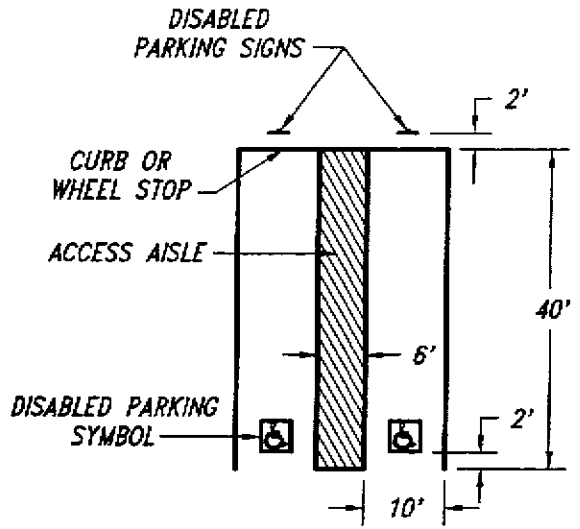

HEAD IN PARKING

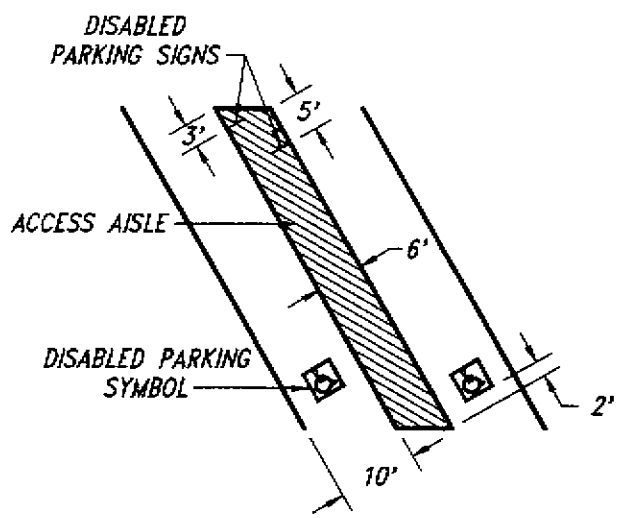

PULL THROUGH PARKING

DISABLED PARKING LAYOUT



SIGN NO: RA-01  
18" x 24"  
BLACK/WHITE  
MUTCD NO: N/A

SIGN NO: RA-02  
18" x 24"  
BLACK/WHITE  
MUTCD NO: N/A

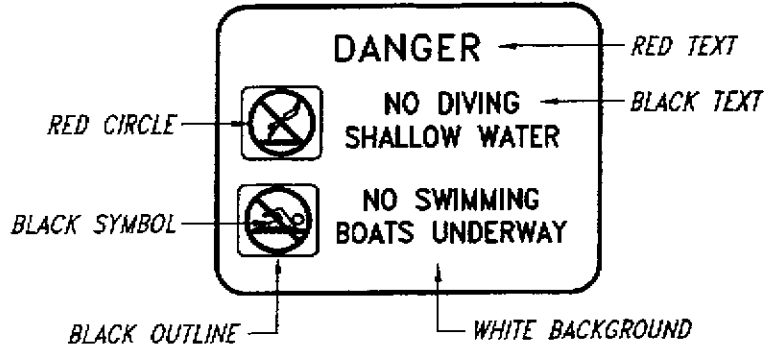

WATERWAY REGULATORY



SIGN NO: IA-01  
8" x 24"  
WHITE/BLUE

SIGN NO: WA-01  
18" x 24"  
BLACK/RED/WHITE  
MUTCD NO: N/A

WATERWAY WARNING

WATERWAY INFORMATIONAL

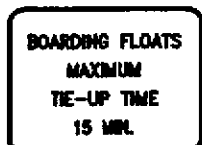
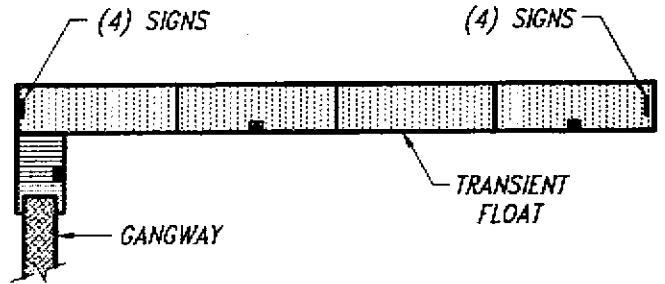
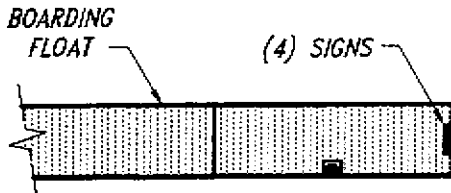

THIS SIDE FACING  
BOARDING FLOAT

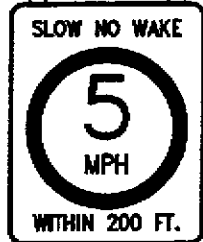

THIS SIDE  
FACING WATERWAY

BOARDING FLOAT SIGN DETAIL

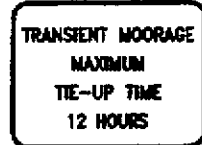

THIS SIDE FACING  
TRANSIENT FLOAT

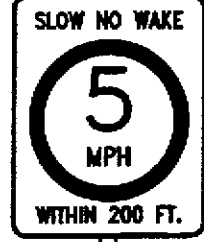

THIS SIDE  
FACING WATERWAY

TRANSIENT FLOAT SIGN DETAIL

WATERWAY SIGNS

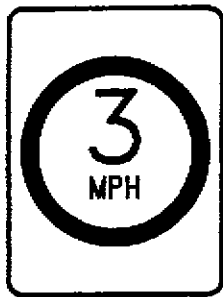

SIGN NO: RW-01  
36" x 48"

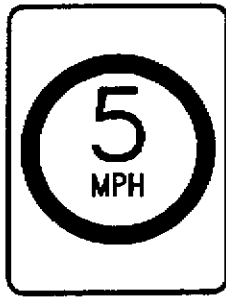

SIGN NO: RW-02  
36" x 48"

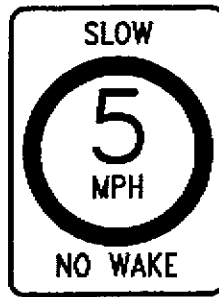

SIGN NO: RW-03  
36" x 48"

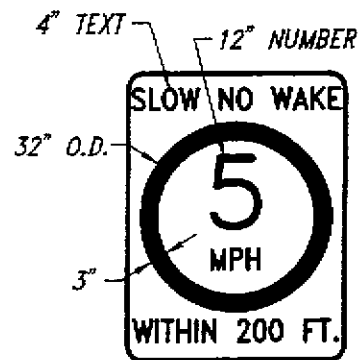

SIGN NO: RW-04  
36" x 48"

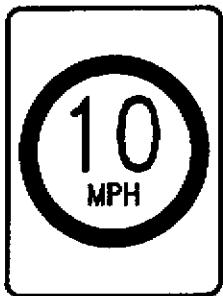

SIGN NO: RW-05  
36" x 48"

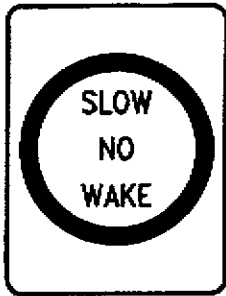

SIGN NO: RW-06  
36" x 48"

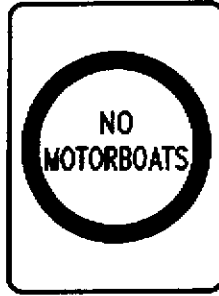

SIGN NO: RW-07  
36" x 48"

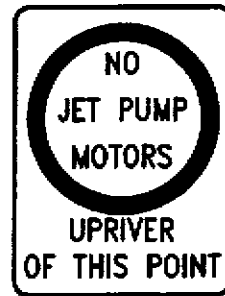

SIGN NO: RW-08  
36" x 48"

### WATERWAY REGULATORY

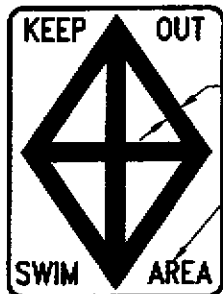

SIGN NO: WW-01  
36" x 48"

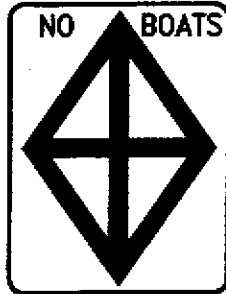

SIGN NO: WW-02  
36" x 48"

### WATERWAY REGULATORY & PROHIBITORY

#### NOTES:

1. THE OUTSIDE DIAMETER OF THE CIRCULAR SYMBOL SHALL BE TWO THIRDS OF THE SIGN HEIGHT.
2. THE THICKNESS OF THE CIRCULAR SYMBOL OUTLINE SHALL BE ONE TENTH OF THE HEIGHT OF THE SYMBOL.
3. SIGN BACKGROUND COLOR IS WHITE, CIRCLE OR TRIANGLE IS INTERNATIONAL ORANGE, LETTERING AND NUMBERS ARE BLACK BLOCK TEXT.

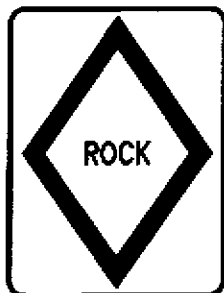

SIGN NO: WW-03  
36" x 48"



SIGN NO: WW-04  
36" x 48"

### WATERWAY WARNING SIGNS

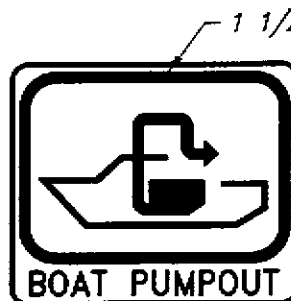

SIGN NO: IW-01  
30" x 36"  
3" TEXT



SIGN NO: IW-02  
30" x 36"  
3" TEXT

### WATERWAY INFORMATIONAL

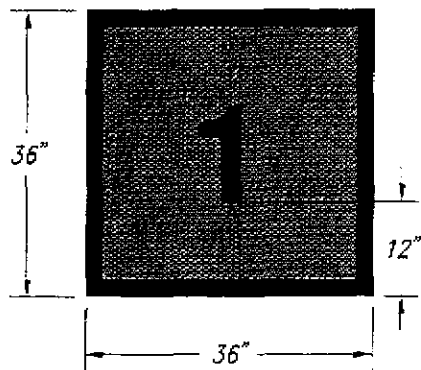

SIGN NO: WW-07  
36" x 36"

**NOTES:**

1. NUMBER IS 12" HIGH AND REFLECTIVE GREEN.
2. BORDER IS 2" WIDE AND REFLECTIVE GREEN.
3. BACKGROUND IS FLUORESCENT GREEN.

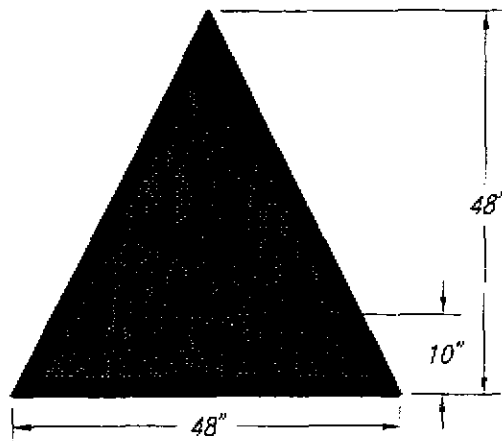

SIGN NO: WW-08  
48" x 48"

**NOTES:**

1. NUMBER IS 12" HIGH AND REFLECTIVE RED.
2. BORDER IS 2" WIDE AND REFLECTIVE RED.
3. BACKGROUND IS FLUORESCENT RED.

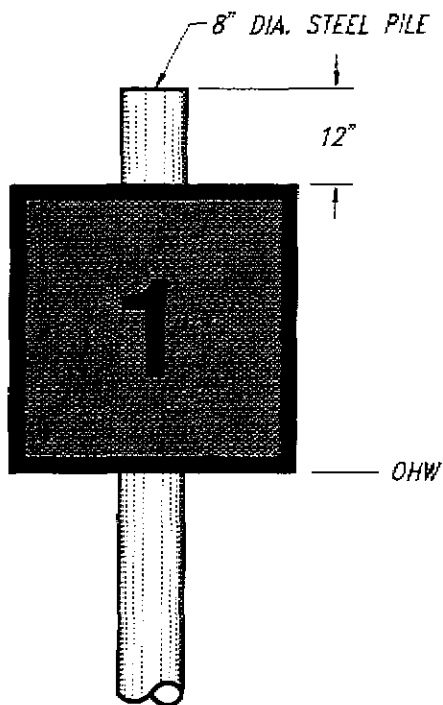

**NOTE:**

DRILL OR PUNCH A 5/16" DIA. HOLE FOR A 1/2" DIA. BOLT (TYP. TWO PLACES). USE BUCKLE BRACKETS TO MOUNT ONE SIGN ON EA. SIDE OF STEEL PILE (TYP.)

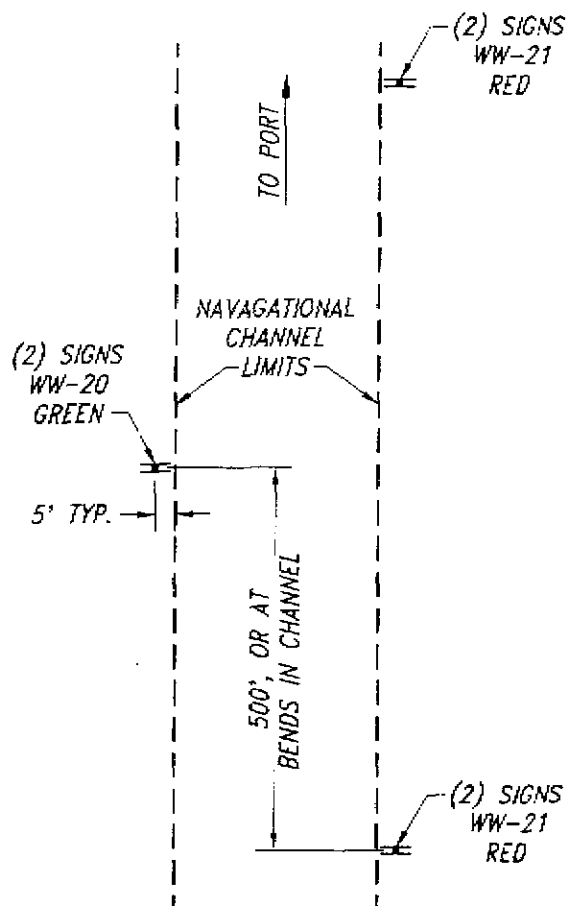

**CHANNEL MARKER LAYOUT**  
NOT TO SCALE

**CHANNEL MARKERS**