



Safety
Facts

SF-2



WOOD STOVE INSTALLATION AND OPERATION

What should I place on a stove on?

For heaters set on legs or pedestals that provide not less than 6 inches of ventilated space beneath the fire chamber or base of the appliance, use closely spaced solid masonry bricks or blocks not less than 2 inches thick. The top surface of the bricks should be covered with sheet metal not less than 24-gauge.

The floor protection should extend not less than 18 inches beyond the appliance on all sides. A floor protector listed by a recognized testing laboratory such as UL may be used if installed in accordance with the installation instructions.

How far should a wood stove be from an unprotected wall or combustible material?

The standard clearance for appliances installed in rooms which are large in comparison to the size of the appliance is 36 inches from the top, sides, back or front of the appliance. Otherwise, install according to the manufacturer's instructions.

Is a masonry veneer covered wall considered safe for reduced clearance?

No! National Fire Protection Association (NFPA) codes permit reduced clearances to combustible walls if adequate protection is provided. Sheetrock, sheet metal, masonry veneer and other thin or non-insulating materials placed directly against walls give little protection. These materials conduct heat very well; they will be almost as hot on their back sides as they are on their exposed sides.

Reduced clearances are acceptable for the following:

- an engineered protection system approved by the inspecting authority having jurisdiction
- products and materials listed for protection purposes
- a non-combustible protector mounted an inch or more away from a combustible wall to allow free circulation of air behind it

The reduction is specified by NFPA and most codes. For example, when required clearance with no protection is 36 inches, a 3 1/2-inch-thick masonry wall with ventilated air space used as a wall protector, reduces clearance by maximum of 66 percent, to 12 inches from the combustible wall.

Can radiating-type wood stoves ever be installed less than 36 inches from combustibles?

Yes. If a UL-listed stove has a heat shield attached, the clearance can be reduced as specified. Or build a heat shield to be mounted 1 inch off the wall on non-combustible spacers. To reduce the standard clearance to 12 inches, the heat shield should be of 28-gauge sheet metal, mounted off the floor to provide unrestricted circulation of air between shield and wall.

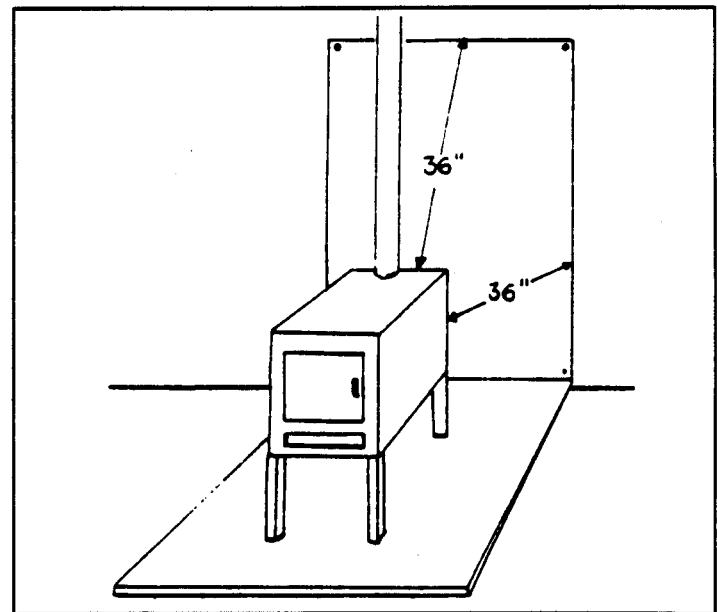

Figure 1



What size heat shield do I need?

Any area within 36 inches of the wood stove should be covered as shown in figure 1.

Does a stovepipe need special clearance to combustibles?

Yes. Clearance should be three times the diameter of the pipe, e.g., a 6-inch pipe needs 18 inches of clearance. Heat shields may be used to reduce the clearance by the same ratio as for the stove. For example, with sheet metal you can reduce the clearance by two-thirds, from 18 inches to 6 inches.

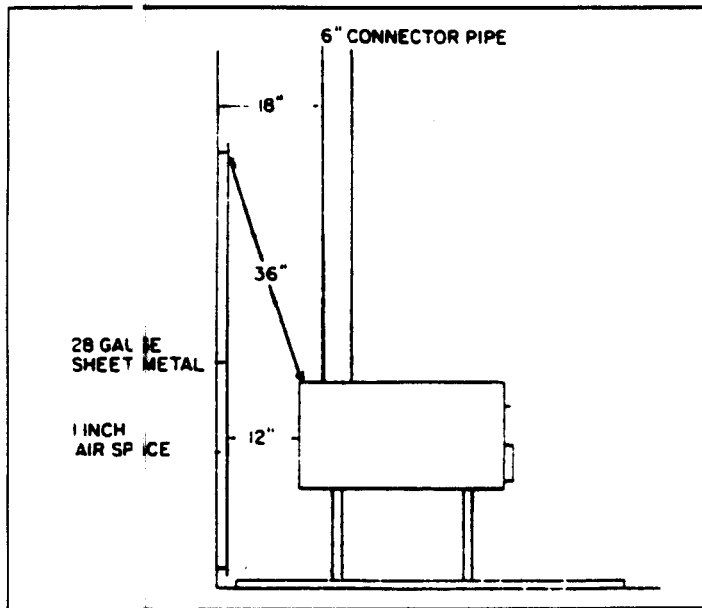

Figure 2

How do you run a stovepipe through a combustible wall or ceiling?

You don't. But if absolutely necessary, the following are approved methods:

- Build a 3.5-inch thick brick masonry wall framed into the combustible wall, with a 12-inch minimum clearance from the clay liner to combustibles.
- Use a solid, insulated, listed factory-built chimney, with a 9-inch air space to combustibles.
- Use a 24-gauge sheet-steel chimney connector with ventilated thimble, plus 6 inches of glass fiber insulation.
- Use a solid, insulated, listed factory-built chimney over a 24-gauge chimney connector, with 1 inch of air space, plus 2 inches from outer wall of chimney section and combustibles.

Connectors must also maintain a pitch of at least 1/4 inch per foot from the appliance to the chimney. Avoid sharp turns, which create excessive resistance to the flow of flue gases, and support and fasten securely with sheet-metal screws, rivets, or other approved means.

Can you vent a wood stove and an oil burner into the same flue?

No. Each should be vented into a separate flue. Multiple connections can cause flue gases and sparks to pass from one flue opening to another, reducing efficiency and igniting unburned gases in the flue.

What about factory-built chimneys?

They are efficient and easy to install, but should be UL-listed. Insulated factory-built chimneys minimize soot and creosote buildup because the inner walls warm rapidly. The necessary clearance from combustibles is marked on each section of UL-listed, factory-built chimneys.

Is a masonry or metal factory-built chimney best?

Both are safe and durable if constructed properly and well maintained. It is important to have an insulated chimney, particularly with an airtight wood stove. Interior chimneys are preferable to exterior because they are warmer. Also, round liners are more efficient than rectangular ones. Appearance and price are other considerations.

Can you use single wall stovepipe for an outside chimney?

No! Smoke pipe was never meant to be used outside. Water and ash form lye that quickly eats away single wall pipe. Also, creosote forms rapidly due to cooling of gases inside the pipe itself.

Can I vent a wood stove into an unlined chimney?

No. All masonry chimneys should have tile liners. Homes built before 1900 often have unlined chimneys, which are hazardous and shouldn't be connected to a wood stove.

What are the safety considerations through fireplaces?

NFPA 211 states the following:

- The flue must be no larger than three times the cross-sectional area of the appliance flue outlet.
- The system must be designed and installed so that it can be inspected and cleaned.
- A solid-fuel burning appliance may NOT vent into or through a factory-built fireplace unless it has been specifically listed for that purpose.

How high should a chimney be?

It should extend at least three feet above the highest point where it passes through the roof. It should be two feet higher than anything within a 10-foot radius, including the roof itself, overhanging trees, adjacent buildings, etc.

How can I control creosote?

Creosote condenses when stack temperatures drop below 250°F, so the type of chimney is very important. An insulated one is desirable. A large, airtight heater in a small home in a "choked" position will produce creosote regardless of the type of wood burned or its moisture content. Minimize creosote formation by:

-
- Using UL-listed wood-burning equipment and chimney materials and installing the unit according to manufacturer's instructions.
 - Proper sizing of chimney and components.
 - Building a small, hot fire for a short period rather than an "idle" fire over a long period, when temperatures are moderate.
 - Keeping a hot fire; many manufacturers recommend opening the damper and allowing the stove to burn hot for at least 15 minutes to burn away small amounts of creosote.
 - Using only well-seasoned hardwoods.
 - Inspecting your system frequently and learning to operate it most efficiently. Clean your chimney accordingly.

Author:

Ronald C. Jester
Extension Safety Specialist

SF-2-10/91

Commercial companies or products are mentioned in this publication solely for the purpose of providing specific information. Mention of a company or product does not constitute a guarantee or warranty of products by the Agriculture Experiment Station or Delaware Cooperative Extension or an endorsement over products of other companies not mentioned.