

Hydroacoustic Evaluation of Fish Passage through Bonneville Dam in 2004



G. R. Ploskey
M. A. Weiland
C. R. Schilt
P. N. Johnson
M. E. Hanks
D. S. Patterson
J. R. Skalski
J. Hedgepeth

FINAL REPORT
December 22, 2005

Prepared for the
U.S. Army Corps of Engineers
under a Related Services Agreement
with the U.S. Department of Energy
Contract DE-AC05-76RLO1830

**Pacific Northwest
National Laboratory**

Operated by Battelle for the
U.S. Department of Energy

This report was prepared as an account of work sponsored by an agency of the United States Government. Neither the United States Government nor any agency thereof, nor Battelle Memorial Institute, nor any of their employees, makes **any warranty, express or implied, or assumes any legal liability or responsibility for the accuracy, completeness, or usefulness of any information, apparatus, product, or process disclosed, or represents that its use would not infringe privately owned rights.** Reference herein to any specific commercial product, process, or service by trade name, trademark, manufacturer, or otherwise does not necessarily constitute or imply its endorsement, recommendation, or favoring by the United States Government or any agency thereof, or Battelle Memorial Institute. The views and opinions of authors expressed herein do not necessarily state or reflect those of the United States Government or any agency thereof.

PACIFIC NORTHWEST NATIONAL LABORATORY
operated by
BATTELLE
for the

UNITED STATES DEPARTMENT OF ENERGY

under Contract: DE-AC05-76RLO1830

Printed in the United States of America

**Available to DOE and DOE contractors from the
Office of Scientific and Technical Information,
P.O. Box 62, Oak Ridge, TN 37831-0062;
ph: (865) 576-8401
fax: (865) 576-5728
email: reports@adonis.osti.gov**

**Available to the public from the National Technical Information Service,
U.S. Department of Commerce, 5285 Port Royal Rd., Springfield, VA 22161
ph: (800) 553-6847
fax: (703) 605-6900
email: orders@ntis.fedworld.gov
online ordering: <http://www.ntis.gov/ordering.htm>**

Hydroacoustic Evaluation of Fish Passage through Bonneville Dam in 2004

G. R. Ploskey
M. A. Weiland
C. R. Schilt^(a)
P. N. Johnson^(a)
M. E. Hanks^(a)
D. S. Patterson^(a)
J. R. Skalski^(b)
J. Hedgepeth^(c)

FINAL REPORT
December 22, 2005

Prepared for the U.S. Army Corps of Engineers
under a Related Services Agreement
with the U.S. Department of Energy

Pacific Northwest National Laboratory
P.O. Box 999
Richland, Washington 99352

(a) BAE Systems, Analytical Solutions, Incorporated
(b) University of Washington
(c) Tenera, Inc.

Abstract

The Portland District of the U.S. Army Corps of Engineers requested that the Pacific Northwest National Laboratory (PNNL) conduct fish-passage studies at Bonneville Dam in 2004. These studies support the Portland District's goal of maximizing fish-passage efficiency (FPE) and obtaining 95% survival for juvenile salmon passing Bonneville Dam. Major passage routes include 10 turbines and a sluiceway at Powerhouse 1 (B1), an 18-bay spillway, and eight turbines and a sluiceway at Powerhouse 2 (B2).

In this report, we present results of four studies related to juvenile salmonid passage at Bonneville Dam. The studies were conducted between April 15 and July 15, 2004, encompassing most of the spring and summer migrations. Studies included evaluations of 1) project fish passage efficiency and other major passage metrics, 2) B2 fish guidance efficiency and gap loss, 3) smolt approach and fate at the B2 Corner Collector (B2CC), and 4) B2 vertical barrier screen head differential. Appendices A through I are presented on the accompanying compact disk (CD). Most are in an Adobe Acrobat portable document format (PDF) and six large tables in Appendix E (E3-E8) are presented only as comma-separated-variable files. The CD also includes a PDF version of the report.

Executive Summary

Background and 2004 Conditions

The Portland District of the U.S. Army Corps of Engineers requested that the Pacific Northwest National Laboratory (PNNL) conduct the following studies related to fish-passage at Bonneville Dam in 2004:

1) Project fish passage efficiency and an assessment of other major passage metrics, 2) B2 fish guidance efficiency and gap loss, 3) smolt approach and fate at the B2 Corner Collector (B2CC), and 4) B2 vertical barrier screen head differential.

We present results of the fourth year in which enough of the Project's many passage routes were sampled to permit estimation of project-wide fish-passage metrics. The other years with extensive fish-passage sampling are 2000, 2001, and 2002. Each of these four years has had environmental and operational factors that make it unique, such as the testing of new passage routes and structural modifications, powerhouse priority, turbine outages, project generation demand, and water availability. The 2004 passage year involved B2 generation priority, river flow that was 82% of the last 10-year average, and a newly completed surface passage route, the B2CC, at the southern end of B2. In previous years of FPE study, turbine intake extensions (TIEs) were installed in every other B2 intake from 11A through 18B, but in 2004, TIEs were not installed at Units 11 through 14 to facilitate southerly flow along the powerhouse toward the B2CC. Three B1 sluiceway entrances (2C, 4C, and 6C) also were opened and were sampled, as were all operating turbine units and spill bays. Besides the new B2CC, the 2004 passage year was unique in that no in-turbine screens were deployed in the 30 B1 turbine intakes. At B2, there were two turbine units with modified gatewell slots (Units 15 and 17) and six unmodified units, as there were in the 2002 study year. Modifications in Units 15 and 17 were designed to increase flow up gatewell slots and to improve fish guidance efficiency (FGE).

Objectives

Project FPE Evaluation

This objective continues the fish-passage studies conducted in 2000-2002 and involves using fixed-aspect hydroacoustics to produce estimates of fish-passage metrics for the spring and summer seasons as well as of temporal and spatial trends and variability in those metrics. Examples of temporal trends include average diel (hourly) trends in fish-passage rates within days and daily trends within seasons. Spatial trends include lateral distributions at B1, the spillway, and B2. Objectives relating to passage-metric estimation and analysis were to

1. Estimate the proportions of smolt-sized fish that passed all of the turbine intakes at the project (above and below in-turbine screens at B2), through sluiceway entrances (including three open sluice gates at B1 as well as the B2CC), and through all spill bays in the spring and summer passage seasons.
2. Estimate a variety of fish-passage metrics, including Project and powerhouse-specific FPE, fish-guidance efficiency (FGE) by turbine unit at B2 (there were no screens deployed at B1 in 2004), and both the efficiency and effectiveness of the spillway, B1 sluiceway, and the B2CC (relative to both the powerhouse or Project as appropriate) by hour, day, and season.

3. Characterize horizontal distributions of smolt-sized fish passing through the Project, B1, B2, and the spillway in spring and summer.
4. Describe changes in vertical and horizontal distributions of smolt-sized fish passing B1 turbine intakes and the B1 sluiceway entrances, B2 turbine intakes (guided and unguided) and the B2CC, and the spillway.
5. Describe both seasonal and diel changes in the passage of smolt-sized fish at B1, B1 sluiceway entrances, B2, the B2CC, and the spillway.

B2 FGE and Gap Loss Evaluation

This effort continued studies to improve FGE at B2 turbine intakes by modifying several aspects of the intake structures. Both Unit 15 and Unit 17 were modified and Unit 13 served as an unmodified control. In 2004, as in 2002, objectives were to:

1. Continuously sample with a pair of hydroacoustic transducers in one intake each of Units 11 and 12 and two intakes of Unit 17 to supplement sampling of the number of guided and unguided fish under the Project FPE evaluation, which sampled only one of three intakes per unit. Units 11 and 12 had no gatewell slot modifications or TIEs and were near the B2CC at the south end of B2, whereas Unit 17 had modified gatewell slots, TIES on A and C slots, and was located just south of Unit 18 on the north end of B2. The goal was to calculate FGE by intake and evaluate effects of intake location and modifications in spring and summer.
2. Evaluate the proportion of fish moving through the gap between the top of the STS and the ceiling of intakes of Units 13 and 17 in spring 2004. Unit 13 had unmodified gatewell slots but did not have TIEs installed upstream of slot A and C trash racks in 2004, as it did in 2003, and it was just two units away from the new B2CC. Unit 17 was a modified unit that had TIES upstream of A and C slots.

Smolt Approach Evaluation at the B2CC

The objectives were to:

1. Sample with a DIDSON mounted on a dual-axis rotator to acquire data on the swim paths of smolts approaching the B2CC entrance three times each season.
2. Process and analyze the data to qualitatively describe fish behavior, distributions, and the probability that fish in various forebay locations would pass into the B2CC or into the adjacent south eddy.

B2 Vertical Barrier Screen (VBS) Head Differential Evaluation

The objectives were to

1. Monitor differential head between the water elevations upstream and downstream of the VBS at modified Unit 17 at B2 to index debris accumulation. We were to alert the Project when debris levels exceeded a preset threshold.
2. Compare the differences in differential head with dam operations.

Methods

Fixed-Aspect Hydroacoustics

We deployed 70 hydroacoustic transducers as part of 17 hydroacoustic systems, each consisting of an echosounder, cables, transducers, an oscilloscope, and a computer to sample fish passage at 16 of 30 B1 turbine intakes, all three open B1 sluiceway entrances, all 18 spill bays, the B2CC entrance, and 12 of 24 B2 turbine intakes from April 15 through July 15, 2004. Nine of 17 systems deployed in 2004 were made up of split-beam echosounders and transducers that provide x and y phase data from which we could estimate location of echoes in the plane perpendicular to range from a transducer. With estimates of target location within the beam we could also estimate fish size, speed, and trajectory, all of which are important for detectability modeling to obtain deployment-specific expansion factors. Split-beam systems also were used to sample sluiceway entrances 2C, 4C, and 6C at B1 and the B2CC. Echosounders used to sample sluiceway entrances were modified to optimize detectability of closely spaced fish by increasing bandwidth from 20 to 100 kHz and transmitting shorter pulse widths (80 instead of 200 μ s) to reduce the target resolution distance (minimum target separation) from 6 inches to about 2.36 inches. Direction of travel information was critical for adjusting estimates of fish passage into the B1 sluiceway entrances to exclude fish that were not entrained and that were not moving toward an entrance. All systems were sampled continuously from April 15 through July 15, 2004. Details about deployments such as locations, beam angles, aiming angles, receiver gains, pulse-repetition rates, and sampling sequences are presented in Sections 2.3.1 through 2.3.3.1 of this report. Other detailed descriptions of methods are described in Method Sections 2.5 (Spatial Expansions), 2.6 (Dam Operations and Fish Passage), 2.7 (Missing Data), 2.8 (Estimating Fish Passage), 2.9 (Adjustment of Passage Estimates and Variances), 2.10 (Estimating Passage Performance), and 2.11 (Comparing Spill-Treatment and Location Effects).

DIDSON Sampling of STS Gap Loss

In spring 2004, we deployed a down-looking Dual-Frequency Identification Sonar (DIDSON) on a laterally moving mount that traversed a horizontal beam, which was lowered by crane into gateway slots of Units 13 and 17 at B2. The DIDSON recorded images of juvenile salmonids moving up into the gateway and through the gap between the top of the STS and the ceiling of the intake. The programmable traversing mount allowed the DIDSON to sample from five lateral locations across the gateway at 10-minute intervals. The traversing part of the 20-ft-wide beam was moved by a stepper motor and controlled by custom designed software on a laptop computer through a serial communication port. Sampling and data-processing details are presented in Section 2.3.3.2 of this report.

DIDSON Sampling of Fish Approach and Fate at the B2CC

A second DIDSON was used to conduct a study to record and track movements of juvenile salmonids approaching the B2CC in spring and summer. The DIDSON was mounted on a ROS PT10 pan and tilt rotator. The rotator and DIDSON were located about 15 ft to the east of the B2CC entrance and were deployed from a 25-ft-long pontoon barge.

Fish approaching the B2CC and south eddy at B2 were imaged with a DIDSON operating in low-frequency mode during three 24-h periods in early, mid, and late spring and summer (9 diel samples each season). The fan of 48 adjacent 0.6°-wide by 12°-deep DIDSON beams was oriented horizontally

throughout the study and covered approximately 30°. The DIDSON was mounted on a pan and tilt rotator that was controlled by a technician with a joystick to keep smolts approaching the B2CC entrance or south eddy within the DIDSON's field of view as long as possible. The aiming angles from the rotator were also incorporated into the DIDSON program using a serial Data Acquisition (DAQ) Module. This allowed pan and tilt angles to be integrated with each frame of the DIDSON data. Rotator coordinates and fish positions in the sample beams were used to describe fish positions. Detailed procedures for tracking fish upstream of the B2CC are described in Section 2.3.3.3 of this report.

Details on fish tracking and filtering criteria are covered in Sections 2.4 through 2.4.3, and coordinate systems, computational fluid dynamics (CFD) modeling, and estimation of fate probabilities associated with smolts approaching the B2CC entrances are described in Sections 2.4.4 through 2.4.6, respectively.

B2 Vertical Barrier Screen (VBS) Head Differential Evaluation

Differential heads in the gatewell and bulkhead slots of A and C intakes of Unit 17 were measured with four Druck PTX 1830 2.5 psig pressure transducers. Details about the deployment, sampling scheme, and data acquisition and processing are presented in Appendix I.

Major Findings

In this section of the summary, we present highlights of findings about environmental conditions, major fish passage-metrics, B2 FGE, gross trends in the spatial and temporal distributions of passage, gap loss at a modified and unmodified unit, and fish approach and fate at the B2CC. Readers interested in finer details about spatial and temporal distributions should also review the appropriate Results sections, which include detailed figures and tables.

Environmental Conditions

Unique environmental conditions that affected estimates of fish passage efficiency in 2004 were the operation of the B2CC, opening of three B1 sluiceway entrances, absence of TIEs on the south half of B2, and no deployment of STSs at B1 turbines. Columbia River discharge was about 82% of the 10-year average discharge, but this level was not so low that it limited spill to benefit juvenile fish passage or raised water temperatures more than 1-2 degrees above the 10-year average. During the 2004 study (April 15 through July 15), Project discharge ranged from 125,000 to 310,000 ft³/s. Spill discharge was about 75% of the 10-year mean from March 1 to April 15, 84% from April 15 through May 31, and 85% from June 1 through July 15. After April 22, daytime spill was about 75,000 cfs, and night spill was up to a cap determined by total dissolved gas saturation in the discharge. Sufficient river flow allowed operators to provide prescribed spill levels for day and night periods each season. Power generation was curtailed to provide for increased spill at night. Constant 24-h spill conditions for six days in summer allowed us to evaluate diel patterns of fish passage independent of diel patterns of discharge.

The species composition of the spring run-at-large, as assayed by the Smolt Monitoring Facility at B2, was dominated numerically by sub-yearling Chinook salmon released from hatcheries (46%), which is typical for Bonneville Dam. Samples taken at the B2 juvenile bypass system (JBS) showed that yearling Chinook salmon were the second most abundant species in spring 2004 (30%), followed by

coho (19%), a weak run of steelhead (3%), and a relatively strong run of sockeye (2%). Passage of non-hatchery sub-yearling Chinook salmon, the most abundant salmonid fish migrating downstream in summer, peaked about the beginning of July.

The forebay CFD model proved very useful for evaluating flow patterns in the B2 forebay. Strong eddies formed on the north and south ends of the forebay whenever six or more turbines were operating, but eddies dissipated after 1 to 2 hours of 2-unit operation. The strength of eddies increased with powerhouse loading from 69,000 to 132,000 cfs. There also was a lot of lateral flow along the face of the powerhouse north and south of Intake 15A. There was clear separation of flow along a line parallel to the dam face and within 45-60 ft of the B2CC entrance. Most of the flow west of the line passed into the B2CC, and most of the flow east of the line passed into the south eddy.

FPE Evaluation of Spring Creek Releases in March

Running the B1 sluiceway and B2CC without spill produced a Project FPE that was nearly as high as that provided by 50,000 cfs of spill, B1 sluiceway operation, and no B2CC, and this was in spite of a poorly performing B1 sluiceway. Project FPE was about 54% during the spill-no B2CC operation, 45% during no spill-B2CC operation, and only 32% under the no spill-no B2CC condition. For some unknown reason, the B1 sluiceway efficiency was only 1.7% during the Spring Creek Hatchery Release sampling while the B2CC operated in March, whereas it averaged 5% under other conditions during the March Spring Creek release and 5.7% during the spring sampling season (April 15 to May 31, 2004). We did not run a formal statistical test on operational conditions during the Spring Creek release because conditions were presented in single four- or five-day blocks that afforded no randomization. However, Project FPE was as high during two of the days of B2CC-only operation as it was during the five days of spill. Under the other two days of B2CC-only operation, Project FPE was only about 12% lower than average FPE under spill. In contrast, four of seven days of no spill and no B2CC produced an FPE that ranged from 16% to 39% lower than FPE during spill. During the no spill-B2CC operation, the B2CC passed about 17.1% of the Spring Creek hatchery fish that were passing the Project and 24% of fish that passed at B2. Project Sluiceway Passage Efficiency, including the B1 and B2 routes, was 18.8% and this was comparable to the 19% efficiency observed in spring, although it was lower than the 26% efficiency estimated for summer.

Major Passage Metrics

Estimates of major passage metric estimates for spring and summer 2004 are presented in Table S.1. The spillway passed 40.3% of fish in 41.7% of flow in spring and 32.7% of fish in 39.2% of flow in summer. The table includes the various estimated passage metrics and the respective 95% confidence limits, which were calculated for both the whole Project and for various portions of the Project, including each powerhouse and the spillway. We also calculated Project FPE without surface passage by applying the estimated FGE of each powerhouse in each season (zero percent at B1 in both seasons, 47.58% in spring and 35.6% in summer at B2) to the total passage at that powerhouse in that season.

Table S.1. Estimates of Major Passage Metrics Based upon Hydroacoustic Sampling from 4/15 through 5/31 (Spring) and from 6/1 through 7/15 (Summer) in 2004. Estimates of percent flow through B1, B2, the spillway, and B1 + B2CC sluiceways are presented for comparisons to fish passage percentages.

Major Passage Metric Estimate	Spring	Summer
Project FPE	73.3 ± 2.30%	70.0 ± 2.3 %
Project FPE with no surface passage	66.7 ± 0.03%	59.3 ± 0.03%
Project FPE - B2 + Spillway (without B1)	81.5 ± 0.02%	76.3 ± 0.03%
B1 Percent of Project Passage	17.1 ± 1.8%	16.1 ± 1.2%
B1 Percent of Project Flow	11.5%	12.3%
B1 FPE	33.3 ± 3.92%	37.6 ± 2.85%
B2 Percent of Project Passage	42.6 ± 2.3%	51.2 ± 1.9%
B2 Percent of Project Flow	46.7%	48.5%
B2 FPE	64.0 ± 4.24%	61.1 ± 3.92%
B2 FGE	47.6 ± 6.62%	35.6 ± 5.77%
Spill Efficiency	40.3 ± 1.70%	32.7 ± 1.30%
Spill Percent of Project Flow	41.7%	39.2%
Spill Efficiency B2 + Spillway (without B1)	48.6 ± 0.02%	38.9 ± 0.02%
Spill Effectiveness	1.0 ± 0.04	0.8 ± 0.03
Spill Effectiveness B2 + Spillway (without B1)	1.0 ± 0.05	1.0 ± 0.04
Project Sluice Efficiency	19.1 ± 0.80%	26.4 ± 1.00%
B1 and B2CC Sluiceway Percent of Flow	3.0%	3.0%
Project Sluice Effectiveness	6.3 ± 0.27	8.8 ± 0.35
B1 Sluice Efficiency re: Project	5.7 ± 0.3%	6.1 ± 0.2%
B1 Sluice Efficiency re: B1	33.3 ± 3.92%	37.6 ± 2.85%
B1 Sluice Effectiveness re: Project	11.2 ± 0.50	12.1 ± 0.48
B1 Sluice Effectiveness re: B1	7.6 ± 0.89	9.3 ± 0.70
B2CC Efficiency re: Project	13.4 ± 0.6%	20.0 ± 0.80%
B2CC Efficiency re: B2	31.4 ± 2.81%	39.6 ± 2.87%
B2CC Effectiveness re: Project	5.3 ± 0.23	8.2 ± 0.32
B2CC Effectiveness re: B2	5.8 ± 0.52	7.7 ± 0.56

Project FPE estimates of 73% in spring and 70% in summer 2004 were made possible primarily by surface passage routes because there were no STSs deployed at B1, spill efficiency was below average, and B2 FGE was about average for non-drought years for which full Project data are available. Fish passage efficiency (FPE) must be viewed in the context of differences in structure and operations. The B1 sluiceway and B2CC passed a very large proportion of the estimated total project fish passage relative to the amount of water discharged through those surface routes. Although the contribution of surface routes to FPE did not completely make up for a lack of screens at B1 or below-average spill efficiency, it did keep spring FPE within 6% of estimates in 2000 and 2002 and summer FPE within 9% of 2000 levels and 4% of 2002 levels, two non-drought years. Surface passage was especially important in maintaining a relatively high (70%) FPE estimate in late summer, when Project FPE often declines. Project FPE calculated with no surface-passage component was about 67% in spring and 60% in summer. In 2004, B2 screen guidance was about average for that structure (just under 50% in spring and just over 35% in summer) and Project spill efficiency was the lowest of the three non-drought years sampled.

The percent of fish passing the spillway (spillway efficiency) was similar to the proportion of water spilled each season (effectiveness = 0.97 in spring and 0.83 in summer), and percent fish and water spilled in spring and summer 2004 was lower than that spilled in non-drought study years. In 2004,

operators spilled 40% of the fish in 42% of the water in spring and 33% of the fish in 39% of the water in summer. In 2000, spill accounted for 49% of flow in spring and 48% in summer (7% and 9% higher than in 2004). Differences in percent spill between 2004 and 2000 could account for all of the difference in spill efficiency in spring and 56% of the difference in summer of those years. In 2002, another non-drought year, operators spilled 49% of the river in spring and 44% in summer (7% and 5% less than in 2004). Differences in percent spill between 2004 and 2002 could account for 58% of the difference in spill efficiency in spring and 56% of the difference in summer of those years.

The big story from the 2004 study was that the B1 sluiceway was especially effective, passing over 11 times greater a proportion of fish than of water in spring and over 12 times greater in summer. At B2, the B2CC effectiveness was less than the B1 sluiceway effectiveness (just 5.3 times greater fish passage proportion in spring; over 8 times greater in summer), but it was still quite impressive relative to the spillway, where effectiveness was less than 1. In 2004, the B1's sluiceway passed only about 4% of the B1 discharge in both spring and summer, and the B2CC passed only about 5% of the total B2 discharge in both spring and summer. Overall, the two surface passage routes combined passed about 6.3 time higher proportion of fish than water in spring and about 8.8 times higher in summer.

Given the far greater effectiveness of surface passage routes over spill, it should be possible to reduce spill and maintain FPE by increasing the number of surface passage routes, provided effectiveness does not decline. Opportunities at Bonneville Dam include increasing the capacity of the B1 sluiceway so that more entrances can be opened and providing for removable spillway weirs at two or three spill bays. A doubling of discharge through additional surface passage routes from about 5% to 10% of Project flow could make surface-passage efficiency comparable to 2004 spill efficiency using just one-fourth of the water spilled. This would allow for some training spill for the spillway weirs.

Comparison of Major Metrics from 2000 through 2004

Since a major purpose of the multi-year effort was to establish a baseline for evaluating future management improvements, we compared major fish passage metrics for the four years that full-Project hydroacoustic studies have been conducted (Table S.2).

The among-year range of estimates of fish-passage metrics was high because of the wide range of sampling, structural, and operational conditions that occurred during four years of hydroacoustic FPE study. This broad baseline can be used to evaluate future management efforts at the Project, although generalizations should be made cautiously by evaluating structural-specific metrics as well as Project-wide metrics. A large hydropower project is not a laboratory and each passage season and year is unique in terms of fish populations, passage conditions, dam operations, methods, and experimental treatments which complicate long-term comparisons. In these four years, there was one year (2000) that involved evaluation of a prototype surface collector at B1 and so B1 had generation priority. There was one year of severe drought and unusually high power generation demand (2001) and one year with episodes of unusually high spillway discharge superimposed on experimental spillway discharge manipulation (2002). Except for 2000, B2 has had generation priority in all of the years studied. In the drought year, 2001, a greater than usual proportion of juvenile fish were captured for transport. In 2002, there was an unusually large crop of naturally produced sockeye (*O. nerka*) smolts.

Table S.2. Estimates of Major Passage Metrics Based upon Hydroacoustic Sampling in 2000, 2001, 2002, and 2004. Headings list some important differences in conditions or sampling among the years.

Major Passage Metric	2000	2001	2002	2004
	PSC (Units 1-6) B1 Priority No Sluiceway Sampled No STS in PSC	Severe Drought B2 Priority No Sluiceway Sampled	B2 Priority B1 Sluiceway Sampled	B2 Priority B1 Sluiceway & B2CC Sampled No B1 Screens
Spring				
Project FPE	79 ± 0.2 %	63 ± 0.3 %	79 ± 0.1 %	73 ± 2.3%
B1 FPE (without Sluiceway)	67 ± 0.4 %	49 ± 2.3 %	37 ± 0.4 %	N/A
B2 FPE	54 ± 0.8 %	57 ± 0.3%	53 ± 0.3 %	64.04 ± 4.24%
B2 + Spillway FPE (without B1)	N/A (B1 Priority)	64 ± 0.3 %	83 ± 0.4 %	81.5 ± 0.02%
Spill Efficiency	44 ± 0.4 %	14 ± 0.2 %	52 ± 0.5 %	40.3 ± 1.7%
Spill Effectiveness	1.36 ± 0.010	0.84 ± 0.004	1.08 ± 0.010	0.97 ± 0.04
Project Sluiceway Efficiency	N/A	N/A	6.0 ± 0.1%	19.1 ± 0.8%
Project Sluiceway Effectiveness	N/A	N/A	21.9 ± 0.01	6.3 ± 0.27
Summer				
Project FPE	79 ± 0.2 %	53 ± 0.4 %	74 ± 0.2 %	70.0 ± 2.3%
B1 FPE (without Sluiceway)	61 ± 0.2 %	40 ± 1.8 %	45 ± 1.2 %	N/A
B2 FPE	35 ± 2.2 %	42 ± 0.4 %	46 ± 0.7 %	61 ± 3.92%
B2 + Spillway FPE (without B1)	N/A(B1 Priority)	54 ± 0.4 %	82 ± 0.5 %	76.26 ± 0.03%
Spill Efficiency	49 ± 0.4 %	20 ± 0.3 %	42 ± 0.5 %	32.7 ± 1.3%
Spill Effectiveness	1.03 ± 0.01	1.83 ± 0.01	0.96 ± 0.01	0.83 ± 0.03
Project Sluiceway Efficiency	N/A	N/A	11.0 ± 0.1%	26.4 ± 1.0%
Project Sluiceway Effectiveness	N/A	N/A	47.9 ± 0.03	8.82 ± 0.35

Estimates of the primary passage metrics (Project FPE, Spill Efficiency, Spill Effectiveness) in 2004 were the lowest of all of the non-drought years. The primary reason for low FPE in 2004 appears to be the lack of a guided-fish fraction for B1 turbines because STSs were not deployed at B1. The lack of B1 screens had no effect, however, on spill efficiency, which in 2004 was 4% and 16% lower than the respective spring and summer estimates for 2000 and 12% and 9% lower than respective spring and summer estimates in 2002. Nevertheless, the proportions of water and of fish passing the Project at B2 were higher in 2004 than they were in 2000 (B1 priority) or in 2002 (Table 4.1), and this accounts for the lower spillway efficiency estimates in 2004.

After examining the four years of results, we can safely conclude that fish passage proportions are generally similar to flow proportions among the three major structures (B1, spillway, and B2), but fish-passage proportions seldom correlate with flow proportions at smaller scales such as individual sluiceway entrances, turbines, or spill bays.

Over the four years studied, hydroacoustic sampling coverage has improved, especially with regard to surface passage. We first sampled the B1 sluiceway gates in 2002, after we developed a new transducer deployment which provided estimates that could be correlated with independent estimates from underwater video cameras. Before 2002, we tried sampling with up-looking split-beam transducers, but

the resulting estimates did not correlate well with video estimates and were considered unreliable. Deployments for sampling were consistent in 2002 and 2004.

Effects of Percent Spill on Spill Efficiency and Project FPE

The relationship between Project FPE and percent spill was not as simple as the spill efficiency relationship, probably because FPE is affected by non-turbine passage such as surface passage or screen-guided fractions as well as spill. The distribution of hourly Project FPE versus percent spill did not appear to be linear in spring or summer. The slopes are basically two-part, with a steep initial rise until percent spill reaches about 40%, followed by a more gradual slope as percent spill increases further. In spring, the plot of hourly points was best fit with a second-order polynomial, which produced an r^2 value that was 9% higher than that for a linear fit. In summer, a quadratic fit was only 2% better than a linear fit ($r^2=0.49$). When daily estimates of the project FPE vs. percent spill were examined, the plots were essentially linear, with r^2 values of 0.55 in spring and 0.45 in summer and slopes equal to 1.2 in spring and 0.8 in summer.

There was much more scatter in regressions of spill efficiency and FPE on spill rate than there was for the regression on percent spill. Increased spill reduces fish passage by other non-turbine routes like sluiceways and screened bypass systems, so FPE is less affected by spillway discharge than is spill efficiency. Ability to control flow proportions diminishes as river flow approaches maximum capacity, and power producers avoid increasing percent spill during drought conditions. In 2004, there was sufficient flow to allow operators to reduce turbine flow to provide for increased spill at night. The efficiency of the B2 screens declined significantly from spring to summer, so the potential to increase FPE by spill or other means like surface passage is greater in summer than in spring.

Effects of Spill Discharge Rate on Spill Efficiency and Project FPE

Percent spill explained much more of the variation in FPE than did spill rate, suggesting that manipulating spill proportions is more important than manipulating spill rate to maximize FPE. Intuitively, up to 100% of flow and fish could be spilled, barring electrical generation considerations, when river discharge is low or moderate. In contrast, high spill discharge during Columbia River flooding probably would not produce the highest FPE because turbine loading also would have to be maximized to accommodate flow. Regressions of daily estimates of FPE were not significantly correlated with spill rate, in part because daily rates were averages of high night spill hours and the lower day spill hours, and in part because spill rate is only one determinant of FPE.

Comparison of Hydroacoustic and Radio Telemetry Estimates

The purpose of our comparison of the passage estimates derived from hydroacoustics and radio telemetry is to better understand the strengths and weaknesses of each method, and to use this knowledge to develop more accurate passage estimates. These are very different methods of estimating fish passage metrics, so substantial differences in the estimates resulting from each is inevitable. Differences in estimates result from varying success at estimating passage among the various routes available, biases unique to each method, and the fact that the methods may sample very different populations depending upon the time of year, the composition of the run-at-large, and the species composition of radio-tagged fish. We truncated spring and summer seasons of hydroacoustic estimates to include only days when both hydroacoustic and

radio telemetry estimates of passage were available to compare hydroacoustic estimates with USGS radio telemetry estimates. The USGS also calculated passage estimates for these time periods.

The spring comparison period was from April 29 through May 31, and the summer comparison period was from June 21 through July 15. Major fish passage metrics from the two methods (hydroacoustic = HA and radio telemetry = RT) are presented in Tables S.3 and S.4. The two estimates of Project FPE in spring were within 1% of each other, and in summer the hydroacoustic estimate (72%) was 9% higher than the RT estimate (63%). The largest differences in efficiency in spring were 25% (B1 sluiceway efficiency) and 27% (B1 FPE) and both were related to B1 sluiceway performance, which was much higher according to radio telemetry detections of steelhead and yearling Chinook salmon than were our estimates for the run at large. Other springtime efficiency estimates were within 14% or less of each other. In 2004, sub-yearling Chinook salmon released from hatcheries dominated the springtime species composition (46%). Yearling Chinook salmon were the second most abundant (30%), followed by coho (19%), a weak run of steelhead (3%), and a relatively strong run of sockeye (2%). The percentages in the spring run at large were quite different from the percentage of juvenile salmonids tagged with radio transmitters. Substantial differences in the species composition of the spring run-at-large and the composition of radio-tagged fish likely explain most of the differences in estimates by hydroacoustics and radio telemetry. Sockeye salmon, which were not tracked by telemetry, made up 2% of the spring run, nearly as much as the 3% composition of steelhead in the run. In summer, the telemetry study tagged only sub-yearling Chinook salmon, which was much more representative of the run-at-large in summer.

In summer, all hydroacoustic estimates of passage metrics were higher than the radio telemetry estimates (Table S.4). The FPE estimates differed by 12% or less, B2 FGE by 11%, and all other efficiency estimates by $\leq 7\%$. Effectiveness measures in summer also were closer than were similar estimates by the two methods in spring. Hydroacoustic estimates of effectiveness in summer were proportionally higher than radio telemetry estimates by 41% (Project sluiceways), 18% (B2CC re: B2), 15% (B1 sluiceway re: B1), 12.5% (spillway), and 10% (B2CC re: Project). At the second powerhouse, the HA estimate of FGE was 11% higher than the RT estimate and the subsequent HA estimate of FPE at B2 was 12% higher than the RT estimate.

Both radio telemetry and hydroacoustics found the B2CC to be highly effective at passing fish. The seasonal trends were reversed, however, with the radio telemetry estimate falling from 42% in spring to 32% in summer while the hydroacoustic estimate rose from 34% in spring to 39% in summer. The higher summer estimate by hydroacoustics is the result of American shad contamination of samples in late summer.

Table S.3. Comparison of Passage Performance Metrics for the Run-at-large, as Measured by Hydroacoustics (HA), and for Yearling Chinook salmon and Steelhead Combined, as Measured by Radio telemetry (RT), during the Overlapping period of April 29-May 31, 2004, at Bonneville Dam. Radio telemetry estimates are weighted by the proportion of run size for each species based on the equation: $RT\ estimate = (RT\ estimate_{CH1} \times proportion\ of\ run_{CH1}) + (RT\ estimate_{STH} \times proportion\ of\ run_{STH})$ and were provided by Scott Evans, USGS.

Passage metric	HA estimate	RT estimate	Difference
Project FPE	72%	73%	-1%
FPE _{B1}	28%	55%	-27%
FPE _{B2}	65%	61%	4%
FGE _{B2}	47%	33%	14%
Spillway efficiency	40%	32%	8%
Spillway effectiveness	0.97	0.77	0.2
Sluiceway Efficiency (B1 + B2CC)	6%	4%	2%
Sluiceway efficiency re: B1	28%	53%	-25%
B2CC efficiency re: Project	14%	25%	-11%
B2CC efficiency re: B2	34%	42%	-8%
Sluiceway effectiveness (B1 + B2CC)	6.7	7.9	-1.2
Sluiceway effectiveness _{B1}	11.4	13.0	-1.6
B2CC effectiveness re: Project	5.8	10.4	-4.6
B2CC effectiveness re: B2	6.5	7.8	-1.3

The most consistent difference in passage efficiency estimates made by hydroacoustic and radio telemetry over the 2004 passage seasons was the estimates of FGE at B2. Hydroacoustic estimates were 14% higher in spring and 11% higher in summer, and these differences were similar in magnitude to findings from previous years (Ploskey et al. 2002b and 2002c). The telemetry sample size was high at B2, and the consistency in the difference of the estimates between seasons may indicate that something other than species composition was causing the estimates to differ, since the species composition of the radio telemetry sample was only an issue in spring. It is possible, therefore, that these differences result from detectability issues. Hydroacoustics is unable to detect gap-loss fish – fish that are guided by the screens but do not enter the JBS because they go through the gaps along the tops and the sides of the STSs and then down into the turbines. We estimated gap loss between the tops of the screens and the intake ceilings to average about 12% in an unmodified unit and about 4% in a modified unit this spring. Although the potential has not been experimentally verified, the telemetry antennas may be able to detect gap-loss fish behind the STSs.

Since HA estimates of FGE at B2 were 14% higher than RT estimates in spring and 11% higher in summer, we examined the estimates of the FGE of individual units at B2 each season (Tables S.5 and S.6). During both spring and summer, HA estimates were nearly always higher than RT estimates, and often by a considerable margin. Differences > 10% occurred at Units 15 through 18 in spring and at Units 14, 15, and 17 in summer.

Table S.4. Comparison of Passage Performance Metrics for the Run-at-large, as Measured by Hydroacoustics (HA), and for Yearling Chinook Salmon and Steelhead Combined, as Measured by Radio Telemetry (RT), during the Overlapping period of June 21-July 15, 2004, at Bonneville Dam. Radio telemetry estimates are weighted by the proportion of run size for each species based on the equation: RT estimate = (RT estimate_{CH1} x proportion of run_{CH1}) + (RT estimate_{STH} x proportion of run_{STH}) and were provided by Scott Evans, USGS.

Passage metric	HA estimate	RT estimate	Difference
Project FPE	72%	63%	9%
FPE _{B1}	55%	52%	3%
FPE _{B2}	60%	48%	12%
FGE _{B2}	35%	24%	11%
Spillway efficiency	32%	29%	3%
Spillway effectiveness	0.8	0.7	0.1
Sluiceway Efficiency (B1 + B2CC)	5%	3%	2%
Sluiceway efficiency re: B1	54%	48%	6%
B2CC efficiency re: Project	23%	21%	2%
B2CC efficiency re: B2	39%	32%	7%
Sluiceway effectiveness (B1 + B2CC)	8.8	5.2	3.6
Sluiceway effectiveness re: B1	7.2	6.1	1.1
B2CC effectiveness re: Project	8.0	7.2	0.8
B2CC effectiveness re: B2	7.1	5.8	1.3

Table S.5. Estimates of Fish Guidance Efficiency (FGE), by Turbine Unit, at B2 for the Run-at-large as Measured by Hydroacoustics (HA) and for Yearling Chinook Salmon and Steelhead Combined, as Measured by Radio Telemetry (RT), from April 29-May 31, 2004.

Location	HA FGE	RT FGE	Difference
Unit 11	42%	42%	0%
Unit 12	46%	36%	10%
Unit 13	45%	35%	10%
Unit 14	39%	35%	4%
Unit 15	61%	35%	26%
Unit 16	55%	37%	18%
Unit 17	55%	32%	23%
Unit 18	41%	24%	17%

Table S.6. Estimates of FGE, by Turbine Unit, at B2 for the Run-at-large as Measured by Hydroacoustics (HA) and for Yearling Chinook Salmon and Steelhead Combined, as Measured by Radio Telemetry (RT), from June 21 through July 15, 2004.

Location	HA FGE	RT FGE	Difference
Unit 11	40%	31%	9%
Unit 12	27%	25%	2%
Unit 13	30%	23%	7%
Unit 14	37%	22%	15%
Unit 15	49%	31%	18%
Unit 16	41%	35%	6%
Unit 17	41%	23%	18%
Unit 18	16%	25%	9%

Gross Spatial Trends in Fish Passage

Horizontal Distributions

On the scale of powerhouses and the spillway, fish passage proportions are generally similar to flow proportions, but fish-passage proportions seldom correlate with flow proportions at smaller scales such as individual sluiceway entrances, turbines, or spill bays. On the broadest of scales, B1 passed 17.1% of fish in 11.5% of flow in spring and 16.1% of fish in 12.3% of flow in summer. In contrast, B2 passed 42.6% of fish in 46.7% of flow in spring and 51.2% of fish in 48.5% of flow in summer. Measures of effectiveness of surface routes relative to spill provide a good example of how fish-passage proportions do not correlate with flow proportions at scales smaller than entire dam structures.

Relative proportion of discharge across routes within a powerhouse was not a good predictor of fish passage at routes within those structures, as evidenced by the sluiceways at B1 passing 33% of all fish and about 4% of discharge in spring and 38% of fish and about 4% of discharge in summer. The effectiveness of the sluiceways at B1 is further illustrated by examining fish density (fish per flow volume) by passage route. The B1 sluiceways were by far the most effective passage routes as compared to all other individual routes (with the exception of the B2CC which was slightly more effective than Sluice 4C in summer). As with specific passage routes within B1, proportional passage within B2 did not follow proportional discharge among routes at that powerhouse. This was especially evident with the B2CC, which passed almost one third of the fish and about 5% of the discharge at B2 in the spring and 40% and 5% of fish and flow, respectively, in summer. These results clearly demonstrate the effectiveness of B2CC operation, and this point is reinforced by looking at passage in terms of fish passage density by route. The B2CC was more than twice as effective as any individual turbine or spill bay in the spring and about 4.5 times as effective as any in the summer.

Operation of the B2CC appeared to alter the typical pattern of horizontal distribution of fish passage observed in prior years. Prior to B2CC construction, the distribution of fish passage across B2 has been characterized by a strong skew towards the south end of the powerhouse in 1996 (Ploskey et al. 1998), 2001 (Ploskey et al. 2002b), and in 2002 (Ploskey et al. 2003). In 2004, turbine passage distributions at B2 were not strongly skewed towards the south end, especially in spring when Unit 18 passed more fish than did any other turbine unit (Figure 3.32). It is likely that a proportion of the spring migrants that would have passed through Units 11-13 without operation of the B2CC are instead passing B2 through the B2CC. Since Unit 11 performed poorly in terms of fish guidance in many sampled years, attracting fish into the B2CC that may have passed into the south end units has to be a benefit. Ploskey et al. (2001a) reported a combined FGE for Units 11-13 of 55% in spring and 30% in summer 1998.

Horizontal distributions of estimated fish passage across turbine units and spill bays were not uniform in 2004, a result observed by a number of investigators in past studies at Bonneville Dam (e.g., Uremovich et al. 1980; Willis and Uremovich 1981; Krcma et al. 1982; Holmberg et al. 1996; Hensleigh et al. 1999; Ploskey et al. 2002a and b, 2003). However, the non-uniform pattern of lateral distribution across turbine units and spill bays observed in 2004 makes some sense when coupled with the pattern of discharge associated with those passage routes. In most instances a rise or fall in estimated fish passage among adjacent routes coincides with a rise or fall in discharge, although the magnitude of the changes are often not comparable between the two variables. Nonetheless, it seems apparent that fluctuating levels of discharge among turbine units and spill bays are contributing to some extent to the non-uniformity of fish passage among these routes.

At the spillway, the discharge/fish passage relationship observed in 2004 may provide for adaptive management of spillway passage. Spill bays 4 and 6 passed fewer fish per water volume than did all other bays in both seasons, so it seems prudent to prioritize spill bay operation during low water years based on effectiveness, if the trends are relatively consistent year-to-year and season-to-season. Determining why some bays are more effective at passing fish than other bays should be a priority research consideration.

Higher passage at sluiceway entrances 2C and 6C than at middle sluice entrance 4C in spring and summer 2004 may have resulted from guidance of fish along the old navigation lock wall adjacent to Unit 1A and along the pier between intakes 6C and 7A. Distributions of passage across the entrances to the sluiceways indicate that fish are likely guided along these structures as Sluice 6C fish were strongly skewed to the north (which is adjacent to the wing wall) and 2C fish were strongly skewed toward the edge nearest the old navigation lock. Passage at Sluiceway Entrance 4C could be depressed by a lack of a guiding structure and by removal of approaching smolts by open sluiceway entrances on either side. Passage distributions at Sluice 4C were concentrated towards the edges, but were skewed towards one side (south) to a much lesser degree than was shown for the other sluiceway entrances.

The higher frequency of passed fish near the edges relative to the centers of the sluiceways observed in 2004 also was observed in 1996 based on up-looking optical cameras mounted on the chain gate at sluiceway 5B (Ploskey et al. 1998). In contrast, estimates based on both hydroacoustics and underwater video cameras in 2002 indicated higher concentrations of fish passing over the middle portion of the entrance at Sluice 7A and lower proportions passing near the sides (Ploskey et al. 2003). Differences in estimated distributions of fish entering sluiceways across years may be due to a number of factors, perhaps primarily the use of disparate methods for estimating passage numbers. Given the improved hydroacoustic deployment for assessing sluiceway passage employed in 2004, and the consistent results across three sluiceways reported herein, we suspect the patterns observed reflect typical B1 sluiceway passage distributions. More clarity to this issue will result from continued sampling using the same techniques in 2005.

Gross Temporal Trends in Fish Passage

Seasonal Trends in Spring and Summer

Project Passage Run Timing Smolt - Index and Hydroacoustics

We found reasonably good agreement between whole-project daily passage estimates by hydroacoustics and those derived from the B2 Smolt Monitoring Facility. There was a substantial and well-defined peak in sub-yearling Chinook salmon (based on the Smolt Monitoring Facility's data) from June 22 through July 7, most likely due to almost 10 million sub-yearling Chinook salmon released from Priest Rapids and Ringold Springs hatcheries from June 14 through June 20 (Ringold Springs) and June 23 (Priest Rapids). We did not consider American shad to be an important source of error in passage estimates in summer 2004, except for the last 11 days of sampling when large numbers of spent shad showed up at surface-passage routes.

Major Fish Passage Metrics

Estimated Project FPE fluctuated considerably in both spring and summer. In spring daily estimated Project FPE was frequently near 80% with a lower period (two days below 60%) from about May 6 through May 14, when sub-yearling smolts dominated the species composition during that period and during the start of the juvenile sockeye salmon passage. Sockeye salmon are thought to migrate deeper than others and might be poorly sampled by the B2 screens. Subyearling Chinook salmon guide rather poorly, at least sometimes (see the early half of the subyearling Chinook salmon peak in summer). In summer, Project FPE estimates generally appear to increase with time, reaching over 80% by July 4. If data collected on or after July 4, when American shad dominated passage at surface routes, are deleted the apparent trend of increasing FGE is eliminated.

Estimated Spill Efficiency was quite variable in spring and summer, oscillating between 19% in late summer and 60% near the end of April (Figure 3.45). The rise at the very end of the summer (after July 12) may have been influenced by early spent adult shad down migrants (see below) but otherwise there was a wide range of daily spill efficiency estimates. Perhaps, since large hatchery releases upstream provide episodes of high Project passage but the spill pattern is driven by the diel trends in passage and generation demand, this fluctuation is just a matter of chance combinations of fish abundance and spill discharge or proportion.

The seasonal trend in spill effectiveness was less variable than that for spill efficiency and showed a more general decline over time. This trend is consistent with some of the variation in spill efficiency being driven by some interaction of spill discharge or proportion and fish abundance and availability for passage.

Project sluiceway efficiency (including both powerhouses and their respective surface-passage routes) increased from 10% to 20% of total Project Passage in early spring (late April) to over 40% by the end of June. Especially in late summer, when Project FPE typically drops off due to low screen guidance of subyearling fish, this is a very important trend. In 2004 when B1 screens were not installed (so all B1 fish except those passing the sluiceway were “unguided”), the B1 sluiceway was a very successful surface-passage route which preserved Project FPE, especially in summer. As daily Project passage estimates declined in summer (except for the abrupt subyearling Chinook salmon passage pulse that began on June 22) the estimated proportion of fish passing the Project by the sluiceways (B1 and the B2CC) generally increased during the last two weeks of sampling, when estimated Project sluiceway efficiency averaged about 45%.

Sampling with the DIDSON at the B2CC in late summer, after July 4, indicated that most of the peak in surface passage after July 4 resulted from detection of American shad. The time-history plot of Project Sluiceway Effectiveness (B1 Sluiceway and B2CC) was similar to that of Project Sluiceway Efficiency.

Diel Trends in Fish Passage

Powerhouse 1

There were very few B1 turbine passage routes available at night, relative to the number available during the daytime, so the hourly patterns of total passage at B1 reflect the diel pattern of turbine operations

more than a diel pattern of fish behavior. True diel patterns of fish passage can only be obtained when operational conditions remain unchanged throughout the diel cycle. At B1, nighttime turbine discharge was about 60% lower in spring and 68% lower in summer to accommodate high nighttime spill.

Spill Passage

Higher nighttime than daytime passage of fish through the spillway was explained by operations that normally provided higher spill discharge at night than during the day and also by smolt behavior independent of diel discharge patterns. Hourly spillway passage mostly reflected the effect of discharge on diel passage, based upon correlations of efficiency with percent spill and spill rate. Spillway passage closely followed the pattern of hourly spillway discharge. As with turbine passage, patterns of diel passage at the spillway can only be revealed if discharge through the spillway remained constant through all hours of the day. This was not the case during most of 2004 when there was higher spillway discharge at night. However, there were six days in summer when spill was deliberately held constant for 24 hours, and these conditions afforded the opportunity to examine diel patterns of spill passage independent of discharge. The diel pattern under constant discharge, like diel results from constant discharge during the drought of 2001 (Ploskey et al. 2002c), clearly showed higher spillway passage at night than during the day. Therefore, higher nighttime passage is not entirely due to increased discharge at night.

Powerhouse 2

Much like passage at B1 and the spillway, diel passage at B2 was largely driven by project operations and probably less so by fish behavior. Discharge through B2 decreased 21% and 28% at night in spring and summer relative to daytime discharge. However, a behavioral component is evident with total turbine passage in the summer; passage increased in the early evening hours just prior to the nighttime decrease in discharge, a trend that supports others' observations that nighttime passage at B2 is typically higher than daytime passage, given equal discharge (Ploskey et al. 1998).

In spite of increased flow and flow proportions through the B2CC at night, fish passage at the B2CC was higher during the day than it was at night. Diel passage patterns at the B2CC probably were driven more by fish behavior than by Project operations since discharge through the B2CC varied < 4% across the diel cycle. Hourly flow through the B2CC remained relatively constant, although the proportion of B2 flow through the B2CC varied by as much as 23% because B2 turbines were often shut down at night to increase spill. The overall pattern of higher passage during daylight hours observed during both seasons in 2004 supports prior observations of fish passage through the old B2 ice-and-trash sluiceway (e.g., Magne et al. 1986; Biosonics 1998; Ploskey et al. 2001a).

Fish Guidance Efficiencies of B2 Turbines

In 2004, the most important factors affecting FGE at B2 appeared to be related to modifications of turbine intakes (a benefit) and the location of sampled intakes relative to TIES. Modified Unit 15 had the highest FGE in spring and summer 2004, and modified Unit 17 tied with unmodified Unit 16 for the second highest FGE out of eight units in spring 2004. In summer 2004, modified Unit 17 tied with Unit 11 for the third highest FGE rank, behind modified Unit 15 and unmodified Unit 16. Two factors likely provided higher FGE at Unit 15 than at other units. Unit 15 had modified intakes, and it is located near the center of B2 where units consistently have higher FGEs than units closer to the ends of the

powerhouse (Ploskey et al. 2003; Ploskey et al. 2002b, 2002c). Sampled intakes between TIES at Units 15 through 18 had estimated FGEs that were 11% higher than those for intakes behind TIEs, and this finding was consistent with earlier findings by Gessel et al. (1991) based upon netting and by Ploskey et al. (2002c and 2003) based on hydroacoustics. Ploskey et al. (2003) reported that intakes between TIEs had 8% to 9% higher FGE than intakes behind TIEs.

Unit proximity to the B2CC may have lowered juvenile fish passage at adjacent units in spring (but not summer), but it apparently had no effect on FGE at Units 11 and 12. The FGE at Unit 11 in 2004 was within 11% of estimates made in spring and summer of 1998, 2001, and 2002, but was higher than estimates made in spring and summer 1996 and 2000.

B2CC Entrance: Smolt Distributions, Approach, and Fate

Fish were tracked during 10 spring days and 7 summer days. The number of 0.5 s movements used for the Markov chain analyses was greater in spring than summer and reflected the number of fish tracked during each period (Table S.7). Track lengths were longer during the day than they were at night. As a result the average per track measures used for the Markov analyses were greater during the day. Some track lengths were very long, the maximum of 258 ft occurred in spring during the day. Median velocity was about 3 ft/s, but somewhat slower at night.

Table S.7. Characteristics of the data used in Markov chain analyses of fish movement

Period	Dates	Fish Tracks (N)	0.5 s Moves (N)	Median Velocity (ft/s)	Median Track Length (ft)	Max Track Length (ft)	Average Measures Per Track
Spring Day	4/26 to 5/26	3,453	18,748	2.94	16.5	258	5.43
Spring Night	4/26 to 5/26	2,328	10,549	2.59	10.8	144	4.53
Summer Day	6/07 to 6/16	1,502	8,696	3.18	16.3	181	5.79
Summer Night	6/06 to 6/17	1,347	6,510	2.68	12.4	133	4.83

The DIDSON and fixed-aspect hydroacoustics tools combined to provide a detailed picture of smolt approach and the distribution of passage into the B2CC. With the DIDSON, we tracked over 5,000 fish in spring and 2,500 fish in summer, and this provided definitive information about the approach and fate of smolts relative to flow conditions, when B2 discharge exceeded 70,000 ft³/s. Under rarer conditions of low powerhouse loading (< 70,000 ft³ / s), too few fish were tracked with the DIDSON to make definitive conclusions about fish approaches and fates. However, regression of hydroacoustic estimates of percent passage on percent discharge at the B2CC provided inference about B2CC efficiency when discharge through B2 was low ($\leq 70,000$ ft³ / s) and the proportion passing the B2CC was high. Twenty percent discharge through the B2CC corresponds to two-unit operation at B2 (5,000 cfs / 0.2 = 25,000 cfs). Two-unit operation most likely would involve Units 11 and 18, the priority units at the powerhouse because of a perceived need for discharge at the powerhouse ends to attract upstream migrating adult salmonids. The latter need probably is much more important during the day than it is at night. Under those conditions, nearly 80% of the fish passing at B2 passed through the B2CC. What we could not separate is how much of this passage is due to the flow percentage and how much is due to the dissolving of north and south eddies under low powerhouse loading, as indicated by the CFD model.

Simultaneous split-beam hydroacoustic and DIDSON counts at the B2CC were highly correlated with a slope of about one, and this indicated that the wideband echo sounder modifications, which were made to reduce pulse duration and maximize target resolution, were successful. We would have expected higher DIDSON counts than hydroacoustic counts if the hydroacoustics were unable to resolve closely spaced targets in schools, which according to the DIDSON were more common than single targets approaching the B2CC.

The distribution of smolt passage into the B2CC entrance was clearly skewed toward the surface and the center of the opening in both spring and summer. American shad detected after July 4 skewed the horizontal distribution in summer toward the southeast, but the distribution had a mode in the center of the entrance when data collected after July 4 were dropped. Huge schools of American shad were imaged with the DIDSON upstream of the B2CC after July 4. The horizontal distribution for each season was produced primarily by a predominance of fish in the upper 5 ft of the water column, but the pattern of horizontal distribution certainly was not consistent among 4-ft depth strata.

The fate of approaching smolts, whether passing into the B2CC or moving upstream into the south eddy, could be reliably predicted from their initial location and the bulk flow in the vicinity of the B2CC. Other factors such as day, night, or time of year had little effect on approach and fate, shifting the fish entrainment zone by only about 5 ft. The high effectiveness estimates for the B2CC may be explained partly by the large south eddy that also collected fish. At first, the south eddy appeared to compete with the B2CC entrance for fish, but the eddy collects fish that missed the B2CC entrance on the first pass, and it likely circulates them where they have additional opportunities to discover the entrance before they are entrained in turbines.

Entrance probabilities calculated from the Markov chain analysis (Figures 3.80 and 3.81 of Results) were higher than those calculated from the vector analysis (Appendix H) and identified a large entrainment zone that was more consistent with field observations and fate based upon examining complete tracks. Complete tracks are those that end in the entrainment zone of the B2CC or in the south eddy. The apparent advantage of the Markov chain may lie in calculating cell-by-cell probabilities based upon all of the tracks collected, whereas the vector analysis relies more upon the direction of movement of individual tracks, some of which may be quite short.

The zone with >90% entrance probability undoubtedly extended much further to the north along the powerhouse face than the 47 ft estimated by the Markov Chain analysis or even the 62 ft that we could sample with the DIDSON. Fish within 30 feet of the powerhouse face, even as far north as Intake 14C, are swept south toward the B2CC entrance by strong flows along the powerhouse. The probability that these fish would enter the zone of estimation by the Markov chain probably exceeds 90% also.

The highest vector analysis probabilities for smolts entering the B2CC were about 15% lower than those provided by the Markov Chain analysis, which provided estimates that comported well with fates defined by the end location of complete tracks.

Gap Losses at B2 Traveling Screens

Mean gap loss of fish using filtered data (N=3 nights) varied from 4.5 to 20% in the six intakes sampled in 2004, with the highest gap-loss estimates in the unmodified intakes. Gap-loss was higher for the A and

C intakes of unmodified Unit 13 than any of the three intakes of modified Unit 17 or Intake B of Unit 13. The general trend was similar to what was observed in 2003 in that gap-loss estimates from DIDSON data range from 11.2% to 14.9% for unmodified units and from 2.9% to 5.0% for modified units (this study and Ploskey et al. 2004). There was no correlation between gap-loss and operating conditions; however, the statistical power is low due to the small sample size and within-sample-period variability in operation levels is low and likely was insufficient to detect variation in gap-loss due to operation levels.

Though the absolute estimates of gap loss for netting, which averaged 3.3% for unmodified units and about 1% for modified units, were lower than DIDSON estimates, the relative estimates for both sampling methods suggest that gateway and STS modifications reduced the loss of fish through the gap by about two-thirds. The absolute difference between the two sampling methods may be due to gear bias. Netting may be underestimating gap-loss by altering flow conditions, especially when the gap net becomes clogged with fish and debris during sampling. DIDSON estimates of gap loss may be overestimated if debris is mistakenly counted as a fish and not eliminated by filters. However, fish rolling off the top of the screen or not fighting the flow at the gap could be discarded by the filters, thereby reducing the gap-loss proportion.

The peak in gateway and gap passage in 2004 was higher during the day than it was at night, which is consistent with what was observed in 2003 (Ploskey et al. 2004). The lateral distribution of fish passage into the gap and gateway was not uniform for any of the intakes or combined unit estimates. This suggests that it is necessary to sample the entire width of the intake to minimize bias.

The effect of gap losses on hydroacoustic and netting estimates of FGE are minimal because such losses are small and affect both the numerator and denominator in the FGE calculation. The FGE estimates for B2 were 47.6 and 35.6 percent in spring and summer 2004, respectively. This was an over estimate of FGE since some of the fish counted as guided by hydroacoustics passed through the gap at the top of the STS and back into the turbine intake. If we subtract spring 2004 gap-loss estimates of 14.9% for unmodified units or 5% for modified units from the guided-fish fraction (numerator) and from the total (denominator), the adjusted FGE is lowered by just 4% for unmodified units and 1.3% in modified units.

Head Differential across B2 Vertical Barrier Screens

A report on temporal changes in the head differential across the upstream and downstream sides of the vertical barrier screen at Unit 17, as the result of debris loading, is presented in Appendix I.

Recommendations

1. We recommend continued study and development of surface routes of passage to increase Project FPE. Probably the most important result of our 2004 hydroacoustic sampling and estimation is the efficacy of the surface passage routes at the two powerhouses to pass a great many fish in remarkably little water (Figures 3.34 and 3.37), especially during daylight (Figures 3.57 and 3.60). We estimate that almost one-fifth (Project Sluiceway Efficiency = 19.1%) of the total passage in spring and about one-fourth (Project Sluiceway Efficiency = 26.4%) of the total run-at-large passed the Project by surface routes in only about 5% of the total Project discharge. Development of surface passage at mainstem dams will only become more important with greater competition among uses of always limited and sometimes very scarce water resources.

2. In light of the very high passage estimates for the B1 sluiceway entrances and the very high effectiveness of the B1 sluiceway, it might be well to attempt to increase the capacity of the B1 sluiceway so that more entrances could be opened or the same number of entrances could be opened more. Toward that end and to further improve understanding of surface attraction and passage, further manipulation and sampling of B1 sluiceway opening configurations may be helpful. The specific entrances and their relation to the wing wall, the powerhouse ends (except 10C), the thalweg, and each other may be important to maximize sluiceway passage.
3. Further DIDSON and other hydroacoustic studies should be conducted to help relate hydraulic patterns and fish entry into surface-passage routes. These should study the effects of the magnitude and direction of attraction plumes and entrance flows that contribute to high-entrance efficiency.
4. The B2CC has changed passage conditions and proportions at B2, perhaps for the long term. However, it may still be prudent to look at turbine unit-specific FGEs, particularly for the end units 11 and 18. Perhaps partly because the TIE deployment was limited to the northern half of B2, the unit-specific FGEs were low (25%-50%) for Units 11-14, whereas Units 15-17 had higher (> 50% except for Unit 17 in summer) FGEs and Unit 18's was low again (see Figure 3.64). The trend to higher FGEs in the center, as opposed to the ends, of B2 has been consistent over several years of sampling. Total discharge and estimated fish passage, however, is highest at the ends of the powerhouse and lower in the interior (Figure 3.32 and 3.34). It may be that the end units have priority for some reason unrelated to fish passage but if the end units have high priority for adult attraction flow, we would again point out that such flows may not be needed at night, when most smolts pass downstream via deep passage routes through spillways and turbines. Switching turbine priority to interior B2 Units 15-17 during night for juvenile downstream passage at night, even if the end units were needed for adult attraction during the day, might substantially reduce the "unguided" proportion of B2 fish that pass through turbines even with the B2CC in operation (Figure 3.54). Of course unintended consequences to hydraulic patterns in the B2 tailrace would have to be considered. Since B2 priority means that those eight turbines pass more water and fish than all of the other Bonneville Dam routes combined (Figures 3.32 and 3.35) then going to some pains to de-emphasize the use of the end units with consistently low FGEs, at least at night when juvenile salmonids pass downstream but adults do not pass upstream, may be warranted.
5. In light of the likely importance of surface routes to pass juvenile salmonids in the least amount of non-turbine flow, it is well that we had PAS modify echosounders to increase bandwidth, which allowed the use of shorter pulse durations and increased target range resolution, allowing us to count fish even when densities were high. More simultaneous sampling with a split-beam system and the DIDSON should be conducted at other surface routes to further understand the effect of bandwidth changes on detectability.
6. This was another year of data that suggest that spilling much over 150,000 cfs at Bonneville Dam may result in diminishing returns in terms of fish passage by spill (Figure 3.29), besides the dangers of high-spill stresses including mechanical damage, tailrace egress, and dissolved gas issues. Results suggest that spill discharge might be allocated more strategically, at least with regard to time of day. During the daytime, spillway efficiency is low (Figure 3.50). There is a strong correlation between percent spill and spillway efficiency, both on an hourly and daily basis (Figure 3.27), probably at least partly because of higher spillway discharge during high spillway-passage nighttime hours, but by spilling more strategically (less during daytime) more water could be saved for generation or surface passage.

7. We recommend designing spill studies with randomized replication of experimental units to identify optimum spill and sluiceway operations for maximizing juvenile fish passage by time of day. We know from the 2001 drought year (very low, nearly constant spill, see Ploskey et al. 2002c) and from the six days and nights of constant spill in 2004 (Figure 3.59) that there is a diel behavioral component to spillway passage that is independent of spillway discharge, with more fish passing at night. If less spillway discharge did not substantially reduce spillway passage during daytime then lower daytime spillway discharge might be possible without meaningful reduction in Project FPE. Lower daytime spill, unless offset by higher generation, would allow the Bonneville pool elevation to increase slightly during the day, thereby slightly increasing surface-route discharges and, potentially at least, surface passage. Of course reducing spill to very low levels any time may have profound and unintended consequences for forebay delay, passage, and tailrace egress as well as changing hydraulic attraction to the spillway and water quality parameters. As electric power demands increase, the strategic spilling of water for fish passage will be more important. Learning the temporal and spatial aspects of operational schemes that maximize FPE with a minimum of water through non-turbine routes will be increasingly important.

Preface

This report was prepared by the Pacific Northwest National Laboratory (PNNL), Richland, Washington, BAE Systems, the School of Aquatic and Fishery Sciences, University of Washington, Seattle, and Tenera, Incorporated. The U.S. Army Corps of Engineers, Portland District provided funding and oversight.

Acknowledgments

Many people made valuable contributions to this study and deserve acknowledgement. Two Portland District biologists, Blaine Ebberts and Dennis Schwartz, provided contract oversight and coordination between the Portland District and the Bonneville Project. Mr. Ebberts was responsible for the project-wide fish-passage efficiency study, and Mr. Schwartz oversaw the B2 fish-guidance-efficiency study, gap-loss evaluation, and head differential monitoring across Unit 17 VBSs. Tim Darland was the primary research coordinator for the Bonneville Dam Project, and Tammy Mackey, and Jon Rerecich were very helpful when Tim was not available. They provided valuable coordination related to Project support, scheduling, and provision of dam-operations data. This study would not have been possible without the support of Randy Price and the other Project riggers, who helped install and remove hydroacoustic equipment. Andy Debraie was the structural foreman and a key contact during installations. Gene LaDouceur was the chief of maintenance.

Laurie Ebner, with the Portland District, selected computational-fluid-dynamics cases to be modeled by Marshall Richmond's team in the PNNL Hydraulic Modeling Group for the B2CC Approach and Fate study. The CFD runs were performed by Cindy Rakowski, and John Serkowski created wonderful animations and figures of flow and fish approaching the B2CC. John Hedgepeth provided fish-track data coordinates for Serkowski's integration with the modeled flow data.

William Nagy of the Fisheries Field Unit, Portland District, worked to develop automated processing software for the DIDSON data files. He also provided valuable advice on the overall hydroacoustic study.

The BAE Systems, Incorporated, provided a wide range of talented staff that supported the hydroacoustic study, gap-loss and fish approach and fate studies. Technicians were led by Kyle Bouchard (Senior Technician) and included Chris Holzer, Jane Marquard, and Joe Mullen. They deployed electronic equipment and miles of cable and kept everything running throughout the study. They also did the 24-h / day DIDSON recording of smolts approaching the B2CC and manual tracking of hydroacoustic fish traces for comparison with the autotracker counts. Electronic equipment was maintained by Charlie Escher. Four other technicians monitored data-acquisition systems 24 hours per day throughout the sampling season so that equipment down time was kept to a minimum. Zachary Ploskey tracked and counted guided and gap-lost fish detections for the gap-loss study, and he, Robert Mueller, Katherine Deters, Jennifer Panther, Nathan Phillips, and Scott Titzler used software developed by John Hedgepeth (Tenera, Inc.) to manually track smolts detected with the DIDSON as the fish approached the B2CC.

Dr. Larry Lawrence with the Engineering Research and Development Center oversaw the BAE Systems subcontract for the Portland District and was the supervisor of the Fisheries Engineering Team in North Bonneville, Washington.

Alan Wirtz of Precision Acoustic Systems in Seattle, Washington, calibrated all hydroacoustic equipment, helped with troubleshooting, and made whatever repairs were required in a timely manner. Schlosser Machine in Hood River fabricated transducer mounts.

Our comparisons of hydroacoustic and radio telemetry estimates of fish passage metrics would not have been possible without estimates and help provided by Scott Evans and Rachel Reagan with the U.S. Geological Survey in Cook, Washington. The radio telemetry and hydroacoustic studies overlapped but also had non-concurrent sample times that had to be eliminated before data could be compared.

Acronyms and Abbreviations

ADCP	acoustic Doppler current profiler
AFEP	Anadromous Fish Evaluation Program
APL	University of Washington Applied Physics Laboratory
B1	Bonneville Dam Powerhouse 1
B2	Bonneville Dam Powerhouse 2
B2CC	Bonneville Dam Powerhouse 2 Corner Collector
BPA	Bonneville Power Administration
cfs	cubic feet per second
CFD	computational fluid dynamics
DAQ	Data Acquisition Module
DIDSON	dual frequency identification sonar
EBA	effective beam angle
EL	elevation
ERDC	U.S. Army Engineer Research and Development Center
ESBS	extended submerged bar screen
FGE	fish guidance efficiency at a turbine or intake [Guided / (Guided + Unguided)]
FPE	fish passage efficiency [Guided / (Guided + Unguided) by Project or powerhouse]
ft	feet
h	hour
HA	hydroacoustics
JBS	Juvenile Bypass System
km	kilometer
M	million
m	meters
NMFS	National Marine Fisheries Service
NOAA	National Oceanic and Atmospheric Administration
OSPN	Oregon State Plane North Zone
PNNL	Pacific Northwest National Laboratory
PSC	Prototype Surface Collector
RT	radio telemetry
s	second
SAS	Statistical Analysis System Code

Hydroacoustic Evaluation of Fish Passage through Bonneville Dam in 2004

SLY	Sluiceway efficiency – (Sluiceway passage / Project passage) or (Sluiceway passage / B1 passage)
SLE	SLY divided by the proportion of total discharge going through the sluiceway. SLE may be relative to the entire Project (Project SLE) or may be relative to an adjacent powerhouse (B1 SLE).
SY	spill passage efficiency (spill passage / total Project passage)
SE	spill effectiveness is SY divided by the proportion of Project discharge going through the spillway
STS	submerged traveling screen
TDG	total dissolved gas
TIE	turbine intake extension
USGS	U.S. Geological Survey
VBS	vertical barrier screen

Contents

Abstract	iii
Executive Summary	v
Preface	xxvii
Acknowledgments.....	xxvii
Acronyms and Abbreviations	xxix
1.0 Introduction	1-1
1.1 Site Description.....	1-1
1.2 2004 Studies.....	1-1
1.2.1 General Description	1-1
1.2.2 Objectives	1-4
1.3 Background.....	1-5
2.0 Materials and Methods	2-1
2.1 Equipment.....	2-1
2.1.1 Fixed-Aspect Hydroacoustics.....	2-1
2.1.2 DIDSON Sampling of STS Gap Loss	2-2
2.1.3 DIDSON Sampling of Fish Approach and Fate at the B2CC	2-2
2.2 Calibrations.....	2-2
2.3 Transducer Deployments and Sampling Schemes	2-3
2.3.1 Sampling B1	2-3
2.3.2 Sampling the Spillway	2-7
2.3.3 Sampling at B2.....	2-8
2.4 Fish Tracking and Filtering Criteria	2-19
2.4.1 Fixed Aspect Hydroacoustic Sampling	2-19
2.4.2 Gatewell and Gap Loss Tracking of DIDSON Data	2-21
2.4.3 Tracking Fish Approaching the B2CC.....	2-22
2.4.4 Coordinate Systems for Fish Approach and Fate at the B2CC	2-23
2.4.5 Computational Fluid Dynamics Modeling.....	2-24
2.4.6 Estimating Fate Probabilities for Fish Approach the B2CC	2-25
2.5 Spatial Expansions	2-30
2.5.1 Fixed-Aspect Hydroacoustic Sampling.....	2-30
2.5.2 B2 Gatewell Sampling of Gap Loss with the DIDSON	2-31
2.6 Dam Operations and Fish Passage.....	2-34
2.7 Missing Data.....	2-34
2.8 Estimating Fish Passage.....	2-35
2.8.1 B1 Passage	2-35
2.8.2 B2 Unguided Passage.....	2-38
2.8.3 B2 Guided Passage.....	2-39
2.8.4 Spill Bay Passage	2-40

2.8.5 Sluiceway Passage.....	2-41
2.8.6 Corner Collector Passage	2-42
2.9 Adjustment of Passage Estimates and Associated Variances	2-43
2.9.1 Sum of Multiple Adjusted Estimates.....	2-44
2.9.2 Adjusting Autotracker Counts by Regression: Ratio Estimator.....	2-44
2.9.3 Adjusting for Direction-of-Travel Proportions	2-45
2.10 Estimating Passage Performance	2-46
2.10.1 Project Fish Passage Efficiency (FPE).....	2-47
2.10.2 Project Fish Passage Efficiency – No Surface Passage.....	2-47
2.10.3 Project Fish Passage Efficiency – B2 + Spillway only	2-48
2.10.4 B1 Fish Passage Efficiency (B1 FPE).....	2-49
2.10.5 B2 Fish Passage Efficiency (B2 FPE).....	2-49
2.10.6 B2 Fish Guidance Efficiency (B2 FGE)	2-49
2.10.7 Spill Efficiency.....	2-50
2.10.8 Spill Efficiency – B2 and Spill only.....	2-50
2.10.9 Spill Effectiveness.....	2-51
2.10.10 Spill Effectiveness – B2 and Spillway only	2-51
2.10.11 Project Sluiceway Efficiency	2-52
2.10.12 Project Sluiceway Effectiveness	2-52
2.10.13 B1 Sluiceway Efficiency Relative to the Project Passage.....	2-53
2.10.14 B1 Sluiceway Efficiency Relative to B1 Passage	2-53
2.10.15 B1 Sluiceway Effectiveness Relative to the Project.....	2-54
2.10.16 B1 Sluiceway Effectiveness Relative to B1	2-54
2.10.17 B2CC Efficiency Relative to Project Passage.....	2-55
2.10.18 B2CC Efficiency Relative to B2 Passage.....	2-55
2.10.19 B2CC Effectiveness Relative to the Project.....	2-56
2.10.20 B2CC Effectiveness Relative to B2	2-56
2.10.21 Combined Sluiceway and Corner Collector Efficiency	2-57
2.10.22 Combined Sluiceway and Corner Collector Effectiveness	2-57
2.10.23 Localized B2 Corner Collector Efficiency	2-58
2.10.24 Localized B2 Corner Collector Effectiveness	2-58
2.10.25 Localized B2 Fish Passage Efficiency	2-59
2.10.26 Localized B2 Fish Passage Effectiveness	2-59
2.11 Comparing Spill-Treatment and Location Effects	2-60
3.0 Results 3-1	
3.1 Environmental Conditions in 2004	3-1
3.1.1 Smolt Migration Characteristics.....	3-1
3.1.2 River Discharge, Forebay Elevation, and Water Temperature.....	3-1
3.1.3 Hydraulic Conditions	3-6
3.2 Hydroacoustic Detectability.....	3-9
3.3 Validation of Autotracking and Count Adjustments.....	3-11

- 3.4 Direction of Travel Adjustments 3-14
- 3.5 FPE Evaluation of Spring Creek Releases in March 3-17
- 3.6 Major Passage Metrics 3-18
 - 3.6.1 Project and Powerhouse FPE 3-19
 - 3.6.2 Spill Efficiency and Effectiveness 3-20
 - 3.6.3 Sluiceway Efficiency and Effectiveness 3-21
 - 3.6.4 Comparison of Major Metrics from 2000 through 2004 3-21
 - 3.6.5 Effects of Percent Spill on Spill Efficiency and Project FPE 3-22
 - 3.6.6 Effects of Spill Discharge Rate on Spill Efficiency and Project FPE 3-24
 - 3.6.7 Comparison of Hydroacoustic and Radio Telemetry Estimates 3-26
- 3.7 Spatial Trends in Fish Passage 3-28
 - 3.7.1 Horizontal Distributions 3-28
 - 3.7.2 Vertical Distributions in Spring and Summer 3-34
- 3.8 Temporal Trends in Fish Passage 3-36
 - 3.8.1 Seasonal Trends in Spring and Summer 3-37
 - 3.8.2 Diel Trends 3-40
- 3.9 Fish Guidance Efficiencies of B2 Turbines 3-53
- 3.10 B2CC Entrance: Smolt Distributions, Approach, and Fate 3-54
 - 3.10.1 DIDSON Tracked-Fish Data 3-54
 - 3.10.2 Comparison of Simultaneous Split-Beam and DIDSON Counts 3-56
 - 3.10.3 Horizontal and Vertical Distributions of Fish Entering the B2CC 3-56
 - 3.10.4 DIDSON Study of Approach and Fate 3-60
- 3.11 Gap Losses at B2 Traveling Screens 3-66
 - 3.11.1 Discharge and Forebay Conditions 3-66
 - 3.11.2 Mean Gap Loss 3-68
 - 3.11.3 Diel Trends in Gap Loss 3-69
- 3.12 Head Differential across B2 Vertical Barrier Screens 3-72
- 4.0 Discussion 4-1
 - 4.1 Environmental Conditions in 2004 4-1
 - 4.2 Hydroacoustic Detectability 4-1
 - 4.3 Validation of Autotracking and Count Adjustments 4-2
 - 4.4 Direction of Travel Adjustments 4-2
 - 4.5 FPE Evaluation of Spring Creek Releases in March 4-2
 - 4.6 Major Passage Metrics 4-3
 - 4.6.1 Project and Powerhouse FPE 4-3
 - 4.6.2 Spill Efficiency and Effectiveness 4-4
 - 4.6.3 Sluiceway Efficiency and Effectiveness 4-4
 - 4.6.4 Comparison of Major Metrics from 2000 through 2004 4-5
 - 4.6.5 Effects of Percent Spill on Spill Efficiency and Project FPE 4-6
 - 4.6.6 Effects of Spill Discharge Rate on Spill Efficiency and Project FPE 4-7
 - 4.6.7 Comparison of Hydroacoustic and Radio Telemetry Estimates 4-8

4.7	Spatial Trends in Fish Passage.....	4-9
4.7.1	Horizontal Distributions.....	4-9
4.7.2	Vertical Distributions.....	4-12
4.8	Temporal Trends in Fish Passage.....	4-13
4.8.1	Seasonal Trends.....	4-13
4.8.2	Diel Trends.....	4-15
4.9	Fish Guidance Efficiencies of B2 Turbines.....	4-18
4.10	B2CC Entrance: Smolt Distributions, Approach, and Fate.....	4-18
4.11	Gap Losses at B2 Traveling Screens.....	4-19
5.0	Recommendations.....	5-1
6.0	References.....	6-1
Appendix A	Transducer Calibrations and Receiver Gains (on CD).....	A.1
Appendix B	Detailed Transducer Locations and Aiming Angles (on CD).....	B-1
Appendix C	Autotracker Definitions and Settings (on CD).....	C-1
Appendix D	Statistical Analysis System Code for Filtering Echo Traces Selected by Autotracking Software (on CD).....	D-1
Appendix E	Hourly Fish Passage, Flow, and Forebay Elevation Estimates (on CD).....	E1-1
Appendix E3	Sums of Fish Passage in Spring (CSV on CD).....	E3-1
Appendix E4	Sums of Fish Passage in Summer (CSV on CD).....	E4-1
Appendix E5	Variance in Fish Passage in Spring (CSV on CD).....	E5-1
Appendix E6	Variance in Fish Passage in Summer (CSV on CD).....	E6-1
Appendix E7	Forebay Elevation and Route-specific Discharge in Spring (CSV on CD).....	E7-1
Appendix E8	Forebay Elevation and Route-specific Discharge in Summer (CSV on CD).....	E8-1
Appendix F	Polynomial Coefficients for Estimating Effective Beam Angle based upon Range from a Transducer (on CD).....	F-1
Appendix G	Analysis of Variance and Least-square Means for FGE Estimates Among B2 Turbine Intakes (on CD).....	G-1
Appendix H	Analysis of the 2004 Bonneville Dam DIDSON Tracking Data (on CD).....	H-1
Appendix I	Monitoring of the Differential Head across VBSs at Bonneville Dam B2 Unit 17 (on CD).....	I-1

Figures

Figure 1.1. Plan View of the Bonneville Dam Project.....	1-2
Figure 1.2. Average Project and Spillway Discharge from 1995 through 2004 during Spring and Summer Migration Seasons	1-6
Figure 2.1. Diagram of a Plan View of the B2CC Entrance in the B2 Forebay Showing the Location of a Pontoon Barge and Four Successive 30° Angles of Coverage by the DIDSON.....	2-3
Figure 2.2. Cross-Sectional View through a B1 Turbine Intake Showing a Single Down-Looking Transducer Beam for Sampling Fish Passage through the Intake, when No STS was Deployed.....	2-5
Figure 2.3. Cross-Sectional View through a B1 Turbine Intake Showing Near-Ceiling Volumes of a Single Down-looking Transducer Beam Compared with that of an Up-Looking Transducer.....	2-6
Figure 2.4. The Relationship between Hourly Estimates for the Same Intake Sampled by Up-Looking and Down-Looking Transducers.....	2-6
Figure 2.5. Forebay View of a Sluiceway Entrance at Intake 2C, 4C, or 6C in 2004 Showing the Deployment of Opposing Split-Beam Transducers for Sampling Fish Passage.....	2-7
Figure 2.6. Cross-Sectional View through a Spill Bay at Bonneville Dam.....	2-8
Figure 2.7. Diagram of a Frontal View of the B2CC Entrance Showing the Acoustic Beams from Six Split-Beam Transducers Deployed from a Barge East of the Entrance	2-9
Figure 2.8. Plan Views of the B2CC Entrance Showing Predicted Water Velocities of 8-10 fps in the Area that Split-Beam Transducers Sampled Fish Passage in 2004.....	2-10
Figure 2.9. Cross-Sectional View through a B2 Turbine Showing Up- and Down-Looking Transducer Beams.....	2-12
Figure 2.10. Cross-Sectional View of a Model of an Un-Modified Intake at B2 Showing the Path and Distribution of Dye Introduced at the Trash Racks on the Left Side.	2-14
Figure 2.11. Cross-Sectional View through Intakes with Un-Modified and Modified Gatewells at B2	2-15
Figure 2.12. Traversing Beam and DIDSON Assembly Deployed in the Gatewell Slots of Intakes at Units 13 and 17.....	2-16
Figure 2.13. Cross-Sectional Diagram of an Unmodified Gatewell Slot of Unit 13 at B2 Showing the Upper End of the STS and the DIDSON Deployment in the Gatewell	2-16
Figure 2.14. Front View of the B2CC Entrance Showing Two Relative Tilt Angles from the Pan and Tilt Rotator for Sampling Two Vertical Sections of the Water Column.	2-19

Figure 2.15. The Computer Screen Display of the DIDSON File Tracking Program “TrackDid”	2-23
Figure 2.16. Forebay Elevations and Pan Angle Corrections Made to the DIDSON at the North Bonneville Dam B2CC.	2-24
Figure 2.17. Fish Tracks from the DIDSON Collected June 15-17, 2004 at the North Bonneville Dam B2 Corner Collector.	2-26
Figure 2.18. Sample Volume Used for Markov Chain Analysis.	2-27
Figure 2.19. Fates where Fish Movements were Absorbed at Edges of the Sample Volume Are as Follows: Collector, Northeast, Southwest, and Reservoir	2-28
Figure 2.20. Fish Movement Speed Measured by the DIDSON during Spring Day 2004 at the B2CC	2-29
Figure 3.1. Smolt Monitoring Program (SMP) Passage Index for March 1 – July 15, 2004, based upon Data from B2.	3-2
Figure 3.2. Percent Composition of Juvenile Salmonids in the Run at Large and Tagged with Radio Telemetry Transmitters in Spring 2004.	3-3
Figure 3.3. Project- and Spill-Discharge Rates for 2004 and the 10-year Average from 1995 through 2004	3-3
Figure 3.4. Spill Discharge Rate by Julian Day and Time in Spring 2004	3-4
Figure 3.5. Spill Discharge Rate by Julian Day and Time within Days	3-4
Figure 3.6. Mean Hourly Spill and Turbine Discharge in Spring and Summer 2004.	3-5
Figure 3.7. Mean Daily Forebay Elevation.	3-5
Figure 3.8. Daily Water Temperature During the 2004 Study and the 10-year Average Water Temperature from DART (http://www.cqs.washington.edu/dart/dart.html).	3-6
Figure 3.9. Plan View of Flow Patterns in the B2 Forebay based upon the CFD Model, when All Eight Turbine Units Were Running.	3-7
Figure 3.10. Plan View of Flow Vectors in the B2 Forebay based upon the CFD Model, when all Eight Turbine Units Were Running	3-7
Figure 3.11. Plan View of Flow Vectors in the B2 Forebay based upon the CFD Model.	3-8
Figure 3.12. Plots of Effective Beam Angle as a Function of Range from Transducers Deployed at Bonneville Dam during the Spring Creek Hatchery Release	3-9
Figure 3.13. Plots of Effective Beam Angle as a Function of Range from Transducers Deployed at Bonneville Dam during Spring 2004.	3-10
Figure 3.14. Plots of Effective Beam Angle as a Function of Range from Transducers Deployed at Bonneville Dam during Summer 2004.	3-10
Figure 3.15. Regressions of Mean Manual-Tracker Estimates of Hourly Fish Passage on Autotracker Estimates for Transducers at B1 Sluice Entrances and in Intakes at Units 2-9.	3-11
Figure 3.16. Regressions of Mean Manual-Tracker Estimates of Hourly Fish Passage on Autotracker Estimates for Transducers at Intake 10B, Spill Bays 1-18 and the B2CC	3-12
Figure 3.17. Regressions of Mean Manual-Tracker Estimates of Hourly Fish Passage on Autotracker Estimates for Transducers at the B2CC and Sampled B2 Intakes at Units 11-16.	3-13

Figure 3.18. Regressions of Mean Manual-Tracker Estimates of Hourly Fish Passage on Autotracker Estimates for Transducers at Sampled B2 Intakes at Units 16-18 3-14

Figure 3.19. Polar Plots of Percent of Fish Traveling Different Directions across the Barrel View of Split-Beam Transducers Deployed at Sluice Entrances and Spill Bays in Spring 2004 3-15

Figure 3.20. Polar Plots of Percent of Fish Traveling Different Directions across the Barrel View of Split-beam Transducers Deployed at Sluice Entrances and Spill Bays in Summer 2004..... 3-16

Figure 3.21. Project FPE, Spill Efficiency, and Sluiceway Efficiency (B1 + B2CC) during Three Operational Conditions Presented to Fish from the Spring Creek Hatchery Release in March..... 3-17

Figure 3.22. Plot of Daily Estimates of Project FPE during Three Operational Conditions Presented to Fish from the Spring Creek Hatchery Release in March. 3-18

Figure 3.23. Project-Wide and Other Fish Passage Efficiency Estimates for Spring and Summer Fish Passage Seasons at Bonneville Dam in 2004. 3-20

Figure 3.24. Estimated Spill Efficiency and Spill Effectiveness for the Bonneville Project and for the Spillway and Each Powerhouse Only for Spring and Summer 2004. 3-20

Figure 3.25. Estimated Sluiceway Efficiency for the Bonneville Project and Each Powerhouse Only for Spring and Summer 2004. 3-21

Figure 3.26. Estimated Sluiceway Effectiveness for the Bonneville Project and Each Powerhouse Only for Spring and Summer 2004. 3-21

Figure 3.27. Regression of Hourly and Daily Estimates of Project Spill Efficiency on Percent Spill in Spring and Summer 2004. 3-23

Figure 3.28. Regression of Hourly and Daily Estimates of Project FPE on Percent Spill in Spring and Summer 2004..... 3-24

Figure 3.29. Regression of Hourly and Daily Estimates of Project Spill Efficiency on Spill Rate in Spring and Summer 2004..... 3-25

Figure 3.30. Regression of Hourly and Daily Estimates of Project Spill Efficiency on Spill Rate in Spring and Summer 2004..... 3-25

Figure 3.31. Percent of Total Passage for all Sampled Passage Routes during Three Operational Conditions at Bonneville Dam for the Spring Creek Release March 1-18, 2004. 3-29

Figure 3.32. Estimated Fish Passage and Flow through all Sampled Routes at Bonneville Dam in Spring of 2004..... 3-30

Figure 3.33. Horizontal Distribution Across the Three Operating B1 Sluiceway Entrances in Spring 2004. 3-31

Figure 3.34. Estimated Fish Density for all Sampled Routes at Bonneville Dam in Spring 2004 3-31

Figure 3.35. Estimated Fish Passage and Flow through all Sampled Routes at Bonneville Dam in Summer of 2004..... 3-32

Figure 3.36. Horizontal Distribution across the Three Operating B1 Sluiceway Entrances in Summer 2004 3-33

Figure 3.37. Estimated Fish Density for all Sampled Routes at Bonneville Dam in Summer 2004 3-33

Figure 3.38. Estimates of Vertical Distributions of Fish within Turbine Intakes at Bonneville Dam First Powerhouse in Spring and Summer 2004.....	3-34
Figure 3.39. Estimates of Vertical Distribution of Fish Passing the Bonneville Dam Spillway in Spring and Summer of 2004	3-35
Figure 3.40. Estimates of Vertical Distributions of Fish within Turbine Intakes at Bonneville Dam Second Powerhouse in Spring and Summer 2004.	3-35
Figure 3.41. Patterns of Run Timing Estimated by Hydroacoustics and by the B2 SMF Smolt Index at Bonneville Dam in 2004.....	3-36
Figure 3.42. Patterns of Adult American Shad and Juvenile Salmonid Run Timing according to Fish Passage Center Counts and Hydroacoustic Counts, respectively	3-37
Figure 3.43. Time Histories of Estimated Route-Specific Passage through B2 and the Spillway.....	3-37
Figure 3.44. Time History of Project FPE Estimates for Bonneville Dam in 2004.....	3-38
Figure 3.45. Time History of Estimated Spill Efficiency.	3-38
Figure 3.46. Time History of Estimated Spillway Effectiveness.....	3-39
Figure 3.47. Time History of Estimated Project Sluiceway Efficiency (B1 and the B2CC).....	3-39
Figure 3.48. Time History of Estimated Project Sluiceway Effectiveness (B1 Sluiceway and the B2CC)	3-40
Figure 3.49. Time History of Estimated Total Project Passage and Sluiceway Efficiency (B1 Sluiceway and the B2CC).....	3-40
Figure 3.50. Patterns of Estimated FPE, Spill Efficiency, Sluiceway Efficiency (B1 and B2CC), B1 Sluiceway Efficiency, and B2CC Efficiency Relative to the Project in 2004.....	3-42
Figure 3.51. Diel Patterns of B1 Fish Passage Efficiency, B2 Fish Passage Efficiency, and B2CC Sluiceway Passage Efficiency (relative to B2) in 2004.	3-43
Figure 3.52. Diel Patterns of Spill Effectiveness, Total Sluice Effectiveness (includes B1 Sluice and B2CC), B1 Sluice Effectiveness, and B2CC Effectiveness Relative to the Project in 2004.	3-44
Figure 3.53. Diel Patterns of B1 Sluice Effectiveness Relative to B1 and B2CC Effectiveness Relative to B2 in 2004.....	3-45
Figure 3.54. Estimates of Diel Trends in Total Project Passage and Total Project Discharge and Total Guided and Unguided Passage at Bonneville Dam in Spring.....	3-46
Figure 3.55. Estimates of Diel Trends in Total Project Passage and Total Project Discharge and Total Guided and Unguided Passage at Bonneville Dam in Summer of 2004.....	3-46
Figure 3.56. Estimated hourly B1 Total Passage, B1 Turbine Passage, and B1 Sluiceway Passage and Associated Discharge in Spring of 2004.....	3-47
Figure 3.57. Estimated Sum of Hourly Fish Passage at B1, B1 Turbines, and the B1 Sluiceway, and Associated Discharge in Summer 2004.....	3-48
Figure 3.58. Estimated Hourly Spillway Passage and Discharge at Bonneville Dam in Spring and Summer of 2004.....	3-49
Figure 3.59. Estimated Hourly Spillway Passage and Discharge at Bonneville Dam during Six Days in Summer 2004.....	3-49

Figure 3.60. Estimated Hourly B2 Total Passage, B2 Turbine Passage, and B2CC Passage and Associated Discharge in Spring 2004.....	3-50
Figure 3.61. Estimated Hourly B2 Total, B2 Turbine, and B2CC Passage and Associated Discharge in Spring 2004.	3-51
Figure 3.62. Estimated Hourly B2 Guided and Unguided Turbine Passage in Spring and Summer of 2004.....	3-52
Figure 3.63. Fish Guidance Efficiency (FGE) Estimates for B2 in Spring and Summer.	3-53
Figure 3.64. Fish Guidance Efficiency (FGE) Estimates for B2 Turbines in Spring and Summer	3-53
Figure 3.65. Fish Guidance Efficiency (FGE) Estimates for Unit 16 and 17 in Spring and Summer.	3-53
Figure 3.66. Plot of Mean Daily FGE in Spring and Summer by Turbine-Intake-Extension Condition.	3-54
Figure 3.67. Regression of Mean B2CC Fish Passage Efficiency on Mean Percent Discharge through the B2CC and Relative to B2 Discharge..	3-55
Figure 3.68. Relationship of the Estimated Number of Fish in Schools for both Hydroacoustic and DIDSON Technologies.	3-56
Figure 3.69. Plot of All Fish as Dots Where They were Detected within Acoustic Sample Volumes of Split-Beam Transducers to Illustrate Sampling Coverage at the B2CC Entrance in Spring and Summer.....	3-56
Figure 3.70. Vertical Distribution of Fish Passing through the B2CC in Spring and Summer, 2004.	3-57
Figure 3.71. Vertical Distribution of Fish Passing through the B2CC in Spring and Summer through July 4, 2004 only.....	3-57
Figure 3.72. Horizontal Distribution of Fish passing through the B2CC in Spring and Summer, 2004.	3-58
Figure 3.73. Horizontal Distribution of Fish Passing through the B2CC in Spring and Summer through July 3, 2004.	3-58
Figure 3.74. Horizontal and Vertical Distribution of Smolt-sized Fish Upstream of the B2CC Entrance in Spring and Summer, 2004.....	3-59
Figure 3.75. Southwest View of the B2CC Entrance Just to the Right of the DIDSON Location and Bathymetry in the Vicinity of the B2CC Entrance.....	3-60
Figure 3.76. Same Southwest View of the B2CC Entrance as Figure 3.73, But Showing a Composite of Smolt Tracks Acquired with the DIDSON in Spring and Summer 2004.	3-61
Figure 3.77. Forty-five Degree Downward Angle and West View of Fish Tracks Approaching the B2CC	3-61
Figure 3.78. Plan View of Fish Tracks Upstream of the B2CC Entrance at B2.....	3-62
Figure 3.79. Plan View of Fish Tracks Upstream of the B2CC Entrance at B2.....	3-62
Figure 3.80. Contours of Fish Passage Probabilities at the B2CC for Spring and Summer 2004, Day and Night	3-64
Figure 3.81. Contours of Fish Passage Probabilities at the Bonneville Dam Corner Collector for Spring and Summer 2004 Day and Night.....	3-65

Figure 3.82. Average Corner Collector Plus Southwest Fate by Distance from Dam.....	3-66
Figure 3.83. Mean and Range of Discharge for Sample Dates, Over the Sampled Duration, at Units 13 and 17.	3-67
Figure 3.84. Mean and Range of Elevation on Sample Dates at Units 13 and 17	3-67
Figure 3.85. B2 Forebay Elevation by 5-Minute Interval over a 24-h Period Corresponding to Diel Sampling with the DIDSON Conducted on May 25-26, 2004.....	3-67
Figure 3.86. Gap Loss as a Percent of Gatewell and Gap-Loss Passage at the Three Intakes of Unmodified Unit 13 and the Three Intakes of Modified Unit 17	3-68
Figure 3.87. Gap Loss as a Percent of Gatewell and Gap-Loss Passage at Unmodified Turbine Unit 13 and Modified Turbine Unit 17	3-68
Figure 3.88. Plot of the Diel Trend of Passage into the Gatewell and Gap from 1400 Hours on May 25 to 1400 Hours on May 26, 2004.	3-69
Figure 3.89. Plot of the Diel Trend in Gap-loss as a Percent of Gatewell and Gap-loss Passage at Intake 17B from 1400 Hours on May 25 to 1400 Hours on May 26, 2004.	3-69
Figure 3.90. Horizontal Distribution of Gap-Lost Fish as a Percentage of Gatewell and Gap Passage at Five Equidistant Positions across the Width of the Gatewell Slot for Each Intake at Unmodified Unit 13 and Modified Unit 17 in 2004.....	3-70
Figure 3.91. Length Frequency Distribution on the Number of Fish Passing through the Gap between the Top of the STS and the Intake Ceiling in Spring 2004.	3-71
Figure 3.92. Length Frequency Distribution on the Number of Fish Passing Up the STS and into the Gatewell in Spring 2004.	3-71
Figure 4.1. Distribution of Proportions of Total Project Discharge and Total Estimated Fish Passage through Different Structures at Bonneville Dam in Spring and Summer of 2004.	4-4
Figure 4.2. Distribution of Project Discharge and Estimated Fish Passage through Three Fish Passage Routes at Bonneville Dam in Spring and Summer of 2004.....	4-5
Figure 4.3. Comparison of Gap Loss as a Percent of Estimated Gatewell and Gap-Loss Passage at B2 Turbine Intakes with Modified and Unmodified Gatewells	4-21

Tables

Table 2.1. Units and Intake Slots that were Offline or Randomly Selected for Sampling in 2004.	2-4
Table 2.2. Statistical Analysis System (SAS) Code Used to Spatially Expand Detected Fish Based Upon the Ratio of the Height of the Truncated Trapezoid Sampled to the Diameter of the Acoustic Beam at the Range of Detection.	2-10
Table 2.3. Intake Slots Randomly Selected for Sampling at B2 during the 2004 Study.	2-11
Table 2.4. Spring 2004 Sampling Schedule for Unmodified Unit 13 and Modified Unit 17.	2-17
Table 2.5. DIDSON Deployment and Sampling Schedule for the B2CC.....	2-18
Table 2.6. Six Aiming Positions Used to Initiate DIDSON Tracking Upstream of the B2CC.....	2-18
Table 2.7. Scenario Runs of the CFD Model Based Upon Day/Night, Forebay Elevation, and Discharge through the B2CC, B2, Spillway, B1, and the Entire Project.	2-25
Table 2.8. Deployment-Specific Variables that were Input to a Stochastic Detectability Model for Estimating Effective Beam Angle as a Function of Range from a Transducer.....	2-32
Table 2.9. Polynomial Inputs for the Detectability Model for Beam Patterns, Fish Trajectories, and Fish Speeds for Every Deployment.....	2-33
Table 3.1. Estimates of Major Passage Metrics Based upon Hydroacoustic Sampling from 4/15 through 5/31 (Spring) and from 6/1 through 7/15 (Summer) in 2004.....	3-19
Table 3.2. Estimates of Major Passage Metrics Based upon Hydroacoustic Sampling in 2000, 2001, 2002, and 2004	3-22
Table 3.3. Comparison of Passage Performance Metrics at Bonneville Dam during the Overlapping period of April 29-May 31, 2004, for the Run-at-large, as Measured by Hydroacoustics, and for Yearling Chinook Salmon and Steelhead Combined, as Measured by Radio Telemetry	3-26
Table 3.4. Comparison of Passage Performance Metrics at Bonneville Dam during the Overlapping Period of June 21-July 15, 2004, for the Run-at-large, as Measured by Hydroacoustics, and for Yearling Chinook Salmon and Steelhead Combined, as Measured by Radio Telemetry	3-27
Table 3.5. Estimates of Fish Guidance Efficiency (FGE), by Turbine Unit, at B2 from April 29-May 31, 2004, for the Run-at-large as Measured by Hydroacoustics and for Yearling Chinook Salmon and Steelhead Combined, as Measured by Radio Telemetry.	3-27
Table 3.6. Estimates of FGE, by Turbine Unit, at B2 from June 21 through July 15, 2004, for the Run-at-large as Measured by Hydroacoustics and for Yearling Chinook Salmon and Steelhead Combined, as Measured by Radio Telemetry	3-28
Table 3.7. Estimated Fish Passage and Percent of Total Flow for All Major Passage Routes at Bonneville Dam for the Spring Creek Release from March 1-18, 2004.	3-29
Table 3.8. Estimated Fish Passage and Percent of Total Flow for all Major Passage Routes at Bonneville Dam in Spring and Summer of 2004.	3-30
Table 3.9. The CFD Model Scenarios, Turbine Units on for the CFD Model Runs and during Data Collection with the DIDSON, and Percent of Tracked Fish Data Collected.....	3-55

Table 3.10. Characteristics of the Data Used in Markov Chain Analyses of Fish Movement.....3-63

Table 3.11. Relative Fates, Probabilities of B2CC Passage, from a 44 Ft X 54 Ft Area
Near the B2CC Based on a Markov Chain Analysis.....3-63

Table 4.1. Percent of Flow and Fish Passing through B2 in 2000, 2002, and 2004.4-6

Table 4.2. Reported and Actual Spill Rates in 2000, 2001, 2002, and 2004.4-7

Table 4.3. Proportion of Fish Passed and Water Discharged by Structure and Season per Year
for Each Year of Full Project Passage Assessment.4-11

Table 4.4. Unit 11 FGE in Years that It Was Sampled with Fixed-Aspect Hydroacoustics.....4-18

Table 4.5. Fish Guidance Efficiency from Hydroacoustic Estimates and Revised Estimates
that Account for Gap Losses of 14.9 for Unmodified Intakes and 5.0 % for
Modified Intakes.....4-23

1.0 Introduction

1.1 Site Description

Bonneville Lock and Dam consists of several dam structures that together complete a span of the Columbia River between Oregon and Washington at River Mile 146.1, about 40 miles east of Portland, Oregon. From the Oregon shore north toward Washington, the Project currently is composed of a navigation lock, a 10-turbine-unit Powerhouse 1 (B1), Bradford Island, an 18-gate spillway, Cascades Island, and an 8-turbine unit Second Powerhouse (B2) (see Figure 1.1).

Bonneville Dam was formally authorized by Congress in the Rivers and Harbor Act of 30 August 1935. This act also provided the authority for the construction of additional hydroelectric generation facilities when requested by the Administrator of Bonneville Power Administration (BPA). The spillway and B1 were constructed between 1933 and 1937 without specific regard for protecting juvenile salmonids migrating downstream. Public Law 329, passed by the 75th Congress on August 20, 1937, provided authority for the completion, maintenance, and operations of Bonneville Dam. Administrative letters of BPA dated January 21, 1965, and February 2, 1965, stated the need for the construction of a second powerhouse (B2). Construction of turbine Units 11 through 18 and two fishway units began in 1974 and was completed in 1982.

Principal passage routes for juvenile salmonids include the spillway and two powerhouses, but within each powerhouse, fish passage can be through ice/trash sluiceways, turbines, or the juvenile bypass system (JBS). Smolts enter the JBS after they encounter screens in the upper part of turbine intakes and are diverted to gatewell slots and orifices opening to a bypass channel. In spring of 2004 the B2 Corner Collector (B2CC) was operational. The B2CC takes advantage of high concentrations of smolts by the south end of B2 and the north side of Cascades Island. The B2CC channel routes fish to the downstream tip of Cascades Island between the spillway and B2 tailwaters.

1.2 2004 Studies

1.2.1 General Description

Bonneville Dam is the most downstream of all of the hydropower dams in the Columbia-Snake River hydropower system. Therefore, more downstream-migrating juvenile salmonids must pass Bonneville Dam than any other dam in the system. The U.S. Army Corps of Engineers, Portland District has made a concerted effort to improve passage conditions for downstream migrants at the Project, because of its downstream position in the system and because it has had consistently low passage-efficiency estimates (Krcma et al. 1982, Gessel et al. 1988 and 1991, Magne 1987, Magne et al. 1986 and 1989, Stansell et al. 1990, Evans et al. 2001a-d and 2003a, 2003b; and Ploskey et al. 1998, 2001a, 2002a–c, and 2003). Gessel et al. (1991) discuss the history of the development of submerged traveling screens (STSs) at Bonneville Dam Second Powerhouse (B2). Other improvements to fish guidance, collection, and passage

are part of ongoing research and engineering activities. The 2004 work reported here is a part of that continuing effort.

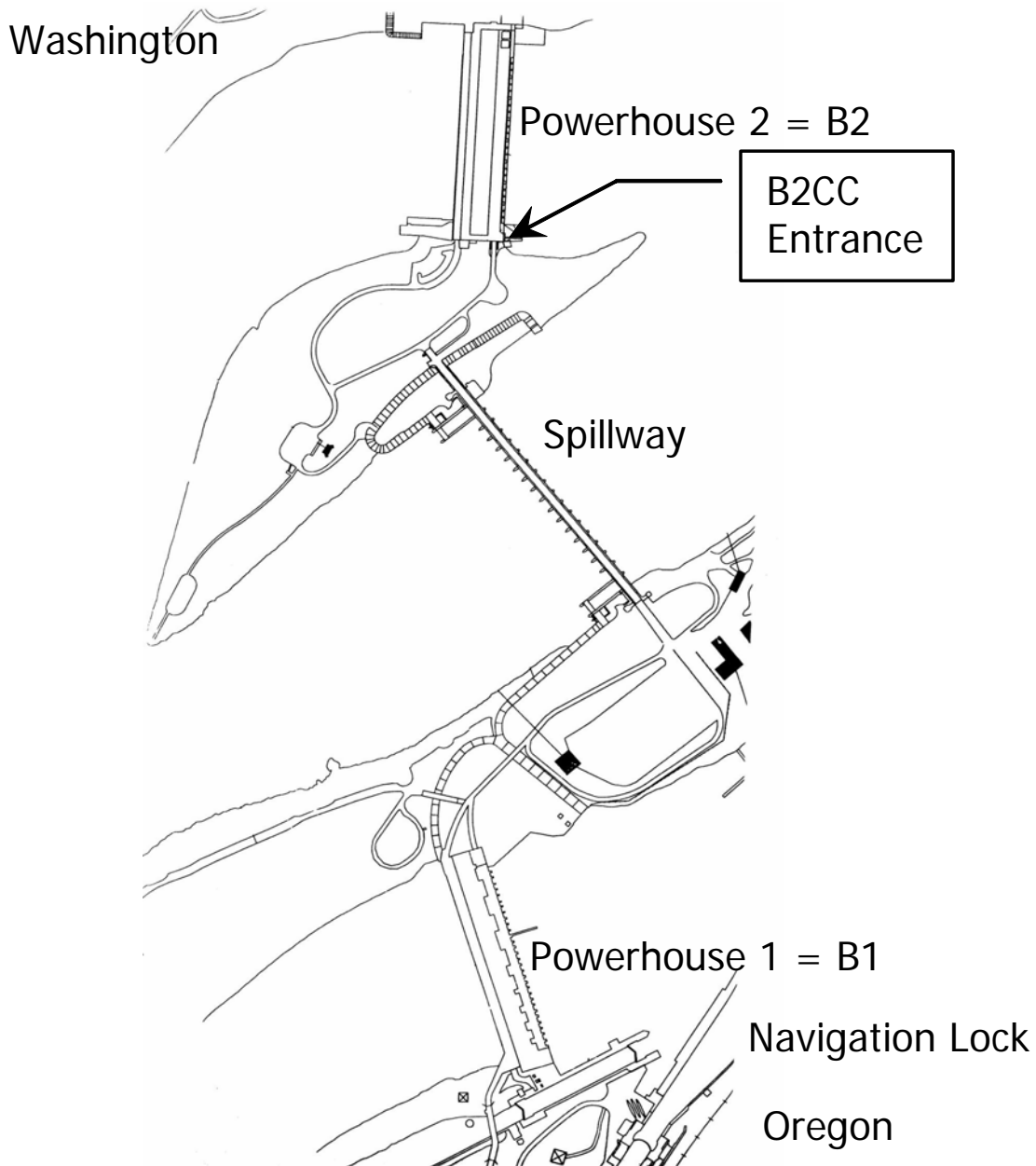

Figure 1.1. Plan View of the Bonneville Dam Project

As in the other years, the 2004 hydroacoustic work involved the estimation of passage and passage metrics for the entire Project as well as spatial and temporal variation in those estimates. It also involved two different Dual-frequency Identification Sonar (DIDSON) studies at B2. In one DIDSON study, we estimated the proportion of the fish guided by STSs up into the gatewells that were lost through the gap between the top of the STS and the intake ceiling back into the turbine intake. The other study sampled smolts in the B2 forebay as they approached the B2CC entrance. We also conducted a study of the

pressure differential across vertical barrier screens (VBS) at B2 to monitor debris loading and clogging of the screens.

In this report, we present results of the fourth year in which enough of the Project's many passage routes (18 turbines, including guided and unguided fractions at B2, 18 spill bays, three sluiceway entrances at B1, and the new B2 Corner Collector (B2CC) were sampled to permit estimation of project-wide fish-passage metrics. The other years with extensive fish-passage sampling are 2000, 2001, and 2002. These same years, including 2004, involved extensive radio-telemetry juvenile passage studies by the USGS at the Project. Each of these four years has had environmental and operational factors that make it unique, such as the testing of new passage routes and structural modifications, powerhouse priority, turbine outages, project generation demand, and water availability.

The 2004 passage year involved B2 generation priority, river flow that was 82% of the last 10- year average, and a newly completed surface passage route, the B2CC, at the southern end of B2. In previous years of FPE study, turbine intake extensions (TIEs) were installed in every other B2 intake from 11A through 18B, but in 2004, TIEs were not installed at Units 11 through 14 to facilitate southerly flow along the powerhouse toward the B2CC. Three B1 sluiceway entrances (2C, 4C, and 6C) also were opened and were sampled, as were all operating turbine units and spill bays. Besides the new B2CC, the 2004 passage year was unique in that no in-turbine screens were deployed in the 30 B1 turbine intakes, where there are three intakes per turbine. In prior years of FPE study, submerged traveling screens (STSs) were deployed in most B1 intakes. The exception was that extended length submersible bar screens were installed in all intakes of Unit 8 and tested in 2001 and 2002. Regional fish managers decided not to have screens deployed at B1 in 2004, after they examined recent survival estimates for fish passing B1 turbines and noted that they were higher than estimates for the B1 juvenile bypass system.

At B2, there were two units with modified gatewell slots (Units 15 and 17), as there were in the 2002 study year. In an attempt to improve fish guidance at B2, several modifications were first made and tested in the gatewells of Unit 15 in 2001; gatewells of Unit 17 were modified for the 2002 study year (Ploskey et al. 2003). These modifications were devised after physical modeling of B2 intakes in 2000 raised concerns that fish guidance efficiency was limited by insufficient flow moving above the STSs and into gatewells. There also was concern that a high proportion of flow, and potentially of fish, was moving through the gap between the top of the STS and the intake ceiling back into the turbine intake. The modifications consisted of removing part of a concrete beam, greatly expanding the surface area of the vertical barrier screen (VBS), and adding a turning vane and gap closure device to direct more water up the slot and away from the gap between the top of the STS and the intake ceiling. The gap-loss part of the 2004 study was only conducted in spring of 2004 due to previously discovered limitations in detecting the smaller summer smolts (Ploskey et al. 2003). The VBSs in the gatewells of Unit 17 were modified prior to the 2004 season. Concrete was removed from the downstream side of the gatewell and sturdier VBSs were installed to handle higher flows into the gatewell and greater debris loading.

1.2.2 Objectives

1.2.2.1 Project FPE Evaluation

This objective continues the fish passage estimation studies we carried out in 2000-2002. As in those studies it involves using fixed-aspect hydroacoustics to produce estimates of fish-passage metrics for the spring and summer seasons as well as of temporal and spatial trends and variability in those metrics. Examples of temporal trends include average diel (hourly) trends in fish-passage rates within days and daily trends within seasons. Spatial trends include lateral distributions at B1, the spillway, and B2. We compare our 2004 results with those of previous hydroacoustic studies to identify effects of structural and operational changes through time, and to compare results of concurrent studies with other methods, in this case only radio telemetry since NMFS did not net at Bonneville Dam in 2004. Our objectives relating to passage-metric estimation and analysis required that we:

1. Estimate the proportions of smolt-sized fish that passed all of the turbine intakes at the project (above and below in-turbine screens at B2), through sluiceway openings with water depths > 1 m (including three open sluice gates at B1 as well as the B2CC), and through all spill bays in the spring and summer passage seasons.
2. Estimate a variety of fish-passage metrics, including Project and powerhouse-specific FPE, fish guidance efficiency (FGE) by turbine unit at B2 (there were no screens deployed at B1 in 2004), and both the efficiency and effectiveness of the spillway, B1 sluiceway, and the B2CC (relative to both the powerhouse or Project as appropriate) by hour, day, and season.
3. Characterize horizontal distributions of smolt-sized fish passing through the Project, B1, B2, and the spillway in spring and summer.
4. Describe changes in vertical and horizontal distributions of smolt-sized fish passing B1 turbine intakes and the B1 sluiceway entrances, B2 turbine intakes (guided and unguided) and the B2CC, and the spillway. There were no screens in place at B1 in 2004 so there were no “guided” samples there.
5. Describe both seasonal and diel changes in the passage of smolt-sized fish at B1, B1 sluiceway entrances, B2, the B2CC, and the spillway.

1.2.2.2 B2 FGE and Gap Loss Evaluation

This objective continues the studies to improve FGE at B2 turbine intakes by modifying several aspects of the intake structures. Both Unit 15 and Unit 17 were modified and Unit 13 serves as the unmodified control. In 2004, as in 2002, we set out to:

1. Continuously sample with a pair of hydroacoustic transducers in one intake each of Units 11 and 12 and two intakes of Unit 17 to provide better estimates of the number of guided and unguided fish than would be obtained in the 2004 FPE study, which sampled only one of three intakes per unit. Units 11 and 12 have no gatewell slot modifications or TIEs and are near the B2CC at the south end of B2, whereas Unit 17 has modified gatewell slots, TIES on A and C slots, and is located just south of Unit 18 on the north end of B2. The objective was to calculate FGE by intake and evaluate effects of intake location and modifications in spring and summer.

2. Evaluate the proportion of fish moving through the gap between the top of the STS and the ceiling of intakes of Units 13 and 17 in spring 2004. Unit 13 has unmodified gatewell slots but will not have TIEs installed upstream of slot A and C trash racks in 2004, as it did in 2003, and it will be just two units away from the new B2CC. Unit 17 is a modified unit that will have TIES upstream of A and C slots.

1.2.2.3 Smolt Approach Evaluation at the B2CC

The objectives were to:

1. Sample with a DIDSON mounted on a dual-axis rotator to acquire data on the swim paths of smolts approaching the B2CC entrance three times each season. The data were to be collected with sufficient precision to allow future integration of fish and flow data should that become necessary to address unforeseen problems.
2. Process and analyze the data to qualitatively describe fish behavior, distributions, and the probability that fish in various forebay locations will pass into the B2CC or into the adjacent south eddy.

1.2.2.4 B2 Vertical Barrier Screen (VBS) Head Differential Evaluation

The objectives of this project were to:

1. Monitor differential head between the water elevations upstream and downstream of the VBS at modified Unit 17 at B2 to index debris accumulation. We were to alert the Project when debris levels exceeded a preset threshold.
2. Compare the differences in differential head with dam operations.

1.3 Background

The U.S. Army Corps of Engineers – Portland District is striving to meet the goal, set in the 2000 Biological Opinion on the Federal Columbia River Power System (NMFS 2000), of maximizing juvenile salmonid fish passage efficiency (FPE, the proportion of all fish passing the Project by non-turbine routes) and obtaining 95% survival for juvenile salmon (*Oncorhynchus spp.*) passing Bonneville Dam.

Project FPE is the estimated proportion of all juvenile salmon passing the Project by non-turbine routes, but FPE also can be calculated for individual powerhouses (B1 and B2) or for either powerhouse plus the spillway. In all cases, FPE is the total estimated non-turbine (spillway and/or surface passage divided by the total passage for a passage season (spring or summer)). The proportions of juvenile salmon that pass through all major passage routes must be estimated to calculate Project FPE, and that had been done at Bonneville Dam for the years 2000-2002 and 2004 by both fixed-aspect hydroacoustics (Ploskey et al. 2002b, 2002c, 2003) and radio telemetry (Evans et al. 2001 a-d and 2003 a and b). This document reports on the 2004 spring and summer hydroacoustic efforts, along with several related studies.

In a typical water year, the goal of maximizing FPE largely determines the operation of the Project. Managers presume that large volumes of spill are necessary to compensate for the low fish guidance efficiency (FGE) of screens at both powerhouses, particularly in summer when the fish guidance efficiencies of screens is especially low. Spill volumes are, in a typical year, limited to between 50,000 and 75,000 ft³/s during the day and up to 120% of the “gas cap” set to control total dissolved gas supersaturation (NMFS 2000), which is harmful to juvenile salmon.

Within those guidelines, however, there is a great deal of variability among passage years. The two most obvious determinants of dam operations are water availability in the reservoir and the demand for hydropower generation. The drought of 2001 was an extreme case wherein discharge was only 62% of the previous ten-year average annual discharge, which, combined with very high generation demand, led to unusually low spill volumes over a curtailed spill season (Ploskey et al. 2002c). Figure 1.2 presents the average daily Project total discharge in the passage seasons (April 15 through July 15) for the last decade (data from Columbia River DART website.). Total project discharge during the drought of 2001 was roughly half (46% in spring and 54% in summer) of what it was in 2000. In 2001, the project spilled 16% of the total discharge in spring and 11% in summer, down from 31% and 50%, respectively, in 2000. Total spill volume was less than a quarter (23%) in spring and less than an eighth (12%) in summer of what it was in 2000, a much more normal water and generation year.

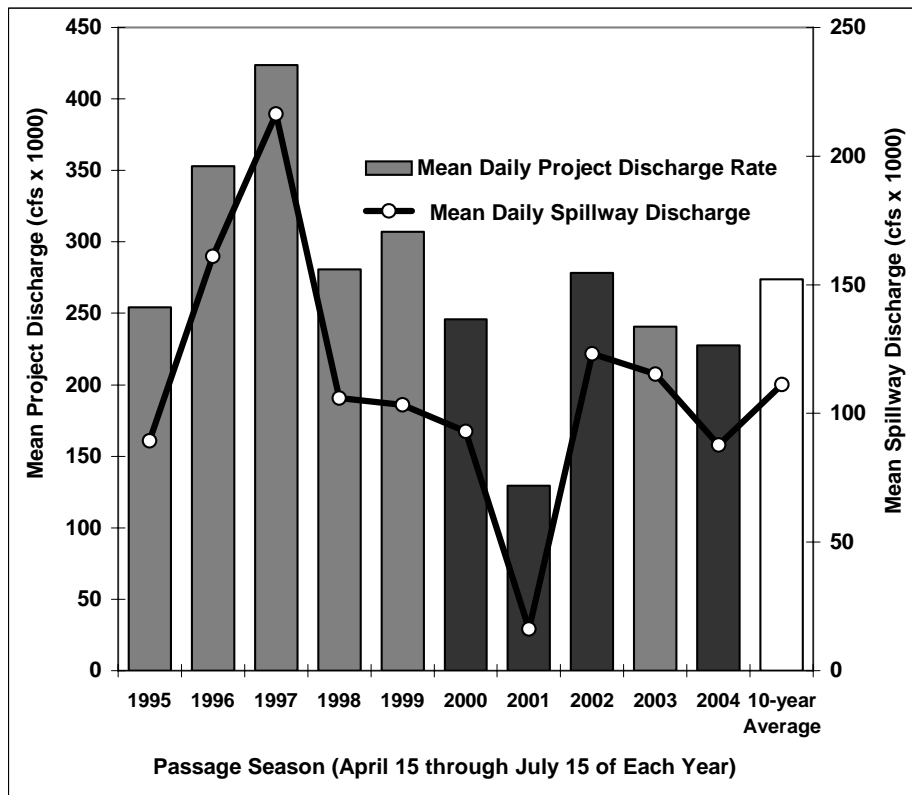

Figure 1.2. Average Project and Spillway Discharge from 1995 through 2004 during Spring and Summer Migration Seasons. Data are from Data Access in Real Time website (<http://www.cbr.washington.edu/dart/>). Black bars indicate years with Project FPE estimates; gray bars represent years without. The white bar represents the 10-year average.

Even without the complications of unusual water years and generation demand, conducting dam operations to enhance fish passage and survival is a complex affair. Spill under 50,000 ft³/s creates eddies and slack water areas in the spillway tailrace. High risk of predation is assumed in the tailrace when currents do not carry juvenile fish downstream quickly. Spill levels above 75,000 ft³/s during the day can lead to high numbers of adult salmon falling back through the spillway, as adults exit the Bradford Island fish ladder and follow the shoreline around to the spillway forebay. Adult salmon do not pass through the ladder at night, and therefore spill can be increased in an attempt to reach 80% FPE for a 24-hour period. However, spill above 120,000 ft³/s typically causes total dissolved gas (TDG) levels to exceed 120% saturation, which is the allowable maximum set by state water-quality standard waivers. Levels of TDG above this may increase fish mortality downstream of the dam.

The Portland District acquired mobile hydroacoustic data on fish distributions in both powerhouse forebays in 1996 (Ploskey et al. 1998) and 1997 (BioSonics Incorporated 1998). For B1, these data indicated that high average fish densities occurred upstream of Units 4 through 6 in spring and upstream of Units 4 through 6 and 8 and 9 in summer. For B2, average fish densities were highest upstream of Units 11 through 13 (adjacent to the south eddy and sluice chute) in spring and in summer. Fish densities also were high upstream of Unit 18 in 1996 but not in 1997. Vertical distribution data usually showed that over 80% of the fish were in the upper 49 ft of the water column. The low fish guidance efficiency of many submerged traveling screens at the Project would not be expected from an examination of the vertical distribution data collected within 33 ft of the dam. If fish did not alter their vertical distribution from what was observed in forebay areas, data from 1996 and 1997 would suggest that fish guidance efficiency usually would exceed 80%. Data acquired from in-turbine sampling and using fixed up-looking transducers deployed on the bottom of the B2 forebay in 2000 also indicated that FGE estimates were much lower than expected from vertical distributions in the forebay (Ploskey et al. 2002b).

Diel (24-hour) patterns of smolt passage are not uniform in either sluiceways (Uremovich et al. 1980; Willis and Uremovich 1981) or the JBS (Hawkes et al. 1991; Wood et al. 1994). Diel passage through the JBS often has a bimodal distribution with a major peak occurring just after dark and a minor peak after sunrise. In contrast, passage through sluiceways usually is higher during the day than at night (Willis and Uremovich 1981). However, patterns apparently are influenced by the operation of sluice gates (Uremovich et al. 1980), flow, unit outages, and species composition (Willis and Uremovich 1981). Netting required to estimate FGE is intensive but, because netting is limited to a few hours per day, it does not provide diel information. Diel patterns of fish passage above and below screens were estimated by hydroacoustics in spring and summer 1996 for randomly selected intakes of every turbine at B2 and every intake of Units 3 and 5 at B1 (Ploskey et al. 1998). Estimates also were made in the spring and summer of 1998 and 2000. These indicate that fish passage through turbines usually is higher at night than it is during the day (Ploskey et al. 2001a; Ploskey et al. 2002a), which is consistent with historical findings at Bonneville Dam and other projects in the Northwest (Thorne and Johnson 1993).

Available data indicate that the horizontal distribution of smolt passage among turbine intakes is not uniform. Gatewell sampling has indicated that the number and location of operating units and sluice gates as well as the species of smolt determine lateral distributions of juvenile salmon at B1 (Willis and Uremovich 1981). Interactions among factors may account for a lack of consistency in measures of horizontal patterns by Uremovich et al. (1980), who found fish concentrated at Units 6, 7, and 10; Willis and Uremovich (1981), who found variable patterns depending on operations; and Krcma et al. (1982),

who observed most fish passage at Units 4 through 6. Much of the FGE data collected at B2 with in-turbine hydroacoustics (e.g., Magne et al. 1989; Stansell et al. 1990) and netting (Gessel et al. 1988; Muir et al. 1989) are of limited value for evaluating the horizontal distribution of passage because they typically focused on one or two units at a time.

In the 1980s and early 1990s, hydroacoustics was used on limited spatial and temporal scales to evaluate sampling potential or relative passage among a few routes. Thorne and Kuehl (1989) evaluated the effects of noise on hydroacoustic assessment of passage within several turbines at B1. Results showed that acoustic sampling is feasible at the units they tested. Magne et al. (1986, 1989), Magne (1987) and Stansell et al. (1990) made hydroacoustic estimates of FGE for turbine Units 11 and 17 and found that estimates were closer to netting estimates by the National Marine Fisheries Service (NMFS) when they sampled longer than just a few hours with hydroacoustic gear (see also Ploskey and Carlson 1999).

The Portland District's Fishery Field Unit attempted hydroacoustic sampling of juvenile salmon passing through several spillway gates in the mid 1980s. Transducers were mounted on the bottom of gates and aimed upward and upstream of vertical. Apparently, noise generated by sound echoing off vortices at some gates masked echoes from juvenile salmon and prevented equalized sampling efforts among gates. BioSonics tested several methods for sampling spillway passage in 1997 (BioSonics Incorporated 1998). Their best approach was to mount their transducers on piers and aim them down toward the ogee just upstream of the gates. BioSonics also designed a mount to deploy transducers and estimate passage through the B2 sluice chute. Transducers were placed at the bottom center of the upstream bulkhead slot and aimed upward vertically and slightly upstream of vertical.

Vertical distributions of juvenile salmon sampled by fixed-aspect hydroacoustics also vary seasonally and daily but this information has not been considered for improving juvenile fish passage at B2. For example, late spring and summer operations at B2 now prioritize the use of turbines 11 and 18 for adult salmon attraction during daytime hours. However, previous studies clearly showed that these units have the lowest FGE for juveniles passing downstream and that juvenile passage through Unit 11 is exceptionally high relative to other B2 units. The FGE of traveling screens was highest at units near the center of the second powerhouse. If Units 11 and 18 did not have turbines or had turbines with much more benign passage conditions than those presently installed, current operations would benefit both adults and juveniles. However, given the low FGE at Units 11 and 18 in summer, 85% to 90% of the juvenile fish passing B2 go through turbines rather than the bypass, at least before the completion and operation of the new B2CC.

A new corner collector, at the south end of B2, was completed in time for operation in the 2004 passage seasons. It is on the site of and replaces the old B2 ice-and-trash sluiceway and its development as a surface-passage route has occurred over several years. Hydroacoustic sampling in 1996 (Ploskey et al. 1998), using both fixed and mobile hydroacoustics, found that Unit 11 had the highest passage of any intake sampled in that year. Ploskey et al. (1998) and BioSonics (1998) found high densities of fish upstream of Units 11-13 when they sampled with mobile hydroacoustics. Like the Fisheries Field Unit in previous years, BioSonics reported that large numbers of fish passed through the sluice chute when that route was available. However, it is not known what contribution the sluice chute or a corner collector could make to guidance at B2 or to project-wide FPE. Data from Ploskey et al. (1998) indicated that the combined FGE of Units 11, 12, and 13 was only 35%. However, operation of the chute increased the combined FGE to 87% after sluice passage was added to the guided fish terms. This finding could be

significant because 1996 mobile hydroacoustic sampling indicated that there was a 2:1 skew in the distribution of fish toward the south end of B2. An important factor contributing to successful fish passage in 1998 was removal of one half of the TIEs at Units 11-14, which increased lateral flow toward the sluice chute. When in place, TIEs reduce lateral flows along the face of the powerhouse. In 2001, with B2 generation priority and TIEs in place, estimated fish passage was again skewed to the south and highest at Unit 11 in both spring and summer (Ploskey et al. 2002c), and similar trends were observed in 2002 (Ploskey et al. 2003). In the 2004 passage seasons the TIEs were in place on intakes 15A and C, 16B, 17A and C, and 18B (alternating intakes of Units 15-18 starting with 15A). There were no TIEs on any of the intakes of Units 11-14, comprising the south half of the powerhouse.

From 1998 through 2000, the Portland District evaluated two distinct smolt bypass approaches for B1, surface flow bypass and extended-length submersible bar screens. The year 2001 was scheduled for a decision on which complement of smolt passage devices to emphasize for long-term smolt protection at B1. The Corps prepared a special document, called the decision document, to analyze the relative merits of surface bypass and screens at B1.

Johnson and Carlson (2000) reviewed the research conducted on surface flow bypass from 1998 through 2000 in the Columbia-Snake River System. The goal of the surface flow bypass program was to develop and evaluate surface bypass and collection prototype concepts that would lead, if justified by prototype test results, to permanent systems for improving survival of juvenile salmon. In 1998, a prototype surface collector (PSC) was installed at Units 3-6 and was extensively studied (see Johnson and Giorgi 1999 for a review). In 1999, limited research occurred to prepare for tests in 2000. In 2000, the PSC was extended from Units 3-6 to also cover Units 1-2, because a noticeable number of radio tagged smolts were observed in 1998 to move obliquely from north to south along the face of the PSC (Hansel et al. 1999). A thorough evaluation of the PSC was conducted in 2000 as part of the Anadromous Fish Evaluation Program (AFEP). The 2000 PSC evaluation emphasized forebay fish behavior as well as PSC performance, i.e., fish passage efficiency and effectiveness.

In 2001, the PNNL and ERDC again used hydroacoustic methods to provide a second set of Project-wide fish-passage, passage efficiency, and passage effectiveness estimates. This study provided similar metrics to those estimated in 2000, but the PSC was not functioning in 2001 and estimates of fish passage through Units 1-6 focused upon the FGEs of the submerged traveling screens instead. In addition, 2001 happened to be a drought year in which spill was limited in duration and amount each season. While the drought provided unique opportunities to examine effect of very low spill and no spill, it also made difficult comparisons of metrics between the two years. In addition, the priority for generation at the powerhouses was reversed from B1 in 2000 when the PSC was tested to B2 in 2001. In 2002, there was a third year of extensive hydroacoustic and radio telemetry sampling at the Project and in 2003 there was no radio-telemetry or fixed-aspect-hydroacoustics study at Bonneville Dam.

This hydroacoustic evaluation was conducted to complement a radio telemetry study because hydroacoustics samples the run at large, whereas telemetry only provides data on individuals of species and age classes that are chosen for study. Estimates of FPE can be made by radio telemetry, but only for tagged fish and under the assumption that tagged fish behave like untagged fish. Radio telemetry provides species-specific information, reservoir passage routes and rates, forebay delay times, and other insights that hydroacoustics cannot. However, radio telemetry cannot provide the robust horizontal and vertical distribution information for assessing changes in fish passage or for suggesting improvements in

fish interception and passage structures or operations. Telemetry sample sizes sometimes may be too small when divided among 36 or more passage routes at a project. Hydroacoustic sampling not only provides overall measures of Project performance, but also can indicate where improvements can be made and what kind and how much of a change might be required. For example, continuous hydroacoustic sampling allows for regression of performance measures (such as spill efficiency) on continuous operations data such as spill volume. These types of regressions can suggest Project operations to optimize juvenile fish passage at a project. Provision of continuous fish-passage data on run-of-river fish is a unique strength of hydroacoustic sampling.

2.0 Materials and Methods

2.1 Equipment

2.1.1 Fixed-Aspect Hydroacoustics

We deployed 70 fixed-aspect hydroacoustic transducers as part of 17 hydroacoustic systems, each consisting of an echosounder, cables, transducers, an oscilloscope, and a computer to sample fish passage at 16 of 30 B1 turbine intakes, all three open B1 sluiceway entrances, all 18 spill bays, the B2CC entrance, and 12 of 24 B2 turbine intakes. Echosounders and computers were protected by uninterruptible power supplies. An echosounder generates electric signals of specific frequency and amplitude and at the required pulse durations and repetition rates. Cables conduct those transmit signals from the echosounder to transducers and return data signals from the transducers to the echosounder. Transducers convert voltages into sound on transmission and sound into voltages after echoes return to the transducer. The oscilloscopes are used to display echo voltages and calibration tones as a function of time, and the computer system controls echosounder activity and records data to a hard disk. All 420-kHz, circular single- or split-beam transducers were controlled by Precision Acoustic Systems (PAS) echosounders and Hydroacoustic Assessments' HARP180 software running on Pentium-class computers. All transducers were manufactured by PAS, except for the 420-kHz circular single beams deployed at the spillway, which were made by BioSonics, Incorporated.

Nine of the 17 systems deployed in 2004 were made up of split-beam echosounders and transducers that provide x and y phase data from which we could estimate the location of echoes in the plane perpendicular to range from a transducer. With estimates of target location within the beam we could also estimate fish size, speed, and trajectory, all of which are important for detectability modeling to obtain deployment-specific expansion factors. The split-beam systems were controlled by PAS 103 echosounders and HARP software. At least one split-beam transducer was deployed in the same way as the many single-beam transducers deployed in the B1 and B2 turbines and at the spill bays. Single-beam passage estimates for spill bays were multiplied by the estimated proportion of fish moving downstream through split-beams to adjust for the inability of single-beam systems to account for direction of travel. Details about these adjustments and associated variance adjustments are described below under Section 2.9.

Split-beam systems also were used to sample sluiceway entrances 2C, 4C, and 6C at B1 and the B2CC. Echosounders used to sample sluiceway entrances were modified to optimize detectability of closely spaced fish by increasing bandwidth from 20 to 100 kHz and transmitting shorter pulse widths (80 instead of 200 μ s) to reduce the target resolution distance (minimum target separation) from 6 inches to about 2.36 inches. Direction of travel information was critical for adjusting estimates of fish passage into the B1 sluiceway entrances to exclude fish that were not entrained and that were not moving toward an entrance.

2.1.2 DIDSON Sampling of STS Gap Loss

In spring 2004, we deployed a down-looking Dual-Frequency Identification Sonar (DIDSON) on a laterally moving mount that traversed a horizontal beam, which was lowered by crane into gateway slots of Units 13 and 17 at B2. The DIDSON recorded images of juvenile salmonids moving up into the gateway and through the gap between the top of the STS and the ceiling of the intake. In the confined gateway sampled in this study the frame rate was limited to 8 to 10 frames/s. The programmable traversing mount allowed the DIDSON to sample from five lateral locations across the gateway at 10-minute intervals. The traversing part of the 20-ft-wide beam was moved by a stepper motor and controlled by custom designed software on a laptop computer through a serial communication port. Stepper motor feedback to the computer provided position information, which could be verified by five position sensors located along the beam. The DIDSON was leased from BAE Systems, Inc. and was serviced before and during the sampling season by Sound Metrics, Inc., Seattle, Washington.

The DIDSON is a non-intrusive device that is not limited by turbidity or light and that is not as sensitive to entrained air as are the 6 to 10 degree beams that are typically used for hydroacoustic sampling. The DIDSON was developed by the Applied Physics Laboratory (APL) at the University of Washington (Belcher et al. 1999) for the Space and Naval Warfare Systems Center harbor surveillance program. It operates at either 1 or 1.8 MHz, depending on whether range or resolution is deemed more important and in the lower, longer range mode, it can receive echoes from objects out to 48 m. In the higher-frequency mode it can provide animated images of fish out to about 12 m. The DIDSON was designed to bridge the gap between existing sonar, which can detect acoustic targets at long ranges but cannot record the shapes or sizes of targets, and optical systems, which can videotape fish in clear water but are limited at low light levels or turbidity. Images within about 12 m of the device, when in high resolution mode, are clear enough that undulating movements of fish and swimming direction can be discerned.

2.1.3 DIDSON Sampling of Fish Approach and Fate at the B2CC

A second DIDSON was used to conduct a study to record and track movements of juvenile salmonids approaching the B2CC in spring and summer. The DIDSON was mounted on a ROS PT10 pan and tilt rotator. The rotator and DIDSON were located about 15 ft to the east of the B2CC entrance and were deployed from a 25-ft.-long pontoon barge (Figure 2.1). This DIDSON also was serviced by Sound Metrics before the sampling season.

2.2 Calibrations

Before deployment, all single and split-beam hydroacoustic equipment was transported to Seattle, Washington, where PAS electronically checked and calibrated the echosounders and transducers using a standard transducer. After calibration, we calculated receiver gains to equalize the output voltages among transducers for on-axis targets ranging in hydroacoustic size from -56 to -35 dB $\parallel 4\pi m^2$ (Appendix A). Lengths of fish corresponding to that acoustic size range would be about 1.3 and 12 inches, respectively, for fish insonified within 21° of dorsal aspect (Love 1977). Inputs for receiver-gain calculations included calibration data (i.e., echosounder source levels and $40 \log$ [range] receiver sensitivities for specific transducers and cable lengths) and acquisition equipment data and settings (installed cable lengths, maximum output voltage, and on-axis target strengths of the smallest and largest fish of interest). In most instances, calibrated and installed cable lengths were identical. When installed cable lengths differed from calibrated cable lengths because we had insufficient cable for a deployment, we used an empirically derived correction factor to compensate for cable length effects on source levels, receiver sensitivity, and receiver gain settings.

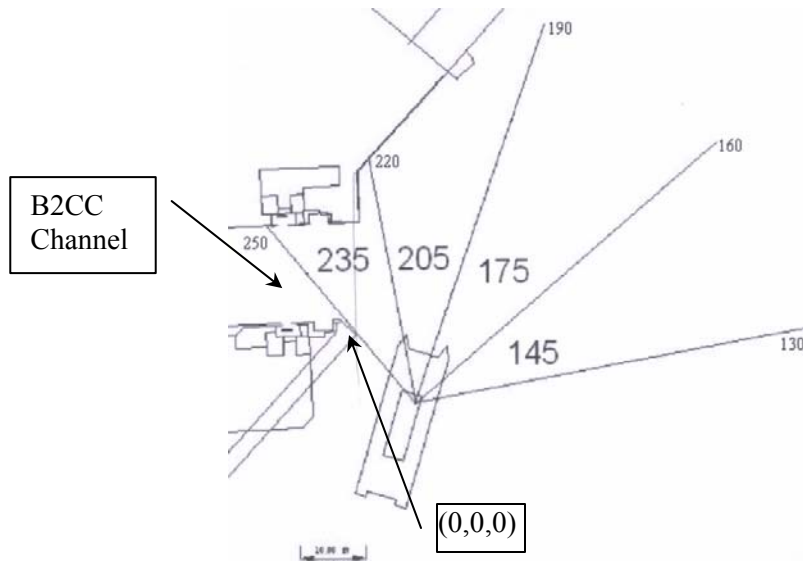

Figure 2.1. Diagram of a Plan View of the B2CC Entrance in the B2 Forebay Showing the Location of a Pontoon Barge and Four Successive 30° Angles of Coverage by the DIDSON. Numbers are rotator pan angles in degrees. The distance across the B2CC entrance through the number 235 was 15 ft. The location indicated by the x, y, z coordinates (0,0,0) was the origin for the Markov Chain grid described in Section 3.3 below.

2.3 Transducer Deployments and Sampling Schemes

This section describes hydroacoustic and DIDSON deployments and sampling schemes. Technical details about transducer locations and aiming angles are presented in Appendix B. In 2004, all equipment was deployed before March 1 to allow us to sample passage of hatchery fish during an extended release from Spring Creek Hatchery (about 11 miles upstream of the Project) in the first two weeks of March. The spring sampling season was from April 15 through May 31, 2004, and summer sampling was from June 1 through July 15, 2004.

2.3.1 Sampling B1

In 2004, submerged travel screens (STSs) at Units 1-7, 9, and 10 and the extended submerged bar screen at Unit 8 were not deployed, so our B1 turbine deployments and sampling scheme in 2004 was modified from what was used in 2000, 2001, and 2002 when screens were present to optimize sampling.

Powerhouse 1 is composed of ten turbine units numbered 1-10, but Unit 1 was offline throughout this study. Each turbine unit has three intake slots. One or two intake slots per turbine unit were randomly selected for monitoring, and spatial strata were assigned to estimate within-unit, among-intake variances in passage estimates (Table 2.1) as described under Estimating Fish Passage below. Unit-hours were considered as temporal strata, with systematic sampling within each intake-hour. Split-beam transducers were installed in Unit 6, but the remaining locations used single-beam transducers. Hydroacoustic sampling was continuous, 24 hours per day, throughout the course of the study, except for 10 to 15 minutes per day when data were downloaded.

Table 2.1. Units and Intake Slots that Were Offline or Randomly Selected for Sampling in 2004

Unit	Intake Slots Sampled	Spatial Strata
1	Offline	
2	A, C	1
3	B, C	2
4	A, B	3
5	A, B	4
6	A, B	5
7	A, C	}
8	C	
9	B	}
10	B	

At each selected intake, a single downward-looking transducer was deployed to monitor fish passage. Transducers were mounted near the top on the downstream side of Trash Rack 1 and aimed downward to sample juvenile salmon passing down into the intake (Figure 2.2). In a preliminary study in fall of 2003, we determined that passage estimates for the near-ceiling volume of a single down-looking transducer and for another up-looking transducer (Figure 2.3) were correlated ($r^2 = 0.79$, see Figure 2.4). The correlation indicated to us that a single down-looking transducer would be adequate to estimate fish passage when an STS is not deployed at B1. The lateral location of each down-looking transducer within an intake was randomized among the north, center, and south sides. Every transducer at B1 transmitted at 25 pings/s to maximize detectability. One single-beam transceiver and computer was used to control seven transducers, so two transceivers were required to sample 14 intakes at the powerhouse.

Acoustic counts for each intake sampled were expanded spatially using Equation 1 (see “Data Processing” below). These spatially expanded numbers of fish and within-hour variances for each of 8 1-minute periods per single-beam-transducer hour, or 20 1-min periods per split-beam-transducer hour, were expanded to a full hour. Hourly passage per intake also was expanded to estimate passage for entire turbine units, as described below (see “Data Processing”). Hourly passage estimates and variances were summed to obtain daily and seasonal estimates.

At sluiceway entrances above turbine intakes 2C, 4C, and 6C, two opposing 6-degree split-beam transducers were aimed across the entrance and sampled throughout spring and summer sampling seasons. One transducer was aimed toward the south and the other transducer was aimed toward the north, as illustrated in Figure 2.5, and only the far half of each beam was used to count fish passing through one half of the entrance. The split-beams provided data on fish speed, trajectory, direction of movement, and target strength. Transducers were fast-multiplexed at 50 pings per second (25 pings / s each) and each sluiceway was sampled for 20 1-min intervals every hour. Echo traces from fish detected at ranges > 9.8 ft from transducers were counted as passing if they met discharge-dependent slope criteria

and were not eliminated by other filters described in Appendix D and were moving downstream toward the entrance. Acoustic counts were expanded spatially using Equation 1 below, but opening height (water depth over the weir) was substituted for opening width so that expansion factors were based upon the ratio of the height of water passing over the chain gate to the diameter of the beam at the range of detection. Spatially expanded numbers in each of the 20 1-minute periods per transducer hour were expanded to a full hour, as was the within-hour variance. Hourly passage estimates and variances were summed to obtain daily and seasonal estimates. All fish passing into the sluice entrances were classified as guided fish for estimating B1 and Project FPE, and because in-turbine screens were not deployed in 2004 and sluice passage was the only guided-fish fraction, sluice-passage efficiency was equivalent to B1 FPE.

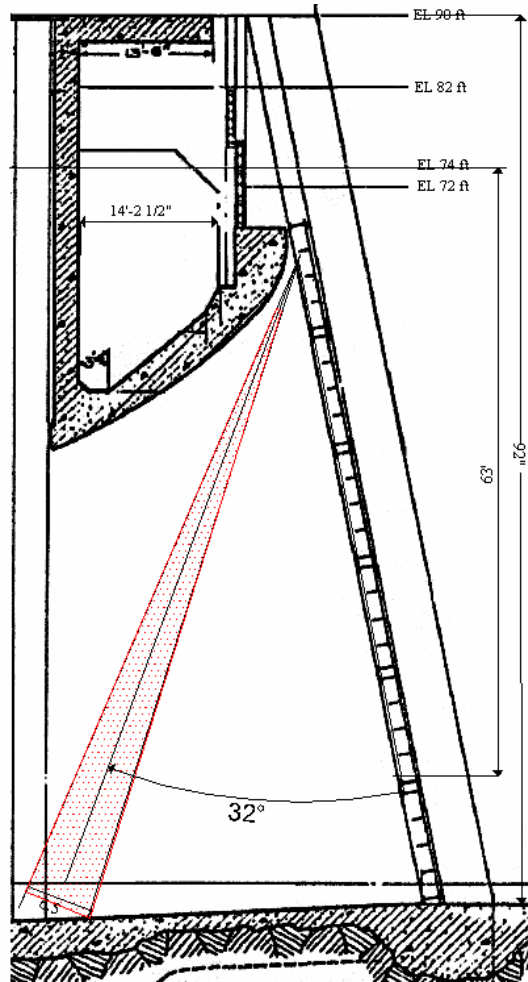

Figure 2.2. Cross-Sectional View through a B1 Turbine Intake Showing a Single Down-Looking Transducer Beam for Sampling Fish Passage through the Intake, when No STS Was Deployed. Flow into the intake is from right to left. Minimum and maximum ranges for tracking fish were 1 and about 22 m, respectively.

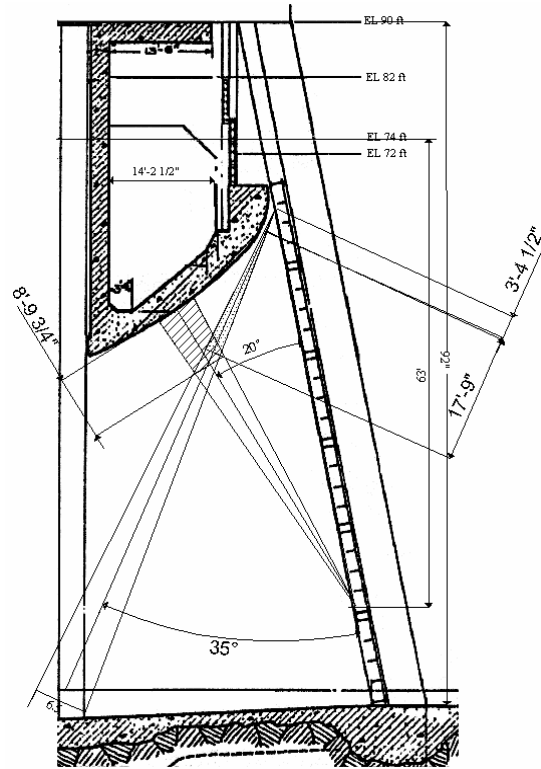

Figure 2.3. Cross-Sectional View through a B1 Turbine Intake Showing Near-Ceiling Volumes of a Single Down-Looking Transducer Beam Compared with that of an Up-Looking Transducer. Flow into the intake is from right to left.

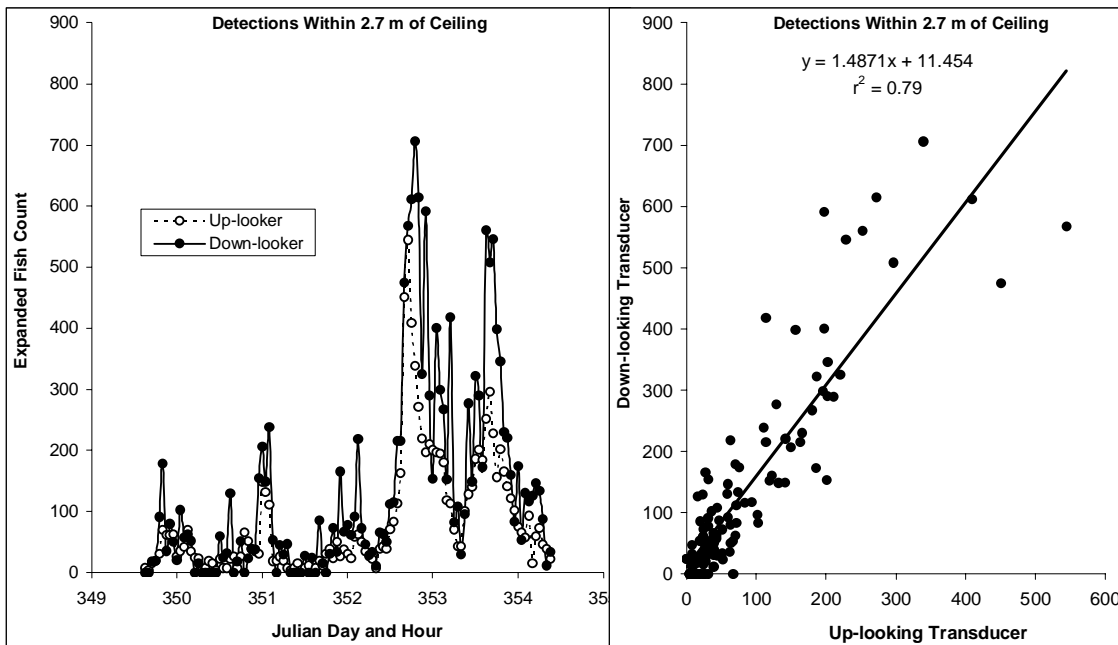

Figure 2.4. The Relationship between Hourly Estimates for the Same Intake Sampled by Up-Looking and Down-Looking Transducers. The left plot shows a time-history of expanded fish counts by Julian day and hour for the same near-ceiling volume sampled by up-looking and down-looking transducers, and the right plot shows a regression of down-looking transducer counts on up-looking transducer counts.

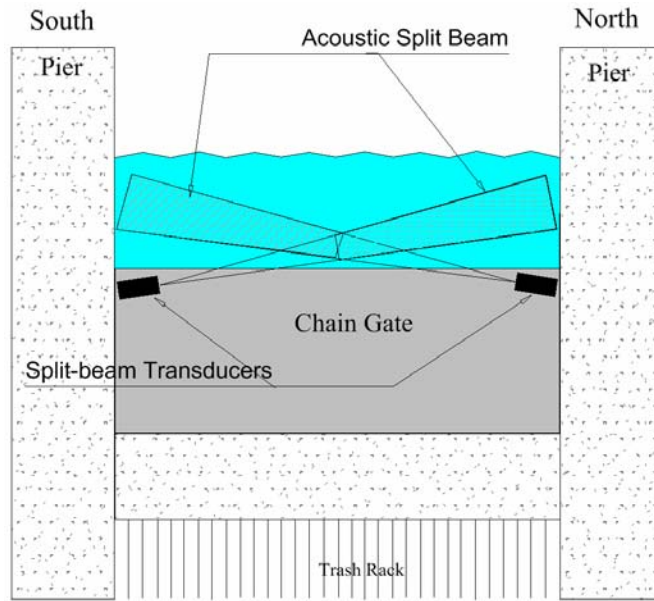

Figure 2.5. Forebay View of a Sluiceway Entrance at Intake 2C, 4C, or 6C in 2004 Showing the Deployment of Opposing Split-Beam Transducers for Sampling Fish Passage. The transducers were mounted 1-ft below the top of the chain gate. The minimum range for sampling fish in each of the acoustic beams was 3 m and the maximum range was the distance to the opposite pier (about 6 m). Flow into the entrance is from the reader's location toward the page.

2.3.2 Sampling the Spillway

Each of the 18 spill bays was sampled with one transducer, and the lateral location of each transducer within a bay was randomly selected to be on the north, center, or south one-third of the bay so that some of the lateral variation in passage within bays would be captured in the variance estimate for the entire spillway. All transducers had a pulse repetition rate of 25 pings per second. Most transducers were 10° single-beams, except for three 10° split-beams on spill bays 5, 7, and 17. The split-beams provided data on fish speed, trajectory, direction of movement, and target strength. Transducers were mounted on spill gates and angled 9° upstream from vertical so that the downstream edges of the beams were within about 4° of spill gates (Figure 2.6). Transducers were at elevation (EL) 56.5 ft when the gate was closed and at EL 69 ft when the gate was opened 12.5 ft. Maximum ranges from the transducer to the ogee were about 32.8 ft (nominal beam diameter = 5.91 ft) when a gate was closed and 45.6 ft (nominal beam diameter = 8 ft) if a gate was raised up 12.5 ft above the ogee. Echo traces from fish detected at ranges > 16 ft from the transducer were counted as passing if they met discharge-dependent slope criteria and were not eliminated by other filters described in Appendix D.

Hydroacoustic sampling was continuous, 24 hours per day, throughout the study, except for 10-15 minutes per day when data were downloaded. Spill bays 5, 7, and 17 with split-beam transducers were sampled for 20 1-minute periods dispersed throughout each hour, and the remaining spill bays with single-beam transducers were sampled for 1 minute at 5-minute intervals for 12 1-minute periods per hour. Acoustic counts for each intake sampled were expanded spatially using Equation 1 (see Data Processing below), and spatially expanded numbers of fish and within-hour variances for each of 12 1-minute periods per single-beam-transducer hour or 20 1-min periods per split-beam-transducer hour were

expanded to a full hour. Hourly passage estimates and variances were summed to obtain daily and seasonal estimates. The maximum gate opening in 2004 was about 7 ft and it provided for about 14,000 cfs of water discharge, although this varied with forebay elevation (head).

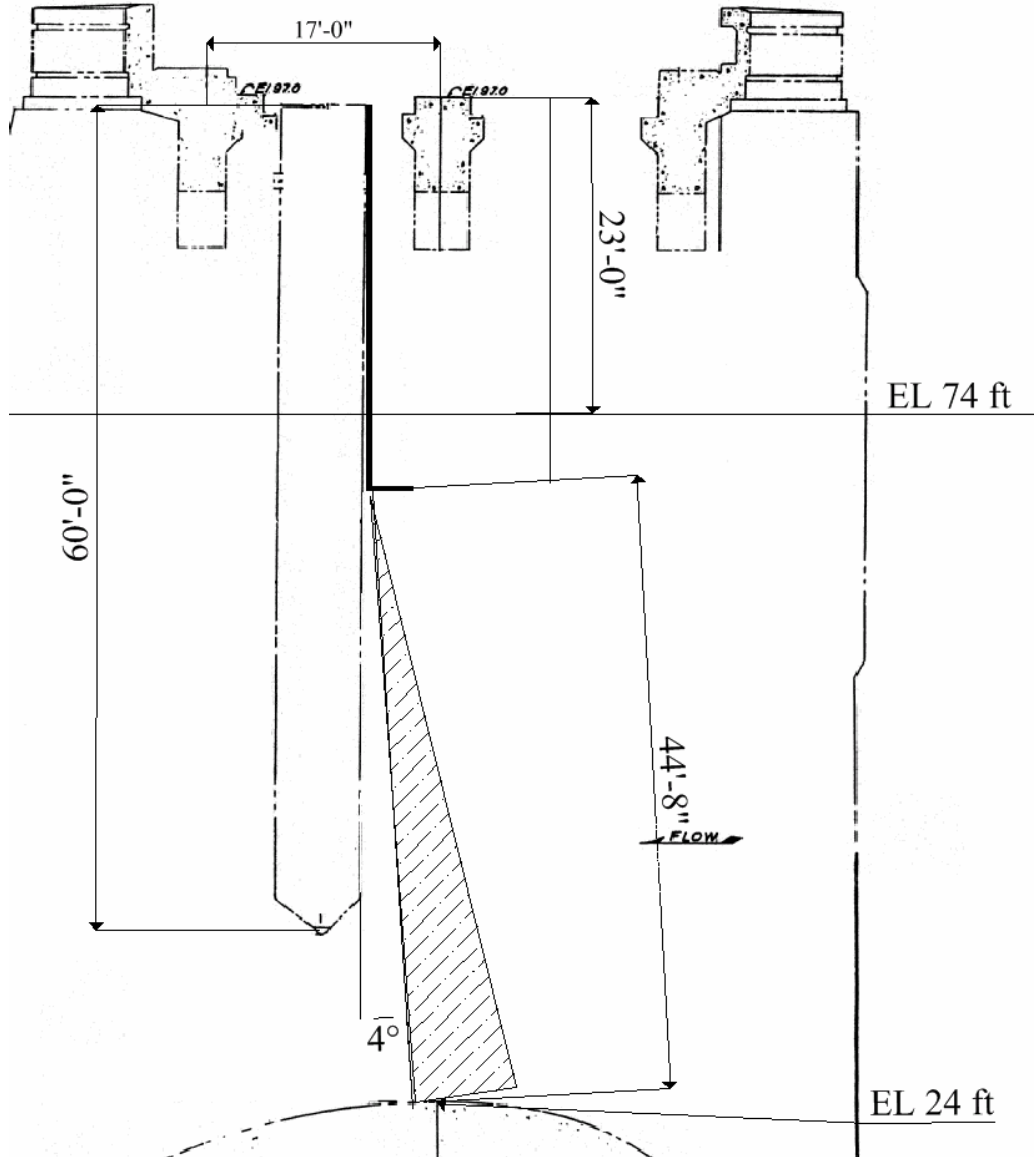

Figure 2.6. Cross-Sectional View through a Spill Bay at Bonneville Dam. The diagram shows a transducer mount on the upstream side of a spill gate and the orientation of the hydroacoustic beam upstream of the spill gate. The minimum range for sampling fish regardless of slope criteria was 5 m from the transducer, and the maximum range was at the concrete ogee. Flow under the gate is from right to left.

2.3.3 Sampling at B2

2.3.3.1 Hydroacoustic Sampling of Fish Passage

We sampled smolt passage into the B2CC entrance and through all turbines at B2 in 2004.

2.3.3.1.1 B2CC Sampling

The B2CC entrance leads to a new sluice channel that was extensively modified in 2003 to transport water and fish down an ogee and out to the downstream tip of Cascades Island, as opposed to a 50-ft free fall onto a concrete surface, as was the case before modifications,. The B2CC was operated for four days in March during the release of sub-yearling Chinook salmon from the Spring Creek Hatchery upstream and 24-h per day throughout the spring and summer out-migration seasons in 2004.

We located six split-beam transducers on a vertical pipe about 15 ft to the east of the B2CC entrance and acoustic beams were aimed across the entrance (Figure 2.7). Fish were detected mostly in side aspect, thereby maximizing signal-to-noise ratios and fish detection. The pipe supporting the vertical array of six transducers was rotated to aim acoustic beams about 12 to 15 ft upstream of the immediate entrance where flows were sufficient to capture smolts (5 to 10 ft / s) but low enough to allow adequate detectability (Figure 2.8). With a pulse repetition rate of 33 pings / s, a fish moving 8 ft / s through the center of an acoustic beam would provide about 7 echoes if it passed into the entrance on the south side and 13 echoes if it passed on the north side. Four echoes were the minimum required to classify an echo trace as a fish. The upper two split-beams had nominal 3-degree acoustic beams to minimize volume reverberation, which was worst near the surface. The lower four transducers had nominal 6-degree acoustic beams. Counts of detected fish were expanded by the ratio of the vertical dimension of a truncated trapezoidal area sampled by each acoustic beam to the diameter of the beam at the range of detection (Table 2.2).

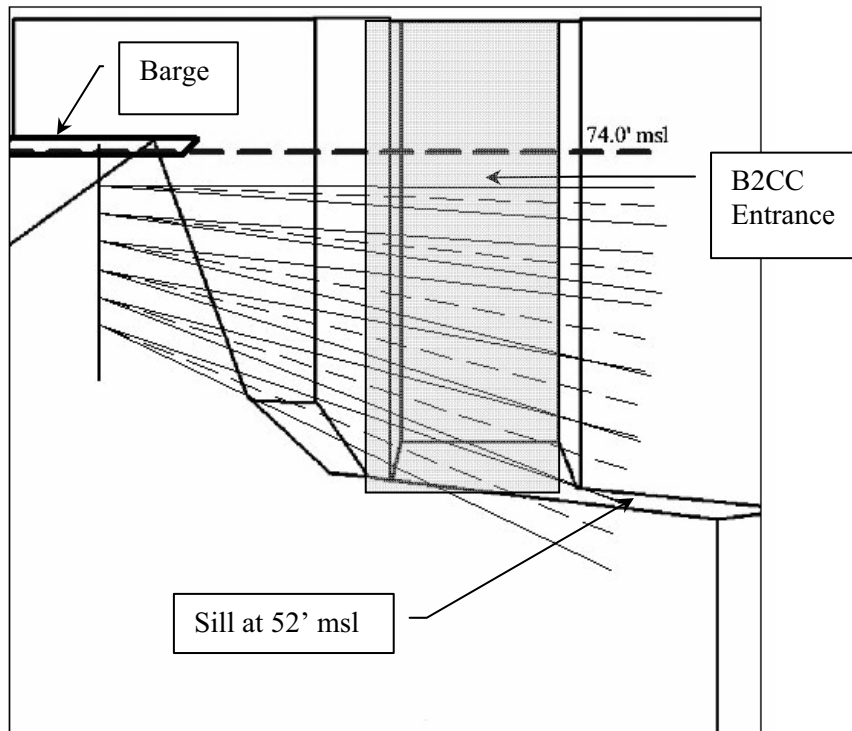

Figure 2.7. Diagram of a Frontal View of the B2CC Entrance Showing the Acoustic Beams from Six Split-Beam Transducers Deployed from a Barge East of the Entrance. Minimum and maximum ranges for tracking fish were 15 and about 29.5-36 ft (depending upon the beam), respectively.

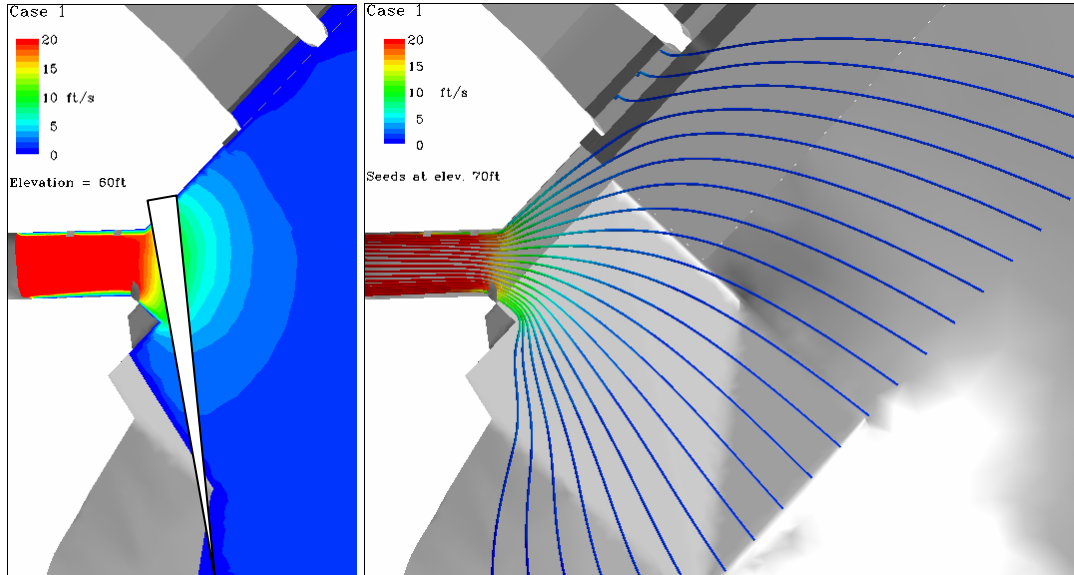

Figure 2.8. Plan Views of the B2CC Entrance Showing Predicted Water Velocities of 8 to 10 fps in the Area that Split-Beam Transducers Sampled Fish Passage in 2004. The transducers were aimed across the entrance as indicated by the triangle in the left diagram. The left figure indicates velocity magnitudes and the right figure shows both magnitude and direction. The CFD runs were made by Cindy Rakowski and the figures were created by John Serkowski, both of PNNL.

Table 2.2. Statistical Analysis System (SAS) Code Used to Spatially Expand Detected Fish Based Upon the Ratio of the Height of the Truncated Trapezoid Sampled to the Diameter of the Acoustic beam at the Range of Detection. System U, V, and W refer to the echosounder and transducer combinations where W included 3° transducers 1 and 2, V included 6° transducers 3 and 4, and U included 6° transducers 5 and 6. Sample region height (SRH) was calculated from regression equations and expanded numbers of fish (EXP_FISH) were calculated from SRH divided by the tangent (TAN) of one half of the effective beam angle (ANGLE) times the mid-range (MID_RANGE).

```

IF SYSTEM IN ('U', 'V', 'W') THEN DO;
  ***Calculate the sample region height in feet;
  IF SYSTEM='W' then do;
    IF MUX_CHANNEL=0 then SRH= 0.0707*range+3.4261;
    IF MUX_CHANNEL=1 then SRH= 0.0570*range+2.01;
  END;
  IF SYSTEM='V' then do;
    IF MUX_CHANNEL=0 then SRH= 0.0855*range+2.002;
    IF MUX_CHANNEL=1 then SRH= 0.0745*range+1.9959;
  END;
  IF SYSTEM='U' then do;
    IF MUX_CHANNEL=0 then SRH= 0.0776*range+1.9916;
    IF MUX_CHANNEL=1 then SRH=-0.3654*range+12.587;
  END;
END;
SRH=SRH/3.281; ***Convert from ft to m;
IF ANGLE=. OR FISH=0 OR ANGLE=0 THEN EXP_FISH=0;
ELSE EXP_FISH=FISH*SRH/(TAN(ANGLE/2*3.1416/180)*MID_RANGE*2);
END;
    
```

Each of the six transducers was sampled for 1 minute, 30 times per hour, and spatially expanded counts were temporally expanded to the whole hour ($\times 2$). Hydroacoustic sampling was continuous, 24 hours per day, except for a 15-minute period each day when data were downloaded. Each transceiver interrogated only one of its two transducers at a time to maximize the pulse repetition rate at 33.3 pings / s.

Transmissions from one transducer and transceiver from each of three transceivers were synchronized. Numbered from the top down, transducers 1, 3, and 5 sampled simultaneously during odd numbered minutes, and transducers 2, 4, and 6 sampled simultaneously during even numbered minutes. Hence, arrays 1-3-5- and 2-4-6- each sampled approximately half of the corner collector entrance. We summed passage estimates from each of the areas sampled to obtain a total for the entrance, and hourly estimates were summed to estimate passage by day and season.

A problem with sampling sluiceway entrances is that fish densities can sometimes be so high that typical hydroacoustic gear with pulse widths of 200 μ s cannot resolve all individual fish unless they are ≥ 6 inches apart. We encountered this problem at a B1 sluiceway entrance in summer 2002 (Ploskey et al. 2003). Therefore, the split-beam transceivers used to sample the B2CC in 2004 had their bandwidth increased from 20 to 100 kHz and pulse widths shortened from 200 to 80 μ s to reduce the target resolution distance from about 6 inches to about 2.36 inches, where resolution distance is the minimum range between resolvable targets.

2.3.3.1.2 B2 Turbine Sampling

There are eight turbine units numbered 11 through 18 at B2, and each turbine unit has three intake slots. One out of three intakes at every turbine unit was randomly selected for sampling, but sampling was supplemented by the B2 FGE study, and this added one additional randomly selected intake for sampling at Units 11 and 12 and two additional intakes at Unit 17. We sampled additional intakes at Units 11, 12, and 17 to increase precision in areas where most fish pass (Units 11 and 12) or where the Region had an interest in FGE performance in a unit with modified gatewell slots (Unit 17). Spatial strata were assigned to estimate within-unit, among-intake variances in passage estimates (Table 2.3) as described under Estimating Fish Passage below.

Table 2.3. Intake Slots Randomly Selected for Sampling at B2 during the 2004 Study

Unit	Intake Slots Sampled	Spatial Strata
11	A, B	1
12	A, C	2
13	B	}
14	B	
15	B	}
16	B	
17	A, B, C	}
18	B	

At every sampled intake, a pair of transducers was mounted on the downstream sides of trash racks 1 and 4 (Figure 2.9). One transducer of each pair was mounted at the bottom of the uppermost trash rack (Trash Rack 1) and aimed downward to sample unguided fish passing below the tip of the traveling screen. The second transducer of each pair was mounted at the middle of the fourth trash rack (Trash Rack 4) from the top and aimed upward to sample guided fish passing above the tip of the screen. The location of transducers within intakes also was randomized among the north, center, and south. A pair of split-beam transducers was deployed in Intake 16 to obtain fish velocity, trajectory, and target strength data for modeling detectability.

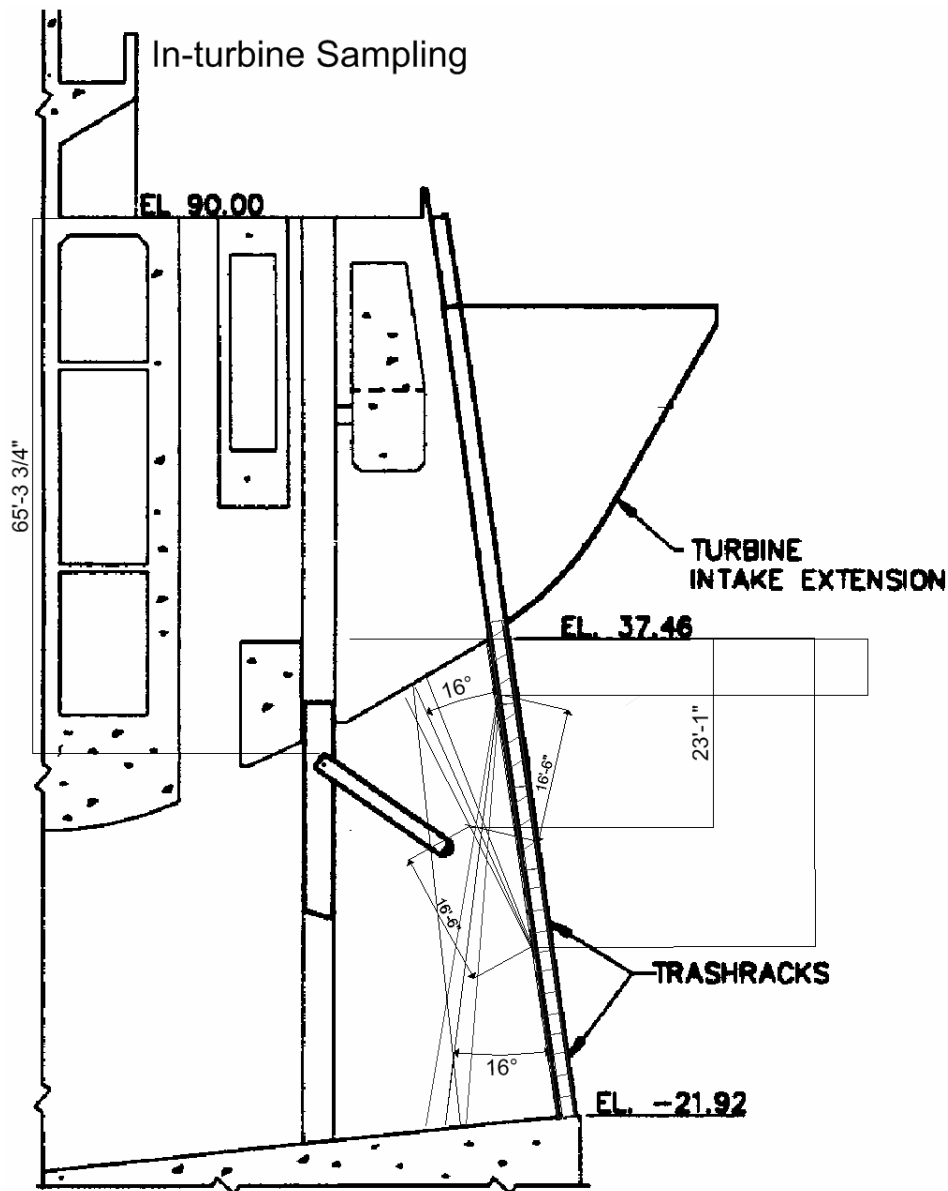

Figure 2.9. Cross-Sectional View through a B2 Turbine Showing Up- and Down-Looking Transducer Beams. The minimum range for sampling guided and unguided fish was 5m in both cases. Flow into the intake is from right to left.

Throughout the study, hydroacoustic sampling was continuous for 24 hours per day, except for a 10-15 min period per system to download data. Single-beam transducers were sampled for 7 or 10 1-minute intervals per hour depending upon the number of transducers on the system. The split-beam transducer was sampled for 20 1-minute intervals per hour. Transducers on each system were sampled sequentially for 1 minute each to allow a high transmit rate of 23 pings / second. Therefore, up-looking and down-looking transducers sampled different minutes within the hour. For each sampled intake, counts of echo traces deemed to represent fish were expanded spatially using Equation 1 (see Data Processing below). Spatially expanded numbers of fish and within-hour variances for each of the 7 or 10 1-minute periods per single-beam-transducer hour or 20 1-min periods per split-beam-transducer hour were expanded to a full hour. Hourly passage estimates and variances were summed to obtain daily and seasonal estimates.

2.3.3.2 DIDSON Sampling of STS Gap Loss

This study examined the effect of gatewell modifications by comparing the proportion of STS-guided fish lost through the gaps between the tops of the STSs and the ceilings of the intakes of unmodified Unit 13 and a modified Unit 17 at B2. Physical modeling of B2 intakes by the Portland District raised concerns that flow moving above the STS and up the gatewell was limiting FGE and that a high proportion of flow was moving through the gap between the top of the STS and the intake ceiling (Figure 2.10). The gap at the top of the STS is about 18 inches high and 20 ft wide in an unmodified gatewell slot and about 6 inches high and 20 ft wide in a modified gatewell slot. In an attempt to improve FGE, the Portland District modified gatewell slots in Unit 15 before the 2001 smolt migration and gatewells at Unit 17 before the 2002 migration. Modifications consisted of removing a lot of concrete, greatly expanding the surface area of the vertical barrier screen (VBS), and adding a turning vane and gap closure device to direct more water up the slot and away from the gap between the top of the STS and the intake ceiling (Figure 2.11). The objective was to increase flow above the STS and up into the gatewell slot, thereby reducing gap loss of fish and increasing smolt guidance efficiency. In 2002, the mesh size of the VBS was reduced from about 0.25 inches to about 0.125 inches to guide salmonid fry.

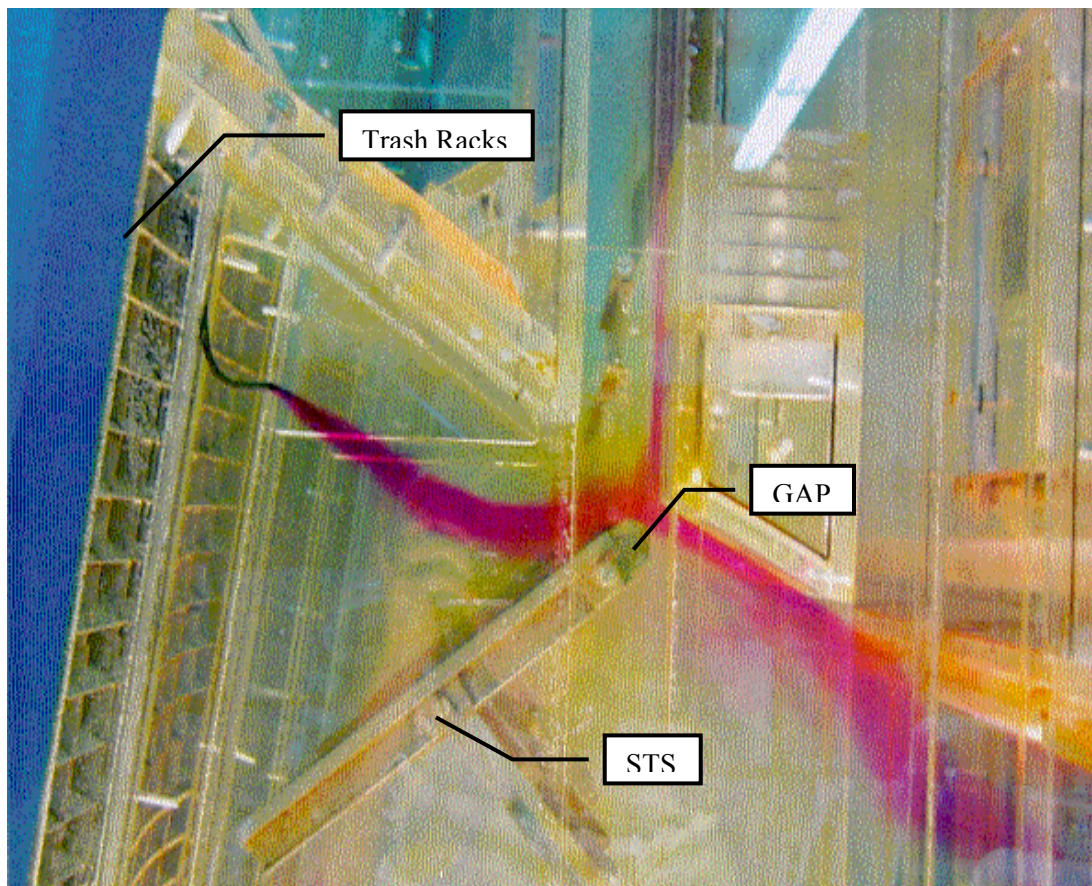

Figure 2.10. Cross-Sectional View of a Model of an Un-modified Intake at B2 Showing the Path and Distribution of Dye Introduced at the Trash Racks on the Left Side. The model was built by the Hydraulics Laboratory of the Engineer Research and Development Center, Vicksburg, MS). Flow into the intake model is from left to right.

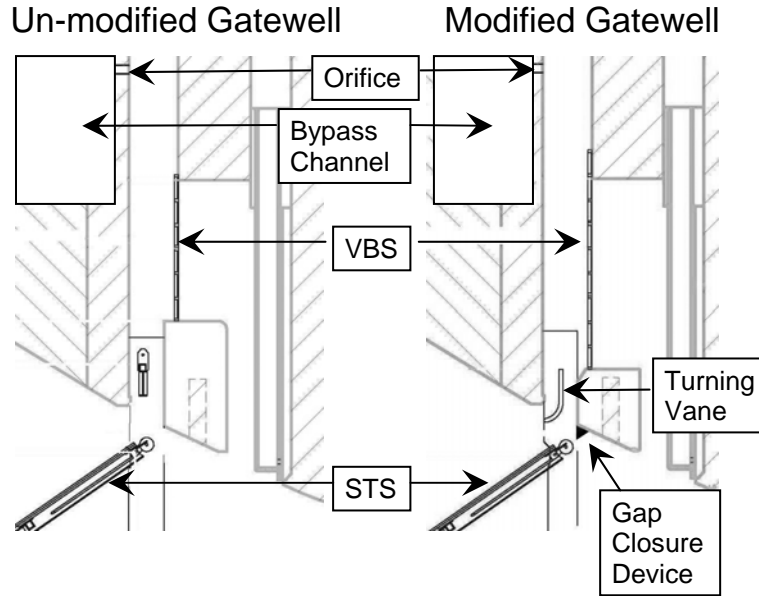

Figure 2.11. Cross-Sectional View through Intakes with Un-modified and Modified Gatewells at B2. Intakes of Units 15 and 17 were modified (right diagram) to increase flow above the submerged traveling screen (STS) and through the vertical barrier screen (VBS), thereby leaving more smolts in the gatewell to find their way to the orifice and juvenile bypass channel. Modifications consisted of removing concrete, increasing the area of the VBS, and adding a turning vane and a gap-closure device. Flow into the intake would be from left to right.

2.3.3.2.1 Deployment

The DIDSON was attached to a mounting plate that was moved along a 20-ft-long horizontal beam by a stepper motor so that samples could be collected at five lateral locations across the gatewell (Figure 2.12). The stepper motor was controlled by custom-designed software on a computer through a serial communication port. The program was downloaded to a Parker 6K2 stepper controller, which sent commands to a Parker Zeta8 indexer and controlled the action of the stepper motor. The controller for the stepper motor was programmed to move the DIDSON along the beam stopping at each of the five lateral locations for 10 min and then proceeding to the next location. The travel time of the DIDSON from one end of the beam and back was two hours, sampling at each of the five locations twice. Feedback from the stepper motor to the computer provided position information, and positions were verified by five Turk proximity sensors located along the beam and illuminated individual position indicator lights in the equipment trailer when the DIDSON passed over the sensor. The imaging rate was 8 to 10 frames/s depending on the amount of entrained air entering the gatewell slot. The DIDSON was aimed down-looking into the gatewell slot with the fan of 96 0.3°-wide by 12°-long beams oriented in an upstream-downstream direction (Figure 2.13) so smolt could be detected in multiple beams as they passed downstream across the composite beams and vertically (up or down in the gatewell).



Figure 2.12. Traversing Beam and DIDSON Assembly Deployed in the Gatewell Slots of Intakes at Units 13 and 17. The stepper motor that moved the DIDSON along the beam is on the left end of the beam and the moving plate with the DIDSON attached is in the middle of the beam. The beam was deployed by riggers using the TIE crane.

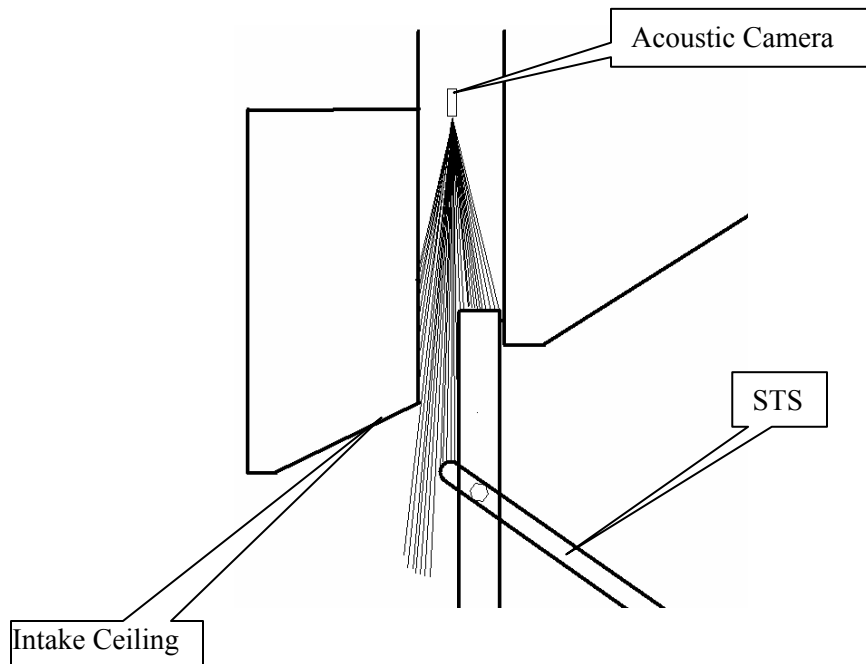

Figure 2.13. Cross-Sectional Diagram of an Unmodified Gatewell Slot of Unit 13 at B2 Showing the Upper End of the STS and the DIDSON Deployment in the Gatewell. Flow would be entering the intake from the right side.

2.3.3.2.2 Sampling

We sampled with the DIDSON for about 12 hours / night for three nights in each of the three unmodified intakes of Unit 13 and for three nights in each of the three intakes of modified intakes of Unit 17 (Table 2.4). Beginning on May 26, intake 17B was sampled for 24 hours to evaluate diel patterns.

Table 2.4. Spring 2004 Sampling Schedule for Unmodified Unit 13 and Modified Unit 17

Date	Intake Sampled Overnight	Presence of Gap Closure Device	Presence of TIE
6-May	13C	No Closure	No TIE
7-May	13C	No Closure	No TIE
8-May	13C	No Closure	No TIE
9-May			
10-May			
11-May			
12-May			
13-May			
14-May			
15-May			
16-May			
17-May	13B	No Closure	No TIE
18-May	13B	No Closure	No TIE
19-May	13B	No Closure	No TIE
20-May	13A	No Closure	No TIE
21-May	13A	No Closure	No TIE
22-May	13A	No Closure	No TIE
23-May			
24-May	17B	Closure	TIE
25-May	17B	Closure	TIE
26-May	17B	Closure	TIE
27-May	17C	Closure	TIE
28-May	17C	Closure	TIE
29-May	17C	Closure	TIE
30-May			
31-May			
1-Jun	17A	Closure	TIE
2-Jun	17A	Closure	TIE
3-Jun	17A	Closure	TIE

2.3.3.3 DIDSON Sampling of Fish Approach and Fate at the B2CC

Fish approaching the B2CC and south eddy at B2 were imaged with a DIDSON operating in low-frequency mode during three 24-h periods in early, mid, and late spring and summer (9 diel samples each season according to the schedule in Table 2.5). The fan of 48 adjacent 0.6°-wide by 12°-deep DIDSON beams was oriented horizontally throughout the study and covered approximately 30° (Figure 2.1). The DIDSON was mounted on a pan and tilt rotator that was controlled by a technician with a joystick to keep smolts approaching the B2CC entrance or south eddy within the DIDSON’s field of view as long as possible. The aiming angles from the rotator were also incorporated into the DIDSON program using a serial Data Acquisition (DAQ) Module. This allowed pan and tilt angles to be integrated with each frame of the DIDSON file. Rotator coordinates and fish positions in the sample beams were used to describe

fish positions through time in 3-D space. Of particular interest were approach paths relative to the boundary between eddy flow and flow into the B2CC entrance.

Fish tracking was initiated randomly in pre-selected zones where fish had a choice about entering the B2CC entrance or swimming away (Figure 2.1). Each zone was divided into three ranges (0-6 m, 6-12 m, and 12-18 m), and technicians were instructed to track fish from all ranges within each pie-shaped zone. Sampling upstream of the entrainment zone where fish could make a choice was important because we could learn nothing about responses to entrance conditions from tracking entrained fish. The number and the behavior of any predators that happened to be detected also were recorded.

Table 2.5. DIDSON Deployment and Sampling Schedule for the B2CC

Install	Remove
1-Mar	15-Mar
19-Apr	22-Apr
3-May	6-May
17-May	20-May
31-May	3-Jun
7-Jun	10-Jun
21-Jun	24-Jun
5-Jul	8-Jul

At the beginning of each 8-h shift, a technician signed in and recorded a qualitative description of weather conditions. Descriptions were recorded again during each shift whenever there was a substantial change in the weather. Technicians rotated the DIDSON to one randomly selected position out of six potential starting positions to initiate sampling (Table 2.6), waiting for up to two minutes for a fish to enter the field of view before rotating to the next prescribed position. Successive aiming positions were obtained from tables of pan-and-tilt angles selected at random from six possible sets without replacement. If a smolt-sized fish or school of fish was observed, the technician flipped a switch to record a 1 for a binary tracking variable in the data stream of image frames to indicate that they were actively tracking a fish. They used the joystick to follow the fish until contact was lost or the limits of travel toward or away from the B2CC entrance had been reached. Limits of travel were 130° and 235° for the horizontal plane (Figure 2.1) and 175° and 215° for the vertical plane (Figure 2.14). When a fish was lost or passed beyond the end of the set rotator limits, technicians flipped the switch again to return the binary tracking variable to zero, indicating that no fish was being tracked as successive frames of images were recorded, and they rotated the DIDSON to the next prescribed sampling position from the table of random aiming positions.

Table 2.6. Six Aiming Positions Used to Initiate DIDSON Tracking Upstream of the B2CC

Sampling Position	Pan angle	Tilt angle
I	145	186
II	175	186
III	205	186
IV	145	198
V	175	198
VI	205	198

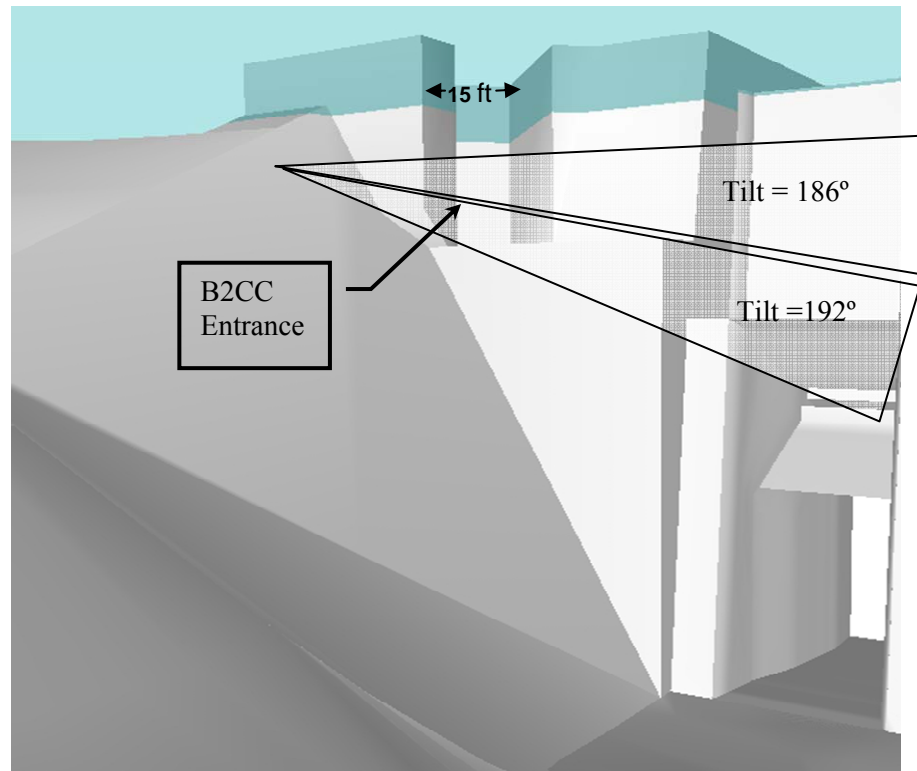

Figure 2.14. Front View of the B2CC Entrance Showing Two Relative Tilt Angles from the Pan and Tilt Rotator for Sampling Two Vertical Sections of the Water Column.

2.4 Fish Tracking and Filtering Criteria

2.4.1 Fixed Aspect Hydroacoustic Sampling

We used autotracking software developed from 1998 through 2002 by the Corps of Engineers and PNNL to process raw data into tracked-fish observations. As in prior years, the hydroacoustic sampling effort for Bonneville Dam in 2004 was so extensive that it was not practical or cost-effective to manually process all of the data required to make reliable fish-passage estimates.

The autotracker software tells the processing computer to:

1. Identify and remove echoes at constant range from structure.
2. Find seed echoes for candidate tracks.
Go to every echo.
Define a 10-ping by 1-m window centered on that echo.
Place all echoes in the window into 5-degree angle bins.
If any bin-count >3, flag the center echo as a candidate seed.

3. Re-examine candidate seed echoes.
Go to every seed-echo window.
Count echoes in all possible line features (Hough transform).
If no echoes in the window are part of a strong line feature then drop the seed echo (to distinguish between dense noise and dense fish tracks).
4. Initiate alpha-beta tracking.
Track forward, starting at each seed echo.
Track backward from the same seed echo after forward tracking has ended.
Check the track segment against criteria (echo density; minimum and maximum gap).
5. Link collinear track segments into single tracks. This involves projecting the first track segment forward and the second segment backward and linking them into one track if the ping gap ≤ 20 pings and the two segments line up and meet a track link criteria.
6. Write out track statistics (echo statistics optional).

We describe and present autotracker parameters and the settings used to process the 2004 data in Appendix C. During most of spring and early summer, we reviewed samples of the autotracker's performance for every deployment on a fish-by-fish basis to evaluate and fine-tune the autotracker and to develop post-processing filters for eliminating false traces from the autotracker's output. We released the autotracker to process data for a given deployment only after we determined that it was missing few of the echo patterns that we would have tracked manually.

In Appendix D, we describe criteria and present SAS code used to reject non-fish traces that the autotracker selected. In another part of the processing program, we eliminated fish detected at ranges less than 1 m for B1 turbines (Figure 2.2), 3 m for B1 sluiceway entrances (Figure 2.5), 5 m for spill bays (Figure 2.6), 4.5 m for the B2CC entrance (Figure 2.7), and 5 m for B2 turbines, both guided and unguided (Figure 2.9). Filtering non-fish traces based upon variables like range, slope, and noise level is a critical part of using autotracking software, because the autotracker is more likely to track an intermittent series of structural echoes or noise than are technicians. Filters were designed to eliminate echo traces that had a high probability of being from structure, noise, or large non-target fish based upon their track statistics.

Although the autotracker was a very efficient tool, we evaluated its performance and post-processing filters in both seasons by comparing counts of fish by the software and by trained technicians. We did extensive training and testing on raw hydroacoustic data from previous years and from early 2004 data before the 2004 tracking season began. In previous years (Ploskey et al. 2001a-c and 2002a-c), we found that there are important and consistent differences that occur among different human trackers of hydroacoustic data and that these differences, if not carefully controlled, can seriously bias counts used either for passage estimates or for quality control and assurance of automatic tracking. For that reason, we always compare our automatically tracked estimates with the average estimate from more than one human tracker. Average hourly counts and variances in 2004 were calculated from counts by three of the four technicians processing data. This approach allowed technicians to manually track a quarter more data than if all four technicians had tracked each hour.

We selected 10 days throughout spring and 10 days throughout summer from which to select manual tracking data. From each of those selected days we chose, for each of the 17 hydroacoustic systems on the dam, three hours of raw data for quality control and assurance analysis. These included the typically highest passage hour in spring (2100 hour) and summer (2200 hour) except for cases when B1 data from

those hours were unavailable because units there were not operating. In those cases, the closest operating hours to the 2100 and 2200 hours were selected from the available data. The high passage hours were selected to provide the best possible range for regression analysis. The other two hours per chosen day were randomly selected. This scheme gave us 60 hours of raw data from each transducer from throughout spring and summer for comparing autotracked and human results. We use hourly samples for comparison because that is the smallest scale on which we produce passage estimates. Raw echogram data were tracked by humans and the autotracker, and the resulting data were filtered and expanded identically.

Each tracker's output, whether from a human or from the autotracker, was processed with a channel-specific software "filter" that automatically rejects traces that do not meet specific criteria. Output files from each human or automatic tracker were post processed identically. Post-processing included deployment-specific "filtering" for trace length, trace slope, echo or target strength, structure, and other regular noise, and other characteristics described in Appendix D. The resulting filtered fish counts on each day were then summed separately to produce the hourly passage estimates for the appropriate passage route.

We compared, by linear regression, human and autotracked counts for each of the transducer channels. A transducer-channel-level analysis is essential because there are important differences in passage characteristics, ranges of interest, trace slopes and lengths, and noise conditions for each transducer's site and aiming angle. Comparing at the system level, which involves several transducer channels with different deployments, could mask error by pooling and thereby obscuring offsetting errors for different channels within a system (Ploskey et al. 2002c). Up-looking transducer channels sampling guided fish have very different noise regimes from those of down-looking-transducer channels and the slopes of regression lines fitted to autotracker and mean human counts often differ too. They can even vary in opposite directions, so that up-looking-transducer channels have higher autotracked counts and down-looking transducer channels have higher human-tracked counts. In those cases, comparing at the system level would mask some of the disagreement between the humans and the autotracker. Even with the same aiming (such as all of the down-looking channels at a powerhouse), different channels have different noise, clutter, and range of interest characteristics. The most appropriate analysis for quality control and assurance is hourly data samples from throughout the sampling seasons and diel cycles comparing filtered and expanded autotracker results to the mean filtered and expanded human results for the same data hours on a channel-by-channel basis.

2.4.2 Gatewell and Gap Loss Tracking of DIDSON Data

The DIDSON data was initially processed by viewing native DIDSON files (ddf format) and counting the number of fish-shaped images observed moving up into the gatewell or through the gap between the top of the STS and the ceiling of the intake. Along with counting the number of fish-shaped images observed, we recorded its range from the DIDSON, number of frames from first to last detection, number of frames the object was detected, shape of the object, if it was on the screen of the STS, if it undulated, and the length of the object. The data was next filtered by these variables using criteria similar to that developed for processing of data in 2003 since the DIDSON can detect non-fish objects such as waterlogged sticks and macrophytes (Ploskey et al. 2004).

In processing spring 2004 data, we deleted observations that met the following criteria:

1. Gatewell-bound objects first detected at ranges < 3 m from the DIDSON or in < 3 frames. Fish within 3 m of the DIDSON and more than 2 m above the top of the screen had a higher probability of being re-circulated through the field of view and counted multiple times than fish detected within 2 m of the top of the screen.
2. Gap-lost objects that were not undulating or crossing stream lines or that were detected in < 4 frames in A or B intakes or in < 5 frames in C intakes.
3. Maximum target length < 70 mm and > 305 mm in spring.

2.4.3 Tracking Fish Approaching the B2CC

A Visual Basic program “TRACKDID” was used to extract spatial information from tracks of individuals and groups of fish in binary files of the DIDSON system. The program operated to interactively identify fish tracks by the user boxing around fish in each frame display using a mouse pointer (Figure 2.15). The relative coordinates of the box’s opposite corners were recorded in ASCII data files with the binary track file name, frame number, date, time, pan angle, tilt angle, roll angle, number of fish in box, and a unique track identification. The roll angle was not an angle *per se* but a field used to indicate a switch set when the observer followed fish as the DIDSON was operated. A TRACKDID option scanned frames for a roll angle indicating active tracking. Normally, when a roll angle of 1 was found (indicating active tracking) the user reversed frames to find the fish track initiation and recorded from that point forward through frames. An additional option allowing frame skipping, by a user input number, increased tracking efficiency. Other options included gain and threshold settings. After files were interactively (manually) tracked, it was discovered that the frame starting range and maximum range were incorrectly computed in the TRACKDID program because it read these parameters from the file header instead of from each frame’s header. Corrections to the computed coordinates of “box” corners were made in a subsequent program.

William Nagy, with the Fisheries Field Unit, began developing an autotracker to facilitate tracking of fish in DIDSON images in the future because manual processing was a very slow and tedious process. As many as 90 boxes might be drawn to spatially and temporally characterize a track lasting just 10 seconds. The automated tracking program was not complete by the end of this study, but it will be available before another such study is launched. Data in the text file was processed to calculate real world coordinates for every recorded position of fish so these tracks could be overlaid upon a computational fluid dynamics (CFD) model grid. We used the fish movement data to compare smolt movements with flow based upon CFD modeling and to estimate the probability of smolt in any forebay location moving into the B2CC entrance.

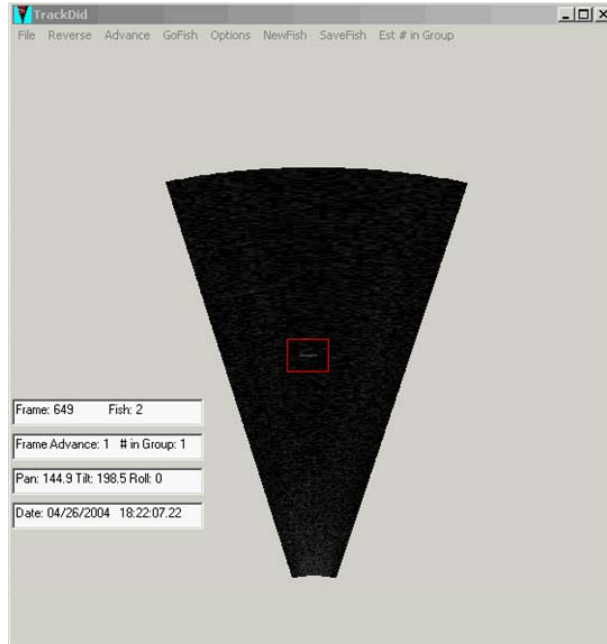

Figure 2.15. The Computer Screen Display of the DIDSON File Tracking Program, "TRACKDID" shows a Red "Box" Created by a User around a Fish Image to Interactively Save the Fish Location Coordinates. The range of the fan is 17.9 m.

2.4.4 Coordinate Systems for Fish Approach and Fate at the B2CC

Several steps were made after obtaining the tracked fish files and prior to Markov chain analysis. These included conversion to fixed coordinate systems, fish track visualization, separation into season and day-night datasets and selection of the volumes to analyze. The process of aligning the relative tracked fish data to fixed coordinates consisted of applying pan angle corrections, river elevation corrections, and rotations and translations to two different coordinate systems. The coordinate system "Oregon State Plane North Zone" (OSPN) was used for three-dimensional visualization and preliminary analysis with modeled flow.

A second coordinate system, used in the Markov chain analysis, was relative to a reference point easting 1632458.16, northing 725359.76 (OSPN feet) at the south corner of the corner collector, and this point was established as the origin ($x, y, z = 0,0,0$ - Figure 2.1). The DIDSON was located at several elevations and orientations based on river water level and mooring structures. It was assumed at a constant x - and y -position, -3.46 ft, -15.16 ft (easting 1632466.89 northing 725346.89 OSPN feet). The rotation angles in Figure 2.1 were relative to raw corrected pan angles of the DIDSON where 169.3° was parallel to the dam. River elevations and pan angle corrections (Figure 2.16) were entered in a computer file "didelev.txt" for input to the program converting tracked fish coordinates. Approximately hourly checks to a reference pier provided corrections to the DIDSON pan angles. Linear interpolation was used to estimate corrections within hours or for missing hourly checks. A polynomial interpolation was made for corrections over a 4-hour period on April 27, 2004, when one of the mooring structures failed.

Sunrise and sunset were used to differentiate day from night and input as "NBsunset.txt". Times were based on a table found at the website <http://aa.usno.navy.mil/data/> of the Astronomical Applications Department, U.S. Naval Observatory, for North Bonneville, Washington, W121°56', N45°39', "Rise and Set for the Sun for 2004."

Output files were named “*.SPL” for Oregon State Plane coordinates, “*.PCA” for relative coordinates, and “*.TEC” for Tecplot visualization in relative coordinates.

Using the two positions of the fish track box (X_1, Y_1) and (X_2, Y_2), their ranges (R_1, R_2), and the tilt angle θ , a single tracked fish position corresponding to the track box (and relative to the pointing angle of DIDSON) was computed as

$$\left(\frac{X_1 + X_2}{2}, \frac{Y_1 \cos(\theta) + Y_2 \cos(\theta)}{2}, \frac{R_1 \sin(\theta) + R_2 \sin(\theta)}{2} \right).$$

This position was corrected by applying river elevation and pan corrections, pan angle, and rotation and translation into positions in the two coordinate systems described above.

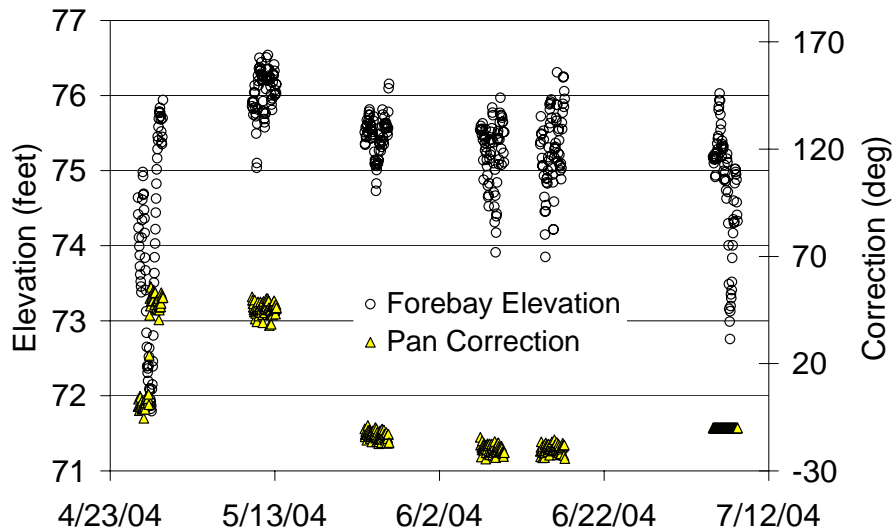

Figure 2.16. Forebay Elevations and Pan Angle Corrections made to the DIDSON at the North Bonneville Dam B2CC.

2.4.5 Computational Fluid Dynamics Modeling

A computational fluid dynamics (CFD) model of the full Bonneville Dam forebay was used to provide hydrodynamics (water velocities, flow patterns) information to complement the biological field studies of the effectiveness of the B2CC as a passage route for juvenile salmonids. The CFD code used in this study was STAR-CD (www.cd-adapco.com), which had been used in previous studies at the Bonneville project (Rakowski et al. 2001a, 2001b). A total of six operational conditions were simulated using the CFD model. These operational scenarios were chosen because they were representative of most flow conditions that occurred during the biological studies.

The domain of the numerical model included B1, B2, the spillway, and about one mile of the Columbia River upstream from the Project. The computational mesh contained about 1.9 million cells and was based on multiple data sources. The forebay bathymetry was developed from multiple detailed field surveys. The data for the engineered structures were based on as-built drawings provided by USACE – CENWP. The numerical model included the three intake bays for each turbine unit at B1 and B2, individual spill bays, fish units, station service flows, and sluiceway outflows at B1 and the B2CC.

The CFD model was validated in the Bonneville forebay to the best available field-measured acoustic Doppler current profiler (ADCP) velocity data (Rakowski et al. 2001b). For a complete description of the mesh development and model validation see Rakowski et al. (2001a) and Rakowski et al. (2001b). Simulation results were provided as velocities and animations of the flow patterns in the B2 forebay.

Evaluation of the turbine, spillway, and total discharge and the forebay elevation data during the sampling period showed that there was not a single consistent set of operating conditions. Consequently, the CFD model was applied for six steady-state operational scenarios representing turbine, spillway, and B2CC discharges and forebay elevations during the dates and times DIDSON images were collected at the B2CC in 2004. Although the steady-state operational scenarios chosen did not exactly match the conditions during the DIDSON sampling, the scenarios were representative of the broad range of flow conditions that occurred during DIDSON sampling. Factors that went into the selection of operational conditions included:

1. DIDSON sampling occurred during chosen condition.
2. The model conditions spread over the normal range of conditions sampled with the DIDSON.
3. Limiting the number of runs based on limited resources.

The project operations for the six scenarios are summarized in Table 2.7. These conditions were selected by Laurie Ebner (Hydraulic Engineer, USACE District, Portland) and Cindy Rakowski (PNNL). John Serkowski with PNNL created detailed computer animations of forebay flow and fish tracks that were invaluable for determining what fish were doing under the various operational conditions.

Table 2.7. Scenario Runs of the CFD Model Based Upon Day/Night (N/D), Forebay Elevation, and Discharge (Q) through the B2CC, B2, Spillway, B1, and the Entire Project (cfs x 1000).

CFD #	N/D	Forebay	B2CC Q	B2 Q	Spill Q	B1 Q	Project Q
1	N	76.0	5.7	29.8	164.5	0	200.0
2	N	75.5	5.5	68.9	154.1	0	228.5
3	D	74.0	5.0	83.3	75.5	0	158.8
4	D	76.1	5.8	98.9	74.9	72.8	252.4
5	D	75.9	5.7	121.5	75.8	65.3	268.3
6	N	75.6	5.6	132.3	75.8	48.1	261.8

2.4.6 Estimating Fate Probabilities for Fish Approaching the B2CC

2.4.6.1 Overview

We used two methods for calculating the probability that fish at various locations upstream of the entrance would enter the B2CC or the eddy south of the entrance. John Hedgepeth applied a Markov Chain analysis and John Skalski and Jim Lady conducted a fish-vector analysis to estimate probabilities of the same fates. The Markov Chain analysis is described below after the description of fish sampling and tracking methods, and the vector analysis methods are described in Appendix H.

2.4.6.2 Markov Chain Volume

The Markov-Chain methods used to analyze fish movement were similar to those used at The Dalles Dam in recent years (Johnson et al. 2004) except that they are applied to the DIDSON instead of an active tracking split-beam sonar. An absorbing Markov chain (Kemeny and Snell 1960) was used to capture fish movement to a particular location, the region where we considered fish were entrained in the B2 corner collector. A Markov chain can model continuous movement in a continuous volume when discrete time steps are chosen and volumetric cells of a sample volume are delineated over which transition movement

probabilities can be calculated. We used a Markov chain to analyze data on fish movements (Figure 2.17) collected by the DIDSON. The resulting Markov chain model allowed us to estimate fish movement probabilities from a given cell within the sample volume to each absorbing cell.

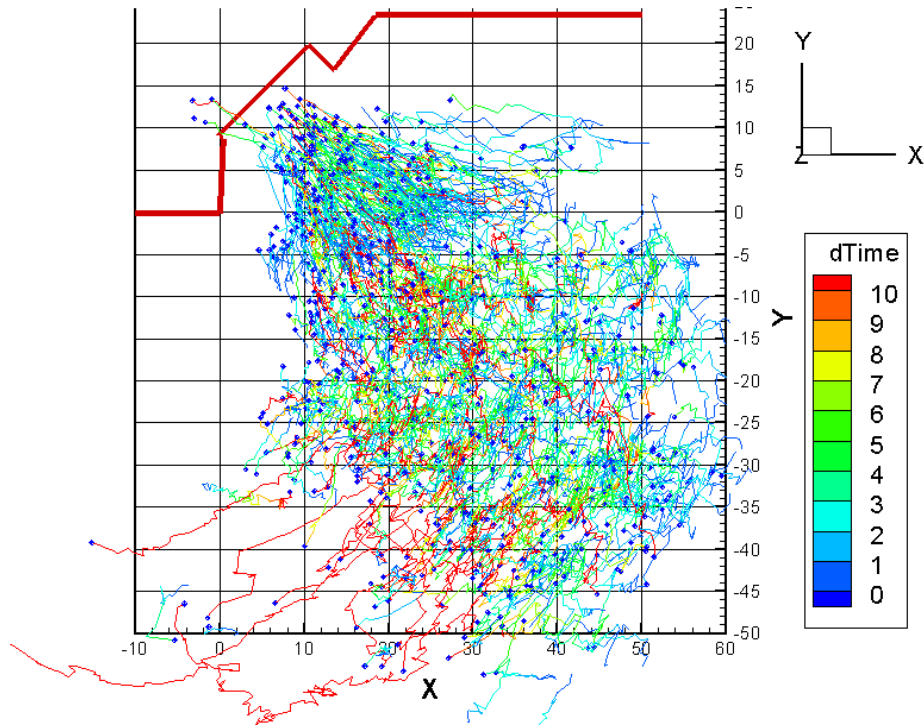

Figure 2.17. Fish Tracks from the DIDSON Collected June 15-17, 2004, at the North Bonneville Dam B2CC. The x- and y- scales are in feet. “dTime” is the time from start of each fish track in seconds. Blue “heads” symbolize ends of fish tracks. Red lines at top indicate dam interface near the corner collector.

The sample volume coordinate system (Figure 2.18) was defined as follows:

- x-dimension was parallel to the dam with northeast movement in the positive x-dimension and southwest movement in the negative x-dimension;
- y-dimension was perpendicular to the dam with movement toward the dam in the positive y-dimension and movement away from the dam in the negative y-dimension;
- z-dimension was vertically in the water column with movement upward in the positive z-dimension and movement downward in the negative z-dimension.

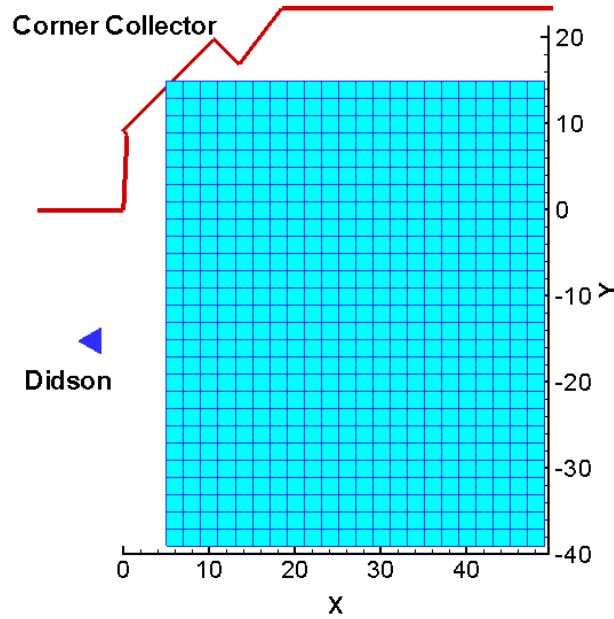

Figure 2.18. Sample Volume Used for Markov Chain Analysis. The x- and y- scales are in feet.

The sample volume was rectangular (Figure 2.18). The volume was 44 ft (13.41 m) across, extended 54 ft (16.46 m) upstream from the dam, and was 30 ft (9.144 m) deep from the surface. The sample volume was chosen to encompass a sufficient number of tracked fish to estimate movement. Fish movement in the volume was randomly sampled by randomly moving between the four zones (Figure 2.1) every two minutes if a fish was not detected. For the Markov chain analysis, the sample volume was partitioned into cells. The three-dimensional sample volume was modified to effectively form a two-dimensional sample volume by allowing the z -dimension of each cell to extend from the surface to $z = -30$ ft. The x - and y -dimensions of cells were 2.0 ft (0.6096 m) on a side. We formed states (Kemeny and Snell 1960) for the Markov chain that corresponded to the location of each volumetric cell (Figure 2.18). The sample volume was 22 cells wide in the x -dimension, 27 cells out from the dam in the y -dimension, and 1 cell deep in the z -dimension (594 total cells and states, including absorption states).

Markov absorbing states (Kemeny and Snell 1960), called “Fates” here, were assigned on edges of the volume, except for one part of the edge nearest the Powerhouse where movement was not allowed through the boundary. In addition, movement was not allowed through the surface or bottom. Fates were calculated as probabilities of absorption into cells at a particular portion or combination of edges of the sample volume as follows: Collector, Northeast, Southwest, and Reservoir (Figure 2.19). Finally, when no movement to a boundary was observed, the fate was called Stagnation. Movement fates to the faces of the sample volume are simply probabilities for movements within the sample volume. In summary, the Markov model included absorption at the faces corresponding to one of four movement fates: Collector, Northeast, Southwest, and Reservoir. Of these, the Collector and the Collector + Southwest fates were used to characterize movement into the B2 corner collector for this study.

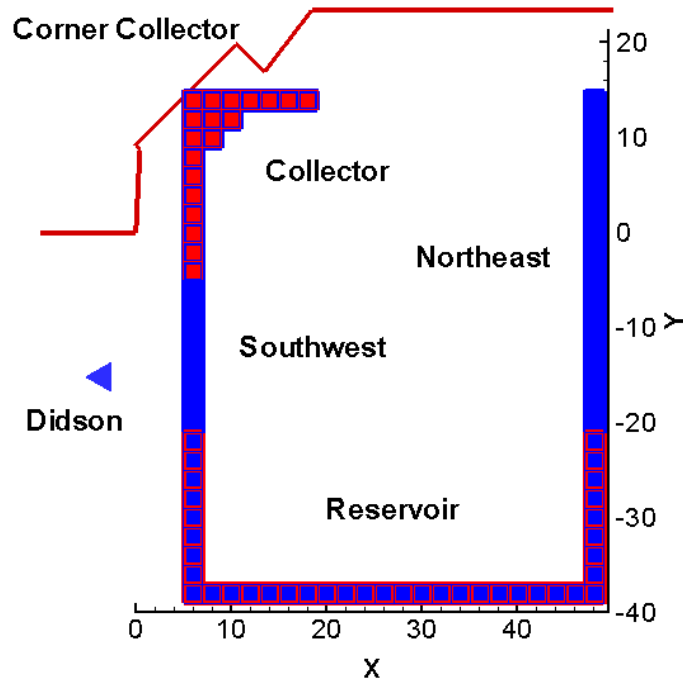

Figure 2.19. Fates where Fish Movements were Absorbed at Edges of the Sample Volume are as Follows: Collector, Northeast, Southwest, and Reservoir

2.4.6.3 Markov Chain Analysis

To determine fate probabilities, we applied a Markov chain analysis (Taylor and Karlin 1998), which described smolt movement as a stochastic process. A stochastic model does not imply that the fish movements are a random process of to and fro motions. Where a deterministic model describes movements as a function of covariates such as flow variables that are believed to govern fish behaviors, the movements are certain and without deviation. Instead, the Markov model describes the fish movements as a function of empirically observed transition probabilities. Taylor and Karlin (1998) noted that a Markov process $\{X_t\}$ is a stochastic process with the property that, given a value X_t , the values of X_s , for $s > t$ are not influenced by the values of X_u for $u < t$. They also pointed out that transition probabilities are functions not only of the initial and final states, but also of the time of transition as well. When the one-step transition probabilities are independent of the time variable, then the Markov chain has stationary probabilities (Karlin 1968). The time of transition was set at 0.5 s and is constrained in our application by the nature of the data, specifically the size of the cells in the sample volume and the frame interval. That is, we chose a transition time small enough to characterize a fish track and (for efficiency in subsequent data manipulations) larger than the frame interval so that the probability of remaining in a cell was not large. The choice of volumetric cell size (2 ft on x- and y-sides) was based on having as many cells as possible given the velocity of fish movements (Spring Day: median speed 2.94 ft/s, average frame interval 0.275 s – Figure 2.20).

Several assumptions were made and verified regarding connectivity in the sample volume for the Markov model. 1) There were no absorbing non-boundary cells; that is, no interior cell's probability was equal to one. 2) Exterior cells' probabilities were set to one as described above. 3) No interior connectivity was forced but calculations relied upon empirical measurements. 4) Where no movement observation from a

cell was measured using the DIDSON camera, then the closest movement was interpolated to that cell using inverse distance squared weights.

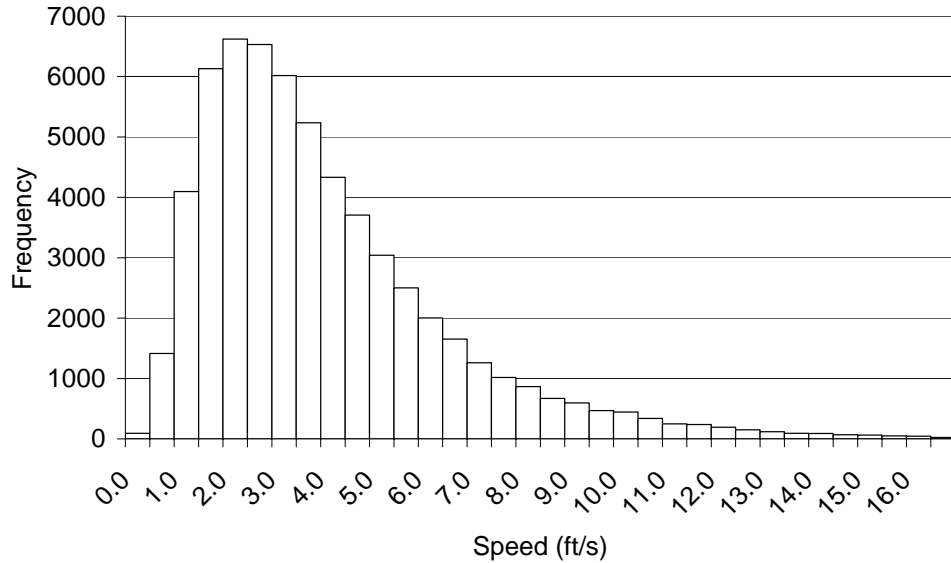

Figure 2.20. Fish Movement Speed Measured by the DIDSON during Spring Day 2004 at the B2CC.

The Markov transition matrix was a square matrix the size of $k \times k$, where k was the number of distinct cells being modeled ($k = 594$). The ij^{th} element in the i^{th} row of the j^{th} column of the transition matrix was the estimated probability (p_{ij}) of moving from cell i to cell j in the next time step. These probabilities were estimated by

$$\hat{p}_{ij} = \frac{n_{ij}}{n_i}$$

Where

n_i = number of observations of smolts in the i th cell;

n_{ij} = number of observations where a smolt in cell i moved to cell j in the next time step.

The transition probabilities for cells (2 ft \times 2 ft) that bordered the edges of the sample volume (e.g., Collector) were set to unity to absorb any movement that reached our defined fates. The transition matrix T was constructed using a time step of 0.5 s, using average position (i.e., \bar{x} , \bar{y} , \bar{z}) during each 0.5-s interval a fish was tracked. This process required that a fish be tracked for at least 1.0 s before the transition matrix was amended to obtain location i from the first interval and location j from the next, and so on. After the transition matrix was formed, it was examined to find cells that were not sampled by the DIDSON. In these instances of no observation, the closest cells in Cartesian space with movement data were found and the movement patterns through those cells were interpolated to the cell with no observations using inverse distance squared weights. We limited the search radius to three cells away in

order to use local data for interpolation. Less than 2% of cells required this interpolation in Spring and less than 3% in Summer.

The transition matrix T for one time step was used to estimate the transition probabilities for two or more time steps as T^t where t = the number of time steps. Matrix T^t is the transition matrix for t time steps and the transition probabilities $p_{ij}^{(t)}$ express the probability of moving from cell i to cell j in t time steps.

The size of t was sufficiently large so that the tracked fish revealed an absorption state or became stagnant. The t -step transition probabilities to absorbing cells were visualized using Amtec Engineering's Tecplot software by contouring the sums of each state's (each representing an x, y, z cell) probabilities over the absorbing surfaces previously described.

2.5 Spatial Expansions

2.5.1 Fixed-Aspect Hydroacoustic Sampling

Detectability modeling and spatial expansions are very important for FPE studies that estimate proportions of fish passing a dam by all major routes or even FGE estimation for a single turbine, because accurate estimates assume that all types of samples have equal detectability. The need for equal detectability applies to radio telemetry as well as to hydroacoustic methods. Differences in deployments make it very unlikely that equal detectability will occur, and therefore some adjustment is required to improve the assumption of equal detectability. For hydroacoustic sampling, we adjust for differences in detectability as a function of range from every transducer by expanding every fish count by the ratio of the width (vertical beams) or depth (horizontal beams) of a passage route to the diameter of the hydroacoustic beam at the range that a fish is detected. Calculating the diameter of the beam at the range of detection requires modeling of the effective-beam angle, which is an index to hydroacoustic detectability.

Effective beam angle (EBA) depends upon the detectability of fish of different sizes in the acoustic beam and is a function of nominal beam width, ping rate, trace criteria, and fish size, aspect, trajectory, velocity, and range. We modeled detectability for every transducer deployment to determine EBA as a function of range from each transducer. We obtained target-strength estimates and fish velocity and trajectory by 1-m range strata from manually tracked split-beam data. These data and other hydroacoustic-acquisition data (e.g., ping rate, target-strength threshold, number of echoes, and maximum ping gaps) were entered into a detectability model. Inputs to the detectability model are presented in Tables 2.8 and 2.9. Model output consisted of EBA as a function of range from a transducer. Polynomials fitted to those data were substituted for EBA in the equation below to correct for differences in detectability by range among transducers and locations.

Polynomial regressions were used to describe the relationships between predictions of effective beam angle with range from a transducer for every type of deployment. Those equations and passage width (or depth) data were used to expand the count of each detected fish and to equalize detectability among sample ranges and deployments. The coding solved a deployment-specific polynomial equation for effective beam angle based upon the range of detection of each individual fish (Appendix F), calculated the corresponding beam diameter at the same range, and multiplied the fish's count (i.e., one) by the ratio of the passage width to the beam diameter. The polynomials presented in Appendix F can be used to generate the detectability curves for each channel. Minimum ranges for modeling detectability (Table 2.8) usually were less than minimum ranges for counting fish (see legends of Figures 2.2, 2.5, 2.6, 2.7, 2.9) to improve curve fitting, but only the portion of the curves where fish were counted were used

for deriving spatial expansion factors. Sampling ranges that were used to solve for effective beam angle truncated the polynomial curves to appropriate ranges.

The count of each fish (1) detected in a hydroacoustic beam was spatially expanded based upon the ratio of the opening width (vertically oriented beams) or depth (horizontal beams) to beam diameter at the range of detection. For nearly horizontal beams such as those deployed at B1 sluiceways or at the B2CC, we substituted forebay elevation – weir elevation (B1 sluiceway entrances) or sample region height (B2CC – see Table 2.2) for OW in the spatial expansion equation:

$$EXP_NUM = \frac{OW}{[MID_R \times TAN(\frac{EBA}{2}) \times 2]}$$

where OW is opening width (or depth), MID_R is the mid-point range of a trace in m, TAN is the tangent, and EBA is the effective beam angle in degrees.

2.5.2 B2 Gatewell Sampling of Gap Loss with the DIDSON

Fish counts were expanded for each fish using the following equation:

$$EC = \frac{GW}{2[FR \times TAN(12/2)]}$$

where EC = expanded count, GW = gatewell width (6.1 m), FR = first range of detection (m), TAN is the tangent, and 12°-long is the angle of each of the 96 0.3°-wide acoustic beams relative to the length of the GW. The expansion increased the count of fish in the gatewell fraction relative to the gap-loss fraction because gap-loss fish were detected at slightly greater range than were fish moving up into the gatewell.

Table 2.8. Deployment-Specific Variables that Were Input to a Stochastic Detectability Model for Estimating Effective Beam Angle as a Function of Range from a Transducer. Constants were as follows: Target Strength threshold = -56 dB; Maximum ping gap = 4; Minimum echo count = 4 echoes in 5 pings; Tilt = 0 since we used beam coordinates for fish plunge and speed. B2CC transducers were numbered from 1 to 6, corresponding to the order of deployment below the water’s surface (top to bottom).

Deployment	Aiming Direction	Min. Range (m)	Max. Range (m)	-3 dB Beam Angle (degrees)	Pulse Repetition Rate (pings/s)	Mean Target Strength (dB 1 µPa)	TS Standard Deviation (dB)	Ping-to-ping TS Correlation
Spring								
B1 Sluice 2C	Lateral	3	6	6	25	-46.2	4.3	0.06365
B1 Sluice 4C	Lateral	3	6	6	25	-46.2	4.0	0.05771
B1 Sluice 6C	Lateral	3	6	6	25	-46.2	3.9	0.13637
B1 Turbine	Down	1	22	6	20	-49.8	2.3	0.20056
Spillway	Down	5	11	10	25	-48.8	2.7	0.18767
B2CC Number 1 and 2	Lateral	3	12	3	33	-46.2	3.4	0.09086
B2CC Numbers 3 and 4	Lateral	3	11	3	33	-46.2	3.4	0.09086
B2CC Number 5	Lateral	3	10	6	33	-46.2	3.4	0.09086
B2CC Number 6 - bottom	Lateral & Down	3	9	6	33	-46.2	3.4	0.09086
B2 Turbines	Down	5	18	6	23	-49.1	2.7	0.05181
B2 Turbines	Up	5	11	6	23	-48.4	2.5	0.17751
Summer								
B1 Sluice 2C	Lateral	3	6	6	25	-47.3	4.2	0.10737
B1 Sluice 4C	Lateral	3	6	6	25	-47.3	4.0	0.12198
B1 Sluice 6C	Lateral	3	6	6	25	-47.3	3.8	0.04906
B1 Turbine	Down	1	22	6	20	-48.7	3.0	0.21436
Spillway	Down	5	11	10	25	-48.3	2.6	0.21436
B2CC Number 1 and 2	Lateral	3	12	3	33	-47.3	3.2	0.16453
B2CC Numbers 3 and 4	Lateral	3	11	3	33	-47.3	3.2	0.15939
B2CC Number 5	Lateral	3	10	6	33	-47.3	4.2	0.15939
B2CC Number 6 - bottom	Lateral & Down	3	9	6	33	-47.3	3.6	0.00774
B2 Turbines	Down	5	18	6	23	-46.91	3.0	0.02287
B2 Turbines	Up	5	11	6	23	-48.5	2.6	0.04855

Table 2.9. Polynomial Inputs for the Detectability Model for Beam Patterns, Fish Trajectories, and Fish Speeds for Every Deployment. For beam shape, B = dB down and x = degrees off axis; for trajectory, plunge = degrees off of horizontal (positive plunge is toward the transducer and negative is away from the transducer) and x = range in m, for speed (m/s), x = range in m.

Deployment	Variable	Polynomial or Constants
B1 Sluice 2C	Beam Shape	$B = -0.380111x^2 + 0.318975x - 0.211505$
	Trajectory	$Plunge = 0.374100x^2 + 1.426380x - 27.581510$
	Speed	$mps = -0.032900x^2 + 0.612420x - 0.737750$
B1 Sluice 4C	Beam Shape	$B = -0.380111x^2 + 0.318975x - 0.211505$
	Trajectory	$Plunge = -2.117625x^2 + 21.34378x - 69.158975$
	Speed	$mps = -0.045705x^2 + 0.706375x - 1.237365$
B1 Sluice 6C	Beam Shape	$B = -0.380111x^2 + 0.318975x - 0.211505$
	Trajectory	$Plunge = -1.831475x^2 + 28.15469x - 105.606695$
	Speed	$mps = -0.035752x^2 + 0.525800x - 0.949457$
B1 Turbine	Beam Shape	$B = -0.380111x^2 + 0.318975x - 0.211505$
	Trajectory	$Plunge = -0.008492x^3 + 0.31244x^2 - 1.994170x - 45.954841$
	Speed	$mps = -0.000440x^2 + 0.013130x + 0.724513$
Spillway	Beam Shape	$B = -0.117569x^2 + 0.150691x - 0.040631$
	Trajectory	$Plunge = 0.277562x^3 - 2.48570x^2 + 6.102111x - 59.111908$
	Speed	$mps = 0.037577x^2 - 0.232651x + 1.224565$
B2CC Number 1 and 2	Beam Shape	$B = -1.468900x^2 + 0.434035x + 0.025965$
	Trajectory	$Plunge = -0.191002x^3 + 3.88570x^2 - 16.060678x - 51.705122$
	Speed	$mps = -0.001689x^3 + 0.02783x^2 + 0.149432x + 0.176274$
B2CC Numbers 3 and 4	Beam Shape	$B = -0.380111x^2 + 0.318975x - 0.211505$
	Trajectory	$Plunge = -0.095627x^3 + 2.55786x^2 - 11.345491x - 49.286615$
	Speed	$mps = -0.011497x^3 + 0.20545x^2 - 0.583497x + 1.074009$
B2CC Number 5	Beam Shape	$B = -0.380111x^2 + 0.318975x - 0.211505$
	Trajectory	$Plunge = 0.050485x^3 - 0.91230x^2 + 10.483696x - 75.491353$
	Speed	$mps = -0.010290x^3 + 0.20819x^2 - 0.737272x + 1.276156$
B2CC Number 6 - bottom	Beam Shape	$B = -0.380111x^2 + 0.318975x - 0.211505$
	Trajectory	$Plunge = 0.110862x^3 - 1.74033x^2 + 13.631925x - 78.451551$
	Speed	$mps = 0.068386x^2 - 0.212030x + 0.789011$
B2 Turbines (Down-looker)	Beam Shape	$B = -0.380111x^2 + 0.318975x - 0.211505$
	Trajectory	$Plunge = -0.024253x^3 + 0.62448x^2 - 1.921930x - 45.628922$
	Speed	$mps = 0.002249x^2 - 0.029847x + 1.499463$
B2 Turbines (Up-looker)	Beam Shape	$B = -0.380111x^2 + 0.318975x - 0.211505$
	Trajectory	$Plunge = 0.094965x^3 - 1.61538x^2 + 5.534516x + 18.825280$
	Speed	$mps = 0.000632x^2 + 0.036896x + 0.825780$

The gap-loss proportion of fish was calculated as follows:

$$GLP = \frac{Gap}{Gap + Gatewell}$$

where GLP = proportion of fish guided by the STS lost through the gap (gap-loss proportion),

Gap = expanded number of fish passing through the gap

Gatewell = expanded number of fish passing up into the gatewell.

We compared estimates of gap-loss proportions among intakes and among units by calculating, graphing, and visually comparing means and overlap of 95% confidence intervals. Means and 95% confidence intervals were calculated from the three nights of sampling at each intake and from the nine nights of sampling at each unit. With only three samples per intake, there were insufficient samples to statistically compare gap loss proportions among intakes with and without TIES at Unit 17.

2.6 Dam Operations and Fish Passage

Operations data, including discharge by spill bay and turbine unit, were provided by Bonneville Dam operators from an automated data acquisition system. Hourly operations data were integrated with fish passage data, and fish passage was set to zero when passage routes were closed for an entire hour. All spill bays happened to be opened and discharging water throughout the spring and summer sampling seasons so closure adjustments were unnecessary, but most turbines were on and off several times a day. This was important because transducers sampled continuously regardless of operations, and samples from closed turbine units or spill bays will include many traces that may be tracked as passed fish, often multiple times, even when a turbine unit is off or a spill bay is closed. Fortunately, operations data were recorded in five-minute intervals so we knew within 2.5 minutes when every turbine was started and shut down each day. Therefore, we were able to set 1-min samples of fish passage to zero whenever a turbine was off. Polynomial regression equations were used to estimate flow into sluiceway entrances at intakes 2C, 4C, and 6C from average hourly forebay elevations, which were obtained from Project operations data. The equations were:

$$CFS_{2C} = -2.643357(FB_{EL})^3 + 585.571096(FB_{EL})^2 - 43107.896270(FB_{EL}) + 1054895.728672$$

$$CFS_{4C} = 0.205128(FB_{EL})^3 - 58.860140(FB_{EL})^2 + 5415.896270(FB_{EL}) - 161243.174825$$

$$CFS_{6C} = -1.617716(FB_{EL})^3 + 346.682984(FB_{EL})^2 - 24662.386946(FB_{EL}) + 582357.579021,$$

where CFS is sluiceway entrance flow and suffixes 2C, 4C, and 6C refer to entrance locations. These equations were provided by Laurie Ebner (Hydraulic Engineer, USACE District, Portland).

Hourly rates and variances in fish passage and hourly rates of water discharge through various routes at Bonneville Dam are presented in Appendix E on the accompanying compact disk. Tables 1 and 2 of Appendix E describe the variables in the comma-separated variable files.

2.7 Missing Data

We made a special effort to make certain that missing samples were accounted for in the spring and summer data sets. First, we created a data set consisting of all possible sample locations and times each season and set an expanded fish variable to missing in every observation. Second, we merged the missing data set with the acquired data set so that counts of expanded fish, if present in the acquired data, overwrote missing counts. When a sample was not acquired for whatever reason, there was nothing in the

acquired data set to overwrite the missing value for expanded fish. Therefore, the observation was appropriately designated as missing, as opposed to an actual zero count, and could be interpolated before data were analyzed.

All hydroacoustic systems were operated continuously, except for about 15 minutes every morning when data were copied from each system's acquisition computer onto a portable FireWire™ hard drive. Rarely equipment failed and data from the affected routes were not collected. Short equipment failures lasting up to 45 minutes were not a problem because fish counts and associated variances could still be estimated from the remaining within-hour samples. Computer lock-ups usually were fixed within an hour because we had staff monitoring systems 24 hours per day.

Missing hourly sums and variances that resulted from equipment outages > 45 minutes were estimated by temporal linear interpolation for periods < 6 hours and by spatial interpolation or linear regression for periods > 6 hours. Occasionally the ratio of guided to unguided numbers at adjacent turbines with similar screens was useful for interpolating estimates of guided or unguided numbers. Regression equations relating hourly variances with hourly sums were sometimes used to estimate missing variance estimates.

2.8 Estimating Fish Passage

This section describes in detail the estimation of fish passage at B1, B2, and the spillway at Bonneville Dam in 2004. Estimates of passage from these methods are used to calculate subsequent measures of fish passage performance (Section 2.10 below). Within every hour, we sampled 7 to 30 minutes systematically depending upon location, and we assumed that these systematic samples would behave as if they were simple random samples. This approach will be unbiased when the passage is random and upwardly biased when there is linear trend, positive autocorrelation, or stratification effect. Negative bias would only occur in unusual situations. We also estimated more than just the temporal variation in passage within intakes by post-stratifying adjacent turbine units and estimating the variation in passage between intakes of the multi-unit strata. This approach usually would include more between-intake variation than we would expect from sampling two or more intakes of individual units because variation among units usually exceeds the variation among intakes within a unit.

Confidence intervals for individual intakes or spill bays were calculated as 1.96 times the square root of temporal variance estimate for the time frame of interest (day, week, or season). The following subsections describe procedures for estimating temporal variances in fish passage through individual intakes and spill bays as first steps for estimating the variance for strata of intakes or bays or for each powerhouse and the spillway.

2.8.1 B1 Passage

The sampling at B1 can be viewed as a two-stage sampling scheme. The first stage is the sampling of intake slots within a stratum composed of neighboring turbine units that were operating simultaneously. Typically, one or two consecutive turbine units would be grouped together to form a stratum, and it would be assumed that two or more intake slots were randomly selected for monitoring. In some instances, the closure of a turbine unit would result in some strata no longer having the within-strata replication needed for variance estimation.

The proposed solution was to post-stratify the operational turbine units into strata according to their proximity to one another. The re-stratification at times is somewhat arbitrary, because there is no single unique way to group the locales. Priority would be given to grouping locations into the most proximal sets of locations possible while still retaining the ability to calculate the spatial sampling variances. The

resulting variance estimates can generally be considered conservative for they often include more between-intake variance than expected under the original sampling design.

The fish passage at B1 (T) is estimated by the quantity

$$\hat{T} = \sum_{i=1}^D \sum_{j=1}^{23} \sum_{k=1}^{K_{ij}} \left[\frac{A_{ijk}}{a_{ijk}} \left[\sum_{l=1}^{a_{ijk}} \hat{T}_{ijkl} \right] \right], \quad (1)$$

where

- \hat{T}_{ijkl} = estimated fish passage in the l th intake slot ($l = 1, \dots, a_{ijk}$) within the k th turbine stratum ($k = 1, \dots, K_{ij}$) during the j th hour ($j = 1, \dots, 24$) on the i th day ($i = 1, \dots, D$);
- a_{ijk} = number of intake slots actually sampled in the k th turbine stratum ($k = 1, \dots, K_{ij}$) during the j th hour ($j = 1, \dots, 24$) on the i th day ($i = 1, \dots, D$);
- A_{ijk} = total number of intake slots within the k th turbine stratum ($k = 1, \dots, K_{ij}$) during the j th hour ($j = 1, \dots, 24$) on the i th day ($i = 1, \dots, D$);
- K_{ij} = number of turbine strata created during the j th hour ($j = 1, \dots, 24$) on the i th day ($i = 1, \dots, D$).

Because of the varying power loads over time, the number of spatial strata (i.e., K_{ij}) formed by post-stratification of adjacent turbine units may vary between hours ($j = 1, \dots, 24$) and days ($i = 1, \dots, D$).

The estimate of \hat{T}_{ijkl} is based on the assumption of simple random sampling within a slot-hour, in which case

$$\hat{T}_{ijkl} = \frac{B_{ijkl}}{b_{ijkl}} \sum_{g=1}^{b_{ijkl}} z_{ijklg} . \quad (2)$$

Combining Equations (1) and (2), the overall estimate of fish passage at B1 during D days can be expressed as

$$\hat{T} = \sum_{i=1}^D \sum_{j=1}^{23} \sum_{k=1}^{K_{ij}} \left[\frac{A_{ijk}}{a_{ijk}} \left[\frac{B_{ijkl}}{b_{ijkl}} \sum_{g=1}^{b_{ijkl}} z_{ijklg} \right] \right], \quad (3)$$

where

- z_{ijklg} = expanded fish count in the g th sampling unit ($g = 1, \dots, b_{ijkl}$) in the l th intake slot ($l = 1, \dots, a_{ijk}$) within the k th turbine stratum ($k = 1, \dots, K_{ij}$) during the j th hour ($j = 1, \dots, 23$) on the i th day ($i = 1, \dots, D$);
- b_{ijkl} = number of sampling units actually observed in the l th intake slot ($l = 1, \dots, a_{ijk}$) within the k th turbine stratum ($k = 1, \dots, K_{ij}$) during the j th hour ($j = 1, \dots, 23$) on the i th day ($i = 1, \dots, D$);

B_{ijkl} = total number of sampling units within the l th intake slot ($l = 1, \dots, a_{ijk}$) within the k th turbine stratum ($k = 1, \dots, K_{ij}$) during the j th hour ($j = 1, \dots, 23$) on the i th day ($i = 1, \dots, D$).

Nominally, $B_{ijkl} = 60$ and $b_{ijkl} = 20 \forall ijkl$. Based on the assumption of simple random sampling

$$\widehat{\text{Var}}(\widehat{T}_{ijkl}) = \frac{B_{ijkl}^2 \left(1 - \frac{b_{ijkl}}{B_{ijkl}}\right) s_{z_{ijkl}}^2}{b_{ijkl}}, \quad (4)$$

where

$$s_{z_{ijkl}}^2 = \frac{\sum_{g=1}^{b_{ijkl}} (z_{ijklg} - \overline{z_{ijkl}})^2}{(b_{ijkl} - 1)}$$

and where

$$\overline{z_{ijkl}} = \frac{1}{b_{ijkl}} \sum_{g=1}^{b_{ijkl}} z_{ijklg}.$$

The variance of \widehat{T} can then be estimated by the formula

$$\widehat{\text{Var}}(\widehat{T}) = \sum_{i=1}^D \sum_{j=1}^{24} \sum_{k=1}^{K_{ij}} \left[\frac{A_{ijk}^2 \left(1 - \frac{a_{ijk}}{A_{ijk}}\right) s_{TU_{ijk}}^2}{a_{ijk}} + \frac{A_{ijk} \sum_{l=1}^{a_{ijk}} \widehat{\text{Var}}(\widehat{T}_{ijkl})}{a_{ijk}} \right], \quad (5)$$

where

$$s_{\widehat{T}_{ijk}}^2 = \frac{\sum_{l=1}^{a_{ijk}} (\widehat{T}_{ijkl} - \widehat{\widehat{T}}_{ijk})^2}{(a_{ijk} - 1)},$$

$$\widehat{\widehat{T}}_{ijk} = \frac{1}{a_{ijk}} \sum_{l=1}^{a_{ijk}} \widehat{T}_{ijkl}.$$

2.8.2 B2 Unguided Passage

The same two-stage sampling scheme used to estimate fish passage at B1 was used to estimate fish passage at B2, Units 11-18. One or two consecutive turbine units (e.g., 11-12, 13-14, ...) were combined to form a stratum with two or more intake slots selected for monitoring. On rare occasions, unit shutdowns because of load demands required further post-stratification to assure within-stratum replication of turbine slots. Under these circumstances, the turbine units at B2 were grouped into four or fewer strata. To accommodate all circumstances, the estimators and variances will be expressed generically.

Using the fish counts from the down-looking transducers, total unguided fish passage at B2 was estimated by the quantity

$$\widehat{HU} = \sum_{i=1}^D \sum_{j=1}^{23} \sum_{k=1}^{K_{ij}} \left[\frac{C_{ijk}}{c_{ijk}} \left[\frac{D_{ijkl}}{d_{ijkl}} \sum_{g=1}^{d_{ijkl}} x_{ijklg} \right] \right], \quad (6)$$

where

- x_{ijklg} = expanded fish passage in the g th sampling unit ($g = 1, \dots, b_{ijkl}$) in the l th intake slot ($l = 1, \dots, a_{ijk}$) within the k th turbine stratum ($k = 1, \dots, K_{ij}$) during the j th hour ($j = 1, \dots, 23$) on the i th day ($i = 1, \dots, D$);
- d_{ijkl} = number of sampling units actually observed in the l th intake slot ($l = 1, \dots, a_{ijk}$) within the k th turbine stratum ($k = 1, \dots, K_{ij}$) during the j th hour ($j = 1, \dots, 23$) on the i th day ($i = 1, \dots, D$);
- D_{ijkl} = total number of sampling units within the l th intake slot ($l = 1, \dots, a_{ijk}$) within the k th turbine stratum ($k = 1, \dots, K_{ij}$) during the j th hour ($j = 1, \dots, 23$) on the i th day ($i = 1, \dots, D$);
- c_{ijk} = number of intake slots actually sampled in the k th turbine stratum ($k = 1, \dots, K_{ij}$) during the j th hour ($j = 1, \dots, 23$) on the i th day ($i = 1, \dots, D$);
- C_{ijk} = total number of intake slots within the k th turbine stratum ($k = 1, \dots, K_{ij}$) during the j th hour ($j = 1, \dots, 23$) on the i th day ($i = 1, \dots, D$);
- K_{ij} = number of turbine strata created during the j th hour ($j = 1, \dots, 23$) on the i th day ($i = 1, \dots, D$).

Nominally, $D_{ijkl} = 60 \forall ijkl$ and $d_{ijkl} = 7, 10, \text{ or } 20$ depending on location.

The variance of \widehat{HU} can then be estimated by the formula

$$\widehat{\text{Var}}(\widehat{HU}) = \sum_{i=1}^D \sum_{j=1}^{23} \sum_{k=1}^{K_{ij}} \left[\frac{C_{ijk}^2 \left(1 - \frac{c_{ijk}}{C_{ijk}} \right) s_{HU_{ijk}}^2}{c_{ijk}} + \frac{C_{ijk} \sum_{l=1}^{c_{ijk}} \widehat{\text{Var}}(\widehat{HU}_{ijkl})}{c_{ijk}} \right], \quad (7)$$

where

$$\widehat{\text{Var}}(\widehat{HU}_{ijkl}) = \frac{D_{ijkl}^2 \left(1 - \frac{d_{ijkl}}{D_{ijkl}}\right) s_{x_{ijkl}}^2}{d_{ijkl}},$$

$$s_{x_{ijkl}}^2 = \frac{\sum_{g=1}^{d_{ijkl}} (x_{ijklg} - \bar{x}_{ijkl})^2}{(d_{ijkl} - 1)},$$

$$\bar{x}_{ijkl} = \frac{1}{d_{ijkl}} \sum_{g=1}^{d_{ijkl}} x_{ijklg},$$

and where

$$s_{\widehat{HU}_{ijk}}^2 = \frac{\sum_{l=1}^{a_{ijk}} (\widehat{HU}_{ijkl} - \widehat{HU}_{ijk})^2}{(a_{ijk} - 1)},$$

$$\widehat{HU}_{ijk} = \frac{1}{a_{ijk}} \sum_{l=1}^{a_{ijk}} \widehat{HU}_{ijkl}.$$

2.8.3 B2 Guided Passage

The same two-stage sampling scheme used to estimate unguided passage (HU) at B2 was used to sample guided passage (HG) at B2. Hence, the estimator for guided fish passage at B2 can be written as

$$\widehat{HG} = \sum_{i=1}^D \sum_{j=1}^{23} \sum_{k=1}^{K_{ij}} \left[\frac{C_{ijk}}{c_{ijk}} \left[\frac{D_{ijkl}}{d_{ijkl}} \sum_{g=1}^{d_{ijkl}} w_{ijklg} \right] \right], \quad (8)$$

where

w_{ijklg} = expanded fish passage in the g th sampling unit ($g = 1, \dots, b_{ijkl}$) in the l th intake slot ($l = 1, \dots, a_{ijk}$) within the k th turbine stratum ($k = 1, \dots, K_{ij}$) during the j th hour ($j = 1, \dots, 23$) on the i th day ($i = 1, \dots, D$).

The estimated variance of \widehat{HG} can then be expressed as

$$\widehat{\text{Var}}(\widehat{HG}) = \sum_{i=1}^D \sum_{j=1}^{23} \sum_{k=1}^{K_{ij}} \left[\frac{C_{ijk}^2 \left(1 - \frac{c_{ijk}}{C_{ijk}}\right) s_{\widehat{HG}_{ijk}}^2}{c_{ijk}} + \frac{C_{ijk} \sum_{l=1}^{c_{ijk}} \widehat{\text{Var}}(\widehat{HG}_{ijkl})}{c_{ijk}} \right] \quad (9)$$

where

$$\widehat{\text{Var}}(\widehat{HG}_{ijkl}) = \frac{D_{ijkl}^2 \left(1 - \frac{d_{ijkl}}{D_{ijkl}}\right) s_{w_{ijkl}}^2}{d_{ijkl}},$$

$$s_{w_{ijkl}}^2 = \frac{\sum_{g=1}^{d_{ijkl}} (w_{ijklg} - \bar{w}_{ijkl})^2}{(d_{ijkl} - 1)},$$

$$\bar{w}_{ijkl} = \frac{1}{d_{ijkl}} \sum_{g=1}^{d_{ijkl}} w_{ijklg},$$

and where

$$s_{\widehat{HG}_{ijk}}^2 = \frac{\sum_{l=1}^{c_{ijk}} (\widehat{HG}_{ijkl} - \widehat{HG}_{ijk})^2}{(c_{ijk} - 1)},$$

$$\widehat{HG}_{ijk} = \frac{1}{c_{ijk}} \sum_{l=1}^{c_{ijk}} \widehat{HG}_{ijkl}.$$

2.8.4 Spill Bay Passage

During spring 2004, hydroacoustic transducers were placed in each of the operational spill bays, one transducer per spill bay. Sampling was envisioned as systematic sampling within individual spill bay-hrs.

The estimate of total spillway passage was estimated by the formula

$$\hat{S} = \sum_{i=1}^H \sum_{j=1}^D \sum_{k=1}^{23} \frac{T_{ijk}}{t_{ijk}} \sum_{l=1}^{t_{ijk}} p_{ijkl}, \quad (10)$$

where

p_{ijkl} = expanded fish passage in the l th sampling interval ($l = 1, \dots, t_{ijk}$) during the k th hour ($k = 1, \dots, 23$) in the j th day ($j = 1, \dots, D$) at the i th spill bay ($i = 1, \dots, 17$);

T_{ijk} = total number of possible sampling units the k th hour ($k = 1, \dots, 23$) in the j th day ($j = 1, \dots, D$) at the i th spill bay ($i = 1, \dots, 17$);

t_{ijk} = actual number of sampling units drawn within the k th hour ($k = 1, \dots, 23$) in the j th day ($j = 1, \dots, D$) at the i th spill bay ($i = 1, \dots, 17$).

Assuming the systematic sampling within an hour can be approximated by a random sampling formula, the estimated variance of \hat{S} can be written as

$$\widehat{\text{Var}}(\hat{S}) = \sum_{i=1}^H \sum_{j=1}^D \sum_{k=1}^{23} \left[\frac{T_{ijk}^2 \left(1 - \frac{t_{ijk}}{T_{ijk}}\right) s_{p_{ijk}}^2}{t_{ijk}} \right], \quad (11)$$

where

$$s_{p_{ijk}}^2 = \frac{\sum_{l=1}^{t_{ijk}} (p_{ijkl} - \bar{p}_{ijk})^2}{(t_{ijk} - 1)},$$

$$\bar{p}_{ijk} = \frac{\sum_{l=1}^{t_{ijk}} p_{ijkl}}{t_{ijk}}.$$

Nominally, $T_{ijk} = 60 \forall ijk$ and $t_{ijk} = 12$ or 20 depending on location.

2.8.5 Sluiceway Passage

For the sluiceways above turbine intakes 2C, 4C, and 6C at B1, the estimation of smolt passage is based on stratified sampling. Each half of one of the sluiceways was considered a spatial stratum. In which case, total sluiceway passage can be estimated by the quantity

$$\widehat{SL} = \sum_{g=1}^3 \sum_{h=1}^2 \sum_{i=1}^D \sum_{j=1}^{23} \frac{E}{e} \sum_{k=1}^e v_{ghijk}, \quad (12)$$

where

v_{ghijk} = expanded fish counts in the k th sample interval ($k = 1, \dots, e$) in the j th hour ($j = 1, \dots, 23$) of the i th day ($i = 1, \dots, D$) at the h th half-section ($h = 1, 2$) of the g th sluiceway ($g = 1, 3$);

E = total number of possible sampling intervals within an hour;

e = actual number of sampling intervals drawn within an hour.

Nominally, $E = 60$ and $e = 20 \forall ghij$.

The variance of \widehat{SL} , based on simple random sampling within an hour, is then

$$\widehat{\text{Var}}(\widehat{SL}) = \sum_{g=1}^3 \sum_{h=1}^2 \sum_{i=1}^D \sum_{j=1}^{23} \left[\frac{E^2 \left(1 - \frac{e}{E}\right) s_{v_{ghij}}^2}{e} \right], \quad (13)$$

where

$$s_{v_{ghij}}^2 = \frac{\sum_{k=1}^e (v_{ghijk} - \bar{v}_{ghij})^2}{(e-1)},$$

$$\bar{v}_{ghij} = \frac{\sum_{k=1}^e v_{ghijk}}{e}.$$

2.8.6 Corner Collector Passage

Sampling at the corner collector can be visualized as stratified random sampling. The collector opening has been spatially stratified by transducers 1-3-5 and transducers 2-4-6. Within these spatial strata, sampling within an hour is assumed to be random sampling. Define the following variables:

- y_{hijk} = expanded fish count in the k th sampling interval ($k = 1, \dots, f$) in the j th hour ($j = 1, \dots, 23$) at the i th half-section ($i = 1, 2$) on the h th day ($h = 1, \dots, D$);
- F = total number of possible sampling intervals within an hour;
- f = actual number of sampling intervals drawn within an hour.

The estimate of total corner collector passage is then calculated as

$$\widehat{CC} = \sum_{h=1}^D \sum_{i=1}^2 \sum_{j=1}^{23} \frac{F}{f} \sum_{k=1}^f y_{hijk}. \quad (14)$$

Nominally, $F = 60$ and $f = 30 \forall hij$.

The variance of \widehat{CC} is based on simple random sampling within an hour, where

$$\widehat{\text{Var}}(\widehat{CC}) = \sum_{h=1}^D \sum_{i=1}^2 \sum_{j=1}^{23} \left[\frac{F^2 \left(1 - \frac{f}{F}\right) s_{y_{hij}}^2}{f} \right], \quad (15)$$

where

$$s_{y_{hij}}^2 = \frac{\sum_{k=1}^f (y_{hijk} - \bar{y}_{hij})^2}{(f-1)},$$

$$\bar{y}_{hij} = \frac{\sum_{k=1}^f y_{hijk}}{f}.$$

2.9 Adjustment of Passage Estimates and Associated Variances

We adjusted autotracker counts and variances in two ways according to the general methods described in subsequent paragraphs of this section.

First, we regressed mean hourly fish counts by three technicians on autotracker counts for each transducer hour and used slopes of regression lines with intercepts forced through zero to convert autotracker counts into mean technician counts and thereby remove systematic bias in autotracker counts among deployments. Regressions provided a measure of the agreement between the two methods in the form of the coefficient of determination (r^2) and a slope with which to assess the degree of under counting or over counting that the autotracker does relative to the human trackers. Plots of the regressions of mean technician counts on autotracker counts for every deployment are presented in the Results section of this report. Manually analyzing the hydroacoustic tracks is generally considered the most reliable and accurate method of processing raw hydroacoustic data. However, because of the sheer magnitude of the data collected, automated tracking algorithms programmed for pattern recognition are often employed to process the raw hydroacoustic data. The pattern recognition abilities of people are generally considered superior to computer algorithms that can only identify patterns that have been pre-specified. To account for errors in pattern recognition, the regression analyses described below were performed.

Second, we examined the azimuth direction of travel of fish through all routes and found that the proportion of fish detected moving downstream through routes was significantly less than 100% for the sluiceway entrances at B1 and for the three spill bays sampled with split-beam transducers (single-beam data lack the phase information that enables direction-of-travel estimates). We reduced counts at sluiceway and spillway routes by multiplying passage estimates by the average hourly proportion of fish detected moving downstream toward the openings. Direction of travel was based upon a line fitted to all echoes in a fish trace.

Let \hat{X} be an estimate of smolt passage and \hat{B} be an estimate of a “calibration” adjustment. The calibration adjustments could include:

1. Adjustment of autotracker counts for manual counts
2. Adjustment of passage numbers for proportion of fish detected that enter a passage route.

The adjusted estimate was written as

$$\tilde{X} = \hat{B}\hat{X} \quad (16)$$

with the associated variance estimator

$$\widehat{Var}(\tilde{X}) = \widehat{Var}(\hat{X})\hat{B}^2 + \widehat{Var}(\hat{B})\hat{X}^2 - \widehat{Var}(\hat{X}) \cdot \widehat{Var}(\hat{B}) \quad (17)$$

when \hat{X} and \hat{B} are estimated independently. The variance can alternatively be expressed as

$$\begin{aligned} \widehat{Var}(\tilde{X}) &= (\hat{B}\hat{X})^2 \left[\frac{\widehat{Var}(\hat{X})}{\hat{X}^2} + \frac{\widehat{Var}(\hat{B})}{\hat{B}^2} - \frac{\widehat{Var}(\hat{X}) \cdot \widehat{Var}(\hat{B})}{\hat{X}^2 \hat{B}^2} \right] \\ &= (\hat{B}\hat{X})^2 \left[CV(\hat{X})^2 + CV(\hat{B})^2 - CV(\hat{X})^2 \cdot CV(\hat{B})^2 \right]. \end{aligned}$$

2.9.1 Sum of Multiple Adjusted Estimates

Assume there are multiple passage estimates, each with their own calibration adjustment that need to be summed such that

$$\tilde{X} = \sum_{i=1}^n \tilde{X}_i = \sum_{i=1}^n \hat{B}_i \hat{X}_i . \quad (18)$$

Then the variance of \tilde{X} was estimated by

$$\begin{aligned} \widehat{Var}(\tilde{X}) &= Var\left(\sum_{i=1}^n \tilde{X}_i\right) \\ \widehat{Var}(\tilde{X}) &= Var\left(\sum_{i=1}^n \hat{B}_i \hat{X}_i\right) \\ &= \sum_{i=1}^n \left[\widehat{Var}(\hat{X}_i) \hat{B}_i^2 + \widehat{Var}(\hat{B}_i) \hat{X}_i^2 - \widehat{Var}(\hat{X}_i) \cdot \widehat{Var}(\hat{B}_i) \right]. \end{aligned} \quad (19)$$

2.9.2 Adjusting Autotracker Counts by Regression: Ratio Estimator

Consider the case of autotracking versus manual counts. Let \hat{X} be the passage estimate based on autotracking and let \tilde{X} be the estimate of passage for manual counts where

$$\tilde{X} = \hat{B} \cdot \hat{X} .$$

The estimator \hat{B} was obtained from the straight-line regression through the origin where

$$y_i = Bx_i$$

and where

y_i = manual count for the i th observation,

x_i = autotracker count for the i th observation.

The regression was plotted as follows:

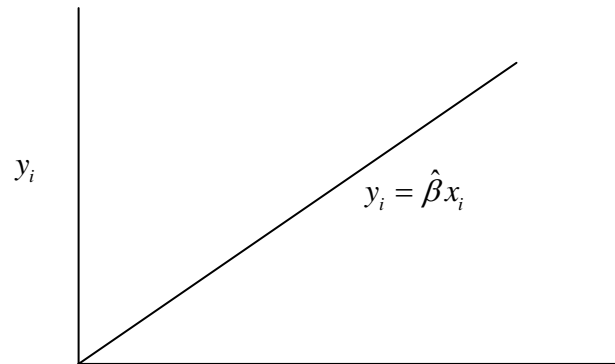

The estimator of the slope was

$$\hat{\beta} = \frac{\sum_{i=1}^n y_i}{\sum_{i=1}^n x_i} \quad (20)$$

The values of x_i and y_i used in the estimation of \hat{B} were hourly counts, as was the estimate of \tilde{X} . The variance of \hat{B} was estimated by the expression

$$\widehat{Var}(\hat{B}) = \frac{\sum_{i=1}^n (y_i - \hat{\beta}x_i)^2}{n(n-1)\bar{x}^2} \quad (21)$$

or equivalently,

$$\widehat{Var}(\hat{B}) = \frac{\sum_{i=1}^n y_i^2 - 2\hat{B}\sum_{i=1}^n y_i x_i + \hat{B}^2 \sum_{i=1}^n x_i^2}{n(n-1)\bar{x}^2} \quad (22)$$

and where

$$\bar{x} = \frac{\sum_{i=1}^n x_i}{n}$$

2.9.3 Adjusting for Direction-of-Travel Proportions

Consider the case where the calibration adjustment is the proportion of observed smolts moving downstream through a passage route. The estimate of the adjustment was

$$\hat{B} = \frac{\hat{V}}{\hat{V} + \hat{W}} \quad (23)$$

Where

\hat{V} = estimated number of smolts that entered the passage route in the i th observation,

\hat{W} = estimated number of smolts that did not enter the passage route in the i th observation.

The variance of \hat{B} in this case was estimated as follows:

$$\widehat{Var}(\hat{B}) = \frac{\hat{B}(1-\hat{B})}{(\hat{V} + \hat{W})} + \hat{B}^2(1-\hat{B})^2 \left[\frac{\widehat{Var}(\hat{V})}{\hat{V}^2} + \frac{\widehat{Var}(\hat{W})}{\hat{W}^2} - \frac{2\widehat{Cov}(\hat{V}, \hat{W})}{\hat{V}\hat{W}} \right] \quad (24)$$

The variance of \hat{V} and \hat{W} depends on how the total passage was estimated from multiple locations over time, so

$$\hat{V} = \sum_{i=1}^L \sum_{j=1}^D \sum_{k=1}^{24} \left[\frac{N}{n} \sum_{l=1}^n v_{ijkl} \right] \quad (25)$$

Where

v_{ijkl} = expanded fish count for the i th sampling interval ($l = 1, \dots, n$) in the k th hour ($k = 1, \dots, 24$) for the j th day ($j = 1, \dots, D$) at the i th location ($i = 1, \dots, L$);

n = number of intervals sampled per hour;

N = number of possible sampling intervals within an hour.

$$\widehat{Var}(\hat{V}) = \sum_{i=1}^L \sum_{j=1}^D \sum_{k=1}^{24} \left[\frac{N^2 \left(1 - \frac{n}{N}\right)}{n} s_{v_{ijk}}^2 \right] \quad (26)$$

$$s_{v_{ijk}}^2 = \frac{\sum_{l=1}^n (v_{ijkl} - \bar{v}_{ijk})^2}{(n-1)},$$

where

$$\bar{v}_{ijk} = \frac{\sum_{l=1}^n v_{ijkl}}{n}.$$

The variance of \hat{W} was computed analogously.

The covariance of \hat{V} and \hat{W} was estimated as follows:

$$\widehat{Cov}(\hat{V}, \hat{W}) = \sum_{i=1}^L \sum_{j=1}^D \sum_{k=1}^{24} \left[\frac{N^2 \left(1 - \frac{n}{N}\right)}{n} cov(v_{ijk}, w_{ijk}) \right] \quad (27)$$

where $cov(v_{ijk}, w_{ijk}) = \frac{\sum_{l=1}^n (v_{ijkl} - \bar{v}_{ijk})(w_{ijkl} - \bar{w}_{ijk})}{(n-1)}.$

2.10 Estimating Passage Performance

Estimates of fish passage through the powerhouses, sluiceways, the corner collector, and the spillway will be used to estimate measures of passage performance. This section presents the estimators and associated variance estimators.

2.10.1 Project Fish Passage Efficiency (FPE)

The project-wide FPE was estimated by the quotient

$$\widehat{FPE} = \frac{[\widehat{S} + \widehat{HG} + \widehat{SL} + \widehat{CC}]}{[\widehat{HU} + \widehat{HG} + \widehat{T} + \widehat{SL} + \widehat{CC} + \widehat{S}]}, \quad (28)$$

where the numerator is the estimated spillway, B2 bypass guided, sluiceway, and B2CC passage, respectively, and the denominator is the total project passage composed of B2 unguided, B2 guided, B1 turbine, B1 sluiceway, B2CC, and spillway passage, respectively. Project FPE can be alternatively expressed as

$$\widehat{FPE} = \frac{\widehat{G}}{\widehat{G} + \widehat{U}}, \quad (29)$$

where

$$\begin{aligned} \widehat{G} &= \widehat{S} + \widehat{HG} + \widehat{SL} + \widehat{CC}, \\ \widehat{U} &= \widehat{HU} + \widehat{T}. \end{aligned}$$

The variance of \widehat{FPE} was estimated by

$$\widehat{\text{Var}}(\widehat{FPE}) = \widehat{FPE}^2 (1 - \widehat{FPE})^2 \left[\frac{\widehat{\text{Var}}(\widehat{G})}{\widehat{G}^2} + \frac{\widehat{\text{Var}}(\widehat{U})}{\widehat{U}^2} \right], \quad (30)$$

where

$$\begin{aligned} \widehat{\text{Var}}(\widehat{G}) &= \widehat{\text{Var}}(\widehat{S}) + \widehat{\text{Var}}(\widehat{HG}) + \widehat{\text{Var}}(\widehat{SL}) + \widehat{\text{Var}}(\widehat{CC}), \\ \widehat{\text{Var}}(\widehat{U}) &= \widehat{\text{Var}}(\widehat{HU}) + \widehat{\text{Var}}(\widehat{T}). \end{aligned}$$

2.10.2 Project Fish Passage Efficiency – No Surface Passage

The project-wide FPE with no surface bypass was estimated by the quotient

$$\widehat{FPE}_{NS} = \frac{[\widehat{S} + \widehat{HG}]}{[\widehat{HU} + \widehat{HG} + \widehat{T} + \widehat{S}]}, \quad (31)$$

where the numerator is the estimated spillway and B2 bypass guided passage, respectively, and the denominator is the total project passage composed of B2 unguided, B2 guided, B1 turbine, and spillway passage, respectively. Sluiceway and B2CC passage were ignored. Project FPE can be alternatively expressed as

$$\widehat{FPE}_{NS} = \frac{\widehat{G}}{\widehat{G} + \widehat{U}}, \quad (32)$$

where

$$\begin{aligned}\hat{G} &= \hat{S} + \widehat{HG}, \\ \hat{U} &= \widehat{HU} + \hat{T}.\end{aligned}$$

The variance of \widehat{FPE} can then be estimated by

$$\widehat{\text{Var}}(\widehat{FPE}_{NS}) = \widehat{FPE}_{NS}^2 (1 - \widehat{FPE}_{NS})^2 \left[\frac{\widehat{\text{Var}}(\hat{G})}{\hat{G}^2} + \frac{\widehat{\text{Var}}(\hat{U})}{\hat{U}^2} \right], \quad (33)$$

where

$$\begin{aligned}\widehat{\text{Var}}(\hat{G}) &= \widehat{\text{Var}}(\hat{S}) + \widehat{\text{Var}}(\widehat{HG}), \\ \widehat{\text{Var}}(\hat{U}) &= \widehat{\text{Var}}(\widehat{HU}) + \widehat{\text{Var}}(\hat{T}).\end{aligned}$$

2.10.3 Project Fish Passage Efficiency – B2 + Spillway only

The project-wide FPE ignoring B1 passage was estimated by the quotient

$$\widehat{FPE}_{B2+Spill} = \frac{[\hat{S} + \widehat{HG} + \widehat{CC}]}{[\widehat{HU} + \widehat{HG} + \widehat{CC} + \hat{S}]}, \quad (34)$$

where the numerator is the estimated spillway, B2 bypass guided, and B2CC passage, respectively, and the denominator is the total project passage ignoring B1 passage and is composed of B2 unguided, B2 guided, B1 turbine, B2CC, and spillway passage, respectively. Project FPE for B2 and the spillway only can be alternatively expressed as

$$\widehat{FPE}_{B2+Spill} = \frac{\hat{G}}{\hat{G} + \hat{U}}, \quad (35)$$

where

$$\begin{aligned}\hat{G} &= \hat{S} + \widehat{HG} + \widehat{CC}, \\ \hat{U} &= \widehat{HU}.\end{aligned}$$

The variance of $\widehat{FPE}_{B2+Spill}$ was estimated by

$$\widehat{\text{Var}}(\widehat{FPE}_{B2+Spill}) = \widehat{FPE}_{B2+Spill}^2 (1 - \widehat{FPE}_{B2+Spill})^2 \left[\frac{\widehat{\text{Var}}(\hat{G})}{\hat{G}^2} + \frac{\widehat{\text{Var}}(\hat{U})}{\hat{U}^2} \right], \quad (36)$$

where

$$\widehat{\text{Var}}(\hat{G}) = \widehat{\text{Var}}(\hat{S}) + \widehat{\text{Var}}(\widehat{HG}) + \widehat{\text{Var}}(\widehat{CC}),$$

$$\widehat{\text{Var}}(\hat{U}) = \widehat{\text{Var}}(\widehat{HU}).$$

2.10.4 B1 Fish Passage Efficiency (B1 FPE)

For B1, FPE is estimated by the quantity

$$\widehat{FPE}_{B1} = \frac{\widehat{SL}}{\hat{T} + \widehat{SL}}, \quad (37)$$

with the associated variance estimator

$$\widehat{\text{Var}}(\widehat{FPE}_{B1}) = \widehat{FPE}_{B1}^2 (1 - \widehat{FPE}_{B1})^2 \left[\frac{\widehat{\text{Var}}(\widehat{SL})}{\widehat{SL}^2} + \frac{\widehat{\text{Var}}(\hat{T})}{\hat{T}^2} \right]. \quad (38)$$

2.10.5 B2 Fish Passage Efficiency (B2 FPE)

For B2, FPE is estimated by the quantity

$$\widehat{FPE}_{B2} = \frac{\widehat{HG} + \widehat{CC}}{\widehat{HU} + \widehat{HG} + \widehat{CC}}, \quad (39)$$

with associated variance estimator

$$\widehat{\text{Var}}(\widehat{FPE}_{B2}) = \widehat{FPE}_{B2}^2 (1 - \widehat{FPE}_{B2})^2 \left[\frac{\widehat{\text{Var}}(\widehat{HU})}{\widehat{HU}^2} + \frac{\widehat{\text{Var}}(\hat{G}_2)}{\hat{G}_2^2} \right], \quad (40)$$

where

$$\hat{G}_2 = \widehat{HG} + \widehat{CC},$$

$$\widehat{\text{Var}}(\hat{G}_2) = \widehat{\text{Var}}(\widehat{HG}) + \widehat{\text{Var}}(\widehat{CC}).$$

2.10.6 B2 Fish Guidance Efficiency (B2 FGE)

For B2, FGE is estimated by the quantity

$$\widehat{FGE}_{B2} = \frac{\widehat{HG}}{\widehat{HU} + \widehat{HG}} \quad (41)$$

where the numerator is the sum of guided fish in all B2 turbines and the denominator is the sum of unguided fish and guided fish in B2 turbines. Surface collection at the B2CC is ignored. The associated variance estimator is

$$\widehat{\text{Var}}\left(\widehat{FGE}_{B2}\right) = \widehat{FGE}_{B2}^2 \left(1 - \widehat{FGE}_{B2}\right)^2 \left[\frac{\widehat{\text{Var}}\left(\widehat{HU}\right)}{\widehat{HU}^2} + \frac{\widehat{\text{Var}}\left(\widehat{HG}\right)}{\widehat{HG}^2} \right] \quad (42)$$

2.10.7 Spill Efficiency

The spill efficiency at the Bonneville project is estimated by the quotient

$$\widehat{SY} = \frac{\widehat{S}}{\left[\widehat{HU} + \widehat{HG} + \widehat{T} + \widehat{SL} + \widehat{CC} + \widehat{S}\right]}, \quad (43)$$

where the numerator is the estimated spillway passage and the denominator is total project passage composed of B2 unguided, B2 guided, B1 turbine, B1 sluiceway, B2CC, and spillway passage, respectively. The variance of \widehat{SY} is estimated by the expression

$$\widehat{\text{Var}}\left(\widehat{SY}\right) = \widehat{SY}^2 \left(1 - \widehat{SY}\right)^2 \left[\frac{\widehat{\text{Var}}\left(\widehat{S}\right)}{\widehat{S}^2} + \frac{\widehat{\text{Var}}\left(\widehat{NS}\right)}{\widehat{NS}^2} \right], \quad (44)$$

where

$$\widehat{NS} = \widehat{HU} + \widehat{HG} + \widehat{T} + \widehat{SL} + \widehat{CC},$$

and where

$$\widehat{\text{Var}}\left(\widehat{NS}\right) = \widehat{\text{Var}}\left(\widehat{HU}\right) + \widehat{\text{Var}}\left(\widehat{HG}\right) + \widehat{\text{Var}}\left(\widehat{T}\right) + \widehat{\text{Var}}\left(\widehat{SL}\right) + \widehat{\text{Var}}\left(\widehat{CC}\right).$$

2.10.8 Spill Efficiency – B2 and Spill Only

The spill efficiency at the Bonneville project when B1 passage is ignored is estimated by the quotient

$$\widehat{SY}_{B2+Spill} = \frac{\widehat{S}}{\left[\widehat{HU} + \widehat{HG} + \widehat{CC} + \widehat{S}\right]}, \quad (45)$$

where the numerator is the estimated spillway passage and the denominator is total project passage composed of B2 unguided, B2 guided, B1 turbine, B1 sluiceway, B2CC, and spillway passage, respectively. The variance of \widehat{SY} is be estimated by the expression

$$\widehat{\text{Var}}\left(\widehat{SY}_{B2+Spill}\right) = \widehat{SY}_{B2+Spill}^2 \left(1 - \widehat{SY}_{B2+Spill}\right)^2 \left[\frac{\widehat{\text{Var}}\left(\widehat{S}\right)}{\widehat{S}^2} + \frac{\widehat{\text{Var}}\left(\widehat{NS}\right)}{\widehat{NS}^2} \right], \quad (46)$$

where

$$\widehat{NS} = \widehat{HU} + \widehat{HG} + \widehat{CC},$$

and where

$$\widehat{\text{Var}}(\widehat{NS}) = \widehat{\text{Var}}(\widehat{HU}) + \widehat{\text{Var}}(\widehat{HG}) + \widehat{\text{Var}}(\widehat{CC}).$$

2.10.9 Spill Effectiveness

The spill effectiveness at the Bonneville project is estimated by the quantity

$$\widehat{SE} = \frac{\left(\frac{\widehat{S}}{V_S} \right)}{\left(\widehat{NS} + \widehat{S} \right)} = \widehat{SY} \cdot \frac{V_T}{V_S}, \quad (47)$$

where

\widehat{S} = Spill passage,

V_S = volume of water spilled,

$\widehat{NS} = \widehat{HU} + \widehat{HG} + \widehat{T} + \widehat{SL} + \widehat{CC}$,

V_T = total volume of water passing the dam during the period of inference, and

\widehat{SY} = spill efficiency.

The variance of \widehat{SE} can be estimated by

$$\widehat{\text{Var}}(\widehat{SE}) = \left(\frac{V_T}{V_S} \right)^2 \cdot \widehat{\text{Var}}(\widehat{SY}). \quad (48)$$

2.10.10 Spill Effectiveness – B2 and Spillway only

The spill effectiveness at the Bonneville project ignoring B1 passage is estimated by the quantity

$$\widehat{SE}_{B2+Spill} = \frac{\left(\frac{\widehat{S}}{V_S} \right)}{\left(\widehat{NS} + \widehat{S} \right)} = \widehat{SY}_{B2+Spill} \cdot \frac{V_T}{V_S}, \quad (49)$$

where

\widehat{S} = Spill passage,

V_S = volume of water spilled,

$\widehat{NS} = \widehat{HU} + \widehat{HG} + \widehat{CC}$,

V_T = total volume of water passing the dam during the period of inference, and

$\widehat{SY}_{B2+Spill}$ = spill efficiency.

The variance of \widehat{SE} can be estimated by

$$\widehat{\text{Var}}\left(\widehat{SE}_{B2+Spill}\right) = \left(\frac{V_T}{V_S}\right)^2 \cdot \widehat{\text{Var}}\left(\widehat{SY}_{B2+Spill}\right). \quad (50)$$

2.10.11 Project Sluiceway Efficiency

Across the entire project, sluiceway efficiency is estimated by the quantity

$$\widehat{SLY} = \frac{\widehat{SL} + \widehat{CC}}{\widehat{HU} + \widehat{HG} + \widehat{T} + \widehat{CC} + \widehat{S} + \widehat{SL}},$$

where the numerator is the estimated B1 sluiceway passage and B2CC passage and the denominator is the total project passage composed of B2 unguided, B2 guided, B1 turbine, B2CC, spillway, and B1 sluiceway passage, respectively. The variance of \widehat{SLY} is estimated by the quantity

$$\widehat{\text{Var}}(\widehat{SLY}) = \widehat{SLY}^2 (1 - \widehat{SLY})^2 \left[\frac{\widehat{\text{Var}}(\widehat{SL} + \widehat{CC})}{(\widehat{SL} + \widehat{CC})^2} + \frac{\widehat{\text{Var}}(\widehat{NSL})}{\widehat{NSL}^2} \right], \quad (51)$$

where

$$\widehat{NSL} = \widehat{HU} + \widehat{HG} + \widehat{T} + \widehat{S}$$

and where

$$\widehat{\text{Var}}(\widehat{NSL}) = \widehat{\text{Var}}(\widehat{HU}) + \widehat{\text{Var}}(\widehat{HG}) + \widehat{\text{Var}}(\widehat{T}) + \widehat{\text{Var}}(\widehat{S}).$$

2.10.12 Project Sluiceway Effectiveness

Project-wide sluiceway effectiveness was estimated by the quantity

$$\begin{aligned} \widehat{SLE} &= \frac{\left(\frac{\widehat{SL} + \widehat{CC}}{V_{SL} + V_{CC}} \right)}{\left(\frac{\widehat{HU} + \widehat{HG} + \widehat{T} + \widehat{CC} + \widehat{S} + \widehat{SL}}{V_T} \right)} \\ &= \widehat{SLY} \left(\frac{V_T}{V_{SL} + V_{CC}} \right) \end{aligned} \quad (52)$$

with associated variance estimator

$$\widehat{\text{Var}}(\widehat{SLE}) = \left(\frac{V_T}{V_{SL} + V_{CC}} \right)^2 \cdot \widehat{\text{Var}}(\widehat{SLY}), \quad (53)$$

where

V_T = total volume of water passing through the project,

V_{SL} = volume of water passing through the sluiceways at B1,

V_{CC} = volume of water passing through the B2CC, and other variables are as defined previously.

2.10.13 B1 Sluiceway Efficiency Relative to the Project Passage

Across the entire project, B1 sluiceway efficiency is estimated by the quantity

$$\widehat{SLY}_{B1:P} = \frac{\widehat{SL}}{\widehat{HU} + \widehat{HG} + \widehat{T} + \widehat{CC} + \widehat{S} + \widehat{SL}},$$

where the numerator is the estimated sluiceway passage through B1 only and the denominator is the total project passage composed of B2 unguided, B2 guided, B1 turbine, B2CC, spillway, and B1 sluiceway passage, respectively. The variance of $\widehat{SLY}_{B1:P}$ is estimated by the quantity

$$\widehat{\text{Var}}(\widehat{SLY}_{B1:P}) = \widehat{SLY}_{B1:P}^2 (1 - \widehat{SLY}_{B1:P})^2 \left[\frac{\widehat{\text{Var}}(\widehat{SL})}{\widehat{SL}^2} + \frac{\widehat{\text{Var}}(\widehat{NSL})}{\widehat{NSL}^2} \right], \quad (54)$$

where

$$\widehat{NSL} = \widehat{HU} + \widehat{HG} + \widehat{T} + \widehat{S}$$

and where

$$\widehat{\text{Var}}(\widehat{NSL}) = \widehat{\text{Var}}(\widehat{HU}) + \widehat{\text{Var}}(\widehat{HG}) + \widehat{\text{Var}}(\widehat{T}) + \widehat{\text{Var}}(\widehat{S}).$$

2.10.14 B1 Sluiceway Efficiency Relative to B1 Passage

Relative to B1 passage, B1 sluiceway efficiency is estimated by the quantity

$$\widehat{SLY}_{B1:B1} = \frac{\widehat{SL}}{\widehat{T} + \widehat{SL}},$$

where the numerator is the estimated sluiceway passage through B1 only and the denominator is the total project passage composed of B2 unguided, B2 guided, B1 turbine, B2CC, spillway, and B1 sluiceway passage, respectively. The variance of $\widehat{SLY}_{B1:B1}$ is estimated by the quantity

$$\widehat{\text{Var}}(\widehat{SLY}_{B1:B1}) = \widehat{SLY}_{B1:B1}^2 (1 - \widehat{SLY}_{B1:B1})^2 \left[\frac{\widehat{\text{Var}}(\widehat{SL})}{\widehat{SL}^2} + \frac{\widehat{\text{Var}}(\widehat{T})}{\widehat{T}^2} \right], \quad (55)$$

where

$$\widehat{T} = \text{B1 turbine passage}$$

2.10.15 B1 Sluiceway Effectiveness Relative to the Project

B1 sluiceway effectiveness relative to the Project was estimated by the quantity

$$\begin{aligned} \widehat{SLE}_{B1:P} &= \frac{\left(\frac{\widehat{SL}}{\widehat{V}_{SL}} \right)}{\left(\frac{\widehat{HU} + \widehat{HG} + \widehat{T} + \widehat{CC} + \widehat{S} + \widehat{SL}}{V_T} \right)} \\ &= \widehat{SLY}_{B1:P} \left(\frac{V_T}{V_{SL}} \right) \end{aligned} \quad (56)$$

with associated variance estimator

$$\widehat{\text{Var}}(\widehat{SLE}_{B1:P}) = \left(\frac{V_T}{V_{SL}} \right)^2 \cdot \widehat{\text{Var}}(\widehat{SLY}_{B1:P}), \quad (57)$$

where

V_T = total volume of water passing through the project,

V_{SL} = volume of water passing through the sluiceways at B1.

2.10.16 B1 Sluiceway Effectiveness Relative to B1

B1 sluiceway effectiveness relative to B1 was estimated by the quantity

$$\begin{aligned} \widehat{SLE}_{B1:B1} &= \frac{\left(\frac{\widehat{SL}}{\widehat{V}_{SL}} \right)}{\left(\frac{\widehat{HU} + \widehat{HG} + \widehat{T} + \widehat{CC} + \widehat{S} + \widehat{SL}}{V_{B1}} \right)} \\ &= \widehat{SLY}_{B1:B1} \left(\frac{V_{B1}}{V_{SL}} \right) \end{aligned} \quad (58)$$

with associated variance estimator

$$\widehat{\text{Var}}(\widehat{SLE}_{B1:B1}) = \left(\frac{V_{B1}}{V_{SL}} \right)^2 \cdot \widehat{\text{Var}}(\widehat{SLY}_{B1:B1}), \quad (59)$$

where

V_{B1} = total volume of water passing through B1,

V_{SL} = volume of water passing through the sluiceways at B1.

2.10.17 B2CC Efficiency Relative to Project Passage

The B2CC efficiency relative to the Project is estimated by the quotient

$$\widehat{CCY} = \frac{\widehat{CC}}{\widehat{HU} + \widehat{HG} + \widehat{T} + \widehat{S} + \widehat{SL} + \widehat{CC}}, \quad (60)$$

where the numerator is the estimate of corner collector passage and the denominator is the total project passage composed of B2 unguided, B2 guided, B1 turbine, spillway, B1 sluiceway, and B2CC passage, respectively. The variance of \widehat{CCY} is estimated by the quantity

$$\widehat{\text{Var}}(\widehat{CCY}) = \widehat{CCY}^2 (1 - \widehat{CCY})^2 \left[\frac{\widehat{\text{Var}}(\widehat{CC})}{\widehat{CC}^2} + \frac{\widehat{\text{Var}}(\widehat{NCC})}{\widehat{NCC}^2} \right], \quad (61)$$

where

$$\widehat{NCC} = \widehat{HU} + \widehat{HG} + \widehat{T} + \widehat{S} + \widehat{SL}$$

and where

$$\widehat{\text{Var}}(\widehat{NCC}) = \widehat{\text{Var}}(\widehat{HU}) + \widehat{\text{Var}}(\widehat{HG}) + \widehat{\text{Var}}(\widehat{T}) + \widehat{\text{Var}}(\widehat{S}) + \widehat{\text{Var}}(\widehat{SL}).$$

2.10.18 B2CC Efficiency Relative to B2 Passage

The B2CC efficiency relative to B2 passage is estimated by the quotient

$$\widehat{CCY}_{B2} = \frac{\widehat{CC}}{\widehat{HU} + \widehat{HG} + \widehat{CC}}, \quad (62)$$

where the numerator is the estimate of corner collector passage and the denominator is B2 passage composed of B2 unguided, B2 guided, and B2CC passage, respectively. The variance of \widehat{CCY}_{B2} is estimated by the quantity

$$\widehat{\text{Var}}(\widehat{CCY}_{B2}) = \widehat{CCY}_{B2}^2 (1 - \widehat{CCY}_{B2})^2 \left[\frac{\widehat{\text{Var}}(\widehat{CC})}{\widehat{CC}^2} + \frac{\widehat{\text{Var}}(\widehat{NCC}_{B2})}{\widehat{NCC}_{B2}^2} \right], \quad (63)$$

where

$$\widehat{NCC}_{B2} = \widehat{HU} + \widehat{HG}$$

and where

$$\widehat{\text{Var}}\left(\widehat{NCC}_{B2}\right) = \widehat{\text{Var}}\left(\widehat{HU}\right) + \widehat{\text{Var}}\left(\widehat{HG}\right).$$

2.10.19 B2CC Effectiveness Relative to the Project

Project-wide corner collector effectiveness is estimated by the quantity

$$\begin{aligned} \widehat{CCE} &= \frac{\left(\frac{\widehat{CC}}{V_{CC}}\right)}{\left(\frac{\widehat{HU} + \widehat{HG} + \widehat{T} + \widehat{S} + \widehat{SL} + \widehat{CC}}{V_T}\right)} \\ &= CCY\left(\frac{V_T}{V_{CC}}\right), \end{aligned} \quad (64)$$

with an associated variance estimator

$$\widehat{\text{Var}}\left(\widehat{CCE}\right) = \left(\frac{V_T}{V_{CC}}\right)^2 \cdot \widehat{\text{Var}}\left(\widehat{CCY}\right), \quad (65)$$

where

V_T = total volume of water passing through the project, and

V_{CC} = volume of water passing through the corner collector.

2.10.20 B2CC Effectiveness Relative to B2

Project-wide corner collector effectiveness relative to B2 is estimated by the quantity

$$\begin{aligned} \widehat{CCE}_{B2} &= \frac{\left(\frac{\widehat{CC}}{V_{CC}}\right)}{\left(\frac{\widehat{HU} + \widehat{HG} + \widehat{T} + \widehat{S} + \widehat{SL} + \widehat{CC}}{V_{B2}}\right)} \\ &= CCY_{B2}\left(\frac{V_{B2}}{V_{CC}}\right), \end{aligned} \quad (64)$$

with an associated variance estimator

$$\widehat{\text{Var}}\left(\widehat{CCE}_{B2}\right) = \left(\frac{V_{B2}}{V_{CC}}\right)^2 \cdot \widehat{\text{Var}}\left(\widehat{CCY}_{B2}\right), \quad (65)$$

where

V_{CC} = volume of water passing through the corner collector, and

V_{B2} = volume of water passing through B2.

2.10.21 Combined Sluiceway and Corner Collector Efficiency

The estimate of the combined sluiceway and corner collector efficiency is calculated by the quantity

$$\widehat{CSLCCE} = \frac{\widehat{SL} + \widehat{CC}}{\widehat{HU} + \widehat{HG} + \widehat{T} + \widehat{S} + \widehat{SL} + \widehat{CC}}, \quad (61)$$

where the numerator estimates smolt passage through the sluiceway and corner collector, and the denominator is the total project passage. The variance of CSLCCE is estimated by the quantity

$$\widehat{\text{Var}}(\widehat{CSLCCE}) = \widehat{CSLCCE}^2 (1 - \widehat{CSLCCE})^2 \left[\frac{\widehat{\text{Var}}(\widehat{A})}{\widehat{A}^2} + \frac{\widehat{\text{Var}}(\widehat{B})}{\widehat{B}^2} \right], \quad (62)$$

where

$$\begin{aligned} \widehat{A} &= \widehat{SL} + \widehat{CC}, \\ \widehat{\text{Var}}(\widehat{A}) &= \widehat{\text{Var}}(\widehat{SL}) + \widehat{\text{Var}}(\widehat{CC}), \\ \widehat{B} &= \widehat{HU} + \widehat{HG} + \widehat{T} + \widehat{S}, \\ \widehat{\text{Var}}(\widehat{B}) &= \widehat{\text{Var}}(\widehat{HU}) + \widehat{\text{Var}}(\widehat{HG}) + \widehat{\text{Var}}(\widehat{T}) + \widehat{\text{Var}}(\widehat{S}). \end{aligned}$$

2.10.22 Combined Sluiceway and Corner Collector Effectiveness

Project-wide sluiceway and corner collector effectiveness is estimated by the quantity

$$\begin{aligned} \widehat{CSLCCN} &= \frac{\left(\frac{\widehat{SL} + \widehat{CC}}{V_{SL} + V_{CC}} \right)}{\left(\frac{\widehat{HU} + \widehat{HG} + \widehat{T} + \widehat{S} + \widehat{SL} + \widehat{CC}}{V_T} \right)} \\ &= CSLCCE \cdot \left(\frac{V_T}{V_{SL} + V_{CC}} \right) \end{aligned} \quad (63)$$

with an associated variance estimator

$$\widehat{\text{Var}}(\widehat{CSLCCN}) = \left(\frac{V_T}{V_{SL} + V_{CC}} \right)^2 \cdot \widehat{\text{Var}}(\widehat{CSLCCE}). \quad (64)$$

2.10.23 Localized B2 Corner Collector Efficiency

The localized efficiency of the corner collector in vicinity of turbine Units 11-18 is estimated by the quantity

$$\widehat{LCCE} = \frac{\widehat{CC}}{\widehat{HU}_{11-18} + \widehat{HG}_{11-18} + \widehat{CC}}, \quad (65)$$

where

\widehat{HU}_{11-18} = estimated unguided fish passage through Units 11-18, B2;

\widehat{HG}_{11-18} = estimated guided fish passage through Units 11-18, B2.

The variance of \widehat{LCCE} is estimated by the quantity

$$\widehat{\text{Var}}(\widehat{LCCE}) = \widehat{LCCE}^2 (1 - \widehat{LCCE})^2 \left[\frac{\widehat{\text{Var}}(\widehat{CC})}{\widehat{CC}^2} + \frac{\widehat{\text{Var}}(\widehat{L})}{\widehat{L}^2} \right], \quad (66)$$

where

$$\widehat{L} = \widehat{HU}_{11-18} + \widehat{HG}_{11-18},$$

$$\widehat{\text{Var}}(\widehat{L}) = \widehat{\text{Var}}(\widehat{HU}_{11-18}) + \widehat{\text{Var}}(\widehat{HG}_{11-18}).$$

2.10.24 Localized B2 Corner Collector Effectiveness

The localized effectiveness of the corner collector in the vicinity of turbine Units 11-18 is estimated by the quantity

$$\begin{aligned} \widehat{LCCN} &= \frac{\left(\frac{\widehat{CC}}{V_{CC}} \right)}{\left(\frac{\widehat{HU}_{11-18} + \widehat{HG}_{11-18} + \widehat{CC}}{V_L} \right)} \\ &= \left(\frac{V_L}{V_{CC}} \right) \widehat{LCCE}, \end{aligned} \quad (67)$$

with associated variance estimator

$$\widehat{\text{Var}}(\widehat{LCCN}) = \left(\frac{V_L}{V_{CC}} \right)^2 \cdot \widehat{\text{Var}}(\widehat{LCCE}), \quad (68)$$

where

V_L = volume of water through the corner collector and turbine Units 11-18, B2.

2.10.25 Localized B2 Fish Passage Efficiency

The localized fish passage efficiency in the vicinity of turbine Units 11-18, B2, is estimated by the quantity

$$\widehat{LFPE}_2 = \frac{\widehat{HG}_{11-18} + \widehat{CC}}{\widehat{HU}_{11-18} + \widehat{HG}_{11-18} + \widehat{CC}}. \quad (69)$$

The variance of \widehat{LFPE}_2 is estimated by the quantity

$$\widehat{\text{Var}}(\widehat{LFPE}_2) = \widehat{LFPE}_2^2 (1 - \widehat{LFPE}_2)^2 \left[\frac{\widehat{\text{Var}}(\widehat{HU}_{11-18})}{\widehat{HU}_{11-18}^2} + \frac{\widehat{\text{Var}}(\widehat{LG})}{\widehat{LG}^2} \right], \quad (70)$$

where

$$\begin{aligned} \widehat{LG} &= \widehat{HG}_{11-18} + \widehat{CC}, \\ \widehat{\text{Var}}(\widehat{LG}) &= \widehat{\text{Var}}(\widehat{HG}_{11-18}) + \widehat{\text{Var}}(\widehat{CC}). \end{aligned}$$

2.10.26 Localized B2 Fish Passage Effectiveness

The localized fish passage effectiveness in the vicinity of turbine Units 11-18, B2, is estimated by the quantity

$$\begin{aligned} \widehat{LFPN}_2 &= \frac{\left(\frac{\widehat{HG}_{11-18} + \widehat{CC}}{V'_L} \right)}{\left(\frac{\widehat{HU}_{11-18} + \widehat{HG}_{11-18} + \widehat{CC}}{V_L} \right)} \\ &= \left(\frac{V_L}{V'_L} \right) \cdot \widehat{LFPE}_2 \end{aligned} \quad (71)$$

with associated variance estimator

$$\widehat{\text{Var}}(\widehat{LFPN}_2) = \left(\frac{V_L}{V'_L} \right) \cdot \widehat{\text{Var}}(\widehat{LFPE}_2), \quad (72)$$

where

V'_L = volume of water passing through the bypass at Units 11-18 at B2 plus the corner collector.

2.11 Comparing Spill-Treatment and Location Effects

We used weighted ANOVA on daily estimates of FGE to evaluate effects of turbine unit location, and the presence or absence of turbine intake extensions (TIES) at B2. Daily FGE estimates were used as replicates in ANOVAs which had either unit or TIE versus no TIE as factors. We used Proc Mixed (SAS) to do the analysis of variance and included repeating Julian day in an AR(1) design to account for autocorrelation within location conditions. We tested for differences among all pairs of least-square means using the LSMEAN statement with Tukey-Kramer adjustment for the unbalanced design each season.

3.0 Results

3.1 Environmental Conditions in 2004

This section contains a description of the environmental conditions during the study in 2004, including smolt species composition, river and spill discharge, and hydraulic conditions.

3.1.1 Smolt Migration Characteristics

The species compositions of spring and summer runs were estimated from smolt-monitoring data collected at the B2 smolt monitoring facility by the Fish Passage Center. Our study encompassed the majority of the downstream migration period for yearling Chinook salmon (*Oncorhynchus tshawytscha*), coho (*O. kisutch*), and sockeye (*O. nerka*) salmon as well as steelhead (*O. mykiss*), and subyearling Chinook salmon (Figure 3.1). In 2004, when discharge and percent spill were slightly below average, sub-yearling Chinook salmon released from hatcheries dominated the springtime species composition (46%). Samples taken at the B2 juvenile bypass system (JBS) showed that yearling Chinook salmon were the second most abundant species in spring 2004 (30%), followed by coho (19%), a weak run of steelhead (3%), and a relatively strong run of sockeye (2%). Passage of non-hatchery subyearling Chinook salmon, the most abundant salmonid fish migrating downstream in summer, peaked around the beginning of July (Figure 3.1). The percentages in the spring run at large were quite different from the percentage of juvenile salmonids tagged with radio transmitters, which tracked only yearling Chinook salmon and yearling steelhead (Figure 3.2).

3.1.2 River Discharge, Forebay Elevation, and Water Temperature

During the 2004 study (April 15 through July 15), Project discharge ranged from 125,000 to 310,000 cfs and for the entire study it was about 82% of the 10-year average discharge (Figure 3.3). Before April 12, 2004, spill was confined to the first week in March during the Spring Creek Hatchery release of sub-yearling Chinook salmon, and this was much more compressed than the 10-year average spill for March (Figure 3.3). In 2004, spill discharge was about 75% of the 10-year mean from March 1 to April 15, 84% from April 15 through May 31, and 85% from June 1 through July 15. After April 22, 2004, daytime spill was about 75,000 cfs, and night spill was up to a cap determined by total dissolved gas saturation in the discharge (Figure 3.4). This diel spill pattern is typical for Bonneville Dam. In summer 2004, the typical diel spill pattern also predominated, except for six days during which spill was deliberately held constant at 50,000 cfs during day and night (Figure 3.5). These periods of constant spill afforded us the opportunity to examine diel patterns of spill passage without the confounding effects of day and night differences in spill discharge. Increased nighttime spill comes at the expense of power generation, as operators alter discharge proportions at the Project in accordance with an experimental design (Figure 3.6). Hourly estimates of water discharge through individual turbines and spill bays from April 15 through July 15, 2004, are presented in Appendix E (Tables E-7 and E-8). Mean forebay elevation was 75.2 ft in spring and 75.1 ft in summer, although on a diel basis the elevation can drop by as much as 3.0 to 3.5 ft (Figure 3.7). Water temperature increased as the study progressed from about 5°C to 21°C, and usually was 1 to 2 degrees above the 10-year average (Figure 3.8).

2004

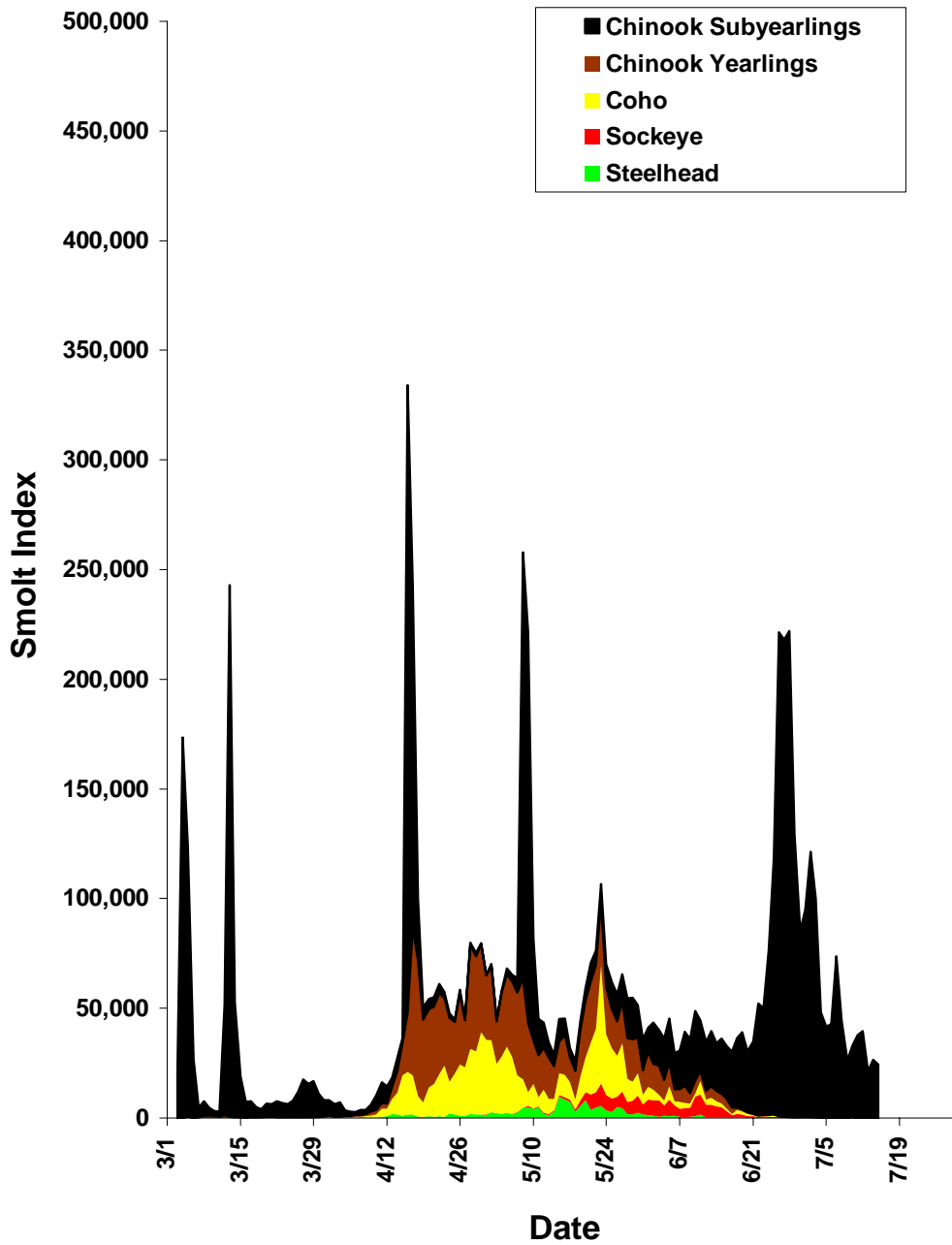

Figure 3.1. Smolt Monitoring Program (SMP) Passage Index for March 1 – July 15, 2004, based upon data from B2. Data were obtained from the DART website in November 2004 (http://www.cqs.washington.edu/dart/pass_com.html).

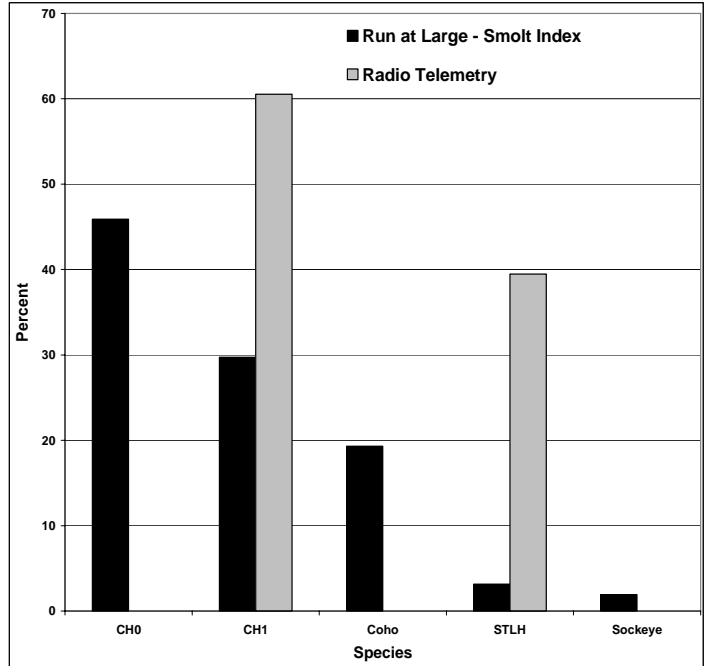

Figure 3.2. Percent Composition of Juvenile Salmonids in the Run at Large and Tagged with Radio Telemetry Transmitters in Spring 2004. Run at large estimates were based upon data from http://www.cqs.washington.edu/dart/pass_com.html and tagged fish percentages were provided by Scott Evans (USGS).

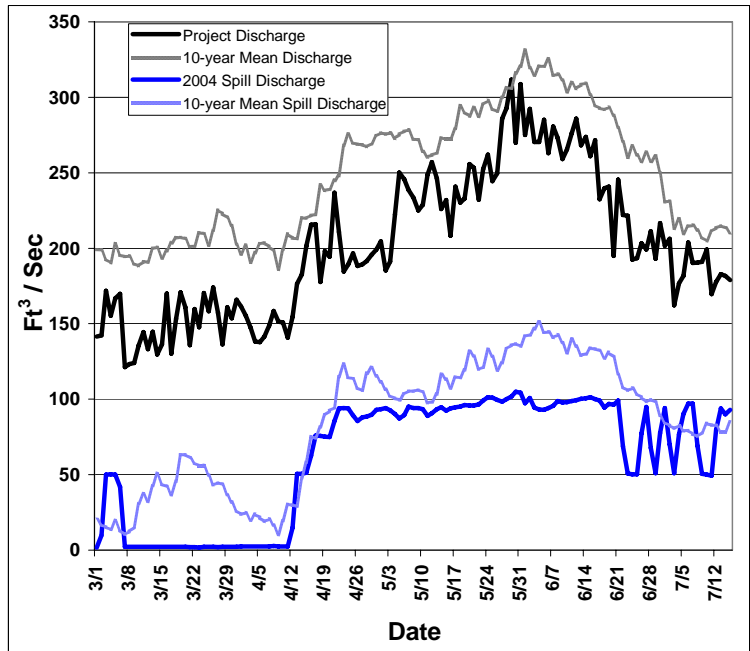

Figure 3.3. Project- and Spill-Discharge Rates for 2004 and the 10-Year Average from 1995 through 2004. Data were obtained from the DART website in November 2004 (<http://www.cqs.washington.edu/dart/river.html>).

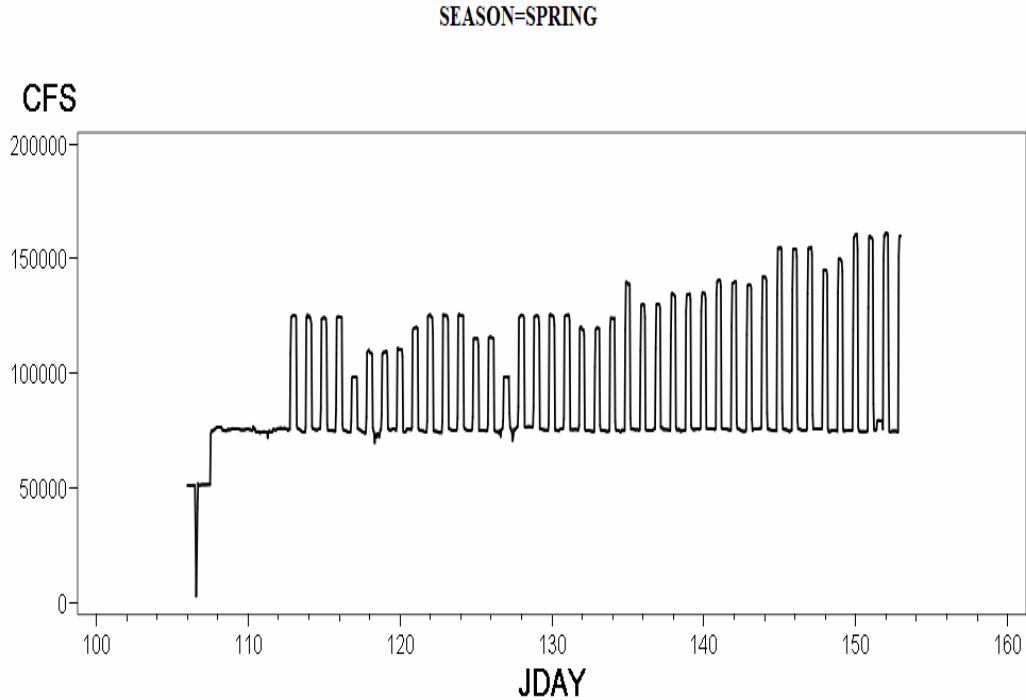

Figure 3.4. Spill Discharge Rate by Julian Day and Time in Spring 2004. Peaks are associated with night spill and the valleys at about 75,000 cfs occur during the daytime. There were no specific spill treatments in spring. Julian days 100 and 150 correspond to April 9 and May 29, 2004, respectively.

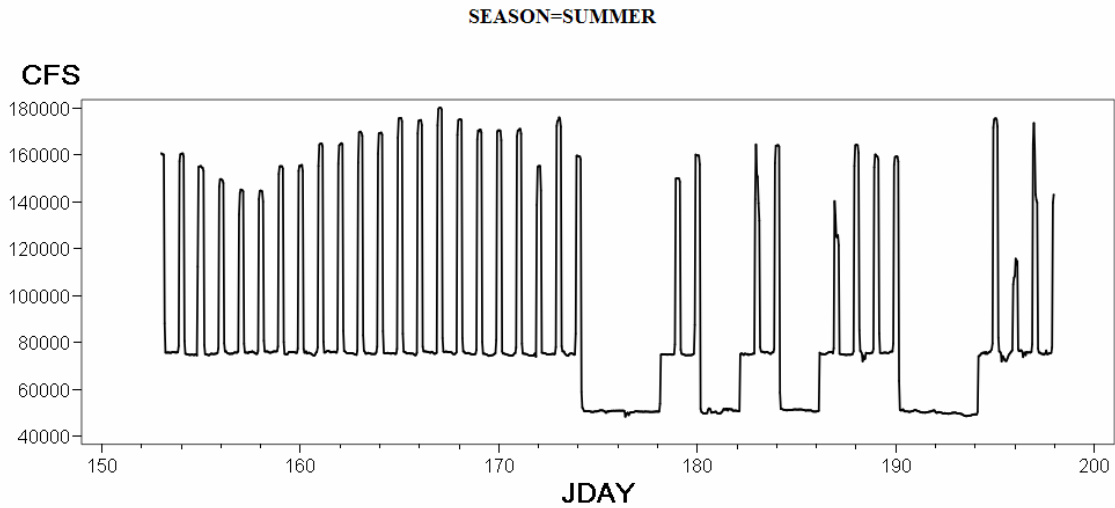

Figure 3.5. Spill Discharge Rate (cfs) by Julian Day (JDAY) and Time within Days. Peaks before Julian day 172 (June 20, 2004) were associated with night spill to the gas cap, and valleys at about 75,000 cfs occurred during the day. There were six days during which spill was held constant at 50,000 cfs (172 = 6/20; 173 = 6/21; 180 = 6/28; 182 = 6/30; 190 = 7/08; and 191 = 7/09) during day and night.

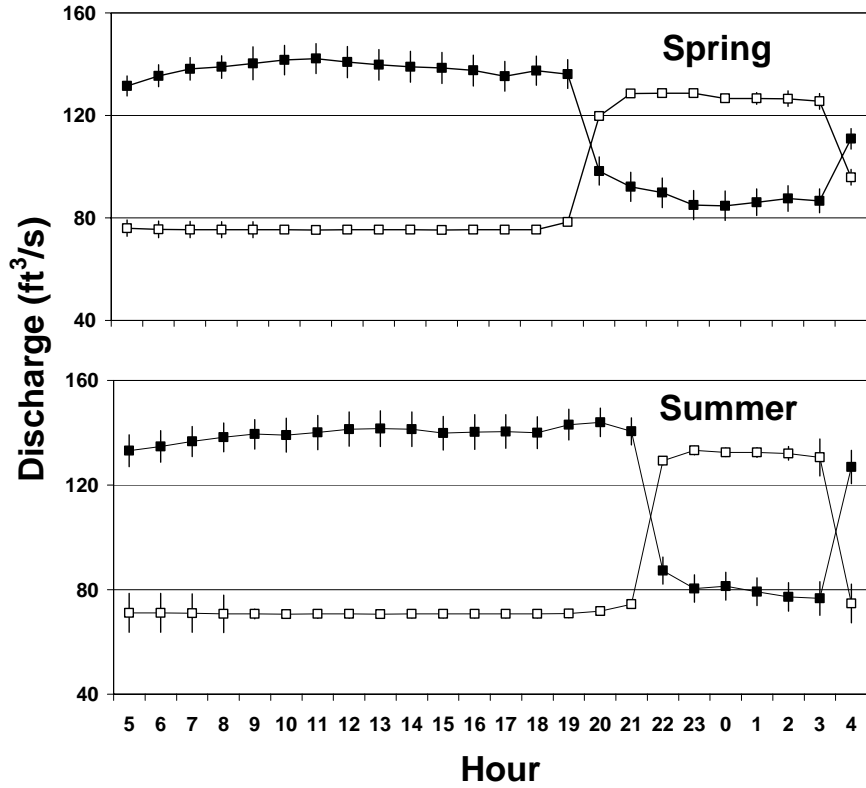

Figure 3.6. Mean Hourly Spill (white squares) and Turbine Discharge (black squares) in Spring and Summer 2004. Vertical bars indicate the standard error of the mean.

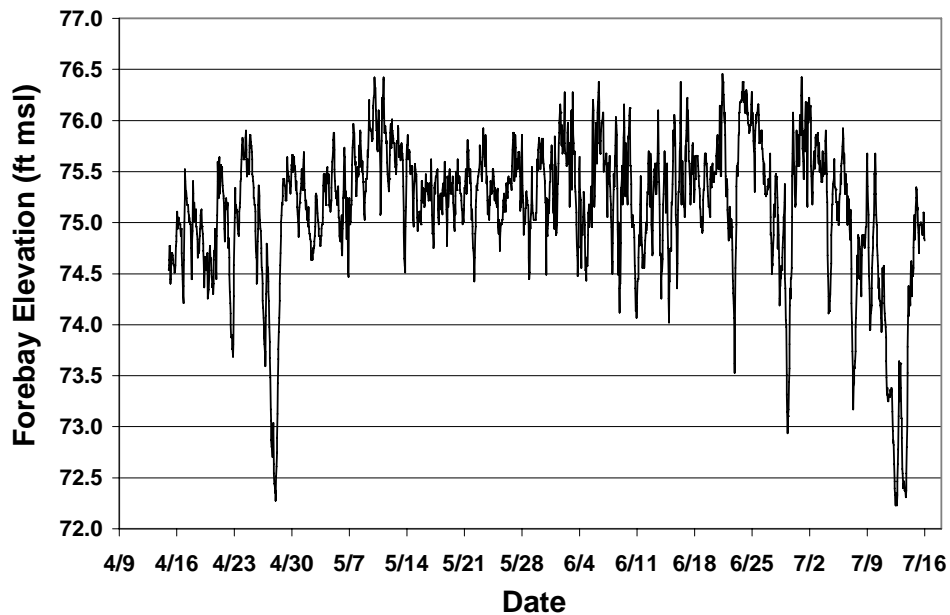

Figure 3.7. Mean Daily Forebay Elevation. Data were obtained from DART (<http://www.cqs.washington.edu/dart/dart.html>), accessed September 2004.

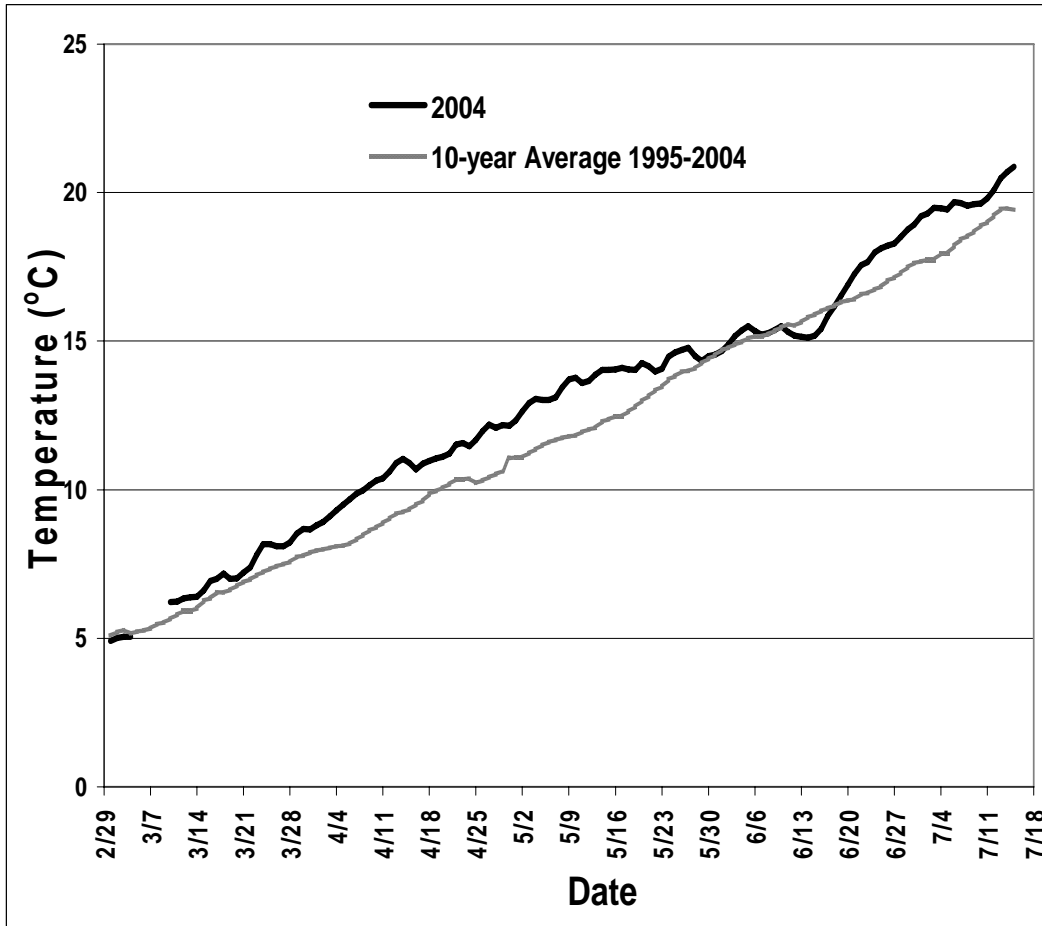

Figure 3.8. Daily Water Temperature during the 2004 Study and the 10-Year Average Water Temperature from DART (<http://www.cqs.washington.edu/dart/dart.html>).

3.1.3 Hydraulic Conditions

Four of the six scenarios (cases) modeled by the Hydrology Group of PNNL (Table 2.6) produced similar flow patterns at the broad scale reported herein. These scenarios were 3, 4, 5, and 6; all had at least 80,000 cfs passing through B2 and created large eddies on the north and south sides of the forebay (Figure 3.9). There also was a lot of lateral flow along the face of the powerhouse north and south of Intake 15A, and upstream of a line parallel to and within 45-60 ft of the B2CC entrance where there was a clear separation of flow (Figure 3.10). Most of the flow west of the line passed into the B2CC, and most of the flow east of the line passed into the south eddy. In Scenario 1, Units 11 and 18 were the only operational units at B2 and no eddies formed in the forebay, but there were too few hours of DIDSON sampling (and fish tracked) under these conditions to evaluate effects of hydrology on fish behavior. Case 2 involved running five units at B2, and it produced unique hydraulics with weaker north and south eddies than did Cases 3-6. Like Case 1, Case 2 only applied to a few of the 432 hours of smolt tracking. Flow vectors for Case 2, Cases 3 and 4 pooled, and Cases 5 and 6 pooled indicate successively increasing velocities along the face of the powerhouse toward the B2CC and stronger separation of flow between the B2CC and the south eddy (Figure 3.11).

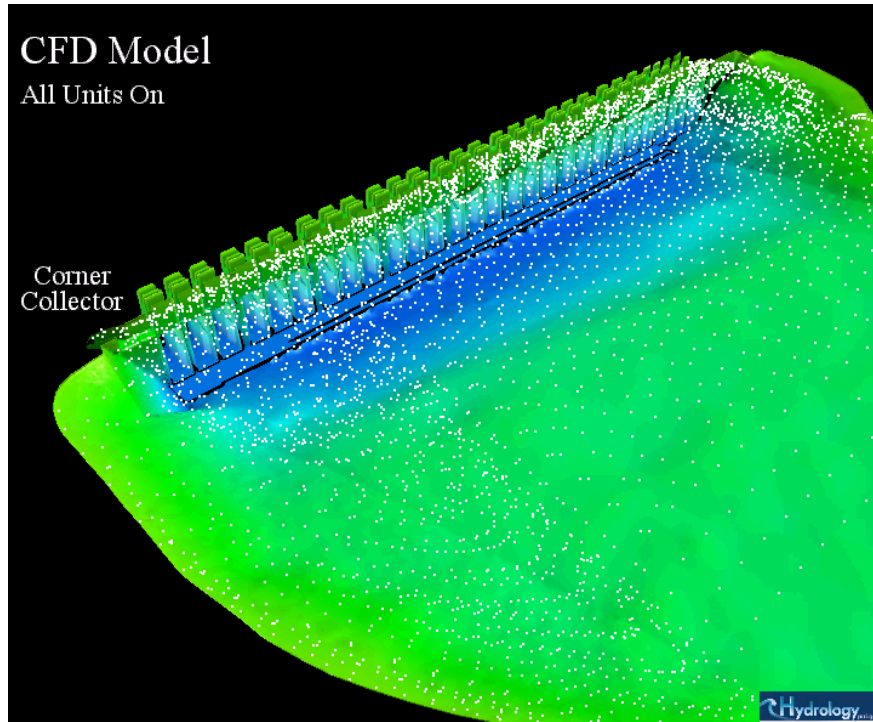

Figure 3.9. Plan View of Flow Patterns in the B2 Forebay Based upon the CFD Model, when All Eight Turbine Units Were Running.

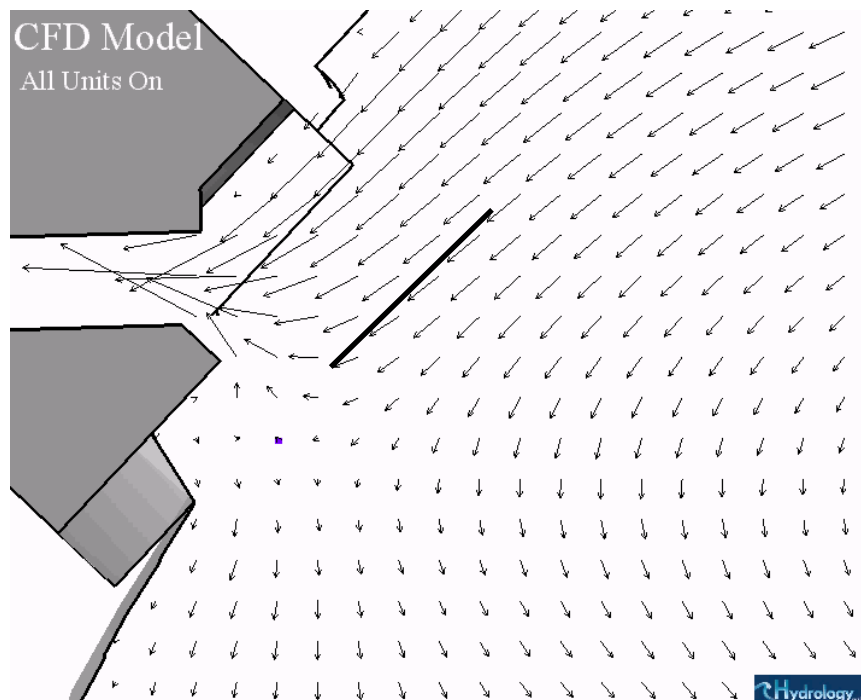

Figure 3.10. Plan View of Flow Vectors in the B2 Forebay Based upon the CFD Model, when All Eight Turbine Units Were Running. The heavy black line about 45 ft upstream of the dam face represents a dividing line for flow passing into the B2CC and into the south eddy.

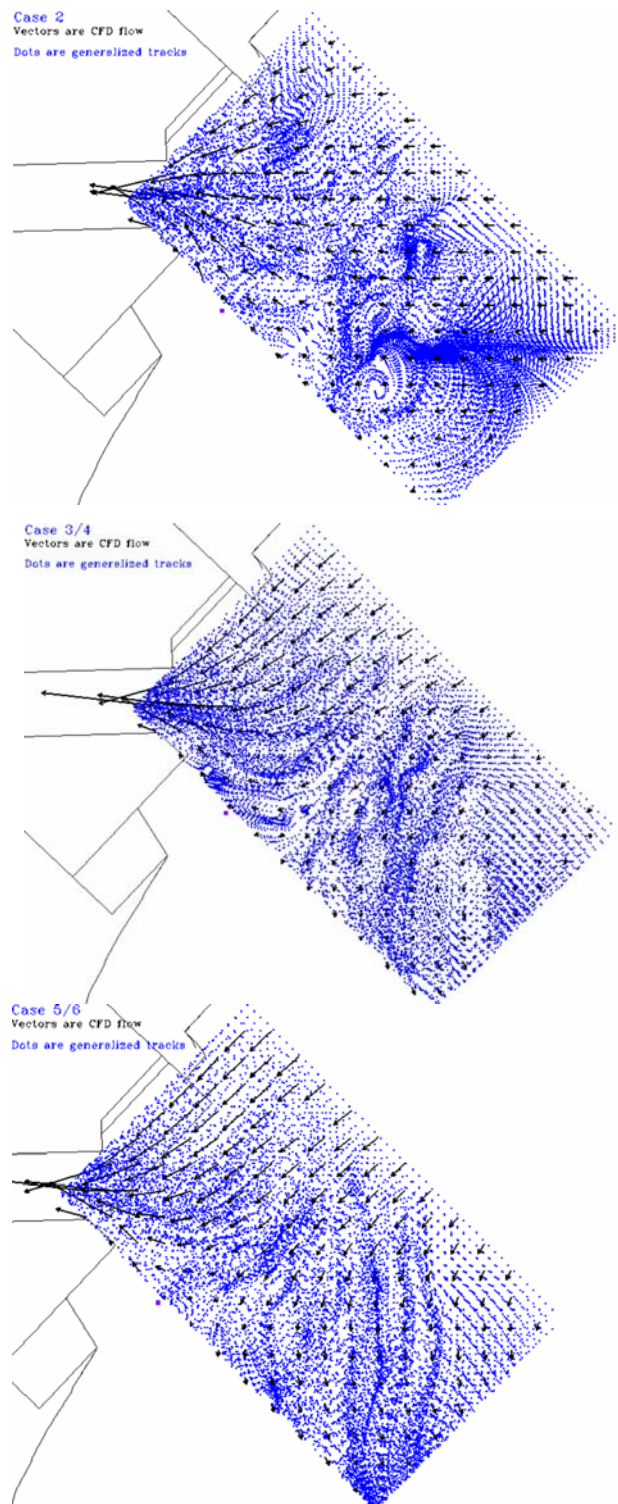

Figure 3.11. Plan View of Flow Vectors in the B2 Forebay Based upon the CFD Model. Flow vectors for Case 2, Cases 3 and 4 pooled, and Cases 5 and 6 pooled, shown from top to bottom, indicating successively increasing velocities along the face of the powerhouse toward the B2CC and increased separation of flow between the B2CC and the south eddy.

3.2 Hydroacoustic Detectability

Detectability curves for every type of deployment were developed for three time periods studied: 1) the Spring Creek Hatchery release from March 1 to 18 (Figure 3.12), 2) the spring migration from April 15 through May 31 (Figure 3.13), and 3) the summer migration from June 1 through July 15 (Figure 3.14). Smaller effective beam angles translate into larger spatial expansion factors. Effective beam angle curves were slightly higher at B1 sluice entrances 4C and 6C than at entrance 2C because water velocities at entrances were lower at the upstream end of the sluiceway channel. Effective beam angle tended to increase with range for locations where water velocities were relatively uniform with range from the transducer because the diameter of acoustic beams and associated probabilities of detection increased with range. Examples include samples from B1 and B2 turbines. Effective beam angles tended to decrease with range from the transducer for locations where velocities increased with range (i.e., the spillway and the B2CC).

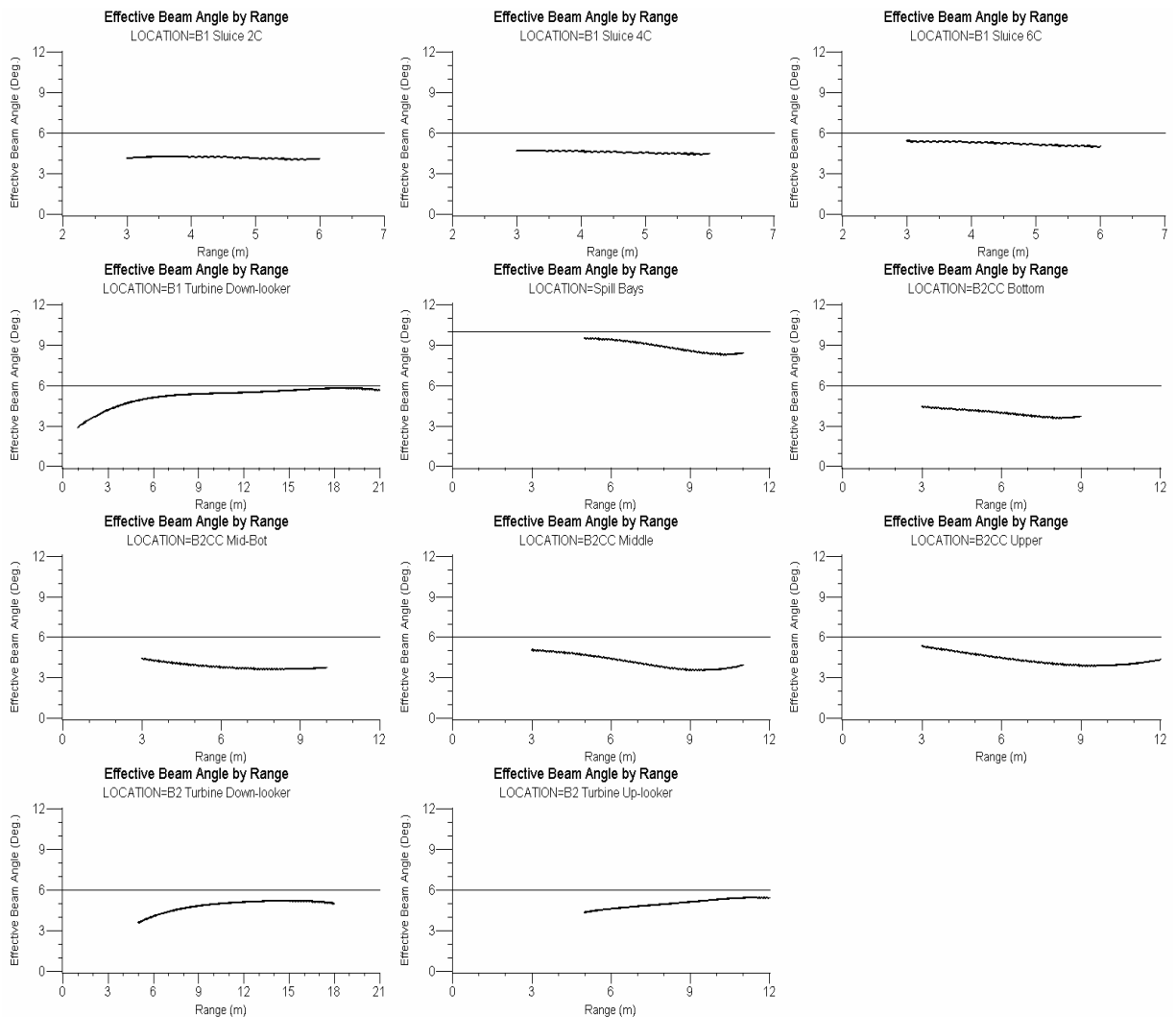

Figure 3.12. Plots of Effective Beam Angle as a Function of Range from Transducers Deployed at Bonneville Dam during the Spring Creek Hatchery Release (March 1-18, 2004). Points joined by a solid line represent the effective beam angle over the range that fish were tracked. Horizontal lines denote nominal beam angles of transducers. Note that both x scales vary among plots.

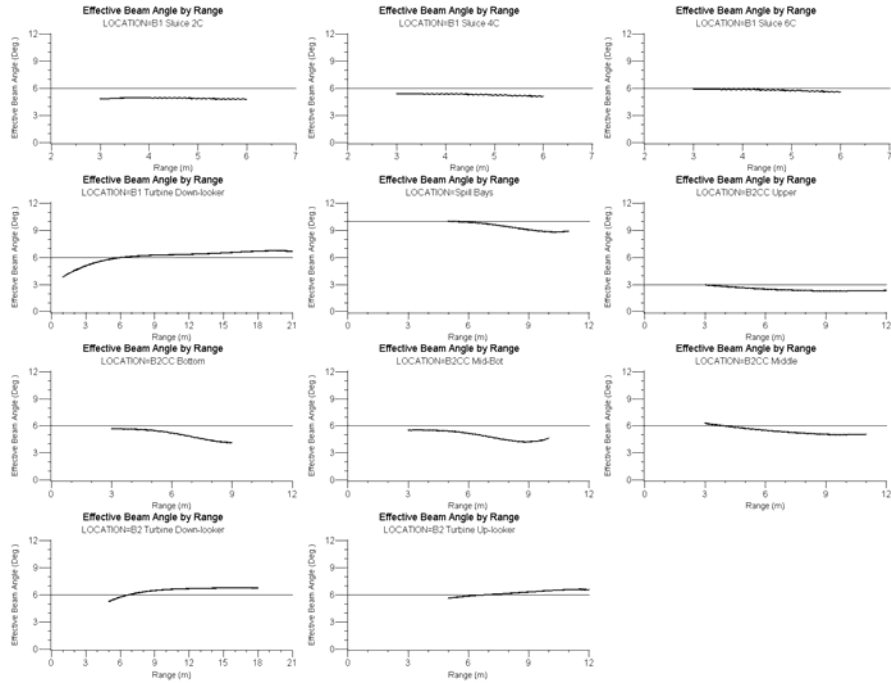

Figure 3.13. Plots of Effective Beam Angle as a Function of Range from Transducers Deployed at Bonneville Dam during Spring 2004. Points joined by a solid line represent the effective beam angle over the range that fish were tracked. Horizontal lines denote nominal beam angles of transducers. Note that both x scales vary among plots.

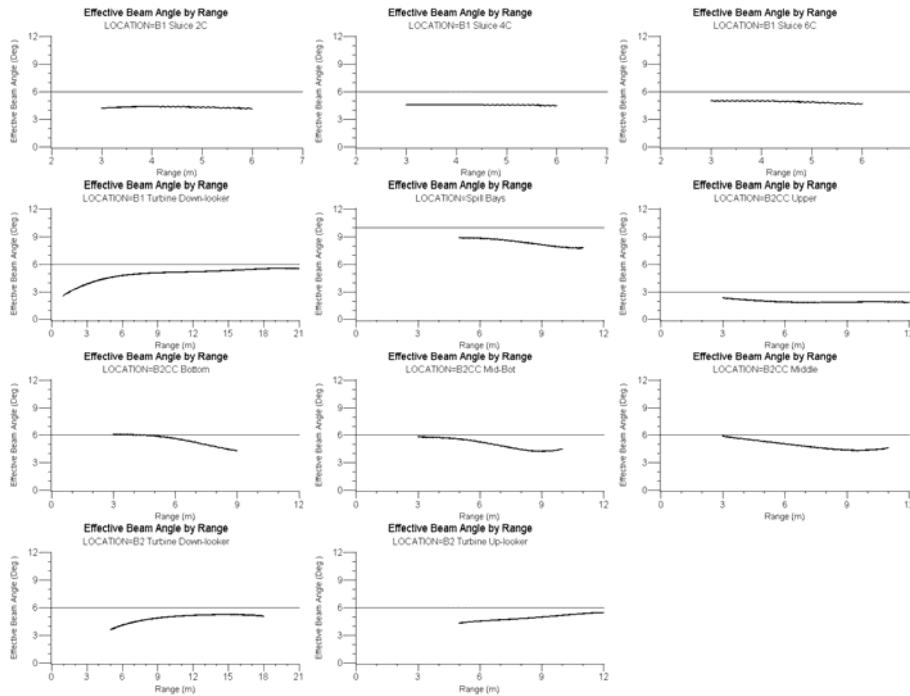

Figure 3.14. Plots of Effective Beam Angle as a Function of Range from Transducers Deployed at Bonneville Dam during Summer 2004. Points joined by a solid line represent the effective beam angle over the range that fish were tracked. Horizontal lines denote nominal beam angles of transducers. Note that both x scales vary among plots.

3.3 Validation of Autotracking and Count Adjustments

We found reasonably good correspondence between average technician counts of fish and autotracker counts for every deployment (Figures 3.15, 3.16, 3.17, and 3.18), but there were deployment-specific differences in fits of regression lines and slopes, and we used slopes to convert autotracker counts into mean technician counts.

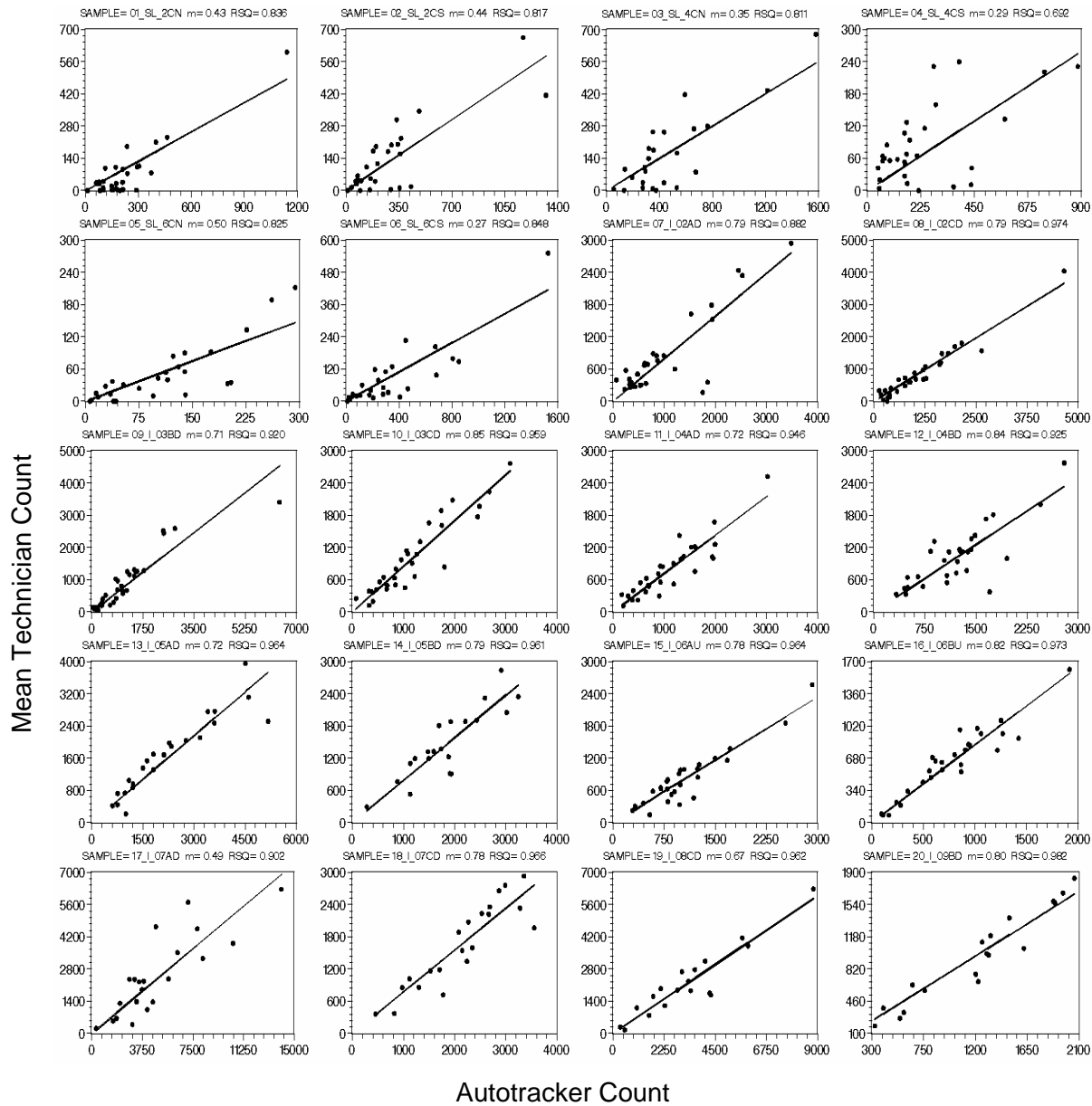

Figure 3.15. Regressions of Mean Manual-Tracker Estimates of Hourly Fish Passage on Autotracker Estimates for Transducers at B1 Sluice Entrances and in Intakes at Units 2-9. Sample names consist of a concatenation of a sequential number, an underscore, one or two letters (SL=sluice; I=intake), another underscore, two digits indicating unit location, a letter indicating intake location (A, B, or C), and a final letter indicating aiming direction (S = south; N=north; D=downward). Abbreviations “m” and “RSQ” refer to the slope of the regression line forced through zero and the coefficient of determination (r² value), respectively.

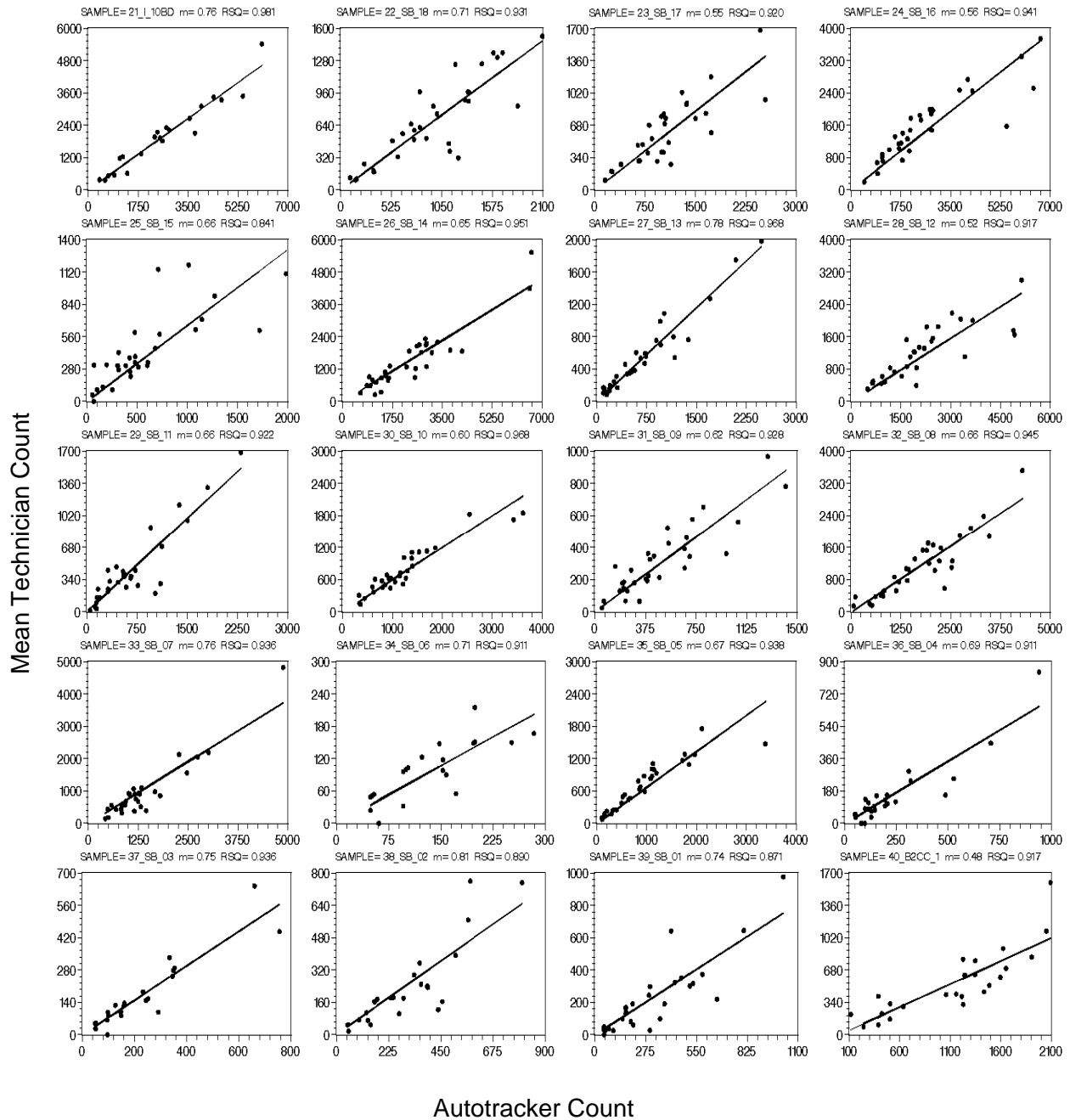

Figure 3.16. Regressions of Mean Manual-Tracker Estimates of Hourly Fish Passage on Autotracker Estimates for Transducers at Intake 10B, Spill Bays 1-18 (listed from south to north – Number 18 to Number 1), and the B2CC. Sample names consist of a concatenation of a sequential number, an underscore, from one to four letters (I=intake; SB=spill bay, B2CC=B2 Corner Collector), another underscore, two digits indicating unit location or spill bay number, and for intakes, a pair of letters, the first indicating slot location (A, B, or C) and second indicating aiming direction (D=downward). All spillway transducers were aimed downward, although that was not indicated in the sample variable. The last number in the sample variable for transducers sampling the B2CC indicates transducer position from top to bottom (1=shallowest and 6=deepest). Abbreviations “m” and “RSQ” refer to the slope of the regression line forced through zero and the coefficient of determination (r^2 value), respectively.

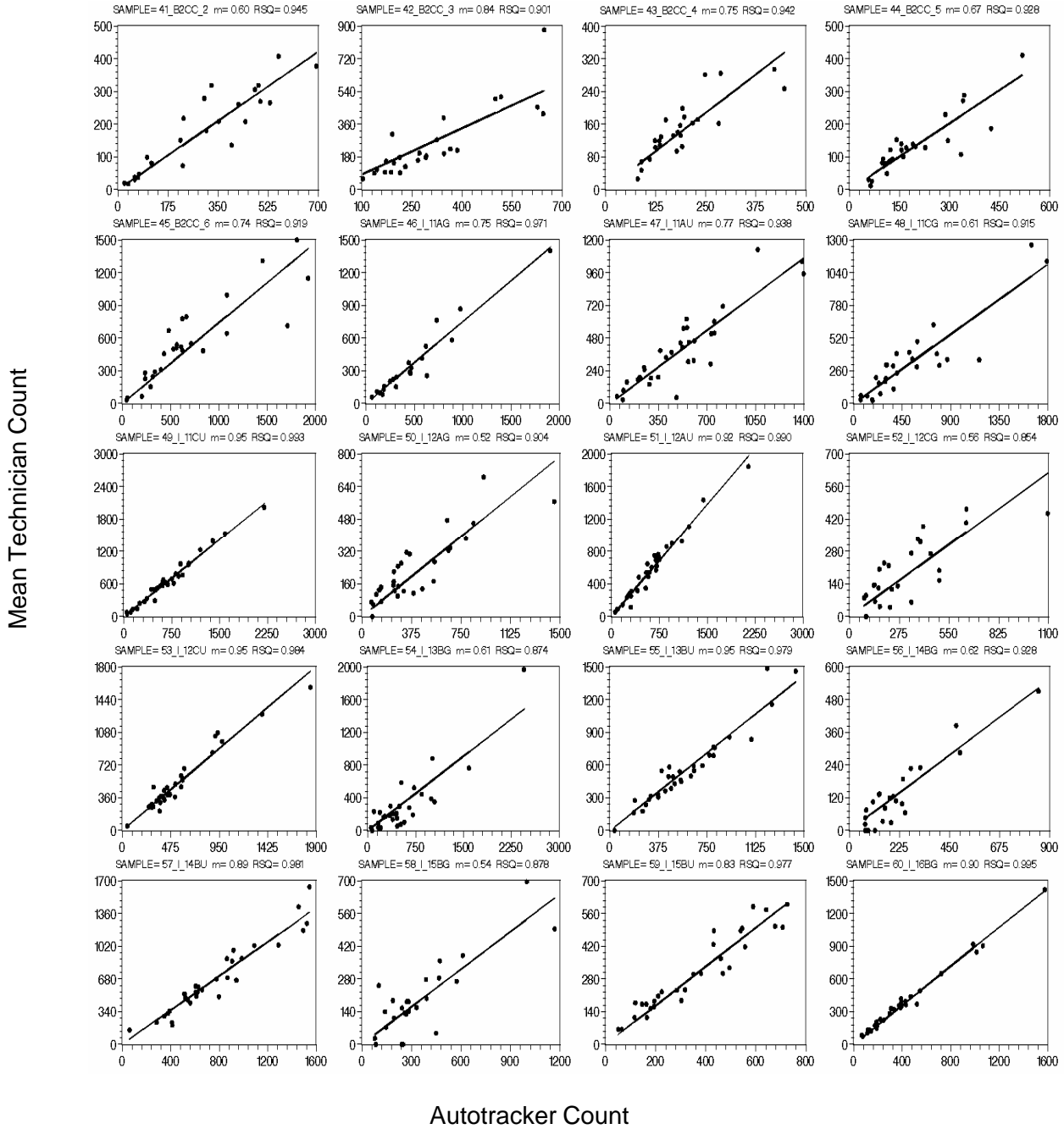

Figure 3.17. Regressions of Mean Manual Tracker Estimates of Hourly Fish Passage on Autotracker Estimates for Transducers at the B2CC and Sampled B2 Intakes at Units 11-16. Sample names consist of a concatenation of a sequential number, an underscore, from one to four letters (I=intake; B2CC=B2 Corner Collector), another underscore, one digit for B2CC samples indicating transducer position from top to bottom (1=shallowest and 6=deepest) of two digits for B2 intakes indicating unit location, and a pair of letters, the first indicating slot location (A, B, or C) and second indicating turbine fraction (G=guided; U=unguided). Abbreviations “m” and “RSQ” refer to the slope of the regression line forced through zero and the coefficient of determination (r² value), respectively.

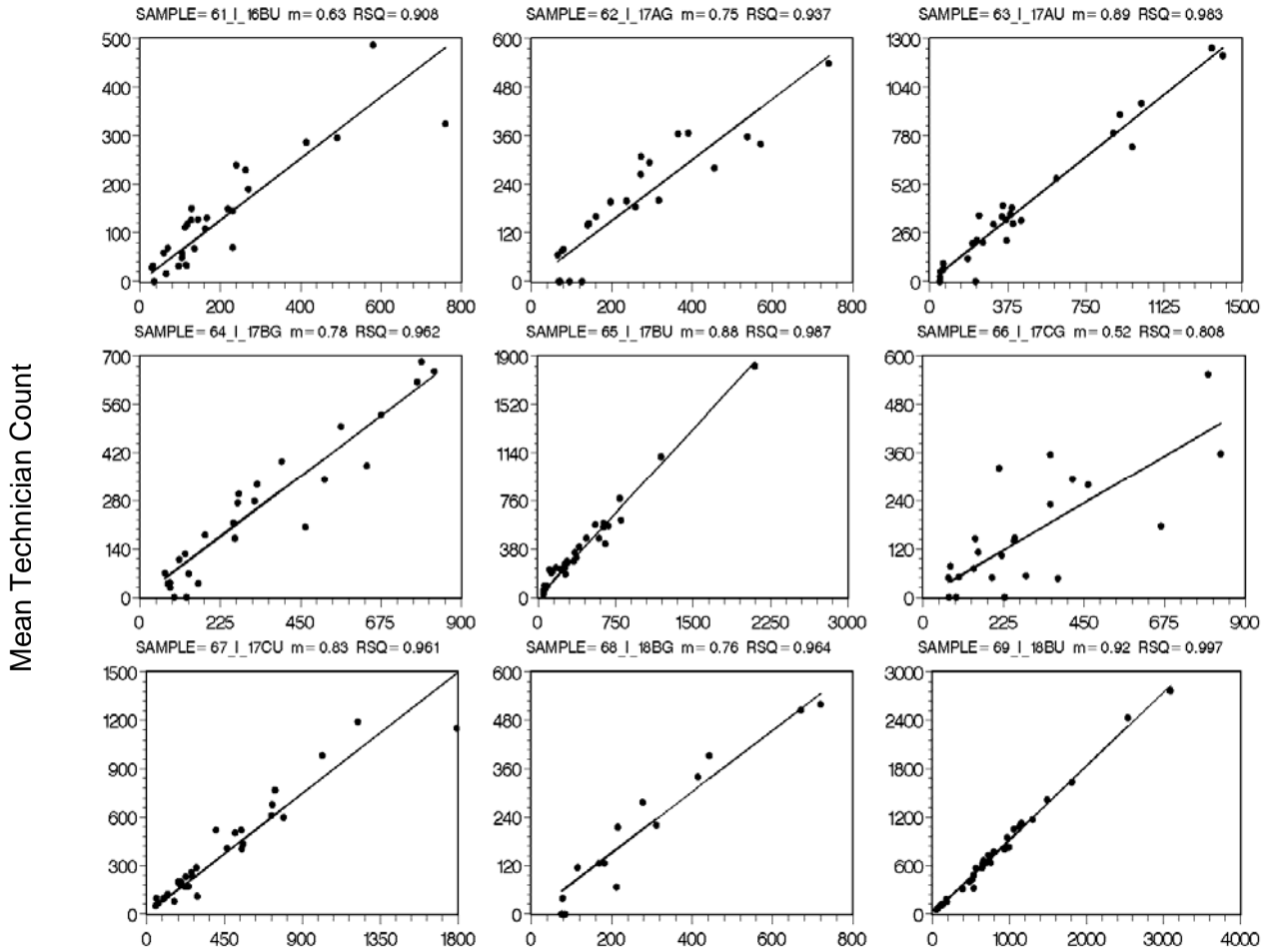

Figure 3.18. Regressions of Mean Manual-Tracker Estimates of Hourly Fish Passage on Autotracker Estimates for Transducers at Sampled B2 Intakes at Units 16-18. Sample names consist of a concatenation of a sequential number, an underscore, a letter (I=intake), another underscore, two digits for B2 intakes indicating unit location, and a pair of letters, the first indicating slot location (A, B, or C) and second indicating turbine fraction (G=guided; U=unguided). Abbreviations “m” and “RSQ” refer to the slope of the regression line forced through zero and the coefficient of determination (r^2 value), respectively.

3.4 Direction of Travel Adjustments

We examined the directions of travel of smolts through split beams sampling each type of passage route where fish were not entrained to evaluate a basic assumption of the acoustic screen model, i.e., that most detected fish were actually passing downstream through the route being sampled. Where fish were entrained in turbine intakes or in the 5,000 cfs flow of the B2CC, the percent of detected fish moving downstream was nearly 100%, allowing for error in phase estimates upon which the direction of travel estimates depend. However, at B1 sluiceways and spill bays sampled with split-beam transducers, the downstream percentages ranged from 76% to 94% in spring (Figure 3.19), and 66% to 91% in summer (Figure 3.20). In analyzing passage data for the B1 sluiceway entrances and the spillway, we reduced the count of fish detected by single beams and split beams by the fraction moving downstream (> 90 and < 270 degrees) through the split-beams so that passage estimates were based only on the fraction that met the assumption of the model.

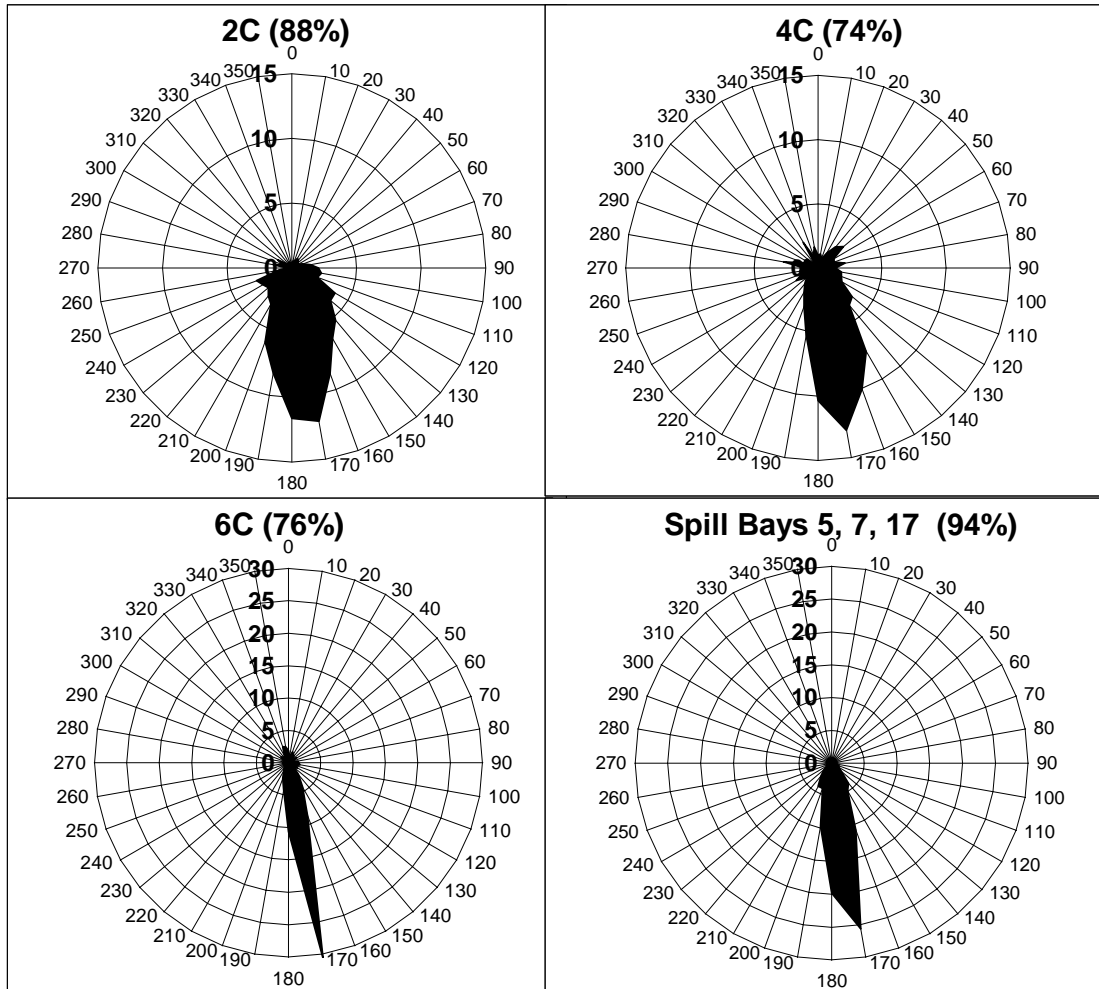

Figure 3.19. Polar Plots of Percent of Fish Traveling Different Directions across the Barrel View of Split-Beam Transducers Deployed at Sluice Entrances and Spill Bays in Spring 2004. Angles > 90° and < 270°, trajectories towards the bottom of the page, indicate movement in a downstream direction across the upstream / downstream plane and the percentage of downstream moving fish is given in parentheses in the titles.

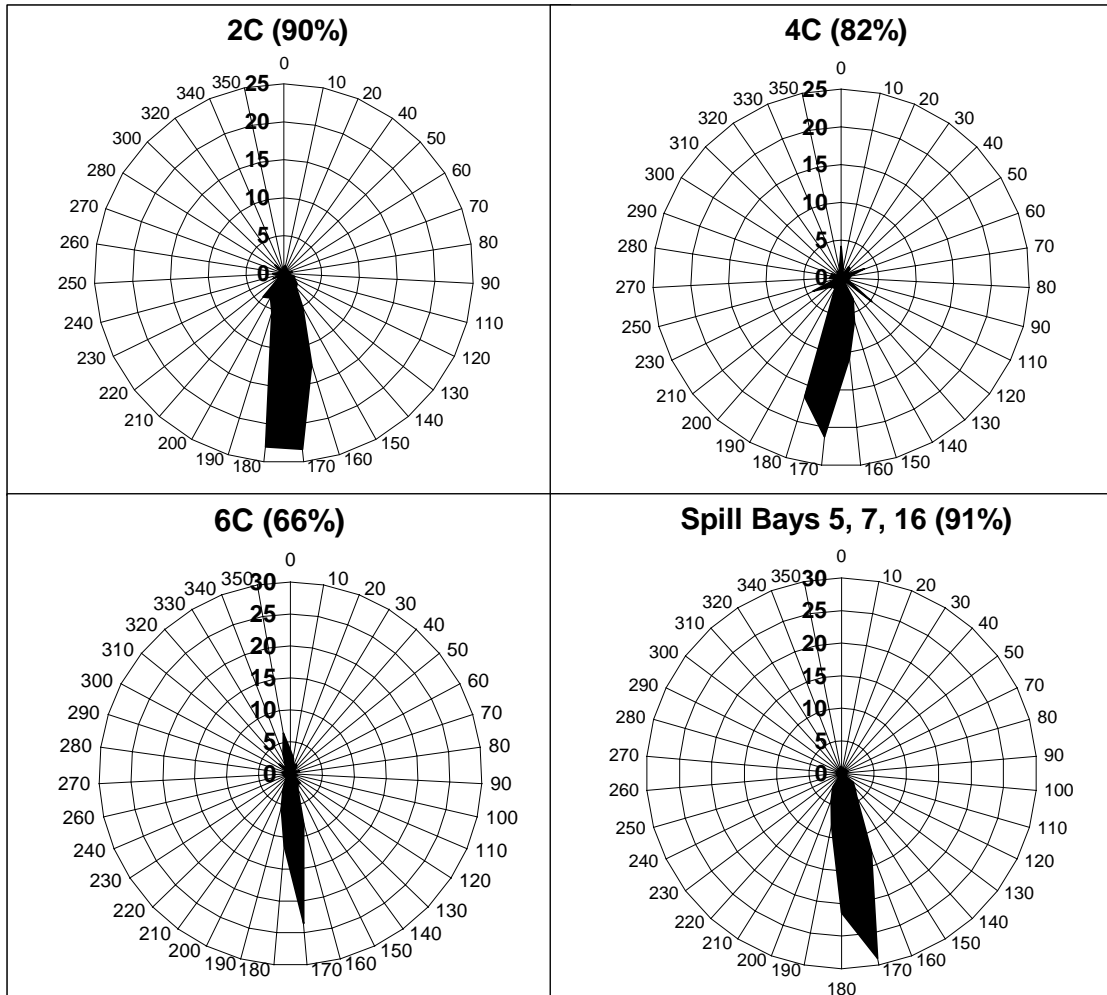

Figure 3.20. Polar Plots of Percent of Fish Traveling Different Directions across the Barrel View of Split-Beam Transducers Deployed at Sluice Entrances and Spill Bays in Summer 2004. Angles > 90° and < 270°, toward the bottom of the page, indicate movement in a downstream direction across the upstream / downstream plane and the percentage of downstream moving fish is given in parentheses in the titles.

3.5 FPE Evaluation of Spring Creek Releases in March

There were three operational conditions presented to fish released from Spring Creek hatchery in March 2004. There were five days of spill but no B2CC operation, four days of B2CC operation but no spill, and about seven days of no spill and no B2CC operation. Throughout all three treatments Project power generation was carried on as usual, with clear B2 priority, and the three B1 sluiceway entrances were open. Project FPE, spill efficiency, and sluiceway efficiency during the three operational conditions are presented in Figure 3.21. Project FPE was about 54% during the spill-no B2CC operation, 45% during no spill-B2CC operation, and only 32% under the no spill, no B2CC condition. Spill of 50,000 cfs resulted in a passage efficiency of 23% for the spillway; this was much lower than the 40% spill efficiency in spring. Passage of fish at the B1 sluiceway contributed little to Project FPE (1.7% to 5.1%) under any of the operational conditions. During the no spill-B2CC operation, the B2CC passed about 17.1% of the Spring Creek hatchery fish that were passing the Project and 24% of fish that passed at B2. Project Sluiceway Passage Efficiency, including the B1 and B2 routes, was 18.8% and this was comparable to the 19% efficiency observed in spring, although it was lower than the 26% efficiency estimated for summer.

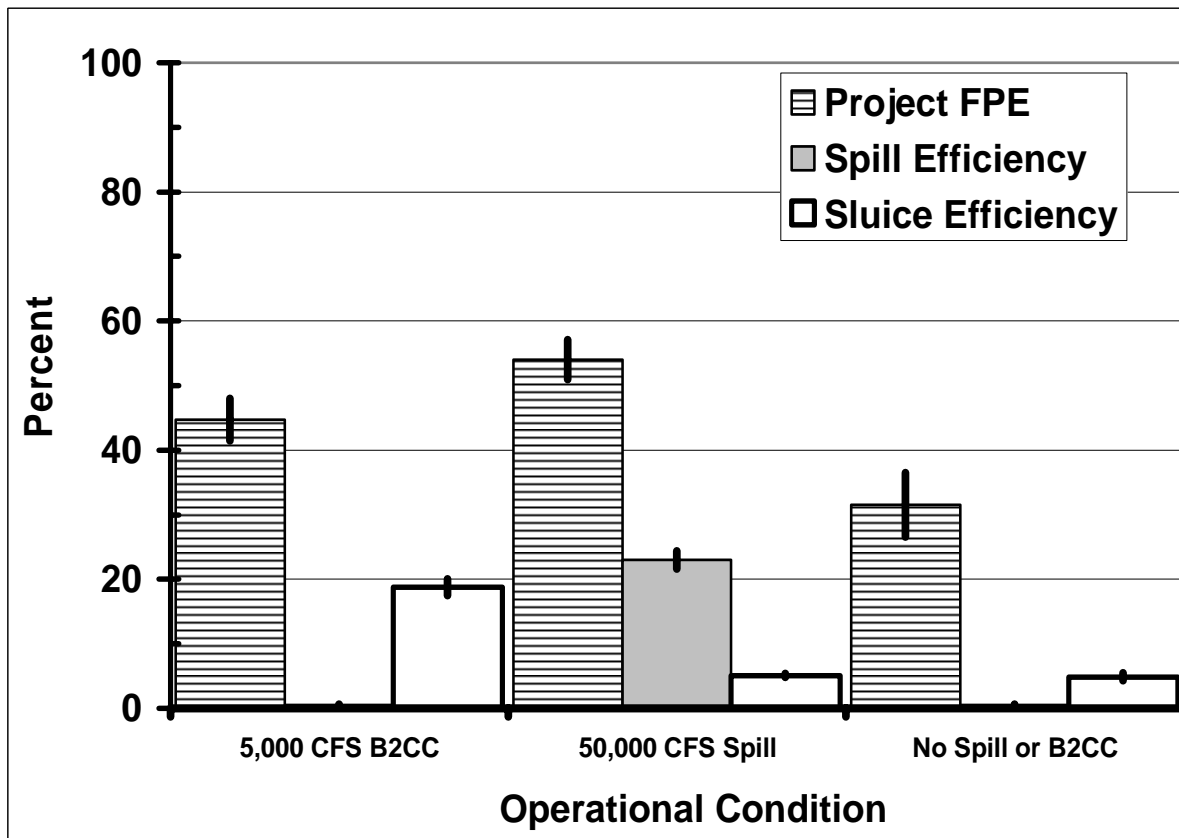

Figure 3.21. Project FPE, Spill Efficiency, and Sluiceway Efficiency (B1 + B2CC) during Three Operational Conditions Presented to Fish from the Spring Creek Hatchery Release in March. Vertical bars are the 95% confidence limits on the estimates.

The spill condition produced the most consistent and among the highest estimates, followed closely by the B2CC treatment in which two of four whole days produced FPE estimates that were similar to those

produced by the spill condition (Figure 3.22). The most variable FPE estimates and usually the lowest occurred under the No Spill or B2CC condition (Figure 3.22).

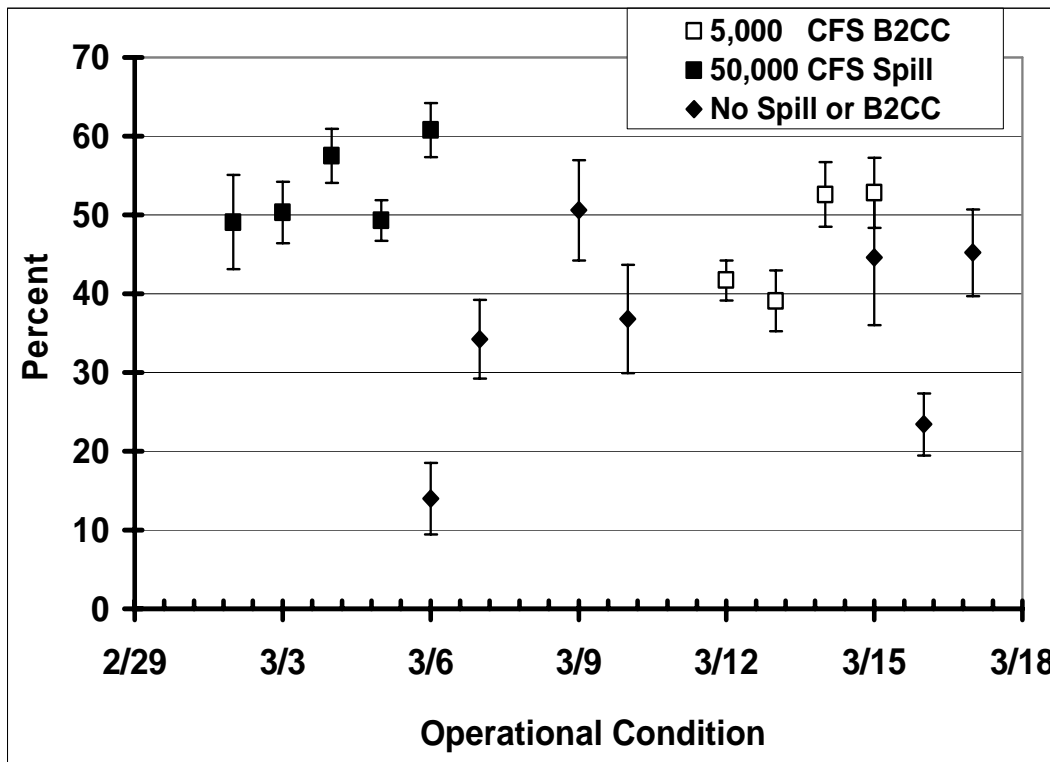

Figure 3.22. Plot of Daily Estimates of Project FPE during Three Operational Conditions Presented to Fish from the Spring Creek Hatchery Release in March. Vertical bars are the 95% confidence limits on the estimates.

3.6 Major Passage Metrics

On the broadest of scales, B1 passed 17.1% of fish in 11.5% of flow in spring and 16.1% of fish in 12.3% of flow in summer. In contrast, B2 passed 42.6% of fish in 46.7% of flow in spring and 51.2% of fish in 48.5% of flow in summer. The spillway passed 40.3% of fish in 41.7% of flow in spring and 32.7% of fish in 39.2% of flow in summer. Estimates of major passage metric estimates for spring and summer 2004 are, for convenient reference, presented in Table 3.1. The table includes the various estimated passage metrics and the respective 95% confidence limits, which we calculated for both the whole Project and for various portions of the Project, including each powerhouse and the spillway. We also calculated Project FPE without surface passage by applying the estimated FGE of each powerhouse in each season (0% at B1 in both seasons, 47.58% in spring and 35.6% in summer at B2) to the total passage at that powerhouse in that season.

Subsequent sections present details and graphical representations of major metrics for spring and summer, including Project and Powerhouse FPE, Spill Efficiency and Effectiveness, and Sluiceway Efficiency and Effectiveness.

Table 3.1. Estimates of Major Passage Metrics Based upon Hydroacoustic Sampling from 4/15 through 5/31 (Spring) and from 6/1 through 7/15 (Summer) in 2004. Estimates of percent flow through B1, B2, the spillway, and B1 + B2CC sluiceways are presented for comparison to fish passage percentages.

Major Passage Metric Estimate	Spring	Summer
Project FPE	73.3 ± 2.30%	70.0 ± 2.3 %
Project FPE with no surface passage	66.7 ± 0.03%	59.3 ± 0.03%
Project FPE - B2 + Spillway (without B1)	81.5 ± 0.02%	76.3 ± 0.03%
B1 Percent of Project Passage	17.1 ± 1.8%	16.1 ± 1.2%
B1 Percent of Project Flow	11.5%	12.3%
B1 FPE	33.3 ± 3.92%	37.6 ± 2.85%
B2 Percent of Project Passage	42.6 ± 2.3%	51.2 ± 1.9%
B2 Percent of Project Flow	46.7%	48.5%
B2 FPE	64.0 ± 4.24%	61.1 ± 3.92%
B2 FGE	47.6 ± 6.62%	35.6 ± 5.77%
Spill Efficiency	40.3 ± 1.70%	32.7 ± 1.30%
Spill Percent of Project Flow	41.7%	39.2%
Spill Efficiency B2 + Spillway (without B1)	48.6 ± 0.02%	38.9 ± 0.02%
Spill Effectiveness	1.0 ± 0.04	0.8 ± 0.03
Spill Effectiveness B2 + Spillway (without B1)	1.0 ± 0.05	1.0 ± 0.04
Project Sluice Efficiency	19.1 ± 0.80%	26.4 ± 1.00%
B1 and B2CC Sluiceway Percent of Flow	3.0%	3.0%
Project Sluice Effectiveness	6.3 ± 0.27	8.8 ± 0.35
B1 Sluice Efficiency re: Project	5.7 ± 0.3%	6.1 ± 0.2%
B1 Sluice Efficiency re: B1	33.3 ± 3.92%	37.6 ± 2.85%
B1 Sluice Effectiveness re: Project	11.2 ± 0.50	12.1 ± 0.48
B1 Sluice Effectiveness re: B1	7.6 ± 0.89	9.3 ± 0.70
B2CC Efficiency re: Project	13.4 ± 0.6%	20.0 ± 0.80%
B2CC Efficiency re: B2	31.4 ± 2.81%	39.6 ± 2.87%
B2CC Effectiveness re: Project	5.3 ± 0.23	8.2 ± 0.32
B2CC Effectiveness re: B2	5.8 ± 0.52	7.7 ± 0.56

3.6.1 Project and Powerhouse FPE

Project-wide FPE estimates are presented in Figure 3.23, as are FPE estimates calculated for various portions of the project. Estimated Project-wide FPE was estimated at 73.3% in spring and 70.0% in summer. When surface (sluiceway) passage was ignored, as if the sluice gates were closed and the fish guidance efficiency of the turbine units (0% on B1 in both seasons, at B2 47.6% in spring and 35.6% in summer), were applied to the appropriate total powerhouse seasonal passage estimates, the FPE results were much lower (66.7% in spring and 59.3% in summer). The B1 FPE estimate, including sluiceway passage, was 33.3% in spring and 37.6% in summer. Without surface passage, the powerhouse FPEs would have been equal to the FGE for each powerhouse.

For only B2 and the spillway (excluding B1), estimated FPE was 81.5% in spring and 76.3% in summer, or over 6% higher in spring and over 10% higher in summer than were the corresponding estimates for the entire project with surface passage, as operated. Our hydroacoustic FPE estimates and other FPE estimates for parts of the Project are presented by season in Figure 3.23.

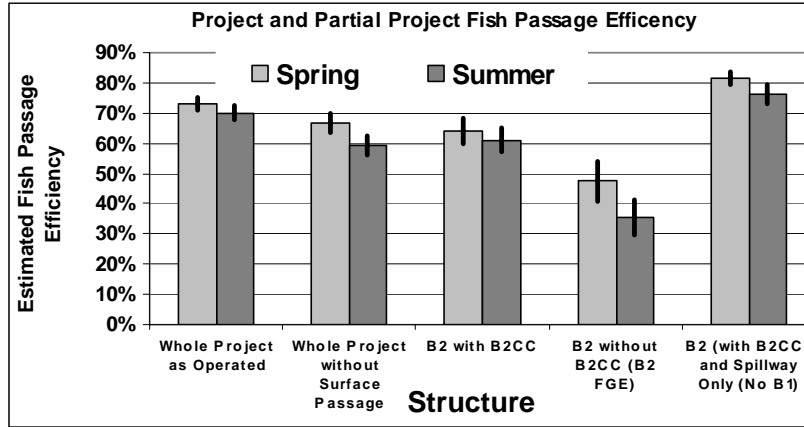

Figure 3.23. Project-Wide and Other Fish Passage Efficiency Estimates for Spring and Summer Fish Passage Seasons at Bonneville Dam in 2004.

3.6.2 Spill Efficiency and Effectiveness

Estimated spill efficiency for the entire project was 40.3% in spring and 32.7% in summer (Figure 3.24). For only B2 and the spillway (excluding B1), estimated FPE was 48.6% in spring and 38.94% in summer. We estimated spill effectiveness for the entire project at 1.0 in spring and 0.8 in summer. For just B2 and the spillway, spill effectiveness was estimated to be 1.0 in spring and 0.9 in summer.

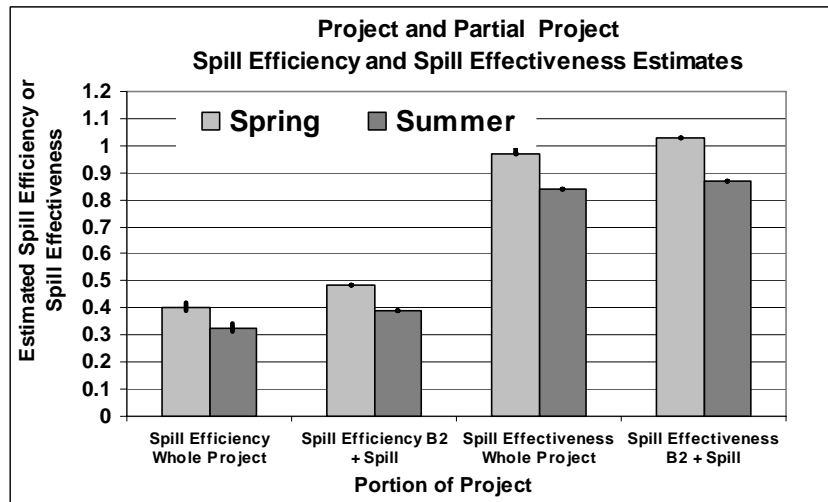

Figure 3.24. Estimated Spill Efficiency and Spill Effectiveness for the Bonneville Project and for the Spillway and Each Powerhouse Only for Spring and Summer 2004.

3.6.3 Sluiceway Efficiency and Effectiveness

Sluice efficiency and effectiveness are computed in several ways. Total Project Sluice Efficiency and Effectiveness combines the sluiceway passage of both B1 and B2 (the B2CC) and compares it to passage and discharge through the whole Project. These project-wide estimates were 19.1% in spring and 26.4% in summer for efficiency and for effectiveness they were 6.3 in spring and 8.8 in summer (Figure 3.25). Next, efficiency and effectiveness are presented for each sluiceway (B1 and the B2CC) separately relative to the whole Project and for each respective powerhouse. Results are presented graphically in Figures 3.25 and 3.26.

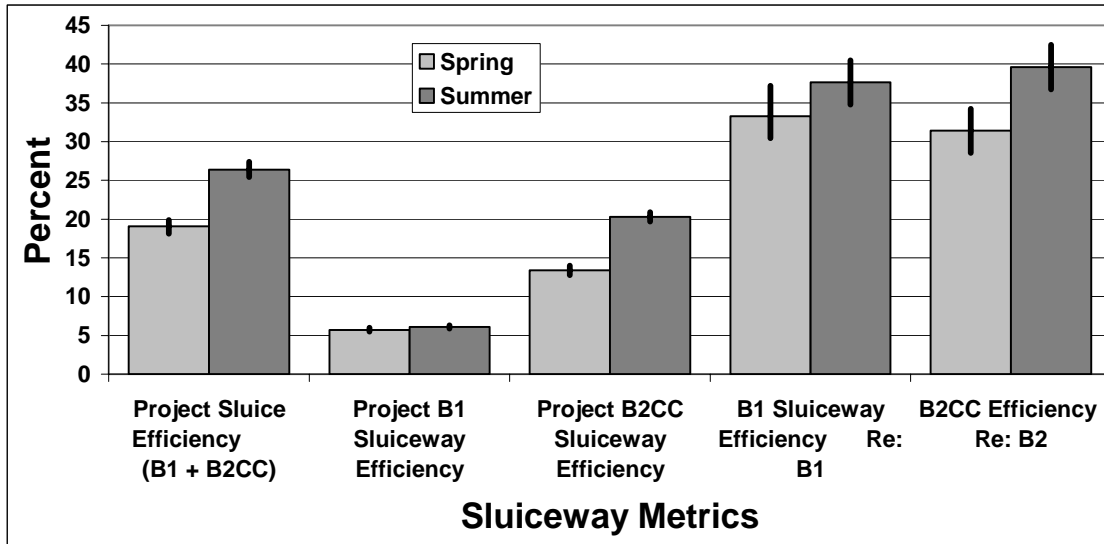

Figure 3.25. Estimated Sluiceway Efficiency for the Bonneville Project and Each Powerhouse Only for Spring and Summer 2004.

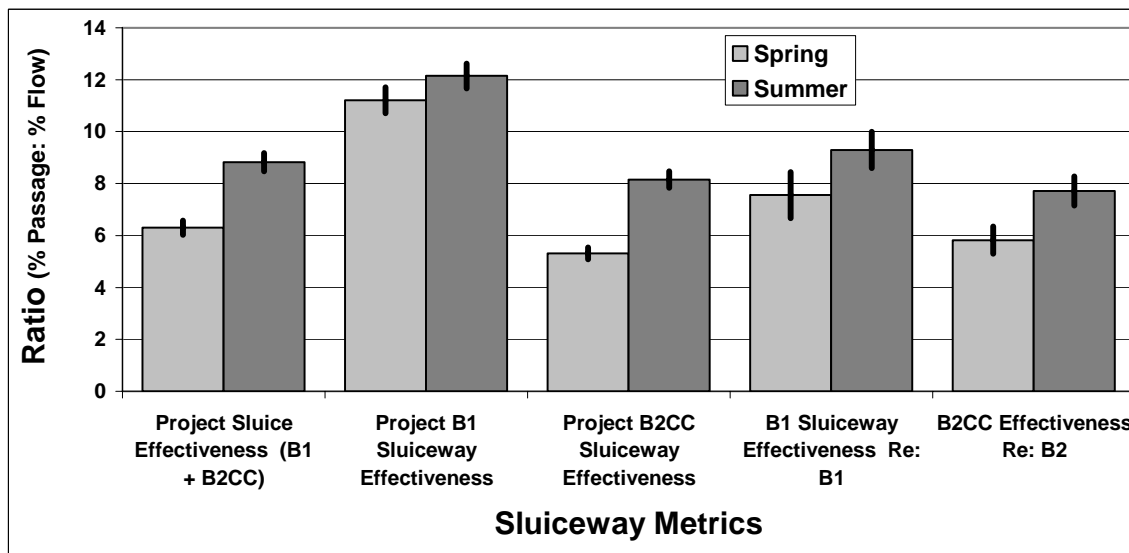

Figure 3.26. Estimated Sluiceway Effectiveness for the Bonneville Project and Each Powerhouse Only for Spring and Summer 2004.

3.6.4 Comparison of Major Metrics from 2000 through 2004

Since a major purpose of the multi-year effort was to establish a baseline for evaluating future management improvements, we compared major fish passage metrics for the four years that full-Project hydroacoustic studies have been conducted (Table 3.2). It is not surprising that 2001, a year of low water and high generation demand, produced most of the lowest passage metrics. In 2000, the only year of B1 generation priority, there were generally high estimates; only B2 FPE was the lowest of the four years. The 2002 passage seasons were variable with high Project and B2 + Spillway FPE (due to high spill efficiency, not guidance at B2, see Ploskey et al. 2003). The 2004 year was marked by very high B2 and B2 + Spill FPE and spill effectiveness estimates. Estimates of Project sluiceway efficiency and

effectiveness, which combine passage estimates for the three B1 sluiceway entrances and the B2CC, were also very high. We estimated that nearly a fifth of total Project passage in spring and just over a quarter of all Project passage in summer was by surface routes. The proportion of fish passed was over six times higher than the proportion of water passed by surface routes in spring, and in summer, the proportion was nearly nine. Interpreting Project sluiceway efficiency and, especially, effectiveness in 2002 (the only other year when B1 sluice entrances were sampled) should be done carefully since it only involved passage at two B1 sluiceway intakes and one of them (Intake 10C) passed very few fish and very little water (Ploskey et al. 2003).

Table 3.2. Estimates of Major Passage Metrics Based upon Hydroacoustic Sampling in 2000, 2001, 2002, and 2004. Headings list some important differences in conditions or sampling among the years.

Major Passage Metric	2000	2001	2002	2004
	PSC (Units 1-6) B1 Priority No Sluiceway Sampled No STS in PSC	Severe Drought B2 Priority No Sluiceway Sampled	B2 Priority B1 Sluiceway Sampled	B2 Priority B1 Sluiceway & B2CC Sampled No B1 Screens
Spring				
Project FPE	79 ± 0.2 %	63 ± 0.3 %	79 ± 0.1 %	73 ± 2.3%
B1 FPE (without Sluiceway)	67 ± 0.4 %	49 ± 2.3 %	37 ± 0.4 %	N/A
B2 FPE	54 ± 0.8 %	57 ± 0.3%	53 ± 0.3 %	64.04 ± 4.24%
B2 + Spillway FPE (without B1)	N/A (B1 Priority)	64 ± 0.3 %	83 ± 0.4 %	81.5 ± 0.02%
Spill Efficiency	44 ± 0.4 %	14 ± 0.2 %	52 ± 0.5 %	40.3 ± 1.7%
Spill Effectiveness	1.36 ± 0.010	0.84 ± 0.004	1.08 ± 0.010	0.97 ± 0.04
Project Sluiceway Efficiency	N/A	N/A	6.0 ± 0.1%	19.1 ± 0.8%
Project Sluiceway Effectiveness	N/A	N/A	21.9 ± 0.01	6.3 ± 0.27
Summer				
Project FPE	79 ± 0.2 %	53 ± 0.4 %	74 ± 0.2 %	70.0 ± 2.3%
B1 FPE (without Sluiceway)	61 ± 0.2 %	40 ± 1.8 %	45 ± 1.2 %	N/A
B2 FPE	35 ± 2.2 %	42 ± 0.4 %	46 ± 0.7 %	61 ± 3.92%
B2 + Spillway FPE (without B1)	N/A (B1 Priority)	54 ± 0.4 %	82 ± 0.5 %	76.26 ± 0.03%
Spill Efficiency	49 ± 0.4 %	20 ± 0.3 %	42 ± 0.5 %	32.7 ± 1.3%
Spill Effectiveness	1.03 ± 0.01	1.83 ± 0.01	0.96 ± 0.01	0.83 ± 0.03
Project Sluiceway Efficiency	N/A	N/A	11.0 ± 0.1%	26.4 ± 1.0%
Project Sluiceway Effectiveness	N/A	N/A	47.9 ± 0.03	8.82 ± 0.35

3.6.5 Effects of Percent Spill on Spill Efficiency and Project FPE

We plotted hourly and daily estimates of Project spill efficiency and FPE against percent spill for spring and summer of 2004 (Figures 3.27 and 3.28). There were 1,109 sampled hours in spring (47 days) and 1,067 sampled hours in summer (45 days). Hourly percent spill ranged from 23% to about 80% in spring and from 20% to 85% in summer. Daily percent spill ranged from 25% to 54% in spring and from 24% to 55% in summer. On the hourly scale, percent spill explained about 72% of spill efficiency in spring (slope = 0.95) and 74% in summer (slope = 0.89). The r^2 statistic for the regression line fitted to daily spill-efficiency and percent-spill data from spring was 50% of the r^2 statistic based upon hourly data in spring (Figure 3.27). In summer, the r^2 statistics for the two time scales was much closer, with $r^2 = 0.74$ for hourly versus $r^2 = 0.62$ for daily.

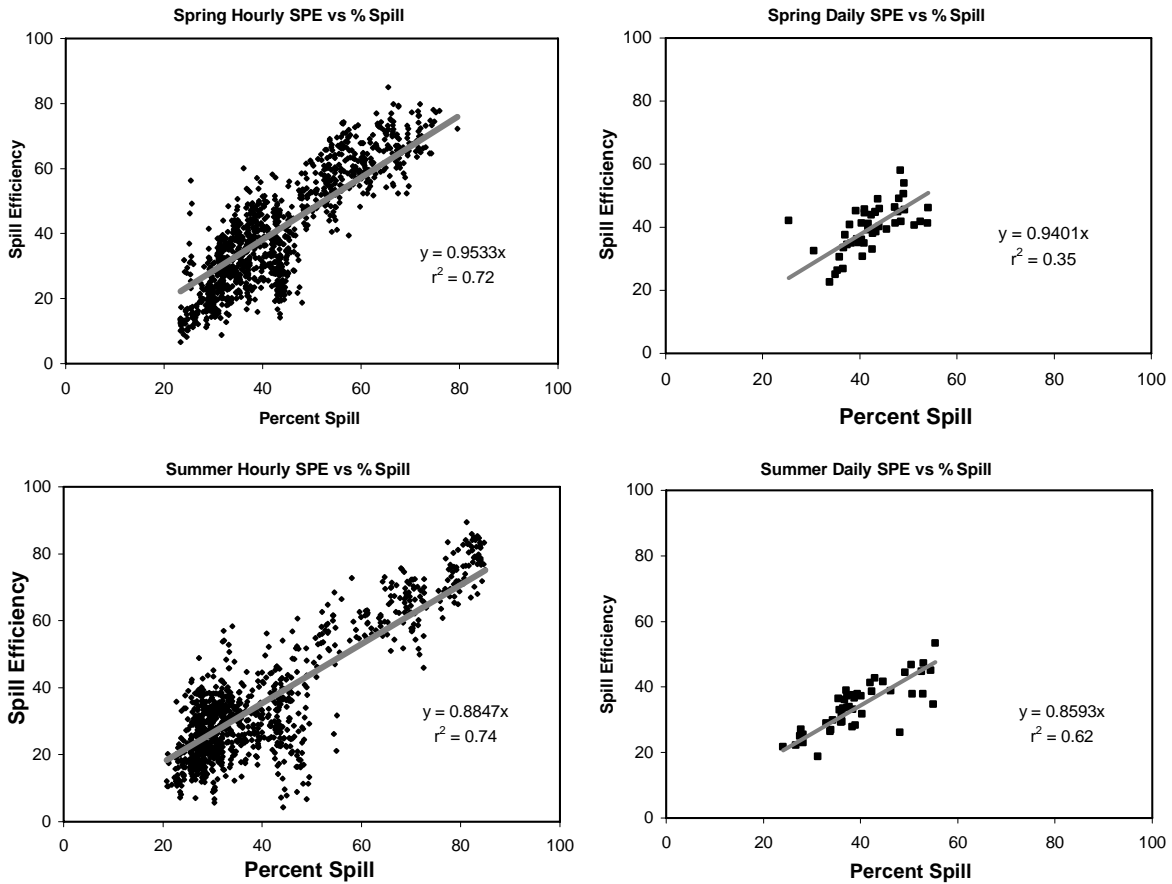

Figure 3.27. Regression of Hourly and Daily Estimates of Project Spill Efficiency on Percent Spill in Spring and Summer 2004.

The distribution of hourly Project FPE versus percent spill did not appear to be linear in spring or summer. The FPE estimates increased linearly only until about 40% spill and then continued to increase but at a much slower rate (Figure 3.28). In spring, the plot of hourly points was best fit with a second-order polynomial, which produced an r^2 value that was 9% higher than that for a linear fit. In summer, a quadratic fit was only 2% better than a linear fit ($r^2=0.49$). When daily estimates of the project FPE vs. percent spill were examined, the plots were essentially linear, with r^2 values of 0.55 in spring and 0.45 in summer and slopes equal to 1.2 in spring and 0.8 in summer.

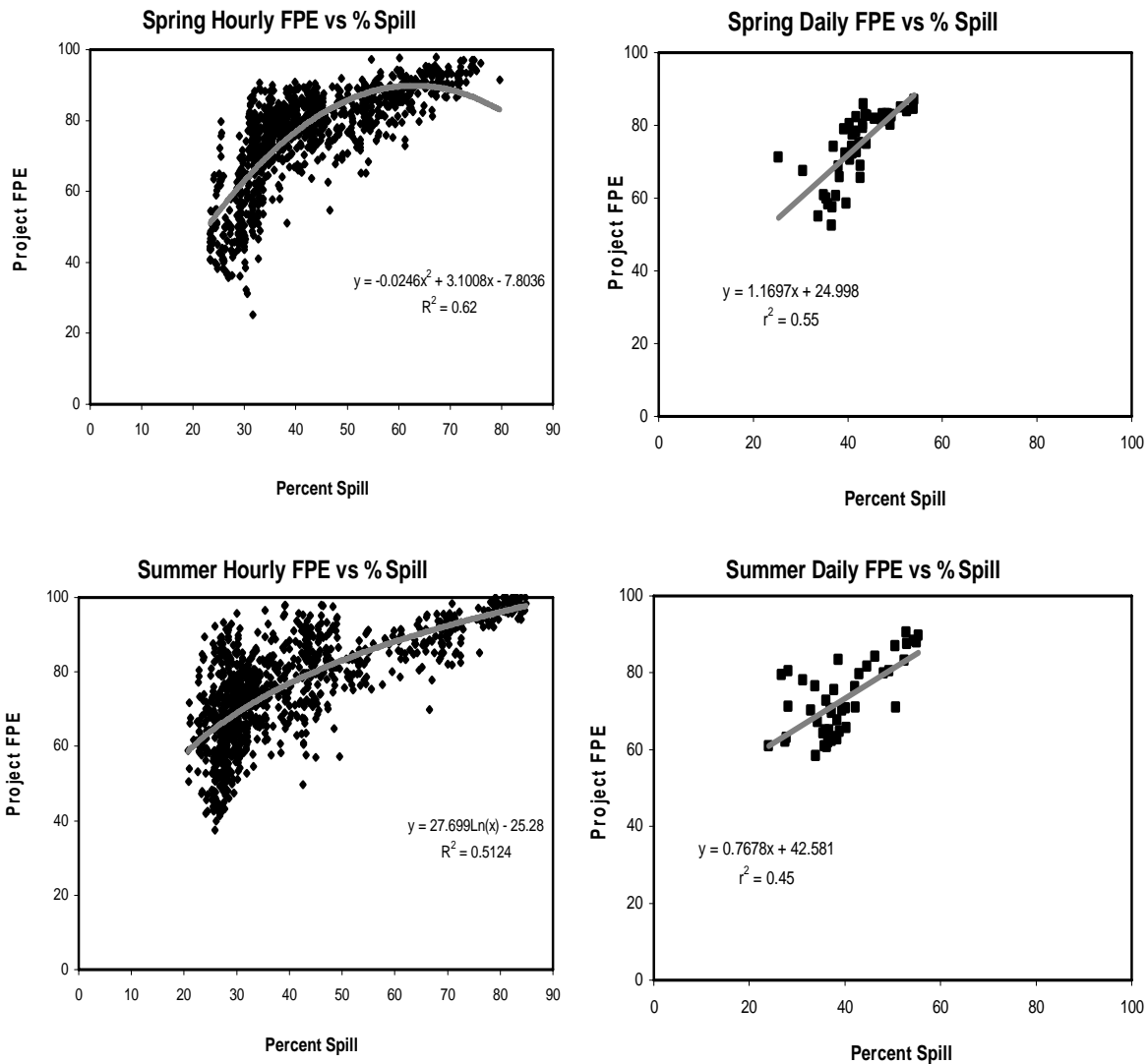

Figure 3.28. Regression of Hourly and Daily Estimates of Project FPE on Percent Spill in Spring and Summer 2004.

3.6.6 Effects of Spill Discharge Rate on Spill Efficiency and Project FPE

Since percent spill is a product of discharge through all routes, we also plotted the absolute spillway discharge against both spill efficiency (Figure 3.29) and Project FPE (Figure 3.30). As in the percent spill analysis, we did this for both hourly and daily data. We found strong correlations of spill efficiency with spill discharge for the hourly estimates ($r^2 = 0.64$ in spring and 0.70 in summer), no correlation for the daily estimates in spring ($r^2 < 0.01$), and a weak correlation of daily spill efficiency with spill rate in summer ($r^2 = 0.41$ - Figure 3.29). We found weak correlations of hourly estimates of Project FPE with hourly spill discharge rate in spring and summer (Figure 3.30), and no significant correlation between Project FPE and spill rate on a daily basis.

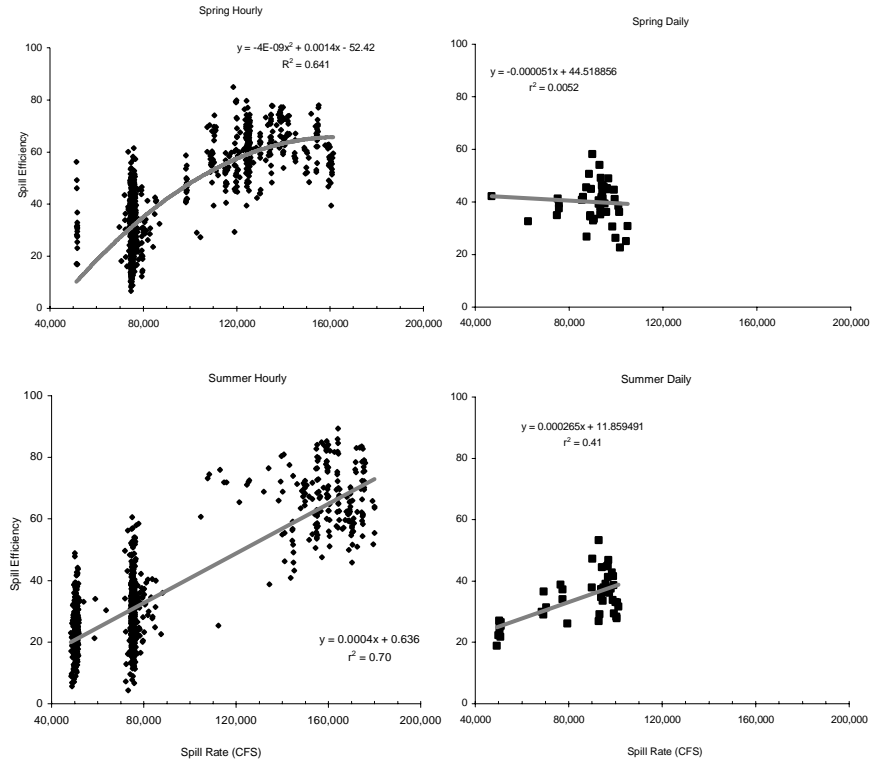

Figure 3.29. Regression of Hourly and Daily Estimates of Project Spill Efficiency on Spill Rate in Spring and Summer 2004.

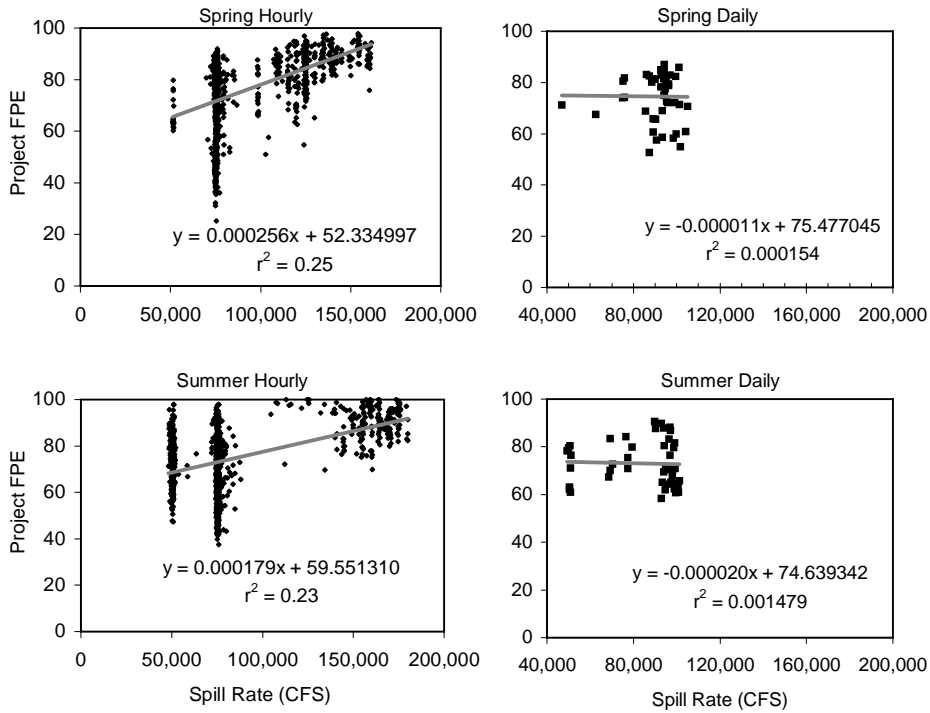

Figure 3.30. Regression of Hourly and Daily Estimates of Project Spill Efficiency on Spill Rate in Spring and Summer 2004.

3.6.7 Comparison of Hydroacoustic and Radio Telemetry Estimates

We truncated spring and summer seasons of hydroacoustic estimates to include only days when both hydroacoustic and radio telemetry estimates of passage were available to compare hydroacoustic estimates with USGS radio telemetry estimates. The USGS also calculated passage estimates for these time periods.

The spring comparison period was from April 29 to May 31, and the summer comparison period was from June 21 to July 15. Major fish passage metrics from the two methods (hydroacoustic = HA and radio telemetry = RT) are presented in Tables 3.3 and 3.4. The two estimates of Project FPE in spring were within 1% of each other, and in summer the hydroacoustic estimate (72%) was 9% higher than the RT estimate (63%). The largest differences in efficiency in spring were 25% (B1 sluiceway efficiency) and 27% (B1 FPE) and both were related to B1 sluiceway performance, which was much higher according to radio telemetry detections of steelhead and yearling Chinook salmon than were our estimates for the run at large. Other springtime efficiency estimates were within 14% or less of each other. Proportional differences in effectiveness estimates between HA and RA for spring were about 20% for the spillway, 15% for the combined sluiceway, 12% for the B1 sluiceway, and 44% for the B2CC relative to the project.

Table 3.3. Comparison of Passage Performance Metrics at Bonneville Dam during the Overlapping Period of April 29-May 31, 2004, for the Run-at-Large, as Measured by Hydroacoustics (HA), and for Yearling Chinook Salmon and Steelhead Combined, as Measured by Radio Telemetry (RT). Radio telemetry estimates are weighted by the proportion of run size for each species based on the equation: RT estimate = (RT estimate_{CH1} x proportion of run_{CH1}) + (RT estimate_{STH} x proportion of run_{STH}) and were provided by Scott Evans, USGS.

Passage Metric	HA Estimate	RT Estimate	Difference
Project FPE	72%	73%	-1%
FPE _{B1}	28%	55%	-27%
FPE _{B2}	65%	61%	4%
FGE _{B2}	47%	33%	14%
Spillway efficiency	40%	32%	8%
Spillway effectiveness	0.97	0.77	0.2
Sluiceway Efficiency (B1 + B2CC)	6%	4%	2%
Sluiceway efficiency re: B1	28%	53%	-25%
B2CC efficiency re: Project	14%	25%	-11%
B2CC efficiency re: B2	34%	42%	-8%
Sluiceway effectiveness (B1 + B2CC)	6.7	7.9	-1.2
Sluiceway effectiveness _{B1}	11.4	13.0	-1.6
B2CC effectiveness re: Project	5.8	10.4	-4.6
B2CC effectiveness re: B2	6.5	7.8	-1.3

In summer, all hydroacoustic estimates of passage metrics were higher than the radio telemetry estimates (Table 3.4). The FPE estimates differed by 12% or less, B2 FGE by 11%, and all other efficiency estimates by $\leq 7\%$. Effectiveness measures in summer also were closer than were similar estimates by the two methods in spring. Hydroacoustic estimates of effectiveness in summer were proportionally higher than radio telemetry estimates by 41% (Project sluiceways), 18% (B2CC re: B2), 15% (B1

sluiceway re: B1), 12.5% (spillway), and 10% (B2CC re: Project). At the second powerhouse the HA estimate of FGE was 11% higher than the RT estimate and the subsequent HA estimate of FPE at B2 was 12% higher than the RT estimate.

Table 3.4. Comparison of Passage Performance Metrics at Bonneville Dam during the Overlapping Period of June 21-July 15, 2004, for the Run-at-Large, as Measured by Hydroacoustics (HA), and for Yearling Chinook Salmon and Steelhead Combined, as Measured by Radio Telemetry (RT). Radio telemetry estimates are weighted by the proportion of run size for each species based on the equation: RT estimate = (RT estimate_{CH1} x proportion of run_{CH1}) + (RT estimate_{STH} x proportion of run_{STH}) and were provided by Scott Evans, USGS. Powerhouse one = B1 and Powerhouse two = B2.

Passage Metric	HA Estimate	RT Estimate	Difference
Project FPE	72%	63%	9%
FPE _{B1}	55%	52%	3%
FPE _{B2}	60%	48%	12%
FGE _{B2}	35%	24%	11%
Spillway efficiency	32%	29%	3%
Spillway effectiveness	0.8	0.7	0.1
Sluiceway Efficiency (B1 + B2CC)	5%	3%	2%
Sluiceway efficiency re: B1	54%	48%	6%
B2CC efficiency re: Project	23%	21%	2%
B2CC efficiency re: B2	39%	32%	7%
Sluiceway effectiveness (B1 + B2CC)	8.8	5.2	3.6
Sluiceway effectiveness re: B1	7.2	6.1	1.1
B2CC effectiveness re: Project	8.0	7.2	0.8
B2CC effectiveness re: B2	7.1	5.8	1.3

Since HA estimates of FGE at B2 were 14% higher than RT estimates in spring and 11% higher in summer, we examined the estimates of the FGE of individual units at B2 each season (Tables 3.5 and 3.6). During both spring and summer, HA estimates were nearly always higher than RT estimates, and often by a considerable margin. Differences > 10% occurred at Units 15-18 in spring and at Units 14, 15, and 17 in summer.

Table 3.5. Estimates of Fish Guidance Efficiency (FGE), by Turbine Unit, at B2 from April 29-May 31, 2004 for the Run-at-Large as Measured by Hydroacoustics (HA) and for Yearling Chinook Salmon and Steelhead Combined, as Measured by Radio Telemetry (RT). Radio telemetry estimates are weighted by the proportion of run size for each species based on the equation: RT FGE = (RT FGE_{CH1} x proportion of run_{CH1}) + (RT FGE_{STH} x proportion of run_{STH}) and were provided by Scott Evans, USGS.

Location	HA FGE	RT FGE	Difference
Unit 11	42%	42%	0%
Unit 12	46%	36%	10%
Unit 13	45%	35%	10%
Unit 14	39%	35%	4%
Unit 15	61%	35%	26%
Unit 16	55%	37%	18%
Unit 17	55%	32%	23%
Unit 18	41%	24%	17%

Table 3.6. Estimates of FGE, by Turbine Unit, at B2 from June 21 through July 15, 2004, for the Run-at-Large as Measured by Hydroacoustics (HA) and for Yearling Chinook Salmon and Steelhead Combined, as Measured by Radio Telemetry (RT). Radio telemetry estimates are weighted by the proportion of run size for each species based on the equation: $RT\ FGE = (RT\ FGE_{CH1} \times \text{proportion of run}_{CH1}) + (RT\ FGE_{STH} \times \text{proportion of run}_{STH})$ and were provided by Scott Evans, USGS.

Location	HA FGE	RT FGE	Difference
Unit 11	40%	31%	9%
Unit 12	27%	25%	2%
Unit 13	30%	23%	7%
Unit 14	37%	22%	15%
Unit 15	49%	31%	18%
Unit 16	41%	35%	6%
Unit 17	41%	23%	18%
Unit 18	16%	25%	9%

3.7 Spatial Trends in Fish Passage

3.7.1 Horizontal Distributions

3.7.1.1 Spring Creek Hatchery Release

Estimated horizontal distributions of fish passage during the Spring Creek release indicated that the majority of both flow and fish passed through B2 for all three operational conditions tested (Table 3.7). During the condition of 5,000 cfs discharge through the B2CC, the B1 Sluiceway passed relatively few fish with almost 5% of the total flow. The B1 Sluiceway discharged less than 1% of the total Project flow during both the spill and no spill/no B2CC conditions, but passed more fish relative to flow (effectiveness = 5.9-6.8) than did the B2CC (effectiveness = 4.2), when it was operating. Plotting fish passage by route as percent of total passage during the three test conditions reveals an apparent effect of B2CC operation on passage into the adjacent operating turbine (Figure 3.31). Unit 12 passed proportionately fewer fish during the B2CC condition than when the B2CC was closed. Unit 11, which is directly adjacent to B2CC, did not operate during the test period. Of all B1 units operating during the three test conditions, Units 3 and 5 passed the highest proportions of fish. During the spill condition, spill bays 7, 8, and 13 passed the most fish while spill bays 4, 6, 11, and 18 passed the fewest fish. Of all B2 units operating during the three test conditions (Units 11 and 17 did not operate), Units 18 and 16 passed the highest and lowest proportion of fish, respectively.

3.7.1.2 Spring

We estimate that slightly over 27 million juvenile salmonids passed Bonneville Dam during the spring sampling period of 2004 (Table 3.8; Figure 3.32). The horizontal distribution of springtime passage for B1, the spillway, and B2 were 17, 40, and 43%, respectively, in general following the ratio of associated discharge through those primary structures. Within powerhouses, however, there was little similarity between discharge and passage proportions. At B1, passage at the three sluiceways (above the 'C' intakes at Units 2, 4, and 6) accounted for 33% of the total fish passed there, while discharge through the sluiceways comprised less than 5% of the total discharge through B1. Sluiceway Entrance 4C passed much fewer fish than did entrances 2C and 6C in spring (Figure 3.32) and summer (Figure 3.35). B1 turbine passage and discharge peaked through Units 2 and 4, whereas Unit 9, which passed the fewest fish, also passed the least amount of water for all operating turbines.

Table 3.7. Estimated Fish Passage and Percent of Total Flow for All Major Passage Routes at Bonneville Dam for the Spring Creek Release from March 1-18, 2004.

Condition	Estimated Fish Passage (thousands)						Percent of Total Flow				
	Total	B1	Spill	B2	B1 Sluice	B2CC	B1	Spill	B2	B1 Sluice	B2CC
5,000 cfs at B2CC	1,124	352	5	767	17	181	33	4	63	5	4
50,000 cfs Spill	1,013	221	233	559	52	0	22	24	54	1	0
No Spill or B2 CC	1,146	529	5	612	54	0	36	3	61	1	0

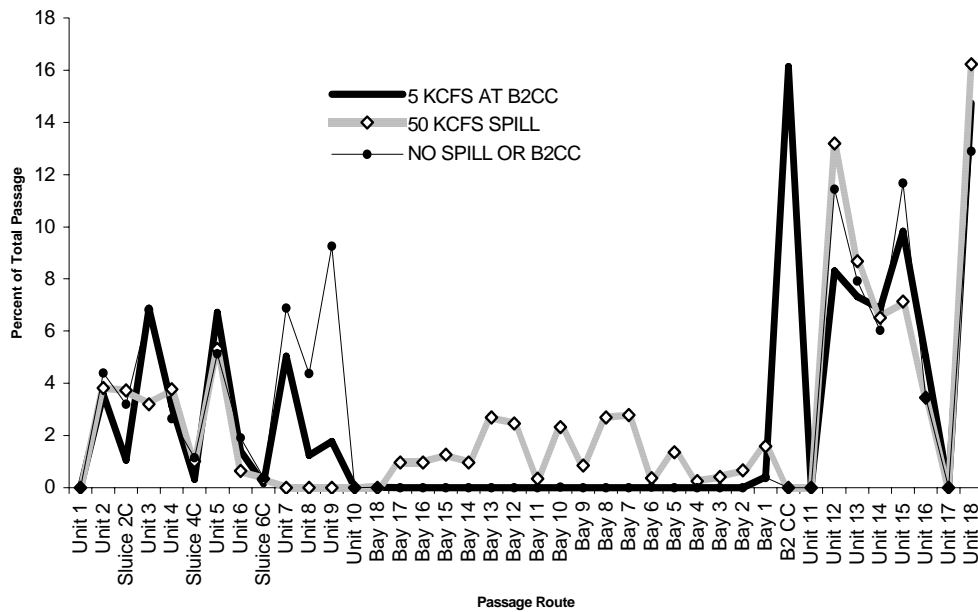

Figure 3.31. Percent of Total Passage for all Sampled Passage Routes during Three Operational Conditions at Bonneville Dam for the Spring Creek Release March 1-18, 2004.

The distribution of passage across the spillway in spring did not follow the distribution of discharge there, contrasting with the passage/discharge distributions observed for B1 (Figure 3.32). Spill bays 3 and 17 passed the greatest volumes of water relative to other spill bays but did not pass large numbers of fish; in fact, Bay 3 passed very few fish relative to other spill bays. Spill bays 6-15 all passed similar volumes of water but disparate numbers of fish. More fish passed through Spill Bay 16 than any other bay.

The B2CC surpassed all other routes in terms of numbers of fish passed (Figure 3.32). At B2, the B2CC passed 31% of all fish in about 5% of all discharge through that powerhouse. Horizontal distribution of passage among turbine units at B2 generally followed flow with Unit 16 passing the least amount of water and the fewest fish relative to the other units. Units 11-13 and 17 all discharged higher volumes of water than did the other units, but Unit 18 passed the most fish.

Table 3.8. Estimated Fish Passage and Percent of Total Flow for all Major Passage Routes at Bonneville Dam in the Spring and Summer of 2004.

Season	Estimated Fish Passage (millions)						Percent of Total Flow				
	Total	B1	Spill	B2	B1 Sluice	B2 CC	B1	Spill	B2	B1 Sluice	B2 CC
Spring	27.0	4.6	10.9	11.5	1.5	3.6	11.5	41.7	46.7	3.0	2.5
Summer	15.8	2.5	5.2	8.1	1.0	3.2	12.3	39.2	48.5	3.0	2.5

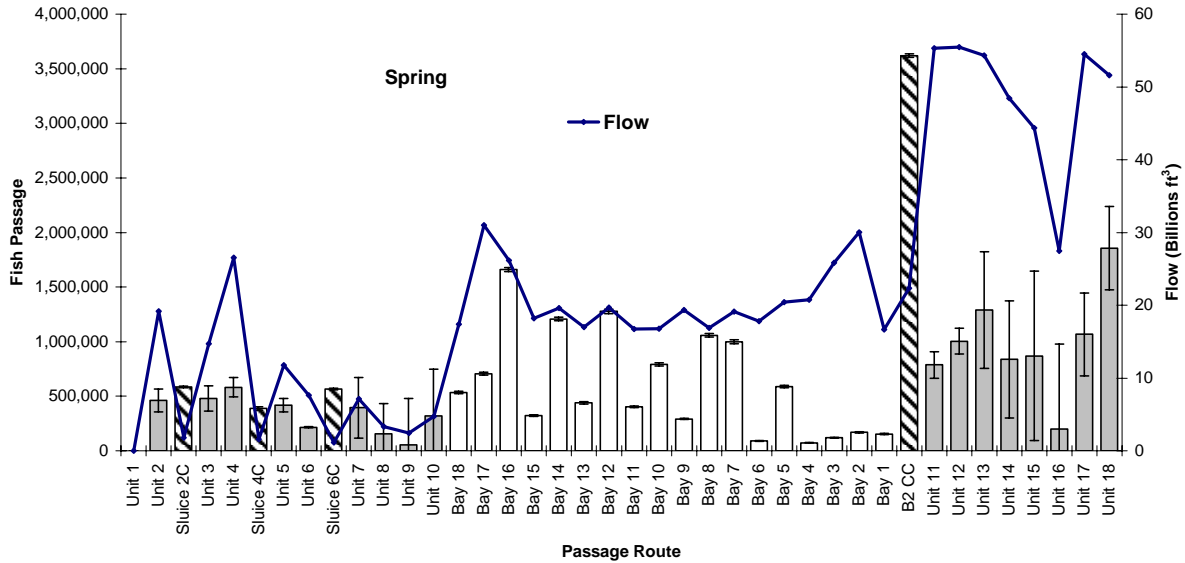

Figure 3.32. Estimated Fish Passage and Flow through all Sampled Routes at Bonneville Dam in Spring of 2004. Turbine units are shown in light gray, spill bays in white, and surface passage routes (B1 sluiceways and B2 CC) in crosshatched black and white. Turbine Unit 1 did not operate in spring of 2004. Error bars represent 95% confidence limits on hydroacoustic estimates. The line represents total spring discharge by passage route.

The horizontal distribution patterns of fish at the B1 sluice entrances during the spring season were characterized by higher concentrations of fish passing within two to three feet from the edges of the sluiceways and smaller proportions of fish passing near the centers of the gates (Figure 3.33). This pattern was consistent across all three B1 entrances, although distributions differed across different entrances as to which side passed greatest proportions of fish. The sluiceway at 6C had greatest passage near the north side whereas distributions for sluices 2C and 4C were skewed toward the south side.

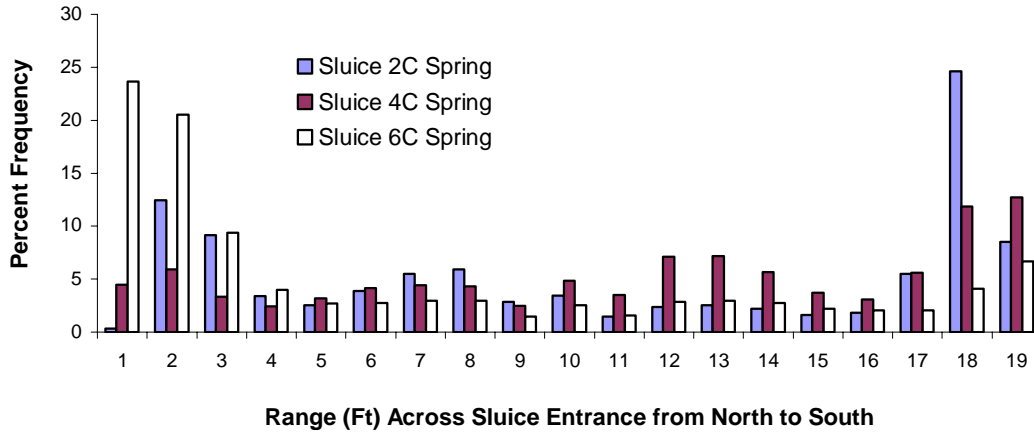

Figure 3.33. Horizontal Distribution across the Three Operating B1 Sluiceway Entrances in Spring 2004.

The estimated horizontal distribution of fish density (fish per water volume) in the spring indicated that each of the surface passage routes (B1 sluiceway entrances and the B2CC) passed much higher densities of fish than did any specific turbine unit or spill bay (Figure 3.34). Of the surface passage routes, Sluice 6C passed the highest density of fish, followed by Sluice 2C, Sluice 4C, and the B2CC. Among the turbine units at B1, the greatest fish densities were passed at the north end of the powerhouse. At the spillway, bays 8, 12, 14, and 16 passed the greatest densities while bays at the north end passed the lowest densities relative to the other spill bays. As compared to all units at B2, Unit 16 passed the lowest density and Unit 18 passed the greatest density of fish.

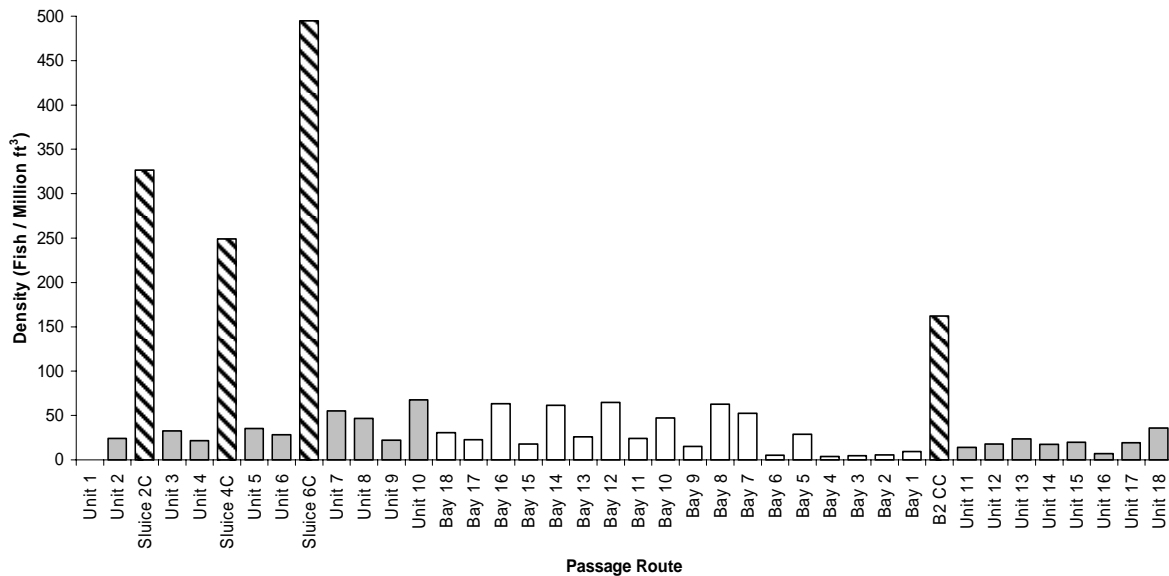

Figure 3.34. Estimated Fish Density (number of fish per water volume) for all Sampled Routes at Bonneville Dam in Spring 2004. Turbine units are shown in light gray, spill bays in white, and surface passage routes (B1 sluiceways and B2CC) in crosshatched black and white. Turbine Unit 1 did not operate in spring of 2004.

3.7.1.3 Summer

We estimate that almost 16 million juvenile salmonids passed the Bonneville Dam during the summer sampling period of 2004 (Table 3.8; Figure 3.35). The horizontal distributions of passage for B1, the spillway, and B2 were 16%, 33%, and 51%, respectively, in general following the ratio of associated discharge through those structures. At B1, passage at the three sluiceways accounted for 38% of the total fish passed there, a 5% increase over what we observed in spring. Discharge through the B1 sluiceways comprised about 4% of total discharge through B1. As in spring, Sluiceway Entrance 4C passed fewer fish than did entrances 2C and 6C. B1 turbine Units 2-5 and 7 all passed about the same number of fish, and, like in spring, discharge was highest through Units 2 and 4. Also as in spring, we estimated that Unit 9 passed the fewest fish and the least water of all operating turbines at B1.

The estimated distribution of passage across the spillway in the summer was similar to the spring distribution, with highest passage occurring at Spill Bay 16 and lowest passage numbers occurring at spill bays 4 and 6 (Figure 3.35; compare with Figure 3.32). As in spring, the horizontal distribution of passage did not follow the distribution of discharge there, contrasting with the passage/discharge distributions observed for B1.

The B2CC had higher estimated passage than did any other individual route (Figure 3.35), as was the case in spring. The B2CC passed 40% of all fish through that structure, an increase of 9% over that in spring with just 5% of the water passing B2. Horizontal distribution of passage among turbine units at B2 generally followed flow with Unit 16 passing the least amount of water and the fewest fish relative to the other units. Unit 13 passed the greatest number of fish, but Unit 17 passed the most water.

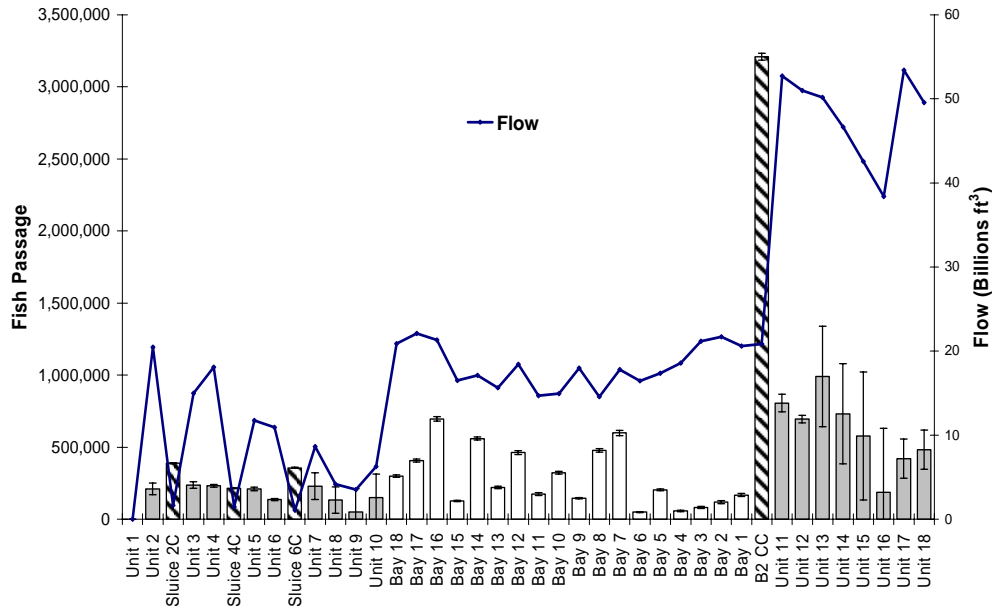

Figure 3.35. Estimated Fish Passage and Flow through all Sampled Routes at Bonneville Dam in Summer of 2004. Turbine units are shown in light gray, spill bays in white, and surface passage routes (B1 sluiceways and B2CC) in crosshatched black and white. Turbine Unit 1 did not operate in summer of 2004. Error bars represent 95% confidence limits on hydroacoustic estimates. The line represents total summer discharge by passage route.

The distribution patterns of fish passage across the sluiceway entrances at B1 in the summer were very similar to those observed in spring with strong skewing of fish concentrations within a few feet of the edges and lower proportions along the center (Figure 3.36). As in spring, the distribution for Sluice 6C favored the north side of the entrance whereas Sluice 2C and 4C indicated higher proportions near the south side.

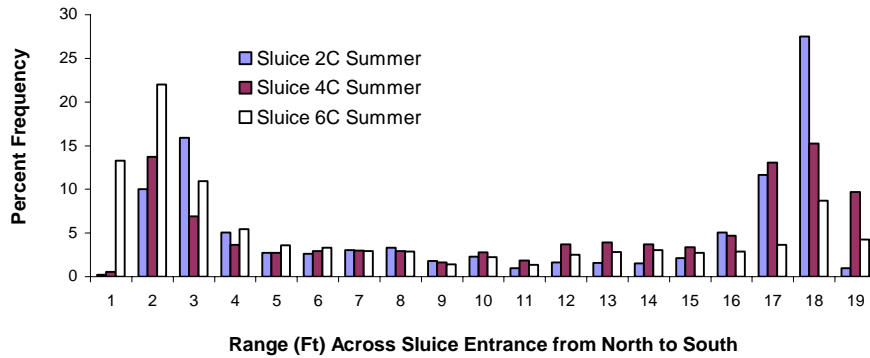

Figure 3.36. Horizontal Distribution across the Three Operating B1 Sluiceway Entrances in Summer 2004

The horizontal distribution of fish density in the summer indicated that each of the surface passage routes passed higher densities of fish than did any one turbine unit or spill bay (Figure 3.37), the same result observed in spring. Of the sluiceway entrances at B1, Sluiceway Entrance 6C passed the highest estimated density of fish, followed by Sluiceway Entrance 2C, and Sluiceway Entrance 4C, as seen in spring. Unlike in spring, the B2CC outperformed Sluiceway Entrance 4C in terms of estimated fish passage density. Among turbine units at B1, greatest estimated fish densities were passed at the north end. At the spillway, spill bays 7, 8, 14, and 16 passed the greatest densities while bays at the north end passed lower densities relative to the other spill bays. As in spring, compared to all units at B2, Unit 16 passed the lowest density and Unit 18 the greatest density of fish.

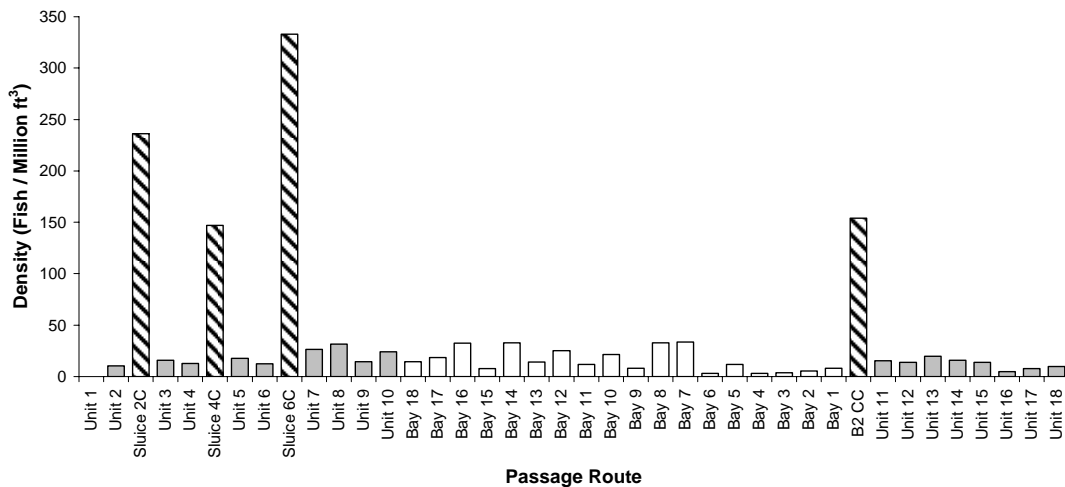

Figure 3.37. Estimated Fish Density (number of fish per water volume) for all Sampled Routes at Bonneville Dam in Summer 2004. Turbine units are shown in light gray, spill bays in white, and surface passage routes (B1 sluiceways and the B2CC) in crosshatched black and white. Turbine Unit 1 did not operate in summer of 2004.

3.7.2 Vertical Distributions in Spring and Summer

The estimated vertical distribution patterns of fish within turbine intakes at B1 were multi-modal during both spring and summer, with modes occurring at a shallow elevation (EL) of about 60 ft. mean sea level, just above midwater (about EL 37 ft), and near the bottom of the turbine entrance (at about EL 6 ft) (Figure 3.38). In the spring, we estimated that the greatest proportions of fish were detected near the lowest elevations, whereas in summer fish were distributed at highest frequencies near the highest elevations.

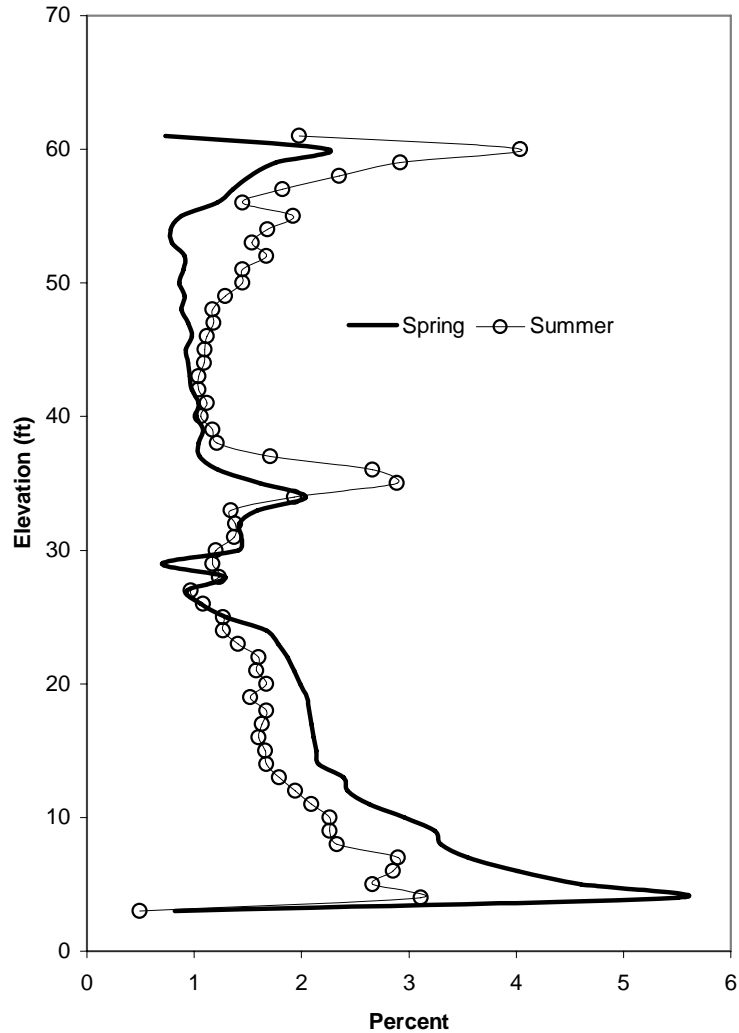

Figure 3.38. Estimates of Vertical Distributions of Fish within Turbine Intakes at Bonneville Dam First Powerhouse in Spring and Summer 2004.

Vertical distribution patterns of fish passing the spillway were similar in spring and summer, characterized by a general increase in percentages with increasing depth (Figure 3.39). However, a slight decrease in percent passage with increasing depth is evident in spring and summer between elevation 37 and 39 ft. Both distributions peaked at about 26 ft elevation, with the peak slightly higher in spring than in summer.

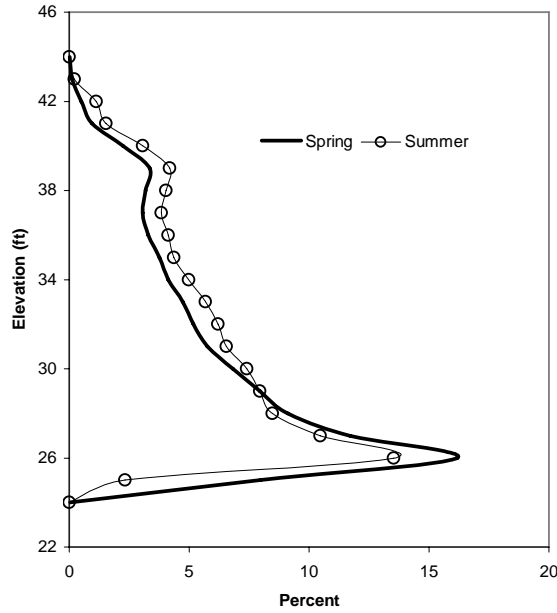

Figure 3.39. Estimates of Vertical Distribution of Fish Passing the Bonneville Dam Spillway in Spring and Summer of 2004. The ogee was located at elevation 24 ft. Fish detected in the upper 28.5 ft of the water column were not necessarily entrained and were not counted unless they also were detected below elevation 44 ft.

Estimated vertical distribution patterns of fish at B2 were similar across seasons and were characterized by a general decrease in proportions with decreasing depth (Figure 3.40). The highest estimated passage proportion occurred at EL 30 ft near the intake ceiling for both spring and summer. Minor peaks contrary to the general pattern of decreasing proportions with increasing depth occurred during the spring at elevations 0 and 21 ft, and in the summer at elevations 0 and 17 ft.

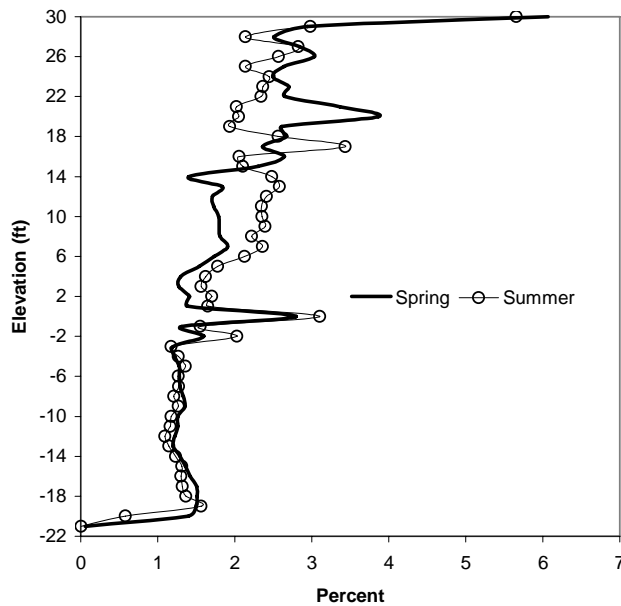

Figure 3.40. Estimates of Vertical Distributions of Fish within Turbine Intakes at Bonneville Dam Second Powerhouse in Spring and Summer 2004.

3.8 Temporal Trends in Fish Passage

3.8.1 Seasonal Trends in Spring and Summer

3.8.1.1 Project Passage Run Timing Smolt - Index and Hydroacoustics

Overall there was good agreement between the daily expanded project passage estimates derived from the fish counts from the B2 smolt monitoring facility (SMF) smolt index and our daily full-project hydroacoustic estimates, each expressed as proportions of the sampled periods (Figure 3.41).

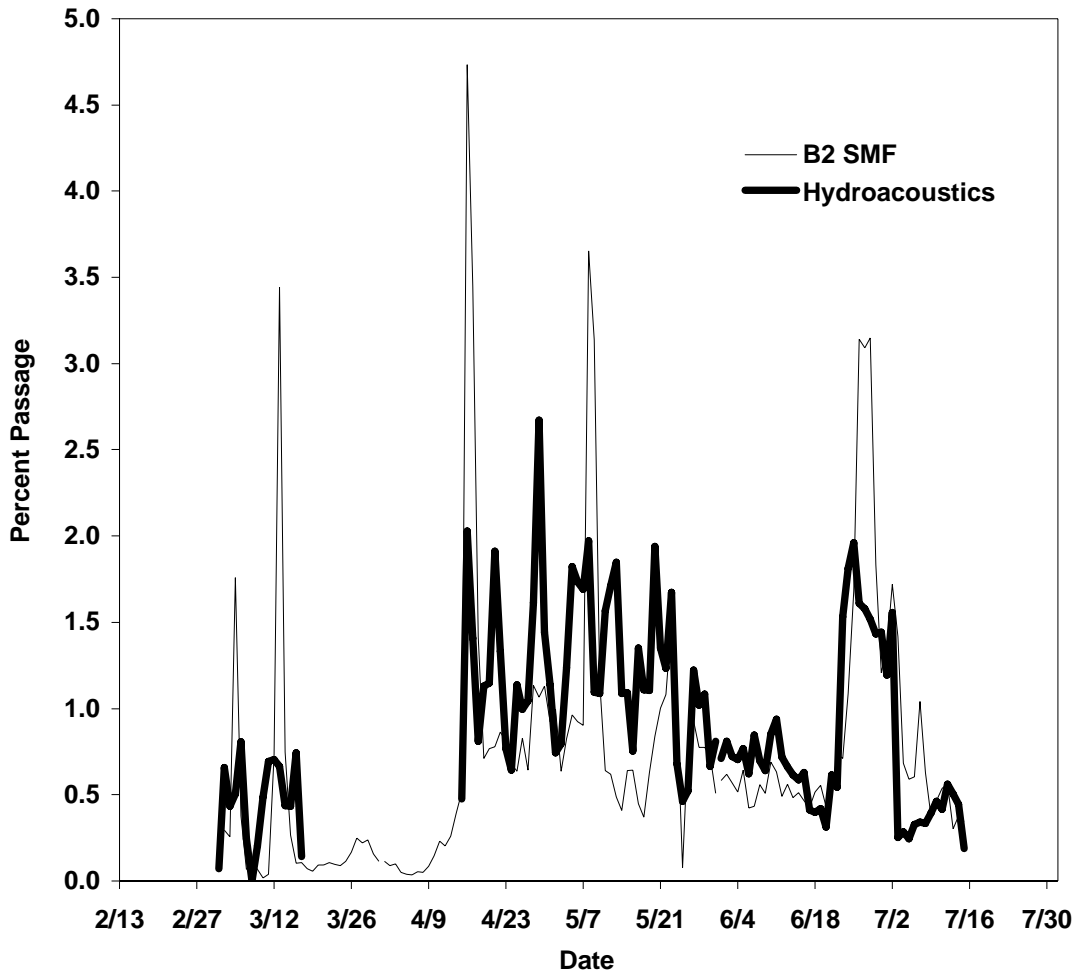

Figure 3.41. Patterns of Run Timing Estimated by Hydroacoustics (heavy line) and by the B2 SMF Smolt Index (thin line) at Bonneville Dam in 2004. The SMP data were obtained from <http://www.cqs.washington.edu/dart/pass.com.html>.

The peak of the upstream migration of adult American shad occurred between the peaks in spring and summer juvenile salmonid out-migrations (Figure 3.42). In some summers, the out migration of spent American shad (*Alosa sapidissima*) can cause false detections by hydroacoustic sampling of the out migration of juvenile salmonids, typically in July. Although the summer peak in our total Project passage estimate was clearly associated with a peak in subyearling Chinook salmon passage, the final small peak in July might have been caused by our inability to filter echo traces from American shad from our data sets. To address this concern we plotted route-specific passage estimates through B2 and the spillway for summer (Figure 3.43). Note that the proportions of estimated fish passage through the various routes

stays fundamentally constant throughout the summer season. Smolt Monitoring Facility data show that the large passage peak began on June 23, with another smaller increase around July 4.

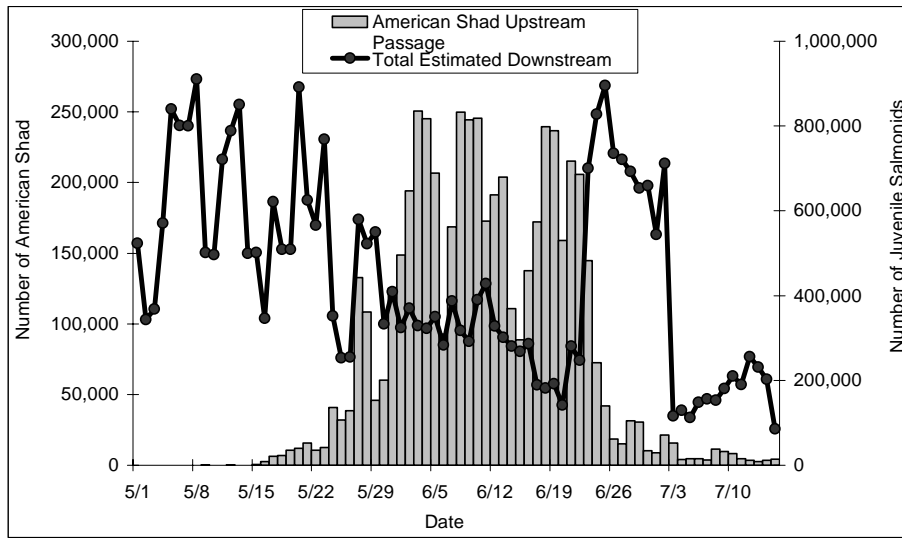

Figure 3.42. Patterns of Adult American Shad and Juvenile Salmonid Run Timing according to Fish Passage Center Counts and Hydroacoustic Counts, respectively. Shad data were obtained from <http://www.cqs.washington.edu/dart/adult.html>.

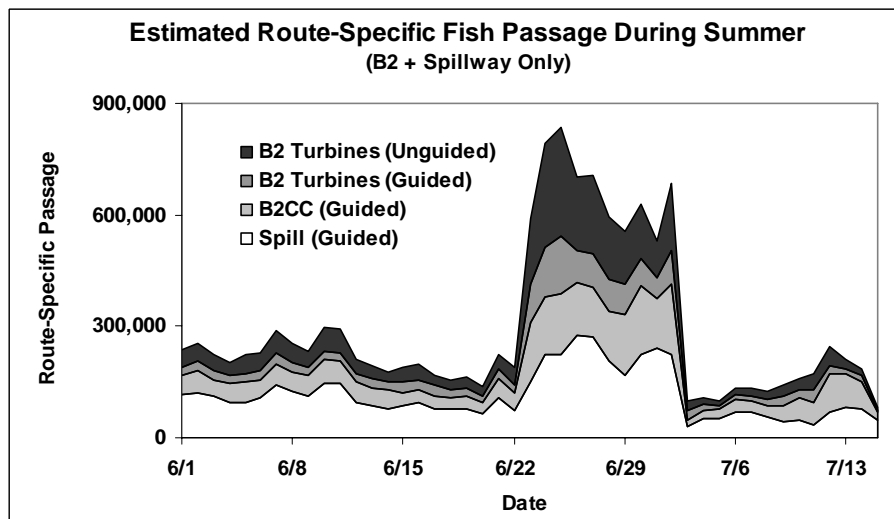

Figure 3.43. Time Histories of Estimated Route-Specific Passage through B2 and the Spillway (excluding B1 for clarity).

3.8.1.2 Major Fish Passage Metrics

The time histories of Project FPE estimates for 2004 are presented in Figure 3.44. Estimated Project FPE was rather episodic with a series of higher daily estimates followed by a series of lower daily estimates. Daily Project FPE estimates were, in general, above 60% and remained above 80% through much of the

spring and some of the summer. There is only a 3.3% reduction in Project FPE from spring to summer and there was a generally increasing trend during summer.

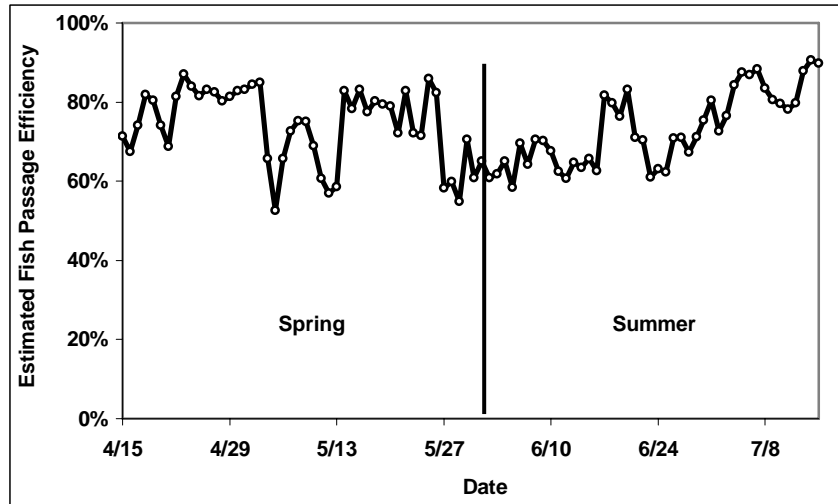

Figure 3.44. Time History of Project FPE Estimates for Bonneville Dam in 2004.

Daily spill efficiency estimates, presented in Figure 3.45, were quite variable, especially in the summer. Estimated spillway efficiency was highest in late April (high = 58% on April 29) and otherwise never rose above 50% until the very end of the summer sampling season on July 15.

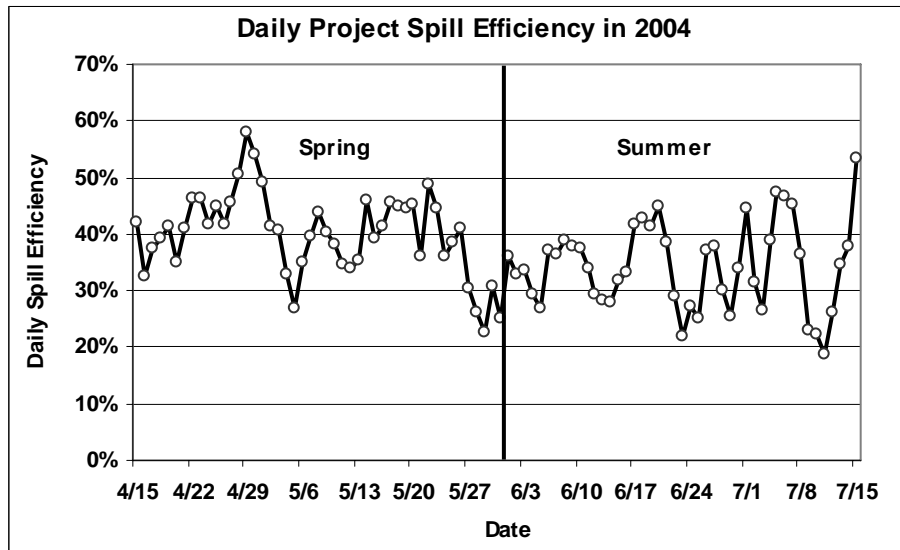

Figure 3.45. Time History of Estimated Spill Efficiency

Daily estimated Project Spill Effectiveness, presented in Figure 3.46, varied around 0.95 in spring and about 0.9 in summer, somewhat less so than estimated Project spill efficiency. Spill effectiveness declined slightly and gradually through the passage year.

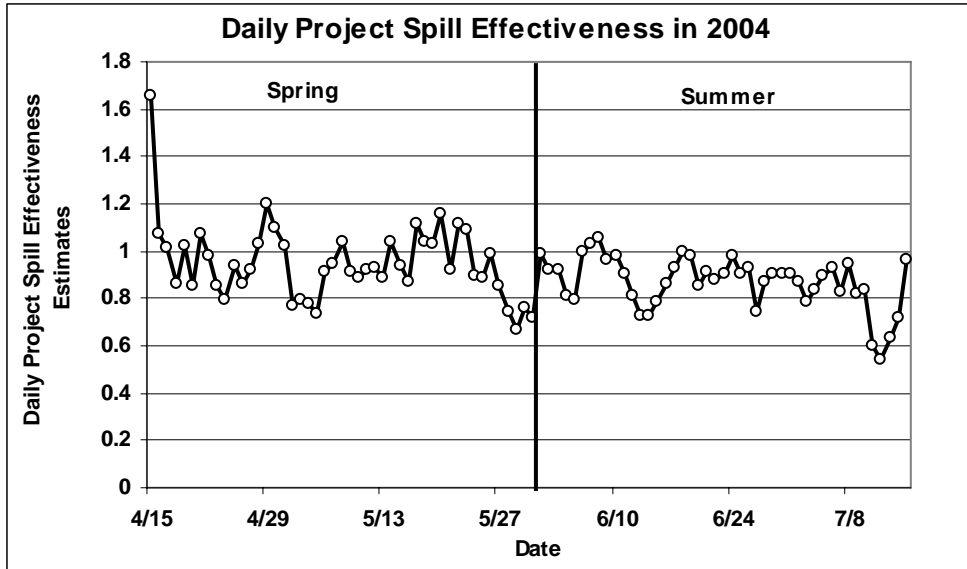

Figure 3.46. Time History of Estimated Spillway Effectiveness

Daily estimates of Project sluiceway efficiency (B1 and the B2CC) varied by 5% to 10% among days but had a general increasing trend from spring through summer (Figure 3.47).

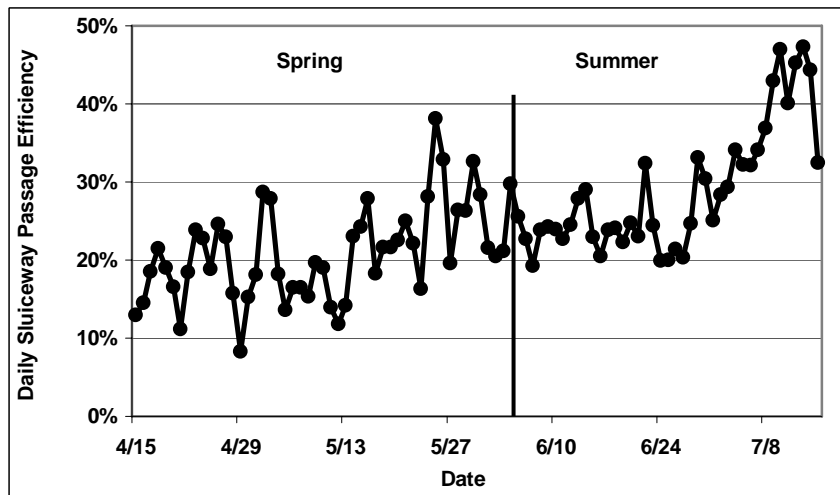

Figure 3.47. Time History of Estimated Project Sluiceway Efficiency (B1 and the B2CC)

The seasonal trend in estimated Project Sluiceway Effectiveness appears in Figure 3.48. Since Project Sluiceway Effectiveness is just Project Sluiceway Efficiency divided by a relatively constant discharge it is not surprising that the time history pattern of Project Sluiceway Effectiveness is similar to that of Project Sluiceway Efficiency. They both increase through both spring and summer.

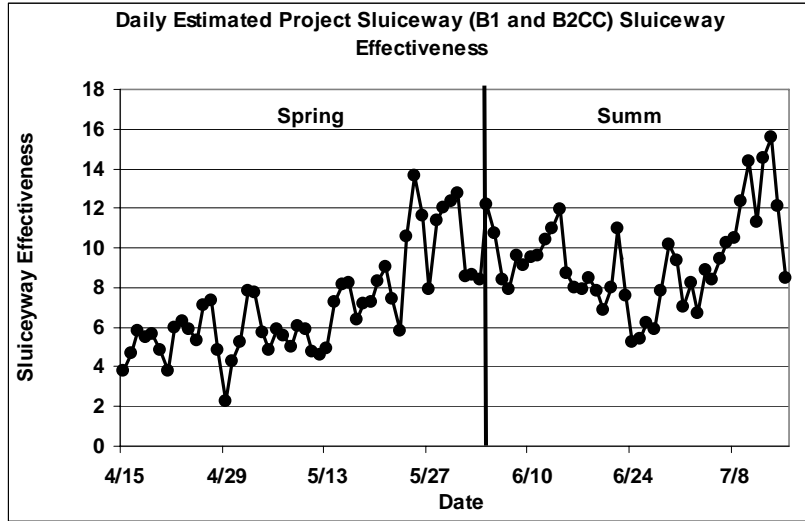

Figure 3.48. Time History of Estimated Project Sluiceway Effectiveness (B1 Sluiceway and the B2CC)

Seasonality of Surface Passage - We considered the time histories of our estimated total Project passage and Project Sluiceway Efficiency (Figure 3.49). As daily Project passage estimates declined in summer (except for the abrupt subyearling Chinook salmon passage pulse that began on June 22), the estimated proportion of fish passing the Project by the sluiceways (B1 and the B2CC) generally increased during the last two weeks of sampling, when estimated Project sluiceway efficiency averaged about 45%.

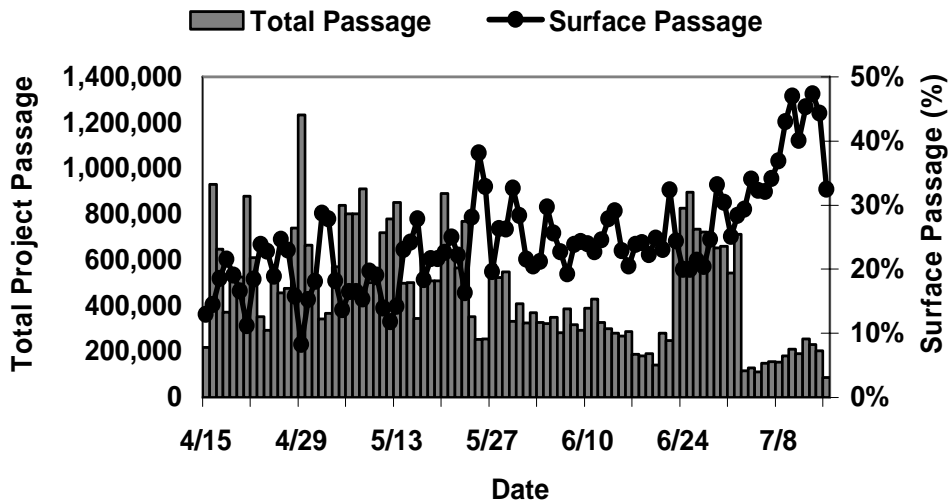

Figure 3.49. Time History of Estimated Total Project Passage and Sluiceway Efficiency (B1 Sluiceway and the B2CC)

3.8.2 Diel Trends

3.8.2.1 Passage Efficiency and Effectiveness Estimates

The diel pattern for Project FPE was similar across seasons, with daytime estimates holding steady between 60% and 70%, and nighttime estimates of about 80% (Figure 3.50). Patterns of estimated hourly

spill efficiency closely resembled those of Project FPE, with relatively uniform estimates during daylight hours before a sustained increase in efficiency during nighttime hours (Figure 3.50), coinciding with higher nighttime spillway discharge. Estimated Spillway Efficiency was slightly higher in spring than it was in summer throughout the diel cycle. Hourly total sluice passage efficiency patterns (including both the B1 sluice and the B2CC) were similar across seasons, but the patterns differed with those of Project FPE and spill efficiency (Figure 3.50). Total sluice passage efficiency was lowest during nighttime hours and peaked during midday hours (1400 to 1900 h), and it was higher during summer than in spring throughout the diel cycle. Hourly patterns of B1 sluice efficiency relative to the Project were similar to those observed for total Project sluice passage efficiency (B1 Sluiceway + B2CC), although spring estimates fluctuated more in the former with midday peaks higher and nighttime lows lower in the spring than in summer (Figure 3.50). The B2CC performed more efficiently in the summer than in spring, with peaks during midday hours and lows during nighttime hours (Figure 3.50). Except for a slight dip in efficiency during nighttime hours, the B2CC showed little diel variation in spring.

The hourly pattern of FPE at B1 was generally similar across seasons, with a gradual increase in efficiency from the morning hours through the late afternoon, a dip prior to sunset, then an increase to a peak at 0300 (Figure 3.51). Estimates of B1 FPE were higher in the summer than in the spring during most hours of the diel cycle. The diel pattern of B2 FPE showed little variability in spring except for a dip in efficiency during nighttime hours and a slight peak at 0700 h (Figure 3.51). Summertime B2 FPE exhibited a dip to its hourly low in the late morning, a peak in the early evening and slight decrease during nighttime hours. The hourly patterns of B2CC efficiency relative to B2 passage for both seasons are similar to the patterns of B2CC efficiency relative to the entire Project (Figure 3.51; see Figure 3.50 to compare). The B2CC efficiency in the spring was relatively unchanged until a slight decline at sunset. In summer, the B2CC was most efficient during midday and least efficient at night.

Diel patterns of spill effectiveness indicated that spill was most effective during nighttime hours in the spring, and in nighttime and early morning in the summer (Figure 3.52). Spill was least effective for passing fish during midday in spring and early evening in summer. The diel patterns of total sluice effectiveness (B1 sluice and B2CC) were similar across seasons, with the sluiceways most effective during the day and least effective at night (Figure 3.52). The sluice at B1 was most effective during daytime hours and least effective at night during both seasons (Figure 3.51). The effectiveness of the B2CC peaked from early afternoon through early evening and was least effective at night in the summer (Figure 3.52). In the spring, there was much less diel variability in B2CC effectiveness than in summer, but a drop in effectiveness was still apparent at night.

Hourly patterns of B1 sluice effectiveness relative to B1 were similar across seasons, with increasing effectiveness through the morning and into the late afternoon and with peaks at 1600 h in the spring and 1800 h in the summer (Figure 3.53). The sluice at B1 was least effective during nighttime hours. The diel patterns of the B2CC effectiveness relative to B2 were similar to those for B1, with effectiveness highest during afternoon hours and lowest during nighttime hours (Figure 3.53).

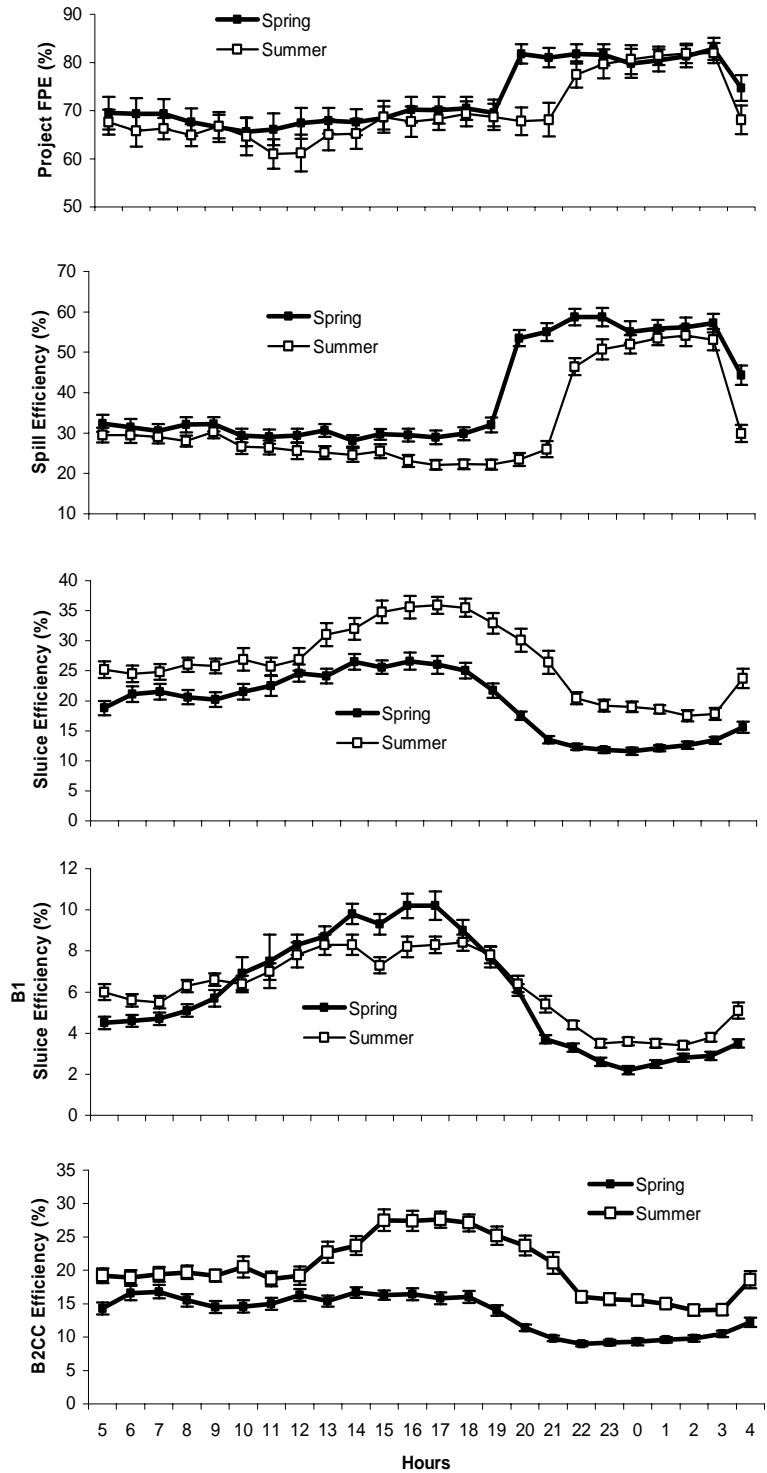

Figure 3.50. Patterns of Estimated FPE, Spill Efficiency, Sluiceway Efficiency (B1 and B2CC), B1 Sluiceway Efficiency, and B2CC Efficiency Relative to the Project in 2004. Error bars represent 95% confidence limits for hydroacoustic estimates.

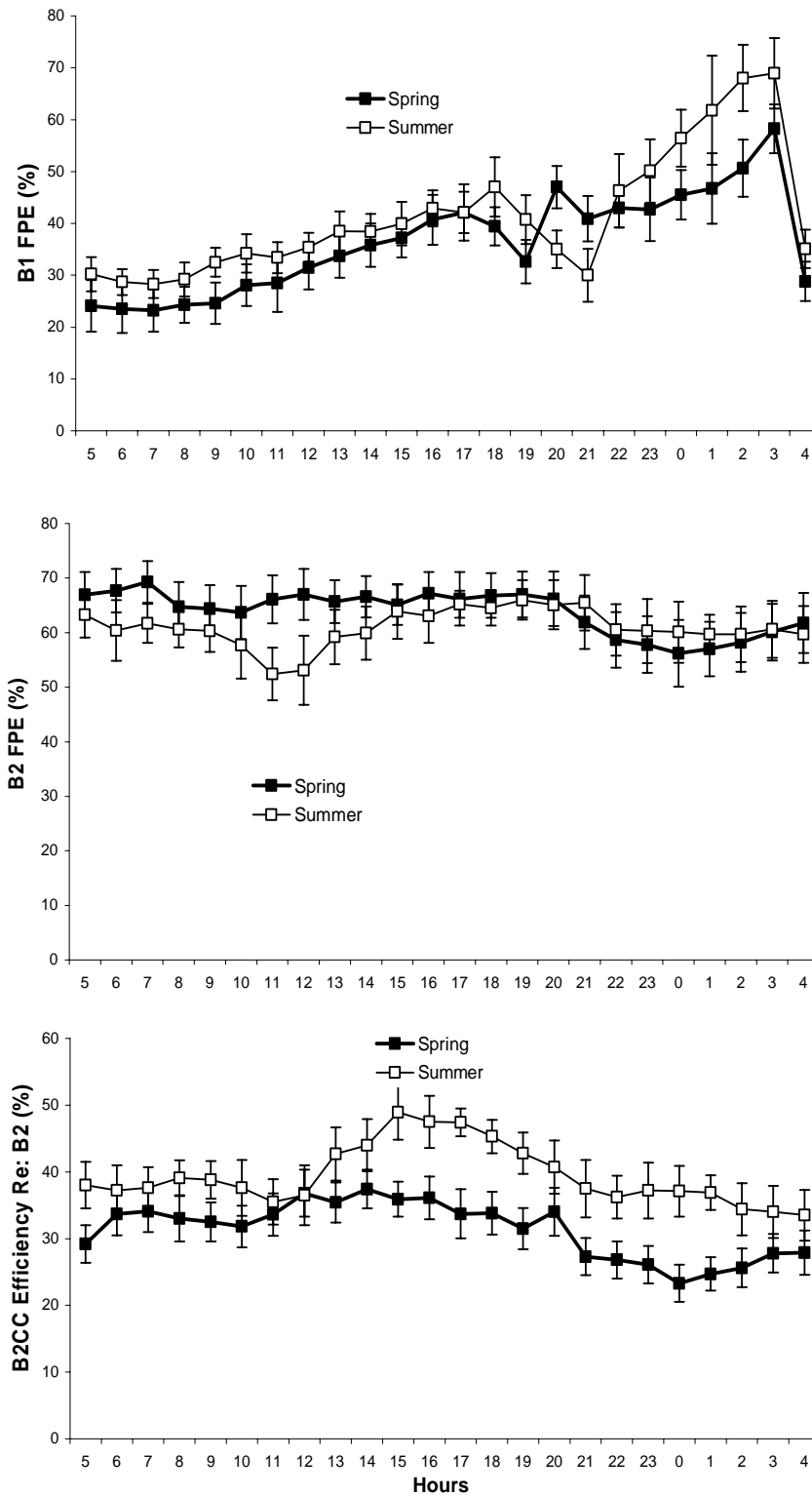

Figure 3.51. Diel Patterns of B1 Fish Passage Efficiency, B2 Fish Passage Efficiency, and B2CC Sluiceway Passage Efficiency (relative to B2) in 2004. Error bars represent 95% confidence limits for hydroacoustic estimates.

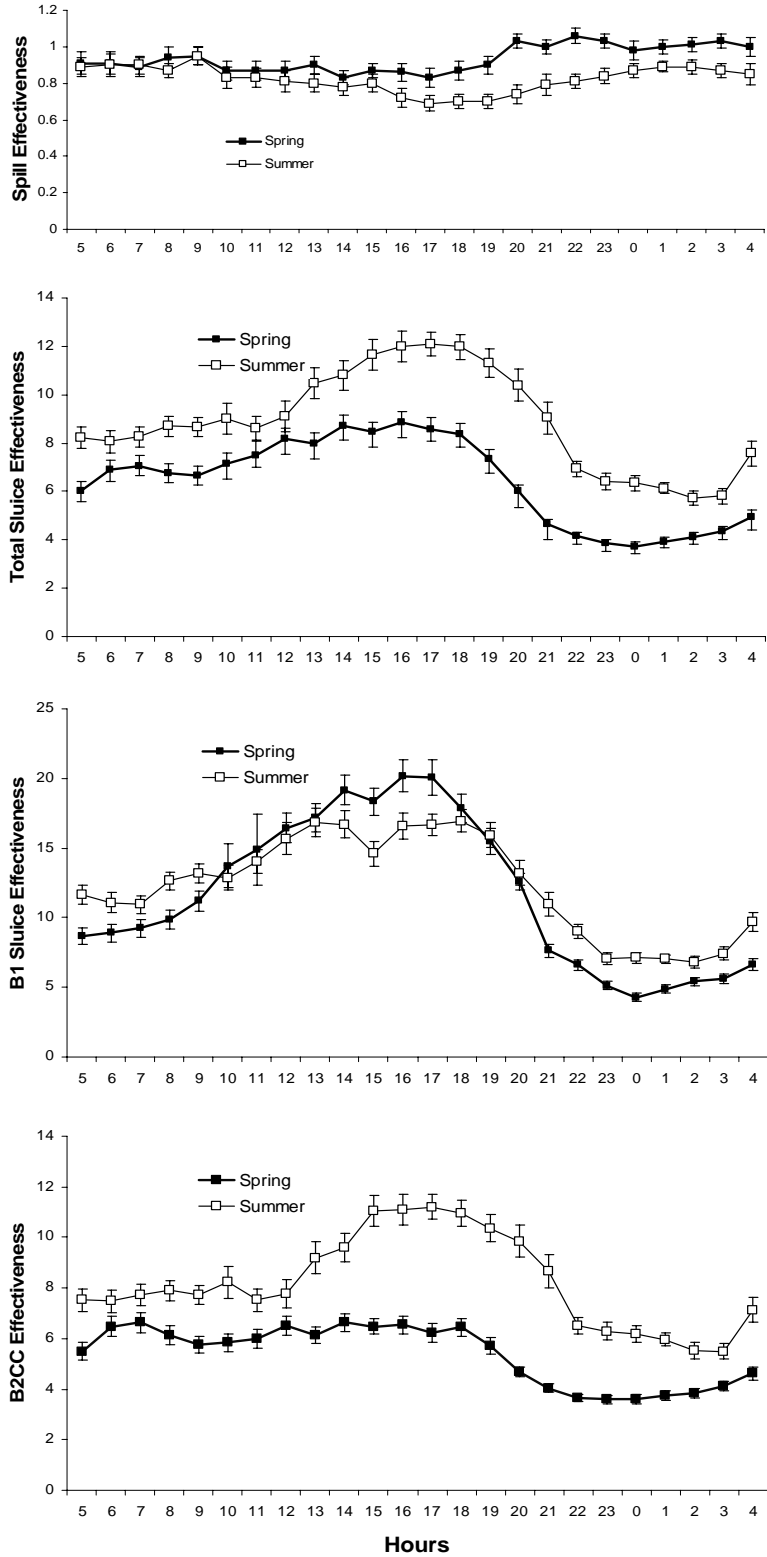

Figure 3.52. Diel Patterns of Spill Effectiveness, Total Sluice Effectiveness (includes B1 Sluice and B2CC), B1 Sluice Effectiveness, and B2CC Effectiveness Relative to the Project in 2004. Error bars represent 95% confidence limits.

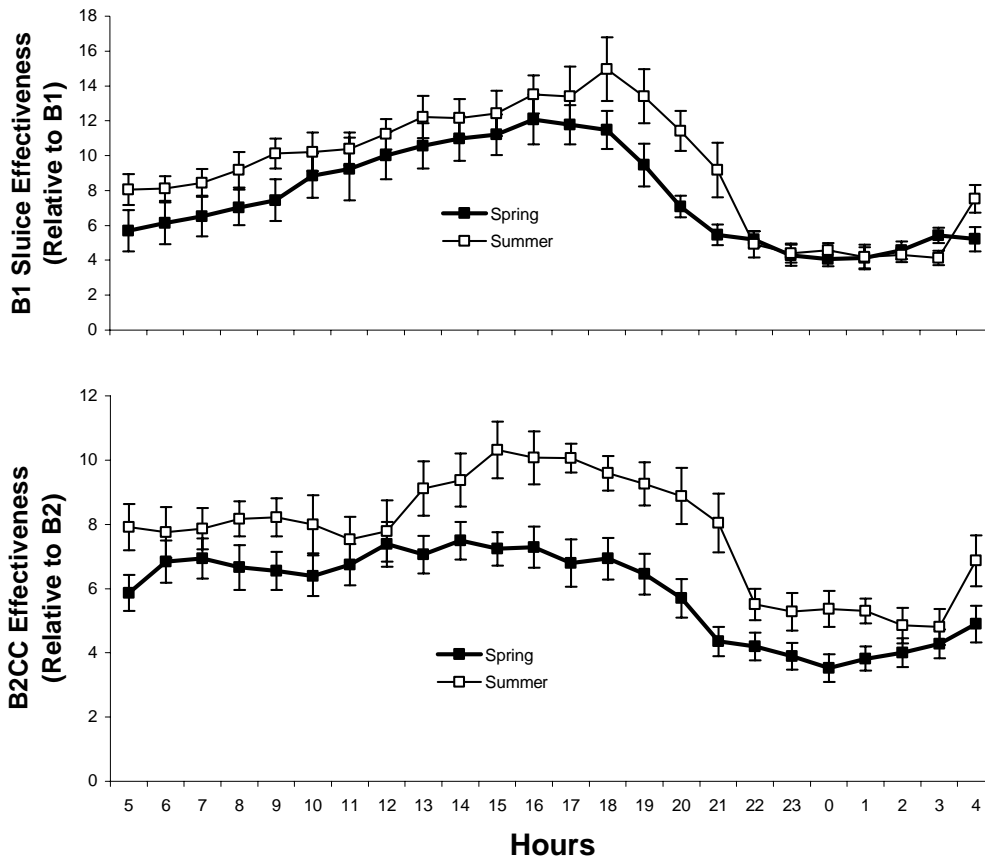

Figure 3.53. Diel Patterns of B1 Sluice Effectiveness Relative to B1 and B2CC Effectiveness Relative to B2 in 2004. Error bars represent 95% confidence limits.

3.8.2.2 Passage Estimates and Guidance Efficiency

3.8.2.2.1 Total Passage

Estimates of total passage through the Project over the diel cycle tracked total project discharge through most hours of the day in both spring (Figure 3.54) and summer (Figure 3.55). In spring, a decreasing trend in both discharge and Project passage is apparent from late morning through 1700 h, and an increase in both discharge and passage is evident through the early evening to peaks at 2100 h. In summer, discharge increased in the late morning and early afternoon but passage did not follow suit, and instead remained relatively stable. Like in spring, summer discharge and passage both increased through the evening period to a peak at 2200 h. During nighttime hours, passage estimates did not in general track Project discharge. In the spring, total guided passage was higher at night than during the day whereas unguided passage revealed no distinct diel pattern other than a gradual decrease throughout the day (Figure 3.54). In the summer, total guided passage also increased at night compared to daytime estimates, and unguided passage indicated some diel patterning with slight peaks at 1100 and 2100 h and a low at 0300 hours (Figure 3.55).

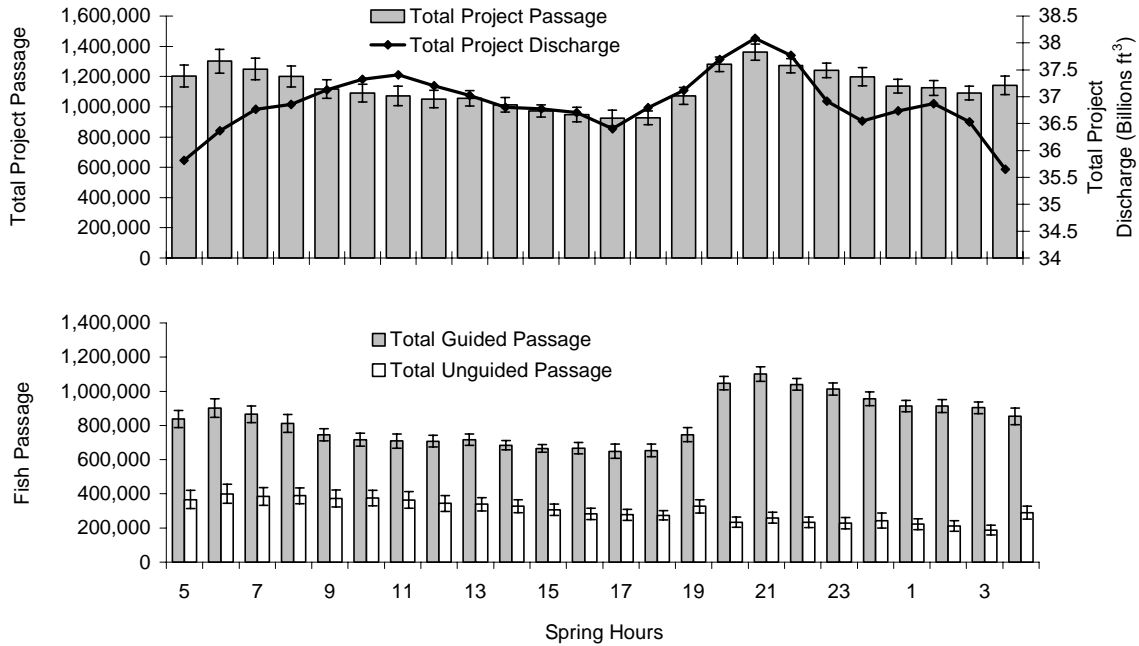

Figure 3.54. Estimates of Diel Trends in Total Project Passage and Total Project Discharge (Top) and Total Guided and Unguided Passage at Bonneville Dam in Spring. Error bars represent 95% confidence limits on fish passage estimates.

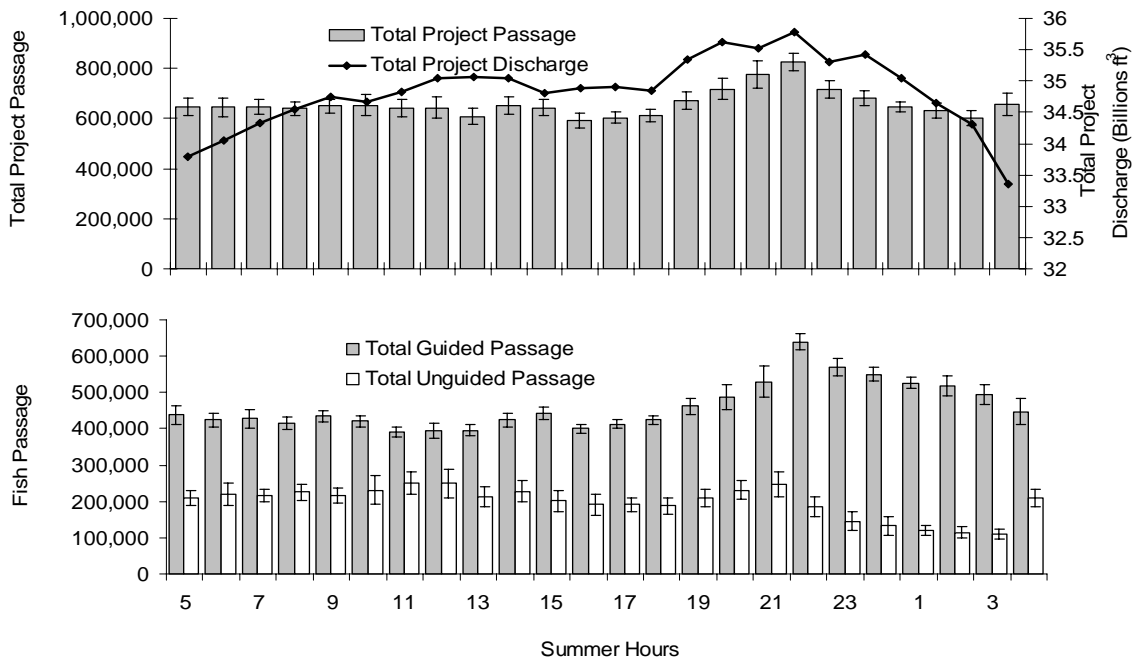

Figure 3.55. Estimates of Diel Trends in Total Project Passage and Total Project Discharge (top) and Total Guided and Unguided Passage at Bonneville Dam in Summer of 2004. Error bars represent 95% confidence limits on fish passage estimates.

3.8.2.2.2 Powerhouse 1

Diel patterns of estimated total passage and turbine passage at B1 closely followed the patterns of hourly discharge in both spring (Figure 3.56) and summer (Figure 3.57). Both total and turbine passage estimates were higher during the day than at night in both seasons. The hourly pattern of B1 sluice passage indicated higher passage during the day than night in both spring (Figure 3.56) and summer (Figure 3.57). Low nighttime passage coincided with the time period of greatest discharge through the B1 sluice in both seasons.

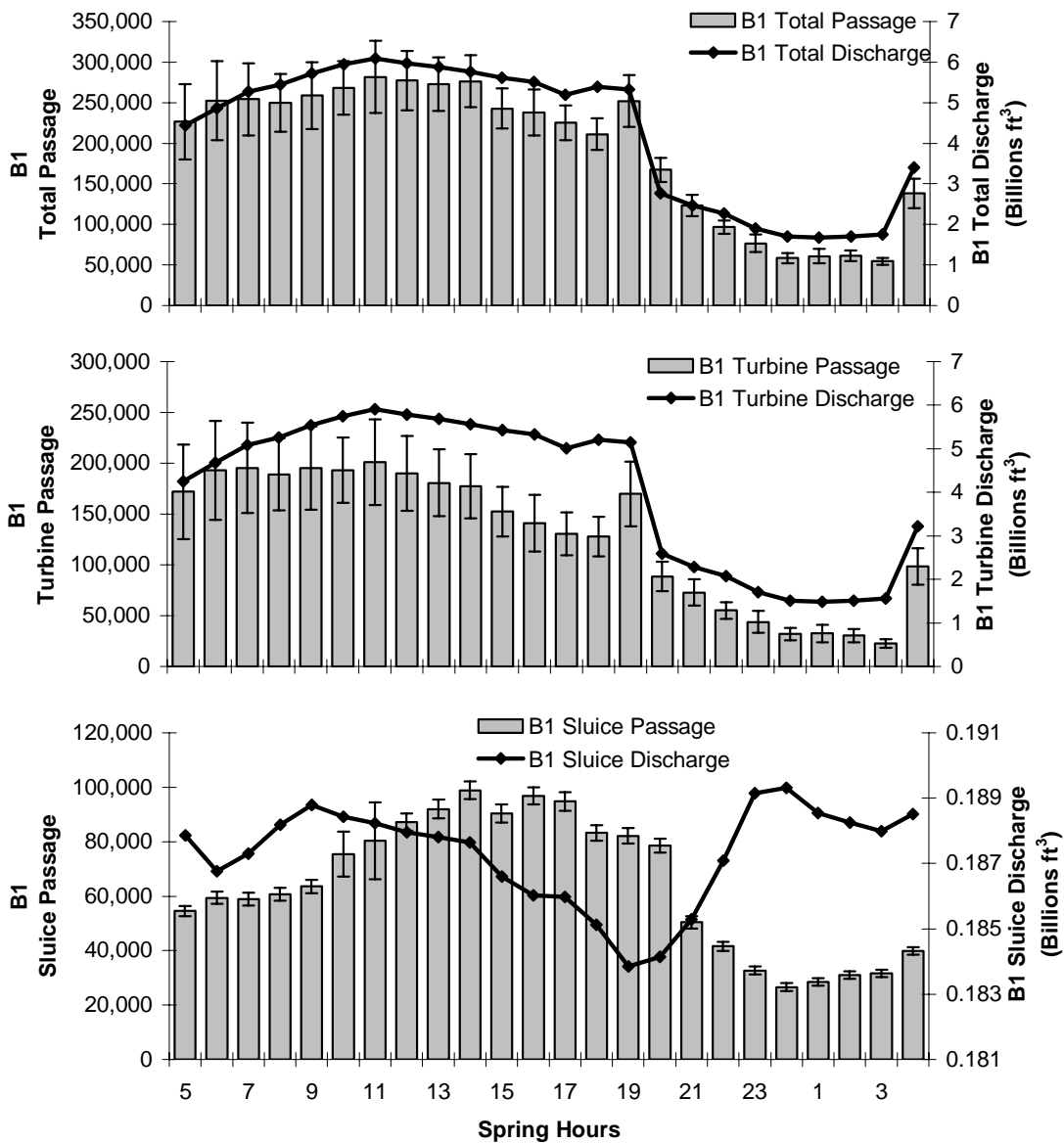

Figure 3.56. Estimated hourly B1 Total Passage, B1 Turbine Passage, and B1 Sluiceway Passag, and Associated Discharge in Spring of 2004. Error bars represent 95% confidence limits on fish passage estimates.

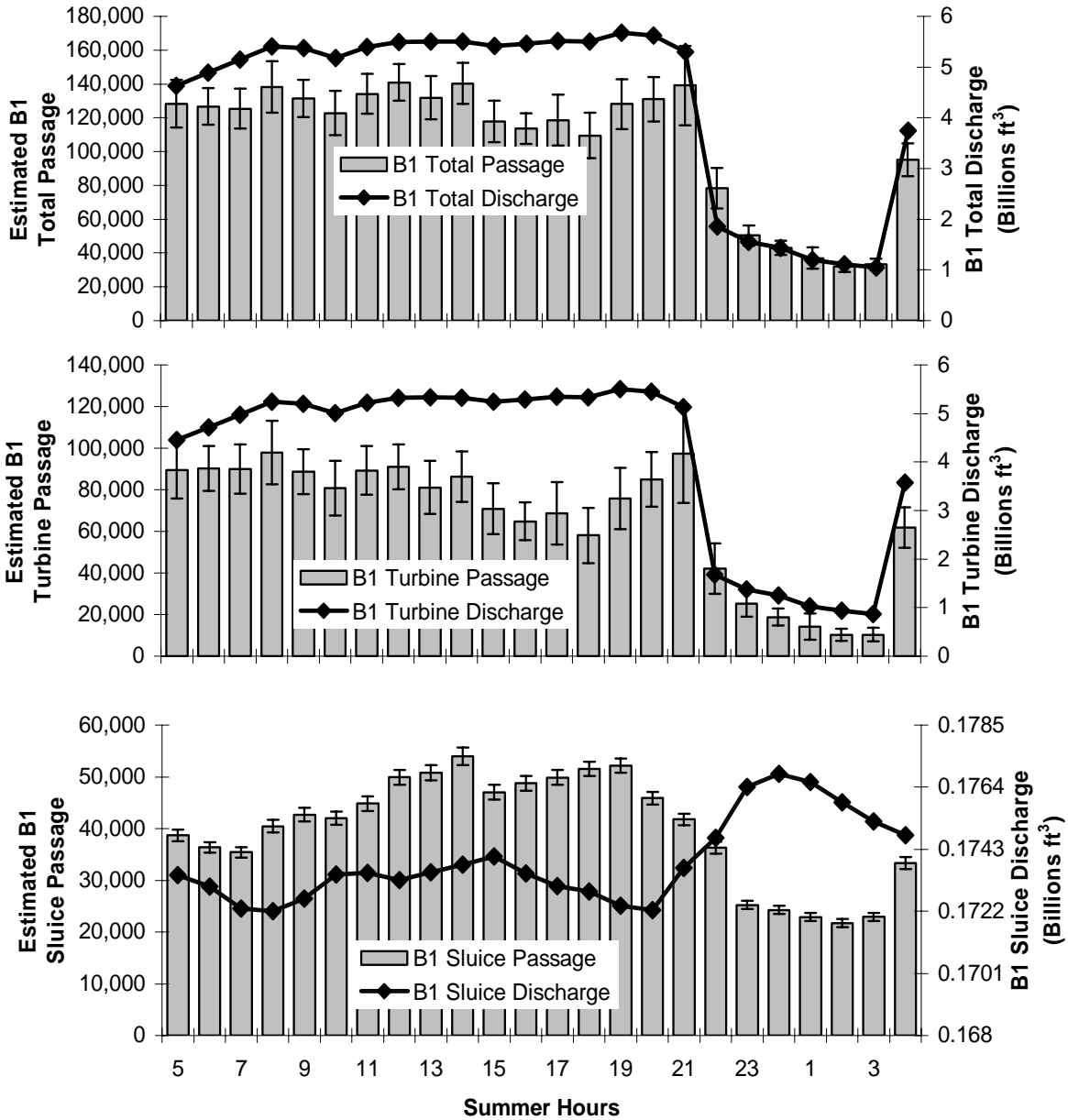

Figure 3.57. Estimated Sum of Hourly Fish Passage at B1, B1 Turbines, and the B1 Sluiceway, and Associated Discharge in Summer 2004. Error bars represent 95% confidence limits on fish passage estimates.

3.8.2.2.3 Spill Passage

The diel distribution of spillway passage closely followed the hourly pattern of spillway discharge during both seasons, with passage and discharge higher during the nighttime hours than during the day (Figure 3.58). On an hourly basis springtime spill passage was generally twice as high as summertime passage. Peaks in spill passage occurred at 2100 and 2200 h in the spring and summer, respectively, and the lowest hourly passage occurred at 1700 h in both seasons.

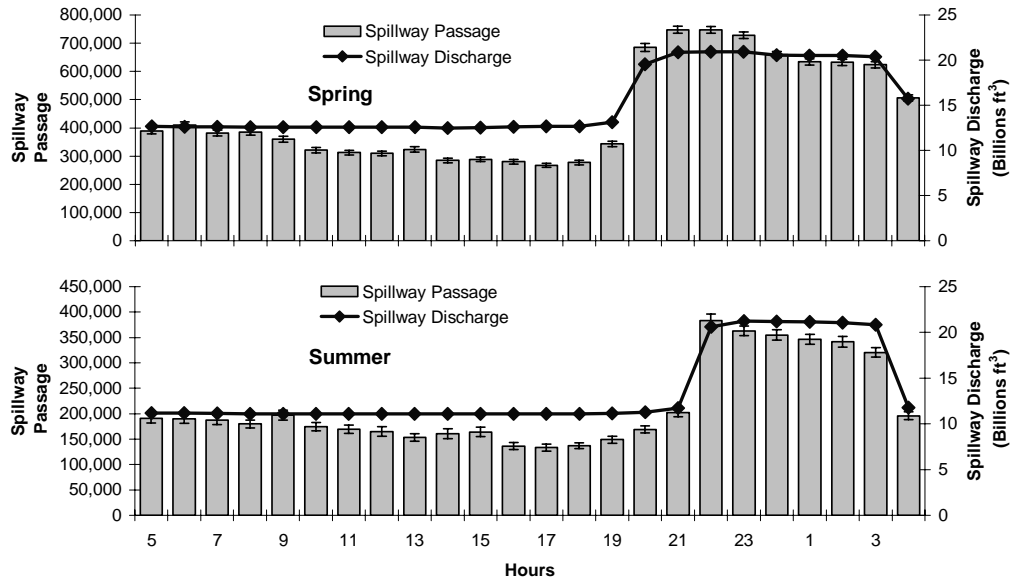

Figure 3.58. Estimated Hourly Spillway Passage and Discharge at Bonneville Dam in Spring and Summer of 2004. Error bars represent 95% confidence limits on fish passage estimates.

There were six days in summer when spill was deliberately held constant for 24 hours, and these conditions afforded us the opportunity to examine diel patterns of spill passage independent of discharge (Figure 3.59). The pattern in Figure 3.59, like diel results from constant discharge during the drought of 2001 (Ploskey et al. 2002c), clearly indicate that the diel pattern observed in Figure 3.58 is not entirely due to increased discharge at night.

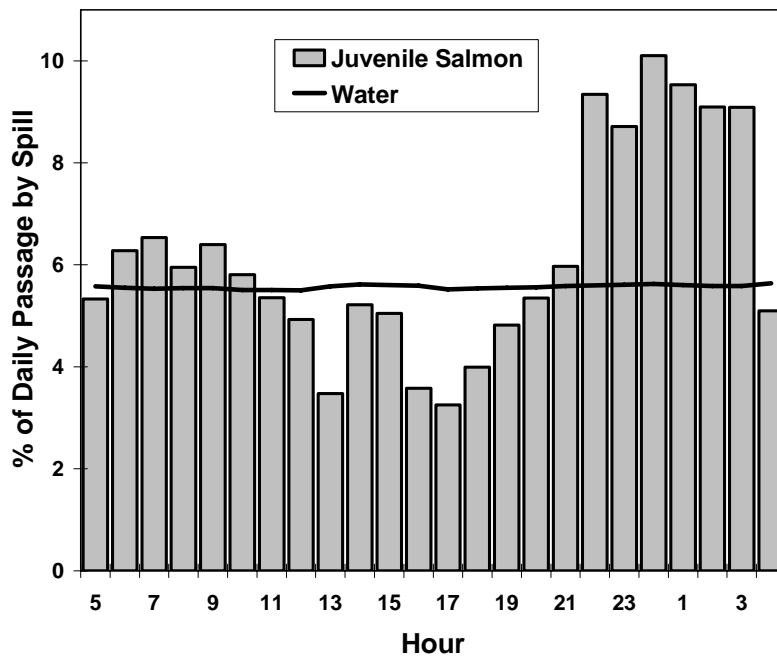

Figure 3.59. Estimated Hourly Spillway Passage and Discharge at Bonneville Dam during Six Days in Summer 2004

3.8.2.2.4 Powerhouse 2

Hourly passage estimates for total and turbine passage at B2 in the spring did not follow associated hourly discharge patterns and indicated little diel patterning other than a slight peak at 0600 h (Figure 3.60). Unlike in spring, there was an apparent relationship between total and turbine passage and associated discharge in the summer, with dips in passage at night coinciding with reductions in discharge (Figure 3.60). In summer, total and turbine passage peaked at 2100 h, and lows occurred at 0300 h. Diel patterns of B2CC passage were dissimilar across seasons, with peaks occurring in the morning in spring (Figure 3.60) and in the afternoon and early evening in summer (Figure 3.61). Diel passage patterns through the B2CC did not follow discharge through the B2CC; highest discharge occurred at night when B2CC passage estimates were lowest relative to other time periods.

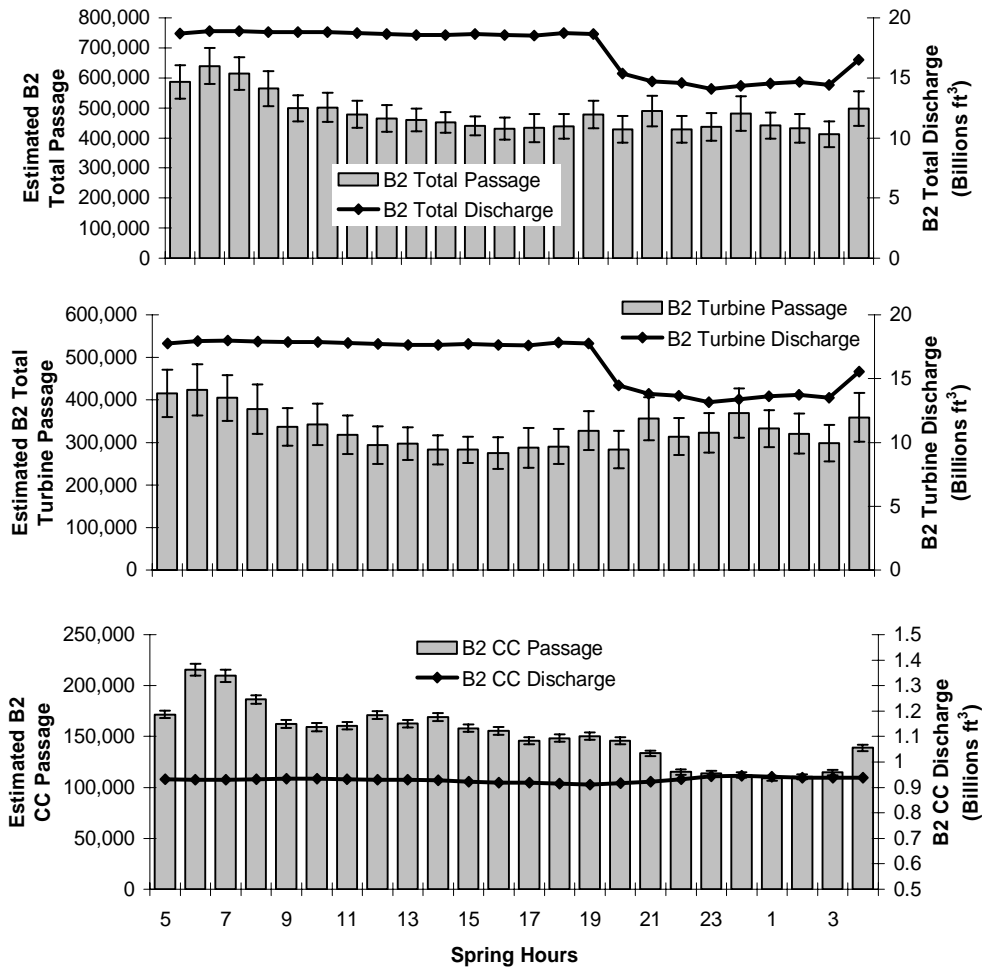

Figure 3.60. Estimated Hourly B2 Total Passage, B2 Turbine Passage (both guided and unguided), and B2CC Passage and Associated Discharge in Spring 2004. Error bars represent 95% confidence limits.

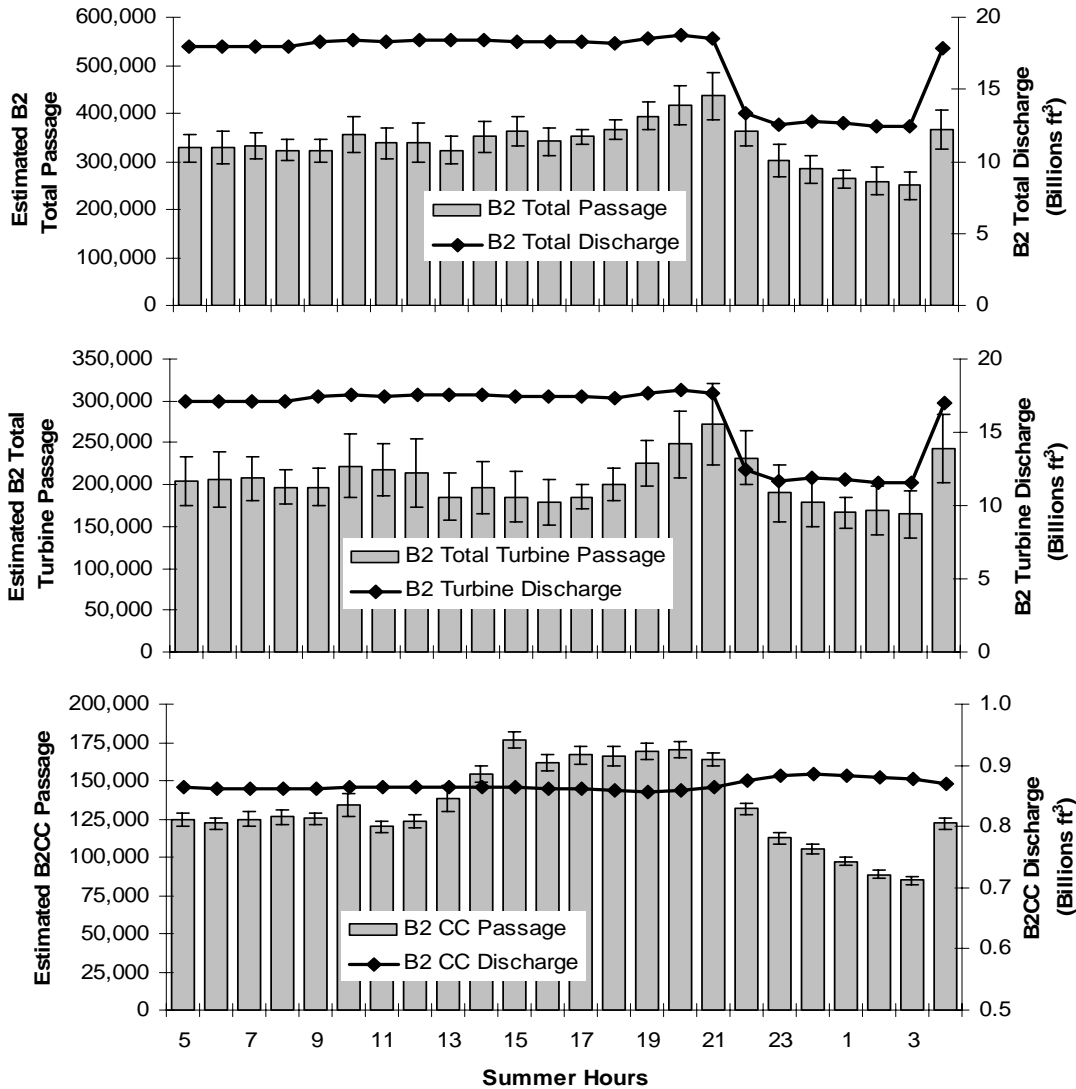

Figure 3.61. Estimated Hourly B2 Total, B2 Turbine, and B2CC Passage and Associated Discharge in Spring 2004. Error bars represent 95% confidence limits.

3.8.2.2.5 Guidance Efficiency

Guided and unguided turbine passage at B2 in the spring revealed little diel patterning other than a slight sustained peak in guided passage during morning hours (Figure 3.62). Similarly, in summer little diel patterning was evident in the unguided passage distribution although two modes of higher passage were apparent, centered on 1100 and 2100 h (Figure 3.62). Guided turbine passage in the summer indicated an increase in passage in the late afternoon culminating in a peak at 2100 h. Unguided turbine passage estimates exceeded those of guided passage for all hours in the summer and all hours in the spring except for 0500-0700 and 1900 h.

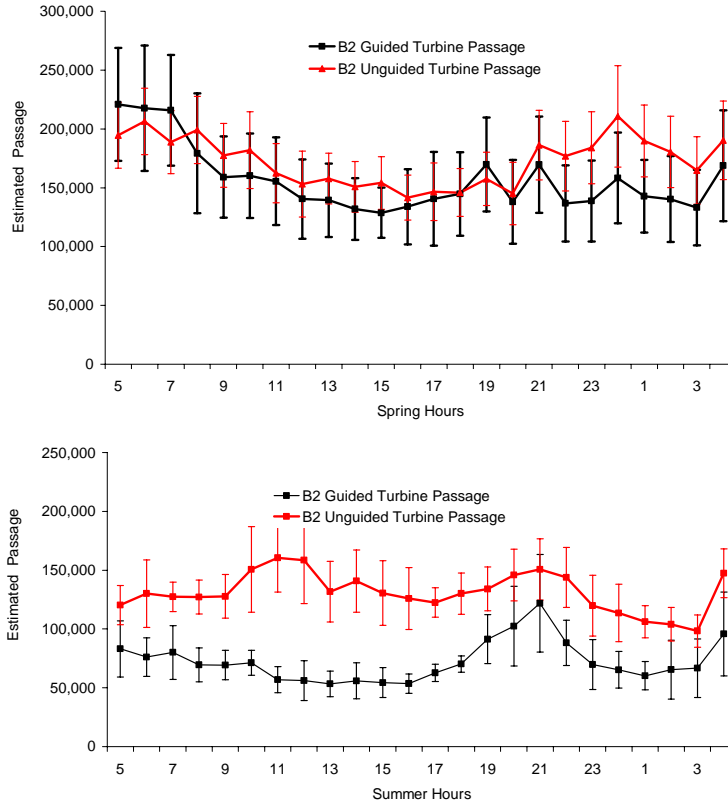

Figure 3.62. Estimated Hourly B2 Guided and Unguided Turbine Passage in Spring and Summer of 2004. Error bars represent 95% confidence limits on passage estimates.

Estimates of diel FGE at B2 indicated a slight decrease in guidance during nighttime hours in spring, although 95% confidence limits suggest that the trend is not significant. There was more of a diel trend in summer with lowest guidance at midday and peak guidance during dusk (Figure 3.63). Spring FGE at B2 was higher than summer FGE, particularly during the day.

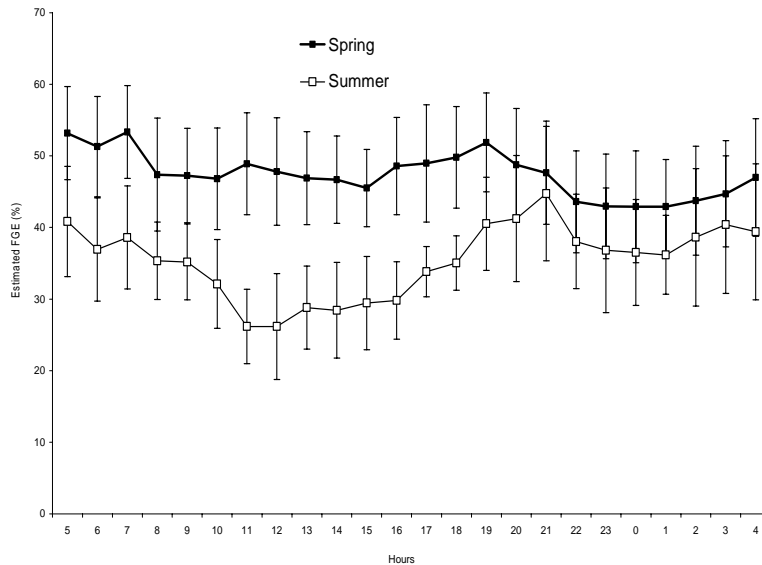

Figure 3.63. Fish Guidance Efficiency (FGE) Estimates for B2 in Spring and Summer. Error bars represent 95% confidence limits on hydroacoustic estimates.

3.9 Fish Guidance Efficiencies of B2 Turbines

Modified Unit 15 provided the highest FGE estimate of any turbine at B2 in spring (59.7%) and summer (51.7%) 2004 (Figure 3.64). Unit 17, the other modified unit at B2, essentially tied for the second highest FGE at B2 in spring (54.1). The FGE estimates for unmodified Unit 16 and modified Unit 17 had overlapping 95% confidence limits (Figure 3.64), and a plot of daily FGE estimates (Figure 3.65) also suggested that small differences in the spring estimates were not significant. In summer, modified Unit 17 provided the third highest FGE estimate (42.4%) at B2, although this estimate probably did not differ significantly from that of Unit 11, given the high variability in the latter estimate, overlapping confidence limits (Figure 3.64), and differences in least square means associated with analysis of variance (Appendix G).

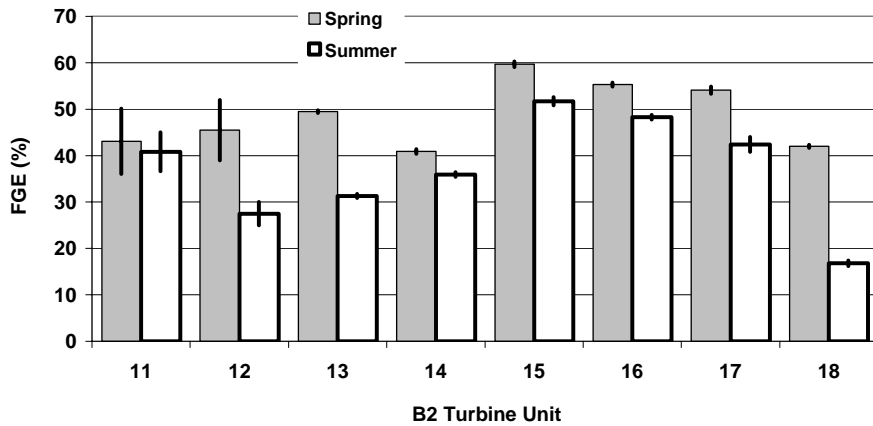

Figure 3.64. Fish Guidance Efficiency (FGE) Estimates for B2 Turbines in Spring and Summer. Error bars represent 95% confidence limits on hydroacoustic estimates.

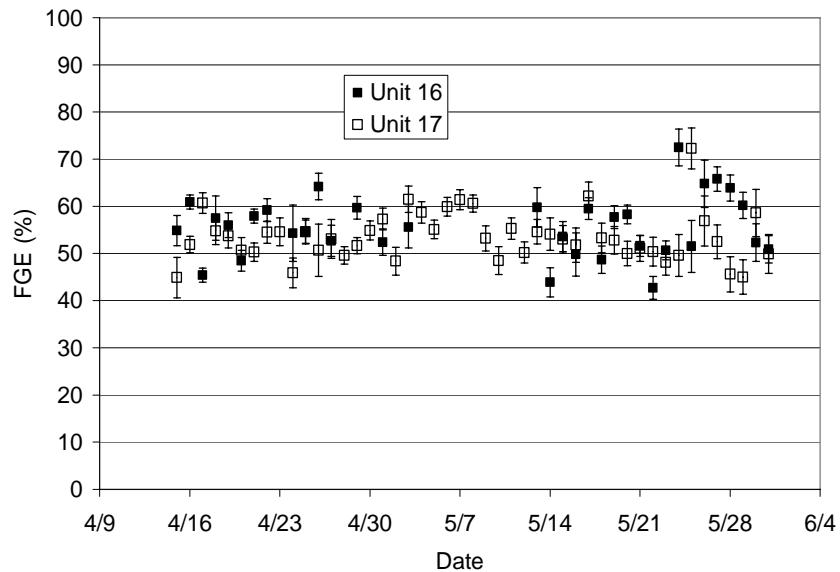

Figure 3.65. Fish Guidance Efficiency (FGE) Estimates for Unit 16 and 17 in Spring and Summer. Error bars represent 95% confidence limits on daily estimates.

When we tested for differences between TIES and No TIE conditions for sampled intakes at Units 15-18, we found that being between TIES provided for an 11% increase in FGE compared with the FGE for intakes behind TIES in both seasons (Figure 3.66; Appendix G). In 2004, Units 15 through 18 had turbine intake extensions (TIEs) on every other intake from 15A through 18B, so some sampled intake openings were between TIES (15B and 17B) while others were behind TIES (16B, 17A, 17C, and 18B). The TIES were removed from Units 11 to 14 in 2004 to facilitate flow toward the B2CC so those intakes were neither between nor behind TIES, and data from those units were not a part of this analysis.

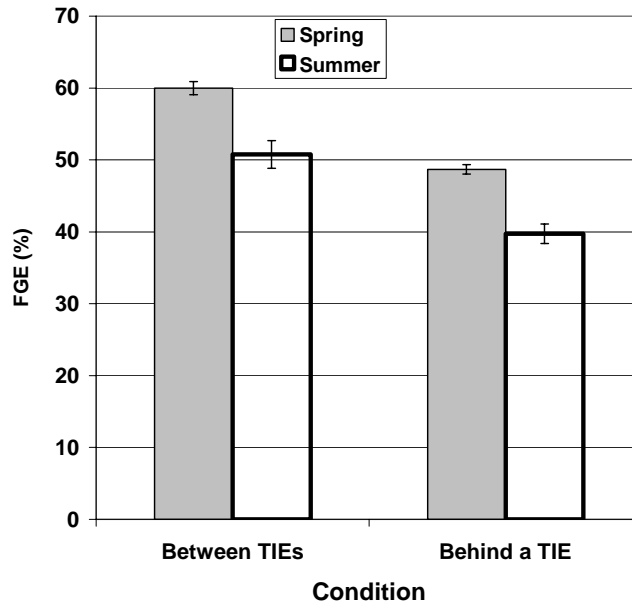

Figure 3.66. Plot of Mean Daily FGE in Spring and Summer by Turbine-Intake-Extension (TIE) Condition.

3.10 B2CC Entrance: Smolt Distributions, Approach, and Fate

3.10.1 DIDSON Tracked-Fish Data

Over 160,500 DIDSON image frames containing fish were manually tracked during processing of the DIDSON data from the B2CC fish approach and fate study. These individual frames made up 7,943 tracks (swim paths) of fish or schools of fish. Of these, 5,333 were tracked during spring data collection: 3,351 during the day and 1,982 at night. In summer, 2,610 fish were tracked: 1,409 during the day and 1,201 at night.

The tracked fish data was merged with the CFD data by operational case based on discharge at B2 only. Cases 3 and 4 were pooled, as were cases 5 and 6 because differences in flow patterns in the B2CC for these pairs of cases were very similar. The remaining four treatments used for our initial analysis did not have equal numbers of tracked fish (Table 3.9). There were few fish tracked during Case 2 and almost none during Case 1 because these hydraulic conditions occurred so rarely (usually at night to accommodate higher spill). Although we had few fish tracks with which to evaluate conditions associated with low powerhouse loading, we were able to use fish-passage data from fixed-aspect hydroacoustics and dam operations data to examine the effect of the percent of B2 flow through the B2CC on the fish-

passage efficiency of the B2CC. Based upon the trend in Figure 3.67, low turbine loading produced the highest proportion of flow through the B2CC and highest B2CC passage efficiencies. What is not obvious from the figure is that B2CC passage efficiency must be zero when the B2CC is closed and 100% when all turbines are off.

Table 3.9. The CFD model scenarios, turbine units on for the CFD model runs and during data collection with the DIDSON, and percent of tracked fish data collected.

Scenario #	Units On	% Data
1	11, 17	< 0.01
2	11, 12, 13, 17, 18	9
3/4	all but 16	26
5/6	all	48
Other	various	17

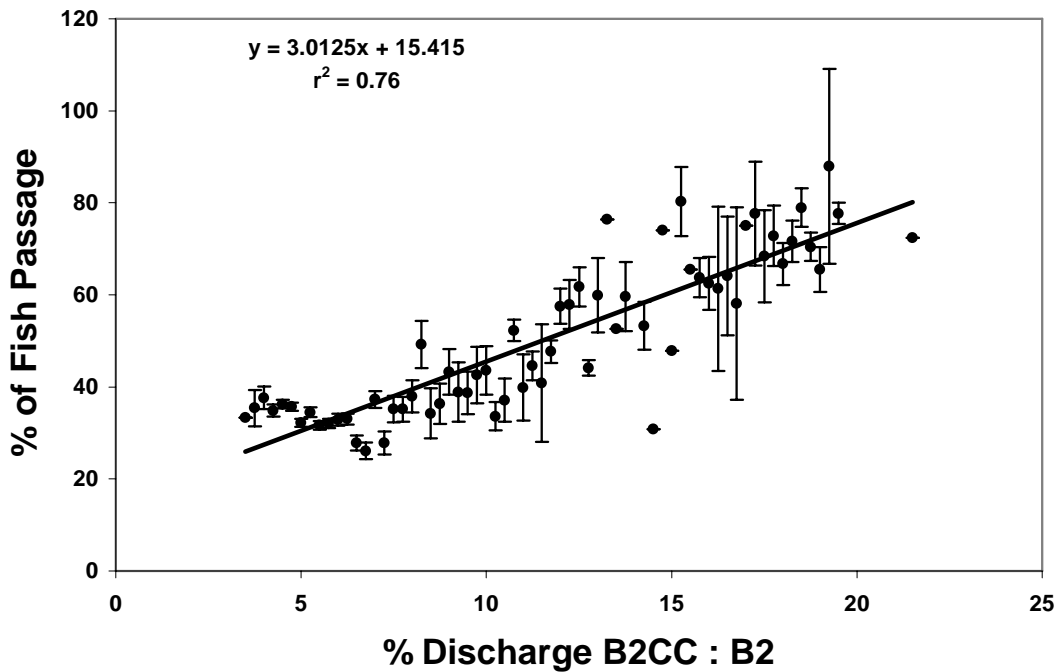

Figure 3.67. Regression of Mean B2CC Fish Passage Efficiency (relative to B2 passage) on Mean Percent Discharge through the B2CC and Relative to B2 Discharge. Vertical bars represent standard errors of the mean estimates.

3.10.2 Comparison of Simultaneous Split-beam and DIDSON Counts

We compared estimates of the number of fish in schools over the same three-hour periods for both DIDSON and hydroacoustic data to validate the performance of the wideband system and the DIDSON. The number of fish in the DIDSON counts was divided by 2 since it was 12-degrees in the vertical plane relative to the 6-degree hydroacoustic transducers. The number of fish detected with wide-band, split-beam hydroacoustics was nearly perfectly correlated with the number detected during simultaneous sampling by the DIDSON (Figure 3.68).

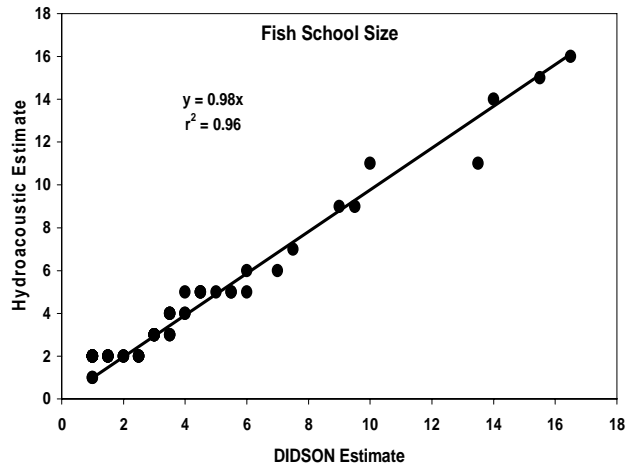

Figure 3.68. Relationship of the Estimated Number of Fish in Schools for both Hydroacoustic and DIDSON Technologies

3.10.3 Horizontal and Vertical Distributions of Fish Entering the B2CC

The coverage of split-beams across the entrance of the B2CC can be visualized by examining a composite plot of all fish detections within the beams in spring and summer (Figure 3.69).

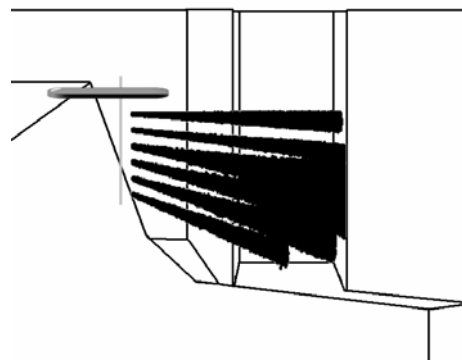

Figure 3.69. Plot of All Fish as Dots Where They Were Detected within Acoustic Sample Volumes of Split-Beam Transducers to Illustrate Sampling Coverage at the B2CC Entrance in Spring and Summer. At low forebay elevations, the bottom two beams were truncated by the sill.

Fish passage at the B2CC was highly skewed toward the surface in both spring and summer (Figure 3.70). The percent of fish passing within 4 ft of the water surface was 63% in spring and 46% in summer. In summer, there was a noticeable peak in passage between the 15- and 20-ft depths, representing about 25%

of the fish passing through the B2CC (Figure 3.70). The vertical distribution trend was similar during the day and night in both seasons, except for the peak in summer at 15 to 20 ft, which was only a daytime occurrence. When we remove summer data collected after July 4, the vertical distribution for summer is very similar to that observed in spring (Figure 3.71).

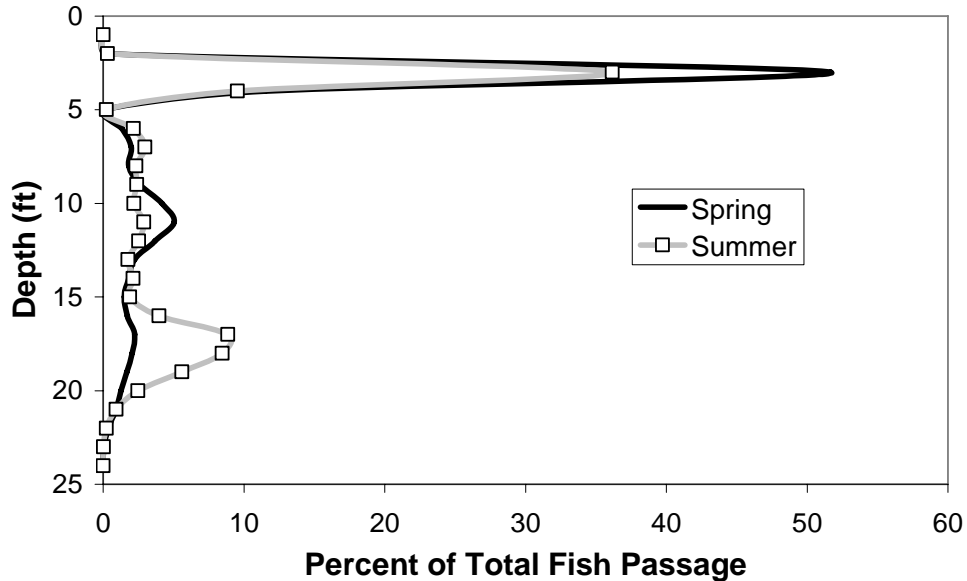

Figure 3.70. Vertical Distribution of Fish Passing through the B2CC in Spring and Summer 2004

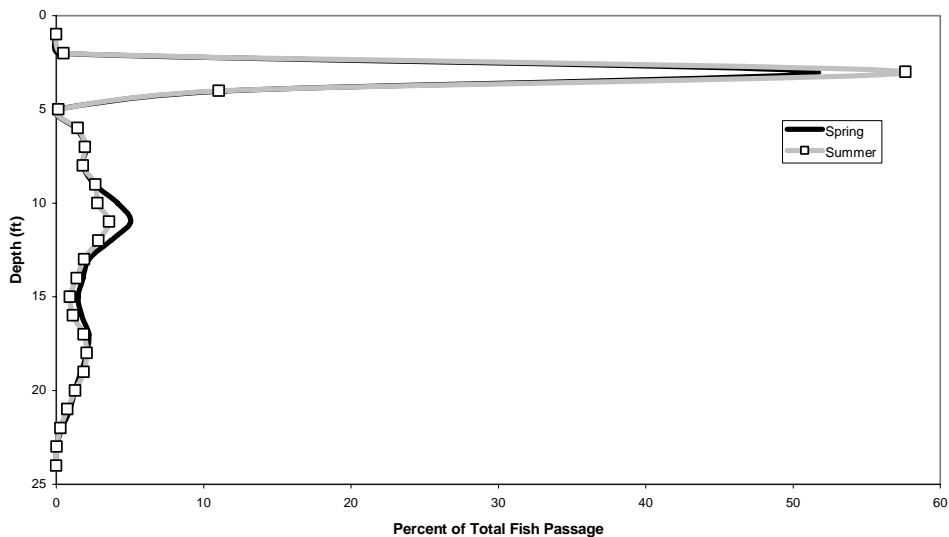

Figure 3.71. Vertical Distribution of Fish Passing through the B2CC in Spring and Summer through July 4, 2004, only

The horizontal distribution of fish passage into the B2CC also had a definite pattern with peak passage near the center of the B2CC entrance in both spring and summer and a second peak toward the south side of the collector in summer (Figure 3.72). The peak on the south side of the entrance in summer disappeared when data collected after July 4 were excluded (Figure 3.73).

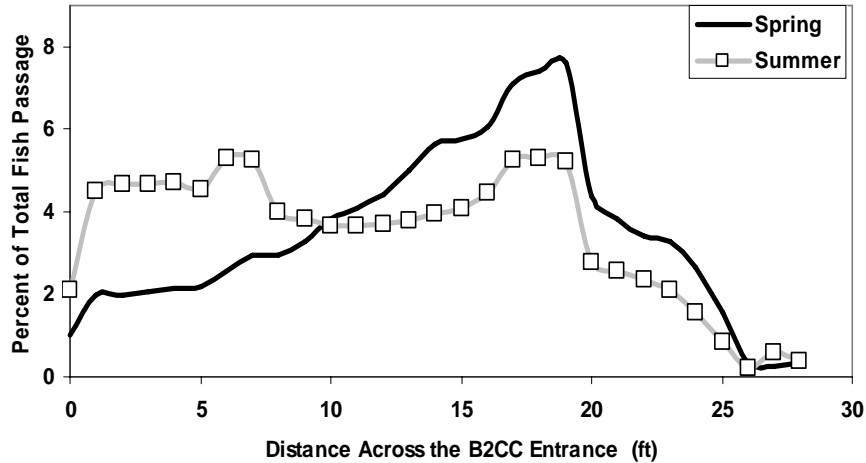

Figure 3.72. Horizontal Distribution of Fish Passing through the B2CC in Spring and Summer, 2004. The entrance narrows to a width of 15 ft, which would correspond to the 10 to 25 ft distance on the x axis. Zero to 10 ft is toward the south of the 15-ft wide opening, and 25 to 30 ft is toward the north.

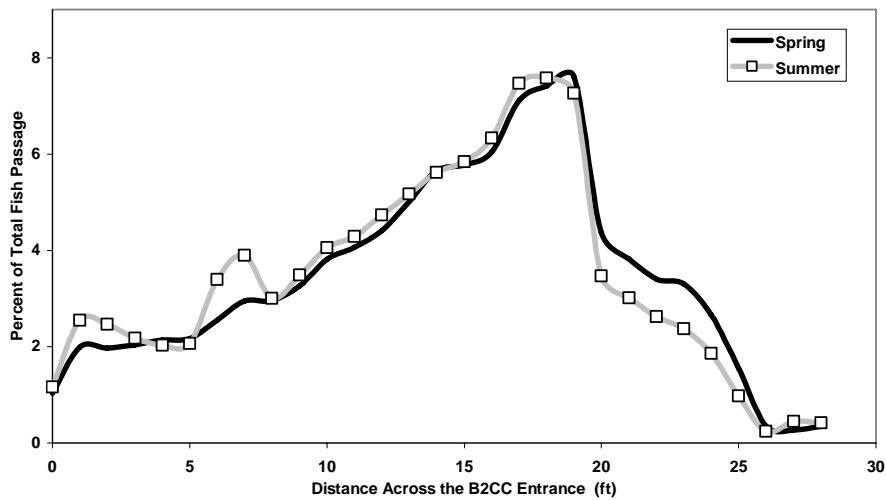

Figure 3.73. Horizontal Distribution of Fish Passing through the B2CC in Spring and Summer through July 3, 2004. The entrance narrows to a width of 15 ft, which would correspond to the 10- to 25-ft distance on the x axis. Zero to 10 ft is toward the south of the 15-ft-wide opening, and 25 to 30 ft is toward the north.

The horizontal distribution for each season (Figure 3.73) was produced primarily by a predominance of fish in the upper 5 ft of the water column (Figure 3.71), but the pattern of horizontal distribution certainly was not consistent among 4-ft depth strata (Figure 3.74). Trends in spring and summer were similar within depth bins, except for some anomalous peaks toward the south end of the entrance at depths of 9 to 20 ft in summer, which could be removed by dropping data collected after July 4. Over 95% of the fish passed in the upper 4 ft of the water column, which explains why the trend in the top plot of Figure 3.74 is very similar to the trend in the composite horizontal distribution (Figure 3.73).

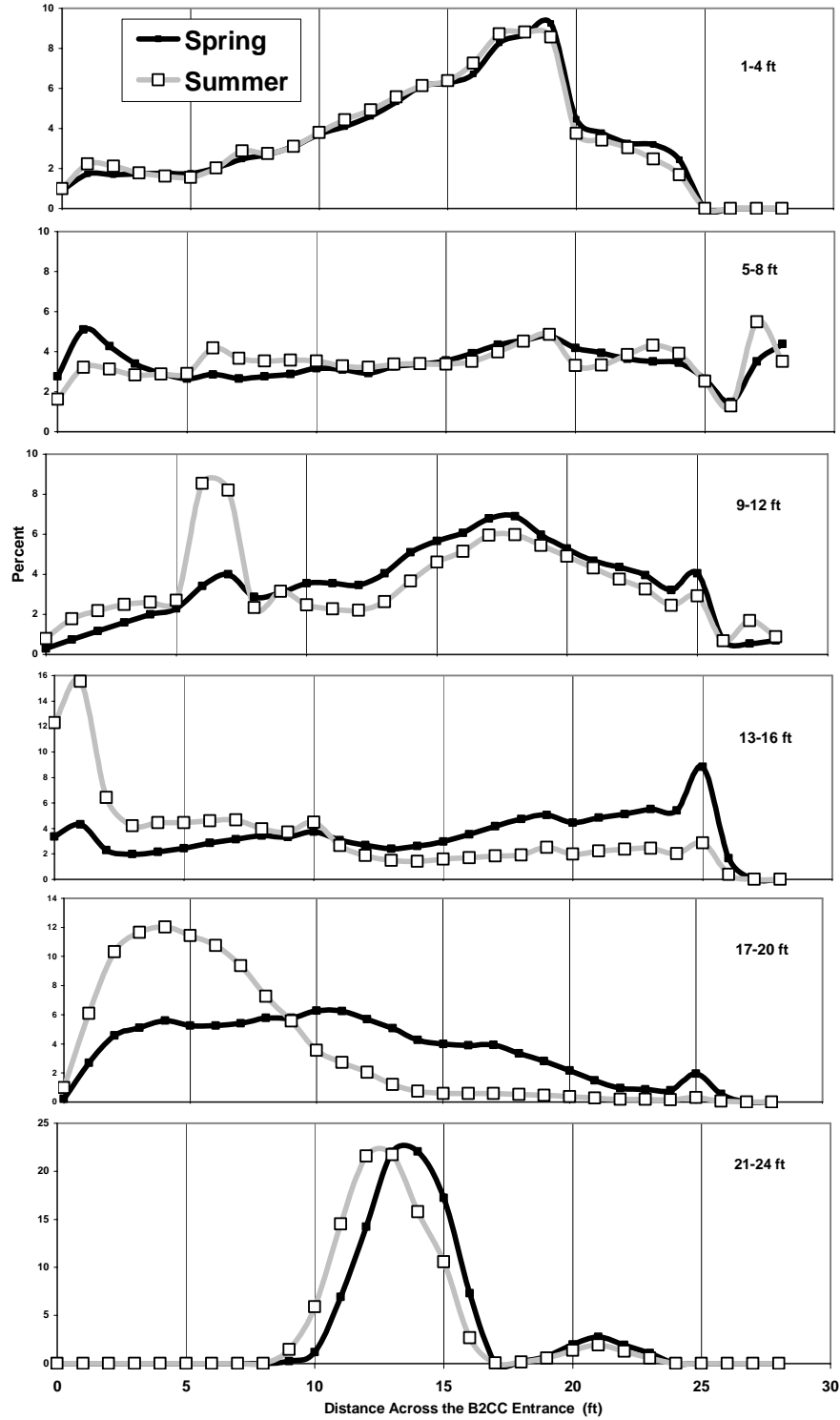

Figure 3.74. Horizontal and Vertical Distribution of Smolt-Sized Fish Upstream of the B2CC Entrance in Spring and Summer 2004. The entrance narrows to a width of 15 ft, which would correspond to the 10 to 25 ft distance on the x axis. Zero to 10 ft is toward the south of the 15-ft-wide opening, and 25 to 30 ft is toward the north.

3.10.4 DIDSON Study of Approach and Fate

The fish-approach-and-fate study based upon sampling with the DIDSON provided valuable information about the probability of collection by the B2CC. The DIDSON was located about 15 ft to the east of the entrance (Figure 3.75). A composite of swim paths of smolts approaching the B2CC in spring and summer helps to visualize the area sampled (Figures 3.76, 3.77, and 3.78). The maximum range of detection from the DIDSON was only about 62 ft.

Although the fate of approaching smolts varied a little among day, night, and season, the fate of approaching smolts was consistently determined by initial location and bulk flow in the vicinity of the B2CC (Figure 3.79). Time of day affected the number of smolts approaching the B2CC, with more smolts approaching during the day than at night (Figures 3.60 and 3.61), but had little effect on fate. Even hydraulic patterns based upon CFD modeling of B2 from 70% to 100% loading of turbines had no discernable effect on fate based upon initial smolt location. After several hours at lower loadings, CFD modeling indicated that the eddies to the south and north of the B2 forebay weakened and dissolved so there was little competition between the B2CC and the south eddy for approaching smolts. The realization of these Case 1 and 2 conditions was rare because there were only a few hours per night of low turbine loading (to accommodate spill) and 1 to 2 hours of low loading were required for flow conditions to stabilize with weak or no eddies. Consequently, we had few fish tracks at the B2CC for Case 1 and 2 scenarios.

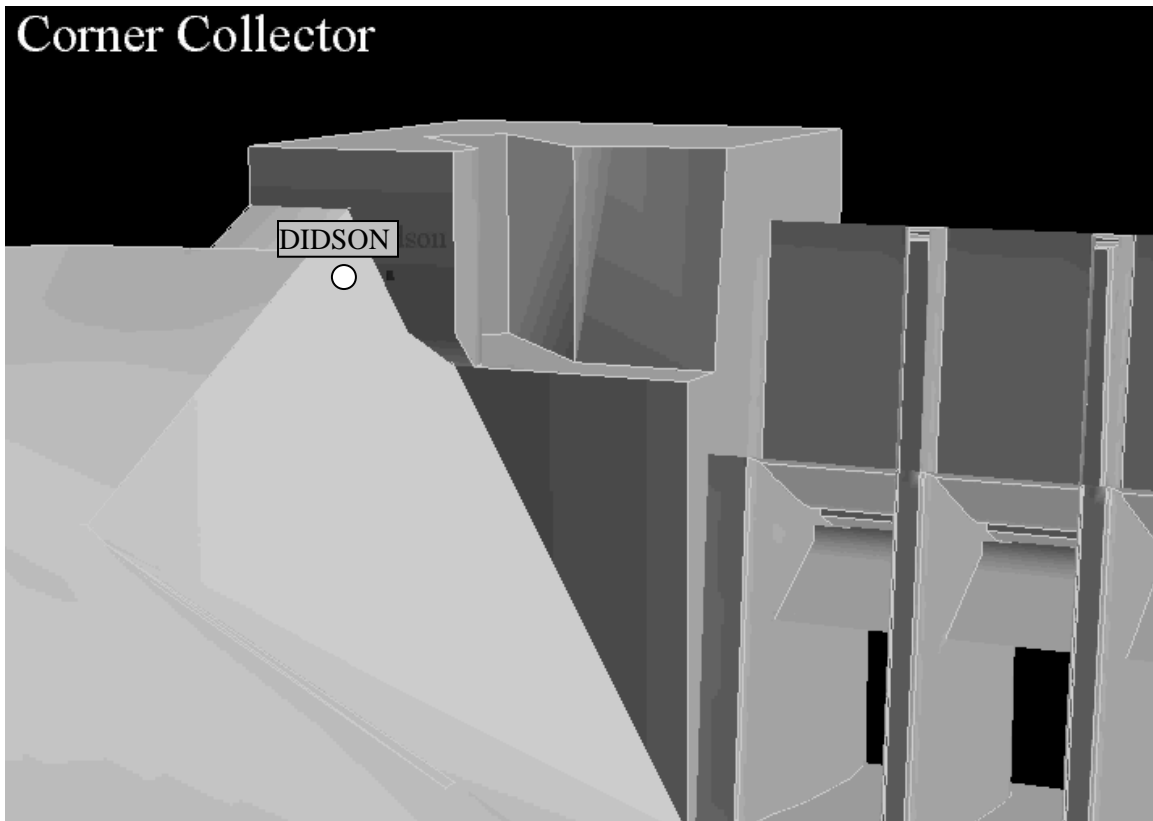

Figure 3.75. Southwest View of the B2CC Entrance Just to the Right of the DIDSON Location (white circle) and Bathymetry in the Vicinity of the B2CC Entrance. Intakes A and B of Unit 11 with deployed submerged traveling screens appear in the lower right corner.

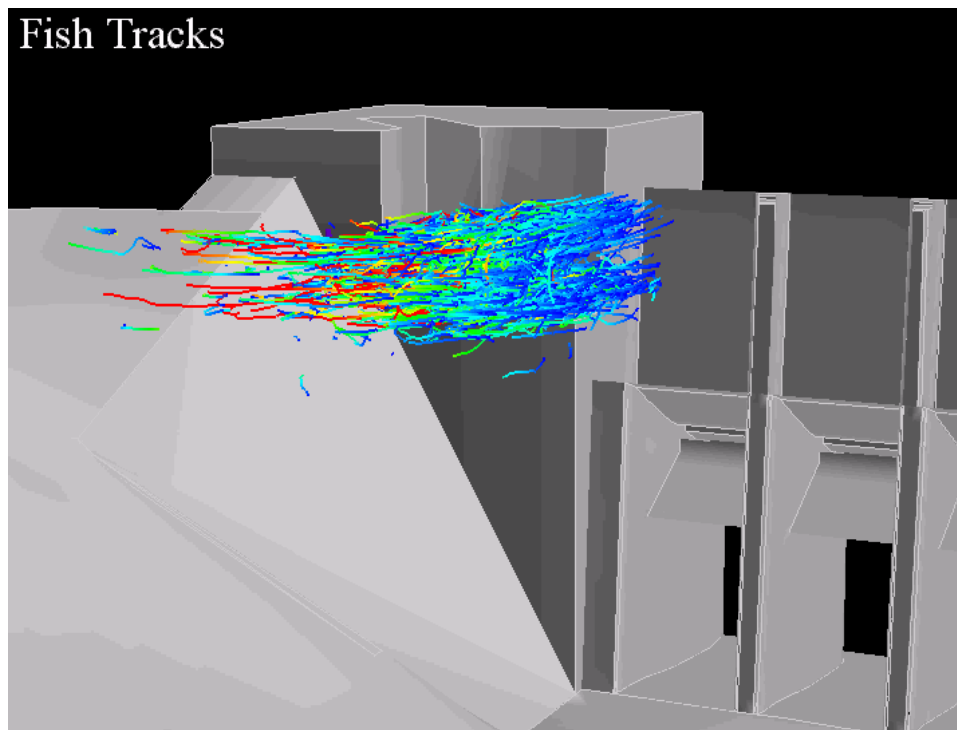

Figure 3.76. Same Southwest View of the B2CC Entrance as Figure 3.75, but Showing a Composite of Smolt Tracks Acquired with the DIDSON in Spring and Summer 2004.

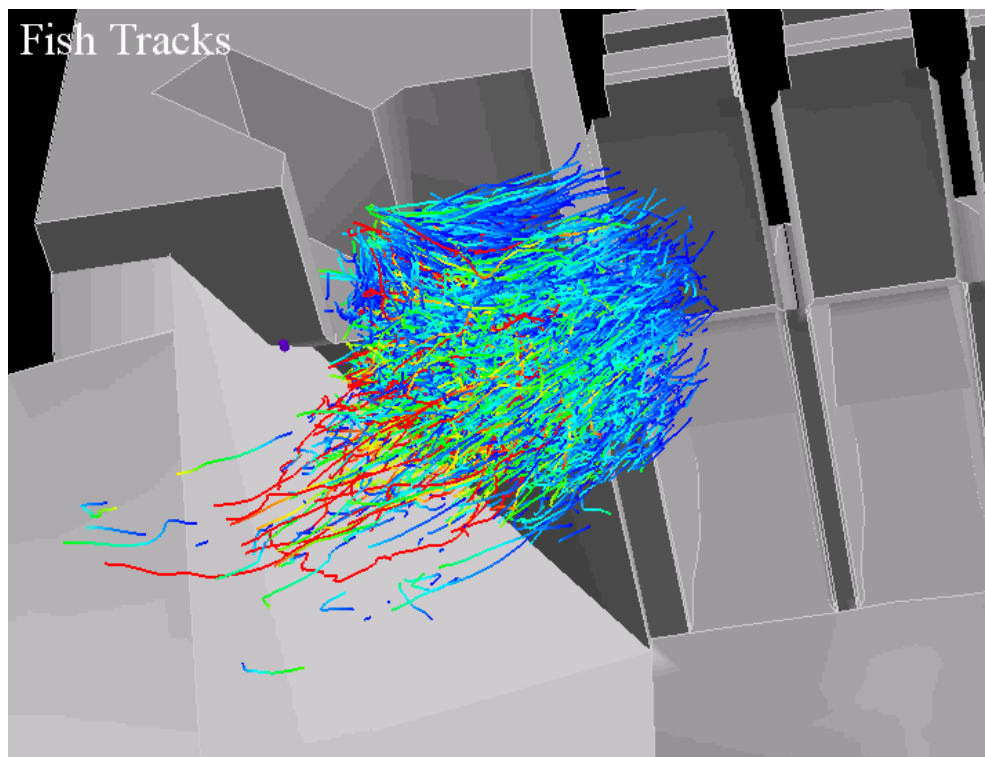

Figure 3.77. Forty-Five Degree Downward Angle and West View of Fish Tracks Approaching the B2CC. Track color indicates duration from short to long, where dark blue is the shortest, followed by light blue, green, yellow, and red (the longest).

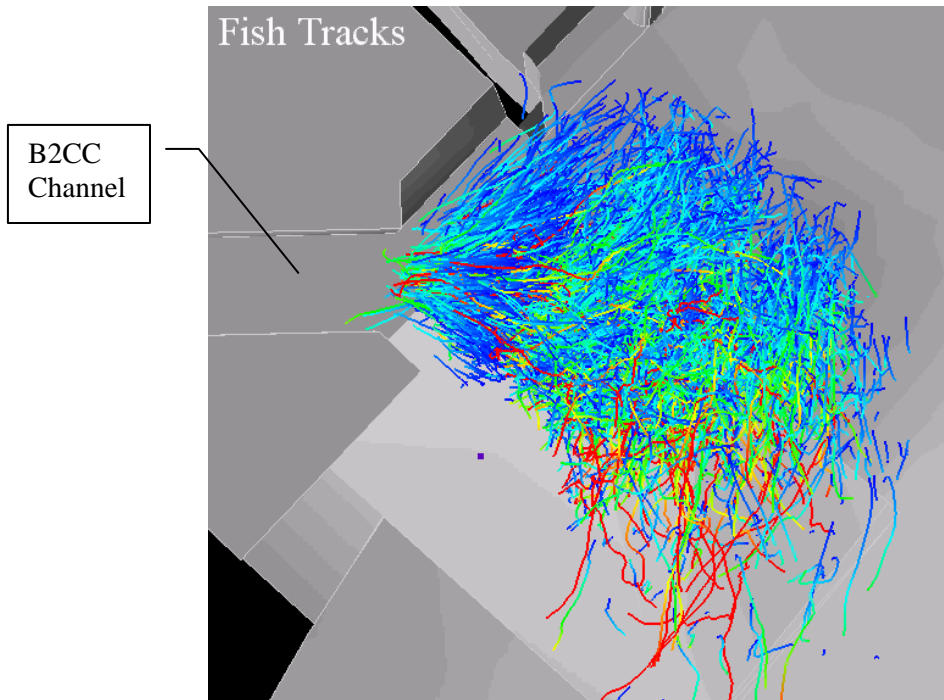

Figure 3.78. Plan View of Fish Tracks Upstream of the B2CC Entrance at B2. Track color indicates duration from short to long, where dark blue is the shortest, followed by light blue, green, yellow, and red (the longest).

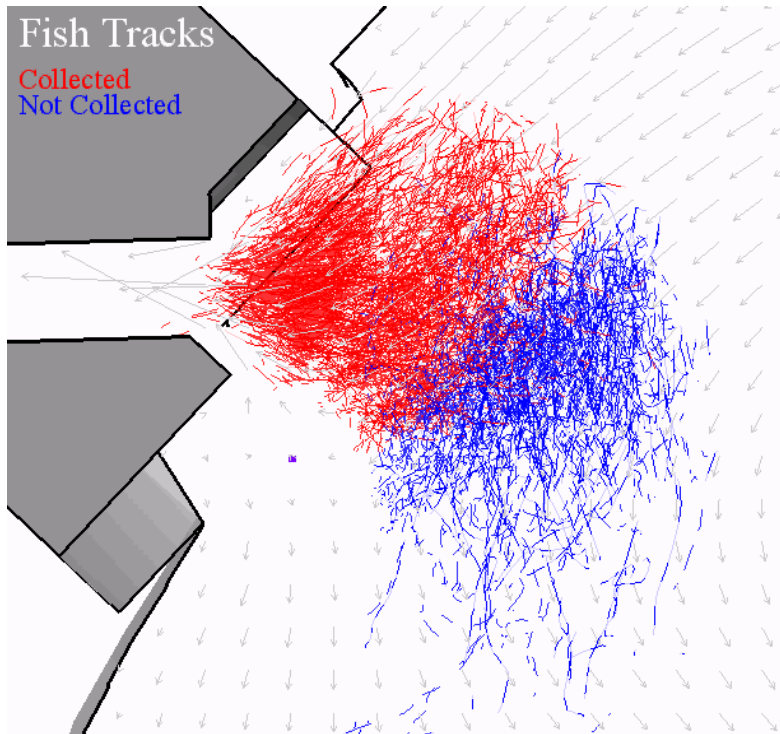

Figure 3.79. Plan View of Fish Tracks Upstream of the B2CC Entrance at B2. Gray arrows are flow vectors based upon CFD modeling. Red tracks are those whose fate was to enter the B2CC, and blue tracks are those whose fate was to enter the south eddy.

Fish were tracked during 10 spring days and 7 summer days. The number of 0.5 s movements (29,297 versus 15,206) used for the Markov chain analyses was greater in spring than summer and reflected the number of fish tracked during each period (Table 3.10). Less than 2% of the 594 cells used in the Markov chain transition matrix required interpolation in Spring and less than 3% in Summer. The numbers of cells interpolated were 6 (Spring Day), 9 (Spring Night), 12 (Summer Day) and 16 (Summer Night). Track lengths were longer during the day than they were at night. As a result, the average per-track measures used for the Markov analyses were greater during the day. Some track lengths were very long, the maximum of 258 ft occurred in spring during the day. Median velocity was about 3 ft/s, but somewhat slower at night.

Table 3.10. Characteristics of the Data Used in Markov Chain Analyses of Fish Movement.

Period	Dates	Fish Tracks (N)	0.5 s Moves (N)	Median Velocity (ft/s)	Median Track Length (ft)	Max Track Length (ft)	Average Measures Per Track
Spring Day	4/26 to 5/26	3,453	18,748	2.94	16.5	258	5.43
Spring Night	4/26 to 5/26	2,328	10,549	2.59	10.8	144	4.53
Summer Day	6/07 to 6/16	1,502	8,696	3.18	16.3	181	5.79
Summer Night	6/06 to 6/17	1,347	6,510	2.68	12.4	133	4.83

Figures 3.80 and 3.81 show the sums of each spatial cell's fates (states) over the corner collector and southwest absorbing edges. The largest passage probabilities were into the corner collector for both seasons (Table 3.11). No stagnation occurred because all fish moved to the edges of the volume analyzed. Very little northeast movement along the dam face was detected.

Figure 3.82 shows that the smallest fish entrainment zone (FEZ) averaged 31.2 ft from the dam based on passage fates of B2CC plus southwest. The FEZ, defined as the point where 90% of the fish are entrained, varied a few feet depending upon season and time of day: Spring Day was 34 ft, Spring Night was 32 ft, Summer Day was 30 ft, and Summer Night was 26 ft.

Table 3.11. Relative Fates, Probabilities of B2CC Passage, from a 44 ft X 54 ft Area near the B2CC Based on a Markov Chain Analysis.

Time Frame	Southwest	Northeast	Reservoir	B2CC	B2CC Plus Southeast
Spring Day	0.07026	0.00097	0.23867	0.69010	0.76036
Spring Night	0.05670	0.00320	0.17977	0.76032	0.81702
Summer Day	0.09307	0.00106	0.26574	0.64013	0.73320
Summer Night	0.05603	0.00000	0.33399	0.60999	0.66601

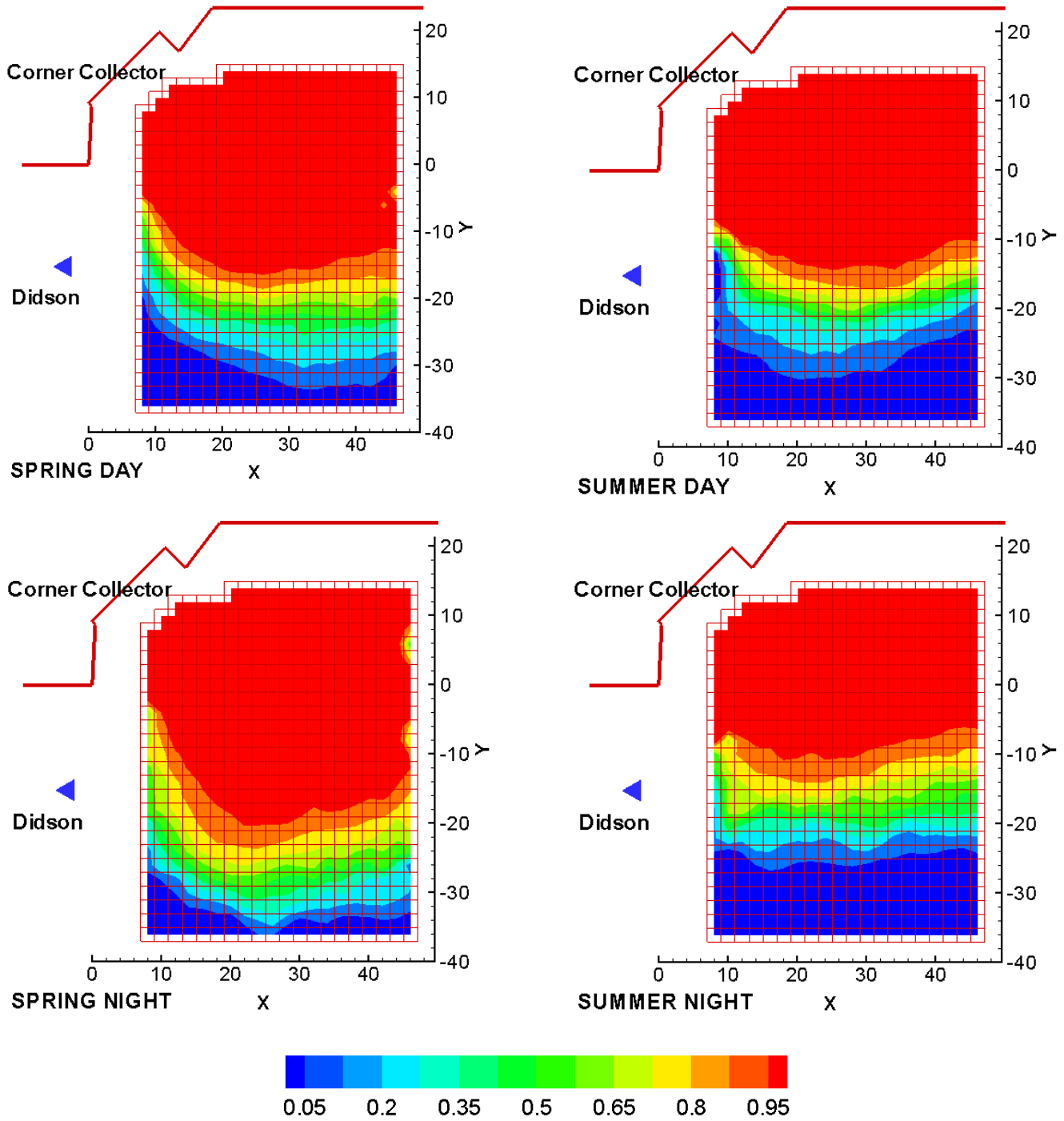

Figure 3.80. Contours of Fish Passage Probabilities at the B2CC for Spring and Summer 2004, Day and Night. Probabilities above are shown for the collector fates, and x- and y-scales are in feet.

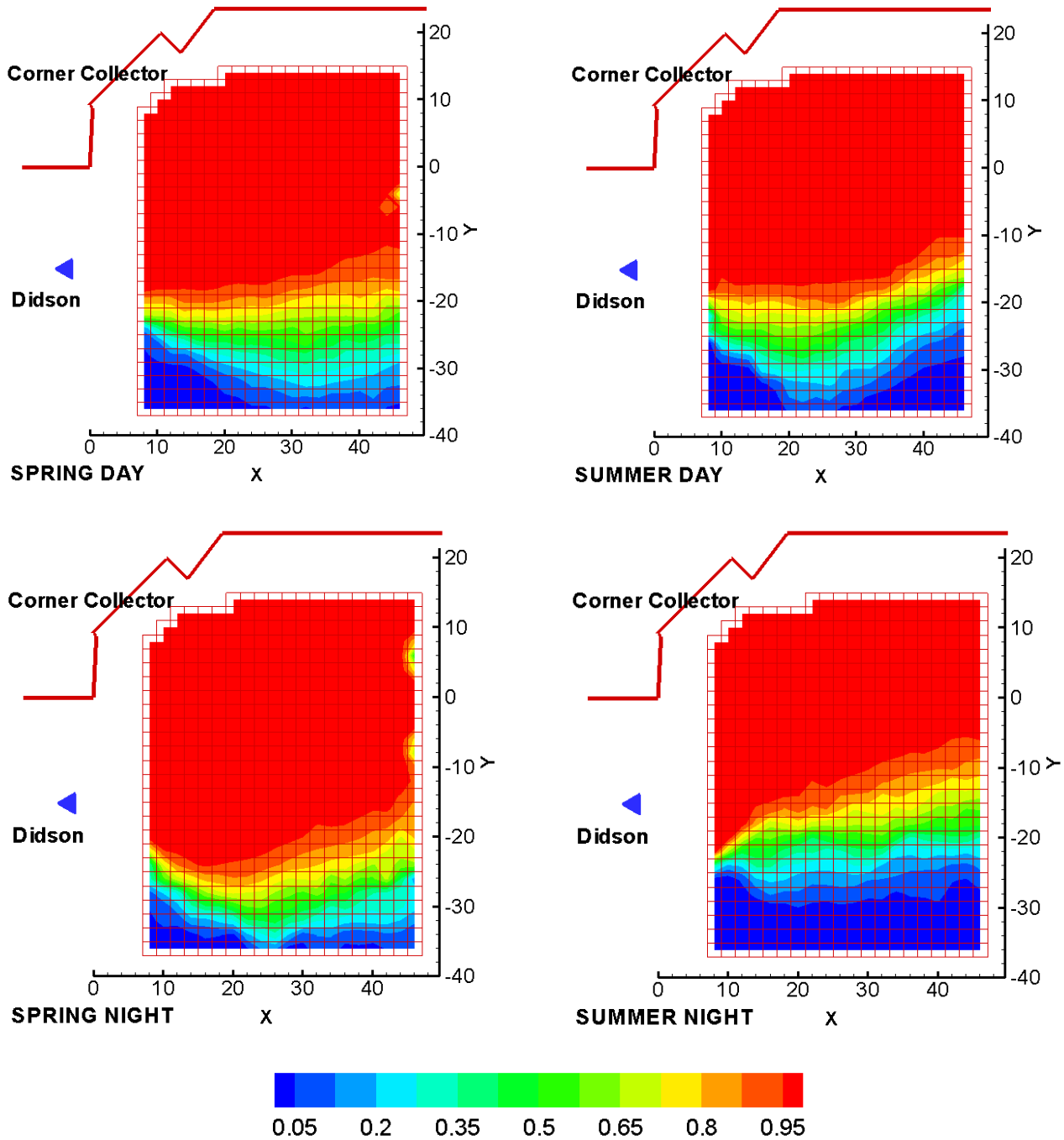

Figure 3.81. Contours of Fish Passage Probabilities at the Bonneville Dam Corner Collector for Spring and Summer 2004, Day and Night. Probabilities above are shown for the Collector+Southwest fates. x- and y-scales are in feet.

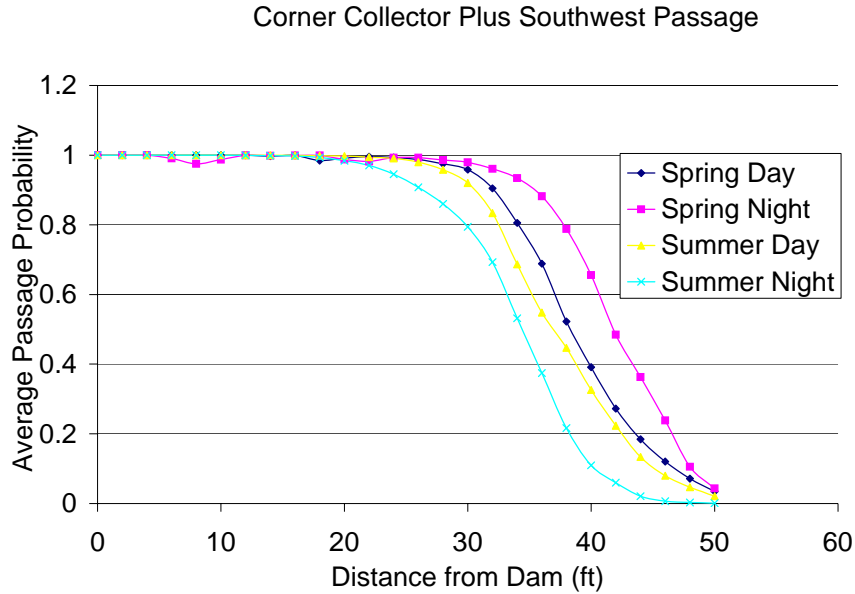

Figure 3.82. Average Corner Collector Plus Southwest Fate by Distance from Dam

On average, smolts within about 35 ft of the powerhouse face and up to about 47 ft north of the B2CC entrance had a >90% probability of entering the collector (Figure 3.82). However, the entrance probability declined quickly for smolts detected > 35 ft east of the dam face and was about 80% at 38 ft, 70% at 40 ft, 60% at 44 ft, and 20% to 30% at 45 to 50 ft (Figure 3.81 and 3.82). Smolts detected within about 40 ft of the B2 dam face and due east of the B2CC entrance also had a high probability of passing south into the eddy.

The smolt vector analysis at the B2CC provided additional independent estimates of fate probabilities for the B2CC and south eddy (Appendix H). The highest vector analysis probabilities for smolts entering the B2CC were about 15% lower than those provided by the Markov Chain analysis, which provides estimates that comport well with fates defined by the end location of the complete tracks.

3.11 Gap Losses at B2 Traveling Screens

3.11.1 Discharge and Forebay Conditions

During the gap-loss sampling, discharge at B2 turbines 13 and 17 varied by as much as 6,300 cfs (Figure 3.83). Mean discharge for all sampling dates varied from 11,960 cfs on May 7 to a high mean daily discharge of 15,790 cfs on May 26. During the study, forebay elevation varied by as much as 1.4 ft within days and by about 2 ft among daily highs and lows (Figure 3.84). During the period of the diel evaluation of gap loss on May 25-26, 2004 the forebay elevation varied by 1 ft from 74.9 to 75.9 ft (Figure 3.85).

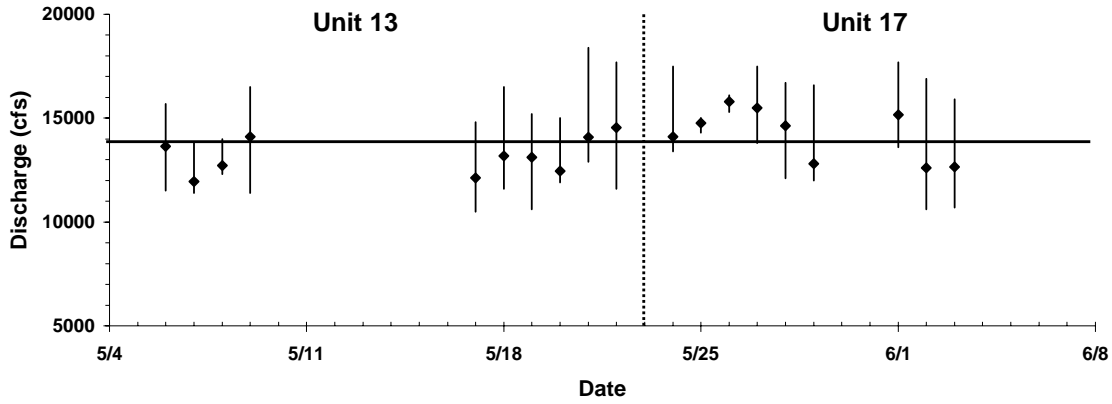

Figure 3.83. Mean and Range of Discharge (cfs) for Sample Dates, over the Sampled Duration, at Units 13 and 17. Unit 13 was sampled from May 6 through May 22, 2004, and Unit 17 was sampled from May 24 through June 3, 2004.

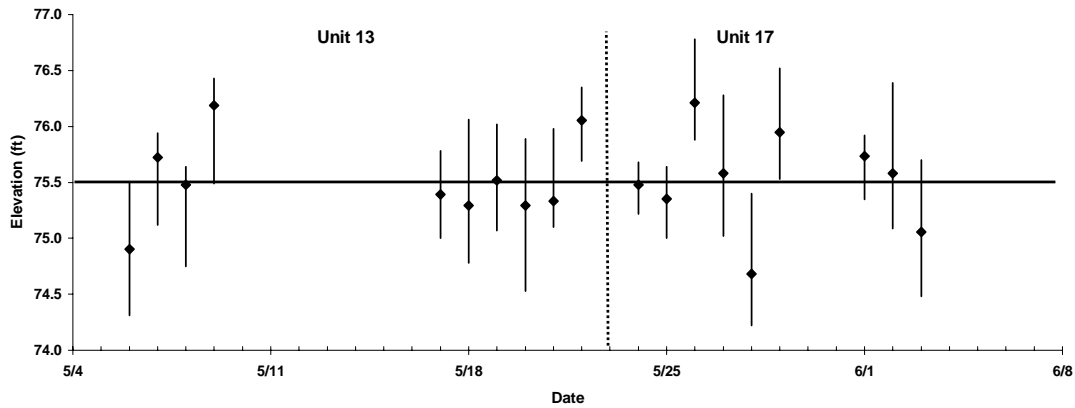

Figure 3.84. Mean and Range of Elevation (ft) on Sample Dates at Units 13 and 17. Unit 13 was sampled from May 6 through May 22, 2004. Unit 17 was sampled from May 24 through June 3, 2004.

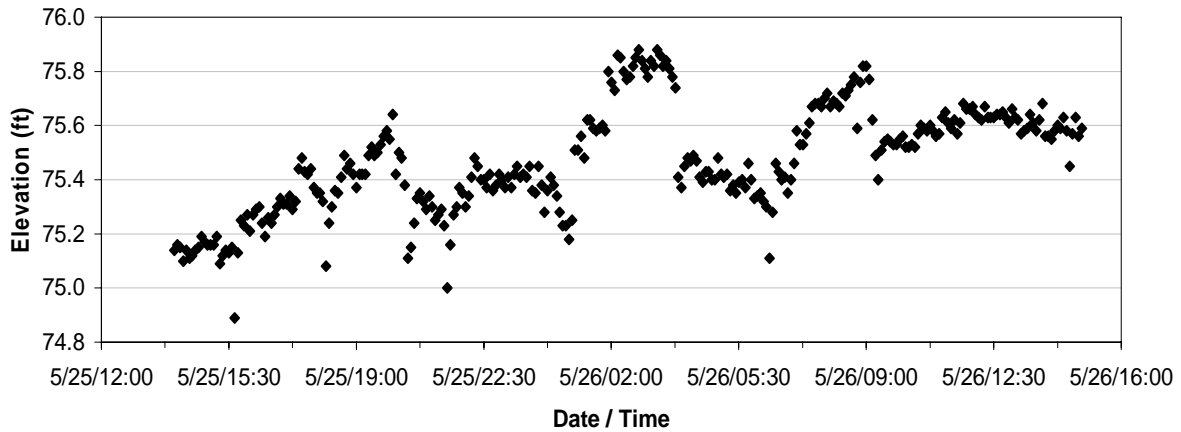

Figure 3.85. B2 Forebay Elevation by 5-minute Intervals over a 24-h Period Corresponding to Diel Sampling with the DIDSON Conducted on May 25-26, 2004.

3.11.2 Mean Gap Loss

Mean gap loss of fish using filtered data (N=3 nights) varied from 4.5 to 20% in the six intakes sampled in 2004, with the highest gap-loss estimates in the unmodified intakes (Figure 3.86). Gap-loss was significantly higher ($P < 0.01$) for the A and C intakes of unmodified Unit 13 than any of the three intakes of modified Unit 17 or Intake B of Unit 13.

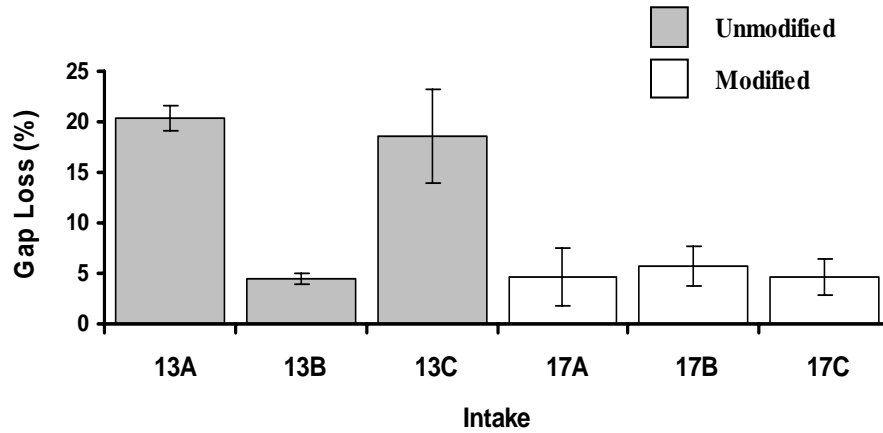

Figure 3.86. Gap Loss as a Percent of Gatewell and Gap-Loss Passage at the Three Intakes of Unmodified Unit 13 and the Three Intakes of Modified Unit 17. Each intake was sampled 3 nights in spring 2004. The vertical bars are 95% confidence intervals about the mean.

When gap-loss estimates for each turbine unit were averaged (N=9 nights), gap loss was significantly higher ($P < 0.01$) for Unit 13 with unmodified gatewells than for Unit 17, which has modified gatewells (Figure 3.87). Gap loss through the modified intakes of Unit 17 was about one-third the gap loss through the unmodified intakes of Unit 13 (Figure 3.87).

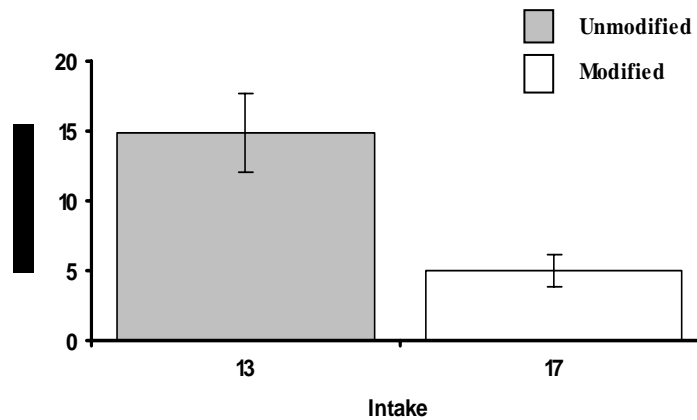

Figure 3.87. Gap-Loss as a Percent of Gatewell and Gap-Loss Passage at Unmodified Turbine Unit 13 and Modified Turbine Unit 17. Each was sampled nine nights in Spring 2004. Vertical bars are 95% confidence intervals about the mean.

3.11.3 Diel Trends in Gap Loss

The diel distribution of fish passage into the gateway slot at Intake 17B had two peaks, a main one in the mid-afternoon (1500-1800 hours) and a second between midnight and 0300 hours (Figure 3.88). The diel distribution of fish passing through the gap had a similar trend with higher numbers passing through the gap between 1500 and 2100. Gap loss as a percent of total gap and gateway detections was highest from 1800 through 2100 hours (Figure 3.89).

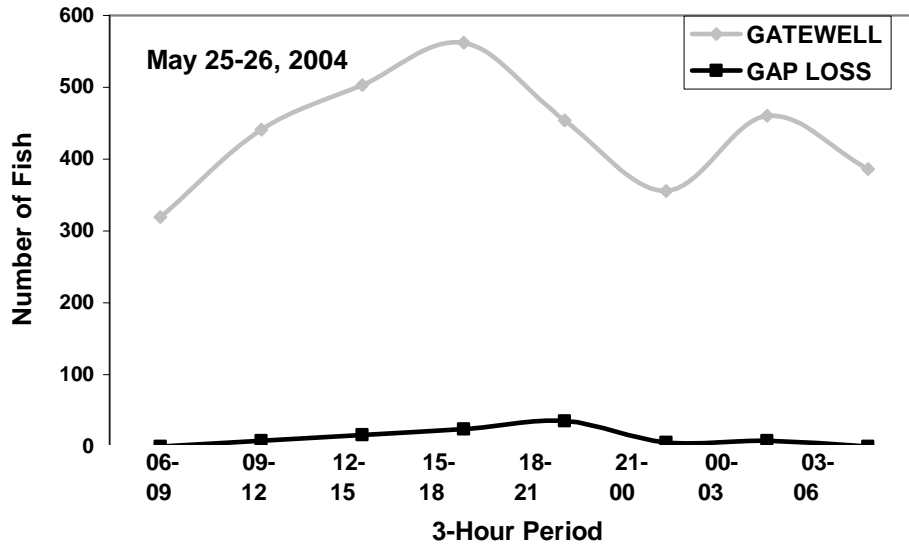

Figure 3.88. Plot of the Diel Trend of Passage into the Gateway and Gap from 1400 Hours on May 25 to 1400 Hours on May 26, 2004.

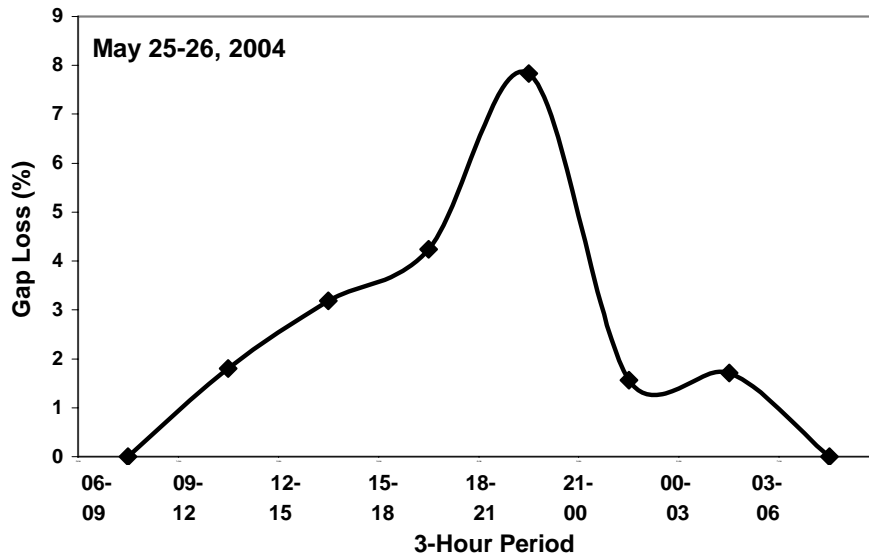

Figure 3.89. Plot of the Diel Trend in Gap Loss as a Percent of Gateway and Gap Loss Passage at Intake 17B from 1400 Hours on May 25 to 1400 Hours on May 26, 2004.

There was no consistent trend in percent gap loss of fish across the width of the gatewell for the six intakes sampled in Unit 13 and 17 (Figure 3.90).

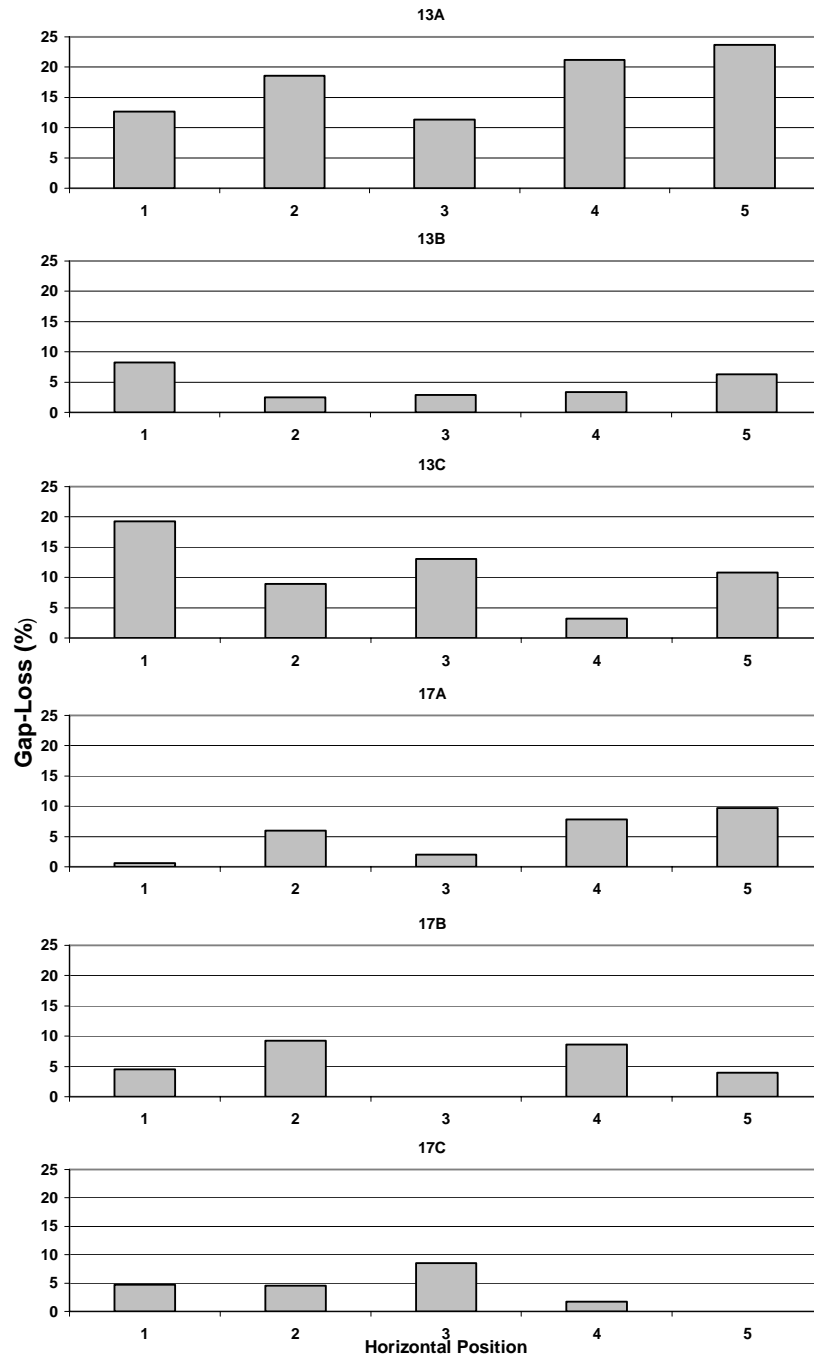

Figure 3.90. Horizontal Distribution of Gap-Lost Fish as a Percentage of Gatewell and Gap Passage at Five Equidistant Positions across the Width of the Gatewell Slot for Each Intake at Unmodified Unit 13 and Modified Unit 17 in 2004.

The length frequency distributions of fish passing through the gap and into the gatewell slots were significantly different ($P < 0.05$) although about 60% of fish were in the 100 to 150 mm length classes for both groups (Figures 3.91 and 3.92). More small fish in the 50 and 75 mm length classes were detected

passing up into the gatewell than passing through the gap and there were slightly more fish in the larger size groups passing into the gap.

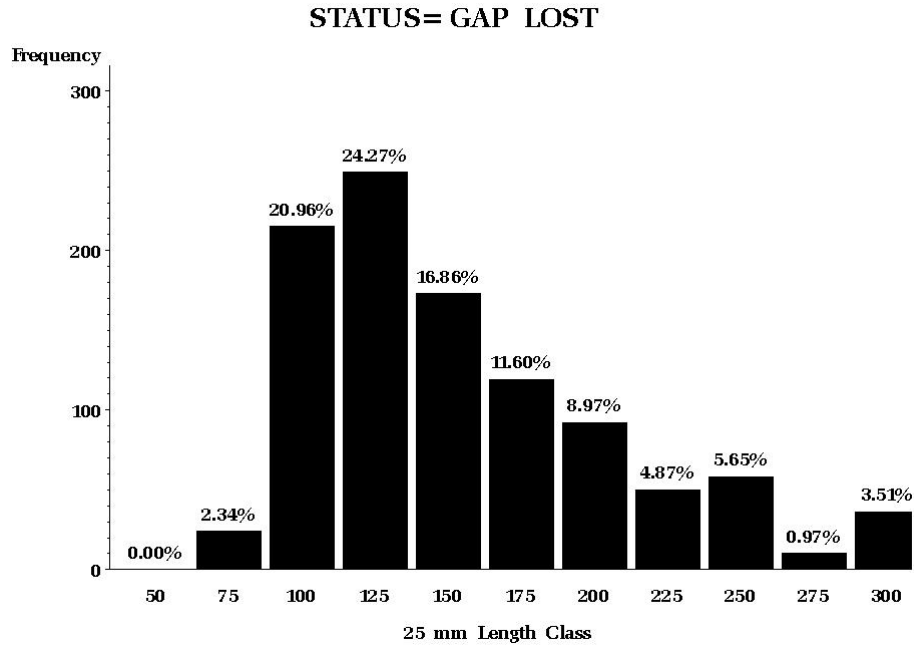

Figure 3.91. Length Frequency Distribution on the Number of Fish Passing through the Gap between the Top of the STS and the Intake Ceiling in Spring 2004

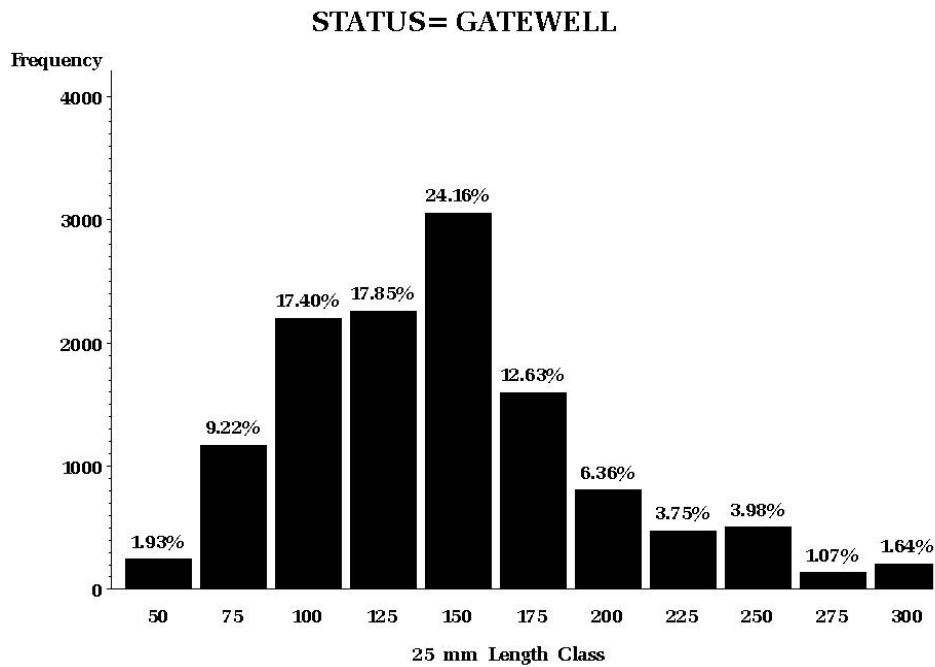

Figure 3.92. Length Frequency Distribution on the Number of Fish Passing Up the STS and Into the Gatewell in Spring 2004

3.12 Head Differential across B2 Vertical Barrier Screens

A report on temporal changes in the head differential across the upstream and downstream sides of the vertical barrier screen at Unit 17, as the result of debris loading, is presented in Appendix I.

4.0 Discussion

4.1 Environmental Conditions in 2004

Unique environmental conditions that affected estimates of fish passage efficiency in 2004 were the operation of the B2CC, opening three B1 sluiceway entrances, absence of TIEs on the south half of B2, and not deploying STSs at B1 turbines. The B1 sluiceways and B2CC passed only 5% of project flow but were much more effective at passing fish than was the spillway. Columbia River discharge was about 82% of the 10-year average discharge, but this level was not so low that it limited operations to benefit juvenile fish passage or raised water temperatures more than 1-2% above the 10-year average. Sufficient river flow allowed operators to provide prescribed spill levels for day and night periods each season. Generation was curtailed to provide for increased spill at night (Figure 3.6). Constant 24-h spill conditions for six days in summer allowed us to evaluate diel patterns of fish passage, independent of diel patterns of discharge. The species composition of the spring run-at-large, as assayed by the Smolt Monitoring Facility at B2, was dominated numerically by sub-yearling Chinook salmon released from hatcheries, which is typical for Bonneville Dam. Substantial differences in the species composition of the spring run-at-large and the composition of radio-tagged fish (Figure 3.2) likely explain most of the differences in estimates by hydroacoustics and radio telemetry. Sockeye salmon, which were not tracked by telemetry, made up 2% of the spring run, nearly as much as the 3% composition of steelhead in the run.

The forebay CFD model proved very useful for evaluating flow patterns in the B2 forebay. Strong eddies formed on the north and south ends of the forebay whenever six or more turbines were operating. The strength of eddies increased with powerhouse loading from 69,000 to 132,000 cfs. Eddies dissipated after 1 to 2 hours of 2-unit operation.

4.2 Hydroacoustic Detectability

The motivation for efforts to improve detectability modeling is the desire to provide hydroacoustic estimates that are quantitative as well as relative indices to fish passage. Ratio estimators such as fish guidance efficiency only require that the hydroacoustic beams sampling guided and unguided fish have equal detectability so that the ratios of counts, not necessarily the counts themselves, are accurate. Combining counts from different locations such as powerhouses and a spillway also requires equal detectability so that counts from different locations are comparable, although the counts themselves may not be accurate. Nevertheless, accurate counts estimated by proper expansion of detected fish have the potential to provide estimates with inherent quantitative value as well as providing acceptable relative estimates.

We are comfortable that detectability was adequate at all deployments in 2004 because most effective beam angles were within 1 to 2 degrees of the transducers' nominal beam angle over ranges at which fish were counted. The only exceptions were the shortest ranges sampled by the down-looking transducers at B1. Nevertheless, spatial expansions incorporated effective beam angle, so there was appropriate compensation for lower detectability even at short ranges.

Our pulse repetition rate of 25 pings / s at the spillway was adequate for even the highest spill discharge observed in 2004. Loss of detectability with increased spill-bay discharge could result in the misinterpretation of relations between spill efficiency or effectiveness and spill discharge.

However, an examination of the mean number of echoes per fish trace and fish counts by discharge range suggested that this was not a problem. Lower detectability may result if fish speeding through the beam at higher discharge provided fewer than the minimum number of echoes. The average number of echoes per fish trace detected at spill bays fell from 9.9 at 3,000-6,000 cfs to 8.7 at 6,000-9,000 cfs to 8.0 at 9,000-12,000 cfs to 7.4 at 12,000-14,000 cfs, the highest discharge observed. Nevertheless, 7.4 echoes per trace are well above the 4-echo minimum criterion, so fish are passing through the center of the beams at the highest discharge levels. These results were consistent with those we obtained in 2002.

4.3 Validation of Autotracking and Count Adjustments

The high coefficients of determination for regressions of average technician counts (of three individuals for each raw data hour) on autotracker counts for each deployment (Figures 3.15 through 3.18) show that the two kinds of data reduction, from raw hydroacoustic echograms to counts, produced similar results. Differences likely result from channel-specific differences in noise regimes. Slopes of most regression lines of mean manual tracker count on autotracker counts were < 1 , so corrections of autotracker counts usually were downward, offsetting the tendency of the autotracker to overestimate passage. This method of evaluation and correction is an adequate method of quality control and assurance for our autotracked estimates. This approach is not only more economical but qualitatively superior to manual tracking by people. Due to the magnitude of the data sets involved in Project-wide sampling and the established individual variation in human trackers (Ploskey et al. 2001b and c, 2002a-c, 2003), manual tracking is neither feasible nor desirable.

4.4 Direction of Travel Adjustments

In 2002, we recommended that an alternate sluiceway entrance located further down the B1 ice and trash sluiceway channel be opened, instead of Entrance 10C; this recommendation was followed and there was increased sluiceway passage in 2004. Even at high forebay elevations, Sluiceway Entrance 10C did not pass much water and as many fish were detected moving upstream as downstream at that entrance in 2002. In contrast, most of the fish detected in our split beams (which allow for direction-of-travel analysis) at the three opened sluiceway entrances (2C, 4C, and 6C) in 2004 were moving in a downstream direction, indicating that most were entrained in the higher velocity flows. The percent of fish traveling downstream at Entrance 2C was higher than that at the more upstream entrances (4C and 6C), because of higher linear water velocities at the more downstream location along the channel.

The percents of fish moving downstream at spill bays that were sampled with split-beam transducers exceeded 90% each season and were comparable to downstream percentages observed at B1 Sluiceway Entrance 2C. We believe this indicates that most fish were entrained at both of these locations. The $\leq 10\%$ not moving downstream at the spillway tended to be detected at short ranges from the transducer where water velocities were lower than velocities near the ogee.

4.5 FPE Evaluation of Spring Creek Releases in March

Running the B1 sluiceway and B2CC without spill produced a Project FPE that was nearly as high as that provided by 50,000 cfs of spill, B1 sluiceway operation, and no B2CC, and this was in spite of a poorly performing B1 sluiceway. For some unknown reason, the B1 sluiceway efficiency was only 1.7% while the B2CC operated in March, whereas it averaged 5% during other conditions in March and 5.7% in spring. We did not run a formal statistical test on operational conditions during the Spring Creek release, because conditions were presented in single four- or five-day blocks that afforded no randomization.

However, Project FPE was as high during two of the days of B2CC-only operation as it was during the five days of spill. Under the other two days of B2CC only operation, Project FPE was only about 12% lower than average FPE under spill. In contrast, four of seven days of no spill and no B2CC produced an FPE that ranged from 16% to 39% lower than FPE during spill.

4.6 Major Passage Metrics

On the scale of powerhouses and the spillway, fish passage proportions are generally similar to flow proportions, but fish-passage proportions seldom correlate with flow proportions at smaller scales such as individual sluiceway entrances, turbines, or spill bays.

4.6.1 Project and Powerhouse FPE

Project FPE estimates of 73% in spring and 70% in summer 2004 were made possible primarily by surface passage routes because there were no STSs deployed at B1, spill efficiency was below average, and B2 FGE was about average for non-drought years for which full-Project data are available. Fish passage efficiency (FPE) must be viewed in the context of differences in structure and operations. The B1 sluiceway and B2CC passed a very large proportion of the estimated total project fish passage relative to the amount of water discharged through those surface routes (Figure 4.1). Although the contribution of surface routes to FPE did not completely make up for a lack of screens at B1 or below-average spill efficiency, it did keep spring FPE within 6% of estimates in 2000 and 2002 and summer FPE within 9% of 2000 levels and 4% of 2002 levels, two non-drought years. Surface passage was especially important in maintaining a relatively high (70%) FPE estimate in late summer, when Project FPE often declines. Project FPE calculated with no surface-passage component was about 67% in spring and 60% in summer. In 2004, B2 screen guidance was about average for that structure (just under 50% in spring and just over 35% in summer) and Project spill efficiency was the lowest of the three non-drought years sampled.

For just B2 and the spillway, FPE was over 80% in spring (the NOAA Fisheries mandated goal) and over 76% in summer. However, this high FPE estimate for part of the Project would not necessarily translate into a high Project FPE if one powerhouse was actually off-line for the passage season. Eliminating one powerhouse from the calculation must increase FPE since a portion of turbine passage is removed from the denominator. In 2004, all of B1's turbine passage was "unguided" (since no screens were installed) and spill passage makes up a more substantial proportion of the total. Changes in operations can have unforeseen consequences and issues of forebay approach, water quality, forebay predation, delay, and tailrace egress must be considered (Ploskey et al. 2003).

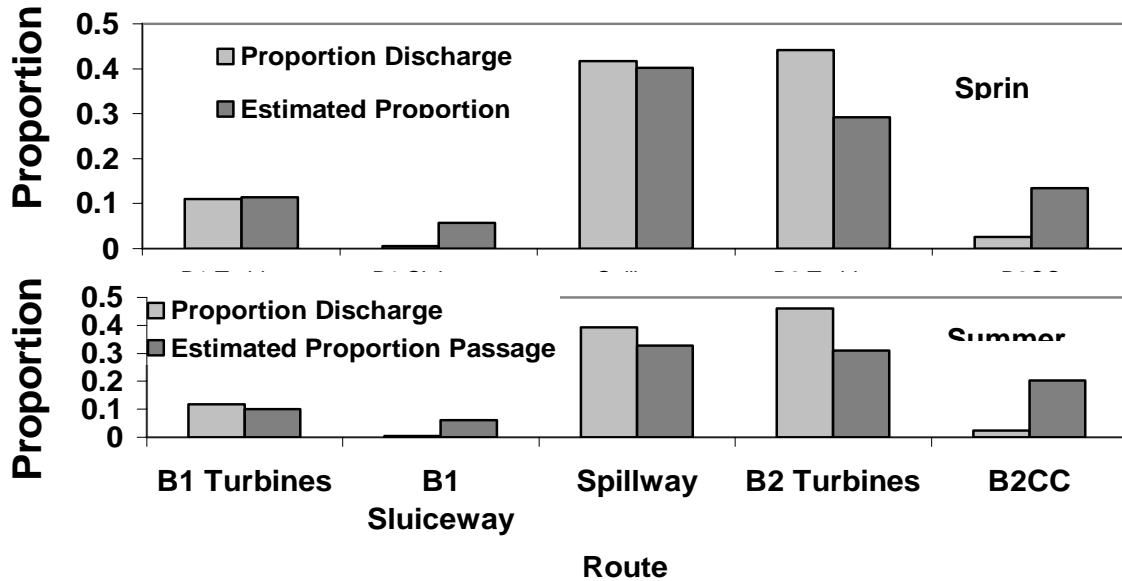

Figure 4.1. Distribution of Proportions of Total Project Discharge and Total Estimated Fish Passage through Different Structures at Bonneville Dam in Spring and Summer of 2004

4.6.2 Spill Efficiency and Effectiveness

The percent of fish passing the spillway (spillway efficiency) was similar to the proportion of water spilled each season (effectiveness = 0.97 in spring and 0.83 in summer), and percent fish and water spilled in spring and summer 2004 was lower than that spilled in non-drought study years. In 2004, operators spilled 40% of the fish in 42% of the water in spring and 33% of the fish in 39% of the water in summer. In 2000, spill accounted for 49% of flow in spring and 48% in summer (7% and 9% higher than in 2004). Differences in percent spill between 2004 and 2000 could account for all of the difference in spill efficiency in spring and 56% of the difference in summer of those years. In 2002, another non-drought year, operators spilled 49% of the river in spring and 44% in summer (7% and 5% more than in 2004). Differences in percent spill between 2004 and 2002 could account for 58% of the difference in spill efficiency in spring and 56% of the difference in summer of those years.

4.6.3 Sluiceway Efficiency and Effectiveness

The big story from the 2004 study was that the B1 sluiceway was especially effective, passing over 11 times greater a proportion of fish than of water in spring and over 12 times greater in summer. At B2, the B2CC effectiveness was less than the B1 sluiceway effectiveness (just 5.3 times greater fish passage proportion in spring; over 8 times greater in summer), but it was still quite impressive relative to the spillway, where effectiveness was less than 1.

Only the surface routes were estimated to pass a greater proportion of fish than of water (“effectiveness” > 1 – Figure 4.2). Figure 4.2 pools passage and discharge proportions by type of passage route, regardless of location.

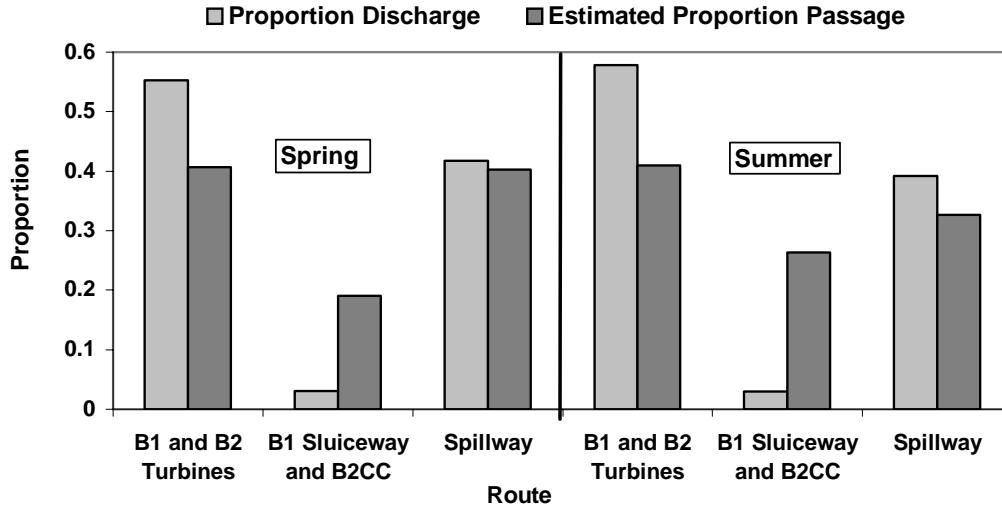

Figure 4.2. Distribution of Project Discharge and Estimated Fish Passage through Three Fish Passage Routes (turbine, surface passage, and spill) at Bonneville Dam in Spring and Summer of 2004

The capacity of surface routes to pass juvenile salmonids quickly in a relatively small discharge is well known (see Ferguson et al. 1998 for a review) and makes the development of surface-passage methods desirable, especially when water availability for passage is low and power demand is high. Ferguson et al. suggested that a powerhouse surface-passage route should pass on the order of 5% to 10% of the total powerhouse discharge. In 2004, B1's sluiceway passed only about 4% of the B1 discharge in both spring and summer and the B2CC passed only about 5% of the total B2 discharge in both spring and summer. Overall, the two surface passage routes combined passed about 6.3 times higher proportion of fish than water in spring and about 8.8 times higher in summer (Figure 4.2).

Given the far greater effectiveness of surface passage routes over spill, it should be possible to reduce spill and maintain FPE by increasing the number of surface passage routes, provided effectiveness does not decline. Opportunities at Bonneville Dam include increasing the capacity of the B1 sluiceway so that more entrances can be opened and providing removable spillway weirs at two or three spill bays. A doubling of discharge through additional surface passage routes from about 5% to 10% of Project flow could make surface-passage efficiency comparable to 2004 spill efficiency using just 1/4 of the water spilled. This would allow for some training spill for spillway weirs. Surface passage may also reduce forebay delay because juvenile salmonids pass dams well by surface routes during daytime whereas many typically hold upstream from powerhouses and spillways until dark (Thorne and Johnson 1993). As always, changes in dam passage routes and project operations can have unforeseen and sometimes unfortunate consequences, so attention should be given to fish welfare throughout the Project passage process from forebay to egress from the tailrace and passage further downstream.

4.6.4 Comparison of Major Metrics from 2000 through 2004

The 2004 passage study was the fourth year (2000-2002 and 2004) in which we produced full-project estimates of juvenile fish passage at Bonneville Dam. These studies provide a means by which managers can evaluate structural and operational changes on fish passage as well as establishing an extensive baseline data set, collected over a wide range of conditions, by which to evaluate future efforts.

The among-year range of estimates of fish-passage metrics was high because of the wide range of sampling, structural, and operational conditions that occurred during four years of hydroacoustic FPE

study. This broad baseline can be used to evaluate future management efforts at the Project, although generalizations should be made cautiously by evaluating structure-specific metrics as well as Project-wide metrics. A large hydropower project is not a laboratory and each passage season and year is unique in terms of fish populations, passage conditions, dam operations, methods, and experimental treatments, which complicate long-term comparisons. In these four years, there was one year (2000) that involved evaluation of a prototype surface collector at B1 and so B1 had generation priority. There was one year of severe drought and unusually high power generation demand (2001) and one year with episodes of unusually high spillway discharge superimposed on experimental spillway discharge manipulation (2002). Except for 2000, B2 has had generation priority in all of the years of study. In the drought year, 2001, a greater than usual proportion of juvenile fish were captured for transport. In 2002, there was an unusually large crop of naturally produced sockeye (*O. nerka*) smolts.

Over the four years studied, hydroacoustic sampling coverage has improved, especially with regard to surface passage. We first sampled the B1 sluiceway gates in 2002, after we developed a new transducer deployment that provided estimates that could be correlated with independent estimates from underwater video cameras. Before 2002, we tried sampling with up-looking split-beam transducers, but the resulting estimates did not correlate well with video estimates and were considered unreliable. Deployments for sampling were consistent in 2002 and 2004.

After examining the four years of results, we can safely conclude that fish passage proportions are generally similar to flow proportions among the three major structures (B1, spillway, and B2), but fish-passage proportions seldom correlate with flow proportions at smaller scales such as individual sluiceway entrances, turbines, or spill bays.

Estimates of the primary passage metrics (Project FPE, Spill Efficiency, Spill Effectiveness) in 2004 were the lowest of all of the non-drought years. The primary reason for low FPE in 2004 appears to be the lack of a guided-fish fraction for B1 turbines because STSs were not deployed at B1. The lack of B1 screens had no effect, however, on spill efficiency, which in 2004 was 4% and 16% lower than the respective spring and summer estimates for 2000 and 12% and 9% lower than respective spring and summer estimates in 2002. Nevertheless, the proportions of water and of fish passing the Project at B2 were higher in 2004 than they were in 2000 (B1 priority) or in 2002 (Table 4.1), and this accounts for the lower spillway efficiency estimates in 2004.

Table 4.1. Percent of Flow and Fish Passing through B2 in 2000, 2002, and 2004

Year	2000	2002	2004	Difference 04-00	Difference 04-02
Element/Season			Spring		
Water	35	40	47	12	7
Fish	19	28	43	24	15
			Summer		
Water	19	35	49	30	14
Fish	7	20	51	44	31

4.6.5 Effects of Percent Spill on Spill Efficiency and Project FPE

Our evaluation of the effect of percent spill and spill rate on fish passage metrics was based upon unadjusted spill data obtained from the project in 2004. After the 2004 study was complete and the data analyzed, we were informed that spill discharge estimates were not accurate, particularly at the lower end of the spill discharge scale (50,000 cfs), because of problems with previous flow estimates at varying gate

heights. Since underestimates also occurred in earlier years of study and remain uncorrected, we decided to leave 2004 spill estimates unadjusted until there is an opportunity to conduct a metadata analysis examining effects of spill percent and rate on Project FPE, spill efficiency, and spill effectiveness in all years studied. Correcting spill rate estimates for all years of study and re-analyzing four years of spill and fish passage data was beyond the scope of this study. The magnitude of errors in spill rate estimates apparently is a function of year and spill rate (Table 4.2).

Table 4.2. Reported and Actual Spill Rates in 2000, 2001, 2002, and 2004.

Reported Spill (cfs)	Actual Spill in 2000 & 2001 (cfs) ^a	Actual Spill in 2002 and 2004 (cfs) ^b
50	44	28
75	67	48
100	90	72
120	110	94
150	139	133
^a $y = 0.000460x^2 + 0.858473x; r^2 = 0.99$ ^b $y = 0.003360x^2 + 0.382345x; r^2 = 1.00$, where x = reported spill and y = actual spill		

We examined the relationships of spill efficiency and FPE as a function of percent spill and spillway discharge using both hourly and daily data. The daily data may reduce autocorrelation concerns, but they obscure trends that result from differences in spill level and metric estimates among hours of the day. Trends suggest that most increases in spill efficiency and FPE result from manipulation of flow proportions rather than from increased spill rate. There was much more scatter in regressions of spill efficiency and FPE on spill rate than there was for the regression on percent spill. Ability to control flow proportions diminishes as river flow approaches maximum capacity, and power producers avoid increasing percent spill during drought conditions. In 2004, there was sufficient flow to allow operators to reduce turbine flow to provide for increased spill at night (Figure 3.6). Increased spill reduces fish passage by other non-turbine routes like sluiceways and screened bypass systems, so FPE is less affected by spillway discharge than is spill efficiency. The efficiency of B2 screens declined significantly from spring to summer, so the potential to increase FPE by spill or other means like surface passage is greater in summer than in spring.

The relationship between Project FPE and percent spill was not as simple as the spill efficiency relationship, probably because FPE is affected by non-turbine passage such as surface passage or screen-guided fractions as well as spill. The FPE data were better fit with quadratic equations than linear equations. The slopes are basically two-part, with a steep initial rise until percent spill reaches about 40%, followed by a more gradual slope as percent spill increases further.

4.6.6 Effects of Spill Discharge Rate on Spill Efficiency and Project FPE

Percent spill explained much more of the variation in FPE than did spill rate, suggesting that manipulating spill proportions is more important than manipulating spill rate to maximize FPE. Intuitively, up to 100% of flow and fish could be spilled, barring electrical generation considerations, when river discharge is low or moderate. In contrast, high spill discharge during Columbia River flooding probably would not

produce the highest FPE because turbine loading also would have to be maximized to accommodate flow. Regressions of daily estimates of FPE were not significantly correlated with spill rate, in part because daily rates were averages of high night spill hours and the lower day spill hours, and in part because spill rate is only one determinant of FPE.

4.6.7 Comparison of Hydroacoustic and Radio Telemetry Estimates

The purpose of our comparison of the passage estimates derived from hydroacoustics and radio telemetry is to better understand the strengths and weaknesses of each method, and to use this knowledge to develop more accurate passage estimates. These are very different methods of estimating fish passage metrics, and so substantial differences in the estimates resulting from each is inevitable. Differences in estimates result from varying success at estimating passage among the various routes available, biases unique to each method, and the fact that the methods may sample very different populations depending upon the time of year, the composition of the run-at-large, and the species composition of radio-tagged fish.

The biggest differences in estimates by the two methods were for sluiceway efficiency and effectiveness (particularly at B1), and differences generally were much greater in spring than they were in summer (compare estimates in Tables 3.3 and 3.4). In 2004, sub-yearling Chinook salmon released from hatcheries dominated the springtime species composition (46%). Yearling Chinook salmon were the second most abundant (30%), followed by coho (19%), a weak run of steelhead (3%), and a relatively strong run of sockeye (2%). The percentages in the spring run at large were quite different from the percentage of juvenile salmonids tagged with radio transmitters (Figure 3.2). In summer, the telemetry study tagged only sub-yearling Chinook salmon, which was much more representative of the run-at-large in summer.

Another possible reason for differences between hydroacoustic and radio telemetry estimates is differences in how well each method detects fish. This ability varies with location, because each location has unique structural and hydraulic characteristics that may affect detectability. Hydroacoustic methods try to compensate for different sampling environments with detectability modeling but there are some situations, such as gap loss (a bias), where we cannot reliably compensate (see below regarding B2 FGE). Telemetry antennas are assumed to detect tagged fish adequately in all locations and under all conditions, but we are unaware of any rigorous tests of this assumption, an issue that may be important at locations like the spillway during high discharge.

Finally, it is likely that sample size effects the precision of radio telemetry estimates, particularly for little-used passage routes. For example, with spill and B2 generation given priority in 2004, telemetry estimates of B1 passage may be based on few fish, especially during periods of low B1 and Project discharge.

It is important to realize that the metrics we choose to compare can affect how successful we are at learning from the comparison. For example, the two estimates of Project FPE in spring were within 1% of each other. These estimates, however, were arrived at very differently. The hydroacoustic estimate of spillway efficiency was 8% higher than the radio telemetry estimate and the hydroacoustic estimate of FPE at B2 was 4% higher than the radio telemetry estimate. These are contrasted with a 27% higher radio telemetry estimate of FPE at B1. Similar Project FPE estimates were arrived at despite the differing efficiency estimates at the powerhouses and the spillway because of offsetting differences in the hydroacoustic and radio telemetry estimates of the numbers of fish passing the project by each powerhouse and the spillway. Our spring estimates of the percent of fish passing by structure differed from the radio telemetry estimate by 12% at B1, by 8% at the spillway, and by 19% at B2. In this case, the differences between the estimates of the powerhouse and spillway efficiencies and of the raw passage

numbers canceled each other out. The finding of very similar Project FPE estimates in spring should be viewed with caution.

Comparisons of other metrics, however, do yield useful information. The variation in the estimates of FPE at B1, for example, indicates that the abilities of the two methods to sample fish at one or both of the passage routes there are not equal. Hydroacoustic FPE was 28% in spring and 55% in summer, while telemetry estimates were 55% and 52% for spring and summer, respectively. Summer estimates at B1, however, are largely biased by dam operations. During nine of the 25 days of the summer overlap between hydroacoustic and radio-telemetry study periods, the B1 turbines were not operated at all and there were several other days with very little turbine discharge. Sluiceway discharge and passage continued, and, with B1 turbine passage impossible, FPE values were over 50%, according to both the hydroacoustic and the radio telemetry estimates. This knowledge leads us to question the validity of the spring radio telemetry estimate, which was also over 50% despite more consistent turbine discharge than was observed in summer. It is possible that behavioral differences between the fishes represented in the different species composition of the radio telemetry sample and of the total smolt population in the spring is reflected by the difference between the hydroacoustic and the radio telemetry estimates. Sample size must also be considered as a source of bias in radio telemetry estimates of passage, since B1 was a relatively little used passage route.

The most consistent difference in passage efficiency estimates made by hydroacoustic and radio telemetry over the 2004 passage seasons was the estimates of FGE at B2. Hydroacoustic estimates were 14% higher in spring and 11% higher in summer, and these differences were similar in magnitude to findings from previous years (Ploskey et al. 2002b and 2002c). The telemetry sample size was high at B2, and the consistency in the difference of the estimates between seasons may indicate that something other than species composition was causing the estimates to differ, since the species composition of the radio telemetry sample was only an issue in spring. It is possible, therefore, that these differences result from detectability issues. Hydroacoustics is unable to detect gap-loss fish – fish that are guided by the screens but do not enter the JBS because they go through the gaps along the tops and the sides of the STSs and then down into the turbines. We estimated gap loss between the tops of the screens and the intake ceilings to average about 12% in an unmodified unit and about 4% in a modified unit this spring. Although the potential has not been experimentally verified, the telemetry antennas may be able to detect gap-loss fish behind the STSs and may provide more valid stand-alone estimates of FGE at B2 than does standard hydroacoustic sampling.

Both radio telemetry and hydroacoustics found the corner collector at B2 to be highly effective at passing fish. The seasonal trends were reversed, however, with the radio telemetry estimate falling from 42% in spring to 32% in summer while the hydroacoustic estimate rose from 34% in spring to 39% in summer. The higher summer estimate by hydroacoustics is the result of American shad contamination of samples in late summer.

4.7 Spatial Trends in Fish Passage

4.7.1 Horizontal Distributions

4.7.1.1 Spring Creek Hatchery Releases

Although we recognize that the Spring Creek sampling was limited in time and sample sizes were relatively small, we nonetheless consider the results instructional. In most instances, the horizontal distribution of fish passage for releases from the Spring Creek Hatchery during the operational conditions tested did not result in any unexpected outcomes, except for the unexpectedly low passage estimates for

the B1 sluiceway entrances. The 5,000 cfs discharge condition through the B2CC resulted in B2 passing an expected majority of fish (68%) and flow (63%) relative to the other primary structures (Table 3.7; Figure 3.31). Similarly, 50,000 cfs of spill yielded 23% of fish passage and 24% flow, at the spillway during that operational scenario. The direct relationship with fish and flow remained strong during the spill condition, as B1 passed 22% of both fish and flow, and B2 passed 55% of fish and 54% of flow. Perhaps most interesting was that during the no spill-no B2CC condition, the relationship between proportional passage and proportional flow was not as direct as was observed during the other conditions. With 36% of total discharge through B1, 46% of the fish passed through that structure whereas 61% of flow and 53% of fish passed through B2 during the no spill-no B2CC condition. These results underscore the influence of B2CC operation on fish passage at B2 and lead to speculation regarding migration route preference of Spring Creek Hatchery-reared juvenile salmon. The data suggest that without the influence of spill or B2CC operation on fish approach behavior to Bonneville Dam, Spring Creek fish may preferentially migrate along the south shore of the Columbia River above the Bonneville Dam Project. Our results contradict the generally accepted adage for passage at primary structures that “fish follow flow,” and we suggest telemetry studies be designed with Spring Creek fish to determine if there exists a migratory preference for these hatchery-reared fish. However, the Spring Creek fish are about 3.5 inches long, which may make tagging impossible.

The assessment of Spring-Creek-released fish passage across the Bonneville Project uncovered an apparent effect of operation of the B2CC on fish passage through turbine units at the south end of B2. The B2CC is adjacent to Unit 11 (which did not operate during the Spring Creek study element) at the south end of B2, and, compared to the other conditions tested, operation of the B2CC resulted in fewer fish passing into Units 12 and 13 (Figure 3.31). The decrease in fish passage into Units 12 and 13 with B2CC operation should be considered good news because, without the B2CC, south units at B2 usually passed the most fish and Unit 11 often had the lowest FGE among the B2 units (Ploskey et al. 1998; Ploskey et al. 2001a; Ploskey et al. 2002b and c).

If the B1 sluiceway efficiency had been constant during all conditions, Project FPE under the B2CC would have been 4% or 5% higher than it was and even closer to the FPE observed during the spill condition. The proportion of sluice passage and flow across operational conditions yielded some unexpected and unexplainable results. With the baseline condition of no spill or B2CC operation, the B1 sluiceways passed almost 5% of the total number of fish and less than 1% of the total discharge, as they did during the 50,000 cfs spill condition. However, during the B2CC condition, the B1 sluiceways passed only about 1.5% of all fish passing the project.

4.7.1.2 Spring and Summer

The proportion of discharge through the primary passage structures (B1, spillway, and B2) was in general a good indicator of fish passage through those structures in 2004 (Table 4.3). The proportional fish passage and discharge estimates by primary structure observed in 2004 compares favorably with estimates derived in other years in which full project passage was assessed (Ploskey et al. 2002a and b, 2003; Table 4.3). An apparent trend emerges when examining proportional passage and discharge across non-drought years at B1 and B2. At B1 proportional passage consistently exceeds proportional discharge for spring and summer for all years. Proportional discharge consistently exceeds proportional passage at B2 during both seasons of each year except during the summer of 2004. The exception to the trend is likely due to the heightened effectiveness of the B2CC in the summer of 2004.

Table 4.3. Proportion of Fish Passed and Water Discharged by Structure and Season (SP = spring, SU = summer) per Year for each Year of Full Project Passage Assessment. A drought occurred in 2001.

Location	Year: Proportion	2000		2001		2002		2004	
		Spring	Summer	Spring	Summer	Spring	Summer	Spring	Summer
B1	Fish Passage	35	43	7	4	19	36	17	16
	Discharge	32	41	7	8	11	21	12	12
Spillway	Fish Passage	44	49	14	20	52	43	40	33
	Discharge	33	48	16	11	49	44	42	39
B2	Fish Passage	21	7	80	72	29	21	43	51
	Discharge	36	11	76	80	40	35	47	49

Relative proportion of discharge across routes within a powerhouse was not a good predictor of fish passage at routes within those structures, as evidenced by the sluiceways at B1 passing 33% of all fish and about 4% of discharge in spring and 38% of fish and about 4% of discharge in summer. The effectiveness of the sluiceways at B1 is further illustrated by examining fish density (fish per flow volume) by passage route. The B1 sluiceways were by far the most effective passage routes as compared to all other individual routes (with the exception of the B2CC, which was slightly more effective than Sluice 4C in summer). Specifically, Sluice 6C performed most effectively, with almost 500 and 330 fish passed per M³ in spring and summer, respectively. In comparison to the most effective turbine unit and spill bay, Sluice 6C outperformed the former by factors of 7 to 10 and the latter by 8 to 10 in spring and summer, respectively. The consistent pattern of effectiveness among B1 sluiceways across seasons provides for an operational strategy for optimizing effective fish passage in years of low water. If water management is a concern, and sluice operation has to be minimized to allow for maximum turbine operation at B1, we recommend Sluice 6C be operated due to its effective performance in 2004. If enough water is available, then Sluice 2C should also be opened.

Higher passage at sluiceway entrances 2C and 6C than at middle sluice entrance 4C in spring and summer 2004 (Figures 3.32 and 3.35) may have resulted from guidance of fish along the old navigation lock wall adjacent to Unit 1C and along the pier between intakes 6C and 7A. Distributions of passage across the entrances to the sluiceways indicate that fish are likely guided along these structures as Sluice 6C fish were strongly skewed to the north (which is adjacent to the wing wall) and 2C fish were strongly skewed towards the edge nearest the old navigation lock (Figures 3.33 and 3.36). Passage at Sluiceway Entrance 4C could be depressed by a lack of a guiding structure and by removal of approaching smolts by open sluiceway entrances on either side. Passage distributions at Sluice 4C were concentrated towards the edges, but were skewed towards one side (south) to a much lesser degree than shown for the other sluiceway entrances, an expected result given the lack of guidance structure.

The higher frequency of passed fish near the edges relative to the centers of the sluiceways observed in 2004 (Figure 3.33 and 3.36) also was observed in 1996 based on up-looking optical cameras mounted on the chain gate at sluiceway 5B (Ploskey et al. 1998). In contrast, estimates based on both hydroacoustics and underwater video cameras in 2002 indicated higher concentrations of fish passing over the middle portion of the entrance at Sluice 7A and lower proportions passing near the sides (Ploskey et al. 2003). Differences in estimated distributions of fish entering sluiceways across years may be due to a number of factors, perhaps primarily the use of disparate methods for estimating passage numbers. Given the improved hydroacoustic deployment for assessing sluiceway passage employed in 2004, and the consistent results across three sluiceways reported herein, we suspect the patterns observed reflect typical B1 sluiceway passage distributions. More clarity to this issue will result from continued sampling using the same techniques in 2005.

As with specific passage routes within B1, proportional passage within B2 did not follow proportional discharge among routes at that powerhouse. This was especially evident with the B2CC, which passed almost one-third of the fish and about 5% of the discharge at B2 in the spring and 40% and 5% of fish and flow, respectively, in summer. These results clearly demonstrate the effectiveness of B2CC operation, and this point is reinforced by looking at passage in terms of fish passage density by route (Figure 3.34 and 3.37). The B2CC was more than twice as effective as any individual turbine or spill bay in the spring and about 4.5 times as effective as any in the summer.

Operation of the B2CC appeared to alter the typical pattern of horizontal distribution of fish passage observed in prior years. Prior to B2CC construction, the distribution of fish passage across B2 had been characterized by a strong skew towards the south end of the powerhouse in 1996 (Ploskey et al. 1998), 2001 (Ploskey et al. 2002c), and in 2002 (Ploskey et al. 2003). In 2004, turbine passage distributions at B2 were not strongly skewed towards the south end, especially in spring when Unit 18 passed more fish than did any other turbine unit (Figure 3.32). It is likely that a proportion of the spring migrants that would have passed through Units 11-13 without operation of the B2CC are instead passing B2 through the B2CC. Since the south end units (particularly Unit 11) have performed poorly in terms of fish guidance in many sampled years, attracting fish into the B2CC that may have passed into the south end units has to be a benefit. Ploskey et al. (2001a) reported a combined FGE for Units 11-13 of 55% in spring and 30% in summer 2000.

Horizontal distributions of estimated fish passage across turbine units and spill bays were not uniform in 2004, a result observed by a number of investigators in past studies at Bonneville Dam (e.g., Uremovich et al. 1980; Willis and Uremovich 1981; Krcma et al. 1982; Holmberg et al. 1996; Hensleigh et al. 1999; Ploskey et al. 2002a and b, 2003). However, the non-uniform pattern of lateral distribution across turbine units and spill bays observed in 2004 makes some sense when coupled with the pattern of discharge associated with those passage routes (Figures 3.32 and 3.35). In most instances a rise or fall in estimated fish passage among adjacent routes coincides with a rise or fall in discharge, although the magnitude of the changes is often not comparable between the two variables. Nonetheless, it seems apparent that fluctuating levels of discharge among turbine units and spill bays are contributing to some extent to the non-uniformity of fish passage among these routes. At the spillway, the discharge/fish passage relationship observed in 2004 may provide for adaptive management of spillway passage. Spill bays 4 and 6 passed the fewest fish per water volume than did all other bays in both seasons (Figures 3.34 and 3.37), so it seems prudent to prioritize spill bay operation during low water years based on effectiveness, if the trends are relatively consistent year-to-year and season-to-season. Determining why some bays are more effective at passing fish than other bays should be a priority research consideration.

4.7.2 Vertical Distributions

Patterns of vertical distribution of fish are important because they can be used to provide estimates for guidance efficiency for existing or proposed screens. Guidance screens at B1 were not deployed in 2004 but, based on the vertical distributions in Figure 3.38 and assuming a cutoff for guided and unguided fish at 21 MSL (based on the elevation of the tip of an STS), the potential FGE across the powerhouse would have been about 48% in spring and 62% in summer. Of course, we cannot know what effect the screens would have on vertical distributions. Nonetheless, the potential screened FGE estimate for spring is comparable to hydroacoustic estimates reported in the past at B1, but the summer estimate is very high relative to results from prior years (Ploskey et al. 2002a and b, 2003). Typically summer migrants tend to be deeper than those in the spring, and this is reflected with lower reported FGE in the summer than in spring in the recent sampled years. The cause of the reversal of that trend, to the higher vertical

distribution of fish in summer than in spring is unknown, but we suspect that the absence of screens at B1 in 2004 may have influenced the distribution of summer migrants, resulting in an increase in frequency of fish at higher elevations. If true, this would argue for considering surface passage routes before in-turbine screens because the latter target surface-oriented fish without affecting the vertical distribution. It is important to note though that the vertical distribution plot presented in Figure 3.38 is a composite graph encompassing all detected fish from each in-turbine deployment at B1 during all time periods. The trends observed do not necessarily represent vertical distributions at all individual B1 turbine intakes.

The vertical distribution of fish at B1 for spring and summer indicated the presence of three primary modes: near intake ceilings, mid-depth, and near the intake floor (Figure 3.38). The near ceiling and near floor modes in vertical distributions were also observed to some extent inside Intake 10B in 2001 (Ploskey et al. 2002b). We surmise that the apparent modes in vertical distribution may reflect migratory preferences of the different salmonid species or size of migrants. However, Chapman and Bjorn (1969) and Everest and Chapman (1972) investigated habitat segregation between juvenile Chinook salmon and steelhead in the Snake River and reported that fish size was positively correlated to depth for both species. Perhaps the peaks in fish distribution near the intake floor represent larger and older steelhead and yearling Chinook salmon while the fish concentrated near the intake ceiling are primarily sub-yearling Chinook salmon. The advancement of ultrasonic 3-D fish tracking methods and technology may, in the near future, provide for better understanding of vertical distribution on a species-specific basis and allow us to better interpret vertical distributions obtained from hydroacoustic methods.

Based on the vertical distribution of fish inside turbine intakes at B2 (Figure 3.40), it is clear that fish were skewed towards the intake ceiling during both seasons, leaving 47.6% in spring and 35.6% in summer in a position to be guided by STSs. The general decreasing frequencies with increasing depth apparent in 2004 was also observed downstream of the trash racks at Intake 15B in 2001 (Ploskey et al. 2002b), although seasonal trends were not completely consistent across these two years. In 2001, higher proportions of fish were evident at deeper elevations ($EI \leq 5$ ft) in summer than in spring, whereas in 2004 at those elevations, spring had slightly higher frequencies than in summer.

4.8 Temporal Trends in Fish Passage

4.8.1 Seasonal Trends

4.8.1.1 Project Passage Run Timing Smolt - Index and Hydroacoustics

Figure 3.41 shows a good agreement between our whole-project daily passage estimates and those derived from the B2 Smolt Monitoring Facility. There was a substantial and well-defined peak in sub-yearling Chinook salmon (based on the Smolt Monitoring Facility's data) from June 22 through July 7, most likely due to the almost 10 million sub-yearling Chinook salmon released from Priest Rapids and Ringold Springs Hatcheries from June 14 through June 20 (Ringold Springs) and June 14 through June 23 (Priest Rapids). Considering that our hydroacoustic beams sample the run at large across the Project and the Smolt Monitoring Facility could sample only those fish guided by the B2 screens (estimated B2 FGE = 47.56% in spring and 35.6% in summer, see Table 3.1) we consider the matching of the two estimates quite good.

We did not consider American shad to be an important source of error in passage estimates in summer 2004, except for the last 11 days of sampling when large numbers of spent shad showed up at surface-passage routes. Figure 3.42 combines the timing of upstream passage of pre-spawned American Shad and our Estimated Total Project Passage run-timing graph. American Shad were likely to be present upstream of Bonneville Dam starting in late May and it is important to investigate the possible error that shad in our

sampling beams might introduce, either by being counted as smolts or obscuring the echo traces of actual smolts. We filtered summer fish counts based on target strength of echoes (see Materials and Methods section) in an attempt to exclude these much larger fish from our results but the spent adult American shad down migration is a very large one and large proportions of echograms can be saturated by echoes from shad schools, especially at shallow depths. Our data show two passage peaks in summer, and the first one precisely matches the timing of a pulse of subyearling Chinook salmon detected by the B2 Smolt Monitoring Facility (Figure 3.41). It also was associated with a peak in the numbers of unguided fish through turbines (Figure 3.48) and therefore was unlikely to be contaminated by shad. However, the final peak in run timing in summer after July 4 and the peak in sluiceway and B2CC passage efficiency (Figure 3.47) and effectiveness (Figure 3.48) after July 4, likely is due to fallback of adult American shad because we recorded very high numbers of shad upstream of the B2CC during this period with the DIDSON.

4.8.1.2 Major Fish Passage Metrics

Estimated Project FPE fluctuated considerably in both spring and summer. In spring daily estimated Project FPE was frequently near 80% with a lower period (two days below 60%) from about May 6 through 14. Figure 3.1, which gives species-specific run timing from the SMF, shows that sub-yearling smolts dominated the species composition during that period, and that it also was the start of the juvenile sockeye salmon passage. Sockeye salmon are thought to migrate deeper than others and might be poorly sampled by the B2 screens. Subyearling Chinook salmon guide rather poorly, at least sometimes (see the early half of the subyearling Chinook salmon peak in summer, Figure 3.43). In summer, Project FPE estimates generally appear to increase with time, reaching over 80% by July 4. If data collected on or after July 4 when American shad-dominated passage at surface routes are deleted, the apparent trend of increasing FGE is eliminated.

Estimated spill efficiency was quite variable in spring and summer, oscillating between as low as 19% in late summer and almost 60% near the end of April (Figure 3.45). The rise at the very end of the summer (after July 12) may have been influenced by early, spent adult shad down migrants (see below) but otherwise there was a wide range of daily spill efficiency estimates. Perhaps since large hatchery releases upstream provide episodes of high Project passage but the spill pattern is driven by the diel trends in passage and generation demand, this fluctuation is just a matter of chance combinations of fish abundance and spill discharge or proportion.

Since Spill Effectiveness is simply Spill Efficiency divided by the proportion of total project discharge that goes through the spillway, it is reasonable that the two time histories should be related. In the case of our 2004 hydroacoustic data, the seasonal trend in spill effectiveness (see Figure 3.46) is less variable and shows a more general trend of decline in spill effectiveness over time than does that for Spill Efficiency (Figure 3.45). This trend is consistent with some of the variation in spill efficiency being driven by some interaction of spill discharge or proportion and fish abundance and availability for passage.

Figure 3.47 shows that Project sluiceway efficiency (including both powerhouses and their respective surface-passage routes) increased from 10% to 20% of total Project Passage in early spring (late April) to over 40% by the end of June. Especially in late summer, when Project FPE typically drops off due to low screen guidance of subyearling fish, this is a very important trend. In 2004 when B1 screens were not installed (and so all B1 fish except those passing the sluiceway were “unguided”), the B1 sluiceway was a very successful surface-passage route which preserved Project FPE, especially in summer. Figure 3.49 shows the same estimated Project sluiceway efficiency curve overlaying the estimated Project passage curve. It is clear that the two surface passage routes had an important role in fish passage throughout the

passage period and especially in summer. Sampling with the DIDSON at the B2CC in late summer, after July 4, indicated that most of the peak in surface passage after July 4 resulted from detection of American shad.

The time-history plot of Project Sluiceway Effectiveness (B1 Sluiceway and B2CC) in Figure 3.48 is quite similar to that of Project Sluiceway Efficiency. That is not surprising since sluiceway discharge, a direct function of pool level above the Project, is relatively constant whereas spill level and proportion change considerably with time of day. The increase in sluiceway efficiency through the summer is even more evident in Project Sluiceway Effectiveness, reaching a high of over 15 (more than 15 times higher proportion of estimated fish passage than proportion of combined sluiceway discharge) in late summer.

4.8.2 Diel Trends

4.8.2.1 Passage Efficiency and Effectiveness Estimates

Total Project FPE and spill efficiency indicated very strong diel patterning, with sustained highs during nighttime hours relative to generally consistent lower estimates during daytime hours in both spring and summer (Figure 3.50). The diel patterning observed for spill efficiency and Project FPE in 2004 was stronger and more consistent than in previous years. In 2000, Project FPE varied < 4% over the diel cycle in spring and summer (Ploskey et al. 2002a). Spill efficiency in 2000 indicated an increase during nighttime hours in the summer, and little patterning in the spring. In the drought year of 2001, there was a slight increase in FPE from day to night in both seasons, as was the case with spill efficiency in the spring (Ploskey et al. 2002b). Spill efficiency in the summer of 2001 in general was lower at night than it was during the day under constant spill. Diel trends in 2002 (Ploskey et al. 2003) most closely resembled those observed in 2004, possibly because of similar water availability and the absence of the PSC in those years.

The B2CC and the B1 sluiceways were most effective at passing fish during the day in both seasons, but especially so in the summer (Figure 3.50). We assumed the influence of daytime passage efficiency through these surface routes would likely be reflected in the diel pattern of Project FPE. This was not the case, at least not to any great extent, as daytime FPE remained relatively constant through the daytime hours although in summer a slight increase is evident through the afternoon and early evening hours. The effect of the B2CC and B1 sluiceway passage on Project FPE was overshadowed by the influence of spillway passage; note the similar patterns among diel spill passage efficiency (Figure 3.50) and spill passage (Figure 3.58) and Project FPE.

Spillway effectiveness showed no diel patterning in either season (Figure 3.52), reflecting the direct relationship of hourly passage to percent spill and spill discharge (Figure 3.58). As spill increased at night, spill passage followed the same pattern, resulting (along with lower power generation at night) in very little diel patterning for spill effectiveness. The B1 sluiceway entrances and B2CC had higher increased effectiveness during the day (Figure 3.52) despite slightly higher increased discharge during nighttime hours through surface routes (e.g., Figures 3.56 and 3.60). Greater sluiceway passage effectiveness during the day underscores the influence of the diel behavioral component of fish passage, in which juvenile salmonids do not necessarily pass in proportion to flow, at least through surface routes.

A very significant finding was that increased spill efficiency and spillway passage was partly due to higher spill rates at night and partly to a natural diel pattern independent of spill. There were six days in summer when spill was held constant for 24 h per day and, in spite of constant spillway discharge, the percent of daily passage by spill doubled (Figure 3.59). This reconfirms a similar finding in the drought year of 2001 when spill was constant throughout spring and summer (Ploskey et al. 2002c).

4.8.2.2 Passage and Guidance Efficiency

4.8.2.2.1 Total Passage

Crepuscular peaks are typical in juvenile salmonid passage at hydropower projects in the Pacific Northwest and 2004 was no exception (Figures 3.54 and 3.55). The general rule of thumb that ‘fish follow flow’ was observed in 2004 in terms of project-wide passage, as peaks in diel passage coincided with peaks in discharge and generally, as discharge decreased, fish passage also decreased. However, flow alone does not explain diel passage patterns; likely fish behavior such as holding during daytime until visual cues are lost may partly explain increased fish passage at twilight. Total guided passage closely resembles total project passage across the diel cycle with higher passage at night, primarily because of the high spill fraction at night and because the daytime-dominated pattern of sluiceway passage is obscured. Total unguided passage, which included all B1 turbine passage and B2 unguided passage had only a slight diel trend (Figures 3.55 and 3.56). This result is somewhat surprising given that unguided fish pass through turbine units, which typically have higher passage at night (Johnson and Giorgi 1999; Johnson and Carlson 2000). The dissimilarity between guided and unguided diel passage patterns in 2004 was largely due to spillway passage, which obscured the effects of unguided nighttime passage through turbine units and daytime-dominated sluiceway passage.

4.8.2.2.2 Powerhouse 1

True diel patterns of fish passage can only be obtained when operational conditions remain unchanged throughout the diel cycle. This certainly was not the case at B1, where hourly patterns of fish passage reflected operational conditions instead of behavioral phenomena. In 2004, to accommodate desired spill patterns, most turbine units at B1 were shut down at night resulting in hourly distributions of turbine passage that were more the product of Project operations than of fish behavior. Nighttime turbine discharge was about 60% lower in spring and about 68% lower in summer than daytime turbine discharge in order to accommodate high nighttime spill. There were very few B1 turbine passage routes available at night, relative to the number available during the daytime. As such, the overall hourly patterns of total passage at B1, although they were influenced by sluiceway passage estimates, were mostly determined by the hourly distribution of turbine passage in both spring (Figure 3.56) and summer (Figure 3.57). The influence of higher daytime passage at the sluiceways is apparent in the total passage plots but the overall character of the total passage patterns across the diel cycle most closely resembles the turbine passage distributions because most fish (67% in spring and 62% in summer) passed B1 through the turbines. In spring, sluiceway passage comprised between 24% and 47% of total passage during daylight hours and between 28% and 58% during nighttime hours. In the summer, estimated B1 sluiceway passage accounted for between 28% and 47% of total B1 daytime passage, and between 29% and 68% of total B1 nighttime passage.

4.8.2.2.3 Spill Passage

As with turbine passage, patterns of diel passage at the spillway can only be revealed if discharge through the spillway remained constant through all hours of the day. This was not the case in most of the 2004 fish passage seasons when there was higher spillway discharge at night. Hourly spillway passage mostly reflects the effect of discharge on diel passage, based upon correlations of efficiency with percent spill and spill rate, so it is not surprising that spillway passage closely followed the pattern of hourly spillway discharge, with peaks occurring at dusk. A similar pattern in estimated spill passage was observed in 2002, when spill discharge was lower during the day than at night (Ploskey et al. 2003). In the low water year of 2001, when spillway discharge remained relatively constant through all hours of the day, increased passage at night was still evident, especially in spring (Ploskey et al. 2002c). The trends

observed in 2001 (Ploskey et al. 2002c) support what others have reported regarding higher passage at night via deep-passage spillway routes (e.g., Thorne and Johnson 1993; Ploskey et al. 2001) and indicates that the hourly passage trends observed at the spillway in 2004 likely have a large behavioral component along with the influence of spill operations. This was clear during the six days of constant spill in summer (Figure 3.59), when there was a strong diel trend under a constant spillway discharge regime.

4.8.2.2.4 Powerhouse 2

Discharge through B2 was not constant across the diel cycle, primarily due to decreases of flow through the turbine units at night of about 21% and 28% in spring and summer, respectively (Figures 3.60 and 3.61). Much like passage at B1 and the spillway, diel passage at B2 was largely driven by project operations and probably less so by fish behavior. However, a behavioral component is evident with total turbine passage in the summer; passage is shown to increase in the early evening hours just prior to the nighttime decrease in discharge (Figure 3.61), a trend that supports others' observations that nighttime passage at B2 is typically higher than daytime passage, given equal discharge (Ploskey et al. 1998).

Diel passage patterns at the B2CC probably were driven more by fish behavior than by Project operations since discharge through the B2CC varied < 4% across the diel cycle. Hourly flow through the B2CC remained relatively constant, although the proportion of B2 flow through the B2CC varied by as much as 23% because B2 turbines were often shut down at night to increase spill (see Figure 3.67). In spite of increased flow and flow proportions at night, fish passage at the B2CC was higher during the day than it was at night (Figures 3.60 and 3.61). In spring, peak estimated B2CC passage occurred at 0600 and 0700 hr and generally declined through the rest of the day and into the early morning hours before increasing at 0300 and 0400 hr. In the summer, passage remained relatively stable through the early daylight hours before increasing in the early afternoon and stabilizing to highs throughout the afternoon and early evening before dropping off during the nighttime hours. The earlier daytime peak in passage in the spring and the later afternoon / early evening peak in passage in summer suggests a difference in how spring and summer migrants find and pass the B2CC. Perhaps the smaller summer migrants are more susceptible to being entrained into the eddy located above the B2CC entrance, accumulating throughout the day and generally delaying their passage until late afternoon and early evening. The explanation for differences in daily passage patterns at the B2CC between spring and summer migrants is unknown, but the overall pattern of higher passage during daylight hours observed during both seasons in 2004 supports prior observations of fish passage through the old B2 ice-and-trash sluiceway (e.g., Magne et al. 1986; Biosonics 1998; Ploskey et al. 2001a).

4.8.2.2.5 Guidance Efficiency

The dip in B2 FGE estimates apparent at night during the spring of 2004 (Figure 3.63) was similar to the trends observed in 2002 (Ploskey et al. 2003) and 1998 (Ploskey et al. 2001a), but different than in 2001 when lows in FGE occurred in the early afternoon (Ploskey et al. 2002c). The prevalence of lower B2 FGE at night across most years in spring is likely explained by the tendency of fish to be deeper at night than during the day. The summertime pattern of diel FGE in 2004, characterized by low guidance estimates at midday (Figure 3.63) more closely resembles the B2 FGE patterns observed during the summer drought period of 2001, when FGE estimates were lower in the day than at night (Ploskey et al. 2002c) patterns from more normal water conditions, as in summer of 2002 when FGE decreased at night (Ploskey et al. 2003). We are uncertain as to the cause of the differences in summertime diel passage observed in 2004, but we speculate that a combination of factors contribute to the variability of B2 FGE estimates. It is clear that diel pattern differences exist in FGE among intakes and within intakes. This variability, coupled with uneven distribution of turbine discharge through the day, muddles the overall

patterns of diel FGE. As noted in Ferguson et al. (2004), estimates of FGE are inherently variable due to other factors such as species, rearing history, stock, fish condition, time of day, environmental conditions and project operations. Spatial and temporal variability results from complex interactions between biological and physical factors such as the arrival of different stocks at a dam throughout the season.

4.9 Fish Guidance Efficiencies of B2 Turbines

In 2004, the most important factors affecting FGE at B2 appeared to be related to modifications of turbine intakes (a benefit) and the location of sampled intakes relative to TIES. Modified Unit 15 had the highest FGE in spring and summer 2004, and modified Unit 17 tied with unmodified Unit 16 for the second highest FGE out of eight units in spring 2004. In summer 2004, modified Unit 17 tied with Unit 11 for the third highest FGE rank, behind modified Unit 15 and unmodified Unit 16. Two factors likely provided higher FGE at Unit 15 than at other units. Unit 15 had modified intakes, and it is located near the center of B2 where, for unknown reasons, units consistently have higher FGEs than units closer to the ends of the powerhouse (Ploskey et al. 2003; Ploskey et al. 2002b, 2002c). The general trend of higher FGE for units near the center of B2 was still evident in spring and summer 2004, although the FGE estimate at Unit 14 was low in spring and that at Unit 11 was high in summer (Figure 3.64).

Sampled intakes between TIES at Units 15 to 18 had estimated FGEs that were 11% higher than those for intakes behind TIES, and this finding was consistent with earlier findings by Gessel et al. (1991) based upon netting and by Ploskey et al. (2002c and 2003) by hydroacoustics. Ploskey et al. (2003) reported that intakes between TIES had 8% to 9% higher FGE than intakes behind TIES.

Unit proximity to the B2CC may have lowered juvenile fish passage at adjacent units in spring (but not summer), as noted in the Results Section 3.7.1, but it apparently had no effect on FGE at Units 11 and 12. The FGE at Unit 11 in 2004 was within 11% of estimates made in the spring and summer of 1998, 2001, and 2002, but were higher than estimates made in spring and summer 1996 and 2000 (Table 4.4). The former B2 ice-and-trash sluiceway was opened during roughly equal numbers of days in 1996 and 1998, closed in 2000, 2001, and 2002, and opened continuously in spring and summer 2004.

Table 4.4. Unit 11 FGE in Years that It Was Sampled with Fixed-Aspect Hydroacoustics

Year:	1996	1998	2000	2001	2002	2004
Spring FGE	16	46	20	50	48	43
Summer	10	35	8	30	38	41

4.10 B2CC Entrance: Smolt Distributions, Approach, and Fate

The DIDSON and fixed-aspect hydroacoustics tools combined to provide a detailed picture of smolt approach and the distribution of passage into B2CC. With the DIDSON, we tracked over 5,000 fish in spring and 2,500 fish in summer, and this provided definitive information about the approach and fate of smolts relative to flow conditions, when B2 discharge exceeded 70,000 ft³ / s. Under conditions of low powerhouse loading (< 70,000 ft³ / s), too few fish were tracked with the DIDSON to make definitive conclusions about fish approaches and fates. However, regression of hydroacoustic estimates of percent passage on percent discharge at the B2CC provided inference about B2CC efficiency when discharge through B2 was low ($\leq 70,000$ ft³ / s) and the proportion passing the B2CC was high (Figure 3.67).

Twenty percent discharge through the B2CC corresponds to two-unit operation at B2 (5,000 cfs / 0.2 = 25,000 cfs). Two-unit operation most likely would involve Units 11 and 18, the priority units at the

powerhouse because of a perceived need for discharge at the powerhouse ends to attract upstream migrating adult salmonids. The latter need probably is much more important during the day than it is at night. Under those conditions, nearly 80% of the fish passing at B2 passed through the B2CC. What we could not separate is how much of this passage is due to the flow percentage and how much is due to the dissolving of north and south eddies under low powerhouse loading, as indicated by the CFD model.

We were pleased that simultaneous split-beam hydroacoustic and DIDSON counts at the B2CC were highly correlated with a slope of about one. This indicated that the wideband echo sounder modifications, which were made to reduce pulse duration and maximize target resolution, were successful. We would have expected higher DIDSON counts than hydroacoustic counts if the hydroacoustics were unable to resolve closely spaced targets in schools, which according to the DIDSON were more common than single targets approaching the B2CC.

The vertical distribution of smolts entering the B2CC was clearly skewed toward the surface and the center of the opening in both spring and summer. American shad detected after July 4 skewed the horizontal distribution in summer toward the southeast, but the distribution had a mode in the center of the entrance when data collected after July 4 were dropped. Huge schools of American shad were imaged with DIDSON upstream of the B2CC after July 4.

The fate of approaching smolts, whether passing into the B2CC or moving upstream into the south eddy, could be reliably predicted from their initial location and the bulk flow in the vicinity of the B2CC. Other factors such as day, night, or time of year had little effect on approach and fate, shifting the fish entrainment zone by about 5 ft. The high effectiveness estimates for the B2CC may be explained partly by the large south eddy that also collected fish. At first, the south eddy appeared to compete with the B2CC entrance for fish, but the eddy collects fish that missed the B2CC entrance on the first pass, and it likely circulates them where they have additional opportunities to discover the entrance before they are entrained in turbines.

Entrance probabilities calculated from the Markov chain analysis (Figures 3.80 and 3.81 of Results) were higher than those calculated from the vector analysis (Appendix H) and identified a large entrainment zone that was more consistent with field observations and fate based upon examining complete tracks. Complete tracks are those that end in the entrainment zone of the B2CC or in the south eddy. The apparent advantage of the Markov chain may lie in calculating cell-by-cell probabilities based upon all of the tracks collected, whereas the vector analysis relies more upon the direction of movement of individual tracks, some of which may be quite short.

The zone with >90% entrance probability undoubtedly extended much further to the north along the powerhouse face than the 47 ft estimated by the Markov Chain analysis or even the 62 ft that we could sample with the DIDSON. Fish within 30 feet of the powerhouse face, even as far north as Intake 14C, are swept south toward the B2CC entrance by strong flows along the powerhouse. The probability that these fish would enter the zone of estimation by the Markov chain probably exceeds 90% also.

4.11 Gap Losses at B2 Traveling Screens

There was no correlation between gap-loss and operating conditions; however, the statistical power due to the small sample size and within-sample-period variability in operation levels is low and may not be sufficient to detect variations in gap loss due to operation levels. Comparison of unit operation level with gap loss showed no significant effect of forebay elevation nor discharge on gap-loss estimates. No correlation between gap loss and unit discharge or forebay elevation was found during testing in 2003 either (Ploskey et al. 2004).

Other studies also show a significant difference in the proportion of fish lost through the gap of modified and unmodified intakes. Gap-loss estimates from DIDSON data range from 11.2% to 14.9% for unmodified units and from 2.9% to 5.0% for modified (this study and Ploskey et al. 2004). Estimates of gap loss from netting data averaged 3.3% for unmodified units (Gessel et al. 1986) and approximately 1% for modified units (Monk et al. 2002, Monk et al. 2004 -- Figure 4.3). Though the absolute estimates of gap loss for the two sampling methods do not agree, the relative estimates for both sampling methods suggest that gatewell and STS modifications reduced the loss of fish through the gap by about two-thirds. The absolute difference between the two sampling methods may be due to gear bias. Netting may be underestimating gap-loss by altering flow conditions, especially when the gap net becomes clogged with fish and debris during sampling. Williams et al. (1996) concluded that FGE estimates by fyke netting were biased by a pressure field created by the fyke nets located under STSs at McNary Dam. DIDSON estimates of gap loss may be overestimated if debris is mistakenly counted as a fish and not eliminated by filters. However, fish rolling off the top of the screen or not fighting the flow at the gap could be discarded by the filters, thereby reducing the gap-loss proportion.

The peak in gatewell and gap passage in 2004 was higher during the day than it was at night, which is consistent with what was observed in 2003 (Ploskey et al. 2004), although strong crepuscular peaks in passage observed in 2003 were not observed in 2004. The peak in both gatewell and gap passage for the diel trend in Intake 17B was in the afternoon between 1500 and 1800 hours, which was also the time of higher proportion of guided fish lost through the gap. This differs from peak passage in 2003 for unmodified Intake 13B, where distinct peak gatewell passage was at sunset (2000-2200 hours), similar to that for turbine passage estimates (Ploskey et al. 2003). Peak gap passage estimates were also made for hours near sunset in 2003, and there was a second peak in gap passage between 0800 and 1000 hours in the morning. In 2004, the gap-loss percentage peaked between 1800 and 2100 hours, which is within an hour of the peak in gap passage in 2003.

The lateral distribution of fish passage into the gap and gatewell was not uniform for any of the intakes or combined unit estimates. This suggests that it is necessary to sample the entire width of the intake to minimize bias. The small sample size, especially for gap-loss fish, may also be a factor, and distribution may become more uniform with a larger sample size. Hydroacoustic tests also have found that lateral fish distribution across turbine intakes is not uniform and had no defined trend (Hanks and Ploskey 2000).

The length-frequency distributions of fish detected in the gatewell and the gap were within the size range and distribution expected for smolts in the Columbia River in spring. The significant difference in the length-frequency distributions between gatewell and gap-loss fish may be a bias with the DIDSON sampling. The gap-loss fish were viewed for fewer frames than were gatewell-guided fish. The median number of frames fish were viewed passing into the gap was 6 compared with a median of 13 frames for fish guided into the gatewell. Small fish may be missed passing into the gap due to the few frames in which to detect them. There is also error in measuring the images of fish that may skew the count of smaller fish. The measuring tool in the DIDSON program has a 1-cm resolution to which it can measure fish. Tests with the DIDSON in a tank of known sizes of fish showed that the measuring tool could measure fish accurately to within 2 cm in all cases (Weiland and Carlson 2003). This is adequate for large fish but is a problem when measuring 50 mm smolt and may bias the size distribution of the smaller fish.

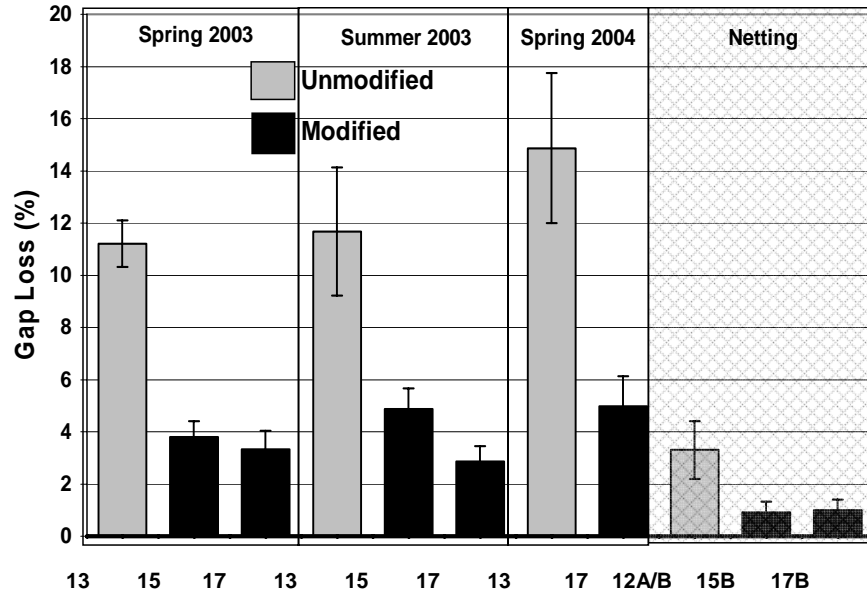

Figure 4.3. Comparison of Gap-Loss as a Percent of Estimated Gatewell and Gap-Loss Passage at B2 Turbine Intakes with Modified and Unmodified Gatewells. Data are for spring and summer 2003 (Ploskey et al. 2004), spring 2004 (current study), and netting of intakes 12A and 12B (Gessel et al. 1986), Intake 15B (Monk et al. 2002), and Intake 17B (Monk et al. 2004).

The effect of gap losses on hydroacoustic and netting estimates of FGE is minimal because such losses are small and affect both the numerator and denominator in the FGE calculation. Loss of fish between the top of the STS and turbine intake ceiling may explain a small part of the differences between FGE estimates by hydroacoustics, netting, and radio telemetry if gap-lost fish are detected by radio telemetry antennas mounted on the downstream side of the STS (Ploskey et al. 2003). The FGE estimates for B2 were 47.6% and 35.6% in spring and summer 2004, respectively. This was an over-estimate of FGE since some of the fish counted as guided by hydroacoustics passed through the gap at the top of the STS and back into the turbine intake. If we subtract spring 2004 gap-loss estimates of 14.9% for unmodified units or 5% for modified units from the guided-fish fraction (numerator) and from the total (denominator), the adjusted FGE is lowered by just 4% for unmodified units and 1.3% for the modified units (Table 4.5).

Using gap-loss estimates of 14.9% for unmodified intakes and 5.0% modified intakes, we also compared the benefit of modifying all of the gatewells and STSs to making no modifications. The calculated potential difference in FGE for B2 if all intakes were modified compared to not being modified was 2.72% in spring and 2.40% in summer (Table 4.5).

Table 4.5. Fish Guidance Efficiency from Hydroacoustic Estimates and Revised Estimates that Account for Gap Losses of 14.9% for Unmodified Intakes and 5.0% for Modified Intakes

	Fish Guidance Efficiency		
	Hydroacoustic Estimate Only	Hydroacoustic Estimate Corrected for Gap Loss in an Unmodified Gatewell	Hydroacoustic Estimate Corrected for Gap Loss in a Modified Gatewell
Spring	47.6%	43.6%	46.3%
Summer	35.6%	32.0%	34.4%

5.0 Recommendations

1. We recommend continued study and development of surface routes of passage to increase Project FPE. Probably the most important finding of our 2004 hydroacoustic sampling and estimation is the efficacy of the surface passage routes at the two powerhouses to pass a great many fish in remarkably little water (Figures 3.34 and 3.37), especially during daylight (Figures 3.57 and 3.60). We estimate that almost one-fifth (Project Sluiceway Efficiency = 19.1%) of the total passage in spring and about one-fourth (Project Sluiceway Efficiency = 26.4%) of the total run at large passed the Project by surface routes in only about 5% of the total Project discharge. Development of surface passage at mainstem dams will only become more important with greater competition among uses of always limited and sometimes very scarce water resources.
2. In light of the very high passage estimates for the B1 sluiceway entrances and the very high effectiveness of the B1 sluiceway, it might be well to attempt to increase the capacity of the B1 sluiceway so that more entrances could be opened or the same number of entrances could be opened more. Toward that end and to further improve understanding of surface attraction and passage, further manipulation and sampling of B1 sluiceway opening configurations may be helpful. The specific entrances and their relation to the wing wall, the powerhouse ends (except 10C), the thalweg, and each other may be important to maximize sluiceway passage.
3. Further DIDSON and other hydroacoustic studies should be conducted to help relate hydraulic patterns and fish entry into surface-passage routes. These should study the effects of the magnitude and direction of attraction plumes and entrance flows that contribute to high-entrance efficiency.
4. The B2CC has changed passage conditions and proportions at B2, perhaps for the long term. However, it may still be prudent to look at turbine unit-specific FGEs, particularly for the end Units 11 and 18. Perhaps partly because the TIE deployment was limited to the northern half of B2, the unit-specific FGEs were low (25-50%) for Units 11-14, whereas Units 15-17 had higher FGEs (> 50% except for Unit 17 in summer) and Unit 18's was low again (see Figure 3.64). The trend to higher FGEs in the center, as opposed to the ends, of B2 has been consistent over several years of sampling. Total discharge and estimated fish passage, however, is highest at the ends of the powerhouse and lower in the interior (Figure 3.32 and 3.34). It may be that the end units have priority for some reason unrelated to fish passage but if the end units have high priority for adult attraction flow, we would again point out that such flows may not be needed at night, when most smolts pass downstream via deep passage routes through spillways and turbines. Switching turbine priority to interior B2 Units 15-17 during night for juvenile downstream passage at night, even if the end units were needed for adult attraction during the day, might substantially reduce the "unguided" proportion of B2 fish that pass through turbines, even with the B2CC in operation (Figure 3.54). Of course unintended consequences to hydraulic patterns in the B2 tailrace would have to be considered. Since B2 priority means that those eight turbines pass more water and fish than all of the other Bonneville Dam routes combined (Figures 3.32 and 3.35) then going to some pains to de-emphasize the use of the end units with consistently low FGEs, at least at night when juvenile salmonids pass downstream but adults do not pass upstream, may be warranted.

5. In light of the likely importance of surface routes to pass juvenile salmonids in the least amount of non-turbine flow, it is well that we had PAS modify echosounders to increase bandwidth, which allowed the use of shorter pulse durations and increased target range resolution, allowing us to count fish even when densities were high. More simultaneous sampling with a split-beam system and the DIDSON should be conducted at other surface routes to further understand the effect of bandwidth changes on detectability.
6. This was another year of data that suggest that spilling much over 150,000 cfs at Bonneville Dam may result in diminishing returns in terms of fish passage by spill (Figure 3.29), besides the dangers of high-spill stresses including mechanical damage, tailrace egress, and dissolved gas issues. Results suggest that spill discharge might be allocated more strategically, at least with regard to time of day. During daytime spillway efficiency is low (Figure 3.50). There is a strong correlation between percent spill and spillway efficiency both on an hourly and on a daily basis (Figure 3.27), probably at least partly because of higher spillway discharge during high spillway-passage nighttime hours, but by spilling more strategically (less during daytime) more water could be saved for generation or surface passage.
7. We recommend designing spill studies with randomized replication of experimental units to identify optimum spill and sluiceway operations for maximizing juvenile fish passage by time of day. We know from the 2001 drought year (very low nearly constant spill, see Ploskey et al. 2002c) and from the six days and nights of constant spill in 2004 (Figure 3.59) that there is a diel behavioral component to spillway passage that is independent of spillway discharge, with more fish passing at night. If less spillway discharge did not substantially reduce spillway passage during daytime, then lower daytime spillway discharge might be possible without a meaningful reduction in Project FPE. Lower daytime spill, unless offset by higher generation, would allow the Bonneville pool elevation to increase slightly during the day, thereby slightly increasing surface-route discharges and, potentially at least, surface passage. Of course reducing spill to very low levels any time may have profound and unintended consequences for forebay delay, passage, and tailrace egress as well as changing hydraulic attraction to the spillway and water quality parameters. As electric power demands, increase the strategic spilling of water for fish passage will be more important. Learning the temporal and spatial aspects of operational schemes that maximize FPE with a minimum of water through non-turbine routes will be increasingly important.

6.0 References

- Belcher, E.O., H.Q. Dinh, D.C. Lynn, T.J. Laughlin. 1999. "Beam forming and imaging with acoustic lenses in small, high-frequency sonars." *Proceeding of Oceans '99: Marine Technology Society (MTS)/IEEE Conference*, Seattle, Washington, Sept. 16-19, 1999. Institution of Electrical Engineers.
- BioSonics, Incorporated. 1998. *Hydroacoustic Evaluation and Studies at Bonneville Dam, Spring/Summer 1997*. Report to the U.S. Army Corps of Engineers Portland District, Portland, Oregon.
- Chapman, D. W. and T. C. Bjorn. 1969. "Distribution of salmonids in streams, with special reference to food and feeding. In T. G. Northcote (ed.). *Symposium on Salmon and Trout in Streams*. H. R. MacMillan Lectures in Fisheries, p. 153-176. Institute of Fisheries, University of British Columbia, Vancouver, BC.
- Evans, S. D., J. M. Plumb, A. C. Braatz, K. S. Gates, N. S. Adams, and D. W. Rondorf. 2001a. *Passage Behavior of Radio-Tagged Yearling Chinook Salmon and Steelhead at Bonneville Dam Associated with the Surface Bypass Program, 2000*. Final report to the U.S. Army Corps of Engineers, Portland District.
- Evans, S. D., N. S. Adams, and D. W. Rondorf. 2001b. *Passage Behavior of Radio-Tagged Subyearling Chinook Salmon at Bonneville Dam Associated with the Surface Bypass Program, 2000*. Final report to the U.S. Army Corps of Engineers, Portland District.
- Evans, S. D., C. D. Smith, N. S. Adams, and D. W. Rondorf. 2001c. *Passage Behavior of Radio-Tagged Yearling Chinook Salmon at Bonneville Dam, 2001*. Final report to the U.S. Army Corps of Engineers, Portland District.
- Evans, S. D., C. D. Smith, N. S. Adams, and D. W. Rondorf. 2001d. *Passage Behavior of Radio-Tagged Subyearling Chinook Salmon at Bonneville Dam, 2001*. Final report to the U.S. Army Corps of Engineers, Portland District.
- Evans, S. D., L. S. Wright, C. D. Smith, R. E. Wardell, N. S. Adams, and D. W. Rondorf. 2003a. *Passage Behavior of Radio-Tagged Yearling Chinook and Steelhead at Bonneville Dam, 2002*. Final report to the U.S. Army Corps of Engineers, Portland District.
- Evans, S. D., L. S. Wright, R. E. Wardell, N. S. Adams, and D. W. Rondorf. 2003b. *Passage Behavior of Radio-Tagged Subyearling Chinook at Bonneville Dam, 2002*. Final report to the U.S. Army Corps of Engineers, Portland District.
- Everest, F. H. and D. W. Chapman. 1972. Habitat selection and spatial interaction by juvenile Chinook salmon and steelhead trout in two Idaho streams. *J. Fish. Res. Board. Can.* 29:91-100.
- Ferguson, J.W., Poe, T.P. and Carlson, T.J., 1998. "Surface-oriented bypass systems for juvenile salmonids on the Columbia River, USA." Chapter 22 in Jungworth, E.M., Schmutz, S., and Weiss, S. (Eds.) *Fish Migration and Fish Bypasses*, pp. 281-299. Blackwell Publishing Fishing News Books, Blackwell Science Ltd Publisher, Oxford, UK.
- Ferguson, J. W., G. M. Matthews, R. L. McComas, R. F. Absolon, D. A. Brege, M. H. Gessel, and L. G. Gilbreath. 2004. *Passage of Adult and Juvenile Salmon through Federal Columbia River Power System Dams*. NOAA Technical Memorandum, Fish Ecology Division, Northwest Fisheries Science Center, National Marine Fisheries Service.

- Gessel, M. H., L. G. Gilbreath, W. D. Muir, and R. F. Krcma. 1986. *Evaluation of Juvenile Collection and Bypass System at Bonneville Dam – 1985*. Report to U. S. Army Corps of Engineers, Contract DACW57-85-H-0001. Northwest Fisheries Science Center 2725, Montlake Blvd., Seattle, Washington.
- Gessel, M. H., B. H. Monk, and J. G. Williams. 1988. *Evaluation of the Juvenile Fish Collection and Bypass Systems at Bonneville Dam 1987*. Annual Report by the National Marine Fisheries Service, Coastal Zone and Estuarine Studies Division to the U.S. Army Engineers Portland District, Portland, Oregon.
- Gessel, M. H., J. G. Williams, D. A. Brege, and R. F. Krcma. 1991. “Juvenile Salmonid Guidance at the Bonneville Dam Second Powerhouse, Columbia River, 1983-1989.” *North American Journal of Fisheries Management* 11:400-412.
- Hansel, H.C., Shivley, R.S., Hensleigh, J.E., Liedtke, B.D., Wardell, R.E., Wertheimer, R.H., and Poe, T. P. 1999. *Movement, Distribution, and Behavior of Radio-Tagged Juvenile Chinook Salmon in the Forebay of Bonneville Dam, 1998*. Annual report of research 1998 to the U.S. Army Corps of Engineers, Portland District.
- Hanks, M. E. and G. R. Ploskey. 2000. *Experimental Hydroacoustic Deployments to Improve Estimates of Fish Guidance Efficiency*. ERDC/EL TR-00-8, U.S. Army Engineer Research and Development Center, Vicksburg, MS.
- Hawkes, L. A., R. D. Martinson, R. F. Absolon, and S. Killins. 1991. *Monitoring of Downstream Salmon and Steelhead at Federal Hydroelectric Facilities*. Annual Report 1990 by the National Marine Fisheries Service, ETSD, to the U.S. Department of Energy, Bonneville Power Administration, Portland, Oregon.
- Hensleigh, J. E., R. S. Shively, H. C. Hansel, J. M. Hardiman, G. S. Holmberg, B. D. Liedtke, T. L. Martinelli, R. E. Wardell, R. H. Wertheimer, and T. P. Poe. 1999. *Movement, Distribution, and Behavior of Radio-Tagged Juvenile Chinook Salmon and Steelhead in John Day, The Dalles, and Bonneville Dam Forebays, 1997*. Final report to the U.S. Army Corps of Engineers, Portland District.
- Holmberg, G. S., R. S. Shively, H. C. Hansel, T. L. Martinelli, M. B. Sheer, J. M. Hardiman, B. D. Liedtke, L. S. Blythe, and T. P. Poe. 1996. *Movement, Distribution, and Behavior of Radio-Tagged Juvenile Chinook Salmon in John Day, The Dalles, and Bonneville Dam Forebays, 1996*. Final report to the U.S. Army Corps of Engineers, Portland District.
- Johnson, G. E. and A. E. Giorgi. 1999. *Development of Surface Flow Bypasses at Bonneville Dam: A Synthesis of Data from 1995 to 1998 and a Draft M&E Plan for 2000*. Draft final report submitted October 8, 1999 to Portland District, U.S. Army Corps of Engineers, Portland, Oregon.
- Johnson, G. E. and T. J. Carlson. 2000. *Monitoring and Evaluation of the Prototype Surface Collector at Bonneville First Powerhouse in 2000: Synthesis of Information on PSC Performance*. U. S. Army Corps of Engineers Draft Report prepared by BioAnalysts, Inc and Battelle.
- Johnson, G., J. Hedgepeth, J. Skalski, and A. Giorgi. 2004. *A Markov chain analysis to determine fish entrainment zones*. *Fisheries Research* 69: 349-358.
- Karlin, S., 1968. *A First Course in Stochastic Processes*. Academic Press, New York.
- Kemeny, J. G. and J. L. Snell, 1960. *Finite Markov Chains*. D. Van Nostrand Company, Inc., Princeton, New Jersey.

- Krcma, R. F., D. DeHart, M. Gessel, C. Long, and C. W. Sims. 1982. *Evaluation of Submersible Traveling Screens, Passage of Juvenile Salmonids through the Ice-Trash Sluiceway, and Cycling of Gatewell-Orifice Operations at the Bonneville First Powerhouse, 1981*. Final Report by the National Marine Fisheries Service, Coastal Zone and Estuarine Studies Div. to the U.S. Army Engineer District, Portland, Oregon.
- Love, R. H. 1977. "Target Strength of an Individual Fish at any Aspect." *Journal of the Acoustical Society of America* 62(6):1397-1403.
- Magne, R. A., D. J. Rawding, and W. T. Nagy. 1986. *Hydroacoustic Monitoring at the Bonneville Dam Second Powerhouse during 1986 Fish Guiding Efficiency Tests*. Fishery Field Unit, U.S. Army Engineer District, Portland, Oregon.
- Magne, R. A. 1987. *Hydroacoustic Monitoring at the Bonneville Dam Project in 1987*. Fishery Field Unit, U.S. Army Engineer District, Portland, Oregon.
- Magne, R. A., R. J. Stansell, and W. T. Nagy. 1989. *A Summary of Hydroacoustic Monitoring at the Bonneville Dam Second Powerhouse in 1988*. Fishery Field Unit, U.S. Army Engineer District, Portland, Oregon.
- Monk, B. H., B. P. Sandford, and D. B. Dey. 1995. *Evaluation of Intake Modifications at Bonneville Dam Second Powerhouse, 1995*. Report of Research by the Fish Ecology Division, Northwest Fisheries Science Center, NOAA Fisheries, for the U.S. Army Engineer District, Portland, Oregon.
- Monk, B. H., B. P. Sandford, D. A. Brege, and J. W. Ferguson. 2002. *Evaluation of Turbine Intake Modifications at the Bonneville Dam Second Powerhouse, 2002*. Report of Research by the Fish Ecology Division, Northwest Fisheries Science Center, NOAA Fisheries, for the U.S. Army Engineer District, Portland, Oregon.
- Monk, B. H., B. P. Sandford, D. A. Brege, and J. W. Ferguson. 2004. *Evaluation of Turbine Intake Modifications at the Bonneville Dam Second Powerhouse*. Report of Research by the Fish Ecology Division, Northwest Fisheries Science Center, NOAA Fisheries, for the U.S. Army Engineer District, Portland, Oregon.
- Muir, W. D., A. E. Giorgi, W. S. Zaugg, and B. R. Beckman. 1989. *An Assessment of the Relationship between Smolt Development and Fish Guidance Efficiency at Bonneville Dam*. Annual Report by the National Marine Fisheries Service, Coastal Zone and Estuarine Studies Division, Northwest Fisheries Center, Seattle, Washington.
- National Marine Fisheries Service (NMFS). 2000. *Biological Opinion. Reinitiation of consultation of the Federal Columbia River Power System, including the juvenile fish transportation program and 19 Bureau of Reclamation projects in Columbia Basin*. National Marine Fisheries Service.
- Ploskey, G. R., P. N. Johnson, W. T. Nagy, M. G. Burczinski, and L. R. Lawrence. 1998. *Hydroacoustic Evaluations of Smolt Passage at Bonneville Dam Including Surface Collection Simulations*. USAE Waterway Experiment Station Technical Report EL-98-4 prepared for the U.S. Army Engineer District, Portland, Oregon.
- Ploskey, G. R. and T. J. Carlson. 1999. Comparison of Hydroacoustic and Net Estimates of Fish Guidance Efficiency of an Extended Submersible Bar Screen at John Day Dam. *North American Journal of Fisheries Management* 19:1066-1079.
- Ploskey, G. R., W. T. Nagy, L. R. Lawrence, D. S. Patterson, C. R. Schilt, P. N. Johnson, and J. R. Skalski. 2001a. *Hydroacoustic Evaluation of Juvenile Salmonid Passage through Experimental*

- Routes at Bonneville Dam in 1998*. Technical Report ERDC/EL TR-01-2, U.S. Army Engineer Research and Development Center, Vicksburg, MS.
- Ploskey, G. R., W.T. Nagy, L.R. Lawrence, M.E. Hanks, C.R. Schilt, P. N. Johnson, G. E. Johnson, D. S. Patterson, and J. R. Skalski. 2001b. *Hydroacoustic Evaluation of Juvenile Salmon Passage at The Dalles Dam: 1999*. Technical Report ERDC/EL TR-01-11, U.S. Army Engineer Research and Development Center, Vicksburg, MS.
- Ploskey, G., T. Poe, A. Giorgi, and G. Johnson. 2001c. *Synthesis of Radio Telemetry, Hydroacoustic, and Survival Studies of Juvenile Salmon at The Dalles Dam (1982-2000)*. Final report Contract Number DACW57-00-D-0009, Task Order Case No. 3. Prepared for the U.S. Army Corps of Engineers, Portland, OR by Battelle Pacific Northwest National Laboratory and BioAnalysts, Inc.
- Ploskey, G.R., C.R. Schilt, M.E. Hanks, J.R. Skalski, W.T. Nagy, P.N. Johnson, D.S. Patterson, J. Kim, and L. Lawrence. 2002a *Hydroacoustic Evaluation of a Prototype Surface Collector and In-Turbine Screens at Bonneville Dam First Powerhouse in 2000*. Technical Report ERDC/ELTR-02-15 of the U.S. Army Research and Development Center, Waterways Experiment Station, Vicksburg, Mississippi.
- Ploskey, G.R., C.R. Schilt, M.E. Hanks, P.N. Johnson, J.R. Skalski, W.T. Nagy, P.N. Johnson, D.S. Patterson, J. Kim, and L. Lawrence. 2002b. *Hydroacoustic Evaluation of Fish Passage through Bonneville Dam in 2000*. Technical Report ERDC/ELTR-02-8 of the U.S. Army Engineer Research and Development Center, Waterways Experiment Station, Vicksburg, Mississippi.
- Ploskey, G.R., C.R. Schilt, M.E. Hanks, P. N. Johnson, J. Kim, J.R. Skalski, D.S. Patterson, W.T. Nagy, and L.R. Lawrence. 2002c *Hydroacoustic Evaluation of Fish-Passage Efficiency at Bonneville Dam in 2001*. PNNL-14047. Pacific Northwest National Laboratory, Richland, Washington.
- Ploskey, G. R., C. R. Schilt, J. Kim, C.W. Escher, and J. R. Skalski. 2003. *Hydroacoustic Evaluation of Fish Passage through Bonneville Dam in 2002*. Report by the Pacific Northwest National Laboratory, Richland, Washington, for the U. S. Army Engineer District, Portland, Oregon.
- Ploskey, G. R., M. A. Weiland, and C. R. Schilt. 2004. *Evaluation of Fish Losses through Screen Gaps at Modified and Unmodified Intakes of Bonneville Dam Second Powerhouse in 2003*. Report PNNL-14539 by the Pacific Northwest National Laboratory, Richland, Washington, for the U. S. Army Engineer District, Portland, Oregon.
- Rakowski C.L., J.A. Serkowski, and M.C. Richmond. 2001a. *Numerical Simulations of the Bonneville Powerhouse 2 Forebay Supporting Fish Guidance Efficiency Improvement Studies*. Draft technical report, Pacific Northwest National Laboratory, Richland, Washington.
- Rakowski C.L., J.A. Serkowski, M.C. Richmond, and K.P. Recknagle. 2001b. *Development and Application of a 3D CFD Model for the Bonneville Project Powerhouse 1 and Powerhouse 2*. PNNL-13593, Pacific Northwest National Laboratory, Richland, Washington
- Stansell R. J., R. A. Magne, W. T. Nagy, and L. M. Beck. 1990. *Hydroacoustic Monitoring of Downstream Migrant Juvenile Salmonids at Bonneville Dam, 1989*. Fishery Field Unit, U.S. Army Engineer District, Portland, Oregon.
- Taylor, H. and S. Karlin. 1998. *An Introduction to Stochastic Modeling*. Academic Press, San Diego, California.
- Thorne, R. E. and E. S. Kuehl. 1989. *Evaluation of Hydroacoustics Techniques for Assessment of Juvenile Fish Passage at Bonneville Powerhouse I*. Final Report by BioSonics Inc., Seattle, Washington, for the U.S. Army Engineer District, Portland, Oregon.

- Thorne, R.E. and G.E. Johnson. 1993. A Review of Hydroacoustic Studies for Estimation of Salmonid Downriver Migration Past Hydroelectric Facilities on the Columbia and Snake Rivers in the 1980s. *Reviews in Fisheries Science* 1 (1) 27-56.
- Uremovich, B. L., S. P. Cramer, C. F. Willis, and C. O. Junge. 1980. *Passage of Juvenile Salmonids through the Ice-Trash Sluiceway and Squawfish Predation at Bonneville Dam, 1980*. Oregon Department of Fish and Wildlife Annual progress report prepared for the U.S. Army Engineer District, Portland, Oregon.
- Weiland, M. A. and T. J. Carlson. 2003. *Technologies for Evaluating Fish Passage through Turbines*. PNNL -14437, prepared for the U. S. Department of Energy, Advance Hydropower Turbine System Program by Pacific Northwest National Laboratory, Richland, Washington.
- Williams, J. G., M. H. Gessel, B. P. Sandford, and J. J. Vella. 1996. *Evaluation of Factors Affecting Juvenile Chinook Salmon Fish Guidance Efficiency*. Report to U.S. Army Corps of Engineers, Walla Walla District, Contract E86910059.
- Willis, C. F. and B. L. Uremovich. 1981. *Evaluation of the Ice and Trash Sluiceway at Bonneville Dam as a Bypass System for Juvenile Salmonids, 1981*. Oregon Department of Fish and Wildlife Annual progress report prepared for the U.S. Army Engineer District, Portland, Oregon.
- Wood, L. A., R. D. Martinson, R. J. Graves, D. R. Carroll, S. D. Killins. 1994. *Monitoring of Downstream Salmon and Steelhead at Federal Hydroelectric Facilities*. Annual Report 1993 by the National Marine Fisheries Service, ETSD to the Bonneville Power Administration, Portland, Oregon.

Appendix A

Transducer Calibrations and Receiver Gains

Appendix A

Transducer Calibrations and Receiver Gains

Appendix A.1. Calibration data and calculated receiver gains for single-beam and split-beam transducers deployed at Powerhouse 1 to provide equal detectability for on-axis targets ranging in acoustic size from -56 to -36 dB. Results for split-beam transducers are presented for the x phase, y phase, and the mean of x and y phases.

Echo-sounder Letter and Channel Number	Trans-ducer Number and Phase (if split beams)	Difference in Cable Length Between Calibrated Cable and Installed Cable (ft)	Receiver	Source	Receiver	Target Strength of Smallest On-axis Target (dB)	Voltage of Smallest On-axis Target (dB)	Voltage of Smallest On-axis Target at 20 dB per Volt (V)	Turbine Intake
			Gain Adjusted for Difference in Cable Length (dB)	Level Adjusted for Difference in Cable Length (dB)	Sensitivity Adjusted for Difference in Cable Length (dB)				
C-1	1	-150	4.71	214.09	-112.80	-56	50	2.50	1B
C-2	2	-150	5.07	213.99	-113.06	-56	50	2.50	2C
C-3	3	-150	6.82	213.22	-114.04	-56	50	2.50	2A
C-4	4	-150	5.17	213.83	-113.00	-56	50	2.50	3B
C-5	5	-150	4.11	214.37	-112.48	-56	50	2.50	3C
C-6	6	-150	6.08	213.50	-113.58	-56	50	2.50	4A
C-7	7	-150	4.25	214.39	-112.64	-56	50	2.50	4B
D-1	9	-150	5.09	214.03	-113.12	-56	50	2.50	5A
D-2	17	-150	3.77	214.91	-112.68	-56	50	2.50	5B
D-3	11	-150	5.39	213.97	-113.36	-56	50	2.50	7A
D-4	10	-150	4.93	214.05	-112.98	-56	50	2.50	7C
D-5	12	-150	5.81	213.69	-113.50	-56	50	2.50	8C
D-6	16	-150	3.94	214.56	-112.50	-56	50	2.50	9B
D-7	14	-150	4.36	214.36	-112.72	-56	50	2.50	10B
R-1	53 (x)	78	1.68	214.46	-105.14	-56	55	2.75	6B
R-1	53 (y)	78	1.58	214.54	-105.12	-56	55	2.75	6B
R-1	53	78	1.63	214.50	-105.13	-56	55	2.75	6B
R-2	51 (x)	78	1.40	214.92	-105.32	-56	55	2.75	6A
R-2	51 (y)	78	1.40	214.90	-105.30	-56	55	2.75	6A
R-2	51	78	1.40	214.91	-105.31	-56	55	2.75	6A

Appendix A.2. Calibration data and calculated receiver gains for split-beam transducers deployed at Powerhouse 1 Sluice way to provide equal detectability for on-axis targets ranging in acoustic size from -56 to -36 dB. Results for split-beam transducers are presented for the x phase, y phase, and the mean of x and y phases.

Echo-sounder Letter and Channel Number	Trans-ducer Number and Phase (if split beams)	Difference in Cable			Receiver Sensitivity Adjusted for Difference in Cable Length (dB)	Target Strength of Smallest Target (dB)	Voltage of Smallest Target (V)	Voltage of Smallest Target at 20 dB per Volt (V)	Spill Bay
		Length Between Calibrated Cable and Installed Cable (ft)	Receiver Gain Adjusted for Difference in Cable Length (dB)	Source Level Adjusted for Difference in Cable Length (dB)					
A-0	414 (x)	0	6.18	217.06	-107.24	-56	60	3.00	Sluice 2C
A-0	414 (y)	0	6.21	217.05	-107.26	-56	60	3.00	Sluice 2C
A-0	414	0	6.19	217.06	-107.25	-56	60	3.00	Sluice 2C
A-1	415 (x)	0	7.21	216.75	-107.96	-56	60	3.00	Sluice 2C
A-1	415 (y)	0	7.24	216.76	-108.00	-56	60	3.00	Sluice 2C
A-1	415	0	7.22	216.76	-107.98	-56	60	3.00	Sluice 2C
A-2	416 (x)	0	7.19	216.79	-107.98	-56	60	3.00	Sluice 4A
A-2	416 (y)	0	7.25	216.79	-108.04	-56	60	3.00	Sluice 4A
A-2	416	0	7.22	216.79	-108.01	-56	60	3.00	Sluice 4A
A-3	417 (x)	0	7.16	216.88	-108.04	-56	60	3.00	Sluice 4A
A-3	417 (y)	0	7.18	216.88	-108.06	-56	60	3.00	Sluice 4A
A-3	417	0	7.17	216.88	-108.05	-56	60	3.00	Sluice 4A
X-0	410 (x)	0	4.05	216.99	-105.04	-56	60	3.00	Sluice 6C
X-0	410 (y)	0	4.05	216.99	-105.04	-56	60	3.00	Sluice 6C
X-0	410	0	4.05	216.99	-105.04	-56	60	3.00	Sluice 6C
X-1	411 (x)	0	3.95	216.97	-104.92	-56	60	3.00	Sluice 6C
X-1	411 (y)	0	4.00	216.96	-104.96	-56	60	3.00	Sluice 6C
X-1	411	0	3.97	216.97	-104.94	-56	60	3.00	Sluice 6C

Appendix A.3. Calibration data and calculated receiver gains for single-beam and split-beam transducers deployed at the spillway to provide equal detectability for on-axis targets ranging in acoustic size from -56 to -36 dB. Results for split-beam transducers are presented for the x phase, y phase, and the mean of x and y phases.

Echo-sounder Letter and Channel Number	Trans-ducer Number and Phase (if split beams)	Difference in Cable Length Between Calibrated Cable and Installed Cable (ft)	Receiver Gain Adjusted for Difference in Cable Length (dB)	Source Level Adjusted for Difference in Cable Length (dB)	Receiver Sensitivity Adjusted for Difference in Cable Length (dB)	Target Strength of Smallest On-axis Target (dB)	Voltage of Smallest On-axis Target (V)	Voltage of Smallest Target at 20 dB per Volt (V)	Spill Bay
F-1	46	-300	8.83164276	211.478	-114.3096428	-56	50	2.50	9
F-2	47	-300	9.80164276	210.988	-114.7896428	-56	50	2.50	11
F-3	48	-100	6.61364276	212.256	-112.8696428	-56	50	2.50	13
F-4	55	-100	8.13364276	212.436	-114.5696428	-56	50	2.50	15
F-5	56	200	5.88164276	213.318	-113.1996428	-56	50	2.50	18
M-0	404 (x)	0	9.57	214.23	-112.80	-56	55	2.75	5
M-0	404 (y)	0	9.50	214.24	-112.74	-56	55	2.75	5
M-0	404	0	9.54	214.24	-112.77	-56	55	2.75	5
M-1	412 (x)	0	12.18	213.02	-114.20	-56	55	2.75	7
M-1	412 (y)	0	12.15	213.03	-114.18	-56	55	2.75	7
M-1	412	0	12.17	213.03	-114.19	-56	55	2.75	7
O-0	113 (x)	0	9.79	211.29	-110.08	-56	55	2.75	17
O-0	113 (y)	0	10.80	211.28	-111.08	-56	55	2.75	17
O-0	113	0	10.30	211.29	-110.58	-56	55	2.75	17
P-1	49	-350	7.52	210.55	-112.07	-56	50	2.50	8
P-2	50	-300	8.13	210.52	-112.65	-56	50	2.50	10
P-3	51	-100	6.25	211.52	-111.77	-56	50	2.50	12
P-4	53	-100	4.62	211.95	-110.57	-56	50	2.50	14
P-5	54	150	1.40	213.66	-109.06	-56	50	2.50	16
Q-1	57	-100	2.65	212.32	-108.97	-56	50	2.50	1
Q-2	42	200	1.37	213.73	-109.10	-56	50	2.50	2
Q-3	43	150	1.49	213.29	-108.78	-56	50	2.50	3
Q-4	44	0	2.30	212.42	-108.72	-56	50	2.50	4
Q-5	45	0	2.40	212.78	-109.18	-56	50	2.50	6

Appendix A.4. Calibration data and calculated receiver gains for single and split-beam transducers to provide equal detectability for on-axis targets ranging from -56 to -36 dB in acoustic size at Powerhouse 2. Results for split-beam transducers are presented for the x phase, y phase, and the mean of x and y phases.

Echo-sounder Letter and Channel Number	Transducer Number and Phase (if split beams)	Difference in Cable Length			Receiver Gain Adjusted for Difference in Cable Length (dB)	Source Level Adjusted for Difference in Cable Length (dB)	Receiver Sensitivity Adjusted for Difference in Cable Length (dB)	Target Strength of Smallest On-axis Target (dB)	Voltage of Smallest On-axis Target (V)	Turbine Intake
		Between Calibrated Cable and Installed Cable (ft)	Receiver Gain Adjusted for Difference in Cable Length (dB)	Source Level Adjusted for Difference in Cable Length (dB)						
U-0	403 (x)	0	4.70	216.44	-105.14	-56	60	3.00	B2CC	
U-0	403 (y)	0	4.68	216.48	-105.16	-56	60	3.00	B2CC	
U-0	403	0	4.69	216.46	-105.15	-56	60	3.00	B2CC	
U-1	405 (x)	0	4.57	216.65	-105.22	-56	60	3.00	B2CC	
U-1	405 (y)	0	4.55	216.67	-105.22	-56	60	3.00	B2CC	
U-1	405	0	4.56	216.66	-105.22	-56	60	3.00	B2CC	
V-0	406 (x)	0	4.16	216.60	-104.76	-56	60	3.00	B2CC	
V-0	406 (y)	0	4.13	216.61	-104.74	-56	60	3.00	B2CC	
V-0	406	0	4.15	216.61	-104.75	-56	60	3.00	B2CC	
V-1	407 (x)	0	4.12	216.62	-104.74	-56	60	3.00	B2CC	
V-1	407 (y)	0	4.06	216.66	-104.72	-56	60	3.00	B2CC	
V-1	407	0	4.09	216.64	-104.73	-56	60	3.00	B2CC	
W-1	54 (x)	0	6.31	221.53	-111.84	-56	60	3.00	B2CC	
W-1	54 (y)	0	6.32	221.56	-111.88	-56	60	3.00	B2CC	
W-1	54	0	6.32	221.55	-111.86	-56	60	3.00	B2CC	
W-0	117 (x)	0	7.63	221.15	-112.78	-56	60	3.00	B2CC	
W-0	117 (y)	0	7.61	221.17	-112.78	-56	60	3.00	B2CC	
W-0	117	0	7.62	221.16	-112.78	-56	60	3.00	B2CC	
E-1	119	0	3.19	215.39	-112.58	-56	50	2.50	11A	
E-2	120	0	3.75	215.11	-112.86	-56	50	2.50	11A	
E-3	121	0	4.04	215.10	-113.14	-56	50	2.50	11C	
E-4	125	0	3.47	215.41	-112.88	-56	50	2.50	11C	
E-5	123	0	3.43	215.35	-112.78	-56	50	2.50	13B	
E-6	124	0	3.37	215.37	-112.74	-56	50	2.50	13B	
G-1	34	0	2.98	215.64	-112.62	-56	50	2.50	12A	
G-2	35	0	3.59	215.49	-113.08	-56	50	2.50	12A	
G-3	36	0	3.96	215.24	-113.20	-56	50	2.50	12C	
G-4	37	0	3.83	215.11	-112.94	-56	50	2.50	12C	
G-5	38	-200	4.76	214.80	-113.56	-56	50	2.50	14B	
G-6	39	-200	4.33	214.81	-113.14	-56	50	2.50	14B	
G-7	40	-200	4.27	215.17	-113.44	-56	50	2.50	15B	
G-8	41	-200	6.16	214.30	-114.46	-56	50	2.50	15B	
H-1	539	0	-0.08	216.96	-110.88	-56	50	2.50	17A	
H-2	540	0	0.16	216.94	-111.10	-56	50	2.50	17A	
H-3	541	0	0.16	216.92	-111.08	-56	50	2.50	17B	
H-4	56	0	4.91	214.77	-113.68	-56	50	2.50	17B	
H-5	57	0	4.18	214.92	-113.10	-56	50	2.50	17C	
H-6	61	0	3.37	215.37	-112.74	-56	50	2.50	17C	
H-7	59	0	4.41	214.95	-113.36	-56	50	2.50	18B	
H-8	32	0	3.36	215.58	-112.94	-56	50	2.50	18B	
I-0	400 (x)	0	1.77	217.47	-108.24	-56	55	2.75	16B	
I-0	400 (y)	0	1.75	217.49	-108.24	-56	55	2.75	16B	
I-0	400	0	1.76	217.48	-108.24	-56	55	2.75	16B	
I-1	401 (x)	0	1.93	217.43	-108.36	-56	55	2.75	16B	
I-1	401 (y)	0	1.99	217.43	-108.42	-56	55	2.75	16B	
I-1	401	0	1.96	217.43	-108.39	-56	55	2.75	16B	

Appendix B

Detailed Transducer Locations and Aiming Angles

Appendix B

Detailed Transducer Locations and Aiming Angles

Appendix B.1. Transducer locations at Powerhouse 1 in 2004. Angle refers to the angle off the trash-rack or extended- submerged-bar-screen (ESBS) plane. Abbreviations are as follows: SB = split-beam; (D) = downstream; Rack = trash rack, where Rack 1 is the uppermost of six trash racks, and its top is at Elevation 69 ft MSL.

System Letter	Channel	Transducer	Beam Angle	Intake or Bay	Structure	Location of Placement on Structure	Elevation (ft)	Aim	Angle (Degrees)
C	1	1	6	1B	Rack 1	4.4 ft below top; 11.0 ft S of N Side	64.6	Down	32
C	2	2	6	2C	Rack 1	4.4 ft below top; 8.8 ft S of N Side	64.6	Down	32
C	3	3	6	2A	Rack 1	4.4 ft below top; 13.2 ft S of N Side	64.6	Down	32
C	4	4	6	3B	Rack 1	4.4 ft below top; 11.0 ft S of N Side	64.6	Down	32
C	5	5	6	3C	Rack 1	4.4 ft below top; 13.2 ft S of N Side	64.6	Down	32
C	6	6	6	4A	Rack 1	4.4 ft below top; 8.8 ft S of N Side	64.6	Down	32
C	7	7	6	4B	Rack 1	4.4 ft below top; 11.0 ft S of N Side	64.6	Down	32
D	1	9	6	5A	Rack 1	4.4 ft below top; 13.2 ft S of N Side	64.6	Down	32
D	2	10	6	5B	Rack 1	4.4 ft below top; 8.8 ft S of N Side	64.6	Down	32
D	3	11	6	7A	Rack 1	4.4 ft below top; 11.0 ft S of N Side	64.6	Down	32
D	4	12	6	7C	Rack 1	4.4 ft below top; 8.8 ft S of N Side	64.6	Down	32
D	5	13	6	8C	Rack 1	4.4 ft below top; 13.2 ft S of N Side	64.6	Down	32
D	6	14	6	9B	Rack 1	4.4 ft below top; 8.8 ft S of N Side	64.6	Down	32
D	7	15	6	10B	Rack 1	4.4 ft below top; 13.2 ft S of N Side	64.6	Down	32
R	1	53	SB 6	6B	Rack 1	4.4 ft below top; 8.8 ft S of N Side	64.6	Down	32
R	2	51	SB 6	6A	Rack 1	4.4 ft below top; 11.0 ft S of N Side	64.6	Down	32
A	0	414	SB 6	Sluice 2C	Chain gate	1-ft from North Side		Side	
A	1	415	SB 6	Sluice 2C	Chain gate	1-ft from South Side		Side	
A	2	416	SB 6	Sluice 4A	Chain gate	1-ft from North Side		Side	
A	3	417	SB 6	Sluice 4A	Chain gate	1-ft from South Side		Side	
X	1	410	SB 12	Sluice 6C	Chain gate	1-ft from North Side		Side	
X	0	411	SB 12	Sluice 6C	Chain gate	1-ft from South Side		Side	

Appendix B.2. Transducer locations at the Spillway in 2004. Spillway transducer elevations depend upon gate position and are presented for a 3 ft opening, the maximum observed in 2004. Angle is the angle of the center of the transducer beam off the spill-gate. Abbreviations are as follows: SB = split-beam; (U) = upstream.

System Letter	Channel	Transducer	Beam Angle	Intake or Bay	Structure	Location of Placement on Structure	Elevation (ft)	Aim	Angle (Degrees)
F	1	46	10	9	Spill Gate	28 ft below the top; 17.1 ft S of N side	59.0	Down	9 (U)
F	2	47	10	11	Spill Gate	28 ft below the top; 28.5 ft S of N side	59.0	Down	9 (U)
F	3	48	10	13	Spill Gate	28 ft below the top; 37.0 ft S of N side	59.0	Down	9 (U)
F	4	55	10	15	Spill Gate	28 ft below the top; 17.1 ft S of N side	59.0	Down	9 (U)
F	5	56	10	18	Spill Gate	28 ft below the top; 28.5 ft S of N side	59.0	Down	9 (U)
M	0	404	SB 10	5	Spill Gate	28 ft below the top; 28.5 ft S of N side	59.0	Down	9 (U)
M	1	412	SB 10	7	Spill Gate	28 ft below the top; 37.0 ft S of N side	59.0	Down	9 (U)
O	0	113	SB 10	17	Spill Gate	28 ft below the top; 28.5 ft S of N side	59.0	Down	9 (U)
P	1	49	10	8	Spill Gate	28 ft below the top; 17.1 ft S of N side	59.0	Down	9 (U)
P	2	50	10	10	Spill Gate	28 ft below the top; 37.0 ft S of N side	59.0	Down	9 (U)
P	3	51	10	12	Spill Gate	28 ft below the top; 28.5 ft S of N side	59.0	Down	9 (U)
P	4	53	10	14	Spill Gate	28 ft below the top; 28.5 ft S of N side	59.0	Down	9 (U)
P	5	54	10	16	Spill Gate	28 ft below the top; 37.0 ft S of N side	59.0	Down	9 (U)
Q	1	57	10	1	Spill Gate	28 ft below the top; 28.5 ft S of N side	59.0	Down	9 (U)
Q	2	42	10	2	Spill Gate	28 ft below the top; 37.0 ft S of N side	59.0	Down	9 (U)
Q	3	43	10	3	Spill Gate	28 ft below the top; 17.1 ft S of N side	59.0	Down	9 (U)
Q	4	44	10	4	Spill Gate	28 ft below the top; 17.1 ft S of N side	59.0	Down	9 (U)
Q	5	45	10	6	Spill Gate	28 ft below the top; 37.0 ft S of N side	59.0	Down	9 (U)

Appendix B.3. Transducer locations at Powerhouse 2 in 2004. Angle refers to the angle off the trash-rack plane. Abbreviations are as follows: SB = split-beam; (D) = downstream; (U) = upstream; Beam = a horizontal beam lowered into the trash-rack slot; Rack = trash rack, where Rack 1 is the uppermost of six trash racks, and its top is at Elevation 38 ft MSL.

System Letter	Channel	Transducer	Beam Angle	Intake or Bay	Structure	Location of Placement on Structure	Elevation (ft)	Aim	Angle ° off Vertical
U	0	403	6	B2CC	Barge	10.5' below water's surface		Side	108
U	1	405	6	B2CC	Barge	12.5' below water's surface		Side	112
V	0	406	6	B2CC	Barge	6.5' below water's surface		Side	100
V	1	407	6	B2CC	Barge	8.5' below water's surface		Side	104
W	0	117	3	B2CC	Barge	2.5' below water's surface		Side	92
W	1	54	3	B2CC	Barge	4.5' below water's surface		Side	96
E	1	119	6	11A	Rack 1	13' S of N side of rack		Down	16
E	2	120	6	11A	Rack 4	13' S of N side of rack		Up	16
E	3	121	6	11C	Rack 1	18.5' S of N Side of rack		Down	16
E	4	125	6	11C	Rack 4	18.5' S of N Side of rack		Up	16
E	5	123	6	13B	Rack 1	8.17' S of N side of rack		Down	16
E	6	124	6	13B	Rack 4	8.17' S of N side of rack		Up	16
G	1	34	6	12A	Rack 1	18.5' S of N Side of rack	30.7	Down	16
G	2	35	6	12A	Rack 4	18.5' S of N Side of rack	4.5	Up	16
G	3	36	6	12C	Rack 1	8.17' S of N side of rack	30.7	Down	16
G	4	37	6	12C	Rack 4	8.17' S of N side of rack	4.5	Up	16
G	5	38	6	14B	Rack 1	13' S of N side of rack	30.7	Down	16
G	6	39	6	14B	Rack 4	13' S of N side of rack	4.5	Up	16
G	7	40	6	15B	Rack 1	13' S of N side of rack	30.7	Down	16
G	8	41	6	15B	Rack 4	13' S of N side of rack	4.5	Up	16
H	1	539	6	17A	Rack 1	18.5' S of N Side of rack	30.7	Down	16
H	2	540	6	17A	Rack 4	18.5' S of N Side of rack	4.5	Up	16
H	3	541	6	17B	Rack 1	8.17' S of N side of rack	30.7	Down	16
H	4	56	6	17B	Rack 4	8.17' S of N side of rack	4.5	Up	16
H	5	57	6	17C	Rack 1	13' S of N side of rack	30.7	Down	16
H	6	61	6	17C	Rack 4	13' S of N side of rack	4.5	Up	16
H	7	59	6	18B	Rack 1	13' S of N side of rack	30.7	Down	16
H	8	32	6	18B	Rack 4	13' S of N side of rack	4.5	Up	16
I	0	400	6	16B	Rack 1	19.75' S of N Side of rack	30.7	Down	16
I	10	401	6	16B	Rack 4	19.75' S of N Side of rack	4.5	Up	16

Appendix C

Autotracker Definitions and Settings

Hydroacoustic Evaluation of Fish Passage through Bonneville Dam in 2004

Appendix C

Autotracker Definitions and Settings

Appendix C.1. Definitions of Autotracking Software Parameters Used for Processing Hydroacoustic Data from Bonneville Dam in 2004.

Parameter	Definition
BlockSize	Maximum number of ping of data to process as a sample
MaxRange	Range (cm) to end autotracking
MinRange	Range (cm) to begin autotracking
StructureThreshold	Fraction of possible echoes in a range bin that triggers assignment as structure
RangeNoise	Range (cm) uncertainty in the position of an echo in range
GateSize	Maximum range about the predicted position of the next echo in which an encounter echo will be added to a fish track
DKMax	The max ping difference the autotracker will check to find the next ping in a track segment
Alpha	Parameter used in an Alpha-Beta tracking formula; Beta was calculated from Alpha as follows: $\text{Beta} = 2(2 - \text{Alpha}) - 4(1 - \text{Alpha})0.5$
LinkGate	Range (cm) over which two colinear tracked segments will be linked
LinkDKMax	The maximum ping difference the autotracker will span to link segments into a track
Maximum Echo or Target Strength	Largest acoustic size acceptable for autotracking. This may be based upon echo strength (dB) from single beams or target strength (dB) from split beams
Minimum Echo or Target Strength	Smallest acoustic size acceptable for tracking. Also known as the on-axis strength of an echo.
NOISE	The number of dilates and erodes used to identify noise regions (greater than 0)(-1 means do not do noise for a channel)
BottomStartRange	The range (in centimeters) to begin the routine to identify the surface or bottom range (should be between min and max range) (if bottom identification is not needed, set value greater than max range)
BottomCtThold	The proportion of a range that must be occupied by echoes > than the bottom amplitude threshold to be marked as bottom. (0 -1)
BottomAmplThold	The minimum echo strength (in decibels) above which echoes will be tallied as bottom or surface echoes
OutputChannel	An option to write out fish with a different channel number than the one assigned at collection (set to -1 to keep original channel number)
DamName	The name of the Dam or other general location of data collection

Hydroacoustic Evaluation of Fish Passage through Bonneville Dam in 2004

Appendix C.2. Autotracking Software Setting Used for Bonneville Dam Data in 2004.

System (Channel) & Aiming Direction	Data Block Size (pings)	Max. Range (m)	Min. Range (m)	Structure Thresh-hold	Range Noise (cm)	Ver-tical Gate Size (cm)	DK- Max	Alpha	Link Gate (cm)	Max. Echo or Target Strength (dB)	Min. Echo or Target Strength (dB)	Noise Level	Range to Start Bottom (cm)	Bottom Count Thres-hold	Bottom Amplitude Threshold (dB)	
A00	SIDE	1500	7	1	0.075	0.2	0.03	4	0.4	0.12	-26	-56	5	36	0.3	-25.99
A01	SIDE	1500	7	1	0.075	0.2	0.03	4	0.4	0.12	-26	-56	5	36	0.3	-25.99
A02	SIDE	1500	7	1	0.075	0.2	0.03	4	0.4	0.12	-26	-56	5	36	0.3	-25.99
A03	SIDE	1500	7	1	0.075	0.2	0.03	4	0.4	0.12	-26	-56	5	36	0.3	-25.99
C01	DOWN	1200	20	1	0.075	0.2	0.12	4	0.4	0.24	-26	-56	5	36	0.3	-25.99
C02	DOWN	1200	20	1	0.075	0.2	0.12	4	0.4	0.24	-26	-56	5	36	0.3	-25.99
C03	DOWN	1200	20	1	0.075	0.2	0.12	4	0.4	0.24	-26	-56	5	36	0.3	-25.99
C04	DOWN	1200	20	1	0.075	0.2	0.12	4	0.4	0.24	-26	-56	5	36	0.3	-25.99
C05	DOWN	1200	20	1	0.075	0.2	0.12	4	0.4	0.24	-26	-56	5	36	0.3	-25.99
C06	DOWN	1200	20	1	0.075	0.2	0.12	4	0.4	0.24	-26	-56	5	36	0.3	-25.99
C07	DOWN	1200	20	1	0.075	0.2	0.12	4	0.4	0.24	-26	-56	5	36	0.3	-25.99
D01	DOWN	1200	20	1	0.075	0.2	0.12	4	0.4	0.24	-26	-56	5	36	0.3	-25.99
D02	DOWN	1200	20	1	0.075	0.2	0.12	4	0.4	0.24	-26	-56	5	36	0.3	-25.99
D03	DOWN	1200	20	1	0.075	0.2	0.12	4	0.4	0.24	-26	-56	5	36	0.3	-25.99
D04	DOWN	1200	20	1	0.075	0.2	0.12	4	0.4	0.24	-26	-56	5	36	0.3	-25.99
D05	DOWN	1200	20	1	0.075	0.2	0.12	4	0.4	0.24	-26	-56	5	36	0.3	-25.99
D06	DOWN	1200	20	1	0.075	0.2	0.12	4	0.4	0.24	-26	-56	5	36	0.3	-25.99
D07	DOWN	1200	20	1	0.075	0.2	0.12	4	0.4	0.24	-26	-56	5	36	0.3	-25.99
E01	DOWN	1385	18	5	0.075	0.2	0.12	4	0.4	0.24	-26	-56	5	36	0.3	-25.99
E02	UP	1385	12	5	0.075	0.2	0.08	4	0.3	0.18	-26	-56	5	36	0.3	-25.99
E03	DOWN	1385	18	5	0.075	0.2	0.12	4	0.4	0.24	-26	-56	5	36	0.3	-25.99
E04	UP	1385	12	5	0.075	0.2	0.08	4	0.3	0.18	-26	-56	5	36	0.3	-25.99
E05	DOWN	1385	18	5	0.075	0.2	0.12	4	0.4	0.24	-26	-56	5	36	0.3	-25.99
E06	UP	1385	12	5	0.075	0.2	0.08	4	0.3	0.18	-26	-56	5	36	0.3	-25.99
F01	DOWN	1500	10.8	5	0.075	0.2	0.12	4	0.5	0.24	-26	-56	5	10	0.05	-25.99
F02	DOWN	1500	10.8	5	0.075	0.2	0.12	4	0.5	0.24	-26	-56	5	10	0.05	-25.99
F03	DOWN	1500	10.6	5	0.075	0.2	0.12	4	0.5	0.24	-26	-56	5	10	0.05	-25.99
F04	DOWN	1500	10.9	5	0.075	0.2	0.12	4	0.5	0.24	-26	-56	5	10	0.05	-25.99
F05	DOWN	1500	10.8	5	0.075	0.2	0.12	4	0.5	0.24	-26	-56	5	10	0.05	-25.99
G01	DOWN	1385	18	5	0.075	0.2	0.12	4	0.4	0.24	-26	-56	5	36	0.3	-25.99
G02	UP	1385	12	5	0.075	0.2	0.08	4	0.3	0.18	-26	-56	5	36	0.3	-25.99
G03	DOWN	1385	18	5	0.075	0.2	0.12	4	0.4	0.24	-26	-56	5	36	0.3	-25.99
G04	UP	1385	12	5	0.075	0.2	0.08	4	0.3	0.18	-26	-56	5	36	0.3	-25.99
G05	DOWN	1385	18	5	0.075	0.2	0.12	4	0.4	0.24	-26	-56	5	36	0.3	-25.99
G06	UP	1385	12	5	0.075	0.2	0.08	4	0.3	0.18	-26	-56	5	36	0.3	-25.99
G07	DOWN	1385	18	5	0.075	0.2	0.12	4	0.4	0.24	-26	-56	5	36	0.3	-25.99
G08	UP	1385	12	5	0.075	0.2	0.08	4	0.3	0.18	-26	-56	5	36	0.3	-25.99
H01	DOWN	1385	18	5	0.075	0.2	0.12	4	0.4	0.24	-26	-56	5	36	0.3	-25.99
H02	UP	1385	12	5	0.075	0.2	0.08	4	0.3	0.18	-26	-56	5	36	0.3	-25.99
H03	DOWN	1385	18	5	0.075	0.2	0.12	4	0.4	0.24	-26	-56	5	36	0.3	-25.99
H04	UP	1385	12	5	0.075	0.2	0.08	4	0.3	0.18	-26	-56	5	36	0.3	-25.99
H05	DOWN	1385	18	5	0.075	0.2	0.12	4	0.4	0.24	-26	-56	5	36	0.3	-25.99
H06	UP	1385	12	5	0.075	0.2	0.08	4	0.3	0.18	-26	-56	5	36	0.3	-25.99
H07	DOWN	1385	18	5	0.075	0.2	0.12	4	0.4	0.24	-26	-56	5	36	0.3	-25.99
H08	UP	1385	12	5	0.075	0.2	0.08	4	0.3	0.18	-26	-56	5	36	0.3	-25.99
I00	UP	1385	18	5	0.075	0.2	0.12	4	0.4	0.24	-26	-56	5	36	0.3	-25.99
I01	DOWN	1385	12	5	0.075	0.2	0.08	4	0.3	0.18	-26	-56	5	36	0.3	-25.99
M00	DOWN	1500	10.5	5	0.075	0.2	0.12	4	0.5	0.24	-26	-56	5	10	0.05	-25.99
M01	DOWN	1500	10.3	5	0.075	0.2	0.12	4	0.5	0.24	-26	-56	5	10	0.05	-25.99
O00	DOWN	1500	11.2	5	0.075	0.2	0.12	4	0.5	0.24	-26	-56	5	10	0.05	-25.99
P01	DOWN	1500	10.9	5	0.075	0.2	0.12	4	0.5	0.24	-26	-56	5	10	0.05	-25.99
P02	DOWN	1500	10.8	5	0.075	0.2	0.12	4	0.5	0.24	-26	-56	5	10	0.05	-25.99
P03	DOWN	1500	10.8	5	0.075	0.2	0.12	4	0.5	0.24	-26	-56	5	10	0.05	-25.99
P04	DOWN	1500	10.9	5	0.075	0.2	0.12	4	0.5	0.24	-26	-56	5	10	0.05	-25.99
P05	DOWN	1500	10.9	5	0.075	0.2	0.12	4	0.5	0.24	-26	-56	5	10	0.05	-25.99
Q01	DOWN	1500	10.5	5	0.075	0.2	0.12	4	0.5	0.24	-26	-56	5	10	0.05	-25.99
Q02	DOWN	1500	11	5	0.075	0.2	0.12	4	0.5	0.24	-26	-56	5	10	0.05	-25.99
Q03	DOWN	1500	10.8	5	0.075	0.2	0.12	4	0.5	0.24	-26	-56	5	10	0.05	-25.99
Q04	DOWN	1500	10.8	5	0.075	0.2	0.12	4	0.5	0.24	-26	-56	5	10	0.05	-25.99
Q05	DOWN	1500	10.7	5	0.075	0.2	0.12	4	0.5	0.24	-26	-56	5	10	0.05	-25.99
R01	DOWN	1200	20	1	0.075	0.2	0.12	4	0.4	0.24	-26	-56	5	36	0.3	-25.99
R02	DOWN	1200	20	1	0.075	0.2	0.12	4	0.4	0.24	-26	-56	5	36	0.3	-25.99
U00	SIDE	500	10.3	1	1	0.2	0.035	4	0.4	0.12	-26	-56	6	36	0.3	-25.99
U01	SIDE	500	9.3	1	1	0.2	0.035	4	0.4	0.12	-26	-56	6	36	0.3	-25.99
V00	SIDE	500	11.1	1	1	0.2	0.035	4	0.4	0.12	-26	-56	6	36	0.3	-25.99
V01	SIDE	500	11.1	1	1	0.2	0.035	4	0.4	0.12	-26	-56	6	36	0.3	-25.99
W00	SIDE	500	11.6	1	1	0.2	0.035	4	0.4	0.12	-26	-56	6	36	0.3	-25.99
W01	SIDE	500	11.6	1	1	0.2	0.035	4	0.4	0.12	-26	-56	6	36	0.3	-25.99
X00	SIDE	1500	7	1	0.075	0.2	0.03	4	0.4	0.12	-26	-56	5	36	0.3	-25.99
X01	SIDE	1500	7	1	0.075	0.2	0.03	4	0.4	0.12	-26	-56	5	36	0.3	-25.99

Appendix D

Statistical Analysis System Code for Filtering Echo Traces Selected by Autotracking Software

Appendix D

Statistical Analysis System Code for Filtering Echo Traces Selected by Autotracking Software

Appendix D.1. Definitions of variables used for filtering echo traces selected by autotracking software in 2004.

Parameter	Definition
System	Corresponds to an echosounder and associated transducers. Echosounder channels and transducer locations are described in Appendix B.
Mux_Channel	Corresponds to a single transducer attached to one specific echosounder channel.
First_Ping	The absolute ping number for the first echo in an a series of echoes forming an echo trace.
Last_Ping	The absolute ping number for the last echo in an a series of echoes forming an echo trace. Last_Ping / Group_Size is the total number of pings in an echo trace.
Group_Size	Describes the number transducers sampled simultaneously (1=slow multiplex; 2=fast multiplex)
Mean_Target_Strength	The average echo amplitude of a fish trace in dB. This would be echo strength for fish detected by single beam transducers. Maximum echo-strength thresholds were set 2.3 dB lower than target-strength thresholds based upon empirical data from the two types of distributions.
Linearity1	The mean cm deviation of echoes from a line fit through a series of echoes forming a trace.
Linearity2	The mean cm deviation of echoes from a parabola fit through a series of echoes forming a trace.
Noise_Count_Average	The number of noise echoes in a window around an echo trace. The window began 5 pings before the first echo and ended 5 pings after the last echo in the trace and was ± 0.5 m in range.
Slope	$(\text{last range} - \text{first range}) / (\text{last relative ping} - \text{first relative ping})$
First_Range	The ranges of the first echoes in an echo trace.
Last_Range	The ranges of the last echoes in an echo trace.
Echo_Count	Number of echoes in track
Noise_Index	Noise Sum / Track echo count
Noise_Count_Average	Noise Count / Track echo count
Contrast	the ratio of average fish echo amplitude to the average noise echo amplitude in the same window
Track_Type	0 if normal, 1 if flat track near clutter
Mean_Echo_Strength	Mean echostrength (not corrected for phase information)
Mean_Pulse_Width	Duration of transmitted pulses

Appendix D.2. Statistical Analysis System (SAS) code for filtering out echo traces that did not meet fish trace criteria in spring 2004. Minimum ranges for sampling guided, unguided, and spilled fish, which are presented in legends of Figures 2.1-2.3, 2.5, and 2.6 were implemented elsewhere in the processing program.

```

IF STATUS EQ 'CLOSED' THEN FISH=0; ***Status comes from HYDRO and refers to the condition of the route;
***Enter global filters for TS, ES, ECHO_COUNT, AND SLOPE;
IF Mean_Echo_Strength > -36 THEN DELETE;
***Enter MUX_CHANNEL specific structural, trace quality, and noise filters to eliminate bad tracks;
IF SYSTEM='A' THEN DO; ***Ready for 2004;
  IF
    (((First_Range + Last_Range) / 2) > 6) OR
    (((First_Range + Last_Range) / 2) < 3) OR
    (Echo_Count = 4 AND ((Linearity1 / Echo_Count) > 0.4)) OR
    (Echo_Count >= 5 AND Echo_Count <= 7 AND ((Linearity1 / Echo_Count) >= 0.5)) OR
    ((Linearity2 / Echo_Count) > 0.5) OR
    (Linearity1 > 10 AND Linearity2 > 10) OR
    (Echo_Count=4 AND ((Noise_Count_Average/((Echo_Count+12)*18))>.01)) OR
    (Echo_Count=5 AND ((Noise_Count_Average/((Echo_Count+12)*18))>.015)) OR
    (Echo_Count =6 AND ((Noise_Count_Average/((Echo_Count+12)*18))>.017)) OR
    (Echo_Count >=7 AND ((Noise_Count_Average/((Echo_Count+12)*18))>.020)) OR
    (Echo_Count >=7 AND ((Noise_Count_Average/((Echo_Count+12)*18))>.018) AND (Linearity1/Echo_Count > 0.25))
  THEN DELETE;
END;
IF SYSTEM='X' THEN DO; ***Ready for 2004;
  IF
    (((First_Range + Last_Range) / 2) > 6) OR
    (((First_Range + Last_Range) / 2) < 3) OR
    (Echo_Count = 4 AND ((Linearity1 / Echo_Count) > 0.4)) OR
    (Echo_Count >= 5 AND Echo_Count <= 7 AND ((Linearity1 / Echo_Count) >= 0.5)) OR
    ((Linearity2 / Echo_Count) > 0.5) OR
    (Linearity1 > 10 AND Linearity2 > 10) OR
    (Echo_Count=4 AND ((Noise_Count_Average/((Echo_Count+12)*18))>.01)) OR
    (Echo_Count=5 AND ((Noise_Count_Average/((Echo_Count+12)*18))>.015)) OR
    (Echo_Count =6 AND ((Noise_Count_Average/((Echo_Count+12)*18))>.017)) OR
    (Echo_Count >=7 AND ((Noise_Count_Average/((Echo_Count+12)*18))>.020)) OR
    (Echo_Count >=7 AND ((Noise_Count_Average/((Echo_Count+12)*18))>.018) AND (Linearity1/Echo_Count > 0.25))
  THEN DELETE;
END;

***Ready for 2004 SPRING;
*****;
IF SYSTEM='C' THEN DO;
  IF MUX_CHANNEL EQ 1 THEN DO; *** CHI DID NOT RUN ALL SPRING;
    IF MUX_CHANNEL EQ 1 THEN DO;
      IF (((First_Range + Last_Range) / 2)>19.05) OR
        (Echo_Count = 4 AND ((Linearity1 / Echo_Count) > 0.4)) OR
        (Echo_Count >= 5 AND Echo_Count <= 7 AND ((Linearity1 / Echo_Count) >= 0.5)) OR
        ((Linearity2 / Echo_Count) > 0.5) OR
        (Slope >= 2.5 OR Slope <= -2.5) OR
        (((Noise_Count_Average) / ((Echo_Count + 10) * 5)) > 0.04)) OR
        (Slope < 0.2)
      THEN DELETE;
    END;
  END;
  IF MUX_CHANNEL EQ 2 THEN DO;
    IF (((First_Range + Last_Range) / 2)>21.34) OR
      (Echo_Count = 4 AND ((Linearity1 / Echo_Count) > 0.4)) OR
      (Echo_Count >= 5 AND Echo_Count <= 7 AND ((Linearity1 / Echo_Count) >= 0.5)) OR
      ((Linearity2 / Echo_Count) > 0.5) OR
      (SLOPE >= 2.5) OR
      (SLOPE < 0) OR
      (((First_Range + Last_Range) / 2) < 21.34) AND (((First_Range + Last_Range) / 2) >= 18.5) AND (SLOPE <
        0.1) OR
      (((First_Range + Last_Range) / 2) < 18.5) AND (((First_Range + Last_Range) / 2) >= 16) AND (SLOPE <
        0.15) OR
      (((First_Range + Last_Range) / 2) < 16) AND (((First_Range + Last_Range) / 2) >= 13.5) AND (SLOPE <
        0.2) OR
      (((First_Range + Last_Range) / 2) < 13.5) AND (((First_Range + Last_Range) / 2) >= 12) AND (SLOPE <
        0.5) OR
      (((First_Range + Last_Range) / 2) < 12) AND (SLOPE < 0.3)) OR
      (((Noise_Count_Average) / ((Echo_Count + 10) * 5)) > 0.04))
    THEN DELETE;
  END;
  IF MUX_CHANNEL EQ 3 THEN DO;
    IF (TRACK_TYPE = 1) OR
      (((First_Range + Last_Range) / 2)>21.56) OR

```

Hydroacoustic Evaluation of Fish Passage through Bonneville Dam in 2004

```
(Echo_Count = 4 AND ((Linearity1 / Echo_Count) > 0.4)) OR
(Echo_Count >= 5 AND Echo_Count <= 7 AND ((Linearity1 / Echo_Count) >= 0.5)) OR
((Linearity2 / Echo_Count) > 0.5) OR
(SLOPE >= 2.5) OR
(((First_Range + Last_Range) / 2) < 21.56) AND (((First_Range + Last_Range) / 2) >= 16) AND (SLOPE <
0.1)) OR
(((First_Range + Last_Range) / 2) < 16) AND (((First_Range + Last_Range) / 2) >= 14.5) AND (SLOPE <
0.2)) OR
(((First_Range + Last_Range) / 2) < 14.5) AND (((First_Range + Last_Range) / 2) >= 13) AND (SLOPE <
0.3)) OR
(((First_Range + Last_Range) / 2) < 13) AND (((First_Range + Last_Range) / 2) >= 9) AND (SLOPE < 0.4))
OR
(((First_Range + Last_Range) / 2) < 9) AND (SLOPE < 0.3)) OR
(((Noise_Count_Average) / ((Echo_Count + 10) * 5)) > 0.04))
THEN DELETE;
END;
IF MUX_CHANNEL EQ 4 THEN DO;
IF (TRACK_TYPE = 1) OR
(((First_Range + Last_Range) / 2) > 21.40) OR

(Echo_Count = 4 AND ((Linearity1 / Echo_Count) > 0.4)) OR
(Echo_Count >= 5 AND Echo_Count <= 7 AND ((Linearity1 / Echo_Count) >= 0.5)) OR
((Linearity2 / Echo_Count) > 0.5) OR
(SLOPE >= 2.5) OR
(((First_Range + Last_Range) / 2) < 20) AND (((First_Range + Last_Range) / 2) >= 13.5) AND (SLOPE <
0.25)) OR
(((First_Range + Last_Range) / 2) < 13.5) AND (((First_Range + Last_Range) / 2) >= 11.8) AND (SLOPE <
6)) OR
(((First_Range + Last_Range) / 2) < 13.5) AND (((First_Range + Last_Range) / 2) >= 11.8) AND
(LINEARITY1 > 5)) OR
(((First_Range + Last_Range) / 2) < 11.8) AND (((First_Range + Last_Range) / 2) >= 10) AND (SLOPE <
0.2)) OR
(((First_Range + Last_Range) / 2) < 10) AND (((First_Range + Last_Range) / 2) >= 7) AND (SLOPE < 0.25))
OR
(((First_Range + Last_Range) / 2) < 7) AND (SLOPE < 0.3)) OR
(((Noise_Count_Average) / ((Echo_Count + 10) * 5)) > 0.04))
THEN DELETE;
END;
IF MUX_CHANNEL EQ 5 THEN DO;
IF (TRACK_TYPE = 1) OR
(((First_Range + Last_Range) / 2) > 21.76) OR

(Echo_Count = 4 AND ((Linearity1 / Echo_Count) > 0.4)) OR
(Echo_Count >= 5 AND Echo_Count <= 7 AND ((Linearity1 / Echo_Count) >= 0.5)) OR
((Linearity2 / Echo_Count) > 0.5) OR
(SLOPE >= 2.5) OR
(((First_Range + Last_Range) / 2) < 20) AND (((First_Range + Last_Range) / 2) >= 15) AND (SLOPE < 0.1))
OR
(((First_Range + Last_Range) / 2) < 15) AND (((First_Range + Last_Range) / 2) >= 12) AND (SLOPE < 0.3))
OR
(((First_Range + Last_Range) / 2) < 12) AND (SLOPE < 0.4)) OR
(((Noise_Count_Average) / ((Echo_Count + 10) * 5)) > 0.04))
THEN DELETE;
END;
IF MUX_CHANNEL EQ 6 THEN DO;
IF (TRACK_TYPE = 1) OR
(((First_Range + Last_Range) / 2) > 20.35) OR

(Echo_Count = 4 AND ((Linearity1 / Echo_Count) > 0.4)) OR
(Echo_Count >= 5 AND Echo_Count <= 7 AND ((Linearity1 / Echo_Count) >= 0.5)) OR
((Linearity2 / Echo_Count) > 0.5) OR
(SLOPE >= 2.5) OR
(((First_Range + Last_Range) / 2) < 20.35) AND (((First_Range + Last_Range) / 2) >= 15) AND (SLOPE <
0.15)) OR
(((First_Range + Last_Range) / 2) < 15) AND (((First_Range + Last_Range) / 2) >= 13.5) AND (SLOPE <
0.3)) OR
(((First_Range + Last_Range) / 2) < 13.5) AND (((First_Range + Last_Range) / 2) >= 12.3) AND (SLOPE <
0.7)) OR
(((First_Range + Last_Range) / 2) < 12.3) AND (((First_Range + Last_Range) / 2) >= 7) AND (SLOPE <
0.25)) OR
(((First_Range + Last_Range) / 2) < 7) AND (SLOPE < 0.35)) OR
(((Noise_Count_Average) / ((Echo_Count + 10) * 5)) > 0.04))
THEN DELETE;
END;
IF MUX_CHANNEL EQ 7 THEN DO;
IF (TRACK_TYPE = 1) OR
(((First_Range + Last_Range) / 2) > 21.64) OR

(Echo_Count = 4 AND ((Linearity1 / Echo_Count) > 0.4)) OR
(Echo_Count >= 5 AND Echo_Count <= 7 AND ((Linearity1 / Echo_Count) >= 0.5)) OR
((Linearity2 / Echo_Count) > 0.5) OR
```

Hydroacoustic Evaluation of Fish Passage through Bonneville Dam in 2004

```
(SLOPE >= 2.5) OR
(((First_Range + Last_Range) / 2) < 21.64) AND (((First_Range + Last_Range) / 2) >= 15) AND (SLOPE <
0.15)) OR
(((First_Range + Last_Range) / 2) < 15) AND (((First_Range + Last_Range) / 2) >= 13.6) AND (SLOPE <
0.25)) OR
(((First_Range + Last_Range) / 2) < 13.6) AND (((First_Range + Last_Range) / 2) >= 13.4) AND
(SLOPE<0.25)) OR
(((First_Range + Last_Range) / 2) < 13.4) AND (((First_Range + Last_Range) / 2) >= 12.6) AND (SLOPE <
0.3)) OR
(((First_Range + Last_Range) / 2) < 12.6) AND (((First_Range + Last_Range) / 2) >= 11.95) AND (SLOPE <
0.6)) OR
(((First_Range + Last_Range) / 2) < 11.95) AND (((First_Range + Last_Range) / 2) >= 8) AND (SLOPE <
0.2)) OR
(((First_Range + Last_Range) / 2) < 8) AND (SLOPE < 0.3)) OR
(((Noise_Count_Average) / ((Echo_Count + 10) * 5)) > 0.04))
THEN DELETE;
END;
END;

IF SYSTEM='D' THEN DO;
IF MUX_CHANNEL EQ 1 THEN DO;
IF (((First_Range + Last_Range) / 2)>21.73) OR

(Echo_Count = 4 AND ((Linearity1 / Echo_Count) > 0.4)) OR
(Echo_Count >= 5 AND Echo_Count <= 7 AND ((Linearity1 / Echo_Count) >= 0.5)) OR
((Linearity2 / Echo_Count) > 0.5) OR
(((First_Range + Last_Range) / 2) < 21.73) AND (((First_Range + Last_Range) / 2) >= 15) AND (SLOPE <
0.15)) OR
(((First_Range + Last_Range) / 2) < 15) AND (((First_Range + Last_Range) / 2) >= 13.15) AND (SLOPE <
0.25)) OR
(((First_Range + Last_Range) / 2) < 13.15) AND (((First_Range + Last_Range) / 2) >= 11.82) AND (SLOPE <
0.5)) OR
(((First_Range + Last_Range) / 2) < 11.82) AND (((First_Range + Last_Range) / 2) >= 10.36) AND (SLOPE <
0.25)) OR
(((First_Range + Last_Range) / 2) < 10.36) AND (((First_Range + Last_Range) / 2) >= 9.65) AND
(SLOPE<0.45)) OR
(((First_Range + Last_Range) / 2) < 9.65) AND (SLOPE < 0.2)) OR
(((Noise_Count_Average) / ((Echo_Count + 10) * 5)) > 0.04))
THEN DELETE;
END;
IF MUX_CHANNEL EQ 2 THEN DO;
IF (TRACK_TYPE=1) OR
(((First_Range + Last_Range) / 2)>21.25) OR

(Echo_Count = 4 AND ((Linearity1 / Echo_Count) > 0.4)) OR
(Echo_Count >= 5 AND Echo_Count <= 7 AND ((Linearity1 / Echo_Count) >= 0.5)) OR
((Linearity2 / Echo_Count) > 0.5) OR
(SLOPE >= 2.5) OR
(SLOPE < 0.2) OR
(((First_Range + Last_Range) / 2) < 21.25) AND (((First_Range + Last_Range) / 2) >= 19.75) AND (SLOPE <
0.15)) OR
(((First_Range + Last_Range) / 2) < 19.75) AND (((First_Range + Last_Range) / 2) >= 18.9) AND (SLOPE <
0.45)) OR
(((First_Range + Last_Range) / 2) < 12.76) AND (((First_Range + Last_Range) / 2) >= 11.64) AND (SLOPE <
0.45)) OR
(((First_Range + Last_Range) / 2) < 10.5) AND (((First_Range + Last_Range) / 2) >= 9.65) AND (SLOPE <
0.45)) OR
(((First_Range + Last_Range) / 2) < 6.5) AND (SLOPE < 0.3)) OR
(((Noise_Count_Average) / ((Echo_Count + 10) * 5)) > 0.04))
THEN DELETE;
END;
IF MUX_CHANNEL EQ 3 THEN DO;
IF (TRACK_TYPE=1) OR
(((First_Range + Last_Range) / 2)>21.66) OR

(Echo_Count = 4 AND ((Linearity1 / Echo_Count) > 0.4)) OR
(Echo_Count >= 5 AND Echo_Count <= 7 AND ((Linearity1 / Echo_Count) >= 0.5)) OR
((Linearity2 / Echo_Count) > 0.5) OR
(LINEARITY1>3.2 AND LINEARITY2>3.2 AND NOISE_COUNT_AVERAGE>3) OR
(SLOPE >= 2) OR
(SLOPE < 0.15) OR
(((First_Range + Last_Range) / 2) < 21.66) AND (((First_Range + Last_Range) / 2) >= 18) AND (SLOPE <
0.1) OR
(((First_Range + Last_Range) / 2) < 18) AND (((First_Range + Last_Range) / 2) >= 15) AND (SLOPE < 0.15))
OR
(((First_Range + Last_Range) / 2) < 15) AND (((First_Range + Last_Range) / 2) >= 13.40) AND (SLOPE <
0.2)) OR
(((First_Range + Last_Range) / 2) < 13.40) AND (((First_Range + Last_Range) / 2) >= 11.57) AND (SLOPE <
0.7)) OR
(((First_Range + Last_Range) / 2) < 10.45) AND (((First_Range + Last_Range) / 2) >= 9.65) AND (SLOPE <
0.7)) OR
```

Hydroacoustic Evaluation of Fish Passage through Bonneville Dam in 2004

```
((((First_Range + Last_Range) / 2) < 6.5) AND (SLOPE < 0.3)) OR
(((Noise_Count_Average) / ((Echo_Count + 10) * 5)) > 0.04))
THEN DELETE;
END;
IF MUX_CHANNEL EQ 4 THEN DO;
IF (TRACK_TYPE=1 AND SLOPE<0.7) OR
(((First_Range + Last_Range) / 2)>21.38) OR

(Echo_Count = 4 AND ((Linearity1 / Echo_Count) > 0.4)) OR
(Echo_Count >= 5 AND Echo_Count <= 7 AND ((Linearity1 / Echo_Count) >= 0.5)) OR
((Linearity2 / Echo_Count) > 0.5) OR
(LINEARITY1>3.2 AND LINEARITY2>3.2 AND NOISE_COUNT_AVERAGE>3) OR
(LINEARITY1>5.5 AND LINEARITY2>5.5 AND SLOPE<0.7) OR
(SLOPE >= 2) OR
(SLOPE < 0.15) OR
(((First_Range + Last_Range) / 2) < 21.38) AND (((First_Range + Last_Range) / 2) >= 18) AND (SLOPE <
0.1) OR
(((First_Range + Last_Range) / 2) < 18) AND (((First_Range + Last_Range) / 2) >= 15) AND (SLOPE < 0.15))
OR
(((First_Range + Last_Range) / 2) < 15) AND (((First_Range + Last_Range) / 2) >= 12.9) AND (SLOPE <
0.2) OR
(((First_Range + Last_Range) / 2) < 12.9) AND (((First_Range + Last_Range) / 2) >= 12.56) AND (SLOPE <
0.5) OR
(((First_Range + Last_Range) / 2) < 12.3) AND (((First_Range + Last_Range) / 2) >= 12.2) AND (SLOPE <
0.5) OR
(((First_Range + Last_Range) / 2) < 11.8) AND (((First_Range + Last_Range) / 2) >= 11.5) AND (SLOPE <
0.5) OR
(((First_Range + Last_Range) / 2) < 10.15) AND (((First_Range + Last_Range) / 2) >= 9.5) AND (SLOPE <
0.5) OR
(((First_Range + Last_Range) / 2) < 6.5) AND (SLOPE < 0.3)) OR
(((Noise_Count_Average) / ((Echo_Count + 10) * 5)) > 0.04))
THEN DELETE;
END;
IF MUX_CHANNEL EQ 5 THEN DO;
IF (TRACK_TYPE=1) OR
(((First_Range + Last_Range) / 2)>22.11) OR

(Echo_Count = 4 AND ((Linearity1 / Echo_Count) > 0.4)) OR
(Echo_Count >= 5 AND Echo_Count <= 7 AND ((Linearity1 / Echo_Count) >= 0.5)) OR
((Linearity2 / Echo_Count) > 0.5) OR
(LINEARITY1>3.5 AND LINEARITY2>3.5 AND NOISE_INDEX>6.5 AND SLOPE<0.85) OR
(LINEARITY1>4.5 AND LINEARITY2>3.5 AND NOISE_COUNT_AVERAGE>3.5) OR
(SLOPE >= 2) OR
(SLOPE < 0.15) OR
(((First_Range + Last_Range) / 2) < 22.11) AND (((First_Range + Last_Range) / 2) >= 19.85) AND (SLOPE <
0.1) OR
(((First_Range + Last_Range) / 2) < 19.85) AND (((First_Range + Last_Range) / 2) >= 19.5) AND (SLOPE <
0.5) OR
(((First_Range + Last_Range) / 2) < 19.5) AND (((First_Range + Last_Range) / 2) >= 12.7) AND (SLOPE <
0.15) OR
(((First_Range + Last_Range) / 2) < 12.7) AND (((First_Range + Last_Range) / 2) >= 11.9) AND (SLOPE <
0.5) OR
(((First_Range + Last_Range) / 2) < 8.61) AND (((First_Range + Last_Range) / 2) >= 8.16) AND (SLOPE <
0.5) OR
(((First_Range + Last_Range) / 2) < 6.5) AND (SLOPE < 0.3)) OR
(((Noise_Count_Average) / ((Echo_Count + 10) * 5)) > 0.04))
THEN DELETE;
END;
IF MUX_CHANNEL EQ 6 THEN DO;
IF (TRACK_TYPE=1) OR
(((First_Range + Last_Range) / 2)>21.59) OR

(Echo_Count = 4 AND ((Linearity1 / Echo_Count) > 0.4)) OR
(Echo_Count >= 5 AND Echo_Count <= 7 AND ((Linearity1 / Echo_Count) >= 0.5)) OR
((Linearity2 / Echo_Count) > 0.5) OR
(LINEARITY1>4.5 AND LINEARITY2>3.5 AND SLOPE<0.5) OR
(SLOPE >= 2.5) OR
(((First_Range + Last_Range) / 2) < 21.59) AND (((First_Range + Last_Range) / 2) >= 15) AND (SLOPE <
0.1) OR
(((First_Range + Last_Range) / 2) < 15) AND (((First_Range + Last_Range) / 2) >= 13.16) AND (SLOPE <
0.15) OR
(((First_Range + Last_Range) / 2) < 13.16) AND (((First_Range + Last_Range) / 2) >= 11.55) AND (SLOPE <
0.8) OR
(((First_Range + Last_Range) / 2) < 10.25) AND (((First_Range + Last_Range) / 2) >= 9.5) AND (SLOPE <
0.7) OR
(((First_Range + Last_Range) / 2) < 9.5) AND (((First_Range + Last_Range) / 2) >= 3) AND (SLOPE < 0.2))
OR
(((First_Range + Last_Range) / 2) < 3) AND (SLOPE < 0.3)) OR
(((Noise_Count_Average) / ((Echo_Count + 10) * 5)) > 0.04))
THEN DELETE;
END;
```

Hydroacoustic Evaluation of Fish Passage through Bonneville Dam in 2004

```

IF MUX_CHANNEL EQ 7 THEN DO;
  IF (TRACK_TYPE=1) OR
    (((First_Range + Last_Range) / 2)>20.39) OR

    (Echo_Count = 4 AND ((Linearity1 / Echo_Count) > 0.4)) OR
    (Echo_Count >= 5 AND Echo_Count <= 7 AND ((Linearity1 / Echo_Count) >= 0.5)) OR
    ((Linearity2 / Echo_Count) > 0.5) OR
    (SLOPE >= 2.5) OR
    (((First_Range + Last_Range) / 2) < 20.39) AND (((First_Range + Last_Range) / 2) >= 19) AND (SLOPE <
      0.1) OR
    (((First_Range + Last_Range) / 2) < 19) AND (((First_Range + Last_Range) / 2) >= 12.25) AND (SLOPE <
      0.15) OR
    (((First_Range + Last_Range) / 2) < 12.25) AND (((First_Range + Last_Range) / 2) >= 10.45) AND (SLOPE <
      0.8) OR
    (((First_Range + Last_Range) / 2) < 10.45) AND (((First_Range + Last_Range) / 2) >= 9.05) AND (SLOPE <
      0.2) OR
    (((First_Range + Last_Range) / 2) < 9.05) AND (((First_Range + Last_Range) / 2) >= 8.56) AND (SLOPE <
      0.7) OR
    (((First_Range + Last_Range) / 2) < 8.56) AND (SLOPE < 0.25)) OR
    (((Noise_Count_Average) / ((Echo_Count + 10) * 5)) > 0.04))
  THEN DELETE;
END;
END;

IF SYSTEM='R' THEN DO;
  IF MUX_CHANNEL EQ 1 THEN DO;
    IF (TRACK_TYPE = 1) OR
      (((First_Range + Last_Range) / 2)>21.99) OR

      (Echo_Count = 4 AND ((Linearity1 / Echo_Count) > 0.4)) OR
      (Echo_Count >= 5 AND Echo_Count <= 7 AND ((Linearity1 / Echo_Count) >= 0.5)) OR
      ((Linearity2 / Echo_Count) > 0.5) OR
      (Slope >= 2.5) OR
      (((First_Range + Last_Range) / 2) < 18) AND (((First_Range + Last_Range) / 2) >= 14) AND (SLOPE < 0.1))
      OR
      (((First_Range + Last_Range) / 2) < 14) AND (((First_Range + Last_Range) / 2) >= 10) AND (SLOPE < 0.2))
      OR
      (((First_Range + Last_Range) / 2) < 10) AND (SLOPE < 0.25)) OR
      (((Noise_Count_Average) / ((Echo_Count + 10) * 5)) > 0.04))
    THEN DELETE;
  END;
  IF MUX_CHANNEL EQ 2 THEN DO;
    IF (TRACK_TYPE = 1) OR
      (((First_Range + Last_Range) / 2)>21.44) OR

      (Echo_Count = 4 AND ((Linearity1 / Echo_Count) > 0.4)) OR
      (Echo_Count >= 5 AND Echo_Count <= 7 AND ((Linearity1 / Echo_Count) >= 0.5)) OR
      ((Linearity2 / Echo_Count) > 0.5) OR
      (SLOPE >= 2.5) OR
      (((First_Range + Last_Range) / 2) < 18) AND (((First_Range + Last_Range) / 2) >= 14) AND (SLOPE < 0.1))
      OR
      (((First_Range + Last_Range) / 2) < 13.75) AND (((First_Range + Last_Range) / 2) >= 13.45) AND (SLOPE <
        0.35) OR
      (((First_Range + Last_Range) / 2) < 14) AND (((First_Range + Last_Range) / 2) >= 10) AND (SLOPE < 0.15))
      OR
      (((First_Range + Last_Range) / 2) < 10) AND (SLOPE < 0.2)) OR
      (((Noise_Count_Average) / ((Echo_Count + 10) * 5)) > 0.04))
    THEN DELETE;
  END;
END;

***Spillway;

IF SYSTEM = 'F' THEN DO;
  *** CH1 *****;
  IF MUX_CHANNEL = 1 THEN DO;
    IF KCPS LE 4.3 THEN DO;
      IF (TRACK_TYPE = 1) OR
        (Echo_Count = 4 AND ((Linearity1 / Echo_Count) > 0.4)) OR
        (Echo_Count >= 5 AND Echo_Count <= 7 AND ((Linearity1 / Echo_Count) >= 0.5)) OR
        ((Linearity2 / Echo_Count) > 0.5) OR
        (LINEARITY1=0 AND LINEARITY2=0 AND SLOPE=0) OR
        (((First_Range + Last_Range) / 2) >= 9.87) OR
        (((First_Range + Last_Range) / 2) < 9.0) AND (((First_Range + Last_Range) / 2) >= 8.5) AND (SLOPE
          < 0.1) OR
        (((First_Range + Last_Range) / 2) < 8.5) AND (((First_Range + Last_Range) / 2) > 7.5) AND (SLOPE <
          0.2) OR
        (((First_Range + Last_Range) / 2) <= 7.5) AND (SLOPE < 0.3)) OR
        (SLOPE>2.5) OR
        (((Noise_Count_Average) / ((Echo_Count + 10) * 5)) > 0.04))
      THEN DELETE;
    END;
  END;

```

Hydroacoustic Evaluation of Fish Passage through Bonneville Dam in 2004

```
END;
IF KCFS GT 4.3 AND KCFS LE 5.3 THEN DO;
  IF (TRACK_TYPE = 1) OR
    (Echo_Count = 4 AND ((Linearity1 / Echo_Count) > 0.4)) OR
    (Echo_Count >= 5 AND Echo_Count <= 7 AND ((Linearity1 / Echo_Count) >= 0.5)) OR
    ((Linearity2 / Echo_Count) > 0.5) OR
    (Echo_Count = 4 AND ((Linearity1 / Echo_Count) > 0.25)) OR
    ((Echo_Count = 5 OR Echo_Count = 6 OR Echo_Count = 7) AND ((Linearity1 / Echo_Count) >= 0.3)) OR
    ((Linearity2 / Echo_Count) > 0.35) OR
    (LINEARITY1=0 AND LINEARITY2=0 AND SLOPE=0) OR
    (((First_Range + Last_Range) / 2) >= 10) OR
    (((First_Range + Last_Range) / 2) < 9.0) AND (((First_Range + Last_Range) / 2) >= 8.5) AND (SLOPE
      < 0.1) OR
    (((First_Range + Last_Range) / 2) < 8.5) AND (((First_Range + Last_Range) / 2) > 7.5) AND (SLOPE <
      0.2) OR
    (((First_Range + Last_Range) / 2) <= 7.5) AND (SLOPE < 0.3)) OR
    (SLOPE>2.5) OR
    (((Noise_Count_Average) / ((Echo_Count + 10) * 5)) > 0.04))
  THEN DELETE;
END;
IF KCFS GT 5.3 AND KCFS LE 6.3 THEN DO;
  IF (TRACK_TYPE = 1) OR
    (Echo_Count = 4 AND ((Linearity1 / Echo_Count) > 0.4)) OR
    (Echo_Count >= 5 AND Echo_Count <= 7 AND ((Linearity1 / Echo_Count) >= 0.5)) OR
    ((Linearity2 / Echo_Count) > 0.5) OR
    (LINEARITY1=0 AND LINEARITY2=0 AND SLOPE=0) OR
    (((First_Range + Last_Range) / 2) > 10.13) OR
    (((First_Range + Last_Range) / 2) < 8.9) AND (((First_Range + Last_Range) / 2) >= 8.5) AND (SLOPE
      < 0.1) OR
    (((First_Range + Last_Range) / 2) < 8.5) AND (((First_Range + Last_Range) / 2) > 7.5) AND (SLOPE <
      0.2) OR
    (((First_Range + Last_Range) / 2) <= 7.5) AND (SLOPE < 0.3)) OR
    (SLOPE>2.5) OR
    (((Noise_Count_Average) / ((Echo_Count + 10) * 5)) > 0.04))
  THEN DELETE;
END;
IF KCFS GT 6.3 AND KCFS LE 7.3 THEN DO;
  IF (TRACK_TYPE = 1) OR
    (Echo_Count = 4 AND ((Linearity1 / Echo_Count) > 0.4)) OR
    (Echo_Count >= 5 AND Echo_Count <= 7 AND ((Linearity1 / Echo_Count) >= 0.5)) OR
    ((Linearity2 / Echo_Count) > 0.5) OR
    (LINEARITY1=0 AND LINEARITY2=0 AND SLOPE=0) OR
    (((First_Range + Last_Range) / 2) > 10.23) OR
    (((First_Range + Last_Range) / 2) < 9.2) AND (((First_Range + Last_Range) / 2) >= 8.2) AND (SLOPE
      < 0.1) OR
    (((First_Range + Last_Range) / 2) < 8.2) AND (((First_Range + Last_Range) / 2) > 7.2) AND (SLOPE <
      0.2) OR
    (((First_Range + Last_Range) / 2) <= 7.2) AND (SLOPE < 0.3)) OR
    (SLOPE>2.5) OR
    (((Noise_Count_Average) / ((Echo_Count + 10) * 5)) > 0.04))
  THEN DELETE;
END;
IF KCFS GT 7.3 THEN DO;
  IF (TRACK_TYPE = 1) OR
    (Echo_Count = 4 AND ((Linearity1 / Echo_Count) > 0.4)) OR
    (Echo_Count >= 5 AND Echo_Count <= 7 AND ((Linearity1 / Echo_Count) >= 0.5)) OR
    ((Linearity2 / Echo_Count) > 0.5) OR
    (LINEARITY1=0 AND LINEARITY2=0 AND SLOPE=0) OR
    (((First_Range + Last_Range) / 2) > 10.32) OR
    (((First_Range + Last_Range) / 2) < 9.0) AND (((First_Range + Last_Range) / 2) >= 8.5) AND (SLOPE
      < 0.1) OR
    (((First_Range + Last_Range) / 2) < 8.5) AND (((First_Range + Last_Range) / 2) > 7.5) AND (SLOPE <
      0.2) OR
    (((First_Range + Last_Range) / 2) <= 7.5) AND (SLOPE < 0.3)) OR
    (SLOPE>2.5) OR
    (((Noise_Count_Average) / ((Echo_Count + 10) * 5)) > 0.04))
  THEN DELETE;
END;
END;
END;
*** CH2 *****;
IF MUX_CHANNEL = 2 THEN DO;
  IF KCFS LE 3.3 THEN DO;
    IF (TRACK_TYPE = 1) OR
      (Echo_Count = 4 AND ((Linearity1 / Echo_Count) > 0.4)) OR
      (Echo_Count >= 5 AND Echo_Count <= 7 AND ((Linearity1 / Echo_Count) >= 0.5)) OR
      ((Linearity2 / Echo_Count) > 0.5) OR
      (((First_Range + Last_Range) / 2) > 9.75) OR
      (((First_Range + Last_Range) / 2) < 8.8) AND (((First_Range + Last_Range) / 2) >= 8.5) AND (SLOPE
        < 0.1) OR
      (((First_Range + Last_Range) / 2) < 8.5) AND (((First_Range + Last_Range) / 2) > 7.5) AND (SLOPE <
```

Hydroacoustic Evaluation of Fish Passage through Bonneville Dam in 2004

```
0.125)) OR
(((First_Range + Last_Range) / 2) <= 7.5) AND (SLOPE < 0.25)) OR
(SLOPE>2.5) OR
((((Noise_Count_Average) / ((Echo_Count + 10) * 5)) > 0.04))
THEN DELETE;
END;
IF KCFS GT 3.3 AND KCFS LE 4.3 THEN DO;
IF (TRACK_TYPE = 1) OR
(Echo_Count = 4 AND ((Linearity1 / Echo_Count) > 0.4)) OR
(Echo_Count >= 5 AND Echo_Count <= 7 AND ((Linearity1 / Echo_Count) >= 0.5)) OR
((Linearity2 / Echo_Count) > 0.5) OR
(((First_Range + Last_Range) / 2) > 9.9) OR
((((First_Range + Last_Range) / 2) < 8.9) AND (((First_Range + Last_Range) / 2) >= 8.9) AND (SLOPE
< 0.1)) OR
((((First_Range + Last_Range) / 2) < 8.9) AND (((First_Range + Last_Range) / 2) > 7.9) AND (SLOPE <
0.125)) OR
((((First_Range + Last_Range) / 2) <= 7.9) AND (SLOPE < 0.25)) OR
(SLOPE>2.5) OR
((((Noise_Count_Average) / ((Echo_Count + 10) * 5)) > 0.04))
THEN DELETE;
END;
IF KCFS GT 4.3 AND KCFS LE 5.3 THEN DO;
IF (TRACK_TYPE = 1) OR
(Echo_Count = 4 AND ((Linearity1 / Echo_Count) > 0.4)) OR
(Echo_Count >= 5 AND Echo_Count <= 7 AND ((Linearity1 / Echo_Count) >= 0.5)) OR
((Linearity2 / Echo_Count) > 0.5) OR
(((First_Range + Last_Range) / 2) > 10.05) OR
((((First_Range + Last_Range) / 2) < 9.0) AND (((First_Range + Last_Range) / 2) >= 8.0) AND (SLOPE
< 0.1)) OR
((((First_Range + Last_Range) / 2) < 8.0) AND (((First_Range + Last_Range) / 2) > 7.0) AND (SLOPE <
0.125)) OR
((((First_Range + Last_Range) / 2) <= 7.0) AND (SLOPE < 0.25)) OR
(SLOPE>2.5) OR
((((Noise_Count_Average) / ((Echo_Count + 10) * 5)) > 0.04))
THEN DELETE;
END;
IF KCFS GT 5.3 AND KCFS LE 6.3 THEN DO;
IF (TRACK_TYPE = 1) OR
(Echo_Count = 4 AND ((Linearity1 / Echo_Count) > 0.4)) OR
(Echo_Count >= 5 AND Echo_Count <= 7 AND ((Linearity1 / Echo_Count) >= 0.5)) OR
((Linearity2 / Echo_Count) > 0.5) OR
(((First_Range + Last_Range) / 2) > 10.2) OR
((((First_Range + Last_Range) / 2) < 9) AND (((First_Range + Last_Range) / 2) >= 8.5) AND (SLOPE <
0.1)) OR
((((First_Range + Last_Range) / 2) < 8.5) AND (((First_Range + Last_Range) / 2) > 7.5) AND (SLOPE <
0.15)) OR
((((First_Range + Last_Range) / 2) <= 7.5) AND (SLOPE < 0.25)) OR
(SLOPE>2.5) OR
((((Noise_Count_Average) / ((Echo_Count + 10) * 5)) > 0.04))
THEN DELETE;
END;
IF KCFS GT 6.3 AND KCFS LE 7.3 THEN DO;
IF (TRACK_TYPE = 1) OR
(Echo_Count = 4 AND ((Linearity1 / Echo_Count) > 0.4)) OR
(Echo_Count >= 5 AND Echo_Count <= 7 AND ((Linearity1 / Echo_Count) >= 0.5)) OR
((Linearity2 / Echo_Count) > 0.5) OR
(((First_Range + Last_Range) / 2) > 10.3) OR
((((First_Range + Last_Range) / 2) < 9.3) AND (((First_Range + Last_Range) / 2) >= 8.3) AND (SLOPE
< 0.1)) OR
((((First_Range + Last_Range) / 2) < 8.3) AND (((First_Range + Last_Range) / 2) > 7.3) AND (SLOPE <
0.15)) OR
((((First_Range + Last_Range) / 2) <= 7.3) AND (SLOPE < 0.25)) OR
(SLOPE>2.5) OR
((((Noise_Count_Average) / ((Echo_Count + 10) * 5)) > 0.04))
THEN DELETE;
END;
IF KCFS GT 7.3 THEN DO;
IF (TRACK_TYPE = 1) OR
(Echo_Count = 4 AND ((Linearity1 / Echo_Count) > 0.4)) OR
(Echo_Count >= 5 AND Echo_Count <= 7 AND ((Linearity1 / Echo_Count) >= 0.5)) OR
((Linearity2 / Echo_Count) > 0.5) OR
(LINEARITY1=0 AND LINEARITY2=0 AND SLOPE=0) OR
(LINEARITY1>15) OR
(((First_Range + Last_Range) / 2) > 10.39) OR
((((First_Range + Last_Range) / 2) < 9.5) AND (((First_Range + Last_Range) / 2) >= 8.5) AND (SLOPE
< 0.1)) OR
((((First_Range + Last_Range) / 2) < 8.5) AND (((First_Range + Last_Range) / 2) > 7.5) AND (SLOPE <
0.15)) OR
((((First_Range + Last_Range) / 2) <= 7.5) AND (SLOPE < 0.2)) OR
(SLOPE>2.5) OR
((((Noise_Count_Average) / ((Echo_Count + 10) * 5)) > 0.04))
```

Hydroacoustic Evaluation of Fish Passage through Bonneville Dam in 2004

```
THEN DELETE;
END;
END;
*** CH3 *****;
IF MUX_CHANNEL = 3 THEN DO;
  IF KCFS LE 2.8 THEN DO;
    IF (TRACK_TYPE = 1) OR
      (Echo_Count = 4 AND ((Linearity1 / Echo_Count) > 0.4)) OR
      (Echo_Count >= 5 AND Echo_Count <= 7 AND ((Linearity1 / Echo_Count) >= 0.5)) OR
      ((Linearity2 / Echo_Count) > 0.5) OR
      (((First_Range + Last_Range) / 2) > 9.68) OR
      (((First_Range + Last_Range) / 2) < 8.7) AND (((First_Range + Last_Range) / 2) >= 8.0) AND (SLOPE
        < 0.1) OR
      (((First_Range + Last_Range) / 2) < 8.0) AND (((First_Range + Last_Range) / 2) > 7.0) AND (SLOPE <
        0.15) OR
      (((First_Range + Last_Range) / 2) <= 7.0) AND (SLOPE < 0.2)) OR
      (SLOPE>2.5) OR
      (((Noise_Count_Average) / ((Echo_Count + 10) * 5)) > 0.04))
    THEN DELETE;
  END;
  IF KCFS GT 2.8 AND KCFS LE 3.2 THEN DO;
    IF (TRACK_TYPE = 1) OR
      (Echo_Count = 4 AND ((Linearity1 / Echo_Count) > 0.4)) OR
      (Echo_Count >= 5 AND Echo_Count <= 7 AND ((Linearity1 / Echo_Count) >= 0.5)) OR
      ((Linearity2 / Echo_Count) > 0.5) OR
      (((First_Range + Last_Range) / 2) > 9.75) OR
      (((First_Range + Last_Range) / 2) < 8.8) AND (((First_Range + Last_Range) / 2) >= 8.0) AND (SLOPE
        < 0.1) OR
      (((First_Range + Last_Range) / 2) < 8.0) AND (((First_Range + Last_Range) / 2) > 7.0) AND (SLOPE <
        0.15) OR
      (((First_Range + Last_Range) / 2) <= 7.0) AND (SLOPE < 0.2)) OR
      (SLOPE>2.5) OR
      (((Noise_Count_Average) / ((Echo_Count + 10) * 5)) > 0.04))
    THEN DELETE;
  END;
  IF KCFS GT 3.2 AND KCFS LE 4.2 THEN DO;
    IF (TRACK_TYPE = 1) OR
      (Echo_Count = 4 AND ((Linearity1 / Echo_Count) > 0.4)) OR
      (Echo_Count >= 5 AND Echo_Count <= 7 AND ((Linearity1 / Echo_Count) >= 0.5)) OR
      ((Linearity2 / Echo_Count) > 0.5) OR
      (((First_Range + Last_Range) / 2) > 9.87) OR
      (((First_Range + Last_Range) / 2) < 8.9) AND (((First_Range + Last_Range) / 2) >= 8.0) AND (SLOPE
        < 0.1) OR
      (((First_Range + Last_Range) / 2) < 8.0) AND (((First_Range + Last_Range) / 2) > 7.0) AND (SLOPE <
        0.15) OR
      (((First_Range + Last_Range) / 2) <= 7.0) AND (SLOPE < 0.2)) OR
      (SLOPE>2.5) OR
      (((Noise_Count_Average) / ((Echo_Count + 10) * 5)) > 0.04))
    THEN DELETE;
  END;
  IF KCFS GT 4.2 AND KCFS LE 5.2 THEN DO;
    IF (TRACK_TYPE = 1) OR
      (Echo_Count = 4 AND ((Linearity1 / Echo_Count) > 0.4)) OR
      (Echo_Count >= 5 AND Echo_Count <= 7 AND ((Linearity1 / Echo_Count) >= 0.5)) OR
      ((Linearity2 / Echo_Count) > 0.5) OR
      (((First_Range + Last_Range) / 2) > 9.99) OR
      (((First_Range + Last_Range) / 2) < 9.0) AND (((First_Range + Last_Range) / 2) >= 8.0) AND (SLOPE
        < 0.1) OR
      (((First_Range + Last_Range) / 2) < 8.0) AND (((First_Range + Last_Range) / 2) > 7.0) AND (SLOPE <
        0.15) OR
      (((First_Range + Last_Range) / 2) <= 7.0) AND (SLOPE < 0.2)) OR
      (SLOPE>2.5) OR
      (((Noise_Count_Average) / ((Echo_Count + 10) * 5)) > 0.04))
    THEN DELETE;
  END;
  IF KCFS GT 5.2 AND KCFS LE 6.3 THEN DO;
    IF (TRACK_TYPE = 1) OR
      (Echo_Count = 4 AND ((Linearity1 / Echo_Count) > 0.4)) OR
      (Echo_Count >= 5 AND Echo_Count <= 7 AND ((Linearity1 / Echo_Count) >= 0.5)) OR
      ((Linearity2 / Echo_Count) > 0.5) OR
      (((First_Range + Last_Range) / 2) > 10.12) OR
      (((First_Range + Last_Range) / 2) < 9) AND (((First_Range + Last_Range) / 2) >= 8.5) AND (SLOPE <
        0.1) OR
      (((First_Range + Last_Range) / 2) < 8.5) AND (((First_Range + Last_Range) / 2) > 7.5) AND (SLOPE <
        0.15) OR
      (((First_Range + Last_Range) / 2) <= 7.5) AND (SLOPE < 0.25)) OR
      (SLOPE>2.5) OR
      (((Noise_Count_Average) / ((Echo_Count + 10) * 5)) > 0.04))
    THEN DELETE;
  END;
  IF KCFS GT 6.3 AND KCFS LE 7.3 THEN DO;
```

Hydroacoustic Evaluation of Fish Passage through Bonneville Dam in 2004

```

IF (TRACK_TYPE = 1) OR
(Echo_Count = 4 AND ((Linearity1 / Echo_Count) > 0.4)) OR
(Echo_Count >= 5 AND Echo_Count <= 7 AND ((Linearity1 / Echo_Count) >= 0.5)) OR
((Linearity2 / Echo_Count) > 0.5) OR
(((First_Range + Last_Range) / 2) > 10.3) OR
((((First_Range + Last_Range) / 2) < 9.3) AND (((First_Range + Last_Range) / 2) >= 8.3) AND (SLOPE
< 0.1)) OR
((((First_Range + Last_Range) / 2) < 8.3) AND (((First_Range + Last_Range) / 2) > 7.3) AND (SLOPE <
0.15)) OR
((((First_Range + Last_Range) / 2) <= 7.3) AND (SLOPE < 0.25)) OR
(SLOPE>2.5) OR
((((Noise_Count_Average) / ((Echo_Count + 10) * 5)) > 0.04))
THEN DELETE;
END;
IF KCFS GT 7.3 THEN DO;
IF (TRACK_TYPE = 1) OR
(Echo_Count = 4 AND ((Linearity1 / Echo_Count) > 0.4)) OR
(Echo_Count >= 5 AND Echo_Count <= 7 AND ((Linearity1 / Echo_Count) >= 0.5)) OR
((Linearity2 / Echo_Count) > 0.5) OR
(((First_Range + Last_Range) / 2) > 10.41) OR
((((First_Range + Last_Range) / 2) < 9.5) AND (((First_Range + Last_Range) / 2) >= 8.5) AND (SLOPE
< 0.1)) OR
((((First_Range + Last_Range) / 2) < 8.5) AND (((First_Range + Last_Range) / 2) > 7.5) AND (SLOPE <
0.15)) OR
((((First_Range + Last_Range) / 2) <= 7.5) AND (SLOPE < 0.2)) OR
(SLOPE>2.5) OR
((((Noise_Count_Average) / ((Echo_Count + 10) * 5)) > 0.04))
THEN DELETE;
END;
END;
*** CH4 *****;
IF MUX_CHANNEL = 4 THEN DO;
IF KCFS LE 3.3 THEN DO;
IF (TRACK_TYPE = 1) OR
(Echo_Count = 4 AND ((Linearity1 / Echo_Count) > 0.4)) OR
(Echo_Count >= 5 AND Echo_Count <= 7 AND ((Linearity1 / Echo_Count) >= 0.5)) OR
((Linearity2 / Echo_Count) > 0.5) OR
(LINEARITY1=0 AND LINEARITY2=0 AND SLOPE=0) OR
(((First_Range + Last_Range) / 2) > 9.85) OR
((((First_Range + Last_Range) / 2) < 8.8) AND (((First_Range + Last_Range) / 2) >= 8.0) AND (SLOPE
< 0.1)) OR
((((First_Range + Last_Range) / 2) < 8.0) AND (((First_Range + Last_Range) / 2) > 7.0) AND (SLOPE <
0.15)) OR
((((First_Range + Last_Range) / 2) <= 7.0) AND (SLOPE < 0.2)) OR
(SLOPE>2.5) OR
((((Noise_Count_Average) / ((Echo_Count + 10) * 5)) > 0.04))
THEN DELETE;
END;
IF KCFS GT 3.3 AND KCFS LE 4.3 THEN DO;
IF (TRACK_TYPE = 1) OR
(Echo_Count = 4 AND ((Linearity1 / Echo_Count) > 0.4)) OR
(Echo_Count >= 5 AND Echo_Count <= 7 AND ((Linearity1 / Echo_Count) >= 0.5)) OR
((Linearity2 / Echo_Count) > 0.5) OR
(LINEARITY1=0 AND LINEARITY2=0 AND SLOPE=0) OR
(((First_Range + Last_Range) / 2) > 9.97) OR
((((First_Range + Last_Range) / 2) < 9.0) AND (((First_Range + Last_Range) / 2) >= 8.0) AND (SLOPE
< 0.1)) OR
((((First_Range + Last_Range) / 2) < 8.0) AND (((First_Range + Last_Range) / 2) > 7.0) AND (SLOPE <
0.15)) OR
((((First_Range + Last_Range) / 2) <= 7.0) AND (SLOPE < 0.2)) OR
(SLOPE>2.5) OR
((((Noise_Count_Average) / ((Echo_Count + 10) * 5)) > 0.04))
THEN DELETE;
END;
IF KCFS GT 4.3 AND KCFS LE 5.3 THEN DO;
IF (TRACK_TYPE = 1) OR
(Echo_Count = 4 AND ((Linearity1 / Echo_Count) > 0.4)) OR
(Echo_Count >= 5 AND Echo_Count <= 7 AND ((Linearity1 / Echo_Count) >= 0.5)) OR
((Linearity2 / Echo_Count) > 0.5) OR
(LINEARITY1=0 AND LINEARITY2=0 AND SLOPE=0) OR
(((First_Range + Last_Range) / 2) > 10.1) OR
((((First_Range + Last_Range) / 2) < 9.1) AND (((First_Range + Last_Range) / 2) >= 8.1) AND (SLOPE
< 0.1)) OR
((((First_Range + Last_Range) / 2) < 8.1) AND (((First_Range + Last_Range) / 2) > 7.1) AND (SLOPE <
0.15)) OR
((((First_Range + Last_Range) / 2) <= 7.1) AND (SLOPE < 0.2)) OR
(SLOPE>2.5) OR
((((Noise_Count_Average) / ((Echo_Count + 10) * 5)) > 0.04))
THEN DELETE;
END;
END;

```

Hydroacoustic Evaluation of Fish Passage through Bonneville Dam in 2004

```

IF KCFS GT 5.3 AND KCFS LE 6.3 THEN DO;
  IF (TRACK_TYPE = 1) OR
    (Echo_Count = 4 AND ((Linearity1 / Echo_Count) > 0.4)) OR
    (Echo_Count >= 5 AND Echo_Count <= 7 AND ((Linearity1 / Echo_Count) >= 0.5)) OR
    ((Linearity2 / Echo_Count) > 0.5) OR
    (LINEARITY1=0 AND LINEARITY2=0 AND SLOPE=0) OR
    (((First_Range + Last_Range) / 2) > 10.23) OR
    (((First_Range + Last_Range) / 2) < 9.2) AND (((First_Range + Last_Range) / 2) >= 8.2) AND (SLOPE
      < 0.1) OR
    (((First_Range + Last_Range) / 2) < 8.2) AND (((First_Range + Last_Range) / 2) > 7.2) AND (SLOPE <
      0.15) OR
    (((First_Range + Last_Range) / 2) <= 7.2) AND (SLOPE < 0.2)) OR
    (SLOPE>2.5) OR
    (((Noise_Count_Average) / ((Echo_Count + 10) * 5)) > 0.04))
  THEN DELETE;
END;
IF KCFS GT 6.3 AND KCFS LE 7.3 THEN DO;
  IF (TRACK_TYPE = 1) OR
    (Echo_Count = 4 AND ((Linearity1 / Echo_Count) > 0.4)) OR
    (Echo_Count >= 5 AND Echo_Count <= 7 AND ((Linearity1 / Echo_Count) >= 0.5)) OR
    ((Linearity2 / Echo_Count) > 0.5) OR
    (LINEARITY1=0 AND LINEARITY2=0 AND SLOPE=0) OR
    (((First_Range + Last_Range) / 2) > 10.36) OR
    (((First_Range + Last_Range) / 2) < 9.36) AND (((First_Range + Last_Range) / 2) >= 8.5) AND (SLOPE
      < 0.1) OR
    (((First_Range + Last_Range) / 2) < 8.5) AND (((First_Range + Last_Range) / 2) > 7.5) AND (SLOPE <
      0.15) OR
    (((First_Range + Last_Range) / 2) <= 7.5) AND (SLOPE < 0.2)) OR
    (SLOPE>2.5) OR
    (((Noise_Count_Average) / ((Echo_Count + 10) * 5)) > 0.04))
  THEN DELETE;
END;
IF KCFS GT 7.3 THEN DO;
  IF (TRACK_TYPE = 1) OR
    (Echo_Count = 4 AND ((Linearity1 / Echo_Count) > 0.4)) OR
    (Echo_Count >= 5 AND Echo_Count <= 7 AND ((Linearity1 / Echo_Count) >= 0.5)) OR
    ((Linearity2 / Echo_Count) > 0.5) OR
    (((First_Range + Last_Range) / 2) > 10.57) OR
    (((First_Range + Last_Range) / 2) < 9.5) AND (((First_Range + Last_Range) / 2) >= 8.5) AND (SLOPE
      < 0.1) OR
    (((First_Range + Last_Range) / 2) < 8.5) AND (((First_Range + Last_Range) / 2) > 7.5) AND (SLOPE <
      0.15) OR
    (((First_Range + Last_Range) / 2) <= 7.5) AND (SLOPE < 0.2)) OR
    (SLOPE>2.5) OR
    (((Noise_Count_Average) / ((Echo_Count + 10) * 5)) > 0.04))
  THEN DELETE;
END;
END;
*** CH5 *****;
IF MUX_CHANNEL = 5 THEN DO;
  IF KCFS LE 3.2 THEN DO;
    IF (TRACK_TYPE = 1) OR
      (Echo_Count = 4 AND ((Linearity1 / Echo_Count) > 0.4)) OR
      (Echo_Count >= 5 AND Echo_Count <= 7 AND ((Linearity1 / Echo_Count) >= 0.5)) OR
      ((Linearity2 / Echo_Count) > 0.5) OR
      (((First_Range + Last_Range) / 2) > 9.94) OR
      (((First_Range + Last_Range) / 2) < 8.8) AND (((First_Range + Last_Range) / 2) >= 8.0) AND (SLOPE
        < 0.1) OR
      (((First_Range + Last_Range) / 2) < 8.0) AND (((First_Range + Last_Range) / 2) > 7.0) AND (SLOPE <
        0.15) OR
      (((First_Range + Last_Range) / 2) <= 7.0) AND (SLOPE < 0.2)) OR
      (SLOPE>2.5) OR
      (((Noise_Count_Average) / ((Echo_Count + 10) * 5)) > 0.04))
    THEN DELETE;
  END;
END;
IF KCFS GT 3.2 AND KCFS LE 5.3 THEN DO;
  IF (TRACK_TYPE = 1) OR
    (Echo_Count = 4 AND ((Linearity1 / Echo_Count) > 0.4)) OR
    (Echo_Count >= 5 AND Echo_Count <= 7 AND ((Linearity1 / Echo_Count) >= 0.5)) OR
    ((Linearity2 / Echo_Count) > 0.5) OR
    (((First_Range + Last_Range) / 2) > 10.1) OR
    (((First_Range + Last_Range) / 2) < 9) AND (((First_Range + Last_Range) / 2) >= 8.5) AND (SLOPE <
      0.1) OR
    (((First_Range + Last_Range) / 2) < 8.5) AND (((First_Range + Last_Range) / 2) > 7.5) AND (SLOPE <
      0.15) OR
    (((First_Range + Last_Range) / 2) <= 7.5) AND (SLOPE < 0.25)) OR
    (SLOPE>2.5) OR
    (((Noise_Count_Average) / ((Echo_Count + 10) * 5)) > 0.04))
  THEN DELETE;
END;
IF KCFS GT 5.3 AND KCFS LE 6.5 THEN DO;

```

Hydroacoustic Evaluation of Fish Passage through Bonneville Dam in 2004

```
IF (TRACK_TYPE = 1) OR
(Echo_Count = 4 AND ((Linearity1 / Echo_Count) > 0.4)) OR
(Echo_Count >= 5 AND Echo_Count <= 7 AND ((Linearity1 / Echo_Count) >= 0.5)) OR
((Linearity2 / Echo_Count) > 0.5) OR
(((First_Range + Last_Range) / 2) > 10.29) OR
((((First_Range + Last_Range) / 2) < 9.3) AND (((First_Range + Last_Range) / 2) >= 8.3) AND (SLOPE
< 0.1)) OR
((((First_Range + Last_Range) / 2) < 8.3) AND (((First_Range + Last_Range) / 2) > 7.3) AND (SLOPE <
0.15)) OR
((((First_Range + Last_Range) / 2) <= 7.3) AND (SLOPE < 0.25)) OR
(SLOPE>2.5) OR
((((Noise_Count_Average) / ((Echo_Count + 10) * 5)) > 0.04))
THEN DELETE;
END;
IF KCFS GT 6.5 AND KCFS LE 7.75 THEN DO;
IF (TRACK_TYPE = 1) OR
(Echo_Count = 4 AND ((Linearity1 / Echo_Count) > 0.4)) OR
(Echo_Count >= 5 AND Echo_Count <= 7 AND ((Linearity1 / Echo_Count) >= 0.5)) OR
((Linearity2 / Echo_Count) > 0.5) OR
(((First_Range + Last_Range) / 2) > 10.48) OR
((((First_Range + Last_Range) / 2) < 9.5) AND (((First_Range + Last_Range) / 2) >= 8.5) AND (SLOPE
< 0.1)) OR
((((First_Range + Last_Range) / 2) < 8.5) AND (((First_Range + Last_Range) / 2) > 7.5) AND (SLOPE <
0.15)) OR
((((First_Range + Last_Range) / 2) <= 7.5) AND (SLOPE < 0.25)) OR
(SLOPE>2.5) OR
((((Noise_Count_Average) / ((Echo_Count + 10) * 5)) > 0.04))
THEN DELETE;
END;
IF KCFS GT 7.75 THEN DO;
IF (TRACK_TYPE = 1) OR
(Echo_Count = 4 AND ((Linearity1 / Echo_Count) > 0.4)) OR
(Echo_Count >= 5 AND Echo_Count <= 7 AND ((Linearity1 / Echo_Count) >= 0.5)) OR
((Linearity2 / Echo_Count) > 0.5) OR
(((First_Range + Last_Range) / 2) > 10.67) OR
((((First_Range + Last_Range) / 2) < 9.4) AND (((First_Range + Last_Range) / 2) >= 8.5) AND (SLOPE
< 0.1)) OR
((((First_Range + Last_Range) / 2) < 8.5) AND (((First_Range + Last_Range) / 2) > 7.5) AND (SLOPE <
0.15)) OR
((((First_Range + Last_Range) / 2) <= 7.5) AND (SLOPE < 0.2)) OR
(SLOPE>2.0) OR
((((Noise_Count_Average) / ((Echo_Count + 10) * 5)) > 0.04))
THEN DELETE;
END;
END;
IF SYSTEM = 'M' THEN DO;
IF MUX_CHANNEL = 0 THEN DO;
IF KCFS LE 4.3 THEN DO;
IF (TRACK_TYPE = 1) OR
(Echo_Count = 4 AND ((Linearity1 / Echo_Count) > 0.4)) OR
(Echo_Count >= 5 AND Echo_Count <= 7 AND ((Linearity1 / Echo_Count) >= 0.5)) OR
((Linearity2 / Echo_Count) > 0.5) OR
(((First_Range + Last_Range) / 2) > 9.80) OR
((((First_Range + Last_Range) / 2) < 8.8) AND (((First_Range + Last_Range) / 2) >= 7.5) AND (SLOPE
< 0.1)) OR
((((First_Range + Last_Range) / 2) < 7.5) AND (SLOPE < 0.2)) OR
((((Noise_Count_Average) / ((Echo_Count + 10) * 5)) > 0.04))
THEN DELETE;
END;
IF KCFS GT 4.3 AND KCFS LE 5.3 THEN DO;
IF (TRACK_TYPE = 1) OR
(Echo_Count = 4 AND ((Linearity1 / Echo_Count) > 0.4)) OR
(Echo_Count >= 5 AND Echo_Count <= 7 AND ((Linearity1 / Echo_Count) >= 0.5)) OR
((Linearity2 / Echo_Count) > 0.5) OR
(((First_Range + Last_Range) / 2) > 9.93) OR
((((First_Range + Last_Range) / 2) < 9.0) AND (((First_Range + Last_Range) / 2) >= 8.0) AND (SLOPE
< 0.1)) OR
((((First_Range + Last_Range) / 2) < 8.0) AND (((First_Range + Last_Range) / 2) > 7.0) AND (SLOPE <
0.15)) OR
((((First_Range + Last_Range) / 2) < 7.0) AND (SLOPE < 0.2)) OR
((((Noise_Count_Average) / ((Echo_Count + 10) * 5)) > 0.04))
THEN DELETE;
END;
IF KCFS GT 5.3 AND KCFS LE 6.3 THEN DO;
IF (TRACK_TYPE = 1) OR
(Echo_Count = 4 AND ((Linearity1 / Echo_Count) > 0.4)) OR
(Echo_Count >= 5 AND Echo_Count <= 7 AND ((Linearity1 / Echo_Count) >= 0.5)) OR
((Linearity2 / Echo_Count) > 0.5) OR
(((First_Range + Last_Range) / 2) > 10.06) OR
```

Hydroacoustic Evaluation of Fish Passage through Bonneville Dam in 2004

```

        (((First_Range + Last_Range) / 2) < 9.0) AND (((First_Range + Last_Range) / 2) >= 8.0) AND (SLOPE
        < 0.1)) OR
        (((First_Range + Last_Range) / 2) < 8.0) AND (((First_Range + Last_Range) / 2) > 7.0) AND (SLOPE <
        0.15)) OR
        (((First_Range + Last_Range) / 2) < 7.0) AND (SLOPE < 0.2)) OR
        (((Noise_Count_Average) / ((Echo_Count + 10) * 5)) > 0.04))
    THEN DELETE;
END;
IF KCFS GT 6.3 AND KCFS LE 7.3 THEN DO;
    IF (TRACK_TYPE = 1) OR
        (Echo_Count = 4 AND ((Linearity1 / Echo_Count) > 0.4)) OR
        (Echo_Count >= 5 AND Echo_Count <= 7 AND ((Linearity1 / Echo_Count) >= 0.5)) OR
        ((Linearity2 / Echo_Count) > 0.5) OR
        (LINEARITY1=0 AND LINEARITY2=0 AND SLOPE=0) OR
        (((First_Range + Last_Range) / 2) > 10.19) OR
        (((First_Range + Last_Range) / 2) < 9.1) AND (((First_Range + Last_Range) / 2) >= 8.5) AND (SLOPE <
        < 0.1)) OR
        (((First_Range + Last_Range) / 2) < 8.5) AND (((First_Range + Last_Range) / 2) > 7.5) AND (SLOPE <
        0.15)) OR
        (((First_Range + Last_Range) / 2) <= 7.5) AND (SLOPE < 0.2)) OR
        (((Noise_Count_Average) / ((Echo_Count + 10) * 5)) > 0.04))
    THEN DELETE;
END;
IF KCFS GT 7.3 THEN DO;
    IF (TRACK_TYPE = 1) OR
        (Echo_Count = 4 AND ((Linearity1 / Echo_Count) > 0.4)) OR
        (Echo_Count >= 5 AND Echo_Count <= 7 AND ((Linearity1 / Echo_Count) >= 0.5)) OR
        ((Linearity2 / Echo_Count) > 0.5) OR
        (((First_Range + Last_Range) / 2) > 10.32) OR
        (((First_Range + Last_Range) / 2) < 9.3) AND (((First_Range + Last_Range) / 2) >= 8.3) AND (SLOPE <
        < 0.1)) OR
        (((First_Range + Last_Range) / 2) < 8.3) AND (((First_Range + Last_Range) / 2) > 7.3) AND (SLOPE <
        0.15)) OR
        (((First_Range + Last_Range) / 2) < 7.3) AND (SLOPE < 0.2)) OR
        (((Noise_Count_Average) / ((Echo_Count + 10) * 5)) > 0.04))
    THEN DELETE;
END;
END;
*** CH1 *****;
IF MUX_CHANNEL = 1 THEN DO; *** KCFS 3.1;
    IF KCFS LE 3.3 THEN DO;
        IF (TRACK_TYPE = 1) OR
            (Echo_Count = 4 AND ((Linearity1 / Echo_Count) > 0.4)) OR
            (Echo_Count >= 5 AND Echo_Count <= 7 AND ((Linearity1 / Echo_Count) >= 0.5)) OR
            ((Linearity2 / Echo_Count) > 0.5) OR
            (((First_Range + Last_Range) / 2) > 9.59) OR
            (((First_Range + Last_Range) / 2) < 8.6) AND (((First_Range + Last_Range) / 2) >= 8.0) AND (SLOPE <
            < 0.1)) OR
            (((First_Range + Last_Range) / 2) < 8.0) AND (((First_Range + Last_Range) / 2) > 7.5) AND (SLOPE <
            0.15)) OR
            (((First_Range + Last_Range) / 2) <= 7.5) AND (SLOPE < 0.2)) OR
            (SLOPE>2.5) OR
            (((Noise_Count_Average) / ((Echo_Count + 10) * 5)) > 0.04))
        THEN DELETE;
    END;
    IF KCFS GT 3.3 AND KCFS LE 3.8 THEN DO;
        IF (TRACK_TYPE = 1) OR
            (Echo_Count = 4 AND ((Linearity1 / Echo_Count) > 0.4)) OR
            (Echo_Count >= 5 AND Echo_Count <= 7 AND ((Linearity1 / Echo_Count) >= 0.5)) OR
            ((Linearity2 / Echo_Count) > 0.5) OR
            ((Linearity1 / Echo_Count) > 0.3 AND (Linearity2 / Echo_Count) > 0.3 AND SLOPE<0.5) OR
            (((First_Range + Last_Range) / 2) > 9.69) OR
            (((First_Range + Last_Range) / 2) > 8.0) AND (SLOPE > 1)) OR
            (((First_Range + Last_Range) / 2) < 8.8) AND (((First_Range + Last_Range) / 2) >= 8.2) AND (SLOPE <
            < 0.1)) OR
            (((First_Range + Last_Range) / 2) < 8.2) AND (((First_Range + Last_Range) / 2) > 7.4) AND (SLOPE <
            0.15)) OR
            (((First_Range + Last_Range) / 2) <= 7.4) AND (SLOPE < 0.2)) OR
            (SLOPE>2.5) OR
            (((Noise_Count_Average) / ((Echo_Count + 10) * 5)) > 0.04))
        THEN DELETE;
    END;
    IF KCFS GT 3.8 AND KCFS LE 4.3 THEN DO;
        IF (TRACK_TYPE = 1) OR
            (Echo_Count = 4 AND ((Linearity1 / Echo_Count) > 0.4)) OR
            (Echo_Count >= 5 AND Echo_Count <= 7 AND ((Linearity1 / Echo_Count) >= 0.5)) OR
            ((Linearity2 / Echo_Count) > 0.5) OR
            (LINEARITY1>4.5 AND LINEARITY2>4.5 AND SLOPE<0.5) OR
            (((First_Range + Last_Range) / 2) > 9.78) OR
            (((First_Range + Last_Range) / 2) < 9.0) AND (((First_Range + Last_Range) / 2) >= 8.0) AND (SLOPE

```

Hydroacoustic Evaluation of Fish Passage through Bonneville Dam in 2004

```

    < 0.1)) OR
    (((First_Range + Last_Range) / 2) < 8.0) AND (((First_Range + Last_Range) / 2) > 7.5) AND (SLOPE <
    0.15)) OR
    (((First_Range + Last_Range) / 2) < 7.5) AND (SLOPE < 0.2)) OR
    (First_Range >= 8.60 AND First_Range <= 8.95 AND Last_Range >= 8.60 AND Last_Range <= 8.95 AND
    SLOPE < 0.8) OR
    (First_Range >= 7.55 AND First_Range <= 7.95 AND Last_Range >= 7.55 AND Last_Range <= 7.95 AND
    SLOPE < 0.8) OR
    (First_Range >= 6.20 AND First_Range <= 6.65 AND Last_Range >= 6.20 AND Last_Range <= 6.65 AND
    SLOPE < 0.8) OR
    (((Noise_Count_Average) / ((Echo_Count + 10) * 5)) > 0.04))
    THEN DELETE;
END;
IF KCFS GT 4.3 AND KCFS LE 5.3 THEN DO;
IF (TRACK_TYPE = 1) OR
(Echo_Count = 4 AND ((Linearity1 / Echo_Count) > 0.4)) OR
(Echo_Count >= 5 AND Echo_Count <= 7 AND ((Linearity1 / Echo_Count) >= 0.5)) OR
((Linearity2 / Echo_Count) > 0.5) OR
(LINEARITY1>4.5 AND LINEARITY2>4.5 AND SLOPE<0.5) OR
(((First_Range + Last_Range) / 2) > 9.89) OR
((((First_Range + Last_Range) / 2) < 9.0) AND (((First_Range + Last_Range) / 2) >= 8.0) AND (SLOPE
< 0.1)) OR
((((First_Range + Last_Range) / 2) < 8.0) AND (((First_Range + Last_Range) / 2) > 7.5) AND (SLOPE <
0.15)) OR
((((First_Range + Last_Range) / 2) < 7.5) AND (SLOPE < 0.2)) OR
((((Noise_Count_Average) / ((Echo_Count + 10) * 5)) > 0.04))
    THEN DELETE;
END;
IF KCFS GT 5.3 AND KCFS LE 6.3 THEN DO;
IF (TRACK_TYPE = 1) OR
(Echo_Count = 4 AND ((Linearity1 / Echo_Count) > 0.4)) OR
(Echo_Count >= 5 AND Echo_Count <= 7 AND ((Linearity1 / Echo_Count) >= 0.5)) OR
((Linearity2 / Echo_Count) > 0.5) OR
(LINEARITY1>4.5 AND LINEARITY2>4.5 AND SLOPE<0.5) OR
(((First_Range + Last_Range) / 2) > 9.99) OR
((((First_Range + Last_Range) / 2) < 9.0) AND (((First_Range + Last_Range) / 2) >= 8.0) AND (SLOPE
< 0.1)) OR
((((First_Range + Last_Range) / 2) < 8.0) AND (((First_Range + Last_Range) / 2) > 7.5) AND (SLOPE <
0.15)) OR
((((First_Range + Last_Range) / 2) < 7.5) AND (SLOPE < 0.2)) OR
((((Noise_Count_Average) / ((Echo_Count + 10) * 5)) > 0.04))
    THEN DELETE;
END;
IF KCFS GT 6.3 AND KCFS LE 7.3 THEN DO;
IF (TRACK_TYPE = 1 AND SLOPE<0.6) OR
(Echo_Count = 4 AND ((Linearity1 / Echo_Count) > 0.4)) OR
(Echo_Count >= 5 AND Echo_Count <= 7 AND ((Linearity1 / Echo_Count) >= 0.5)) OR
((Linearity2 / Echo_Count) > 0.5) OR
((Linearity1 / Echo_Count) >= 0.3 AND (Linearity2 / Echo_Count) >= 0.3 AND SLOPE<0.5) OR
(((First_Range + Last_Range) / 2) > 10.1) OR
((((First_Range + Last_Range) / 2) < 9.0) AND (((First_Range + Last_Range) / 2) >= 8.5) AND (SLOPE
< 0.1)) OR
((((First_Range + Last_Range) / 2) < 8.5) AND (((First_Range + Last_Range) / 2) > 7.5) AND (SLOPE <
0.15)) OR
((((First_Range + Last_Range) / 2) <= 7.5) AND (SLOPE < 0.2)) OR
((((Noise_Count_Average) / ((Echo_Count + 10) * 5)) > 0.04))
    THEN DELETE;
END;
IF KCFS GT 7.3 THEN DO;
IF (TRACK_TYPE = 1) OR
(Echo_Count = 4 AND ((Linearity1 / Echo_Count) > 0.4)) OR
(Echo_Count >= 5 AND Echo_Count <= 7 AND ((Linearity1 / Echo_Count) >= 0.5)) OR
((Linearity2 / Echo_Count) > 0.5) OR
(LINEARITY1>4.5 AND LINEARITY2>4.5 AND SLOPE<0.5) OR
(((First_Range + Last_Range) / 2) > 10.21) OR
((((First_Range + Last_Range) / 2) < 9.2) AND (((First_Range + Last_Range) / 2) >= 8.2) AND (SLOPE
< 0.1)) OR
((((First_Range + Last_Range) / 2) < 8.2) AND (((First_Range + Last_Range) / 2) > 7.2) AND (SLOPE <
0.15)) OR
((((First_Range + Last_Range) / 2) < 7.2) AND (SLOPE < 0.2)) OR
((((Noise_Count_Average) / ((Echo_Count + 10) * 5)) > 0.04))
    THEN DELETE;
END;
END;
END;
IF SYSTEM = 'O' THEN DO;
*** CH1 *****;
IF MUX_CHANNEL = 00 THEN DO;

```

Hydroacoustic Evaluation of Fish Passage through Bonneville Dam in 2004

```
IF KCFS LE 4.5 THEN DO;
  IF (TRACK_TYPE = 1) OR
    (Echo_Count = 4 AND ((Linearity1 / Echo_Count) > 0.4)) OR
    (Echo_Count >= 5 AND Echo_Count <= 7 AND ((Linearity1 / Echo_Count) >= 0.5)) OR
    ((Linearity2 / Echo_Count) > 0.5) OR
    (((First_Range + Last_Range) / 2) > 9.74) OR
    (((First_Range + Last_Range) / 2) < 9.0) AND (((First_Range + Last_Range) / 2) > 8.0) AND (SLOPE <
      0.1)) OR
    (((First_Range + Last_Range) / 2) < 8.0) AND (((First_Range + Last_Range) / 2) > 7.0) AND (SLOPE <
      0.15)) OR
    (((First_Range + Last_Range) / 2) < 7.0) AND (SLOPE < 0.2)) OR
    (((Noise_Count_Average) / ((Echo_Count + 10) * 5)) > 0.04))
  THEN DELETE;
END;
IF KCFS GT 4.5 AND KCFS LE 5.3 THEN DO;
  IF (TRACK_TYPE = 1) OR
    (Echo_Count = 4 AND ((Linearity1 / Echo_Count) > 0.4)) OR
    (Echo_Count >= 5 AND Echo_Count <= 7 AND ((Linearity1 / Echo_Count) >= 0.5)) OR
    ((Linearity2 / Echo_Count) > 0.5) OR
    ((First_Range + Last_Range) / 2) > 9.92) OR
    (((First_Range + Last_Range) / 2) <= 9.5) AND (((First_Range + Last_Range) / 2) >= 9.25) AND
      (SLOPE < 0.5)) OR
    (((First_Range + Last_Range) / 2) < 9.0) AND (((First_Range + Last_Range) / 2) > 8.0) AND (SLOPE <
      0.1)) OR
    (((First_Range + Last_Range) / 2) < 8.0) AND (((First_Range + Last_Range) / 2) > 7.0) AND (SLOPE <
      0.15)) OR
    (((First_Range + Last_Range) / 2) < 7.0) AND (SLOPE < 0.2)) OR
    (((Noise_Count_Average) / ((Echo_Count + 10) * 5)) > 0.04))
  THEN DELETE;
END;
IF KCFS GT 5.3 AND KCFS LE 6.3 THEN DO;
  IF (TRACK_TYPE = 1) OR
    (Echo_Count = 4 AND ((Linearity1 / Echo_Count) > 0.4)) OR
    (Echo_Count >= 5 AND Echo_Count <= 7 AND ((Linearity1 / Echo_Count) >= 0.5)) OR
    ((Linearity2 / Echo_Count) > 0.5) OR
    ((First_Range + Last_Range) / 2) > 10.1) OR
    (((First_Range + Last_Range) / 2) < 9.0) AND (((First_Range + Last_Range) / 2) > 8.0) AND (SLOPE <
      0.1)) OR
    (((First_Range + Last_Range) / 2) < 8.0) AND (((First_Range + Last_Range) / 2) > 7.0) AND (SLOPE <
      0.15)) OR
    (((First_Range + Last_Range) / 2) < 7.0) AND (SLOPE < 0.2)) OR
    (((Noise_Count_Average) / ((Echo_Count + 10) * 5)) > 0.04))
  THEN DELETE;
END;
IF KCFS GT 6.3 AND KCFS LE 7.8 THEN DO;
  IF (TRACK_TYPE = 1) OR
    (Echo_Count = 4 AND ((Linearity1 / Echo_Count) > 0.4)) OR
    (Echo_Count >= 5 AND Echo_Count <= 7 AND ((Linearity1 / Echo_Count) >= 0.5)) OR
    ((Linearity2 / Echo_Count) > 0.5) OR
    ((First_Range + Last_Range) / 2) > 10.27) OR
    (((First_Range + Last_Range) / 2) < 9.65) AND (((First_Range + Last_Range) / 2) >= 9.5) AND (SLOPE
      < 0.5)) OR
    (((First_Range + Last_Range) / 2) < 9.3) AND (((First_Range + Last_Range) / 2) > 8.3) AND (SLOPE <
      0.1)) OR
    (((First_Range + Last_Range) / 2) < 8.3) AND (((First_Range + Last_Range) / 2) > 7.3) AND (SLOPE <
      0.15)) OR
    (((First_Range + Last_Range) / 2) < 7.3) AND (SLOPE < 0.2)) OR
    (((Noise_Count_Average) / ((Echo_Count + 10) * 5)) > 0.04))
  THEN DELETE;
END;
IF KCFS GT 7.8 AND KCFS LE 8.5 THEN DO;
  IF (TRACK_TYPE = 1) OR
    (Echo_Count = 4 AND ((Linearity1 / Echo_Count) > 0.4)) OR
    (Echo_Count >= 5 AND Echo_Count <= 7 AND ((Linearity1 / Echo_Count) >= 0.5)) OR
    ((Linearity2 / Echo_Count) > 0.5) OR
    ((First_Range + Last_Range) / 2) > 10.36) OR
    (((First_Range + Last_Range) / 2) < 9.99) AND (((First_Range + Last_Range) / 2) > 9.73) AND (SLOPE
      < 0.85)) OR
    (((First_Range + Last_Range) / 2) < 9.65) AND (((First_Range + Last_Range) / 2) > 8.4) AND (SLOPE
      < 0.1)) OR
    (((First_Range + Last_Range) / 2) < 8.4) AND (((First_Range + Last_Range) / 2) > 7.4) AND (SLOPE <
      0.15)) OR
    (((First_Range + Last_Range) / 2) < 7.4) AND (SLOPE < 0.2)) OR
    (((Noise_Count_Average) / ((Echo_Count + 10) * 5)) > 0.04))
  THEN DELETE;
END;
IF KCFS GT 8.5 AND KCFS LE 9.8 THEN DO;
  IF (TRACK_TYPE = 1) OR
    (Echo_Count = 4 AND ((Linearity1 / Echo_Count) > 0.4)) OR
    (Echo_Count >= 5 AND Echo_Count <= 7 AND ((Linearity1 / Echo_Count) >= 0.5)) OR
    ((Linearity2 / Echo_Count) > 0.5) OR
```

Hydroacoustic Evaluation of Fish Passage through Bonneville Dam in 2004

```

(((First_Range + Last_Range) / 2) > 10.65) OR
(((First_Range + Last_Range) / 2) < 9.7) AND (((First_Range + Last_Range) / 2) > 8.7) AND (SLOPE <
0.1)) OR
(((First_Range + Last_Range) / 2) < 8.7) AND (((First_Range + Last_Range) / 2) > 7.7) AND (SLOPE <
0.15)) OR
(((First_Range + Last_Range) / 2) < 7.7) AND (SLOPE < 0.2)) OR
(((Noise_Count_Average) / ((Echo_Count + 10) * 5)) > 0.04))
THEN DELETE;
END;
IF KCFS GT 9.8 AND KCFS LE 10.8 THEN DO;
IF (TRACK_TYPE = 1) OR
(Echo_Count = 4 AND ((Linearity1 / Echo_Count) > 0.4)) OR
(Echo_Count >= 5 AND Echo_Count <= 7 AND ((Linearity1 / Echo_Count) >= 0.5)) OR
((Linearity2 / Echo_Count) > 0.5) OR
(((First_Range + Last_Range) / 2) > 10.84) OR
(((First_Range + Last_Range) / 2) < 9.5) AND (((First_Range + Last_Range) / 2) > 8.5) AND (SLOPE <
0.1)) OR
(((First_Range + Last_Range) / 2) < 8.5) AND (((First_Range + Last_Range) / 2) > 7.5) AND (SLOPE <
0.15)) OR
(((First_Range + Last_Range) / 2) < 7.5) AND (SLOPE < 0.2)) OR
(((Noise_Count_Average) / ((Echo_Count + 10) * 5)) > 0.04))
THEN DELETE;
END;
IF KCFS GT 10.8 AND KCFS LE 11.8 THEN DO;
IF (TRACK_TYPE = 1) OR
(Echo_Count = 4 AND ((Linearity1 / Echo_Count) > 0.4)) OR
(Echo_Count >= 5 AND Echo_Count <= 7 AND ((Linearity1 / Echo_Count) >= 0.5)) OR
((Linearity2 / Echo_Count) > 0.5) OR
((First_Range + Last_Range) / 2) > 11.03) OR
(((First_Range + Last_Range) / 2) < 10.0) AND (((First_Range + Last_Range) / 2) > 8.5) AND (SLOPE <
0.1)) OR
(((First_Range + Last_Range) / 2) < 8.5) AND (((First_Range + Last_Range) / 2) > 7.0) AND (SLOPE <
0.15)) OR
(((First_Range + Last_Range) / 2) < 7.0) AND (SLOPE < 0.2)) OR
(((Noise_Count_Average) / ((Echo_Count + 10) * 5)) > 0.04))
THEN DELETE;
END;
IF KCFS GT 11.8 THEN DO;
IF (TRACK_TYPE = 1) OR
(Echo_Count = 4 AND ((Linearity1 / Echo_Count) > 0.4)) OR
(Echo_Count >= 5 AND Echo_Count <= 7 AND ((Linearity1 / Echo_Count) >= 0.5)) OR
((Linearity2 / Echo_Count) > 0.5) OR
(((First_Range + Last_Range) / 2) > 11.22) OR
(((First_Range + Last_Range) / 2) < 10.0) AND (((First_Range + Last_Range) / 2) > 8.5) AND (SLOPE <
0.1)) OR
(((First_Range + Last_Range) / 2) < 8.5) AND (((First_Range + Last_Range) / 2) > 7.0) AND (SLOPE <
0.15)) OR
(((First_Range + Last_Range) / 2) < 7.0) AND (SLOPE < 0.2)) OR
(((Noise_Count_Average) / ((Echo_Count + 10) * 5)) > 0.04))
THEN DELETE;
END;
END;
END;
IF SYSTEM = 'P' THEN DO;
*** CH1 *****;
IF MUX_CHANNEL = 1 THEN DO;
IF KCFS LE 3.3 THEN DO;
IF (TRACK_TYPE = 1) OR
(Echo_Count = 4 AND ((Linearity1 / Echo_Count) > 0.4)) OR
(Echo_Count >= 5 AND Echo_Count <= 7 AND ((Linearity1 / Echo_Count) >= 0.5)) OR
((Linearity2 / Echo_Count) > 0.5) OR
(LINEARITY1>5 AND LINEARITY2>5 AND NOISE_INDEX>=7) OR
((First_Range + Last_Range) / 2) > 9.92) OR
(((First_Range + Last_Range) / 2) <= 9.92) AND (((First_Range + Last_Range) / 2) >= 9.2) AND
(SLOPE < -1)) OR
(((First_Range + Last_Range) / 2) < 9.2) AND (((First_Range + Last_Range) / 2) >= 8.4) AND (SLOPE <
0.06)) OR
(((First_Range + Last_Range) / 2) < 8.4) AND (((First_Range + Last_Range) / 2) >= 7.5) AND (SLOPE <
0.1)) OR
(((First_Range + Last_Range) / 2) < 7.5) AND (((First_Range + Last_Range) / 2) >= 6) AND (SLOPE <
0.15)) OR
(((First_Range + Last_Range) / 2) < 6) AND (SLOPE < 0.25)) OR
(NOISE_INDEX>=5 AND ((LINEARITY1/ECHO_COUNT)>=0.3)) OR
(SLOPE<-1.5) OR
(SLOPE>2) OR
(((Noise_Count_Average) / ((Echo_Count + 10) * 5)) > 0.04))
THEN DELETE;
END;
IF KCFS GT 3.3 AND KCFS LE 4.3 THEN DO;
IF (TRACK_TYPE = 1) OR

```

Hydroacoustic Evaluation of Fish Passage through Bonneville Dam in 2004

```

(Echo_Count = 4 AND ((Linearity1 / Echo_Count) > 0.4)) OR
(Echo_Count >= 5 AND Echo_Count <= 7 AND ((Linearity1 / Echo_Count) >= 0.5)) OR
((Linearity2 / Echo_Count) > 0.5) OR
(((First_Range + Last_Range) / 2) > 10.04) OR
((((First_Range + Last_Range) / 2) < 9.0) AND (((First_Range + Last_Range) / 2) >= 8.0) AND (SLOPE
< 0.1)) OR
((((First_Range + Last_Range) / 2) < 8.0) AND (((First_Range + Last_Range) / 2) >= 7.0) AND (SLOPE
< 0.15)) OR
((((First_Range + Last_Range) / 2) < 7.0) AND (SLOPE < 0.25)) OR
(SLOPE<-1.5) OR
(SLOPE>2) OR
(((Noise_Count_Average) / ((Echo_Count + 10) * 5)) > 0.04))
THEN DELETE;
END;
IF KCFS GT 4.3 AND KCFS LE 5.3 THEN DO;
IF (TRACK_TYPE = 1) OR
(Echo_Count = 4 AND ((Linearity1 / Echo_Count) > 0.4)) OR
(Echo_Count >= 5 AND Echo_Count <= 7 AND ((Linearity1 / Echo_Count) >= 0.5)) OR
((Linearity2 / Echo_Count) > 0.5) OR
(((First_Range + Last_Range) / 2) > 10.16) OR
((((First_Range + Last_Range) / 2) < 9.2) AND (((First_Range + Last_Range) / 2) >= 8.2) AND (SLOPE
< 0.1)) OR
((((First_Range + Last_Range) / 2) < 8.2) AND (((First_Range + Last_Range) / 2) >= 7.2) AND (SLOPE
< 0.15)) OR
((((First_Range + Last_Range) / 2) < 7.2) AND (SLOPE < 0.25)) OR
(SLOPE<-1.5) OR
(SLOPE>2) OR
(((Noise_Count_Average) / ((Echo_Count + 10) * 5)) > 0.04))
THEN DELETE;
END;
IF KCFS GT 5.3 AND KCFS LE 6.3 THEN DO;
IF (TRACK_TYPE = 1) OR
(Echo_Count = 4 AND ((Linearity1 / Echo_Count) > 0.4)) OR
(Echo_Count >= 5 AND Echo_Count <= 7 AND ((Linearity1 / Echo_Count) >= 0.5)) OR
((Linearity2 / Echo_Count) > 0.5) OR
(((First_Range + Last_Range) / 2) > 10.28) OR
((((First_Range + Last_Range) / 2) < 9.3) AND (((First_Range + Last_Range) / 2) >= 8.3) AND (SLOPE
< 0.1)) OR
((((First_Range + Last_Range) / 2) < 8.3) AND (((First_Range + Last_Range) / 2) >= 7.3) AND (SLOPE
< 0.15)) OR
((((First_Range + Last_Range) / 2) < 7.3) AND (SLOPE < 0.25)) OR
(SLOPE<-1.5) OR
(SLOPE>2) OR
(((Noise_Count_Average) / ((Echo_Count + 10) * 5)) > 0.04))
THEN DELETE;
END;
IF KCFS GT 6.3 THEN DO;
IF (TRACK_TYPE = 1) OR
(Echo_Count = 4 AND ((Linearity1 / Echo_Count) > 0.4)) OR
(Echo_Count >= 5 AND Echo_Count <= 7 AND ((Linearity1 / Echo_Count) >= 0.5)) OR
((Linearity2 / Echo_Count) > 0.5) OR
(((First_Range + Last_Range) / 2) > 10.4) OR
((((First_Range + Last_Range) / 2) <= 10.4) AND (((First_Range + Last_Range) / 2) >= 8.9) AND
(SLOPE > 1)) OR
((((First_Range + Last_Range) / 2) < 9.4) AND (((First_Range + Last_Range) / 2) >= 8.5) AND (SLOPE
< 0.1)) OR
((((First_Range + Last_Range) / 2) < 8.5) AND (((First_Range + Last_Range) / 2) >= 7.5) AND (SLOPE
< 0.15)) OR
((((First_Range + Last_Range) / 2) < 7.5) AND (SLOPE < 0.2)) OR
(SLOPE<-1.5) OR
(SLOPE>2) OR
(((Noise_Count_Average) / ((Echo_Count + 10) * 5)) > 0.04))
THEN DELETE;
END;
END;
*** CH2 *****;
IF MUX_CHANNEL = 2 THEN DO;
IF KCFS LE 3.4 THEN DO;
IF (TRACK_TYPE = 1) OR
(Echo_Count = 4 AND ((Linearity1 / Echo_Count) > 0.4)) OR
(Echo_Count >= 5 AND Echo_Count <= 7 AND ((Linearity1 / Echo_Count) >= 0.5)) OR
((Linearity2 / Echo_Count) > 0.5) OR
(((First_Range + Last_Range) / 2) > 9.87) OR
((((First_Range + Last_Range) / 2) < 9.0) AND (((First_Range + Last_Range) / 2) >= 8.0) AND (SLOPE
< 0.1)) OR
((((First_Range + Last_Range) / 2) < 8.0) AND (((First_Range + Last_Range) / 2) >= 7.0) AND (SLOPE
< 0.15)) OR
((((First_Range + Last_Range) / 2) < 7.0) AND (SLOPE < 0.17)) OR
(((Noise_Count_Average) / ((Echo_Count + 10) * 5)) > 0.04))
THEN DELETE;

```

Hydroacoustic Evaluation of Fish Passage through Bonneville Dam in 2004

```

END;
IF KCFS GT 3.4 AND KCFS LE 5.5 THEN DO;
  IF (TRACK_TYPE = 1) OR
    (Echo_Count = 4 AND ((Linearity1 / Echo_Count) > 0.4)) OR
    (Echo_Count >= 5 AND Echo_Count <= 7 AND ((Linearity1 / Echo_Count) >= 0.5)) OR
    ((Linearity2 / Echo_Count) > 0.5) OR
    (((First_Range + Last_Range) / 2) > 10.11) OR
    (((First_Range + Last_Range) / 2) < 9.11) AND (((First_Range + Last_Range) / 2) >= 8.11) AND
      (SLOPE < 0.1)) OR
    (((First_Range + Last_Range) / 2) < 8.11) AND (((First_Range + Last_Range) / 2) >= 7.11) AND
      (SLOPE < 0.15)) OR
    (((First_Range + Last_Range) / 2) < 7.11) AND (SLOPE < 0.17)) OR
    (((Noise_Count_Average) / ((Echo_Count + 10) * 5)) > 0.04))
  THEN DELETE;
END;
IF KCFS GT 5.5 AND KCFS LE 6.4 THEN DO;
  IF (TRACK_TYPE = 1) OR
    (Echo_Count = 4 AND ((Linearity1 / Echo_Count) > 0.4)) OR
    (Echo_Count >= 5 AND Echo_Count <= 7 AND ((Linearity1 / Echo_Count) >= 0.5)) OR
    ((Linearity2 / Echo_Count) > 0.5) OR
    (((First_Range + Last_Range) / 2) > 10.23) OR
    (((First_Range + Last_Range) / 2) < 9.2) AND (((First_Range + Last_Range) / 2) >= 8.2) AND (SLOPE
      < 0.1)) OR
    (((First_Range + Last_Range) / 2) < 8.2) AND (((First_Range + Last_Range) / 2) >= 7.2) AND (SLOPE
      < 0.15)) OR
    (((First_Range + Last_Range) / 2) < 7.2) AND (SLOPE < 0.2)) OR
    (SLOPE > 2) OR
    (SLOPE < -1) OR
    (((Noise_Count_Average) / ((Echo_Count + 10) * 5)) > 0.04))
  THEN DELETE;
END;
IF KCFS GT 6.4 THEN DO;
  IF (TRACK_TYPE = 1) OR
    (Echo_Count = 4 AND ((Linearity1 / Echo_Count) > 0.4)) OR
    (Echo_Count >= 5 AND Echo_Count <= 7 AND ((Linearity1 / Echo_Count) >= 0.5)) OR
    ((Linearity2 / Echo_Count) > 0.5) OR
    (((First_Range + Last_Range) / 2) > 10.35) OR
    (((First_Range + Last_Range) / 2) < 9.35) AND (((First_Range + Last_Range) / 2) >= 8.35) AND
      (SLOPE < 0.1)) OR
    (((First_Range + Last_Range) / 2) < 8.35) AND (((First_Range + Last_Range) / 2) >= 7.35) AND
      (SLOPE < 0.15)) OR
    (((First_Range + Last_Range) / 2) < 7.35) AND (SLOPE < 0.2)) OR
    (SLOPE > 2) OR
    (SLOPE < -1) OR
    (((Noise_Count_Average) / ((Echo_Count + 10) * 5)) > 0.04))
  THEN DELETE;
END;
END;
*** CH3 *****;
IF MUX_CHANNEL = 3 THEN DO;
  IF KCFS LE 4.3 THEN DO;
    IF (TRACK_TYPE = 1) OR
      (Echo_Count = 4 AND ((Linearity1 / Echo_Count) > 0.4)) OR
      (Echo_Count >= 5 AND Echo_Count <= 7 AND ((Linearity1 / Echo_Count) >= 0.5)) OR
      ((Linearity2 / Echo_Count) > 0.5) OR
      (((First_Range + Last_Range) / 2) > 9.9) OR
      (((First_Range + Last_Range) / 2) < 9.0) AND (((First_Range + Last_Range) / 2) >= 8.0) AND (SLOPE
        < 0.1)) OR
      (((First_Range + Last_Range) / 2) < 8.0) AND (((First_Range + Last_Range) / 2) >= 7.0) AND (SLOPE
        < 0.15)) OR
      (((First_Range + Last_Range) / 2) < 7.0) AND (SLOPE < 0.2)) OR
      (SLOPE > 2) OR
      (SLOPE < -1) OR
      (((Noise_Count_Average) / ((Echo_Count + 10) * 5)) > 0.04))
    THEN DELETE;
  END;
  IF KCFS GT 4.3 AND KCFS LE 5.3 THEN DO;
    IF (TRACK_TYPE = 1) OR
      (Echo_Count = 4 AND ((Linearity1 / Echo_Count) > 0.4)) OR
      (Echo_Count >= 5 AND Echo_Count <= 7 AND ((Linearity1 / Echo_Count) >= 0.5)) OR
      ((Linearity2 / Echo_Count) > 0.5) OR
      (((First_Range + Last_Range) / 2) > 10.04) OR
      (((First_Range + Last_Range) / 2) < 9.0) AND (((First_Range + Last_Range) / 2) >= 8.0) AND (SLOPE
        < 0.1)) OR
      (((First_Range + Last_Range) / 2) < 8.0) AND (((First_Range + Last_Range) / 2) >= 7.0) AND (SLOPE
        < 0.15)) OR
      (((First_Range + Last_Range) / 2) < 7.0) AND (SLOPE < 0.2)) OR
      (SLOPE > 2) OR
      (SLOPE < -1) OR
      (((Noise_Count_Average) / ((Echo_Count + 10) * 5)) > 0.04))
    THEN DELETE;
  END;

```

Hydroacoustic Evaluation of Fish Passage through Bonneville Dam in 2004

```

END;
IF KCFS GT 5.3 AND KCFS LE 6.3 THEN DO;
  IF (TRACK_TYPE = 1) OR
    (Echo_Count = 4 AND ((Linearity1 / Echo_Count) > 0.4)) OR
    (Echo_Count >= 5 AND Echo_Count <= 7 AND ((Linearity1 / Echo_Count) >= 0.5)) OR
    ((Linearity2 / Echo_Count) > 0.5) OR
    (((First_Range + Last_Range) / 2) > 10.18) OR
    (((First_Range + Last_Range) / 2) < 9.2) AND (((First_Range + Last_Range) / 2) >= 8.2) AND (SLOPE
      < 0.1) OR
    (((First_Range + Last_Range) / 2) < 8.2) AND (((First_Range + Last_Range) / 2) >= 7.2) AND (SLOPE
      < 0.15) OR
    (((First_Range + Last_Range) / 2) < 7.2) AND (SLOPE < 0.2) OR
    (SLOPE>2) OR
    (SLOPE<-1) OR
    (((Noise_Count_Average) / ((Echo_Count + 10) * 5)) > 0.04))
  THEN DELETE;
END;
IF KCFS GT 6.3 AND KCFS LE 7.5 THEN DO;
  IF (TRACK_TYPE = 1 AND (((First_Range + Last_Range) / 2) < 9.65)) OR
    (Echo_Count = 4 AND ((Linearity1 / Echo_Count) > 0.4)) OR
    (Echo_Count >= 5 AND Echo_Count <= 7 AND ((Linearity1 / Echo_Count) >= 0.5)) OR
    ((Linearity2 / Echo_Count) > 0.5) OR
    (((First_Range + Last_Range) / 2) > 10.28) OR
    (((First_Range + Last_Range) / 2) < 9.2) AND (((First_Range + Last_Range) / 2) >= 8.2) AND (SLOPE
      < 0.1) OR
    (((First_Range + Last_Range) / 2) < 8.2) AND (((First_Range + Last_Range) / 2) >= 7.2) AND (SLOPE
      < 0.15) OR
    (((First_Range + Last_Range) / 2) < 7.2) AND (SLOPE < 0.2) OR
    (SLOPE>2) OR
    (SLOPE<-1) OR
    (((Noise_Count_Average) / ((Echo_Count + 10) * 5)) > 0.04))
  THEN DELETE;
END;
IF KCFS GT 7.5 THEN DO;
  IF (TRACK_TYPE = 1 AND (((First_Range + Last_Range) / 2) < 9.65)) OR
    (Echo_Count = 4 AND ((Linearity1 / Echo_Count) > 0.4)) OR
    (Echo_Count >= 5 AND Echo_Count <= 7 AND ((Linearity1 / Echo_Count) >= 0.5)) OR
    ((Linearity2 / Echo_Count) > 0.5) OR
    (((First_Range + Last_Range) / 2) > 10.38) OR
    (((First_Range + Last_Range) / 2) < 9.4) AND (((First_Range + Last_Range) / 2) >= 8.4) AND (SLOPE
      < 0.1) OR
    (((First_Range + Last_Range) / 2) < 8.4) AND (((First_Range + Last_Range) / 2) >= 7.4) AND (SLOPE
      < 0.15) OR
    (((First_Range + Last_Range) / 2) < 7.4) AND (SLOPE < 0.2) OR
    (SLOPE>2) OR
    (SLOPE<-1) OR
    (((Noise_Count_Average) / ((Echo_Count + 10) * 5)) > 0.04))
  THEN DELETE;
END;
END;
*** CH4 *****;
IF MUX_CHANNEL = 4 THEN DO;
  IF KCFS LE 4.3 THEN DO;
    IF (TRACK_TYPE = 1) OR
      (Echo_Count = 4 AND ((Linearity1 / Echo_Count) > 0.4)) OR
      (Echo_Count >= 5 AND Echo_Count <= 7 AND ((Linearity1 / Echo_Count) >= 0.5)) OR
      ((Linearity2 / Echo_Count) > 0.5) OR
      (((First_Range + Last_Range) / 2) > 9.96) OR
      (((First_Range + Last_Range) / 2) < 9.0) AND (((First_Range + Last_Range) / 2) >= 8.0) AND (SLOPE
        < 0.1) OR
      (((First_Range + Last_Range) / 2) < 8.0) AND (((First_Range + Last_Range) / 2) >= 7.0) AND (SLOPE
        < 0.15) OR
      (((First_Range + Last_Range) / 2) < 7.0) AND (SLOPE < 0.2) OR
      (SLOPE>2) OR
      (SLOPE<-1) OR
      (((Noise_Count_Average) / ((Echo_Count + 10) * 5)) > 0.04))
    THEN DELETE;
  END;
  IF KCFS GT 4.3 AND KCFS LE 5.3 THEN DO;
    IF (TRACK_TYPE = 1) OR
      (Echo_Count = 4 AND ((Linearity1 / Echo_Count) > 0.4)) OR
      (Echo_Count >= 5 AND Echo_Count <= 7 AND ((Linearity1 / Echo_Count) >= 0.5)) OR
      ((Linearity2 / Echo_Count) > 0.5) OR
      (((First_Range + Last_Range) / 2) > 10.07) OR
      (((First_Range + Last_Range) / 2) < 9.0) AND (((First_Range + Last_Range) / 2) >= 8.0) AND (SLOPE
        < 0.1) OR
      (((First_Range + Last_Range) / 2) < 8.0) AND (((First_Range + Last_Range) / 2) >= 7.0) AND (SLOPE
        < 0.15) OR
      (((First_Range + Last_Range) / 2) < 7.0) AND (SLOPE < 0.2) OR
      (SLOPE>2) OR
    
```

Hydroacoustic Evaluation of Fish Passage through Bonneville Dam in 2004

```

        (SLOPE<-1) OR
        (((Noise_Count_Average) / ((Echo_Count + 10) * 5)) > 0.04))
    THEN DELETE;
END;
IF KCFS GT 5.3 AND KCFS LE 6.3 THEN DO;
    IF (TRACK_TYPE = 1) OR
        (Echo_Count = 4 AND ((Linearity1 / Echo_Count) > 0.4)) OR
        (Echo_Count >= 5 AND Echo_Count <= 7 AND ((Linearity1 / Echo_Count) >= 0.5)) OR
        ((Linearity2 / Echo_Count) > 0.5) OR
        (((First_Range + Last_Range) / 2) > 10.18) OR
        (((First_Range + Last_Range) / 2) < 9.2) AND (((First_Range + Last_Range) / 2) >= 8.2) AND (SLOPE
            < 0.1) OR
        (((First_Range + Last_Range) / 2) < 8.2) AND (((First_Range + Last_Range) / 2) >= 7.2) AND (SLOPE
            < 0.15)) OR
        (((First_Range + Last_Range) / 2) < 7.2) AND (SLOPE < 0.2)) OR
        (SLOPE>2) OR
        (SLOPE<-1) OR
        (((Noise_Count_Average) / ((Echo_Count + 10) * 5)) > 0.04))
    THEN DELETE;
END;
IF KCFS GT 6.3 AND KCFS LE 7.3 THEN DO;
    IF (TRACK_TYPE = 1 AND (((First_Range + Last_Range) / 2) < 9.65)) OR
        (Echo_Count = 4 AND ((Linearity1 / Echo_Count) > 0.4)) OR
        (Echo_Count >= 5 AND Echo_Count <= 7 AND ((Linearity1 / Echo_Count) >= 0.5)) OR
        ((Linearity2 / Echo_Count) > 0.5) OR
        (((First_Range + Last_Range) / 2) > 10.3) OR
        (((First_Range + Last_Range) / 2) < 9.3) AND (((First_Range + Last_Range) / 2) >= 8.3) AND (SLOPE
            < 0.1) OR
        (((First_Range + Last_Range) / 2) < 8.3) AND (((First_Range + Last_Range) / 2) >= 7.3) AND (SLOPE
            < 0.15)) OR
        (((First_Range + Last_Range) / 2) < 7.3) AND (SLOPE < 0.2)) OR
        (SLOPE>2) OR
        (SLOPE<-1) OR
        (((Noise_Count_Average) / ((Echo_Count + 10) * 5)) > 0.04))
    THEN DELETE;
END;
IF KCFS GT 7.3 THEN DO;
    IF (TRACK_TYPE = 1) OR
        (Echo_Count = 4 AND ((Linearity1 / Echo_Count) > 0.4)) OR
        (Echo_Count >= 5 AND Echo_Count <= 7 AND ((Linearity1 / Echo_Count) >= 0.5)) OR
        ((Linearity2 / Echo_Count) > 0.5) OR
        (((First_Range + Last_Range) / 2) > 10.42) OR
        (((First_Range + Last_Range) / 2) < 9.4) AND (((First_Range + Last_Range) / 2) >= 8.4) AND (SLOPE
            < 0.1) OR
        (((First_Range + Last_Range) / 2) < 8.4) AND (((First_Range + Last_Range) / 2) >= 7.4) AND (SLOPE
            < 0.15)) OR
        (((First_Range + Last_Range) / 2) < 7.4) AND (SLOPE < 0.2)) OR
        (SLOPE>2) OR
        (SLOPE<-1) OR
        (((Noise_Count_Average) / ((Echo_Count + 10) * 5)) > 0.04))
    THEN DELETE;
END;
END;
*** CH5 *****;
IF MUX_CHANNEL = 5 THEN DO;
    IF KCFS LE 5.3 THEN DO;
        IF (TRACK_TYPE = 1) OR
            (Echo_Count = 4 AND ((Linearity1 / Echo_Count) > 0.4)) OR
            (Echo_Count >= 5 AND Echo_Count <= 7 AND ((Linearity1 / Echo_Count) >= 0.5)) OR
            ((Linearity2 / Echo_Count) > 0.5) OR
            (((First_Range + Last_Range) / 2) > 10.15) OR
            (((First_Range + Last_Range) / 2) < 9.2) AND (((First_Range + Last_Range) / 2) >= 8.2) AND (SLOPE
                < 0.1) OR
            (((First_Range + Last_Range) / 2) < 8.2) AND (((First_Range + Last_Range) / 2) >= 7.2) AND (SLOPE
                < 0.15)) OR
            (((First_Range + Last_Range) / 2) < 7.2) AND (SLOPE < 0.2)) OR
            (SLOPE>2) OR
            (SLOPE<-1) OR
            (((Noise_Count_Average) / ((Echo_Count + 10) * 5)) > 0.04))
        THEN DELETE;
    END;
    IF KCFS GT 5.3 AND KCFS LE 6.3 THEN DO;
        IF (TRACK_TYPE = 1) OR
            (Echo_Count = 4 AND ((Linearity1 / Echo_Count) > 0.4)) OR
            (Echo_Count >= 5 AND Echo_Count <= 7 AND ((Linearity1 / Echo_Count) >= 0.5)) OR
            ((Linearity2 / Echo_Count) > 0.5) OR
            (((First_Range + Last_Range) / 2) > 10.30) OR
            (((First_Range + Last_Range) / 2) < 9.3) AND (((First_Range + Last_Range) / 2) >= 8.3) AND (SLOPE
                < 0.1) OR
            (((First_Range + Last_Range) / 2) < 8.3) AND (((First_Range + Last_Range) / 2) >= 7.3) AND (SLOPE
                < 0.15)) OR

```

Hydroacoustic Evaluation of Fish Passage through Bonneville Dam in 2004

```

        (((First_Range + Last_Range) / 2) < 7.3) AND (SLOPE < 0.2)) OR
        (SLOPE>2) OR
        (SLOPE<-1) OR
        (((Noise_Count_Average) / ((Echo_Count + 10) * 5)) > 0.04))
    THEN DELETE;
END;
IF KCFS GT 6.3 AND KCFS LE 7.3 THEN DO;
    IF (TRACK_TYPE = 1) OR
        (Echo_Count = 4 AND ((Linearity1 / Echo_Count) > 0.4)) OR
        (Echo_Count >= 5 AND Echo_Count <= 7 AND ((Linearity1 / Echo_Count) >= 0.5)) OR
        ((Linearity2 / Echo_Count) > 0.5) OR
        (((First_Range + Last_Range) / 2) > 10.46) OR
        (((First_Range + Last_Range) / 2) < 9.5) AND (((First_Range + Last_Range) / 2) >= 8.5) AND (SLOPE
            < 0.1) OR
        (((First_Range + Last_Range) / 2) < 8.5) AND (((First_Range + Last_Range) / 2) >= 7.5) AND (SLOPE
            < 0.15)) OR
        (((First_Range + Last_Range) / 2) < 7.5) AND (SLOPE < 0.2)) OR
        (SLOPE>2) OR
        (SLOPE<-1) OR
        (((Noise_Count_Average) / ((Echo_Count + 10) * 5)) > 0.04))
    THEN DELETE;
END;
IF KCFS GT 7.3 AND KCFS LE 8.3 THEN DO;
    IF (TRACK_TYPE = 1) OR
        (Echo_Count = 4 AND ((Linearity1 / Echo_Count) > 0.4)) OR
        (Echo_Count >= 5 AND Echo_Count <= 7 AND ((Linearity1 / Echo_Count) >= 0.5)) OR
        ((Linearity2 / Echo_Count) > 0.5) OR
        (((First_Range + Last_Range) / 2) > 10.62) OR
        (((First_Range + Last_Range) / 2) < 9.6) AND (((First_Range + Last_Range) / 2) >= 8.6) AND (SLOPE
            < 0.1) OR
        (((First_Range + Last_Range) / 2) < 8.6) AND (((First_Range + Last_Range) / 2) >= 7.6) AND (SLOPE
            < 0.15)) OR
        (((First_Range + Last_Range) / 2) < 7.6) AND (SLOPE < 0.2)) OR
        (SLOPE>2) OR
        (SLOPE<-1) OR
        (((Noise_Count_Average) / ((Echo_Count + 10) * 5)) > 0.04))
    THEN DELETE;
END;
IF KCFS GT 8.3 THEN DO;
    IF ((TRACK_TYPE = 1) AND (SLOPE < 0.8)) OR
        (Echo_Count = 4 AND ((Linearity1 / Echo_Count) > 0.4)) OR
        (Echo_Count >= 5 AND Echo_Count <= 7 AND ((Linearity1 / Echo_Count) >= 0.5)) OR
        ((Linearity2 / Echo_Count) > 0.5) OR
        (((First_Range + Last_Range) / 2) > 10.77) OR
        (((First_Range + Last_Range) / 2) < 9.8) AND (((First_Range + Last_Range) / 2) >= 8.8) AND (SLOPE
            < 0.1) OR
        (((First_Range + Last_Range) / 2) < 8.8) AND (((First_Range + Last_Range) / 2) >= 7.8) AND (SLOPE
            < 0.15)) OR
        (((First_Range + Last_Range) / 2) < 7.8) AND (SLOPE < 0.2)) OR
        (SLOPE<-1.5) OR
        (SLOPE>3) OR
        (((Noise_Count_Average) / ((Echo_Count + 10) * 5)) > 0.04))
    THEN DELETE;
END;
END;
END;
IF SYSTEM = 'Q' THEN DO;
*** CH1 *****;
    IF MUX_CHANNEL = 1 THEN DO;
        IF KCFS LE 3.2 THEN DO;
            IF (TRACK_TYPE = 1) OR
                (Echo_Count = 4 AND ((Linearity1 / Echo_Count) > 0.4)) OR
                (Echo_Count >= 5 AND Echo_Count <= 7 AND ((Linearity1 / Echo_Count) >= 0.5)) OR
                ((Linearity2 / Echo_Count) > 0.5) OR
                (LINEARITY1=0 AND LINEARITY2=0 AND SLOPE=0) OR
                (((First_Range + Last_Range) / 2) > 9.72) OR
                (((First_Range + Last_Range) / 2) < 9.25) AND (((First_Range + Last_Range) / 2) >= 8.25) AND
                    (SLOPE < 0.1)) OR
                (((First_Range + Last_Range) / 2) < 8.25) AND (((First_Range + Last_Range) / 2) >= 7.25) AND
                    (SLOPE < 0.15)) OR
                (((First_Range + Last_Range) / 2) < 7.25) AND (SLOPE < 0.2)) OR
                (SLOPE>2) OR
                (SLOPE<-1) OR
                (((Noise_Count_Average) / ((Echo_Count + 10) * 5)) > 0.04))
            THEN DELETE;
        END;
    END;
    IF KCFS GT 3.2 AND KCFS LE 5.4 THEN DO;
        IF (TRACK_TYPE = 1) OR
            (Echo_Count = 4 AND ((Linearity1 / Echo_Count) > 0.4)) OR
            (Echo_Count >= 5 AND Echo_Count <= 7 AND ((Linearity1 / Echo_Count) >= 0.5)) OR

```

Hydroacoustic Evaluation of Fish Passage through Bonneville Dam in 2004

```

        ((Linearity2 / Echo_Count) > 0.5) OR
        (((First_Range + Last_Range) / 2) > 9.97) OR
        (((First_Range + Last_Range) / 2) < 9.2) AND (((First_Range + Last_Range) / 2) >= 8.2) AND (SLOPE
        < 0.1) OR
        (((First_Range + Last_Range) / 2) < 8.2) AND (((First_Range + Last_Range) / 2) >= 7.2) AND (SLOPE
        < 0.15)) OR
        (((First_Range + Last_Range) / 2) < 7.2) AND (SLOPE < 0.2) OR
        (SLOPE>2) OR
        (SLOPE<-1) OR
        (((Noise_Count_Average) / ((Echo_Count + 10) * 5)) > 0.04))
    THEN DELETE;
END;
IF KCFS GT 5.4 AND KCFS LE 7.4 THEN DO;
    IF (TRACK_TYPE = 1) OR
        (Echo_Count = 4 AND ((Linearity1 / Echo_Count) > 0.4)) OR
        (Echo_Count >= 5 AND Echo_Count <= 7 AND ((Linearity1 / Echo_Count) >= 0.5)) OR
        ((Linearity2 / Echo_Count) > 0.5) OR
        (((First_Range + Last_Range) / 2) > 10.22) OR
        (((First_Range + Last_Range) / 2) < 9.2) AND (((First_Range + Last_Range) / 2) >= 8.2) AND (SLOPE
        < 0.1) OR
        (((First_Range + Last_Range) / 2) < 8.2) AND (((First_Range + Last_Range) / 2) >= 7.2) AND (SLOPE
        < 0.15)) OR
        (((First_Range + Last_Range) / 2) < 7.2) AND (SLOPE < 0.2) OR
        (SLOPE>3) OR
        (SLOPE<-1) OR
        (((Noise_Count_Average) / ((Echo_Count + 10) * 5)) > 0.04))
    THEN DELETE;
END;
IF KCFS GT 7.4 THEN DO;
    IF (TRACK_TYPE = 1) OR
        (Echo_Count = 4 AND ((Linearity1 / Echo_Count) > 0.4)) OR
        (Echo_Count >= 5 AND Echo_Count <= 7 AND ((Linearity1 / Echo_Count) >= 0.5)) OR
        ((Linearity2 / Echo_Count) > 0.5) OR
        (((First_Range + Last_Range) / 2) > 10.47) OR
        (((First_Range + Last_Range) / 2) < 9.5) AND (((First_Range + Last_Range) / 2) >= 8.5) AND (SLOPE
        < 0.1) OR
        (((First_Range + Last_Range) / 2) < 8.5) AND (((First_Range + Last_Range) / 2) >= 7.5) AND (SLOPE
        < 0.15)) OR
        (((First_Range + Last_Range) / 2) < 7.5) AND (SLOPE < 0.2) OR
        (SLOPE>3) OR
        (SLOPE<-1) OR
        (((Noise_Count_Average) / ((Echo_Count + 10) * 5)) > 0.04))
    THEN DELETE;
END;
END;
END;
*** CH2 *****;
IF MUX_CHANNEL = 2 THEN DO;
    IF KCFS LE 5.3 THEN DO;
        IF (TRACK_TYPE = 1) OR
            (Echo_Count = 4 AND ((Linearity1 / Echo_Count) > 0.4)) OR
            (Echo_Count >= 5 AND Echo_Count <= 7 AND ((Linearity1 / Echo_Count) >= 0.5)) OR
            ((Linearity2 / Echo_Count) > 0.5) OR
            (((First_Range + Last_Range) / 2) > 9.97) OR
            (((First_Range + Last_Range) / 2) < 9.2) AND (((First_Range + Last_Range) / 2) >= 8.2) AND (SLOPE
            < 0.1) OR
            (((First_Range + Last_Range) / 2) < 8.2) AND (((First_Range + Last_Range) / 2) >= 7.2) AND (SLOPE
            < 0.15)) OR
            (((First_Range + Last_Range) / 2) < 7.2) AND (SLOPE < 0.2) OR
            (SLOPE>2) OR
            (SLOPE<-1) OR
            (((Noise_Count_Average) / ((Echo_Count + 10) * 5)) > 0.04))
        THEN DELETE;
    END;
    IF KCFS GT 5.3 AND KCFS LE 6.3 THEN DO;
        IF (TRACK_TYPE = 1) OR
            (Echo_Count = 4 AND ((Linearity1 / Echo_Count) > 0.4)) OR
            (Echo_Count >= 5 AND Echo_Count <= 7 AND ((Linearity1 / Echo_Count) >= 0.5)) OR
            ((Linearity2 / Echo_Count) > 0.5) OR
            (((First_Range + Last_Range) / 2) > 10.14) OR
            (((First_Range + Last_Range) / 2) < 9.2) AND (((First_Range + Last_Range) / 2) >= 8.2) AND (SLOPE
            < 0.1) OR
            (((First_Range + Last_Range) / 2) < 8.2) AND (((First_Range + Last_Range) / 2) >= 7.2) AND (SLOPE
            < 0.15)) OR
            (((First_Range + Last_Range) / 2) < 7.2) AND (SLOPE < 0.2) OR
            (SLOPE>2) OR
            (SLOPE<-1) OR
            (((Noise_Count_Average) / ((Echo_Count + 10) * 5)) > 0.04))
        THEN DELETE;
    END;
    IF KCFS GT 6.3 AND KCFS LE 7.5 THEN DO;

```

Hydroacoustic Evaluation of Fish Passage through Bonneville Dam in 2004

```

IF (TRACK_TYPE = 1) OR
(Echo_Count = 4 AND ((Linearity1 / Echo_Count) > 0.4)) OR
(Echo_Count >= 5 AND Echo_Count <= 7 AND ((Linearity1 / Echo_Count) >= 0.5)) OR
((Linearity2 / Echo_Count) > 0.5) OR
(((First_Range + Last_Range) / 2) > 10.3) OR
((((First_Range + Last_Range) / 2) < 9.3) AND (((First_Range + Last_Range) / 2) >= 8.3) AND (SLOPE
< 0.1)) OR
((((First_Range + Last_Range) / 2) < 8.3) AND (((First_Range + Last_Range) / 2) >= 7.3) AND (SLOPE
< 0.15)) OR
((((First_Range + Last_Range) / 2) < 7.3) AND (SLOPE < 0.2)) OR
(SLOPE>3) OR
(SLOPE<-1) OR
((((Noise_Count_Average) / ((Echo_Count + 10) * 5)) > 0.04))
THEN DELETE;
END;
IF KCFS GT 7.5 AND KCFS LE 8.7 THEN DO;
IF (TRACK_TYPE = 1) OR
(Echo_Count = 4 AND ((Linearity1 / Echo_Count) > 0.4)) OR
(Echo_Count >= 5 AND Echo_Count <= 7 AND ((Linearity1 / Echo_Count) >= 0.5)) OR
((Linearity2 / Echo_Count) > 0.5) OR
(((First_Range + Last_Range) / 2) > 10.54) OR
((((First_Range + Last_Range) / 2) < 9.5) AND (((First_Range + Last_Range) / 2) >= 8.5) AND (SLOPE
< 0.1)) OR
((((First_Range + Last_Range) / 2) < 8.5) AND (((First_Range + Last_Range) / 2) >= 7.5) AND (SLOPE
< 0.15)) OR
((((First_Range + Last_Range) / 2) < 7.5) AND (SLOPE < 0.2)) OR
(SLOPE>3) OR
(SLOPE<-1) OR
((((Noise_Count_Average) / ((Echo_Count + 10) * 5)) > 0.04))
THEN DELETE;
END;
IF KCFS GT 8.7 THEN DO;
IF ((TRACK_TYPE = 1) AND (SLOPE < 0.8)) OR
(Echo_Count = 4 AND ((Linearity1 / Echo_Count) > 0.4)) OR
(Echo_Count >= 5 AND Echo_Count <= 7 AND ((Linearity1 / Echo_Count) >= 0.5)) OR
((Linearity2 / Echo_Count) > 0.5) OR
(((First_Range + Last_Range) / 2) > 10.77) OR
((((First_Range + Last_Range) / 2) < 9.8) AND (((First_Range + Last_Range) / 2) >= 8.8) AND (SLOPE
< 0.1)) OR
((((First_Range + Last_Range) / 2) < 8.8) AND (((First_Range + Last_Range) / 2) >= 7.8) AND (SLOPE
< 0.15)) OR
((((First_Range + Last_Range) / 2) < 7.8) AND (SLOPE < 0.2)) OR
(SLOPE<-1.5) OR
(SLOPE>3) OR
((((Noise_Count_Average) / ((Echo_Count + 10) * 5)) > 0.04))
THEN DELETE;
END;
END;
*** CH3 *****;
IF MUX_CHANNEL = 3 THEN DO;
IF KCFS LE 5.3 THEN DO;
IF (TRACK_TYPE = 1) OR
(Echo_Count = 4 AND ((Linearity1 / Echo_Count) > 0.4)) OR
(Echo_Count >= 5 AND Echo_Count <= 7 AND ((Linearity1 / Echo_Count) >= 0.5)) OR
((Linearity2 / Echo_Count) > 0.5) OR
(((First_Range + Last_Range) / 2) > 9.97) OR
((((First_Range + Last_Range) / 2) < 9.2) AND (((First_Range + Last_Range) / 2) >= 8.2) AND (SLOPE
< 0.1)) OR
((((First_Range + Last_Range) / 2) < 8.2) AND (((First_Range + Last_Range) / 2) >= 7.2) AND (SLOPE
< 0.15)) OR
((((First_Range + Last_Range) / 2) < 7.2) AND (SLOPE < 0.2)) OR
(SLOPE>2) OR
(SLOPE<-1) OR
((((Noise_Count_Average) / ((Echo_Count + 10) * 5)) > 0.04))
THEN DELETE;
END;
IF KCFS GT 5.3 AND KCFS LE 6.3 THEN DO;
IF (TRACK_TYPE = 1) OR
(Echo_Count = 4 AND ((Linearity1 / Echo_Count) > 0.4)) OR
(Echo_Count >= 5 AND Echo_Count <= 7 AND ((Linearity1 / Echo_Count) >= 0.5)) OR
((Linearity2 / Echo_Count) > 0.5) OR
(((First_Range + Last_Range) / 2) > 10.14) OR
((((First_Range + Last_Range) / 2) < 9.2) AND (((First_Range + Last_Range) / 2) >= 8.2) AND (SLOPE
< 0.1)) OR
((((First_Range + Last_Range) / 2) < 8.2) AND (((First_Range + Last_Range) / 2) >= 7.2) AND (SLOPE
< 0.15)) OR
((((First_Range + Last_Range) / 2) < 7.2) AND (SLOPE < 0.2)) OR
(SLOPE>2) OR
(SLOPE<-1) OR
((((Noise_Count_Average) / ((Echo_Count + 10) * 5)) > 0.04))
THEN DELETE;

```

Hydroacoustic Evaluation of Fish Passage through Bonneville Dam in 2004

```

END;
IF KCFS GT 6.3 AND KCFS LE 7.3 THEN DO;
  IF (TRACK_TYPE = 1) OR
    (Echo_Count = 4 AND ((Linearity1 / Echo_Count) > 0.4)) OR
    (Echo_Count >= 5 AND Echo_Count <= 7 AND ((Linearity1 / Echo_Count) >= 0.5)) OR
    ((Linearity2 / Echo_Count) > 0.5) OR
    (((First_Range + Last_Range) / 2) > 10.32) OR
    (((First_Range + Last_Range) / 2) < 9.3) AND (((First_Range + Last_Range) / 2) >= 8.3) AND (SLOPE
      < 0.1) OR
    (((First_Range + Last_Range) / 2) < 8.3) AND (((First_Range + Last_Range) / 2) >= 7.3) AND (SLOPE
      < 0.15) OR
    (((First_Range + Last_Range) / 2) < 7.3) AND (SLOPE < 0.2) OR
    (SLOPE>3) OR
    (SLOPE<-1) OR
    (((Noise_Count_Average) / ((Echo_Count + 10) * 5)) > 0.04))
  THEN DELETE;
END;
IF KCFS GT 7.3 AND KCFS LE 8.3 THEN DO;
  IF (TRACK_TYPE = 1) OR
    (Echo_Count = 4 AND ((Linearity1 / Echo_Count) > 0.4)) OR
    (Echo_Count >= 5 AND Echo_Count <= 7 AND ((Linearity1 / Echo_Count) >= 0.5)) OR
    ((Linearity2 / Echo_Count) > 0.5) OR
    (((First_Range + Last_Range) / 2) > 10.49) OR
    (((First_Range + Last_Range) / 2) < 9.5) AND (((First_Range + Last_Range) / 2) >= 8.5) AND (SLOPE
      < 0.1) OR
    (((First_Range + Last_Range) / 2) < 8.5) AND (((First_Range + Last_Range) / 2) >= 7.5) AND (SLOPE
      < 0.15) OR
    (((First_Range + Last_Range) / 2) < 7.5) AND (SLOPE < 0.2) OR
    (SLOPE>3) OR
    (SLOPE<-1) OR
    (((Noise_Count_Average) / ((Echo_Count + 10) * 5)) > 0.04))
  THEN DELETE;
END;
IF KCFS GT 8.3 THEN DO;
  IF (TRACK_TYPE = 1) OR
    (Echo_Count = 4 AND ((Linearity1 / Echo_Count) > 0.4)) OR
    (Echo_Count >= 5 AND Echo_Count <= 7 AND ((Linearity1 / Echo_Count) >= 0.5)) OR
    ((Linearity2 / Echo_Count) > 0.5) OR
    (((First_Range + Last_Range) / 2) > 10.77) OR
    (((First_Range + Last_Range) / 2) < 9.5) AND (((First_Range + Last_Range) / 2) >= 8.8) AND (SLOPE
      < 0.1) OR
    (((First_Range + Last_Range) / 2) < 8.8) AND (((First_Range + Last_Range) / 2) >= 7.8) AND (SLOPE
      < 0.15) OR
    (((First_Range + Last_Range) / 2) < 7.8) AND (SLOPE < 0.2) OR
    (SLOPE<-1.5) OR
    (SLOPE>3) OR
    (((Noise_Count_Average) / ((Echo_Count + 10) * 5)) > 0.04))
  THEN DELETE;
END;
END;
*** CH4 *****;
IF MUX_CHANNEL = 4 THEN DO;
  IF KCFS LE 4.3 THEN DO;
    IF (TRACK_TYPE = 1) OR
      (Echo_Count = 4 AND ((Linearity1 / Echo_Count) > 0.4)) OR
      (Echo_Count >= 5 AND Echo_Count <= 7 AND ((Linearity1 / Echo_Count) >= 0.5)) OR
      ((Linearity2 / Echo_Count) > 0.5) OR
      (((First_Range + Last_Range) / 2) > 9.96) OR
      (((First_Range + Last_Range) / 2) < 9.0) AND (((First_Range + Last_Range) / 2) >= 8.0) AND (SLOPE
        < 0.1) OR
      (((First_Range + Last_Range) / 2) < 8.0) AND (((First_Range + Last_Range) / 2) >= 7.0) AND (SLOPE
        < 0.15) OR
      (((First_Range + Last_Range) / 2) < 7.0) AND (SLOPE < 0.2) OR
      (SLOPE>2) OR
      (SLOPE<-1) OR
      (((Noise_Count_Average) / ((Echo_Count + 10) * 5)) > 0.04))
    THEN DELETE;
  END;
  IF KCFS GT 4.3 AND KCFS LE 5.3 THEN DO;
    IF (TRACK_TYPE = 1) OR
      (Echo_Count = 4 AND ((Linearity1 / Echo_Count) > 0.4)) OR
      (Echo_Count >= 5 AND Echo_Count <= 7 AND ((Linearity1 / Echo_Count) >= 0.5)) OR
      ((Linearity2 / Echo_Count) > 0.5) OR
      (((First_Range + Last_Range) / 2) > 10.07) OR
      (((First_Range + Last_Range) / 2) < 9.0) AND (((First_Range + Last_Range) / 2) >= 8.0) AND (SLOPE
        < 0.1) OR
      (((First_Range + Last_Range) / 2) < 8.0) AND (((First_Range + Last_Range) / 2) >= 7.0) AND (SLOPE
        < 0.15) OR
      (((First_Range + Last_Range) / 2) < 7.0) AND (SLOPE < 0.2) OR
      (SLOPE>2) OR
    THEN DELETE;
  END;

```

Hydroacoustic Evaluation of Fish Passage through Bonneville Dam in 2004

```

        (SLOPE<-1) OR
        (((Noise_Count_Average) / ((Echo_Count + 10) * 5)) > 0.04))
    THEN DELETE;
END;
IF KCFS GT 5.3 AND KCFS LE 6.3 THEN DO;
    IF (TRACK_TYPE = 1) OR
        (Echo_Count = 4 AND ((Linearity1 / Echo_Count) > 0.4)) OR
        (Echo_Count >= 5 AND Echo_Count <= 7 AND ((Linearity1 / Echo_Count) >= 0.5)) OR
        ((Linearity2 / Echo_Count) > 0.5) OR
        (((First_Range + Last_Range) / 2) > 10.19) OR
        (((First_Range + Last_Range) / 2) < 9.2) AND (((First_Range + Last_Range) / 2) >= 8.2) AND (SLOPE
            < 0.1) OR
        (((First_Range + Last_Range) / 2) < 8.2) AND (((First_Range + Last_Range) / 2) >= 7.2) AND (SLOPE
            < 0.15)) OR
        (((First_Range + Last_Range) / 2) < 7.2) AND (SLOPE < 0.2)) OR
        (SLOPE>2) OR
        (SLOPE<-1) OR
        (((Noise_Count_Average) / ((Echo_Count + 10) * 5)) > 0.04))
    THEN DELETE;
END;
IF KCFS GT 6.3 AND KCFS LE 7.3 THEN DO;
    IF (TRACK_TYPE = 1) OR
        (Echo_Count = 4 AND ((Linearity1 / Echo_Count) > 0.4)) OR
        (Echo_Count >= 5 AND Echo_Count <= 7 AND ((Linearity1 / Echo_Count) >= 0.5)) OR
        ((Linearity2 / Echo_Count) > 0.5) OR
        (((First_Range + Last_Range) / 2) > 10.3) OR
        (((First_Range + Last_Range) / 2) < 9.3) AND (((First_Range + Last_Range) / 2) >= 8.3) AND (SLOPE
            < 0.1) OR
        (((First_Range + Last_Range) / 2) < 8.3) AND (((First_Range + Last_Range) / 2) >= 7.3) AND (SLOPE
            < 0.15)) OR
        (((First_Range + Last_Range) / 2) < 7.3) AND (SLOPE < 0.2)) OR
        (SLOPE>3) OR
        (SLOPE<-1) OR
        (((Noise_Count_Average) / ((Echo_Count + 10) * 5)) > 0.04))
    THEN DELETE;
END;
IF KCFS GT 7.3 THEN DO;
    IF (TRACK_TYPE = 1) OR
        (Echo_Count = 4 AND ((Linearity1 / Echo_Count) > 0.4)) OR
        (Echo_Count >= 5 AND Echo_Count <= 7 AND ((Linearity1 / Echo_Count) >= 0.5)) OR
        ((Linearity2 / Echo_Count) > 0.5) OR
        (((First_Range + Last_Range) / 2) > 10.5) OR
        (((First_Range + Last_Range) / 2) < 9.5) AND (((First_Range + Last_Range) / 2) >= 8.5) AND (SLOPE
            < 0.1) OR
        (((First_Range + Last_Range) / 2) < 8.5) AND (((First_Range + Last_Range) / 2) >= 7.5) AND (SLOPE
            < 0.15)) OR
        (((First_Range + Last_Range) / 2) < 7.5) AND (SLOPE < 0.2)) OR
        (SLOPE>3) OR
        (SLOPE<-1) OR
        (((Noise_Count_Average) / ((Echo_Count + 10) * 5)) > 0.04))
    THEN DELETE;
END;
END;
*** CH5 *****;
IF MUX_CHANNEL = 5 THEN DO;
    IF KCFS LE 3.3 THEN DO;
        IF (TRACK_TYPE = 1) OR
            (Echo_Count = 4 AND ((Linearity1 / Echo_Count) > 0.4)) OR
            (Echo_Count >= 5 AND Echo_Count <= 7 AND ((Linearity1 / Echo_Count) >= 0.5)) OR
            ((Linearity2 / Echo_Count) > 0.5) OR
            (((First_Range + Last_Range) / 2) > 9.72) OR
            (((First_Range + Last_Range) / 2) < 9.0) AND (((First_Range + Last_Range) / 2) >= 8.5) AND (SLOPE
                < 0.1) OR
            (((First_Range + Last_Range) / 2) < 8.5) AND (((First_Range + Last_Range) / 2) >= 7.5) AND (SLOPE
                < 0.15)) OR
            (((First_Range + Last_Range) / 2) < 7.5) AND (SLOPE < 0.2)) OR
            (SLOPE>2) OR
            (SLOPE<-1) OR
            (((Noise_Count_Average) / ((Echo_Count + 10) * 5)) > 0.04))
        THEN DELETE;
    END;
    IF KCFS GT 3.3 AND KCFS LE 4.3 THEN DO;
        IF (TRACK_TYPE = 1) OR
            (Echo_Count = 4 AND ((Linearity1 / Echo_Count) > 0.4)) OR
            (Echo_Count >= 5 AND Echo_Count <= 7 AND ((Linearity1 / Echo_Count) >= 0.5)) OR
            ((Linearity2 / Echo_Count) > 0.5) OR
            (((First_Range + Last_Range) / 2) > 9.87) OR
            (((First_Range + Last_Range) / 2) < 9.0) AND (((First_Range + Last_Range) / 2) >= 8.0) AND (SLOPE
                < 0.1) OR
            (((First_Range + Last_Range) / 2) < 8.0) AND (((First_Range + Last_Range) / 2) >= 7.0) AND (SLOPE
                < 0.15)) OR

```

Hydroacoustic Evaluation of Fish Passage through Bonneville Dam in 2004

```

        (((First_Range + Last_Range) / 2) < 7.0) AND (SLOPE < 0.2)) OR
        (SLOPE>2) OR
        (SLOPE<-1) OR
        (((Noise_Count_Average) / ((Echo_Count + 10) * 5)) > 0.04))
    THEN DELETE;
END;
IF KCFS GT 4.3 AND KCFS LE 5.3 THEN DO;
    IF (TRACK_TYPE = 1) OR
        (Echo_Count = 4 AND ((Linearity1 / Echo_Count) > 0.4)) OR
        (Echo_Count >= 5 AND Echo_Count <= 7 AND ((Linearity1 / Echo_Count) >= 0.5)) OR
        ((Linearity2 / Echo_Count) > 0.5) OR
        (((First_Range + Last_Range) / 2) > 10.01) OR
        (((First_Range + Last_Range) / 2) < 9.0) AND (((First_Range + Last_Range) / 2) >= 8.0) AND (SLOPE
            < 0.1) OR
        (((First_Range + Last_Range) / 2) < 8.0) AND (((First_Range + Last_Range) / 2) >= 7.0) AND (SLOPE
            < 0.15)) OR
        (((First_Range + Last_Range) / 2) < 7.0) AND (SLOPE < 0.2)) OR
        (SLOPE>2) OR
        (SLOPE<-1) OR
        (((Noise_Count_Average) / ((Echo_Count + 10) * 5)) > 0.04))
    THEN DELETE;
END;
IF KCFS GT 5.3 AND KCFS LE 6.3 THEN DO;
    IF (TRACK_TYPE = 1) OR
        (Echo_Count = 4 AND ((Linearity1 / Echo_Count) > 0.4)) OR
        (Echo_Count >= 5 AND Echo_Count <= 7 AND ((Linearity1 / Echo_Count) >= 0.5)) OR
        ((Linearity2 / Echo_Count) > 0.5) OR
        (((First_Range + Last_Range) / 2) > 10.16) OR
        (((First_Range + Last_Range) / 2) < 9.2) AND (((First_Range + Last_Range) / 2) >= 8.2) AND (SLOPE
            < 0.1) OR
        (((First_Range + Last_Range) / 2) < 8.2) AND (((First_Range + Last_Range) / 2) >= 7.2) AND (SLOPE
            < 0.15)) OR
        (((First_Range + Last_Range) / 2) < 7.2) AND (SLOPE < 0.2)) OR
        (SLOPE>2) OR
        (SLOPE<-1) OR
        (((Noise_Count_Average) / ((Echo_Count + 10) * 5)) > 0.04))
    THEN DELETE;
END;
IF KCFS GT 6.3 AND KCFS LE 7.3 THEN DO;
    IF (TRACK_TYPE = 1) OR
        (Echo_Count = 4 AND ((Linearity1 / Echo_Count) > 0.4)) OR
        (Echo_Count >= 5 AND Echo_Count <= 7 AND ((Linearity1 / Echo_Count) >= 0.5)) OR
        ((Linearity2 / Echo_Count) > 0.5) OR
        (((First_Range + Last_Range) / 2) > 10.3) OR
        (((First_Range + Last_Range) / 2) < 9.3) AND (((First_Range + Last_Range) / 2) >= 8.3) AND (SLOPE
            < 0.1) OR
        (((First_Range + Last_Range) / 2) < 8.3) AND (((First_Range + Last_Range) / 2) >= 7.3) AND (SLOPE
            < 0.15)) OR
        (((First_Range + Last_Range) / 2) < 7.3) AND (SLOPE < 0.2)) OR
        (SLOPE>2) OR
        (SLOPE<-1) OR
        (((Noise_Count_Average) / ((Echo_Count + 10) * 5)) > 0.04))
    THEN DELETE;
END;
IF KCFS GT 7.3 THEN DO;
    IF (TRACK_TYPE = 1) OR
        (Echo_Count = 4 AND ((Linearity1 / Echo_Count) > 0.4)) OR
        (Echo_Count >= 5 AND Echo_Count <= 7 AND ((Linearity1 / Echo_Count) >= 0.5)) OR
        ((Linearity2 / Echo_Count) > 0.5) OR
        (((First_Range + Last_Range) / 2) > 10.5) OR
        (((First_Range + Last_Range) / 2) < 9.5) AND (((First_Range + Last_Range) / 2) >= 8.5) AND (SLOPE
            < 0.1) OR
        (((First_Range + Last_Range) / 2) < 8.5) AND (((First_Range + Last_Range) / 2) >= 7.5) AND (SLOPE
            < 0.15)) OR
        (((First_Range + Last_Range) / 2) < 7.5) AND (SLOPE < 0.2)) OR
        (SLOPE>2) OR
        (SLOPE<-1) OR
        (((Noise_Count_Average) / ((Echo_Count + 10) * 5)) > 0.04))
    THEN DELETE;
END;
END;
END;
IF SYSTEM='E' THEN DO;
    IF MUX_CHANNEL EQ 1 OR MUX_CHANNEL EQ 3 OR MUX_CHANNEL EQ 5 THEN DO;
        IF
            (ECHO_COUNT <6) OR
            (Echo_Count = 4 AND ((Linearity1 / Echo_Count) > 0.4)) OR
            (Echo_Count >= 5 AND Echo_Count <= 7 AND ((Linearity1 / Echo_Count) >= 0.5)) OR
            ((Linearity2 / Echo_Count) > 0.5) OR
            (((Noise_Count_Average) / ((Echo_Count + 10) * 5)) > 0.04)) OR

```

Hydroacoustic Evaluation of Fish Passage through Bonneville Dam in 2004

```
NOISE_COUNT_AVERAGE > 2.5 OR

(SLOPE >= 2.5 OR SLOPE <= -2.5) OR
(First_Range < 8.50 AND Slope < 0.5) OR
(First_Range >= 8.50 AND First_Range <=15.00 AND Slope < 0.23) OR
(First_Range > 15.00 AND Slope < 0.2) OR
(Track_Type = 1) THEN DELETE;
END;
IF MUX_CHANNEL EQ 2 OR MUX_CHANNEL EQ 4 OR MUX_CHANNEL EQ 6 THEN DO;
IF
(ECHO_COUNT <4) OR
(Echo_Count = 4 AND ((Linearity1 / Echo_Count) > 0.4)) OR
(Echo_Count >= 5 AND Echo_Count <= 7 AND ((Linearity1 / Echo_Count) >= 0.5)) OR
((Linearity2 / Echo_Count) > 0.5) OR
(((Noise_Count_Average) / ((Echo_Count + 10) * 5)) > 0.04)) OR
(SLOPE >= 0.6 OR SLOPE <= -0.6) OR
(Echo_Count < 8 AND Linearity1 > 1 AND Noise_Count_Average > 2) OR
((Linearity1 > 2) AND (Linearity2 > 2) AND (Noise_Count_Average > 4)) OR
(Linearity1 > 2 AND Linearity2 > 2 AND Noise_Count_Average >= 2) OR
(First_Range > 11.2 AND Last_Range > 11.2) OR
(((First_Range + Last_Range)/ 2) > 10.8) AND (Slope > 0.35 OR Slope < -0.35)) OR
(Track_Type = 1) THEN DELETE;
END;
END;
IF SYSTEM='G' THEN DO;
IF MUX_CHANNEL EQ 1 OR MUX_CHANNEL EQ 3 OR MUX_CHANNEL EQ 5 OR MUX_CHANNEL EQ 7 THEN DO;
IF
(ECHO_COUNT < 6) OR
(Echo_Count = 4 AND ((Linearity1 / Echo_Count) > 0.4)) OR
(Echo_Count >= 5 AND Echo_Count <= 7 AND ((Linearity1 / Echo_Count) >= 0.5)) OR
((Linearity2 / Echo_Count) > 0.5) OR
(((Noise_Count_Average) / ((Echo_Count + 10) * 5)) > 0.04)) OR
NOISE_COUNT_AVERAGE > 2.5 OR

(SLOPE >= 2.5 OR SLOPE <= -2.5) OR
(First_Range < 8.50 AND Slope < 0.5) OR
(First_Range >= 8.50 AND First_Range <=15.00 AND Slope < 0.23) OR
(First_Range >= 15.00 AND Slope < 0.2) OR
(Track_Type = 1) THEN DELETE;
END;
IF MUX_CHANNEL EQ 2 OR MUX_CHANNEL EQ 8 THEN DO;
IF
(ECHO_COUNT <4) OR
(Echo_Count = 4 AND ((Linearity1 / Echo_Count) > 0.4)) OR
(Echo_Count >= 5 AND Echo_Count <= 7 AND ((Linearity1 / Echo_Count) >= 0.5)) OR
((Linearity2 / Echo_Count) > 0.5) OR
(((Noise_Count_Average) / ((Echo_Count + 10) * 5)) > 0.04)) OR
(SLOPE >= 0.6 OR SLOPE <= -0.6) OR
(Echo_Count < 8 AND Linearity1 > 1 AND Noise_Count_Average > 2) OR
((Linearity1 > 2) AND (Linearity2 > 2) AND (Noise_Count_Average > 4)) OR
(Linearity1 > 2 AND Linearity2 > 2 AND Noise_Count_Average >= 2) OR
(First_Range > 11.2 AND Last_Range > 11.2) OR
(((First_Range + Last_Range)/ 2) > 10.5) AND (Slope > 0.35 OR Slope < -0.35)) OR
(Track_Type = 1) THEN DELETE;
END;
IF MUX_CHANNEL EQ 4 THEN DO;
IF
(ECHO_COUNT <4) OR
(Echo_Count = 4 AND ((Linearity1 / Echo_Count) > 0.4)) OR
(Echo_Count >= 5 AND Echo_Count <= 7 AND ((Linearity1 / Echo_Count) >= 0.5)) OR
((Linearity2 / Echo_Count) > 0.5) OR
(((Noise_Count_Average) / ((Echo_Count + 10) * 5)) > 0.04)) OR
(SLOPE >= 0.6 OR SLOPE <= -0.6) OR
(Echo_Count < 8 AND Linearity1 > 1 AND Noise_Count_Average > 2) OR
((Linearity1 > 2) AND (Linearity2 > 2) AND (Noise_Count_Average > 4)) OR
(Linearity1 > 2 AND Linearity2 > 2 AND Noise_Count_Average >= 2) OR
(First_Range > 11.2 AND Last_Range > 11.2) OR
(((First_Range + Last_Range)/ 2) > 10.5) AND (Slope > 0.35 OR Slope < -0.35)) OR
(First_Range > 9.5 AND First_Range < 10 AND Last_Range > 9.5 AND Last_Range < 10) OR
(First_Range > 10.2 AND First_Range < 10.5 AND Last_Range > 10.2 AND Last_Range < 10.5) OR
(Track_Type = 1) THEN DELETE;
END;
IF MUX_CHANNEL EQ 6 THEN DO;
IF
(ECHO_COUNT <4) OR
(Echo_Count = 4 AND ((Linearity1 / Echo_Count) > 0.4)) OR
(Echo_Count >= 5 AND Echo_Count <= 7 AND ((Linearity1 / Echo_Count) >= 0.5)) OR
((Linearity2 / Echo_Count) > 0.5) OR
(((Noise_Count_Average) / ((Echo_Count + 10) * 5)) > 0.04)) OR
(SLOPE >= 0.6 OR SLOPE <= -0.6) OR
```

Hydroacoustic Evaluation of Fish Passage through Bonneville Dam in 2004

```
(Echo_Count < 8 AND Linearity1 > 1 AND Noise_Count_Average > 2) OR
((Linearity1 > 2) AND (Linearity2 > 2) AND (Noise_Count_Average > 4)) OR
(Linearity1 > 2 AND Linearity2 > 2 AND Noise_Count_Average >= 2) OR
(First_Range > 11.2 AND Last_Range > 11.2) OR
(((First_Range + Last_Range) / 2) > 10.5) AND (Slope > 0.35 OR Slope < -0.35)) OR
(First_Range > 8.7 AND First_Range < 9 AND Last_Range > 8.7 AND Last_Range < 9) OR
(Track_Type = 1) THEN DELETE;
END;
END;

IF SYSTEM='H' THEN DO;
IF MUX_CHANNEL EQ 1 OR MUX_CHANNEL EQ 3 THEN DO;
IF
(ECHO_COUNT <6) OR
(ECHO_COUNT < 6) OR
(Echo_Count = 4 AND ((Linearity1 / Echo_Count) > 0.4)) OR
(Echo_Count >= 5 AND Echo_Count <= 7 AND ((Linearity1 / Echo_Count) >= 0.5)) OR
((Linearity2 / Echo_Count) > 0.5) OR
((Echo_Count = 5 OR Echo_Count = 6 OR Echo_Count = 7) AND ((Linearity1 / Echo_Count) >= 0.4)) OR
(((Noise_Count_Average) / ((Echo_Count + 10) * 5)) > 0.04)) OR
NOISE_COUNT_AVERAGE > 2.5 OR

(SLOPE >= 2.5 OR SLOPE <= -2.5) OR
(First_Range < 8.50 AND Slope < 0.5) OR
(First_Range >= 8.50 AND First_Range <=15.00 AND Slope < 0.23) OR
(First_Range > 15.00 AND Slope < 0.2) OR
(First_Range > 16.8 AND Last_Range > 16.8) OR
(Track_Type = 1) THEN DELETE;
END;
IF MUX_CHANNEL EQ 5 THEN DO; ***Run loose the first time through and tighten later;
IF
(ECHO_COUNT <6) OR
(Echo_Count = 4 AND ((Linearity1 / Echo_Count) > 0.4)) OR
(Echo_Count >= 5 AND Echo_Count <= 7 AND ((Linearity1 / Echo_Count) >= 0.5)) OR
((Linearity2 / Echo_Count) > 0.5) OR
(((Noise_Count_Average) / ((Echo_Count + 10) * 5)) > 0.04)) OR
(SLOPE >= 2.5 OR SLOPE <= -2.5) OR
(First_Range < 8.50 AND Slope < 0.5) OR
(First_Range >= 8.50 AND First_Range <=15.00 AND Slope < 0.23) OR
(First_Range > 15.00 AND Slope < 0.2) OR
(Track_Type = 1) THEN DELETE;
END;
IF MUX_CHANNEL EQ 7 THEN DO;
IF
(ECHO_COUNT < 6) OR
(Echo_Count = 4 AND ((Linearity1 / Echo_Count) > 0.4)) OR
(Echo_Count >= 5 AND Echo_Count <= 7 AND ((Linearity1 / Echo_Count) >= 0.5)) OR
((Linearity2 / Echo_Count) > 0.5) OR
(((Noise_Count_Average) / ((Echo_Count + 10) * 5)) > 0.04)) OR
NOISE_COUNT_AVERAGE > 2.5 OR

(SLOPE >= 2.5 OR SLOPE <= -2.5) OR
(First_Range < 8.50 AND Slope < 0.5) OR
(First_Range >= 8.50 AND First_Range <=15.00 AND Slope < 0.23) OR
(First_Range > 15.00 AND Slope < 0.2)OR (Track_Type = 1) THEN DELETE;
END;
IF MUX_CHANNEL EQ 2 OR MUX_CHANNEL EQ 4 THEN DO;
IF
(ECHO_COUNT < 4) OR
(Echo_Count = 4 AND ((Linearity1 / Echo_Count) > 0.4)) OR
(Echo_Count >= 5 AND Echo_Count <= 7 AND ((Linearity1 / Echo_Count) >= 0.5)) OR
((Linearity2 / Echo_Count) > 0.5) OR
(((Noise_Count_Average) / ((Echo_Count + 10) * 5)) > 0.04)) OR
(SLOPE >= 0.8 OR SLOPE <= -0.8) OR
(First_Range > 11.2 AND Last_Range > 11.2)
THEN DELETE;
END;
IF MUX_CHANNEL EQ 6 THEN DO; ***Run loose and then tighten later;
IF
(ECHO_COUNT < 4) OR
(Echo_Count = 4 AND ((Linearity1 / Echo_Count) > 0.4)) OR
(Echo_Count >= 5 AND Echo_Count <= 7 AND ((Linearity1 / Echo_Count) >= 0.5)) OR
((Linearity2 / Echo_Count) > 0.5) OR
(((Noise_Count_Average) / ((Echo_Count + 10) * 5)) > 0.04)) OR
(SLOPE >= 0.8 OR SLOPE <= -0.8) OR
(First_Range > 11 AND Last_Range > 11) OR
(((First_Range+Last_Range)/2) >10.8) AND Slope >-0.1 AND Slope <0.1) OR
(Track_Type = 1) OR
(Echo_Count < 8 AND Linearity1 > 1 AND Noise_Count_Average > 2) OR
((Linearity1 > 2) AND (Linearity2 > 2) AND (Noise_Count_Average > 4)) OR
(Linearity1 > 2 AND Linearity2 > 2 AND Noise_Count_Average >= 2) OR
```

Hydroacoustic Evaluation of Fish Passage through Bonneville Dam in 2004

```

      (((First_Range + Last_Range)/ 2) > 10.5) AND (Slope > 0.35 OR Slope < -0.35) OR (Track_Type = 1))
    THEN DELETE;
  END;
IF MUX_CHANNEL EQ 8 THEN DO;
  IF
    (ECHO_COUNT < 4) OR
    (Echo_Count = 4 AND ((Linearity1 / Echo_Count) > 0.4)) OR
    (Echo_Count >= 5 AND Echo_Count <= 7 AND ((Linearity1 / Echo_Count) >= 0.5)) OR
    ((Linearity2 / Echo_Count) > 0.5) OR
    (((Noise_Count_Average) / ((Echo_Count + 10) * 5)) > 0.04)) OR
    (SLOPE >= 0.6 OR SLOPE <= -0.6) OR
    (First_Range > 11 AND Last_Range > 11) OR
    (((First_Range+Last_Range)/2) >10.8) AND Slope >-0.1 AND Slope <0.1) OR
    (Track_Type = 1) OR
    (Echo_Count < 8 AND Linearity1 > 1 AND Noise_Count_Average > 2) OR
    ((Linearity1 > 2) AND (Linearity2 > 2) AND (Noise_Count_Average > 4)) OR
    (Linearity1 > 2 AND Linearity2 > 2 AND Noise_Count_Average >= 2) OR
    (((First_Range + Last_Range)/ 2) > 10.5) AND (Slope > 0.35 OR Slope < -0.35) OR
    (Track_Type = 1))
    THEN DELETE;
  END;
END;
IF SYSTEM='I' THEN DO;
  IF MUX_CHANNEL EQ 0 THEN DO; ***Carl's down-looker;
    IF
      (ECHO_COUNT < 6) OR
      (Echo_Count = 4 AND ((Linearity1 / Echo_Count) > 0.4)) OR
      (Echo_Count >= 5 AND Echo_Count <= 7 AND ((Linearity1 / Echo_Count) >= 0.5)) OR
      ((Linearity2 / Echo_Count) > 0.5) OR
      (((Noise_Count_Average) / ((Echo_Count + 10) * 5)) > 0.04)) OR
      NOISE_COUNT_AVERAGE > 2.5 OR
      (SLOPE >= 2.5 OR SLOPE <= -2.5) OR
      (First_Range < 8.50 AND Slope < 0.5) OR
      (First_Range >= 8.50 AND First_Range <=15.00 AND Slope < 0.23) OR
      (First_Range > 15.00 AND Slope < 0.2) OR
      (First_Range > 16.8 AND Last_Range > 16.8) OR
      (Track_Type = 1) THEN DELETE;
    END;
  IF MUX_CHANNEL EQ 1 THEN DO; ***Carl's up-looker;
    IF
      (ECHO_COUNT < 4) OR
      (Echo_Count = 4 AND ((Linearity1 / Echo_Count) > 0.4)) OR
      (Echo_Count >= 5 AND Echo_Count <= 7 AND ((Linearity1 / Echo_Count) >= 0.5)) OR
      ((Linearity2 / Echo_Count) > 0.5) OR
      (((Noise_Count_Average) / ((Echo_Count + 10) * 5)) > 0.04)) OR
      (SLOPE >= 0.6 OR SLOPE <= -0.6) OR
      (Echo_Count < 8 AND Linearity1 > 1 AND Noise_Count_Average > 2) OR
      ((Linearity1 > 2) AND (Linearity2 > 2) AND (Noise_Count_Average > 4)) OR
      (Linearity1 > 2 AND Linearity2 > 2 AND Noise_Count_Average >= 2) OR
      (First_Range > 11.2 AND Last_Range > 11.2) OR
      (((First_Range + Last_Range)/ 2) > 10.5) AND (Slope > 0.35 OR Slope < -0.35)) OR
      (Track_Type = 1) THEN DELETE;
    END;
  END;
END;
IF SYSTEM='W' THEN DO;
  IF MUX_CHANNEL EQ 0 THEN DO;
    IF (
      ((Track_Type=1) AND ((First_Range+Last_Range)/2 > 9)) OR
      ((First_Range+Last_Range)/2 > 10.5) OR
      (Noise_Count_Average > 7 AND Contrast < 0) OR
      (Noise_Count_Average > 15) OR
      (Echo_Count=4 AND ((Noise_Count_Average/((Echo_Count+12)*18))>.01)) OR
      (Echo_Count=5 AND ((Noise_Count_Average/((Echo_Count+12)*18))>.015)) OR
      (Echo_Count =6 AND ((Noise_Count_Average/((Echo_Count+12)*18))>.017)) OR
      (Echo_Count >=7 AND ((Noise_Count_Average/((Echo_Count+12)*18))>.020)) OR
      (Echo_Count >=7 AND ((Noise_Count_Average/((Echo_Count+12)*18))>.018) AND (Linearity1/Echo_Count >
        0.25)) OR
      (Echo_Count = 4 AND ((Linearity1 / Echo_Count) > 0.4)) OR
      (Echo_Count >= 5 AND Echo_Count <= 7 AND ((Linearity1 / Echo_Count) >= 0.5)) OR
      ((Linearity2 / Echo_Count) > 0.5) OR
      (Linearity1 > 10) OR
      (SLOPE < -4)
    ) THEN DELETE;
  END;
  IF MUX_CHANNEL EQ 1 THEN DO;
    IF (
      ((Track_Type=1) AND ((First_Range+Last_Range)/2 > 9)) OR
      (Noise_Count_Average > 7 AND Contrast < 0) OR

```

Hydroacoustic Evaluation of Fish Passage through Bonneville Dam in 2004

```

(Noise_Count_Average > 15) OR
(Echo_Count=4 AND ((Noise_Count_Average/((Echo_Count+12)*18))>.01)) OR
(Echo_Count=5 AND ((Noise_Count_Average/((Echo_Count+12)*18))>.015)) OR
(Echo_Count = 6 AND ((Noise_Count_Average/((Echo_Count+12)*18))>.017)) OR
(Echo_Count >=7 AND ((Noise_Count_Average/((Echo_Count+12)*18))>.020)) OR
(Echo_Count >=7 AND ((Noise_Count_Average/((Echo_Count+12)*18))>.018) AND (Linearity1/Echo_Count >
0.25)) OR
(Echo_Count = 4 AND ((Linearity1 / Echo_Count) > 0.4)) OR
(Echo_Count >= 5 AND Echo_Count <= 7 AND ((Linearity1 / Echo_Count) >= 0.5)) OR
((Linearity2 / Echo_Count) > 0.5) OR
(Linearity1 > 10) OR
(SLOPE < -4)
) THEN DELETE;
END;
END;

IF SYSTEM='V' THEN DO;
IF MUX_CHANNEL EQ 0 THEN DO;
IF (
(Echo_Count = 4 AND ((Linearity1 / Echo_Count) > 0.4)) OR
(Echo_Count >= 5 AND Echo_Count <= 7 AND ((Linearity1 / Echo_Count) >= 0.5)) OR
((Linearity2 / Echo_Count) > 0.5) OR
SLOPE < -4 OR
(Echo_Count=4 AND ((Noise_Count_Average/((Echo_Count+12)*18))>.01)) OR
(Echo_Count=5 AND ((Noise_Count_Average/((Echo_Count+12)*18))>.015)) OR
(Echo_Count = 6 AND ((Noise_Count_Average/((Echo_Count+12)*18))>.017)) OR
(Echo_Count >=7 AND ((Noise_Count_Average/((Echo_Count+12)*18))>.020)) OR
(Echo_Count >=7 AND ((Noise_Count_Average/((Echo_Count+12)*18))>.018) AND (Linearity1/Echo_Count >
0.25)) OR
(Linearity1 < 0.5 AND Linearity2 < 0.5 AND Slope = 0 ) OR
(First_Range > 10 AND Last_Range > 10 AND (Slope > -0.15 AND Slope < 0.15) AND ((Noise_Count_Average)
/ ((Echo_Count + 10)*6)) > 0.045)) OR
(First_Range > 10.7 AND Last_Range > 10.7) OR
((First_Range + Last_Range)/2 > 9 AND (Slope > -0.1 AND Slope < 0.1) AND ((Noise_Count_Average) /
((Echo_Count + 10)*6)) > 0.045)) OR
(First_Range > 2 AND First_Range < 2.5 AND Last_Range > 2 AND Last_Range < 2.5 AND Slope > -0.1 AND
Slope < 0.1) OR
(First_Range > 5.4 AND First_Range < 5.7 AND Last_Range > 5.4 AND Last_Range < 5.7 AND Slope > -0.1
AND Slope < 0.1) OR
(First_Range > 6.4 AND First_Range < 7.2 AND Last_Range > 6.4 AND Last_Range < 7.2 AND Slope > -0.2
AND Slope < 0.2) OR
(First_Range > 7 AND First_Range < 7.4 AND Last_Range > 7 AND Last_Range < 7.4 AND Slope > -0.1 AND
Slope < 0.1) OR
(First_Range > 8 AND First_Range < 8.2 AND Last_Range > 8 AND Last_Range < 8.2 AND Slope > -0.1 AND
Slope < 0.1) OR
ECHO_COUNT < 5 AND ECHO_COUNT / ((LAST_PING / GROUP_SIZE + 1) - FIRST_Ping / GROUP_SIZE) < 0.8 OR
ECHO_COUNT >=5 AND ECHO_COUNT <=6 AND ECHO_COUNT / ((LAST_PING / GROUP_SIZE + 1) - FIRST_Ping /
GROUP_SIZE) < 0.7
) THEN DELETE;
END;
IF MUX_CHANNEL EQ 1 THEN DO;
IF (
((Track_Type=1) AND ((First_Range+Last_Range)/2 > 9)) OR
(Noise_Count_Average > 7 AND Contrast < 0) OR
(Noise_Count_Average > 15) OR
(Echo_Count=4 AND ((Noise_Count_Average/((Echo_Count+12)*18))>.01)) OR
(Echo_Count=5 AND ((Noise_Count_Average/((Echo_Count+12)*18))>.015)) OR
(Echo_Count = 6 AND ((Noise_Count_Average/((Echo_Count+12)*18))>.017)) OR
(Echo_Count >=7 AND ((Noise_Count_Average/((Echo_Count+12)*18))>.020)) OR
(Echo_Count >=7 AND ((Noise_Count_Average/((Echo_Count+12)*18))>.018) AND (Linearity1/Echo_Count >
0.25)) OR
(Echo_Count = 4 AND ((Linearity1 / Echo_Count) > 0.4)) OR
(Echo_Count >= 5 AND Echo_Count <= 7 AND ((Linearity1 / Echo_Count) >= 0.5)) OR
((Linearity2 / Echo_Count) > 0.5) OR
(Linearity1 > 10) OR
(SLOPE < -4) OR
(First_Range > 10 AND Last_Range > 10 AND (Slope > -0.15 AND Slope < 0.15) AND ((Noise_Count_Average)
/ ((Echo_Count + 10)*6)) > 0.045)) OR
(First_Range > 10.7 AND Last_Range > 10.7) OR
(First_Range > 8 AND First_Range < 8.2 AND Last_Range > 8 AND Last_Range < 8.2 AND Slope > -0.1 AND
Slope < 0.1) OR
(First_Range > 8.2 AND First_Range < 8.4 AND Last_Range > 8.2 AND Last_Range < 8.4 AND Slope > -0.1
AND Slope < 0.1) OR
(First_Range > 8.4 AND First_Range < 8.6 AND Last_Range > 8.4 AND Last_Range < 8.6 AND Slope > -0.1
AND Slope < 0.1) OR
(First_Range > 8.6 AND First_Range < 8.8 AND Last_Range > 8.6 AND Last_Range < 8.8 AND Slope > -0.1
AND Slope < 0.1) OR
(First_Range > 8.8 AND First_Range < 9.0 AND Last_Range > 8.8 AND Last_Range < 9.0 AND Slope > -0.1
AND Slope < 0.1) OR
(First_Range > 8.1 AND First_Range < 8.3 AND Last_Range > 8.1 AND Last_Range < 8.3 AND Slope > -0.1
AND Slope < 0.1) OR

```

Hydroacoustic Evaluation of Fish Passage through Bonneville Dam in 2004

```
(First_Range > 8.3 AND First_Range < 8.5 AND Last_Range > 8.3 AND Last_Range < 8.5 AND Slope > -0.1
AND Slope < 0.1) OR
(First_Range > 8.5 AND First_Range < 8.7 AND Last_Range > 8.5 AND Last_Range < 8.7 AND Slope > -0.1
AND Slope < 0.1) OR
(First_Range > 8.7 AND First_Range < 8.9 AND Last_Range > 8.7 AND Last_Range < 8.9 AND Slope > -0.1
AND Slope < 0.1) OR
(First_Range > 8.9 AND First_Range < 9.1 AND Last_Range > 8.9 AND Last_Range < 9.1 AND Slope > -0.1
AND Slope < 0.1)
) THEN DELETE;
END;
END;

IF SYSTEM='U' THEN DO; ***On the bottom during spring creek - using U filters;
IF MUX_CHANNEL EQ 0 THEN DO;
reg=0.6374*fb_el-38.263;
IF (
((First_Range+Last_Range)/2 >=(reg-1) AND Track_Type=1) OR
((First_Range+Last_Range)/2 >=(reg-0.1)) OR
(((First_Range+Last_Range)/2 > (reg - 1)) AND (Slope >-0.2 and Slope < 0.2)) OR
(Echo_Count=4 AND (First_Range+Last_Range)/2 >=reg-0.6) OR
(Noise_Count_Average > 7 AND Contrast < 0) OR
(Noise_Count_Average > 15) OR
(Noise_Count_Average > 7.5 AND Slope > 2.5) OR
(Noise_Count_Average > 7.5 AND Slope < -2.5) OR
(Echo_Count=4 AND ((Noise_Count_Average/((Echo_Count+12)*18))>.01)) OR
(Echo_Count=5 AND ((Noise_Count_Average/((Echo_Count+12)*18))>.015)) OR
(Echo_Count =6 AND ((Noise_Count_Average/((Echo_Count+12)*18))>.017)) OR
(Echo_Count >=7 AND ((Noise_Count_Average/((Echo_Count+12)*18))>.020)) OR
(Echo_Count >=7 AND ((Noise_Count_Average/((Echo_Count+12)*18))>.018) AND (Linearity1/Echo_Count >
0.25)) OR
(Echo_Count = 4 AND ((Linearity1 / Echo_Count) > 0.4)) OR
(Echo_Count >= 5 AND Echo_Count <= 7 AND ((Linearity1 / Echo_Count) >= 0.5)) OR
((Linearity2 / Echo_Count) > 0.5)
) then delete;
END;
IF MUX_CHANNEL EQ 1 THEN DO;
reg=0.2209*fb_el-8.6451;
if (
((First_Range+Last_Range)/2 >=(reg-2) AND Track_Type=1) OR
((First_Range+Last_Range)/2 >=(reg-0.1)) OR
(((First_Range+Last_Range)/2 > (reg - 0.15)) AND (Slope >-0.2 and Slope < 0.2)) OR
(Echo_Count=4 AND (First_Range+Last_Range)/2 >=reg-0.6) OR
(Noise_Count_Average > 7 AND Contrast < 0) OR
(Noise_Count_Average > 15) OR
(Noise_Count_Average > 7.5 AND Slope > 2.5) OR
(Noise_Count_Average > 7.5 AND Slope < -2.5) OR
(Echo_Count=4 AND ((Noise_Count_Average/((Echo_Count+12)*18))>.01)) OR
(Echo_Count=5 AND ((Noise_Count_Average/((Echo_Count+12)*18))>.015)) OR
(Echo_Count =6 AND ((Noise_Count_Average/((Echo_Count+12)*18))>.017)) OR
(Echo_Count >=7 AND ((Noise_Count_Average/((Echo_Count+12)*18))>.020)) OR
(Echo_Count >=7 AND ((Noise_Count_Average/((Echo_Count+12)*18))>.018) AND (Linearity1/Echo_Count >
0.25)) OR
(Echo_Count=4 AND ((Noise_Count_Average/((Echo_Count+12)*18))>.008) AND Track_type=1) OR
(Echo_Count=5 AND ((Noise_Count_Average/((Echo_Count+12)*18))>.012) AND Track_type=1) OR
(Echo_Count =6 AND ((Noise_Count_Average/((Echo_Count+12)*18))>.014) AND Track_type=1) OR
(Echo_Count =7 AND ((Noise_Count_Average/((Echo_Count+12)*18))>.017) AND Track_type=1) OR
(Echo_Count >=8 AND ((Noise_Count_Average/((Echo_Count+12)*18))>.019) AND Track_type=1) OR
(Echo_Count = 4 AND ((Linearity1 / Echo_Count) > 0.4)) OR
(Echo_Count >= 5 AND Echo_Count <= 7 AND ((Linearity1 / Echo_Count) >= 0.5)) OR
((Linearity2 / Echo_Count) > 0.5)
) then delete;
END;
END;
RUN;
```

Appendix D-3. Statistical Analysis System (SAS) code for filtering out echo traces that did not meet fish trace criteria in summer 2004. Minimum ranges for sampling guided, unguided, and spilled fish, which are presented in legends of Figures 2.1-2.3, 2.5, and 2.6 were implemented elsewhere in the processing program.

```

IF STATUS EQ 'CLOSED' THEN FISH=0; ***Status comes from HYDRO and refers to the condition of the route;
***Enter global filters for TS, ES, ECHO_COUNT, AND SLOPE;
IF Mean_Echo_Strength GT -45 THEN DELETE;
***Enter MUX_CHANNEL specific structural, trace quality, and noise filters to eliminate bad tracks;
IF SYSTEM='A' THEN DO; ***Ready for 2004;
  IF
    (((First_Range + Last_Range) / 2) > 6) OR
    (((First_Range + Last_Range) / 2) < 3) OR
    (Echo_Count = 4 AND ((Linearity1 / Echo_Count) > 0.4)) OR
    (Echo_Count >= 5 AND Echo_Count <= 7 AND ((Linearity1 / Echo_Count) >= 0.5)) OR
    ((Linearity2 / Echo_Count) > 0.5) OR
    (Linearity1 > 10 AND Linearity2 > 10) OR
    (Echo_Count=4 AND ((Noise_Count_Average/((Echo_Count+12)*18))>.01)) OR
    (Echo_Count=5 AND ((Noise_Count_Average/((Echo_Count+12)*18))>.015)) OR
    (Echo_Count =6 AND ((Noise_Count_Average/((Echo_Count+12)*18))>.017)) OR
    (Echo_Count >=7 AND ((Noise_Count_Average/((Echo_Count+12)*18))>.020)) OR
    (Echo_Count >=7 AND ((Noise_Count_Average/((Echo_Count+12)*18))>.018) AND (Linearity1/Echo_Count > 0.25))
  THEN DELETE;
END;
IF SYSTEM='X' THEN DO; ***Ready for 2004;
  IF
    (((First_Range + Last_Range) / 2) > 6) OR
    (((First_Range + Last_Range) / 2) < 3) OR
    (Echo_Count = 4 AND ((Linearity1 / Echo_Count) > 0.4)) OR
    (Echo_Count >= 5 AND Echo_Count <= 7 AND ((Linearity1 / Echo_Count) >= 0.5)) OR
    ((Linearity2 / Echo_Count) > 0.5) OR
    (Linearity1 > 10 AND Linearity2 > 10) OR
    (Echo_Count=4 AND ((Noise_Count_Average/((Echo_Count+12)*18))>.01)) OR
    (Echo_Count=5 AND ((Noise_Count_Average/((Echo_Count+12)*18))>.015)) OR
    (Echo_Count =6 AND ((Noise_Count_Average/((Echo_Count+12)*18))>.017)) OR
    (Echo_Count >=7 AND ((Noise_Count_Average/((Echo_Count+12)*18))>.020)) OR
    (Echo_Count >=7 AND ((Noise_Count_Average/((Echo_Count+12)*18))>.018) AND (Linearity1/Echo_Count > 0.25))
  THEN DELETE;
END;

***Ready for 2004 SPRING;
*****;
IF SYSTEM='C' THEN DO;
  IF MUX_CHANNEL EQ 1 THEN DO; *** CHI DID NOT RUN ALL SPRING;
    IF MUX_CHANNEL EQ 1 THEN DO;
      IF (((First_Range + Last_Range) / 2)>19.05) OR
        (Echo_Count = 4 AND ((Linearity1 / Echo_Count) > 0.4)) OR
        (Echo_Count >= 5 AND Echo_Count <= 7 AND ((Linearity1 / Echo_Count) >= 0.5)) OR
        ((Linearity2 / Echo_Count) > 0.5) OR
        (Slope >= 2.5 OR Slope <= -2.5) OR
        (((Noise_Count_Average) / ((Echo_Count + 10) * 5)) > 0.04)) OR
        (Slope < 0.2)
      THEN DELETE;
    END;
  END;
  IF MUX_CHANNEL EQ 2 THEN DO;
    IF (((First_Range + Last_Range) / 2)>21.34) OR
      (Echo_Count = 4 AND ((Linearity1 / Echo_Count) > 0.4)) OR
      (Echo_Count >= 5 AND Echo_Count <= 7 AND ((Linearity1 / Echo_Count) >= 0.5)) OR
      ((Linearity2 / Echo_Count) > 0.5) OR
      (SLOPE >= 2.5) OR
      (SLOPE < 0) OR
      (((First_Range + Last_Range) / 2) < 21.34) AND (((First_Range + Last_Range) / 2) >= 18.5) AND (SLOPE <
        0.1) OR
      (((First_Range + Last_Range) / 2) < 18.5) AND (((First_Range + Last_Range) / 2) >= 16) AND (SLOPE <
        0.15) OR
      (((First_Range + Last_Range) / 2) < 16) AND (((First_Range + Last_Range) / 2) >= 13.5) AND (SLOPE <
        0.2) OR
      (((First_Range + Last_Range) / 2) < 13.5) AND (((First_Range + Last_Range) / 2) >= 12) AND (SLOPE <
        0.5) OR
      (((First_Range + Last_Range) / 2) < 12) AND (SLOPE < 0.3)) OR
      (((Noise_Count_Average) / ((Echo_Count + 10) * 5)) > 0.04))
    THEN DELETE;
  END;
  IF MUX_CHANNEL EQ 3 THEN DO;
    IF (TRACK_TYPE = 1) OR
      (((First_Range + Last_Range) / 2)>21.56) OR

```

Hydroacoustic Evaluation of Fish Passage through Bonneville Dam in 2004

```
(Echo_Count = 4 AND ((Linearity1 / Echo_Count) > 0.4)) OR
(Echo_Count >= 5 AND Echo_Count <= 7 AND ((Linearity1 / Echo_Count) >= 0.5)) OR
((Linearity2 / Echo_Count) > 0.5) OR
(SLOPE >= 2.5) OR
(((First_Range + Last_Range) / 2) < 21.56) AND (((First_Range + Last_Range) / 2) >= 16) AND (SLOPE <
0.1)) OR
(((First_Range + Last_Range) / 2) < 16) AND (((First_Range + Last_Range) / 2) >= 14.5) AND (SLOPE <
0.2)) OR
(((First_Range + Last_Range) / 2) < 14.5) AND (((First_Range + Last_Range) / 2) >= 13) AND (SLOPE <
0.3)) OR
(((First_Range + Last_Range) / 2) < 13) AND (((First_Range + Last_Range) / 2) >= 9) AND (SLOPE < 0.4))
OR
(((First_Range + Last_Range) / 2) < 9) AND (SLOPE < 0.3)) OR
(((Noise_Count_Average) / ((Echo_Count + 10) * 5)) > 0.04))
THEN DELETE;
END;
IF MUX_CHANNEL EQ 4 THEN DO;
IF (TRACK_TYPE = 1) OR
(((First_Range + Last_Range) / 2) > 21.40) OR

(Echo_Count = 4 AND ((Linearity1 / Echo_Count) > 0.4)) OR
(Echo_Count >= 5 AND Echo_Count <= 7 AND ((Linearity1 / Echo_Count) >= 0.5)) OR
((Linearity2 / Echo_Count) > 0.5) OR
(SLOPE >= 2.5) OR
(((First_Range + Last_Range) / 2) < 20) AND (((First_Range + Last_Range) / 2) >= 13.5) AND (SLOPE <
0.25)) OR
(((First_Range + Last_Range) / 2) < 13.5) AND (((First_Range + Last_Range) / 2) >= 11.8) AND (SLOPE <
6)) OR
(((First_Range + Last_Range) / 2) < 13.5) AND (((First_Range + Last_Range) / 2) >= 11.8) AND
(LINEARITY1 > 5)) OR
(((First_Range + Last_Range) / 2) < 11.8) AND (((First_Range + Last_Range) / 2) >= 10) AND (SLOPE <
0.2)) OR
(((First_Range + Last_Range) / 2) < 10) AND (((First_Range + Last_Range) / 2) >= 7) AND (SLOPE < 0.25))
OR
(((First_Range + Last_Range) / 2) < 7) AND (SLOPE < 0.3)) OR
(((Noise_Count_Average) / ((Echo_Count + 10) * 5)) > 0.04))
THEN DELETE;
END;
IF MUX_CHANNEL EQ 5 THEN DO;
IF (TRACK_TYPE = 1) OR
(((First_Range + Last_Range) / 2) > 21.76) OR

(Echo_Count = 4 AND ((Linearity1 / Echo_Count) > 0.4)) OR
(Echo_Count >= 5 AND Echo_Count <= 7 AND ((Linearity1 / Echo_Count) >= 0.5)) OR
((Linearity2 / Echo_Count) > 0.5) OR
(SLOPE >= 2.5) OR
(((First_Range + Last_Range) / 2) < 20) AND (((First_Range + Last_Range) / 2) >= 15) AND (SLOPE < 0.1))
OR
(((First_Range + Last_Range) / 2) < 15) AND (((First_Range + Last_Range) / 2) >= 12) AND (SLOPE < 0.3))
OR
(((First_Range + Last_Range) / 2) < 12) AND (SLOPE < 0.4)) OR
(((Noise_Count_Average) / ((Echo_Count + 10) * 5)) > 0.04))
THEN DELETE;
END;
IF MUX_CHANNEL EQ 6 THEN DO;
IF (TRACK_TYPE = 1) OR
(((First_Range + Last_Range) / 2) > 20.35) OR

(Echo_Count = 4 AND ((Linearity1 / Echo_Count) > 0.4)) OR
(Echo_Count >= 5 AND Echo_Count <= 7 AND ((Linearity1 / Echo_Count) >= 0.5)) OR
((Linearity2 / Echo_Count) > 0.5) OR
(SLOPE >= 2.5) OR
(((First_Range + Last_Range) / 2) < 20.35) AND (((First_Range + Last_Range) / 2) >= 15) AND (SLOPE <
0.15)) OR
(((First_Range + Last_Range) / 2) < 15) AND (((First_Range + Last_Range) / 2) >= 13.5) AND (SLOPE <
0.3)) OR
(((First_Range + Last_Range) / 2) < 13.5) AND (((First_Range + Last_Range) / 2) >= 12.3) AND (SLOPE <
0.7)) OR
(((First_Range + Last_Range) / 2) < 12.3) AND (((First_Range + Last_Range) / 2) >= 7) AND (SLOPE <
0.25)) OR
(((First_Range + Last_Range) / 2) < 7) AND (SLOPE < 0.35)) OR
(((Noise_Count_Average) / ((Echo_Count + 10) * 5)) > 0.04))
THEN DELETE;
END;
IF MUX_CHANNEL EQ 7 THEN DO;
IF (TRACK_TYPE = 1) OR
(((First_Range + Last_Range) / 2) > 21.64) OR

(Echo_Count = 4 AND ((Linearity1 / Echo_Count) > 0.4)) OR
(Echo_Count >= 5 AND Echo_Count <= 7 AND ((Linearity1 / Echo_Count) >= 0.5)) OR
((Linearity2 / Echo_Count) > 0.5) OR
```

Hydroacoustic Evaluation of Fish Passage through Bonneville Dam in 2004

```
(SLOPE >= 2.5) OR
(((First_Range + Last_Range) / 2) < 21.64) AND (((First_Range + Last_Range) / 2) >= 15) AND (SLOPE <
0.15)) OR
(((First_Range + Last_Range) / 2) < 15) AND (((First_Range + Last_Range) / 2) >= 13.6) AND (SLOPE <
0.25)) OR
(((First_Range + Last_Range) / 2) < 13.6) AND (((First_Range + Last_Range) / 2) >= 13.4) AND
(SLOPE<0.25)) OR
(((First_Range + Last_Range) / 2) < 13.4) AND (((First_Range + Last_Range) / 2) >= 12.6) AND (SLOPE <
0.3)) OR
(((First_Range + Last_Range) / 2) < 12.6) AND (((First_Range + Last_Range) / 2) >= 11.95) AND (SLOPE <
0.6)) OR
(((First_Range + Last_Range) / 2) < 11.95) AND (((First_Range + Last_Range) / 2) >= 8) AND (SLOPE <
0.2)) OR
(((First_Range + Last_Range) / 2) < 8) AND (SLOPE < 0.3)) OR
(((Noise_Count_Average) / ((Echo_Count + 10) * 5)) > 0.04))
THEN DELETE;
END;
END;

IF SYSTEM='D' THEN DO;
IF MUX_CHANNEL EQ 1 THEN DO;
IF (((First_Range + Last_Range) / 2)>21.73) OR

(Echo_Count = 4 AND ((Linearity1 / Echo_Count) > 0.4)) OR
(Echo_Count >= 5 AND Echo_Count <= 7 AND ((Linearity1 / Echo_Count) >= 0.5)) OR
((Linearity2 / Echo_Count) > 0.5) OR
(((First_Range + Last_Range) / 2) < 21.73) AND (((First_Range + Last_Range) / 2) >= 15) AND (SLOPE <
0.15)) OR
(((First_Range + Last_Range) / 2) < 15) AND (((First_Range + Last_Range) / 2) >= 13.15) AND (SLOPE <
0.25)) OR
(((First_Range + Last_Range) / 2) < 13.15) AND (((First_Range + Last_Range) / 2) >= 11.82) AND (SLOPE <
0.5)) OR
(((First_Range + Last_Range) / 2) < 11.82) AND (((First_Range + Last_Range) / 2) >= 10.36) AND (SLOPE <
0.25)) OR
(((First_Range + Last_Range) / 2) < 10.36) AND (((First_Range + Last_Range) / 2) >= 9.65) AND
(SLOPE<0.45)) OR
(((First_Range + Last_Range) / 2) < 9.65) AND (SLOPE < 0.2)) OR
(((Noise_Count_Average) / ((Echo_Count + 10) * 5)) > 0.04))
THEN DELETE;
END;
IF MUX_CHANNEL EQ 2 THEN DO;
IF (TRACK_TYPE=1) OR
(((First_Range + Last_Range) / 2)>21.25) OR

(Echo_Count = 4 AND ((Linearity1 / Echo_Count) > 0.4)) OR
(Echo_Count >= 5 AND Echo_Count <= 7 AND ((Linearity1 / Echo_Count) >= 0.5)) OR
((Linearity2 / Echo_Count) > 0.5) OR
(SLOPE >= 2.5) OR
(SLOPE < 0.2) OR
(((First_Range + Last_Range) / 2) < 21.25) AND (((First_Range + Last_Range) / 2) >= 19.75) AND (SLOPE <
0.15)) OR
(((First_Range + Last_Range) / 2) < 19.75) AND (((First_Range + Last_Range) / 2) >= 18.9) AND (SLOPE <
0.45)) OR
(((First_Range + Last_Range) / 2) < 12.76) AND (((First_Range + Last_Range) / 2) >= 11.64) AND (SLOPE <
0.45)) OR
(((First_Range + Last_Range) / 2) < 10.5) AND (((First_Range + Last_Range) / 2) >= 9.65) AND (SLOPE <
0.45)) OR
(((First_Range + Last_Range) / 2) < 6.5) AND (SLOPE < 0.3)) OR
(((Noise_Count_Average) / ((Echo_Count + 10) * 5)) > 0.04))
THEN DELETE;
END;
IF MUX_CHANNEL EQ 3 THEN DO;
IF (TRACK_TYPE=1) OR
(((First_Range + Last_Range) / 2)>21.66) OR

(Echo_Count = 4 AND ((Linearity1 / Echo_Count) > 0.4)) OR
(Echo_Count >= 5 AND Echo_Count <= 7 AND ((Linearity1 / Echo_Count) >= 0.5)) OR
((Linearity2 / Echo_Count) > 0.5) OR
(LINEARITY1>3.2 AND LINEARITY2>3.2 AND NOISE_COUNT_AVERAGE>3) OR
(SLOPE >= 2) OR
(SLOPE < 0.15) OR
(((First_Range + Last_Range) / 2) < 21.66) AND (((First_Range + Last_Range) / 2) >= 18) AND (SLOPE <
0.1)) OR
(((First_Range + Last_Range) / 2) < 18) AND (((First_Range + Last_Range) / 2) >= 15) AND (SLOPE < 0.15))
OR
(((First_Range + Last_Range) / 2) < 15) AND (((First_Range + Last_Range) / 2) >= 13.40) AND (SLOPE <
0.2)) OR
(((First_Range + Last_Range) / 2) < 13.40) AND (((First_Range + Last_Range) / 2) >= 11.57) AND (SLOPE <
0.7)) OR
(((First_Range + Last_Range) / 2) < 10.45) AND (((First_Range + Last_Range) / 2) >= 9.65) AND (SLOPE <
0.7)) OR
```

Hydroacoustic Evaluation of Fish Passage through Bonneville Dam in 2004

```
((((First_Range + Last_Range) / 2) < 6.5) AND (SLOPE < 0.3)) OR
(((Noise_Count_Average) / ((Echo_Count + 10) * 5)) > 0.04))
THEN DELETE;
END;
IF MUX_CHANNEL EQ 4 THEN DO;
IF (TRACK_TYPE=1 AND SLOPE<0.7) OR
(((First_Range + Last_Range) / 2)>21.38) OR

(Echo_Count = 4 AND ((Linearity1 / Echo_Count) > 0.4)) OR
(Echo_Count >= 5 AND Echo_Count <= 7 AND ((Linearity1 / Echo_Count) >= 0.5)) OR
((Linearity2 / Echo_Count) > 0.5) OR
(LINEARITY1>3.2 AND LINEARITY2>3.2 AND NOISE_COUNT_AVERAGE>3) OR
(LINEARITY1>5.5 AND LINEARITY2>5.5 AND SLOPE<0.7) OR
(SLOPE >= 2) OR
(SLOPE < 0.15) OR
(((First_Range + Last_Range) / 2) < 21.38) AND (((First_Range + Last_Range) / 2) >= 18) AND (SLOPE <
0.1) OR
(((First_Range + Last_Range) / 2) < 18) AND (((First_Range + Last_Range) / 2) >= 15) AND (SLOPE < 0.15))
OR
(((First_Range + Last_Range) / 2) < 15) AND (((First_Range + Last_Range) / 2) >= 12.9) AND (SLOPE <
0.2) OR
(((First_Range + Last_Range) / 2) < 12.9) AND (((First_Range + Last_Range) / 2) >= 12.56) AND (SLOPE <
0.5) OR
(((First_Range + Last_Range) / 2) < 12.3) AND (((First_Range + Last_Range) / 2) >= 12.2) AND (SLOPE <
0.5) OR
(((First_Range + Last_Range) / 2) < 11.8) AND (((First_Range + Last_Range) / 2) >= 11.5) AND (SLOPE <
0.5) OR
(((First_Range + Last_Range) / 2) < 10.15) AND (((First_Range + Last_Range) / 2) >= 9.5) AND (SLOPE <
0.5) OR
(((First_Range + Last_Range) / 2) < 6.5) AND (SLOPE < 0.3)) OR
(((Noise_Count_Average) / ((Echo_Count + 10) * 5)) > 0.04))
THEN DELETE;
END;
IF MUX_CHANNEL EQ 5 THEN DO;
IF (TRACK_TYPE=1) OR
(((First_Range + Last_Range) / 2)>22.11) OR

(Echo_Count = 4 AND ((Linearity1 / Echo_Count) > 0.4)) OR
(Echo_Count >= 5 AND Echo_Count <= 7 AND ((Linearity1 / Echo_Count) >= 0.5)) OR
((Linearity2 / Echo_Count) > 0.5) OR
(LINEARITY1>3.5 AND LINEARITY2>3.5 AND NOISE_INDEX>6.5 AND SLOPE<0.85) OR
(LINEARITY1>4.5 AND LINEARITY2>3.5 AND NOISE_COUNT_AVERAGE>3.5) OR
(SLOPE >= 2) OR
(SLOPE < 0.15) OR
(((First_Range + Last_Range) / 2) < 22.11) AND (((First_Range + Last_Range) / 2) >= 19.85) AND (SLOPE <
0.1) OR
(((First_Range + Last_Range) / 2) < 19.85) AND (((First_Range + Last_Range) / 2) >= 19.5) AND (SLOPE <
0.5) OR
(((First_Range + Last_Range) / 2) < 19.5) AND (((First_Range + Last_Range) / 2) >= 12.7) AND (SLOPE <
0.15) OR
(((First_Range + Last_Range) / 2) < 12.7) AND (((First_Range + Last_Range) / 2) >= 11.9) AND (SLOPE <
0.5) OR
(((First_Range + Last_Range) / 2) < 8.61) AND (((First_Range + Last_Range) / 2) >= 8.16) AND (SLOPE <
0.5) OR
(((First_Range + Last_Range) / 2) < 6.5) AND (SLOPE < 0.3)) OR
(((Noise_Count_Average) / ((Echo_Count + 10) * 5)) > 0.04))
THEN DELETE;
END;
IF MUX_CHANNEL EQ 6 THEN DO;
IF (TRACK_TYPE=1) OR
(((First_Range + Last_Range) / 2)>21.59) OR

(Echo_Count = 4 AND ((Linearity1 / Echo_Count) > 0.4)) OR
(Echo_Count >= 5 AND Echo_Count <= 7 AND ((Linearity1 / Echo_Count) >= 0.5)) OR
((Linearity2 / Echo_Count) > 0.5) OR
(LINEARITY1>4.5 AND LINEARITY2>3.5 AND SLOPE<0.5) OR
(SLOPE >= 2.5) OR
(((First_Range + Last_Range) / 2) < 21.59) AND (((First_Range + Last_Range) / 2) >= 15) AND (SLOPE <
0.1) OR
(((First_Range + Last_Range) / 2) < 15) AND (((First_Range + Last_Range) / 2) >= 13.16) AND (SLOPE <
0.15) OR
(((First_Range + Last_Range) / 2) < 13.16) AND (((First_Range + Last_Range) / 2) >= 11.55) AND (SLOPE <
0.8) OR
(((First_Range + Last_Range) / 2) < 10.25) AND (((First_Range + Last_Range) / 2) >= 9.5) AND (SLOPE <
0.7) OR
(((First_Range + Last_Range) / 2) < 9.5) AND (((First_Range + Last_Range) / 2) >= 3) AND (SLOPE < 0.2))
OR
(((First_Range + Last_Range) / 2) < 3) AND (SLOPE < 0.3)) OR
(((Noise_Count_Average) / ((Echo_Count + 10) * 5)) > 0.04))
THEN DELETE;
END;
```

Hydroacoustic Evaluation of Fish Passage through Bonneville Dam in 2004

```

IF MUX_CHANNEL EQ 7 THEN DO;
  IF (TRACK_TYPE=1) OR
    (((First_Range + Last_Range) / 2)>20.39) OR

    (Echo_Count = 4 AND ((Linearity1 / Echo_Count) > 0.4)) OR
    (Echo_Count >= 5 AND Echo_Count <= 7 AND ((Linearity1 / Echo_Count) >= 0.5)) OR
    ((Linearity2 / Echo_Count) > 0.5) OR
    (SLOPE >= 2.5) OR
    (((First_Range + Last_Range) / 2) < 20.39) AND (((First_Range + Last_Range) / 2) >= 19) AND (SLOPE <
      0.1) OR
    (((First_Range + Last_Range) / 2) < 19) AND (((First_Range + Last_Range) / 2) >= 12.25) AND (SLOPE <
      0.15) OR
    (((First_Range + Last_Range) / 2) < 12.25) AND (((First_Range + Last_Range) / 2) >= 10.45) AND (SLOPE <
      0.8) OR
    (((First_Range + Last_Range) / 2) < 10.45) AND (((First_Range + Last_Range) / 2) >= 9.05) AND (SLOPE <
      0.2) OR
    (((First_Range + Last_Range) / 2) < 9.05) AND (((First_Range + Last_Range) / 2) >= 8.56) AND (SLOPE <
      0.7) OR
    (((First_Range + Last_Range) / 2) < 8.56) AND (SLOPE < 0.25)) OR
    (((Noise_Count_Average) / ((Echo_Count + 10) * 5)) > 0.04))
  THEN DELETE;
END;
END;

IF SYSTEM='R' THEN DO;
  IF MUX_CHANNEL EQ 1 THEN DO;
    IF (TRACK_TYPE = 1) OR
      (((First_Range + Last_Range) / 2)>21.99) OR

      (Echo_Count = 4 AND ((Linearity1 / Echo_Count) > 0.4)) OR
      (Echo_Count >= 5 AND Echo_Count <= 7 AND ((Linearity1 / Echo_Count) >= 0.5)) OR
      ((Linearity2 / Echo_Count) > 0.5) OR
      (Slope >= 2.5) OR
      (((First_Range + Last_Range) / 2) < 18) AND (((First_Range + Last_Range) / 2) >= 14) AND (SLOPE < 0.1))
      OR
      (((First_Range + Last_Range) / 2) < 14) AND (((First_Range + Last_Range) / 2) >= 10) AND (SLOPE < 0.2))
      OR
      (((First_Range + Last_Range) / 2) < 10) AND (SLOPE < 0.25)) OR
      (((Noise_Count_Average) / ((Echo_Count + 10) * 5)) > 0.04))
    THEN DELETE;
  END;
  IF MUX_CHANNEL EQ 2 THEN DO;
    IF (TRACK_TYPE = 1) OR
      (((First_Range + Last_Range) / 2)>21.44) OR

      (Echo_Count = 4 AND ((Linearity1 / Echo_Count) > 0.4)) OR
      (Echo_Count >= 5 AND Echo_Count <= 7 AND ((Linearity1 / Echo_Count) >= 0.5)) OR
      ((Linearity2 / Echo_Count) > 0.5) OR
      (SLOPE >= 2.5) OR
      (((First_Range + Last_Range) / 2) < 18) AND (((First_Range + Last_Range) / 2) >= 14) AND (SLOPE < 0.1))
      OR
      (((First_Range + Last_Range) / 2) < 13.75) AND (((First_Range + Last_Range) / 2) >= 13.45) AND (SLOPE <
        0.35) OR
      (((First_Range + Last_Range) / 2) < 14) AND (((First_Range + Last_Range) / 2) >= 10) AND (SLOPE < 0.15))
      OR
      (((First_Range + Last_Range) / 2) < 10) AND (SLOPE < 0.2)) OR
      (((Noise_Count_Average) / ((Echo_Count + 10) * 5)) > 0.04))
    THEN DELETE;
  END;
END;

***Spillway;

IF SYSTEM = 'F' THEN DO;
  *** CH1 *****;
  IF MUX_CHANNEL = 1 THEN DO;
    IF KCPS LE 4.3 THEN DO;
      IF (TRACK_TYPE = 1) OR
        (Echo_Count = 4 AND ((Linearity1 / Echo_Count) > 0.4)) OR
        (Echo_Count >= 5 AND Echo_Count <= 7 AND ((Linearity1 / Echo_Count) >= 0.5)) OR
        ((Linearity2 / Echo_Count) > 0.5) OR
        (LINEARITY1=0 AND LINEARITY2=0 AND SLOPE=0) OR
        (((First_Range + Last_Range) / 2) >= 9.87) OR
        (((First_Range + Last_Range) / 2) < 9.0) AND (((First_Range + Last_Range) / 2) >= 8.5) AND (SLOPE <
          0.1) OR
        (((First_Range + Last_Range) / 2) < 8.5) AND (((First_Range + Last_Range) / 2) > 7.5) AND (SLOPE <
          0.2) OR
        (((First_Range + Last_Range) / 2) <= 7.5) AND (SLOPE < 0.3)) OR
        (SLOPE>2.5) OR
        (((Noise_Count_Average) / ((Echo_Count + 10) * 5)) > 0.04))
      THEN DELETE;
    END;
  END;

```

Hydroacoustic Evaluation of Fish Passage through Bonneville Dam in 2004

```

END;
IF KCFS GT 4.3 AND KCFS LE 5.3 THEN DO;
  IF (TRACK_TYPE = 1) OR
    (Echo_Count = 4 AND ((Linearity1 / Echo_Count) > 0.4)) OR
    (Echo_Count >= 5 AND Echo_Count <= 7 AND ((Linearity1 / Echo_Count) >= 0.5)) OR
    ((Linearity2 / Echo_Count) > 0.5) OR
    (Echo_Count = 4 AND ((Linearity1 / Echo_Count) > 0.25)) OR
    ((Echo_Count = 5 OR Echo_Count = 6 OR Echo_Count = 7) AND ((Linearity1 / Echo_Count) >= 0.3)) OR
    ((Linearity2 / Echo_Count) > 0.35) OR
    (LINEARITY1=0 AND LINEARITY2=0 AND SLOPE=0) OR
    (((First_Range + Last_Range) / 2) >= 10) OR
    (((First_Range + Last_Range) / 2) < 9.0) AND (((First_Range + Last_Range) / 2) >= 8.5) AND (SLOPE
      < 0.1) OR
    (((First_Range + Last_Range) / 2) < 8.5) AND (((First_Range + Last_Range) / 2) > 7.5) AND (SLOPE <
      0.2) OR
    (((First_Range + Last_Range) / 2) <= 7.5) AND (SLOPE < 0.3)) OR
    (SLOPE>2.5) OR
    (((Noise_Count_Average) / ((Echo_Count + 10) * 5)) > 0.04))
  THEN DELETE;
END;
IF KCFS GT 5.3 AND KCFS LE 6.3 THEN DO;
  IF (TRACK_TYPE = 1) OR
    (Echo_Count = 4 AND ((Linearity1 / Echo_Count) > 0.4)) OR
    (Echo_Count >= 5 AND Echo_Count <= 7 AND ((Linearity1 / Echo_Count) >= 0.5)) OR
    ((Linearity2 / Echo_Count) > 0.5) OR
    (LINEARITY1=0 AND LINEARITY2=0 AND SLOPE=0) OR
    (((First_Range + Last_Range) / 2) > 10.13) OR
    (((First_Range + Last_Range) / 2) < 8.9) AND (((First_Range + Last_Range) / 2) >= 8.5) AND (SLOPE
      < 0.1) OR
    (((First_Range + Last_Range) / 2) < 8.5) AND (((First_Range + Last_Range) / 2) > 7.5) AND (SLOPE <
      0.2) OR
    (((First_Range + Last_Range) / 2) <= 7.5) AND (SLOPE < 0.3)) OR
    (SLOPE>2.5) OR
    (((Noise_Count_Average) / ((Echo_Count + 10) * 5)) > 0.04))
  THEN DELETE;
END;
IF KCFS GT 6.3 AND KCFS LE 7.3 THEN DO;
  IF (TRACK_TYPE = 1) OR
    (Echo_Count = 4 AND ((Linearity1 / Echo_Count) > 0.4)) OR
    (Echo_Count >= 5 AND Echo_Count <= 7 AND ((Linearity1 / Echo_Count) >= 0.5)) OR
    ((Linearity2 / Echo_Count) > 0.5) OR
    (LINEARITY1=0 AND LINEARITY2=0 AND SLOPE=0) OR
    (((First_Range + Last_Range) / 2) > 10.23) OR
    (((First_Range + Last_Range) / 2) < 9.2) AND (((First_Range + Last_Range) / 2) >= 8.2) AND (SLOPE
      < 0.1) OR
    (((First_Range + Last_Range) / 2) < 8.2) AND (((First_Range + Last_Range) / 2) > 7.2) AND (SLOPE <
      0.2) OR
    (((First_Range + Last_Range) / 2) <= 7.2) AND (SLOPE < 0.3)) OR
    (SLOPE>2.5) OR
    (((Noise_Count_Average) / ((Echo_Count + 10) * 5)) > 0.04))
  THEN DELETE;
END;
IF KCFS GT 7.3 THEN DO;
  IF (TRACK_TYPE = 1) OR
    (Echo_Count = 4 AND ((Linearity1 / Echo_Count) > 0.4)) OR
    (Echo_Count >= 5 AND Echo_Count <= 7 AND ((Linearity1 / Echo_Count) >= 0.5)) OR
    ((Linearity2 / Echo_Count) > 0.5) OR
    (LINEARITY1=0 AND LINEARITY2=0 AND SLOPE=0) OR
    (((First_Range + Last_Range) / 2) > 10.32) OR
    (((First_Range + Last_Range) / 2) < 9.0) AND (((First_Range + Last_Range) / 2) >= 8.5) AND (SLOPE
      < 0.1) OR
    (((First_Range + Last_Range) / 2) < 8.5) AND (((First_Range + Last_Range) / 2) > 7.5) AND (SLOPE <
      0.2) OR
    (((First_Range + Last_Range) / 2) <= 7.5) AND (SLOPE < 0.3)) OR
    (SLOPE>2.5) OR
    (((Noise_Count_Average) / ((Echo_Count + 10) * 5)) > 0.04))
  THEN DELETE;
END;
END;
END;

*** CH2 *****;
IF MUX_CHANNEL = 2 THEN DO;
  IF KCFS LE 3.3 THEN DO;
    IF (TRACK_TYPE = 1) OR
      (Echo_Count = 4 AND ((Linearity1 / Echo_Count) > 0.4)) OR
      (Echo_Count >= 5 AND Echo_Count <= 7 AND ((Linearity1 / Echo_Count) >= 0.5)) OR
      ((Linearity2 / Echo_Count) > 0.5) OR
      (((First_Range + Last_Range) / 2) > 9.75) OR
      (((First_Range + Last_Range) / 2) < 8.8) AND (((First_Range + Last_Range) / 2) >= 8.5) AND (SLOPE
        < 0.1) OR
      (((First_Range + Last_Range) / 2) < 8.5) AND (((First_Range + Last_Range) / 2) > 7.5) AND (SLOPE <

```

Hydroacoustic Evaluation of Fish Passage through Bonneville Dam in 2004

```

        0.125)) OR
        (((First_Range + Last_Range) / 2) <= 7.5) AND (SLOPE < 0.25)) OR
        (SLOPE>2.5) OR
        (((Noise_Count_Average) / ((Echo_Count + 10) * 5)) > 0.04))
    THEN DELETE;
END;
IF KCFS GT 3.3 AND KCFS LE 4.3 THEN DO;
    IF (TRACK_TYPE = 1) OR
        (Echo_Count = 4 AND ((Linearity1 / Echo_Count) > 0.4)) OR
        (Echo_Count >= 5 AND Echo_Count <= 7 AND ((Linearity1 / Echo_Count) >= 0.5)) OR
        ((Linearity2 / Echo_Count) > 0.5) OR
        (((First_Range + Last_Range) / 2) > 9.9) OR
        (((First_Range + Last_Range) / 2) < 8.9) AND (((First_Range + Last_Range) / 2) >= 8.9) AND (SLOPE
            < 0.1)) OR
        (((First_Range + Last_Range) / 2) < 8.9) AND (((First_Range + Last_Range) / 2) > 7.9) AND (SLOPE <
            0.125)) OR
        (((First_Range + Last_Range) / 2) <= 7.9) AND (SLOPE < 0.25)) OR
        (SLOPE>2.5) OR
        (((Noise_Count_Average) / ((Echo_Count + 10) * 5)) > 0.04))
    THEN DELETE;
END;
IF KCFS GT 4.3 AND KCFS LE 5.3 THEN DO;
    IF (TRACK_TYPE = 1) OR
        (Echo_Count = 4 AND ((Linearity1 / Echo_Count) > 0.4)) OR
        (Echo_Count >= 5 AND Echo_Count <= 7 AND ((Linearity1 / Echo_Count) >= 0.5)) OR
        ((Linearity2 / Echo_Count) > 0.5) OR
        (((First_Range + Last_Range) / 2) > 10.05) OR
        (((First_Range + Last_Range) / 2) < 9.0) AND (((First_Range + Last_Range) / 2) >= 8.0) AND (SLOPE
            < 0.1)) OR
        (((First_Range + Last_Range) / 2) < 8.0) AND (((First_Range + Last_Range) / 2) > 7.0) AND (SLOPE <
            0.125)) OR
        (((First_Range + Last_Range) / 2) <= 7.0) AND (SLOPE < 0.25)) OR
        (SLOPE>2.5) OR
        (((Noise_Count_Average) / ((Echo_Count + 10) * 5)) > 0.04))
    THEN DELETE;
END;
IF KCFS GT 5.3 AND KCFS LE 6.3 THEN DO;
    IF (TRACK_TYPE = 1) OR
        (Echo_Count = 4 AND ((Linearity1 / Echo_Count) > 0.4)) OR
        (Echo_Count >= 5 AND Echo_Count <= 7 AND ((Linearity1 / Echo_Count) >= 0.5)) OR
        ((Linearity2 / Echo_Count) > 0.5) OR
        (((First_Range + Last_Range) / 2) > 10.2) OR
        (((First_Range + Last_Range) / 2) < 9) AND (((First_Range + Last_Range) / 2) >= 8.5) AND (SLOPE <
            0.1)) OR
        (((First_Range + Last_Range) / 2) < 8.5) AND (((First_Range + Last_Range) / 2) > 7.5) AND (SLOPE <
            0.15)) OR
        (((First_Range + Last_Range) / 2) <= 7.5) AND (SLOPE < 0.25)) OR
        (SLOPE>2.5) OR
        (((Noise_Count_Average) / ((Echo_Count + 10) * 5)) > 0.04))
    THEN DELETE;
END;
IF KCFS GT 6.3 AND KCFS LE 7.3 THEN DO;
    IF (TRACK_TYPE = 1) OR
        (Echo_Count = 4 AND ((Linearity1 / Echo_Count) > 0.4)) OR
        (Echo_Count >= 5 AND Echo_Count <= 7 AND ((Linearity1 / Echo_Count) >= 0.5)) OR
        ((Linearity2 / Echo_Count) > 0.5) OR
        (((First_Range + Last_Range) / 2) > 10.3) OR
        (((First_Range + Last_Range) / 2) < 9.3) AND (((First_Range + Last_Range) / 2) >= 8.3) AND (SLOPE
            < 0.1)) OR
        (((First_Range + Last_Range) / 2) < 8.3) AND (((First_Range + Last_Range) / 2) > 7.3) AND (SLOPE <
            0.15)) OR
        (((First_Range + Last_Range) / 2) <= 7.3) AND (SLOPE < 0.25)) OR
        (SLOPE>2.5) OR
        (((Noise_Count_Average) / ((Echo_Count + 10) * 5)) > 0.04))
    THEN DELETE;
END;
IF KCFS GT 7.3 THEN DO;
    IF (TRACK_TYPE = 1) OR
        (Echo_Count = 4 AND ((Linearity1 / Echo_Count) > 0.4)) OR
        (Echo_Count >= 5 AND Echo_Count <= 7 AND ((Linearity1 / Echo_Count) >= 0.5)) OR
        ((Linearity2 / Echo_Count) > 0.5) OR
        (LINEARITY1=0 AND LINEARITY2=0 AND SLOPE=0) OR
        (LINEARITY1>15) OR
        (((First_Range + Last_Range) / 2) > 10.39) OR
        (((First_Range + Last_Range) / 2) < 9.5) AND (((First_Range + Last_Range) / 2) >= 8.5) AND (SLOPE
            < 0.1)) OR
        (((First_Range + Last_Range) / 2) < 8.5) AND (((First_Range + Last_Range) / 2) > 7.5) AND (SLOPE <
            0.15)) OR
        (((First_Range + Last_Range) / 2) <= 7.5) AND (SLOPE < 0.2) OR
        (SLOPE>2.5) OR
        (((Noise_Count_Average) / ((Echo_Count + 10) * 5)) > 0.04))

```

Hydroacoustic Evaluation of Fish Passage through Bonneville Dam in 2004

```
THEN DELETE;
END;
END;
*** CH3 *****;
IF MUX_CHANNEL = 3 THEN DO;
  IF KCFS LE 2.8 THEN DO;
    IF (TRACK_TYPE = 1) OR
      (Echo_Count = 4 AND ((Linearity1 / Echo_Count) > 0.4)) OR
      (Echo_Count >= 5 AND Echo_Count <= 7 AND ((Linearity1 / Echo_Count) >= 0.5)) OR
      ((Linearity2 / Echo_Count) > 0.5) OR
      (((First_Range + Last_Range) / 2) > 9.68) OR
      (((First_Range + Last_Range) / 2) < 8.7) AND (((First_Range + Last_Range) / 2) >= 8.0) AND (SLOPE
        < 0.1) OR
      (((First_Range + Last_Range) / 2) < 8.0) AND (((First_Range + Last_Range) / 2) > 7.0) AND (SLOPE <
        0.15) OR
      (((First_Range + Last_Range) / 2) <= 7.0) AND (SLOPE < 0.2)) OR
      (SLOPE>2.5) OR
      (((Noise_Count_Average) / ((Echo_Count + 10) * 5)) > 0.04))
    THEN DELETE;
  END;
  IF KCFS GT 2.8 AND KCFS LE 3.2 THEN DO;
    IF (TRACK_TYPE = 1) OR
      (Echo_Count = 4 AND ((Linearity1 / Echo_Count) > 0.4)) OR
      (Echo_Count >= 5 AND Echo_Count <= 7 AND ((Linearity1 / Echo_Count) >= 0.5)) OR
      ((Linearity2 / Echo_Count) > 0.5) OR
      (((First_Range + Last_Range) / 2) > 9.75) OR
      (((First_Range + Last_Range) / 2) < 8.8) AND (((First_Range + Last_Range) / 2) >= 8.0) AND (SLOPE
        < 0.1) OR
      (((First_Range + Last_Range) / 2) < 8.0) AND (((First_Range + Last_Range) / 2) > 7.0) AND (SLOPE <
        0.15) OR
      (((First_Range + Last_Range) / 2) <= 7.0) AND (SLOPE < 0.2)) OR
      (SLOPE>2.5) OR
      (((Noise_Count_Average) / ((Echo_Count + 10) * 5)) > 0.04))
    THEN DELETE;
  END;
  IF KCFS GT 3.2 AND KCFS LE 4.2 THEN DO;
    IF (TRACK_TYPE = 1) OR
      (Echo_Count = 4 AND ((Linearity1 / Echo_Count) > 0.4)) OR
      (Echo_Count >= 5 AND Echo_Count <= 7 AND ((Linearity1 / Echo_Count) >= 0.5)) OR
      ((Linearity2 / Echo_Count) > 0.5) OR
      (((First_Range + Last_Range) / 2) > 9.87) OR
      (((First_Range + Last_Range) / 2) < 8.9) AND (((First_Range + Last_Range) / 2) >= 8.0) AND (SLOPE
        < 0.1) OR
      (((First_Range + Last_Range) / 2) < 8.0) AND (((First_Range + Last_Range) / 2) > 7.0) AND (SLOPE <
        0.15) OR
      (((First_Range + Last_Range) / 2) <= 7.0) AND (SLOPE < 0.2)) OR
      (SLOPE>2.5) OR
      (((Noise_Count_Average) / ((Echo_Count + 10) * 5)) > 0.04))
    THEN DELETE;
  END;
  IF KCFS GT 4.2 AND KCFS LE 5.2 THEN DO;
    IF (TRACK_TYPE = 1) OR
      (Echo_Count = 4 AND ((Linearity1 / Echo_Count) > 0.4)) OR
      (Echo_Count >= 5 AND Echo_Count <= 7 AND ((Linearity1 / Echo_Count) >= 0.5)) OR
      ((Linearity2 / Echo_Count) > 0.5) OR
      (((First_Range + Last_Range) / 2) > 9.99) OR
      (((First_Range + Last_Range) / 2) < 9.0) AND (((First_Range + Last_Range) / 2) >= 8.0) AND (SLOPE
        < 0.1) OR
      (((First_Range + Last_Range) / 2) < 8.0) AND (((First_Range + Last_Range) / 2) > 7.0) AND (SLOPE <
        0.15) OR
      (((First_Range + Last_Range) / 2) <= 7.0) AND (SLOPE < 0.2)) OR
      (SLOPE>2.5) OR
      (((Noise_Count_Average) / ((Echo_Count + 10) * 5)) > 0.04))
    THEN DELETE;
  END;
  IF KCFS GT 5.2 AND KCFS LE 6.3 THEN DO;
    IF (TRACK_TYPE = 1) OR
      (Echo_Count = 4 AND ((Linearity1 / Echo_Count) > 0.4)) OR
      (Echo_Count >= 5 AND Echo_Count <= 7 AND ((Linearity1 / Echo_Count) >= 0.5)) OR
      ((Linearity2 / Echo_Count) > 0.5) OR
      (((First_Range + Last_Range) / 2) > 10.12) OR
      (((First_Range + Last_Range) / 2) < 9) AND (((First_Range + Last_Range) / 2) >= 8.5) AND (SLOPE <
        0.1) OR
      (((First_Range + Last_Range) / 2) < 8.5) AND (((First_Range + Last_Range) / 2) > 7.5) AND (SLOPE <
        0.15) OR
      (((First_Range + Last_Range) / 2) <= 7.5) AND (SLOPE < 0.25)) OR
      (SLOPE>2.5) OR
      (((Noise_Count_Average) / ((Echo_Count + 10) * 5)) > 0.04))
    THEN DELETE;
  END;
  IF KCFS GT 6.3 AND KCFS LE 7.3 THEN DO;
```

Hydroacoustic Evaluation of Fish Passage through Bonneville Dam in 2004

```

IF (TRACK_TYPE = 1) OR
(Echo_Count = 4 AND ((Linearity1 / Echo_Count) > 0.4)) OR
(Echo_Count >= 5 AND Echo_Count <= 7 AND ((Linearity1 / Echo_Count) >= 0.5)) OR
((Linearity2 / Echo_Count) > 0.5) OR
(((First_Range + Last_Range) / 2) > 10.3) OR
((((First_Range + Last_Range) / 2) < 9.3) AND (((First_Range + Last_Range) / 2) >= 8.3) AND (SLOPE
< 0.1)) OR
((((First_Range + Last_Range) / 2) < 8.3) AND (((First_Range + Last_Range) / 2) > 7.3) AND (SLOPE <
0.15)) OR
((((First_Range + Last_Range) / 2) <= 7.3) AND (SLOPE < 0.25)) OR
(SLOPE>2.5) OR
((((Noise_Count_Average) / ((Echo_Count + 10) * 5)) > 0.04))
THEN DELETE;
END;
IF KCFS GT 7.3 THEN DO;
IF (TRACK_TYPE = 1) OR
(Echo_Count = 4 AND ((Linearity1 / Echo_Count) > 0.4)) OR
(Echo_Count >= 5 AND Echo_Count <= 7 AND ((Linearity1 / Echo_Count) >= 0.5)) OR
((Linearity2 / Echo_Count) > 0.5) OR
(((First_Range + Last_Range) / 2) > 10.41) OR
((((First_Range + Last_Range) / 2) < 9.5) AND (((First_Range + Last_Range) / 2) >= 8.5) AND (SLOPE
< 0.1)) OR
((((First_Range + Last_Range) / 2) < 8.5) AND (((First_Range + Last_Range) / 2) > 7.5) AND (SLOPE <
0.15)) OR
((((First_Range + Last_Range) / 2) <= 7.5) AND (SLOPE < 0.2)) OR
(SLOPE>2.5) OR
((((Noise_Count_Average) / ((Echo_Count + 10) * 5)) > 0.04))
THEN DELETE;
END;
END;
*** CH4 *****;
IF MUX_CHANNEL = 4 THEN DO;
IF KCFS LE 3.3 THEN DO;
IF (TRACK_TYPE = 1) OR
(Echo_Count = 4 AND ((Linearity1 / Echo_Count) > 0.4)) OR
(Echo_Count >= 5 AND Echo_Count <= 7 AND ((Linearity1 / Echo_Count) >= 0.5)) OR
((Linearity2 / Echo_Count) > 0.5) OR
(LINEARITY1=0 AND LINEARITY2=0 AND SLOPE=0) OR
(((First_Range + Last_Range) / 2) > 9.85) OR
((((First_Range + Last_Range) / 2) < 8.8) AND (((First_Range + Last_Range) / 2) >= 8.0) AND (SLOPE
< 0.1)) OR
((((First_Range + Last_Range) / 2) < 8.0) AND (((First_Range + Last_Range) / 2) > 7.0) AND (SLOPE <
0.15)) OR
((((First_Range + Last_Range) / 2) <= 7.0) AND (SLOPE < 0.2)) OR
(SLOPE>2.5) OR
((((Noise_Count_Average) / ((Echo_Count + 10) * 5)) > 0.04))
THEN DELETE;
END;
IF KCFS GT 3.3 AND KCFS LE 4.3 THEN DO;
IF (TRACK_TYPE = 1) OR
(Echo_Count = 4 AND ((Linearity1 / Echo_Count) > 0.4)) OR
(Echo_Count >= 5 AND Echo_Count <= 7 AND ((Linearity1 / Echo_Count) >= 0.5)) OR
((Linearity2 / Echo_Count) > 0.5) OR
(LINEARITY1=0 AND LINEARITY2=0 AND SLOPE=0) OR
(((First_Range + Last_Range) / 2) > 9.97) OR
((((First_Range + Last_Range) / 2) < 9.0) AND (((First_Range + Last_Range) / 2) >= 8.0) AND (SLOPE
< 0.1)) OR
((((First_Range + Last_Range) / 2) < 8.0) AND (((First_Range + Last_Range) / 2) > 7.0) AND (SLOPE <
0.15)) OR
((((First_Range + Last_Range) / 2) <= 7.0) AND (SLOPE < 0.2)) OR
(SLOPE>2.5) OR
((((Noise_Count_Average) / ((Echo_Count + 10) * 5)) > 0.04))
THEN DELETE;
END;
IF KCFS GT 4.3 AND KCFS LE 5.3 THEN DO;
IF (TRACK_TYPE = 1) OR
(Echo_Count = 4 AND ((Linearity1 / Echo_Count) > 0.4)) OR
(Echo_Count >= 5 AND Echo_Count <= 7 AND ((Linearity1 / Echo_Count) >= 0.5)) OR
((Linearity2 / Echo_Count) > 0.5) OR
(LINEARITY1=0 AND LINEARITY2=0 AND SLOPE=0) OR
(((First_Range + Last_Range) / 2) > 10.1) OR
((((First_Range + Last_Range) / 2) < 9.1) AND (((First_Range + Last_Range) / 2) >= 8.1) AND (SLOPE
< 0.1)) OR
((((First_Range + Last_Range) / 2) < 8.1) AND (((First_Range + Last_Range) / 2) > 7.1) AND (SLOPE <
0.15)) OR
((((First_Range + Last_Range) / 2) <= 7.1) AND (SLOPE < 0.2)) OR
(SLOPE>2.5) OR
((((Noise_Count_Average) / ((Echo_Count + 10) * 5)) > 0.04))
THEN DELETE;
END;

```

Hydroacoustic Evaluation of Fish Passage through Bonneville Dam in 2004

```

IF KCFS GT 5.3 AND KCFS LE 6.3 THEN DO;
  IF (TRACK_TYPE = 1) OR
    (Echo_Count = 4 AND ((Linearity1 / Echo_Count) > 0.4)) OR
    (Echo_Count >= 5 AND Echo_Count <= 7 AND ((Linearity1 / Echo_Count) >= 0.5)) OR
    ((Linearity2 / Echo_Count) > 0.5) OR
    (LINEARITY1=0 AND LINEARITY2=0 AND SLOPE=0) OR
    (((First_Range + Last_Range) / 2) > 10.23) OR
    (((First_Range + Last_Range) / 2) < 9.2) AND (((First_Range + Last_Range) / 2) >= 8.2) AND (SLOPE
      < 0.1) OR
    (((First_Range + Last_Range) / 2) < 8.2) AND (((First_Range + Last_Range) / 2) > 7.2) AND (SLOPE <
      0.15) OR
    (((First_Range + Last_Range) / 2) <= 7.2) AND (SLOPE < 0.2)) OR
    (SLOPE>2.5) OR
    (((Noise_Count_Average) / ((Echo_Count + 10) * 5)) > 0.04))
  THEN DELETE;
END;
IF KCFS GT 6.3 AND KCFS LE 7.3 THEN DO;
  IF (TRACK_TYPE = 1) OR
    (Echo_Count = 4 AND ((Linearity1 / Echo_Count) > 0.4)) OR
    (Echo_Count >= 5 AND Echo_Count <= 7 AND ((Linearity1 / Echo_Count) >= 0.5)) OR
    ((Linearity2 / Echo_Count) > 0.5) OR
    (LINEARITY1=0 AND LINEARITY2=0 AND SLOPE=0) OR
    (((First_Range + Last_Range) / 2) > 10.36) OR
    (((First_Range + Last_Range) / 2) < 9.36) AND (((First_Range + Last_Range) / 2) >= 8.5) AND (SLOPE
      < 0.1) OR
    (((First_Range + Last_Range) / 2) < 8.5) AND (((First_Range + Last_Range) / 2) > 7.5) AND (SLOPE <
      0.15) OR
    (((First_Range + Last_Range) / 2) <= 7.5) AND (SLOPE < 0.2)) OR
    (SLOPE>2.5) OR
    (((Noise_Count_Average) / ((Echo_Count + 10) * 5)) > 0.04))
  THEN DELETE;
END;
IF KCFS GT 7.3 THEN DO;
  IF (TRACK_TYPE = 1) OR
    (Echo_Count = 4 AND ((Linearity1 / Echo_Count) > 0.4)) OR
    (Echo_Count >= 5 AND Echo_Count <= 7 AND ((Linearity1 / Echo_Count) >= 0.5)) OR
    ((Linearity2 / Echo_Count) > 0.5) OR
    (((First_Range + Last_Range) / 2) > 10.57) OR
    (((First_Range + Last_Range) / 2) < 9.5) AND (((First_Range + Last_Range) / 2) >= 8.5) AND (SLOPE
      < 0.1) OR
    (((First_Range + Last_Range) / 2) < 8.5) AND (((First_Range + Last_Range) / 2) > 7.5) AND (SLOPE <
      0.15) OR
    (((First_Range + Last_Range) / 2) <= 7.5) AND (SLOPE < 0.2)) OR
    (SLOPE>2.5) OR
    (((Noise_Count_Average) / ((Echo_Count + 10) * 5)) > 0.04))
  THEN DELETE;
END;
END;
*** CH5 *****;
IF MUX_CHANNEL = 5 THEN DO;
  IF KCFS LE 3.2 THEN DO;
    IF (TRACK_TYPE = 1) OR
      (Echo_Count = 4 AND ((Linearity1 / Echo_Count) > 0.4)) OR
      (Echo_Count >= 5 AND Echo_Count <= 7 AND ((Linearity1 / Echo_Count) >= 0.5)) OR
      ((Linearity2 / Echo_Count) > 0.5) OR
      (((First_Range + Last_Range) / 2) > 9.94) OR
      (((First_Range + Last_Range) / 2) < 8.8) AND (((First_Range + Last_Range) / 2) >= 8.0) AND (SLOPE
        < 0.1) OR
      (((First_Range + Last_Range) / 2) < 8.0) AND (((First_Range + Last_Range) / 2) > 7.0) AND (SLOPE <
        0.15) OR
      (((First_Range + Last_Range) / 2) <= 7.0) AND (SLOPE < 0.2)) OR
      (SLOPE>2.5) OR
      (((Noise_Count_Average) / ((Echo_Count + 10) * 5)) > 0.04))
    THEN DELETE;
  END;
END;
IF KCFS GT 3.2 AND KCFS LE 5.3 THEN DO;
  IF (TRACK_TYPE = 1) OR
    (Echo_Count = 4 AND ((Linearity1 / Echo_Count) > 0.4)) OR
    (Echo_Count >= 5 AND Echo_Count <= 7 AND ((Linearity1 / Echo_Count) >= 0.5)) OR
    ((Linearity2 / Echo_Count) > 0.5) OR
    (((First_Range + Last_Range) / 2) > 10.1) OR
    (((First_Range + Last_Range) / 2) < 9) AND (((First_Range + Last_Range) / 2) >= 8.5) AND (SLOPE <
      0.1) OR
    (((First_Range + Last_Range) / 2) < 8.5) AND (((First_Range + Last_Range) / 2) > 7.5) AND (SLOPE <
      0.15) OR
    (((First_Range + Last_Range) / 2) <= 7.5) AND (SLOPE < 0.25)) OR
    (SLOPE>2.5) OR
    (((Noise_Count_Average) / ((Echo_Count + 10) * 5)) > 0.04))
  THEN DELETE;
END;
IF KCFS GT 5.3 AND KCFS LE 6.5 THEN DO;

```

Hydroacoustic Evaluation of Fish Passage through Bonneville Dam in 2004

```

IF (TRACK_TYPE = 1) OR
(Echo_Count = 4 AND ((Linearity1 / Echo_Count) > 0.4)) OR
(Echo_Count >= 5 AND Echo_Count <= 7 AND ((Linearity1 / Echo_Count) >= 0.5)) OR
((Linearity2 / Echo_Count) > 0.5) OR
(((First_Range + Last_Range) / 2) > 10.29) OR
((((First_Range + Last_Range) / 2) < 9.3) AND (((First_Range + Last_Range) / 2) >= 8.3) AND (SLOPE
< 0.1)) OR
((((First_Range + Last_Range) / 2) < 8.3) AND (((First_Range + Last_Range) / 2) > 7.3) AND (SLOPE <
0.15)) OR
((((First_Range + Last_Range) / 2) <= 7.3) AND (SLOPE < 0.25)) OR
(SLOPE>2.5) OR
((((Noise_Count_Average) / ((Echo_Count + 10) * 5)) > 0.04))
THEN DELETE;
END;
IF KCFS GT 6.5 AND KCFS LE 7.75 THEN DO;
IF (TRACK_TYPE = 1) OR
(Echo_Count = 4 AND ((Linearity1 / Echo_Count) > 0.4)) OR
(Echo_Count >= 5 AND Echo_Count <= 7 AND ((Linearity1 / Echo_Count) >= 0.5)) OR
((Linearity2 / Echo_Count) > 0.5) OR
(((First_Range + Last_Range) / 2) > 10.48) OR
((((First_Range + Last_Range) / 2) < 9.5) AND (((First_Range + Last_Range) / 2) >= 8.5) AND (SLOPE
< 0.1)) OR
((((First_Range + Last_Range) / 2) < 8.5) AND (((First_Range + Last_Range) / 2) > 7.5) AND (SLOPE <
0.15)) OR
((((First_Range + Last_Range) / 2) <= 7.5) AND (SLOPE < 0.25)) OR
(SLOPE>2.5) OR
((((Noise_Count_Average) / ((Echo_Count + 10) * 5)) > 0.04))
THEN DELETE;
END;
IF KCFS GT 7.75 THEN DO;
IF (TRACK_TYPE = 1) OR
(Echo_Count = 4 AND ((Linearity1 / Echo_Count) > 0.4)) OR
(Echo_Count >= 5 AND Echo_Count <= 7 AND ((Linearity1 / Echo_Count) >= 0.5)) OR
((Linearity2 / Echo_Count) > 0.5) OR
(((First_Range + Last_Range) / 2) > 10.67) OR
((((First_Range + Last_Range) / 2) < 9.4) AND (((First_Range + Last_Range) / 2) >= 8.5) AND (SLOPE
< 0.1)) OR
((((First_Range + Last_Range) / 2) < 8.5) AND (((First_Range + Last_Range) / 2) > 7.5) AND (SLOPE <
0.15)) OR
((((First_Range + Last_Range) / 2) <= 7.5) AND (SLOPE < 0.2)) OR
(SLOPE>2.0) OR
((((Noise_Count_Average) / ((Echo_Count + 10) * 5)) > 0.04))
THEN DELETE;
END;
END;
IF SYSTEM = 'M' THEN DO;
IF MUX_CHANNEL = 0 THEN DO;
IF KCFS LE 4.3 THEN DO;
IF (TRACK_TYPE = 1) OR
(Echo_Count = 4 AND ((Linearity1 / Echo_Count) > 0.4)) OR
(Echo_Count >= 5 AND Echo_Count <= 7 AND ((Linearity1 / Echo_Count) >= 0.5)) OR
((Linearity2 / Echo_Count) > 0.5) OR
(((First_Range + Last_Range) / 2) > 9.80) OR
((((First_Range + Last_Range) / 2) < 8.8) AND (((First_Range + Last_Range) / 2) >= 7.5) AND (SLOPE
< 0.1)) OR
((((First_Range + Last_Range) / 2) < 7.5) AND (SLOPE < 0.2)) OR
((((Noise_Count_Average) / ((Echo_Count + 10) * 5)) > 0.04))
THEN DELETE;
END;
IF KCFS GT 4.3 AND KCFS LE 5.3 THEN DO;
IF (TRACK_TYPE = 1) OR
(Echo_Count = 4 AND ((Linearity1 / Echo_Count) > 0.4)) OR
(Echo_Count >= 5 AND Echo_Count <= 7 AND ((Linearity1 / Echo_Count) >= 0.5)) OR
((Linearity2 / Echo_Count) > 0.5) OR
(((First_Range + Last_Range) / 2) > 9.93) OR
((((First_Range + Last_Range) / 2) < 9.0) AND (((First_Range + Last_Range) / 2) >= 8.0) AND (SLOPE
< 0.1)) OR
((((First_Range + Last_Range) / 2) < 8.0) AND (((First_Range + Last_Range) / 2) > 7.0) AND (SLOPE <
0.15)) OR
((((First_Range + Last_Range) / 2) < 7.0) AND (SLOPE < 0.2)) OR
((((Noise_Count_Average) / ((Echo_Count + 10) * 5)) > 0.04))
THEN DELETE;
END;
IF KCFS GT 5.3 AND KCFS LE 6.3 THEN DO;
IF (TRACK_TYPE = 1) OR
(Echo_Count = 4 AND ((Linearity1 / Echo_Count) > 0.4)) OR
(Echo_Count >= 5 AND Echo_Count <= 7 AND ((Linearity1 / Echo_Count) >= 0.5)) OR
((Linearity2 / Echo_Count) > 0.5) OR
(((First_Range + Last_Range) / 2) > 10.06) OR

```

Hydroacoustic Evaluation of Fish Passage through Bonneville Dam in 2004

```

        (((First_Range + Last_Range) / 2) < 9.0) AND (((First_Range + Last_Range) / 2) >= 8.0) AND (SLOPE
        < 0.1)) OR
        (((First_Range + Last_Range) / 2) < 8.0) AND (((First_Range + Last_Range) / 2) > 7.0) AND (SLOPE <
        0.15)) OR
        (((First_Range + Last_Range) / 2) < 7.0) AND (SLOPE < 0.2)) OR
        (((Noise_Count_Average) / ((Echo_Count + 10) * 5)) > 0.04))
    THEN DELETE;
END;
IF KCFS GT 6.3 AND KCFS LE 7.3 THEN DO;
    IF (TRACK_TYPE = 1) OR
        (Echo_Count = 4 AND ((Linearity1 / Echo_Count) > 0.4)) OR
        (Echo_Count >= 5 AND Echo_Count <= 7 AND ((Linearity1 / Echo_Count) >= 0.5)) OR
        ((Linearity2 / Echo_Count) > 0.5) OR
        (LINEARITY1=0 AND LINEARITY2=0 AND SLOPE=0) OR
        (((First_Range + Last_Range) / 2) > 10.19) OR
        (((First_Range + Last_Range) / 2) < 9.1) AND (((First_Range + Last_Range) / 2) >= 8.5) AND (SLOPE <
        < 0.1)) OR
        (((First_Range + Last_Range) / 2) < 8.5) AND (((First_Range + Last_Range) / 2) > 7.5) AND (SLOPE <
        0.15)) OR
        (((First_Range + Last_Range) / 2) <= 7.5) AND (SLOPE < 0.2)) OR
        (((Noise_Count_Average) / ((Echo_Count + 10) * 5)) > 0.04))
    THEN DELETE;
END;
IF KCFS GT 7.3 THEN DO;
    IF (TRACK_TYPE = 1) OR
        (Echo_Count = 4 AND ((Linearity1 / Echo_Count) > 0.4)) OR
        (Echo_Count >= 5 AND Echo_Count <= 7 AND ((Linearity1 / Echo_Count) >= 0.5)) OR
        ((Linearity2 / Echo_Count) > 0.5) OR
        (((First_Range + Last_Range) / 2) > 10.32) OR
        (((First_Range + Last_Range) / 2) < 9.3) AND (((First_Range + Last_Range) / 2) >= 8.3) AND (SLOPE <
        < 0.1)) OR
        (((First_Range + Last_Range) / 2) < 8.3) AND (((First_Range + Last_Range) / 2) > 7.3) AND (SLOPE <
        0.15)) OR
        (((First_Range + Last_Range) / 2) < 7.3) AND (SLOPE < 0.2)) OR
        (((Noise_Count_Average) / ((Echo_Count + 10) * 5)) > 0.04))
    THEN DELETE;
END;
END;
*** CH1 *****;
IF MUX_CHANNEL = 1 THEN DO; *** KCFS 3.1;
    IF KCFS LE 3.3 THEN DO;
        IF (TRACK_TYPE = 1) OR
            (Echo_Count = 4 AND ((Linearity1 / Echo_Count) > 0.4)) OR
            (Echo_Count >= 5 AND Echo_Count <= 7 AND ((Linearity1 / Echo_Count) >= 0.5)) OR
            ((Linearity2 / Echo_Count) > 0.5) OR
            (((First_Range + Last_Range) / 2) > 9.59) OR
            (((First_Range + Last_Range) / 2) < 8.6) AND (((First_Range + Last_Range) / 2) >= 8.0) AND (SLOPE <
            < 0.1)) OR
            (((First_Range + Last_Range) / 2) < 8.0) AND (((First_Range + Last_Range) / 2) > 7.5) AND (SLOPE <
            0.15)) OR
            (((First_Range + Last_Range) / 2) <= 7.5) AND (SLOPE < 0.2)) OR
            (SLOPE>2.5) OR
            (((Noise_Count_Average) / ((Echo_Count + 10) * 5)) > 0.04))
        THEN DELETE;
    END;
    IF KCFS GT 3.3 AND KCFS LE 3.8 THEN DO;
        IF (TRACK_TYPE = 1) OR
            (Echo_Count = 4 AND ((Linearity1 / Echo_Count) > 0.4)) OR
            (Echo_Count >= 5 AND Echo_Count <= 7 AND ((Linearity1 / Echo_Count) >= 0.5)) OR
            ((Linearity2 / Echo_Count) > 0.5) OR
            ((Linearity1 / Echo_Count) > 0.3 AND (Linearity2 / Echo_Count) > 0.3 AND SLOPE<0.5) OR
            (((First_Range + Last_Range) / 2) > 9.69) OR
            (((First_Range + Last_Range) / 2) > 8.0) AND (SLOPE > 1)) OR
            (((First_Range + Last_Range) / 2) < 8.8) AND (((First_Range + Last_Range) / 2) >= 8.2) AND (SLOPE <
            < 0.1)) OR
            (((First_Range + Last_Range) / 2) < 8.2) AND (((First_Range + Last_Range) / 2) > 7.4) AND (SLOPE <
            0.15)) OR
            (((First_Range + Last_Range) / 2) <= 7.4) AND (SLOPE < 0.2)) OR
            (SLOPE>2.5) OR
            (((Noise_Count_Average) / ((Echo_Count + 10) * 5)) > 0.04))
        THEN DELETE;
    END;
    IF KCFS GT 3.8 AND KCFS LE 4.3 THEN DO;
        IF (TRACK_TYPE = 1) OR
            (Echo_Count = 4 AND ((Linearity1 / Echo_Count) > 0.4)) OR
            (Echo_Count >= 5 AND Echo_Count <= 7 AND ((Linearity1 / Echo_Count) >= 0.5)) OR
            ((Linearity2 / Echo_Count) > 0.5) OR
            (LINEARITY1>4.5 AND LINEARITY2>4.5 AND SLOPE<0.5) OR
            (((First_Range + Last_Range) / 2) > 9.78) OR
            (((First_Range + Last_Range) / 2) < 9.0) AND (((First_Range + Last_Range) / 2) >= 8.0) AND (SLOPE

```

Hydroacoustic Evaluation of Fish Passage through Bonneville Dam in 2004

```

    < 0.1)) OR
    (((First_Range + Last_Range) / 2) < 8.0) AND (((First_Range + Last_Range) / 2) > 7.5) AND (SLOPE <
    0.15)) OR
    (((First_Range + Last_Range) / 2) < 7.5) AND (SLOPE < 0.2)) OR
    (First_Range >= 8.60 AND First_Range <= 8.95 AND Last_Range >= 8.60 AND Last_Range <= 8.95 AND
    SLOPE < 0.8) OR
    (First_Range >= 7.55 AND First_Range <= 7.95 AND Last_Range >= 7.55 AND Last_Range <= 7.95 AND
    SLOPE < 0.8) OR
    (First_Range >= 6.20 AND First_Range <= 6.65 AND Last_Range >= 6.20 AND Last_Range <= 6.65 AND
    SLOPE < 0.8) OR
    (((Noise_Count_Average) / ((Echo_Count + 10) * 5)) > 0.04))
    THEN DELETE;
END;
IF KCFS GT 4.3 AND KCFS LE 5.3 THEN DO;
IF (TRACK_TYPE = 1) OR
(Echo_Count = 4 AND ((Linearity1 / Echo_Count) > 0.4)) OR
(Echo_Count >= 5 AND Echo_Count <= 7 AND ((Linearity1 / Echo_Count) >= 0.5)) OR
((Linearity2 / Echo_Count) > 0.5) OR
(LINEARITY1>4.5 AND LINEARITY2>4.5 AND SLOPE<0.5) OR
(((First_Range + Last_Range) / 2) > 9.89) OR
((((First_Range + Last_Range) / 2) < 9.0) AND (((First_Range + Last_Range) / 2) >= 8.0) AND (SLOPE
< 0.1)) OR
((((First_Range + Last_Range) / 2) < 8.0) AND (((First_Range + Last_Range) / 2) > 7.5) AND (SLOPE <
0.15)) OR
((((First_Range + Last_Range) / 2) < 7.5) AND (SLOPE < 0.2)) OR
((((Noise_Count_Average) / ((Echo_Count + 10) * 5)) > 0.04))
    THEN DELETE;
END;
IF KCFS GT 5.3 AND KCFS LE 6.3 THEN DO;
IF (TRACK_TYPE = 1) OR
(Echo_Count = 4 AND ((Linearity1 / Echo_Count) > 0.4)) OR
(Echo_Count >= 5 AND Echo_Count <= 7 AND ((Linearity1 / Echo_Count) >= 0.5)) OR
((Linearity2 / Echo_Count) > 0.5) OR
(LINEARITY1>4.5 AND LINEARITY2>4.5 AND SLOPE<0.5) OR
(((First_Range + Last_Range) / 2) > 9.99) OR
((((First_Range + Last_Range) / 2) < 9.0) AND (((First_Range + Last_Range) / 2) >= 8.0) AND (SLOPE
< 0.1)) OR
((((First_Range + Last_Range) / 2) < 8.0) AND (((First_Range + Last_Range) / 2) > 7.5) AND (SLOPE <
0.15)) OR
((((First_Range + Last_Range) / 2) < 7.5) AND (SLOPE < 0.2)) OR
((((Noise_Count_Average) / ((Echo_Count + 10) * 5)) > 0.04))
    THEN DELETE;
END;
IF KCFS GT 6.3 AND KCFS LE 7.3 THEN DO;
IF (TRACK_TYPE = 1 AND SLOPE<0.6) OR
(Echo_Count = 4 AND ((Linearity1 / Echo_Count) > 0.4)) OR
(Echo_Count >= 5 AND Echo_Count <= 7 AND ((Linearity1 / Echo_Count) >= 0.5)) OR
((Linearity2 / Echo_Count) > 0.5) OR
((Linearity1 / Echo_Count) >= 0.3 AND (Linearity2 / Echo_Count) >= 0.3 AND SLOPE<0.5) OR
(((First_Range + Last_Range) / 2) > 10.1) OR
((((First_Range + Last_Range) / 2) < 9.0) AND (((First_Range + Last_Range) / 2) >= 8.5) AND (SLOPE
< 0.1)) OR
((((First_Range + Last_Range) / 2) < 8.5) AND (((First_Range + Last_Range) / 2) > 7.5) AND (SLOPE <
0.15)) OR
((((First_Range + Last_Range) / 2) <= 7.5) AND (SLOPE < 0.2)) OR
((((Noise_Count_Average) / ((Echo_Count + 10) * 5)) > 0.04))
    THEN DELETE;
END;
IF KCFS GT 7.3 THEN DO;
IF (TRACK_TYPE = 1) OR
(Echo_Count = 4 AND ((Linearity1 / Echo_Count) > 0.4)) OR
(Echo_Count >= 5 AND Echo_Count <= 7 AND ((Linearity1 / Echo_Count) >= 0.5)) OR
((Linearity2 / Echo_Count) > 0.5) OR
(LINEARITY1>4.5 AND LINEARITY2>4.5 AND SLOPE<0.5) OR
(((First_Range + Last_Range) / 2) > 10.21) OR
((((First_Range + Last_Range) / 2) < 9.2) AND (((First_Range + Last_Range) / 2) >= 8.2) AND (SLOPE
< 0.1)) OR
((((First_Range + Last_Range) / 2) < 8.2) AND (((First_Range + Last_Range) / 2) > 7.2) AND (SLOPE <
0.15)) OR
((((First_Range + Last_Range) / 2) < 7.2) AND (SLOPE < 0.2)) OR
((((Noise_Count_Average) / ((Echo_Count + 10) * 5)) > 0.04))
    THEN DELETE;
END;
END;
END;
IF SYSTEM = 'O' THEN DO;
*** CH1 *****;
IF MUX_CHANNEL = 00 THEN DO;

```

Hydroacoustic Evaluation of Fish Passage through Bonneville Dam in 2004

```
IF KCFS LE 4.5 THEN DO;
  IF (TRACK_TYPE = 1) OR
    (Echo_Count = 4 AND ((Linearity1 / Echo_Count) > 0.4)) OR
    (Echo_Count >= 5 AND Echo_Count <= 7 AND ((Linearity1 / Echo_Count) >= 0.5)) OR
    ((Linearity2 / Echo_Count) > 0.5) OR
    (((First_Range + Last_Range) / 2) > 9.74) OR
    (((First_Range + Last_Range) / 2) < 9.0) AND (((First_Range + Last_Range) / 2) > 8.0) AND (SLOPE <
      0.1)) OR
    (((First_Range + Last_Range) / 2) < 8.0) AND (((First_Range + Last_Range) / 2) > 7.0) AND (SLOPE <
      0.15)) OR
    (((First_Range + Last_Range) / 2) < 7.0) AND (SLOPE < 0.2)) OR
    (((Noise_Count_Average) / ((Echo_Count + 10) * 5)) > 0.04))
  THEN DELETE;
END;
IF KCFS GT 4.5 AND KCFS LE 5.3 THEN DO;
  IF (TRACK_TYPE = 1) OR
    (Echo_Count = 4 AND ((Linearity1 / Echo_Count) > 0.4)) OR
    (Echo_Count >= 5 AND Echo_Count <= 7 AND ((Linearity1 / Echo_Count) >= 0.5)) OR
    ((Linearity2 / Echo_Count) > 0.5) OR
    ((First_Range + Last_Range) / 2) > 9.92) OR
    (((First_Range + Last_Range) / 2) <= 9.5) AND (((First_Range + Last_Range) / 2) >= 9.25) AND
      (SLOPE < 0.5)) OR
    (((First_Range + Last_Range) / 2) < 9.0) AND (((First_Range + Last_Range) / 2) > 8.0) AND (SLOPE <
      0.1)) OR
    (((First_Range + Last_Range) / 2) < 8.0) AND (((First_Range + Last_Range) / 2) > 7.0) AND (SLOPE <
      0.15)) OR
    (((First_Range + Last_Range) / 2) < 7.0) AND (SLOPE < 0.2)) OR
    (((Noise_Count_Average) / ((Echo_Count + 10) * 5)) > 0.04))
  THEN DELETE;
END;
IF KCFS GT 5.3 AND KCFS LE 6.3 THEN DO;
  IF (TRACK_TYPE = 1) OR
    (Echo_Count = 4 AND ((Linearity1 / Echo_Count) > 0.4)) OR
    (Echo_Count >= 5 AND Echo_Count <= 7 AND ((Linearity1 / Echo_Count) >= 0.5)) OR
    ((Linearity2 / Echo_Count) > 0.5) OR
    ((First_Range + Last_Range) / 2) > 10.1) OR
    (((First_Range + Last_Range) / 2) < 9.0) AND (((First_Range + Last_Range) / 2) > 8.0) AND (SLOPE <
      0.1)) OR
    (((First_Range + Last_Range) / 2) < 8.0) AND (((First_Range + Last_Range) / 2) > 7.0) AND (SLOPE <
      0.15)) OR
    (((First_Range + Last_Range) / 2) < 7.0) AND (SLOPE < 0.2)) OR
    (((Noise_Count_Average) / ((Echo_Count + 10) * 5)) > 0.04))
  THEN DELETE;
END;
IF KCFS GT 6.3 AND KCFS LE 7.8 THEN DO;
  IF (TRACK_TYPE = 1) OR
    (Echo_Count = 4 AND ((Linearity1 / Echo_Count) > 0.4)) OR
    (Echo_Count >= 5 AND Echo_Count <= 7 AND ((Linearity1 / Echo_Count) >= 0.5)) OR
    ((Linearity2 / Echo_Count) > 0.5) OR
    ((First_Range + Last_Range) / 2) > 10.27) OR
    (((First_Range + Last_Range) / 2) < 9.65) AND (((First_Range + Last_Range) / 2) >= 9.5) AND (SLOPE
      < 0.5)) OR
    (((First_Range + Last_Range) / 2) < 9.3) AND (((First_Range + Last_Range) / 2) > 8.3) AND (SLOPE <
      0.1)) OR
    (((First_Range + Last_Range) / 2) < 8.3) AND (((First_Range + Last_Range) / 2) > 7.3) AND (SLOPE <
      0.15)) OR
    (((First_Range + Last_Range) / 2) < 7.3) AND (SLOPE < 0.2)) OR
    (((Noise_Count_Average) / ((Echo_Count + 10) * 5)) > 0.04))
  THEN DELETE;
END;
IF KCFS GT 7.8 AND KCFS LE 8.5 THEN DO;
  IF (TRACK_TYPE = 1) OR
    (Echo_Count = 4 AND ((Linearity1 / Echo_Count) > 0.4)) OR
    (Echo_Count >= 5 AND Echo_Count <= 7 AND ((Linearity1 / Echo_Count) >= 0.5)) OR
    ((Linearity2 / Echo_Count) > 0.5) OR
    ((First_Range + Last_Range) / 2) > 10.36) OR
    (((First_Range + Last_Range) / 2) < 9.99) AND (((First_Range + Last_Range) / 2) > 9.73) AND (SLOPE
      < 0.85)) OR
    (((First_Range + Last_Range) / 2) < 9.65) AND (((First_Range + Last_Range) / 2) > 8.4) AND (SLOPE
      < 0.1)) OR
    (((First_Range + Last_Range) / 2) < 8.4) AND (((First_Range + Last_Range) / 2) > 7.4) AND (SLOPE <
      0.15)) OR
    (((First_Range + Last_Range) / 2) < 7.4) AND (SLOPE < 0.2)) OR
    (((Noise_Count_Average) / ((Echo_Count + 10) * 5)) > 0.04))
  THEN DELETE;
END;
IF KCFS GT 8.5 AND KCFS LE 9.8 THEN DO;
  IF (TRACK_TYPE = 1) OR
    (Echo_Count = 4 AND ((Linearity1 / Echo_Count) > 0.4)) OR
    (Echo_Count >= 5 AND Echo_Count <= 7 AND ((Linearity1 / Echo_Count) >= 0.5)) OR
    ((Linearity2 / Echo_Count) > 0.5) OR
```

Hydroacoustic Evaluation of Fish Passage through Bonneville Dam in 2004

```

(((First_Range + Last_Range) / 2) > 10.65) OR
(((First_Range + Last_Range) / 2) < 9.7) AND (((First_Range + Last_Range) / 2) > 8.7) AND (SLOPE <
0.1)) OR
(((First_Range + Last_Range) / 2) < 8.7) AND (((First_Range + Last_Range) / 2) > 7.7) AND (SLOPE <
0.15)) OR
(((First_Range + Last_Range) / 2) < 7.7) AND (SLOPE < 0.2)) OR
(((Noise_Count_Average) / ((Echo_Count + 10) * 5)) > 0.04))
THEN DELETE;
END;
IF KCFS GT 9.8 AND KCFS LE 10.8 THEN DO;
IF (TRACK_TYPE = 1) OR
(Echo_Count = 4 AND ((Linearity1 / Echo_Count) > 0.4)) OR
(Echo_Count >= 5 AND Echo_Count <= 7 AND ((Linearity1 / Echo_Count) >= 0.5)) OR
((Linearity2 / Echo_Count) > 0.5) OR
(((First_Range + Last_Range) / 2) > 10.84) OR
(((First_Range + Last_Range) / 2) < 9.5) AND (((First_Range + Last_Range) / 2) > 8.5) AND (SLOPE <
0.1)) OR
(((First_Range + Last_Range) / 2) < 8.5) AND (((First_Range + Last_Range) / 2) > 7.5) AND (SLOPE <
0.15)) OR
(((First_Range + Last_Range) / 2) < 7.5) AND (SLOPE < 0.2)) OR
(((Noise_Count_Average) / ((Echo_Count + 10) * 5)) > 0.04))
THEN DELETE;
END;
IF KCFS GT 10.8 AND KCFS LE 11.8 THEN DO;
IF (TRACK_TYPE = 1) OR
(Echo_Count = 4 AND ((Linearity1 / Echo_Count) > 0.4)) OR
(Echo_Count >= 5 AND Echo_Count <= 7 AND ((Linearity1 / Echo_Count) >= 0.5)) OR
((Linearity2 / Echo_Count) > 0.5) OR
((First_Range + Last_Range) / 2) > 11.03) OR
(((First_Range + Last_Range) / 2) < 10.0) AND (((First_Range + Last_Range) / 2) > 8.5) AND (SLOPE <
< 0.1)) OR
(((First_Range + Last_Range) / 2) < 8.5) AND (((First_Range + Last_Range) / 2) > 7.0) AND (SLOPE <
0.15)) OR
(((First_Range + Last_Range) / 2) < 7.0) AND (SLOPE < 0.2)) OR
(((Noise_Count_Average) / ((Echo_Count + 10) * 5)) > 0.04))
THEN DELETE;
END;
IF KCFS GT 11.8 THEN DO;
IF (TRACK_TYPE = 1) OR
(Echo_Count = 4 AND ((Linearity1 / Echo_Count) > 0.4)) OR
(Echo_Count >= 5 AND Echo_Count <= 7 AND ((Linearity1 / Echo_Count) >= 0.5)) OR
((Linearity2 / Echo_Count) > 0.5) OR
(((First_Range + Last_Range) / 2) > 11.22) OR
(((First_Range + Last_Range) / 2) < 10.0) AND (((First_Range + Last_Range) / 2) > 8.5) AND (SLOPE <
< 0.1)) OR
(((First_Range + Last_Range) / 2) < 8.5) AND (((First_Range + Last_Range) / 2) > 7.0) AND (SLOPE <
0.15)) OR
(((First_Range + Last_Range) / 2) < 7.0) AND (SLOPE < 0.2)) OR
(((Noise_Count_Average) / ((Echo_Count + 10) * 5)) > 0.04))
THEN DELETE;
END;
END;
END;
IF SYSTEM = 'P' THEN DO;
*** CH1 *****;
IF MUX_CHANNEL = 1 THEN DO;
IF KCFS LE 3.3 THEN DO;
IF (TRACK_TYPE = 1) OR
(Echo_Count = 4 AND ((Linearity1 / Echo_Count) > 0.4)) OR
(Echo_Count >= 5 AND Echo_Count <= 7 AND ((Linearity1 / Echo_Count) >= 0.5)) OR
((Linearity2 / Echo_Count) > 0.5) OR
(LINEARITY1>5 AND LINEARITY2>5 AND NOISE_INDEX>=7) OR
((First_Range + Last_Range) / 2) > 9.92) OR
(((First_Range + Last_Range) / 2) <= 9.92) AND (((First_Range + Last_Range) / 2) >= 9.2) AND
(SLOPE < -1)) OR
(((First_Range + Last_Range) / 2) < 9.2) AND (((First_Range + Last_Range) / 2) >= 8.4) AND (SLOPE <
< 0.06)) OR
(((First_Range + Last_Range) / 2) < 8.4) AND (((First_Range + Last_Range) / 2) >= 7.5) AND (SLOPE <
< 0.1)) OR
(((First_Range + Last_Range) / 2) < 7.5) AND (((First_Range + Last_Range) / 2) >= 6) AND (SLOPE <
0.15)) OR
(((First_Range + Last_Range) / 2) < 6) AND (SLOPE < 0.25)) OR
(NOISE_INDEX>=5 AND ((LINEARITY1/ECHO_COUNT)>=0.3)) OR
(SLOPE<-1.5) OR
(SLOPE>2) OR
(((Noise_Count_Average) / ((Echo_Count + 10) * 5)) > 0.04))
THEN DELETE;
END;
IF KCFS GT 3.3 AND KCFS LE 4.3 THEN DO;
IF (TRACK_TYPE = 1) OR

```

Hydroacoustic Evaluation of Fish Passage through Bonneville Dam in 2004

```

(Echo_Count = 4 AND ((Linearity1 / Echo_Count) > 0.4)) OR
(Echo_Count >= 5 AND Echo_Count <= 7 AND ((Linearity1 / Echo_Count) >= 0.5)) OR
((Linearity2 / Echo_Count) > 0.5) OR
(((First_Range + Last_Range) / 2) > 10.04) OR
((((First_Range + Last_Range) / 2) < 9.0) AND (((First_Range + Last_Range) / 2) >= 8.0) AND (SLOPE
< 0.1)) OR
((((First_Range + Last_Range) / 2) < 8.0) AND (((First_Range + Last_Range) / 2) >= 7.0) AND (SLOPE
< 0.15)) OR
((((First_Range + Last_Range) / 2) < 7.0) AND (SLOPE < 0.25)) OR
(SLOPE<-1.5) OR
(SLOPE>2) OR
(((Noise_Count_Average) / ((Echo_Count + 10) * 5)) > 0.04))
THEN DELETE;
END;
IF KCFS GT 4.3 AND KCFS LE 5.3 THEN DO;
IF (TRACK_TYPE = 1) OR
(Echo_Count = 4 AND ((Linearity1 / Echo_Count) > 0.4)) OR
(Echo_Count >= 5 AND Echo_Count <= 7 AND ((Linearity1 / Echo_Count) >= 0.5)) OR
((Linearity2 / Echo_Count) > 0.5) OR
(((First_Range + Last_Range) / 2) > 10.16) OR
((((First_Range + Last_Range) / 2) < 9.2) AND (((First_Range + Last_Range) / 2) >= 8.2) AND (SLOPE
< 0.1)) OR
((((First_Range + Last_Range) / 2) < 8.2) AND (((First_Range + Last_Range) / 2) >= 7.2) AND (SLOPE
< 0.15)) OR
((((First_Range + Last_Range) / 2) < 7.2) AND (SLOPE < 0.25)) OR
(SLOPE<-1.5) OR
(SLOPE>2) OR
(((Noise_Count_Average) / ((Echo_Count + 10) * 5)) > 0.04))
THEN DELETE;
END;
IF KCFS GT 5.3 AND KCFS LE 6.3 THEN DO;
IF (TRACK_TYPE = 1) OR
(Echo_Count = 4 AND ((Linearity1 / Echo_Count) > 0.4)) OR
(Echo_Count >= 5 AND Echo_Count <= 7 AND ((Linearity1 / Echo_Count) >= 0.5)) OR
((Linearity2 / Echo_Count) > 0.5) OR
(((First_Range + Last_Range) / 2) > 10.28) OR
((((First_Range + Last_Range) / 2) < 9.3) AND (((First_Range + Last_Range) / 2) >= 8.3) AND (SLOPE
< 0.1)) OR
((((First_Range + Last_Range) / 2) < 8.3) AND (((First_Range + Last_Range) / 2) >= 7.3) AND (SLOPE
< 0.15)) OR
((((First_Range + Last_Range) / 2) < 7.3) AND (SLOPE < 0.25)) OR
(SLOPE<-1.5) OR
(SLOPE>2) OR
(((Noise_Count_Average) / ((Echo_Count + 10) * 5)) > 0.04))
THEN DELETE;
END;
IF KCFS GT 6.3 THEN DO;
IF (TRACK_TYPE = 1) OR
(Echo_Count = 4 AND ((Linearity1 / Echo_Count) > 0.4)) OR
(Echo_Count >= 5 AND Echo_Count <= 7 AND ((Linearity1 / Echo_Count) >= 0.5)) OR
((Linearity2 / Echo_Count) > 0.5) OR
(((First_Range + Last_Range) / 2) > 10.4) OR
((((First_Range + Last_Range) / 2) <= 10.4) AND (((First_Range + Last_Range) / 2) >= 8.9) AND
(SLOPE > 1)) OR
((((First_Range + Last_Range) / 2) < 9.4) AND (((First_Range + Last_Range) / 2) >= 8.5) AND (SLOPE
< 0.1)) OR
((((First_Range + Last_Range) / 2) < 8.5) AND (((First_Range + Last_Range) / 2) >= 7.5) AND (SLOPE
< 0.15)) OR
((((First_Range + Last_Range) / 2) < 7.5) AND (SLOPE < 0.2)) OR
(SLOPE<-1.5) OR
(SLOPE>2) OR
(((Noise_Count_Average) / ((Echo_Count + 10) * 5)) > 0.04))
THEN DELETE;
END;
END;
*** CH2 *****;
IF MUX_CHANNEL = 2 THEN DO;
IF KCFS LE 3.4 THEN DO;
IF (TRACK_TYPE = 1) OR
(Echo_Count = 4 AND ((Linearity1 / Echo_Count) > 0.4)) OR
(Echo_Count >= 5 AND Echo_Count <= 7 AND ((Linearity1 / Echo_Count) >= 0.5)) OR
((Linearity2 / Echo_Count) > 0.5) OR
(((First_Range + Last_Range) / 2) > 9.87) OR
((((First_Range + Last_Range) / 2) < 9.0) AND (((First_Range + Last_Range) / 2) >= 8.0) AND (SLOPE
< 0.1)) OR
((((First_Range + Last_Range) / 2) < 8.0) AND (((First_Range + Last_Range) / 2) >= 7.0) AND (SLOPE
< 0.15)) OR
((((First_Range + Last_Range) / 2) < 7.0) AND (SLOPE < 0.17)) OR
(((Noise_Count_Average) / ((Echo_Count + 10) * 5)) > 0.04))
THEN DELETE;

```

Hydroacoustic Evaluation of Fish Passage through Bonneville Dam in 2004

```

END;
IF KCFS GT 3.4 AND KCFS LE 5.5 THEN DO;
  IF (TRACK_TYPE = 1) OR
    (Echo_Count = 4 AND ((Linearity1 / Echo_Count) > 0.4)) OR
    (Echo_Count >= 5 AND Echo_Count <= 7 AND ((Linearity1 / Echo_Count) >= 0.5)) OR
    ((Linearity2 / Echo_Count) > 0.5) OR
    (((First_Range + Last_Range) / 2) > 10.11) OR
    (((First_Range + Last_Range) / 2) < 9.11) AND (((First_Range + Last_Range) / 2) >= 8.11) AND
      (SLOPE < 0.1)) OR
    (((First_Range + Last_Range) / 2) < 8.11) AND (((First_Range + Last_Range) / 2) >= 7.11) AND
      (SLOPE < 0.15)) OR
    (((First_Range + Last_Range) / 2) < 7.11) AND (SLOPE < 0.17)) OR
    (((Noise_Count_Average) / ((Echo_Count + 10) * 5)) > 0.04))
  THEN DELETE;
END;
IF KCFS GT 5.5 AND KCFS LE 6.4 THEN DO;
  IF (TRACK_TYPE = 1) OR
    (Echo_Count = 4 AND ((Linearity1 / Echo_Count) > 0.4)) OR
    (Echo_Count >= 5 AND Echo_Count <= 7 AND ((Linearity1 / Echo_Count) >= 0.5)) OR
    ((Linearity2 / Echo_Count) > 0.5) OR
    (((First_Range + Last_Range) / 2) > 10.23) OR
    (((First_Range + Last_Range) / 2) < 9.2) AND (((First_Range + Last_Range) / 2) >= 8.2) AND (SLOPE
      < 0.1)) OR
    (((First_Range + Last_Range) / 2) < 8.2) AND (((First_Range + Last_Range) / 2) >= 7.2) AND (SLOPE
      < 0.15)) OR
    (((First_Range + Last_Range) / 2) < 7.2) AND (SLOPE < 0.2)) OR
    (SLOPE > 2) OR
    (SLOPE < -1) OR
    (((Noise_Count_Average) / ((Echo_Count + 10) * 5)) > 0.04))
  THEN DELETE;
END;
IF KCFS GT 6.4 THEN DO;
  IF (TRACK_TYPE = 1) OR
    (Echo_Count = 4 AND ((Linearity1 / Echo_Count) > 0.4)) OR
    (Echo_Count >= 5 AND Echo_Count <= 7 AND ((Linearity1 / Echo_Count) >= 0.5)) OR
    ((Linearity2 / Echo_Count) > 0.5) OR
    (((First_Range + Last_Range) / 2) > 10.35) OR
    (((First_Range + Last_Range) / 2) < 9.35) AND (((First_Range + Last_Range) / 2) >= 8.35) AND
      (SLOPE < 0.1)) OR
    (((First_Range + Last_Range) / 2) < 8.35) AND (((First_Range + Last_Range) / 2) >= 7.35) AND
      (SLOPE < 0.15)) OR
    (((First_Range + Last_Range) / 2) < 7.35) AND (SLOPE < 0.2)) OR
    (SLOPE > 2) OR
    (SLOPE < -1) OR
    (((Noise_Count_Average) / ((Echo_Count + 10) * 5)) > 0.04))
  THEN DELETE;
END;
END;
*** CH3 *****;
IF MUX_CHANNEL = 3 THEN DO;
  IF KCFS LE 4.3 THEN DO;
    IF (TRACK_TYPE = 1) OR
      (Echo_Count = 4 AND ((Linearity1 / Echo_Count) > 0.4)) OR
      (Echo_Count >= 5 AND Echo_Count <= 7 AND ((Linearity1 / Echo_Count) >= 0.5)) OR
      ((Linearity2 / Echo_Count) > 0.5) OR
      (((First_Range + Last_Range) / 2) > 9.9) OR
      (((First_Range + Last_Range) / 2) < 9.0) AND (((First_Range + Last_Range) / 2) >= 8.0) AND (SLOPE
        < 0.1)) OR
      (((First_Range + Last_Range) / 2) < 8.0) AND (((First_Range + Last_Range) / 2) >= 7.0) AND (SLOPE
        < 0.15)) OR
      (((First_Range + Last_Range) / 2) < 7.0) AND (SLOPE < 0.2)) OR
      (SLOPE > 2) OR
      (SLOPE < -1) OR
      (((Noise_Count_Average) / ((Echo_Count + 10) * 5)) > 0.04))
    THEN DELETE;
  END;
  IF KCFS GT 4.3 AND KCFS LE 5.3 THEN DO;
    IF (TRACK_TYPE = 1) OR
      (Echo_Count = 4 AND ((Linearity1 / Echo_Count) > 0.4)) OR
      (Echo_Count >= 5 AND Echo_Count <= 7 AND ((Linearity1 / Echo_Count) >= 0.5)) OR
      ((Linearity2 / Echo_Count) > 0.5) OR
      (((First_Range + Last_Range) / 2) > 10.04) OR
      (((First_Range + Last_Range) / 2) < 9.0) AND (((First_Range + Last_Range) / 2) >= 8.0) AND (SLOPE
        < 0.1)) OR
      (((First_Range + Last_Range) / 2) < 8.0) AND (((First_Range + Last_Range) / 2) >= 7.0) AND (SLOPE
        < 0.15)) OR
      (((First_Range + Last_Range) / 2) < 7.0) AND (SLOPE < 0.2)) OR
      (SLOPE > 2) OR
      (SLOPE < -1) OR
      (((Noise_Count_Average) / ((Echo_Count + 10) * 5)) > 0.04))
    THEN DELETE;
  END;

```

Hydroacoustic Evaluation of Fish Passage through Bonneville Dam in 2004

```

END;
IF KCFS GT 5.3 AND KCFS LE 6.3 THEN DO;
  IF (TRACK_TYPE = 1) OR
    (Echo_Count = 4 AND ((Linearity1 / Echo_Count) > 0.4)) OR
    (Echo_Count >= 5 AND Echo_Count <= 7 AND ((Linearity1 / Echo_Count) >= 0.5)) OR
    ((Linearity2 / Echo_Count) > 0.5) OR
    (((First_Range + Last_Range) / 2) > 10.18) OR
    (((First_Range + Last_Range) / 2) < 9.2) AND (((First_Range + Last_Range) / 2) >= 8.2) AND (SLOPE
      < 0.1) OR
    (((First_Range + Last_Range) / 2) < 8.2) AND (((First_Range + Last_Range) / 2) >= 7.2) AND (SLOPE
      < 0.15) OR
    (((First_Range + Last_Range) / 2) < 7.2) AND (SLOPE < 0.2) OR
    (SLOPE>2) OR
    (SLOPE<-1) OR
    (((Noise_Count_Average) / ((Echo_Count + 10) * 5)) > 0.04))
  THEN DELETE;
END;
IF KCFS GT 6.3 AND KCFS LE 7.5 THEN DO;
  IF (TRACK_TYPE = 1 AND (((First_Range + Last_Range) / 2) < 9.65)) OR
    (Echo_Count = 4 AND ((Linearity1 / Echo_Count) > 0.4)) OR
    (Echo_Count >= 5 AND Echo_Count <= 7 AND ((Linearity1 / Echo_Count) >= 0.5)) OR
    ((Linearity2 / Echo_Count) > 0.5) OR
    (((First_Range + Last_Range) / 2) > 10.28) OR
    (((First_Range + Last_Range) / 2) < 9.2) AND (((First_Range + Last_Range) / 2) >= 8.2) AND (SLOPE
      < 0.1) OR
    (((First_Range + Last_Range) / 2) < 8.2) AND (((First_Range + Last_Range) / 2) >= 7.2) AND (SLOPE
      < 0.15) OR
    (((First_Range + Last_Range) / 2) < 7.2) AND (SLOPE < 0.2) OR
    (SLOPE>2) OR
    (SLOPE<-1) OR
    (((Noise_Count_Average) / ((Echo_Count + 10) * 5)) > 0.04))
  THEN DELETE;
END;
IF KCFS GT 7.5 THEN DO;
  IF (TRACK_TYPE = 1 AND (((First_Range + Last_Range) / 2) < 9.65)) OR
    (Echo_Count = 4 AND ((Linearity1 / Echo_Count) > 0.4)) OR
    (Echo_Count >= 5 AND Echo_Count <= 7 AND ((Linearity1 / Echo_Count) >= 0.5)) OR
    ((Linearity2 / Echo_Count) > 0.5) OR
    (((First_Range + Last_Range) / 2) > 10.38) OR
    (((First_Range + Last_Range) / 2) < 9.4) AND (((First_Range + Last_Range) / 2) >= 8.4) AND (SLOPE
      < 0.1) OR
    (((First_Range + Last_Range) / 2) < 8.4) AND (((First_Range + Last_Range) / 2) >= 7.4) AND (SLOPE
      < 0.15) OR
    (((First_Range + Last_Range) / 2) < 7.4) AND (SLOPE < 0.2) OR
    (SLOPE>2) OR
    (SLOPE<-1) OR
    (((Noise_Count_Average) / ((Echo_Count + 10) * 5)) > 0.04))
  THEN DELETE;
END;
END;
*** CH4 ****;
IF MUX_CHANNEL = 4 THEN DO;
  IF KCFS LE 4.3 THEN DO;
    IF (TRACK_TYPE = 1) OR
      (Echo_Count = 4 AND ((Linearity1 / Echo_Count) > 0.4)) OR
      (Echo_Count >= 5 AND Echo_Count <= 7 AND ((Linearity1 / Echo_Count) >= 0.5)) OR
      ((Linearity2 / Echo_Count) > 0.5) OR
      (((First_Range + Last_Range) / 2) > 9.96) OR
      (((First_Range + Last_Range) / 2) < 9.0) AND (((First_Range + Last_Range) / 2) >= 8.0) AND (SLOPE
        < 0.1) OR
      (((First_Range + Last_Range) / 2) < 8.0) AND (((First_Range + Last_Range) / 2) >= 7.0) AND (SLOPE
        < 0.15) OR
      (((First_Range + Last_Range) / 2) < 7.0) AND (SLOPE < 0.2) OR
      (SLOPE>2) OR
      (SLOPE<-1) OR
      (((Noise_Count_Average) / ((Echo_Count + 10) * 5)) > 0.04))
    THEN DELETE;
  END;
  IF KCFS GT 4.3 AND KCFS LE 5.3 THEN DO;
    IF (TRACK_TYPE = 1) OR
      (Echo_Count = 4 AND ((Linearity1 / Echo_Count) > 0.4)) OR
      (Echo_Count >= 5 AND Echo_Count <= 7 AND ((Linearity1 / Echo_Count) >= 0.5)) OR
      ((Linearity2 / Echo_Count) > 0.5) OR
      (((First_Range + Last_Range) / 2) > 10.07) OR
      (((First_Range + Last_Range) / 2) < 9.0) AND (((First_Range + Last_Range) / 2) >= 8.0) AND (SLOPE
        < 0.1) OR
      (((First_Range + Last_Range) / 2) < 8.0) AND (((First_Range + Last_Range) / 2) >= 7.0) AND (SLOPE
        < 0.15) OR
      (((First_Range + Last_Range) / 2) < 7.0) AND (SLOPE < 0.2) OR
      (SLOPE>2) OR
    THEN DELETE;
  END;

```

Hydroacoustic Evaluation of Fish Passage through Bonneville Dam in 2004

```

        (SLOPE<-1) OR
        (((Noise_Count_Average) / ((Echo_Count + 10) * 5)) > 0.04))
    THEN DELETE;
END;
IF KCFS GT 5.3 AND KCFS LE 6.3 THEN DO;
    IF (TRACK_TYPE = 1) OR
        (Echo_Count = 4 AND ((Linearity1 / Echo_Count) > 0.4)) OR
        (Echo_Count >= 5 AND Echo_Count <= 7 AND ((Linearity1 / Echo_Count) >= 0.5)) OR
        ((Linearity2 / Echo_Count) > 0.5) OR
        (((First_Range + Last_Range) / 2) > 10.18) OR
        (((First_Range + Last_Range) / 2) < 9.2) AND (((First_Range + Last_Range) / 2) >= 8.2) AND (SLOPE
            < 0.1) OR
        (((First_Range + Last_Range) / 2) < 8.2) AND (((First_Range + Last_Range) / 2) >= 7.2) AND (SLOPE
            < 0.15)) OR
        (((First_Range + Last_Range) / 2) < 7.2) AND (SLOPE < 0.2)) OR
        (SLOPE>2) OR
        (SLOPE<-1) OR
        (((Noise_Count_Average) / ((Echo_Count + 10) * 5)) > 0.04))
    THEN DELETE;
END;
IF KCFS GT 6.3 AND KCFS LE 7.3 THEN DO;
    IF (TRACK_TYPE = 1 AND (((First_Range + Last_Range) / 2) < 9.65)) OR
        (Echo_Count = 4 AND ((Linearity1 / Echo_Count) > 0.4)) OR
        (Echo_Count >= 5 AND Echo_Count <= 7 AND ((Linearity1 / Echo_Count) >= 0.5)) OR
        ((Linearity2 / Echo_Count) > 0.5) OR
        (((First_Range + Last_Range) / 2) > 10.3) OR
        (((First_Range + Last_Range) / 2) < 9.3) AND (((First_Range + Last_Range) / 2) >= 8.3) AND (SLOPE
            < 0.1) OR
        (((First_Range + Last_Range) / 2) < 8.3) AND (((First_Range + Last_Range) / 2) >= 7.3) AND (SLOPE
            < 0.15)) OR
        (((First_Range + Last_Range) / 2) < 7.3) AND (SLOPE < 0.2)) OR
        (SLOPE>2) OR
        (SLOPE<-1) OR
        (((Noise_Count_Average) / ((Echo_Count + 10) * 5)) > 0.04))
    THEN DELETE;
END;
IF KCFS GT 7.3 THEN DO;
    IF (TRACK_TYPE = 1) OR
        (Echo_Count = 4 AND ((Linearity1 / Echo_Count) > 0.4)) OR
        (Echo_Count >= 5 AND Echo_Count <= 7 AND ((Linearity1 / Echo_Count) >= 0.5)) OR
        ((Linearity2 / Echo_Count) > 0.5) OR
        (((First_Range + Last_Range) / 2) > 10.42) OR
        (((First_Range + Last_Range) / 2) < 9.4) AND (((First_Range + Last_Range) / 2) >= 8.4) AND (SLOPE
            < 0.1) OR
        (((First_Range + Last_Range) / 2) < 8.4) AND (((First_Range + Last_Range) / 2) >= 7.4) AND (SLOPE
            < 0.15)) OR
        (((First_Range + Last_Range) / 2) < 7.4) AND (SLOPE < 0.2)) OR
        (SLOPE>2) OR
        (SLOPE<-1) OR
        (((Noise_Count_Average) / ((Echo_Count + 10) * 5)) > 0.04))
    THEN DELETE;
END;
END;
*** CH5 *****;
IF MUX_CHANNEL = 5 THEN DO;
    IF KCFS LE 5.3 THEN DO;
        IF (TRACK_TYPE = 1) OR
            (Echo_Count = 4 AND ((Linearity1 / Echo_Count) > 0.4)) OR
            (Echo_Count >= 5 AND Echo_Count <= 7 AND ((Linearity1 / Echo_Count) >= 0.5)) OR
            ((Linearity2 / Echo_Count) > 0.5) OR
            (((First_Range + Last_Range) / 2) > 10.15) OR
            (((First_Range + Last_Range) / 2) < 9.2) AND (((First_Range + Last_Range) / 2) >= 8.2) AND (SLOPE
                < 0.1) OR
            (((First_Range + Last_Range) / 2) < 8.2) AND (((First_Range + Last_Range) / 2) >= 7.2) AND (SLOPE
                < 0.15)) OR
            (((First_Range + Last_Range) / 2) < 7.2) AND (SLOPE < 0.2)) OR
            (SLOPE>2) OR
            (SLOPE<-1) OR
            (((Noise_Count_Average) / ((Echo_Count + 10) * 5)) > 0.04))
        THEN DELETE;
    END;
    IF KCFS GT 5.3 AND KCFS LE 6.3 THEN DO;
        IF (TRACK_TYPE = 1) OR
            (Echo_Count = 4 AND ((Linearity1 / Echo_Count) > 0.4)) OR
            (Echo_Count >= 5 AND Echo_Count <= 7 AND ((Linearity1 / Echo_Count) >= 0.5)) OR
            ((Linearity2 / Echo_Count) > 0.5) OR
            (((First_Range + Last_Range) / 2) > 10.30) OR
            (((First_Range + Last_Range) / 2) < 9.3) AND (((First_Range + Last_Range) / 2) >= 8.3) AND (SLOPE
                < 0.1) OR
            (((First_Range + Last_Range) / 2) < 8.3) AND (((First_Range + Last_Range) / 2) >= 7.3) AND (SLOPE
                < 0.15)) OR

```

Hydroacoustic Evaluation of Fish Passage through Bonneville Dam in 2004

```

        (((First_Range + Last_Range) / 2) < 7.3) AND (SLOPE < 0.2)) OR
        (SLOPE>2) OR
        (SLOPE<-1) OR
        (((Noise_Count_Average) / ((Echo_Count + 10) * 5)) > 0.04))
    THEN DELETE;
END;
IF KCFS GT 6.3 AND KCFS LE 7.3 THEN DO;
    IF (TRACK_TYPE = 1) OR
        (Echo_Count = 4 AND ((Linearity1 / Echo_Count) > 0.4)) OR
        (Echo_Count >= 5 AND Echo_Count <= 7 AND ((Linearity1 / Echo_Count) >= 0.5)) OR
        ((Linearity2 / Echo_Count) > 0.5) OR
        (((First_Range + Last_Range) / 2) > 10.46) OR
        (((First_Range + Last_Range) / 2) < 9.5) AND (((First_Range + Last_Range) / 2) >= 8.5) AND (SLOPE
            < 0.1) OR
        (((First_Range + Last_Range) / 2) < 8.5) AND (((First_Range + Last_Range) / 2) >= 7.5) AND (SLOPE
            < 0.15)) OR
        (((First_Range + Last_Range) / 2) < 7.5) AND (SLOPE < 0.2)) OR
        (SLOPE>2) OR
        (SLOPE<-1) OR
        (((Noise_Count_Average) / ((Echo_Count + 10) * 5)) > 0.04))
    THEN DELETE;
END;
IF KCFS GT 7.3 AND KCFS LE 8.3 THEN DO;
    IF (TRACK_TYPE = 1) OR
        (Echo_Count = 4 AND ((Linearity1 / Echo_Count) > 0.4)) OR
        (Echo_Count >= 5 AND Echo_Count <= 7 AND ((Linearity1 / Echo_Count) >= 0.5)) OR
        ((Linearity2 / Echo_Count) > 0.5) OR
        (((First_Range + Last_Range) / 2) > 10.62) OR
        (((First_Range + Last_Range) / 2) < 9.6) AND (((First_Range + Last_Range) / 2) >= 8.6) AND (SLOPE
            < 0.1) OR
        (((First_Range + Last_Range) / 2) < 8.6) AND (((First_Range + Last_Range) / 2) >= 7.6) AND (SLOPE
            < 0.15)) OR
        (((First_Range + Last_Range) / 2) < 7.6) AND (SLOPE < 0.2)) OR
        (SLOPE>2) OR
        (SLOPE<-1) OR
        (((Noise_Count_Average) / ((Echo_Count + 10) * 5)) > 0.04))
    THEN DELETE;
END;
IF KCFS GT 8.3 THEN DO;
    IF ((TRACK_TYPE = 1) AND (SLOPE < 0.8)) OR
        (Echo_Count = 4 AND ((Linearity1 / Echo_Count) > 0.4)) OR
        (Echo_Count >= 5 AND Echo_Count <= 7 AND ((Linearity1 / Echo_Count) >= 0.5)) OR
        ((Linearity2 / Echo_Count) > 0.5) OR
        (((First_Range + Last_Range) / 2) > 10.77) OR
        (((First_Range + Last_Range) / 2) < 9.8) AND (((First_Range + Last_Range) / 2) >= 8.8) AND (SLOPE
            < 0.1) OR
        (((First_Range + Last_Range) / 2) < 8.8) AND (((First_Range + Last_Range) / 2) >= 7.8) AND (SLOPE
            < 0.15)) OR
        (((First_Range + Last_Range) / 2) < 7.8) AND (SLOPE < 0.2)) OR
        (SLOPE<-1.5) OR
        (SLOPE>3) OR
        (((Noise_Count_Average) / ((Echo_Count + 10) * 5)) > 0.04))
    THEN DELETE;
END;
END;
END;
IF SYSTEM = 'Q' THEN DO;
    *** CH1 *****;
    IF MUX_CHANNEL = 1 THEN DO;
        IF KCFS LE 3.2 THEN DO;
            IF (TRACK_TYPE = 1) OR
                (Echo_Count = 4 AND ((Linearity1 / Echo_Count) > 0.4)) OR
                (Echo_Count >= 5 AND Echo_Count <= 7 AND ((Linearity1 / Echo_Count) >= 0.5)) OR
                ((Linearity2 / Echo_Count) > 0.5) OR
                (LINEARITY1=0 AND LINEARITY2=0 AND SLOPE=0) OR
                (((First_Range + Last_Range) / 2) > 9.72) OR
                (((First_Range + Last_Range) / 2) < 9.25) AND (((First_Range + Last_Range) / 2) >= 8.25) AND
                    (SLOPE < 0.1)) OR
                (((First_Range + Last_Range) / 2) < 8.25) AND (((First_Range + Last_Range) / 2) >= 7.25) AND
                    (SLOPE < 0.15)) OR
                (((First_Range + Last_Range) / 2) < 7.25) AND (SLOPE < 0.2)) OR
                (SLOPE>2) OR
                (SLOPE<-1) OR
                (((Noise_Count_Average) / ((Echo_Count + 10) * 5)) > 0.04))
            THEN DELETE;
        END;
    END;
    IF KCFS GT 3.2 AND KCFS LE 5.4 THEN DO;
        IF (TRACK_TYPE = 1) OR
            (Echo_Count = 4 AND ((Linearity1 / Echo_Count) > 0.4)) OR
            (Echo_Count >= 5 AND Echo_Count <= 7 AND ((Linearity1 / Echo_Count) >= 0.5)) OR

```

Hydroacoustic Evaluation of Fish Passage through Bonneville Dam in 2004

```

        ((Linearity2 / Echo_Count) > 0.5) OR
        (((First_Range + Last_Range) / 2) > 9.97) OR
        (((First_Range + Last_Range) / 2) < 9.2) AND (((First_Range + Last_Range) / 2) >= 8.2) AND (SLOPE
        < 0.1) OR
        (((First_Range + Last_Range) / 2) < 8.2) AND (((First_Range + Last_Range) / 2) >= 7.2) AND (SLOPE
        < 0.15)) OR
        (((First_Range + Last_Range) / 2) < 7.2) AND (SLOPE < 0.2) OR
        (SLOPE>2) OR
        (SLOPE<-1) OR
        (((Noise_Count_Average) / ((Echo_Count + 10) * 5)) > 0.04))
    THEN DELETE;
END;
IF KCFS GT 5.4 AND KCFS LE 7.4 THEN DO;
    IF (TRACK_TYPE = 1) OR
        (Echo_Count = 4 AND ((Linearity1 / Echo_Count) > 0.4)) OR
        (Echo_Count >= 5 AND Echo_Count <= 7 AND ((Linearity1 / Echo_Count) >= 0.5)) OR
        ((Linearity2 / Echo_Count) > 0.5) OR
        (((First_Range + Last_Range) / 2) > 10.22) OR
        (((First_Range + Last_Range) / 2) < 9.2) AND (((First_Range + Last_Range) / 2) >= 8.2) AND (SLOPE
        < 0.1) OR
        (((First_Range + Last_Range) / 2) < 8.2) AND (((First_Range + Last_Range) / 2) >= 7.2) AND (SLOPE
        < 0.15)) OR
        (((First_Range + Last_Range) / 2) < 7.2) AND (SLOPE < 0.2) OR
        (SLOPE>3) OR
        (SLOPE<-1) OR
        (((Noise_Count_Average) / ((Echo_Count + 10) * 5)) > 0.04))
    THEN DELETE;
END;
IF KCFS GT 7.4 THEN DO;
    IF (TRACK_TYPE = 1) OR
        (Echo_Count = 4 AND ((Linearity1 / Echo_Count) > 0.4)) OR
        (Echo_Count >= 5 AND Echo_Count <= 7 AND ((Linearity1 / Echo_Count) >= 0.5)) OR
        ((Linearity2 / Echo_Count) > 0.5) OR
        (((First_Range + Last_Range) / 2) > 10.47) OR
        (((First_Range + Last_Range) / 2) < 9.5) AND (((First_Range + Last_Range) / 2) >= 8.5) AND (SLOPE
        < 0.1) OR
        (((First_Range + Last_Range) / 2) < 8.5) AND (((First_Range + Last_Range) / 2) >= 7.5) AND (SLOPE
        < 0.15)) OR
        (((First_Range + Last_Range) / 2) < 7.5) AND (SLOPE < 0.2) OR
        (SLOPE>3) OR
        (SLOPE<-1) OR
        (((Noise_Count_Average) / ((Echo_Count + 10) * 5)) > 0.04))
    THEN DELETE;
END;
END;
END;
*** CH2 *****;
IF MUX_CHANNEL = 2 THEN DO;
    IF KCFS LE 5.3 THEN DO;
        IF (TRACK_TYPE = 1) OR
            (Echo_Count = 4 AND ((Linearity1 / Echo_Count) > 0.4)) OR
            (Echo_Count >= 5 AND Echo_Count <= 7 AND ((Linearity1 / Echo_Count) >= 0.5)) OR
            ((Linearity2 / Echo_Count) > 0.5) OR
            (((First_Range + Last_Range) / 2) > 9.97) OR
            (((First_Range + Last_Range) / 2) < 9.2) AND (((First_Range + Last_Range) / 2) >= 8.2) AND (SLOPE
            < 0.1) OR
            (((First_Range + Last_Range) / 2) < 8.2) AND (((First_Range + Last_Range) / 2) >= 7.2) AND (SLOPE
            < 0.15)) OR
            (((First_Range + Last_Range) / 2) < 7.2) AND (SLOPE < 0.2) OR
            (SLOPE>2) OR
            (SLOPE<-1) OR
            (((Noise_Count_Average) / ((Echo_Count + 10) * 5)) > 0.04))
        THEN DELETE;
    END;
    IF KCFS GT 5.3 AND KCFS LE 6.3 THEN DO;
        IF (TRACK_TYPE = 1) OR
            (Echo_Count = 4 AND ((Linearity1 / Echo_Count) > 0.4)) OR
            (Echo_Count >= 5 AND Echo_Count <= 7 AND ((Linearity1 / Echo_Count) >= 0.5)) OR
            ((Linearity2 / Echo_Count) > 0.5) OR
            (((First_Range + Last_Range) / 2) > 10.14) OR
            (((First_Range + Last_Range) / 2) < 9.2) AND (((First_Range + Last_Range) / 2) >= 8.2) AND (SLOPE
            < 0.1) OR
            (((First_Range + Last_Range) / 2) < 8.2) AND (((First_Range + Last_Range) / 2) >= 7.2) AND (SLOPE
            < 0.15)) OR
            (((First_Range + Last_Range) / 2) < 7.2) AND (SLOPE < 0.2) OR
            (SLOPE>2) OR
            (SLOPE<-1) OR
            (((Noise_Count_Average) / ((Echo_Count + 10) * 5)) > 0.04))
        THEN DELETE;
    END;
    IF KCFS GT 6.3 AND KCFS LE 7.5 THEN DO;

```

Hydroacoustic Evaluation of Fish Passage through Bonneville Dam in 2004

```

IF (TRACK_TYPE = 1) OR
(Echo_Count = 4 AND ((Linearity1 / Echo_Count) > 0.4)) OR
(Echo_Count >= 5 AND Echo_Count <= 7 AND ((Linearity1 / Echo_Count) >= 0.5)) OR
((Linearity2 / Echo_Count) > 0.5) OR
(((First_Range + Last_Range) / 2) > 10.3) OR
((((First_Range + Last_Range) / 2) < 9.3) AND (((First_Range + Last_Range) / 2) >= 8.3) AND (SLOPE
< 0.1)) OR
((((First_Range + Last_Range) / 2) < 8.3) AND (((First_Range + Last_Range) / 2) >= 7.3) AND (SLOPE
< 0.15)) OR
((((First_Range + Last_Range) / 2) < 7.3) AND (SLOPE < 0.2)) OR
(SLOPE>3) OR
(SLOPE<-1) OR
((((Noise_Count_Average) / ((Echo_Count + 10) * 5)) > 0.04))
THEN DELETE;
END;
IF KCFS GT 7.5 AND KCFS LE 8.7 THEN DO;
IF (TRACK_TYPE = 1) OR
(Echo_Count = 4 AND ((Linearity1 / Echo_Count) > 0.4)) OR
(Echo_Count >= 5 AND Echo_Count <= 7 AND ((Linearity1 / Echo_Count) >= 0.5)) OR
((Linearity2 / Echo_Count) > 0.5) OR
(((First_Range + Last_Range) / 2) > 10.54) OR
((((First_Range + Last_Range) / 2) < 9.5) AND (((First_Range + Last_Range) / 2) >= 8.5) AND (SLOPE
< 0.1)) OR
((((First_Range + Last_Range) / 2) < 8.5) AND (((First_Range + Last_Range) / 2) >= 7.5) AND (SLOPE
< 0.15)) OR
((((First_Range + Last_Range) / 2) < 7.5) AND (SLOPE < 0.2)) OR
(SLOPE>3) OR
(SLOPE<-1) OR
((((Noise_Count_Average) / ((Echo_Count + 10) * 5)) > 0.04))
THEN DELETE;
END;
IF KCFS GT 8.7 THEN DO;
IF ((TRACK_TYPE = 1) AND (SLOPE < 0.8)) OR
(Echo_Count = 4 AND ((Linearity1 / Echo_Count) > 0.4)) OR
(Echo_Count >= 5 AND Echo_Count <= 7 AND ((Linearity1 / Echo_Count) >= 0.5)) OR
((Linearity2 / Echo_Count) > 0.5) OR
(((First_Range + Last_Range) / 2) > 10.77) OR
((((First_Range + Last_Range) / 2) < 9.8) AND (((First_Range + Last_Range) / 2) >= 8.8) AND (SLOPE
< 0.1)) OR
((((First_Range + Last_Range) / 2) < 8.8) AND (((First_Range + Last_Range) / 2) >= 7.8) AND (SLOPE
< 0.15)) OR
((((First_Range + Last_Range) / 2) < 7.8) AND (SLOPE < 0.2)) OR
(SLOPE<-1.5) OR
(SLOPE>3) OR
((((Noise_Count_Average) / ((Echo_Count + 10) * 5)) > 0.04))
THEN DELETE;
END;
END;
*** CH3 *****;
IF MUX_CHANNEL = 3 THEN DO;
IF KCFS LE 5.3 THEN DO;
IF (TRACK_TYPE = 1) OR
(Echo_Count = 4 AND ((Linearity1 / Echo_Count) > 0.4)) OR
(Echo_Count >= 5 AND Echo_Count <= 7 AND ((Linearity1 / Echo_Count) >= 0.5)) OR
((Linearity2 / Echo_Count) > 0.5) OR
(((First_Range + Last_Range) / 2) > 9.97) OR
((((First_Range + Last_Range) / 2) < 9.2) AND (((First_Range + Last_Range) / 2) >= 8.2) AND (SLOPE
< 0.1)) OR
((((First_Range + Last_Range) / 2) < 8.2) AND (((First_Range + Last_Range) / 2) >= 7.2) AND (SLOPE
< 0.15)) OR
((((First_Range + Last_Range) / 2) < 7.2) AND (SLOPE < 0.2)) OR
(SLOPE>2) OR
(SLOPE<-1) OR
((((Noise_Count_Average) / ((Echo_Count + 10) * 5)) > 0.04))
THEN DELETE;
END;
IF KCFS GT 5.3 AND KCFS LE 6.3 THEN DO;
IF (TRACK_TYPE = 1) OR
(Echo_Count = 4 AND ((Linearity1 / Echo_Count) > 0.4)) OR
(Echo_Count >= 5 AND Echo_Count <= 7 AND ((Linearity1 / Echo_Count) >= 0.5)) OR
((Linearity2 / Echo_Count) > 0.5) OR
(((First_Range + Last_Range) / 2) > 10.14) OR
((((First_Range + Last_Range) / 2) < 9.2) AND (((First_Range + Last_Range) / 2) >= 8.2) AND (SLOPE
< 0.1)) OR
((((First_Range + Last_Range) / 2) < 8.2) AND (((First_Range + Last_Range) / 2) >= 7.2) AND (SLOPE
< 0.15)) OR
((((First_Range + Last_Range) / 2) < 7.2) AND (SLOPE < 0.2)) OR
(SLOPE>2) OR
(SLOPE<-1) OR
((((Noise_Count_Average) / ((Echo_Count + 10) * 5)) > 0.04))
THEN DELETE;

```

Hydroacoustic Evaluation of Fish Passage through Bonneville Dam in 2004

```

END;
IF KCFS GT 6.3 AND KCFS LE 7.3 THEN DO;
  IF (TRACK_TYPE = 1) OR
    (Echo_Count = 4 AND ((Linearity1 / Echo_Count) > 0.4)) OR
    (Echo_Count >= 5 AND Echo_Count <= 7 AND ((Linearity1 / Echo_Count) >= 0.5)) OR
    ((Linearity2 / Echo_Count) > 0.5) OR
    (((First_Range + Last_Range) / 2) > 10.32) OR
    (((First_Range + Last_Range) / 2) < 9.3) AND (((First_Range + Last_Range) / 2) >= 8.3) AND (SLOPE
      < 0.1) OR
    (((First_Range + Last_Range) / 2) < 8.3) AND (((First_Range + Last_Range) / 2) >= 7.3) AND (SLOPE
      < 0.15) OR
    (((First_Range + Last_Range) / 2) < 7.3) AND (SLOPE < 0.2) OR
    (SLOPE>3) OR
    (SLOPE<-1) OR
    (((Noise_Count_Average) / ((Echo_Count + 10) * 5)) > 0.04))
  THEN DELETE;
END;
IF KCFS GT 7.3 AND KCFS LE 8.3 THEN DO;
  IF (TRACK_TYPE = 1) OR
    (Echo_Count = 4 AND ((Linearity1 / Echo_Count) > 0.4)) OR
    (Echo_Count >= 5 AND Echo_Count <= 7 AND ((Linearity1 / Echo_Count) >= 0.5)) OR
    ((Linearity2 / Echo_Count) > 0.5) OR
    (((First_Range + Last_Range) / 2) > 10.49) OR
    (((First_Range + Last_Range) / 2) < 9.5) AND (((First_Range + Last_Range) / 2) >= 8.5) AND (SLOPE
      < 0.1) OR
    (((First_Range + Last_Range) / 2) < 8.5) AND (((First_Range + Last_Range) / 2) >= 7.5) AND (SLOPE
      < 0.15) OR
    (((First_Range + Last_Range) / 2) < 7.5) AND (SLOPE < 0.2) OR
    (SLOPE>3) OR
    (SLOPE<-1) OR
    (((Noise_Count_Average) / ((Echo_Count + 10) * 5)) > 0.04))
  THEN DELETE;
END;
IF KCFS GT 8.3 THEN DO;
  IF (TRACK_TYPE = 1) OR
    (Echo_Count = 4 AND ((Linearity1 / Echo_Count) > 0.4)) OR
    (Echo_Count >= 5 AND Echo_Count <= 7 AND ((Linearity1 / Echo_Count) >= 0.5)) OR
    ((Linearity2 / Echo_Count) > 0.5) OR
    (((First_Range + Last_Range) / 2) > 10.77) OR
    (((First_Range + Last_Range) / 2) < 9.5) AND (((First_Range + Last_Range) / 2) >= 8.8) AND (SLOPE
      < 0.1) OR
    (((First_Range + Last_Range) / 2) < 8.8) AND (((First_Range + Last_Range) / 2) >= 7.8) AND (SLOPE
      < 0.15) OR
    (((First_Range + Last_Range) / 2) < 7.8) AND (SLOPE < 0.2) OR
    (SLOPE<-1.5) OR
    (SLOPE>3) OR
    (((Noise_Count_Average) / ((Echo_Count + 10) * 5)) > 0.04))
  THEN DELETE;
END;
END;
*** CH4 *****;
IF MUX_CHANNEL = 4 THEN DO;
  IF KCFS LE 4.3 THEN DO;
    IF (TRACK_TYPE = 1) OR
      (Echo_Count = 4 AND ((Linearity1 / Echo_Count) > 0.4)) OR
      (Echo_Count >= 5 AND Echo_Count <= 7 AND ((Linearity1 / Echo_Count) >= 0.5)) OR
      ((Linearity2 / Echo_Count) > 0.5) OR
      ((First_Range + Last_Range) / 2) > 9.96) OR
      (((First_Range + Last_Range) / 2) < 9.0) AND (((First_Range + Last_Range) / 2) >= 8.0) AND (SLOPE
        < 0.1) OR
      (((First_Range + Last_Range) / 2) < 8.0) AND (((First_Range + Last_Range) / 2) >= 7.0) AND (SLOPE
        < 0.15) OR
      (((First_Range + Last_Range) / 2) < 7.0) AND (SLOPE < 0.2) OR
      (SLOPE>2) OR
      (SLOPE<-1) OR
      (((Noise_Count_Average) / ((Echo_Count + 10) * 5)) > 0.04))
    THEN DELETE;
  END;
  IF KCFS GT 4.3 AND KCFS LE 5.3 THEN DO;
    IF (TRACK_TYPE = 1) OR
      (Echo_Count = 4 AND ((Linearity1 / Echo_Count) > 0.4)) OR
      (Echo_Count >= 5 AND Echo_Count <= 7 AND ((Linearity1 / Echo_Count) >= 0.5)) OR
      ((Linearity2 / Echo_Count) > 0.5) OR
      (((First_Range + Last_Range) / 2) > 10.07) OR
      (((First_Range + Last_Range) / 2) < 9.0) AND (((First_Range + Last_Range) / 2) >= 8.0) AND (SLOPE
        < 0.1) OR
      (((First_Range + Last_Range) / 2) < 8.0) AND (((First_Range + Last_Range) / 2) >= 7.0) AND (SLOPE
        < 0.15) OR
      (((First_Range + Last_Range) / 2) < 7.0) AND (SLOPE < 0.2) OR
      (SLOPE>2) OR
    THEN DELETE;
  END;

```

Hydroacoustic Evaluation of Fish Passage through Bonneville Dam in 2004

```

        (SLOPE<-1) OR
        (((Noise_Count_Average) / ((Echo_Count + 10) * 5)) > 0.04))
    THEN DELETE;
END;
IF KCFS GT 5.3 AND KCFS LE 6.3 THEN DO;
    IF (TRACK_TYPE = 1) OR
        (Echo_Count = 4 AND ((Linearity1 / Echo_Count) > 0.4)) OR
        (Echo_Count >= 5 AND Echo_Count <= 7 AND ((Linearity1 / Echo_Count) >= 0.5)) OR
        ((Linearity2 / Echo_Count) > 0.5) OR
        (((First_Range + Last_Range) / 2) > 10.19) OR
        (((First_Range + Last_Range) / 2) < 9.2) AND (((First_Range + Last_Range) / 2) >= 8.2) AND (SLOPE
            < 0.1) OR
        (((First_Range + Last_Range) / 2) < 8.2) AND (((First_Range + Last_Range) / 2) >= 7.2) AND (SLOPE
            < 0.15)) OR
        (((First_Range + Last_Range) / 2) < 7.2) AND (SLOPE < 0.2)) OR
        (SLOPE>2) OR
        (SLOPE<-1) OR
        (((Noise_Count_Average) / ((Echo_Count + 10) * 5)) > 0.04))
    THEN DELETE;
END;
IF KCFS GT 6.3 AND KCFS LE 7.3 THEN DO;
    IF (TRACK_TYPE = 1) OR
        (Echo_Count = 4 AND ((Linearity1 / Echo_Count) > 0.4)) OR
        (Echo_Count >= 5 AND Echo_Count <= 7 AND ((Linearity1 / Echo_Count) >= 0.5)) OR
        ((Linearity2 / Echo_Count) > 0.5) OR
        (((First_Range + Last_Range) / 2) > 10.3) OR
        (((First_Range + Last_Range) / 2) < 9.3) AND (((First_Range + Last_Range) / 2) >= 8.3) AND (SLOPE
            < 0.1) OR
        (((First_Range + Last_Range) / 2) < 8.3) AND (((First_Range + Last_Range) / 2) >= 7.3) AND (SLOPE
            < 0.15)) OR
        (((First_Range + Last_Range) / 2) < 7.3) AND (SLOPE < 0.2)) OR
        (SLOPE>3) OR
        (SLOPE<-1) OR
        (((Noise_Count_Average) / ((Echo_Count + 10) * 5)) > 0.04))
    THEN DELETE;
END;
IF KCFS GT 7.3 THEN DO;
    IF (TRACK_TYPE = 1) OR
        (Echo_Count = 4 AND ((Linearity1 / Echo_Count) > 0.4)) OR
        (Echo_Count >= 5 AND Echo_Count <= 7 AND ((Linearity1 / Echo_Count) >= 0.5)) OR
        ((Linearity2 / Echo_Count) > 0.5) OR
        (((First_Range + Last_Range) / 2) > 10.5) OR
        (((First_Range + Last_Range) / 2) < 9.5) AND (((First_Range + Last_Range) / 2) >= 8.5) AND (SLOPE
            < 0.1) OR
        (((First_Range + Last_Range) / 2) < 8.5) AND (((First_Range + Last_Range) / 2) >= 7.5) AND (SLOPE
            < 0.15)) OR
        (((First_Range + Last_Range) / 2) < 7.5) AND (SLOPE < 0.2)) OR
        (SLOPE>3) OR
        (SLOPE<-1) OR
        (((Noise_Count_Average) / ((Echo_Count + 10) * 5)) > 0.04))
    THEN DELETE;
END;
END;
*** CH5 *****;
IF MUX_CHANNEL = 5 THEN DO;
    IF KCFS LE 3.3 THEN DO;
        IF (TRACK_TYPE = 1) OR
            (Echo_Count = 4 AND ((Linearity1 / Echo_Count) > 0.4)) OR
            (Echo_Count >= 5 AND Echo_Count <= 7 AND ((Linearity1 / Echo_Count) >= 0.5)) OR
            ((Linearity2 / Echo_Count) > 0.5) OR
            (((First_Range + Last_Range) / 2) > 9.72) OR
            (((First_Range + Last_Range) / 2) < 9.0) AND (((First_Range + Last_Range) / 2) >= 8.5) AND (SLOPE
                < 0.1) OR
            (((First_Range + Last_Range) / 2) < 8.5) AND (((First_Range + Last_Range) / 2) >= 7.5) AND (SLOPE
                < 0.15)) OR
            (((First_Range + Last_Range) / 2) < 7.5) AND (SLOPE < 0.2)) OR
            (SLOPE>2) OR
            (SLOPE<-1) OR
            (((Noise_Count_Average) / ((Echo_Count + 10) * 5)) > 0.04))
        THEN DELETE;
    END;
    IF KCFS GT 3.3 AND KCFS LE 4.3 THEN DO;
        IF (TRACK_TYPE = 1) OR
            (Echo_Count = 4 AND ((Linearity1 / Echo_Count) > 0.4)) OR
            (Echo_Count >= 5 AND Echo_Count <= 7 AND ((Linearity1 / Echo_Count) >= 0.5)) OR
            ((Linearity2 / Echo_Count) > 0.5) OR
            (((First_Range + Last_Range) / 2) > 9.87) OR
            (((First_Range + Last_Range) / 2) < 9.0) AND (((First_Range + Last_Range) / 2) >= 8.0) AND (SLOPE
                < 0.1) OR
            (((First_Range + Last_Range) / 2) < 8.0) AND (((First_Range + Last_Range) / 2) >= 7.0) AND (SLOPE
                < 0.15)) OR

```

Hydroacoustic Evaluation of Fish Passage through Bonneville Dam in 2004

```

        (((First_Range + Last_Range) / 2) < 7.0) AND (SLOPE < 0.2)) OR
        (SLOPE>2) OR
        (SLOPE<-1) OR
        (((Noise_Count_Average) / ((Echo_Count + 10) * 5)) > 0.04))
    THEN DELETE;
END;
IF KCFS GT 4.3 AND KCFS LE 5.3 THEN DO;
    IF (TRACK_TYPE = 1) OR
        (Echo_Count = 4 AND ((Linearity1 / Echo_Count) > 0.4)) OR
        (Echo_Count >= 5 AND Echo_Count <= 7 AND ((Linearity1 / Echo_Count) >= 0.5)) OR
        ((Linearity2 / Echo_Count) > 0.5) OR
        (((First_Range + Last_Range) / 2) > 10.01) OR
        (((First_Range + Last_Range) / 2) < 9.0) AND (((First_Range + Last_Range) / 2) >= 8.0) AND (SLOPE
            < 0.1) OR
        (((First_Range + Last_Range) / 2) < 8.0) AND (((First_Range + Last_Range) / 2) >= 7.0) AND (SLOPE
            < 0.15)) OR
        (((First_Range + Last_Range) / 2) < 7.0) AND (SLOPE < 0.2)) OR
        (SLOPE>2) OR
        (SLOPE<-1) OR
        (((Noise_Count_Average) / ((Echo_Count + 10) * 5)) > 0.04))
    THEN DELETE;
END;
IF KCFS GT 5.3 AND KCFS LE 6.3 THEN DO;
    IF (TRACK_TYPE = 1) OR
        (Echo_Count = 4 AND ((Linearity1 / Echo_Count) > 0.4)) OR
        (Echo_Count >= 5 AND Echo_Count <= 7 AND ((Linearity1 / Echo_Count) >= 0.5)) OR
        ((Linearity2 / Echo_Count) > 0.5) OR
        (((First_Range + Last_Range) / 2) > 10.16) OR
        (((First_Range + Last_Range) / 2) < 9.2) AND (((First_Range + Last_Range) / 2) >= 8.2) AND (SLOPE
            < 0.1) OR
        (((First_Range + Last_Range) / 2) < 8.2) AND (((First_Range + Last_Range) / 2) >= 7.2) AND (SLOPE
            < 0.15)) OR
        (((First_Range + Last_Range) / 2) < 7.2) AND (SLOPE < 0.2)) OR
        (SLOPE>2) OR
        (SLOPE<-1) OR
        (((Noise_Count_Average) / ((Echo_Count + 10) * 5)) > 0.04))
    THEN DELETE;
END;
IF KCFS GT 6.3 AND KCFS LE 7.3 THEN DO;
    IF (TRACK_TYPE = 1) OR
        (Echo_Count = 4 AND ((Linearity1 / Echo_Count) > 0.4)) OR
        (Echo_Count >= 5 AND Echo_Count <= 7 AND ((Linearity1 / Echo_Count) >= 0.5)) OR
        ((Linearity2 / Echo_Count) > 0.5) OR
        (((First_Range + Last_Range) / 2) > 10.3) OR
        (((First_Range + Last_Range) / 2) < 9.3) AND (((First_Range + Last_Range) / 2) >= 8.3) AND (SLOPE
            < 0.1) OR
        (((First_Range + Last_Range) / 2) < 8.3) AND (((First_Range + Last_Range) / 2) >= 7.3) AND (SLOPE
            < 0.15)) OR
        (((First_Range + Last_Range) / 2) < 7.3) AND (SLOPE < 0.2)) OR
        (SLOPE>2) OR
        (SLOPE<-1) OR
        (((Noise_Count_Average) / ((Echo_Count + 10) * 5)) > 0.04))
    THEN DELETE;
END;
IF KCFS GT 7.3 THEN DO;
    IF (TRACK_TYPE = 1) OR
        (Echo_Count = 4 AND ((Linearity1 / Echo_Count) > 0.4)) OR
        (Echo_Count >= 5 AND Echo_Count <= 7 AND ((Linearity1 / Echo_Count) >= 0.5)) OR
        ((Linearity2 / Echo_Count) > 0.5) OR
        (((First_Range + Last_Range) / 2) > 10.5) OR
        (((First_Range + Last_Range) / 2) < 9.5) AND (((First_Range + Last_Range) / 2) >= 8.5) AND (SLOPE
            < 0.1) OR
        (((First_Range + Last_Range) / 2) < 8.5) AND (((First_Range + Last_Range) / 2) >= 7.5) AND (SLOPE
            < 0.15)) OR
        (((First_Range + Last_Range) / 2) < 7.5) AND (SLOPE < 0.2)) OR
        (SLOPE>2) OR
        (SLOPE<-1) OR
        (((Noise_Count_Average) / ((Echo_Count + 10) * 5)) > 0.04))
    THEN DELETE;
END;
END;
END;
IF SYSTEM='E' THEN DO;
    IF MUX_CHANNEL EQ 1 OR MUX_CHANNEL EQ 3 OR MUX_CHANNEL EQ 5 THEN DO;
        IF
            (ECHO_COUNT <6) OR
            (Echo_Count = 4 AND ((Linearity1 / Echo_Count) > 0.4)) OR
            (Echo_Count >= 5 AND Echo_Count <= 7 AND ((Linearity1 / Echo_Count) >= 0.5)) OR
            ((Linearity2 / Echo_Count) > 0.5) OR
            (((Noise_Count_Average) / ((Echo_Count + 10) * 5)) > 0.04)) OR

```

Hydroacoustic Evaluation of Fish Passage through Bonneville Dam in 2004

```
NOISE_COUNT_AVERAGE > 2.5 OR

(SLOPE >= 2.5 OR SLOPE <= -2.5) OR
(First_Range < 8.50 AND Slope < 0.5) OR
(First_Range >= 8.50 AND First_Range <=15.00 AND Slope < 0.23) OR
(First_Range > 15.00 AND Slope < 0.2) OR
(Track_Type = 1) THEN DELETE;
END;
IF MUX_CHANNEL EQ 2 OR MUX_CHANNEL EQ 4 OR MUX_CHANNEL EQ 6 THEN DO;
IF
(ECHO_COUNT <4) OR
(Echo_Count = 4 AND ((Linearity1 / Echo_Count) > 0.4)) OR
(Echo_Count >= 5 AND Echo_Count <= 7 AND ((Linearity1 / Echo_Count) >= 0.5)) OR
((Linearity2 / Echo_Count) > 0.5) OR
(((Noise_Count_Average) / ((Echo_Count + 10) * 5)) > 0.04)) OR
(SLOPE >= 0.6 OR SLOPE <= -0.6) OR
(Echo_Count < 8 AND Linearity1 > 1 AND Noise_Count_Average > 2) OR
((Linearity1 > 2) AND (Linearity2 > 2) AND (Noise_Count_Average > 4)) OR
(Linearity1 > 2 AND Linearity2 > 2 AND Noise_Count_Average >= 2) OR
(First_Range > 11.2 AND Last_Range > 11.2) OR
(((First_Range + Last_Range)/ 2) > 10.8) AND (Slope > 0.35 OR Slope < -0.35)) OR
(Track_Type = 1) THEN DELETE;
END;
END;
IF SYSTEM='G' THEN DO;
IF MUX_CHANNEL EQ 1 OR MUX_CHANNEL EQ 3 OR MUX_CHANNEL EQ 5 OR MUX_CHANNEL EQ 7 THEN DO;
IF
(ECHO_COUNT < 6) OR
(Echo_Count = 4 AND ((Linearity1 / Echo_Count) > 0.4)) OR
(Echo_Count >= 5 AND Echo_Count <= 7 AND ((Linearity1 / Echo_Count) >= 0.5)) OR
((Linearity2 / Echo_Count) > 0.5) OR
(((Noise_Count_Average) / ((Echo_Count + 10) * 5)) > 0.04)) OR
NOISE_COUNT_AVERAGE > 2.5 OR

(SLOPE >= 2.5 OR SLOPE <= -2.5) OR
(First_Range < 8.50 AND Slope < 0.5) OR
(First_Range >= 8.50 AND First_Range <=15.00 AND Slope < 0.23) OR
(First_Range >= 15.00 AND Slope < 0.2) OR
(Track_Type = 1) THEN DELETE;
END;
IF MUX_CHANNEL EQ 2 OR MUX_CHANNEL EQ 8 THEN DO;
IF
(ECHO_COUNT <4) OR
(Echo_Count = 4 AND ((Linearity1 / Echo_Count) > 0.4)) OR
(Echo_Count >= 5 AND Echo_Count <= 7 AND ((Linearity1 / Echo_Count) >= 0.5)) OR
((Linearity2 / Echo_Count) > 0.5) OR
(((Noise_Count_Average) / ((Echo_Count + 10) * 5)) > 0.04)) OR
(SLOPE >= 0.6 OR SLOPE <= -0.6) OR
(Echo_Count < 8 AND Linearity1 > 1 AND Noise_Count_Average > 2) OR
((Linearity1 > 2) AND (Linearity2 > 2) AND (Noise_Count_Average > 4)) OR
(Linearity1 > 2 AND Linearity2 > 2 AND Noise_Count_Average >= 2) OR
(First_Range > 11.2 AND Last_Range > 11.2) OR
(((First_Range + Last_Range)/ 2) > 10.5) AND (Slope > 0.35 OR Slope < -0.35)) OR
(Track_Type = 1) THEN DELETE;
END;
IF MUX_CHANNEL EQ 4 THEN DO;
IF
(ECHO_COUNT <4) OR
(Echo_Count = 4 AND ((Linearity1 / Echo_Count) > 0.4)) OR
(Echo_Count >= 5 AND Echo_Count <= 7 AND ((Linearity1 / Echo_Count) >= 0.5)) OR
((Linearity2 / Echo_Count) > 0.5) OR
(((Noise_Count_Average) / ((Echo_Count + 10) * 5)) > 0.04)) OR
(SLOPE >= 0.6 OR SLOPE <= -0.6) OR
(Echo_Count < 8 AND Linearity1 > 1 AND Noise_Count_Average > 2) OR
((Linearity1 > 2) AND (Linearity2 > 2) AND (Noise_Count_Average > 4)) OR
(Linearity1 > 2 AND Linearity2 > 2 AND Noise_Count_Average >= 2) OR
(First_Range > 11.2 AND Last_Range > 11.2) OR
(((First_Range + Last_Range)/ 2) > 10.5) AND (Slope > 0.35 OR Slope < -0.35)) OR
(First_Range > 9.5 AND First_Range < 10 AND Last_Range > 9.5 AND Last_Range < 10) OR
(First_Range > 10.2 AND First_Range < 10.5 AND Last_Range > 10.2 AND Last_Range < 10.5) OR
(Track_Type = 1) THEN DELETE;
END;
IF MUX_CHANNEL EQ 6 THEN DO;
IF
(ECHO_COUNT <4) OR
(Echo_Count = 4 AND ((Linearity1 / Echo_Count) > 0.4)) OR
(Echo_Count >= 5 AND Echo_Count <= 7 AND ((Linearity1 / Echo_Count) >= 0.5)) OR
((Linearity2 / Echo_Count) > 0.5) OR
(((Noise_Count_Average) / ((Echo_Count + 10) * 5)) > 0.04)) OR
(SLOPE >= 0.6 OR SLOPE <= -0.6) OR
```

Hydroacoustic Evaluation of Fish Passage through Bonneville Dam in 2004

```
(Echo_Count < 8 AND Linearity1 > 1 AND Noise_Count_Average > 2) OR
((Linearity1 > 2) AND (Linearity2 > 2) AND (Noise_Count_Average > 4)) OR
(Linearity1 > 2 AND Linearity2 > 2 AND Noise_Count_Average >= 2) OR
(First_Range > 11.2 AND Last_Range > 11.2) OR
(((First_Range + Last_Range) / 2) > 10.5) AND (Slope > 0.35 OR Slope < -0.35)) OR
(First_Range > 8.7 AND First_Range < 9 AND Last_Range > 8.7 AND Last_Range < 9) OR
(Track_Type = 1) THEN DELETE;
END;
END;

IF SYSTEM='H' THEN DO;
IF MUX_CHANNEL EQ 1 OR MUX_CHANNEL EQ 3 THEN DO;
IF
(ECHO_COUNT <6) OR
(ECHO_COUNT < 6) OR
(Echo_Count = 4 AND ((Linearity1 / Echo_Count) > 0.4)) OR
(Echo_Count >= 5 AND Echo_Count <= 7 AND ((Linearity1 / Echo_Count) >= 0.5)) OR
((Linearity2 / Echo_Count) > 0.5) OR
((Echo_Count = 5 OR Echo_Count = 6 OR Echo_Count = 7) AND ((Linearity1 / Echo_Count) >= 0.4)) OR
(((Noise_Count_Average) / ((Echo_Count + 10) * 5)) > 0.04)) OR
NOISE_COUNT_AVERAGE > 2.5 OR

(SLOPE >= 2.5 OR SLOPE <= -2.5) OR
(First_Range < 8.50 AND Slope < 0.5) OR
(First_Range >= 8.50 AND First_Range <=15.00 AND Slope < 0.23) OR
(First_Range > 15.00 AND Slope < 0.2) OR
(First_Range > 16.8 AND Last_Range > 16.8) OR
(Track_Type = 1) THEN DELETE;
END;
IF MUX_CHANNEL EQ 5 THEN DO; ***Run loose the first time through and tighten later;
IF
(ECHO_COUNT <6) OR
(Echo_Count = 4 AND ((Linearity1 / Echo_Count) > 0.4)) OR
(Echo_Count >= 5 AND Echo_Count <= 7 AND ((Linearity1 / Echo_Count) >= 0.5)) OR
((Linearity2 / Echo_Count) > 0.5) OR
(((Noise_Count_Average) / ((Echo_Count + 10) * 5)) > 0.04)) OR
(SLOPE >= 2.5 OR SLOPE <= -2.5) OR
(First_Range < 8.50 AND Slope < 0.5) OR
(First_Range >= 8.50 AND First_Range <=15.00 AND Slope < 0.23) OR
(First_Range > 15.00 AND Slope < 0.2) OR
(Track_Type = 1) THEN DELETE;
END;
IF MUX_CHANNEL EQ 7 THEN DO;
IF
(ECHO_COUNT < 6) OR
(Echo_Count = 4 AND ((Linearity1 / Echo_Count) > 0.4)) OR
(Echo_Count >= 5 AND Echo_Count <= 7 AND ((Linearity1 / Echo_Count) >= 0.5)) OR
((Linearity2 / Echo_Count) > 0.5) OR
(((Noise_Count_Average) / ((Echo_Count + 10) * 5)) > 0.04)) OR
NOISE_COUNT_AVERAGE > 2.5 OR

(SLOPE >= 2.5 OR SLOPE <= -2.5) OR
(First_Range < 8.50 AND Slope < 0.5) OR
(First_Range >= 8.50 AND First_Range <=15.00 AND Slope < 0.23) OR
(First_Range > 15.00 AND Slope < 0.2)OR (Track_Type = 1) THEN DELETE;
END;
IF MUX_CHANNEL EQ 2 OR MUX_CHANNEL EQ 4 THEN DO;
IF
(ECHO_COUNT < 4) OR
(Echo_Count = 4 AND ((Linearity1 / Echo_Count) > 0.4)) OR
(Echo_Count >= 5 AND Echo_Count <= 7 AND ((Linearity1 / Echo_Count) >= 0.5)) OR
((Linearity2 / Echo_Count) > 0.5) OR
(((Noise_Count_Average) / ((Echo_Count + 10) * 5)) > 0.04)) OR
(SLOPE >= 0.8 OR SLOPE <= -0.8) OR
(First_Range > 11.2 AND Last_Range > 11.2)
THEN DELETE;
END;
IF MUX_CHANNEL EQ 6 THEN DO; ***Run loose and then tighten later;
IF
(ECHO_COUNT < 4) OR
(Echo_Count = 4 AND ((Linearity1 / Echo_Count) > 0.4)) OR
(Echo_Count >= 5 AND Echo_Count <= 7 AND ((Linearity1 / Echo_Count) >= 0.5)) OR
((Linearity2 / Echo_Count) > 0.5) OR
(((Noise_Count_Average) / ((Echo_Count + 10) * 5)) > 0.04)) OR
(SLOPE >= 0.8 OR SLOPE <= -0.8) OR
(First_Range > 11 AND Last_Range > 11) OR
(((First_Range+Last_Range)/2) >10.8) AND Slope >-0.1 AND Slope <0.1) OR
(Track_Type = 1) OR
(Echo_Count < 8 AND Linearity1 > 1 AND Noise_Count_Average > 2) OR
((Linearity1 > 2) AND (Linearity2 > 2) AND (Noise_Count_Average > 4)) OR
(Linearity1 > 2 AND Linearity2 > 2 AND Noise_Count_Average >= 2) OR
```

Hydroacoustic Evaluation of Fish Passage through Bonneville Dam in 2004

```

      (((First_Range + Last_Range)/ 2) > 10.5) AND (Slope > 0.35 OR Slope < -0.35) OR (Track_Type = 1))
    THEN DELETE;
  END;
  IF MUX_CHANNEL EQ 8 THEN DO;
    IF
      (ECHO_COUNT < 4) OR
      (Echo_Count = 4 AND ((Linearity1 / Echo_Count) > 0.4)) OR
      (Echo_Count >= 5 AND Echo_Count <= 7 AND ((Linearity1 / Echo_Count) >= 0.5)) OR
      ((Linearity2 / Echo_Count) > 0.5) OR
      (((Noise_Count_Average) / ((Echo_Count + 10) * 5)) > 0.04)) OR
      (SLOPE >= 0.6 OR SLOPE <= -0.6) OR
      (First_Range > 11 AND Last_Range > 11) OR
      (((First_Range+Last_Range)/2) >10.8) AND Slope >-0.1 AND Slope <0.1) OR
      (Track_Type = 1) OR
      (Echo_Count < 8 AND Linearity1 > 1 AND Noise_Count_Average > 2) OR
      ((Linearity1 > 2) AND (Linearity2 > 2) AND (Noise_Count_Average > 4)) OR
      (Linearity1 > 2 AND Linearity2 > 2 AND Noise_Count_Average >= 2) OR
      (((First_Range + Last_Range)/ 2) > 10.5) AND (Slope > 0.35 OR Slope < -0.35) OR
      (Track_Type = 1))
    THEN DELETE;
  END;
  END;
  IF SYSTEM='I' THEN DO;
    IF MUX_CHANNEL EQ 0 THEN DO; ***Carl's down-looker;
      IF
        (ECHO_COUNT < 6) OR
        (Echo_Count = 4 AND ((Linearity1 / Echo_Count) > 0.4)) OR
        (Echo_Count >= 5 AND Echo_Count <= 7 AND ((Linearity1 / Echo_Count) >= 0.5)) OR
        ((Linearity2 / Echo_Count) > 0.5) OR
        (((Noise_Count_Average) / ((Echo_Count + 10) * 5)) > 0.04)) OR
        NOISE_COUNT_AVERAGE > 2.5 OR
        (SLOPE >= 2.5 OR SLOPE <= -2.5) OR
        (First_Range < 8.50 AND Slope < 0.5) OR
        (First_Range >= 8.50 AND First_Range <=15.00 AND Slope < 0.23) OR
        (First_Range > 15.00 AND Slope < 0.2) OR
        (First_Range > 16.8 AND Last_Range > 16.8) OR
        (Track_Type = 1) THEN DELETE;
      END;
    IF MUX_CHANNEL EQ 1 THEN DO; ***Carl's up-looker;
      IF
        (ECHO_COUNT < 4) OR
        (Echo_Count = 4 AND ((Linearity1 / Echo_Count) > 0.4)) OR
        (Echo_Count >= 5 AND Echo_Count <= 7 AND ((Linearity1 / Echo_Count) >= 0.5)) OR
        ((Linearity2 / Echo_Count) > 0.5) OR
        (((Noise_Count_Average) / ((Echo_Count + 10) * 5)) > 0.04)) OR
        (SLOPE >= 0.6 OR SLOPE <= -0.6) OR
        (Echo_Count < 8 AND Linearity1 > 1 AND Noise_Count_Average > 2) OR
        ((Linearity1 > 2) AND (Linearity2 > 2) AND (Noise_Count_Average > 4)) OR
        (Linearity1 > 2 AND Linearity2 > 2 AND Noise_Count_Average >= 2) OR
        (First_Range > 11.2 AND Last_Range > 11.2) OR
        (((First_Range + Last_Range)/ 2) > 10.5) AND (Slope > 0.35 OR Slope < -0.35)) OR
        (Track_Type = 1) THEN DELETE;
      END;
    END;
  END;
  IF SYSTEM='W' THEN DO;
    IF MUX_CHANNEL EQ 0 THEN DO;
      IF (
        ((Track_Type=1) AND ((First_Range+Last_Range)/2 > 9)) OR
        ((First_Range+Last_Range)/2 > 10.5) OR
        (Noise_Count_Average > 7 AND Contrast < 0) OR
        (Noise_Count_Average > 15) OR
        (Echo_Count=4 AND ((Noise_Count_Average/((Echo_Count+12)*18))>.01)) OR
        (Echo_Count=5 AND ((Noise_Count_Average/((Echo_Count+12)*18))>.015)) OR
        (Echo_Count =6 AND ((Noise_Count_Average/((Echo_Count+12)*18))>.017)) OR
        (Echo_Count >=7 AND ((Noise_Count_Average/((Echo_Count+12)*18))>.020)) OR
        (Echo_Count >=7 AND ((Noise_Count_Average/((Echo_Count+12)*18))>.018) AND (Linearity1/Echo_Count >
          0.25)) OR
        (Echo_Count = 4 AND ((Linearity1 / Echo_Count) > 0.4)) OR
        (Echo_Count >= 5 AND Echo_Count <= 7 AND ((Linearity1 / Echo_Count) >= 0.5)) OR
        ((Linearity2 / Echo_Count) > 0.5) OR
        (Linearity1 > 10) OR
        (SLOPE < -4)
      ) THEN DELETE;
    END;
    IF MUX_CHANNEL EQ 1 THEN DO;
      IF (
        ((Track_Type=1) AND ((First_Range+Last_Range)/2 > 9)) OR
        (Noise_Count_Average > 7 AND Contrast < 0) OR

```

Hydroacoustic Evaluation of Fish Passage through Bonneville Dam in 2004

```
(Noise_Count_Average > 15) OR
(Echo_Count=4 AND ((Noise_Count_Average/((Echo_Count+12)*18))>.01)) OR
(Echo_Count=5 AND ((Noise_Count_Average/((Echo_Count+12)*18))>.015)) OR
(Echo_Count = 6 AND ((Noise_Count_Average/((Echo_Count+12)*18))>.017)) OR
(Echo_Count >=7 AND ((Noise_Count_Average/((Echo_Count+12)*18))>.020)) OR
(Echo_Count >=7 AND ((Noise_Count_Average/((Echo_Count+12)*18))>.018) AND (Linearity1/Echo_Count >
0.25)) OR
(Echo_Count = 4 AND ((Linearity1 / Echo_Count) > 0.4)) OR
(Echo_Count >= 5 AND Echo_Count <= 7 AND ((Linearity1 / Echo_Count) >= 0.5)) OR
((Linearity2 / Echo_Count) > 0.5) OR
(Linearity1 > 10) OR
(SLOPE < -4)
) THEN DELETE;
END;
END;
IF SYSTEM='V' THEN DO;
IF MUX_CHANNEL EQ 0 THEN DO;
IF (
(Echo_Count = 4 AND ((Linearity1 / Echo_Count) > 0.4)) OR
(Echo_Count >= 5 AND Echo_Count <= 7 AND ((Linearity1 / Echo_Count) >= 0.5)) OR
((Linearity2 / Echo_Count) > 0.5) OR
SLOPE < -4 OR
(Echo_Count=4 AND ((Noise_Count_Average/((Echo_Count+12)*18))>.01)) OR
(Echo_Count=5 AND ((Noise_Count_Average/((Echo_Count+12)*18))>.015)) OR
(Echo_Count = 6 AND ((Noise_Count_Average/((Echo_Count+12)*18))>.017)) OR
(Echo_Count >=7 AND ((Noise_Count_Average/((Echo_Count+12)*18))>.020)) OR
(Echo_Count >=7 AND ((Noise_Count_Average/((Echo_Count+12)*18))>.018) AND (Linearity1/Echo_Count >
0.25)) OR
(Linearity1 < 0.5 AND Linearity2 < 0.5 AND Slope = 0 ) OR
(First_Range > 10 AND Last_Range > 10 AND (Slope > -0.15 AND Slope < 0.15) AND ((Noise_Count_Average)
/ ((Echo_Count + 10)*6)) > 0.045)) OR
(First_Range > 10.7 AND Last_Range > 10.7) OR
((First_Range + Last_Range)/2 > 9 AND (Slope > -0.1 AND Slope < 0.1) AND ((Noise_Count_Average) /
((Echo_Count + 10)*6)) > 0.045)) OR
(First_Range > 2 AND First_Range < 2.5 AND Last_Range > 2 AND Last_Range < 2.5 AND Slope > -0.1 AND
Slope < 0.1) OR
(First_Range > 5.4 AND First_Range < 5.7 AND Last_Range > 5.4 AND Last_Range < 5.7 AND Slope > -0.1
AND Slope < 0.1) OR
(First_Range > 6.4 AND First_Range < 7.2 AND Last_Range > 6.4 AND Last_Range < 7.2 AND Slope > -0.2
AND Slope < 0.2) OR
(First_Range > 7 AND First_Range < 7.4 AND Last_Range > 7 AND Last_Range < 7.4 AND Slope > -0.1 AND
Slope < 0.1) OR
(First_Range > 8 AND First_Range < 8.2 AND Last_Range > 8 AND Last_Range < 8.2 AND Slope > -0.1 AND
Slope < 0.1) OR
ECHO_COUNT < 5 AND ECHO_COUNT / ((LAST_PING / GROUP_SIZE + 1) - FIRST_Ping / GROUP_SIZE) < 0.8 OR
ECHO_COUNT >=5 AND ECHO_COUNT <=6 AND ECHO_COUNT / ((LAST_PING / GROUP_SIZE + 1) - FIRST_Ping /
GROUP_SIZE) < 0.7
) THEN DELETE;
END;
IF MUX_CHANNEL EQ 1 THEN DO;
IF (
((Track_Type=1) AND ((First_Range+Last_Range)/2 > 9)) OR
(Noise_Count_Average > 7 AND Contrast < 0) OR
(Noise_Count_Average > 15) OR
(Echo_Count=4 AND ((Noise_Count_Average/((Echo_Count+12)*18))>.01)) OR
(Echo_Count=5 AND ((Noise_Count_Average/((Echo_Count+12)*18))>.015)) OR
(Echo_Count = 6 AND ((Noise_Count_Average/((Echo_Count+12)*18))>.017)) OR
(Echo_Count >=7 AND ((Noise_Count_Average/((Echo_Count+12)*18))>.020)) OR
(Echo_Count >=7 AND ((Noise_Count_Average/((Echo_Count+12)*18))>.018) AND (Linearity1/Echo_Count >
0.25)) OR
(Echo_Count = 4 AND ((Linearity1 / Echo_Count) > 0.4)) OR
(Echo_Count >= 5 AND Echo_Count <= 7 AND ((Linearity1 / Echo_Count) >= 0.5)) OR
((Linearity2 / Echo_Count) > 0.5) OR
(Linearity1 > 10) OR
(SLOPE < -4) OR
(First_Range > 10 AND Last_Range > 10 AND (Slope > -0.15 AND Slope < 0.15) AND ((Noise_Count_Average)
/ ((Echo_Count + 10)*6)) > 0.045)) OR
(First_Range > 10.7 AND Last_Range > 10.7) OR
(First_Range > 8 AND First_Range < 8.2 AND Last_Range > 8 AND Last_Range < 8.2 AND Slope > -0.1 AND
Slope < 0.1) OR
(First_Range > 8.2 AND First_Range < 8.4 AND Last_Range > 8.2 AND Last_Range < 8.4 AND Slope > -0.1
AND Slope < 0.1) OR
(First_Range > 8.4 AND First_Range < 8.6 AND Last_Range > 8.4 AND Last_Range < 8.6 AND Slope > -0.1
AND Slope < 0.1) OR
(First_Range > 8.6 AND First_Range < 8.8 AND Last_Range > 8.6 AND Last_Range < 8.8 AND Slope > -0.1
AND Slope < 0.1) OR
(First_Range > 8.8 AND First_Range < 9.0 AND Last_Range > 8.8 AND Last_Range < 9.0 AND Slope > -0.1
AND Slope < 0.1) OR
(First_Range > 8.1 AND First_Range < 8.3 AND Last_Range > 8.1 AND Last_Range < 8.3 AND Slope > -0.1
AND Slope < 0.1) OR
```

Hydroacoustic Evaluation of Fish Passage through Bonneville Dam in 2004

```
(First_Range > 8.3 AND First_Range < 8.5 AND Last_Range > 8.3 AND Last_Range < 8.5 AND Slope > -0.1
AND Slope < 0.1) OR
(First_Range > 8.5 AND First_Range < 8.7 AND Last_Range > 8.5 AND Last_Range < 8.7 AND Slope > -0.1
AND Slope < 0.1) OR
(First_Range > 8.7 AND First_Range < 8.9 AND Last_Range > 8.7 AND Last_Range < 8.9 AND Slope > -0.1
AND Slope < 0.1) OR
(First_Range > 8.9 AND First_Range < 9.1 AND Last_Range > 8.9 AND Last_Range < 9.1 AND Slope > -0.1
AND Slope < 0.1)
) THEN DELETE;
END;
END;

IF SYSTEM='U' THEN DO; ***On the bottom during spring creek - using U filters;
IF MUX_CHANNEL EQ 0 THEN DO;
reg=0.6374*fb_el-38.263;
IF (
((First_Range+Last_Range)/2 >=(reg-1) AND Track_Type=1) OR
((First_Range+Last_Range)/2 >=(reg-0.1)) OR
(((First_Range+Last_Range)/2 > (reg - 1)) AND (Slope >-0.2 and Slope < 0.2)) OR
(Echo_Count=4 AND (First_Range+Last_Range)/2 >=reg-0.6) OR
(Noise_Count_Average > 7 AND Contrast < 0) OR
(Noise_Count_Average > 15) OR
(Noise_Count_Average > 7.5 AND Slope > 2.5) OR
(Noise_Count_Average > 7.5 AND Slope < -2.5) OR
(Echo_Count=4 AND ((Noise_Count_Average/((Echo_Count+12)*18))>.01)) OR
(Echo_Count=5 AND ((Noise_Count_Average/((Echo_Count+12)*18))>.015)) OR
(Echo_Count =6 AND ((Noise_Count_Average/((Echo_Count+12)*18))>.017)) OR
(Echo_Count >=7 AND ((Noise_Count_Average/((Echo_Count+12)*18))>.020)) OR
(Echo_Count >=7 AND ((Noise_Count_Average/((Echo_Count+12)*18))>.018) AND (Linearity1/Echo_Count >
0.25)) OR
(Echo_Count = 4 AND ((Linearity1 / Echo_Count) > 0.4)) OR
(Echo_Count >= 5 AND Echo_Count <= 7 AND ((Linearity1 / Echo_Count) >= 0.5)) OR
((Linearity2 / Echo_Count) > 0.5)
) then delete;
END;
IF MUX_CHANNEL EQ 1 THEN DO;
reg=0.2209*fb_el-8.6451;
if (
((First_Range+Last_Range)/2 >=(reg-2) AND Track_Type=1) OR
((First_Range+Last_Range)/2 >=(reg-0.1)) OR
(((First_Range+Last_Range)/2 > (reg - 0.15)) AND (Slope >-0.2 and Slope < 0.2)) OR
(Echo_Count=4 AND (First_Range+Last_Range)/2 >=reg-0.6) OR
(Noise_Count_Average > 7 AND Contrast < 0) OR
(Noise_Count_Average > 15) OR
(Noise_Count_Average > 7.5 AND Slope > 2.5) OR
(Noise_Count_Average > 7.5 AND Slope < -2.5) OR
(Echo_Count=4 AND ((Noise_Count_Average/((Echo_Count+12)*18))>.01)) OR
(Echo_Count=5 AND ((Noise_Count_Average/((Echo_Count+12)*18))>.015)) OR
(Echo_Count =6 AND ((Noise_Count_Average/((Echo_Count+12)*18))>.017)) OR
(Echo_Count >=7 AND ((Noise_Count_Average/((Echo_Count+12)*18))>.020)) OR
(Echo_Count >=7 AND ((Noise_Count_Average/((Echo_Count+12)*18))>.018) AND (Linearity1/Echo_Count >
0.25)) OR
(Echo_Count=4 AND ((Noise_Count_Average/((Echo_Count+12)*18))>.008) AND Track_type=1) OR
(Echo_Count=5 AND ((Noise_Count_Average/((Echo_Count+12)*18))>.012) AND Track_type=1) OR
(Echo_Count =6 AND ((Noise_Count_Average/((Echo_Count+12)*18))>.014) AND Track_type=1) OR
(Echo_Count =7 AND ((Noise_Count_Average/((Echo_Count+12)*18))>.017) AND Track_type=1) OR
(Echo_Count >=8 AND ((Noise_Count_Average/((Echo_Count+12)*18))>.019) AND Track_type=1) OR
(Echo_Count = 4 AND ((Linearity1 / Echo_Count) > 0.4)) OR
(Echo_Count >= 5 AND Echo_Count <= 7 AND ((Linearity1 / Echo_Count) >= 0.5)) OR
((Linearity2 / Echo_Count) > 0.5)
) then delete;
END;
END;
RUN;
```

Appendix E

Hourly Fish Passage, Flow, and Forebay Elevation Estimates

Appendix E

Hourly Fish Passage, Flow, and Forebay Elevation Estimates

Appendix E.1. List of Appendix E Tables Contained in CSV Files Stored Separately on CD

Table	Description
Appendix E-3	Hourly estimates of fish passage for spring 2004.
Appendix E-4	Hourly estimates of fish passage for summer 2004.
Appendix E-5	Hourly estimates of fish-passage variances for spring 2004.
Appendix E-6	Hourly estimates of fish-passage variances for summer 2004.
Appendix E-7	Hourly estimates of turbine-unit and spill-bay specific discharge and average forebay water surface elevation for spring 2004.
Appendix E-8	Hourly estimates of turbine-unit and spill-bay specific discharge and average forebay water surface elevation for summer 2004.

Appendix E.2. Definitions of Variables in Headings of Appendix E Tables in CSV Files on CD

Variable	Definition	Variable	Definition
Begins with S_	Hourly sum of spatially and temporally expanded estimates of fish passage		
Begins with V_	Hourly sum of temporally expanded variances		
Begins with TU_	Turbine		
Begins with SB_	Spill bay		
Ends with CFS	Cubic ft / s		
Contains SL2CS	Sluice Entrance 2C south half	Contains SB4	Spillway bay 4
Contains SL2CN	Sluice Entrance 2C north half	Contains SB3	Spillway bay 3
Contains SL4CS	Sluice Entrance 4C south half	Contains SB2	Spillway bay 2
Contains SL4CN	Sluice Entrance 4C north half	Contains SB1	Spillway bay 1
Contains SL6CS	Sluice Entrance 6C south half	Contains B2CC1	B2 Corner Collector 1
Contains SL6CN	Sluice Entrance 6C north half	Contains B2CC2	B2 Corner Collector 2
Contains I1BD	Intake 1B Downlooker	Contains B2CC3	B2 Corner Collector 3
Contains I2AD	Intake 2A Downlooker	Contains B2CC4	B2 Corner Collector 4
Contains I2CD	Intake 2C Downlooker	Contains B2CC5	B2 Corner Collector 5
Contains I3BD	Intake 3B Downlooker	Contains B2CC6	B2 Corner Collector 6
Contains I3CD	Intake 3C Downlooker	Contains I11AG	Intake 11A Guided
Contains I4AD	Intake 4A Downlooker	Contains I11AU	Intake 11A Unguided
Contains I4BD	Intake 4B Downlooker	Contains I11CG	Intake 11C Guided
Contains I5AD	Intake 5A Downlooker	Contains I11CU	Intake 11C Unguided
Contains I5BD	Intake 5B Downlooker	Contains I12AG	Intake 12A Guided
Contains I6AD	Intake 6A Downlooker	Contains I12AU	Intake 12A Unguided
Contains I6BD	Intake 6B Downlooker	Contains I12CG	Intake 12C Guided
Contains I7AD	Intake 7A Downlooker	Contains I12CU	Intake 12C Unguided
Contains I7CD	Intake 7C Downlooker	Contains I13BG	Intake 13B Guided
Contains I8CD	Intake 8C Downlooker	Contains I13BU	Intake 13B Unguided
Contains I9BD	Intake 9B Downlooker	Contains I14BG	Intake 14B Guided
Contains I10BD	Intake 10B Downlooker	Contains I14BU	Intake 14B Unguided
Contains SB18	Spillway bay 18	Contains I15BG	Intake 15B Guided
Contains SB17	Spillway bay 17	Contains I15BU	Intake 15B Unguided
Contains SB16	Spillway bay 16	Contains I16BG	Intake 16B Guided
Contains SB15	Spillway bay 15	Contains I16BU	Intake 16B Unguided
Contains SB14	Spillway bay 14	Contains I17AG	Intake 17A Guided
Contains SB13	Spillway bay 13	Contains I17AU	Intake 17A Unguided
Contains SB12	Spillway bay 12	Contains I17BG	Intake 17B Guided
Contains SB11	Spillway bay 11	Contains I17BU	Intake 17B Unguided
Contains SB10	Spillway bay 10	Contains I17CG	Intake 17C Guided
Contains SB9	Spillway bay 9	Contains I17CU	Intake 17C Unguided
Contains SB8	Spillway bay 8	Contains I18BG	Intake 18B Guided
Contains SB7	Spillway bay 7	Contains I18BU	Intake 18B Unguided
Contains SB6	Spillway bay 6	FB_EL	Forebay Elevation
Contains SB5	Spillway bay 5		

Appendix F

Polynomial Coefficients for Estimating Effective Beam Angle based Upon Range from a Transducer

Appendix F

Polynomial Coefficients for Estimating Effective Beam Angle based Upon Range from a Transducer

The equation for estimating effective beam angle from polynomial coefficients is

$$EA = C5 + C4 \cdot R + C3 \cdot R^2 + C2 \cdot R^3 + C1 \cdot R^4,$$

Where R = range from the transducer and C1, C2, C3, C4, and C5 are coefficients in Appendix F.1 for spring and Appendix F.2 for summer.

Appendix F.1. Coefficients for Estimating Effective Beam Angle from Range from the Transducer in Spring 2004

System & Channel	Location	C1	C2	C3	C4	C 5
B1						
A00	Sluice Entrance 2C N	4.96E-03	-0.052449405	3.29E-02	0.99461535	2.559999091
A01	Sluice Entrance 2C S	4.96E-03	-0.052449405	3.29E-02	0.99461535	2.559999091
A02	Sluice Entrance 4A N	7.46E-03	-0.113560521	0.580416103	-1.173559113	6.167141642
A03	Sluice Entrance 4A S	7.46E-03	-0.113560521	0.580416103	-1.173559113	6.167141642
X00	Sluice Entrance 6C N	0.011174247	-0.187399063	1.110417068	-2.799582411	8.451429231
X01	Sluice Entrance 6C S	0.011174247	-0.187399063	1.110417068	-2.799582411	8.451429231
C01	Intake 01B	-1.23E-04	6.56E-03	-0.125486426	1.063625809	2.863815786
C02	Intake 02C	-1.23E-04	6.56E-03	-0.125486426	1.063625809	2.863815786
C03	Intake 02A	-1.23E-04	6.56E-03	-0.125486426	1.063625809	2.863815786
C04	Intake 03B	-1.23E-04	6.56E-03	-0.125486426	1.063625809	2.863815786
C05	Intake 03C	-1.23E-04	6.56E-03	-0.125486426	1.063625809	2.863815786
C06	Intake 04A	-1.23E-04	6.56E-03	-0.125486426	1.063625809	2.863815786
C07	Intake 04B	-1.23E-04	6.56E-03	-0.125486426	1.063625809	2.863815786
D01	Intake 05A	-1.23E-04	6.56E-03	-0.125486426	1.063625809	2.863815786
D02	Intake 05B	-1.23E-04	6.56E-03	-0.125486426	1.063625809	2.863815786
R01	Intake 06A	-1.23E-04	6.56E-03	-0.125486426	1.063625809	2.863815786
R02	Intake 06B	-1.23E-04	6.56E-03	-0.125486426	1.063625809	2.863815786
D03	Intake 07A	-1.23E-04	6.56E-03	-0.125486426	1.063625809	2.863815786
D04	Intake 07C	-1.23E-04	6.56E-03	-0.125486426	1.063625809	2.863815786
D05	Intake 08C	-1.23E-04	6.56E-03	-0.125486426	1.063625809	2.863815786
D06	Intake 09B	-1.23E-04	6.56E-03	-0.125486426	1.063625809	2.863815786
D07	Intake 10B	-1.23E-04	6.56E-03	-0.125486426	1.063625809	2.863815786
Spillway						
Q01	Spill Bay 1	1.45E-03	-3.02E-02	0.161454118	-8.45E-02	9.263939222
Q02	Spill Bay 2	1.45E-03	-3.02E-02	0.161454118	-8.45E-02	9.263939222
Q03	Spill Bay 3	1.45E-03	-3.02E-02	0.161454118	-8.45E-02	9.263939222
Q04	Spill Bay 4	1.45E-03	-3.02E-02	0.161454118	-8.45E-02	9.263939222
M00	Spill Bay 5	1.45E-03	-3.02E-02	0.161454118	-8.45E-02	9.263939222
Q05	Spill Bay 6	1.45E-03	-3.02E-02	0.161454118	-8.45E-02	9.263939222
M01	Spill Bay 7	1.45E-03	-3.02E-02	0.161454118	-8.45E-02	9.263939222
P01	Spill Bay 8	1.45E-03	-3.02E-02	0.161454118	-8.45E-02	9.263939222
F01	Spill Bay 9	1.45E-03	-3.02E-02	0.161454118	-8.45E-02	9.263939222
P02	Spill Bay 10	1.45E-03	-3.02E-02	0.161454118	-8.45E-02	9.263939222
F02	Spill Bay 11	1.45E-03	-3.02E-02	0.161454118	-8.45E-02	9.263939222
P03	Spill Bay 12	1.45E-03	-3.02E-02	0.161454118	-8.45E-02	9.263939222
F03	Spill Bay 13	1.45E-03	-3.02E-02	0.161454118	-8.45E-02	9.263939222
P04	Spill Bay 14	1.45E-03	-3.02E-02	0.161454118	-8.45E-02	9.263939222
F04	Spill Bay 15	1.45E-03	-3.02E-02	0.161454118	-8.45E-02	9.263939222
P05	Spill Bay 16	1.45E-03	-3.02E-02	0.161454118	-8.45E-02	9.263939222
O00	Spill Bay 17	1.45E-03	-3.02E-02	0.161454118	-8.45E-02	9.263939222
F05	Spill Bay 18	1.45E-03	-3.02E-02	0.161454118	-8.45E-02	9.263939222

Footnote: The last letter in the location name for B2 intake transducers indicates aiming direction (U = up; D = down)

Appendix F.1 (Continued). Coefficients for Estimating Effective Beam Angle from Range from the Transducer in Spring 2004

System & Channel	Location	C1	C2	C3	C4	C 5
			B2			
E01	Intake 11AD	-1.61E-04	9.21E-03	-0.198032795	1.919812363	-0.393382442
E02	Intake 11AU	-1.34E-03	4.47E-02	-0.552589864	3.146573782	-1.020505055
E03	Intake 11CD	-1.61E-04	9.21E-03	-0.198032795	1.919812363	-0.393382442
E04	Intake 11CU	-1.34E-03	4.47E-02	-0.552589864	3.146573782	-1.020505055
G01	Intake 12AD	-1.61E-04	9.21E-03	-0.198032795	1.919812363	-0.393382442
G02	Intake 12AU	-1.34E-03	4.47E-02	-0.552589864	3.146573782	-1.020505055
G03	Intake 12CD	-1.61E-04	9.21E-03	-0.198032795	1.919812363	-0.393382442
G04	Intake 12CU	-1.34E-03	4.47E-02	-0.552589864	3.146573782	-1.020505055
E05	Intake 13BD	-1.61E-04	9.21E-03	-0.198032795	1.919812363	-0.393382442
E06	Intake 13BU	-1.34E-03	4.47E-02	-0.552589864	3.146573782	-1.020505055
G05	Intake 14BD	-1.61E-04	9.21E-03	-0.198032795	1.919812363	-0.393382442
G06	Intake 14BU	-1.34E-03	4.47E-02	-0.552589864	3.146573782	-1.020505055
G07	Intake 15BD	-1.61E-04	9.21E-03	-0.198032795	1.919812363	-0.393382442
G08	Intake 15BU	-1.34E-03	4.47E-02	-0.552589864	3.146573782	-1.020505055
I00	Intake 16BD	-1.61E-04	9.21E-03	-0.198032795	1.919812363	-0.393382442
I01	Intake 16BU	-1.34E-03	4.47E-02	-0.552589864	3.146573782	-1.020505055
H01	Intake 17AD	-1.61E-04	9.21E-03	-0.198032795	1.919812363	-0.393382442
H02	Intake 17AU	-1.34E-03	4.47E-02	-0.552589864	3.146573782	-1.020505055
H03	Intake 17BD	-1.61E-04	9.21E-03	-0.198032795	1.919812363	-0.393382442
H04	Intake 17BU	-1.34E-03	4.47E-02	-0.552589864	3.146573782	-1.020505055
H05	Intake 17CD	-1.61E-04	9.21E-03	-0.198032795	1.919812363	-0.393382442
H06	Intake 17CU	-1.34E-03	4.47E-02	-0.552589864	3.146573782	-1.020505055
H07	Intake 18BD	-1.61E-04	9.21E-03	-0.198032795	1.919812363	-0.393382442
H08	Intake 18BU	-1.34E-03	4.47E-02	-0.552589864	3.146573782	-1.020505055
W00	B2CC 1	-1.31E-05	2.99E-04	1.14E-02	-0.267912181	3.670202072
W01	B2CC 2	-1.31E-05	2.99E-04	1.14E-02	-0.267912181	3.670202072
U00	B2CC 5	4.28E-03	-8.99E-02	0.621570234	-1.776628851	7.35666581
U01	B2CC 6	3.39E-03	-6.75E-02	0.418286022	-1.030863894	6.541111681
V00	B2CC 3	2.94E-04	-7.38E-03	8.53E-02	-0.679749987	7.750909675
V01	B2CC 4	2.94E-04	-7.38E-03	8.53E-02	-0.679749987	7.750909675

Footnote: The last letter in the location name for B2 intake transducers indicates aiming direction (U = up; D = down)

Appendix F.2. Coefficients for Estimating Effective Beam Angle from Range from the Transducer in Summer 2004

System & Channel	Location	C1	C2	C3	C4	C 5
B1						
A00	Sluice Entrance 2C N	1.67E-03	1.11E-03	-0.297500163	1.928770227	0.941428219
A01	Sluice Entrance 2C S	1.67E-03	1.11E-03	-0.297500163	1.928770227	0.941428219
A02	Sluice Entrance 4A N	1.44E-03	-3.14E-02	0.230000099	-0.688625783	5.292857238
A03	Sluice Entrance 4A S	1.44E-03	-3.14E-02	0.230000099	-0.688625783	5.292857238
X00	Sluice Entrance 6C N	1.24E-02	-0.206237285	1.215416193	-3.07595869	7.894285338
X01	Sluice Entrance 6C S	1.24E-02	-0.206237285	1.215416193	-3.07595869	7.894285338
C01	Intake 01B	-1.13E-04	6.13E-03	-0.119772944	1.042988432	1.664538077
C02	Intake 02C	-1.13E-04	6.13E-03	-0.119772944	1.042988432	1.664538077
C03	Intake 02A	-1.13E-04	6.13E-03	-0.119772944	1.042988432	1.664538077
C04	Intake 03B	-1.13E-04	6.13E-03	-0.119772944	1.042988432	1.664538077
C05	Intake 03C	-1.13E-04	6.13E-03	-0.119772944	1.042988432	1.664538077
C06	Intake 04A	-1.13E-04	6.13E-03	-0.119772944	1.042988432	1.664538077
C07	Intake 04B	-1.13E-04	6.13E-03	-0.119772944	1.042988432	1.664538077
D01	Intake 05A	-1.13E-04	6.13E-03	-0.119772944	1.042988432	1.664538077
D02	Intake 05B	-1.13E-04	6.13E-03	-0.119772944	1.042988432	1.664538077
R01	Intake 06A	-1.13E-04	6.13E-03	-0.119772944	1.042988432	1.664538077
R02	Intake 06B	-1.13E-04	6.13E-03	-0.119772944	1.042988432	1.664538077
D03	Intake 07A	-1.13E-04	6.13E-03	-0.119772944	1.042988432	1.664538077
D04	Intake 07C	-1.13E-04	6.13E-03	-0.119772944	1.042988432	1.664538077
D05	Intake 08C	-1.13E-04	6.13E-03	-0.119772944	1.042988432	1.664538077
D06	Intake 09B	-1.13E-04	6.13E-03	-0.119772944	1.042988432	1.664538077
D07	Intake 10B	-1.13E-04	6.13E-03	-0.119772944	1.042988432	1.664538077
Spillway						
Q01	Spill Bay 1	1.29E-03	-3.02E-02	0.207395099	-0.447202876	8.92321
Q02	Spill Bay 2	1.29E-03	-3.02E-02	0.207395099	-0.447202876	8.92321
Q03	Spill Bay 3	1.29E-03	-3.02E-02	0.207395099	-0.447202876	8.92321
Q04	Spill Bay 4	1.29E-03	-3.02E-02	0.207395099	-0.447202876	8.92321
M00	Spill Bay 5	1.29E-03	-3.02E-02	0.207395099	-0.447202876	8.92321
Q05	Spill Bay 6	1.29E-03	-3.02E-02	0.207395099	-0.447202876	8.92321
M01	Spill Bay 7	1.29E-03	-3.02E-02	0.207395099	-0.447202876	8.92321
P01	Spill Bay 8	1.29E-03	-3.02E-02	0.207395099	-0.447202876	8.92321
F01	Spill Bay 9	1.29E-03	-3.02E-02	0.207395099	-0.447202876	8.92321
P02	Spill Bay 10	1.29E-03	-3.02E-02	0.207395099	-0.447202876	8.92321
F02	Spill Bay 11	1.29E-03	-3.02E-02	0.207395099	-0.447202876	8.92321
P03	Spill Bay 12	1.29E-03	-3.02E-02	0.207395099	-0.447202876	8.92321
F03	Spill Bay 13	1.29E-03	-3.02E-02	0.207395099	-0.447202876	8.92321
P04	Spill Bay 14	1.29E-03	-3.02E-02	0.207395099	-0.447202876	8.92321
F04	Spill Bay 15	1.29E-03	-3.02E-02	0.207395099	-0.447202876	8.92321
P05	Spill Bay 16	1.29E-03	-3.02E-02	0.207395099	-0.447202876	8.92321
O00	Spill Bay 17	1.29E-03	-3.02E-02	0.207395099	-0.447202876	8.92321
F05	Spill Bay 18	1.29E-03	-3.02E-02	0.207395099	-0.447202876	8.92321

Footnote: The last letter in the location name for B2 intake transducers indicates aiming direction (U = up; D = down)

Appendix F.2 (Continued). Coefficients for Estimating Effective Beam Angle from Range from the Transducer in Summer 2004.

System & Channel	Location	C1	C2	C3	C4	C 5
B2						
E01	Intake 11AD	-1.91E-04	9.88E-03	-0.199486565	1.895610275	-1.949705777
E02	Intake 11AU	-1.48E-03	5.03E-02	-0.622641394	3.481782545	-2.859116111
E03	Intake 11CD	-1.91E-04	9.88E-03	-0.199486565	1.895610275	-1.949705777
E04	Intake 11CU	-1.48E-03	5.03E-02	-0.622641394	3.481782545	-2.859116111
G01	Intake 12AD	-1.91E-04	9.88E-03	-0.199486565	1.895610275	-1.949705777
G02	Intake 12AU	-1.48E-03	5.03E-02	-0.622641394	3.481782545	-2.859116111
G03	Intake 12CD	-1.91E-04	9.88E-03	-0.199486565	1.895610275	-1.949705777
G04	Intake 12CU	-1.48E-03	5.03E-02	-0.622641394	3.481782545	-2.859116111
E05	Intake 13BD	-1.91E-04	9.88E-03	-0.199486565	1.895610275	-1.949705777
E06	Intake 13BU	-1.48E-03	5.03E-02	-0.622641394	3.481782545	-2.859116111
G05	Intake 14BD	-1.91E-04	9.88E-03	-0.199486565	1.895610275	-1.949705777
G06	Intake 14BU	-1.48E-03	5.03E-02	-0.622641394	3.481782545	-2.859116111
G07	Intake 15BD	-1.91E-04	9.88E-03	-0.199486565	1.895610275	-1.949705777
G08	Intake 15BU	-1.48E-03	5.03E-02	-0.622641394	3.481782545	-2.859116111
I00	Intake 16BD	-1.91E-04	9.88E-03	-0.199486565	1.895610275	-1.949705777
I01	Intake 16BU	-1.48E-03	5.03E-02	-0.622641394	3.481782545	-2.859116111
H01	Intake 17AD	-1.91E-04	9.88E-03	-0.199486565	1.895610275	-1.949705777
H02	Intake 17AU	-1.48E-03	5.03E-02	-0.622641394	3.481782545	-2.859116111
H03	Intake 17BD	-1.91E-04	9.88E-03	-0.199486565	1.895610275	-1.949705777
H04	Intake 17BU	-1.48E-03	5.03E-02	-0.622641394	3.481782545	-2.859116111
H05	Intake 17CD	-1.91E-04	9.88E-03	-0.199486565	1.895610275	-1.949705777
H06	Intake 17CU	-1.48E-03	5.03E-02	-0.622641394	3.481782545	-2.859116111
H07	Intake 18BD	-1.91E-04	9.88E-03	-0.199486565	1.895610275	-1.949705777
H08	Intake 18BU	-1.48E-03	5.03E-02	-0.622641394	3.481782545	-2.859116111
W00	B2CC 1	-3.12E-04	7.15E-03	-3.65E-02	-0.140505707	2.938358355
W01	B2CC 2	-3.12E-04	7.15E-03	-3.65E-02	-0.140505707	2.938358355
U00	B2CC 5	3.17E-03	-6.33E-02	0.400225642	-1.083177459	6.947499633
U01	B2CC 6	3.10E-03	-0.066498946	0.452720424	-1.296010872	7.479444716
V00	B2CC 3	1.01E-03	-2.21E-02	0.179187233	-0.905251118	7.531515656
V01	B2CC 4	1.01E-03	-2.21E-02	0.179187233	-0.905251118	7.531515656

Footnote: The last letter in the location name for B2 intake transducers indicates aiming direction (U = up; D = down)

Appendix G

Analysis of Variance and Least-square Means for FGE Estimates among B2 Turbine Intakes

Appendix G.1. Analysis of Variance and Tests for Differences in Least Square Means in FGE among B2 Turbine Units in Spring 2004

```

----- SEASON=SPRING -----

The Mixed Procedure

Model Information

Data Set                WORK.UNIT
Dependent Variable      FGE
Covariance Structure    Autoregressive
Estimation Method       REML
Residual Variance Method Profile
Fixed Effects SE Method Model-Based
Degrees of Freedom Method Between-Within

Class Level Information

Class   Levels   Values
UNIT    8         11 12 13 14 15 16 17 18
JDAY    47        106 107 108 109 110 111 112
                113 114 115 116 117 118 119
                120 121 122 123 124 125 126
                127 128 129 130 131 132 133
                134 135 136 137 138 139 140
                141 142 143 144 145 146 147
                148 149 150 151 152

Dimensions

Covariance Parameters      2
Columns in X                9
Columns in Z                0
Subjects                    376
Max Obs Per Subject        1

Number of Observations

Number of Observations Read      376
Number of Observations Used      363
Number of Observations Not Used   13

The SAS System

----- SEASON=SPRING -----

The Mixed Procedure

Iteration History

Iteration   Evaluations   -2 Res Log Like   Criterion
-----
0           1           2474.68060283
1           1           2474.68060283   0.00000000

Convergence criteria met but final hessian is not positive
definite.
    
```

Covariance Parameter Estimates

Cov Parm	Estimate
AR(1)	0
Residual	57.2371

Fit Statistics

-2 Res Log Likelihood	2474.7
AIC (smaller is better)	2478.7
AICC (smaller is better)	2478.7
BIC (smaller is better)	2486.5

Null Model Likelihood Ratio Test

DF	Chi-Square	Pr > ChiSq
1	0.00	1.0000

Type 3 Tests of Fixed Effects

Effect	Num DF	Den DF	F Value	Pr > F
UNIT	7	355	41.56	<.0001

The SAS System

----- SEASON=SPRING -----

The Mixed Procedure

Least Squares Means

Effect	UNIT	Estimate	Standard Error	DF	t Value	Pr > t
UNIT	11	43.8489	1.1035	355	39.73	<.0001
UNIT	12	46.8617	1.1035	355	42.46	<.0001
UNIT	13	49.6702	1.1035	355	45.01	<.0001
UNIT	14	40.3426	1.1035	355	36.56	<.0001
UNIT	15	60.4532	1.1035	355	54.78	<.0001
UNIT	16	55.6500	1.2975	355	42.89	<.0001
UNIT	17	53.5851	1.1035	355	48.56	<.0001
UNIT	18	40.9745	1.1035	355	37.13	<.0001

Hydroacoustic Evaluation of Fish Passage through Bonneville Dam in 2004

Differences of Least Squares Means							
Effect	UNIT	_UNIT	Estimate	Standard Error	DF	t Value	Pr > t
UNIT	11	12	-3.0128	1.5606	355	-1.93	0.0543
UNIT	11	13	-5.8213	1.5606	355	-3.73	0.0002
UNIT	11	14	3.5064	1.5606	355	2.25	0.0253
UNIT	11	15	-16.6043	1.5606	355	-10.64	<.0001
UNIT	11	16	-11.8011	1.7033	355	-6.93	<.0001
UNIT	11	17	-9.7362	1.5606	355	-6.24	<.0001
UNIT	11	18	2.8745	1.5606	355	1.84	0.0663
UNIT	12	13	-2.8085	1.5606	355	-1.80	0.0728
UNIT	12	14	6.5191	1.5606	355	4.18	<.0001
UNIT	12	15	-13.5915	1.5606	355	-8.71	<.0001
UNIT	12	16	-8.7883	1.7033	355	-5.16	<.0001
UNIT	12	17	-6.7234	1.5606	355	-4.31	<.0001
UNIT	12	18	5.8872	1.5606	355	3.77	0.0002
UNIT	13	14	9.3277	1.5606	355	5.98	<.0001
UNIT	13	15	-10.7830	1.5606	355	-6.91	<.0001
UNIT	13	16	-5.9798	1.7033	355	-3.51	0.0005
UNIT	13	17	-3.9149	1.5606	355	-2.51	0.0126
UNIT	13	18	8.6957	1.5606	355	5.57	<.0001
UNIT	14	15	-20.1106	1.5606	355	-12.89	<.0001
UNIT	14	16	-15.3074	1.7033	355	-8.99	<.0001
UNIT	14	17	-13.2426	1.5606	355	-8.49	<.0001
UNIT	14	18	-0.6319	1.5606	355	-0.40	0.6858
UNIT	15	16	4.8032	1.7033	355	2.82	0.0051
UNIT	15	17	6.8681	1.5606	355	4.40	<.0001
UNIT	15	18	19.4787	1.5606	355	12.48	<.0001
UNIT	16	17	2.0649	1.7033	355	1.21	0.2262
UNIT	16	18	14.6755	1.7033	355	8.62	<.0001
UNIT	17	18	12.6106	1.5606	355	8.08	<.0001

Appendix G.2. Analysis of Variance and Tests for Differences in Least Square Means in FGE among B2 Turbine Units in Summer 2004

```

The SAS System
----- SEASON=SUMMER -----

The Mixed Procedure

Model Information

Data Set                WORK.UNIT
Dependent Variable      FGE
Covariance Structure    Autoregressive
Estimation Method       REML
Residual Variance Method Profile
Fixed Effects SE Method Model-Based
Degrees of Freedom Method Between-Within

Class Level Information

Class   Levels   Values
UNIT    8         11 12 13 14 15 16 17 18
JDAY    45        153 154 155 156 157 158 159
          160 161 162 163 164 165 166
          167 168 169 170 171 172 173
          174 175 176 177 178 179 180
          181 182 183 184 185 186 187
          188 189 190 191 192 193 194
          195 196 197

Dimensions

Covariance Parameters      2
Columns in X               9
Columns in Z               0
Subjects                   360
Max Obs Per Subject        1

Number of Observations

Number of Observations Read      360
Number of Observations Used      349
Number of Observations Not Used   11

The SAS System
----- SEASON=SUMMER -----

The Mixed Procedure

Iteration History

Iteration   Evaluations   -2 Res Log Like   Criterion
          0             1           2676.35647588
          1             1           2676.35647588           0.00000000

Convergence criteria met but final hessian is not positive
definite.
    
```

Covariance Parameter Estimates

Cov Parm	Estimate
AR(1)	0
Residual	137.29

Fit Statistics

-2 Res Log Likelihood	2676.4
AIC (smaller is better)	2680.4
AICC (smaller is better)	2680.4
BIC (smaller is better)	2688.1

Null Model Likelihood Ratio Test

DF	Chi-Square	Pr > ChiSq
1	0.00	1.0000

Type 3 Tests of Fixed Effects

Effect	Num DF	Den DF	F Value	Pr > F
UNIT	7	341	43.66	<.0001

The SAS System

----- SEASON=SUMMER -----

The Mixed Procedure

Least Squares Means

Effect	UNIT	Estimate	Standard Error	DF	t Value	Pr > t
UNIT	11	42.0689	1.7467	341	24.08	<.0001
UNIT	12	30.2844	1.7467	341	17.34	<.0001
UNIT	13	35.8867	1.7467	341	20.55	<.0001
UNIT	14	34.5578	1.7467	341	19.78	<.0001
UNIT	15	55.4791	1.7869	341	31.05	<.0001
UNIT	16	52.8122	1.8299	341	28.86	<.0001
UNIT	17	43.5800	1.7467	341	24.95	<.0001
UNIT	18	18.7700	1.8527	341	10.13	<.0001

Hydroacoustic Evaluation of Fish Passage through Bonneville Dam in 2004

Differences of Least Squares Means							
Effect	UNIT	_UNIT	Estimate	Standard Error	DF	t Value	Pr > t
UNIT	11	12	11.7844	2.4702	341	4.77	<.0001
UNIT	11	13	6.1822	2.4702	341	2.50	0.0128
UNIT	11	14	7.5111	2.4702	341	3.04	0.0025
UNIT	11	15	-13.4102	2.4988	341	-5.37	<.0001
UNIT	11	16	-10.7433	2.5297	341	-4.25	<.0001
UNIT	11	17	-1.5111	2.4702	341	-0.61	0.5411
UNIT	11	18	23.2989	2.5462	341	9.15	<.0001
UNIT	12	13	-5.6022	2.4702	341	-2.27	0.0240
UNIT	12	14	-4.2733	2.4702	341	-1.73	0.0845
UNIT	12	15	-25.1946	2.4988	341	-10.08	<.0001
UNIT	12	16	-22.5278	2.5297	341	-8.91	<.0001
UNIT	12	17	-13.2956	2.4702	341	-5.38	<.0001
UNIT	12	18	11.5144	2.5462	341	4.52	<.0001
UNIT	13	14	1.3289	2.4702	341	0.54	0.5910
UNIT	13	15	-19.5924	2.4988	341	-7.84	<.0001
UNIT	13	16	-16.9255	2.5297	341	-6.69	<.0001
UNIT	13	17	-7.6933	2.4702	341	-3.11	0.0020
UNIT	13	18	17.1167	2.5462	341	6.72	<.0001
UNIT	14	15	-20.9213	2.4988	341	-8.37	<.0001
UNIT	14	16	-18.2544	2.5297	341	-7.22	<.0001
UNIT	14	17	-9.0222	2.4702	341	-3.65	0.0003
UNIT	14	18	15.7878	2.5462	341	6.20	<.0001
UNIT	15	16	2.6669	2.5576	341	1.04	0.2978
UNIT	15	17	11.8991	2.4988	341	4.76	<.0001
UNIT	15	18	36.7091	2.5739	341	14.26	<.0001
UNIT	16	17	9.2322	2.5297	341	3.65	0.0003
UNIT	16	18	34.0422	2.6040	341	13.07	<.0001
UNIT	17	18	24.8100	2.5462	341	9.74	<.0001

Appendix G.3. Analysis of Variance and Tests for Differences in Least Square Means in FGE among TIE and No TIES Conditions for Intakes at Units 15-18 in Spring 2004

```

Intakes at Units 15-18 - Effect of TIES
----- SEASON=SPRING -----

The Mixed Procedure

Model Information

Data Set                WORK.TIE
Dependent Variable      FGE
Covariance Structure    Autoregressive
Estimation Method       REML
Residual Variance Method Profile
Fixed Effects SE Method Model-Based
Degrees of Freedom Method Between-Within

Class Level Information

Class   Levels   Values
TIE      2      NT T
JDAY    47      106 107 108 109 110 111 112
          113 114 115 116 117 118 119
          120 121 122 123 124 125 126
          127 128 129 130 131 132 133
          134 135 136 137 138 139 140
          141 142 143 144 145 146 147
          148 149 150 151 152

Dimensions

Covariance Parameters      2
Columns in X                3
Columns in Z                0
Subjects                    282
Max Obs Per Subject        1

Number of Observations

Number of Observations Read      282
Number of Observations Used      269
Number of Observations Not Used   13

Intakes at Units 15-18 - Effect of TIES
----- SEASON=SPRING -----

The Mixed Procedure

Iteration History

Iteration   Evaluations   -2 Res Log Like   Criterion
          0             1       1922.97586663
          1             1       1922.97586663       0.00000000

Convergence criteria met but final hessian is not positive
definite.
    
```

Covariance Parameter Estimates	
Cov Parm	Estimate
AR(1)	0
Residual	75.7865

Fit Statistics	
-2 Res Log Likelihood	1923.0
AIC (smaller is better)	1927.0
AICC (smaller is better)	1927.0
BIC (smaller is better)	1934.3

Null Model Likelihood Ratio Test		
DF	Chi-Square	Pr > ChiSq
1	0.00	1.0000

Type 3 Tests of Fixed Effects				
Effect	Num DF	Den DF	F Value	Pr > F
TIE	1	267	103.08	<.0001
Intakes at Units 15-18 - Effect of TIES				

----- SEASON=SPRING -----

The Mixed Procedure						
Least Squares Means						
Effect	TIE	Estimate	Standard Error	DF	t Value	Pr > t
TIE	NT	59.9713	0.8979	267	66.79	<.0001
TIE	T	48.6686	0.6581	267	73.96	<.0001

Differences of Least Squares Means							
Effect	TIE	_TIE	Estimate	Standard Error	DF	t Value	Pr > t
TIE	NT	T	11.3027	1.1132	267	10.15	<.0001

Appendix G.4. Analysis of Variance and Tests for Differences in Least Square Means in FGE among TIE and No TIES Conditions for Intakes at Units 15-18 in Summer 2004

```

----- SEASON=SUMMER -----
                                The Mixed Procedure

                                Model Information

Data Set                        WORK.TIE
Dependent Variable              FGE
Covariance Structure            Autoregressive
Estimation Method               REML
Residual Variance Method        Profile
Fixed Effects SE Method         Model-Based
Degrees of Freedom Method       Between-Within

                                Class Level Information

Class   Levels   Values
TIE     2        NT T
JDAY    45       153 154 155 156 157 158 159
                               160 161 162 163 164 165 166
                               167 168 169 170 171 172 173
                               174 175 176 177 178 179 180
                               181 182 183 184 185 186 187
                               188 189 190 191 192 193 194
                               195 196 197

                                Dimensions

Covariance Parameters          2
Columns in X                   3
Columns in Z                   0
Subjects                       270
Max Obs Per Subject            1

                                Number of Observations

Number of Observations Read     270
Number of Observations Used     258
Number of Observations Not Used  12

                                Intakes at Units 15-18 - Effect of TIES
----- SEASON=SUMMER -----

                                The Mixed Procedure

                                Iteration History

Iteration   Evaluations   -2 Res Log Like   Criterion
          0             1           2212.61992202
          1             1           2212.61992202   0.00000000

Convergence criteria met but final hessian is not positive
definite.
    
```

Covariance Parameter Estimates	
Cov Parm	Estimate
AR(1)	0
Residual	319.78

Fit Statistics	
-2 Res Log Likelihood	2212.6
AIC (smaller is better)	2216.6
AICC (smaller is better)	2216.7
BIC (smaller is better)	2223.8

Null Model Likelihood Ratio Test		
DF	Chi-Square	Pr > ChiSq
1	0.00	1.0000

Type 3 Tests of Fixed Effects				
Effect	Num DF	Den DF	F Value	Pr > F
TIE	1	256	22.04	<.0001

Intakes at Units 15-18 - Effect of TIES

SEASON=SUMMER

The Mixed Procedure						
Least Squares Means						
Effect	TIE	Estimate	Standard Error	DF	t Value	Pr > t
TIE	NT	50.7648	1.9063	256	26.63	<.0001
TIE	T	39.7394	1.3715	256	28.98	<.0001

Differences of Least Squares Means							
Effect	TIE	_TIE	Estimate	Standard Error	DF	t Value	Pr > t
TIE	NT	T	11.0254	2.3484	256	4.69	<.0001

Appendix H

Analysis of the 2004 Bonneville Dam DIDSON Tracking Data

Hydroacoustic Evaluation of Fish Passage through Bonneville Dam in 2004

Analysis of the 2004 Bonneville Dam

DIDSON Tracking Data

Prepared for:
Gene Ploskey
Battelle Pacific Northwest National Lab
P.O. Box 241
North Bonneville, Washington 98639

Prepared by:
John R. Skalski
Jim Lady
Columbia Basin Research
School of Aquatic and Fishery Sciences
University of Washington
1325 Fourth Avenue, Suite 1820
Seattle, Washington 98101

15 November 2004

Introduction

During spring and summer 2004, the DIDSON was used to track smolt movements in and about the Bonneville 2 corner collector (B2CC) at Bonneville Dam. The DIDSON provided two-dimensional positioning of smolts in time. For each fish track, xy coordinates were provided, along with a time stamp (t) for repeated observation as the fish moved in the vicinity of the DIDSON. Tracks with three or more observations were analyzed in this report.

The goal of the analysis was to characterize the propensity for smolts to enter the B2CC and to compare the probability of entrainment under alternative scenarios. This analysis used minimal assumptions to estimate entrainment rates and to provide a contrast with the Markov analysis of the same data performed by John Hedgepeth.

Statistical Methods

1.1 Track Analysis

The series of x , y , t time-space coordinates were analyzed separately for each DIDSON track. The principal axis of movement (PAM) was defined as the linear vector that best characterized the primary direction of smolt movement in two-dimensional space. The vector of movement was estimated using separate linear regressions for each dimension of the form

$$x_i = \alpha_1 + \beta_1 t_i$$

and

$$y_i = \alpha_2 + \beta_2 t_i,$$

where

x_i = x coordinate (i.e., parallel to dam face) at time t_i ,

y_i = y coordinate (i.e., perpendicular to dam face) at time t_i ,

t_i = time of the i th track observation.

Hence, the PAM was defined as

$$\begin{bmatrix} x_i \\ y_i \end{bmatrix} = \begin{bmatrix} \hat{\alpha}_1 + \hat{\beta}_1 t_i \\ \hat{\alpha}_2 + \hat{\beta}_2 t_i \end{bmatrix}.$$

1.2 Proportion of Tracks to Boundary Conditions

The zone of ensonification about the DIDSON was envisioned as a quarter-circle (Figure 1) centered at the barge where the DIDSON was mounted. The edges of the quarter-circle were then subdivided into three absorption or boundary conditions, i.e., B2CC (220° line), eddy (130° line), and forebay (Figure 1).

For each fish, the calculated principal axis of movement was used to project the fish track to the boundary of the quarter-circle. Hence, each fish track was translated to a multiple Bernoulli response of either contacting the B2CC, eddy, or forebay location.

These projections to the boundary conditions were performed two ways. One approach was to use the entire DIDSON track. These data provided multinomial counts to later be compared under alternative conditions. The other approach was to use the DIDSON tracks once a fish entered a zone within the quarter-circle (Figure 2). These results were used to estimate the probabilities of entrainment by locale within the quarter-circle.

1.3 Comparison of B2CC Operations

The DIDSON data were collected and analyzed separately for spring and summer; day and night. These classifications resulted in a 2 x 2 factorial design. General linear models using a logit-link and binomial-error structure were used to compare the proportion of fish passing into the B2CC (i.e., PAM projected into the B2CC) under alternative conditions. Quasi-likelihood methods based on analysis of deviance (ANODEV) were used to test the main effect of season, and time of day. A degree-of-freedom table for the ANODEV is depicted below:

Figure 1. Schematic of ensonified zone about the DIDSON at Bonneville Dam, subdividing the edges of the field into B2CC, eddy, and forebay locations.

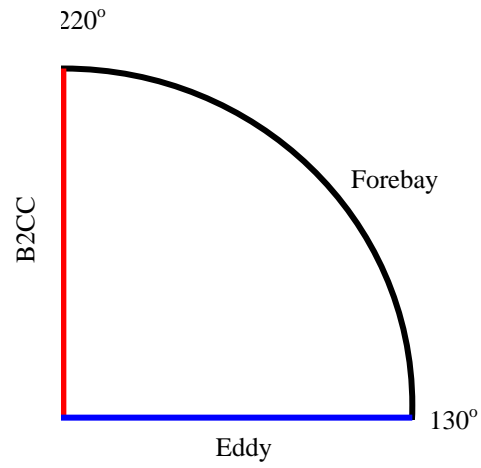
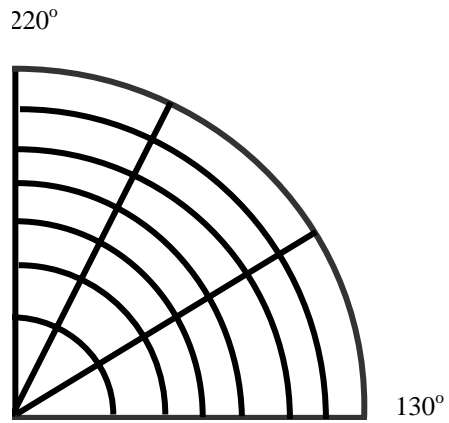

Figure 2. Schematic of how the ensonified quarter-circle about the DIDSON was subdivided into separate cells (i.e., wedges) to estimate the localized probabilities of entrainment.



Source	DF
Total _{Cor}	3
Season	1
Day/Night	1
Error	1

Interaction plots and 95% confidence intervals were calculated to illustrate the observed patterns of entrainment.

1.4 Mapping Zones of Entrainment

Using the proportions of fish entrained into the B2CC by location (Figure 2), contour maps of the zone of entrainment were constructed using a contouring routine in *S-Plus*. The various contours map the probabilities of entrainment radiating away from the B2CC entrance. The contours provide a visual representation of the expected percentages of entrainment through the B2CC as a function of forebay location. Zones of entrainment can be visually compared between spring/summer and day/night. For each monitoring period, the average probability of a PAM being directed towards the B2CC was calculated over the entire zone of ensonification. These proportions were calculating by integrating over the surface of the 3D plots. These average proportions (i.e., probabilities) can be compared to rank the likelihood of entrainment under the different scenarios of spring/summer and day/night.

Results

1.5 Quantitative Comparison of the Probabilities of Entrainment

The calculated PAM is an index or simplification of the complex movement patterns of a fish. Its purpose is to characterize the general direction of movement and project that trend to the boundaries of the DIDSON semicircle. The key assumption in using PAM is that fish continue in the same general direction after leaving the DIDSON observations as when observed. While this assumption cannot be confirmed, it need not be absolutely true to compare movement between monitoring scenarios. As long as any projection bias is constant, relative movements

between monitoring scenarios can be compared, although the actual values for the estimated entrainment proportion may be biased.

Table 1 summarizes the counts of fish projected into the three boundary conditions for each of the four monitoring conditions. Table 2 reports the observed proportions of fish with projections into the three boundary conditions for each of the four monitoring conditions. Using the marginals for entering the B2CC, generalized linear model (GLM) analysis assessed the effects of day/night and spring/summer on entrance efficiency. The resulting ANODEV table and corresponding F-tests are presented in Table 3. No significant difference in B2CC entrainment was observed between night/day ($P = 0.5471$) and spring/summer ($P = 0.1975$). It is not surprising these tests are not significant because of the minimal number of degrees of freedom. Table 4 summarizes the proportions of PAMs projected into the B2CC by season and time of day. Spring-night conditions had the highest B2CC use projections (0.4605 , $\widehat{SE} = 0.0126$), while summer-night conditions had the lowest projections (0.2762 , $\widehat{SE} = 0.0140$). Figure 3 presents the season by day/night interaction plot for the proportion of fish with PAMs toward the B2CC.

1.6 Graphical Comparisons of Entrainment Projections

Table 4 suggests differences between day/night and spring/summer in the proportions of PAMs into the B2CC. Gridding the zone of ensonification (Figure 2), the proportions of PAMs projected into the B2CC by locations were computed for each of the four day/night, spring/summer scenarios (Figures 4-7). These observed projections were then contoured to provide 3D plots of zones of entrainment in the vicinity of the B2CC. For each scenario, raw counts, localized proportions, 3D contour and 2D contour plots are provided. In estimating the proportions, neighboring cell counts were pooled to produce minimum counts of 10 or more in most circumstances. The same spatial pattern of pooled cells were used in all four scenarios to enhance comparability between figures. The perspective of the 3D contour plot is with the 130° eddy boundary in front and looking down the 220° axis. For the 2D contour plot, the 130° and 200° axes are labeled.

To compare the B2CC performance under the four different time periods, the area under the 3D contour plots was integrated to calculate an average proportion (Table 5). The spring –

night scenario had the higher average entrainment proportion, 0.307, summer – day the lowest proportion, 0.201.

These performance matrices again suggest B2CC passage was greater under spring-night conditions. These proportions can be interpreted as the average probability of entrainment across the ensonified zone. Alternatively, the proportion can be interpreted as the probability of entrainment for a randomly positioned fish in the ensonified zone.

1.7 Graphical Comparison of Movement into the Eddy

Another response considered was the proportion of PAMs directed toward the 130° axis (Figure 1) and into the eddy at Bonneville Dam. Three-dimensional contours of the proportions or probabilities of a PAM directed toward the eddy were constructed for spring – day (Figure 8), spring – night (Figure 9), summer – day (Figure 10), and summer – night (Figure 11). In all cases, except in the immediate vicinity of the B2CC, the vast majority of fish tracks were towards the eddy. The summer – day scenario had the highest probability of fish movement into the eddy, 0.741, and spring – night the lowest, 0.585 (Table 5).

Table 1. Counts of DIDSON tracks where principal axis of movement (PAM) contracted the B2CC , eddy, or forebay boundaries (Figure 1) under different monitoring conditions.

Season	Day/Night	B2CC	Eddy	Forebay	Total
Spring	Day	846	1169	137	2152
Spring	Night	716	715	124	1555
Summer	Day	375	811	79	1265
Summer	Night	277	684	55	1016

Table 2. Percentages of DIDSON tracks where PAMs contacted the B2CC, eddy, or forebay boundaries (Figure 1) under different monitoring conditions.

Season	Day/Night	B2CC	Eddy	Forebay
Spring	Day	0.3931	0.5432	0.0637
Spring	Night	0.4605	0.4598	0.0797
Summer	Day	0.2964	0.6411	0.0601
Summer	Night	0.2726	0.6732	0.0541

Table 3. The ANODEV table testing the main effects of day/night and season on the proportion of PAMs projected into the B2CC.

Source	DF	DEV	MDEV	F	P
TotalCor	3	131.5652			
Day/Night	1	5.2514	5.2514	$F_{1,1} = 0.4511$	0.6235
Season	1	114.6731	114.6731	$F_{1,1} = 9.8511$	0.1964
Error	1	11.6407	11.6407		

Table 4. Proportions of PAMs projected into the B2CC under the combination of day/night and season at Bonneville Dam in 2004.

Condition	Sample Size	Proportion	SE
Spring – Day	2152	0.3931	0.0153
Spring – Night	1555	0.4605	0.0126
Summer – Day	1265	0.2964	0.0128
Summer – Night	1016	0.2726	0.0140

Table 5. Average proportions or probabilities of smolts entering the B2CC or moving into the eddy based on the integration of the 3D contour plots.

Condition	Average Proportion into B2CC	Average Proportion into Eddy
Spring – Day	0.263	0.663
Spring – Night	0.307	0.585
Summer – Day	0.201	0.723
Summer – Night	0.211	0.741

Figure 3. Proportions of PAMs into the B2CC and associated 95% confidence intervals for smolt at Bonneville Dam spring/summer and night/day in 2004.

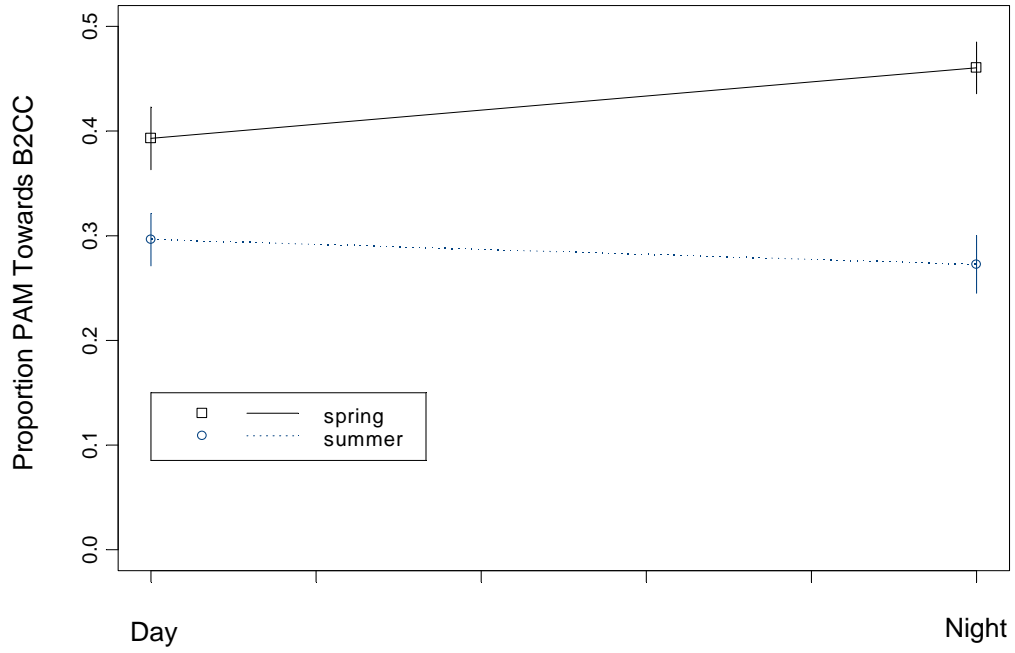
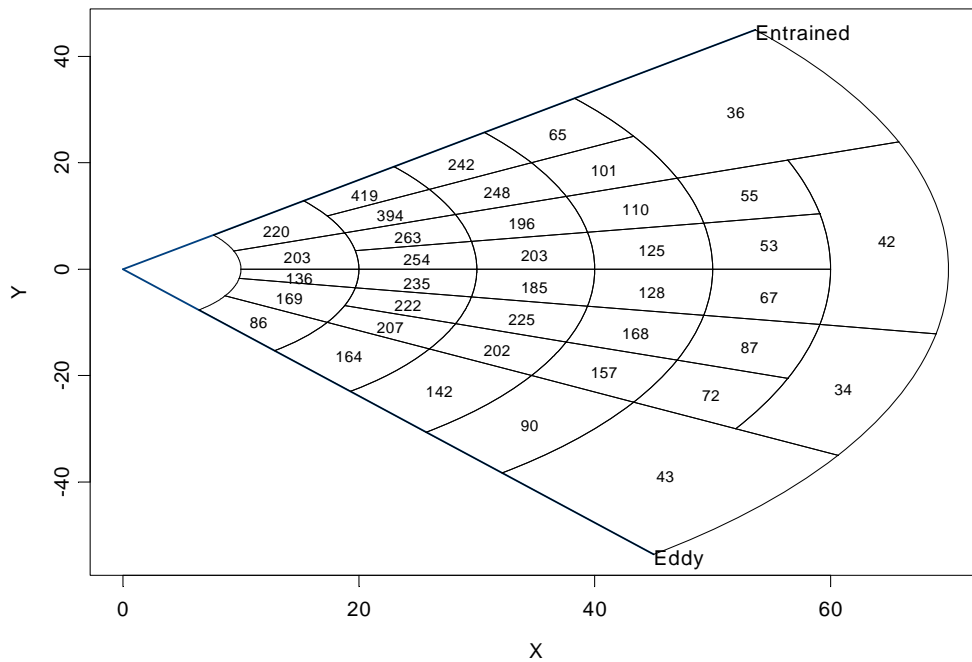

Figure 4. Graphical plots of the proportions of PAMs projected into the B2CC as a function of forebay location for the spring – day scenario at Bonneville Dam in 2004. Subplots (a) raw counts by location, (b) observed proportions by location, (c) 3D contour plot looking down the 220° axis, and (d) 2D contour plot.

a. Raw counts by location



b. Observed proportions by location

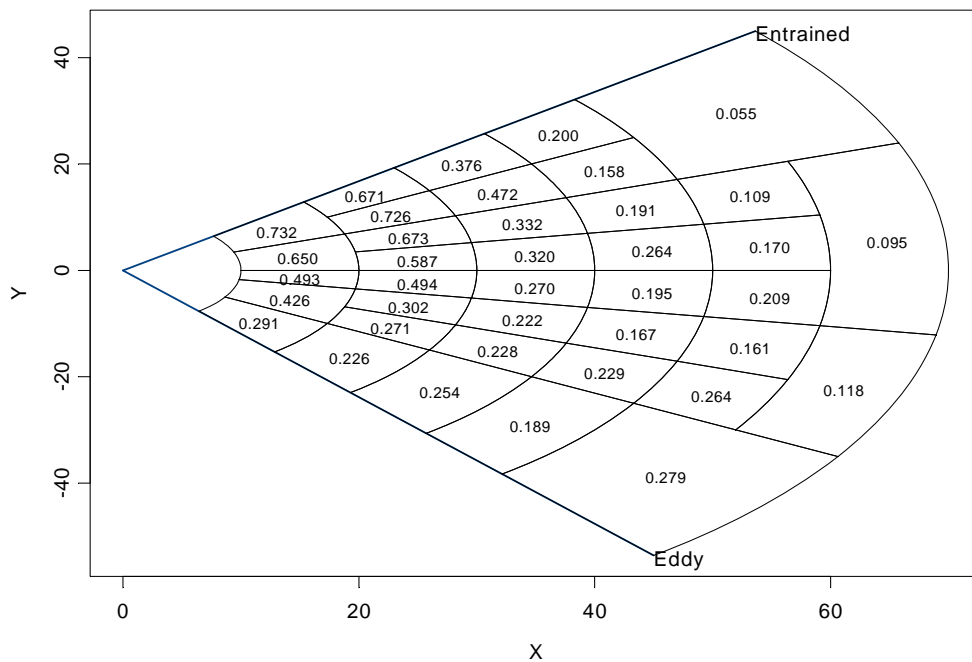
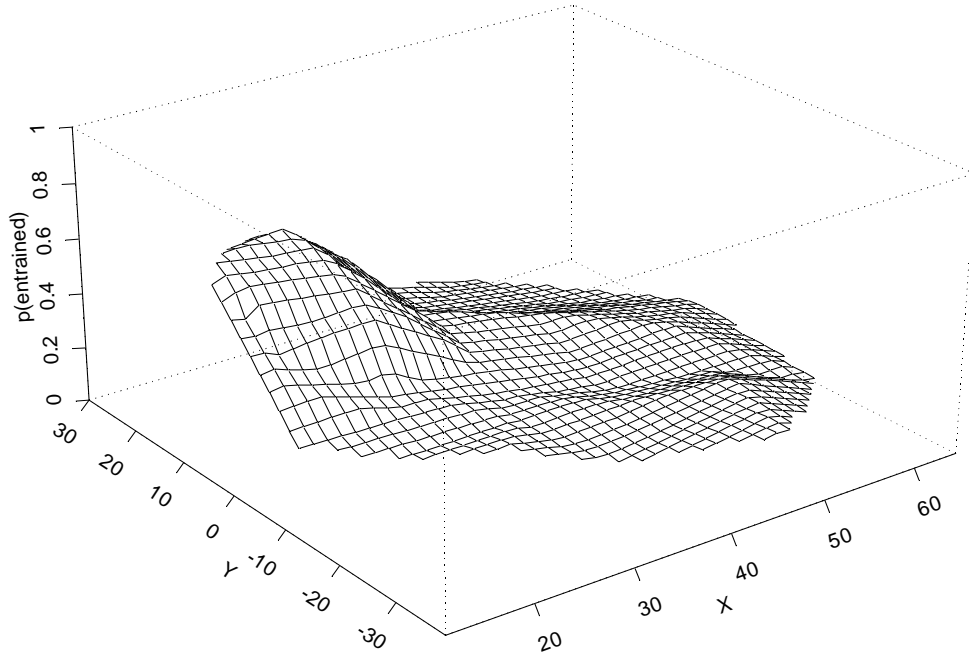

Figure 4. (Continued)

c. 3D contour plot looking down the 220° axis



d. 2D contour plot

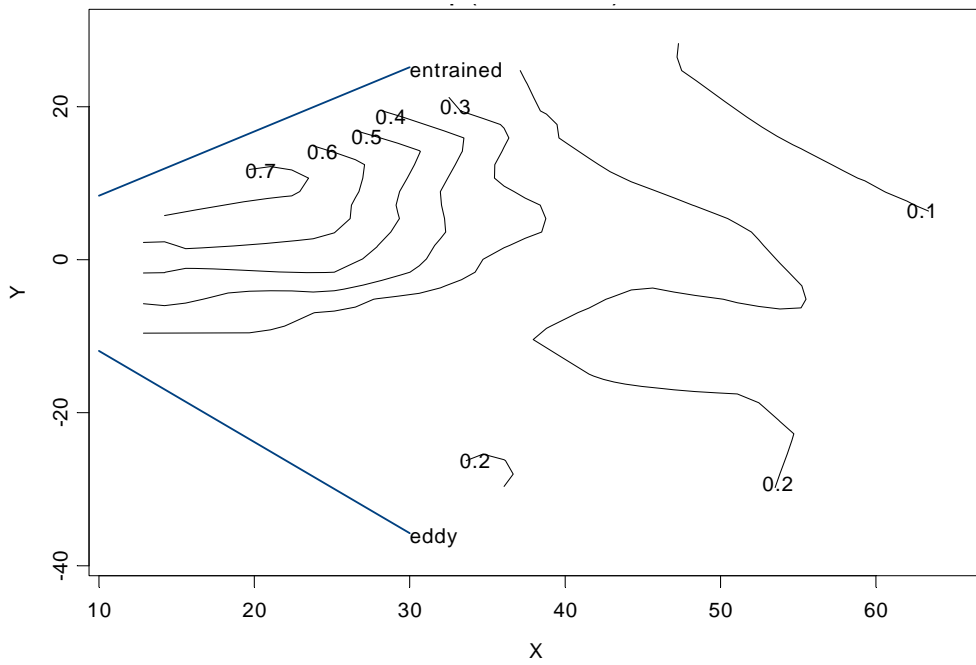
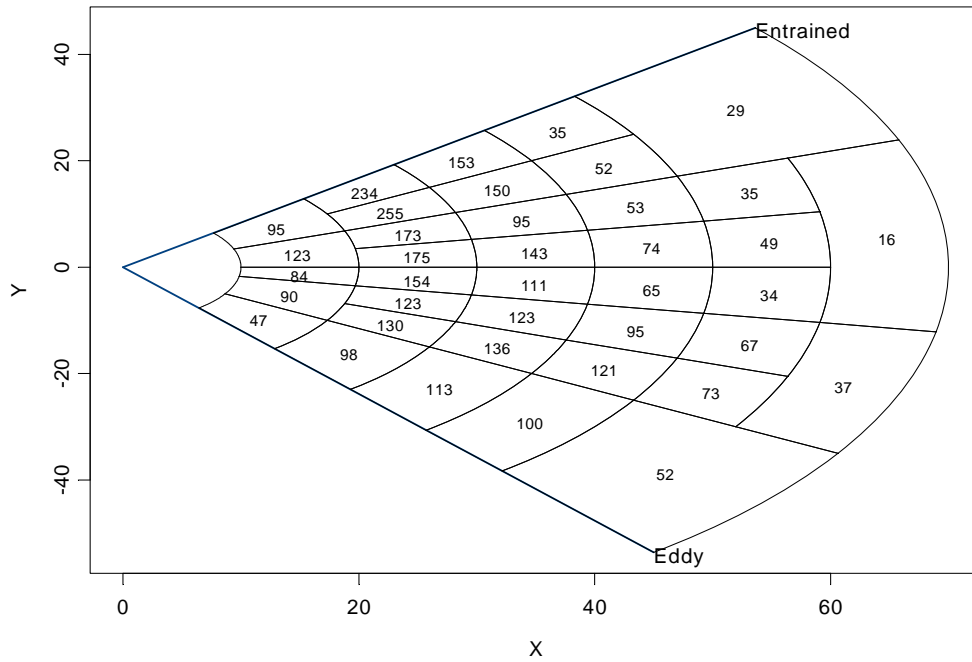

Figure 5. Graphical plots of the proportions of PAMs projected into the B2CC as a function of forebay location for the spring – night scenario at Bonneville Dam in 2004. Subplots (a) raw counts by location, (b) observed proportions by location, (c) 3D contour plot looking down the 220° axis, and (d) 2D contour plot.

a. Raw counts by location



b. Observed proportions by location

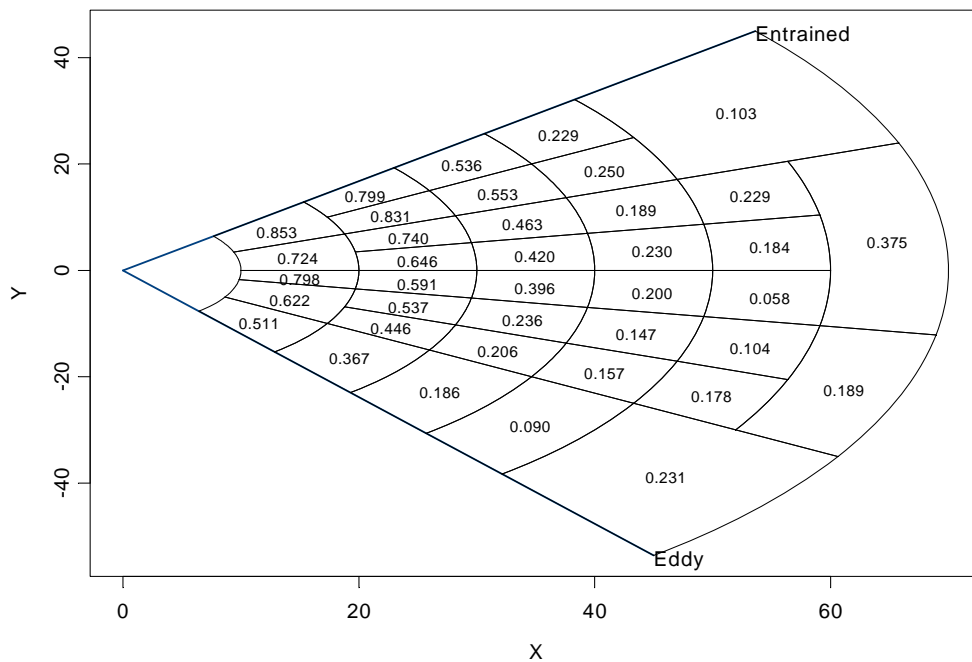
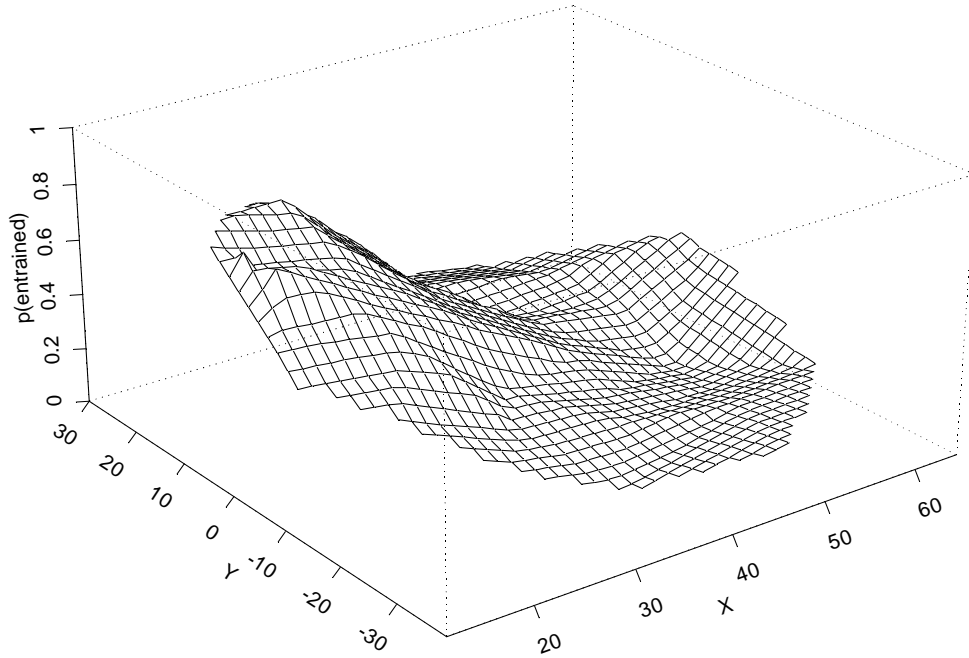

Figure 5. (Continued)

c. 3D contour plot looking down the 220° axis



d. 2D contour plot

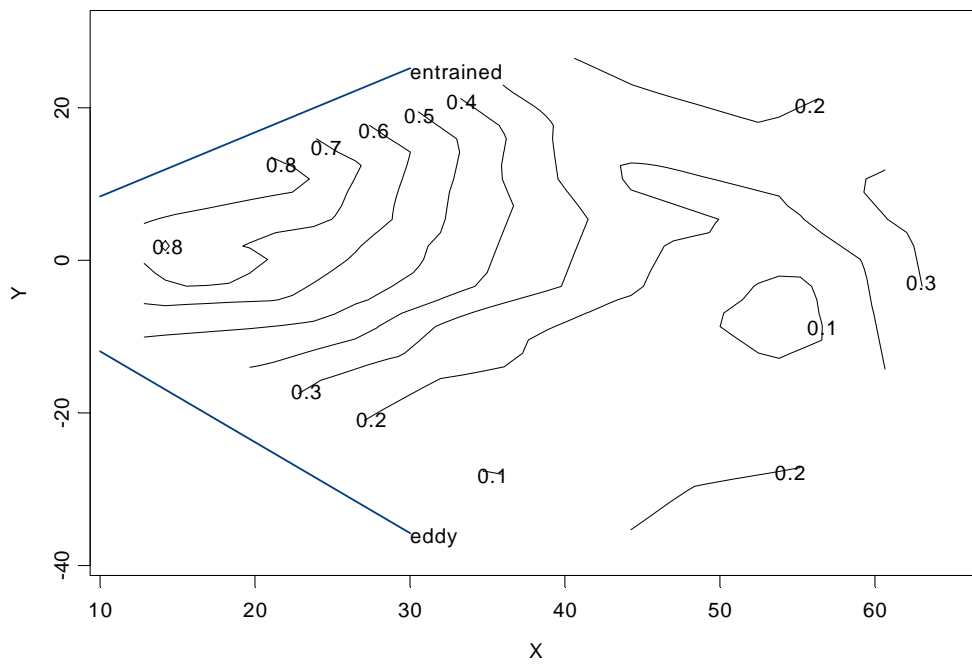
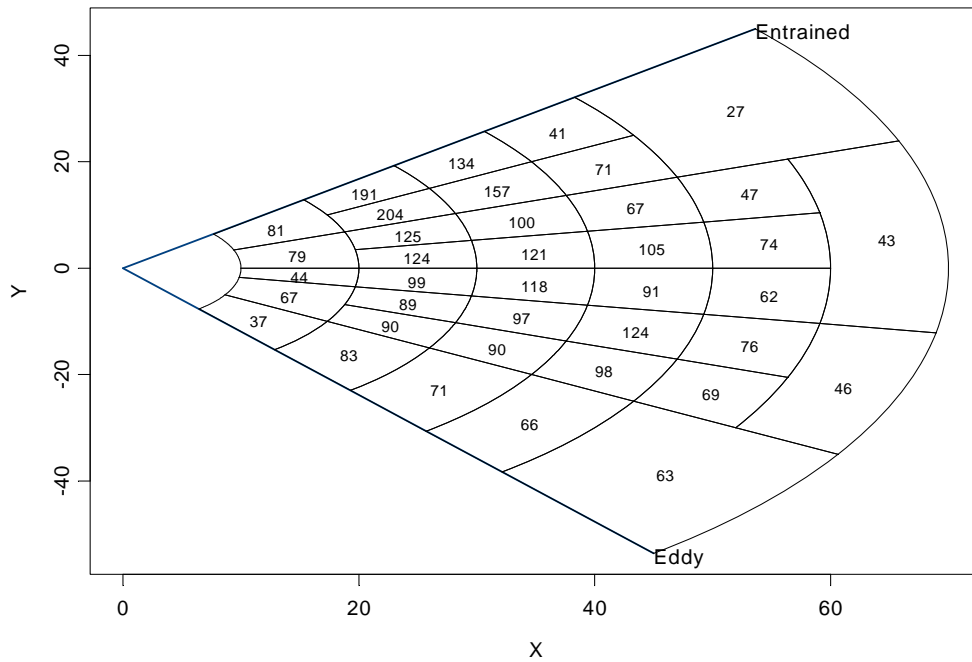

Figure 6. Graphical plots of the proportions of PAMs projected into the B2CC as a function of forebay location for the summer – day scenario at Bonneville Dam in 2004. Subplots (a) raw counts by location, (b) observed proportions by location, (c) 3D contour plot looking down the 220° axis, and (d) 2D contour plot.

a. Raw counts by location



b. Observed proportions by location

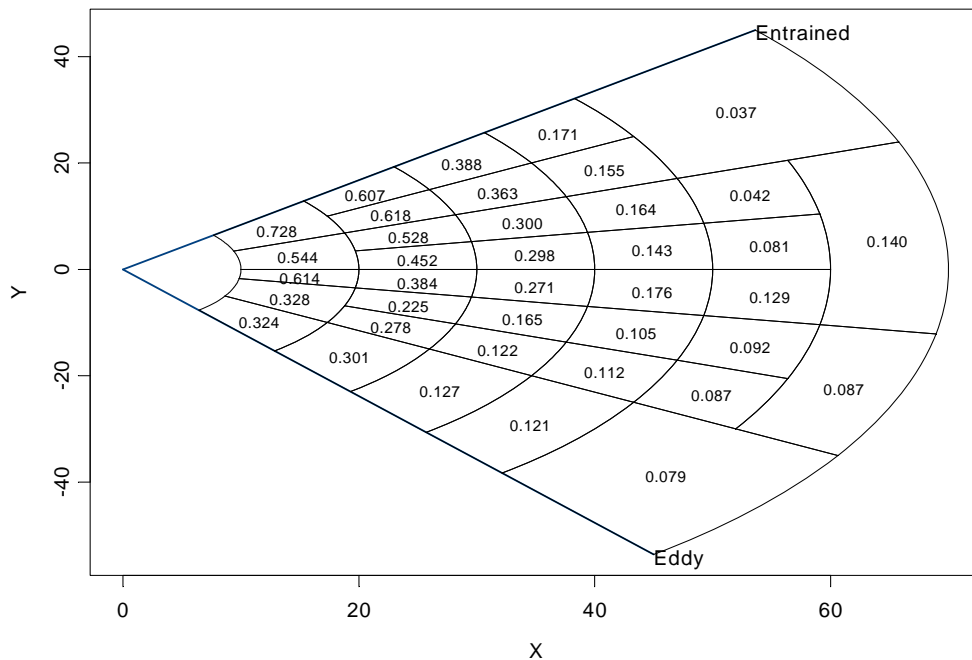
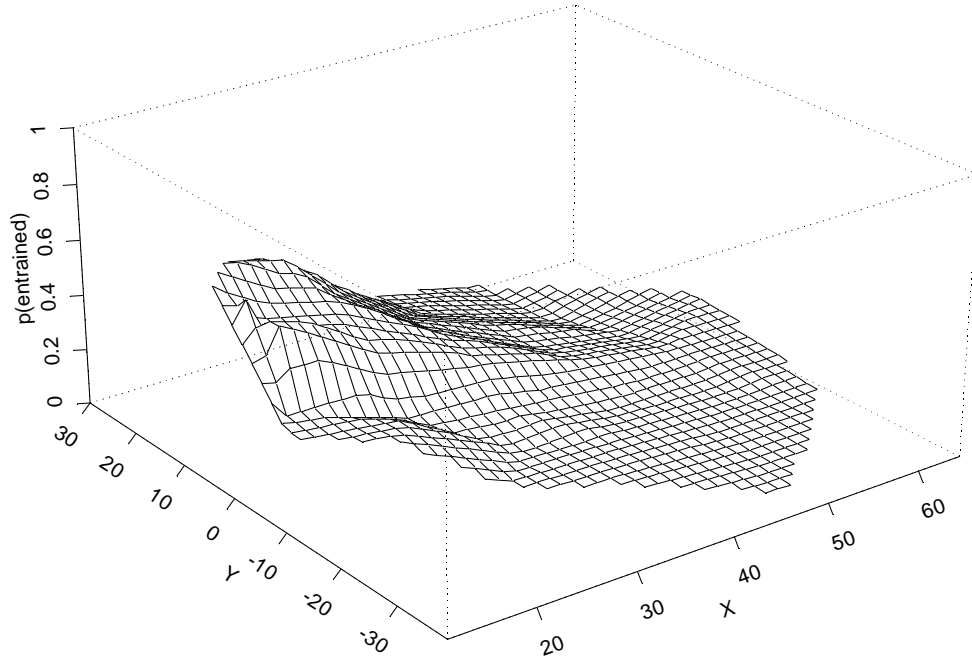

Figure 6. (Continued)

c. 3D contour plot looking down the 220° axis



d. 2D contour plot

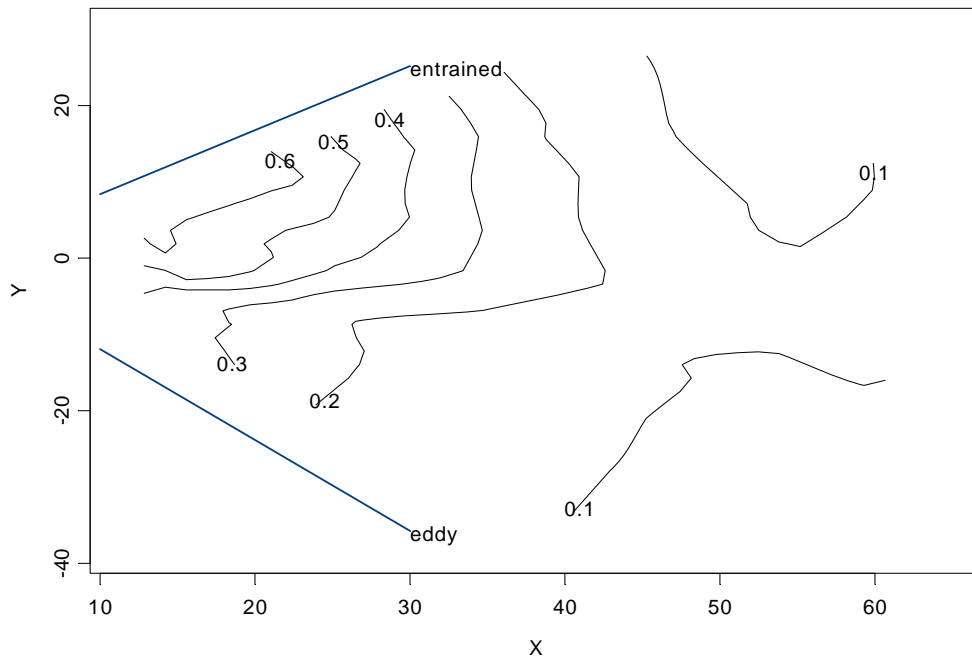
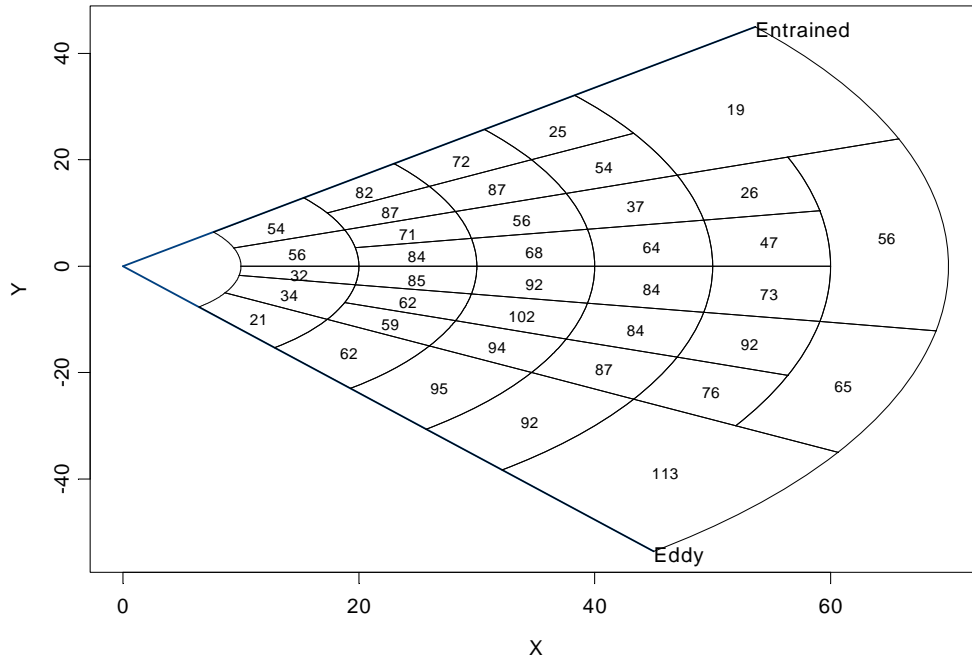

Figure 7. Graphical plots of the proportions of PAMs projected into the B2CC as a function of forebay location for the summer – night scenario at Bonneville Dam in 2004. Subplots (a) raw counts by location, (b) observed proportions by location, (c) 3D contour plot looking down the 220° axis, and (d) 2D contour plot.

a. Raw counts by location



b. Observed proportions by location

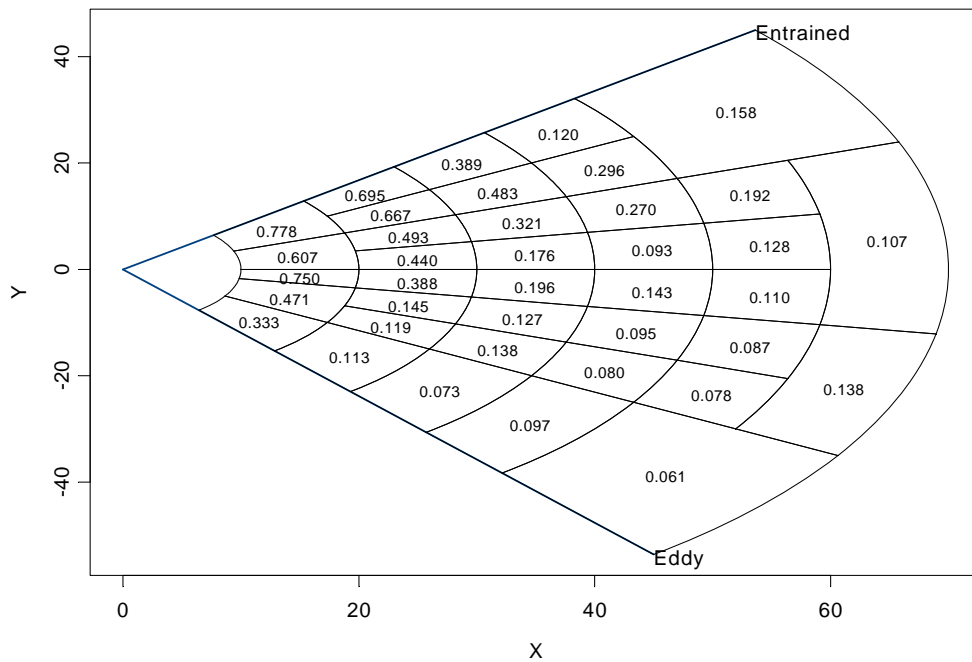
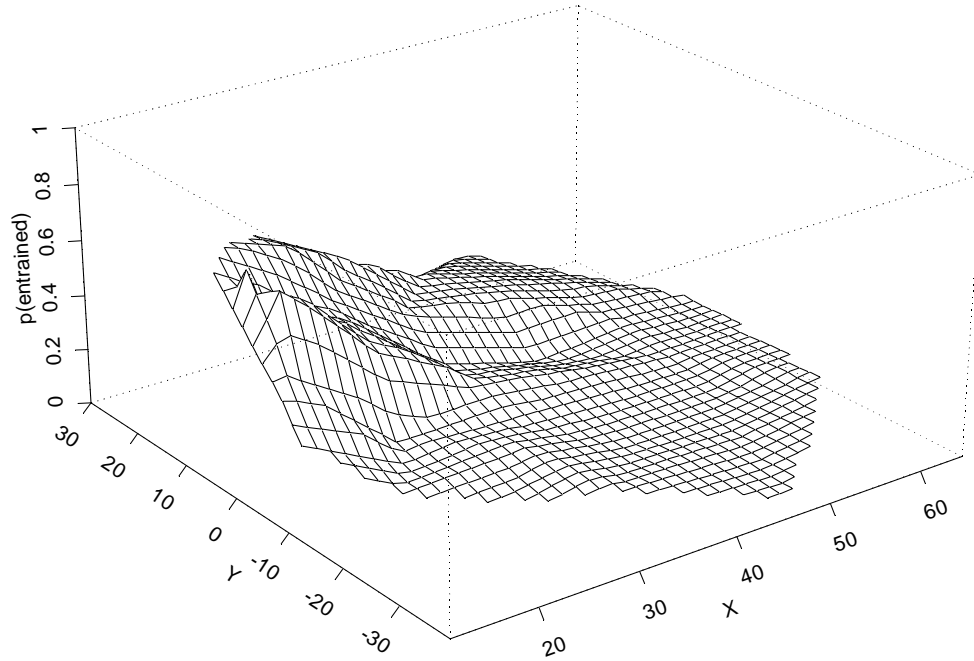

Figure 7. (Continued)

c. 3D contour plot looking down the 220° axis



d. 2D contour plot

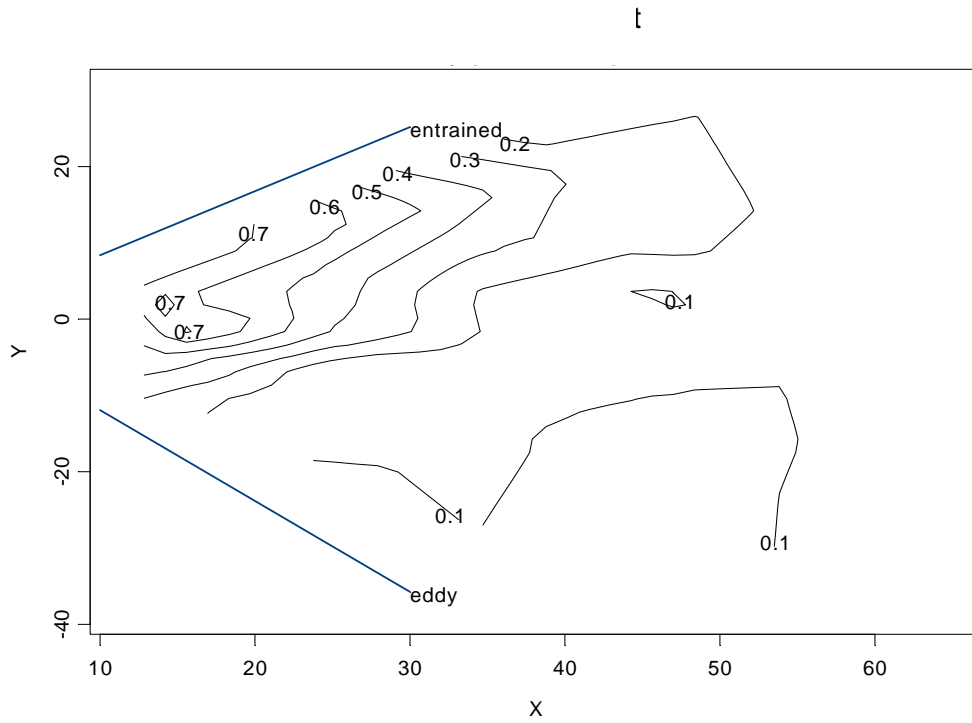

Figure 8. Three-dimensional contour plot of the proportion of PAMs directed towards the eddy of Bonneville Dam during the spring – day monitoring period.

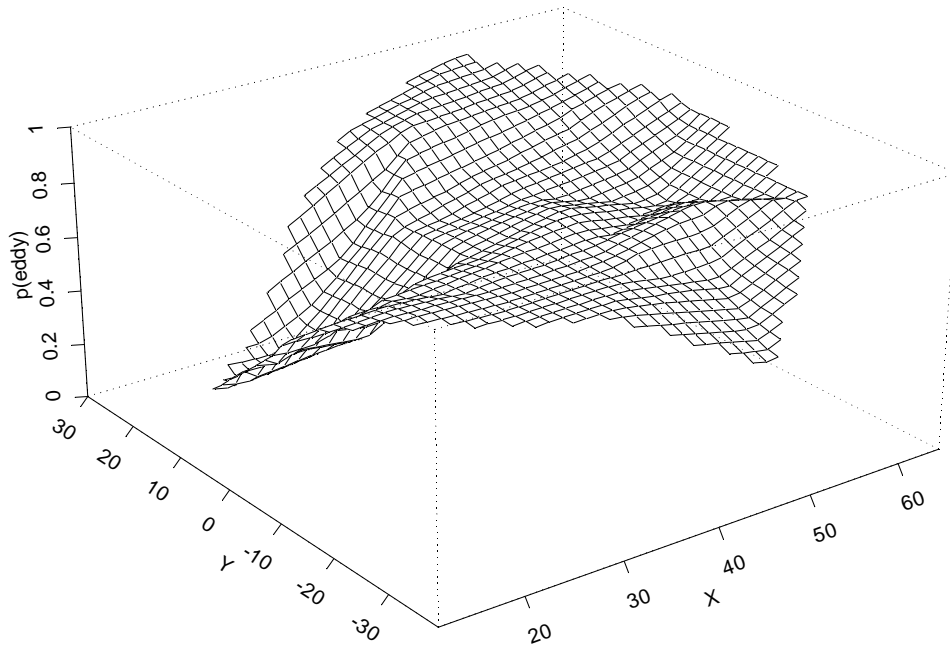

Figure 9. Three-dimensional contour plot of the proportion of PAMs directed towards the eddy of Bonneville Dam during the spring – night monitoring period.

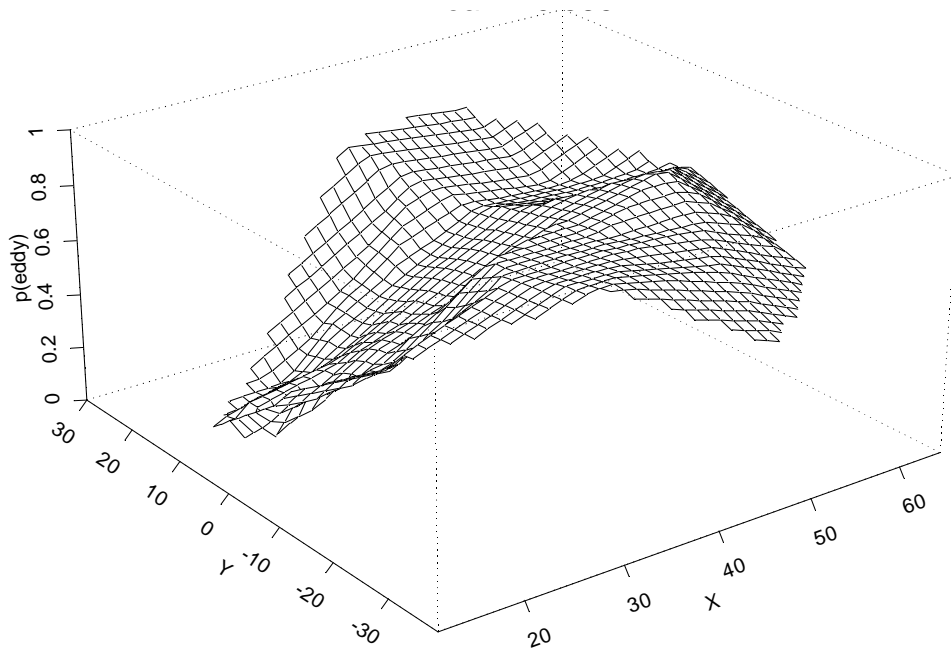

Figure 10. Three-dimensional contour plot of the proportion of PAMs directed towards the eddy of Bonneville Dam during the summer – day monitoring period.

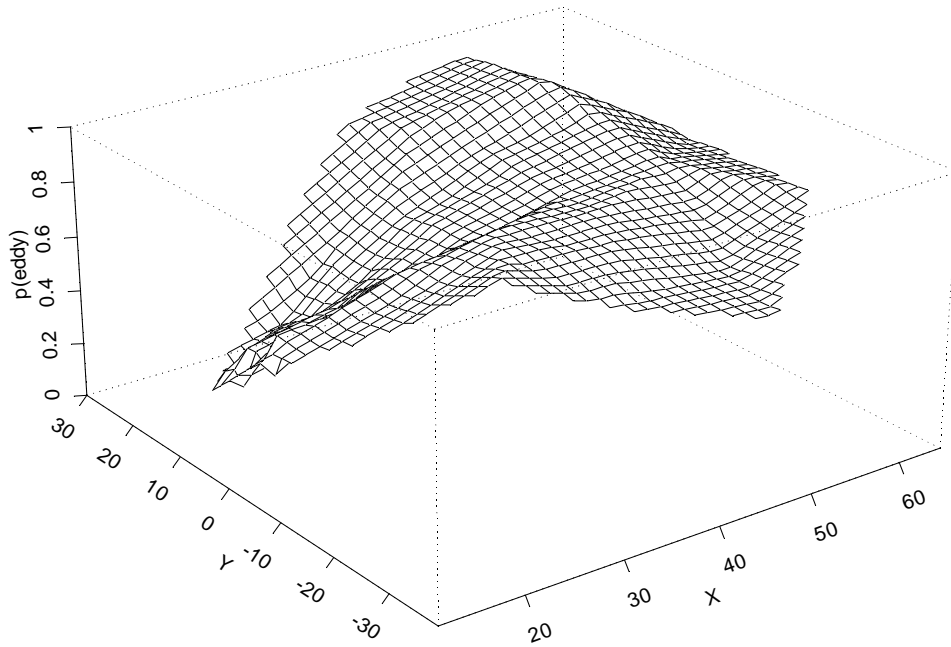
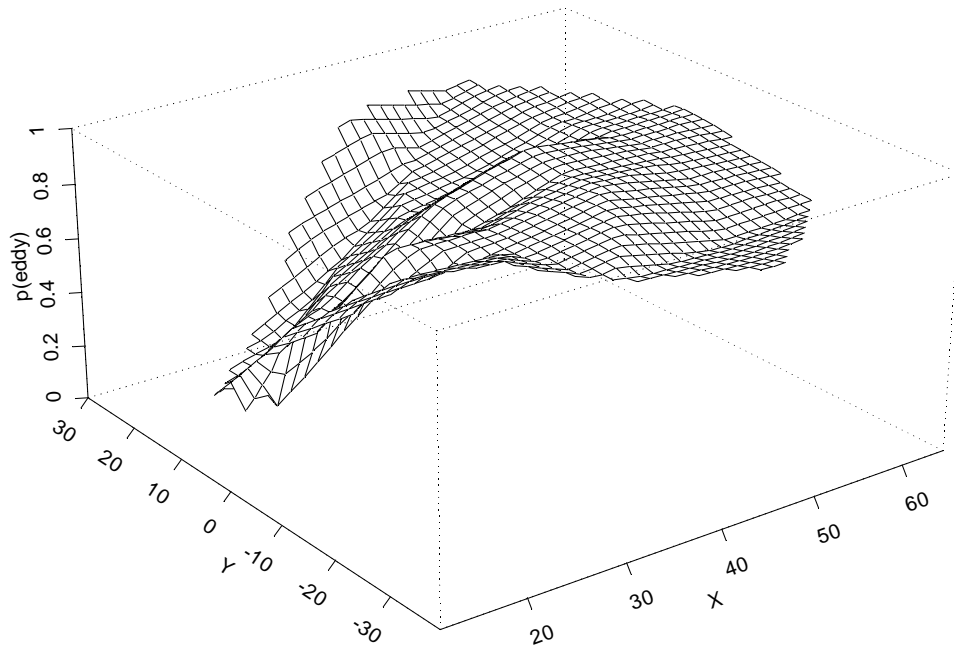

Figure 11. Three-dimensional contour plot of the proportion of PAMs directed towards the eddy of Bonneville Dam during the summer – night monitoring period.



Appendix I

Monitoring of the Differential Head across Vertical Barrier Screens at Bonneville Dam Powerhouse 2 Unit 17

Appendix I

Monitoring of the Differential Head across Vertical Barrier Screens at Bonneville Dam Powerhouse 2 Unit 17

Background

Modifications were made to the turbine intakes and submerged traveling screens (STS) at Bonneville Dam Second Powerhouse. Changes were made to reduce the loss of fish guided by the STS that passed through a gap at the top of the screen back into the turbine intake. These changes include a gap closure device in the gap between the top of the STS and the ceiling of the turbine intake and a turning vein on the STS directing the flow at the top of the STS up into the gateway. These changes have increased flows into the gatewells resulting in increased pressure on the vertical barrier screens (VBS). Flows in unmodified intakes are approximately 304 cfs into the gateway and 202 cfs through the gap at turbine operation of 17,300 cfs. Flows in modified intakes are approximately 487 and 79 cfs into the gateway and through the gap, respectively (Randall Lee, personal communication). Increased flows into the gatewells of modified intakes have caused failure of VBSs.

Changes have been made to the VBSs to reduce the chance of failure. Differential head measurements between the water elevations upstream and downstream at the VBS were measured in 2003 by Pacific Northwest National Lab as a safeguard to monitor against VBS failure and also to summarize the main factors causing increases in differential head across the VBS. During winter 2003 the gatewells of turbine unit 17 were modified. Concrete was removed and new more robust VBS's were installed.

Objectives

The main objectives of this project were to measure differential head between the water elevations upstream and downstream of the VBS at Bonneville Dam Second Powerhouse, monitor increases in head differential due to debris accumulation, and alert the Project when debris levels exceed a preset threshold. A secondary objective was to compare the differences in differential head with dam operations data.

Methods

Differential head was measured with four Druck PTX 1830 2.5 psig pressure transducers. Each transducer was mounted inside a 2 in diameter PVC stilling well. One pressure transducer and stilling well was deployed in the gateway slot upstream of the VBS in both the A and C intakes of unit 17. The stilling wells were attached to the steel guide at the north end of the gatewells and firmly secured with a c-clamp. The transducers and stilling wells deployed downstream of the VBS were installed in the bulkhead slot. The deck plates were removed and using a man basket the pressure transducers were mounted to the north wall of the bulkhead slot in both the A and C intakes of unit 17. All four transducers were installed at 70 ft elevation (mean sea level) and the cables routed to a vented waterproof surface box (Druck model STE 110). A multi-conductor wire with all transducer leads attached was routed from the surface box to a trailer where the wires were connected to a Campbell Scientific CR10X data logger. The data logger controlled the sample rate and stored the data temporarily until downloaded to a computer and archived.

Pressure measurements were collected simultaneously at each of the four pressure transducers at five minute intervals during the juvenile salmonid sampling season from April 26 through July 15, 2004 and divided into two seasons with spring being April 26 through May 30 and summer June 1 through July 15. Pressure data was processed and correlated with dam operations provided by Bonneville Dam operations and fisheries biologists.

Results

Seasonal Trends

Differential head averaged 8.5 in across the VBS in the A intake during spring and 8.4 in during summer. Differential head averaged 6.1 and 6.2 in across the VBS in the C intake in spring and summer, respectively. The maximum differential head measured in the A intake was 15.2 and 15.9 in across the VBS in spring and summer respectively. Maximum differential head was 12.2 and 14.1 in across the VBS in the C intake in spring and summer, respectively (Table I.1). The threshold set for maximum differential head was initially 18 in but was changes to 15.6 in on June 16 after it was determined that this threshold was probably too liberal. The revised threshold was exceeded once on June 11 in the A intake during a 5 minute period at 2300 where the differential head reached 15.90 in (Figure I.1). The duration where the threshold was exceeded was short and correlated with a short peak in discharge. The differential head for the previous 5 minute period was 14.96 in and was 14.06 in for the 5 minute period following the peak. This shows that the differential head can be quite dynamic.

Table I.1. Mean and Maximum Differential Head (in) Measured across the VBSs of Unit 17 Intakes A and C in Spring and Summer 2004

	Spring		Summer	
	A	C	A	C
Mean	8.52	6.06	8.40	6.22
Maximum	15.18	12.16	15.90	14.08

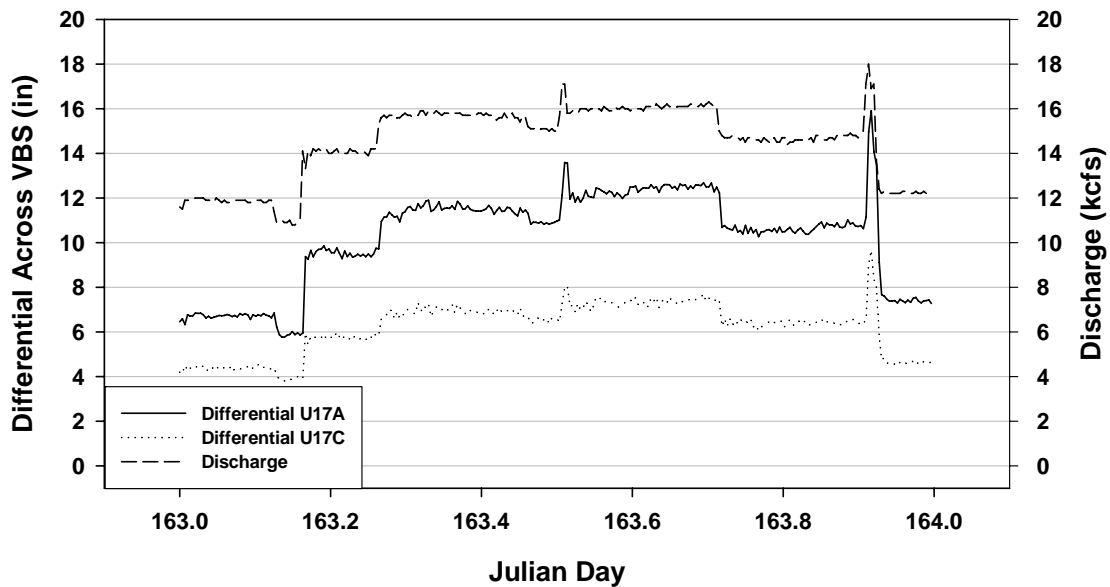

Figure I.1. Differential Head (in) across the VBS at Turbine Unit 17 Intakes A and C, and Operation Level Discharge for the Unit on June 11, 2004. Note: The peak at 2300 hours exceeded the set threshold for differential head for intake A.

Correlation with Operations Data

Differential head for both the A and C intakes were highly correlated with discharge of the unit. For the A intake, unit discharge explained about 85 percent of the change in differential head in both spring and summer, and 68 to 70 percent of the variation in spring and summer for intake C (Table I.2). Higher correlation is expected for the A intake since it passes more water. Forebay elevation and unit differential head (forebay elevation-tailwater elevation) were also significantly correlated with differential head across the VBS but the correlation was much weaker. Forebay elevation was very weakly correlated and all three variables: head, forebay elevation and discharge are autocorrelated. Plots of differential head against turbine discharge show the good correlation between the two variables (Figure I.2 and I.3).

Table I.2. Regression coefficients and fit of differential head data to independent variables in the spring and summer for both A and C intakes of unit 17.

Season	Intake	Independent Variable	R-square	Slope	Intercept
Spring	A	kcfs	0.8587	0.76637	-2.03991
		Fbay	0.0804	0.99029	-66.27500
		Head	0.2204	-0.55946	-39.80036
	C	kcfs	0.6977	0.60232	-2.22980
		Fbay	0.0635	0.76724	-51.87962
		Head	0.4155	-0.66979	43.54891
Summer	A	kcfs	0.8524	1.23361	-8.34635
		Fbay	0.0161	0.27809	-12.26639
		Head	0.2815	-0.40345	31.54826
	C	kcfs	0.6773	1.00327	-7.34868
		Fbay	0.0042	0.12991	-3.31400
		Head	0.3627	-0.41806	30.21541

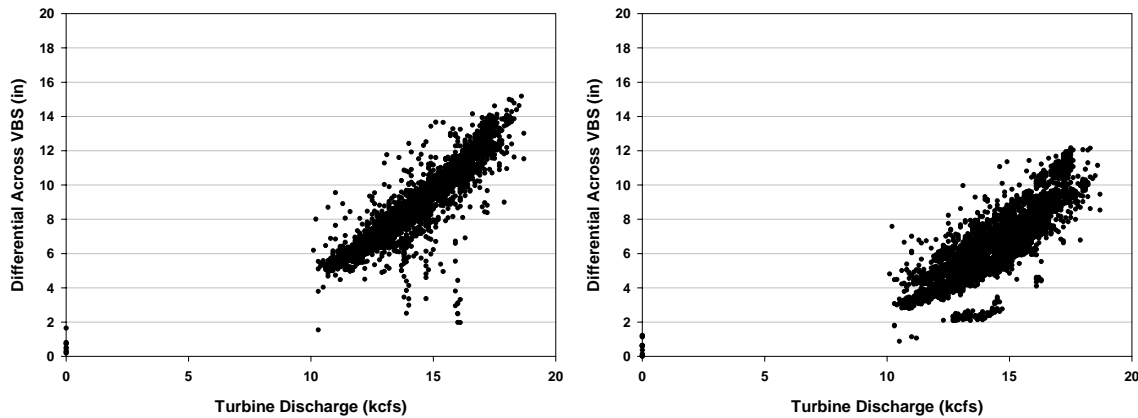

Figure I.2. Differential head across the VBS relative to turbine discharge for unit 17 intake A (left) and intake C (right) in the spring 2004.

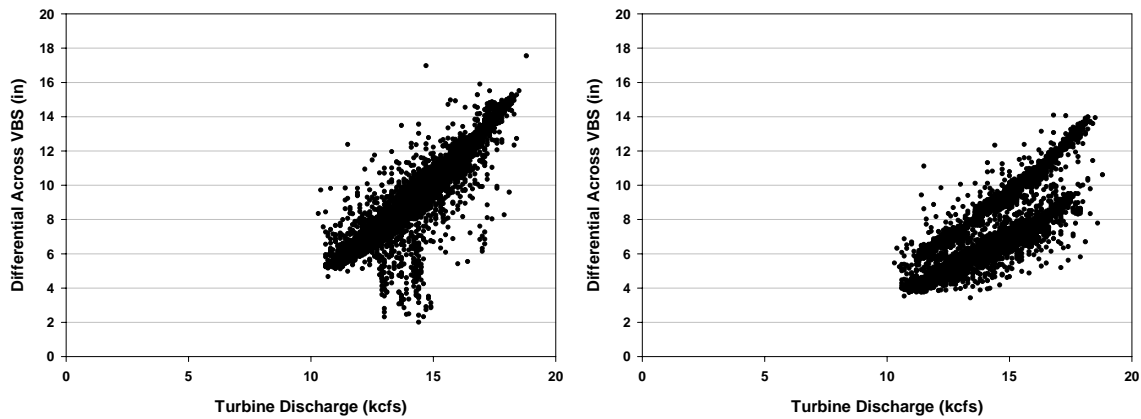

Figure I.3. Differential head across the VBS relative to turbine discharge for unit 17 intake A (left) and intake C (right) in the summer 2004.

Some of the outliers in the scatter plot are related to shifts in operation levels of the unit. In summer for intake C there were two distinct trends in differential head relative to discharge (Figure I.3). The upper of the two groups of points correspond to measurements before June 9 at 1400 hours and the lower of the two groups of points correspond to measurements collected after 1400. The VBS was cleaned at this time (Figure I.4). This change in trend shows that debris loading of the screen can also significantly affect differential head across the VBS. At discharge less than 14,000 kcfs the cleaning reduced the differential head by about 2 in and at discharge above 16,000 kcfs the cleaning of the VBS reduced the differential head by about 4 in.

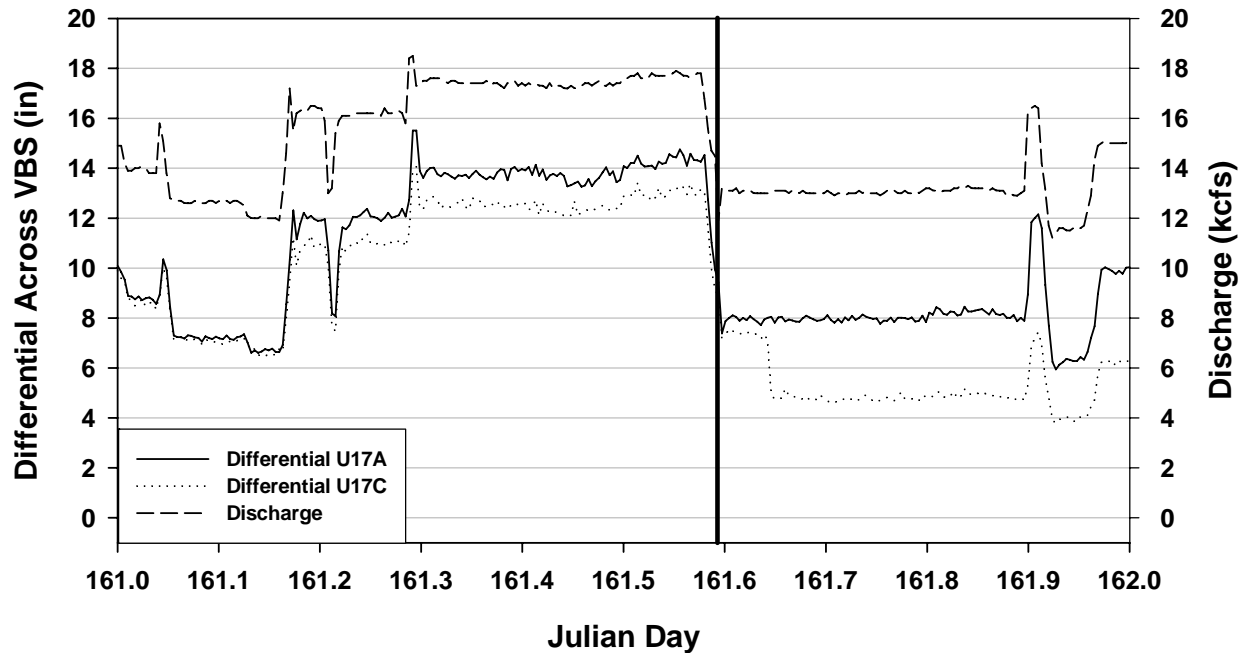

Figure I.4. Differential head (in) across the VBS at turbine unit 17 intakes A and C, and operation level discharge for the unit on June 9, 2004. Note: The vertical line denotes the approximate time that the VBS in the A intake was cleaned.

The screen in the A intake was cleaned in the morning on June 14. There was a decrease in differential head across the VBS of about 1 in (Figure I.5). The change was noticeable but was not as significant as the difference when the JBS in the C intake was cleaned.

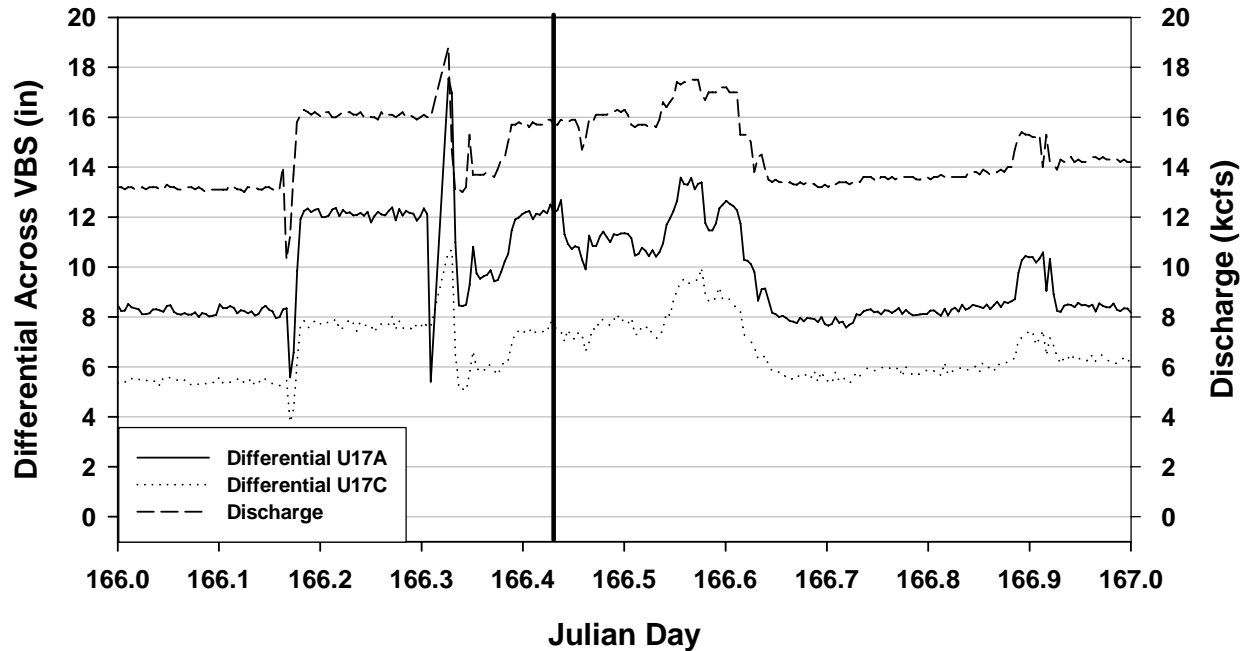

Figure I.5. Differential head (in) across the VBS at turbine unit 17 intakes A and C, and operation level discharge for the unit on June 14, 2004. Note: The vertical line denotes the approximate time that the VBS in the A intake was cleaned.

Conclusions

1. Discharge through the turbine has the greatest influence on differential head across the VBS of the A and C intakes.
2. Debris buildup on the screens has a significant influences on differential head across the VBS of the A and C intakes.

Weekly plots of differential head and discharge levels for spring and summer are provided below (Figures I.6 to I.18).

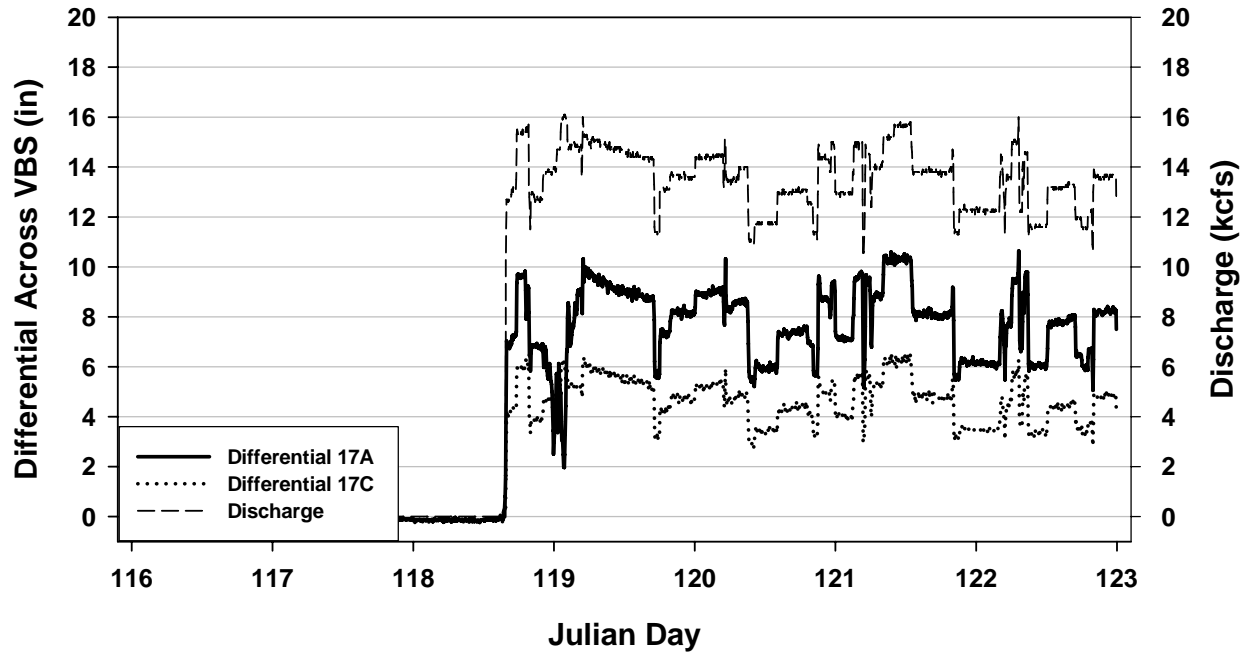

Figure I.6. Differential head (in) across the VBS at turbine unit 17 intakes A and C, and operation level discharge for the unit on April 26 through May 1, 2004. Note: Unit 17 was off line until 1600 on April 27.

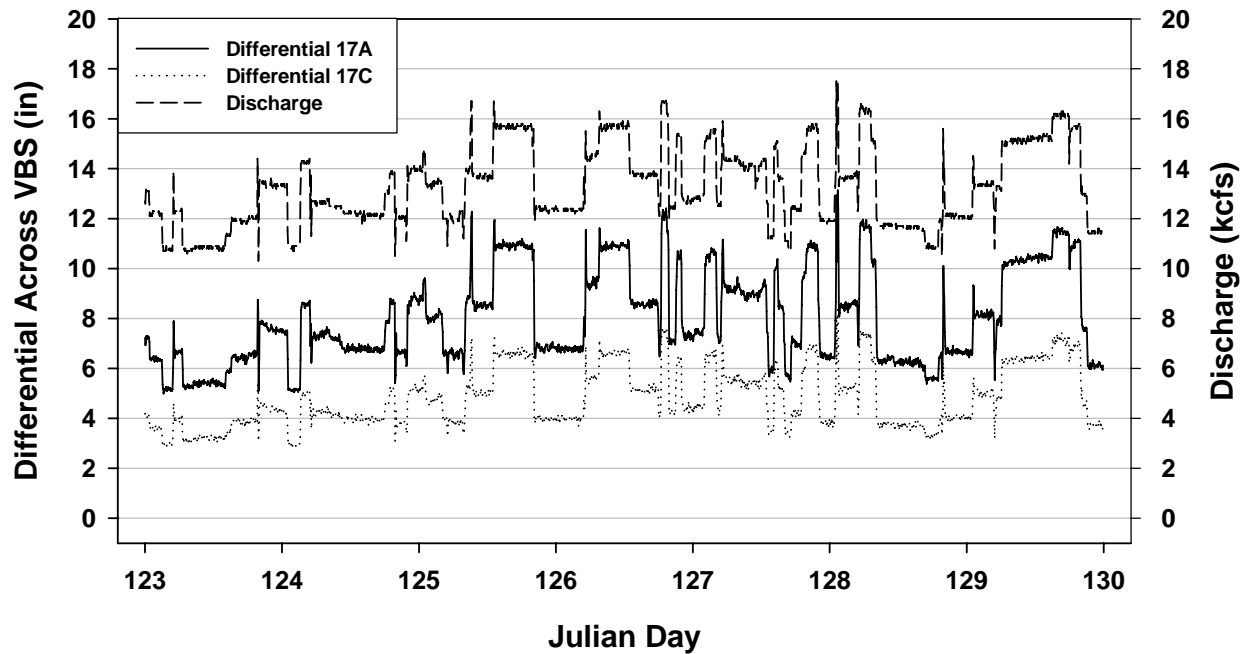

Figure I.7. Differential head (in) across the VBS at turbine unit 17 intakes A and C, and operation level discharge for the unit on May 2 through May 8, 2004.

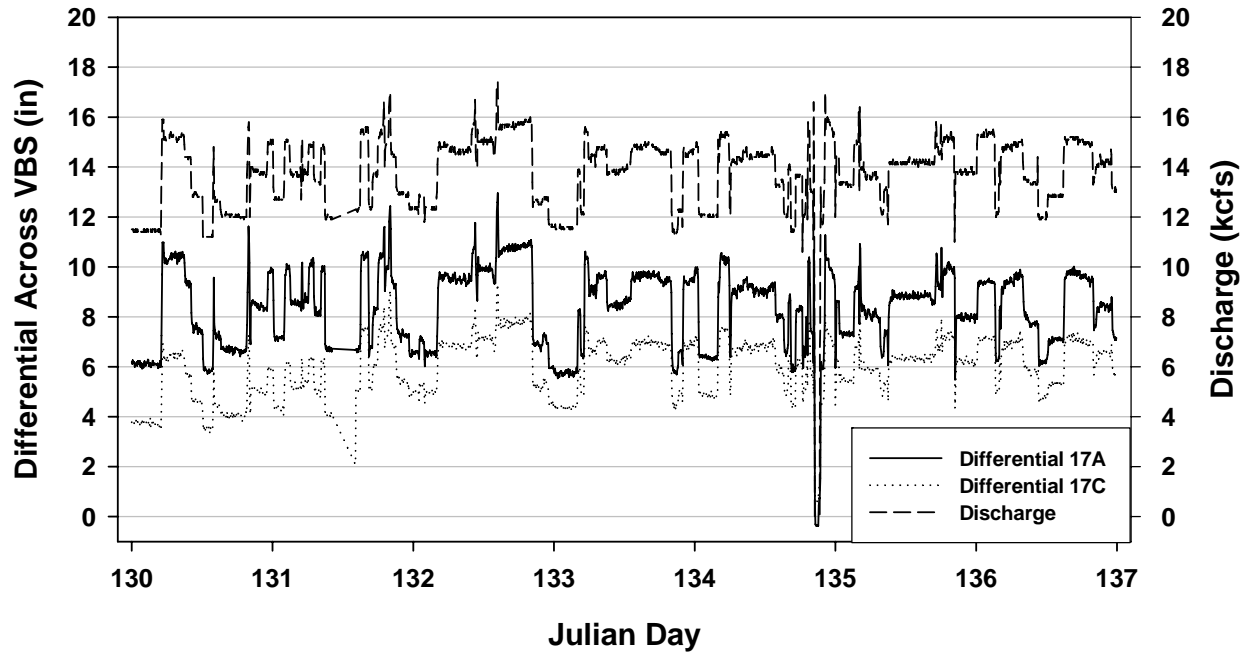

Figure I.8. Differential head (in) across the VBS at turbine unit 17 intakes A and C, and operation level discharge for the unit on May 9 through May 15, 2004.

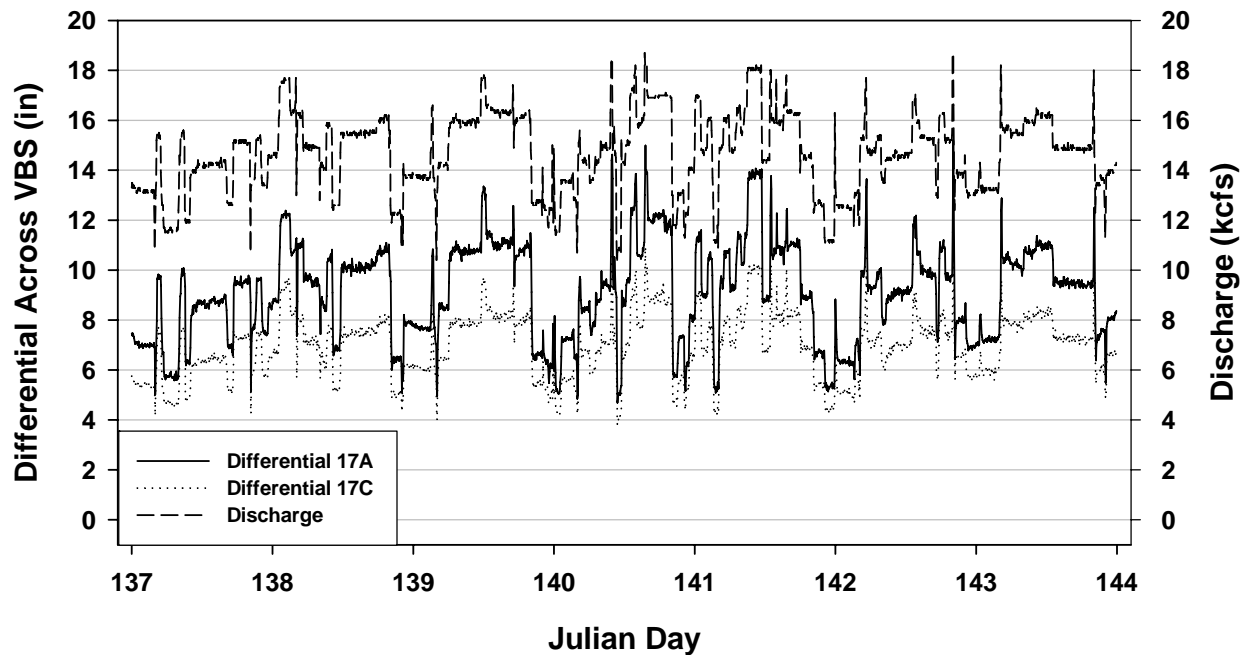

Figure I.9. Differential head (in) across the VBS at turbine unit 17 intakes A and C, and operation level discharge for the unit on May 16 through May 22, 2004.

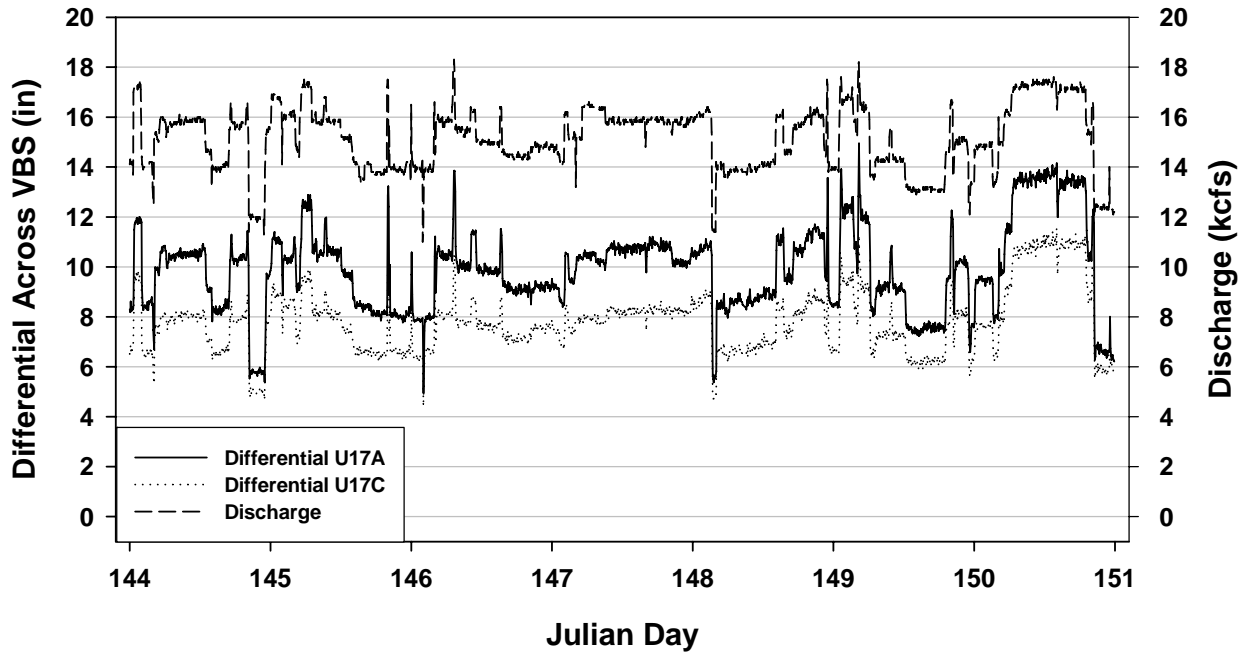

Figure I.10. Differential head (in) across the VBS at turbine unit 17 intakes A and C, and operation level discharge for the unit on May 23 through May 29, 2004.

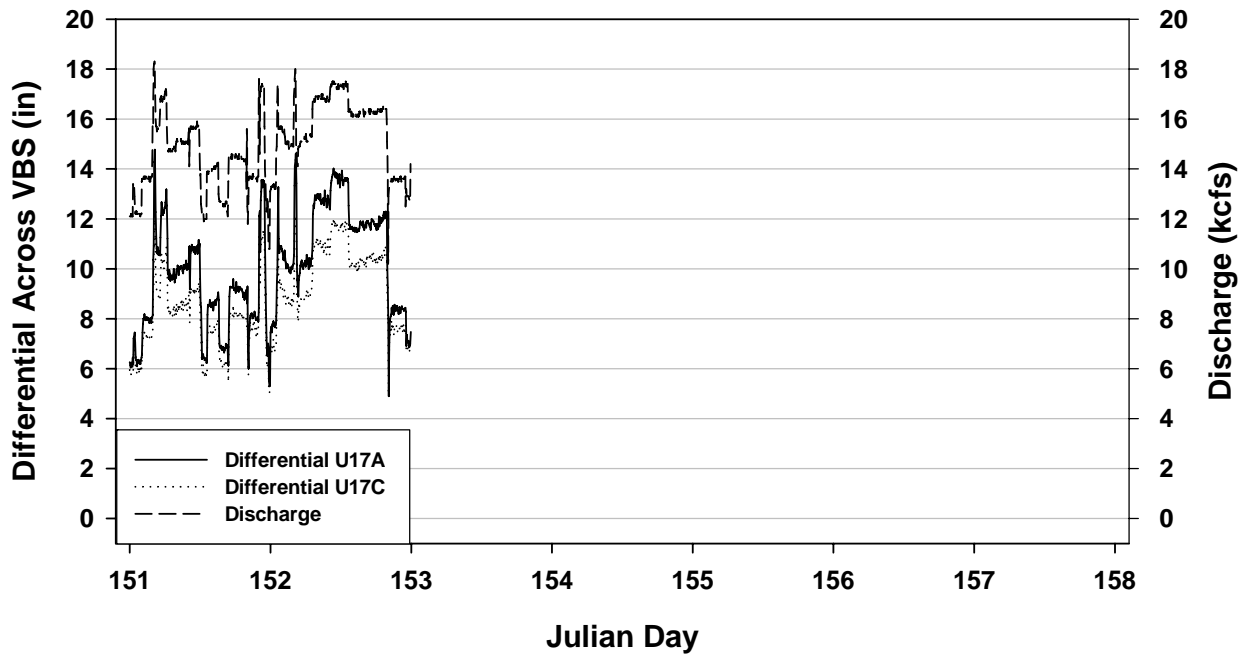

Figure I.11. Differential head (in) across the VBS at turbine unit 17 intakes A and C, and operation level discharge for the unit on May 30 through May 31, 2004.

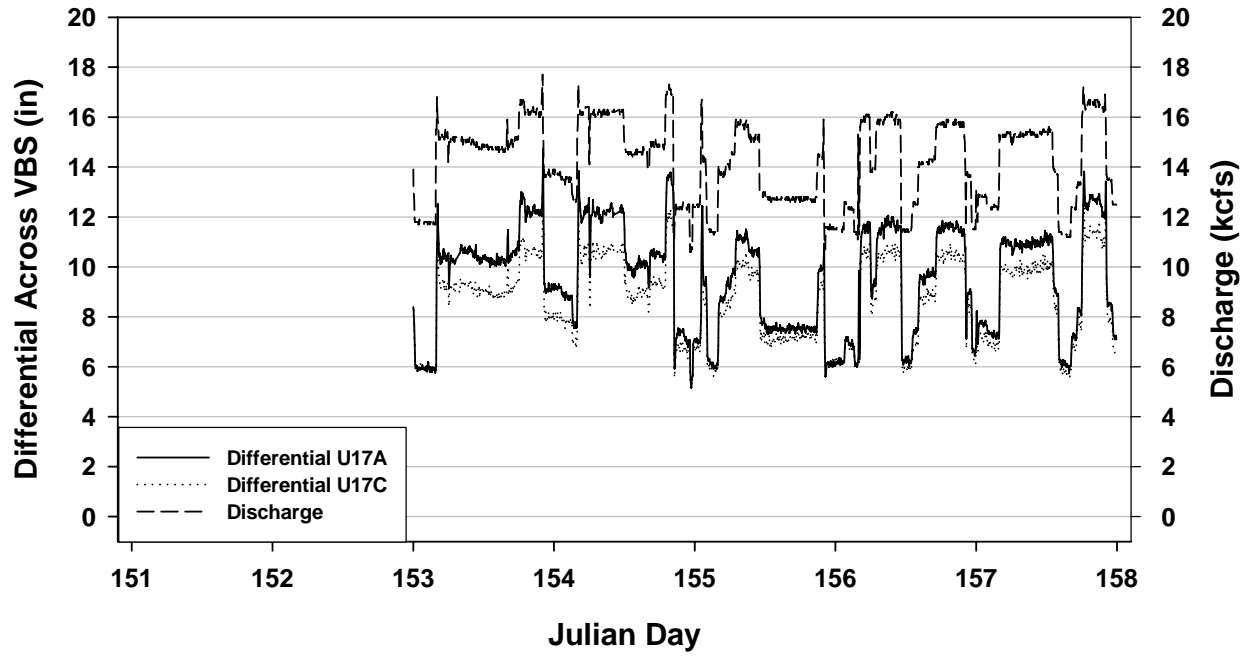

Figure I.12. Differential head (in) across the VBS at turbine unit 17 intakes A and C, and operation level discharge for the unit on June 1 through June 5, 2004.

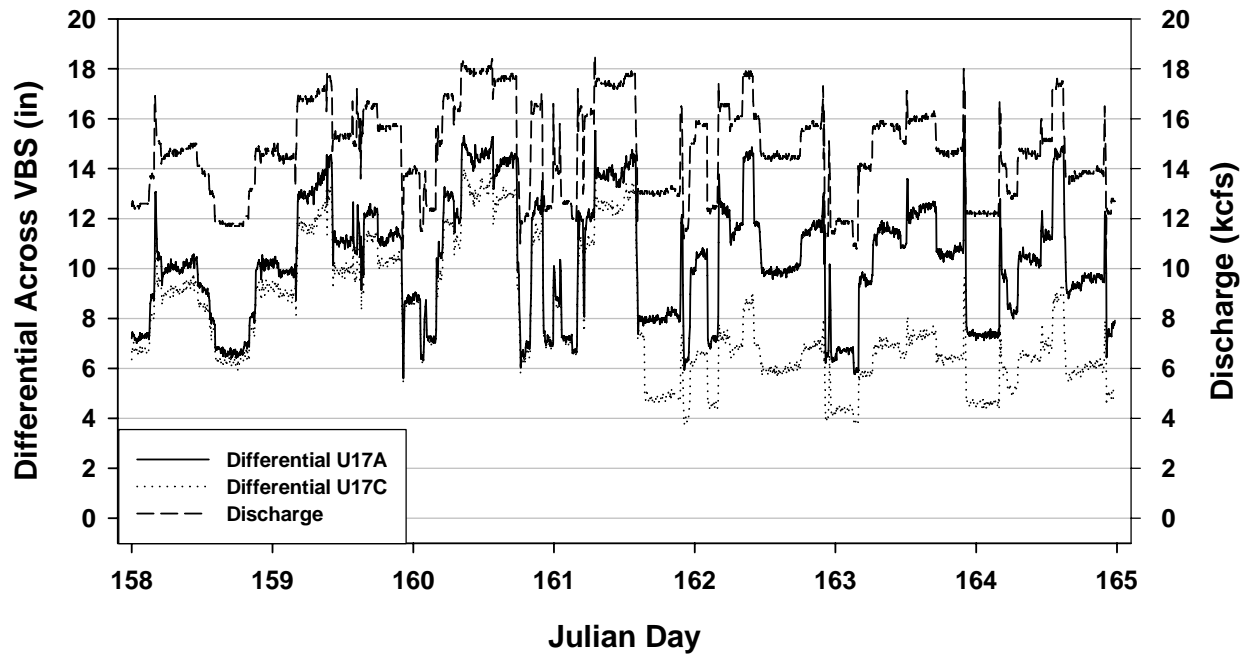

Figure I.13. Differential head (in) across the VBS at turbine unit 17 intakes A and C, and operation level discharge for the unit on June 6 through June 12, 2004.

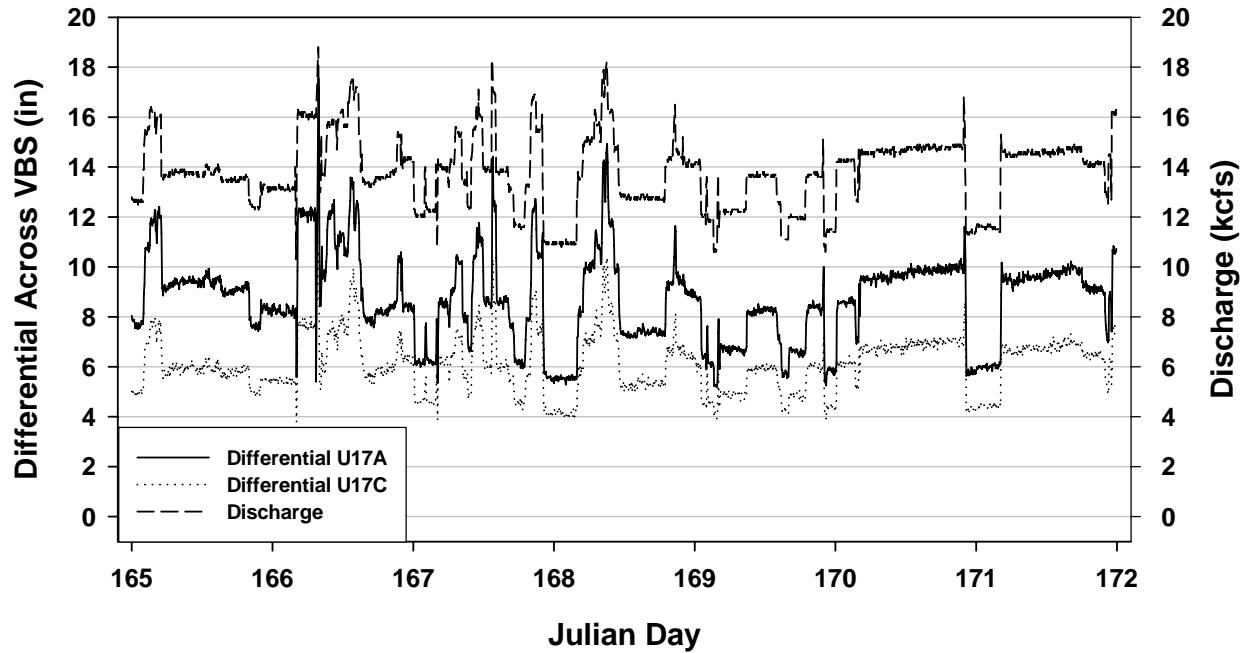

Figure I.14. Differential head (in) across the VBS at turbine unit 17 intakes A and C, and operation level discharge for the unit on June 13 through June 19, 2004.

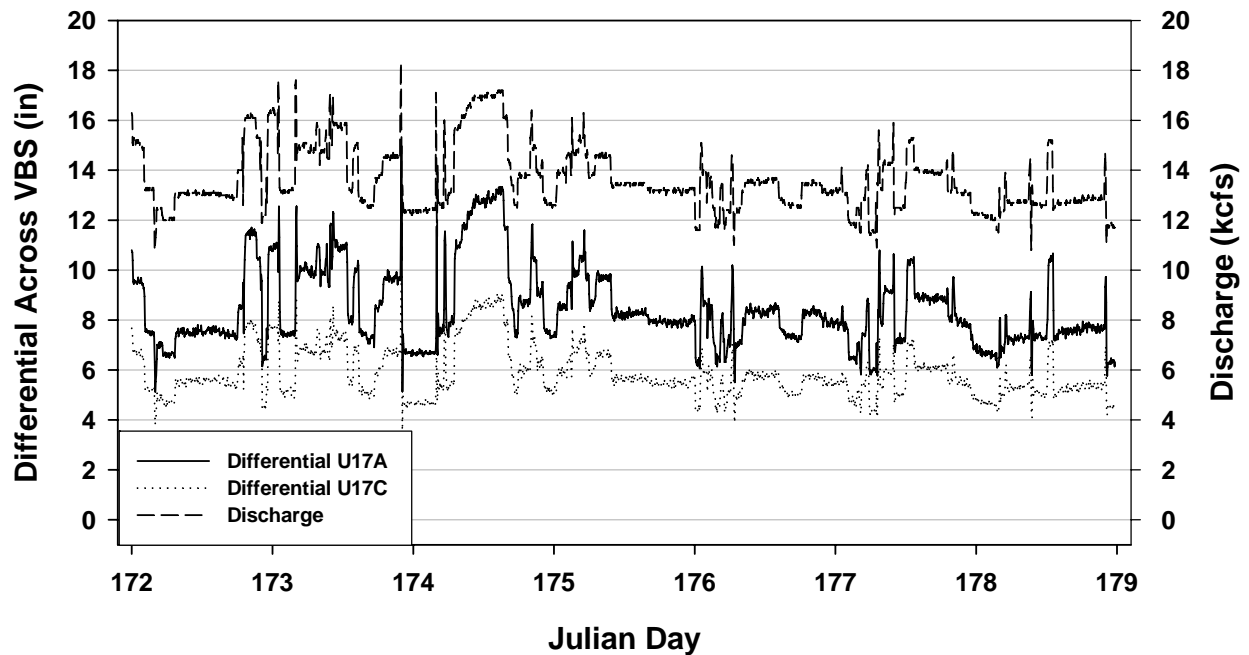

Figure I.15. Differential head (in) across the VBS at turbine unit 17 intakes A and C, and operation level discharge for the unit on June 20 through June 26, 2004.

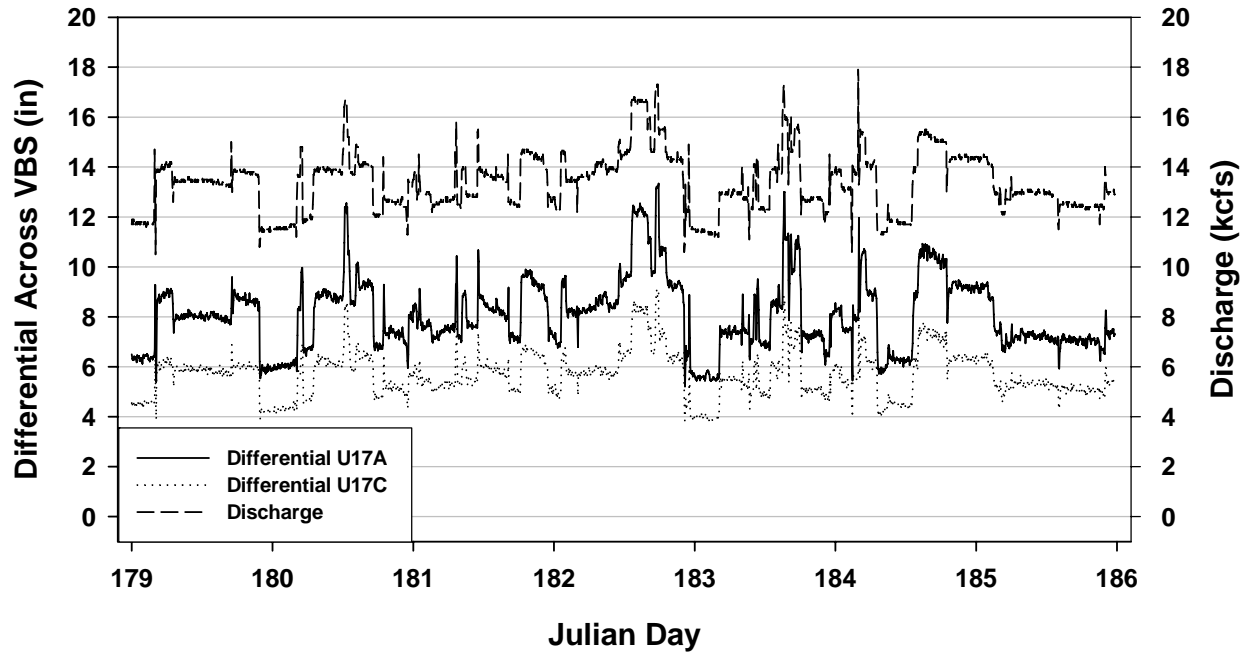

Figure I.16. Differential head (in) across the VBS at turbine unit 17 intakes A and C, and operation level discharge for the unit on June 27 through July 3, 2004.

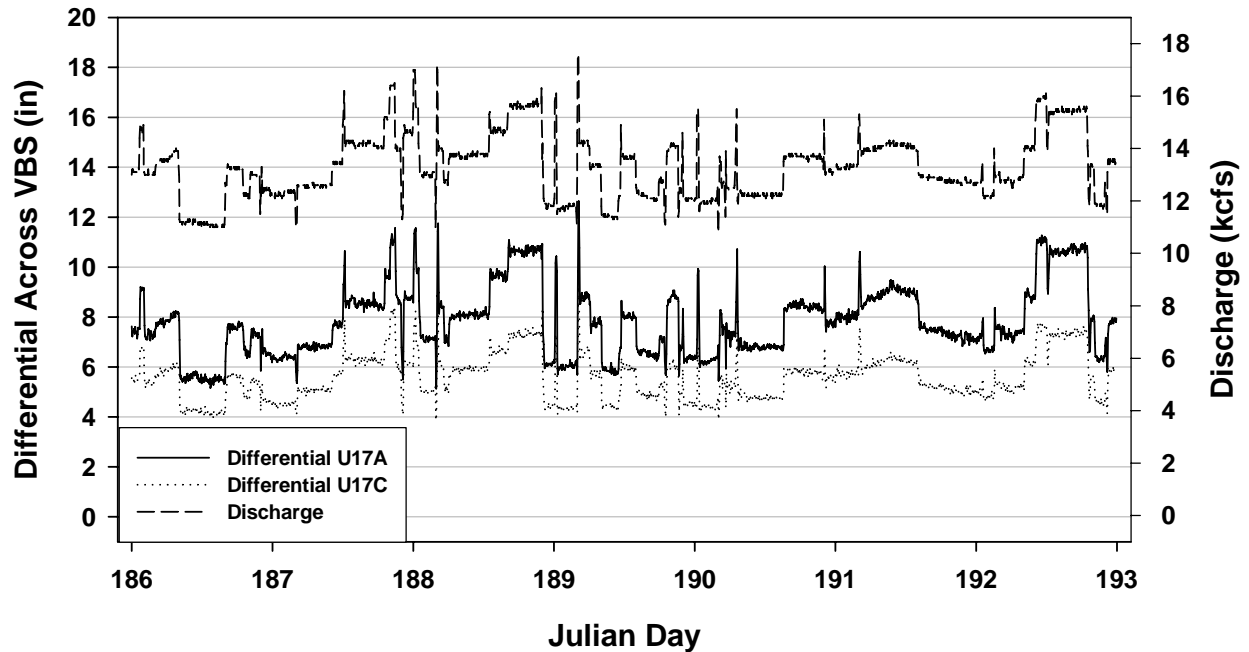

Figure I.17. Differential head (in) across the VBS at turbine unit 17 intakes A and C, and operation level discharge for the unit on July 4 through July 10, 2004.

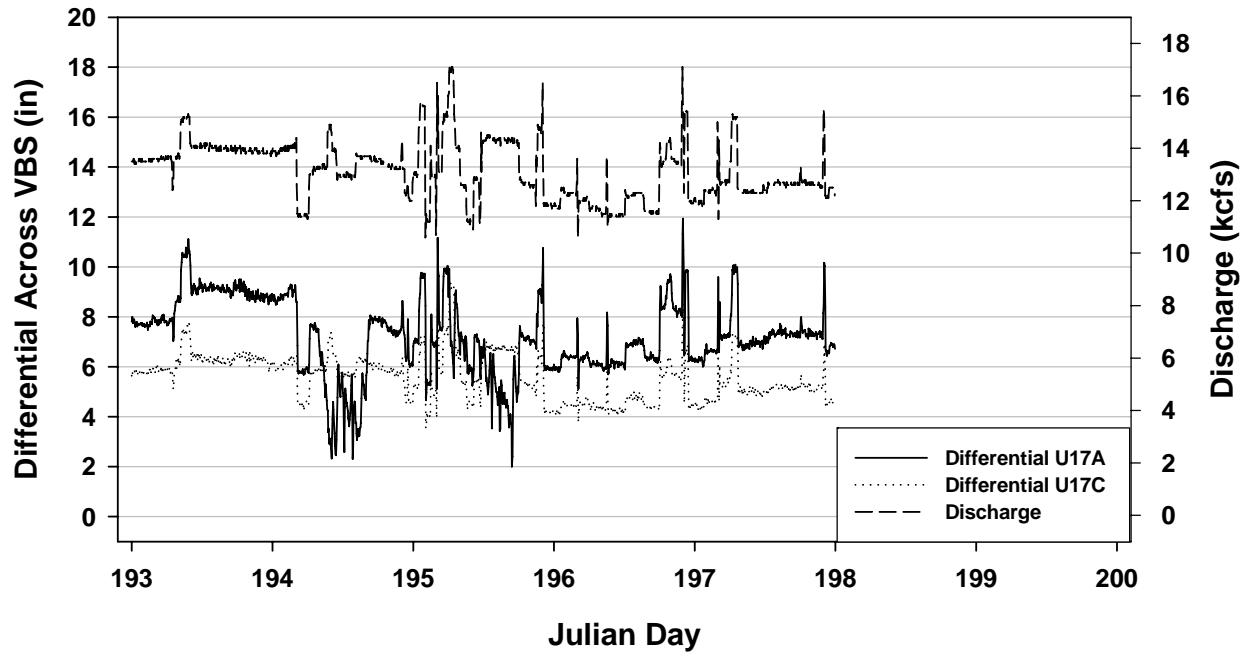

Figure I.18. Differential head (in) across the VBS at turbine unit 17 intakes A and C, and operation level discharge for the unit on July 11 through July 15, 2004.