

CHAPTER 43

**CONTROL OF INDUSTRIAL STACK EMISSIONS**

*Engineering Staff\**

*George D. Clayton & Associates*

**INTRODUCTION**

Simply defined, pollution is the wrong substance in the wrong place at the wrong time. Air pollution existed long before man discovered fire. Volcanic eruptions, dust storms, forest fires and other natural phenomena have released millions of tons of pollutants into the air since the beginning of time.

With the advent of the industrial revolution, continuous exposure to a variety of gaseous and particulate materials became commonplace. The synergistic effects of these chemicals on health has led to several air pollution disasters throughout the United States. The first recorded episode oc-

curred in Donora, Pennsylvania in 1948, when 20 people died during a five-day atmospheric inversion.

In addition to health effects, pollutants in the air can cause extensive economic damage. The poisoning of livestock by lead and zinc, the destruction of crops by sulfur dioxide, ozone and fluorides, and the damage to neighborhoods by smoke, dust and gaseous pollutants combined carry an economic price tag ranging between 10 and 60 billion dollars per year. One estimate given for the personal cost to a resident living in a relatively polluted community is \$84 per year. This figure includes only those costs resulting from the maintenance of the household itself.

The cost to industry of reducing emissions to the level required by the Clean Air Act will entail

\*The following staff members participated in writing this chapter: George T. McCollough, Delno Malzahn, John E. Mutchler and George D. Clayton.

**TABLE 43-1.**  
Stationary Sources  
Estimates of Potential and Reduced Emission  
Levels and Associated Costs  
[298 Metropolitan Areas]

Source	Year	Quantity of Emissions <sup>1</sup> (Thousands of Tons per Year)						Control Costs (Millions of Dollars)	
		Part	SO <sub>x</sub>	CO	HC	F	Pb	Investment	Annual
Solid Waste Disposal	1967	1,110	—	3,770	1,400	—	—		
	FY 76 W/O <sup>2</sup>	1,500	—	5,450	2,020	—	—		
	FY 76 W <sup>3</sup>	185	—	414	293	—	—	201	113
Stationary Fuel Combustion	1967	3,247	11,416	—	—	—	—		
	FY 76 W/O	3,867	14,447	—	—	—	—		
	FY 76 W	930	4,697	—	—	—	—	2,432	1,006
Industrial Processes	1967	4,601	5,156	7,520	1,412	53	20		
	FY 76 W/O	6,053	6,229	10,040	1,736	73	30		
	FY 76 W	453	1,720	539	849	9	10	3,877	1,095
<b>TOTAL</b>	1967	8,958	16,572	11,290	2,812	53	20		
	FY 76 W/O	11,420	20,676	15,490	3,756	73	30		
	FY 76 W	1,568	6,417	953	1,142	9	10	6,510	2,214

<sup>1</sup>Emission abbreviations are: particulates (Part), sulfur oxides (SO<sub>x</sub>), carbon monoxide (CO), hydrocarbons (HC), fluorides (F), and lead (Pb). Blanks in the table indicate the emission levels meet the applicable regulation or that emissions are negligible or do not exist.

<sup>2</sup>Estimates without implementation of the Clean Air Act, for fiscal year 1976.

<sup>3</sup>Estimates with implementation of the Clean Air Act, for fiscal year 1976.

From "The Economics of Clean Air, Senate Document No. 92-67" annual report of the Administration of the EPA to Congress.

a total investment of \$6.5 billion by 1976, according to one estimate. By that year the associated total annual control cost including depreciation, operating and maintenance costs will amount to an estimated \$2.2 billion (Table 43-1).

### LEGISLATION

Federal air pollution legislation was enacted because of the inconsistency of local air pollution control regulations and the increasing deterioration of the nation's air quality. The first Federal legislation concerning air pollution (Public Law 84-159) was enacted in 1955; it authorized a program of research and technical assistance to the states. This legislation was amended and strengthened in 1963, 1965 and again in 1966.

The Air Quality Act of 1967, more commonly called the "Clean Air Act" represented a major shift in the enforcement level of air pollution regulations. Introduced into this Act was the concept of "air quality control regions" within a single state or interstate area. The state or states having jurisdiction in a particular region were empowered to set standards of air quality, based on desired ambient air levels and guided by criteria published by the Department of Health, Education and Welfare. Initial and ongoing emission standards were also established so that compliance would insure the attainment and maintenance of desired air quality.

Within three years, the discrepancies arising in ambient standards among different air quality regions and the lack of national air quality standards led to the Clean Air Amendments of 1970. Under these amendments, states are required to adopt implementation plans (emission limitations) for the entire air region, with priority to be given to development of plans for areas where air pollution is most serious. National emission standards or limits have been established for certain new or newly-modified stationary sources for particulate, sulfur dioxide, sulfuric acid, nitrogen dioxide and plume opacity. In addition, national emission standards for hazardous chemicals such as beryllium, mercury and asbestos were set on existing sources.

### CONTROL CONSIDERATIONS

The aggregate demands for improvement of air quality created by the existence of health hazards, economic damage, public pressure and legal requirements would seem to place industry in a position of "clean-up or shut-down." The degree of control necessary to fulfill these demands dictates the efficiency and sophistication of required abatement systems.

Once the required collection efficiency is determined for a single emission source, five basic factors of the source process must be characterized before proper design of an appropriate system can be undertaken:

- 1) The chemical and physical properties of the atmospheric effluent must be measured. These include size, density, shape, size-spectrum, chemical composition and corrosiveness.

- 2) The carrier exhaust gas must be characterized, including temperature, humidity, density and pressure.
- 3) Estimation of process factors such as volumetric flowrate, velocity and particulate gaseous concentrations must be made.
- 4) Construction factors including equipment size, layout, materials of construction and safety requirements must be determined.
- 5) Operational factors, such as maintenance, utility and disposal costs must be obtained.

Comparative cost data for collector designs is based on a variety of process variables. Emission abatement costs increase as the total volume of gas to be treated is increased. Careful analysis of the equipment included in the collector system, plus the installation and maintenance costs, must be made for an optimum design choice between alternative systems. Table 43-2 presents curves to obtain preliminary cost estimates. It is important to note that the installed cost may exceed the cost of the collection device as shipped by the manufacturer by a factor ranging between 100 and 400 percent.

Equipment modification and the substitution of process materials can often be the most effective means of solving air pollution problems. Substantial reduction of the loading in effluent air streams can be brought about by replacement of raw materials or fuel types used. For example, conversion from coal to natural gas as a combustion fuel dramatically reduces sulfur dioxide and particulate emissions.

Modifications to the plant design which suppress contaminant formation at the source are, of course, the ideal solution. In addition, any design change which concentrates the contaminant loading to the collecting device into a smaller air volume, reduces the size and cost of the collector needed, since most collecting devices are designed on the volume rate of air to be handled and are relatively insensitive to changes in contaminant loading.

Good plant layout, construction and house-keeping can be an effective system for contaminant suppression. The prevention of leaks, periodic vacuuming and "hosing down" procedures and the elimination of open piles of chemicals are a few of the many possible methods for lowering emissions within the plant area.

The engineer, after carefully studying the costs related to such factors as: 1) the need for controls; 2) the degree of control required; and 3) potential process changes, has available to him a variety of types, designs and manufacturers of control devices. Proper selection of the optimum system requires a thorough understanding of the characteristics of process factors, along with a fundamental knowledge of the principles associated with each type of control equipment.

Table 43-3 includes a summary of the characteristics of particles and the effective range of certain collection devices. Table 43-4 includes the operating mechanisms and minimum size data for 90% collection efficiency. For a more detailed discussion, the equipment types are divided into

TABLE 43-2.  
Cost Estimates of Dust Collecting Equipment

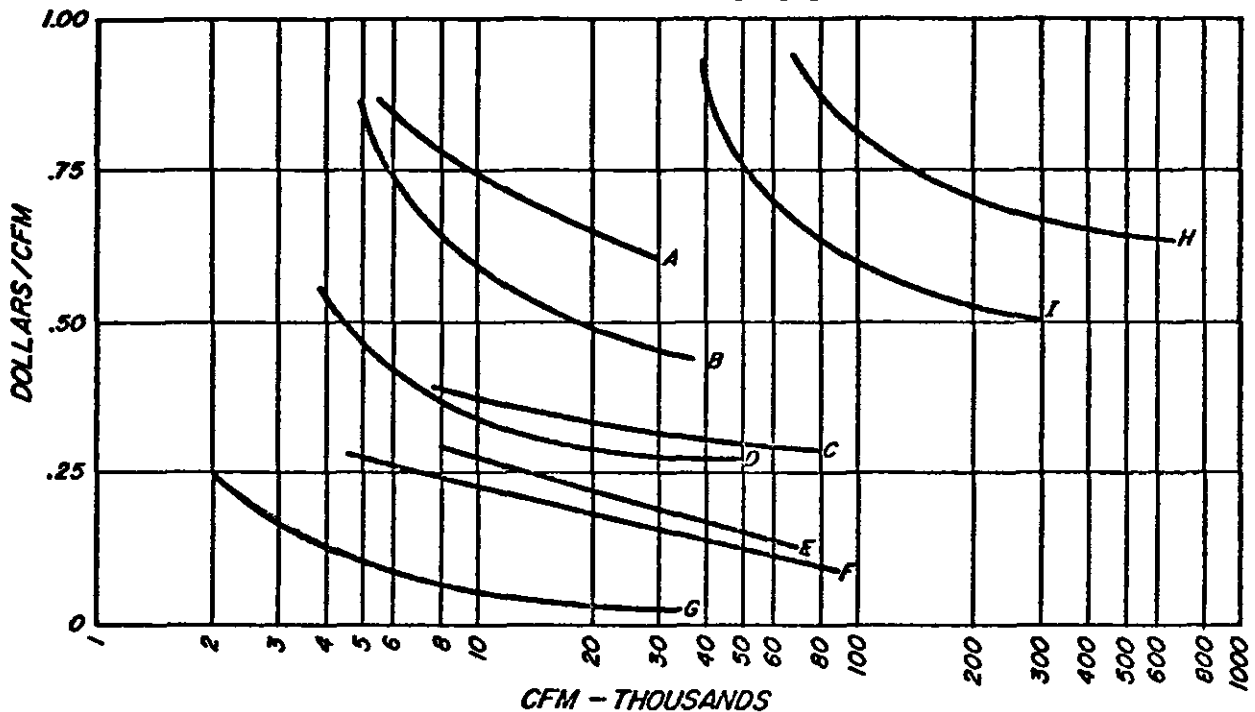

- A—High temperature fabric collector (continuous duty)
- B—Reverse jet fabric collector (continuous duty)
- C—Wet collector (maximum cost range)
- D—Intermittent duty fabric collector
- E—High efficiency centrifugal collector
- F—Wet collector (minimum cost range)
- G—Low pressure drop cyclone (maximum cost range)
- H—High voltage precipitators

- I—High voltage precipitators (minimum cost range)

Note 1: Cost based on collector section only. Cost does not include ducting, water requirement, power requirement or exhausters (unless exhaust is integral part of secondary air circuit.)

"Industrial Ventilation — A manual of Recommended Practice" 12th Edition, Committee on Industrial Ventilation, American Conference of Governmental Industrial Hygienists, Lansing, Michigan.

six broad, general categories: 1) mechanical separators; 2) filtration devices; 3) wet collectors; 4) electrostatic precipitators; 5) gas adsorbers; and 6) combustion incinerators.

### Mechanical Separators

These devices impart either inertial or gravitational forces on the particle to remove it from the carrier stream. The range of particle sizes consistent with effective collection efficiencies is 15 to 40 microns in diameter; a sharp dropoff of collection efficiency occurs with particles smaller than 15 microns in diameter. Industrial use is limited to applications where the particulate is very coarse or the separator is used in series with other devices.

The many varieties of mechanical separators can be divided into three broad categories: gravity chambers, cyclone collectors and impingement separators.

**Gravity Chambers.** These chambers are the oldest and least efficient method of dust collection. They consist of a low-velocity enclosure where the larger contaminant particles are removed by the force of gravity. Particles smaller than 40 $\mu$  in diameter usually pass through, uncollected.

Collection efficiency is related to the terminal settling velocity,  $U_t$ , and is expressed in the following equation:

$$\eta = \frac{100 U_t A_h}{Q}$$

where:  $\eta$  = % collection efficiency by weight

$U_t$  = particle terminal settling velocity, ft./min.

$A_h$  = horizontal area of chamber, ft<sup>2</sup>

$Q$  = volumetric flowrate of gas, ft<sup>3</sup>/min.

An increase in the effective horizontal area,  $A_h$ , through the use of horizontal baffles, or a decrease in volumetric flowrate and velocity profile, favorably affects collection efficiency.

Advantages of gravity settlers include: low initial cost (between 5¢ and 25¢ per cfm), simple construction and a slight pressure drop. These advantages are offset by an inability to remove particles smaller than 40 microns in diameter and large space requirements.

Gravity chambers are most useful as a pre-cleaning stage before treatment by a higher collection efficiency device. The removal of large-

TABLE 43-3.  
Properties of Aerosols

		Particle Diameter, microns ( $\mu$ )										
		0.0001	0.001	0.01	0.1	1	10	100	1,000	10,000		
Equivalent Sizes	Angstrom Units, Å											
	Theoretical Mesh (Used very infrequently)											
Electromagnetic Waves	X-Rays		Ultraviolet		Visible Solar Radiation		Near Infrared		Far Infrared		Microwaves (Radar, etc.)	
	Gas Dispersals	Solid:	Fume		Mist		Dust					
Technical Definitions	Liquid:							Spray				
	Soil:	International Soil Classification System adopted by Internat. Soc. Soil Sci. Since 1934										
Common Atmospheric Dispersals			Smog				Clouds and Fog		Mist-Drizzle		Rain	
Typical Particles and Gas Dispersoids	<p>Molecular diameters calculated from viscosity data at 0°C.</p>		Rosen Smoke		Tobacco Smoke		Metallurgical Dusts and Fumes		Fertilizer, Ground Limestone		Fly Ash	
			Carbon Black		Zinc Oxide Fume		Athena Nuclei		Contact Sulfuric Mist		Pulverized Coal	
Methods for Particle Size Analysis			Ultramicroscope		Electron Microscope		Ultracentrifuge		X-Ray Diffraction		Nuclei Counter	
			Impingers		Microscope		Centrifuge		Adsorption		Light Scattering	
Types of Gas Cleaning Equipment			Ultrasonics (very limited industrial applications)		High Efficiency Air Filters		Thermal Precipitation (used only for sampling)		Electrical Precipitators		Setting Chambers	
			Liquid Scrubbers		Cloth Collectors		Packed Beds		Common Air Filters		Impingement Separators	
Terminal Gravitational Settling* (for spheres, sp. gr. 2.0)	In Air at 25°C, 1 atm.	Reynolds Number	10 <sup>-12</sup>	10 <sup>-11</sup>	10 <sup>-10</sup>	10 <sup>-9</sup>	10 <sup>-8</sup>	10 <sup>-7</sup>	10 <sup>-6</sup>	10 <sup>-5</sup>	10 <sup>-4</sup>	10 <sup>-3</sup>
	In Water at 25°C.	Reynolds Number	10 <sup>-10</sup>	10 <sup>-9</sup>	10 <sup>-8</sup>	10 <sup>-7</sup>	10 <sup>-6</sup>	10 <sup>-5</sup>	10 <sup>-4</sup>	10 <sup>-3</sup>	10 <sup>-2</sup>	10 <sup>-1</sup>
Particle Diffusion Coefficient,** cm <sup>2</sup> /sec.	In Air at 25°C, 1 atm.		10 <sup>-11</sup>	10 <sup>-10</sup>	10 <sup>-9</sup>	10 <sup>-8</sup>	10 <sup>-7</sup>	10 <sup>-6</sup>	10 <sup>-5</sup>	10 <sup>-4</sup>	10 <sup>-3</sup>	10 <sup>-2</sup>
	In H <sub>2</sub> O at 25°C.		10 <sup>-11</sup>	10 <sup>-10</sup>	10 <sup>-9</sup>	10 <sup>-8</sup>	10 <sup>-7</sup>	10 <sup>-6</sup>	10 <sup>-5</sup>	10 <sup>-4</sup>	10 <sup>-3</sup>	10 <sup>-2</sup>

Reprinted by permission of Stanford Research Inst. J. 8, 95 (1961).

Characteristics of particles and particle dispersions. Courtesy Stanford Research Institute.

Source: "Air Pollution Manual". Part II, p. 13, American Industrial Hygiene Association, Akron, Ohio.

**TABLE 43-4.**  
**General Classification of Particulate Collectors**

Control Device	Class	Force	Particle Diameter for 90% Removal in Microns
Settling Chamber	Mechanical	Gravity	50
Impingement Separator	Mechanical	Inertial Impingement	25
Cyclone (Small Diameter)	Mechanical	Centrifugal	>5
Cyclone (Large Diameter)	Mechanical	Centrifugal	25
Baghouse	Filtration	Inertial Impingement + Electrostatic + Diffusional	>1
Panel Filters	Filtration	Inertial Impingement + Electrostatic + Diffusional	>1
Mat Filters	Filtration	Inertial Impingement + Electrostatic + Diffusional	10
Deep Filter Beds	Filtration	Inertial Impingement + Electrostatic + Diffusional	1
Spray Chamber	Scrubber	Inertial Impingement	25
Packed Tower	Scrubber	Inertial Impingement	5
Cyclone Scrubbers	Scrubber	Inertial Impingement + Centrifugal	5
Venturi	Scrubber	Inertial Impingement + Centrifugal	>1
Wet Inertial (Mechanical)	Scrubber	Inertial Impingement + Centrifugal	5
Orifice	Scrubber	Inertial Impingement + Centrifugal	5
Single-Stage High Voltage	Electrostatic Precipitators	Electrostatic Attraction	>1
Two-Stage Low Voltage	Electrostatic Precipitators	Electrostatic Attraction	>1

Source: "Air Pollution Manual". Part II, p. 13, American Industrial Hygiene Association, Akron, Ohio.

size particulates which may prove erosive to a second-stage cleaner optimizes the system by increasing the efficiency and life of the second collector.

*Impingement Separators.* Impingement separators encompass a large, heterogeneous group of collection devices, all of which are based on the inertial force of a particle to accomplish its removal from the carrier gas stream.

The separator utilizes a network of baffles to collect or concentrate the particulates, as depicted in Figure 43-1. As the particles moving in the gas stream approach a stationary target, the air will deflect around the impingement target, carrying with it the lighter particles. The inertial force of the heavier particles causes them to cross the fluid streamlines, strike the target, and be removed, as shown in Figure 43-2.

The target efficiency of impingement is the percentage of particles which collide with the stationary object. This value can be obtained graphically from the separation number,  $N_s$ , which is a dimensionless value obtained from classical hydrodynamics and reported graphically in Figure 43-3.

$$N_s = \frac{D_p^2 V \rho_p}{18\mu D_b}$$

where:  $N_s$  = Separation number, dimensionless  
 $D_p$  = particle diameter, feet  
 $V$  = relative velocity gas to target, ft./sec.  
 $\rho_p$  = particle density, lb./ft.<sup>3</sup>  
 $\mu$  = gas viscosity, lb./ft.-sec.  
 $D_b$  = target diameter, ft.

The collection efficiency increases with increasing particle size, gas velocity and particle density; but overall efficiency is quite low, in the range of 50-80%, with particles smaller than 20 microns uncollected. Optimum designs, therefore, utilize small openings between baffles and high gas velocities.

Advantages of impingement separators include: low cost (from 15¢ to 30¢ per cfm), simple construction and trouble-free operation. Disadvantages include low overall efficiency, erosion of baffles and corrosion.

Impingement collectors find use throughout industry as: precleaners for more elaborate devices, collection devices where large particles are involved and devices that concentrate the particulates, in a smaller percentage of the gas stream. *Cyclone Collectors.* The most prevalent type of mechanical collector in use today is the cyclone. It operates on the principle of creating a vortex from the inlet gas stream velocity.

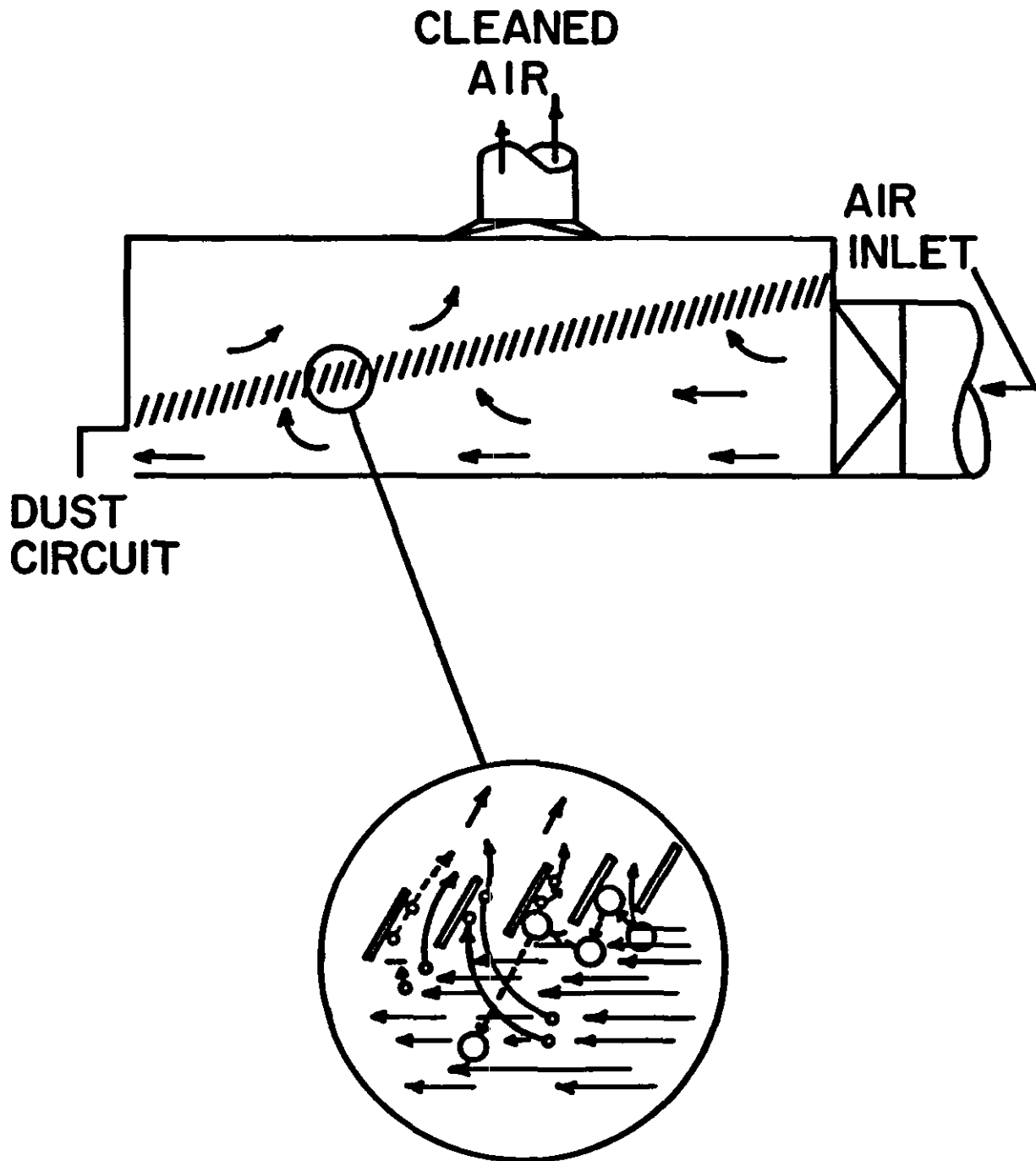

American Industrial Hygiene Association: Air Pollution Manual. Akron, Ohio, 1968, part II, p. 34.

Figure 43-1. Flat Lower Impingement Separator.

The entrained particles are drawn outward by centrifugal force, where they impinge on the wall surface and are removed by gravity to a collection point. The air flows in a double vortex, spiraling downward at the outside periphery and returning upward through the inside regions as shown in Figure 43-4.

During cyclonic separation, the gas stream velocity may increase several times over the inlet conditions. The separation mechanism is similar

to gravitational settling except that the force acts centrifugally instead of gravitationally, resulting in an increased force on the particle. In small-diameter cyclones, this value may reach upwards of 2500 times the force of gravity.

One typical equation for calculation of the size of particles collected is listed below:

$$D_{pc} = \sqrt{\frac{9 \mu b}{2\pi N_e V_1 (\rho_p - \rho_e)}}$$

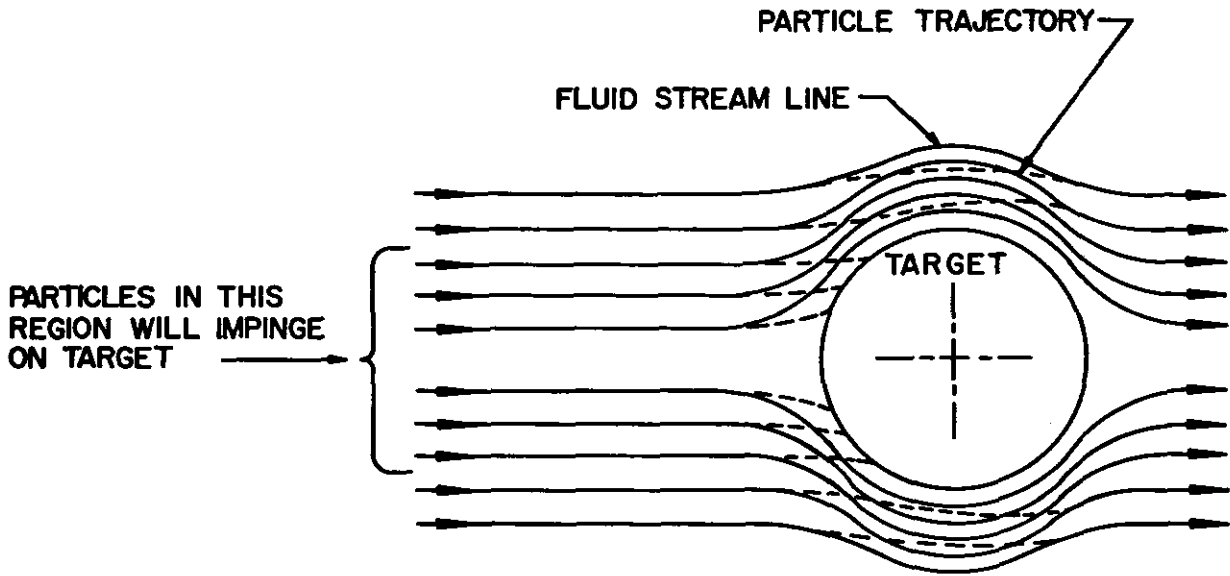

Stern: Air Pollution, 2nd Edition. Academic Press, p. 401.

Figure 43.2. Physics of Impingement.

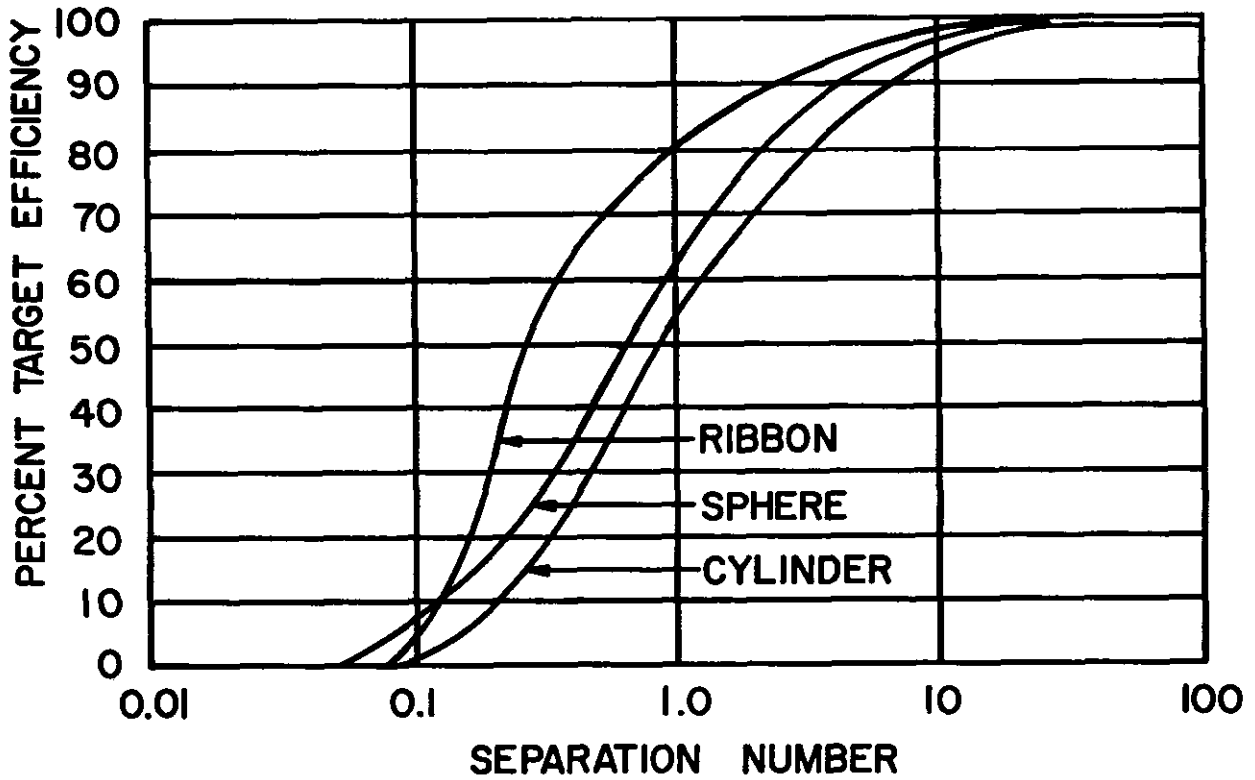

Stern: Air Pollution, 2nd Edition. Academic Press, p. 401.

Figure 43-3. Target Efficiency of Impingement.

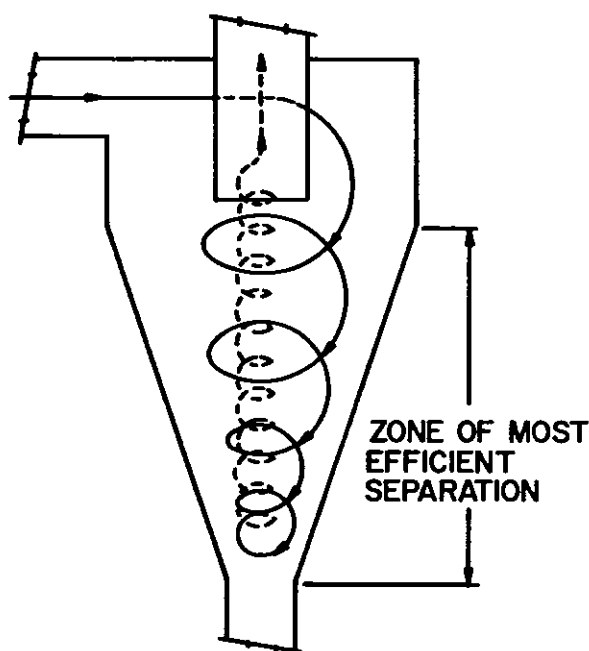

Air Pollution Engineering Manual, Department of Health, Education and Welfare, 1967, p. 93.

Figure 43-4. A Simplified Cyclone Collector.

where:  $D_{50}$  = diameter of particle collected at 50% efficiency

$\mu$  = gas viscosity, lbs./sec.-ft.

$b$  = cyclone inlet, ft.

$N_t$  = number of turns within the cyclone (approximately 5)

$V_1$  = inlet gas velocity, ft./sec.

$\rho_p$  = particle density, lb./ft.<sup>3</sup>

$\rho_g$  = gas density, lb./ft.<sup>3</sup>.

Caution is recommended in applying this equation to a design problem since the cyclone may be a poor classifier by particle size due to the variation of factors such as radius of rotation, distance from the wall and tangential velocity.

In design consideration, the factor of primary importance is the cyclone's radius. Collection efficiency increases as the radius is reduced. This is due to the increased centrifugal force created on the particle. Pressure drop increases with efficiency.

Small diameter or high efficiency cyclones have seen increased application in the last few years. Often, an arrangement of cyclones in parallel is used to handle high-volumetric flowrates rather than one large-diameter cyclone.

Cyclones have widespread use due to several inherent advantages: low initial cost (from 10¢ to 50¢/cfm) for simple construction, moderate pressure drop and low maintenance requirements. Disadvantages include: low collection efficiencies for particles below 5 microns and erosion from impingement of particulate matter.

#### Filtration Devices

Filtration is an effective technique for control-

ling emissions in the form of dust or fume from a carrier stream. Collection efficiencies of over 99.9% have been recorded in some applications. Three classes of filters exist: mat filters, ultrafilters and fabric filters. Of the three, the latter is the most important for industrial applications of air pollution control.

Mat filters are extremely porous, containing 97-99% void space. They have limited life and are usually used as process air cleaners. Ultrafiltration involves deep filter beds used for high efficiency removal requirements such as radio-active wastes. Baghouses or panel filters utilize fabrics to effect separation and are common throughout industry for a multitude of applications.

Fabric filters are employed in two basic designs, panel filters and baghouses. Panel filters are composed of individual filters, one or two inches thick. These panels filter out the particulate, as the gas flows through the medium. Baghouses are composed of long sleeves of fabric, up to 45 feet in length. These bags filter the air as it passes through the cloth. Periodic cleaning is important to both types to prevent excessive pressure drops from developing. Some mechanisms used for reducing the filter buildup of particulates are mechanical shaking, reverse air jet and low-frequency sound generation. A typical baghouse is shown in Figure 43-5.

The fabric weave often has interstices on the order of 100 microns, yet collection efficiencies of over 90% are reached on particles of one micron in diameter. Obviously, the filtering mechanism cannot be simple sieving. The theory of fabric filtration is not well developed. Empirically, the cloth openings quickly fill, as large-diameter particles "bridge over" the openings. Forces of electrostatic attraction appear to exert the greatest influence, but other forces, such as Brownian diffusion, impingement and gravitational settling may contribute to the overall process.

The cake of particles that develops becomes the filtering medium. As this cake grows thicker, increasingly smaller particles are collected and the pressure drop increases. Periodic cleaning must be performed to limit the pressure drop to design levels.

The pressure drop through a fabric filter and the cost of the device are the two most important factors in the design of a collection system for fabric filters. Generally, an increase in cloth area will enhance efficiency, lower the pressure drop and lengthen the fabric life through a reduced cleaning interval, but it also increases the cost of the device.

Three variables of design are used to determine the ultimate pressure drop in the system:

1. Filter ratio, which is the ratio of carrier gas volumetric flowrate to filter area;
2. Type of cloth and weave selected;
3. Time period of cleaning and method utilized.

The pressure drop is the sum of the resistances of the cloth and the filter cake and can be calculated from the following formula:

$$\Delta P_t = \Delta P_f + \Delta P_c = K_2 L_1 V^2$$



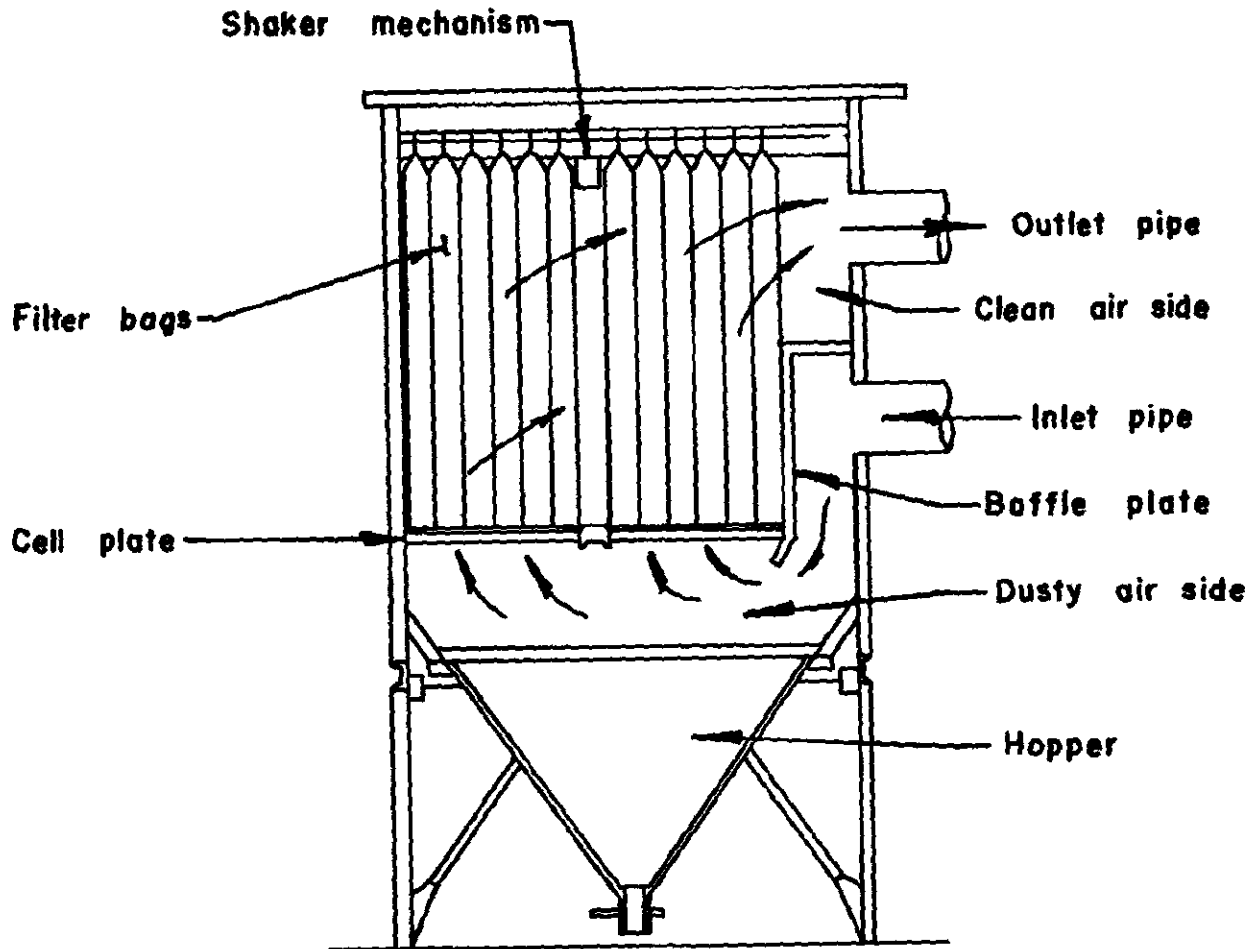

American Industrial Hygiene Association: Air Pollution Manual. Akron, Ohio, 1968, part II, p. 48.

Figure 43-5. Single Compartment Baghouse Filter.

where:  $\Delta P_t$  = Pressure drop at time  $t$  due to dust cake,  $\text{lb}_f/\text{ft}^2$

$\Delta P_r$  = total filter resistance at time  $t$ ,  $\text{lb}_f/\text{ft}^2$

$\Delta P_1$  = initial filter resistance of cleaned filter,  $\text{lb}_f/\text{ft}^2$

$K_z$  = proportionality constant,  $\frac{\text{lb}_f \text{ sec}^2}{\text{lb}_m \text{ ft}}$

$L_x$  = dust concentration in carrier gas,  $\text{lb}_m/\text{ft}^3$

$t$  = time since cleaning

$V$  = superficial filtering velocity,  $\text{ft}/\text{sec}$ .

The filter ratio affects the pressure drop by determining the loading rate on the filter. A ratio of three cubic feet per minute per square foot of cloth area is an average value for common dusts. Excessive loading leads to rapid filter buildup. This, in turn, requires a shorter cleaning interval and lowers the life of the cloth. The resistance of the cleaned cloth is determined by material and weave pattern.

The selection of cloth type depends on the

temperature of the gas stream and the abrasive characteristics of the particulate. Table 43-5 illustrates some of the more common fabric materials.

Advantages of fabric filters include:

- 1) Upwards of 99% collection efficiency for virtually all particle sizes;
- 2) Moderate power requirements; and
- 3) Dry disposal of collection efficiency.

Disadvantages include:

- 1) High cost (between 30¢ and \$2.50/cfm);
- 2) Large space requirements;
- 3) High maintenance and replacement costs;
- 4) Control of moisture in the dusts; and
- 5) Cooling for high temperature gas streams.

#### Wet Collectors

Wet collectors or scrubbers effect separation of both particulate and gaseous phase contaminants. Particle removal is accomplished by mechanisms similar to those operating in mechanical separators. In a wet collector the particles first impinge upon discrete droplets or sheets of liquid, and then subsequent separation of the liquid removes the particulates from the gas stream. Removal of gaseous components takes place by the

**TABLE 43-5**  
**Properties of Fiber Materials Used as Filters**

Fiber	Physical characteristics							
	Relative strength	Specific gravity	Normal moisture content (%)	Maximum usable temperature (°F)	Relative resistance to attack by			Other attribute
					Acid	Base	Organic solvent	
Cotton	Strong	1.6	7	180	Poor	Medium	Good	Low cost
Wool	Medium	1.3	15	210	Medium	Poor	Good	—
Paper	Weak	1.5	10	180	Poor	Medium	Good	Low cost
Polyamide (nylon)	Strong	1.1	5	220	Medium	Good	Good <sup>a</sup>	Easy to clean
Polyester (Dacron)	Strong	1.4	0.4	280	Good	Medium	Good <sup>b</sup>	—
Acrylonitrile (Orlon)	Medium	1.2	1	250	Good	Medium	Good <sup>c</sup>	—
Vinylidene chloride	Medium	1.7	10	210	Good	Medium	Good	—
Polyethylene	Strong	1.0	0	250	Medium	Medium	Medium	—
Tetrafluoroethylene	Medium	2.3	0	500	Good	Good	Good	Expensive
Polyvinyl acetate	Strong	1.3	5	250	Medium	Good	Poor	—
Glass	Strong	2.5	0	550	Medium	Medium	Good	Poor resistance to abrasion
Graphitized fiber	Weak	2.0	10	500	Medium	Good	Good	Expensive
Asbestos	Weak	3.0	1	500	Medium <sup>d</sup>	Medium	Good	—
"Nomex" nylon	Strong	1.4	5	450	Good	Medium	Good	Poor resistance to moisture

<sup>a</sup>"Air Pollution" 2nd Edition, Stern, A. C. ed., Academic Press, New York, N. Y., 1968.

<sup>b</sup>Except phenol and formic acid.

<sup>c</sup>Except phenol.

<sup>d</sup>Except heated acetone.

<sup>e</sup>Except SO<sub>2</sub>.

principle of absorption. This process proceeds through diffusional movement of the gas component towards the liquid upon which it absorbs by a concentration gradient across the interface region.

Wet collectors find industrial applications where one or more of the following conditions exist:

- 1) Polluting gaseous components need to be controlled;
- 2) Combustible situations would occur if dry collection were used;
- 3) A humid gas effluent is encountered; and
- 4) Cooling of the effluent is desired.

**Gas Absorption.** Gas absorption occurs either through a chemical reaction with the contacting liquid or by simple physical equilibrium of solubility. In a system where a reaction occurs, equilibrium between the gas and liquid phases for a component is impossible, since in the liquid phase a reaction removes the component from solution. This allows for separation of the component in excess of equilibrium values.

In a system involving simple gas solubility in water, Henry's Law can be used to calculate the equilibrium mole fractions in the liquid and vapor phases.

$$P_A = H X_A$$

where:  $P_A$  = partial pressure of gas A

$H$  = Henry's Law constant

$X_A$  = mole fraction of gas A dissolved in the liquid.

Mass transfer of the gas to the liquid controls the rate at which this equilibrium is approached. A concentration profile exists across both the liquid and gas interface (Figure 43-6). This driving force causes the molecules of the absorbent gas to diffuse from an area of higher gas concentration to an area of lower concentration, the interface.

Since the gas phase diffusion is usually the rate-determining step, the flux at the interface can be determined by the following equation:

$$N_A = K_G A P \Delta Y$$

where:  $N_A$  = moles transferred per hour, m/hr.

$K_G$  = mass transfer coefficient, hr./lb.-ft.<sup>2</sup>

$P$  = total pressure, lb./ft.<sup>2</sup>

$A$  = interface area, ft.<sup>2</sup>

$\Delta Y$  = driving force, lb.-ft.

**Gas Absorption Equipment.** Absorption equipment operates on the principles of gaseous or liquid dispersion. Packed towers, venturi scrubbers and spray towers operate by liquid dispersion. Tray towers and sparging equipment operate by

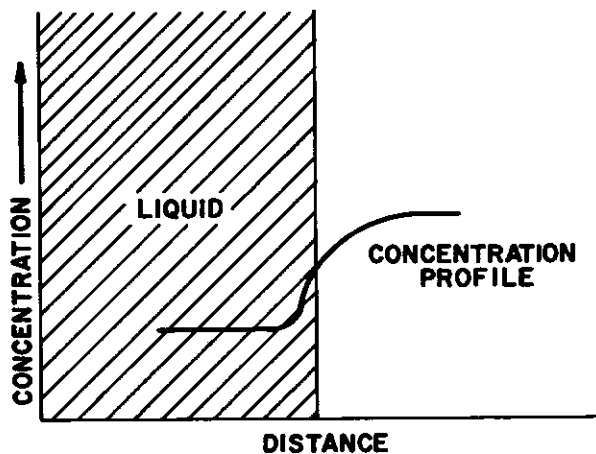

Figure 43-6. Concentration vs. Position in Liquid and Gas.

gas dispersion.

**Particle Collection.** Particle collection proceeds by a two-step process. First, the particle is contacted by a liquid droplet and is "wetted"; then the wetted particles are removed from the carrier gas. In some collectors, the liquid serves only to clean the impingement surfaces. Mechanisms for wetting the particle include:

- 1) Impingement upon liquid droplets;
- 2) Brownian diffusion;
- 3) Condensation of water around a particle as the gas dips below its dewpoint; and
- 4) Electrostatic attraction between the droplet and the particle.

The wetted particles are removed through impingement and/or centrifugal force, depending on the type of device. The wetting of the particle increases its mass, allowing it to be readily removed by inertial force. Overall design and collection efficiency equations are not well developed and depend on the type of equipment. Decreasing water droplet size and increasing relative gas velocities will improve collection efficiency.

**Particle Collection Equipment.** All types of wet scrubbers including those that are used for gas absorption remove particulates to some degree. Generally, those devices that utilize high energy contact between the gas stream and small spray droplets achieve the greatest particle collection efficiency. A list of wet collecting devices is included below:

1. spray chambers
2. cyclone-type scrubbers
3. orifice-type scrubbers
4. mechanical scrubbers
5. mechanical-centrifugal collectors
6. venturi scrubbers
7. packed towers
8. wet filters.

Simplified drawings of several of the devices are depicted in Figures 43-7 through 43-10.

**Discussion of Wet Collectors.** Water pollution problems are always associated with wet scrubbers

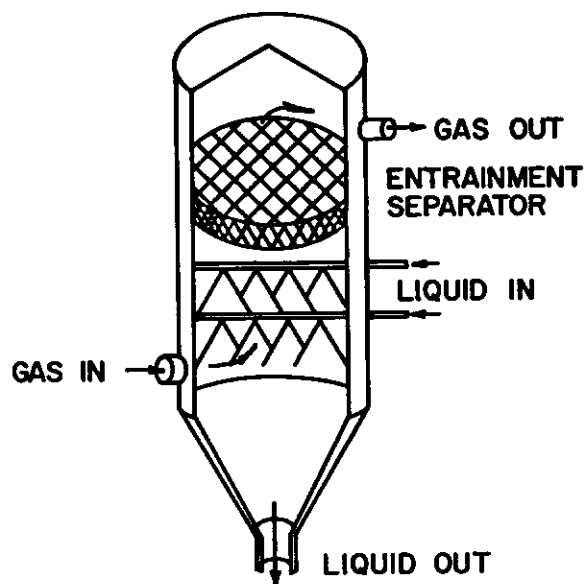

Stern: Air Pollution, 2nd Edition. Academic Press, p. 474.

Figure 43-7. Spray Tower.

and should be considered when evaluating possible systems. It is often necessary to settle out the particulate sludge with flocculants and to adjust the pH before the water can be returned on-stream. Other problems include: freezing of process water, corrosion and increased opacity of the plume due to condensing liquid. Advantages of a wet collector include:

1. constant pressure drop
2. dust removal problems eliminated
3. treatment of high temperature and humid gases
4. compact design
5. moderate costs (between 25¢ and 75¢/cfm).

#### Electrostatic Precipitators

Electrostatic precipitation is a collection process that utilizes a field of charged gas ions to charge the particle followed by attraction to a collection electrode. This device is sometimes called the Cottrell Process, after Frederick Gardner Cottrell, who invented and designed the first electrostatic precipitator.

Three processes are involved in the operation of all electrostatic precipitators: particle charging, particle collection and removal of collected material. If particle charging and collection are separated, a two-stage precipitator results; otherwise, the unit is a single-stage precipitator. Most industrial use is of the latter design, as shown in Figure 43-11.

Particle charging occurs through the formation of a highly-charged region of unipolar gas ions called the corona field. The corona field forms from the electrical voltage potential between the electrodes. If this voltage potential becomes too large, sparking will occur and the corona field will

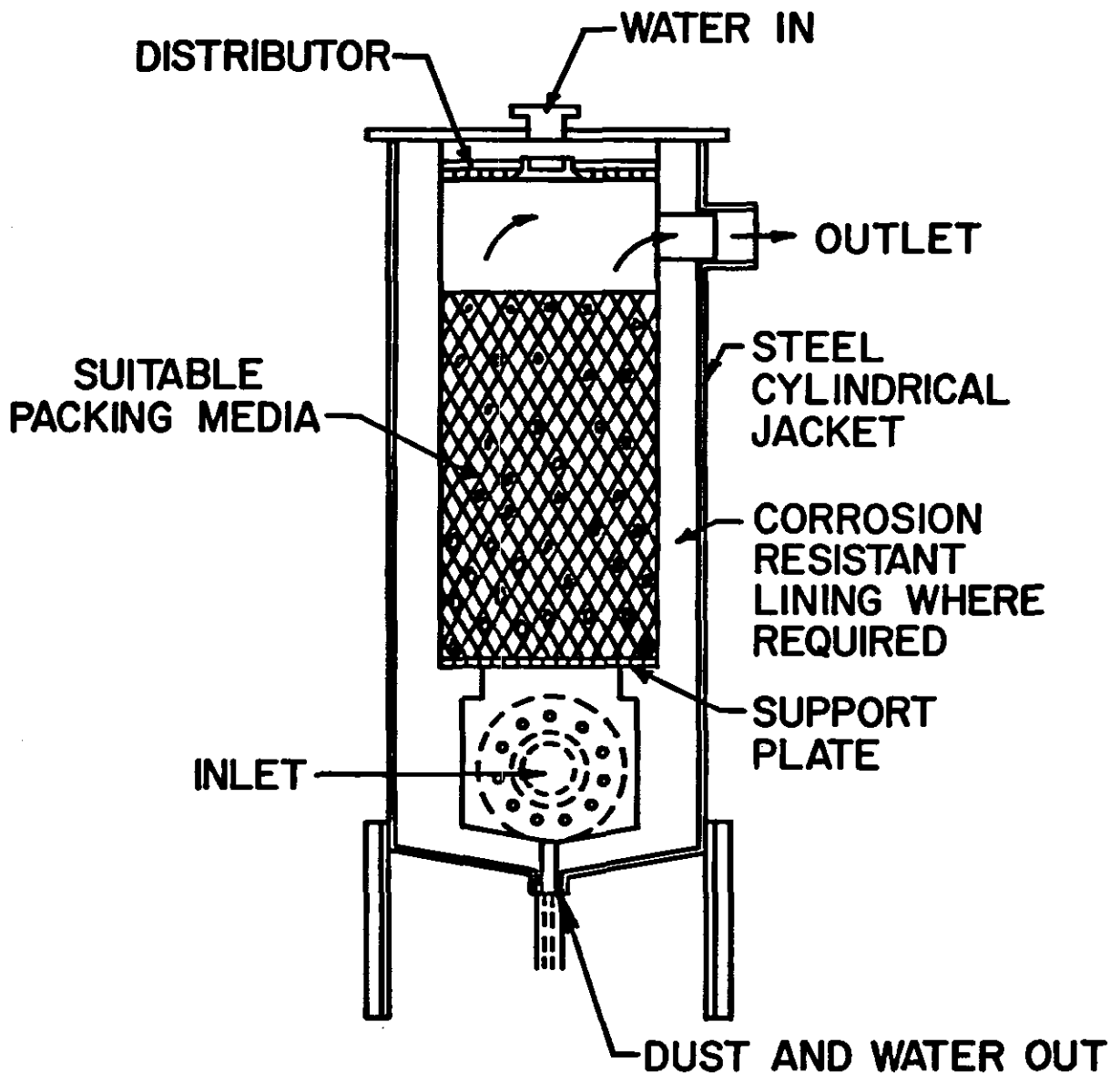

American Conference of Governmental Industrial Hygienists — Committee on Industrial Ventilation: Industrial Ventilation — A Manual of Recommended Practice, 12th Edition. Lansing, Michigan, 1972, p. 474.

Figure 43-8. Packed Scrubber.

be disturbed. The particles flowing through the corona field charge themselves by collision with charged gas ions and move towards the oppositely charged electrode where collection occurs. Removal from the electrode is effected by a mechanical shaker.

There is no theoretical limit to the size of the particles that can be collected. Collection efficiencies are related to the size of the equipment, with efficiencies of over 99% obtainable. The following equation can be used to calculate the efficiency of collection:

$$E_f = 100 - 100 \left[ \exp \frac{-A E_o E_p a}{V 2 \pi \eta} \right]$$

where:  $E_f$  = percent efficiency  
 $A$  = surface area of collecting electrodes,  $\text{ft}^2$   
 $V$  = volumetric flowrate,  $\text{ft}^3/\text{min}$ .  
 $E_o$  = charging field, volts/ft.  
 $E_p$  = collecting field, volts/ft.  
 $a$  = particle radius, ft.  
 $\eta$  = gas viscosity,  $\text{lb./hr. ft}$ .

From the equation, it can be seen that an increase in voltage and surface area coupled with a decrease in volumetric flowrate gives optimum operating conditions.

Initial cost for an electrostatic collector runs

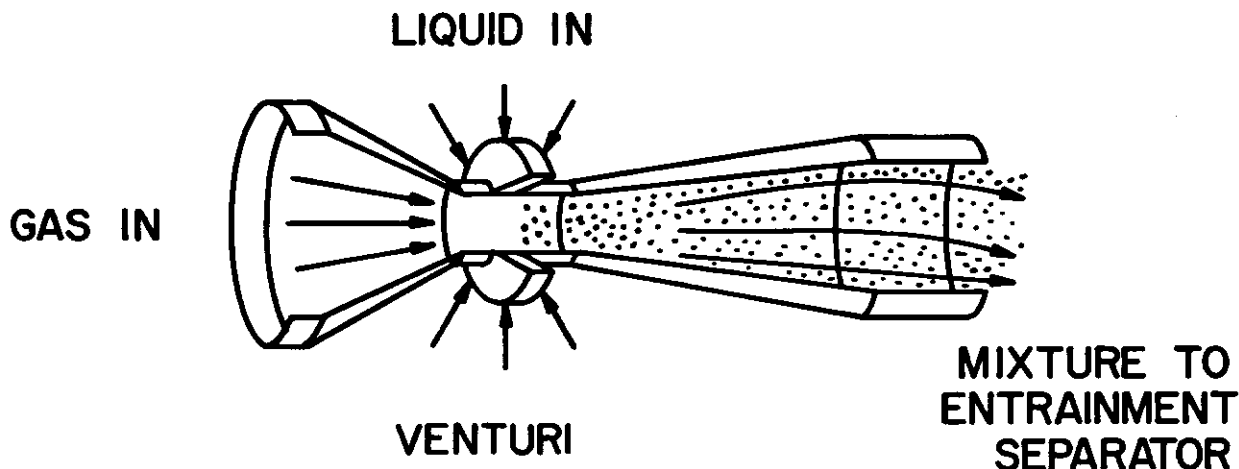

Stern: Air Pollution, 2nd Edition. Academic Press, p. 474 (9, 10) and p. 440 (11).

Figure 43-9. Venturi Scrubber.

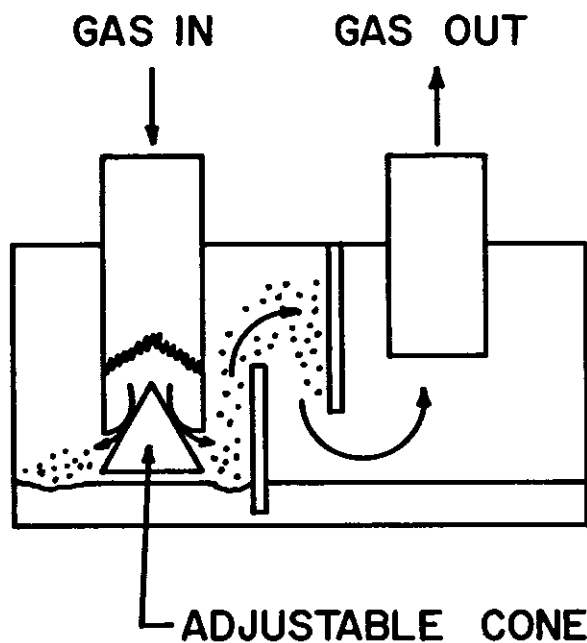

Stern: Air Pollution, 2nd Edition. Academic Press, p. 474 (9, 10) and p. 440 (11).

Figure 43-10. Doyle Impingement Scrubber.

from 80¢ to \$2.50/cfm, with erected cost approximately 1.7 times the initial cost. Power costs are quite low, since energy is required only to separate the particle without having to do work on the carrier gas.

Electrostatic precipitators have many advantages, including:

1. high efficiency
2. dry collection of dusts
3. low pressure drop
4. ability to collect mists and corrosive acids
5. low maintenance costs
6. low operating costs

7. collection efficiency can be adjusted by unit size
  8. ability to handle gases up to 1500°F.
- Disadvantages include:
1. high initial cost (between 80¢ and \$2.50/cfm)
  2. frequent need for a precleaner
  3. large space requirements
  4. difficulty in collecting materials with extremely high or low electrical resistivity.

#### Gas Adsorbers

Adsorption is a useful process for controlling highly odorous, radioactive or toxic gases. This process involves retention of molecules from the gas phase onto a solid surface. Van Der Waals' forces, ionic attraction, secondary chemical bonds and capillary condensation — all have a role in the adsorption of the gas onto the solid surface.

Two general types of adsorbers exist: fixed bed and regenerative. In addition, recirculation may be utilized to increase the effectiveness of the device. Fixed bed adsorbers are economical only when the average contaminant concentration is less than a few parts per million. Regenerative adsorbers are designed to handle much heavier loadings with the additional advantage of recovery of the contaminant solvent which may have a high economic value. A typical fixed bed adsorber is shown in Figure 43-12.

The mechanism of adsorption progresses in three distinct steps:

- 1) The adsorbent moves to the solid surface;
- 2) Physical bonding occurs; and
- 3) Adsorbent is removed through treatment with steam, hot brines or other methods.

In design of adsorbent systems, increased removal efficiency is often obtained if conditions of high pressure and low temperature are maintained. The high efficiency of adsorbers is offset by the many associated problems. Equipment costs may run as high as \$35.00 per pound of vapor removed with operating costs running about five dollars per pound of vapor removed. Other prob-

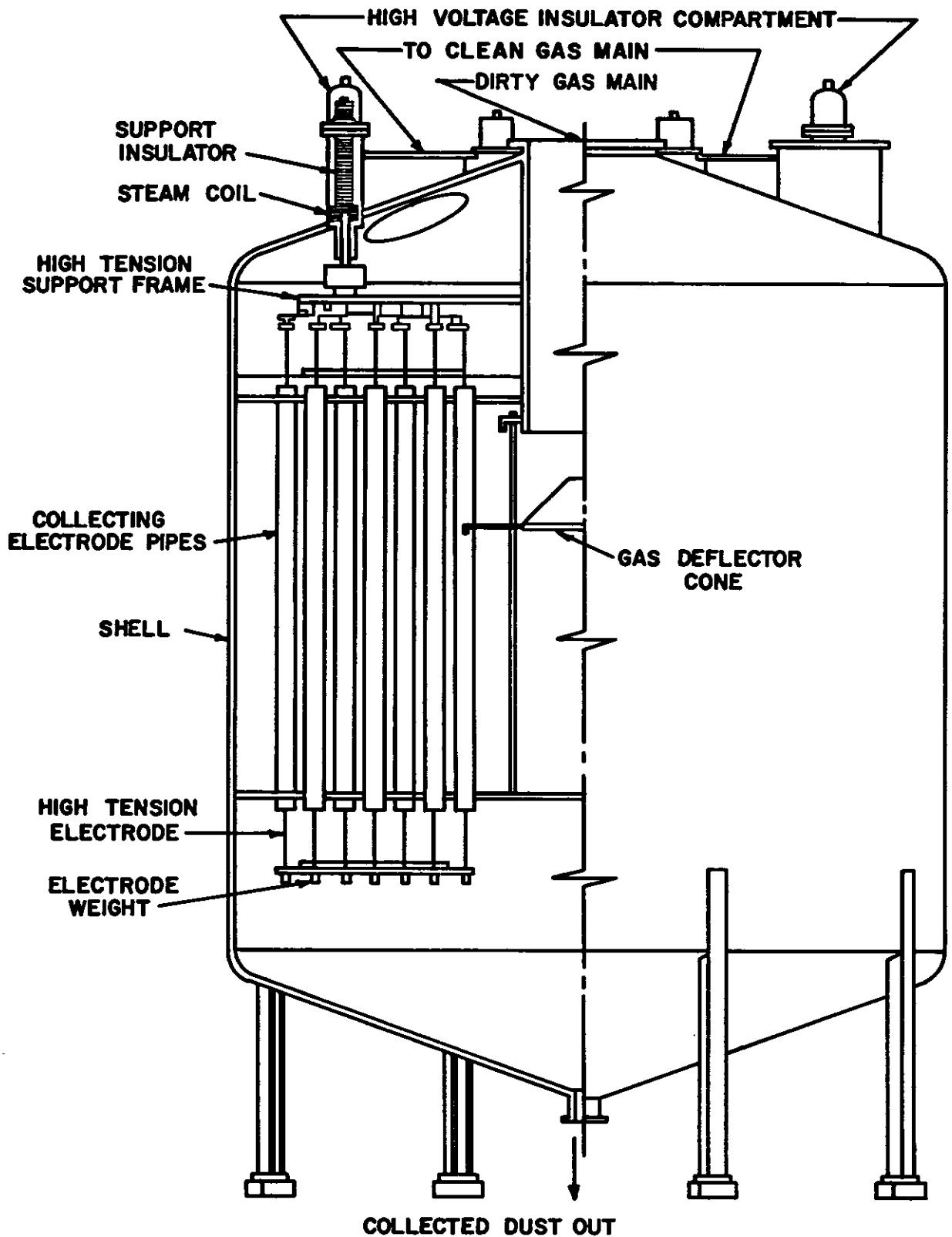

Stern: Air Pollution, 2nd Edition. Academic Press, p. 474 (9, 10) and p. 440 (11).

Figure 43-11. Tube-Type Electrostatic Precipitator.

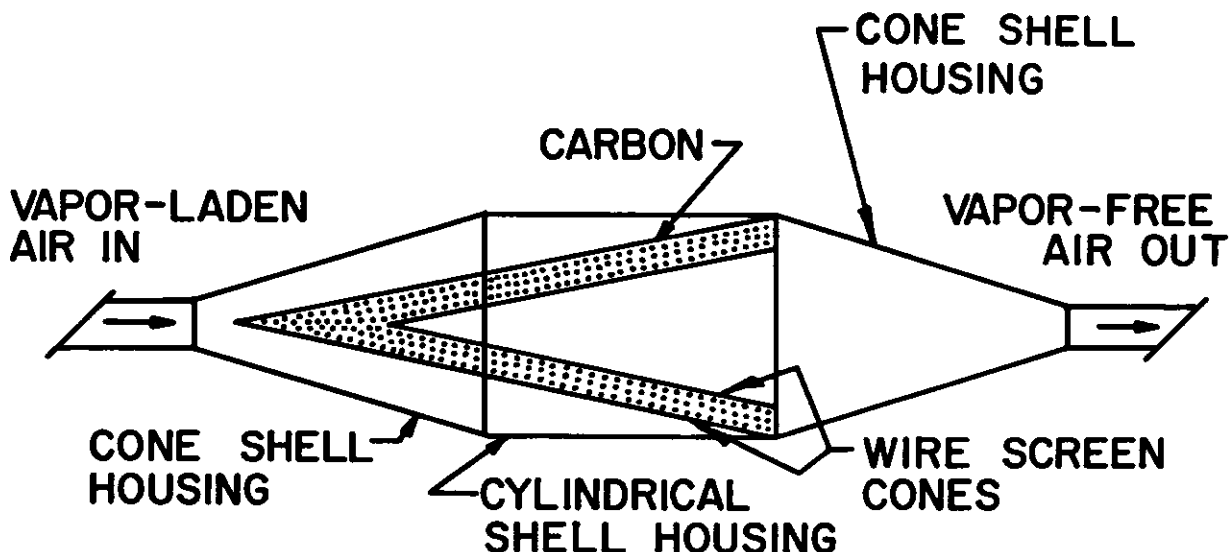

Air Pollution Engineering Manual, Department of Health, Education and Welfare, 1967, p. 197 and p. 172.

Figure 43-12. Fixed Bed Adsorber.

lems include corrosion and particulate contamination of the device.

#### Combustion Incinerators

Combustion incineration is a process that utilizes oxidation reactions for emission control. Combustion afterburners find numerous industrial applications and can be used for any of the following situations:

1. odor control
2. reduction in opacity of the plume
3. conversion of carbon monoxide to carbon dioxide
4. reduction of organic vapors and particulate emissions.

Combustion devices come in two types, direct flame and catalytic combustion. Direct flame incineration involves the burning of additional fuel to reach temperatures high enough for destruction of the gas or aerosol mixtures. Complete combustion yields  $H_2O$  and  $CO_2$ , whereas incomplete combustion may produce even more offensive compounds than originally found. A typical direct flame incinerator is shown in Figure 43-13.

Catalytic combustion utilizes a catalyst, normally a noble metal, to lower the activation energy of the oxidizing reactions to reduce the temperature and fuel costs required for oxidation. Combustion may even become self-sustaining if the concentration of combustibles in the gas stream is sufficiently high.

In designing or operating a flame combustion device, care should be taken to see that the temperature, residence time and turbulent mixing are sufficient for complete oxidation. One satisfactory method of achieving this goal is to admit the contaminant gases into a throat where the burner is located. High velocities can be obtained for thorough mixing of the gases in the region of highest temperature. A retention time of 0.3 to 0.5 second and operating temperature ranges between  $850^{\circ}F$ - $1500^{\circ}F$  have been found to be satisfactory for most applications. Efficiencies of

98% or higher can often be obtained in a well-designed incinerator.

The decision of whether to use flame or catalytic combustion is based on economic considerations and operational characteristics. Costs for flame and catalytic combustion vary widely, depending on the amount, types and concentration of pollutants to be burned. Some of the operational differences are listed below:

- 1) Generation of nitrogen oxides is reduced using catalytic combustion;
- 2) Catalysts require periodic cleaning and regeneration;
- 3) Integration of catalysts into the design of equipment permitting heat recovery is much easier.

#### SUMMARY

This chapter has stressed the standard pollution control equipment in existence today: mechanical separators, filtration devices, wet collectors, electrostatic precipitators, gas adsorbers and combustion incinerators. These devices are listed and evaluated for comparison in Table 43-6.

One area which has been neglected is the water pollution and solid waste potential of air pollution control devices. Obviously, devices which reduce atmospheric emissions must eventually accumulate materials that must be disposed of by other means. A frequent argument against the use of wet collectors is the resulting liquid waste.

In many cases the collected materials can be used productively. They may be recycled back into the process stream, put to use in another plant application or (rarely) sold. All too frequently, however, the liquid wastes are simply discharged to city waste treatment systems, or directly into the waterways, while solid wastes are hauled away to landfills or incinerators.

The design of any air pollution control system must include consideration for potential pollution effects. A control system for one specific

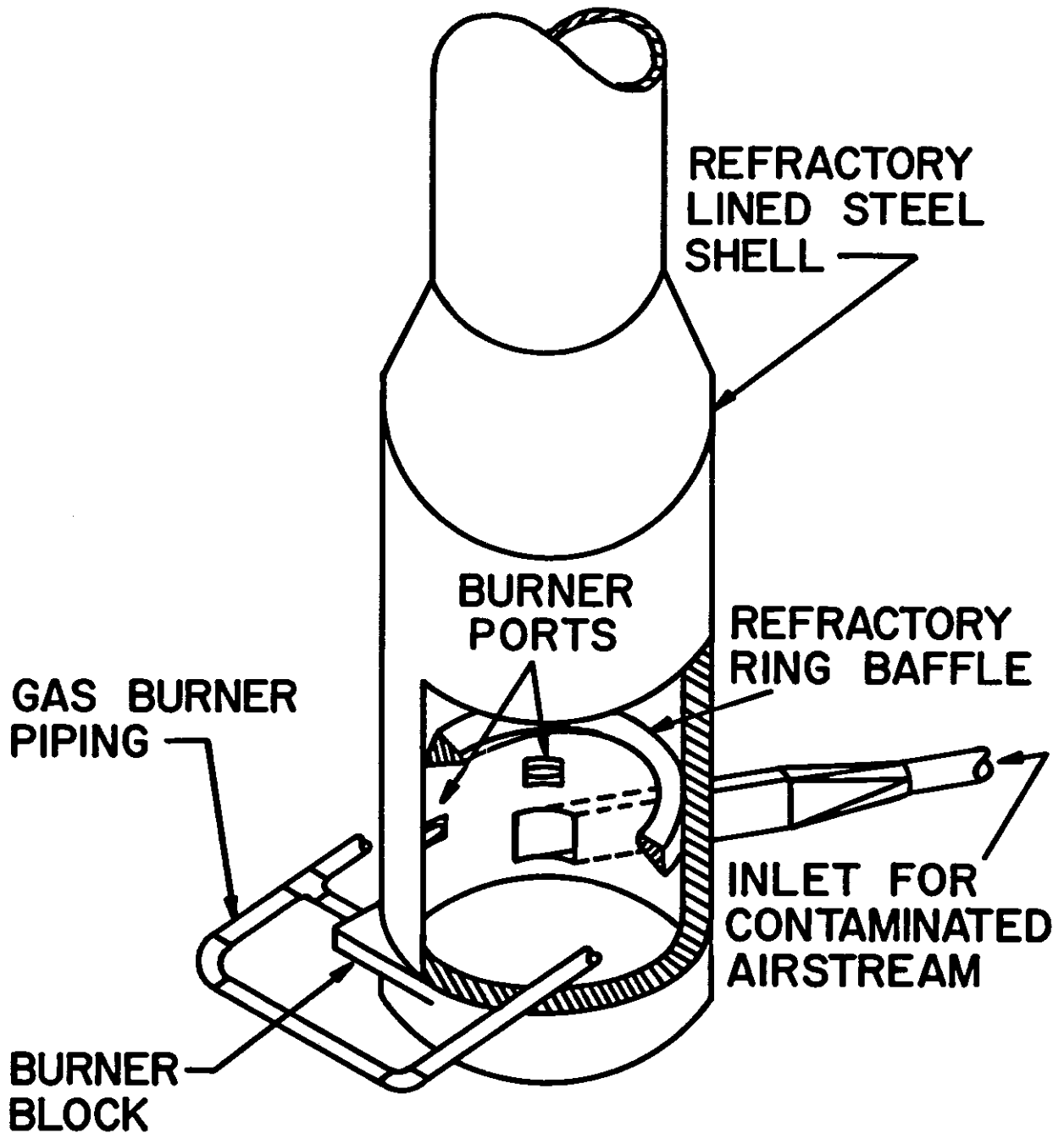

Air Pollution Engineering Manual, Department of Health, Education and Welfare, 1967, p. 197 and p. 172.

Figure 43-13. Direct-Fired Afterburner.

airborne contaminant may involve more than just the design of an air pollution control device. An evaluation of the overall waste disposal system for the total operation may result in numerous additional modifications before all potential pollution sources are adequately controlled.

#### Preferred Reading

1. STRAUSS, W. *Industrial Gas Cleaning*, International Series of Monographs in Chemical Engineering, Volume 8, Pergamon Press, New York (1966).
2. STERN, A. C. *Air Pollution, Volume III — Sources of Air Pollution and Their Control*, Environmental

Science Monograph Series, Academic Press, New York (1968).

3. DANIELSON, J. A. *Air Pollution Engineering Manual*, U. S. Department of Health, Education and Welfare, Public Health Service, Cincinnati, Ohio (1967).
4. LUND, H. F. *Industrial Pollution Control Handbook*, McGraw-Hill Book Company, New York (1971).
5. *Air Pollution Manual, Part II: Control Equipment*, American Industrial Hygiene Association, 66 South Miller Road, Akron, Ohio 44313 (1968).
6. *Journal of the Air Pollution Control Association*, Pittsburgh, Pennsylvania.



**TABLE 43-6.**  
**Comparison of Pollution Control Equipment**

Device	To Control	Advantages	Disadvantages	Costs	Examples
Mechanical Separators	Medium to large diameter particles	<ol style="list-style-type: none"> <li>1) Low initial cost</li> <li>2) Simple construction</li> <li>3) Ease of operation</li> <li>4) Use as precleaners</li> </ol>	<ol style="list-style-type: none"> <li>1) Low efficiency</li> <li>2) Erosion of components</li> <li>3) Cannot remove small particles</li> <li>4) Large space requirements</li> </ol>	Low initial cost (5¢-25¢ per cfm)	<ol style="list-style-type: none"> <li>1) Gravity Chambers</li> <li>2) Impingement Separators</li> <li>3) Cyclone Collectors</li> </ol>
Filtration Devices	Dusts, fumes	<ol style="list-style-type: none"> <li>1) High collection efficiency on small particles</li> <li>2) Moderate power requirements</li> <li>3) Dry disposal</li> </ol>	<ol style="list-style-type: none"> <li>1) High costs</li> <li>2) Large space requirements</li> <li>3) Must control moisture and temperature of gas stream</li> </ol>	High costs (30¢-\$2.50 per cfm)	<ol style="list-style-type: none"> <li>1) Fabric Filters</li> <li>2) Mat Filters</li> <li>3) Ultrafilters</li> </ol>
Wet Collectors	High-temperature, moisture-laden gases	<ol style="list-style-type: none"> <li>1) Constant pressure drop</li> <li>2) Elimination of dust removal problems</li> <li>3) Compact design</li> </ol>	<ol style="list-style-type: none"> <li>1) Disposal of waste water may be expensive and troublesome</li> </ol>	Moderate (between 25¢ and 75¢ per cfm)	<ol style="list-style-type: none"> <li>1) Spray Chambers</li> <li>2) Cyclone, Orifice, Venturi Scrubbers</li> <li>3) Mechanical Scrubbers</li> <li>4) Mechanical-Centrifugal Collectors</li> </ol>
Electrostatic Precipitators	All sizes of particles—even very small mists which form free-running liquids	<ol style="list-style-type: none"> <li>1) High efficiency</li> <li>2) Dry dust collection</li> <li>3) Low pressure drop</li> <li>4) Can collect mists and corrosive acids</li> </ol>	<ol style="list-style-type: none"> <li>1) Often requires precleaner</li> <li>2) Large space requirements</li> <li>3) Cannot collect some high/low resistivity materials</li> <li>4) High initial cost</li> </ol>	High initial costs—low operating costs & low maintenance costs	<ol style="list-style-type: none"> <li>1) Single-stage Precipitators</li> <li>2) Two-stage Precipitators</li> </ol>
Gas Adsorbers	Highly odorous, radioactive or toxic gases	<ol style="list-style-type: none"> <li>1) Contaminant solvent may be recovered</li> </ol>	<ol style="list-style-type: none"> <li>1) High equipment &amp; operating costs</li> <li>2) Corrosion</li> <li>3) Contamination</li> </ol>	High equipment and operating costs	<ol style="list-style-type: none"> <li>1) Fixed Bed</li> <li>2) Regenerative</li> </ol>
Combustion Incinerators	Odors, plume opacity, carbon monoxide, organic vapors	<ol style="list-style-type: none"> <li>1) Capable of reaching high efficiency operation</li> <li>2) Catalytic combustion reduces NO<sub>x</sub> pollutants</li> </ol>	<ol style="list-style-type: none"> <li>1) Must burn additional fuel or add catalyst</li> <li>2) Incomplete combustion can further complicate original problem</li> <li>3) Catalysts require periodic cleaning &amp; regeneration</li> </ol>	Vary widely depending upon application	<ol style="list-style-type: none"> <li>1) Direct Flame</li> <li>2) Catalytic Combustion</li> </ol>



**CONTROL OF INDUSTRIAL WATER EMISSIONS**

*Thomas J. Powers*

**INTRODUCTION**

Industry uses water for almost every conceivable purpose from nuclear shielding to washing down floors. Every water use is important and each source of used water must be known and evaluated. By far the greatest volume of industrial water use is for heat exchange. The smallest water use is in products such as beverages and water-based latex paints.

Man cannot use water without adding something to it. That "something" may be heat, suspended materials or dissolved substances. The more water is used, the more materials are added to it until its usefulness is impaired and a condition of pollution exists. Industrial water use must be so managed that pollution is avoided.

Control of water emissions from industry to

the environment requires a thorough knowledge of the volume of water used per unit time and the quality of the used water. Adequate control also demands a knowledge of the quality standards for both emitted water and receiving water.

Water emissions may best be identified and categorized by the service from which the used water originates. There would then be used water from (Fig. 44-1):

1. Treatment of incoming water
2. Sanitary services
3. Boiler operation
4. Housekeeping
5. Heat exchange
6. Unit processes
7. Roof and yard drainages.

Having identified all used water sources and

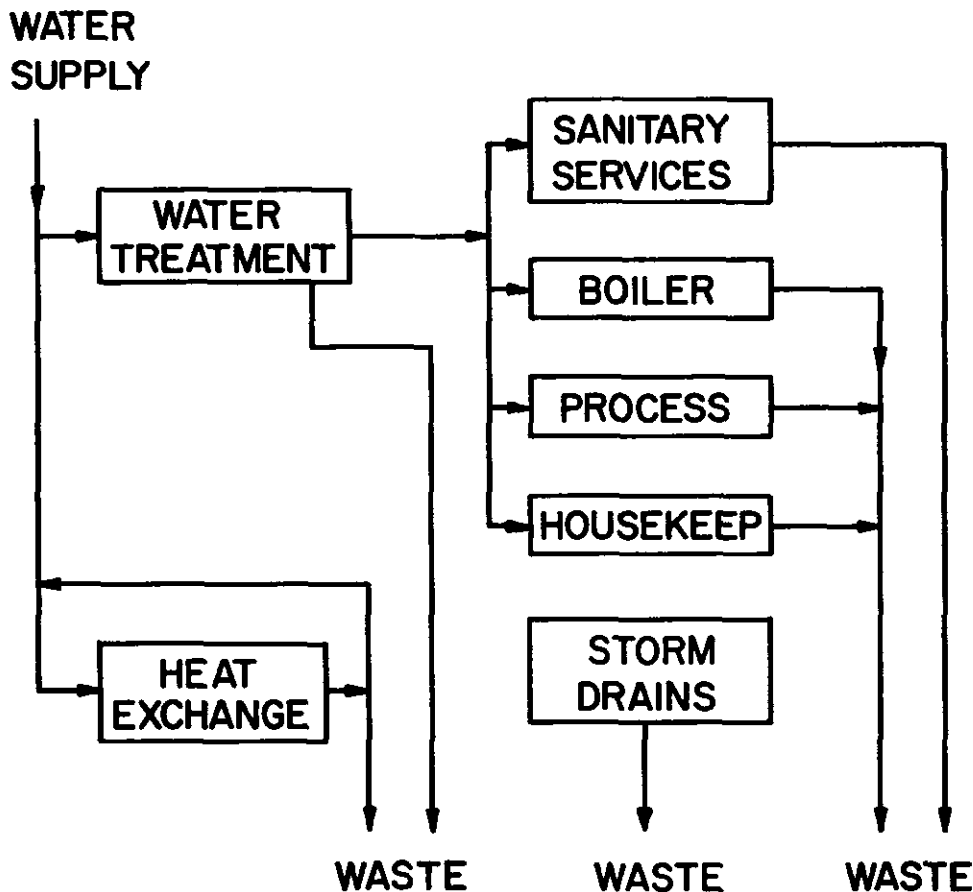

Figure 44-1. Origins of Industrial Water Emissions.

quality, the environmental engineer must review the control methods most applicable and economic for each waste water source. Combinations of waste waters are quite often possible and desirable, but careful analysis of the water quality and the control methods are necessary to indicate compatibility.

Modern small industry will probably find it most economic to purchase potable water from a public supply and to purchase waste water treatment services for those wastes which are compatible with biologic systems. Extreme caution must be used on the potable water supply to avoid any cross-connections. It is also necessary to know accurately the waste water flowrate and quality so that design is adequate to insure control of water emissions to meet standards.

The discussions presented here are not referenced. The author has presented a list of excellent texts which answer almost all of the specific questions which might arise. The references in the texts will guide the reader to articles covering almost every type of waste water problem encountered in industry.

Throughout this chapter emphasis is placed on the necessity for proper measurement of waste flows, proper sampling and accurate analyses together with laboratory experiments to arrive at sound judgments. There is no substitute for sound engineering based on facts derived in this manner.

## IDENTIFICATION OF USED WATER SOURCES

### Wastes from Water Treatment

Treatment of incoming water to achieve the water quality necessary for each use is a necessity for many industries. Whenever solids must be removed, a waste water source results.

**Clarifier Underflows.** Ordinary sedimentation using coagulants such as aluminum or iron salts and flocculant aids is practiced widely on water from surface sources. The settled material removed from the bottom of the settling tank is called sludge and is usually about 8% solids and 92% water. The composition of the solids is the same as the solids in the incoming water plus the coagulant hydrates and filter aids. The sludges can be further dewatered by settling in ponds, by vacuum filtration or by centrifugation. The water resulting from further dewatering should be recycled to the raw water source. The only water lost is to the sludge cake, usually 50% to 75% of the cake weight.

Water softening is the removal of calcium and magnesium ions from the water and can be accomplished by a cation exchanger or by the treatment of the water with lime followed by soda ash. The settled sludge from lime-soda softening will contain calcium carbonate and magnesium hydroxide. By recycling the sludge in the process a final concentration for disposal might contain up to 25% solids and 75% water. Further dewatering can yield up to 50% solids.

Sedimentation, even with flocculant aids, seldom results in a water with less than 20.0 mg/l of suspended solids. Usually sedimentation is fol-

lowed by filtration to remove particles down to about 20 microns.

**Filter Backwash.** Filter backwash is a waste water which contains the solids washed from a filter usually in a concentration about ten times the concentration fed to the filters. This water should be recycled back to a sedimentation tank inflow so that the water is not lost and the solids become a part of the sedimentation tank underflow sludge.

Filters are also used to separate precipitated iron from well water which has been aerated to oxidize the ferrous iron to the ferric state. The wash water from these filters should be ponded and the water returned to the system.

**Ion-Exchange Regeneration.** Water treatment by ion-exchange is widely used for water softening where a cation exchange material removes the calcium and magnesium by replacement with sodium. The regenerant is common NaCl and the waste water resulting from regeneration contains CaCl<sub>2</sub>, MgCl<sub>2</sub>, and the excess NaCl used. The waste water volume resulting from regeneration is usually about 4 bed volumes and the frequency of regeneration depends on the amount of calcium and magnesium in the incoming water.

Complete demineralization using both cation and anion exchangers produces water very close to distilled water. The regenerants may be ammonium hydroxide, caustic, sulfuric acid or hydrochloric acid. The cation exchange replaces all cations with hydrogen giving an acid water which is degassed to remove CO<sub>2</sub> and SO<sub>2</sub>, and the anion exchanger then replaces regenerant anions with hydroxyl ion. The regenerant streams contain all of the substances contained in the original water less the acid gases blown out plus the excess of regenerant added. The waste volume is usually of the order of 6 bed volumes per regeneration.

The regeneration brines from ion-exchange water treatment are of no value and cannot be recycled; they are true waste waters.

### Waste Waters from Sanitary Services

Every industry must provide potable water approved by the State Health Department for sanitary services. Drinking water, washbasins, laundry, toilets, showers (including safety showers) and kitchens should be furnished with potable water. The environmental engineer should constantly be on the lookout for cross connections between potable and non-potable sources. Whenever it is necessary to use potable water as an alternate in a non-potable system, the potable water should be delivered to a head tank and re-pumped to the non-potable system (Fig. 44-2). A suitable color code for each water system can help prevent erroneous connections. Toilets, washrooms and showers should be sewered separately together with laundry and kitchen wastes, to a segregated system called the sanitary sewer. Drinking fountains, safety showers and eye baths are usually placed strategically for workmen's maximum convenience and need not be sewered to the sanitary system.

The waste water resulting from sanitary ser-

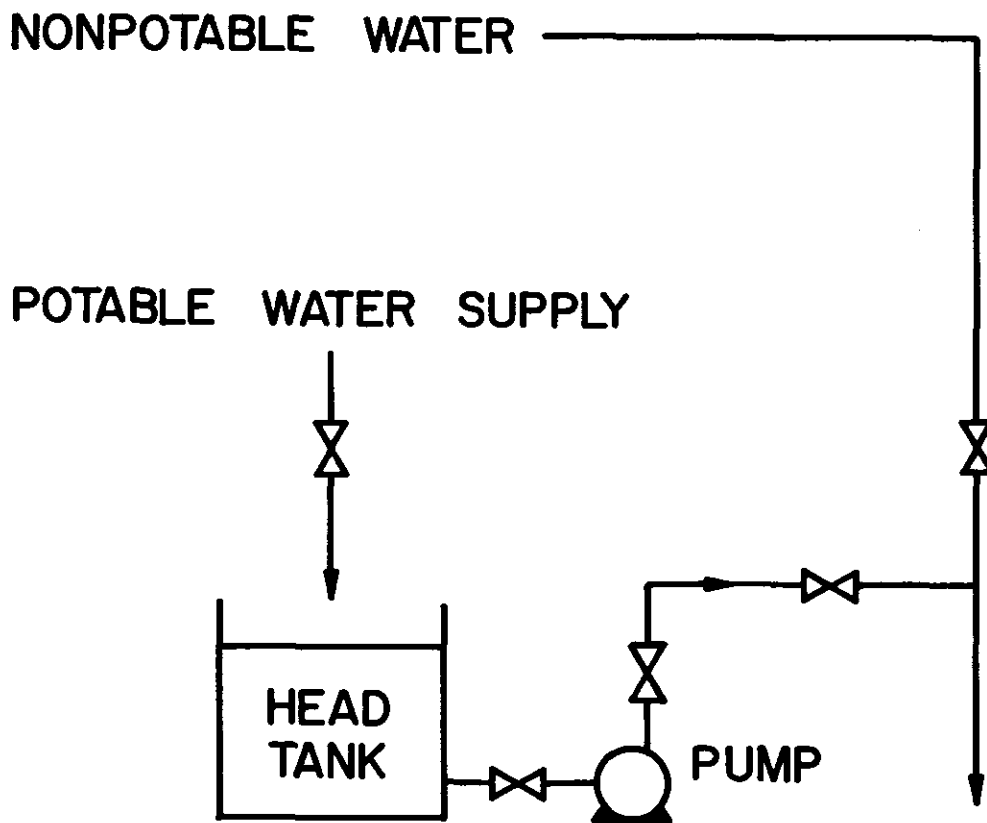

Figure 44-2. Equipment to Avoid Cross-Connections.

vices will be about 20 gallons per person per shift. The waste water should be limited to 100 mg/l of suspended solids and a B.O.D. of about 120 mg/l. If laundry and kitchen wastes are added, the volume will be about 30 gallons per person per shift.

#### Waste Waters from Boiler Operation

Many industries operate boilers to produce process steam and plant heat. These boilers are usually low pressure boilers (150 psi) and do not require demineralized water for make-up, but almost all use internal boiler treatment. The chemicals added to boiler feed are for the purpose of holding compounds in solution as water is evaporated and to prevent water entrainment in the steam.

**Boiler Blow-Down.** In order to maintain the solids in the boiler at a manageable level it is necessary to purge the boiler periodically. This is called boiler blow-down. Naturally this represents a considerable heat loss which can be minimized by exchanging the heat to the boiler feed. The resulting water is highly mineralized and must be considered a waste. The total dissolved solids will be 3500-5000 mg/l.

**Ash Sluice Water from Combustion of Coal.** Most low pressure coal fired boilers are stoker fed and seldom require fly ash control. Ashes are usually sluiced with water to an ash pit. The overflow water from ash handling is alkaline and must be considered as waste water. If fly ash is collected,

it also is usually sluiced to a pit.

**Boiler Cleaning Solutions.** Fouled boiler tubes result in decreased efficiency and must be cleaned periodically (1-2 years). Chemical cleaning is widely used and the low pressure boiler can be cleaned using hydrochloric acid which contains substances to inhibit its attack on metallic iron. Many industries require that the cleaning contractor haul spent cleaning solutions off-site although in some instances the spent solutions are discharged to the ash pit where residual alkali neutralizes some of the acid and iron is precipitated.

High pressure boilers require more sophisticated cleaning methods using organic materials such as citric acid and versines since hydrochloric acid should not be used on stainless type steels. These spent cleaning solutions contain copper and nickel chelates and require separate handling.

#### Waste Waters from Housekeeping

Almost every industry maintains service hoses which are used to wash down equipment and floors. This is not only for appearance but also for personnel safety and product quality control. The food industries in particular must shut down all production periodically and remove all traces of putrescible substances from materials handling equipment and floors. It is common practice to run production for two shifts and use the third shift for a complete clean-up.

Service hoses with 50 psi water pressure will

deliver from 15 to 30 gpm. Several hoses being used at a time will result in a considerable flow from the building.

The engineer should attempt to minimize water use and yet accomplish the purpose. Leaving hoses running is a very common mistake which must be corrected constantly.

#### Water Used for Heat Exchange

As stated previously the use of water as a heat exchange medium is by far the greatest industrial water use. Once-through cooling is extensively practiced because it is the simplest and cheapest system as long as sufficient water is available. Heat has become known as a pollutant because of the changes in the water biota due to increased temperatures. Heat added to surface waters is slowly transferred to the atmosphere until the water and air above it reach equilibrium.

Once-through cooling adds very little to a water except heat; however, a 20-25°F rise in the water temperature is common.

**Cooling Towers.** Heat exchange water which is in short supply or which may cause thermal pollution is recovered for re-use by causing the heat to be rapidly dissipated to the atmosphere through use of cooling towers. The recycle of cooling water over cooling towers necessitates treatment of the water to prevent scale and corrosion in the heat exchange piping. The cooling tower will lose about 2.0% of the water by evaporation, about 1.0% by entrainment and 10% by the purge required to maintain a constant solids content (Fig. 44-3). The purge loss will contain about 1000 mg/l of total solids, plus the amount of zinc, chromium and other chemicals added to condition the water.

**Barometric Condensers.** It is quite common to use a steam jet to pull a vacuum on a distillation or evaporation process. One source of heat exchange water which may not be included in the cooling water system is the barometric quench condenser (Fig. 44-4). This type of condenser can contain sizable quantities of product if a small vacuum leak develops in the system. It is advisable to use an inner-after condenser rather than the quench condenser when the product being handled is a major pollutant (Fig. 44-5).

**Product Heat Exchangers.** Heat exchangers which are used to cool a product should have readily accessible water sampling points downstream from the units. A small leak in a tube can account for a sizable product loss even though the pressure is greater on the water side. The velocity of the water past a pin hole leak can create a suction, causing product to enter the cooling water stream.

#### Unit Processes

The water which comes in direct contact with raw materials, intermediates, by-products or products is called process water. The inadvertent loss of materials to heat exchange equipment and clean-up of floors has previously been discussed.

**Raw Material Purification.** Many raw materials are transported by water and unwanted impurities are washed or dissolved away. Many examples of this water use are found in the food industry. Sugar beets are sluiced to screens ahead of slicers. The flume water washes dirt and debris from the beets and also dissolves some sugar depending on the condition of the beet.

The quality of the process water from the canning industry can be directly related to the condition of the vegetables or fruit as received.

## COOLING TOWER

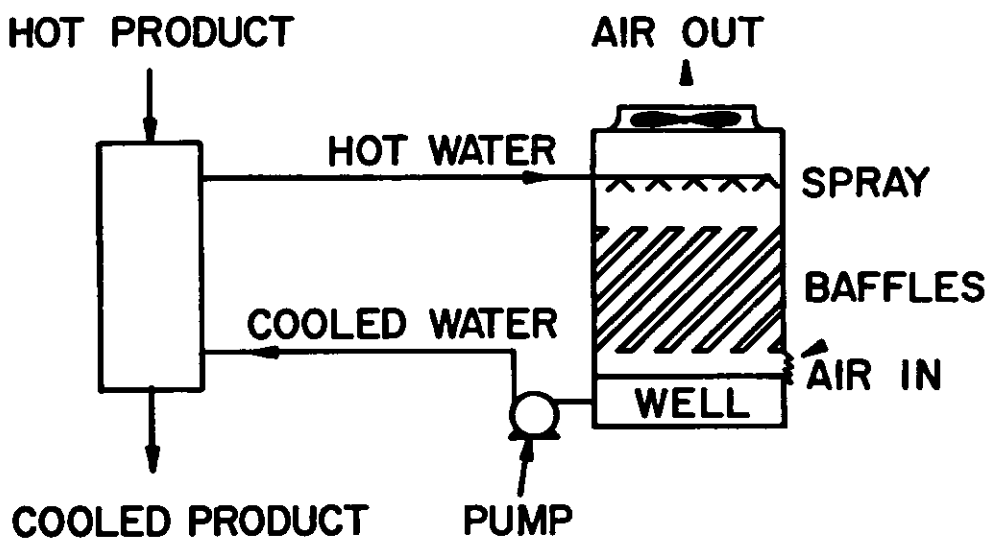

Figure 44-3. Cooling Tower.

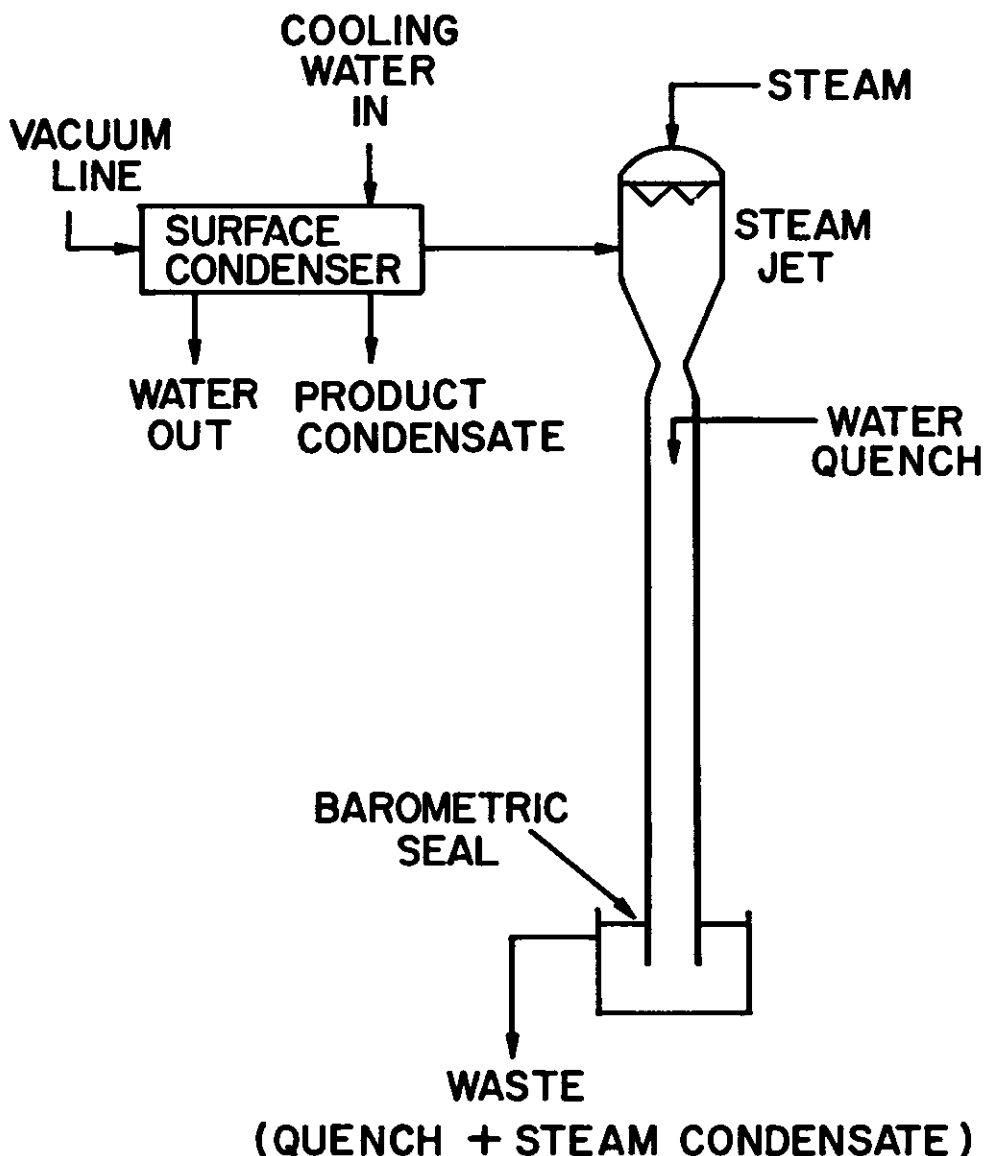

Figure 44-4. Barometric Quench Condenser.

**Reaction Vessel Cleaning.** One of the most important waste water sources from unit processes is the clean-up of vessels from batch reactions. These waters are usually quite concentrated, are discharged intermittently and often require special handling.

**Raffinates.** Solvent extraction of materials from water is a common industrial process. The water remaining after the extraction is called a raffinate. As a rule these are strong wastes containing by-products, some product and some solvent.

**Vent Gas Scrubbers.** Whenever gases are released from a process they are usually scrubbed with water. If the gas is valuable, such as hydrogen, it may be scrubbed to remove impurities and recovered for use. Many vent gases such as chlorine, hydrogen cyanide, hydrogen sulfide or phosgene may be dangerous and must be removed by efficient scrubbing equipment (see Chapter 43). The water wastes from vent scrubbers can be the most important waste water to measure and evaluate

for control.

**Condensates.** Whenever steam is used or is formed in a process it is generally condensed using a heat exchanger or a quench condenser. Many condensates are pure water and can be re-used, but almost all condensates are subject to receiving impurities. Continuous monitoring of condensates is a must to achieve process control as well as control of water emission.

#### Roof and Yard Drainage

The design of the sewer system should provide a segregation of water run-off from factory roofs and yards. Raw materials and products are often lost to roofs or grounds. Pressure reaction vessels with frangible reliefs often vent materials to roofs. Tank car loading is bound to result in some spills. Storage tanks develop leaks. If control of water emission is to be achieved the environmental engineer cannot overlook roof and yard drainage. These waste waters should be monitored and the necessary controls installed and maintained.

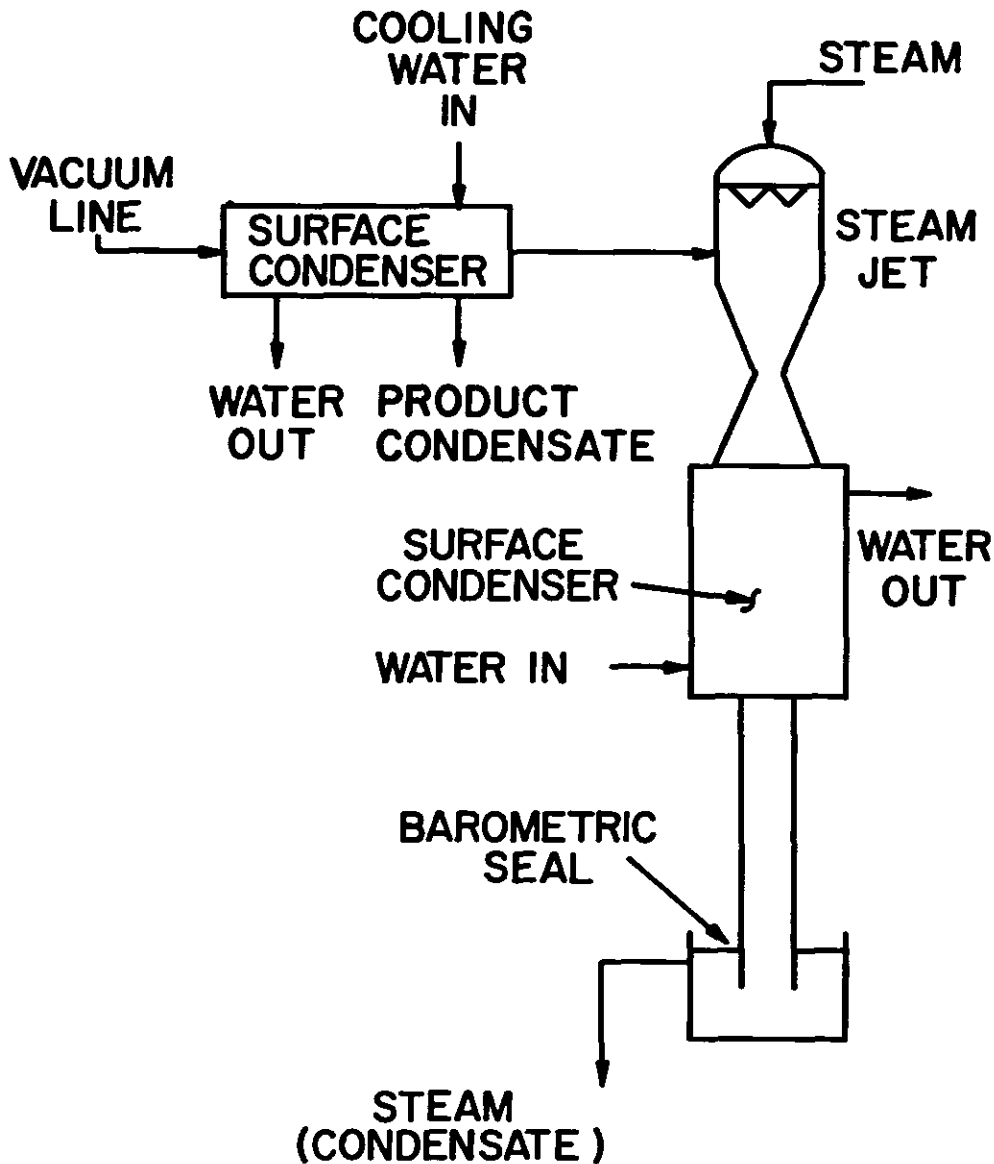

Figure 44-5. Barometric Inner Condenser.

### CONTROL METHODS FOR WATER EMISSIONS

#### Waste Inventory

In considering the control of industrial water emissions it is well to remember that things happen in industry. A good philosophy to follow in design is that if it can happen, it will. One of the most valuable and useful tools in the control of water emissions is impervious storage facilities into which high concentration, low volume and intermittent waste waters may be inventoried and from which waste may be monitored, recycled or treated to achieve control. Where land is at a premium, waste inventory can be achieved by pumping to holding tanks. It may be advisable to inventory each process waste separately near the production equipment and feed from these at a steady rate to the proper control method.

The chemical industry has used waste storage

of brines with controlled discharge to streams at high flows for many years.

#### Raw Material Change

As is the case in control of air pollutant emissions it is sometimes necessary and feasible to avoid the production of a waste by changing the raw material. For instance, a tannery might change from salted hides to fresh hides and avoid the problem created by washing salt from the preserved hides. If the purification of the raw material creates a waste water problem it may be possible to have the supplier remove the impurity prior to shipping.

#### Process Change

There are many processes which have inherent losses to water. Most of these are in the wet process industries where raw materials are dissolved in water or transported by water. It is possible in some instances to change the process and relieve



the losses to the waste water. The environmental engineer should review each process with process engineers to minimize water contact and the production of waste materials. Major process changes may take years to accomplish and be very costly, but if a waste can be avoided or made into a useful product, the long term economics can be favorable.

#### **Direct Burning**

The direct burning of organic residues from industrial processes is a common method of ultimate disposal. Minimizing water and concentrating the waste water stream to more than 10% organic content permits the use of direct burning at reasonable cost. A very good example of this is the waste liquor from sulfite pulp mills. Both fluidized bed combustion and direct burning have been used.

Wet combustion using air or oxygen to 300°C resulting in pressures up to 1750 psi has also been used on sludges in some municipalities, but has not yet been used extensively on strong industrial wastes.

#### **Vaporization and Catalytic Burning**

The catalytic burner is used extensively to control odorous air emissions (Chapter 43) and can also be used to destroy organic matter if the water waste is first vaporized. This technique has been used on nonrecoverable solutions of lower alcohols.

#### **Control of Water Emissions by Recycle**

The containment and utilization of waste waters by recycle is common to most industries. Water conservation practices such as counter-current washing and the re-use of cooling water does not mean the reduction of pollutants but rather a concentration in a smaller volume.

Recycle of water usually entails the addition of chemicals to control corrosion, scaling and bacterial growths. However, the recycle of weak solutions which contain raw materials, intermediates or product may be an economic necessity and should be investigated thoroughly.

#### **Subsurface Disposal**

The loss of polluted water to fresh ground water must be avoided. This is not easy and requires a knowledge of subsurface geology and hydrology. Sewers collecting acid wastes must be designed to carry that waste without loss to the ground. Sewers subject to hot water release must not break due to thermal shock. Dyked areas which might retain polluted water should be made impervious.

Disposal by deep well is an engineered method of ultimate disposal which is politically and geologically possible in many parts of the country where porous and permeable sedimentary formations containing connate brines exist. The waste waters which have been so disposed are usually brines or waters containing highly toxic or odorous materials which cannot be treated effectively and which should not be allowed to pollute the ground or surface water. The chemical and oil refining industries have used deep well disposal in Texas, Indiana, Ohio, Louisiana and Florida. The depth of these wells is usually 1500 to 6000 feet.

While deep well disposal is not exactly a last resort method, most State agencies will demand a review of alternate control techniques. The volume of waste water a formation can accept safely is finite. The deep formation disposal capacity is a valuable resource and should be reserved for those wastes which must not be allowed to invade man's environment.

If deep well disposal is being considered, a competent hydrologist or geologist should be employed to develop a feasibility report and preliminary costs. Starting with the State Water Pollution Control agency, all regulatory agencies must approve. The design of surface equipment and the well design cannot be trusted to inexperienced engineers. Drilling of the well and its completion should be closely supervised by an engineer knowledgeable in these matters. Too many failures have been the result of poor design and execution.

#### **Treatment to Standard Quality**

Very seldom is it possible to eliminate, contain or destroy waste waters to a degree which will permit release to public waters without treatment of some sort to meet a quality standard.

Most municipal waste water treatment plants control the quality of industrial waste discharge to municipal sewers through ordinances establishing limits on pH, suspended solids and biochemical oxygen demand. Industries producing waste waters exceeding the standards are required to pre-treat the waste or to pay a surcharge or both. Sanitary sewage is described as having pH 6-9, suspended solids — 350 mg/l, B.O.D. — 300 mg/l. In addition to the control of these three parameters, it is necessary to restrict the waste waters from industry to those wastes containing substances which are compatible with the treatment process being used. Practically all municipal waste water treatment systems use biologic processes. Since the municipality must also treat to a standard quality it cannot afford to receive wastes which will upset or poison the biologic process. Substances highly toxic to bacteria must not be allowed to reach the treatment process. Other substances which may not be toxic but which have a high chlorine demand may also be refused.

*Physical and Chemical Treatment Methods: Neutralization.* The first treatment step toward control will probably be neutralization to achieve an effluent stream having a pH between 6-9. Aside from proper inventory, neutralization may be the only treatment needed in some instances. On the other hand, neutralization may cause precipitation of insoluble materials and require further treatment. It is also possible to use the neutralizing power of one waste when properly mixed with another. The cheapest alkali usually available is finely ground limestone,  $\text{CaCO}_3$ , and next is  $\text{CaO}$ , which should be slaked to  $\text{Ca(OH)}_2$ . One source of waste  $\text{Ca(OH)}_2$  is from the manufacture of acetylene from calcium carbide. Laboratory experiments should be performed to develop the most economic neutralization system.

*Screening.* The use of coarse and fine screens to remove large suspended particles is a first treatment step in many industries, especially the food

industry. Screening may also be the only pretreatment required before discharge to a municipal system. Fine screens remove those particles which may overload skimming and sludge handling equipment in further treatment steps. Sometimes screenings will be of some value as stock feed but mostly they are hauled off-site for burial or spreading on the land.

**Sedimentation-Flotation.** Solids removal by settling is the universal primary treatment step. All settling systems should be designed, although many small industries dig a hole in the ground and hope for miracles. Flow-through settling ponds are used extensively in the mineral processing industries. These ponds must be designed to give adequate solids storage for long periods of time before settling capability is lost. Dual ponds permit the use of a fresh pond while the filled pond is being excavated.

Where land is costly, the use of designed clarifiers permits the continuous use of a stable settling capacity and the dewatering of solids for off-site disposal.

Clarifiers are usually designed to receive water at 600-1000 gallons per square foot per day. Flocculation chambers can also be included so that coagulants and flocculants can readily be applied to upgrade not only the solids removal efficiency but also hydraulic capacity. It is usually most economical to remove as many settleable and colloidal materials as possible in the primary settling step. Here again laboratory experiments with various coagulants and flocculants guide the engineer's judgment of the best system and engineering parameters.

A well designed and properly operated clarifier should deliver an effluent of about 25 mg/l suspended solids.

Sludges from the underflow of clarifiers will usually contain about 5-8% solids. The accumulation of inorganic sludges in dyked areas is common industrial practice. Dewatering by vacuum filters, sand beds or centrifuges permits hauling sludges off-site or, in the case of organic solids, prepares them for sanitary landfill or incineration. The safe disposal of sludges from waste water treatment can account for 50% of the total treatment cost and therefore requires detailed study.

In some cases the character of the solids in a waste water may cause the engineer to select flotation as the solids-separation process. Oily and greasy materials having a specific gravity close to water can be made to trap other particles and, by using dissolved air under pressure, the fine bubbles which are released to a flotation tank cause the suspended materials to rise to the top of the tank where they can be skimmed off readily.

Laboratory experiments can quickly evaluate flotation efficiency and the effectiveness of adding coagulants. Most water treatment equipment suppliers have flotation equipment which can be engineered after design parameters are established.

**Chemical Treatment.** The use of chemicals for neutralization and as aids in the sedimentation process has been mentioned. Chemicals are also used to precipitate undesirable ions such as mer-

cury and other heavy metals, fluorides and phosphates. Hexavalent chromium can be reduced by  $\text{SO}_2$  and precipitated as trivalent chromium.

The use of chlorine as a disinfectant for municipal waste water prior to discharge is a requisite in most states.

Chlorination of industrial wastes for disinfection may be important in some industries where the dissemination of disease organisms to the environment is likely. The most important use of chlorine in industrial waste treatment is as an oxidant to destroy highly toxic or odorous substances. The standard treatment of cyanides from the plating industry is oxidation by alkaline chlorination. One pound of cyanide requires 7.35 pounds of chlorine. Chemical oxidation using chlorine, ozone or permanganate will cost more than 50 cents per pound of organic matter destroyed. This cost usually dictates that chemical oxidation be used only as a final polishing method after the bulk of the organic matter has been removed by some less expensive method.

**Adsorption.** There has been a renewed interest in the use of activated carbon for the removal of soluble organic materials from waste waters. Activated carbon has a broad spectrum of pore size, but is most effective in the removal of larger molecules ( $\text{C}_2$  and above). The cost of granular activated carbon is usually more than 30 cents per pound. It is evident that at least ten regenerations must be effected if the adsorption cost is to be made competitive with chemical oxidation. Here again the use of activated carbon is usually limited to threshold treatment.

**Extraction.** Solvent extraction is a production technique used extensively in the chemical industry. The extraction of phenol from water using caustic-washed benzene is a classic example. Since most solvents are soluble in water to some degree, it is then necessary to strip the solvent from the waste. An ideal situation might be the use of water-insoluble waste from one process to extract the water-soluble waste material from another process water.

### Biological Waste Treatment Methods

**General.** Bacteria can utilize an amazing number of organic compounds as the carbon source in their metabolism, which is the basis for many systems to remove organic materials from water. By providing an environment conducive to bacterial growth one can achieve rapid utilization of complex mixtures of soluble organic materials. End products of bacterial carbon utilization are carbon dioxide and protein.

Since biological treatment depends on the production of protein, it is necessary that nitrogen and phosphorus in a usable form be available to build protein molecules. All living cells require carbon, nitrogen, oxygen and phosphorus. Oxygen can come from the free oxygen dissolved in water in which case the biologic system is called *aerobic*. If the oxygen comes from a combined source such as  $\text{NO}_3$  or  $\text{SO}_4$ , the system is *anaerobic*.

**Anaerobic Biological Treatment.** Anaerobic bacteria use combined oxygen, and the entire system is one of reduction. The end products of anaerobic bacterial action are  $\text{CO}_2$ ,  $\text{CH}_4$ ,  $\text{NH}_3$ ,  $\text{H}_2\text{S}$  and

fatty acids. The  $\text{CO}_2$  is in excess of the  $\text{NH}_3$  production and the  $\text{NH}_3$  combines with the  $\text{CO}_2$  to form ammonium bicarbonate. Material equivalent to one pound of Chemical Oxygen Demand (COD) fed to the anaerobic process should yield about 5.6 cubic feet of  $\text{CH}_4$ .

The use of anaerobic treatment by industry has been restricted largely to the food industry. Too often the industry has used merely an open pond and let nature take its course. Improper design and control have resulted in the uncontrolled production of  $\text{H}_2\text{S}$  and amino acids causing odor nuisances.

Properly designed and contained anaerobic treatment plants can remove effectively and cheaply as much as 90% of the B.O.D. from a strong organic waste. Proper mixing, recycled solids, off-gas containment and temperature control are requisite to achieve 90% removal in as little as 24 hours retention time. Anaerobic treatment should be considered for any waste which has a B.O.D. of more than 2000 mg/l. Temperature should be maintained at about 95°F.

Usually anaerobic treatment is followed by aerobic treatment for two reasons. The anaerobic process develops considerable non-settleable solids and produces acetic and propionic acids. The aerobic process then metabolizes the organic acids and flocculates the colloidal particles.

The best example of anaerobic treatment is the stabilization of the organic matter contained in municipal waste water treatment plant sludges. The digester effectively removes about 50% of the total organic matter contained in sludges. The gas from a well-operated digester will contain about 65% methane and 34%  $\text{CO}_2$  with variable amounts of  $\text{H}_2\text{S}$ .

An interesting adaptation of the anaerobic process is the removal of nitrogen from a waste water containing nitrates. A low molecular-weight carbon source such as methanol is fed to an acclimatized system to reduce the nitrate to gaseous nitrogen. The single carbon minimizes sludge production, but other soluble organics can be used.

Sludge lagoons can be rendered odorless if sufficient sodium nitrate is present in the water over the sludge.

**Aerobic Biological Treatment.** Aerobic biological treatment of high volume, low organic, industrial waste waters is quite common, primarily because of low cost. Oxygen from air can, through biologic oxidation, be made to oxidize a pound of carbon for about 10 cents, including amortization and operation of the facilities. The cheapest chemical methods range upward from 50 cents per pound of carbon oxidized. Then too, bacteria can readily metabolize materials such as acetates which are extremely difficult to oxidize chemically.

Many methods are used to accomplish biological oxidation.

(a) The earliest method was the *oxidation pond* which is still effective in warm climates if sufficient surface area and depth are provided. Without continuous sludge removal, a pond quickly becomes anaerobic on the bottom. Sufficient

retention time for solids permits the flow-through part of the pond to remain aerobic. Many pulp and paper mills have used aerated ponds to assure sufficient oxygen and minimize the land area needed. All biological reactions are temperature dependent, so in order to maintain effective treatment the water should remain above 50°F or the retention time required to achieve a standard quality becomes too great and economy is lost. Another factor in the retention time is the amount of biological solids kept in suspension. The aerated pond usually has no more solids in suspension than one half the B.O.D. concentration.

With proper depth for sludge, observations on oxidation ponds have led engineers to design for about 50 lbs. B.O.D. loading per acre per day.

(b) The *trickling filter* was an outgrowth of the old contact tank. It was observed that biological slimes adhered to surfaces in natural streams. The contact tank was merely a tank filled with large stones into which the waste water was directed and operated on the fill and draw principle. The slimes on the rocks obtained oxygen from the air drawn into the tank on the discharge cycle. By spraying the waste water and permitting it to trickle down through a bed of stones, the process permitted more air to contact the waste and hence increased the loading as well as the oxidation efficiency. There is no filtering action as such in the so-called trickling filter. Soluble organics are converted to protein; colloidal matter, if present, can be absorbed in the slimes. The slimes adhering to the media will become anaerobic next to the media surface. As the slimes become thicker, they slough away from the media and become suspended solids in the effluent.

The development of the rotary distributor further increased the usefulness of the trickling filter by insuring complete and uniform distribution over the entire rock surface.

The use of plastic shapes which provide a known surface-volume relationship have improved removal efficiencies and have permitted the use of increased depths so that these units have become known as oxidation towers.

The trickling filter should not be used on wastes which have a high suspended organic solids content. Solids absorbed in the slimes can quickly go anaerobic, and the odors can be a nuisance. The oxidation tower has its best place in the rapid conversion of soluble materials to insoluble protein. In this case the indicated removals are in the neighborhood of 50%. The unit then serves to pre-treat medium strength wastes ahead of activated sludge.

Rock trickling filters can seldom be loaded to more than 50 lbs. B.O.D. per day per 1000 cu. ft. of media. The plastic media-units have been used with loadings of 500 lbs. B.O.D. per day per 1000 cu. ft.

(c) *Activated sludge* is a process in which flocculated biological slimes are settled and returned to the aeration tank to maintain a high ratio of acclimatized sludge mass to carbon.

The activated sludge process has been the subject of much research since 1914. Each year

investigators have added a little to our understanding of the process until we now can formulate the various relationships and design facilities with a fair amount of accuracy.

With highly concentrated waste waters containing rapidly metabolized substances the main problem is to dissolve oxygen as fast as the bacteria can use it. A well acclimated return sludge will convert soluble organic material to protein as rapidly as oxygen is made available. A limited oxygen supply will increase the time of conversion to the point that the protein growth phase is still in progress at the end of the aeration tank. When this condition occurs sludge will be lost over the settling tank weirs and effluent quality is poor. An overloaded activated plant is extremely difficult to manage and usually goes from bad to worse because of the inability to condition properly the return sludge so that flocculation

takes place before reaching the settling tanks.

Accurate evaluation of waste waters and laboratory experimentation are necessary to define the design and operation of an efficient activated sludge system.

#### **Recommended Reading**

1. ECKENFELDER, W. WESLEY, JR.: *Industrial Water Pollution Control*. McGraw-Hill Book Company — New York, 1966.  
(Laboratory procedures to develop design criteria with excellent recent references.)
2. NEMEROW, NELSON M.: *Liquid Wastes of Industry*. Addison-Wesley Publishing Co., Reading, Mass., 1971.  
(Theories, Practices and Treatment — replete with specific industry references.)
3. *Principles of Industrial Waste Treatment*. John Wiley & Sons, New York, 1955.  
(General review of industrial waste problems and solutions.)