

A Publication of the
**National Wildfire
Coordinating Group**

Sponsored by
United States
Department of Agriculture

United States
Department of the Interior

National Association of
State Foresters



Water Handling Equipment Guide

Prepared by:
**NWCG Fire Equipment
Working Team**

PMS 447-1

October 2003

NFES No.1275

Fifth Edition



The National Wildfire Coordinating Group (NWCG) has developed this information for the guidance of its member agencies and is not responsible for the interpretation or use of this information by anyone except its member agencies. The use of trade, firm or corporation names in this publication is for the information and convenience of the reader and does not constitute an endorsement by NWCG of any product or service to the exclusion of others that may be suitable.

Comments regarding the contents of this publication or new equipment inputs should be directed to: National Wildfire Coordinating Group, Chairperson, Fire Equipment Working Team, c/o Director, Fire & Aviation Management, USDA Forest Service, P.O. Box 96090, Washington, D.C. 20090-6090.

Additional copies of this publication may be ordered from: National Interagency Fire Center, ATTN: Great Basin Cache Supply Office, 3833 South Development Avenue, Boise, ID 83705. Order NFES 1275.

Check the current NWCG NFES Catalog Part 2: Publications for current price and ordering procedures. The catalog may be found at www.nwcg.gov/pms/pubs/pubs.htm.

Water Handling Equipment Guide

Fifth Edition
October 2003

Prepared by:
**NWCG Fire Equipment
Working Team**

Water Handling Equipment Guide

This Interagency *Water Handling Equipment Guide* has been developed and published by the NWCG Fire Equipment Working Team (FEWT). A subcommittee was formed in 1980 and development of this *Guide* was accomplished in 1981 and 1982 with the first, second, third, and the fourth editions being published in June of 1983, 1985, 1988, and 1994 respectively. The NWCG FEWT subcommittee for the fifth edition consisted of:

Ralph Taylor – USDA Forest Service

Robert Stroud, Jr. – USDI Bureau of Land Management

Tom Hutchison – USDA Forest Service

Steve Maurer – New Jersey Forest Fire Service

Mark Crow – Florida Division of Forestry

Mark Zavala – USDA Forest Service

Kate Dargan – California Department of Forestry and Fire Protection

John Craney – California Department of Forestry and Fire Protection

Dan McKenzie – USDA Forest Service

Dale Dague – USDA Forest Service (Chairperson)

Water Handling Equipment Guide

Fifth Edition

Introduction

Through a survey of Federal and State wildland fire fighting agencies, a need was expressed to identify government owned and operated interagency water handling equipment and to disseminate this information to field users. The pictures, performance, and equipment descriptions found within this *Guide* represent the various types of pumps, equipment, and other components found in the fire community and offered by manufacturers. ***It is not meant to indicate sponsorship or validation of any particular manufacturer or product.***

The primary objective of the *Guide* is to provide field users in wildland firefighting agencies with a basic information document on water handling equipment. Within the wildland fire community, every imaginable type of water handling equipment is in use. **This *Guide* does not contain all water handling equipment in use**, but does contain equipment components that are (1) commercially available or economically reproducible, (2) interagency in scope or application, and (3) currently in use. To qualify for being reproducible, there normally has to be the availability of specifications and drawings that have been tested.

The information contained in this latest edition has been completely updated to incorporate recently developed concepts in wildland fire organization, changes in equipment, and deletion of no longer used or available items. Appendixes have been expanded to provide a ready source of technical data and conversion factors required by the practitioner.

Agency-developed systems or components portrayed, but not available from a vendor or manufacturer as a unit, are included to promote standardization among agencies, resulting in reduced equipment costs and increased efficiency and safety.

Users are encouraged to submit new equipment ideas at any time. See appendix J for Mobile Equipment Input Data Sheet. Information submitted will be reviewed for inclusion in the next revision of the *Guide*. (See inside front cover for the address.)

CONTENTS

I. WATER PUMPING EQUIPMENT

A. Pumps	1
1. Hand operated	3
2. Mini lightweight portable	4
3. Lightweight portable	7
4. Heavy portable	12
5. Floatable	19
6. Mountable	22
7. Pumps—retired	30
8. Engine driven	37
B. Fire Engines	38
1. Engine matrix	39
2. ICS type: 2	41
3. ICS type: 3	42
4. ICS type: 4	59
5. ICS type: 5	68
6. ICS type: 6	69
7. ICS type: 7	86
8. Other type	91
C. Water Tenders	93
1. Water tender matrix	93
2. ICS type: 2	94
3. ICS type: 3	96
4. Other type	102
D. Nonhighway Equipment	103
E. Trailer-Mounted Equipment	113
F. Water Tanks	116
G. Plumbing	117
1. Typical engine plumbing diagram	117
2. Valve numbering system	117

II. FOAM GENERATING EQUIPMENT

A. Foam Proportioners	118
1. Manually regulated proportioning systems	118
2. Automatic regulating proportioning systems	120
3. Summary of foam proportioners	123
4. Foam accessories	124
B. Compressed Air Foam Systems (CAFS)	125
C. Foam Nozzles	126
1. Conventional nozzles	126
2. Aspirating nozzles	126
3. Aspirating nozzle designs	127

III. WATER DELIVERY COMPONENTS AND ACCESSORIES

A. Hose	128
1. General	128
2. Design criteria	128
3. Hose types	128
B. Hose Dispensers and Storage	133
1. Reels	133
2. Baskets	134
3. Packs	134
4. Hose packing boxes and devices	138
5. Trays	139
6. Storage	140
C. Hose Accessories	141
1. Discharge and friction loss calculators	141
2. Hose shut-off clamps	142
3. Kits and accessories	143
4. Hose rollers	144
5. Hydrant and spanner wrenches	146
D. Hose Test and Maintenance Equipment	149
1. In-line gauge	149
2. Hose washers	149
3. Hose dryers	150
4. Hose cutters and coupling expanders	151
5. Hose testers	152
E. Fittings and Connections	153
1. General	153
2. Lugs, threads, couplers, and gaskets	153
3. Fittings and connections	156
F. Nozzles	166
1. General	166
2. Design criteria	166
3. Nozzle types and descriptions	167
4. Nozzle tips	171
5. Applicator pipe	172
G. Water Storage Tanks (Folding/Collapsible)	173
H. Water Diversion and Storage Devices	174
1. Portable dam	174
2. Gravity sock	174
I. Specialized Equipment	175
1. Remotely activated pump (structure protection)	175
2. Sprinkler kit	175

IV. APPENDIXES

A. Nozzle Flow Rates	177
B. Pressure and Flow Rates	181
C. Flow Determination, Pump Testing, and Gauges	191
D. Service Test for Fire Hose	199
E. Specifications and Standards	205
F. Metric System Equivalents/Conversion Factors ..	211
G. Suppliers	217
H. Acronyms and Abbreviations	225
I. Definitions	229
J. Blank Equipment Input Data Sheet	237

WATER PUMPING EQUIPMENT

Pumps

I. WATER-PUMPING EQUIPMENT

For the purpose of this *Guide*, water-pumping equipment has been divided into five categories: pumps (a fire pump and power source), fire engines, water tenders, specialized, and plumbing.

A. Pumps

Pumps are either centrifugal or positive displacement; both types are used in wildland firefighting equipment. The centrifugal pumps employ outward force from a center of rotation (known as the eye) to move or discharge water. With these pumps the volume will vary with speed (rpm) and pressure. Centrifugal pumps are usually larger than positive displacement pumps and are employed for higher volumes.

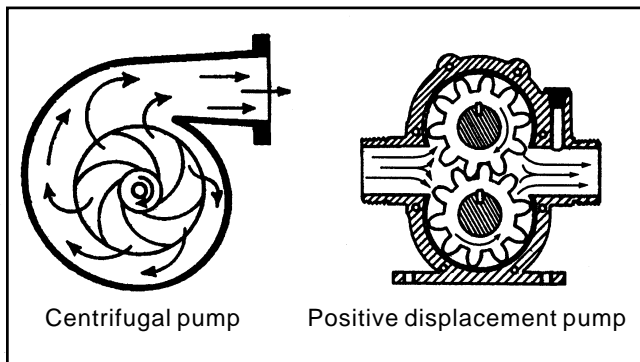

Figure 1—Pumps.

Positive displacement pumps move a quantity of water with each stroke or revolution of the piston or impeller. Volume depends primarily upon speed (rpm). To a lesser extent volume may decrease at higher pressures due to reduction in pump efficiency. The rotary gear, vane, cam-and-piston, and rotary piston are typical units. Most are self-priming. Most require relief valves to handle line surges, overloads, and flows not needed at the nozzle. Typical gear pumps have tight tolerances between the rotating parts and the pump housing.

For purposes of this *Guide*, a pump is a combination of a fire pump and a power source. Components normally include engine controls, starter, spark arrester and muffler, pump primer, pressure gauge, fittings, connections, valves, and frame.

Hand pumps are operated by hand in a push-pull action. Water is drawn from a backpack-type tank through a hose connection.

Volume pumps are designed for moving large volumes of water at low pressure to fill engines or water tenders.

Special Considerations

- **The size of the job**—The perimeter to be worked with water, the volume of fuels involved, the size and arrangement of fuel, and the distance from the fire to water source.
- **The fire characteristics**—Smoldering, creeping, running, crowning, and spotting.
- **The number and kind of exposures ahead of the fire**—Involving standing snags, down rotten logs, red slash, structures and improvements, or a stand of timber.
- **The static head, friction loss, and nozzle pressure needed**—All affect pressure requirements.
- **Other factors**—Establish flow (gal/min) and pressure (psi) requirements to meet job expectations.
- **Hearing safety sound level**—Ensures that the pump will comply with Occupational Safety and Health Administration (OSHA) standards. If the pump unit produces more than 90 decibels (dBA) at the operator's ear, a label shall be attached as required by OSHA.
- **Air pollution**—Environmental Protection Agency (EPA) Phase 1 emission standards have been in effect since production model year 1997 and are referenced in 40CFR Parts 9 and 90 of July 3, 1995. Pumps have been developed and are currently available that offer low emissions. Reference *EPA and CARB Emissions Standards To Control Nonroad Exhaust Emissions of Fire Pumps and Chain Saws, 0251 1204–SDTDC, December 2002*.

The EPA Phase 2 will require more stringent emission standards to further reduce the hydrocarbons plus oxides of nitrogen by an additional 59 percent beyond the current Phase 1 standards. Phase 2 standards are scheduled for phasing in by 2007.

WATER PUMPING EQUIPMENT

Pumps

Note: Tampering with a certified engine may reduce the life span and performance of the engine and is against the law and subject to a civil penalty/fine.

Work Assignments

The typical assignments for a wildland fire pump are demanding and require rugged equipment. The following should be taken into consideration during the pump selection process:

- Flow (gal/min) requirements are highly variable; water conservation is important.
- Service is through lightweight, small-diameter hose lines, where friction loss is high.
- Hose lays are often long.
- Hose is often laid up steep slopes, with resulting high static head pressures.
- Water is normally under high static suction lifts from source to pump.
- Engine power will be reduced as altitude increases.
- Temperatures are often high.
- Hours of work are long.
- Long service life is required.
- Weight is an extremely important factor, particularly with portable pumps.
- Available water is often abrasive and corrosive.
- Pump reliability is extremely important.
- Ease of operation and maintenance.
- Performance versus initial investment and repairs.

This section covering pumps is not meant to be all inclusive. The pumps described herein are a representative sampling based on information received during the national input solicitation for the revision of this publication. They are not intended to be an endorsement of any product and may not meet some agency's standards. More information can be obtained directly from the manufacturers listed in appendix G of this publication, or from the General Services Administration Schedule 42 (539) at www.fss.gsa.gov.

WATER PUMPING EQUIPMENT Hand operated— Pumps

1. Hand operated

In many areas of the United States, the backpack pump is a primary fireline tool. These hand-operated pumps are designed to pump water from a backpack tank, which is rigid or collapsible. They are available from various suppliers (see appendix G) and through the *GSA Wildfire Protection Equipment and Supplies Catalog*.

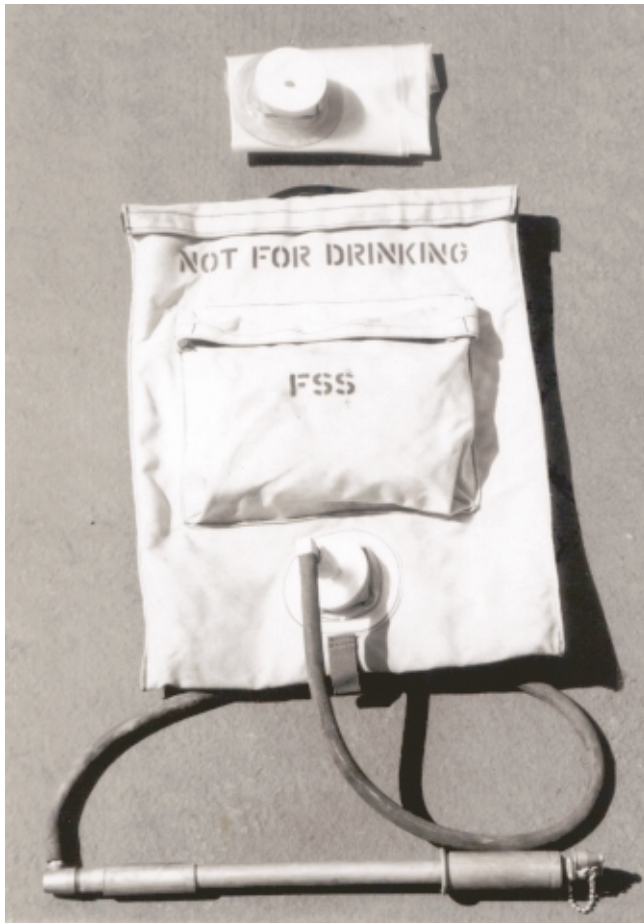

Trombone pump with collapsible bag.

- Pump: Hand operated, push-pull action, single- or double-acting, carried on backpack tank.
- Performance: Variable, depending on operator action (approximately 0.75 gal/min).
- Tank capacity: 4 to 5 gallons



Trombone pump with rigid tank.

- Construction and material:
 - Pump: brass, or other noncorrosive materials.
 - Tank: galvanized stainless steel, nylon duck with replaceable liner, or polyethylene.
 - Hose: rubber, Federal Specification A-A-59567
 - Quick-connect fittings: stainless steel, or other noncorrosive materials.
 - Straps: nylon, padded carrying straps.
- Written materials: Specifications are available from various suppliers (appendix G) and:

USDA Forest Service
Technology and Development Center
444 East Bonita Avenue
San Dimas, CA 91773
Phone: 909-599-1267

WATER PUMPING EQUIPMENT

Pumps—Mini lightweight portable

2. Mini lightweight portable

These pumps weigh less than 30 pounds and are designed for one person to carry. They are ideal where small, lightweight equipment is desired. They are designed for light-duty initial attack in remote locations by helicopter or smokejumper operations or any other situation where weight and/or space limitations are a consideration.

Pump		Engine			
Make	Wildfire Equipment Inc.	Make	Honda		
Model	Mini-Striker	Model	GXH50		
Type	Single-stage centrifugal	Horsepower	2.5	RPM	7,000
Priming	Manual	Ignition type	Magneto		
Inlet size	1½ inch NPSH	Cylinders	1		
Outlet size	1½ inch NPSH	Fuel used	Gasoline		
Height (in)	15¾	Width (in)	10¾	Fuel pump available	No
Length (in)	15¾	Dry weight (lb)	20		



Manufacturer

Wildfire Equipment Inc.
1100 Norman, Suite 200, Lachine, Quebec, Canada H8S 1A6

Pump Performance Value

PSI	0	25	50	75	85
GAL/MIN	56	51	32	8	0

Hearing safety sound level **Data not provided by pump manufacturer**

Description

USDA qualification code	N/A	Integral or removable handles	Removable
Cooling method	Air cooled	Relief valve	No
Starting system	Recoil	Backpack & straps	No
2- or 4-stroke cycle	4 stroke	Special tools or accessories	None
Pressure gauge	Optional		
Integral or removable base	Removable		

WATER PUMPING EQUIPMENT Mini lightweight portable— Pumps

Pump		Engine			
Make	Mercedes Textiles Ltd.	Make	Honda		
Model	Wick 80-4H	Model	GX31		
Type	Single stage, centrifugal	Horsepower	1.5	RPM	7,000
Priming	Manual	Ignition type	Electronic		
Inlet size	1½ inch NPSH	Cylinders	1		
Outlet size	1½ inch NPSH	Fuel used	Gasoline		
Height (in)	11	Width (in)	11	Fuel pump available	Yes
Length (in)	14	Dry weight (lb)	17.8		



Manufacturer

Hydro-Wick Industries Ltd.
287 St. Jean Ouest, East Angus, Quebec, Canada J0B1R0

Pump Performance Values

PSI	0	20	30	42	53	60	73
GAL/MIN	55	44	38	26	13	7	0

Hearing safety sound level **Data not provided by pump manufacturer**

Description

USDA qualification code	N/A	Integral or removable handles	Removable
Cooling method	Air cooled	Relief valve	No
Starting system	Recoil	Backpack & straps	No
2- or 4-stroke cycle	4 stroke	Special tools or accessories	None
Pressure gauge	No		
Integral or removable base	Removable		

WATER PUMPING EQUIPMENT

Pumps—Mini lightweight portable

Pump		Engine		
Make	Mercedes Textiles Ltd.	Make	Honda	
Model	Wick 100-4H	Model	GXH50	
Type	Centrifugal	Horsepower	2.5	RPM 7,000
Priming	Manual	Ignition type	Electronic	
Inlet size	1½ inch NPSH	Cylinders	1	
Outlet size	1½ inch NPSH	Fuel used	Gasoline	
Height (in)	16	Width (in)	11	Fuel pump available No
Length (in)	14	Dry weight (lb)	20.2	



Manufacturer

Hydro-Wick Industries Ltd.
287 St. Jean Ouest, East Angus, Quebec, Canada J0B1R0

Pump Performance Values

PSI	0	35	55	77	85	95 100
GAL/MIN	69	46	33	17	10	4 0

Hearing safety sound level **Data not provided by pump manufacturer**

Description

USDA qualification code	N/A	Integral or removable handles	Removable
Cooling method	Air cooled	Relief valve	No
Starting system	Recoil	Backpack & straps	No
2- or 4-stroke cycle	4 stroke	Special tools or accessories	None
Pressure gauge	No		
Integral or removable base	Removable		

WATER PUMPING EQUIPMENT Lightweight portable—Pumps

3. Lightweight portable

These pumps weigh from 30 to 60 pounds and are designed to be carried by one to two persons. They are designed for light-duty initial attack or any other situation where weight and/or space limitations are a consideration. Engine, starter, pump, controls, fittings, and other accessories are included as a complete assembly. The fuel tank and fuel hose with primer are sometimes carried separately from the engine and pump.

Pump		Engine	
Make	Wildfire Equipment Inc.	Make	Briggs & Stratton
Model	BE-S	Model	133437
Type	Positive displacement	Horsepower	6 RPM 3,600
Priming	Self-priming	Ignition type	Electronic
Inlet size	1 inch NPSH	Cylinders	1
Outlet size	1 inch NPSH	Fuel used	Gasoline
Height (in)	14	Width (in)	15 Fuel pump available No
Length (in)	17½	Dry weight (lb)	45



Manufacturer

Wildfire Equipment Inc.
1100 Norman, Suite 200, Lachine, Quebec, Canada H8S1A6

Pump Performance Values

PSI	50	100	150	200
GAL/MIN	11	10	9	8

Hearing safety sound level **Data not provided by pump manufacturer**

Description

USDA qualification code	N/A	Integral or removable handles	Integral
Cooling method	Air cooled	Relief valve	Optional
Starting system	Electric w/backup recoil	Backpack & straps	No
2- or 4-stroke cycle	4 stroke	Special tools or accessories	None
Pressure gauge	Optional		
Integral or removable base	Removable		

WATER PUMPING EQUIPMENT

Pumps—Lightweight portable

Pump		Engine	
Make	Hale Products	Make	US Motor Power
Model	20FP-C8P Fyr-Pak	Model	Power Bee
Type	Centrifugal	Horsepower	8 RPM 7,000
Priming	Manual	Ignition type	Electronic
Inlet size	1½ inch NST	Cylinders	1
Outlet size	1½ inch NST	Fuel used	Gasoline-oil mixture
Height (in)	13	Width (in)	16½ Fuel pump available Yes
Length (in)	32	Dry weight (lb)	34

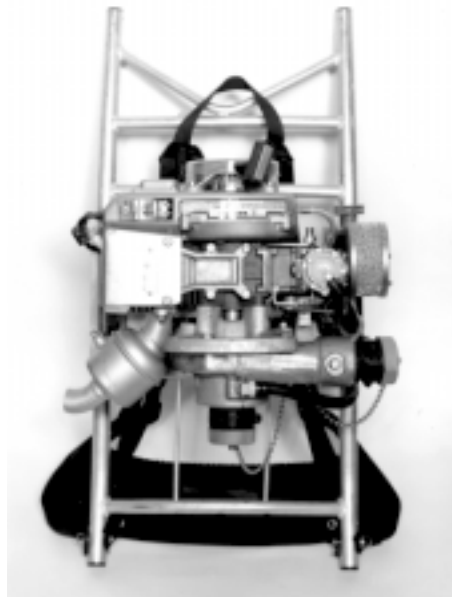

Manufacturer

Hale Products
700 Spring Mill Avenue, Conshohocken, PA 19428

Pump Performance Values

PSI	40	140	205
GAL/MIN	70	40	10

Hearing safety sound level **Data not provided by pump manufacturer**

Description

USDA qualification code	N/A	Integral or removable Handles	N/A
Cooling method	Air cooled	Relief valve	No
Starting system	Recoil	Backpack & straps	Yes
2- or 4-stroke cycle	2 stroke	Special tools or accessories	None
Pressure gauge	No		
Integral or removable base	N/A		

WATER PUMPING EQUIPMENT Lightweight portable—Pumps

Pump		Engine		
Make	Hale Products	Make	US Motor Power	
Model	20 FP-C8FR Fyr-Port	Model	Power Bee	
Type	Centrifugal	Horsepower	8	RPM 7,000
Priming	Manual	Ignition type	Electronic	
Inlet size	1½ inch NST	Cylinders	1	
Outlet size	1½ inch NST	Fuel used	Gasoline-oil mixture	
Height (in)	19½	Width (in)	16	Fuel pump Yes
Length (in)	17½	Dry weight (lb)	50¹	



Manufacturer

Hale Products
700 Spring Mill Avenue, Conshohocken, PA 19428

Pump Performance Values

PSI	10	100	175
GAL/MIN	70	45	10

Hearing safety sound level **Data not provided by pump manufacturer**

Description

USDA qualification code	N/A	Integral or removable base	Integral
Cooling Method	Air cooled	Integral or removable handles	Removable
Starting System	Recoil	Relief valve	No
2- or 4-stroke cycle	2 stroke	Backpack & straps	No
Pressure gauge	No	Special accessories or tools	None

Remarks

¹ Wraparound frame shown. Skid mounted option (20FP-C8SK) also available at 35 pounds.

WATER PUMPING EQUIPMENT

Pumps —Lightweight portable

Pump		Engine		
Make	Wildfire Equipment Inc.	Make	Rotax	
Model	Mark 3	Model	185 cc	
Type	4-stage, centrifugal	Horsepower	10	RPM 5,000
Priming	Manual	Ignition type	Magneto	
Inlet size	2 inch NPSH	Cylinders	1	
Outlet size	1½ inch NPSH	Fuel used	Gasoline-oil mixture	
Height (in)	16¼	Width (in)	12	Fuel pump available No
Length (in)	23	Dry weight (lb)	55	

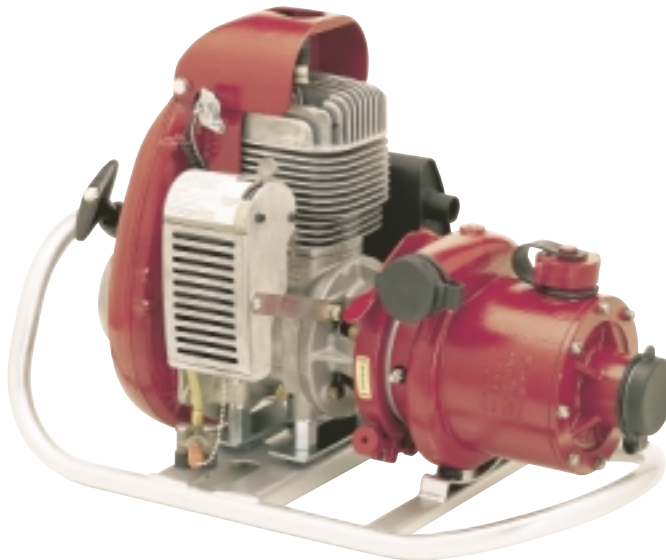

Manufacturer

Wildfire Equipment Inc.
1100 Norman, Suite 200, Lachine, Quebec, Canada H8S 1A6

Pump Performance Values

PSI	50	75	100	150	200	250	300	350	380
GAL/MIN	89	83	78	65	52	38	25	9	0

Hearing safety sound level **Warning label required**

Description

USDA qualification code	2-C-60-200/35	Integral or removable handles	No
Cooling method	Air cooled	Relief valve	No
Starting system	Recoil w/ backup Manual	Backpack & straps	Optional
2-or 4-stroke cycle	2 stroke	Special accessories or tools	Spark plug wrench, grease gun included
Pressure gauge	Optional		
Integral or removable base	No		

Remarks

Forest Service—USDA qualified: July 25, 2001
 Meets Forest Service—USDA Specification 5100-274

WATER PUMPING EQUIPMENT Lightweight portable—Pumps

Pump		Engine		
Make	Mercedes Textiles Ltd.	Make	Solo	
Model	Wick-375	Model	210	
Type	Centrifugal	Horsepower	10	RPM 5,700
Priming	Manual	Ignition type	Electronic	
Inlet size	2 inch NPSH	Cylinders	1	
Outlet size	1½ inch NPSH	Fuel used	Gasoline-oil mixture	
Height (in)	14½	Width (in)	14¼	Fuel pump available Yes
Length (in)	22¾	Dry weight (lb)	53.5	

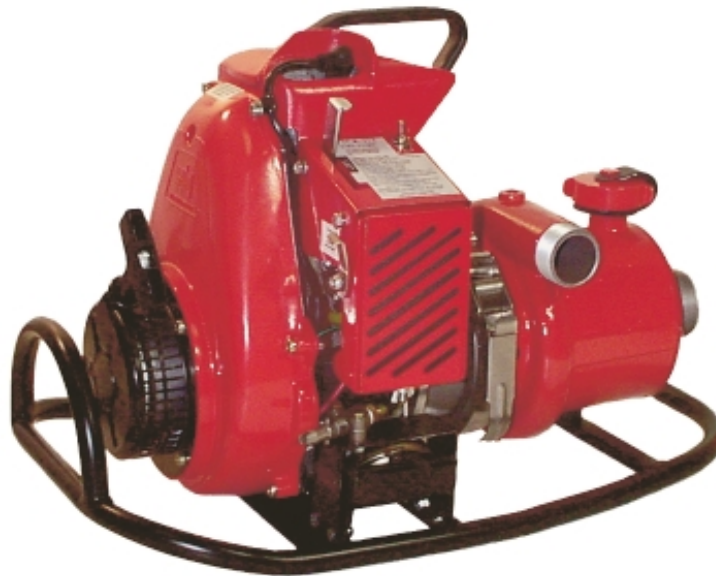

Manufacturer

Hydro-Wick Industries Ltd.
287 St. Jean Ouest, East Angus, Quebec, Canada J0B1R0

Pump Performance Values

PSI	0	110	180	260	360
GAL/MIN	90	77	56	29	0

Hearing safety sound level **Warning label required**

Description

USDA qualification code	N/A	Handles	Removable
Cooling method	Air cooled	Relief valve	No
Starting system	Recoil w/ backup manual	Backpack & straps	Optional
2- or 4-stroke cycle	2 stroke	Special accessories or tools	Quick-connect fuel line
Pressure gauge	No		
Integral or removable base	Removable		

WATER PUMPING EQUIPMENT

Pumps —Heavy portable

4. Heavy portable

These pumps are heavier than 60 pounds; mounting and carrying frames may be included, depending on the purpose. Engine, electric or rope starter, fuel tank, pump, controls, fittings, and other accessories are included as a complete assembly.

Pump		Engine	
Make	Wildfire Equipment Inc.	Make	Briggs & Stratton
Model	BB-4	Model	I/C
Type	4-stage, Centrifugal	Horsepower	18 RPM 4,000
Priming	Exhaust	Ignition type	Electronic
Inlet size	2 inch NPSH	Cylinders	2
Outlet size	1½ inch NPSH	Fuel used	Gasoline
Height (in)	19	Width (in)	19 Fuel pump available Yes
Length (in)	34	Dry weight (lb)	143

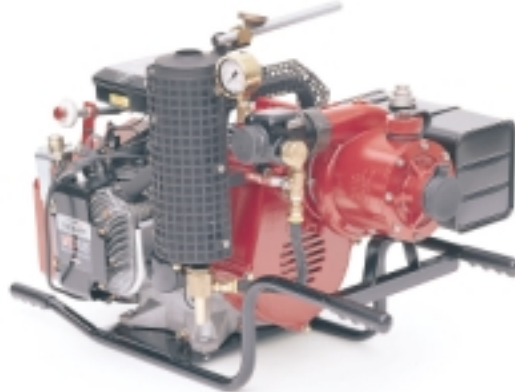

Manufacturer

Wildfire Equipment Inc.
1100 Norman, Suite 200, Lachine, Quebec, Canada H8S 1A6

Pump Performance Values

PSI	50	100	150	200	250	300	350	400
GAL/MIN	105	98	85	78	66	53	40	14

Hearing safety sound level **Data not provided by pump manufacturer**

Description

USDA Qualification Code	C-175-15/60¹	Integral or removable handles	Integral
Cooling method	Air cooled	Relief valve	No
Starting system	Electric	Backpack & straps	N/A
2- or 4-stroke cycle	4 stroke	Special tools or accessories	Dual-circuit alternator, pump seal
Pressure gauge	Optional		
Integral or removable base	Integral		

Remarks

Forest Service—USDA qualified: August 8, 1994 Meets Forest Service—USDA specification 5100-273

¹ Alternate coding: C-175-25/40, C-175-20/50

WATER PUMPING EQUIPMENT Heavy portable—Pumps

Pump		Engine		
Make	Berkeley Pumps	Make	Robin	
Model	B1½XQBS-18	Model	EH63	
Type	Centrifugal	Horsepower	18	RPM 3,600
Priming	None	Ignition type	Electronic	
Inlet size	2 inch NPT	Cylinders	2	
Outlet size	1½ inch	Fuel used	Gasoline	
Height (in)	26	Width (in)	17	Fuel pump available Yes
Length (in)	24¼	Dry weight (lb)	250	



Manufacturer

Sta-Rite Industries
1215 South Adams Street, Grand Island, NE 68801

Pump Performance Values

	180	200	250	280
PSI	180	200	250	280
GAL/MIN	90	69	43	31

Hearing safety sound level **Data not provided by pump manufacturer**

Description

USDA qualification code	N/A	Integral or removable handles	No
Cooling method	Air cooled	Relief valve	No
Starting system	Electric	Backpack & straps	N/A
2- or 4-stroke cycle	4 stroke	Special tools or accessories	None
Pressure gauge	No		
Integral or removable base	Removable		

WATER PUMPING EQUIPMENT

Pumps —Heavy portable

Pump		Engine	
Make	Hale Products	Make	Briggs & Stratton Vanguard
Model	HP100	Model	3504000 Series
Type	Centrifugal	Horsepower	18 RPM 3,600
Priming	Exhaust Venturi	Ignition type	Electronic
Inlet Size (in)	2 inch NPT	Fuel	Gasoline
Outlet Size (in)	2 inch NPT	Fuel pump	Yes
Height (in)	22$\frac{3}{8}$	Width (in)	19$\frac{5}{8}$ Cylinders 2
Length (in)	35$\frac{1}{2}$	Dry weight (lb)	185



Manufacturer

Hale Products
700 Spring Mill Avenue, Conshohocken, PA 19428

Pump Performance Values

PSI	50	150	200	275
GAL/MIN	155	100	65	15

Hearing safety sound level **Data not provided by pump manufacturer**

Description

USDA qualification code	N/A	Integral or removable handles	Integral
Cooling method	Air cooled	Relief valve	Yes
Starting system	Electric	Backpack & straps	N/A
2- or 4-stroke cycle	4 stroke	Special accessories or tools	None
Pressure gauge	Yes		
Integral or removable base	Integral		

WATER PUMPING EQUIPMENT Heavy portable—Pumps

Pump		Engine		
Make	Hale Products	Make	Briggs & Stratton Vanguard	
Model	HP400	Model	3504000 Series	
Type	Centrifugal	Horsepower	18	RPM 3,600
Priming	Exhaust	Ignition type	Electronic	
Inlet size	3 inch NPT	Cylinders	2	
Outlet size	4-inch Victaulic	Fuel used	Gasoline	
Height (in)	22½	Width (in)	19½	Fuel pump available Yes
Length (in)	25½	Dry weight (lb)	184	



Manufacturer

Hale Products
700 Spring Mill Avenue, Conshohocken, PA 19428

Pump Performance Values

PSI	25	50	75	100
GAL/MIN	500	320	210	95

Hearing safety sound level **Data not provided by pump manufacturer**

Description

USDA qualification code	N/A	Integral or removable handles	Integral
Cooling Method	Air cooled	Relief Valve	Yes
Starting System	Electric w/backup recoil	Backpack & Straps	N/A
2- or 4-stroke cycle	4 stroke	Special accessories or tools	None
Pressure gauge	Yes		
Integral or removable base	Integral		

WATER PUMPING EQUIPMENT

Pumps —Heavy portable

Pump		Engine		
Make	MalloryCo	Make	Honda	
Model	M88	Model	GX270K1QAE2	
Type	Positive displacement	Horsepower	9	RPM 3,600
Priming	Self-priming	Ignition type	Electronic	
Inlet size	1½ inch NPT	Cylinders	1	
Outlet size	1½ inch NPT	Fuel used	Gasoline	
Height (in)	22	Width (in)	18	Fuel pump available No
Length (in)	27	Dry weight (lb)	135	



Manufacturer

MalloryCo
 1040 Industrial Way, Longview, WA 98632

Pump Performance Values

PSI	50	100	150
GAL/MIN	50	40	25

Hearing safety sound level **Data not provided by pump manufacturer**

Description

USDA qualification code	N/A	Integral or removable handles	Optional
Cooling method	Air cooled	Relief valve	Optional
Starting system	Electric	Backpack & straps	N/A
2- or 4-stroke cycle	4 stroke	Special tools or accessories	Spark plug wrench
Pressure gauge	Optional		
Integral or removable base	Removable		

WATER PUMPING EQUIPMENT Heavy portable—Pumps

Pump		Engine			
Make	Edwards Manufacturing Inc.	Make	Briggs & Stratton		
Model	TSD-25	Model	256427		
Type	Positive displacement	Horsepower	11	RPM	3,000
Priming	Self-priming	Ignition type	Magneto		
Inlet size	1½ inch NPT	Cylinders	1		
Outlet size	1½ inch NPT	Fuel used	Gasoline		
Height (in)	18	Width (in)	18	Fuel pump available	No
Length (in)	30	Dry weight (lb)	122		

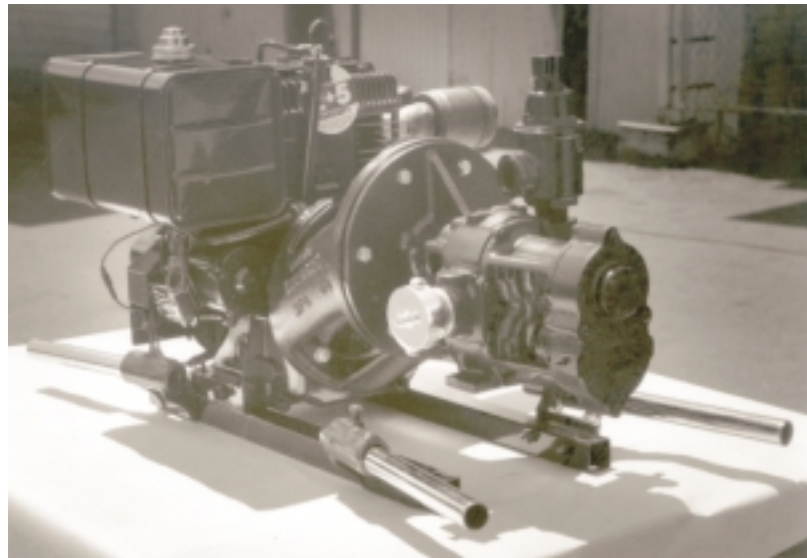

Manufacturer

Edwards Manufacturing Inc.
2441 SE Stubb Street, Milwaukie, OR 97222

Pump Performance Values

	100	150	200	250
PSI				
GAL/MIN	40	38	36	34

Hearing Safety sound Level **Data not provided by pump manufacturer**

Description

USDA qualification code	N/A	Integral or removable handles	Removable
Cooling method	Air cooled	Relief valve	Yes
Starting system	Manual	Backpack & straps	N/A
2- or 4- stroke cycle	4 stroke	Special tools or accessories	Packing adjusting wrench
Pressure gauge	Optional		
Integral or removable base	Removable		

WATER PUMPING EQUIPMENT

Pumps —Heavy portable

Pump		Engine			
Make	Wildfire Equipment Inc.	Make	Honda		
Model	Ultra-Striker	Model	GX390K1		
Type	3-stage, centrifugal	Horsepower	13	RPM	3,600
Priming	Exhaust	Ignition type	Magneto		
Inlet size	2 inch NPSH	Cylinders	1		
Outlet size	1½ inch NPSH	Fuel used	Gasoline		
Height (in)	19	Width (in)	17	Fuel pump available	No
Length (in)	29	Dry weight (lb)	126		

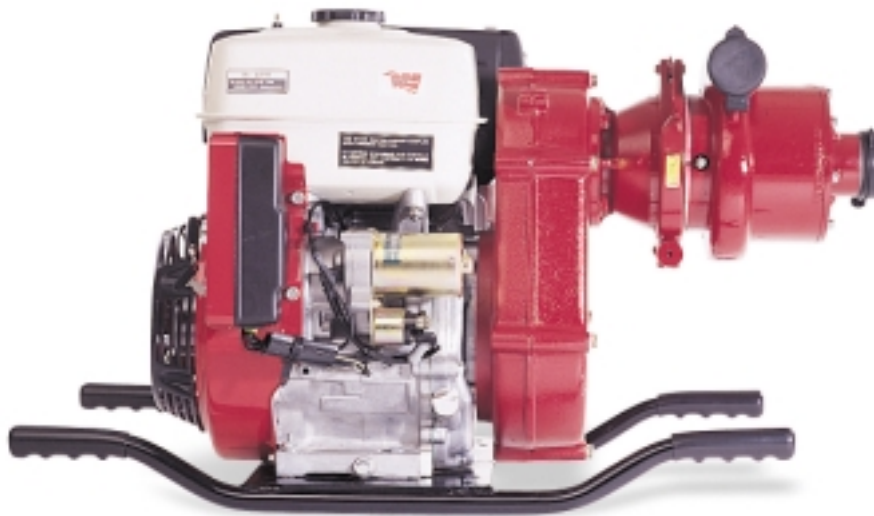

Manufacturer

Wildfire Equipment Inc.
1100 Norman, Suite 200, Lachine, Quebec, Canada H8S 1A6

Pump Performance Values

PSI	5	120	150	190	225	265	315	335
GAL/MIN	102.3	84.2	71.9	60.3	46.3	32.7	6.7	0

Hearing safety sound level **Data not provided by pump manufacturer**

Description

USDA Qualification Code	N/A	Integral or removable handles	Integral
Cooling method	Air cooled	Relief valve	No
Starting system	Electric	Backpack & straps	N/A
2- or 4-stroke cycle	4 stroke	Special tools or accessories	None
Pressure gauge	Yes		
Integral or removable base	Removable		

WATER PUMPING EQUIPMENT Floatable—Pumps

5. Floatable

These pumps float and can be carried by one person. A complete assembly includes an engine, fuel tank, rope starter, pump, controls, fittings, floating collar, strainer, and other accessories.

Pump		Engine			
Make	W. S. Darley & Co.	Make	Briggs & Stratton		
Model	Dolphin HEF12BS	Model	I/C		
Type	Centrifugal	Horsepower	12	RPM	3,600
Priming	Self-priming	Ignition type	Magneto		
Inlet size	6-inch smooth bore	Cylinders	1		
Outlet size	2½ inch NST	Fuel used	Gasoline		
Height (in)	20	Width (in)	30	Fuel pump available	No
Length (in)	32½	Dry weight (lb)	120		



Manufacturer

W.S. Darley & Co.
200 East Walnut Street, Chippewa Falls, WI 54729

Pump Performance Values

PSI	20	45	50	65
GAL/MIN	405	250	200	100

Hearing safety sound level **102 dBA at full throttle (Warning label required)**

Description

USDA qualification code	N/A	Integral or removable handles	Integral
Cooling method	Air cooled	Relief valve	No
Starting system	Recoil	Backpack & straps	N/A
2- or 4-stroke cycle	4 stroke	Special tools or accessories	None
Pressure gauge	No		
Integral or removable base	N/A		

WATER PUMPING EQUIPMENT

Pumps—Floatable

Pump		Engine	
Make	Waterous Company	Make	U. S. Motor Power
Model	Floto-Pump	Model	Power Bee 82029
Type	Centrifugal	Horsepower	8 RPM 6,250
Priming	Self-priming	Ignition type	Magneto
Inlet size	N/A	Cylinders	1
Outlet size	1½ inch NH	Fuel used	Gasoline-oil mixture
Height (in)	16	Width (in)	20 Fuel pump available No
Length (in)	28	Dry weight (lb)	42



Manufacturer

Waterous Company
 125 Hardman Avenue South, South St. Paul, MN 55075-2456

Pump Performance Values¹

PSI	35	75	105	130	150	170
GAL/MIN	60	50	40	30	20	10

Hearing safety sound level **Data not provided by pump manufacturer**

Description

USDA qualification code	N/A	Integral or removable handles	N/A
Cooling method	Air cooled	Relief valve	No
Starting system	Recoil	Backpack & straps	N/A
2- or 4-stroke cycle	2 stroke	Special tools or accessories	None
Pressure gauge	No		
Integral or removable base	N/A		

Remarks

¹ Values are for high-pressure model.

WATER PUMPING EQUIPMENT Floatable—Pumps

Pump		Engine		
Make	Hale Products	Make	US Motor Power	
Model	20FB-C8 Fyr Flote	Model	Power Bee	
Type	Centrifugal	Horsepower	8	RPM 7,000
Priming	Self-priming	Ignition type	Electronic	
Inlet size	2 inch nonthreaded	Cylinders	1	
Outlet size	1½ inch NST	Fuel used	Gasoline-oil mixture	
Height (in)	16	Width (in)	20	Fuel pump available Yes
Length (in)	28¼	Dry weight (lb)	49	



Manufacturer

Hale Products
700 Spring Mill Avenue, Conshohocken, PA 19428

Pump Performance Values

PSI	0	90	170
GAL/MIN	140	50	10

Hearing safety sound level **Data not provided by pump manufacturer**

Description

USDA qualification code	N/A	Integral or removable handles	No
Cooling method	Air cooled	Relief valve	No
Starting system	Recoil	Backpack & straps	No
2- or 4-stroke cycle	2 stroke	Special tools or accessories	None
Pressure gauge	No		
Integral or removable base	Removable		

WATER PUMPING EQUIPMENT

Pumps—Mountable

6. Mountable

These pumps are normally mounted on wildland fire equipment and vary in weight between 140 and 360 pounds. Engine, electric or rope starter, fuel tank, pump, controls, and other accessories are included as a complete assembly.

Pump		Engine		
Make	W. S. Darley & Co.	Make	Lombardini	
Model	1½ AGE 21LD	Model	PLD-560-2	
Type	Centrifugal	Horsepower	26	RPM 2,600
Priming	Manual	Ignition type	Compression	
Inlet size	2 inch NPT	Cylinders	2	
Outlet size	2 ea. 1½ inch NPT	Fuel used	Diesel	
Height (in)	22¾	Width (in)	24½	Fuel pump available Yes
Length (in)	35½	Dry weight (lb)	187	



Manufacturer

W. S. Darley & Co.
 200 East Walnut Street, Chippewa Falls, WI 54729

Pump Performance Values

PSI	120	195	235
GAL/MIN	180	120	60

Hearing safety sound level **Data not provided by pump manufacturer**

Description

USDA qualification code	N/A	Integral or removable base	Integral
Cooling method	Air cooled	Integral or removable handles	N/A
Starting system	Electric	Relief valve	No
2- or 4-stroke cycle	4 stroke	Backpack & straps	N/A
Pressure gauge	Optional	Special tools or accessories	No

Remarks

The Darley 1½ AGE is also available with a diesel 26 HP Briggs & Stratton water-cooled engine or a gasoline 18 HP Briggs & Stratton Air cooled engine. Weight and performance will vary with each combination.

WATER PUMPING EQUIPMENT Mountable—Pumps

Pump		Engine			
Make	W. S. Darley & Co.	Make	Lombardini		
Model	2½ AGE 26LD	Model	N/A		
Type	Centrifugal	Horsepower	26	RPM	2,600
Priming	Manual	Ignition type	Compression		
Inlet size	2½ inch NPT	Cylinders	2		
Outlet size	2 ea. 1½ inch and, 1 ea. 2½ inch NPT	Fuel used	Diesel		
Height (in)	24	Width (in)	24	Fuel pump available	Yes
Length (in)	34	Dry weight (lb)	330		

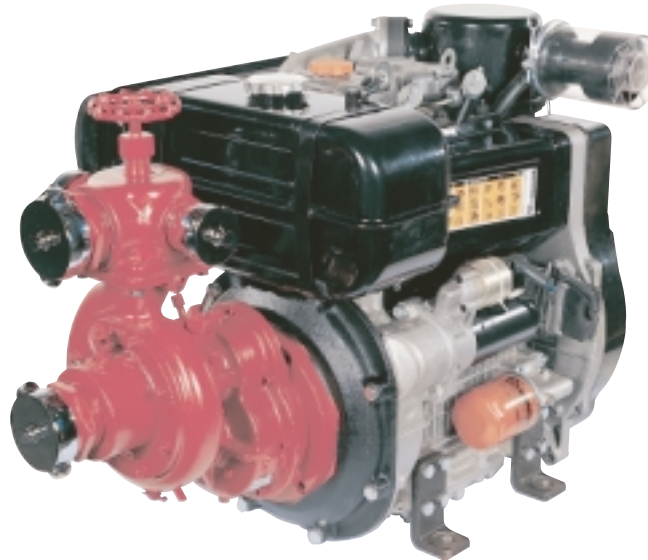

Manufacturer

W. S. Darley & Co.
200 East Walnut Street, Chippewa Falls, WI 54729

Pump Performance Values

PSI	80	125	180	190
GAL/MIN	300	200	100	50

Hearing safety sound level **Data not provided by pump manufacturer**

Description

USDA qualification code	N/A	Integral or removable base	Integral
Cooling method	Air cooled	Integral or removable handles	N/A
Starting system	Electric	Relief valve	No
2- or 4-stroke cycle	4 stroke	Backpack & straps	N/A
Pressure gauge	Optional	Special tools or accessories	No

Remarks

The Darley 2½ AGE is also available with a gasoline 31 HP Briggs & Stratton Vanguard water-cooled engine or a gasoline 24 HP Onan air-cooled engine. Weight and performance will vary with each combination.

WATER PUMPING EQUIPMENT

Pumps—Mountable

Pump		Engine			
Make	Robwen	Make	Briggs & Stratton		
Model	180	Model	Vanguard		
Type	Centrifugal	Horsepower	18	RPM	7,200
Priming	Manual	Ignition type	Electronic		
Inlet size	2 inch NPT	Cylinders	2		
Outlet size	1½ inch NPT	Fuel used	Gasoline		
Height (in)	21	Width (in)	24	Fuel pump available	No
Length (in)	25	Dry weight (lb)	224		



Manufacturer

Robwen Inc.
 1989 Blake Avenue, Los Angeles, CA 90039

Pump Performance Values

PSI	100	130	190	235	250	250
GAL/MIN	110	100	70	50	20	10

Hearing safety sound level **Data not provided by pump manufacturer**

Description

USDA qualification code	N/A	Integral or removable handles	N/A
Cooling method	Air cooled	Relief valve	No
Starting system	Electric w/backup recoil	Backpack & straps	N/A
2- or 4-stroke cycle	4 stroke	Special tools or accessories	None
Pressure gauge	Optional		
Integral or removable base	Removable		

WATER PUMPING EQUIPMENT Mountable—Pumps

Pump		Engine		
Make	Waterous	Make	Volkswagen	
Model	E200-A	Model	ADG	
Type	Centrifugal	Horsepower	57	RPM 4,000
Priming	Electric or manual (optional)	Ignition type	Compression	
Inlet size	4 inch NH	Cylinders	4	
Outlet size	2 ea. 2½ inch¹	Fuel used	Diesel	
Height (in)	28	Width (in)	25	Fuel pump available Yes
Length (in)	47	Dry weight (lb)	570	

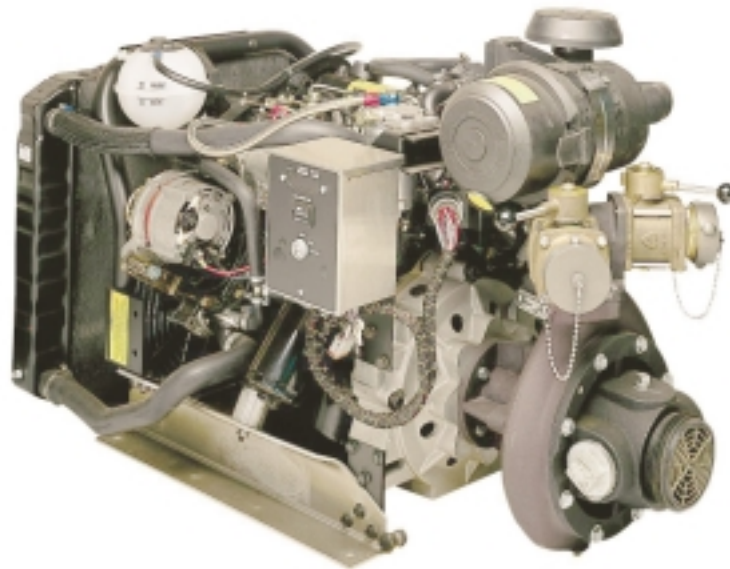

Manufacturer

Waterous Company
125 Hardman Avenue South, South St. Paul, MN 55075–2456

Pump Performance Values

PSI	60	200	210
GAL/MIN	650	250	0

Hearing safety sound level **95 to 97 dBA (Warning label required)**

Description

USDA Qualification Code	N/A	Integral or removable base	Removable
Cooling method	Water cooled	Integral or removable handles	N/A
Starting system	Electric	Relief valve	Optional
2- or 4-stroke cycle	4 stroke	Backpack & straps	N/A
Pressure gauge	No	Special tools or accessories	No

Remarks

¹ Five discharge combinations are available. See Waterous Company for details.

WATER PUMPING EQUIPMENT

Pumps—Mountable

Pump		Engine	
Make	Waterous	Make	Volkswagen
Model	E200-B	Model	ADF
Type	Centrifugal	Horsepower	67 RPM 4,000
Priming	Electric or manual (optional)	Ignition type	Electronic
Inlet size	4 inch NH	Cylinders	4
Outlet size	2 ea. 2½ inch¹	Fuel used	Gasoline
Height (in)	30½	Width (in)	31½ Fuel pump available Yes
Length (in)	47	Dry weight (lb)	570

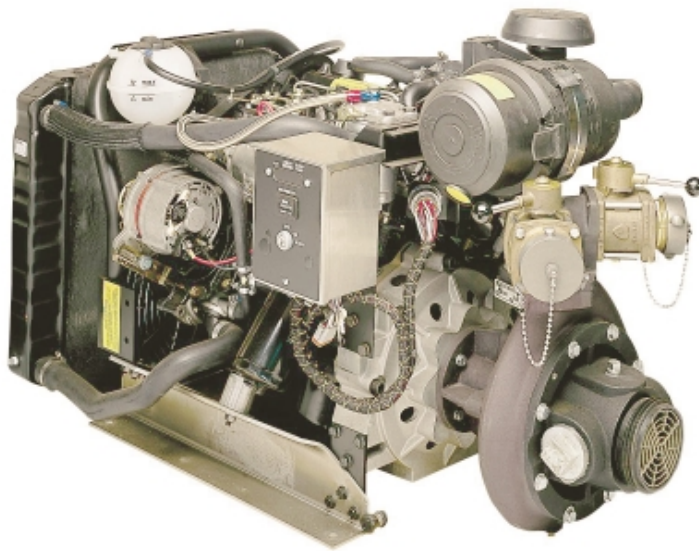

Manufacturer

Waterous Company
125 Hardman Avenue South, South St. Paul, MN 55075-2456

Pump Performance Values

PSI	88	160	210
GAL/MIN	600	400	200

Hearing safety sound level **95 to 97 dBA (Warning label required)**

Description

USDA Qualification Code	N/A	Integral or removable base	Removable
Cooling method	Water cooled	Integral or removable handles	N/A
Starting system	Electric	Relief valve	Optional
2- or 4-stroke cycle	4 stroke	Backpack & straps	N/A
Pressure gauge	No	Special tools or accessories	None

Remarks

¹ Five discharge combinations are available. See Waterous Company for details.

WATER PUMPING EQUIPMENT Mountable—Pumps

Pump		Engine			
Make	Waterous	Make	Kubota		
Model	E301-A	Model	V1305E-2		
Type	Centrifugal	Horsepower	30	RPM	3,000
Priming	Manual	Ignition type	Compression		
Inlet size	2 inch NPT	Fuel used	Diesel		
Outlet size	1½ inch NPT	Fuel pump available	Yes		
Height (in)	42½	Width (in)	23	Cylinders	2
Length (in)	42	Dry weight (lb)	535		

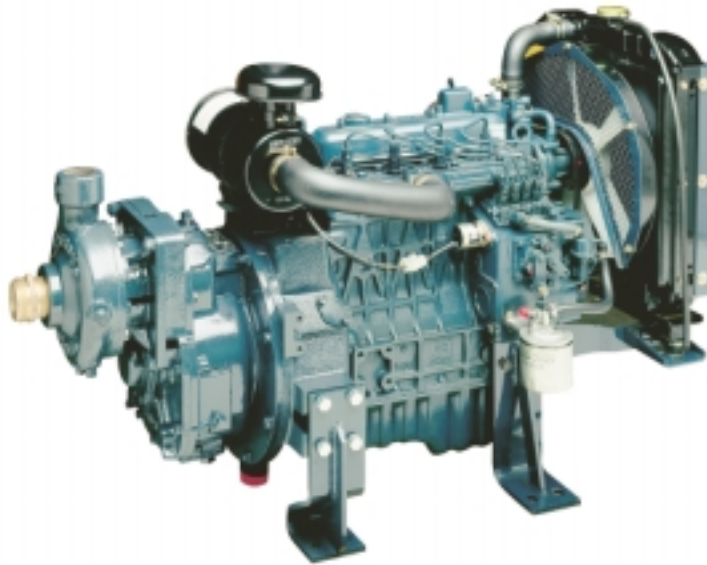

Manufacturer

Waterous Company
125 Hardman Avenue South, South St. Paul, MN 55075-2456

Pump Performance Values

PSI	100	230	330
GAL/MIN	170	100	50

Hearing safety sound level **Data not provided by pump manufacturer**

Description

USDA qualification code	N/A	Integral or removable handles	N/A
Cooling method	Water cooled	Relief valve	Yes
Starting system	Electric	Backpack & straps	N/A
2- or 4-stroke cycle	4 stroke	Special tools or accessories	No
Pressure gauge	No		
Integral or removable base	Removable		

WATER PUMPING EQUIPMENT

Pumps—Mountable

Pump		Engine		
Make	Waterous	Make	Kubota	
Model	E302-A	Model	V1305E-2	
Type	Centrifugal	Horsepower	30	RPM 3,000
Priming	Self-priming	Ignition type	Compression	
Inlet size	3 inch NPT	Cylinders	2	
Outlet size	2 inch NPT	Fuel used	Diesel	
Height (in)	42½	Width (in)	23	Fuel pump available Yes
Length (in)	43	Dry weight (lb)	553	

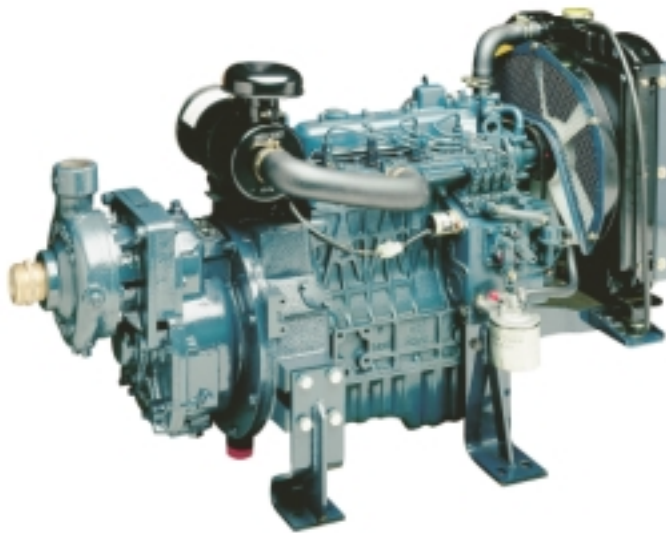

Manufacturer

Waterous Company
 125 Hardman Avenue South, South St. Paul, MN 55075-2456

Pump Performance Values

PSI	180	205	210
GAL/MIN	200	150	50

Hearing safety sound level **Data not provided by pump manufacturer**

Description

USDA Qualification Code	N/A	Integral or removable handles	N/A
Cooling method	Water cooled	Relief valve	Yes
Starting system	Electric	Backpack & straps	N/A
2- or 4-stroke cycle	4 stroke	Special tools or accessories	No
Pressure gauge	No		
Integral or removable base	Removable		

WATER PUMPING EQUIPMENT Mountable—Pumps

Pump		Engine		
Make	Waterous	Make	Briggs & Stratton	
Model	E501-A	Model	DM 950D	
Type	Centrifugal	Horsepower	26.5	RPM 3,600
Priming	Manual	Ignition type	Compression	
Inlet size	2 inch NPT	Cylinders	3	
Outlet size	1½ inch NPT	Fuel used	Diesel	
Height (in)	24½	Width (in)	19½	Fuel pump available Yes
Length (in)	34	Dry weight (lb)	265	

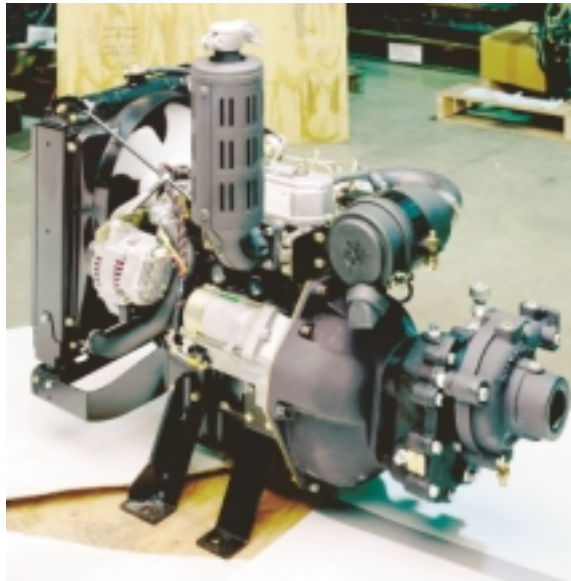

Manufacturer

Waterous Company
125 Hardman Avenue South, South St. Paul, MN 55075–2456

Pump Performance Values

PSI	40	300	420
GAL/MIN	120	80	40

Hearing safety sound level **Data not provided by pump manufacturer**

Description

USDA qualification code	N/A	Integral or removable base	Removable
Cooling method	Water cooled	Integral or removable handles	N/A
Starting system	Electric	Relief valve	Yes
2- or 4-stroke cycle	4 stroke	Backpack & straps	N/A
Pressure gauge	Yes	Special tools or accessories	No

Remarks

The Waterous E500 series pump is also available with a gasoline 31 HP Briggs & Stratton water-cooled engine.

WATER PUMPING EQUIPMENT

Pumps—Retired

7. Pumps in use but no longer available; parts still available

These pumps are widespread in use but are no longer being produced by the manufacturer. Replacement parts are still readily available.

Pump		Engine		
Make	Hale Products	Make	Briggs & Stratton	
Model	20-FD-B25	Model	25217	
Type	Centrifugal	Horsepower	11	RPM 3,600
Priming	Exhaust	Ignition type	Magneto	
Inlet size	2 inch NH	Cylinders	1	
Outlet size	1½ inch NH	Fuel used	Gasoline-oil mixture	
Height (in)	18¼	Width (in)	22	Fuel pump available No
Length (in)	24	Weight (lb)	132	

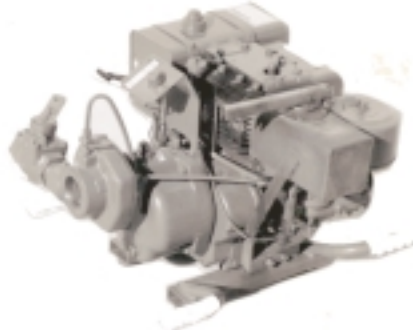

Manufacturer

Hale Fire Pump Co.
700 Spring Mill Avenue, Conshohocken, PA 19428

Pump Performance Values

1½ in	PSI	50	75	100	125	150	166	175	200	225	250	275
suction	GAL/MIN	60.5	60	58	53	47	43	40.5	34	26.5	19.5	10.5
2½ in	PSI	50	75	100	125	150	170	175	200	225	250	
suction	GAL/MIN	77	75	69	61	54	48	46	38	31	22	

Hearing safety sound level **104 dBA (Warning label required)**

Description

USDA qualification code	C-175-15-50¹	Integral or removable handles	Removable
Cooling method	Air cooled	Relief valve	No
Starting system	Electric	Backpack & straps	N/A
2- or 4- stroke cycle	4 stroke	Special tools or accessories	None
Pressure gauge	Optional		
Integral or removable base	Removable		

Remarks

Forest Service—USDA qualified: December 7, 1979
 Meets Forest Service—USDA Specification 5100-273b
¹Alternate coding: C-175-20/35, C-175-25/20

WATER PUMPING EQUIPMENT Retired—Pumps

Pump		Engine			
Make	Homelite Consumer Products, Inc.	Make	Homelite		
Model	FP 150	Model	FP 150		
Type	Centrifugal	Horsepower	6.8	RPM	7,500
Priming	Manual	Ignition type	Magneto		
Inlet size (in)	1½ inch NH	Cylinders	1		
Outlet size (in)	1½ inch NH	Fuel used	Gasoline-oil mixture		
Height (in)	15	Width (in)	19	Fuel pump available	No
Length (in)	16	Weight (lb)	29		



Manufacturer

Homelite Textron
14401 Carowinds Boulevard, Charlotte, NC 28217

Pump Performance Values

PSI	50	75	100	125	150	175	190
GAL/MIN	51	46	40.5	34.5	26.5	16	0

Hearing safety sound level **107 dBA (Warning label required)**

Description

USDA qualification code	C-30-150/25¹	Integral or removable handles	Integral
Cooling Method	Air cooled	Relief valve	No
Starting System	Manual	Backpack & Straps	Optional
2- or 4- stroke cycle	2 stroke	Special tools or accessories	Foot valve, combination spark plug wrench/screw driver
Pressure gauge	Optional		
Integral or removable base	Integral		

Remarks

Forest Service—USDA qualified: July 15, 1980
Meets Forest Service—USDA Specification 5100-274b

¹Alternate coding: C-30-175/15

WATER PUMPING EQUIPMENT

Pumps—Retired

Pump		Engine			
Make	Waterous Company	Make	Lister Petter		
Model	P100-A	Model	LPA2		
Type	Centrifugal	Horsepower	14.1	RPM	3,600
Priming	Manual	Ignition type	Compression		
Inlet size	2½ inch NPT	Cylinders	2		
Outlet size	1½ inch NPT	Fuel used	Diesel		
Height (in)	31	Width (in)	24	Fuel pump available	Yes
Length (in)	24	Dry weight (lb)	275		



Manufacturer

Waterous Company
 125 Hardman Avenue South, South St. Paul, MN 55075

Pump Performance Values

PSI	35	125	135
GAL/MIN	200	100	50

Hearing safety sound level **Data not provided by pump manufacturer**

Description

USDA qualification code	N/A	Integral or removable handles	N/A
Cooling method	Air cooled	Relief valve	Yes
Starting system	Electric	Backpack & straps	N/A
2- or 4-stroke cycle	4 stroke	Special tools or accessories	NH thread adapters
Pressure gauge	No		
Integral or removable base	N/A		

WATER PUMPING EQUIPMENT Retired—Pumps

Pump		Engine		
Make	Wildfire Equipment Inc.	Make	Wisconsin	
Model	WA-7	Model	BKND	
Type	Positive displacement	Horsepower	6.8	RPM 3,600
Priming	None	Ignition type	Magneto	
Inlet size	1 inch NPT	Cylinders	1	
Outlet size	1 inch NPT	Fuel used	Gasoline	
Height (in)	20	Width (in)	18	Fuel pump available No
Length (in)	27	Weight (lb)	98	

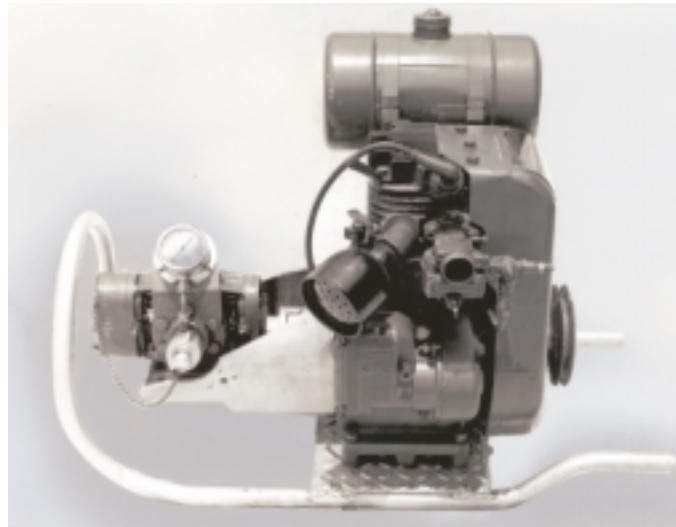

Manufacturer

**Wildfire Equipment Inc.
1100 Norman, Suite 200, Lachine, Quebec, Canada H8S 1A6**

Pump Performance Values

	50	100	150	200	250
PSI					
GAL/MIN	26	25	24	21	17

Hearing safety sound level **100 dBA (Warning label required)**

Description

USDA Qualification Code	P-130-15/20¹	Integral or removable handles	Removable
Cooling method	Air cooled	Relief valve	Yes
Starting system	Rope or electric	Backpack & straps	N/A
2- or 4- stroke cycle	4 stroke	Special tools or accessories	Packing gland & wrench
Pressure gauge	Optional		
Integral or removable base	Removable		

Remarks

Forest Service—USDA qualified: March 18, 1960
Meets Forest Service—USDA Specification 5100-273b
¹Alternate coding: P-130-20/20 P-130-25/15

WATER PUMPING EQUIPMENT

Pumps—Retired

Pump		Engine	
Make	Wildfire Equipment Inc.	Make	Briggs & Stratton
Model	B1-11	Model	Industrial Plus
Type	Centrifugal	Horsepower	11 RPM
Priming	Manual	Ignition type	Electronic
Inlet size (in)	1 ½ inch NPSH	Cylinders	1
Outlet size (in)	1 ½ inch NPSH	Fuel used	Gasoline
Height (in)	20	Width (in)	21 ½
Length (in)	28	Weight (lb)	112
		Fuel pump available	No

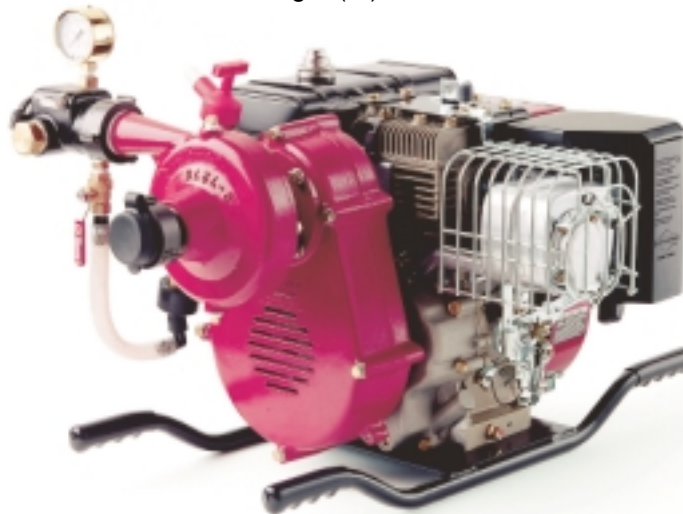

Manufacturer

Wildfire Equipment Inc.
1100 Norman, Suite 200, Lachine, Quebec, Canada H8S 1A6

Pump Performance Values

PSI	0	40	135	180	260
GAL/MIN	64	59	46	25	0

Hearing safety sound level **Data not provided by pump manufacturer**

Description

USDA qualification code	C-130-15/40	Integral or removable handles	Removable
Cooling method	Air cooled	Relief valve	No
Starting system	Electric	Backpack & straps	N/A
2- or 4-stroke cycle	4 stroke	Special tools or accessories	None
Pressure gauge	Yes		
Integral or removable base	Removable		

Remarks

Forest Service—USDA qualified: August 8, 1994
 Meets Forest Service—USDA Specification 5100-273

WATER PUMPING EQUIPMENT Retired—Pumps

Pump		Engine		
Make	Wildfire Equipment Inc.	Make	Rotax	
Model	Mark 26	Model	95 cc	
Type	Centrifugal	Horsepower	5	RPM 5,000
Priming	Manual	Ignition type	Magneto	
Inlet size	2 inch NPSH	Cylinders	1	
Outlet size	1½ inch NPSH	Fuel used	Gasoline-oil mixture	
Height (in)	14	Width (in)	11	Fuel pump available Yes
Length (in)	19	Weight (lb)	38	

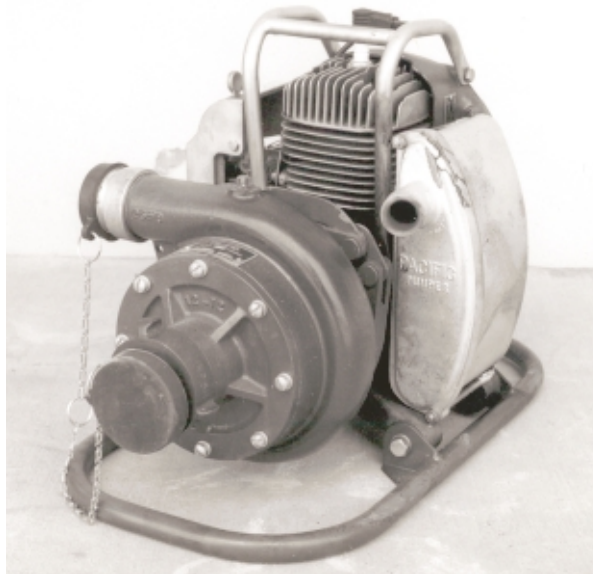

Manufacturer

Wildfire Equipment Inc.
1100 Norman, Suite 200, Lachine, Quebec, Canada H8S 1A6

Pump Performance Values

PSI	0	50	100	150	160
GAL/MIN	84	72	50	18	0

Hearing safety sound level **Data not provided by pump manufacturer**

Description

USDA qualification code	N/A	Integral or removable handles	Removable
Cooling method	Air cooled	Relief valve	No
Starting system	Recoil	Backpack & straps	Yes
2- or 4- stroke cycle	2 stroke	Special tools or accessories	Spark plug wrench, grease gun
Pressure gauge	None		
Integral or removable base	Removable		

WATER PUMPING EQUIPMENT

Pumps —Retired

Pump		Engine			
Make	Wildfire Equipment Inc.	Make	Wisconsin		
Model	WX-10	Model	AENLD		
Type	Positive displacement	Horsepower	8.3	RPM	3,400
Priming	None	Ignition type	Magneto		
Inlet size	1½ inch	Cylinders	1		
Outlet size	1½ inch	Fuel used	Gasoline		
Height (in)	23½	Width (in)	20½	Fuel pump available	No
Length (in)	29½	Weight (lb)	144		

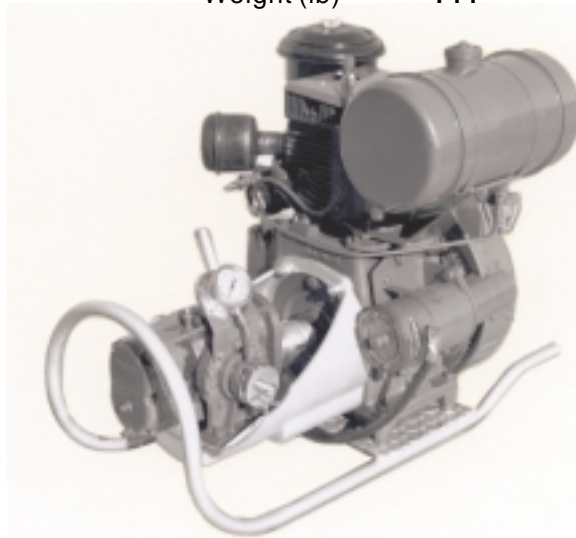

Manufacturer

Wildfire Equipment Inc.
1100 Norman, Suite 200, Lachine, Quebec, Canada H8S 1A6

Pump Performance Values

	50	100	150	200
PSI				
GAL/MIN	45	43	32	24

Hearing safety sound level **98.5 dBA (Warning label required)**

Description

USDA Qualification Code	P-175-15/30¹	Integral or removable handles	Removable
Cooling Method	Air cooled	Relief valve	Yes
Starting System	Recoil or electric	Backpack & straps	N/A
2- or 4- stroke cycle	4 stroke	Special tools or accessories	Packing gland and wrench
Pressure gauge	Optional		
Integral or removable base	Removable		

Remarks

Forest Service—USDA qualified: March 18, 1960
 Meets Forest Service—USDA Specification 5100-273b
¹Alternate coding: P-175-20/20

WATER PUMPING EQUIPMENT Engine driven—Pumps

8. Engine driven

These pumps are normally driven by the vehicle's engine. They are coupled to the engine by a power take-off unit (pto), hydraulic drive, V-belts, or chain drives. They are generally used where large volumes or high pressures are needed. These were previously identified as power take-off pumps.



WATER PUMPING EQUIPMENT Fire Engines—

B. Fire Engines

Using the Fire Equipment Working Team (FEWT) and the National Fire Protection Association (NFPA), the National Wildfire Coordinating Group (NWCG) categorizes information on fire engines into logical groups and provides common options often requested by fire managers. The Incident Command System (ICS) uses this engine type system based on the equipment capability. The table below shows NWCG minimum performance requirements for structure and wildland engine resource types. Additional information for required crew training and equipment recommendations can be found at the internet site for the National Wildfire Coordinating Group –<http://www.nwcg.gov/>.

Table 1—NWCG engine types—minimum requirements.

Components	Structure Engines		Wildland Engines				
	1	2	3	4	5	6	7
Pump Rating							
minimum flow (gal/min)	1,000+	250+	150	50	50	30	10
at rated pressure (psi)	150	150	250	100	100	100	100
Tank Capacity Range (gal)	400+	400+	500+	750+	400-750	150-400	50-200
Hose (feet)							
2½ inch	1,200	1,000	~	~	~	~	~
1½ inch	400	500	500	300	300	300	~
1 inch	~	~	500	300	300	300	200
Ladders (feet)	48	48	~	~	~	~	~
Master Stream (gal/min)	500	~	~	~	~	~	~
Personnel (minimum)	4	3	2	2	2	2	2

WATER PUMPING EQUIPMENT Engine matrix—Fire Engines

This section lists many of the different initial attack engines used in the United States and describes the wide variety of vehicle sizes, pump, and tank size configurations. The data displayed in this section is intended to assist individuals interested in outfitting an initial attack wildland engine. Many of the following engines could possibly be reclassified from one NWCG ICS type to another by changing the basic equipment compliment, personnel staffing, or level of training.

Sheet No.	NWCG ICS Type	Tank Capacity (gallons)	Pump Rating (gal/min @ 150 psi)	Pump Drive	Equipment Designator	Agency
1	2	500	1,250	PTO	Model 18	California Department of Forestry
2	3	500	300	PTO	Model 1	California Department of Forestry
3	3	500	300	PTO	Model 5	California Department of Forestry
4	3	650	500	Auxiliary engine	Model 9	California Department of Forestry
5	3	1,200	500	Auxiliary engine	Model 11	California Department of Forestry
6	3	500	500	Hydraulic	Model 14	California Department of Forestry
7	3	500	500	Hydraulic	Model 15	California Department of Forestry
8	3	650	500	Hydraulic	Model 17	California Department of Forestry
9	3	650	500	Hydrostatic	Urban interface unit	Texas Forest Service
10	3	600	225	PTO	Model 70 and 71	USDA Forest Service (R-3)
11	3	600	225	PTO	Model 46	USDA Forest Service (R-3)
12	3	500	400	PTO	Model 62	USDA Forest Service (R-5)
13	3	600	350	PTO	Model 75	USDA Forest Service (R-6)
14	3	1,000	350	PTO	Model 80	USDA Forest Service (R-6)
15	3	500	500	PTO	BLM 665 Model 14	USDI Bureau of Land Mgmt
16	3	525-750	100	PTO	BLM 665 engine	USDI Bureau of Land Mgmt
17	3	500	500	PTO	FWS Model 15	USDI Fish and Wildlife Service
18	4	1,000	85	Auxiliary engine	2½ ton 6 by 6	Connecticut DEP Forestry
19	4	800	80	Auxiliary engine	FEPP Brush patrol	Florida Division of Forestry
20	4	800	85	Auxiliary engine	4800 Large 4 by 4	Michigan DNR
21	4	900	85	Auxiliary engine	2½ ton 6 by 6	Michigan DNR
22	4	1,400	85	Auxiliary engine	5 ton 6 by 6	Michigan DNR
23	4	750	85	Flywheel	Engine 44	New Mexico State Forestry
24	4	700	85	Auxiliary engine	Model 52	USDA Forest Service (R-1)
25	4	2,400	140	Auxiliary engine	BLM 668 UEX engine	USDI Bureau of Land Mgmt
26	4	500-865	140	Auxiliary engine	BLM 667 engine	USDI Bureau of Land Mgmt
27	4	850	N/A	Auxiliary engine	850 gallon pumper	Wisconsin DNR
28	5	500	100	Auxiliary engine	Wildland engine	Florida Division of Forestry
29	6	250	100	Auxiliary engine	Brush patrol	Alabama Forestry Commission
30	6	300	110	Auxiliary engine	Grass patrol 4 by 4	East Bay Regional Parks
31	6	300	80	Auxiliary engine	Wildland brush patrol	Florida Division of Forestry
32	6	175	85	Auxiliary engine	M-1008	Michigan DNR
33	6	250	85	Auxiliary engine	Hummer	Michigan DNR
34	6	300	N/A	Auxiliary engine	Wheeled ATV	New Jersey Forest Fire Service
35	6	250	60	Auxiliary engine	Initial attack brush truck	New Jersey Forest Fire Service
36	6	200-300	85	Auxiliary engine	Model 52	USDA Forest Service (R-1)
37	6	200	85	Auxiliary engine	Model 41	USDA Forest Service (R-5)

WATER PUMPING EQUIPMENT

Fire Engines— Engine matrix

Sheet No.	NWCG ICS Type	Tank Capacity (gallons)	Pump Rating (gal/min @ 150 psi)	Pump Drive	Equipment Designator	Agency
38	6	300	85	Auxiliary engine	Model 33U	USDA Forest Service (R-6)
39	6	300	90	PTO	Model 45	USDA Forest Service (R-6)
40	6	200	72	Auxiliary engine	E 3-1	USDA Forest Service (R-9)
41	6	280	50	Auxiliary engine	GSA FT 60HD/IA	USDA Forest Service (R-9)
42	6	300	85	Auxiliary engine	Superior NF, Type 6	USDA Forest Service (R-9)
43	6	250	100	Auxiliary engine	Type VI slip on	USDA Forest Service (R-9)
44	6	300	100	Auxiliary engine	BLM 662 engine	USDI Bureau of Land Mgmt
45	6	250	90	Auxiliary engine	Brush patrol	Virginia Dept. of Forestry
46	7	150	65	Auxiliary engine	IA wildland engines	North Carolina DFR
47	7	100	11	Auxiliary engine	BE-S slip-on unit	USDA Forest Service (R-9)
48	7	125	36	Belt driven	B-2	USDA Forest Service (R-9)
49	7	75-125	30	Auxiliary engine	Type VII slip on	USDA Forest Service (R-9)
50	7	150	20	Auxiliary engine	Wisconsin IA	Wisconsin DNR
51	N/A	50-75	85	Auxiliary engine	Model 20	USDA Forest Service (R-5)

WATER PUMPING EQUIPMENT Engine Data Sheet No. 1

Agency: CDF

Equipment Designator: Model 18

ICS Type: 2

Summary: Tank Capacity—gallons 500
 Pump Rating—gal/min @ psi 1,000 @ 150
 Pump Drive—Midship
 Mobile Attack Capability?—Yes
 Number Crew Personnel—6
 Foam System Available?—Yes Gallons—20
 All-Wheel Drive? —No



General Description: The Model 18 engines are designed for both wildland and structure firefighting. The engine has excellent off-highway and mobile-attack performance. More equipment storage and pumping capacities were added while maintaining a minimum increase in overall size, compared to the Model 17. The engine has a 1,250 gal/min two-stage pump, and a midship 150 gal/min auxiliary single-stage pump. The tank capacity is 500 gallons. The engine is also equipped with class A foam. There is seating for six firefighters, all inside the cab.

Pump: Manufacturer: Darley Model: LDM
 Type: Centrifugal
 Performance: gal/min (max) at free flow; 1,250
 gal/min @ max psi = 1,000 @ 150
 Primer Type: Electric

Tank: Material: Polypropylene
 Construction: Baffles? Yes
 If steel, is the tank corrosion treated? N/A

Controls and Gauges: Hand Throttle? Yes Pressure Gauge? Yes Automatic shutdown? No

Valves: Tank-to-Pump? Yes Pump-to-Tank? Yes

Overboard Discharge:	Quantity	5	4	1
	Size	2½ inch	1½ inch	1 inch reel line

Suction:	Quantity	2	1
	Size	6 inch	2½ inch

Priming Valve Handle: Manual
Suction Valve Handle: Manual
Tank-to-Plumbing Shut-Off? Yes
Gravity Tank Drain/Dump? Yes
 Type—¼ turn valve

Manufacturer: Spartan
Manufacturer Model Year: 1997
Engine Fuel Type: Diesel
Vehicle Operating Weight: 34,000
Brake Type: Air

Discharge Valve Handle: Manual
Adjustable Pressure Relief? Yes
Pump and Plumbing Drain? Yes
Rock Trap/Plumbing Strainer? Yes
 Type—Inlet screen

Cab/Axle Distance: 117 inch
GVW Rating: 38,500
Horsepower Rating: 300
Transmission Type: MTB 643 Allison

Written Materials:

Specifications and drawings are available from: California Department of Forestry
 Davis Equipment Facility
 5800 Chiles Road
 Davis, CA 95616

WATER PUMPING EQUIPMENT

Engine Data Sheet No. 2

Agency: CDF

Equipment Designator: Model 1

ICS Type: 3

Summary: Tank Capacity (gallons)— 500
 Pump Rating—300 gal/min @ 150 psi
 Pump Drive—PTO
 Mobile Attack Capability?—Yes
 Number Crew Personnel—6
 Foam System Available?—See description
 Gallons—
 All-Wheel Drive? —No



General Description: This Model 1 is classified as a heavy fire engine and can carry six firefighters. It is a two-wheel drive engine with excellent climbing capabilities. The power to the rear wheels is delivered through an automatic Allison 600 Series transmission. The power is directed through a split-shaft transmission or power divider to either the driving wheels or the main pump. The main pump can only be used for stationary pumping.

The auxiliary pump is driven by its own engine and is used for mobile attack. The four-person crew compartment is at the rear and features two fire blankets rolled up in canisters. The engine carries two live reels, along with 1-, 1½-, and 2½-inch water outlets. The principle pump control panel is outside with a second set of controls for the auxiliary pump located in the cab. Compartments for fire tools, self-contained breathing apparatus, suction hose for both pumps, hose fittings, nozzles, and other miscellaneous equipment, including a hose roller, form the body around the engine. This engine may have a foam system added at a later date with varying gallonage.

Pump: Manufacturer—Waterous Model—CPK-2
 Type—Centrifugal
 Performance: gal/min (max) at free flow—300
 gal/min @ max psi = 500 @ 250
 Primer Type—Electric

Tank: Material— Steel
 Construction: Baffles?— Yes
 If steel, is the tank corrosion treated?—Yes

Controls and Gauges: Hand Throttle?— Yes Pressure Gauge?— Yes Automatic shutdown?— No

Valves: Tank-to-Pump?— Pump-to-Tank?—Yes

Overboard Discharge: Quantity 2 4 2
 Size 2½ inch 1½ inch 1-inch reel line

Suction: Quantity 2
 Size 3 inch

Priming Valve Handle: Manual
Suction Valve Handle: Manual
Tank-to-Plumbing Shut-Off? Yes
Gravity Tank Drain/Dump? Yes
 Type— Pipe plug

Manufacturer: IHC International
Manufacturer Model Year: 1988
Engine Fuel Type: Diesel
Vehicle Operating Weight: 21,000
Brake Type: Air

Discharge Valve Handle: Manual
Adjustable Pressure Relief? No
Pump and Plumbing Drain? Yes
Rock Trap/Plumbing Strainer? Yes
 Type— Inlet screen

Cab/Axle Distance: 84 inch
GVW Rating: 26,300
Horsepower Rating: 180 - 210
Transmission Type: Allison 5 speed

Written Materials: Specifications and drawings are available from: California Department of Forestry
 Davis Mobile Equipment Facility
 5800 Chiles Road
 Davis, CA 95616

WATER PUMPING EQUIPMENT

Engine Data Sheet No. 3

Agency: CDF

Equipment Designator: Model 5

ICS Type: 3

Summary: Tank Capacity (gallons)— 500
 Pump Rating—300 gal/min @ 150 psi
 Pump Drive—PTO
 Mobile Attack Capability?— Yes
 Number Crew Personnel—6
 Foam System Available?—See description
 Gallons—
 All-Wheel Drive? —Yes



General Description: This Model 5 is classified as a heavy fire engine and can carry six firefighters. It is a four-wheel drive engine with excellent climbing capabilities. The power to the rear wheels is delivered through an automatic Allison 600 Series transmission. The power is directed through a split-shaft transmission or power divider to either the driving wheels or the main pump. This function is handled through a transfer case with the power for the pump taken through a pto. The main pump can be used only for stationary pumping.

The auxiliary pump is driven by its own engine and is used for mobile attack. The four-person crew compartment is at the rear and features two fire blankets rolled up in canisters. The engine carries two live reels, along with 1-, 1½-, and 2½-inch water outlets. The principle pump control panel is outside with a second set of controls for the auxiliary pump located in the cab. Compartments for fire tools, self-contained breathing apparatus, suction hose for both pumps, hose fittings, nozzles, and other miscellaneous equipment, including a hose roller, form the body around the engine. This engine may have a foam system added at a later date with varying gallonage.

Pump: Manufacturer—Waterous	Model—CPK-2	Tank: Material— steel	
Type—Centrifugal		Construction: Baffles?— Yes	
Performance: gal/min (max) at free flow—300		If steel, is the tank corrosion treated?— Yes	
gal/min @ max psi = 500 @ 250			
Primer Type— Electric			
Controls and Gauges: Hand Throttle?— Yes	Pressure Gauge?— Yes	Automatic shutdown?— No	
Valves: Tank-to-Pump?—	Pump-to-Tank?—Yes		
Overboard Discharge: Quantity	2	4	2
Size	2½ inch	1½ inch	1-inch reel line
Suction: Quantity	2		
Size	3 inch		

Priming Valve Handle: Manual
Suction Valve Handle: Manual
Tank-to-Plumbing Shut-Off? Yes
Gravity Tank Drain/Dump? Yes
 Type— Pipe plug
Manufacturer: IHC International
Manufacturer Model Year: 1988/1989
Engine Fuel Type: Diesel
Vehicle Operating Weight: 21,000-22,000
Brake Type: Air

Discharge Valve Handle: Manual
Adjustable Pressure Relief? No
Pump and Plumbing Drain? Yes
Rock Trap/Plumbing Strainer? Yes
 Type— Inlet screen
Cab/Axle Distance: 84 inch
GVW Rating: 27,800
Horsepower Rating: 180 - 210
Transmission Type: Allison 5 speed

Written Materials: Specifications and drawings are available from: California Department of Forestry
 Davis Mobile Equipment Facility
 5800 Chiles Road
 Davis, CA 95616

WATER PUMPING EQUIPMENT

Engine Data Sheet No. 4

Agency: CDF

Equipment Designator: Model 9

ICS Type: 3

Summary: Tank Capacity (gallons)— 650
 Pump Rating—500 gal/min @ 150 psi
 Pump Drive—Auxiliary engine
 Mobile Attack Capability?—Yes
 Number Crew Personnel—6
 Foam System Available?—Yes
 Gallons—20
 All-Wheel Drive? —No



General Description: The Model 9 carries a crew of six and is a two-wheel drive diesel heavy fire engine. Three crewmembers ride in a backwards-facing compartment immediately behind the cab. In an emergency, the compartment can be closed off with a sliding curtain. An auxiliary engine drives the single pump. The principal pump controls are outside, but some are duplicated in the cab. Compartments for fire tools, self-contained breathing apparatus, suction hose, hose fittings and nozzles, and other miscellaneous equipment form the body around the tank.

Pump: Manufacturer—Darley	Model—HE-500	Tank: Material— stainless steel
Type—Centrifugal		Construction: Baffles?— Yes
Performance: gal/min (max) at free flow—500		If steel, is the tank corrosion treated?— N/A
gal/min @ max psi = 500 @ 150		
Primer Type— Electric		

Controls and Gauges: Hand Throttle?— Yes Pressure Gauge?— Yes Automatic shutdown?— No

Valves: Tank-to-Pump?—Yes Pump-to-Tank?—Yes

Overboard Discharge: Quantity	3	6	2
Size	2½ inch	1½ inch	1-inch reel line

Suction: Quantity	1	2
Size	4 inch	2½ inch

Priming Valve Handle: Manual
Suction Valve Handle: Manual
Tank-to-Plumbing Shut-Off? Yes
Gravity Tank Drain/Dump? Yes
 Type— ¼ turn valve

Manufacturer: Mack
Manufacturer Model Year: 1996
Engine Fuel Type: Diesel
Vehicle Operating Weight: 25,000
Brake Type: Air

Discharge Valve Handle: Manual
Adjustable Pressure Relief? No
Pump and Plumbing Drain? Yes
Rock Trap/Plumbing Strainer? Yes
 Type— Inlet screen
Cab/Axle Distance: 123 inch
GVW Rating: 33,000
Horsepower Rating: 220
Transmission Type: MTB-653/Retarder

Written Materials: Specifications and drawings are available from: California Department of Forestry
 Davis Mobile Equipment Facility
 5800 Chiles Road
 Davis, CA 95616

WATER PUMPING EQUIPMENT

Engine Data Sheet No. 5

Agency: CDF

Equipment Designator: Model 11

ICS Type: 3

Summary: Tank Capacity (gallons)— 1,200
 Pump Rating—500 gal/min @ 150 psi
 Pump Drive—Auxiliary engine
 Mobile Attack Capability?—Yes
 Number Crew Personnel—3
 Foam System Available?—See description
 Gallons—
 All-Wheel Drive? —No



General Description: The Model 11 carries a crew of three and is a two-wheel drive diesel heavy fire engine. It replaced the CDF Model 8. The single pump is driven by its own separate motor, which permits the engine to be used for either mobile attack or stationary pumping. Two live reels are carried at the front of and on top of the tank. Three 2½-inch outlets, four 1½-inch outlets, and two 2½ inch suction inlets are provided. All are gated. The 4-inch main pump suction is capped. The principal pump controls are outside, but some are duplicated in the cab. Compartments for fire tools, self-contained breathing apparatus, suction hose, hose fittings and nozzles, and other miscellaneous equipment, including a hose roller, form the body around the tank. This engine may have had a foam system added at a later date with varying gallonages.

Pump: Manufacturer—Darley Model—HE-500 Type—Centrifugal Performance: gal/min (max) at free flow—500 gal/min @ max psi = 500 @ 150 Primer Type— Electric	Tank: Material— stainless steel Construction: Baffles?— Yes If steel, is the tank corrosion treated?— N/A
--	--

Controls and Gauges: Hand Throttle?— Yes Pressure Gauge?— Yes Automatic shutdown?— No

Valves: Tank-to-Pump?—Yes Pump-to-Tank?—Yes

Overboard Discharge:	Quantity Size	3 2½ inch	6 1½ inch	2 1-inch reel line
-----------------------------	------------------	--------------	--------------	-----------------------

Suction:	Quantity Size	1 4 inch	2 2½ inch
-----------------	------------------	-------------	--------------

Priming Valve Handle: Manual
Suction Valve Handle: Manual
Tank-to-Plumbing Shut-Off? Yes
Gravity Tank Drain/Dump? Yes
 Type— ¼ turn valve

Manufacturer: Ford
Manufacturer Model Year: 1989
Engine Fuel Type: Diesel
Vehicle Operating Weight: 30,000
Brake Type: Air

Discharge Valve Handle: Manual
Adjustable Pressure Relief? No
Pump and Plumbing Drain? Yes
Rock Trap/Plumbing Strainer? Yes
 Type— Inlet screen
Cab/Axle Distance: 141 inch
GVW Rating: 35,000
Horsepower Rating: 215
Transmission Type: MTB-653/Retarder

Written Materials: Specifications and drawings are available from: California Department of Forestry
 Davis Mobile Equipment Facility
 5800 Chiles Road
 Davis, CA 95616

WATER PUMPING EQUIPMENT

Engine Data Sheet No. 6

Agency: CDF

Equipment Designator: Model 14

ICS Type: 3

Summary: Tank Capacity (gallons)— 500
 Pump Rating—500 gal/min @ 150 psi
 Pump Drive—Hydraulic
 Mobile Attack Capability?—Yes
 Number Crew Personnel—5
 Foam System Available?—Yes
 Gallons—20
 All-Wheel Drive? —Yes



General Description: The model 14 is a four-wheel drive type 3 fire engine. The engine has a 500 gallons per minute, two-stage pump, hydrostatically driven pump. The tank holds 500 gallons of water. The engine has a 20 gallon capacity foam unit. For additional firefighter safety, all personnel sit inside the cab. They all face forward for their comfort. One note, CDF Model 14 and 15 engines are basically the same, with the exception of the chassis, four-wheel drive versus two-wheel drive.

<p>Pump: Manufacturer—Darley Model—JMP-500 Type—Centrifugal Performance: gal/min (max) at free flow—500 gal/min @ max psi = 80 @ 600 Primer Type— Electric</p>	<p>Tank: Material— stainless steel Construction: Baffles?— Yes If steel, is the tank corrosion treated?— N/A</p>
---	---

Controls and Gauges: Hand Throttle?— Yes Pressure Gauge?— Yes Automatic shutdown?— No

Valves: Tank-to-Pump?—Yes Pump-to-Tank?—Yes

Overboard Discharge:	Quantity	2	5	2
	Size	2½ inch	1½ inch	1-inch reel line

Suction:	Quantity	1	2
	Size	4 inch	2½ inch

Priming Valve Handle: Manual
Suction Valve Handle: Electric
Tank-to-Plumbing Shut-Off? Yes
Gravity Tank Drain/Dump? Yes
 Type— ¼ turn valve

Manufacturer: International
Manufacturer Model Year: 1996
Engine Fuel Type: Diesel
Vehicle Operating Weight: 26,000-27,000
Brake Type: Air

Discharge Valve Handle: Manual
Adjustable Pressure Relief? Yes
Pump and Plumbing Drain? Yes
Rock Trap/Plumbing Strainer? Yes
 Type— Inlet screen
Cab/Axle Distance: 49 inch
GVW Rating: 33,000
Horsepower Rating: 220
Transmission Type: MTB-643/Retarder

Written Materials: Specifications and drawings are available from: California Department of Forestry
 Davis Mobile Equipment Facility
 5800 Chiles Road
 Davis, CA 95616

WATER PUMPING EQUIPMENT Engine Data Sheet No. 7

Agency: CDF

Equipment Designator: Model 15

ICS Type: 3

Summary: Tank Capacity (gallons)— 500
 Pump Rating—500 gal/min @ 150 psi
 Pump Drive—Hydraulic
 Mobile Attack Capability?—Yes
 Number Crew Personnel—5
 Foam System Available?—Yes
 Gallons—20
 All-Wheel Drive? —No



General Description: The model 15 is a two-wheel drive type 3 fire engine. The engine has a 500 gallons per minute, two-stage pump, hydrostatically driven pump. The tank holds 500 gallons of water. The engine has a 20 gallon capacity foam unit. For additional firefighter safety, all personnel sit inside the cab. They all face forward for their comfort. One note, CDF Model 14 and 15 engines are basically the same, with the exception of the chassis, four-wheel drive versus two-wheel drive.

Pump: Manufacturer—Darley Model—JMP-500
 Type—Centrifugal
 Performance: gal/min (max) at free flow—500
 gal/min @ max psi = 80 @ 600
 Primer Type— Electric

Tank: Material— stainless steel
 Construction: Baffles?— Yes
 If steel, is the tank corrosion treated?— N/A

Controls and Gauges: Hand Throttle?— Yes Pressure Gauge?— Yes Automatic shutdown?— No

Valves: Tank-to-Pump?—Yes Pump-to-Tank?—Yes

Overboard Discharge:

Quantity	2	5	2
Size	2½ inch	1½ inch	1-inch reel line

Suction:

Quantity	1	2
Size	4 inch	2½ inch

Priming Valve Handle: Manual
Suction Valve Handle: Electric
Tank-to-Plumbing Shut-Off? Yes
Gravity Tank Drain/Dump? Yes
 Type— ¼ turn valve

Manufacturer: International
Manufacturer Model Year: 1996
Engine Fuel Type: Diesel
Vehicle Operating Weight: 25,000
Brake Type: Air

Discharge Valve Handle: Manual
Adjustable Pressure Relief? Yes
Pump and Plumbing Drain? Yes
Rock Trap/Plumbing Strainer? Yes
 Type— Inlet screen

Cab/Axle Distance: 49 inch
GVW Rating: 33,000
Horsepower Rating: 220
Transmission Type: MD 3560 Allison

Written Materials: Specifications and drawings are available from: California Department of Forestry
 Davis Mobile Equipment Facility
 5800 Chiles Road
 Davis, CA 95616

WATER PUMPING EQUIPMENT

Engine Data Sheet No. 8

Agency: CDF

Equipment Designator: Model 17

ICS Type: 3

Summary: Tank Capacity (gallons)— 650
 Pump Rating—500 gal/min @ 150 psi
 Pump Drive—Hydraulic
 Mobile Attack Capability?—Yes
 Number Crew Personnel—6
 Foam System Available?—Yes
 Gallons—20
 All-Wheel Drive? —No



General Description: The Model 17 is assigned in those urban interface areas with difficult access and some full-service needs. Compact over all, size is maintained with good mobile attack performance. The engine has a hydrostatic driven, two-stage pump, rated at 500 gal/min. The engine carries 650 gallons of water. There is ample hose bed space for either a typical wildland hose compliment or a structure type hose compliment. The engine is also equipped with class A foam. There is seating for six firefighters, all inside the cab.

Pump: Manufacturer—Darley Model—JMP-500
 Type—Centrifugal
 Performance: gal/min (max) at free flow—500
 gal/min @ max psi = 80 @ 600
 Primer Type— Electric

Tank: Material— Polypropylene
 Construction: Baffles?— Yes
 If steel, is the tank corrosion treated?— N/A

Controls and Gauges: Hand Throttle?— Yes Pressure Gauge?— Yes Automatic shutdown?— No

Valves: Tank-to-Pump?—Yes Pump-to-Tank?—Yes

Overboard Discharge:

Quantity	3	5	2
Size	2½ inch	1½ inch	1-inch reel line

Suction:

Quantity	2	1
Size	4 inch	2½ inch

Priming Valve Handle: Manual
Suction Valve Handle: Manual
Tank-to-Plumbing Shut-Off? Yes
Gravity Tank Drain/Dump? Yes
 Type— ¼ turn valve

Manufacturer: Spartan
Manufacturer Model Year: 1991
Engine Fuel Type: Diesel
Vehicle Operating Weight: 35,000
Brake Type: Air

Discharge Valve Handle: Manual
Adjustable Pressure Relief? Yes
Pump and Plumbing Drain? Yes
Rock Trap/Plumbing Strainer? Yes
 Type— Inlet screen

Cab/Axle Distance: 136 inch
GVW Rating: 39,000
Horsepower Rating: 240
Transmission Type: MTB 643 Allison

Written Materials: Specifications and drawings are available from: California Department of Forestry
 Davis Mobile Equipment Facility
 5800 Chiles Road
 Davis, CA 95616

WATER PUMPING EQUIPMENT

Engine Data Sheet No. 9

Agency: Texas Forest Service

Equipment Designator: Urban Interface Unit

ICS Type: 3

Summary: Tank Capacity (gallons)— 650
 Pump Rating—500 gal/min @ 150 psi
 Pump Drive—Hydrostatic
 Mobile Attack Capability?—Yes
 Number Crew Personnel—3
 Foam System Available?—Yes
 Gallons—20
 All-Wheel Drive? —Yes



General Description: This engine can be operated from inside the cab as well as from the pump panel. A remote controlled master stream appliance mounted on the front bumper can also be controlled from inside the cab. This engine is used for wildland and interface fires, as well as training.

Pump: Manufacturer—Darley Model—JMP-500
 Type—Centrifugal
 Performance: gal/min (max) at free flow—500
 gal/min @ max psi = 80 @ 600
 Primer Type— Electric

Tank: Material— stainless steel
 Construction: Baffles?— Yes
 If steel, is the tank corrosion treated?—N/A

Controls and Gauges: Hand Throttle?— Yes Pressure Gauge?— Yes Automatic shutdown?— No

Valves: Tank-to-Pump?—Yes Pump-to-Tank?—Yes

Overboard Discharge:	Quantity	2	5	2
	Size	1 inch	1½ inch	2½ inch

Suction:	Quantity	2
	Size	2½ inch

Priming Valve Handle: Manual
Suction Valve Handle: Electric
Tank-to-Plumbing Shut-Off? Yes
Gravity Tank Drain/Dump? Yes
 Type— pipe plug

Manufacturer: International
Manufacturer Model Year: 2001
Engine Fuel Type: Diesel
Vehicle Operating Weight: 26,440
Brake Type: Air

Discharge Valve Handle: Manual
Adjustable Pressure Relief? Yes
Pump and Plumbing Drain? Yes
Rock Trap/Plumbing Strainer? Yes
 Type— Inlet screen

Cab/Axle Distance: 63.75 inch
GVW Rating: 33,000
Horsepower Rating: 330
Transmission Type: Automatic

Written Materials: Specifications and drawings are available from: Texas Forest Service
 P.O. Box 1000
 Pittsburg, TX 75686

WATER PUMPING EQUIPMENT

Engine Data Sheet No. 10

Agency: USDA Forest Service (SW Region, R3)

Equipment Designator: Model 70/71

ICS Type: 3

Summary: Tank Capacity (gallons)— 600
Pump Rating—225 gal/min @ 150 psi
Pump Drive—PTO
Mobile Attack Capability?—Yes
Number Crew Personnel—3 to 5
Foam System Available?—Yes
Gallons—40
All-Wheel Drive? —Yes



General Description: The Model 70 is built on a 2-door cab and the Model 71 is built on a 4-door cab with dual live reels, high output alternator, cruise control, dual 50-gallon fuel tanks, and scene lighting for night operations.

Pump: Manufacturer—Hale Model—CBP
Type—Centrifugal
Performance: gal/min (max) at free flow—250
gal/min @ max psi = 100 @ 400
Primer Type— Electric

Tank: Material— Polypropylene
Construction: Baffles?— Yes
If steel, is the tank corrosion treated?—N/A

Controls and Gauges: Hand Throttle?— Yes Pressure Gauge?— Yes Automatic shutdown?— Yes

Valves: Tank-to-Pump?—Yes Pump-to-Tank?—Yes

Overboard Discharge:	Quantity	2	3
	Size	1 inch	1½ inch

Suction:	Quantity	2
	Size	2½ inch

Priming Valve Handle: Electric
Suction Valve Handle: Manual
Tank-to-Plumbing Shut-Off? Yes
Gravity Tank Drain/Dump? No
Type—

Manufacturer: International
Manufacturer Model Year: 2001
Engine Fuel Type: Diesel
Vehicle Operating Weight: 28,000
Brake Type: Air

Discharge Valve Handle: Manual
Adjustable Pressure Relief? No
Pump and Plumbing Drain? Yes
Rock Trap/Plumbing Strainer? Yes
Type— Inlet screen

Cab/Axle Distance: 84 inch
GVW Rating: 33,000
Horsepower Rating: 250
Transmission Type: Manual

Written Materials: Specifications and drawings are available from: USDA Forest Service
444 East Bonita Avenue
San Dimas, CA 91773

WATER PUMPING EQUIPMENT Engine Data Sheet No. 11

Agency: USDA Forest Service (SW Region, R3)

Equipment Designator: Model 46

ICS Type: 3

Summary: Tank Capacity (gallons)— 600
 Pump Rating—225 gal/min @ 150 psi
 Pump Drive—PTO
 Mobile Attack Capability?—Yes
 Number Crew Personnel—3 to 5
 Foam System Available?—Yes
 Gallons—40
 All-Wheel Drive? —Yes



General Description: The Model 46 is built on a 2-door or 4-door cab with dual live reels, high output alternator, cruise control, dual 50-gallon fuel tanks, and scene lighting for night operations.

Pump: Manufacturer—Hale Model—CBP
 Type—Centrifugal
 Performance: gal/min (max) at free flow—250
 gal/min @ max psi = 100 @ 400
 Primer Type— Electric

Tank: Material— Polypropylene
 Construction: Baffles?— Yes
 If steel, is the tank corrosion treated?—N/A

Controls and Gauges: Hand Throttle?— Yes Pressure Gauge?— Yes Automatic shutdown?— Yes

Valves: Tank-to-Pump?—Yes Pump-to-Tank?—Yes

Overboard Discharge:	Quantity	2	3
	Size	1 inch	1½ inch

Suction:	Quantity	2
	Size	2½ inch

Priming Valve Handle: Manual
Suction Valve Handle: Manual
Tank-to-Plumbing Shut-Off? Yes
Gravity Tank Drain/Dump? No
 Type—

Manufacturer: International
Manufacturer Model Year: 2001
Engine Fuel Type: Diesel
Vehicle Operating Weight: 28,000
Brake Type: Air

Discharge Valve Handle: Manual
Adjustable Pressure Relief? No
Pump and Plumbing Drain? Yes
Rock Trap/Plumbing Strainer? Yes
 Type— Inlet screen
Cab/Axle Distance: 84 inch
GVW Rating: 33,000
Horsepower Rating: 250
Transmission Type: Automatic

Written Materials: Specifications and drawings are available from: USDA Forest Service
 444 East Bonita Avenue
 San Dimas, CA 91773

WATER PUMPING EQUIPMENT

Engine Data Sheet No. 12

Agency: USDA Forest Service (PSW Region, R5)

Equipment Designator: Model 62

ICS Type: 3

Summary: Tank Capacity (gallons)— 500
 Pump Rating—500 gal/min @ 150 psi
 Pump Drive—PTO
 Mobile Attack Capability?—Yes
 Number Crew Personnel—5
 Foam System Available?—Yes
 Gallons—40
 All-Wheel Drive? —Yes



General Description: The Model 62 is built on a four door cab in both two- and four-wheel drive versions. It features a single live reel in the rear compartment, self-contained breathing apparatus seats, high output alternator, transmission retarder, and cruise control. The unit has a single 70 gallon fuel tank, front bumper extension with preconnect line, hard covered and lighted hose bed, in-cab water level gauge, and scene lighting for night operations.

Pump: Manufacturer—Darley Model—JMP-500
 Type—Centrifugal
 Performance: gal/min (max) at free flow—500
 gal/min @ max psi = 80 @ 600
 Primer Type— Electric

Tank: Material— Polypropylene
 Construction: Baffles?— Yes
 If steel, is the tank corrosion treated?—N/A

Controls and Gauges: Hand Throttle?— Yes Pressure Gauge?— Yes Automatic shutdown?— Yes

Valves: Tank-to-Pump?—Yes Pump-to-Tank?—Yes

Overboard Discharge:

Quantity	1	3	1
Size	2½ inch	1½ inch	1 inch

Suction:

Quantity	4
Size	4 inch

Priming Valve Handle: Electric
Suction Valve Handle: Pneumatic
Tank-to-Plumbing Shut-Off? Yes
Gravity Tank Drain/Dump? Yes
 Type—1 ½ inch gravity drain
Manufacturer: International
Manufacturer Model Year: 2001
Engine Fuel Type: Diesel
Vehicle Operating Weight: 28,500-29,000
Brake Type: Air

Discharge Valve Handle: Manual/pneumatic
Adjustable Pressure Relief? Yes
Pump and Plumbing Drain? Yes
Rock Trap/Plumbing Strainer? Yes
 Type— Inlet screen
Cab/Axle Distance: 55 inch
GVW Rating: 33,000
Horsepower Rating: 300
Transmission Type: Automatic

Written Materials: Specifications and drawings are available from: USDA Forest Service
 444 East Bonita Avenue
 San Dimas, CA 91773

WATER PUMPING EQUIPMENT

Engine Data Sheet No. 13

Agency: USDA Forest Service (PNW Region, R6)

Equipment Designator: Model 75

ICS Type: 3

Summary: Tank Capacity (gallons)— 600
Pump Rating—350 gal/min @ 150 psi
Pump Drive—PTO
Mobile Attack Capability?—Yes
Number Crew Personnel—3 to 5
Foam System Available?—Yes
 Gallons—25
All-Wheel Drive? —Yes



General Description: The Model 75 consists of a custom made aluminum apparatus body and includes hose beds and cross lay protection line beds. Compartments have adjustable shelving and sweep out floors. Options include a master stream appliance, compound pressure gauge, and adjustable pressure relief valve.

Pump: Manufacturer—Darley Model—HM350
Type—Centrifugal
Performance: gal/min (max) at free flow—420
 gal/min @ max psi = 0 @ 400
Primer Type— Electric

Tank: Material— Polypropylene
Construction: Baffles?— Yes
If steel, is the tank corrosion treated?—N/A

Controls and Gauges: Hand Throttle?— Yes Pressure Gauge?— Yes Automatic shutdown?—No

Valves: Tank-to-Pump?—Yes Pump-to-Tank?—Yes

Overboard Discharge:	Quantity	5	2
	Size	1½ inch	1 inch

Suction:	Quantity	2
	Size	2½ inch

Priming Valve Handle: Manual

Suction Valve Handle: No

Tank-to-Plumbing Shut-Off? No

Gravity Tank Drain/Dump? Yes
Type— Pipe plug

Manufacturer: IHC or Freightliner

Manufacturer Model Year: 2001

Engine Fuel Type: Diesel

Vehicle Operating Weight: 26,000

Brake Type: Air

Discharge Valve Handle: Manual

Adjustable Pressure Relief? No

Pump and Plumbing Drain? Yes

Rock Trap/Plumbing Strainer? Yes
Type— Inlet screen

Cab/Axle Distance: 84 inch

GVW Rating: 28,000

Horsepower Rating: 250

Transmission Type: Automatic

Written Materials: Specifications and drawings are available from: USDA Forest Service
Pacific Northwest Region
Fire and Aviation Management
P.O. Box 3623
Portland, OR 97208

WATER PUMPING EQUIPMENT

Engine Data Sheet No. 14

Agency: USDA Forest Service (PNW Region, R6)

Equipment Designator: Model 80

ICS Type: 3

Summary: Tank Capacity (gallons)— 1,000
 Pump Rating—350 gal/min @ 150 psi
 Pump Drive—PTO
 Mobile Attack Capability?—Yes
 Number Crew Personnel—3 to 5
 Foam System Available?—Yes
 Gallons—25
 All-Wheel Drive? —Yes



General Description: The Model 80 consists of a custom made aluminum apparatus body and includes hose beds and cross lay protection line beds. Compartments have adjustable shelving and sweep out floors. Options include a master stream appliance, compound pressure gauge, and adjustable pressure relief valve.

Pump: Manufacturer—Darley Model—HM350
 Type—Centrifugal
 Performance: gal/min (max) at free flow—420
 gal/min @ max psi = 0 @ 400
 Primer Type— Electric

Tank: Material— Polypropylene
 Construction: Baffles?— Yes
 If steel, is the tank corrosion treated?—N/A

Controls and Gauges: Hand Throttle?— Yes Pressure Gauge?— Yes Automatic shutdown?—No

Valves: Tank-to-Pump?—Yes Pump-to-Tank?—Yes

Overboard Discharge:

Quantity	5	2
Size	1½ inch	1 inch

Suction:

Quantity	2
Size	2½ inch

Priming Valve Handle: Manual

Suction Valve Handle: No

Tank-to-Plumbing Shut-Off? No

Gravity Tank Drain/Dump? Yes

Type— pipe plug

Manufacturer: IHC or Freightliner

Manufacturer Model Year: 2001

Engine Fuel Type: Diesel

Vehicle Operating Weight: 28,000

Brake Type: Air

Discharge Valve Handle: Manual

Adjustable Pressure Relief? No

Pump and Plumbing Drain? Yes

Rock Trap/Plumbing Strainer? Yes

Type— Inlet screen

Cab/Axle Distance: 100 inch

GVW Rating: 33,000

Horsepower Rating: 250

Transmission Type: Automatic

Written Materials: Specifications and drawings are available from: USDA Forest Service
 Pacific Northwest Region
 Fire and Aviation Management
 P.O. Box 3623
 Portland, OR 97208

WATER PUMPING EQUIPMENT

Engine Data Sheet No. 15

Agency: USDI Bureau of Land Management

Equipment Designator: BLM 665 (Model 14)

ICS Type: 3

Summary: Tank Capacity (gallons)— 500
 Pump Rating—500 gal/min @ 150 psi
 Pump Drive—PTO
 Mobile Attack Capability?—Yes
 Number Crew Personnel—5
 Foam System Available?—Yes
 Gallons—30
 All-Wheel Drive? —Yes



General Description: Type III interface engine with 500 gal/min 2-stage Darley PTO main pump, and a 150 gal/min @ 125 psi auxiliary pump. It is equipped with an optional 125 cfm CAFS system, and a 2001 Foam Pro foam injection unit.

Pump: Manufacturer—Darley Model—JMP-500
 Type—Centrifugal
 Performance: gal/min (max) at free flow—500
 gal/min @ max psi = 80 @ 600
 Primer Type— Electric

Tank: Material— Polypropylene
 Construction: Baffles?— Yes
 If steel, is the tank corrosion treated?—N/A

Controls and Gauges: Hand Throttle?— Yes Pressure Gauge?— Yes Automatic shutdown?—Yes

Valves: Tank-to-Pump?—Yes Pump-to-Tank?—Yes

Overboard Discharge:	Quantity	2	3
	Size	1 inch	2½ inch

Suction:	Quantity	2	1
	Size	2½ inch	4 inch

Priming Valve Handle: Electric
Suction Valve Handle: Manual
Tank-to-Plumbing Shut-Off? Yes
Gravity Tank Drain/Dump? Yes
 Type— ¼ turn valve

Discharge Valve Handle: Manual
Adjustable Pressure Relief? Yes
Pump and Plumbing Drain? Yes
Rock Trap/Plumbing Strainer? Yes
 Type—Inlet screen

Manufacturer: Navistar
Manufacturer Model Year: Current
Engine Fuel Type: Diesel
Vehicle Operating Weight: 28,000
Brake Type: Air

Cab/Axle Distance: 49 inch
GVW Rating: 33,000
Horsepower Rating: 300
Transmission Type: Automatic

Written Materials: Specifications and drawings are available from: National Interagency Fire Center
 Bureau of Land Management
 Fire Equipment Development Unit
 3833 South Development Avenue
 Boise, ID 83705

WATER PUMPING EQUIPMENT

Engine Data Sheet No. 16

Agency: USDI Bureau of Land Management

Equipment Designator: BLM 665 Interface

ICS Type: 3

Summary: Tank Capacity (gallons)— 525 to 750
 Pump Rating—300 gal/min @ 150 psi
 Pump Drive— PTO
 Mobile Attack Capability?—Yes
 Number Crew Personnel—3 to 6
 Foam System Available?—Yes
 Gallons—25
 All-Wheel Drive? —Yes



General Description: This model was developed for interface and offroad wildland suppression activities in the Western States. The model shown is of standard configuration with four-wheel drive, 33,000 GVW chassis, 250 turbo-diesel, 5-speed automatic transmission with retarder. The engine body is constructed of 304 stainless steel. The tank is constructed of high impact polypropylene in 525- and 750-gallon sizes with 25 gallon integral foam concentrate cell. Primary pumping system is PTO, the auxiliary pumping system is powered by a 26 horsepower water-cooled diesel, foam injection is a 2001 Foam Pro. From this base unit a wide variety of pumping packages can be constructed, various cab configurations allow for crews of three to six.

Pump: Manufacturer—Waterous
 Model—CPK-2
 Type—Centrifugal
 Performance: gal/min (max) at free flow—195
 gal/min @ max psi = 15 @ 400
 Primer Type— Electric

Tank: Material— Polypropylene
 Construction: Baffles?— Yes
 If steel, is the tank corrosion treated?—N/A

Controls and Gauges: Hand Throttle?— Yes Pressure Gauge?— Yes Automatic shutdown?—Yes
Valves: Tank-to-Pump?— Pump-to-Tank?—Yes

Overboard Discharge:

	Quantity	2	2	2
Size	2½ inch	1½ inch	1 inch	

Suction:

	Quantity	1	1	1
Size	3 inch	2½ inch	2 inch	

Priming Valve Handle: Electric
Suction Valve Handle: Manual
Tank-to-Plumbing Shut-Off? Yes
Gravity Tank Drain/Dump? Yes
 Type—2½ inch ¼ turn valve
Manufacturer: User Option
Manufacturer Model Year: Current
Engine Fuel Type: Diesel
Vehicle Operating Weight: 31,000
Brake Type: Air

Discharge Valve Handle: Manual
Adjustable Pressure Relief? Yes
Pump and Plumbing Drain? Yes
Rock Trap/Plumbing Strainer? Yes
 Type—Inlet screen
Cab/Axle Distance: 99 inch
GVW Rating: 33,000
Horsepower Rating: 250 to 300
Transmission Type: Automatic

Written Materials: Specifications and drawings are available from: National Interagency Fire Center
 Bureau of Land Management
 Fire Equipment Development Unit
 3833 South Development Avenue
 Boise, ID 83705

WATER PUMPING EQUIPMENT

Engine Data Sheet No. 17

Agency: USDI Fish and Wildlife Service

Equipment Designator: FWS Model 15

ICS Type: 3

Summary: Tank Capacity (gallons)— 500
 Pump Rating—500 gal/min @ 150 psi
 Pump Drive—PTO
 Mobile Attack Capability?—Yes
 Number Crew Personnel—6
 Foam System Available?—Yes
 Gallons—30
 All-Wheel Drive? —No



General Description: This Fish and Wildlife engine model is utilized for wildland and interface fire suppression. The engine package is mounted on a 4900 Navistar and is two-wheel drive. The engine is 300 horsepower and transmission is automatic.

Pump: Manufacturer—Darley Model—JMP-500
 Type—Centrifugal
 Performance: gal/min (max) at free flow—500
 gal/min @ max psi = 80 @ 600
 Primer Type— Electric

Tank: Material— Polypropylene
 Construction: Baffles?— Yes
 If steel, is the tank corrosion treated?—N/A

Controls and Gauges: Hand Throttle?— Yes Pressure Gauge?— Yes Automatic shutdown?—Yes

Valves: Tank-to-Pump?—Yes Pump-to-Tank?—Yes

Overboard Discharge:	Quantity	3	2	2
	Size	1½ inch	2½ inch	1 inch

Suction:	Quantity	2
	Size	2½ inch

Priming Valve Handle: Electric
Suction Valve Handle: Manual
Tank-to-Plumbing Shut-Off? Yes
Gravity Tank Drain/Dump? Yes
 Type— ¼ turn valve

Manufacturer: Navistar
Manufacturer Model Year: Current
Engine Fuel Type: Diesel
Vehicle Operating Weight: 26,000
Brake Type: Air

Discharge Valve Handle: Manual
Adjustable Pressure Relief? Yes
Pump and Plumbing Drain? Yes
Rock Trap/Plumbing Strainer? Yes
 Type— Inlet screen

Cab/Axle Distance: 49 inch
GVW Rating: 33,000
Horsepower Rating: 300
Transmission Type: Automatic

Written Materials: Specifications and drawings are available from: National Interagency Fire Center
 USDI Fish and Wildlife Service
 3833 South Development Avenue
 Boise, ID 83705

WATER PUMPING EQUIPMENT

Engine Data Sheet No. 18

Agency: Connecticut DEP Forestry/Fire Control

Equipment Designator: 2½ ton, 6 by 6

ICS Type: 4

Summary: Tank Capacity (gallons)— 1,000
 Pump Rating—85 gal/min @ 150 psi
 Pump Drive—Auxiliary engine
 Mobile Attack Capability?—Yes
 Number Crew Personnel—2
 Foam System Available?—Yes
 Gallons—5
 All-Wheel Drive? —Yes



General Description: All wheel drive, military 2½ ton truck with a 1,000 gallon tank, BB-4 centrifugal, four-stage pump, Robwen Flow-mix 500 foam proportioner, and live reel with 300 feet of 1-inch hose.

Pump: Manufacturer—Wajax-Pacific Model—BB-4 Type—Centrifugal
 Performance: gal/min (max) at free flow—110
 gal/min @ max psi = 14 @ 400
 Primer Type—Exhaust

Tank: Material—Fiberglass
 Construction: Baffles?—Yes
 If steel, is the tank corrosion treated?—N/A

Controls and Gauges: Hand Throttle?—Yes Pressure Gauge?—Yes Automatic shutdown?—Yes

Valves: Tank-to-Pump?—Yes Pump-to-Tank?—No

Overboard Discharge:

Quantity	1	1
Size	10 inch	1 inch

Suction:

Quantity	1
Size	2 inch

Priming Valve Handle: Manual
Suction Valve Handle: Manual
Tank-to-Plumbing Shut-Off? Yes
Gravity Tank Drain/Dump? Yes
 Type—Electric quick dump
Manufacturer: AM General
Manufacturer Model Year: 1975
Engine Fuel Type: Diesel
Vehicle Operating Weight:
Brake Type: Air/hydraulic

Discharge Valve Handle: Manual
Adjustable Pressure Relief? No
Pump and Plumbing Drain? Yes
Rock Trap/Plumbing Strainer? No
 Type—
Cab/Axle Distance: 90 inch
GVW Rating: 23,520
Horsepower Rating: 150
Transmission Type: Manual

Written Materials: Specifications and drawings are available from: Roscommon Equipment Center
 c/o Forest Fire Experiment Station
 P.O. Box 68
 Roscommon, MI 48653

WATER PUMPING EQUIPMENT

Engine Data Sheet No. 19

Agency: Florida Division of Forestry

Equipment Designator: FEPP Brush Patrol

ICS Type: 4

Summary: Tank Capacity (gallons)—800
 Pump Rating—80 gal/min @ 150 psi
 Pump Drive—Auxiliary engine
 Mobile Attack Capability?—Yes
 Number Crew Personnel—2
 Foam System Available?—Yes
 Gallons—5
 All-Wheel Drive? —Yes



General Description: Military 2.5 ton, all wheel drive, brush patrol. Very good off-road patrol on prescribed burns, mop-up, and line patrol. Repair parts are easy to find.

Pump: Manufacturer—Robwen Model—180
 Type—Centrifugal
 Performance: gal/min (max) at free flow—110
 gal/min @ max psi = 10 @ 250
 Primer Type— Manual

Tank: Material— Polypropylene
 Construction: Baffles?—Yes
 If steel, is the tank corrosion treated?—N/A

Controls and Gauges: Hand Throttle?— Yes Pressure Gauge?— Yes Automatic shutdown?—Yes

Valves: Tank-to-Pump?—Yes Pump-to-Tank?—Yes

Overboard Discharge:	Quantity	1	1	1
	Size	1½ inch	1 inch	1-inch booster

Suction:	Quantity	1
	Size	2½ inch

Priming Valve Handle: Manual
Suction Valve Handle: Manual
Tank-to-Plumbing Shut-Off? Yes
Gravity Tank Drain/Dump? Yes
 Type— Pipe plug
Manufacturer: Kaiser Jeep
Manufacturer Model Year: 1966
Engine Fuel Type: Multi fuel
Vehicle Operating Weight: 16,500
Brake Type: Air/hydraulic

Discharge Valve Handle: Manual
Adjustable Pressure Relief? Yes
Pump and Plumbing Drain? Yes
Rock Trap/Plumbing Strainer? Yes
 Type—Inlet screen
Cab/Axle Distance: 130/148 inch
GVW Rating: 18,530
Horsepower Rating: 134
Transmission Type: Manual

Written Materials: Specifications and drawings are available from: Florida Division of Forestry
 3125 Conner Boulevard
 Tallahassee, FL 32399

WATER PUMPING EQUIPMENT

Engine Data Sheet No. 20

Agency: Michigan Dept. of Natural Resources

Equipment Designator: 4800 Large 4 by 4

ICS Type: 4

Summary: Tank Capacity (gallons)— 800
Pump Rating—85 gal/min @ 150 psi
Pump Drive—Auxiliary engine
Mobile Attack Capability?—Yes
Number Crew Personnel—2
Foam System Available?—Yes
Gallons—5 -12
All-Wheel Drive? —Yes



General Description: Integral low profile tank is mounted on International four-wheel drive chassis. Unit consists of tank, pump, two live reels and foam proportioner. Cab operated nozzles also available. The truck has guards and limb risers for off-road operation as well as a 20,000 pound hydraulic winch. Some units have hydraulically operated fire plows.

Pump: Manufacturer—Wildfire-Pacific Model—BB-4 **Tank:** Material— Steel
Type—Centrifugal Construction: Baffles?— Yes
Performance: gal/min (max) at free flow—110 If steel, is the tank corrosion treated?— Yes
gal/min @ max psi = 14 @ 400
Primer Type— Exhaust

Controls and Gauges: Hand Throttle?—Yes Pressure Gauge?—Yes Automatic shutdown?—Yes

Valves: Tank-to-Pump?—Yes Pump-to-Tank?—Yes

Overboard Discharge: Quantity 1 2
Size 1½ inch 1 inch

Suction: Quantity 1
Size 2 inch

Priming Valve Handle: Manual
Suction Valve Handle: Manual
Tank-to-Plumbing Shut-Off? Yes
Gravity Tank Drain/Dump? Yes
Type— Manual 4-inch butterfly valve
Manufacturer: International
Manufacturer Model Year: 1994-2001
Engine Fuel Type: Diesel
Vehicle Operating Weight: 24,180
Brake Type: Air

Discharge Valve Handle: Manual
Adjustable Pressure Relief? No
Pump and Plumbing Drain? Yes
Rock Trap/Plumbing Strainer? No
Type—
Cab/Axle Distance: 72 inch
GVW Rating: 28,000
Horsepower Rating: 210
Transmission Type: Manual

Written Materials: Specifications and drawings are available from: Roscommon Equipment Center
c/o Forest Fire Experiment Station
P.O. Box 68
Roscommon, MI 48653

WATER PUMPING EQUIPMENT Engine Data Sheet No. 21

Agency: Michigan Dept. of Natural Resources

Equipment Designator: 2½ ton 6 by 6

ICS Type: 4

Summary: Tank Capacity (gallons)— 900
 Pump Rating—85 gal/min @ 150 psi
 Pump Drive—Auxiliary engine
 Mobile Attack Capability?—Yes
 Number Crew Personnel—2
 Foam System Available?—Yes
 Gallons—5
 All-Wheel Drive? —Yes



General Description: Integral, low profile tank, is mounted on a military 2½ ton, all-wheel drive vehicle. Unit consists of tank, pump, two live reels, and a foam proportioner. Cab operated nozzles are also available. The truck has guards and limb risers for off-road operation. Some units have hydraulically operated fire plows.

Pump: Manufacturer—Wildfire-Pacific Model—BB-4 **Tank:** Material— steel
 Type—Centrifugal Construction: Baffles?— Yes
 Performance: gal/min (max) at free flow—110 If steel, is the tank corrosion treated?— Yes
 gal/min @ max psi = 14 @ 400
 Primer Type— Exhaust

Controls and Gauges: Hand Throttle?— Yes Pressure Gauge?— Yes Automatic shutdown?—Yes

Valves: Tank-to-Pump?—Yes Pump-to-Tank?—Yes

Overboard Discharge:

Quantity	1	2
Size	1½ inch	1 inch

Suction:

Quantity	1
Size	2 inch

Priming Valve Handle: Manual
Suction Valve Handle: Manual
Tank-to-Plumbing Shut-Off? Yes
Gravity Tank Drain/Dump? Yes
 Type— Manual 4-inch butterfly valve
Manufacturer: Military
Manufacturer Model Year: Various
Engine Fuel Type: Multifuel
Vehicle Operating Weight: 22,000
Brake Type: Air/hydraulic

Discharge Valve Handle: Manual
Adjustable Pressure Relief? No
Pump and Plumbing Drain? Yes
Rock Trap/Plumbing Strainer? No
 Type—
Cab/Axle Distance: 76 inch
GVW Rating: 23,000
Horsepower Rating: Various
Transmission Type: Manual

Written Materials: Specifications and drawings are available from: Roscommon Equipment Center
 c/o Forest Fire Experiment Station
 P.O. Box 68
 Roscommon, MI 48653

WATER PUMPING EQUIPMENT

Engine Data Sheet No. 22

Agency: Michigan Dept. of Natural Resources

Equipment Designator: 5 ton 6 by 6

ICS Type: 4

Summary: Tank Capacity (gallons)— 1,400
 Pump Rating—85 gal/min @ 150 psi
 Pump Drive—Auxiliary engine
 Mobile Attack Capability?—Yes
 Number Crew Personnel—2
 Foam System Available?—Yes
 Gallons—12
 All-Wheel Drive? —Yes



General Description: Integral, low profile tank, mounted on military 5-ton, all-wheel drive vehicle. Unit consists of tank, pump, two live reels, and a foam proportioner. Cab operated nozzles also available. The truck has guards and limb risers for off-road operation. Some units have hydraulically operated fire plows.

Pump: Manufacturer—Wildfire-Pacific Model—BB-4
 Type—Centrifugal
 Performance: gal/min (max) at free flow—110
 gal/min @ max psi = 14 @ 400
 Primer Type— Exhaust

Tank: Material— Steel
 Construction: Baffles?— Yes
 If steel, is the tank corrosion treated?— Yes

Controls and Gauges: Hand Throttle?— Yes Pressure Gauge?— Yes Automatic shutdown?—Yes

Valves: Tank-to-Pump?—Yes Pump-to-Tank?—Yes

Overboard Discharge:

Quantity	1	2
Size	1½ inch	1 inch

Suction:

Quantity	1
Size	2 inch

Priming Valve Handle: Manual
Suction Valve Handle: Manual
Tank-to-Plumbing Shut-Off? Yes
Gravity Tank Drain/Dump? Yes
 Type— Manual 6-inch butterfly valve
Manufacturer: Military
Manufacturer Model Year: Various
Engine Fuel Type: Multifuel
Vehicle Operating Weight: 34,720
Brake Type: Air/hydraulic

Discharge Valve Handle: Manual
Adjustable Pressure Relief? No
Pump and Plumbing Drain? Yes
Rock Trap/Plumbing Strainer? No
 Type—
Cab/Axle Distance: 90 inch
GVW Rating: 46,810
Horsepower Rating: 195
Transmission Type: Manual

Written Materials: Specifications and drawings are available from: Roscommon Equipment Center
 c/o Forest Fire Experiment Station
 P.O. Box 68
 Roscommon, MI 48653

WATER PUMPING EQUIPMENT

Engine Data Sheet No. 23

Agency: New Mexico State Forestry

Equipment Designator: Engine 44

ICS Type: 4

Summary: Tank Capacity (gallons)— 750
 Pump Rating—85 gal/min @ 150 psi
 Pump Drive—Flywheel
 Mobile Attack Capability?—Yes
 Number Crew Personnel—3
 Foam System Available?—Yes
 Gallons—25
 All-Wheel Drive? —Yes



General Description: 1983 International 2½ ton four-wheel drive with a 1,000 gallon drop tank with a quick dump valve. It is used to nurse ICS Type 6 or heavier engines during initial attack.

Pump: Manufacturer—Wildfire-Pacific Model—BB-4 Type—Centrifugal Performance: gal/min (max) at free flow—110 gal/min @ max psi = 14 @ 400 Primer Type— Exhaust
Tank: Material— Polypropylene Construction: Baffles?— Yes If steel, is the tank corrosion treated?—N/A

Controls and Gauges: Hand Throttle?— Yes Pressure Gauge?— Yes Automatic shutdown?—No

Valves: Tank-to-Pump?—Yes Pump-to-Tank?—Yes

Overboard Discharge:

Quantity	2	2
Size	1½ inch	1-inch reel line

Suction:

Quantity	1
Size	1½ inch

Priming Valve Handle: Manual
Suction Valve Handle: Manual
Tank-to-Plumbing Shut-Off? Yes
Gravity Tank Drain/Dump? Yes
 Type— 6-inch dump plug
Manufacturer: International
Manufacturer Model Year: 1983
Engine Fuel Type: Diesel
Vehicle Operating Weight:
Brake Type: Air

Discharge Valve Handle: Manual
Adjustable Pressure Relief? No
Pump and Plumbing Drain? Yes
Rock Trap/Plumbing Strainer? No
 Type—
Cab/Axle Distance: 72 inch
GVW Rating: 24,000
Horsepower Rating: 210
Transmission Type: Automatic

Written Materials: Specifications and drawings are available from: EMNRD—State Forestry Division
 Las Vegas District
 HC 33 Box 109 #4
 Las Vegas, NM 87701

WATER PUMPING EQUIPMENT

Engine Data Sheet No. 24

Agency: USDA Forest Service (Northern Region, R1 and Intermountain Region, R4)

Equipment Designator: Model 52

ICS Type: 4

Summary: Tank Capacity (gallons)— 700
 Pump Rating—85 gal/min @ 150 psi
 Pump Drive—Auxiliary engine
 Mobile Attack Capability?—Yes
 Number Crew Personnel—2 to 5
 Foam System Available?—Yes
 Gallons—5
 All-Wheel Drive? —Yes



General Description: The Model 52 fire package is designed for easy mount and dismount from a 9 foot 6 inch to 12 foot flat bed truck. Unit consists of a fiberglass or polypropylene tank, 18 horsepower pump, two live reels, storage compartments, and appropriate plumbing.

Pump: Manufacturer—Wildfire Model—BB-4
 Type—Centrifugal
 Performance: gal/min (max) at free flow—110
 gal/min @ max psi = 14 @ 400
 Primer Type— Other

Tank: Material— Fiberglass or polypropylene
 Construction: Baffles?— Yes
 If steel, is the tank corrosion treated?— N/A

Controls and Gauges: Hand Throttle?— Yes Pressure Gauge?— Yes Automatic shutdown?—Yes

Valves: Tank-to-Pump?—Yes Pump-to-Tank?—Yes

Overboard Discharge:

Quantity	3	2
Size	1½ inch	1 inch

Suction:

Quantity	2
Size	2 inch

Priming Valve Handle: Manual
Suction Valve Handle: Manual
Tank-to-Plumbing Shut-Off? Yes
Gravity Tank Drain/Dump? Yes
 Type—Manual 10-inch dump valve
Manufacturer: User Option
Manufacturer Model Year: Varies
Engine Fuel Type: Diesel or gas
Vehicle Operating Weight: Varies
Brake Type: Varies

Discharge Valve Handle: Manual
Adjustable Pressure Relief? No
Pump and Plumbing Drain? Yes
Rock Trap/Plumbing Strainer? Yes
 Type— Inlet screen
Cab/Axle Distance: Varies
GVW Rating: 26,000
Horsepower Rating: Varies
Transmission Type: Varies

Written Materials: Specifications and drawings are available from: USDA Forest Service
 Model 52 Program
 Aerial Fire Depot
 5765 West Broadway
 Missoula, MT 59808

WATER PUMPING EQUIPMENT

Engine Data Sheet No. 25

Agency: USDI Bureau of Land Management

Equipment Designator: BLM 668 UEX

ICS Type: 4

Summary: Tank Capacity (gallons)—2,400
 Pump Rating—140 gal/min @ 150 psi
 Pump Drive—Auxiliary engine
 Mobile Attack Capability?—Yes
 Number Crew Personnel—6
 Foam System Available?—Yes
 Gallons—50
 All-Wheel Drive? —Yes



General Description: This BLM model was developed for extreme duty off-road wildfire suppression activities in the Western States. The unit is constructed to NFPA 1906 Wildland Fire Engine standards. This model has full time all wheel drive, independent suspension, and central tire inflation (CTI). The truck's transmission is a 6-speed Twin Disc automatic. The truck is powered by a 400 horsepower turbo diesel. The tank is constructed of high impact polypropylene and shielded in 304 stainless steel. The tank carries 2,400 gallons with 50 gallons foam concentrate and has equipment storage built into the top. The optional pumping system on this unit is powered by a 42 horsepower water-cooled diesel designed to produce full pump performance at 5,000 feet and 100 °F; foam injection is a 1601 Foam Pro. The unit shown in the picture is equipped with an optional Darley/Odin Derringer 70 cfm CAFS foam system and equipped with a master stream appliance on the front bumper. Various cab configurations allow for crews of two to six.

Pump: Manufacturer—Waterous Model—CPT-1
 Type—Centrifugal
 Performance: gal/min (max) at free flow—180
 gal/min @ max psi = 50 @ 330
 Primer Type— Electric

Tank: Material— Polypropylene
 Construction: Baffles?— Yes
 If steel, is the tank corrosion treated?—N/A

Controls and Gauges: Hand Throttle?— Yes Pressure Gauge?— Yes Automatic shutdown?—Yes

Valves: Tank-to-Pump?—Yes Pump-to-Tank?—Yes

Overboard Discharge:	Quantity	3	2
	Size	1½ inch	1 inch

Suction:	Quantity	2
	Size	2 inch

Priming Valve Handle: Electric
Suction Valve Handle: Manual
Tank-to-Plumbing Shut-Off? Yes
Gravity Tank Drain/Dump? Yes
 Type—10-inch manual valve

Manufacturer: Tatra
Manufacturer Model Year: Current
Engine Fuel Type: Diesel
Vehicle Operating Weight: 56,000
Brake Type: Air

Discharge Valve Handle: Manual
Adjustable Pressure Relief? No
Pump and Plumbing Drain? Yes
Rock Trap/Plumbing Strainer? Yes
 Type— Inlet screen

Cab/Axle Distance: 122½ inch
GVW Rating: 58,000
Horsepower Rating: 400
Transmission Type: Automatic

Written Materials: Specifications and drawings are available from: National Interagency Fire Center
 Bureau of Land Management
 Fire Equipment Development Unit
 3833 South Development Avenue
 Boise, ID 83705

WATER PUMPING EQUIPMENT

Engine Data Sheet No. 26

Agency: USDI Bureau of Land Management

Equipment Designator: BLM 667

ICS Type: 4

Summary: Tank Capacity (gallons)—500 to 865
 Pump Rating—140 gal/min @ 150 psi
 Pump Drive—Auxiliary engine
 Mobile Attack Capability?—Yes
 Number Crew Personnel—3 to 6
 Foam System Available?—Yes
 Gallons—25
 All-Wheel Drive? —Yes



General Description: This BLM model was developed for off road suppression activities in the Western States. The model shown is built to NFPA 1906 Wildland fire engine standards. This is the standard 667 configuration with four-wheel drive, 33,000 GVW chassis, 250 turbo-diesel, 5-speed automatic transmission with retarder. The engine body is constructed of 304 stainless, tank is constructed of high impact polypropylene in 500- and 865-gallon sizes with 25-gallon integral foam concentrate cell. The pumping system is powered by a 30 horsepower water-cooled diesel designed to produce full pump performance at 5,000 feet and 100 °F; foam injection is a 1601 Foam Pro unit. A 55 cfm CAFS unit is available for this engine. From this base unit a wide variety of pumping packages have been constructed, various cab configurations allow for crews of three to six. This model and other configurations are being used by the USFWS, USNPS, USFS, Dept. of Defense, State of Alaska, and Mexico.

Pump: Manufacturer—Waterous Model—CPT-1
 Type—Centrifugal
 Performance: gal/min (max) at free flow—195
 gal/min @ max psi = 15 @ 400
 Primer Type— Electric

Tank: Material— Polypropylene
 Construction: Baffles?— Yes
 If steel, is the tank corrosion treated?—N/A

Controls and Gauges: Hand Throttle?— Yes Pressure Gauge?— Yes Automatic shutdown?—Yes
Valves: Tank-to-Pump?— Pump-to-Tank?—Yes

Overboard Discharge: Quantity 3 2
 Size 1½ inch 1 inch

Suction: Quantity 2
 Size 2 inch

Priming Valve Handle: Electric
Suction Valve Handle: Manual
Tank-to-Plumbing Shut-Off? Yes
Gravity Tank Drain/Dump? Yes
 Type—Manual 2½ inch ¼ turn valve
Manufacturer: User Option
Manufacturer Model Year: Current
Engine Fuel Type: Diesel
Vehicle Operating Weight: 29,000
Brake Type: Air

Discharge Valve Handle: Manual
Adjustable Pressure Relief? No
Pump and Plumbing Drain? Yes
Rock Trap/Plumbing Strainer? Yes
 Type—Inlet screen
Cab/Axle Distance: 88 inch
GVW Rating: 33,000
Horsepower Rating: 250 to 300
Transmission Type: Automatic

Written Materials: Specifications and drawings are available from: National Interagency Fire Center
 Bureau of Land Management
 Fire Equipment Development Unit
 3833 South Development Avenue
 Boise, ID 83705

WATER PUMPING EQUIPMENT

Engine Data Sheet No. 27

Agency: Wisconsin Dept. of Natural Resources

Equipment Designator: 850 gallon pumper

ICS Type: 4

Summary: Tank Capacity (gallons)—850
 Pump Rating—N/A
 Pump Drive—Auxiliary engine
 Mobile Attack Capability?—Yes
 Number Crew Personnel—3
 Foam System Available?—Yes
 Gallons—25
 All-Wheel Drive? —No



General Description: This Wisconsin 850-gallon unit is equipped with a fiberglass utility body with handtool/equipment storage on two sides. It has an 850-gallon water tank made of polypropylene, a Darley 355 gal/min centrifugal water pump, live reel with 100 feet of 1-inch hose, and a Robwen foam proportioner. The foam unit is supplied by a 25-gallon reservoir which is integral to the 850-gallon water tank. All controls are conveniently mounted on a rear facing panel. The unit also pulls a tiltbed trailer loaded with a John Deere 450 crawler tractor equipped with a mounted fire plow and water tanks.

Pump: Manufacturer—Darley Model—2BE-18
 Type—Centrifugal
 Performance: gal/min (max) at free flow—355
 gal/min @ max psi = 50 @ 140
 Primer Type— Manual

Tank: Material— Polypropylene
 Construction: Baffles?— Yes
 If steel, is the tank corrosion treated?—N/A

Controls and Gauges: Hand Throttle?—Yes Pressure Gauge?—Yes Automatic shutdown?—No

Valves: Tank-to-Pump?—Yes Pump-to-Tank?—Yes

Overboard Discharge:

Quantity	1	3	1
Size	1 inch	1½ inch	2½ inch

Suction:

Quantity	1
Size	2½ inch

Priming Valve Handle: Manual
Suction Valve Handle: Manual
Tank-to-Plumbing Shut-Off? Yes
Gravity Tank Drain/Dump? Yes
 Type—Manual 10-inch quick dump
Manufacturer: User Option
Manufacturer Model Year: Varies
Engine Fuel Type: Diesel
Vehicle Operating Weight: 25,780
Brake Type: Air

Discharge Valve Handle: Manual
Adjustable Pressure Relief? No
Pump and Plumbing Drain? Yes
Rock Trap/Plumbing Strainer? No
 Type—
Cab/Axle Distance: 101 inch
GVW Rating: 35,000
Horsepower Rating: 300
Transmission Type: Automatic

Written Materials: Specifications and drawings are available from: Wisconsin Dept. of Natural Resources
 Neil H. LeMay Forestry Center
 518 West Somo Avenue
 Tomahawk, WI 54487

WATER PUMPING EQUIPMENT

Engine Data Sheet No. 28

Agency: Florida Division of Forestry

Equipment Designator: Wildland engine

ICS Type: 5

Summary: Tank Capacity (gallons)— 500
 Pump Rating—100 gal/min @ 150 psi
 Pump Drive—Auxiliary engine
 Mobile Attack Capability?—Yes
 Number Crew Personnel—2
 Foam System Available?—Yes
 Gallons—5
 All-Wheel Drive? —Yes



General Description: This is a four-wheel drive Ford F550 initial attack vehicle, with a 500-gallon aluminum tank and light bar.

Pump: Manufacturer—Darley Model—2BE20H
 Type—Centrifugal
 Performance: gal/min (max) at free flow—375
 gal/min @ max psi = 100 @ 120
 Primer Type— Exhaust

Tank: Material— Aluminum
 Construction: Baffles?—Yes
 If steel, is the tank corrosion treated?—N/A

Controls and Gauges: Hand Throttle?—Yes Pressure Gauge?—Yes Automatic shutdown?—Yes

Valves: Tank-to-Pump?—Yes Pump-to-Tank?—Yes

Overboard Discharge:

Quantity	1	1	1
Size	2½ inch	1½ inch	1-inch booster

Suction:

Quantity	1
Size	2½ inch

Priming Valve Handle: Manual
Suction Valve Handle: Manual
Tank-to-Plumbing Shut-Off? Yes
Gravity Tank Drain/Dump? Yes
 Type— ¼ turn valve

Manufacturer: Ford
Manufacturer Model Year: 2001
Engine Fuel Type: Diesel
Vehicle Operating Weight: 13,900
Brake Type: Hydraulic

Discharge Valve Handle: Manual
Adjustable Pressure Relief? Yes
Pump and Plumbing Drain? Yes
Rock Trap/Plumbing Strainer? No
 Type—

Cab/Axle Distance: 60 inch
GVW Rating: 17,500
Horsepower Rating: 210
Transmission Type: Automatic

Written Materials: Specifications and drawings are available from: Florida Division of Forestry
 3125 Conner Boulevard
 Tallahassee, FL 32399

WATER PUMPING EQUIPMENT

Engine Data Sheet No. 29

Agency: Alabama Forestry Commission

Equipment Designator: Brush patrol

ICS Type: 6

Summary: Tank Capacity (gallons)— 250
 Pump Rating—100 gal/min @ 150 psi
 Pump Drive—Auxiliary engine
 Mobile Attack Capability?—Yes
 Number Crew Personnel—2
 Foam System Available?—No
 Gallons—
 All-Wheel Drive? —Yes



General Description: This is a one ton, four-wheel drive, dual wheel vehicle with a slip on tank, used for initial attack and mop-up.

Pump: Manufacturer—Kuppa Model—100
 Type—Centrifugal
 Performance: gal/min (max) at free flow—100
 gal/min @ max psi = 26 @ 460
 Primer Type— Exhaust

Tank: Material— Fiberglass
 Construction: Baffles?—Yes
 If steel, is the tank corrosion treated?—N/A

Controls and Gauges: Hand Throttle?—Yes Pressure Gauge?—Yes Automatic shutdown?—No

Valves: Tank-to-Pump?—Yes Pump-to-Tank?—Yes

Overboard Discharge: Quantity 1 1 1
 Size 1 inch 1½ inch 1-inch booster

Suction: Quantity 1
 Size 1½ inch

Priming Valve Handle: None
Suction Valve Handle: None
Tank-to-Plumbing Shut-Off? Yes
Gravity Tank Drain/Dump? Yes
 Type— Gate valve

Manufacturer: Ford
Manufacturer Model Year: 1992
Engine Fuel Type: Diesel
Vehicle Operating Weight: 10,100
Brake Type: Hydraulic

Discharge Valve Handle: Manual
Adjustable Pressure Relief? Yes
Pump and Plumbing Drain? Yes
Rock Trap/Plumbing Strainer? Yes
 Type— Inlet screen

Cab/Axle Distance: 60 inch
GVW Rating: 11,500
Horsepower Rating: 200
Transmission Type: Automatic

Written Materials: Specifications and drawings are available from: Alabama Forestry Commission
 513 Madison Avenue
 Montgomery, AL 36130

WATER PUMPING EQUIPMENT

Engine Data Sheet No. 30

Agency: East Bay Regional Parks (CA)

Equipment Designator: Grass patrol 4 by 4

ICS Type: 6

Summary: Tank Capacity (gallons)— 300
 Pump Rating—110 gal/min @ 150 psi
 Pump Drive—Auxiliary engine
 Mobile Attack Capability?—Yes
 Number Crew Personnel—2
 Foam System Available?—Yes
 Gallons—20
 All-Wheel Drive? —Yes



General Description: This unit consists of a 15,000 GVW cab/chassis, custom aluminum body with SCBA compartments. The 300 gallon unit has no live reel but has a front bumper swivel discharge, dual cross lays (side), and rear discharge with a Foam Pro 1600 proportioner unit.

Pump: Manufacturer—Darley Model—1½ AGE 24 Onan **Tank:** Material—Polypropylene
 Type—Centrifugal Construction: Baffles?—Yes
 Performance: gal/min (max) at free flow—110 If steel, is the tank corrosion treated?—N/A
 gal/min @ max psi = 40 @ 275
 Primer Type— Electric

Controls and Gauges: Hand Throttle?—Yes Pressure Gauge?—Yes Automatic shutdown?—Yes

Valves: Tank-to-Pump?—Yes Pump-to-Tank?—Yes

Overboard Discharge: Quantity 4
 Size 1½ inch

Suction: Quantity 1
 Size 2 inch

Priming Valve Handle: Manual
Suction Valve Handle: Manual
Tank-to-Plumbing Shut-Off? Yes
Gravity Tank Drain/Dump? No
 Type—
Manufacturer: Ford
Manufacturer Model Year: Varies
Engine Fuel Type: Diesel
Vehicle Operating Weight: 13,500
Brake Type: Hydraulic

Discharge Valve Handle: Manual
Adjustable Pressure Relief? No
Pump and Plumbing Drain? Yes
Rock Trap/Plumbing Strainer? No
 Type—
Cab/Axle Distance: 60 inch
GVW Rating: 15,000-17,000
Horsepower Rating: 235
Transmission Type: Automatic

Written Materials: Specifications and drawings are available from: East Bay Regional Park District
 2501 Grizzly Peak Road
 Berkeley, CA 94706

WATER PUMPING EQUIPMENT

Engine Data Sheet No. 31

Agency: Florida Division of Forestry

Equipment Designator: Wildland brush patrol

ICS Type: 6

Summary: Tank Capacity (gallons)— 300
 Pump Rating—80 gal/min @ 150 psi
 Pump Drive—Auxiliary engine
 Mobile Attack Capability?—Yes
 Number Crew Personnel—2
 Foam System Available?—Yes
 Gallons—5
 All-Wheel Drive? —Yes



General Description: One-ton GMC four-wheel drive initial attack engine, tool boxes, light bar with aluminum tank.

Pump: Manufacturer—Robwen Model—180
 Type—Centrifugal
 Performance: gal/min (max) at free flow—110
 gal/min @ max psi = 10 @ 250
 Primer Type— Electric

Tank: Material— Aluminum
 Construction: Baffles?—Yes
 If steel, is the tank corrosion treated?— N/A

Controls and Gauges: Hand Throttle?—Yes Pressure Gauge?—Yes Automatic shutdown?—Yes

Valves: Tank-to-Pump?—Yes Pump-to-Tank?—Yes

Overboard Discharge:

Quantity	1	1
Size	1½ inch	1-inch booster

Suction:

Quantity	1
Size	2 inch

Priming Valve Handle: Manual
Suction Valve Handle: Manual
Tank-to-Plumbing Shut-Off? Yes
Gravity Tank Drain/Dump? Yes
 Type— Pipe plug
Manufacturer: GMC
Manufacturer Model Year: 1993
Engine Fuel Type: Diesel
Vehicle Operating Weight: 13,573
Brake Type: Hydraulic

Discharge Valve Handle: Manual
Adjustable Pressure Relief? Yes
Pump and Plumbing Drain? Yes
Rock Trap/Plumbing Strainer? Yes
 Type— Inlet screen
Cab/Axle Distance: 60 inch
GVW Rating: 15,000
Horsepower Rating: 210
Transmission Type: Automatic

Written Materials: Specifications and drawings are available from: Florida Division of Forestry
 3125 Conner Boulevard
 Tallahassee, FL 32399

WATER PUMPING EQUIPMENT

Engine Data Sheet No. 32

Agency: Michigan Dept. of Natural Resources

Equipment Designator: M-1008

ICS Type: 6

Summary: Tank Capacity (gallons)— 175
 Pump Rating—85 gal/min @ 150 psi
 Pump Drive—Auxiliary engine
 Mobile Attack Capability?—Yes
 Number Crew Personnel—2
 Foam System Available?—Yes
 Gallons—5
 All-Wheel Drive? —Yes



General Description: The cargo box of the military M1008 is removed and replaced with a flat steel bed. Polypropylene tank, pump, and proportioner are mounted to the steel bed along with the storage units.

Pump: Manufacturer—Wildfire-Pacific Model—BB-4
 Type—Centrifugal
 Performance: gal/min (max) at free flow—110
 gal/min @ max psi = 14 @ 400
 Primer Type— Exhaust

Tank: Material— Polypropylene
 Construction: Baffles?— Yes
 If steel, is the tank corrosion treated?— N/A

Controls and Gauges: Hand Throttle?—Yes Pressure Gauge?—Yes Automatic shutdown?—Yes

Valves: Tank-to-Pump?—Yes Pump-to-Tank?—Yes

Overboard Discharge:

Quantity	1	1
Size	1½ inch	1 inch

Suction:

Quantity	1
Size	2 inch

Priming Valve Handle: Manual
Suction Valve Handle: Manual
Tank-to-Plumbing Shut-Off? Yes
Gravity Tank Drain/Dump? Yes
 Type— Pipe plug
Manufacturer: GM
Manufacturer Model Year: late 90's
Engine Fuel Type: Diesel
Vehicle Operating Weight: 8,300
Brake Type: Hydraulic

Discharge Valve Handle: Manual
Adjustable Pressure Relief? No
Pump and Plumbing Drain? Yes
Rock Trap/Plumbing Strainer? No
 Type—
Cab/Axle Distance: 60 inch
GVW Rating: 9,400
Horsepower Rating: 135
Transmission Type: Automatic

Written Materials: Specifications and drawings are available from: Roscommon Equipment Center
 c/o Forest Fire Experiment Station
 P.O. Box 68
 Roscommon, MI 48653

WATER PUMPING EQUIPMENT Engine Data Sheet No. 33

Agency: Michigan Dept. of Natural Resources

Equipment Designator: Hummer

ICS Type: 6

Summary: Tank Capacity (gallons)— 250
 Pump Rating—85 gal/min @ 150 psi
 Pump Drive—Auxiliary engine
 Mobile Attack Capability?—Yes
 Number Crew Personnel—2
 Foam System Available?—Yes
 Gallons—5
 All-Wheel Drive? —Yes



General Description: A “T”-shaped polypropylene tank is mounted into the cargo area of an AM General Hummer. These units were modified by Fire Attacker, Petersburg, MI, using a concept developed by the MDNR. Some units have central tire inflation.

<p>Pump: Manufacturer—Wildfire-Pacific Model—BB-4 Type—Centrifugal Performance: gal/min (max) at free flow—110 gal/min @ max psi = 14 @ 400 Primer Type— Exhaust</p>	<p>Tank: Material— Polypropylene Construction: Baffles?— Yes If steel, is the tank corrosion treated?—N/A</p>
---	--

Controls and Gauges: Hand Throttle?—Yes Pressure Gauge?—Yes Automatic shutdown?—Yes

Valves: Tank-to-Pump?—Yes Pump-to-Tank?—Yes

Overboard Discharge:	Quantity	1	1
	Size	1½ inch	1 inch

Suction:	Quantity	1
	Size	2 inch

Priming Valve Handle: Manual
Suction Valve Handle: Manual
Tank-to-Plumbing Shut-Off? Yes
Gravity Tank Drain/Dump? Yes
 Type— Pipe plug
Manufacturer: AM General
Manufacturer Model Year: 1992 to 1995
Engine Fuel Type: Diesel
Vehicle Operating Weight: 10,800
Brake Type: Hydraulic

Discharge Valve Handle: Manual
Adjustable Pressure Relief? No
Pump and Plumbing Drain? Yes
Rock Trap/Plumbing Strainer? No
 Type—
Cab/Axle Distance: N/A
GVW Rating: 10,800
Horsepower Rating: 150
Transmission Type: Automatic

Written Materials: Specifications and drawings are available from: Roscommon Equipment Center
 c/o Forest Fire Experiment Station
 P.O. Box 68
 Roscommon, MI 48653

WATER PUMPING EQUIPMENT

Engine Data Sheet No. 34

Agency: New Jersey Forest Fire Service

Equipment Designator: All terrain engine

ICS Type: 6

Summary: Tank Capacity (gallons)— 300
Pump Rating—N/A
Pump Drive—Auxiliary engine
Mobile Attack Capability?—Yes
Number Crew Personnel—2
Foam System Available?—No
Gallons—
All-Wheel Drive? —Yes



General Description: This is an all-wheel drive, all terrain articulating vehicle acquired through the FEPP program known as a Gamma Goat. It is fitted with a custom built fiberglass tank, equipped with a firefighting water pump and has had brush guards added to protect the operator and the vehicle.

Pump: Manufacturer—Hale Model—25FB-B25
Type—Centrifugal
Performance: gal/min (max) at free flow—350
gal/min @ max psi = 25 @ 118
Primer Type— Exhaust

Tank: Material— Fiberglass
Construction: Baffles?— Yes
If steel, is the tank corrosion treated?—N/A

Controls and Gauges: Hand Throttle?—Yes Pressure Gauge?—Yes Automatic shutdown?—No

Valves: Tank-to-Pump?—Yes Pump-to-Tank?—Yes

Overboard Discharge: Quantity 2
Size 1½ inch

Suction: Quantity 1
Size 1½ inch

Priming Valve Handle: Manual
Suction Valve Handle: Manual
Tank-to-Plumbing Shut-Off? Yes
Gravity Tank Drain/Dump? Yes
Type— Manual gate valve
Manufacturer: AM General
Manufacturer Model Year: 1970
Engine Fuel Type: Diesel
Vehicle Operating Weight: 10,820
Brake Type: Hydraulic

Discharge Valve Handle: Manual
Adjustable Pressure Relief? No
Pump and Plumbing Drain? Yes
Rock Trap/Plumbing Strainer? No
Type—
Cab/Axle Distance: N/A
GVW Rating: 11,000
Horsepower Rating: 53
Transmission Type: Manual

Written Materials: Specifications and drawings are available from: New Jersey Forest Fire Service
P.O. Box 404, 4th Floor
Trenton, NJ 08625-0404

WATER PUMPING EQUIPMENT

Engine Data Sheet No. 35

Agency: New Jersey Forest Fire Service

Equipment Designator: Initial attack brush truck

ICS Type: 6

Summary: Tank Capacity (gallons)— 250
 Pump Rating—60 gal/min @ 150 psi
 Pump Drive—Auxiliary engine
 Mobile Attack Capability?—Yes
 Number Crew Personnel—3
 Foam System Available?—No
 Gallons—
 All-Wheel Drive? —Yes



General Description: This four-wheel drive truck is reinforced on all sides and underneath for protection from trees, brush, and rocks. It is utilized for aggressive initial attack in off-road situations through brush and tree cover types.

Pump: Manufacturer—Hale Model—HPX-200
 Type—Centrifugal
 Performance: gal/min (max) at free flow—250
 gal/min @ max psi = 40 @ 165
 Primer Type— Manual

Tank: Material— Aluminum
 Construction: Baffles?— Yes
 If steel, is the tank corrosion treated?—N/A

Controls and Gauges: Hand Throttle?—Yes Pressure Gauge?—Yes Automatic shutdown?—No

Valves: Tank-to-Pump?—Yes Pump-to-Tank?—Yes

Overboard Discharge:

Quantity	2	3
Size	1½ inch	1 inch

Suction:

Quantity	1
Size	1½ inch

Priming Valve Handle: Manual
Suction Valve Handle: Manual
Tank-to-Plumbing Shut-Off? Yes
Gravity Tank Drain/Dump? No
 Type—

Manufacturer: Ford
Manufacturer Model Year: 2000 and up
Engine Fuel Type: Diesel
Vehicle Operating Weight: 11,600
Brake Type: Hydraulic

Discharge Valve Handle: Manual
Adjustable Pressure Relief? No
Pump and Plumbing Drain? Yes
Rock Trap/Plumbing Strainer? No
 Type—

Cab/Axle Distance: 60 inch
GVW Rating: 12,500
Horsepower Rating: 235
Transmission Type: Manual/automatic

Written Materials: Specifications and drawings are available from: New Jersey Forest Fire Service
 P.O. Box 404, 4th Floor
 Trenton, NJ 08625-0404

WATER PUMPING EQUIPMENT

Engine Data Sheet No. 36

Agency: USDA Forest Service (Northern Region, R1)

Equipment Designator: Model 52

ICS Type: 6

Summary: Tank Capacity (gallons)— 200-300
 Pump Rating—85 gal/min @ 150 psi
 Pump Drive—Auxiliary engine
 Mobile Attack Capability?—Yes
 Number Crew Personnel—2 to 3
 Foam System Available?—Yes
 Gallons—5
 All-Wheel Drive? —Yes



General Description: The Model 52 Type 6 fire package is designed for easy mount and dismount from a 9½ foot flat bed. The unit consists of a fiberglass/polypropylene tank, 18 horsepower pump, live reel, storage compartments, and appropriate plumbing.

Pump: Manufacturer—Wildfire Model—BB-4
 Type—Centrifugal
 Performance: gal/min (max) at free flow—110
 gal/min @ max psi =14 @ 400
 Primer Type— Other

Tank: Material— Fiberglass/polypropylene
 Construction: Baffles?— Yes
 If steel, is the tank corrosion treated?—N/A

Controls and Gauges: Hand Throttle?—Yes Pressure Gauge?—Yes Automatic shutdown?—Yes

Valves: Tank-to-Pump?—Yes Pump-to-Tank?—Yes

Overboard Discharge:	Quantity	3	1
	Size	1½ inch	1 inch

Suction:	Quantity	2
	Size	2 inch

Priming Valve Handle: Manual
Suction Valve Handle: Manual
Tank-to-Plumbing Shut-Off? Yes
Gravity Tank Drain/Dump? Yes
 Type—1½ inch ball valve

Manufacturer: User Option
Manufacturer Model Year: Varies
Engine Fuel Type: Diesel or gas
Vehicle Operating Weight: Varies
Brake Type: Varies

Discharge Valve Handle: Manual
Adjustable Pressure Relief? No
Pump and Plumbing Drain? Yes
Rock Trap/Plumbing Strainer? Yes
 Type—Inlet screen

Cab/Axle Distance: Varies
GVW Rating: 15,000 to 17,500
Horsepower Rating: Varies
Transmission Type: Varies

Written Materials: Specifications and drawings are available from: USDA Forest Service
 Model 52 Program
 Aerial Fire Depot
 5765 West Broadway
 Missoula, MT 59808

WATER PUMPING EQUIPMENT Engine Data Sheet No. 37

Agency: USDA Forest Service (PSW Region, R5)

Equipment Designator: Model 41

ICS Type: 6

Summary: Tank Capacity (gallons)— 200
Pump Rating—85 gal/min @ 150 psi
Pump Drive—Auxiliary engine
Mobile Attack Capability?—Yes
Number Crew Personnel—3
Foam System Available?—Yes
Gallons—5
All-Wheel Drive? —Yes



General Description: The Model 41 fire package consists of an engine, pump, live reel or hose basket, plumbing, control panel, automatic regulating foam system, and a 50- to 200-gallon water tank on a skid plate that slides into a low profile utility body truck.

Pump: Manufacturer—Robwen Model—180
Type—Centrifugal
Performance: gal/min (max) at free flow—110
gal/min @ max psi = 10 @ 250
Primer Type—Other

Tank: Material— Polypropylene or fiberglass
Construction: Baffles?— Yes
If steel, is the tank corrosion treated?—N/A

Controls and Gauges: Hand Throttle?—Yes Pressure Gauge?—Yes Automatic shutdown?—Yes

Valves: Tank-to-Pump?—Yes Pump-to-Tank?—Yes

Overboard Discharge:	Quantity	1	1
	Size	1½ inch	1 inch

Suction:	Quantity	1
	Size	2 inch

Priming Valve Handle: Manual
Suction Valve Handle: Manual
Tank-to-Plumbing Shut-Off? No
Gravity Tank Drain/Dump? Yes
Type—Pipe plug
Manufacturer: Ford
Manufacturer Model Year: 2001
Engine Fuel Type: Gasoline
Vehicle Operating Weight: 11,750
Brake Type: Hydraulic

Discharge Valve Handle: Manual
Adjustable Pressure Relief? Yes
Pump and Plumbing Drain? No
Rock Trap/Plumbing Strainer? Yes
Type—Inlet screen
Cab/Axle Distance: 60 inch
GVW Rating: 15,000
Horsepower Rating: 310
Transmission Type: Automatic

Written Materials: Specifications and drawings are available from: USDA Forest Service
444 East Bonita Avenue
San Dimas, CA 91773

WATER PUMPING EQUIPMENT

Engine Data Sheet No. 38

Agency: USDA Forest Service (PNW Region, R6)

Equipment Designator: Model 33U

ICS Type: 6

Summary: Tank Capacity (gallons)— 300
 Pump Rating—85 gal/min @ 150 psi
 Pump Drive—Auxiliary engine
 Mobile Attack Capability?—Yes
 Number Crew Personnel—3
 Foam System Available?—Yes
 Gallons—15
 All-Wheel Drive? —Yes



General Description: The Model 33U consists of a custom made aluminum apparatus body and includes hose beds. Compartments have adjustable shelving and sweep out floors.

Pump: Manufacturer—Wildfire Model—BB-4
 Type—Centrifugal
 Performance: gal/min (max) at free flow—110
 gal/min @ max psi = 14 @ 400
 Primer Type— Electric

Tank: Material— Polypropylene
 Construction: Baffles?— Yes
 If steel, is the tank corrosion treated?— N/A

Controls and Gauges: Hand Throttle?—Yes Pressure Gauge?—Yes Automatic shutdown?—Yes

Valves: Tank-to-Pump?—Yes Pump-to-Tank?—Yes

Overboard Discharge: Quantity 3 2
 Size 1½ inch 1 inch

Suction: Quantity 1
 Size 2½ inch

Priming Valve Handle: Manual
Suction Valve Handle: Manual
Tank-to-Plumbing Shut-Off? No
Gravity Tank Drain/Dump? No
 Type—

Manufacturer: Ford or GM
Manufacturer Model Year: 2001
Engine Fuel Type: Diesel
Vehicle Operating Weight: 14,000
Brake Type: Hydraulic

Discharge Valve Handle: Manual
Adjustable Pressure Relief? No
Pump and Plumbing Drain? Yes
Rock Trap/Plumbing Strainer? Yes
 Type— Inlet screen

Cab/Axle Distance: 60 inch
GVW Rating: 15,000
Horsepower Rating: 235
Transmission Type: Manual

Written Materials: Specifications and drawings are available from: USDA Forest Service
 Pacific Northwest Region
 Fire and Aviation Management
 P.O. Box 3623
 Portland, OR 97208

WATER PUMPING EQUIPMENT

Engine Data Sheet No. 39

Agency: USDA Forest Service (PNW Region, R6)

Equipment Designator: Model 45

ICS Type: 6

Summary: Tank Capacity (gallons)— 300
Pump Rating—90 gal/min @ 150 psi
Pump Drive—PTO
Mobile Attack Capability?—Yes
Number Crew Personnel—3
Foam System Available?—Yes
Gallons—25
All-Wheel Drive? —Yes



General Description: The Model 45 consists of a custom made aluminum apparatus body and includes hose beds. Compartments have adjustable shelving and sweep out floors.

Pump: Manufacturer—Gorman Rupp Model—02F1 **Tank:** Material— Polypropylene
Type—Centrifugal Construction: Baffles?— Yes
Performance: gal/min (max) at free flow—180 If steel, is the tank corrosion treated?—N/A
gal/min @ max psi = 15 @ 250
Primer Type— Electric

Controls and Gauges: Hand Throttle?— Yes Pressure Gauge?— Yes Automatic shutdown?—No

Valves: Tank-to-Pump?—Yes Pump-to-Tank?—Yes

Overboard Discharge:	Quantity	2	2
	Size	1½ inch	1 inch

Suction:	Quantity	2
	Size	2½ inch

Priming Valve Handle: No
Suction Valve Handle: No
Tank-to-Plumbing Shut-Off? Yes
Gravity Tank Drain/Dump? No
Type—

Manufacturer: Ford or GM
Manufacturer Model Year: 2001
Engine Fuel Type: Diesel
Vehicle Operating Weight: 14,000
Brake Type: Hydraulic

Discharge Valve Handle: Manual
Adjustable Pressure Relief? No
Pump and Plumbing Drain? Yes
Rock Trap/Plumbing Strainer? Yes
Type— Inlet screen

Cab/Axle Distance: 60 inch
GVW Rating: 15,000
Horsepower Rating: 235
Transmission Type: Manual

Written Materials: Specifications and drawings are available from: USDA Forest Service
Pacific Northwest Region
Fire and Aviation Management
P.O. Box 3623
Portland, OR 97208

WATER PUMPING EQUIPMENT

Engine Data Sheet No. 40

Agency: USDA Forest Service (Eastern Region, R9)

Equipment Designator: E-3-1

ICS Type: 6

Summary: Tank Capacity (gallons)— 200
 Pump Rating—72 gal/min @ 150 psi
 Pump Drive—Auxiliary engine
 Mobile Attack Capability?—Yes
 Number Crew Personnel—3
 Foam System Available?—Yes
 Gallons—15
 All-Wheel Drive? —Yes



General Description: This GMC four-wheel drive, dual wheel, Type 6 engine is used during initial attack, mop-up, and structure protection procedures.

Pump: Manufacturer—Robwen Model—CAFS 180
 Type—Centrifugal
 Performance: gal/min (max) at free flow—100
 gal/min @ max psi = 72 @ 150
 Primer Type— Electric

Tank: Material— Polypropylene
 Construction: Baffles?— Yes
 If steel, is the tank corrosion treated?—N/A

Controls and Gauges: Hand Throttle?—Yes Pressure Gauge?—Yes Automatic shutdown?—Yes

Valves: Tank-to-Pump?—Yes Pump-to-Tank?—Yes

Overboard Discharge:

Quantity	2	1
Size	1½ inch	1 inch

Suction:

Quantity	1
Size	2 inch

Priming Valve Handle: Manual
Suction Valve Handle: Manual
Tank-to-Plumbing Shut-Off? Yes
Gravity Tank Drain/Dump? Yes
 Type— 1½ inch pipe plug

Manufacturer: GMC
Manufacturer Model Year: 1996
Engine Fuel Type: Gasoline
Vehicle Operating Weight: 11,000
Brake Type: Hydraulic

Discharge Valve Handle: Manual
Adjustable Pressure Relief? Yes
Pump and Plumbing Drain? Yes
Rock Trap/Plumbing Strainer? Yes
 Type— Inlet screen

Cab/Axle Distance: 64 inch
GVW Rating: 12,000
Horsepower Rating: 200
Transmission Type: Automatic

Written Materials: Specifications and drawings are available from: USDA Forest Service
 Baldwin Ranger District
 650 North Michigan Avenue
 P.O. Box Drawer D
 Baldwin, MI 49304

WATER PUMPING EQUIPMENT Engine Data Sheet No. 41

Agency: USDA Forest Service (Eastern Region, R9)

Equipment Designator: GSA FT60HD/Initial Attack

ICS Type: 6

Summary: Tank Capacity (gallons)— 280
Pump Rating—50 gal/min @ 150 psi
Pump Drive—Auxiliary engine
Mobile Attack Capability?—Yes
Number Crew Personnel—3
Foam System Available?—Yes
Gallons—20
All-Wheel Drive? —Yes



General Description: Four-wheel drive on/off road initial attack unit with reinforced front and rear. Winch on front with spray bars on either side of front bumper for mobile attack. Single live reel on top.

Pump: Manufacturer—Berkley Model—B1-½ XQBS-18 Type—Centrifugal Performance: gal/min (max) at free flow—120 gal/min @ max psi = 31 @ 280 Primer Type—Other
Tank: Material— Polypropylene Construction: Baffles?— Yes If steel, is the tank corrosion treated?— N/A

Controls and Gauges: Hand Throttle?—Yes Pressure Gauge?—Yes Automatic shutdown?—No

Valves: Tank-to-Pump?—Yes Pump-to-Tank?—Yes

Overboard Discharge: Quantity 1 3
Size 1½ inch 1 inch

Suction: Quantity 1
Size 3 inch

Priming Valve Handle: Manual
Suction Valve Handle: Manual
Tank-to-Plumbing Shut-Off? Yes
Gravity Tank Drain/Dump? Yes
Type— Pipe plug

Manufacturer: GM
Manufacturer Model Year: 1996
Engine Fuel Type: Gasoline
Vehicle Operating Weight: 12,000
Brake Type: Hydraulic

Discharge Valve Handle: Manual
Adjustable Pressure Relief? No
Pump and Plumbing Drain? Yes
Rock Trap/Plumbing Strainer? No
Type—

Cab/Axle Distance: 60 inch
GVW Rating: 15,000
Horsepower Rating: 230
Transmission Type: Automatic

Written Materials: Specifications and drawings are available from: USDA Forest Service
Superior National Forest
Fleet Manager
8901 Grand Avenue Place
Duluth, MN 55808–45701

WATER PUMPING EQUIPMENT

Engine Data Sheet No. 42

Agency: USDA Forest Service (Eastern Region, R9)

Equipment Designator: Superior NF, Type 6

ICS Type: 6

Summary: Tank Capacity (gallons)— 300
 Pump Rating—85 gal/min @ 150 psi
 Pump Drive—Auxiliary engine
 Mobile Attack Capability?—Yes
 Number Crew Personnel—3
 Foam System Available?—Yes
 Gallons—10
 All-Wheel Drive? —Yes



General Description: The Superior National Forest Type 6 is built on a four-wheel drive chassis and commercial service body. The pump unit is a slip-on fire package with a 300-gallon polypropylene tank, auxiliary engine driven centrifugal pump, and class A foam system with 10-gallon reservoir. Dual live reels are located on the right and left decks of the service body.

Pump: Manufacturer—Wildfire Model—BB-4
 Type—Centrifugal
 Performance: gal/min (max) at free flow—110
 gal/min @ max psi = 14 @ 400
 Primer Type—Other

Tank: Material— Polypropylene
 Construction: Baffles?— Yes
 If steel, is the tank corrosion treated?— N/A

Controls and Gauges: Hand Throttle?—Yes Pressure Gauge?—Yes Automatic shutdown?—Yes

Valves: Tank-to-Pump?—Yes Pump-to-Tank?—Yes

Overboard Discharge:

Quantity	2	2
Size	1 1/2 inch	1 inch

Suction:

Quantity	1
Size	2 inch

Priming Valve Handle: Manual
Suction Valve Handle: Manual
Tank-to-Plumbing Shut-Off? Yes
Gravity Tank Drain/Dump? Yes
 Type—1 1/2 inch manual ball valve
Manufacturer: Ford
Manufacturer Model Year: 2001
Engine Fuel Type: Diesel
Vehicle Operating Weight: 15,500
Brake Type: Hydraulic

Discharge Valve Handle: Manual
Adjustable Pressure Relief? No
Pump and Plumbing Drain? Yes
Rock Trap/Plumbing Strainer? Yes
 Type—Inlet screen
Cab/Axle Distance: 60 inch
GVW Rating: 17,500
Horsepower Rating: 235
Transmission Type: Automatic

Written Materials: Specifications and drawings are available from: USDA Forest Service
 Superior National Forest
 Fleet Manager
 8901 Grand Avenue Place
 Duluth, MN 55808–45701

WATER PUMPING EQUIPMENT

Engine Data Sheet No. 43

Agency: USDA Forest Service (Eastern Region, R9)

Equipment Designator: Type VI slip-on

ICS Type: 6

Summary: Tank Capacity (gallons)—250
Pump Rating—100 gal/min @ 150 psi
Pump Drive—Auxiliary engine
Mobile Attack Capability?—Yes
Number Crew Personnel—3
Foam System Available?—Yes
Gallons—25
All-Wheel Drive? —No



General Description: This 250 gallon slip-on fire package is mounted in a utility body with six boxes for storage. The unit has an integrated foam unit with a full pump panel, full gauges, and hand throttle on panel. Unit also has a live reel with hose.

Pump: Manufacturer—Cascade Model—24124 Type—Centrifugal Performance: gal/min (max) at free flow—unknown gal/min @ max psi = 23 @ 300 Primer Type—Electric

Tank: Material—Polypropylene Construction: Baffles?—Yes If steel, is the tank corrosion treated?—N/A

Controls and Gauges: Hand Throttle?—Yes Pressure Gauge?—Yes Automatic shutdown?—Yes

Valves: Tank-to-Pump?—Yes Pump-to-Tank?—Yes

Overboard Discharge:	Quantity	1	1
	Size	1½ inch	1 inch

Suction:	Quantity	1
	Size	2 inch

Priming Valve Handle: Manual
Suction Valve Handle: No
Tank-to-Plumbing Shut-Off? Yes
Gravity Tank Drain/Dump? No
Type—

Manufacturer: Dodge
Manufacturer Model Year: 1996
Engine Fuel Type: Gasoline
Vehicle Operating Weight: 10,750
Brake Type: Hydraulic

Discharge Valve Handle: Manual
Adjustable Pressure Relief? No
Pump and Plumbing Drain? No
Rock Trap/Plumbing Strainer? No
Type—

Cab/Axle Distance: 60 inch
GVW Rating: 11,000
Horsepower Rating: 230
Transmission Type: Automatic

Written Materials: Specifications and drawings are available from: USDA Forest Service
Wayne National Forest
Fleet Manager
219 Columbus Road
Athens, OH 45701

WATER PUMPING EQUIPMENT

Engine Data Sheet No. 44

Agency: USDI Bureau of Land Management

Equipment Designator: BLM 662 ID

ICS Type: 6

Summary: Tank Capacity (gallons)—300
 Pump Rating—100 gal/min @ 150 psi
 Pump Drive—Auxiliary engine
 Mobile Attack Capability?—Yes
 Number Crew Personnel—3 to 6
 Foam System Available?—Yes
 Gallons—25
 All-Wheel Drive? —Yes



General Description: This BLM model was developed for offroad wildland suppression activities in the Western States. The model shown is the BLM's standard configuration with four-wheel drive. This engine's body is constructed of aluminum load floor and fire resistant composite fiberglass body. The tank is constructed of high impact polypropylene 300-gallon capacity with 15- to 25-gallon intergal foam concentrate cell. The pumping system is powered by a 26 horsepower water-cooled diesel, foam injection is a 1601 Foam Pro unit. Options are available for high pumping capacities and 60 cfm CAFS. From this base unit a wide variety of pumping packages have been constructed, various cab configurations allow for crews of three to six. This model and other configurations are being used by the USFWS, USNPS, USFS, Dept. of Defense, State of Alaska, and various municipalities.

Pump: Manufacturer—Waterous Model—501A
 Type—Centrifugal
 Performance: gal/min (max) at free flow—105
 gal/min @ max psi = 35 @ 400
 Primer Type— Electric

Tank: Material— Polypropylene
 Construction: Baffles?— Yes
 If steel, is the tank corrosion treated?—N/A

Controls and Gauges: Hand Throttle?—Yes Pressure Gauge?—Yes Automatic shutdown?—Yes

Valves: Tank-to-Pump?—Yes Pump-to-Tank?—Yes

Overboard Discharge:	Quantity	1	1
	Size	1½ inch	1 inch

Suction:	Quantity	2
	Size	2 inch

Priming Valve Handle: Electric or manual

Suction Valve Handle: Manual

Tank-to-Plumbing Shut-Off? Yes

Gravity Tank Drain/Dump? Yes
 Type—Manual 1½ inch ¼ turn valve

Manufacturer: Ford F-450

Manufacturer Model Year: Current

Engine Fuel Type: Diesel

Vehicle Operating Weight: 13,800

Brake Type: Hydraulic

Discharge Valve Handle: Manual

Adjustable Pressure Relief? No

Pump and Plumbing Drain? Yes

Rock Trap/Plumbing Strainer? Yes
 Type—Inlet screen

Cab/Axle Distance: 60 inch

GVW Rating: 15,000/17,500

Horsepower Rating: 235

Transmission Type: Varies

Written Materials: Specifications and drawings are available from: National Interagency Fire Center
 Bureau of Land Management
 Fire Equipment Development Unit
 3833 South Development Avenue
 Boise, ID 83705

WATER PUMPING EQUIPMENT

Engine Data Sheet No. 45

Agency: Virginia Department of Forestry

Equipment Designator: Brush patrol

ICS Type: 6

Summary: Tank Capacity (gallons)— 250
 Pump Rating—90 gal/min @ 150 psi
 Pump Drive—Auxiliary engine
 Mobile Attack Capability?—Yes
 Number Crew Personnel—2
 Foam System Available?—Yes
 Gallons—5
 All-Wheel Drive? —Yes



General Description: Military Hummer with good ground clearance for enhanced road capabilities. The 250-gallon tank works well for initial attack and mop-up. Has extra cab protection for working in the woods and a winch.

<p>Pump: Manufacturer—Darley Model—1½ AGE 18 Type—Centrifugal Performance: gal/min (max) at free flow—120 gal/min @ max psi = 20 @ 270 Primer Type— Exhaust</p>	<p>Tank: Material—Polypropylene Construction: Baffles?— Yes If steel, is the tank corrosion treated?—N/A</p>
--	---

Controls and Gauges: Hand Throttle?—Yes Pressure Gauge?—Yes Automatic shutdown?—No

Valves: Tank-to-Pump?—Yes Pump-to-Tank?—Yes

Overboard Discharge:	Quantity	1	1
	Size	1½ inch	1 inch

Suction:	Quantity	1
	Size	2½ inch

Priming Valve Handle: Manual
Suction Valve Handle: Manual
Tank-to-Plumbing Shut-Off? Yes
Gravity Tank Drain/Dump? Yes
 Type—Pipe plug
Manufacturer: AM General
Manufacturer Model Year: 1995
Engine Fuel Type: Diesel
Vehicle Operating Weight: 10,500
Brake Type: Hydraulic

Discharge Valve Handle: Manual
Adjustable Pressure Relief? No
Pump and Plumbing Drain? Yes
Rock Trap/Plumbing Strainer? Yes
 Type—Inlet screen
Cab/Axle Distance: N/A
GVW Rating: 12,000
Horsepower Rating: 160
Transmission Type: 4 speed automatic

Written Materials: Specifications and drawings are available from: Virginia Department of Forestry
 900 Natural Resources Drive
 Suite 800
 Charlottesville, VA 22903

WATER PUMPING EQUIPMENT

Engine Data Sheet No. 46

Agency: North Carolina Div. of Forest Resources

Equipment Designator: Initial attack wildland engine

ICS Type: 7

Summary: Tank Capacity (gallons)— 150
 Pump Rating—65 gal/min @ 150 psi
 Pump Drive—Auxiliary engine
 Mobile Attack Capability?—Yes
 Number Crew Personnel—2
 Foam System Available?—Yes
 Gallons—3
 All-Wheel Drive? —Yes



General Description: This is a four-wheel drive pickup with a slip-on fire package. Roughly 250 of these units are deployed across North Carolina.

Pump: Manufacturer—Wildfire Pacific Model—Mark 3
 Type—Centrifugal
 Performance: gal/min (max) at free flow—98
 gal/min @ max psi = 0 @ 380
 Primer Type— Exhaust

Tank: Material—Fiberglass or aluminum
 Construction: Baffles?— Yes
 If steel, is the tank corrosion treated?—N/A

Controls and Gauges: Hand Throttle?—Yes Pressure Gauge?—Yes Automatic shutdown?—No

Valves: Tank-to-Pump?—Yes Pump-to-Tank?—Yes

Overboard Discharge: Quantity 1
 Size 1½ inch

Suction: Quantity 1
 Size 2 inch

Priming Valve Handle: Manual
Suction Valve Handle: Manual
Tank-to-Plumbing Shut-Off? Yes
Gravity Tank Drain/Dump? Yes
 Type—Pipe plug
Manufacturer: User Option
Manufacturer Model Year: Varies
Engine Fuel Type: Diesel
Vehicle Operating Weight: 8,000
Brake Type: Hydraulic

Discharge Valve Handle: Manual
Adjustable Pressure Relief? Yes
Pump and Plumbing Drain? Yes
Rock Trap/Plumbing Strainer? Yes
 Type—Inlet screen
Cab/Axle Distance: 60 inch
GVW Rating: 8,650
Horsepower Rating: Varies
Transmission Type: Varies

Written Materials: Specifications and drawings are available from: North Carolina Div. of Forest Resources
 512 North Salisbury Street
 Raleigh, NC 27626

WATER PUMPING EQUIPMENT

Engine Data Sheet No. 47

Agency: USDA Forest Service (Eastern Region, R9)

Equipment Designator: BE-S slip-on

ICS Type: 7

Summary: Tank Capacity (gallons)— 100
 Pump Rating—11 gal/min @ 150 psi
 Pump Drive—Auxiliary engine
 Mobile Attack Capability?—Yes
 Number Crew Personnel—2 to 3
 Foam System Available?—No
 Gallons—
 All-Wheel Drive? —Yes



General Description: The Wildfire BE-S slip-on fire package has a 100-gallon tank with a 200 foot 1-inch live reel. It is mounted on a Ford 1-ton chassis with equipment boxes carrying a leaf blower, chain saw, and 400 feet of 1½-inch hose. The unit shown has a 2-gallon foam inductor connected to the live reel.

Pump: Manufacturer—Wildfire Model—BE-S
 Type—Positive displacement
 Performance: gal/min (max) at free flow—N/A
 gal/min @ max psi = 11 @ 50
 Primer Type—Self priming

Tank: Material— Polypropylene
 Construction: Baffles?— Yes
 If steel, is the tank corrosion treated?—N/A

Controls and Gauges: Hand Throttle?—Yes Pressure Gauge?—Yes Automatic shutdown?—Yes

Valves: Tank-to-Pump?—Yes Pump-to-Tank?—Yes

Overboard Discharge: Quantity 2
 Size 1 inch

Suction: Quantity 1
 Size 1 inch

Priming Valve Handle: No
Suction Valve Handle: Manual
Tank-to-Plumbing Shut-Off? Yes
Gravity Tank Drain/Dump? Yes
 Type— 2-inch pipe plug

Manufacturer: Ford
Manufacturer Model Year: 2001
Engine Fuel Type: Gasoline
Vehicle Operating Weight: 10,500
Brake Type: Hydraulic

Discharge Valve Handle: Manual
Adjustable Pressure Relief? Yes
Pump and Plumbing Drain? No
Rock Trap/Plumbing Strainer? No
 Type—

Cab/Axle Distance: 60 inch
GVW Rating: 11,200
Horsepower Rating: 260
Transmission Type: Automatic

Written Materials: Specifications and drawings are available from: USDA Forest Service
 Monongahela National Forest
 Gauley Ranger District
 200 Sycamore Street
 Elkins, WV 26241

WATER PUMPING EQUIPMENT

Engine Data Sheet No. 48

Agency: USDA Forest Service (Eastern Region, R9)

Equipment Designator: B-2

ICS Type: 7

Summary: Tank Capacity (gallons)— 125
 Pump Rating—36 gal/min @ 150 psi
 Pump Drive—Auxiliary engine
 Mobile Attack Capability?—Yes
 Number Crew Personnel—2 to 3
 Foam System Available?—Yes
 Gallons—5
 All-Wheel Drive? —Yes



General Description: The Ford F350 four-wheel drive Type 7 engine is used during initial attack, mop-up, and as holding unit on prescribed burns. Also available as a six-passenger vehicle (Model B-9).

Pump: Manufacturer—Cascade Fire Model—14270 **Tank:** Material— Fiberglass
 Type—Centrifugal Construction: Baffles?— Yes
 Performance: gal/min (max) at free flow—N/A If steel, is the tank corrosion treated?—N/A
 gal/min @ max psi = 16½ @ 225
 Primer Type—Other

Controls and Gauges: Hand Throttle?— Yes Pressure Gauge?— Yes Automatic shutdown?—Yes

Valves: Tank-to-Pump?—Yes Pump-to-Tank?—No

Overboard Discharge: Quantity 1 1
 Size 1½ inch 1 inch

Suction: Quantity 1
 Size 1½ inch

Priming Valve Handle: Manual
Suction Valve Handle: Manual
Tank-to-Plumbing Shut-Off? Yes
Gravity Tank Drain/Dump? Yes
 Type— 1½ inch pipe plug
Manufacturer: Ford
Manufacturer Model Year: 2000
Engine Fuel Type: Gasoline
Vehicle Operating Weight: 8,200
Brake Type: Hydraulic

Discharge Valve Handle: Manual
Adjustable Pressure Relief? Yes
Pump and Plumbing Drain? Yes
Rock Trap/Plumbing Strainer? No
 Type—
Cab/Axle Distance: 60 inch
GVW Rating: 9,900
Horsepower Rating: 260
Transmission Type: Automatic

Written Materials: Specifications and drawings are available from: USDA Forest Service
 Baldwin Ranger District
 650 North Michigan Avenue
 P.O. Box Drawer D
 Baldwin, MI 49304

WATER PUMPING EQUIPMENT Engine Data Sheet No. 49

Agency: USDA Forest Service (Eastern Region, R9)

Equipment Designator: Type VII slip-on

ICS Type: 7

Summary: Tank Capacity (gallons)— 75 to 125
 Pump Rating—30 gal/min @ 150 psi
 Pump Drive—Auxiliary engine
 Mobile Attack Capability?—Yes
 Number Crew Personnel—2 to 3
 Foam System Available?—No
 Gallons—
 All-Wheel Drive? —Yes



General Description: This 75-gallon or 125-gallon, slip-on fire package is mounted in the bed of a standard truck. The live reel carrying 200 feet of 3/4-inch hose is top mounted. A storage box for tools is mounted to the rear of the bed.

Pump: Manufacturer—Western Fire Model—Forester **Tank:** Material— Fiberglass
 Type—Centrifugal Construction: Baffles?—Yes
 Performance: gal/min (max) at free flow—30 If steel, is the tank corrosion treated?—N/A
 gal/min @ max psi = 30 @ 200
 Primer Type—Other

Controls and Gauges: Hand Throttle?—Yes Pressure Gauge?—Yes Automatic shutdown?—Yes

Valves: Tank-to-Pump?—Yes Pump-to-Tank?—No

Overboard Discharge: Quantity 1 1
 Size 1½ inch ¾ inch

Suction: Quantity 1
 Size 1½ inch

Priming Valve Handle: Manual
Suction Valve Handle: Manual
Tank-to-Plumbing Shut-Off? Yes
Gravity Tank Drain/Dump? Yes
 Type—1½ inch pipe plug
Manufacturer: Ford
Manufacturer Model Year: 1994
Engine Fuel Type: Gasoline
Vehicle Operating Weight: 7,987
Brake Type: Hydraulic

Discharge Valve Handle: Manual
Adjustable Pressure Relief? Yes
Pump and Plumbing Drain? Yes
Rock Trap/Plumbing Strainer? Yes
 Type—Inlet screen
Cab/Axle Distance: 60 inch
GVW Rating: 8,600
Horsepower Rating: 210
Transmission Type: Automatic

Written Materials: Specifications and drawings are available from: USDA Forest Service
 Wayne National Forest
 Fleet Manager
 219 Columbus Road
 Athens, OH 45701

WATER PUMPING EQUIPMENT

Engine Data Sheet No. 50

Agency: Wisconsin Dept. of Natural Resources

Equipment Designator: Initial Attack

ICS Type: 7

Summary: Tank Capacity (gallons)—150
 Pump Rating—20 gal/min @ 150 psi
 Pump Drive—Auxiliary engine
 Mobile Attack Capability?—Yes
 Number Crew Personnel—2
 Foam System Available?—Yes
 Gallons—5
 All-Wheel Drive? —Yes



General Description: The Wisconsin 150 gallon four-wheel drive initial attack unit features an aluminum flat rack body with side mounted tool/equipment cabinets and a slip-on polypropylene water tank. The slip-on unit has a mounted Darley/Davey water pump, live reel with 100 feet of 1-inch lightweight booster hose, Robwen foam proportioner, and a rear mounted control panel.

Pump: Manufacturer—Darley/Davey Model—AK282
 Type—Centrifugal
 Performance: gal/min (max) at free flow—120
 gal/min @ max psi = 20 @ 155
 Primer Type— Other

Tank: Material— Polypropylene
 Construction: Baffles?— Yes
 If steel, is the tank corrosion treated?—N/A

Controls and Gauges: Hand Throttle?— Yes Pressure Gauge?— No Automatic shutdown?—No

Valves: Tank-to-Pump?— Yes Pump-to-Tank?—Yes

Overboard Discharge:

Quantity	2	1
Size	1 inch	1½ inch

Suction:

Quantity	1
Size	1½ inch

Priming Valve Handle: N/A

Suction Valve Handle: Manual

Tank-to-Plumbing Shut-Off? Yes

Gravity Tank Drain/Dump? Yes

Type—Pipe plug

Manufacturer: Varies

Manufacturer Model Year: Varies

Engine Fuel Type: Diesel

Vehicle Operating Weight: 8,600

Brake Type: Hydraulic

Discharge Valve Handle: Manual

Adjustable Pressure Relief? No

Pump and Plumbing Drain? Yes

Rock Trap/Plumbing Strainer? Yes

Type— Inlet screen

Cab/Axle Distance: 60 inch

GVW Rating: 9,200

Horsepower Rating: 195

Transmission Type: Automatic

Written Materials: Specifications and drawings are available from: Wisconsin Dept. of Natural Resources
 Neil H. LeMay Forestry Center
 518 West Somo Avenue
 Tomahawk, WI 54487

WATER PUMPING EQUIPMENT Engine Data Sheet No. 51

Agency: USDA Forest Service (PSW Region, R5)

Equipment Designator: Model 20

ICS Type: N/A

Summary: Tank Capacity (gallons)— 50 to 75
 Pump Rating—85 gal/min @ 150 psi
 Pump Drive—Auxiliary engine
 Mobile Attack Capability?—Yes
 Number Crew Personnel—2
 Foam System Available?—Yes
 Gallons—5
 All-Wheel Drive? —Yes



General Description: The Model 20 fire package consists of an engine, pump, live reel or hose basket, plumbing, control panel, and a 50- to 75-gallon water tank on a skid plate that slides into a low profile utility body truck.

Pump: Manufacturer—Robwen Model—180
 Type—Centrifugal
 Performance: gal/min (max) at free flow—110
 gal/min @ max psi = 10 @ 250
 Primer Type—Other

Tank: Material— Polypropylene or fiberglass
 Construction: Baffles?— Yes
 If steel, is the tank corrosion treated?—N/A

Controls and Gauges: Hand Throttle?—Yes Pressure Gauge?—Yes Automatic shutdown?—Yes

Valves: Tank-to-Pump?—Yes Pump-to-Tank?—Yes

Overboard Discharge:	Quantity	1	1
	Size	1½ inch	1 inch

Suction:	Quantity	1
	Size	2 inch

Priming Valve Handle: Manual
Suction Valve Handle: Manual
Tank-to-Plumbing Shut-Off? No
Gravity Tank Drain/Dump? Yes
 Type—Pipe plug
Manufacturer: Ford
Manufacturer Model Year: 2002
Engine Fuel Type: Gasoline
Vehicle Operating Weight: 8,920
Brake Type: Hydraulic

Discharge Valve Handle: Manual
Adjustable Pressure Relief? No
Pump and Plumbing Drain? Yes
Rock Trap/Plumbing Strainer? Yes
 Type—Inlet screen
Cab/Axle Distance: 60 inch
GVW Rating: 9,700
Horsepower Rating: 310
Transmission Type: Automatic

Written Materials: Specifications and drawings are available from: USDA Forest Service
 444 East Bonita Avenue
 San Dimas, CA 91773

WATER PUMPING EQUIPMENT

Water tender matrix—Water Tenders

C. Water Tenders

Water tenders are designed to transport large quantities of water. The National Wildfire Coordinating Group (NWCG) categorizes information on water tenders into logical groups providing common options often requested by fire managers. The Incident Command System (ICS) uses this water tender typing system based on equipment capabilities. The table below shows NWCG minimum requirements for water tender resource types.

Table 2—NWCG water tender types—minimum requirements.

Components	Water Tender Types		
	1	2	3
Tank capacity (gallons)	5,000+	2,500+	1,000+
Pump capacity (gal/min)	300+	200+	200+
Off load capacity (gal/min)	300+	200+	200+
Maximum refill time (minutes)	30	20	15

This section contains a small sample of water tenders (ground tankers), which are found in various parts of the country. There are numerous designs, sizes, and capacities available for users to choose from.

Sheet No.	NWCG ICS Type	Tank Capacity (gallons)	Pump Rating (gal/min @ 150 psi)	Pump Drive	Equipment Designator	Agency
1	2	3,500	500	PTO	BLM 669 water tender	USDI Bureau of Land Mgmt.
2	2	6,000	250	Auxiliary engine	Water tender	Florida Division of Forestry
3	3	1,200	250	PTO	1,200 gallon tender	New Jersey Forest Fire Service
4	3	1,100	N/A	Auxiliary engine	1,100 gallon tender	New Jersey Forest Fire Service
5	3	1,000	N/A	PTO	1,000 gallon tender	New Jersey Forest Fire Service
6	3	3,500	N/A	Auxiliary engine	3,500 gallon off-road tender	New Jersey Forest Fire Service
7	3	1,400	N/A	Auxiliary engine	1,400 gallon tender	New Jersey Forest Fire Service
8	3	1,500	350	PTO	Wildland tender	USDA Forest Service (R-5)
9	N/A	500	N/A	Auxiliary engine	500 gallon tender	New Jersey Forest Fire Service

WATER PUMPING EQUIPMENT

Water Tender Data Sheet No. 1

Agency: USDI Bureau of Land Mangement
Equipment Designator: BLM 669 Water Tender
ICS Type: 2

Summary: Tank Capacity—(gallons)— 3,500
 Pump Rating—500 gal/min @ 150 psi
 Pump Drive—PTO
 Mobile Attack Capability?—Yes
 Number Crew Personnel—3
 Foam System Available?— Yes
 Gallons—20
 All-Wheel Drive? —No



General Description: This BLM water tender model is constructed to the NFPA 1906 Wildland Fire Engine Standard. This model was developed for off-road suppression activities in the Western States. The model is a 6 by 4, also available with all-wheel drive, FL112 Freightliner with various transmissions available. The truck is powered by a 415 horsepower, C12 Caterpillar turbo diesel. The tank is constructed of 304 stainless steel and is braced and baffled for hard use. The interior of the tank is coated with a two-part epoxy plastic coating to absorb stress and vibrations on wash board, secondary, and gravel roads. A wide variety of pumping capabilities and foam injection systems are available. The engine is equipped with live reels and discharge road sweeps which are air actuated; each can be operated independently from the cab. The unit has an option for a master stream appliance on the top or front bumper and controlled from the cab. Other sizes and pumping capacities and configurations are available.

Pump: Manufacturer: Waterous Model: CLVK
 Type: Centrifugal
 Performance: gal/min (max) at free flow; 500
 gal/min @ max psi = 250 @ 250
 Primer Type: Electric

Tank: Material: 304 Stainless steel
 Construction: Baffles? Yes
 If steel, is the tank corrosion treated? Yes

Controls and Gauges: Hand Throttle? Yes Pressure Gauge? Yes Automatic shutdown? Yes

Valves: Tank-to-Pump? Yes Pump-to-Tank? Yes

Overboard Discharge:	Quantity	2	2
	Size	2½ inch	1 inch
Suction:	Quantity	1	1
	Size	6 inch	2½ inch

Priming Valve Handle: Electric
Suction Valve Handle: Electric
Tank-to-Plumbing Shut-Off? Yes
Gravity Tank Drain/Dump? Yes
 Type—10-inch manual butterfly valve

Manufacturer: Freightliner
Manufacturer Model Year: Current
Engine Fuel Type: Diesel
Vehicle Operating Weight: 59,000
Brake Type: Air

Discharge Valve Handle: Manual
Adjustable Pressure Relief? Yes
Pump and Plumbing Drain? Yes
Rock Trap/Plumbing Strainer? Yes
 Type—Inlet screen

Cab/Axle Distance: 145½ inch
GVW Rating: 64,000
Horsepower Rating: 410
Transmission Type: Various

Written Materials: Specifications and drawings are available from: National Interagency Fire Center
 Bureau of Land Mangement
 Fire Equipment Development Unit
 3833 South Development Avenue
 Boise, ID 83705

WATER PUMPING EQUIPMENT Water Tender Data Sheet No. 2

Agency: Florida Division of Forestry

Equipment Designator: Water tender, semi

ICS Type: 2

Summary: Tank Capacity (gallons)— 6,000
 Pump Rating—250 gal/min @ 150 psi
 Pump Drive—Auxiliary engine
 Mobile Attack Capability?—Yes
 Number Crew Personnel—2
 Foam System Available?— Yes
 Gallons—100
 All-Wheel Drive? —No



General Description: This is a stainless steel 6,000 gallon semitrailer with a truck tractor using an auxiliary pump and top mounted master stream appliance. Also used for potable water in disasters.

Pump: Manufacturer—Hale Model—HP 500
 Type—Centrifugal
 Performance: gal/min (max) at free flow—500
 gal/min @ max psi = 125 @ 225
 Primer Type—Electric

Tank: Material— Stainless steel
 Construction: Baffles?— Yes
 If steel, is the tank corrosion treated?—N/A

Controls and Gauges: Hand Throttle?—Yes Pressure Gauge?—Yes Automatic shutdown?— No

Valves: Tank-to-Pump?—Yes Pump-to-Tank?—Yes

Overboard Discharge:	Quantity	2	2
	Size	2½ inch	1½ inch

Suction:	Quantity	1
	Size	4 inch

Priming Valve Handle: Electric
Suction Valve Handle: Manual
Tank-to-Plumbing Shut-Off? Yes
Gravity Tank Drain/Dump? Yes
 Type— ¼ turn 4-inch valve

Manufacturer: Brenner Trailers
Manufacturer Model Year: 1986
Engine Fuel Type: N/A
Vehicle Operating Weight: 68,000
Brake Type: Air

Discharge Valve Handle: Manual
Adjustable Pressure Relief? No
Pump and Plumbing Drain? Yes
Rock Trap/Plumbing Strainer? No
 Type—

Cab/Axle Distance: N/A
GVW Rating: 68,000
Horsepower Rating: N/A
Transmission Type: N/A

Written Materials: Specifications and drawings are available from: Florida Division of Forestry
 3125 Conner Boulevard
 Tallahassee, FL 32399

WATER PUMPING EQUIPMENT

Water Tender Data Sheet No. 3

Agency: New Jersey Forest Fire Service

Equipment Designator: Tender

ICS Type: 3

Summary: Tank Capacity (gallons)— 1,200
 Pump Rating—250 gal/min @ 150 psi
 Pump Drive—PTO
 Mobile Attack Capability?— No
 Number Crew Personnel—3
 Foam System Available?— No
 Gallons—
 All-Wheel Drive? —No



General Description: The tank and pump were commercially obtained and installed on this tender. The aluminum tank is oval in design to reduce stress points created by a rectangular shape. This tender is used to resupply engines when water sources are not close by.

Pump: Manufacturer—Hale Model—unknown
 Type—Centrifugal
 Performance: gal/min (max) at free flow—250
 gal/min @ max psi = unknown
 Primer Type— Electric

Tank: Material—Aluminum
 Construction: Baffles?—Yes
 If steel, is the tank corrosion treated?—N/A

Controls and Gauges: Hand Throttle?—Yes Pressure Gauge?—Yes Automatic shutdown?—No

Valves: Tank-to-Pump?— Yes Pump-to-Tank?—Yes

Overboard Discharge: Quantity 1 2
 Size 2½ inch 1½ inch

Suction: Quantity 1
 Size 2½ inch

Priming Valve Handle: Manual
Suction Valve Handle: Manual
Tank-to-Plumbing Shut-Off? Yes
Gravity Tank Drain/Dump? Yes
 Type— Manual ¼ turn valve

Manufacturer: Chevrolet
Manufacturer Model Year: 1985
Engine Fuel Type: Gasoline
Vehicle Operating Weight: 24,500
Brake Type: Air

Discharge Valve Handle: Manual
Adjustable Pressure Relief? No
Pump and Plumbing Drain? Yes
Rock Trap/Plumbing Strainer? No
 Type—

Cab/Axle Distance: 84 inch
GVW Rating: 28,000
Horsepower Rating: 210
Transmission Type: Manual

Written Materials: Specifications and drawings are available from: New Jersey Forest Fire Service
 P.O. Box 404, 4th Floor
 Trenton, NJ 08625-0404

WATER PUMPING EQUIPMENT

Water Tender Data Sheet No. 4

Agency: New Jersey Forest Fire Service

Equipment Designator: Tender

ICS Type: 3

Summary: Tank Capacity (gallons)— 1,100
 Pump Rating—N/A
 Pump Drive—Auxiliary engine
 Mobile Attack Capability?— Yes
 Number Crew Personnel—3
 Foam System Available?— No
 Gallons—
 All-Wheel Drive? —No



General Description: This tender's tank, made of aluminum, was fabricated by fire equipment specialists at the agency's R&D shop out of plates of aluminum stock. The pump and plumbing were then installed. This tender is utilized for refilling other engines when a water supply is not close by.

Pump: Manufacturer—Hale Model—30FB-B42
 Type—Centrifugal
 Performance: gal/min (max) at free flow—350
 gal/min @ max psi = 25 @ 118
 Primer Type— Other

Tank: Material— Aluminum
 Construction: Baffles?—Yes
 If steel, is the tank corrosion treated?—N/A

Controls and Gauges: Hand Throttle?— Yes Pressure Gauge?— Yes Automatic shutdown?— No

Valves: Tank-to-Pump?— Yes Pump-to-Tank?—Yes

Overboard Discharge:	Quantity	1	2
	Size	2½ inch	1½ inch

Suction:	Quantity	1
	Size	2½ inch

Priming Valve Handle: Manual
Suction Valve Handle: Manual
Tank-to-Plumbing Shut-Off? Yes
Gravity Tank Drain/Dump? Yes
 Type— Manual ¼ turn valve
Manufacturer: Ford
Manufacturer Model Year: 1991
Engine Fuel Type: Gasoline
Vehicle Operating Weight: 20,000
Brake Type: Hydraulic

Discharge Valve Handle: Manual
Adjustable Pressure Relief? No
Pump and Plumbing Drain? Yes
Rock Trap/Plumbing Strainer? No
 Type—
Cab/Axle Distance: 84 inch
GVW Rating: 26,000
Horsepower Rating: 230
Transmission Type: Manual

Written Materials: Specifications and drawings are available from: New Jersey Forest Fire Service
 P.O. Box 404, 4th Floor
 Trenton, NJ 08625-0404

WATER PUMPING EQUIPMENT

Water Tender Data Sheet No. 5

Agency: New Jersey Forest Fire Service

Equipment Designator: Tender

ICS Type: 3

Summary: Tank Capacity (gallons)— 1,000
 Pump Rating—N/A
 Pump Drive—PTO
 Mobile Attack Capability?— No
 Number Crew Personnel—3
 Foam System Available?— No
 Gallons—
 All-Wheel Drive? —No



General Description: This tender is used to resupply engines at the fire scene. It has minimal brush protection on the front of the vehicle.

Pump: Manufacturer—Hale Model—Unknown
 Type—Centrifugal
 Performance: gal/min (max) at free flow—500
 gal/min @ max psi = Unknown
 Primer Type— Other

Tank: Material— Aluminum
 Construction: Baffles?—Yes
 If steel, is the tank corrosion treated?—N/A

Controls and Gauges: Hand Throttle?— Yes Pressure Gauge?— Yes Automatic shutdown?— No

Valves: Tank-to-Pump?— Yes Pump-to-Tank?—Yes

Overboard Discharge: Quantity 1 2
 Size 2½ inch 1½ inch

Suction: Quantity 1
 Size 2½ inch

Priming Valve Handle: Manual
Suction Valve Handle: Manual
Tank-to-Plumbing Shut-Off? Yes
Gravity Tank Drain/Dump? No
 Type—

Manufacturer: Chevrolet
Manufacturer Model Year: 1983
Engine Fuel Type: Gasoline
Vehicle Operating Weight: 26,000
Brake Type: Air

Discharge Valve Handle: Manual
Adjustable Pressure Relief? No
Pump and Plumbing Drain? Yes
Rock Trap/Plumbing Strainer? No
 Type—

Cab/Axle Distance: 84 inch
GVW Rating: 30,000
Horsepower Rating: 210
Transmission Type: Manual

Written Materials: Specifications and drawings are available from: New Jersey Forest Fire Service
 P.O. Box 404, 4th Floor
 Trenton, NJ 08625-0404

WATER PUMPING EQUIPMENT

Water Tender Data Sheet No. 6

Agency: New Jersey Forest Fire Service

Equipment Designator: 3,500 gallon off-road tender

ICS Type: 3

Summary: Tank Capacity (gallons)— 3,500
 Pump Rating—N/A
 Pump Drive—Auxiliary engine
 Mobile Attack Capability?— Yes
 Number Crew Personnel—2
 Foam System Available?— No
 Gallons—
 All-Wheel Drive? —Yes



General Description: This unit is a converted military 5-ton transport obtained through the FEPP program. It is used in an area of the state with few paved roads and limited availability of water sources for resupplying engines.

Pump: Manufacturer—Hale Model—25FA
 Type—Centrifugal
 Performance: gal/min (max) at free flow—225
 gal/min @ max psi = 25 @ 100
 Primer Type— Other

Tank: Material— Aluminum
 Construction: Baffles?—Yes
 If steel, is the tank corrosion treated?—N/A

Controls and Gauges: Hand Throttle?— Yes Pressure Gauge?— Yes Automatic shutdown?— No

Valves: Tank-to-Pump?— Yes Pump-to-Tank?—Yes

Overboard Discharge:	Quantity	1	2
	Size	2½ inch	1½ inch

Suction:	Quantity	1
	Size	2½ inch

Priming Valve Handle: Manual
Suction Valve Handle: Manual
Tank-to-Plumbing Shut-Off? Yes
Gravity Tank Drain/Dump? No
 Type—

Manufacturer: Mack
Manufacturer Model Year: 1978
Engine Fuel Type: Gasoline
Vehicle Operating Weight: 44,000
Brake Type: Air/hydraulic

Discharge Valve Handle: Manual
Adjustable Pressure Relief? No
Pump and Plumbing Drain? Yes
Rock Trap/Plumbing Strainer? No
 Type—

Cab/Axle Distance: 128 inch
GVW Rating: 55,000
Horsepower Rating: 180
Transmission Type: Manual

Written Materials: Specifications and drawings are available from: New Jersey Forest Fire Service
 P.O. Box 404, 4th Floor
 Trenton, NJ 08625-0404

WATER PUMPING EQUIPMENT

Water Tender Data Sheet No. 7

Agency: New Jersey Forest Fire Service

Equipment Designator: Tender

ICS Type: 3

Summary: Tank Capacity (gallons)— 1,400
Pump Rating—N/A
Pump Drive—Auxiliary engine
Mobile Attack Capability?— Yes
Number Crew Personnel—3
Foam System Available?— No
Gallons—
All-Wheel Drive? —Yes



General Description: This unit is a converted military 5-ton vehicle obtained through the FEPP program and is used to resupply engines in unimproved roads. The tank was formerly used to transport gasoline and has been refitted and equipped to pump water.

Pump: Manufacturer—Hale Model—25FZZ
Type—Centrifugal
Performance: gal/min (max) at free flow—160
gal/min @ max psi = 50@100
Primer Type— Other

Tank: Material— Stainless steel
Construction: Baffles?— Yes
If steel, is the tank corrosion treated?— N/A

Controls and Gauges: Hand Throttle?— Yes Pressure Gauge?— Yes Automatic shutdown?— No

Valves: Tank-to-Pump?— Yes Pump-to-Tank?—Yes

Overboard Discharge: Quantity 3
Size 1½ inch

Suction: Quantity 1
Size 2½ inch

Priming Valve Handle: Manual
Suction Valve Handle: Manual
Tank-to-Plumbing Shut-Off? Yes
Gravity Tank Drain/Dump? No
Type—

Manufacturer: AM General
Manufacturer Model Year: 1984
Engine Fuel Type: Diesel
Vehicle Operating Weight: 32,000
Brake Type: Air

Discharge Valve Handle: Manual
Adjustable Pressure Relief? No
Pump and Plumbing Drain? Yes
Rock Trap/Plumbing Strainer? No
Type—

Cab/Axle Distance: 96 inch
GVW Rating: 80,000
Horsepower Rating: 240
Transmission Type: Manual

Written Materials: Specifications and drawings are available from: New Jersey Forest Fire Service
P.O. Box 404, 4th Floor
Trenton, NJ 08625-0404

WATER PUMPING EQUIPMENT

Water Tender Data Sheet No. 8

Agency: USDA Forest Service (PSW Region, R5)

Equipment Designator: Wildland tender

ICS Type: 3

Summary: Tank Capacity (gallons)— 1,500
 Pump Rating—350 gal/min @ 150 psi
 Pump Drive—PTO
 Mobile Attack Capability?—Yes
 Number Crew Personnel—2
 Foam System Available?—Yes
 Gallons—20
 All-Wheel Drive? —No



General Description: The 1,500-gallon Wildland tender is mounted on a two-wheel drive truck chassis with conventional cab. It is equipped with a single live reel, front and rear spray heads, a foam system, storage compartments, and equipment racks.

Pump: Manufacturer—Darley Model—HM350
 Type—Centrifugal
 Performance: gal/min (max) at free flow—350
 gal/min @ max psi = 350 @ 150
 Primer Type— Electric

Tank: Material— Stainless steel
 Construction: Baffles?— Yes
 If steel, is the tank corrosion treated?— N/A

Controls and Gauges: Hand Throttle?— Yes Pressure Gauge?— Yes Automatic shutdown?— Yes

Valves: Tank-to-Pump?—Yes Pump-to-Tank?—Yes

Overboard Discharge:

Quantity	4	1
Size	2½ inch	1 inch

Suction:

Quantity	2
Size	3 inch

Priming Valve Handle: Electric
Suction Valve Handle: Manual
Tank-to-Plumbing Shut-Off? No
Gravity Tank Drain/Dump? Yes
 Type— 6-inch air dump
Manufacturer: International
Manufacturer Model Year: 2002
Engine Fuel Type: Diesel
Vehicle Operating Weight: 30,500
Brake Type: Air

Discharge Valve Handle: Manual
Adjustable Pressure Relief? No
Pump and Plumbing Drain? Yes
Rock Trap/Plumbing Strainer? No
 Type—
Cab/Axle Distance: 98 inch
GVW Rating: 35,000
Horsepower Rating: 310
Transmission Type: Automatic

Written Materials: Specifications and drawings are available from: USDA Forest Service
 San Dimas Technology
 & Development Center
 444 East Bonita Avenue
 San Dimas, CA 91773

WATER PUMPING EQUIPMENT

Water Tender Data Sheet No. 9

Agency: New Jersey Forest Fire Service

Equipment Designator: Tender

ICS Type: N/A

Summary: Tank Capacity (gallons)— 500
Pump Rating—N/A
Pump Drive—Auxiliary engine
Mobile Attack Capability?— Yes
Number Crew Personnel—3
Foam System Available?— No
Gallons—
All-Wheel Drive? —Yes



General Description: Acquired through the FEPP program, this truck is intended for off-road water supply, mop-up, and patrol on fire roads.

Pump: Manufacturer—Hale Model—30FB-B42
Type—Centrifugal
Performance: gal/min (max) at free flow—350
gal/min @ max psi = 25@118
Primer Type— Exhaust

Tank: Material— Aluminum
Construction: Baffles?— Yes
If steel, is the tank corrosion treated?—N/A

Controls and Gauges: Hand Throttle?— Yes Pressure Gauge?— Yes Automatic shutdown?— No

Valves: Tank-to-Pump?— Yes Pump-to-Tank?—Yes

Overboard Discharge: Quantity 2
Size 1½ inch

Suction: Quantity 1
Size 2½ inch

Priming Valve Handle: Manual
Suction Valve Handle: Manual
Tank-to-Plumbing Shut-Off? Yes
Gravity Tank Drain/Dump? No
Type—

Manufacturer: GMC
Manufacturer Model Year: 1988
Engine Fuel Type: Gasoline
Vehicle Operating Weight: 18,000
Brake Type: Hydraulic

Discharge Valve Handle: Manual
Adjustable Pressure Relief? No
Pump and Plumbing Drain? Yes
Rock Trap/Plumbing Strainer? No
Type—

Cab/Axle Distance: 107 inch
GVW Rating: 21,200
Horsepower Rating: 215
Transmission Type: Manual

Written Materials: Specifications and drawings are available from: New Jersey Forest Fire Service
P.O. Box 404, 4th Floor
Trenton, NJ 08625-0404

WATER PUMPING EQUIPMENT Nonhighway Equipment—

D. Nonhighway Equipment

This section represents a variety of nonhighway mechanized water handling equipment. These have been fabricated to meet the specific needs of a geographic area.

Sheet No.	Tank Capacity (gallons)	Pump Rating (gal/min @ 150 psi)	Pump Drive	Equipment Designator	Agency
1	850	80	Auxiliary engine	Tracked water carrier M548	Florida Division of Forestry
2	800	65	Auxiliary engine	M548	Michigan DNR
3	300	65	Hydraulic	Skidder plow	Michigan DNR
4	120	N/A	Auxiliary engine	Tracked ATV	New Jersey Forest Fire Service
5	125	N/A	Auxiliary engine	Wheeled ATV	New Jersey Forest Fire Service
6	500	85	Auxiliary engine	Tracked water carrier M548	USDI Fish and Wildlife Service
7	15	N/A	Electric	Wheeled ATV	USDA Forest Service (R-9)
8	150	20	Hydraulic	Tractor plow unit	Wisconsin DNR
9	200	20	Auxiliary engine	Tracked unit	Wisconsin DNR

WATER PUMPING EQUIPMENT

Nonhighway Equipment Data Sheet No. 1

Agency: Florida Division of Forestry

Equipment Designator: Tracked water carrier, M548

ICS Type: N/A

Summary: Tank Capacity (gallons)— 850
 Pump Rating—80 gal/min @ 150 psi
 Pump Drive—Auxiliary engine
 Mobile Attack Capability?—Yes
 Number Crew Personnel—2
 Foam System Available?—Yes
 Gallons—20
 All-Wheel Drive? —Tracked



General Description: Military M548 tracked cargo carrier with polypropylene tank, remote master stream appliance, rear view video camera, and fully caged. Good on initial attack, prescribed burns, patrolling fire lines, and as a water source.

Pump: Manufacturer—Robwen Model—180
 Type—Centrifugal
 Performance: gal/min (max) at free flow—110
 gal/min @ max psi = 10 @ 250
 Primer Type—Exhaust

Tank: Material— Polypropylene
 Construction: Baffles?—Yes
 If steel, is the tank corrosion treated?—N/A

Controls and Gauges: Hand Throttle?—Yes Pressure Gauge?—Yes Automatic shutdown?—Yes

Valves: Tank-to-Pump?— Yes Pump-to-Tank?—Yes

Overboard Discharge:

Quantity	1	1	2
Size	1 inch	1½ inch	1-inch booster

Suction:

Quantity	1	1
Size	2 inch	2½ inch

Priming Valve Handle: Manual
Suction Valve Handle: Manual
Tank-to-Plumbing Shut-Off? Yes
Gravity Tank Drain/Dump? Yes
 Type—Manual ¼ turn valve
Manufacturer: U. S. Military
Manufacturer Model Year: 1968
Engine Fuel Type: Diesel
Vehicle Operating Weight: 15,000
Brake Type: Hydraulic

Discharge Valve Handle: Electric
Adjustable Pressure Relief? No
Pump and Plumbing Drain? Yes
Rock Trap/Plumbing Strainer? Yes
 Type— Inlet screen
Cab/Axle Distance: N/A
GVW Rating: 28,290
Horsepower Rating: 225
Transmission Type: Automatic

Written Materials: Specifications and drawings are available from: Florida Division of Forestry
 3125 Conner Boulevard
 Tallahassee, FL 32399

WATER PUMPING EQUIPMENT

Nonhighway Equipment Data Sheet No. 2

Agency: Michigan Dept. of Natural Resources

Equipment Designator: M548

ICS Type: N/A

Summary: Tank Capacity (gallons)— 800
 Pump Rating—65 gal/min @ 150 psi
 Pump Drive—Auxiliary engine
 Mobile Attack Capability?— Yes
 Number Crew Personnel—4
 Foam System Available?— Yes
 Gallons— 5
 All-Wheel Drive? —Tracked



General Description: The M548 is the light armor version of the Bradley military family. The body is aluminum. The cab top, limb risers, and water tank are based on Roscommon Equipment Center design. It has rubber pads on the track and can travel up to 33 mph. At 105.75 inches wide, it must be transported as a wide load.

Pump: Manufacturer—Wildfire-Pacific Model—Mark 3
 Type—Centrifugal
 Performance: gal/min (max) at free flow—98
 gal/min @ max psi = 0 @380
 Primer Type— Exhaust

Tank: Material— Steel
 Construction: Baffles?— Yes
 If steel, is the tank corrosion treated?— Yes

Controls and Gauges: Hand Throttle?— Yes Pressure Gauge?— Yes Automatic shutdown?— Yes

Valves: Tank-to-Pump?— Yes Pump-to-Tank?—Yes

Overboard Discharge:

Quantity	1	2
Size	1½ inch	1 inch

Suction:

Quantity	1
Size	2 inch

Priming Valve Handle: Manual
Suction Valve Handle: Manual
Tank-to-Plumbing Shut-Off? Yes
Gravity Tank Drain/Dump? Yes
 Type— Manual
Manufacturer: Military
Manufacturer Model Year: 1964 to 1984
Engine Fuel Type: Diesel
Vehicle Operating Weight: 23,700
Brake Type: Hydraulic

Discharge Valve Handle: Manual
Adjustable Pressure Relief? No
Pump and Plumbing Drain? Yes
Rock Trap/Plumbing Strainer? No
 Type—
Cab/Axle Distance: N/A
GVW Rating: 28,500
Horsepower Rating: 115
Transmission Type: Automatic

Written Materials: Specifications and drawings are available from: Roscommon Equipment Center
 c/o Forest Fire Experiment Station
 P.O. Box 68
 Roscommon, MI 48653-0068

WATER PUMPING EQUIPMENT

Nonhighway Equipment Data Sheet No. 3

Agency: Michigan Dept. of Natural Resources

Equipment Designator: Skidder plow

ICS Type: N/A

Summary: Tank Capacity (gallons)— 300
 Pump Rating—65 gal/min @ 150 psi
 Pump Drive—Hydraulic
 Mobile Attack Capability?— Yes
 Number Crew Personnel—1
 Foam System Available?— Yes
 Gallons— 5
 All-Wheel Drive? —Yes



General Description: Based on a grapple skidder with grapple removed and wheelbase lengthened to 130 inches by stretching the rear frame. Includes integrated tank, fire plow, hydraulically operated Mark 3 pump head, foam proportioner, and a remote controlled master stream appliance. Rear live reel is available for mop-up work.

Pump: Manufacturer—Wildfire-Pacific Model—Mark 3
 Type—Centrifugal
 Performance: gal/min (max) at free flow—98
 gal/min @ max psi = 0 @380
 Primer Type— Other

Tank: Material— Steel
 Construction: Baffles?— Yes
 If steel, is the tank corrosion treated?— Yes

Controls and Gauges: Hand Throttle?— Yes Pressure Gauge?— Yes Automatic shutdown?— Yes

Valves: Tank-to-Pump?— Yes Pump-to-Tank?—Yes

Overboard Discharge:	Quantity	1	1
	Size	1½ inch	1 inch

Suction:	Quantity	1
	Size	2 inch

Priming Valve Handle: Manual
Suction Valve Handle: Manual
Tank-to-Plumbing Shut-Off? Yes
Gravity Tank Drain/Dump? Yes
 Type— Pipe plug

Manufacturer: John Deere
Manufacturer Model Year: 1996
Engine Fuel Type: Diesel
Vehicle Operating Weight: 24,500
Brake Type: Hydraulic

Discharge Valve Handle: Manual
Adjustable Pressure Relief? No
Pump and Plumbing Drain? Yes
Rock Trap/Plumbing Strainer? No
 Type—

Cab/Axle Distance: Unknown
GVW Rating: 28,500
Horsepower Rating: 115
Transmission Type: Automatic

Written Materials: Specifications and drawings are available from: Roscommon Equipment Center
 c/o Forest Fire Experiment Station
 P.O. Box 68
 Roscommon, MI 48653-0068

WATER PUMPING EQUIPMENT

Nonhighway Equipment Data Sheet No. 4

Agency: New Jersey Forest Fire Service

Equipment Designator: Tracked ATV

ICS Type: N/A

Summary: Tank Capacity (gallons)—120
 Pump Rating—N/A
 Pump Drive—Auxiliary engine
 Mobile Attack Capability?— Yes
 Number Crew Personnel—1
 Foam System Available?— No
 Gallons—
 All-Wheel Drive? —Tracked



General Description: This is a highly maneuverable all-terrain tracked vehicle used for extensive mop-up work.

Pump: Manufacturer—Honda Model—Mini-Striker
 Type—Centrifugal
 Performance: gal/min (max) at free flow—56
 gal/min @ max psi =0@85
 Primer Type— Other

Tank: Material— Steel
 Construction: Baffles?— Yes
 If steel, is the tank corrosion treated?— Yes

Controls and Gauges: Hand Throttle?— Yes Pressure Gauge?— Yes Automatic shutdown?— No

Valves: Tank-to-Pump?— Yes Pump-to-Tank?—No

Overboard Discharge: Quantity 1
 Size 1½ inch

Suction: Quantity 1
 Size 1½ inch

Priming Valve Handle: Manual
Suction Valve Handle: Manual
Tank-to-Plumbing Shut-Off? Yes
Gravity Tank Drain/Dump? Yes
 Type— Manual gate valve
Manufacturer: Bombardier
Manufacturer Model Year: 1973
Engine Fuel Type: Gasoline
Vehicle Operating Weight: 4,000
Brake Type: Manual

Discharge Valve Handle: Manual
Adjustable Pressure Relief? No
Pump and Plumbing Drain? Yes
Rock Trap/Plumbing Strainer? No
 Type—
Cab/Axle Distance: N/A
GVW Rating: 4,800
Horsepower Rating: 113
Transmission Type: Manual

Written Materials: Specifications and drawings are available from: New Jersey Forest Fire Service
 P.O. Box 404, 4th Floor
 Trenton, NJ 08625-0404

WATER PUMPING EQUIPMENT

Nonhighway Equipment Data Sheet No. 5

Agency: New Jersey Forest Fire Service

Equipment Designer: Wheeled ATV

ICS Type: N/A

Summary: Tank Capacity (gallons)—125
Pump Rating—N/A
Pump Drive—Auxiliary engine
Mobile Attack Capability?— Yes
Number Crew Personnel—2
Foam System Available?— No
Gallons—
All-Wheel Drive? —Yes



General Description: This Kawasaki Mule four-wheel drive is small and maneuverable in various terrain. Equipped with a slip-on unit that can be removed and placed as a pumping station at the fire scene.

Pump: Manufacturer—Honda Model—Mini-Striker
Type—Centrifugal
Performance: gal/min (max) at free flow—56
gal/min @ max psi =0@85
Primer Type— Manual

Tank: Material—Aluminum
Construction: Baffles?— Yes
If steel, is the tank corrosion treated?—N/A

Controls and Gauges: Hand Throttle?— Yes Pressure Gauge?— No Automatic shutdown?— No

Valves: Tank-to-Pump?— Yes Pump-to-Tank?—Yes

Overboard Discharge: Quantity 1
Size 1½ inch

Suction: Quantity 1
Size 1½ inch

Priming Valve Handle: Manual
Suction Valve Handle: Manual
Tank-to-Plumbing Shut-Off? Yes
Gravity Tank Drain/Dump? Yes
Type— Manual ¼ turn valve
Manufacturer: Kawasaki
Manufacturer Model Year: 2001
Engine Fuel Type: Diesel
Vehicle Operating Weight: 1,600
Brake Type: Hydraulic

Discharge Valve Handle: Manual
Adjustable Pressure Relief? No
Pump and Plumbing Drain? Yes
Rock Trap/Plumbing Strainer? No
Type—
Cab/Axle Distance: N/A
GVW Rating: 1,630
Horsepower Rating: Not listed
Transmission Type: Automatic

Written Materials: Specifications and drawings are available from: New Jersey Forest Fire Service
P.O. Box 404, 4th Floor
Trenton, NJ 08625-0404

WATER PUMPING EQUIPMENT

Nonhighway Equipment Data Sheet No. 6

Agency: USDI Fish and Wildlife Service

Equipment Designator: Tracked water carrier, M548

ICS Type: N/A

Summary: Tank Capacity (gallons)—500
 Pump Rating—85 gal/min @ 150 psi
 Pump Drive—Auxiliary engine
 Mobile Attack Capability?— Yes
 Number Crew Personnel—2
 Foam System Available?— Yes
 Gallons— 5
 All-Wheel Drive? —Tracked



General Description: Military M548 tracked cargo carrier with 500 gallon tank, fully caged, good on initial attack, prescribe burns, patrolling fire lines, and as a water source. Total length of the vehicle is 230.2 inches.

Pump: Manufacturer—Wajax Model—BB-4
 Type—Centrifugal
 Performance: gal/min (max) at free flow—110
 gal/min @ max psi = 14 @ 400
 Primer Type— Exhaust

Tank: Material—Fiberglass
 Construction: Baffles?— Yes
 If steel, is the tank corrosion treated?—N/A

Controls and Gauges: Hand Throttle?— Yes Pressure Gauge?— Yes Automatic shutdown?— Yes

Valves: Tank-to-Pump?— Yes Pump-to-Tank?—Yes

Overboard Discharge:	Quantity	1	1
	Size	1 inch	1½ inch

Suction:	Quantity	1
	Size	2 inch

Priming Valve Handle: Manual
Suction Valve Handle: Manual
Tank-to-Plumbing Shut-Off? Yes
Gravity Tank Drain/Dump? Yes
 Type— Pipe plug
Manufacturer: Military/FMC
Manufacturer Model Year: 1986
Engine Fuel Type: Diesel
Vehicle Operating Weight: 28,000
Brake Type: Hydraulic

Discharge Valve Handle: Electric
Adjustable Pressure Relief? Yes
Pump and Plumbing Drain? Yes
Rock Trap/Plumbing Strainer? Yes
 Type— Inlet screen
Cab/Axle Distance: N/A
GVW Rating: 28,290
Horsepower Rating: 225
Transmission Type: Manual

Written Materials: Specifications and drawings are available from: USDI Fish and Wildlife Service
 Dismal Swamp National Wildlife Refuge
 Suffolk, VA 23439

WATER PUMPING EQUIPMENT

Nonhighway Equipment Data Sheet No. 7

Agency: USDA Forest Service (Eastern Region, R9)

Equipment Designator: Wheeled ATV

ICS Type: N/A

Summary: Tank Capacity (gallons)— 15
 Pump Rating—N/A
 Pump Drive—Electric
 Mobile Attack Capability?—Yes
 Number Crew Personnel—1
 Foam System Available?—No
 Gallons—
 All-Wheel Drive? —Yes



General Description: The 15-gallon tank with a 5-foot-long hose is mounted to a metal frame which is mounted on an ATV. The pump uses a 12-volt battery for operation.

Pump: Manufacturer—S&N Sprayer Model—2135-561
 Type—Positive displacement
 Performance: gal/min (max) at free flow—20
 gal/min @ max psi = 2 @ 50
 Primer Type—Manual

Tank: Material— Polyurethane
 Construction: Baffles?— No
 If steel, is the tank corrosion treated?— N/A

Controls and Gauges: Hand Throttle?— Yes Pressure Gauge?— No Automatic shutdown?— Yes

Valves: Tank-to-Pump?—No Pump-to-Tank?—No

Overboard Discharge: Quantity 1
 Size ¾ inch

Suction: Quantity N/A
 Size N/A

Priming Valve Handle: No
Suction Valve Handle: No
Tank-to-Plumbing Shut-Off? No
Gravity Tank Drain/Dump? No
 Type—

Manufacturer: User option
Manufacturer Model Year: Varies
Engine Fuel Type: Gasoline
Vehicle Operating Weight: Varies
Brake Type: Hydraulic

Discharge Valve Handle: No
Adjustable Pressure Relief? No
Pump and Plumbing Drain? No
Rock Trap/Plumbing Strainer? No
 Type—

Cab/Axle Distance: N/A
GVW Rating: 1,050
Horsepower Rating: 26
Transmission Type: Manual

Written Materials: Specifications and drawings are available from: USDA Forest Service
 Wayne National Forest
 13700 U.S. Highway 33
 Nelsonville, OH 45764

WATER PUMPING EQUIPMENT Nonhighway Equipment Data Sheet No. 8

Agency: Wisconsin Dept. of Natural Resources

Equipment Designator: Tractor plow unit

ICS Type: T-P 5

Summary: Tank Capacity (gallons)— 150
 Pump Rating—20 gal/min @ 150 psi
 Pump Drive—Hydraulic
 Mobile Attack Capability?—Yes
 Number Crew Personnel—1
 Foam System Available?—No
 Gallons—
 All-Wheel Drive? —Tracked



General Description: The Wisconsin dozer-plow unit is designed for fireline construction with its hydraulically operated middle buster fire plow and front mounted 6-way angling blade. A full canopy water shower system is incorporated in each unit for operator protection. The two side mounted 75-gallon water tanks and hydraulically driven Hypro model 7560XL water pump are mounted behind the operator and primarily used to support the shower system. They also prove useful in wetting down hot spots next to the fireline as well as during mop-up operations.

Pump: Manufacturer—Hypro Model—7560XL
 Type—Positive displacement
 Performance: gal/min (max) at free flow—20
 gal/min @ max psi = 20 @ 185
 Primer Type— Self-priming

Tank: Material— Steel
 Construction: Baffles?— Yes
 If steel, is the tank corrosion treated?— Yes

Controls and Gauges: Hand Throttle?— Yes Pressure Gauge?—Yes Automatic shutdown?— No

Valves: Tank-to-Pump?—Yes Pump-to-Tank?—Yes

Overboard Discharge: Quantity 1
 Size 1 inch

Suction: Quantity 1
 Size 1 inch

Priming Valve Handle: N/A
Suction Valve Handle: Manual
Tank-to-Plumbing Shut-Off? Yes
Gravity Tank Drain/Dump? Yes
 Type— Pipe plug
Manufacturer: John Deere
Manufacturer Model Year: Varies
Engine Fuel Type: Diesel
Vehicle Operating Weight: 21,725
Brake Type: Hydraulic

Discharge Valve Handle: Manual
Adjustable Pressure Relief? Yes
Pump and Plumbing Drain? Yes
Rock Trap/Plumbing Strainer? Yes
 Type— Inlet screen
Cab/Axle Distance: N/A
GVW Rating: N/A
Horsepower Rating: 75
Transmission Type: Hydrostatic

Written Materials: Specifications and drawings are available from: Wisconsin Dept. of Natural Resources
 Neil H. LeMay Forestry Center
 518 West Somo Avenue
 Tomahawk, WI 54487

WATER PUMPING EQUIPMENT

Nonhighway Equipment Data Sheet No. 9

Agency: Wisconsin Dept. of Natural Resources

Equipment Designator: Tracked unit

ICS Type: N/A

Summary: Tank Capacity (gallons)— 200
 Pump Rating—20 gal/min @ 150 psi
 Pump Drive—Auxiliary engine
 Mobile Attack Capability?—Yes
 Number Crew Personnel—2
 Foam System Available?—Yes
 Gallons— 5
 All-Wheel Drive? —Tracked



General Description: The Bombardier Muskeg tracked unit is equipped with a 200-gallon stainless steel tank with mounted Darley/Davey water pump, live reel with 100 feet of 1-inch hose, and a Robwen foam proportioner. The unit is designed for wet ground/marsh fires that are inaccessible by more conventional equipment.

Pump: Manufacturer—Darley/Davey Model—AK282 **Tank:** Material— Stainless steel
 Type—Centrifugal Construction: Baffles?— Yes
 Performance: gal/min (max) at free flow—120 If steel, is the tank corrosion treated?— N/A
 gal/min @ max psi = 20 @ 155
 Primer Type— Self-priming

Controls and Gauges: Hand Throttle?— Yes Pressure Gauge?—No Automatic shutdown?— No

Valves: Tank-to-Pump?—Yes Pump-to-Tank?—Yes

Overboard Discharge: Quantity 2 1
 Size 1 inch 1½ inch

Suction: Quantity 1
 Size 1½ inch

Priming Valve Handle: N/A
Suction Valve Handle: Manual
Tank-to-Plumbing Shut-Off? Yes
Gravity Tank Drain/Dump? Yes
 Type— Pipe plug
Manufacturer: Bombardier
Manufacturer Model Year: 2000
Engine Fuel Type: Diesel
Vehicle Operating Weight: 14,760
Brake Type: Hydraulic

Discharge Valve Handle: Manual
Adjustable Pressure Relief? No
Pump and Plumbing Drain? Yes
Rock Trap/Plumbing Strainer? Yes
 Type— Inlet screen
Cab/Axle Distance: N/A
GVW Rating: 19,000
Horsepower Rating: 110
Transmission Type: Automatic

Written Materials: Specifications and drawings are available from: Wisconsin Dept. of Natural Resources
 Neil H. LeMay Forestry Center
 518 West Somo Avenue
 Tomahawk, WI 54487

WATER PUMPING EQUIPMENT Trailer-Mounted Equipment

E. Trailer-Mounted Equipment

This section lists and describes specialized equipment that requires an accompanying power source for transporting, and is utilized by various fire management agencies to assist in the suppression of wildfires.

Sheet No.	Tank Capacity (gallons)	Pump Rating (gal/min @ 150 psi)	Pump Drive	Equipment Designator	Agency
1	2,500	80	Auxiliary engine	Water tender tracked trailer	Florida Division of Forestry
2	N/A	N/A	N/A	Water handling equipment cache	Georgia Forestry Commission

WATER PUMPING EQUIPMENT

Trailer-Mounted Equipment Data Sheet No. 1

Agency: Florida Division of Forestry

Equipment Designator: Water tender, tracked trailer

ICS Type: N/A

Summary: Tank Capacity (gallons)— 2,500
 Pump Rating—80 gal/min @ 150 psi
 Pump Drive—Auxiliary engine
 Mobile Attack Capability?—No
 Number Crew Personnel—2
 Foam System Available?— Yes
 Gallons—20
 All-Wheel Drive? —N/A



General Description: A 2,500 gallon steel tank is mounted on a rubber-tracked trailer. Has diesel pump with master stream appliance, and one live reel; best pulled with a D-6/JD 750 size crawler. Very low ground pressure, good for mop-up, soggy areas, or as water supply.

Pump: Manufacturer—Berkeley Model—B1½ XQBS 26 **Tank:** Material— Steel
 Type—Centrifugal Construction: Baffles?— Yes
 Performance: gal/min (max) at free flow—100 If steel, is the tank corrosion treated?—Yes
 gal/min @ max psi = 40 @ 260
 Primer Type—Exhaust

Controls and Gauges: Hand Throttle?— Yes Pressure Gauge?— No Automatic shutdown?— No

Valves: Tank-to-Pump?— Yes Pump-to-Tank?—Yes

Overboard Discharge:

Quantity	1	2	1
Size	3 inch	1½ inch	1-inch booster

Suction:

Quantity	1
Size	2 inch

Priming Valve Handle: Manual
Suction Valve Handle: Manual
Tank-to-Plumbing Shut-Off? Yes
Gravity Tank Drain/Dump? No
 Type—

Manufacturer: Caterpillar
Manufacturer Model Year: 2000
Engine Fuel Type: N/A
Vehicle Operating Weight: 30,000
Brake Type: N/A

Discharge Valve Handle: Manual
Adjustable Pressure Relief? Yes
Pump and Plumbing Drain? Yes
Rock Trap/Plumbing Strainer? Yes
 Type— Inlet screen

Cab/Axle Distance: N/A
GVW Rating: 35,000
Horsepower Rating: N/A
Transmission Type: N/A

Written Materials: Specifications and drawings are available from: Florida Division of Forestry
 3125 Conner Boulevard
 Tallahassee, FL 32399

WATER PUMPING EQUIPMENT

Trailer-Mounted Equipment Data Sheet No. 2

Agency: Georgia Forestry Commission

Equipment Designator: Water handling equipment cache

ICS Type: N/A

Summary: Tank Capacity (gallons)—N/A
 Pump Rating—N/A
 Pump Drive—N/A
 Mobile Attack Capability?—
 Number Crew Personnel—1
 Foam System Available?—
 Gallons—
 All-Wheel Drive? —



General Description: FEPP trailer equipped with lift gate, carries a generous cache of portable pumps, hoses, adapters, fittings, nozzles, portable tanks, and tools for use in mopping up wildland fires. The cache is maintained at State headquarters by a water handling specialist who deploys with the cache on incidents.

Pump: Manufacturer—N/A Model—
 Type—
 Performance: gal/min (max) at free flow—
 gal/min @ max psi =
 Primer Type—

Tank: Material—
 Construction: Baffles?—
 If steel, is the tank corrosion treated?—

Controls and Gauges: Hand Throttle?— Pressure Gauge?— Automatic shutdown?—

Valves: Tank-to-Pump?— Pump-to-Tank?—

Overboard Discharge: Quantity
 Size

Suction: Quantity
 Size

Priming Valve Handle:
Suction Valve Handle:
Tank-to-Plumbing Shut-Off?
Gravity Tank Drain/Dump?
 Type—

Manufacturer:
Manufacturer Model Year:
Engine Fuel Type:
Vehicle Operating Weight:
Brake Type:

Discharge Valve Handle:
Adjustable Pressure Relief?
Pump and Plumbing Drain?
Rock Trap/Plumbing Strainer?
 Type—

Cab/Axle Distance:
GVW Rating:
Horsepower Rating:
Transmission Type:

Written Materials: Specifications and drawings are available from: Georgia Forestry Commission
 P.O. Box 819
 Macon, GA 31202

WATER PUMPING EQUIPMENT

Water Tanks

F. Water Tanks

Water tank design should contribute to the safety and longevity of the fire vehicle. The vehicle's center of gravity should be as low as possible, and because a tank full of water is very heavy, the placement and size of tank is important. Low profile rectangular shaped tanks are preferred. They provide good stability on side slopes and driving. Tanks should be placed at a position on the vehicle frame that will correctly distribute the weight of water to both front and rear axles under loaded conditions. This position is normally found on, or just in front of the rear axle. If the payload is too far forward, the result is often overloading of the front axle. If it is too far to the rear, the steering of the vehicle will be affected.

Baffles in the tank are essential to prevent rapid movement of water on slopes, cornering, and stopping. Without baffles, inertia of the water in the tank, could cause vehicle rollover, contribute to tank failure, or braking difficulties. When installed, baffles should allow movement of water at the bottom of the tank and airflow at the top.

Tanks may be constructed of mild steel, stainless steel, fiberglass, polypropylene, aluminum, or polyurethane. Choice of material will be based on cost, ease of manufacture, tank weight, and resistance to corrosion. Steel tanks should be coated to protect from corrosion. Stainless steel may be more expensive, but the costs may be offset by factors such as warranties, longevity, ease of maintenance, and resistance to corrosion.

Fiberglass tanks are generally more costly than steel tanks, but are corrosion free.

High impact copolymer plastics (polypropylene) are becoming the material of choice for the construction of fire engine water tanks by a large number of municipalities, States, and Federal agencies. This material is extremely strong, durable, and is ultraviolet-light stabilized to prevent deterioration from exposure to sunlight. This material has a long service life, cannot be affected by fire fighting chemicals, and can be used in potable water applications. This material can be used in the construction of tanks in almost any size or shape.

Polyurethane tanks should be avoided if at all possible. Plastics of this type are normally found in rotationally molded round tanks. These tanks tend to be brittle and subject to breakage from impact. They are normally not stabilized to resist deterioration due to sunlight (ultraviolet rays).

Due to the cleaning action of foam concentrate in solution, steel tanks in fire equipment with a foam system should be avoided if possible. Foam concentrates will reduce useful life of the steel tank several fold. Tank fabrication should be left to experienced manufacturers possessing the experience to properly design and engineer the tanks, baffles, inlets, outlets, and sumps. Tank manufacturers are listed in appendix G.

WATER PUMPING EQUIPMENT Plumbing

G. Plumbing

Figure 2—Typical engine plumbing diagram (centrifugal).

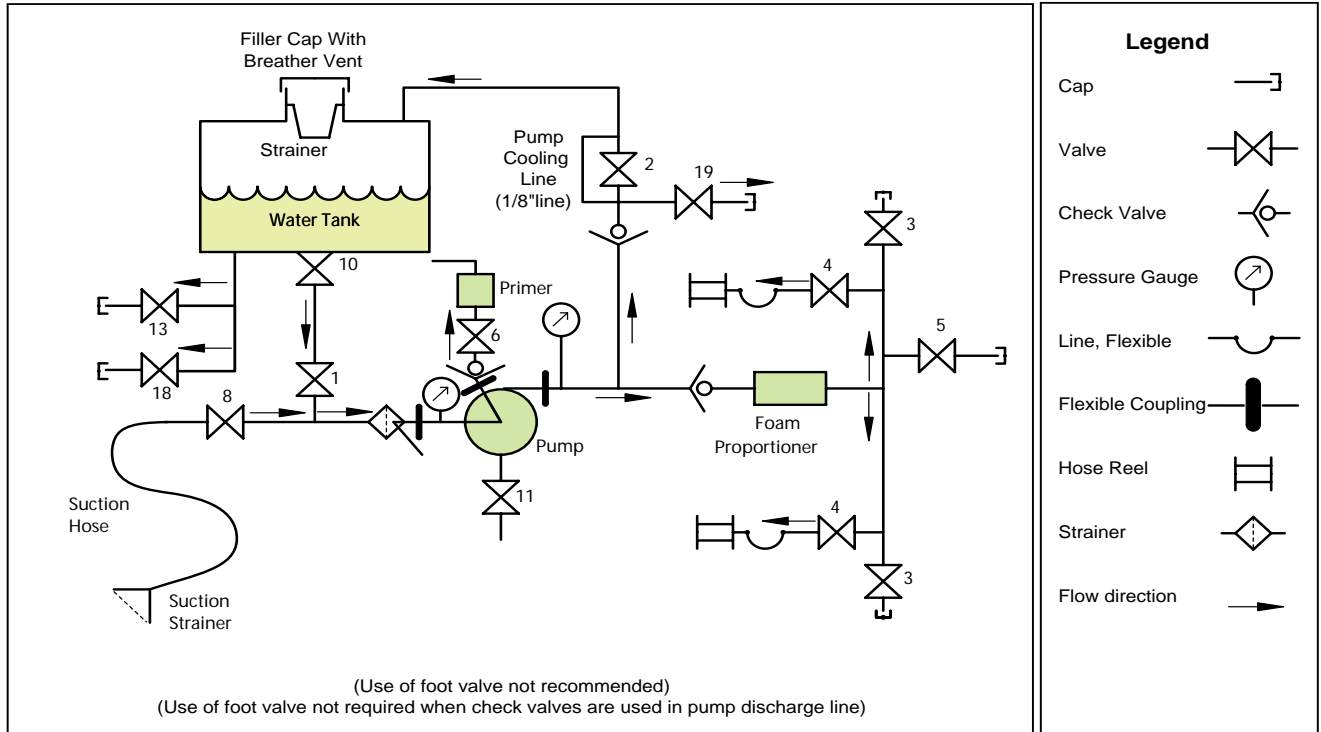

Valve Numbering System

The numbering system below has been adopted by the USDA Forest Service (other systems may also be available).

- | | |
|--|---|
| No. 1 from tank to pump | No. 11 pump or piping drain valve |
| No. 2 from pump to tank | No. 12 pump coolant clean-out* |
| No. 3 from pump to overboard discharge | No. 13 gravity tank drain |
| No. 4 from pump to hose reel or basket discharge | No. 14 foam-differential-valve shunt* |
| No. 5 from pump to small auxiliary discharge(3/4 in) | No. 15 pump transfer valve* |
| No. 6 from pump to primer | No. 16 engine cooler line* |
| No. 7 adjustable pressure relief valve* | No. 17 pump bypass* |
| No. 8 from overboard suction intake to pump | No. 18 low volume gravity (back pack fill) |
| No. 9 reserve supply from tank to pump* | No. 19 water only valve for eductor or water transfer |
| No. 10 tank to piping shut-off valve | No. 20 feed #2, #13 and/or #19* |

* Valve not utilized in this diagram.

FOAM GENERATING EQUIPMENT

Foam Proportioners

II. FOAM GENERATING EQUIPMENT

A. Foam Proportioners

There are a number of systems used to proportion foam concentrate into water streams for use with standard nozzles, aspirating nozzles, or compressed air foam systems (CAFS). The two basic types of foam concentrate proportioning systems are manually regulated and automatic regulating. The system that gives the most consistent and desirable results is an automatic regulating proportioning system that injects directly into the discharge side of the water pump.

Manually regulated proportioning systems include:

- Batch mixing
- Suction-side proportioner
- In-line eductor
- Variable flow bypass eductor
- Around-the-pump proportioner
- Direct injection manually regulated proportioner

Automatic regulating proportioning systems include:

- Balanced pressure venturi proportioning systems
 - Bladder tank proportioner
 - Pump proportioner
- Water motor meter proportioner
- Direct injection automatic regulating proportioner

1. Manually Regulated Proportioning Systems

Manual regulation systems, which must be monitored and changed manually, are frequently used. They have less precise regulation of concentrate addition and the resulting foam quality is highly variable.

a. Batch mixing

The simplest method of making a foam solution is to manually add foam concentrate to the water supply. This method, called batch mixing, is convenient for conventional water pumping systems. A measured volume of concentrate is poured into a measured volume of water to yield a foam solution of the recommended strength. Batching is potentially wasteful

because the required volumes of both water and concentrate must be estimated, especially when refilling a partially full tank. The concentrate should be added to water, because adding water to the foam concentrate causes excessive foaming in the tank as the water is added. Since the foam concentrate is heavier than water, mixing or recirculation of the concentrate/water mixture is required to obtain a homogeneous solution. The solution should be used as soon as possible for optimum performance. Despite a number of limitations, batch mixing is a common proportioning method for engines, portable tanks, bladders, and extinguishers, and is considered a backup method if the on-line proportioner fails to work.

b. Suction-side proportioner

The suction-side proportioner uses a water pump vacuum to add foam concentrate, via an in-line tee and regulating valve, to the water stream on the inlet side of the pump. At specific flow conditions the regulator is proportional. However, the in-line tee has no influence on vacuum, so the regulator cannot maintain a given mix ratio as waterflow changes without a manual adjustment. Because the regulator sends concentrate through the pump and the tank, when recirculating, its limitations are similar to those of batch mixing.

c. In-line eductor

The in-line eductor (or in-line proportioning system) drafts foam concentrate from a container to the pressure side of the water stream using venturi action. As pressurized water flows through the venturi, an area of negative pressure is created at the venturi throat. Atmospheric pressure forces the foam concentrate into the negative pressure area of the eductor.

Eductors work on any pump that can generate sufficient pressure and are compatible with pump capabilities. They are usually proportional at one waterflow rate. Because they are designed to operate within specific concentration ranges, a different eductor may be required to

FOAM GENERATING EQUIPMENT

Foam Proportioners

operate at a concentration outside that range. In some cases diluting the concentrate may allow use of the eductor at hand.

Eductors eliminate many of the problems associated with concentrate exposure to pump and tank. They also allow for proportioning while the tank is refilled or while the pump is fed from a hydrant. Eductors are most appropriate for applications of constant waterflow near the discharge nozzle. The in-line eductor system has a pressure loss in the 25 to 60 percent range.

The in-line eductor proportioning systems can be set up and adjusted to function properly and will continue to work well as long as no changes are made. If changes are made such as reducing the size of the nozzle (such as shutting down a nozzle when two are in use), adding hose, or adding elevation at the hose outlet, the proportion may change or the system may not work at all. This results in the in-line eductor proportioning system being very situation sensitive. Therefore, these systems should be avoided, or when used utilized with caution and concern in wildfire suppression conditions where low flows and long, small diameter hose lays are employed.

d. Variable flow bypass eductor

The variable flow bypass eductor proportioner is a modification of the in-line eductor proportioner. The bypass eductor proportioner is a manually regulated proportioning system and has the same large pressure loss (25 to 60 percent) associated with the in-line eductor. It is also situation sensitive like the in-line eductor. However, when a waterflow change occurs, it may be possible to adjust the system so it will continue to work.

e. Around-the-pump proportioner

The around-the-pump proportioner diverts a portion of the pump discharge through an in-line proportioner back to the suction side of the pump. This loop around the pump is used to draw concentrate up through the venturi and into the main water stream.

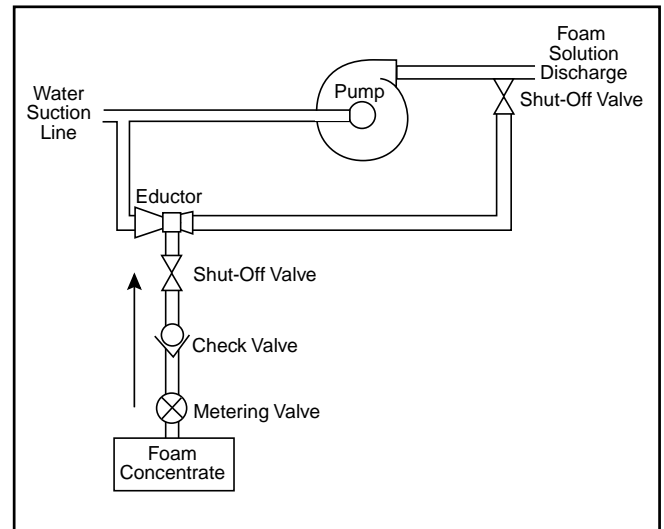

Figure 3—Around-the-pump proportioner schematic.

The around-the-pump system works on portable or built-in pumps of any size or output. Water tank refilling and pump nursing do not affect this system's performance. Around-the-pump devices are not automatic regulating. The venturi does not adjust the concentrate flow when the waterflow changes. The adjustment is done manually. When waterflow has stopped, the shutoff valve at the venturi MUST be turned off to prevent foam concentrate from being drawn into the discharge water line. The around-the-pump proportioner is more flexible than the eductor, but it introduces concentrate to the pump and tank in the same way as the suction-side regulator. Therefore, the same corrosion, cleansing, cavitation, and other related problems also limit the around-the-pump-proportioner.

f. Direct injection manually regulated proportioner

In a direct injection manually regulated proportioning system a small positive-displacement metering pump injects foam concentrate directly into the water stream on the discharge side or intake side of the pump. The rate of foam concentrate injection can be adjusted to give the desired foam solution. However, when the

FOAM GENERATING EQUIPMENT

Foam Proportioners

waterflow rate changes, the foam concentrate injection rate must be manually changed in order to keep the foam solution at the same desired percentage. These units usually have a low water cut-off switch to stop foam concentrate flow when waterflow is stopped.

2. Automatic Regulating Proportioning Systems

Automatic regulating proportioning systems are designed to minimize the limitations of manually regulated proportioning systems. Specifically, they proportion accurately over wide ranges of water flow or pressure, adjusting automatically to changes in water flow and pressure to maintain the desired mix ratio. Foam concentrate is added on the discharge side of the pump to avoid tank and pump problems. The mix ratio can be quickly changed during operation. The proportioners place no restrictions on hose length, number of hoselays, or nozzles.

a. *Balanced pressure venturi proportioning systems*

The automatic regulating, balanced pressure venturi proportioning system is in wide use—both in the bladder tank system and the pump system.

Bladder tank proportioner—The balanced pressure bladder tank proportioner uses a small diversion of water to pressurize a tank with a bladder containing foam concentrate. The concentrate passes through a metering valve before it enters the water stream on the low pressure section of a pressure differential valve or venturi. Concentrate is added according to the difference in pressure at the differential valve or venturi. As waterflow increases, the difference in pressure increases and foam concentrate flow increases proportionately. The bladder tank proportioner has no moving parts and requires no external power. It can be portable for storage and dispensing. When the bladder is being filled on a single tank unit, concentrate flow is interrupted.

Pump proportioner—The balanced pressure pump proportioner senses water pressure with a pilot operated relief valve. The pilot operated relief valve makes foam concentrate pressure equal to water pressure. A pump delivers concentrate to a venturi in the water line according to the pressure at the relief valve. A metering valve allows for selection or change of the desired mix ratio. If the relief valve senses water pressure of 150 psi, then the foam concentrate pressure will be 150 psi. Concentrate enters the water stream in proportion to the pressure differential across the venturi. Excess foam concentrate is relieved to the concentrate tank. Refilling the concentrate tank does not interrupt concentrate flow. Foam concentrate flow and pressure are provided by an externally powered pump.

b. *Water motor meter proportioner*

In a water motor meter proportioning system a positive displacement water motor drives a positive displacement foam concentrate metering pump. The ratio of the water motor displacement to the displacement of the metering pump is the ratio of the desired foam solution.

The water motor meter proportioning system requires no external power. However, when operating near zero flow the system tends not to run. Also in the design of the system, the water motor must have an output shaft on each side to balance the side loading. If a water motor is used with only a shaft coming out one side, the unit will start and run well when there is no downstream pressure; however, when there is downstream pressure (as is generally the case when firefighting) the unit tends not to start.

c. *Direct injection automatic regulating proportioner*

The electronically controlled direct injection automatic regulating proportioner adds concentrate based on measured waterflow. An in-line flow sensor determines waterflow past the pump. A microprocessor receives electronic signals

FOAM GENERATING EQUIPMENT

Foam Proportioners

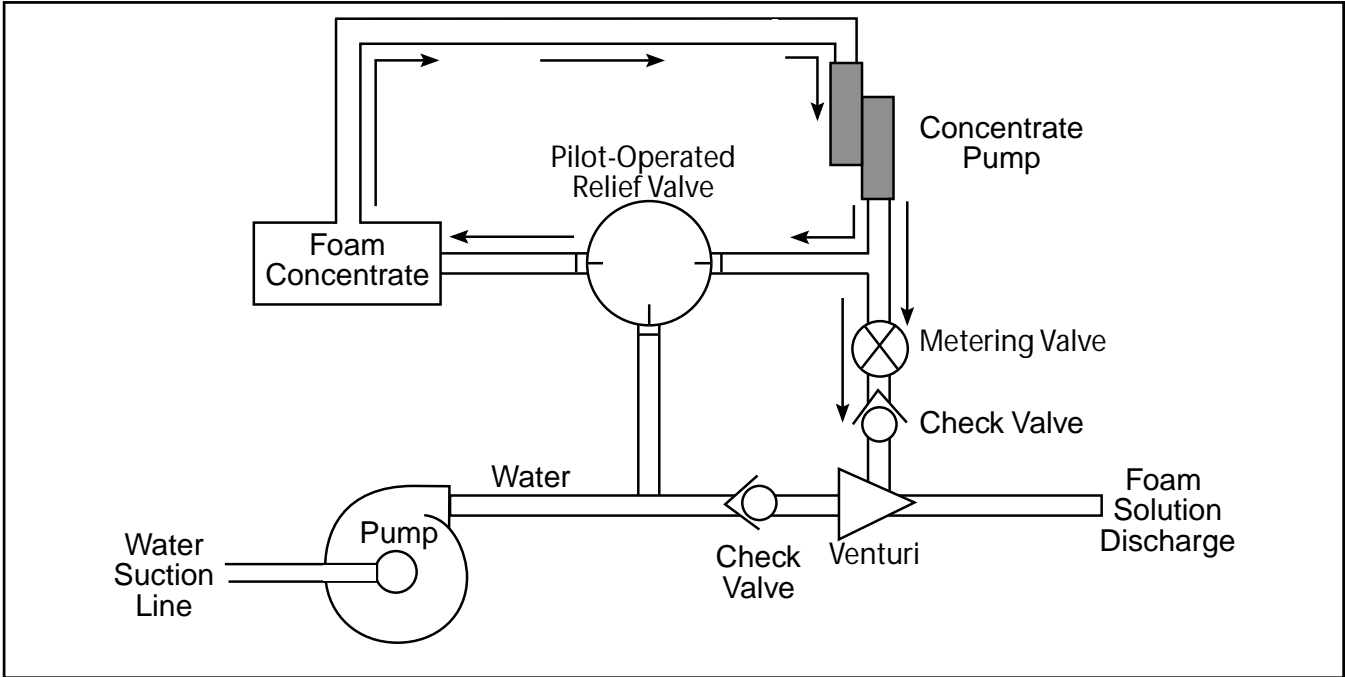

Figure 4—Balanced pressure pump proportioner schematic.

of mix ratio from the control panel and waterflow from the flow sensor. The processor then commands a pump to deliver concentrate at a proportional rate. This proportioner is capable of providing more than one foam concentrate type when more than one storage container is linked to the pump. The pump runs only on demand.

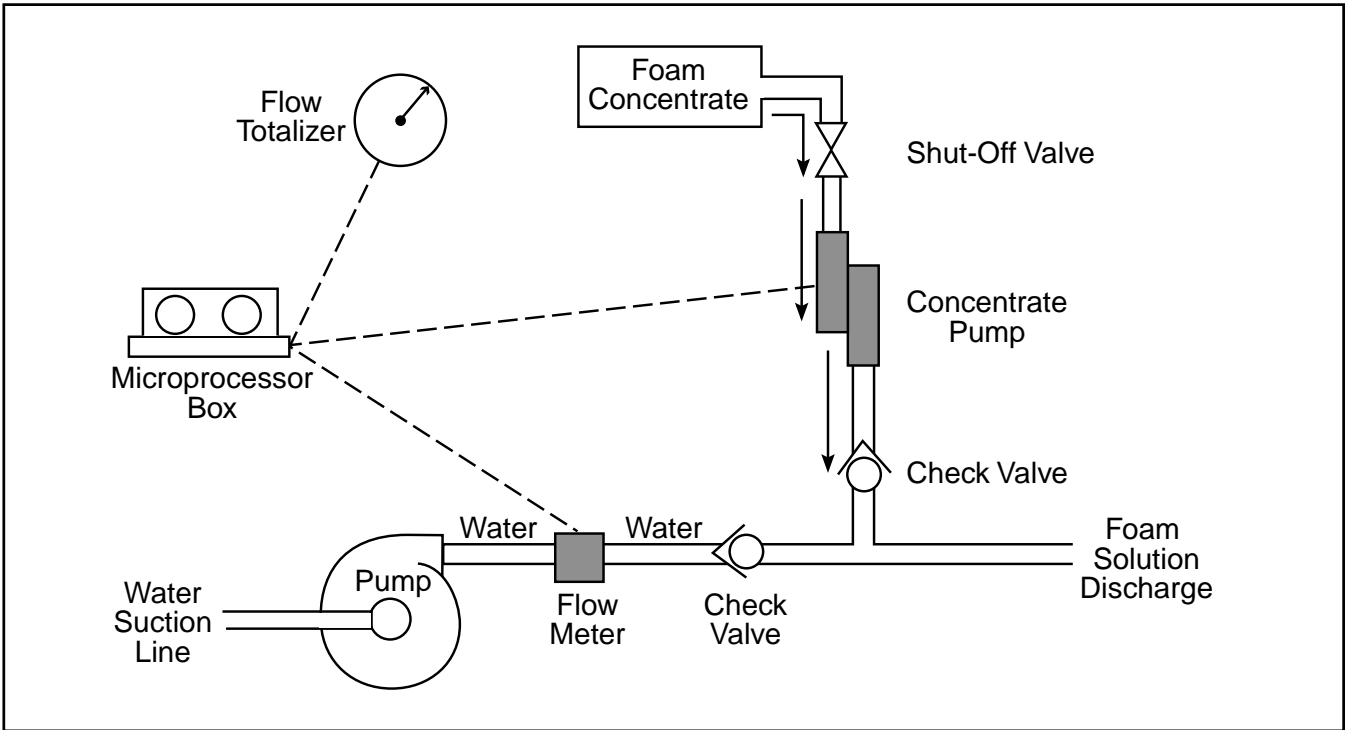

Figure 5—Direct injection proportioner schematic.

FOAM GENERATING EQUIPMENT

Foam Proportioners

Table 3—Advantages and disadvantages of proportioning devices.

Advantages	Proportioners*									
	Manually regulated						Automatic regulating			
	1	2	3	4	5	6	7a	7b	8	9
Maintain desired mix ratio with changes in waterflow & pressure	X						X	X	X	X
Unlimited hose length	X	X			X	X	X	X	X	X
Unlimited number of hose lines	X	X			X	X	X	X	X	X
Easily adjusted mix ratios		X	X	X	X	X	X	X		X
No moving parts	X	X	X	X	X		X			
No loss in water pressure		X	X			X	X			X
No loss or low loss in water pressure	X	X			X	X	X	X	X	X
Operate from pressure source	X		X	X	X	X	X	X	X	X
Requires no equipment investment	X									
Refill foam while operating		X	X	X	X	X		X	X	X
Can indicate foam concentrate remaining	X	X	X	X	X	X		X	X	X
No external power required	X	X	X	X	X		X		X	
Disadvantages										
Tank and pump corrosion	X	X			X					
Plumbing corrosion	X	X			X					
Pump cavitation	X	X			X					
Possible pump priming difficulties	X	X			X					
Foaming in tank	X	X			X					
Water tank refill fluid level obscured	X	X			X					
Clean water supply contamination	X	X			X					
Removes lubricants from pump	X	X			X					
Possible use of more concentrate than required		X	X	X	X	X				
Possible use of less concentrate than required		X	X	X	X	X				
Possible inconsistent dispersion of concentrate		X	X	X	X	X				
Foam solution degradation	X									
Cleaning required after every use	X	X	X	X	X					
Specific waterflow requirements			X							
Specific pressure requirements			X	X						
Limited nozzle elevation			X	X						
Must match hose length and nozzle			X	X						
Limited hose length and size			X	X						
High discharge pressure loss			X	X						
Cannot operate from water pressure source		X								
Dependent on pump vacuum		X								
Concentrate viscosity affected		X	X	X	X		X	X		
Concentrate resupply interrupts concentrate input							X			
Requires auxiliary power						X		X		X
Accurate Water Flow Range										
Any flow, single mix ratio	X								X	
Single flow, single mix ratio without adjustment		X	X	X	X	X				
Any flow, any mix ratio (between 0.1 and 1.0 percent for class A foam)							X	X		X
Initial Equipment Investment										
\$ 0 - \$ 500	X	X	X	X	X					
\$ 500 - \$1,000										
\$1,000 - \$2,000						X				
\$2,000 - \$4,000							X	X	X	
\$4,000 - \$6,000										X

FOAM GENERATING EQUIPMENT

Foam Proportioners

*Key to Proportioning Systems

Manually regulated

- 1 = Batch mixing
- 2 = Suction-side proportioner
- 3 = In-line eductor
- 4 = Variable flow bypass eductor
- 5 = Around-the-pump proportioner
- 6 = Direct injection manually regulated proportioner

Automatic regulating

- 7 = Balanced pressure venturi proportioning systems
 - a = Venturi bladder tank proportioner
 - b = Venturi pressure pump proportioner
- 8 = Water motor meter proportioner
- 9 = Direct injection automatic regulating proportioner

3. Summary of Foam Proportioners

- Batch mixing should be considered as the backup proportioning system when another type of proportioning system fails or when no other proportioning system is available.
- While manually regulated foam concentrate proportioning systems are generally the lowest initial cost, they may be in fact the highest cost systems over the operating life of the system because they can proportion more foam concentrate than necessary or, worse yet, not proportion enough or any at all.
- Because of the many shortcomings of the manually regulated proportioning systems, automatic regulating proportioning systems have been developed to reduce these limitations found in the manually regulated proportioning systems. Specifically, the automatic regulating proportioning systems are designed to remain proportional over a wide range of flows and are not affected by changes in engine pressure, changes in hose length and size, or changes in nozzle adjustments, size, or elevation.
- The use of manually regulated proportioning systems should be avoided in wildfire suppression operations where low flows and long, small diameter hose lays are used and where frequent changes in waterflow are necessary.
- The use of automatic regulating proportioning systems injecting into the discharge side of the pump should be encouraged.

FOAM GENERATING EQUIPMENT

Foam Proportioners

4. Foam Accessories

a. Foam pickup tube

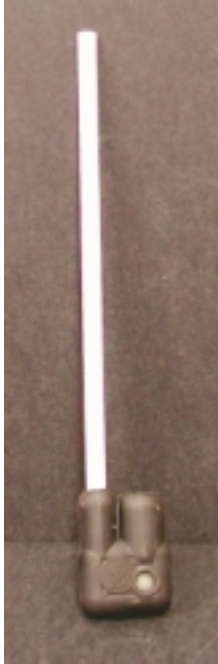

Figure 6 —Foam pickup tube.

When a foam proportional system intake to the water stream is on the suction side of the pump, the pump will lose prime when the foam concentrate is exhausted or the foam concentrate pickup line comes out of the supply container. A pickup tube attachment is available to prevent this. This attachment has a check valve that is seated when the foam concentrate is exhausted, preventing the pump from sucking air and losing prime. This pickup tube is available commercially and will work on the suction-side proportioning system and also on the around-the-pump proportioning system where this is a frequent occurrence.

b. Portable foam concentrate meter



Figure 7—Portable foam concentrate meter.

The Institute of Geological and Nuclear Sciences of New Zealand has developed and made available a direct reading portable foam concentrate percent meter that can be used to test a proportioner system in the field. This meter works by reading the conductivity of the water the foam solution is being made with. This direct reading foam concentrate percent meter is called a Digifoam™, and is available commercially.

FOAM GENERATING EQUIPMENT

Compressed Air Foam Systems (CAFS)

B. Compressed Air Foam Systems

Compressed Air Foam Systems (CAFS) produce high-energy foam by injecting compressed air into the foam solution. This system includes a water pump, compressed air source, foam solution, pressure gauges, and assorted valves; it does not require an aspirated nozzle. Foam is produced differently with CAFS than aspirating systems. Air from the compressor is injected into the foam solution. This air represents stored energy for use in the discharge of foam. Once the air and foam solution are combined, they mix, agitate, and expand to produce foam. The mixing and agitation occurs in a hose line or a specialized mixing chamber. When hose is used to produce the foam, approximately 100 to 150 feet of hose is required. Mixing chambers are usually used when foam discharge must occur close to the pump, such as with a master stream appliance.

Air and water pressures from the compressor and pump should be matched. Because of the energy provided by the air compressor, gallon for gallon, compressed air foam is propelled farther than discharges from aspirating or standard water nozzles.

Almost any shutoff or nozzle, full flow or fog pattern, will work with CAFS. The nozzle type affects the type of foam that will be discharged. For example, a full-flow shutoff will provide the best foam, while a variable-pattern nozzle will break up the bubbles and create an air-charged foam solution. Each application has its place in fire suppression.

The advantages of CAFS are:

- The foam type can be easily changed by changing the ratio of water to air.
- Hose lines are considerably lighter than conventional water lines.
- Less foam concentrate is used.
- CAFS can be pumped higher and farther than plain water at the same pressure and reduces water consumption.
- Bubbles are more uniform, creating a more durable foam.
- CAFS increases the efficiencies of water use.
- The air compressor can be used separately to run pneumatic tools.

The limitations of CAFS are:

- The system is more complex than traditional pumping systems, and requires education and training.
- Maintenance requires more expertise and time.
- The large amount of energy stored in the hose can be difficult to control; thus, if an operator is not properly trained or prepared it can be unsafe.
- Purchase price.
- Weight and size of the module.

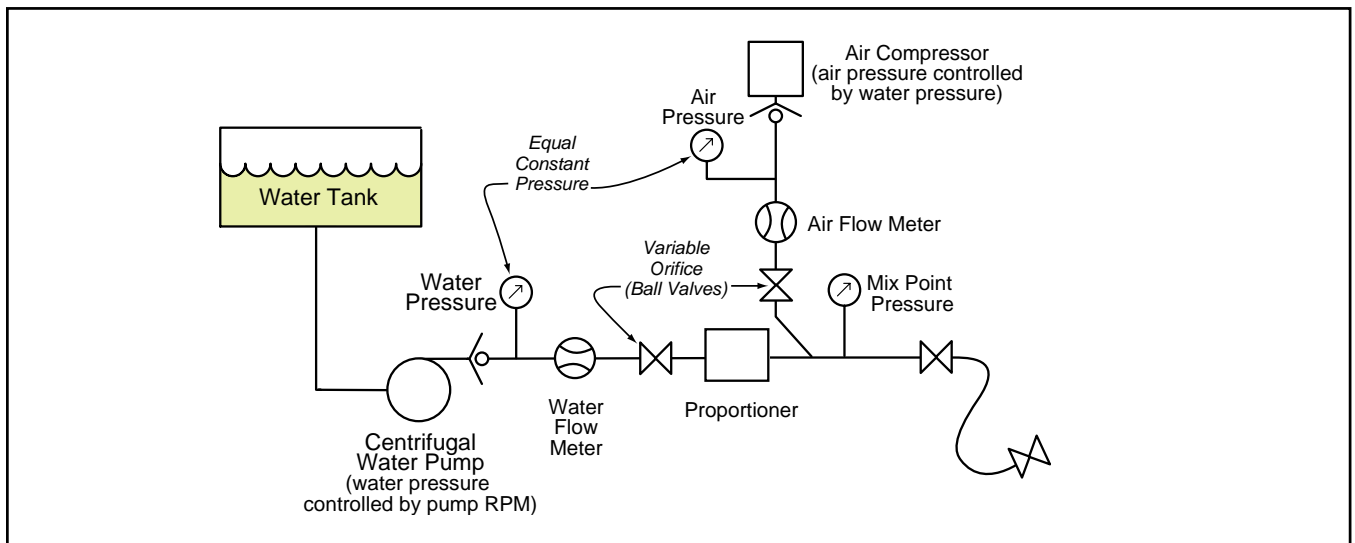

Figure 8—Compressed air foam system (CAFS) schematic.

FOAM GENERATING EQUIPMENT

Foam Nozzles

C. Foam Nozzles

1. Conventional Nozzles

Conventional nozzles, such as straight stream, spray, and combination, are a simple way to deliver foam solution with existing equipment when the objective is rapid wetting of the fuel and foam is not needed. The unstable foam applied in this manner is essentially wet water that enhances wetting of fuel, penetration, and spread of the water but does not give sufficient foam structure to provide insulation or heat reflection.

2. Aspirating Nozzles

Aspirating nozzles use energy from the water pump to create foam. Energy, in the form of water pressure, is delivered by the pump to the aspirating nozzle. The nozzle restricts the flow of foam solution that causes air to be drawn into the foam solution stream. The air and foam solution mix in a chamber and are discharged as foam.

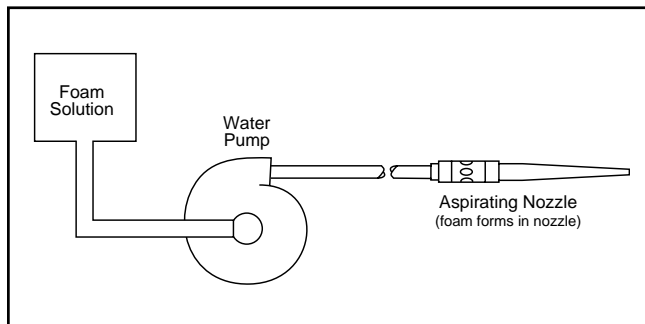

Figure 9—Nozzle aspirating foam systems.

a. Low-expansion nozzles

Low-expansion nozzles have small openings for air. They can produce a volume of foam up to 20 times the amount of foam solution used to make the foam, or a 20:1 expansion ratio. These nozzles focus pump energy into a narrow chamber that creates a limited airflow. Smaller volumes of foam are produced, but they are projected great distances.

There are two variations in nozzle design based on where the air is drawn into the nozzle. Air can be drawn into the back of the nozzle (figure 10) or into the front (figure 11).

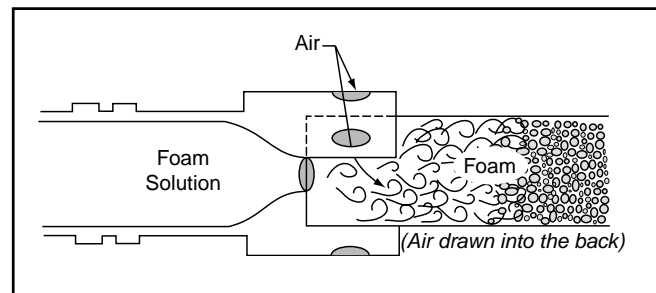

Figure 10—Low-expansion aspirating nozzle.

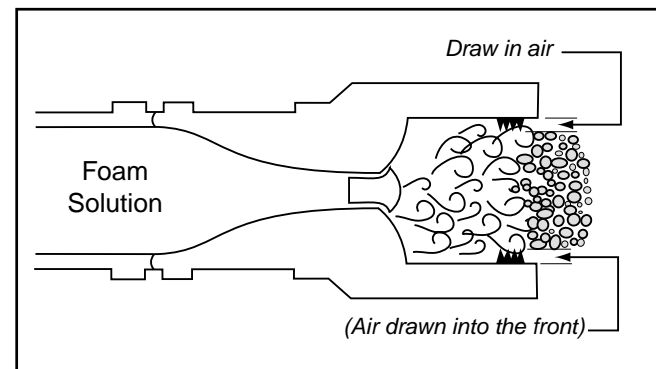

Figure 11—Low-expansion aspirating nozzle.

FOAM GENERATING EQUIPMENT

Foam Nozzles

b. Medium-expansion nozzles

Medium-expansion nozzles have much larger air openings than low-expansion nozzles. They can produce expansions from 20:1 up to 200:1, depending on the design of the nozzle. A medium-expansion nozzle has a wide chamber that draws in a large amount of air, which in turn slows down the stream velocity. There are screens located inside the chamber that are necessary for bubble formation.

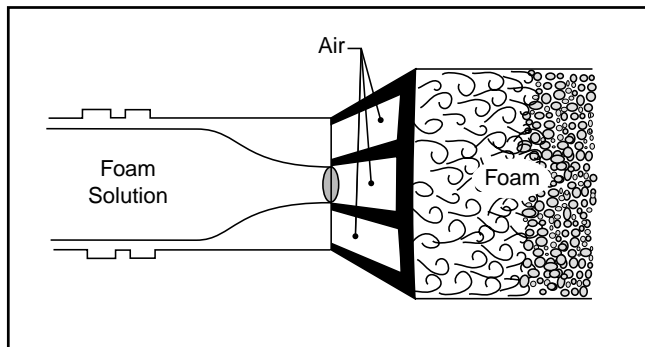

Figure 12—Medium-expansion aspirating nozzle.

c. High-expansion nozzles

High-expansion nozzles work along the same lines as the medium expansion ones, but put out a larger volume of foam. They can produce expansions in excess of 200:1. High-expansion nozzles are not commonly used in wildland fire applications, but can be effective in certain situations.

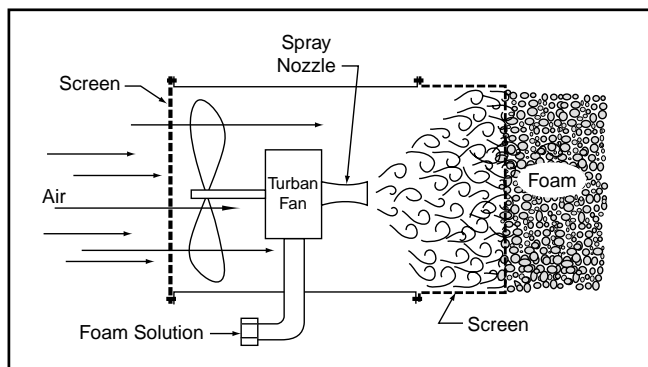

Figure 13—High-expansion aspirating nozzle.

3. Aspirating Nozzle Designs

Aspirating nozzles are designed for specific waterflows, water pressures, and mix ratios of foam solution. Nozzles may be single or variable flow by design. Water pressure is normally between 100 and 150 psi. Mix ratio is usually $\frac{1}{2}$ of 1 percent. Changes in any of these variables affect foam production.

Single pattern, low-expansion nozzles are designed for only one discharge pattern. There are also low expansion nozzles that provide several discharge patterns. These nozzles offer a variety of patterns that may include long-range straight stream, fog, or spray, and foam patterns. Low expansion nozzles are commonly used for direct attack because of their extended discharge distances. They can also be used for pretreatment of aerial fuels and mopup.

Medium-expansion nozzles are generally designed for lower pressures than low expansion nozzles. Low pressures are required to build and maintain the larger bubbles of medium-expansion foam. Medium-expansion nozzles are best on surface applications at short distances. They can be used to create fire barriers during indirect attack or prescription burning, and are very useful for rapid mopup.

Advantages of aspirated nozzles are:

- Relatively inexpensive and simple.
- They do not require extensive training.
- Easy to maintain.
- Many are attachments to common water nozzles.

Limitations of aspirated nozzles are:

- Ability to change the foam type is limited.
- Foam will not cling to vertical surfaces as well as compressed air foam.
- Water pressure from the water stream is "robbed" to produce foam.
- More foam concentrate is used than compressed air foam systems.

WATER DELIVERY COMPONENTS AND ACCESSORIES

Hose

III. WATER DELIVERY COMPONENTS AND ACCESSORIES

A. Hose

1. General

Firehose provides the essential means of transporting water from a stream, lake, hydrant, or engine to the fire. The hose selected must withstand the necessary pressures involved, yet be flexible and lightweight enough to handle. Most hose in use is purchased by Federal Supply Services (GSA) under specifications developed by the USDA Forest Service. The wildland firefighting agencies purchase approximately 3 million feet of small diameter (1 and 1½ inch) firehose annually.

The care and maintenance of firehose is described in NFPA 1962, 2003 edition. Service test pressures and procedures are in Chapter 5 of this standard (see appendix D). A review of the appropriate acronyms and definitions will be helpful when using this section on firehose (see appendixes H and I).

2. Design Criteria

The nominal outside diameters of all jacketed hose furnished under USDA Forest Service specifications are controlled. A saving thereby results, since coupling bowls for all jacketed hoses are identical and interchangeable. The outside diameter (OD) for 1-inch hose is 1¼ inches and for 1½-inch hose, it is 1¾ inches. In general fire department practice, the inside diameter (ID) is controlled and the OD varies with the jacket thickness, the type of liner, and other variables.

Jacketed fire hose elongates when pressurized. Most hose also twists under working pressure, and the direction of twist must be to tighten, not loosen, the couplings. Jacketed hose also tends to warp and rise. For example, a cotton synthetic jacket in a 50-foot length should not warp more than 25 inches from a straight line, nor rise more than 8 inches when pressurized to 450 psi. Fire hose is hydrostatically tested in accordance with the testing procedure as required by the procurement contract, if procured under USDA

Forest Service specifications. All USDA Forest Service hose specifications require qualification prior to procurement by GSA.

A list of qualified hose is available from:

USDA Forest Service
Technology and Development Center
444 East Bonita Avenue
San Dimas, CA 91773
Phone: 909-599-1267

3. Hose Types

a. Cotton jacket rubber lined

Standard cotton jackets have a working pressure of 250 psi. Cotton is more resistant to heat and flame damage than synthetic fibers. Hot embers, however, may cause small pinholes. Cotton-jacketed hose in most agencies has been replaced with lightweight hoses (see b, c, and d).

Type: Single-jacket fabric, rubber lined.

Construction and material: The jacket consists of woven cotton yarn. The liner is petroleum-based thermoplastic polyester elastomer with a smooth inner surface. The jacket and liner are bonded together.

Flow rate: Friction loss relative to hose diameters is basically the same as the cotton-synthetic lined hose. Slight differences may be due to type of lining and roughness of inside surface of the lining.

Weight: 1-inch has maximum weight of 28 lb/100 ft; 1½ inch 33 lb/100 ft.

Written material: Federal specification A-A-59226 available from General Supply Administration (GSA).

b. Cotton-synthetic lined

This hose is used where higher working pressures are required. It has a working pressure of 450 psi. The cotton fibers run lengthwise (warp), and the synthetic fillers run crosswise, to form the weave. This combination makes a lighter, stronger jacket, but is subject to heat and flame damage. Grade A liners, capable of

WATER DELIVERY COMPONENTS AND ACCESSORIES

Hose

withstanding long periods of weather aging and high ozone conditions without checking or cracking are also available. Combination fabric jackets come in both 1- and 1½ inch diameters, and are usually furnished in 50- and 100-foot lengths.

Type: Single jacket fabric, rubber lined.

Construction and materials: The jacket consists of woven cotton and polyester filler yarn. The liner is a petroleum-based thermoplastic polyester elastomer with a smooth inner surface. The jacket and liner are bonded together.

Available from GSA:

100 foot
1 inch (20.38 lb/100 feet)
NSN 4210-00-777-1591

100 foot
1½ inch (26.88 lb/100 feet)
NSN 4210-00-777-1592

Written material: Specification 5100-186c is available from:

USDA Forest Service
Technology and Development Center
444 East Bonita Avenue
San Dimas, CA 91773
Phone: 909-599-1267

c. Synthetic lightweight lined type I hose

Type: Single jacket fabric, lined, mildew resistant, with a working pressure of 45 psi.

Construction and materials: The jacket consists of interwoven synthetic warp and filler yarns. The liner consists of synthetic rubber or a combination of other synthetic material with a smooth inner surface. The lining is fully bonded to the jacket.

Available from GSA:

100 foot
1 inch (9.38 lb/100 feet*)
NSN 4210-01-166-8122

100 foot
1½ inch (15.88 lb/100 feet*)
NSN 4210-01-165-6597
(*Weight is after mildew treatment, with the couplings.)

Written material: Specification 5100-187b is available from:

USDA Forest Service
Technology and Development Center
444 East Bonita Avenue
San Dimas, CA 91773
Phone: 909-599-1267

d. Abrasion resistant synthetic lightweight lined type II hose

Type: Lined, woven single-jacket, abrasion, and mildew resistant, with a working pressure of 450 psi.

Construction and materials: The jacket consists of synthetic filler yarn woven around the hose throughout its length with warp yarn interwoven to enhance abrasion resistance. The liner is composed of natural or synthetic rubber compound or thermoplastic. The hose is treated to be mildew resistant.

Available from GSA:

100 foot
1 inch (9.00 lb/100 feet*)
NSN pending

100 foot
1½ inch (14.00 lb/100 feet*)
NSN pending
(*Weight is after mildew treatment, with the couplings.)

WATER DELIVERY COMPONENTS AND ACCESSORIES

Hose

Written materials: Specification 5100-187b.

USDA Forest Service
Technology and Development Center
444 East Bonita Avenue
San Dimas, CA 91773
Phone: 909-599-1267

e. Double-jacketed hose

Double-jacketed hose is heavier and more costly than single-jacketed hose. In practice, some engines carry one or two lengths of double-jacketed hose for the first lengths in the lay to reduce excessive losses from bursts closer to the engine.

Type: Double-jacketed, rubber-lined, with a working pressure of 400 psi.

Construction and materials: There are two jackets constructed of 100 percent virgin spun polyester yarn. The liner is a petroleum-based thermoplastic polyester elastomer with a smooth inner surface. The inside jacket and liner are bonded together.

Flow rate: Friction loss relative to hose diameters is basically the same as the cotton-synthetic lined hose. Slight differences may be due to the type of lining and roughness of the inside surface of the lining.

Weight: Weights of hoses are as follows (weights may vary depending on tolerance):

1½ inch 38 lb/100 ft; 2½ inch 68 lb/100 ft.

Written material: Federal specification A-A-59226 is available from General Services Administration (GSA).

f. Rubber lined, braided high pressure hose

Rubber-lined, rubber-covered, high-pressure hose is used as “hardline” on engine live reels. Forest Service specifications require a heavy-duty, noncollapsible water hose of braided and

molded construction. This hose is designed for use on hot fire lines with little possibility of damage. The hose can be wiped off with a dry rag after use. Abrasion resistance is high and the exterior covering is not readily damaged by the usual solvents. High-pressure hose (¾ inch ID) is available in 50-foot coupled lengths. This category also includes booster hose, which is not included in Specification 5100-185e.

Type: Compound rubber cover, multiple plies yarn reinforcement, and rubber-inner lining, with a working pressure of 600 psi. Booster hose has a working pressure of 800 psi.

Construction and materials: Multiple layers of braided or knit piles of cotton or synthetic yarn are embedded in rubber compound cover. The inner lining consists of a tube of rubber. The lining and cover are bonded together.

Available from GSA:

50 foot
¾ inch ID (28 lb/50 feet)
NSN 4210-00-595-1838

Written material: Fire equipment suppliers (see appendix G). Specification 5100-185e is available from:

USDA Forest Service
Technology and Development Center
444 East Bonita Avenue
San Dimas, CA 91773
Phone: 909-599-1267

g. Woven fabric hardline hose.

This hose is used as an initial attack hose and is available in ¾-inch and 1-inch diameter and in 50-, 100-, and 150-foot lengths. The lightweight construction includes a woven fabric jacket, a plastic helical reinforcement component, and a coating to improve abrasion resistance. It handles like a lay-flat hose yet performs like a rigid reel hose and provides water repellency, abrasion, oil and chemical resistance.

WATER DELIVERY COMPONENTS AND ACCESSORIES

Hose

Type: Semi-rigid hardline hose, with a working pressure of 300 psi.

Construction and materials: Lightweight woven fabric of spun polyester warp yarns with plastic helical reinforcement component and elastomer extruded tubing.

Weight: Uncoupled ¾-inch (lb/100 feet) = 16; 1-inch (lb/100 feet) = 21.

Available: Fire equipment suppliers (see appendix G).

50 foot
1 inch
10.5 lb/50 feet (uncoupled)
Commercially available

100 foot
1 inch
21.0 lb/100 feet (uncoupled)
Commercially available

Written material: *Hardline Hose Comparison Study*, Tech Tip 0251 1307—SDTDC, is available from:

USDA Forest Service
Technology and Development Center
444 East Bonita Avenue
San Dimas, CA 91773
Phone: 909-599-1267

h. Relay-supply large diameter hose

A single-jacket relay-supply hose has seen increasing use in the United States by fire departments. The single-jacket, made of all-synthetic fibers, is coated inside and out with a thin protective coating. The hose is available in 3½-, 4-, 4½-, 5-, and 6-inch diameters, and is often coupled with a lightweight aluminum alloy quick-connect coupling.

The hose is intended for supply line use only from a water source to the engine. It is **not** intended to move large volumes of water long distances, and **never** to a manifold or on the discharge side of an engine. Limited use has been made of this hose at airtanker bases for loading. Usually this hose performs poorly when subjected to a kink test.

i. Garden hose

Garden hose (pencil hose) is **not** recommended for general fire use, even though it has been used in some areas. Constructed of rubber or collapsible synthetic materials, difficulty in maintaining standard working pressures, and the uncertainty of buying premium products make this use hazardous. When garden hose is pressurized, a “scissor-like” condition occurs that increases the diameter and shortens the hose significantly. This can cause coupling failures and—when on hose reels—damage in and around the reel hub attachment and failure of some reel hubs.

Available from GSA: Synthetic garden hose NSN 4210-01-167-1061.

j. Suction hose, heavy duty

Hard-suction draft hose is used on all engines and with all portable pumps. Under Forest Service Specification 5100-184c, the hose is made of a natural or synthetic-rubber tube; a jacket consisting of cotton warp yarns or other suitable yarns interwoven with a helix or helixes of round spring-temper wire and fillers of yarn; and a synthetic-rubber outer covering. The coupled hose is designed for a hydrostatic-proof pressure test of 100 psi and a vacuum of 25 inches of mercury without internal blistering, undue distortion, or leakage. Suction hoses are usually furnished in 8- and 10-foot lengths. Soft suction is now widely accepted in fire department practice where engines connect directly to hydrants. The weight savings and flexibility of these 2½- to 6-inch diameters are significant factors.

WATER DELIVERY COMPONENTS AND ACCESSORIES

Hose

Available from GSA:

8 foot
1½ inch
10.48 lb/8 foot
NSN 4210-00-889-1774

10 foot
1½ inch
12.88 lb/10 foot
NSN 4210-00-889-1775

8 foot
2½ inch
20.40 lb/8 foot
only commercially available

10 foot
2½ inch
25.00 lb/10 foot
only commercially available

Written material: Specification 5100-184c is available from:

USDA Forest Service
Technology and Development Center
444 East Bonita Avenue
San Dimas, CA 91773
Phone: 909-599-1267

k. Suction hose, lightweight

New technology presents a lighter construction with comparable performance, capable of holding a vacuum of 25 inches of mercury and a hydrostatic proof pressure higher than the rubber draft hose, at a proof of 600 psi. It has an encapsulation treatment for enhanced abrasion resistance and the manufacturer claims an increased resistance to acids, oils, chemicals, and salt water.

Type: Woven fabric jacket suction hose

Construction and materials: Woven fabric jacket and a plastic helical reinforcement component have an encapsulation treatment. The extruded tubing is an ozone resistant, and age resistant EPDM extruded elastomer.

Weight: 1½ inch 45 lb/100 foot; 2 inch 50 lb/100 foot.

Available: Fire equipment suppliers (see appendix G).

Written materials: *Draft Hose Comparison Study*, Tech Tip 0351 1309, March 2003 SDTDC, is available from:

USDA Forest Service
Technology and Development Center
444 East Bonita Avenue
San Dimas, CA 91773
Phone: 909-599-1267

l. Cotton-synthetic self-protecting (weeping) hoses

These hoses are used as replacement for linen (unlined) hose. Cotton-synthetic hoses are lightweight, treated to prevent mildew, and designed for uniform weeping, fast drying time, and high-heat resistance. Synthetic hoses are designed for high working pressures, high temperatures, and abrasion-resistance; they may be lined for antifriction and hose-weep control to protect the hose.

Written material: Fire equipment suppliers (see appendix G).

Note: Unlined (linen) hose is no longer available. Refer to USDA Forest Service *Wildland Fire Hose Guide*, February 1997, NFES 1308.

WATER DELIVERY COMPONENTS AND ACCESSORIES

Hose Dispensers and Storage

B. Hose Dispensers and Storage

There are several methods of storing fire hose and dispensing them for wildland firefighting. Many ingenious systems probably have been developed by fire crews to suit their own special needs. Fire equipment suppliers have some general-purpose equipment available, especially hose reels that are produced in manufacturing plants.

Rubber-lined, rubber-covered, high-pressure hose (also called booster hose) is normally stored and dispensed on live reels. Woven lined and unlined types of hose may be stored in baskets, as hose packs, on trays, or rolled and stored in compartments and are dispensed by hand. Hard suction draft hose is normally stored in a plastic or metal bin in a side compartment, or stored in tubes or trays.

1. Reels

A hose reel basically consists of a drum, side rims, revolving joint on one end, self-aligning bearing on the other end, frame, inlet and outlet hose connections, electric or hand-crank rewind, and a brake. Various sizes are available. Rubber or fabric hoses in $\frac{3}{4}$ or 1 inch sizes are used on the reels that are usually connected to the pump and kept filled with water ready for use; thus considering it as a "live reel."



Construction and material: Constructed of steel or aluminum. Drum and rims may be open or closed. Swivel joint connection may be capable of operating at hydrostatic pressures of at least 600 psi. Rewind by hand crank, electric motor, or by hand using side rims. Brakes maintain position of reel and hose. Hose reel information is available from equipment suppliers. Normal use is with 150 to 250 foot high-pressure rubber hose.

Written material: Hose reel manufacturers (see appendix G). Specification 5100-340 is available from:

USDA Forest Service
Technology and Development Center
444 East Bonita Avenue
San Dimas, CA 91773

WATER DELIVERY COMPONENTS AND ACCESSORIES

Hose Dispensers and Storage

2. Baskets

Hose baskets in this *Guide* are those that are normally used with fire engines for wildland firefighting. They consist of a rectangular-, circular-, or oval-shaped container. The wooden duckboard bottom keeps the hose off the metal floor and prevents mildew and abrasion damage. A water repellent fabric cover protects the hose from the elements. The hose may be connected to the pump, kept filled with water, and ready for immediate use; thus considering it as a “live hose basket.”



Construction and material: Constructed of steel sides, wooden duckboards on the bottom, and water repellent-type fabric cover. Fabric type $\frac{3}{4}$ - or 1-inch fire hose connected to the engine through a hole in the side of the basket. Length of hose depends on size and type. Normal use is 200 foot 1-inch single cotton-synthetic jacket lined hose. Basic advantage is not to obstruct rear view of the driver and has no moving parts.

Written material: Drawing available from:

USDA Forest Service
Technology and Development Center
444 East Bonita Avenue
San Dimas, CA 91773

3. Packs

Hose packs in this *Guide* are portable types that a firefighter can carry, usually as a backpack. They may consist of a lightweight frame or board, or require no packboard or frame. Straps are used to contain the hose. Usually jigs are used to fold or wind the hose for proper fit. The hose is dispensed from the container as the loose end is pulled off, or the hose-carrying individual walks away with the loose end anchored, or—if the hose is in a roll—it is rolled out. Rapid deployment is the main objective.

a. Forester hose packsack



Construction and material: Dark green heavy-duty nylon duck cloth. Includes shoulder straps and a chest strap. The top closes with a drawstring and a zippered pocket flap.

Written material: GSA *Wildfire Protection Equipment and Supplies* catalog and fire equipment suppliers (see appendix G).

WATER DELIVERY COMPONENTS AND ACCESSORIES

Hose Dispensers and Storage

b. Rhode Island hose pack



Construction and material: Hose rolled on a Rhode Island hose roller is opened and connected in a hose bag. Hose will then lay precoupled without kinking.

Written material:

Dept. of Environmental Management
Division of Forest Environment
1037 Hartford Pike
North Scituate, RI 02857

c. Canadian style hose pack



Construction and material: Cordura nylon outer pack with cardboard box inside to hold hose. The pack holds 400 feet of 1½-inch synthetic weeping hose. The hose is woven on a plywood jig and then inserted into a cardboard box. The cardboard box reduces the need to have every pack in the Cordura nylon outer pack. Once a box is used, it can be taken out of the pack and a full one put in. Approximate weight is 54 pounds.

Written material:

Northeast Interagency Fire Cache
402 SE 11th Street
Grand Rapids, MN 55744

WATER DELIVERY COMPONENTS AND ACCESSORIES

Hose Dispensers and Storage

d. Gansner hose pack



Construction and materials: Progressive hose lay that requires no packboard; stiffness of the hose is used as support. Hose is bound with tie-cords and shoulder straps are loops of hose. Capacity is 100 feet each of 1- and 1½-inch fire hose.

Written material:

USDA Forest Service
Pacific Southwest Region
Plumas National Forest
Mount Hough Ranger District
39696 Highway 70
Quincy, CA 95971

e. Modified Gansner hose pack (Cleveland National Forest)



Construction and material: Same materials as the Gansner hose pack, only a different configuration that does not deploy hose as the firefighter advances. The 1½-inch hose is used to suppress wildfire, and the 1-inch hose is used for laterals that are only charged when and if needed after the initial suppression action. Can be utilized in heavier fuels where more water volume is desired. Requires no packboard, stiffness of hose is used as support. Hose is bound with nylon shroud cord and 1½-inch hose is looped for shoulder straps. Contains a 1½-inch gated wye valve with reducer and adapter. Approximate weight with hose is 22 pounds. A training CD is also available.

WATER DELIVERY COMPONENTS AND ACCESSORIES

Hose Dispensers and Storage



There is also an additional variation to the Cleveland National Forest-modified Gansner hose pack. This variation requires that the hose be prepacked in two separate configurations. One hose pack contains two 100-foot lengths of 1½-inch hose, with a hose line tee fitting connecting them, which allows for the addition of a lateral hose when and if it is needed. The second hose pack contains three 100-foot lengths of 1-inch hose, each packed independently so they can be deployed as lateral hoses at existing hose line tee fitting locations as needed.

Written material:

USDA Forest Service
Pacific Southwest Region
Cleveland National Forest
10845 Rancho Bernardo Road,
Suite 200
San Diego, CA 92127-2107

f. Travis hose pack



Construction and materials: Progressive hose lay that requires a heavy duty nylon duck packsack to harness 100 feet each of 1-inch and 1½-inch all-synthetic hose capacity. Total weight is 27 pounds. A training CD is also available.

Written material and training CD:

USDA Forest Service
Prescott National Forest
Henry Y.H. Kim Fire Center
2400 Melville Drive
Prescott, AZ 86301

WATER DELIVERY COMPONENTS AND ACCESSORIES

Hose Dispensers and Storage

g. *Pondosa pack*



Construction and materials: Two 100 foot lengths of 1½-inch all-synthetic hose single donut roll with female coupling outside and one 100 foot length all-synthetic hose single donut roll with female coupling outside. A hose line tee and a 1½-inch NH by 1 inch NPSH reducer is included and an adjustable barrel combination nozzle is attached to the 1 inch hose. The pack is constructed of polypropylene webbing, 1,000 Denier Cordura, and acetyl buckles.

Written material:

Corvallis Fire Department
400 NW Harrison Boulevard
Corvallis, OR 97330

There are numerous additional packs available that are not listed in this section. For additional information on commercial packs available see appendix G, Suppliers.

4. Hose packing boxes and devices

a. *Gansner pack*

The boxes and devices seen here are used to produce the Gansner hose pack (see 3.d). Similar boxes are used to produce other types of hose packs. Step-by-step procedures for packing the Gansner hose pack are available.



Written material:

USDA Forest Service
Pacific Southwest Region
Plumas National Forest
Mount Hough Ranger District
39696 Highway 70
Quincy, CA 95971

WATER DELIVERY COMPONENTS AND ACCESSORIES

Hose Dispensers and Storage

b. Travis pack

The device shown here is used to assemble the Travis hose pack (see 3.e.). Step-by-step procedures for packing the Travis hose pack are available.

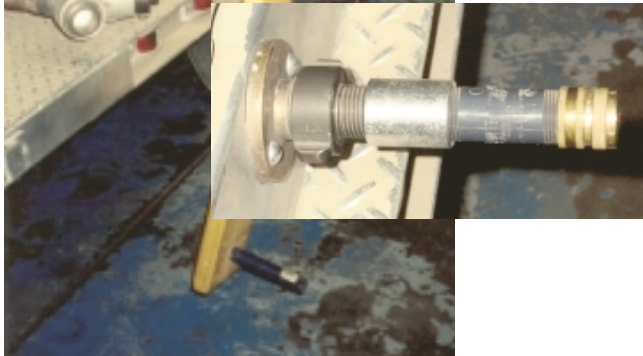

5. Trays



Hose trays are used to contain and store fire hose neatly so that when needed the trays can be dispensed efficiently with a minimum of time. Capacity can be up to 2,000 feet of hose, depending on the type of hose and the engine size. The trays are custom made to suit the engine. The advantages of trays are that they can be assembled before loading on the engine and additional standby trays can be made ready. Trays are usually made of wood, aluminum, or expanded metal. Duckboard floors prevent mildew and reduce abrasion damage. In addition to hose trays on engines, hose trays can be used on specialized vehicles such as hose trucks and hose trailers. Many variations are in existence, and commercial sources are available.

Written material and training CD:

USDA Forest Service
Prescott National Forest
Henry Y.H. Kim Fire Center
2400 Melville Drive
Prescott, AZ 86301

WATER DELIVERY COMPONENTS AND ACCESSORIES

Hose Dispensers and Storage

6. Storage



Hard suction draft hose is normally used on engines. The hard suction draft hose used is usually in 8- or 10-foot lengths, and ranging in diameter from 1 to 6 inches. Exceptions in length and diameter can be found. Due to the inflexibility of the draft hose sections, storage methods vary. Draft hose normally is stored within a side compartment, or placed within external tubes or trays. A plastic or metal bin may be attached to the forward end of slip-on units for rolled suction hose storage.



Indoor hose storage—When fire hose (particularly fabric type) is properly maintained and stored, it will have an extended life and provide dependable service on the fireline. Storage racks can be constructed to provide a neat, well-ventilated hose storage area. There are other methods that can be “homemade” and just as practical.

Written material: Fire equipment suppliers (see appendix G).

WATER DELIVERY COMPONENTS AND ACCESSORIES

Hose Accessories

C. Hose Accessories

Miscellaneous accessories that are useful in wildland firefighting support activities include such items as hose discharge and friction loss calculators, hose shutoff clamps, mop-up kits, hose rollers, water storage tanks, hydrant wrenches, and others.

Purpose: The slide rule is used to perform friction loss and nozzle discharge calculations.

Available: National Interagency Fire Cache NFES 0897, fire equipment suppliers (see appendix G).

1. Discharge and friction loss calculators

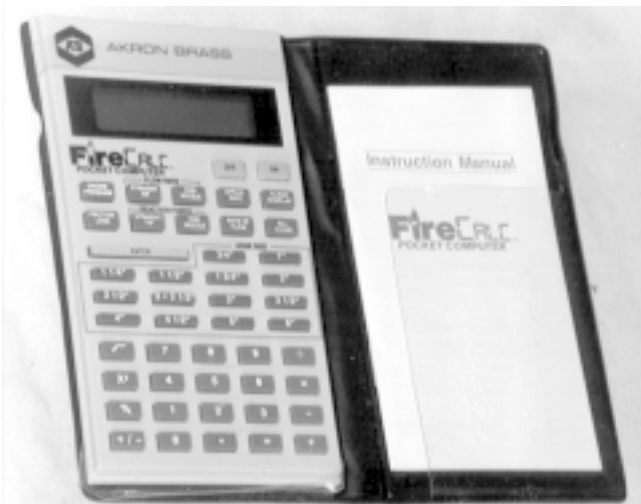

Type: Hand-held calculator

Construction and material: Pocket size, plastic.

Purpose: This hand-held calculator is preprogrammed to solve water hydraulic problems common to firefighting.

Available: Fire equipment suppliers (see appendix G).



Type: Personal data assistant (PDA).

Construction and material: Pocket size, plastic.

Purpose: Hand-held organizer, fire hose software can be purchased to solve firefighting hydraulics problems. Several different models are available in various price ranges.

Available: Fire equipment suppliers (see appendix G).

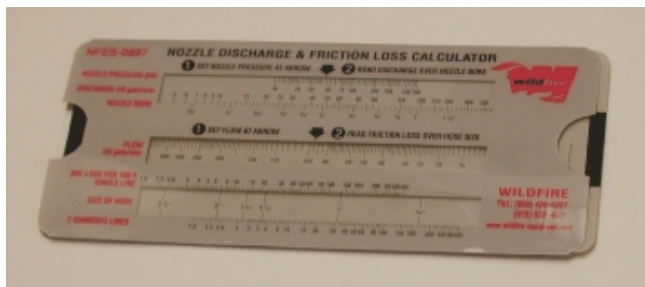

Type: Hand-held slide rule

Construction and material: Pocket size, plastic.

WATER DELIVERY COMPONENTS AND ACCESSORIES

Hose Accessories

2. Hose shutoff clamps

a. Hose shutoff clamp



Type: Two-piece jaws with lever arm.

Construction and material: Pocket size, hand operated, light, corrosion-resistant alloy.

Purpose: Shutoff water in hose line to prevent loss of water when a fire hose bursts, or for other purposes—such as rapid changing of nozzles, hoses, and so on.

Available from GSA: NSN 4210-00-767-7123.

Written material: Fire equipment suppliers (see appendix G). For specification 5100-245c:

USDA Forest Service
Technology and Development Center
444 East Bonita Avenue
San Dimas, CA 91773
909-599-1267

b. Hose shutoff clamp inserts



Type: Inserts for two-piece jaws with lever arm.

Construction and material: Inserts are fabricated of various materials including cotton-synthetic or lightweight synthetic fire hose, bicycle inner tube, duct tape, rubber or plastic liners and rubber bands.

Purpose: Hose clamps without the inserts will slip out of position (when used with lightweight synthetic fire hose) thus not clamping effectively under normal working pressure.

Written material: Instructions for construction are detailed in the Tech Tip *Hose Clamp Inserts For Use On Lightweight Synthetic Fire Hose*, 5100 9651 1305-SDTDC, June 1996 which is available from:

USDA Forest Service
Technology and Development Center
444 East Bonita Avenue
San Dimas, CA 91773
909-599-1267

WATER DELIVERY COMPONENTS AND ACCESSORIES

Hose Accessories

3. Kits and accessories



a. Mop-up accessories, three-person

Type: Three-person, mop-up kit.

Construction and material: Kit consists of hose, hose line tees, reducers, wyes, applicators, nozzles, gaskets, shutoff valves, spanners, and more. Quantities sufficient for a three-person operation.

Purpose: Provide necessary mop-up tools in an identified, standardized kit.

Available from GSA: NSN 4210-01-321-4206.

b. Helicopter slingable suppression water bag accessory kit



Type: Accessory kit attachment for a 72 gallon helicopter slingable suppression water bag.

Construction and materials: Rugged nylon pack-cloth with snap hooks for attachment to water tank. A pre-attached rope is provided for tethering the suppression water bag on steep slopes. Also supplied are 10 rolls of synthetic garden hose, 5 each 3/4-inch nozzles, wyes, ball valves, 1-inch to 3/4-inch reducers, and 2 backpack pumps. All accessories are stored in special pockets of suppression water bag kit. Shoulder straps for carrying empty suppression water bag and accessories are included in kit.

Availability and written materials:

Missoula Smokejumper Unit
Aerial Fire Depot
Box 6, Airport Terminal
Missoula, MT 59801

WATER DELIVERY COMPONENTS AND ACCESSORIES

Hose Accessories

4. Hose rollers a. Hand roller



Type: Wall-mounted, hand crank.

Construction and material: roller made of steel which pivots on a pin bracket which mounts on a post or wall. Equipped with quick release and designed for 1- or 1½ - inch, 50- and 100-foot fire hose.

Available: Fire equipment suppliers (see appendix G).

b. Rhode Island hose roller



Type: Action roll (roll fold).

Construction: Commercially available hose roller modified by Rhode Island to be powered by an electric motor.

Available: Rhode Island Division of Forest Environment and Wildfire Equipment Inc.

WATER DELIVERY COMPONENTS AND ACCESSORIES

Hose Accessories

c. Fire cache hose roller



Type: Electric single roll for 1 inch, 1½ inch, 1¾ inch, 2 inch, and quarter-turn coupled hose.

Construction and material: Push plate release mechanism. Two roller bearings provide the tension. Powered by a ¼-hp single-phase electric motor which is activated by foot pedal. A portable generator may also be ordered to provide power source.

Available: Specifications available from:

USDA Forest Service
Technology and Development Center
444 East Bonita Avenue
San Dimas, CA 91773
909-599-1267

d. Redmond cache hose roller



Type: Gas powered.

Construction and material: A 5-hp Briggs & Stratton engine; two stations that will roll single- or double-rolled hose, with foot controls.

Available: Specifications available from:

USDA Forest Service
Redmond Fire Center
Airport Way
Redmond, OR 97756

WATER DELIVERY COMPONENTS AND ACCESSORIES

Hose Accessories

e. Synthetic garden hose hand roller



Type: Hand-held.

Construction and materials: Hand crank operated plastic roller designed to roll 50-foot lengths of synthetic garden hose (pencil hose).

Available: National Fire Cache System, NFES 0666.

5. Hydrant and spanner wrenches

Hydrant wrenches can be obtained in various sizes to fit water hydrant stems. Spanner wrenches can be obtained in various sizes to fit any connection combination (rocker, slotted, or pin lugs). Combination wrenches are available that can handle both hydrant stems and spanner lugs.

a. Hydrant wrench

Type: Municipal fire hydrant.

Construction and material: Designed to fit multiple valve stem sizes. Other optional uses for rocker pin lug spanner may be included. Made of steel or other alloy metal.

Size: $\frac{3}{4}$, 1, and 1½ inch.

Available: Fire equipment suppliers (see appendix G).



WATER DELIVERY COMPONENTS AND ACCESSORIES

Hose Accessories

b. Adjustable hydrant wrench

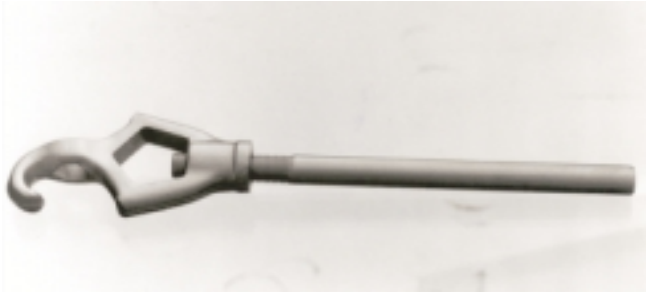

Type: Rocker lug, pin, or slotted.

Construction and material: Adjustable, cast or forged. Made from manganese bronze, aluminum alloy, or bronze.

Sizes: Fire coupling $\frac{3}{4}$ to 2 inch, and other sizes.

Available from GSA: NSN 5120-00-288-8849.

d. Universal spanner



Type: Pin or rocker lug.

Construction and material: Standard type is provided with gas cock slot and pin bar at end.

Sizes: Fit pin or rocker lugs $\frac{3}{4}$ to 3 inch.

Available: Fire equipment suppliers (see appendix G).

c. Lightweight spanner wrench



Type: Pin or rocker lug.

Construction and material: Combination sizes, pocket fit; Forest Service specification 5100-101b.

Size: 1 to 1½ inch.

Available from GSA: NSN 5120-00-596-1426.

e. Combination spanner



Type: Pin or rocker lug.

Construction and material: Combination sizes, pocket fit.

Size: 1 to 2½ inch.

Available from GSA: NSN 5120-00-596-1427.

WATER DELIVERY COMPONENTS AND ACCESSORIES

Hose Accessories

f. Folding spanner



Type: Slotted or rocker lug.

Construction and material: Folding, plastic, metal, or fiberglass.

Sizes: 1½ to 2½ inch.

Available: Fire equipment suppliers (see appendix G).

g. Quick-connect (quarter-turn) spanners



Type: Rocker lug

Construction and material: Cast aluminum alloy

Size: ¾ to 2 inch

Available: Fire equipment suppliers (see appendix G).

WATER DELIVERY COMPONENTS AND ACCESSORIES

Hose Test and Maintenance Equipment

D. Hose Test and Maintenance Equipment

Testing and maintenance equipment for hoses and fire pumps is available from fire equipment companies. This type of equipment is useful in fire cache maintenance facilities and in fire stations. For proper maintenance, hoses should be washed, dried, and repaired. Pumps should be cleaned, adjusted, and repaired. Engines, pumps, and hoses should be pressure tested. All this requires appropriate tools and equipment. See appendix C for gauge quality and accuracy information.

1. In-line gauge



Type: In-line pump discharge pressure.

Construction and material: Short tube inlet and male outlet, and a pressure gauge on the side of the tube. Female end may be swiveled and have lugs. Hose threads are on both ends. Sizes are varied up to 2½ inches. Pressure gauge ranges up to 600 psi. The tube is made of steel or brass.

Purpose: Testing pump discharge and hose pressure performance.

Available: Fire equipment suppliers (see appendix G).

2. Hose washers

a. Mechanical hose washer



Type: Powered mechanical hose washer.

Construction and material: Inlet for water-source connection. Uniform washing, multiple scrub brushes, one-person operation. Use clear water or detergent.

Purpose: High-volume hose washing.

Available: Fire equipment suppliers (see appendix G).

b. Manual hose washer



Type: Cylinder.

Construction: Cylinder with 1½-inch water source connection.

Action: Hose is passed through cylinder against water stream so that dislodged particles are washed away from hose.

Available: Fire equipment suppliers (see appendix G).

WATER DELIVERY COMPONENTS AND ACCESSORIES

Hose Test and Maintenance Equipment

3. Hose dryers

a. Electric dryer



Though many fire control agencies rely on air-drying of fire hose, mechanical dryers are available with either gas or electric heat for fast, safe, and effective drying of fire hose as well as clothing. The systems work with prewarmed dry air circulating through the drying chamber with five to six air changes per minute.

Available: Fire equipment suppliers (see appendix G).

b. Air dryers



Typical hose drying rack.



South Zone Fire Cache hose tower.
Drawings available from:

USDA Forest Service
South Zone Fire Cache
1310 South Cucamonga Avenue
Ontario, CA 91761

WATER DELIVERY COMPONENTS AND ACCESSORIES

Hose Test and Maintenance Equipment

4. Hose cutters and coupling expanders

a. Hose cutters



When fabric-type fire hoses are to be cut and recoupled, a reasonably accurate cutting tool should be used to produce a square and clean-cut edge. The cutter illustrated above was designed to specifically cut fire hoses. It is capable of cutting hose sizes up to 2½ inches.

Written material: Fire equipment suppliers (see appendix G).

b. Expanders

Expanders, either manual or power operated, are used for attaching fire hose couplings. Expanders are available in 1- to 3-inch sizes, with larger sizes available.

Available: Fire equipment suppliers (see appendix G).

• Hand expander



• Hand-operated hydraulic expander



WATER DELIVERY COMPONENTS AND ACCESSORIES

Hose Test and Maintenance Equipment

- Power expander



5. Hose testers



Fire hose is subject to deterioration after use on fires and prolonged storage (subject to the elements of nature). A high-pressure test pump is essential for acceptance and service testing of all fire hose to assure compliance with specification, determine serviceability, permit discarding or repair of defective material, and for testing the adequacy of recoupling jobs. Standard equipment usually includes a pump, suction connection, hose connection(s), pressure gauge, bypass and pressure-regulating valves, and may be hand operated or engine driven. Specific features and additional details are given in suppliers' catalogs.

WATER DELIVERY COMPONENTS AND ACCESSORIES

Fittings and Connections

E. Fittings and Connections

1. General

Connections and fittings considered in this *Guide* are those that are normally connected by hand or spanner wrenches. Threads are varied, and each fire agency has its own standards. The NFPA standards are prevalent. Construction materials are brass, aluminum, or others as specified by purchaser. Lugs are rocker, pin, or long-handled type. Gaskets are usually located with each female hose thread connection. Quick-connect type couplings are in service. Water handling technical specifications are available from the GSA website at fss.gsa.gov/fire.

2. Lugs, threads, couplings, and gaskets

a. Lugs



Pin hole lug

The photograph illustrates the many variations found among lugs made by different manufacturers. Other types of lugs include the pin, pinhole, and long handle. A knurled, nonslip surface is often used on the base of a nozzle to assist in breaking the connection. Two or three lugs are required on the swivel section of couplings, connections, valves, and wyes. Lugs are acceptable, but not required, on male coupling sections.

WATER DELIVERY COMPONENTS AND ACCESSORIES

Fittings and Connections

b. Threads

Hose threads are said to be straight or parallel. A water seal is formed as the external thread lip seats against a recessed gasket in the internal thread section. In contrast, water-pipe threads are tapered and seal against themselves.

“NH” is an abbreviation of American National Fire Hose Connection Screw Thread for garden, chemical, and fire protection hose. “NPSH” is the abbreviation for American National hose coupling threads; i.e., National Pipe Straight Hose couplings for threads and nipples. The tables below show the threads currently in use.

Hose Thread Tables

Table 4—Threads used in current Municipal/Department of Defense practices.

Nominal size (inch)	Threads per inch	Maximum male diameter (inch)	NFPA symbol
¾	8	1.38	NH
1	8	1.38	NH
1½	9	1.99	NH
2	8	2.52	NH
2½	7½	3.07	NH
3	6	3.62	NH
3½	6	4.24	NH
4	4	5.01	NH

Table 5—Threads currently used by many wildland fire agencies.

Nominal size (inch)	Threads per inch	Maximum male diameter (inch)	NWCG symbol
¾	11½	1.06	GHT
1	11½	1.30	NPSH
1½	9	1.99	NH
2	11½	2.35	NPSH
2½	7½	3.07	NH
4	4	5.01	NH

In wildland fire service, the larger diameter threads are used primarily for suction hose couplings. The 1½-inch size is by far the most common in forestry practice and is used for distribution lines. The 1-inch connection is used on most nozzle bases, on 1-inch hose, and on ¾-inch hard-rubber hose for reels.

The tips for straight stream and fog nozzles have ¾ inch 11½ GHT thread in general forestry/wildland practice as provided in Forest Service Specification 5100-244b. The NFPA standard calls for ¾-inch connections to be 8 NH threads. Use of ¾-inch garden hose couplings are designed for low pressure, low flow (mop-up) fire service use.



Higbee cut. To prevent mutilation and cross threading, and to facilitate rapid coupling, fire hose connections and fittings are manufactured with the first thread cut away or blunted. This is referred to as “blunt start” or the Higbee cut.

WATER DELIVERY COMPONENTS AND ACCESSORIES

Fittings and Connections

c. Quick-connect (quarter-turn) couplings

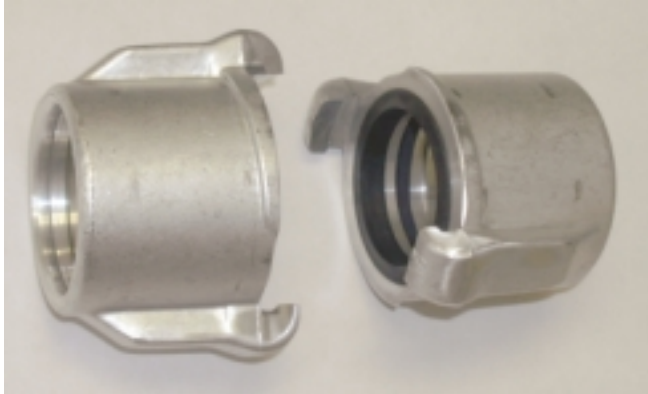

The quarter-turn (QT) hose coupler has become standard within some agencies. This coupler has the advantage of being quick and sexless. There are no male or female fittings, and one coupler size can be used on a range of hose size from $\frac{3}{4}$ to $1\frac{1}{2}$ inch. This allows for a simple system to reducing hose size, as it is not necessary to stock 1- and $1\frac{1}{2}$ -inch thread adapters, double male couplings and double female couplings, reducers, and increasers. Adapters are available for connecting to pumps, wyes, and nozzles. Fittings of 1 and $1\frac{1}{2}$ inch connect interchangeably. Only a quarter of a turn is required to couple and uncouple hose, connections, and fittings.

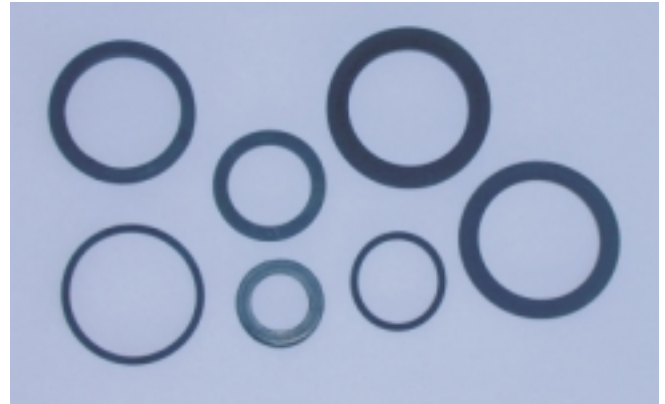

The OD of gaskets has never been standardized, and depends entirely on the width of the gasket seat in the hose bowl. On rubber-lined hose, this dimension must be measured and a gasket provided with an OD wide enough to prevent seepage between the rubber liner and the outside emerging, ensuring a watertight fit. Seepage will cause hose “blistering” to develop and eventually rupture the hose.

Available from GSA (Forest Service Specification 5100-190a):

1 inch
NSN 5330-00-720-2621

$1\frac{1}{2}$ inch
NSN 5330-00-239-1873

2 inch
NSN 5330-00-239-1875

$2\frac{1}{2}$ inch
NSN 5330-00-239-1877

4 inch
Available through various fire equipment suppliers (see appendix G).

d. Gaskets

Gaskets provide a seal for threaded connections to prevent leakage when fire hose and fittings are coupled together. They are made of soft rubber, and fit into the female end of the hose fitting against a seat provided in the manufacturing process. Gaskets are commonly $\frac{1}{16}$ inch larger than the normal ID of the hose on which used. They vary in thickness with the hose diameter ($\frac{1}{8}$ inch for hose of $\frac{3}{4}$ - to $1\frac{1}{2}$ -inch ID, $\frac{3}{16}$ inch for $2\frac{1}{2}$ - inch ID, to $\frac{1}{4}$ inch for hose of 4-inch ID, and $\frac{3}{8}$ inch for 5-inch ID and larger). Other gasket sizes are also commercially available.

WATER DELIVERY COMPONENTS AND ACCESSORIES

Fittings and Connections

3. Fittings and connections

These items include the many different types of couplings, connections, adapters, increasers, reducers, wyes, and valves required in wildland fire hose lays. If the item attaches to a fire hose lay, it should be found here. Consult the GSA *Wildfire Protection Equipment and Supplies Catalog* for many of these items or visit the website at fss.gsa.gov/fire.

a. Thread adapter



Type: Female to male with lugs.

Threads: Different hose threads on opposite ends as specified.

Size: Same on opposite ends.

Available from GSA:

1½ inch NH-F by 1½ inch NPSH-M
NSN 4210-01-079-9284

1½ inch NPSH-F by 1½ inch NH-M
NSN 4210-01-079-9283

Quick-connect quarter-turn (QT) male and female adapters



Type: Threaded to quick-connect with lugs.

Threads: As specified.

Size: 1 or 1½ inch to 1½ inch QT

Available: Fire equipment suppliers (appendix G)

1 inch NPSH by 1½ inch QT

1½ inch NH by 1½ inch QT

WATER DELIVERY COMPONENTS AND ACCESSORIES

Fittings and Connections

b. Reducer



Type: Female to male with lugs.

Threads: Same or different hose threads on both ends as specified.

Size: Different on opposite ends.

Available from GSA:

1 inch NPSH by $\frac{3}{4}$ inch NH
NSN 4210-01-079-9286

1 $\frac{1}{2}$ inch NH by 1 inch NPSH
NSN 4210-00-975-2969

1 $\frac{1}{2}$ inch NPSH by 1 inch NPSH
NSN 4210-00-294-2648

2 $\frac{1}{2}$ inch NH by 1 $\frac{1}{2}$ inch NH
Available from national fire cache:
NFES #2230
or, from fire equipment suppliers
(appendix G).

c. Increaser



Type: Female to male with lugs.

Threads: Same or different hose threads on both ends as specified.

Size: Different on opposite ends.

Available from GSA:

$\frac{3}{4}$ inch NH by 1 inch NPSH
NSN 4210-01-080-6531

1 inch NPSH by 1 $\frac{1}{2}$ inch NH
NSN 4210-01-080-6532

WATER DELIVERY COMPONENTS AND ACCESSORIES

Fittings and Connections

d. Double female coupling



Type: Swivel female ends with lugs.

Threads: Same hose threads on both ends as specified.

Size: Same on both ends as specified.

Available from GSA:

1 inch NPSH
NSN 4210-01-080-1457

1½ inch NH
NSN 4210-01-081-8749

e. Double male coupling



Type: Male ends with lugs.

Threads: Same hose threads on both ends as specified.

Size: Same on both ends as specified.

Available from GSA:

1 inch NPSH
NSN 4210-01-080-1458

1½ inch NH
NSN 4210-01-079-9285

WATER DELIVERY COMPONENTS AND ACCESSORIES

Fittings and Connections

f. Hose line tee



Type: Three-port design: inlet, branch, and outlet, with chain and cap for branch port.

Threads: Inlet and outlet same hose threads as specified.

Size: Same both ends and branch or as specified.

Available from GSA:

1 inch NPSH by 1 inch NPSH by $\frac{3}{4}$ inch NH
NSN 4210-01-081-0418

1 inch NPSH by 1 inch NPSH by 1 inch NPSH
NSN 4210-01-080-1459

$1\frac{1}{2}$ inch NH by $1\frac{1}{2}$ inch NH by 1 inch NPSH
NSN 4210-01-080-1460

g. Hose line tee with valve



Type: With valve branch, female with lug one end, male opposite end and on branch.

Threads: Inlet and outlet same hose threads as specified.

Size: As specified.

Available from GSA:

$1\frac{1}{2}$ inch NH by $1\frac{1}{2}$ inch NH by 1 inch NPSH
NSN 4210-01-081-0417

WATER DELIVERY COMPONENTS AND ACCESSORIES

Fittings and Connections

h. Ejector



Type: Straight type with foot valve.

Threads: Pipe thread adapted to hose thread as specified.

Size: As specified.

For further information regarding ejectors, reference *Water Ejectors for Use in Wildland Firefighting, 0251 1205-SDTDC, December 2002* which is available from:

USDA Forest Service
Technology and Development Center
444 East Bonita Avenue
San Dimas, CA 91773
909-599-1267

i. Bleeder valve



Type: In-line hose branch with wrench to bleed water for backpack tank.

Threads: Female one end, male other end, hose threads as specified.

Size: 1½ inch

WATER DELIVERY COMPONENTS AND ACCESSORIES

Fittings and Connections

j. Check and bleeder valve



Type: Swing check valve with bleeder valve with branch male, swivel inlet with lugs.

Threads: Female inlet, male outlet, hose threads as specified, 1 inch NPSH male branch.

Size: 1½-inch inlet and outlet.

k. Ball valve shutoff



Type: Ball with lever handle, swivel inlets.

Threads: Female inlet, male outlet, hose threads as specified.

Size: 1-inch and 1½-inch inlets and outlets as specified.

Available from GSA:

1 inch NPSH
NSN 4210-01-165-6599

1½ inch NH
NSN 4210-01-165-6600

WATER DELIVERY COMPONENTS AND ACCESSORIES

Fittings and Connections

l. Suction strainer



Type: Low-velocity, globe-shaped.

Threads: Female hose threads as specified.

Size: As specified.

Available: Fire equipment suppliers (see appendix G).

m. Foot valve

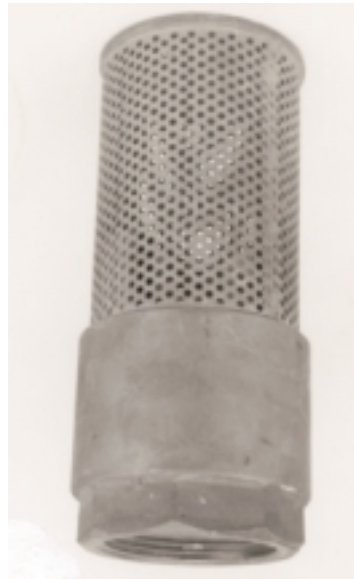

Type: Spring action with strainer female connection.

Threads: Female adapted to hose threads as specified.

Size: As specified.

Available from GSA:

1½ inch NH
NSN 4820-00-126-5114

WATER DELIVERY COMPONENTS AND ACCESSORIES

Fittings and Connections

n. Pressure relief valve



Type: In-line hose branch with spring-loaded relief valve and adjustment nut, swivel-inlet with lugs.

Threads: Female inlet, male outlet, NH threads, 1 inch NPSH threads.

Size: 1½-inch inlet and outlet.

Available: Fire equipment suppliers (see appendix G).

o. Lightweight pressure reducing valve with gauge



Type: Pressure reducing valve with pressure gauge.

Threads: Female inlet and outlet, NPT threads.

Size: Various sizes available.

Available: Fire equipment suppliers (see appendix G).

WATER DELIVERY COMPONENTS AND ACCESSORIES

Fittings and Connections

p. Gated wye valve



Type: Swivel inlet, gate valve branch outlets with handles.

Threads: Female inlet, male outlets, hose threads as specified.

Available from GSA:

1 inch NPSH
NSN 4210-00-126-5108

1½ inch NH
NSN 4210-00-984-3475

q. Plain wye



Type: Swivel inlet, branch outlets.

Threads: Female inlet, male outlets, hose threads as specified.

Size: 1½- to 6-inch inlet and 1½- or 2½-inch outlets are available.

Available: Fire equipment suppliers (see appendix G).

WATER DELIVERY COMPONENTS AND ACCESSORIES

Fittings and Connections

r. Siamese gated wye valve



Type: Two swivel inlets, ball gate valve branch inlets with handles.

Threads: Two female inlets, male outlet, threads as specified.

Size: 1½-inch and 2½-inch inlets and outlets same size as specified.

Available: Fire equipment suppliers (see appendix G).

s. Siamese wye



Type: Two swivel inlets, single outlet.

Threads: Two female inlets, male outlet, threads as specified.

Size: 1½-inch and 2½-inch inlets and outlets same size as specified.

Available: Fire equipment suppliers (see appendix G).

WATER DELIVERY COMPONENTS AND ACCESSORIES

Nozzles

F. Nozzles

1. General

There are many varieties of fire hose nozzles available to the firefighter. The municipal types, which apply large volumes of water, are **not** often practical in wildland fire situations. The shortage of water precludes any excessive usage. Nozzles are designed to do a variety of tasks. The types of nozzles found most often for wildland fires are the adjustable combination barrel, plain, twin, or multiple tips.

2. Design criteria

The following design or selection criteria have evolved from many years of wildland fire practices and numerous detailed studies.

a. Rate of application

Normally, flow is limited to 30 gpm for $\frac{3}{4}$ - and 1-inch lines and 100 gpm for the $1\frac{1}{2}$ -inch lines.

b. Application characteristics

Combination nozzles that provide both straight stream and spray patterns are required.

Good pattern—Nozzles that produce solid cone patterns are highly desirable. Less desirable nozzles have distinct hollow cones, voids, and flat, fan-shaped patterns. Some sprays look like the ribs of an umbrella as water is projected in jet streams. While combination features are desirable, some nozzles show a wide range of discharge flows, increasing with the spray cone angle. These latter patterns are a potential waste of water.

Water droplet size—Fine sprays offer better cooling and more protection to the nozzle person from excessive fire temperatures. Water droplets should be in the 0.14- to 0.39-inch size range to be most effective. Nozzles should produce uniform droplet size over a wide range of pressures.

c. Nozzle pressure

The operating range for the nozzles presented in this section are described for a 100-psi nozzle discharge pressure. Flow is reduced to about 70 percent when the nozzle pressure is reduced from 100 to 50 psi.

d. Control valves

Nozzle shutdown, flow, and pattern variations are controlled on ball valve types by a one-quarter-turn lever or handle, or tip selection. Shutdown and patterns from straight stream to fog on other nozzles are controlled by rotating the body of the nozzle from shutoff through fog to straight stream. The best of these nozzles are marked, indexed, or referenced to allow efficient operation by inexperienced firefighters.

e. Tips

If flows and patterns are varied by exchanging tips, the tips will be provided with $\frac{3}{4}$ -inch GH threads and meet the requirements of USDA Forest Service Specification 5100-244d. Standard spray tips are available from 3 to 24 gal/min. Numerous adjustable nozzles go to much higher flow rates. Ability to vary the spray is important. Variable straight streams are required for the full range of working pressures. Straight stream tips range from $\frac{1}{8}$ to $\frac{3}{8}$ inch.

f. Clogging

Since water delivery equipment picks up water in open sources at the nearest water chance, foreign matter and silt are often a problem; thus, spray nozzles should be equipped with adequate screens that can be easily removed and serviced.

g. Base-inlet

All 1-inch nozzles are provided with 1-inch $1\frac{1}{2}$ NPSH threads. All $1\frac{1}{2}$ -inch nozzles are provided with $1\frac{1}{2}$ inch 9 NH threads. Rocker lugs or a knurled base are required on all nozzles.

WATER DELIVERY COMPONENTS AND ACCESSORIES

Nozzles

h. Weight

Weight is an important factor, so lightweight material is desirable. Most all-brass nozzles have been eliminated from practical wildland fire use. Nozzles should preferably weigh no more than 2 pounds. Lightweight plastic materials may not withstand higher working pressures and rigorous use under wildland fire applications.

i. Cost

Simple, trouble-free construction providing the performance listed in items "a" through "h" is necessary. Expensive materials, such as brass, and highly polished or plated hardware and accessories, are not necessary for wildland fire applications.

Representative nozzles in widespread use that meet most of the above requirements are available under Forest Service Specification 5100-240 (nozzle, twin-tip, shutoff, 1-inch base, straight stream and fog tip). Twin tip nozzles are furnished by the Federal Supply Service as catalog item NSN 4210-00-640-1892; Barrel nozzles are available under Forest Service Specification 5100-539 (nozzle with shutoff, combination barrel). A 1-inch base is furnished by the Federal Supply Service as item NSN 4210-01-165-6603. The 1½-inch base is furnished as item 4210-01-167-1123.

3. Nozzle types and descriptions

For simplicity, nozzles can be grouped into several broad classes. If the nozzle can produce either a straight stream or a spray, it is classed as a combination type. A few nozzles can produce both patterns simultaneously, but their flow requirements are high. The more common types are listed as follows:

a. Ball shutoff with tip



Type: Single-tip, ball or cylinder lever valve shutoff, ½-inch bore, ¾-inch GHT outlet for interchangeable tips.

Action: Sequence shutoff (lever forward), straight stream or spray.

Available from GSA: NSN 4210-00-203-3519.

Weight: Approximately 1 pound, 3 ounces.

Base (inlet): 1 inch, 11½ NPSH.

Material and finish: Smooth sand-cast brass, or forged aluminum.

Performance: See twin-tip nozzle performance table for flow and pressure ranges.

WATER DELIVERY COMPONENTS AND ACCESSORIES

Nozzles

b. Smooth bore screw tip



Type: Plain 3/16-inch, 1/4-inch and 3/8-inch bore, 3/4-inch GHT outlet, with tip holder bracket.

Action: Nonadjustable, interchangeable tips (straight stream or spray).

Weight: Approximately 2 pounds, without tips.

Length: 7-inch maximum.

Base (inlet): 1 1/2 inch 9 NH.

Material and finish: Smooth sand cast brass or lexan.

Performance (flow and pressure):

c. Twin tip (forester)

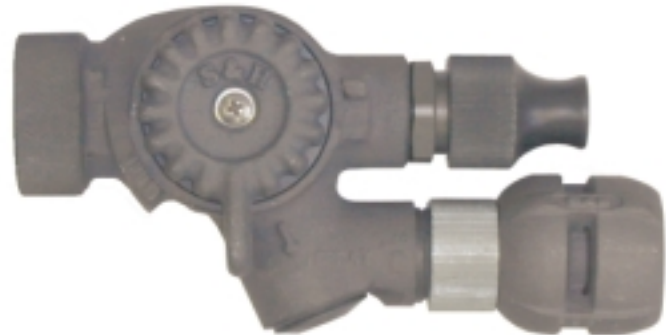

Type: Combination spray, straight stream, 1/2-inch bore, two 3/4-inch GHT outlets.

Action: Sequence shutoff, spray (fog), straight stream.

Weight: Approximately 2 pounds, 2 ounces.

Length: 7 inch.

Base (inlet): 1 inch, 11 1/2 NPSH.

Material and finish: Brushed cast aluminum alloy, knurled handgrip.

Performance (flow and pressure): Nozzle used with straight stream and spray tips (see tables on pages 171 and 172).

Available from GSA: NSN 4210-00-640-1892.

Tip size (inch)	Average Flow @ 100 psi (gal/min)	Minimum Horizontal range (feet)
3/16	10.5	34
1/4	18.7	40
3/8	42.1	41

Available: Fire equipment suppliers (see appendix G).

WATER DELIVERY COMPONENTS AND ACCESSORIES

Nozzles

d. Adjustable barrel combination



Type: Adjustable combination.

Action: Sequence shutoff, straight stream, spray.

Available from GSA:

1 inch NPSH polycarbonate
NSN 4210-00-085-2291

1½ inch NH polycarbonate
NSN 4210-00-181-8872

1 inch NPSH anodized aluminum
NSN 4210-01-165-6603

1½ inch NH anodized aluminum
NSN 4210-01-167-1123

e. Hydro-fog combination



Type: Adjustable combination barrel.

Action: Fog, straight stream, shutoff.

Weight: Varies by manufacturer and material.

Length: Varies by manufacturer and material.

Base (inlet): 1 inch NPSH; 1½ inch NH.

Material and finish: Brushed anodized aluminum, neoprene rubber bumper, stainless steel fog tip.

Typical performance (flow and pressure):

Size (inch)	Flow (gal/min)	Pressure (psi)
1	23	100
1½	95	100

Available: Fire equipment suppliers (see appendix G).

WATER DELIVERY COMPONENTS AND ACCESSORIES

Nozzles

f. Selectable gallonage



Selectable gallonage fog nozzles with gallonage selections of 5 to 350 gal/min, within operation quick flush.

The wide range of gallonage settings, ease of maintenance, size, weight, and durability make these versatile nozzles. They are available as direct-connect nozzles with integral stainless ball shutoff, or as a fog tip with twist shutoff. Models feature a flush without shutting down.

Type: selectable gallonage.

Action: Constant flow in each setting; quick-change seat.

Material and finish: Hard coat anodized; rubber bumper protection; lightweight construction.

Available: Fire equipment suppliers (see appendix G).

g. Fire hose mop-up nozzle (garden hose)



Garden hose nozzles are used for mop-up work. USDA Forest Service Specification 5100-243 covers material and construction of this nozzle.

Type: Adjustable 3/4-inch inlet.

Action: Adjustable spray, straight stream.

Material and finish: Brass or aluminum.

Garden Hose Nozzle Performance Ratings:

Position	Min. discharge @ 100 psi (gal/min)
1—High-velocity, low-discharge, wide-angle spray	4
2—Straight stream spray	5
3—Low-velocity, high-discharge spray	8

Available from GSA: NSN 4730-00-595-1103.

WATER DELIVERY COMPONENTS AND ACCESSORIES

Nozzles

4. Nozzle tips

Since nozzle tips are comparatively small (in size), $\frac{3}{4}$ -inch GHT has been adopted for the base thread. The USDA Forest Service maintains Specification 5100-244 on straight stream and spray tips. This specification lists five different diameter straight stream tips and eight different flows (gal/min) in spray tips. The bore diameter is identified on the outlet flange of the straight stream tips, and the flow (gal/min) is stamped on the body of the spray tips. The spray tips are designed to withstand a pressure of 600 psi. Straight stream tips are designed to withstand a pressure of 200 psi. Materials and construction are detailed in Forest Service Specification 5100-244.

a. Straight stream



Straight stream tips are designed and inspected to produce the following performance:

Tip size (inch)	Min. stream @ 100 psi (feet)*	Min. Flow rate @ 100 psi (gal/min)	Max. Flow rate @ 100 psi (gal/min)
$\frac{1}{8}$	29	4.2	5.2
$\frac{3}{16}$	34	9.4	11.6
$\frac{1}{4}$	40	16.8	20.6
$\frac{5}{16}$	41	25.3	32.1
$\frac{3}{8}$	41	37.9	46.3

*Measured 36 inches above the ground, and to the center of the area where the stream strikes the ground.

Available from GSA:

$\frac{3}{16}$ inch
NSN 4210-00-203-3855

$\frac{1}{4}$ inch
NSN 4210-00-177-6135

$\frac{3}{8}$ inch
NSN 4210-00-203-3845

WATER DELIVERY COMPONENTS AND ACCESSORIES

Nozzles

b. Spray



The spray requirements specify a uniform solid-cone mist with a minimum horizontal range of 12 feet. The flow rate at a tip pressure of 100 psi must be within the range shown in the following table:

Tip No.	Discharge Angle (deg)		Flow rate (gal/min)	
	Min.	Max.	Min.	Max.
3	18	22	2.0	4.0
6	18	22	5.0	7.0
8	18	22	7.0	9.9
9	26	30	8.0	10.0
12	26	30	11.0	13.0
15	26	30	13.5	16.5
18	26	30	16.5	19.5
24	26	30	22.5	25.5

Available from GSA:

Size 3
NSN 4210-00-204-3358

Size 6
NSN 4210-00-204-3386

5. Applicator pipe



An applicator pipe, or wand, is available for reaching under logs, roots, stumps, and into the base of piled fuels. It can be used in deep duff, peat, and sawdust. The applicator is 52 inches long, comes apart in the middle, and has a 15-degree bend near the end. All connections are 3/4-inch GHT male threads to accommodate a special low-flow spray tip (3 gal/min with a 60 degree pattern). It is also a component of the Mop-up Kit.

Available from GSA: NSN 4210-01-412-5688

WATER DELIVERY COMPONENTS AND ACCESSORIES

Water Storage Tanks

G. Water Storage Tanks (Folding/Collapsible)



Type: Helicopter slingable suppression water bag

Construction and material: Integral sling straps with a 4-inch steel cargo ring. Replaceable PVC liner inside bag on 55-gallon size. The 72- and 134-gallon sizes are constructed of heavy-duty vinyl with a 4-inch filler and a valved 1-inch discharge hose. Three reinforced straps with a large ring serve as a lifting sling for aerial use.

Sizes: 55-, 72- and 134-gallon

Available from GSA: NSN 8465-01-369-2148 for 55-gallon; 72- and 134-gallon available through fire equipment suppliers (see appendix G). See section C, Hose Accessories for helicopter slingable water suppression bag accessory kit.

Type: Auxiliary storage tank.

Construction and material: May be self-supporting, pyramidal, or pillow-shaped collapsible canvas tanks; or steel or anodized aluminum tubing frame with Hypalon or vinyl tank liner having grommeted edges for attaching to a frame. Each type is foldable for easy storage and transport.

Sizes: 75 to 300 gallons for normal relay type use, large 600-, 1,000-, 1,200-, 1,500-, 1,600-, 1,800-, 2,000-, 2,100-, 2,500-, 3,000-, 4,000- and 5,000-gallon capacities.

Available: Fire equipment suppliers (see appendix G).

WATER DELIVERY COMPONENTS AND ACCESSORIES

Water Diversion and Storage Devices

H. Water Diversion and Storage Devices

1. Portable dam

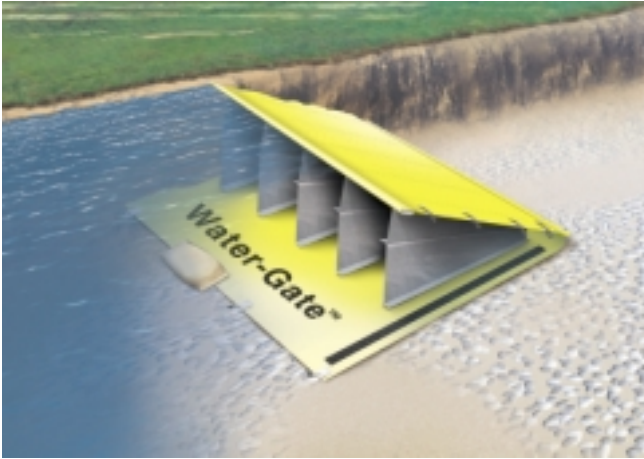

Type: Reusable, portable

Construction and material: Polyethylene covered with PVC. Self-supporting. Float system sewn at front of barrier to automatically rise according to water level.

Sizes: 21- or 28-inch height, 35- or 50-foot length standard sizes. Other sizes are also available.

Available: Fire equipment suppliers (see appendix G).

2. Gravity sock



Type: Canvas, 3- to 4-foot long; 8-inch to 15-inch inlet, upstream feed.

Threads: Male hose thread outlet as specified.

Size: 1½ inch.

Available: Fire equipment suppliers (see appendix G).



WATER DELIVERY COMPONENTS AND ACCESSORIES

Specialized Equipment

I. Specialized Equipment

1. Remotely activated pump (structure protection)



Type: Remotely activated BB-4 pump.

Purpose: Provide firefighters with a way to remotely activate pumps from overhead to charge sprinkler systems for structure protection.

Construction and materials: A BB-4 pump, powered by an 18 horsepower Briggs & Stratton engine, is outfitted with an electronic ground receiver system and 12 volt power booster battery pack that allows a handheld transmitter to activate the system. A strobe light attached to the pump signals activation.

Weight: 143 pounds.

Available: Fire equipment suppliers (see appendix G).

Written materials: *Remotely Activated Structure Pump*, Tech Tip 0251 1315, July 2002 - SDTDC, is available from:

USDA Forest Service
Technology and Development Center
444 East Bonita Avenue
San Dimas, CA 91773
Telephone: 909-599-1267

2. Sprinkler kit



Type: Sprinkler kit

Purpose: Provide standardized items necessary to set up sprinkler system.

Construction and materials: Kit consists of eight sprinkler heads, shutoff valves, in-line tees, risers, couplings, adapters, extensions, u-bolts, hold down pins, rope, and tent stakes. An adjustable wrench and hammer are also included in the carton.

Weight: 50 pounds

Available: National Fire Cache System, NFES 0920

APPENDIX A

APPENDIXES A—Nozzle Flow Rates

Flow discharge of smooth bore nozzles in gallons per minute (gal/min)

Head (psi)	Head (ft)	Velocity of discharge (ft/sec)	Nozzle flow (gal/min) @ ea. tip orifice size*							
			1/8 inch	3/16 inch	1/4 inch	3/8 inch	1/2 inch	5/8 inch	3/4 inch	1 inch
10	23.1	38.6	1.5	3.3	5.9	13	24	37	53	95
15	34.6	47.3	1.8	4.1	7.3	16	29	45	65	116
20	46.2	54.6	2.1	4.7	8.4	19	34	52	75	134
25	57.7	61.0	2.3	5.3	9.4	21	38	59	84	150
30	69.3	66.9	2.6	5.8	10	23	41	64	92	164
35	80.3	72.2	2.8	6.2	11	25	44	69	100	177
40	92.4	77.2	3.0	6.7	12	27	47	74	107	190
45	103.9	81.8	3.1	7.1	13	28	50	79	113	201
50	115.5	86.3	3.3	7.5	13	30	53	83	119	212
55	127.0	90.4	3.5	7.8	14	31	56	87	125	222
60	138.6	94.5	3.6	8.2	15	33	58	91	131	232
65	150.1	98.3	3.8	8.5	15	34	60	94	136	242
70	161.7	102	3.9	8.8	16	35	63	98	141	251
75	173.2	106	4.1	9.1	16	37	65	101	146	260
80	184.8	109	4.2	9.4	17	38	67	105	151	268
85	196.3	113	4.3	9.7	17	39	69	108	156	277
90	207.9	116	4.4	10	18	40	71	111	160	285
95	219.4	119	4.6	10	18	41	73	114	164	292
100	230.9	122	4.7	11	19	42	75	117	169	300
105	242.4	125	4.8	11	19	43	77	120	173	307
110	254.0	128	4.9	11	20	44	79	123	177	315
115	265.5	131	5.0	11	20	45	80	126	181	322
120	277.1	134	5.1	12	21	46	82	128	185	329
125	288.6	136	5.2	12	21	47	84	131	189	335
130	300.2	139	5.3	12	21	48	86	134	192	342
135	311.7	142	5.4	12	22	49	87	136	196	349
140	323.3	144	5.5	12	22	50	89	139	200	355
145	334.8	147	5.6	13	23	51	90	141	203	361
150	346.4	150	5.7	13	23	52	92	144	207	367
175	404.1	161	6.2	14	25	56	99	155	223	397
200	461.9	173	6.6	15	27	60	106	166	239	424
250	577.4	193	7.4	17	30	67	119	185	267	474
300	692.8	211	8.1	18	32	73	130	203	292	520

* Based on $\text{gal/min} = 30d^2(\text{NP})^{1/2}$

Where: d = nozzle diameter, inches

NP = nozzle pressure head, psi

APPENDIX B

Background

During fire suppression activities that require hose lays it is important to size up the situation and make some quick but beneficial hydraulic calculations. Some items to consider are pump capability needed, adequacy of water source, and the type of hose lay to use. Friction loss in fire hose may result in the inability of firefighters to complete their mission.

Friction loss is the result of turbulence within the water (fluids) and the resistance along the inside wall of fire hose. Friction loss is one of the factors that must be taken into consideration when determining pump capabilities. The amount of friction loss is affected by diameter and length of hose, and the number of fittings (appliances) used.

San Dimas Technology and Development Center has tested pressure loss due to friction on a number of commonly used fire hose and have developed tables that can be copied, cut, and laminated for use in the field. Also there are formulas to assist in friction loss determination.

Five Significant Hydraulic Relationships...Governing Friction Loss

1. *For the same flow, friction loss varies approximately inversely as the **fifth power** of the diameter of the hose.*

This means if the flow remains the same, increasing the size of the hose can drastically reduce the friction loss; or, the bigger the hose (with the same flow) the smaller the friction loss. Double the diameter of the hose (with the same flow) and the friction loss will be reduced to $\frac{1}{32}$, or about 3 percent.

2. *In the same size hose, friction loss varies approximately as the square of the flow.*

This means that the resultant friction loss increases more rapidly than the increase in flow. For example, if the flow is doubled, the friction loss becomes 4 times as much. If the flow is tripled, the friction loss becomes 9 times as much; if the flow is quadrupled, the friction loss becomes 16 times as much as it was originally.

3. *Friction loss in hose varies directly as the length of the line, provided all other conditions are equal.*

If identical gallons per minute are flowing, the friction loss in 500 feet of hose will be five times the friction loss in 100 feet of the same size and quality hose. (If you double the length of the line you double the friction loss).

4. *Friction loss is affected by the roughness of the inside of the hose in relation to the diameter.*

The rougher the hose, the more the friction loss. The smaller the hose with the same roughness, the greater the friction loss.

5. *For a given flow the friction loss in hose is approximately the same no matter what the water pressure may be.*

This means that when water is flowing through a hose at a certain number of linear feet per minute, the friction loss is the same whether the pressure is 50 psi or 400 psi.

APPENDIXES

B—Pressure and Flow Rates

Friction loss (psi/100 ft) in hose
(SDTDC test values except for 2½ inch which is from NFPA C* = 2)

Flow (gal/min)	Hose size (ID) and type												
	5/8-in GH	3/4-in (HP) Straight High Pressure Rubber Hardline	3/4-in (HP) Spooled High Pressure Rubber Hardline	1-in High Pressure Rubber Hardline (Booster)	1 in CSRL [186] Synthetic I [187]	1-in Lightweight Synthetic II [187]	1-in Woven Fabric Hardline	1½-in CSRL [186] Synthetic I [187]	1½-in Lightweight Synthetic I [187]	1½-in Lightweight Synthetic II [187]	1¾-in Lightweight Synthetic II	2½-in (Lined)	
5	6	5	6	1-in High Pressure Rubber Hardline (Booster)	1	1	1	1	2				
10	23	13	17	3	3	3	4	2	1				
15	45	27	34	6	5	8	9	6	1	1			
20	78	42	53	9	9	9	16	9	2	2			
25	92	62	79	15	14	11	24	15	3	2	2		
30		86	109	21	20	18	34	20	3	3	5	2	
40		91	115	37	33	24	59	35	5	6	8	2	
50				56	49	42	80	55	8	8	12	3	
60				71	67	63		71	11	12	18	5	
70									15	16	24	6	
80									19	19	31	8	
90									24	25	39	11	
100									27		14	2	
150												5	
200												8	
250												13	
300												18	
350												25	
400												32	
C**	1931	1010	1130	228	212	286	379	228	31	33	49	14	2

* C = coefficient of friction
 ** average friction loss coefficient
 [] USFS specification

**Comparative Diameters and Weights (100-ft) Lengths
(Coupled)**

Hose Type	ID (in)	FS Spec	Jacket	Working (Rated) Pressure (psi)	Dry Weight (psi)	Water (gal) (lb)	Weight Water (lb)	Total Weight (lb)
Garden (GH)	5/8	None	Single	200	2	1.6	13	15
High pressure rubber hardline	3/4	185	—	600	56	2.3	19	75
High pressure rubber hardline (Booster)	1	None	—	800	63	4.1	34	97
Cotton-synthetic rubber-lined (CSRL)	1	186	Single	450	20	4.1	34	54
Lightweight Synthetic I	1	187	Single	450	9	4.1	34	43
Lightweight Synthetic II	1	187	Single	450	9	4.1	34	43
Woven fabric hardline	1	None	Single	300	17	4.1	34	51
Cotton-synthetic rubber-lined (CSRL)	1-1/2	186	Single	450	27	9.2	77	104
Lightweight Synthetic I	1-1/2	187	Single	450	16	9.2	77	93
Lightweight Synthetic II	1-1/2	187	Single	450	14	9.2	77	91
Lightweight Synthetic II	1-3/4	None	Single	450	20	12.5	104	124
Lined	2-1/2	None	Double	400	23	25.4	213	236

NA = not available

Coupling sets (1 1/2 inch) vary in weight from 0.9 to 1.6 pounds.

APPENDIXES

B—Pressure and Flow Rates

Friction Loss Tables

The following tables should help the firefighter in determining the required pump pressure. The chart includes different hose diameters, hose lengths, tip orifice sizes, elevations above the nozzle, and nozzle pressure of 100 psi. When looking at the tables the firefighter can see that some required pump pressures are larger than their pump capabilities. This should alert the engine captains that 2 to 3 pumps (Mark III) might be required to obtain the desired flow.

Friction loss in hose lays and appliances is very complex; however, very good predictions of the pressure loss of hose lays can be made by applying the following formula:

This formula was used to generate the pump pressures in the following tables:

$$FL = C(Q/100)^2(L/100) + Z/2.31 + 100$$

- Where: **FL** is friction loss in psi
- C** varies with corresponding hose size and is specified below each table
- Q** is gallons per minute
- L** is hose length, ft
- Z** is nozzle elevation above pump, ft
- 100** is nozzle pressure in psi

Note: To calculate head pressure multiply 43 psi per 100 feet vertical change in elevation. Example: 500 feet vertical change would be 5 x 43 = 215 psi head pressure.

**Pump Pressures for 100-psi Nozzle Pressure
5/8 inch hose (high pressure)**

Tip orifice size (in)	1/8	3/16	1/4	5/16	3/8	
Flow (gal/min)	4.7	10.5	18.7	28.7	42.1	
Nozzle reaction (lb)	2.5	5.5	9.8	15.3	22.0	
Loss/100 ft (psi)	4	22	70	165	354	
Hose length (ft)	Nozzle above pump (ft)	Required pump pressure (psi)				
100	0	104	122	170	265	454
100	100	148	165	213	308	498
150	0	107	133	205	347	632
150	100	150	176	248	390	675
200	0	109	144	240	429	809
200	100	152	187	283	473	852
250	0	111	155	275	512	986
250	100	154	198	318	555	1,029
300	0	113	166	310	594	1,163
300	100	157	209	353	638	1,207
300	200	200	253	396	681	1,250
400	0	118	188	380	759	1,518
400	100	161	231	423	802	1,561
400	200	204	275	466	846	1,605
400	300	248	318	510	889	1,648
500	0	122	210	450	924	1,872
500	100	165	254	493	967	1,916
500	200	209	297	536	1,010	1,959
500	300	252	340	580	1,054	2,002

C = 2,000 for practical use

APPENDIXES
B—Pressure and Flow Rates

Pump Pressures for 100-psi Nozzle Pressure
¾ inch hose (high pressure)

Tip orifice size (in)	⅛	⅜	¼	⅝	¾	
Flow (gal/min)	4.7	10.5	18.7	28.7	42.1	
Nozzle reaction (lb)	2.5	5.5	9.8	15.3	22.0	
Loss/100 ft (psi)	2	12	38	91	195	
Hose length (ft)	Nozzle above pump (ft)	Required pump pressure (psi)				
100	0	102	112	138	191	295
100	100	146	155	182	234	338
150	0	104	118	158	236	392
150	100	147	161	201	279	436
200	0	105	124	177	281	490
200	100	148	168	220	325	533
250	0	106	130	196	327	587
250	100	149	174	239	370	631
300	0	107	136	215	372	685
300	100	151	180	259	415	728
300	200	194	223	302	458	771
400	0	110	149	254	462	880
400	100	153	192	297	506	923
400	200	196	235	340	549	966
400	300	240	278	384	592	1,010
500	0	112	161	292	553	1,075
500	100	155	204	336	596	1,118
500	200	199	247	379	640	1,161
500	300	242	291	422	683	1,205

C = 1,100 for practical use

If a significant amount of hose is left on the live reel, the friction loss will be increased.

APPENDIXES

B—Pressure and Flow Rates

Pump Pressures for 100-psi Nozzle Pressure
1-inch hose

Tip orifice size (in)	$\frac{1}{8}$	$\frac{3}{16}$	$\frac{1}{4}$	$\frac{5}{16}$	$\frac{3}{8}$	$\frac{1}{2}$	
Flow (gal/min)	4.7	10.5	18.7	28.7	42.1	74.7	
Nozzle reaction (lb)	2.5	5.5	9.8	15.3	22.0	39.3	
Loss/100 ft (psi)	1	3	8	19	40	127	
Hose length (ft)	Nozzle above pump (ft)	Required pump pressure (psi)					
100	0	101	103	108	119	140	227
100	100	144	146	151	162	184	271
200	0	101	105	116	138	181	354
200	100	144	148	159	181	224	398
300	0	102	108	124	156	221	482
300	100	145	151	167	200	265	525
300	200	188	194	210	243	308	568
400	0	102	110	132	175	262	609
400	100	145	153	175	218	305	652
400	200	189	197	218	262	348	695
400	300	232	240	262	305	392	739
500	0	103	113	140	194	302	736
500	100	146	156	183	237	345	779
500	200	189	199	226	280	389	823
500	300	232	242	270	324	432	866
1,000	0	105	125	180	288	504	1,372
1,000	100	148	168	223	331	547	1,416
1,000	200	192	212	266	374	591	1,459
1,000	300	235	255	310	418	634	1,502
1,000	400	278	298	353	461	677	1,545
1,000	500	321	342	396	504	721	1,589
1,000	600	365	385	439	548	764	1,632

C = 228 for practical use

APPENDICES
B—Pressure and Flow Rates

Pump Pressures for 100-psi Nozzle Pressure
1½ inch hose (high pressure)

Tip orifice size (in)	⅛	⅜	¼	⅝	¾	½	
Flow (gal/min)	4.7	10.5	18.7	28.7	42.1	74.7	
Nozzle reaction (lb)	2.5	5.5	9.8	15.3	22.0	39.25	
Loss/100 ft (psi)	0	0	1	2	5	17	
Hose length (ft)	Nozzle above pump (ft)	Required Pump pressure (psi)					
100	0	100	100	101	102	105	117
100	100	143	144	144	146	149	160
200	0	100	101	102	105	111	133
200	100	143	144	145	148	154	177
300	0	100	101	103	107	116	150
300	100	143	144	146	151	159	194
300	200	187	188	190	194	203	237
400	0	100	101	104	110	121	167
400	100	144	145	147	153	165	210
400	200	187	188	191	196	208	254
400	300	230	231	234	240	251	297
500	0	100	102	105	112	127	184
500	100	144	145	149	156	170	227
500	200	187	188	192	199	213	270
500	300	230	232	235	242	256	314
1,000	0	101	103	110	125	153	267
1,000	100	144	147	154	168	196	311
1,000	200	187	190	197	211	240	354
1,000	300	231	233	240	255	283	397
1,000	400	274	276	284	298	326	441
1,000	500	317	320	327	341	370	484
1,000	600	360	363	370	384	413	527
2,000	0	101	107	121	149	206	435
2,000	100	145	150	164	193	250	478
2,000	200	188	193	208	236	293	521
2,000	300	231	236	251	279	336	565
2,000	400	274	280	294	323	380	608
2,000	500	318	323	337	366	423	651
2,000	600	361	366	381	409	466	695
2,000	700	404	410	424	452	509	738
2,000	800	448	453	467	496	553	781
3,000	0	102	110	131	174	260	602
3,000	100	145	153	175	217	303	645
3,000	200	189	197	218	261	346	689
3,000	300	232	240	261	304	389	732
3,000	400	275	283	305	347	433	775
3,000	500	318	326	348	391	476	819
3,000	600	362	370	391	434	519	862
3,000	700	405	413	435	477	563	905
3,000	800	448	456	478	520	606	949

C = 30 for practical use

APPENDIXES

B—Pressure and Flow Rates

**Pump Pressures for 100-psi Nozzle Pressure
1¾ inch hose (high pressure)**

Tip orifice size (in)	⅛	⅜	¼	⅝	¾	½	
Flow (gal/min)	4.7	10.5	18.7	28.7	42.1	74.7	
Nozzle reaction (lb)	2.5	5.5	9.8	15.3	22.0	39.25	
Loss/100 ft (psi)	0	0	0	1	2	8	
Hose length (ft)	Nozzle above pump (ft)	Required pump pressure (psi)					
100	0	100	100	100	101	102	108
100	100	143	143	144	144	146	151
200	0	100	100	101	102	105	116
200	100	143	144	144	146	148	159
300	0	100	100	101	103	107	123
300	100	143	144	145	147	151	167
300	200	187	187	188	190	194	210
400	0	100	101	102	105	110	131
400	100	143	144	145	148	153	175
400	200	187	187	189	191	197	218
400	300	230	230	232	234	240	261
500	0	100	101	102	106	112	139
500	100	143	144	146	149	156	182
500	200	187	187	189	192	199	226
500	300	230	231	232	236	242	269
1,000	0	100	102	105	112	125	178
1,000	100	144	145	148	155	168	221
1,000	200	187	188	191	198	211	265
1,000	300	230	231	235	241	255	308
1,000	400	273	275	278	285	298	351
1,000	500	317	318	321	328	341	395
1,000	600	360	361	365	371	385	438
2,000	0	101	103	110	123	150	256
2,000	100	144	146	153	166	193	300
2,000	200	187	190	196	210	236	343
2,000	300	230	233	240	253	279	386
2,000	400	274	276	283	296	323	429
2,000	500	317	320	326	340	366	473
2,000	600	360	363	370	383	409	516
2,000	700	404	406	413	426	453	559
2,000	800	447	449	456	469	496	603
3,000	0	101	105	115	135	174	334
3,000	100	144	148	158	178	218	378
3,000	200	188	191	201	221	261	421
3,000	300	231	235	245	264	304	464
3,000	400	274	278	288	308	348	508
3,000	500	317	321	331	351	391	551
3,000	600	361	364	374	394	434	594
3,000	700	404	408	418	438	477	637
3,000	800	447	451	461	481	521	681

C = 14 for practical use

APPENDIX C

APPENDIXES

C—Flow Determination, Pump Testing, and Gauges

This appendix was developed to showcase reliable and inexpensive methods to determine flow rates and pressure requirements for wildland engines. These methods have proven effective given the lower flow rates experienced with wildland engines. Additionally, this appendix defines the appropriate gauges needed to properly perform these test methods.

Hose Flow Rate Determination by the Splash Method

Firefighting personnel can determine the flow rate of fire hose or a pump by using readily available equipment at almost no cost. The equipment used is a short piece of pipe, a tape measure, a level, and a plumb bob. Knowing how to perform the splash flow rate test can be very handy, since accurate flow meters are often not readily available.

This method of determining pump flow rate is very accurate and needs no calibration. It is based on the principle that when an object is released, it falls at a given rate, independent of its horizontal velocity. (This is the same principle as when a gun is level and on level ground when fired and at the same time a second bullet is dropped from the same height as the gun, both bullets will hit the ground at the same time.) When water is released from a pipe positioned at a given height from the ground, it always hits the ground in the same time regardless of horizontal velocity.

As explained in detail below, how far away from the pipe exit that the water hits the ground is directly proportional to the water's horizontal velocity as it exits the pipe. Further, the horizontal velocity is directly proportional to the amount of water coming out of the pipe, and depends on the area of the pipe opening. Knowing this area, the height of the pipe exit above the ground, and the distance out from the pipe that the water hits the ground; the water flow rate can be accurately calculated using the formula given at the very end of this text. The splash pump/hose flow method is as follows:

A. Couple a short length of 3 to 4 feet of pipe, of known inside diameter, to the hose coming from the pump. In some cases, as flow rates approach maximum, hose ripple can occur. To prevent this, use either hard suction hose or a longer pipe.

B. Mount the pipe level, horizontally, at a convenient height "h" above the ground. Select the height suggested in the table for the pipe size and flow range you are going to use to avoid having to do a sequence of calculations.

C. Run the pump and have the water splash on the ground.

D. Measure the distance ("D") along the ground from the end of the pipe to where the water hits the ground. At the time of the measurement, the hose must be running full of water. Let a plumb bob hang from the pipe exit down to the ground. Start measuring "D" at this point. (See figure C1.)

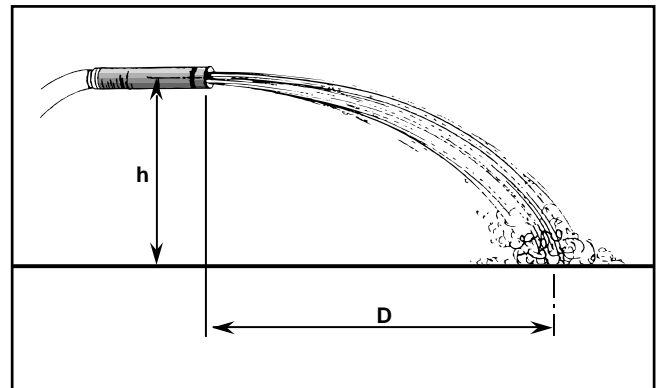

Figure C1—Relation of pipe exit to "h" and "D"

How far out from the end of the pipe that the water hits the ground, depends on the horizontal velocity as the water exits the end of the pipe. The higher the exit velocity, the higher the "D" i.e., "D" is directly proportional to water flow velocity. Knowing "D" and the height of the pipe ("h") above the ground, the velocity of the water out of the pipe can be determined. From this and the pipe exit area, the flow rate can be calculated.

To obtain the flow rate in gallons per minute (gal/min) for the pipe size being used when employing the height suggested in table C1, multiply "D" by the gal/min per inch found in the final column of the table. Be sure to check the inside diameter of the pipe being used to see if it is as listed in the table. If it is not, the flow formula, presented following the table, must be used—as would be the case for any setup, pipe size, or height, that is not presented in the table.

APPENDIXES

C—Flow Determination, Pump Testing, and Gauges

Mounting the pipe on a forklift is a very convenient way of holding the pipe, since now the pipe can easily be adjusted either horizontally or vertically. (See figure C2.) If the test is conducted at a station or work center, a pipe can be mounted permanently on a stand or building and permanent marks can be placed on the ground. These marks can be in gal/min. This would permit flow tests to be conducted very quickly and easily.

Remember that a splash test only determines the flow rate in gal/min from the pump. To check pump performance, the pressure at which the water is flowing must also be known. The engine pressure gauge can be used to obtain this pressure by partially closing the overboard discharge valve to create a resistance for the pump.



Figure C2—Splash test with 1½ inch pipe at suggested height of 54¼ inches; the calculated flow rate is 84 gal/min.

There is a limited number of pipe sizes and practical heights for the water to fall from each of these pipes. Subsequently, the following table has been developed:

Table C1—Splash Test Table

Pipe size (inch)	Pipe ID (inch)	Pipe opening area (sq inch)	Flow range (gal/min)	Suggested height (inch)	Unit linear flow @ suggested height [(gal/min)/inch]
½	0.62	0.30	2 - 10	18 ¾	0.25
¾	0.82	0.53	5 - 20	29 ⅞	0.35
1	1.05	0.86	10 - 40	38 ⅞	0.5
1¼	1.38	1.50	20 - 100	45 ⅞	0.8
1½	1.61	2.04	40 - 150	54 ¼	1.0
2	2.07	3.36	60 - 250	65 ⅞	1.5
2½	2.47	4.79	100 - 400	74 ¾	2
3	3.07	7.39	150 - 600	79 ⅞	3
4	4.03	12.73	200 - 900	84 ½	5
5	5.05	20.01	300 - 1200	81 ½	8
6	6.07	28.89	400 - 1600	108 ¾	10

For pipe ID's or heights not listed in the table, the flow rate can be calculated using the following formula:

$$\text{Flow (gal/min)} = \frac{3.61 \times AD}{\sqrt{h}}$$

Where:

A = Area, in square inches, of the pipe opening = (3.14) x (r²)

r = ½ of the pipe's ID in inches

D = Distance along ground, in inches, from the pipe exit to the midpoint of where the main body of water splashes.

h = Height above ground, in inches, of the midpoint of the pipe exit.

3.61 = Constant that adjusts the answer for measurement units used in formula.

APPENDIXES

C—Flow Determination, Pump Testing, and Gauges

Pump Testing by Using a Square-Edge Orifice

An inexpensive and reliable test method to ensure that pump engines meet flow and pressure requirements has been developed for field use. Pump testing using the square-edged orifice system requires a pressure gauge, hose line tee, and a hose cap machined (or drilled if machining equipment is not available) to the proper diameter (see figure C3). The advantages of using a square-edge orifice is the simplicity of the design which can be easily assembled in the field for all resource functions to test the gallons per minute (flow) and the pounds per square inch (pressure) of most pumps.



Figure C3 – Photo of square-edged orifice system.

By knowing the orifice diameter required for a certain flow and pressure, a hose cap can be drilled or machined to that diameter. Table C2 shows examples of orifice sizes that would be required to test flow and pressure rates of pumps on fire engines listed in the (NWCG engine resource types) Wildland Fire Engine Guide (SDTDC document 0051 1203). Also included in table C2 is the orifice size required for pumps that are used in most Forest Management contracts for fire protection.

Table C2—Example of orifice sizes

Resource Types	Orifice size (in)	Flow* (gal/min)	Pressure* (psi)	Line and Tee** size (in)
Type 1 Engine	2.102	1,000	150	4
Type 2 Engine	1.051	250	150	2½
Type 3 Engine	0.716	150	250	2½
Type 4 Engine	0.520	50	100	1½
Type 5 Engine	0.520	50	100	1½
Type 6 Engine	0.403	30	100	1½ or 1
Type 7 Engine	0.233	10	100	1½ or 1
Forest Mgmt	0.3125	23	175 at sea level	1 ½ or 1

*Flow (gal/min) and pressure (psi) listed for fire engines in the chart are National Wildfire Coordination Group (NWCG) type ratings for fire engines.

**Line and tee size can be larger but not smaller.

It is very important that the drilling of the hose cap be very accurate (see table C2) and the edge to the flow is sharp and square. Machining the orifice opening will provide the most accurate results; however, if the hose cap is drilled it should also be renamed to provide better accuracy. The reason for using a sharp square-edge orifice and not a smooth bore nozzle is that a sharp square-edge orifice can easily be described and made while smooth bore nozzles are much more difficult to describe and are made in many different variations having different flow rates.

Flow through a square-edge orifice can be found by the following formula:

$$Q = 29.81 * C_d * d^2 * \sqrt{P}$$

When:

- Q = flow in gallon per minute
- C_d = orifice discharge coefficient (NFPA recommends using .62)
- d = orifice diameter in inches
- P = pressure in psi

APPENDIXES

C—Flow Determination, Pump Testing, and Gauges

By knowing the flow in gallon per minute (Q) and the pressure in psi (P) the orifice diameter can be found by the following formula:

$$d = \sqrt{\frac{Q}{29.9 \cdot 0.62 \cdot \sqrt{P}}}$$

The pressure gauge should be a Grade 1A or better, and be calibrated annually. A Grade 1A pressure gauge can have a permissible error of 1 percent of full scale (for example a 200 psi Grade 1A pressure gauge can have a permissible error of ± 2 psi anywhere on the scale).

The recommended line and tee size should also be adhered to (see table C2). Smaller lines and tees should not be used, as the accuracy will not be maintained. The ratio of the orifice diameter to the diameter of the tee has an effect on the flow and pressure reading. Using a smaller line and tee than recommended could negatively affect the accuracy of the test.

Test Procedures

1. Select desired size square-edge orifice and attach to proper size in-line tee.
2. Attach the in-line tee to the overboard discharge or pump outlet.
3. Start pump, open desired overboard discharge or pump outlet valve, increase pump throttle to maximum.
4. If desired pressure is not reached, the pump does not pass.

Parts list

- One pressure gauge (grade 1A or better)
- One in-line tee (1 inch, 1½ inch, 2½ inch, or 4 inch)
- One appropriate size cap, with appropriate size orifice machined in center.
- One 4-foot length of 300-psi rubber line, with swivel and ¼ inch NPT (National Pipe Thread) fitting on each end.
- ⅜-inch straight-stream nozzle tip tapped with ¼-inch NPT threads.

Additional information about the square-edged orifice system can be obtained from:

USDA Forest Service
Technology and Development Center
444 East Bonita Avenue
San Dimas, CA 91773

Gauge Accuracy Information

When testing pumps as outlined in the previous section of this appendix, as well as for performing standard operations with fire apparatus, the use of quality gauges is necessary. To assist in meeting this requirement the following information is provided when selecting a gauge for pump testing and general fire apparatus needs.

Accuracy is defined as the difference (error) between the true value and the indication expressed as a percent of the span (span is the range of the gauge). It includes the combined effects of method, observer, apparatus, and environment. Accuracy error includes hysteresis and repeatability errors but not friction error. It is determined under specific conditions. Normally 73.4 °F (23 °C), and 29.92 inch Hg barometric pressure.

Accuracy of a pressure gauge may be expressed as percent of span or percent of indicated reading. Percent of span is the most common method. For example, the span of a 0-100 psi gauge is 100 psi. Percent of indicated reading is usually limited to precision test gauges.

The following are American Society of Mechanical Engineers (ASME) B40.1 accuracy grades.

Grade 4A. Gauges offer the highest accuracy and are calibrated to ± 0.1 percent of span over the entire range of the gauge. The gauges are called laboratory precision test gauges and are generally 8½-, 12- or 16-inch dial sizes. These high-accuracy gauges may be temperature compensated. They must be handled carefully in order to retain accuracy.

Grade 3A. Gauges are calibrated to an accuracy of ± 0.25 percent of span over the entire range of the gauge. The gauges are called test gauges and are

C—Flow Determination, Pump Testing, and Gauges

generally 4½-, 6-, or 8½-inch dial sizes. The gauges are generally not temperature compensated.

Grade 2A. Gauges are calibrated to an accuracy of ±0.5 percent of span over the entire range of the gauge. These gauges are generally used by the petrochemical industry for process measurement. They are often referred to as process gauges and are usually supplied as 4½- and 6-inch dial sizes and are not temperature compensated.

Grade 1A. Gauges are calibrated to an accuracy of ±1 percent over the entire range of the gauge. These gauges are high-quality industrial gauges and are supplied in 2½-, 3½-, and 4½-inch dial sizes.

Grade A. Gauges are calibrated to an accuracy of ±1 percent of span over the middle half of the scale and ±2 percent of span over the first and last quarters of the scale. These gauges are often referred to as industrial gauges and are usually supplied in 2½-, 3½-, and 4½-inch dial sizes.

Grade B. Gauges are calibrated to an accuracy of ±1 percent of span over the middle half of the scale and ±3 percent of span over first and last quarters of the scale. This accuracy of gauge represents the majority of those manufactured and used for pressure measurement on water pumps, swimming pool filters, air compressors, filter regulation, etc. These gauges are often referred to as commercial or utility gauges and are supplied in 1½-, 2-, 2½-, 3½-, and 4½-inch dial sizes.

Grade C. Gauges are calibrated to an accuracy of ±3 percent of span over the middle half of the scale and ±4 percent of span over the first and last quarters of the scale. These are used in similar applications as Grade B gauges except that they are less accurate.

Grade D. Gauges are calibrated to an accuracy of ±5 percent of span over the entire scale. These 5 percent gauges are used as indicators when minimal accuracy is required for application on water pumps and swimming pool filters.

Table C3—Accuracy Examples

Type of Gauge	Grade	Permissible Error % of Span			Max. Friction (% of span)
		Lower 25 %	Middle 50%	Upper 25%	
Precision 4A test	4A	0.1	0.1	0.1	See note below
Test	3A	0.25	0.25	0.25	0.25
Process	2A	0.5	0.5	0.5	0.5
Industrial/ Hydraulic	1A	1.0	1.0	1.0	1.0
Industrial/ Hydraulic	A	2.0	1.0	2.0	1.0
Commercial/ Utility	B	3.0	2.0	3.0	2.0

NFPA 1906 requires grade B or better gauges; however, lesser grade gauges are available but do not meet this requirement and are not satisfactorily accurate for use on fire apparatus. Grade 2A, 3A, and 4A gauges, although highly accurate, exceed the needs of fire apparatus and are extremely expensive.

APPENDIX D

Service Test Pressure Procedure

Long-term maintenance includes testing, repair or replacement of impaired hose, cleaning and drying, and proper long-term storage. Service testing is performed in order to determine if hose is suitable to continue in use.

Before subjecting any hose to a hydrostatic pressure test, it should be subjected to a close visual examination. Remove damaged hose from the test area.

Safety in testing

When conducting a hose test involving high pressures, there is a potential for serious accidents. Follow all recommended procedures. Be careful and use common sense.

General safety measures

Couplings mounted crooked on the hose are easier to find when the hose is charged. It is also more dangerous.

Fire hose should not be used to transport potable water. Never drink water from fire hose.

When testing, personnel should never stand: (1) in front of the free end of the hose, (2) on the right side of the hose, (3) closer than 15 feet on the left side of the hose, or (4) straddle a hose in the test layout during the test. Left is referenced when facing the free end of the hose, opposite the pressure source.

Air is a compressible substance

In performing Service Pressure Tests, be extra careful to remove all air from the hose before the nozzle or end cap is closed and the pressure is raised. Air is a compressible substance and when greatly compressed, the hose may burst at a pinpoint. In addition, the hose may whip around violently if the pressure is released suddenly, such as when a hose bursts. A blown-off coupling or an expansion ring can act as a missile or bullet, resulting in serious injury or damage to property.

Retesting recoupled hose

Retesting repaired or recoupled fire hose can be extremely dangerous. Hose that has been repaired or recoupled should be retested at a test pressure of at least 50 percent greater than the service test pressure.

Test setup

Provide a test area that will allow connection of the hydrostatic test equipment to an adequate water source. Only use water to pressure test fire hose. The surface of the test area should be level, smooth, and free of any materials that could damage the hose. The hose will be hydrostatic pressure tested at a minimum of 300 psi.

A hose testing machine, a stationary pump, or a fire engine can be used. The hose test layout should be connected to the pump source. If the pump source is a fire engine, it should not be attached to any discharge outlet at, or adjacent to, the pump operator's position. Shut-off nozzles or test caps should be attached to the far end of the line.

The gauge used to read the test pressure should be certified at least annually.

The water connection on the test valve outlet should be as close to the ground as possible. This will decrease the amount of pocketed air at the inlet end when filling the hose for pressure testing.

Hose test sample preparation

Each length of hose to be tested simultaneously should be of the same service test pressure and, collectively, should be considered the hose test layout. The total length of any hose line, in the hose test layout to be service tested, should not exceed 300 feet. The hose test layout should be straight without kinks or twists.

Hose that has just been repaired or recoupled must be tested at one length increments only for safety purposes, before being returned to

APPENDIXES

D—Service Test for Fire Hose

service. Each hose should be marked at the back of each coupling to assist in determining any coupling hose slippage during the test.

Test method

With the inlet valve open and the nozzle or test cap valve open, the pressure should be gradually raised to 45 psi (+ 5 psi tolerance). Fully charge the hose by exhausting all the air out of the hose line. This is done by raising the discharge end of each hose line above the highest point in the system. Close the nozzle or cap slowly, and then the inlet valve should be closed. It is very important that all safety requirements be observed. This includes being very careful to remove all air from the hose before the nozzle or end cap is closed and the pressure is raised.

After pressurizing the hose to 45 psi (+ 5 psi tolerance), check for leakage at the coupling. Tighten with a spanner wrench if necessary. If the coupling appears to be mounted crooked, remove the hose from service. Couplings mounted crooked are easier to find when the hose is charged.

All personnel, other than those required to perform the remainder of the procedure, should leave the area. The pressure will be raised slowly, over more than 15 seconds, to the service test pressure of a minimum 300 psi and held for 3 minutes.

When the service test pressure is achieved, inspect the hose for leaks along the hose length and at the couplings. Test personnel should maintain a distance of at least 15 feet to the left side of the nearest hose line. Left referenced when facing the free end, opposite the pressure source.

After maintaining the service test pressure of 300 psi for 3 minutes, drain the hose lay by shutting down the pump, closing the hose valve, and opening the nozzle or cap.

The marks placed on the hose at the back of the couplings should be observed for coupling slippage. If the coupling has slipped, the hose will have failed the test.

The hose has failed the service test if it did not pass the visual exam and the service pressure test. This includes hose that has burst, leaked, or couplings that have slipped or leaked.

Remove the hose from the test apparatus and allow hose that passed service pressure testing to drain.

Additional Test Requirements For Unlined, Hardline, and Suction Hose

Unlined, linen or weeping hose

Unlined weeping hose should have a 5-minute wet-soak at 50 psi to condition the linen yarn prior to applying the service test pressure. If the service test pressure cannot be obtained at a maximum flow rate of 20 gal/min, the unlined linen hose should be removed from service and condemned.

Hardline and suction hose

Hardline hose should be service tested annually to 150 percent of its rated working pressure. Hardline hose is rated for a working pressure up to 600 psi and should be service tested at 900 psi. Suction hose should be service tested annually at 50 percent of its proof pressure. Suction hose is rated for a proof pressure up to 100 psi and should be service tested at 50 psi.

In addition, suction hose should be dry vacuum tested annually to a vacuum of 25-inches mercury. Attach the hose to a suction source with the free end sealed and connected to an accurate vacuum-measuring instrument. Obtain a vacuum of 25-inches mercury and shut the vacuum pump off. The hose should maintain 25-inches mercury vacuum for 5 minutes, with no loss of vacuum, with the vacuum pump off. Disconnect the hose from the suction source and examine the lining for collapse or failure.

Cleaning and drying

After use, all hose should be thoroughly cleaned, including hose that has been tested or retested. Hose may be washed and drained outside when necessary, though hose should not be dried in intense direct sunlight. If dirt

and dust cannot be removed thoroughly by brushing, or if the hose has come in contact with harmful chemicals, it should be washed. If detergent is used, use a mild solution and rinse thoroughly with clean water.

Wet hose should be drained and completely dried before being placed in service or storage. Hose should not be dried on hot pavements or under intense sunlight. Wet hose, even the lightweight all-synthetic, should be thoroughly dried. Cotton-synthetic hose has been treated for mildew protection but will mildew under prolonged wet conditions. In addition, linen hose must be thoroughly dried immediately after testing to avoid mildew.

Allow the jacket to dry completely by hanging a 50-foot length of hose from the middle. Hang a 100-foot length of hose from the middle and allow to drain for a minimum of 4 hours. After 4 hours, double the hose and continue to dry for 2 to 3 days or longer as required. The couplings should be off the ground at all times.

Salvaging bad hose

All hose failing the visual exam and the pressure test should be tagged, repaired, or disposed of as per your agencies guidelines. In the field, tie a knot in failed hose to avoid reuse. If a 100-foot length of hose fails, it should be shortened to 50 feet. If a 50-foot length of hose fails, it should be shortened to no less than 45 feet. Good couplings should be salvaged from discarded hose.

Hose that has been repaired or recoupled should be retested at a test pressure of at least 50 percent greater than the service test pressure.

Place a readily visible, distinguishing mark noting the location of the hose defect, before sending it in. Good couplings should be salvaged from any hose not repairable. For defective couplings, the couplings should be cut from the hose and the hose sent in for recoupling. When a length of hose is recoupled, the tailpiece gasket should be replaced. For additional information, consult the "Fire Equipment Storage and Refurbishing Standards," National Wildfire Coordinating Group, NFES Number 2249, November 1994.

APPENDIX E

APPENDICES

E—Specifications and Standards

USDA FOREST SERVICE SPECIFICATIONS/ STANDARDS

- 5100-101c Wrench, spanner, fire hose
- 5100-102d Couplings, fire and suction hose
- 5100-105d Strainer, suction hose
- 5100-107c Fire hose connections and fittings
- 5100-108e Couplings, lightweight, fire and suction hose
- 5100-183h Hose, linen, 1-in and 1½-in
- 5100-184c Hose suction
- 5100-185e Hose, rubber, high-pressure ¾-in
- 5100-186c Hose, cotton-synthetic jacketed, lined, 1-in and 1½-in
- 5100-187b Hose, fire, lightweight synthetic, type 1 & type 2, lined, woven jacket, 1 in and 1½ in
- 5100-00192 Forged quarter turn couplings, new interim
- 5100-238c Shut-off, valve, ball
- 5100-239c Nozzle with shut-off, combination barrel
- 5100-240d Nozzle, twin tip, shut-off, 1-in base
- 5100-241d Nozzle, shut-off
- 5100-242d Nozzle, screw-tip, 1½-in
- 5100-243c Nozzle, garden hose
- 5100-244d Nozzle tips, straight-stream and spray
- 5100-245c Clamp, fire hose, shut-off
- 5100-256b Pump, fire, backpack, hand-operated
- 5100-257c Tank, fire, backpack
- 5100-273d Pumper, engine-driven
- 5100-274c Pumper, lightweight, portable
- 5100-275b Pumper, portable, floating
- 5100-305b Wetting agent
- 5100-340b Reel, hose, booster
- 5100-341a Tanker, slip-on, metal, end mounted, 125-, 200-gallon, Model 21
- 5100-343b Tanker, slip-on, fiberglass-reinforced resin, capacity 75-, 125-, 200-gallon, Model 30

- 5100-344b Pumper, belt-driven, vehicle engine
- 5100-346b Tanker, slip-on, 50-gallon, Model 10
- 5100-347c Tanker, slip-on, metal, end mounted, 75-, 125-, 200-gallon, Model 20
- 5100-349b Tanker, slip-on, 300-gallon, Model 51
- 5100-380d Valve, wye
- 5100-382c Valve, check and bleeder
- 5100-383b Valve, foot, with strainer
- 5100-01c Spark arresters for internal combustion engines
- 5100-107c Fire hose connections and fittings
- 5100-190b Threads, gaskets, and rocker lugs, connections and fittings, fire hose
- 5100-500e Accessories, external-loading, helicopter

NATIONAL FIRE PROTECTION ASSOCIATION (NFPA), INC. STANDARDS

- NFPA 1901 *Standards for Automotive Fire Apparatus*
- NFPA 1906 *Standard for Wildland Fire Apparatus*
- NFPA 1961 *Fire hose*
- NFPA 1962 *Standard for the care, use, and service testing of fire hose, including connections and nozzles*
- NFPA 1963 *Standard for fire hose connections*

APPENDIXES

E—Specifications and Standards

CROSS REFERENCE OF FEDERAL NUMBERS

[NOTE: NFES = National Fire Equipment System of the National Wildfire Coordinating Group (NWCG)]

National Stock Number (NSN) (In ascending order)	NFES No.	Forest Service Number	Item
4210-00-126-5108	0259	5100-380d	Valve, wye, gated, 1 inch
		5100-184c	Hose, suction, 1 inch, 8-foot length
4210-00-177-6135	0737	5100-244d	Nozzle tips, straight-stream
		5100-105d	Strainer, suction hose, 2½ inch
		5100-241d	Nozzle, shut-off
4210-00-203-3845	0638	5100-244d	Nozzle tip, ⅜ inch
4210-00-203-3855	0637	5100-244d	Nozzle tip, ⅜ inch
4210-00-204-3358	0635	5100-244d	Nozzle tip, spray, No. 3, 2 to 4 gal/min, fog
4210-00-204-3386	0636	5100-244d	Nozzle tip, spray, No. 6, 5 to 7 gal/min, fog
4210-00-294-2648	0418	5100-107c	Reducer, 1½ to 1 inch
4210-00-595-1838	1220	5100-185e	Hose, rubber, high-pressure, ¾ inch
4210-00-889-1774	1808	5100-184c	Hose, suction, 1½ inch; 8-foot length
4210-00-640-1892	0024	5100-240d	Nozzle, twin tip, shut-off, 1 inch
4210-00-767-7123	0046	5100-245c	Clamp, fire hose, shut-off, 1 to 1½ inch hose
4210-00-777-1591	0966	5100-186c	Hose, rubber-lined, cotton-synthetic 1 inch, 100-foot length
4210-00-777-1592	0967	5100-186c	Hose, rubber-lined, cotton-synthetic, 1½ inch, 100-foot length
4210-00-889-1775	0115	5100-184c	Hose, suction, 1½ inch; 10-foot length
4210-00-975-2969	0010	5100-107c	Reducer, 1½ to 1 inch
		5100-105d	Strainer, suction hose, 1½ inch
4210-00-984-3475	0231	5100-380d	Valve, wye, gated, 1½ inch
4210-01-079-9283	0007	5100-107c	Thread adapter, 1½ inch NPSH to 1½ inch NH
4210-01-079-9284	0006	5100-107c	Thread adapter, 1½ inch NH to 1½ inch NPSH
4210-01-079-9285	0856	5100-107c	Double male coupling, 1½ inch
4210-01-079-9286	0733	5100-107c	Reducer 1 to ¾ inch
4210-01-080-1457	0710	5100-107c	Double female coupling, 1 inch NPSH
4210-01-080-1458	0916	5100-107c	Double male coupling, 1 inch NPSH
4210-01-080-1459	2240	5100-107c	Hose line tee, cap & chain, 1 inch
4210-01-080-1460	0731	5100-107c	Hose line tee, cap & chain, 1½ inch
4210-01-080-6531	2235	5100-107c	Increaser, ¾ to 1 inch
4210-01-080-6532	0416	5100-107c	Increaser, 1 to 1½ inch
4210-01-081-0417	0230	5100-107c	Hose line tee, valve, 1½ inch

APPENDIXES E—Specifications and Standards

National Stock Number (NSN) (in ascending order)	NFES No.	Forest Service Number	Item
4210-01-081-0418	1809	5100-107c	Hose line tee, 1 to ¾ inch
4210-01-081-0419	2229	5100-107c	Reducer, 2½ NPSH to 1½ inch NH
4210-01-081-8749	0857	5100-107c	Double female coupling, 1½ inch NH
4210-01-081-8751	2210	5100-107c	Cap, tee with chain, 1½ inch NH
4210-01-082-0575	0732	5100-107c	Cap, tee with chain, 1 inch NPSH
4210-01-165-6597	1239	5100-187b	Hose, synthetic, lined, 1½ inch, 100-foot length
4210-01-165-6599	1201	5100-238c	Shut off, valve, ball, 1 inch
4210-01-165-6600	1207	5100-238c	Shut-off, valve, ball, 1½ inch
4210-01-165-6603	1081	5100-239c	Nozzle, shut-off, comb. barrel, 1 inch
4210-01-166-8122	1238	5100-187b	Hose, synthetic, lined, 1 inch, 100-foot length
4210-01-167-1061	1016		Hose, synthetic, garden, ⅝ inch, 50-foot length
4210-01-167-1123	1082	5100-239c	Nozzle, shut-off, comb. barrel, 1½ inch
4320-00-289-8912	1149	5100-256b	Backpack pump, complete outfit
4320-00-595-0762	0151	5100-256b	Pump, single action, trombone
4320-00-890-5879	0601	5100-274c	Pump, lightweight, portable w/accessories
4320-01-495-3633	0148	5100-274c	Pump, lightweight, portable, backpack
4730-00-595-1103	0136	5100-243c	Nozzle, garden hose
4820-00-126-5114	0212	5100-383b	Valve, foot, with strainer, 1½ inch
5120-00-596-1426	0234	5100-101c	Wrench, spanner, 1 and 1½ inch
5120-00-596-1427	0235	5100-101c	Wrench, spanner, 1, 1½, and 2½ inch
5330-00-239-1873	0254	5100-190b	Gasket, fire hose, 1½ inch
5330-00-239-1875	0742	5100-190b	Gasket, fire hose, 2 inch
5330-00-239-1877	2326	5100-190b	Gasket, fire hose, 2½ inch
5330-00-720-2621	0743	5100-190b	Gasket, fire hose, 1 inch
6850-01-111-2200	1316	5100-305b	Wetting agent

APPENDIX F

APPENDIXES

F—Metric System Equivalents/Conversion Factors

The following metric system equivalents and approximate conversion factors are provided for common measurements encountered in the wildland fire agencies.

LINEAR MEASURE			LIQUID MEASURE		
1 centimeter=	10 millimeters=	0.394 inch	1 centiliter=	10 milliliters=	0.338 fl ounce
1 decimeters=	10 centimeters=	3.94 inches	1 deciliter=	10 centiliters=	3.38 fl ounces
1 meter=	10 decimeters=	39.37 inches	1 liter=	10 deciliters=	33.82 fl ounces
			1 liter =		0.264 gallon
1 dekameter=	10 meters=	32.8 feet	1 dekaliter=	10 liters=	2.64 gallons
1 hectometer=	10 dekameters=	328.08 feet	1 hectoliter=	10 dekaliters=	26.42 gallons
1 kilometer=	10 hectometers=	3,280.8 feet	1 kiloliter=	10 hectoliters=	264.18 gallons

WEIGHTS			SQUARE MEASURE		
1 centigram=	10 milligrams=	0.154 grain	1 sq centimeter=	100 sq millimeters=	0.155 sq in
1 decigram=	10 centigrams=	1.54 grains	1 sq decimeter=	100 sq centimeters=	15.5 sq in
1 gram=	10 decigrams=	0.035 ounce	1 sq meter (centare)=	100 sq decimeters=	10.76 sq ft
1 dekagram=	10 grams=	0.35 ounces	1 sq dekameter (are)=	100 sq meters=	1,076.4 sq ft
1 hectogram=	10 dekagrams=	3.52 ounces	1 sq hectometer (hectare)=	100 sq dekameters=	2.47 acres
1 kilogram=	10 hectograms=	2.205 pounds	1 sq kilometer=	100 sq hectometers=	0.386 sq mi
1 quintal=	100 kilograms=	220.46 pounds			
1 metric ton=	10 quintals=	1.1 short tons			

CUBIC MEASURE		
1 cu centimeter=	1000 cu millimeters=	0.0610 cu inch
1 cu meter=	1000 cu decimeters=	35.31 cu feet
1 cu decimeter=	1000 cu centimeters=	61.02 cu inches
1 gallon =	231.0 cu in =	0.134 cu ft= 3.79 liters

APPENDIXES

F—Metric System Equivalents/Conversion Factors

VOLUME (CAPACITY)	U.S. MEASURE	METRIC EQUIVALENT
One hose length = 100 feet		
5/8-inch ID =	1.59 gallons =	6.03 liters
3/4-inch ID =	2.30 gallons =	4.69 liters
1-inch ID =	4.08 gallons =	15.4 liters
1 1/2-inch ID =	9.18 gallons =	34.7 liters
1 3/4-inch ID =	12.5 gallons =	47.3 liters

Tank size (gallons)

Rectangle =	Length x width x height (inches) x 0.00433
Cylinder =	3.14 x diameter squared x height (or length) (inches) x 0.00108

WEIGHT

1 gallon (3.79 L) of water at 20 °C (68 °F) =	8.33 pounds =	3.78 kilograms
---	---------------	----------------

PRESSURE

1 foot of water head (column of water)=	0.433 psi (approx. 1/2 psi)=	2.98 kPa
1 psi =	2.31 feet = (approx. 2 feet of water head)	6.89 kPa
1 psi =	2.04 inch Hg	
1 inch of Hg =	0.491 psi =	3.39 kPa
Atmospheric pressure =	14.696 psi @ sea level (or 29.92 inch Hg) =	101 kPa @ sea level
1,000 foot increase in elevation =	approx. 1/2 psi decrease in atmospheric pressure	

DRAFT

1 inch of mercury =	approx. 1 foot lift (1.135 ft) = 0.346 meter lift
---------------------	---

DRAFTING GUIDELINES

Elevation	Suction Lift (feet) Theoretical	Suction Lift (feet) Practical	Vacuum (in. Hg*)
Sea level	34.0	22	19.5
2,640 feet (1/2 mile)	30.8	20	17.7
5,280 feet (1 mile)	27.8	17	15.0
7,920 feet (1 1/2 mile)	25.1	15	13.3
10,560 feet (2 mile)	22.8	14	12.4

* At practical suction lift when water not flowing (no foot valve).

APPENDIXES

F—Metric System Equivalents/Conversion Factors

To Change	To	Multiply By
inches	centimeters	2.54
feet	meters	0.305
yards	meters	0.914
miles	kilometers	1.60
sq. inches	sq. centimeters	6.451
sq. feet	sq. meters	0.0929
sq. yards	sq. meters	0.836
sq. miles	sq. kilometers	2.590
acres	sq. hectometers	0.405
cubic feet	cubic meters	0.0283
cubic yards	cubic meters	0.765
fluid ounces	milliliters	29.57
pints	liters	0.473
quarts	liters	0.946
gallons	liters	3.785
ounces	grams	28.349
pounds	kilograms	0.454
short tons	metric tons	0.907
pound-feet	newton-meters	1.355
pound-inches	newton-meters	0.113

To Change	To	Multiply By
ounce-inches	newton-meters	0.007062
centimeters	inches	0.394
meters	feet	3.281
meters	yards	1.094
kilometers	miles	0.621
sq. centimeters	sq. inches	0.155
sq. meters	square feet	10.764
sq. meters	sq. yards	1.196
sq. kilometers	sq. miles	0.386
sq. hectometer	acres	2.471
cubic meters	cubic feet	35.315
cubic meters	cubic yards	1.308
milliliters	fluid ounces	0.0338
liters	pints	2.113
liters	quarts	1.057
liters	gallons	0.264
grams	ounces	0.0353
kilograms	pounds	2.205
metric tons	short tons	1.102

APPENDIXES

F—Metric System Equivalents/Conversion Factors

Temperature (Exact)
 °F = Fahrenheit °C = Celsius
 $^{\circ}\text{F}=(^{\circ}\text{C}\times 9/5)+32$ $^{\circ}\text{C}=5/9\times(^{\circ}\text{F}-32)$

Fahrenheit	Celsius	Fahrenheit	Celsius
-20	-28.9	66	18.9
-18	-27.8	68	20
-16	-26.7	70	21.1
-14	-25.6	72	22.2
-12	-24.4	74	23.3
-10	-23.3	76	24.4
-8	-22.2	78	25.6
-6	-21.1	80	26.7
-4	-20	82	27.8
-2	-18.9	84	28.9
0	-17.8	86	30
2	-16.7	88	31.1
4	-15.6	90	32.2
6	-14.4	92	33.3
8	-13.3	94	34.4
10	-12.2	96	35.6
12	-11.1	98	36.7
14	-10	100	37.8
16	-8.9	102	38.9
18	-7.8	104	40
20	-6.7	106	41.1
22	-5.6	108	42.2
24	-4.4	110	43.3
26	-3.3	112	44.4
28	-2.2	114	45.6
30	-1.1	116	46.7
32	0	118	47.8
34	1.1	120	48.9
36	2.2	122	50
38	3.3	124	51.1
40	4.4	126	52.2
42	5.6	128	53.3
44	6.7	130	54.4
46	7.8	132	55.6
48	8.9	134	56.7
50	10	136	57.8
52	11.1	138	58.9
54	12.2	140	60
56	13.3	142	61.1
58	14.4	144	62.2
60	15.6	146	63.3
62	16.7	148	64.4
64	17.8	150	65.6

APPENDIX G

This section is not intended to be a complete listing, nor is it intended to imply any endorsement of any of the manufacturers or distributors. You are encouraged to research the best manufacturer or distributor for your situation. Please check with your department's policy for purchasing of equipment or supplies.

Fire Hose Couplings

Kochek Co. Inc.
271 Old Colony Rd.
Box 369
Eastford, CT 06242
www.kochek.com

Red Head Brass, Inc.
643 Legion Dr.
P.O. Box 566
Shreve, OH 44676
www.redheadbrass.com

Action Coupling and Equipment Inc.
8248 County Road 245
P.O. Box 99
Holmesville, OH 44633
www.actioncoupling.com

Fire Hose Manufacturers

Angus Fire
141 Junny Rd.
Angier, NC 27501
www.angusfire.com

Firequip
1026 N. Main St.
P. O. Drawer 2598
Burlington, NC 27216
www.Firequip.com

Heiman Fire Equipment, Inc.
248 Highway 60 Blvd.
Ashton, IA 51232
www.heimanfireequipment.com

Niedner Limited
675 Merrill St.
Coaticook, Quebec
Canada J1A-2S8
www.niedner.com

Snap-Tite Hose, Inc.
Distributor: National Fire Hose Co.
217 Titusville Rd.
Union City, PA 16438
www.nationalfirehose.com

Nozzles/Valves

Akron Brass Co.
P.O. Box 86
Wooster, OH 44691
www.akronbrass.com

KCR Manufacturing, Inc.
2710 North Interstate Ave.
Portland, OR 97227-1608
503-281-8346
kcr@pacifier.com

Task Force Tips
2800 East Evans Ave.
Valparaiso, IN 46383-6940
www.tft.com

Teems, Inc.
1281 Logan Ave.
Costa Mesa, CA 92626
714-957-0465

United Fire Safety Co., Ltd.
3732 Bowen Rd.
P. O. Box 328
Lancaster, NY 14086
www.unitedfire.com

KK Products
2800 E. Evans Ave.
Valparaiso, IN 46383
www.tft.com

S & H Products, Inc.
5891 Nolan St.
Arvada, CO 80003
www.s-hproducts.com

APPENDIXES

G—Suppliers

Elkhart Brass Mfg. Co. Inc.
1302 West Beardsley Ave.
P.O. Box 1127
Elkhart, IN 46515
www.elkhartbrass.com

Cast Machined Products
6735 East 38th Ave.
Denver, CO 80207
303-377-1052

Pumps

CET Fire Pumps Mfg.
116 Consumer Sq.
Suite 358
Plattsburgh, NY 12901
www.fire-pump.com

Honda Power Equipment Group
4900 Marconi Dr.
Alpharetta, GA 30005-8847
www.hondapowerequipment.com

Sta-Rite Industries, Inc.
Berkeley Pump Co.
293 South Wright St.
Delavan, WI 53115
www.starite.com

Edwards Manufacturing Co.
2441 S.E. Stubbs St.
Milwaukie, OR 97222
www.edwardsmfg.com

Gorman-Rupp
305 Bowman St.
P. O. Box 1217
Mansfield, OH 44901
www.gormanrupp.com

H.D. Hudson Mfg. Co.
(Backpack pump & tank)
500 North Michigan Ave.
Chicago, IL 60611
www.hdHUDSON.com

Homelite Consumer Products, Inc.
1428 Pearman Dairy Rd.
Anderson, SC 29625
www.homelite.com

Hale Fire Pump Co.
700 Spring Mill Ave.
Conshohocken, PA 19428
www.haleproducts.com

Waterous Company
125 Hardman Avenue South
South St. Paul, MN 55075-2456
www.waterousco.com

W.S. Darley & Co.
(Digifoam)
2000 Anson Dr.
Melrose Park, IL 60160
www.wsdarley.com

Shindaiwa Inc.
11975 SW Herman Rd.
Tualatin, OR 97062
www.shindaiwa.com

Hose Reels

Aero-Motive Manufacturing Co.
P.O. Box 2678
Kalamazoo, MI 49003
www.aeromotive.com

American Reeling Devices, Inc.
15 Airpark Vista Blvd.
Dayton, NV 89403
www.americanreeling.com

Metal Masters
3862 Depot Rd.
Hayward, CA 94545
510-352-1230

CoxReels, Inc.
6720 S. Clementine Ct.
Tempe, AZ 85283
www.coxreels.com

Hannay Clifford B & Son, Inc.
533 State Route 143
Westerlo, NY 12193
www.hannayreels.com

General Suppliers

Cascade Fire Equipment Co.
(in-line gauge)
P.O. Box 4248
Medford, OR 97501
www.cascadefire.com

Cordova Fire Equipment Co.
(in-line gauge)
12355 Quicksilver Dr.
Rancho Cordova, CA 95742
www.cordovafire.com

Circul Air Corp.
(mechanical hose washer)
350 Pfungsten Rd.
Suite 105
Northbrook, IL 60062
www.circul-air-corp.com

Mulligan & Associates
P.O. Box 819
Canby, OR 97013
[www.kcmull@web-ster.com](mailto:kcmull@web-ster.com)

LN Curtis & Sons
1800 Peralta St.
Oakland, CA 94607
www.lncurtis.com

Valley Fire & Safety Company
115 B Commercial Blvd.
Martinez, GA 30907
www.valleyfireandsafety.com

Vico & Sons Mfg. & Supply
(gaskets)
P.O. Box 1977, Dept. T
Orange, CA 92862
714-997-4744

Wildfire Equipment Inc.
3951 Development Dr., Suite #4
Sacramento, CA 95838
www.wildfire-equipment.com

Mallory Company
1040 Industrial Way
P.O. Box 2068
Longview, WA 98632
www.malloryco.com

Mercedes Textiles Limited
16633 Hymus Blvd.
Kirkland, Quebec, Canada H9H 4R9
www.mercedestextiles.com

Vescio Threading Co., Inc.
14002 Anson Avenue
Santa Fe Springs, CA 90670
www.plantfloor.com

General Services Administration
501 W. Felix Street
Ft. Worth, TX 76115
www.gsaadvantage.gov

Tank Manufacturers

Custom Fiberglass Products
R.D. #1
Box 1227
Orwigsburg, PA 17961
www.cfpfiretanks.com

John Manion Associates
1052 Centre Turnpike
Orwigsburg, PA 17961
www.manionassociates.com

Fireflex Manufacturing, Ltd.
Distributor: Mulligan & Associates
www.sei-ind.com

FOL-DA-TANK Co.
1275 11th Street West
P.O. Box 110
Milan, IL 61264
www.foldatank.com

United Plastic Fabricating Inc.
165 Flagship Dr
North Andover, MA 01845
www.unitedplastic.com

Western Shelter Systems
830 Wilson St.
P.O. Box 2729
Eugene, OR 97402
www.westernshelter.com

APPENDIXES

G—Suppliers

Specialized Equipment Suppliers

Rice Hydro Equipment Mfg.
(hose tester)
3500 Arrowhead Dr.
Carson City, NV 89706
www.ricehydro.com

Hawthorne Screw Machine
(machining)
12355 Quicksilver Drive
Rancho Cordova, CA 95742
www.plantfloor.com

NoShok
(gauges)
110 West Bagley Rd
Berea, OH 44018
www.noshok.com

Ashcroft
(gauges)
250 East Main Street
Stratford, CT 06614–5145
www.ashcroft.com

Cole-Parmer Instrument Company
(gauges)
25 East Bunker Ct.
Vernon Hills, IL 60061
www.coleparmer.com

SEI Industries Ltd.
7400 Wilson Ave.
Delta, BC Canada V4G 1E5
www.sei-ind.com

Watts Industries, Inc.
(pressure regulator)
815 Chestnut St.
North Andover, MA 01845
www.wattsreg.com

Pocket Mobility Inc.
(friction loss calculator software)
2735-B Iris Ave.
Boulder, CO 80304
www.pocketmobility.com

MegaSecur Inc.
145 Jutras Blvd. East, Suite 3
Victoriaville, QC Canada G6P 4L8
www.megasecur.com

Fire Apparatus Manufacturers

American LaFrance
11710 Statesville Blvd.
Cleveland, NC 27013
www.americanlafrance.com

Becker Fire Equipment
1275 N. 6 Mile Rd.
Casper, WY 82604
www.beckerfire.com

Boise Mobile Equipment
900 W Boeing St.
Boise, ID 83705
www.bmefire.com

West-Mark
2704 Railroad Ave.
Ceres, CA 95307
www.west-mark.com

Danko Emergency Equipment
304 Range Line
Snyder, NE 68664
www.danko.net

Emergency One
1601 SW 37th Ave.
Ocala, FL 34474
www.emergencyone.com

FWD Corp. (Seagrave Fire Apparatus)
105 E. 12th St.
Clintonville, WI 54929
www.seagrave.com

HME, Inc.
1950 Byron Center Ave. SW
Grand Rapids, MI 49509
www.hmetruck.com

J&J Acquisition (S & S Fire Apparatus)
4353 W. 1900 N-48
Fairmont, IN 46928
www.ssfire.com

Kovatch Mobile Equipment
1 Industrial Complex
Nesquehoning, PA 18240
www.kovatch.com

Phenix Enterprises
1785 Mount Vernon Ave.
Pomona, CA 91768
www.phenixent.com

Pierce Manufacturing
2600 American Dr.
P.O. Box 2017
Appleton, WI 54913
www.piercemfg.com

Skaggs Company
3828 S. Main St.
Salt Lake City, UT 84115
www.skaggscompanies.com

Ochoco Manufacturing
2668 NE 3rd St.
Prineville, OR 97754
www.omco-mfg.com

Foam Systems and Accessories

Robwen, Inc.
1989-A Blake Ave.
Los Angeles, CA 90039
www.robwen.com

HyPro Corp.
375 5th Ave. NW
New Brighton, MN 55112
www.hypropumps.com

Machinery R & D
(foam pickup tube)
P.O. Box 1146
Twin Falls, ID 83301
www.idahofire.com

Ron Rochna—Foam Professionals
(high-expansion foam generators)
1004 Water St.
Cove, OR 97824
www.rochna.com

Compressed Air Foam Systems (CAFS)

Darley-Odin Foam Div
P.O. Box 327
Toledo, OR 07391
www.wsdarley.com

Waterous-Pneumax
125 Hardman Ave S.
South St. Paul, MN 55075-2426
www.waterousco.com

APPENDIX H

APPENDIXES

H—Acronyms and Abbreviations

Acronyms and abbreviations used in this *Guide* are listed here, along with their meaning, to provide a ready reference for users of the *Guide*.

ANSI	American National Standards Institute	GVWR	Gross vehicle weight rating
ASTM	American Society for Testing and Materials	Hg	Mercury
ATV	All-terrain vehicle	HP	High pressure (hose)
BIA	Bureau of Indian Affairs, USDI	hp	Horsepower
BLM	Bureau of Land Management, USDI	ICS	Incident Command System
°C	Degrees Celsius	ID	Inside diameter
CA	Cab to axle of motor-driven vehicle	in	Inch(es)
CAFS	Compressed air foam system	IPT	Iron pipe thread
CARB	California Air Resources Board	lb	Pound(s)
CJRL	Cotton-jacketed, rubber-lined (hose)	LPG	Liquefied Petroleum Gas
CSRL	Cotton-Synthetic jacketed, rubber-lined (hose)	LDH	Large diameter hose
CDF	California Department of Forestry and Fire Protection	mph	Miles per hour
CW	Curb weight of motor-driven vehicle	MTDC	Missoula Technology & Development Center
DJRL	Double-jacketed rubber-lined (hose)	NBFU	National Board of Fire Underwriters
DOI	Department of the Interior	NFES	National Fire Equipment System
EPA	Environmental Protection Agency	NFPA	National Fire Protection Association
°F	Degrees Fahrenheit	NH	National Hose
Fed	Federal	NIFC	National Interagency Fire Center, Boise, ID
FEMA	Federal Emergency Management Agency	NIIMS	National Interagency Incident Management Systems
FEPP	Federal Excess Personal Property	NIST	National Institute of Standards and Technology
FEWT	Fire Equipment Working Team	NPS	National Park Service
FS	Forest Service, USDA	NPSH	National Pipe Straight Hose
ft	Feet (foot)	NPT	National Pipe Thread
FWS	Fish and Wildlife Service, USDI	NSN	National Stock Number
gal	Gallon(s)	NST	National Standard Thread
GH	Garden hose	NWCG	National Wildfire Coordinating Group
GHT	Garden hose thread	OD	Outside diameter
Gal/min	Gallons per minute	OSHA	Occupational Safety and Health Administration
GSA	General Services Administration	oz	ounce
GVW	Gross vehicle weight	PMS	Publication Management System (of NIIMS)
		psi	Pounds per square inch

APPENDIXES

H—Acronyms and Abbreviations

psig	Pounds per square inch gauge
pto	Power take off
QPL	Qualified Products List
QT	Quarter turn
R-1, etc.	Region 1 through Region 10, USDA Forest Service
rpm	Revolutions per minute
SIPT	Straight iron pipe thread
S-S	Straight-stream
SDTDC	San Dimas Technology and Development Center
spec	Specification
TPI	Threads per inch
UL	Underwriter's Laboratories
USDA	U.S. Department of Agriculture
USDI	U.S. Department of the Interior
WHEG	Water Handling Equipment Guide

APPENDIX I

These definitions are applicable to wildland firefighting activities. There may be other words, phrases, or terminology that are encountered, but those below are the less familiar or prone to be misunderstood.

Abrasion—Grinding or wearing away of a surface by rough materials.

Adhesion—Bonding or adherence between rubber lining and the jacket.

Alkali extract—A laboratory test procedure where alkali is extracted by boiling a sample hose jacket in a mixture of sodium carbonate and sodium hydroxide, and then determining the difference in weight of the sample.

Apparatus—A motor-driven vehicle, or group of vehicles, designed and constructed for the purpose of fighting fires. May be of different types such as engines, water tenders, and so on.

Aspirate (foam)—To draw in gases (or other substances) nozzle-aspirating systems draw air into the nozzle to mix with the foam solution.

Backing—A layer or rubber material used to provide adhesion between the inner tube and the outer jacket.

Baffle—Partitions in a tank that reduce shifting of water load.

Burst pressure—The ultimate breaking strength of the hose, generally specified to be two times the "rated pressure" for Forest Service-qualified hose.

Cavitation—Caused by reduced pressure and conversely increased vacuum on the water inside the suction of a pump, as a result of the following:

1. Excessive lift
2. Small or long suction hose
3. Blocked or small strainer
4. Warm water
5. High altitude
6. Combination of any

Coating—Protective material applied to a hose jacket to produce a smooth finish. Impregnate process in which a dye or chemical is forced into the yarns to mildew treat or coat the jacket for various reasons.

Construction—The type of fiber used, tensile strength of the fiber, number of ends, and number of picks per inch in a fire hose jacket.

Continuous performance (85 percent—pump test)—Eighty-five percent point established from a maximum. Performance test of a pump and corrected to sea level.

Cotton—Spun cotton fiber yarn woven into a hose.

Cotton-synthetic—Cotton yarn combined with polyester yarn filler for abrasion resistance.

Crimp—The waviness of the yarn in a woven jacket. The difference in distance between two points on a yarn as it lies in a fabric, and their same two points when the yarn has been removed and straightened.

Curb weight (vehicle)—Weight of a vehicle including full fuel tank, cooling system, crankcase, spare wheel, and other standard equipment.

Cure—The act of vulcanization. In fire hose, the vulcanization of the tube to the jacket.

Cycles (engine)—Complete power cycle of an engine—including intake, compression, power, and exhaust strokes.

APPENDIXES

I—Definitions

Dacron—A synthetic polyester fiber. The first manmade fiber ever used in fire hoses. High-strength, low-stretch material ideally suited for fire hoses.

Denier—A unit of weight; used to express the yarn number of polyester and other continuous filament fibers.

Density altitude—Pressure altitude corrected for temperature.

Elastomer—An elastic substance similar to rubber.

Elongation—The increase in length caused by applied force or pressure. It may be measured at any specified load or pressure and is expressed as a percentage of the original length.

End—One thread of the warp, either before weaving or in the jacket.

Engine—Gasoline, or other fuel-powered machine that drives a pump, transmission, or other device.

Erosion—Act of eroding or wearing away of a surface by the impingement of abrasive materials.

Expansion ring—Thin brass or aluminum ring that is used to seat the hose jacket to the coupling and hose bowl gasket forming a secure, watertight seal.

Extrusion—The formation of a desired shape by ejecting through a shaped opening.

Flexibility—The amount of force required to compress a sample hose, or the amount of force to turn a sample hose around a roller drum.

Filament—A single continuous strand of indefinite length, such as manmade polyester. Compared to stable fibers such as cotton, a filament possesses extreme length and often may be measured in thousands of yards without a break.

Filler—The yarn that interlaces with the warp yarn to produce a woven jacket.

Foam—A fire extinguishing chemical that forms bubbles when mixed with water and reduces combustion by cooling, moistening, and excluding oxygen.

Foot valve—Spring action check valve usually used at the lower end of suction hose often incorporating a strainer.

Friction loss—The result of turbulence within the water (fluids) and the resistance along the inside wall of fire hose or pipe.

Fully backed—The process by which the tube is bonded 360 degrees around within the jacket.

Gear ratio—The ratio of the input driving element (shaft) to the output element (shaft).

Gross Vehicle Weight Rating—Maximum allowable vehicle weight.

Head—Pressure due to elevation of water. Equals 0.433 psi per foot of elevation. Back pressure.

Higbee cut—Removal of the end of the first thread to simplify and facilitate rapid coupling connections (also known as “blunt start”).

Horsepower—Engine work capacity. One horsepower (hp) equals 33,000-ft/lb work per minute. (Gross hp is directly off the engine drive shaft; net hp includes power remaining after power to accessories is subtracted.)

Hose bowl—Indentation on the inside of a hose coupling in which a rubber gasket is installed to provide the seal between the hose jacket, coupling, and expansion ring.

Hose lay—Arrangement of connected lengths of fire hose and accessories on the ground from the pump to the nozzle.

Hypalon—A synthetic rubber with excellent ozone, weathering, and acid resistance. Widely used in fire hose to retard abrasion.

Hysteresis—The under reading of an instrument (such as a pressure gauge) with increasing values (pressure is going up) and the over reading with decreasing values (pressure is going down).

Impeller—Rotating part, or blades, of a pump that transfers energy to movement of water.

Impinge—Projection of a substance into another; such as, projection of a stream of fluid or chemical product at high velocity.

Impregnate—To infuse a substance with particles of another substance. In fiber hose, a process in which a dye or chemical is forced into the yarns to mildew treat or coat the jacket for various reasons.

Jacket—A seamless, tubular, woven fabric used as the outer covering of a hose.

Kill switch—Automatic energy or engine shut-off feature resulting from pressure or vacuum loss.

Kink—The bursting of a sample hose when kinked (bent over itself) and tied, then hydrostatic pressure applied.

Kink pressure test—The testing of a sample hose when kinked (bent over itself), tied, and then pressurized.

Leakage rate—The amount of water seeping through a sample hose (unlined) in a special trough in a given time period.

Lined hose—A hose that is lined with a tube of petroleum-based thermoplastic or polyester elastomer.

Liner—The innermost continuous petroleum base, thermoplastic, polyester elastomer element of fire hose.

Live reel—Reel capable of supporting and operating a length of hose while under working pressure.

Loose-at-fold—The process by which a tube is not bonded 360 degrees around in the jacket.

Maximum hydraulic units—Unit of measure in testing of a pump. The highest value obtained when multiplying pressure by flow of a performance curve of a pump.

Maximum performance—The maximum flow at various pressures of a pump with peak revolutions per minute of the engine or motor.

Mildew—Growth of organic matter produced by fungi. It will discolor and cause deterioration of the woven fabric.

Mildew resistant—Designed to withstand the growth of mildew and mold without any deteriorating effect on the fabric.

Mildew treatment—The chemical treatment on a hose jacket to resist organic growth that would deteriorate the hose jacket fibers.

Neoprene—A synthetic rubber. Excellent resistance to many chemicals, weathering, ozone, heat, cold, and abrasion. Ideally suited for fire hose liners where prolonged storage is a factor.

Nylon—A synthetic fiber named by E.I. Dupont Co. used in wearing apparel and other commercial and industrial applications where elongation is not a factor.

One-hundred-hour endurance—Same value as the maximum hydraulic units, but at 85 percent of the maximum performance corrected to sea level (Forest Service-USDA specification).

Operating pressure—The pressure at which a system is operating.

APPENDIXES

I—Definitions

Oven aging—The deterioration of a hose lining observed under a 7-power microscope after heating in an oven at a given temperature and time.

Ozone aging—The deterioration of a hose lining or jacket observed under a 7-power microscope after exposure to a given amount of ozone and time.

Pick—Circular yarn woven between longitudinal warp ends that form a pick on one turn of the finished jacket.

Polyester—A synthetic material either spun or filament. Can be used in both the warp and filler yarn in fire hose.

Polyethylene—Any of various partially crystalline lightweight thermoplastics that are resistant to chemicals and moisture, have good insulating properties, and are used especially in packaging, insulation and sometimes for wildland engine water tanks.

Polypropylene—A copolymer plastic, usually black, that is strong, ultraviolet resistant, not effected by chemicals and a good choice for wildland engine water tanks.

Polyurethane—This type plastic normally is used for round molded tanks, is not ultraviolet resistant, a poor choice for fire control use.

Power take-off—An output shaft on an engine, transmission, or transfer case of a motorized vehicle that delivers engine power to auxiliary equipment.

Priming—Filling pump with water when pump is taking water not under a pressure head. Necessary for centrifugal pumps.

Pump performance value—Same value as the maximum hydraulic units at 85 percent. (Also same as qualified rating. USDA Forest Service specification.)

Qualified rating—Same value as pump performance value (USDA Forest Service standard).

Rated Pressure—The maximum "operating pressure" of a component or system. Also known as "working pressure" in Forest Service specifications.

Retardant (fire)—A substance that reduces or inhibits flammability of combustible material by chemical or physical action.

Rise—The height hose lifts from its original flat position once hydrostatic pressure is applied.

Service test pressure—The pressure applied to a hose during periodic testing to determine if the hose can remain in service.

Slip-on unit—A self-contained unit including an auxiliary engine driven pump, piping, a tank, and hose storage that is designed to be placed on a truck chassis, utility bed, flat bed, or trailer. Such units can typically be attached and removed from the vehicle with a minimum amount of time and effort.

Spun yarn—A textile yarn spun and twisted from staple-length fiber, either natural or synthetic.

Sulfur content—The percent by weight of sulfur contained in a rubber hose lining as determined chemically in a laboratory test.

Suppressant—Agent that extinguishes the flaming and glowing phases of combustion by direct application to the burning fuel. (Water is a suppressant agent.)

Surge—Rapid increase in flow resulting in rise in pressure.

Tandem—One behind another. (In firefighting operation, a relay operation with short lines between pumps.)

Twist—The twisting of a hose when hydrostatic pressure is applied. The twisting is either left or right as observed in the direction of flow.

Uniform leakage—The wetting and close up period of a dry unlined hose.

Unlined hose—A woven hose that does not incorporate a tube. Designed to seep, and manufactured of linen yarn. Normally used as emergency hose, but used in wildland fires due to its resistance to hot spots that would burn through other types of hose.

USDA Qualification—The purpose of the qualification process is to determine if a manufacturer's product conforms to USDA Forest Service specifications. For example, the qualification of pumps includes a visual inspection, a priming test, a drafting test, an engine test, an endurance performance test, a spark arrester test, and a sound test. Testing and evaluation is conducted by the government at the expense of the contractor. Once a product is determined to meet the minimum specification requirements, the product is assigned a Qualified Products List (QPL) number and is added to the QPL. The QPL is a USDA Forest Service list of products that have been examined, tested, and have satisfied all applicable qualification requirements and may be used by any interested party.

Warp—The amount of deviation from a straight line when the hose is hydrostatically tested; usually expressed in inches.

Water extraction—The pH content of a hose jacket determined after boiling in distilled water in a laboratory test.

Water hammer—The series of shocks, sounding like hammer blows, produced by suddenly reducing the flow of a fluid in a pipe or hose such as when a valve is rapidly closed.

Wetting agent—Detergent type chemical that when added to water reduces surface tension and increases penetration into fuels.

Wet water—Water treated with wetting agent.

Wheel base—Distance from centerlines of front axle to rear axle of a motor-driven vehicle or center of tandem axles

Working pressure—The maximum "operating pressure" of a component or system. Identified as "WP" on Forest Service-qualified fire hose. Also known as "rated pressure."

Yarn number (cotton)—A conventional relative measure of fineness as applied to yarns. Coarse yarns have low numbers and fine yarns have high numbers.

APPENDIX J

APPENDIXES
J—Mobile Equipment Input Data Sheet

Agency: _____

Equipment Designator: _____

ICS Type: _____

Summary: Tank Capacity—gallons _____
 Pump Rating— _____ gal/min @ 150 psi
 Pump Drive— _____
 Mobile Attack Capability?—Yes/No
 Number Crew Personnel— _____
 Foam System Available?—Yes/No Gallons— _____
 All-Wheel Drive? —Yes/No



General Description: _____

Pump: Manufacturer: _____ Model: _____ Type: Centrifugal/Positive displacement Performance: gal/min (max) at free flow; _____ gal/min @ max psi = _____ Primer Type: Electric/Exhaust/Manual/Air/Self	Tank: Material: _____ Construction: Baffles? Yes/No If steel, is the tank corrosion treated? Yes/No
--	--

Controls and Gauges: Hand Throttle? Yes/No Pressure Gauge? Yes/No Automatic shutdown? Yes/No

Valves: Tank-to-Pump? Yes/No Pump-to-Tank? Yes/No

Overboard Discharge: Quantity _____
 Size _____

Suction: Quantity _____
 Size _____

Priming Valve Handle: _____
 Suction Valve Handle: _____
 Tank-to-Plumbing Shut-Off? Yes/No
 Gravity Tank Drain/Dump? Yes/No

Discharge Valve Handle: _____
 Adjustable Pressure Relief? Yes/No
 Pump and Plumbing Drain? Yes/No
 Rock Trap/Plumbing Strainer? Yes/No

Chassis: Type _____
 Manufacturer: _____
 Manufacturer Model Year: _____
 Engine Fuel Type: _____
 GVW (Operating Weight): _____
 Brake Type: _____

Type _____
 Cab/Axle Distance: _____
 GVWR: _____
 Horsepower Rating: _____
 Transmission Type: _____

Written Materials:
 Specifications and drawings are available from: _____

APPENDIXES

J—Mobile Equipment Input Data Sheet

Agency: Name only

Equipment Designator: Agency and/or manufacturer’s model name and number, i.e., Model 667, S&S Wildland, FS Model 60, brush patrol, initial attack, brush-buster, etc.

ICS Type: See the following NWCG resource-typing chart for Water Tenders and Engines.

Minimum Standards for Water Tender Type						Minimum Standards For Engine Type							
Resource	Components	1	2	3	4	Components	1	2	3	4	5	6	7
Water Tender	Pump, gal/min	300	200	200	~	Pump Capacity (GPM)	1,000	500	120	70	50	50	20
	Tank, Gallons	5,000	2,500	1,000	~	Tank capacity (Gallons)	400	400	300	750	500	200	125
						Hose, 2½ inch (Feet)	1,200	1,000	~	~	~	~	~
						Hose, 1½ inch (Feet)	400	500	1000	300	300	300	200
						Hose, 1 inch (Feet)	200	300	800	300	300	300	200
						Ladder (Feet)	20	20	~	~	~	~	~
						Heavy Stream (gal/min)	500	~	~	~	~	~	~
						Personnel (Minimum)	4	3	3	3	3	3	3

Summary: Pump Drive – i.e., PTO, auxiliary engine hydrostatic, V-belt, flywheel, or electric.

General Description: Describe any unique or special features not already included in this data sheet that may be of interest to others. An example is attached: *“This unit consists of a low-profile service body, 250-gallon steel tank, hose reel, and plumbing. The unit is intended for off-road use and is reinforced front, rear, and both sides for protection from trees and rocks.”*

Tank: Material—i.e., mild steel, stainless steel, polypropylene, plastic, fiberglass, aluminum.

Controls and Gauges: Automatic shutdown—Does the unit have an automatic shutdown of the pumping system controlled by oil pressure, water temperature, or low water?

Valves: Priming valve handle, discharge valve handle, suction valve handle, gravity tank drain/dump—Are these valves controlled manually, electrically, or pneumatically?
 Rock trap/plumbing strainer—Is apparatus equipped with a plumbed strainer/rock trap on the inlet side of the pump (excluding any devices on the suction hose)?

Chassis: Manufacturer—i.e., Dodge, Ford, Chevy, GMC, International, etc.
 Model year—If several model years of this same type vehicle are used, this can be noted in the “General Description” section.
 Gross Vehicle Weight Rating (GVWR)—The maximum allowable weight for the vehicle including fuel, water, operator, passengers, and payload. This is determined by the manufacturer of the vehicle and is identified on the door post of the vehicle as Vehicle GVWR.
 Gross Vehicle Weight (GVW)—The total weight of the vehicle loaded with fuel, water, operator, passengers, and payloads, ready for response. This is sometimes referred to as the operating weight.
Note: On vehicles older than 1990, the GVWR is shown as the GVW for that vehicle. Care should be taken when determining the Gross Vehicle Weight of the loaded vehicle to insure that it does not exceed the Gross Vehicle Weight Rating.
 Transmission Type—Standard or automatic.
 Cab-to-Axle Distance—The distance from the rear of the cab to the center of the rear axle(s) recorded in inches.
 Engine fuel type—Diesel, gasoline, etc.
 Brake type—Hydraulic, air, etc.

Written Materials: Agency name, contact person, mailing address, telephone number, fax number, e-mail address.

