



H. M. M. M. M.

KLIMENT
TIMIRYAZEV



THE LIFE
of the
PLANT

TEN POPULAR
LECTURES

FOREIGN LANGUAGES
PUBLISHING HOUSE
MOSCOW
1958

The present edition is the authorized English translation of Timiryazev's *The Life of the Plant*. The translation was made by A. Sheremetyeva and published in London in 1912. Professor A. N. Beketov's review of the book and the forewords to the second, third, fourth, fifth, sixth, seventh, eighth and ninth Russian editions have been translated by R. Dixon. The English translation has been checked with the Russian text of the book included in Volume IV of Timiryazev's *Works* (Moscow, 1938) and the appropriate changes have been made.

This online edition of this public domain book was produced by The Soil and Health Library in 2008.

CONTENTS

	<i>Page</i>
TRANSLATOR'S NOTE	9
FOREWORD TO THE ENGLISH TRANSLATION	10
REVIEW OF THE LIFE OF THE PLANT BY PROF. A. N. BEKETOV	17
FOREWORD TO THE FIRST EDITION	21
FOREWORD TO THE SECOND EDITION	22
FOREWORD TO THE THIRD EDITION	26
FOREWORD TO THE FOURTH EDITION	29
FOREWORD TO THE FIFTH EDITION	29
FOREWORD TO THE SIXTH EDITION	30
FOREWORD TO THE SEVENTH EDITION	31
FOREWORD TO THE EIGHTH EDITION	32
FOREWORD TO THE NINTH EDITION	35

THE LIFE OF THE PLANT

I. SCIENCE AND SOCIETY. EXTERNAL AND INTERNAL STRUCTURE OF THE PLANT

The general public's meagre knowledge of botany. Two old-fashioned types of botanists. The contemporary trend of science. Morphology and physiology; form and life. Two reasons for the comparative backwardness of botany: the logical and the practical reason. Art and science. Agriculture and the physiology of the plant. Science and the general public in mutual relationship.

Survey of the external organs of a flowering plant. Metamorphosis. Spore-bearing plants—of earlier date and simpler in structure than seed-plants. A spore—a cell. The cell—the foundation and beginning of every organism. These facts in relation to the problem of the origin of organisms. Treatment of subject

II. THE CELL

Law of the conservation of matter. Origin of plant-substance—in the external environment. Elements and compounds entering into the composition of plants. Three fundamental groups of chemical compounds: albuminoids, carbohydrates, fats. Chemical and microscopic investigation of the plant.

Absorption of nutrient substances by the plant. General conception of the diffusion of matter. Diffusion of gases and liquids. Colloids and crystalloids. Transformation of substances in the cell explains their absorption. Fundamental mechanism of the nutrition of the cell.....•.....

III. THE SEED

Structure of the seed and external phenomena of germination. Three conditions of germination: water, air, heat. Mechanical function of water. Chemical function of water. Ferments. Diastase. Pepsin. Insectivorous plants. Independence of the parts of the embryo. Artificial nutrition of the embryo. Mechanism for the translocation of the nutrient substances in the plant.

The seed in relation to air; evolution of carbonic acid, absorption of oxygen—respiration. Loss in weight and rise of temperature as a result of respiration. Importance of the surrounding temperature. Temperatures: maxima, minima, and optima. Effect of the age of the seed on its germination. Longevity of seeds. General characteristics of the period of germination. Division of labour between different organs of the plant, already apparent in the lowest plants.

IV. THE ROOT

Function of the root. Composition of the soil. Method for defining the necessary nutrient substances. Artificial cultures. Cultures without organic matter. Water cultures. Importance of nitrogen, potassium, iron, silicon. The necessary nutrient substances absorbed by the root. Nutrient substances in the soil for immediate use and in reserve. Absorbent properties of the soil. Importance of saltpetre in the soil. Assimilation of nitrogen by leguminous plants. Form in which nutrient substances are found in the soil.

Structure of the root. Its striking elongation and the purpose of this character. The root in relation to liquid and solid substances. General mechanism for the absorption of nutrient substances by the root.

V. THE LEAF

Function of the leaf. The nutrient substance assimilated by the leaf. The leaf in relation to carbonic acid. Structure of the leaf. Evolution of oxygen. Decomposition of carbonic acid in water. Obviousness of the experiment. Decomposition of carbonic acid in an artificial mixture of gases and in the atmospheric air. Formation of a carbohydrate (starch) in the chloroplast.

The decomposition of carbonic acid from the point of view of the transformation of energy. Nutrition of the plant at the expense of organic matter. Fungi and parasites. Physiological functions of the leaf.

VI. THE STEM

Function of the stem, secondary as a medium between the leaf and the root. Forms of stems. Internal structure. Cell, fibre, and vessel. Three types of tissue: nutritive, mechanical, and conducting. Connective tissue and bundles. Structure of stems in monocotyledonous and dicotyledonous plants. Wood and bark.

Ascending current of water. Its course and destination. Participation of the root—its water-raising power. Participation of the leaves—evaporation of water. Function of the stomata. Function of the vessels. Function of bordered pits. Velocity of the sap. Purpose of the cork tissue. Movement of nutrient substances formed by the leaf. Course of this movement. Function of the sieve and latex-tubes. Causes of this movement. Formation of stores of nutrient substances.

VII. GROWTH

Nutrition and growth. Direction of growth in the root and stem. Attraction by the earth. Turgidity of tissues. Mode of action of gravity. Influence of light. Heliotropism. Methods of measuring growth. Influence of temperature. Thermotropism.

Growth and multiplication of cells. Division of the nucleus. The proximate effect of light on the growth of the cell-walls. Effect of pressure on the form of cells. Growth mechanism of cells. Possibility of hearing plants vegetate. The art of experiment

VIII. THE FLOWER AND THE FRUIT

Sexual and asexual reproduction of plants. The flower. Essential parts of the flower—ovule and pollen. Fertilization. Fertilization in the lowest plants. Adaptations securing the fertilization of flowering plants.

Function of the so-called non-essential parts of a flower. Self-fertilization and cross-fertilization. Cooperation of wind and insects. Parts of the flower attracting insects. Special forms of flowers adapted to cross-fertilization by insects. The part played by art in the production of cultivated varieties. Purpose of selection. Insufficiency of physiological knowledge of the nature of the sexual process.

Various types of fruit and their transportation by air, water, and animals. Viviparous plants. The scattering of seeds: yellow acacia, touch-me-not and squirting cucumber. Transportation by air: samara and pappus. Transportation by water: cocoa-nut. Transportation by animals: tenacious fruits and edible fruits. Mistletoe. Self-planting: Linaria, feather-grass. Is the plant intelligent?

IX. THE PLANT AND THE ANIMAL

Current ideas as to the difference between plants and animals. Capacity for movement in a plant. Microscopic movements: of protoplasm, zoospores, and antherozoids. Movements of organs in the highest plants under the influence of external conditions (heat, light). Sensitive organs. Mechanism of these movements. Spontaneously moving organs. Utility of various movements.

Similarity between the internal processes of movement in plants and animals. Similarity in the processes of nutrition. Similarity in the process of respiration. Respiration and fermentation. Similarity between the phenomena of stimulation and anaesthesia in plants and animals. Is a plant

capable of consciousness? The difference between plants and animals is not that of quality but of quantity—not in kind, but in degree. The sum-total of experimental physiology does not exhaust the problems of the science.

X. ORIGIN OF ORGANIC FORMS

The adaptive character of organic forms can be explained only by the historical process of their development. Palaeontology, morphology, and embryology together testify to the genetic connection between organisms. This conclusion conflicts with the once prevalent conviction as to the permanency of species. Are species really invariable? Logical fallacy underlying this opinion.

Why does the historical process lead to perfection? Darwin's theory. The struggle for existence and natural selection. Explanation of the absence of transitional forms. What we have to be content with in explaining particular cases of adaptation. Analytical and synthetical paths followed by the reader. General conclusion and aim of the course.

APPENDIX

THE PLANT AS A SOURCE OF ENERGY

Twofold significance of food for the animal organism—as a building material and as a source of energy. Conception of work and energy, actual and potential. Law of the conservation of energy. Mechanical theory of heat. Chemical affinity. The animal organism, considered as a mechanism. Combustion and respiration.

Necessity for the existence in nature of a process the inverse of combustion and respiration. Priestley's discovery. Decomposition of carbonic acid by the plant. This process considered from the point of view of the theory of the conservation of energy. Robert Mayer. Production of organic matter by the plant. Chlorophyll, its optical properties, and the explanation they afford of its function in nature. Economic value of the process taking place in the green organs of plants. Theoretical limit to (the) productiveness of the earth. General inference.

SUBJECT INDEX

TRANSLATOR'S NOTE

In presenting this book to the English public my sincere thanks are due to my friend Miss E. I. Boyd, M.A., who kindly undertook the revision of the M.S., and has shown the closest interest in the translation and its publication.

I should like also to acknowledge a debt of gratitude to Professor Seward of Cambridge, and Professor Vinogradov of Oxford for their kind help in regard to the publication of the book.

My best thanks are due to Mr. D. Thoday, of Trinity College, Cambridge, Lecturer in Plant Physiology in the University of Manchester, for his valuable assistance in the matter of scientific revision and the correction of proofs.

A. Sheremetyeva

*St. Petersburg,
November 1911*

FOREWORD TO THE ENGLISH TRANSLATION

A glance at the preface to the first Russian edition will, I hope, convince the English reader that I was fully aware of the exceptional difficulties of the task I had undertaken. Seven editions in the course of thirty-five years have in a certain degree contributed to dispel my fears, but on being-asked to give my assent to this English translation I experienced afresh the same feeling of diffidence at the prospect of addressing a new audience. Just at that moment I came across that admirable article by Professor Armstrong on *The Future of Science in Our Schools** I was glad to see that not only in its general tendency, but even in the choice of matter and in the order of exposition, my book seemed to answer the present requirements of English schools as formulated by so eminent an authority as Professor Armstrong. The inspection of the table of contents of this book will suffice to show that even in details it agrees with the short programme proposed by Professor Armstrong (l.c., pp. 438, 439); both begin with the analysis of flour and culminate in an exposition of Darwin's theory.

* Presidential Address to the Association of Public School Science Masters, delivered January 13th, 1910. *Science Progress*, January 1910, p. 417.



Timiryazev wearing a Doctor's gown
Glasgow University, 1902
(Timiryazev Museum)

"The main thing we ought to teach our youth is *to see* something." This maxim of John Ruskin, chosen by Professor Armstrong as a heading to his article, has ever been present to the author of this book. A pair of healthy eyes and occasionally a good lens is all that is required *to see* the external forms of our common plants. But how different is the case when we are expected *to show* even the commonest phenomena of plant life, for the most part invisible, and in so many respects quite different from the familiar manifestations of animal life!—think only of respiration without inspiring and expiring, or of feeding on air. At every step we require more or less complicated, or, what is highly desirable but not so easily attainable, the simplest possible apparatus.* Moreover, all the results obtained must be considered from the general point of view of those two sister (or rather mother) sciences—physics and chemistry. In this respect I have consistently complied with Professor Armstrong's precept to which I readily subscribe: "Whatever we teach in

our schools, chemistry must not be neglected; it is the science of life, life being but a succession of chemical changes: it is therefore the basis of physiology."

* I may perhaps be allowed to add that I believe I was the first to introduce lecture experiments into my annual courses on plant physiology, which began in 1870. At least, at a much later date, Professor Julius Sachs, the head of the German school of physiologists, as I was told in 1877 by one of his assistants, never introduced any *Vorlesungsversuche* into his lectures.

I fully expect that not a few of my botanical colleagues may consider some passages of chapter VII out of date; but I must frankly confess I consider a return in a certain sense to the sound notions of Andrew Knight or A. P. De Candolle, of Dutrochet or Hofmeister may prove to be a desirable corrective to the alarming spread of the *Reizphysiologie* with its morbid outgrowth of "Neovitalism" and "Phytopsychochemistry," and their natural corollary, anti-Darwinism. Nowadays in our pursuit after the quasi-nervous stimuli we have nearly lost out of sight the object stimulated and the mode of action of the external agents. No less an authority than Sir Joseph Thomson has recently warned us that even in the higher realms of science "something more grossly mechanical, a model, is felt by many to be more suggestive and manageable, and for them a more powerful instrument of research." . . . I really think that some such models as those formerly proposed by De Candolle for the heliotropic effect or by Hofmeister for the elucidation of geotropism, adapted of course to the growing exigencies of the time, might bring back the study of the mechanism of growth to a more promising field of research.



Timiryazev wearing a Doctor's gown,
Cambridge University, 1911
(Timiryazev Museum)

That the ideas I venture to advocate are not so utterly out of date may be inferred from the fact that similar ideas have been recently advanced by a representative of a much younger generation of botanists, by the regretted Professor Barnes.* For my part, I am as firmly convinced as I was forty years ago that the "mechanistic conception" and Darwinism have been bequeathed by the "wonderful century" to the still infant science of plant physiology as the two sure guides for its further evolution, and I may adduce in support of this opinion the eloquent testimony of the late Professor Boltzmann: "If I were asked, how will our century be called by the coming generations—the century of iron, of steam, or of electricity?—I would reply, in all earnest, it will be called the century of the mechanical interpretation of nature, the century of Darwin."**

* "In fact there is an inclination after endowing protoplasm with such properties as 'irritability,' 'automaticity,' and 'self-regulation,' to be satisfied with these words and there make an end."—"I propose only to present some suggestions on the matter of these phenomena as a contribution towards a mechanistic conception of plant." . . . *The Nature of Physiological Response. The Botanical Gazette*, New York, 1910, pp. 322-323.

** *Das zweite Hauptgesetz der mechanischen Wärmetheorie*, 1886. *Populare Schriften*, von Professor Ludwig Boltzmann, 1905, p. 28.

It is impossible for me to bring to a close this prefatory notice without expressing my best thanks to Miss Cheremeteff for having undertaken and successfully completed this translation.

As a foreigner I am, of course, not entitled to judge of the literary merits of the translation, but on the other hand, having carefully read through the whole of the proofs of this volume, I am bound to bear witness to the many and considerable difficulties overcome by the translator.

My warmest thanks are also due to my colleagues, Professor Seward of Cambridge and Professor Vinogradov of Oxford (lately of Moscow), for their friendly help with regard to the publication of the book.

K. Timiryazev

*Moscow,
January 1912*

REVIEW OF THE LIFE OF THE PLANT

by Prof. A. N. Beketov*

* This review by Andrei Nikolayevich Beketov, professor of botany at Petersburg University and a prominent popularizer of botany in Russia, preceded the author's foreword in the fifth and following editions of *The Life of the Plant*.

A. N. Beketov was Timiryazev's first botany teacher and Timiryazev attached great value to his opinion.— *Ed.*

Professor Timiryazev's *The Life of the Plant* has already received due appreciation from the educated¹ public and this proves how widely it has been read in spite of the seriousness of the contents. The reason for this is the skill with which it is written. I do not know of a single work on botany accessible to the general public in any of the main languages of the civilized world which is comparable with this one.

Professor Timiryazev's book gives an exposition of the whole of general botany in a concise form but if attentively read it provides a complete and thorough idea of the exterior and inner (anatomical) structure of the plant and all its physiological functions. At the same time the book is very interesting to read. This is the result not only of great talent in the exposition but of the thoroughness, too, with which the plan has been thought out. Everything in the book is concentrated, and strives, so to speak, towards one principal aim—to explain the phenomena which take place in the plant and form its life. Hence both anatomy (the science of the cell and the tissues) and morphology are set forth only insofar as is necessary for a clear understanding of the various vital phenomena of the plant. There is no superfluous accumulation of facts, for the aim of the book is by no means to exhaust the whole content of science but to provide the reader with a strictly scientific idea of the way the plant fulfils the tasks of its life. Interest in the subject is thus aroused and the road to a more profound study of it is shown.

Moreover, the author everywhere dwells on experiments and the course of observations. His exposition is mainly inductive. By reading even only the chapters (IV and V) in which the experiments on artificial nutrition and the chlorophyll functions (absorption and decomposition of carbonic acid) of the leaves are dealt with, one not only acquires knowledge but at the same time penetrates with the author into the very methods of precise physiological experiments and is amazed by the subtlety and depth of thought displayed to wring from Nature the answer to the questions posed. This insistence which the author shows to set forth on every possible occasion the process of the experiments and investigations is particularly valuable. Not to mention the fact that this method allows him to prove to the thinking reader the correctness of the scientific suppositions, it also precludes dogmatism and the pedantic didacticism which is so often harmful to generally accessible works and, finally, precludes loquacity which puts the reader off and

does not give him the most important information in a precise form.

* *Pflanzenleben*, von Anton Kerner von Marilaun, Leipzig, 1881.

A striking example of this vague, I would say garrulous, exposition is provided by the German publication which bears the same name as Professor Timiryazev's work,* and, judging by appearances, could arouse in somebody the desire to translate, it into Russian. The first volume alone, which is devoted to the structure and life of plants, contains 733 large-size pages, 20 beautifully executed water-colours and 553 excellent xylographies. An enormous mass of facts are accumulated in it, but the fundamentals are not only lost, they are often erroneous.



Diploma of Fellow of the London Royal Society conferred on Timiryazev in 1911 (Timiryazev Museum)

It therefore goes without saying that if I were asked which book it is preferable to read to get to know the life of plants I would name Timiryazev's and not mention Kerner, rather referring the reader to the specialized works from which the latter drew his material.

FOREWORD TO THE FIRST EDITION

For about a quarter of a century there has been a great gap in the botanical literature of the west of Europe, as also of Russia, since there has been no book that might inform the public in a popular way of the present state of vegetable physiology. I decide to publish these lectures in the hope, were it only in slight measure, of meeting this end. In submitting this book to the judgement of the public, I fully realize the difficulties of the undertaking. Every popular exposition, precisely because of its popular nature, deprives the author of the possibility of expressing *the whole truth*, i.e., of criticizing from all sides the facts he brings forward; and, moreover, it obliges him not to say *anything but the truth*, a requirement that can scarcely be complied with in a science which is far from being firmly established. Hence it is clear that a popular exposition of such a science as the physiology of plants presents many more difficulties than a similar exposition, for instance, of chemistry or physics.

The second requirement for such a book is that the author should give up for a while his usual point of view, that of a specialist; and should, so to speak, step back a little in order to see what science looks like at a distance. The main condition for success consists in the selection of such a point of view as will be close enough to allow of the observation of main details, and yet not too close to spoil by detail the impression of the whole. It is not for me to decide whether I have been fortunate enough to find such a point or not.

The position of an author of a popular book differs also from that of an author of a special treatise, in that he is deprived of any opportunity for self-justification or defence. He surrenders himself defenceless into the hands of his judges. The reader appears as his first and last court of appeal. A specialist may consider his exposition to be conscientious, to have overcome considerable difficulties; but if his work so much as displeases the reader, it will fail of its aim and be therefore doomed.

I hope that I may find as kindly critics among my readers as I had the privilege of finding in my audiences. They have appreciated the difficulty of my task, and have indulgently criticized its fulfilment.*

*Petrovskoye-Razumovskoye,
30th March, 1878*

* These lectures were delivered during the winter of 1876 in the Moscow Museum of Applied Knowledge. "The Plant as a Source of Energy," placed in the appendix, was delivered at St. Petersburg in the Russian Technical Society in the spring of 1875.

FOREWORD TO THE SECOND EDITION

In my foreword to the first edition I pointed out that the absence of a popular outline of the physiology of plants is felt in all European literatures as well as in ours. U. Saxe expressed the same thought in his foreword to his last work, which was intended to fill this gap.**

** Vorlesungen über Pflanzenphysiologie, 1882.

Saxe's book has not yet been published in the Russian translation, but even if it had been, I do not think it would be accessible to non-specialists; more than that, I doubt whether it could be called popular even from the standpoint of the German public, who are more accustomed to this type of reading.



Timiryazev's study, Timiryazev Museum, Moscow

The considerations which justified the publication of the first edition are therefore also valid in respect of the second. This differs little from the first. In books of this kind moderate size, which does not frighten the reader who has little leisure, is a factor not to be neglected. That is why, in going over my book for the second edition, I have endeavoured first of all to avoid the by no means rare mistake as a result of which, for example, some short books swell in subsequent editions to a bulky collection of knowledge, thus departing from their original purpose. I tried to improve that which I found was weak in the first edition, changed what proved to be inexact and added only the most essential of what had been newly discovered—in five years science makes many new acquisitions which are entitled to be included in a short, generally accessible outline.

I do not share the opinion expressed by Saxe in the work just mentioned, that readers "wish to know and must know" only the outlook of the author; that for them "it is absolutely immaterial whether others think that way or not." I therefore tried in the whole of my exposition to touch only upon such facts as are fully proved or generally acknowledged; and in cases in which I was obliged to express opinions contrary to the dominating views, I endeavoured, as far as possible, to express them in such a form that the reader could judge for himself. For one thing I can vouch—not once did I allow myself to express any opinion whatsoever in a dogmatic form, knowing that there are weighty and as yet non-refuted objections to it.

For greater convenience the book has been provided with a detailed table of contents and an index.

THE LIFE OF THE PLANT

BY C. A. TIMIRIAZEFF

PROFESSOR EMERITUS MOSCOW UNIVERSITY
CORRESPONDING MEMBER OF THE ACADEMY OF SCIENCE, ST. PETERSBURG
LL.D. GLASGOW; SC.D. CAMBRIDGE
D. SC. GENÈVE
F.R.S.

Translated from the
Revised and corrected Seventh Russian Edition by
MISS ANNA CHÉRÉMÉTEFF

WITH ILLUSTRATIONS

LONGMANS, GREEN, AND CO.

39 PATERNOSTER ROW, LONDON
NEW YORK, BOMBAY, AND CALCUTTA

1912

Title page of the first English edition of *The Life of the Plant*
by K. Timiryazev. 1912



Sir,

I am directed by the Royal Society
to express their thanks for your book entitled

The Life of the Plant. Translation by Miss Anna
Chérémotoff. 1912.

and to assure You that the Society duly
appreciate this mark of consideration.

I have the honor to be
Sir
Your obedient Servant
R. Harrison

To Prof. C.A. Timiriaseff,
For. Mus., N.S.
Assistant Secretary
and Librarian R.S.

Letter of thanks sent to Timiryazev by the London Royal
Society (Timiryazev Museum)

Confining myself to these explanations, I deliver this
second edition to the judgement of the reader with the same
hope which I expressed at the end of the foreword to the first.

Kuntsevo,
July 8, 1884

FOREWORD TO THE THIRD EDITION

The second (double) edition of the present book, which
appeared a few years ago, has justified the hope expressed in
its opening pages that a popular exposition of the general
principles of plant physiology could reckon on readers
interested in the phenomena of plant life which are called to
play such an important economic role in our own life. The
increasing significance which is attached in our country to
scientific agriculture will in time naturally justify the
conviction to which I gave expression that plant physiology
will eventually have the same place in agronomics as the
physiology of man already has in medicine, and the
achievement of this result will, of course, be promoted by the

spreading of knowledge of the fundamentals of botany not only in universities but among the broader reading public.

In the present edition, as in the previous ones, I have endeavoured above all not to go beyond the framework of a book destined for reading and for the first acquaintance with the subject, not for its assiduous study. It will therefore be understood that the new changes and additions which have been made still touch only the very greatest acquisitions science has made since the preceding issue.

Outwardly this edition has the advantage over the second that the number of drawings has been increased by almost one-third and many old illustrations have been replaced by new ones.

I do not consider it superfluous to say a few words about the phototypes that have been appended. I have heard reproaches that the reader could obtain from the book only information about the life of plants under laboratory conditions and found no pictures of the free life of plants in the open. But I am of the opinion that one can set about this latter task only if one has the brush of a Shishkin or the pen of a Turgenev. He who is not gifted with such talents, will find it more useful to avail himself of the means which modern photography places at the disposal of every amateur. I am convinced that, intelligently guided by artistic taste, that new weapon of research could promote the development of the "feeling for Nature" that is still so rare among us.* We know by name the famous oaks and beeches of Fontainebleau, but I am sure that there are a good many Muscovites who have never seen the Kuntsevo oak; we find interest in poor descriptions of the luxuriant tropical nature but pay no attention to the beauty of an out-of-the-way corner in the woods an hour's journey from the Kremlin. I think that the two studies appended will be more eloquent in helping the reader to understand the power which the individual plant attains and the complicated intertwining of countless individual lives on a tiny sod of earth than the usual enumeration of the giants of the vegetable kingdom or rows of figures explaining the geometrical progression of the propagation of plants. And how many such subjects can the thinking connoisseur of the beauties of Nature notice when he wanders through fields and woods with his camera. In concluding I take the liberty of expressing the hope that I will succeed in attaining my aim as regards my new readers too: that I will arouse in them what every study must begin with—love for the object studied.

*Moscow,
January 1894*

K. Timiryazev

* See my article "Photography and Feeling for Nature" in the collection of my lectures *Vital Problems of Natural Science Today*, Moscow, 1908. [See *Works*, Vol. V, pp. 227-39,—Ed.]

FOREWORD TO THE FOURTH EDITION

An attentive observer of our contemporary reality may notice a consoling phenomenon—the awakening of a new interest in natural science which involuntarily reminds one of the state of mind at the end of the fifties and beginning of the sixties. There is no doubt that this desire is a living stream refreshing the stagnant waters of indifference to strictly scientific thought with their unhealthy miasmas, mysticism, metaphysical empty talk and all kinds of decadence—these signs of stagnation or retrogression of thought.

It is only by this general state of mind of the modern reader that I can explain the particular fact that in a little over a year it has been found necessary to put out a new edition of this book, whose aim is to excite the curiosity of the reader and urge him to further study in the field of natural science, which is equally important as far as theory and application to the demands of life are concerned. Whoever cherishes the success of living and wholesome social thought must rejoice when he realizes that in the midst of the general and concerted efforts he too has succeeded in putting his shoulder to the wheel and promoting, if only in a negligible measure, the resumption of its progress, which for a time seemed to have slowed down.

K. Timiryazev

*Moscow,
May 1896*

* April 9, 1897—thirtieth anniversary of the beginning of K. Timiryazev's scientific and pedagogical activity.—*Ed.*

FOREWORD TO THE FIFTH EDITION

In sending off this new edition of my book I can only express, as in the last edition, a feeling of joyful wonder at the rapid increase in the number of its new readers.

This time, however, I also consider it my moral duty to add profound and ardent gratitude to the large number of former readers who expressed such flattering sympathy on the day, ever memorable to me, of April 9.* It is they, and they alone, who determined the success of my book and can consider it the work of their own hands.

K. Timiryazev

Moscow, 1897

FOREWORD TO THE SIXTH EDITION

The repeated demand for this book, in spite of the fact that more than a quarter of a century has passed since it first appeared, proves that it corresponds to an urgent requirement of the readers. Such a long period, it seems to me, enables the author to adopt an objective attitude to his work. Repeating the foreword to the first edition, I may say that the hopes

which I expressed in concluding it have been justified beyond my most daring expectations. At the beginning I was consoled by the attitude adopted towards my book by the best representatives of the generation of scientists to which my teachers belonged, by the attitude of people like Zimin, Savich (the astronomer), and A. N. Beketov. Being now advanced in years myself, I cherish still more the attitude of the rising generations towards me—I always saw their sympathy as the best reward for my desire to help those who sincerely sought knowledge as best I could and to place the dignity of science above all everyday considerations.

As in the preceding editions, my only concern has been not to pass over in silence the very biggest acquisitions of science for which place can be found in a book for the general public, and at the same time to protect the book against outlooks which not infrequently pass as the last word in science but which, unfortunately, are signs of the degeneration of critical thought in the last decades.

A considerable number of the drawings have been done anew for this edition by A. N. Stroganov, for which I convey to him my sincerest gratitude.

K. Timiryazev

Moscow, May 1904

FOREWORD TO THE SEVENTH EDITION

The preceding edition was almost sold out in two years—two years such as our country never saw in all the centuries of its existence.

Does not this small fact, together with other similar ones, prove the incorrectness of the opinion so often expressed that in recent years political questions have completely deprived all other kinds of reading of their interest? It seems to me that side by side with this completely natural arousing of a passionate, feverish interest in questions which, for the first time in our country, have acquired not only a bookish but also a vital interest, and perhaps, thanks to this movement which has stirred minds, there has been a far wider demand for books devoted to strictly scientific knowledge.

It is with a feeling of profound gratitude that I reread every time the review of my clear, unforgettable teacher, A. N. Beketov, with which the publishers of the last editions thought fit to preface my book. If my book has all the qualities which he finds in it, it has fulfilled the main task which I had in mind—that of showing the reader what experimental science is and why it must be the best school for life.

Not everybody who reads this book can be a botanist, but everybody, I hope, will derive from reading it a true idea of the attitude which science adopts towards its tasks, how it discovers new and reliable truths. And the habit of strict thought that is acquired by this reading will be extended to

the discussion of the more complicated facts which, whether he wishes it or not, life will present him with.

And that is also the main aim of self-education, the wide spreading of which is one of the most urgent demands of today.

K. Timiryazev

1907

FOREWORD TO THE EIGHTH EDITION

Although, as I said in the first foreword, I am opposed in the main to purposeless luxurious scientific booklets with pictures, the two splendid water-colour reproductions by A. N. Stroganov which are appended are precisely one of those cases when the art of the painter renders science an indispensable service. I have had repeated occasions to note that, precisely in this case, no description can render what is conveyed by the brush of the artist: people who had got to know the most interesting living being by descriptions would pass by it without even recognizing it.

In the present edition a gap which was pointed out long ago has been filled—*the fruit*. The reason for this gap is that the book was originally a series of lectures. This addition was not included in the lecture on the flower, which was already fairly long, and it was not sufficient for a separate lecture. Nevertheless, it is very substantial from the *philosophical* question (as people like to say now, *a propos* and out of *propos*) connected with it, a question which I referred to a long time ago and which the official German botanists and philosophers* and their Russian worshippers did not understand.

* See my "Summing-up of a Hundred Years' Plant Physiology," 1901. [*Works*, Vol. V, *Selected Works*, Vol. II.—Ed.]

Having started to speak about gaps I cannot refrain from pointing out that many of our young botanists probably considered this gap in my work a substantial one and hastened to fill it up in their popular productions. But it was a deliberate omission on my part; it was the part of the book about which an English critic said that I knew what to be silent about. This applied to all the fantastic nonsense about sensitive organs and intellectual abilities of plants that were dwelt on in such detail by various Français and Nemetzes and, repeating them, our young popularizers too. At present even more serious German botanists (for example, Jost in the last edition of his book**) prudently turn away from it. I protected my readers against all this beforehand, which was, of course, only to their advantage.

** Jost, L. *Vorlesungen über Pflanzenphysiologie*.—Ed.

During the proof-reading I went over my preceding forewords—those sincere exchanges of opinion between the author and the reader—and I noticed that feelings of hope and despair alternated in them, which in turn were naturally

sources of agitation not only for the author and the reader of this book. So it is now too: after the surge of hope accompanying a beneficial thunderstorm which freshened for a while the choking atmosphere of Russian life, there has come a period of still gloomier despair, of frustrated social hopes, which, as always in history, caused a fall in the interest in anything that is vital and wholesome, indifference and apathy to the demands of life, a desire to numb oneself by some means and to stifle the feeling of gnawing dissatisfaction. The same was reflected in the field of thought. More than ever one can complain "of the stagnant waters of indifference to strictly scientific thought with their unhealthy miasmas, mysticism, metaphysical empty talk and all kinds of decadence—these signs of stagnation or retrogression of thought."*

* From the foreword to the fourth edition. ** "Self-Educated Writers," *Sovremennyy Mir*, February 1911, p. 189.

But a ray of hope is once more gleaming and this time from a more distant, and therefore immeasurably wide horizon. As the rays of the rising sun are reflected in every drop of dew, as the tide of the sea washes every grain of sand on the beach, so the mighty upsurge of the social movement is manifest in individual facts of life, no matter how negligible they are. A few years ago I was shown a letter written by a modest toiler, a village priest who spoke of my works *The Life of the Plant* and *Agriculture and Plant Physiology* as of classical books to which it is most desirable to give wider dissemination in the countryside; and quite recently in an article by M. Gorky** who so ardently defends the young generation against all sorts of unwholesome trends in modern thought, I was able to read the following lines:

"One is amazed that here, in the settlement of Snegov, Kherson Gubernia, or in Os, Perm Gubernia, people know the names of . . . and Timiryazev. His *Life of the Plant* is often asked for."

Can it be, I used to think, that my book has already come into the hands of his Nil, that representative of the healthy young generation who so simply and ingeniously defined the moral task of life as: help one, hinder another? Can it be that the simple, healthy word of science is already coming to the help of young, healthy Russian democracy? In spite of oneself there comes to one's mind the by no means vain but encouraging, consoling dream: and what if, in fact

*In that, perhaps, my people I served,
That healthy thought I roused by my word?*

K. Timiryazev

Demyanovo, May 1914

FOREWORD TO THE NINTH EDITION

At the end of the last foreword (p. 34) I expressed the hope that salvation from reaction which had stifled the liberation movement of 1904-1905, under the consoling impression of which I completed the seventh edition (p. 31)—that this salvation would come this time from the people themselves. But of course neither I nor anybody else imagined that it would come so soon, that it would be so radical, but would be bought at such a price as all the horrors of murderous five years' war with all its consequences, general ruin and profound perversion of wide circles inherited from the through and through rotten tsarist and capitalist system. Having achieved their great and urgent historic feat, the Russian people may yet for a long time be obliged to strain their efforts alone to defend their conquests against the intrigues of countless external and the treachery of still worse internal enemies instead of concentrating all their strength on the tasks of general construction and of erecting on the ruins of the old putrid system a new one, based on the firm foundation of genuine power of the people and enlightenment. The truest and necessary helper in this creative feat of the people must be truth, not ostentatious science which serves the exploiters of the people; and for that it must explain its true significance to the people in a *popular*, that is, a simple form. For more than half a century I have been speaking to the Russian people in the simple language that progressive English scientists suggest as an example in relations with their more cultured people. All the more ardent is my wish that this language should be used to the profit of the Russian people in the broad educational construction that is going to be undertaken and which must be based on science as the means for the fight against the legacy of the bourgeois system, "mysticism, metaphysical empty talk and all kinds of decadence," which were so clearly typical of the years of reaction and tyranny, the last days and years of the expiring tsarist and bourgeois system.

K. Timiryazev

December 1919

THE LIFE OF THE PLANT

Chapter I
SCIENCE AND SOCIETY.
EXTERNAL AND INTERNAL STRUCTURE
OF THE PLANT

The general public's meagre knowledge of botany. Two old-fashioned types of botanists. The contemporary trend of science. Morphology and physiology; form and life. Two reasons for the comparative backwardness of botany: the logical and the practical reason. Art and science. Agriculture and the physiology of the plant. Science and the general public in mutual relationship.

Survey of the external organs of a flowering plant. Metamorphosis. Spore-bearing plants—of earlier date and simpler in structure than seed-plants. A spore—a cell. The cell—the foundation and beginning of every organism. These facts in relation to the problem of the origin of organisms. Treatment of subject.

It is almost the first time in Moscow that a plant physiologist has the occasion to set forth in a popular form and before such a numerous audience the main fundamentals of the teaching on the life of the plant. Bearing in mind the exceptional character of this exposition, I think it will not be superfluous to say a few words on the present state of our science and its relations to society. I presume that I shall not be mistaken in saying that there is hardly a branch of science of which such a confused idea reigns in our society as of botany. Hence it is easy to understand that society is apathetic towards it, and that there is hardly a branch of natural science which arouses so little interest as botany. It is of course a long time back to the Moscow of Griboyedov, where people exclaimed with astonishment, almost indignation:

*A chemist he, a botanist,
My nephew Fyodor, the Prince.*

But I wish merely to point to the circumstance that, given the present favourable disposition towards natural science, the chemist, the physiologist and geologist appear to have succeeded in winning a more honourable place than the botanist.

It is not, I think, much beside the mark to say that the word "botanist" still calls up in the minds of many even well educated people not conversant with science one of two pictures. Either they expect in the botanist a tedious pedant with an inexhaustible vocabulary of double-barrelled Latin names, sometimes most barbarous, who is able to name at a glance any kind of plant, and also ready on occasion, it may be, to describe (quite incorrectly) their medicinal properties—the type of botanist who bores one to death and is certainly incapable of exciting any interest in his subject: or, on the other hand, "botanist" depicts the somewhat less sombre

figure of the passionate lover of flowers, who flits like a butterfly from one bloom to another, admiring their bright colouring, inhaling their perfume, singing the praises of the proud rose and the modest violet—in other words, the elegant adept of the *amabilis scientia*, as botany was called in olden times. These are the two extreme types associated in the minds of so many people with the word "botany," and I am afraid I know it by personal experience! A botanist is either a pedantic nomenclator or an amateur horticulturist, an apothecary or an aesthete; but in no sense is he a man of science. The real man of science seems to stand screened behind these types, if such a person as a scientific botanist exists at all. And, after all, what kind of science is botany? What are its aims? What are the ideas which control it, if it is indeed working out any ideas at all? If the public seems ignorant on these points, the fault lies partly with botanists themselves, and partly with the historical development of science. Let us consider these conditions.

Living organic Nature meets us under a twofold guise. We find her in bodily forms, i.e., in plants and animals, and we observe her in phenomena, i.e., in life itself. We call living beings organisms, because they are made up of organs or instruments. Every organ, every instrument has a certain function peculiar to itself, and bears at the same time a certain relation to the general life of the whole organism. It is impossible to study organs apart from their function, or organisms detached from their life —almost as impossible as to study a piece of mechanism and its parts without regard to their function. Who would have the patience to study the description of the parts of a mechanism, say of a clock, without any explanation of their function? Such a study would be not only tedious but fruitless. Likewise, it is obviously impossible to become acquainted with the working of a machine without knowing its construction. It follows that the independent study of an organism from the two arbitrary points of view mentioned above, i.e., in relation to its form and its functions, is artificial and even illogical. These artificial points of view, however, and a corresponding division of the subject, long ago became established in science. Biology, the science of living beings, was split into two branches: (1) the study of forms, called anatomy or, more generally, *morphology*, and (2) the study of phenomena, of life, called *physiology*. This division was caused partly by the necessity for applying the principle of the division of labour to the manipulation of such large numbers of accumulated facts, partly by differences in the methods of investigation, and also partly by difference of aim in the two branches of this particular science. The one observes and describes, the other experiments and explains. The impossibility of carrying such a division of the subject to a logical issue proves how artificial it is. In fact it can never be strictly applied. The morphologist is bound to describe the function of an organ and the physiologist its structure. Nevertheless, this division of the science of botany, and particularly the narrow specialization of scientific activity, threaten to become a

serious danger for the future, a confusion of tongues as at Babel: for surely the morphologist will cease to understand the physiologist, and the physiologist will cease to take interest in the work of the morphologist; every specialist will shut himself up in his narrow province, without troubling himself as to what takes place outside of it. The existence of these two provinces is, nevertheless, an inevitable fact, owing to a necessity against which it is entirely futile to demur. It is nevertheless clear that these two provinces are capable in very different degree of attracting general attention, the attention of people not conversant with science and only interested in its supreme achievements.

A simple description or enumeration of the plants and animals about us cannot excite any general interest, although the number of people who find pleasure in an acquaintance with the native flora and fauna does prove a certain degree of scientific development in the public. The fragmentary description of remarkable plants and animals arouses but little interest, being too hackneyed, and suitable only for children's books, or for occasional illustrated publications for grown-up people. General attention may perhaps be attracted by some marvel, such as a carnivorous plant devouring living people, an absurdity which appeared some time ago in many foreign papers as well as in our own dailies, and even slipped into more specialized publications.

The situation is different with regard to the explanation of phenomena common to all the organisms of both kingdoms, the study of the fundamental laws of life. This can and must attract the attention of all thinking men who wish to understand what is going on around them. The same holds true in the inorganic world. Mineralogy, which is a simple description of matter that forms the crust of the earth, certainly cannot excite the same interest as chemistry, which explains phenomena taking place as the result of the reaction of substances, or as geology, which recites the history of our planet.

There is no doubt therefore that physiology rather than morphology, function rather than structure, and life rather than form, may be expected to attract general attention. Let us now see which of the two tendencies has been the more fully worked out in botany—is it the one which deals with life or the other which confines itself to lifeless forms?

The history of science shows that botanists have spent nearly all their energies upon the latter kind of work. Men of science have devoted themselves entirely to that extreme of the subject, forgetting the life of which the body is but the vehicle. At no very distant period the great majority of botanists belonged to the first of the types described above, and even today not a few may be found ready to repeat the words of a French zoologist who, in the course of an exciting debate in the Paris Academy, prided himself upon the fact that during the whole of his scientific career he had not expressed a single idea, but had only defined and described, described and defined. If we turn from the exponents of such old-fashioned ideas to our contemporary scholars, we shall

find many who may criticize their predecessors and recognize the superiority of the physiological tendency of the present day, but who nevertheless work along the same exclusively morphological lines. According to these modern scientists, a botanist is a man who spends his life over a microscope, i.e., a man who goes on examining and describing microscopically minute organisms, or else microscopically minute details of large organisms. Although apparently different, the activity of both is essentially analogous: the only difference between them lies in the scale of their operations. While the one observes with the naked eye or the lens, the other uses the microscope; but both do no more than observe and describe, and the description of a fungus or of a water-weed does not differ from the description of a grass or of a tree. The one and the other forget that the chief object of the physiologist is not to describe but to explain and command Nature; his method must not be that of a passive observer, but rather that of an active experimenter; he must engage in strife with Nature, and by the power of his mind extort from her answers to his questions, so that he may master and subordinate her at will, provoke or arrest the phenomena of life, direct or vary them.

Of course, among the representatives of the exclusively morphological, or descriptive, tendency there have been powerful minds, who have thrown light upon the mass of accumulated material and made it live—a little further on we shall even study an illustration of this—but on the whole their energies have been spent upon conceptions inaccessible to the uninitiated, and therefore they have not been able to excite any general interest. The fine simplicity of some morphological laws, the harmony of natural systems of classification which stand as wonderful memorials to the power of the human mind, all this is lost to those who are without the knowledge of the details necessary for the understanding of it.

It is therefore evident that up to the present time botany has been developing mostly along the lines which least interest the public. As we have already seen, the reason lies partly in the historical course of the development of science and partly with botanists themselves. The historical development of every science requires that the more complicated be preceded by the more elementary, and it is obvious that the problems of physiology are much more complicated than those of morphology, and presuppose a greater store of information. The description of organic forms does not necessitate any preliminary knowledge. In order to explain the phenomena of life, on the other hand, i.e., to resolve them into the simplest physical and chemical phenomena—which is, as a matter of fact, the object of physiology—it is necessary to start with some knowledge of these phenomena. A morphologist need be but a morphologist, whereas a physiologist must to a certain extent be at once a physicist, a chemist, and a morphologist. It was in fact inevitable that the physiological tendency should develop later in the history of science, i.e., only after physics

and chemistry had reached a certain point of development. That the backwardness of physiology as a science was nevertheless due in large measure to the one-sidedness of botanists themselves is proved by the fact that while the latter were still engaged exclusively in the study of form, chemists and physicists were penetrating into the attractive province of the life of the plant and founding the science of plant physiology. The fundamental principles of physiology were therefore formulated by chemists and physicists and not by botanists. The backwardness of botanists in this direction is even more striking when we compare what has been done in the sphere of the physiology of plants with that which has been done in animal physiology. This may seem somewhat paradoxical: the problem of the physiology of plants is far simpler than that of the physiology of animals. The life of plants is far less complicated than the life of animals, and yet our knowledge of the latter is much fuller and more definite. However, there are perhaps some extenuating circumstances which may be advanced in the defence of botanists. The progress of the science of animal physiology can be explained by causes lying outside the province of science, by considerations of a practical kind.

To develop and prosper, every science requires the moral and material support of society; but, on the other hand, society takes practical interest only in things which it considers useful. Society has already been convinced of the usefulness of animal physiology, while the idea of the usefulness of the physiology of plants has only just dawned. Almost every science owes its origin to an art of some sort, just as every art in its turn is the outcome of some need in man. This appears to be the inevitable course of the development of human knowledge. To begin with, man appreciates knowledge merely as a means towards obtaining the fullest possible amount of material enjoyment; only in a later stage does knowledge become to him in itself a source of enjoyment. Intellectual aspirations are then as exacting as material wants. Knowledge considered as a means to an end is art; knowledge considered as an end in itself is science. Medicine is the art under whose wing the physiology of animals developed. After many unsuccessful efforts to solve its own problems by means of rough empiricism or abstract thought medicine came to the conclusion that it must go further back to study the laws of animal life and join hands with science; thus it was that the science of animal physiology arose and developed in the medical schools. But, together with the necessity for preserving physical health to which medicine answers, man has other needs; he requires food, clothing, a roof over his head, and means of locomotion. He obtains the majority of these commodities directly or indirectly from plants which he cultivates and tends. It is only after studying the laws of their existence, after learning by observation or experiment from the plant itself the means by which it accomplishes its aims, that we are able to direct its energies to our advantage and oblige it to yield us the best and most abundant fruit. Obviously the

physiology of plants must be made the foundation of agriculture. Agriculture, like medicine, rambled on for a long time in the sterile provinces of empiricism and speculation before it came to this conclusion. The same thing has happened there as happened in medicine so many years previously.

Rational agriculture is a much younger science than rational medicine; consequently the necessity for a knowledge of the physiology of the plant, and a demand for such knowledge, arose also later. But the necessity having once arisen, it cannot remain without influence upon the fate of the physiology of plants. The physiology of plants will develop in the schools of agriculture in the same way as the physiology of animals developed in the schools of medicine. A whole network of "experimental stations" has already spread over Germany and America; the government in France, private individuals and societies in England, are working towards the same end; even poor Italy, overburdened with debt though she be, is making an effort to pursue the same course.

In all such "stations," as well as in other agricultural institutions, experimental physiology has established itself beside agriculture, and is setting to work to further its progress, and gaining at the same time the advantage of the precious experience it has accumulated during so many centuries. So must it be on the analogy of other sciences, and so doubtless it will be. Meanwhile, however, a comparison of these modest experimental stations and the still more modest botanical laboratories of West European and our Universities with the luxurious palaces in which medicine dwells, and especially a comparison of the insignificant number of botanists engaged in physiological research with the thousands of doctors who are and have been engaged all over Europe in the study of the physiology of animals, make patent to every one the fact that this extraordinary number of workers accounts for the appearance of such men as Helmholtz, Claude Bernard, Du Bois-Reymond, and others, beside whom botanical physiologists can as yet cite not a single name. This wealth of equipment, and especially the wealth of mental energy which has been expended upon the subject, has conditioned the success of animal physiology as a science, and may be regarded as an extenuating circumstance for the backwardness of the physiology of plants.

Happily, however, during recent years a fresh aspect of botany has been discovered: life has begun to attract attention which hitherto was exclusively devoted to form. The public, at least in the West, has realized at the same time that the physiology of plants tends to an end not merely useful, but even necessary, to society; that it is served by this science in the same way as by other sciences, which have already gained their civil rights.

I must explain myself. I do not wish it to be understood from what I have said that I expect science to aspire exclusively to utilitarian ends, as if I found its highest

sanction in its practical tendency. On the contrary this practical tendency, which characterizes the infancy of a science, cannot and must not be its aim. Throughout the development of a pure science its results find application spontaneously. The development of a science can be determined only by the logical sequence of its achievements, never by the external pressure of necessity. Scientific thought, like every other form of mental activity, can work only under conditions of absolute liberty. Oppressed by the weight of utilitarian demands, science can produce but pitiable artificial work, after the same kind as any meagre and mechanical work of art fashioned under similar circumstances. We may ransack the archives of any science and yet find scarcely one daring idea, one brilliant generalization which owed its origin to its application; and, *vice versa*, history is full of examples of discoveries, which, though unassociated with any practical purpose, have become the source of innumerable practical issues.

Now I must summarize this rather lengthy introduction. Comparatively speaking, botany meets with no great amount of sympathy from the public, which interprets it wrongly on the ground of its having pursued objects and been engaged with ideas which could interest but the small class of the initiated. This tendency, caused in the first instance by the inevitable historical development of the sciences, was fostered and is fostered still by the attitude of most botanical scholars. Recently, however, a new and refreshing trend of thought has been observable gradually forcing its way to the front, viz., the trend of thought of experimental physiology. The new awakening of interest is being followed by the realization of the utility of this science. Agriculture is beginning to demand a knowledge of the physiology of the plant, and in this way the solidarity of interests between science and society is being established. Whereas, however, this community of interests does not on the one hand authorize society to dictate to science its modes of action or the method of its further development, neither has science on the other hand any right to retire as it were into a sanctuary, to conceal itself from the public gaze, expecting its utility to be taken on trust. If the votaries of science wish it to attract the sympathy and support of the public, they must remember that they are the servants of the same public, that occasionally they must step forward as trustees and duly render their account. This is what we have accomplished, they must say; this is what we are accomplishing, and this is what we are going to accomplish: judge how far our activity has been fruitful, and consequently what you may expect in the future.

Personally I think this is a problem for what may be called popular scientific literature, for popular lectures—a problem often lost sight of because those who set out to treat scientific subjects in a popular way generally devote their attention to but one side of their aim, namely, how they may teach in the easiest and most amusing way.

* * *

I have said, that in order to understand the life of a plant it is necessary to study its form; in order to understand the working of a machine a study of its construction is needed. Let us glance at the external, formal manifestations of the life of a plant, the observation of which does not require any preliminary study, nor any technical method of investigation.

Let us begin our sketch with the awakening of the plant's life after the winter's slumber. In what state will the spring find it? Where is hidden the origin of this new life? It lies concealed in the seed which has maintained its vitality under the shelter of the soil and the thick cover of snow. It is maintained in buds, which have endured the misery of the cold under the protection of their scales. By the action of the warm spring sun every bare piece of ground produces green shoots; on every tree or bush buds swell, burst, and lose their unsightly and already useless scales. The seed and the bud—those are the two organs to which daily experience attributes the origin of the plant's life. It is therefore with an investigation of them that we shall begin our study.

First, what is a seed and what are its component parts? Let us investigate the well-known seed of a bean. If soaked in water it will swell and become detached from its skin, or coat. Under the seed-coat we shall find it split into two fleshy or rather hard and cartilaginous parts. In between these will be found inserted a small body connecting them together. With the naked eye, or, better still, with the help of a lens, a small germ plant, a young shoot, consisting of a tiny stem with leaves and rootlet, is easily recognized (Fig. 1). This shoot binds together the two halves of the seed, which are called the *cotyledons*. These, though much larger than the shoot itself, are nothing but two appendages of it. But what is the nature of these cotyledons? Botanists say they are leaves. Those colourless, round, fleshy bodies, which remain underground, are called leaves not without reason, as we shall immediately see. We have only to pass from a bean to its nearest relative—say the haricot—to find cotyledons appearing above the soil and becoming green like ordinary leaves (Fig. 2). In the maple and the ash the cotyledons are still more like a common leaf, and the lime actually has small thin green leaves with well-marked veins and crenate outlines. Therefore, the cotyledons of a bean, though they grow underground and are far from reminding us of actual leaves by their colouring or appearance, must be nevertheless regarded as such. Following upon those first organs, so unlike leaves, there appear as the stem elongates, real leaves, though not yet of the shape we are accustomed to meet on a grown-up plant. Here is, for instance, a young ash plant. Everybody knows the shape of its leaf. Several pairs of leaflets are distributed on a common stalk with one leaflet more at the top. In this way a whole leaf consists of seven, nine, or more leaflets. This is called a compound leaf. What, then, do we



Fig. 1

notice here (Fig. 3)? The two fleshy, tongue-shaped cotyledons are followed by two toothed leaves with prominent venation, which are simple, not compound, leaves. If we look further up the stem we shall notice other leaves composed of three leaflets, higher up others of five, and lastly of seven or nine leaflets; i.e., here commence leaves like those of which the foliage of a grown-up tree is generally composed. This passage from the cotyledon to the true leaf has happened gradually; it includes a whole series of intermediate forms. We receive involuntarily from the series the impression that one of these organs is formed from the other, and that these are the intermediate stages through which a leaf has to pass.



Fig. 2



Fig. 3

Let us now consider the bud of a tree, say of a maple, of a horse-chestnut, or of any bush, like that of the currant. We find peculiar organs on the outside of them: dark brown, thin, tough, sometimes sticky and resinous scales. If we pull the bud to pieces or let it open by itself, then tear off its parts one by one and spread them out in a row, we notice the following facts. First in the series are several scales darkly coloured, short, obtuse, almost round in shape (Fig. 4). Then this shape becomes more and more elongated and the colouring passes into green; we notice on the top of one of these scales an indefinite rather crumpled protuberance, which further on increases in size and opens out. This protuberance is a real slightly wrinkled little leaf. The deeper within the bud the more clearly this protuberance reveals itself as the part of the leaf which is called the *lamina*, while the distended part of the first scales becomes narrower and more elongated, taking the true stem-like form of a *petiole* (Fig. 4, horse-chestnut, and Fig. 5, currant bush). This is therefore the same phenomenon

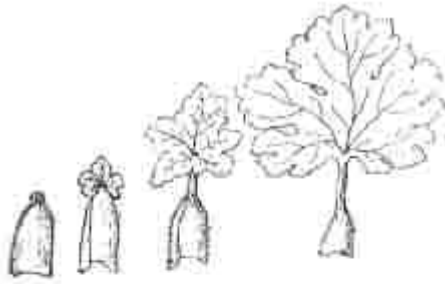

Fig. 4



Fig. 5

as in the young ash: there the cotyledon and here the scale passes into a leaf, through a graded series of intermediate forms. And again the suspicion arises that these are one and the same organ, only modified in appearance according to their special functions.

Having thus started with a seed or with a bud, we have arrived at the typical leaf which makes up all the green foliage of plants. Having produced such a leaf the plant seems to have reached the beaten track and produces one leaf after another, modelling them as it were according to the same pattern, casting them, so to speak, in the same mould. But the leaves are not the only product of a

growing plant; at a certain age it produces other organs such as flowers and fruit. As a rule the transformation of leaves into quite distinct flower organs happens suddenly; but cases are frequent in which the appearance of the flower is anticipated by changes revealed in the upper leaves. Let us study the well-known garden peony. Everybody knows its leaves (Fig. 6). Starting from the lowest and passing up the stem towards the flower we notice that the shape of the leaf changes until it becomes at last almost unrecognizable. At first the whole leaf consists of eleven or nine leaflets distributed in threes. At a certain point we have only three leaflets; in the interval between these two kinds of leaves we are also likely to find such as have seven and five leaflets. In the end the whole leaf consists of only a single leaflet. The process is the converse of that noticed in the ash. There the shape of the leaf became gradually more complicated, whereas here it becomes less so, passing through the same stages but in the reverse order. So far the simple leaflet has entirely resembled the upper part of the whole leaf, but gradually it also changes its appearance: its short petiole broadens into a flat scale, while the lamina continually

decreases until it becomes a small, green, tongue-shaped object on the top of the scale; later still it appears like a small bristle in the topmost hollow of the scale, and at last disappears altogether. We are left with a thin yellowish-green scale, reddish at the edge. Our leaf has gone through its entire transformation before our very eyes, so to speak. Its lamina has disappeared, while its petiole has changed into an organ, similar in origin and purpose to the scale studied in the bud of the chestnut. The one as well as the other represents a petiole, developed like a lamina. As the one protects the young leaves of the bud, so the other protects the inner delicate parts of the flower. This organ is called a *sepal*, and the whole whorl of such leaves the *calyx*. Thus a sepal is nothing but a modified leaf. In many cases this fact is obvious—as, for instance, in the sepal of the rose, which keeps its thin lamina. Very few flowers give us the same opportunity as the peony of following this gradual transformation.



Fig. 6

The sepals in a flower are followed by a number of leaves coloured white or some other bright shade with a satin or velvet surface, so vainly imitated in artificial flowers; these are *petals*, forming together the *corolla*. This seems a great leap; the sepal and the petal of a rose have no similarity. But let us put aside the rose and pass to other flowers. Even in the peony some connection between a sepal and a petal can be traced in the red border of the former and in the notch of the upper part of the latter, which is similar to that in the sepal. In the *Camellia*, however, we are thoroughly perplexed as to where the sepals end and the petals begin, so gradual and unnoticeable is the passage from the hard green sepal to the delicate white or red petal. So a petal is nothing but a modified sepal, which in its turn is a modified leaf. It follows that a petal is nothing but a leaf.

Let us now peep into the inside of a flower, and choose for our purpose one of the larger flowers, say a lily. From the centre of the flower several organs project, composed of a thin stalk, on the top of which are inserted crosswise two yellow oblong sacks split longitudinally. The slit discloses a dry dust, orange in colour, the *pollen*. These organs are called the *stamens*; the receptacles containing the pollen are the *anthers*, and the stalk bearing them the *filament*. One would think that a stamen and a petal have no connection whatever. But let us look for a suitable illustration before jumping to a conclusion. Probably every one is familiar with the white water-lily, so common in our streams and ponds, with its large almost round leaves and its flowers floating on the surface of the water. Let us pull one of these white flowers to pieces and spread out its several parts, as we did with the bud of the chestnut, beginning with the outermost, i.e., the external white petals, and ending with the part nearest the centre of the flower, the organ, composed of the yellow receptacles filled with pollen and a filament rather flat in form, in which we easily recognize a stamen (Fig. 7). We

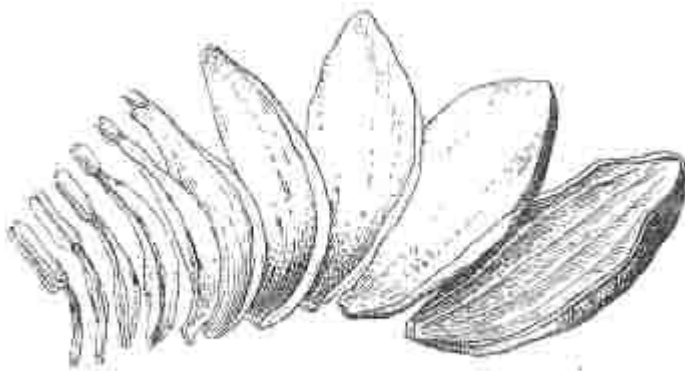

Fig. 7

notice once again the same imperceptible transformation: here is a typical white petal; on the top of it appear two yellow spots, which increase in size as the base of the petal becomes narrower; two oblong receptacles become clearly marked, and the base of the petal transforms itself into a narrow filament. Here at last is a real stamen, the anthers of which split longitudinally and shed the pollen. The petal has passed into a stamen. The possibility of such a transformation is proved by horticulturists who produce reverse transformations, changing stamens into petals. Such staminate flowers changed into petaloid are called *double*.* Take, for example, the common peony. It has five petals and many stamens, but the double peony has many petals and correspondingly few stamens. On closer observation we shall become convinced that the inner petals are the transitional form of stamens: on the edge of the bright-red, slightly wrinkled petal are situated yellow anthers more or less well developed. In the dog-rose, which is the prototype of our rose, we notice only five petals and a great number of stamens; in the rose some of the stamens have been

transformed into petals: this is why their number is greater than five. Double flowers are also of interest from the physiological standpoint, because they can be produced artificially. The outer scale-leaves of the bud can also be artificially transformed into real leaves. We therefore reach the conclusion that the transformation of one kind of leaf into another can be demonstrated not only by observation, but also by means of experiment, generally by far the more convincing method.

* In Nature as a rule the different parts of flowers probably appeared in the same way as in the case of the double flowers just described, i.e., the stamens were transformed into petals, and not the petals into stamens.

Proceeding with our study we reach the very heart of the flower. After the stamens we meet the last organ of a flower—I say the last because it forms its central part and thus terminates its growth and consequently the



Fig. 8

growth of the part of the stem which ends in the flower itself. This organ is called the *carpel* or *pistil* on account of its form, which, with its swelled base (*ovary*), elongated neck (*style*), and rounded top (*stigma*) is very like a pestle (Fig. 8, flower of cherry).

There may be one or many carpels in a flower. The lowest part of a carpel, the ovary, is hollow inside, so that the whole organ is like a small bottle. This cavity contains one, several, or even many bodies, round and white, called *ovules*. We meet this organ again with distrust. This time there seems to be not a trace of likeness to a leaf, but another successful choice of illustration will prove that this organ also is derived from one or many little leaves. Some abnormal flowers will give us the necessary clue. For instance in the double flowers of the cherry or wild cherry the carpel often transforms itself from a bottle-shaped organ into tiny leaves, one or two in number (Fig. 9).* In many cases it is even unnecessary to refer to abnormal plants to see the leaf-like character of the carpel and the resultant fruit. It is enough to glance at the fruit of a leguminous plant, such as a bean, or still better the fruit of the peony, to be convinced that it is nothing but a leaf, the edges of which have curved over and grown together, thus forming an organ with a longitudinal join (suture) with a hollow space inside. In other cases the ripe fruit in bursting shows quite clearly that it, and consequently the carpel from which it developed, consists of several little leaves grown together at their edges. The carpel, then, has been derived from one or more little leaves modified in form. But not in all abnormal flowers are the carpels transformed into real leaves as we see it in the cherry. In other cases the carpel transforms

itself into organs more closely related to it, such as stamens and petals. The transformation of a pistil into a stamen can sometimes be studied in the flower of a willow. Occasionally bright red petals can be found in the centre of double peonies with white, shiny ovules on their edges. These are surely carpels which have become transformed into petals, but which have kept their ovules. It follows that a pistil can transform itself into all the preceding organs, i.e., into stamens, petals, and real green leaves. Does not this prove that all these organs are of one and the same origin?

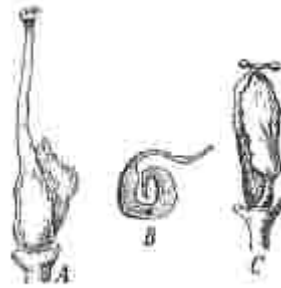

Fig. 9

* *A*—pistil partly transformed into a leaf; *B*—the same pistil in a transverse section; *C*—pistil transformed into two leaves.

In our analysis of the plant we have reached its topmost organ—the carpel; we cannot proceed any further—we can only go deeper into the interior of the carpel, the cavity of the ovary. We shall find there ovules, as has already been said. What are these ovules? In the flowers where carpels have changed into green leaves we notice small green leaflets or whole leaf-buds on their edges at places where we should expect ovules. Here again the answer will be provided by some abnormal flowers. Therefore ovules and parts of ovules are nothing but leaflets or parts of leaflets. Thus we conclude that all the parts of a flower are nothing but modified leaves, and the whole flower is nothing but a transformed leaf-bud. This opinion is supported by the not uncommon cases of flowers from the centres of which grow shoots covered with leaves. Such twigs have also been known to grow out of the cavity of the ovary; when cut off and planted they have occasionally taken root.

But what becomes of the ovule—not the abnormal one, which grows into a green leaf, but the ordinary normal one? After a plant has flowered and the petals have fallen off, after the stamens have died and the ovary has changed into the fruit, the ovules will become transformed into seeds, containing the embryos of new plants. Here evidently our description of the external features of a plant ends. I have unrolled before you the whole picture of the outward manifestations of the life of the plant. We started with the seed and we have returned to it, and have thus completed the full cycle of a plant's life. This cycle will be followed by another, and so on through the infinite succession of generations. I have tried to enliven the tedium of this enumeration of organs, which is indispensable for my subsequent exposition, by linking them together by the one leading idea of transformation or the *metamorphosis* of organs, an idea for which science is mainly indebted to the scientist and poet Goethe. Examined from this point of view the life of a plant is like a phantasmagoria, a successive series

of changing magic-lantern pictures. An organ has only time to assume before you a definite shape, when it already loses its configuration, becomes unrecognizable, changes into something indefinite, and then gradually becomes again more distinct, appearing this time in another form, as another organ, and so on: the one replaces the other, the one passes imperceptibly into the other, until the whole cycle of development is closed and the primary and original organ reappears. So far we have had only the leaf organs in view, but beside them the body of the plant reveals two other organs, the beginnings of which are to be found already in the seed: these are the stem which supports the leaves and the root. These two organs, apparently so different and growing in different environments, are in some rare cases, however, capable of transforming themselves into each other: the stem sinks into the soil and assumes the character of the root, or the root grows up into the air, covers itself with leaves, and assumes the character of the stem. Hence the stem and the root, forming the *axis* of which they are the two modified forms adapted to different conditions of existence, and the appendage of the axis—the leaf—with its manifold variations (scales, petals, stamens, and so forth) are the fundamental external organs produced by a normally developed plant during its lifetime.

* * *

In accordance with the general conception of the life of a plant we have thus far taken it for granted that it begins and ends with the seed. Doubts, however, arise as to our right to attribute the origin, the real starting-point of the life of a plant to the seed. May we not perhaps go further back and find out its ultimate origin? For the seed we have been describing is still a very complicated body; we find in its embryo a complete little plant with practically all its parts already developed.

In order to discover this simplest starting-point of plant life we must turn to plants which are exceptions to the general rule of the typical plant

we

by an

can
for a
your

and

of

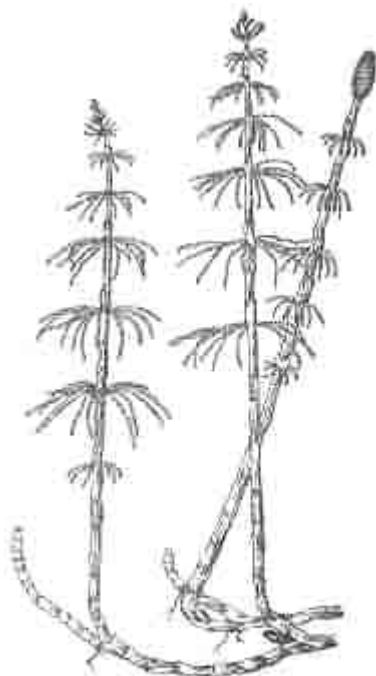

of the typical
with seeds and
flowers, which
have just been
considering.

Suppose
effort of
imagination you
detach yourself
moment from
present
environment
transport
yourself in
thought to one
the picturesque
landscapes of

Russia, say the neighbourhood of Moscow, and suppose you try to recall your impressions of a walk down into the ravine of Kuntsevo. As you descend into the green thicket with its



Fig. 10

damp atmosphere, impregnated with many exhalations, you will notice quite a singular kind of vegetation. At every step the waving fronds of ferns grow from the floor or the slopes of the ravine, like bunches of green ostrich feathers, or the crowns of palms stuck into the soil (Fig. 10).

Lower down along the swampy bank of the stream, in the water itself, or in some marshy pool, you will see a brush-like mass of horsetails crowded together here and

there with little black cones still surviving on their tips (Fig.

11). Such a scene always strikes us as strange and uncommon. Involuntarily one feels that this vegetation is

totally different from that left behind at the top of the ravine. This

subconscious impression is no illusion. This world of ferns and horse-tails is in very truth a singular world; it is a sample of the vegetable world which used to cover our planet in bygone geological epochs.

Those ferns and horse-tails, and other plants closely related to them and very common in our woods, like these dry, moss-like, creeping plants, with their yellowish cones occasionally upraised, called club-moss (Fig.

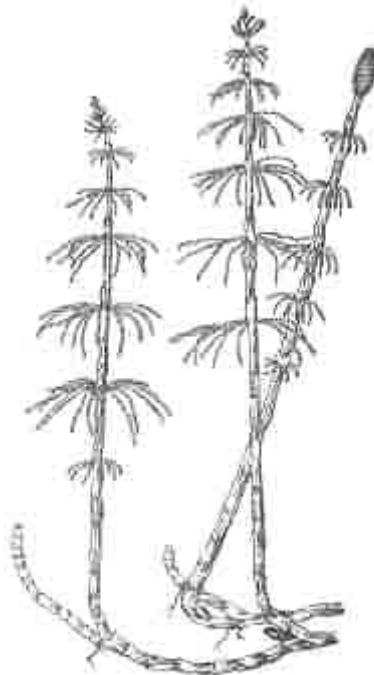

Fig. 11

12), all these plants, I

say, or rather forms related to them, used to be the prevalent vegetation on our planet in the period when our coalbeds were formed. Coal contains the remains of whole trunks which belonged to them and the impressions of their leaves and fruit. These remains enable us to reproduce with the help of a certain amount of imagination the aspect of the former

vegetation of our planet, the landscapes that no human eye ever looked upon. The forests of that remote period contained tree-like ferns which exist today only in certain moist tropical countries and in hothouses. Our short, creeping club-moss existed then as a stately, scaly tree, *Lapidodendron*, whereas our humble horse-tail, which reaches the height of some dozen feet only in a few places in South America, was represented by the similar but tree-like *Calarnites*, *Equisetites*, and others.

I have just used an expression which needs explanation, and which will naturally take us back to the main thread of our argument. I have said that the club-moss is related to ferns and horse-tails, and that all the existing forms of these plants are related to fossils. Wherein consists that relationship and wherein do these ferns, horsetails, and club-mosses differ from coniferous and broad-leaved trees?

Some peculiarities in the life of ferns long ago attracted the attention even of unscientific people. There is a poetic fancy in Russia that ferns flower on St. John's eve. This legend is based on the noticeable fact that ferns never bloom, never have flowers like other plants. The same is true of horse-tails and club-mosses. All these plants are known by the name of *flowerless plants*. But if they are without flowers they must be also devoid of seeds, which are usually formed from the ovules of flowers.* How do they then reproduce themselves? If we look at the underside of a fern-leaf, at the black cones of the horse-tail and the yellow cones of club-moss, we shall notice that towards maturity they all present the following general characteristic: if you shake them over a sheet of white paper you get some very fine powder, brown or yellow in colour. This powder is composed of very minute



Fig. 12

bodies, visible only through a microscope, and so small in size that a row of them one inch in length would contain something like one thousand of them. Every such grain of powder can produce a new plant. Here is the so-called *Lycopodium powder*, yellow, soft to the touch, which falls from the cones of the club-moss (Fig. 12), and is used by chemists for powdering pills. I throw a handful of this powder into the flame of a candle and the cloud of dust is illuminated with lightning-like flashes, an effect used in former days to represent

lightning on the stage. In this explosion have perished in their embryonic state millions of future plants. These microscopic

bodies are called *spores* by botanists, and all the plants derived from them and devoid of flowers and seeds are called *spore-bearing plants*. Beside the plants already mentioned this class comprises *mosses*, *water-weeds* called green slime in everyday language, and also *fungi*, a group which includes moulds as well as mushrooms.

* Later we shall see that that inference is not quite correct.

Thus we notice that a spore-plant, whether microscopic mould or tree-fern, owes its origin to an invisible grain of dust—a spore. What is this spore? Is it not the simplest starting-point of plant life, for which we have been seeking and which we could not think that we had found in the seed?

As a matter of fact microscopic investigation shows that the spore consists of a bladder with a solid exterior, containing within it liquid and semi-liquid matter. This is the so-called *cell*, and it is to the cell that we must look for the simplest origin of every organism; we are unable to split it into parts capable of independent existence; it marks the limit of morphological analysis; it is the organic unit. This being the case, a question at once occurs to us: could we not also trace a seed back to a single cell, for surely it does not arise straight away with its root, stem, and cotyledons? We shall have an opportunity in a subsequent lecture of proving that every seedling also starts from a single cell. We shall discover this cell in the ovule when we come to know its structure better. Hence it follows that every seed-plant or spore-plant starts its existence as a single cell. The only difference between them consists in the fact that in the case of the spore-bearing plant the cell becomes separated from the plant which has produced it; whereas in the seed-plant the cell develops and grows into a complicated organ, a seed, and only in that form separates itself from the maternal plant. All that lives, be it the simplest plant or man, start from a single cell. Some microscopic plants and even some that are visible to the naked eye preserve their unicellular condition throughout their lifetime; whereas others as they develop become more complicated in their structure and form two, several, millions of cells out of the original one.

Thus every plant not only springs from a cell, but consists of cells in all its parts. Cells are, so to speak, the bricks out of which the body of the plant is built.

This can easily be proved by very simple means. Examine, for instance, a thin slice of a ripe water-melon, and you will see that it consists of bubbles very loosely joined together and having the appearance of glass beads. These are cells, which generally lose their mutual coherence in the flesh of a ripe fruit and become detached. In other cases this coherence is not broken naturally, but can be broken up artificially. For instance, a slice of raw potato presents a compact body in which it is difficult to perceive a definite structure of any kind, without the help of a microscope; but if you look closely at a boiled potato you will see quite clearly,

even with the naked eye, that it consists of separate cells. Boiling water, or rather the action of steam during the process of boiling, has destroyed the coherence between the cells and liberated them. It is somewhat more difficult to separate the cells in more compact organs. But there is no organ too hard to render such a process impossible, were it even a piece of wood, a cherry stone, or the seed of a palm, such as *Phytelephas macrocarpa*, which is as hard as ivory, and is sometimes used by turners instead of it. To break up the cohesion of cells in such compact bodies we must necessarily seek the help of chemical reagents.

It is not even necessary, however, to destroy the cohesion of cells to be convinced of the fact that vegetable matter is composed of them: if we cut very thin and transparent slices with a razor from any part of a plant we can soon satisfy ourselves with the help of a microscope that these are composed of cells, closely compacted together, forming what is known as *cellular tissue*.

It is clear from what has been said that it is impossible to become acquainted with the structure and life of plant organs without an acquaintance with the cell. As in chemistry we start the study of substances with the elements and then proceed to their combinations, so in botany the study of the organs of plants must be preceded by that of their *elementary organ*—the cell.

* * *

We have now collected enough facts to be able to make a general plan for these lectures. During its life-history the plant produces a series of organs, the external aspect of which, together with their relation towards their environment, makes it evident that they serve very different purposes and perform very different functions. It is clear that the function of the root which sinks into the soil is different from that of the green leaf which grows up into the air towards the light; that the function of the cotyledon is different from that of the petal; that the function of the stamen with its pollen so easily disseminated in the air is not the same as that of the ovule buried deep in the ovary. The physiologist first of all must discover the purpose of every organ, i.e., its function. Hence a twofold problem confronts him from the outset: given an organ, to find its function; and given a function, to find the organ. Evidently he has first to study the function of the elementary organ, the cell, in its general and special manifestations. Later on, when he becomes convinced of the perfect way in which the organs fulfil their purpose and are adapted to their environment, when he learns how necessary and well balanced is their mutual interaction, resulting as it does in the general life of the organism, he then begins to realize that his problem is not yet solved, that from behind all the particular questions there emerges the most general of problems, the question of all questions. How have all these wonderful organs evolved? How have all the organisms

themselves arrived at that degree of perfection which strikes us so forcibly when we study living Nature?

By thus including this general question among those which confront physiology, it is evident that we take our stand among those students of Nature who consider the solution of this question feasible and timely. It is notorious that there have been two schools working in the province of natural science, two parties engaged in warfare. The extremists of the one school saw in living Nature nothing but a collection, a kind of museum, of immutable living things, cast in definite fixed forms. According to them the work of the student of natural science resolved itself into an endeavour to make a general catalogue of those forms, label them and arrange them in a collection. The other school looked upon organic Nature as a vast whole which is ever changing and transforming itself. Today the organic world is different from what it was yesterday, and tomorrow will be different from what it is today. The forms of life at present on our planet have derived greater perfection from less perfect ancestors by means of gradual modifications. This school has Darwin as its head, Darwin who harmonized the whole mass of accumulated evidence and gave strictly definite direction to its hitherto indefinite trend. Obviously the question as to how organs and organisms have originated and perfected themselves cannot exist for exponents of the first-mentioned theory. According to their point of view these organisms have never formed nor developed; they arose perfectly formed; they were created in the same perfect form as we see them now. Only those who are convinced of the fact that organic beings are by nature capable of transformation, that they developed the one from the other, becoming more complicated or more simple as the case may be, but always improving, only those can raise the question as to how organic forms have developed and why they are so well adapted to their functions and environment. I will do my best in my final lecture to investigate the answers that science at its present stage of development is able to give to these questions; nevertheless I should be sorry to miss this opportune occasion for demonstrating the superiority of the modern theory, if not conclusively, at least so far as to show how facts, otherwise incomprehensible, are thereby elucidated.

In choosing and comparing certain striking examples I have tried to explain the cycle of the life-history of the plant from the point of view of the theory of metamorphosis. Let us consider some of the facts above stated. If plants were created in final, perfectly definite forms, what purpose is to be attributed to all the transitional organs, such as petals and non-petals, stamens and non-stamens (as in the water-lily), or to those appendages at the top of the sepals of the peony? Taken independently these transitional organs are quite useless, since they fulfil neither the purpose of the organ from which they have developed, nor of the organ into which they are about to change (this is why they have survived only in a few exceptional cases). They are utterly incomprehensible

from the point of view of individual acts of creation. But they will acquire a very definite meaning as soon as we admit the other explanation, as soon as we accept the theory that all the numberless organic forms in Nature have not been created finally nor in isolation, but have gradually developed the one from the other, becoming more or less complicated as the case may be, but always improving, i.e., adapting themselves to the conditions of their existence. Then we see in those transitional forms real stages of development, gradual steps towards perfection, towards the improvement of the organ necessary to the plant. Only then will the theory of metamorphosis, admitted by the exponents of the opposite theory, however obscure and metaphysical it may be from their point of view, acquire perfectly real and definite meaning. This metamorphosis is the expression in space of what has taken place in time. Those thick, colourless cotyledons as well as these bright perfumed petals have been derived from the origin of the common leaf, and have gradually adapted themselves to their new functions; and those intermediate, transitional forms are nothing but the surviving formal evidences of the process of transformation. They are memorials which enable us to build up the history of the vegetable world. This is the reason of their being so precious to science. But are we entitled to affirm that the vegetable world has a history? Geology answers in the affirmative, and we have just studied an illustration of the fact. We have seen that our ferns, horsetails, and club-mosses are only degenerate descendants of former mighty masters of the soil; degenerate forms, forced nowadays to hide themselves in the depths of forests, or at the bottom of ravines, to escape from the aggressive denizens of the vegetable world of today. This means that the earth used to be inhabited by other plants, and that these belonged to the simpler spore-plants, which have receded before our more perfect seed-plants. Hence the fact of metamorphosis, as well as many other similar facts which we shall consider later on, on the one hand, and geology, on the other, prove that the plant world has a history of its own, and therefore that our question as to the origin of vegetable forms is perfectly legitimate.

The physiologist's horizon thus becomes wider and wider. After studying the life of separate organs, beginning with the elementary organ from which all others are formed, i.e., the cell; after studying the general effect of the interaction of these organs, i.e., the life-history of the plant as a whole, he tries to grasp, in so far as it is accessible to him, the life of the plant world as a whole, and thus attempts to shed light on the greatest and most mysterious problem—the problem of the origin of the plant and the reason of its perfection, in other words, the problem of the harmony and purposiveness of the plant world.

Before we step forward, however, on this gradually rising synthetic path, we must go a little deeper in our analysis. We have dissected the plant into organs and the organs into cells, but so far we have only examined the

external structure of the cell. We must peep into its interior, into the microscopic laboratory, where the innumerable substances produced by the plant are formed. We must study them and disintegrate them into their elements. For this purpose balance and chemical reagents will come to the assistance of our microscope. This study will form the subject of the next chapter.

Chapter II

THE CELL

Law of the conservation of matter. Origin of plant-substance—in the external environment. Elements and compounds entering into the composition of plants. Three fundamental groups of chemical compounds: albuminoids, carbohydrates, fats. Chemical and microscopic investigation of the plant.

Absorption of nutrient substances by the plant. General conception of the diffusion of matter. Diffusion of gases and liquids. Colloids and crystalloids. Transformation of substances in the cell explains their absorption. Fundamental mechanism of the nutrition of the cell.

The most remarkable fact in the life of the plant is its *growth*. When we analyse the phenomenon of growth we realize that it consists in the multiplication of cells. If we examine it still more closely we realize that it involves the appearance and accumulation of matter in places where it was before absent. We put an acorn into the ground and an oak appears; we drop an imperceptible grain of dust, a spore, and a tree-like fern springs up. The question naturally arises: whence came this substance? Evidently this question presupposes the conviction that matter cannot be newly created, nor disappear. This law of the non-disappearance, or the conservation, of matter underlies all scientific conceptions of Nature. The ancients admitted that *ex nihilo nil fit*, but they would certainly have been in a sore quandary had they been asked, for instance, to prove that burnt matter has not ceased to exist, or to decide whence comes the substance of the plant. Only by long-continued and laborious experimenting could the law of the conservation of matter as applied to the phenomena of plant life be demonstrated. Even in these days people unfamiliar with the results of science still believe that the growing substance of the plant is derived from the soil, whereas the error of this theory was proved more than three hundred years ago. Van-Helmont, one of the forerunners of the scientific epoch of Natural Science, one of those clear and fearless minds who steered the way for positive science notwithstanding the hampering snares of scholastic metaphysics, at once a mystic and an ingenious experimenter—Van-Helmont, I say, made the first exact experiment, which tended towards the solution of the problem of the origin of the plant substance. This experiment is remarkable not only because it is the first exact experiment in the province of plant physiology, but also because it was among the first cases in which a balance was used as a means for solving a problem in chemistry. It is well known that chemistry owes to Van-Helmont the original application of this instrument, which later on, in the hands of Lavoisier, revolutionized that science. Let us describe Van-Helmont's experiment in his own words. "I placed," he says, "two hundred pounds of earth, previously dried in an oven, in an earthenware pot and planted a willow slip in it, weighing five

pounds. Within five years the willow slip weighed one hundred and sixty-nine pounds, three ounces. The pot was regularly watered with rain and distilled water. The pot was large, and buried in the soil; and, that it might be protected from dust, it was covered with perforated tin foil. I did not weigh the leaves shed by the plant during the four successive autumns. At the end of the five years I redried the earth and found that it weighed the same amount of two hundred pounds minus two ounces, which meant that water alone had been sufficient for the production of one hundred and sixty-four pounds of wood, bark, and roots" (*Ortus medlcinae*, p. 109). This experiment proved beyond doubt that earth or rather soil cannot be considered the exclusive or even the chief source of vegetable matter. Van-Helmont saw it in the water he used for watering the plant; we know, however, that the plant derives its substance not only from earth and water but also from the air. Nevertheless, Van-Hielmont's inference was perfectly correct as far as he could go. In his day science had no definite conception of the third, i.e., the gaseous, form of matter. It is to him that science owes the first idea of gases, and even the very introduction of the word *gas*. Not before the end of last century and the development of the chemistry of gases, could the origin of the substance of the plant be fully explained. This explanation followed as a result of the investigations of the three men of science: Priestley, Ingenhouss, and Senebier.

In order to find out which of the components of this threefold medium—earth, water, and air—participate in the formation of the plant, we must know the composition of the plant itself. Since Lavoisier, chemistry has taught us that matter not only cannot be created, but in a certain sense does not even change; that there exist a certain number of so-called simple substances or elements, incapable of transforming one into the other. Therefore, when we find some element present in a plant, we look for it in the surrounding medium, knowing that it must have penetrated thence and could not have been created in the plant, nor produced within it from some other element.

By no means all the chemical elements are to be found in plants, and even of those which do occur, we shall mention only the principal ones, i.e., those which play a prominent part in the life of the plant. In order to get an idea of the chemical composition of a plant, we submit it to the action of a high temperature. Water evaporates first, and at a temperature a little above 100°C. we obtain the so-called dry matter of the plant. This is the first step in our analysis. It shows that different parts of a plant contain water in very different proportions (see table on p. 83). At a higher temperature we notice that the dry vegetable matter turns brown and black, and then becomes charred, until it begins to glow and burn with a flame, leaving in the end a heap of ashes, very small in comparison with the quantity of substance with which we started. Most of this substance must therefore have burned away and volatilized. If we carry out this combustion with certain precautions and collect the

volatile gases, we discover that the part of the vegetable matter which burns away consists of four elements: solid carbon and three gases—*oxygen, hydrogen, and nitrogen*. This combustible part, which always contains carbon, as is shown by the fact that it chars before it burns, is called the organic substance of the plant. It is called organic because it enters into the composition of all organisms. At first people thought that organic matter could be formed only in living bodies, in organisms, and that only less complicated substances, which make up dead or inorganic nature, could be produced artificially in laboratories. But this opinion has been shaken by recent progress in organic chemistry. Chemists can now produce a great number of bodies, the formation of which used to be considered a mystery of the living organism. All organic substances do not necessarily consist of all four elements; some of them are composed of three only, carbon, hydrogen, and oxygen; or only of two, carbon and hydrogen. Moreover, these same elements are combined in different proportions in different substances, so that obviously in different plants, or in different parts of the same plant, the elements will be present in different proportions. Nevertheless, by taking the mean of a number of analyses of various plants and of their component parts, we can form an estimate of the average elementary composition of a plant. One hundred parts of dry vegetable matter contain on an average:

45.0	per	cent	of	carbon
6.5	"	"	of	hydrogen
1.5	"	"	of	nitrogen
42.0	"	"	of	oxygen
5.0	"	"	of	ash

This table gives a clear idea of the ratios in which the solid and gaseous elements must combine in order to produce a certain amount of vegetable matter. When we pass from the combustible organic part of a plant to study the ash, we find that a greater number of elements enter into the composition of the latter. We shall here enumerate only the principal ones, having to return to the closer study of them in our fourth lecture.

ELEMENTS

In the organic matter

Carbon
Hydrogen
Oxygen
Nitrogen

In the ash

Sulphur	Potassium
Phosphorus	Magnesium
Chlorine	Calcium
Silicon	Iron

The first four elements of the ash form acids, which with the four metals mentioned in the second column form salts.

When once we know of which elements a plant is composed, and knowing also that elements are incapable of transformation one into the other, we can say beforehand what are the sources from which these substances have been derived.

In the air, in the atmosphere, a plant comes into touch with free oxygen and nitrogen, and with small quantities of carbonic acid—a gas composed of carbon and oxygen—and also with very small quantities of nitrogen combined with oxygen and hydrogen. In the soil, besides the substances just mentioned, the plant comes into touch with others, which, owing to their non-volatility, cannot exist in the air; these are salts which contain the other elements found in the plant. Some of these salts are dissolved in the water of the soil, and so form parts of the liquid environment of the plant; others exist in solid form.

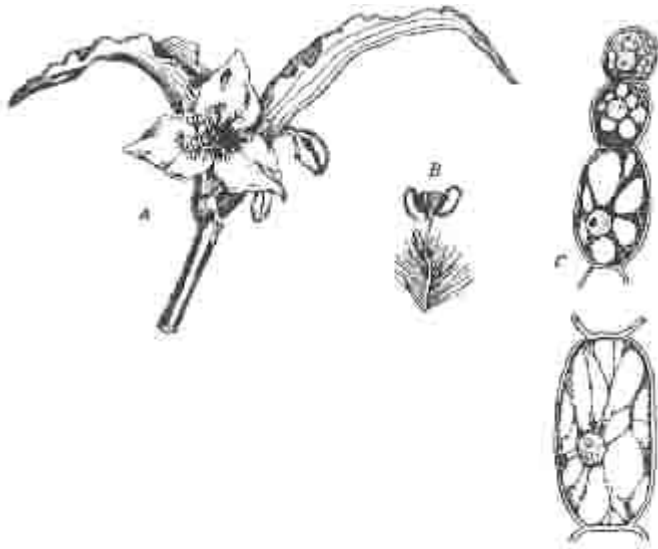

Fig. 13

So far we have only disentangled the chemical elements of which the body of a plant is composed; or, rather, we have discovered the elements into which the substance of the plant can be broken up: for this purpose we had to destroy the plant itself, to burn it down. This elementary analysis does not, however, give us any information as to the substances or compounds which enter into the composition of a living plant. For this purpose another course must be followed; and, first of all, as has been already said, we must peep into the cell, the microscopic laboratory where all kinds of matter, produced by the plant, are formed.

It is not difficult to see a cell, every part of a plant consists of them; but to see it alive, uninjured, is easy only in such parts as consist of single cells or of single rows of cells; such, for instance, as hairs. Many people will know by sight, if not by name, a plant very generally grown indoors and in hothouses with long, narrow leaves and violet-coloured flowers with three petals—I mean *Tradescantia virginica* (spiderwort) (Fig. 13, *A*). The stamens of this flower are made conspicuous by a great number of violet hairs (Fig. 13, *B*), each of which consists of round or oval cells, arranged in a row, like a rosary. If you detach one of these threads with a needle and place it under the microscope you will notice

younger cells at the tip of it which are nearly round, whereas at the bottom the cells are older and oblong (Fig. 13, C).

To begin with, we distinguish in such a cell between its thin and perfectly transparent wall and the actual contents of the cell. At first the cavity of the cell is filled by a uniform, semi-fluid mass called *protoplasm*, with a round body called a *nucleus* embedded in it, which we shall study later on. Subsequently little spots appear in the semi-fluid protoplasm, like cheese eyes, so to speak, filled with liquid. Thus the contents of the cell become separated into two parts, the protoplasm and the liquid cell-sap, becoming more and more frothy. Later still the proportion of sap to protoplasm increases; the volume of the protoplasm diminishes relatively as that of the cell-sap augments. In the end almost the entire cavity of the cell becomes filled with the watery sap, and the protoplasm remains only as a thin layer, lining the inner wall of the cell, or stretching from one wall to the other in little strands. In *Tradescantia* such a differentiation of the contents of the cell is particularly well marked, because the cell-sap is violet in colour while the protoplasm is colourless. Besides these two substances, protoplasm and cell-sap, we also frequently notice in the cavity of the cell something of a different kind—small, shining drops with an oily appearance, or round, colourless little grains, the characteristics of which will be studied later. At a later stage the contents of the cell sometimes disappear, and the cavity fills with air. Such a skeleton of a cell must be considered dead. The dry, sapless part of a tree, for instance, may be considered as formed of such dead cells. Thus in a living, active cell the microscope reveals the following substances: the wall, the protoplasm, the sap, and occasionally other bodies such as drops or grains.

So much for the microscope. Now let us return to chemistry with its balance and reagents; but this time let us stop a little earlier in our analysis without reducing the plant right down to its elements. We shall try to separate out the different substances which enter into the composition of the plant without destroying them, dealing with them as they actually exist in the plant. In a word let us study the *proximate* constituents of a plant—I say *proximate* in contradistinction to the *ultimate* constituents, which are the elements.

Evidently it is impossible to study here all the various substances which the vegetable world produces—everything we find at our grocers' and chemists' shops, at the carpenters' and the confectioners', in spinning factories and at dyeworks. We shall limit ourselves to the commonest bodies, or rather groups of bodies, without a study of which it is impossible to understand vegetable life.

Let us choose for an illustration some vegetable organ, say grains of corn. Let us take them in a powdered form, as flour. As we shall see in a moment, flour represents a heterogeneous mixture of substances. To separate them let us prepare a small lump of dough, and wash it a long while with water, working and kneading it with our hands. At first the water runs off milky-white in colour, but gradually it

becomes quite clear. We have now instead of dough a lump of something, greyish-white in colour, sticky, and flexible like indiarubber or leather. This is called *gluten*, and is that constituent part of flour which makes dough sticky. If, on the other hand, we let the water stand which ran off during the washing we observe that it becomes quite clear, while a very thin white sediment, quite soft to the touch, forms at the bottom of the glass. This is *starch*, the well-known substance which is used for dressing linen and also in the kitchen. Thus we have separated the flour, simply by washing it, into two of its components: *gluten* and *starch*. If we had mixed the flour with ether and let it stand, then poured off the ether and let it evaporate in an open dish, we should have obtained an *oily* residue. Thus flour or grains of corn consist chiefly of three substances: *gluten*, *starch*, and *oil*. The methods of separating these substances which have just been described may serve as a rough but obvious example of a so-called *proximate* analysis. In such an analysis we try if possible to extract substances, without altering them, by taking advantage of their properties of dissolving or not dissolving, of volatilizing, crystallizing, and so on.

These three bodies, starch, gluten and fat, may be taken as representatives of the three principal and most widely diffused groups of vegetable substances. These groups are known as *carbohydrates*, *albuminoids*, and *fats*. Other substances are generally met with either in comparatively small quantities or else in exceptional organs or plants, and consequently do not affect the general phenomena of vegetable life. Here is a table giving the proportions in which these proximate constituents are present in various widely differing vegetable products. These analyses fully endorse what has just been said about the large mass of the plant consisting of the three classes of compounds which have been enumerated.

In 100 parts	Clover Plant	Wheat Flour	Lupine Seeds	Flax Seeds (i.e. linseed)
Carbohydrates	16.6	74.8	45.5	26.2
Albuminoids	3.7	11.8	34.5	23.5
Oils	0.8	1.2	6.0	37.0
Ash	1.7	0.7	3.5	5.0
Water	78.0	12.6	14.5	12.3

The carbohydrates are so called because hydrogen and oxygen are combined in them in the same ratio as they are found in water; since they also contain carbon, they *seem* to be composed of carbon and water. The following substances belong to this group of carbohydrates: common cane sugar, beetroot sugar, and grape sugar, or *glucose*, which is found in old raisins; gums, such as the gum which oozes out of the stems of cherry-trees; starch; and, lastly, cellulose, the substance which forms the solid skeleton of the plant, its cell-walls, and which is used in our cotton and linen cloths, and in paper. The carbohydrate group is sometimes spoken of also

as the sugars, because some of the members of the group, as we have just seen, are actual sugars, while others can be easily changed into sugar. For instance, by treating starch with dilute sulphuric acid starch sugar is obtained. Cellulose can also be changed into sugar if treated with the same acid. The same method will transform old rags into sugar. The carbohydrates we have mentioned seem to fall into a series: cane-sugar and glucose are easily soluble in water and capable of crystallization; gums, like cherry gum for instance, are soluble in water, forming a thick viscous liquid, but are incapable of crystallization; starch does not dissolve in cold water, but swells in hot water, forming a sort of paste; lastly, cellulose neither dissolves nor swells in cold or hot water.

Now let us see how we can detect the presence at least of the chief of these substances. They are all colourless, but we possess means of producing in them certain characteristic colour changes. The colourless liquid in this glass is a solution of grape sugar, the other glass contains a bright blue liquid. I pour the colourless liquid from the first glass into the blue liquid in the second, and slightly heat the mixture. It becomes turbid, then turns a dirty green colour, and finally forms a yellow precipitate which turns brown, then bright red, and sinks to the bottom of the glass, leaving the liquid colourless. Therefore grape sugar produces a red precipitate in our blue liquid; or, in other words, this blue liquid, otherwise called Fehling's solution, by changing colour reveals the presence of grape sugar. This reaction is so delicate that it will betray in a liquid the presence of the most minute quantity of this sugar. Thus we have in Fehling's solution a valuable reagent for detecting the presence of very small quantities of grape sugar. In iodine we have a similar reagent for detecting the presence of starch. I take a large beaker of water, add to it a few drops of starch solution and stir. I have thus in the liquid minute traces of starch. I add to it a few drops of iodine solution, yellow in colour, and the liquid at once turns blue. In the same way if I drop iodine solution on a lump of dough or a piece of bread, I get a dark blue, almost black spot, because starch is contained in both substances; but if I drop some iodine solution on a piece of gluten, I do not get any black spot, because the starch has been previously washed out with water. So iodine stains the colourless starch blue, and therefore serves as a reagent for detecting starch. We have now to find means for a similar detection of cellulose. Iodine by itself does not stain it blue, but iodine and zinc chloride will. We have only to drop this solution on a sheet of white paper, which, as we know, is cellulose, to produce on it a blue spot. Such are our reagents, our means for detecting the most widely diffused carbohydrates, grape sugar, starch, and cellulose.

Now let us pass to another group, that of *albuminoids*. These are found either in solution, as in the juice of the cabbage, or in a solid form, e.g., the gluten we have just obtained from our wheat grain. As soon, however, as we heat cabbage juice, we see it turn into flakes: the albumen has "set" or coagulated in the same way as an egg "sets" when it

is boiled. Chemistry presents a whole series of reagents by which we can detect the presence of albumen. Let us experiment with one of these reagents, the most obvious if not the most certain. I have in a glass a certain quantity of the white of an egg in water. I add to it some ordinary syrup of sugar, together with concentrated sulphuric acid. A precipitate forms which dissolves again, and all the liquid gradually turns a splendid red colour. In this way albuminoids can be detected by means of sulphuric acid and sugar.

There remains a third group, that of oils and fats. We have no clear and simple reagents to produce in them such characteristic changes of colour: but instead, as we have already noticed, we have only to treat a substance in which the presence of oil or fat is suspected with ether, and the ether will dissolve them. Then if we expose this solution to the air, and let the ether volatilize, we get oil or fat with its characteristic properties.

Now we can reproduce in cells under a microscope all the reactions we have mentioned. Suppose we add sugar and sulphuric acid to water in which a cell is being observed. We shall notice the protoplasm turning pink, which proves that it consists chiefly of albuminous substances. Let us use Fehling's solution, and if the cell-sap contains any trace of grape sugar we shall get a red precipitate. We add a drop of iodine solution, and notice that the small colourless grains in the cavity of the cell turn blue: this indicates the presence of starch. We take next iodine dissolved in zinc chloride solution, and the whole cell-wall turns blue, which means that it consists of cellulose. Finally we add ether, and notice that the drops which had attracted our attention by their oily appearance have disappeared, have dissolved, which proves that they were drops of oil. Such is the way that chemical analysis and microscopic investigation work hand in hand, mutually supplementing each other. Analysis shows (see table on p. 83) that the substances most abundant in the plant are carbohydrates, and the microscope confirms this fact, showing that carbohydrates form the cell-wall, appear in the shape of grains of starch, or are dissolved in the cell-sap in the form of sugar. Analysis shows that in relative abundance albuminoids take the second place, and also that the younger parts of a plant are comparatively richer in nitrogenous substances than older parts; the microscope demonstrates that protoplasm consists chiefly of albuminous substances, containing nitrogen, and that this protoplasm is the predominating constituent in young cells. Lastly, both microscope and analysis point to the presence of fatty substances in the plant and in the cell.

* * *

We have now made acquaintance with the principal substances contained in a vegetable cell. Earlier we had come to the conclusion that the cell builds up all these substances from gases, salts, etc., which surround it. In other words it must feed from the outside. Every cell must draw its food

from the soil, from the air, or from some neighbouring cell. A question naturally arises here: in what way can this cell, this little bladder without any opening, or any mouth or jaw, attract and absorb surrounding substances?

To explain this first phase in the nutrition of the vegetable cell we must turn aside from it for a while, we must turn aside even from botany itself, and study some purely physical phenomena; we must study certain general properties of matter manifested in dead as well as in living nature. We shall often use this method in the future. It is the only sure method whenever we wish to find the explanation of vital phenomena; for, in the language of physiologists, *to explain* means to reduce complicated vital processes to more simple physico-chemical phenomena. Physics teaches us that particles of matter are endowed with motion, that we do not know any matter without motion. This motion is most clearly manifested in fluids, and more especially in the gaseous state of matter. Particles of gaseous matter are endowed with rapid motion: they tend to disperse until they fill up all spaces unoccupied by them; this goes on until they are equally distributed everywhere throughout the region accessible to them.

This capacity, this tendency of matter to spread in space, is called *diffusion*. It is a simple matter to prove the existence of the phenomena of diffusion, especially in respect of gaseous and volatile substances. We have only to sprinkle a few drops of ether to smell it in an instant not only in the immediate neighbourhood but also in the remotest corners of the room. The ether has changed into vapour, and that vapour has distributed itself throughout the whole room. The diffusion of liquids is also easily demonstrated. I only need to remind you of the probably well-known experiment with water and wine. We gently pour some claret on to the surface of water, and notice that the liquids form two distinct layers; but little by little the sharp boundary between them



Fig 14

disappears, the wine permeates the water and the water the wine, so that both liquids mingle together. We can perform here a similar but still more striking experiment (Fig. 14). Here are two almost colourless liquids which, when poured into each other, produce a blood-red liquid. We pour the denser of the two liquids into this long, narrow beaker, then with care the lighter one on the top of it. A narrow layer of red solution appears between them; but in time this narrow, hardly visible red line will broaden, and at the end of this lecture will be several inches in breadth; while in several hours, or it

may be days, the whole liquid will be a uniform red colour. Apparently both liquids interpenetrate each other. This depends on motion—peculiar to their particles, and therefore invisible—on their tendency to spread in space; otherwise we cannot explain how, in spite of the force of gravity, the lighter

particles sink to the bottom while the heavier rise to the surface.

Different substances are endowed in a different degree with this property of diffusion—in other words, particles of different substances move with different velocities. This is best demonstrated with gases. This vessel (Fig. 15) made of very porous clay (a) is joined below to a glass tube (b) immersed at its lowest end in water coloured red. Both vessel and tube contain air. The object of this apparatus is to demonstrate the slightest change in the volume of air, contained both in the vessel and the tube. If by any chance the volume increases, air will begin to escape in bubbles through the coloured liquid. On the other hand if the volume of air in the apparatus decreases, the coloured liquid will rise in the tube. In the meantime neither happens because the air inside the vessel is just like that outside. But if we surround the vessel with another kind of air, with another gas, it is clear that a mutual interchange of gases will take place through the porous wall, which can be penetrated by them; each of them will strive to permeate the other. Obviously if the two gases tend to spread, and their particles move at different velocities, a temporary change of volume will result in the apparatus; the volume will increase or decrease, according as the gas without enters more quickly or more slowly than the gas within escapes. A similar phenomenon will take place in a few minutes on the threshold of this hall. Let us suppose that there are three hundred persons at present in the hall; and, further, that one hundred of them are bored with this lecture (all too prolonged) and are impatient to hear the end of it and to leave the hall; while another hundred persons are standing outside waiting to enter for the next lecture. If the former leave the hall in the same hurry as the latter enter it the number of people in the hall will remain the same. But if those outside, not feeling so weary after an hour's mental effort, should prove more energetic, the number of people in the hall in the first instance will increase, the hall will fill up, and only later, when those wishing to leave actually do so, will the number remaining decrease to the original three hundred. The same thing happens here. If I surround this porous vessel with gas, the particles of which enter more quickly than the particles of air contained in it pass out, the vessel will for a short time contain more particles of gas than it can actually hold, and the superfluity of gas will escape in bubbles from the end of the tube. I take a glass bell full of hydrogen. Since this gas is lighter than air, it can be kept for a certain time in a vessel with its opening turned down. I lower the bell (c) over the porous vessel (a). The inside of the vessel contains ordinary air; outside, under the bell, is hydrogen. If particles of hydrogen are endowed with more rapid motion



FIG. 15

than particles of air, the inner volume of gas must increase, and you hear and see the bubbles of gas bubbling through the coloured liquid in the beaker. I lift up the bell now; the conditions are altogether reversed; hydrogen is now inside the vessel, air outside it; hydrogen moves towards the outside, air passes in; but particles of hydrogen move more quickly than those of air, so the volume inside the apparatus decreases, and you notice the red liquid rising quickly in the glass tube (*b*).

Therefore gases, even more than liquids, are capable of diffusion, i.e., are capable of permeating all spaces as yet unoccupied by them. The hydrogen rushed into the vessel only because the latter contained no hydrogen, and later rushed out of the vessel only because none was present in the air of this hall. Likewise all gaseous matter, and also matter dissolved in liquids, tends to occupy the whole space accessible to it, and to spread uniformly through it.

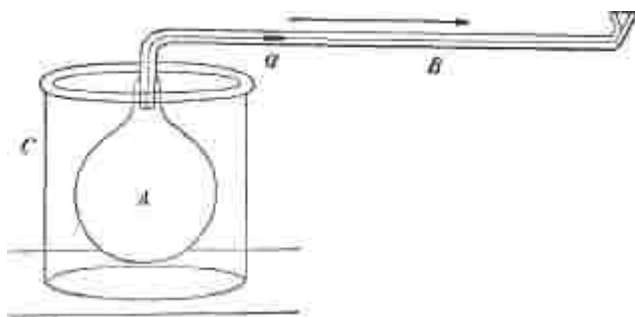

Fig. 16

Now let us see in what relation the phenomena of the diffusion of gases and liquids stand to our question concerning the nutrition of the cell. Here is an apparatus reminding us pretty closely of a cell (Fig. 16). It is a thin bladder moistened with water and transparent as glass, made out of a substance like cellulose or rather actually made of cellulose itself, only a little modified chemically. This is nothing but *collodion*, such as is used by photographers. The bladder (*A*) is joined to a horizontal glass tube (*B*) which contains a drop of a coloured liquid (*a*). We can judge whether the volume of air in the bladder increases or decreases according to the movement of the drop towards or from the bladder. I let the bladder down into the broad and empty vessel (*C*) and pour into it some carbonic acid. You cannot see it because carbonic acid is a gas as colourless as air. But I am correct in saying that I pour in the carbonic acid because it is heavier than air, and so can be poured from one vessel into another while remaining totally invisible. Carbonic acid can be kept for a certain length of time in a vessel open at the top in the same way as hydrogen can be kept for a short time in a vessel open at the bottom. After having introduced carbonic acid into the vessel surrounding the bladder, the drop of coloured liquid trembles and then runs along in the direction of the arrow, thus demonstrating that carbonic acid has begun to penetrate through the moist wall of the bladder, which is our artificial cell, and, moreover, that it is doing so more quickly than the air is escaping from

the bladder. In the same way a vegetable cell has no need to attract or imbibe gases, such as carbonic acid, which, owing to its property of diffusion, will penetrate independently any cell devoid of it.

Now let us observe the behaviour of vegetable cells towards substances dissolved in the water of the soil. Let us take some oblong bladders made of the same collodion and fix them to the extremities of lamp glasses (Fig. 17). Suppose these collodion bladders

represent root-cells, by means of which the plant comes into contact with the nutrient substances contained in the soil. A plant, as we know from its chemical composition, needs among other things iron salts. We choose these for our illustration, because they give very obvious reactions by which it is easy to detect slight traces

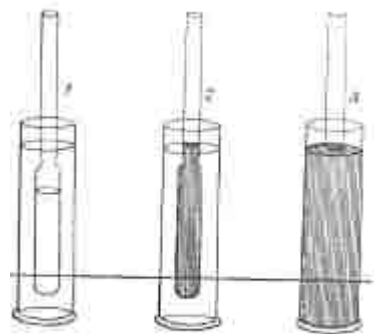

Fig. 17

of them in a solution. I have, for instance, some water in this glass. I add to it a few drops of an iron salt and then some of another liquid (a solution of *tannin*), and the solution previously as colourless as water turns as black as ink; in fact it is not quite correct to say *as* ink, because it actually is ink. We put into the vessel which contains water a bladder of collodion also filled with water (1). Then we pour some iron salt into the vessel and some tannin into the bladder. Almost immediately a greyish tint appears near the inner wall of the bladder, and in a few minutes all the liquid

in the bladder is turned into ink (2). We notice therefore that the iron salt spontaneously penetrates into our cell; and we know that this process will continue as long as the solution of the salt in the cell is weaker than that in the vessel outside it, for only then will as many particles enter the cell as pass out of it—in a word, until equilibrium is established. But here a question arises: can an equilibrium of that kind be reached in our illustration? Apparently not; as soon as our iron salt penetrates into our cell, it enters into combination with the tannin, forming what for the sake of brevity we shall call ink. Therefore the cell will contain ink, but no more iron salt, and if it does not contain any iron salt a fresh supply of the salt will enter from the vessel outside; this in turn will become ink, and so on. If the bladder contains a sufficient quantity of tannin, the equilibrium will never be reached, and the iron salt will diffuse into our cell in a continual stream. Thus we have only to take the collodion bladder containing the solution of tannin, and put it down into the vessel containing the solution of iron salt, to withdraw from this solution the whole of its salt and transfer it into the bladder. Let us put aside this apparatus for a few hours or days, and we shall find that there is no more iron salt in the outer

vessel: our artificial cell will consume it, will absorb it completely.

Apparently we are approaching the simple physical explanation of the way nutrient substances enter into the vegetable cell. We have seen that a gaseous or soluble substance penetrates into a cell spontaneously, and goes on penetrating into it until it finds itself present equally on both sides of the cell-wall. We have noticed further that this equilibrium will never be established if the substance which penetrates into the cell is transformed there and enters into a new combination. In that case it will rush into the cell in a perpetual and continuous stream, and become precipitated therein. We perceive here one of the reasons why the mass of a plant increases, i.e., why matter becomes accumulated in it; but to complete our explanation we require one more link in the chain. The process of the accumulation of matter in a cell will become quite clear only in so far as we admit that substances enter freely from outside into the cell, and that those into which these are transformed inside the cell, i.e., substances within the cell, do not again escape from it. The experiment we have just performed fully confirms this. In fact the liquid blackens only inside the collodion bladder; outside, it is as colourless as water. This would not have happened could tannin, or its compound with the iron salt, ink, pass through the cell-wall. To verify this let us perform the converse experiment. Let us pour some iron salt into the cell and some tannin into the outer vessel. In a few moments black streams will be noticed in the outer vessel, and in the end the whole liquid in it will become so black that the bladder will be invisible (3, Fig. 17). Let us take it out of the vessel—the solution inside of it is as colourless as it was at first. Without doubt it is only the iron salt which passes freely through the membrane, with equal ease in either direction; but neither tannin, nor its compound with iron, can pass through it. It follows that two kinds of substances exist: some of them are capable of passing through the membrane of the cell, others are not; the iron salt serves as an illustration of the former kind and tannin of the latter.

Indeed these two substances may serve as types of two great classes of chemical bodies. Those of the one class pass easily through vegetable or animal membranes; those of the other pass with difficulty. We have noticed in speaking of the diffusion of liquids that some diffuse more quickly, others more slowly; some are more mobile, others less. We may now add that those substances which diffuse slowly are precisely those that pass still more slowly through membranes. Chemists call substances of the former class *crystalloids*, since they are all capable of crystallization; substances of the latter class they call *colloids*, i.e., gum-like substances; these are all incapable of crystallization.

We have here at once an explanation of our experiment, and a general key to the phenomena which take place in the nutrition of a vegetable cell. It is the iron salt which moves towards the tannin, not the tannin towards the iron, because the iron salt is a crystalloid, whereas tannin is a colloid.

Going back to the nutrition of the cell we meet, roughly speaking, the same phenomenon. What, in fact, are the substances a cell finds in its environment? Gases, water, and salts dissolved in water; that is, crystalloid substances—which means, generally speaking, extremely mobile substances which "readily pass through the cell membrane. What substances does such a cell contain, into what does it transform the substances absorbed from the outside? It transforms them chiefly into albuminoids, oils, gums, starch, or cellulose—in other words, into colloids, scarcely mobile substances which will not pass through membranes or into other substances totally insoluble. This may be easily grasped with the aid of the following table:

MAIN SUBSTANCES	
Vegetable Substances	Their Sources
Cellulose	Carbonic acid
Starch	Water
Albuminoids	Salts
Oils	

Insoluble bodies and colloids	Gases and crystalloids
-------------------------------	------------------------

Throughout its life the cell is continually surrounded by substances which easily diffuse into it. Thus, for instance, the carbonic acid of the air rushes constantly into every cell with which it comes into contact. But if this carbonic acid remained in the cell unchanged, only a very little of it would penetrate into the cell; however, as we shall see later on, once in the cell it is changed: carbonic acid and water form a carbohydrate, and this transformation leaves room for the entry of fresh quantities of carbonic acid. Therefore, the two phases of nutrition: the diffusion of nutrient substances and their transformation into the very substance of the cell, their assimilation, are closely related to each other. One process is conditioned by the other: did assimilation not take place there would be no more diffusion; did diffusion not take place there would be no matter for assimilation. Moreover, since by means of such assimilation the substance is transformed into a hardly mobile or even totally immobile form, it does not diffuse away again, but accumulates in the cell.

When we examine the nutrition of the plant from such a general, physical point of view, we get a conception of it quite different from the usual current ideas upon the subject. It is not the plant, nor the cell, which attracts or imbibes nutrient substances; on the contrary, it is the nutrient substance itself, which rushes into the cell owing to its inherent mobility. A cell is simply a microscopic centre, where the equilibrium of the surrounding substances is constantly disturbed, a kind of whirlpool, into which these very mobile substances rush in a continual stream, and within which they lose their mobility, are transformed, and become deposited. A vegetable cell is a trap which lets things pass easily one way, but does not let them out again. In this way

we come to understand the fundamental feature of vegetable life: increase of mass, accumulation of matter.

As we shall soon see, these general ideas as to the nutrition of the cell will prove to be essential at almost every step in our study of the phenomena of the nutrition of the whole plant. The nutrition of the root by substances in the soil, the aerial nutrition of leaves by the atmosphere, or the nutrition of one organ at the expense of another adjacent to it—to arrive at the explanation of any of these phenomena we shall have recourse to the same fundamental causes: (1) diffusion, i.e., the property by which substances spread, rush from where they are present to where they are absent, and (2) transformation, i.e., the passage of substances from very mobile to less mobile or quite immobile forms.

In this way the study of the fundamental phenomena underlying the nutrition of a vegetable cell brings us to the conclusion that they are really phenomena of diffusion, not essentially peculiar to living organisms, but following rather from the general properties of matter. We come to the conclusion that so fundamental a process as nutrition is conditioned by laws common to both animate and inanimate nature.

Chapter III

THE SEED

Structure of the seed and external phenomena of germination. Three conditions of germination: water, air, heat. Mechanical function of water. Chemical function of water. Ferments. Diastase. Pepsin. Insectivorous plants. Independence of the parts of the embryo. Artificial nutrition of the embryo. Mechanism for the translocation of the nutrient substances in the plant.

The seed in relation to air; evolution of carbonic acid, absorption of oxygen—respiration. Loss in weight and rise of temperature as a result of respiration. Importance of the surrounding temperature. Temperatures: maxima, minima, and optima. Effect of the age of the seed on its germination. Longevity of seeds. General characteristics of the period of germination. Division of labour between different organs of the plant, already apparent in the lowest plants.

Let us begin our survey of the living functions of a plant with the awakening of the seed after its long winter rest under the snow, or at the moment when it is cast into the earth in spring. Probably no other phenomenon in the life of a plant has attracted so much attention as this, its first manifestation. Scientists, philosophers, and poets have alike meditated upon it; a mystic and poetic veil hangs over it; we find in it the personification of life itself, the symbol of awakening from dreams and death. There is something indeed attractive, something that stimulates thought in this sudden awakening of activity in an object hitherto apparently indistinguishable from the rest of inanimate nature. In fact there is something enigmatical about this hidden and arrested life which suddenly bursts forth again. Without indulging in the poetical fancies with which imagination loves to enshroud this phenomenon, let us try to submit it to strict scientific analysis; let us try to reduce it, complicated as it is, to its lowest terms and explain the difference between a resting seed and an active one. We may thus discover wherein the very impulse consists which provokes this activity.

Outwardly the renewed activity of a seed is manifested by its swelling" and by the consequent rupture of its seed-coat, followed by the appearance first of the root and then of the plumule, i.e., of the stem with its first leaves. These organs develop and increase in size every day. It is obvious that this development must proceed at the expense of some substance, which serves as food for the growing parts. Yet, notwithstanding its rapid growth, it is just at this period of germination that the plant is practically independent of the soil. As a rule germination takes place in the soil; but here is a brush-like mass of green cress grown on felt, and there are seeds of maize and beans grown on thin gauze net and, therefore, surrounded merely by air and having their root-tips only in distilled water.

On examining germinating seeds such as beans more closely, we notice that while the root and the stem with its

young leaves increase in size, the first pair of leaves, the cotyledons, become wrinkled, are gradually absorbed, and become smaller (Fig. 18). This observation may serve as an indication of the fact that the development of some parts of a shoot takes place at the expense of others.

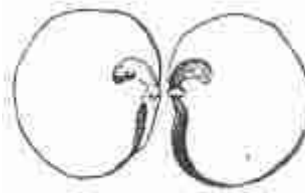

Fig. 18

Other seeds, such as grasses, present a somewhat more complicated structure than the seeds of beans. If we split a grain of wheat longitudinally, we find under the seedcoat two perfectly distinct parts (see Fig. 19: *b*—whole grain; *c, d*—the separate parts). At the base of the figure, a little to one side, there is a small body which is simply a seedling, an

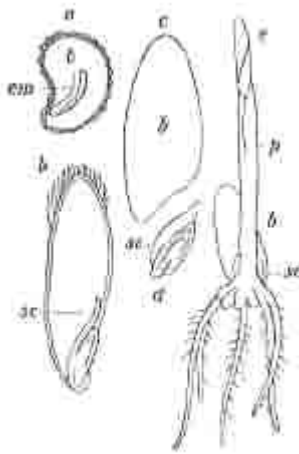

Fig. 19

embryonic plant, such as can easily be seen in any germinating seed (see Fig. 19 *b, d, e*). We notice in it a leaf-bud and the beginning of a root. The remaining larger portion of the seed is filled with a white, uniform, mealy mass called the *endosperm* (Fig. 19 *c; b*). The part of the embryo lying close to the endosperm is called the *scutellum* (Fig. 19 *b, d; sc*—scutellum). It is a kind of modified leaf and represents the cotyledon of the embryo. In this case we find only one cotyledon instead of two.

The nature as well as the position of the endosperm may differ in different seeds. In grasses, for instance, it is mealy; it is such endosperm which forms the essential part of flour, the embryo being comparatively small. The embryo lies to one side, and comes into contact with the endosperm only by means of its scutellum. In the poppy, on the other hand, the embryo is surrounded by the endosperm, and embedded in it; and the endosperm is not mealy, but is fatty and oily (see Fig. 19 *a; b*—endosperm, *em*—embryo). Lastly, in coffee beans the greater part of the seed consists of hard, horny endosperm, and the very small embryo is on one side enveloped by the endosperm. A curious experiment will reveal the presence of the embryo. Coffee beans are known to have already lost their germinating power when they reach us; in fact they possess that capacity only for a few days after being gathered; but if soaked in boiling water, or, still better, in a solution of caustic alkali, we notice what appears to be the germination of a seed which is certainly dead. In an hour, or even less, a small snow-white rootlet protrudes from a slit in the testa; sometimes the entire little embryo is pushed out afterwards. What happens is this: the endosperm of the coffee bean, although as hard as horn, becomes soft and very elastic

through the action of the boiling water or of the alkali, and in swelling compresses the embryo and squeezes it from its place.

We see therefore that seeds may be of two kinds: in some we find very well developed fleshy cotyledons; in others mealy, oily, or hard and horny endosperm. Just as cotyledons shrink and decrease in size during germination, so also the endosperm disappears little by little, being apparently absorbed. This arouses the suspicion as to whether the decrease of substance in the cotyledon or endosperm is not connected in some way with the increase in size of the shoot, i.e., whether the development of the young plant is not achieved at the expense of the food-substances stored up in

the cotyledon or endosperm. But all these substances are also present in a resting seed; why then is their displacement manifested only during germination? The answer to this question will be apparent if we recall what we learnt in our last lecture. The nutrient substances in the endosperm or cotyledons exist in a solid and, generally speaking, insoluble form. You remember our analysis of flour, i.e., of powdered seeds. We detected there insoluble starch, insoluble gluten, and oil. All these substances are immobile and incapable of diffusion from one cell to another, a property which is quite essential to them as reserve foods, since otherwise they would not remain stored up.

Hence we have in the seed an embryo, and in a certain part of the embryo the cotyledons; or in its immediate neighbourhood, in the endosperm, we have stores of nutrient substances in an immobile form, and on that account inaccessible to the embryo. We now inquire what conditions must be fulfilled in order that the embryo may make use of these stores, may bring into circulation this sunk capital.

These conditions are well known. Water is needed—for the seed does not germinate in dry soil; heat is needed—for a seed sown during a cold spring does not show any sign of development until the sun warms it; lastly, air is needed—for a seed buried deeply in the soil may remain very long without germinating.

Thus water, heat, and air are the three essential conditions which awaken the seed to life. Let us investigate them in turn.

* . * . *

First of all water. Seeds generally contain very little water (see table on p. 83). This is one of their essential peculiarities. A seed which is not dry loses its most important property—the power of concealing life, of living through winters, years, and even centuries in a dormant condition. If the seed is not 'dry it cannot be preserved; we cannot get good seed in a wet autumn—grain then germinates in the sheaves or even before the corn is cut. For a seed to remain in the resting state the principal condition is thus the absence of water. As soon as the seed is brought into contact with water

we notice an immediate awakening to life. The seed swells and breaks the seed-coat which protects it.

This absorption of water is generally accompanied by a considerable manifestation of energy. An English scientist named Hales studied this phenomenon as early as the beginning of the eighteenth century. He filled a small iron pot with moistened beans, and covered them with a lid upon which he placed a weight. He proved in this way that bean seeds as they swell can lift nearly two hundred pounds. Hofmeister has demonstrated that seeds swelling under similar circumstances exercise on the walls of the vessel containing them a pressure equal to that of several atmospheres. Anatomists make use of this property of seeds when they wish to separate the bones of the skull: the cavity of the skull is usually filled with peas, which are then moistened. The bones of the skull separate at the sutures owing to the strong and uniform pressure all over the inner surface of the skull.

Such is the mechanical effect of water upon seeds; it enables them to shed their coats which they no longer need, and to overcome the resistance of the surrounding particles of soil. But the chemical action of water is still more important: without it the solution and consequently the transfer of the stores of nutrient substances cannot take place. Water, however, is not alone sufficient for the purpose, because all these substances, as we have seen, are insoluble in water; in order to become available for nutrition they must first of all be changed into other substances. Starch, for instance, could be dissolved in water if previously changed into the sugar, glucose. Such a transformation is possible—the preparation of starch sugar is based upon it, and it can easily be proved that such a transformation actually takes place. We have only to taste a raw barley grain and then a malted grain, i.e., a germinating barley grain, to realize that the former is tasteless whereas the latter is sweet. But perhaps the taste has deceived us; in that case we can avail ourselves of a test I described in our last lecture. We have seen how the blue liquid—Fehling's solution—gives with glucose a bright red precipitate. We take malt mixed with water, add to it Fehling's solution, and get a red precipitate. We cut off a thin slice of a germinating seed, place it under the microscope, add a drop of the same Fehling's solution, and get a red colouration in the cells. Therefore the taste as well as the more conclusive chemical reaction prove that sugar, glucose, appears in the germinating seed. But is it true that this sugar is formed from starch? Both quantitative analysis and microscopic investigation answer this question. The former shows that throughout the germination of the seed the quantity of starch contained in it decreases. The latter reveals a change in the starch grains: they lose their characteristic form, appear as if corroded, and sometimes break into pieces like ice that has been thawed. They do, in fact, dissolve away.

Now let us try and explain the reason for such a transformation of starch into sugar. We can produce this transformation artificially by using sulphuric acid; but seeds

cannot obtain any free sulphuric acid. A special substance called *diastase* appears instead of it during the period of germination, producing on starch quite a similar effect. *Diastase* may serve as a representative of a whole group of substances generally called ferments. The word "ferment" usually denotes a substance which when used in a minute quantity is able to produce the chemical transformation of other substances. There are many such ferments. Bitter almonds, for instance, in themselves have no characteristic taste or scent; these qualities are produced in them by means of a ferment, which begins to act as soon as the seed is brought into contact with water. Mustard seeds, too, would not have their pungent odour and taste unless they contained the ferment, *myrosine*, which with water decomposes a substance contained in them (the salt of the so-called *myronic acid*) and liberates the pungent *mustard oil*. A very curious experiment demonstrates this phenomenon. Chemists sell mustard plasters which consist of two sheets of paper, to be laid one upon the other and then moistened with water. Neither leaf by itself constitutes the mustard plaster, but the characteristic pungent odour of mustard is produced as soon as they are brought in contact with each other. This is because one of the sheets is smeared with the ferment and the other with the substance upon which the ferment acts; the effect of the ferment only manifests itself when the sheets are moistened. These examples are quite sufficient to illustrate the action of vegetable ferments. A similar effect is also produced by *diastase*, which is easily obtained from malt liquor, i.e., liquid obtained from germinating grain. One part of this *diastase* dissolved in water is sufficient to turn into sugar more than a thousand parts of starch; the warmer the liquid the more quickly does this transformation take place.

Thus the nutrition of the embryo of the seed by means of the starch stored in its endosperm or cotyledons becomes quite comprehensible. It is curious that this' process is exactly similar to that which takes place during the nutrition of an animal organism. The saliva, and the gastric and other juices secreted by the alimentary canal, contain ferments which like *diastase* change starch into sugar. It is quite easy to realize this: if we suck a piece of bread a little longer than usual, we notice a sweet taste. Thus both animals and plant-embryos can make use of insoluble starch by changing it into soluble sugar.

A similar change must also take place in seeds, like coffee beans or date seeds, with hard and horny endosperms. The character of the endosperm is in such seeds due to the very hard cellulose walls of the cell. During germination this cellulose dissolves and serves to feed the embryo. This dissolution aroused the suspicion that a special ferment was concerned, and the existence of such a ferment has since been proved.

Let us pass to the second group of foods stored up in the plant, to the albuminoids. In wheat grains and flour, as we have already seen, they are present in the insoluble and therefore immobile form of *gluten*; but even soluble

albumens, such as the white of a hen's *egg*, or the soluble albumen that occurs in vegetable endosperms, are immobile, because they are *colloids*, i.e., substances which do not pass through membranes. In order to pass from one cell to another, and thus to serve as food to plants, albuminoids must go through a transformation similar to the transformation of starch into glucose.

The study of the nutrition of an animal organism will give us once more the key to the explanation of the phenomena which take place in a germinating seed. Gastric juice contains a ferment called *pepsine*, which with a few drops of an acid has the property of turning insoluble albuminoids into soluble ones; for instance, the white of a boiled *egg*, or the albumen of cooked meat, into soluble substances, called *peptones*. These are not only soluble in water, but are also capable of passing through animal and vegetable membranes. For a long time nothing of the kind was ever observed in the vegetable world, and so long the translocation of albuminoids remained unexplained; but at last almost simultaneously discoveries were made in totally different directions which demonstrated the transformation of albuminoids in vegetable organisms.

Even as early as the eighteenth century a plant called the catch-fly had been observed to seize, by means of its irritable leaves, insects which came into contact with them in their flight and then use them as food. This fact, however, had not been sufficiently appreciated: the sceptical even cast doubts upon the existence of the phenomenon, and it might eventually have been quite overlooked had not Darwin paid attention to it. Darwin added considerably to the list of such *carnivorous* plants, and acquainted botanists with curious details as to their functions. We shall postpone to a future lecture the description of the mechanical side of such phenomena, and here consider them only in so far as they illustrate the fact of a plant's capacity for using as food an insoluble albuminoid. These phenomena of digestion in plants were studied by Darwin more especially in the sundew, a plant fairly common in marshes. The mucilage secreted by the hairs with which the leaves of this plant are covered and which seize upon the insects, contains a substance apparently similar to pepsine. This substance, in the presence of an acid produced by the hairs of the sundew when irritated, like gastric juice, has the power of rendering albuminoids soluble. Insects which, in the natural¹ course of things, fall on these leaves and fragments of meat or white of egg placed upon the leaves, as in Darwin's experiments, alike become dissolved and assimilated by the plant. These experiments which proved that it is possible to feed a plant with insoluble albuminoids led scientists to look for ferments like pepsine in germinating seeds. Their discovery was not long delayed. Such ferments were found first in leguminous plants, and then in other such as hemp and flax, and, lastly, in malted barley. A ferment verisimilar to gastric juice in its effects has also been discovered in the latex of *Carica papaya*. The nutrition of the embryo at the expense of the stores of

albuminoids is now comprehensible: the pepsine-like ferment which develops during germination acts upon the albuminoid, transforming it into a soluble, diffusible form. In addition a certain quantity of albuminoid matter undergoes a still greater transformation during germination into bodies capable of crystallization—i.e., into crystalloids—which diffuse still more readily.

Thus the embryo of a grass seed, for instance, not only feeds upon the same starch or gluten that we use in eating bread, but also digests them in the same way as we do; treats them with similar ferments, and changes them into glucose and peptones. We know less about nutrition at the expense of the stores of fatty substances, though we have some indications in this direction also. Oils as such are generally unable to pass through cell-walls moistened with water. They consist, however, of so-called fatty acids in combination with glycerine, a substance easily soluble in water; and certain facts suggest that during germination oil is decomposed into its constituents, acid and glycerine, likewise by means of a ferment. Moreover, it is well known that fatty acid when set free furthers the breaking-up of oil in water into very fine drops with the formation of so-called emulsions, such as the white oily liquids we call "milk"—cow's milk, coconut-milk, and so on. This formation of emulsions plays a great part in the nutrition of an animal's organism; very likely it also plays a certain part in the nutrition of the embryos of oily seeds.

The first stage in the nutrition of a young seedling has now been explained. By the action of water and ferments the immobile material stored up within the seed is brought into circulation, and becomes available to the seedling. We can easily prove that the development of the embryo takes place at the expense of the stored material. We have only to cut off the cotyledons of a leguminous plant to stop the further development of the embryo, even though its root and stem have already attained to some degree of development. The cessation of further growth in the embryo cannot be explained by the fact of its having been wounded; on the contrary, experiments prove that it has still considerable vitality. We can cut it in pieces, in various ways, and each segment will develop if only a connection with the cotyledons containing the food-store be maintained. In fact, if we cut off the rootlet, leaving the plumule connected with the cotyledons, the stem will develop even more quickly than if it had been attached to an uninjured embryo; and, *vice versa*, if we cut off the plumule, leaving the rootlet connected with the cotyledons, the rootlet will develop more strongly than if it had been attached to an uninjured embryo. In these cases one of the two organs evidently uses the food stored up for both. In seeds with endosperm (albuminous seeds) the embryo is not organically connected with the source of its food supply; it may be closely attached to the endosperm, or even surrounded by it, but in either case it can be separated from it without being injured; this is why albuminous seeds are the best specimens for the study of the nutritive phenomena of the embryo. In cereals the endosperm, originally dry and

farinaceous, becomes less dense on germination, till it resembles gruel or milk. Meanwhile, the outer cells of the scutellum, the part of the embryo adjacent to the endosperm (*sc* in Fig. 19), grow out as papillae into the softened endosperm, and absorb the nutrient solution from it. The embryos of buckwheat and of many other plants find themselves under still more favourable conditions. They simply swim in the semi-fluid mass of the endosperm, and absorb the nutrient substances with their entire surface. If in such seeds we remove the embryo from the endosperm, it will stop growing; but its development can be maintained artificially if, after removing it from the endosperm, we enclose it within a lump of dough made of flour or starch. That the embryo obtains its food from the dough is shown not only by its successful development, but also by the signs of decomposition in the grains of starch in the immediate neighbourhood of the embryo.

We have several times spoken of the embryo absorbing the nutrient substances from the cotyledons or the endosperm, but evidently this is only a metaphorical expression, and the translocation of the nutrient substances into the embryo has to be explained on the basis of the general phenomena of diffusion, which were studied in our last lecture. We have seen that during germination every nutrient substance passes into a soluble form; and these solutions, according to the laws of diffusion, have to distribute themselves equally in all parts of the seed, including the embryo. The part played by diffusion ends, however, with this equal distribution of substances, and the attainment of equilibrium. What is it, then, that disturbs this equilibrium, and, so to speak, transfers the centre of gravity from the endosperm to the embryo? How can we explain this transfer of substance from the endosperm to the embryo? We can do so in the same way as in our last lecture we explained the passage of the iron salt from the outer vessel into our artificial cell, by the reconversion of the diffusing substances into insoluble compounds. The substances in solution which penetrate into the embryo are used up in the development of new organs. Glucose, a soluble carbohydrate, is thus converted into the insoluble carbohydrate cellulose, of which the walls of the new cells are built up. The soluble and diffusible albuminoids are transformed into the insoluble and non-diffusible protoplasm of these cells. This transformation, as we already know, will cause the diffusion of fresh quantities of glucose into the embryo, and so on. This dissolution and precipitation of substances in a seedling, this drift of matter from endosperm to embryo, will continue as long as they are in contact with one another. Let us imagine that two persons have agreed to share their movable belongings from time to time in equal parts; then let us suppose that one of the two persons is so imprudent as to gradually exchange his immovable property into movable, whereas, on the contrary, the other exchanges part of his movable property for immovable. In the end all the property of the former will have passed into the hands of the latter. This is precisely how an embryo acquires its food from

the endosperm and the cotyledons. It absorbs the food because of its growth, and it grows because of the food it absorbs—here cause and effect are mutually connected very intimately, as they are in any vital function.

We therefore see that underlying the nutritive phenomena of the embryo there are the same general phenomena of diffusion and transformation, by means of which the nutrition of the cell was explained in our last lecture. This parallel might, indeed, have been expected, since the life of the embryo is the sum of the life of the cells which compose it.

* * *

We have now proved that during the process of germination matter is only translocated from one organ to another within the seed. Notwithstanding the apparent increase in size and the growth of the young plant, we can prove by weighing the seed and the seedling that no increase in substance really takes place during this period. Simple weighing would, however, be insufficient for the purpose; if we record the weight first of the seed and then of the seedling developed from it, we certainly do notice that the latter is heavier than the former; but this is easily explained. We have seen that different parts of a plant contain very different quantities of water: seeds scarcely contain any water, while the plant as a whole contains a considerable quantity.* During germination water is absorbed first by the whole seed and eventually by the rootlet, a fact which explains the addition in weight. If, on the other hand, we had dried both the seed and the seedling at a temperature of 100°, and determined their weight in a dry state, we should have found that the plant has lost in dry weight during the process of germination, although it has increased in size. The question arises: what has become of the lost substance? As a rule we do not notice any excretion by plants of dry or liquid matter such as takes place in animals, and even if there were any such excretion, having taken it into consideration, we should still find that the whole of the loss in weight was not by any means accounted for. We can only conclude that the seed loses some of its substance in the form of gaseous products which disappear into the air.

* See table of analyses on p. 83.

This supposition brings us to the consideration of the second of the three conditions of germination, defined a little while ago, namely, the importance of air. Air, as we know, consists of oxygen and nitrogen. Experiments point to the fact that seeds require oxygen. A seed buried deeply in the soil, or remaining under water which is never changed, does not germinate; but it likewise does not germinate, or if already begun, the process stops short, if the seed be surrounded with air deprived of oxygen. It needs oxygen, undoubtedly. Wherein, however, does the function of the oxygen consist?

It is easy to prove that oxygen is absorbed by the seed. Now oxygen maintains combustion; in its absence burning bodies become extinguished. Therefore, if germinating seeds absorb oxygen and we leave them for a certain length of time in a limited volume of air, we shall deprive that air of oxygen and so rob it of the property of maintaining combustion. Ten hours ago we laid some germinating seeds at the bottom of this wide-mouthed vessel, tightly closed with a glass stopper. I open it now and introduce into it a burning taper; it is at once extinguished. Evidently the air in this vessel does not contain oxygen any longer. The oxygen has been absorbed by the seeds.

Having observed before how close is the parallel between the nutrition of seeds and animals, we may legitimately raise the question whether also seeds do not use oxygen for the same purpose as animals? May they not use it for respiration? Respiration, as we all know, is in its essence combustion. We inhale oxygen; it is carried by the blood all through the body, and oxidizes or burns up part of its carbon and hydrogen, giving them off in carbonic acid and water. We can see this in the following simple experiment, which proves that the gases we inhale and exhale are different in kind, and that the gas exhaled contains carbonic acid. The two following tests serve to distinguish carbonic acid from other gases. If carbonic acid is passed through lime water, i.e., through water in which quicklime has been dissolved, this clear solution becomes clouded with a milky precipitate of chalk, i.e., calcium carbonate, a compound of lime with carbonic acid. I take a flask (Fig. 20, *A*) into which two bent tubes are introduced through the cork; one of them goes right down into the lime water, while the other, the shorter one, ends above the surface of the liquid. I start by taking the shorter tube (*a*) into my mouth and inhaling air through it. The external air enters through the other long tube, and passes in bubbles through the liquid, which remains transparent. I turn the vessel, take the end of the long tube (*b*) into my mouth, and exhale the air; the air repasses in bubbles through the liquid which immediately becomes turbid. In order to prove that the white precipitate at the bottom is really chalk, and that it contains carbonic acid, I add a few drops of vinegar—the precipitate dissolves with effervescence, and these effervescing bubbles of gas are nothing but the carbonic acid which I have just exhaled.

Another test for carbonic acid is as follows. All caustic alkalis readily absorb carbonic acid. I take a glass tube with some carbonic acid in it, close its open end with my finger, and sink it into a vessel containing an alkaline solution. When I take away my finger, which has been blocking the mouth of the tube, the liquid rushes into it and fills it. The carbonic acid contained in it has disappeared, i.e., it has been absorbed by the liquid.

With these means at our disposal for detecting the presence of carbonic acid, we can now return to the question: do germinating seeds breathe? We have answered already one part of the question; we have seen that germinating seeds

cannot get on without oxygen, and that they absorb it; we have now to show that they exhale carbonic acid, in exchange for the oxygen they inhale. For the sake of clearness I will give another form to the experiment. A stream of common air is driven into this intermediate vessel through an aperture indicated by an arrow (Fig. 20, *B*). (How this is done does not

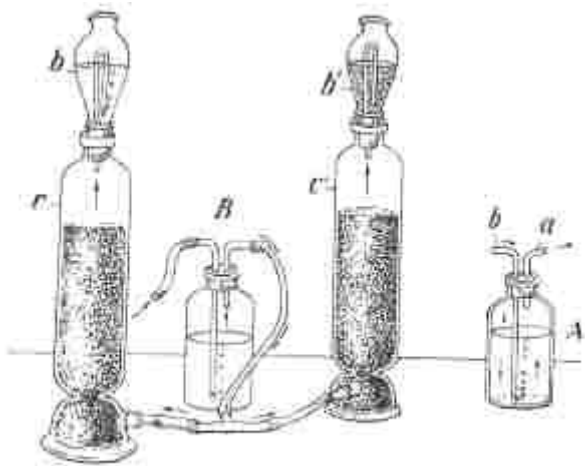

Fig. 20

concern us here, as it is only a technical detail having nothing to do with the main point of the experiment.) The air passes in bubbles through the solution of caustic alkali, depositing in it those traces of carbonic acid which are always present in the air, especially in a room where so many people are breathing. From this vessel the stream of air, now 'deprived of carbonic acid, divides into two parts, passes (as indicated by arrows on the figure) through two vessels (*c* and *c'*), and, emerging from each, bubbles through the lime water in the funnels (*b* and *b'*) at the top of them. The vessels are identical, a stream of the same air is driven into both of them; but there is this 'difference, that the one marked *c'* contains a layer of living germinating hemp or bean seeds, while the other contains similar seeds previously poisoned with corrosive sublimate. The air in passing through the apparatus continually plays over the surface of the seeds, and then passes through the liquid in the funnels *b* and *b'*. You notice already the difference which manifests itself: while the liquid maintains its transparency in the left funnel, it becomes turbid and turns milky white in the right one, and within a short time a considerable layer of chalk is precipitated. Evidently air after passing over a layer of living, germinating seeds contains carbonic acid. Seeds, therefore, absorb oxygen and give off carbonic acid. We have now to show that these two processes are correlated, i.e., that carbonic acid is given off in place of oxygen which has been absorbed. This can be demonstrated by the following experiment, which at the same time allows us to judge of the energy with which this process of respiration proceeds. A narrow glass bell *a* (Fig. 21) is divided into two parts by wire gauze; some germinating hemp seeds are scattered in the upper part, while in the lower,

which is closed with an indiarubber stopper, a small beaker is placed containing a solution of caustic alkali. The upper aperture of the bell is likewise corked with an indiarubber stopper through which passes a bent manometric tube containing a column of coloured liquid and provided at *b* with a stopcock. This stopcock is open for the purpose of keeping the air inside and outside the apparatus in equilibrium. Whenever this stopcock is closed the column of coloured liquid rises in the left limb of the manometer and falls in the right one, so that its level will very soon reach *c* on one side and *c'* on the other. The meaning of this experiment is obvious: the seeds in the upper part of the vessel give off carbonic acid,

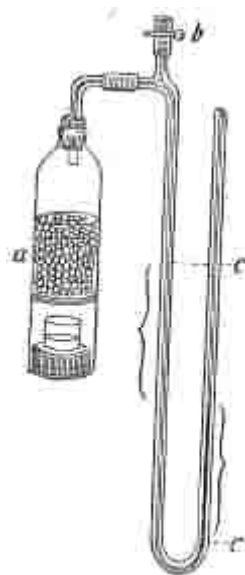

Fig. 21

which as we know is greedily absorbed by caustic alkali, some of which is contained in the beaker below them; consequently, there is a decrease in the volume of air in the whole apparatus, manifested by the rising of the column of liquid in the left limb of the manometer. This experiment proves that carbonic acid appears in exchange for another gas, absorbed by the seeds; because, if carbonic acid were only *added* to the air enclosed in the apparatus, one of two things would happen: either the volume of air in the apparatus would increase, or else it would remain unaltered (on the supposition that the whole of the carbonic acid produced is absorbed by the alkali). The decrease in volume depends on the absorption of oxygen by the seeds; in place of this oxygen an equal volume of carbonic acid is generally given off, and this is absorbed by the caustic alkali. Hence, this decrease of volume serves both to measure the quantity of oxygen inhaled and of carbonic acid exhaled. The column of liquid rises so quickly that I shall have to open the stopcock (*b*) several times during the lecture in order to keep the coloured liquid from running over into the bell. This continual motion of the liquid in the manometer demonstrates without further explanation the invisible, inaudible, and yet fairly energetic breathing of the seeds.

The latest investigations prove that the formation of diastase, a ferment already familiar to us, is apparently closely connected with respiration. When seeds, already swollen in water, were enclosed in a vessel filled with hydrogen instead of air, they never developed, nor was any diastase to be discovered in them; whereas, when seeds of the same kind were left in contact with air they sent out shoots containing diastase. Thus it is that we come to an understanding of one of the immediate results of the respiration which awakens plants to life.

Respiration as such explains the continual loss of dry matter, the fact which called our attention to the relation of

the seed to the air. Respiration is a slow and continual combustion of the carbon and hydrogen of an organic substance, and as a matter of fact, if we compare the analysis of a seed with that of the seedling which has grown out of it, the decrease in dry weight has to be put down precisely to those elements, whereas the quantity of nitrogen shows no change.

* * *

Having proved that a process of respiration takes place in the germinating seed similar to that in the animal organism, we may now go a step further and ask: is not this process followed in the vegetable organism by the same results as in the case of the animal organism? Respiration, being as a matter of fact slow combustion, keeps up the temperature of the animal, warms it; will it not warm in the same way a young germinating plant, providing it with the heat necessary for its development? This question brings us to the consideration of the third of the three conditions on which germination depends, i.e., to the consideration of the effects of heat.

Even without exact experiment we notice by general observation that seeds become perceptibly warmer during germination, evidently owing to respiration. Long ago it was noticed that during the malting process the heaps of germinating barley grain get so warm that the rise in temperature can be detected without a thermometer, simply by plunging one's hand into them. It has been noticed also that rotten seeds spontaneously burn, although here to normal vital processes there are added processes of decay which are due to the activity of certain micro-organisms. In more exact experiments, in which micro-organisms were excluded as far as possible, a rise of forty, fifty, and even more degrees above the surrounding temperature has been observed. Apparently this heating process is of advantage to growing seedlings, because numerous observations made by farmers and also more exact experiments by botanists have proved that the rapidity of germination, i.e., of the first appearance of the rootlet and the further growth of the embryo, depends directly upon the temperature; and, moreover, that for different plants there are different limits at which germination is arrested. For a great number of plants we can determine the lowest and the highest temperatures at which germination will begin; between these two limits the rapidity of growth increases up to a certain temperature, beyond which it begins to decrease. In this way we distinguish three temperatures: the *minimum* and the *maximum*, forming the two limits of possible germination, and then the *optimum*, at which the process is most successful, i.e., the most rapid. Our cereals, for instance, generally begin to germinate at about 35°-40° Fahrenheit, and the higher the temperature the quicker the development; but beyond 66°-68° Fahrenheit the process slackens again, and almost stops at 100°. For a long time it was supposed that at 32°F., i.e., at the freezing-point of water, all active life, and

consequently germination also, were impossible; but recently the interesting discovery was made that seeds can germinate even in ice. The experiment was as follows: a small cavity was hollowed in a piece of ice, seeds were placed in the hollow and covered with another piece of ice; the whole block was then placed in a box surrounded with a layer of ice two feet thick. Two batches of seeds were treated in this way, one in January and another in March, and kept in a cellar. Two months afterwards, i.e., in March and May respectively, seeds of the most various plants, such as wheat, rye, beans, cabbage, mustard, were found germinating; their tiny rootlets were piercing through the ice. This strange, unexpected but quite authentic experiment, as well as similar facts concerning the blossoming of some alpine plants, which flower even in the snow, are probably to be explained by the fact that heat is generated by the respiration of plants and is capable of melting ice in the immediate neighbourhood of the plants in question. Life was formerly considered impossible at 32°F., among other reasons, because water should freeze at that temperature; but this is a mistake, for it is known that water may not freeze even at a temperature below 32°; for instance, it does not freeze even at 10°F. in very narrow capillary tubes.

We see, then, that germination (and, generally speaking, this is true of all vital processes) can take place only within the narrow range of temperature between the limits 32° and 104°F. These limits do not, however, apply to resting seeds. Owing to their dryness they are able to bear without injury much greater extremes of temperature. When thoroughly dried, seeds can be exposed on the one hand to such high temperatures as 250°-320°F., and on the other hand to very low temperatures, obtained by means of liquid air, without losing their capacity for germination. A resting seed is thus distinguished by possessing to a remarkable degree the power of enduring great extremes of temperature, and this endurance constitutes one of its important attributes. Such is the significance of heat, the third factor by which germination is conditioned. We must not, however, suppose that the accelerating effect of heat, the repressing influence of cold, and the fact of limits of temperature, constitute a peculiarity of living organisms as such. On the contrary, we know that the majority of the chemical and physical processes at work in it depend on the temperature. With an increase of temperature, diffusion and the conduction of liquids are accelerated in narrow capillary vessels; with an increase of temperature, too, diastase acts more rapidly upon starch. But, we might ask, if physical and chemical processes are accelerated by a rise in temperature, why is it that a further rise in temperature depresses the vital activity of the seed? Why is it that an intermediate, most favourable temperature exists at all? Is this really a peculiarity of the living organism? In the meantime no such supposition is necessary. We know that if heat furthers some chemical processes, which contribute to the acceleration of vital processes, it also brings about other effects with which life is incompatible.

Albuminoids, for instance, such as enter into the composition of protoplasm, the foundation of every living cell, coagulate like the white of an egg at about 144°F., and probably begin to change even before that temperature. Obviously, if a rise in temperature causes at the same time processes both favourable and unfavourable to the activity of the seed, that activity will be most energetic at a certain mean temperature when the salutary and the noxious effects of temperature present the most advantageous combination. Thus we see nothing in the effects of temperature on the germinating seed that would induce us to give up the physico-chemical explanation of phenomena taking place under its influence.

There is one more aspect of the life of seeds, an aspect as yet unfortunately far from being explained, and that is the difference of degree to which different seeds preserve their vitality, i.e., their power to germinate. Some seeds preserve it for years, or even centuries. Others can germinate only within a few days after being separated from the parent plant, and then lose the capacity very quickly; such are, for instance, coffee beans and willow seeds. Others, again, can germinate only after a considerable lapse of time. In this last group we find most of the stone fruits. Here also closer investigation will probably enable us to discover the immediate cause of these phenomena. As a matter of fact the property of conserving during many years the capacity for germination should not strike us as strange. If a seed does not contain the necessary water, or is isolated from atmospheric influences by its membranes, or in some other way one or other of the conditions for chemical changes is therefore not fulfilled, it is difficult to imagine what influence time can have, once the possibility of mechanical injury is removed. There are indubitable facts which prove that seeds taken out of a herbarium, in which they had lain for more than a hundred years, germinated very successfully. Another illustration frequently cited is the so-called "mummy wheat" which remained in Egyptian tombs for more than a thousand years; but this case is not authenticated. The capacity for remaining in a dormant state during so many years without losing the power of reviving is not the exclusive property of seeds alone. Many of the lowest, microscopic animals, when in the condition of a dry powder, can be kept for years in that state, and revive again as soon as they are moistened with water. The other extreme, the loss within a few days of the capacity for germination, is harder to explain. The facts here seem rather to bespeak some special vitality in the seed which is gradually lost. Yet such facts are not beyond explanation nor without analogy elsewhere. Coffee beans, for instance, have their nutrient material stored up in great part as cellulose, which makes their endosperm hard and horny. Very probably the solubility of this endosperm varies greatly in course of time, since cellulose is able to undergo such changes even outside the organism. Freshly precipitated cellulose, or cellulose kept in a moist condition, easily dissolves in a certain reagent, but the same cellulose when dried and forming dense and horny masses becomes almost insoluble.

Possibly something of the kind happens in coffee beans, so that only the fresh beans contain cellulose capable of passing into a soluble state. As to the last category of seeds, those that sometimes require several years to germinate, such as the seeds of stone fruits, the mere mechanical obstacles they have to overcome may be regarded as one cause of such a delay. Indeed germination can frequently be accelerated by making incisions in the hard wall of the seed.

* * *

Let us now sum up all we have found out about the phenomenon of germination, and let us try to define the general characteristics of this unique period in the life of the plant.

The period of germination is unique because of the fact that during its course the plant does not require any external supply of food; it subsists on the food stored up in the endosperm or in the cotyledons. Three factors are indispensable to arouse the seed to activity; these are water, the oxygen of the air, and heat. Water acts in a twofold way: mechanically and chemically. Mechanically, it causes the seed to swell, tears off its membranes, and supplies the energy necessary for overcoming the resistance of the surrounding particles of the soil; chemically, it first dissolves the various ferments, and then with the help of these the insoluble substances stored up in reserve. These solutions flow into the embryo and are spent in its growth, in which they are once more transformed into an insoluble or hardly diffusible form.

Respiration, apparently a function of every organism, every living thing on the earth, with very few exceptions which will be mentioned later, manifests itself in the germinating seed. At the same time it accounts for the loss in dry weight and the rise in temperature, noticed in germinating seeds. In this way the seedling, in spite of its increase in bulk, not only shows no increase in substance during that period, but on the contrary expends its substance. During germination it is only transformation which takes place, and not assimilation. Consequently, we have arrived at the conclusion that the phenomena of the assimilation of nutrient substances and the phenomena of growth do not always take place simultaneously; and the period of germination may be best characterized by saying that it is a period of *growth without assimilation*.

This period in the life of the plant may be more or less compared to the period of education and development in man. Both plant and man are incapable of independent and productive activity before they reach the close of that period. They exist at the expense of stores carefully accumulated by the preceding generation, though man can scarcely be said to gain by the comparison; on the contrary, it is the plant that sets an example worthy to be followed. On the one hand parental plants, after having accumulated a modest inheritance, do not seek to secure an idle and careless

existence for their children; they simply endow them with what is strictly necessary for their development and well-being; and, on the other hand, their children do not dissipate their inheritance: they spend it on their proper development and the generation of energy indispensable for the first struggle for life that awaits them.

At the close of this period we find the plant already provided with organs well formed and quite ready for use. It is very curious that certain plants pass the whole period of germination without separating from the parent plant. Such is *Rhizophora Mangle*, which grows on the shores of the tropical seas, on strips of land generally covered at high tide. The seeds of this plant germinate in the fruit and form long, heavy, and sharp-pointed roots while still growing upon the maternal plant. After having reached a certain stage of development they break away, and falling vertically stick by means of their roots into the mud, and continue their existence without any interruption whatever.*

* See Table I, Fig. 1, on page 289.

At the end of the period of germination the physiological division of labour manifests itself in the plant. From the general physiological point of view the plant represents two more or less well-developed surfaces—the surface of the root and that of the leaf—adapted to its corresponding twofold environment; both these surfaces are connected through the intermediate organ, the stem. Such is the general physiological scheme of the plant, a scheme that manifests itself very early, even at the lowest stages of plant life. There are weeds, for instance, which consist of single cells, but which have parts analogous to leaf, root, and stem. Here is a weed (*Botrydium*), not uncommonly found on flooded plains, consisting of a green, round head and a colourless branching base, something like a root (Fig. 22, to the left), by which it is fixed to the soil. This is only a simple bladder, but in it we notice already two physiologically differentiated parts. Another more striking example is a weed found in the seas of warm countries (Fig. 22).

A specimen of this seaweed (*Caulerpa*) picked up at Puzzuoli, in the bay of Naples, when straightened out on a sheet of paper, covers an area as large as the palm of the hand and sometimes even larger. This giant cell, one of the largest in the entire organic world, presents expanded parts remarkably similar to green leaves, stems, and colourless rootlets. The stems spread along the bottom of the sea, the leaf-like laminae grow up vertically, while the rootlets bury themselves in the ooze; and this is nevertheless one and the same cell, having one continuous cavity.*

* Fig. 22 represents two species of *Caulerpa*—the upper one is the common *Caulerpa prolifera*, found in the Mediterranean.

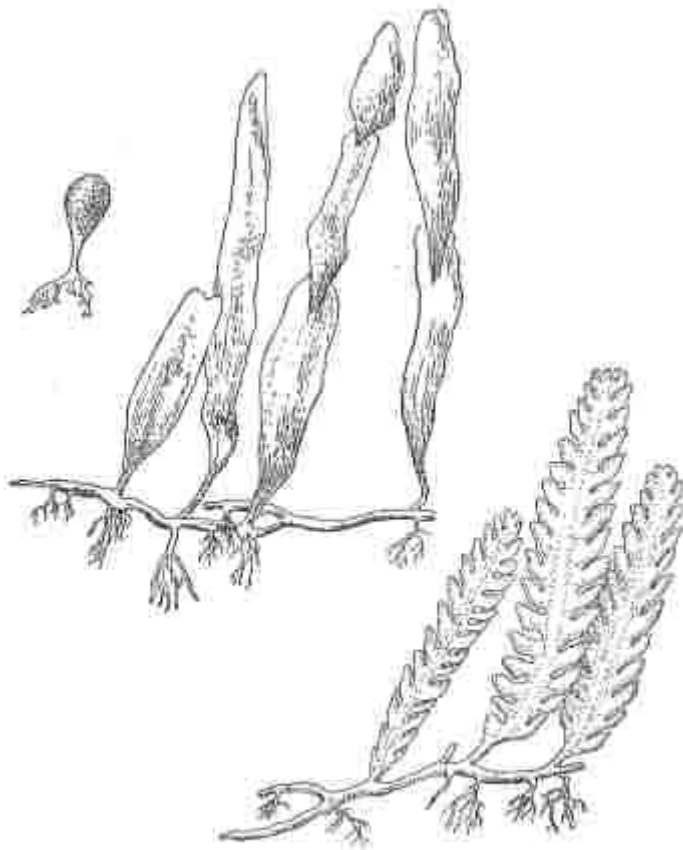

Fig. 22

Such dissimilar organs as the root, leaf, and stem must evidently fulfil absolutely different functions; and therefore in our subsequent study of the life of the plant, we must study separately the life of these organs.

There is, however, one more question to be settled: when does the period of germination come to an end, and the independent life of a plant begin? As a matter of fact the period of germination ends the moment the stores of food become exhausted; the independent life of the plant begins when the activity of the leaves becomes apparent; but in order that this may happen, the leaves must be exposed to the action of light, in the absence of which they will never become green, but will remain yellow and unhealthy. Thus we have finally one more peculiarity of the period of germination: during its course the plant is completely independent of light, and does not require it; this is why that period can be passed in total darkness, underneath the soil. But the independent life of the plant starts with the first ray of light which falls on its green leaf; it then begins to develop new organs at the expense of surrounding inorganic compounds instead of from food stored up within itself. The decrease in weight diminishes and soon passes into an increase. *Assimilation* of matter begins.

Chapter IV

THE ROOT

Function of the root. Composition of the soil. Method for defining the necessary nutrient substances. Artificial cultures. Cultures without organic matter. Water cultures. Importance of nitrogen, potassium, iron, silicon. The necessary nutrient substances absorbed by the root. Nutrient substances in the soil for immediate use and in reserve. Absorbent properties of the soil. Importance of saltpetre in the soil. Assimilation of nitrogen by leguminous plants. Form in which nutrient substances are found in the soil.

Structure of the root. Its striking elongation and the purpose of this character. The root in relation to liquid and solid substances. General mechanism for the absorption of nutrient substances by the root.

We saw at the end of our last lecture that during the period of germination the young plant does not exhibit the most characteristic feature of vegetable life, increase in mass. On the contrary, in spite of a visible increase in volume, it loses continually in dry weight, burning away part of its substance in respiration.

It is only when the organs become individualized and begin to fulfil their natural functions, the root sinking into the soil and the stem with the leaves stretching into the air towards the light, it is only then that the full and independent life of the plant manifests itself in the real assimilation of matter from the external environment.

We know already what kind of matter is thus assimilated: it consists of the twelve elements already enumerated. We have now to settle a further question: From what part of the environment does the plant obtain these various substances—from the soil, water, or air; and what are the means by which they enter the plant? We shall learn at the same time which of the two organs, the root or the leaf, is to be considered the nutritive organ of the plant, or whether they both serve that purpose, each in its own way.

Let us begin with the root, since the problem seems simpler in connection with this organ. Scarcely any one has ever doubted the fact that the root serves the purpose of nourishing the plant, and it is fairly easy to prove that at least one form of nutrient substances cannot penetrate into the plant otherwise than through the root. Thus, for instance, substances that enter into the composition of ash cannot exist under normal conditions in a gaseous state; it is for this reason that after complete combustion they remain in the ash and do not volatilize with the rest of the vegetable matter. Consequently, all that is found in ash must be looked for in the soil; and therefore we conclude that such substances enter the plant through its root. As to the other elements, however, they may be in the soil as well as in the air. We remain as yet uncertain with regard to them: we cannot tell, until we get clear evidence from an experiment, whether they are obtained

from the soil or from the air, and so whether they penetrate into the plant through its root or through its leaves.

Let us turn our attention first of all to the root; let us see *what* it absorbs from the soil, *how* it absorbs it, and *why* it absorbs precisely *that* which is indispensable to the plant.

But before we begin the study of the root and its functions, we must become acquainted with the environment in which it manifests its activity, and cast a passing glance at the soil itself and its composition.

Every kind of soil which is covered with vegetation has two classes of components, which are sharply differentiated; these are the combustible and non-combustible, the organic and inorganic substances. The organic part, which is merely the residue of decayed plants, gives the soil its black colour. This black matter, which is burnt away when soil is calcined, is called humus. Even the blackest soils, however, the real moulds, contain comparatively small quantities of humus, rarely more than 10 per cent. Soil which has been thoroughly calcined and therefore deprived of decaying organic matter no longer appears black, but yellow or red. The mineral parts of the soil which remain after calcining, and are in bulk its main constituents, can be divided into three groups according to their degree of solubility. One part of them, the smallest, dissolves in water; the second, larger part does not dissolve in water, but dissolves in acids; and, lastly, the third and by far the largest part does not dissolve either in water or in acids. These three degrees of solubility correspond roughly to the three degrees of accessibility of those substances to the plant. The substances of the first group which dissolve in the water of the soil are apparently easily accessible to the plant; the substances of the second group are less accessible; while the substances of the last group are totally inaccessible to the plant, unless in the course of many years they are partly transformed into substances belonging to one of the first two groups.

Thus at any given moment we find among the mineral constituents of the soil, first, a basis, useless at present, but containing stores of food which will be available in the remote future; next, stores of food within comparatively easy reach of the plant; and, lastly, a very small quantity of matter which serves the plant for immediate use. The truth of this statement can be easily proved. We have only to take the most fertile soil, to calcine it, and to treat it with an acid, in order to get an almost white residue which will prove totally sterile.

It follows that we may look upon the greater part of the soil at any given time as a substratum which merely serves to hold plants firmly, without taking any immediate part in their nutrition. The food of the plant must be sought in the remaining component parts of the soil, i.e., in the humus, and in those parts which dissolve in water and acids. Let us see how the twelve elements discovered in the plant are distributed in these parts. The organic humus contains four elements: carbon, hydrogen, nitrogen and oxygen. Substances soluble in water and acids consist of salts containing all the

elements found in the ash of the plant, together with two other compounds containing *nitrogen*, namely saltpetre, a salt of nitric acid, and ammonia, a compound of nitrogen and hydrogen. Hence, the four elements of organic matter, the elements of ash and the two compounds of nitrogen, nitric acid and ammonia, are the substances to which the analysis of the soil points as the *possible* sources of food for the roots of the plant. Let us see which of these *possible* sources will prove to be the *actual indispensable* sources. In order to find this out we must interrogate the plant itself, by placing it under such circumstances as to oblige it to give us an answer to the question.

How otherwise, indeed, can we determine what substances are really necessary for the nutrition of the plant? At first sight it would seem quite sufficient to analyse the plant and determine which substances enter into its composition, and to declare these the necessary substances. But doubts at once arise as to the soundness of such a conclusion. Many of the substances found in the plant might clearly be, as it were, luxuries; their presence might even be accidental and useless, following merely as the result of their existence in the environment. We can only recognize, as *necessary*, such substances in the absence of which the very existence and development of the plant are impossible. This can be determined only by means of an exact experiment like the one which proved the sterility of the insoluble mineral substratum of the soil. The essential conditions for such an experiment are as follows: we provide one plant with *all* the substances discovered by analysis in the plant itself, or in the soil on which it successfully grows; another exactly similar plant beside it we supply with *these same substances, omitting one*, and observe the consequences. If we do not notice any apparent difference in the development of the two plants, we may conclude that the eliminated substance is not important for the nutrition of the plant; but if under exactly the same conditions we get a weaker plant in the second case, we shall be justified in attributing the difference to the difference in the conditions, i.e., to the absence of the eliminated substance. This chapter in the physiology of the plant affords us a series of good, simple illustrations of a strict and repeated application of the second canon of inductive reasoning:

"If an instance in which the phenomenon under investigation occurs, and an instance in which it does not occur, have every circumstance in common save one, that one occurring only in the former, the circumstance in which alone the two instances differ is the cause, or an indispensable part of the cause, of the phenomenon."*

* J. S. Mill, A System of Inductive Logic, etc., p. 256.

Thus by eliminating one after another all the substances discovered in the plant and in the soil, we discover which of them is absolutely indispensable as food for the plant. Let us study the principal results of these experiments.

First of all our attention centres upon the organic substances, the products of decay. Everyday experience proves that dark soils are more fertile than light ones. It would seem, then, that the black humus must form the main food of the plant. Yet exact experiment tells quite a different tale. We may thoroughly calcine black mould, burning away the whole of the organic matter in it, and yet it remains a soil in which a plant will normally develop. We can grow on such a *white* soil a plant that could not be distinguished from any grown on the best of moulds. Therefore, it is not from the humus that the plant obtains its food. It can grow without it. We have already seen that the largest part of the mineral matter in the soil, the part we have called the insoluble substratum, is useless as food; so the circle of substances which can be looked upon as food for the plant becomes still narrower: it is reduced to those substances which are soluble in water and acids.

It would be futile, however, to attempt to grow a plant in artificial soil composed exclusively of nutrient substances; for instance, in plant ash. Such soil would be totally unfit for the purpose; the nutrient substances would be in much too concentrated a form, and the plant would certainly perish. In order to serve the purposes of nutrition, these substances must be mixed and diluted with other inactive matter, such as is found in the insoluble mineral substances of the soil. But if such be the meaning of the latter we can surely substitute for it other substances, less complicated in composition. Indeed, experiment shows that artificial soils can be prepared out of sand, crushed pumice-stone, glass beads, and similar materials. By adding to such foundations the necessary nutrient substances we can obtain very fertile soils.

We are now within a step of the method for reducing artificial cultures to the simplest form imaginable. If a considerable part of the natural soil as well as the artificial soils just enumerated serve merely for purposes of uniformly distributing and, so to speak, diluting the nutrient substances, would it not be possible to use instead distilled water in which all the nutrient substances necessary to the plant have been dissolved? Experiments extending over many years, accompanied by many failures, were crowned at last with complete success. Today, with certain precautions, we can substitute for soil an entirely transparent medium, and grow the most diverse plants in a watery solution, rearing them to the same normal size which they reach in the most fertile soils.

We take for the purpose a glass jar (Fig. 23) containing *three* or *four* pounds of distilled water, and dissolve in it something like six or seven grains of a mixture of different salts; it is important that the amount of salts in the solution should not exceed *two parts in one thousand*, otherwise the solution will be too concentrated. We fix a seedling of any plant whatever to the lid of the jar in such a way that only its rootlets will be immersed in the water. Then we shall be able to observe the development of the aerial part of the plant, and also that of the root, which is now entirely exposed to view.

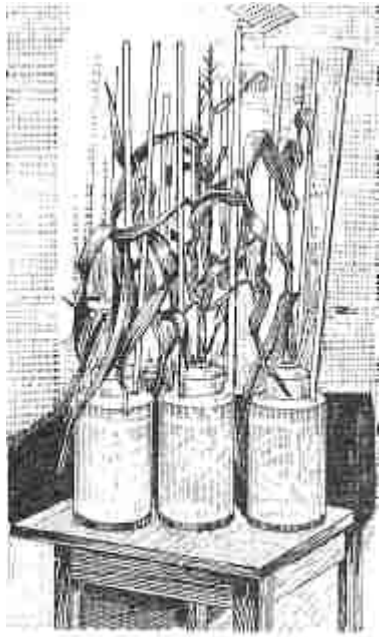

Fig. 23

The photographic plates reproduced a little later on (Figs. 26, 27, 30) record the results of experiments made in 1896 at the Nizhny Novgorod exhibition. I attribute a particular significance to them, because it is doubtful whether such experiments in all their stages and details were ever before performed in the same way in the presence of so many thousands of spectators. With great pleasure do I recall one sceptic, a local inhabitant of Nizhny Novgorod, who acknowledged that he used to observe our water cultures day after day with

the sinister intention of convicting us of quackery; but in the end he became enthusiastic and thoroughly convinced.

Our problem is now reduced to this: of all the mass of black mould surrounding the plant, it is only an insignificant pinch of a mixture of certain salts that is at any given moment indispensable for its nutrition. Now let us find out which of the chemical elements entering into the composition of these salts are essential. It has been necessary for this purpose to make a series of experiments either with white sterile soil into which necessary salts had been introduced, or with culture solutions as described above.

Here are experiments showing the necessity of *nitrogen* for plants (Fig. 25). We take two flowerpots filled with a soil calcined and washed with an acid, and consequently white and sterile. To one of them the ash of plants has been added, containing all the mineral substances that exist in a plant; to the other the same ash has been added and also *nitrogen* in the form of a nitrate, namely, saltpetre. Sunflower seeds exactly similar in weight were planted in both pots, two in each. They have come up, but a distinct difference is evident at the end of the experiment: the first flower-pot contains two miserable,



Fig. 24

unhealthy plants, scarcely rising above the soil; the second contains two healthy specimens with flowers and seeds, leaves and stem being as well developed as those of sunflowers grown simultaneously in the best garden soils.* Yet the only difference between the two experiments consists in the fact that to the second flower-pot some saltpetre, i.e., *nitrogen*, was added. Similar results might have been reached had nitrogen in the form of an ammonium salt, instead of saltpetre, been used. The inference is that plants need nitrogen.



Fig. 25

* Fig. 25 represents on the left-hand side plants grown with saltpetre (for the sake of comparison a leaf of a garden specimen is given), and on the right plants grown without saltpetre. This is the classical experiment of Boussingault.

Here is another experiment. We take several jars containing nutrient solutions; some of the jars contain all the necessary salts, others the same salts *minus* that of potassium. We place exactly similar buckwheat seeds in every jar. After

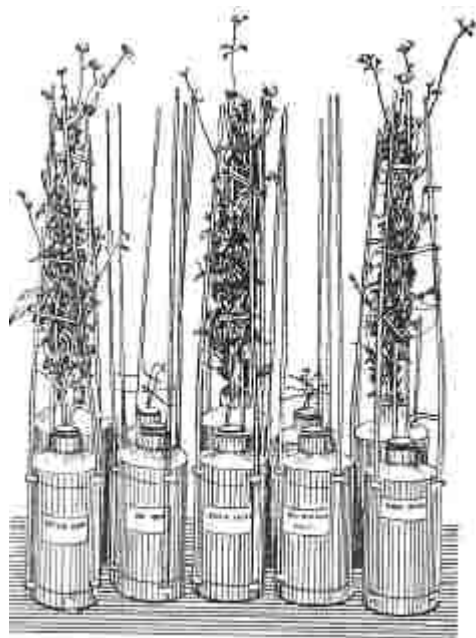

Fig. 26

a certain time we notice that the former jars contain healthy plants which flower and produce ripe seeds, while in the rest, instead of developing well, the plants are weak or have perished.

We may repeat these experiments many times over, and always get the same results. The inference is that the plant needs *potassium*, that it cannot exist without *potassium*.

You see on this table the results of

similar experiments also made with buckwheat seeds (Fig. 26). The first, third, and fifth row received a complete

nutrient solution, the second received no nitrogen, the fourth no potassium nor phosphoric acid.



Fig. 27

The results speak for themselves. Here is one more experiment, the most obvious and striking of all in its results. Among the salts found to be indispensable for the nutrition of the plant, there stands that of iron; it enters into the composition of the ash of the plant in very minute quantities. This salt cannot be used as a solution in water cultures, because it forms with another

substance equally indispensable for the nutrition of the plant, phosphoric acid, a precipitate insoluble in water. We shake up this white insoluble precipitate in the liquid, so as to bring it into contact with the surface of the roots. We take several jars: some with entirely clear solutions, which means that they do not contain any iron salt; others with a certain degree of turbidity, owing to the presence of the iron salt. Suppose we grow a plant such as maize in each of these solutions. At the end of two or three weeks we already notice a sharp difference between them. While the full nutrient solution produces a normal plant that will flower and produce ripe seeds, the other will produce a plant with only a few narrow and unhealthy leaves and will soon die altogether (Fig. 27). These leaves, moreover, will show a remarkable peculiarity: the first two or three of them will be of the usual green colour, but the rest will be white. It is clear that the absence of iron has stopped the development of the plant, and has resulted in a peculiar disease, a "pallid sickness," called chlorosis. The following simple experiment will attest the accuracy of this inference; we have only to add some of this iron salt to the solution hitherto without it to see the sickly condition coming to an end, the plant becoming green and growing; moreover, we have only to moisten one part of a totally white and sick leaf with an iron salt to see a green spot appearing soon after on that very place.* Our attention has already been drawn more than once to the similarity between the vital functions of vegetable and animal organisms; the action of the iron salts presents a striking illustration of this point. Such unfortunate cases as the following may have been happening quite lately: somebody of your acquaintance feels

ill, the illness being accompanied, among other symptoms, by an unusual pallor. A doctor is summoned. He begins at once by examining the gums, and then prescribes pills or medicine. The patient takes the medicine and after a time regains his healthy appearance. The remedy contains iron. The same iron that brings back healthy colour to a faded cheek brings back the natural green colour to a white leaf.

* In the middle of Fig. 27 we see a vigorous specimen of maize still in flower reaching the top of the green house; on either side are two specimens of a smaller variety (*Cinquantino*) already bearing full-grown cobs; in between are two specimens grown without any iron salt

Results similar to those just described in connection with nitrogen, potassium, and iron, can be obtained in the same way in respect of phosphorus, sulphur, chlorine, lime, and magnesium. All these substances have proved to be indispensable for the nutrition of the plant which sooner or later perishes without them.

But among the constituents of the ash of the plant we find silicon. Silicon, together with oxygen, forms silica, which in a pure form occurs in nature as rock crystal, and in a little less pure form as quartz, white sand, etc. The same silica forms the main constituent of glass. This silica is also found in many plants, in their cell-walls, making them brittle like glass; if we burn such a cell we are left with a glassy skeleton, which under the microscope preserves the outward form of the living cell in its minutest details. By very unpleasant experience every one has had opportunities of learning the existence of such *glassy* cells. The stinging hair of the nettle is simply a long-pointed cell, the walls of which, especially at the top, are as brittle as glass, because they are full of silica; this is why they pierce the skin so easily, break in the wound, and inject their poisonous sap. Large quantities of silica are contained in the straw of cereals and in the stem of the horse-tails. The latter are so hard that carpenters use them for polishing wood. Silica, then, is found very generally among plants, and we might suppose it to be indispensable to the plant. An idea has grown up to the effect that it not only adds hardness to the external tissue of cereals, but even gives solidity and firmness to the whole body of the straw; it has been supposed that by increasing the supply of silica in our cultivated cereals, these would be less readily laid by wind and heavy rain, which do so much damage to corn. But direct experiment has put an end to all these suppositions, which before seemed so probable. Cultures in artificial soils as well as in solutions deprived of silica have proved that quite normal specimens of cereals develop even in the entire absence of silica; a plant must therefore be able to exist without silica. Further, experiments on a larger scale have been made actually in the open fields, the soil being manured with silicates; but these experiments gave a negative result. Plants in a silicated soil were laid worse than those in untreated soil. It might have been suggested that the manure had not reached the plant, but analysis proved that the plants

had really become richer in silica. This incomprehensible result was to a certain extent explained when, after the general analysis of the plant, particular analyses were made of its several parts. It appeared then that it was the leaves and not the stem or the straw which became richer in silica; and therefore the increase of silica might work rather to the detriment of the plant, making it top-heavy and more liable to fall, instead of contributing to its steadiness. Eventually it transpired that a plant can exist without silica, and that its presence has nothing to do with the firmness of the straw, as was formerly believed. We shall see in one of our subsequent lectures that the *laying of crops* is to be explained by other causes, and therefore can be averted by other means.

So, then, in striking silica out of the list of the elements present in the ash given in the second chapter, and by substituting for it the indispensable nitrogen, we get *eight* elements that exhaust the list of substances which must necessarily be supplied to the root in order to nourish the plant. Four of them—*nitrogen, phosphorus, sulphur, and chlorine*—form acids. These acids by combining in pairs with the four metals—*potassium, calcium, magnesium, and iron*—produce four salts. These four salts satisfy all the requirements of the root; they furnish all the nutrient solutions used for the experiments we have made. The most sterile soils, when watered with such a solution, become fertile in the sense of becoming quite fit for the purpose of *feeding* the plant.

Such are the results, so brilliant in their simplicity, to which the study of the physiology of the root has brought us. Let us, however, remember that this *simplicity* is the result of many years' stubborn labour of scores of scientific investigators.

A question naturally arises here: would it be right to conclude that all the other substances which form the main bulk of the soil are quite useless to the plant? Evidently not. Some of the substances, while they do not serve as food at any given moment, may be of use as food at some future time; others, without taking any direct part in nutrition, may indirectly contribute towards it. For instance, besides saltpetre and ammonia, the soil contains considerably larger quantities of nitrogen in the form of organic matter. Yet this nitrogen is of no immediate use for the purposes of nutrition; soil, which contains nitrogen only in that form, is almost sterile; but this nitrogen may gradually change into ammonia and nitric acid, and then serve as food. This is an example of a substance useless at any given moment, yet serving as a future supply of food. Substances in the soil may be useful to the plant in still other ways. They are of value to it by reason of their capacity for retaining moisture, and for absorbing heat, and they help to hold the nutrient substances and distribute them uniformly.

With regard to this last property the capacity of the soil for *absorption* is remarkable. If we fill a funnel with soil and water it with some nutrient solution, and then collect the water after it has passed through the soil, we find that it contains very little of the nutrient substances. Ammonia,

phosphoric acid, and potassium are especially absorbed; all these, as we have seen, being elements necessary to the plant. This remarkable property of the soil is of great importance in the economy of nature. Substances necessary to the plant, i.e., those that exist in the soil in very limited quantities, are thereby prevented from being washed away by the rain, and are kept in the soil, which only gradually gives them up to the water circulating between its hard particles.

Nitric acid forms an exception to this rule, as it is rather easily washed from the soil; yet, as we have seen, it supplies the plant with nitrogen, the most important of nutrient elements. The investigations of scientific agriculturists are drawing the attention of farmers more and more urgently to the necessity of utilizing this substance as fully as possible by means of cultivated plants. It is in this very relation of the plant to the nitric acid in the soil that an explanation has been sought for the part played by leguminous plants in the rotation of crops. Until quite lately their role seemed very mysterious. Leguminous plants contain more nitrogen than cereals, and yet nitrogenous manures affect them less than cereals. Moreover, when leguminous plants are cultivated in alternation with cereals in an unmanured soil, cereal crops are gathered as heavy as any succeeding the bare fallow. This seemed to show that leguminous plants, instead of exhausting the soil, even enrich it, an opinion which would have been strictly justified could it only have been proved that leguminous plants absorb nitrogen from the air instead of from the soil. Yet this was for a long time contradicted by exact experiments.

The only other possible explanation of the relation of the leguminous plants to nitrogen lay in the fact that, developing a network of roots which sank very deeply into the soil, and growing in the soil for a longer time, leguminous plants absorbed more completely the stores of nitric acid, which under other circumstances were washed away by the rain and therefore lost to the farmer. Such a utilization of the nitric acid in the soil would to a certain degree explain why it is that crops of leguminous plants produce more nitrogen than other plants; and, moreover, leave an excess of the nitrogen in a form in which it cannot be washed away by the rain, namely, in the remains of their roots, for the benefit of the succeeding plants.

Nevertheless, this explanation was unsatisfactory, and the question remained unanswered until it suddenly received an explanation about the end of the eighties. This discovery is one of the most brilliant contributions of recent years to the theory of the nutrition of the plant, and we may therefore dwell on it at some length. As has already been said, saltpetre manures, while they exercise such an essential influence upon cereals, sometimes remain entirely without effect upon leguminous plants. One such experiment is represented in Fig. 28 (lower half). Two pots of oats (marked by the letters *KP*) received all the necessary mineral manures with the exception of saltpetre; two other pots (marked by the letters *KPS*) received the same mineral manures with the addition of

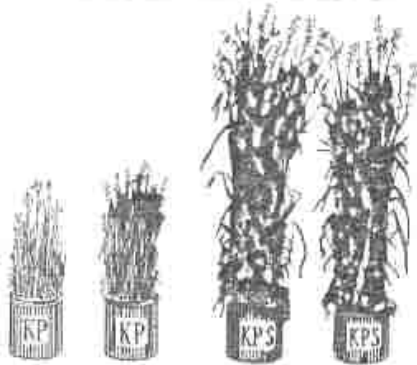
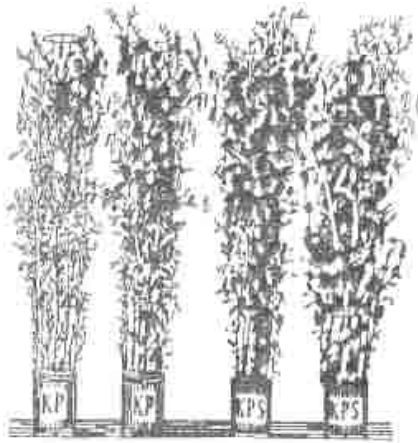

Fig. 28

saltpetre: the result speaks for itself. A similar experiment was made with peas (at the top of the figure), and the result was negative; the presence of saltpetre was not manifested in any way whatever. This means that peas can procure nitrogen for themselves, even if it is not present in the soil.

Evidently beans can obtain nitrogen from the air; but under what circumstances? In raising this question investigators recalled the fact that certain small swellings were noticed even by the ancients on the roots of leguminous plants.

These nodules (Fig. 29) appear in consequence of the roots becoming infected by certain bacteria, apparently widely distributed in the soil. This can be proved very simply. A leguminous plant is grown in an aqueous solution in such a way that some of the roots are in one vessel, while the rest are in another. The solution in one of the vessels is previously boiled, whereas a small quantity of water, in which soil containing bacteria has been standing, is added to the other. Nodules do not appear on the roots immersed in the boiled and sterilized solution. The fact that the assimilation of nitrogen from the air depends upon the presence of such bacteria in the soil can be proved in the following way (Fig. 30). A row of glass vessels containing peas are filled with soil deprived of nitrogen, but infected with soil-washings containing bacteria; while another row are filled with soil sterilized by means of heat, and watered with



Fig. 29

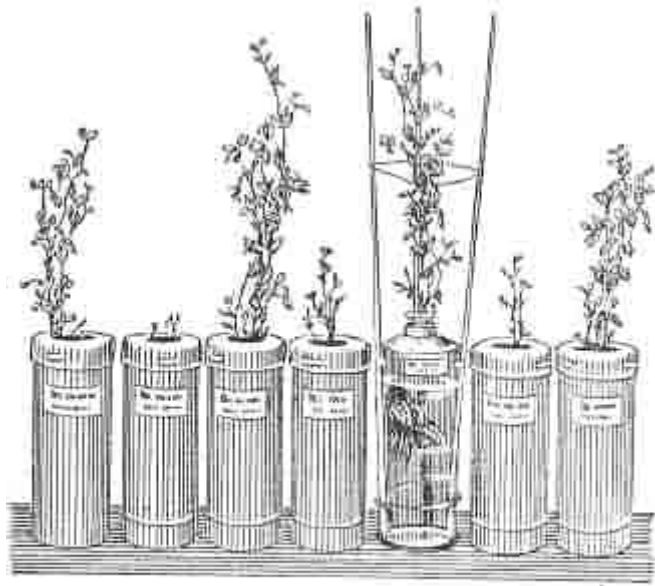

Fig. 30

the same soil-washings previously boiled, and therefore also sterilized. The result is marvellous: only plants (Fig. 30, odd numbers) grown in the soil that contained the bacteria which form nodules, have developed normally; the others (Fig. 30, even numbers) have perished. This proves that property which differentiates peas and likewise all leguminous plants from cereals, namely, the property of assimilating free nitrogen from the air, is bound up with the capacity of their roots for becoming infected by certain soil bacteria. How and where this assimilation of nitrogen takes place has not yet, however, been fully explained.

In view of the fact mentioned above that the soil-water is such an extremely weak solution of nutrient salts, it may well be asked whether it is really sufficient for the nutrition of plants? We can answer this question by reference to the following calculations. We know the quantity of rain that falls on a certain area of land; we also know the quantity of nutrient substances that this rain water can extract from the soil; on the other hand we know the quantity of ash contained in a whole crop, gathered from the same area of land. These data are sufficient to provide an answer to our question whether this liquid food is sufficient. It is only the most fertile soils for which the answer is in the affirmative, in all other cases the answer is negative. In general the liquid food alone is not sufficient for the plant. Evidently it must also use substances insoluble in the soil-water. But in that case the root must, so to speak, seek out its own food, searching round all the neighbouring particles of the soil in order to find among the mass of sterile matter minute particles of the nutrient substances so sparsely scattered in it. This brings us directly to the consideration of the second question we have raised. Having ascertained wherein the food of the root consists, let us now try to find out *how* it gets it.

* * *

In order to discover how the root fulfils its function, we must begin by studying its structure.

In external appearance a root belongs to one or other of two clearly differentiated types. It either grows vertically downward as a single continuous trunk which gradually tapers to a fine thread, e.g., the beet, the carrot, flax; or else it branches at once, almost at the surface of the soil, into a tuft of thread-like fibres, such as those of our cereals—rye, wheat, and so on. Roots of the former kind are called *tap-roots*; of the latter, *fibrous roots*. These two extreme types have many modifications, but they underlie all the variety of forms presented by this organ.

Every root, whether tap-root, single fibre, or lateral root, grows in the same way as the stem, by elongating and expanding at the apex. But we notice a great difference when we compare the apex of the stem with that of the root. If we remove all the leaves of a bud, thus laying bare the apex of the stem, the so-called "growing point," we find that it is the youngest and also the most

tender part of the stem, consisting of minute, undeveloped cells. If we examine at the same time the apex of the root, which is generally bare already since there are no leaves to remove, we sometimes see with the naked eye, but better with a lens, and better still with a microscope, that it presents an untidy and ragged appearance.

It seems to be covered with a cap consisting of several rows of cells, the outer of which have already lost coherence, and only stick together by means of a kind of mucilage. This *cap* is nothing but the external dying layers of tissue, which cover and protect the young and tender tissue of the growing point lying under them (Fig. 31).* Sometimes this cap can be pulled off the root-tip like a glove. The physiological purpose of this organ is easily understood; it serves as a shield, under the cover of which the delicate growing point of the root pushes its way into the soil. If the growing point of the root ended with the unprotected youngest cells, it would evidently not be able to fulfil its function; it is only by pushing forward the cap that it is able to force its way without serious harm through the hard, rough, and sharp particles of the soil.

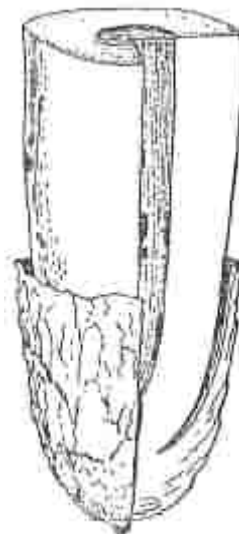

Fig. 31

* Fig. 31 shows under a low power the growing point of the root with its cap.

At a short distance from the very tip, protected by the cap, the whole external surface of the root is covered with

long thin hairs (Fig. 32).* Every such hair is simply a very much elongated cell of the surface layer. Further from the tip this belt of hairs comes to an end; there the surface of the root is protected by a hardened outer layer (Fig. 32) which has lost its hairs. Still further up this layer becomes torn, and is replaced by another protective tissue like that which covers the stems of trees, and which botanists generally call cork; like all cork it is impervious to water. Thus the root is differentiated into three zones: the cap at the very tip of the root, then a belt of hairs, and, lastly, the oldest part with a dried skin and a corky tissue. This oldest portion cannot absorb water and nutrient substances; the very tip is also unable to absorb, or at any rate absorbs inadequately, a fact which can be proved experimentally. The absorbing surface of the root is in fact confined to the belt of hairs, which are in the highest degree permeable to water, far more so than the tissues composing the aerial parts of the plant.

* Fig. 32 shows a young root (*A*) covered with hairs; a similar root with particles of soil sticking to the hairs (*B*); an older branched root with old parts already without hairs (*C*); and part of the transverse section of a root under the microscope, showing the structure of the hairs and their adhesion to the particles of the soil (*D*).

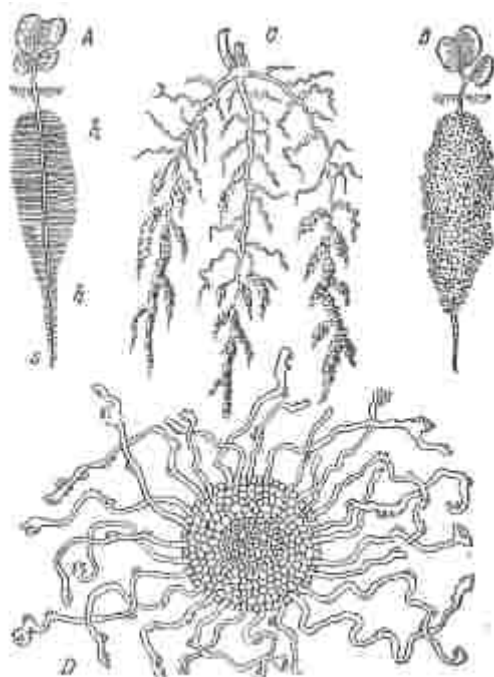

Fig. 32

The root is especially interesting to us as an organ of absorption, and it is important from this point of view to form some idea of its length, and also of the extent of its absorbing surface. A mere glance at the root of any plant which has been thoroughly washed and freed from particles of soil shows us how considerable its full length must be if all its numberless branches and fibres were joined end to end. But the boldest conjecture falls far short of the reality. A German scientist undertook the following labourious task: providing

himself with a pair of forceps, a measuring scale, a pair of compasses, and an almost inexhaustible stock of patience, he actually measured the length of a wheat root down to its minutest ramifications. The result obtained was astounding. It turned out that the total length of the root was 510 metres. However considerable that figure may be it does not represent the whole length of the absorbing surface of the root. As a matter of fact it is the hairs which present the actual absorbing surface. Let us see how many such hairs the wheat plant possesses—no difficult matter in round numbers. Determining under the microscope how many occur on one square millimetre and then multiplying this by the number of square millimetres in the total surface of the root, we get approximately ten million. If we multiply this number by the average length of the hairs we get the enormous length of *twenty kilometres* (twelve and a half miles). Such is the path traversed by the wheat root together with all its hairs in the volume of soil contained in a common flower-pot. I said the path traversed by the root together with all its hairs, for in point of fact this figure does not represent their length at any one moment in the life of the plant. All the root hairs do not work simultaneously. Thus for instance in Fig. 32, C, only the lower parts of the root are active; there are no hairs higher up, and there is no need for them there; in that region they have already done their work, and have exhausted the nutrient substances from the hard particles of the soil. If we now calculate the total surface of all the hairs, together with the fibres that bear them, on the root of a wheat plant during its lifetime, we find that this surface is almost a hundred times larger than the area of land allotted in the fields to each wheat plant. If, on the other hand, we calculate the volume of these hairs which cover a length of nearly thirteen miles, we find that they could all be packed into a vessel of the size of a thimble (about 1.5 cubic centimetres).

Thus in the root we have an organ which, especially in its hairs, presents a large surface, although its volume is insignificant, owing to the fact that this volume is stretched out to so extraordinary a length. Here Nature has had recourse to a trick similar to the one attributed by poetic legend to Dido, the foundress of Carthage. Dido obtained for the asking as much land as could be measured by a single bullock's hide. As it turned out, that same hide was made to enclose the whole future site of Carthage, for Dido cut the hide into very narrow strips. But the strips of Dido are not to be compared with root hairs, which are considerably finer than a human hair.

It is most difficult adequately to realize the great physiological importance of this prevalent development in length. The root is thereby able at the smallest possible expenditure of building material to encompass the greatest possible number of particles of the soil, and to come into the closest possible contact with them. The data we possess are sufficient to calculate approximately the distance of the particles of the soil from the surface of the root hairs of our wheat plant.

For this purpose we must turn to the statistical method, the procedure adopted by statisticians; they, neglecting the individuality of separate persons, speak only of the average man, the average scale of living, and so on, and describe phenomena in terms of average quantities. Let us follow their example, and try to depict in the most obvious way the volume of soil occupied by an *average* root fibre of wheat. We know the average area in a field occupied by each plant; we know the depth of soil occupied by the roots, and hence know the volume of soil occupied by each plant. This glass jar contains that measured quantity. Suppose that we wished to transfer this soil to a vessel or rather a tube *one-third of a mile* in length, i.e., of the length of our root, what would the diameter of such a tube be? The answer works out to *three millimetres*. If the root fibres with their hairs were introduced into a glass tube with this internal diameter, the hairs would touch the wall of the tube.* Therefore, if all the fibres of the root were distributed quite uniformly in the soil allotted to them, every fibre would occupy just a cylinder of soil, pierced through in all directions by its hairs; and, consequently, the greatest distance of a particle of the soil from a root hair would be equal to half the distance between the neighbouring hairs of the same root; this would be something like one-fifteenth of a millimetre. This calculation gives us therefore the greatest distance from which our *average* fibre must obtain its food, and it gives us an idea of the close contact into which a root comes with the hard particles of the soil. Obviously it is not every root fibre that finds itself in such *favourable* conditions. I repeat, this is only a statistical average giving us a clear illustration of the perfect absorbing powers of the root. This adaptation is the more perfect in that the root becomes specially developed in those parts of the soil where it finds the most nutrient substances. This fact has been proved in the following way. A plant was grown in a flower-pot filled with alternate layers of fertile and sterile soil. Roots developed very luxuriantly in the fertile soil, but only poor and meagre fibres were produced in the sterile soil. This fact together with the great length of the hairs seems to indicate that roots must themselves go in search of their food, and that the liquid food furnished to them by means of water is generally inadequate. This supposition apparently finds confirmation in the fact that roots of plants grown in solutions or in soil submerged in water have very few hairs, if any at all; and yet the plants do not seem to suffer. It is, therefore, sufficiently evident that nutrient substances in a liquid medium penetrate the root very readily, so that it has no need of a particularly large surface.

* During the lecture this fact was illustrated by means of a lamp glass and its brush.

We have said more than once that a root probably obtains food also from the hard particles of the soil; but how is this to be explained? The surface layer of the root with its hairs consists of small cells, which have, of course, no

apertures in their walls. The particles of the soil can come into very close contact with the root hairs, as is shown in Fig. 32, *D*, but never pierce their walls. How can we reconcile these contradictory facts, that solid bodies serve as food to the root and yet do not pass through its cell-walls? In order to explain this apparent contradiction, we have recourse to the following experiment. A glass jar is filled up to the very top with water, and then covered with a bladder. The external surface of the bladder is carefully wiped with blotting-paper, so that it appears to be quite dry. We scatter some chalk powder on the surface. Chalk is a solid body; the bladder does not contain any apertures; and yet we soon find that the chalk disappears from the surface of the bladder, passes through it, and appears in the solution inside the jar. We need not wait until all the chalk disappears from the surface of the bladder, for we possess very delicate reagents for detecting the presence of lime in water. This colourless liquid (ammonium oxalate), for example, has the property of forming a white precipitate with soluble lime salts. I pour some of it into the water taken out of jar before the experiment; there is no precipitate. I take some of the water out of the jar some time after the chalk has been lying on the bladder; I pour into it some of the reagent, and get an abundant white precipitate, which means that the water already contains lime; that is, part of the chalk has passed through the bladder. This experiment, which rather surprises us at first, can be very simply explained. However carefully we wipe the bladder with the blotting-paper, it only seems to be dry; in reality it is always suffused with the liquid that washes its inner surface, and this liquid was not simply water, but water slightly acidified with acetic acid. Therefore the bladder is moistened with an acid, and acids, as we know, dissolve chalk. The chalk dissolves at every point of contact with the moistened bladder, and this solution passes through the bladder into the jar. All this happens imperceptibly, and so it appears as if a dry solid body passes in some incomprehensible way through a dry bladder. We gather from this experiment that if only cell-walls be moistened with an acid, solid bodies dissolving in that acid can easily pass through them.

Does not something of this kind happen in roots? In order to prove the possibility of such a phenomenon it is necessary to show that the surface of roots gives an acid reaction. For this purpose we have only to apply to the root a piece of litmus paper, which chemists use for detecting the presence of acids. Under the action of acids the blue colour of this paper changes to red. The root-tips do actually leave a red trace on the blue paper. There are indications which point to the fact that sometimes this acid is actually acetic acid which we used in our last experiment. Moreover, the root, like every other part of the plant, is continually breathing and giving off carbonic acid. This can be proved by an experiment similar to the one demonstrating the respiration of germinating seeds. Now carbonic acid dissolves many substances which are insoluble in water. Here is, for instance, water into which

phosphate of lime in the form of a very fine powder is stirred; two very important nutrient substances, calcium and phosphorus, have thus been mixed with the water. I pass through this water a stream of carbonic acid, and in a short time the turbidity disappears—the salt has dissolved.

So, then, roots have an acid reaction and, moreover, give off carbonic acid; and these acids must act as solvents on the surrounding particles of the soil, the more so because the hairs, as we have seen, come into the very closest contact with, and almost grow into, these particles (see Fig. 32, *D*). But perhaps instead of all these indirect considerations it would be well to prove by experiment that roots produce such a solvent effect on the solid particles of the soil. Let us take for this purpose a piece of white marble carefully polished—marble in its chemical composition is practically chalk—and let us bury it at the bottom of a flat flower-pot. Then let us plant something in the pot, say a bean. The roots of the bean plant will soon reach the piece of marble, and will spread over it, closely adhering to its polished surface. If in a few days we take out the piece of marble, wash it, dry it, and then examine it, holding it to the light, we shall notice on its smooth surface, which reflects the light, some dull worm-like traces. These are the imprints of the roots, which in adhering to the polished marble have eaten out their image upon it by the action of their acid surface. These impressions are certainly not very deep, but they are nevertheless perfectly clear.*

* These imprints can be made clearer by rubbing them with powdered graphite.

There can be no further doubt, after what has been said, that a plant is able to obtain its food from the solid particles of the soil as well as from solutions. This fact can be made doubly sure by the following curious experiment. The root of a plant of suitable age was carefully washed and divided into two tufts, one of which was sunk in water, while the other was buried in soil, and given no water. Nevertheless, the plant has continued to develop. It has absorbed water with the one tuft of roots, while with the other it has taken from the solid particles of the soil the substances necessary for its nutrition.

Lastly, there are such plants as lichens, for instance, which settle like froth and scum upon the inhospitable surface of rocks and stones, and even, it is said, attach themselves to the surface of polished glass, destroying these bodies in drawing out of them the mineral food they require. It is a remarkable fact that these plants are distinguished by the abundance of acids in them, especially oxalic acid.

* . * . *

We have now to answer the last of the three questions raised at the beginning of the lecture. *Why* is it that, among the various substances with which the roots come into contact in the soil, they attract especially those that are necessary to the plant? Let us study the fact itself more closely before we

answer this question. If a plant is grown in a solution of two salts, say saltpetre and common table-salt, it is soon evident that the root entirely absorbs one of these salts, namely, the saltpetre, while it scarcely draws at all upon the common salt, which it does not require. Such facts were formerly disconcerting to scientists; it looked as if roots could discriminate between the different substances and *choose* their own food, accepting one substance and refusing another. How, indeed, can such discrimination be explained? Surely we cannot admit that a root is endowed with will-power or instinct? The explanation is very simple, and we came across it some time ago. You remember our artificial cell and the behaviour of iron salt towards it (see Chapter II). Similarly, both saltpetre and common salt easily diffuse, and therefore both will penetrate into the cells of the root, and hence into the rest of the plant. But the subsequent fate of the two salts inside the plant will be totally different. The saltpetre will be decomposed, and its nitrogen will serve to form albuminoids and other complicated nitrogenous compounds:* as the result of this transformation fresh quantities of saltpetre will enter the plant, will again be transformed into the substance of the plant, and this process will continue indefinitely. It is different in the case of the common salt. According to the laws of diffusion it will pass into the plant until a solution of equal strength be formed within and without the plant; then its further absorption will cease. If there should by any chance happen to be more of it inside the plant than outside, according to the same laws of diffusion, the superfluity will pass back again from within the plant to the solution. Now it is clear why just those substances which are transformed and assimilated by the plant, being necessary to it (as is saltpetre in our experiment), are extracted from the solution, whereas those which are useless to the plant (as is the common salt in our experiment) remain untouched in the solution, or, to be more accurate, almost untouched.

* We are entitled to make this assertion because we can grow a plant by furnishing it with saltpetre as the sole source of nitrogen.

It is therefore quite unnecessary to presuppose any rational will, habits, tastes or instinct in order to explain the discriminating property of the root—simple laws of physics are sufficient for the purpose.

We must leave the root here and pass in our next chapter to another organ, the leaf. It is obviously impossible to exhaust such a rich subject in one short chapter; but I think that what we have now learned is sufficient to give us a general idea of the life of the root, which in such a limited space covers a course of many miles, and sucks, eats into, and breaks up, the soil with its million hairs, and absorbs from it the soluble mineral substances so sparsely scattered in it—nitrogen and the elements of its ash, those eight elements without which the very existence of the plant is impossible.

Chapter V

THE LEAF

Function of the leaf. The nutrient substance assimilated by the leaf. The leaf in relation to carbonic acid. Structure of the leaf. Evolution of oxygen. Decomposition of carbonic acid in water. Obviousness of the experiment. Decomposition of carbonic acid in an artificial mixture of gases and in the atmospheric air. Formation of a carbohydrate (starch) in the chloroplast.

The decomposition of carbonic acid from the point of view of the transformation of energy. Nutrition' of the plant at the expense of organic matter. Fungi and parasites. Physiological functions of the leaf.

In the present lecture let us undertake the study in general outline of the life of the leaf. This task will be a little more difficult and complex than that undertaken in our last lecture, since there appears to be more confusion, among people not conversant with science, about the leaf than about any other plant organ. No other vegetable organ has suffered so much injustice. For centuries, even down to the close of the eighteenth century, people refused to see any direct utility in the leaf. From time immemorial they had admitted as indisputable the utility of the root as an organ of nutrition, and of the flower and seed as organs of reproduction; but the leaf continued to enjoy the superficial reputation of a showy but useless ornament: the utmost that people would consent to see in it was an organ for the excretion of noxious vapours. Yet, as we soon shall find, the leaf is as necessary as the root in the nutrition of the plant; moreover, it is the leaf that obtains for the plant what is quantitatively and qualitatively its principal food. It may, indeed, be said that the leaf embodies the very essence of a plant's life.

The erroneous ideas which prevailed for such a long time with regard to the leaf and its significance are fully accounted for by the peculiarity of the processes of nutrition which go on in this organ. These are totally different, both as regards the nature of the food absorbed and the mode of its absorption, from the nutritive processes of the animal organism, which involuntarily recur to our mind whenever we speak of nutrition. It is owing to this marked difference that these processes form the most characteristic and essential feature of vegetable life.

We already know in part what substances are absorbed as food by the leaf. They must evidently be those substances which enter into the composition of the plant, but are not absorbed by the root.

We have seen that among the eleven elements enumerated in our last chapter (the twelfth, silicon, was proved to be useless to the plant), the seven elements of the ash: phosphorus, sulphur, chlorine, potassium, calcium, magnesium, and iron, together with nitrogen, enter by way of the root; and that water also, consisting of hydrogen and oxygen, enters the plant by the same path. There still remains *carbon*—the foundation of all organic substance. So far we

have not troubled about it in our artificial cultures of plants, though these contain a thousand times, even many thousand times, as much carbon as the seeds we took for our experiment. Quantitatively carbon forms the most important constituent of the plant (something like 45 per cent), yet we did not supply it to the root, but even systematically removed it from the surrounding soil. This means that a plant can live without absorbing carbon by its root.

These experiments are not, however, sufficient to tell us the way the plant obtains carbon in the natural conditions of life. To say that a plant *can live without absorbing* carbon through its roots is obviously different from saying that a plant is *unable to absorb* carbon by its roots, although this mistake is often made. It has not yet been proved that a plant is unable to obtain its carbon from the organic substance of the soil. The discussion of this point would, however, carry us too far afield; moreover, it is of little interest, because it is easy to show that if carbon obtained in this way takes any part at all in the life of the plant, that part is insignificant, and therefore scarcely worth our attention. If plants extracted their carbon exclusively or even chiefly from the organic substance of the soil, then soil covered with vegetation, the products of which are periodically removed in one way or another, must in course of time become poorer in humus; on the contrary, everyday experience shows that soil becomes richer in humus when it is under cultivation, as in corn-land, pasture, or wood. In cultivating our fields we extract from them every year in the form of crops more organic substances than we introduce into them in the form of manures; and yet soil carefully manured becomes richer in humus. It is clear that ultimately plants do not reduce the amount of organic substances present in the soil, but even increase it; and therefore they cannot find at all events their principal source of carbon in the soil. But if not in the soil it must be in the air; and if so, it is probably absorbed by an organ pre-eminently aerial—by the leaf. Let us see what is the source of the carbonaceous food in the air and how it is obtained by the plant.

Together with nitrogen and oxygen, atmospheric air also contains a very small quantity, measured in ten-thousandth parts, of carbonic acid. This gas, although colourless and in appearance indistinguishable from air, is a compound of carbon and oxygen. No one will, I am sure, doubt the accuracy of this statement, yet we must see the proof of it, as of every other statement, as far as possible with our own eyes; and it is possible in the present case. In order to detect the presence of carbon in carbonic acid, we must remove the oxygen. This can be done by causing the oxygen to combine with a body having still stronger affinity for it. Such is, for instance, the metal magnesium, the wire of which burns with a dazzling light. I light this piece of wire and sink it into a glass jar containing common air; the wire burns down and a perfectly white ash drops to the bottom of the jar: this is magnesia, a compound of the metal magnesium and oxygen. I repeat the experiment, sinking the wire this time into a jar of carbonic acid; it must now procure oxygen for itself by

separating it from the carbon, which will then be set free. As a matter of fact the wire does not burn so quietly this time, but crackles as if so many weak explosions were taking place, and black soot is deposited on the walls of the glass vessel. This is the free carbon.

Great stores of carbon are therefore always present in the atmosphere though in an invisible form.

All water in contact with the air contains carbonic acid, and plants which grow submerged in water are thus able to obtain it. It is by experimenting with the leaves of submerged plants that the interchange of gases between a leaf and its environment is most readily demonstrated. Here are several experiments which can easily be made on any clear sunny morning.

Let us gather some leaves and place them while fresh under a glass bell, filled up to the top with water and then inverted in another glass vessel (Fig. 33). We fill them in a pail of water in which it is easy to sink both bell and vessel. If we use common water, or still better water through which carbonic acid has been passed, and then set the apparatus in the light, we shall soon notice the lower surface of the leaves becoming covered with a silvery layer of bubbles. A little later a considerable amount of gas will be accumulated in the upper part of the bell, while the surplus water will be displaced into the outer vessel, as is shown in Fig. 33.



Fig. 33

Let us repeat this experiment with boiled water, or with water deprived of carbonic acid. We shall not see any bubbles of gas. We infer that leaves give off gas, but only in water containing carbonic acid.

We are astonished at first to notice that bubbles are given off only on the lower surface of the leaf; but this phenomenon will be explained as soon as we become acquainted with the microscopic structure of the leaf. We notice in every leaf, or rather in its lamina, two different parts, which are readily distinguishable: the nerves or veins, and in between them the ground tissue of the leaf. On closer examination we find that the upper and lower surfaces are covered with a layer of tissue, the epidermis, which is easily peeled off; and if we prepare the leaf, by macerating it well in water, we can separate it into three layers, the upper epidermis, the middle part, and the lower epidermis. From this middle part, consisting of the ground tissue and the veins, we can remove the former by carefully beating the leaf with a soft brush and get a beautiful thin transparent network of ribs and veins like a cobweb. We shall consider later the significance of this part of the leaf; meanwhile let us confine our attention to the ground tissue and the epidermis. The epidermis consists of one layer of cells, distributed in one plane; the ground tissue is porous and spongy, with spaces of

considerable size filled with air. Because of these air spaces leaves float in water; but if we pump all the air out of them under the water, they will sink, becoming at the same time darker in colour and more transparent; this is because water has taken the place of air in

between the cells. After these preliminary explanations we shall now understand this diagram which shows in a magnified and somewhat diagrammatic form a little square of leafy tissue cut out somewhere between the veins (Fig. 34). Here sections in both the transverse and the longitudinal planes are shown, as well as the lower surface of the leaf. The

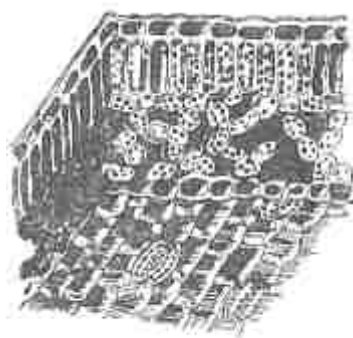

Fig. 34

The ground tissue consists of two kinds of cells: in the upper part of the leaf the cells are cylindrical in shape and arranged like stakes in a palisade, vertical to the surface of the leaf. In the rest of the leaf the cells are of varied and irregular form, with considerable spaces between them. All the cells of the ground tissue, especially those of the palisade layer, contain minute green granules; we shall return to them presently, only noting here by the way that the leaf, like all green parts, is in itself colourless, and owes its colour to those granules. The epidermis which we see here in surface view and in section consists of flat, oblong, almost tabular cells. Between them on the lower surface of the leaf there are scattered organs of a special form—one of them happens to be cut in half at the edge of the section. We notice that it consists of two cells, each curved into an arch, forming between them an oblong slit. These are apertures, like ventilators, in the lower epidermis, leading into the leaf from the outside air; they are called *stomata*. Their number is enormous. One lime leaf contains *more than a million of them*; and this number need excite no dismay, because the method of reckoning the stomata is very simple and precise. The restriction of these organs mainly to the lower surface of leaves explains why it is that, in experiments such as the one described above, gas is observed to be given off in most cases on the lower surface of the leaves. We shall return later on to these stomata.

Let us see what kind of gas is given off by a leaf when sunlight acts upon it. For this purpose we must wait until a sufficient quantity of gas is accumulated under the glass bell (Fig. 33). Then we take out the cork and introduce a slightly smouldering splinter into the neck of the bell. It instantly glows and bursts into flame, scattering sparks in all directions. This is the regular test for oxygen. Therefore the air given off by leaves is oxygen, or a gas very rich in oxygen. We have already seen that this experiment is successful only when carbonic acid is dissolved in the water. Is there not some connection then between the presence of carbonic acid and the formation of oxygen? Evidently our

experiment does not give a sufficient answer to the question. In order to find out what happens to the carbonic acid, we make another experiment. Let us take an apparatus consisting

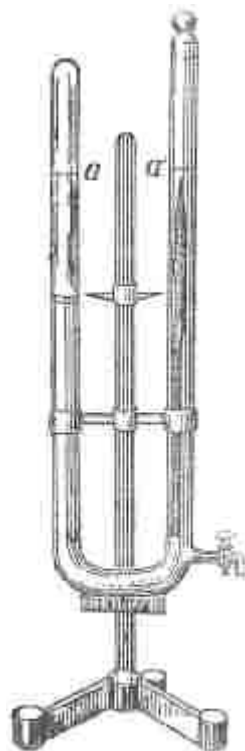

Fig. 35

of a tube in the shape of a horseshoe (Fig. 35), with one side closed and the other with a stopper.* We pour some water into the tube and introduce carbonic acid in such a way as to fill the space in the left-hand closed end of the tube up to the movable pointer on the stand (as is shown on the figure). We lower the long leaf of a cereal into the right-hand open end of the tube, and having filled the tube up to the very top with water close it with the stopper, taking care not to leave air bubbles below it. Then we place the apparatus in the light. As before, the leaf becomes covered with minute bubbles, and these, after reaching a certain size, rise to the upper part of the tube; here there accumulates a perceptible and ever-increasing quantity of gas. While the volume of gas constantly increases in the right-hand side of the tube the volume of carbonic acid diminishes in the left. At the moment when the level of the

water in the right-hand side reaches a' the level in the left-hand side will also be at a . Evidently the gas in the right-hand side is oxygen; but to be quite sure, we can withdraw the stopper and test the gas with a splinter. Once having proved that it is indeed oxygen, we refill the tube with water and repeat the experiment. Again we get a certain quantity of oxygen while a corresponding quantity of carbonic acid disappears from the other side of the tube. We know it is carbonic acid because we introduced it ourselves, but for greater certainty, after several similar experiments, we fill up the right-hand side of the tube with water, replace the stopper and, turning the whole tube upside down, transfer the remaining gas from the left into the right-hand side. If we test this gas we find not only that a smouldering splinter does not glow in it but that even a burning one will be extinguished. This means that the gas was and remains carbonic acid. What happens in this experiment is easily understood: carbonic acid continually dissolves in water in the left-hand side of the tube; but the solution in the right arm is decomposed under the influence of the leaf and oxygen is given off. Consequently a fresh quantity of carbonic acid dissolves and so on. This experiment proves very clearly, though not very exactly, that in passing *by the leaf* from one part of the tube into the other, carbonic acid changes into oxygen. During this process of decomposition the volume of carbonic acid which disappears at one end of the tube and the volume of oxygen which appears at the other end are approximately equal. We

learn from chemistry that when carbon burns in oxygen and carbonic acid is formed a given volume of oxygen forms an equal volume of carbonic acid. In our experiment, therefore, the carbonic acid is entirely decomposed; all its oxygen is given off, while all its carbon remains in the plant.

* Known as Hofmann's apparatus, very much used in the practical teaching of chemistry.

We can perform this experiment still more satisfactorily by using some large floating leaves of the water-lily. Water plants have the peculiarity that their stomata are scattered over the upper surface of the lamina which is in contact with the air; its air cavities are continuous with similar cavities in the petiole.

We let the lamina of such a leaf float in a wide vessel, and introduce the stalk into a graduated tube filled with water. When we hold the tube erect, bubbles of air begin rising from the cut end of the petiole filling the tube until the water level is the same in both the tube and the vessel. The upflow of bubbles of air, that gets into the leaf through the stomata, shows that while the water level in the tube is higher, the pressure on the petiole end is less than that of the air on the lamina floating in the vessel. We refill the tube with water and introduce the stalk into it again, while we sink the lamina in water under a piece of glass with a circular cut for the stalk, shown on

Fig. 36, behind the

vessel. Let us commence by using boiled water, i.e., water without any trace of carbonic acid. We do not see anything taking place. We add some mineral water containing carbonic acid, and cover the vessel with a piece of cardboard; and again we do not observe anything. But the moment we remove the cardboard and expose the apparatus to

sunlight, a current of bubbles rushes from the cut end of the petiole. We collect the gas and measure its volume: from what we already know we decide that this gas, which is given off exclusively in presence of carbonic acid and in sunlight, contains oxygen.

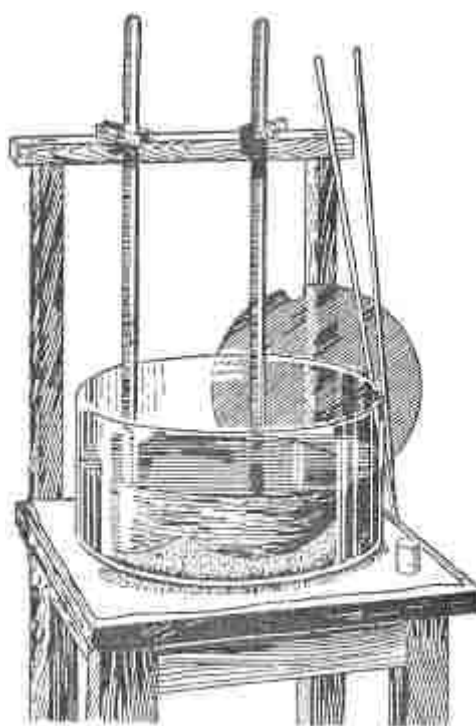

Fig. 36.

Let us gently draw the petiole out of the tube, close the latter with a finger, reverse it, and introduce into it a glowing splinter. It burns with a bright flame. We remove the splinter, extinguish the flame, and repeat the experiment ten times over with the same result, and conclude that this is actually a gas rich in oxygen. A leaf exposed to sunlight transforms carbonic acid into oxygen.

We have so far been experimenting in the presence of sunlight, but this phenomenon of the breaking up of carbonic acid by the plant can be demonstrated any time to a large audience by means of an improved magic lantern much in vogue nowadays—which throws on the screen a magnified image of the plant and the tube in which the gas given off by the plant is investigated.

Here is one of the most convenient forms of this experiment (Fig. 37). A small glass cell made of a glass tube bent into the shape of a horseshoe (*e*) and two glass plates (*d*) form a kind of aquarium in which common water plants are grown. If we arrange for a sufficiently strong source of light, either sunlight, electric, or limelight, we can throw upon the screen an image seven or more feet across of this minute aquarium (diminished by one half in Fig. 37), and we observe at all places where the stems or the petioles of the leaves are cut across that a curious phenomenon is exhibited by the plant: it gives off bubbles of oxygen in place of carbonic acid it has decomposed.*

* Water plants have no stomata on their submerged parts but are provided instead with internal air cavities, into which oxygen diffuses coming off later in bubbles through any chance apertures.

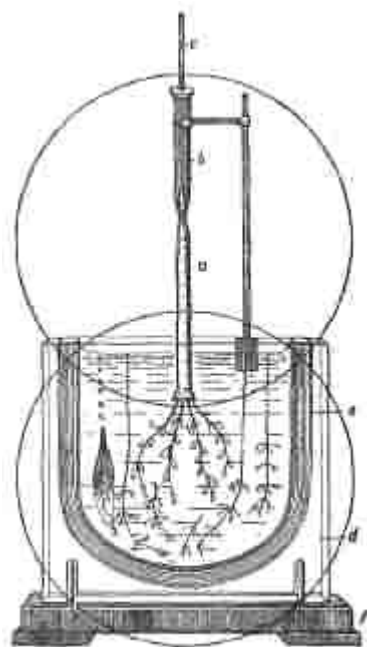

Fig. 37

In order that this may happen we must have a strong light, and the water must contain carbonic acid; in the absence of either of these two conditions the giving off of bubbles will not be observed; but, on the other hand, if the sunlight or the electric light is strong enough the bubbles rise in a continuous stream, like a string of beads. We have now to prove that this gas is oxygen, or rather that it is rich in oxygen, since it generally contains an admixture of other gases that are present in solution in the water. For this purpose we pass the ends of several branches under the

widened end of the graduated tube (*a*), which is full of water like that in the basin, and collect the gas which comes off.

This tube is tightly closed at its narrow end with a stopper in the form of a glass rod (c) which passes right through its wider part (b). When a sufficient quantity of gas is thus collected we proceed to test it.* It might be oxygen given off by the plant, or atmospheric air, or carbonic acid dissolved in the water and therefore capable of penetrating into the cavities of the plant. We pour some solution of caustic alkali into the wide funnel-like upper part of the tube and gently raise the glass rod so that the alkali may pass into the lower part which is marked with divisions. Alkali, as we already know, absorbs carbonic acid.** At the beginning the tube showed, say, fifty divisions of gas; there will be only forty-eight left after the absorption of the carbonic acid. Then we pour another substance into the funnel, a solution of so-called *pyrogalllic acid*, which has the property of absorbing oxygen, becoming dark brown in colour during the process. We lift up the rod, and as soon as the first drops of this liquid penetrate into the tube and come into contact with the gas contained in it, the liquid becomes coloured and the volume of the gas rapidly decreases. In the end we shall have something like fifteen divisions of gas instead of forty-eight. This remaining gas is nitrogen, and this means that we had thirty-three parts of oxygen. Not more than five parts of oxygen will have penetrated with the fifteen parts of nitrogen in the form of atmospheric air, so that twenty-eight out of thirty-three divisions represent oxygen given off by the plant owing to the decomposition of carbonic acid.

* The circles on Fig. 37 represent the circles of light thrown on the screen by the magic lantern; in order to get a larger image we look first at one part of the apparatus and then at the other.

** See Chapter III.

The apparatus we have just described, together with electric light, makes it possible for us today to demonstrate before an audience on a dark winter evening a phenomenon that generally takes place in nature only in the daytime during the warm season of the year; we can throw it upon the screen as easily as an ordinary lantern slide. Of course the apparatus can also be used without the lantern as a simple and convenient method of investigation.

So far we have been studying the decomposition of carbonic acid by plants submerged in water. This form of experiment is the most convenient for a preliminary study of this phenomenon, because it clearly shows the giving off of gases by the plant. We must now ascertain whether the same kind of decomposition also takes place as the result of contact of the leaf with air which contains carbonic acid.

Here is a very rough and simple form of experiment, by which the phenomenon was demonstrated for the first time a hundred years ago by the great chemist Priestley. We take a glass jar (as in Fig. 33), pour into it a small quantity of water and fix at the bottom of the jar a lighted bit of candle, of course large enough to stick up out of the water. We cover this bit of candle with a glass bell (similar to the one in Fig.

33) in such a way that its edges dip into the water at the bottom of the jar. The air in the jar will be thus enclosed and isolated by a layer of water from the external atmosphere. The bit of candle will go on burning under the glass bell for a while and then die out. This means that the oxygen necessary for the process of combustion has already been exhausted from the air under the glass bell, and has been replaced by carbonic acid, as the result of the combustion. If at this moment we were to introduce (through the neck of the bell) a burning splinter, it would certainly die out in the same way as the candle. But if we carefully introduce some leaves or a green branch into the glass bell through the water, and place the whole apparatus for a long time out in the light, we shall find eventually that the splinter will continue to burn under the bell—which will mean that oxygen has reappeared. Apparently the plant has transformed into oxygen the carbonic acid formed by the burning candle. We might have given another form to the experiment: we might have put a mouse under the bell instead of the candle and taken its death as a proof of the fact that the air under the bell no longer contained a sufficient quantity of oxygen for respiration. Then introducing a green branch under it and exposing it to the sun, we could have restored to the air its power of supporting respiration by giving back to it oxygen.

Hitherto in all our experiments we have studied only qualitatively the transformation of carbonic acid into oxygen under the influence of the plant, or rather we have estimated the relation between the disappearance of carbonic acid and the appearance of oxygen only approximately. For the quantitative study of this phenomenon science is provided with other methods incomparably more precise, but the description of them would be out of place here on account of the technical details involved. I will only say that in those methods we make use of the property of carbonic acid, already familiar to us, of being absorbed by caustic alkali. A definite amount of carbonic acid is supplied to a plant, or to a single leaf, placed in a graduated glass tube closed at its upper end, which is then exposed to the light. The experiment being over, we determine, by means of an alkali, the quantity of carbonic acid remaining in the tube. Knowing how much gas was introduced, and how much is left, we can tell how much has disappeared.

This method has helped to solve many interesting problems; for instance, that of determining the percentage of carbonic acid in the air most favourable for the plant. The experiment proves it to be something like eight per cent; a greater percentage is evidently noxious to the plant.

Another question dealing with the same point deserves our attention. We have proved experimentally that plants decompose carbonic acid supplied to them in our apparatus; but it is questionable whether we are entitled to infer from these experiments that a plant in its natural condition is also able to decompose the carbonic acid of the air. You remember that we supplied in our experiments comparatively large quantities of carbonic acid to the plant, as a rule in the

proportion of several parts in a hundred, whereas the atmosphere contains only a *few ten-thousandth parts* of it. It may seem unlikely that a plant should be able to discover and assimilate the particles of carbonic acid so sparingly diffused in the air. In order to settle this question, the renowned French chemist, Boussingault, made the experiment which we will now demonstrate. We take a large glass globe with three apertures (Fig. 38). A vine branch with leaves is introduced through the lower opening into the globe, while still

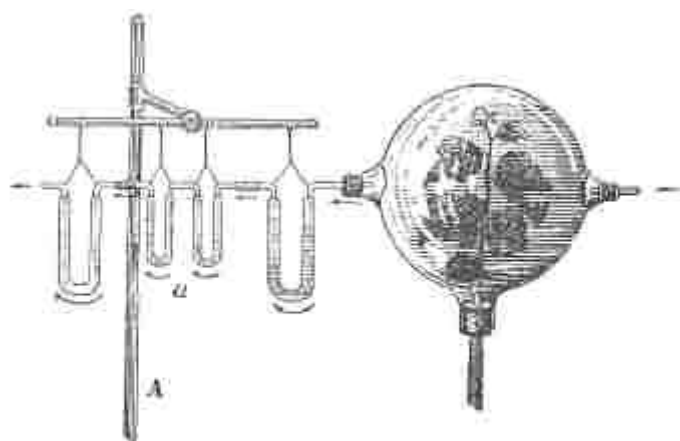

Fig. 38

connected with the vine, and therefore under perfectly natural conditions. With the help of an *aspirator* a continual stream of fresh external air, as is shown by the arrows on the figure, is slowly passed, first through the glass bell and then through the apparatus *A* connected with it. We mark on the aspirator the volume of air passed through the globe during the experiment; we also analyse the air of the place where the experiment is made, and determine the proportion of carbonic acid contained in it. Once we know the amount of air which has been passed through the globe containing the plant, and the proportion of carbonic acid contained in the air, we can easily determine the quantity of carbonic acid that has *entered* it. We have now only to determine the quantity of carbonic acid that *has come out* of the globe in order to find out how much of it has been decomposed by the leaves. The apparatus *A* serves this purpose. I will briefly describe its significance, again leaving out all technical details, since my point is merely to explain the fundamental idea of the experiment and not the way it is carried out. The main part of this apparatus consists of two bent glass tubes (*a*) through which the stream of aspirated air passes, and which are meant to absorb the carbonic acid. For this purpose one of them contains small pieces of caustic alkali. Caustic alkali will become heavier in absorbing carbonic acid; and therefore what we have to do is to unfasten the part of the apparatus marked *a* and to weigh it before and after the experiment. The increase in weight will indicate the quantity of carbonic acid remaining in the air after it passes out of the globe. It happened that under favourable conditions of illumination the air came out of the

ball almost deprived of carbonic acid. Consequently, in passing over the green surface of the illuminated plant, the air has left behind it almost all its carbonic acid; in spite of the fact that its particles are so scantily diffused in the atmosphere, lost, so to speak, in the mass of its other components. This result will become more comprehensible if we recall the diffusion of carbonic acid into our artificial cell.* Then carbonic acid pressed into the cell only because the cell contained none of this gas; but in the leaf also, since it is continually decomposed, it disappears without, so to speak, leaving any traces; and therefore, according to the laws of diffusion, it must continually *be* replaced by fresh quantities from the atmosphere.

* See Chapter II.

Boussingault's classical experiment was made more than half a century ago, and has hardly ever been repeated since, because it is too complicated. Lately a distinguished English chemist, Horace Brown, undertook a whole series of similar experiments of an improved form, by which he succeeded in removing any remaining doubts upon the subject. The insignificance of the total area of the minute openings afforded by the stomata made it still seem incomprehensible, however, that a plant should succeed in extracting from the atmosphere the meagre proportion of carbonic acid contained in it, until it was discovered that, owing to peculiarities in the diffusion of gases, demonstrated for the first time in Brown's experiments, carbonic acid enters the leaf through these stomatal apertures almost in the same quantity as it would diffuse had the whole surface of the leaf taken part in the process of absorption. Horace Brown wittily remarked, in commenting upon this remarkable discovery, that a plant evidently knows more about physics than we are inclined to admit! His experiments also showed that if the percentage of carbonic acid in the air were increased five times, from the usual proportion of 2/10,000 to 1/1000, the quantity decomposed by the plant also increased to about five times as much; a result which justifies us in concluding with greater certainty than before, how successfully the plant can use up the atmospheric carbonic acid, seemingly available in such minute quantities.

* * *

On coming into contact with a green plant in sunlight carbonic acid is decomposed: its oxygen is set free, while its carbon is deposited in the plant. Let us try to trace the further fate of this carbon inside the plant. Let us again turn to the microscope. Almost without exception every observation of this phenomenon, and every experiment, point to the conclusion that this process takes place only in the green parts of the plant. We can really say with certainty that if an organ is not green, it does not decompose carbonic acid; while if it does decompose it, the green colouring matter

when not directly visible is hidden by other colouring substances. These green granules, which contain this green colouring matter, called *chlorophyll*, serve as organs in which the decomposition of carbonic acid takes place. Apart from chlorophyll there is no assimilation of carbon in the plant.

Chlorophyll is found in cells in bodies of varied form, in

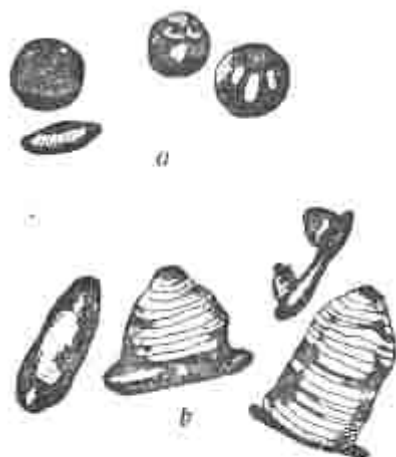

Fig. 39

small granules, or in disc-shaped (Fig. 39)* or band-shaped bodies (Fig. 66, right). These bodies are called *chloroplasts*. If we keep a plant in the dark for a time and then examine these chloroplasts under a microscope their structure appears quite uniform (Fig. 39, *a*, on the left); but if we then set the plant in the light, we find after a certain length of time, occasionally after even a few minutes, that tiny granules have appeared

in them (Fig. 39, *a*, on the right). In some plants these granules increase in size, in time protrude themselves and continue to grow on the side in contact with the chloroplast (Fig. 39, *b*). They then have a characteristic stratified appearance, and we recognize them as grains of starch. We need not, however, wait until they develop; we can detect starch in a granule as small as a pin point by colouring it blue with iodine, a reaction with which we are already familiar.

* Fig. 39, *a*—on the left chloroplasts without starch; on the right— with starch grains inside them; *b*—chloroplasts with large starch grains,

Starch grains, then, are formed in the chloroplasts, and continue to grow where they are in contact with chlorophyll. We can easily prove that the formation of starch is connected with the decomposition of carbonic acid. To begin with, no starch is formed in the chloroplasts when the plant is not supplied with carbonic acid; nor, in the second place, is there any formation of starch in the dark. Thus starch is formed and carbonic acid decomposed only in presence of chlorophyll; both processes are conditioned by the presence of light, and only when carbonic acid is present and being decomposed does any starch appear.

It therefore seems more and more evident that starch is the very substance we are looking for, which is formed out of the carbon in carbonic acid. Its composition supports the conclusion: like other carbohydrates it can be regarded, as the name suggests, as made up of carbon and water. Cells always contain water; so we may explain the origin of a carbohydrate by supposing water and carbonic acid to combine, and at the

same time all the oxygen of the latter to be withdrawn. Such is the course of events as far as they are known to us; but we must remember that our information on this subject is as yet far from being complete. We know that a cell receives carbonic acid and water, gives off oxygen and forms a carbohydrate; we know that these processes must have a causal connection, that they take place in the same chloroplast and follow upon each other with striking rapidity. As to how it all happens, where the oxygen comes from, whether it is produced entirely from carbonic acid or also partly from water (which is more probable), and whether other simpler or perhaps more complicated combinations precede the formation of starch—up to the present we do not know anything about these questions, and it would certainly be out of place to enter here into speculative comment upon phenomena as yet unexplained by science.

It is far more important to remember that, in observing these processes of carbonic acid decomposition and starch formation, we are witnessing one of the most important phenomena of life, one on which depends not only the life of the leaf and of the plant, but the life of the whole organic world. This transformation of the simple inorganic substances, carbonic acid and water, into the organic substance, starch, represents the sole natural process by which organic matter is formed upon our planet. All organic substances, however diverse they may be, and wherever they are found, whether in plant, animal, or man, had their origin in the leaf, have been formed from substances manufactured by the leaf. Nature does not possess any other laboratory for the formation of organic matter, except the leaf, or, more strictly, the chloroplast. In every other organ and organism, organic matter is merely transformed; only here does it arise anew from inorganic matter. From starch, for instance, is formed soluble sugar which reaches the furthest parts of the plant by passing from one cell to another. From this sugar the hard skeleton of the plant called cellulose is formed. And, lastly, from this same sugar and the inorganic substance, ammonia, the most complicated organic substances, such as proteids, can be formed.

Thus the leaf assimilates carbon, and within itself forms an organic compound with which not only the plant itself but the whole animal kingdom is also supplied.

We have at last arrived at the source of carbon in the plant, and have explained how it penetrates into it. We have thus explained the first stage of the phenomenon of nutrition; we now know whence and by what means all the elements that enter into the composition of the plant are obtained, carbon being the last of the series.

* * *

So far we have been examining the activity of the leaf and of the plant in general, exclusively from the chemical point of view—from the point of view of the transformation of matter. Starting from the fundamental law of chemistry,

that matter is neither created nor destroyed, we tried to discover the sources of the matter composing the plant, the way in which it penetrates into the plant, and the changes it undergoes during the process.

But the vegetable body is a storehouse, so to speak, of energy as well as matter—heat energy for instance. Burning a single seed of a birch-tree will not warm our frozen hands for a moment, whereas a birch-tree a hundred years old will serve to heat our stove for many a day. A birch-tree, therefore, accumulates heat during its lifetime, which we use as such, or else as a source of mechanical force.

Where does this heat, this energy, come from? We raised a similar question with regard to matter. Just as we admit that matter neither disappears nor is created, so do we also assume that neither does energy disappear, nor is it created. In fact just as the chemists of the last century came to the conclusion that matter is indestructible, so also the physicists of the present day have come to the conclusion that energy is never destroyed. The different sources of energy may suffer endless change, passing from one form into another, or become concealed in a state of tension; but they are never destroyed, never created anew.

What is this latent energy, this heat concealed in our fuel, and whence does it come, since it could not arise spontaneously? In order to explain this we must glance again at the chemical phenomena already familiar to us that take place in the leaf, but this time from the purely physical point of view of the transformation of energy involved.

All chemical phenomena can be divided into two categories: those in which heat, light, electricity—in a word energy—*appears, is given off*; and those in which energy *disappears, is absorbed*. Phenomena of the former category take place spontaneously, or require but an insignificant impulse to start them; those of the latter kind on the contrary require an external supply of energy, which can be absorbed in the process.

Most of the phenomena of chemical combination fall under the former of the two categories; most of the phenomena of chemical decomposition fall under the latter. *Burning*, i.e., combining with oxygen, may serve as the simplest example of chemical combination. The converse phenomenon of unburning, the withdrawal of oxygen from a body, which is called *reduction*, may serve as the simplest example of decomposition.

We can try to demonstrate what takes place during chemical combination and decomposition, i.e., during combustion and reduction, by means of the following simple model consisting of two little balls of lead at the end of thin threads (Fig. 40).

The cause of any chemical combination lies in the fact that chemical substances are endowed with a tendency, a kind of gravitation, towards each other. We call that tendency chemical affinity. Particles of carbon and oxygen tend towards each other in the way these balls *a* and *b* do if I move them apart and leave them to themselves. But we know that

the impact of one body against another produces heat and sometimes light. Heat and light developing from this impact, i.e., from invisible collisions between particles of carbon and hydrogen and particles of oxygen, are indeed the heat and light that we observe in a burning flame.

We thus perceive the cause of spontaneous chemical combination, and the reason why it is accompanied by the development of heat. In combining, chemical elements are only yielding to a mutual

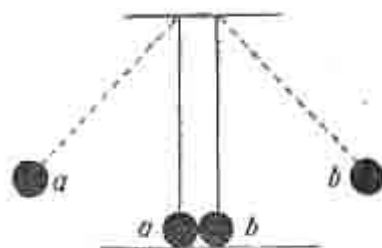

Fig. 40

attraction, just as these balls are, but having knocked against each other they are warmed, and give off heat.

The phenomena of decomposition are quite different. In order to decompose a chemical compound we must expend a certain amount of energy. In our illustration the same quantity of energy is required to drive the balls away from each other as will be manifested at the impact of the bodies against each other, when I withdraw my hands. This equality in the quantity of energy employed in decomposition and liberated during combination is easily illustrated by our mechanical contrivance. In order to move one ball away from the other I must raise it, must overcome the force of gravity. I estimate the quantity of energy expended in this instance by my work, and this work is measured by the product of the weight of the ball multiplied by the height to which it is raised. But just at the moment when the balls hit each other, the falling ball is endowed with energy sufficient to raise to the same height a ball of the same weight. We draw this conclusion from the fact that if it had not come into contact with the other ball it would have swung like a pendulum to the other side, and raised itself to the same height, i.e., it would have raised its own weight to the same height from which it has just fallen. In the same way, in order to break up a compound, to overcome the affinity of two chemical bodies and separate them, it is necessary to employ the same amount of energy as was liberated at the moment of their combination. If a certain amount of carbon burning in oxygen gives off, say, one thousand units of heat, then in order to set free this carbon from the carbonic acid which is formed, and overcome its affinity for the oxygen, we must of necessity employ the same one thousand units of heat. We can, indeed, decompose carbonic acid, i.e., liberate its carbon, as we have seen, only by exposing the compound to the high temperature of burning magnesium.

However, this case of the decomposition of carbonic acid by means of magnesium cannot serve as an example of a simple process of decomposition, because a combination of magnesium with oxygen takes place at the same time. For a long time chemists thought that the decomposition of such stable compounds as carbonic acid and water could not take

place without the cooperation of a third body, possessing a still stronger affinity for oxygen, but they have comparatively recently come to the conclusion that the action of heat alone is sufficient to cause the decomposition, or the *dissociation* of carbonic acid and water. According to modern physics heat is a kind of motion—a rapid, invisible, but palpable vibration of the particles of a body. In heating any compound body to a very high temperature, we bring its particles into such a state of vibration, and loosen them to such an extent, that their mutual coherence finally breaks down, causing decomposition. To give an example: at a very high temperature water vapour does not exist any longer as such, but as a mixture of hydrogen and oxygen.

During such a process of decomposition energy is absorbed: but what happens to this energy? It cannot disappear—that would contradict the law of the conservation of energy. It passes during the process into a latent condition of tension. Every one is familiar with instances of energy stored in a latent state among everyday mechanical phenomena: a sledge-hammer ready to fall upon a stake which is being driven into the soil; a bow bent ready to shoot an arrow—these are simple cases of energy stored in the form of tension. This expression sounds curious, however, when applied to light or heat. Can such forms of energy as light or heat be stored? Could I, for instance, get hold of a certain amount of light or heat, such as that evolved during the combustion of magnesium wire, and keep it, say, until tomorrow? I not only can, but I have already done so. When I dipped a burning wire into a vessel of carbonic acid, I employed a certain amount of this energy in the decomposition of carbonic acid with the liberation of carbon. I can burn this carbon tomorrow; or I can bequeath it to remote posterity, and they by burning it will enjoy the light and heat that we store today, in using them to decompose carbonic acid.

It follows that carbon, like any other combustible material (wood in the stove, food in our body), although naturally free, always tends to combine with oxygen, and therefore represents a store of energy; and, in every chemical process in which a non-combustible body changes into a combustible body, there is a storing up of energy.

In the end we come to the conclusions: (1) that the decomposition of carbonic acid and the setting free of carbon can only take place on condition that some external source of energy is employed in the process; and (2) that the energy so employed passes into a reserve form.

Having these facts in view let us return to our leaf. A precisely similar process takes place there. Out of non-combustible carbonic acid combustible starch, wood, etc., are formed. It is clear that this process cannot take place without the cooperation of some external source of energy. Indeed, as has already been said more than once, the decomposition of carbonic acid takes place only under the influence of light; the activity of the leaf does not begin until a ray of light falls upon its surface. This ray of light is indeed the energy by

which the decomposition of carbonic acid is brought about, and which is absorbed and stored in the process.

To make matters still clearer, let us compare the phenomena of light with those of heat. We have seen that heat is motion, which by loosening the particles of a body causes its decomposition. But light is also motion, a regular, undulatory form of motion. The following rough comparison will help us to explain the decomposing effect of light. Suppose two light bodies, say two wooden balls, float side by side on a smooth surface of water. We throw a stone into the water near them. Circles will radiate from the stone, and every time a new wave passes under the floating balls it will separate them, will break the connection between them, driving one of them up to its crest, and plunging the other into its hollow. To this stone, which produces the circles in the water, we may compare the sun, with the waves of light continually running from it and diverging to infinity; with the sole difference that these waves travel about 190,000 miles a second, and are so fine, and follow upon one another so rapidly, that on the average 50,000 of them are included within a single inch.

These waves, following upon one another at an almost inconceivable rate, come into contact in the leaf with still smaller atoms of carbon and oxygen, combined in carbonic acid, loosen them and break up their combination. The oxygen is set free while the carbon immediately enters into combinations of another kind. The first of these new compounds that we recognize under the microscope is starch.

We have just seen how the heat and light of the burning magnesium can be stored. The same is true of the rays of the sun. We cannot simply seize and shut up a ray of sunlight; but we grow plants for the purpose, and these not only extract carbon from the air by means of their leaves, but together with the carbon absorb and store, concealed in it, the sun's rays. It is the rays of the summer sun which warm us in our firewood; it is again the same rays that give us light in our candles for our long winter evenings. The form of the leaf finds its physiological significance in this function of light absorption. For this the flat form is more efficient than any other. The area of the light-absorbing leaf-surface is in some plants eighty times as large as the area of the soil they cover.

It is only now that we can fully appreciate the significance of the processes that take place in the leaf. In the first place there is the assimilation of one of the most important elements that enter into the composition of the plant—carbon—and at the same time a transformation of inorganic into organic matter. As we have already said, all organic matter in plants and animals comes directly or indirectly from the leaf; while the process of its manufacture in the leaf links up the whole organic world to the sun. The leaf serves as intermediary between any manifestation of energy in the organic world and the sun, the universal source of energy. It is not the plant alone, but also the whole of the animal world, man included, that profits by the energy of the sun stored up by the plant. We have seen that a seed gets

warm during germination. This heat is derived from respiration, the combustion of some part of the organic matter bequeathed to the seed by the parent plant. In the formation of this organic matter, the sun's energy has been employed. The seed, therefore, germinating in the soil, profits by the heat of the rays of the sun absorbed by the parent plant. Similarly, when we use organic matter as food, we also take in the rays of the sun latent in it, and use them to warm our bodies or set them in motion.

This means that the leaf, the only natural laboratory where organic matter for both animal and vegetable kingdoms is prepared anew, in this assimilation of carbon stores up the energy of the sun's rays, thus becoming the source also of energy, the retailer of heat and light to the whole organic world.

We have spoken in general terms till now of carbonic acid being decomposed in the leaf, of the rays of the sun being absorbed by the leaf, and so on; but we can express, ourselves much more definitely. In speaking of the assimilation of carbon in contradistinction to the assimilation of other nutrient substances, we can determine quite clearly the microscopic seat of the process. It is the green chloroplast. We can show that certain of the sun's rays are really absorbed by chlorophyll, and that it is just those rays which are absorbed which bring about the decomposition of carbonic acid, the initial stage in the assimilation of carbon, and also the formation of starch, its final stage. The green colour, which depends upon the peculiar absorption of light by the chlorophyll in the chloroplast, is thus not an accidental property of the plant, but is closely bound up with the most essential process of its nutrition. It is not the leaf as a whole, but the chloroplast that colours it green, which serves as a connecting link between the sun and all things living upon the earth.*

* The necessity for maintaining in due proportion the different parts of this course prevents me from working out as fully as it deserves this most interesting chapter in the physiology of the plant. Those who wish to study more closely this side of the life of the plant will find a more detailed exposition of the subject in a chapter appended to the course entitled *The Plant as a Source of Energy*, which in its turn presents a popular exposition of the principal results of my special work *On the Assimilation of Light by the Plant*, and of my further researches in the same direction. These facts are set forth in still greater detail in a lecture entitled *The Plant and the Energy of the Sun* (in my *Lectures and Addresses*, Moscow, 1888), and in my Croonian lecture *The Cosmical Function of the Green Plant*.—*Proceedings of the Royal Society*, 1903.

We have now studied the function of the green leaf. Plants without green organs are unable to manufacture organic matter for themselves out of carbonic acid, but are obliged to live at the expense of organic matter made by other plants. *Fungi*, for instance, the plants we generally call mushrooms and the microscopic *moulds*, can exist only on soil already containing organic matter: every attempt to grow them in a medium devoid of such matter proves fruitless. Plants feeding on other plants by attaching themselves to their

stems or roots belong to the same category: e.g., the *broom-rape*, which grows on the roots of hemp; the *dodder* (*Cuscuta*), which twists round the stems of hop, flax, and clover, and clings to them until it finally exhausts them altogether. All these plants have either ugly scales of some other colour than green in place of leaves, or else do not possess leaves at all. They are therefore incapable of independent existence, but suck the sap of other plants. Such plants are called *parasites*. All of them, and especially the minute fungi, which cause various diseases in plants, give farmers much trouble and frequently rob them of entire crops.

* * *

Thus it is the function of the leaf that accounts for the necessary matter and energy received by all organic world, man included. Though the latter, for centuries, stubbornly refused to regard the leaf as a necessary or even useful organ.

This centuries-old injustice, this dire ingratitude was consecrated even in poetry. Every one of us has known from childhood Krylov's fable "The Leaves and the Roots."* This fable, however, is based on an absolutely wrong conception of the function of the leaf. Krylov has libelled the leaves and, being a botanist, I undertake to be their counsel for the defence and tell you another fable which agrees more with Nature and, although less poetical, has a more exact moral.

* Krylov—famous Russian fabulist.—*Tr.*

You know the meaning of Krylov's fable. The roots are those

*Whose work-hardened hands by their labour
Give us privileged ones the favour
To devote all our life to science and art,
And the passionate dreams of our heart.*

The roots are the "common" folk who

*Trudge along through the life of hardship
In the endless and dawnless night.*

The leaves are we, who "devote all our life to science and art," we, who make use of light and air for the "passionate dreams of our heart" at our leisure moments. Attributing productive activity only to the roots, Krylov deduces that the leaves are nothing but useless finery, and, stressing this, he demands that they be at least grateful to their roots.

Have the leaves, the living green leaves, no other destiny than to whisper to the breezes, to give shelter to shepherds and shepherdesses? Is gratitude all that the leaves owe the roots for their services? No. Now we know that the leaf plays a no lesser role in the plant's nutrition than the root. In this lecture we have seen what happens to a plant and its leaves if

the root does not provide it with iron which it gets from the soil with such difficulty. In the next lecture we shall see what happens to the root when the leaves stop supplying it with that aerial, impalpable food which they get with the help of sunlight.

The leaves Krylov speaks of bear no resemblance to living leaves. And if it is flattering to be compared to the latter, it is a disgrace and an insult to be compared to the former.

But if the fable is changed, its moral is likewise changed. What moral can we draw from our fable? Only one: if we are to be compared to the leaves let it be an all-round comparison. Being the leaves, we supply our roots with that energy—knowledge—whose absence makes the strongest hands helpless. Being the leaves, we must supply our roots with that light—science—whose absence often makes the most noble efforts futile.

If we fail in this, if our light is darkness, or if, like the leaves of the fabulist, we don't pay the roots for their services in the same coin, if we do all the taking and give nothing in exchange, then less flattering comparisons may be found in Nature's vocabulary. Fungi, mould, parasites —this is what we should be called in this case.

Such is the moral we can draw from what we so far know of the living leaves, not those that live in the fabulist's imagination. Although somewhat rigorous, this moral is quite in accord with Nature's laws.

Chapter VI

THE STEM

Function of the stem, secondary as a medium between the leaf and the root. Forms of stems. Internal structure. Cell, fibre, and vessel. Three types of tissue: nutritive, mechanical, and conducting. Connective tissue and bundles. Structure of stems in monocotyledonous and dicotyledonous plants. Wood and bark.

Ascending current of water. Its course and destination. Participation of the root—its water-raising power. Participation of the leaves—evaporation of water. Function of the stomata. Function of the vessels. Function of bordered pits. Velocity of the sap. Purpose of the cork tissue. Movement of nutrient substances formed by the leaf. Course of this movement. Function of the sieve and latex tubes. Causes of this movement. Formation of stores of nutrient substances.

If we consider the plant exclusively from the point of view of nutrition, we are entitled, as has already been said, to see in it simply two strongly developed surfaces adapted to the twofold medium in which the plant lives. These are the root-surface and the leaf-surface: the former, being adapted to the solid medium, the soil, is developed specially in length, because the root must come into contact with the greatest possible number of particles of the soil; the latter, being adapted to the absorption of atmospheric particles and, especially, to the absorption of the light that falls upon it, is developed especially in one plane. Owing to such an arrangement, under favourable conditions scarcely a particle of the soil can escape the root, nor a single ray of sunshine be lost to the plant.

The substances absorbed by the root and the leaf are totally different, but at the same time are equally necessary to the plant. Evidently the existence of each of these organs, the very existence indeed of the whole plant, requires that there should be constant intercourse between them.

The organ joining the two surfaces, which bears the leaves and serves as intermediary between them and the root, is the stem. As an intermediary this stem is not an organ so essentially necessary to the plant as the root or the leaf, and it is therefore sometimes very poorly developed; but where, on the contrary, it is well developed it plays the most prominent part in determining the general aspect of the plant, and, in fact, the aspect of the whole vegetation of a locality.

Everybody knows, for instance, the *meadow plantain*, consisting of a bundle of leaves gathered into a rosette and lying almost flat upon the ground. In this case the stem is scarcely developed at all, and this is why the leaves are so closely brought together. Something of the kind, only on a larger scale, is illustrated by the American agave, which grows out of doors in southern Europe, and also in our greenhouses here in the north. That plant consists simply of a bundle of very large, fleshy leaves, almost seven feet in

length, which once in ten years throw out a flowering stem like a huge candelabra about twenty-eight feet high. We find a stem very slightly developed also in a certain extremely curious African plant. Picture to yourselves a vast expanse of barren steppe, on some parts of which are what appear to be stumps or logs scarcely rising above the soil, and slightly hollowed like funnels with little furrows across them. On both sides of the stump, from the furrows at its edges, there stretch two broad strap-like objects from four to seven feet in length—coarse and leathery, at first greenish in colour but turning brown at the edges, and torn into narrow strips—looking, in fact, quite tattered. Here and there at the edges of the stumps there grow small branches with minute cones like those of the fir-tree. This is *Welwitschia*, surnamed *mirabilis*, wonderful, on account of all its remarkable characters. The significance of its various parts is as follows: the stump, always half-buried in the soil and merging gradually into the root, is the trunk of this tree; it is seldom more than two feet in height, although the plant itself may live to be a hundred years old. The two tattered shreds described above are a pair of leaves which the plant keeps during the whole of its existence; dying at the edges they gradually grow from the base, and reach a very great age.

Let us pass from these stunted almost stemless plants to the tall graceful palms which Endlicher called *Principes*, i.e., the princes of the vegetable world. Their trunks grow upwards as straight vertical pillars with a crown of leaves at the top like the very columns for which it is believed they served as model. But the trunks of the palms represent only a one-sided development—development in length; they are very tall and graceful, but they do not usually branch or increase in thickness. A totally different aspect as well as the greatest development in size is seen in the trunks of our broad-leaved trees and our fir-trees. They, throughout their existence, increase in thickness and throw out branches, and may thus reach very great dimensions. Thus, for instance, within the circle of the bark of a Californian Wellingtonia, there would even be room for dances; a small chapel has been fitted up within the hollow of a huge chestnut-tree on Mount Etna; while travellers tell us that whole caravans find shelter under the green shade of the baobab. Although such giants do not exist in Russia even in the forests, we can still find hoary denizens of the past like the oak of Kuntsevo. Its mighty trunk rises from the bottom of a deep ravine, while its summit towers above the lime- and aspen-trees that are crowded all along the edges of the ravine.*

* A lot of fuss has been made of late about "the preservation of Nature's monuments." Special bodies of officials with handsome pay are to be formed to tackle this problem. I have been watching the Kuntsevo oak for forty years running and I know only one botanist who deigned to pay any attention to it. He made a "profound" statement in *Natural Science and Geography* that "there is nothing *particular* about this oak." Judging by the splendid water-colour presented to me by A. N Stroganov in 1913, this giant of Moscow's suburbs is in danger, having been stripped of large patches of its bark. [The Kuntsevo oak was struck by lightning.—*Ed.*] By

the way, it's good that our school children are taught "tree-planting," but it would be better still to tell them that by injuring the tree-bark they destroy wonderful "Nature's monuments."

Such are the dimensions that can be attained by a stem in the fulfilment of its destiny, bearing a canopy of foliage, the large leafy surface for the absorption of the rays of the sun; and one cannot fail to see how well it is adapted to this purpose. We have only to remember the partial obscurity which reigns in a pine wood, even on a sunny day, to realize that the needles must be distributed on the stem in the most advantageous way if, in spite of their insignificant breadth, they are to arrest as many rays of light as possible. Indeed, although the distribution of the leaves on a stem seems at a first glance entirely haphazard, a closer investigation reveals remarkable regularity in their arrangement. The first person who called attention to this fact was, I believe, the famous Leonardo da Vinci; but it was not until the nineteenth century that the phenomenon was studied in any detail by botanists. This regularity of distribution is seen mainly in the way the leaves are distributed on the stem, so that as far as possible they neither screen nor shade one another, and at the same time leave no free spaces through which the rays of the sun may pass to no purpose. This statement can be verified by a mere glance at the rosette of leaves on the plantain. They alternate in such a way that only the ninth leaf covers the first (i.e., the very lowest). Certainly the more leaves are separated the one from the other the less they shade one another; but a great development of the leaf system is only possible when the stem has reached certain dimensions. In most cases this can be attained only at great expenditure of building material, because in order to bear a great number of leaves the stem must be very steady and firm.

There are plants, however, which do produce *a* great number of leaves and reach a great height, while at the same time economizing their building material. These are the climbing plants, the thin delicate stems of which select other plants or inanimate objects as supports. Twisting and turning round these they climb to a considerable height, and produce a large mass of foliage which they could not support unaided. Such are, for instance, the hop, the bindweed, the ivy, and many other plants growing in tropical forests and known under the general name of *lianes*.

* * *

In general the stem has a twofold function: it must bear leaves and conduct the nutrient sap from the root to the leaf and from the leaf to the root. For this purpose it must evidently be equipped with something that will give it solidity, firmness, elasticity, and other mechanical properties; but at the same time it must have some system of canals, or some other kind of passage for the conduction of saps. In order to understand how the stem proceeds to serve these purposes, we must study its structure and, first of all, the

structure of the actual cells, the bricks, as we called them in our first lecture, out of which the plant is built up.

If we make a very thin transverse section of wood, we at once notice that it is perforated with very minute holes. These are the cavities of cells. We have already studied the inside of the cell, and its chemical contents. In the present instance, we are mainly interested in it as building material from the mechanical point of view; and in this connection the main part is played by its solid skeleton, its wall, upon which the entire form of the plant depends.

When isolated, the cell is for the most part spherical in form; when connected with other cells, as is the case in tissues, this spherical form passes into the polygonal (as is represented on Fig. 41, 1). A polygonal form shows that throughout its lifetime the cell has uniformly developed in all directions, whereas if it develops mostly in two directions, i.e., along two axes, a flat tabular form will result. Such tabular cells are formed mostly at the surface of organs; they constitute the epidermis of the plant (Fig. 41, 2). Lastly, the cell may develop almost exclusively in one direction, along one of its axes only. Then instead of a polygonal or a flat, tabular cell, a very narrow and elongated *fibre* appears (as is represented on Fig. 41, 5 and 6). Such long fibres form most

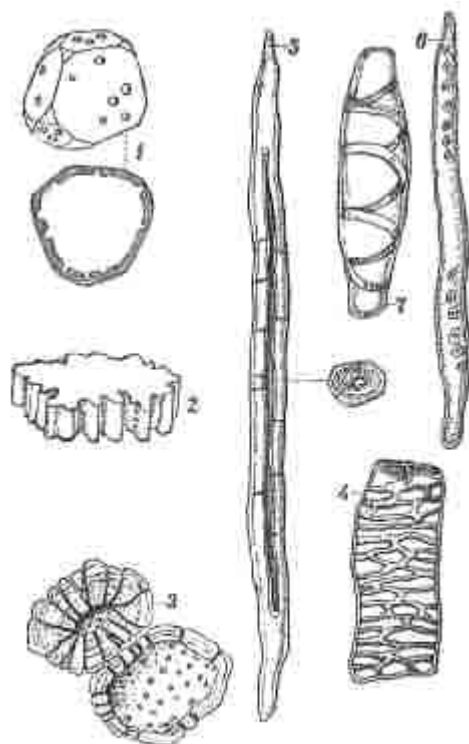

Fig. 41

of the wood of trees; but even they are not the very longest, and the fibre-like cells of flax, for instance, which are used in spinning, are sometimes a thousand times longer than their own diameter, so that we could only represent them here on their true scale by a single line. Cells not only vary in general outline and external appearance, but the very wall of the cell as such may vary widely in structure; it is

either uniform and thin (as in Fig. 41, 1 and 2), or thickened everywhere in concentric layers (Fig. 41, 3 and 5); or, lastly, these inner layers may not be uniformly deposited on the cell-wall, but only at certain places, thus forming the most curious patterns. For instance, if only small parts of the cell-wall remain unthickened, the cell as a whole, instead of being

uniformly transparent, will appear spotted, and in transverse section will be found canals perforating the thickness of the cell-wall and corresponding to these spots (Fig. 41, 1 and 3. It is at the same time curious that the canals of neighbouring cells generally correspond, so that these spots, *pores*, or *pits*, as they are called, are simply points where adjoining cells are divided only by the very thin primary membrane through which the sap can easily diffuse. Sometimes even this extremely thin cell-wall disappears, and the cavities of neighbouring cells are brought into open communication with each other. On the other hand, if most of the cell-wall remains unthickened, the thickenings appearing on the inner side will present the most varied forms of nets, rings, spirally-twisted bands, etc. (Fig. 41, 4 and 7). Such varieties of form in thickenings and pores are generally described and enumerated with special care by micrographers. To physiologists, on the other hand, form as such, however curious it may be in itself, does not present any interest as long as its significance, the part it plays in the life of the plant, is unrecognized; and this is precisely the case with regard to the different forms of thickening. It is only comparatively recently that attempts have been made to explain these structures from the physiological point of view. We shall briefly return to this matter a little further on.

These two considerations, viz., the general outline of the cell and the structure of its walls, do not, however, exhaust the ways in which cell structure may vary. Cells can also become fused into more complicated organs, generally known as *vessels* or *tubes*. These are generally formed by the perforation or the total disappearance by absorption of the transverse partitions between vertical rows of cells. For instance, if a row of cells with spiral thickenings lose the transverse partitions which divide them from each other (Fig. 42, I, on the left), a continuous tube called a spiral vessel will appear (Fig. 42, I, on the right).

Sometimes, however, as we have said, vertical rows of cells, in transforming themselves into tubes, do not entirely lose their transverse partitions, but communicate with each other by means of pores, larger or smaller as the case may be. One form of such tubes is very curious: the transverse walls of the component cells are perforated with minute pores and form a sort of sieve, and the cells themselves are called *sieve-tubes*. One such

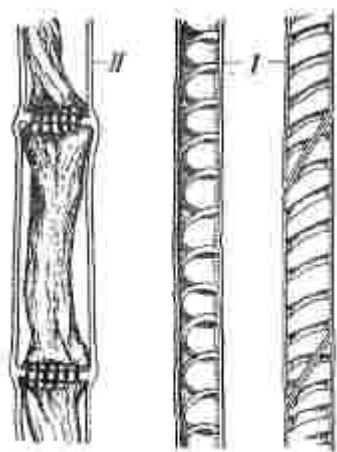

Fig. 42

cell fused with two others into a single tube is represented in Fig. 42, II. The contents of these cells can communicate through their pores. Very minute grains of starch have been

observed in these pores, and we shall soon see how important is their physiological significance. As well as the vessels and sieve-tubes, which are long and straight tubes, we come across others which branch and interweave and form a whole complicated network of communicating canals. Such tubes generally contain *white* or sometimes yellow sap; hence their name of *latex* tubes. Plants containing latex are known more or less to everybody: e.g., the dandelion and the poppy which exude a white sap when slightly wounded; the bloodwort, probably known to us all since our childhood, from the injured stems and leaf veins of which a yellow sap escapes; lastly, the common *Ficus*, which is grown indoors with us, and which, like some other tropical plants, secretes an abundant latex, known under the name of *indiarubber* when it is dried. These different kinds of latex are contained in a complicated system of branching and interwoven tubes to be found all over the plant, but especially in its rind and leaves.

All these elementary organs of the plant can be divided into three groups, to which different functions are mostly, if not exclusively, natural. These three groups or categories are the following: cells proper, fibres, and tubes. In the cells the processes of nutrition take place, i.e., the formation and transformation of the nutrient substances. They contain the chlorophyll; in them the stores of albuminous matter are deposited, and also starch, sugar, crystals of mineral salts, and so on. The cells are the laboratories and warehouses of the plant. Fibres serve mainly for mechanical purposes, their contents being of no value whatever. Their chief end is served by their elongated form and by their walls, which are sometimes so much thickened as to entirely fill the cavity (as is shown in Fig. 41,5). Recent investigations have shown that the material out of which these mechanical elements are formed, as well as their structure and especially their distribution in the stems, render them wonderfully well adapted to their function, which is to impart to the various parts of the plant the necessary firmness and elasticity with all possible economy of building material. Investigation has proved, for instance, the remarkable fact that the material out of which these fibres are formed is almost as strong as iron in some respects, and that the fibres are distributed according to the laws of engineering. The tubes, belonging to the third category, serve mainly as sap conductors.

Let us now see how these elements, so various in structure and function, are distributed in the plant.

Cells proper form a *connective* or *fundamental* tissue, i.e., the foundation of all organs connecting all their various parts together, while fibres and tubes (or *vessels*) are grouped together in strands, called *vascular bundles*, which pass through this fundamental tissue. We see this best of all in leaves. The middle part of the leaf between the upper and under epidermis is occupied, as we already know, by the fundamental tissue, through which run veins or nerves. These are the bundles, and they are either long and straight, running parallel to one another, or they interlace in a complicated fashion, forming a network of which only a faint idea is

obtained on simply glancing at the leaf. In order to realize the thinness and delicacy of this network, we have only to let the leaf rot in water for some time; then we shall be able without difficulty to remove with a soft brush both the epidermis and the fundamental tissue of the leaf, and separate this network of nerves, to which no lace can be compared for delicacy.* The name "nerves" is not very happily chosen, since these organs have *almost* nothing in common with the nerves of animals. If any analogy is necessary it would be more appropriate to compare them to a skeleton and a vascular system combined, since they form the hard skeleton of the leaf, and also a system of canals for the translocation of nutrient substances. I have expressed myself rather carefully in saying that they have *almost* nothing in common with the nerves of animals; because, as we shall see, there is a theory that they are the paths by which irritation is transmitted in the plant. If this theory be confirmed we shall evidently have to recognize in them a certain, though remote, resemblance to the nerves of animals.

* Other parts of the plant can be treated in the same way, and then semi-transparent "phantom" bouquets, so to speak, can be made of them.

The same nerves or veins so apparent in the leaf extend also into the stem, where they are less sharply defined, and do not strike the eye in the same way. Different plants, however, present a very different structure in this respect. Let us examine two very common examples. In the *monocotyledonous***

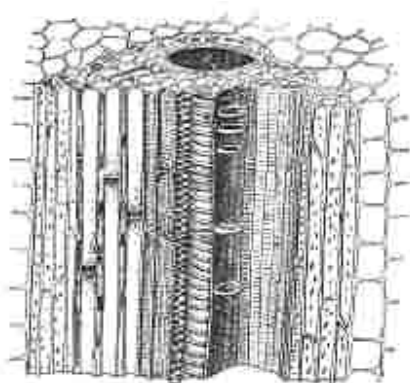

Fig. 43

class of plants, to which for instance our cereals, asparagus, and palms belong, these bundles are scattered in the fundamental tissue as is shown in the transverse section of Fig. 44, *I*. A longitudinal and transverse section of one of these bundles with its surrounding fundamental tissue, from the stem of maize, is shown very much magnified in Fig. 43.* Here it is clearly seen that the bundle consists of different vessels, with spiral, netlike, or ring-shaped thickenings, etc., sieve-tubes, and also fibres; whereas the surrounding tissue consists of ordinary cells.

** So called on account of their possessing only one cotyledon.

* A transverse and longitudinal section has been taken of the stem of maize, showing a single vascular bundle together with the surrounding fundamental tissue. The large aperture, surrounded by small ones, is the opening of a very large vessel. A number of smaller vessels are cut longitudinally.



Fig. 44

This structure of the monocotyledonous stem is more clearly seen if a section of it is placed for a time in a suitable stain, say a solution of fuchsin. Then, as in Fig. 44, *I*, the bundles in the transverse section will appear as red spots on the colourless ground of the fundamental tissue.

Quite a different structure is presented by the stems of conifers and dicotyledons,** to which all our forest trees belong, such as the oak, lime, maple, etc. In order to understand the structure of these stems, it is necessary to enter into some anatomical details, without which further exposition of the subject would be useless.

** I.e., flowering plants possessing two cotyledons.

Botanists, as well as non-botanists, differentiate three parts in the transverse sections of the trunk of a tree: the bark or rind, the wood—showing a series of concentric rings—and the pith (Fig. 44, *III*). But botanists go further and distinguish also between the fundamental tissues and the fibrous and vascular bundles, the same distinction as has been already clearly seen in the stems of the monocotyledons.

Let us try and make this point clear. We see the predominance of the fundamental tissue in the stem of a monocotyledon; bundles are scattered in it indiscriminately, and are also surrounded by it. But suppose these bundles were distributed regularly in a circle, and, moreover, were so much developed that only comparatively narrow layers of fundamental tissue were left between them, we should then have such a stem as is shown in Fig. 44, *II*.* Such in reality is the structure of a very young stem of any of our forest trees in its first year. The fundamental tissue in it is found in the middle of the ring of vascular bundles; this is the *pith* or *medulla*. We also see it in the form of narrow rays diverging from the pith in between the bundles; these are the so-called *medullary rays*; lastly, we see on the outside of this ring the so-called *primary cortex*, generally green and sappy, and composed of small cells. Thus every vascular bundle enclosed between two medullary rays has in transverse section the form of a triangle with its apex turned towards the centre.

* Fig. 44, *I*—The stem of a palm or of asparagus. *II*—"Structure of the stem of an annual dicotyledon. *III*—Stem of a dicotyledonous tree. All three are shown in transverse section.

This triangular form of the bundles is also preserved in an old stem. The dark diverging rays seen in Fig. 44, *III*

represent medullary rays, and the lighter triangles between them are vascular bundles. Thus the bundles form the predominant part in the perennial trunk of a tree; the fundamental tissue is found in between the bundles in the form of narrow medullary rays, sometimes almost invisible: hence it is clear also that the difference between the bundles and the fundamental tissue is not so well defined as in the case of monocotyledons, and is only seen under the microscope.*

* See Fig. 61, showing a small section of wood cut across, with a medullary ray.

The principal part of the stem of our forest trees consists, therefore, of vascular bundles; this is not, however, their most striking peculiarity. They differ from monocotyledons, such as palms, in that they increase in bulk during the whole of their existence— which is quite impossible to the monocotyledons—owing to the following anatomical arrangement. We all know that the rind of our forest trees is sharply differentiated from the wood; in spring when the plant is full of sap it even peels off easily. Non-botanists presume, and formerly even botanists also presumed, that there is a space in between the rind and the wood, which is filled, especially in spring, with a thick liquid, out of which the new parts of the plant can be formed. Exact microscopic investigation has proved that there is no such space, but at that part of the stem there is a ring of exceedingly delicate juicy tissue capable of continually forming new cells—hence its name of *formative* tissue, otherwise cambium. In Fig. 44, *II*, the cambium is shown as a dark ring which cuts across the vascular bundles as well as the medullary rays, the whole stem being divided by it into two parts—the wood lying inside the ring, and the rind lying outside it. Owing to the presence of this continuous circular formative layer, which is absent from the monocotyledons because their vascular bundles are scattered instead of being distributed in a regular circle, the stems of dicotyledons and conifers are capable of long continued growth in thickness. Every year this formative tissue deposits new rows of cells towards both the wood and the bark; only the wood increases more rapidly (Fig. 44, *III*), and the rows of its cells are deposited more evenly; this is why it presents the regular alternation of annual rings that we notice on every transverse section of a tree. Let us now see what is the anatomical structure of these two kinds of vascular tissue on either side of the formative tissue, i.e., in the wood and in the rind. On the wood side we find almost exclusively fibres called wood fibres (Fig. 41, *6*) and various vessels, pitted, reticulate, spiral, and so on, but no sieve-tubes. On the bark side we find very elongated fibres with very thick walls (Fig. 41, *5*), similar to the fibres of the plants used for spinning that we mentioned before, and the only tubes we meet are the *sieve-tubes* mentioned above (Fig. 42, *II*). The fibres form the part of the rind generally called *bast*; it is highly developed in

lime-trees for instance, and is used for splints, bast-strings, and so on. It is from this bast that all fibres having the structure we have described, wherever they are found, have received the name of *bast*. The transverse section of an old tree will, therefore, present the following parts: on the outside the part which we have called the *primary cortex*; here, as we shall soon see, a special tissue serving as a protection to the tree is formed at a later period; then under the primary cortex there is a layer of vascular tissue consisting mostly of bast and sieve-tubes; we shall call this part the *secondary cortex* to differentiate it from the primary; then comes a ring of formative tissue; nearer still to the centre is the wood, and, lastly, in the very centre, the pith. We shall content ourselves with these anatomic particulars; they may have seemed rather tedious, especially when presented in such a necessarily terse form, yet they are indispensable for the understanding of the physiological activity of the stem. Now we enter upon the investigation of the question: what are the paths by which the sap of the plant moves, i.e., by means of which the natural interchange is effected between the substances absorbed by the root and elaborated by the leaves?

* * *

Let us start with the former, as being the simpler case, that is, with the passage of substances, from the root towards the aerial parts of the plant, the so-called *ascending* current. This current furnishes all parts of the plant with the water they require, and in addition, with the salts dissolved in it. It is quite easy to discover the path of the moving water, because the want of the necessary quantity of it is generally betrayed by the plant fading. Therefore, by making transverse incisions at different places on the stem of a living plant, and observing where and when it begins to fade, we can easily see whether we have cut across the path of the ascending current of water or not. Experiment has proved that we can cut through the whole of the rind, and even peel it right off, without making the plant wither, which means that its aerial parts go on receiving water from the soil. We can also cut through the pith, which by the way often dies naturally in old trees, leaving hollows at the heart of them; in course of time decay spreads also to the inner layers of old wood, and yet the tree does not seem to suffer for a long time. Apparently the ascending current of water must flow through the wood, and moreover through the young wood. This inference is also proved by another experiment which has already been mentioned, by the experiment in which the vascular bundles are stained by coloured solutions. This experiment gives specially clear results with leaves which are variegated, or wholly white. In a short time the whole network of veins stands out in colour on the white ground. Microscopic investigations show that the wood vessels are the first to become stained, which means that wood is to be considered as the course for the ascending current of water in the stem.

And how can we explain the reason of this ascent of water, sometimes to a height of three hundred feet? The reason of this movement must lie in the stem, as well as in the root; in the stem, because stems and branches when cut off a tree continue to absorb water, carrying it to the leaves; in the root, because if the stem be cut off close to the ground, and even more so if the upper part of the root be cut, water will exude from the cut surface of the part remaining in the soil. Let us first study this phenomenon of the exudation of water from the upper cut end of the root, which is apparently the primary cause of the penetration of water into the stem. It was long ago noticed that sap flowed in abundance from some wounded or cut stems; to this phenomenon the name of "bleeding" has been given. It was thought to be the exclusive property of certain woody stems, and to take place only at certain seasons of the year; this bleeding is specially profuse in the vine in spring. Comparatively recent investigations have shown, however, that this phenomenon is common to all plants, herbs as well as trees; and that it takes place all the year round, although certainly with very varying intensity. In order to see this bleeding, and to measure its force, the following method is used: a stem is cut across not far from the ground, and we attach to the stump, with the help of an indiarubber tube, a small bent glass tube, if we only want to gather and measure the quantity of liquid exuded; whereas, if we want to find out the pressure under which the sap is driven out through the section we use another tube of the form shown on Fig. 45, on the left. This doubly bent tube, filled partly with water and partly with mercury, is simply a manometer, serving to measure the pressure under which the sap of the plant is exuded. The sap drives the mercury before it as it flows into the tube; it is by the rise of the column of mercury in the open bent part of the tube that we estimate the pressure. Experiment has shown that this pressure can be equal to that of a column of water thirty-six feet high, i.e., water is driven out of the section so vigorously that it might still come out even if a column of water thirty-six feet high had been made to press upon the cut surface. How can we explain this property of the root to raise water to such a height? The following experiment will give us the answer. Let us take a small glass bell (Fig. 45, on the right, *b*), close its lower opening with a bladder and introduce a cork with a glass tube into its neck,

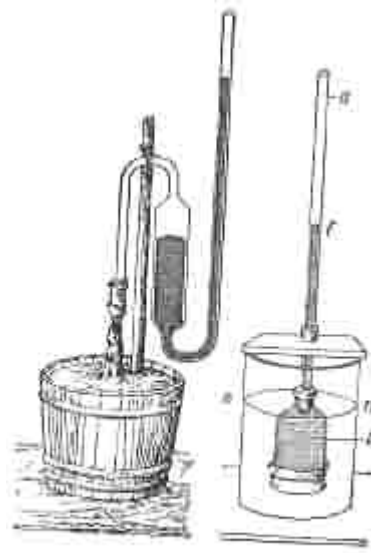

Fig. 45

and sink the whole as shown in the figure into a basin of water. If the glass bell also contained water, there would be no interchange between the water of the outer and inner vessels, so long as the level is the same in both vessels, at n , because otherwise water would soak through the bladder under its own pressure from the vessel where its level is higher into the one where it is lower. But let us suppose that a solution is introduced into the inner vessel instead of water, a solution of some substance found in the cells of plants, say sugar, which, as we know, is found in abundance in the roots of the beetroot, for instance. Then a phenomenon rather perplexing at first sight will be observed, even rather contradictory to what has just been said about the tendency of water to reach a common level in two vessels communicating with one another through a membrane. The solution of sugar—which can be coloured to make it more conspicuous—will quickly rise in the glass tube and soon reach a considerable height (f). The explanation of this fact is as follows: according to the laws of diffusion the water and the solution of sugar tend to mix, the one moving towards the inner vessel, the other towards the outside of it. But the particles of water move more quickly than those of sugar; therefore the water will pass into the sugar with greater rapidity than the sugar into the water; moreover, water passes through a bladder far more easily than sugar; therefore, by the joint working of these two causes, the current of water into the inner vessel will be far more rapid than the opposite movement of sugar, and hence the rise of the solution in the tube which at first seemed incomprehensible because it contradicts the laws of hydrostatics. We should get the same effect, though less clearly, if instead of sugar we took albumen, gum, or some other substance generally found in vegetable cells. Therefore here also the phenomenon resolves itself into diffusion, complicated by the presence of the membrane. Phenomena of this kind have been called *osmotic*. The rate of this diffusion, all other conditions being equal, will also depend on the area of contact between the two liquids, in our case on the size of the opening closed by the bladder. Suppose we grant that our apparatus presents a certain resemblance to a root-cell, a root-hair, and remember how large is the area of contact between such root-hairs and the water of the soil: we shall then soon realize what the result must be if such an apparatus is multiplied a million times, however microscopic it may be. Every cell greedily absorbs water and squeezes it through its presumably thinner inner wall into vessels which send it up to the root into the stem.

Such is the explanation we can give of the *water-raising capacity* of the root or *root pressure*. Alone it is probably insufficient to explain the raising of water to the summit of the highest trees; and we also know that cut stems sunk into water are themselves able to absorb it. But in order to explain the reason of this absorption of water by the stem, we must first of all begin by studying the part played in this process by the leaves. The best way to do this is to perform the following

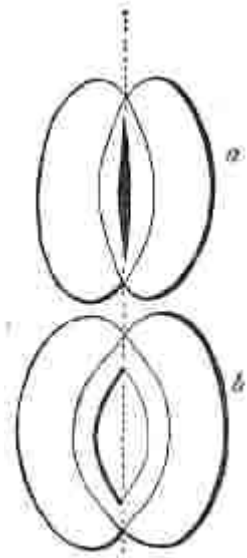

Fig. 47

experiment. We cut off a small branch, say of a birch-tree, covered with leaves and dip its cut end in water. On taking the branch out of water we notice a drop suspended at the cut part, but in half a minute, if not less, the drop will be absorbed; we dip the branch in again and notice once more the rapid disappearance of the drop, showing the greediness with which our branch absorbs the water provided for it.

The root drives water into the stem; the stem greedily absorbs it and drives it further on. What will become of this water when all the parts of the plant are saturated with it? Apparently, if it continually enters at one end it must pass out at the other. This passing out of water is very clearly observed under certain special circumstances. If

on a warm damp evening in May or June we bend to the ground after the sun has set and glance at the surface of a field of oats, we shall observe round drops on the very tips of the upright blades. If we patiently observe one leaf for some time, we shall see the little drop growing larger and larger until it rolls down; in its place, at the very edge of the leaf, another drop will appear, and so on. The same phenomenon will be observed if oats are sown on a plate covered with a glass bell. Small drops of water will continually appear at the tips of the leaves and disappear whenever the glass bell is removed. This phenomenon is seen in some plants much more clearly, and they give off water in considerable quantities. Anatomical investigation has even revealed special apertures in these leaves at the points of exudation. But such exudation of water in the form of drops is a comparatively rare case. It generally happens under the conditions just described, i.e. when the surrounding air is saturated with water vapour; but, as a rule, plants give off water in great quantities in the form of invisible vapour.

We can realize the amount of water evaporated by plants from the following approximate calculations: one acre of oats evaporates during the summer from 150 to 250 tons of water; an acre of mixed meadow grass something like 750 tons.

We can determine this amount of evaporated water in

many ways. Here is one of the simplest and most exact methods. The pot in which a plant is growing is placed in a glass or tin vessel and covered with a glass or tin plate with a hole through it for the stem (Fig. 46). In this way evaporation from the

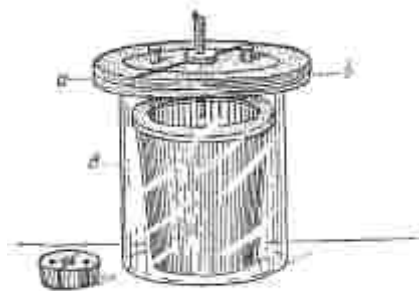

Fig. 46

surface of the soil and the pot is prevented, and if we weigh the whole apparatus from time to time we know that the loss in weight is due to evaporation from the plant. We can also take two glass bells of equal size, a little smaller than the leaf the evaporation of which we are going to investigate, so that the leaf can be held tightly between them (carefully, of course, so as not to crush it, but at the same time in such a way that the greased edges of the bells are tightly fixed to it). Under each bell we place some substance which greedily absorbs water vapour, such as sulphuric acid for instance, so that it may absorb the water which evaporates from the leaf. By weighing the vessels containing the sulphuric acid we shall find out the amount of water it has absorbed. In this way we can solve many interesting problems. We learn, for instance, that it is the lower side of the leaf, i.e., the one which, as we have seen, bears the stomata,* that gives off water vapour most actively. It appears that these stomata are to be looked upon as the regulators of evaporation. When the plant is saturated with water the slit-like aperture of the stoma opens wide (Fig. 47, *b*) and evaporation increases; but as soon as the leaves begin to fade, whether on account of too much evaporation, or too little water, the stomata contract and almost close (Fig. 47, *a*); evaporation decreases and the plant revives. We also learn from similar experiments that leaves with a bright shiny surface evaporate less than leaves such as grass; this is the reason why plants with shiny leaves apparently stand dry, torrid climates more easily. Lastly, such experiments teach us that young leaves evaporate more quickly than old ones of the same plant, and this fact affords a partial explanation of why the nutrient sap flows precisely to these young growing organs.

* See Chapter V.

Having learned what a considerable quantity of water is evaporated by the leaves, we can return to the investigation of the actual mechanism of this movement in the stem.

This question has attracted special notice of late, and yet it cannot be said to have been settled quite satisfactorily. It is true that there are many explanations of the phenomenon, but their very abundance proves that none of them is completely satisfactory. Let us then dwell only on facts easily verified by experiment. To begin with, it was necessary to decide what course the stream of water takes up the stem: does it pass by way of the cavities, or within the walls of the vessels? Contrary to the first most natural supposition that the sap circulates in the cavities of the vessels, since this would appear to be their simplest course and since these cavities form continuous channels through the plant, it has been pointed out that vessels are not generally filled with liquid, but contain bubbles of air alternating with columns of liquid. Yet this very presence of air, which at first was an objection to the theory that water circulated through the vessels, is now taken as a key to the explanation of the phenomenon. It happens that this air generally exists in a very rarefied state,

and that owing to this circumstance every vessel acts as a pump. We can demonstrate this fact by the following simple experiment: a stem of any kind is bent down into a vessel containing mercury until one part of it is sunk under the mercury, and it is then cut across *under the mercury*. If we make longitudinal sections of the same stem later on, we shall see that mercury has penetrated into the cavities of the vessels in the form of the finest threads. This phenomenon is seen best if the microscopic preparation is lighted from above instead of in the usual way from below; then we clearly see in the vessels bright threads of mercury like that seen in the

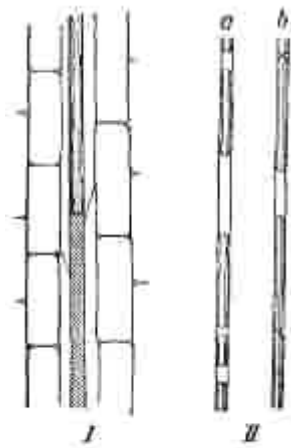

Fig. 48

capillary tube of a thermometer (Fig. 48, *I*).* Let us remember that mercury does not rise by itself as, for instance, water does in a capillary tube, but that on the contrary it can only be forced into such tubes by pressure—the narrower the tubes the greater must the pressure be. But the diameter of plant vessels is much narrower than the diameter of the capillary tubes with which experiments in physics are generally made. Hence we can measure approximately the degree of its rarefaction that brings about this aspiration of mercury. Two questions naturally

arise: why is no equilibrium established between the rarefied gases in the vessels and the external atmosphere? and, what is the reason of that rarefaction? The first question is answered very simply: the air inside the vessels is separated from the external parts of the plant, containing air at the general atmospheric pressure, by a layer of impenetrable tissue, which entirely isolates it from the external atmosphere. But whenever the internal parts of an organism come into contact with the atmosphere by means of a transverse section, the equilibrium between the internal and external atmosphere is suddenly established. This is why it is necessary to cut through the stem under mercury. However quickly we dip a cut stem into mercury, we shall always remain without any result whatever. But if we leave the end of a cut stem sunk in mercury for some time, we shall find that mercury will begin to rise in its vessels. This experiment will give us an answer to the second of the questions raised above—how is the origin of this rarefied atmosphere to be explained? Its explanation is as follows. Leaves evaporate water, and hence more concentrated solutions of substances contained in them are formed in their cells. These solutions, as we have already seen (Fig. 45, on the right), draw fresh quantities of water from the neighbouring cells, and thus from cell to cell absorb the water stored in the vessels. But if water be drawn out of the vessels, the air of the bubbles alternating with it takes its place, and increases in volume, i.e., becomes rarefied. As a

result of this rarefaction, a fresh quantity of water is absorbed by the vessels from the cells of the root. The truth of this inference can be proved by direct experiments. If we make a section of the tip of a stem (bearing leaves) transparent enough to be placed in a drop of water under the microscope, we shall be able to learn the following facts. If small particles of a powdered substance are suspended in the drop of water, we shall notice them tending towards the apertures of the vessels and flowing right through them. The bubbles that we see in the vessels will either decrease in volume with the decrease of evaporation from the leaves, or else increase, i.e., the air will become rarefied, with the increase of evaporation from the leaves (Fig. 48, *II, a* and *b*)**

* Microscopes for handing round to the audience at lectures are specially convenient and have been much used of late years. They are provided with concave metallic mirrors which concentrate the light upon the upper surface of the object.

** In Fig. 48, *II, a* and *b*, two consecutive stages of one and the same vessel are shown under the microscope during vigorous evaporation of water from the leaves. By comparing them we notice that drops of water have decreased at *b*, while air bubbles have correspondingly increased.

Despite, therefore, the many doubts cast upon the subject, the part played by the vessels, as the aqueducts of the plant, can no longer be disputed. Together with the explanation of the part played by the vessels, the significance of one more peculiarity of their structure which long puzzled the most celebrated anatomists has also been explained.

This is the so-called *bordered pit* found in vessels and conducting fibres (tracheides). They are easily observed in the wood of our fir-trees, e.g., in a very thin section of almost any match-stick. If we make a longitudinal section in the plane of the axis and diameter of the trunk (a radial section), we shall notice on the walls of the vascular fibres numerous rings with double outlines (Fig. 49, *A, a* and *b*). On closer

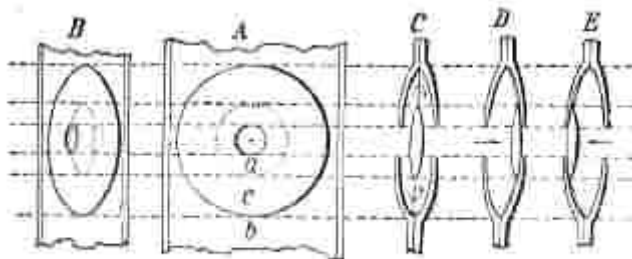

Fig. 49

observation we notice a third less definite circle (c) lying between *a* and *b*. If the longitudinal section does not lie in the plane of the diameter of the trunk, but intersects it at a more or less acute angle, the figure will change. Instead of the surface view of the pit we shall see it at an angle, say of 45° (*B*), and ascertain that there generally are two inner (small) rings. In order to understand the structure of the pit more clearly, we must make a third section at right angles to section *A*. This will give us the profile of the pit, i.e., its

section (*C, D, E*), which will explain everything to us. It happens that the common walls of the two adjoining cells form here a cavity shaped like a lens, the margin of which corresponds to the outer ring of the pit (*b*). * This cavity seems to be formed, as it were, by two watch-glasses, perforated in the middle with round apertures (*a* in *A*). These apertures lie one below the other, so that their outlines blend into a single inner ring (*a*). In *B* both circles are seen, owing to the fact that we are looking at them obliquely. The lens-shaped cavity is divided into halves by a very thin membrane stretched across it, the centre of which is thickened like a disc (*C*). The edges of this disc, generally visible through the glass-like transparent cell-wall, give the impression of the middle ring (*c* in *A* and *B*). Having realized the arrangement of these pits, and knowing that the air and water in them are under tension like that produced by a suction pump, their significance is easily understood. They are valves—most perfect [valves. When the suction pressure in the vessels is not great, water passes through the thin membrane (as shown by the arrows at *C*). The resistance of these membranes to the movement of water is insignificant: if we let fall a drop of water upon the upper cut end of a long branch, the exudation of a similar drop from the lower cut end follows almost instantaneously. But these thin membranes might easily break under pressure such as we have observed in vessels. The membrane then curves, and the disc applies itself to the one or the other aperture according to the direction of the pressure (as indicated by the arrows at *D* and *E*). Thus the bordered pit is shown to be a very conveniently arranged double valve, adapted to a variety of pressure in vessels. These valves secure the uniform distribution of water in plants.

* Dotted lines are drawn to show the corresponding parts of all the figures.

Having seen that water moves through the vessels, and also the reason for this movement, we must try and discover its rate. We proceed as follows: we put the cut end of a branch of the plant to be examined into water which contains a small quantity of some substance the presence of which is easily detected in a plant; thus, if we cut the stem across at intervals after some time, we can discover the height to which the water had time to rise during the experiment. The very greatest height ever reached in this way is approximately seven feet per hour.

Evaporation from the leaves, which constantly draws water from the aerial parts of the plant, is therefore the principal reason for the absorption of fresh quantities of water from the root into the stem. But, one must ask, why do we ascribe this function of evaporation to the leaves and not to the stem? The anatomical structure of the stem gives us the answer to this question. It is only at a very young stage that the stem has a skin or epidermis like that of the leaves; this very early dies, splits, and falls off, while underneath it, in the part of the stem called the primary cortex, there is formed a

corky tissue. It is called cork because it is strongly developed in a certain species of oak, where it forms the material out of which bottle corks are manufactured. The structure as well as the external appearance of this tissue may vary very much: thus, for instance, in the cork oak it forms a continuous layer several inches thick; while in the birch-tree it is only a thin and scaly bark. In all cases, however, it has the same general property, namely, that it is impermeable to water, and thereby forms a kind of impervious covering on the stem guarding it from unnecessary or even harmful evaporation. It is a curious fact that this cork tissue spontaneously appears when a vegetable organ is wounded, that is, just when it becomes exposed to abnormal evaporation, and thus puts an end to this unhealthy condition. Thus, for instance, we have only to wound any vegetable organ and thereby lay it bare and leave its inner tissues unprotected, and in a short time we shall see the skin of cork tissue forming over the wound.

Thus the root drives water into the stem, the stem carries it along to the leaves, the leaves evaporate it into the air. It is only in the conjoint and uniform fulfilment of all these functions that the activity of the plant will be completely normal. The balance is upset when the plant evaporates more than it absorbs—then it withers; the balance is also upset if the plant has no time to evaporate all the water it absorbs—then it begins to exude it in the form of drops, such as we notice on the blades of grass on warm damp evenings when, owing to the saturation of the atmosphere with water vapour, evaporation from the leaves has almost ceased.

* * *

We pass now to the investigation of another movement of the nutrient substances, tending not towards the leaf, but from the leaf towards all parts of the plant, including the root. The fact that there must be such a movement is evident *a priori*, because the organic matter out of which all the parts of the plant are built up is formed in the leaf; the fact that it actually exists is clearly proved by the following simple experiment. Let us cut off a willow branch and place it in water. After a few days or weeks a kind of excrescence appears round the lower cut end of the branch, and from this excrescence there spring little roots. Evidently these rootlets must have been formed at the expense of matter obtained from the leaf, or else of matter which was already on the way from it, i.e., in the stem. Let us try to show the way by which it has come down to the newly-formed roots, using for the purpose the same method as we used in determining the course of the rising sap. Let us make a circular cut in the rind right down to the cambium, as is shown in Fig. 50, and place our branch in water for several weeks. We shall notice that the roots will appear this time not at the lower part of the stem, but at the upper edge of the circular cut; in cutting across the rind we have evidently barred the way for the nutrient substances which moved down the stem. It follows that the circular cut in the rind, which does not hinder the

ascent of the sap from the root, completely stops the sap moving in the opposite direction. This means that whereas the sap rising from the root passes by way of the wood, the sap coming from the leaves passes by way of the rind.

The truth of this inference is also proved by another experiment. Let us choose a branch of some plant, on which fruit has only just begun to set, and let us cut a ring in the bark between the fruit and the nearest leaves: the fruit will cease to develop. Thus the



Fig. 50

circular cut in the rind, which separates an organ, such as the root or the fruit, from the leaves it feeds on, will deprive that organ of the very possibility of development. We have therefore proved beyond doubt that the nutrient substances serving to build up the various organs of the plant move through the rind. But the rind, as we have already seen, presents a complicated structure; we differentiate in it the primary and secondary rind; by way of which of these two systems does the nutrient sap move? Again let us repeat our girdling experiment; but this time we carefully cut only through the external part, the bark proper, being careful not to injure the secondary rind, i.e., the bast of the vascular bundles. We get results similar to those of the former experiment, i.e., roots are formed at the base of the branch. This proves that the movement takes place by way of the secondary rind. Let us venture one step further, and determine by which elements of the secondary rind this sap moves. We know that they are mainly two in number: bast fibres and sieve-tubes. A comparison of the mere form of these two elements makes it probable that the latter fulfil the functions we are considering, because the fibres have very thick walls with almost no cavities, whereas the sieve-tubes have broad canals, communicating with each other by means of open pits, through which not only liquid and semi-liquid substances but even minute grains of starch can pass. This probability changes into certainty after the following experiment. We take an oleander branch and manipulate it in the same way as we manipulated the willow branch in our second experiment, i.e., we cut off a complete ring of the bark right down to the cambium. A wholly unexpected result follows. Roots are formed not only at the edge of the cut, but also at the base of the branch—it follows that the nutrient substances pass otherwise than by way of the rind. This apparent contradiction is fully explained when we learn that the stem of the oleander shows a deviation from the typical structure of the stem above described. Besides the sieve-tubes

in the bark, bundles of these elements are also found in the pith; and it is these which, in spite of the circular cut in the bark, convey the sap to the lower part of the stem. Thus all these four obvious experiments with willow and oleander branches gradually and systematically reduce the circle of possible suggestions, and in the end point decidedly to the sieve-tubes as the course along which the nutrient substances of the plant spread—the plastic substances, so called because they serve the purpose of building up new parts in the plant.

Recent investigations as to the distribution of the latex tubes in a leaf lend a certain colour to the suggestion that they likewise serve as a very convenient course for the movement of the nutrient sap. This suggestion is based upon the fact that they are generally found in the immediate neighbourhood of the green tissue of the leaf where nutrient substances are manufactured. This suggestion is supported by the observation that the loss of latex exhausts some plants.

After having traced the course of the movement of the sap from the leaves, we have still to find out the causes which set it in motion. Again, for the last time, the key to the puzzle is found in diffusion—the word which like a constant refrain is repeated every time there is any question as to the absorption or translocation of matter into the plant from the external medium, or from one part of the plant to another. According to the laws of diffusion, matter when dissolved apparently flows especially to places where it is changed into an insoluble form, either being deposited in store for the future, or simply spent in the building up of the solid parts of the plant.* The nutrient substances are deposited all along the system of vascular bundles. Cells surrounding these bundles are generally very rich in starch, and occasionally also in crystals and other matter. We have observed the storage of nutrient substances in the endosperm of the seed; similar storage, only in much larger quantities, is also found in other parts of the plant. It is deposited, for instance, in the pith, in the medullary rays, in a word, in the fundamental tissue of the stems. In the pith of the sago-palm, starch is stored in quantities which can be measured by hundreds of pounds; potato tubers also store starch, the beetroot an abundance of sugar, cabbage heads or turnip roots the most varied nutrient substances; lastly, in the fleshy leaves of the aforementioned agave, sugar is stored up during many years. In fact, there is scarcely any vegetable organ which may not become the receptacle and store-house of nutrient substances. These stores are either used up the next year after they are deposited, as is the case with the beetroot or cabbage, where the stores are spent on the development of the stem and flower organs in the second year of the plant's existence; or else they are accumulated during many years, as is the case with the sugar in the leaves of the agave, which is eventually spent in the formation of huge branching inflorescence bearing the flowers and fruit. In every case storage is only a temporary, transitory destination of nutrient substances: their final destination is reached only when they are entirely used up in the formation of new parts of the plant, of new organs,

new cells, i.e., when they contribute to its *growth*. Thus after having studied the phenomena of nutrition, in the sense of absorption, digestion, and translocation of food, we can pass in our next chapter to the study of the phenomena of *growth*.

* See chapters II and III.

Chapter VII

GROWTH

Nutrition and growth. Direction of growth in the root and stem. Attraction by the earth. Turgidity of tissues. Mode of action of gravity. Influence of light. Heliotropism. Methods of measuring growth. Influence of temperature. Thermotropism.

Growth and multiplication of cells. Division of the nucleus. The proximate effect of light on the growth of the cell-walls. Effect of pressure on the form of cells. Growth mechanism of cells. Possibility of hearing plants vegetate. The art of experiment.

In the folklore of some northern people the gods and diviners are endowed with a faculty for not only seeing but even hearing the grass grow. In the present chapter we shall investigate the question whether the eye and ear of a simple mortal can ever develop such acuteness as to see and hear the growth of a plant. Let us begin by settling in what sense we are going to use this term. By growth, in the narrow sense of the word, we shall understand the increase in bulk of the plant, which takes place as a result of the transformation of the assimilated food substances into the solid skeleton of its structure, consisting mainly of cell-walls. Thus, although growth necessarily presupposes nutrition, these two processes are not bound to take place simultaneously. Growth can also take place under conditions which make nutrition for the time impossible, as in the absence of light. These two processes may in fact be carried on in different places and at different times. Growth is usually most active in the youngest parts of the plant, which develop at the expense of the activity of organs already developed and serving mainly for the purposes of nutrition. These two main functions of vegetable life, nutrition and growth, are sharply separated in time, particularly in those cases enumerated in our last lecture, where growth takes place at the expense of abundant stores of food, often the accumulation of many years. We have already seen that during germination the increase in bulk of the seedling does not depend on a corresponding addition of matter, but is accompanied by a continual and important loss of substance, owing to respiration.

Let us begin our survey of the phenomena of growth with the moment the little root and stem emerge from the germinating seed, when the one seeks, so to speak, to escape from the light as quickly as possible and buries itself in the ground, while the other stretches up into the air to meet the light. The first question that ought naturally to arise in our mind when we investigate this phenomenon, but probably one which seldom occurs to people, so accustomed are we to the fact, is: Why do the root and stem grow in different directions, the one into the soil, the other into the air; the one downwards, the other upwards?

This point has perplexed scientists very much, and even now it cannot be considered settled in all its details. In seeking the cause of this phenomenon scientists very naturally turned to light and the moisture in the soil. It has been pointed out that stems grow towards the light and roots away from it; and consequently it has been said that light must be looked upon as the external force which conditions the direction of growth. But this theory is pretty easily proved to be untenable. The direction of the organs in question will be the same in the absence of light; moreover, if seeds are sown in a sieve suspended above a window so that they are lighted only from beneath, after passing through the layer of earth the roots will equally pass through the holes of the sieve and continue to grow towards the light, while the stems will grow upwards and therefore away from the light. The other theory that the direction of the root is determined by the moisture of the soil is disproved by an experiment, in which germinating seeds are surrounded by moist earth or embedded in a wet sponge. The degree of moisture in such cases is uniform, and yet the direction of the root and stem will be, as before, perpendicular.

Thus the main direction of growth of root and stem bears no permanent relation to light or moisture; it is only their position with regard to the horizon that is permanent: the root grows always downwards, the stem upwards; in other words and speaking more strictly, since this phenomenon is observed all over the globe, at the antipodes as well as here with us, the root is directed towards the centre of the globe, and the stem away from it. This very constancy of direction points to the fact that the force to which it is due must be gravity, i.e., the attraction of our planet. This can be proved by experiment. If this direction of the parts of the plant depends upon the force of gravity, then by eliminating its action we shall arrest the phenomenon itself; by modifying the force we shall modify the phenomenon also; finally, by substituting for this force another, which acts in a different direction, we shall change the direction of the phenomenon correspondingly. But how shall we actually do this? How can we remove any body on the surface of the earth from the earth's attraction? How can we arrange matters so as to prevent the plant from having a top and a bottom? It is clear that we cannot do it literally. We can, however, make gravity act at short intervals in opposite directions and thus counterbalance its own influence. For this purpose let us fix a germinating seed to the rim of a rotating wheel (e.g., a wheel set in motion by electromagnetic power). If the wheel moves in a horizontal plane (as is shown in Fig. 51, *A, I*) it will certainly not prevent the root from growing downwards and the stem upwards. But if the wheel moves in a vertical plane (Fig. 51, *B, I*), or, what comes to the same thing, if we fix the germinating seed to the minute hand of a clock, it is clear that at every half-turn the position of the root and stem will change; in the end a top and a bottom, a right hand and a left hand side will cease to exist for the seedling; the continual action of the force of gravity in any one direction will be

prevented. Experiments performed under these conditions have proved that the root and the stem may be made to assume any desired position, and generally to keep growing in the direction in which they have been fixed (see Fig. 51, B, 1).

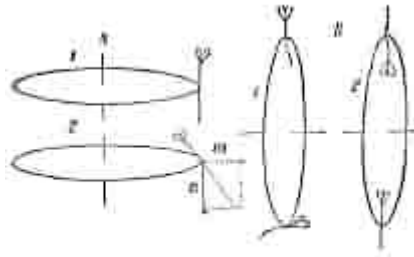

Fig. 51

So far we have supposed the wheel to rotate slowly, but yet quickly enough to prevent the seed from remaining a long time in the same position with regard to the horizon; now let us make it rotate more quickly. In this case a *centrifugal* force will be set up, just as when we quickly twirl in the air a heavy body of some kind at the end of a rope. This force acts, as it were, from the centre to the circumference, as is easily seen by the following experiment. A ring is placed on a smooth spoke near the axle of a wheel which rotates horizontally. As soon as the wheel begins to rotate at a moderate rate the ring begins to slide down the spoke until it touches the rim of the wheel. Therefore when this centrifugal force acts upon bodies it compels them to move in the direction away from the centre towards the circumference of the wheel. It is clear that this force cannot remain without influence upon germinating seeds. In fact if we make the wheel *B* rotate fairly rapidly we shall observe that rootlets and stems will assume a certain definite position: the rootlets will grow in the direction of the force, i.e., away from the centre, while the stems will stretch towards the centre of the wheel (Fig. 51, B, 2).

Now let us see what will be the effect of a wheel rotating quickly in a horizontal position. Obviously the conditions will be different here from what they were in the case of the vertical rotation. There the influence of the force of gravity was completely neutralized and the centrifugal force alone was directive. When the wheel rotates horizontally, on the other hand, both forces act. The force of gravity alone would have induced the root to point in the direction indicated by the arrow *n* (Fig. 51, A, 2). Centrifugal force alone would have caused it to point in the direction indicated by the arrow *m*. With both forces acting simultaneously it must necessarily assume an intermediate position, as is shown in the figure—a position that will be nearer to the horizontal the stronger the action of the centrifugal force, i.e., the larger the wheel and the more quickly it rotates. Experiment fully confirms this hypothesis.

Thus the direction of the different parts of the plant depends upon a force tending towards the centre of the earth. By neutralizing the action of that force (as on a slowly rotating vertical wheel) we destroy its influence. By the action of another force (as in the experiment with the wheel rotating quickly in a horizontal position) we modify the effect accordingly. But only one force is known to us which corresponds to these facts, and that is the force of gravity, i.e., the attraction of our planet. Finally, we can cause similar

phenomena by substituting centrifugal force for the force of gravity (as in the experiment with a wheel rotating quickly in a vertical position). We shall then see that the two organs tend in the corresponding directions, i.e., the root in the direction of the action of the force, the stem in the opposite direction.

It follows that the attraction of the earth is the force which determines the permanent direction of the growth of the stem and root. But it is one thing to indicate the force to which a phenomenon is due and quite a different thing to explain just why and how this force acts in that way.

As a matter of fact it would be quite easy to understand that the force of gravity would make the root grow towards the centre of the earth; but how are we to understand that, under the influence of the very same force of gravity, the stem tends on the contrary *away* from the centre of the earth? This is, nevertheless, exactly what does happen. It is not only that a stem placed vertically continues to grow in this direction, but even a stem laid horizontally bends sharply upwards. Here is a

small seedling of cress, which some hours ago was placed flat on a glass plate (*a, b*, Fig. 52). Its little stem has turned up as you notice, has reached the position of *n* from that of *m*.

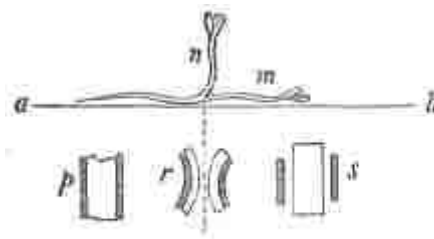

Fig. 52

Here is some cress,

grown up on a piece of felt. First the felt lay horizontally, later on I placed it on its edge, then successively upside down, on the other edge, and horizontally again. In this way the stems have changed their position four times with regard to the horizon and after having described a whole circle, and twisted themselves into a knot they continue to grow upwards. It is clear that under the force of gravity the stem turns away from the direction of its action. How is this to be explained? We must, of course, always keep in view not the stem only, but also the root. Only such an explanation can be considered satisfactory as will explain both the reason why the stem rises and at the same time the reason why the same thing does not happen to the root. The desired explanation must consist in a difference of structure of some kind between the stem and the root, because we cannot admit that one and the same force will act on exactly similar bodies in a different way.

Let us see what explanation we can find for the upward growth of stems. In order to do this we must begin by studying a curious property of vegetable organs, a phenomenon known as the *tension of tissues*. Let us cut a long piece from the middle of a young growing stem, as is shown in Fig. 52, *p*, where the shaded part represents the epidermis and cortex, and let us moisten it with water to prevent it from drying up; then let us split it longitudinally into two halves with a sharp knife. Both parts will

immediately curve as in Fig. 52, *r*. This curvature can only be caused either by the outer side of each part becoming shorter or the inner side longer than before, or both at the same time. At all events we come to the conclusion that in the undivided section the external and internal parts are in a mutually strained state; the one stretches the other, and is itself restrained in its tendency to elongate by the resistance the other offers to extension. We can prove this fact by making two slits instead of one, and separating the external tissue in two parts and disengaging from between them the middle tissues (Fig. 52, *s*). We shall now actually see that the middle part will stretch and become longer than it was before at *p*, while the external parts will shrink and become shorter than they were at *p*. It is clear that the inner parts of the stem tend to elongate, but being opposed in this tendency by the external parts stretch these instead. This mutual tension of tissues plays a very important part in the life of a plant; it is to this property that delicate and succulent stems owe their rigidity. Tissues consisting of very thin cell-walls and liquids would not by themselves be rigid. It is only when cells become overfilled with liquid till their walls distend, and the inner tissues press upon the outer ones and themselves are compressed, that an organ becomes turgid, and does not easily bend over or droop as do fading stems in which, owing to an insufficiency of water, the tension of the membranes in individual cells as well as the mutual tension of the tissues is weakened.

Let us make a comparison, rather rough it is true, but one which will give us a general idea of what takes place in the plant during its growth. I hold a glove in my hand. Its empty fingers hang down. I breathe air into one of the fingers and seize it near its base,—now it can preserve the vertical as well as the horizontal position without drooping, or bending. This finger filled with air represents to a certain extent a cell overfilled with sap or a stem, the external parts of which remain stiff under the outward pressure of its more rapidly growing inner parts.

Let us now discover the relation between all that has so far been explained and our original question: Why is it that a stem laid in a horizontal position curves upwards by itself?

Whilst a stem remains in a vertical position, the force of gravity acts uniformly on all its parts; but as soon as we place it in a horizontal position, the conditions change. Owing either to a stronger current of the nutrient substances or to other causes, the lower part will grow and stretch more quickly than the upper. We already know that the tendency of the inner part of the stem to stretch is continually checked by the resistance of the epidermis outside. But in the horizontal stem the lower half of this inner part will grow more quickly and will at the same time stretch the epidermis unequally—stretching the lower and nearer part more strongly than the upper and more distant part.* Moreover, the lower epidermis itself will grow more quickly than the upper, and consequently will more easily yield to stretching. This explanation is also supported by the fact that upward

curvature in a lying stem only takes place in the part which grows most rapidly; in parts where growth has already stopped such a phenomenon is impossible. Therefore by placing the stem in a horizontal position we cause in it unequal and unsymmetrical growth; the lower side gets ahead of the upper, the stem curves and rises. But this method of argument may appear unconvincing; in that case it can be enforced by a direct experiment. Let us take two similar stems, leaving the one to grow vertically and obliging the other to grow horizontally by pushing it through a narrow glass tube where it will not be able to curve. After a certain time let us split the latter stem into an upper and a lower half. The moment we do so the upper part will shorten and the lower elongate, and if we compare them with the length of a vertical stem we shall see that the upper half of the horizontal stem is shorter and the lower longer than the vertical stem, as was to be expected. What is true of a horizontal stem can be applied also to one in an inclined position: as soon as a stem deviates from the perpendicular, the force of gravity by causing increased growth of the lower side of the stem brings it back to its vertical position.

* It is quite clear that the resistance exerted by the upper half of the epidermis against the tendency to stretch will be stronger because it acts so to speak on the longer arm of the lever, whereas the lower acts on its shorter arm (see Fig. 53, II, c').

Now we understand why it is that owing to the force of gravity the stem curves in a direction contrary to the direction of this force. But a question arises: Why is it that the same thing does not happen to the root? You see now that our closer investigation of the phenomenon has reversed the question. At first we thought it quite natural and comprehensible that the root should grow along the line of the force of gravity, and incomprehensible that the stem should grow in a contrary direction; whereas now we understand why the stem grows exactly as it does, and find it difficult to understand why it is that the root grows differently. Let us turn for an explanation of this apparent contradiction to the

following model. Let us imagine two wooden discs (Fig. 53, I, c and d), joined by means of springs to a crossbar (b). Two pliable indiarubber rods (a, a) joined by a transverse handle (e) are passed through holes in this bar. Their ends press against the centres of the discs c and d. If we push these rods in the direction of

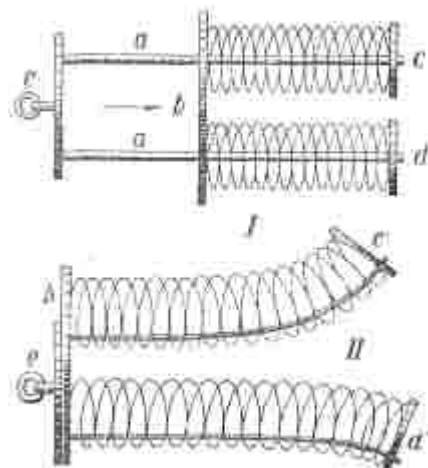

Fig. 53

the arrow, we shall separate the coils of the spirals and bring the two springs into a state of tension. The indiarubber rods in our figure are meant to represent the rapidly growing axial parts of organs, while the compressed coils represent the slower growing external tissues of these organs, distended by the growth of the inner parts. This movement demonstrates symmetrical growth, and the tension of tissues resulting from it. Let us now try to show by means of the same figure unsymmetrical growth, such as is caused by the action of the force of gravity, in which the lower part of an organ grows more quickly. We do this by making the points of contact of the indiarubber rods with the discs lie this time near their lower edge instead of at their centres (Fig. 53, *II*). On pushing in the handle as before, we notice quite a different result; while the lower spiral elongates in a straight line, or even hangs down a little (*d'*) under its own weight, the upper one curves upwards (*c'*) more or less sharply. This result is easily explained by the construction of the model. The springs are chosen purposely of varying elasticity: the upper one of much thicker wire exerts a stronger resistance to the movement of the bar than the lower one of thinner wire. We infer that the unequal, unsymmetrical pressure manifests itself in a visible curve only when there is a certain degree of mutual tension between the parts. Evidently the same can be applied to growth. Unequal and unsymmetrical growth will be followed by a sharp and perceptible curvature of the organ only when this organ attains a certain degree of turgidity owing to the mutual tension of tissues. But does a young growing root actually show such tension of tissues as we saw in the stem? A glance at such a root will convince us of the absence of such tension inside it. If we hold a stem horizontally it will not bend, nor droop, whereas a root will frequently hang down like a stem already withered. If we study the structure of the epidermis in the stem and the root, we shall find a further difference which has long attracted the attention of anatomists. The epidermis of the stem consists of cells with thicker walls, and, moreover, is covered with a special membrane which it is difficult to moisten with water, and which is very elastic; on the other hand the epidermis of the root consists of cells with thinner walls, it easily absorbs water, and therefore is more easily stretched, and less elastic than the epidermis of the stem. If now we make a direct experiment similar to the one we made with the stem, we shall see that there is not the same tension in the root as in the stem. If we split a length of root into two halves (like the stem in Fig. 52, *r*), no curvature will be noticed in these halves; if it be cut into three parts (52, *s*) no elongation of the middle part, nor shortening of the outer part, will be noticed. To sum up, the root has none of the tension of tissues peculiar to the stem; its external parts grow as quickly as the inner ones. This is also evident from one more property of the root: a young root generally elongates more quickly than a stem, and this is why it does not show any tension, which is nothing but restrained growth.

Thus if the force of gravity does not cause the upward curvature of the growing root-tip, this is partly explained by the absence of a mechanical condition necessary for the purpose: it lacks the corresponding tension of tissues. Our model shows how, given merely a difference in the structure of two organs, we may get entirely opposite results from a similar action of the force of gravity. It is useful to remember this whenever physiological facts are discussed. If one and the same external factor causes different effects in different organs, we must admit either a difference in the properties of the organs or a complexity in that same factor. This second alternative is impossible with regard to the force of gravity; but the difference in the tension of tissues is certainly not the only possible difference between the properties of the stem and root.

Our explanation would be perfectly satisfactory could we further prove that the lower half of a root lying in a horizontal position grows more quickly than its upper half, as is the case with the stem; and that *in spite* of this, owing to its own weight, it *passively* bends down like our spiral *d', II* in Fig. 53. Some experiments seemed to prove this, but doubts have arisen in connection with them, because contradictory results have been subsequently obtained, so that the question as to the *mode of action* of the force of gravity upon the root must be considered as still open.* Further on we shall see that this question becomes considerably complicated, and that in order to explain the phenomenon we must take into account not only the structure of entire organs, or of the tissues that form them, but also the details of the structure of the cells forming these tissues.

* For instance, the considerations generally brought forward by botanists concerning the growth of the root-tip in mercury are far from being convincing, two different phenomena having been confounded in these experiments: *growth* (of the whole organ in length) and *curvature* (depending only upon the *difference* in growth of the upper and lower sides of the curving part). A root exerts its pressure first of all because it grows, and it is quite obvious that this pressure caused by growth has nothing to do with the weight of the root, any more than the weight of the flexible rod (Fig. 53, *II, d'*) when overcoming a certain resistance and at the same time bending *passively* downwards.

* * *

Now let us see what other external conditions influence the phenomena of growth. In looking for the causes which determine the natural, vertical direction of growth of both the stem and root, we have proved that it does not depend on the light. Further, we have seen that growth is possible even when light is completely absent: potatoes and turnips put out long shoots in the total darkness of cellars. The same can be proved by experimenting with any seed or shoot: they all will grow in the dark.

Are we entitled to infer from this that light does not influence growth? Not in the least. A very simple experiment will prove how considerable this influence is. If we let cress

seeds germinate in two pots filled with exactly similar soil, placing one of them in the dark and leaving the other, in the light, the difference will not be long in showing itself. Cress grown in the dark will sometimes be ten times longer than that grown in the light; but its stems will be slender and unhealthy, and many of them will droop. Cress grown in the light will have short but healthy, thick and turgid stems. This means that light is not without an influence upon the growth or rather the elongation of stems; but this action is not an accelerating or favouring of growth in length, but, on the contrary, an *inhibiting* of it. The influence of light is not limited to this retardation of growth. If we have a plant in a room so that it receives light always from one side, we shall see that its young growing stem will bend over and turn to the light, as we generally say. Evidently we have no right to attribute any attractive power to the rays of the sun, and there is no need to have recourse to such a futile hypothesis. By comparing the two experiments just described we can infer what is the explanation of this phenomenon—of the turning of stems towards the light. Light retards the growth of stems, but a one-sided illumination will not act with the same effect on both sides of the stem—the front will receive all the light and the back will always remain in the shade. The front will consequently grow a little more slowly than the back, and the result will be the turning towards the light. In a word we have here a case contrary to the action of gravity. The force of gravity *accelerates* growth on the side turned towards the centre of the earth—the stem *withdraws* from it. Light *retards* growth on the side turned towards its source—the stem *turns* to it. The name *heliotropism* has been given to this phenomenon.

But if light retards the growth of stems, does it not follow that plants must grow chiefly during the night? This question has been raised many a time, and has been settled in various ways. These contradictions must not puzzle us, because the point itself is a very complicated one, and the observation of growth at such short intervals requires rather delicate methods of investigation, which science has come to possess only recently. In fact, apart from some rare cases,* growth in length during an interval of ten to twelve hours is not considerable enough to be easily observed, if experimental methods had not stepped in to help us where our sense organs appear to fail. Let us see what are the methods science possesses for demonstrating longitudinal increase in growth, which, owing to its insignificance, escapes immediate observation. We turn for the purpose to the microscope, i.e., we can magnify the object of observation, or use another method which will demonstrate in a magnified form not the plant itself, but simply its motion called by us growth. The most convenient microscope for the purpose is the so-called "solar microscope," which makes it possible by means of sunlight, or some other sufficiently strong artificial source of light, to throw the image of an object considerably magnified upon a screen, as we shall now proceed to do with the root-tip of germinating cress. Once on the screen we shall

draw a pencil line round the image and leave the root growing (in water), and return to it at the end of the lecture to see that it has succeeded in growing considerably in the interval.

Meanwhile, here is a figure showing (Fig. 54) the successive outlines of a wheat root, observed every five or ten minutes for an hour.** The sensitiveness of the method as demonstrated in this instance leaves nothing to be desired, but it would be less convenient for investigating the growth of larger organs or whole plants; in such a case we have to use the second of the methods indicated, i.e., instead of magnifying the growing organ itself, we magnify only the motion of the growing parts. We use for the purpose an apparatus, the main part of which consists of an index fixed to the axis of a small pulley (Fig. 55, *I, a*). Over the pulley a silk thread is thrown to

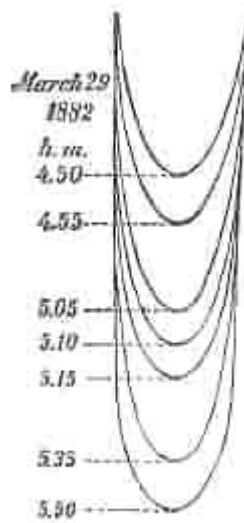

Fig. 54

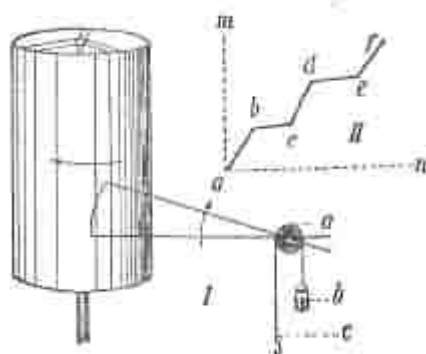

Fig. 55

one end of which a small weight (*b*) is attached, and to the other a small hook (*c*) made of thin wire. Catching the apex of any stem with the hook (a small wound as the result of the prick will not do it any harm) we let the weight hang freely on the other side of the pulley, and pull down the silk thread. Let us

now suppose that our stem has grown a little; what will be the consequence? In growing, the stem will slightly loosen the silk thread, and the weight will fall as far as the plant has grown; at the same time the silk thread lying close to the pulley will oblige it to make a turn of correspondingly insignificant magnitude owing to the friction it exerts upon it. With the pulley the index will also turn; but its point will naturally trace a much wider course, so that an imperceptible movement on the part of the tip of the growing stem will cause an already very considerable movement of the index point. This latter movement will exceed the former as many times as the length of the index exceeds half the diameter of the block. In our apparatus half the diameter of the block is equal to two millimetres, the length of the index is twenty centimetres, i.e., a hundred times as much; therefore every increase in the length of the stem will be shown by a movement of the point of the index a hundred times as great. The advantage of this instrument is obvious. We may fasten

behind the index a circular scale with divisions, like those on a clock, and read what division the index points to from time to time.

* Such are, for instance, the shoots of the bamboo, and the inflorescences of *Agave* mentioned in one of the previous chapters, which grow several inches a day; such are also the spiral stalks of *Vallisneria*, a plant known to all lovers of indoor aquariums (see Chapter VIII).

** Fig. 54 shows the successive outlines of a wheat root, projected by means of a microscope and a magic lantern.

But we can do something better still: we can turn this apparatus into an automatic one, and make the plant itself record the progress of its own growth during the different hours of the day. For this purpose let us apply the point of the index to a cylinder, the axis of which is set in motion by clock-work, so that it makes a complete rotation in twenty-four hours in the direction indicated by the arrow. In order that the index of the apparatus should trace a visible line it is convenient to blacken the surface of the cylinder with a layer of soot. Naturally, if the cylinder moves very rapidly in comparison with the movement of the index, the line traced on it will be almost horizontal (as is *a . . . n* in Fig. 55, *II*). On the other hand, if the arrow moves very rapidly in comparison with the rotation of the cylinder, it will trace an almost vertical line (*a . . . m*). If the arrow moves at a moderate rate the line will be oblique: the steeper its inclination the quicker must the movement of the index have been; the more the line slants, the slower the movement of the index. A glance at the line *a, b, c, d, e, f* shows that the stem grew rapidly from *a* to *b*, slowly from *b* to *c*, and so on. Knowing how long the cylinder was revolving, we can tell also to what hours of the day the rapid growth and the slow growth respectively correspond, and are able to trace the influences controlling such acceleration and retardation. The plant, so to speak, writes down its own impressions, as we have already said.

The sensitiveness of the indications of this apparatus depends upon the length of the index. It is inconvenient in many ways to use a very long index; and therefore, when we wish to have a very sensitive apparatus such as will enable us to observe growth during exceedingly short intervals of time, during one minute, for instance, or, as in the present case, to demonstrate this phenomenon of growth to a large audience, we have recourse to another method. We use something intangible instead of the index—a ray of light, to which we can give any desired length without technical inconvenience. For this purpose, instead of the index we fix to the axis of the pulley a small mirror (Fig. 56, *mn*). Light coming from a lamp or a candle placed in front of this mirror will be reflected and form a bright spot somewhere on the wall. The little hook at the end of the silk thread is fixed as before to the plant, and naturally every increase in growth which results in even the minutest rotation of the pulley, and the mirror connected with it, will cause a considerable displacement of the spot of light. If the index magnified the amount of growth

a hundred times, the apparatus with the mirror will magnify it many thousand times, or, generally speaking, any desired number of times, since the magnification only depends on the distance of the mirror from the wall. In order to be able to judge more conveniently, as well as more exactly, of the displacement of the patch of light,

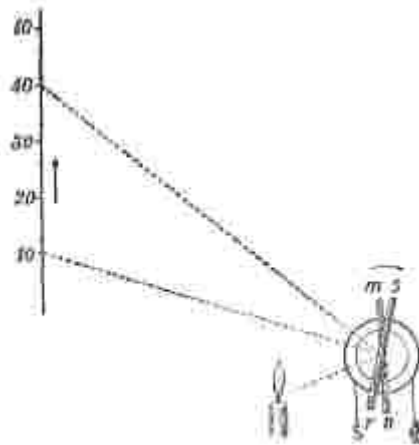

Fig. 50

large divisions are marked on the wall. Let us notice the mark at which it stands at present—it is exactly on the figure 10—and let us leave the plant (which happens to be a shoot of asparagus) to grow in peace, and then return to it at the end of our lecture.

Possessing such perfect means for observing growth, botanists have been able to study a whole range of questions concerning these phenomena. Thus, for instance, the reason for the abovementioned fluctuation in the rate of growth with night and day has been investigated. In order to settle this question it was necessary to realize that light is not the only condition that influences growth; it is affected also by the amount of moisture, and especially by temperature.

By growing plants in the dark and a constant amount of moisture, and varying only the temperature, we find that they grow more quickly at a high and more slowly at a low temperature. If we make the temperature rise and fall alternately, we shall notice that the index of the recording apparatus described above will draw upon the surface of the cylinder a line similar to the line *a, b, c, d, e, f* (Fig. 55), where every more steeply inclined part of the line will correspond to a warmer interval and every more sloping part to a colder one. This means that heat acts in an opposite way to light: while light retards growth, heat on the contrary accelerates it; which as a matter of fact was known very long ago to gardeners, who base upon it their method of *forcing* plants, accelerating or retarding their growth in order to make them develop in readiness for a certain date. Evidently the question as to the time when the plant grows most is not as simple as it seemed to be. It is dark in the night but also colder; it is light in the daytime but also warmer. It is difficult to say beforehand which of the two influences will preponderate in any case; the only obvious thing is that growth must be most energetic during a dark and warm night, and least energetic on a bright and cold day.

We have brought forward the simplest explanation of the phenomena of heliotropism, i.e., of the inclination of stems towards the source of light; but many people are not satisfied with it, because together with the general

phenomenon of bending *towards light*, there are also cases, comparatively rare it is true, of bending away *from light*; or, as it is sometimes stated, amid the preponderating phenomena of *positive* heliotropism there are some rare cases of *negative* heliotropism. This objection, which has obliged many botanists to give up the explanation just brought forward, may be easily removed on the strength of the more recent discovery that *one-sided heating* can cause phenomena similar to those of heliotropism, and called *thermotropic* phenomena. Evidently the result of thermotropism will be quite the opposite. Heat accelerates growth—therefore the heated part will grow more quickly and the organ will bend away from the source of heat. But sunshine acts at the same time both as light and as heat; it is obvious, therefore, that according as the one or the other influence predominates the organ will bend either towards or away from the light. We have just mentioned that the production of different effects attributed to a single factor may depend either upon a difference in the properties of the organs or upon the complexity of the apparently simple factor. Here we have, it appears, an example of the latter case.

The way in which botanists conceived the dependence of growth upon external influences became of necessity considerably more complex after the brilliant and always original investigations of Darwin. He showed that the point affected by the external influence may not coincide with the place where its effect is manifested. Thus, for instance, the force of gravity appears to act chiefly on the root-tip, although its effect is manifested by geotropic curvature in the region of most vigorous growth, lying some distance from the tip. We come to this conclusion because rootlets, the tips of which have been cut off, hardly ever curve until a new root-tip is produced. Stems appear to behave differently; but on the other hand some shoots show a similar behaviour in relation to light, a phenomenon which is not observed in roots. Thus, for instance, the tips of an oat seedling and, especially, of the seedling of canary grass are remarkably sensitive to light. If we cover these with caps made of tinfoil, the heliotropic curvature generally observed in the lower parts is considerably weakened.

These facts were sufficient to make some botanists think that in the root-tip and at the tip of the seedlings of cereals there existed special sense organs, which communicated their impressions to the growing parts in some unknown way and caused them to curve. We shall see presently that there is no reason whatever for presupposing any such sense organs or nerves in plants; here we need only say in passing that there is no reason whatever for such an explanation of the facts just described until other simpler explanations have been exhausted; and this condition, for all scientific explanation, is as yet far from being fulfilled in the sphere we are now engaged in studying.

Having now grasped in general outline the influence of the chief external agencies, light, heat, and the attraction of the earth, let us try and study more closely the very essence of

the phenomena in question. So far we have investigated the plant as a whole; but the life of the plant is the sum total of the life of innumerable cells. Let us see how the development of cells is related to the general phenomena of growth. We know that every cell in the course of its lifetime increases in size, changes its shape and the structure of its walls—in a word, grows. We also know that whatever be the size of the plant, it commences as a single cell and eventually contains millions of them. It is evident that the growth of a whole plant depends upon two phenomena, the growth of single cells and their reproduction.

* * *

It is now necessary for us to catch a glimpse of how these phenomena of the growth and reproduction of cells, which underlie the growth of the plant as a whole, take place. We must choose for the purpose appropriate material, an organ or organism in which we can study a living cell without disturbing it. We find such appropriate material in the filamentous weeds that form the main part of what is generally known as "green slime." If we place one of these green filaments under a microscope, we shall see that it consists of a single straight row of cells. Fig. 57 shows at the top such a cell with the green matter we have called chlorophyll, which gives plants their green colour distributed in a very characteristic way. Here it forms green bands with toothed edges, twisted spirally round the inner surface of the cell-wall: hence its Latin name of *Spirogyra*. Apart from this peculiarity the cells of *Spirogyra* do not differ in any way from the ordinary type of a cell. The same wall of cellulose is found in them, and within it the same protoplasm and cell-sap; while in the middle, like a spider in its web, we find a nucleus connected with the wall by very fine strands of protoplasm. We can observe such a filamentous weed in a drop of water under the microscope for several hours, and even days, and submit it during that time to different temperatures, and to varying illumination. In this way we see, for instance, that in the absence of light cells grow or rather elongate more quickly than in the presence of light. Light has a similar retarding influence on the multiplication of cells; at all events under normal conditions, this process takes place mainly and sometimes even exclusively at night. Formerly investigators had to arm themselves with much patience: they either had to sit up part of the night to observe one and the same cell, or else to lay aside, in spirits of wine, specimen filaments every hour or so, and subsequently observe the successive steps of the process in these different cells.* Nowadays the same result may be reached in a far easier way: when a vessel containing the weed is placed for the night in a cool place like a cellar, the process of multiplication is arrested till the next day, so that in this way we can always take advantage of the more pleasant hours of the day-time instead of the less pleasant hours of night for observing the process in the same cell.

* Under continual artificial illumination division also takes place in the presence of light. Evidently the light does not directly preclude division, but rather promotes the activity of the cell in another direction.

The process itself is very simple. It consists in the *division*, the splitting into two of the contents of a single cell. This happens in the following way: when a cell has reached the stage of development at which it divides, two outgrowths from the wall appear projecting into the cavity of the cell (Fig. 57, C, D). The cells under investigation are cylindrical

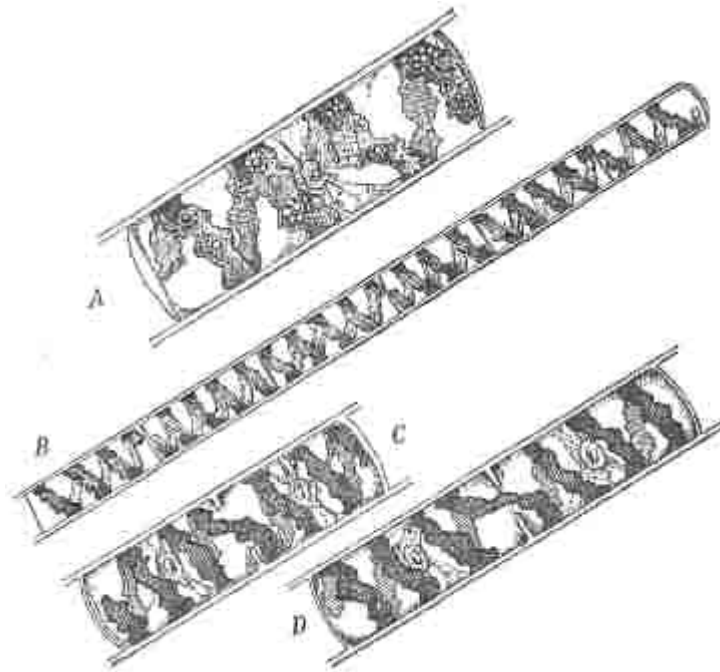

Fig 57.

in form. By making them rotate round a longitudinal axis by cautiously rolling them to and fro under the microscope, we see that the outgrowths just mentioned retain the same appearance whatever be the position of the cell. This means that they are not simply a pair of horns, as might have been supposed at first sight, but a whole ring encircling the inside of the cell. If we go on observing the same cell we shall notice that this girdle will grow deeper and deeper into the cell, dividing its contents in half. About this time two nuclei are observed instead of the single central one. In the end the girdle joins up completely in the middle, forming a continuous partition across the cell. Two cells are thus formed out of the one, each with its own nucleus protoplasm and chlorophyll band, and separated by a partition of the same cellulose that forms the external walls. A similar process of division takes place in each of the newly-formed cells after it has reached maturity, and so on. In the end a whole series, a whole filament, of cells is formed out of a single cell.

Such is the process of division in the simplest cases observed, but in most cases it takes place a little differently. Scientists were struck by the fact that during the growth of

tissues in the highest plants, one has never the chance of observing the abovementioned gradual ingrowth of a new partition into the cell cavity. The partition seemed to appear almost instantaneously, but on closer investigation they found out that here also it is formed gradually, though in a little different way. This became apparent when due attention was paid to a part of the cell we have already mentioned more than once, and upon which we shall now dwell. This is the cell nucleus, to which whole volumes have lately been devoted. In *Spirogyra* we do notice that the process of cell division is preceded by the division of the nucleus, but in most cases the connection between the two processes is closer still. The division of the cells is preceded by a series of changes which take place in the nucleus with invariable uniformity, and, what is very curious, are almost identical in the cell division of plants and of animals. Under the microscope two component substances can be easily differentiated in the nucleus; the one is easily stained with different colouring matters, the other is not. Some time before division takes place, the easily stained substance—chromatin, or nuclein—has the appearance of a bundle of tangled threads (Fig. 58, *A*). Later on these threads break into short pieces,

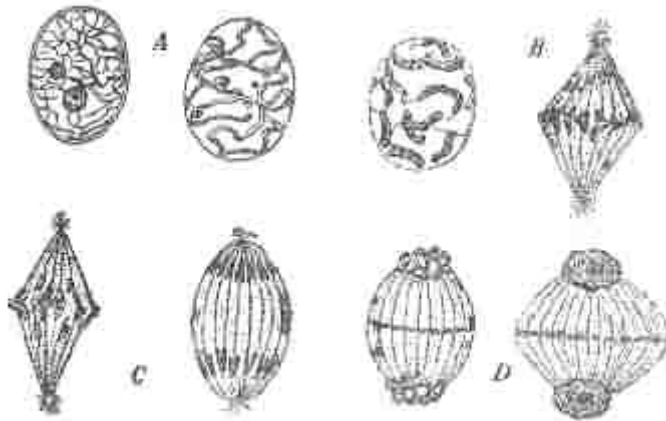

Fig. 58

which group themselves (as is shown in Fig. 58, *B*, on the right) in the equatorial plane of the nucleus. Later still these pieces, of which there are usually a definite number, split into halves and are drawn towards the poles of the nucleus, which by this time has assumed the configuration of a spindle, with a striped appearance (these stripes are not stained, hence the substance which forms them is called *achromatin*, Fig. 58, *C*). When the chromatin has gathered at the poles and become bunched up together, so that we have already two nuclei (Fig. 58, *D*) and division of the nucleus is complete, the division of the cell begins. Again in the equatorial plane of the spindle, there appear minute grains (Fig. 59, *1*) which blend later on into a kind of plate consisting of the same substance as the cell-wall, i.e., of cellulose (Fig. 59, *2*). As it forms, this plate pushes itself against the cellwall, and we see a partition dividing the cell into two parts (Fig. 59, *3*). Each of the

newly-formed cells has a nucleus of its own, and starts an independent existence, grows, and on reaching a certain dimension divides in its turn.

We had before a general explanation as to why the plants elongate more quickly in the dark. This depends on the fact that both the elongation of the cells and their division—the two

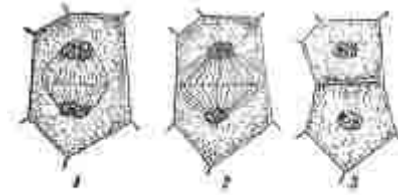

Fig. 39

phenomena which determine the growth of organs as a whole—take place more energetically in the absence of light. But can we not find out the approximate cause of this inhibitive effect of light? There are investigations which do to a certain extent explain this phenomenon, and which at the same time are connected with a question of great practical importance. It was long ago known that stems grown in the dark appear to be more watery and to have less tension in their tissues. They are in general less turgid, as is easily seen in cress grown in the light and in the dark. But a difference similar to that noticed in these extreme cases (i.e., between stems grown in the light and in total darkness) could be shown—to a smaller degree, it is true—in plants grown respectively in the shade and in a bright light. The suggestion has been made that some such effect might explain the laying of crops which, as we saw, people have vainly attempted to explain by want of silicon (see Chapter IV). This supposition might well have been based upon the fact that for the most part it is cereals which are sown very thickly that are badly laid, while this never happens with thin crops, however strange it may seem at first sight. The following method was used in order to shade the plants of a crop artificially. One or more plants were surrounded with a drainpipe; as soon as the straw rose above it, a second pipe was added on the top of the first, and so on. It is clear that under such circumstances the plant received light only from above, being always shaded at the sides. As was expected, these conditions produced very high, weak, and flexible straw. On submitting this straw and normal healthy straw to a comparative microscopic investigation, the following difference was observed: the former had perceptibly longer cells, but the walls were considerably thinner than those of the latter, the cells of which were shorter and had thicker walls. It follows that light does not, so to speak, retard growth, but apparently only modifies its direction. Instead of growing in all directions, the cell-walls thicken. The same difference has been observed when healthy straw is compared under the microscope with laid straw, as may be seen by comparing the transverse sections of two pieces of straw, one of each kind, in Fig. 60. All the cell-walls of the normal one (on the right-hand side) are much thicker, and the lower rows (the external layers of the straw) are even so thick that the cavity is reduced almost to a point. (The lines in Fig. 60, joining the cavities of

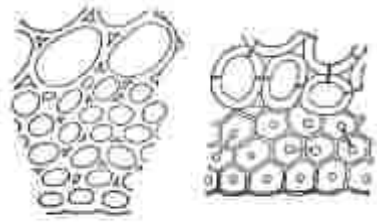

Fig. 60

adjoining cells, are the pits, as in Fig. 41, 3). As well as having their walls thus thickened, the cells of the straw of a normal specimen are considerably shorter in longitudinal section. Therefore, it is in a

too rapid elongation of the straw, together with an insufficient thickening of the cell-walls caused by mutual overshadowing in a thick crop, that we must look for the real reason of the laying of crops. This bad effect can be prevented by sowing the seed more thinly, or by drilling. Then every plant will get sufficient light for its normal development.

These facts lead us to contradict one more current idea about the growth of the plant. We have already seen that growth does not always imply increase in matter—during germination the increase in volume is accompanied by a loss of substance. We now see that growth does not always imply the elongation or expansion of an organ, because sometimes growth can show itself in a different way—in a thickening of the cell-walls. Strictly speaking, we see that a plant grows only when its cell-walls grow, whether in length, in breadth, or in *thickness*.

But it is not only light which may modify the form of cells. Occasionally this is also possible as the result of strictly mechanical causes. We have, seen in our last lecture that so-called annual rings are noticed on the transverse section of the trunk of a tree (Fig. 44, III). These rings are most clearly marked in fir-trees—in a pine, for instance. The reason for such rings appears to be connected with the periodical cessation of the vegetative processes during the winter. Nevertheless, if in spring, i.e., after the winter's rest, new rows of quite similar cells were added to the cells deposited the previous autumn there would be no difference whatever between the adjoining layers; the boundary between them would be imperceptible, and they would all blend into one continuous mass. The layers are clearly marked only because the wood formed in spring is distinctly different from the wood formed the previous autumn. Even with the naked eye we may see that two parts can be differentiated in every annual ring: the spring or early wood which lies nearer the pith, and the autumn or late wood which lies nearer the bark; the former is looser and therefore lighter in colour, the latter is denser and consequently darker. We notice this alternation of dark and light layers in every splinter, even in a match. The microscope betrays the immediate reason for this difference. This figure (Fig. 61) shows a small piece of pine wood, the transverse section of a match. Across the middle of it runs the boundary between two annual layers.* In the lower part lie some summer and all the autumn cells, say of last year; in the upper the spring cells of the present year. The sharp transition from the autumn to the spring cells is easily perceived: the former have a flat shape, thick walls, small and narrow cavities; the others are almost square, have thin walls and

large cavities. For a long time botanists could not account for this change in the form of the cells laid down at different seasons of the year, until they conceived the idea that the fact must depend on the mutual pressure, the mutual tension of the tissues.

We made acquaintance a little while ago with phenomena of longitudinal tension, i.e., of tension

depending on the unequal elongation of different tissues in a stem. Similar inequalities of growth can and do also take place in the transverse direction.

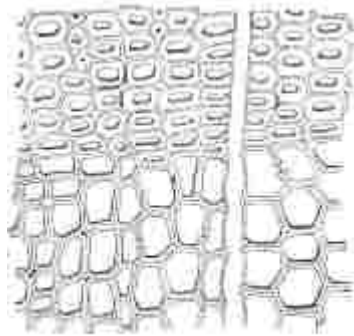

Fig. 61

* The transverse line dividing the section into two parts—to the right and to the left—is the medullary ray (see previous chapter).

The bark is continually compressing the wood which grows more quickly than itself, and in its turn it is continually stretched and strained by the latter. This is proved by the longitudinal fissures that generally appear in the bark owing to the internal pressure of the wood. It is not difficult to see that the smoothest bark is usually in a taut condition, and therefore presses on the wood. If we make a longitudinal cut with a knife, we shall see that the wound will gape; or, better still, if we cut off a ring of bark and replace it immediately (without giving it time to dry) in the same place, we shall notice that the edges will no longer fit and no effort will bring them together again. This means that the bark presses like an iron ring on the growing wood, and the more the latter develops the stronger is the pressure it has to overcome. Evidently this pressure will continually increase, and in autumn reach its maximum. Owing to this increasing pressure the cells of the wood will become increasingly flat. The truth of these statements is fully supported by experiment. If the pressure on the wood is artificially increased at the beginning of spring by an iron ring being girt round it, cells similar to the autumn ones will appear at those places throughout the year; whereas, on the contrary, if the pressure of the bark is weakened in summer and autumn by means of longitudinal cuts, we shall find in those places throughout the year cells similar to those found in the spring. Such, therefore, are the changes of form in the cells, which can be caused simply by mechanical means.*

* Another curious effect of a purely mechanical influence upon the growth of tissues has been demonstrated. The movements of the trunks of trees caused by the wind (as was shown at the beginning of the nineteenth century by a famous English scientist, Knight, who also discovered the effect upon growth of the force of gravity), as well as the subjection of the growing parts to artificial strain (as has been demonstrated by some contemporary German botanists), lead to an increased development of mechanical tissues. Thus mechanical tissues develop most strongly when they are most needed.

Can we not go a step further now and explain the very mechanism of growth—why it is that a cell grows, and how it is that under the influence of external agents growth takes this or that direction? The fundamental mechanism of the growth of cells is explained by botanists in the following way. Owing to chemical changes in the albuminous substances of the protoplasm, there appear substances which absorb water very greedily; drops of watery fluid,* the so-called *vacuoles*, appear in the cell. These vacuoles blend into a general vacuole which drives the whole protoplasm back against the cell-wall (Fig. 62, 1, *Vac.*), so that the protoplasm assumes the

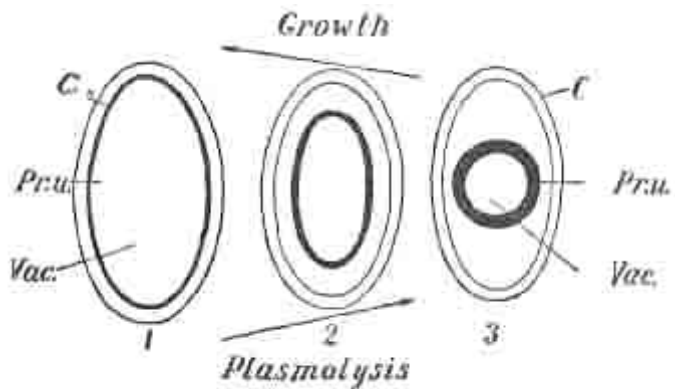

Fig. 62

form of a bladder, called the *primordial utricle* (Fig. 62, 1, *Pr. u.*). Into this vacuole, as into our apparatus in Fig. 45 under the influence of substances dissolved in it, there will pass osmotically larger and larger quantities of water; and since a cell is like a whole bladder, this increasing volume of cell-sap will press on the wall and oblige it to stretch—to grow. The protoplasm meanwhile will go on producing on its external surface adjacent to the cell-wall fresh quantities of cellulose.

* See Chapter II, Fig. 13.

That cellulose is formed by the protoplasm is proved by the following neat experiment. We cut a living cell under the microscope, and let part of the protoplasm out into water. This protoplasm, like any other liquid in a free state, assumes a spherical form, and in a short time produces cellulose on its surface, transforming itself into a new cell. It is most curious that only those portions of protoplasm which contain a nucleus possess this property of forming new cells. Thus, there is a close connection between the growth of cells and the nucleus. During the normal growth of cells a similarly close relation is observed between the protoplasm and nucleus and the formation of cellulose. During this process the walls are thickened either uniformly all over their inner surface, or only at certain parts of it, and this depends on the relative positions of the protoplasm and the nucleus.

On the strength of what has been said, the process of growth comes to this. A mixture of substances, called

protoplasm, consisting mainly of albuminoids, in breaking down and undergoing chemical transformation, on the one hand, gives rise to substances that dissolve in the cell-sap and osmotically attract water—hence the increase of the vacuole and the stretching of the cell-wall; on the other hand, owing to the same breaking down of the protoplasm, cellulose is formed, i.e., the material with which the walls of a growing cell are built. If our explanation is correct, on reversing the conditions we shall get a phenomenon contrary to growth, i.e., instead of an increase a decrease in the size of the cell, and particularly of the vacuole and the protoplasmic bladder distended by it. This conclusion is in fact supported by the following simple experiment.

If the increase in the volume of cells and, therefore, of whole organs depends on the supply of water attracted by the solution in the vacuole, by surrounding the cell or the organ instead with a solution that will draw the water out of the vacuole we shall cause a decrease in its volume. Let us actually observe under a microscope a living cell in a solution of sugar or salt more concentrated than the cell-sap. We shall notice that the volume of the cell will decrease (Fig. 62, 1 and 2), and when the wall consisting of solid matter cannot reduce itself any longer the protoplasm will loosen itself from the cell-wall, and owing to its surface tension will follow the further decrease of the vacuole (Fig. 62, 2), and in the end shrink into a regular little ball (Fig. 62, 3). This shrinking of the protoplasmic bladder is termed for the sake of brevity *plasmolysis*. Evidently we may conclude that the fundamental mechanism of growth is the converse of that of plasmolysis.* Even if we have no microscope at hand we can easily prove the truth of what has been said. Let us take the succulent stem of any herbaceous plant, measure its length exactly, and place it in a solution of common kitchen salt containing five per cent of salt. After a short time let us measure its length again. We shall notice that the stem has considerably shortened, which means that here we have a phenomenon the reverse of growth. Suppose we transfer the stem back into water. It will regain its former size, and go on living and growing. Therefore, this experiment gives us an opportunity for verifying our explanation of the mechanism of growth, without injuring the stem in any way.

* We have indicated this symbolically with arrows in Fig. 62. As has been already said, the wall, consisting of solid matter, is unable to contract as completely as the primordial utricle. *C* means cellulose; *Pr. u.*—primordial utricle; *Vac.*—vacuole.

If the increased pressure of the sap on the cell-wall be somehow arrested; for instance, if during the process of absorbing water the cell should lose it by evaporation, the cellulose formed from the protoplasm will go on forming on the inner side of the undistended wall and cause it to thicken. This thickened wall, in its turn, yields still less to the pressure of the sap, and retards the growth of the cell still further. Thus we may explain the abovementioned fact that checking the growth of straw goes hand in hand with the thickening of its

cell-walls. We notice at the same time that this retardation in the growth of organs and the simultaneous thickening of their cell-walls must happen whenever there is a deficiency of water. Probably the inhibitive influence of light upon growth, which we have already studied, depends upon the fact that plants evaporate more water in the light; and therefore the pressure of sap upon the cell-wall, which causes growth, will not be so great as when there is an abundance of water, in the shade or in the dark. If the phenomena of heliotropism may thus be connected with the phenomena of the evaporation of water, perhaps we may also explain in the same way the particular case of the *transmission* of the effects of heliotropism in Darwin's experiments upon the seedlings of cereals. You remember the energy with which these organs exude water at the tips—from which we may conclude that these same tips give off water vapour at a similar rate. This loss of water must be made up by the lower girdle of growth. Hence one-sided illumination will cause one-sided transpiration and growth, as the result of which there will be a curvature towards the light.

We have already seen that the growth of *tissues* can be retarded by direct mechanical pressure (as in the growth of the wood); now we notice that it can be also retarded by the weakening of the internal pressure, and this retardation is accompanied in both cases by greater thickening of the cell-walls. Under the influence of a one-sided action of external factors, the growth of *whole tissues* will be irregular, causing the curvature of whole organs. But similar unequal growth may also be manifested in *different parts of one and the same cell*, according to the distribution of the protoplasm and the nucleus, as we have already seen. It has, in fact, been noticed that whenever single cells curve, accumulations of protoplasm become noticeable on the concave side. This side is probably more thickened, and offers greater resistance to the osmotic pressure of the sap, and gets less distended. We may add that it is not the thickness of the cell-walls alone which figures in the phenomena of growth: the chemical and physical properties of the cell-wall may vary, and make it more or less resistant and elastic. It has been proved that a certain ferment exists which softens the cellulose of the cell-wall. The local appearance of this ferment can influence the direction of the growth of the cell and its external outlines. Perhaps these facts will furnish us in their turn with a clue to the explanation of another of Darwin's observations which we mentioned before—his observation concerning decapitated roots. Very possibly during the cell's earliest period, when it is consequently lying close to the root-tip, there is an irregular distribution of the protoplasm and the nucleus, etc., which may result in a subsequent irregular growth and a curvature of the whole organ. ;

Only now can we fully estimate the endless variety of the effects of external conditions upon the growth of organs, tissues, cells, or even parts of cells, and the complicated combinations all these phenomena may present when taken together; and only now can we realize what a mistake is made

when, instead of trying first of all to find out these possible explanations, people make up their minds that in the phenomena of growth are to be seen the results of some psychical, almost conscious, activity of the plant.

* * *

But we must now return to our cress and asparagus. You may have noticed, while I have been talking, how the patch of light has been steadily creeping up the wall; it is no longer at the tenth division, but somewhere near the fortieth. This is because the mirror has passed from the position *mn* to that of *rs*; so we have seen for ourselves how the plant grows. At the same time the root-tip of the cress has long ago moved beyond the circle traced round it with the pencil, and has considerably elongated. This means that we can observe not only the result of this process, not only its immediate cause, i.e., the growth and division of cells, but that we can also grasp the very process, i.e., the very movement that we call growth.*

* In order to ascertain how much the plant has really grown, we have only to measure the distance between the axis of the pulley and the wall. The real increase in growth, as has been already said, will be as many times smaller than the visible transposition of the image of light as is this distance greater than half the diameter of the block. Evidently, if people at the back of this large audience can be shown with the help of this apparatus the growth of a stem during the interval of an hour or even half an hour, the observer standing nearer will be able to notice the displacement of the beam of light during the interval of one minute. In fact this method permits of our observing, minute by minute, the increase in length of the stem; and of seeing the movement, so to speak, as if it were the movement of a minute hand on a clock.

We have thus performed the first part of the task we set ourselves at the beginning of this lecture. But what of the second part? Can we *hear* how the plant vegetates? Can we, for instance, make the plant tell us by means of sounds of some kind how it thrives; whether it is hungry or satisfied? The following experiment will show us that we can. A plant is being grown in an artificial soil* under a glass bell, with its flange carefully ground (Fig. 63, *A*). We know, however, that one of the most important sources of a plant's life is the carbonic acid of the atmosphere. How can we guarantee a continual source of carbonic acid to the plant under the glass bell; and, still more, how can we learn that the plant actually uses it?

* See Chapter IV.

We know that the activity of plants and animals is diametrically opposed with regard to the atmospheric gases. Plants absorb carbonic acid and give off oxygen; animals absorb oxygen and give off carbonic acid. Hence, if we placed an animal under the glass bell along with the plant, both would thrive together. But we can substitute an apparatus for the animal (Fig. 63, *B*), which, so far as the

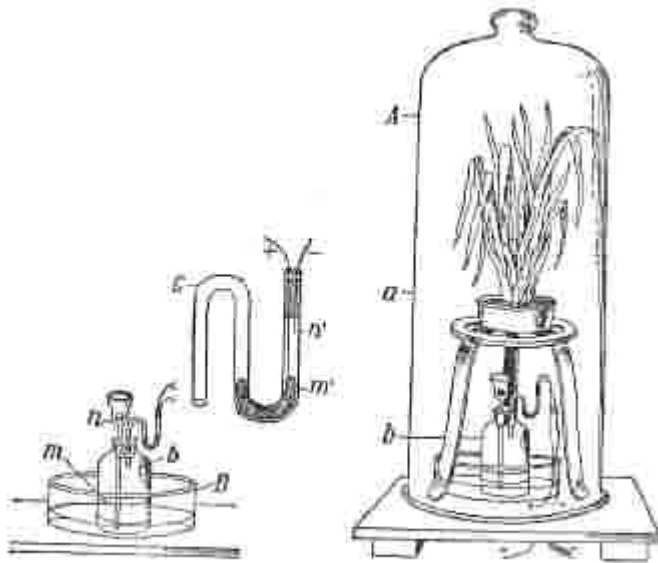

Fig. 63

exchange of gases goes, will act precisely in the same way as an animal would. It will be in a certain sense an artificial animal. This is how the apparatus is arranged. A liquid greedily absorbing the oxygen of the air is poured into a glass basin.* A glass jar is placed in the middle of the basin; through the cork of the jar the tube of a glass funnel is passed right down to the bottom, and also another tube twice bent. An acid is poured into the jar, while a ball of marble or chalk is placed in the funnel. Let us see what happens to the apparatus when it is hermetically covered by the bell *A*. There is air under the bell; therefore there is also oxygen. This oxygen will be absorbed by the liquid in the basin,** as a result the volume of air (*a*) under the bell will decrease; the pressure of air under the bell will diminish; and, if it diminishes, the small volume of air (*b*), contained in the jar, above the acid, will begin to expand, and, pressing upon the acid, will oblige it to rise in the tube and to appear in the funnel (i.e., the level of the acid in the beginning at *m* will be now at *n*, Fig. 63, *B*). But here it will meet the ball of marble or chalk, and will oblige it to give off its carbonic acid.*** This carbonic acid will replace the oxygen absorbed, and will go on being given off until the former pressure is established under the bell *A*; then the air in the jar (*b*) will fall back to its original Volume; the acid at the same time will go down from *n* again to *m*, and everything will settle down until the liquid in the glass basin, after having absorbed a fresh quantity of oxygen, upsets the balance again between the air under the bell (*a*) and the air of the jar (*b*). Was I not right in calling this apparatus an artificial animal? It breathes; it absorbs oxygen and gives off carbonic acid, and almost in the same quantities. The plant is placed on a tripod in the upper part of the bell; it will use the carbonic acid given off by the apparatus, and will itself in its turn give off oxygen, that will be absorbed by the liquid in the basin of the apparatus *B*. To sum up: between the plant and the apparatus *B* there will be a similar circulation of

matter as between a plant and an animal. The plant under the bell will be provided with a periodical automatic source of carbonic acid. The plant will thus be supplied with carbonic acid until the little marble ball is entirely dissolved, a matter of days and weeks. Without coming into contact with the marble, the plant is thus able to nibble it all up, and use its carbonic acid for food.**** But in order to know whether everything is right under the bell, i.e., that carbonic acid is being given off and decomposed by the plant, the apparatus *B* is supplied with the following adjustment. Into the twice bent tube *C* (shown in greater detail in Fig. 63, *C*) a drop of mercury is introduced. Evidently, whenever, owing to the expansion of the air *b* (Fig. *B*), the level of the acid in the funnel rises from *m* to *n*, the level of mercury in the tube *C* will likewise rise from *m'* to *n'* (Fig. *C*). Two insulated conductors joined to a common electric bell are introduced into the open end of this tube. One of the conductors is always immersed in the mercury, the other stops a little higher up, and comes into contact with the mercury only when the latter rises to *n'*. The moment this happens the electric circuit is closed, and the bell rings. It is pretty easy to regulate the apparatus in such a way that the giving off of carbonic acid will happen only when there is very little of it left under the bell, and that the bell will always ring whenever carbonic acid is given off. Just as the giving off of carbonic acid ceases when the acid returns to its former level *m*, so the bell ceases to ring when the drop of mercury returns to its former position and opens the circuit. But if, owing to some defect in the apparatus, carbonic acid should not be given off in time, the bell will go on ringing without stopping. I am sorry not to be able to show the apparatus at work, for reasons I have already explained more than once: its action depends on the giving off of oxygen by the plant, and this process takes place exclusively in daylight. But I can nevertheless give you an idea of how it works. If we rapidly cool the air under the bell (*a*) its volume will decrease as it would have done in consequence of the absorption of oxygen; and this decrease in volume, provided that the apparatus is in good working order, must be followed by the same result—the giving off of carbonic acid by the marble ball and the ringing of the bell. In order to quickly cool the air inside the bell, I have sprinkled it with some ether. The air has cooled, has decreased in volume; the column of acid has moistened the marble. The marble has effervesced in giving off carbonic acid, and the bell instantly rings. But the effect of the momentary cooling ceases; the usual order is re-established—and the bell stops ringing.

* In order to absorb oxygen in presence of carbonic acid Saussure's well-known mixture can be used consisting of iron filings, flowers of sulphur, and water; as well as a solution of cuprous chloride (*CuCl*) and kitchen salt, or a solution of chromous chloride (*CrCl₂*). Phosphorus (dangerous in summer) may also be used.

** The liquid used does not absorb carbonic acid—chemistry offers us a wide range of such liquids.

*** See Chapter III.

**** By weighing this little ball from time to time we can determine approximately the amount of carbonic acid absorbed by the plant in so many days or weeks.

Thus every time the plant is threatened with a lack of carbonic acid, the latter is given off by the apparatus *B*, and this is accompanied by the ringing of the bell. If the apparatus gets out of order, if carbonic acid ceases to be given off—the bell rings without ceasing.

If I had asked you a few minutes ago whether it were possible to oblige the plant every time it is hungry, every time it is merely threatened by hunger, to inform us of the fact by ringing a bell, you would probably have considered it an untimely joke. And yet this is exactly the significance of our apparatus. It is kept working by the activity of the plant, by its power of decomposing carbonic acid and giving off oxygen. We take advantage of this faculty in order to oblige the plant to inform us from time to time by a short ringing of the bell when its feeding was going on successfully, and by beating an alarm, calling for help, whenever it was threatened by hunger. In a word we oblige the plant to let us know by means of conventional sounds how it thrives.

We can now give a positive answer to the question raised at the beginning of this lecture: we can not only see but even hear how the plant vegetates. The experiments by which we have studied the various stages of the process give us at the same time a clear idea of the contrivances to which we must have recourse in investigating Nature. We are not content with the passive part of the observer, but enter into a struggle with her, during which the experimental art offers us a whole range of tools and methods. The plant is dumb, it does not answer our questions—we oblige it to write; it cannot talk—we oblige it to ring; somehow or other we obtain from it an answer to the question raised. It is vain to look upon this experimental art, as many do, as almost a mechanical activity, something inferior to abstract thought. The mistake was made even by the great Goethe himself. In distinguishing a certain duality, a certain discord between the two ways of investigating truth, between theory and experiment, he made Faust speak of Nature in the following way:

*Geheimnissvotl am lichten Tag
Lässt sich Natur des Schlelers nicht berauben,
Und was sie deinem Geist nicht offenbaren mag,
Das zwingst du ihr nicht ab mit Hebeln und mit
Schrauben.*

Certainly it was neither lever nor press that extorted the mystery from Nature—it was the far-sighted meditation and the stubborn will of the investigator that have done it. The tool for investigation is as much the product of a creative mind as the theory confirmed by it: it is the very same thought in palpable form. Is it not strange that while one might have seen for centuries in almost any old city of

Europe collections of those disgraceful instruments of torture by which man vainly tried to extort truth from his fellow creatures, it was only in 1876 that for the first time the idea occurred of collecting in one place the glorious implements man has used during three centuries in his struggle with Nature, in the course of which he has triumphantly come to wring from her one great truth after another.* Is it not strange still to hear the naivete with which people wonder that educated folk can choose some frog or blade of grass as a subject of study; or their open lamentations that the study of Nature, by engrossing the human mind with material subjects, diverts it from higher problems, makes it narrow and causes it to degenerate. In so saying they frequently cast sad glances on the past, as if the human mind used then to be concentrated exclusively on topics more worthy of its attention. Is such a reproach justified? Is it true that natural sciences narrow the mind, degenerate it? Is it true that they are less worthy of man's attention than other sciences, when, as we have just persuaded ourselves, these natural sciences occasionally give man access to regions where in the good old times only the immortal gods were given to tread?

* In 1876 there was an exhibition in London of instruments and apparatus used in the experimental sciences, with an interesting historical section devoted to apparatus that had served famous scientists in their investigations.

Chapter VIII

THE FLOWER AND THE FRUIT

Sexual and asexual reproduction of plants. The flower. Essential parts of the flower—ovule and pollen. Fertilization. Fertilization in the lowest plants. Adaptations securing the fertilization of flowering plants.

Function of the so-called non-essential parts of a flower. Self-fertilization and cross-fertilization. Cooperation of wind and insects. Parts of the flower attracting insects. Special forms of flowers adapted to cross-fertilization by insects. The part played by art in the production of cultivated varieties. Purpose of selection. Insufficiency of physiological knowledge of the nature of the sexual process.

*Various types of fruit and their transportation by air, water and animals. Viviparous plants. The scattering of seeds: yellow acacia, touch-me-not and squirting cucumber. Transportation by air: samara and pappus. Transportation by water: coconut. Transportation by animals: tenacious fruits and edible fruits. Mistletoe. Self-planting: *Linaria*, feather-grass. Is the plant intelligent?*

The nutrient substances spent in the building up of the solid parts of the plant reach their final destination in the phenomena of growth. Thus the life of a plant resolves itself into nutrition and growth. A plant feeds in order to grow, grows in order to feed, i. e., to enlarge the surface of its food-absorbing organs. These two conjoint processes may last a very long time; in some plants they last even thousands of years; yet they always reach a limit, though as a matter of fact we are unable to explain the necessity for such a limit, or to understand why one and the same vegetable organism should not exist for an indefinite length of time. Let us imagine a plant that produces surface runners, like those of the strawberry, or underground stems, so-called rhizomes, like those of the couch-grass (*Triticum repens*): these new parts will spread out and cover an ever wider area; old parts will die away, and consequently the connection between them and the young parts will break: they will separate, but nevertheless they will continue to be parts of one and the same plant, which, while destroyed at one end, will go on growing at the other. Or let us take another example from among trees: a well-known Indian fig-tree, the banyan-tree, produces adventitious roots from its outstretched branches. These roots reach the ground, thicken, and form pillar-like supports to the branches, furnishing them at the same time with necessary food. In this way a single tree may cover whole acres of land. The main trunk may get destroyed here also; but I do not think this fact would prevent branches which have taken root from continuing their existence for an indefinite length of time. The capacity of the plant for reproduction is not limited to such spreading; it is also manifested in another way. Whole parts of plants, such as stems with leaves, may acquire a special form and then free themselves from the plant that has produced them; such are,

for instance, the little bulbs formed in the angles between the leaves and stems of lilies, and also the tubers that appear on the underground stems of potatoes, in which we can recognize branches only changed in form. We may consider all the plants which spring from these organs as individualized ramifications which have separated from one and the same plant, in consequence of its own rapid spreading. It might seem that these and similar methods of so-called *vegetative* reproduction are quite sufficient to make the life of a single plant secure for an unlimited length of time; but matters turn out otherwise. It happens that vegetable life cannot be infinitely prolonged in one direction; it is bound from time to time to interrupt its course, to ascend again to its source, so that, starting once more from the very beginning, as a single cell, it may retrace the same course in the same order of continuity. In a word, we notice in the life of plants, as well as in the life of animals, a necessary succession of generations, and in each generation an invariable sequence of different stages of development, that we call age. Moreover, it happens that for this periodical renovation not one, but two beings must participate in the formation of a new organism. This is the phenomenon of sexual reproduction. At all levels on the organic ladder, beginning with the weed and ending with man, it presents one and the same phenomenon, which is the blending into one of two beings, two lives, ultimately two cells.

This inference, that in order to maintain vegetable life, periodical sexual renovation is necessary, is proved by the fact that, apart from the very lowest representatives of the vegetable kingdom which stand, so to speak, on the threshold of the organic world, we do not know a single vegetable group that maintains its existence exclusively by means of a vegetative process, by asexual reproduction as it is generally called; not one that does not also go through the process of sexual reproduction.

Let us see under what form this phenomenon takes place in the vegetable kingdom.

At first, the existence of two sexes was noticed only in some plants, mainly in those that had flowers; hence the name of *Phanerogams* given to them by Linnaeus in the eighteenth century in contradistinction to the *Cryptogams*. Today the name Cryptogam has lost its meaning, because phenomena of sexual reproduction have been discovered in all classes of plants, with the exception of the very simplest organisms, where it probably does not exist.

The idea that this process must take place in the flower, and that the fruit and seed, i.e., a young embryo-plant, are the result of this process, originated long ago; but as a definite scientific theory it has not more than two centuries of history behind it.

The idea must have been suggested by such plants as have two kinds of flowers distributed on different individuals. Such are many trees, e.g., the willow, the aspen, the juniper, and also hemp. All these plants produce two kinds of flowers: those that bear the fruit and the seed, and those that possess

only stamens, which do not transform themselves into fruit, but are necessary in that they contribute to the formation of fruit in other flowers. The first plant which attracted man's attention in this connection was probably the date-palm. At all events we read that people in the markets of Babylon and the Arabs of later days used to sell the male flowers of this palm that they might be hung by the purchasers among the female flowers to pollinate them; for this plan was seen to be followed by more abundant crops of fruit. We call those flowers female that contain a pistil which after the petals fall transforms itself into fruit; by male flowers we understand those that contain only stamens which produce the fertile dust or pollen and die when the flower withers. It is not, however, in all plants that the male and female, the staminate and pistillate, flowers are distributed on separate individuals. In many cases they grow on one and the same plant, as in the birch, the oak, the pine, and in maize; while in the considerable majority of plants stamens and pistils are found together in one and the same flower, i.e., the flowers are hermaphrodite. Such is the flower shown in Fig. 64.

Let us consider the part played by stamens in the formation of the fruit. A stamen, as we already saw in our first lecture, is in its most perfect form a more or less well-developed filament, to the end of which are attached two oblong sacks, which split longitudinally and shed a kind of dust, as a rule yellow in colour. Every such grain of dust represents a cell, commonly spherical in form, with a double wall: the external layer is thick and generally very elaborate, while the inner layer is thinner and simpler. The external layer has usually some pores closed with lids which can spring open on occasion.

The pistil in its simplest and most regular form looks like a bottle (Figs. 64 and 65, on the right-hand side). Its large ovary, the inside of which is hollow, contains ovules, one, several, or even a great number as in the poppy.



FIG. 64

The elongated part, the style, is occasionally traversed by a canal; but in most cases the style is solid, though its tissue is porous and spongy, its cells not coming into close contact with each other but having spaces

between them. This style ends at its apex in a broadened part called the stigma, which may be flat like a button, delicately branched like a feather, or indeed of almost any shape. The surface of the stigma is generally covered with short hairs and secretes a sticky fluid. The ovule enclosed within the cavity of the ovary, if split longitudinally, presents the following structure: the central part, the so-called nucleus, is surrounded by a double wall, through one end of which a canal passes right down to the nucellus. This canal may be directed upwards, or downwards as in Fig. 65. In the part of the

nucellus near the canal, a very big cell attracts our attention. This cell has been called the embryo-sac (Fig. 65), because it is here, as we shall see later on, that the embryo of the plant develops.

Such in general terms is the structure of these two flower organs—the stamen and the pistil. Their most essential parts are the ovule, which has to undergo fertilization, and the pollen grain, by which the process of fertilization is effected.

In order that fertilization may take place, the pollen grain must first of all reach the surface of the stigma, to which it easily adheres by reason of the hairs and sticky fluid. The means by which this end is achieved in Nature will be studied later on; in artificial breeding, in horticulture, it is found convenient to convey the pollen to the stigma with a brush. What happens next? The distance between the surface of the stigma and the ovule is still great. In what way does the pollen affect the latter? This question preoccupied botanists for a long time, and gave rise to a series of more or less fruitless suggestions. It was supposed that the pollen grains sink down to the ovary; that they burst on the stigma and let out their contents which reach the ovule; even that they act from a distance by means of some kind of emanation. Not one of these hypotheses proved true when exact microscopic investigations at last solved the problem. Whenever a pollen grain reaches the stigma or a suitable liquid, say a solution of sugar (but not water, in which it generally bursts), it begins to germinate, the inner wall protrudes through one of the pores in the external wall as a tube, into which the contents of the grain are conveyed.

The tube goes on growing at the apex and reaches a considerable length. As it grows forward, it often dies behind. These *pollen-tubes* push their way down through the porous tissue of the style, sometimes for a long distance, as in the cactus, for instance, where the style is several inches long. Once inside the ovary, the pollen-tubes reach the entrance of the ovule, make their way to the nucellus down the canal and gain entrance to the embryo-sac. The pollen-tubes reach the canal of the ovule almost haphazard; but the accident happens fairly frequently, because the number of pollen-tubes which penetrate into the ovary is generally considerable. Observations have, however, been made under the microscope which point to the fact that pollen-tubes are definitely attracted towards the tissue of the stigma or style, if it lies sufficiently near to them. This tissue seems to attract them even after it has been killed by boiling. New

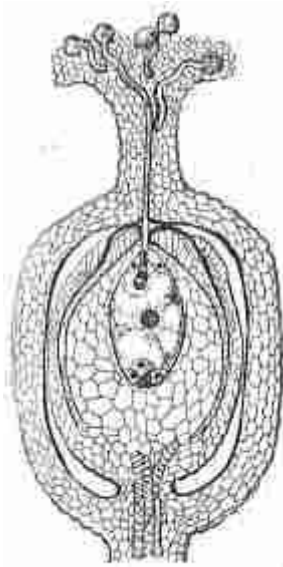

Fig. 65

investigations have demonstrated that certain substances, such as diastase, can attract the tubes. Thus, there is no mystery about this attraction.

Meanwhile events are occurring in the nucellus. In the upper part of the embryo-sac three little cells are formed out of its protoplasm. These cells have no cellulose wall, and are therefore only spherical lumps of thick protoplasm each with a nucleus. One of them is called the egg-cell or ovum, because it is the actual origin of the future embryo of the plant. This is therefore the primary cell we were looking for; from which, as we mentioned, every plant arises, be it a spore-bearing plant or a seed-plant.* The egg-cell is enclosed in the uppermost part of the embryo-sac so that the tip of the pollen-tube, on reaching the nucellus down the canal of the ovule, comes into close contact with the egg-cell. Recent investigations have proved that the act of fertilization really consists in the passage of a nucleus, from the end of the pollen-tube, through the softened and dissolved wall of the tube into the embryo-sac (the wall of which also becomes softened or dissolved), and its fusion there with the nucleus of the ovum. It is curious to notice that half of the chromatin substance involved in this process, i.e., half the total number of rods, belong to the male and half to the female nuclei respectively, so that the first nucleus of the embryo, formed by their fusion, contains chromatin from both paternal and maternal organisms. This fact explains very obviously why the properties of the parent plants are blended in their posterity. We shall soon see that in the flowerless plants we can still more easily be convinced of the fusion of the substance of male and female cells. The nature of this phenomenon, the chemistry of the process, is almost unknown to us. A ferment has been discovered among the constituents of the pollen grain, and moreover during pollination increased chemical activity is known to be generally displayed by flowers: they greedily absorb oxygen and give off carbonic acid, and this respiration is accompanied by a perceptible rise in temperature of the whole flower, and especially of the stamens.

* See Chapter I.

However, the result of this fusion manifests itself in the awakening of formative activity in the embryonic cell. It surrounds itself with a cellulose wall, becomes divided by a partition, thus becoming two cells instead of one. The first partition is followed by another, then by a third, and so on, till a multicellular body is formed, which grows and develops into the seedling which we met with in our first lecture, in talking of the seed. Sometimes a single seed has several embryos. This does not often happen. There are several embryos in the seeds of an orange, for instance, but they have quite a peculiar origin, and it would be useless to enter here upon a description of the process. Throughout the development of the embryo stores of nutrient substances are formed in other parts of the ovule, in the embryo-sac, and in

the nucellus; this will be the part of the seed which we have called the endosperm.* The endosperm being a store of food, it may either be absorbed by the embryo while the seed is still on the maternal plant, in which case the ripe seed will not contain any endosperm, like the seeds of beans; or, on the other hand, most of the endosperm may be preserved in the ripe seed, as in cereals, buckwheat, the poppy, etc.

* See Chapter III.

The effects of fertilization are not limited to the development of the embryo, and the transformation of the ovule into the seed; its influence also extends to the carpel, which grows after fertilization and develops into the fruit.

Such in very general outline is the formal morphological aspect—the only one known to us—of this phenomenon of fertilization. Let us now observe how the same process takes place at the other pole of the vegetable kingdom, among the simplest plants, like the weeds and the moulds.

Here is a microscopic weed, *Spirogyra*, which 'we have already studied, with its characteristic spiral bands of chlorophyll (Fig. 66, right-hand side). At a certain stage of development the filaments, of which the organism consists, become parallel to each other, as is shown in the plate. In some cells the contents gather into lumps, round or oblong in shape. Meanwhile the walls of two adjacent cells form swellings, which grow towards each other and meet; the partition dividing them is absorbed and vanishes, and the contents of the two cells fuse, the contents of the right-hand cell flowing into the left, or *vice versa*. The spherical mass thus produced surrounds itself with a wall, and becomes a spore. When set free this spore is capable of germination, and will give rise to a new organism, a new filament of *Spirogyra*.

Here, then, we meet with an extremely simple process of fertilization: two cells fuse in order to form *a new cell* which serves the purpose of reproducing the organism. This

phenomenon, in a still simpler form, is met with in a microscopic fungus—a mould. This mould consists of a thin very much branched tube (Fig. 66, left-hand side) in which no transverse partition is to be seen; which means that the whole organism consists of a single cell. In some parts of this cell short branches

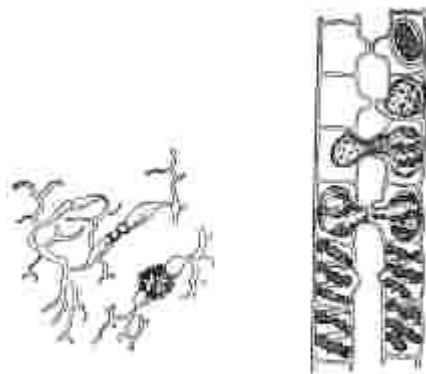

Fig. 66

appear, stretching towards each other. Whenever they meet, the ends of the branches are separated from the rest of the plant by partitions, and swell. Later on the wall disappears

where the ends meet, and the contents fuse, thus forming a single cell—the spore.

Thus in the simplest spore-bearing plants, as well as in the flowering plants, the phenomenon of fertilization consists in the fusion of the contents of two cells. This phenomenon is even more obvious in spore-bearing plants, because we can actually observe there the fusion of two cells. In the simplest cases we have described, no difference has been noticed in the aspect of the male and female cells, although a closer study of their structure does reveal a distinction between them; but in other more complicated spore-bearing plants the male cell differs entirely from the female cell in form as well as in character. While the female is non-motile, the male moves about like a microscopic animal, and penetrates (by its own activity) into the organ containing the female cell. There it fuses with it, dissolving in it, so to speak, and fertilizes it.*

* In 1897 such motile cells were found in the pollen-tubes of some seed plants.

We can follow with still greater certainty the effect of the pollen upon the ovule by means of experiment. In the first place we know that if the stigma is not pollinated the flower will fade without producing any seed or fruit; further, when pollen-tubes have been made to act under the microscope upon ovules, removed from the ovary, it has been found that the effects of fertilization were manifested only when a pollen-tube came into contact with an ovule. Finally, the participation of the male element has been most conclusively proved by experiments in artificial hybridization. If the pistil of a flower is pollinated from another flower, differing from the first, say in the colouring of the petals, it is possible in some cases to produce a plant with variegated flowers, i.e., flowers which have both the colour of the petals of the one in which the pistil was fertilized, and the colour of the other, the pollen of which was used. Obviously the effect of the male cell has manifested itself in the plant which resulted from the process of fertilization.

In order to accomplish the requisite pollination, plants are provided with a number of various adaptations. Let us dwell on some of them. Here is a plant (*Pilea*) rather insignificant in appearance, but grown in hothouses on account of the following curious property: whenever the flowering plant, covered with unsightly little flowers, is sprinkled with water, small clouds of dust rise here and there from its surface as if from minute explosions. This phenomenon is due to the stamens of this plant (coiled inside the flower and very hygroscopic) suddenly uncoiling like springs, and shedding the pollen out of their broken pollen-sacs. The pollen scattered in this way easily reaches the stigma. Let us study another case, this time a plant living in quite a different medium—a water plant. All lovers of indoor aquaria are familiar with their most common inhabitant, *Vallisneria*. The stamens and pistils of *Vallisneria* are found on different flowers, and these are distributed on different

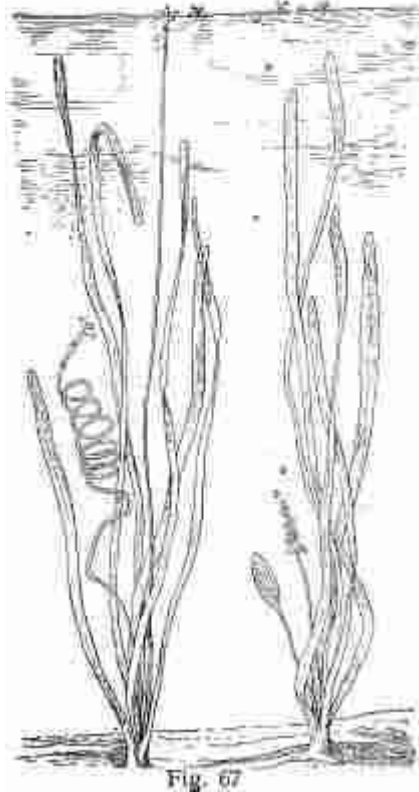
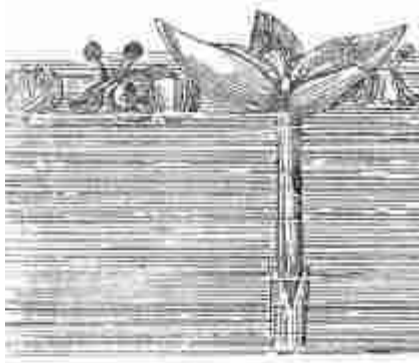

plants (Fig. 67). Both the male and female flowers 'develop under water. But fertilization is impossible under water. Gardeners know, for instance, that rain during the flowering period interferes with fertilization. Under these conditions the flowers remain sterile and produce no fruit. In order that the fertilization of *Vallisneria* may take place in the air the plant is provided with the following ingenious adaptation. The female flowers (left-hand side) grow almost at the bottom of the water, on very long but tightly coiled stalks. When the flowering season approaches these stalks uncoil and grow, thus bringing the female flowers up to the surface of the water. By this time the male flowers which develop similarly at the bottom of the water (right-hand side) are torn from their stalks

and also rise to the surface of the water. Floating among the female flowers they open their anthers and shed their pollen, some of which falls on the stigmas of the female flowers. When the flowering period is over, the stalk of the female flower coils up again, carrying the fertilized flower down to the bottom of the water, where the further development of the fruit takes place.

The significance in a plant's life of the pollen and the ovule—the essential parts of the flower—is now quite clear. The adaptations described above which make for their mutual interaction are also comprehensible. But another question springs up: what is the significance of the remaining parts of the flower? What is the purpose of the calyx? What is the use of the carpel which only hinders the access of pollen to the ovules? Why have the petals such bright colours and sometimes such fantastic shapes? What is the purpose of the perfume of flowers, and, finally, of the sweet honey-like fluid secreted at the bottom of the corolla by the well-known clover, dead-nettle, and many other flowers? Let us try to

answer these questions. The significance of the calyx and the carpel is the most intelligible of them all. The former, like the external scales of leaf-buds, guards the inner more delicate organs of the flower during their development; the latter plays the same part towards the ovules enclosed within it. In the experiments on the fertilization of ovules detached from the ovary, that we have just described, the experimenter met considerable difficulties in struggling with minute parasitic organisms, *bacteria*, which have so terrible a reputation owing to the infectious diseases they produce. When we wish to preserve organic matter from decay, we must protect it from becoming infected with bacteria. This we do by keeping it in hermetically closed vessels, or at least guarding it from the access of the germs of these organisms, floating about in the air, by closing the necks of the vessels with cotton wool. The cavity of the ovary is exactly the kind of vessel in which the ovule and the seed may safely develop without coming into contact with the germs of parasitic bacteria floating in the air. But an objection may be raised here: if on reaching the surface of the stigma the pollen grains germinate and their pollen-tubes reach the ovule, why should not bacteria flying about in the air likewise develop on the stigma and reach the ovule in the same way? The same observer to whom we are indebted for the explanation just brought forward of the significance of the ovary, has also explained the special significance of the stigma. Pollen grains developing outside the flower (under the microscope) suffer from bacteria in the same way as ovules. In order to prevent their attacks he slightly acidified the liquid in which the pollen grains germinated. This slightly acid reaction, which was harmless to the pollen grains, did actually prevent the development of bacteria. On testing the stigma itself, he found it also had an acid reaction. Thus, while it lets the pollen-tubes pass through, the stigma apparently prevents the access of bacteria to the ovary.

* * *

But how do the bright petals, the perfume, and the honey glands serve the flower? At first sight their function seems to be purely aesthetic. Formerly, when man considered himself the centre of the universe, when even the sun was believed to revolve around him, it was easy enough to admit that everything existed for the benefit of his eye, his sense of smell, or his taste. But gradually, with the development of science, this point of view lost more and more its hold. On the other hand, failing to observe in these parts of the flower any immediate purpose, botanists were in the habit of calling them non-essential. They looked upon them simply as the plant's bridal dress, to use a poetical and metaphorical expression. Both opinions proved to be wrong. To begin with, all these organs turned out to exist not at all for man, but for insects, and, above all, for the plant itself; secondly, they proved to be very essential, something even absolutely necessary for plants; without them the so-called essential

organs themselves would not have answered their purpose; and, finally, they were proved to be useful precisely in so far as they are bright, perfumed, and sweet, i.e., in so far as they serve as bait for insects. Let us explain the matter.

The ecclesiastical and civil laws of most nations, except those at the lowest stage of civilization, censure, forbid, and even persecute marriages between near relations. Doctors and physiologists have tried to prove by statistics the justice of this law so widespread over the earth, and indeed there is abundant proof that near relationship between parents has a very bad effect on their children's health. Today such proofs are scarcely needed any longer, because a whole series of investigations prove that it not only applies to man and the animal kingdom, but also to the vegetable kingdom; that this law is general for all the organic world. Nothing so convinces us of this truth as the plant.

We know, as a fact, that the fertilization of the pistil by pollen from the same flower is less successful, and gives a less vigorous posterity than when the pollen comes from another flower. Moreover, there are plants in which selfpollination is absolutely fruitless, e.g., *Corydalis*. There are also plants with two or even three kinds of flowers, e.g., the primrose, the purple loosestrife, and the different species of flax. The pistils and stamens of these flowers are of different lengths, and moreover long pistils occur in the same

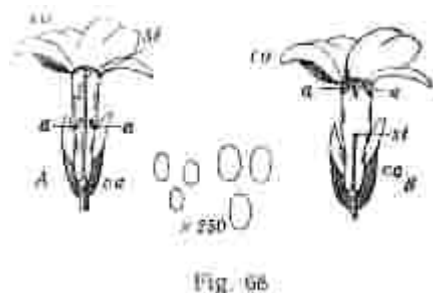

flower with short stamens (Fig. 68, *A*) and *vice versa* (*B*). For successful fertilization, it is necessary to transfer pollen to the stigma from stamens corresponding in height, which means that the pollen must always be taken from

another flower.* There are plants where fertilization with the pollen of another variety turns out to be more fruitful than self-fertilization. Finally, quite trustworthy investigators have described cases in which self-fertilization acts like poison; the stigma of a self-pollinated pistil appears as if singed, and the flower dies without forming fruit, whereas pollen taken from other flowers effects fertilization. Thus a number of facts prove empirically the existence of a general law, according to which cross fertilization is beneficial and self-fertilization comparatively harmful to the organism.

* In the middle of Fig. 68 the pollen grains of *A* and *B*, which are of different sizes, are shown.

The existence of this law once admitted, the significance of a number of peculiarities in the structure of the flower, otherwise inexplicable, becomes clear. A great number of facts have been accumulated in botanical literature in support of the theory that the structure of flowers is adapted to cross-

fertilization, especially through the agency of insects. Let us here dwell only on the most prominent outlines of this theory.

The following considerations can be brought forward in support of the theory that a showy appearance, perfume, and honey glands exist for the purpose of attracting insects, which in flying from one flower to the other promote cross-fertilization. In the first place, all these characters exist only during the period of pollination, after which they disappear. Secondly, there is a marked difference between plants in which pollination is effected by means of wind and those in which it is effected through the agency of insects. Flowers of the former kind are generally small and unsightly, are never highly coloured, and possess neither perfume nor honey. Such are the majority of trees, e.g., the pine, the birch, the aspen, and so forth. On the other hand, these plants produce an abundance of pollen. Clouds of yellow dust falling on the soil or on the surface of water have even given rise to superstitious beliefs in rains of sulphur. It is noteworthy that such flowers generally bloom in early spring, when the undeveloped leaves cannot prevent the scattering of the pollen.

It is clear, nevertheless, that such a waste of material probably precious to the plant, a waste inevitable during pollination by the wind, must be a very great disadvantage to the plant. Apparently it is more profitable to a plant to produce less pollen and to secure more accurately its transference to the stigmas of other plants. This economical purpose is evidently served by insects. Honey glands, the so-called nectaries, entice insects to visit flowers; the bright colouring, the size and the perfume of flowers serve as means for attracting them. It has been proved that bees possess the faculty for distinguishing between colours. By smearing with honey differently coloured surfaces, we can train insects to associate the impression of a certain colour with the presence of honey. Cross-fertilization takes place as a result of a division of sexes in the flowers themselves; the staminate and pistillate flowers may be distributed either on one and the same plant or on different plants; while in hermaphrodite flowers cross-fertilization is achieved by the ripening of stamens and pistils at different times, whereby self-fertilization becomes impossible. But most convincing of all are the numerous facts which show all the parts of the flower to be adapted in structure and disposition to the form and habits of the visiting insect, so that in flying from one flower to another the insect is bound to touch the stamen of one flower, and then with the same part of its body the stigma of another. Let us limit ourselves to a few illustrations.

There are many flowers the parts of which, instead of being arranged in the usual regular way round the centre, are distributed in such a way that right and left sides, top and bottom can be distinguished. Labiate flowers may serve as an example (Fig. 69, 2). Such a form is obviously very convenient for insects; the lower lip serves as a platform or balcony, on which the insect alights when in the act of passing its proboscis into the tube of the corolla at the bottom

of which the sugary nectar lies. But in doing so it rubs its back against the anthers (Fig. 69, 1 and 2, *m*), and when it alights upon another flower it rubs its back covered with pollen against the stigma (*p*). Self-pollination is quite impossible in this case, because the stigma develops later than the stamens of the same flower, and it can receive pollen only

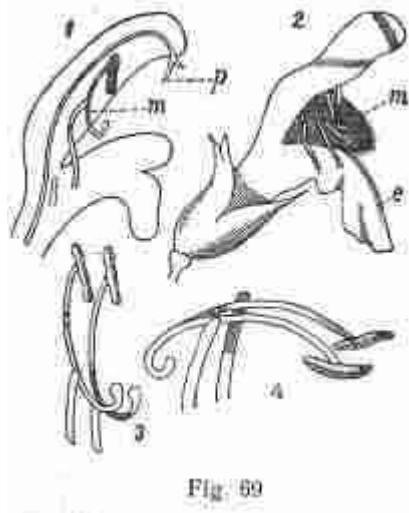
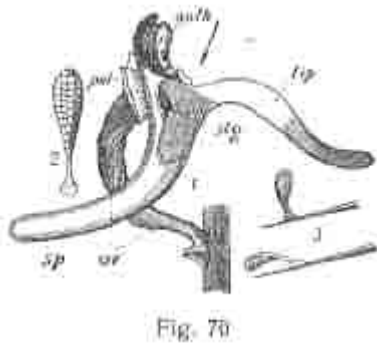

Fig. 69

from another flower. In another labiate flower, the common sage, the following curious adaptation is found (the sage flower is shown in Fig. 69). The stamens are of an unusual form, having the anthers fixed to the top of a long cross-piece, which is balanced on a short stalk (in Fig. 69, 1, a flower is shown split longitudinally, with one stamen (*m*); in Fig. 69, 3, the two stamens are shown separately). The lower ends of these cross-pieces bar the entrance to the tube of the corolla, at the bottom of which, as has been already said, there lies some sugary liquid. The moment the insect pushes its proboscis into the tube, it sets in motion these lower ends of the cross-pieces, which like levers come into position 4 from position 3 (Fig. 69). At the same time the anthers descend on the back of the insect (Fig. 69, 2, *m*) and cover it with pollen. Another still more striking method of pollination is found among the orchids, where in most cases pollination would be almost impossible without the agency of insects, and the flowers would be doomed to continual sterility. The flowers of this family are distinguished by their fantastic shapes, for which they are so commonly grown in hothouses. It may be sufficient to mention among the wild representatives of the group the butterfly orchis (*Platanthera*). Let us imagine such a flower with all its petals torn off, with the exception of the lowest which is in the shape of a lip and is elongated at the base into a tube, called the spur (Fig. 70, *sp*). * The pistil and stamens of this flower are equally singular in shape: the pistil consists of a long twisted ovary (*ov*), on the top of which, without any style whatever, the stigma rests, in the shape of a sticky spot at the very entrance into the tube of the spur (*stg*). The stamen has no filament, but consists of an anther only (*anth*), situated close to the stigma. But all this does not exhaust the peculiarities of this plant. Its pollen is not fine dust, but is gathered in each of the two lobes of the anther into a lump, on a stalk which ends at the bottom in a sticky knob on the outside of the anther (Fig. 70, 2). Evidently since the pollen is not set free by itself it cannot reach without external assistance even the stigma of the same flower, although it lies



so close to it. This very assistance is given by the insect. In settling upon the lip, it thrusts its proboscis into the tube of the spur, at the bottom of which a sugary fluid is generally secreted, distinctly seen in *Platanthera*. The insect invariably comes up against the viscous knob sticking out of the stamen,

and in flying off the flower carries away its mass of pollen. This arrangement of the flower is so accurate, and works so perfectly, that even a needle cannot be thrust into the spur in the direction of the arrow (Fig. 70, 1) without being removed with the mass of pollen adhering to it, as is shown in Fig. 70, 3. At first this mass of pollen stands upright, but in a few minutes it bends forward (Fig. 70, 3). The same thing happens to the pollen mass adhering to the insect. When it flies off to another flower, where the same process is repeated, it leans with the pollen mass exactly against the viscous stigmatic surface (*stg*) and leaves there part of the pollen. The fact that everything actually takes place in the way described above can be proved from insects caught during their visitation of these flowers. On their proboscis and head masses of pollen have been often found adhering in considerable numbers. Consequently, the fertilization of such flowers cannot take place without the participation of insects and resolves itself into cross fertilization, always an advantage to the plant. The importance to the plant that its floral parts should have just these and not other forms becomes quite apparent.

* Fig. 70 shows the flower of an orchid, all the petals of which are removed except the lip, which is split into two, to show the entrance into the spur and the position of the stigma.

Let us consider another striking example where all the parts of the flower appear to be adapted to the same end, i.e., to cross-fertilization by means of insects. This plant is *Aristolochia*. Its pale yellow flower has a tubular corolla swollen into a ball at the base, expanded and cut obliquely at the apex. The long ovary with a number of ovules (Fig. 71) passes immediately without any style into a lobed stigma. Stamens without any filaments and closely attached to the pistil are situated right down under the stigma. The narrow tube of the corolla is lined with stiff hairs pointing towards the inside of the flower, as is shown on the plate (71, upper section). The whole arrangement is like a mouse-trap. Owing to this position of the hairs the insect easily crawls inside the flower, but cannot come out again; the flower is a trap where the insect finds a stigma already mature and ready for fertilization, together with stamens not yet fully developed. If the insect comes from another flower it rubs pollen on the

stigma. Some time later the stamens ripen and split; the insects restlessly move about in their prison (71, upper section) and get covered with pollen; but this pollen on reaching the stigma does not provoke self-fertilization, because the stigma has already withered. The hairs of the corolla soon afterwards wither and fall off (71, lower



Fig. 71

section), the door of the prison is open, and the insect, covered with pollen, flies out to be caught again by a similar trap in another flower. Later on, the upper lobe of the corolla withers, and bending over closes the entrance into the flower (71, lower section); and the whole flower until then erect, droops. In this way fertilized flowers escape useless visits from insects. This adaptation works as successfully as the mechanism for the fertilization of the orchids, so that we can tell almost with certainty from the external

appearance of the flower whether we shall find insects inside it or not. The number of insects thus temporarily imprisoned in a flower is sometimes considerable.

We may, then, assuredly see in the so-called unessential parts of the flower, such as the bright colouring of the corolla, its fantastic shapes and honey glands, very perfect adaptations of the flower to the purposes already indicated. Perfume probably has a like purpose. Like colour it serves to attract insects. It has even been noticed that flowers, which exhale in the night a very strong perfume, are visited by night insects. Yet the exhalation of volatile, aromatic substances can serve another purpose in the plant. To begin with, plants need a more or less high temperature in order to flower, which is partly supplied to them by the above mentioned rise in temperature as the result of respiration; but, on the other hand, during clear, calm nights plants are known to be exposed to considerable cooling owing to strong irradiation. To prevent this cooling we have only to cover the plant with a glass bell which arrests the heat rays emitted by the plant, and thereby prevents unnecessary cooling. But this very property of the glass belongs also to all volatile substances such as are exhaled by flowers; they strongly arrest radiant heat.

In order to ascertain how considerable is the atmosphere of the volatile, so-called ethereal oils, surrounding scented plants, we have only to apply a lighted match to the strongly scented flower of *Dictamnus*. We see in amazement one

flower and then the whole bush of flowers enveloped in a bluish flame. This means that the vapours of ethereal oils excreted by glands with which the flower organs of this plant are supplied have become ignited.

Therefore, during calm, clear summer nights, i.e., exactly when there is a danger of cooling owing to irradiation, the flowers are surrounded with a transparent cloud, an atmosphere of these emanations, which, by arresting like the glass bell the heat radiating from the flowers, preserve them from excessive cooling.*

* Plants are known to be preserved from cooling in the night by the lighting of a fire in their neighbourhood, which will make a cloud round them and prevent them from losing too much heat by irradiation.

Thus one more disappointment has been added to the many that science has been causing the pride of man from the moment it proved that it is not the sun that revolves round him, but he round the sun—namely, that this variegated carpet of flowers, glowing with all the colours of the rainbow and emitting the most delicate perfumes, has never existed for his sake—the king of Nature—but for midges and insects, and, above all, for the sake of the plant itself.

But with every new achievement of science, although it has involved his parting with unjustified claims, man has only been gaining in real importance. So is it in this case: if he has to admit that flowers were not created for his sake, he can surely console himself with the thought that they are partly created by him. We have only to compare the plants in our flower gardens, kitchen gardens, and cultivated fields with wild plants to agree with this statement. A glance at any cultivated plant, at any garden flower, or any vegetable reveals in them the guiding hand and thought of man. His claims, sometimes even only a passing whim of fashion, have changed natural things in accordance with those claims and whims. Fancy demands, for instance, that a small, irregular, pale, three-coloured flower of heart's-ease should become big, of one colour, almost black, and round; and here, before our very eyes, as if by some magic power, we see it actually becoming bigger, darker, and rounder. The question arises, by what means has man attained this result? how has he obliged Nature to contribute to his ends, to follow obediently his indications?

The procedure is very simple: man has been working on these lines for ever so long without realizing it; and it is only recently, after having grasped the treasures of knowledge accumulated during centuries of practice, that science has presented in their true light the simplicity and universality of the method employed. This procedure is as follows. Seeds obtained from one and the same plant never produce two absolutely similar plants; differences invariably appear. If these plants be left to grow and reproduce themselves, their differences will soon vanish owing to cross-fertilization, and a permanent, mean, typical form will be produced. Quite a different result will be obtained if a form distinct from others

in some point or other be removed and isolated; its peculiarities will in most cases pass to its posterity. If in the new generation we again isolate the specimens which have attracted our attention by a striking peculiarity, we shall emphasize the peculiarity in every generation, and eventually fix it. This is the method of *selection*.

In horticulture this method of selection is often applied in the simplest and at the same time most effective way. It consists in the destruction in every generation of all the plants that fail to answer the purpose in view. By repeating this operation of selection in every subsequent generation, and so strengthening minute and scarcely noticeable characters of the plant, man seems to cast it in a new mould, feature by feature, and to realize an anticipated ideal. It is worth noticing that, while thus breeding plants and animals, man has applied this principle of selection to himself as well, although unhappily only in the reverse order. For ages he has generally chosen the best representatives of his own kind from the physical point of view and condemned them to certain death. This experiment with humanity proves, though of course in the negative direction, the success of the principle of selection. Such was, for instance, one of the results of Napoleon's work. His endless wars have resulted in the decrease of the average stature in France.

Thus the principle of selection affords man a powerful means for improving organisms, for perfecting them, and the simplest application of this principle consists in the extermination of organisms that do not correspond to his aim. Let us remember this conclusion, which will later on prove to be the key to the explanation of phenomena taking place in Nature.

Let us sum up what we have learnt in this lecture.

There is a law underlying organic Nature according to which the cell though able to produce such giants as the Wellingtonia and the Baobab, the age of which is reckoned by thousands of years, is yet unable to reproduce itself endlessly in the same vegetative way. The maintenance of vegetable forms requires that they should occasionally be renewed by the union of two separate cells. The significance, meaning, and necessity of this law of the existence of two sexes is quite obscure; it is only an empirical law, based upon the conjoint testimony of all the facts known to us.*

* It is worth mentioning that certain seaweeds present a curious instance of the sexual process taking place between three cells instead of two, a phenomenon which has no analogy in the rest of organic nature. One of these three cells, being the element fertilized by the second cell, is at the same time the fertilizing element of the third. This fact, quite authentic although unique, together with the fact of the absence of any sex whatever in the simplest organisms, prevents us from too broad generalizations, from metaphysical theories concerning the existence of a certain organic polarity, and so on.

It may be that we are entitled to see in this law only one of the many manifestations of a more general law—the law of the utility of the physiological division of labour, which

expresses itself in the fact that the functions fulfilled in the simplest organisms by a single cell distribute themselves over different cells as the organism increases in complexity. The cell may be unable to reproduce itself successfully in all its parts in a long series of generations, and perhaps this labour is divided between two cells, each of which works out only a certain part of the future organism, and taken by itself may be even incapable of further development. But wherein does the difference lie between these two cells? Which is the element of development each of them contributes? These problems are the problems of the future. There is but one thing that can be inferred from the facts we know, which is, that along with the growing complexity of organisms, certain external differences arise between the sexual cells, and at the same time we observe that the degree of relationship between them increases. So far as the significance of the sexes is concerned, we are as yet completely in the dark, and it is better to abstain from any explanation at all than to indulge in vague hypotheses with no facts behind them.

The main function of the flower is to form a seed, i.e., an embryo, within the growing and changing ovule. This type of seed formation is observed, however, in only a few seed-plants, e.g., conifers, in our country, and tropical sago-palms, whose leaves are sometimes placed on the graves together with wreaths. If we pluck the scales off a fir- or pine-cone we shall find a seed with a pappus at the base of each one. Squirrels know this and tear off the scales to get at the seeds. Such plants are called *gymnosperms* and are the simplest of the flowering plants, since they have no ovary or flower covers. Geology helps to define that the *gymnosperms* are more ancient than the more perfect *angiosperms*. The organ, which, as we know (Chapter I), encloses the ovules, is called pistil. When fertilized ovules develop into seeds the pistil turns into a new organ—the fruit. The pistil, as you have seen in Chapter I, consists of carpels—one (as in the peony, Fig. 6, p. 55) or more. In their turn, these carpels are nothing but leaves, that have been modified in a peculiar way, with ovules at their edges. Sometimes not only the pistil but also the adjacent flower parts go to form the fruit.

The fruits are even more varied than the flowers, I believe. They may contain one or more seeds, be dry, be formed by one or more carpels, and may crack in most ingenious ways to disperse their seeds. They may be juicy or fleshy, and may ripen simultaneously with the seeds. Both the seed and the fruit not only fall when ripe, but may have special devices for scattering. Moreover, besides scattering, they can travel, and their means of transportation are air, water and animals.

All this is observed when the plant reproduces by seeds, which can be, to a certain extent, compared to the ova of animals. There are very rare cases, however, when a plant can be called viviparous in a sense, i.e., its embryos develop on the body of the parent plant and, when separated, grow on their own without any change. In such cases the role of the fruit is quite unimportant. I mentioned one of this class—

Rhizophora Mangle—in Chapter III. These plants are rather curious owing to their peculiar mode of life. They grow on the seashore of continents and islands lying within the tropical zone and washed by the tide. Under these conditions the seeds of ordinary seed-plants would be carried away by the tide into the open sea. Mangrove avoids this danger in the following way. The fruit and the seed hardly develop and serve as a sort of a short-lived intermediate organ between the parent plant and its quickly developing child. The part below the cotyledons is the quickest to grow; it perforates the fruit-wall (Table I, Fig. 1) and grows into a long and heavy organ, sharpened at the lower end. This organ easily breaks off from the cotyledons, falls upright and sticks into the soft silt. In a few hours it strikes root and spreads out the foliole that was enclosed between the cotyledons. Thus, under these seemingly unfavourable conditions, the future life of the plant is quite provided for and the offspring goes on living uninterruptedly.

More examples could be given of the various types of fruit and how it provides for the further existence of the embryo.

Cereals are probably the simplest of fruits. Laymen take their grains for seeds, and, indeed, it's quite a job to distinguish what is seed and what is fruit in a grain. With the help of a magnifying glass we can see the remnants of stigmas on its top. There occur cases of viviparous stipa among cereals. This property is permanent with *Poa vivipara*, and occasional, in damp weather, with our cultivated cereals.

The many-seed fruits are more varied in shapes: they are either follicles (peony, Fig. 6, p. 55), formed by one carpel, or most various capsules, formed by several carpels and opening differently to scatter the seeds. In most cases they split along the seams formed by two adjoining carpels; besides, they may open by throwing off the cover or by forming pores (the poppy), etc. The seeds may simply fall to the ground, in other cases they may have hairs to make them fly (asp, maple, etc. Table I, Fig. 2). There are most curious cases when the fruit not only opens for the seeds to escape, but catapults them. The simplest example is the pods of the common garden yellow acacia. The two folds of its pod crack open and coil like watchsprings, pushing out the ripe seeds. An interesting mechanism for scattering is observed in the touch-me-not, growing in shady places. Delicate light-yellow flowers in the shape of a horn sway on its thin stems. In a few weeks the plant forms green oblong fruits, pointed at both ends. When you clasp this fruit in your palm, you are startled by the way it seems to struggle, like a strong beetle desperately fighting its way out. When you open your hand you will see five separate twisted folds and the scattered seeds on it. Just nip off the tip of the fruit and it will burst, its seeds flying in all directions (Table I, Fig. 3). This illustrates the phenomena of mutual tension of tissues that was discussed in Chapter VII. The outside tissue has already lost part of its water, while the inner tissues have it in excess. Thus each fold tends to coil outwards or even twist spirally, thus forcing the seed out. In

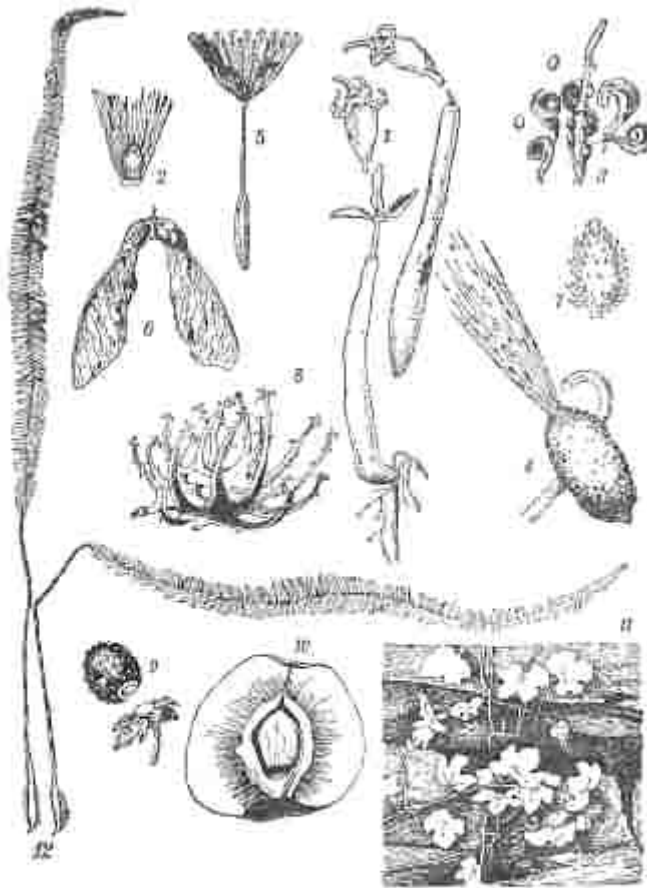

Table I

1—the viviparous fruit of *Rhizophora Mangle*; 2—a poplar seed with a pappus; 3—the cracking fruit of a touch-me-not; 4—the bursting fruit of a squirting cucumber; 5—the seed of a John-go-to-bed-at-noon with a pappus; 6—a maple samara; 7—the many-hooked fruit of *Xanthium*; 8—the tenacious fruit of *Harpagophyton*; 9—a fleshy wild strawberry fruit; 10—a fleshy peach drupe; 11—the emptying of capsules of *Linaria*; 12—the self-planting of a feather-grass seed.

the Caucasus there grows a plant known as the *squirting cucumber* (*Ecballium elaterium*). When slightly pushed, the ripe fruit of this plant detaches from its stem and squirts its liquid contents to a considerable distance (Table I, Fig. 4). The mechanism is the same: the tense outward tissue presses on the fruit's contents, just as in a perforated rubber ball.

As was mentioned above, the seeds are dispersed by air, water and animals. The air helps in the cases of the *dandelion* and *John-go-to-bed-at-noon* (Table I, Fig. 5). Their ripe fruit has a *pappus*, a downy appendage, which enables it to be caught by the wind and carried far away. Similar devices, called *samara*, are observed in the maple (Table I, Fig. 6), ash, birch-tree, etc. The samara is characteristic only of tree-seeds that fall from a certain height, while the *pappus* is met in both, low and high, plants.

Water transports not only the seeds of water plants but also those of land plants, and, curiously enough, the largest of all known fruits—palm nuts, e.g., the *coconuts* and, larger still, the nuts of *Lodoicea*. The fruits of the latter are the pride of all natural science museums. The story goes that the first

such nut was presented to Emperor Rudolph by a traveller, who received in reward as many golden coins as the shell could hold. The nuts fall into the sea from the palms on the coast and are carried to the far shores of the continent and islands. The outer shell of these nuts is waterproof and the next fibrous layer contains air which keeps the nuts afloat. Then follows a very hard shell which holds a liquid kernel—coconut milk. This liquid is a sort of fresh-water supply which the embryo needs on its sea travels.

Animals also take part in transportation of seeds. The fruit may stick to the animal's body, mainly to its hair, and travel together with the animal, to leave it as casually as it was caught. Thus many plants get into new areas with exported wool. The animals, however, in no way profit by being the vehicles of the seeds. On the contrary, their life may be endangered. Ordinarily the barbed or hooked seeds (Table I, Fig. 7) stick to the animal until they touch some other object and fall to the ground. But this is not always the case. The stipa of the feathergrass (the *stipa capillata* species) is needle-sharp at the bottom and has long barbs at the top. When dry, these barbs twist and entwine round everything they come in contact with. When caught in a sheep's fleece, they get entangled in it and pierce the animal's skin, thus causing the animal great pain. Sometimes there are so many of these plants on pastures that the skins of the sheep that graze there lose their value owing to numerous perforations. Still more dangerous is the fruit of *Harpagophyton* (Table I, Fig. 8), which grows in South Africa. Lebbcock states that it gets entangled in the lion's mane, and when the animal tries to bite it out, it drives its barbs into its mouth. The lion is unable to pull the seed out and often dies of starvation. These dangerous forms of fruit hardly serve the purpose of seed spreading, they are rather means of self-defence.

Another way of spreading seeds is much more safe and profitable for the animal. Here we have mutual profit, as in the case of insects pollinating flowers. The birds and animals are attracted by tasty, juicy fruits—e.g., wild strawberry (Table I, Fig. 9), or stone fruits: cherry, bird-cherry, peach (Table I, Fig. 10), raspberry, etc.—and promote the spreading of their seeds that come out with their excrements. To have its seeds spread in this way, the fruit must be tasty, easily noticed by the animal, and must have seeds that can pass uninjured through the animal's digestive system. While the seeds are unripe, the fruit is sour and tart; besides, being green, it is hardly noticeable in the foliage. As soon as the seeds are ripe and have formed a protective covering, the fruit becomes rich in sugar, carbohydrates, and other nutritive matter. Now it is brightly coloured, mostly red and yellow. This way of spreading is still better for the future plant since the soil it will grow on has been richly fertilized.

Agronomists strongly recommend steeping the seeds in liquid manure and coating them with mineral fertilizers before sowing. They find this the most economical way of using fertilizers. The plant seems to have anticipated this idea. For some plants this way of spreading through the

digestive system of an animal is the only efficient one, accounting for the peculiar mode of their existence. An example is the mistletoe, a parasite plant, which grows in the south of this country and does a lot of harm to orchards. Its bright white fruits are devoured by birds, who leave their excrements on other branches. The mistletoe seeds, coated with a very sticky matter contained in birds' droppings, adhere to the tree trunk and strike root, thus continuing their parasitic existence.

Everyone knows that, when sowing, man first scatters seeds and then covers them with earth. Here are two examples of how plants cope with this problem. You probably know a creeping plant (*Linaria*, Table I, Fig. 11) that climbs rocks and old walls. Its dry capsules easily burst, letting out small dry seeds. The seeds seem unable to stay on the hard steep surface. But the capsules manage to penetrate into tiny cracks before opening, thus providing shelter for the seeds. This is easily explained. The fruit stems possess what we call *negative heliotropism*. This phenomenon was discussed in our lecture on growth. We can easily prove by growing this plant in a flower-pot that the flower stems bend to the light and the fruit stems away from it. This property is of no use in a flower-pot, but when creeping over a crack in a wall, fruit stems bend into it, thus preserving the seeds.

Another plant that does its own planting, probably the most remarkable of them all, is the *pinnate feather-grass*, the beauty of our southern steppelands. The stipa of the plant has a long pinnate barb (Table I, Fig. 12) that is easily carried far over the steppe by the wind. The stipa ends in a very sharp appendage which sticks into the earth at the fall. Being highly hygroscopic, the barb soon bends at two places in its lower hairless part, assuming an almost horizontal position. Then the vertical part of the barb starts twisting. The moving horizontal part eventually comes up against some blade or straw, thus providing the twisting vertical part with a pivot. The sharp end of the stipa corkscrews into the earth. The seed remains fast in the earth, anchored by the coarse hairs growing upwards on its sides. We might suppose that when the atmosphere grows damp the seed will come out of the earth again. The sequence of the process will be the same: first the feather frees itself, then it assumes the vertical position and starts untwisting itself from its axis, but without setting the buried seed in motion. Therefore, the stipa is driven in when it twists but does not move when it untwists. Apparently, final success depends on the sequence of the two main movements: the bending of the pinnate barb and its twisting. There is hardly any other plant showing such intelligence or, to use the philosophers' pet word, such purposiveness.

Of late quite a school of these botanist-philosophers has arisen which asserts, in respect of the phenomena described above, that we must ascribe conscious activity to the plant, acknowledge that it can feel and reason, and consequently it can direct its activity.*

* In Germany this school is represented by Franais, whose teaching on the soul of the plant fills two large profusely illustrated volumes. In this country it is represented by Academicians Famintsin and Rorodin, and, in particular, by Prof. Polovtsev who tries to suggest in his textbook that the plant feels and reasons.

We can answer these philosophers: yes, we observe most intelligent activity in an absolutely dry, lifeless organ. Apparently, this intelligence is only seeming. And we should seek an explanation for such phenomena not in an imaginary intelligence of a plant, not in its supposed likeness to animals or even to man, but in the precision of modern science, as we shall see in our last lecture. Now let us discuss how plants and animals resemble one another in real life and in what they differ.

Chapter IX

THE PLANT AND THE ANIMAL

Current ideas as to the difference between plants and animals. Capacity for movement in a plant. Microscopic movements: of protoplasm, zoospores, and antherozoids. Movements of organs in the highest plants under the influence of external conditions (heat, light). Sensitive organs. Mechanism of these movements. Spontaneously moving organs. Utility of various movements.

Similarity between the internal processes of movement in plants and animals. Similarity in the processes of nutrition. Similarity in the process of respiration. Respiration and fermentation. Similarity between the phenomena of stimulation and anaesthesia in plants and animals. Is a plant capable of consciousness? The difference between plants and animals is not that of quality but of quantity—not in kind, but in degree. The sum-total of experimental physiology does not exhaust the problems of the science.

In the previous chapters we have studied three functions of a vegetable organism: nutrition, growth, and reproduction, which, from a certain point of view, may be regarded as a particular case of growth. On glancing at Nature superficially, and regarding only such forms and phenomena as we meet at every step, we might easily come to the conclusion that all the vital activities of the plant are summed up in these three functions. This idea has found expression more or less from time immemorial in some such definition of vegetable life as that *plants live* (i.e., grow and feed) but *are deprived of motion*, with the occasional addition of *voluntary motion*. This absence of motion and outward activity is looked upon as the essential point of difference between plants and animals; and *vice versa*, this is why a man, whose life is spent lazily, in little more than eating and sleeping, is said to be vegetating. But is such a general statement about the plant justifiable? A broader outlook upon the vegetable kingdom and a closer study of the plant will soon prove how hasty such an opinion is. We find with amazement that, far from being absent, the phenomena of motion are even widely spread in the vegetable world.

Let us turn first of all to the microscope and study with its help a fully developed uninjured cell under the most natural conditions possible. We choose for this purpose hairs found on the surface of stems and leaves or of young roots, and consisting either of a single cell or of a single row of cells; or we may make a delicate section with a sharp razor of a leaf or stem of a water plant, such as *Vallisneria** so thin as to be transparent, being at the same time careful not to injure the uncut cells. Water plants are convenient simply because microscopic investigations are generally made in water, which means that the cell remains in its natural medium. If all the natural conditions are fulfilled, i.e., if the temperature is not too low and the cells are not injured, one of the most curious phenomena ever presented by the organic world

reveals itself in a short time to our eyes. The cell-sap, or rather that part of the cell contents which we have called protoplasm,** and which as a layer of thick liquid lines the inner surface of the cell-walls, or stretches in strands across the cavity of the cell, which is filled with a thinner sap—this protoplasm moves in every cell, slowly at first, then more and more quickly.*** This movement is seen especially clearly in cases (such as *Vallisneria*) where bright green chlorophyll grains are suspended in the protoplasm. These grains, carried by the rapid current of the protoplasm can be seen flowing along one of the longitudinal cell-walls, turning along the transverse wall to the other longitudinal wall, and from it again along the second transverse wall, to come back to the point of departure and repeat over and over again that circular voyage. This rapid rotating movement of the protoplasm can be observed in one and the same cell for hours and even days. In cells in which the protoplasm forms a general network of strands, the movement is not limited to the circular current along the walls, but is also seen to flow in thin streams across the cavity of the cell. Such a movement can be observed in any hair, such as the familiar hairs of *Tradescantia* (see Fig. 13) or the stinging hairs of the nettle, and also in the cells of the flesh of fruit, as, for instance, the large cells visible to the naked eye making up the ripest parts of a water-melon. We have but to take some of these cells with a needle and place them under a microscope to notice this curious streaming movement of the protoplasm in every one of them. Thus the protoplasm in these cells is in continuous movement. This movement is spontaneous: it is not provoked by any external physical agents, although such agents as heat or electricity may affect it, accelerating, retarding, or even entirely arresting it. So many and such varied illustrations of this movement are known to us, that it seems most likely it is characteristic of the protoplasm of all cells, at all events at a certain period of their existence.

* A plant to be found in any aquarium. The curious phenomena taking place in this plant during the period of pollination have been described in the previous chapter (Fig. 67).

** See Chapter II.

*** It should be borne in mind that motion is magnified by the microscope—actually it is very slow, not faster than that of the minute hand of a watch

Sometimes this movement of the protoplasm manifests itself in a still more curious way, and so strongly as to be seen even with the naked eye. There is a group of organisms so peculiar that for a long time scientists wondered whether they were to be considered plants or animals. Even nowadays some people reckon them as a separate third kingdom, although it might be more reasonable to range them among the simplest plants, along with the fungi. These organisms are called *slime* fungi, because during the greater part of their existence they present but a mass of protoplasm without any structure whatever, without any cell-walls, and therefore like slime, colourless, or of a brownish or bright yellow colour.

These organisms appear on the surface of decaying wood, leaves, etc. One such organism specially well known occurs on the piles of bark accumulated in tanneries. It appears in masses without any definite shape, looking like thick cream, only yellow in colour, penetrating amongst the pieces of bark in thin filaments, or collecting on their surface in variously branched or compact masses. If we mark in one way or another the position of these semi-liquid masses (called plasmodia) and remember their outlines, we shall be greatly surprised in a short time to notice that they have moved considerably from the place they occupied and have also changed their shape. By observing one of the fine branches of a plasmodium, or better still by examining it under a microscope, we come to the conclusion that it actually does move. These branches form protuberances, *pseudopodia*, into which the protoplasm of the neighbouring parts flow. The protuberance so formed is soon drawn back again and becomes absorbed into the general mass; another one appears drawing the protoplasm in its turn. Thus stretching and contracting again the plasmodium creeps about (Figs. 72 and 73), tending for the most part in some definite direction; it changes its position, creeps towards the light, crawls over every object in its path, e.g., a sheet of paper or glass—in a word it wanders, until it is arrested by the approach of the period of reproduction. Then it transforms itself into an indefinite scone-like shape, the size of the palm of the hand, with a very brittle wall, and inside a very fine dust is formed, reminding us of the dust we raise when we tread on a ripe puff-ball. This dust consists mainly of minute cells, spores, serving to reproduce the organism. In germinating, the spores of our slime fungus shed their cell-wall and soon transform themselves into microscopic lumps of protoplasm, which are continually changing their shape (Fig. 72). Though on a smaller scale they exhibit the same creeping movement as that described in the case of plasmodia, a fact which is easily understood, since plasmodia themselves, masses of protoplasm visible to the naked eye, are formed by the coalescence of a very great number of these microscopic lumps derived from the spores (Fig. 73).



Fig. 72

Thus we see that protoplasm, the foundation of every cell, vegetable as well as animal, is endowed with a peculiar movement, inadequately accounted for as yet, and manifested indifferently whether surrounded by a wall or entirely free as in the case of the plasmodia of the slime fungi.*

* There is a satisfactory attempt to explain this movement from the physical point of view. Unfortunately we cannot dwell on it, because it would take us too far into physics; we can only say that by mixing two

liquids we can obtain, under the microscope, forms and movements exactly similar to these.

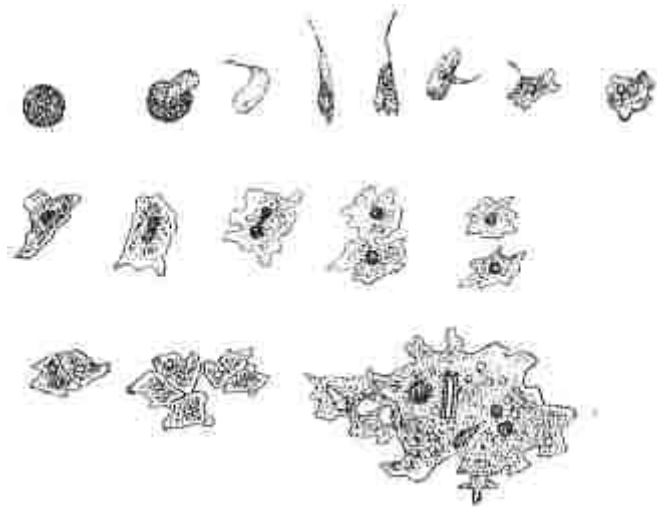

Fig. 73

These instances do not exhaust the phenomena of movement, exhibited by the vegetable cell. So far we have studied one kind of motion, the streaming movement of shapeless masses; let us now study the progressive movements of whole cells. The spore plants give us numerous illustrations of such phenomena. Let us choose a few of them at random, taking them mainly from among plants that we see every day. If we pick up a dead fly and throw it into a glass of water, we notice in two or three days a soft white down, forming a kind of halo round the body of the fly (Fig. 74). This is a

mould, i.e., a microscopic fungus. If we examine under the microscope its radiating branches, we shall observe at their ends oblong sacks, filled with colourless grains (Fig. 74). If we leave some of these sacks in water under the microscope and look at them occasionally, we shall almost certainly catch one of them at the moment when its end



Fig. 74

breaks and lets out the grains it enclosed. These grains will cluster at the opening. We shall notice that every one of them has two cilia attached to one side. But in a few moments the whole mass of them will quiver: first one grain, then another, and then all of them will stir, rush round as in a whirlpool and disperse, moving their cilia so rapidly that they are now scarcely visible. For a long time they continue to rush about, swimming across the field of the microscope, knocking against each other or anything else they meet, then bounding back and rushing in another direction.

It is impossible to distinguish this movement from that of the infusoria, and it is so contradictory to the current ideas as to the non-motility of the plant, that the first observers of similar phenomena refused to believe the evidence of their own eyes; they would not believe that these bodies were of a vegetable nature. They attributed this movement to animals developed inside the plant. These motile cells after a lime come to rest, germinate, and give rise to a new organism—they are therefore spores. In order to mark their resemblance to animals, they are called *zoospores*, i.e., animal-spores, or rather motile, wandering spores. Let us study one more *zoospore*, but from another class of plants, the water-weeds. There appears on submerged objects in ponds, streams, and ditches, occasionally also upon the surface of very damp soils, a bright green weed consisting of a single much-branched tubular cell. If we leave such a weed in summer in a glass of water, we shall notice every morning a curious phenomenon: a narrow, bright green line will appear on the surface of the water, at the side of the glass which faces the light. If we move the glass so as to turn the green edge away from the light, we shall observe that the green line will disappear, to reappear again at the side towards the light. We can repeat this experiment many times and always obtain the same result. This green matter is evidently capable of movement, and moves always towards the light. Let us investigate the constituents of this green matter and its origin. We place it in a drop of water under the microscope and notice that it swarms with green cells swimming to and fro (Fig. 75, *I*, on the top). The cells have no walls; they consist of a lump of protoplasm spangled with shimmering cilia all over the surface. Let us now turn our attention to the weed itself and see what is its relation to these motile green cells. We shall notice pin-head swellings at the end of its green tubes, filled with a darker green and thicker mass (Fig. 75, *J*). If we observe such a swelling for some time (the observation must be made early in the morning, because in the day-time this phenomenon ceases), we shall notice that the green mass gathers into a round or rather an oval lump, creeps out of the sack, which is ruptured at the top, and begins to move (Fig. 75, *J*). This is a large zoospore formed out of the protoplasm of our water-weed.

The movements exhibited by spore plants are not limited to the zoospores. We saw in the previous chapter that these plants are clearly differentiated in sex, but for the sake of simplicity we chose cases where both male and female cells are non-motile, and come into

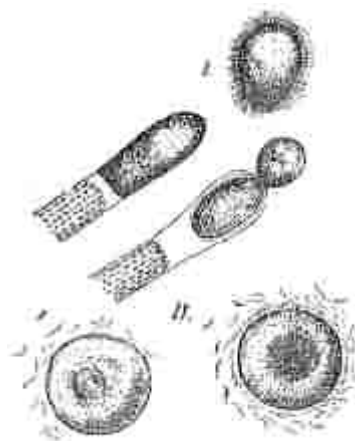

Fig. 75.

contact only by fusion. But in a greater number of cases the male cell is motile, and therefore seeks out the female which is enclosed in a special organ. In very rare cases both male and female cells are motile, like the zoospores just described: their movements bring them together, make them meet and fuse into a single mass, into one cell, one spore. As a matter of fact in weeds, mosses, ferns, horse-tails, and club-mosses it is only the male cell which is motile; it also assumes most frequently the shape of a rod twisted into a spiral and provided with cilia. These so-called *antherozoids* are endowed with a double movement: they move quickly forward and also rotate round their axis. Thus fertilization, secured in seed-plants by complicated adaptations by which the non-motile pollen of a flower is transferred to a stigma, is here accomplished by the motility of the male cells themselves, the antherozoids.* The antherozoids of mosses are most easily seen. If in the spring we gather a stem of a big moss, which forms round, soft, green tufts in woods and marshes, and if we press between the fingers the unsightly brown clusters of modified leaves, seen at that season at the ends of many of the stems, small whitish drops will exude. Every such drop will contain millions of antherozoids. Fig. 75, II, shows the fertilization of a female cell of a seaweed, found in the Baltic Sea and called *Fucus*. This cell is non-motile by itself, but antherozoids swarm round it, often surround it with a thick layer, and thus carry it away with them.

* We have noticed in the previous chapter that antherozoids have been discovered in the pollen-tubes of some plants. In the next chapter we shall be able to appreciate the importance of this fact.

Thus, the vegetable world observed under the microscope turns out to be full of motion: in the cells of the watermelon the protoplasm moves; in every weedy pool there swarm myriads of zoospores; in the drops of evening dew there move the antherozoids of mosses and ferns, finding their way to female cells in order to fertilize them.' But do we not notice phenomena of motion in a more obvious form, in those organs and plants that we can observe with the naked eye and which are naturally associated in our minds with the word "plant"? Such phenomena can indeed be easily demonstrated, although they do not occur as often as microscopic movements. They are especially striking in plants growing in warm countries or in our hothouses; the reason of which is easily understood. All kinds of motion in plants are accelerated with rise of temperature: thus, for instance, the movements of protoplasm can be accelerated or arrested at will by subjecting the cells under investigation to heat or cold.

We must differentiate two kinds of motion when we speak of movement in the organs of the highest plants. Some of them are slow and gradual; like growth they can be observed only by their results, and they generally depend on the influence of variable external conditions. Others are rapid

and abrupt like the movements of animals; and, as in animals, they are either provoked by external irritation, or take place without any stimulus whatever, apparently quite spontaneously.

Phenomena known under the name of *sleep* movements belong to the first class. We mean by these the changes in position of leaves and parts of flowers at different hours of the day and night which are manifested by nearly all plants, but most obviously by some of them. If you look at a field of pink clover, you will get a different impression of it according to the time of day. In the day-time its surface will be more uniform, because the leaflets are almost horizontal, and catch the light falling right down upon them with the whole of their surface turned up to the sky. In the twilight, on the contrary, the surface of the field will look dishevelled, and if we examine more closely the separate leaflets, we shall notice that all the three blades of the leaf are *raised*; they are now turning their edges instead of their surface up to the sky; the two side blades are folded together, while the third is pressed against their common edge. Other plants have the lamina of their leaves bent down in the nocturnal position, and so appear as if withered; in the case of the clover, on the contrary, they are raised, and so it is clear that we have to do with quite a peculiar mechanical phenomenon.

Sleep movements in flower organs are even more distinctly seen. Thus, for instance, in the early morning or in the twilight we do not see any of the yellow heads of the dandelion which spoil so often the uniform green of our lawns. This is because these flowers open only in the light: on a dull day they may likewise remain closed. Other flowers, on the contrary, close in the day-time. This is the case with the goat's-beard (John-go-to-bed-at-noon), the yellow flowers of which are very much like those of the dandelion, only larger in size. They open early in the morning and close by ten or eleven. These phenomena attracted much attention among botanists of the eighteenth century. It was even suggested that *floral hours* might be observed; the hours of the day being defined by the opening and closing of different flowers.

These phenomena are easily proved to depend on the action of light and heat. The crocus is especially convenient for the purpose. Its large flower opens in the daytime and closes at night; but the same phenomenon can be caused by placing it alternately in the light and in the shade, or removing it from a warm place to a cold one, and *vice versa*. A difference of temperature of ten or twenty degrees makes it close and open again in a few minutes. We can explain these phenomena by unequal growth or by the tension of tissues in the upper and lower, or outer and inner layers of the moving organ. We have already seen that light retards growth; consequently, under its influence, the growth of the outer layers will be checked while the inner layers will outgrow them, and the organ as a whole will tend to curve outwards. As a result the flower will open. Now it is the inner (or upper) side that becomes exposed to greater illumination, while the outer (or lower) side, being shaded, will outgrow it and the

flower will close. Similar reasoning can be applied to the effect of changes in temperature.

Such is the nature of these phenomena. They can ultimately be attributed to irregular growth, and, as a matter of fact, they are generally observed in organs that have not stopped growing.* The movements of another class are different. These take place quickly, almost instantaneously, as a result of irritation, or even without any stimulus whatever, and apparently quite spontaneously. Let us study a few cases of this kind of phenomenon, beginning with the simplest, observed in the well-known barberry. In the centre of the yellow flowers of this plant, which are very like small roses, there is a pistil with the stigma surrounded by six stamens (*p*,

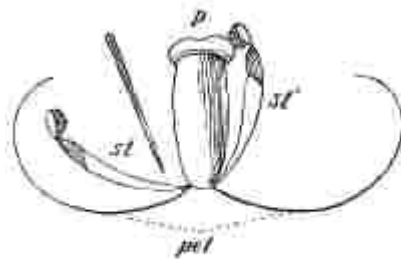

Fig. 76

Fig. 76).** These grow normally in the position shown at *st* on the left. But as soon as we touch the base of the filament with a needle (as shown in the figure), the stamen suddenly moves and assumes the position *st'* on the right-hand side, i.e., applies itself to the stigma. It remains for a

time in this position, then gradually returns to the normal position to again apply itself to the stigma as soon as irritated. Movements as the result of irritation, though of a somewhat different kind, are also characteristic of the stamens of the corn-flower, the thistle, the artichoke, and other plants.

* Some cases of these phenomena, however, fall rather into another class; they depend on the presence of a special tissue in which the quantity of water changes, hence also the tension of the cells. It is obvious that in such cases the phenomenon may also be observed in fully developed plants. Such are, for instance, the sleep movements of leaves.

** Fig. 76 is a longitudinal section of the barberry flower: *pet* marks the position of the petals; *st* and *st'*, the stamens; *p*, the pistil with the stigma.

These are all movements of very small, if not exactly microscopic, organs, and hence do not produce so startling an impression as does the movement of the irritated leaves of the sensitive mimosa, which grows in our greenhouses. It is curious to witness the amazement of a person who has never before heard of this plant, and sees for the first time the way it folds its leaves on being slightly disturbed. It is only then that we realize how deeply rooted is the conviction, based as it is upon daily experience, that motion is not a characteristic of plants. Normally, the leaf of the mimosa has the appearance shown in Fig. 77 on the right-hand side. This is a so-called compound leaf. Its main leaf-stalk bears four stalks spread out like a fan, and each of these in its turn bears a considerable number of leaflets distributed in pairs. We have only to touch such a leaf or irritate it in some way and it will move. The leaflets will raise themselves in pairs, and fold like the wings

of a butterfly at rest. The four spreading stalks will lay themselves together, and the main leaf-stalk will eventually droop, and sink downwards. The whole plant will look like 'the leaf on the left-hand side of Fig. 77. The higher the surrounding temperature the quicker the movement. When the irritation ceases the leaf will gradually reassume its former position. Fresh irritation produces again a similar phenomenon.

Apparently we have here an impetuous movement, caused by some external stimulus, reminding us very strongly of the movement of an animal when it tries to avoid some irritating contact.

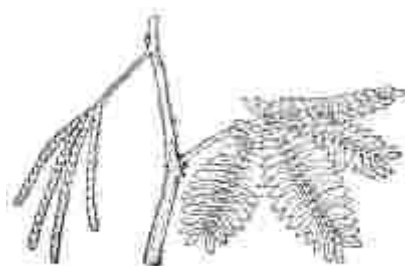

Fig. 77

Can we give any explanation of this

phenomenon? Yes and no. We can indicate the proximate mechanism of the movement, but as yet cannot explain the nature of the stimulation, caused by irritation and in its turn producing the movement. This movement takes place at the points where the leaflets are attached to the stalks, where these are attached to the main petiole, and, lastly, where the latter is attached to the stem. At all these points, the joints or articulations, special swellings or cushions are found. These leaf cushions or pulvini are formed of a tissue, the cells of which are overfilled with sap, and as a result these parts are in a constant state of tension. The moment the leaves are irritated the tension is suddenly released; it is even reversed. Thus, for instance, the tension of the tissues of the lower half of the pulvinus which forms the base of the leaf-stalk supports it horizontally, and even in a rather uplifted position (as on the right-hand side of the figure). But whenever irritated this part of the cushion loses its tension, becomes floppy, loses its turgidity; it is then unable to support the petiole, which sinks or rather is bent down by the upper half of the pulvinus, which has preserved its turgidity. Thus the two parts of the cushion—the upper and the lower—are in constant antagonism. In a normal condition the tension of the lower part predominates and the petiole is held up; at the moment of irritation, when the tension of the lower part ceases, the preponderance is in favour of the upper part which bends the leaf down. At places where individual leaflets are attached to the stalks, the reverse phenomenon happens: the upper part of the pulvinus (appearing here in the form of a white knob the size of a millet seed) is always more strained than the lower; the leaves are consequently widely spread horizontally, or even slightly bent down, but at the moment of irritation the tension of this upper part breaks down, and the leaves, being left under the influence of the tension of the lower part only, rise and draw together in pairs. So the cause of this movement lies in the sudden, almost instantaneous loss of turgidity in the tissue of one of the two halves of the

pulvinus: from being turgid it suddenly becomes flaccid, the balance between the two antagonistic halves of the organ is upset, and the leaf or leaflet moves in the corresponding direction. But how can we account for this sudden collapse, this loss of tension? The microscope reveals the fact that the tissue which has this curious property of losing its tension consists of cells with thinner walls than the cells of the opposite antagonistic side of the pulvinus; and, moreover, that the cells of this irritable tissue alternate with spaces filled with air. At the moment of irritation these spaces become filled with a liquid, as is easily proved. We have only to fix our eyes on the thickened pulvinus at the base of the petiole to see a sort of shade pass across that place at the moment of irritation; the spot suddenly becomes darker. The same thing happens even more distinctly if several pairs of leaves are suddenly but gently clutched with both hands in such a way that they are irritated, but at the same time not allowed to fold. We shall notice, then, that the thickened pulvini, compared above to the millet seeds and lying at the base of every leaflet, will change in colour; from dull white they become transparent green. The moment we let the leaves go, they will fold. What causes this sudden change in colour? It is the same cause which produces a dark spot on the white surface of the snow, a filter paper, or ground glass when we sprinkle them with water. The whiteness in all these cases depends upon the reflection of light by countless minute surfaces in contact with the atmosphere; but whenever water is substituted for the air, there is no longer the same reflection; the bodies become more transparent and hence less bright. A direct experiment, however, shows this explanation to be the true one. We have only to make a slight incision on the lower side of the pulvinus of the leaf-stalk to see that a drop exudes from the incision at the moment of motion. If a similar incision is made on a leaf, which has already drooped owing to irritation, the drop of water will not exude. This water, exuded from the cells and occupying the intercellular spaces in the tissue, is absorbed or evaporated in the course of time; the cells become refilled with water, and the tissue regains its tension until a subsequent irritation.

Ultimately, therefore, the cause of the phenomenon which has attracted our attention resolves itself into the fact that water is rapidly exuded from the thin-walled cells of the irritable tissue overfilled with it, and consequently this tissue as quickly loses its turgidity. But why is irritation followed by the exudation of water, and what is the energy that forces the cells to be overfilled with water? We are unable as yet to answer these questions, but very probably we are dealing here with electrical phenomena, as we shall see further on.

Let us pass on to another example. At the end of the eighteenth century a plant was discovered in the marshes of North America, the movements of which are more striking still. I mean the so-called catch-fly (Fig. 78). The upper part of the leaf has the form and function of a trap. Whenever we touch the hairs upon its surface, or whenever an insect imprudently creeps on to it, the two sides of the trap

immediately fold together and do not let their victim out again. The more agitated the entrapped insect becomes, the more tightly do the walls of its prison close. This struggle between the plant and the animal ends always in the death of the animal.

The mimosa and the catch-fly are instances of plants capable of manifesting movements in response to the slightest external stimulus; but here is also a plant in which movements take place without any external stimulus whatever*—*Desmodium* or *Hedysarutn*—coming

from the West Indies and belonging to the so-called *Papilionaceae* and therefore akin to our bean, clover, and other plants. Imagine that, of the three leaflets which form the compound leaf of the clover, the uppermost were to become greatly elongated and the two side ones were but slightly

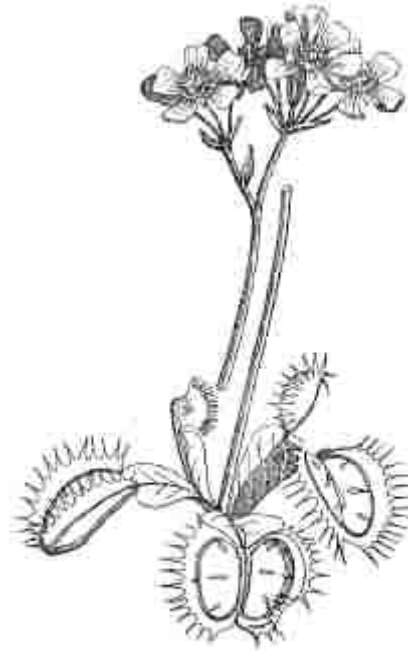

Fig. 78

developed so that they were much smaller than the third. Such is the leaf of *Desmodium*, shown in Fig. 79. If now we take our stand on a bright hot day before this plant, which is often grown in our hothouses, we shall notice in less than a minute a slight shudder passing here and there over its leaves. Let us concentrate our attention on some particular leaf which arrests us by such unexpected



Fig. 79

movement, and we shall soon perceive one of the most striking phenomena in the vegetable world. At first the two leaflets are in a horizontal position. Suddenly one of them changes this position by an abrupt movement, by a bound, so to speak, and it is found at a considerable angle with the horizon. Another and yet another such abrupt movement, and it is raised vertically. Meanwhile the opposite leaflet is lowered by a similar series of abrupt movements, by internal shocks. Then the leaflets change their parts. The raised one falls and the lowered one rises. This movement seems to be regular, produced by inner pulsation, provided the plant has sufficient light and heat. As the temperature falls, the intervals between every two movements will become longer,

and eventually the movement will be no more jerky, but slow and continual, and only to be noticed when attention is drawn to the relative position of the leaflets. Finally, if the temperature falls, say, to 68° F., the movements will cease altogether, the plant will become chilled. But warmed again it will recommence to wave its small leaflets.

* The idea of *voluntary* movements in plants was current till quite recently, providing consolation to those who hold that the plant has a soul. An Indian physicist, however, has deprived them of this source of consolation. [The physicist in question is Jagadis Hunder Bose— author of investigations on irritation and responsive movements of the plant. A detailed account of his works can be found in Timiryazev's article "Major Successes for Botanists in the Early Twentieth Century." *Works*, Vol. VIII.—*Ed.*]

The study of all these phenomena of motion leads of necessity to the question as to the purpose they serve for the plant. Apparently their significance varies according to the case. The movements of spores and antherozoids, of the stamens of barberry, etc., are obvious: they are useful, if not necessary, for purposes of fertilization and the distribution of plants. The sleep movements of flowers, the folding of their outward wrappings during the night, probably saves them from cooling, which is so dangerous to them. The sleep movements of leaves have probably the same effect: by folding or turning their edges upwards in the condition of sleep the leaves present a comparatively small surface from which heat can radiate; consequently they escape too great cooling, and are less accessible to morning frosts, during which plants are frequently frozen (actually because of irradiation) although the thermometer may not have fallen to 32° F. The purpose of the movements of the catch-fly is obvious: the very name of the plant expresses it; for, as we shall see later on, together with certain other plants, the catch-fly in reality feeds upon captured insects. The use of motion in the irritable leaves of mimosa is less obvious. Nobody has apparently even tried to explain its purpose. Only more or less probable suggestions can be brought forward in this connection. Anyone who has observed the effects of heavy showers and hailstorms will certainly have noticed how it chips the foliage of our trees. Such delicate organs as the leaves of mimosa would suffer still more from tropical storms, if the first drops of rain did not cause them to gather their outstretched leaflets together and fold them against the stem. These leaves, therefore, behave like the rush in the fable: they weather storms which shatter oak-trees. I repeat, this is only a conjecture, the accuracy of which can be verified only by observation on the spot where these curious plants grow. It is much more difficult to explain the object of the continuous movements of the leaflets of *Desmodium*, unless we admit that these movements serve the plant to scare away pernicious insects, attracted by its sweet juicy foliage.* If this be true, plants would seem to use their capacity for movement for two different ends: for getting rid of enemies

on the one hand and for catching and feeding upon them on the other.

* The same explanation may hold with regard to mimosa; at all events I have observed cases when mimosas in our hothouses perished from certain white lice, which found their abode at the very articulations of the leaf. This is possible only in cases where the leaf has lost its irritability. The tissue of the articulations must specially attract insects, on account of the abundant sugary substances it contains.

Let us leave these conjectures for the present** and study another question: Are we entitled to consider the movements of plants described above as similar to those in animals, or can some essential difference be established between these two categories of phenomena? So far as the movement of protoplasm is concerned, it does not present any difference whatever in the two kingdoms. The same may be said of the movements of the zoospores and antherozoids: here also no difference can be established between the movements of vegetable and animal organisms, which is proved by the fact that the earliest investigators refused to believe their own eyes and mistook for animals the motile organs of plants.

** All these explanations which I brought forward as conjectures forty years ago have been proved by subsequent investigators and adopted by almost all botanists.

The case is rather different when we compare the movements of the higher plants with those of animals. At all events we do not find in the plant any special tissue adapted for movement, any muscular fibre capable of contraction. Yet we can hardly base upon this difference in structure a fundamental difference between the phenomena. A comparison of the conditions which determine and accompany the movements of the higher plants and animals points rather to similarity than difference between them. We know, for instance, that motion in animals is closely bound up with respiration: the contracting muscle absorbs more oxygen, gives off more carbonic acid than, a resting muscle, and it is this oxidizing process that serves as the main source of the energy used in muscular activity. Now, does the plant present phenomena similar to the respiration of animals? We have already met with cases which prove this in the affirmative. During the germination of seeds, the development of buds, and especially during the flowering period, these vegetable organs greedily absorb oxygen and give off carbonic acid, while their temperature noticeably rises. This phenomenon is manifested by all parts of the plant during its whole lifetime, but with the difference that the green parts also decompose carbonic acid and give off oxygen much more energetically under the action of light, so that this process conceals the respiration taking place simultaneously with it.* But is respiration connected with motion? Experiments answer in the affirmative, although the nature of this connection is not as yet clear to us. If we arrest

the supply of oxygen to the plant, all the phenomena of movement will cease accordingly: the protoplasm will stop flowing, the stamens of the barberry, the leaves of the mimosa, will lose their irritability, and only after being placed for a considerable time in an atmosphere containing oxygen will these phenomena recur. Consequently the movements of plants as well as the movements of animals are closely connected with respiration.

* See Chapter V.

Let us proceed with our comparison. Muscles become heated by contraction; their temperature rises to a measurable though insignificant degree; the same is to be observed in plants. By applying to the pulvinus of the leafstalk of mimosa a very sensitive thermometer called a thermopile, it has been found possible to show that the temperature rises at the moment of motion. In muscles at rest, as also in a state of tension, the presence of an electric current is noticed. If a circuit connected with a sensitive galvanometer is closed (with all due precautions) by means of a muscle of a frog, the needle of the galvanometer will swing and manifest the current in the circuit. A similar though weaker current will become apparent, if instead of a muscle, a leaf of the catch-fly is introduced into the circuit. The similarity does not stop there. If the muscle is made to contract, a slight decrease in the strength of the current is observed at the moment of contraction, the needle of the galvanometer goes back: this is the *negative variation of the current*. The same phenomenon takes place in the case of the catch-fly. At the moment when the two parts of the leaf fold together a negative variation in the current becomes apparent. Again a very small but always measurable interval of time passes between the moment of irritation and the contraction of a muscle: this is known as the latent period of excitation. A similar though more considerable interval is noticed in the case of the leaf between the moments of irritation and movement.

Thus the similarity between the movements of the catch-fly and of animals does not lie solely in the outward manifestations of these movements but also in the internal processes which accompany them. As we have seen, it is true that the movements of vegetable organs resolve themselves in the most obvious cases into the exudation of water from the cells of the irritable tissue overfilled with it, while the movements of animals result from the contraction of muscles, a change in their actual form; but the contraction of muscles is not an elementary phenomenon. Will it not likewise reduce itself ultimately into the mutual rearrangement of the elementary solid particles and liquids which enter into the composition of the muscle?*

* This supposition of mine is now advanced also by the physiologists. It is possible that the overfilling of cells with water, its sudden exudation, the presence of a current and its variation—all these details of the process of motion in vegetable organs will find an explanation

in the phenomena of electrodiffusion. It would be out of place to enter into greater details about them at present.

Thus the main wall of partition breaks down which used to differentiate the vegetable kingdom from the animal. Movement is not exclusively confined to animals; it also takes place among plants. But if this distinction does not hold good, can we not find something else in its place? Let us consecutively review the characteristics of the life of organisms, which were supposed to be peculiar to the representatives of this or that kingdom.

Let us commence with the mode of nutrition. Plants are generally said to feed upon simple inorganic matter: carbonic acid, water, salts; while animals feed upon complicated organic compounds. Generally speaking this is true, but the rule has nevertheless many exceptions. For instance, the large class of fungi comprises plants which feed exclusively upon complicated organic compounds, hence these organisms can exist only on soils rich in humus—decomposing organic matter—or else as parasites, feeding upon other organisms. But fungi are not alone in feeding upon ready formed organic matter; there are parasites also among the highest representatives of the vegetable kingdom. Some of these are lacking in green colouring matter, such as the dodder (*Cuscuta*), for instance, which clings to our field plants, like the hop, and lives entirely at the expense of its victim. Others, such as the mistletoe, which attacks oaks, fruit-trees and other trees, although capable of independently providing themselves with food, probably also use in great measure substances formed by the plant on which they live.

Moreover, modern researches, especially those of Darwin, have acquainted us with a whole series of plants which, though provided with green organs, feed upon animal food and, what is more curious, digest this food in the same way as animals. These are known under the name of *insectivorous* plants. Here are some examples. The abovementioned catch-fly is the most curious of them all. If a leaf of the catch-fly once gets hold of an insect, it does not reopen until it has sucked out of it everything it can, leaving behind a bare insoluble skeleton. A similar experiment can be made by taking instead of the insect a piece of raw or cooked meat, or the hard-boiled white of an egg. The leaf will immediately fold up and only reopen when all trace of the food supplied has gone. The catch-fly, as we have already said, lives in the marshes of North America, but some of our own marshes provide us also with a plant, which, though related to the catch-fly, yet attains the same end, i.e., feeds upon insects, by means of a somewhat different adaptation. This plant is the sundew (*Drosera*). Its small leaves are covered with a certain kind of hairs, the ends of which secrete drops of a viscid liquid. This liquid used to be taken for dew, hence the name of the plant. The insect which imprudently settles upon the leaf sticks to it. The leaf then quickly manifests an extremely curious kind of movement. The hairs from all sides tend towards one and the same point, where the

imprisoned animal lies; the glands at the tips of the hairs secrete their sap profusely, and it dissolves the solid particles of the nutrient substances, transforming them into a condition in which they become easily absorbed by the cells of the hairs. When the food is completely absorbed the hairs expand again and are ready to meet another visitor in the same way. The large peculiar leaves of *Nepenthes*, *Sarracenia* and *Cephalotus* found at lower latitudes are not less curious, as well as the minute leaflets of the bladderwort (*Utricularia*) in our streams and ponds. One part of the leaf of the three former plants develops into a pitcher, which in the case of *Cephalotus* is, moreover, covered with a lid, while in the bladderwort the finely subdivided submerged leaves are provided with similar little organs. The pitchers were long ago observed to contain a liquid. Formerly this liquid was thought to be water, and only recently it has been proved to possess the property of dissolving solid organic food substances. Closer investigation of these pitchers has revealed in them very complicated adaptations for catching insects. They contain parts which secrete sweet sap and therefore serve to attract insects, and also very smooth surfaces over which the insects cannot help sliding down into the trap, and lastly, hard hairs with tips turned inwards to prevent the victim from coming out of its trap. But what is this liquid secreted by the plant, what is this process by which the solid food is dissolved, and has it anything in common with what we generally call the *digestion* of food in an animal organism? As we have already seen,* careful investigations have proved that there is a remarkable similarity between these two processes.

* See Chapter III.

As in the gastric juice of animals, in which the dissolution of albuminoids takes place under the influence of a special ferment, *pepsin*, so also in the liquids secreted by all insectivorous plants the presence of a similar ferment has been discovered. Just as there *pepsin* acts only in presence of a small quantity of free acid, so also here, at the moment when the plant is irritated, an acid reaction of the secretion can be easily demonstrated.*

* Recently doubts have arisen as to the utility for the plant of this absorption of organic matter. While paying a visit to Darwin I had an opportunity of seeing some unpublished experiments of the great scientist, which prove the significance of the process above described from the point of view of nutrition. Several sundew plants were grown by him under a glass bell, so as to save them from insects. Half of them received meat, half did not. At the time I saw them (in July) the plants which received meat were far bigger and more healthy in appearance than the others. (*Note to the first edition,*)

Thus the process of nutrition cannot afford us any sure criteria for differentiating plants from animals: fungi, parasites, and especially insectivorous plants, present a complete analogy with the nutrition of animals. In fact, if,

taking into consideration all that has been said about these plants, we had described an imaginary organism, which by means of antennae caught insects and conveyed them into a cavity of its body covered with glands; if, moreover, we had said that these glands secreted a juice that dissolved albuminoids and then absorbed them as food, everyone would certainly have believed that we meant an animal of some kind; yet all these features would have been those of very distinct and typical plants. If the nutrition of plants can thus so closely resemble the nutrition of animals, perhaps the nutrition of animals, on the other hand, will never present us with a parallel to the phenomenon, which is characteristic of plants, of nutrition at the expense of inorganic substances. But neither can this be maintained, the property of decomposing carbonic acid being, as we have seen, peculiar to a special organ, namely, the *chloroplast*, and we can name several animal organisms containing chlorophyll.*

* This chlorophyll belongs, however, probably to algae which have found their way into the animal organisms in question.

Now let us proceed to another supposed distinction based upon the process of respiration. When the interchange of gases taking place in plants, and resulting in the decomposition of carbonic acid and the accumulation of carbon, was erroneously compared to respiration, the following antithesis used to be brought forward: the respiration of animals consists in the absorption of oxygen and the giving off of carbonic acid; the respiration of plants—in the absorption of carbonic acid and the giving off of oxygen. We now know, however, that the decomposition of carbonic acid cannot be compared to respiration, that this is a case of nutrition—a peculiar kind of nutrition by means of air; we also know that another process takes place simultaneously—real respiration, but that this latter process can be observed only when we investigate either colourless organs, or green organs in the absence of light when the opposite process of decomposition does not take place. This process of respiration will certainly appear sluggish if compared with the respiration of a mammal, or a bird. Carbonic acid is given off in great quantities by the latter, and the resulting rise of temperature above the temperature of the surrounding medium is very apparent; whereas in the majority of cases plants passively acquire the temperature of the medium. But if we compare the respiration of plants with that of the so-called cold-blooded animals, e.g., with frogs, or even with the respiration of mammals in a state of torpor (for instance during their winter sleep), we shall see that in both cases the respiration does not differ so sharply from the respiration of plants, either in the quantity of gaseous interchange, or in the difference in temperature of the organism from the surrounding temperature.

A question arises here: Is respiration one of the processes absolutely necessary to the organism of the plant? We have seen that motion of any kind ceases in the absence

of oxygen. For a long time the growth of cells was also believed to be impossible without oxygen, but it now appears that another chemical process can be substituted for respiration, a process similar to it in its results. This process is called fermentation, and consists in the decomposition of sugar—glucose—into alcohol and carbonic acid. This process underlies the manufacture of alcohols, i.e., the manufacture of wines, the distilling of spirits, the brewing of beer, etc. In all these cases fermentation takes place owing to the development in the fermenting liquids of a peculiar microscopic organism, a fermenting fungus known as yeast. The yeast cells grow and multiply without oxygen. The process of fermentation differs essentially from respiration in the fact that it is not accompanied by the absorption of oxygen, but is similar to it in that in both cases carbonic acid and heat are given off.* It is probably this very heat that furnishes the plant with the energy necessary for its development. Fermentation appears to be a sort of *succedaneum* of respiration. But this process is not as useful to the plant as respiration, because for the same expenditure of sugar much less energy in the form of heat is generated. Formerly the process of fermentation was considered essentially peculiar to the yeast fungus, but now it appears that any plant or vegetable organ placed in an atmosphere devoid of oxygen begins to give off carbonic acid, without absorbing oxygen, and forms alcohol, i.e., begins to decompose its stores of sugars and to ferment. The yeast fungus, which ferments the sugars in the liquid where it develops, evidently cannot suffer from this process in the same way as the higher plants, which destroy their own substance unproductively during fermentation. This circumstance, together with the accumulation of alcohol in their cells—given off by yeast into the surrounding liquid—probably explains why it is that higher plants cannot maintain their life by means of the process of fermentation; in the absence of oxygen all their movements as well as growth come to an end, and if they are kept a long time in such an atmosphere they finally die.

* During respiration carbonic acid is formed at the expense of the oxygen of the air, while during fermentation it is formed at the expense of oxygen contained in sugar itself. Something like the combustion of tinder or gunpowder takes place here. We know that both these substances can burn without air at the expense of the oxygen in the saltpetre which enters into their composition.

Therefore fermentation can only maintain the existence of lower organisms, and even these but for a short time, because they also appear to need respiration from time to time; whereas higher organisms cannot endure fermentation even for a very short time. Happily natural conditions in Nature do not expose them to this danger. They begin to ferment only when exposed to an artificially confined atmosphere, e.g., when they are enclosed under a glass bell, from which oxygen has been removed—in a word, when they suffocate. We cannot simply say to an organism: Cease to

live. It is true it either lives or dies; but while it lives it clings to life. Failing to find in the surrounding medium the necessary conditions for life, it reacts on itself, and during this internal process breaks down, becomes exhausted, and dies. But the moment we remove it from the suffocating atmosphere, and by taking off the glass bell give the organism the chance of breathing freely, fermentation stops at once; the pathological process of fermentation is replaced by the physiological process of respiration, the work of destruction is replaced by that of construction; healthy and normal life asserts its rights, and motion and development follow as fellow-travellers. Hence respiration conditions the very existence of organisms, be they animals or plants.

Much has already been said about the impossibility of establishing any difference between the two kingdoms, on the ground of the presence or absence of movement. One more question remains to be discussed. Is the plant capable of *voluntary* movement? Before answering this question we must agree as to what we mean by *voluntary* movement, or speaking generally by a voluntary phenomenon. If the term implies a phenomenon produced *without cause* science will not admit such even in the sphere of animal life; if the term implies a phenomenon produced by internal, hidden causes, then voluntary may also in the meantime be understood to connote the movements of protoplasm, antherozoids, and the leaves of *Desmodium*, because all these movements take place without any apparent stimulus, under the influence of internal forces peculiar to the organism.* But if capable of movement why may not a plant also feel? If we allow the response to stimulus, i.e., irritability, stimulation, to be a sign of feeling we are bound to recognize this faculty in the plant. In fact if a man is pinched, tickled, or pricked without responding to these stimuli, we decide that he has become insensible (become unconscious); but as soon as he begins to respond to them, by some movement, we say that he has regained his senses (regained consciousness).** If this is the indication to be followed, then mimosa, the catch-fly, etc., are apparently endowed with sensitiveness, because they do respond to different stimuli, be it a prick, or a light touch, a burn, an electric shock, or some chemical action. There are some especially striking cases in which plants do not respond to every stimulus in the same way, but seem to discriminate between them. For instance, contact with nitrogenous organic substances causes quicker movements in the hairs of the sundew, and a more energetic secretion of its digestive juices, than contact with particles of inorganic matter, which cannot serve it as food. Were it an animal we should say that its mouth waters, that it greedily throws itself upon a dainty morsel.

* See footnote about the movement of *Desmodium* on page 322.

** We know, however, that the reverse conclusion is not correct. By the action of some poisons we can deprive an animal of the capacity for responding by a movement to stimulation, without at the same time depriving it of the capacity for feeling.

Granted that the plant is endowed with sensitiveness, can we not deprive it of this property, make it insensible to all kinds of stimulus? Experiment proves that we are actually able to do so; moreover, that we attain this end by using the same means as when we wish to bring a man into an insensible condition. We can anaesthetize a plant in the same way as we anaesthetize a man before a serious surgical operation. We oblige it to inhale the vapour of ether or chloroform. For this purpose we have only to cover a pot of mimosa with a glass bell, and place a sponge under it filled with ether or chloroform. After remaining a certain length of time under the glass bell the mimosa will lose its capacity for movement. However much stimulated, it will no longer fold its leaflets, but after being exposed again to fresh air, free from noxious vapours, it will regain its sensitiveness, its irritability. In order that this experiment may succeed we must not expose the plant too long to the influence of anaesthetics, or it may never revive, but will irrevocably perish. The same thing happens with a man's organism. Unfortunately sad cases of death happen fairly frequently as a result of the imprudent use of chloroform.

A nervous system has often been taken as the attribute of an animal; but, as a matter of fact, a nervous system is not found in all animals. On the other hand, if the existence is established of special tracks in plants (as is suggested by some scientists), by means of which irritation is communicated more quickly than by others, we shall have to acknowledge that these are physiologically somewhat analogous to nerves. Thus irritation in mimosa, for instance, is transmitted by a special system of tubes, by means of hydrostatic pressure.* Such an apparatus may best be compared with a pneumatic bell. This case obviously does not present any real analogy to the nervous system.

* Latest researches testify to the complexity of this process.

Now a last question: Is the plant endowed with consciousness? We shall answer this question by raising another: Are all animals endowed with it? If we do not refuse it to the lower animals, why should we deny it in the case of the plant? And if we do refuse it to the simplest animal, tell me, where, at what degree of organic development, does this *threshold* of consciousness lie? Where is the limit beyond which an object becomes a subject? How can we escape this dilemma? Shall we not rather admit that consciousness is widespread in Nature, that it smoulders in lower beings and glows in a bright spark only in the mind of man? Or, had we not better stop at the point where the thread of positive knowledge breaks off, at the border line beyond which stretches the limitless province of speculation ever captivating us by its elusive vastnesses, ever escaping the limits of experimental inquiry?***

*** Several botanists (Korzhinsky and Famintsin in Russia) have recently advocated the theory of the psychical activity of plants. I would

only point out that this theory has not brought forward a single argument based upon fact. Only metaphysical, not scientific, considerations can be adduced in its defence today, just as a quarter of a century ago when I first raised the question. I would also remark that to explain comparatively simple phenomena of vegetable life by comparing them with much more complicated phenomena of psychical life in animals is to leave the track by which every science, every kind of knowledge, has advanced until now. See concluding part of Chapter VIII, pp. 303-04, and also my pamphlet *Centenary Results of Plant Physiology*, pp. 46-52.

* * *

So, then, neither in the life of the animal nor in that of the plant have we found a single feature specially peculiar to the one or to the other; not a single indication by means of which any and every organism might be classified in the one or the other kingdom. Is there then no difference between plants and animals?

The difference is, in truth, very apparent; it is too deeply rooted in our minds to be given up so easily. Common sense based upon everyday experience persists in repeating, whatever we may say, that a tree will always be a tree and a horse a horse, that a whole abyss lies between them.

How can we reconcile this contradiction? Sometimes the difference *is* plain, sometimes it *is not*. The issue is simple and the contradiction comprehensible. It is based upon a logical fallacy, on the strength of which man attributes real existence to abstract ideas, the creations of his own mind. Unfortunately this fallacy is very widespread, and has not a little thwarted the success of natural science. As a matter of fact there are no plants or animals as such, but a single undivided world. Plants and animals are only averages, typical conceptions that we form for ourselves, abstracting from certain characters of the organism, attributing special significance to some properties, and neglecting, almost ignoring, the rest. These conceptions, moreover, were formed at a time when only the outstanding representatives of these groups were known. So long as the comparison dealt with a tree and a horse, no misunderstanding was possible; but the matter appeared in quite a different light when all living beings had to be taken into consideration as a whole. Then the unity of the organic world had to be admitted, and the realization dawned that all our divisions are only the production of our own mind. I agree that the former conception was among the greatest acquired by the human mind; it would have been quite impossible to master without it the chaos of individual forms. We must not lose sight, however, of the real value of the logical method we are using; we must not identify types and abstract ideas with real existences.

Granting, however, that such a dualism does not exist in the organic world, that instead of considering plants and animals as two absolutely different categories of beings we are to realize them only as two typical conceptions, nevertheless once our mind has formed these two conceptions we must do our best to describe them, pointing out the

peculiarities to which we give preference, and which of them we connect with the conception of a plant.

I do not think we can offer today any shorter and more appropriate definition than that expressed in the old saying, that "a plant grows, but is deprived of voluntary movement." Let us try to discover a more definite meaning for this saying. The movement of an animal, as indeed any kind of motion, is governed by general mechanical laws. The peculiarity of the animal consists in the fact that the centre of the forces acting upon it lies within itself, hence its independence of external conditions. The source of these forces is concealed in the process of oxidation. This takes place all over the body, manifests itself in respiration, and becomes the source of the heat and motion, which, on the whole, characterize the animal in contradistinction to the plant. I say "on the whole," because we have only just found ample proof that these processes are also met with in plants; but there they recede into the background, because completely screened by other predominant processes. We have already seen* that under the action of light the green parts of the plant manifest a phenomenon exactly opposite to that of oxidation, i.e., the decomposition of carbonic acid, accompanied by the accumulation of carbon. This process is almost twenty times as vigorous as the respiration of plants, so that, for instance, to one pound of carbon burning down in a plant, twenty pounds of it are formed: the plant uses for its requirements only one-twentieth of all the carbon deposited in it, hence the accumulation of matter, the enormous increase in mass, that startles us in the phenomena of *growth*. Whereas, in the case of animals at the stage of full development, a certain balance becomes established between gain and loss of matter; in the case of plants, growth, i.e., accumulation of matter, takes place almost as long as they live.** However, this accumulation of matter depends entirely upon the sun; hence the utter dependence of plants upon external conditions, and the passivity which so sharply differentiates them from the independent activity of animals.

* See Chapter V.

** This comparison is, however, not quite accurate. It is more accurate to consider as the individual in a plant a separate shoot which has a limited growth, rather than the whole plant, which, like a tree for instance, presents a complicated organism. It grows like a coral for an indefinite length of time.

It follows that the difference between plants and animals is not qualitative, but only quantitative. The same processes take place in both kingdoms, but some of them predominate in the one and some in the other. If in the end we have oxidation, waste of matter and manifestation of energy, we have before us the type of an animal; if, on the other hand, we have deoxidation, accumulation of matter, absorption of energy, we have the type of a plant. Plants and animals have divided labour between them. Animals use up the matter and energy stored by plants; plants in their turn derive the energy

they require from the sun. Animals depend on plants and plants depend on the sun.

We arrive in this way at the most general conception of the life of the plant, at the realization of its principal function, the part it plays in the organic world. It plays the part of mediator between the sun and the animal world. The plant—or rather, its most typical organ, the chloroplast—is the link which unites the activity of the whole organic world, all that we call life, to the centre of energy in our solar system. Such is the *cosmical function of the plant*.

When the type of a green oak rises before our imagination, rustling its luxuriant foliage in summer, bare and frozen in winter, enduring all the fluctuations of the external temperature; when we think of that oak year after year, century after century increasing in organic mass, yet always fixed to the same place, and then look at a Russian trotter flying like an arrow, giving off in winter clouds of vapour, and learn that it uses both in winter and in summer quantities of hay and grain; when we subsequently learn that these opposite external phenomena are only the necessary results of the chemical processes which predominate in the one or the other case; then the antithesis between plants and animals stands out clearly before us. But when we venture to cast a general glance not only upon these typical representatives, but upon all plants and animals and upon the whole of their functions, we are compelled to realize the inadequacy of such an antithesis. The contradiction vanishes, and everything becomes comprehensible the moment we admit that the stream of organic life, working its course in the beginning along a single bed, has subsequently divided into two branches; so that now, standing at their mouth, we seem to see two independent currents. It is only when we try to follow both currents along their entire course till we rise to their common source that we come to the conclusion that they are only two branches of one and the same potent stream of life.

* * *

With this we sum up the survey of the vital functions of the plant. We have studied the structure of its different organs, have learnt their significance, and have thus solved a twofold problem, which is always facing the physiologist: given an organ, to find its function; given a function, to find an organ corresponding to it. We have observed how perfectly every single organ fulfils its function, how well it is adapted to its environment, how indispensable is the reciprocal activity of different organs, and how harmoniously they work together in the general life of the plant; how remarkable is the cooperation of certain organisms, though belonging to different kingdoms of the organic world; how harmonious is the reciprocal activity of these two kingdoms taken together. The study of all these facts seems to justify us in saying we have reached the end of our course. But it is precisely here, at this apparent limit, that the physiologist begins to realize, though faintly, that his subject is not

exhausted, that beyond all these particular problems there arises the most general and universal inquiry: Why is it that all these organs, all these beings are so perfect, so wonderfully adapted to their environment and functions? The more striking the fact, the more perfect the organism, the more haunting is the question: Why is it so perfect? By what means has it reached this perfection? Is it worthwhile to go through such a long course in order to hear at the end the laconic answer: *I do not know*, nor understand, nor shall ever understand. It is true that a naturalist is liable to say this, is even more liable with sincerity to give this answer than any other investigator; but, at the same time, he most willingly grasps the first opportunity for an explanation, most jealously defends those provinces of knowledge into which faint rays of light have succeeded in penetrating.

The degree to which science is able to satisfy, in the present case, the natural curiosity of the human mind, and offer a key to what has been considered as the essential feature of the organic world—its perfection, harmony, or purposiveness—will be studied in our next chapter.

Chapter X

ORIGIN OF ORGANIC FORMS

The adaptive character of organic forms can be explained only by the historical process of their development. Palaeontology, morphology, and embryology together testify to the genetic connection between organisms. This conclusion conflicts with the once prevalent conviction as to the permanency of species. Are species really invariable? Logical fallacy underlying this opinion.

Why does the historical process lead to perfection? Darwin's theory. The struggle for existence and natural selection. Explanation of the absence of transitional forms. What we have to be content with in explaining particular cases of adaptation. Analytical and synthetical paths followed by the reader. General conclusion and aim of the course.

We came to the conclusion in our last chapter that every thinking man, who turns his attention to the phenomena of organic Nature, and still more so the naturalist, who studies them more thoroughly, becomes convinced that the organic world as a whole, as also in its several parts, is marked by one common characteristic which we try to express by the words perfection, harmony, purposiveness, etc. This conviction in its turn is succeeded by the involuntary desire, the irresistible demand for an explanation of this most salient feature of living beings. Formerly, on reaching this stage in his investigations of Nature, the naturalist considered his course had come to an end. He accepted this fact of the perfection and harmony as a primary, an elementary phenomenon, beyond the reach of further scientific analysis; and according to the particular turn of his mind he either fell into silence, or gave vent to enthusiastic effusions on this gratifying theme. But besides this preponderating opinion some courageous pioneers in the domain of science ever and anon gave voice to the demand that this general characteristic of organic forms should be treated in the same way as particular phenomena, i.e., that, not satisfied with the simple statement of the fact, science should try to explain it in a more rational way, should treat it as a particular case depending upon other more general laws; that, not resting satisfied with the empirical knowledge that such is the case, science should strive towards the deductive conclusion, that such must be the case. What can these general laws ultimately be if, starting with them, we arrive as a necessary conclusion at the startling perfection of the organic world? We shall devote this our last chapter to answering this question.

Hitherto, whenever we have undertaken to explain particular phenomena of vegetable life, we have always tried to explain them by more general and comprehensive physical and chemical laws. In the majority of cases we have succeeded more or less fully, without even once having had recourse to the mysterious *vital force* of which such lavish

application was made by earlier physiologists. We have not proved the inadequacy of this said vital force with its indefinite attributes and intangible sphere of action; we have not even ventured to refute its very existence; we have simply not found room for it in our lectures—and we have never had cause to regret it.

But now the question arises: Can this method of explanation be applied to all the facts of vegetable life? Are we able, for instance, to explain by means of physical forces alone the origin of the remarkable and perfectly adapted forms which we studied especially in our last two chapters? Can we, for instance, by any possible combination of physical forces at work at the present moment, explain the formation of the flower of the sage plant, so wonderfully adapted in all its details to the cooperation of insects in the process of cross-fertilization so beneficial to the plant? Or can we by the same means explain why the leaves of the catch-fly or the sundew possess all the necessary mechanical and chemical properties for making them perfect implements for catching and devouring insects? Apparently not. Evidently all these forms, or rather their expediency, cannot in the least be accounted for as a necessary outcome of the interaction of the substances and forces under the influence of which the organism investigated has been formed. But if we cannot account for these forms by starting from the conditions of their individual existence, can we not find the desired explanation by some other method?

When a historian or a politician studies the life of a nation, and at a certain period of its existence comes across a certain phenomenon which is not the direct result of the morals and customs current at that particular time, nor of the contemporary conditions of life, or when he finds a very perfect and fully organized form of government or society, he has recourse to historical causes in order to explain them. Failing to find a ready answer in the present, he looks for it back into the past. Are we not entitled to use the same method for explaining phenomena in Nature? When an organ appears extremely well adapted to its function, when we see an organism in full harmony with its environment, and yet feel that the contemporary influences at work upon the individual organism are inadequate to explain its origin, are we not then entitled to assume that this perfection did not arise suddenly, but has been accomplished by a slow process of historical development, and that in this way the adaptation has been in the long run wrought by the same physical forces as are at work at the present time? Are we not entitled to assume that physical forces which may be unable to affect so deeply a single organism are yet able to cause a distinct change in the course of a long series of generations?

In order to admit such an interpretation of Nature, we must begin by proving two propositions: firstly, that the organic world has its history; and secondly, that this historical process inevitably and infallibly leads to perfection. If we succeed in proving the truth of these statements, we shall

obviously have found the general key to the explanation of the perfection of organic forms.

* * *

Has a plant its history? We have in passing already frequently answered this question in the affirmative, but we have had no occasion as yet to consider the whole body of proof that exists in support of such a statement. This proof is given first of all by geology. We have already seen in our first lecture that the vegetation of our planet is not the same today as it was in former geological epochs, and that the more remote is the epoch investigated the simpler are its forms. The first to appear are horse-tails, ferns and club-mosses—all spore-plants; eventually seed-plants appear, and of these the conifers come first; whereas the latest, the most complicated and perfected in their organization, are the dicotyledons, which today predominate on our planet. Thus, in course of time, to types already existing new types of plants have been added which have overcome them in point of numbers; and, moreover, the simplest have been followed by the more complex. As we have already seen in our first lecture, this fundamental geological fact can be explained by two contradictory hypotheses: either the new types were formed anew, quite independently from those that existed before them, or they have arisen from them by means of transformation, and therefore are directly related to them. I call both of these theories hypotheses, and we cannot repeat it too often, because the exponents of the first theory have applied this term with remarkable persistence and assurance to the second theory alone, forgetting that the one they hold is as much a hypothesis as the other; that it is an arbitrary interpretation and not a simple statement of fact.

Let us try to estimate the relative merit of these two hypotheses. Let us see which of them agrees the better with reality, explains the greater number of facts, meets fewer contradictions—in a word, satisfies the better the conditions we have to require of every scientific hypothesis.

The idea that one plant may have arisen from another, an oak from a birch, a rose from a lily, appears so strange at first, that the mind cannot easily grasp it. But is it easier to realize that a cotyledon, a petal, a stamen, a pistil have arisen from a leaf, so dissimilar to them all? And yet when we discussed the theory of metamorphosis in our first chapter, we were driven to the conclusion that all these organs, so different in form, structure and function, are nevertheless merely the outcome of the transformation of a single organ, the leaf. We arrived at this conclusion on the strength of the following considerations. Firstly, on the ground of the existence of insensible transitions; e.g., we have seen a series of organs in the water lily, neither petals, nor stamens, but similar to both, so that it is quite impossible to say where the one ends and the other begins. The second consideration in favour of the gradual transformation of organs is based upon the monstrosities to be found in plants, i.e., cases in which one

organ accidentally acquires the form of another, e.g., when the pistil of a peony assumes the shape of a red petal with ovules at its edges. Cases are most convincing in which such transformation is caused artificially, as for instance in double flowers, where stamens become transformed into additional petals; as also in experiments, where the outer scales of leaf-buds are transformed into actual leaves. Since these considerations force us to admit the possibility of the transformation of one organ into another quite different from it, we are bound to admit more easily still the possibility of such transition between similar organs in different plants. Once we admit that a stamen has arisen from a leaf, we can admit with greater assurance that the leaf of one plant can arise from the leaf of another; the flower of one plant from that of another. We are forced to do so on the strength of the very considerations just brought forward, i.e., on the strength of the existence of transitional forms and of so-called monstrosities, i.e., direct transformations. Let us dwell upon some examples.

When we were discussing flowers we had an opportunity of studying the sage, a plant used by chemists, and remarkable for its adaptations for cross-fertilization by means of insects. We will try to demonstrate the existence of gradual stages in the formation of this most interesting flower from an apparently quite different flower, regular and radially symmetrical in form. The sage belongs to the family of labiate flowers, so called on account of their corolla having in most cases two lips. The wild thyme, mint, and other plants also belong to this class. Botanists agree that the *Boragineae* are in many respects very much like the *Lablatae*. We may take the forget-me-not as a representative of the *Boragineae*. Everybody knows that the blue corolla of this flower forms at its base a short tube, and spreads out at the top, dividing into five equal rounded lobes. If we peep into the inside of the tube we notice five similar yellow anthers, with their filaments attached to the tube (Fig. 80).* Can we admit that the two-lipped flower of the sage with its two peculiar stamens could have descended from this regular star-like flower of forget-me-not with its five stamens? If we succeed in demonstrating in other representatives of the same two families a series of intermediate forms between the extreme cases we have selected, we shall make this supposition most probable. To begin with, we must point out the fact that among the class of *Boragineae*, all the flowers are not as regular as the forget-me-not. In the viper's bugloss, for instance, the corolla already shows signs of bilateral symmetry, i.e., the top and the bottom have begun to be differentiated, although not so strongly as to form two distinct lips (Fig. 80, 2): at the same time the five stamens are differentiated in size; the upper one especially (Fig. 80, 2, *m*) is considerably smaller than the others. On the other hand not all labiate flowers have a distinctly two-lipped corolla; e.g., mint, where the flowers are almost regular. Consequently, the

transition from a regular to a two-lipped corolla might have



Fig. 80

occurred gradually. Let us pass to the stamens. The *Boragineae* have five, the *Labiatae* four, stamens, of which the two lower are larger and the two upper are smaller (Fig. 80, 4, *n, n*). What has become of the fifth? Whenever an organism lacks an organ, the existence of which can be deduced by analogy with other organisms, we generally find that one of two changes has taken place: the organ has either transformed itself into another organ, undergone a metamorphosis, or else has entirely disappeared, become atrophied, and other organs developed instead. The fact of such compensation, or correlation, in the development of parts was observed by Goethe, to whom, as we know, science owes its theory of metamorphosis. If one stamen, namely, the upper one, disappears in labiate flowers (the very same stamen which in the viper's bugloss is already much smaller than others, Fig. 80, 2, *m*), what arises in its place? We notice that the disappearance of this stamen coincides with the strong development of the upper lip, and hence we may suppose that the stamen has transformed itself into the petaloid organ, which joins the two upper petals and forms the upper lip. This need not puzzle us, because the transformation of the stamen into a petal and the fusion of parts in a flower is a very common phenomenon. This can also be proved by the fact that in mint, where the bilabiate corolla is very feebly developed, a fifth stamen is not seldom preserved. An example taken from among other plants will make this inference still more conclusive. Two other families, the so-called *Solanaceae* (e.g., potato) and the *Scrophulariaceae* (e.g., red rattle, foxglove, etc.), are correlated in exactly the same way as the *Boragineae* and *Labiatae*. The *Solanaceae* have a regular flower and five stamens; the *Scrophulariaceae* have a two-lipped flower and four stamens. However here, and especially in the figwort, we become quite convinced that the uppermost fifth stamen has been transformed into a petal, and has fused with the two upper petals (Fig. 80, 3, *m*).

* Fig. 80, 1 shows the corolla of the forget-me-not; 2, of the viper's bugloss; 3, of the figwort; 4, of the wild thyme; 5, of the sage. All the corollae are split along the lower lip and stretched out. The corolla of the sage is also cut along the upper lip.

We can, therefore, explain how the regular flower of the forget-me-not with five stamens could gradually have become transformed into a two-lipped flower with only four stamens,

characteristic of the majority of the *Labiatae*. The sage has only two stamens. Let us follow the fate of the other two. By examining the tube of the corolla of this plant, splitting it longitudinally, we find, a little above the two developed stamens—exactly at the spots occupied by smaller stamens in other *Labiatae*—two scarcely visible atrophied stamens (Fig. 69, Fig. 80, 5, *n, n*). According to Goethe's theory, mentioned earlier, the remaining two stamens have attained their greater size at the expense of the undeveloped ones, and have thus acquired the peculiar structure already familiar to us (Fig. 69). This peculiarity in the form of the two stamens presents in its turn different degrees of complication in different species of sage, which proves that it did not arise suddenly but by a series of gradual changes. The description of these transitional forms would, however, require too much time as well as too many diagrams* to be dwelt upon here. We might have made clear by exactly similar arguments how another still more curious flower—the orchid—could have arisen from a regular flower such as the lily. Morphology or the comparative anatomy of plants is full of such examples; we may say it entirely consists of them.

* We came to the conclusion in discussing the flower, that the whole function of this complicated staminal apparatus consists in the promotion of cross-fertilization by means of insects. This cross-fertilization would evidently be more perfectly achieved were the flowers differentiated in sex, i.e., if some flowers contained pistils and others stamens. In this case this complicated and gradually developed staminal apparatus would become useless, and in fact in other species of sage, e.g., in the field sage, in addition to the hermaphrodite flowers female flowers are also found; in these we are able to observe the way this curious and now useless apparatus gradually became atrophied; how it has reappeared in reverse order through almost all the phases, which it must have passed through, during its evolution.

Thus, if the theory of metamorphosis explains how, by means of a range of insensible transitions, different organs of one and the same plant have been derived from each other, the anatomical study of similar organs in different plants brings us to the similar conclusion, that one vegetable form could have been derived from another; otherwise, what other meaning can we attribute to these rudimentary or rather degenerate organs which meet us at every step, and demonstrate a gradual transition between dissimilar forms?

The study of organisms in the embryonic stage proves this theory still more conclusively. All the data of embryology testify that similarities and homologies, which escape attention in fully developed organisms, become comprehensible when the history of their development is studied. Thus, for instance, there is no wider or more fundamental difference in the vegetable kingdom than that between spore-plants and seed-plants; an impassable abyss seems to lie between these two sub-kingdoms, and yet Hofmeister managed to bridge even this gulf. The study of the history of the development of the higher spore-plants and of the lowest seed-plants has revealed the existence of a connection between these groups, and has even shown the

course which this transition must have taken. We have already seen that the most typical spore-plants, such as ferns, are fertilized by means of antherozoids, whereas seed-plants are fertilized by means of pollen-tubes. Hofmeister predicted, on the ground of his far-reaching investigations, that inside the pollen-tubes of certain flowering plants antherozoids would necessarily be discovered, and twenty years after his death this prediction was actually fulfilled. The exact sciences, such as astronomy, physics, and chemistry, pride themselves upon such predictions. Hofmeister's prediction is the most brilliant in the domain of morphology.* The Gymnosperms, to which our conifers belong, form a link between the two sub-kingdoms of the vegetable world. It is in some members of this group that antherozoids have been discovered. But we have already seen that, quite apart from this deduction concerning the history of development, geology had already demonstrated that such was the chronological sequence in the appearance of these groups upon our planet.** Let us recall one of the results of the preceding chapter, bearing on the impossibility of establishing any physiological border line between plants and animals—the fact that the origin of all organisms, the cell, or rather simply a speck of protoplasm, is alike in all living beings, and we shall inevitably admit the unity of the organic world, the relationship, the immediate connection between all that lives on the earth.

* It is very strange that Prof. Borodin has found it possible not even to mention the name of the great scientist in his detailed work upon this subject (*The Process of Fertilization in the Vegetable Kingdom*).

** A recent discovery of a distinguished English botanist, Professor D. H. Scott, has proved, from the palaeontological point of view as well, the connection between ferns and the gymnosperms in which the antherozoids were found—a new triumph for Hofmeister.

It may seem strange, even incomprehensible, that this conclusion could have met with opposition in the face of such concordant and diverse evidence from all the departments of biology. We do still meet such opposition even today.

In order to explain the origin of the divergence of view among scientists, we must dwell for a short time upon certain technical and perhaps tedious details, without which, however, the reason for this controversy will remain incomprehensible. An investigator of the organic world very soon arrives at the conclusion that organisms present different degrees of mutual *affinity*, as it is generally called. In order to express the degrees of affinity in the systematic description of organisms, these are generally associated in groups, and the groups marked by terms which indicate the degree of relationship that exists between them; such are the terms family, genus, etc. The smallest group in which the forms are most similar to each other, the group which represents the collective unit, so to speak, out of which other groups are formed, was called by Linnaeus a *species*. Out of species the genus is formed, out of genera families, and so on. E.g., a violet and a heart's-ease represent, according to Linnaeus, two

species of the genus *Viola*; two poplars—the black and the white—are two species of the genus *Populus*; a donkey and a horse fall into the same genus *Equus*, the wolf and the dog into the genus *Canis*, and so on. The determination of the groups called species marked a great advance in science: it rendered possible the strictly systematic classification of organisms. However, after having established this collective unit of their system, i.e., the species, the systematists, not so much Linnaeus himself as his followers, declared that a species is something actually stable, invariable in space or time; that species have always been and will ever be what they are at present; that the transformation of one species into another is out of the question altogether, and hence that the theory of the common origin of all organisms is quite inadmissible. So far we have been discussing data which have been gathered by the theory of metamorphosis, by comparative morphology, embryology, and palaeontology, and which testify to the possibility of the transition of forms of one family into those of another (e.g., from *Boraginaceae* into *Labiatae*), the possibility of transition from a spore- to a seed-plant, the impossibility of finding any line of demarcation between the vegetable and the animal world, etc. But what can be the significance of all these facts if it is true that no transition is possible in the case of beings most closely related, in the case of species of the same genus? If the violet and the heart's-ease have always been so different from each other, if they are unable to vary, if species are immutable, then certainly all our considerations as to transition from one family to another, from one order to another in the vegetable kingdom, as also from one kingdom to another, are futile. Hence it is clear that the problem of the common origin of organic beings (and therefore, as we have already seen, of the wider problem still, of the cause of their perfection) is bound up with the problem of the variability, or, speaking more generally, of the origin of species. That is how Darwin's book, which caused a revolution in science, came to bear such a dry and technical title.

Is it really true, as was steadily affirmed by a majority of naturalists, that species are immutable? In the first place we know that no two exactly similar forms exist in Nature: plants grown from seeds of one and the same fruit vary one from another. Hence entire similarity is out of the question, and, as a matter of fact, no one has ever suggested it. Moreover, we know perfectly well that even within the limits of a species there may be narrower groups of beings still more closely resembling one another. Thus the species, serving as a unit for groups of a higher order, in its turn breaks up into units of a lower order. Everybody knows how different are the races of dogs, how diverse the kinds of wheat, how numerous the variety of flowers appearing year by year in gardeners' catalogues. Where is the famous immutability of species? The exponents of this theory have a ready answer. They say: "Within the limits of species variation may certainly occur, but the range of these variations is limited; the degree of difference between the varieties can never be as great as that

between species"; in other words, new species cannot be formed in the same way as new varieties. Therefore the question as to the immutability of species resolves itself into the question of limitation in variation, or rather into the significance of variations. After such a categorical affirmation of the difference between a species and a variety, those who uphold the immutability of species might be expected to give an exact definition of both terms, and to provide a criterion whereby we may know when we are dealing with two varieties of a single species, and when with two independent species. Not at all: they not only give nothing of the kind, but neither can they do so, because species as well as varieties defy definition. We shall soon see why. Starting with the *a priori* conviction that one species cannot arise from another, those who maintain their immutability generally follow a rule which says that two forms, connected by transitional forms, however unlike they may themselves be, cannot be acknowledged as independent species. Guided by the same rule, however, the opponents of the theory point to species between which transitional forms have been discovered. The others answer: "This means that we have been mistaken, that we have taken for a species something which in the main is a variation." Obviously arguing in circles like this keeps up appearances. Affirming that species are invariable, they may easily assign the term variety to every variable form, in the absence of any positive sign which would differentiate a species from a variety. There was a time, however, when those who maintained the immutability of species did cherish the hope of establishing the difference between species and varieties upon some positive physiological feature. A conviction arose that all the representatives of a species, all its variations, however different they may be amongst themselves, can intercross, producing hybrids capable of further reproduction; and that, on the contrary, species are unable to produce hybrids, or, if they happen to do so, the hybrids are bound to be sterile. It has even been presumed that Nature has of set purpose made species invariable. After having produced a certain number of specific forms Nature has taken the trouble to preserve them for ever invariable, by preventing them from the possibility of varying as the result of their forming hybrids. When we discussed fertilization, we stated facts which definitely contradicted this theory. We have seen that fertilization by means of the pollen of the same or a similar plant is sometimes less productive than that by means of pollen of another different plant, and even that fertilization with the pollen of another species is sometimes more productive than that with the pollen of the same species. Realizing that it is impossible to advance any positive criterion for differentiating species from variations, the exponents of this theory love to plead "intuition" as a guide to investigators in the solution of this problem. The precarious nature, however, of this famous adjunct intuition is well proved by the following instances. It so happens that as long as a genus contains but few species botanists agree as to their number; but as soon as a genus contains more than, say, four

species they begin to disagree. How far this disagreement may carry them is shown by the following example: according to some botanists the genus *Hieracium* contains twenty species, according to others three hundred. The same disagreement holds with regard to the blackberry, willows, and many other plants. Evidently some botanists take for a species what for others is only a variety. In view of these contradictions, systematists have coined the expression *good species* to differentiate the evident and universally acknowledged species from doubtful ones. These manifold contradictions unmistakably bring us to the conclusion that it is impossible to draw a hard and fast line between a species and a variety, that it is impossible always and infallibly to apply to reality conceptions of this kind. This inference necessarily raises the question whether some logical fallacy has not slipped into the argument, as was the case when we discussed the difference between plants and animals. Perhaps neither species nor variety exist in Nature as two qualitatively different categories. Perhaps they are but typical conceptions, creations of our own mind. Let us try to make this clear by an example. We clearly realize the difference between a child and a grown-up man. Moreover, we differentiate between babies and adults, youths, mature and old men; and these conceptions are entirely in accordance with reality, otherwise they would not have arisen in our mind. It does not, however, follow that they must be applied without exception to all cases. Nobody would ever think of affirming that questions must or can be decided, in any and every case, such as: Have we before us an adult or a youth, a grown-up person or an old man? and so on; and yet it is with such problems that systematists struggle when they have to decide whether a *doubtful* species is to be considered a species or a variety. Species and variations are clearly differentiated in most cases; but it does not follow that they should be two categories essentially different; on the contrary, the difference between them is entirely one of quantity. They are two quantities passing gradually into one another: at one extreme we have slight individual variations, succeeded by sub-varieties, then *obvious varieties*, doubtful species, and, lastly, *good species** In a word, the only logical solution to this problem of species and varieties, so full of contradictions, consists in the acceptance of Darwin's formulae: "A variety is an incipient species"; "a species is a strongly-marked variety"; just as a child is an undeveloped man, and a grown-up man is a developed child, nor can any line of demarcation be drawn where the child ends and the man begins. Let us carry our comparison further. Supposing that a being of some kind with a very short period of existence were to raise the question whether a grown-up man develops from a child, or whether they are both quite independent beings. It would be impossible for our imaginary being to see this transformation because of the shortness of its own existence; yet by observing a whole series of slightly varying transitional forms between a suckling and an old man, by observing that all these beings vary before his eyes though to a very small

degree, and vary in one direction only, i.e., become older, our imaginary being would come to the conclusion that the child he sees before him will in time become an old man, and that just as truly the old man has also been a child in his time. Let us also suppose that another similar imaginary being should criticize this conclusion by saying: "I maintain that a grown-up man has never been a child, and will maintain this statement until I see the transformation take place before my very eyes, which, as a matter of fact, could never happen." Tell me, pray, who is in the right? Is it the one who reduces the whole of his experience to terms of a strictly logical inference, or is it the other who obstinately indulges in a kind of pseudo-philosophical scepticism, repudiating both the testimony of experience and the requirements of logic? Yet this is exactly the position of the two opposite camps with regard to the question of species. Not only the life of a single man, but even many generations are as nothing when compared with the period of time necessary for the formation of a new species; yet scientists who repudiate the immutability of species, seeing the variability of organic beings and taking into consideration the impossibility of establishing a difference between a species and a variety, inevitably come to the conclusion that species have arisen from varieties; that varieties are only consecutive steps towards the formation of new species.

* In fact, while systematists were able formerly to end their classification with species, today four subdivisions more are admitted within the limits of the species.

However conclusive this method of proof may be, there is no doubt that the actual observation of the formation of new species would have been more conclusive still. If species do vary, may they not within the confines of history have varied so much as to give rise to new species? This cannot possibly be proved with regard to organisms in their natural conditions, since we cannot keep them under observation for a sufficiently long period of time. The solution of this problem, though still presenting great difficulties, is becoming a little simpler in relation to cultivated plants and domesticated animals, concerning which historical data do exist. Our greatest difficulty is to prove that different races of animals or plants, sharply differentiated one from the other, do actually descend from one and the same species. Darwin managed to prove it fully in some cases, particularly with regard to the breeds of pigeons. He proved that contemporary breeds vary so much that had they been discovered in their natural environment they would not only have been classified as different species but even in different genera, and yet they did undoubtedly arise from one and the same pigeon.

Those who maintain the hypothesis of the immutability of species have one more argument in reserve, and also a very important one. They say: Granted that species descend one from another, how can we account for the absence of all the minute transitional forms which must have existed? Why

have they disappeared? Why is it that species generally represent groups of beings entirely distinct from each other? In passing let us remember that the very fact of the absence of transitional forms between species is in many cases doubtful, because, as we have already seen, whenever such transition is manifested between two species, the exponents of the immutability of species deny them specific rank. However, this argument holds good in the great majority of cases: really *good* species, as a matter of fact, are not connected with each other by transitional forms, and this fact was the main obstacle to all the early endeavours to prove the origin of species by means of variation; they all collapsed in face of this crushing argument. As we proceed to study the very essentials of the conception of the origin of species by variation, we shall see in what relation this argument stands to Darwin's theory. At present we need only note the fact that this theory has employed in its own defence the very weapon of its adversaries; it entirely accounts for the absence of transitional forms. Indeed their very existence would have served as a strong argument against it. This is one of its essential points, the reason for its ascendancy over other attempts of the same kind.

* * *

So far we have brought forward arguments and done our best to refute those who have contradicted the fact that the organic world has a history. We have tried to prove by means of concordant evidence from all departments of biology that the *affinity* of organisms, admitted by all naturalists without exception, can only be explained by their close *relationship*. Hence organisms have a genealogy, a history. Turning to the second half of our problem, we must now prove that this historical process necessarily leads to the perfection of organisms, implying by perfection the adaptation of the organ to its function, of the organism to its environment. Observing that the organic world presents beings in all stages from the simplest to the more perfect, and realizing that this perfection corresponds with the chronological order in the appearance of these beings upon the earth, many naturalists have even seen in this fact a proof that the organic world is endowed with a tendency towards perfection, and that this property needs no further explanation. Others again have tried to give a more rational explanation of the fact, though with ill success for the most part. Darwin was the first to point out the immediate causes, very general laws of Nature, which result in the progressive development, the *evolution*, of the organic world. He used for this purpose a method which appears paradoxical at first sight, and the logical significance of which is even yet misunderstood; or, rather, will never be understood by many of its opponents, whatever explanations may be offered for it. In order to find out how it is that by means of historical development the organic world has reached the degree of perfection we observe in it, Darwin started by inquiring how man reaches the same end, how he improves his artificial

breeds of plants and animals—and he came to the conclusion that the main factor in the accomplishment of this end is *selection*, consisting, as we have already seen,* in the selection from every generation of only those organisms which correspond most closely to the ends in view. In its simplest and most perfect form selection consists in the extermination of all unfit individuals. For instance, when a gardener wishes to produce or to preserve a certain variety in a plant, he simply exterminates all the plants which do not correspond to his ideal.

* See Chapter VIII.

Darwin next raises another question: Does not Nature also advance towards perfection by means of a similar selection? One has scarcely time to word this question before the opponents of the theory raise their voices in premature triumph and make exclamations such as, "Can there be anything in common between a process directed by the rational will of man and the action of the blind forces of Nature? You undertake to explain the origin of organic forms by physical laws, and yet you start by personifying Nature, by endowing it with rational activity, with a capacity for selection." Unmoved by exclamations of that kind, which are mere *words*, let us study facts in order to understand the great man's idea. First of all Darwin dwells on cases of what he calls unconscious selection. In years of famine savages are obliged to kill some of their domestic animals. As a matter of course they preserve the best, hence quite unconsciously improve the race. They do this, indeed, against their will, for had they the choice they would quite willingly preserve even the less satisfactory ones. By selecting individual animals they improve the race in course of time, and yet in respect of the result attained they work as a blind, unconscious elementary force.

Can we then admit unconscious selection in Nature? In order to make the question less startling let us put it a little differently, and look at it in another light. We have seen that in its simplest form the process of selection reduces itself to the extermination of unsatisfactory forms. Therefore we can substitute this question by another: Do the unsatisfactory forms become exterminated in Nature? Such a process of extermination would be equivalent to improvement, a perfecting process. Science answers this question in the most decided affirmative: Yes, it says, they do become exterminated in Nature to a very large extent, and with inexorable strictness. This phenomenon is based upon a property common to all organic beings. This property consists in the fact that in the reproduction of organisms is always involved their multiplication. This fact is so universal, so constant, that the two expressions are often interchangeable, multiplication being used as a synonym for reproduction. In fact we cannot name a single organism which would normally produce only one single being during its lifetime. On the contrary multiplication generally takes place in ever-

increasing geometrical progression. This fact has very important consequences, the significance of which was first indicated by Darwin. We shall only fully realize the rapidity with which organic beings reproduce themselves if we take the trouble to calculate the whole posterity of a single organism in a given number of years. Thus, for instance, if all the posterity of a single dandelion were preserved during ten or twelve years it would cover all the *terra firma* of our globe. Yet the dandelion is not particularly productive. According to Darwin our commonest orchid, the spotted orchis, produces no fewer than 180,000 seeds a year, so that even the grandchildren of a single plant would cover the earth with a close green carpet. Nor is this the limit to productiveness. There are orchids the seeds of which are counted by millions. Let us, too, recall the spores—the invisible grains of dust—formed on the under side of fern leaves; each of these is able to produce a new plant.

What is the natural result of this enormous multiplication of organisms without exception, this tendency of every one of them to occupy the whole earth? It is obvious: the majority of these organisms perish. We may even say that the proportion which survives is insignificant as compared with that doomed to perish. A hard struggle sets in for the representatives of every new generation, issuing in the arrival of a very small number of victors. What determines the survival of these selected forms? What circumstances decide the result of the competition in their favour? Obviously their own superiority, the perfection of their organization—implying by perfection, as has been already said, the adaptation of the organ to its function, of the organism to its environment. In the majority of cases we are not even able to realize wherein that superior adaptation lies, because the advantage in struggle for existence may depend on a variety of properties, sometimes even the opposite of one another. In one case the survival of the plant is due to the fact that it germinated before its fellows, appeared before them, at the banquet of life, and had time to seize a place in the universe; in another case, on the contrary, the selected, i.e., the surviving, plant will be the one which has germinated later than its fellows, and thus has happened to be preserved from late frosts which kill its too hasty rivals. *The struggle for existence* and its necessary outcome, the survival of the fittest, or, as Darwin metaphorically puts it, *natural selection*, is the necessary logical outcome of the law of the rapid multiplication of organic forms.* Such deductive proofs are not the only ones that can be brought forward in support of the fact of the struggle for existence and selection; immediate observation brings us to the same inference. We have only to take a mixture of flower seeds, say of sweet peas of different colour, and gather all the seeds each year and sow them again on the same bed, to find in a few years' time that some colours will oust the others from the bed. This means that even such an insignificant character as colour (most likely some property correlated with it, which escapes our immediate observation) can decide the victory in the struggle

for existence. The same result is observed in experiments in manuring natural meadows. We have seen that nitrogenous manures and mineral salts containing phosphoric acid and potassium constitute beyond doubt useful and indispensable food for every plant. But if we manure a natural meadow containing a certain percentage of grasses and a certain percentage of leguminous plants, we notice that when we use exclusively nitrogenous manures the cereals get the upper hand of the leguminous plants. On the other hand, by using manures without nitrogen the advantage is all on the side of the leguminous plants. Both manures are useful for both kinds of plants, although to a different degree, and according to that difference the success in the struggle for existence falls to the one or to the other. Lastly, as has been rightly observed, we have but to recall the pains taken by a farmer to save his fields from being overrun with weeds, to realize the struggle our cultivated plants have to maintain, and how easily they would perish if left to themselves. Hence the fact of the struggle for existence, as the outcome of the law of geometrical progression in the multiplication of organic beings, obvious as any mathematical truth, is proved by direct experiment. This struggle in the same logically inevitable way leads to natural selection, i.e., to more and more perfect adaptation, although it may be liable to escape our notice in any single generation. If we take the testimony of geology into account as to the almost immeasurable space of time that has elapsed since organisms appeared upon the earth, we shall readily agree that the process of selection, acting with such inexorable severity and during such a lengthy period of time, can fully account for both the variety of organic forms and the perfection of their adaptation.

* The metaphorical use of the word *selection* has led many critics astray (as has been already mentioned): they said that the very expression "selection" points to the fact that Darwin was obliged to ascribe conscious activity to Nature. If formerly it was only slow people who could be led into this error, today, after the explanation given by Darwin, it is only people unscrupulous in their choice of methods of argument who can have recourse to such quibbling.

Thus the evolution of organic forms and their infallible trend towards perfection may be considered as a necessary logical outcome of the three fundamental properties of organisms. These are the capacity for variation, the capacity for transmitting variations to posterity, i.e., heredity, and the capacity for multiplication, which is invariably connected with reproduction.

The capacity of organisms for variation is indisputable. We do not know of any two absolutely similar beings. Yet the causes of variation, and the relation which variation bears to selection, need some further explanation. The primary cause which produces changes in an organism must lie in the indirect or immediate influence of their external conditions; and then comes the influence of secondary causes, such as correlation in the development of parts, the exercise of organs, and so on. In most cases it is, however, very difficult

to discover the connection between a variation and its cause. We then call the variation accidental, though science cannot admit accidental phenomena in the literal sense of the word. We call it accidental in so far as its primary cause is concealed from us. The difficulties we meet in trying to unravel the connection between a variation and its cause depend mainly upon two circumstances: in the first place it is rather late to look for a cause when the variation has already manifested itself: secondly, external influences very seldom produce a lasting effect upon a fully-developed organism; this probably happens more frequently in the case of organisms in the embryonic stage of their development, for it is obvious that the earlier the influence is exerted the more far-reaching its consequences. The influence of any disturbing factor is generally very strong in the earliest stages of development. This can be proved, for instance, by the fact that it is impossible to propagate some sorts otherwise than by asexual reproduction, because the influence of the second parent in the process of sexual reproduction is strong enough to affect the whole organism to such an extent as to interfere with the transmission of the desired character. One of the secondary causes of variation must be looked for in the action of a law called the *correlation of growth*, which consists for instance in the excessive development of one part being accompanied by the under-development of another. Having at a given time only a certain quantity of nutrient substances to dispose of, Nature, as Goethe says, "in order to be lavish in one direction is forced to economize in another." Lastly, once formed, the organ is apparently able to go on developing precisely in so far as it is being used.*

* It has not yet been explained what variations obtained as the result of exercise are inherited, and which are not.

Variations when occurring under the influence of physical conditions may equally well be useful or harmful to the organism; it is only the struggle for existence and selection which control variation in a definite way by destroying harmful deviations and preserving useful ones; so that scarcely perceptible variations, when accumulated during a long series of generations, in the end are considerably accentuated. Let us try to explain by means of an illustration what part of the phenomenon may belong to variation as such, and what part to the subsequent action of selection. A while back we tried to explain the course by which a symmetrical flower is derived from a regular one. We pointed out a whole series of transitional forms, but of course this does not explain the primary origin of bilateral symmetry, the primary deviation from regularity. We may conjecture with a certain degree of probability that this transformation has taken place under the influence of the force of gravity acting upon the branches as they developed. We have seen* that growing organs change the direction of their growth under the influence of the force of gravity, and this change of direction depends upon irregularity of growth in the upper and lower

parts of an organ. The same effect is also manifested in another way: horizontal branches become unlike on their upper and lower sides; the leaves, uniformly distributed on all sides of the erect main stem, in horizontal branches distribute themselves in one horizontal plane, and so on.

* See Chapter VII.

A considerable number of similar facts concerning flowers apparently justify this opinion. Flowers of one and the same plant have been observed to be regular or slightly symmetrical, according to the place they occupy on the flower axis. Thus, for instance, plants with regular flowers, having lateral flowers either in an almost horizontal or in a drooping position, often acquire a slightly bilateral form; while the apical flowers of the same cluster, or erect flowers, preserve an entirely regular form. This phenomenon is observed in campanulas and other plants. On the other hand, in plants with entirely symmetrical flowers, such as those of the *Labiatae*, *Orchidaceae*, and other families, the apical flower often acquires a regular form. This is the case in the sage. All the lateral flowers have a characteristic two-lipped form, while the apical flower is sometimes quite regular. Recent experiments have adduced direct evidence in support of this suggestion. On removing the effect of the earth's attraction by means described in Chapter VII, it was found possible to transform bilaterally symmetrical flowers artificially into regular, radially symmetrical flowers. Thus the first appearance of longitudinal symmetry in a flower may be ascribed to the action of the force of gravity, the rest will follow as the effect of selection. Since it is beyond doubt on the one hand that cross-fertilization effected by insects is useful to plants and gives rise to a more vigorous and healthy generation, and on the other hand that for insects, which visit the flowers for their honey, the lower lip of the flower presents a convenient platform, it is clear that in every generation amid plants struggling for existence those which possess this bilabiate form more sharply differentiated have more chance of survival. Similarly, partly owing to the force of gravity and partly on the strength of the law we have just mentioned of correlation of growth, first one, then all the three upper stamens become atrophied, while the two lower ones increase in size, and under the influence of selection develop their peculiar shape, which is that most useful to the plant. We gather from this example that in order to explain the origin of a given form, be it even a very complicated one, we have but to settle the following three points: that the original variation might have arisen under the influence of physical forces (acting upon the organism generally in its embryonic stage, and only seldom when it is fully developed), that there exists a series of transitional forms, and—the most important of the three—that this transformation is useful to the organism itself. Then it becomes obvious that under the influence of *natural selection* such a form not only might, but necessarily must, have arisen.

Hence the explanation of the harmony, of the perfection of the organic world, suggested by Darwin does not turn out to involve any *a priori* endowment of the plant with a tendency towards perfection, with any inborn progressive activity. On the contrary, according to that theory, variations as such may equally well be useful or harmful. But owing to selection every harmful variation, precisely because of its harmfulness, is doomed to extermination sooner or later, whereas every useful adaptation is transmitted to future generations. The general progression, the drift towards perfection, is effected by exterminating everything that is harmful, and by accumulating slowly and gradually useful properties. Thus the perfection of the organic world no longer appears in itself as an incomprehensible end, but as an eminently conceivable result of authentic natural causes well known to everybody.

Curiously enough another great thinker came to a similar conclusion before Darwin; with the difference, however, that according to the current ideas of his time he could not admit the theory of the mutability of species. Auguste Comte writes as follows in the third volume of his *Positive Philosophy*: "Without doubt every organism finds itself necessarily related to a certain combination of external conditions. It does not at all follow, however, that the former of these two correlated forces has been produced by, any more than it could have itself produced, the other. We have simply to deal with two forces in a state of equilibrium, totally independent of each other as also essentially different. If we imagine all sorts of organisms to be consecutively exposed to the action of all sorts of external conditions in the course of a sufficiently long lapse of time, we shall clearly see that the great majority of these organisms ought necessarily to disappear; only those that satisfy the fundamental law of equilibrium mentioned above should survive. In all probability such a system of elimination has established the biological harmony, which we observe on our planet, and which goes on changing before our eyes." The similarity of both opinions consists in that biological harmony, for both Comte and Darwin, is the result of the elimination of all that is inharmonious, and inconsistent with the fundamental law of equilibrium between the organism and its environment. Comte does not indicate the mode of this elimination of unsatisfactory organisms, nor the reason of its inevitable and fatal necessity; and besides, for him, adherent as he was of the immutability of species, this harmony ought to have appeared as something stable, something that had already attained its end; while for Darwin, the advocate of the unlimited variation of organic forms, this equilibrium is unstable, a harmony ever progressing and never reaching its end. Now, if this harmony is unstable it cannot be absolute; and this is altogether consistent with reality. We never meet with absolute perfection in Nature. The eye is rightly considered the most perfect of organs, and yet it is of the eye that Helmholtz, the greatest authority in his subject, and at the same time an enemy of all idle talk, said that had he received

from an optician an apparatus with similar defects he would have sent it back to be repaired!

We see, therefore, that Darwin's theory explains the reason of the perfection of organisms by starting from fundamental properties of bodies well known to every one, and without having recourse to arbitrary premises. Upon this rests its superiority to all former attempts of the kind. Its other great advantage consists in turning to its own account one of the strongest objections which former supporters of the theory of the variability of organic forms were unable to overcome. This objection consists in the absence of transitional forms between really *good* species. In fact, if species are related to each other there must exist links between them, some transitional forms. To this Darwin's theory says: such forms must indeed have existed, but they have disappeared in course of time, and their disappearance is one of the necessary results of the struggle for existence and of selection. Before entering into this question let us observe that an entirely false representation is very often made of the transitional form which connects two other forms. Such a form is generally considered to be the middle form in the literal sense of the word, a form which contains in itself the attributes of both the forms which it links together; whereas in reality it may be almost entirely lacking in the characteristic attributes of either of them. Very often objections of the following kind are raised: if the birch and the oak are related to each other show us an organism that would be half one and half the other. In all probability such an organism has never existed in Nature. Organisms that exist today are related to each other not because they may have originated the one from the other, but because they proceed from common ancestors; and very probably had we found the real link between two contemporary forms, i.e., the form of the ancestor upon which their relationship is founded, we should not have recognized it as such, because it would have presented in very slight degree, if indeed at all, the characteristic attributes of its two descendants. Let us take an example from among cultivated plants. The cabbage, for instance, is distinguished by remarkable variety in the development of its organs; in some kinds of cabbage the head is composed of thickened leaves, in others the stem presents a turnip-like swelling, in others the inflorescences turn into fleshy organs well known to everybody. In a fourth kind the stem grows tall, and hardens, so that sticks may be made out of it; in a fifth the leaves acquire a bright colour, and so on. Obviously no one would ever suppose that the progenitor of all these forms, and hence also the transitional form, which serves as the link between them, possessed all these characters. As a matter of fact the wild original form of cabbage does not present a single one of these extreme characters. It is therefore very possible that in some cases the real connecting form should escape our attention. But it is beyond doubt, nevertheless, that in the majority of cases transitional forms between species no longer exist, and, as has just been observed, according to Darwin's theory this very

absence of them is one of the results of natural selection. For the sake of clearness we shall again refer to a comparison with artificial selection. When different varieties of cabbage arose, people who cultivated them evidently began to care for the most rare and extreme representatives of the several kinds. The specialist in the cauliflower did not worry about stems or leaves; what he cared for was only the inflorescence, which he desired to be large and fleshy. A specialist in the decorative kind of cabbage cared only about the colouring and the form of the leaves; one and the same plant could not produce at the same time both a head and a walking-stick, and so on. It is clear that plants which did not show an extreme development of some special character, but combined many of them less sharply defined, were no longer cultivated, were even destroyed, and hence were bound to disappear.

Consequently the appearance of more clearly defined representatives was inevitably followed by the extermination of the less clearly defined, as a result of which the connection between extreme forms would break down and a series of variations disconnected with each other would come into existence. Something of this kind was bound to take place in the natural order of things, where any new form can prevail only if it is more perfect than others; in such a case it is evidently bound to thrust out, to extinguish the others.

Darwin also points out that it is to the advantage of every being to become as different as possible from its own kind, because the less alike are the needs of two forms the less **will** be the struggle between them, the greater the possibility of their adaptation to the same environment, without any struggle whatever. Farmers have long known that the same plant cannot be grown for any length of time on the same field, that it is necessary to change it from year to year to another place; partly upon this fact the rotation of crops is based. But what is true in time appears to be true also in space: farmers also know that from a certain area of land more hay can be gathered when mixed grass is sown than when the grass seed is uniform. Therefore it can scarcely be doubted that new forms are bound to expel, to extirpate their less perfect predecessors, and that of forms which arise simultaneously the more strongly differentiated have more chance of surviving. Thus, in varying, every organic form tends to break up into subordinate groups, and during the process the links between these forms are lost; so that the result is the appearance of a series of divergent groups without any trace of immediate transition, and yet bearing evident tokens of either very close, or more remote, resemblance to one another, which used to be vaguely denoted by the term *affinity*, and which nowadays we simply call *relationship*. In a word, the present order of the organic world, with its specific and generic as well as other still larger groups, is but a necessary result of their common origin by means of natural selection.

With this we close the long chain of argument which contemporary biology, as represented by the great Darwin, can offer in explanation of the perfection and harmony of the

organic world. Let us cast a glance back over what we have said on the subject. If we are able to analyse the majority of vital phenomena into their simplest physico-chemical principles, and can explain them by causes now at work, we are nevertheless obliged to go back to historical causes in order to explain all that concerns the evolution of the forms. In order to explain the perfection of organisms by this method, we must begin by proving that they actually have a history, and then that this historical development tends towards perfection. The united testimony of all the branches of biological science, of classification, comparative morphology, embryology, palaeontology, goes to prove the common origin of organic forms. The only objection to this theory is the belief in the immutability of specific forms; but the criticism of the very conception of species, and moreover certain facts with regard to domesticated animals, which have been established within the limits of human memory, remove this objection. Having proved that all the facts speak in favour of, and nothing against, the conclusion that the organic world has a history, we studied the very nature of this historical process. Starting from such obvious properties of all organisms as variability, heredity, and the rapid rate of multiplication, we came to the conclusion that this historical process inevitably leads an organism towards perfection, through what Darwin rightly called "natural selection." His theory does not therefore give any ready explanation of the existence of this or that special form, of this or that particular case; it indicates the general method by which this explanation may be arrived at in any given case. If we are able to discover the original cause of variation, and further to indicate the continuous series of transitional forms (as we tried to do in the case of the sage), the origin of the most complicated form, provided it be useful to the actual organism, **will** no more be puzzling; it will be a question of time and selection. This explains why naturalists hail Darwin's theory as the crowning of the stately structure of modern physiology. It really offers the key to the solution of the problem of the origin of organisms, gives a reason for their perfection, and solves the question we raised at the beginning of this chapter.

* * *

Having undertaken the study of the life of the plant, we tried in our first chapter to analyse this complicated phenomenon into its elements, by showing that a plant consists of organs, that these organs consist of simpler organs still—of cells—which in their turn present an aggregate of certain chemical bodies. On the ground of this analysis we then studied in the opposite, ascending, synthetic order, first the properties of these substances, then the life of the cell, the life of organs, the life of the whole plant, and, lastly, in this concluding chapter, the life of the whole organic world. This apparently exhausts our problem, brings us to the end of the course through which I undertook to be your guide; a long

and toilsome way, wearying at times, but not, as I hope, utterly fruitless. If for some of you, ladies and gentlemen, here present, the plant ceases to be a lifeless object marked by a Latin label, or an object exclusively of aesthetic enjoyment, and becomes also a source of fuller intellectual enjoyment; if by the discoveries of the microscope it assumes enormous dimensions, and becomes sufficiently transparent for you to look into the depths of the numberless cells where you will perceive protoplasm—the origin of all life—in ceaseless motion like the tide of the sea; if the same mental glance shows you the root buried deep in the ground, imbibing its liquid food and corroding the particles of the soil all along its course of many miles; if the green leaf revives in your imagination the idea of that insignificant chlorophyll granule, wherein takes place the wondrous process of the transformation of the sun's rays into chemical energy, source of all the manifestations of life on our planet; if you see in a flower surrounded by busy insects something more than a curious form, and involuntarily recall the wonderful ties which bind together the two kingdoms of Nature; if, finally, a dense mass of forest thicket or the luxuriant vegetation of a meadow where wild herbs crowd and intertwine, spreading the broad surface of their toothed leaves in the sun, stretching up their narrow blades, coiling round some chosen victim, stretching themselves from its summit to another, everywhere and always manifesting but one and the same tendency to take possession of the largest possible stretch of land, of the greatest amount of air and light—if this familiar everyday picture involuntarily recalls to your mind a whole range of new ideas, of the laws which inevitably and inexorably govern the organic world, leading it on to perfection and harmony—in a word, if a glance at a plant raises an endless file of questions in your mind, questions that demand answers, or better still if the desire comes to you to put these questions to Nature herself and to extort answers from her—I consider that our time has not been wasted, and I feel I may comfort myself with the thought that by affording you in the future some moments of conscious delight in Nature I have the opportunity of repaying, were it only in small measure, the debt of gratitude I owe to your long and indulgent attention.

APPENDIX

THE PLANT AS A SOURCE OF ENERGY*

* Public lecture delivered before the Technical Society in St. Petersburg in 1875.

"Can we really admit that all the sunbeams falling on this our earth are lost without further use, or should we not rather assume that they are but transformed when absorbed by the emerald green of the leaves?"

SHCHERBINA

We all know that if a man is deprived of food he grows lean. This fact is obvious and is understood by everybody, because from the logical point of view it is not difficult to connect these two phenomena, leanness and absence of food. A man's body, like everything else under the sun, becomes wasted; it uses itself up. This waste is replaced by food. It is not difficult to imagine the food substance transforming itself into the substance of the body, though it will be long ere science arrives at the explanation of all the details of the process.

Less obvious, though not less known, is the other aspect of the effect of food, another side of its influence upon our organism. Want or insufficiency of food causes loss of energy. A man or an animal when hungry grows weak. Food restores strength. The more work is done by an organism, the more food is required. Everybody knows that when a horse is expected to do hard work it receives an extra portion of oats to help it to do that work. This fact is universally known, and yet reflection alone is not sufficient to explain it.

Thus we see that food not only serves to build up the vital mechanism of our body, it also sets this mechanism in motion. Feeding a man or an animal not only sustains his body—which is obvious; it also maintains his strength—which demands explanation. We ask: what energy can be concealed in a sack of oats, a loaf of bread, a piece of meat? The answer is far from being a simple one, and does not occur to every mind.

In order to get a satisfactory answer to this question it will be necessary to study the properties of vegetable substance, and also the conditions of its production. We say "vegetable substance," because we know that animal food proceeds indirectly from, vegetable food. Meat is only grass or grain transformed by an animal organism.

But before we tackle this problem we must agree as to the exact meaning of certain terms we are going to use. First, what do we mean by energy? We will try to explain it by some examples. Such a method of explaining scientific truths is certainly not very exact, but on the other hand it is one of the easiest and quickest, and therefore the most convenient in the present case.

Man gets a conception of energy from his own experience, from his own sensations. Energy is defined in mechanics as the "*capacity of producing work,*" and "*work consists in motion against resistance.*" Let us study first of all

some instances of the manifestation of energy, commencing with that most familiar to us, the energy of our muscles.

Let us imagine two leaden balls, kept in the position C and O_2 (Fig. 1) by means of two steel springs to which they are attached.

By overcoming the resistance of the springs, and moving the balls to C' and O'_2 I do *work*, as it is generally called in

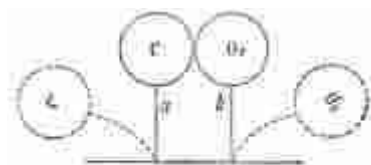

Fig. 1

mechanics. I do similar

work when, by lifting a weight, I overcome its tendency to fall upon the earth when, so to speak, I tear it away from the earth. The raising of weights is the very simplest illustration of work; such is the work of a porter, for instance. We know that in that kind of work the greater the weight, and the greater the height through which it has to be raised, the greater the amount of energy which has to be expended. If we raise a unit of weight, i.e., a pound or a kilogramme through a unit of height, i.e., a foot or a metre, we do a unit of work: a foot-pound, a kilogramme-metre will therefore be units of mechanical work, with which we compare and by which we measure all work.

Thus I did work when I separated the two balls. I used a certain amount of energy, which can be measured in terms of work done. Let us see what happened to our balls. Their relative position has changed, and they have acquired the power to move, without the application of any external force, I just remove my hands, thereby ceasing to exert any influence, and the balls are set in motion: they return to their former position and knock against each other. Evidently they possess energy in the new position into which I brought them, and they had none in that from which I removed them. This energy is latent, but ready to manifest itself at any moment in motion.

This simple example clearly demonstrates the two different states, the two types of energy, so to speak: the *active*, apparent energy, manifested in the motion (of my hand, of the balls), and the *latent* energy, accumulated or stored, like the energy of a bent bow. We see familiar examples all around us: the energy manifested by a falling weight and the energy accumulated in a weight which may fall; the energy manifested by an unbending bow, and that which is accumulated in a bent one. All these are cases of active and latent energy respectively. I must add that the weight once fallen, or the bow unbent, does not possess any energy whatever, either active, or latent.

It is evident, however, that these two types of energy are essentially different. In the first case it is manifest, in the second there exists only the *possibility* of its manifestation. We have just seen that bodies possess energy either as a consequence of motion, or by virtue of their position (e.g., a weight raised, or our separated balls). The first kind of energy is called *actual* or *kinetic* energy, whereas energy depending

on position has been called *potential* energy, i.e., energy existing as *tension*. Therefore, energy becomes manifested in motion, and is concealed in a state of tension. Both kinds are mutually transformable; our balls present an obvious illustration of this fact. Actual energy exerted in separating these balls has not disappeared, but has transformed itself into potential energy, into the tension of the springs. In that state it can be stored and kept, and then used again whenever wanted, retransformed into actual energy, into motion, and moreover at pleasure either directly or gradually. Every day of our lives we make such a storage of energy in winding our watches: the kinetic energy of the hand which does the winding transforms itself into the potential energy of the watch-spring, which in the course of twenty-four hours gradually passes into the state of actual energy, shown by the moving hands. Something analogous to this happens when a man saves money for his old age; he transforms the superfluity of his actual energy, mechanical or intellectual, into potential energy, so that he may use it when his actual energy comes to an end. On all sides in Nature we see similar transformations of motion into tension and *vice versa*. Keeping this transformation in view we soon arrive at the conclusion that energy as a rule does not arise anew nor disappear, that it is eternal; in other words we become convinced that all the work done, or which can be done in the universe by the forces of Nature at any given moment, does not increase, nor decrease, but remains the same. This broadest physical generalization, called the law of the "conservation of energy," is "the highest law in physical science which our faculties permit us to perceive" (Faraday).

There are, however, cases in which this law seems not to hold; energy seems sometimes to use itself up, and motion instead of changing into tension seems to vanish altogether. We have exactly such a case in our balls. I separate them and let go. The balls knock against each other, and seem to lose in this very knock all the energy acquired from the movement of my hand. They do not move any longer, neither have they any capacity for motion, i.e., tension. It seems evident that energy has disappeared. But this is only apparent. The moment the balls knocked against each other, the moment their motion disappeared, there appeared another kind of energy—heat. In knocking, the balls became heated. It would be rather difficult to prove this in the present case, because the rise in temperature is only slight, but the fact cannot be doubted by any one who has ever struck fire. Illustrations of this transformation of energy are to be met with at every step. When metal is bored the borings and the bore become very hot; a piece of wood can be set on fire by rubbing it against another piece of wood; sparks fly from under the brake of a train when it is suddenly stopped; a leaden bullet partly melts when it hits against a solid obstacle. These phenomena of the transformation of mechanical energy into heat long ago attracted attention; they led the famous Boyle, more than two centuries ago, to express an idea, which has been scientifically developed only within the present generation:

"When we drive a big nail into a wooden plank," writes Boyle, "we notice that it requires a great many blows before it becomes heated; but when we drive it down to its head, so that it cannot move any longer, a few blows are sufficient to make it hot. While every blow of the hammer drives the nail deeper and deeper into the wood, a progressive movement of its mass is provoked; but the moment this movement is checked the shock produced by the blow, unable any longer either to drive the nail any further or split it, is *necessarily* bound to spend itself on the inner oscillation of particles; and heat as we know consists of such motion."

Modern physics actually teaches that heat is a rapid invisible but palpable oscillation of particles in a body. Thus the visible motion of balls produced by the movement of my hand has passed into the invisible motion of the particles of the balls. This motion, i.e., heat, was communicated first to bodies in the nearest neighbourhood of the balls; then, spreading more and more, it is dispersed in space. It is dispersed, but has not ceased to exist. The energy, used by me to separate the balls, has not vanished entirely. In doing this work I ultimately raised the temperature of the universe though to an infinitely slight degree. Innumerable investigations have shown that during this transformation of mechanical work into heat or, *vice versa*, of heat into mechanical work, a constant, strictly quantitative ratio is observed. A certain amount of mechanical work on transformation gives rise to a definite amount of heat and *vice versa*. The quantity which expresses this constant ratio is called the mechanical equivalent of heat. It can be determined in various ways: here is the simplest and most obvious, although not a very accurate method of determination, which was devised by the French scientist Hirn. It consists roughly in the following: a heavy iron hammer is made to fall from a certain height upon an anvil on which a piece of lead is laid. This piece of lead becomes hot from the blow of the hammer. We take a kilogramme-metre for the unit of work, as explained before, and for the unit of heat the rise in temperature of one kilogramme of water by one degree Centigrade. Knowing the weight of the hammer as well as the height from which it falls, knowing also the weight of lead and the amount of heat it has acquired, possessing moreover some other data, which we will not mention here, we can find out how many units of work have been expended as well as into how many units of heat they have been transformed. Exact determinations give the value of 427 for the mechanical equivalent of heat. This number indicates the constant ratio by which heat transforms itself into mechanical work or *vice versa*. This means that a unit of heat on transformation into work gives 427 units of mechanical work, i.e., can do work equal to raising 427 kilogrammes to the height of one metre, or of one kilogramme to the height of 427 metres. On the other hand, by expending 427 units of mechanical work to heat water, we can raise the temperature of one kilogramme of it by one degree.

We have mentioned many examples of the transformation of mechanical energy into heat; examples of the opposite are also often met with. The steam engine may be taken as a striking illustration; heat developed by burning fuel becomes transformed through the medium of steam into mechanical work. The heat of the sun evaporates water from the surface of the earth, causes it to rise to a certain height whence it falls down again upon the earth, runs from the mountains into the valleys and thence into the ocean, producing all the way mechanical work, e.g., setting in motion our mills. The same energy of the sun heats the atmosphere at certain spots, so as to produce those terrible manifestations of mechanical energy known as whirlwinds, hurricanes, etc.

So, then, heat transforms itself into mechanical work and *vice versa*, and during these processes a strict quantitative ratio is maintained. The same is true with regard to other forces of nature, such as light, electricity, chemical affinity. They are all capable of mutual transformation either immediately or by acquiring the latent form of tension, which subsequently manifests itself in one way or another. It is only as we continually keep in mind this possibility of the mutual transformation of different forces that we come to realize how true is the law of the conservation of energy.

Let us dwell for a little upon the correlation that exists between heat and chemical affinity, for it will naturally bring us back to the question raised at the beginning of this lecture. Chemistry teaches that the atoms of the elements are endowed with mutual affinity in various degrees. The atoms of heterogeneous bodies tend towards each other in much the same way as bodies tend towards the earth, or as these balls tend towards each other by reason of their springs. Our model is meant to illustrate in an obvious way this very fact of chemical affinity. The ball marked by the letter *C* represents carbon, the ball O_2 oxygen. The atoms of carbon and oxygen tend to combine and to form carbonic acid, in which two atoms of oxygen are combined to one of carbon (CO_2). In the same way the atoms of hydrogen (*H*) tend to combine with the atoms of oxygen and form water, H_2O , in which two atoms of hydrogen are combined with one of oxygen. On the other hand, the atoms of carbon and hydrogen are endowed with a comparatively much weaker affinity, and therefore, even though combined with each other, tend at the first opportunity to recombine each in its turn with oxygen, thus forming carbonic acid and water.

At the moment of combination the atoms knock against each other in the same way as these balls do. But whenever bodies knock against each other heat is generated. The same takes place in the case of the blows of atoms. These blows, this collision of the particles of carbon and hydrogen with those of oxygen, is exactly what we mean by combustion. Just as heat and light are generated the moment steel is knocked against a flint, so the blow of the particles of oxygen of the air against the particles of carbon and hydrogen in coal-gas generates the heat and light that we observe in the gas

flame. The only difference between the two processes consists in that in the first case we see the motion, the blow, as well as the accompanying phenomena, i.e., light and heat; whereas in the latter case we see only these phenomena, and get an idea of the collision of particles only from the results. Before combustion we have a hydrocarbon (i.e., a compound of carbon and hydrogen), the coal-gas, and oxygen, and after combustion carbonic acid and water.

Therefore every atom of carbon and hydrogen stands to oxygen in the same relation as the ball *C* stands to the ball *O*₂. Like the balls they are in a state of tension, and possess a store of latent *potential energy* which we call *chemical affinity* or *chemical attraction*. In the separated atoms of carbon and hydrogen we have a fresh illustration of the potential *energy of position*, which at the moment of the collision of atoms in combustion passes into the *energy of motion*, i.e., into heat and light.

This state of tension in the atoms of carbon, this tendency of theirs to unite with the atoms of oxygen, does not attract our attention in daily life, because an impulse is necessary to produce their combination. In order to burn a piece of coal we must set fire to it, i.e., the process of combustion must be initiated from without. This tendency of carbon to combine with oxygen is, however, manifested more obviously in phenomena of spontaneous combustion. It has long been known, for instance, that rotting hay in stacks is capable of taking fire spontaneously, but a case of it has only recently been investigated in Germany. When some large haystacks were opened in consequence of spontaneous combustion being indicated by the smoke coming out of them, it appeared that the hay inside was already charred, and that the soft, shiny, graphite-like carbon caught fire directly it came into contact with the air. It appeared later on that such spontaneously combustible carbon could be prepared artificially if hay was charred in the absence of air; in a sealed glass-tube, for instance. Carbon prepared in this way catches fire the moment it comes into contact with the air. This and similar examples obviously prove that combustion, i.e., combination with oxygen, can take place spontaneously, i.e., without any previous setting on fire.

Both carbon and hydrogen have the property of combining separately with oxygen, and of developing heat and light during the process; hence they each possess energy stored in the form of chemical tension. But the same is true with regard to compounds of carbon and hydrogen as well as of any substance capable of combining with oxygen, i.e., capable of combustion. Substances of which plants and animals—all organic bodies—are built are combustible, and therefore are stores of latent energy.

We use these stores when we burn wood or coal in our engines. The potential chemical energy transforms itself into actual energy during the process, into motion of particles, i.e., into heat, which in its turn transforms itself into external mechanical work, and so into the visible motion of bodies such as the motion of our locomotives. This collision between

the atoms of carbon and hydrogen and those of oxygen can, however, take place without any such ostensible liberation of energy as occurs in combustion; they can combine without any visible manifestation of light, without the production of high temperature. This happens when combination does not take place suddenly, but gradually. In both cases the quantity of heat liberated by the combustion of a certain quantity of carbon will be the same, but its liberation in the first case covers a longer period of time, and hence is less obvious. Respiration is a good illustration of this slow combustion. Everything that breathes, whether man or animal, slowly burns away. This is easily proved by placing a burning candle, or a living bird or mouse, under a glass bell. We shall soon see that the results will be identically the same: the candle will cease to burn, the animal will die; while the air, in which before the experiment oxygen was present and no carbonic acid, will now contain carbonic acid, and the oxygen will have correspondingly decreased in quantity. Thus the carbon of every living organism continually combines with the oxygen of the air, burning down into carbonic acid.

In order to restore this continuous waste of his body, man is obliged to take in fresh quantities of carbonaceous matter in the form of food. Food in the organism plays the same part as fuel in an engine, i.e., it burns down, though of course not directly, being first transformed into the substance of our body. What is lost to the organism as matter is acquired as energy. But we can accept the following statement as an axiom, says the famous physiologist, Claude Bernard: *"Every manifestation of activity in a living organism is necessarily connected with the destruction of a part of its matter."* In the organism as well as in an engine a certain proportion of matter burns down, and this is accompanied either by the manifestation of heat, or by the mechanical work into which this heat is transformed, such as the work of our muscles. According to Frankland, a pound of wheat bread stores up something like 75,000 foot-pounds of potential energy. There is no doubt that an organism, just like an engine, cannot transform into useful work all the energy stored up within it in the form of fuel, i.e., all the potential energy of the oxidizable parts of its food. Physiological experiments prove, however, that in this respect the living organism far outstrips any steam engine.

* * *

We have proceeded so far towards the solution of the question raised above that we already know the kind of energy contained in our food: it is the latent energy of its carbon and hydrogen which are always ready to combine with the oxygen of the air. A fresh problem, arises at this point in the course of our investigation. Wood burns, animals burn, man burns, everything burns, and yet nothing burns right away. Forests are burnt down, and yet vegetation is not exterminated. Generations pass away, but mankind is always alive. If everything were only to burn away, the surface of the

earth would contain neither plants nor animals any longer: there would soon be only carbonic acid and water.

Evidently another process must also be going on in Nature, a process contrary to combustion, during which the substances entirely burnt down are "unburnt," transformed into substances once more capable of burning. The formation of carbonic acid must be accompanied by a reverse process, the decomposition of the carbonic acid produced by universal combustion.

The first man whose attention was drawn to the logical necessity for such a process in Nature was the great chemist Priestley. As a matter of course this idea could not present itself to his mind in the same form, or with the same precision and clearness, as it appears to us now; hence we are the more amazed at the brilliant deduction, at the ingenious conception to which the world owes one of its greatest discoveries in biology. Priestley proved by a series of experiments that continual combustion, or continual respiration in a limited volume of air, makes that air unfit for further combustion, for further respiration: in it a lighted candle goes out, an animal dies. Therefore, argued Priestley, all the atmosphere should become unfit for combustion, or for life; yet the many centuries of the world's existence testify to the contrary. Apparently there exists a process in Nature which restores this *bad* air into *good* air. Is this not due to plants? On the 18th of August, 1772, Priestley made the following experiment. He introduced under a glass bell over water, where a candle had previously gone out, or a mouse had died, a plant (mint), and kept it there for a time. The plant did not perish; it even continued to develop, and when after a few days a mouse, or a burning candle, was again introduced under the glass bell, it appeared that the air had actually been renewed, that it had acquired once more the properties of maintaining combustion and respiration. Hardly ever in any province of knowledge has a single experiment been followed by greater results. The same stroke demonstrated the most characteristic sides of the life of plants and animals, and the mutual relationship which exists between the two kingdoms of Nature. Priestley's contemporaries appreciated the importance of this discovery. The Royal Society conferred on him the coveted Copley medal; and the President of the Society, Sir John Pringle, expressed the importance of Priestley's achievement in the following eloquent, though somewhat rhetorical, words:

"From this discovery," says he, "we are assured that no vegetable grows in vain, but that, from the oak of the forest to the grass in the field, every individual plant is serviceable to mankind; if not always distinguished by some private virtue, yet making a part of the whole, which cleanses and purifies our atmosphere. In this the fragrant rose and deadly nightshade cooperate; nor is the herbage, nor the woods that flourish in the most remote and unpeopled regions, unprofitable to us, nor we to them; considering how constantly the winds convey to them our vitiated air for our relief and for their nourishment."

Priestley's inference was that the plant restored air vitiated by respiration, and made it again able to maintain respiration. His discovery of oxygen which soon followed, and the determination of the composition of carbonic acid, provided the explanation of the nature of this connection between the two organic kingdoms. The animal inhales oxygen and exhales carbonic acid; the plant inhales carbonic acid and exhales oxygen, retaining (precipitating) carbon. Plants and animals present a chemical antithesis. A series of further investigations showed that this process, which decomposes carbonic acid and restores good air, has yet another more important significance, which is that it provides the plant with food. Carbon remains inside the plant, forms its organic matter, and serves to build up its body. It follows that the carbonic acid of the atmosphere must be considered the main food of a plant. Although this function was long attributed to the black particles of the soil, i.e., to humus, the inadequacy of this view was established by exact experiments.

Priestley, however, had to experience one of the greatest disappointments that ever befell a scientist. He failed some time after, when he tried to repeat the experiment which made him so famous: he could not obtain his former results; the plants persisted in refusing to decompose carbonic acid and set free oxygen. Although these disappointments did not shake his confidence in his earlier experiments, it became evident, nevertheless, that some condition important for the experiment had been overlooked, owing to which fact the experiment could not be repeated. This condition neglected by Priestley was soon after discovered by Ingenhousz. In order to fully appreciate this discovery we shall dwell a little longer on the nature of the phenomenon itself.

Let us for the last time turn to our balls. We have been comparing chemical combination or combustion with the concussion of two balls against each other; heat and light liberated during the process serve as a measure of the affinity or tension, i.e., of the mutual attraction of these bodies (represented in our illustration by the tension of the coils). In order to separate them again, to break up the connection between them, in order to bring the balls into the former free position, we must on the contrary expend energy, and expend as much of it as is liberated at the moment of collision. Thus it becomes evident that a phenomenon contrary to that of combustion has to be accompanied not by liberation, or development of energy, but on the contrary by its absorption and expenditure. While combination, i.e., combustion, takes place spontaneously, decomposition requires the participation of an extraneous force. In order to burn down a piece of coal we must set fire to it, after which it burns without any external assistance. We have noticed that in some cases coal can also burn spontaneously, when it comes into contact with the oxygen of the air. On the other hand, in order to decompose carbonic acid and water, we must expose them to a very high temperature. Formerly it was supposed that the decomposition of such stable compounds was impossible

without the cooperation of a third body, endowed with a still greater affinity for oxygen, and so able to sever that oxygen from hydrogen and carbon. But not so very long ago the attention of chemists was drawn to phenomena of decomposition, or dissociation, as they were called, apart from the action of any third body. In order to be dissociated, carbonic acid or water must be passed through red-hot tubes. Under the influence of the motion thus communicated to their particles, i.e., of heat, the connection between them becomes loosened, so to speak; the compounds break down into their component parts, which must be immediately removed, lest on cooling they should recombine and prevent us from obtaining a complete separation. The amount of heat liberated at the moment of combination and absorbed at the moment of dissociation is strictly definite. There are exactly as many units of heat liberated during the oxidation of a pound of carbon into carbonic acid, as there are units of heat absorbed during the liberation of this pound of carbon from carbonic acid.

Thus we come to the conclusion that the dissociation of carbonic acid, which takes place in the plant, must be accompanied by the absorption of heat, of energy speaking generally, and also that the amount of carbon precipitated in this way in the plant may serve as a measure for this absorption. But whence will the plant obtain this energy so essential to it? It cannot create it, because • energy cannot be created. Apparently it must acquire it from without. The dissociation of carbonic acid in a plant can take place only on condition that there is a continual supply of energy from an outside source. This was the condition which escaped Priestley's attention, and the discovery of which made Ingenhousz famous.* Ingenhousz showed that the dissociation of carbonic acid inside the plant takes place exclusively in the sunlight. In Priestley's later experiments the plants probably did not get enough sunlight, and therefore did not dissociate carbonic acid.

* Such is the current opinion, but lately, after a careful study of the question, I have come to the conclusion that Ingenhousz' priority is more than doubtful, and that the fact of the dependence of this process on sunlight was discovered by Priestley.

Sunshine, the rays of the sun, are the very energy which loosens and separates the particles of carbon from those of oxygen during the decomposition of carbonic acid. Such an expression as "sunshine is a source of energy" may sound strange at first. We know from daily experience how pleasant it is to warm oneself in the sun, and yet a long chain of arguments and calculations is necessary to persuade us that this is not only a source of energy, but even a very considerable source of energy—moreover, that this is almost the only source of energy used by man. In fact, apart from the energy of the tide, used in some parts of Europe, and which depends on the attraction of the moon (and also of the sun), all the other motive forces, all other sources of energy

directly or indirectly depend upon the energy of sunlight. The flow of water in rivers and the circulation of air in the atmosphere, which set in motion our mills, are due to the sun. The latent energy of fuel, as we have already seen and shall presently see in greater detail, proceeds from the sun. Even phenomena so remote as those of electricity, which we use for practical purposes, can be connected with the activity of the sun. It is the sun that shines in a Voltaic arc obtained by means of a galvanic battery, which is easy to prove. The electric current which makes the carbon white-hot is the result of the oxidation in the batteries of a certain amount of metallic zinc. This zinc, however, is not found in Nature as a metal; it is generally found in combination with oxygen, i.e., entirely burnt down. In order to deoxidize it, to restore its capacity for combustion, oxygen must be removed from it. This is done by means of coal, which combines with the oxygen of the zinc ore, and burns down to carbonic acid. But this coal, be it pit coal or wood charcoal, has been derived in the plant from carbonic acid, dissociated by sunlight. Thus it is that the rays of the sun are connected with those of the electric light. The visible, kinetic energy of the sunlight, expended in the decomposition of carbonic acid in plants, takes the form of latent potential energy, concealed in carbon after it has been liberated from the carbonic acid. This potential energy of carbon then passes over to the zinc during the process of deoxidation of the zinc ore; carbon burns down and metallic zinc is obtained capable of combustion. Zinc oxidizes in the galvanic battery, burns down, and its potential energy transforms itself into the actual energy of the electric current, appearing as light in the white-hot carbons. Such is the complicated chain of transformations of energy, which connect phenomena that take place on our planet with the activity of the sun. We can, however, form a more definite idea as to the significance of the radiation of energy from the sun, by making an approximate calculation of the amount of energy afforded by the sun. We can determine the number of units of heat cast by the sun upon a given area of our planet; and then, knowing the mechanical equivalent of heat, we can express the energy of sunlight in units of mechanical work. According to the calculations of Mouchot the sunlight that falls during eight or ten hours on a bright day upon the surface of a square metre in Paris can do work approximately equal to one horse-power. Ericsson calculated that if all the heat of the sun that falls upon the roofs of Philadelphia were to be used, it would amount to the force of 5,000 steam engines, each of 20 horsepower. Further on, calculating the enormous amount of heat that falls upon the earth, he exclaims: "Archimedes undertook to lift the world by a lever, whereas I maintain that by concentrating the heat of the sun we could obtain a force capable of arresting the motion of the earth." Both Mouchot and Ericsson, however, did not confine themselves to calculations: they made experiments, which clearly demonstrated the stores of energy presented by the rays of the sun. Mouchot made several very simple kinds of apparatus, in which it was possible to boil water, soup, and

vegetables as well as to bake bread exclusively by means of the heat of the sun. In the end he also made some steam and hot-air engines set in motion by the sun. Of all the applications of sunlight suggested by Mouchot, his pumps for irrigating fields are perhaps the most curious. They not only act by means of energy obtained free of cost, but also work most effectually. They are regulated according to the very need for water: the amount of water is regulated by the amount of the radiant energy of the sun, hence also according to the severity of the drought.*

* See my pamphlet *Struggle of Plants with Drought*, Moscow, 1893.

We can prove easily enough from what has been said that sunlight is a powerful source of energy, and that this very energy decomposes carbonic acid in plants. The plant is unable to provide itself with the energy necessary for the purpose, it only plays the part of a mechanism, if I may so say, of a connector for transmitting the energy of the sun.

The plant therefore presents a regular contrast to the animal from the physical as well as the chemical point of view. The life of the plant consists in a continual transformation of the energy of sunlight into latent chemical energy; while the life of the animal, on the contrary, manifests the transformation of chemical latent energy into heat and motion. The spring is wound up in the one to unwind in the other.

* * *

We should be wrong, however, if we imagined that this function of the sunlight became intelligible the moment Ingenhousz discovered its participation in the process of the dissociation of carbonic acid. More than half a century had to pass before the actual mechanical details of the process were worked out. This achievement science owes to Mayer and Helmholtz. While light in former days was talked of only as an incomprehensible though beneficial influence, Mayer was the first to state that sunlight is actually used up in the literal sense of the word, and is absorbed by the plant; that the energy of the ray transforms itself into chemical tension; that in burning fuel, and in the vital processes of our organism, we use the stored up energy of the sun. It would be better to listen to his own eloquent way of putting it: ,

"Nature, says he, seems to have set itself to capture the light that falls upon our planet, to transform the most mobile of all forces into an immobile form, and to conserve it as such. With this end in view it has covered the crust of the earth with organisms, which, during their lifetime, absorb the sunlight and form at the expense of this energy the stores of latent chemical energy incessantly accumulated. These organisms are *plants*. The vegetable world is a kind of storehouse, where the sun's rays become "arrested and stored for further use. The physical existence of mankind depends on this economical solicitude of Nature, and a single glance at

our luxuriant vegetation involuntarily provokes the sensation of prosperity."

Thus it is that in the dissociation of carbonic acid and the formation of organic plant substance we have essential conditions for any technical process. We possess in the sunlight a motive power; in the plant—a machine to which the motive power is applied; in the carbonic acid—a raw material; in the organic matter of the plant—the manufactured product.

Let us investigate more closely the inner mechanism of this process.

Let us study first of all the source of energy, the sunbeam. We know that the sunlight, like any other white light, is not homogeneous; we know that it consists of many heterogeneous rays, differing, among other things, in their colour. Rays of seven different colours are generally discriminated; they are the colours of the rainbow—red, orange, yellow, green, blue, indigo, violet. This decomposing of a colourless ray into its seven component colours is best performed by means of a glass prism. If a small aperture is made in a shutter facing the sun, the sunlight in passing through this aperture will produce on the floor an image of the sun in the form of a round patch. Now if we place a prism with its edge downwards in front of the aperture, the image will move on to the wall; but instead of a round patch we shall obtain a band showing the seven colours of the rainbow just mentioned: the band will be red at one edge and violet at the other. This rainbow band is called a *spectrum*. Whenever a ray of white light falls upon the surface of a body of any kind, it becomes partly or entirely absorbed. If all the rays become absorbed by the body, its surface appears black; if all the rays are reflected in equal measure its surface appears white. If some of the rays are absorbed and others reflected, the body acquires the colour of those rays which are reflected from the body and strike our eye. The same holds true with regard to transparent bodies. If the body absorbs all the rays it is not transparent, it is opaque; if it lets all the rays pass through it, it is entirely transparent, and as colourless as water or glass; but if the body arrests some rays and lets others pass through it, it will acquire the colour of the rays it lets through. If we analyse by means of a prism the light reflected by a coloured body, or the light which has passed through a coloured body, it is obvious that we shall no longer obtain an entire spectrum of seven colours, but one from which the absorbed rays will be absent.

Vegetation presents us with a similar phenomenon. In bright sunlight forests and meadows appear green. It is clear that if the leaf reflects the green colour it must absorb part of the white light which it received.

Before drawing any inference, however, from this fact, let us investigate more closely the cause of the green colour of the leaves. Whatever 'green part of a plant we may choose for investigation under the microscope, we very soon arrive at the conclusion that in itself it is colourless; it consists of bubbles called cells, the walls of which are as transparent as

glass, and the liquid which fills them as colourless as water. But this liquid contains bodies or grains emerald green in colour. They are generally called chlorophyll granules or *chloroplasts*. It is to these granules containing chlorophyll that the plant owes its green colour, in much the same way as the blood owes its colour to the red corpuscles which flow in the colourless lymph. Now let us observe what happens to the sunlight when it falls upon the surface of the green leaf; which rays are going to pass through the leaf and which will be arrested by it? For this purpose we must let a ray of light pass through the leaf, and then analyse it by means of a prism. When we do so we notice the difference which takes place in the spectrum. The rays absent in the spectrum, those in place of which black spaces are observed, have obviously been arrested by the leaf, have been absorbed by its substance. We can perform this experiment more exactly still. Since the colour of the plant depends on the chlorophyll, we can study the absorption of light by the chlorophyll itself. Chlorophyll can be extracted from leaves by means of spirit. We all know that any kind of infusion of leaves acquires a splendid green colour, which is the colour of the chlorophyll. Therefore instead of nearly opaque leaves we can use for our experiment a nearly transparent chlorophyll solution. We fill a glass with this solution and place it in the path of the sunlight, and then proceed to analyse with a prism the light we thus obtain. This is the kind of spectrum we get. The extreme red rays (from *A* to *B*, Fig. 2) will have passed through unabsorbed; whereas in place of the brightest red, the orange and part of the yellow rays, the spectrum will have a

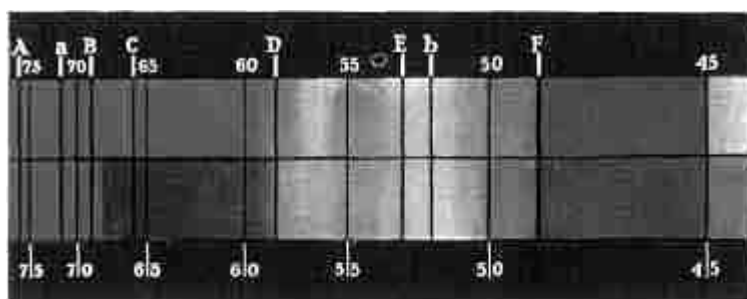

Fig. 2

black band (Fig. 2 from *B* to *D*);* the green rays (between *D* and a little to the right of *b*) will not be absorbed, and will give a green band in the spectrum; the blue and violet rays will be likewise absorbed. Hence, instead of all the seven colours the spectrum of chlorophyll will show only two coloured bands: a dark red and a bright green, with a black space between them. Hence we conclude that the green colour of a plant is not pure, but a mixture of green and red. This can be easily proved by a curious experiment. The commonest blue glass absorbs green rays and lets through some red rays. It follows that if we look at green vegetation through a piece of this glass it will arrest green rays on their way to our eyes,

and let through only red rays. German opticians have taken advantage of this fact, and offered the public a rather amusing instrument called the *erythrophytoscope*, which is simply a kind of blue spectacles, but the moment you put them on the whole world changes its aspect,. A fantastic landscape with coral woods and meadows unrolls itself under a deep blue sky. It might be useful to draw the attention of some artists to this fact who are in the habit of colouring their landscapes with that malachite green colour, never to be observed in Nature! In their unsuccessful endeavours to represent Nature, these artists probably tend to portray her in the clearest green possible, whereas the colour of our vegetation is in fact a mixture of green and red.**

* Fig. 2 represents a photograph of the absorption spectrum of chlorophyll. The blackest part lies within the red part of the spectrum. The process of photographing the spectra has presented great difficulties, even down to our own day. In the summer of 1893 I succeeded in obtaining satisfactory photographs, which were demonstrated at a congress of naturalists and physicians at Moscow in January 1894. The letters mark the so-called Fraunhofer lines of the spectrum of the sun.

** It is difficult to give any definite advice on the subject in the absence of necessary technical information. The spectrum of chrome green is nearest of all mineral green colours to the spectrum of chlorophyll, its green colour being a mixture of red and green rays. At all events we cannot obtain the green colour of foliage by mixing together yellow and blue (the blue of the spectrum).

We must, however, return to the main object in view. We wanted to know which rays are absorbed by the plant, and we found that chlorophyll absorbs certain red, orange, and yellow rays, as a result of which its spectrum presents a black to and in place of them. This fact can be tested even for a single chlorophyll granule under a microscope. This time instead of throwing the spectrum upon a wall, we can obtain it under the microscope by means of a lens, and in this spectrum off the size of a pin's head we investigate our chloroplast. We notice then that it appears transparent green in the green part of the spectrum, transparent red in the extreme red, and entirely opaque, as black as soot, in the red rays (marked by *BC* in Fig. 2) absorbed by the solution. This means that the living grains of chlorophyll also absorb these rays.

Thus when they fall upon a (plant or rather upon the chloroplasts enclosed in its cells, certain of the sun's rays become absorbed, cease to be light any longer,. But there is no loss of energy: it has only changed, passing into a state of tension. What kind of work is done by these rays in a plant? Let us recall the conclusion we have just arrived at, that sunlight decomposes carbonic acid in plants. May not this work take place at the expense of just those rays absorbed by the chlorophyll granules? This suggestion gains in probability when we learn that the chloroplast is the very organ, the very apparatus in which the decomposition of carbonic acid takes place. Priestley noticed that the decomposition of carbonic acid and the giving off of oxygen take place exclusively in

the green parts of the plant, i.e., in leaves or green stems. He was even able to prove that this activity is due to the green substance. If a vessel of water or some kind of extract is allowed to stand in the light, a green deposit soon appears on the walls of the vessel. Nowadays we know that this deposit is composed of microscopic plants, of algae; but in Priestley's time this fact was not known, and the deposit was even known as "Priestley's matter." Priestley was able to prove that this matter gave off oxygen. This experiment already showed that the green substance decomposed carbonic acid, even outside the leaf or stem, and that it was precisely to this green substance that these functions were due. Other doubts, however, rose later on. There are plants which are not green in Nature, and yet they also decompose carbonic acid. Such are the numerous plants with red, black, and other coloured leaves, which are more and more gaining a footing in our gardens and greenhouses; such are also the brown and red weeds growing at the bottom of the sea. In the former the matter has been easily explained. The variegated colour in such plants depends on bright solutions which exist in their cell-sap, and which conceal the green chloroplasts. These are easily seen under a microscope, and can be also revealed in the following way. We have only to dip a red or almost black leaf of *Coleus*, or some other plant with similarly coloured leaves, into dilute sulphurous acid, and it immediately turns green. This depends on the fact that in decolorizing the red pigment sulphurous acid does not affect the chlorophyll. It was rather more difficult to prove the presence of chlorophyll in seaweeds. It was impossible to find the green grains in them even under a microscope; they were all brown or red. Chemistry, however, showed that the green chlorophyll is concealed behind another substance. It is easy enough to observe this fact simply by walking by the seaside. Weeds cast on the shore very often manifest as they decompose all shades of colour from their natural colour to green. This is because in dead plants the more brightly coloured substances are washed away by water, while chlorophyll remains insoluble. Thus, even here the decomposition of carbonic acid takes place only in parts which contain chlorophyll granules. This rule has no exception. As has been already said, we must see in a chloroplast the apparatus, the mechanism, to which the energy of the sun is applied. It was very interesting to test by means of an experiment the truth of this hypothesis, and to see whether the decomposition of carbonic acid actually did take place at the expense of rays absorbed by the chlorophyll. In order to do so we had only to perform Priestley's experiment simultaneously in different parts of the spectrum. The experiment was performed in the following way: a series of glass tubes (Fig. 3, II, 1, 2, 3, 4, 5) were filled with a mixture of air together with a certain percentage of carbonic acid. Green leaves from the very same plant and of similar size were introduced into each of them. Then the vessels were exposed to the spectrum of the sun obtained in a perfectly dark room. After a few hours it was determined, by analysing the gas, in which tubes the carbonic acid had decomposed and

in which not—those in which it had decomposed more, and those in which less.

This experiment entirely proved the hypothesis. It turned out that the decomposition of carbonic acid took place exclusively in rays which corresponded to the black band in the spectrum of chlorophyll (Fig. 3, *I, Red*— and Fig. 2 between *B* and *D*), which means that rays which do not get absorbed by the chlorophyll do not decompose carbonic acid;

whereas rays which become absorbed decompose it the more, the more they themselves are absorbed. This is graphically illustrated in Fig. III. From the line *ab* perpendiculars are drawn, the length of which corresponds to the amount of carbonic acid decomposed in the corresponding parts of the spectrum (*I*) in tubes 1, 2, 3, 4, 5 (*II*). The broken line 1, 2, 3, 4, 5 (*III*) clearly shows the part of the spectrum in the sphere of which carbonic acid is decomposed most energetically.

Thus spectroscopic investigation serves to prove on the one hand that certain rays of the sun, after having crossed without any modification immeasurable depths of space, on meeting on their way a chlorophyll granule cease to be light any longer, disappear in performing work of some sort. On the other hand, the experiment in the spectrum just described points to the fact that it is these very rays which cause the decomposition of carbonic acid into carbon and oxygen, and are used up in this chemical work. We may conclude that a complete correlation is to be observed between the accumulation and expenditure of energy in the plant.

We have thus discovered the source of energy and also the apparatus to which this energy is applied, i.e., the chloroplast. We have seen the work done during the process; we have now to discover the product obtained, to follow the further fate of the carbon liberated from the carbonic acid and to realize what is produced from that carbon in the plant. Here our curiosity can be satisfied by the microscope.

We take a green organ of some kind, say a leaf, and dissect it so as to investigate it under a microscope; or, what is better still, we take a vegetable body, such as a green alga, commonly called green slime, which can be directly observed under a microscope. Having made sure that the chloroplasts do not contain any foreign body to begin with,* we expose the green organ to sunlight either in the open air or in an artificial atmosphere containing carbonic acid, i.e., we place it under conditions favourable to the decomposition of carbonic acid. After some time we again investigate the chloroplasts

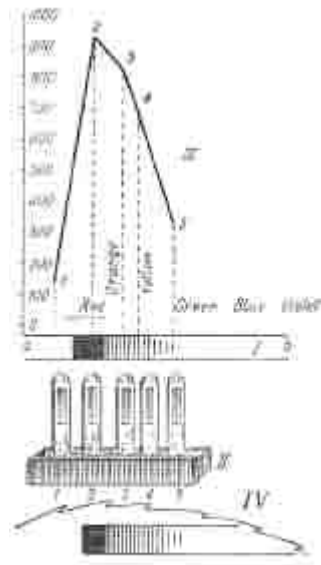

Fig. 3

under a microscope, and discover in them colourless grains which were not there before. It is 'easily proved that these grains consist of starch. Among the properties of starch is that of turning dark blue under the action of a solution of iodine, It is by this method that we detect starch in the chloroplast. The formation of starch, however, is not observed in the absence of light or carbonic acid; hence we are justified in concluding that the formation of starch is the result of the decomposition of carbonic acid. This is confirmed by the rapidity with which the one phenomenon is followed by the other. The decomposition of carbonic acid is manifested a few seconds after sunlight falls upon the surface of the leaf, and five minutes later starch is already found in the chloroplast. This correlation of the two processes becomes still more apparent if we take into consideration the chemical composition of starch. Starch can serve as a representative and type of the group of vegetable substances known as *carbohydrates*. The carbohydrates contain carbon, hydrogen, and oxygen. Their name is derived from the fact that in them hydrogen and oxygen are in the same ratio as in water, so that they seem to consist of carbon and water. In order to form a carbohydrate out of carbonic acid and water, we have only to remove all the oxygen from carbonic acid, i.e., we must perform exactly what takes place in a plant during the decomposition of carbonic acid. Therefore carbohydrates have precisely the same composition as would be expected of substances formed in the plant from carbonic acid and water.

* Which is ensured by keeping the plant in the dark for some time.

In this way the microscope fully confirms the results obtained by means of analysis. Whenever carbonic acid is broken down in a chlorophyll granule carbohydrates form inside it. The following example is a good proof of this correlation of the two processes. A bright spectrum of the sun is thrown in a dark room upon the leaf of a living plant, previously deprived of starch. In an hour's time the leaf is removed, decolorized with spirit, and treated with a solution of iodine. It appears that starch has formed in those parts of the spectrum alone which are absorbed by the chlorophyll, and the greater the absorption the more abundant the formation of starch; in other words, the leaf obtains an impression of the spectrum of chlorophyll in the form of starch coloured 'almost black by iodine (Fig. 3, *IV*—compare with Figs. 2 and 3, *I*).

The group of carbohydrates forms the largest component of our vegetable food. Thus starch forms three-fourths of the weight of a wheat grain and four-fifths of the dry matter of the potato. There are many substances besides starch which belong to this group, e.g., sugar, and cellulose, the substance which forms the solid skeleton of plants, from thin blades of grass to the trunks of trees. All these bodies have a similar composition, and differ only in their greater or less density and other physical properties. Sugar, for instance, dissolves in water; starch does not, it only swells and forms a kind of

semi-liquid paste; cellulose scarcely swells at all. In a sense we can say that starch is condensed sugar, and cellulose condensed starch. Other carbohydrates can be easily derived from starch. As a matter of fact sugar is artificially obtained [from starch in the manufacture of potato molasses. Cellulose has not yet been prepared artificially, but certainly is derived from starch in the plant: thus, for example, the starch of the germinating seeds of cereals changes into the cellulose of which the rootlet is built up.

Albuminoids form the second predominant group of vegetable substances after the carbohydrates. They are called: albuminoids from their likeness to the albumen of an egg. Wheat flour, taken as an example of vegetable food, contains something like 17 per cent of albuminoid matter, called gluten. Therefore, if starch and albuminoids are subtracted from cereal seeds, there will be only a small percentage left for all other substances. In addition to carbon, hydrogen, and oxygen, nitrogen enters into the composition of albuminoid substances.

Though starch, as we have seen, cannot be formed otherwise than with the cooperation of light, the formation of albuminoids in a plant does not require light, or any other external source of energy. It depends instead upon the presence of ready carbohydrates. If some plants are only provided with a carbohydrate of some kind, say sugar, and some source of nitrogen, say ammonia, they are sure to form albuminoids even in total darkness. According to exact experiment, without touching the problem unsolved as yet by chemists, as to the relation which exists between carbohydrates and albuminoids, we may say that plants are able to form albuminoids from a carbohydrate and ammonia. A physiologist can say to a chemist: give me sugar, ammonia, and a cell, and I will give you in return as much of an albuminoid as you wish. Its manufacture may certainly not always be very profitable, but in the present case its very possibility, if even only in theory, is very important.

Without entering into details as to the origin of other vegetable substances, less important to man as compared with albuminoids, we may nevertheless apply to them what has been said about the albuminoids, and thus arrive at the conclusion that the agency of sunlight is necessary only for the formation of starch or, speaking more generally, of carbohydrates from carbonic acid and water; no other substances require sunlight for their formation.

We can only now appreciate fully the significance of the processes taking place in the chlorophyll granule under the action of sunlight.

In the first place, from the chemical point of view, it is here that inorganic matter, carbonic acid and water, is transformed into organic matter—here lies the source and origin of all the heterogeneous substances out of which the organic world is built up. On the other hand, from the physical point of view, the chlorophyll granule represents an apparatus for capturing the sun's rays, which then are laid up in store for future use.

Plants form organic matter out of the air, and stores of energy out of sunlight. They represent in every respect the machine invented by Mouchot and Ericsson—the machine set in motion by the energy of the sun, free of cost. This explains the result of the farmer's labour: by expending but a comparatively small amount of substance in the form of manure, he obtains great masses of organic matter; by expending a certain quantity of energy he acquires great stores of it in the form of fuel and food. He burns down a forest, feeds sheep on the grass of his meadows, sells the corn of his fields, and yet everything returns to him again in the form of air, which, under the influence of sunlight, again acquires the form of forests, fields, and corn. With the assistance of plants he transforms air and light which have no market value into marketable quantities. He trades in air and *sunlight*.

* * *

These considerations dispose of the theories occasionally heard concerning the fate awaiting humanity when chemists shall have discovered the secret of synthesizing complicated organic bodies, and have found means of preparing artificial food. On the strength of what has already been achieved by synthetic chemistry, we can scarcely doubt that in the future, it may be at no very distant date, science will realize these expectations. At all events there is no such fundamental difference between what has been already achieved and what yet remains to be done as to make such a hope improbable. And then if food actually becomes artificial, will not agriculture be a thing of the past? Will not land lose its value? Will not the economic order of things entirely change? Let us see how far these conjectures are true. We saw that to form an organic body energy is required. On burning down a pound of bread eight hundred and ninety units of heat are produced. Therefore, to form it either naturally or artificially, a similar amount of heat must be used, or speaking more generally a similar amount of energy. Whence is this energy to be obtained? The only source of energy free of cost is the sun. Therefore, in order to produce artificial food our remote posterity will have to imitate plants by covering the surface of the earth with artificial absorbers of sunlight. Such imitation cannot be said to be an easy matter, because from this point of view the plant presents a very perfect apparatus. A glance at the thickness of the grass in any meadow is enough to convince us of the fact that every bit of soil is at present utilized. Calculations furnish us with data still more eloquent. Thus, for instance, the total surface of the leaves of a clover plant exceeds twenty-six times the area of the land occupied *by* the plant, so that an acre of clover is equal to twenty-six acres of green surface absorbing the rays of the sun. Other plants occupy even larger surfaces still. The sainfoin has a leaf-surface thirty-eight and lucerne eighty-five times larger than the areas

they occupy. Mixed grasses would probably give still higher numbers.

Here another curious theoretical problem occurs to us: Can we indefinitely increase by means of plants the amount of organic matter obtainable from a certain area of land? Can we expect that by means of improvements we shall indefinitely increase the productiveness of our soil, or has it a limit? This is the problem of the future fate of humanity. The data we already possess permit us to decide this question in the affirmative. There is a limit, and we are even able to determine it approximately. We have already said many times that the formation of organic matter in a plant is accompanied by the absorption of as much heat as is liberated in burning it down. Thus, for instance, if a plant liberates 1,000 units of heat when it burns, we may conclude that *at least* a similar amount of the heat of the sun has been used up in its growth; and however we may manure our soil and cultivate our land, if the sun does not provide it with these 1,000 units of heat we shall not get our plant.

Thus it is that, knowing on the one hand the amount of combustible matter (to be ascertained by analysis) contained in a crop obtained from a certain area of land, and knowing on the other hand the amount of heat cast by the sun upon this area, we have all the necessary data for calculating the profit and loss of the energy of the sun in our field, and hence can decide what proportion of it we use and what there is yet to be used. Such calculations for the crops which yield the largest amount of organic matter, the richest harvest, bring us to the following conclusions. The largest annual increase of matter in woods represents something like $1/700^{\text{th}}$ of all the amount of heat received by the area of land which they occupy during the six-month period of growth. The increase in bulk of the roots is not taken into this calculation. The Jerusalem artichoke, one of the plants which undergoes the most intensive cultivation, uses in this way $1/800^{\text{th}}$ of all the energy it receives from the sun. The organic matter in the richest crop of hay (rye-grass), including the root remains, stores up $1/135^{\text{th}}$ of the energy of the sunlight. Lastly, the best crops of oats and rye (grain, straw, and root remains) represent $1/80^{\text{th}}$ of all the energy they receive from the sun. Thus by means of a plant we are able to avail ourselves approximately of a quantity varying from $1/1000^{\text{th}}$ to $1/100^{\text{th}}$ of the total amount of sunlight which falls upon the surface of our forests and fields during the growing period.* Are we therefore entitled to say that by improving our methods of culture we shall be able to increase the crops by one hundred if not by one thousand times before we reach the limit of productiveness? Is the plant able to store up all the energy it receives from the sun? Certainly not. We know that no mechanism or organism makes exception to this rule, or transforms into useful work all the energy obtained; and this consideration alone is sufficient to prove that the physiological limit of vegetable productiveness cannot coincide with the physical. Contrary to the figures just mentioned, which have been taken from the results of various

cultures, an objection of the following kind can be brought forward: although field vegetation, as we have seen, presents a highly developed surface for absorption, we cannot, however, say that it absorbs all the sunlight that falls upon it. The following experiment will give us from this point of view more trustworthy statistics. By exposing to sunlight green leaves with a surface of accurately measured area, determining by means of analysis the amount of carbonic acid decomposed by this leaf in the best light, say during the space of an hour, and determining also the amount of heat that falls upon the selected surface of the leaf during that hour, we shall obtain all the data necessary for calculating the correlation between the absorption of energy and its utilization in decomposing carbonic acid. Direct experiments of this kind gave on the average $1/100^{\text{th}}$ of all the energy received, $1/55^{\text{th}}$ at the best. Some recent calculations show that this quantity can be increased to $1/20^{\text{th}}$. This last figure may probably be considered as approaching the limit of physiological productiveness, because the plants in these experiments were placed under the most favourable conditions possible. Thus we see how closely all our most intensive cultures approach what we have called the physiological limit, i.e., the largest amount of organic matter which can be obtained by means of a plant from a given area of land.

* It is clear that these numbers are not very strict. The number quoted for the amount of heat that falls upon a given area, taken from Pouillet's data, is only approximately true.

Even at this limit, however, only $1/100^{\text{th}}$ and in the best instance $1/20^{\text{th}}$ of the energy received is retained. This will cease to puzzle us if we consider the fact that apart from this uniquely productive work from man's point of view, other work takes place in the plant, entirely unproductive for man.* In the first place the plant evaporates during the whole of its lifetime such great quantities of water that in amazement we are inclined to discredit the figures. The evaporation of this quantity of water apparently requires much more heat than is used in the decomposition of carbonic acid. Therefore, together with the productive work in the formation of organic matter, the plant uses still more energy in work useless to man—in evaporation. But this, although the most important, is not the only other expenditure of energy in a plant. The plant absorbs that water from the soil, and therefore has to raise it to a certain height. This work may be expressed in foot-kilogrammes. It may be neglected in the case of our field plants, but is considerable in our trees.** We can imagine what a large amount of work underlies the raising of the masses of water evaporated in forests by giant trees like the eucalyptus of Australia, the tops of which, according to one botanist, might have cast their shadow even on the summit of the pyramid of Cheops. However, evaporation and the raising of water are not achieved solely by the energy derived immediately from the heat of the sun, though a considerable amount is certainly supplied in this way. To these causes of

unprofitable waste of the sun's energy must also be added another. We cannot avail ourselves of all the organic matter stored up by the plant during its lifetime, because it uses, burns down, part of that matter itself. We can say that it uses in this way as much as $1/20^{\text{th}}$ of all the matter, so that as regards the accumulation of organic matter the plant makes twenty steps forward and one backward.

* It is still more important to take into account the fact that a leaf cannot even absorb all the light of the sun: otherwise it would be black instead of green. Modern investigations prove that the leaf absorbs on the average 25 per cent of all the radiant energy received from the sun—this is the physical limit; 5 per cent are utilized in physiological experiments, and 1 per cent in the fields.

** The raising of the sap to a great height may be considered as unproductive, only with regard to the production of matter, but on the other hand it is all-important as it furnishes us with timber.

All these causes of waste of the sun's energy which we have enumerated illustrate for us, so to speak, the expenses of the production of organic matter by the plant. We see, therefore, that although the plant is a very perfect apparatus for utilizing the energy of the sun, it nevertheless leaves much to be desired, since at the best it transforms into work useful for man only $1/100^{\text{th}}$ or $1/200^{\text{th}}$ of all the energy it obtains from the sun. Man has to face the problem either of perfecting the plant in this respect, or of inventing in its place an artificial apparatus, which shall utilize a greater percentage of the energy acquired, and moreover work the whole year round. How far he will succeed is for the future to decide. One thing is certain, that when by means of his artificial apparatus man shall gather from all the free area of land about a hundred times more organic matter than is contained in the richest crop today, he will be able to say that he has reached the limit; that he can go no further. Man will then make no further demand of the soil or his art, for more fuel or more food—he will not be able to get any more, because the sun will not be able to give any more. Then the law of Malthus will manifest itself in all its ominous cogency: mankind will have to keep, a strict account of life and death; it will have to take account of the death-rate before reproducing itself, as has been already anxiously suggested by perspicacious economists. No extra mouth, in the literal sense of the word, will then find room at the banquet of Nature. Will mankind ever attain this limit? By what new processes of synthesis will Berthelots of the future benefit it? What new sun-machines will be furnished by future Mouehots and Ericssons? Who can tell? One thing is certain, that our planet will acquire then a very dismal aspect. When man shall have arrived at the utilization of all the energy of the sun instead of only part of it as we do at present, then, instead of the emerald green of our meadows and woods, our planet will be covered with the uniform mournful black surface of artificial light-absorbers. Lord Kelvin foretold that our planet will find its death from *cold*, that our world would be wrapped in its icy embrace; but I do not think this prophecy has alarmed

more than a very few. It will come to pass long after our day, and we all know the proverb; *après moi le déluge*. Yet we cannot help shuddering at the idea of what life will be like when the earth is transformed into a universal factory, with no possible escape into the open even on a holiday, even for a single hour!

Let us turn from this gloomy and fantastic picture of what I am happy to say is a very remote future, and go back to the question raised at the beginning of this lecture, which we are now able to answer fully and categorically. We can do so best under the following figure. Once upon a time a ray of sunlight fell somewhere upon the earth. It did not fall, however, upon sterile soil, but upon a green blade of wheat, or rather upon a chlorophyll granule. The ray was extinguished when it struck the granule; it ceased to *be* light any longer, but it did not cease to exist. It was used up in the work it did inside the granule: it broke the connection between the atoms of carbon and oxygen which were combined as carbonic acid. The liberated carbon in some way or other combined with water and formed starch. This starch was transformed into sugar, and after many peregrinations inside the plant was precipitated again inside the grain as starch, or as gluten. In either case it entered into the composition of bread, which serves us as food. It was transformed into our muscles, into our nerves. And now in our organisms atoms of carbon strive to recombine with the oxygen which is carried by the blood to all the parts of our body. The ray of sunlight, concealed in these atoms during this process in the form of chemical tension, re-acquires the form of actual energy. It is this ray of sunlight which warms us, and by which we move. Maybe it sparkles in our brains at the present moment.

This illustration is the most detailed answer which science can give in reply to our question. We can express it shortly in three words. Food plays in our organism the part of a source of energy only because it is a *preserve of sunshine*.

The scientific importance of this result is obvious. It will also be appreciated by people indifferent to scientific truths. A poetical dreamer who looks sadly upon the prosaic labour of a scientist will be pleased to learn from him that he—the poet himself—is much the same ethereal being, built of air and light, as the immaterial productions of his fancy. The haughty noble who prides himself upon his ancestry, and looks down somewhat contemptuously upon the modest lot of the toilers in the field of science, will certainly treat with more respect this same science on hearing that she entitles him as well as the Emperor of China to call himself "the Son of the Sun."*

* Helmholtz: *Ueber die Wechselwirkung der Naturkräfte*, p. 127.

TO THE READER

The Foreign Languages Publishing House would be glad to have your opinion of this book and its design and any suggestions you may have for future publications.

Please send them to 21, Zubovsky Boulevard, Moscow, U.S.S.R.