

**HETA 94-0244-2431
JUNE 1994
MEMPHIS FIRE DEPARTMENT
MEMPHIS, TENNESSEE**

**NIOSH INVESTIGATORS:
Ted A. Pettit, M.S.
Tim R. Merinar, M.S.**

I. SUMMARY

On April 15, 1994, the Division of Safety Research (DSR) received a request from the International Association of Fire Fighters (IAFF) for technical assistance in investigating the circumstances of the deaths of two fire fighters in Memphis, Tennessee, on April 11, 1994. The IAFF requested technical assistance in determining if the self-contained breathing apparatus (SCBA) failed or contributed to the fire fighters' deaths, assessing the accountability of personnel utilizing SCBA in the hazard area, and evaluating the training of command and suppression personnel. This request was handled as a National Institute for Occupational Safety and Health (NIOSH) Health Hazard Evaluation.

From April 19 to 23, 1994, NIOSH investigators from the Division of Safety Research travelled to Memphis, Tennessee, to conduct an investigation of this incident. The investigation was coordinated through the Memphis Fire Department, and consisted of four phases: (1) the interview of several fire fighters, fire chiefs, union representatives, safety personnel, fire investigators, and the director of fire services; (2) a site visit to the eleven-story high rise apartment building involved in the fire; (3) the review of respirator maintenance records of the fire department; (4) and the evaluation of breathing apparatus (4 units) worn by the first respondents to the fire. Based on the results of this investigation, NIOSH investigators identified several contributing factors to this incident: (1) adherence to established departmental policies and procedures at the fire scene; (2) implementation of an adequate respirator maintenance program; (3) fire fighter accountability at the fire scene; and (4) use of Personal Alert Safety System (PASS) devices at the fire scene.

On the basis of the information obtained during this investigation, the NIOSH investigators concluded that there were four contributing factors to this incident: (1) Adherence to established departmental policies and procedures at the fire scene; (2) implementation of an adequate respirator maintenance program; (3) fire fighter accountability at the fire scene; and (4) the use of Personal Alert Safety System (PASS) devices at the fire scene. Recommendations for command and safety

KEY WORDS: SIC 9224 (Fire Departments), fire fighters,

death, self-contained breathing apparatus, SCBA.

II. INTRODUCTION

On April 15, 1994, the Division of Safety Research (DSR) received a request from the International Association of Fire Fighters (IAFF) for technical assistance in investigating the circumstances of the deaths of two fire fighters in Memphis, Tennessee, on April 11, 1994. The IAFF requested technical assistance in determining if the self-contained breathing apparatus (SCBA) failed or contributed to the fire fighters' deaths, assessing the accountability of personnel utilizing SCBA in the hazard area, and evaluating the training of command and suppression personnel. This request was handled as a NIOSH Health Hazard Evaluation.

From April 19 to 23, 1994, NIOSH investigators from the Division of Safety Research travelled to Memphis, Tennessee, to conduct an investigation of this incident. The investigation was coordinated through the Memphis Fire Department, and consisted of four phases: (1) the interview of several fire fighters, fire chiefs, union representatives, safety personnel, fire investigators, and the director of fire services; (2) a site visit to the eleven-story high rise apartment building involved in the fire; (3) the review of respirator maintenance records of the fire department; (4) and the evaluation of breathing apparatus (4 units) worn by the first respondents to the fire. A copy of the Memphis Fire Department procedures for high rise fires was obtained during the investigation. A copy of respirator maintenance calibration records and procedures for respirator maintenance was not available during the investigation. These procedures and records were requested from the Memphis Fire Department in a letter dated April 28, 1994, to the Director of Fire Services. On May 11, 1994, NIOSH received a letter from the Memphis Fire Department dated May 6, 1994, along with several documents. These included copies of the Memphis Fire Department Training Manual, Fire Station No. 5/9, Book No. 13; two training bulletins; a one page document titled Airmask Policy rev 10/88; an Air Mask Repair and Maintenance Form; an MSA Regulator Repair Personnel certificate; an Inspection & Maintenance Check List for SCBA; and a copy of the MSA Inspection and Maintenance Procedures for the Ultralite II and Custom 4500 Pressure Demand Air Masks. The cover letter stated that the criteria for recycling regulators is once every six months.

III. BACKGROUND

On April 11, 1994, at 0205 hours, a call was placed to the Memphis Fire Department from the security service for a high rise apartment building in Memphis, reporting a possible fire on the ninth floor.

Engine Company 7 and Snorkel 13 were the first respondents and arrived at the apartment high rise at 0208 hours. Engine Company 7, being the first on the scene, assumed command. Fire Fighter No. 1 (victim No. 1), Fire Fighter No. 2 (victim No. 2), and Fire Fighter No. 3 of Engine Company 7, and Fire Fighter No. 4 and No. 5 of Snorkel 13 entered the building through the main lobby; they were aware that the annunciator board was showing possible fires on the ninth and tenth floors. All five fire fighters used the lobby elevator and proceeded to the ninth floor (lobby command radioed Fire Fighter No. 1 that smoke was showing from a ninth floor window). When the doors of the elevator opened on the ninth floor, the hall was filled with thick black smoke. Fire Fighters No. 1, No. 2, No. 4, and No. 5 stepped off the elevator. Fire Fighter No. 3, who was carrying the hotel pack (two 50-foot lengths of hose) was still on the elevator, holding the door open with his foot, as he struggled to don his self-contained breathing apparatus (SCBA). Fire Fighter No. 3's foot slipped off the elevator door, allowing the door to close and the elevator to return to the ground floor, with Fire Fighter No. 3 still inside. Note: This elevator was not equipped with fire fighter control.

Fire Fighters No. 1, No. 2, No. 4 and No. 5 entered the small ninth floor lobby (see Figure) directly in front of the elevator. Fire Fighter No. 2 was experiencing problems with his SCBA. Fire Fighter No. 4 stated that he heard air leaking from the back of Fire Fighter No. 2's SCBA and heard Fire Fighter No. 2 cough. Fire Fighter No. 2 radioed that he was having difficulties and asked for the location of the stairwell. Fire Fighter No. 1 was heard on the radio to say "I've got him." At this point, Fire Fighter No. 1 and Fire Fighter No. 2 proceeded into the hallway, turning right. It is not known if Fire Fighter No. 1 was aware that Fire Fighter No. 3 was not on the ninth floor at this time.

Fire Fighter No. 4 and Fire Fighter No. 5 entered the hallway and turned left, reporting zero visibility (due to thick black smoke). Excessive heat forced them to retreat after they had gone some 15 to 20 feet down the hall. They proceeded back down the hall, past the elevator lobby, and encountered a male resident, who attacked Fire Fighter

No. 5, knocking him to the floor, and forcibly removed his facepiece. Fire Fighter No. 4 heard the commotion, and went to assist Fire Fighter No. 5. The two fire fighters and the resident moved through the doorway of the apartment, where the fire fighters were able to subdue the resident. At this point the low air alarm on Fire Fighter No 5's SCBA was sounding. Fire Fighter No. 5 then broke out a window to provide fresh air to the resident, in an effort to calm him. Fire Fighter No. 4 attempted to close the door to the hallway; however, the excessive heat from the hallway prevented him from closing the door. Both fire fighters and the resident had to be rescued from the ninth floor apartment window by a ladder truck. NOTE: It was not known at the time that a 31-year-old female victim (victim No. 3) was in the same apartment. Her body was found when the fire was under control and a search was conducted of the ninth floor.

Fire Fighters No. 6, No. 7, and No. 8 from Engine Company 1 arrived on the scene at 0209 hours (upon arrival, they observed a window on the ninth floor blow out) and proceeded up the West End stairwell to the ninth floor, carrying a hotel pack and extra air tanks. Fire Fighter No. 6 and Fire Fighter No. 8 entered the ninth floor with a charged fire hose, and crawled down the smoke-filled hall, for approximately 60 feet (the hallway was 104 feet long) before extreme heat forced them to retreat. Neither fire fighter could see anything in the dense smoke and became disoriented (they were within 6 feet of the exit door and could not see it). As they retreated, they crawled over something they thought may have been a piece of furniture, although they did not remember any furniture being there when they entered the hallway.

Fire Fighter No. 3 from Engine Company 7, after riding the elevator to the ground floor lobby, obtained a replacement SCBA, and climbed the stairs at the west end of the building to the ninth floor. Fire Fighter No. 3 opened the ninth floor exit door and saw Fire Fighter No. 6 and Fire Fighter No. 8 in trouble. He grabbed Fire Fighter No. 6 and pulled him through the doorway into the stairwell. He then reopened the door and pulled Fire Fighter No. 8 into the stairwell.

At 0224 hours, Rescue Squad 2 arrived at the scene and proceeded up the west end stairwell to the ninth floor. They asked, "Where are the 7's?" (referring to the fire fighters on Engine Company 7). The response was, "We don't know the location of the 7's." Fire Fighter No. 9 and Fire Fighter No. 10 of Rescue Squad 2 opened the ninth floor exit

door, and as they entered, spotted a downed fireman approximately 9 feet from the door, tangled in wire cables. After the fire these were determined to be television cables that had been attached to the hallway ceiling in plastic tubing - the extreme heat caused the plastic to melt, allowing the cables to fall to the floor. The downed fireman was Fire Fighter No. 2 of Engine Company 7 (his body may have been what Fire Fighters No. 6 and No. 8 encountered in the hallway). Fire Fighter No. 2 was unresponsive and was still wearing his SCBA. He was removed from the ninth floor and carried down the stairs to the eighth floor, where advanced life support was started immediately. The fire fighters of Rescue Squad 2 then entered the first apartment to the left of the exit door and found Fire Fighter No. 1 in the corner of the apartment. He was in a kneeling position - his head facing into the corner, holding his mask to his face and was unresponsive. Fire Fighter No. 1 was removed from the ninth floor and carried down the stairs to the eighth floor where advanced life support was started. Both fire fighters were removed within minutes and taken to a local hospital, where advanced life support was continued; however, neither responded to life-saving measures and they were both pronounced dead by the attending physician. Fire Fighter No. 1 was found in the same apartment where a second civilian victim (a 19-year-old female) was found.

The PASS (personal alert safety system) devices worn by both fire fighters (victims) were not activated, therefore, no audible alarm was given when the fire fighters went down.

Several other fire fighters and fire companies from the Memphis Fire Department responded to this fire, however, only those directly involved on the ninth floor are cited in this report. As part of the NIOSH investigation, the SCBAs worn by Fire Fighters No. 1, No. 2, No. 4, and No. 5 were sent to the NIOSH Laboratories in Morgantown, West Virginia, for evaluation and testing (see Appendix for a complete report on the NIOSH evaluation of these respirators).

IV. INVESTIGATION

The City of Memphis has a population of approximately one million people. The Memphis Fire Department is comprised of approximately 1400 workers, of which 900 are fire fighters. On April 11, 1994, a fire broke out in a high-rise apartment building in Memphis that resulted in four fatalities—two fire fighters and two civilians. The IAFF contacted NIOSH and requested an investigation be conducted into the circumstances of this fire.

The NIOSH investigative team leader contacted the Memphis Fire Department on April 15, 1994, to inform the fire department investigation liaison official of the request received from the IAFF. During this telephone conversation, a request was made by NIOSH to the Memphis Fire Department for their assistance and cooperation in conducting an on-site investigation. Permission for the investigation was given by the Memphis Fire Department, and the NIOSH investigators travelled to Memphis during the week of April 19 to 23, 1994, to conduct the investigation.

The NIOSH investigators met with the Memphis Fire Department liaison investigator on April 19, 1994, to discuss the purpose of the NIOSH investigation, and review the details of the incident. On April 20, 1994, the NIOSH investigators met with the director and assistant director of fire services, and the department liaison investigator to conduct an opening conference. After the opening conference, the NIOSH investigative team met with the five-member fire department investigative team appointed by the fire director to investigate this incident. The NIOSH team was briefed on the incident and viewed video tapes taken the night of the fire (taken from the outside of the building).

On the afternoon of April 20, the NIOSH team and three members of the fire department investigative team toured the ninth-floor fire scene. A walk through of the ninth floor was conducted; starting with the elevator lobby area, then proceeding to the point of origin of the fire, then following the path of the fire. Next, the suspected path of the fire fighters the night of the incident, was followed to the locations where the victims (two fire fighters and two civilians) were found.

After leaving the fire scene, the NIOSH investigators and the complete fire department investigative team convened at the fire department training center to inspect the fire fighters' protective equipment and clothing used the night of the fire. This equipment had been secured as evidence the night of the fire, and had been locked in a storage area at the training center. The NIOSH team observed the fire department team inspect, record, and videotape each piece of equipment and clothing.

On the morning of April 21, the NIOSH team met with union representatives and the fire department liaison investigator to discuss the purpose of the NIOSH investigation.

On the afternoon of April 21, the NIOSH team interviewed several fire fighters who were on the scene the night of the incident, including those who were first respondents, and those who assisted in the rescue.

On April 22, the NIOSH team met with the fire director, deputy fire director, and the fire department liaison investigator. The NIOSH team requested permission to inspect, conduct a records review, and tour the respirator maintenance facility. The NIOSH team was accompanied to the respirator maintenance facility by the fire department's five-member investigative team appointed by the Director of fire services.

After leaving the respirator maintenance facility, the NIOSH team requested a second site visit to the fire scene. The five-member investigative team accompanied the NIOSH team during this site visit. After the site visit to the fire scene, the NIOSH team accompanied the fire department liaison investigator to the training center to make arrangements to ship the respirators back to the NIOSH laboratory in Morgantown, West Virginia, for further evaluation.

The observation made by the NIOSH team during the investigation was that the SCBA are sent to the Air-Mask Maintenance Shop only when they malfunction. The NIOSH investigation team requested information documenting the procedure by which SCBA are returned to the Air-Mask Maintenance Shop for regularly scheduled preventative maintenance and testing to ensure that they continue to function as a NIOSH-approved SCBA. The existence of such a procedure could not be supported by documentation.

The overall documentation and record keeping for the Air-Mask Maintenance Shop was also deficient. The NIOSH investigation team requested any records pertaining to maintenance, standard-operating procedures, test procedures, test equipment calibration records, and test results of respirators used by the fire department. The only records that were obtained were handwritten on a 5- by 7-inch yellow pad of writing paper and on a xerox copy of an Air-Mask Repair and Maintenance Form. The only Air-Mask Maintenance Form that was obtained for any of the four SCBA shipped to NIOSH for testing was for SCBA #77 and dated 11/8/93. The only indication of maintenance on this form was a handwritten note which said "Adj. lever arm assem." and was signed by the repair person. Notations in the yellow notepad were dated from 11/16/92 to 04/21/94, and generally consisted of the date, the SCBA number, the regulator serial

number, and either a brief description of the maintenance performed, or an "OK." This yellow notepad appeared to be a daily log of the repair person's activities and not a record of routine or preventative maintenance.

Cause of Death:

The medical examiner listed the cause of death for the two fire fighters as follows:

Fire Fighter No. 1 - Asphyxia - smoke inhalation
Carbon Monoxide level in blood at 7.7%

Fire Fighter No. 2 - Smoke and Carbon Monoxide Inhalation
Carbon Monoxide level in blood at 17.4%

V. RECOMMENDATIONS/DISCUSSION

Recommendation #1: The fire department should conduct frequent retraining of fire personnel on fire department policies and procedures so that proper procedures are instinctive under emergency and stress conditions. [8,9]

Discussion: The Memphis Fire Department written policy on high rise fires was reviewed, and the policy states "at no time will the team take the elevator to the fire floor." The lights on the annunciator board in the lobby indicated that there was possible trouble on the ninth and tenth floors. Although this location had been the scene of several false alarm calls in the past, and it was assumed this was another routine call, the fire fighters had two warnings that there was a fire on the ninth floor: lobby command radioed that smoke was observed coming from the ninth floor window, and the hallway was filled with smoke when the elevator doors opened. Five fire fighters went up the elevator to the ninth floor, and one fire fighter returned to the ground floor with the hotel (standpipe) pack. The lobby command should have been alerted that four fire fighters were on the ninth floor with no fire fighting equipment, thereby, alerting fire command that a rapid intervention team needed to be assembled.

Recommendation # 2: The fire department should develop and implement written maintenance procedures for the self-contained breathing apparatus (SCBA) [3-5, 7]

Discussion: From the information gathered on this investigation, it appears that the respirator maintenance program is deficient. The observation is supported by the

NIOSH evaluation and testing of four SCBA's from the Memphis Fire Department used in this incident (see Appendix). Each of these four SCBA failed at least two of five performance tests that were conducted by NIOSH to determine if the SCBA were in an approved configuration and met the performance requirements of Title 30, Code of Federal Regulations, Part 11.

The fire department should develop a comprehensive record keeping system that includes the following:

- 1) A written procedure that establishes a policy for returning each SCBA to the Air-Mask Maintenance Shop on a regular basis for preventive maintenance. This procedure should provide for a tracking system that ensures the SCBA will be returned at the proper intervals. Title 30, CFR, 11.2(a) states that respirators ... shall be approved for use in hazardous atmospheres where they are maintained in an approved condition and are the same in all respects as those devices for which a certificate of approval has been issued The MSA Inspection and Maintenance Procedures for the Ultralite II and Custom 4500 Pressure Demand Air Masks, page 6, states that MSA recommends the regulator be tested at least once a year and overhauled at least once every 3 years.
- 2) Establish a record keeping system that will record the results of:
 - a) Regular calibration of the MSA test equipment as recommended by the Inspection and Maintenance Procedures for the Ultralite II and Custom 4500 Pressure Demand Air Masks on page 4.1, Flow Testing Section.
 - b) Performance tests conducted on a regular basis.
 - c) Any repairs made during both routine preventative maintenance and necessary maintenance on SCBA taken out of service.

These records should identify the SCBA and regulator identification numbers, test equipment identification numbers, date, a description of the service action including parts (and part numbers) involved, and identification of the repair person.

- 3) Establish a record keeping system for tracking the SCBA cylinders to ensure that the cylinders are hydro-

statically retested and recertified every three years as required by DOT in 49 CFR 179.34(e)(13) and NIOSH in 30 CFR 11.80(a).

Recommendation #3: The fire department should ensure that fire command always maintains close accountability for all personnel at a fire scene. [6, 8, 9, 11]

Discussion: Accountability for all fire fighters at a fire scene is paramount, and one of the fire commands' most important duties. The question was asked at the fire scene, "Where are the 7's?" This should have been a signal that the 7's were not accounted for, and should have generated an emergency search response. One method of accountability would be a buddy or team system, whereby, if any part of a team is not accounted for, fire command is notified immediately, signaling that a potential life-threatening problem may exist.

Recommendation #4: The fire department should mandate the wearing and use of the PASS devices when fire fighters are involved in fire fighting, rescue, or other hazardous duties.[8]

Discussion: The PASS (Personal Alert Safety System) device is a small electrical device worn by the fire fighter and will emit a distinctive audible alarm if the fire fighter is motionless for more than 30 seconds. Both fire fighter victims were wearing the device, however, neither device had been activated.

Recommendation #5: Municipalities should review, and amend where necessary, existing elevator codes to ensure that they require both Phase I (recall) and Phase II (fire fighter control) for all elevators having a total travel distance greater than 25 feet. [1, 2]

Discussion: Fire fighter entrapment by the action of automatic elevators is a recognized hazard in the fire service. Many years ago, elevator codes and installation practices were changed to minimize the danger that fire fighters would be trapped in elevators and to facilitate their safe use for access to a fire on an upper floor. American Society for Mechanical Engineers (ASME) standards were developed to require Phase I (recall), and Phase II (fire fighter control) for all elevators. This ensures that in an emergency, the fire fighter has control of the elevator.

VI. REPORT DISTRIBUTION AND AVAILABILITY

Copies of this report may be freely reproduced and are not copyrighted. Single copies of this report will be available for a period of 90 days from the date of this report from

the NIOSH Publications Office, 4676 Columbia Parkway, Cincinnati, Ohio 45226. To expedite your request, include a self-addressed mailing label along with your written request. After this time, copies may be purchased from the National Technical Information Service (NTIS), 5285 Port Royal, Springfield, Virginia 22161. Information regarding the NTIS stock number may be obtained from the NIOSH Publications Office at the Cincinnati address. Copies of this report have been sent to:

1. Charles E. Smith, Director, Division of Fire Services, 65 S. Front Street, Memphis, TN 38103-2498.
2. Billy Chitwood, Union Representative, Memphis Fire Department, 5950 Lamar, Memphis, TN 38118.
3. Richard M. Duffy, Director, OHS, IAFF, 1750 New York Avenue, Washington, D.C. 20006.
4. Commissioner, Tennessee Department of Health and Environment, 344 Cordell Hull Building and Fifth Avenue North, Nashville, TN 37219.
5. Commissioner, Tennessee Department of Labor, 501 Union Building, Suite A - 2nd Floor, Nashville, TN 37243-0655.

VII. REFERENCES

1. American Society of Mechanical Engineers. ASME A17.1 - 1990, Safety Codes for Elevators and Escalators (as amended), Section 211, American Society of Mechanical Engineers, New York, NY
2. American Society of Mechanical Engineers. ASME A17.3 - 1990, Safety Code for Existing Elevators and Escalators (as amended), American Society of Mechanical Engineers, New York, NY
3. 29 Code of Federal Regulations 1910.134, Respiratory Protection.
4. 30 Code of Federal Regulations 11, Respiratory Protective Devices, Tests for Permissibility, Fees.
5. 49 Code of Federal Regulations 173, Shippers-General Requirements for Shipments and Packaging.

Figure:

Karl Snyder, Ph.D
Agricultural Engineer
Safety Controls Section
Protective Technology Branch
Division of Safety Research

Paul Moore
Safety Engineer
Trauma Investigations Section
Surveillance and Field
Investigations Branch
Division of Safety Research

Editorial Review:

Paul Keane
Writer-Editor
Information Management and
Dissemination Activity
Division of Safety Research

DIAGRAM OF THE NINTH FLOOR

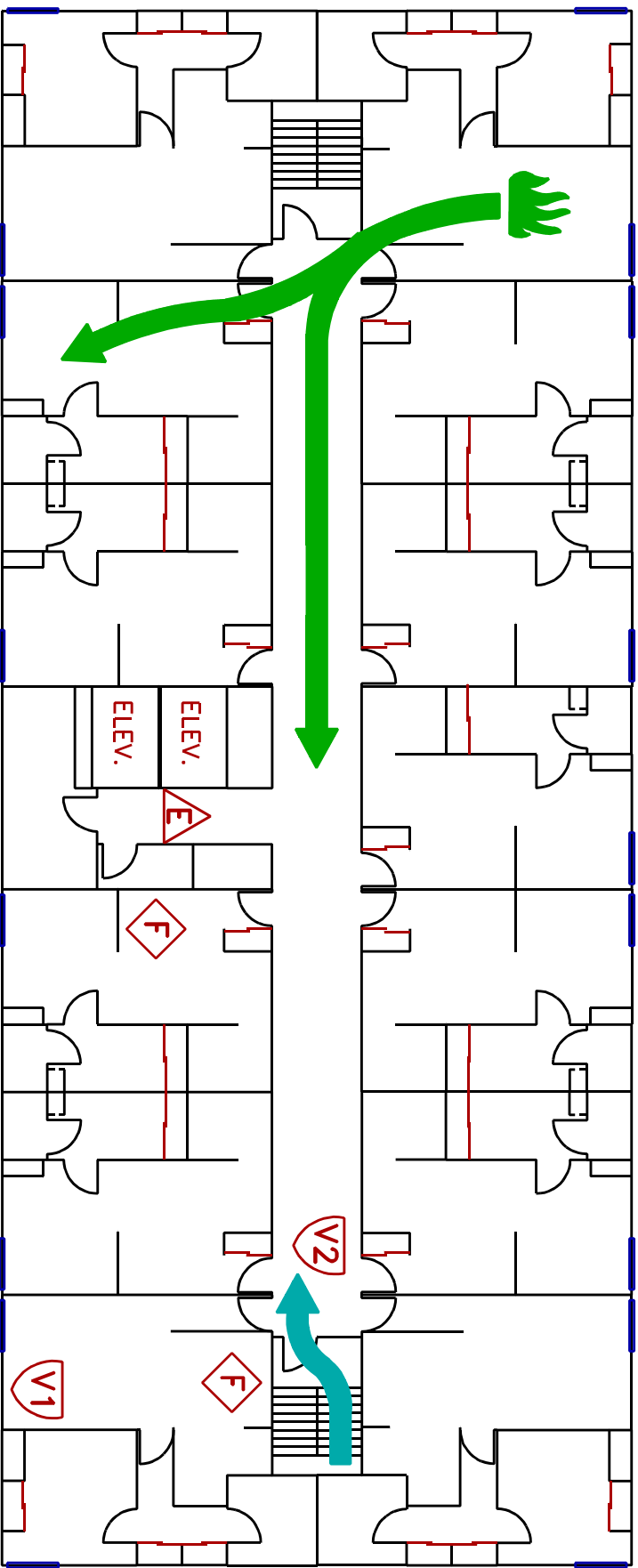

START OF FIRE



DIRECTION OF FIRE AND SMOKE



ELEVATOR LOBBY



LOCATION OF FIREFIGHTER VICTIM #1



LOCATION OF FIREFIGHTER VICTIM #2



LOCATION OF FEMALE VICTIMS



PATH OF RESCUING FIREFIGHTERS

APPENDIX

May 12, 1994

Acting Chief, ASRS/CQAB

Conformance Investigation of Self-Contained Breathing Apparatus
from Memphis, Tennessee, Fire Department. TN-07073

Ted A. Pettit, Acting Chief TIS, SFIB
Through: Acting Chief, SFIB
 Acting Director, DSR
 Chief, CQAB

Background

In a letter dated April 15, 1994, Mr. Richard M. Duffy, International Association of Fire Fighters, requested that the National Institute for Occupational Safety and Health (NIOSH) examine the self-contained breathing apparatus (SCBA) worn and used by two Memphis, Tennessee, fire fighters at the time of their deaths. A copy of the letter from Mr. Duffy is attached as Attachment One.

On April 19, 1994, Mr. Ted Pettit, Acting Chief, Trauma Investigations Section, and I traveled to Memphis to investigate the circumstances involving the fire fighter fatalities, and to examine the respirators involved. At the time of the incident, the fire fighters were part of fire fighting operations on the ninth floor of an eleven-story apartment building located in Memphis, Tennessee.

Part of the investigation in Memphis centered on the inspection of the SCBA and their shipment to NIOSH in Morgantown for performance testing. The Air-Mask Maintenance Program at the Memphis Fire Department was also reviewed. Because of questions surrounding the performance of at least one other SCBA during the incident, a total of four SCBA were shipped to NIOSH for testing. These include the two SCBA used by the deceased fire fighters, as well as two others assigned to the same Engine Company and believed to have been used during the incident. Complete details of the NIOSH on site investigation can be found in the Health Hazard Evaluation report of this incident (HETA: 94-0244).

The four respirators were received at NIOSH on April 26, 1994, and stored under lock in Room 178B prior to testing.

SCBA Inspection

The respirators were examined and tested by personnel of the Air-Supplied Respirator Section, Certification and Quality Assurance Branch, on May 2, 1994, in Room 176 of the Appalachian Laboratory for Occupational Safety and Health. Those present were Michael Commodore, Doug Riffle, Louis Smith, and myself. The units were photographed and the inspection and testing process video taped by Mike Moore, also of NIOSH.

The four SCBA were inspected in the condition as received. The SCBA were marked for identification by the Memphis Fire Department as numbers 175, 633, (both used by the deceased fire fighters), 77, and 557. The results of this inspection are presented as Attachment Two and summarized in Table One. Although damage and non-conformances were detected on all of the SCBA during the inspection process, it was determined that the four SCBA were in safe enough condition to conduct performance testing. These damaged areas include a bent cylinder valve and deformed threads on the regulator outlet of SCBA # 175, a mis-seated exhalation valve spring in SCBA # 633, no facepiece received with SCBA # 77, and no facepiece head harness received with SCBA # 557. Additionally, current hydrostatic test dates could not be identified on any of the four cylinders.

SCBA Testing

Each SCBA was tested in the condition as received from the Memphis Fire Department. The only exceptions were that a facepiece from NIOSH record material was used to facilitate testing on both # 77 and # 557, and the cylinder valve connection on # 77 was tightened before testing. This connection was tightened because testing would not have been possible otherwise due to excessive leakage. No other attempts were made to alter the condition of the SCBA. Selected performance tests were conducted on each SCBA to determine if they functioned as NIOSH-approved SCBA. These tests included the Positive Pressure Test, Rated Service Time (duration) Test, Exhalation Breathing Resistance Test, Gas Flow Test, and Remaining Service Life Indicator (Alarm) Test. The specific test requirements are contained in Title 30, Code of Federal Regulations, Part 11, Subpart H, and are summarized in the NIOSH test report for this investigation (Attachment Three). At the request of the Memphis Fire Department, each SCBA cylinder was charged to the pressure as indicated on the Memphis Fire Department Daily Inspection and Maintenance Check List. These pressures were:

Unit # 175 - 2000 PSI
Unit # 633 - 2100 PSI
Unit # 77 - 2200 PSI

Unit # 557 - 2400 PSI

The standard NIOSH duration test is done at full cylinder pressure which for these SCBA would be 2216 PSI.

The results of the testing are presented in the NIOSH Test Report (Attachment Three) and summarized in Table Two.

Summary of Results

The SCBA were all manufactured by Mine Safety Appliances Company (MSA) of Pittsburgh, Pennsylvania. Three of the four SCBA did not have NIOSH approval labels on them as required by Title 30, Code of Federal Regulation (CFR) Part 11.33(e). Dates of manufacture were identified on the SCBA facepieces and cylinders, but it is not known how long these components were with the rest of the SCBA assembly since it is common practice to interchange or replace cylinders (and to some extent facepieces). Each of the four SCBA failed to meet the performance requirements of at least two of the five bench tests that were performed.

Unit # 175 failed the Positive Pressure (11.70(a)(2)(ii), Rated Service Time (11.85-10), and Gas Flow (11.85-8) tests. In addition, the Remaining Service Life Indicator (Alarm) setting was not within the required tolerances (11.82(F)). Deformed threads on the regulator outlet caused the breathing tube to "catch" and appear to be fully engaged when the threads were tightened about halfway. This unit was received in this condition and so it was tested in this condition. Air was leaking continuously from this connection because it was not fully tightened. As the Gas Flow Test was being conducted, the inhalation valve inside the facepiece stuck shut on two separate occasions, resulting in a complete loss of airflow from the regulator to the facepiece. The air resumed flowing after the bypass valve was opened fully, causing the inhalation valve to "pop open." During the Rated Service Time Test, the alarm did not function as it was designed. The alarm sounded and then quit a number of times. The alarm should sound when the cylinder pressure drops to approximately 25% of the rated service time or pressure.

Unit # 633 failed the Rated Service Time (11.85-10) Test. In addition, the Remaining Service Life Indicator (Alarm) setting was not within the required tolerances (11.82(F)). When this SCBA was inspected, the positive-pressure exhalation valve spring was found to be off the seat, causing the valve to stick open. This resulted in continuous outward leakage of air during testing. Qualitative positive-pressure and negative-pressure fit tests should have detected the leaking exhalation valve.

Unit # 77, identified by the Memphis Fire Department as "Engine # 7," failed the Positive Pressure (11.70(a)(2)(ii), Rated Service Time (11.85-10), and Gas Flow (11.85-8) Tests. In addition, the Remaining Service Life Indicator (Alarm) setting was not within the required tolerances (11.82(F)).

Unit # 557, identified by the Memphis Fire Department as "Lobby," failed the Positive Pressure (11.70(a)(2)(ii), and Gas Flow (11.85-8) Tests. In addition, the Remaining Service Life Indicator (Alarm) setting was not within the required tolerances (11.82(F)). During the Rated Service Time Test, the alarm sounded when the SCBA was pressurized at the start of the test, but as the pressure was depleted from the cylinder the alarm did not sound at all.

Upon the completion of the inspections and testing, the SCBA were then stored under lock in Room 176 pending return to the Memphis Fire Department. The SCBA were shipped to the Memphis Fire Department on May 12, 1994.

Conclusions

Each of the four SCBA was inspected and tested in the condition as received from the Memphis Fire Department to determine if they were in an approved condition and met the performance requirements for NIOSH approval. Damage and nonconforming areas are summarized in Table One. Each SCBA failed to meet at least two of the Title 30, Code of Federal Regulation, Part 11 performance requirements. The test results are summarized in Table Two. These failures were significant enough to reduce the protection provided by the SCBA. Each SCBA did not function as a NIOSH-approved, open-circuit, positive pressure, 30-minute rated SCBA.

Current hydrostatic recertification dates could not be identified on any of the four cylinders. In general, all aluminum and fiberglass reinforced aluminum cylinders must be reinspected and hydrostatically retested every three years in accordance with U.S. Department of Transportation (DOT) regulation Title 49, Code of Federal Regulations, Part 173.34(e)(13). The use of non-DOT approved cylinders is a technical violation of the NIOSH respirator certification, since 30 CFR 11.80(a) requires compressed breathing gas containers (cylinders) to meet minimum DOT requirements.

Timothy R. Merinar

Attachments:

cc:

A. Amendola

R. Metzler

ATTACHMENT ONE

Letter from Richard Duffy to NIOSH Requesting HHE

ATTACHMENT TWO

NIOSH Respirator Field Problem
Incoming Inspection Report Summary

Task#:.....07073 Problem Source:.....Memphis Fire Dept.
Date Received:...4/27/94 Description:.....Fatality
Date Inspected:..5/02/94 Insp. Performed by:..Merinar,Riffle,
Commodore,Smith

Manufacturer:.....MSA Other ID: #175

=====
TC Approval#: None found Type: OC,PD,SCBA.

Components and Observations

1. Facepiece: Date Code was 2/89. Facepiece was still attached and "medium" size. The straps were pulled over the top of the facepiece and vision through the facepiece was severely restricted. Soot covered the entire facepiece. The exhalation valve spring was okay. The lens was cracked on the users' left side. There was no nose cup. Head harness date was 5/89.
2. Breathing Tube/Low-Pressure Hose: The breathing tube was very dirty with soot. Cracking was evident in the corrugations but not to the point of causing a problem. When the shipping box was opened, the tube was threaded one-half turn from completely on.
3. Regulator: The mainline and bypass valves were both closed. The gauge showed zero pressure, and there was soot in several places. All the screws were in place and the serial number was behind the belt bracket, so could not be recorded. There was damage to the threads on the outlet, but the hose was able to be threaded on. The threads "caught" at one rough place when the tube was approximately one-half way threaded on. No quick fill adapter.
4. High-Pressure Hose: The hose protective wrap was missing about 2 to 3 inches, otherwise the hose was in generally good condition.
5. Alarm: Alarm was soot covered with the plunger half out. Alarm was tight in place. Connection to the cylinder was also tight. The O-ring looked worn. There were no cuts or scraps.

6. Cylinder/Valve Assembly: Labelled as DOT-E-8059-2216 PSI. The valve position was closed. Threads were OK, the gauge read zero, and the valve stem was bent. Some of the valve knob was broken off. The bent valve stem caused the knob to hit the alarm body at one point in the rotation of the stem. Manufactured by Accurex Co, 3/80. SN: M-2784. Was sold to MSA. #2784 stamped in the neck. No warning labels, or recertification labels (after 5/86) were present.
7. Backframe: No approval label was found. Dirty, but in good condition.
8. Harness Assembly: The black harness material was discolored from exposure to heat, resulting in several red areas were observed. The reflective tape was coming off and the left shoulder adjustment strap was severely twisted. The strap was not properly laced through the left buckle.
9. Hood/SAR Hoses/Other: Not Applicable

**NIOSH Respirator Field Problem
Incoming Inspection Report Summary**

Task#:.....07073 **Problem Source:**.....Memphis Fire Dept.
Date Received:...4/27/94 **Description:**.....Fatality
Date Inspected:..5/02/94 **Insp. Performed by:**..Merinar,Riffle,
Commodore,Smith

Manufacturer:.....MSA **Other ID:** #633

=====
TC Approval#: TC-13F-138 **Type:** OC,PD,SCBA

Components and Observations

1. Facepiece: Size medium with the exhalation valve spring off the seat. Soot was inside the exhalation valve. Mfg. date of 9/89. Facepiece was dirty with the lens scratched. The top of the lens was not properly seated into the sealing gasket. The head strap was dated September 1989.
2. Breathing Tube/Low-Pressure Hose: Generally looked OK. There was soot in the corrugations, and no nose cup.
3. Regulator: The mainline valve was fully opened and the bypass valve was fully closed. The rubber guard was off the pressure gauge, the gauge read zero, and there was a belt-bracket screw missing. The housing was "normally" scratched. The SN(?) was 435202.
4. High-Pressure Hose: Wrapping showed wear, but otherwise, no damage was noted. Ferrules looked corroded and the connection at the cylinder was hand tight.
5. Alarm: Dirty with debris. Bell had corrosion pits on both sides. High pressure O-ring intact, plunger was half out, and there was soot inside the bell.
6. Cylinder/Valve Assembly: Labeled as DOT-E-7277. The valve position was almost fully opened. Gauge read empty, and the rubber protector was out of position. Warning labels were not readable. Mfg was SCI on 6/89. #2219 was stenciled by the Memphis Fire Dept. No stamp dates of hydrostatic testing visible. 30 Minute, 2216 PSIG labelled.
7. Backframe: Engraved with #633 by Memphis Fire Dept.
8. Harness Assembly: Labelled with TC-13F-138, MSA Ultralite. Oct 12,1988 on label. The label was generally difficult to read from the effects of the heat. Straps were worn, but in good condition. The W.E. Bridges name was on the unit with a tag.
9. Hood/SAR Hoses/Other: Not applicable.

**NIOSH Respirator Field Problem
Incoming Inspection Report Summary**

Task#:.....07073 **Problem Source:**.....Memphis Fire Dept.
Date Received:...4/27/94 **Description:**.....Fatality
Date Inspected:..5/02/94 **Insp. Performed by:**..Merinar,Riffle,
Commodore,Smith
Manufacturer:.....MSA **Other ID:** #77, Engine No. 7.

=====
TC Approval#: None visible. **Type:** OC,PD,SCBA

Components and Observations

1. Facepiece: No facepiece came with unit.
2. Breathing Tube/Low-Pressure Hose: None with the unit.
3. Regulator: The mainline valve was fully opened and the bypass valve fully closed. The Regulator body was in good condition and clean. Rubber gauge cover was slightly off the gauge. All screws were in place. The SN was under the belt bracket so could not be read. There was no quick-fill adapter. The threads were damaged, but worked. There was a new regulator cover.
4. High-Pressure Hose: Wrapping was cut back 2 to 3 inches. Otherwise, no other damage to the hose was noted.
5. Alarm: Alarm turned 180 deg out of position, but otherwise no other damage was noted.
6. Cylinder/Valve Assembly: Labelled as CTC-DOT-E 7277 2216. The valve position was almost fully opened. The cylinder gauge indicated zero pressure, and the connection between the cylinder and the HP hose was loose. Soot was in the neck area only. Valve threads were OK. #2134 was stenciled on the cylinder by the Memphis Fire Dept. Mfg by SCI, sold to MSA. Valve knob was bent out of normal position, and there were no hydrostatic test dates visible. Tank was fiberglass-wrapped aluminum.
7. Backframe: No approval label found, but in generally good condition.
8. Harness Assembly: Reflective material OK, and there were no red markings.
9. Hood/SAR Hoses/Other: Not Applicable

**NIOSH Respirator Field Problem
Incoming Inspection Report Summary**

Task#:.....07073 **Problem Source:**.....Memphis Fire Dept.
Date Received:...4/27/94 **Description:**.....Fatality
Date Inspected:..5/02/94 **Insp. Performed by:**..Merinar,Riffle,
Commodore,Smith
Manufacturer:.....MSA **Other ID:** #577, "Lobby"

=====
TC Approval#: None found. **Type:** OC,PD,SCBA

Components and Observations

1. Facepiece: Very clean. No head straps. BM-13D-17 approval number on the facepiece. Mfg date of 9/81. Exhalation valve was clean and there was no nose cup.
2. Breathing Tube/Low-Pressure Hose: The connection to the facepiece was tight. Tube was in good shape. Corrugations were clean and minimal cracking at bottom of corrugation, and the end of the tube was slightly deformed. Threaded into the regulator.
3. Regulator: The mainline valve was fully opened and the bypass valve was fully closed. The body was clean, all screws in place, pressure gauge read zero, and there was no rubber gauge protection. The SN was not readily visible as it was beneath the belt bracket.
4. High-Pressure Hose: Good condition, ferrules clean.
5. Alarm: Loose and a little pitted. Plunger was half-way out, and the O-ring intact. In generally good condition, and hand-tightened to the tank.
6. Cylinder/Valve Assembly: The valve position was fully closed. The gauge read about 700 PSI, and the cylinder was in generally good condition. #1964 was stenciled on by the Memphis Fire Dept. Labelled as CTC-DOT-E-7277 2216 PSI. Mfg by SCI 9/86, and sold to MSA. No visible markings of hydrostatic test dates.
7. Backframe: No NIOSH approval label found. Unit #577 was on the backframe.
8. Harness Assembly: In generally good condition, with no red discoloration.
9. Hood/SAR Hoses/Other: Not Applicable

TABLE ONE

Summary of Problem Areas

SCBA #	Problem areas noted during SCBA inspection
175	<ol style="list-style-type: none"> 1. No NIOSH Approval Label. 2. Threads on regulator outlet damaged. Breathing tube appeared tight when only half-way threaded into regulator. 3. Facepiece lens cracked vertically on user's left side. 4. High-pressure O-ring in cylinder connection worn but no visible cuts or nicks. 5. Cylinder valve stem bent. 6. Last hydrostatic test date on cylinder # 1460 was identified as 5/86. 7. Shoulder harness straps discolored indicating excessive heat exposure.
633	<ol style="list-style-type: none"> 1. Exhalation valve spring off seat. Valve blocked open. 2. Facepiece lens outside of sealing gasket at top center. 3. Rubber cover on cylinder gauge slightly out of position. 4. No hydrostatic test date identified on cylinder # 2219. Cylinder manufacture date - 6/89. 5. One belt bracket screw missing from regulator body.
77 Engine # 7	<ol style="list-style-type: none"> 1. No NIOSH Approval Label. 2. No facepiece received from Memphis F.D. 3. Rubber cover on regulator pressure gauge slightly pushed out of position. 4. Cylinder valve stem bent. 5. Connection between cylinder and high-pressure hose loose as received. 6. No hydrostatic test date identified on cylinder # 2134. Cylinder manufacture date - 4/89.
557 Lobby	<ol style="list-style-type: none"> 1. No NIOSH Approval Label. 2. Facepiece received from Memphis F.D. did not have any headstraps. 3. No rubber cover on regulator pressure gauge. 4. Alarm bell loose. 5. No hydrostatic test date identified on cylinder # 1964. Cylinder manufacture date - 9/86.

ATTACHMENT THREE

National Institute for Occupational Safety and Health
Certification and Quality Assurance Branch
Air Supplied Respirator Section

Test Report

TN-07073

MSA units from the Memphis Fire Department

Mike Commodore

May 3, 1994

I. Background:

On May 2, 1994, four units were received from the field problem coordinator for testing. These units were sent to NIOSH for examination by the Memphis Fire Department.

II. Test Outline:

Note: Unit #175 did not have any flow into the facepiece as received. After examination, the inhalation valve was found stuck to the valve seat. The bypass was used to free the valve before testing began.

A. Positive Pressure Test - 11.70(a)(2)(ii)

Requirement -

Pressure-Demand Type Breathing Apparatus - An apparatus in which the pressure inside the facepiece in relation to the immediate environment is positive during both inhalation and exhalation.

Procedure -

A breathing machine with a 622 kg.-m./min. cam operating at 24 RPM with a 40 Lpm vol. (115 LPM peak flow) is connected to an anthropometric head for cycling. A pressure tap in the head is connected to a transducer which in turn is connected to a strip chart recorder for determining the pressure in the facepiece.

Results -

The breathing curve for unit #633 remained positive (i.e. above ambient).

The inhalation portion of the breathing curve for units #77,

#175, and #557 fell below ambient.

B. Rated service time - Sec. 11.85-10

Requirement -

- (a) Service time will be measured with a breathing machine.
- (b) The open circuit apparatus will be classified according to the length of time it supplied air or oxygen to the breathing machine.
- (c) The service time obtained in this test will be used to classify the open circuit apparatus in accordance with 11.53.

Procedure -

A breathing machine with a 622 kg.-m./min. cam operating at 24 RPM with a 40 Lpm vol. is connected to an anthropometric head for cycling. A pressure tap in the head is connected to a transducer which in turn is connected to a strip chart recorder for determining the pressure in the facepiece. The breathing machine will be run until the inhalation portion of the breathing curve falls below the minimum requirement.

Results -

unit #77 - 29.74 minutes
unit #175 - 23.92 minutes
unit #557 - 32.42 minutes
unit #633 - 17.75 minutes

The times for units #77, #175, and #557 are the actual times the unit supplied air to the breathing machine. These units fell below the minimum requirement initially.

unit #77

- 1. The cylinder was charged to 2200 psig on the cylinder gauge.
- 2. The unit, as received, did not have a facepiece. A facepiece from record material was used for testing.
- 3. The inhalation portion of the breathing curve fell below the requirement initially and throughout testing.

unit #175

- 1. The cylinder was charged to 2000 psig on the cylinder gauge.
- 2. The unit was tested as received. The breathing tube to regulator connection was not fully tightened and leaked air continuously during testing.

3. The alarm was intermittent during testing. It sounded initially during testing at 16.97 min., quit at 17.14 min., restarted at 17.37 min., quit at 17.79 min., restarted at 17.96 min., quit at 22.11 min. and never restarted.
4. The inhalation portion of the breathing curve fell below the requirement initially and throughout testing.

unit #557

1. The cylinder was charged to 2400 psig on the cylinder gauge.
2. The unit, as received, did not have a harness on the facepiece. A facepiece from record material was used for testing.
3. The alarm did not sound during testing.
4. The inhalation portion of the breathing curve fell below the requirement initially and throughout testing.

unit #633

1. The cylinder was charged to 2100 psig on the cylinder gauge.
2. The exhalation valve spring was off its seat and leaked air continuously throughout the test.

C. Breathing Resistance Test; Exhalation Sec. 11.85-6 (c).

Requirement -

The static pressure (at zero flow) in the facepiece shall not exceed 1.5 inches of water pressure.

Procedure -

The mask is mounted on a head form. The probe in the head form is connected to a slant manometer for measuring static pressure.

Results -

Unit #77 - 1.12" H₂O

Unit #175 - 0.84" H₂O

Unit #557 - 0.80" H₂O

Unit #633 - 1.20" H₂O

It must be noted that the true reading for static pressure on unit

#633 could not be obtained, because the exhalation valve spring was off its seat and the regulator was continuously flowing.

D. Gas Flow Test - Sec. 11.85-8

Requirement -

Flow shall be 200 lpm when facepiece pressure of demand unit is lowered by 2 inches of pressure when full cylinder pressure is applied and also at 500 psig. With a pressure demand unit, measure flow at 0 facepiece pressure.

Procedure -

A pressure tap in the anthropometric head is connected to a slant tube manometer for determining when the pressure inside the facepiece is at zero. A mass flow meter is connected in line between the anthropometric head and an adjustable vacuum source to measure flow. The SCBA cylinder is replaced by a test stand which is adjusted initially to full cylinder pressure. The vacuum source is adjusted during the test to maintain the required pressure inside the facepiece. The procedure is then repeated with the test stand adjusted to 500 psig.

Results -

Unit #77 - Full Cylinder	Pressure - 99.1 Lpm
	500 psig - 90.6 Lpm
Unit #175 - Full Cylinder	Pressure - 124.6 Lpm
	500 psig - 121.8 Lpm
Unit #557 - Full Cylinder	Pressure - 116.1 Lpm
	500 psig - 144.4 Lpm
Unit #633 - Full Cylinder	Pressure - 314.4 Lpm
	500 psig - 308.7 Lpm

E. Remaining Service Life Indicator - Section 11.82(F)

Requirement -

Each remaining service life indicator or warning device shall give an alarm when the remaining service life of the apparatus is reduced within a range of 20 to 25% of its rated service time or pressure.

Procedure -

To measure the pressure at which the alarm sounds, a calibrated gauge is connected in line between the air supply bottle and the regulator. The unit is then bled down through the regulator bypass valve. When the alarm sounds, the pressure on the gauge is noted. This procedure is repeated six times. The time at which the alarm sounds is noted during the rated service time test.

Results -

	Time (min)	Pressure (psig)
Unit #77	22.64	560
Unit #175	*16.97	600
Unit #557	**	540
Unit #633	13.15	560

* The alarm was intermittent during the rated service time test (see rated service time test for exact results)

** The alarm did not sound during the rated service time test.

III. Disposition:

At the conclusion of testing the units were placed in a locked chamber in room 176 pending further instructions from the field problem coordinator.

TABLE TWO

Summary of Test Results
MSA SCBA From Memphis Fire Department
NIOSH Task No. TN-07073

For complete results see NIOSH Test Report dated 5/3/93

NIOSH Tests From 30 CFR Part 11	Unit # 175	Unit # 633	Unit # 77	Unit # 557	Test Require
Positive Pressure (In. Water Col) ¹ - 11.70(a)(2)(ii)	<0.0 Fail	>0.0 Pass	<0.0 Fail	<0.0 Fail	>0.0 " water column
Rated Service Time - ² (Minutes) - 11.85-10	23.92 Fail	17.75 Fail	29.74 Fail	32.42 Pass	>30.00 minutes
Breathing Resistance (Exhalation) (In. Water Col) - 11.85-6(c)	0.84 Pass	1.20 Pass	1.12 Pass	0.80 Pass	<1.50 " water column
Gas Flow Test (LPM) Full Cylinder - 500 PSI - 11.85-8	124.6 121.8 Fail	314.4 308.7 Pass	99.1 90.6 Fail	116.1 144.4 Fail	>200 liters per minute
Remaining Service Life Indicator (Alarm) Test PSI - Time - 11.82(F)	600 16.97* Fail	560 13.15 Fail	560 22.64 Fail	540 ** Fail	20-25% of rated time & Press.

¹ A facepiece from NIOSH record material was used with Units # 77 and # 557 for all tests.

² All cylinders were charged to the pressure indicated on the Inspection and Maintenance Check List for each SCBA, per the request of the Memphis Fire Department.

- Unit # 175 - 2000 PSI on cylinder gauge
- Unit # 633 - 2100 PSI on cylinder gauge
- Unit # 77 - 2200 PSI on cylinder gauge
- Unit # 557 - 2400 PSI on cylinder gauge

Standard NIOSH test is run at full cylinder - i.e., 2216 PSI