

## APPLICATION EQUIPMENT AND CALIBRATION REFERENCES

### NOZZLE TYPE

Many types of spray nozzles are available, each providing different flow rates, spray angles, droplet sizes, and spray patterns. Some commonly used nozzle types are shown in Figures 1 and 2. Nozzles that produce flat-fan spray patterns are in Figure 1, and those that produce cone spray patterns are in Figure 2.

Table 1 may be used as a guideline for selecting the proper nozzle type for each application. Nozzle manufacturers often code spray nozzles to indicate specific spray characteristics. The tip number may indicate the nozzle type, flow rate, and spray-fan angle. Other characteristics are identified, with letters representing specific operating conditions. Many nozzles are now color-coded for ease of identification, and Table 2 gives the color codes used by the International Organization for Standardization (ISO).

### SPRAYER CALIBRATION GUIDELINES

#### VARIABLES AFFECTING APPLICATION RATE

Three variables affect the amount of spray mixture applied per acre: the nozzle flow rate, the ground speed of the sprayer, and the effective sprayed width per nozzle.

The gallons of spray applied per acre may be determined from the three variables in the following equation:

$$\text{GPA} = \frac{\text{GPM} \times 5,940}{\text{MPH} \times W}$$

where

GPA = spray applied, in gallons per acre

GPM = output per nozzle, in gallons per minute

MPH = ground speed, in miles per hour

W = effective sprayed width per nozzle, in inches.

For broadcast spraying, W = the nozzle spacing.

For band spraying, W = the bandwidth. For row-crop applications (such as spraying from drop pipes or directed spraying), W = row spacing (or bandwidth) divided by the number of nozzles per row (or band).

5,940 = a constant to convert gallons per minute, miles per hour, and inches to gallons per acre

#### SELECTING THE PROPER NOZZLE TIP

The proper nozzle size may be selected by determining the required flow rate from each nozzle at a selected application rate (GPA), ground speed (MPH), and effective sprayed width (W) in inches per nozzle. The required flow rate per nozzle may be determined from the following equation:

$$\text{GPM} = \frac{\text{GPA} \times \text{MPH} \times W}{5,940}$$

Select a nozzle that gives the required flow rate and droplet sizes when the nozzle is operated within the recommended pressure range.

The range of droplet sizes emitted from a nozzle is called the droplet spectrum. Droplet spectra are grouped into six categories. The American Society

---

*The information in this chapter is provided for educational purposes only. Product trade names have been used for clarity, but reference to trade names does not imply endorsement by the University of Illinois; discrimination is not intended against any product. The reader is urged to exercise caution in making purchases or evaluating product information.*

*Label registrations can change at any time. Thus the recommendations in this chapter may become invalid. The user must read carefully the entire, most recent label and follow all directions and restrictions. Purchase only enough pesticide for the current growing season.*

of Agricultural and Biological Engineers (ASABE) S572 standard, or set of rules, describes the categories as *very fine*, *fine*, *medium*, *coarse*, *very coarse*, or *extremely coarse*. These terms are listed in Table 3, along with the standard colors that are used to represent them in nozzle catalog charts. To apply pesticides using the optimum droplet size, choose nozzles based on the desired droplet spectrum category. This will help balance drift reduction with target coverage. Table 4 gives recommended droplet size spectrums for the same applications listed in Table 1.

#### CALIBRATING THE SPRAYER

Install the selected nozzle tips on the sprayer. Determine the flow rate for each nozzle in ounces per minute (OPM) from the following equation:

$$\text{OPM} = \text{GPM} \times 128 \text{ (1 gallon} = 128 \text{ ounces)}$$

Measure the flow rate using a flow meter, or collect the output from a nozzle using a container marked in ounces. Adjust the pressure until the required GPM or OPM is collected. Check the nozzle flow rate frequently. Adjust the pressure to compensate for small changes in output resulting from nozzle wear. Replace the nozzle tips and recalibrate when the output has changed 10 percent or more from that of a new nozzle or when the pattern has become uneven.

#### FLOW RATE

Nozzle flow rate varies with spraying pressure. The relationship between GPM and pressure (pounds per square inch, or PSI) is as follows:

$$\frac{\text{GPM}_1}{\text{GPM}_2} = \frac{\sqrt{\text{PSI}_1}}{\sqrt{\text{PSI}_2}}$$

With this relationship, doubling the flow through the nozzle requires increasing the pressure by a factor of four. The equation may be used to determine nozzle flow rates achieved at various pressures.

#### EXAMPLE:

If a certain nozzle has a flow rate of 0.6 GPM at a pressure of 40 PSI, what would the flow rate be if the nozzle were operated at 15 PSI?

#### SOLUTION:

Rearrange the formula to obtain  $\text{GPM}_2$ :

$$\text{GPM}_2 = \frac{\sqrt{\text{PSI}_2}}{\sqrt{\text{PSI}_1}} \times \text{GPM}_1$$

Solve for the new flow rate:

$$\text{GPM}_2 = \frac{\sqrt{15 \text{ PSI}}}{\sqrt{40 \text{ PSI}}} \times 0.6 \text{ GPM}$$

$$\text{GPM}_2 = \frac{3.873}{6.325} \times 0.6$$

$$\text{GPM}_2 = 0.61 \times 0.6 = 0.4$$

#### EFFECT OF SOLUTION DENSITY ON NOZZLE FLOW RATE

Density is the weight of a solution per unit volume (pounds per gallon). Specific gravity (SG) is the weight of a solution relative to water, which weighs 8.34 pounds per gallon. Nozzle flow rate varies inversely with the square root of specific gravity. Conversion factors to compare flow rates of solutions of any known density may be calculated as follows:

$$\text{Conversion factor} = \sqrt{\text{SG}}$$

Table 5 may be used to predict the flow rate for various solutions and to select the proper nozzle size from a nozzle catalog table. Because nozzle tables are based on spraying water, the conversion factors from the table may be multiplied by the desired GPM or GPA to determine the water flow rate for the solution being sprayed. Use the converted GPM or GPA to select the proper nozzle size from the catalog.

#### EXAMPLE:

$$3 \text{ GPM (28\% N)} \times 1.13 = 3.39 \text{ (water)}$$

If the flow rate (GPM) or application rate (GPA) of water is known, the GPM or GPA of a solution may be predicted by dividing the flow or application rate by the conversion factor.

#### EXAMPLE:

$$20 \text{ GPA (water)} \div 1.13 = 17.7 \text{ GPA (28\% N)}$$

## MEASURING GROUND SPEED

To measure ground speed, mark off a distance in the field to be sprayed or in a field with similar surface conditions. Suggested distances are 100 feet for speeds up to 5 miles per hour, 200 feet for speeds from 6 to 10 miles per hour, and at least 300 feet for speeds above 10 miles per hour. At the engine throttle setting and gear used for actual spraying, determine the travel time between the measured stakes. Calculate ground speed using Table 6, or apply the following formula:

$$\text{Travel speed (MPH)} = \frac{\text{distance (feet)} \times 60}{\text{time (seconds)} \times 88}$$

## SPRAY OVERLAP

For uniform application, each nozzle type must be operated at a spacing and height that provide a specific spray overlap. The overlap may vary from 20 percent to more than 100 percent. The percent overlap or spray coverage is illustrated in Figure 3 and Table 7 and may be calculated from the following formulas:

$$\text{Percent overlap} = \frac{\text{spray coverage} - \text{nozzle spacing}}{\text{nozzle spacing}}$$

$$\text{Spray coverage} = (\text{nozzle spacing} \times \text{percent overlap}) + \text{nozzle spacing}$$

## SPRAY-ANGLE COVERAGE AT VARIOUS HEIGHTS

Table 8 lists the theoretical coverage of spray patterns, as calculated from the included angle of the spray and the distance from the nozzle orifice (Figure 4). These values are based on the assumption that the spray angle remains the same throughout the entire spray distance. In practice, the tabulated spray angle does not hold for long spray distances. Adjust the spray height to give proper spray overlap. Table 9 lists suggested minimal spray heights.

## NOZZLE WEAR

Nozzle tips are available in a variety of materials, including ceramic, hardened stainless steel, stainless steel, various polymers, and brass. Ceramic and hardened stainless steel are the most wear-resistant materials but also are the most expensive. Stainless steel tips have excellent wear resistance when used with either corrosive or abrasive products. Many of the polymers are also resistant to corrosion and abrasion, and have

a wear life similar to stainless steel. Polymers, however, are more sensitive to physical damage, such as can occur from improper cleaning. Brass tips wear rapidly when used to apply abrasive products such as wettable powders, and they are corroded by some liquid fertilizers.

## TECHNIQUES FOR REDUCING SPRAY DRIFT

When pesticides are applied, there is always a chance that some will escape from the target area. Although drift cannot be eliminated completely, the use of proper equipment and spraying techniques maintains drift deposits within acceptable limits. The type of nozzle, pressure, height, and spray volume all affect the off-target movement. The ability to reduce drift is no better than the weakest component in the spraying procedure. A summary of recommended procedures for minimizing spray drift is given in Table 10. Many of these procedures deal in some manner with increasing spray droplet size. Larger spray droplets are more resistant to drift.

One practice available for minimizing drift damage is the use of drift-control additives to increase the size of spray droplets. Tests indicate that downwind drift deposits are reduced from 50 to 80 percent with the use of drift-control additives. They do not eliminate drift, however, and common sense must remain the primary factor in reducing drift damage. A number of additives are commercially available; they must be mixed and applied according to label directions to be effective.

## PRESSURE DROP THROUGH SPRAYING SYSTEMS

Hoses and fittings must be selected to keep pressure drops within acceptable limits. Tables 11 to 13 give pressure drops through various sizes of hose, pipe, and coupling. The information in Table 14 is provided for reference in making any conversions needed to calibrate spray equipment properly during pesticide application.

**Table 1. Recommended nozzle types for various applications made with a boom sprayer**

Type of application	Extended-range flat-fan	Twin flat-fan	Pre-orifice and drift-reduction flat-fan	Turbo flat-fan	Air-induction flat-fan	Flood, turbo-flood, and high-flow	Hollow-cone
Contact insecticide and fungicide	R	HR	R	R	R	—	—
Systemic insecticide and fungicide	R	R	R	HR	HR	—	—
Postemergence contact herbicide	R	HR	R	R	R	—	—
Postemergence systemic herbicide	R	—	R	HR	HR	R	—
Preemergence herbicide	—	—	R	R	R	HR	—
Incorporated soil-applied pesticide	—	—	R	R	R	HR	—

HR denotes that nozzle type is highly recommended for this application.

R denotes that nozzle type is recommended for this application.

— denotes that nozzle type is not recommended for this application.

**Table 2. ISO 10625 nozzle colors**

Flow rate at 40 PSI, gal./min*	Flow rate at 300 kPa, L/min	Color
0.1	0.4	Orange
0.15	0.6	Green
0.2	0.8	Yellow
0.3	1.2	Blue
0.4	1.6	Red
0.5	2.0	Brown
0.6	2.4	Gray
0.8	3.2	White

\*Metric is the standard. Equivalent U.S. units are approximations only.

**Table 3. ASABE S572 classification by droplet spectra**

Classification category	Symbol	Color code (in catalog tables)
Very fine	VF	Red
Fine	F	Orange
Medium	M	Yellow
Coarse	C	Blue
Very coarse	VC	Green
Extremely coarse	XC	White

**Table 4. Droplet size spectra recommended for various pesticide uses**

Droplet spectrum (by ASABE S572)	Contact insecticide and fungicide	Systemic insecticide and fungicide	Postemergence contact herbicide	Postemergence systemic herbicide	Preemergence herbicide	Incorporated soil-applied pesticide
Very fine (VF)	..	..	..	..	..	..
Fine (F)	X	..	..	..	..	..
Medium (M)	X	X	X	X	..	..
Coarse (C)	..	X	..	X	X	X
Very coarse (VC)	..	..	..	..	X	X
Extremely coarse (XC)	..	..	..	..	..	X

X denotes that droplet size spectrum is recommended for this application.

.. denotes that droplet size spectrum is not recommended for this application.

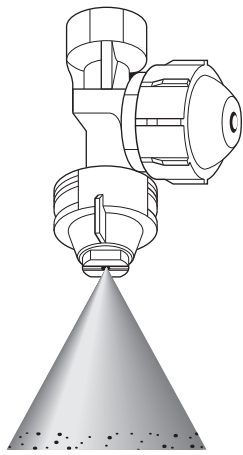

Even Flat-Fan

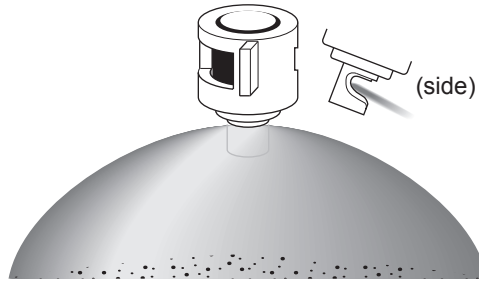

Flooding Flat-Fan (front)

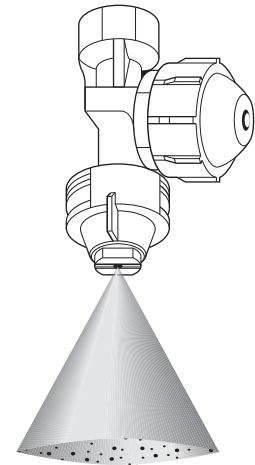

Extended-Range Flat-Fan

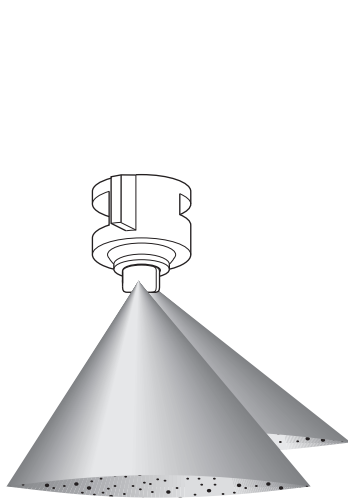

Twin-Orifice Flat-Fan

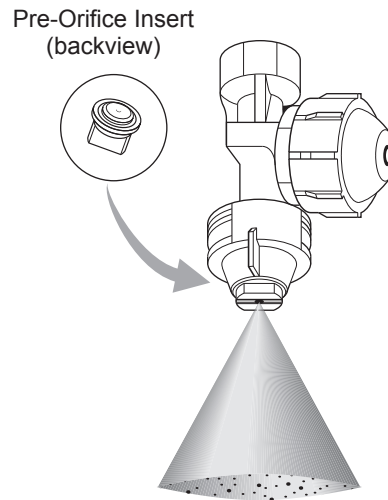

Drift-Reduction Pre-Orifice Flat-Fan

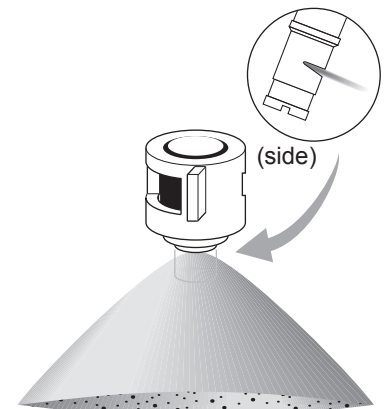

Turbo-Flood Flat-Fan

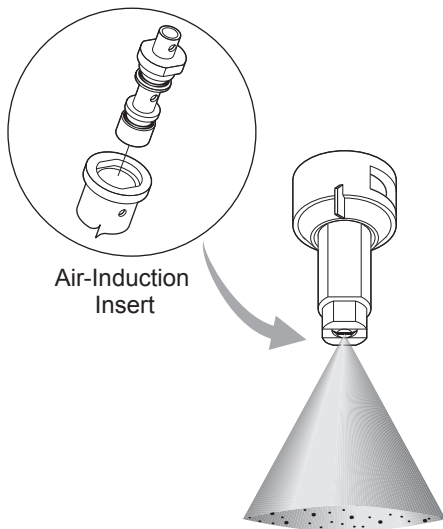

Air-Induction Flat-Fan

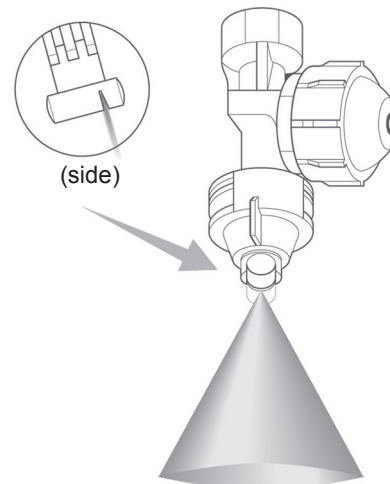

Turbo Flat-Fan (front)

Figure 1. Spray nozzles that produce flat-fan spray patterns.

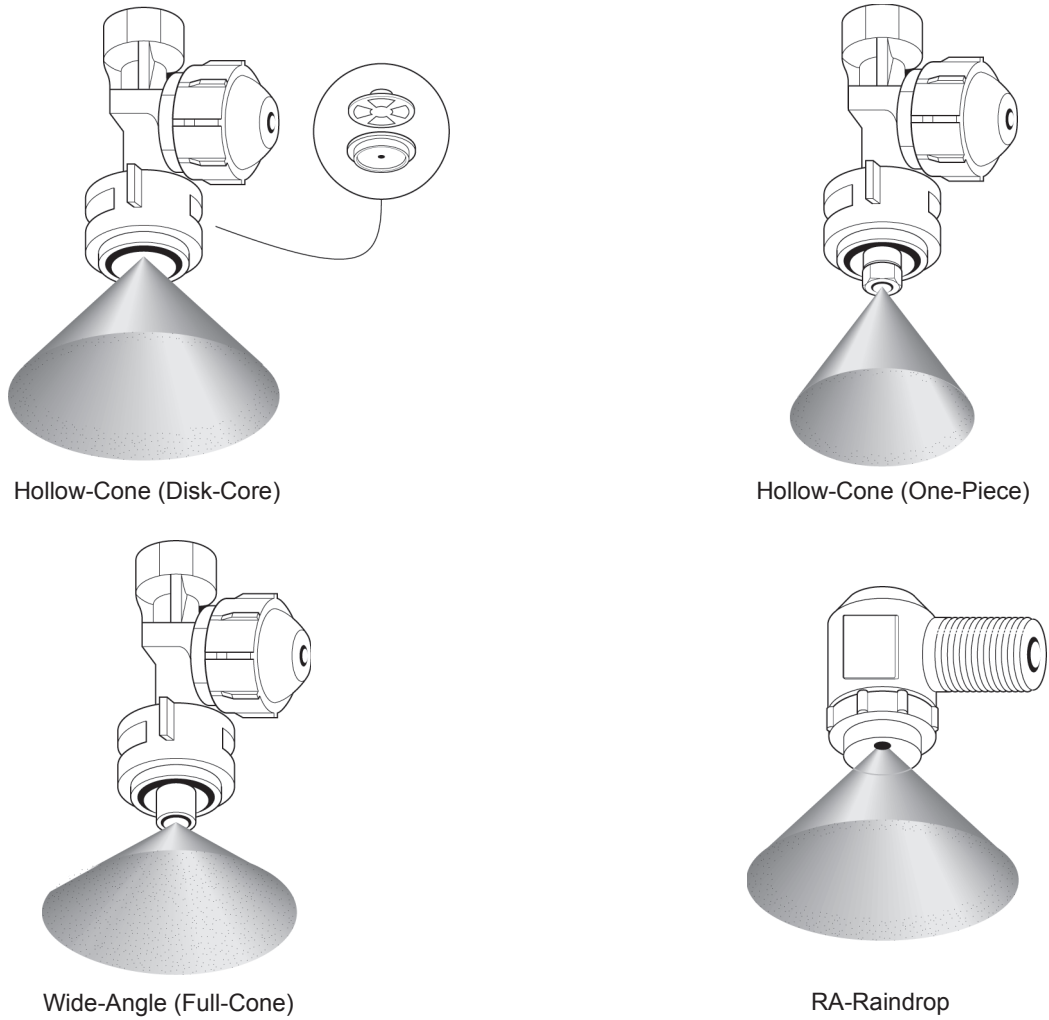

Figure 2. Spray nozzles that produce cone spray patterns.

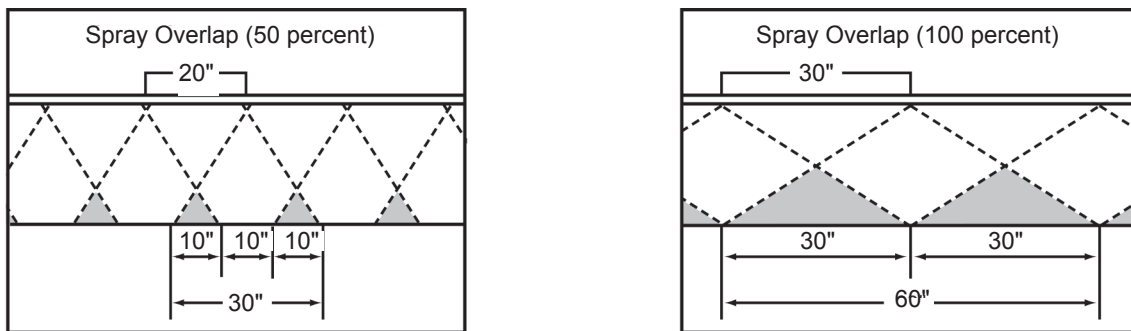

Figure 3. Examples of 50 percent and 100 percent spray overlap.

**Table 5. Specific gravities and conversion factors for selected solution weights**

Solution weight, lb/gal.	Specific gravity	Conversion factor
7.0	0.84	0.92
8.0	0.96	0.98
8.34 <sup>a</sup>	1.00	1.00
9.0	1.08	1.04
10.0	1.20	1.10
10.65 <sup>b</sup>	1.28	1.13
11.0	1.32	1.15
12.0	1.44	1.20
14.0	1.68	1.30

NOTE: This table is based on theoretical solution densities only and may vary in actual practice because of differing solution characteristics. Figures apply to flood but not Raindrop nozzles.

<sup>a</sup>Water.

<sup>b</sup>28% nitrogen.

**Table 6. Time required to obtain various travel speeds**

Speed, MPH	Travel time, seconds		
	100 ft	200 ft	300 ft
3.0	23	45	68
3.5	20	39	58
4.0	17	34	51
4.5	15	30	45
5.0	14	27	41
6.0		23	34
7.0		19	29
8.0		17	26
9.0		15	23
10.0		14	20
11.0			19
12.0			17
13.0			16
14.0			15
15.0			14

**Table 7. Spray coverage required to obtain proper overlap of spray patterns**

Overlap (%)	Spray coverage (width of spray pattern) in inches at various nozzle spacings						
	20"	25"	30"	35"	40"	50"	60"
20	24	30	36	42	48	60	72
30	26	33	39	46	52	65	78
40	28	35	42	49	56	70	84
50	30	38	45	53	60	75	90
60	32	40	48	56	64	80	96
70	34	43	51	60	68	85	102
80	36	45	54	63	72	90	108
90	38	48	57	67	76	95	114
100	40	50	60	70	80	100	120
110	42	53	63	74	84	105	126
150	50	63	75	88	100	125	150

**Table 8. Computed spray coverage at different spray heights for various spray angles**

Spray angle, degrees	Spray coverage (width of spray pattern) in inches at various distances from nozzle orifice										
	6"	8"	12"	15"	18"	24"	30"	36"	42"	48"	60"
15	1.6	2.1	3.2	3.9	4.7	6.3	7.9	9.5	11.1	12.6	15.8
25	2.7	3.5	5.3	6.6	8.0	10.6	13.3	15.9	18.6	21.2	26.6
30	3.2	4.3	6.4	8.0	9.7	12.8	16.0	19.3	22.4	25.9	32.0
40	4.3	5.8	8.7	10.9	13.0	17.4	21.6	26.2	30.6	34.9	42.8
45	4.9	6.6	9.9	12.4	14.9	19.8	24.8	29.8	34.8	39.7	49.6
50	5.6	7.4	11.2	14.0	16.8	22.4	28.0	33.6	39.1	44.8	56.0
60	6.9	9.2	13.9	17.3	20.8	27.6	34.6	41.6	48.4	55.4	69.2
65	7.6	10.2	15.2	19.1	22.9	30.5	38.1	45.8	53.2	61.0	76.4
70	8.2	11.2	16.8	21.0	25.2	33.6	42.0	50.4	59.8	67.2	84.0
73	8.8	11.8	17.8	22.2	26.6	36.4	44.4	53.2	62.0	71.0	88.5
75	9.2	12.3	18.4	23.0	27.6	36.8	46.0	55.2	64.2	73.5	92.0
80	10.1	13.4	20.1	25.2	30.2	40.2	50.2	60.4	72.5	80.8	100.0
90	12.0	16.0	24.0	30.0	36.0	48.0	60.0	72.0	84.0	96.0	120.0
100	14.3	19.1	28.6	35.8	42.4	57.2	71.4	86.0	100.0	114.6	143.0
120	20.8	27.8	41.6	52.0	62.4	83.0	104.0	125.0	145.8	166.2	208.0
140	33.0	44.0	65.9	82.4	98.9	131.9	164.8	197.8	230.8	263.8	329.7

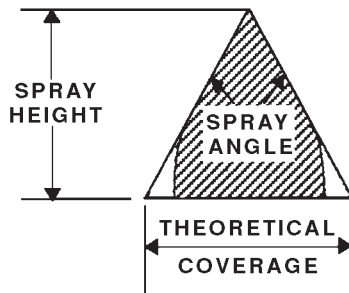
**Figure 4. Theoretical coverage of spray pattern.****Table 9. Suggested minimal spray heights for given angles of flat-fan nozzles**

Spray angle	20-inch spacing	30-inch spacing
65°	22" to 24"	33" to 36"
73°	20" to 22"	29" to 36"
80°	18" to 20"	26" to 28"
110°	16" to 18"	20" to 22"
120°	14" to 16"	18" to 20"



**Table 10. Summary of recommended procedures for reducing drift damage**

Recommended procedure	Example	Explanation
Select a nozzle type that produces coarse droplets.	Turbo, air-induction, Raindrop, wide-angle full-cone, flooding.	Use droplets as large as practical to provide necessary coverage.
Use the lower end of the pressure range.	Use less than 30 PSI for extended-range flat-fan nozzles.	Higher pressures generate many more small droplets (less than 100 microns).
Lower the boom height.	Use as low a boom height as possible to maintain uniform distribution. Use drops for systemic herbicides in corn.	Wind speed increases with height. Boom height a few inches lower can reduce off-target drift.
Increase the nozzle size.	If normal gallonage is 15 to 20 GPA, increase to 25 to 30 GPA.	Larger-capacity nozzles reduce spray depositing off target.
Spray when wind speeds are less than 10 MPH and moving away from sensitive plants.	Leave a buffer zone if sensitive plants are downwind. Spray buffer zone when wind changes.	More of the spray volume moves off target as wind increases.
Do not spray when the air is completely calm.	Absolutely calm air generally occurs in early morning or late afternoon.	Absolutely calm air reduces air mixing, and spray can move slowly downwind.
Use a drift-control additive when needed.	Several long-chain polymers are available.	Drift-control additives increase the average droplet size produced by the nozzles.

**Table 11. Pressure drop for water flow through various hose sizes (in good, smooth condition)**

Flow, GPM	Pressure drop in pounds per square inch (10-foot lengths—without couplings)								
	¼" ID	⅜" ID	⅞" ID	½" ID	⅝" ID	¾" ID	1" ID	1¼" ID	1½" ID
0.2	0.3								
0.3	0.6								
0.4	1.0								
0.5	1.4	0.2							
0.6	2.0	0.3							
0.8	3.3	0.5							
1.0		0.7	0.3						
1.5		1.4	0.6	0.4					
2.0		2.4	1.1	0.6					
2.5		3.4	1.7	0.9					
3.0			2.4	1.2	0.4				
4.0				2.0	0.7				
5.0				2.9	1.0	0.4			
6.0				4.0	1.4	0.6			
8.0					2.6	0.9	0.3		
10					3.6	1.4	0.4		
15						3.0	0.8	0.3	
20							1.4	0.5	0.2
25							2.0	0.7	0.3
30							2.8	0.9	0.4
40								1.6	0.5
50								2.5	0.8
60								3.4	1.2
70									1.6
80									2.0
90									2.6
100									3.0

ID = inside diameter.

**Table 12. Flow of water through schedule 40 steel pipe of various sizes (seamless or welded construction in good, clean condition)**

Flow, GPM	Pressure drop in pounds per square inch (10-foot lengths)								
	1/8" ID	1/4" ID	3/8" ID	1/2" ID	3/4" ID	1" ID	1 1/4" ID	1 1/2" ID	2" ID
0.3	0.42								
0.4	0.70	0.16							
0.5	1.1	0.24							
0.6	1.5	0.33							
0.8	2.5	0.54	0.13						
1.0	3.7	0.83	0.19	0.06					
1.5	8.0	1.8	0.40	0.12					
2.0	13.4	3.0	0.66	0.21	0.05				
2.5		4.5	1.0	0.32	0.08				
3.0		6.4	1.4	0.43	0.11				
4.0		11.1	2.4	0.74	0.18	0.06			
5.0			3.7	1.1	0.28	0.08			
6.0			5.2	1.6	0.38	0.12			
8.0			9.1	2.8	0.66	0.20	0.05		
10				4.2	1.0	0.30	0.08		
15					2.2	0.64	0.16	0.08	
20					3.8	1.1	0.28	0.13	
25						1.7	0.42	0.19	0.06
30						2.4	0.59	0.27	0.08
35								0.36	0.11
40								0.47	0.14
45									0.17
50									0.20
60									0.29
70									0.38
80									0.50
90									0.62
100									0.76

ID = inside diameter.

**Table 13. Approximate friction loss in pipe fittings in terms of equivalent feet of straight pipe**

Pipe size, standard weight	Actual inside diameter, inches	Gate value FULL OPEN	Globe value FULL OPEN	45° elbow	Run or standard tee	Standard elbow or run of tee reduced ½	Standard tee through side outlet
½	0.269	0.1	8	0.3	0.4	0.7	1.4
¼	0.364	0.2	11	0.5	0.6	1.1	2.2
½	0.622	0.3	18	0.7	1.1	1.7	3.3
¾	0.824	0.4	23	0.9	1.4	2.1	4.2
1	1.049	0.5	29	1.2	1.8	2.6	5.3
1¼	1.380	0.7	38	1.6	2.3	3.5	7.0
1½	1.610	0.8	45	1.9	2.7	4.1	8.1
2	2.067	1.1	58	2.4	3.5	5.2	10.4
2½	2.469	1.3	69	2.9	4.2	6.2	12.4
3	3.068	1.6	86	3.6	5.2	7.7	15.5
4	4.026	2.1	113	4.7	6.8	10.2	20.3
5	5.047	2.7	142	5.9	8.5	12.7	25.4
6	6.065	3.2	170	7.1	10.2	15.3	31.0

**Table 14. Reference information for making calibration conversions**

<b>STANDARD ABBREVIATIONS</b>		<b>MISCELLANEOUS EQUIVALENTS</b>	
GPA =	gallons per acre	1 acre =	43,560 square feet = 0.405 hectares
GPM =	gallons per minute	1 hectare =	2.471 acres
GPH =	gallons per hour	1 gallon per acre =	9.35 liters per hectare
MPH =	miles per hour	1 mile =	5,280 feet = 1,610 meters = 1.61 kilometers
OPM =	ounces per minute	1 pound per square inch =	0.070 kilogram/centimeter <sup>2</sup> = 6.895 kilopascals
PSI =	pounds per square inch	1 pound =	0.454 kilogram
<b>VOLUME AND LIQUID MEASURES</b>		1 inch =	2.54 centimeters
8 fluid ounces =	1 cup = 236.6 ml		
2 cups =	32 tablespoons = 1 pint = 473.1 ml		
2 pints =	64 tablespoons = 1 quart = 946.2 ml		
8 pints =	4 quarts = 1 gallon = 128 fluid ounces = 3,785 ml		
<b>METRIC CONVERSION FACTORS</b>			
During the next few years, a gradual transition to metric (SI) units is expected in the agricultural industry. To facilitate use of these units, selected metric terms and conversion factors are given here.			
To measure	Multiply	By	To obtain
Length	inches	25.40	millimeters (mm)
	inches	2.540	centimeters (cm)
	feet	0.3048	meters (m)
	miles	1.609	kilometers (km)
Area	acres	46.7	square meters (m <sup>2</sup> )
	acres	0.4047	hectares (ha)
Volume	gallons	3.785	cubic decimeters (dm <sup>3</sup> )
	gallons	3.785	liters (L)
	imperial gallons	4.546	liters (L)
Flow rate	gallons/hour (GPH)	3.785	liters/hour (L/h)
	gallons/minute (GPM)	3.785	liters/minute (L/min)
Application rate	gallons/acre (GPA)	9.353	liters/hectare (L/ha)
Pressure	pounds/inch <sup>2</sup> (PSI)	6.895	kilopascals (kPa)
Speed	miles/hour (MPH)	1.609	kilometers/hour (KMH)

**AUTHORS****Loren E. Bode and Scott Bretthauer***Department of Agricultural and Biological Engineering*

