

Component Technology Development

The Argonne National Laboratory Advanced Powertrain Research Facility is at the forefront of hybrid and electric vehicle research. As modern hybrid and electrically driven vehicles move from theory to production, the components used in these vehicles must be of both higher efficiency as well as lower cost to make these vehicles more accessible.

Background

The four main components used in drivetrain electrification are energy storage systems, power electronics, electric machines/gearboxes, and control systems. Argonne is actively pursuing increased performance and efficiency of these components along with reducing manufacturing costs. Cost reduction is addressed by reducing materials cost/quantity, reducing labor/processing steps, increasing performance for the same components, and optimizing efficiency for the same materials cost.

Energy Storage System Components

Argonne has partnered with Maxwell Technologies to investigate the benefits of actively combining high power density ultracapacitors via power electronics with high energy density Li-Ion (or other future chemistry) batteries. This combination potentially reduces the net ESS cost and provides full acceleration and braking power at low temperatures or high battery SOC. This also allows the I²R losses to be moved from the battery to the capacitor bank. The electronics actively decouple the load transients from the battery, allowing a wider SOC window and less oversizing for end-of-life performance requirements. Similarly, reducing the packaging complexity and cost for ultracapacitors can achieve several goals. Shown here is Maxwell Technology's oval capacitor form factor, compared to the standard 650 Farad/2.7v package.

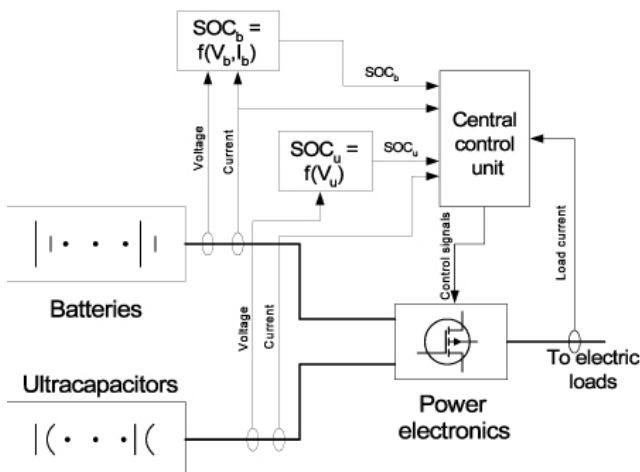

Energy Storage System

Components, continued

This new package has an improved fill factor when stacking capacitors into a bank, as well as greatly simplified coaxial terminations. Instead of bus bars on top and bottom, both (+/-) terminals are on the top, allowing a much more compact interconnect bus bar and cell balancing system.

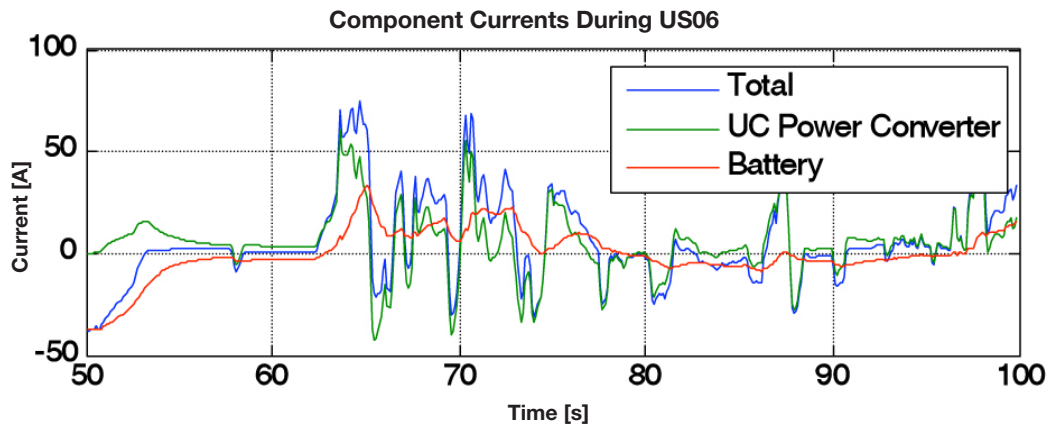
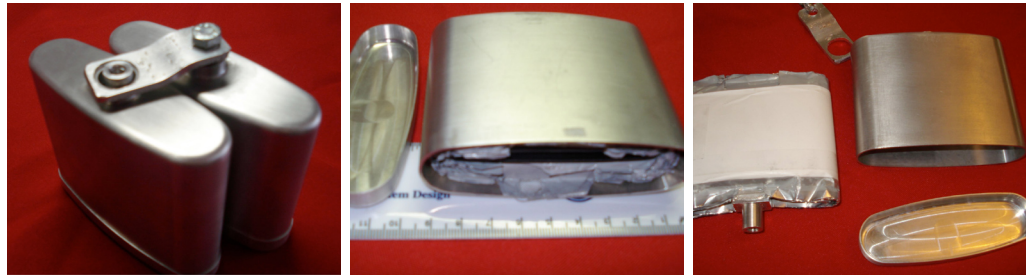

Electric Machines/Gearbox Components

The DOE Vehicle Technologies Program has set performance and cost targets for a 55kW/30kW hybrid vehicle electric machine. A segmented stator fractional slot (2/5) surface permanent magnet prototype machine has been designed and built that meets these targets. This machine focuses on low materials cost (\$200), low rotor losses, 95% efficiency at 20% load, and constant power from 2800-14,000 rpm, with 105°C coolant. Proximity losses in the stator windings are minimized using a bundle of 19 strands/#18 magnet wire instead of Litz wire, with comparable performance and reduced cost.

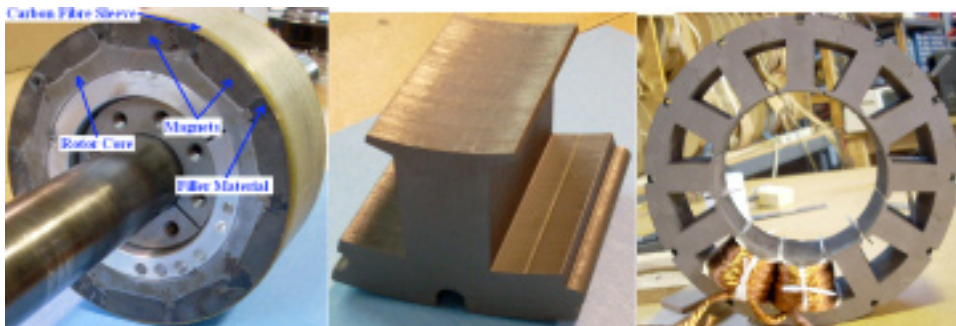

For further information, contact

Ted Bohn
tbohn@anl.gov

November 2008



UChicago
Argonne LLC

Argonne National Laboratory is a
U.S. Department of Energy laboratory
managed by UChicago Argonne, LLC



U.S. Department of Energy
**Energy Efficiency
and Renewable Energy**
Bringing you a prosperous future where energy
is clean, abundant, reliable, and affordable