



# WATER PUMPING

The Solar Alternative



**Sandia National Laboratories**

A Department of Energy  
Multiprogram National Laboratory

Issued by Sandia National Laboratories, operated for the United States Department of Energy by Sandia Corporation.

**NOTICE:** This report was prepared as an account of work sponsored by an agency of the United States Government. Neither the United States Government nor any agency thereof, nor any of their employees, nor any of their contractors, subcontractors, or their employees, makes any warranty, express or implied, or assumes any legal liability or responsibility for the accuracy, completeness, or usefulness of any information, apparatus, product, or process disclosed, or represents that its use would not infringe privately owned rights. Reference herein to any specific commercial product, process, or service by trade name, trademark, manufacturer, or otherwise, does not necessarily constitute or imply its endorsement, recommendation, or favoring by the United States Government, any agency thereof or any of their contractors or subcontractors. The views and opinions expressed herein do not necessarily state or reflect those of the United States Government, any agency thereof or any of their contractors.

Printed in the United States of America. This report has been reproduced directly from the best available copy.

Available to DOE and DOE contractors from  
Office of Scientific and Technical Information  
PO Box 62  
Oak Ridge, TN 37831  
Prices available from (615) 576-8401, FTS 626-8401

Available to the public from  
National Technical Information Service  
US Department of Commerce  
5285 Port Royal Rd  
Springfield, VA 22161  
NTIS price codes  
Printed copy: A06  
Microfiche copy: A01

**Cover design: Gene Clardy, Sandia National Laboratories**

**Cover photo: Anne V. Poore, Sandia National Laboratories**

SAND87-0804  
Unlimited Release

## **WATER PUMPING: THE SOLAR ALTERNATIVE**

Michael G. Thomas  
Photovoltaic Systems Design Assistance Center  
Sandia National Laboratories  
Albuquerque, NM 87185-0753

### **ABSTRACT**

This report was prepared to provide an introduction into understanding the characteristics, including economics, of photovoltaically powered water pumping systems. Although thousands of these systems exist worldwide, many potential users do not know how to decide whether or not photovoltaic pumping systems are an attractive option for them. This report provides current information on design options, feasibility assessment, and system procurement so that the reader can make an informed decision about water pumping systems, especially those powered with photovoltaics.

## **PREFACE**

Major contributions to this document were made by Solavolt International, Chronar Trisolar Corp., and I. T. Power. Industry, government, and private organizations reviewed this information to eliminate questions and to check its accuracy. The final document, edited by the Photovoltaic Systems Design Assistance Center staff, is based on the original inputs and the comments of the reviewers.

# CONTENTS

| Chapter |   | PAGE      |
|---------|---|-----------|
| 1       | <b>INTRODUCTION</b>                                       | <b>1</b>  |
|         | Background  | 1         |
|         | Suitability of System to Moderate Pumping Needs           | 1         |
| 2       | <b>DESIGN CONSIDERATIONS FOR PV-POWERED WATER SYSTEMS</b> | <b>4</b>  |
|         | PV System Power Production                                | 4         |
|         | Types of Water Pumps                                      | 5         |
|         | Types of Motors   | 5         |
|         | Energy Storage: Batteries                                 | 7         |
|         | Energy Storage: Water Tanks                               | 7         |
|         | Controls: What is Needed                                  | 7         |
|         | Determining Water Needs                                   | 7         |
|         | Daily Insolation Levels                                   | 9         |
|         | Orientation and Location of Photovoltaic Arrays           | 9         |
|         | Tilt of Photovoltaic Arrays                               | 9         |
|         | Determining Peak Water Flow                               | 11        |
|         | Water Production  | 11        |
|         | Static and Dynamic Heads                                  | 12        |
| 3       | <b>SYSTEM SELECTION</b>                                   | <b>15</b> |
|         | Sizing Systems and Selecting Equipment                    | 15        |
|         | The Effect of Varying Solar Radiation on Output           | 18        |
|         | Equipment Type vs. Pumping Requirement                    | 21        |
|         | Specifying System Performance                             | 22        |
| 4       | <b>COST AND ECONOMICS OF PUMPING SYSTEMS</b>              | <b>23</b> |
|         | Determining the Cost-Effectiveness of a Pumping System    | 23        |
|         | Measuring Cost-Effectiveness of a Pumping System          | 23        |
|         | Measuring Life-Cycle Costs of a Pumping System            | 23        |

# CONTENTS

(Continued)

| Chapter  |   | Page      |
|----------|---|-----------|
|          | Cost Appraisal of a PV-Powered Pumping System   | 24        |
|          | Capital and Installation Costs  | 24        |
|          | Pump Costs  | 25        |
|          | Pump Replacement Costs  | 26        |
|          | Evaluating the Costs of a Diesel Pumping System                                       | 29        |
|          | Special Considerations  | 29        |
|          | Comparing Costs of a Diesel System  | 29        |
|          | Comparative Costs of Other Pumping Systems  | 31        |
| <b>5</b> | <b>PREPARING A REQUEST FOR PROPOSAL</b>   | <b>33</b> |
|          | Preparing a Technical Specification   | 33        |
|          | Scope of Work   | 34        |
|          | Qualified Bidders   | 34        |
|          | Warranty and Spare Parts  | 34        |
|          | Price and Delivery  | 34        |
|          | Evaluating Responses (Optional Recommendations)                                       | 34        |
|          | Detailed Assessment   | 35        |
|          | <b>BIBLIOGRAPHY</b>   | <b>36</b> |
|          | <b>LIST OF MANUFACTURERS</b>  | <b>37</b> |
|          | <b>Appendix</b>   |           |
|          | A    Insolation Availability  | A-1       |
|          | B    Sample Calculations of System Sizing, Equipment<br>Selection and Cost Evaluation | B-1       |

## FIGURES

| Figure |  |   |
|--------|--|---|
| 1      | Regions of Applicability for Various Pumping Options | 3 |
| 2      | PV dc-Electric Generator                             | 4 |
| 3      | Block Diagram of PV-Powered Water Pumping System     | 5 |
| 4      | Types of Water Pumps                                 | 6 |

## **FIGURES** (Continued)

| <b>Figure</b> |   | <b>Page</b> |
|---------------|---|-------------|
| 5             | Winter Insolation Contours  | 10          |
| 6             | Total Dynamic Head (TDH) Factors  | 13          |
| 7             | Hydraulic Energy Nomograph  | 16          |
| 8             | Array Power Nomograph   | 17          |
| 9             | Typical Daily Variations in Solar Radiation                                 | 19          |
| 10            | Relation between Peak Daily Insolation and Performance of Centrifugal Pumps | 20          |
| 11            | Relative Energy Output at Various Tilt Angles                               | 20          |
| 12            | Centrifugal Pump and Volumetric Pump Output                                 | 21          |
| 13            | Pumpset Type vs. Pumping Regime   | 22          |
| 14            | Procedures for Cost Appraisal of a Water Pumping System                     | 28          |

## **TABLES**

| <b>Table</b> |   |    |
|--------------|---|----|
| 1            | Comparison of Pumping Options                               | 2  |
| 2            | Typical Daily Water Usage for Farm Animals                  | 8  |
| 3            | Maximum Daily Pumped Water Requirements for Crop Irrigation | 8  |
| 4            | Friction Losses in Head (ft) per 100 ft of 1.5-inch Pipe    | 14 |
| 5            | Cost, Discount and NPV Examples                             | 24 |
| 6            | LCCs for the Hypothetical PV Pumping System                 | 27 |
| 7            | LCCs for a Hypothetical Diesel Pumping System               | 31 |
| 8            | Cost Data for Wind-Powered, Animal-Powered and Hand Pumps   | 32 |





# WATER PUMPING: THE SOLAR ALTERNATIVE

## 1.0 INTRODUCTION

### Background

The availability of water has never been more important than today. The United Nations, while naming the 1980s as the "Decade for Water," estimates that it would take more than \$90 billion to meet the world's current deficits for clean water alone. As we approach the 1990s, it is clear that even with vast sums of money, the water needs of tens of millions of people will not be met by the end of the decade.

Although methods for water delivery have been known for thousands of years, problems still remain. The simplest and most economical way is to divert rain or river water by a gravity flow system to the desired location. This method is not available in much of the world, at least not on a regular or demand basis. Where this is not possible, manual pumping has been the most common method for many years. Although these pumps require regular maintenance and must be attended, their use is critical to water supply, especially for human consumption, throughout the world. This method, in fact, has been chosen by the United Nations as the primary method in their programs to alleviate the water supply problems in the world.

Moving large volumes of water and/or pumping from deep wells cannot be done effectively with hand pumps, but requires the use of mechanical pumps powered by engines or electric motors. Engine-powered systems are providing water to larger communities throughout the world. The infrastructure of the large communities can provide the fuel and maintenance required by the engines.

There are also many thousands of solar-powered systems in the world today, powered by wind generators or photovoltaic (PV) arrays. The PV-powered systems have demonstrated higher reliability and lower costs than the alternative methods in a large

class of applications. This report describes the characteristics of PV-powered pumping systems including their ease of procurement and installation, and small maintenance requirements, which account for their growing popularity.

No single pumping technique is suitable for the entire range of existing applications. Each type of pump has its own set of appropriate applications. Solar pumps are particularly useful for intermediate applications like small villages (100-1,000 inhabitants) and moderate agricultural needs. This report provides a methodology for selecting the best system design for a particular application. Often a combination of techniques (e.g., manual and solar) can dramatically reduce costs and improve the reliability of a pumping network, or provide the design flexibility to cover a wide range of applications.

### Suitability of System to Moderate Pumping Needs

Some circumstances have made PV power the preferred choice, especially where there is adequate solar resource and moderate water demand. Characteristics of the three pumping options available for water delivery (manual, solar, and diesel) are listed in Table 1.

These advantages/disadvantages have been analyzed many times. Generally, these analyses identify three distinct ranges of applicability (Figure 1). Ranges of pumping requirements are expressed in meters to the fourth power per day, calculated by multiplying the head (the distance the water needs to be lifted, measured in meters) and the flow volume (measured in cubic meters per day). Simply stated, hand pumps are well suited to needs for small volumes at low-to-moderate head ( $50 \text{ m}^4$ ). For large volumes and high head ( $> 2,000 \text{ m}^4$ ), engines are required.

For years, the large region between the two curves in Figure 1 has been met less than optimally by either oversized diesel-powered systems or by a number of hand pumps. An oversized diesel can meet the

load, but it must operate inefficiently at partial power. Multiple hand pumps require a well for each pump and the costs of digging the wells can exceed the cost of the rest of the pumping system. Because PV systems

**Table 1**

**Comparison of Pumping Options**

| <b>Pump Type</b>        | <b>Principal Advantages</b>  | <b>Disadvantages</b>  |
|-------------------------|--|---|
| Hand<br>(manual)        | Low cost<br>Simple technology<br>Easy maintenance<br>Clean<br>No fuel requirement<br>Applicable to hand-dug wells  | Regular maintenance<br>Low flow<br>Absorbs time and energy that might be used more productively elsewhere<br>Uneconomic use of expensive borehole |
| Solar<br>(PV-powered)   | Low maintenance<br>Clean<br>No fuel needed<br>Easy to install<br>Reliable Long life<br>Unattended operation<br>Low recurrent costs<br>System is modular and can be matched closely to need | Relatively high capital cost<br>Lower output in cloudy weather  |
| Diesel (or gas)-powered | Moderate capital cost<br>Can be portable<br>Extensive experience<br>Easy to install  | Maintenance often inadequate, reducing life<br>Fuel often expensive and supply intermittent<br>Noise, dirt and fume problems                      |

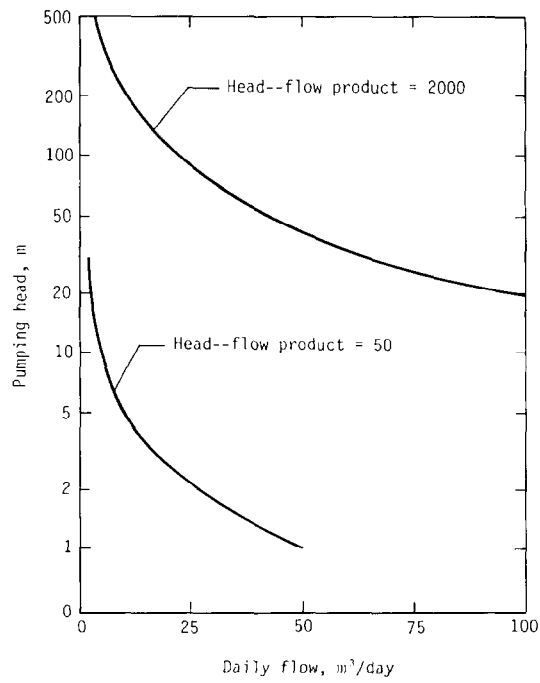

Figure 1. Regions of Applicability for Various Pumping Options

are modular, sizing to meet the specific requirements in this area is easily and economically accomplished. A detailed treatment of these options is in "A Comparative Assessment of Photovoltaics, Hand Pumps, and Diesels for Rural Water Supply," SAND87-7015, Sandia National Laboratories, Albuquerque, May 1988.

PV-powered systems require only that there be adequate sunshine and a source of water. The number of PV-powered systems in the world is probably limited only by the fact that PV-power is a new technology, and many potential users are simply unfamiliar with it.

## 2.0 DESIGN CONSIDERATIONS FOR PV-POWERED WATER SYSTEMS

### PV System Power Production

PV power is produced directly by sunlight shining on an array of PV modules, requires no moving parts, and is extremely simple and reliable. Many materials respond to visible light; the most common is silicon, a constituent of ordinary sand. A thin, silicon cell, 10 cm across, can produce more than 1 watt (W) of dc electrical power under clear-sky conditions.

Generally, many individual cells are combined into modules sealed between layers of glass or transparent polymer to protect the electric circuit from the environment (Figure 2). These modules are capable of producing

tens of watts of power. Several modules are then connected in an array to provide enough power to run a motor-pump set in a pumping system. This array is usually mounted on a simple, inexpensive structure oriented toward the sun at an inclination angle close to the latitude of the site. This ensures that ample energy from the sun will shine on the array during all seasons of the year.

A PV-powered water system is basically similar to any other water system (Figure 3). All PVpowered pumping systems have, as a minimum, a PV array, a motor, and a pump. The array can be coupled directly to a dc motor or, through an inverter, to an ac

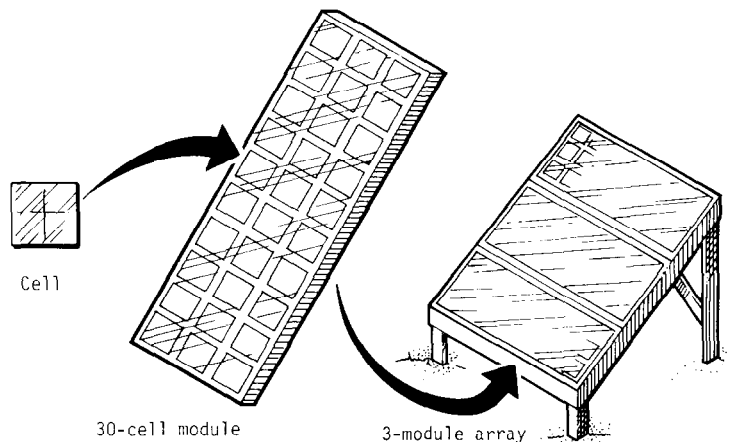

Figure 2. PV dc-Electric Generator

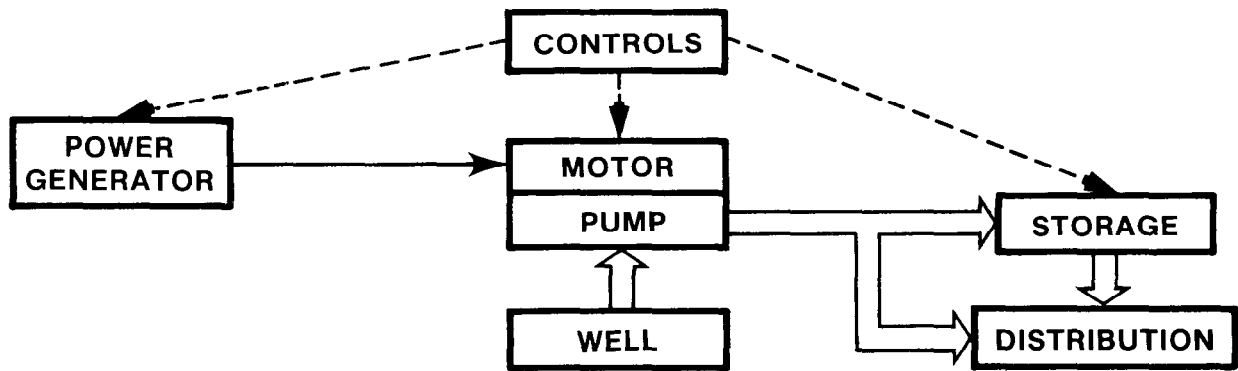

Figure 3. Block Diagram of PV-Powered Water Pumping System

motor. For both ac and dc systems a battery bank can be used to store energy or the water can be stored. The motor is connected to any one of a variety of variable-speed pumps.

### Types of Water Pumps

Pumps of many different varieties are suitable for inclusion in a PV-powered pumping system. They do, however, fall broadly into two categories, **centrifugal** (rotodynamic) and **volumetric** (positive displacement), which have inherently different characteristics. Figure 4 shows three common types of pumps.

Centrifugal pumps are ideally suited for conditions of moderate-to-high flow in tube wells, cisterns, or other reservoirs. These pumps are designed for a fixed head and their water output increases with rotational speed. Their efficiency decreases at heads and flows away from their design point. Centrifugal pumps have been installed with capacities as high as 1,200 cubic meters/day and can be used for flow rates as low as 10-15 cubic meters/day. However, these pumps are not recommended for suction lifts higher than 5-6 meters.

Volumetric pumps have a water output that is almost independent of head but directly proportional to volume. There are many different types of volumetric pumps. The most interesting for inclusion in PV-powered pumping systems are the counter-balanced piston pumps (usually called jack or donkey pumps) and the progressive cavity pumps (sometimes called screw pumps). The efficiency of these pumps increases as the head increases. Volumetric pumps are ideally suited for conditions of low flow rates and/or high lifts. Pumps of this type have been installed with flow rates as low as 0.3 cubic meters/day and as high as 40 cubic meters/day, and with lifts from as little as 10 meters to as great as 500 meters.

### Types of Motors

The choice of the motor for a PV-powered system is dependent on the size requirement, need for the motor to be submersible or not, and availability of driving electronics. Three basic types are **permanent magnet dc** motors (brushed or brushless type), **wound-field dc** motors, and ac motors.

The choice of a dc motor is attractive because PV arrays supply dc power.

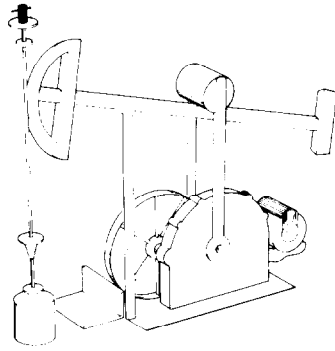

**JACK PUMP  
(VOLUMETRIC)**

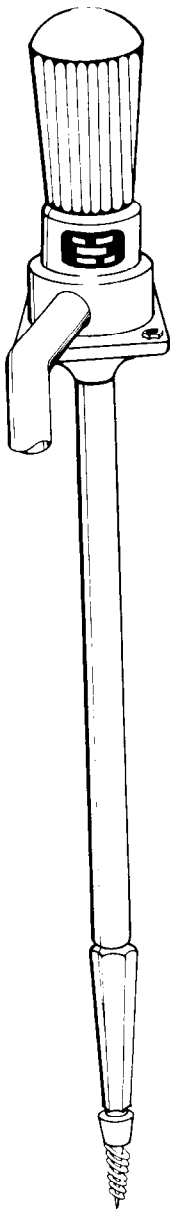

**VERTICAL TURBINE  
(CENTRIFUGAL)**

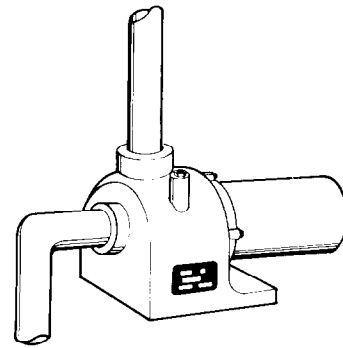

**SELF PRIMING  
(CENTRIFUGAL)**

Figure 4. Types of Water Pumps

However, ac motors in conjunction with dc-ac inverters can be used for high-power applications.

The criteria for choosing a motor are: efficiency, price, reliability and availability. Generally, the wattage determines the choice of the motor: permanent magnet dc motors under 2,250 watts (3 horsepower), wound-field dc motors for 2,250-7,500 watts (3-10 horsepower), and ac motors above 7,500 watts (10 horsepower).

Generally, ac motors are limited to high-power applications in PV-powered pumping systems because they require inverters, thereby introducing additional costs and some energy loss. Although ac systems are usually less efficient than dc motors, special improved-efficiency models are now available for PV systems.

### **Energy Storage: Batteries**

A pump powered by a PV array supplies water during sunlight hours only, unless storage batteries are included. Should batteries be included? Introducing batteries into the photovoltaic-powered pumping system may decrease its reliability and increase its maintenance requirements. The inclusion of batteries is justified when the maximum yield of the well during sunlight hours is insufficient to meet the daily water requirement; alternatively, a new well could be dug.

### **Energy Storage: Water Tanks**

Water storage is an important consideration, regardless of the intended use for the water. Pumps without batteries will not produce any water when the sun does not shine. This is least troublesome in those places where the water is for irrigation. The evapotranspiration of plants is proportional to the solar intensity: plants need less water during those periods when the pump produces less water. Also, two to three days of water storage is usually available at the root zone of plants. Water needs for livestock and humans also vary in relation to solar intensity. However, several days' water storage in a tank or reservoir is recommended. Three days is a typical storage size, but local

weather conditions and water use should determine the optimum size to meet the needs.

### **Controls: What is Needed**

For efficient operation, it is necessary that the voltage/current characteristics of the pumpset match those of the array. There are three basic ways in which a pumpset can be connected to a PV array. The simplest is to directly couple the pumpset and array. Another method is to interpose a battery. The third is to use an electronic controller.

The operation characteristics of centrifugal pumps are reasonably well matched to the output of PV arrays. Therefore, the two are most often directly coupled. This direct coupling requires that gear ratios, motor speed, and voltage and pump stage characteristics be carefully chosen for proper operation. Array matching to pump characteristics is complicated by the limited number of pump sizes.

Electronic controls can enhance performance of a well-matched array-pump system by 10-15%. These controls are frequently used in locations with fluctuating water levels or weather characteristics.

The operating characteristics of volumetric pumps are badly matched to the output of PV arrays. Batteries can improve this match and allow the motor to be started at low sun levels. However, batteries have drawbacks, as outlined above.

Maximum power controllers (MPCs) are usually used with volumetric pumps. They employ "intelligent" electronic devices to transform the array output to match pumpset power requirements. These controls allow operation over a wide range of irradiance levels, water levels, and flow rates. In addition, they solve the volumetric pump starting problem. Electronic controls typically consume 4-7% of the array's power output.

### **Determining Water Needs**

The designer of a water system needs to know the volume of water required per day and how far the water is to be transported

**Table 2****Typical Daily Water Usage for Farm Animals**

| <b>Animal</b> | <b>Water Usage (liters/animal)</b> |
|---------------|------------------------------------|
| Horses        | 50                                 |
| Dairy cattle  | 40                                 |
| Steers        | 20                                 |
| Pigs          | 20                                 |
| Sheep         | 5                                  |
| Goats         | 5                                  |
| Chickens      | 0.1                                |

and, for PV-powered systems, the amount of energy available from the sun. The designer can then design several alternate systems and determine the cost of each.

Three different needs should be considered to determine the quantity of water to be pumped by a water system:

- Water for drinking and cooking
- Water for livestock
- Water for crop irrigation.

Human and animal water needs can be estimated by multiplying the daily usage by the population. Typical daily requirements for farm animals are shown in Table 2.

Determining water needs for humans is somewhat more complicated because water usage varies based on village size, location,

and lifestyle. For planning the introduction of mechanical pumping systems into a village currently using hand pumps, a daily usage of 40 liters/person/day is suggested. For a larger town, where indoor toilets and showers are more common, a consumption figure of 100 liters/person/day is often used.

It is more complex to estimate the water requirements for an irrigation application, and this is beyond the scope of this report. Crop type, meteorological factors (temperature, humidity, wind speed, and cloud cover), method of irrigation, and season of the year are the principal factors to be considered. Trickle or low-loss channel irrigation techniques are more suitable for use with PV-powered pumps than flood or

**Table 3****Maximum Daily Pumped Water Requirements for Crop Irrigation**

| <b>Crop</b>         | <b>Water Usage</b>    |
|---------------------|-----------------------|
| Rural village farms | 60m <sup>3</sup> /ha  |
| Rice                | 100m <sup>3</sup> /ha |
| Cereals             | 45m <sup>3</sup> /ha  |
| Sugar Cane          | 66m <sup>3</sup> /ha  |
| Cotton              | 55m <sup>3</sup> /ha  |

(ha = hectacre)



sprinkler techniques. Water requirements for several common crops are presented in Table 3. **However, local practice and local experience are probably the best guide to water requirements for a specific application.**

Water usage is the first requirement to be determined. If water usage varies over the year, the mean daily water requirements for each month must be calculated. For drinking and livestock watering, water needs will be about the same every month, but water needs for crop irrigation vary over the growing season. **The critical month from a design viewpoint is the one with the minimum ratio of sunlight available to the amount of water required.** The month with the least sunlight is the month in which the least power is produced by the PV system.

\*\*\*\*\*

The hypothetical village has 115 people who are presently limited to water from a hand-dug well. Water for crop irrigation and livestock watering is available from another source. The village is growing and is expected to double in population in a few years. Therefore, using the 40-liters/person/day figure for water consumption, the village will soon need a minimum of 40 liters  $\times$  230 people = 9,200 liters (9.2 m<sup>3</sup>) per day, year-round.\*

\*\*\*\*\*

### **Daily Insolation Levels**

The power produced by a PV system depends on the insolation (amount of sunlight) available. This insolation varies for each site and month-to-month, due to seasonal and climatic variations. Insolation is usually measured in sun-hours (1 sun hour = 1 kWh/m<sup>2</sup>, about equal in intensity to

---

\*In this report, paragraphs or calculations set off from the rest of the text by rows of asterisks are portions of a typical worked example of a water-pumping system design.

sunshine on a clear summer day at solar noon).

If water needs stay the same year-round, solar design calculations should be based on the month with the lowest insolation levels to ensure adequate water throughout the year. If water is to be used for crop irrigation, the months with the lowest insolation often correspond to those in which crop demand for water is lowest; thus, calculations do not need to be as conservative as those for drinking water only. If water consumption varies throughout the year, the system design should be based on the ratio of water required to insolation available. The month in which this ratio is largest will determine the PV array size. When determining irradiation for a specific location, data should be obtained from the nearest available meteorological station and allowance made for any known local climate differences.

### **Orientation and Location of Photovoltaic Arrays**

Orientation refers to the position of a surface relative to true south. Although photovoltaic arrays that face within 15° of true south receive almost full sunshine, any unobstructed, generally south-facing surface is a potential array location. In many areas, a slightly westerly orientation is preferable to due south to avoid morning haze or fog. An array should not be shaded by obstructions like buildings or trees. Obstructions that cause no interference in summer may cast long shadows when the winter sun is low in the sky.

### **Tilt of Photovoltaic Arrays**

Module surfaces tilted at a right angle to the sun's rays catch the most sunshine per unit area. An angle equal to the local latitude is the closest approximation to that tilt or slope on a year-round basis. This means that the ideal pitch of an array for year-round operation is about the same as the number of degrees of local latitude. If the water needs are not the same throughout the year, a higher or lower array-tilt angle may be advanta-

Figure 5. Winter Insolation Contours

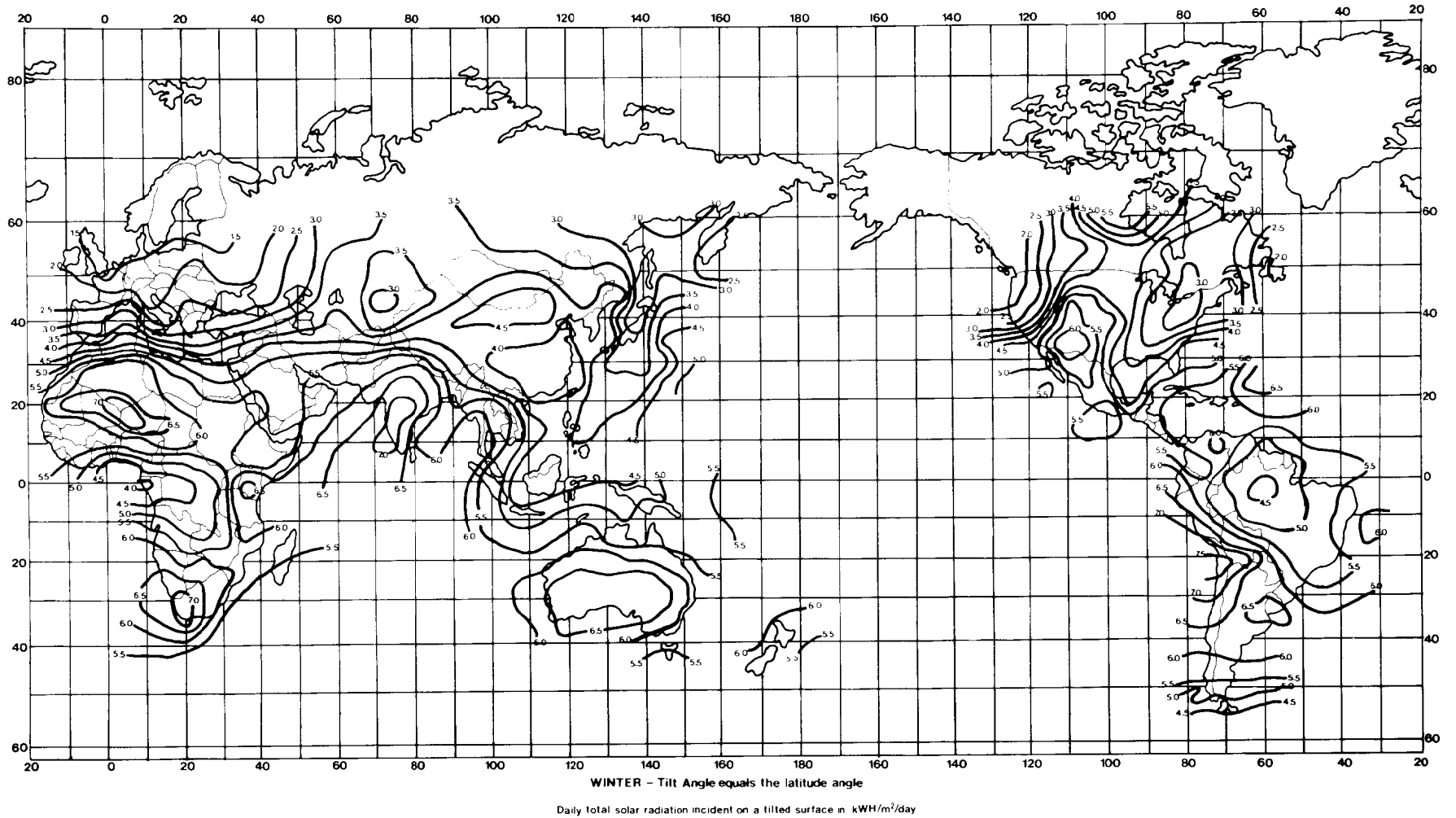

geous and lead to better system performance. For example, if the summer months have the highest water needs, an array tilt of 15° less than the latitude angle is recommended. Similarly, if the winter months have the highest water needs, increasing the tilt by 15° should be considered.

The daily total insolation incident on a south-facing surface tilted at an angle equal to the local latitude during the winter season is shown in Figure 5. A set of insolation availability maps for all seasons of the year and for three tilt angles is contained in Appendix A. This seasonal value will be adequate for preliminary design and costing purposes. Note that the number of sun-hours at a site is different from the total number of hours the sun is shining. The worldwide yearly average insolation is 5 sun-hours (or 5 kWh/m<sup>2</sup>/day). Base your design on the site closest in both distance and climate conditions to your own.

\*\*\*\*\*

The hypothetical village receives 5 sun-hours/day during the winter. Based on Figure 5 the village could be located in central Africa, north-central South America, etc.

\*\*\*\*\*

## Determining Peak Water Flow

As mentioned above, insolation is measured in sun-hours. If, for example, 5 sun-hours/day are available at a site, this does not mean that the sun produces 1 full sun-hour for 5 hours. In actuality, the sun produces less than 1 "full sun" for a period longer than 5 hours. The maximum required water flow in liters/h will be approximately the system's requirement divided by the number of sun-hours. Dividing this figure by 3,600 seconds/hour gives the maximum expected water flow in liters/s.

\*\*\*\*\*

Since the village's projected growth requires that 9,200 liters be pumped each day, and 5 sun-hours per day of insolation is available, the peak flow rate from the system will be 9,200 liters/5 sun-hours = 1,840 liters/h = 0.5 liters/s.

\*\*\*\*\*

The next step is to determine whether the village well is capable of producing that flow.

## Water Production

The amount of water produced by the well, like the amount of water needed by a village, is one of the most important factors in the design of a pumping system. A correctly operating pumping system should not exceed the well's production. For example, if a well can produce only 0.5 liter/s, a pumping system capable of pumping twice that amount will only pump the well dry. For that reason, and for future planning, it is important to know how much water a well can produce. (In the illustrative example, the productivity of the well is presumed to be known. If new wells are required, the hydrology of the site must be assessed.)

There are techniques commonly used to determine the amount of water a well can produce. The method presented here will work with both shallow, hand-dug wells and deep-tube wells. To perform this test, a portable pump is needed that is capable of pumping at a rate at least as high as the peak required rate. A means is needed for measuring the water level in the well, either a measuring rule or a line with knots tied every half-meter, for example.

First, measure the depth-to-water in the well (the static water level). Install the pump, and let it pump water until the water level stabilizes. Now, with the pump still operating, measure the depth-to-water again. To ensure that the level has stabilized, check it at several time intervals. Now, measure the water flow rate by filling a container of known volume and measuring the time required to do so. For accuracy, perform this

step several times and average the results. The flow rate should be at least as high as the peak flow rate required by the village (see above). If the water level drops to the bottom of the well (i.e., the well is pumped dry), the well does not produce enough water for the village's needs. In this case, the well should be deepened or another well dug.

It is important that the pump inlet be placed below the lowest expected drawdown level to prevent the pump from running dry. This does not increase water lift (head), because head is calculated from the well's water level, not from the pump level. If a marginal well is to be used and there is a danger of the well being overpumped, a device (a float switch, a float shutoff valve, or a recirculating float valve, depending on the application) should be incorporated to protect the well from running dry.

**NOTE:** The water in the well does not always stay at the same level throughout the year. To be sure the well will produce enough water year-round, measurements should be made during the driest month of the year, when the water level in the well and the recharge rate are usually the lowest.

### Static and Dynamic Heads

Static head is the distance from the static water level in the well to the top of the tank where the water is stored or the highest point to which it will be pumped. In a potable water system, the water is usually stored in a tank high enough for gravity to feed the water at pressure to the users. If a pressure tank is used instead of a gravity-feed tank, 1 kg/cm<sup>2</sup> of positive pressure in the tank is equal to 10 m of static head. In an irrigation or livestock-watering system, a surface level tank or reservoir is frequently used.

\*\*\*\*\*

The well previously discussed has a depth-to-water of 4.2 m. If the water is

pumped into a tank 4 m above ground level to provide gravity water flow, the well's total static head is 8.2 m.

\*\*\*\*\*

When the well is pumped, the water level drops (drawdown), and the water being pumped through the pipe causes frictional losses. These additional factors make up the total dynamic head (TDH) (Figure 6).

TDH is the sum of the static head, the drawdown distance, and the distance equivalent of the friction of the water in the pipe. Since drawdown and friction losses are both dependent on the pumping rate, TDH should always be specified at a particular flow rate. The higher the flow rate, the larger the TDH.

Pipe friction losses are based on the inside diameter of the pipe (the larger the pipe, the lower the friction loss), the pipe length, the number and kinds of bends in the pipe, and the flow rate. In a PV-powered pumping system, it is important to keep friction as low as possible. For this reason, a larger pipe size should be used than would be used with conventional water systems. Table 4 lists head loss for 1.5-in pipe for various materials and flow rates. Data on other pipe sizes are readily available. We recommend keeping the total friction losses to less than 10% of the static head.

\*\*\*\*\*

In the hypothetical system, let us assume that we use 210 ft (64 m) of 1.5-in (3-cm) diameter plastic pipe to reach the storage tank from the well. The resulting friction loss is approximately 0.3 m (1.1 ft). Thus, total dynamic head is 4.2 m (depth-to-water) + 1.5 m (drawdown on Figure 6) + 4 m (tank elevation) + 0.3 m (friction loss) = 10 m.

\*\*\*\*\*

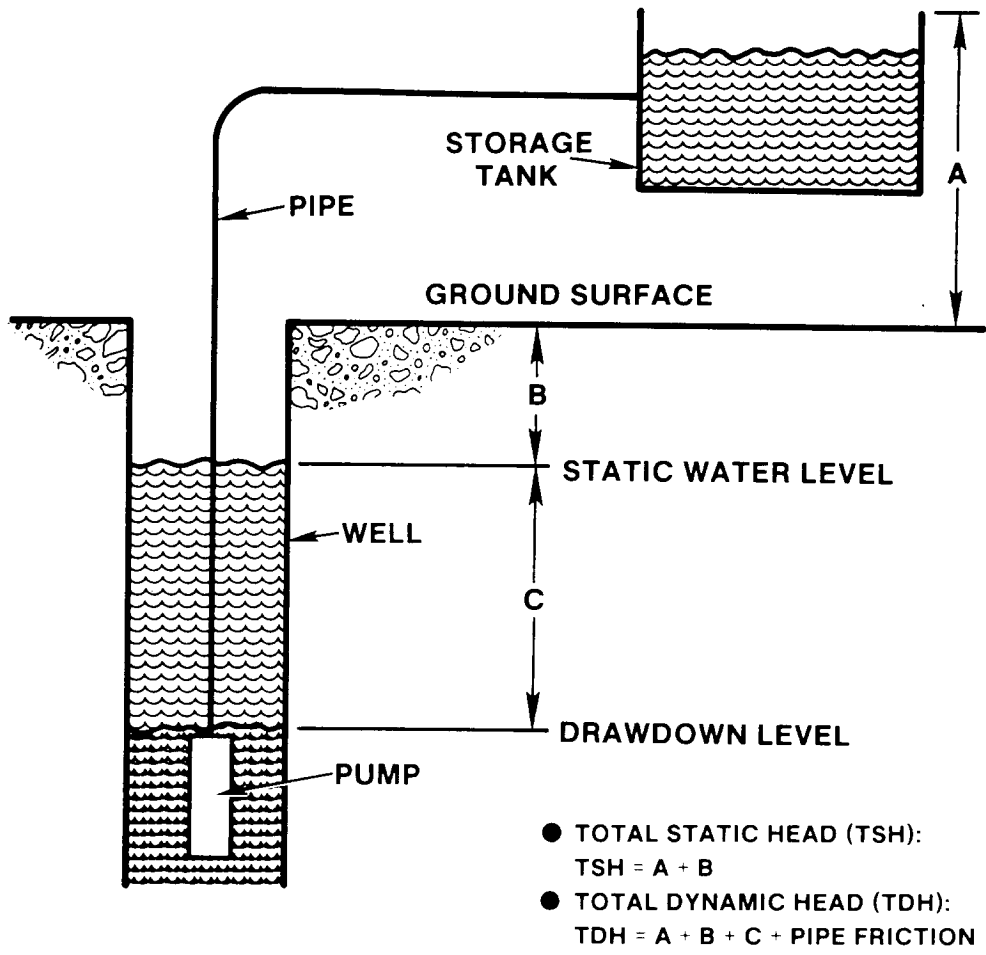

Figure 6. Total Dynamic Head (TDH) Factors

**Table 4**  
**Friction Losses in Head (ft) per 100 ft of 1.5-inch Pipe**

| Flow Rate<br>(gal/min)/(l/sec) | Head Loss |        |         |
|--------------------------------|-----------|--------|---------|
|                                | Steel     | Copper | Plastic |
| 6/0.4                          | 0.57      | 0.36   | 0.31    |
| 8/0.53                         | 0.96      | 0.61   | 0.52    |
| 10/0.67                        | 1.45      | 0.92   | 0.79    |
| 12/0.80                        | 2.04      | 1.29   | 1.10    |
| 15/1.0                         | 2.95      | 1.86   | 1.59    |
| 20/1.33                        | 5.24      | 3.31   | 2.83    |
| 25/1.67                        | 7.90      | 5.00   | 4.26    |
| 30/2.0                         | 11.1      | 7.00   | 6.00    |
| 40/2.67                        | 18.9      | 12.0   | 10.2    |
| 50/3.33                        | 28.5      | 14.9   | 15.4    |
| 60/4.0                         | 40.0      | 25.3   | 21.6    |
| 70/4.67                        | 53.2      | 33.9   | 28.7    |
| 80/5.33                        | 68.1      | 43.1   | 36.8    |
| 90/6.0                         | 84.7      | 53.6   | 45.7    |
| 100/6.67                       | 103       | 65.1   | 56.6    |

## 3.0 System Selection

In the previous chapter we looked at a number of options for a PV water-pumping system. We also discussed the evaluation of water requirements and the capacities of existing wells. In this chapter we will combine this information to choose the system configuration and its components. The choice of components is dependent on the configuration. Several possible designs may emerge. If the availability of components is restricted, then the choice of configurations is limited to those that use the available components. Otherwise, the choice can be made by several techniques in current use.

The basic design of a PV water system is straightforward. After the water need has been determined the water source is tested for its capacity. If the capacity is equal to or greater than the need, selection of components begins.

### Sizing Systems and Selecting Equipment

As used in this guide, the term “sizing” means estimating the required size or capacity of all major photovoltaic system elements so that the system will be able to satisfactorily serve the intended load.

Potential users of PV-powered water-pumping systems will want to estimate system size, performance, and cost in order to gauge usefulness for a particular application. Most methods to do this are complex and require computer programs to obtain precise answers. This section outlines a simple method intended to assist potential buyers in making rough estimates. These estimates should be within 20% of the “true” value for systems with some sort of voltage regulation. (Without voltage control, as is the case for a direct-coupled system, array efficiency can be decreased by as much as 50%.)

This chapter contains two nomographs (Figures 7 and 8) to assist the potential buyer, freeing this person from making the above detailed calculations. These nomo-

graphs can be used to determine the size of the PV array required to meet the hydraulic load during the critical design period. In addition, they generate the information needed to select motor and pump size.. If after reading this section, you have questions on this procedure, there is a complete example provided in Appendix B. The nomographs replace the following basic steps in system sizing:

1. Calculate the hydraulic load —The average daily energy load in kilowatt hours is calculated for the peak month in each season. The hydraulic load is directly proportional to the daily water volume-head product.
2. Estimate system losses — This includes mismatch effects and losses in the wires, electronic controls, pump, and motor. The losses in the pump (40-60%) and motor (10-20%) dominate.
3. Determine local insolation —The appropriate amount of input solar radiation (insolation) to the photovoltaic system at the application site may be obtained from Appendix A for various tilt angles. Average daily values for spring, summer, autumn, and winter are included in the charts.
4. Determine the “critical” design period — The available solar insolation varies as the seasons change, as may the water requirements or water level in the well. For this reason, the worst combination of load and insolation must be identified. It is this combination that determines the “size” of the system.

This worst combination can be identified by constructing a table of average seasonal insolation and load values, and then determining the season with the lowest ratio of insolation to load.

This value is then used in the next step:

5. Calculate the array power —After steps 1-4 have been completed, the array power is calculated. PV arrays are usually rated by specifying their output in watts under “standard” conditions of





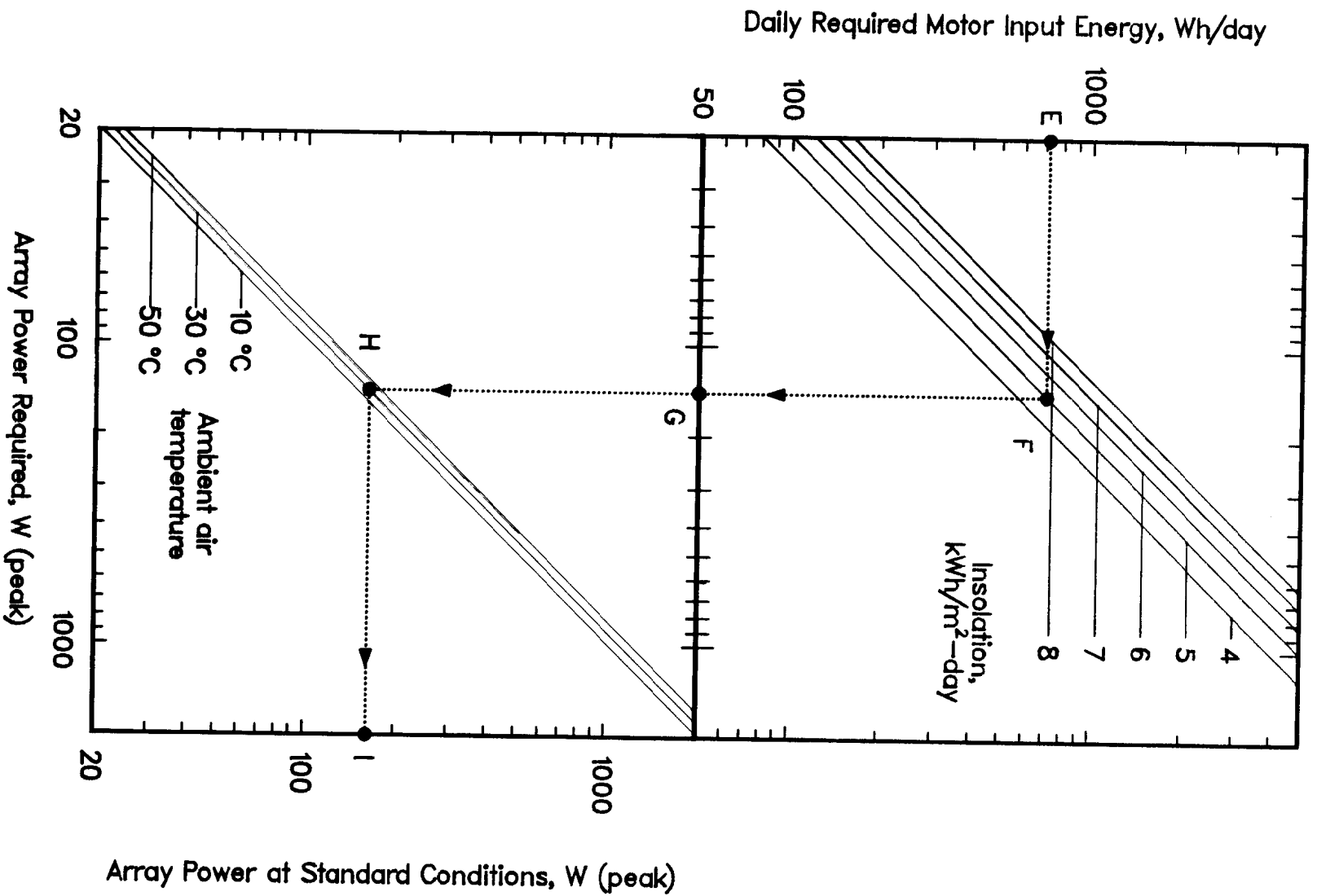

Figure 8. Array Power Nomograph

100 mW/cm<sup>2</sup> insolation with the cell temperature at 25°C. This output is, however, adversely affected by temperature, falling approximately 0.5% per degree centigrade above this standard. Since normal cell temperature is approximately 30° C above ambient air temperature (which, in turn, is often well above 25°C), actual array output may be significantly less than rated power.

The starting point is Point A on the Hydraulic Energy Nomograph. This water requirement must be specified by the user. Moving next to Point B, (the pumping head at the well site) leads to Point C (the hydraulic energy) Point D (an estimate of system efficiency) leads to Point E (which gives the daily required motor energy). Now, move to the Array Power Nomograph.

Starting at Point E (daily required motor energy, as determined on the previous nomograph), move to Point F (the insolation level). The value for insolation level can be obtained from local sources or Appendix A. Point F leads to Point G (the array power requirement). The motor rating should exceed the array power by 25% to protect against motor overloading. Last, Point H (the ambient air temperature obtained from local weather data) leads to the rated array power,  $W_p$ , Point I.

\*\*\*\*\*

Following this procedure, we obtain an array size of 160  $W_p$  for the hypothetical system.

\*\*\*\*\*

Centrifugal pumps achieve maximum efficiency only when operating at design capacity; when pumping at less than design capacity the efficiency is less. Since the power output of a PV system is constantly changing, the long-term average efficiency of a centrifugal pump is hard to predict, but will be less than its rated efficiency at

design capacity. In contrast, the efficiency of a volumetric pump is constant throughout its operating range. The following section describes some of the interactions among insolation, PV array output, and pumping efficiency. The nomographs account for these phenomena over the long-term average.

## The Effect Of Varying Solar Radiation On Output

A major factor in sizing systems is the nature of solar radiation—it changes throughout the day, is affected by the weather, and changes from season to season.

This variation in input power does not greatly affect systems that are able to deliver water in proportion to the ambient solar intensity: they produce less water when the solar level is low and produce more when the solar level is high. This evens out over time.

This variation does affect pumping systems where water output is nonlinear with solar intensity, e.g., the water output does not vary directly with the speed at which the pump operates. The implications for output are complex. In addition, they highlight the importance of properly defining the desired average daily water delivery in the purchase specifications, and requiring a well-defined acceptance test.

**Daily Variations** — The most important characteristic of insolation is its diurnal pattern. The expected power available to a fixed flat-plate array over a 24-hour period under clear skies is represented by a hill-shaped curve that increases from sunrise to noon and decreases thereafter until sunset. In general, volumetric pumps are linear, and when coupled to a “smart” electronic controller, can fully utilize the available solar radiation. Centrifugal pumps are nonlinear—efficiency and, hence, water production decrease when these pumps are operated away from an optimum design condition. Manufacturers should take these effects into account when quoting average daily flow rates. Figure 9 illustrates these variations. The preceding sizing nomographs (Figures 7 and 8) allow for this.

**Weather Variations** — Cloudy weather considerably reduces the amount of insolation, and thus the output of photovoltaic systems. Solar insolation tables include adjustments for weather variations because these variations are normally present as average daily levels over a full month. Therefore, weather variations do not, on the average, affect the water delivery of linear systems, e.g., volumetric pumps. However, centrifugal pumps are considerably affected. The accompanying curve (Figure 10) shows the drop in water output with the drop in solar radiation. When sizing photovoltaic-powered centrifugal pumps in areas that experience weather conditions of generally decreased or overcast insolation (fog, haze, dust, dispersed clouds, or smog), use a maximum value of 80 mW/cm<sup>2</sup> instead of 100 mW/cm<sup>2</sup> for the daily solar profile. This lower peak value at noon, coupled with the average daily insolation level (kWh/m<sup>2</sup>/day) in the solar tables, should account for those weather variations.

**Seasonal Variations** — Since there are seasonal differences in the daily path of the sun across the sky, the amount of solar ener-

gy striking a fixed array will vary seasonally. Note that these effects are due only to annual changes in sun angle and are distinct from typical seasonal changes in insolation due to changing weather patterns.

Figure 11 illustrates the effect for array tilt angles equal to the latitude and equal to latitude plus or minus 15°. In this figure, array outputs are normalized and appear as fractions of the output from an array at latitude tilt.

The output of a volumetric pump depends on the amount of total daily solar insolation striking the array. By contrast, the output of a centrifugal pump is affected by the peak value of the solar insolation as well as by the amount. For a fixed-tilt-angle array, peak power will vary seasonally as the sun's angle with respect to the array changes. Figure 12 illustrates this effect.

Purchase specification should require manufacturers to account for this effect and the other effects described in this section when presenting expected water output. The techniques presented earlier did account for these effects.

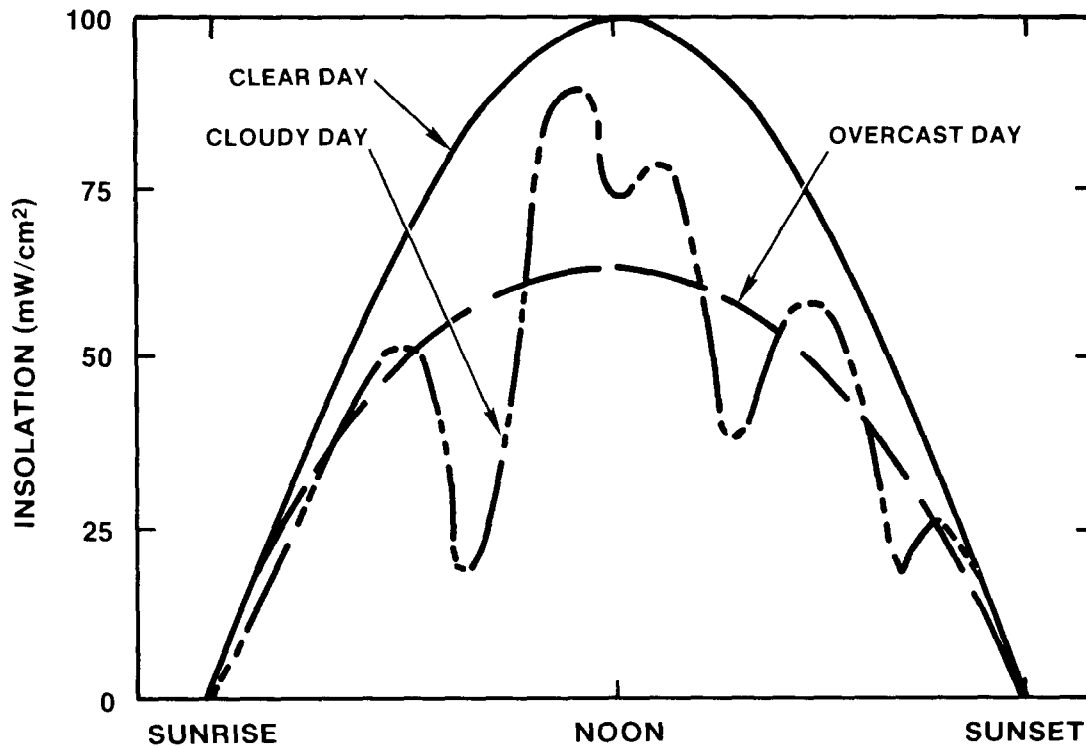

Figure 9. Typical Daily Variations in Solar Radiation

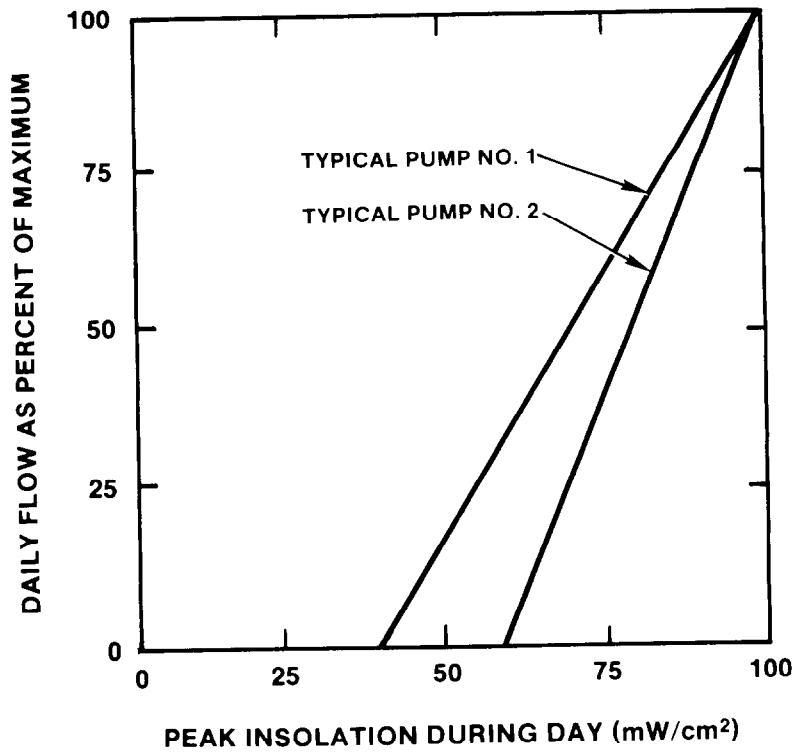

Figure 10. Relation between Peak Daily Insolation and Performance of Centrifugal Pumps

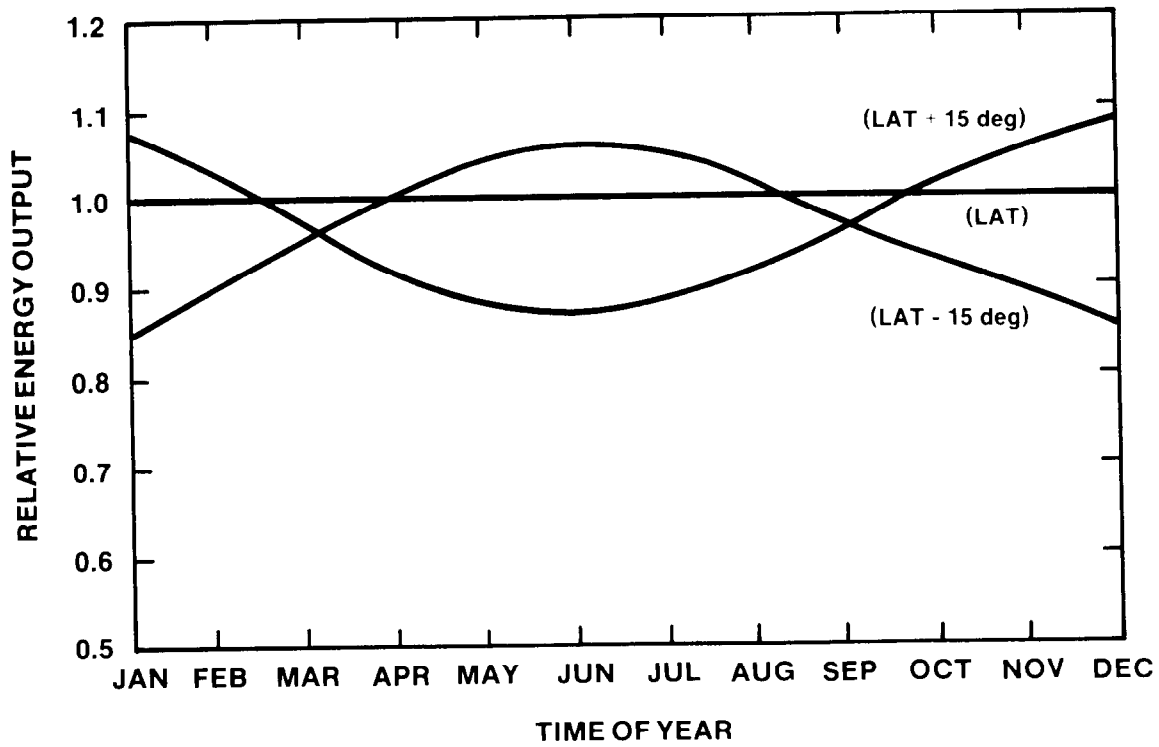

Figure 11. Relative Energy at Various Tilt Angles

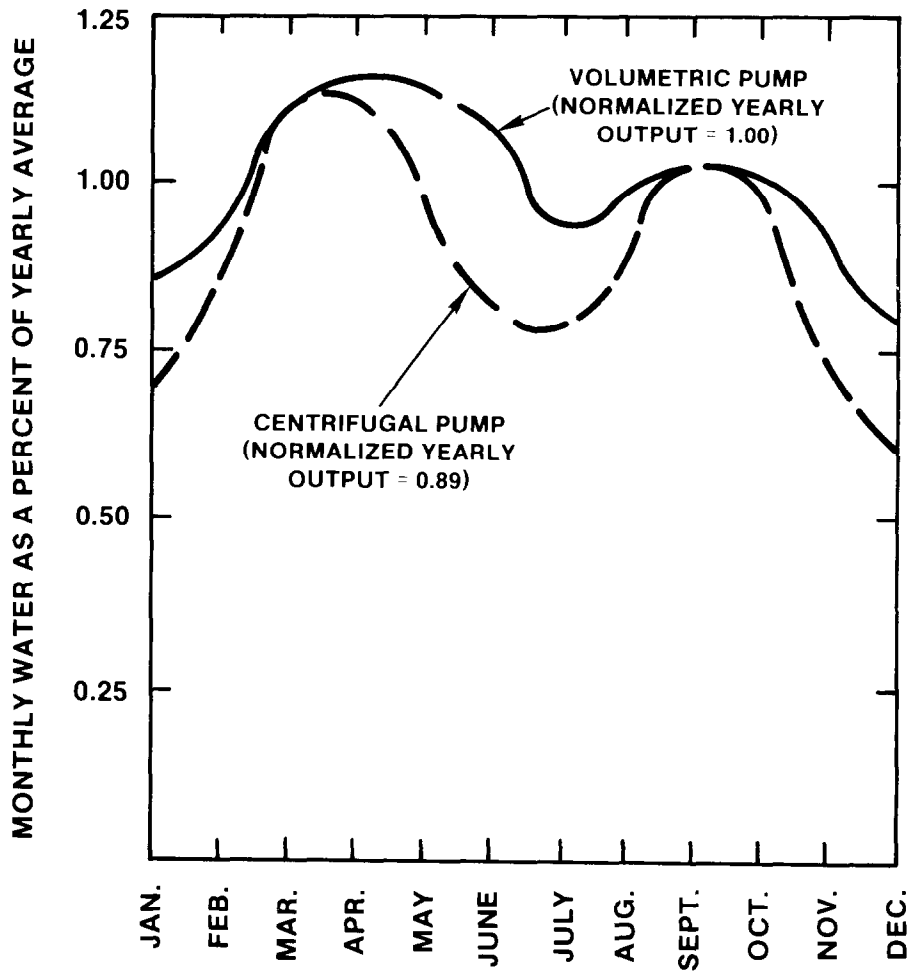

Figure 12. Centrifugal Pump and Volumetric Pump Output (Array at Fixed Tilt Angle Equal to Latitude Angle)

### Equipment Type vs. Pumping Requirement

The best type of equipment for a particular pumping application depends on daily water requirement, pumping head, suction lift, and water source (e.g., tube well or open well). Generally, positive displacement pumps are best for low flows (under 15

$m^3/day$ ) and high heads (30-500m). Submersible centrifugal pumps are best for high flow rates (25-100  $m^3/day$ ) and medium heads (10-30 m). Self-priming pumps should be investigated for high flow rates and low heads (under 5 m). Figure 13 presents the most suitable pump types for the different ranges of head and flow when using photovoltaic power.

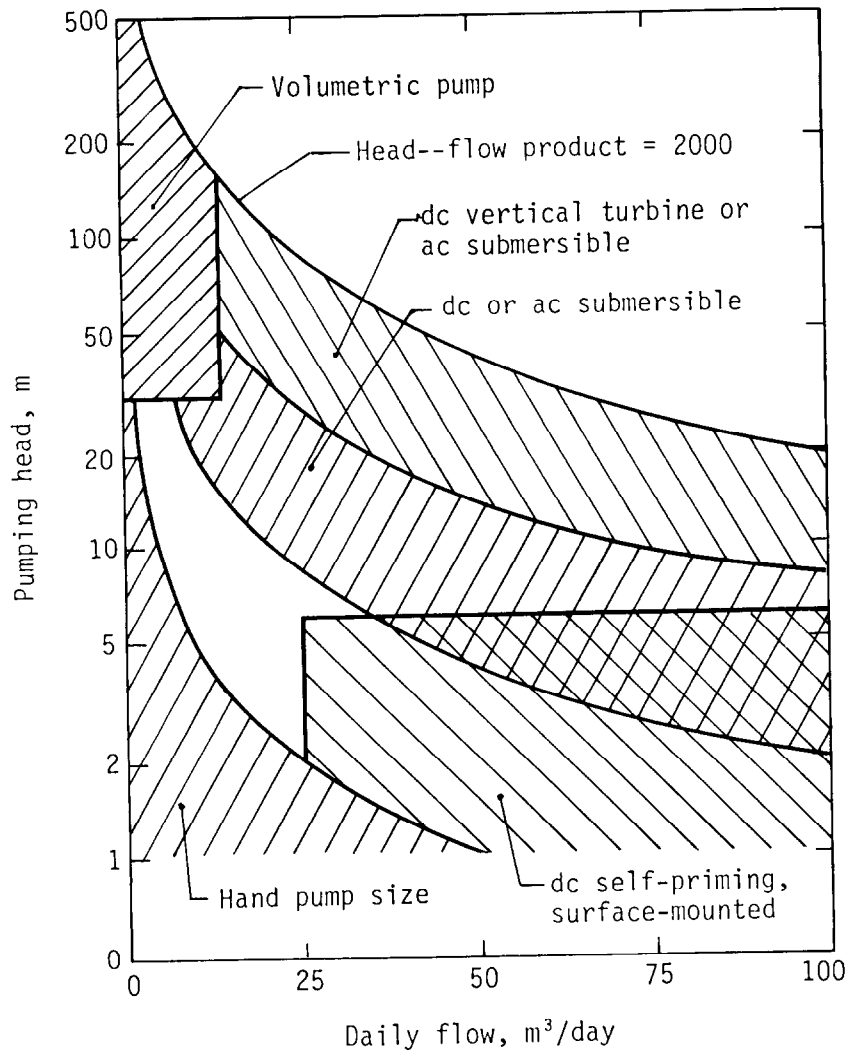

Figure 13. Pumpset Types vs. Pumping Regime

### Specifying System Performance

Utilizing the information in this chapter in conjunction with the nomographs and other computational aids should allow a potential buyer

- to determine the technical viability of using photovoltaic-powered pumping systems, and
- to estimate the "size" of the system.

Next, Chapter 4 allows the buyer to estimate the economic worth of the system. In many cases, this determination leads to the preparation of purchase specifications and to the acquisition of one or more photovoltaic-powered pumping units.

## 4.0 Cost and Economics of Pumping Systems

### Determining the Cost-Effectiveness of a Pumping System

To be cost-effective, the PV option must be less expensive (over the system's life) than feasible mechanical pumping alternatives, such as diesel, wind, or other electric systems. In many remote areas, hand pumps will be the norm for village water supply, and the costs of hand pump use will be the baseline against which other mechanical systems are compared.

In order for PV-powered pumping systems to come into widespread use, they must be attractive to users and investors, as well as to policymakers. For example, although a policymaker may place a high premium on foreign exchange savings, the individual farmer will be more concerned with the money saved on fuel (based on delivered local fuel prices) and by such issues as reliability and availability of power or fuel. This is particularly important in more remote areas, where logistical concerns, i.e., delivery costs for fuel, system downtime caused by missing spare parts or lack of trained repair personnel, etc., can often result in a pumping system being abandoned.

### Measuring Cost-Effectiveness of a Pumping System

Although there are several acceptable measures of economic cost-effectiveness, the most objective and widely used by large organizations is the life-cycle cost (LCC) analysis. We will also keep track of initial capital, because this measure is also important. In practice, when the pumping system is to supply drinking water, it is most important to establish the comparative life-cycle cost of PV versus other pumping systems, because the economic benefits of supplying drinking water are difficult to quantify. For example, if both a diesel and a PV pump can reliably furnish the same quantity of water, it is safe to assume that they provide equal

benefits. In this case, the lower cost option is preferred.

In LCC analysis, the net present value (NPV) of all the capital and recurring costs for the test project (in this case, PV-powered pumps) is compared to the NPV of all the costs of competitive projects. If the NPV of costs of PV-powered pumping is less than the costs of the alternatives, PV should be first choice for the power source.

For irrigation systems, the benefits—potential increases in agricultural output—are quantifiable, that is, an additional volume of water translates into a larger herd of livestock or additional hectares of crops under cultivation—items that have a measurable market value. However, attempting to measure these benefits is beyond the scope of this document, since benefits to crop and livestock production vary widely with local circumstances. In these circumstances, it must be shown both that the pumping system selected is the least cost option and that the value of increased yields (benefits) more than offsets the added cost of the pumping system. The value of these benefits over the life of the project is calculated in the same manner as the costs, i.e., the NPV of all the annual benefits is calculated and compared to the NPV of the costs. In this chapter, step-by-step instructions are provided for evaluating costs. In Appendix B, a worked example of system cost evaluation is provided via a nomograph, eliminating the separate steps.

### Measuring Life-Cycle Costs of a Pumping System

A pumping system will last a certain time before it needs replacement. In a PV system, for example, the panels should last 20-30 years, whereas the pump may have to be replaced every 5-10 years. The "life of the system" is the life of the component with the longest replacement interval (the modules in this example). The LCCs are the initial cost of the complete, installed system in year 0,

**Table 5**

**Cost, Discount, and NPV Examples**

| Year | Cost (\$) | Discount Factor      | NPV (\$)                     |
|------|-----------|----------------------|------------------------------|
| 0    | 100       | 1/1                  | 100/1 = 100                  |
| 1    | 110       | 1/1.1                | 110/1.1 = 100                |
| 2    | 121       | 1/(1.1) <sup>2</sup> | 121/(1.1) <sup>2</sup> = 100 |

plus a replacement pump (with installation) in year 10, plus annual operation, repair and maintenance expenses.

For an irrigation example, the “life-cycle benefits” can be measured in terms of increased agricultural production in each year of the pumping system’s life (for this example the minimum life is assumed to be 20 years).

Benefits and costs are likely to occur at different points in time. The economic method for making future costs of benefits directly comparable to those that occur today is to apply a discount rate to all future costs and benefits. For example, with a 10% discount rate, this means that a \$100 cost today may be considered equivalent to a \$110 cost incurred 1 yr from today, or a \$121 cost incurred 2 years from today, etc. This is because the capital, when otherwise invested, would provide the investor with additional funds over future time. Alternatively, each of the costs has an NPV of \$100.

Mathematically,  $NPV = C/(1+d)^y$  where NPV = net present value, C cost at year ‘y’, d = discount rate, and y = year in which the cost occurs. For the above example, the NPV of year 2 cost is  $NPV = 121/(1.1)^2 = 121/1.21 = 100$ . The relationship among cost, discount factor, and NPV is shown in Table 5.

Note that the discount factor (10%/yr in the present example) is based on a chosen rate of return (after inflation) of monies that could have been invested in an alternative financial endeavor. If this analysis were performed based on an economy with an annual inflation rate of 10%, the discount factor would be 20% to keep the net discount factor at 10%. A discount factor of 10% (after inflation) is com-

monly used for LCC analysis. However, a higher or lower value may be chosen, based on the specific investor’s financial requirements.

This discussion assumes that the costs associated with the project follow the overall inflation rate. If certain costs are expected to change at a different rate (fuel costs, for example), it may be advisable to apply a differential inflation rate to these items.

**Cost Appraisal of a PV- Powered Pumping System**

The following information is needed for the cost appraisal of a water-pumping system:

- Economic: Period of analysis  
(usually equal to the lifetime of the longest lived component)  
Discount rate  
Differential inflation rates for certain items (if any)
- Technical: Lifetime of each main component in years
- Costs: Capital cost for complete system  
Capital cost for replacement components  
Annual maintenance and repair cost  
Installation costs

**Capital and Installation Costs** — There are four major elements in the capital costs of a PV-powered water system:

1. PV array modules
2. Balance-of-system (BOS) components (structures, wiring, control devices, etc.)



3. Water pump and motor
4. Water storage and distribution network

**NOTE:** All costs given in this section are general estimates to be used for project feasibility analysis only.

Since the storage and distribution system would be the same for all power sources for the water-pumping projects, we will disregard it for the purposes of this analysis. Note, however, that a larger capital expenditure for the storage system may be required with a PV system than for other types of water-pumping systems. This is because of the recommended 3 sunless days' water storage for PV systems.

**PV modules:** Current (1987) costs from the factory are about  $\$8.75/W_p$  for 50 or fewer modules and about  $\$7.50/W_p$  for quantities of 100 to 250 modules. Even lower costs (as low as  $\$6.00/W_p$ ) are available for larger procurements but would usually require that the modules be bought in large single purchase-order lots. Significant reduction in module costs is anticipated in the future. (See your local supplier for specific costs.)

The array BOS components are those elements directly associated with the PV array. Experience indicates that these components represent about 15% of the PV module costs, or  $\$1.13$  to  $\$1.31/W_p$ .

**Water pumps:** Costs for pumps vary depending on the type required for the application. The various types of pumps and their respective selection criteria were discussed previously. The following estimates include all electrical and mechanical hardware required but omit pipework and other costs associated with the distribution system.

- Submersible centrifugal pumps: Use a base cost of  $\$2,000$ .
- Surface centrifugal pumps: Use a base cost of  $\$500$  plus  $\$1/W_p$ . (Example: A  $200-W_p$  system would cost approximately  $\$500 + \$200$  for a total pump price of  $\$700$ .)
- Lineshaft turbine and jack pumps: Use a base cost of  $\$2,500 = \$1/W_p$ . (Example: A  $5-kW_p$  system would cost approximately  $\$2,500 + \$5,000$  for a total pump cost of  $\$7,500$ .)

Costs of PV equipment are expected to stabilize over the next few years, with a possible decline in prices thereafter as new technologies become available. The BOS component costs will remain about the same. Future water pump costs should go down as the demand for PV-powered pumping goes up worldwide.

Installation costs for PV systems, due to their requirement for array foundations, additional shipping cost, labor to assemble the structures, etc., are higher than costs for diesel systems and roughly equal to those costs for a wind-power system. As a guideline, a figure of  $\$0.50/W_p$  of PV array can be used. For pump installation, the following estimates can be used:

- Submersible centrifugal -  $\$200 + 0.50/W_p$
- Surface centrifugal -  $\$100 + 0.50/W_p$
- Lineshaft turbine or jack pump -  $\$500 + 0.50/W_p$

\*\*\*\*\*

For the hypothetical water pumping system, capital budgetary costs would be estimated as shown below.

|  |                |
|--|----------------|
| 1. $160-W_p$ array @ $\$8.75/W_p$ (delivered)        | \$1,400        |
| 2. Balance-of-system components (15% of array costs) | 210            |
| 3. Submersible centrifugal pump                      | 2,000          |
| 4. Installation ( $\$200$ for pump + $\$0.50/W_p$ )  | 280            |
| <b>TOTAL:</b>  | <b>\$3,890</b> |

This example is marginal between a surface centrifugal pump and a submersible pump. The cost for the more expensive system is shown.

\*\*\*\*\*

Note that for these analyses, installation costs are based on local technical personnel performing installation tasks. Turnkey

installations, for which the PV equipment supplier performs pre-installation site visits, actual installation/checkout, and detailed documentation, will cause the installed costs to rise. Note also that site work (well drilling, clearing and leveling the land, trenching for pipes, etc.) is not included in these installation cost estimates.

Operations and Maintenance (O&M) Costs — The operating costs of a PV pump are nil. The cost of maintaining the pump is difficult to estimate because of variations in local repair capabilities, but a figure of \$20 plus  $\$0.02/W_p$  per year can be used as a general guideline, depending on the system size and pump type used. Repair costs can vary greatly from year to year, depending on the nature of the repair and whether it can be handled within the country concerned.

\*\*\*\*\*

For the hypothetical 160- $W_p$  pumping system, the O&M costs would be approximately  $\$20 = (0.02 \cdot 160) = \$23.20$  per year.

\*\*\*\*\*

**Pump Replacement Costs** — Experience has shown that the pump and motor subsystem is likely to need replacement after about 10 years, perhaps earlier in a difficult rural environment. For pump replacement costs, use the information for initial capital and installation costs given earlier.

\*\*\*\*\*

For the hypothetical pump system, replacement costs are  $\$2,000$  (capital) +  $\$200$  (installation) =  $\$2,200$ .

\*\*\*\*\*

Table 6 lists these costs over a 20-year projected system life, using the LCC method described earlier. The example used is the hypothetical village water pumping system.

Table 6 uses a 10% discount rate and, for simplicity, assumes zero differential inflation. The discount factor is obtained by  $d = 1/(1.1)^y$ , where  $y = \text{year}$ . For example, the discount factor in year 9 is  $1/(1.1)^9 = 0.424$ . NPV is found by taking the sum of capital, replacement, and O&M costs multiplied by the discount factor for the same year.

The overall step-by-step procedure is summarized in Figure 14.

**Table 6**  
**LCCs for the Hypothetical PV Pumping System**

| Year             | Capital Costs (\$) | Replacement Cost for Subsystem | O&M (\$) | Discount Factor | NPV(\$)         |
|------------------|--------------------|--------------------------------|----------|-----------------|-----------------|
| 0                | 3,890              |                                | 23.20    | 1.0             | 3,913.20        |
| 1                |                    |                                | 23.20    | .909            | 21.09           |
| 2                |                    |                                | 23.20    | .826            | 19.17           |
| 3                |                    |                                | 23.20    | .751            | 17.43           |
| 4                |                    |                                | 23.20    | .683            | 15.85           |
| 5                |                    |                                | 23.20    | .621            | 14.41           |
| 6                |                    |                                | 23.20    | .564            | 13.10           |
| 7                |                    |                                | 23.20    | .513            | 11.91           |
| 8                |                    |                                | 23.20    | .467            | 10.82           |
| 9                |                    |                                | 23.20    | .424            | 9.84            |
| 10               |                    | 2,200                          | 23.20    | .386            | 858.14          |
| 11               |                    |                                | 23.20    | .350            | 8.13            |
| 12               |                    |                                | 23.20    | .319            | 7.39            |
| 13               |                    |                                | 23.20    | .290            | 6.72            |
| 14               |                    |                                | 23.20    | .263            | 6.11            |
| 15               |                    |                                | 23.20    | .239            | 5.55            |
| 16               |                    |                                | 23.20    | .218            | 5.05            |
| 17               |                    |                                | 23.20    | .198            | 4.59            |
| 18               |                    |                                | 23.20    | .180            | 4.17            |
| 19               |                    |                                | 23.20    | .164            | 3.79            |
| 20               |                    |                                | 23.20    | .149            | 3.45            |
| <b>Total NPV</b> |                    |                                |          |                 | <b>4,959.91</b> |

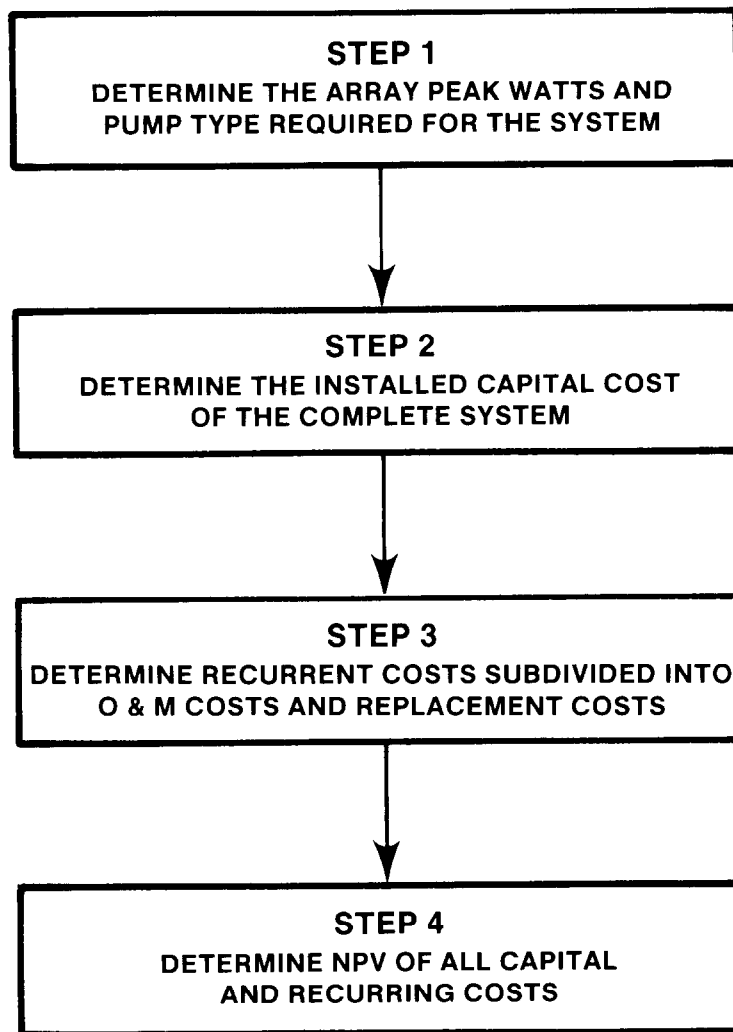

Figure 14. Procedures for Cost Appraisal of a Water Pumping System

## Evaluating the Costs of a Diesel Pumping System

When comparing PV with diesel as an option for a pumping system, an NPV calculation of initial replacement, and O&M costs should be made for both systems to determine which is the most cost-effective over the projected system life. This section discusses the factors in costing diesel pumping systems. Detailed design of diesel pumping systems is beyond the scope of this document.

### Special Considerations —

**1. Minimum Diesel Engine Sizing.** Due to efficiencies of scale, diesel engines suitable for pumping systems are usually 2.5 kW (3.35 HP) or larger. This means that for pumping systems requiring lower power, almost any procured diesel engine will be underutilized. As a result, diesel capital costs are higher than needed based on power requirements; however, this is partially offset by lower fuel and maintenance costs, since the diesel engine will be able to pump the required water in a shorter period of time. Care must be taken in an NPV calculation to ensure that the pumping rate of this relatively large diesel pump does not exceed the well's recharge rate. It may thus be impractical to use a diesel engine in some small-system applications, and no economic analysis is required in this case.

**2. Logistics of Fuel and Parts Supply.** Comparisons between diesel and other systems may take into account costs for diesel fuel and parts based on both being readily accessible. However, remote pumping sites are often removed from the nearest location where parts, fuel, and repair persons are available. Thus, fuel costs are escalated because of logistics and transportation requirements. More important, though, is the difficulty in getting a qualified repairman to the scene of a disabled system. Importing a service technician from another area can substantially raise the costs of a service trip. If the repairman requires an additional part, repair is often delayed for several days, placing the village's water supply in jeopardy. The remote system is often inoperable for days or weeks while awaiting fuel,

parts, or services. The costs associated with these periods are difficult to quantify but should be factored into any remote system costing analysis. This is also a problem for PV systems, but the anticipated frequency of maintenance is much less.

Based on these considerations, we note that the projected costs of a remote diesel system are increased by 100% over the same system located near a major urban area.

### Comparing Costs of a Diesel System —

A rigorous procedure to estimate the required size of the diesel pump is beyond the scope of this document, but for many situations, the simplified procedure given below will be adequate.

On the assumption that, for practical reasons, it would not be acceptable to run a diesel pump for more than 8 h/day, the hydraulic power rating of the diesel pump is obtained by dividing the peak month daily hydraulic energy requirement,  $E_h$ , by 8, where

$$E_h = [9.8 \cdot \text{TDH (m)} \cdot \text{Daily Water Requirements (m}^3\text{)}] / 3,600 .$$

Assuming an average pump efficiency of 50%, the required power rating of the diesel engine,  $P_d$ , is given by  $E_h/4$ . Since the minimum size of a diesel engine suitable for use with pumping systems is about 2.5 kW if  $E_h/4 < 2.5$  kW,  $P_d$  should be taken as 2.5 kW. In this case, the pump would run for less than 8 h/day to produce the required output. The engine rating is

$$P_d = E_h/4 \text{ kW, but not less than 2.5 kW .}$$

Having thus estimated the power rating of the diesel engine, the installed capital cost of the pumping system can be estimated. If the installed cost per kilowatt is  $C_d$ , the capital cost is

$$\text{CAP}_d = C_d \cdot P_d .$$

The current value of  $C_d$  for typical diesel pumping systems is about \$1,600/kW, including delivery and installation. Therefore, a 2.5-kW system (the minimum practical size) would cost about \$4,000.

The next step is to calculate the replacement cost. Experience has shown that the life of the engine and pump in the difficult

operating conditions typical for rural installations is 5 to 10 years, depending on operating hours and the quality of maintenance. For present purposes, an average life of 7 years is assumed, after which time the complete system must be replaced at the original capital cost.

Assuming that the owner of the diesel pump makes no charge for operating the system, operating costs (excluding fuel) are nil. Maintenance costs for a diesel pumping system vary widely. Sometimes this can be estimated on the basis of running hours or as a proportion of capital cost. However, maintenance costs are largely independent of size up to about 10 kW engine rating, since they are mainly determined by the frequency of servicing visits and the charges made for each service. For diesel pumps in this size range, typical maintenance costs are \$200 to \$900 per year.

To calculate the annual fuel cost,  $AFC_d$ , the total number of running hours is required, as given approximately by:

$$T_d = 2 \cdot E_{h, \text{tot}} / P_d,$$

where  $E_{h, \text{tot}}$  is the total annual hydraulic energy requirement in kilowatt-hours (i.e., the sum of the daily hydraulic energy requirements).  $P_d$  is the diesel engine rating, as determined above. This relationship assumes an average efficiency of 50% for the ratio of hydraulic power to engine-rated power.

The average fuel consumption under typical operating conditions depends principally on engine size, but other factors include the quality of maintenance, the ambient temperature, and the actual hydraulic load. If the cost of diesel fuel delivered to the site is  $C_f$ /liter, and the average fuel consumption is  $f_d$  liters/kW of engine rating per hour, the annual fuel cost is

$$AFC_d = T_d \cdot f_d \cdot P_d \cdot C_f.$$

Based on field observations, typical average consumption figures for engine sizes up to 10 kW are rating per hour of operation, about 0.5 liter/kWh of engine rating per hour of operation. Delivered fuel costs range from \$0.20 to \$1.50 per liter. We take \$0.30/liter as the base assumption for a near-urban area. The estimated average cost

of fuel over the period of analysis should be used for the calculation, taking into account any expected real price inflation of fuel (i.e., the inflation of fuel prices relative to general inflation).

\*\*\*\*\*

For our hypothetical system,

$$E_h \frac{9.8 \cdot 10 \cdot 9.2}{3,600} = 0.25 \text{ kWh}.$$

and

$$P_d = E_h / 4 = 0.063,$$

so a minimum-sized diesel of 2.5 kW is required and the capital cost is  $2.5 \cdot \$1,600 = \$4,000$ . Now, total annual hours of operation are

$$T_d = 2 \cdot E_{h, \text{tot}} / P_d = 2 \cdot 0.25 \text{ kWh} \cdot 365 / 2.5 = \sim 75 \text{ h}.$$

Note that this relatively large diesel engine must operate for only 75 h/yr to provide the required water. It therefore would pump water at a far higher rate than the PV-powered pump, possibly overpumping the well. It also represents a case where diesel is not a reasonable technical choice. Nonetheless, we shall look at the costs for comparison purposes.

The annual fuel cost is

$$AFC_d = 75 \cdot 0.5 \cdot 2.5 \cdot 0.5 = \sim \$50.$$

Since our example system will operate at a very low duty cycle, low maintenance costs will be incurred. For the near-urban case, we will assume \$200/year O&M costs. Table 7 is an LCC cost analysis for this system.

**NOTE:** Discount and inflation assumptions as in PV case (Table 7). NPV is the sum of capital, replacement, O&M, and fuel costs multiplied by the discount factor. Note that this analysis was done for a near-urban site. For a remote location, the costs of diesel operation would be even higher.

For the same amount of pumped water as in the PV case, the NPV for the diesel system case can be directly compared to that for an

equivalent PV-powered pumping system. Thus, for this application, a PV-powered system would be significantly more economical.

The results of the comparison between PV and diesel pumping systems will be influenced by changes in any of the key assumptions used. Increases in fuel price sharply increase the cost of pumping with diesel, relative to PV. The use of a higher discount rate improves the relative cost of the diesel, because most of the cost of the PV system occurs in the first year and is not sensitive to the discount factor.

For the same reason (that recurrent costs of PV are low), PV-powered systems are little affected by rising future prices, whereas the cost of diesel pumping may be strongly affected.

### Comparative Costs of Other Pumping Systems

The procedures outlined above for calculating the cost for a solar or a diesel pump system may be applied to other types of pumps, such as wind-powered pumps, animal-powered pumps, and hand pumps. It is particularly important to make the comparison for identical hydraulic duties, i.e., the volume of water supplied per day to a common point, for the same degree of reliability.

When water costs are calculated for different pumping systems and for the conditions relating to particular applications at specified sites, the results will be strongly dependent on certain assumptions. For example, PV-powered pumps will, in general, provide cheaper water for low-head and low-water-

**Table 7**  
LCCs for a Hypothetical Diesel Pumping System

| Year             | Capital & Replacement Costs (\$) | O&M (\$) | Fuel Cost (\$) | Discount Factor | NPV(\$)         |
|------------------|----------------------------------|----------|----------------|-----------------|-----------------|
| 0                | 4,000                            | 200      | 50             | 1.000           | 4,250.00        |
| 1                |                                  | 200      | 50             | .909            | 227.25          |
| 2                |                                  | 200      | 50             | .826            | 206.50          |
| 3                |                                  | 200      | 50             | .751            | 187.75          |
| 4                |                                  | 200      | 50             | .683            | 170.75          |
| 5                |                                  | 200      | 50             | .621            | 155.25          |
| 6                |                                  | 200      | 50             | .564            | 141.00          |
| 7                | 4,000                            | 200      | 50             | .513            | 2,180.25        |
| 8                |                                  | 200      | 50             | .467            | 116.25          |
| 9                |                                  | 200      | 50             | .424            | 106.00          |
| 10               |                                  | 200      | 50             | .386            | 96.50           |
| 11               |                                  | 200      | 50             | .350            | 87.50           |
| 12               |                                  | 200      | 50             | .319            | 79.75           |
| 13               |                                  | 200      | 50             | .290            | 72.50           |
| 14               | 4,000                            | 200      | 50             | .263            | 1,117.75        |
| 15               |                                  | 200      | 50             | .239            | 59.75           |
| 16               |                                  | 200      | 50             | .218            | 54.50           |
| 17               |                                  | 200      | 50             | .198            | 49.50           |
| 18               |                                  | 200      | 50             | .180            | 45.00           |
| 19               |                                  | 200      | 50             | .164            | 41.00           |
| 20               |                                  | 200      | 50             | .149            | 37.25           |
| <b>Total NPV</b> |                                  |          |                |                 | <b>9,482.50</b> |

volume situations, provided the water demand is reasonably well matched to the solar energy availability.

\*\*\*\*\*

Wind-powered pumps may produce cheaper water at sites where the average wind speeds during the period of maximum water demand are higher than about 3 m/s (10.8 km/h).

The costs of animal-powered pumps are strongly dependent on the assumptions made regarding capital costs, lifetime, power input, and feeding costs. Hand pumps are similarly dependent on these fac-

tors plus the cost assumed for labor needed to operate them. An important point concerning both animal-powered and hand pumps is that their input powers are limited, and as the lift increases, the flow rate decreases and the pump and borehole need to be replicated. This is particularly important if the borehole is expensive. Borehole costs for deep wells may exceed all other costs.

The final choice of a pumping system should not be based solely on costs. Other factors, such as reliability and ease of maintenance are also important; in these respects, PV-powered pumps offer significant advantages over diesel and hand pumps. Table 8 overviews various costs for wind-powered, animal-powered, and hand pumps.

**Table 8**  
**Cost Data for Wind-Powered, Animal-Powered, and Hand Pumps**

|                                     | Pump Type   |                                       |   |
|-------------------------------------|---|---------------------------------------|---|
|                                     | Wind  | Animal                                | Hand  |
| Hydraulic output rating of one pump | Depends on wind regime                              | 210 W                                 | 36 W  |
| Capital cost of pump                | 330/m <sup>2</sup> of rotor area (1 m < dia < 10 m) | 300/animal = 6.2/W of hydraulic power | 240 to 320 per pump unit = 6.50 to 9/W of hydraulic power |
| Borehole cost (\$)                  | 25 to 75/m  |                                       |   |
| Storage tank cost (\$)              | 100 to 300/m <sup>3</sup>                           |                                       |   |
| Lifetime                            |   |                                       |   |
| - power source                      | 20 to 30 yr   | 10 yr                                 | n/a   |
| - pump                              | 5 to 10 yr  | 10 to 15 yr                           | 5 to 10 yr  |
| Maintenance cost (\$)               |   |                                       |   |
| - per year                          | 50  | 10                                    | 50  |
| - per 1000 h                        | 6   | —                                     | —   |
| Operating time (h/day)              | up to 24  | 5 to 8                                | 6 to 8  |
| Operating cost (\$)                 | —   | 2.5/animal-day                        | 1 per man-day   |



## 5.0 Preparing a Request for Proposal

The proposed water-pumping site has now been evaluated, and both water needs and the power required to produce that water have been determined. How to estimate the costs of a PV-powered water-pumping installation and how to make economic comparisons between PV-powered and competing systems have been discussed. If a PV-powered system is best for your application, the next step is to begin the procurement process.

Buying the components from individual vendors and assembling them on-site to your own design specifications can be a problem. The difficulties of proper design, installation, and checkout, coupled with the difficulty of securing a system warranty, may make purchasing a system on a component level inadvisable except for the most knowledgeable and experienced users.

The choices are two: (1) purchase a total system designed by a qualified vendor and have it installed and checked out for you or (2) perform the installation and test of a vendor-designed and supplied system yourself. The first of these choices, the turnkey system, is recommended for agencies with limited experience in PV pumping applications. Although capital costs for a turnkey system can be higher than for a customer-installed system, these additional costs can be more than offset by the guarantee of a properly installed and operational system. If the turnkey option is chosen, a training session is a good option to be included as a proposal requirement, so that your agency can acquire the expertise to install this type of system in the future.

In either case a performance specification must be prepared that requires design calculations and performance guarantees. This technical specification is a critical component in procuring the system. We recommend using the local standard procurement practices along with the technical specifications for the PV-powered pumping system.

### Preparing a Technical Specification

The technical specification, combined with standard procurement requirements and terms, must be stated. Since the bidders' designs are based on this specification, you should incorporate, **at a minimum**, the following information:

- Daily water needs (on a monthly basis) and use of the water
- Type and quality of water source
- Static water level
- Drawdown (water level in the well) as a function of flow rate
- Height (or pressure) of the storage tanks and the type of tanks used
- Type, length, and diameter of required pipework
- Average monthly insolation data (over a 1-year period) for the site
- Average monthly temperature data (over a 1-year period) for the site
- Soil conditions (used to determine the optimum array and tank foundations)

If any of these data are unavailable to you, it should be specifically stated, along with instructions to bidders regarding the assumptions they are to make regarding the missing data. Also, include any other data you might have for the site. Occasionally, an apparently unrelated item of information may provide the bidders with the means to offer a more cost-effective system. As much information as possible regarding environmental conditions should be listed, including average and extreme values of ambient air temperature, relative humidity, wind speed, water temperature, and water quality (physical and chemical). The possibility of sand storms, hurricane winds, and other environmental extremes should be mentioned.

Remember, though, not to include design choices or equipment selections in the specification. Doing so will compromise the buyer's position should the unit fail to produce the required water output. Instead, the

technical specification should specify required performance only.

**Scope of Work** — The specification should include details of any special requirements for packing for shipment, documentation, and insurance until the system is delivered to the purchaser.

A list should be given of the work and services to be carried out by others, for example, clearance through customs, transport to the site, construction of foundations, erection and system startup, operation, and routine maintenance.

Bidders should be required to specifically state any assumptions and deviations from the specification in their design analysis.

**Acceptance Test** — **The best protection for the buyer is to include an acceptance test in the specifications so that the bidder knows final payment will not be made unless the equipment passes the test.**

The acceptance test is of utmost importance and should be designed with care because the output of a PV-powered pumping system is heavily dependent upon many variables, including weather conditions, ambient temperature, and time of year. Further, the output of most PV-powered pumping systems is nonlinear: a drop in the level of solar radiation leads to a disproportionately greater drop in the amount of water being pumped. For these reasons, the acceptance test should consist of a series of measurements of pump water output as a function of irradiance level and temperature to determine system performance under the various conditions that will be encountered.

**Qualified Bidders** — After including the acceptance test in the technical specification, the next greatest protection is to buy the unit from a bidder who is active in the field. These manufacturers supply systems that work. It is unwise to buy a system from a manufacturer of limited experience—such manufacturers do not yet understand what level of experience is needed to make the proper choices in designing a PV-powered pumping system. Including criteria to qualify bidders will guard against inexperienced bidders. Buyers should follow the old adage, “Ask the person who owns one.”

Bidders should be required to complete a

questionnaire to demonstrate their experience and resources to meet the requirements of the project. The questionnaire should cover such matters as experience in PV-pumping technology and recommended maintenance requirements.

**Warranty and Spare Parts** — The buyer should require a full-coverage warranty for a period of time sufficient to assess the pumping system’s acceptable performance. Typically, this period is 1 year, but the period can be negotiated. Warranties up to 5 years are common.

Buyers should also request separate cost information for an extended warranty period of an additional 2 to 5 years, at least. This will allow the buyer to evaluate the cost of the warranty separately.

The supplier should be asked to include a list of required tools and spare parts for the extended warranty period, plus extra numbers of small items that may be lost during installation or maintenance (e.g., nuts, bolts, cable clamps, etc.).

The supplier should also be asked to detail in his proposal the warranty period and technical support after installation, including manuals. Especially important to warranty service is the availability of service within the region, or at least in a timely fashion.

**Price and Delivery** — The bidder should complete a schedule of prices covering the main items, including the design, manufacture, and testing of the complete system; transportation of materials from the factory to the point of delivery; spare parts and tools; preparation of documentation, transportation, and labor for turnkey installations; and any other items. The currency and terms of payment may be specified or left open for the supplier to complete. The supplier should also state the delivery period.

**Evaluating Responses (Optional Recommendations)** — Each proposal received should be checked to ensure that the system offered is complete, that it can be delivered within the maximum delivery period, and that an acceptable warranty can be provided.

**Detailed Assessment** — The proposals that satisfy the preliminary evaluation should then

be assessed in detail under the following four headings, with approximately equal importance being attached to each:

**1. Compliance with the Specification.** The performance of the proposed system should be carefully assessed to ensure that it meets the requirements of the specification. Justification for any deviations should be carefully evaluated.

**2. System Design.** The suitability of the system for the intended use should be assessed, taking into account such matters as ease of operation and maintenance, general complexity, reliability, safety features, lifetime of individual components and parts subject to wear and tear, etc. The adequacy of the supporting documentation should also be consid-

ered. Emphasis should be placed on the field reliability of the system design being proposed, since this can significantly impact the long-term success of the water pumping project.

**3. Capital and Life Cycle Costs.** Besides comparing systems on the basis of initial capital cost, a comparison should be made using life cycle costing, based on maintenance and repair costs incurred during the life of the system.

**4. Overall Credibility of Supplier.** The experience and resources of the supplier relevant to PV-powered pumping technology in developing countries should be assessed, together with the proposals for warranty, after-sales service, training, and documentation.

## Bibliography

1. "Small-Scale Solar-Powered 8. Irrigation Pumping Systems: Phase I Project Report," Sir William Halcrow & Partners in association with Intermediate Technology Development Group Ltd., World Bank, July 1981.
  2. "Small-Scale Solar-Powered Irrigation Pumping Systems: Technical and Economic Review," Sir William Halcrow & Partners in association with Intermediate Technology Development Group Ltd., World Bank, September 1981.
  3. "Small-Scale Solar-Powered Pumping Systems: The Technology, Its Economics and Advancement" (Report prepared for World Bank under UNDP Project GL0/80/003). Halcrow/ I. T. Power, World Bank, June 1983.
  4. "Solar Water Pumping - A Handbook," J. P. Kenna and W. B. Gillett, I. T. Publications, London, 1985.
  5. "Village Water Supply," WorldBank, Washington, DC, 1976.
  6. "Small Community Water Supplies: Technology of Small Water Supply Systems in 15. Developing Countries," I. R. C., The Hague, August 1981.
  7. "Wind Technology Assessment Study" (for UNDP/World Bank Project GL0/80/003). I. T. Power Ltd., February 1983.
  8. "Crop Water Requirements," J. Doorenbos and W. O. Praitt, FAO, Rome, 1977.
  9. "Community Water Supply and Sewage Disposal in Developing Countries," World Health Statistics, Vol. 26, No. 11, 1973.
  10. "Small Scale Irrigation," P. H. Stern, I. T. Publications, 1980.
  11. "Evaluating the Technical and Economic Performance of Photovoltaic Pumping Systems: A Methodology" (Prepared for USAID, Africa Bureau), I. T. Power, Washington, DC, 1985.
  12. "Field Performance of Diesel Pumps and Their Relative Economics with Windpumps," I. T. Power, Reading, UK, 1985.
  13. "A Guide to the Photovoltaic Revolution," P. D. Maycock and E. N. Shirewalt, Rodale Press, Emmaus, PA, 1985.
  14. Meridian Report on Evaluation of International Photovoltaic Projects, 1986, SAND85-7018, Sept. 1986.
  15. "Solar Pumping Update, 1986," World Bank and I. T. Power, Inc.
-

## **List of Manufacturers**

For the most recent and comprehensive list of U.S. manufacturers, distributors, and suppliers, see:

“The Solar Source Book”

“Solar Electricity: A Directory of the U.S. Photovoltaic Industry”

Copies of these documents are available from Linda Ladas, Solar Energy Industries Association, 1732 North Lynn Street, Suite 610, Arlington, VA 22209, U.S.A. Telephone (703) 524-6100.

---



# Appendix A

## Insolation Availability

The following charts are included for use when information regarding local insolation is not available. It is suggested that prior to using these charts, in-country meteorological stations, universities, government ministries or other information depositories be contacted to determine if they have more complete or accurate data.

The seasons mentioned in the titles for each chart (spring, summer, autumn and

winter) are those for the northern hemisphere. In the southern hemisphere, the seasons will be reversed. Also, the tilt angle, defined as the angle at which a PV array is raised from the horizontal in order to capture the sun's rays, is measured with the array pointing south in the northern hemisphere and with the array pointing north in the southern hemisphere.

Figure A-1. Insolation Availability (Latitude + 15° Tilt, Winter)

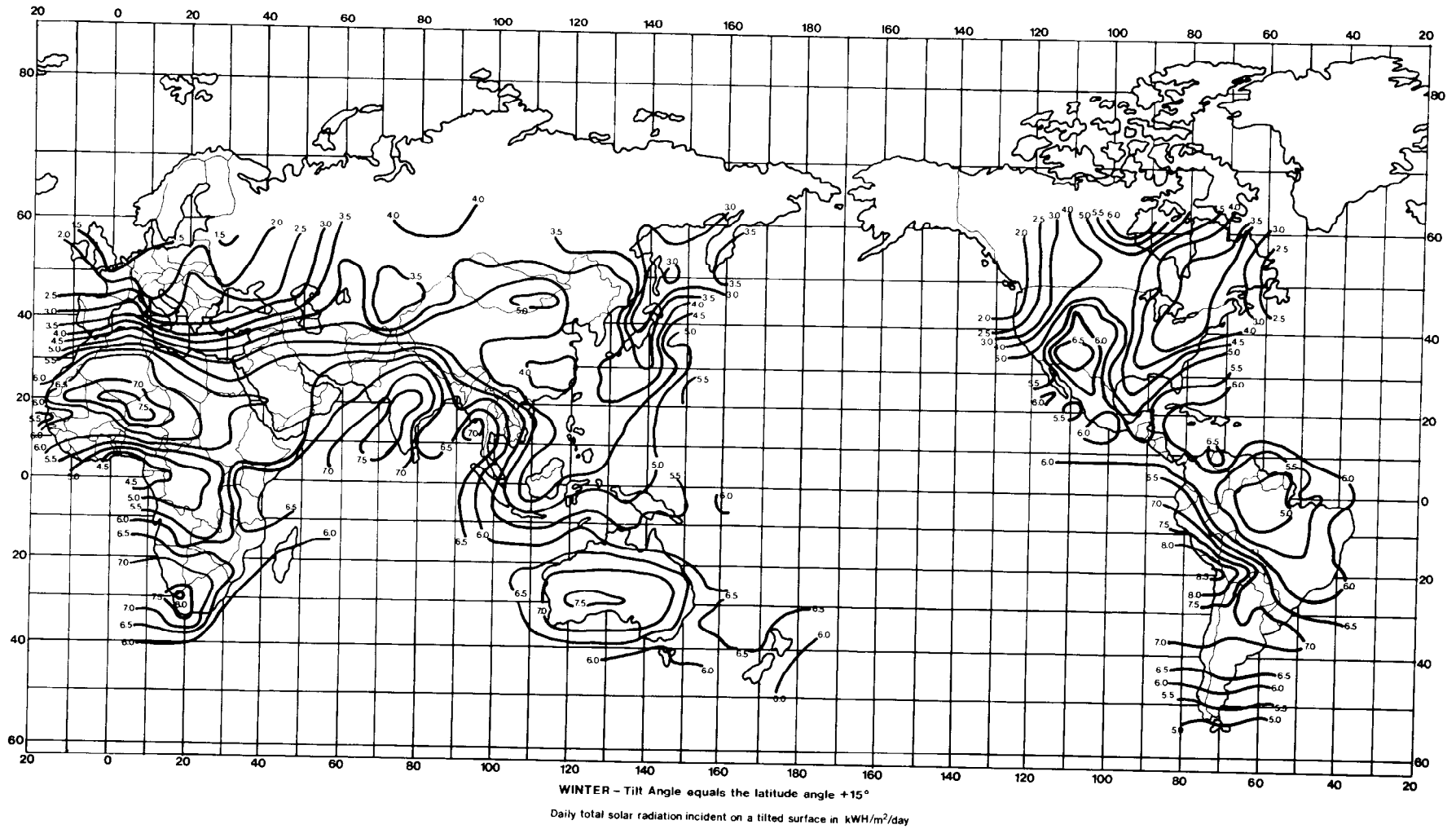



Figure A-2: Insolation Availability (Latitude + 15° Tilt, Summer)

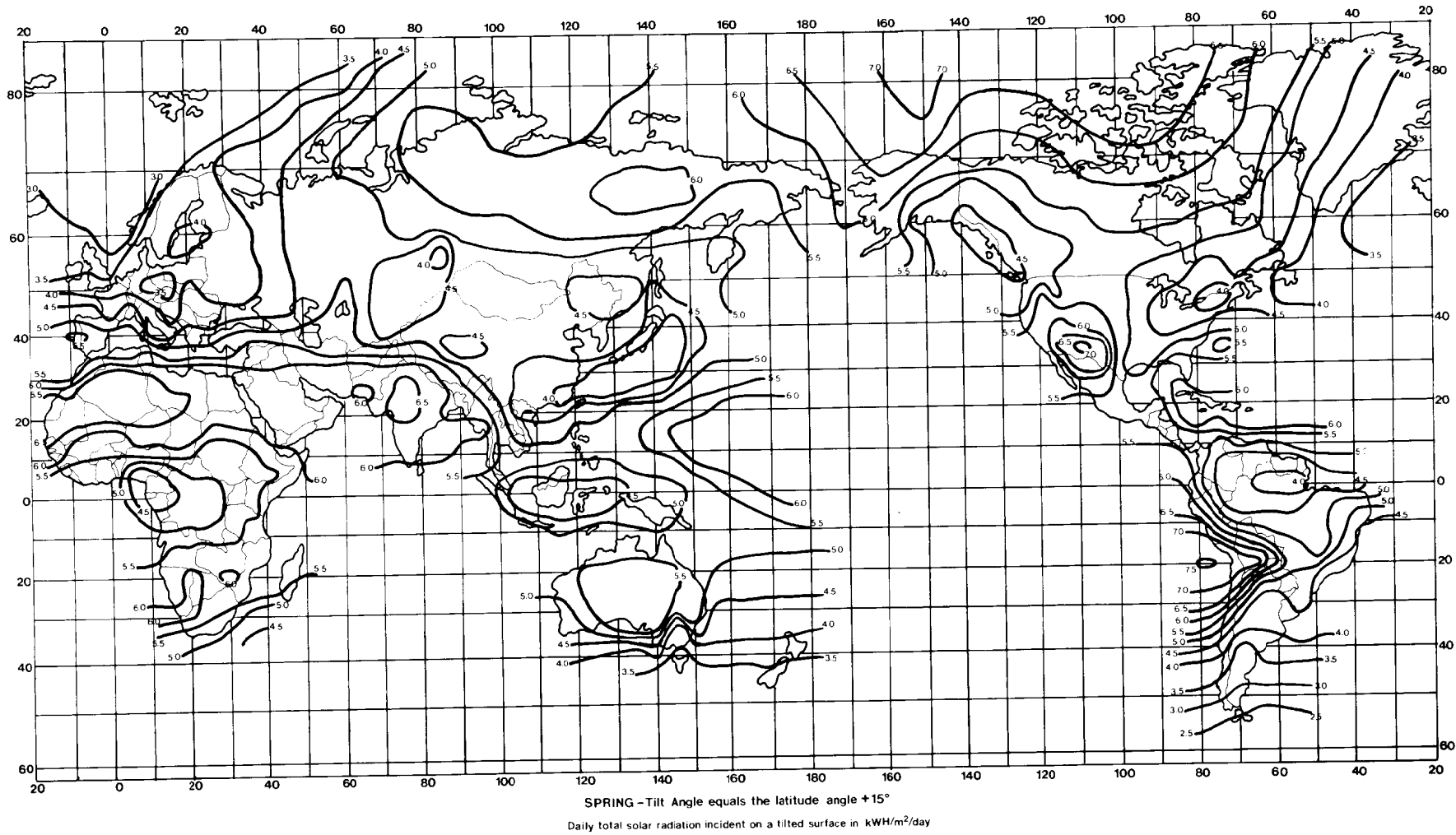

Figure A-3. Insolation Availability (Latitude + 15° Tilt, Summer)

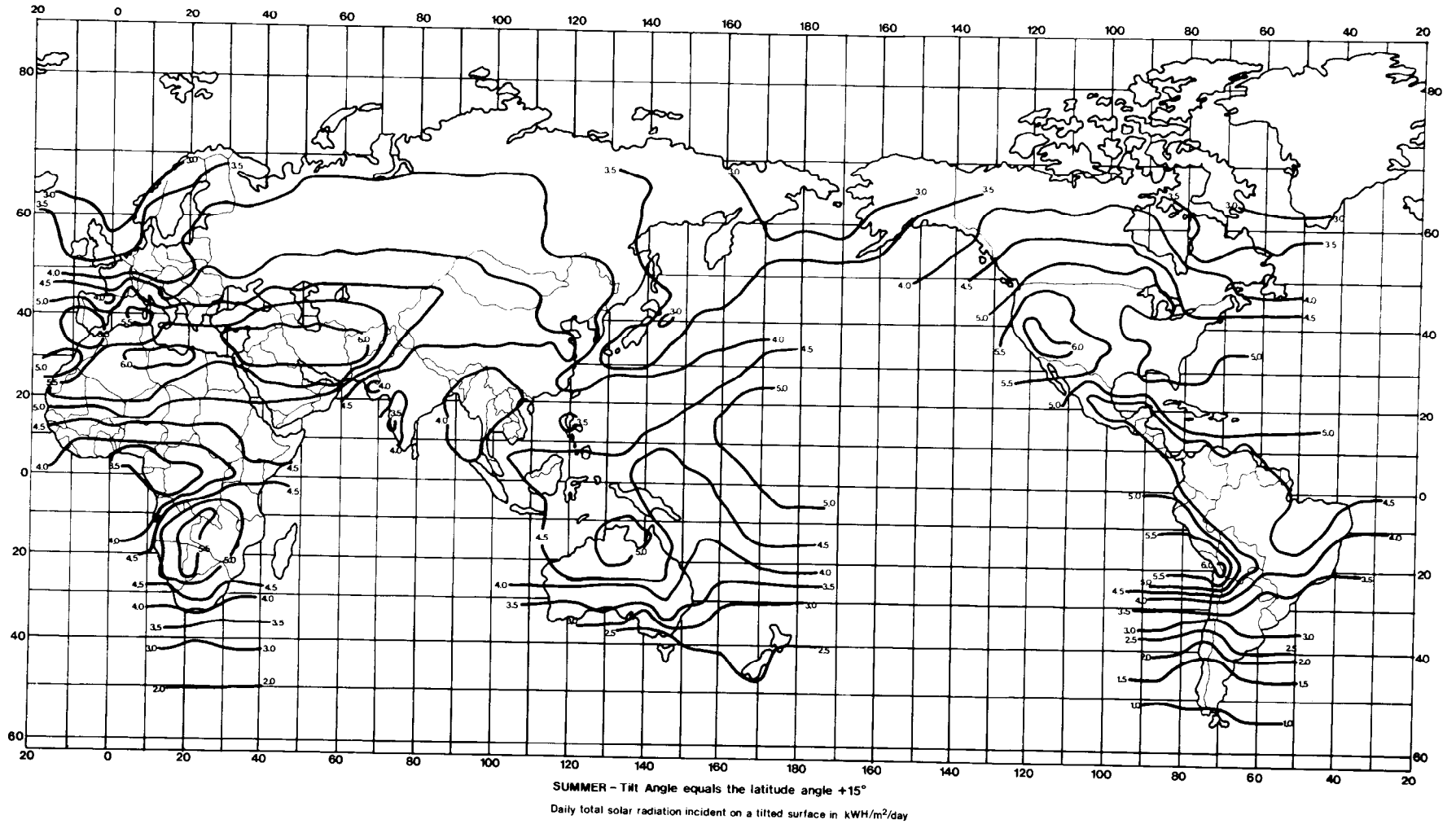

Figure A-4. Insolation Availability (Latitude + 15° Tilt, Autumn)

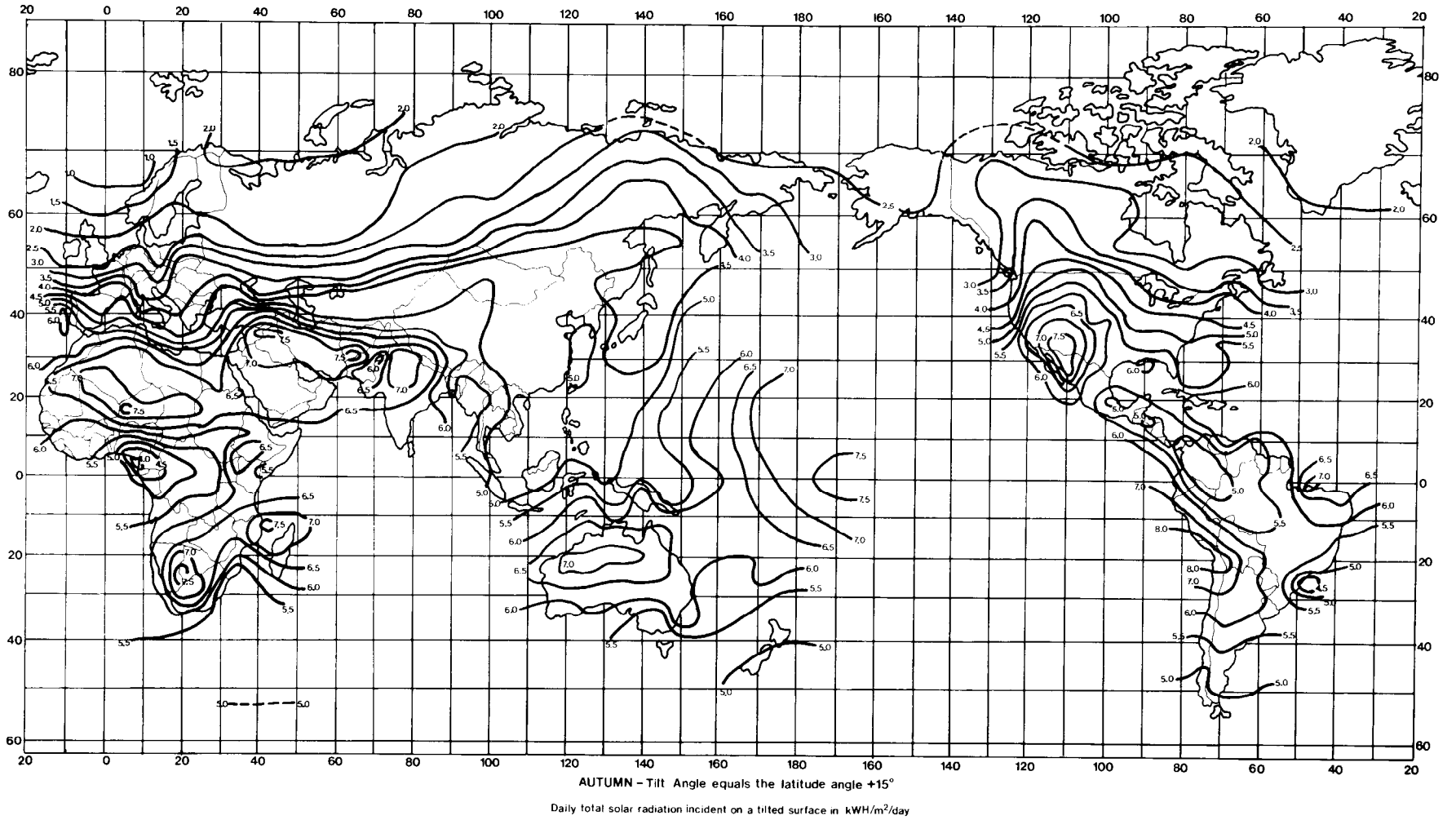

Figure A-5. Insolation Availability (Latitude Tilt, Winter)

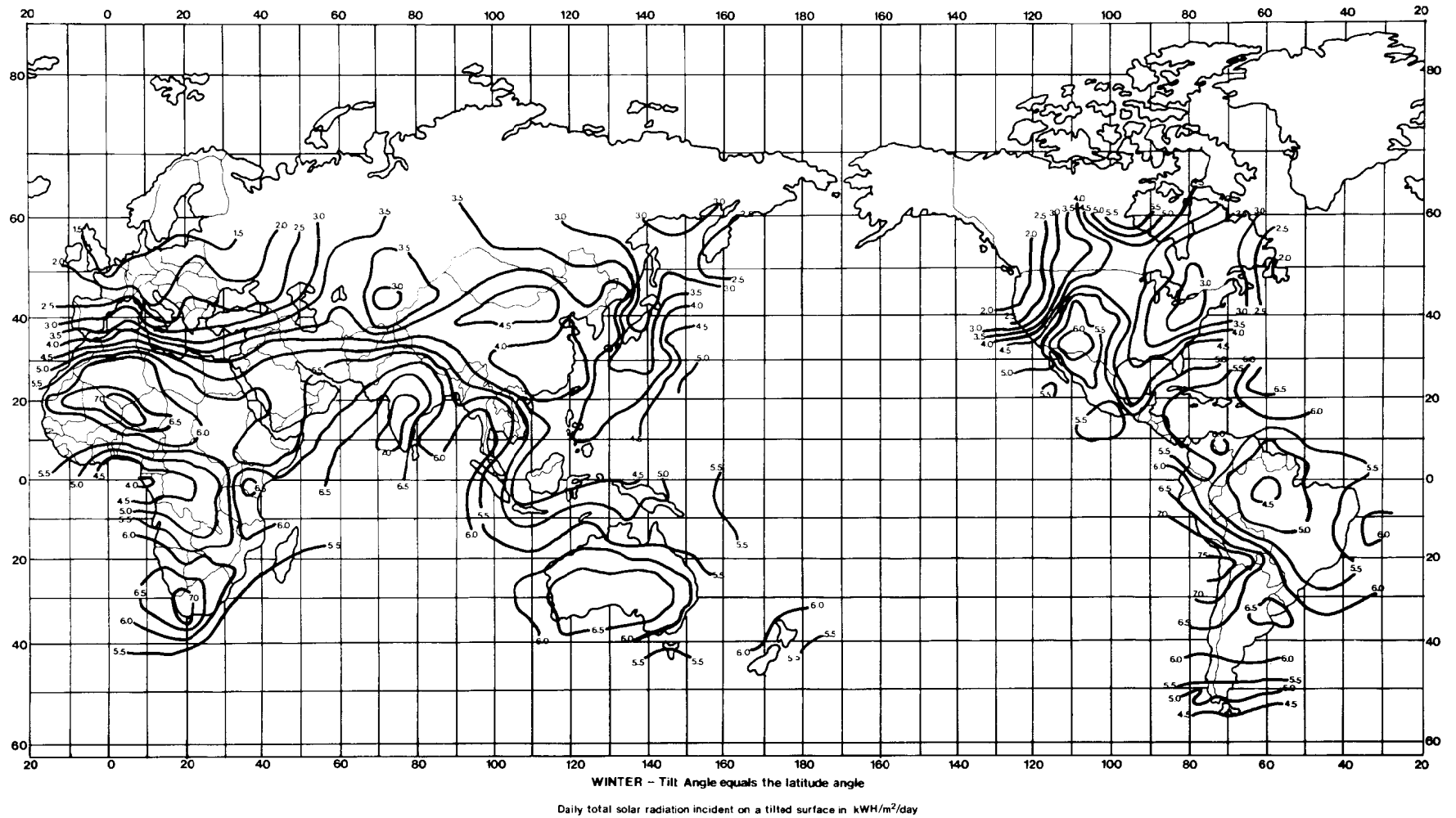

Figure A-6. Insolation Availability (Latitude Tilt, Spring)

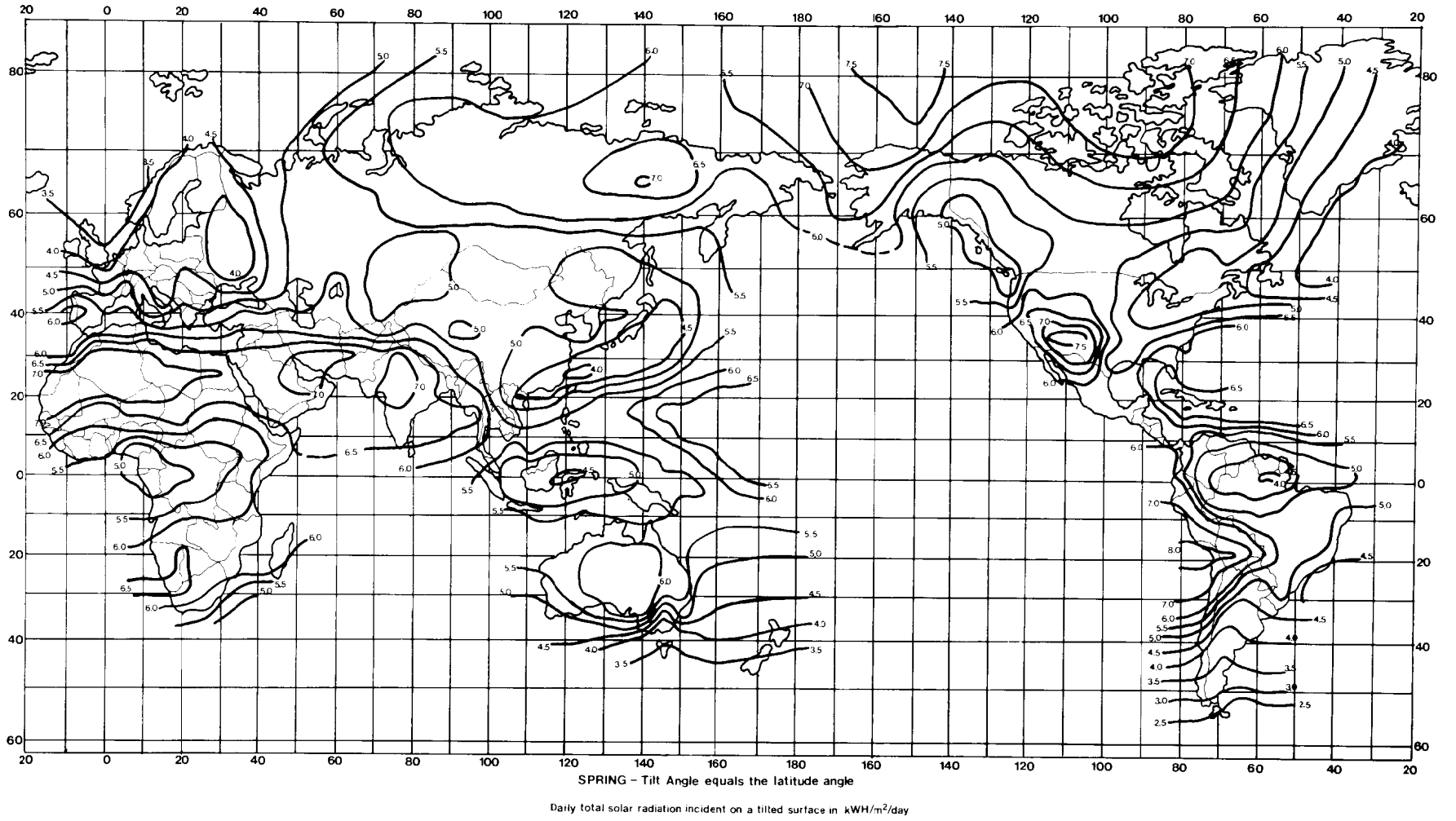

Figure A-7. Insolation Availability (Latitude Tilt, Summer)

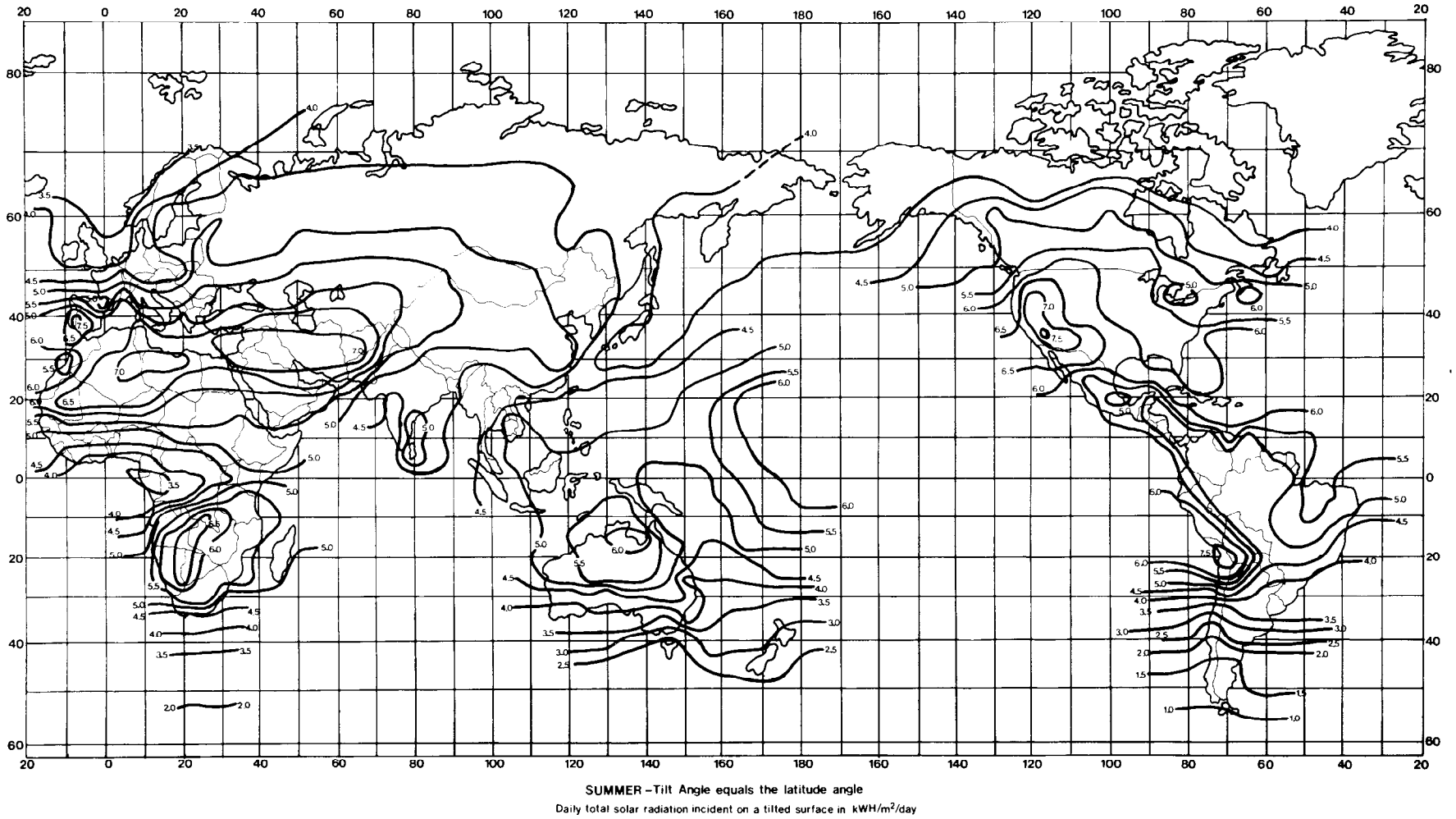

Figure A-8: Insolation Availability (Latitude Tilt, Autumn)

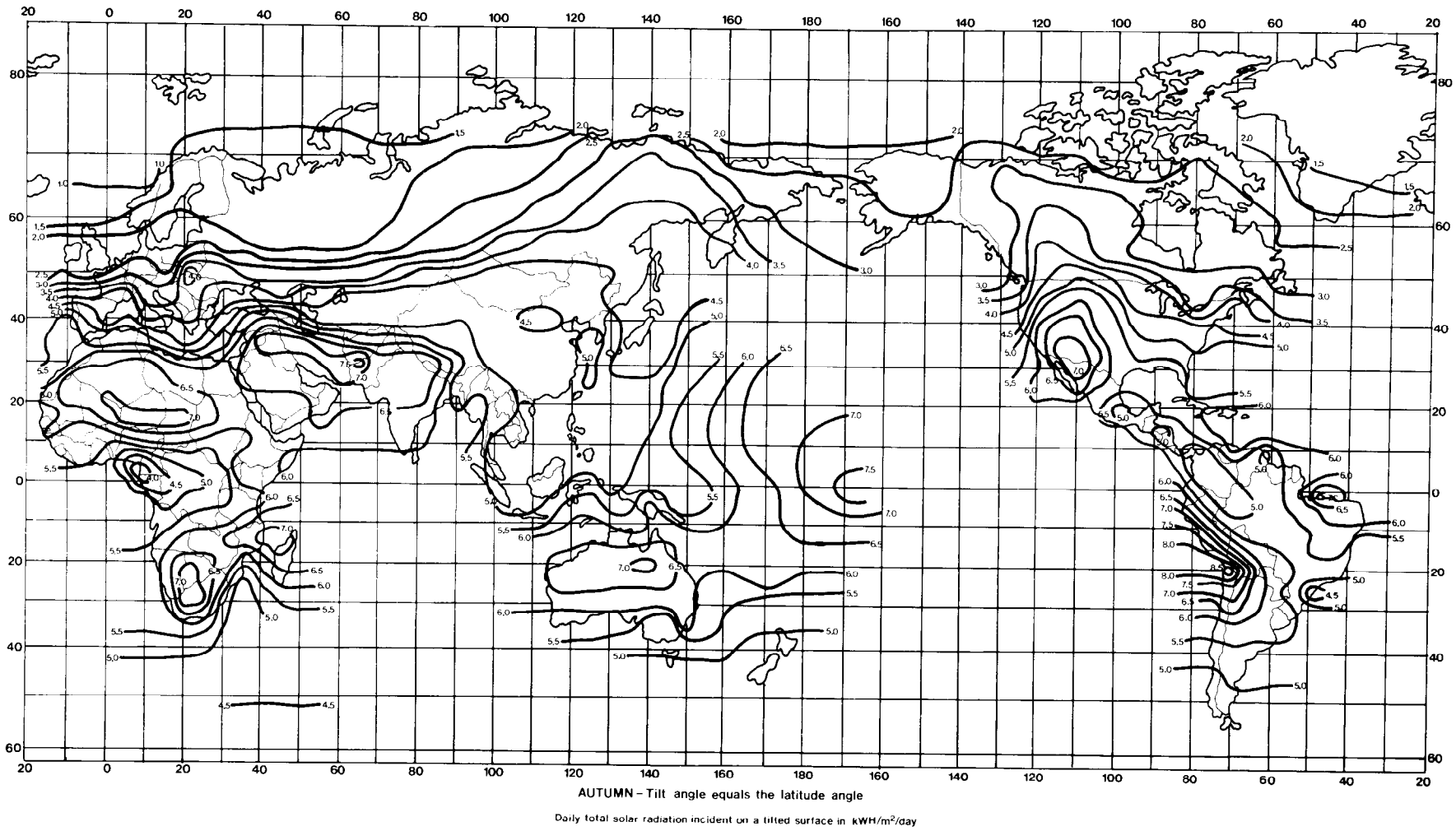

Figure A-9. Insolation Availability (Latitude -15° Tilt, Winter)

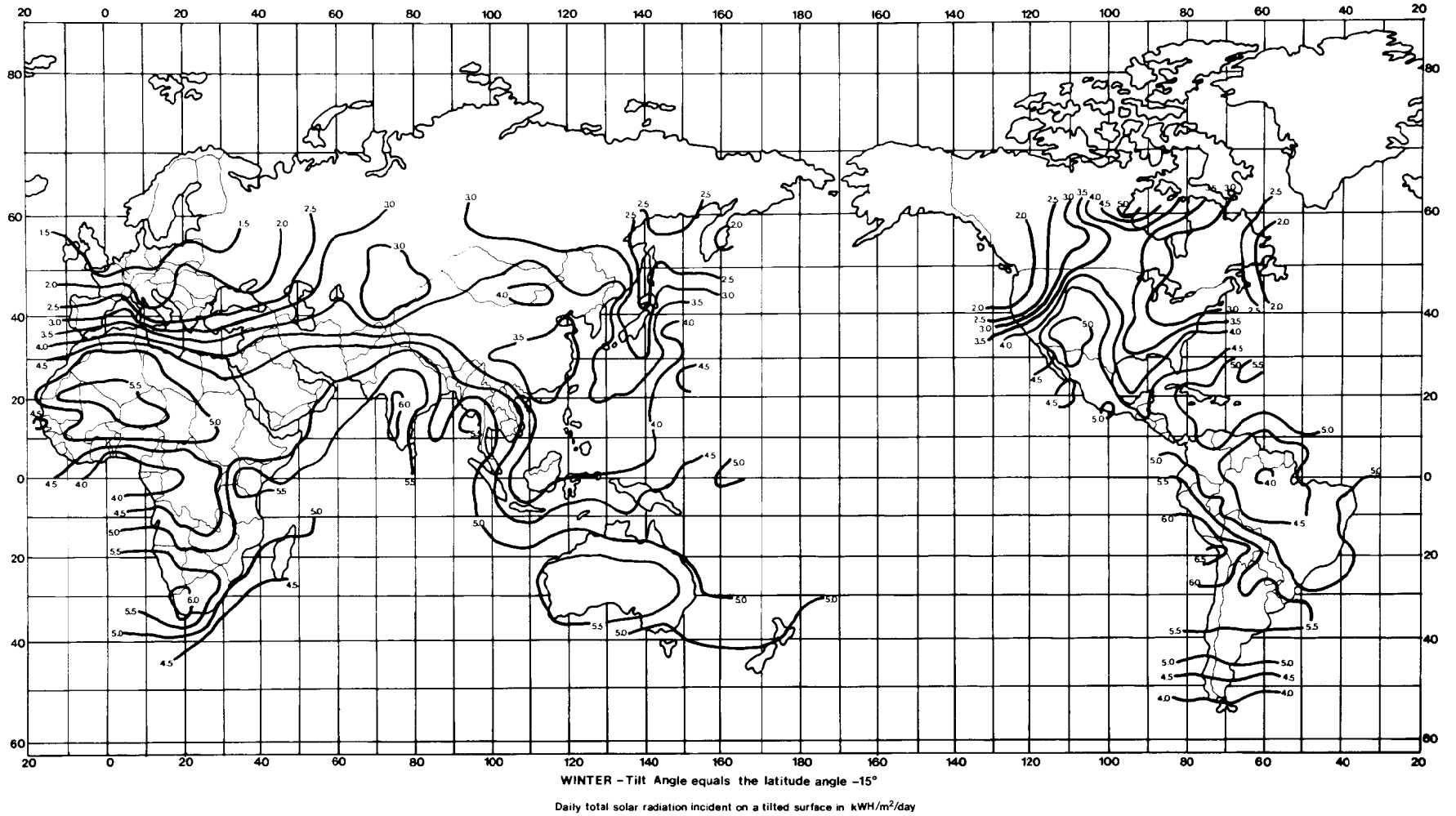



Figure A-10. Insolation Availability (Latitude - 15° Tilt, Spring)

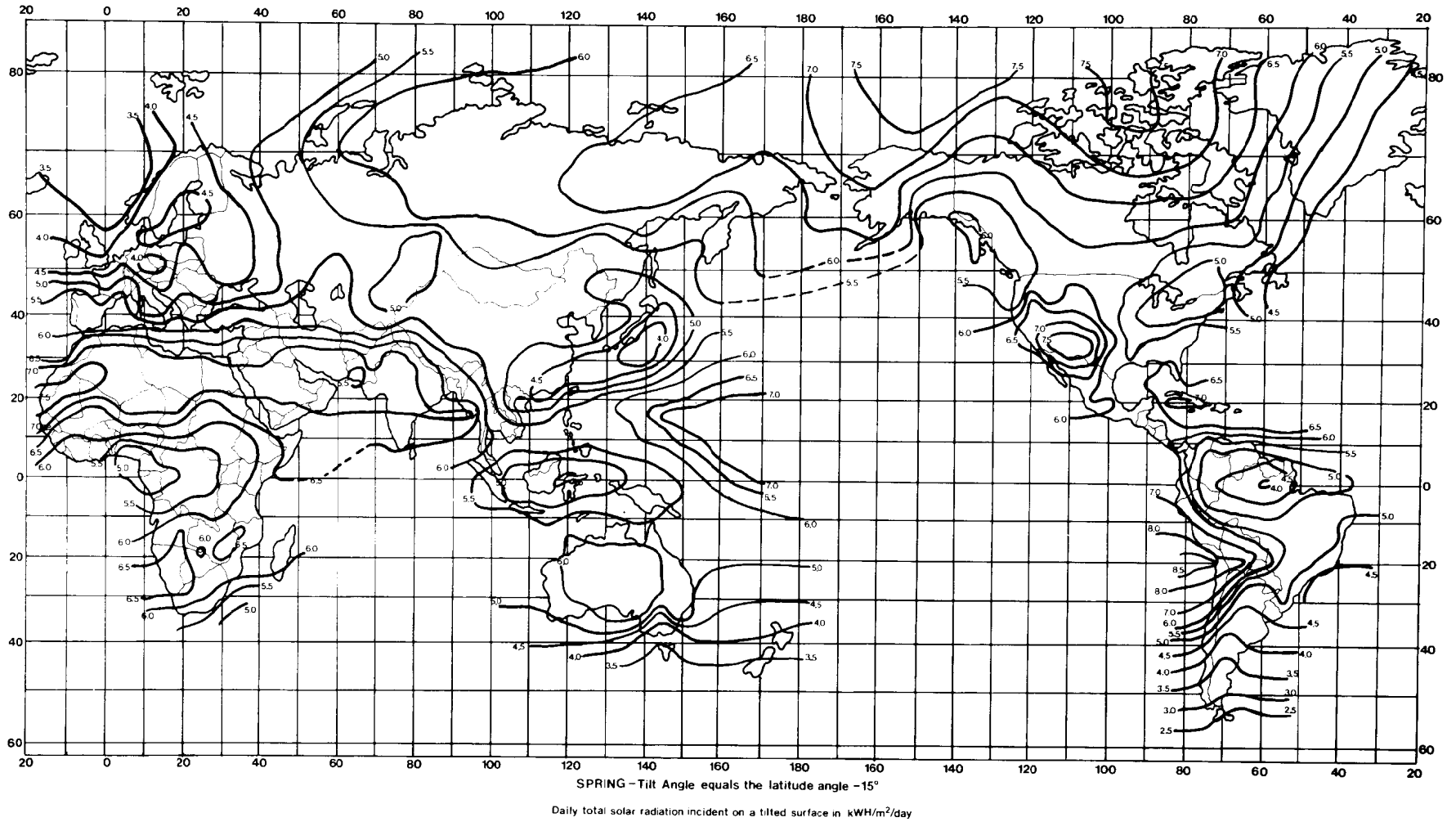

Figure A-11. Insolation Availability (Latitude -15° Tilt, Summer)

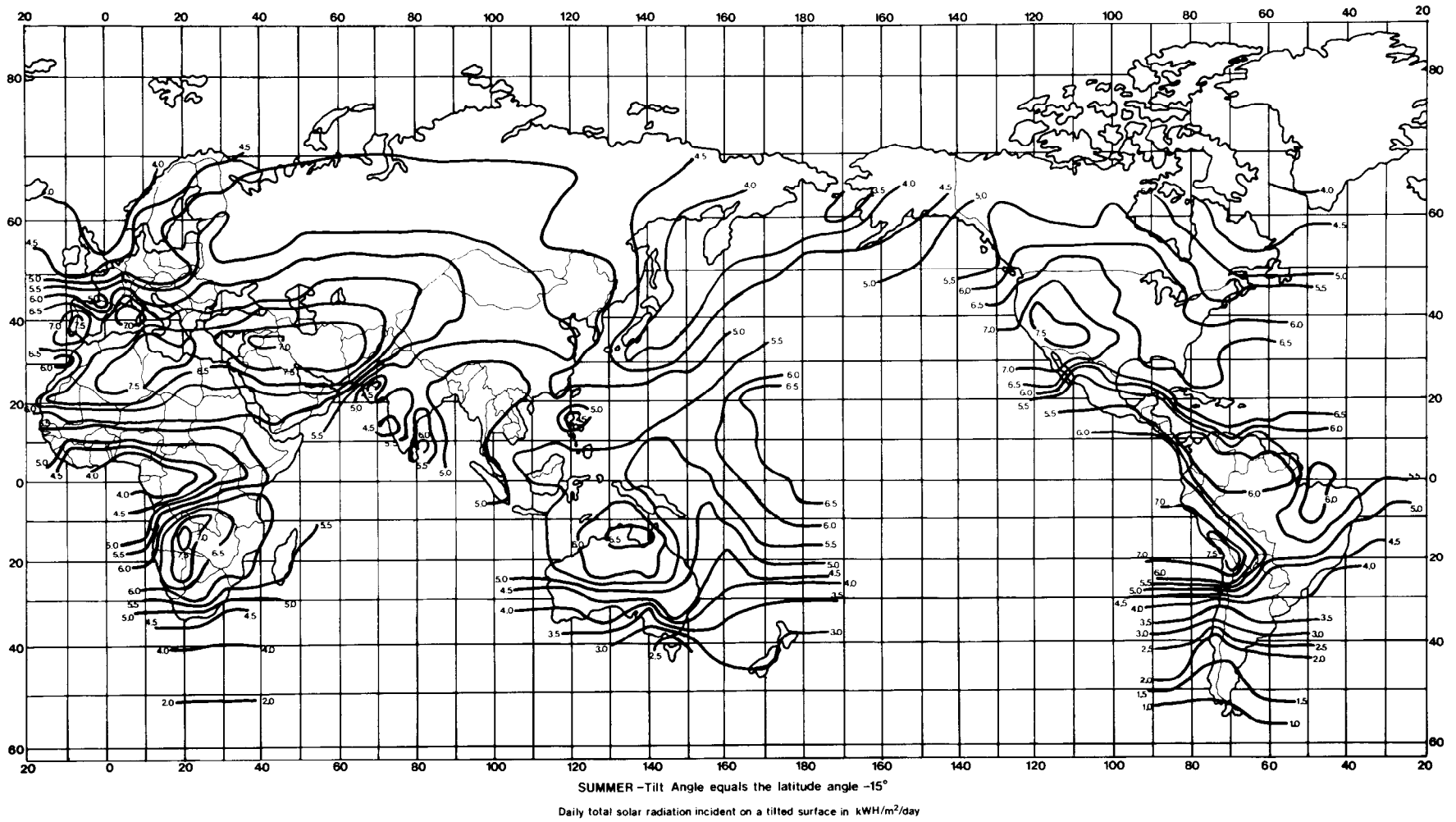
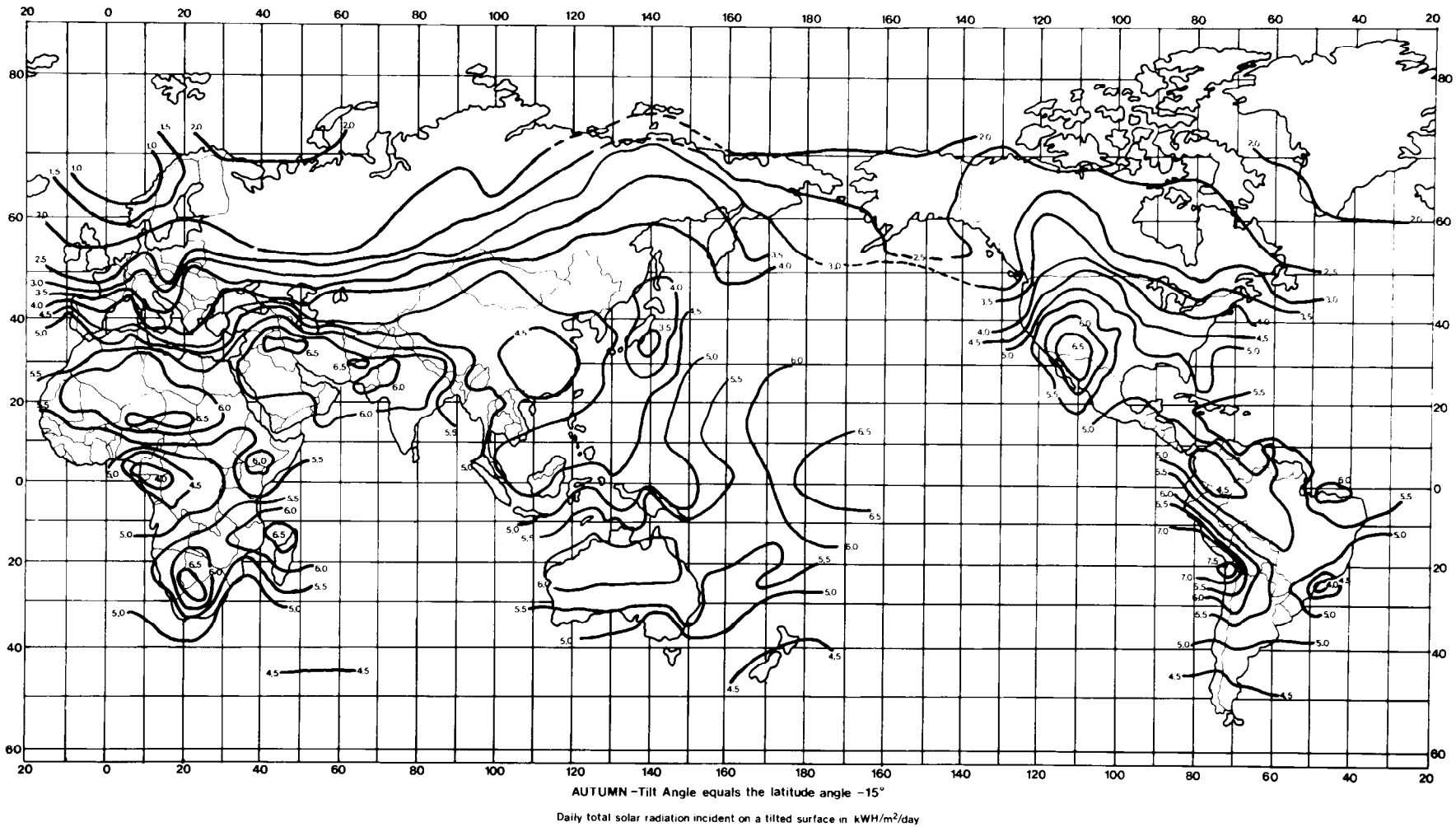

Figure A-12. Insolation Availability (Latitude +15° Tilt, Autumn)





# Appendix B

## Simple Calculations of System Sizing, Equipment Selection, and Cost Evaluation

A typical case is shown for the sample calculations. The following assumptions were made:

1. Flow & Head:

| Season | Required Daily Flow (m <sup>3</sup> /day) | total Dynamic Head (m) | Average Ambient Temperature (°C) |
|--------|---|------------------------|----------------------------------|
| Spring | 11  | 12                     | 24                               |
| Summer | 22  | 15                     | 36                               |
| Autumn | 18  | 15                     | 30                               |
| Winter | 15  | 12                     | 14                               |

2. Location: Phoenix, Arizona
3. Array tilt angle: latitude -15°
4. Discount rate: 7.5% per annum

Step 1: Determine whether pump is centrifugal or volumetric from Figure 13, p. 24. From the figure it is seen that the pump will be of the centrifugal type.

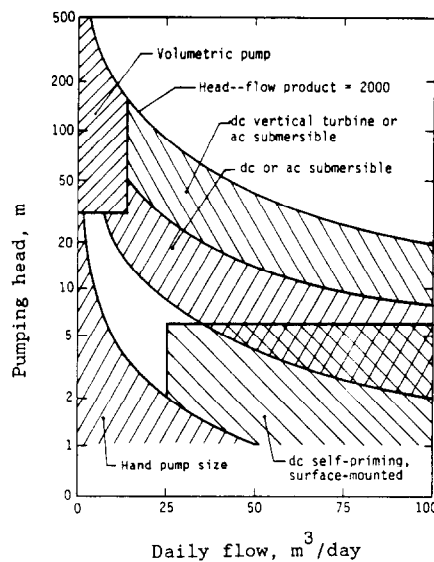

Pumpset Type vs. Pumping Regime

Step 2: Calculate hydraulic load and motor input energy from Figure 7, p. 17. This shows the following:

| Season | Daily Hydraulic Energy<br>(watt-hours/day) | Motor Input Energy<br>(watt-hours/day) |
|--------|--|--|
| Spring | 360  | 1030                                   |
| Summer | 900  | 2570                                   |
| Autumn | 740  | 2100                                   |
| Winter | 490  | 1400                                   |

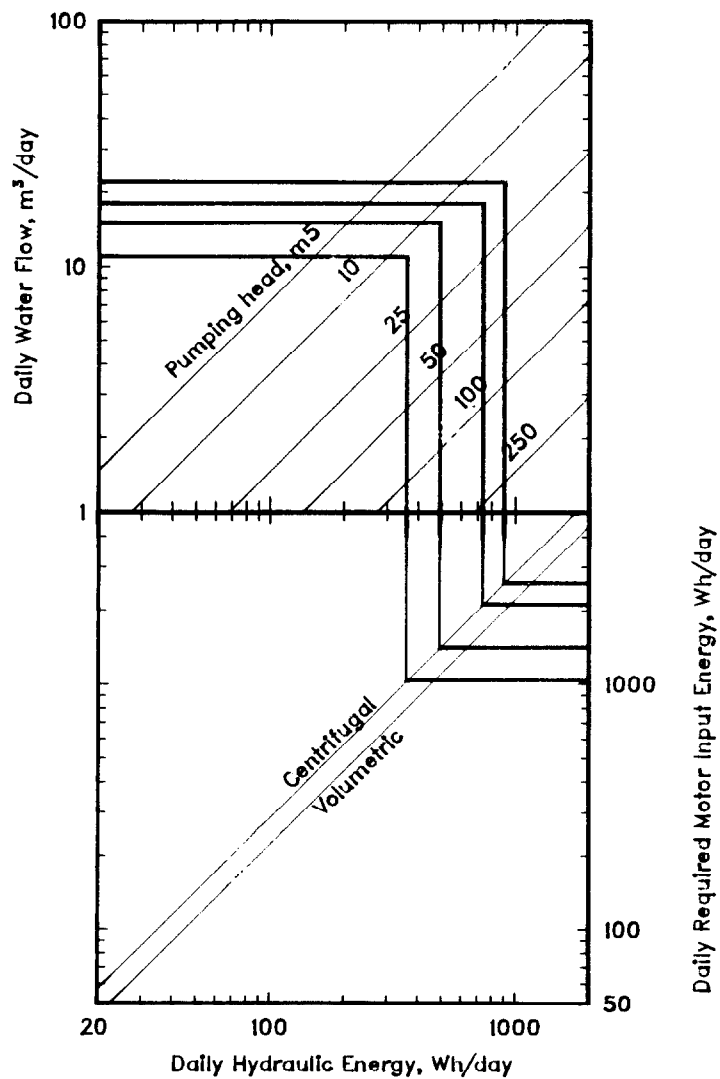

Nomograph of Hydraulic Energy

Step 3: Determine insolation from Appendix A charts. Tilt angle equals latitude -15 deg. This shows the following:

| Season | Insolation<br>kW/m <sup>2</sup> /day |
|--------|--------------------------------------|
| Spring | 7.5                                  |
| Summer | 7.5                                  |
| Autumn | 6.5                                  |
| Winter | 4.6                                  |

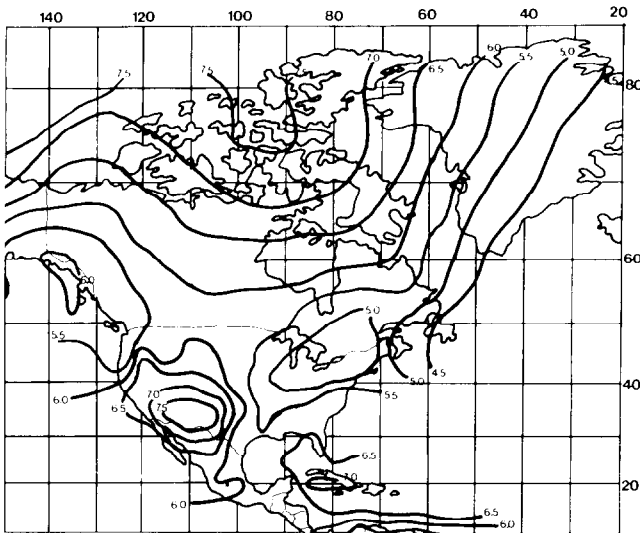

**SPRING**

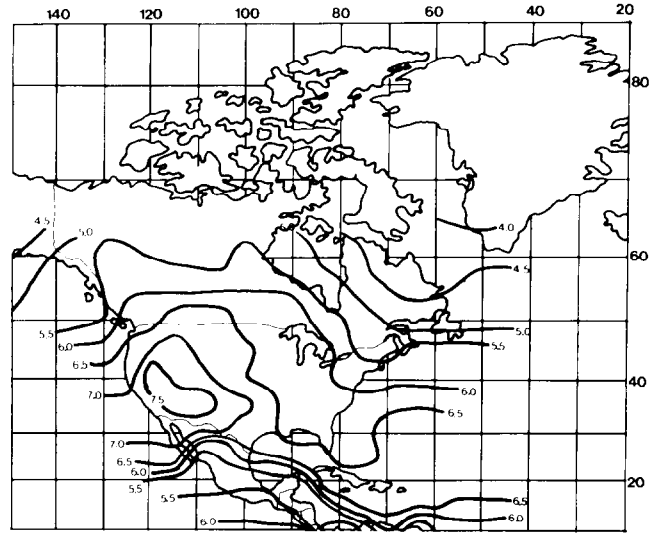

**SUMMER**

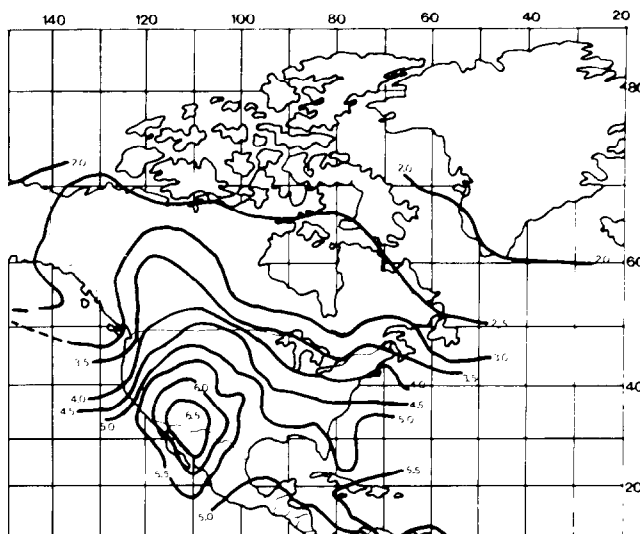

**AUTUMN**

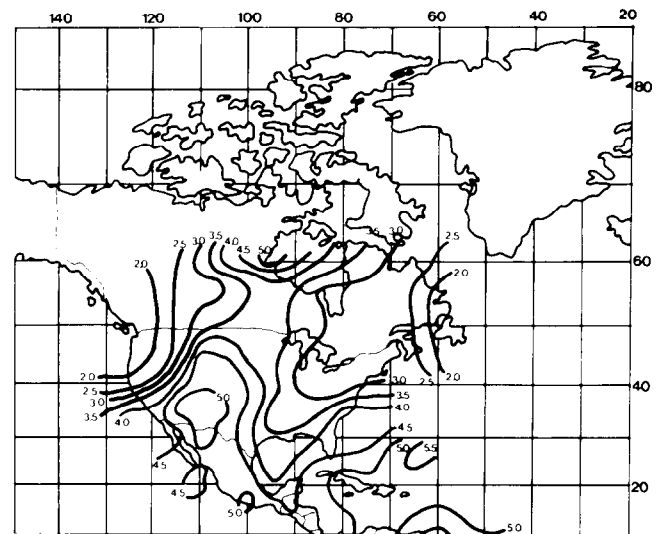

**WINTER**

Step 4: Determine array power at standard conditions from Figure 8, p. 18. This shows the following:

| Season | Array Power at Standard Conditions* (WATTS-PEAK) |
|--------|--|
| Spring | 150  |
| Summer | 390  |
| Autumn | 360  |
| Winter | 310  |

\* Standard conditions are insolation equal to 100 mW/cm<sup>2</sup> and cell temperature equal to 25° C.

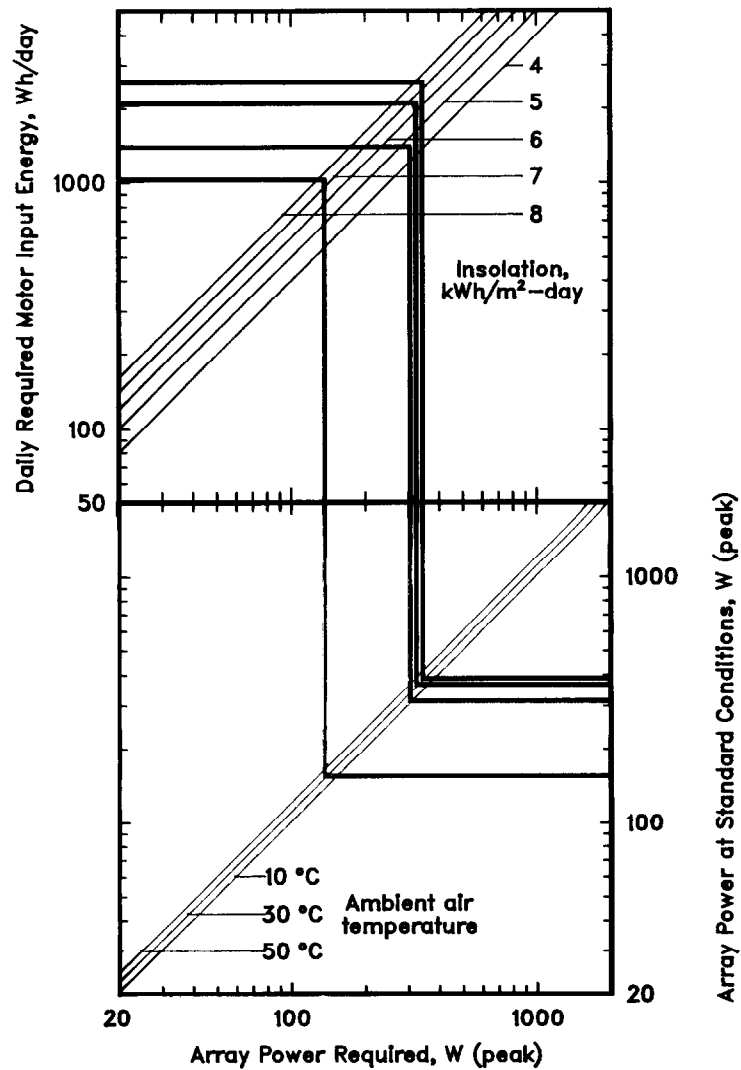

Array Power Nomograph



Step 5: Determine approximately system cost and annualized system cost from the figure below. The system cost exclusive of installation is approximately \$13/watt. This yields an estimated system cost of \$5,070 (exclusive of shipping and installation) and an annualized system cost of \$500/year at 7.5% discount rate.

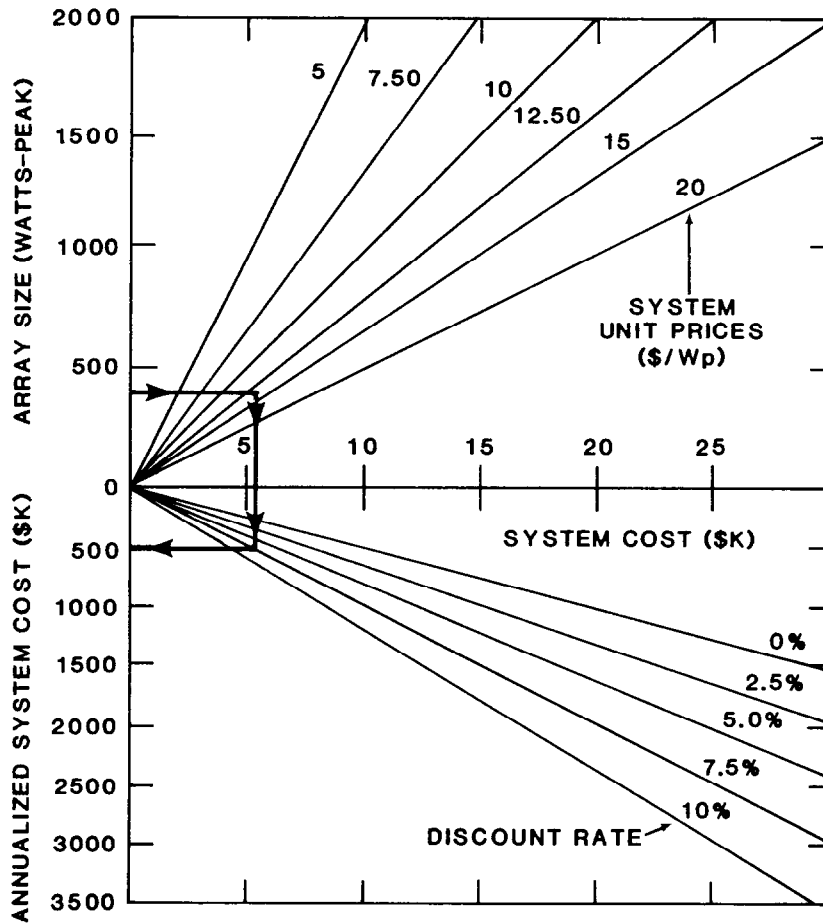

Annualized System Costs for Specified Array Size System Prices and Selection Discount Rates (N = 20 Years)

Summary: Thus, a centrifugal-type pump with an array of 390 watts rated at standard conditions (100 mW/cm<sup>2</sup> insolation with cell temperature equal to 25°C) will meet the flow and head requirements in all seasons. The system's estimated cost, less installation and shipping, will be \$5,070 with an annualized cost of \$500/year at a 7.5% discount rate.



## Printing History

Printed April 1987

Second Printing, September 1987

Third Printing, December 1988

Fourth Printing, November 1989

Fifth Printing, May 1990

Sixth Printing, March 1991

Seventh Printing, January 1992

Eighth Printing, October 1992

Ninth Printing, October 1993

Tenth Printing, August 1994

Eleventh Printing, January 1996