

General Configuration

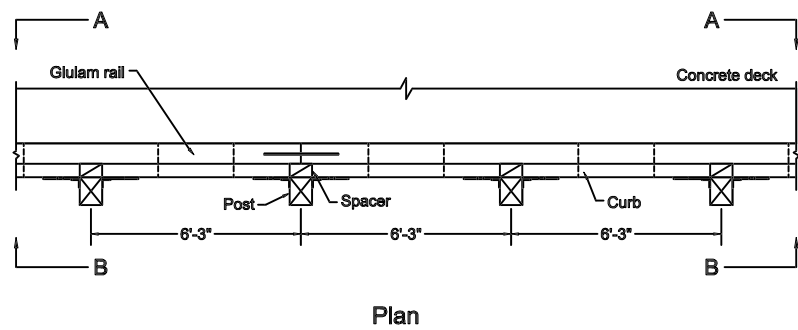

Section A-A

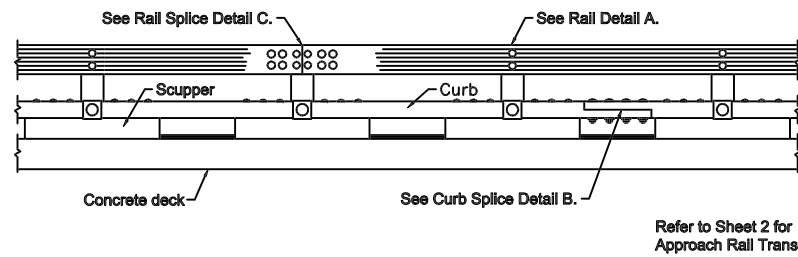

Section B-B

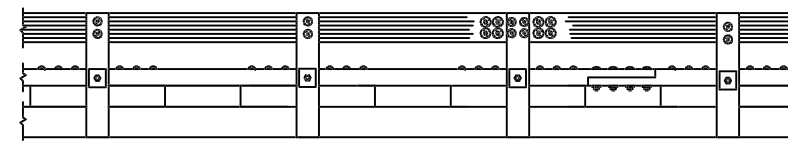

Refer to Sheet 2 for Approach Rail Transition.

A Railing Details

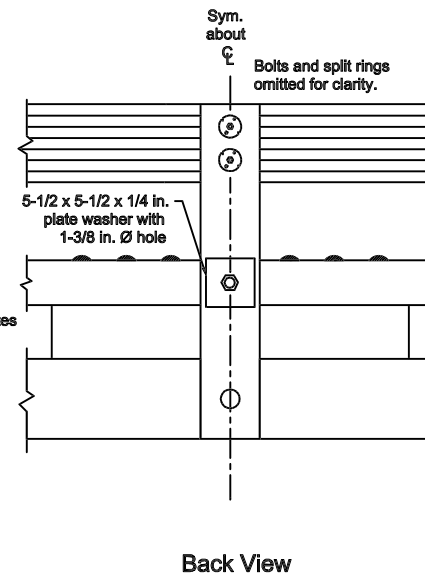
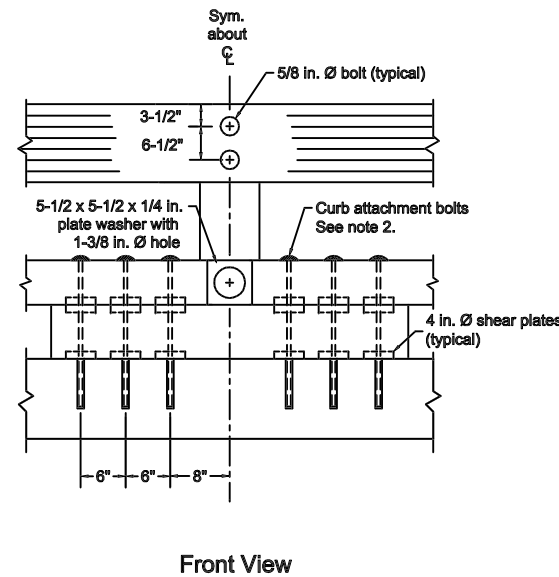
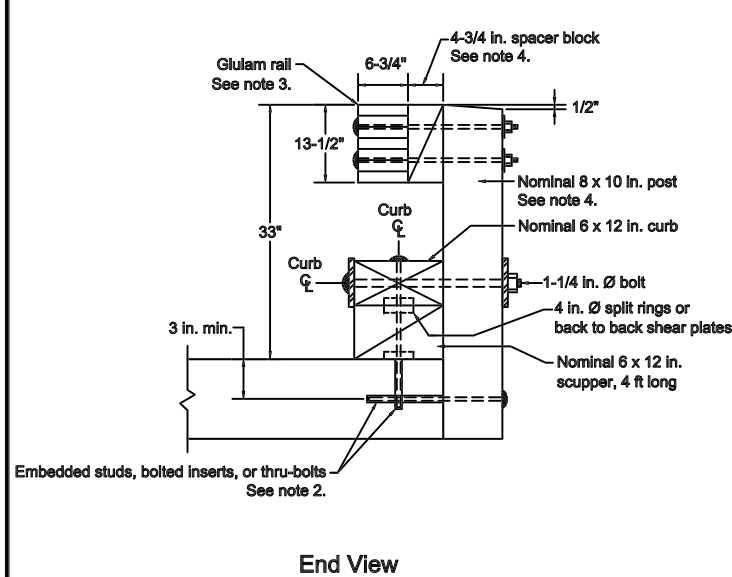

B Curb Splice Detail

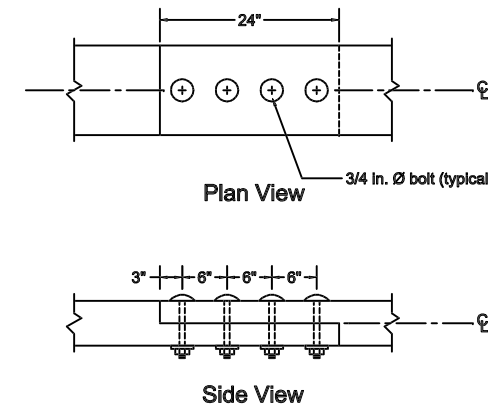

C Rail Splice Details

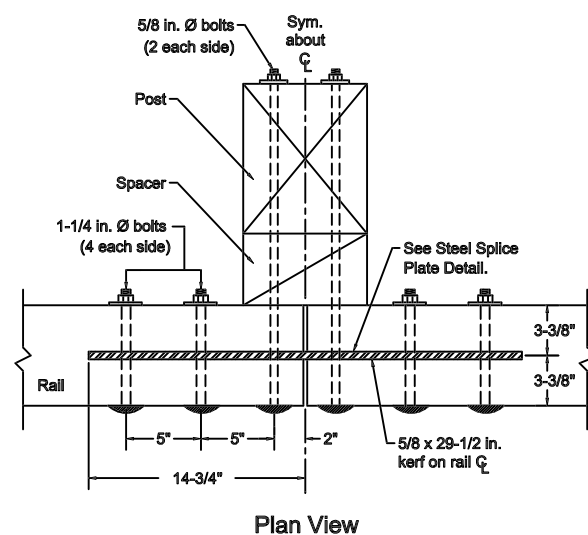
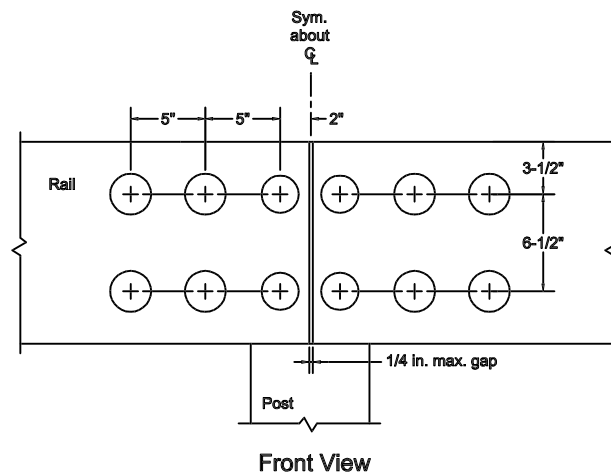

Steel Splice Plate

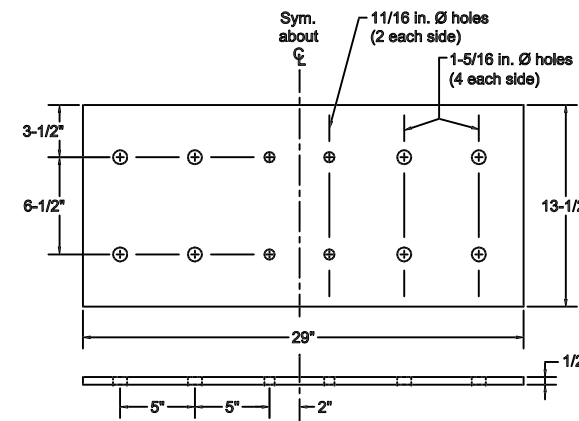

Design

1. This bridge railing was successfully crash tested on a longitudinal wood deck to the requirements for Test Level 4 (TL-4), as outlined in NCHRP Report 350. Adaptation of this railing from a longitudinal wood deck to a concrete deck is based on test measurements and the ultimate capacity of deck attachment hardware.

2. Curb and post connections, such as attachment to the concrete deck, shall be with connections, such as embedded studs, bolted inserts, or thru-bolts. The minimum ultimate shear capacity of each connection shall not be less than 16,000 lb. Internal reinforcement of the concrete shall be designed accordingly to resist these ultimate loads.

3. Dimensions given for glued-laminated (glulam) timber rails are actual dimensions. The depth of the glulam may be increased to a maximum of 13-3/4 in. to allow for other standard glulam sizes. In such cases, detail dimensions shall be verified and modified accordingly.

4. Dimensions for wood posts, curbs, and scuppers are given as nominal dimensions. Actual dimensions may be a maximum of 1/2 in. less than the stated nominal dimensions, depending on material surfacing. Dimensions for spacer block depth are actual dimensions.

5. Curb and rail splices shall be located so that curb and rail members are continuous over not less than two posts. Curb splices shall be located a minimum of 1.5 post spacings away from rail splices. It is recommended that glulam rails be continuous over the length of the bridge.

Materials

6. Sawn lumber and glulam shall comply with the requirements of AASHTO M168 and shall be pressure treated with wood preservative in accordance with AASHTO M133.

7. Bridge rail shall be horizontally laminated glulam, visually graded western species Combination No. 2, or visually graded Southern Pine Combination No. 48. Other species and grades of glulam may be used, provided the minimum tabulated values are not less than the following:
 $F_b = 1,800 \text{ lb/in}^2$ $E = 1,800,000 \text{ lb/in}^2$

8. Posts, curbs, scuppers, and spacer blocks may be sawn lumber or glulam. When sawn lumber is used, material shall be visually graded No. 1 Southern Pine or visually graded No. 1 Douglas Fir-Larch. Glulam and other species and grades of sawn lumber may be used, provided the minimum tabulated values are not less than the following:
 $F_b = 1,350 \text{ lb/in}^2$ $E = 1,500,000 \text{ lb/in}^2$

9. Steel plates and shapes shall comply with the requirements of ASTM A36.

10. Bolts shall comply with ASTM A307 requirements, Grade 2, and should preferably be dome-head timber bolts. Bolts on the rail traffic face shall be dome head.

11. Split rings shall be manufactured from SAE 1010 hot-rolled carbon steel (SAE J412). Shear plates shall be malleable iron manufactured according to ASTM A47, Grade 32510.

12. All steel components and fasteners shall be galvanized in accordance with AASHTO M111 or M232 or shall otherwise be provided with adequate corrosion protection. Galvanizing of high-strength steel bars shall follow the recommendations of the bar manufacturer so as not to adversely affect the mechanical properties of the steel.

Fabrication and Construction

13. To the extent possible, all wood shall be cut, drilled, and completely fabricated prior to pressure treatment with preservatives. When field fabrication of wood is required or if wood is damaged, all cuts, bore holes, and damage shall be immediately field treated with wood preservative in accordance with AASHTO M133.

14. Unless noted, malleable iron washers shall be provided under bolt heads and under nuts that are in contact with wood. When the size and strength of the head are sufficient to develop connection strength without wood crushing, washers may be omitted under heads of dome-head timber bolts.

15. Tops of rail posts and top of the rail splice plate shall be sealed with roofing cement or otherwise protected from direct exposure to weather.

The bridge railings depicted on these drawings were developed and crash tested under a cooperative research agreement between the Midwest Roadside Safety Facility of the University of Nebraska-Lincoln, the USDA Forest Service, Forest Products Laboratory, and the U.S. DOT Federal Highway Administration.



Crash-Tested Wood Bridge Railings for Concrete Decks

Glulam Timber Rail with Curb
NCHRP 350 Test Level 4 (TL-4)

August 1998

Sheet 1 of 2