

General Configuration

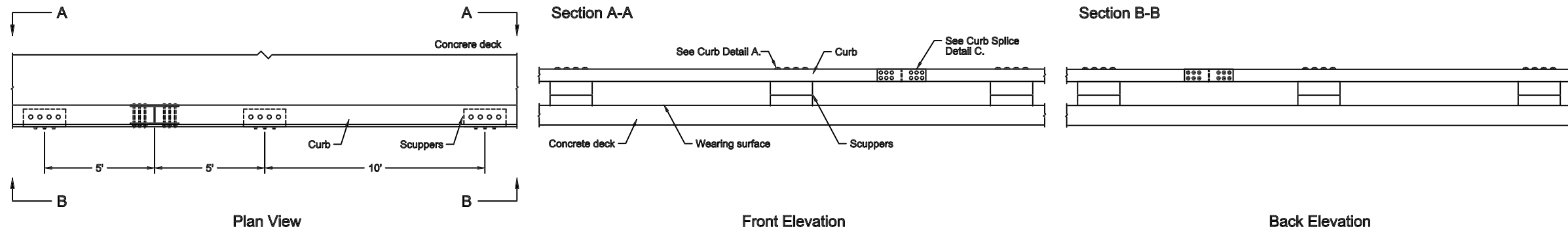

Design

1. This curb railing was successfully crash tested on a longitudinal wood deck to the requirements for Test Level 1 (TL-1), as outlined in NCHRP Report 350. Adaptation of this railing from a longitudinal wood deck to a concrete deck is based on test measurements and the ultimate capacity of deck attachment hardware.
2. Curb and post connections, such as attachment to the concrete deck, shall be with connections, such as embedded studs, bolted inserts, or thru-bolts. The minimum ultimate shear capacity of each connection shall not be less than 16,000 lb. Internal reinforcement of the concrete shall be designed accordingly to resist these ultimate loads.
3. Actual height of the curb railing rail shall be 17-3/4 to 18-3/4 in. above the traveled way.
4. Dimensions for glued-laminated (glulam) timber components are actual dimensions. Dimensions for sawn lumber components are nominal dimensions. Actual sawn lumber dimensions may be up to a maximum of 1/2 in. less than nominal dimensions to permit the use of surfaced or rough-sawn material.
5. Curb railing splices are midway between scuppers and shall be located so that curb is continuous over not less than two scuppers. It is recommended that the glulam curbs be continuous over the length of the bridge.

Materials

6. Sawn lumber and glulam shall comply with the requirements of AASHTO M168 and shall be pressure treated with wood preservative in accordance with AASHTO M133. Glulam shall be manufactured using wet use adhesives to an industrial appearance grade.
7. Curb railing shall be visually graded glulam, western species Combination No. 2, or Southern Pine Combination No. 48. Other species and grades of glulam may be used, provided the minimum tabulated values are not less than the following:
 $F_b = 1,800 \text{ lb/in}^2$ $E = 1,800,000 \text{ lb/in}^2$
8. Scuppers may be sawn lumber or glulam. When sawn lumber is used, material shall be visually graded No. 1 Southern Pine or visually graded No. 1 Douglas Fir-Larch. Glulam and other species and grades of sawn lumber may be used, provided the minimum tabulated values are no less than the following:
 $F_b = 1,350 \text{ lb/in}^2$ $E = 1,500,000 \text{ lb/in}^2$
9. Steel plates and shapes shall comply with the requirements of ASTM A36.
10. Bolts shall comply with ASTM A307 requirements, Grade 2, and should preferably be dome-head timber bolts. Bolts on traffic face of rail shall be dome head.
11. Split rings shall be manufactured from SAE 1010 hot-rolled carbon steel (SAE J412). Shear plates shall be malleable iron manufactured according to ASTM A47, Grade 32510.
12. All steel components and fasteners shall be galvanized in accordance with AASHTO M111 or M232 or shall otherwise be provided with adequate corrosion protection.

A Curb Details

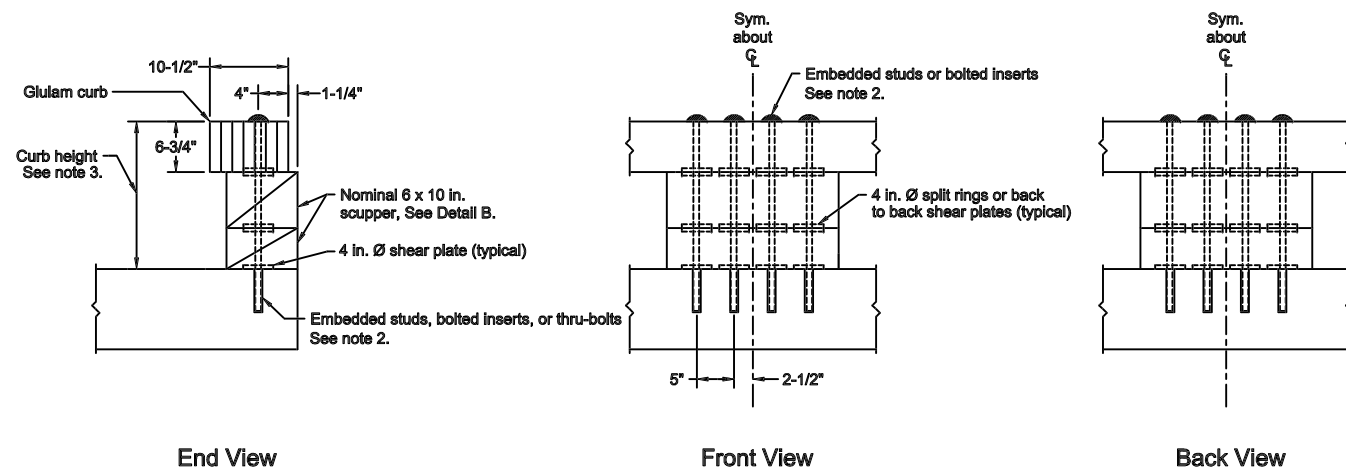

B Scupper Detail

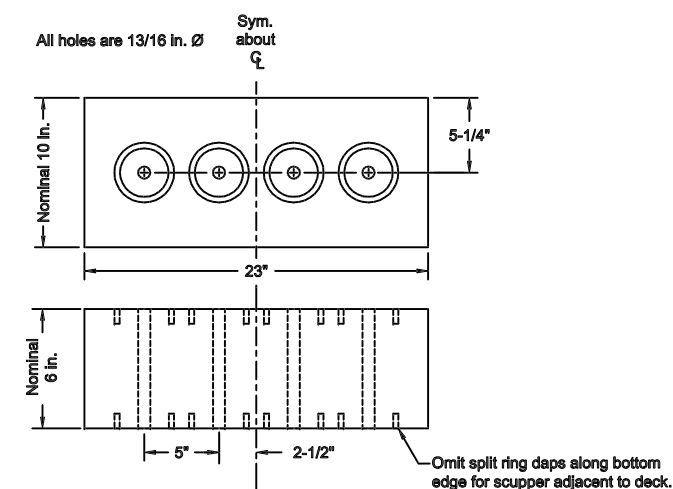

C Curb Splice Details

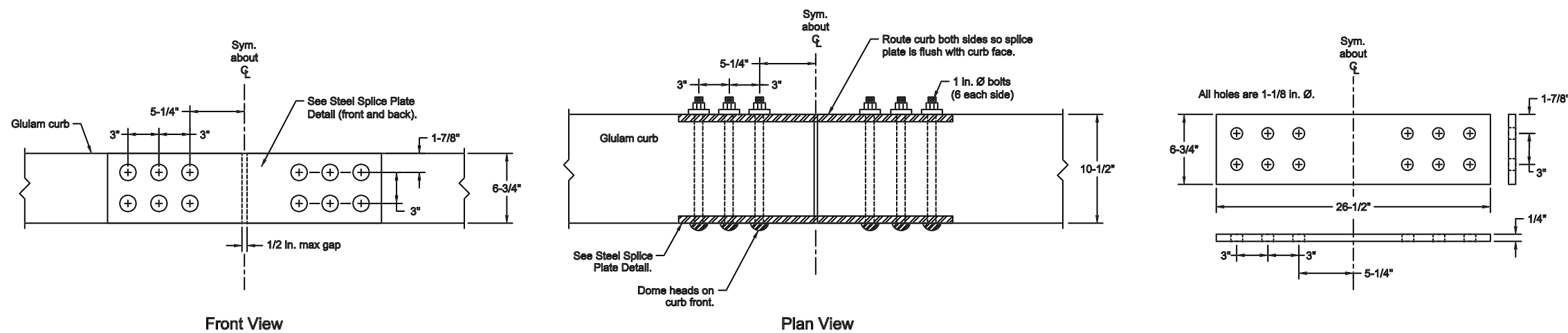

Fabrication and Construction

13. To the extent possible, all wood shall be cut, drilled, and completely fabricated prior to pressure treatment with preservatives. When field fabrication of wood is required or if wood is damaged, all cuts, bore holes, and damage shall be immediately treated with wood preservative in accordance with AASHTO M133.
14. Unless noted, malleable iron washers shall be provided under bolt heads and under nuts that are in contact with wood. When the size and strength of the head are sufficient to develop connection strength without wood crushing, washers may be omitted under heads of dome-head timber bolts.
15. Tops of rail posts shall be sealed with roofing cement or otherwise protected from direct exposure to weather.

The bridge railings depicted on these drawings were developed and crash tested under a cooperative research agreement between the Midwest Roadside Safety Facility of the University of Nebraska-Lincoln, the USDA Forest Service, Forest Products Laboratory, and the U.S. DOT Federal Highway Administration.



Crash-Tested Wood Bridge Railings for Concrete Decks

Curb Railing
NCHRP 350 Test Level 1 (TL-1)

August 1998

Sheet 1 of 1