

A Closer Look

Wood Science

YANR-7e

ALABAMA COOPERATIVE EXTENSION SYSTEM / ALABAMA A&M AND AUBURN UNIVERSITIES ALABAMA 36849-5612

4-H Woodworking Exhibit Plan

A Treasure Box

Materials Needed

One 36" piece of 1" x 4" soft wood for the sides and end (actual dimensions: $\frac{3}{4}$ " x $3\frac{1}{2}$ " x 36")

One 24" piece of 1" x 8" soft wood for the top and bottom (actual dimensions: $\frac{3}{4}$ " x $7\frac{1}{4}$ " x 24")

No. 6 finishing nails

Sandpaper (80 grit and 220 grit)

Two 1" x 1" hinges

$\frac{1}{2}$ " wood screws (8)

Tools Needed

Pencil

Ruler

Square

Handsaw

Screwdriver

Hammer

Small paintbrush

How to Make a Treasure Box

1. Using the ruler and square, cut the 1" x 4" board for the sides and ends. Saw two pieces $9\frac{1}{2}$ " long for the front and back and two pieces $7\frac{1}{4}$ " long for the sides.
2. Saw the 1" x 8" board into two pieces 11" long for the top and bottom.
3. Cut a 2" strip along back edge of the top piece for hinge attachment.
4. Assemble the sides and ends, using No. 6 finishing nails.
5. Nail the bottom to the sides and ends. Nail the 2" strip to the top back edge of the box.
6. Sand the box and top, stain, and varnish.
7. To finish your box, assemble the top by installing two hinges (1" x 1"), $\frac{1}{2}$ " from each end of your Treasure Box.
8. Your Treasure Box may now be used to store your collectibles, such as baseball cards, arrowheads, pictures of friends, 4-H ribbons, or other valuable items such as money, jewelry, or cosmetics.

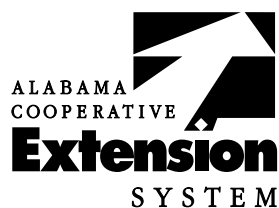
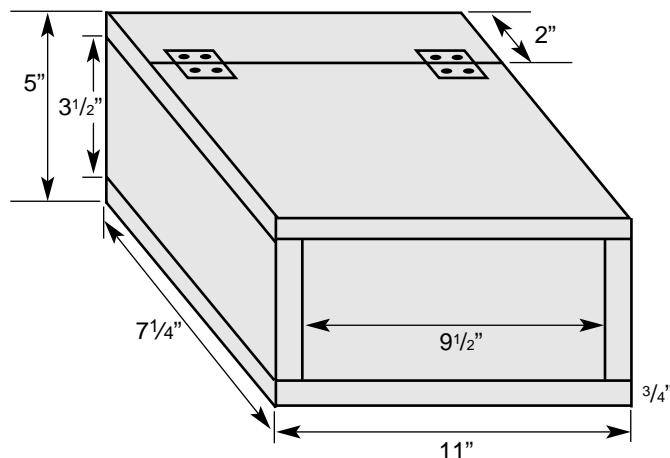

YANR-7e

Bob Drakeford, *Extension Specialist*, Volunteer Programs, Auburn University. Originally designed by **Roger Vines**, *Coosa County Extension Agent*. Approved by state 4-H Wood Science Committee—Roger Vines, Chairman, Thomas Futral, Henry Dorough, and Chip East.

Issued in furtherance of Cooperative Extension work in agriculture and home economics, Acts of May 8 and June 30, 1914, and other related acts, in cooperation with the U.S. Department of Agriculture. The Alabama Cooperative Extension System (Alabama A&M University and Auburn University) offers educational programs, materials, and equal opportunity employment to all people without regard to race, color, national origin, religion, sex, age, veteran status, or disability.

Web Only, Revised July 2000, YANR-7e

