

UNITED STATES DEPARTMENT OF AGRICULTURE
Rural Utilities Service

RUS BULLETIN 1728F-804

SUBJECT: Specifications and Drawings for 12.47/7.2 kV Line Construction

Incorporated by reference in 7 CFR Part 1728

TO: All RUS Electric Borrowers
RUS Electric Staff

EFFECTIVE DATE: October 2005

OFFICE OF PRIMARY INTEREST: Distribution Branch, Electric Staff Division

FILING INSTRUCTIONS: This bulletin is a revision of previous RUS Bulletin 50-3 (D-804), (dated May 9, 1983) "Specifications and Drawings for 12.5/7.2 kV Line Construction" and has been renumbered, renamed and updated as RUS Bulletin 1728F-804, "Specifications and Drawings for 12.47/7.2 kV Line Construction." Replace previous Bulletin 50-3 with this bulletin. This bulletin should be filed with 7 CFR 1728.

PURPOSE: The specifications and drawings of this bulletin have been published to set forth RUS requirements, specifications and standards for the construction of 12.47/7.2 kV overhead electric distribution lines and associated equipment and construction assembly units that RUS electric borrowers install.

GENERAL: This new bulletin 1728F-804 was derived from previous RUS Bulletin 50-3 identified above. Listed below are some of the significant changes and additions that were made during the update of this bulletin:

- (a) RUS has discontinued 82 assemblies and 24 guide drawings previously in Bulletin 50-3. Borrowers shall no longer use these discontinued assemblies and guide drawings for new construction.
- (b) A total of 167 assemblies and 8 guide drawings were re-used, redrawn, and renumbered using the new RUS standard numbering format. (New Exhibit 5 at the end of the bulletin briefly explains the new numbering format.) The new drawings of these re-used assemblies and guide drawings show in parentheses the old assembly and guide drawing numbers from Bulletin 50-3. Borrowers must use the new assembly and guide drawing numbers, however, **borrowers may elect to continue using the old numbers of these assembly and guide drawings, but only for the 167 assemblies and 8 guide drawings and their old numbers if they make the following changes:**

- (1) Make washer additions or changes on 37 of the re-used assemblies, and,
- (2) Make other slight material changes to 35 of the old assemblies.
- (c) Exhibit 3 at the end of this bulletin tabulates: (1) all of the discontinued assemblies and guide drawings of old Bulletin 50-3, (2) all of the re-used assemblies and guide drawings with both their old and new numbers, and (3) the required washer and material changes (if any) in the transition from the re-used old assembly to the new assembly.
- (d) This new bulletin contains a total of 214 new assemblies (95 of which are narrow profile assemblies) and 32 new guide drawings.
- (e) The bulletin has been reformatted into 19 separate sections or categories. Each of the sections contains an index of drawings and the construction drawings of assemblies designed to perform a similar function. Ten of the sections contain new and revised construction specifications and informational details pertaining to the assemblies within the section.
- (f) "Design parameters", which define and usually limit maximum line angles or mechanical loading (tension), have been added to most of the drawings.
- (g) New tables have been added to define maximum line angles on pole top assemblies and permitted unbalanced conductor tensions on crossarm assemblies. Page 1 of Exhibit 1 documents the formula and data used to determine the maximum line angles in the tables in Exhibit 1. Exhibit 2 documents the formula and data used to determine permitted unbalanced conductor tensions on crossarms.
- (h) Each drawing has been given a new, shorter, and more uniform title or name.
- (i) Three sets of coordinated "narrow profile," one, two and three-phase assemblies for all line angles have been incorporated into this bulletin.
- (j) New specifications explaining the conditions that borrowers may modify the assemblies and drawings of this bulletin are provided in the "General Construction Specifications."
- (k) New specifications and conditions for the use of stirrups were added in Section L.
- (l) New specifications and conditions for grounding or insulating guy wires were added in Section G.



Curtis M. Anderson
Acting Administrator
Rural Utilities Service

April 1, 2005

Date

BULLETIN 1728F-804: INDEX

<u>SECTION</u>	<u>CATEGORY DESCRIPTIONS</u>
1-a	<i>General Construction Specifications</i>
1-b	<i>Conductor Installation Specifications</i>
1-c	<i>Construction Specifications for Pole Top Assemblies</i>
1-d	<i>Narrow Profile Assemblies Grouped by Bracket Configuration</i>
A	<u>SINGLE-PHASE PRIMARY POLE TOP ASSEMBLY UNITS</u> Index A Single-Phase Primary Pole Top Construction Drawings
B	<u>TWO-PHASE PRIMARY POLE TOP ASSEMBLY UNITS</u> Index B Two-Phase Primary Pole Top Construction Drawings
C	<u>THREE-PHASE PRIMARY POLE TOP ASSEMBLY UNITS</u> Index C Three-Phase Primary Pole Top Construction Drawings
D	<u>DOUBLE-CIRCUIT PRIMARY POLE TOP ASSEMBLY UNITS</u> Index D Double-Circuit Primary Pole Top Construction Drawings
E	<u>GUYING ASSEMBLY UNITS</u> Index E <i>Construction Specifications for Guys</i> Guying Construction Drawings
F	<u>ANCHOR ASSEMBLY UNITS</u> Index F <i>Construction Specifications for Anchoring</i> <i>Soil Classifications (Table)</i> Anchor Construction Drawings
G	<u>TRANSFORMER ASSEMBLY UNITS</u> Index G <i>Construction Specifications for Transformers</i> Transformer Construction Drawings
H	<u>GROUNDING ASSEMBLY UNITS</u> Index H <i>Construction Specifications for Grounding</i> Grounding Construction Drawings

BULLETIN 1728F-804: INDEX

(Continued)

<u>SECTION</u>	<u>CATEGORY DESCRIPTIONS</u>
J	<u>SECONDARY ASSEMBLY UNITS</u> Index J <i>Construction Specifications for Secondary Conductors and Services</i> Secondary Construction Drawings
K	<u>SERVICE ASSEMBLY UNITS</u> Index K Service Construction Drawings
L	<u>TYING ASSEMBLY UNITS</u> Index L <i>Construction Specifications for Connectors, Stirrups, Clamps, Taps and Jumpers</i> Tying Guide Drawings
M	<u>MISCELLANEOUS ASSEMBLY UNITS AND GUIDES</u> Index M <i>Right-of-Way Clearing Specifications</i> Miscellaneous Construction Drawings and Guides
N	<u>NEUTRAL ASSEMBLY UNITS</u> Index N Neutral Construction Drawings
P	<u>PROTECTION ASSEMBLY UNITS</u> Index P <i>Construction Specifications for Raptor Protection</i> Protection Construction Drawings
Q	<u>METERING ASSEMBLY UNITS</u> Index Q Metering Construction Drawings
R	<u>OIL CIRCUIT RECLOSER ASSEMBLY UNITS</u> Index R Oil Circuit Recloser Construction Drawings
S	<u>SECTIONALIZING ASSEMBLY UNITS</u> Index S Sectionalizing Construction Drawings

BULLETIN 1728F-804: INDEX

(Continued)

<u>SECTION</u>	<u>CATEGORY DESCRIPTIONS</u>
W	<u>WOOD POLES, CROSSARMS AND BRACES</u> Index W <i>Construction Specifications for Poles and Crossarms</i> <i>Pole Setting Depths (Table)</i> Pole and Crossarm Guides and Assembly Drawings
Y	<u>VOLTAGE ALTERATION EQUIPMENT ASSEMBLY UNITS</u> Index Y Voltage Alteration Equipment Construction Drawings
<u>EXHIBITS</u>	
1	<u>CALCULATIONS AND TABLES OF MAXIMUM LINE ANGLES</u> Calculation of Maximum Line Angles Table I: Maximum Line Angles (Pin Insulators) - 500 lbs./Conductor Table II: Maximum Line Angles (Pin Insulators) - 750 lbs./Conductor Table III: Maximum Line Angles (Pin Insulators) - 1,000 lbs./Conductor Table IV: Maximum Line Angles (Pin Insulators) - 1,500 lbs./Conductor Table V: Maximum Line Angles (Pin Insulators) - 2,000 lbs./Conductor Table VI: Maximum Line Angles (Spool Insulators) - 1,500 lbs./Conductor Table VII: Maximum Line Angles (Spool Insulators) - 2,250 lbs./Conductor
2	<u>LONGITUDINAL LOADING ON CROSSARM ASSEMBLIES</u> TABLE A: Permitted Unbalanced Conductor Tension - (1 phase/side of pole) TABLE B: Permitted Unbalanced Conductor Tension - (2 phases/side of pole)
3	<u>DISPOSITION OF ASSEMBLIES IN BULLETIN 50-3 (D 804)</u>
4	<u>NEW ASSEMBLIES AND GUIDE DRAWINGS IN BULLETIN 1728F-804</u>
5	<u>RUS STANDARD FORMAT AND MEANING OF OVERHEAD DISTRIBUTION ASSEMBLY NUMBERS</u>
6	<u>TABLE OF SELECTED SI TO METRIC CONVERSIONS</u>

GENERAL CONSTRUCTION SPECIFICATIONS

All construction shall be performed in a safe, thorough, and skillful manner in accordance with the staking sheets, plans and specifications, and the construction drawings.

The provisions of 7 CFR 1724.50, "Compliance with National Electrical Safety Code (NESC)" apply to all borrower electric system facilities regardless of the source of financing. A borrower must ensure that its electric system including all distribution, transmission, and generating facilities, is designed, constructed, operated, and maintained in accordance with all of the applicable provisions of:

- (1) the most current provisions of the NESC, and
- (2) all applicable and current electrical and safety requirements of any State or local governmental entity.

Any electrical standard requirements established by RUS are in addition to, and not a substitution for nor modification of (1) and (2) listed immediately above.

The permitted loading, strength, and spacing (separation) of structures, assemblies and conductors shown on the assembly drawings in this bulletin are based on and are in compliance with the 2002 Edition of the NESC.

Copies of the NESC may be obtained from the Institute of Electrical and Electronics Engineers, Inc., (IEEE) at the following address:

IEEE Customer Service
445 Hoes Lane, PO Box 1331
Piscataway, NJ 08855-1331
Telephone: 1-800-678-4333

Overhead distribution circuits shall be constructed with not less than the Grade C strength requirements as described in section 26, Strength Requirements, of the NESC when subjected to the loads specified in NESC Section 25, Loadings for Grades B and C. Distribution lines that underbuild transmission circuits or that cross over limited access highways and railroad tracks shall be constructed with not less than the Grade B strength requirements as described in NESC Section 26.

The drawings of equipment and materials shown in the construction assemblies depict the general categories of items found in RUS Informational Publication 202-1, "List of Materials Acceptable for Use on Systems of RUS Electrification Borrowers" ("List of Materials"). Any drawing of any piece of equipment or material that resembles a specific product of a manufacturer is unintentional.

GENERAL CONSTRUCTION SPECIFICATIONS (Cont.)

Materials to be used for construction are designated by one or two lower-case alphabetic characters shown on the drawings and in the "ITEM" column in the drawing material blocks. For example, "b" designates a steel, pole top pin. A borrower shall use, at its discretion, any of the applicable pole top pins from category "b" of the "List of Materials

The drawings in this bulletin show the use of two, 4 1/4 inch, American National Standards Institute (ANSI) Class 52-9A suspension insulators for 12.47/7.2 kV primary deadends. However, borrowers may alternatively use two, 6-inch, ANSI Class 52-1 suspension insulators, or one polymer distribution insulator, all of which are contained in category "k" in the "List of Materials." In the case of polymer insulators, the quantity ("QTY") of the insulators to be used must be modified accordingly in the material blocks of the drawings.

Normally crossarm pins and post-type insulators come equipped with washers and locknuts. Thus, the washers and locknuts for crossarm pins are not tallied in the "QTY" (quantity) columns in the material boxes on the construction drawings. However, the crossarm pin washers and locknuts are shown on the construction drawings in parenthesis to depict proper construction. If crossarm pins or post type insulators are purchased without washers, locknuts or studs, the quantity totals in the material boxes on the construction drawings will need to be adjusted accordingly.

Locknuts shall be installed on all threaded material and hardware in addition to nuts and washers. The threads on installed bolts shall protrude past the lock washers a minimum of one inch but not more than two inches.

Sometimes it may be prudent or necessary to modify RUS standard distribution assemblies to solve encountered construction problems. For example, a standard C6.1 assembly may need to be modified with heavy-duty crossarm braces (assembly W3.2) to support large conductors. RUS has not produced the scores of new assemblies like the example because the resulting bulletin would be quite unwieldy. Therefore, borrowers themselves may develop and use assemblies similar to the example without additional RUS approval. Borrowers' assemblies not specifically approved by RUS shall not have component spacing less than, or permitted longitudinal loads (strengths) greater than those on correlated RUS standard assemblies. Borrowers need to properly account for the new assembly material and assign assembly numbers recognizably different than RUS standard assembly numbers.

RUS approval and assembly number changes are not required to add the following types of information to RUS assembly drawings: material inventory numbers, bolt lengths, jumper wire sizes, types of connectors, armor rods, etc.

CONDUCTOR INSTALLATION SPECIFICATIONS

Conductors shall be handled with care and shall not be trampled on or run over by vehicles. Each reel shall be examined and the wire shall be inspected for cuts, kinks, or other damage. Damaged portions shall be cut out and the conductor spliced. The conductors shall be pulled over suitable rollers or stringing blocks properly mounted on the pole or crossarm to prevent binding or damage while stringing.

Conductors shall be sagged evenly and in accordance with the conductor manufacturer's recommendations. The air temperature at the time and place of sagging shall be determined by the use of a certified thermometer. The sag of all conductors after stringing shall be in accordance with the engineer's instructions.

For new construction, splices shall be no closer than 1,000 feet from one another and there shall be no more than 3 splices per mile in any primary phase or neutral conductor. Furthermore, splices shall not be located within 10 feet of any supporting structure. For all construction, splices shall not be located in Grade B crossing spans and preferably not in adjacent spans. Splices shall be installed in accordance with the manufacturer's specifications and recommendations.

All conductors shall be cleaned thoroughly by wirebrushing before splicing or installing connectors or clamps. A suitable oxidation inhibitor shall be applied before splicing or applying connectors over aluminum conductor.

CONSTRUCTION SPECIFICATIONS FOR POLE TOP ASSEMBLIES

The neutral conductor shall be installed on the same side (preferably the roadside) of all tangent and small angle poles throughout each line section. See “Construction Specifications for Poles and Crossarms” in Section W of this bulletin for additional pole and crossarm construction specifications.

Neutral attachments may be lowered on standard pole top assemblies a distance not exceeding 2 feet for the purpose of economically meeting conductor clearance requirements of the NESC.

Neutral attachments may be lowered on standard pole top assemblies a distance not exceeding an additional 6 feet for the purpose of performing construction and future line maintenance on these assemblies from bucket trucks designed for such work.

The conductor shall be tied to the top groove of pin-type or post-type insulators on tangent poles. On angle structures the conductor shall be tied on the side of the insulator opposite the direction of the strain. Pin-type and post-type insulators shall be tight on the pins and brackets, respectively, and the top groove shall be in line with the conductor after tying. Borrowers shall not allow any upstrain on pin-type or post-type insulators.

A 3 inch by 3 inch (minimum), square, curved washer (item “d”) shall be used abutting the pole when installing primary deadend, neutral deadend and guy assemblies directly to the pole. These washers mitigate the crushing of wood fibers and facilitate the permitted longitudinal loads shown on the construction drawings.

A 2 ¼ inch (minimum) square washer shall be placed under the shoulder of 7.2 kV crossarm insulator pins whose surface area abutting the crossarm is less than 4 square inches. These washers mitigate the crushing of wood fibers and facilitate the permitted transverse loading shown in the maximum line angle tables in Exhibit 1.

The maximum line angles on tangent construction assemblies shall be limited to 5 degrees for small conductors and 2 degrees for conductors larger than # 1/0 because of likely slippage of the neutral conductor off of a spool-type insulator. Furthermore, based on additional calculations by the design engineer, these maximum line angles may need to be reduced for NESC Grade B construction.

Deadend and suspension angle pole top assemblies attached directly to poles shall be designed to hold the sum of all expected loads multiplied by the appropriate overload factors of NESC Table 253-1.

RUS has applied the applicable strength factors for Grade C construction from NESC Table 261-1A in the calculations for permitted longitudinal loading shown in the design parameters on the drawings. The permitted longitudinal loading on primary deadend assemblies attached directly to poles is based on 50 percent of the rated ultimate strength of the suspension insulators shown on the assembly drawings.

CONSTRUCTION SPECIFICATIONS FOR POLE TOP ASSEMBLIES (cont.)

The maximum line angles for pole top primary assemblies in the tables in Exhibit 1 are based on the RUS designated maximum load on crossarm insulator pins, post type insulators, or pole top pins and the assumed conductor tensions tabulated on page 1 of Exhibit 1. The applicable overload factors from NESC Table 253-1, for Grade C construction, have already been applied in the calculations for the maximum line angles. For large conductor sizes, the design engineer may need to calculate new (smaller) maximum line angles for NESC Grade B construction.

The permitted unbalanced conductor tensions on primary deadend assemblies attached to crossarms are based on the results of the equations and methodology explained in Exhibit 2 of this bulletin. RUS has applied the overload factors of NESC Table 253-1 and used the assumed conductor tensions tabulated on page 1 of Exhibit 1 to calculate the permitted unbalanced conductor tensions shown in Tables A and B of Exhibit 2 of this bulletin. The permitted unbalanced conductor tensions on crossarm assemblies shall be reduced by 40 percent for NESC Grade B construction.

RUS categorizes conductor sizes as follows:

- **Small conductors** are conductors with a rated breaking strength of less than 4,500 pounds (20,000 newtons), e.g., 1/0 Aluminum Conductor - Steel Reinforced (ACSR) and smaller.
- **Large conductors** are conductors with a rated breaking strength of 4,500 pounds (20,000 newtons) or greater but less than 10,000 pounds (45,000 newtons), e.g., 2/0 ACSR through 4/0 ACSR or 336.4 kcmil (18/1) ACSR.
- **Extra large conductors** are conductors with a rated breaking of 10,000 pounds (45,000 newtons) or greater, e.g., 266.8 kcmil (26/7) ACSR and larger.

Primary pole top assemblies identified as “large conductors” in the drawing titles shall be used to support large and extra large conductors. Large conductor assemblies may also be used for small conductors. Furthermore, large and extra large conductors may be installed on assemblies not designated as large conductors provided that the expected transverse or longitudinal loads (multiplied by the appropriate NESC overload factors) do not exceed the permitted loads or tensions shown on the design parameters of the drawings. For any conductor size, the horizontal, vertical or transverse loads shall not exceed the permitted strength of crossarms, crossarm pins, insulators, or insulator bracket assemblies. Usually, extra large conductors require that pin type and post type insulators have a “C” neck for conductor sizes up through 477.0 (18/1) ACSR and “J” necks for conductor sizes up to 795 kcmil, depending on the armor rods selected.

NARROW PROFILE ASSEMBLIES GROUPED BY BRACKET CONFIGURATION

"STANDARD" ASSEMBLIES (1-foot, 9-inch spacing)			
(APPLICATIONS: Convert existing standard 1-phase; Standard pole framing)			
<u>MAX. LINE ANGLES</u>	<u>1-PHASE</u>	<u>2-PHASE</u>	<u>3-PHASE</u>
Tangent	A1.1, A1.2	B1.1N, B1.2N	C1.1N, C1.2N
"	A1.1P, A1.2P	B1.1NP, B1.2NP	C1.1NP, C1.2NP
" (NESC Grade B)	A2.1, A2.2	B2.1N, B2.2N	C2.1N, C2.2N
" (NESC Grade B)	A2.1P, A2.2P	B2.1NP, B2.2NP	C2.1NP, C2.2NP
Table I	A1.3	B1.3N	C1.3N
Table II	A1.3P	B1.3NP	C1.3NP
Table III	A2.3	B2.3N	C2.3N
Table III			C2.3NG
Table IV	A2.3P	B2.3NP	C2.3NP

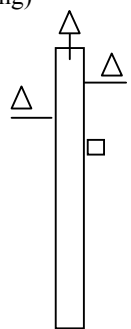

"STAGGERED" ASSEMBLIES (2-foot spacing)			
(APPLICATIONS: New construction; Transmission underbuild)			
<u>MAX. LINE ANGLES</u>	<u>1-PHASE</u>	<u>2-PHASE</u>	<u>3-PHASE</u>
Tangent	A1.4N, A1.5N	B1.4N, B1.5N	C1.4N, C1.5N
"	A1.4NP, A1.5NP	B1.4NP, B1.5NP	C1.4NP, C1.5NP
" (NESC Grade B)	A2.4N, A2.5N	B2.4N, B2.5N	C2.4N, C2.5N
" (NESC Grade B)	A2.4NP, A2.5NP	B2.4NP, B2.5NP	C2.4NP, C2.5NP
Table II	A1.6N	B1.6N	C1.6N
Table II	A1.6NP	B1.6NP	C1.6NP
Table IV	A2.6N	B2.6N	C2.6N
Table IV	A2.6NP	B2.6NP	C2.6NP

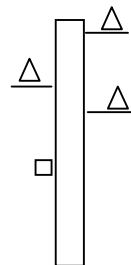

"VERTICAL" ASSEMBLIES (4-foot spacing)			
(APPLICATIONS: Large line angles; Tree and building clearances)			
<u>MAX. LINE ANGLES</u>	<u>1-PHASE</u>	<u>2-PHASE</u>	<u>3-PHASE</u>
Tangent		B1.7N, B1.8N	C1.7N, C1.8N
"		B1.7NP, B1.8NP	C1.7NP, C1.8NP
" (NESC Grade B)	<i>(Same as "Staggered" Assemblies)</i>	B2.7N, B2.8N	C2.7N, C2.8N
" (NESC Grade B)		B2.7NP, B2.8NP	C2.7NP, C2.8NP
Table II		B1.9N	C1.9N
Table II		B1.9NP	C1.9NP
Table IV		B2.9N	C2.9N
Table IV		B2.9NP	C2.9NP

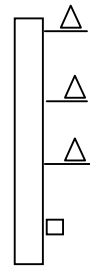

MISC. ASSEMBLIES	
A1.04N, A1.04NP	Single support brackets and insulators (Single-phase, Table II)
A2.04N, A2.04NP	Double support brackets and insulators (Single-phase, Table IV)
A5.3NG	Single-phase tap guide (Narrow profile)
A5.4NG	Single-phase tap guide with cutout and arrester (Narrow profile)
D1.4N, D1.4NP	Single support - Double-circuit ("Staggered assembly", Tangent)
D1.45, D1.5NP	Single support - Double-circuit ("Staggered assembly", Tangent)
D2.9N, D2.9NP	Double support - Double-circuit ("Vertical assembly", Table IV)
P1.1NG	Surge arrester on narrow profile bracket (Single-phase, Guide)
S1.1N	Cutout on narrow profile bracket (Single-phase)

Note: Number suffixes "N", "P", and "G" denote Narrow profile assembly, Post type insulator assembly, and Guide drawing (no materials), respectively.

INDEX A

SINGLE-PHASE PRIMARY POLE TOP ASSEMBLY UNITS

<u>DRAWING NUMBERS</u>		<u>DRAWING TITLE (DESCRIPTION)</u>
1728F-804	Bulletin 50-3	
(New)	(Old)	
A1.01	(M5-2)	SINGLE SUPPORT - PRIMARY
A1.01P	(M5-18)	
A1.011	(M5-5)	
A1.011P	(M5-7)	
A1.011L		
A1.04N		SINGLE SUPPORT – NARROW PROFILE
A1.04NP		
A1.1	(A1)	SINGLE SUPPORT (TANGENT)
A1.2	(A1A)	
A1.1P	(A1P)	SINGLE SUPPORT (TANGENT) (POST INSULATORS)
A1.2P	(A1AP)	
A1.3		SINGLE SUPPORT
A1.3P		SINGLE SUPPORT (POST INSULATORS)
A1.4N		SINGLE SUPPORT – NARROW PROFILE (TANGENT)
A1.5N		
A1.4NP		SINGLE SUPPORT – NARROW PROFILE (TANGENT)
A1.5NP		(POST INSULATORS)
A1.6N		SINGLE SUPPORT – NARROW PROFILE
A1.6NP		SINGLE SUPPORT – NARROW PROFILE (POST INSULATORS)
A1.11	(A9-1)	SINGLE SUPPORT ON CROSSARM
A1.11P	(A9-1P)	SINGLE SUPPORT ON CROSSARM (POST INSULATORS)
A1.12G		SINGLE PHASE JUNCTION GUIDE
A2.01		DOUBLE SUPPORT - PRIMARY
A2.01P		
A2.021		
A2.021P		
A2.04N		DOUBLE SUPPORT – NARROW PROFILE
A2.04NP		
A2.1	(A1-1)	DOUBLE SUPPORT (TANGENT)
A2.2	(A1-1A)	

SINGLE-PHASE PRIMARY POLE TOP ASSEMBLY UNITS

<u>DRAWING NUMBERS</u>		<u>DRAWING TITLE (DESCRIPTION)</u>
1728F-804 (New)	Bulletin 50-3 (Old)	
A2.1P A2.2P	(A1-1P) (A1-1AP)	DOUBLE SUPPORT (TANGENT) (POST INSULATORS)
A2.3	(A2)	DOUBLE SUPPORT
A2.3P	(A2P)	DOUBLE SUPPORT (POST INSULATORS)
A2.4N A2.5N		DOUBLE SUPPORT – NARROW PROFILE (TANGENT)
A2.4NP A2.5NP		DOUBLE SUPPORT – NARROW PROFILE (TANGENT) (POST INSULATORS)
A2.6N		DOUBLE SUPPORT – NARROW PROFILE
A2.6NP		DOUBLE SUPPORT – NARROW PROFILE (POST INSULATORS)
A2.21	(A9)	DOUBLE SUPPORT ON CROSSARMS
A2.21P	(A9P)	DOUBLE SUPPORT ON CROSSARMS (POST INSULATORS)
A3.1 A3.2 A3.3	(A3)	SUSPENSION ANGLE
A3.4 A3.5 A3.6 A3.7 A3.8 A3.9		SUSPENSION ANGLE
A4.1	(A4)	DEADEND ANGLE (90° - 150°)
A4.2		DEADEND ANGLE (15° - 90°)
A5.01 A5.02 A5.03	(M5-24) (M5-8)	SINGLE DEADENDS
A5.1 A5.2 A5.3	(A5) (A5-2)	SINGLE DEADENDS

SINGLE-PHASE PRIMARY POLE TOP ASSEMBLY UNITS

<u>DRAWING NUMBERS</u>		<u>DRAWING TITLE (DESCRIPTION)</u>
1728F-804 (New)	Bulletin 50-3 (Old)	
A5.4		SINGLE DEADENDS
A5.5		
A5.6		
A5.7		
A5.8		
A5.9		
A5.2G		SINGLE PHASE TAP GUIDE
A5.3NG		SINGLE PHASE TAP GUIDE – NARROW PROFILE
A5.4NG		SINGLE PHASE TAP GUIDE – NARROW PROFILE (WITH CUTOUT AND ARRESTER)
A5.21	(A7)	SINGLE DEADEND ON CROSSARMS
A5.31	(A7-1)	
A6.1	(A6)	DOUBLE DEADEND (STRAIGHT)
A6.2		DOUBLE DEADEND (FEED THROUGH)
A6.21	(A8)	DOUBLE DEADEND ON CROSSARMS
A6.22G		DOUBLE DEADEND GUIDE (FEED THROUGH ON CROSSARMS)

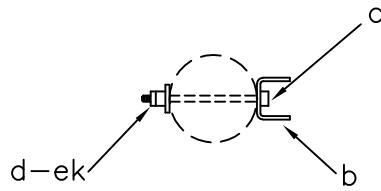

SECTION A-A

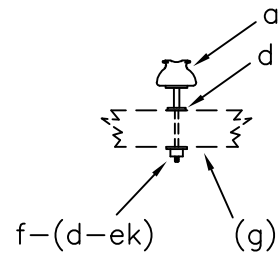

A1.011

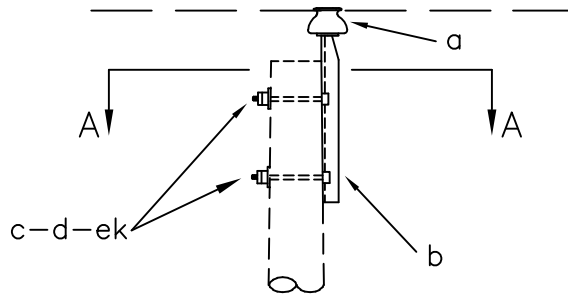
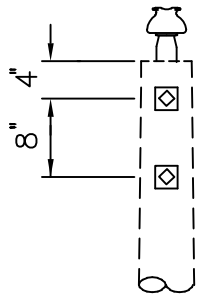

A1.01

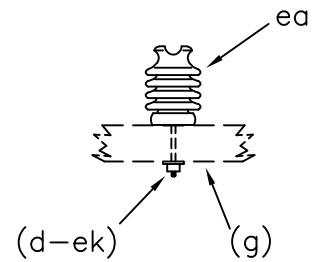

A1.011P

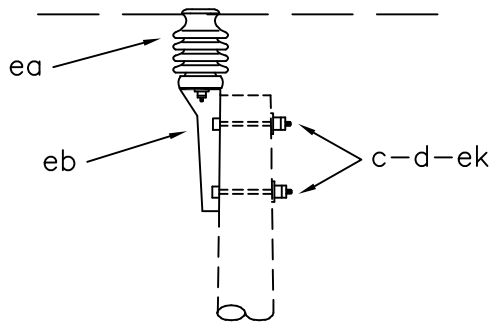
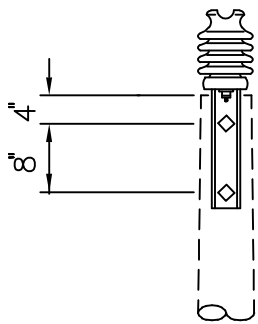

A1.01P

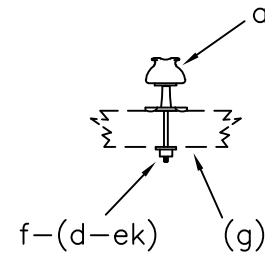

A1.011L

ASSEMBLY: A1.

ITEM	MATERIAL	01	01P	011	011P	011L
a	Insulator, pin type (12.47/7.2 kV)	1		1		1
b	Pin, pole top, 20"	1				
c	Bolt, machine, 5/8" x req'd length	2	2			
d	Washer, square, 2 1/4"	2	2	1		
f	Pin, crossarm steel, 5/8" x 10 3/4"			1		
f	Pin, crossarm steel, clamp type					1
ea	Insulator, post type (12.47/7.2 kV)		1		1	
eb	Bracket, pole top		1			
ek	Locknuts	2	2			

ASSEMBLY NUMBERS	
NEW	(OLD)
A1.01	(M5-2)
A1.01P	(M5-18)
A1.011	(M5-5)
A1.011P	(M5-7)
A1.011L	

DESIGN PARAMETERS:

A1.01: See TABLE I
 A1.01P: See TABLE II
 A1.011: See TABLE II
 A1.011P: See TABLE II
 A1.011L: See TABLE III

SINGLE SUPPORT-PRIMARY

APRIL 2005

RUS

1 - PHASE PRIMARY
 12.47/7.2 kV

A1.01,A1.01P
 A1.011,A1.011P
 A1.011L

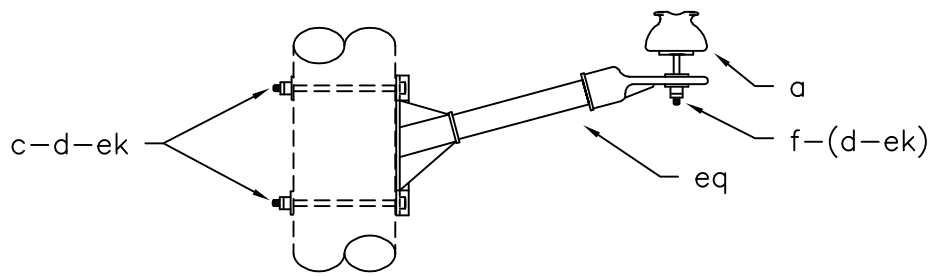

A1.04N

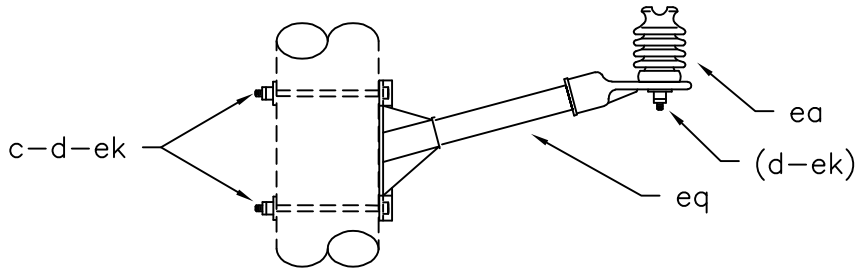

A1.04NP

ASSEMBLY: A1.		04N	04NP
ITEM	MATERIAL	QTY	QTY
a	Insulator, pin type (12.47/7.2 kV)	1	
c	Bolt, machine, 5/8" x req'd length	2	2
d	Washer, square 2 1/4"	2	2
(f)	(Pin, crossarm, 5/8" x 6 1/2")	(1)	
ea	Insulator, post type (12.47/7.2kV)		1
ek	Locknuts	2	2
eq	Bracket, insulator/equipment	1	1

(If req'd)

Design Parameters: MAXIMUM LINE ANGLES: See Table II	SINGLE SUPPORT-NARROW PROFILE		
	APRIL 2005	1 - PHASE PRIMARY	A1.04N
	RUS	12.47/7.2 kV	A1.04NP

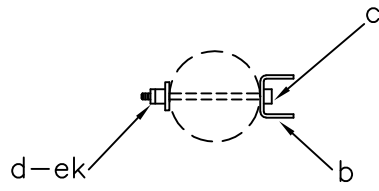

PLAN

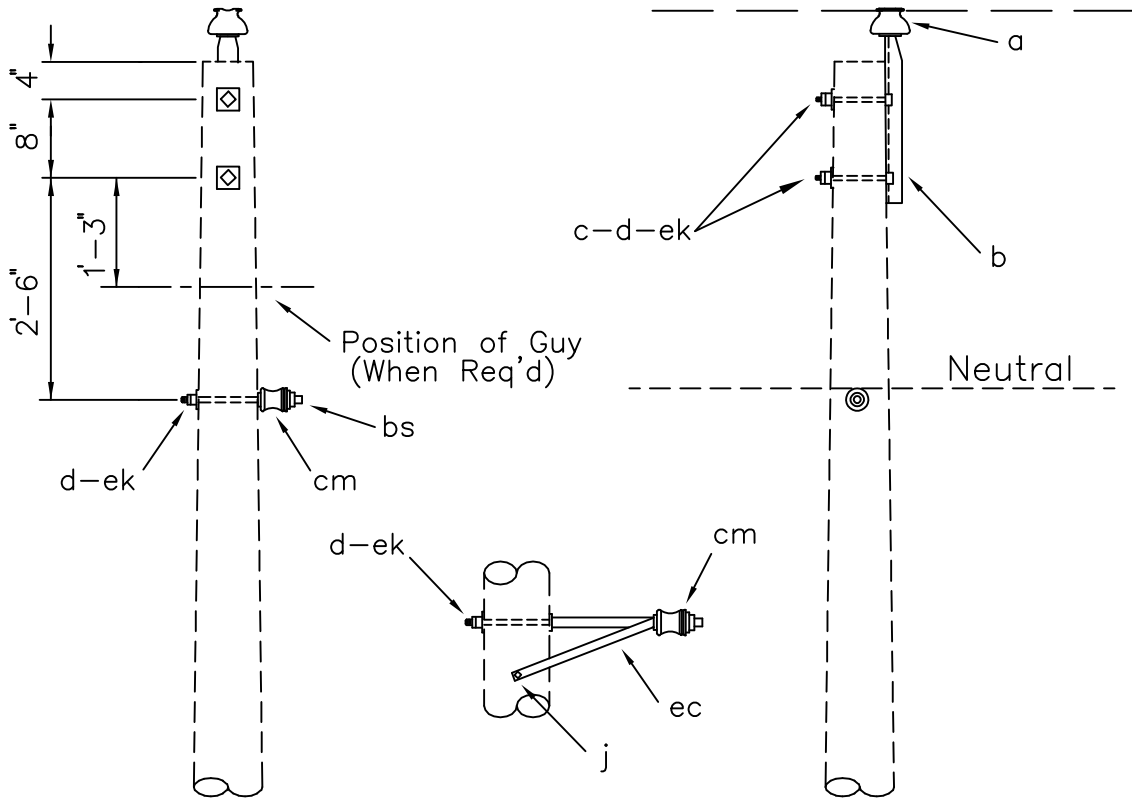

Specify A1.2 for offset neutral assembly

ASSEMBLY:

ITEM	MATERIAL	A1.1 QTY	A1.2 QTY
a	Insulator, pin type (12.47/7.2 kV)	1	1
b	Pin, pole top, 20"	1	1
c	Bolt, machine, 5/8" x req'd length	2	2
d	Washer, square 2 1/4"	3	3
j	Screw, lag, 1/2" x 4"		2
bs	Bolt, single, upset	1	
cm	Insulator, spool, 3"	1	1
ec	Bracket, offset neutral		1
ek	Locknuts	3	3

DESIGN PARAMETERS:

MAXIMUM LINE ANGLES:
 5° - Small Conductors
 2° - Larger than #1/0

SINGLE SUPPORT
(TANGENT)

APRIL 2005

RUS

1 - PHASE PRIMARY
 12.47/7.2 kV

A1.1 (A1)
 A1.2 (A1A)

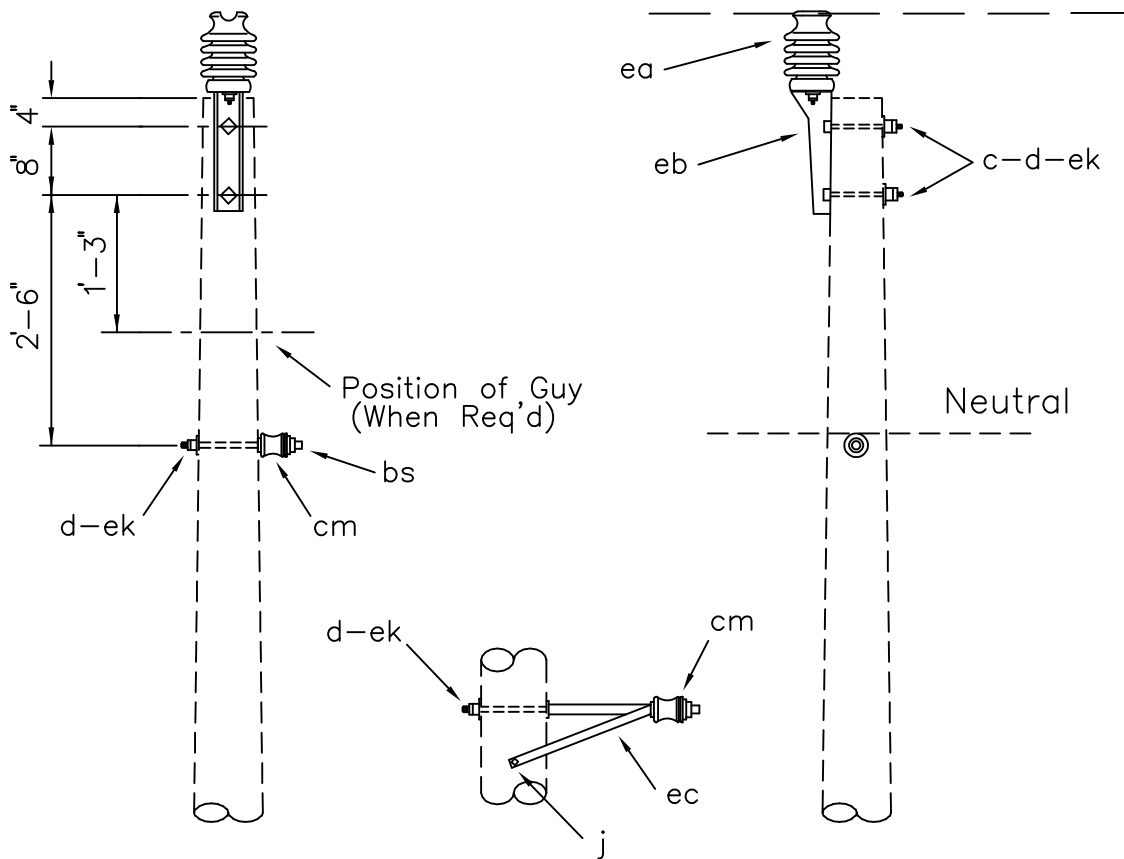

Specify A1.2P for
offset neutral assembly

ASSEMBLY: A1

ITEM	MATERIAL	ASSEMBLY: A1	
		.1P	.2P
		QTY	QTY
c	Bolt, machine, 5/8" x req'd length	2	2
d	Washer, square 2 1/4"	3	3
j	Screw, lag, 1/2" x 4"		2
bs	Bolt, single, upset	1	
cm	Insulator, spool, 3"	1	1
ea	Insulator, post type (12.47/7.2 kV)	1	1
eb	Bracket, pole top	1	1
ec	Bracket, offset neutral		1
ek	Locknuts	3	3

DESIGN PARAMETERS:

MAXIMUM LINE ANGLES:
5° - Small Conductors
2° - Larger than #1/0

SINGLE SUPPORT (TANGENT)
(POST INSULATORS)

APRIL 2005

RUS

1 - PHASE PRIMARY
12.47/7.2 kV

A1.1P (A1P)
A1.2P (A1AP)

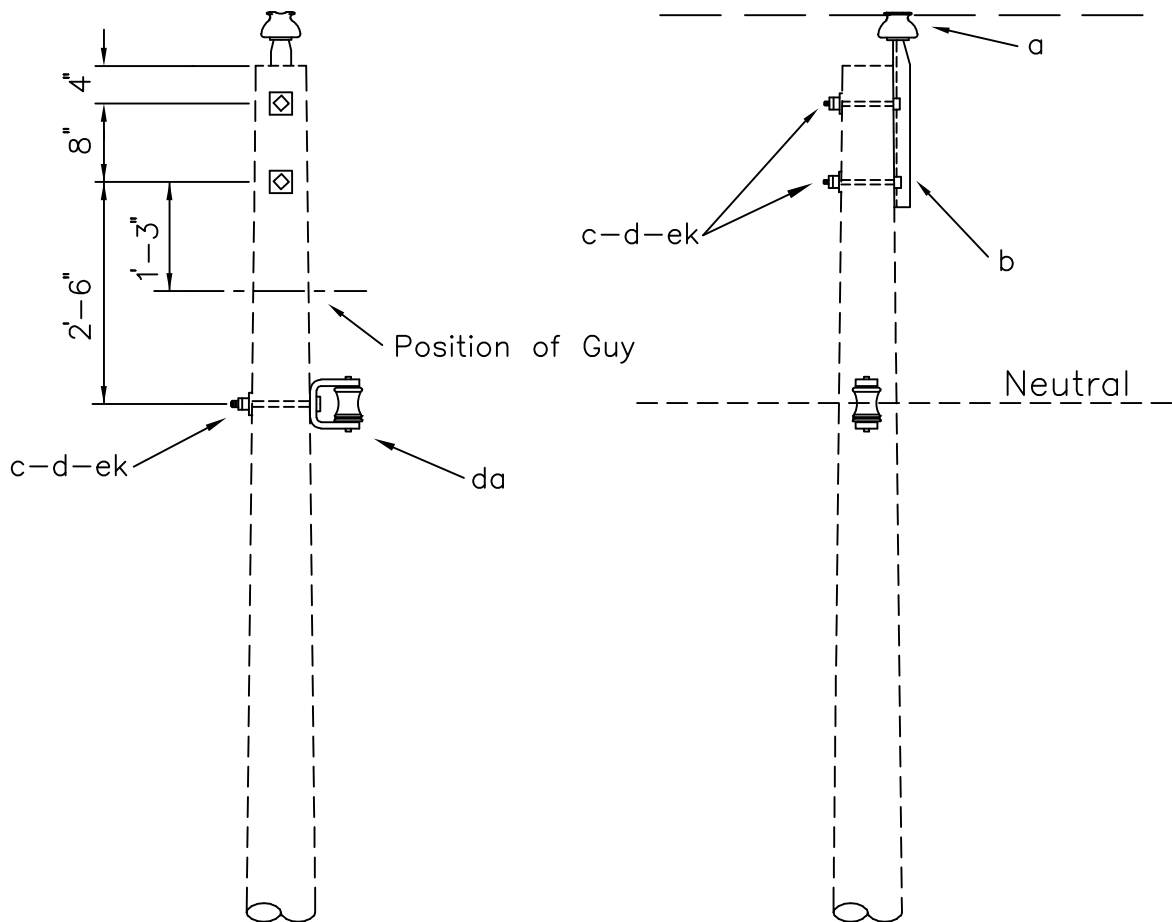

ITEM	QTY	MATERIAL
a	1	Insulator, pin type (12.47/7.2 kV)
b	1	Pin, pole top, 20"
c	3	Bolt, machine, 5/8" x req'd length
d	3	Washer, square, 2 1/4"
da	1	Bracket, insulated
ek	3	Locknuts

DESIGN PARAMETERS:

See TABLE I

SINGLE SUPPORT

APRIL 2005

RUS

1 - PHASE PRIMARY
12.47/7.2 kV

A1.3

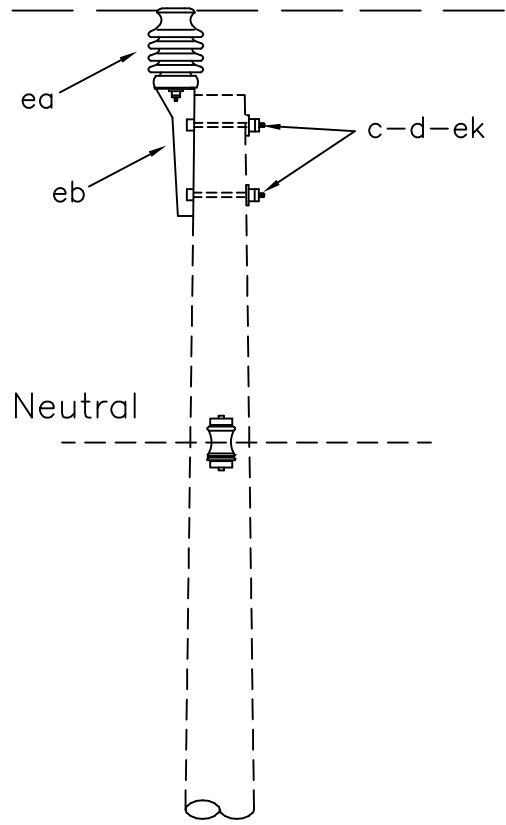
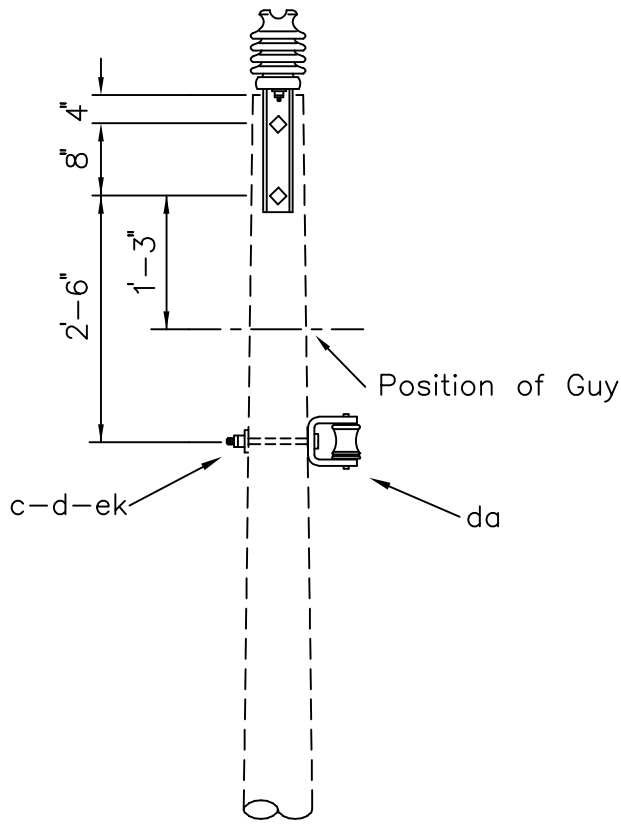

ITEM	QTY	MATERIAL
c	3	Bolt, machine, 5/8" x req'd length
d	3	Washer, square, 2 1/4"
da	1	Bracket, insulated
ea	1	Insulator, post type (12.47/7.2 kV)
eb	1	Bracket, pole top
ek	3	Locknuts

DESIGN PARAMETERS: See TABLE II	SINGLE SUPPORT (POST INSULATORS)		
	APRIL 2005	1 - PHASE PRIMARY	
	RUS	12.47/7.2 kV	A1.3P

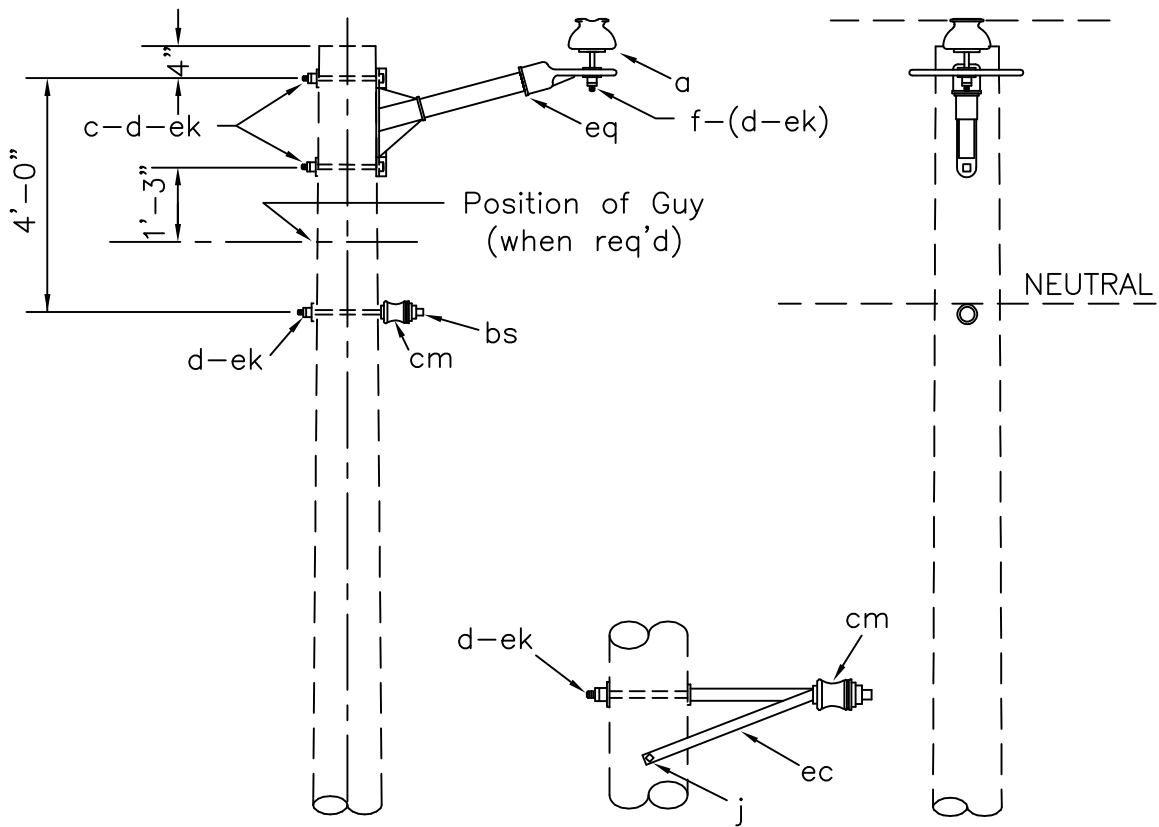

Specify A1.5N for
offset neutral assembly

		Assembly: A1.	
ITEM	MATERIAL	4N QTY	5N QTY
a	Insulator, pin type (12.47/7.2 kV)	1	1
c	Bolt, machine, 5/8" x req'd length	2	2
d	Washer, square 2 1/4"	3	3
(f)	(Pin, crossarm, 5/8" x 6 1/2")	(1)	(1)
j	Screw, lag, 1/2" x 4"		2
bs	Bolt, single, upset	1	
cm	Insulator, spool, 3"	1	1
ec	Bracket, offset neutral		1
ek	Locknuts	3	3
eq	Bracket, insulator/equipment	1	1

(If req'd)

Design Parameters:
Maximum Line Angles
5° - Small Conductors
2° - Larger than #1/0

SINGLE SUPPORT-NARROW PROFILE
(TANGENT)

APRIL 2005

1 - PHASE PRIMARY
12.47/7.2 kV

A1.4N
A1.5N

RUS

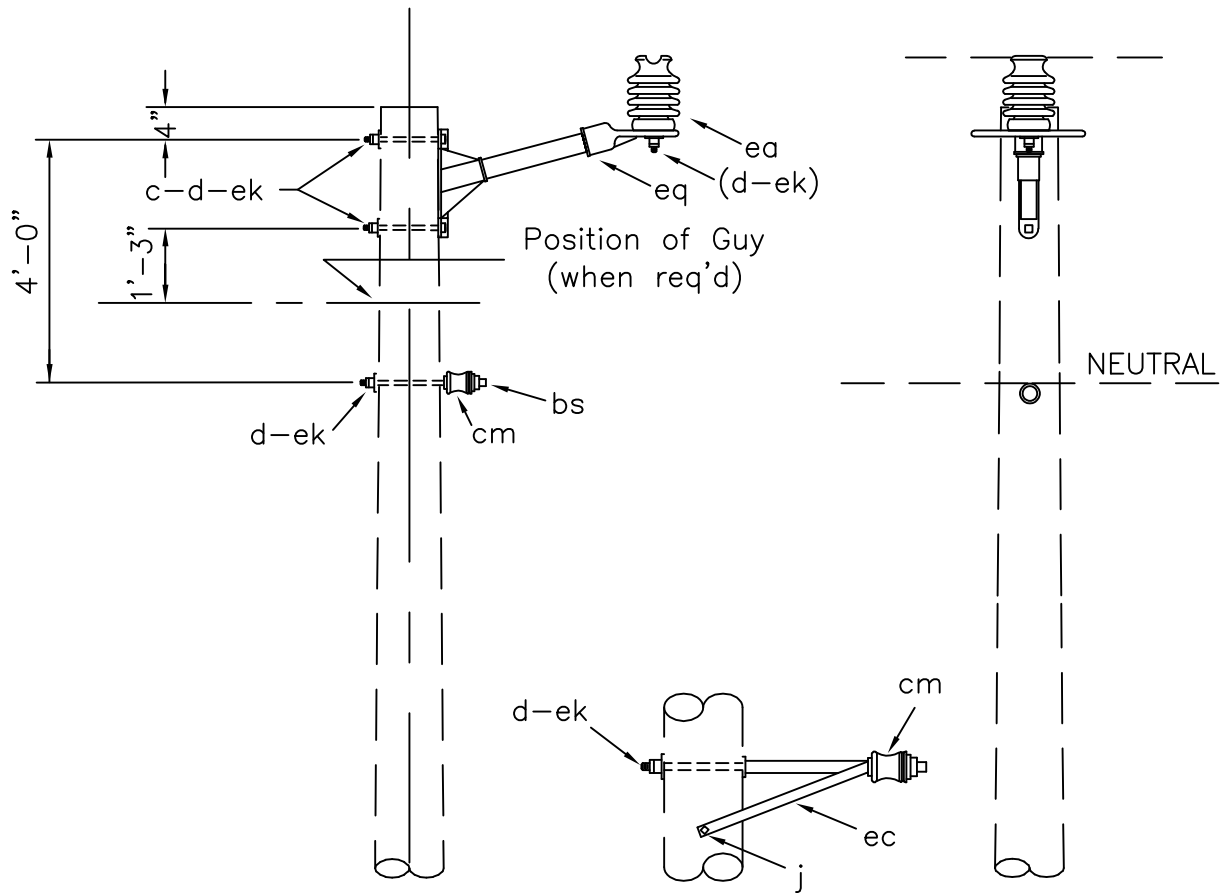

Assembly: VA1.4NP5NP

ITEM	MATERIAL	QTY	QTY
c	Bolt, machine, 5/8" x req'd length	2	2
d	Washer, square 2 1/4"	3	3
j	Screw, lag, 1/2" x 4"		2
bs	Bolt, single, upset	1	
cm	Insulator, spool, 3"	1	1
ea	Insulator, post type (12.47/7.2 kV)	1	1
ec	Bracket, offset neutral		1
ek	Locknuts	3	3
eq	Bracket, insulator/equipment	1	1

Design Parameters:
 Maximum Line Angles
 5° - Small conductors
 2° - Larger than #1/0

SINGLE SUPPORT-NARROW PROFILE
 (TANGENT) (POST INSULATORS)

APRIL 2005

1 - PHASE PRIMARY

A1.4NP

RUS

12.47/7.2 kV

A1.5NP

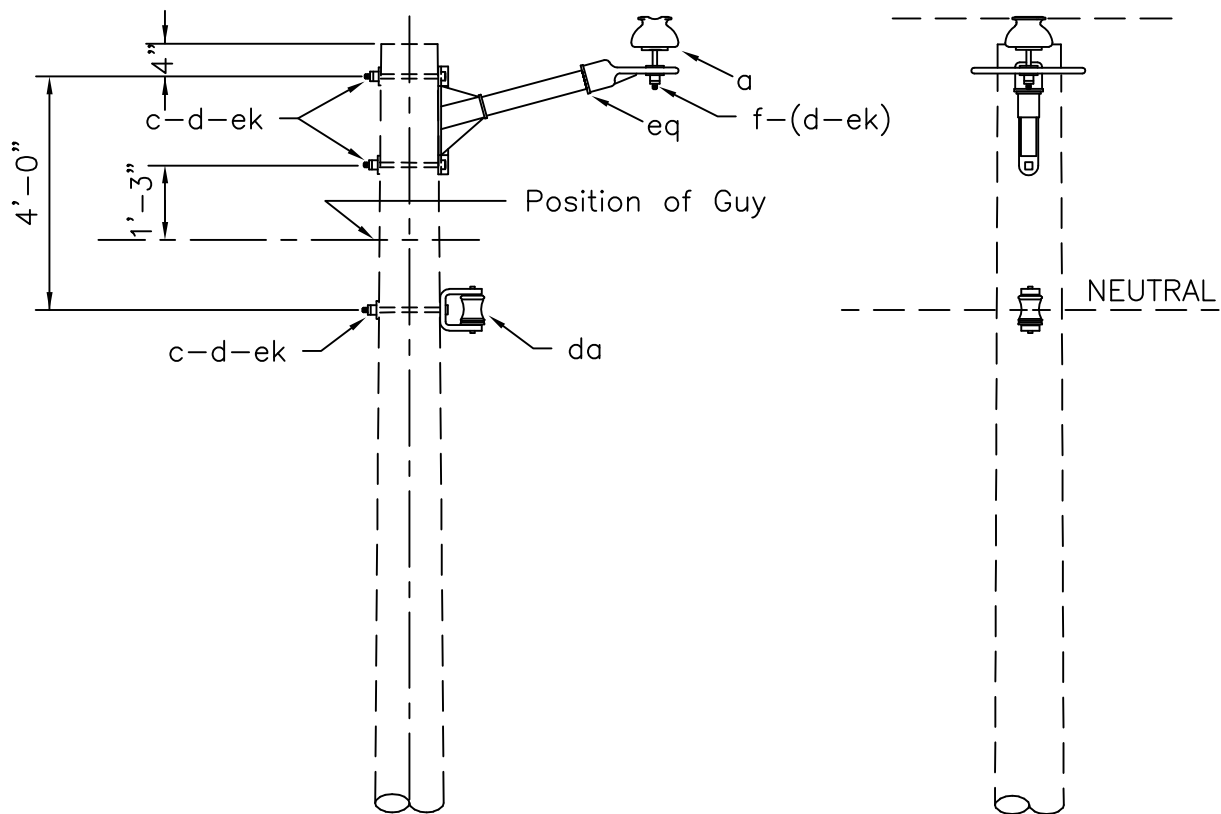

Assembly: A1. 6N

ITEM	MATERIAL	QTY
a	Insulator, pin type (12.47/7.2 kV)	1
c	Bolt, machine, 5/8" x req'd length	3
d	Washer, square 2 1/4"	3
(f)	(Pin, crossarm, 5/8" x 6 1/2")	(1) (If req'd)
da	Bracket, insulated	1
ek	Locknuts	3
eq	Bracket, insulator/equipment	1

Design Parameters:
Maximum Line Angles
See TABLE II

SINGLE SUPPORT-NARROW PROFILE

APRIL 2005

1 - PHASE PRIMARY

RUS

12.47/7.2 kV

A1.6N

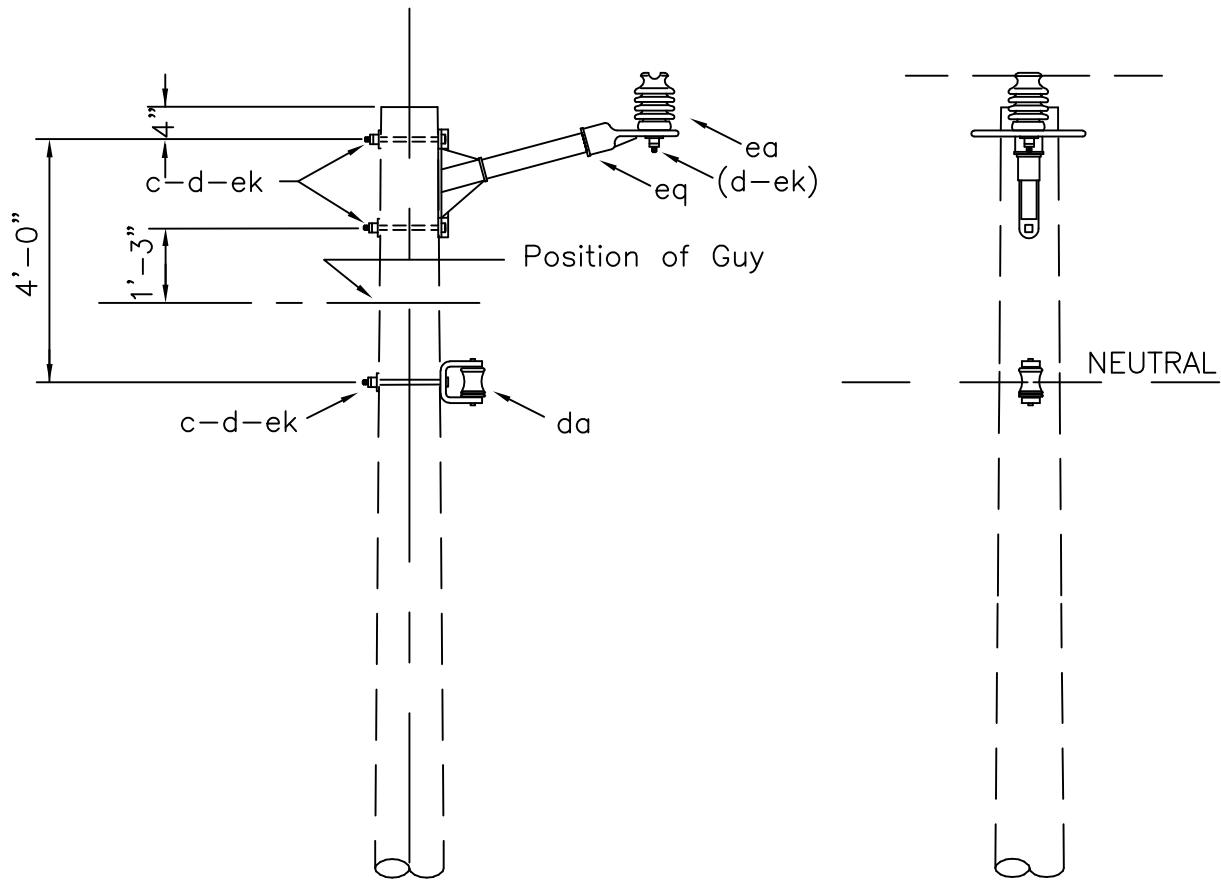

Assembly: A1. 6NP

ITEM	MATERIAL	QTY
c	Bolt, machine, 5/8" x req'd length	3
d	Washer, square 2 1/4"	3
da	Bracket, insulated	1
ea	Insulator, post type (12.47/7.2 kV)	1
ek	Locknuts	3
eq	Bracket, insulator/equipment	1

Design Parameters:

MAXIMUM LINE ANGLES:
See TABLE II

SINGLE SUPPORT-NARROW PROFILE
(POST INSULATORS)

APRIL 2005

RUS

1 - PHASE PRIMARY
12.47/7.2 kV

A1.6NP

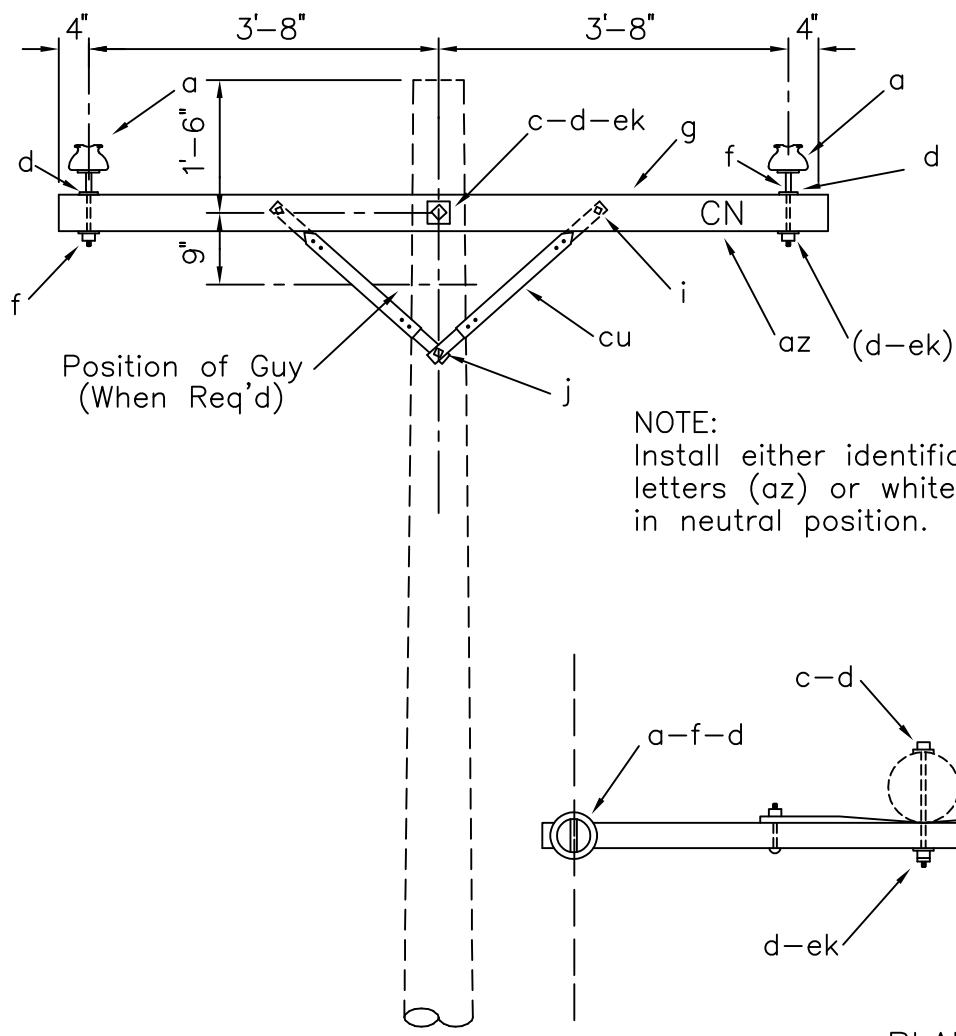

NOTE:
Install either identification
letters (az) or white insulator
in neutral position.

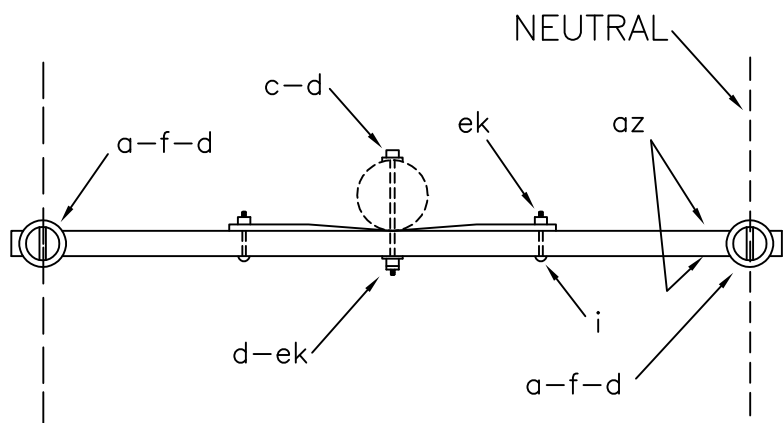

PLAN

ITEM	QTY	MATERIAL
a	1	Insulator, pin type, 15 kV, white
a	1	Insulator, pin type (12.47/7.2 kV)
c	1	Bolt, machine, 5/8" x req'd length
d	4	Washer, square, 2 1/4"
f	2	Pin, crossarm, steel, 5/8" x 10 3/4"
g	1	Crossarm, 3 5/8" x 4 5/8" x 8' - 0"
i	2	Bolt, carriage, 3/8" x 4 1/2"
j	1	Screw, lag, 1/2" x 4"
az	4	Letters, 2" C, 2" N, with 1" nails
cu	2	Brace, 28"
ek	3	Locknuts

DESIGN PARAMETERS:
See TABLE II

SINGLE SUPPORT ON CROSSARM

APRIL 2005	1 - PHASE PRIMARY 12.47/7.2 kV	A1.11 (A9-1)
RUS		

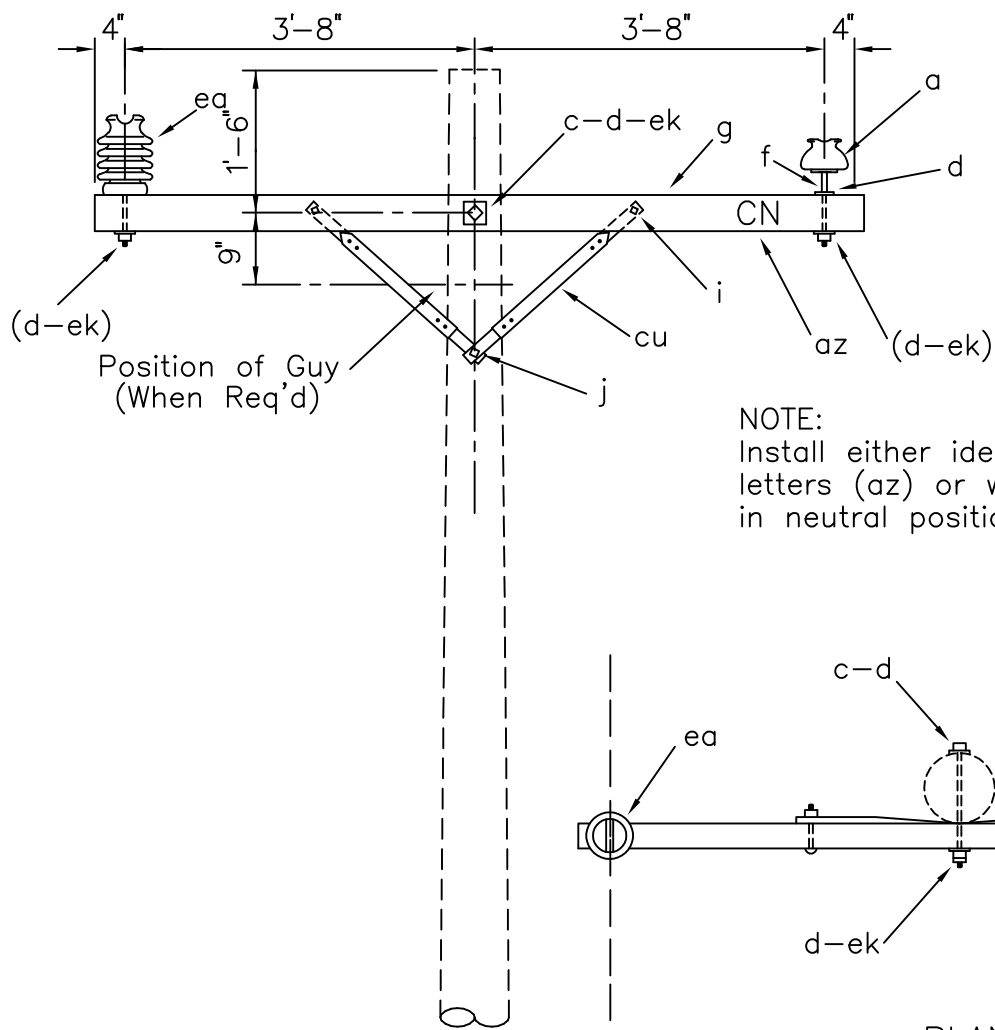

NOTE:
Install either identification
letters (az) or white insulator
in neutral position.

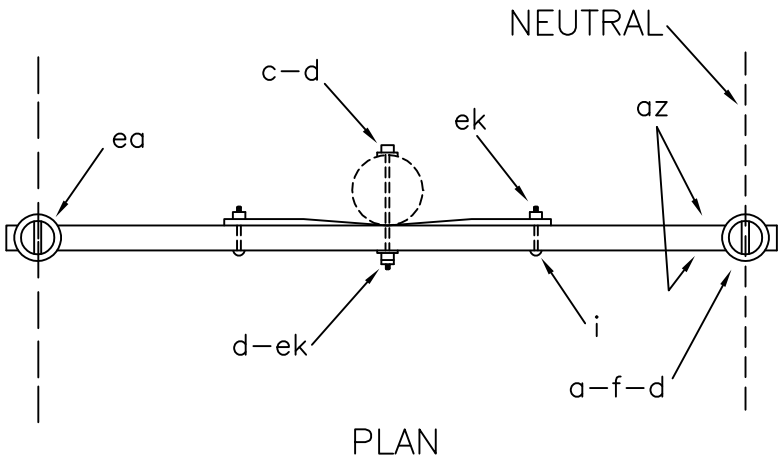

PLAN

ITEM	QTY	MATERIAL
a	1	Insulator, pin type, 15 kV, white
c	1	Bolt, machine, 5/8" x req'd length
d	3	Washer, square, 2 1/4"
f	1	Pin, crossarm, steel, 5/8" x 10 3/4"
g	1	Crossarm, 3 5/8" x 4 5/8" x 8' - 0"
i	2	Bolt, carriage, 3/8" x 4 1/2"
j	1	Screw, lag, 1/2" x 4"
az	4	Letters, 2" C, 2" N, with 1" nails
cu	2	Brace, 28"
ea	1	Insulator, post type (12.47/7.2 kV)
ek	3	Locknuts

DESIGN PARAMETERS:
See TABLE II

SINGLE SUPPORT ON CROSSARM
(POST INSULATORS)

APRIL 2005

1 - PHASE PRIMARY
12.47/7.2 kV

RUS

A1.11P (A9-1P)

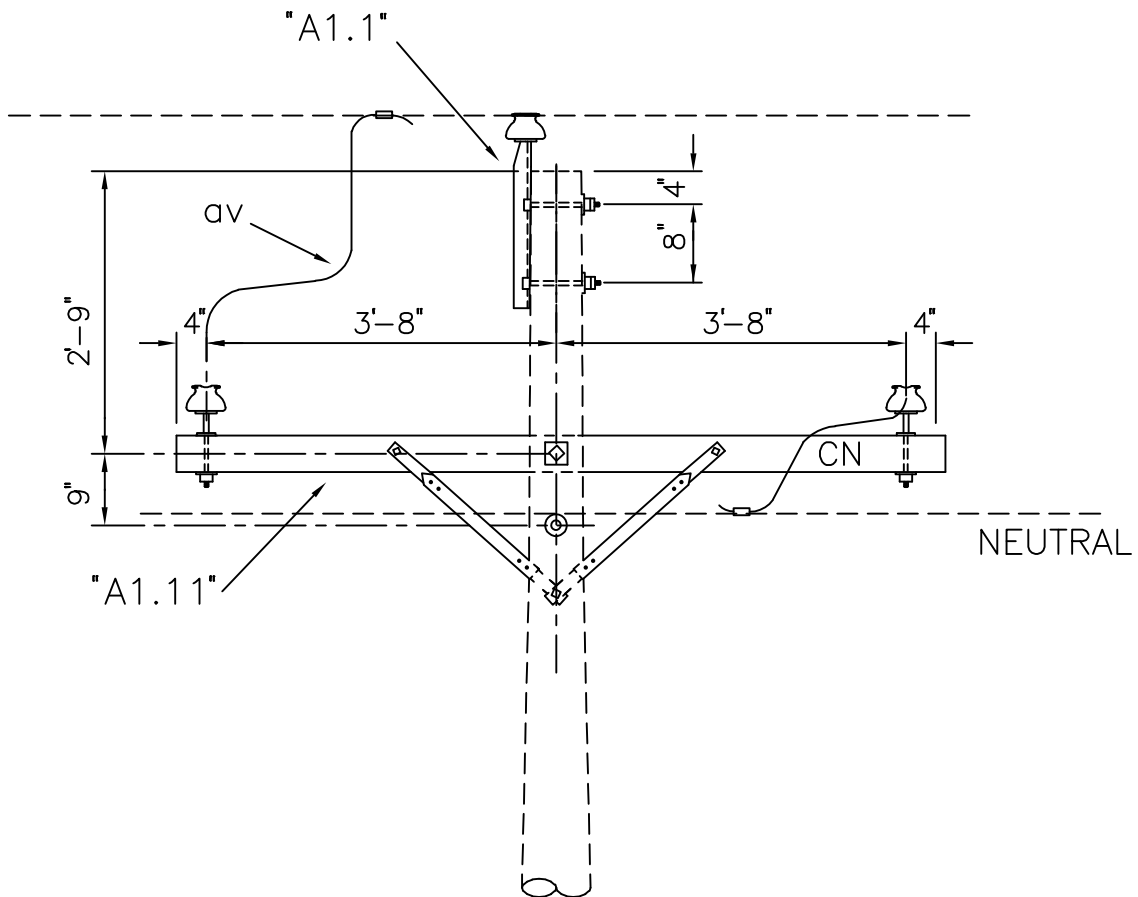
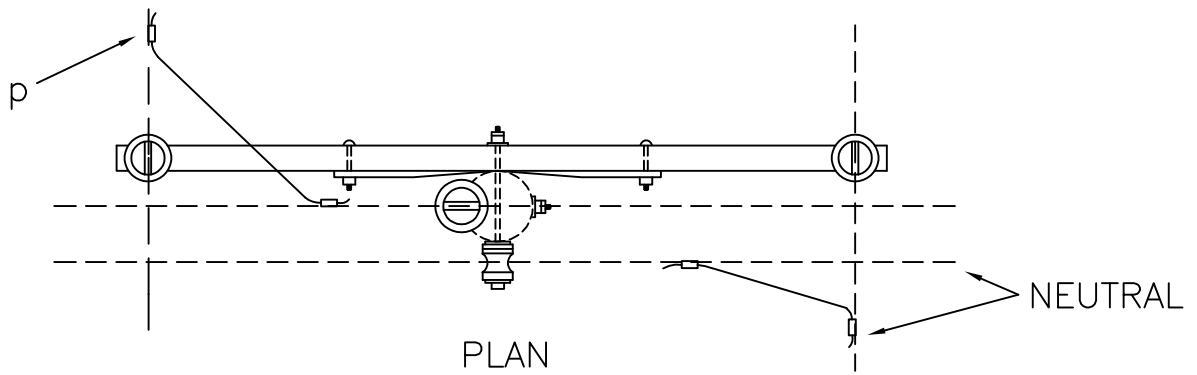

ITEM	QTY	MATERIAL
	1	A1.1 Primary Assembly
	1	A1.11 Primary Assembly
P		Connectors, as req'd
av		Jumpers, as req'd

DESIGN PARAMETERS:

See: "A1.1"
"A1.11"

SINGLE PHASE JUNCTION GUIDE

APRIL 2005

RUS

1 - PHASE PRIMARY
12.47/7.2 kV

A1.12G

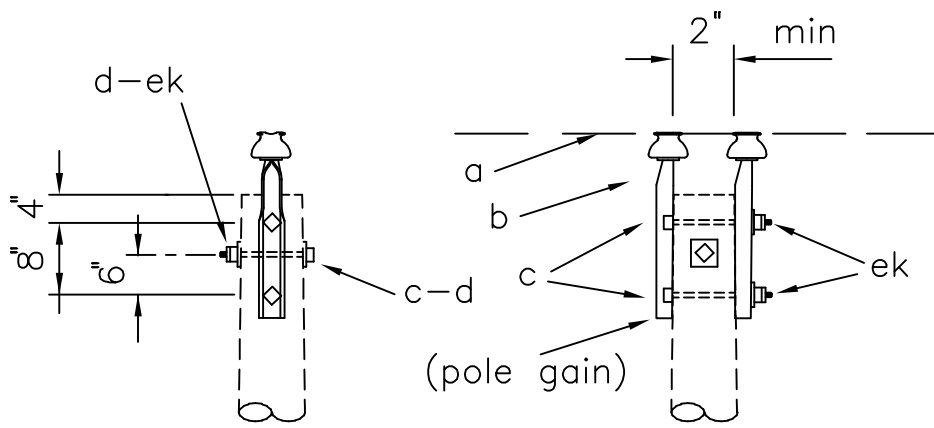

A2.01

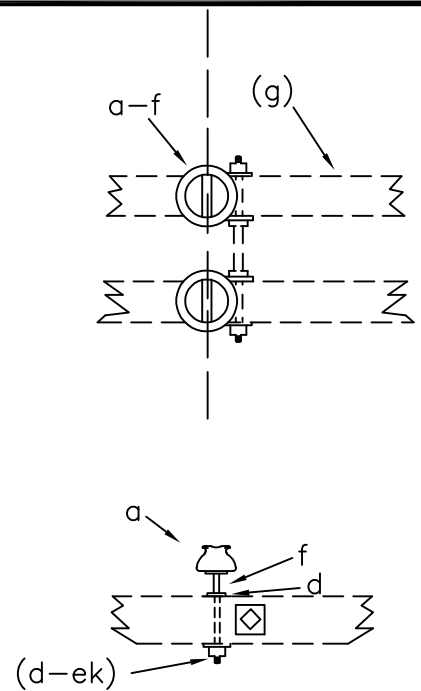

A2.021

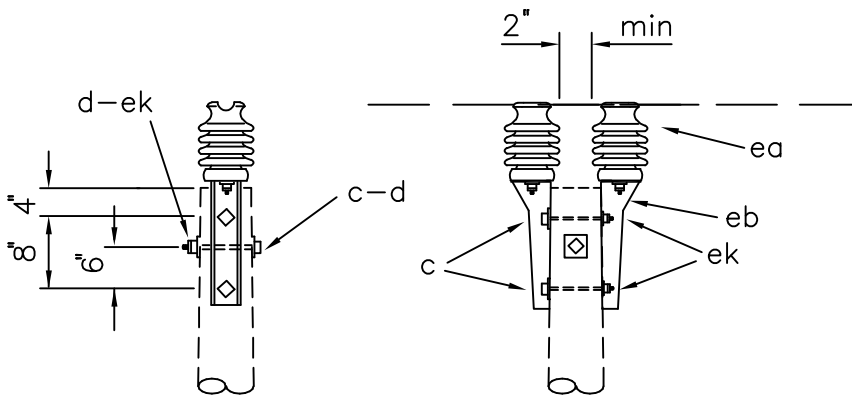

A2.01P

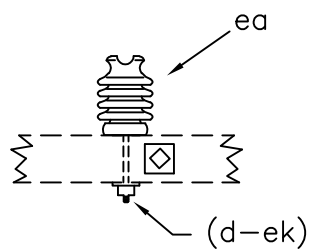
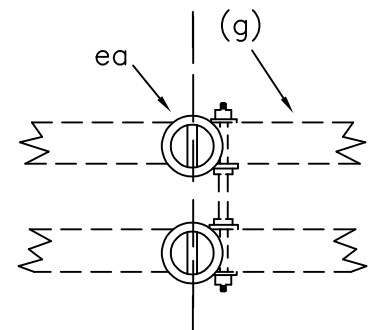

A2.021P

ASSEMBLY: A2.

ITEM	MATERIAL	01	01P	021	021P
		QTY	QTY	QTY	QTY
a	Insulator, pin type (12.47/7.2 kV)	2		2	
b	Pin, pole top, 20	2			
c	Bolt, machine, 5/8" x req'd length	3	3		
d	Washer, square, 2 1/4"	2	2	2	
f	Pin, crossarm steel, 5/8" x 10 3/4"			2	
ea	Insulator, post type (12.47/7.2 kV)		2		2
eb	Bracket, pole top		2		
ek	Locknuts	3	3		

DESIGN PARAMETERS:

A2.01: See TABLE III
 A2.01P: See TABLE IV
 A2.021: See TABLE IV
 A2.021P: See TABLE IV

DOUBLE SUPPORT-PRIMARY

APRIL 2005	1 - PHASE PRIMARY 12.47/7.2 kV	A2.01,A2.01P A2.021,A2.021P
RUS		

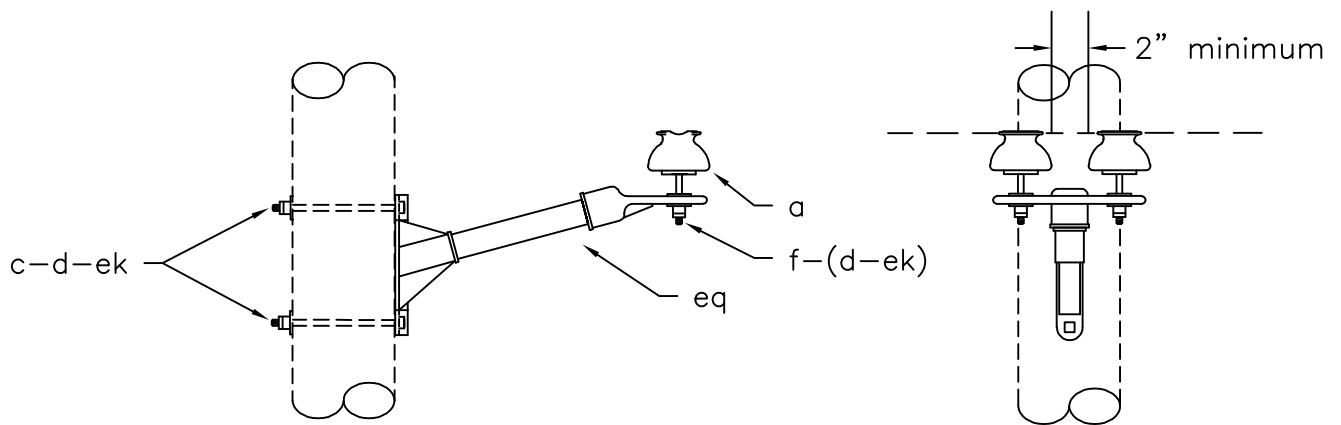

A2.04N

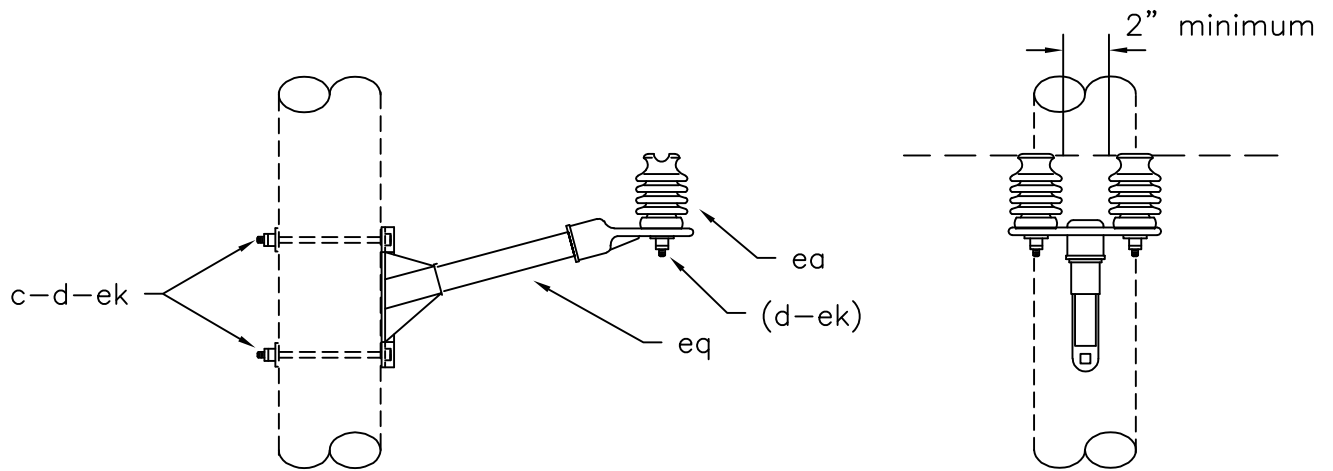

A2.04NP

ASSEMBLY: A2. 04N 04NP

ITEM	MATERIAL	QTY	QTY
a	Insulator, pin type (12.47/7.2 kV)	2	
c	Bolt, machine, 5/8" x req'd length	2	2
d	Washer, square 2 1/4"	2	2
f	Pin, crossarm, 5/8" x 6 1/2"	2	
ea	Insulator, post type (12.47/7.2kV)		2
ek	Locknuts	2	2
eq	Bracket, insulator/equipment	1	1

Design Parameters:

MAXIMUM LINE ANGLES:
See Table IV

DOUBLE SUPPORT-NARROW PROFILE

APRIL 2005

RUS

1 - PHASE PRIMARY
12.47/7.2 kV

A2.04N
A2.04NP

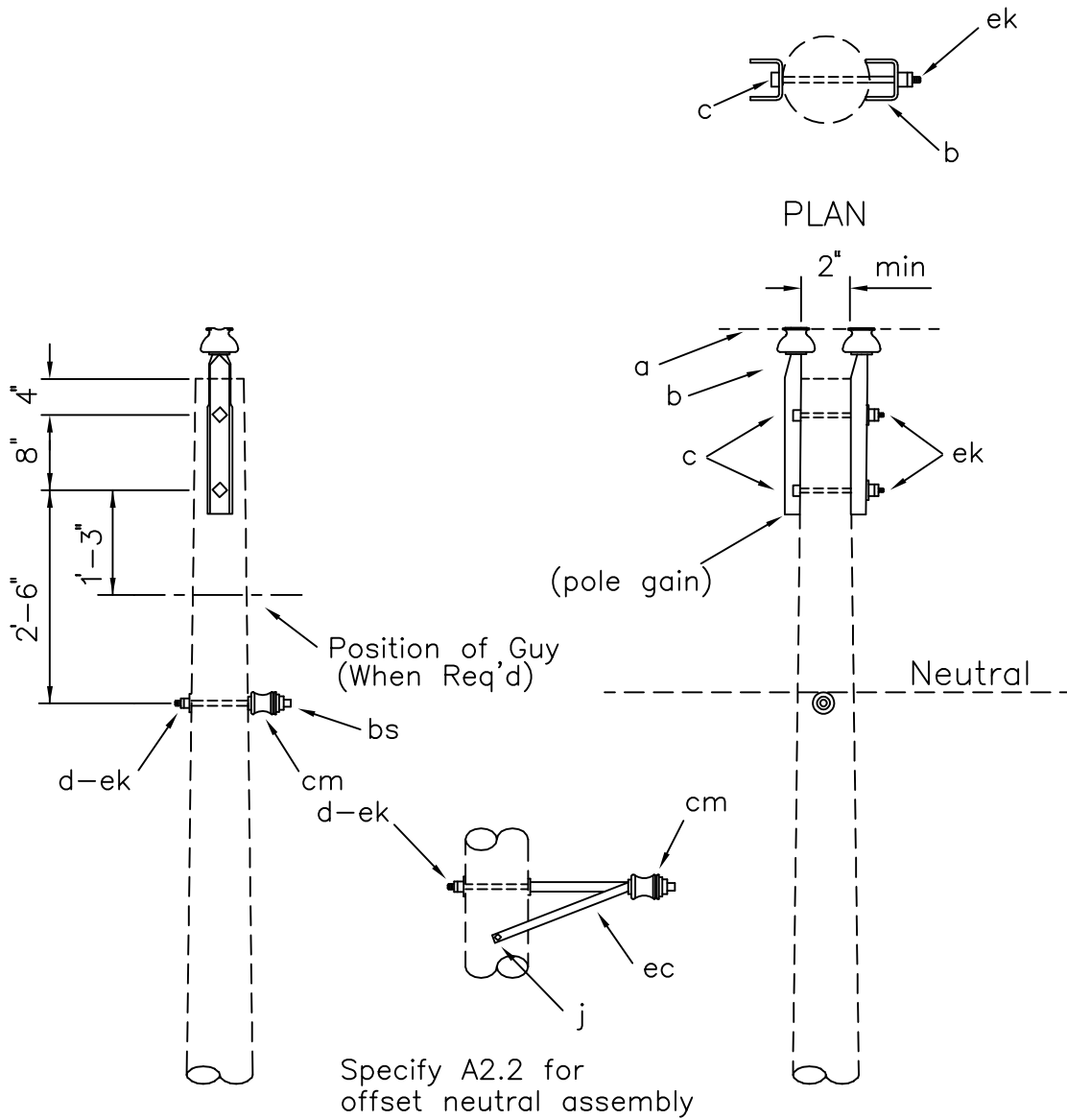

NOTE: These assemblies used for NESC Grade B construction.

ASSEMBLY:

ITEM	MATERIAL	A2.1 QTY	A2.2 QTY
a	Insulator, pin type (12.47/7.2 kV)	2	2
b	Pin, pole top	2	2
c	Bolt, machine, 5/8" x req'd length	2	2
d	Washer, square 2 1/4"	1	1
j	Screw, lag, 1/2" x 4"		2
bs	Bolt, single, upset	1	
cm	Insulator, spool, 3"	1	1
ec	Bracket, offset neutral		1
ek	Locknuts	3	3

DESIGN PARAMETERS:

MAXIMUM LINE ANGLES:
 5° - Small Conductors
 2° - Larger than #1/0

DOUBLE SUPPORT
(TANGENT)

APRIL 2005

RUS

1 - PHASE PRIMARY
 12.47/7.2 kV

A2.1 (A1-1)
 A2.2 (A1-1A)

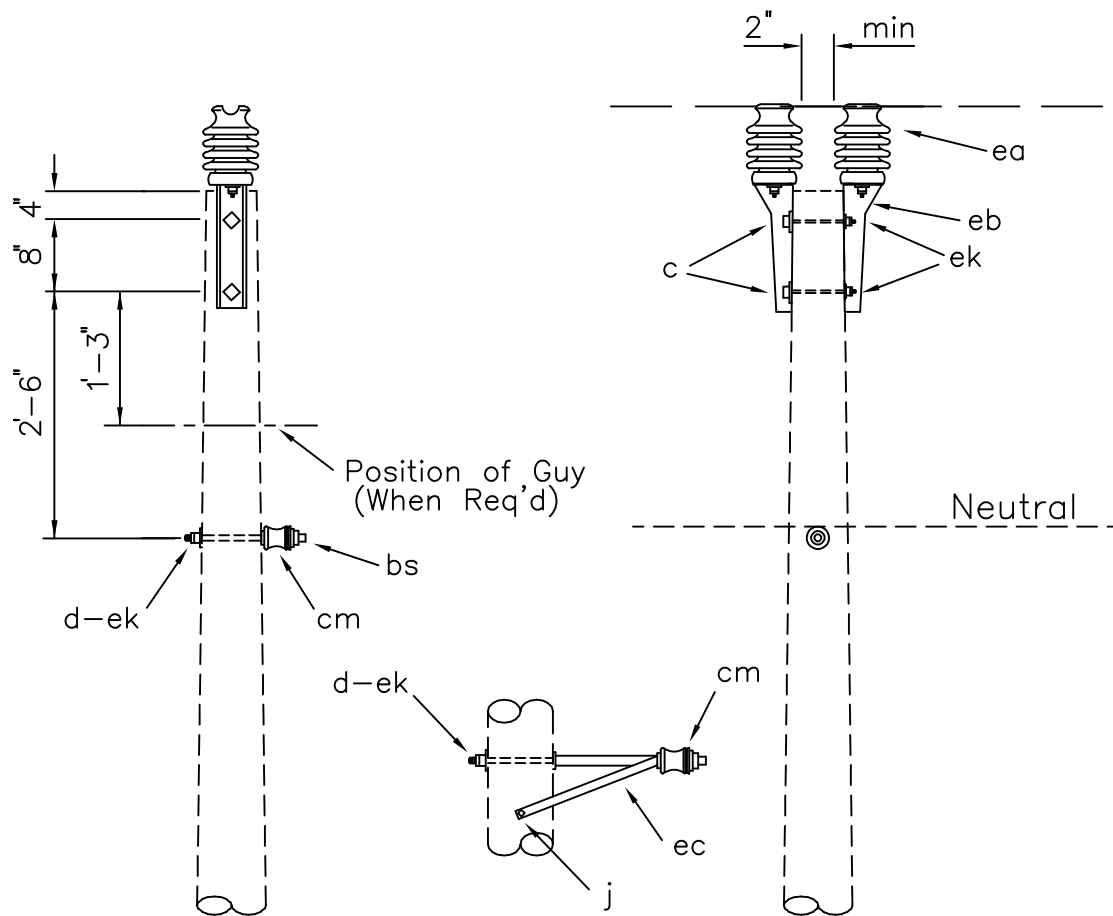

Specify A2.2P for offset neutral assembly

NOTE: These assemblies used for NESC Grade B construction.

ASSEMBLY: A2

ITEM	MATERIAL	ASSEMBLY: A2	
		.1P QTY	.2P QTY
c	Bolt, machine, 5/8" x req'd length	2	2
d	Washer, square 2 1/4"	1	1
j	Screw, lag, 1/2" x 4"		2
bs	Bolt, single, upset	1	
cm	Insulator, spool, 3"	1	1
ea	Insulator, post type (12.47/7.2 kV)	2	2
eb	Bracket, pole top	2	2
ec	Bracket, offset neutral		1
ek	Locknuts	3	3

DESIGN PARAMETERS:

MAXIMUM LINE ANGLES:
 5° - Small Conductors
 2° - Larger than #1/0

DOUBLE SUPPORT - (TANGENT)
 (POST INSULATORS)

APRIL 2005

RUS

1 - PHASE PRIMARY
 12.47/7.2 kV

A2.1P (A1-1P)
 A2.2P (A1-1AP)

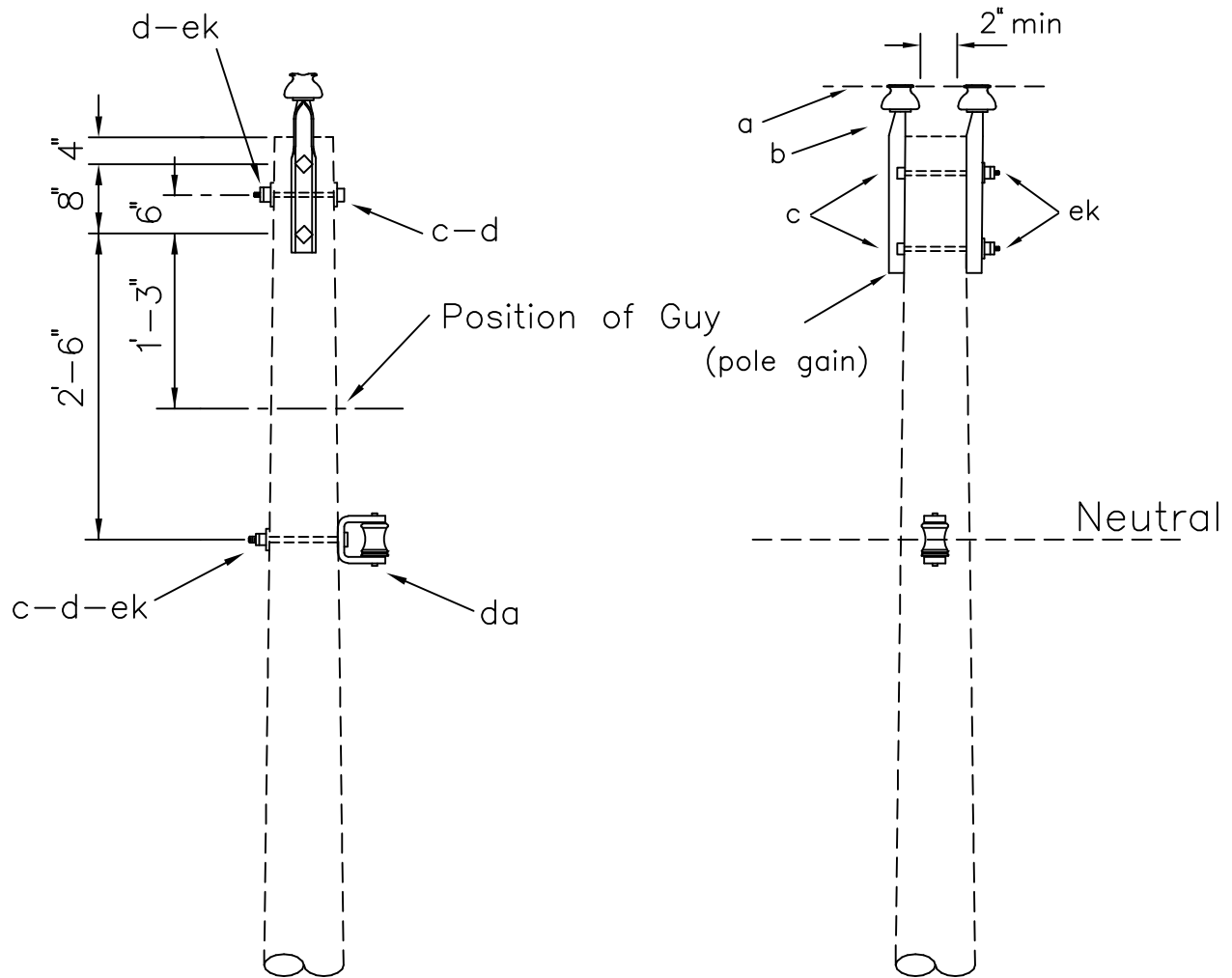

ITEM	QTY	MATERIAL
a	2	Insulator, pin type (12.47/7.2 kV)
b	2	Pin, pole top
c	4	Bolt, machine, 5/8" x req'd length
d	3	Washer, square, 2 1/4"
da	1	Bracket, insulated
ek	4	Locknuts

DESIGN PARAMETERS:
See TABLE III

DOUBLE SUPPORT

APRIL 2005

1 - PHASE PRIMARY
12.47/7.2 kV

RUS

A2.3 (A2)

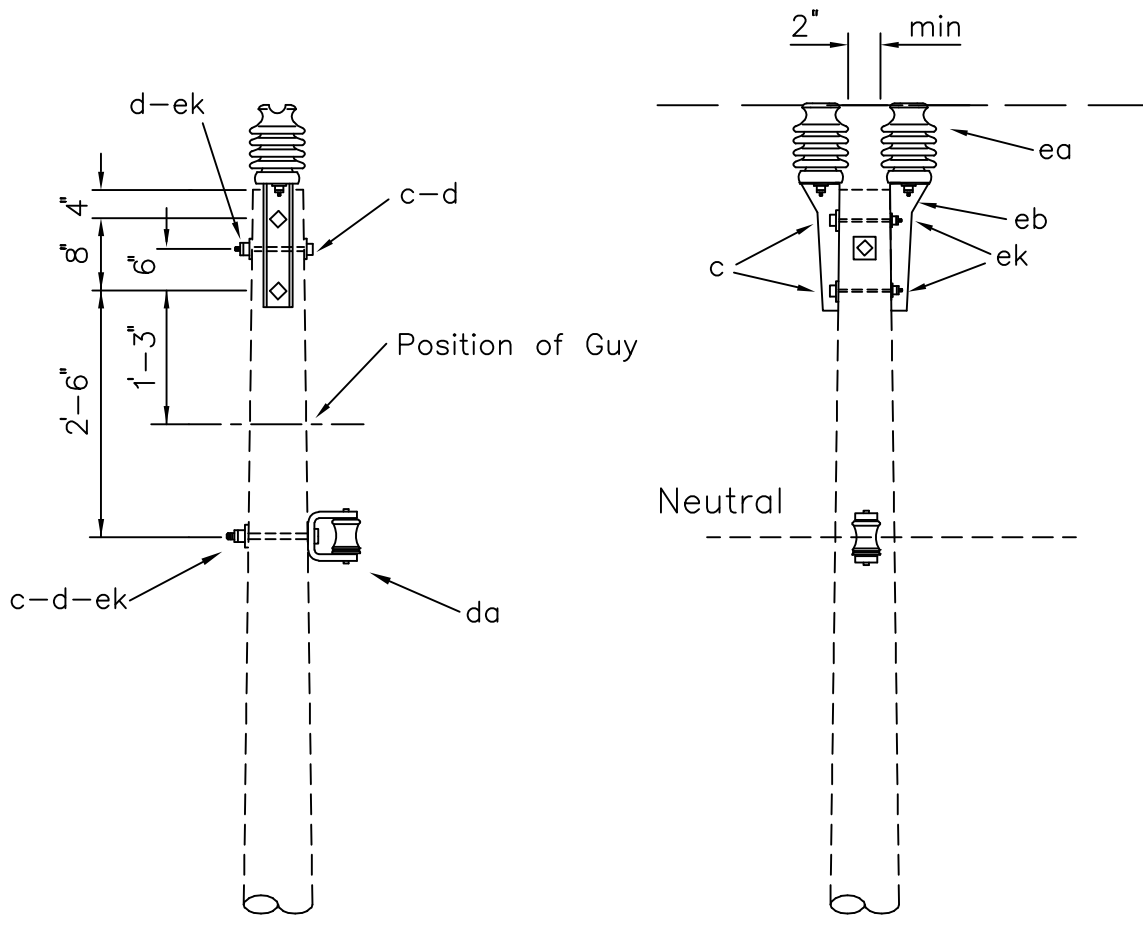

ITEM	QTY	MATERIAL
c	4	Bolt, machine, 5/8" x req'd length
d	3	Washer, square, 2 1/4"
da	1	Bracket, insulated
ea	2	Insulator, post type (12.47/7.2 kV)
eb	2	Bracket, pole top
ek	4	Locknuts

DESIGN PARAMETERS: See TABLE IV	DOUBLE SUPPORT (POST INSULATORS)		
	APRIL 2005	1 - PHASE PRIMARY	
	RUS	12.47/7.2 kV	A2.3P (A2P)

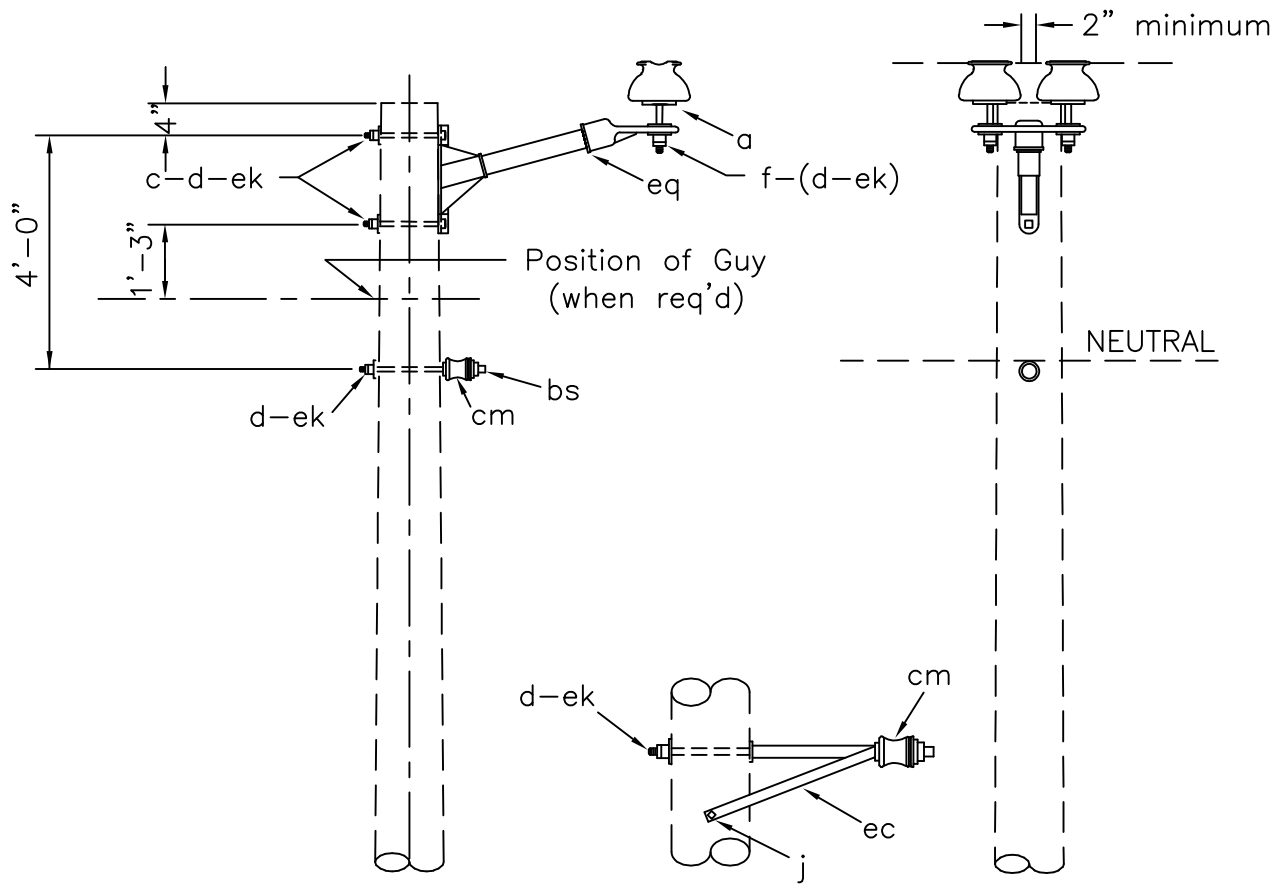

Specify A2.5N for offset neutral assembly

NOTE: These assemblies used for NESC Grade B construction.

		Assembly: A2.	
ITEM	MATERIAL	4N QTY	5N QTY
a	Insulator, pin type (12.47/7.2 kV)	2	2
c	Bolt, machine, 5/8" x req'd length	2	2
d	Washer, square 2 1/4"	3	3
f	Pin, crossarm, 5/8" x 6 1/2"	2	2
j	Screw, lag, 1/2" x 4"		2
bs	Bolt, single, upset	1	
cm	Insulator, spool, 3"	1	1
ec	Bracket, offset neutral		1
ek	Locknuts	3	3
eq	Bracket, insulator/equipment	1	1

Design Parameters:
 Maximum Line Angles
 5° - Small Conductors
 2° - Larger than #1/0

DOUBLE SUPPORT-NARROW PROFILE
 (TANGENT)

APRIL 2005

1 - PHASE PRIMARY
 12.47/7.2 kV

A2.4N
 A2.5N

RUS

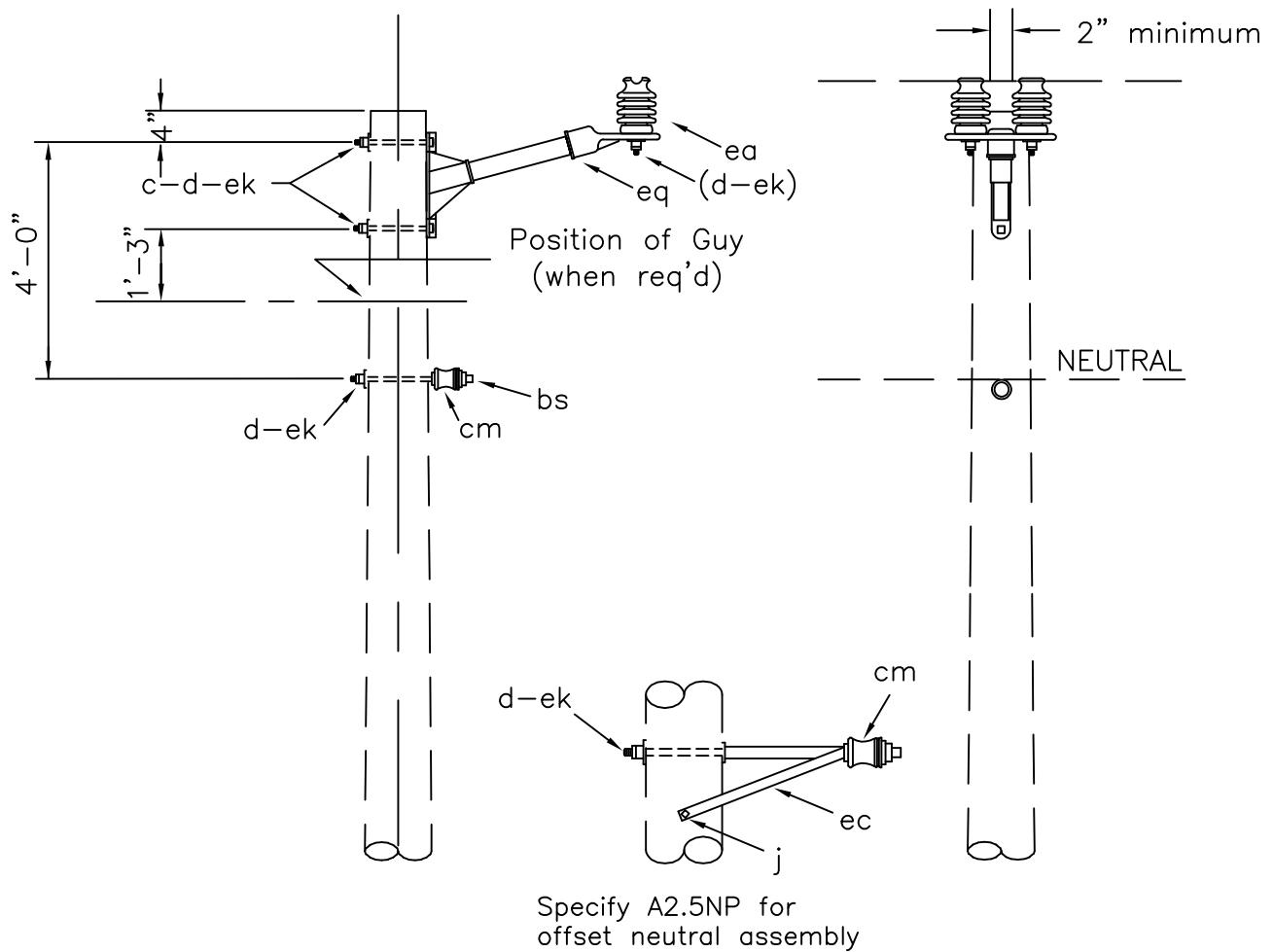

NOTE: These assemblies used for NESC Grade B construction.

		Assembly: A2.	
ITEM	MATERIAL	4NP QTY	5NP QTY
c	Bolt, machine, 5/8" x req'd length	2	2
d	Washer, square 2 1/4"	3	3
j	Screw, lag, 1/2" x 4"		2
bs	Bolt, single, upset	1	
cm	Insulator, spool, 3"	1	1
ea	Insulator, post type (12.47/7.2 kV)	2	2
ec	Bracket, offset neutral		1
ek	Locknuts	3	3
eq	Bracket, insulator/equipment	1	1

Design Parameters:
 Maximum Line Angles
 5° - Small conductors
 2° - Larger than #1/0

DOUBLE SUPPORT-NARROW PROFILE
 (TANGENT) (POST INSULATORS)

APRIL 2005

1 - PHASE PRIMARY
 12.47/7.2 kV

A2.4NP
 A2.5NP

RUS

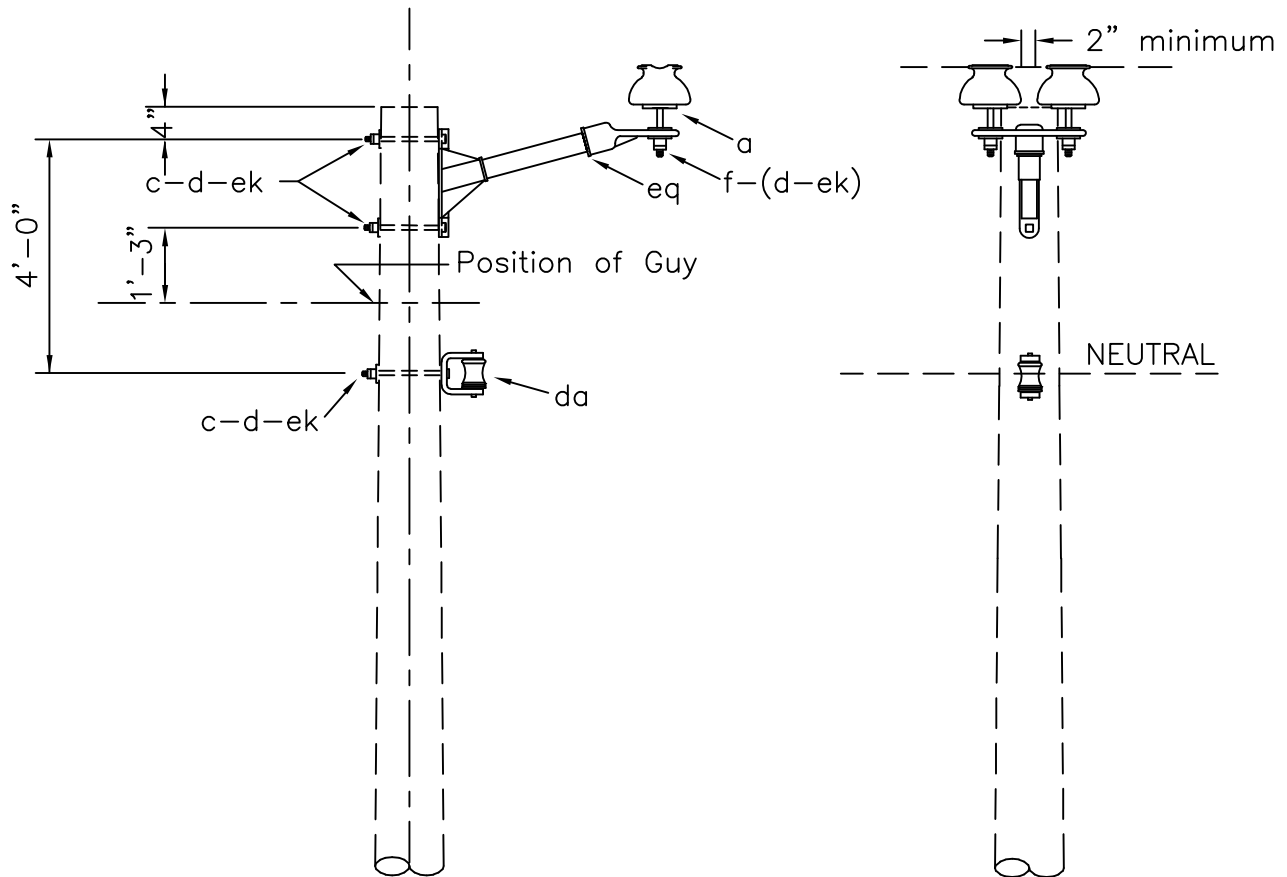

Assembly: A2.6N

ITEM	MATERIAL	QTY
a	Insulator, pin type (12.47/7.2 kV)	2
c	Bolt, machine, 5/8" x req'd length	3
d	Washer, square 2 1/4"	3
f	Pin, crossarm, 5/8" x 6 1/2"	2
da	Bracket, insulated	1
ek	Locknuts	3
eq	Bracket, insulator/equipment	1

Design Parameters:
Maximum Line Angles
See TABLE IV

DOUBLE SUPPORT-NARROW PROFILE

APRIL 2005

1 - PHASE PRIMARY

RUS

12.47/7.2 kV

A2.6N

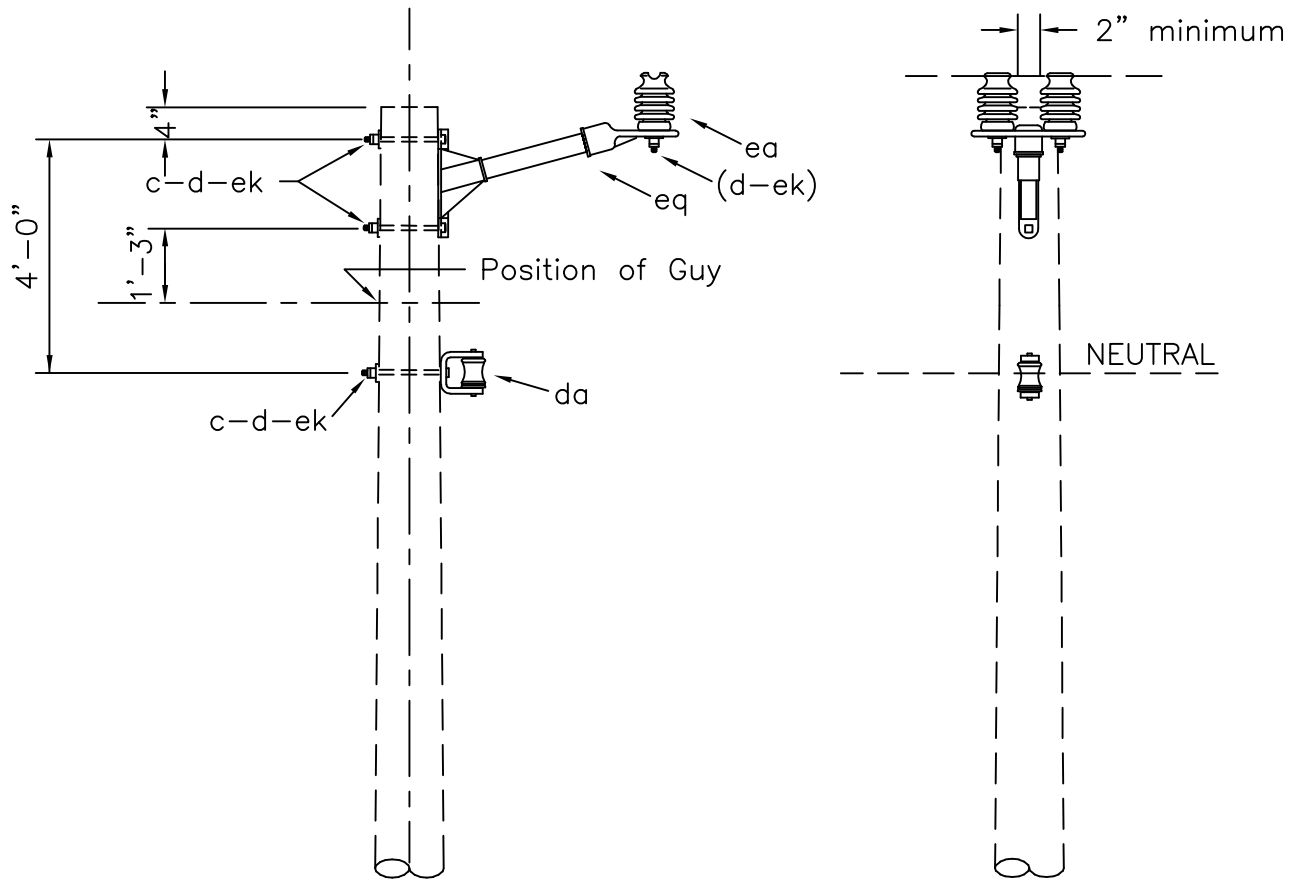

Assembly: A2. 6NP

ITEM	MATERIAL	QTY
c	Bolt, machine, 5/8" x req'd length	3
d	Washer, square 2 1/4"	3
da	Bracket, insulated	1
ea	Insulator, post type (12.47/7.2kV)	2
ek	Locknuts	3
eq	Bracket, insulator/equipment	1

Design Parameters:
Maximum Line Angles
See TABLE IV

DOUBLE SUPPORT-NARROW PROFILE
(POST INSULATORS)

APRIL 2005

1 - PHASE PRIMARY

RUS

12.47/7.2 kV

A2.6NP

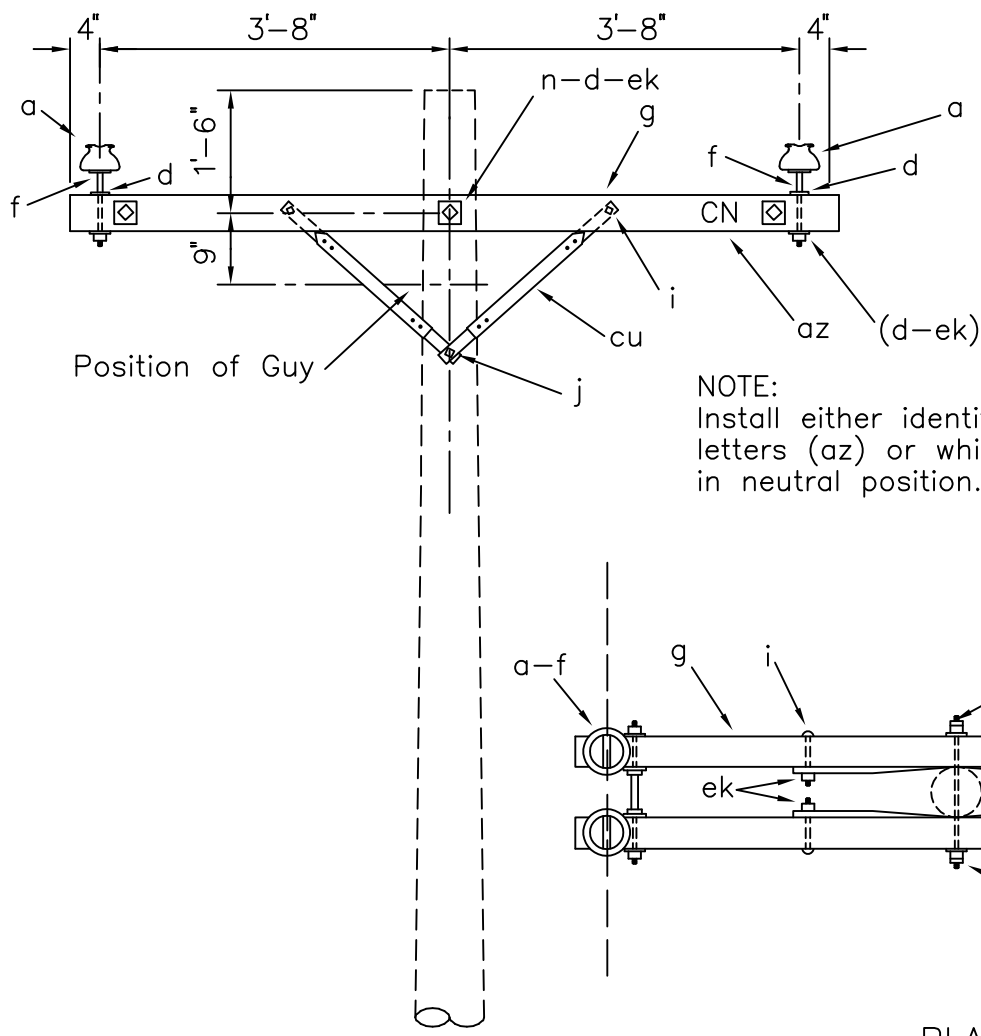

NOTE:
Install either identification
letters (az) or white
insulators
in neutral position.

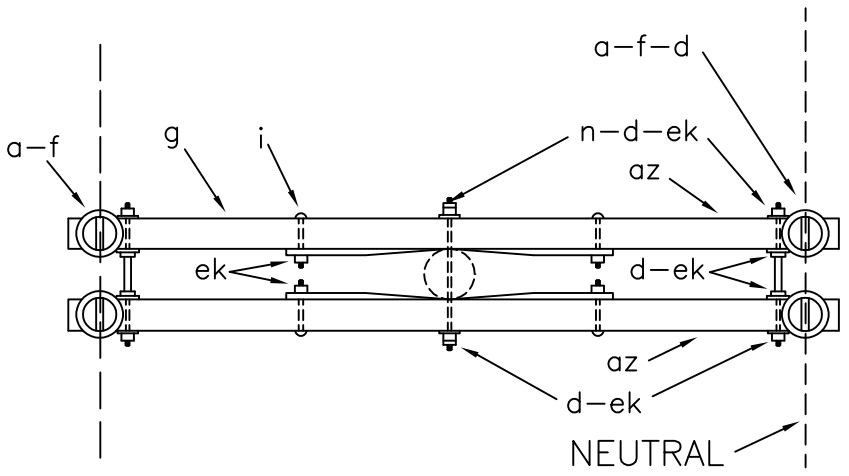

PLAN

ITEM	QTY	MATERIAL
a	2	Insulator, pin type 15 kV white
a	2	Insulator, pin type (12.47/7.2 kV)
d	14	Washer, square, 2 1/4"
f	4	Pin, crossarm, steel, 5/8" x 10 3/4"
g	2	Crossarm, 3 5/8" x 4 5/8" x 8' 0"
i	4	Bolt, carriage, 3/8" x 4 1/2"
j	2	Screw, lag, 1/2" x 4"
n	3	Bolt, double arm, 5/8" x req'd length
az	4	Letters, 2" C, 2" N, with 1" nails
cu	4	Brace, 28"
ek	14	Locknuts

DESIGN PARAMETERS:
See TABLE IV

DOUBLE SUPPORT ON CROSSARMS

APRIL 2005
RUS

1 - PHASE PRIMARY
12.47/7.2 kV

A2.21 (A9)

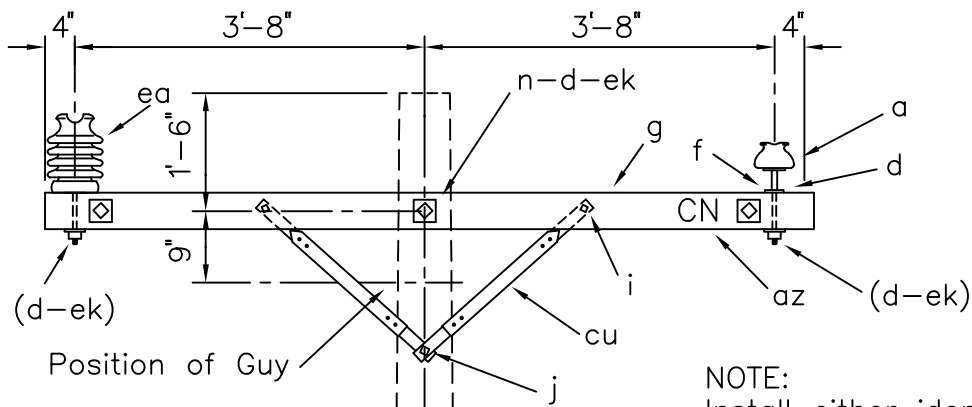

NOTE:
Install either identification
letters (az) or white insulator
in neutral position.

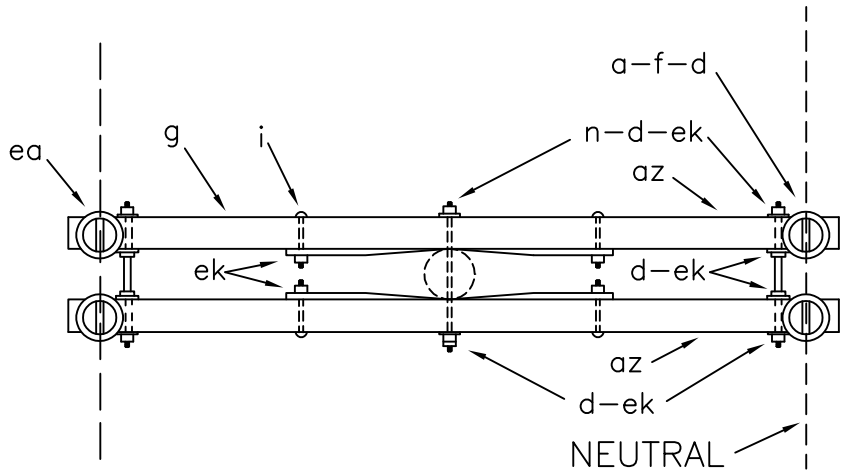

PLAN

ITEM	QTY	MATERIAL
a	2	Insulator, pin type, 15 kV, white
d	12	Washer, square, 2 1/4"
f	2	Pin, crossarm, steel, 5/8" x 10 3/4"
g	2	Crossarm, 3 5/8" x 4 5/8" x 8' 0"
i	4	Bolt, carriage, 3/8" x 4 1/2"
j	2	Screw, lag, 1/2" x 4"
n	3	Bolt, double arm, 5/8" x req'd length
az	4	Letters, 2" C, 2" N, with 1" nails
cu	4	Brace, 28"
ea	2	Insulator, post type (12.47/7.2 kV)
ek	14	Locknuts

DESIGN PARAMETERS:
See TABLE IV

DOUBLE SUPPORT ON CROSSARMS
(POST INSULATORS)

APRIL 2005	1 - PHASE PRIMARY 12.47/7.2 kV	A2.21P (A9P)
RUS		

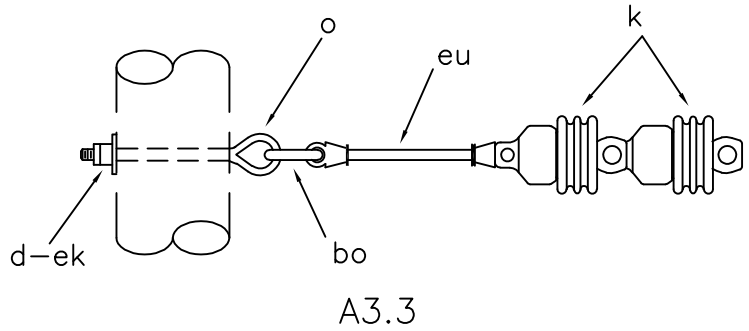
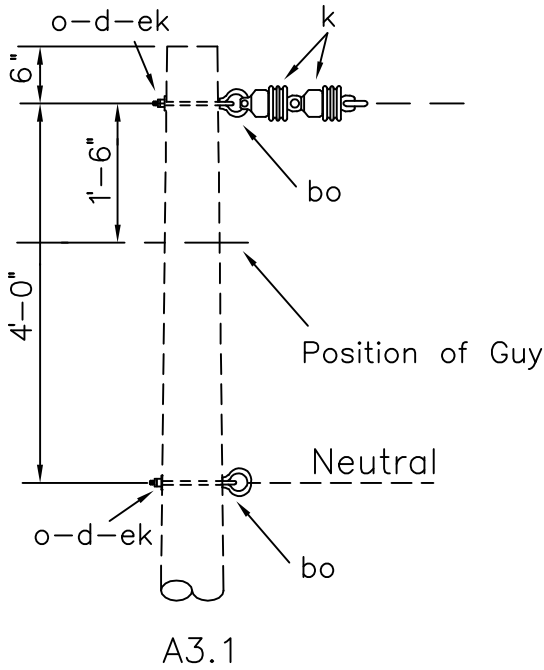
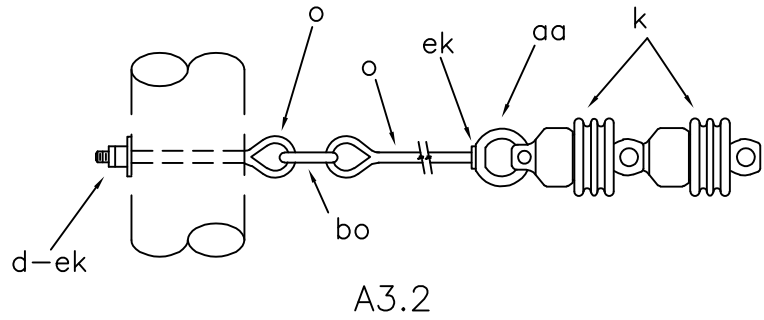
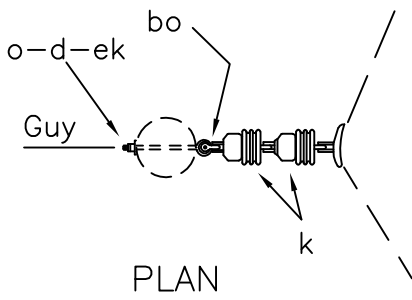

ASSEMBLY: A3

ITEM	MATERIAL	.1	.2	.3
		QTY	QTY	QTY
d	Washer, square, 3", curved	2	2	2
k	Insulator, suspension, 4 1/4"	2	2	2
o	Bolt, eye, 5/8"x req'd length	2	3	2
aa	Nut, eye		1	
bo	Shackle, anchor	2	2	2
ek	Locknuts	2	3	2
eu	Link, extension, insulated			1
(du)	(Link, extension) - (optional)			(1)

DESIGN PARAMETERS:

PERMITTED TRANSVERSE
LOAD= 5000 lbs./Conductor
20° - 60°: #1/0 ACSR & Larger
30° - 60°: Smaller Conductors

SUSPENSION ANGLE

APRIL 2005

RUS

1 - PHASE PRIMARY
12.47/7.2 kV

A3.1,A3.2,A3.3
(A3)

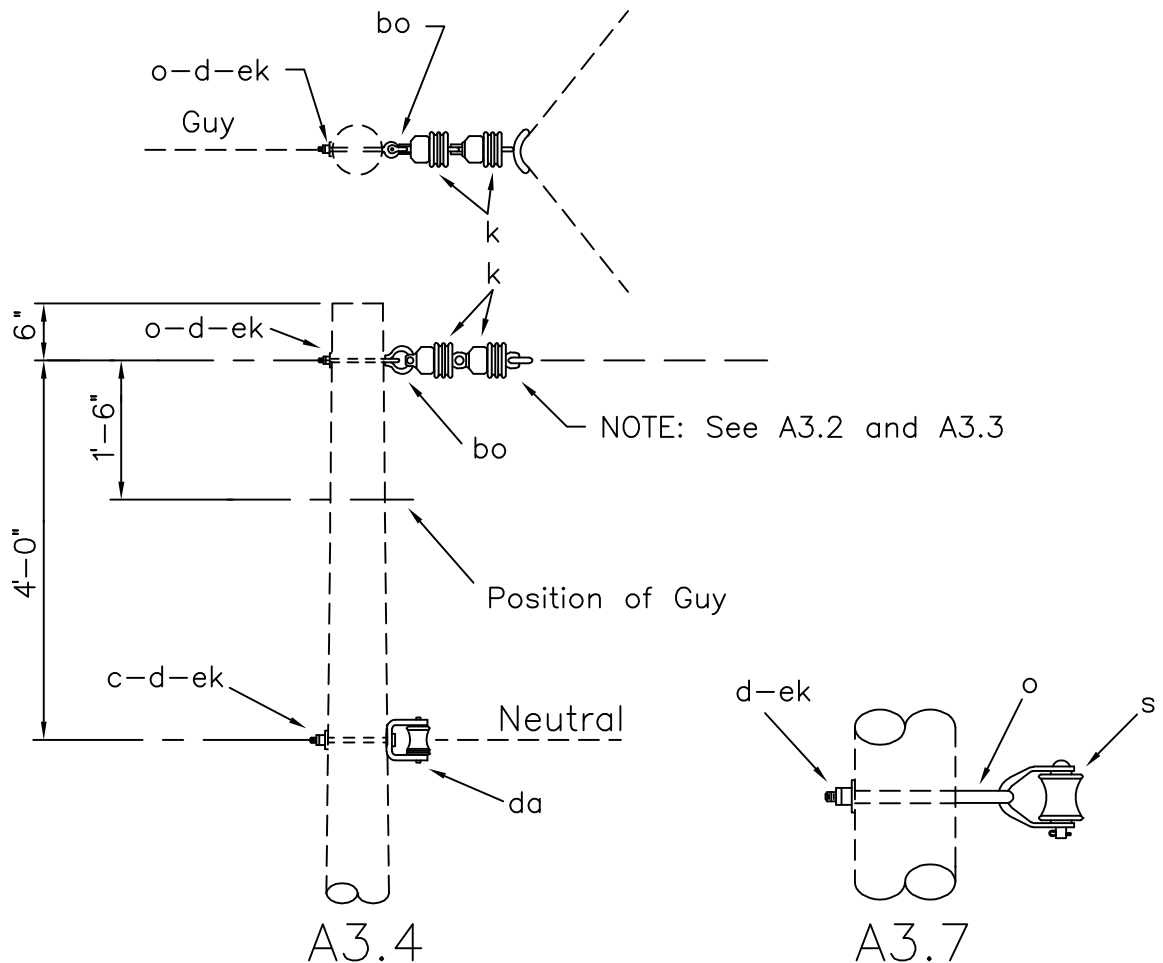

- A3.5 = A3.4 neutral subassembly + A3.2 primary subassembly
- A3.6 = A3.4 neutral subassembly + A3.3 primary subassembly
- A3.8 = A3.7 neutral subassembly + A3.2 primary subassembly
- A3.9 = A3.7 neutral subassembly + A3.3 primary subassembly

ASSEMBLY: A3		.4	.5	.6	.7	.8	.9
ITEM	MATERIAL	QTY	QTY	QTY	QTY	QTY	QTY
c	Bolt, machine, 5/8" x req'd length	1	1	1			
d	Washer, square, 3", curved	2	2	2	2	2	2
k	Insulator, suspension, 4 1/4"	2	2	2	2	2	2
o	Bolt, eye, 5/8"x req'd length	1	2	1	2	3	2
s	Clevis, secondary, swinging, insulated				1	1	1
aa	Nut, eye		1			1	
bo	Shackle, anchor	1	1	1	1	1	1
da	Bracket, insulated	1	1	1			
ek	Locknuts	2	3	2	2	3	2
eu	Link, extension, insulated			1			1
(du)	(Link, extension) - (optional)			(1)			(1)

DESIGN PARAMETERS:

For ANSI Class 53-2 Spool Insulator (1 3/4") See Table VI

For ANSI Class 53-4 Spool Insulator (3") See Table VII

SUSPENSION ANGLE

APRIL 2005	1 - PHASE PRIMARY 12.47/7.2 kV	A3.4 - A3.9
RUS		

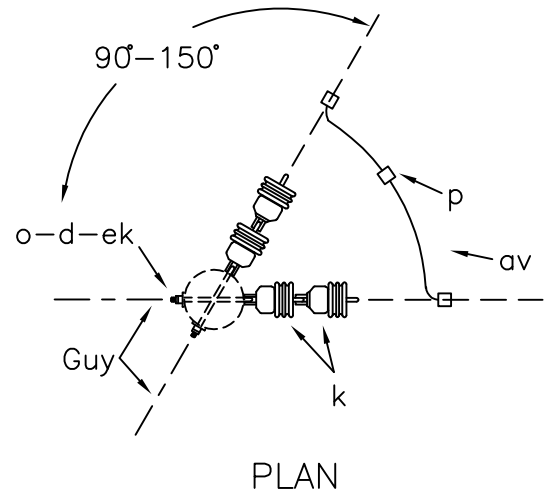
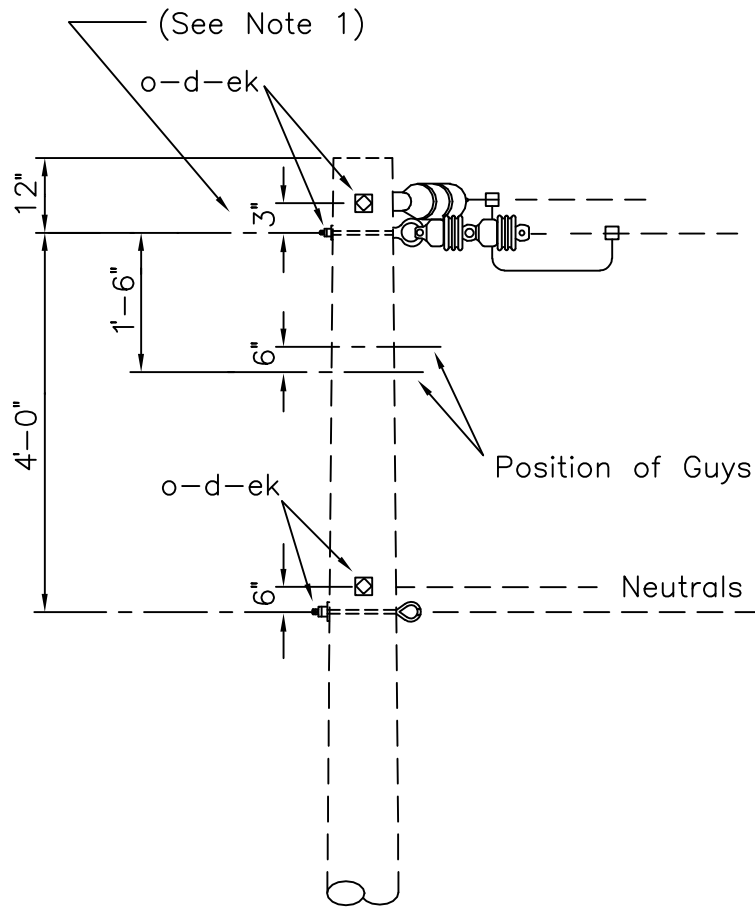

NOTES:

- 1, Separate 6" (top position only) when angle equals 90°.
2. Other combinations of deadend assemblies (A5.1 through A5.9) may be used, (e.g., two A5.3's; or one A5.1 plus one A5.7). Record alternative assemblies separately on staking sheets.
CAUTION: Use the appropriate permitted longitudinal loads.

ITEM	QTY	MATERIAL
d	4	Washer, square, 3", curved
k	4	Insulator, suspension, 4 1/4"
o	4	Bolt, eye, 5/8" x req'd length
p		Connectors, as req'd
av		Jumpers, as req'd
ek	4	Locknuts

DESIGN PARAMETERS:
PERMITTED LONGITUDINAL
LOAD = 5000 lbs./Conductor

DEADEND ANGLE (90°-150°)

APRIL 2005

1 - PHASE PRIMARY
12.47/7.2 kV

RUS

A4.1 (A4)

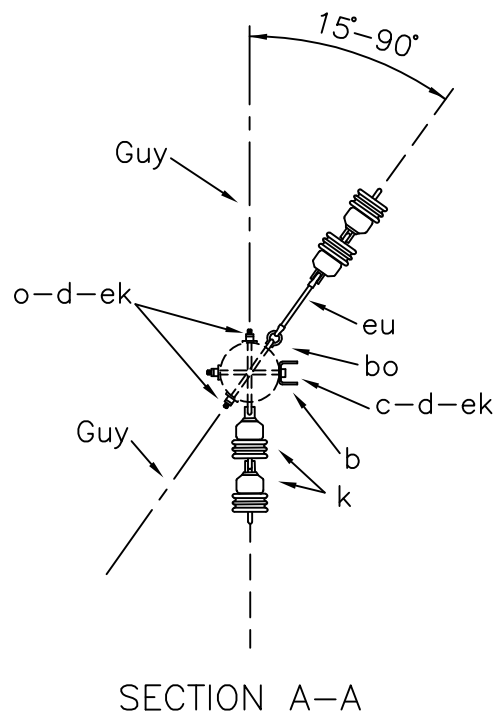
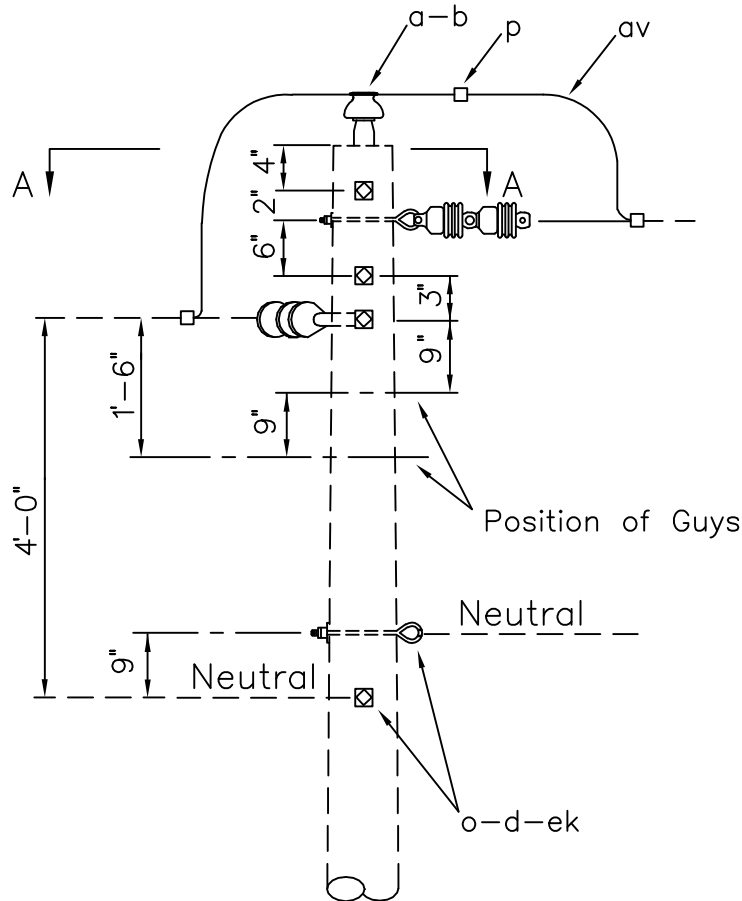

NOTES:

1. Use 3" curved washers, "d", on eyebolts, "o".
2. Other combinations of deadend assemblies (A5.1 through A5.9) may be used, (e.g., one A1.01 plus two A5.3's; or one A1.01 plus one A5.1 plus one A5.7). Record alternative assemblies separately on staking sheets. CAUTION: Use the appropriate permitted longitudinal loads.

ITEM	QTY	MATERIAL
a	1	Insulator, pin type (12.47/7.2 kV)
b	1	Pin, pole top, 20 "
c	2	Bolt, machine, 5/8 x req'd length
d	2	Washer, square, 2 1/4 "
d	4	Washer, square, 3, curved
k	4	Insulator, suspension, 4 1/4
o	4	Bolt, eye, 5/8 x req'd length
p		Connectors, as req'd
av		Jumpers, as req'd
bo	1	Shackle, anchor
ek	6	Locknuts
eu	1	Link, extension, insulated
(du)	(1)	(Link, Extension)(Optional)

DESIGN PARAMETERS:
 PERMITTED LONGITUDINAL
 LOAD = 5000 lbs./Conductor

DEADEND ANGLE (15°-90°)

APRIL 2005

1 - PHASE PRIMARY
 12.47/7.2 kV

A4.2

RUS

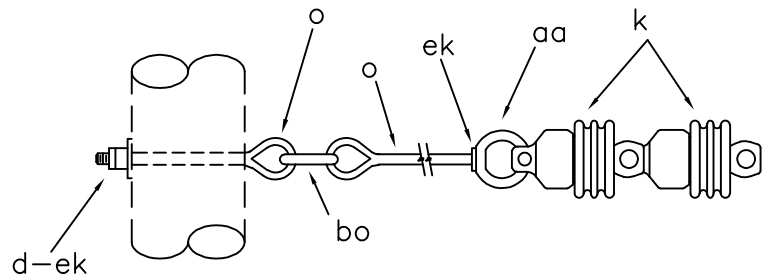

A5.02

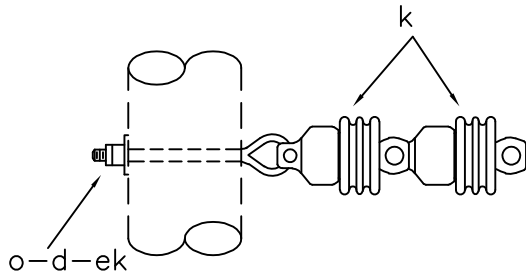

A5.01

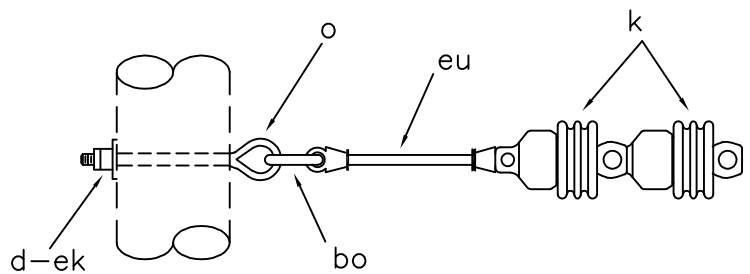

A5.03

NOTE: When connecting to existing bolt end, use eyenut "aa" and locknut "ek" instead of eyebolt subassembly "o-d-ek".

		ASSEMBLY: A5		
ITEM	MATERIAL	.01 QTY	.02 QTY	.03 QTY
d	Washer, square, 3", curved	1	1	1
k	Insulator, suspension, 4 1/4"	2	2	2
o	Bolt, eye, 5/8"x req'd length	1	2	1
aa	Nut, eye		1	
bo	Shackle, anchor		1	1
ek	Locknuts	1	2	1
eu	Link, extension, insulated			1
(du)	(Link, extension) - (optional)			(1)

DESIGN PARAMETERS:
PERMITTED LONGITUDINAL
LOAD = 5000 lbs./Conductor

SINGLE DEADENDS

APRIL 2005

1 - PHASE PRIMARY
12.47/7.2 kV

A5.01,A5.02,A5.03
(M5-24),(M5-8)

RUS

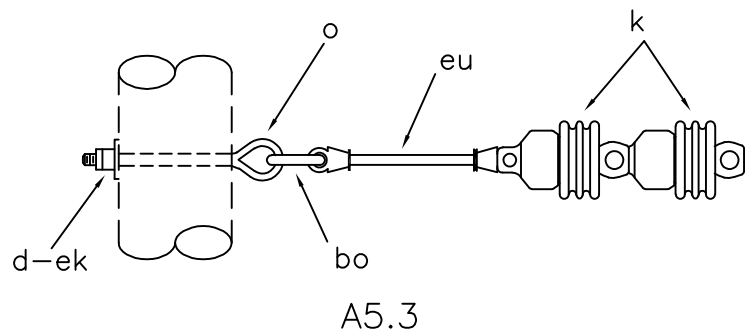
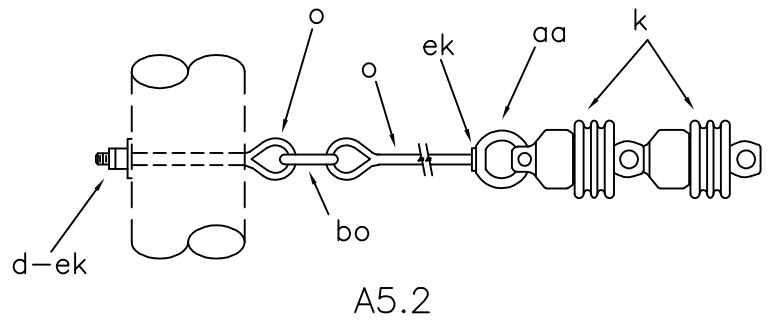
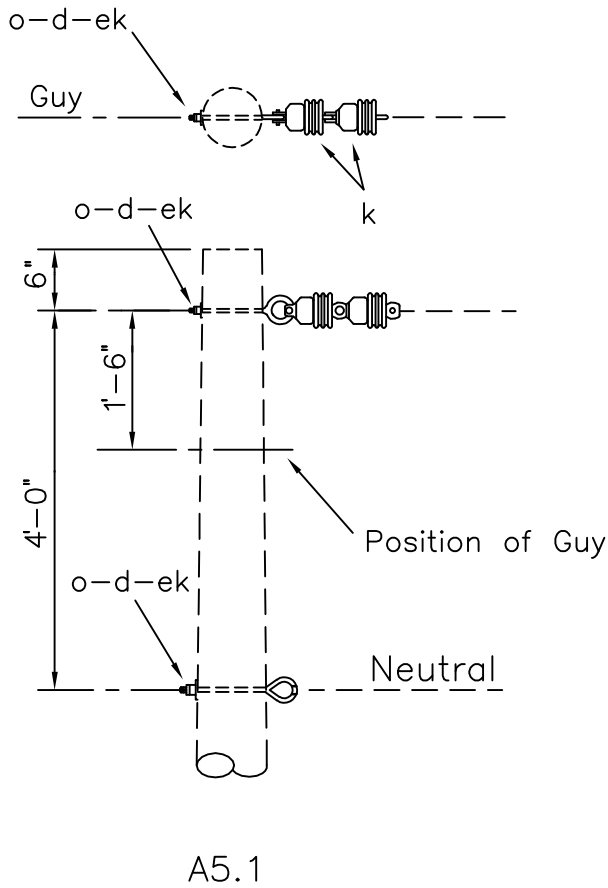

NOTE: When connecting to existing bolt end, use eye nut "aa" and locknut "ek" instead of eyebolt subassembly "o-d-ek".

		ASSEMBLY: A5		
ITEM	MATERIAL	.1 QTY	.2 QTY	.3 QTY
d	Washer, square, 3", curved	2	2	2
k	Insulator, suspension, 4 1/4"	2	2	2
o	Bolt, eye, 5/8"x req'd length	2	3	2
P	Connectors, as req'd			
aa	Nut, eye		1	
av	Jumper's, as req'd			
bo	Shackle, anchor		1	1
ek	Locknuts	2	3	2
eu	Link, extension, insulated			1
(du)	(Link, extension) - (optional)			(1)

DESIGN PARAMETERS:
 PERMITTED LONGITUDINAL
 LOAD = 5000 lbs./Conductor

SINGLE DEADENDS

APRIL 2005

RUS

1 - PHASE PRIMARY
 12.47/7.2 kV

A5.1,A5.2,A5.3
 (A5),(A5-2)

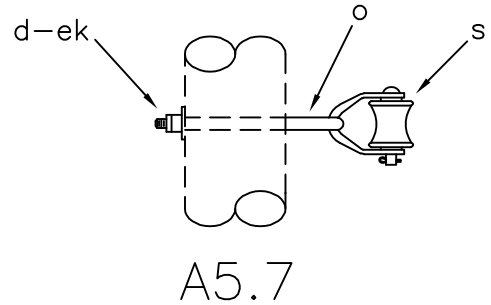
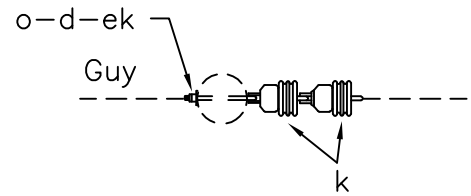
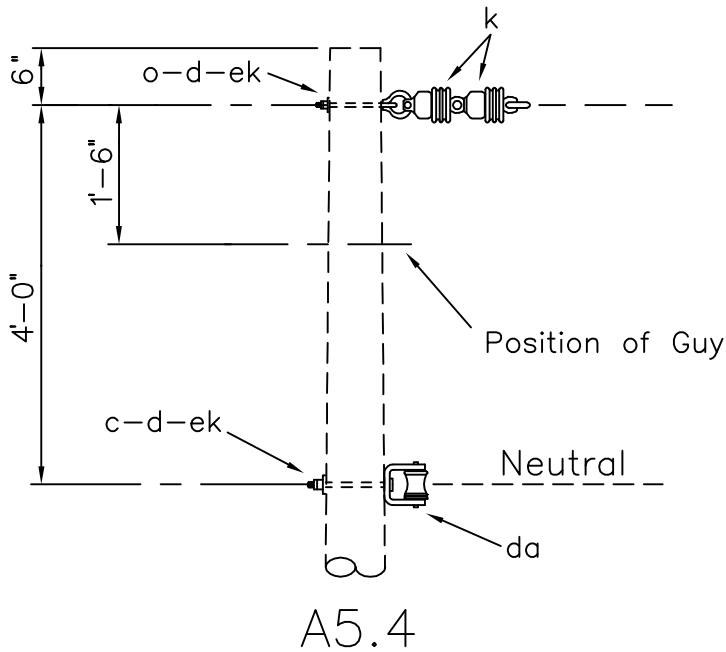

- A5.5 = A5.4 neutral assembly + A5.2 primary subassembly
- A5.6 = A5.4 neutral assembly + A5.3 primary subassembly
- A5.8 = A5.7 neutral assembly + A5.2 primary subassembly
- A5.9 = A5.7 neutral assembly + A5.3 primary subassembly

NOTE: When connecting to existing bolt end, use eyenut "aa" and locknut "ek" instead of eyebolt subassembly "o-d-ek".

ASSEMBLY: A5		.4	.5	.6	.7	.8	.9
ITEM	MATERIAL	QTY	QTY	QTY	QTY	QTY	QTY
c	Bolt, machine, 5/8" x req'd length	1	1	1			
d	Washer, square, 3", curved	2	2	2	2	2	2
k	Insulator, suspension, 4 1/4"	2	2	2	2	2	2
o	Bolt, eye, 5/8"x req'd length	1	2	1	2	3	2
P	Connectors, as req'd						
s	Clevis, secondary, swinging, insulated				1	1	1
aa	Nut, eye		1			1	
av	Jumpers, as req'd						
bo	Shackle, anchor		1	1		1	1
da	Bracket, insulated	1	1	1			
ek	Locknuts	2	3	2	2	3	2
eu	Link, extension, insulated			1			1
(du)	(Link, extension) - (optional)			(1)			(1)

DESIGN PARAMETERS: PERMITTED LONGITUDINAL LOAD For ANSI Class 53-2 Spool Insulator (1 3/4"): 1,500 lbs For ANSI Class 53-4 Spool Insulator (3"): 2,250 lbs	SINGLE DEADENDS	
	APRIL 2005	1 - PHASE PRIMARY
	RUS	12.47/7.2 kV
		A5.4 - A5.9

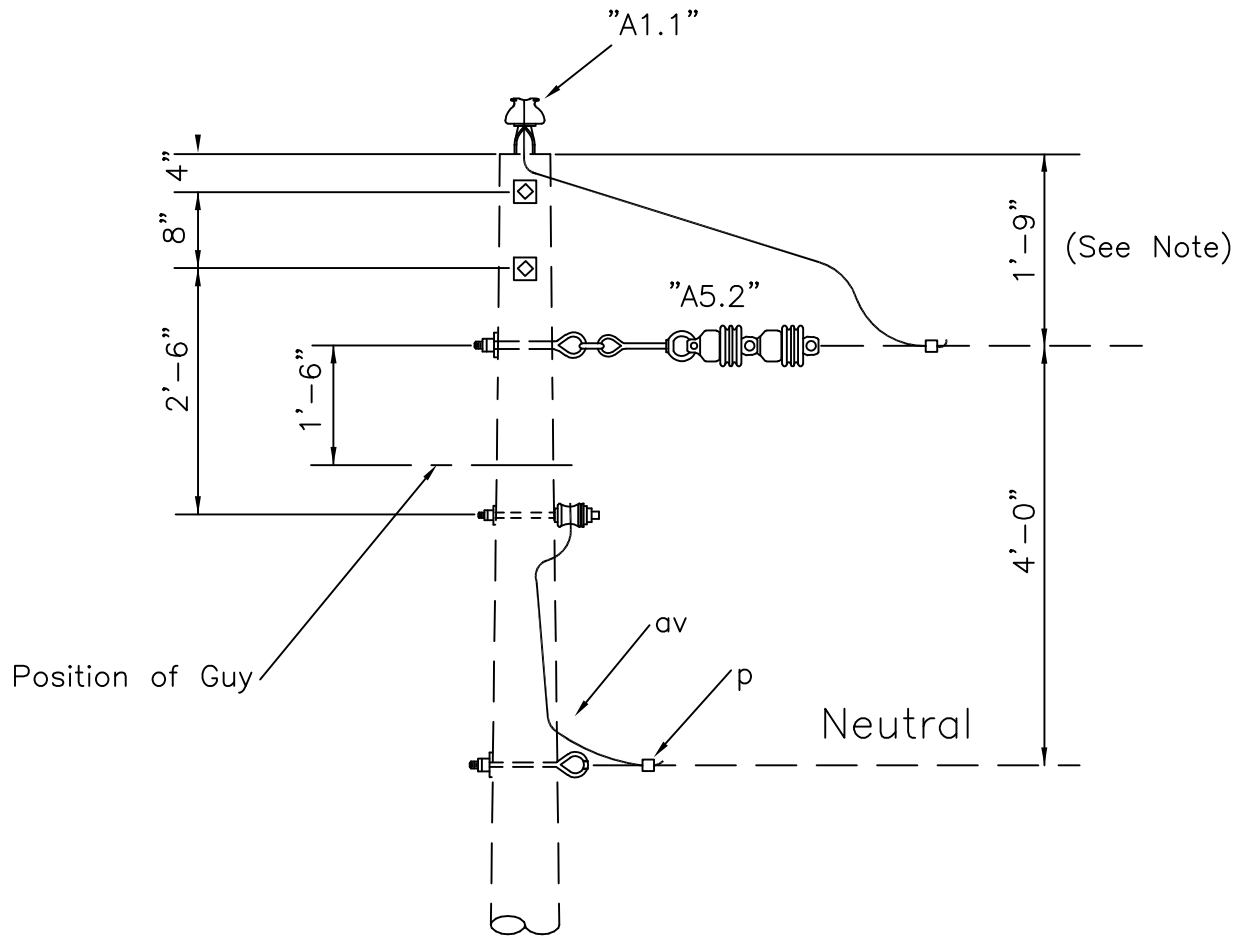

NOTES:

1. Tap assembly may be installed 6" from top of pole when perpendicular to line. Raise neutral and guy attachment 15" also.
2. Any deadend assembly, A5.1 through A5.9, may be used.

ITEM	QTY	MATERIAL
	(1)	(A1.1 Primary Assembly)
	1	A5.2 Primary Assembly
P		Connectors, as req'd
av		Jumpers, as req'd

DESIGN PARAMETERS:
 PERMITTED LONGITUDINAL
 LOAD = 5000 lbs./Conductor

SINGLE PHASE TAP GUIDE

APRIL 2005

1 - PHASE PRIMARY
 12.47/7.2 kV

RUS

A5.2G

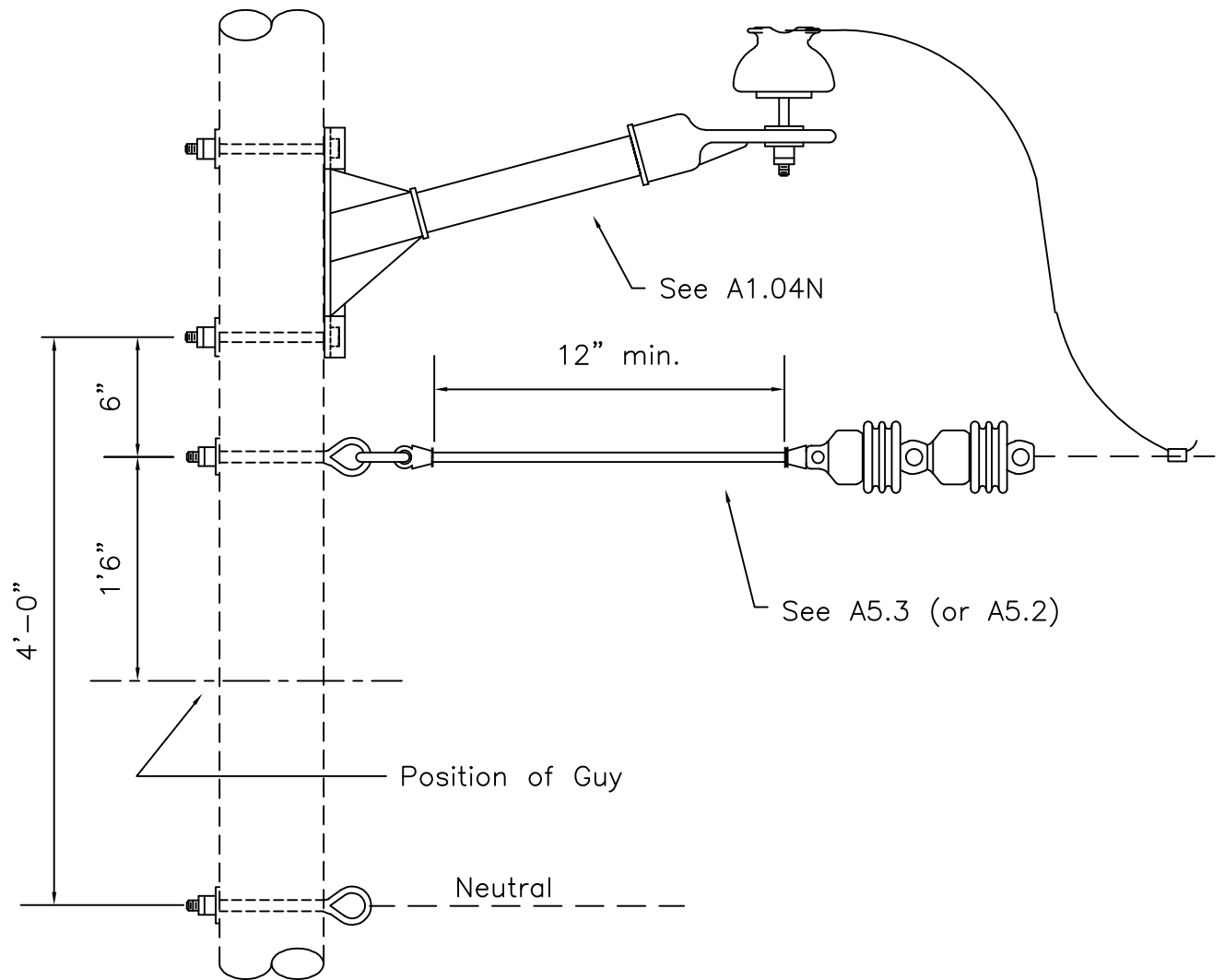

ITEM	MATERIAL	QTY
	A1.04N Primary Assembly (Narrow Profile)	1
	A5.3 Primary Assembly	1
p	Connectors, as req'd	
av	Jumpers, as req'd	

DESIGN PARAMETERS:
 PERMITTED LONGITUDINAL
 LOAD = 5000 lbs./Conductor

SINGLE PHASE TAP GUIDE

APRIL 2005

1 - PHASE PRIMARY
 12.47/7.2 kV

RUS

A5.3NG

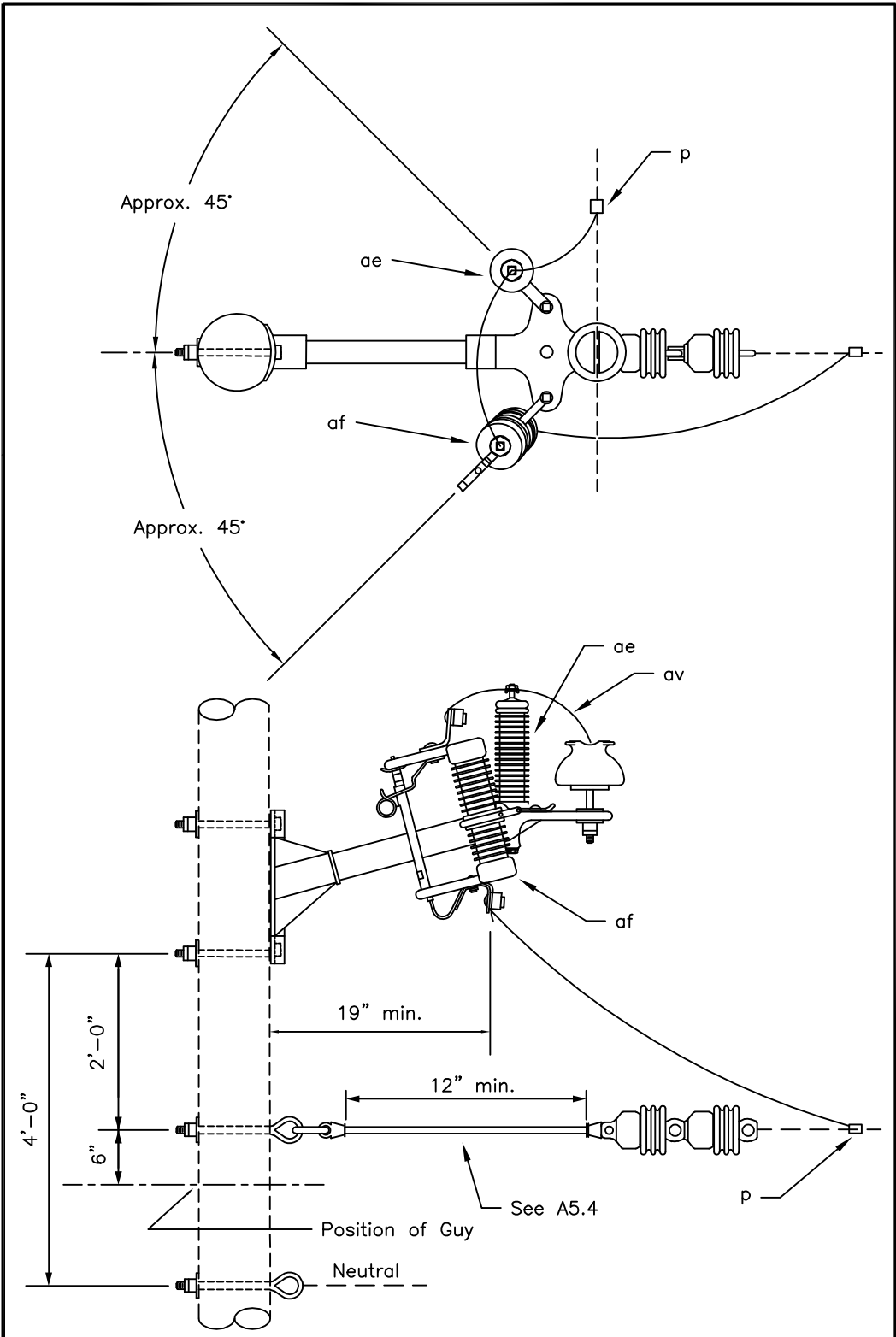

ITEM	MATERIAL	QTY
	A1.04N Primary Assembly (Narrow Profile)	1
	A5.4 Primary Assembly	1
P	Connectors, as req'd	
ae	Arrester, surge (9kV)	1
af	Cutout, dist. open (15kV)	1
av	Jumpers, as req'd	

DESIGN PARAMETERS: PERMITTED LONGITUDINAL LOAD = 5000 lbs./Conductor	SINGLE PHASE TAP GUIDE – NARROW PROFILE (WITH CUTOUT AND ARRESTER)	
	APRIL 2005 RUS	1 – PHASE PRIMARY 12.47/7.2 kV

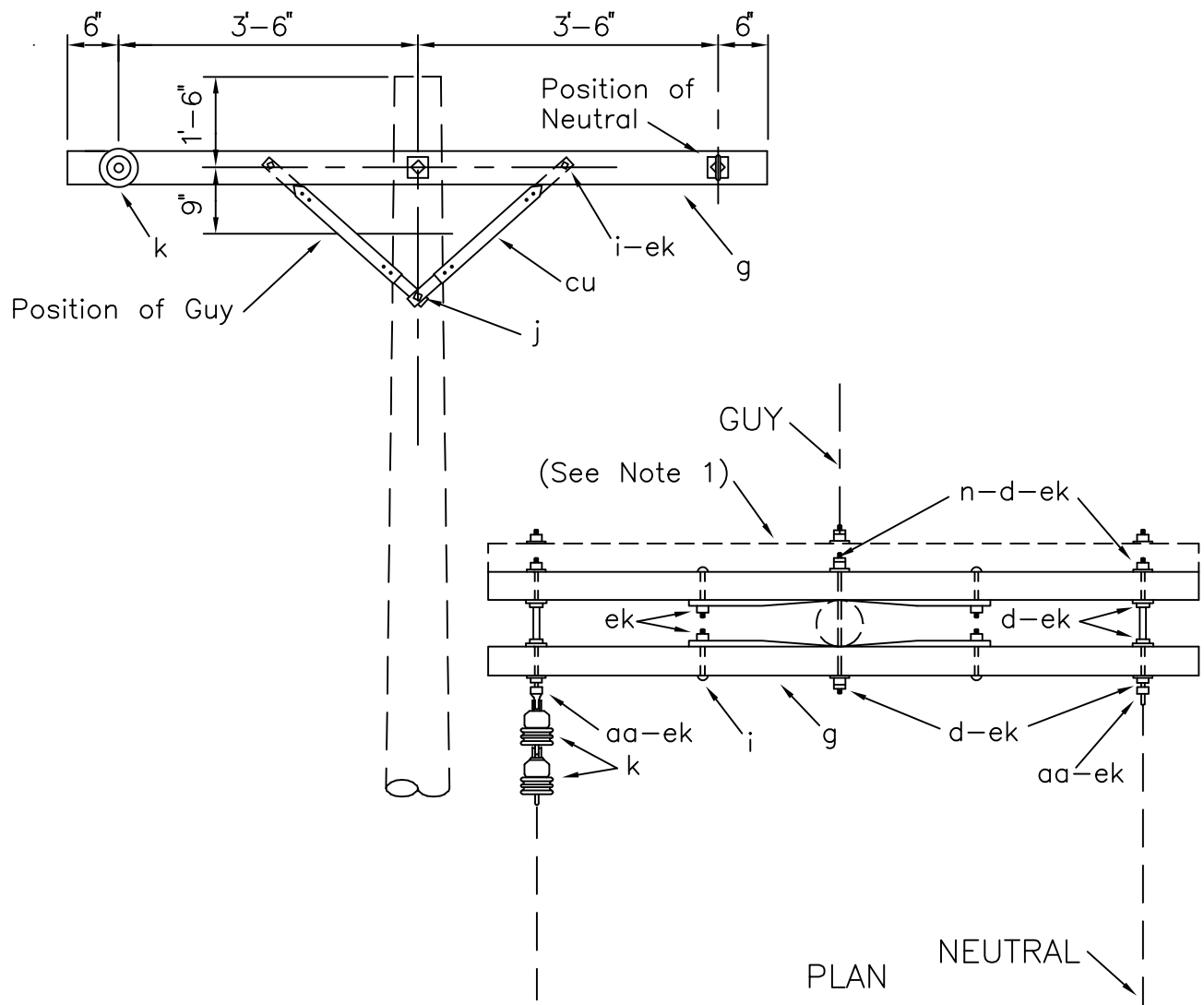

NOTES:

1. Designate as A5.31 for assembly with three crossarms.
2. Double arming eye bolt, item "dy," may be used instead of double arming bolt, item "n," and eyenut, item "aa."

ITEM	QTY	MATERIAL
d	10	Washer, square, 2 1/4"
g	2	Crossarm, 3 5/8" x 4 5/8" x 8'0"
i	4	Bolt, carriage, 3/8" x 4 1/2"
j	2	Screw, lag, 1/2" x 4"
k	2	Insulator, suspension, 4 1/4"
n	3	Bolt, double arming, 5/8" x req'd length
aa	2	Nut, eye, 5/8"
cu	4	Brace, 28"
ek	16	Locknuts

DESIGN PARAMETERS:

PERMITTED UNBALANCED
CONDUCTOR TENSION:
See Table A (Exhibit 2)

SINGLE DEADEND ON CROSSARMS

APRIL 2005

RUS

1 - PHASE PRIMARY
12.47/7.2 kV

A5.21 (A7)
A5.31 (A7-1)

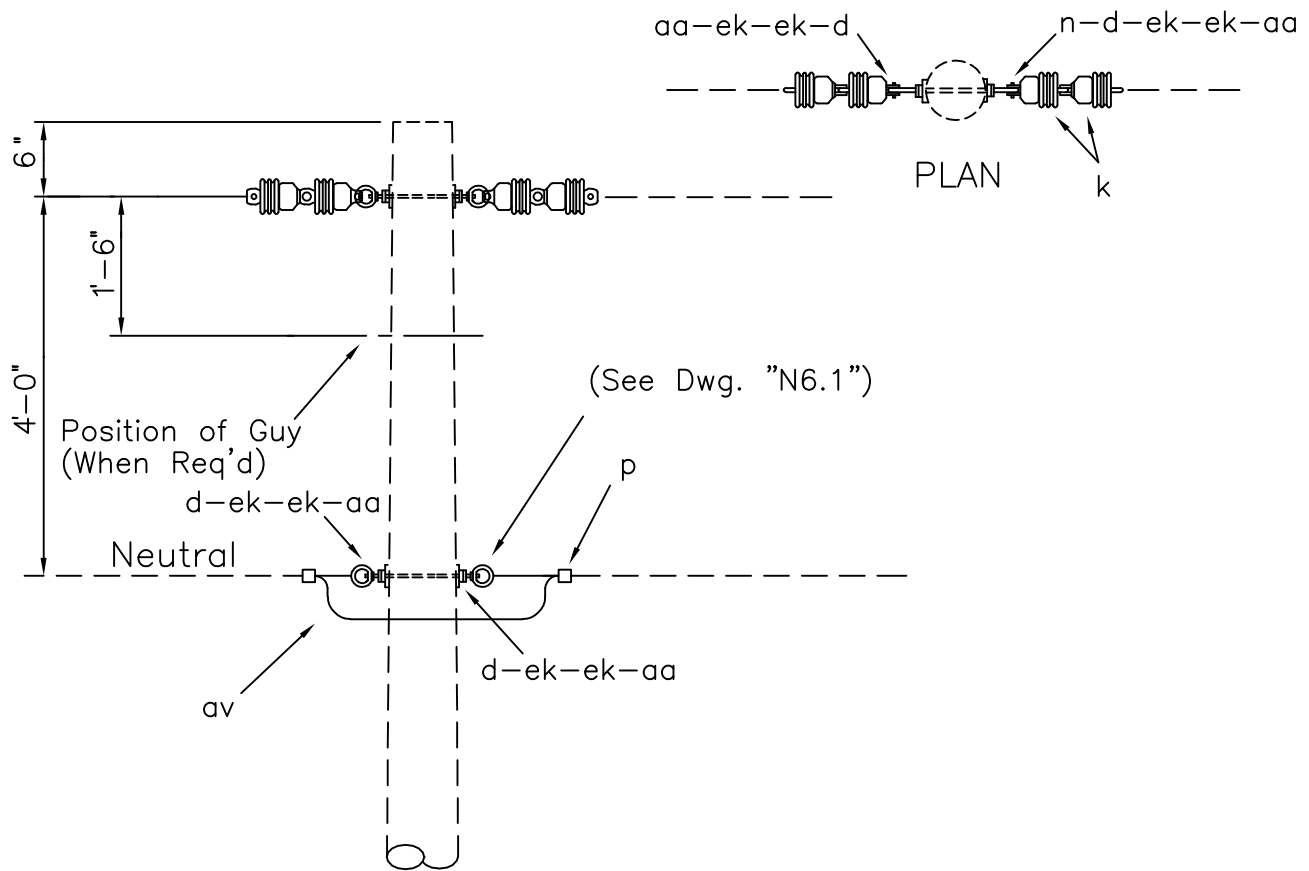

NOTES:

1. Single deadend assemblies A5.02 or A5.03 may optionally be installed
2. Maximum line angle may be increased to 15° by installing anchor shackles, item "bo", to (horizontal) eyenuts and installing side guy as req'd.

ITEM	QTY	MATERIAL
o	*	Bolt, eye, 5/8" x req'd length
bo	*	Shackle, anchor
eu	*	Link, extension, insulated
d	4	Washer, square, 3", curved
k	4	Insulator, suspension, 4 1/4"
n	2	Bolt, double arming, 5/8" x req'd length
p		Connectors, as req'd
aa	4	Nut, eye, 5/8" (or as req'd)
av		Jumpers, as req'd
ek	8	Locknuts (or as req'd)

* Optional - Quantity as req'd

DESIGN PARAMETERS:

PERMITTED
LONGITUDINAL LOAD=
5000 lbs./Conductor

MAXIMUM LINE
ANGLE = 5° (See Note)

DOUBLE DEADEND (STRAIGHT)

APRIL 2005

RUS

1 - PHASE PRIMARY
12.47/7.2 kV

A6.1 (A6)

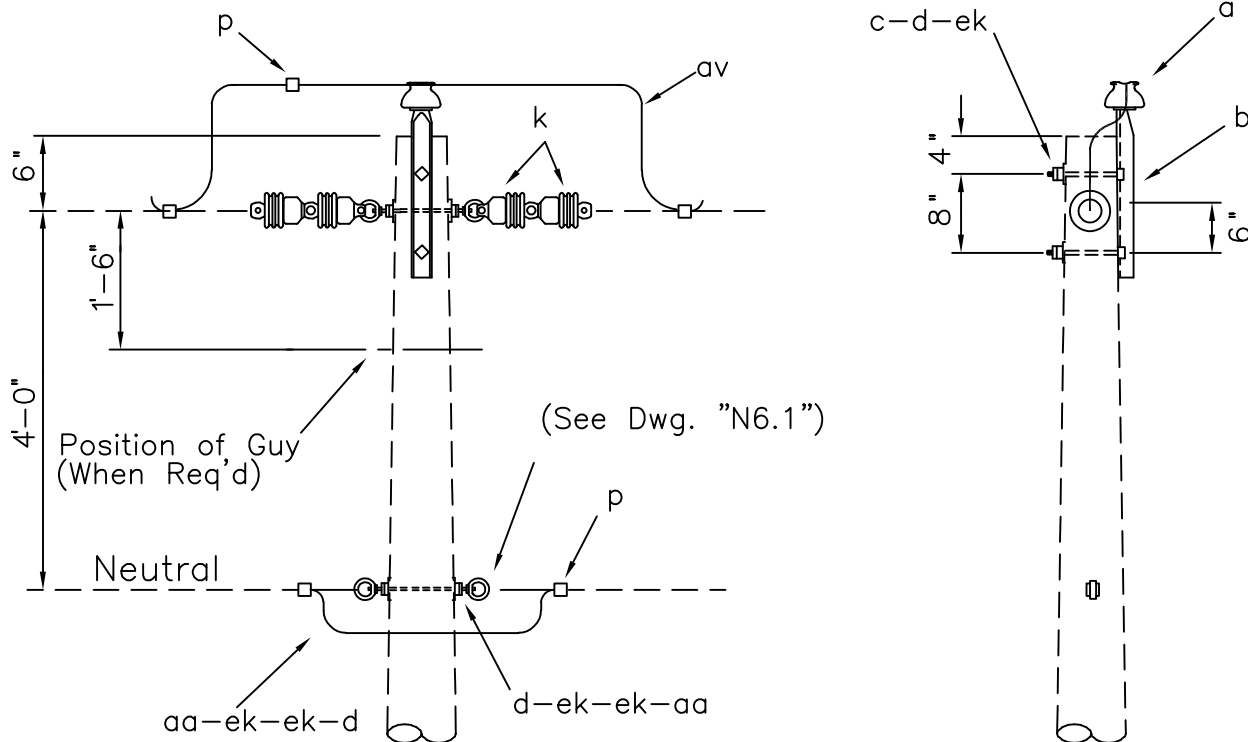

NOTES:

1. Single deadend assemblies A5.02 or A5.03 may optionally be installed.
2. Maximum line angle may be increased to 15° by installing anchor shackles, item "bo", to (horizontal) eyenuts and installing side guy as req'd.

ITEM	QTY	MATERIAL
o	*	Bolt, eye, 5/8" x req'd length
bo	*	Shackle, anchor
eu	*	Link, extension, insulated
a	1	Insulator, pin type (12.47/7.2 kV)
b	1	Pin, pole top, 20"
c	2	Bolt, machine, 5/8" x req'd length
d	2	Washer, square, 2 1/4"
d	4	Washer, square, 3," curved
k	4	Insulator, suspension, 4 1/4"
n	2	Bolt, double arming, 5/8" x req'd length
p		Connectors, as req'd
aa	4	Nut, eye, 5/8"
av		Jumpers, as req'd
ek	10	Locknuts

* Optional - Quantity as req'd

DESIGN PARAMETERS:

PERMITTED
LONGITUDINAL LOAD=
5000 lbs./Conductor

MAXIMUM LINE
ANGLE = 5° (See Note)

DOUBLE DEADEND
(FEED THROUGH)

APRIL 2005

RUS

1 - PHASE PRIMARY
12.47/7.2 kV

A6.2

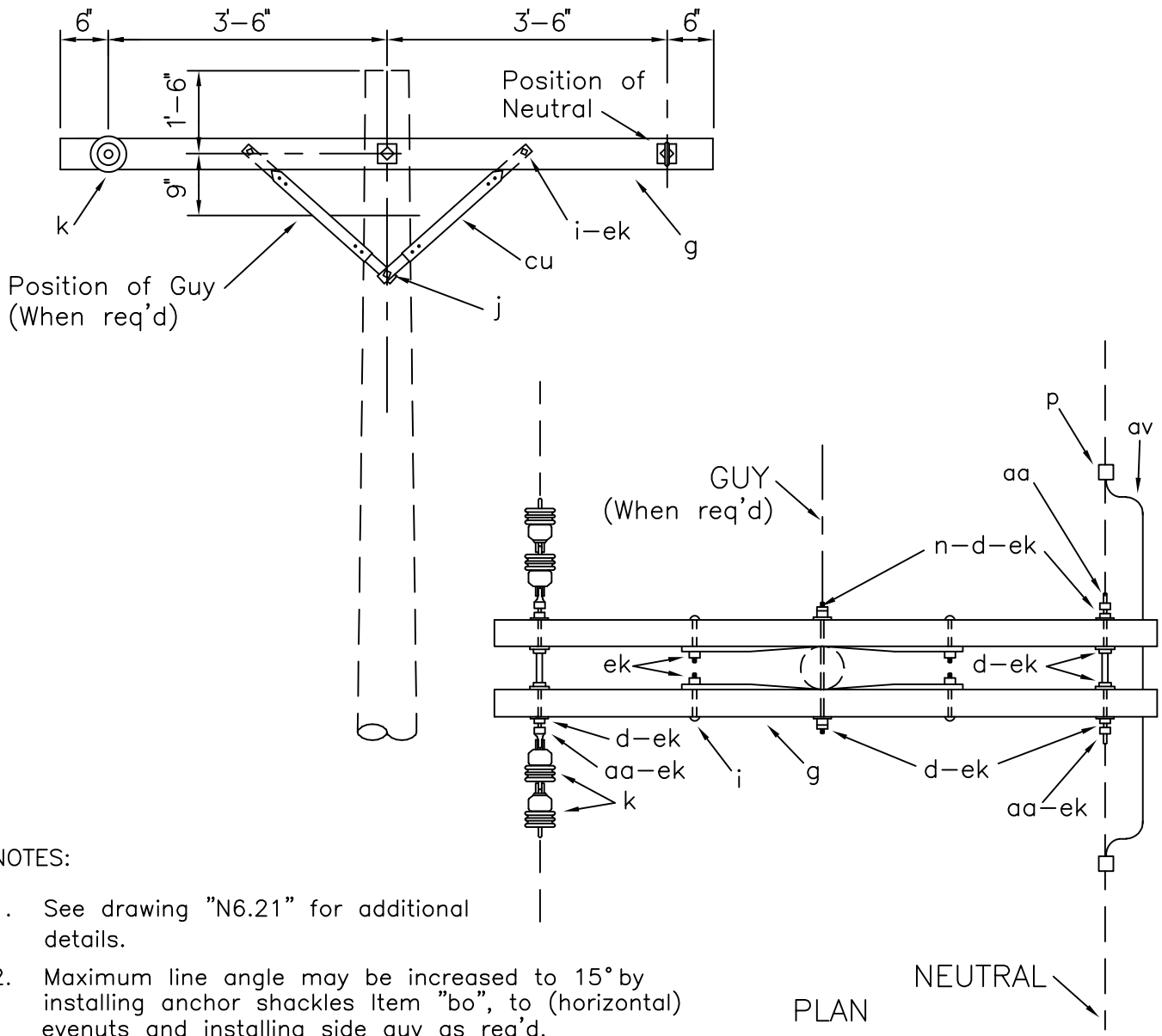

NOTES:

1. See drawing "N6.21" for additional details.
2. Maximum line angle may be increased to 15° by installing anchor shackles Item "bo", to (horizontal) eyenuts and installing side guy as req'd.

ITEM	QTY	MATERIAL
d	10	Washer, square, 2 1/4"
g	2	Crossarm, 3 5/8" x 4 5/8" x 8'0"
i	4	Bolt, carriage, 3/8" x 4 1/2"
j	2	Screw, lag, 1/2" x 4"
k	4	Insulator, suspension, 4 1/4"
n	3	Bolt, double arming, 5/8" x req'd length
p		Connectors, as req'd
aa	4	Nut, eye, 5/8"
av		Jumpers, as req'd
cu	4	Brace, wood, 28"
ek	18	Locknuts

DESIGN PARAMETERS:
 PERMITTED UNBALANCED
 CONDUCTOR TENSION:
 See Table A (Exhibit 2)
 MAXIMUM ALLOWABLE LINE
 ANGLE = 5° (See Note 2)

DOUBLE DEADEND ON CROSSARMS

APRIL 2005	1 - PHASE PRIMARY	
RUS	12.47/7.2 kV	A6.21 (A8)

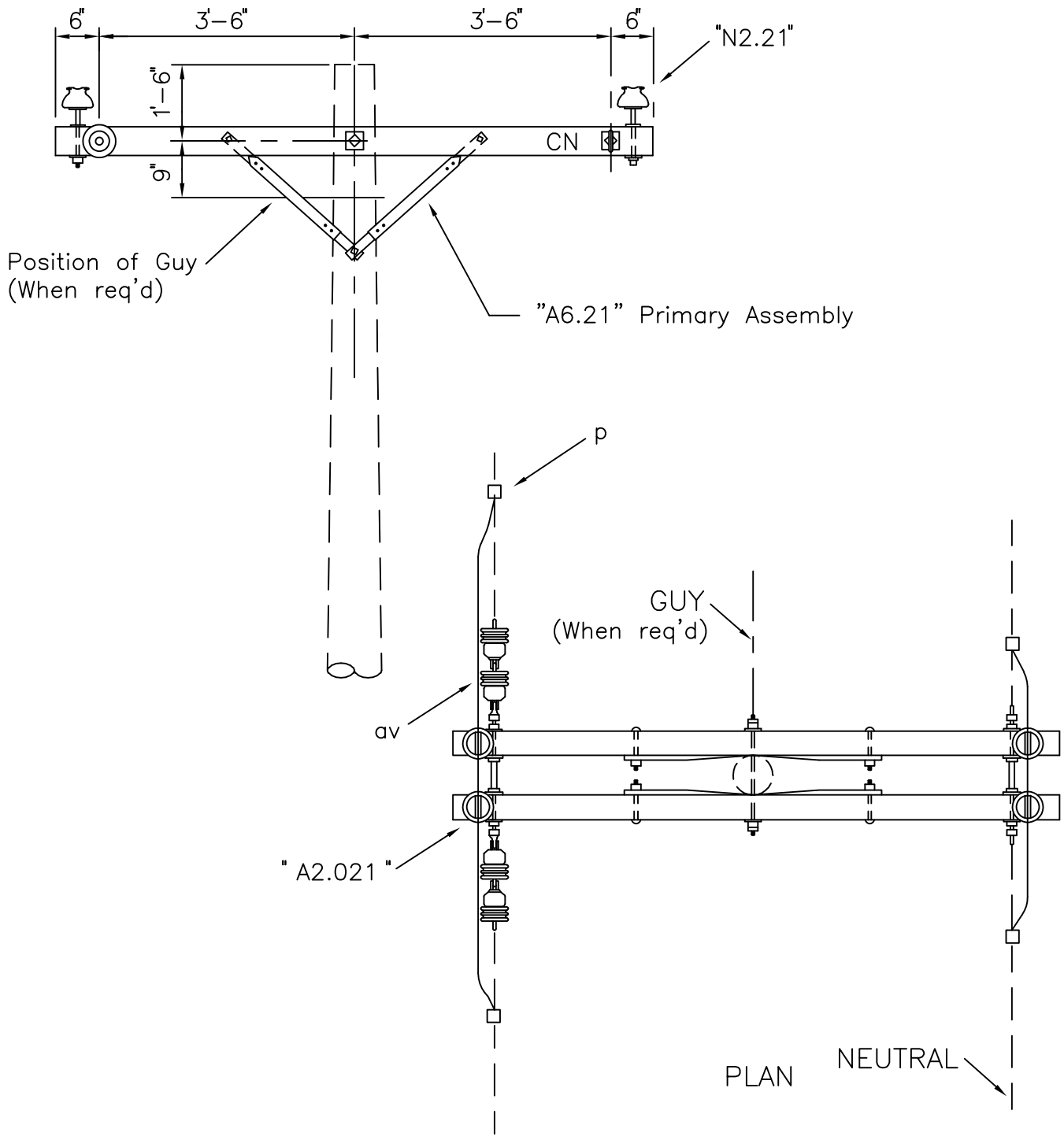

ITEM	QTY	MATERIAL
	1	A6.21 Primary Assembly
	1	A2.021 Primary Assembly
	1	N2.21 Neutral Assembly
P		Connectors, as req'd
av		Jumpers, as req'd

DESIGN PARAMETERS:
 PERMITTED UNBALANCED
 CONDUCTOR TENSION:
 See Table A (Exhibit 2)
 MAXIMUM LINE
 ANGLE = 5° (See Dwg. A6-21)

DOUBLE DEADEND GUIDE (FEED THROUGH ON CROSSARMS)		
APRIL 2005	1 - PHASE PRIMARY	A6.22G
RUS	12.47/7.2 kV	

INDEX B

TWO-PHASE PRIMARY POLE TOP ASSEMBLY UNITS

<u>DRAWING NUMBERS</u>		<u>DRAWING TITLE (DESCRIPTION)</u>
1728F-804 (New)	Bulletin 50-3 (Old)	
B1.1N B1.2N		SINGLE SUPPORT – NARROW PROFILE (TANGENT)
B1.1NP B1.2NP		SINGLE SUPPORT – NARROW PROFILE (TANGENT) (POST INSULATORS)
B1.3N		SINGLE SUPPORT – NARROW PROFILE
B1.3NP		SINGLE SUPPORT – NARROW PROFILE (POST INSULATORS)
B1.4N B1.5N		SINGLE SUPPORT – NARROW PROFILE (TANGENT)
B1.4NP B1.5NP		SINGLE SUPPORT – NARROW PROFILE (TANGENT) (POST INSULATORS)
B1.6N		SINGLE SUPPORT – NARROW PROFILE
B1.6NP		SINGLE SUPPORT – NARROW PROFILE (POST INSULATORS)
B1.7N B1.8N		SINGLE SUPPORT – NARROW PROFILE (TANGENT)
B1.7NP B1.8NP		SINGLE SUPPORT – NARROW PROFILE (TANGENT) (POST INSULATORS)
B1.9N		SINGLE SUPPORT – NARROW PROFILE
B1.9NP		SINGLE SUPPORT – NARROW PROFILE (POST INSULATORS)
B1.11 B1.12	(B1) (B1A)	SINGLE SUPPORT ON CROSSARM (TANGENT)
B1.11P B1.12P	(B1P) (B1AP)	SINGLE SUPPORT ON CROSSARM (TANGENT) (POST INSULATORS)
B1.13		SINGLE SUPPORT ON CROSSARM
B1.13P		SINGLE SUPPORT ON CROSSARM (POST INSULATORS)

TWO-PHASE PRIMARY POLE TOP ASSEMBLY UNITS

<u>DRAWING NUMBERS</u>		<u>DRAWING TITLE (DESCRIPTION)</u>
1728F-804 (New)	Bulletin 50-3 (Old)	
B1.14	(B9-1)	SINGLE SUPPORT, NEUTRAL ON CROSSARM
B1.14P	(B9-1P)	SINGLE SUPPORT, NEUTRAL ON CROSSARM (POST INSULATORS)
B2.1N B2.2N		DOUBLE SUPPORT – NARROW PROFILE (TANGENT)
B2.1NP B2.2NP		DOUBLE SUPPORT – NARROW PROFILE (TANGENT) (POST INSULATORS)
B2.3N		DOUBLE SUPPORT – NARROW PROFILE
B2.3NP		DOUBLE SUPPORT – NARROW PROFILE (POST INSULATORS)
B2.4N B2.5N		DOUBLE SUPPORT – NARROW PROFILE (TANGENT)
B2.4NP B2.5NP		DOUBLE SUPPORT – NARROW PROFILE (TANGENT) (POST INSULATORS)
B2.6N		DOUBLE SUPPORT – NARROW PROFILE
B2.6NP		DOUBLE SUPPORT – NARROW PROFILE (POST INSULATORS)
B2.7N B2.8N		DOUBLE SUPPORT – NARROW PROFILE (TANGENT)
B2.7NP B2.8NP		DOUBLE SUPPORT – NARROW PROFILE (TANGENT) (POST INSULATORS)
B2.9N		DOUBLE SUPPORT – NARROW PROFILE
B2.9NP		DOUBLE SUPPORT – NARROW PROFILE (POST INSULATORS)
B2.21	(B2)	DOUBLE SUPPORT ON CROSSARMS
B2.21P	(B2P)	DOUBLE SUPPORT ON CROSSARMS (POST INSULATORS)
B2.22	(B9)	DOUBLE SUPPORT, NEUTRAL ON CROSSARMS
B2.22P	(B9P)	DOUBLE SUPPORT, NEUTRAL ON CROSSARMS (POST INSULATORS)

TWO-PHASE PRIMARY POLE TOP ASSEMBLY UNITS

<u>DRAWING NUMBERS</u>		<u>DRAWING TITLE (DESCRIPTION)</u>
1728F-804 (New)	Bulletin 50-3 (Old)	
B2.24 B2.25	(B1-1) (B1-1A)	DOUBLE SUPPORT ON CROSSARMS - TANGENT
B2.24P B2.25P	(B1-1P) (B1-1AP)	DOUBLE SUPPORT ON CROSSARMS - TANGENT (POST INSULATORS)
B3.1 B3.2 B3.3	(B3)	SUSPENSION ANGLE
B3.4 B3.5 B3.6 B3.7 B3.8 B3.9		SUSPENSION ANGLE
B4.1G	((B4-1))	DEADEND ANGLE GUIDE (90° – 150°)
B4.2G		DEADEND ANGLE GUIDE (15° – 90°)
B5.1 B5.2 B5.3	(B5-1)	SINGLE DEADENDS
B5.4 B5.5 B5.6 B5.7 B5.8 B5.9		SINGLE DEADENDS
B5.21 B5.31	(B7) (B7-1)	SINGLE DEADEND ON CROSSARMS
B6.21	(B8)	DOUBLE DEADEND CROSSARMS

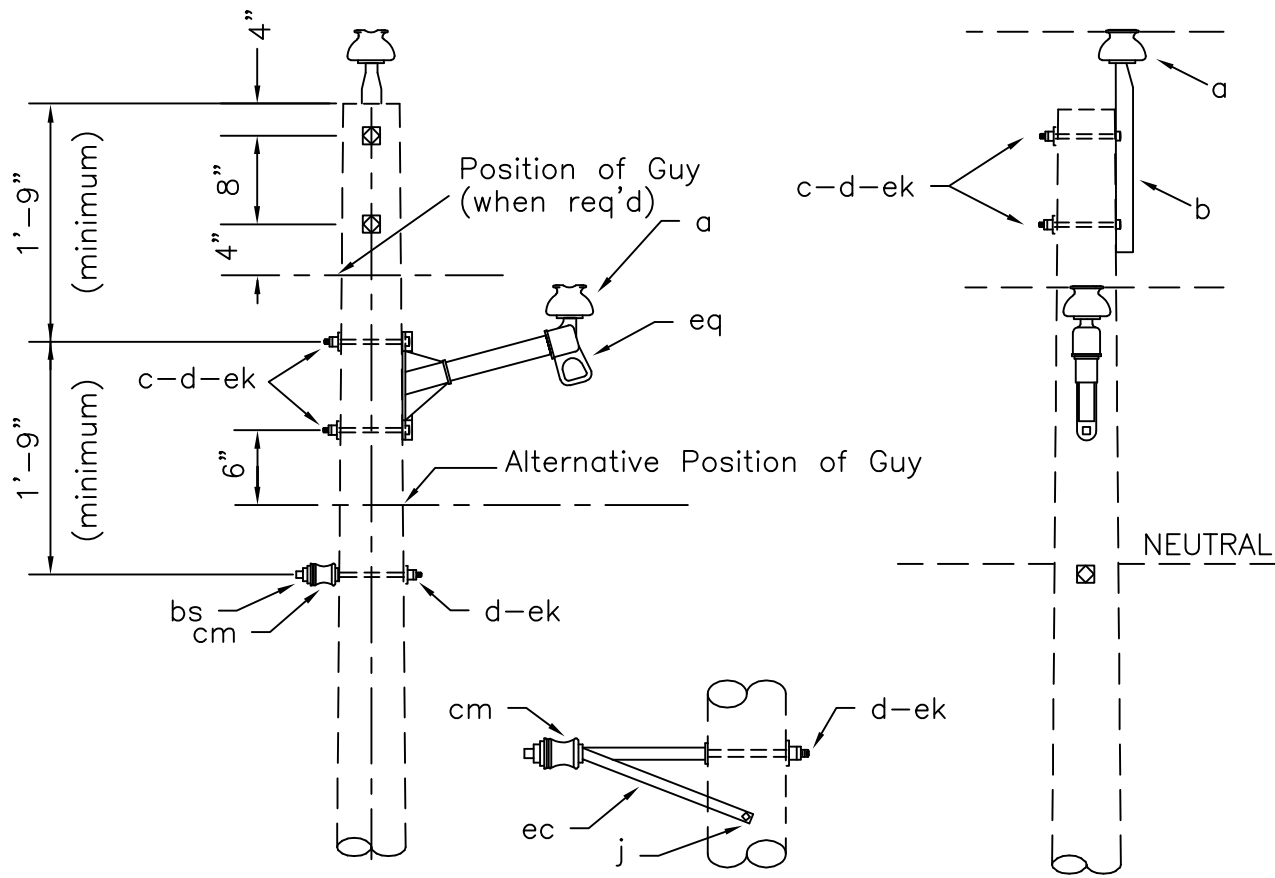

Specify B1.2N for
offset neutral assembly

ASSEMBLY: B1.

ITEM	MATERIAL	1N QTY	2N QTY
a	Insulator, pin type (12.47/7.2 kV)	2	2
b	Pin, pole top, 20"	1	1
c	Bolt, machine, 5/8" x req'd length	4	4
d	Washer, square 2 1/4"	5	5
(f)	(Pin, crossarm, 5/8" x 6 1/2")	(1)	(1)
j	Screw, lag, 1/2" x 4"		2
bs	Bolt, single, upset	1	
cm	Insulator, spool, 3"	1	1
ec	Bracket, offset neutral		1
ek	Locknuts	5	5
eq	Bracket, insulator/equipment	1	1

(If req'd)

Design Parameters: MAXIMUM LINE ANGLES: 5°—Small Conductors 2°—Larger than #1/0	SINGLE SUPPORT—NARROW PROFILE (TANGENT)		
	APRIL 2005	2 — PHASE PRIMARY	B1.1N
	RUS	12.47/7.2 kV	B1.2N

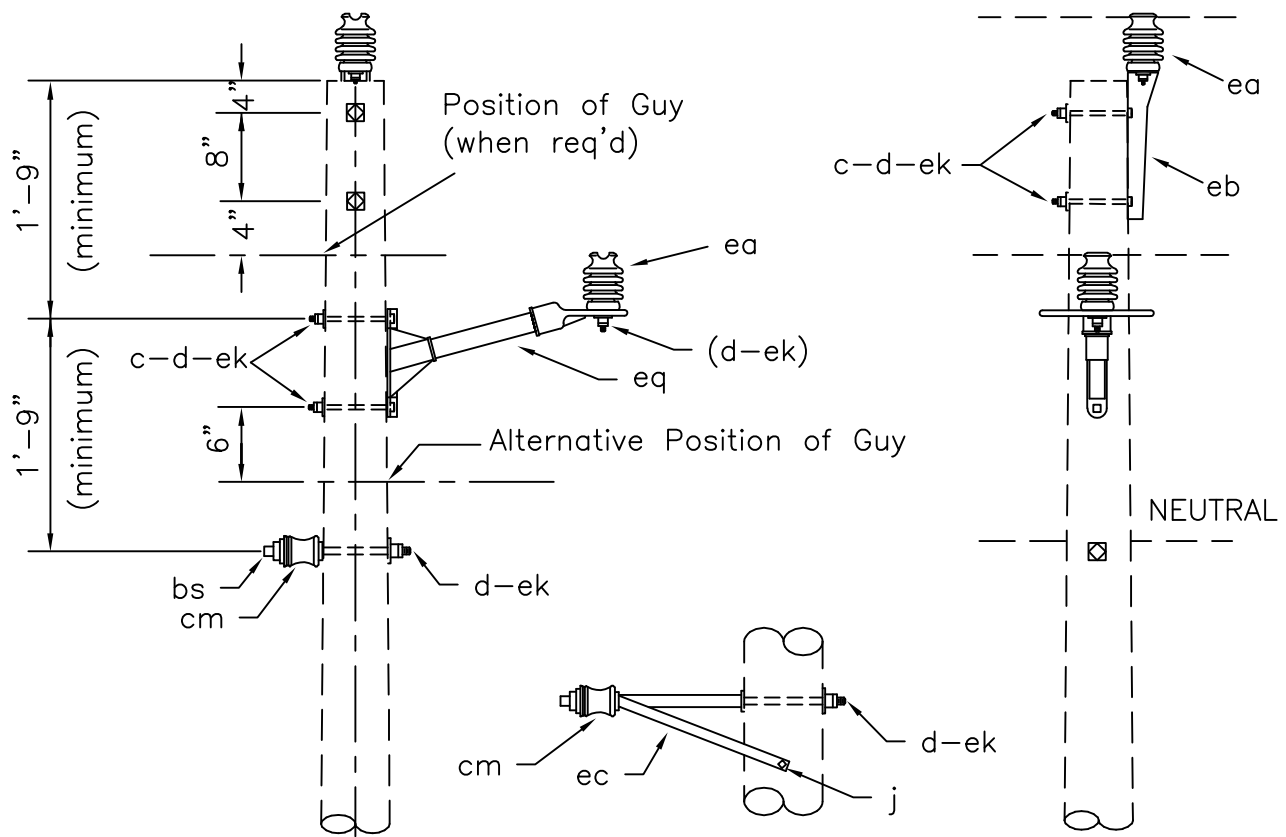

Specify B1.2NP for offset neutral assembly

ASSEMBLY: B1. 1NP 2NP

ITEM	MATERIAL	QTY	QTY
c	Bolt, machine, 5/8" x req'd length	4	4
d	Washer, square 2 1/4"	5	5
j	Screw, lag, 1/2" x 4"		2
bs	Bolt, single, upset	1	
cm	Insulator, spool, 3"	1	1
ea	Insulator, post type (12.47/7.2 kV)	2	2
eb	Bracket, pole top	1	1
ec	Bracket, offset neutral		1
ek	Locknuts	5	5
eq	Bracket, insulator/equipment	1	1

Design Parameters:

MAXIMUM LINE ANGLES:
 5°-Small Conductors
 2°-Larger than #1/0

SINGLE SUPPORT-NARROW PROFILE
 (TANGENT) (POST INSULATORS)

APRIL 2005

RUS

2 - PHASE PRIMARY
 12.47/7.2 kV

B1.1NP
 B1.2NP

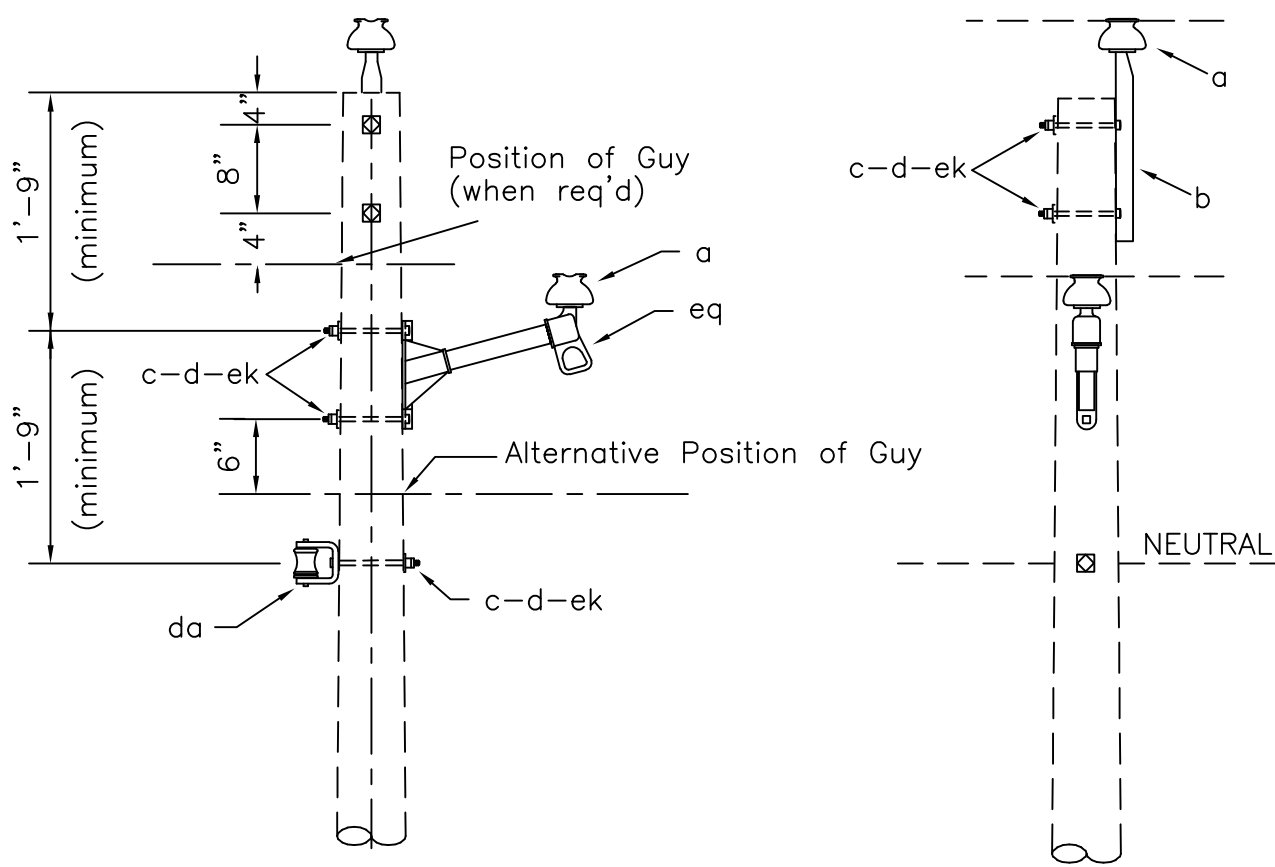

ASSEMBLY: B1. 3N

ITEM	MATERIAL	QTY
a	Insulator, pin type (12.47/7.2 kV)	2
b	Pin, pole top, 20"	1
c	Bolt, machine, 5/8" x req'd length	5
d	Washer, square 2 1/4"	5
(f)	(Pin, crossarm, 5/8" x 6 1/2")	(1) (If req'd)
da	Bracket, insulated	1
ek	Locknuts	5
eq	Bracket, insulator/equipment	1

Design Parameters: MAXIMUM LINE ANGLES: See TABLE I	SINGLE SUPPORT-NARROW PROFILE		
	APRIL 2005	2 - PHASE PRIMARY	B1.3N
	RUS	12.47/7.2 kV	

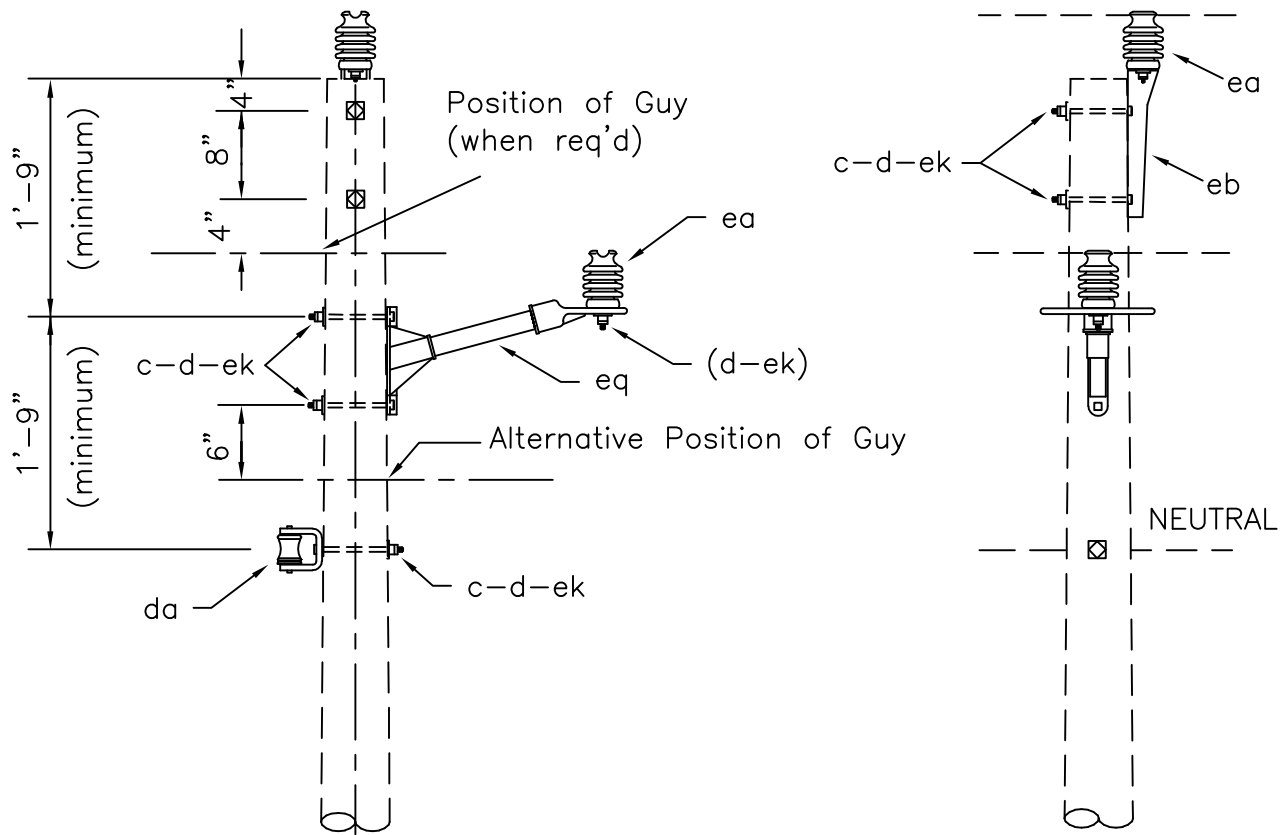

ASSEMBLY: B1. 3NP

ITEM	MATERIAL	QTY
c	Bolt, machine, 5/8" x req'd length	5
d	Washer, square 2 1/4"	5
da	Bracket, insulated	1
ea	Insulator, post type (12.47/7.2 kV)	2
eb	Bracket, pole top	1
ek	Locknuts	5
eq	Bracket, insulator/equipment	1

Design Parameters:

MAXIMUM LINE ANGLES:
See TABLE II

SINGLE SUPPORT-NARROW PROFILE
(POST INSULATORS)

APRIL 2005

RUS

2 - PHASE PRIMARY
12.47/7.2 kV

B1.3NP

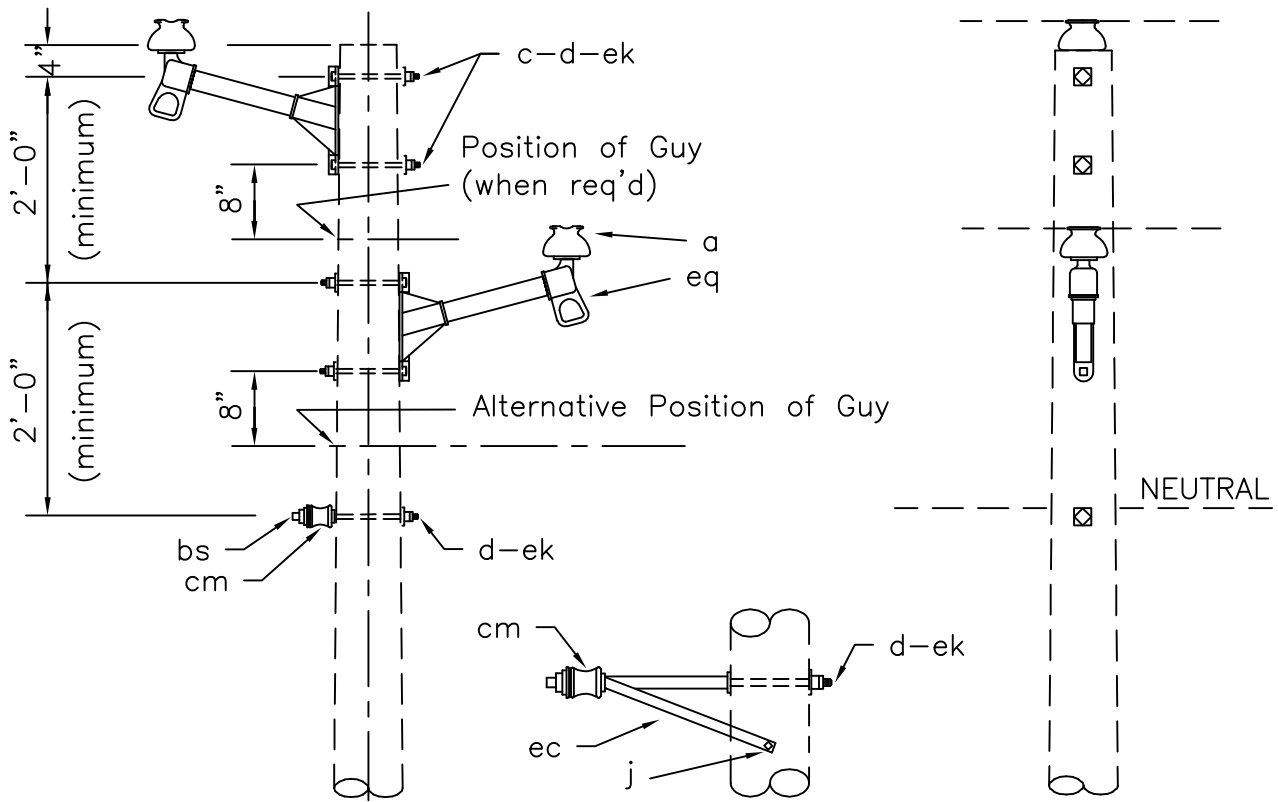

Specify B1.5N for
offset neutral assembly

ASSEMBLY: B1.		4N	5N
ITEM	MATERIAL	QTY	QTY
a	Insulator, pin type (12.47/7.2 kV)	2	2
c	Bolt, machine, 5/8" x req'd length	4	4
d	Washer, square 2 1/4"	5	5
(f)	(Pin, crossarm, 5/8" x 6 1/2")	(2)	(2)
j	Screw, lag, 1/2" x 4"		2
bs	Bolt, single, upset	1	
cm	Insulator, spool, 3"	1	1
ec	Bracket, offset neutral		1
ek	Locknuts	5	5
eq	Bracket, insulator/equipment	2	2

(If req'd)

Design Parameters:

MAXIMUM LINE ANGLES:
5°—Small Conductors
2°—Larger than #1/0

SINGLE SUPPORT—NARROW PROFILE
(TANGENT)

APRIL 2005

RUS

2 — PHASE PRIMARY
12.47/7.2 kV

B1.4N
B1.5N

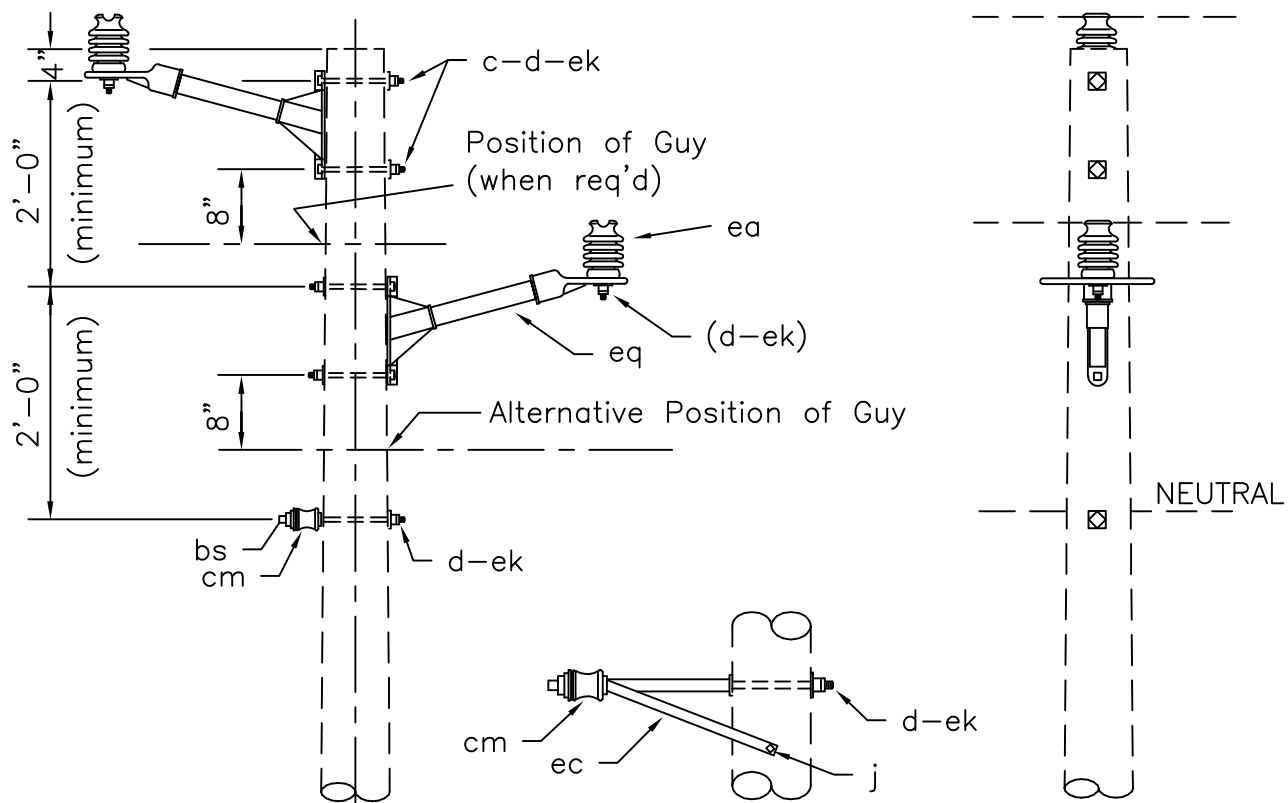

Specify B1.5NP for
offset neutral assembly

ASSEMBLY: B1.4NP 5NP

ITEM	MATERIAL	QTY	QTY
c	Bolt, machine 5/8" x req'd length	4	4
d	Washer, square 2 1/4"	5	5
j	Screw, lag, 1/2" x 4"		2
bs	Bolt, single, upset	1	
cm	Insulator, spool, 3"	1	1
ea	Insulator, post type (12.47/7.2 kV)	2	2
ec	Bracket, offset neutral		1
ek	Locknuts	5	5
eq	Bracket, insulator/equipment	2	2

Design Parameters:

MAXIMUM LINE ANGLES:
5°-Small Conductors
2°-Larger than #1/0

SINGLE SUPPORT-NARROW PROFILE
(TANGENT) (POST INSULATORS)

APRIL 2005

RUS

2 - PHASE PRIMARY
12.47/7.2 kV

B1.4NP
B1.5NP

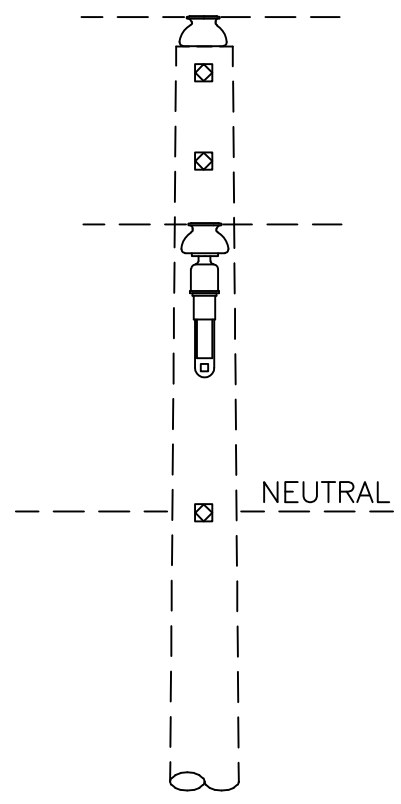
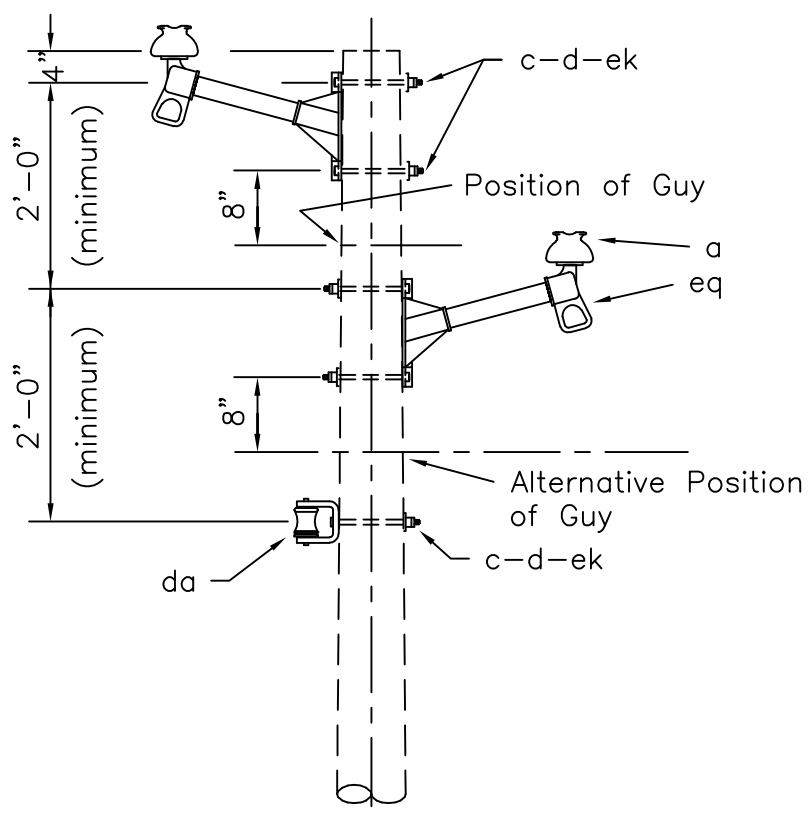

ASSEMBLY: B1. 6N

ITEM	MATERIAL	QTY
a	Insulator, pin type (12.47/7.2 kV)	2
c	Bolt, machine, 5/8" x req'd length	5
d	Washer, square 2 1/4"	5
(f)	(Pin, crossarm, 5/8" x 6 1/2")	(2) (If req'd)
da	Bracket, insulated	1
ek	Locknuts	5
eq	Bracket, insulator/equipment	2

Design Parameters: MAXIMUM LINE ANGLES: See TABLE II	SINGLE SUPPORT-NARROW PROFILE		
	APRIL 2005	2 - PHASE PRIMARY	B1.6N
	RUS	12.47/7.2 kV	

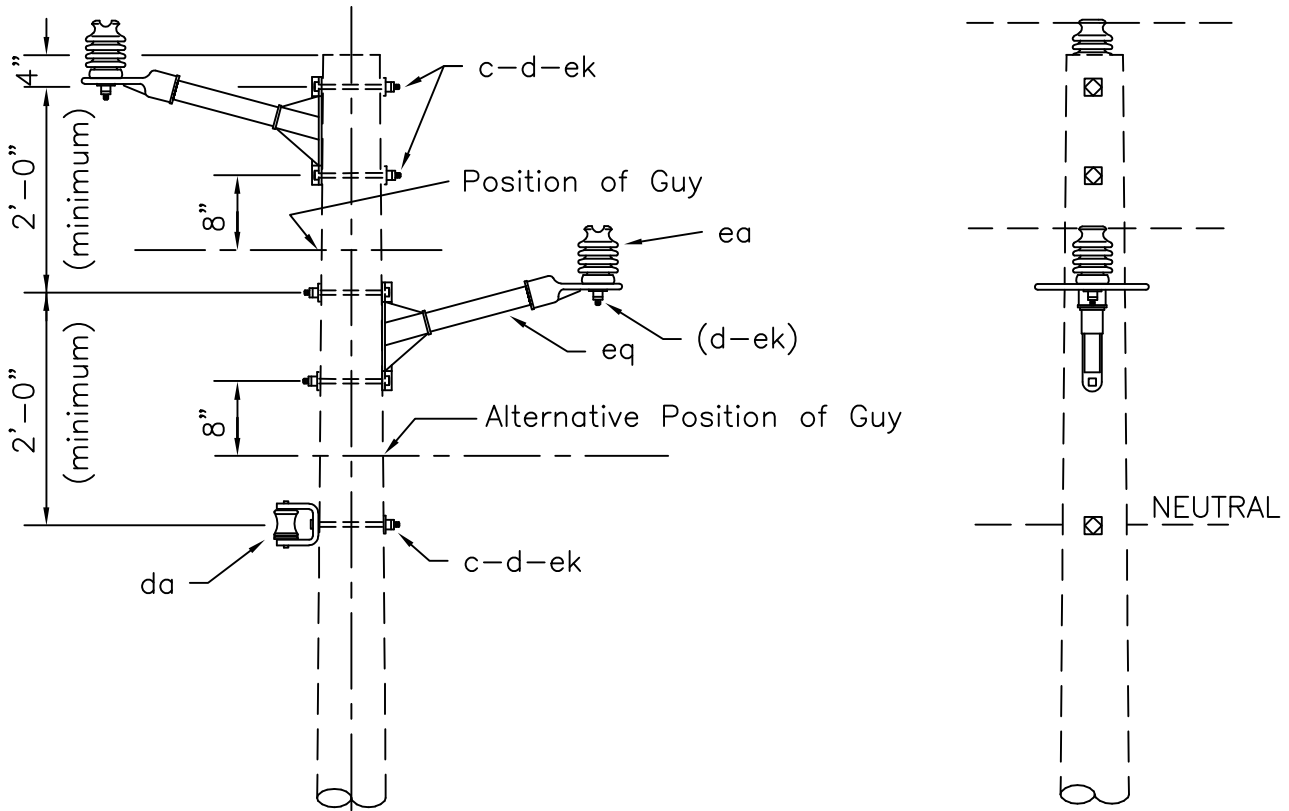

ASSEMBLY: B1.6NP

ITEM	MATERIAL	QTY
c	Bolt, machine 5/8" x req'd length	5
d	Washer, square 2 1/4"	5
da	Bracket, insulated	1
ea	Insulator, post type (12.47/7.2 kV)	2
ek	Locknuts	5
eq	Bracket, insulator/equipment	2

Design Parameters:

MAXIMUM LINE ANGLES:
See TABLE II

SINGLE SUPPORT-NARROW PROFILE
(POST INSULATORS)

APRIL 2005

RUS

2 - PHASE PRIMARY
12.47/7.2 kV

B1.6NP

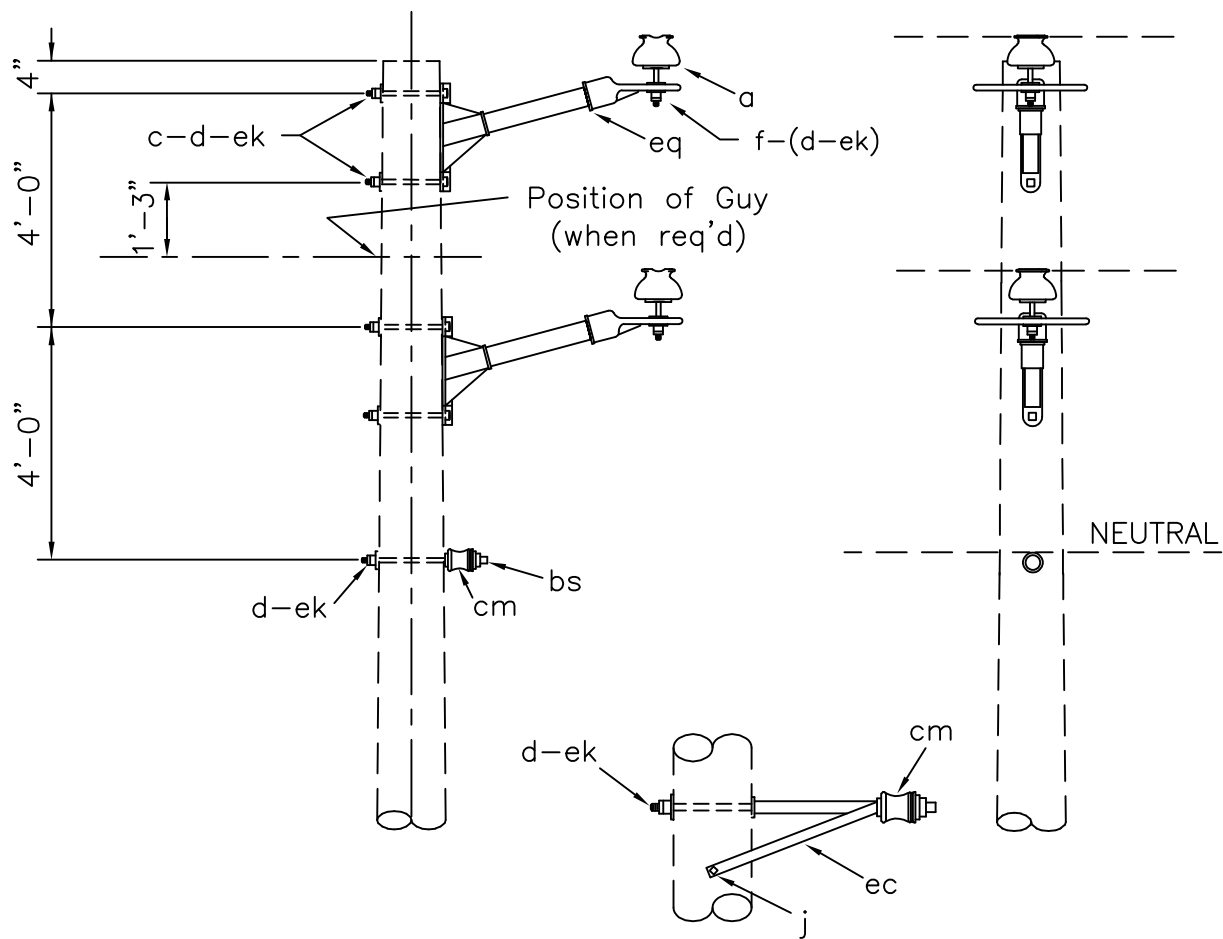

Specify B1.8N for
offset neutral assembly

		Assembly: B1.	
		7N	8N
ITEM	MATERIAL	QTY	QTY
a	Insulator, pin type (12.47/7.2 kV)	2	2
c	Bolt, machine, 5/8" x req'd length	4	4
d	Washer, square 2 1/4"	5	5
(f)	(Pin, crossarm, 5/8" x 6 1/2")	(2)	(2) (If req'd)
j	Screw, lag, 1/2" x 4"		2
bs	Bolt, single, upset	1	
cm	Insulator, spool, 3"	1	1
ec	Bracket, offset neutral		1
ek	Locknuts	5	5
eq	Bracket, insulator/equipment	2	2

Design Parameters:
Maximum Line Angles
5° - Small Conductors
2° - Larger than #1/0

SINGLE SUPPORT-NARROW PROFILE
(TANGENT)

APRIL 2005

2 - PHASE PRIMARY
12.47/7.2 kV

B1.7N
B1.8N

RUS

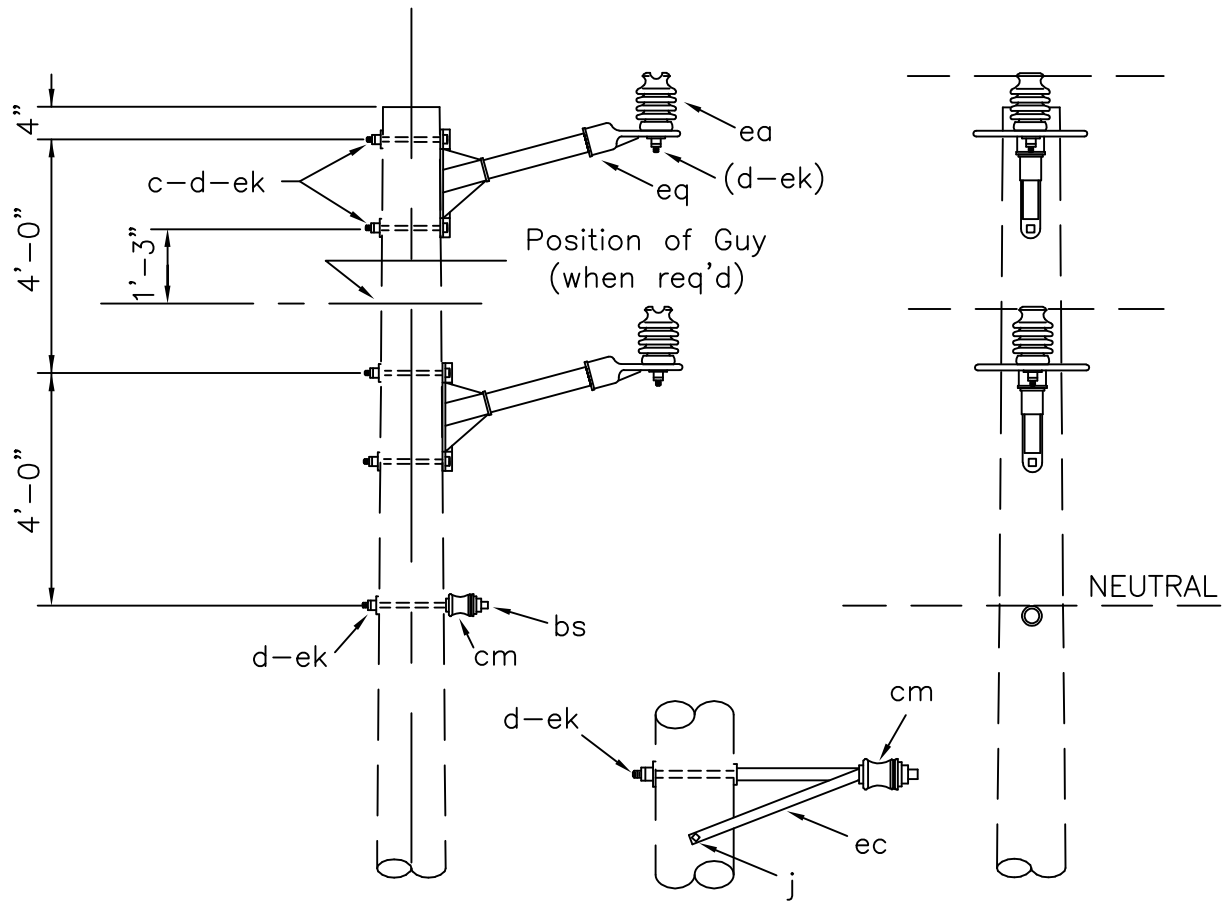

Specify B1.8NP for
offset neutral assembly

Assembly: B1.		7NP	8NP
ITEM	MATERIAL	QTY	QTY
c	Bolt, machine, 5/8" x req'd length	4	4
d	Washer, square 2 1/4"	5	5
j	Screw, lag, 1/2" x 4"		2
bs	Bolt, single, upset	1	
cm	Insulator, spool, 3"	1	1
ea	Insulator, post type (12.47/7.5 kV)	2	2
ec	Bracket, offset neutral		1
ek	Locknuts	5	5
eq	Bracket, insulator/equipment	2	2

Design Parameters: Maximum Line Angles 5° - Small conductors 2° - Larger than #1/0	SINGLE SUPPORT-NARROW PROFILE (TANGENT) (POST INSULATORS)		
	APRIL 2005	2 - PHASE PRIMARY	B1.7NP
	RUS	12.47/7.2 kV	B1.8NP

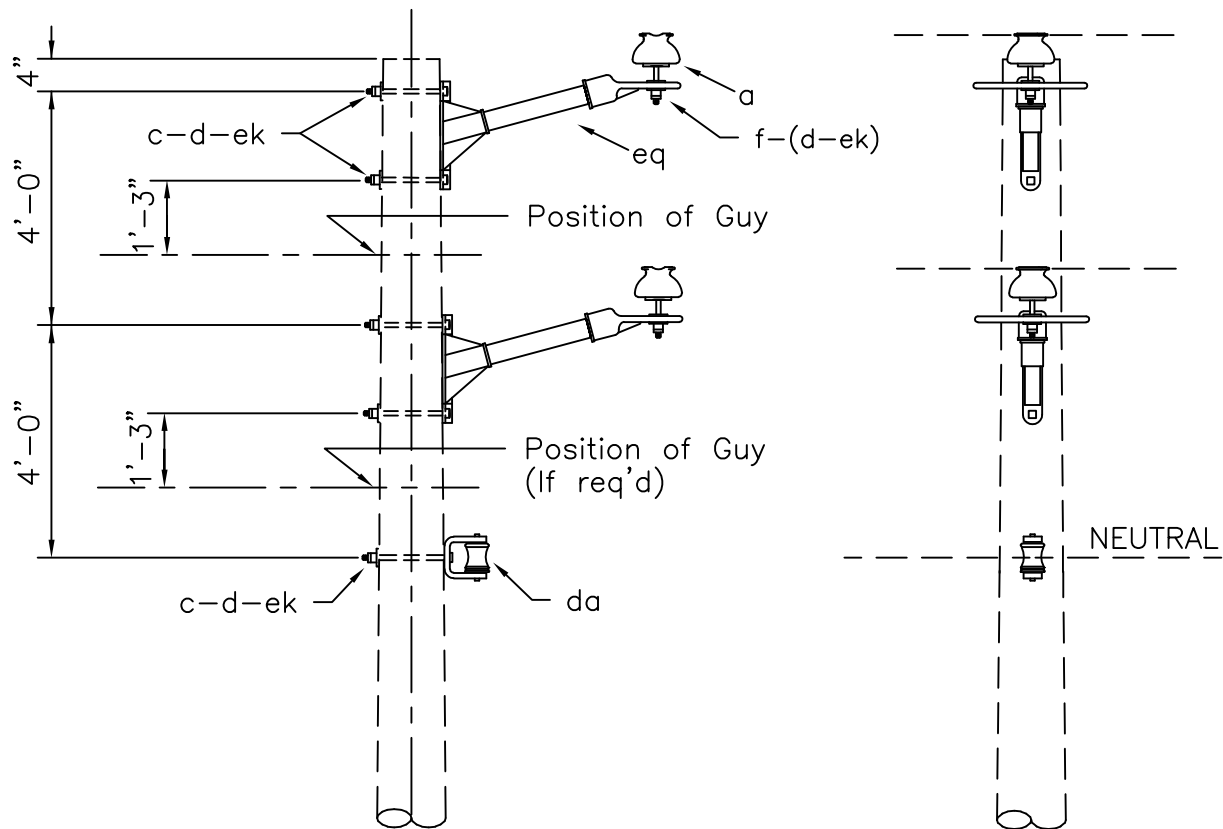

Assembly: B1. 9N

ITEM	MATERIAL	QTY
a	Insulator, pin type (12.47/7.2 kV)	2
c	Bolt, machine, 5/8" x req'd length	5
d	Washer, square 2 1/4"	5
(f)	(Pin, crossarm, 5/8" x 6 1/2")	(2) (If req'd)
da	Bracket, insulated	1
ek	Locknuts	5
eq	Bracket, insulator/equipment	2

Design Parameters:
Maximum Line Angles
See TABLE II

SINGLE SUPPORT-NARROW PROFILE

APRIL 2005

2 - PHASE PRIMARY

RUS

12.47/7.2 kV

B1.9N

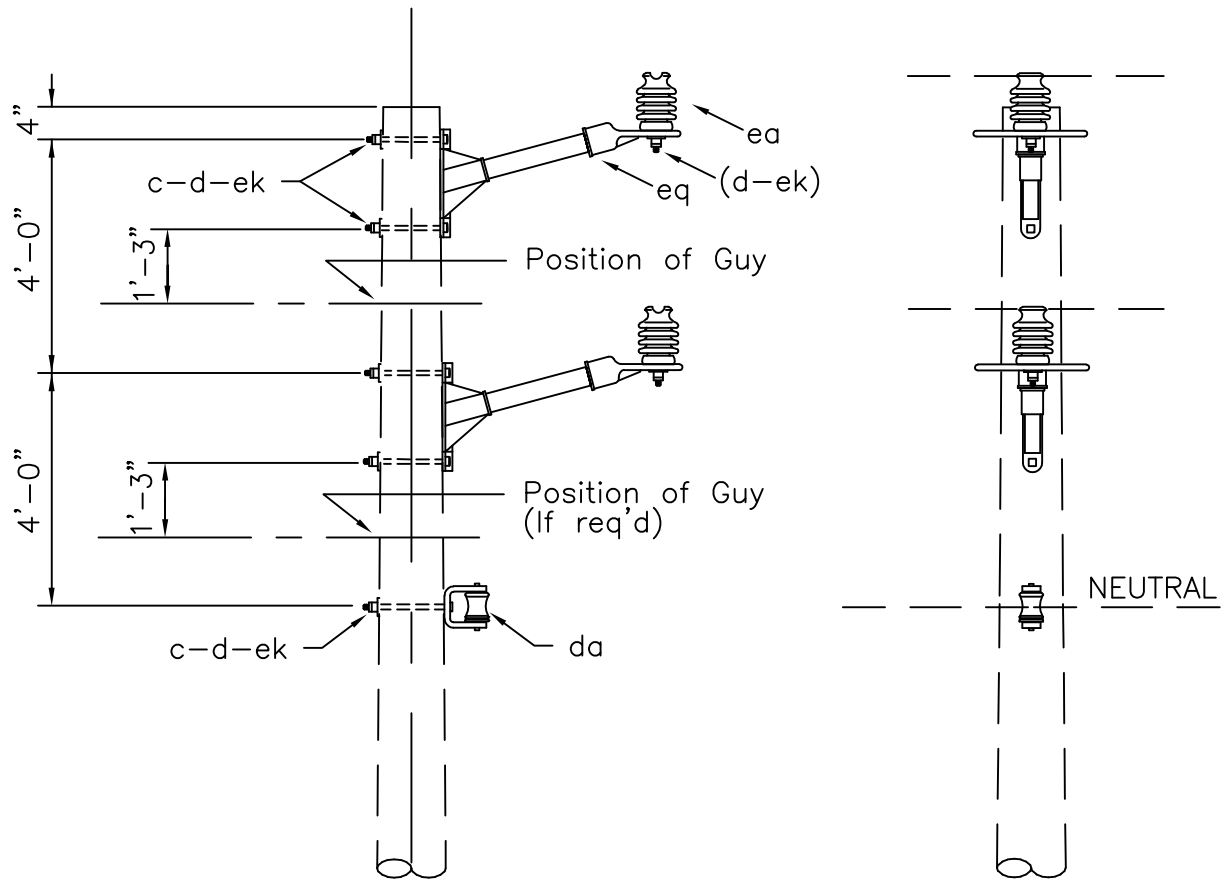

Assembly: B1. 9NP

ITEM	MATERIAL	QTY
c	Bolt, machine, 5/8" x req'd length	5
d	Washer, square 2 1/4"	5
da	Bracket, insulated	1
ea	Insulator, post type (12.47/7.5 kV)	2
ek	Locknuts	5
eq	Bracket, insulator/equipment	2

Design Parameters:

MAXIMUM LINE ANGLES:
See TABLE II

SINGLE SUPPORT-NARROW PROFILE
(POST INSULATORS)

APRIL 2005

RUS

2 - PHASE PRIMARY
12.47/7.2 kV

B1.9NP

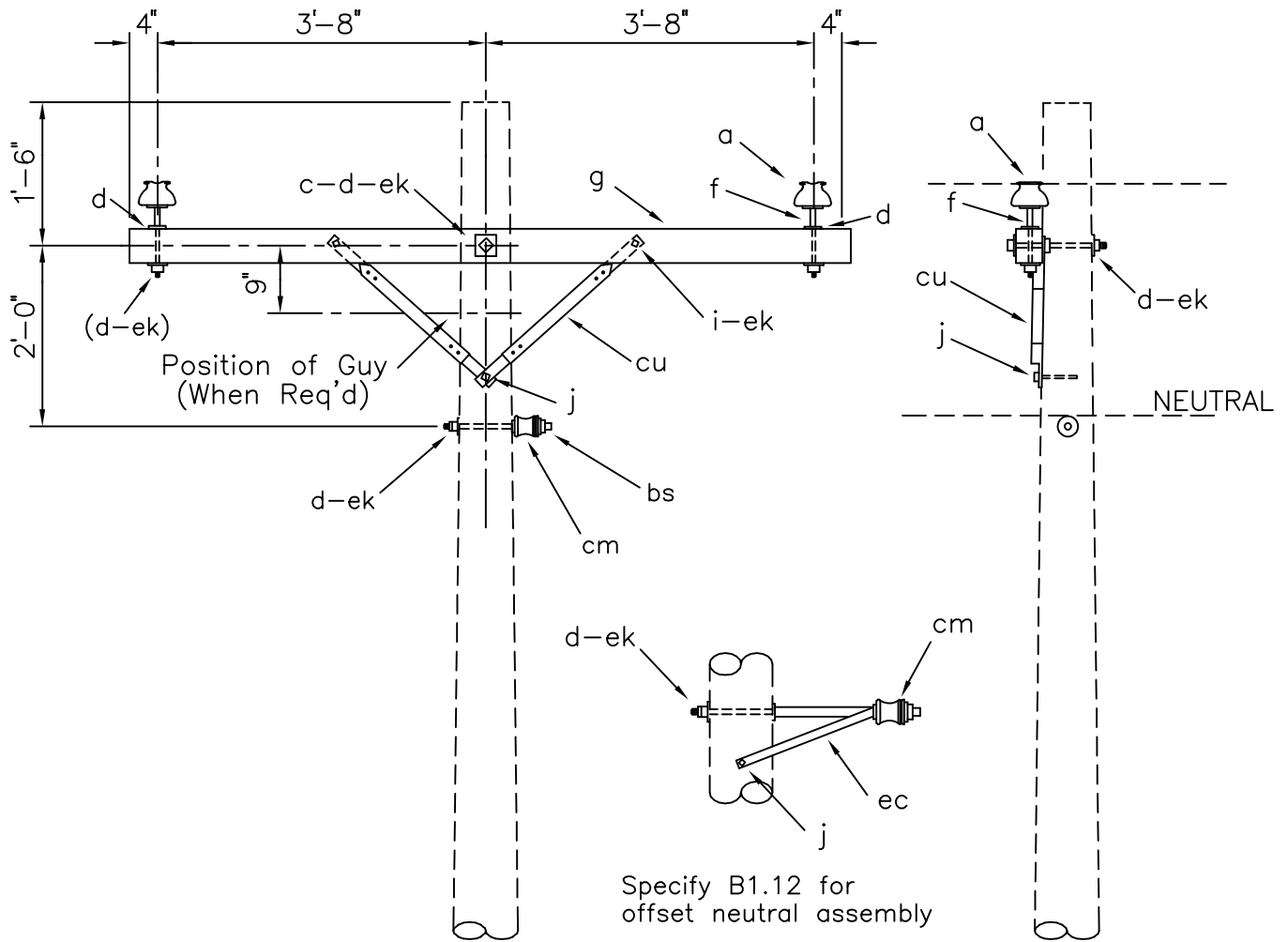

ASSEMBLY: B1. 11 12

ITEM	MATERIAL	QTY	QTY
a	Insulator, pin type (12.47/7.2 kV)	2	2
c	Bolt, machine, 5/8" x req'd length	1	1
d	Washer, square, 2 1/4"	5	5
f	Pin, crossarm steel, 5/8" x 10 3/4"	2	2
g	Crossarm, 3 5/8" x 4 5/8" x 8'-0"	1	1
i	Bolt, carriage, 3/8" x 4 1/2"	2	2
j	Screw, lag, 1/2" x 4"	1	3
bs	Bolt, single, upset	1	
cm	Insulator, spool, 3"	1	1
cu	Brace, 28"	2	2
ec	Bracket, offset, neutral		1
ek	Locknuts	4	4

DESIGN PARAMETERS:
 MAXIMUM LINE ANGLES:
 5° - Small Conductors
 2° - Larger than #1/0

SINGLE SUPPORT ON CROSSARM
 (TANGENT)

APRIL 2005	2 - PHASE PRIMARY 12.47/7.2 kV	B1.11 (B1)
RUS		B1.12 (B1A)

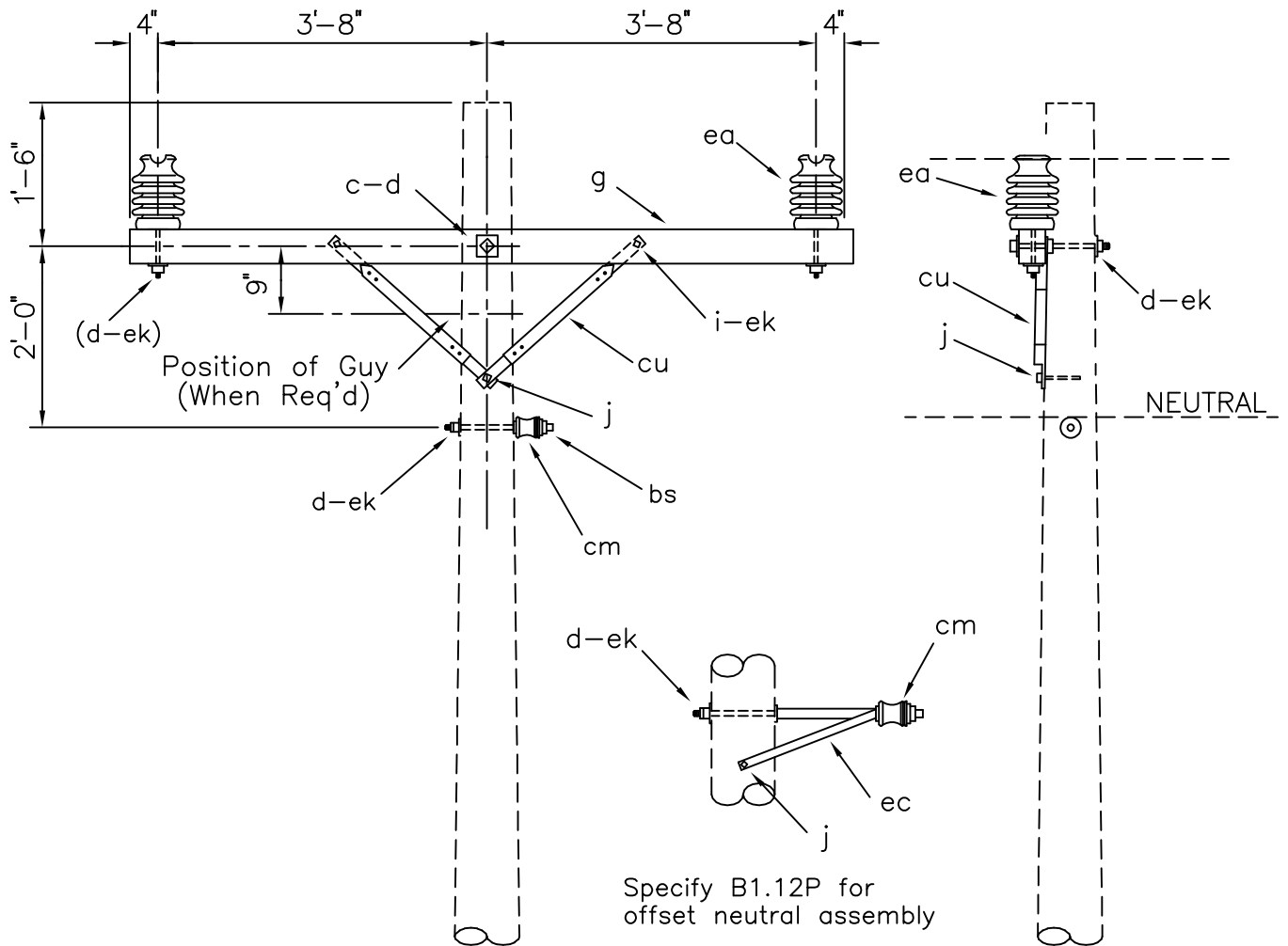

ASSEMBLY: B1.

ITEM	MATERIAL	11P QTY	12P QTY
c	Bolt, machine, 5/8" x req'd length	1	1
d	Washer, square, 2 1/4"	3	3
g	Crossarm, 3 5/8" x 4 5/8" x 8'-0"	1	1
i	Bolt, carriage, 3/8" x 4 1/2"	2	2
j	Screw, lag, 1/2" x 4"	1	3
bs	Bolt, single, upset	1	
cm	Insulator, spool, 3"	1	1
cu	Brace, 28"	2	2
ea	Insulator, post type, (12.47/7.2 kV)	2	2
ec	Bracket, offset, neutral		1
ek	Locknuts	4	4

DESIGN PARAMETERS:

MAXIMUM LINE ANGLES
 5° - Small Conductors
 2° - Larger than #1/0

SINGLE SUPPORT ON CROSSARM
 (TANGENT) (POST INSULATORS)

APRIL 2005

RUS

2 - PHASE PRIMARY
 12.47/7.2 kV

B1.11P (B1P)
 B1.12P (B1AP)

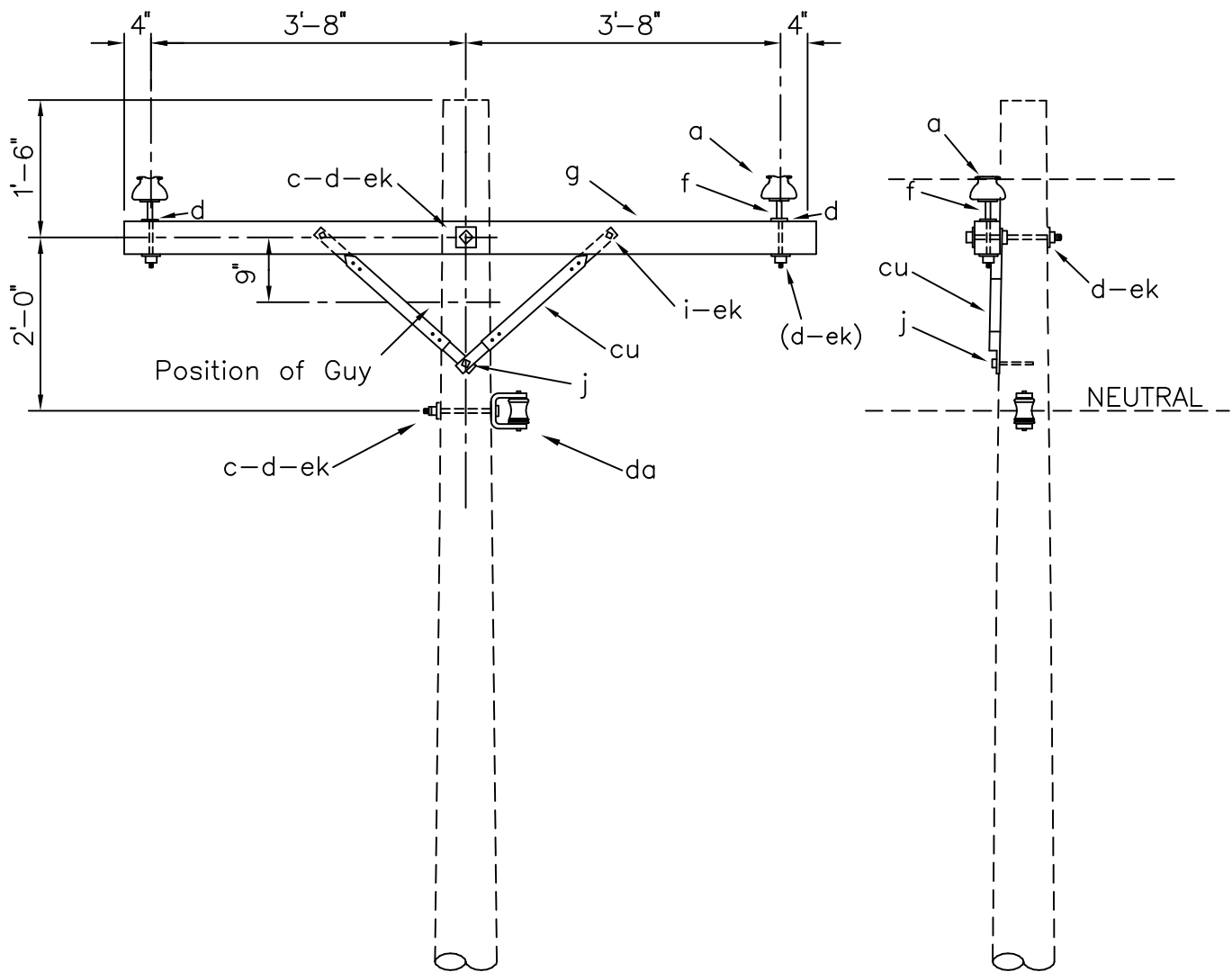

ITEM	QTY	MATERIAL
a	2	Insulator, pin type (12.47/7.2 kV)
c	2	Bolt, machine, 5/8" x req'd length
d	5	Washer, square, 2 1/4"
f	2	Pin, crossarm, steel, 5/8" x 10 3/4"
g	1	Crossarm, 3 5/8" x 4 5/8" x 8' - 0"
i	2	Bolt, carriage, 3/8" x 4 1/2"
j	1	Screw, lag, 1/2" x 4"
cu	2	Brace, 28"
da	1	Bracket, insulated
ek	4	Locknuts

DESIGN PARAMETERS:

See TABLE II

SINGLE SUPPORT ON CROSSARM

APRIL 2005

RUS

2 - PHASE PRIMARY
12.47/7.2 kV

B1.13

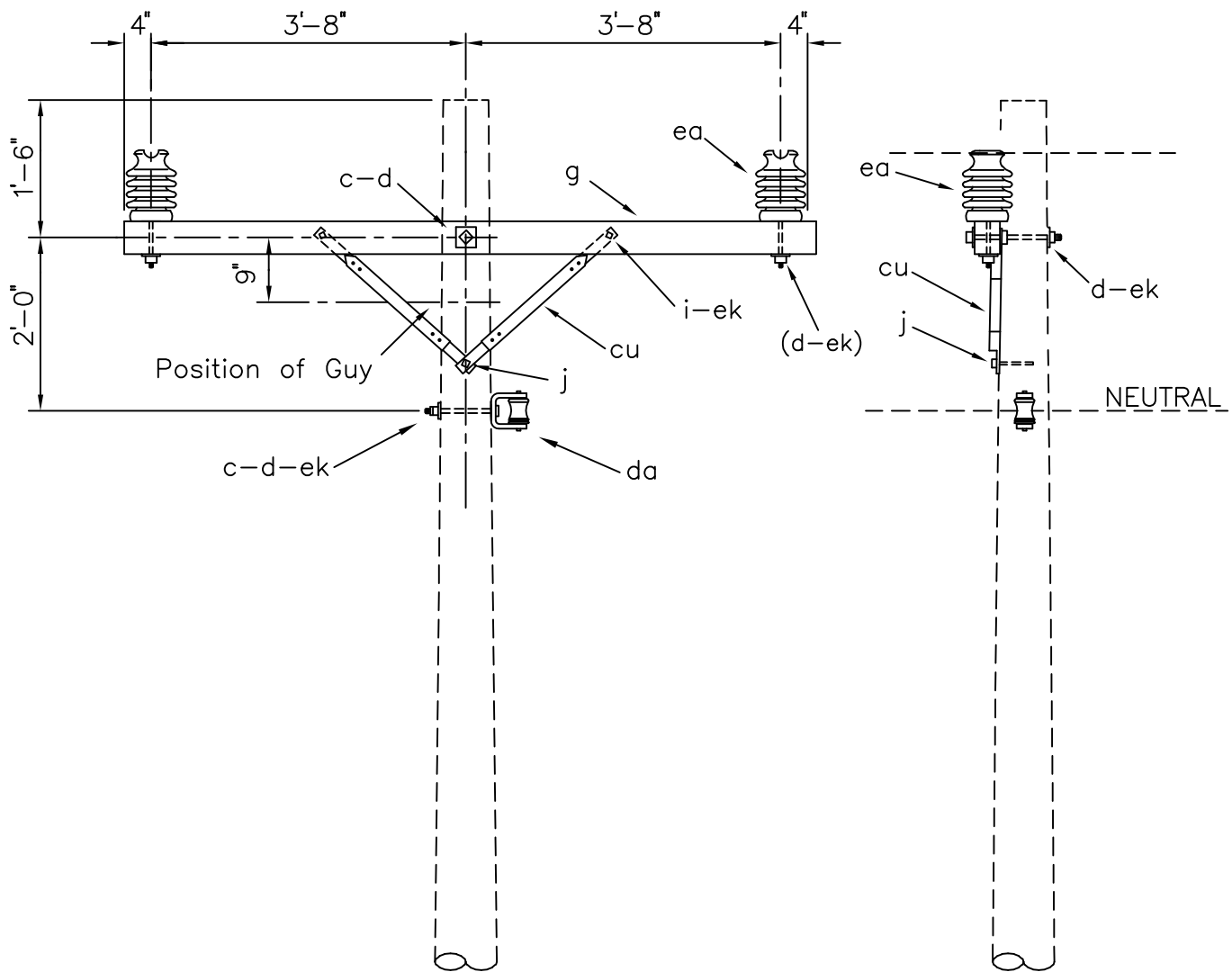

ITEM	QTY	MATERIAL
c	2	Bolt, machine, 5/8" x req'd length
d	3	Washer, square, 2 1/4"
g	1	Crossarm, 3 5/8" x 4 5/8" x 8' - 0"
i	2	Bolt, carriage, 3/8" x 4 1/2"
j	1	Screw, lag, 1/2" x 4"
cu	2	Brace, 28"
da	1	Bracket, insulated
ea	2	Insulator, post type (12.47/7.2 kV)
ek	4	Locknuts

DESIGN PARAMETERS:

See TABLE II

SINGLE SUPPORT ON CROSSARM
(POST INSULATORS)

APRIL 2005

RUS

2 - PHASE PRIMARY
12.47/7.2 kV

B1.13P

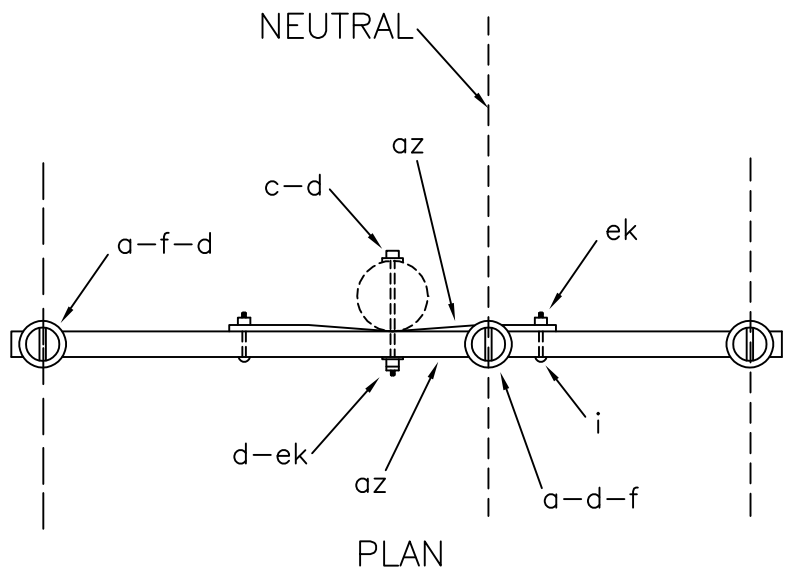
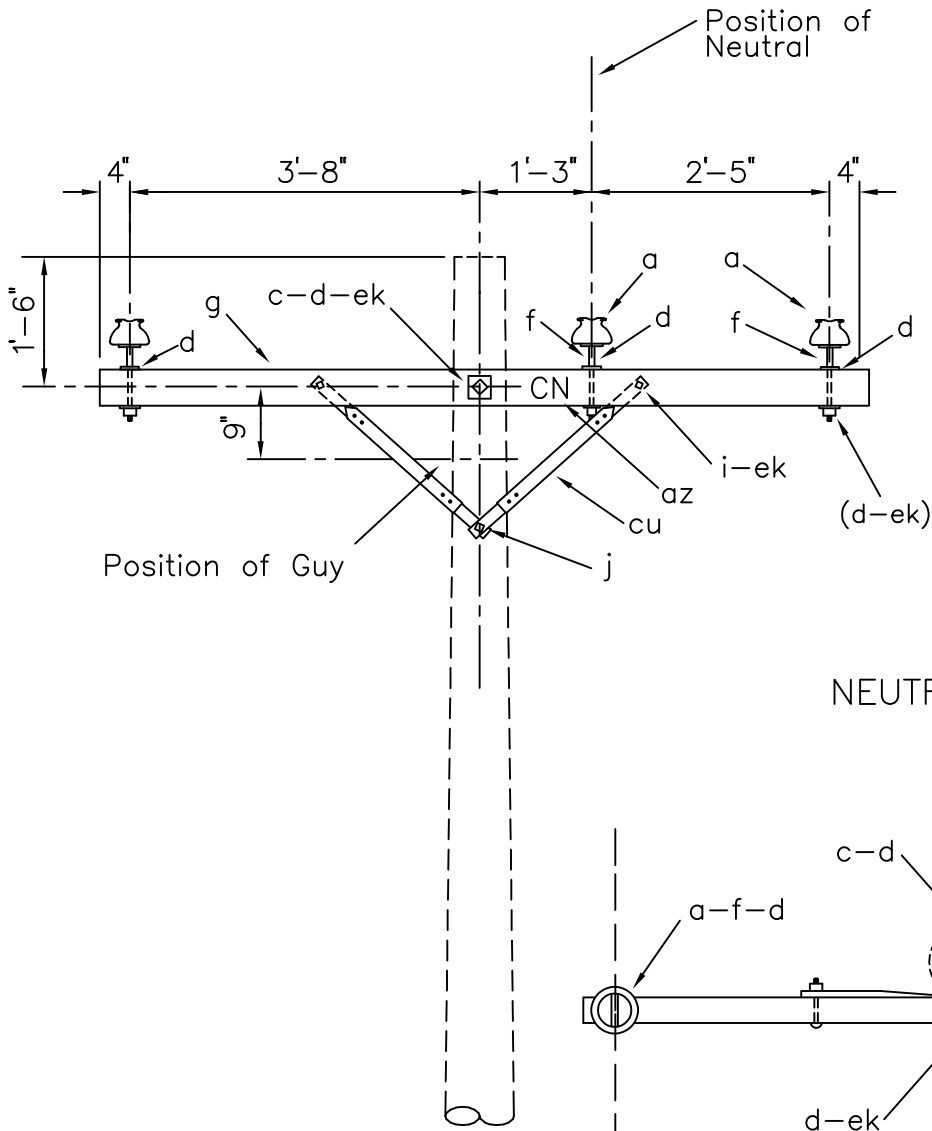

ITEM	QTY	MATERIAL
a	1	Insulator, pin type, 15 kV, white
a	2	Insulator, pin type (12.47/7.2 kV)
c	1	Bolt, machine, 5/8" x req'd length
d	5	Washer, square, 2 1/4"
f	3	Pin, crossarm, steel, 5/8" x 10 3/4"
g	1	Crossarm, 3 5/8" x 4 5/8" x 8' - 0"
i	2	Bolt, carriage, 3/8" x 4 1/2"
j	1	Screw, lag, 1/2" x 4"
az	4	Letters, 2" C, 2" N, with nails
cu	2	Brace, 28"
ek	3	Locknuts

NOTE:

Install either identification letters (az) or white insulator in neutral position.

DESIGN PARAMETERS:
See TABLE II

SINGLE SUPPORT, NEUTRAL ON CROSSARM

APRIL 2005
RUS

2 - PHASE PRIMARY
12.47/7.2 kV

B1.14
(B9-1)

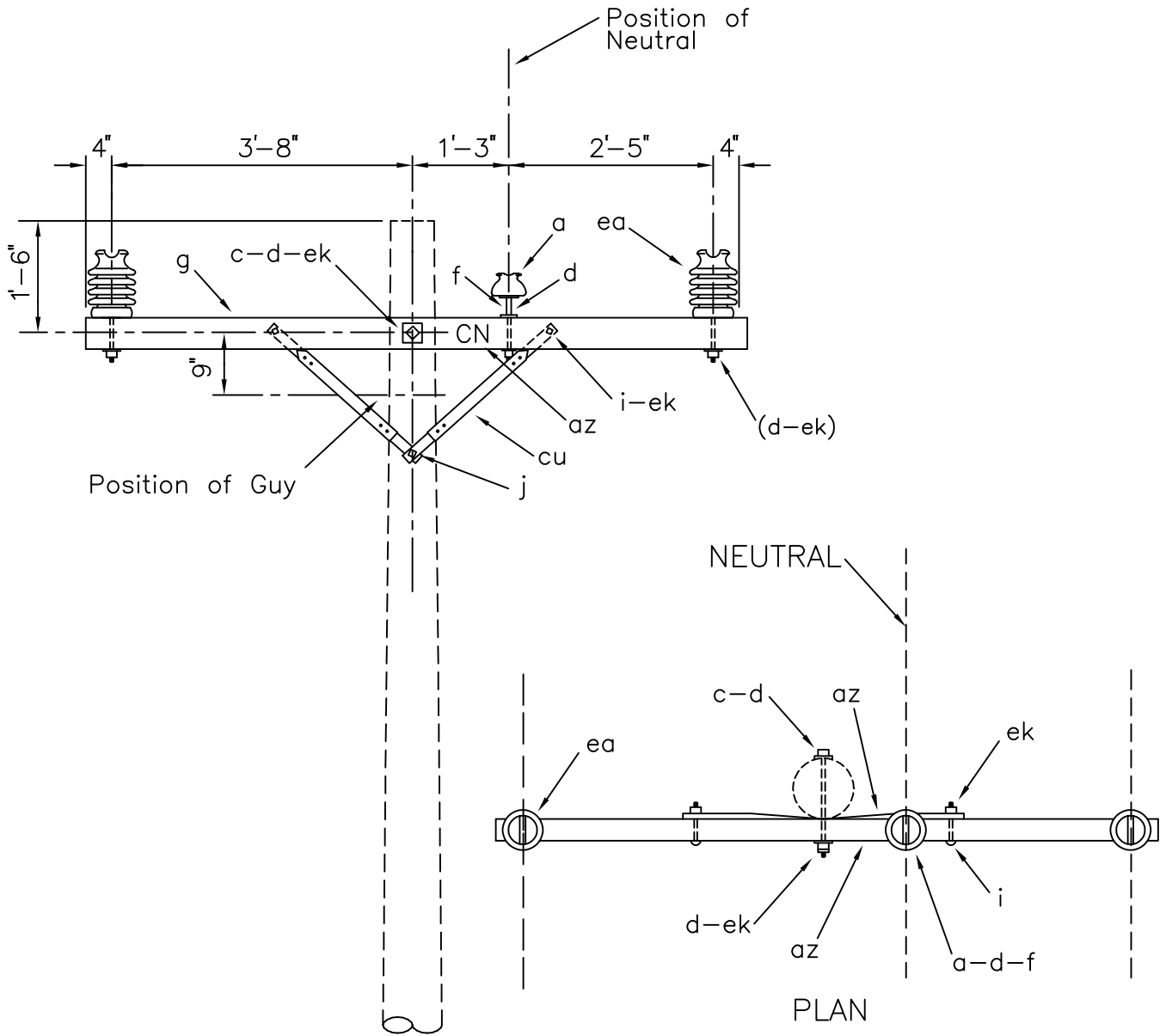

ITEM	QTY	MATERIAL
a	1	Insulator, pin type, 15 kV, white
c	1	Bolt, machine, 5/8" x req'd length
d	3	Washer, square, 2 1/4"
f	1	Pin, crossarm, steel, 5/8" x 10 3/4"
g	1	Crossarm, 3 5/8" x 4 5/8" x 8' - 0"
i	2	Bolt, carriage, 3/8" x 4 1/2"
j	1	Screw, lag, 1/2" x 4"
az	4	Letters, 2" C, 2" N, with nails
cu	2	Brace, 28"
ea	2	Insulator, post type (12.47/7.2 kV)
ek	3	Locknuts

NOTE:
Install either identification letters (az) or white insulator in neutral position.

DESIGN PARAMETERS: See TABLE II		SINGLE SUPPORT, NEUTRAL ON CROSSARM (POST INSULATORS)	
APRIL 2005	2 - PHASE PRIMARY	B1.14P	
RUS	12.47/7.2 kV	(B9-1P)	

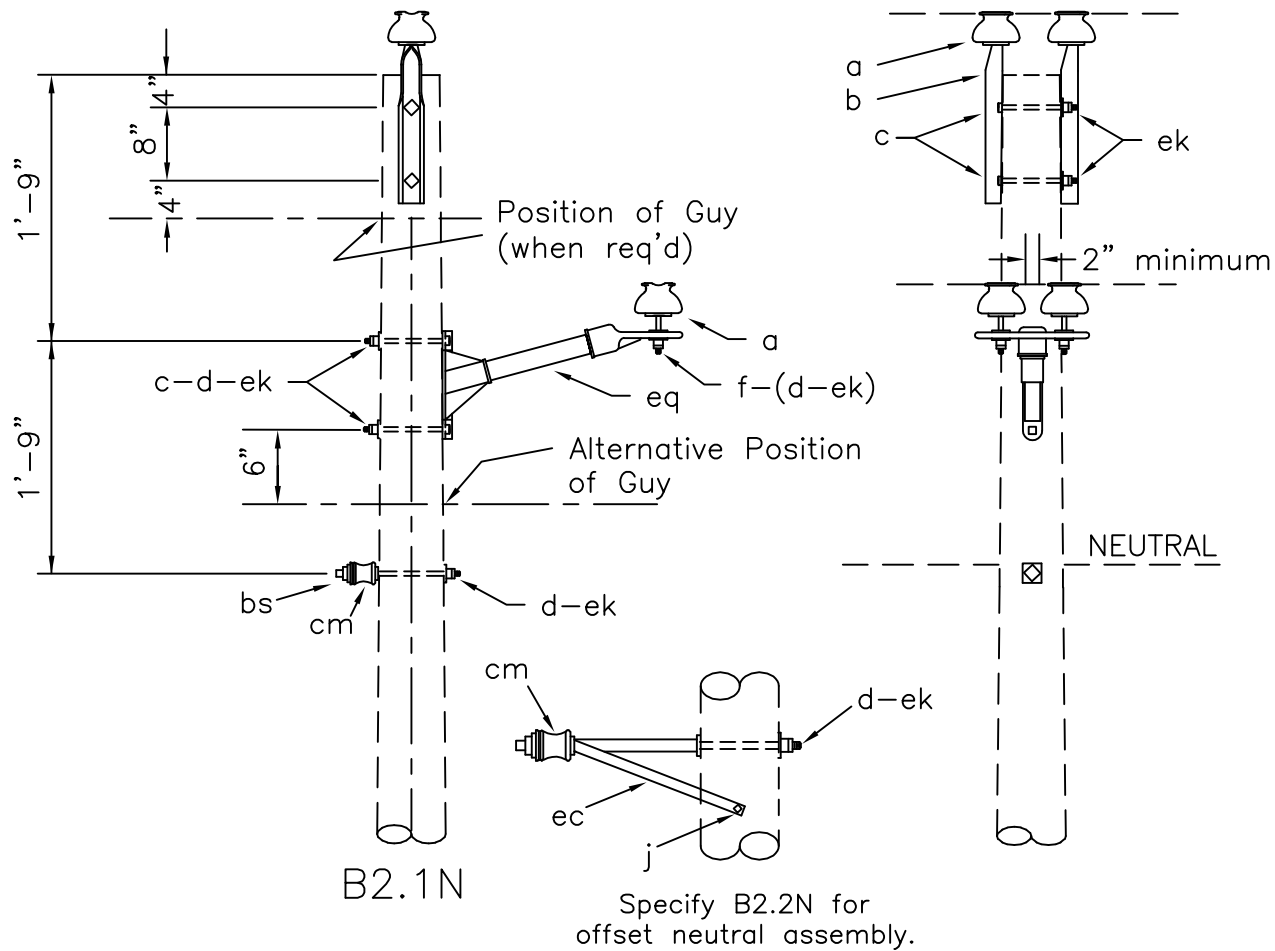

NOTE: These assemblies used for NESC Grade B construction.

ASSEMBLY: B2.		1N	2N
ITEM	MATERIAL	QTY	QTY
a	Insulator, pin type (12.47/7.2 kV)	4	4
b	Pin, pole top, 20"	2	2
c	Bolt, machine, 5/8" x req'd length	4	4
d	Washer, square 2 1/4"	3	3
f	Pin, crossarm, 5/8" x 6 1/2"	2	2
j	Screw, lag 1/2" x 4"		2
bs	Bolt, single upset	1	
cm	Insulator, spool, 3"	1	1
ec	Bracket, offset neutral		1
ek	Locknuts	5	5
eq	Bracket, insulator/equipment	1	1

Design Parameters: MAXIMUM LINE ANGLES: 5° - Small Conductors 2° - Larger than #1/0	DOUBLE SUPPORT-NARROW PROFILE (TANGENT)		
	APRIL 2005	2 - PHASE PRIMARY 12.47/7.2 kV	B2.1N
	RUS		B2.2N

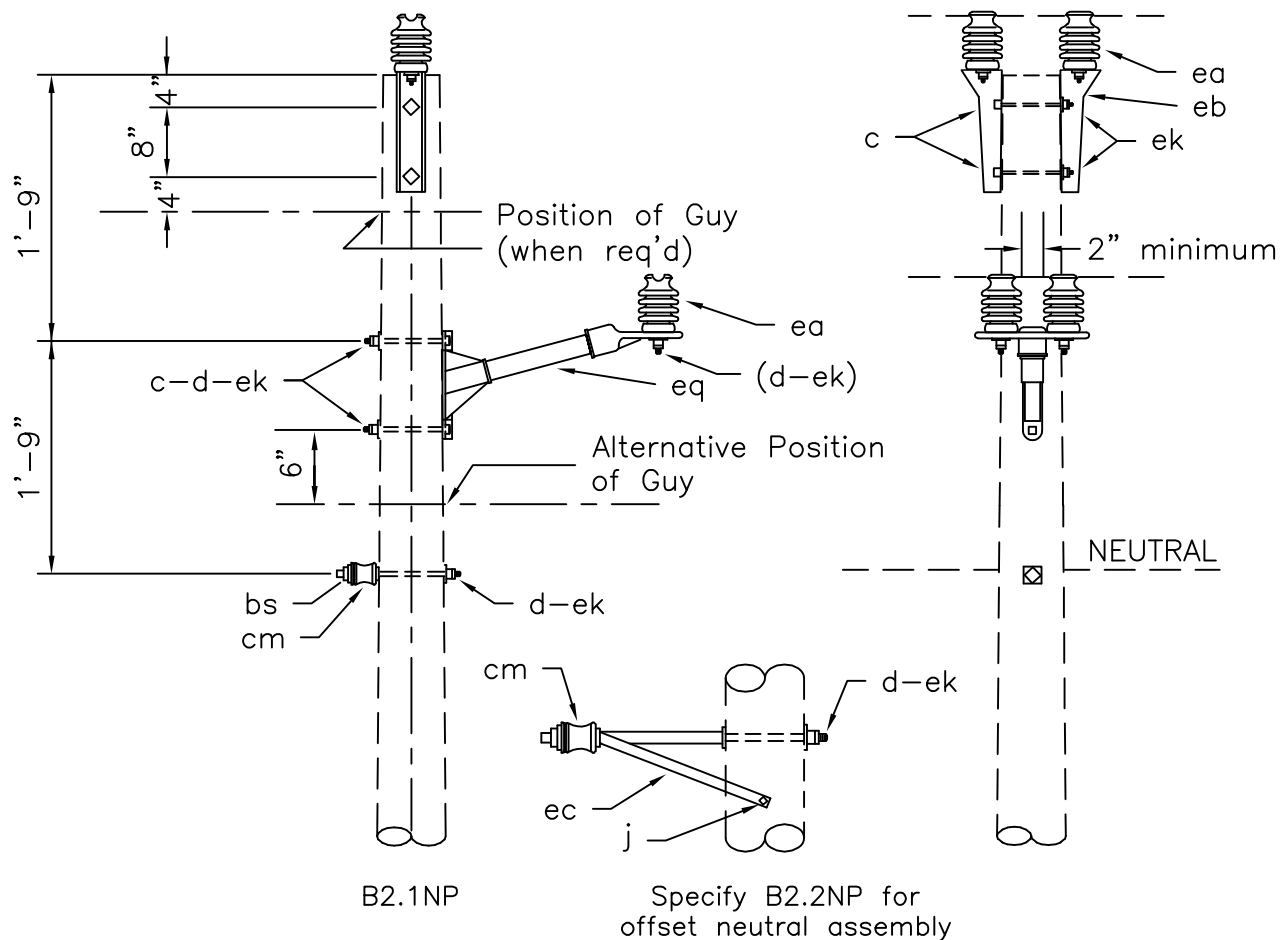

NOTE: These assemblies used for NESC Grade B construction.

ASSEMBLY: B2.		1NP	2NP
ITEM	MATERIAL	QTY	QTY
c	Bolt, machine, 5/8" x req'd length	4	4
d	Washer, square 2 1/4"	3	3
j	Screw, lag 1/2" x 4"		2
bs	Bolt, single upset	1	
cm	Insulator, spool, 3"	1	1
ea	Insulator, post type (12.47/7.5 kV)	4	4
eb	Bracket, pole top	2	2
ec	Bracket, offset neutral		1
ek	Locknuts	5	5
eq	Bracket, insulator/equipment	1	1

Design Parameters: Maximum Line Angles: 5° - Small Conductors 2° - Larger than #1/0	DOUBLE SUPPORT-NARROW PROFILE (TANGENT) (POST INSULATORS)		
	APRIL 2005	2 - PHASE PRIMARY	B2.1NP
	RUS	12.47/7.2 kV	B2.2NP

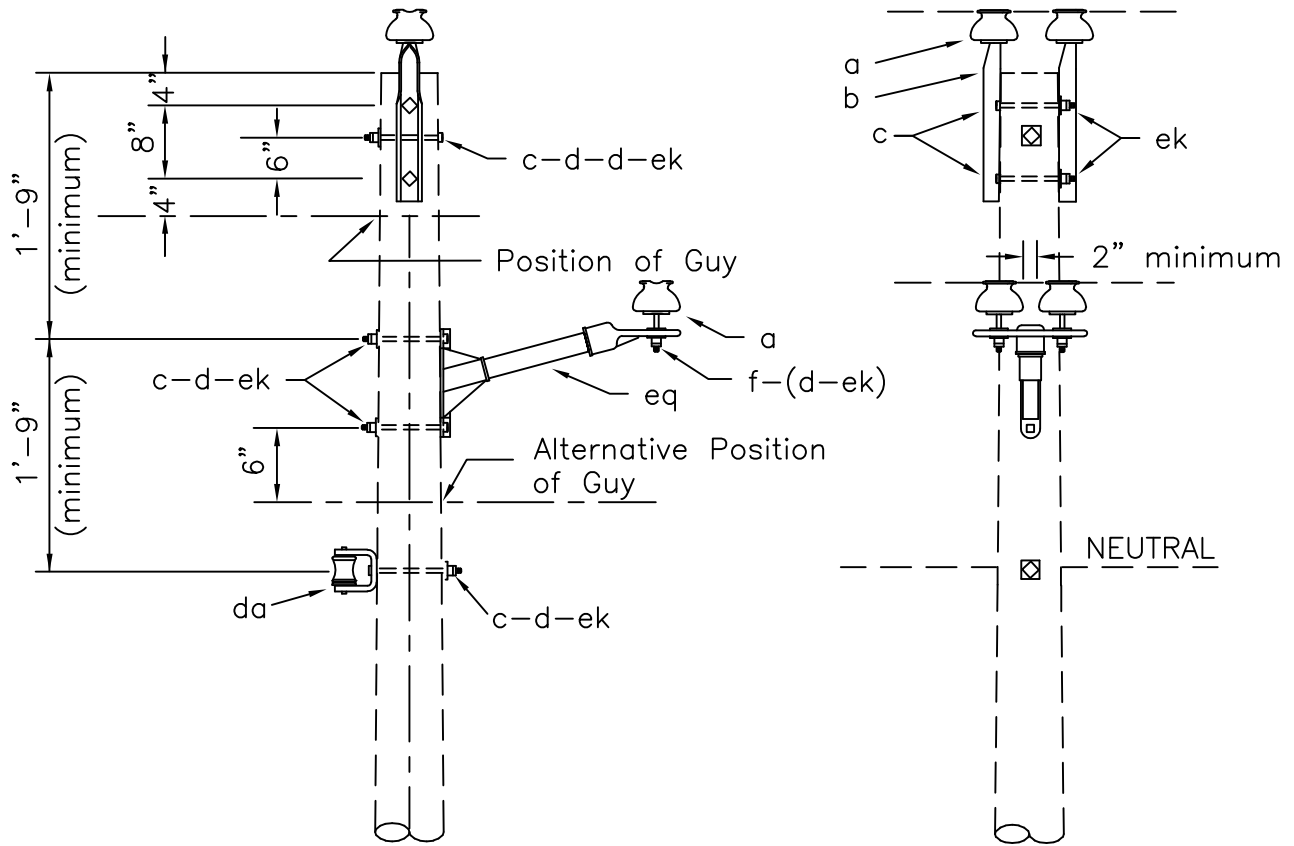

ASSEMBLY: B2. 3N

ITEM	MATERIAL	QTY
a	Insulator, pin type (12.47/7.2 kV)	4
b	Pin, pole top, 20"	2
c	Bolt, machine, 5/8" x req'd length	6
d	Washer, square 2 1/4"	5
f	Pin, crossarm, 5/8" x 6 1/2"	2
da	Bracket, insulated	1
ek	Locknuts	6
eq	Bracket, insulator/equipment	1

Design Parameters:

MAXIMUM LINE ANGLES:
See Table III

DOUBLE SUPPORT-NARROW PROFILE

APRIL 2005

RUS

2 - PHASE PRIMARY
12.47/7.2 kV

B2.3N

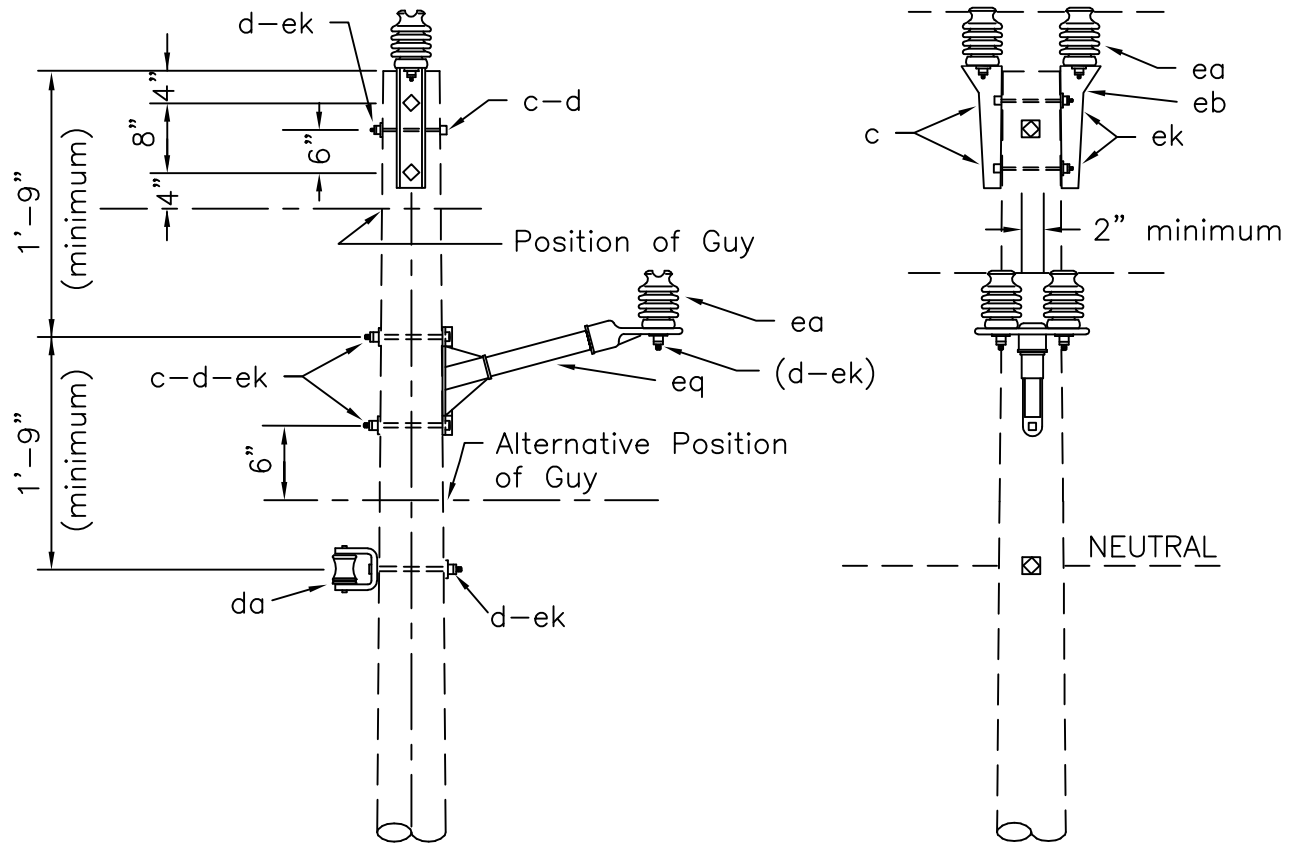

ASSEMBLY: B2. 3NP

ITEM	MATERIAL	QTY
c	Bolt, machine, 5/8" x req'd length	6
d	Washer, square 2 1/4"	5
da	Bracket, insulated	1
ea	Insulator, post type (12.47/7.2 kV)	4
eb	Bracket, pole top	2
ek	Locknuts	6
eq	Bracket, insulator/equipment	1

Design Parameters:
Maximum Line Angles:
See TABLE IV

DOUBLE SUPPORT-NARROW PROFILE
(POST INSULATORS)

APRIL 2005

2 - PHASE PRIMARY
12.47/7.2 kV

RUS

B2.3NP

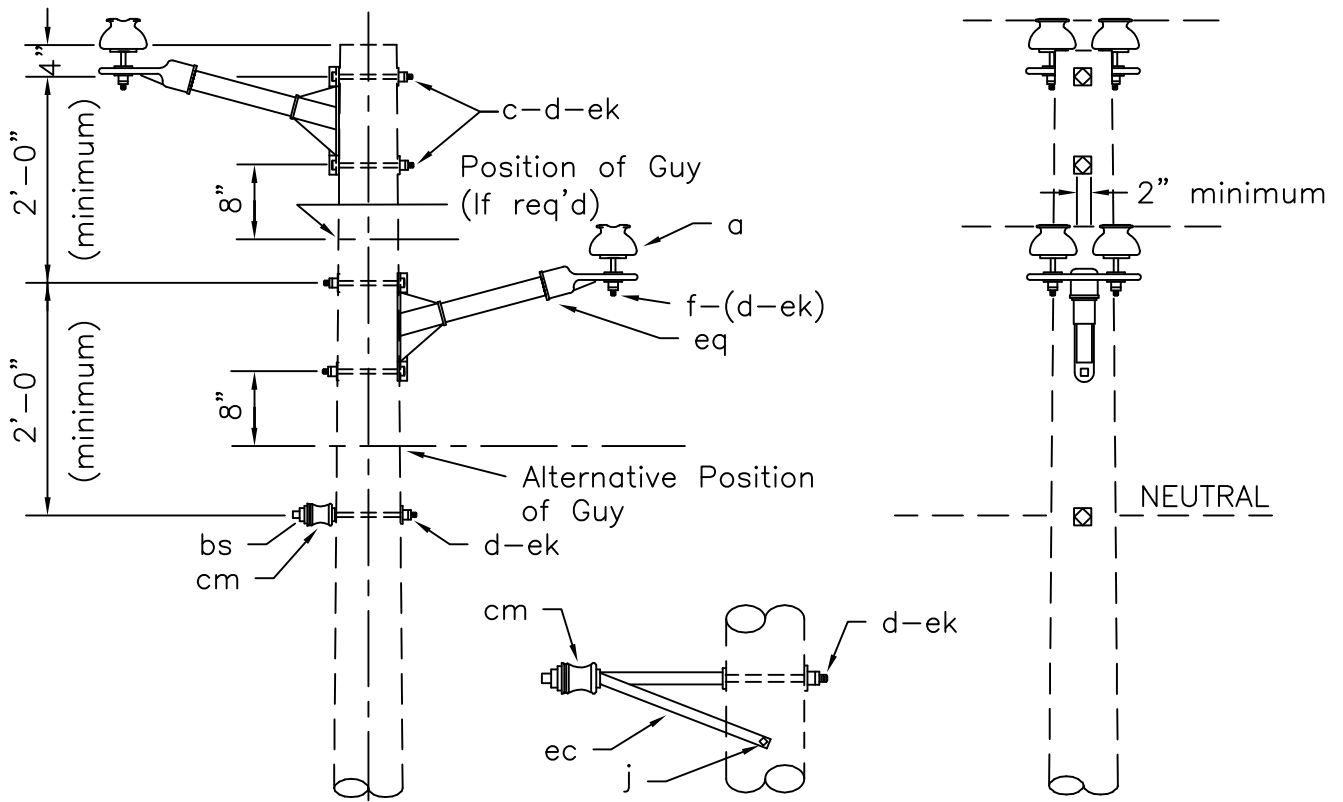

Specify B2.5N for offset neutral assembly

NOTE: Use these assemblies for NESC Grade B construction.

ASSEMBLY: B2.		4N	5N
ITEM	MATERIAL	QTY	QTY
a	Insulator, pin type (12.47/7.2 kV)	4	4
c	Bolt, machine, 5/8" x req'd length	4	4
d	Washer, square 2 1/4"	5	5
f	Pin, crossarm, 5/8" x 6 1/2"	4	4
j	Screw, lag, 1/2" x 4"		2
bs	Bolt, single, upset	1	
cm	Insulator, spool, 3"	1	1
ec	Bracket, offset neutral		1
ek	Locknuts	5	5
eq	Bracket, insulator/equipment	2	2

Design Parameters:

MAXIMUM LINE ANGLES:

- 5° - Small Conductors
- 2° - Larger than #1/0

DOUBLE SUPPORT-NARROW PROFILE
(TANGENT)

APRIL 2005

RUS

2 - PHASE PRIMARY
12.47/7.2 kV

B2.4N
B2.5N

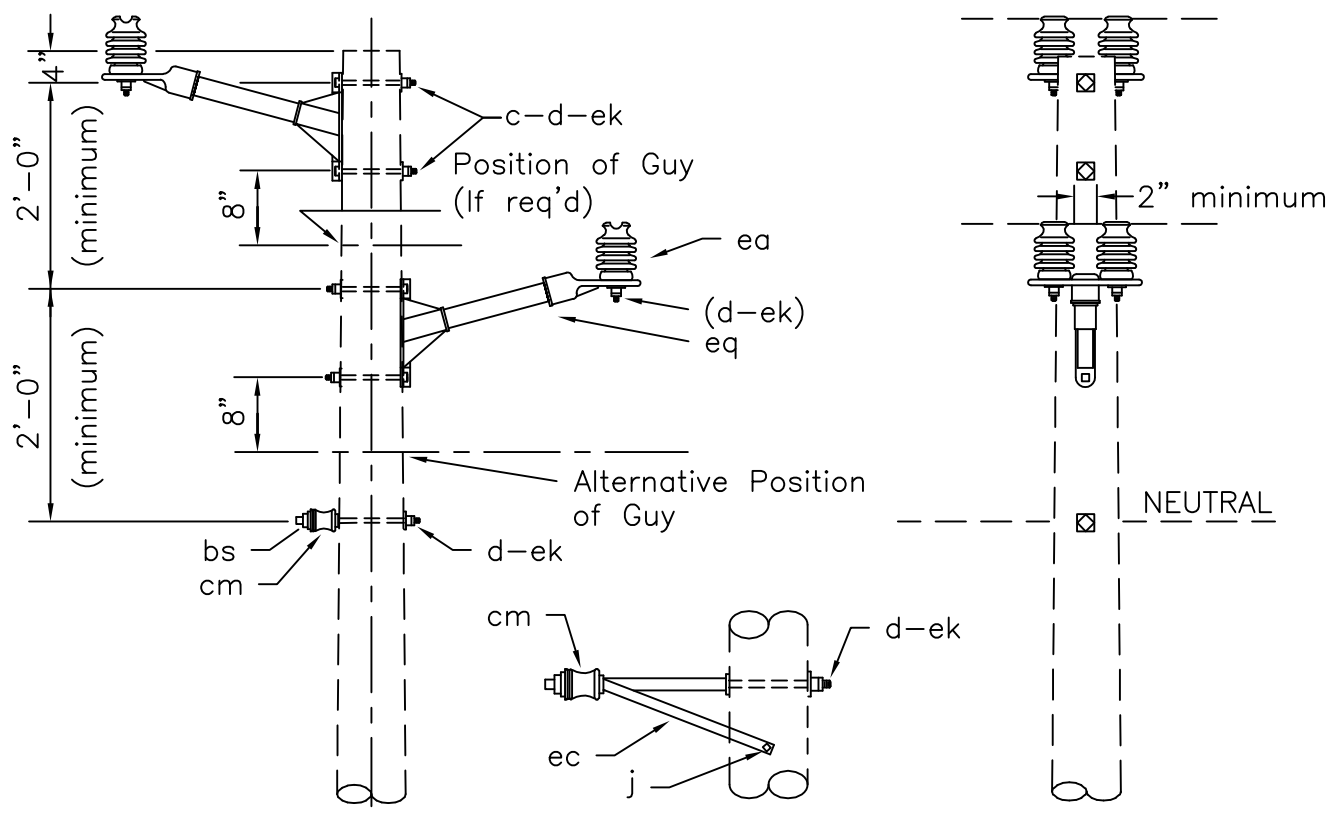

Specify B2.5NP for offset neutral assembly

NOTE: Use these assemblies for NESC Grade B construction.

ASSEMBLY: B2. 4NP 5NP

ITEM	MATERIAL	QTY	QTY
c	Bolt, machine, 5/8" x req'd length	4	4
d	Washer, square 2 1/4"	5	5
j	Screw, lag, 1/2" x 4"		2
bs	Bolt, single, upset	1	
cm	Insulator, spool, 3"	1	1
ea	Insulator, post type (12.47/7.2 kv)	4	4
ec	Bracket, offset neutral		1
ek	Locknuts	5	5
eq	Bracket, insulator/equipment	2	2

Design Parameters:
 MAXIMUM LINE ANGLES:
 5° - Small Conductors
 2° - Larger than #1/0

DOUBLE SUPPORT-NARROW PROFILE (TANGENT)(POST INSULATORS)		
APRIL 2005	2 - PHASE PRIMARY	B2.4NP
RUS	12.47/7.2 kv	B2.5NP

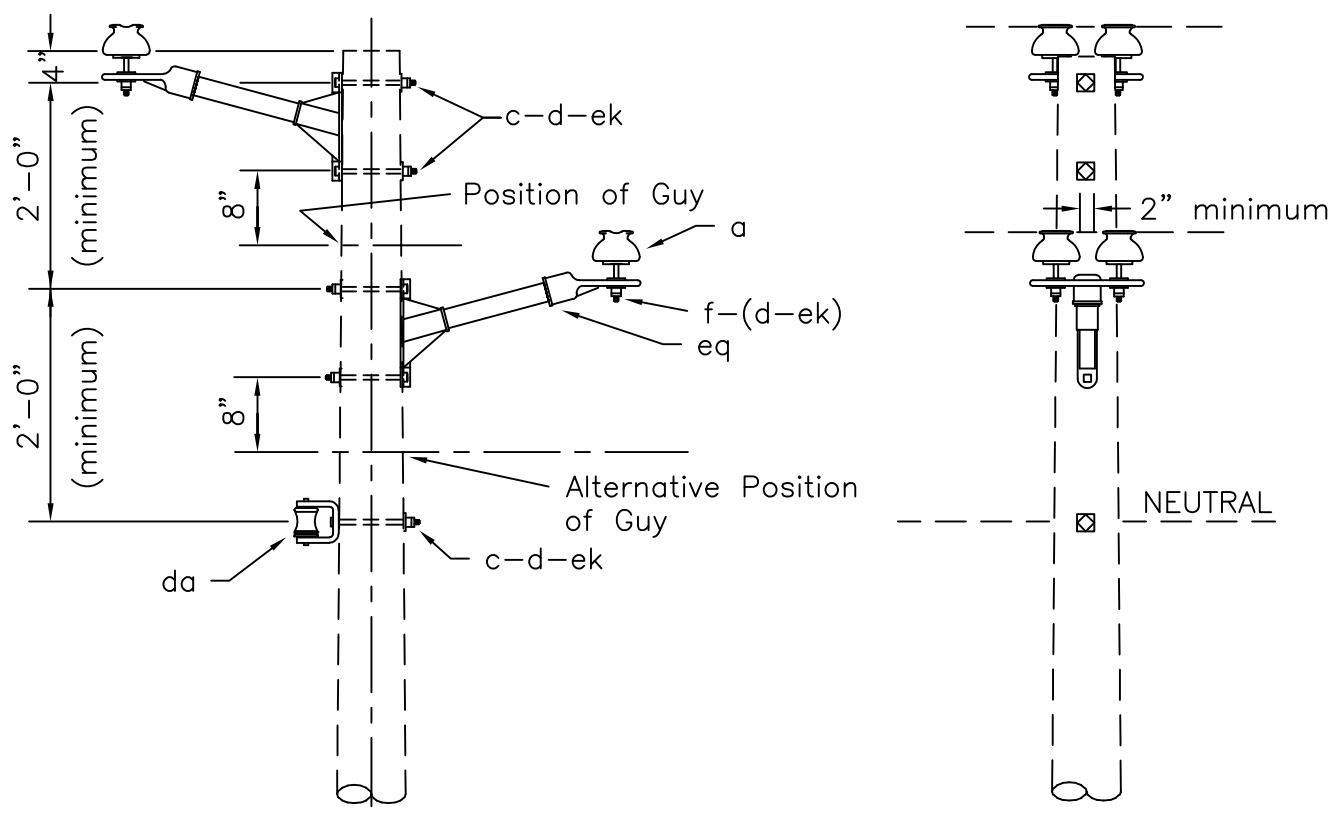

ASSEMBLY: B2. 6N

ITEM	MATERIAL	QTY
a	Insulator, pin type (12.47/7.2 kV)	4
c	Bolt, machine, 5/8" x req'd length	5
d	Washer, square 2 1/4"	5
f	Pin, crossarm, 5/8" x 6 1/2"	4
da	Bracket, insulated	1
ek	Locknuts	5
eq	Bracket, insulator/equipment	2

Design Parameters: MAXIMUM LINE ANGLES: See TABLE IV	DOUBLE SUPPORT-NARROW PROFILE		
	APRIL 2005	2 - PHASE PRIMARY	B2.6N
	RUS	12.47/7.2 kV	

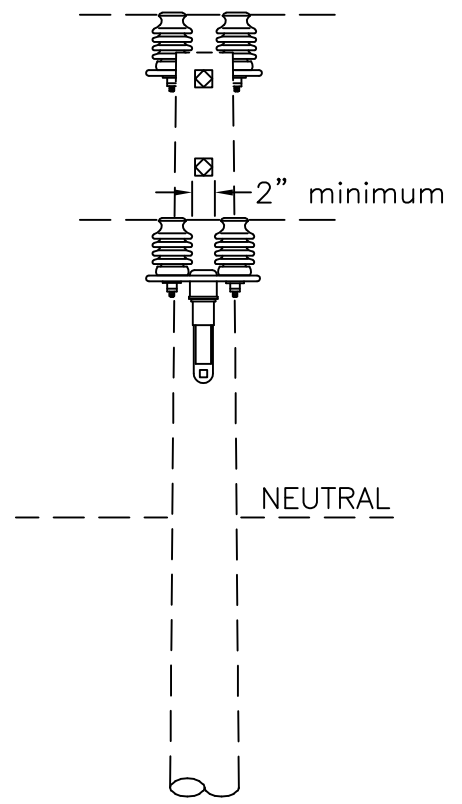
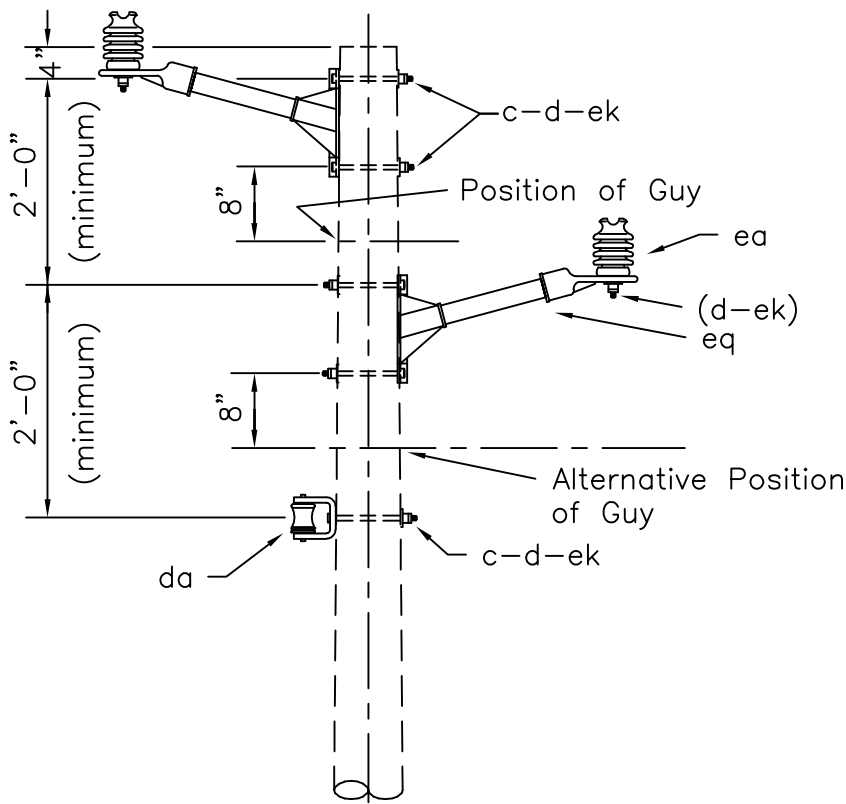

ASSEMBLY: B2.6NP

ITEM	MATERIAL	QTY
c	Bolt, machine, 5/8" x req'd length	5
d	Washer, square 2 1/4"	5
da	Bracket, insulated	1
ea	Insulator, post type (12.47/7.2kV)	4
ek	Locknuts	5
eq	Bracket, insulator/equipment	2

Design Parameters:

MAXIMUM LINE ANGLES:
See TABLE IV

DOUBLE SUPPORT-NARROW PROFILE
(POST INSULATORS)

APRIL 2005

RUS

2 - PHASE PRIMARY
12.47/7.2 kV

B2.6NP

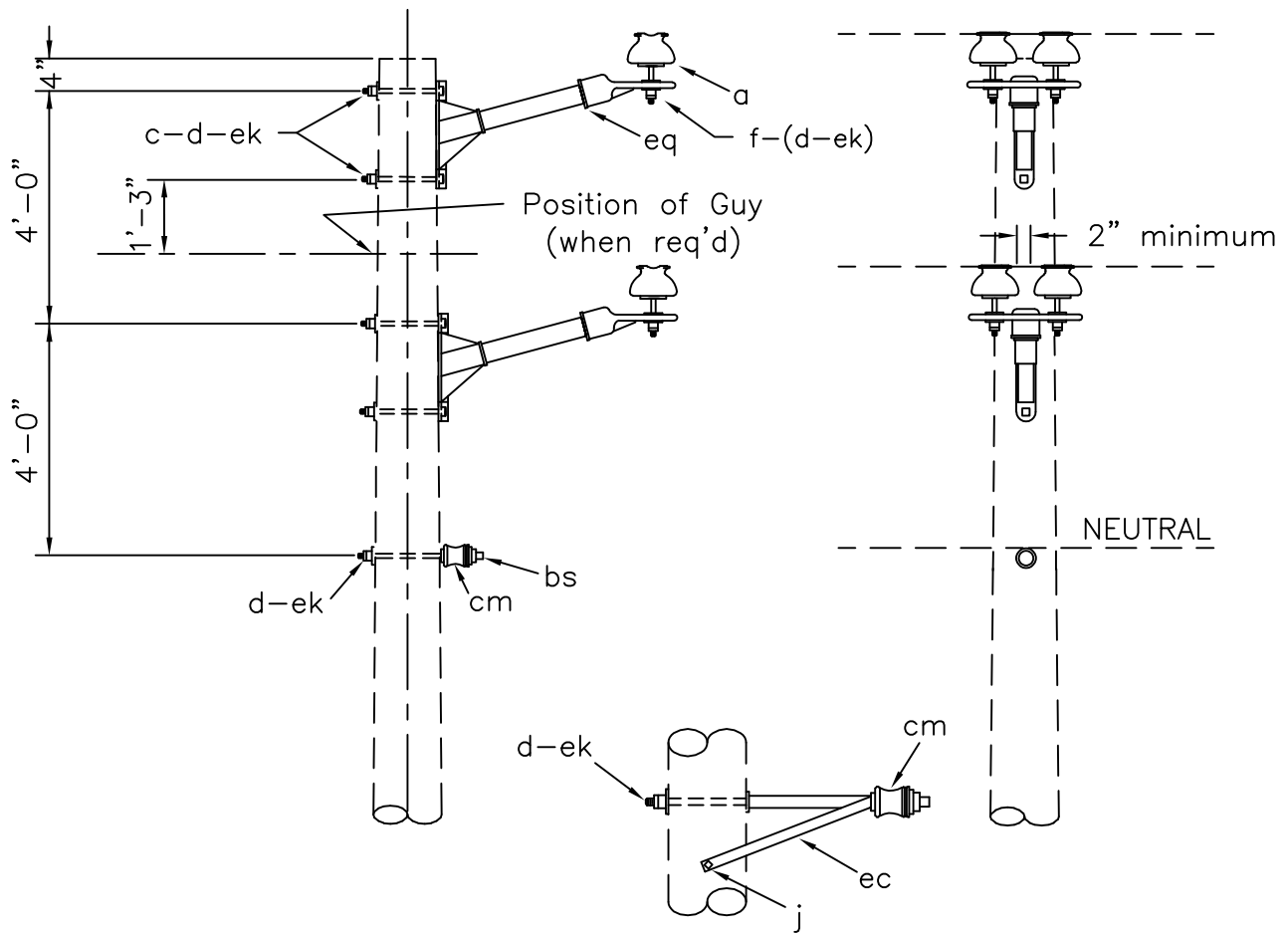

Specify B2.8N for
offset neutral assembly

NOTE: These assemblies used for NESC Grade B construction.

		Assembly: B2.	
ITEM	MATERIAL	7N	8N
a	Insulator, pin type (12.47/7.2 kV)	4	4
c	Bolt, machine, 5/8" x req'd length	4	4
d	Washer, square 2 1/4"	5	5
f	Pin, crossarm, 5/8" x 6 1/2"	4	4
j	Screw, lag, 1/2" x 4"		2
bs	Bolt, single, upset	1	
cm	Insulator, spool, 3"	1	1
ec	Bracket, offset neutral		1
ek	Locknuts	5	5
eq	Bracket, insulator/equipment	2	2

Design Parameters:
Maximum Line Angles
5° - Small Conductors
2° - Larger than #1/0

DOUBLE SUPPORT-NARROW PROFILE
(TANGENT)

APRIL 2005

RUS

2 - PHASE PRIMARY
12.47/7.2 kV

B2.7N
B2.8N

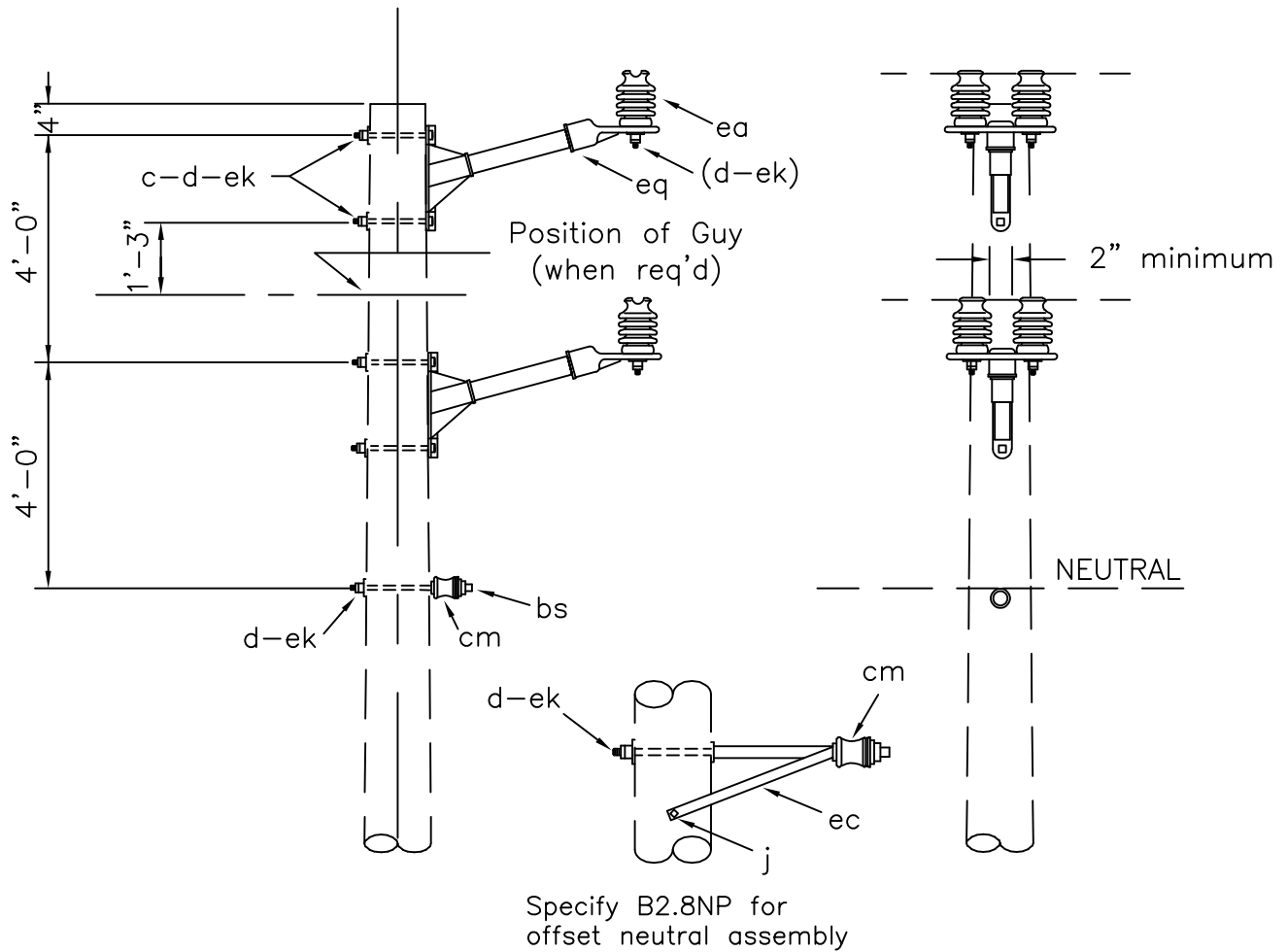

NOTE: These assemblies used for NESC Grade B construction.

		Assembly: B2.	
ITEM	MATERIAL	7NP QTY	8NP QTY
c	Bolt, machine, 5/8" x req'd length	4	4
d	Washer, square 2 1/4"	5	5
j	Screw, lag, 1/2" x 4"		2
bs	Bolt, single, upset	1	
cm	Insulator, spool, 3"	1	1
ea	Insulator, post type (12.47/7.2 kV)	4	4
ec	Bracket, offset neutral		1
ek	Locknuts	5	5
eq	Bracket, insulator/equipment	2	2

Design Parameters:
 Maximum Line Angles
 5° - Small conductors
 2° - Larger than #1/0

DOUBLE SUPPORT-NARROW PROFILE
 (TANGENT) (POST INSULATORS)

APRIL 2005

2 - PHASE PRIMARY
 12.47/7.2 kV

B2.7NP
 B2.8NP

RUS

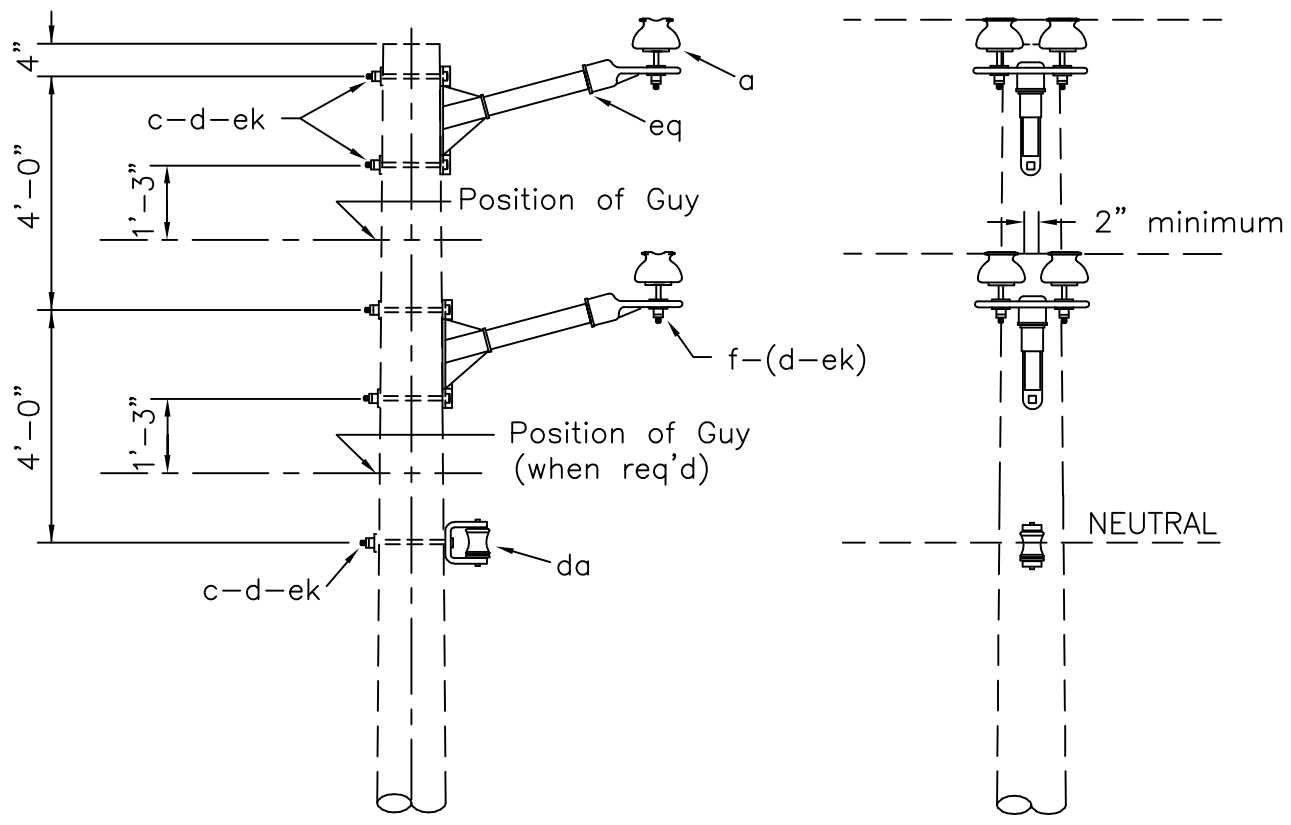

Assembly: B2.9N		QTY
ITEM	MATERIAL	
a	Insulator, pin type (12.47/7.2 kV)	4
c	Bolt, machine, 5/8" x req'd length	5
d	Washer, square 2 1/4"	5
f	Pin, crossarm, 5/8" x 6 1/2"	4
da	Bracket, insulated	1
ek	Locknuts	5
eq	Bracket, insulator/equipment	2

Design Parameters: Maximum Line Angles See TABLE IV	DOUBLE SUPPORT-NARROW PROFILE		
	APRIL 2005	2 - PHASE PRIMARY	B2.9N
	RUS	12.47/7.2 kV	

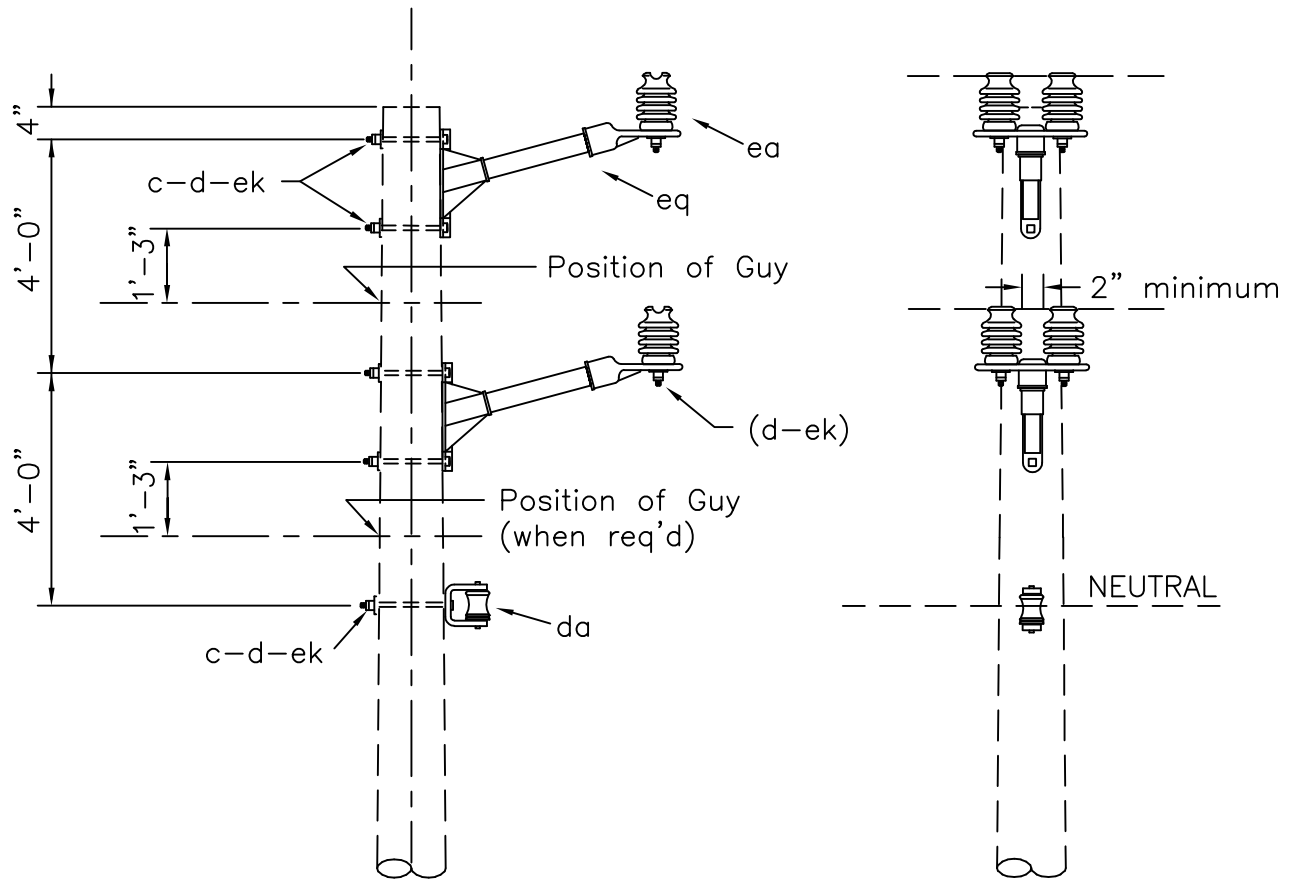

Assembly: B2.9NP

ITEM	MATERIAL	QTY
c	Bolt, machine, 5/8" x req'd length	5
d	Washer, square 2 1/4"	5
da	Bracket, insulated	1
ea	Insulator, post type (12.47/7.2 kV)	4
ek	Locknuts	5
eq	Bracket, insulator/equipment	2

Design Parameters:
Maximum Line Angles
See TABLE IV

DOUBLE SUPPORT-NARROW PROFILE
(POST INSULATORS)

APRIL 2005	2 - PHASE PRIMARY	B2.9NP
RUS	12.47/7.2 kV	

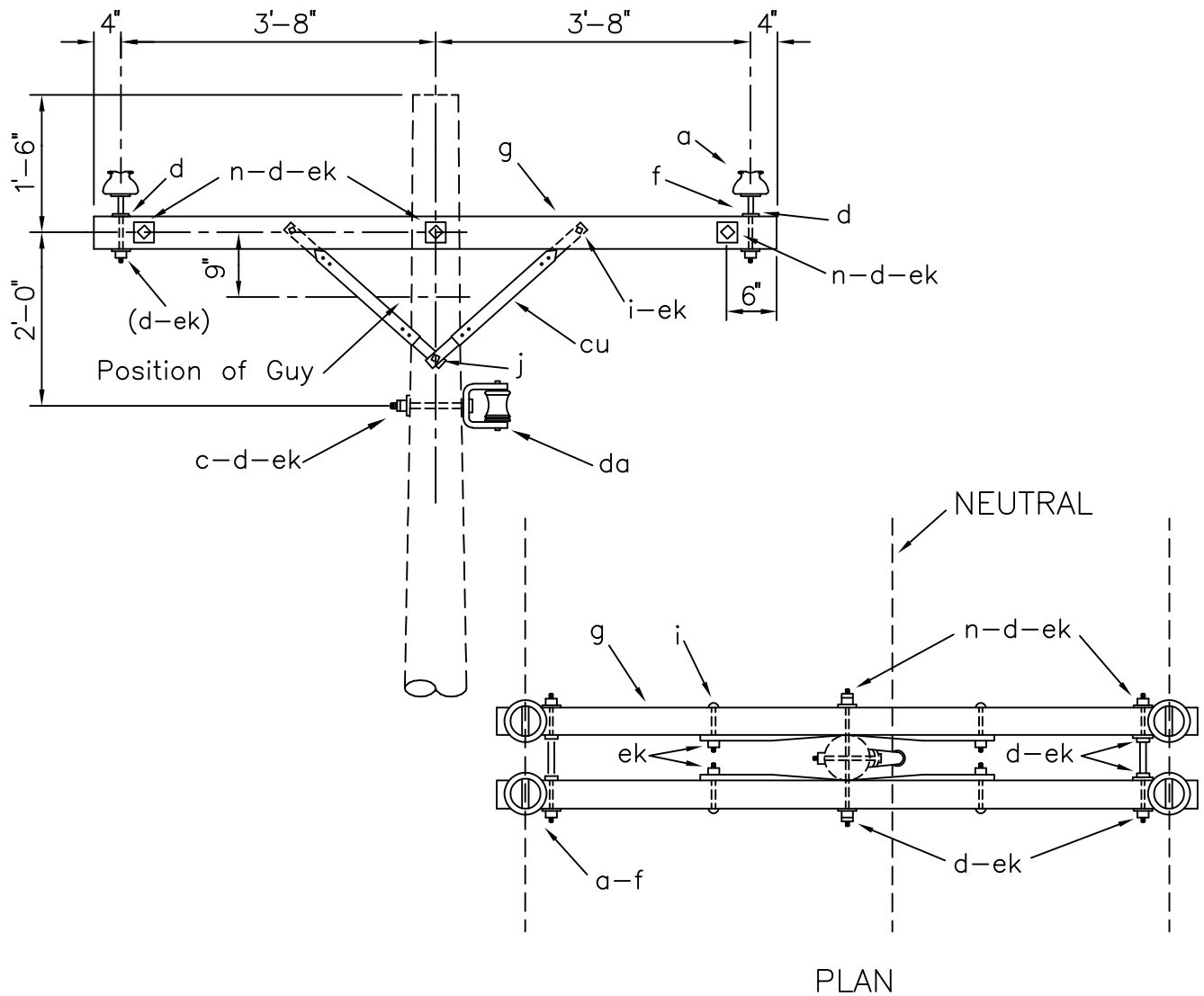

ITEM	QTY	MATERIAL
a	4	Insulator, pin type (12.47/7.2 kV)
c	1	Bolt, machine, 5/8" x req'd length
d	15	Washer, square, 2 1/4"
f	4	Pin, crossarm, steel, 5/8" x 10 3/4"
g	2	Crossarm, 3 5/8" x 4 5/8" x 8' 0"
i	4	Bolt, carriage, 3/8" x 4 1/2"
j	2	Screw, lag, 1/2" x 4"
n	3	Bolt, double arm, 5/8" x req'd length
cu	4	Brace, 28"
da	1	Bracket, insulated
ek	15	Locknuts

DESIGN PARAMETERS:

See TABLE IV

DOUBLE SUPPORT ON CROSSARMS

APRIL 2005

RUS

2 - PHASE PRIMARY
12.47/7.2 kV

B2.21
(B2)

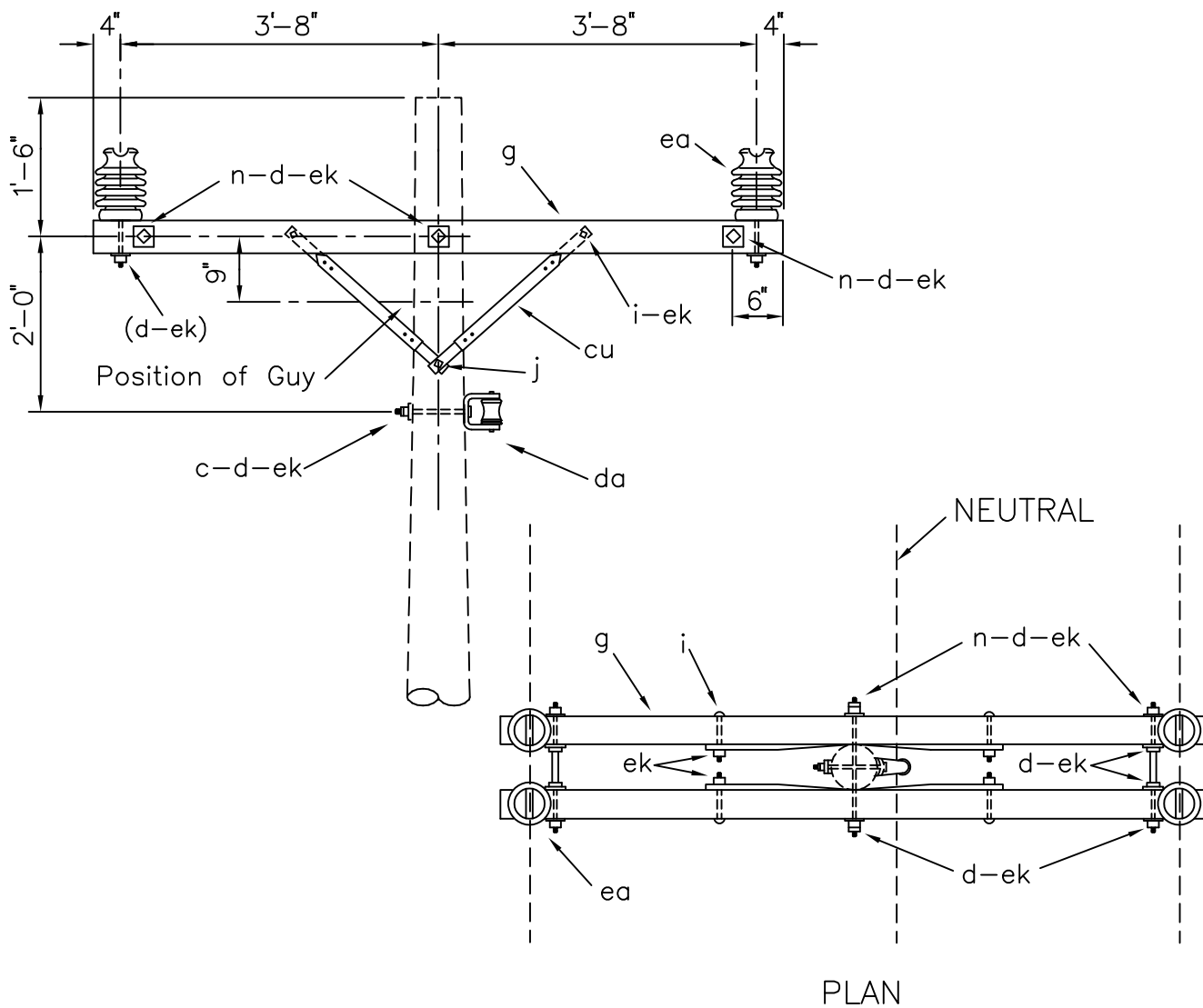

ITEM	QTY	MATERIAL
c	1	Bolt, machine, 5/8" x req'd length
d	11	Washer, square, 2 1/4"
g	2	Crossarm, 3 5/8" x 4 5/8" x 8' 0"
i	4	Bolt, carriage, 3/8" x 4 1/2"
j	2	Screw, lag, 1/2" x 4"
n	3	Bolt, double arm, 5/8" x req'd length
cu	4	Brace, 28"
da	1	Bracket, insulated
ea	4	Insulator, post type (12.47/7.2 kV)
ek	15	Locknuts

DESIGN PARAMETERS:
See TABLE IV

DOUBLE SUPPORT ON CROSSARMS
(POST INSULATORS)

APRIL 2005	2 - PHASE PRIMARY 12.47/7.2 kV	B2.21P (B2P)
RUS		

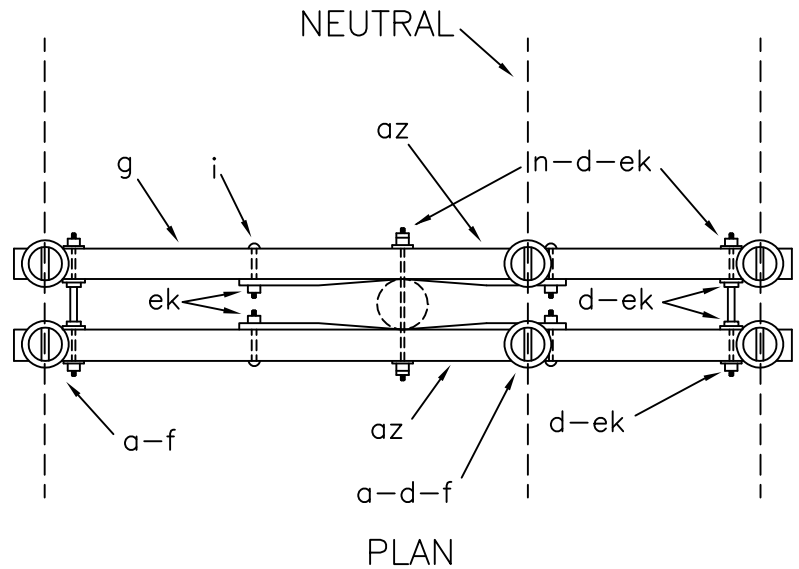
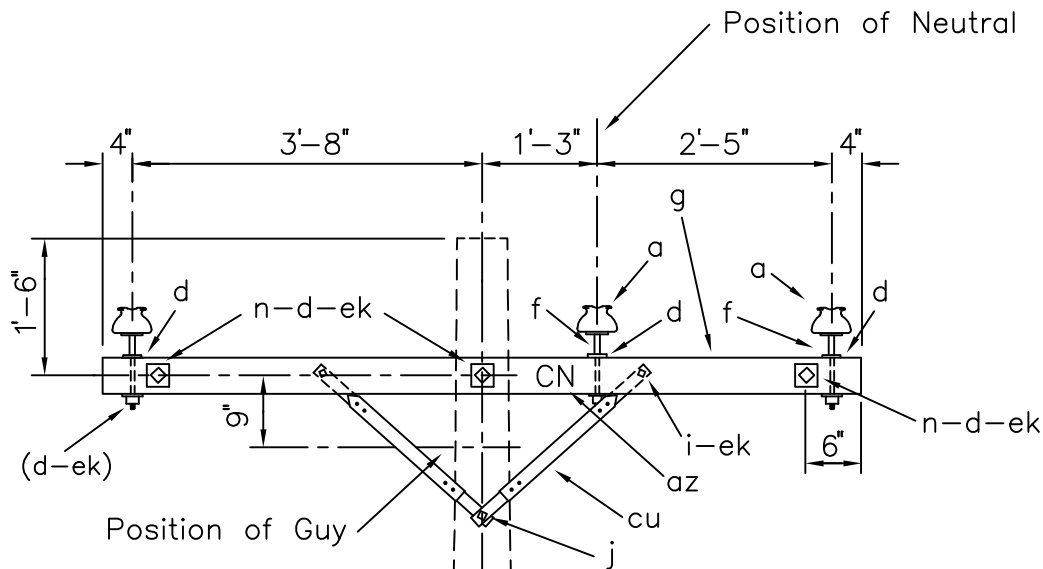

ITEM	QTY	MATERIAL
a	2	Insulator, pin type, white, (15 kV)
a	4	Insulator, pin type (12.47/7.2 kV)
d	16	Washer, square, 2 1/4"
f	6	Pin, crossarm, steel, 5/8" x 10 3/4"
g	2	Crossarm, 3 5/8" x 4 5/8" x 8' - 0"
i	4	Bolt, carriage, 3/8" x 4 1/2"
j	2	Screw, lag, 1/2" x 4"
n	3	Bolt, double arm, 5/8" x req'd length
az	4	Letters, 2" C, 2" N, with nails
cu	4	Brace, 28"
ek	14	Locknuts

NOTE:

Install either identification letters (az) or white insulators in neutral position.

DESIGN PARAMETERS:

See TABLE IV

DOUBLE SUPPORT, NEUTRAL ON CROSSARMS

APRIL 2005

RUS

2 - PHASE PRIMARY
12.47/7.2 kV

B2.22
(B9)

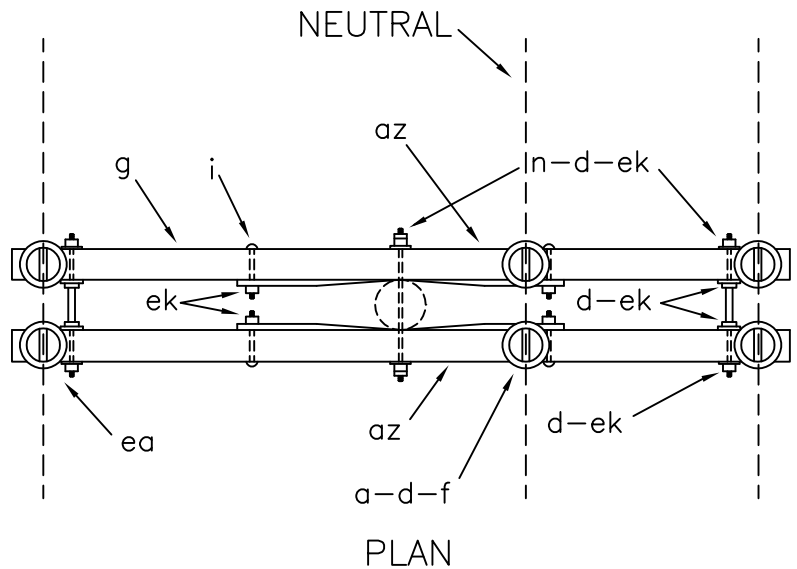
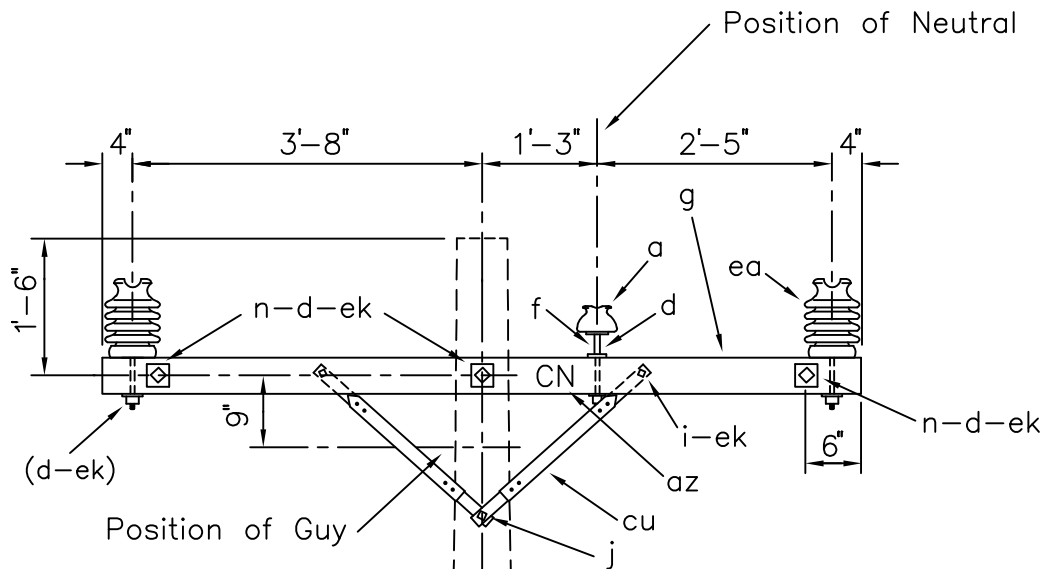

ITEM	QTY	MATERIAL
a	2	Insulator, pin type, white, (15 kV)
d	12	Washer, square, 2 1/4"
f	2	Pin, crossarm, steel, 5/8" x 10 3/4"
g	2	Crossarm, 3 5/8" x 4 5/8" x 8' 0"
i	4	Bolt, carriage, 3/8" x 4 1/2"
j	2	Screw, lag, 1/2" x 4"
n	3	Bolt, double arm, 5/8" x req'd length
az	4	Letters, 2" C, 2" N, with nails
cu	4	Brace, 28"
ea	4	Insulator, post type (12.47/7.2 kV)
ek	14	Locknuts

NOTE:

Install either identification letters (az) or white insulators in neutral position.

DESIGN PARAMETERS:

See TABLE IV

DOUBLE SUPPORT, NEUTRAL ON CROSSARMS
(POST INSULATORS)

APRIL 2005

RUS

2 - PHASE PRIMARY
12.47/7.2 kV

B2.22P
(B9P)

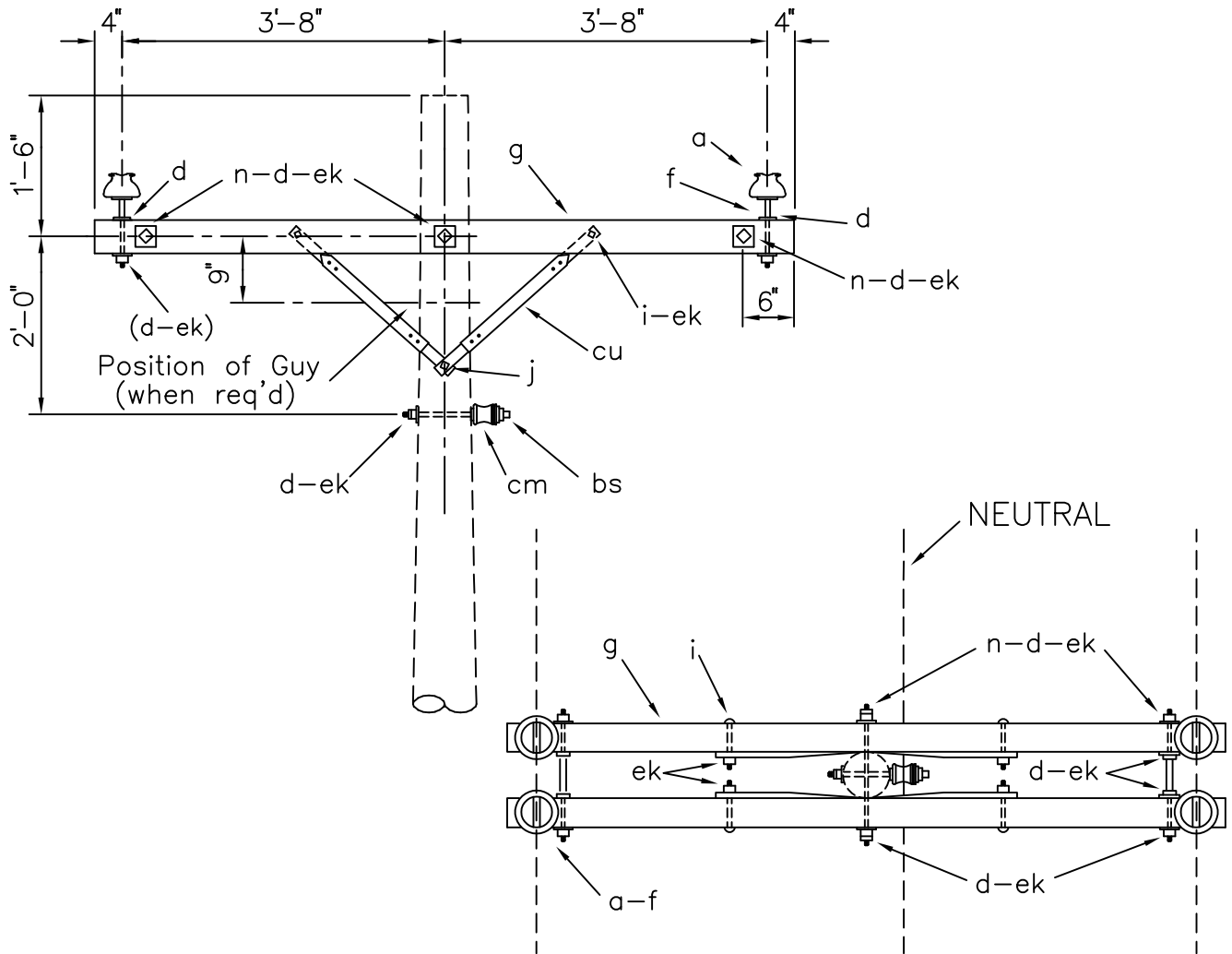

NOTE: These assemblies used for NESC Grade B construction.

PLAN

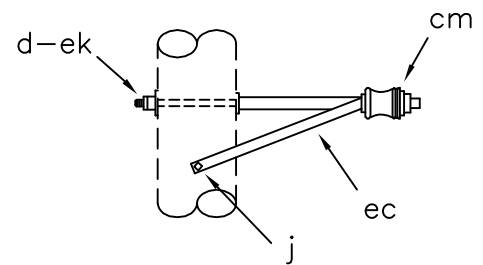

Specify B2.25 for offset neutral assembly

ASSEMBLY: B2. 24 25

ITEM	MATERIAL	QTY	QTY
a	Insulator, pin type (12.47/7.2kV)	4	4
d	Washer, square 2 1/4"	15	15
f	Pin, crossarm, steel, 5/8" x 10 3/4"	4	4
g	Crossarm, 3 5/8" x 4 5/8" x 8'-0"	2	2
i	Bolt, carriage, 3/8" x 4 1/2"	4	4
j	Screw, lag, 1/2" x 4"	2	4
n	Bolt, double arm, 5/8" x req'd length	3	3
bs	Bolt, single, upset	1	
cm	Insulator, spool, 3"	1	1
cu	Brace, 28"	4	4
ec	Bracket, offset neutral		1
ek	Locknuts	15	15

DESIGN PARAMETERS:

MAXIMUM LINE ANGLES:
 5°-Small Conductors
 2°-Larger than #1/0

DOUBLE SUPPORT ON CROSSARMS-TANGENT

APRIL 2005

RUS

2 - PHASE PRIMARY
 12.47/7.2 kV

B2.24,B2.25
 (B1-1,B1-1A)

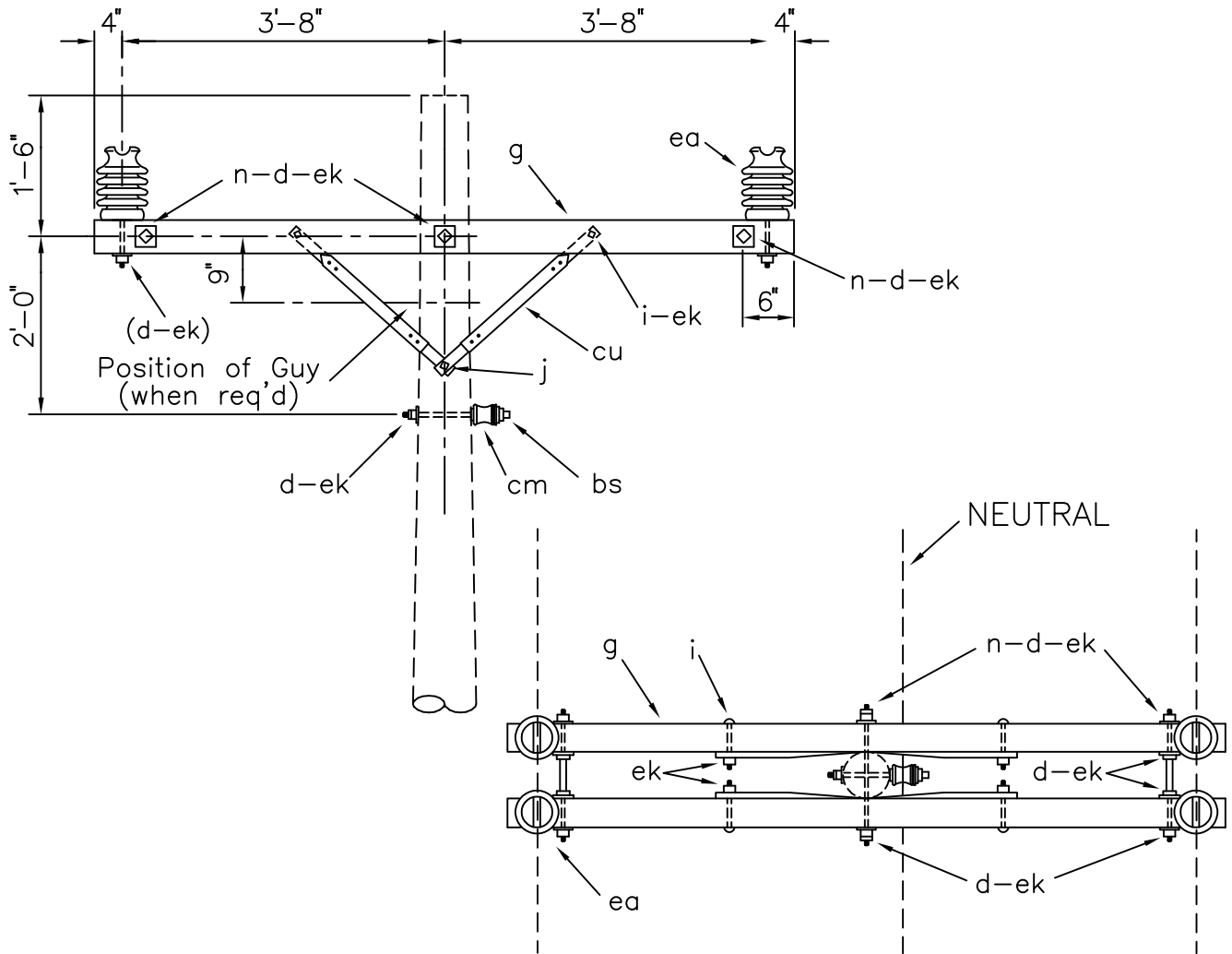

NOTE: These assemblies used for NESC Grade B construction.

PLAN

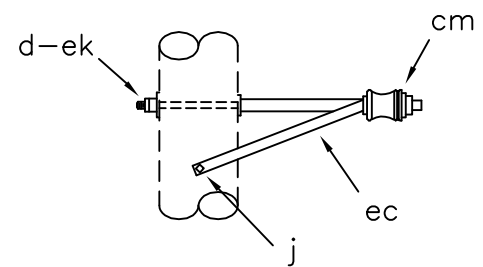

Specify B2.25P for offset neutral assembly

ASSEMBLY: B2. 24P 25P

ITEM	MATERIAL	QTY	QTY
d	Washer, square 2 1/4"	11	11
g	Crossarm, 3 5/8" x 4 5/8" x 8'-0"	2	2
i	Bolt, carriage, 3/8" x 4 1/2"	4	4
j	Screw, lag, 1/2" x 4"	2	4
n	Bolt, double arm, 5/8" x req'd length	3	3
bs	Bolt, single, upset	1	
cm	Insulator, spool, 3"	1	1
cu	Brace, 28"	4	4
ea	Insulator, post type (12.47/7.2kV)	4	4
ec	Bracket, offset neutral		1
ek	Locknuts	11	11

DESIGN PARAMETERS:

MAXIMUM LINE ANGLES:
 5°-Small Conductors
 2°-Larger than #1/0

DOUBLE SUPPORT ON CROSSARMS-TANGENT
 (POST INSULATORS)

APRIL 2005

RUS

2 - PHASE PRIMARY
 12.47/7.2 kV

B2.24P,B2.25P
 (B1-1P,B1-1AP)

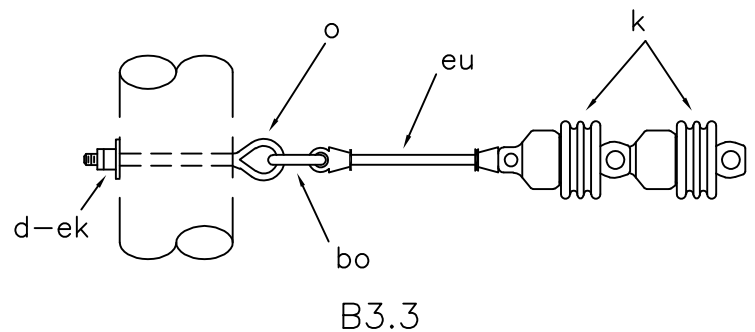
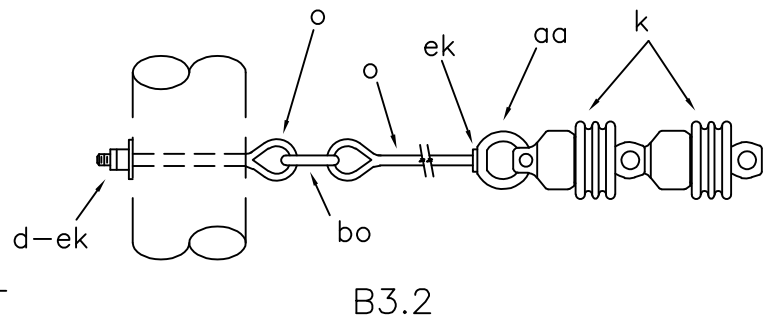
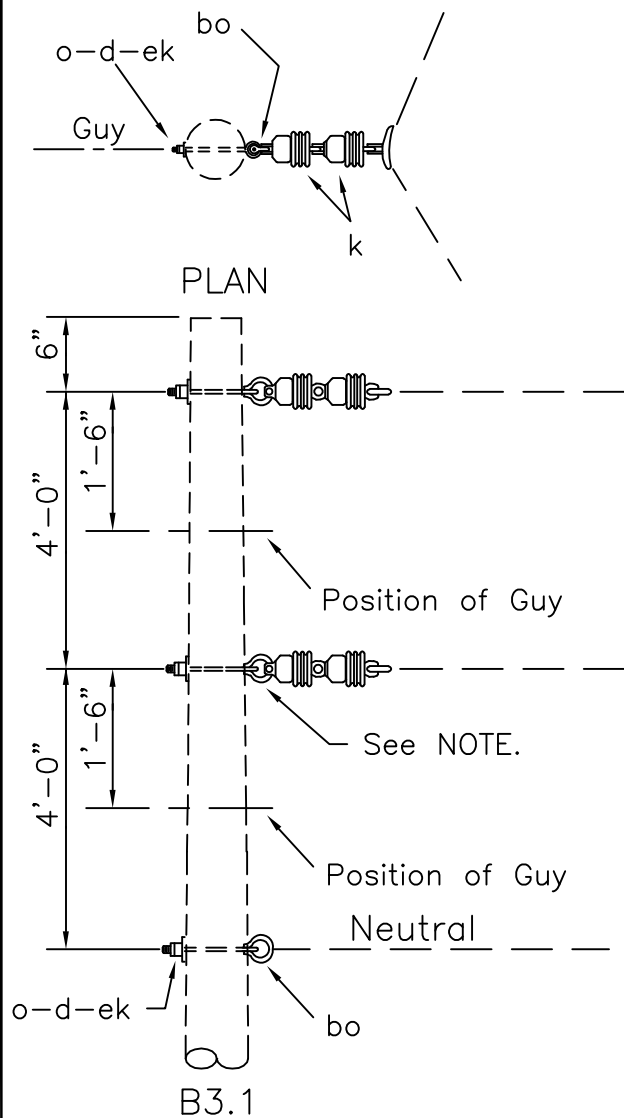

NOTE: Extension link (item "eu" or "du") or eye bolt (item "o"), eye nut (item "aa") and locknut (item "ek") may be installed in lower primary position. Adjust material as required.

ASSEMBLY: B3		.1	.2	.3
ITEM	MATERIAL	QTY	QTY	QTY
d	Washer, square, 3", curved	3	3	3
k	Insulator, suspension, 4 1/4"	4	4	4
o	Bolt, eye, 5/8"x req'd length	3	5	3
aa	Nut, eye		2	
bo	Shackle, anchor	3	3	3
ek	Locknuts	3	5	3
eu	Link, extension, insulated			2
(du)	(Link, extension) - (optional)			(2)

DESIGN PARAMETERS:

PERMITTED TRANSVERSE
LOAD= 5000 lbs./Conductor
20° - 60°: #1/0 ACSR & Larger
30° - 60°: Smaller Conductors

SUSPENSION ANGLE

APRIL 2005

2 - PHASE PRIMARY
12.47/7.2 kV

B3.1,B3.2,B3.3
(B3)

RUS

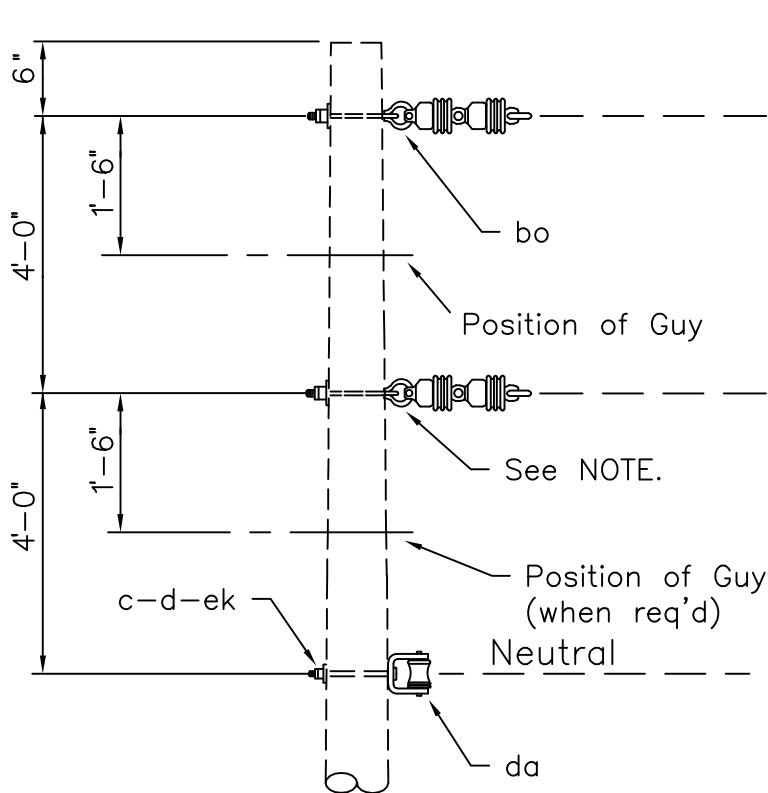

B3.4

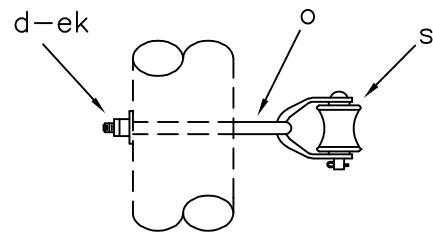
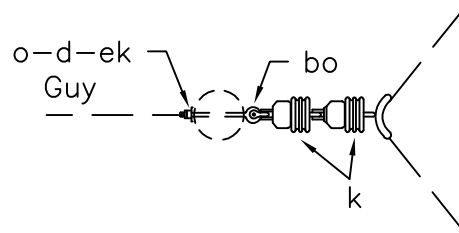

B3.7

- B3.5 = B3.4 neutral assembly + B3.2 primary subassembly
- B3.6 = B3.4 neutral assembly + B3.3 primary subassembly
- B3.8 = B3.7 neutral assembly + B3.2 primary subassembly
- B3.9 = B3.7 neutral assembly + B3.3 primary subassembly

NOTE: Extension link (item "eu" or "du") or eye bolt (item "o"), eye nut (item "aa") and locknut (item "ek") may be installed in lower primary position. Adjust material as required.

ASSEMBLY: B3		.4	.5	.6	.7	.8	.9
ITEM	MATERIAL	QTY	QTY	QTY	QTY	QTY	QTY
c	Bolt, machine, 5/8" x req'd length	1	1	1			
d	Washer, square, 3", curved	3	3	3	3	3	3
k	Insulator, suspension, 4 1/4"	4	4	4	4	4	4
o	Bolt, eye, 5/8"x req'd length	1	2	1	2	3	2
s	Clevis, secondary, swinging, insulated				1	1	1
aa	Nut, eye		2			2	
bo	Shackle, anchor	2	2	2	2	2	2
da	Bracket, insulated	1	1	1			
ek	Locknuts	3	5	3	3	5	3
eu	Link, extension, insulated			2			2
(du)	(Link, extension) - (optional)			(2)			(2)

DESIGN PARAMETERS:

For ANSI Class 53-2 Spool Insulator (1 3/4") See Table VI

For ANSI Class 53-4 Spool Insulator (3") See Table VII

SUSPENSION ANGLE

APRIL 2005

RUS

2 - PHASE PRIMARY
12.47/7.2 kV

B3.4 - B3.9

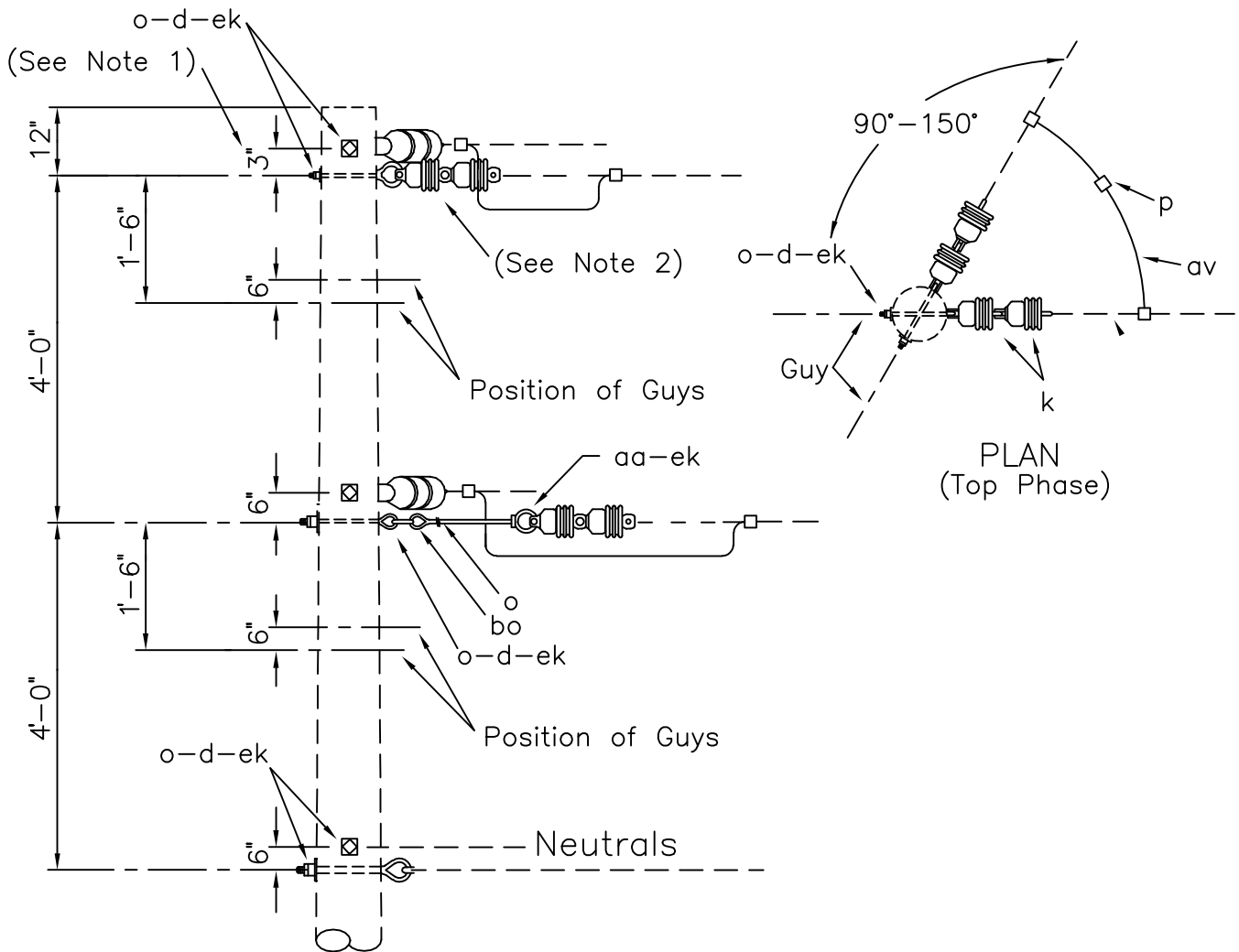

NOTES:

1. Separate 6" (top position only) when angle equals 90°.
2. This drawing shows two A5.1 plus two A5.02 assemblies and their material as an example. Any combination of B5.1 – B5.9, A4.1 – A5.9 and A5.03 assemblies may be installed. Record assemblies separately on staking sheets.
CAUTION: Use the appropriate permitted longitudinal loads.

ITEM	QTY	MATERIAL
		Primary Assemblies, as req'd (See Note 2)
p		Connectors, as req'd
av		Jumpers, as req'd

DESIGN PARAMETERS:
PERMITTED LONGITUDINAL
LOAD = 5000 lbs./Conductor

DEADEND ANGLE GUIDE (90°-150°)

APRIL 2005

2 - PHASE PRIMARY
12.47/7.2 kV

B4.1G
(B4-1)

RUS

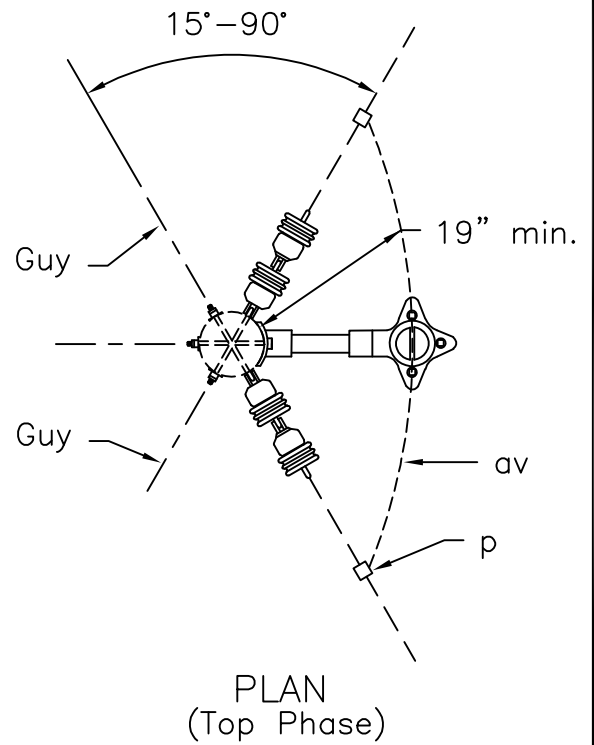
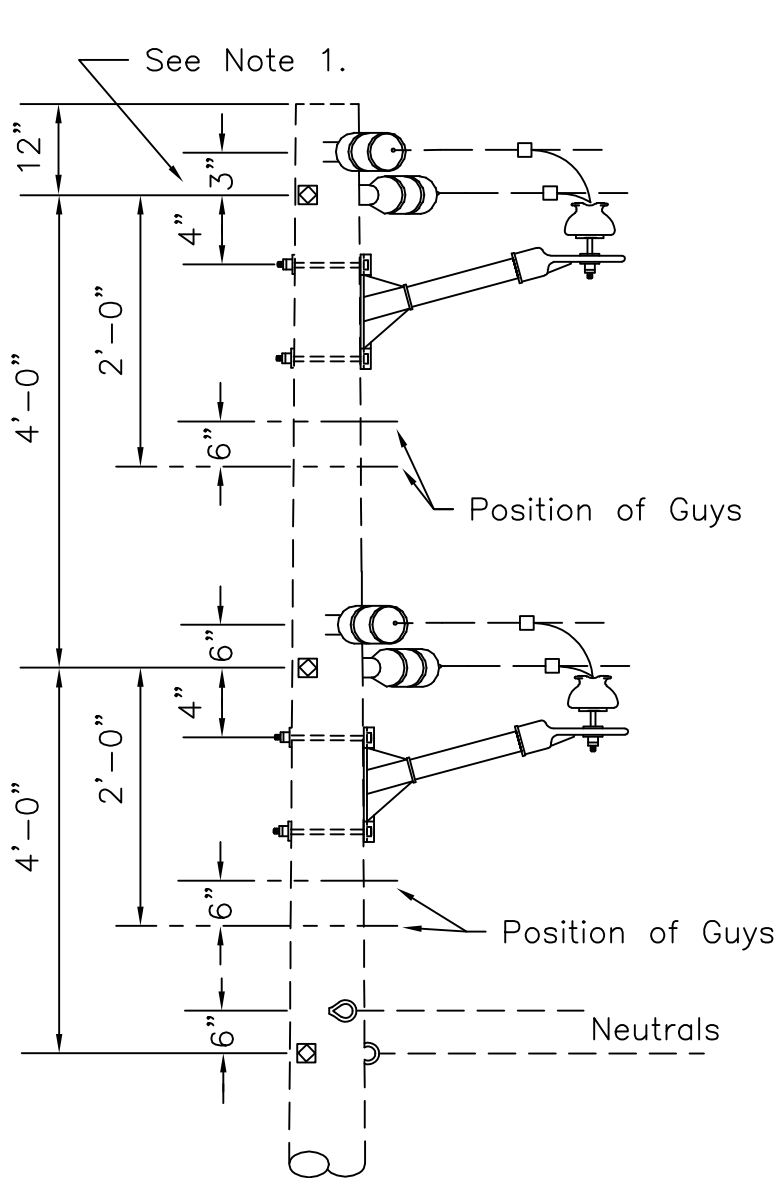

NOTES:

1. Separate 6" (top position only) when angle equals 90°.
2. This drawing shows two B5.1 and two A1.04N assemblies as an example. Any combination of two A1.04N plus B5.1 – B5.9, A5.1 – A5.9 and A5.01 – A5.03 assemblies may be installed. Record assemblies separately on staking sheets.
CAUTION: Use the appropriate permitted longitudinal loads.

ITEM	QTY	MATERIAL
		Primary Assemblies, as req'd (See Note 2)
	2	A1.04N primary assemblies
p		Connectors, as req'd
av		Jumpers, as req'd

DESIGN PARAMETERS:
PERMITTED LONGITUDINAL
LOAD = 5000 lbs./Conductor

DEADEND ANGLE GUIDE (15°-90°)

APRIL 2005

2 - PHASE PRIMARY
12.47/7.2 kV

B4.2G

RUS

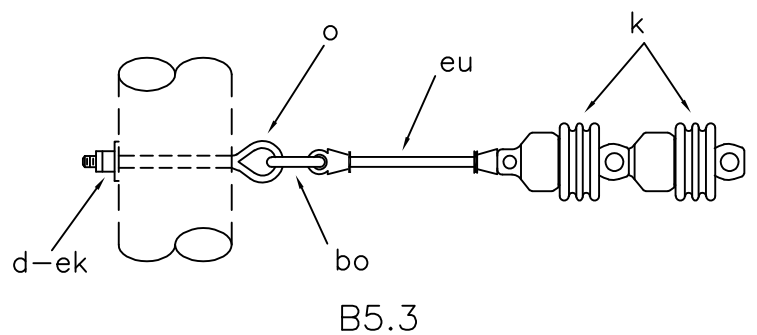
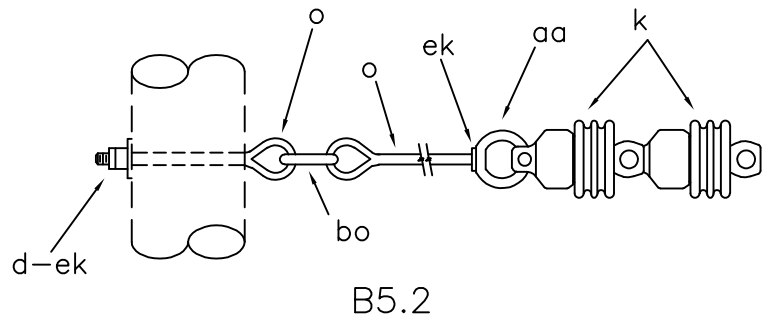
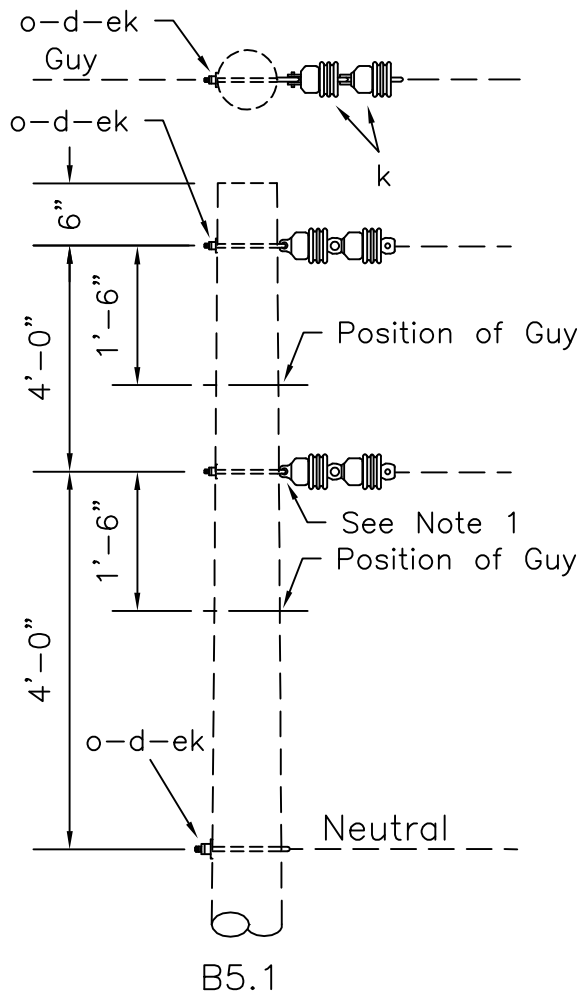

- NOTES: 1. Extension link (item "eu" or "du") or eye bolt (item "o"), eye nut (item "aa") and locknut (item "ek") may be installed in lower primary position. Adjust material as required.
2. When connecting to existing bolt end, use eye nut "aa" and lock nut "ek" instead of eye bolt subassembly "o-d-ek".

ASSEMBLY: B5		.1	.2	.3
ITEM	MATERIAL	QTY	QTY	QTY
d	Washer, square, 3", curved	3	3	3
k	Insulator, suspension, 4 1/4"	4	4	4
o	Bolt, eye, 5/8"x req'd length	3	4	3
p	Connectors, as req'd			
aa	Nut, eye		1	
av	Jumper's, as req'd			
bo	Shackle, anchor		1	1
ek	Locknuts	3	4	3
eu	Link, extension, insulated			2
(du)	(Link, extension) - (optional)			(2)

DESIGN PARAMETERS:
 PERMITTED LONGITUDINAL
 LOAD = 5000 lbs./Conductor

SINGLE DEADENDS

APRIL 2005

2 - PHASE PRIMARY
 12.47/7.2 kV

B5.1,B5.2,B5.3
 (B5-1)

RUS

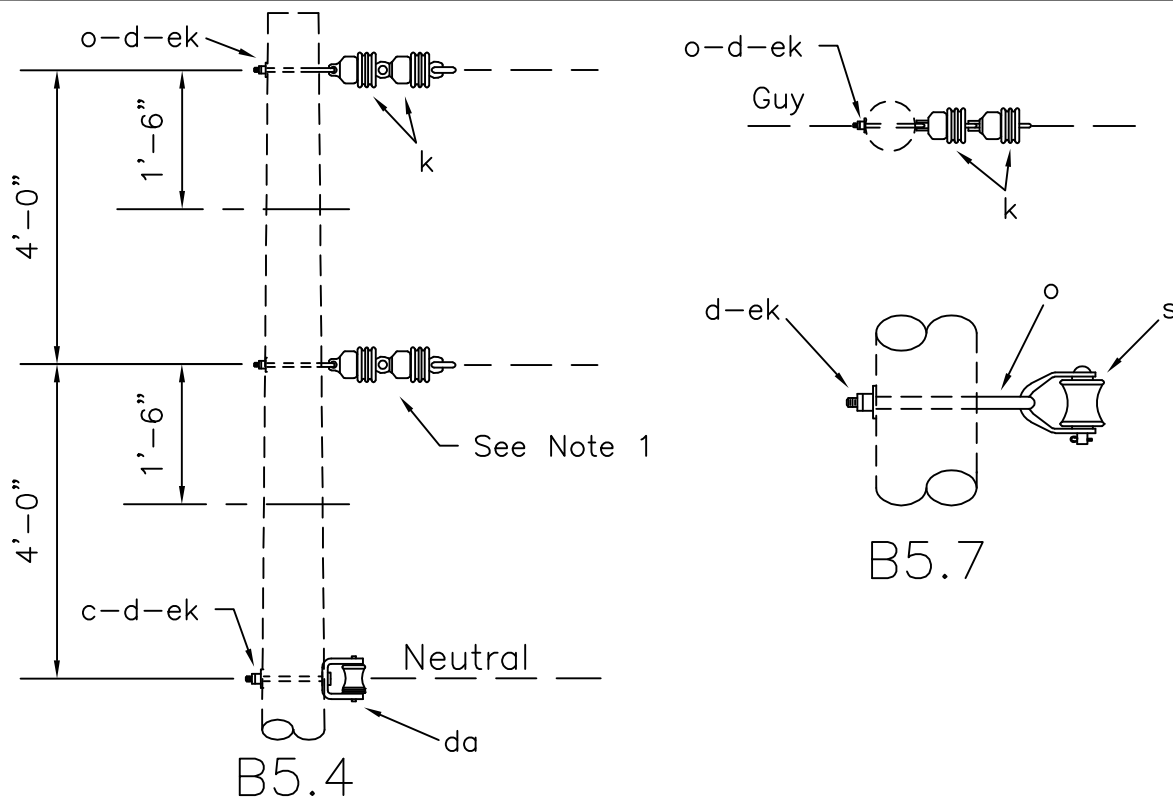

- B5.5 = B5.4 neutral assembly + B5.2 primary subassembly
- B5.6 = B5.4 neutral assembly + B5.3 primary subassembly
- B5.8 = B5.7 neutral assembly + B5.2 primary subassembly
- B5.9 = B5.7 neutral assembly + B5.3 primary subassembly

NOTES: 1. Extension link (item "eu" or "du") or eyebolt (item "o"), eye nut (item "aa") and locknut (item "ek") may be installed in lower primary position. Adjust material as required.

2. When connecting to existing bolt end, use eye nut "aa" and locknut "ek" instead of eyebolt subassembly "o-d-ek".

ASSEMBLY: B5		.4	.5	.6	.7	.8	.9
ITEM	MATERIAL	QTY	QTY	QTY	QTY	QTY	QTY
c	Bolt, machine, 5/8" x req'd length	1	1	1			
d	Washer, square, 3", curved	3	3	3	3	3	3
k	Insulator, suspension, 4 1/4"	4	4	4	4	4	4
o	Bolt, eye, 5/8"x req'd length	2	3	2	3	4	3
P	Connectors, as req'd						
s	Clevis, secondary, swinging, insulated				1	1	1
aa	Nut, eye		1			1	
av	Jumpers, as req'd						
bo	Shackle, anchor		2	2		2	2
da	Bracket, insulated	1	1	1			
ek	Locknuts	3	4	3	3	4	3
eu	Link, extension, insulated			2			2
(du)	(Link, extension) - (optional)			(2)			(2)

DESIGN PARAMETERS: PERMITTED LONGITUDINAL LOAD For ANSI Class 53-2 Spool Insulator (1 3/4"): 1,500 lbs For ANSI Class 53-4 Spool Insulator (3"): 2,250 lbs	SINGLE DEADENDS		
	APRIL 2005	2 - PHASE PRIMARY	B5.4 - B5.9
	RUS	12.47/7.2 kV	

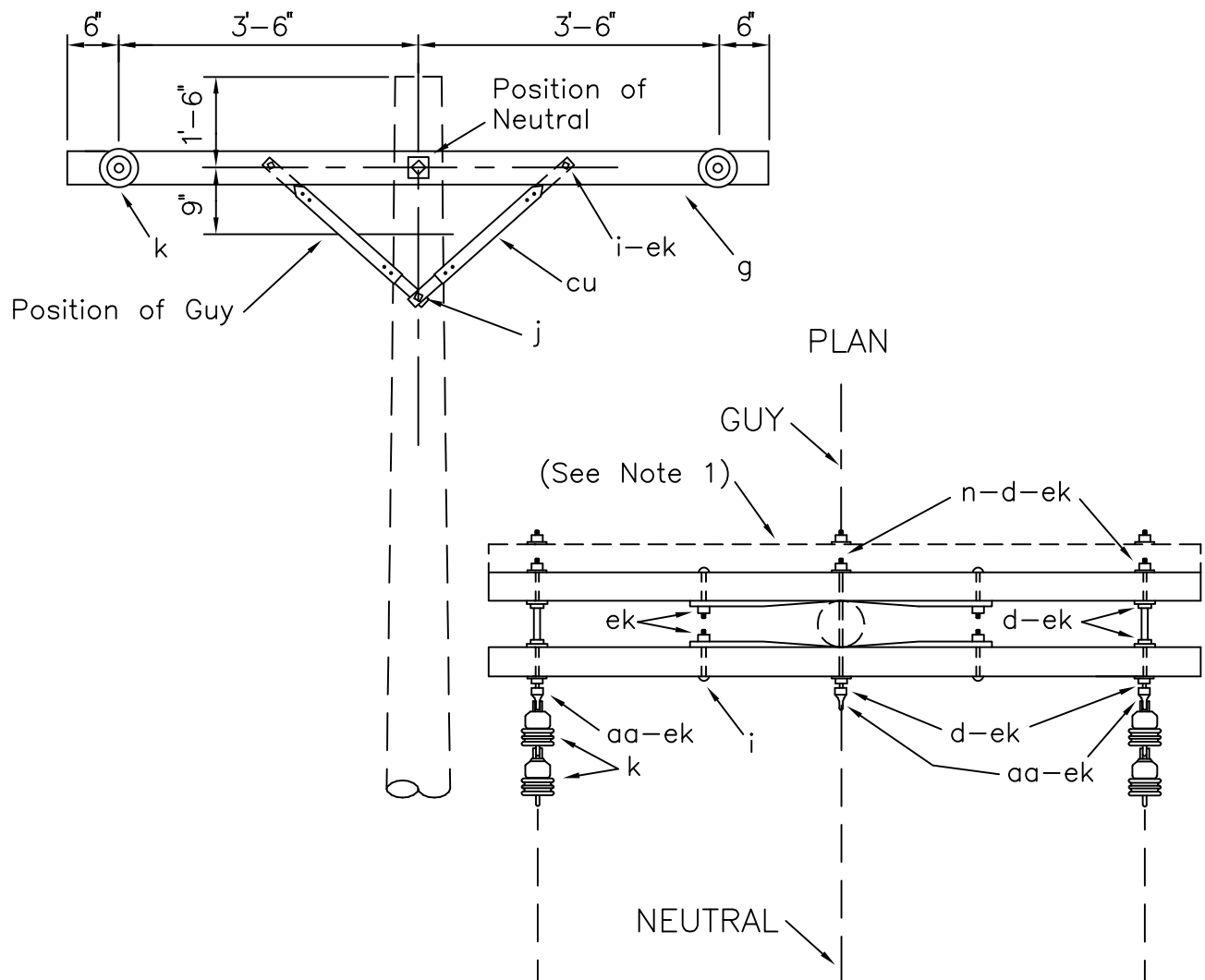

NOTES:

1. Designate as B5.31 for assembly with three crossarms.
2. Double arming eye bolt, item "dy", may be used instead of double arming bolt, item "n", and eyenut, item "aa".

3. See assembly B6.21 for alternative neutral position and materials.

ITEM	QTY	MATERIAL
d	10	Washer, square, 2 1/4"
g	2	Crossarm, 3 5/8" x 4 5/8" x 8'-0"
i	4	Bolt, carriage, 3/8" x 4 1/2"
j	2	Screw, lag, 1/2" x 4"
k	4	Insulator, suspension, 4 1/4"
n	3	Bolt, double arming, 5/8" x req'd length
aa	3	Nut, eye, 5/8"
cu	4	Brace, 28"
ek	17	Locknuts

DESIGN PARAMETERS:

PERMITTED UNBALANCED
CONDUCTOR TENSION:
See Table A (Exhibit 2)

SINGLE DEADEND ON CROSSARMS

APRIL 2005

RUS

2 - PHASE PRIMARY
12.47/7.2 kV

B5.21 (B7)
B5.31 (B7-1)

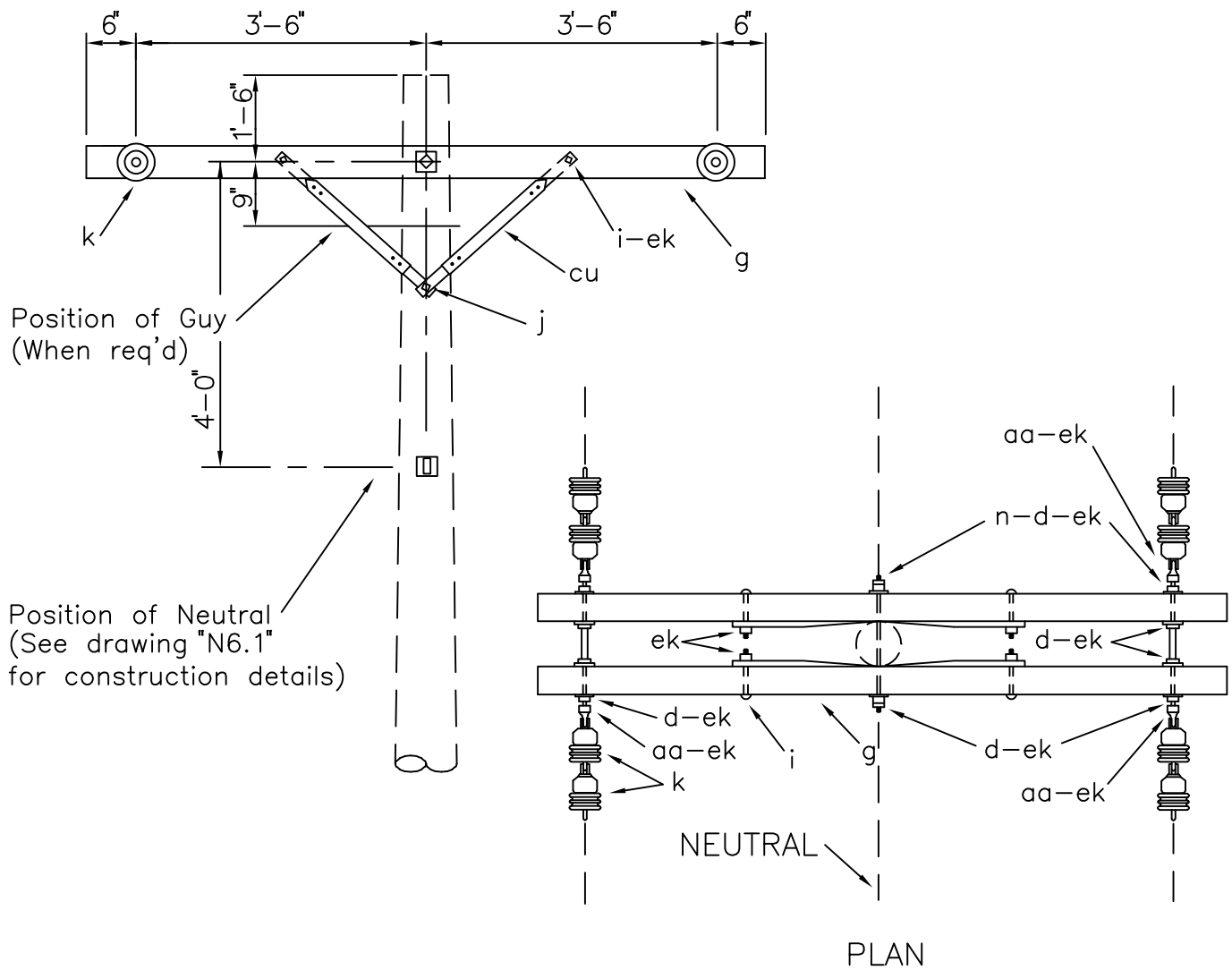

NOTES:

1. Double arming bolt, item "n", and eye nut, item "aa" may be replaced with double arming eye bolt, item "dy".
2. Maximum line angle may be increased to 15° by installing anchor shackles, item "bo", to (horizontal) eyenuts and installing side guy as req'd.
3. See assembly B5.21 for alternative neutral position and materials.

ITEM	QTY	MATERIAL
d	10	Washer, square, 2 1/4"
d	2	Washer, square, 3", curved
g	2	Crossarm, 3 5/8" x 4 5/8" x 8'0"
i	4	Bolt, carriage, 3/8" x 4 1/2"
j	2	Screw, lag, 1/2" x 4"
k	8	Insulator, suspension, 4 1/4"
n	4	Bolt, double arming, 5/8" x req'd length
aa	6	Nut, eye, 5/8"
cu	4	Brace, 28"
ek	22	Locknuts

DESIGN PARAMETERS:

PERMITTED UNBALANCED
CONDUCTOR TENSION:
See Table A (Exhibit 2)

DOUBLE DEADEND ON CROSSARMS

APRIL 2005

RUS

2 - PHASE PRIMARY
12.47/7.2 kV

B6.21 (B8)

THREE-PHASE PRIMARY POLE TOP ASSEMBLY UNITS

<u>DRAWING NUMBERS</u>		<u>DRAWING TITLE (DESCRIPTION)</u>
1728F-804 (New)	Bulletin 50-3 (Old)	
C1.1N C1.2N		SINGLE SUPPORT – NARROW PROFILE (TANGENT)
C1.1NP C1.2NP		SINGLE SUPPORT – NARROW PROFILE (TANGENT) (POST INSULATORS)
C1.3N		SINGLE SUPPORT – NARROW PROFILE
C1.3NP		SINGLE SUPPORT – NARROW PROFILE (POST INSULATORS)
C1.4N C1.5N		SINGLE SUPPORT – NARROW PROFILE (TANGENT)
C1.4NP C1.5NP		SINGLE SUPPORT – NARROW PROFILE (TANGENT) (POST INSULATORS)
C1.6N		SINGLE SUPPORT – NARROW PROFILE
C1.6NP		SINGLE SUPPORT – NARROW PROFILE (POST INSULATORS)
C1.7N C1.8N		SINGLE SUPPORT – NARROW PROFILE (TANGENT)
C1.7NP C1.8NP		SINGLE SUPPORT – NARROW PROFILE (TANGENT) (POST INSULATORS)
C1.9N		SINGLE SUPPORT – NARROW PROFILE
C1.9NP		SINGLE SUPPORT – NARROW PROFILE (POST INSULATORS)
C1.11 C1.12	(C1) (C1A)	SINGLE SUPPORT ON CROSSARM (TANGENT)
C1.11L C1.12L	(C1-2)	SINGLE SUPPORT ON CROSSARM (TANGENT) (LARGE CONDUCTORS)
C1.11P C1.12P	(C1P) (C1AP)	SINGLE SUPPORT ON CROSSARM (TANGENT) (POST INSULATORS)
C1.13		SINGLE SUPPORT ON CROSSARM
C1.13L	(C1-4)	SINGLE SUPPORT ON CROSSARM (LARGE CONDUCTORS)
C1.13P		SINGLE SUPPORT ON CROSSARM (POST INSULATORS)

THREE-PHASE PRIMARY POLE TOP ASSEMBLY UNITS

<u>DRAWING NUMBERS</u>	<u>DRAWING TITLE (DESCRIPTION)</u>
1728F-804 (New)	Bulletin 50-3 (Old)
C1.41	(C9-1) SINGLE SUPPORT, NEUTRAL ON CROSSARM
C1.41L	(C9-3) SINGLE SUPPORT, NEUTRAL ON CROSSARM (LARGE CONDUCTORS)
C1.41P	(C9-1P) SINGLE SUPPORT, NEUTRAL ON CROSSARM (POST INSULATORS)
C1.81G	THREE-PHASE JUNCTION GUIDE
C2.1N C2.2N	DOUBLE SUPPORT – NARROW PROFILE (TANGENT)
C2.1NP C2.2NP	DOUBLE SUPPORT – NARROW PROFILE (TANGENT) (POST INSULATORS)
C2.3N	DOUBLE SUPPORT – NARROW PROFILE
C2.3NG	DOUBLE SUPPORT – NARROW PROFILE (ALTERNATIVE GUYING GUIDE)
C2.3NP	DOUBLE SUPPORT – NARROW PROFILE (POST INSULATORS)
C2.4N C2.5N	DOUBLE SUPPORT – NARROW PROFILE (TANGENT)
C2.4NP C2.5NP	DOUBLE SUPPORT – NARROW PROFILE (TANGENT) (POST INSULATORS)
C2.6N	DOUBLE SUPPORT – NARROW PROFILE
C2.6NP	DOUBLE SUPPORT – NARROW PROFILE (POST INSULATORS)
C2.7N C2.8N	DOUBLE SUPPORT – NARROW PROFILE (TANGENT)
C2.7NP C2.8NP	DOUBLE SUPPORT – NARROW PROFILE (TANGENT) (POST INSULATORS)
C2.9N	DOUBLE SUPPORT – NARROW PROFILE
C2.9NP	DOUBLE SUPPORT – NARROW PROFILE (POST INSULATORS)

THREE-PHASE PRIMARY POLE TOP ASSEMBLY UNITS

<u>DRAWING NUMBERS</u>	<u>DRAWING TITLE (DESCRIPTION)</u>	
1728F-804 (New)	Bulletin 50-3 (Old)	
C2.21	(C2)	DOUBLE SUPPORT ON CROSSARMS
C2.21L	(C1-3)	DOUBLE SUPPORT ON CROSSARMS (LARGE CONDUCTORS)
C2.21P	(C1-3P)	DOUBLE SUPPORT ON CROSSARMS (POST INSULATORS)
C2.24 C2.25	(C1-1) (C1-1A)	DOUBLE SUPPORT ON CROSSARMS - TANGENT
C2.24P C2.25P	(C1-1P) (C1-1AP)	DOUBLE SUPPORT ON CROSSARMS - TANGENT (POST INSULATORS)
C2.51	(C9)	DOUBLE SUPPORT, NEUTRAL ON CROSSARMS
C2.51L	(C9-2)	DOUBLE SUPPORT, NEUTRAL ON CROSSARMS (LARGE CONDUCTORS)
C2.51P	(C9-2PL)	DOUBLE SUPPORT, NEUTRAL ON CROSSARMS (POST INSULATORS)
C2.52	(C2-1)	DOUBLE SUPPORT ON 10-FOOT CROSSARMS
C2.52L	(C2-2)	DOUBLE SUPPORT ON 10-FOOT CROSSARMS (LARGE CONDUCTORS)
C2.52P	(C2-2PL)	DOUBLE SUPPORT ON 10-FOOT CROSSARMS (POST INSULATORS)
C3.1 C3.2 C3.3	(C3)	SUSPENSION ANGLE
C3.4 C3.5 C3.6 C3.7 C3.8 C3.9		SUSPENSION ANGLE
C3.1L	(C3-1)	SUSPENSION ANGLE (LARGE CONDUCTORS)

THREE-PHASE PRIMARY POLE TOP ASSEMBLY UNITS

<u>DRAWING NUMBERS</u>		<u>DRAWING TITLE (DESCRIPTION)</u>
1728F-804 (New)	Bulletin 50-3 (Old)	
C4.1G	((C4-1))	DEADEND GUIDE (90° – 150°)
C4.2G		DEADEND GUIDE (15° – 90°)
C5.1 C5.2 C5.3	(C5-1)	SINGLE DEADENDS - VERTICAL
C5.4 C5.5 C5.6 C5.7 C5.8 C5.9		SINGLE DEADENDS - VERTICAL
C5.11G		SINGLE PHASE TAP GUIDE
C5.21 C5.31	(C7) (C7-1)	SINGLE DEADEND ON CROSSARMS
C5.21L C5.32L		SINGLE DEADEND ON CROSSARMS (LARGE CONDUCTORS)
C5.22 C5.32	(C7-2)	SINGLE DEADEND ON CROSSARMS - ALTERNATIVE
C5.71L	(C7A)	SINGLE DEADEND ON CROSSARM ASSEMBLY
C5.82G		THREE PHASE HORIZONTAL TAP GUIDE
C6.21 C6.31	(C8)	DOUBLE DEADEND ON CROSSARMS
C6.21L C6.311	(C8-3)	DOUBLE DEADEND ON CROSSARMS (LARGE CONDUCTORS)
C6.52 C6.53		DOUBLE DEADEND ON 10-FOOT CROSSARMS
C6.52G		DOUBLE DEADEND ON 10-FOOT CROSSARMS (FEEDTHROUGH GUIDE)
C6.91G		DOUBLE DEADENDS (BUCKARMS) GUIDE

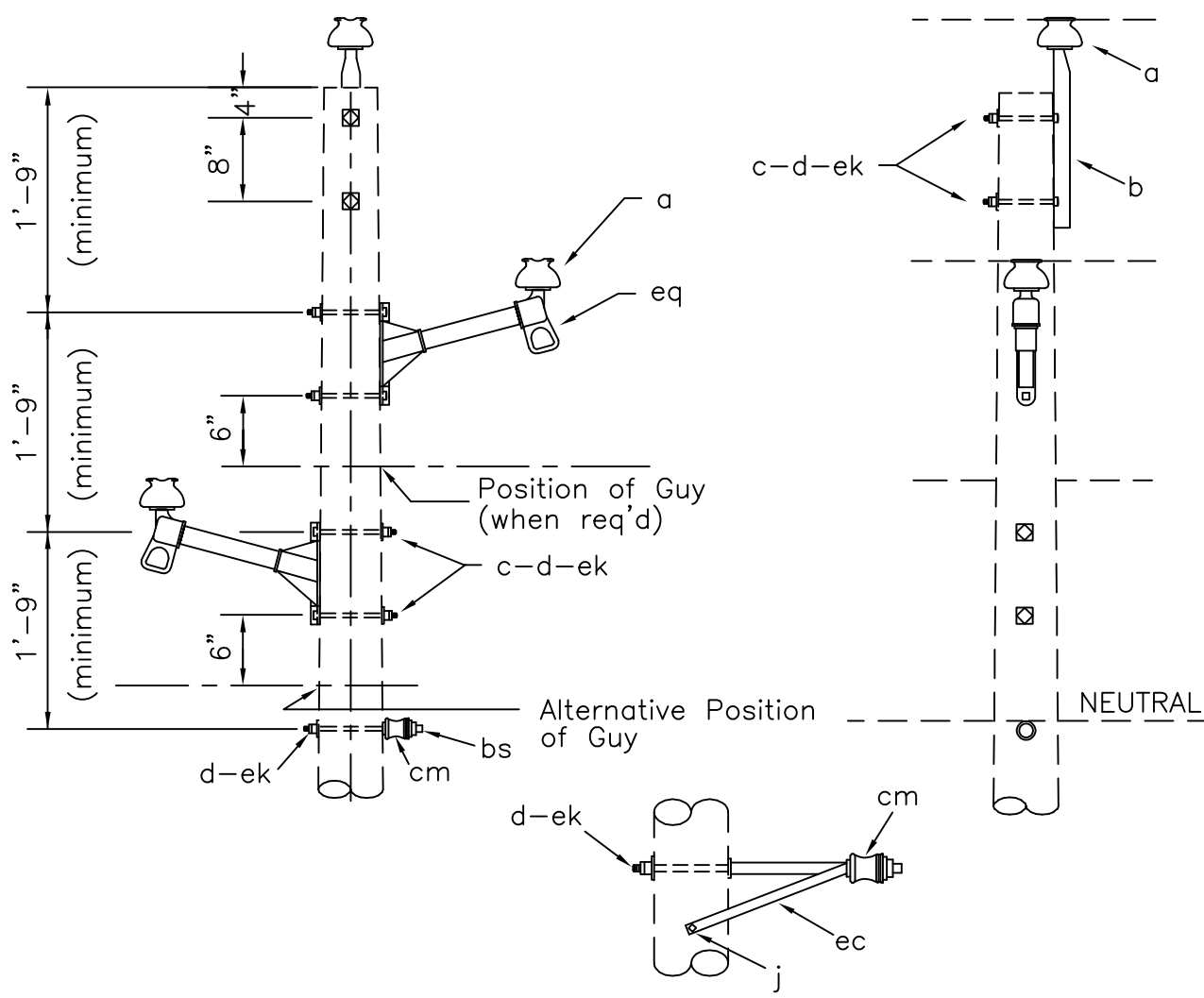

Specify C1.2N for offset neutral assembly

ASSEMBLY: C1. 1N 2N

ITEM	MATERIAL	QTY	QTY
a	Insulator, pin type (12.47/7.2 kV)	3	3
b	Pin, pole top, 20"	1	1
c	Bolt, machine, 5/8" x req'd length	6	6
d	Washer, square 2 1/4"	7	7
(f)	(Pin, crossarm, 5/8" x 6 1/2")	(2)	(2)
j	Screw, lag, 1/2" x 4"		2
bs	Bolt, single, upset	1	
cm	Insulator, spool, 3"	1	1
ec	Bracket, offset neutral		1
ek	Locknuts	7	7
eq	Bracket, insulator/equipment	2	2

(If req'd)

Design Parameters: MAXIMUM LINE ANGLES: 5°—Small Conductors 2°—Larger than #1/0	SINGLE SUPPORT—NARROW PROFILE (TANGENT)		
	APRIL 2005	3 — PHASE PRIMARY	C1.1N
	RUS	12.47/7.2 kV	C1.2N

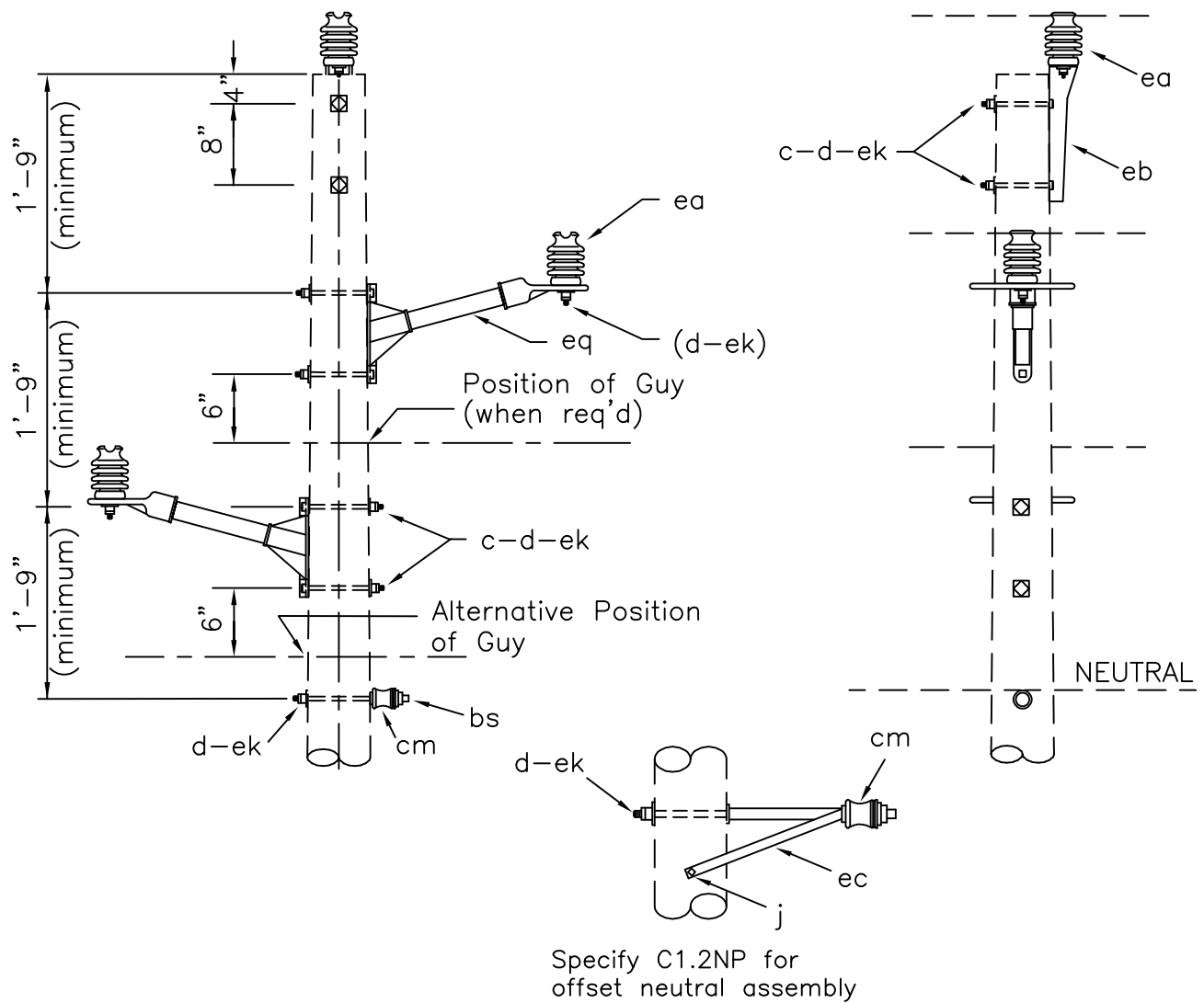

ASSEMBLY: C1. 1NP 2NP

ITEM	MATERIAL	QTY	QTY
c	Bolt, machine, 5/8" x req'd length	6	6
d	Washer, square 2 1/4"	7	7
j	Screw, lag, 1/2" x 4"		2
bs	Bolt, single, upset	1	
cm	Insulator, spool, 3"	1	1
ea	Insulator, post type (12.47/7.2 kV)	3	3
eb	Bracket, pole top	1	1
ec	Bracket, offset neutral		1
ek	Locknuts	7	7
eq	Bracket, insulator/equipment	2	2

Design Parameters:

MAXIMUM LINE ANGLES:
 5°-Small Conductors
 2°-Larger than #1/0

SINGLE SUPPORT-NARROW PROFILE
 (TANGENT) (POST INSULATORS)

APRIL 2005

RUS

3 - PHASE PRIMARY
 12.47/7.2 kV

C1.1NP
 C1.2NP

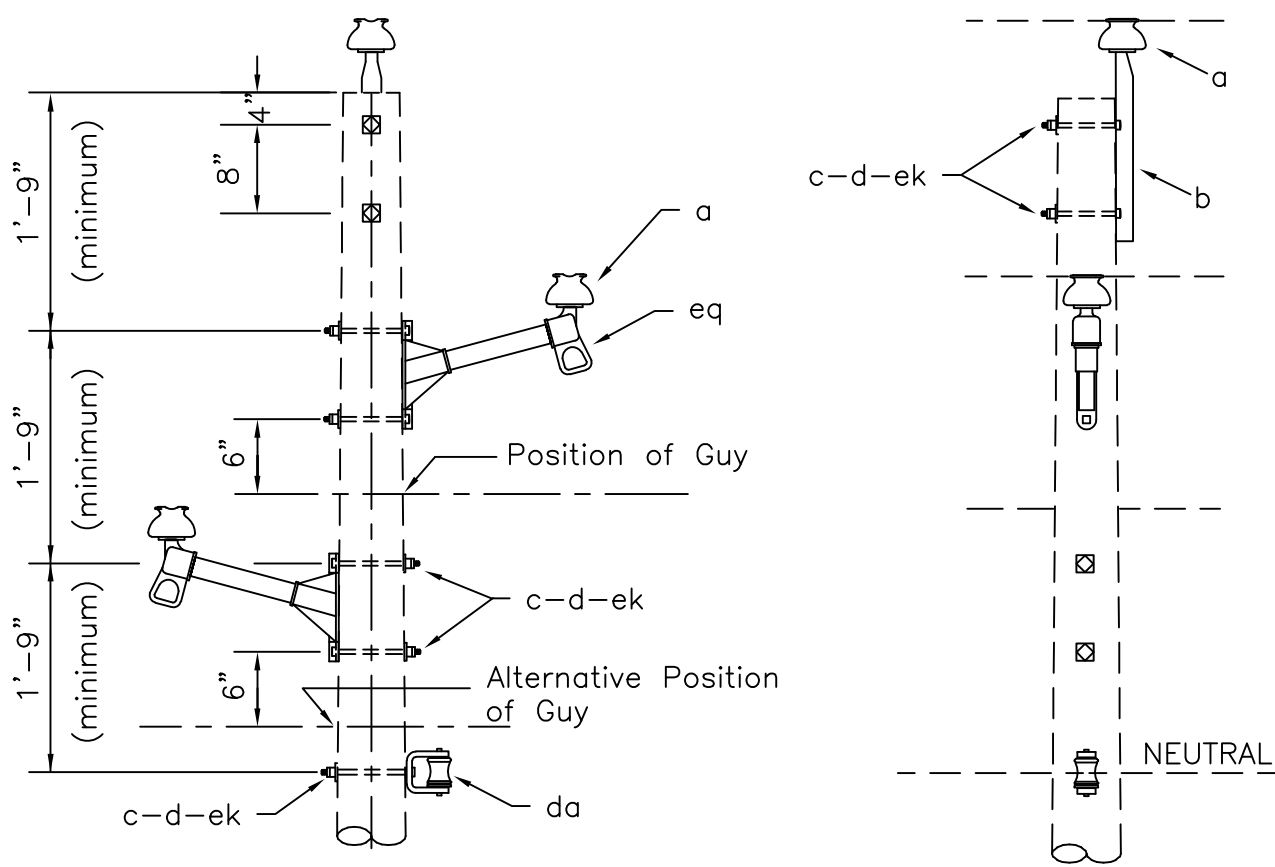

NOTE: If additional or alternative guying is required, frame pole according to C2.3NG.

ASSEMBLY: C1.		3N
ITEM	MATERIAL	QTY
a	Insulator, pin type (12.47/7.2 kV)	3
b	Pin, pole top, 20"	1
c	Bolt, machine, 5/8" x req'd length	7
d	Washer, square 2 1/4"	7
(f)	(Pin, crossarm, 5/8" x 6 1/2")	(2) (If req'd)
da	Bracket, insulated	1
ek	Locknuts	7
eq	Bracket, insulator/equipment	2

Design Parameters: MAXIMUM LINE ANGLES: See TABLE I	SINGLE SUPPORT-NARROW PROFILE		
	APRIL 2005	3 - PHASE PRIMARY	C1.3N
	RUS	12.47/7.2 kV	

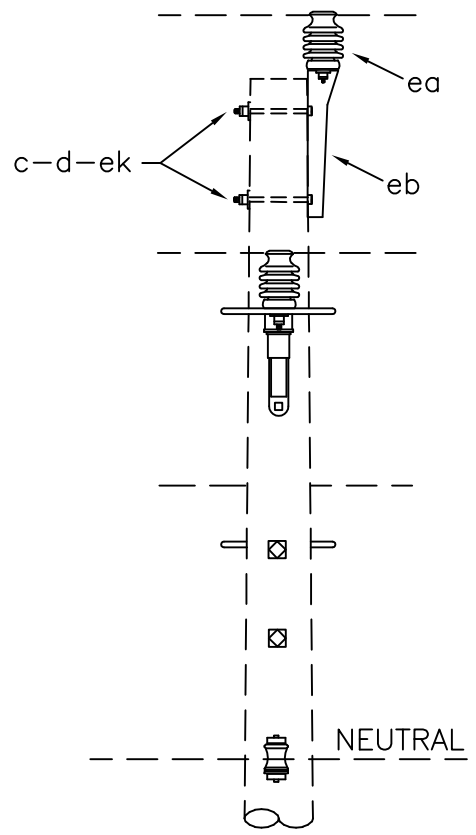
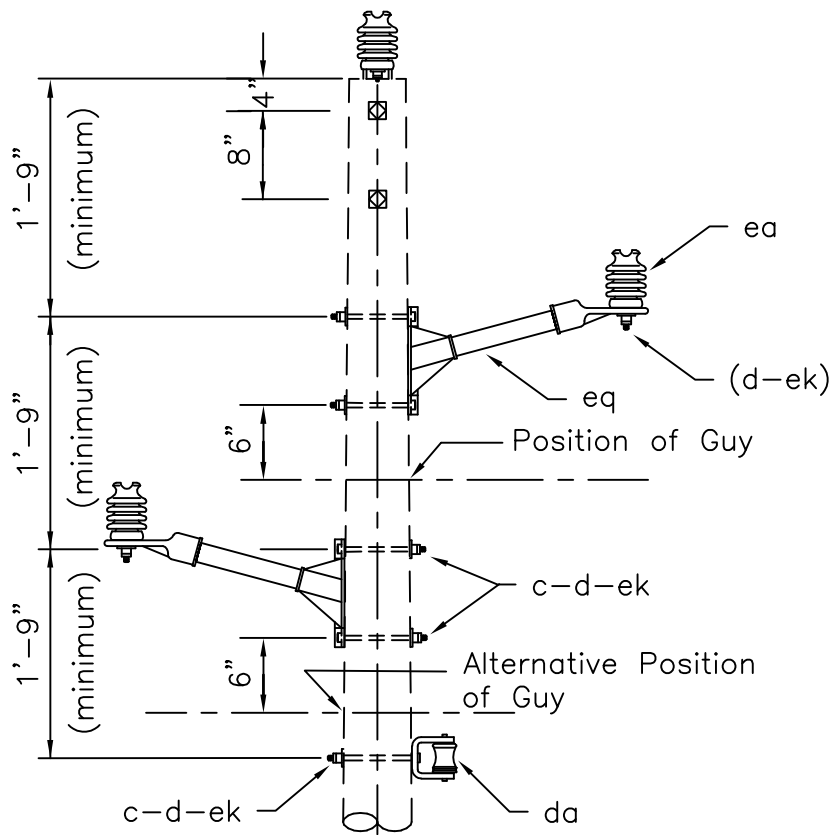

ASSEMBLY: C1.3NP

ITEM	MATERIAL	QTY
c	Bolt, machine, 5/8" x req'd length	7
d	Washer, square 2 1/4"	7
da	Bracket, insulated	1
ea	Insulator, post type (12.47/7.2 kV)	3
eb	Bracket, pole top	1
ek	Locknuts	7
eq	Bracket, insulator/equipment	2

Design Parameters:

MAXIMUM LINE ANGLES:
See TABLE II

SINGLE SUPPORT-NARROW PROFILE
(POST INSULATORS)

APRIL 2005

RUS

3 - PHASE PRIMARY
12.47/7.2 kV

C1.3NP

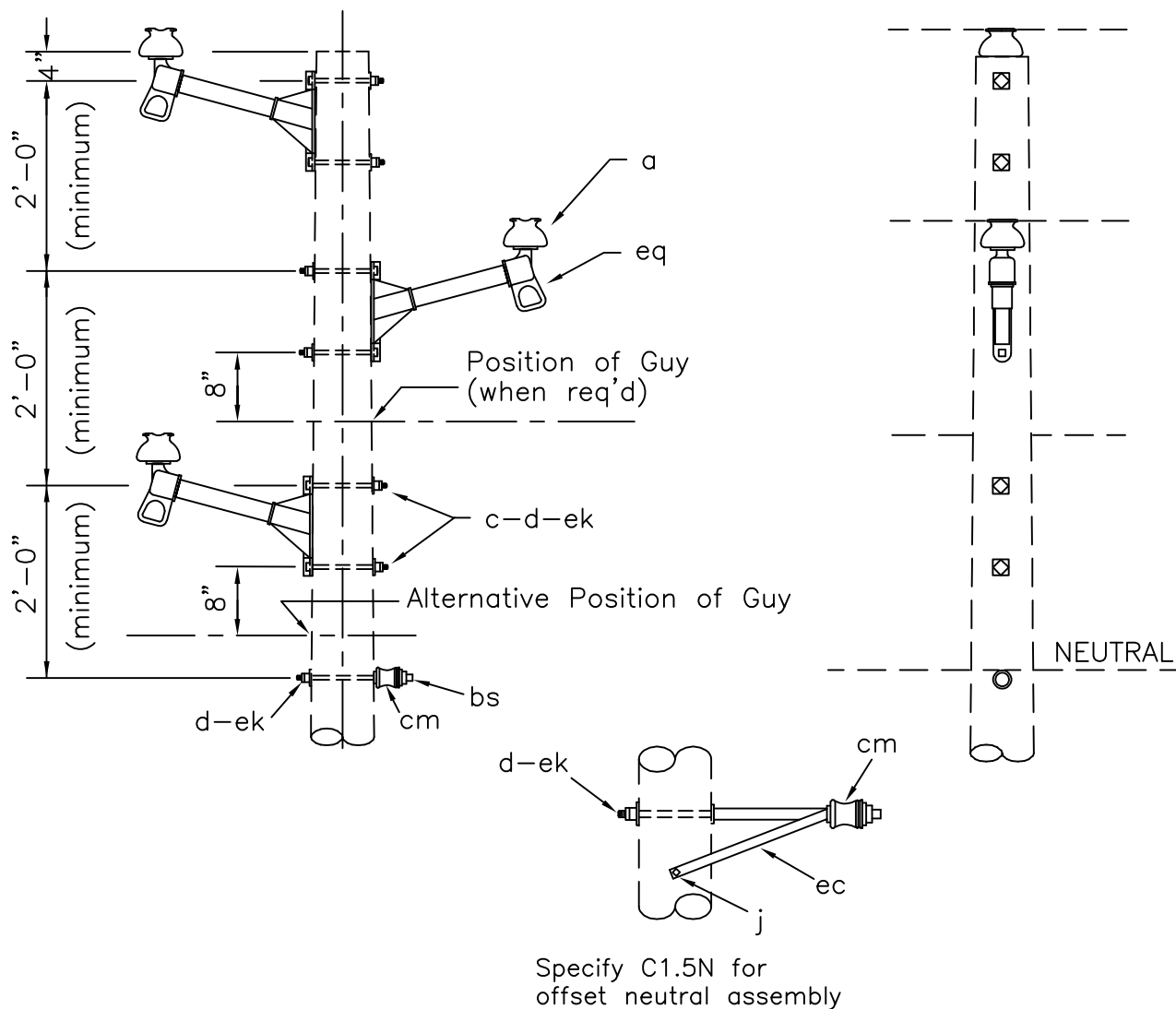

ASSEMBLY: C1.		4N	5N
ITEM	MATERIAL	QTY	QTY
a	Insulator, pin type (12.47/7.2 kV)	3	3
c	Bolt, machine, 5/8" x req'd length	6	6
d	Washer, square 2 1/4"	7	7
(f)	(Pin, crossarm, 5/8" x 6 1/2")	(3)	(3)
j	Screw, lag, 1/2" x 4"		2
bs	Bolt, single, upset	1	
cm	Insulator, spool, 3"	1	1
ec	Bracket, offset neutral		1
ek	Locknuts	7	7
eq	Bracket,insulator/equipment	3	3

(If req'd)

Design Parameters: MAXIMUM LINE ANGLES: 5°-Small Conductors 2°-Larger than #1/0	SINGLE SUPPORT-NARROW PROFILE (TANGENT)		
	APRIL 2005	3 - PHASE PRIMARY	C1.4N
	RUS	12.47/7.2 kV	C1.5N

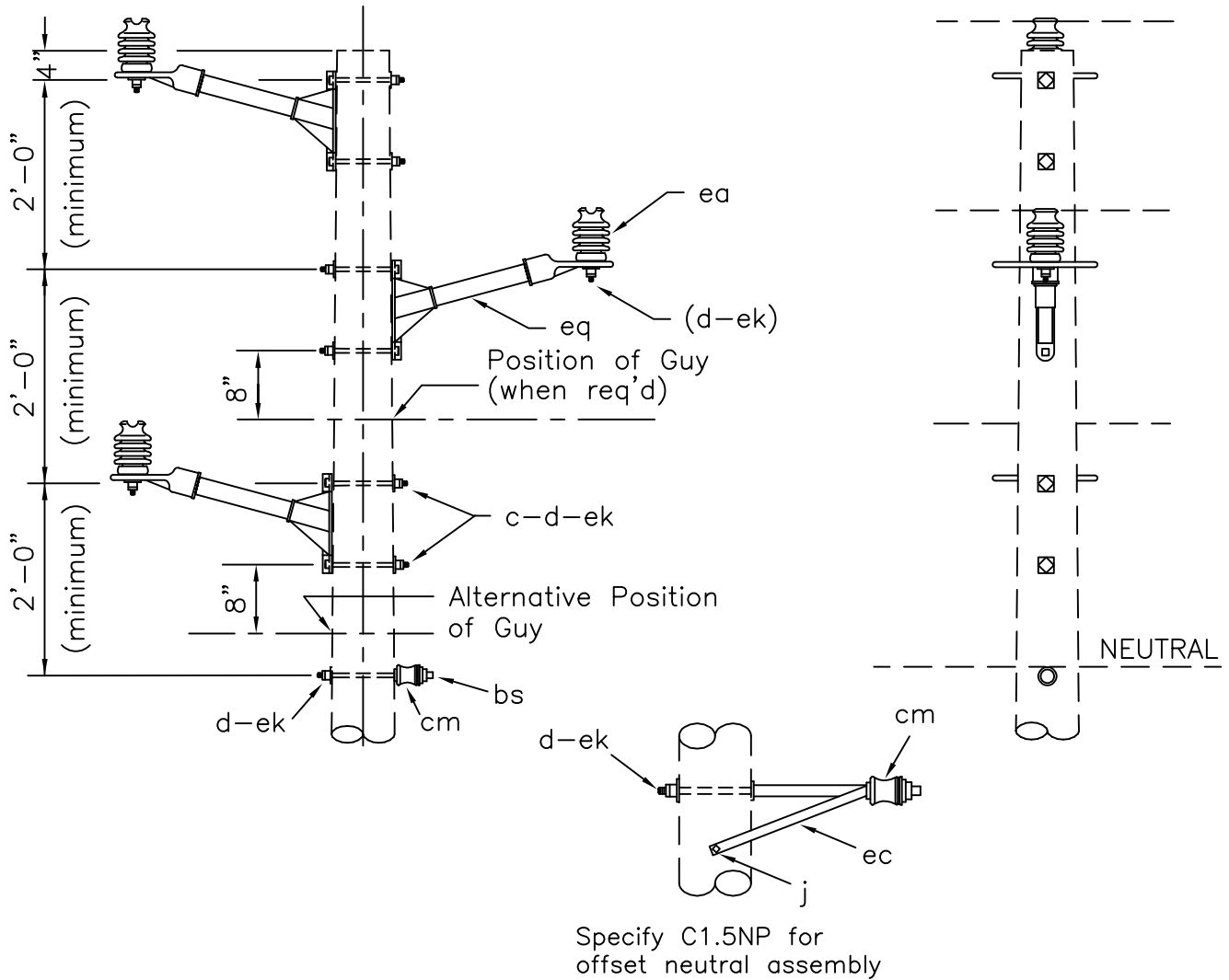

ASSEMBLY: C1. 4NP 5NP

ITEM	MATERIAL	QTY	QTY
c	Bolt, machine 5/8" x req'd length	6	6
d	Washer, square 2 1/4"	7	7
j	Screw, lag, 1/2" x 4"		2
bs	Bolt, single, upset	1	
cm	Insulator, spool, 3"	1	1
ea	Insulator, post type (12.47/7.2 kV)	3	3
ec	Bracket, offset neutral		1
ek	Locknuts	7	7
eq	Bracket, insulator/equipment	3	3

Design Parameters:

MAXIMUM LINE ANGLES:
 5°-Small Conductors
 2°-Larger than #1/0

SINGLE SUPPORT-NARROW PROFILE
 (TANGENT) (POST INSULATORS)

APRIL 2005

RUS

3 - PHASE PRIMARY
 12.47/7.2 kV

C1.4NP
 C1.5NP

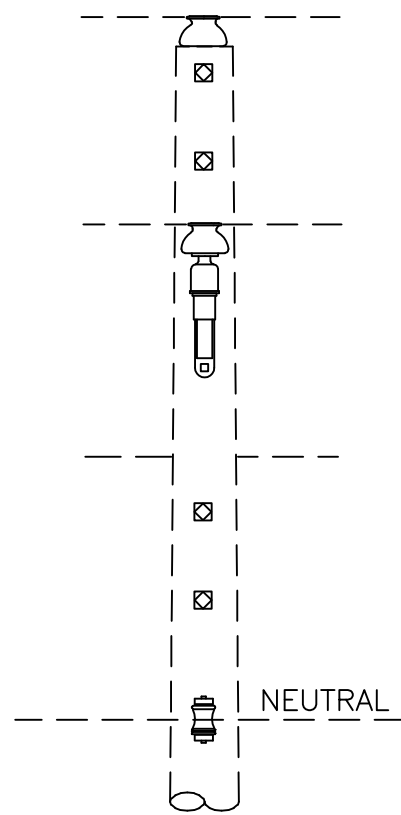
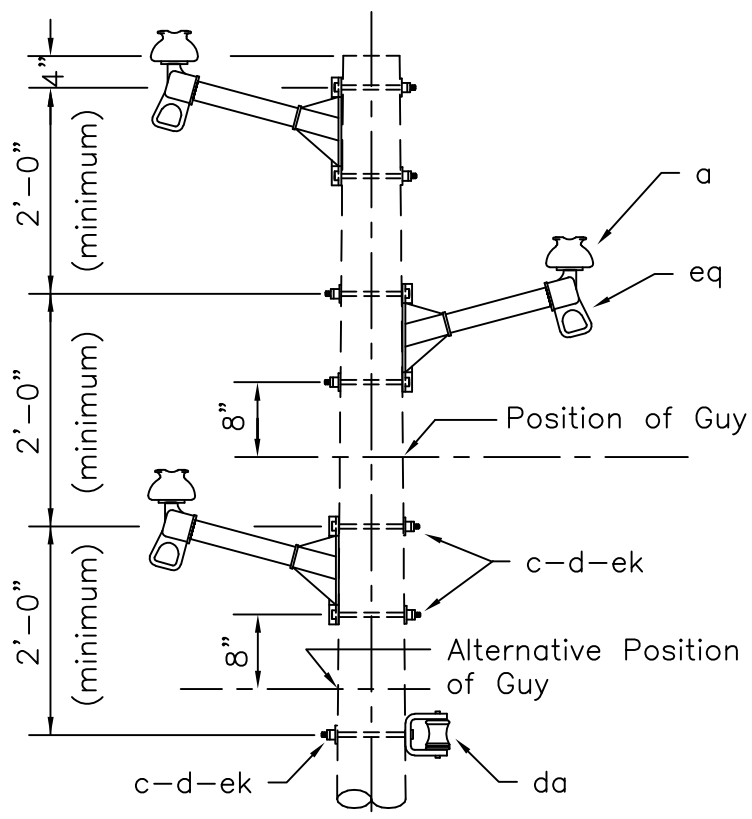

ASSEMBLY: C1. 6N

ITEM	MATERIAL	QTY
a	Insulator, pin type (12.47/7.2 kV)	3
c	Bolt, machine, 5/8" x req'd length	7
d	Washer, square 2 1/4"	7
(f)	(Pin, crossarm, 5/8" x 6 1/2")	(3) (If req'd)
da	Bracket, insulated	1
ek	Locknuts	7
eq	Bracket, insulator/equipment	3

Design Parameters:
Maximum Line Angles
See TABLE II

SINGLE SUPPORT-NARROW PROFILE

APRIL 2005
RUS

3 - PHASE PRIMARY
12.47/7.2 kV

C1.6N

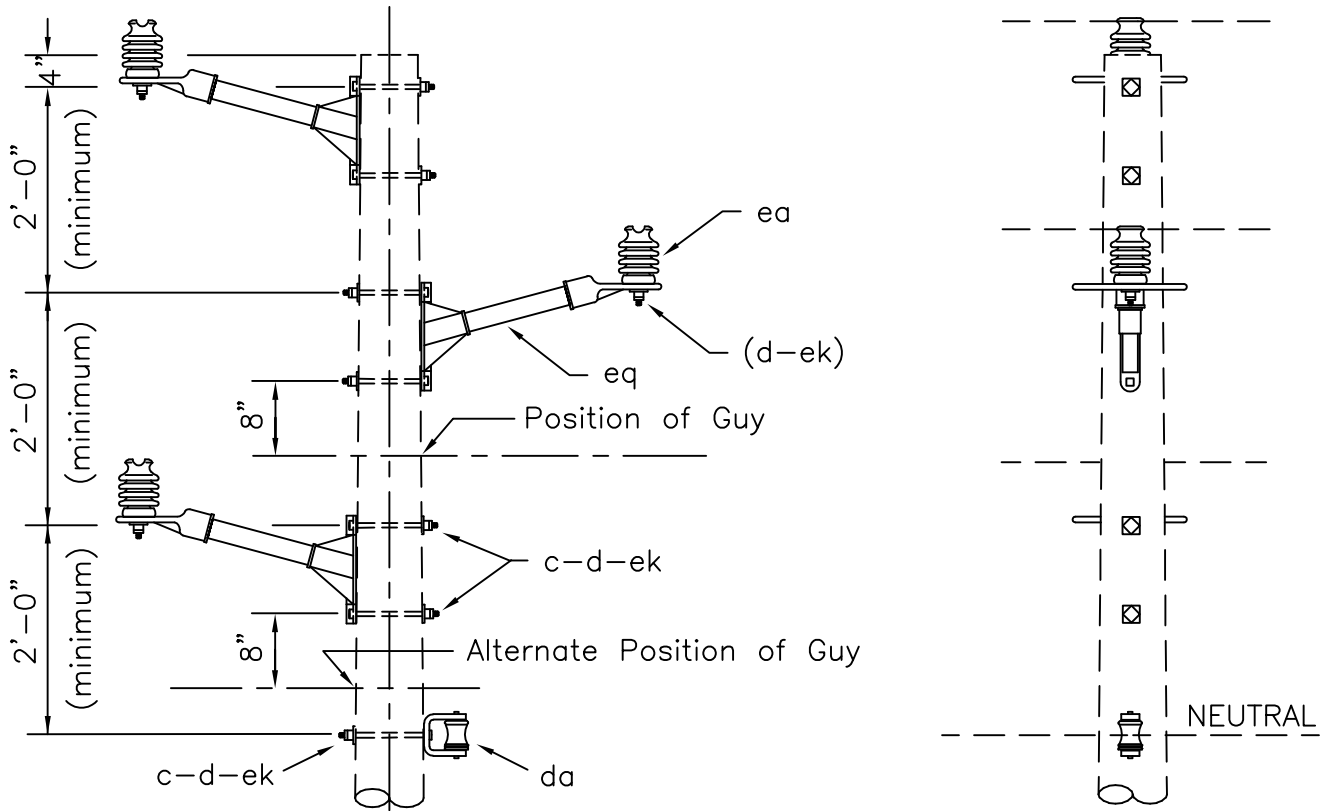

ASSEMBLY: C1.6NP

ITEM	MATERIAL	QTY
c	Bolt, machine 5/8" x req'd length	7
d	Washer, square 2 1/4"	7
da	Bracket, insulated	1
ea	Insulator, post type (12.47/7.2 kV)	3
ek	Locknuts	7
eq	Bracket, insulator/equipment	3

Design Parameters:

MAXIMUM LINE ANGLES:
See TABLE II

SINGLE SUPPORT-NARROW PROFILE
(POST INSULATORS)

APRIL 2005

RUS

3 - PHASE PRIMARY
12.47/7.2 kV

C1.6NP

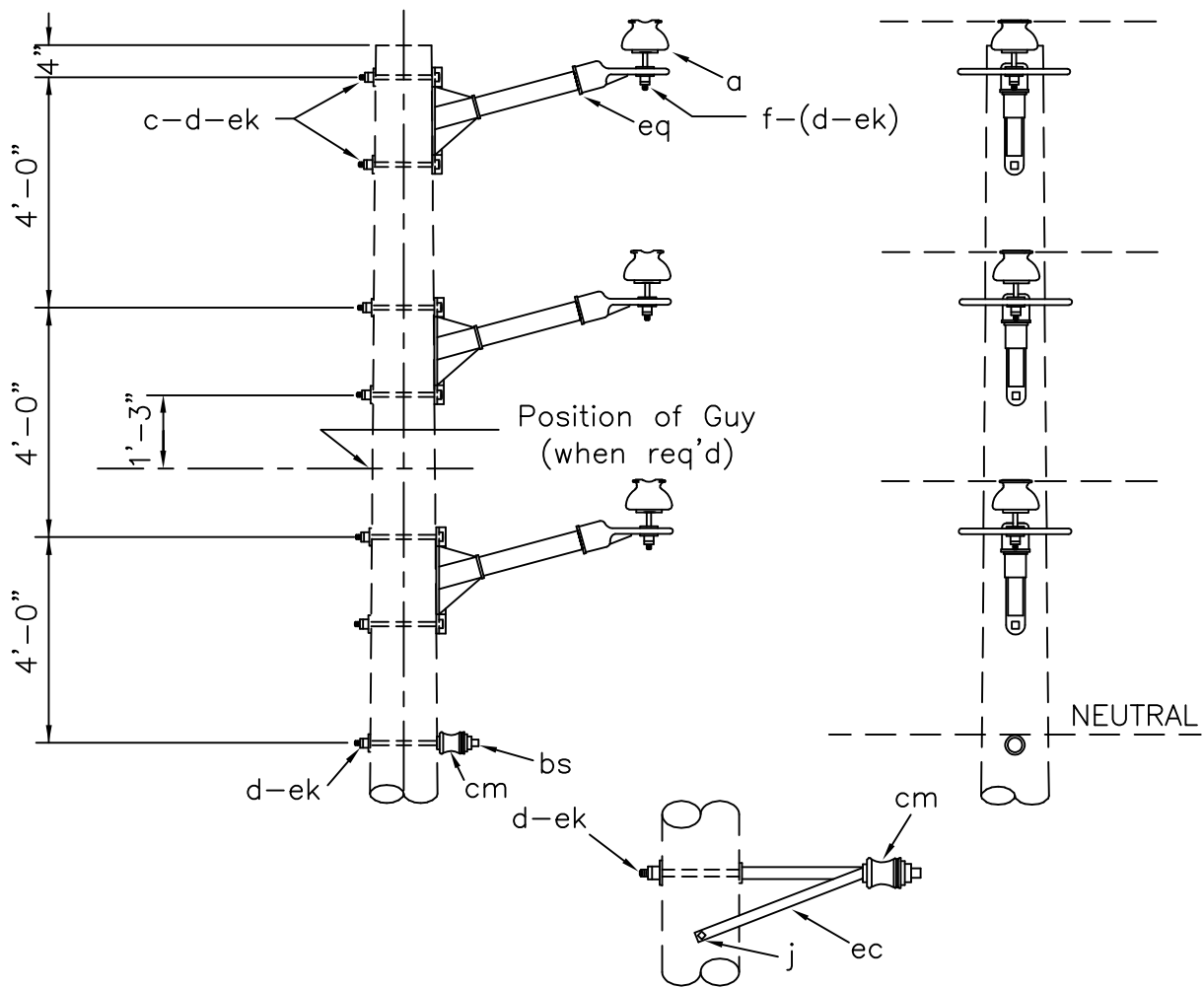

Specify C1.8N for offset neutral assembly

		Assembly: C1.	
ITEM	MATERIAL	7N	8N
a	Insulator, pin type (12.47/7.2 kV)	3	3
c	Bolt, machine, 5/8" x req'd length	6	6
d	Washer, square 2 1/4"	7	7
(f)	(Pin, crossarm, 5/8" x 6 1/2")	(3)	(3)
j	Screw, lag, 1/2" x 4"		2
bs	Bolt, single, upset	1	
cm	Insulator, spool, 3"	1	1
ec	Bracket, offset neutral		1
ek	Locknuts	7	7
eq	Bracket, insulator/equipment	3	3

(If req'd)

Design Parameters:
 Maximum Line Angles
 5° - Small Conductors
 2° - Larger than #1/0

SINGLE SUPPORT-NARROW PROFILE
(TANGENT)

APRIL 2005

3 - PHASE PRIMARY
12.47/7.2 kV

C1.7N
C1.8N

RUS

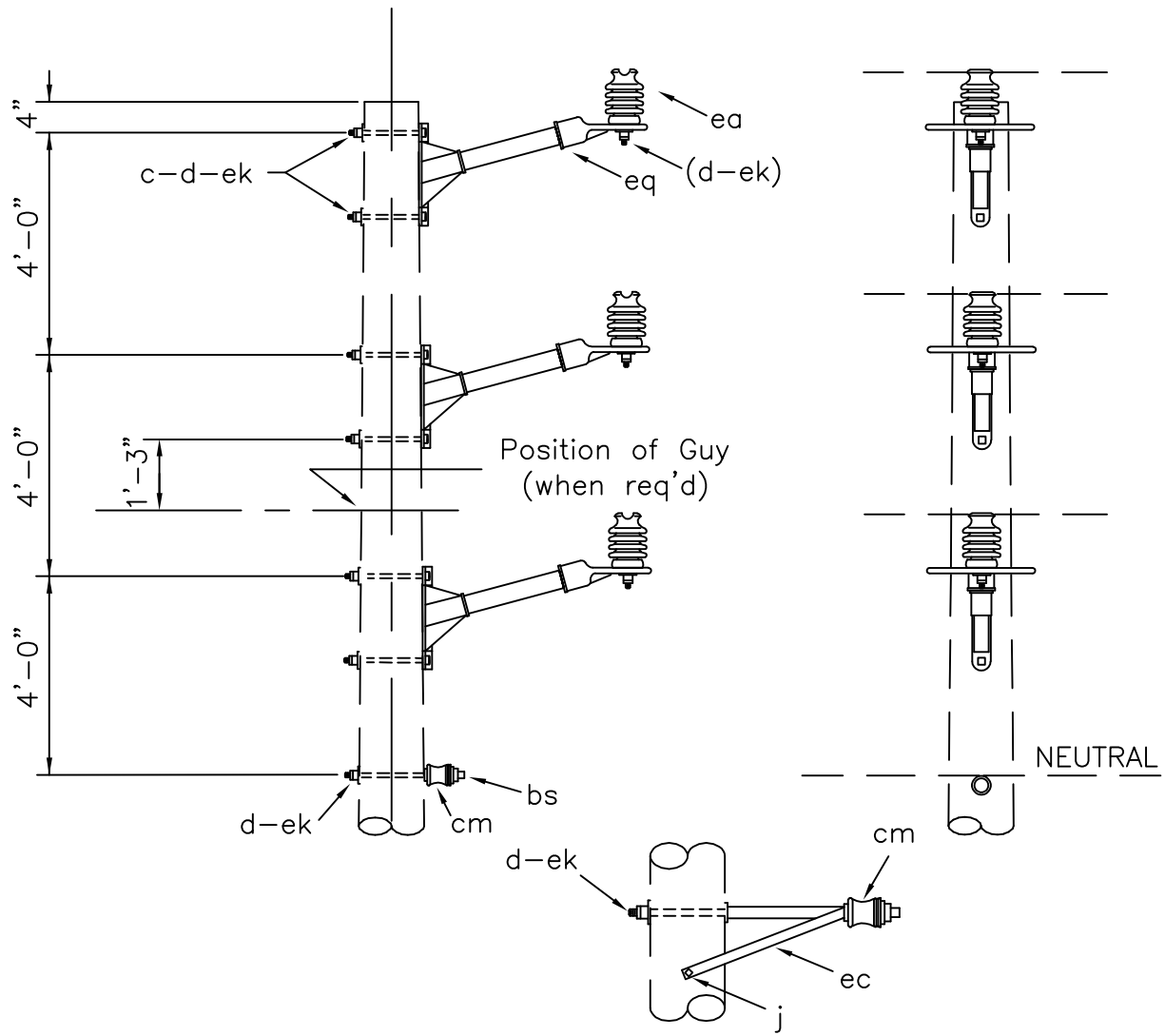

Assembly: C1. 7NP 8NP

ITEM	MATERIAL	QTY	QTY
c	Bolt, machine, 5/8" x req'd length	6	6
d	Washer, square 2 1/4"	7	7
j	Screw, lag, 1/2" x 4"		2
bs	Bolt, single, upset	1	
cm	Insulator, spool, 3"	1	1
ea	Insulator, post type (12.47/7.5 kV)	3	3
ec	Bracket, offset neutral		1
ek	Locknuts	7	7
eq	Bracket, insulator/equipment	3	3

Design Parameters:
 Maximum Line Angles
 5° - Small conductors
 2° - Larger than #1/0

SINGLE SUPPORT-NARROW PROFILE
 (TANGENT) (POST INSULATORS)

APRIL 2005	3 - PHASE PRIMARY	C1.7NP
RUS	12.47/7.2 kV	C1.8NP

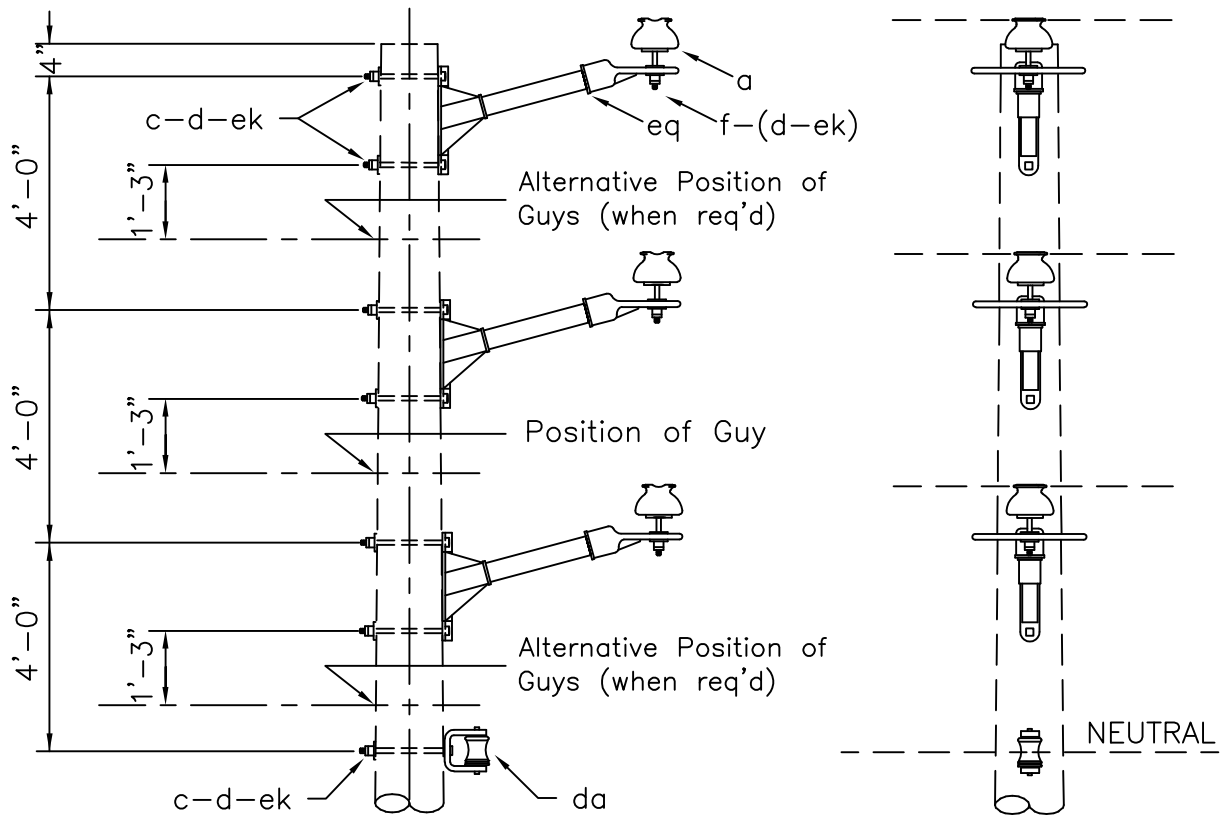

Assembly: C1. 9N

ITEM	MATERIAL	QTY
a	Insulator, pin type (12.47/7.2 kV)	3
c	Bolt, machine, 5/8" x req'd length	7
d	Washer, square 2 1/4"	7
(f)	(Pin, crossarm, 5/8" x 6 1/2")	(3) (If req'd)
da	Bracket, insulated	1
ek	Locknuts	7
eq	Bracket, insulator/equipment	3

Design Parameters:
Maximum Line Angles
See TABLE II

SINGLE SUPPORT-NARROW PROFILE

APRIL 2005

3 - PHASE PRIMARY

RUS

12.47/7.2 kV

C1.9N

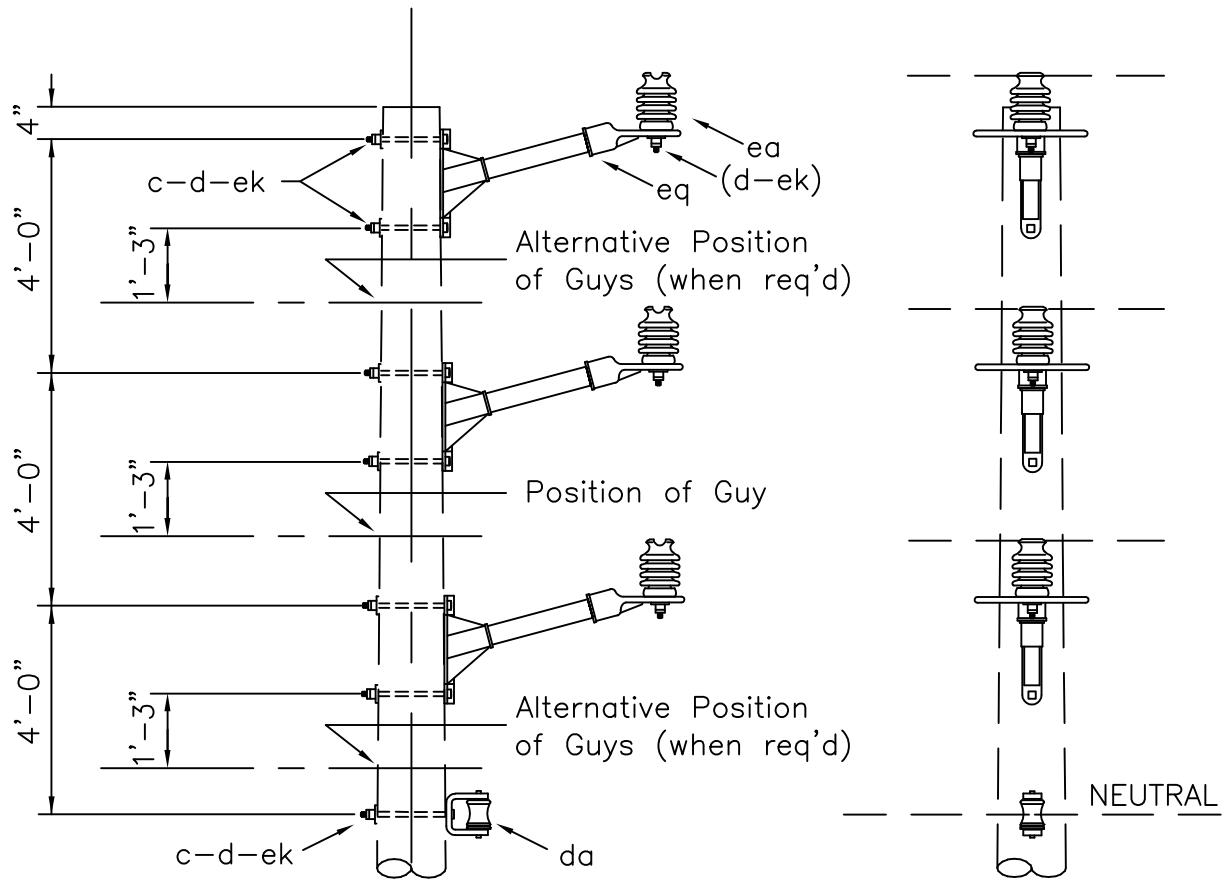

Assembly: C1. 9NP

ITEM	MATERIAL	QTY
c	Bolt, machine, 5/8" x req'd length	7
d	Washer, square 2 1/4"	7
da	Bracket, insulated	1
ea	Insulator, post type (12.47/7.2 kV)	3
ek	Locknuts	7
eq	Bracket, insulator/equipment	3

Design Parameters: MAXIMUM LINE ANGLES: See TABLE II	SINGLE SUPPORT-NARROW PROFILE (POST INSULATORS)		
	APRIL 2005	3 - PHASE PRIMARY	C1.9NP
	RUS	12.47/7.2 kV	

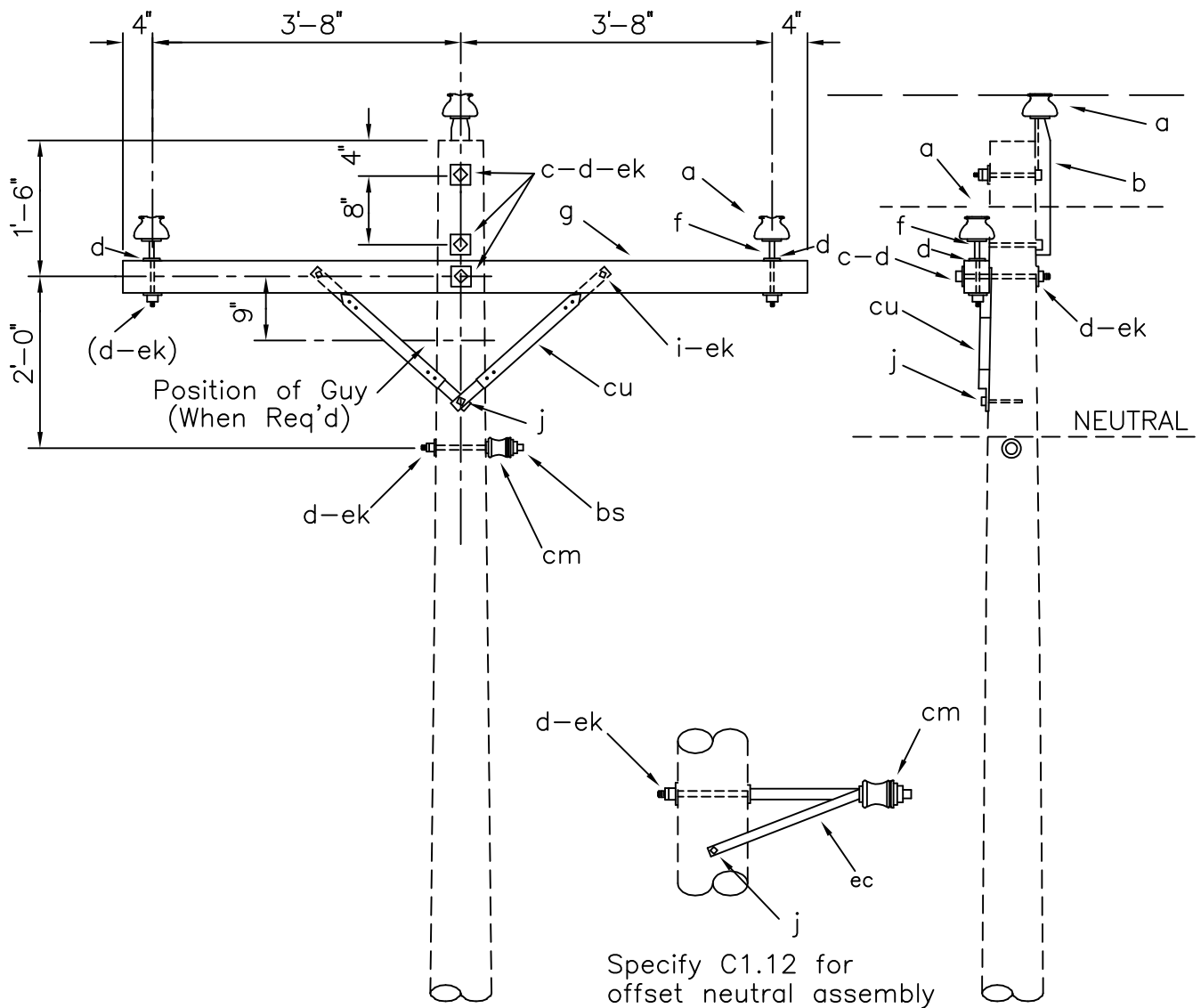

ASSEMBLY: C1. 11 12

ITEM	MATERIAL	QTY	QTY
a	Insulator, pin type, (12.47/7.2 kV)	3	3
b	Pin, pole top, 20"	1	1
c	Bolt, machine, 5/8 x req'd length	3	3
d	Washer, square, 2 1/4"	7	7
f	Pin, crossarm, steel, 5/8" x 10 3/4"	2	2
g	Crossarm, 3 5/8" x 4 5/8" x 8'-0"	1	1
i	Bolt, carriage, 3/8" x 4"	2	2
j	Screw, lag, 1/2" x 4"	1	3
bs	Bolt, single, upset	1	
cm	Insulator, spool, 3"	1	1
cu	Brace, 28"	2	2
ec	Bracket, offset neutral		1
ek	Locknuts	6	6

DESIGN PARAMETERS:

MAXIMUM LINE ANGLES:
 5° - Small Conductors
 2° - Larger than #1/0

SINGLE SUPPORT ON CROSSARM
 (TANGENT)

APRIL 2005

RUS

3 - PHASE PRIMARY
 12.47/7.2 kV

C1.11 (C1)
 C1.12 (C1A)

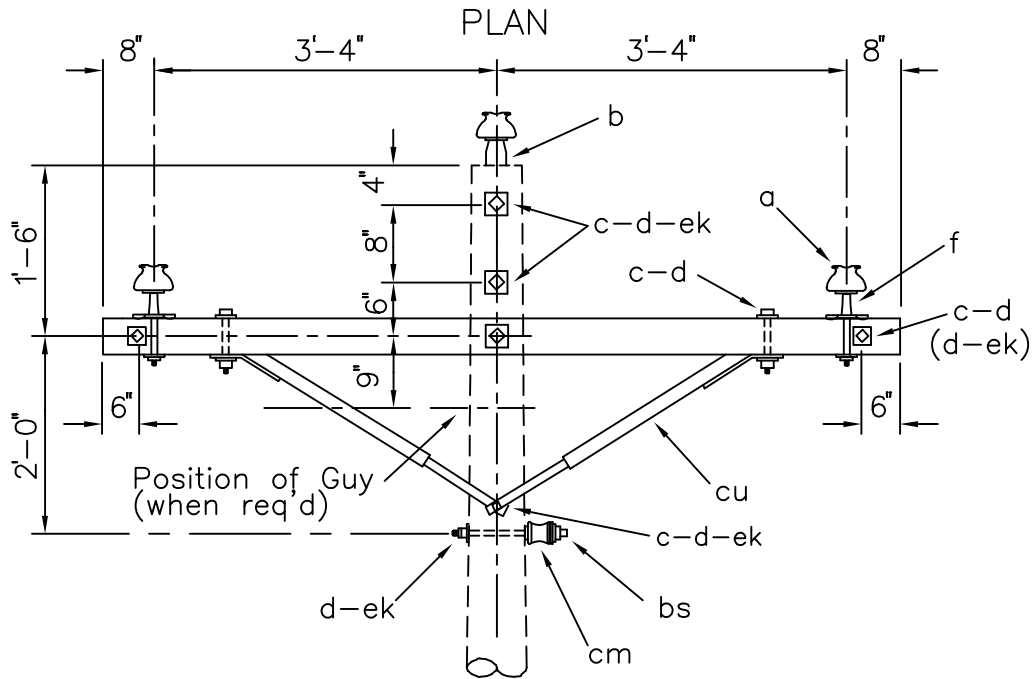
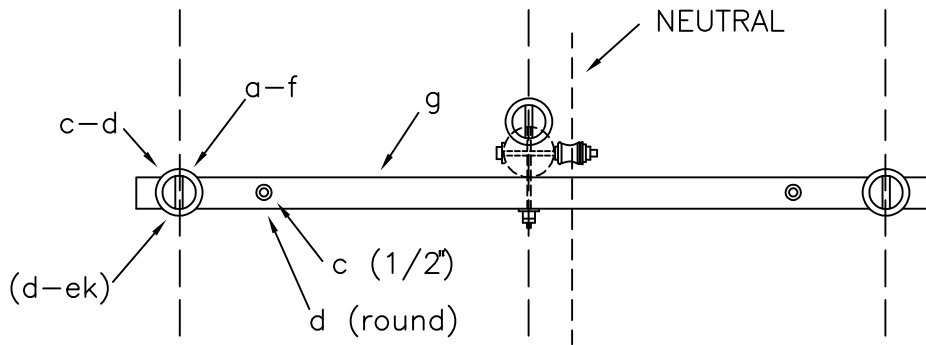

ASSEMBLY: C1.

ITEM	MATERIAL	11L QTY	12L QTY
a	Insulator, pin type, (12.47/7.2 kV)	3	3
b	Pin, pole top, 20"	1	1
c	Bolt, machine, 1/2" x req'd length	2	2
c	Bolt, machine, 5/8" x req'd length	6	6
d	Washer, round, 1 3/8"	2	2
d	Washer, square, 2 1/4"	10	10
f	Pin, crossarm, clamp type	2	2
g	Crossarm, 3 5/8" x 4 5/8" x 8'-0"	1	1
j	Screw, lag, 1/2" x 4"		2
bs	Bolt, single, upset	1	
cm	Insulator, spool, 3"	1	1
cu	Brace, wood, 60" span	1	1
ec	Bracket, offset neutral		1
ek	Locknuts	9	9

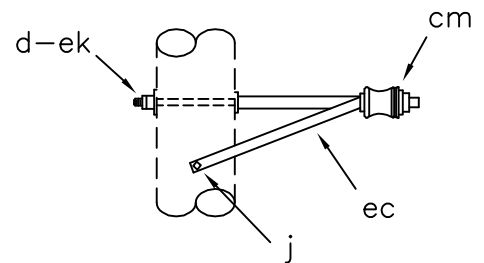

Specify C1.12L for offset neutral assembly

DESIGN PARAMETERS:
 MAXIMUM LINE ANGLE:
 2° - (Large Conductors)

SINGLE SUPPORT ON CROSSARM
 (TANGENT) (LARGE CONDUCTORS)

APRIL 2005

RUS

3 - PHASE PRIMARY
 12.47/7.2 kV

C1.11L (C1-2)
 C1.12L

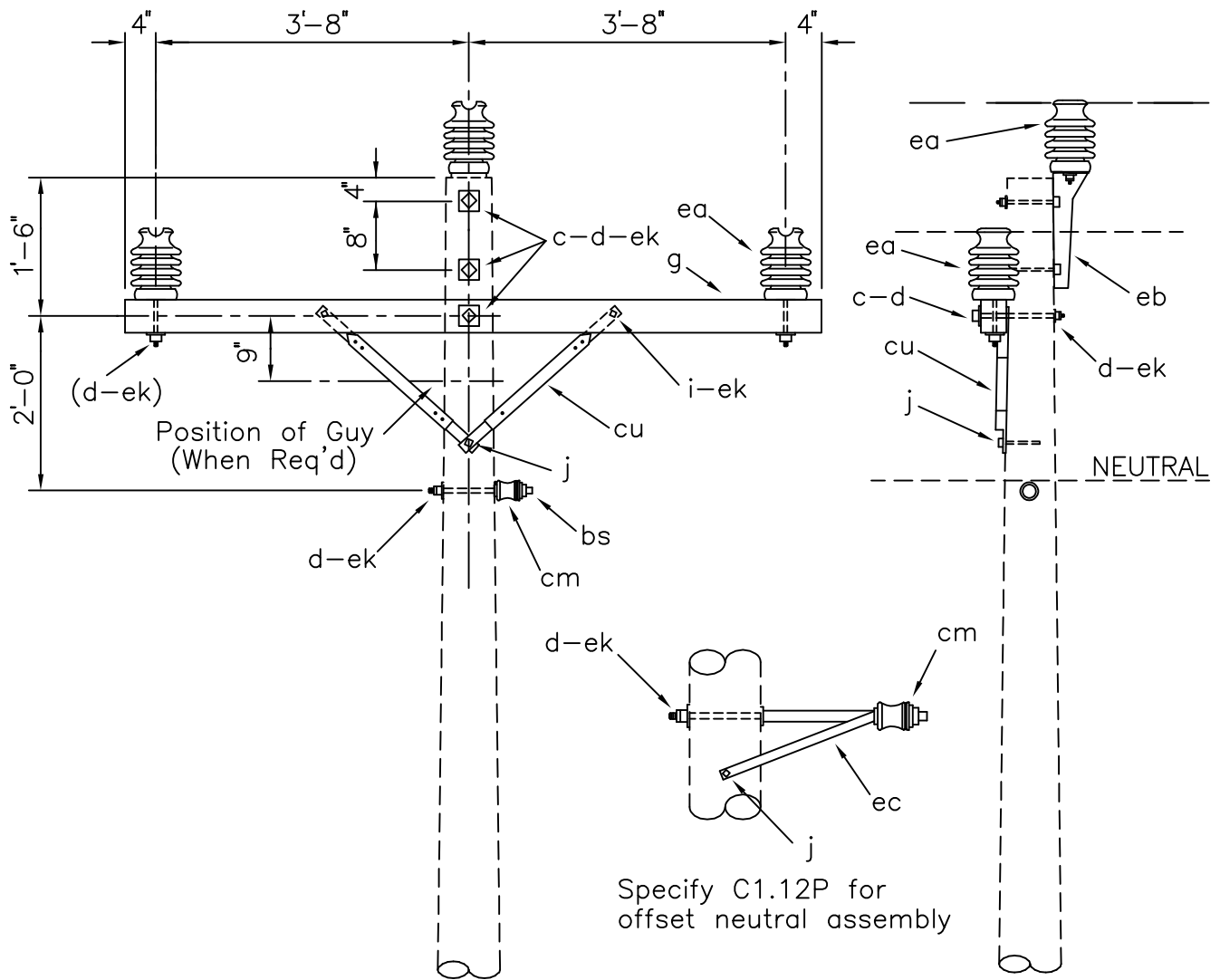

ASSEMBLY: C1.

ITEM	MATERIAL	11P QTY	12P QTY
c	Bolt, machine, 5/8" x req'd length	3	3
d	Washer, square, 2 1/4"	5	5
g	Crossarm, 3 5/8" x 4 5/8" x 8'-0"	1	1
i	Bolt, carriage, 3/8" x 4"	2	2
j	Screw, lag, 1/2" x 4"	1	3
bs	Bolt, single, upset	1	
cm	Insulator, spool, 3"	1	1
cu	Brace, 28"	2	2
ea	Insulator, post type (12.47/7.2 kV)	3	3
eb	Bracket, pole top	1	1
ec	Bracket, offset neutral		1
ek	Locknuts	6	6

DESIGN PARAMETERS:

MAXIMUM LINE ANGLES:
 5° - Small Conductors
 2° - Larger than #1/0

SINGLE SUPPORT ON CROSSARM
 (TANGENT) (POST INSULATORS)

APRIL 2005

RUS

3 - PHASE PRIMARY
 12.47/7.2 kV

C1.11P (C1P)
 C1.12P (C1AP)

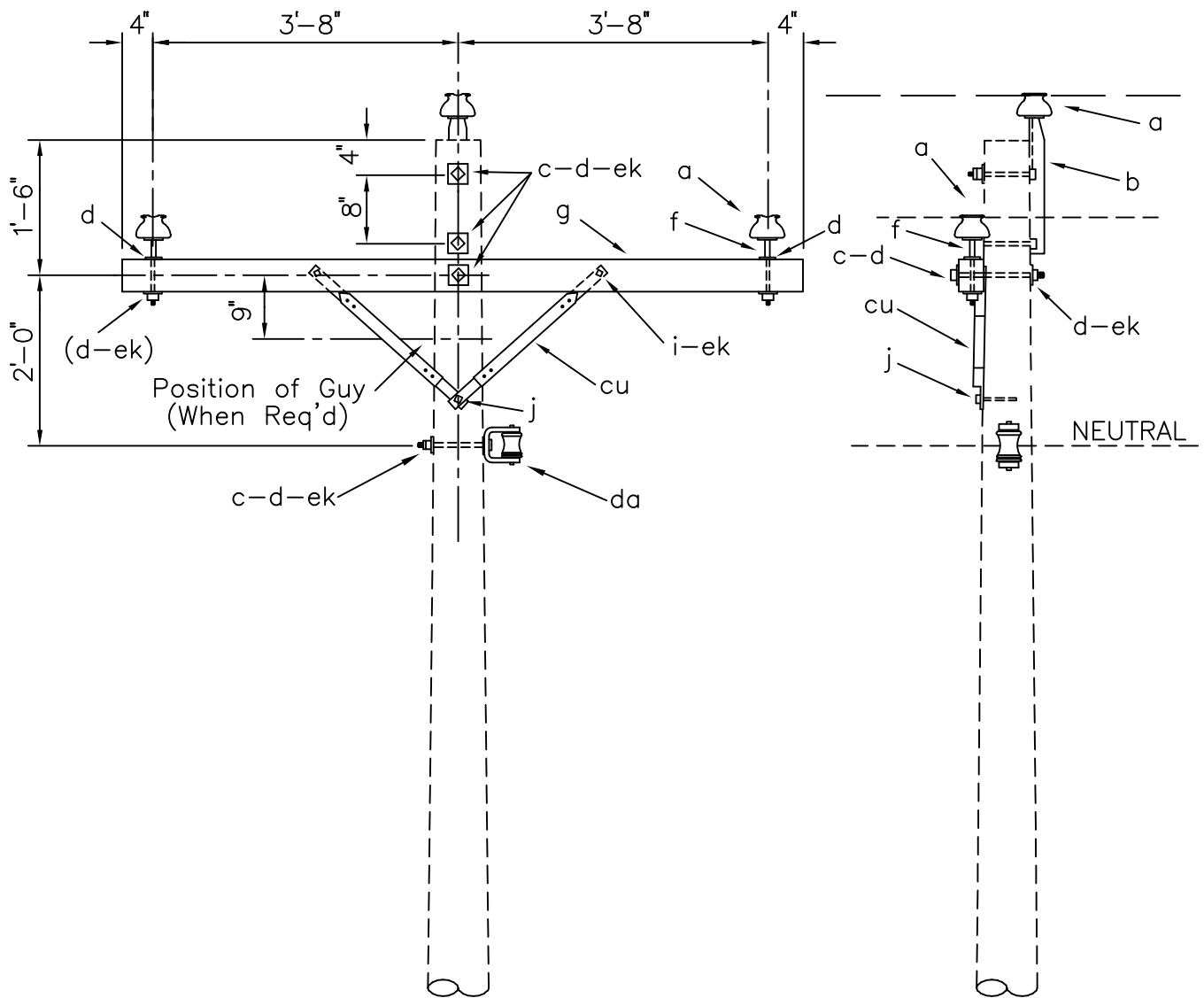

ITEM	QTY	MATERIAL
a	3	Insulator, pin type (12.47/7.2 kV)
b	1	Pin, pole top, 20°
c	4	Bolt, machine, 5/8" x req'd length
d	7	Washer, square, 2 1/4"
f	2	Pin, crossarm, steel, 5/8" x 10 3/4"
g	1	Crossarm, 3 5/8" x 4 5/8" x 8' - 0"
i	2	Bolt, carriage, 3/8" x 4 1/2"
j	1	Screw, lag, 1/2" x 4"
cu	2	Brace, 28"
da	1	Bracket, insulated
ek	6	Locknuts

DESIGN PARAMETERS:

See TABLE I

SINGLE SUPPORT ON CROSSARM

APRIL 2005

RUS

3 - PHASE PRIMARY
12.47/7.2 kV

C1.13

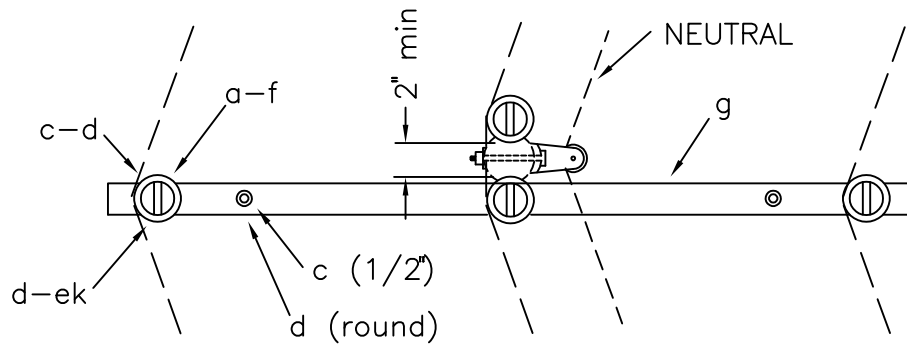

PLAN

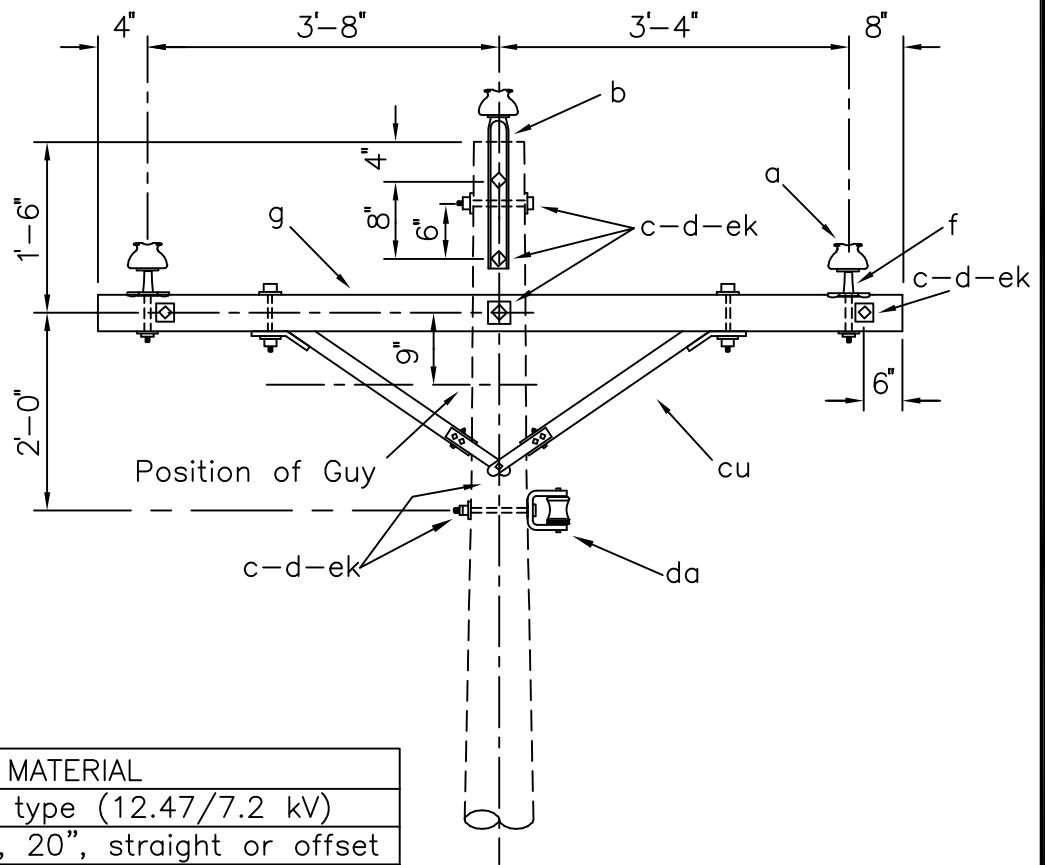

ITEM	QTY	MATERIAL
a	4	Insulator, pin type (12.47/7.2 kV)
b	2	Pin, pole top, 20", straight or offset
c	2	Bolt, machine, 1/2" x req'd length
c	8	Bolt, machine, 5/8" x req'd length
d	2	Washer, round, 1 3/8"
d	12	Washer, square, 2 1/4"
f	2	Pin, crossarm, clamp type
g	1	Crossarm, 3 5/8" x 4 5/8" x 8' 0"
cu	1	Brace, wood, 60" span
da	1	Bracket, insulated
ek	10	Locknuts

DESIGN PARAMETERS:

See TABLE III

SINGLE SUPPORT ON CROSSARM
(LARGE CONDUCTORS)

APRIL 2005

RUS

3 - PHASE PRIMARY
12.47/7.2 kV

C1.13L
(C1-4)

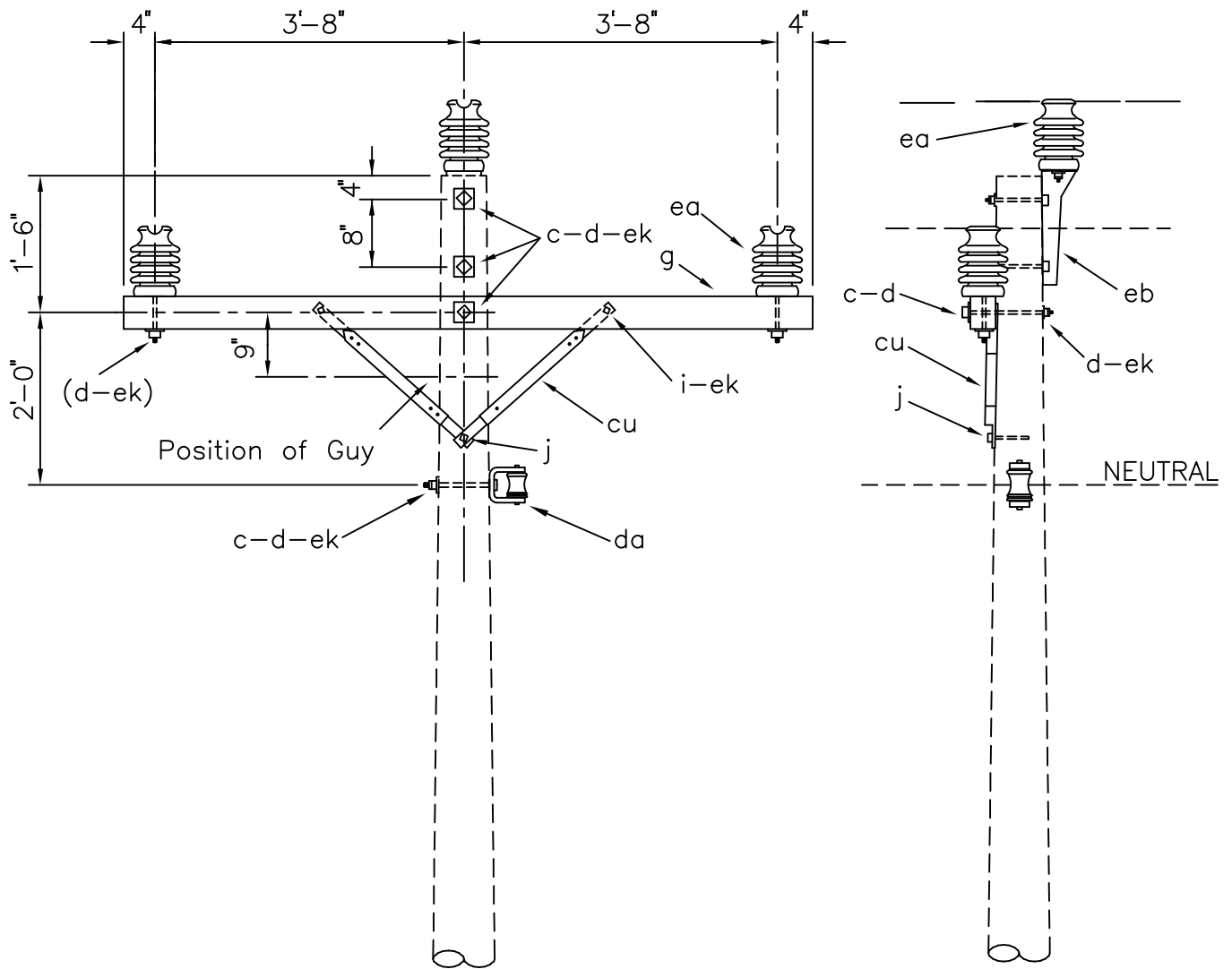

ITEM	QTY	MATERIAL
c	4	Bolt, machine, 5/8" x req'd length
d	5	Washer, square, 2 1/4"
g	1	Crossarm, 3 5/8" x 4 5/8" x 8' - 0"
i	2	Bolt, carriage, 3/8" x 4 1/2"
j	1	Screw, lag, 1/2" x 4"
cu	2	Brace, 28"
da	1	Bracket, insulated
ea	3	Insulator, post type (12.47/7.2 kV)
eb	1	Bracket, pole top
ek	6	Locknuts

DESIGN PARAMETERS:
See TABLE II

SINGLE SUPPORT ON CROSSARM
(POST INSULATORS)

APRIL 2005

3 - PHASE PRIMARY
12.47/7.2 kV

RUS

C1.13P

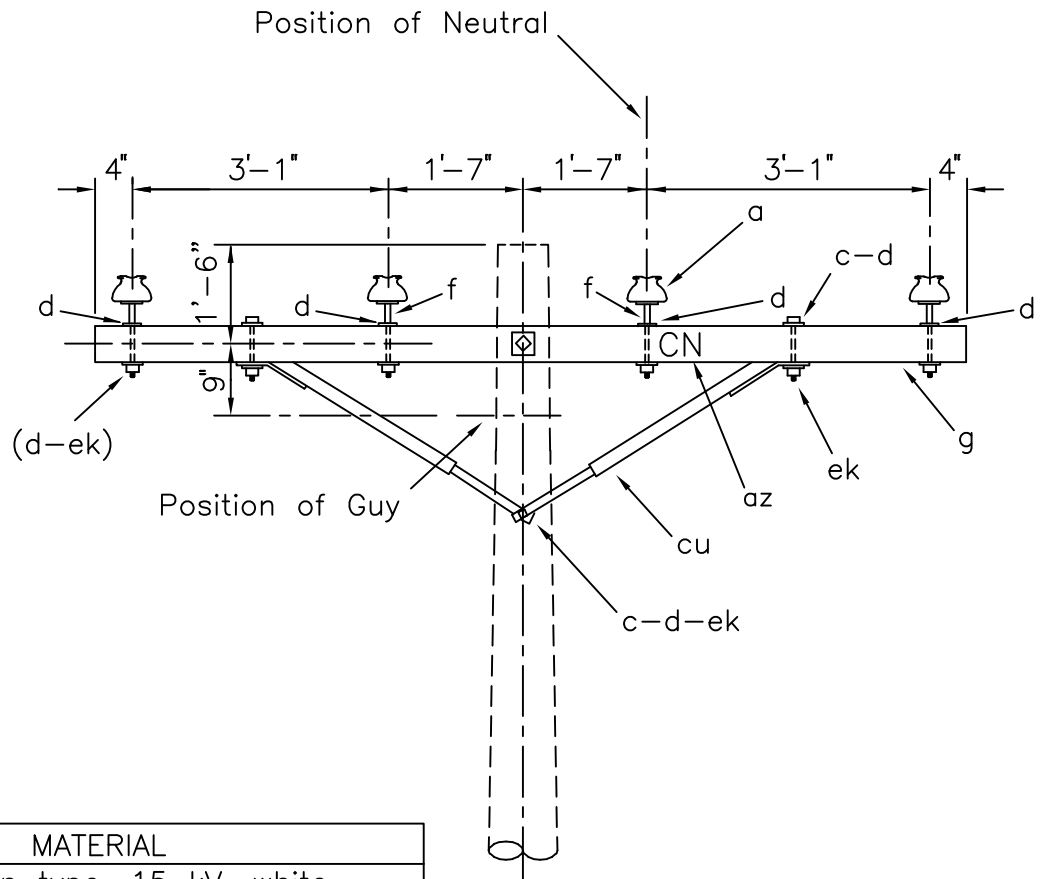
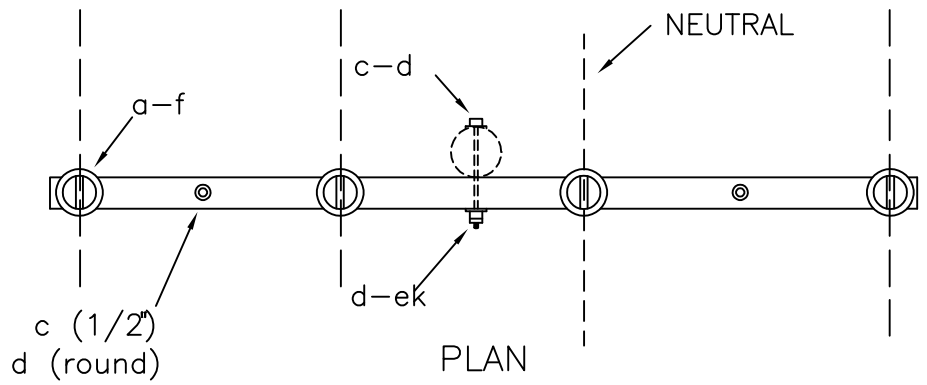

NOTE: Install either identification letters (az) or white insulator in neutral position.

ITEM	QTY	MATERIAL
a	1	Insulator, pin type, 15 kV, white
a	3	Insulator, pin type (12.47/7.2 kV)
c	2	Bolt, machine, 1/2" x req'd length
c	2	Bolt, machine, 5/8" x req'd length
d	2	Washer, round, 1 3/8"
d	7	Washer, square, 2 1/4"
f	4	Pin, crossarm, steel, 5/8" x 10 3/4"
g	1	Crossarm, 3 5/8" x 4 5/8" x 10'-0"
az	4	Letters, 2" C, 2" N, with 1" nails
cu	1	Brace, wood, 60" span
ek	4	Locknuts

DESIGN PARAMETERS:

See TABLE II

SINGLE SUPPORT, NEUTRAL ON CROSSARM

APRIL 2005

RUS

3 - PHASE PRIMARY
12.47/7.2 kV

C1.41
(C9-1)

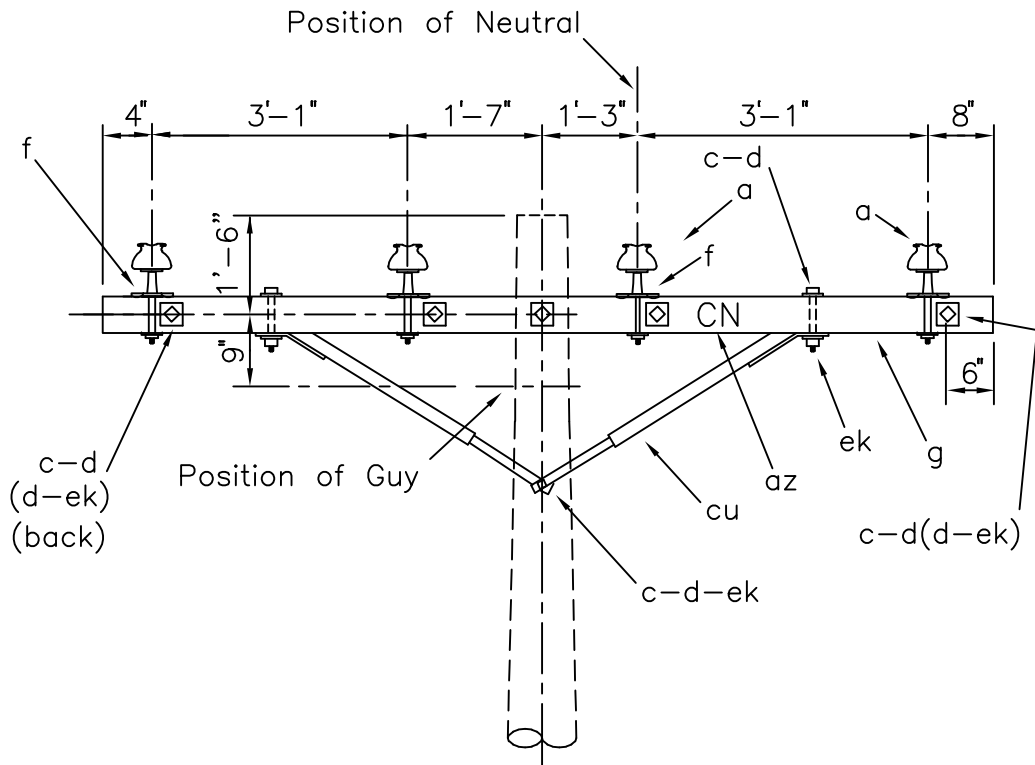
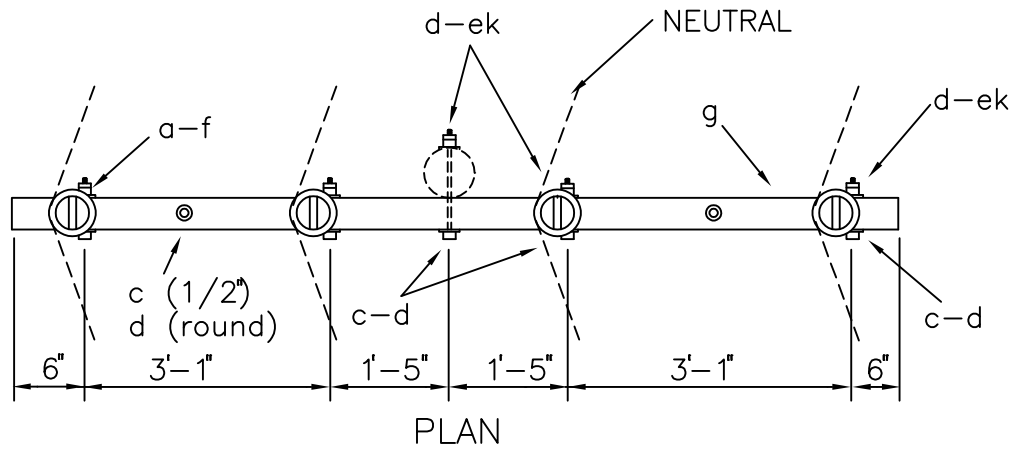

ITEM	QTY	MATERIAL
a	1	Insulator, pin type, 15 kv, white
a	3	Insulator, pin type (12.47/7.2 kv)
c	2	Bolt, machine, 1/2" x req'd length
c	6	Bolt, machine, 5/8" x req'd length
d	2	Washer, round, 1 3/8"
d	11	Washer, square, 2 1/4"
f	4	Pin, crossarm, steel clamp type
g	1	Crossarm, 3 5/8" x 4 5/8" x 10'-0"
az	4	Letters, 2" C, 2" N, with 1" nails
cu	1	Brace, wood, 60" span
ek	8	Locknuts

NOTE: Install either identification letters (az) or white insulator in neutral position.

DESIGN PARAMETERS:

See TABLE III

SINGLE SUPPORT, NEUTRAL ON CROSSARM
(LARGE CONDUCTORS)

APRIL 2005

RUS

3 - PHASE PRIMARY
12.47/7.2 kv

C1.41L
(C9-3)

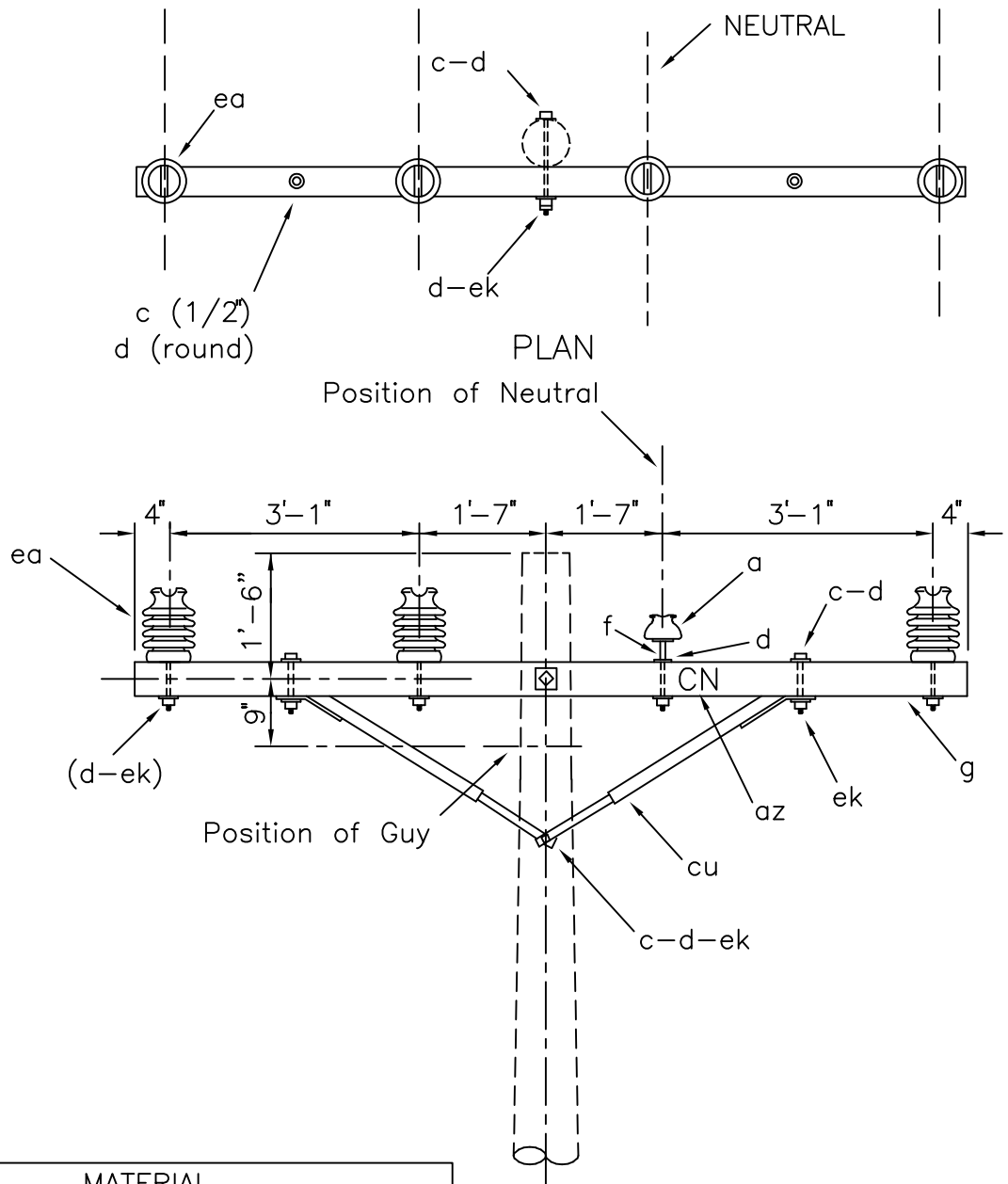

ITEM	QTY	MATERIAL
a	1	Insulator, pin type, 15 kV, white
c	2	Bolt, machine, 1/2" x req'd length
c	2	Bolt, machine, 5/8" x req'd length
d	2	Washer, round, 1 3/8"
d	4	Washer, square, 2 1/4"
f	1	Pin, crossarm, steel, 5/8" x 10 3/4"
g	1	Crossarm, 3 5/8" x 4 5/8" x 10'-0"
az	4	Letters, 2" C, 2" N, with 1" nails
cu	1	Brace, wood, 60" span
ea	3	Insulator, post type (12.47/7.2 kV)
ek	4	Locknuts

NOTE: Install identification letters (az) in neutral position. (optional)

DESIGN PARAMETERS: See TABLE II	SINGLE SUPPORT, NEUTRAL ON CROSSARM (POST INSULATORS)		
	APRIL 2005	3 - PHASE PRIMARY	C1.41P
	RUS	12.47/7.2 kV	(C9-1P)

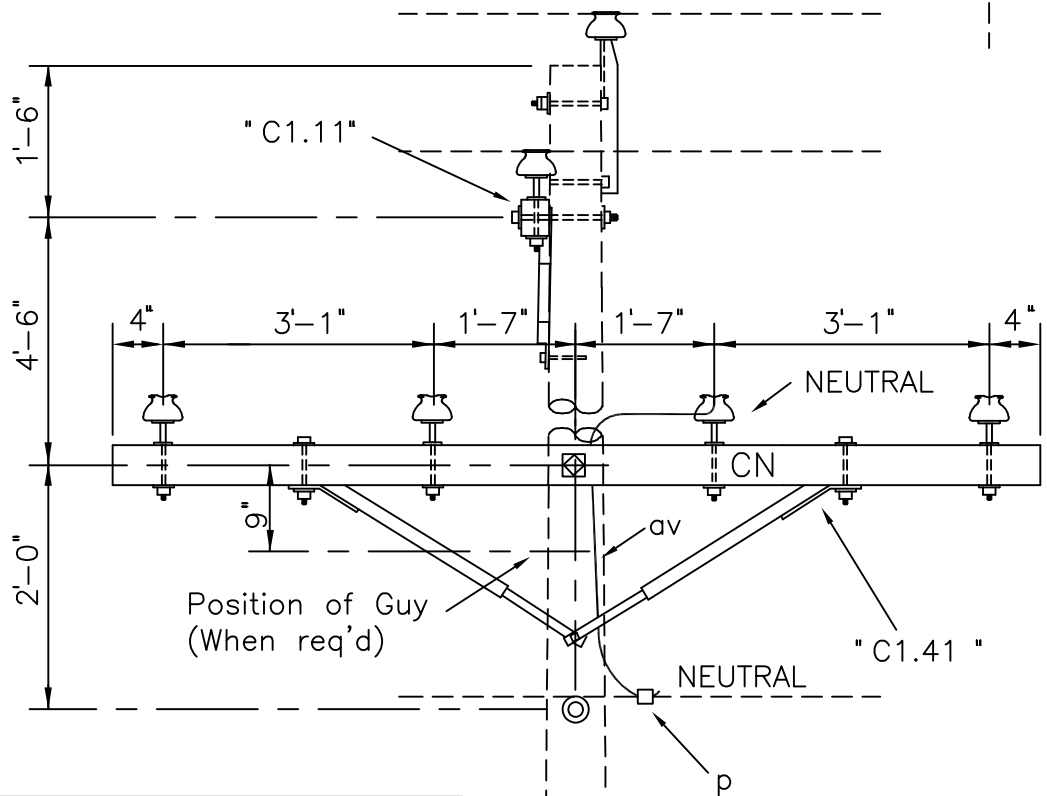
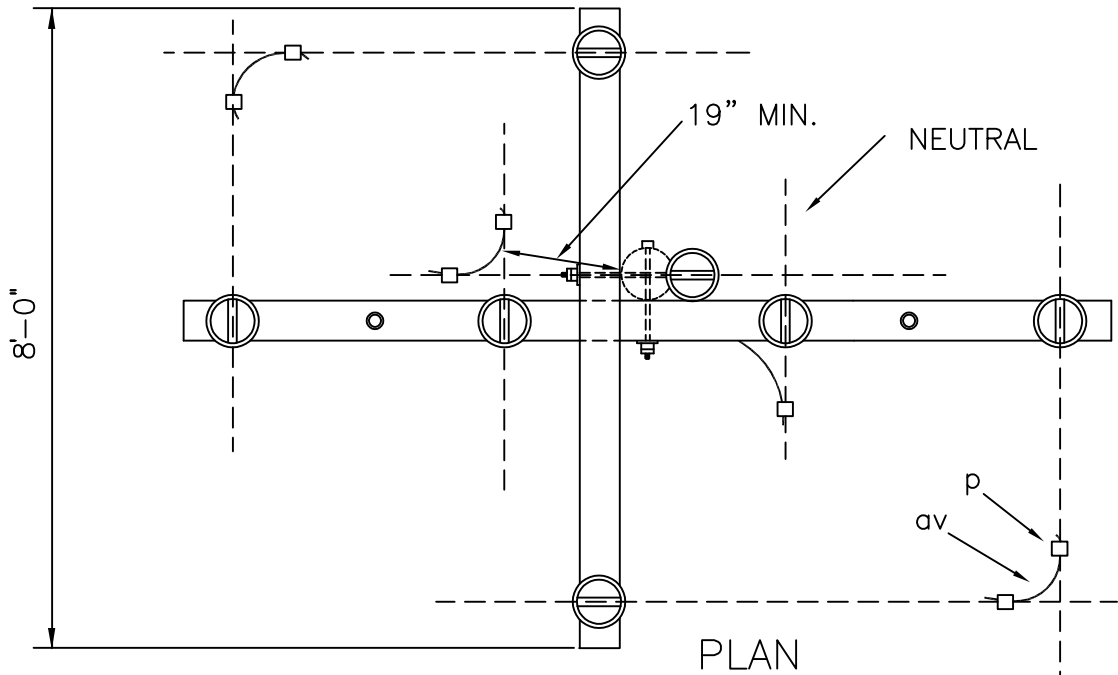

ITEM	QTY	MATERIAL
	1	C1.11 Primary Assembly
	1	C1.41 Primary Assembly
p		Connectors, as req'd
av		Jumpers, as req'd

DESIGN PARAMETERS:

MAXIMUM LINE ANGLES:

5° - Small Conductors
2° - Larger than #1/0

THREE PHASE JUNCTION GUIDE

APRIL 2005

RUS

3 - PHASE PRIMARY
12.47/7.2 kV

C1.81G

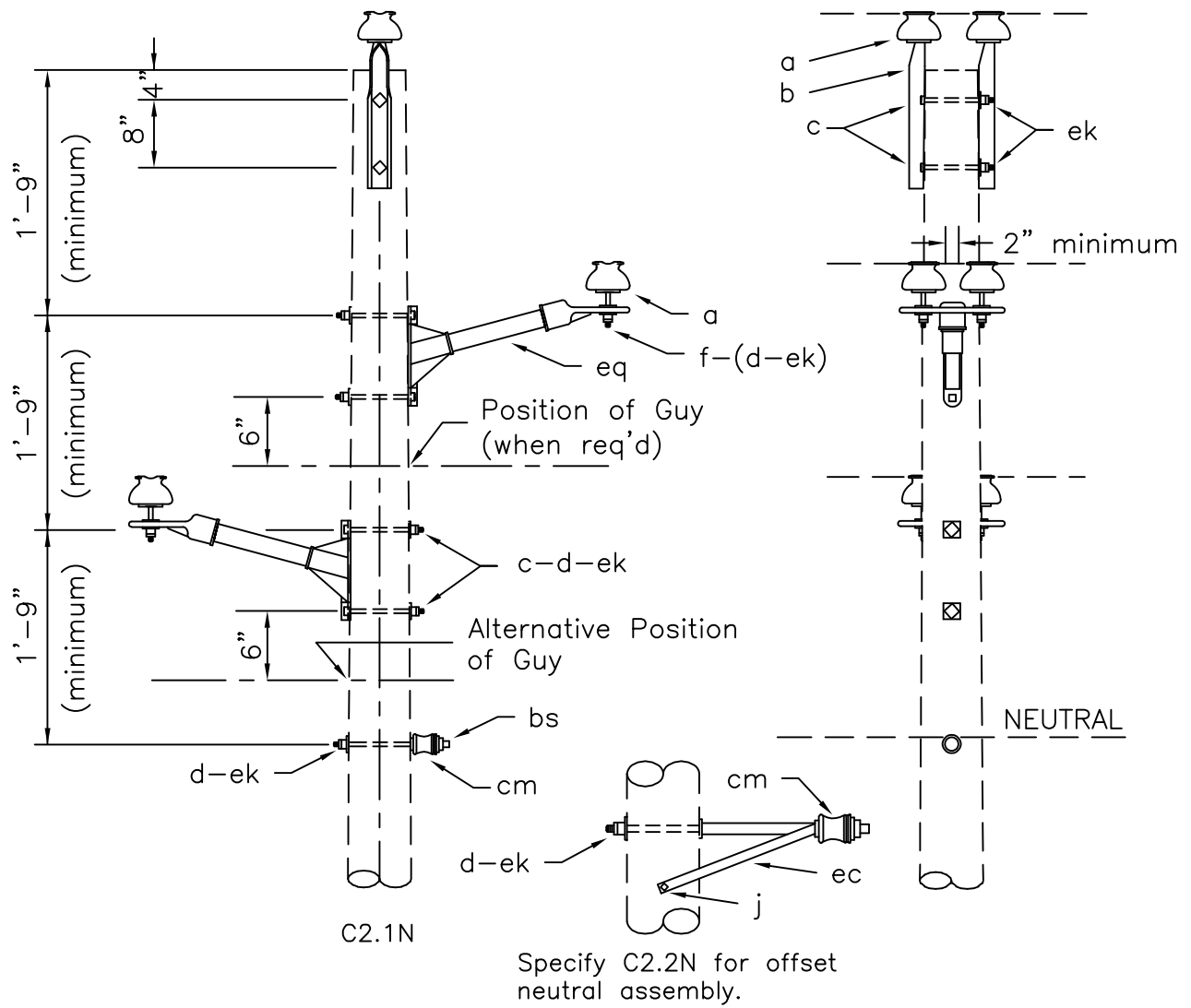

NOTES: These assemblies used for NESC Grade B construction.

ASSEMBLY: C2.		1N	2N
ITEM	MATERIAL	QTY	QTY
a	Insulator, pin type (12.47/7.2 kV)	6	6
b	Pin, pole top, 20"	2	2
c	Bolt, machine, 5/8" x req'd length	6	6
d	Washer, square 2 1/4"	5	5
f	Pin, crossarm, 5/8" x 6 1/2"	4	4
j	Screw, lag, 1/2" x 4"		2
bs	Bolt, single upset	1	
cm	Insulator, spool, 3"	1	1
ec	Bracket, offset neutral		1
ek	Locknuts	7	7
eq	Bracket, insulator/equipment	2	2

Design Parameters: MAXIMUM LINE ANGLES: 5° - Small Conductors 2° - Larger than #1/0	DOUBLE SUPPORT-NARROW PROFILE (TANGENT)		
	APRIL 2005	3 - PHASE PRIMARY 12.47/7.2 kV	C2.1N
	RUS		C2.2N

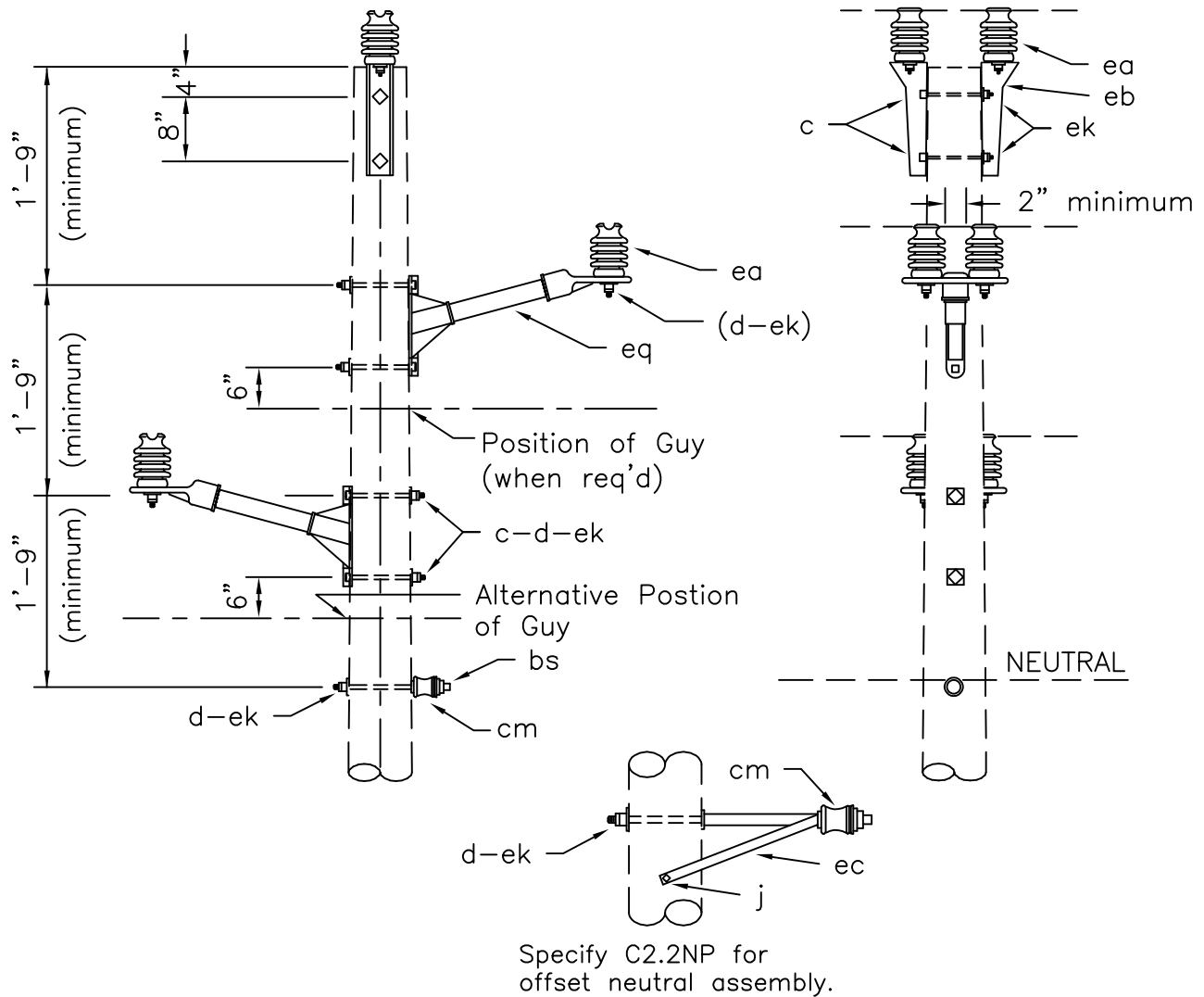

NOTES: These assemblies used for NESC Grade B construction.

ASSEMBLY: C2.		1NP	2NP
ITEM	MATERIAL	QTY	QTY
c	Bolt, machine, 5/8" x req'd length	6	6
d	Washer, square 2 1/4"	5	5
j	Screw, lag, 1/2" x 4"		2
bs	Bolt, single upset	1	
cm	Insulator, spool, 3"	1	1
ea	Insulator, post type (12.47/7.2 kV)	6	6
eb	Bracket, pole top	2	
ec	Bracket, offset neutral		1
ek	Locknuts	7	7
eq	Bracket, insulator/equipment	2	2

Design Parameters:

MAXIMUM LINE ANGLES:
 5° - Small Conductors
 2° - Larger than #1/0

DOUBLE SUPPORT-NARROW PROFILE
 (TANGENT) (POST INSULATORS)

APRIL 2005

RUS

3 - PHASE PRIMARY
 12.47/7.2 kV

C2.1NP
 C2.2NP

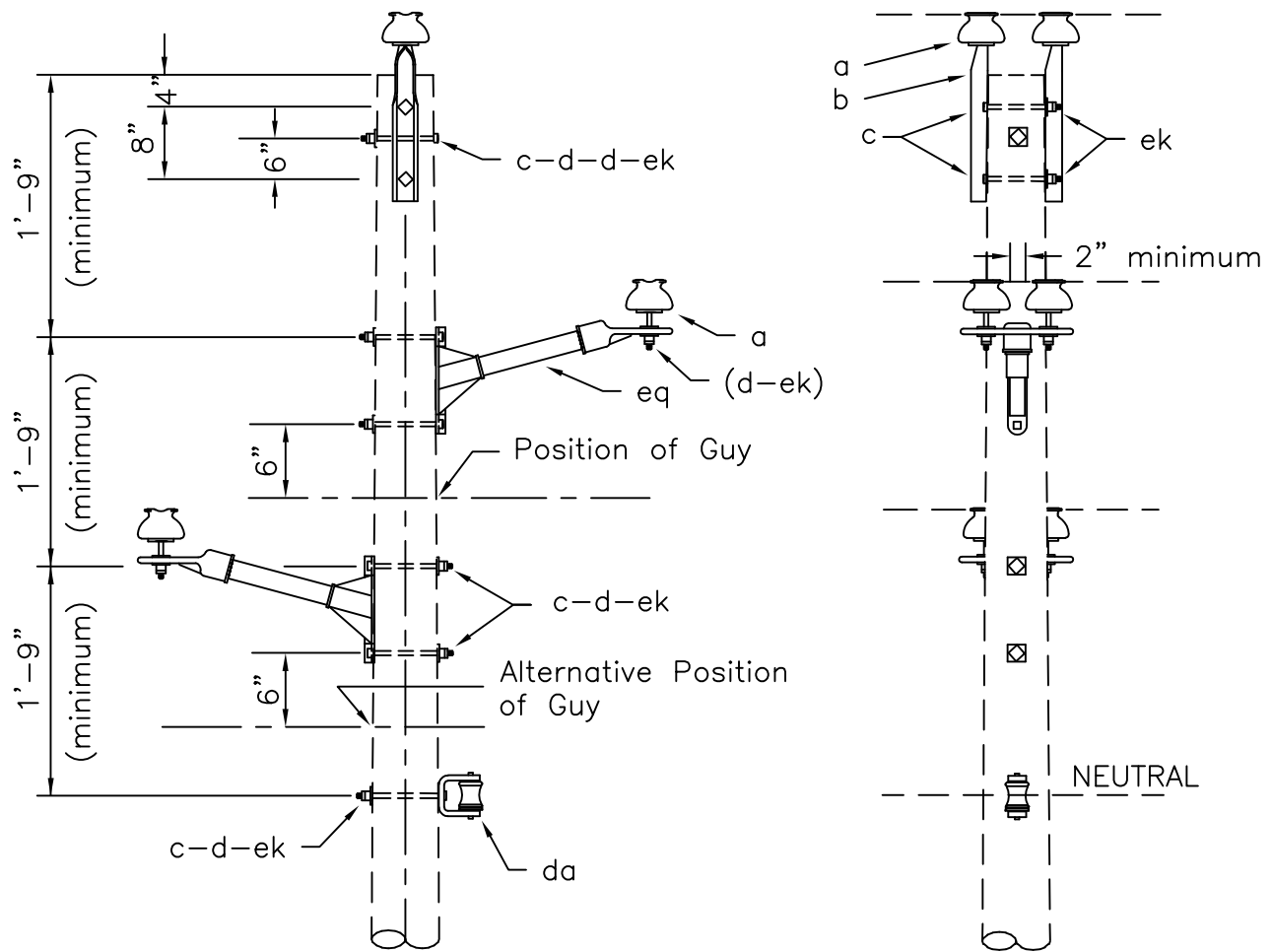

NOTES: If additional or alternative guying is required frame pole according to C2.3NG.

ASSEMBLY: C2.		3N
ITEM	MATERIAL	QTY
a	Insulator, pin type (12.47/7.2 kV)	6
b	Pin, pole top, 20"	2
c	Bolt, machine, 5/8" x req'd length	8
d	Washer, square 2 1/4"	7
f	Pin, crossarm, 5/8" x 6 1/2"	4
da	Bracket, insulated	1
ek	Locknuts	8
eq	Bracket, insulator/equipment	2

Design Parameters:

MAXIMUM LINE ANGLES:
See Table III

DOUBLE SUPPORT-NARROW PROFILE

APRIL 2005

RUS

3 - PHASE PRIMARY
12.47/7.2 kV

C2.3N

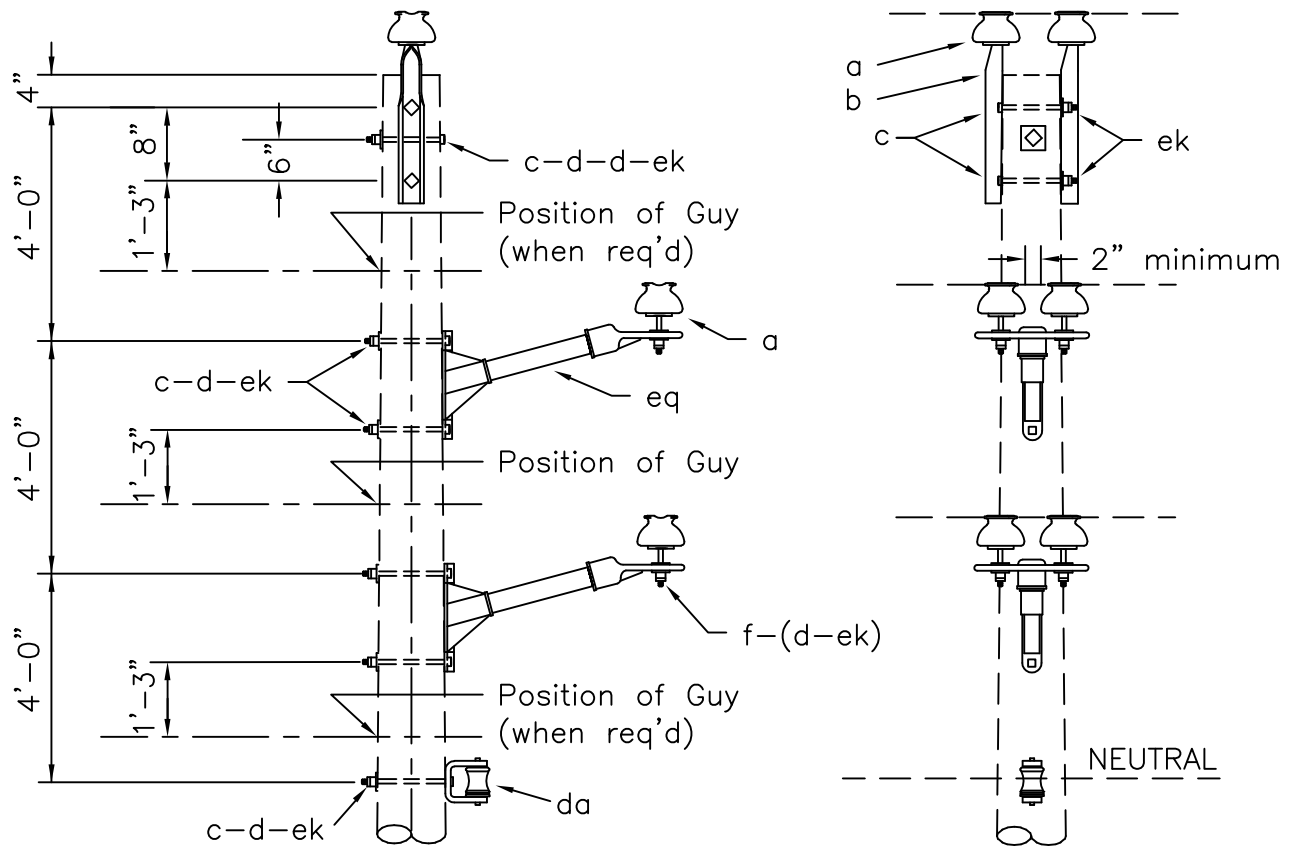

Design Parameters:

MAXIMUM LINE ANGLES:
See Table III

DOUBLE SUPPORT-NARROW PROFILE
(ALTERNATIVE GUYING GUIDE)

APRIL 2005

RUS

3 - PHASE PRIMARY
12.47/7.2 kV

C2.3NG

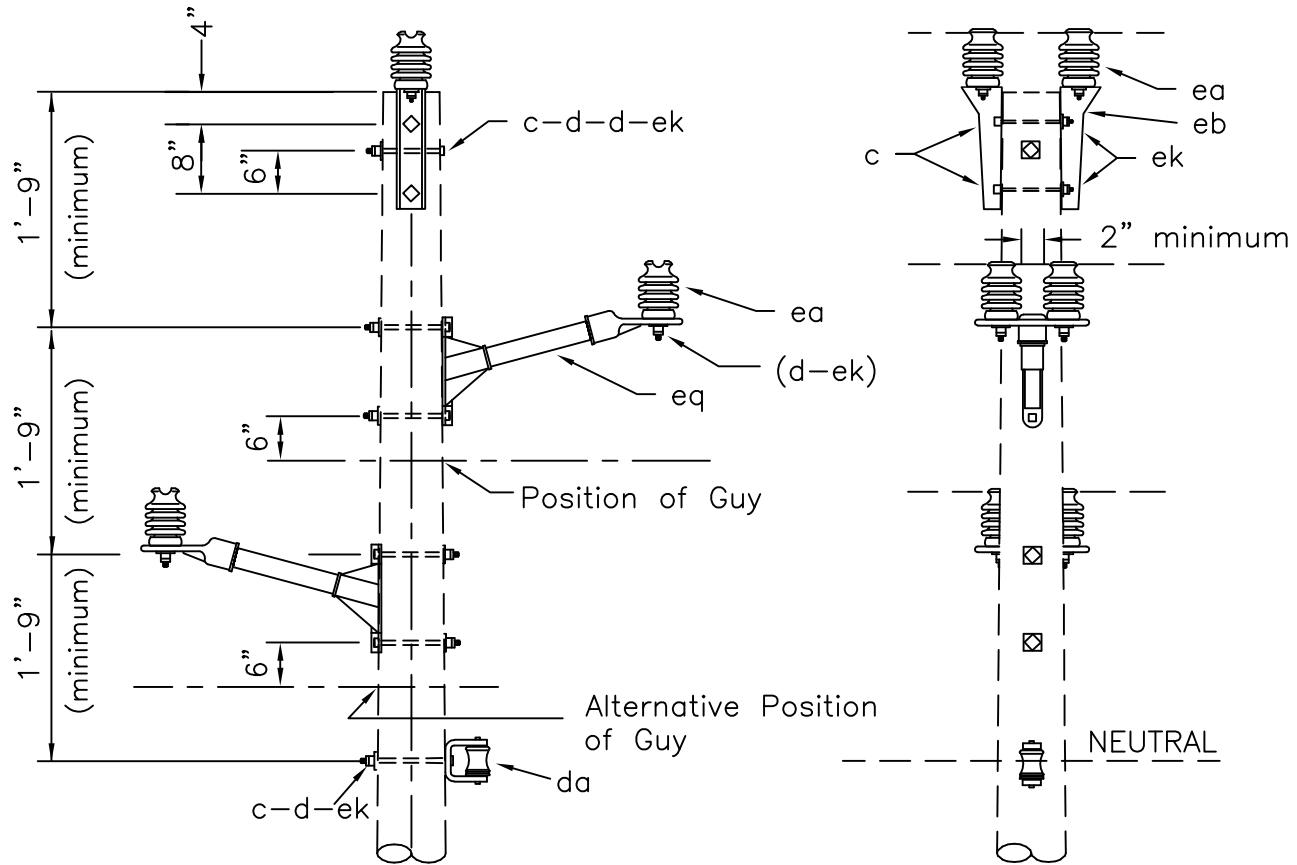

NOTES: If additional or alternative guying is required, frame pole according to C2.3NG

ASSEMBLY: C2.3NP		
ITEM	MATERIAL	QTY
c	Bolt, machine, 5/8" x req'd length	8
d	Washer, square 2 1/4"	7
da	Bracket, insulated	1
ea	Insulator, post type (12.47/7.5 kV)	6
eb	Bracket, pole top	2
ek	Locknuts	8
eq	Bracket, insulator/equipment	2

Design Parameters:
Maximum Line Angles:
See TABLE IV

DOUBLE SUPPORT-NARROW PROFILE
(POST INSULATORS)

APRIL 2005

2 - PHASE PRIMARY
12.47/7.2 kV

RUS

C2.3NP

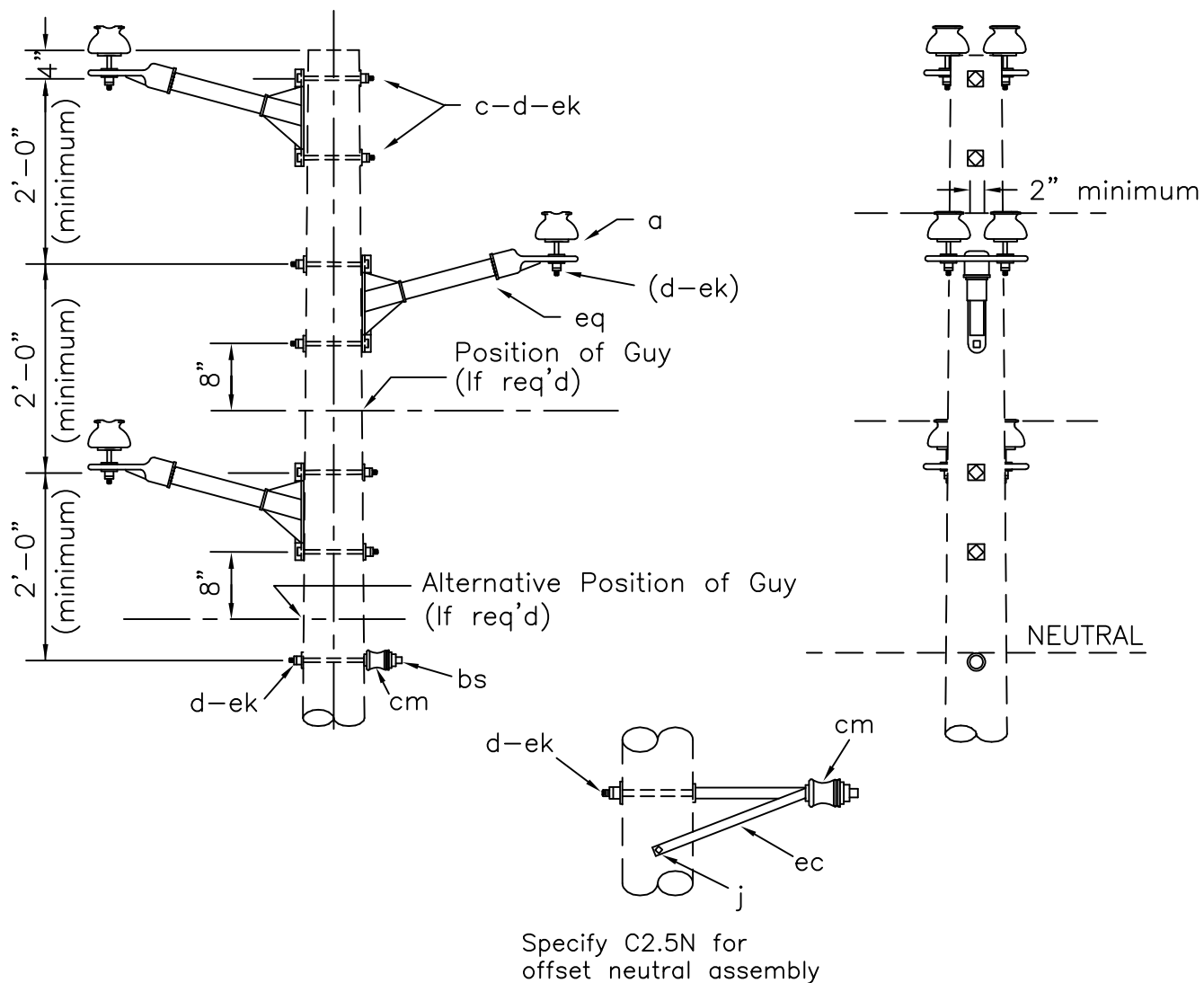

NOTE: These assemblies used for NESC Grade B construction.

ASSEMBLY: C2.		4N	5N
ITEM	MATERIAL	QTY	QTY
a	Insulator, pin type (12.47/7.2 kV)	6	6
c	Bolt, machine, 5/8" x req'd length	6	6
d	Washer, square 2 1/4"	7	7
f	Pin, crossarm, 5/8" x 6 1/2"	6	6
j	Screw, lag, 1/2" x 4"		2
bs	Bolt, single, upset	1	
cm	Insulator, spool, 3"	1	1
ec	Bracket, offset neutral		1
ek	Locknuts	7	7
eq	Bracket, insulator/equipment	3	3

Design Parameters: MAXIMUM LINE ANGLES: 5°-Small Conductors 2°-Larger than #1/0	DOUBLE SUPPORT-NARROW PROFILE (TANGENT)		
	APRIL 2005	3 - PHASE PRIMARY	C2.4N
	RUS	12.47/7.2 kV	C2.5N

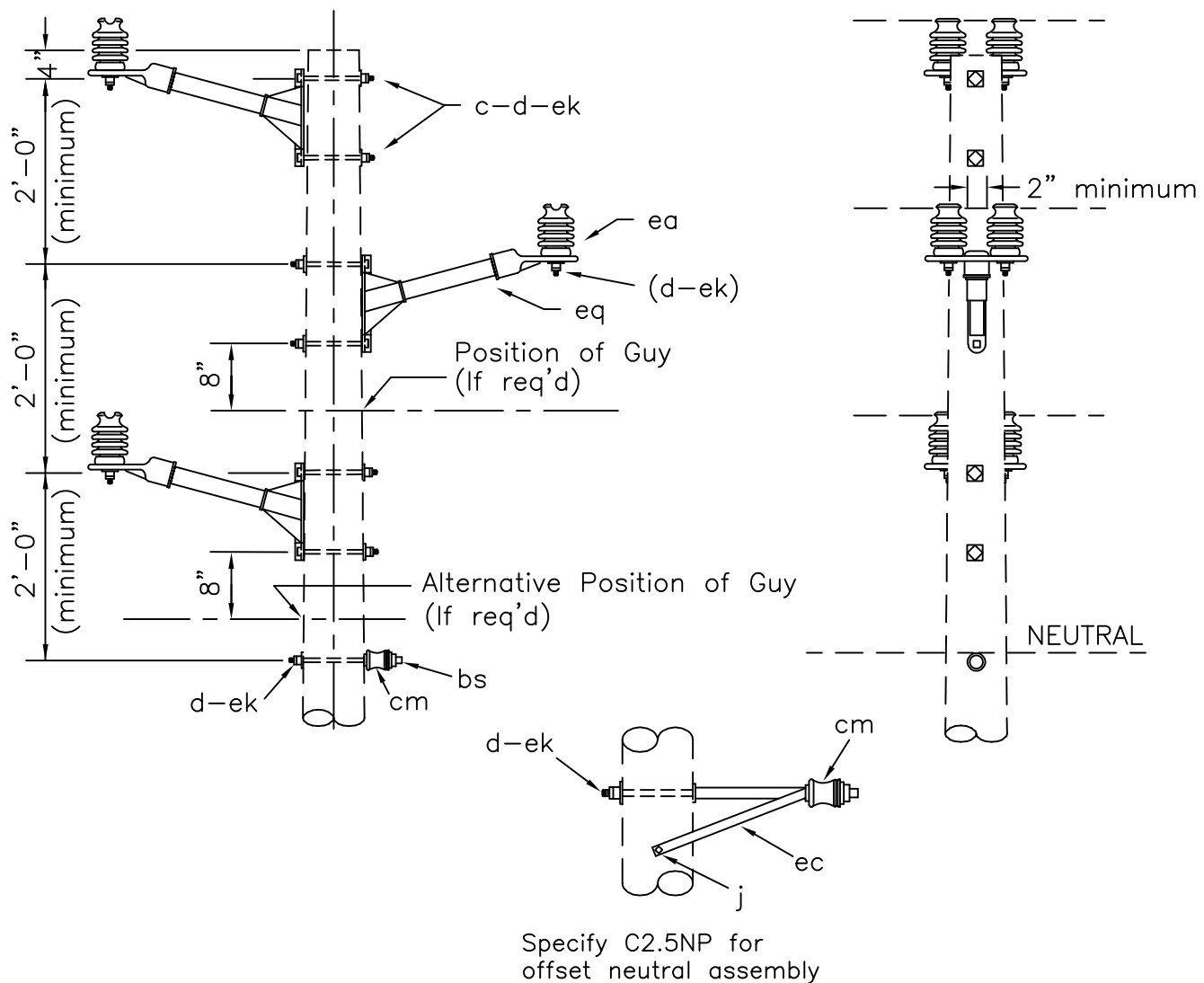

NOTE: These assemblies used for NESC Grade B construction.

ASSEMBLY: C2.		4NP	5NP
ITEM	MATERIAL	QTY	QTY
c	Bolt, machine, 5/8" x req'd length	6	6
d	Washer, square 2 1/4"	7	7
j	Screw, lag, 1/2" x 4"		2
bs	Bolt, single, upset	1	
cm	Insulator, spool, 3"	1	1
ea	Insulator, post type, (12.47/7.2kV)	6	6
ec	Bracket, offset neutral		1
ek	Locknuts	7	7
eq	Bracket, insulator/equipment	3	3

Design Parameters: MAXIMUM LINE ANGLES: 5°-Small Conductors 2°-Larger than #1/0	DOUBLE SUPPORT-NARROW PROFILE (TANGENT)(POST INSULATORS)		
	APRIL 2005	3 - PHASE PRIMARY	C2.4NP
	RUS	12.47/7.2 kV	C2.5NP

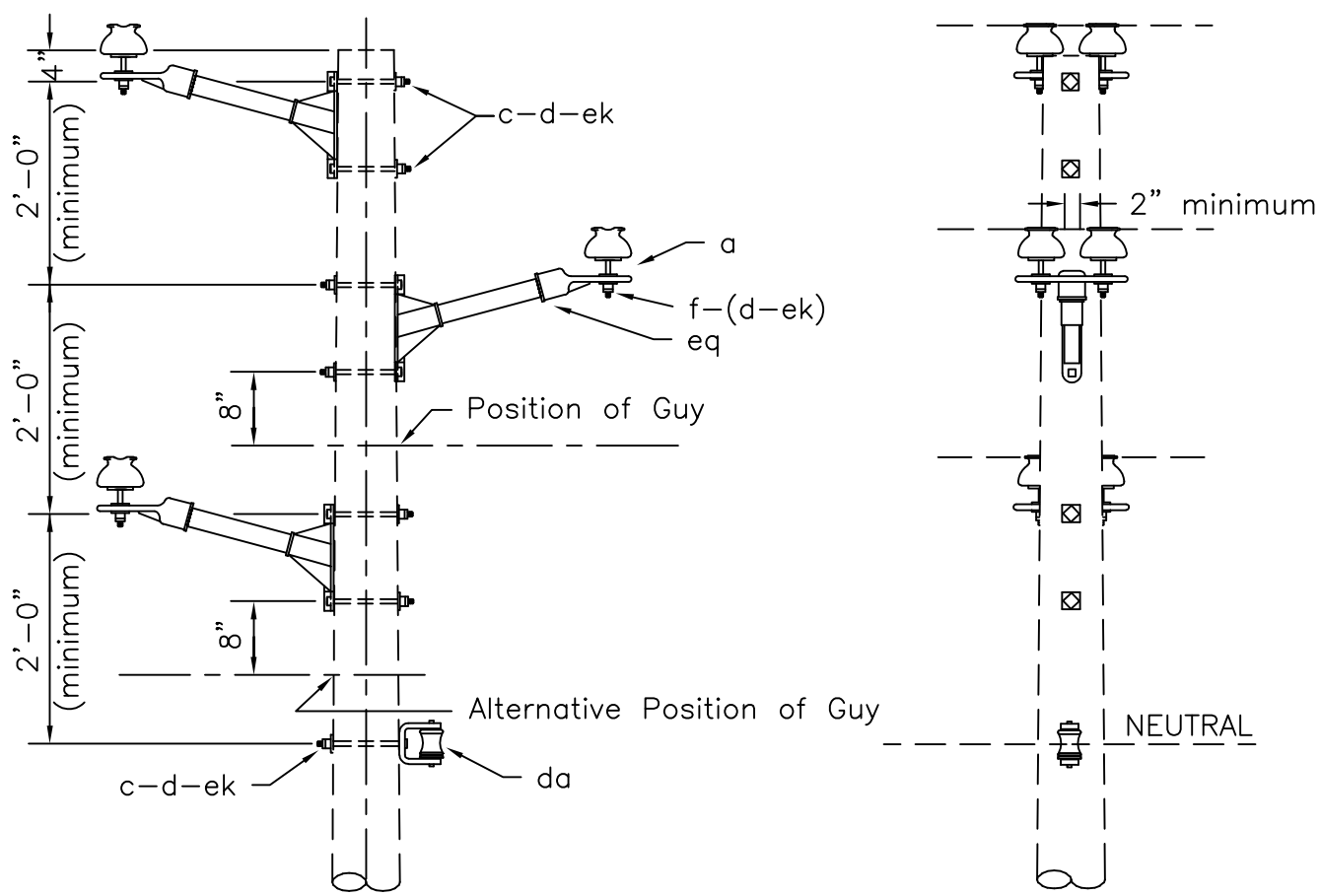

NOTE: If additional guying is required, use assembly C2.9N.

ASSEMBLY: C2.		6N
ITEM	MATERIAL	QTY
a	Insulator, pin type (12.47/7.2 kV)	6
c	Bolt, machine, 5/8" x req'd length	7
d	Washer, square 2 1/4"	7
f	Pin, crossarm, 5/8" x 6 1/2"	6
da	Bracket, insulated	1
ek	Locknuts	7
eq	Bracket, insulator/equipment	3

Design Parameters:

MAXIMUM LINE ANGLES:
See TABLE IV

DOUBLE SUPPORT-NARROW PROFILE

APRIL 2005

3 - PHASE PRIMARY

RUS

12.47/7.2 kV

C2.6N

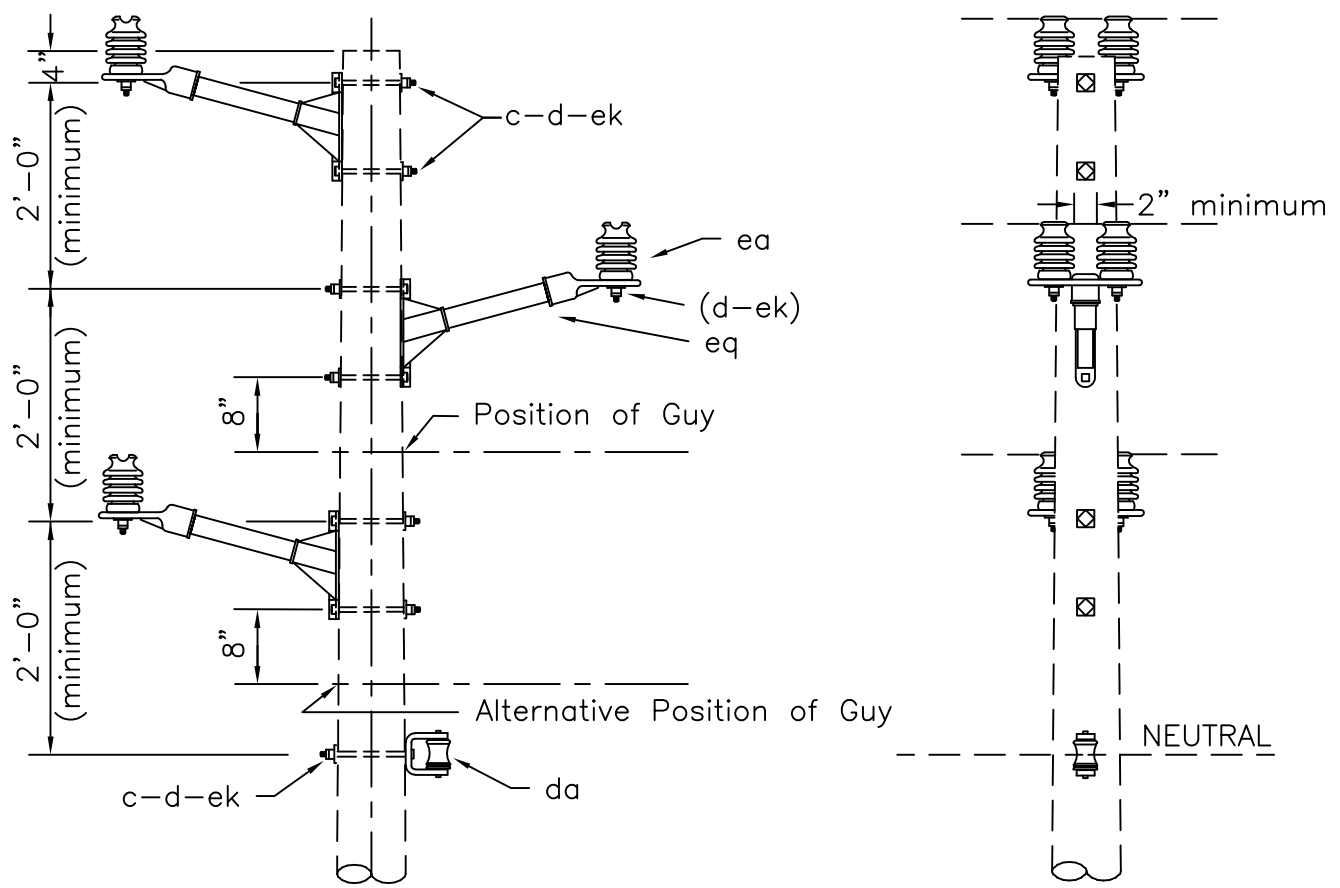

NOTE: If additional guying is required, use assembly C2.9NP.

ASSEMBLY: C2.6NP

ITEM	MATERIAL	QTY
c	Bolt, machine, 5/8" x req'd length	7
d	Washer, square 2 1/4"	7
da	Bracket, insulated	1
ea	Insulator, post type (12.47/7.2kV)	6
ek	Locknuts	7
eq	Bracket, insulator/equipment	3

Design Parameters:

MAXIMUM LINE ANGLES:
See TABLE IV

DOUBLE SUPPORT-NARROW PROFILE
(POST INSULATORS)

APRIL 2005

RUS

3 - PHASE PRIMARY
12.47/7.2 kV

C2.6NP

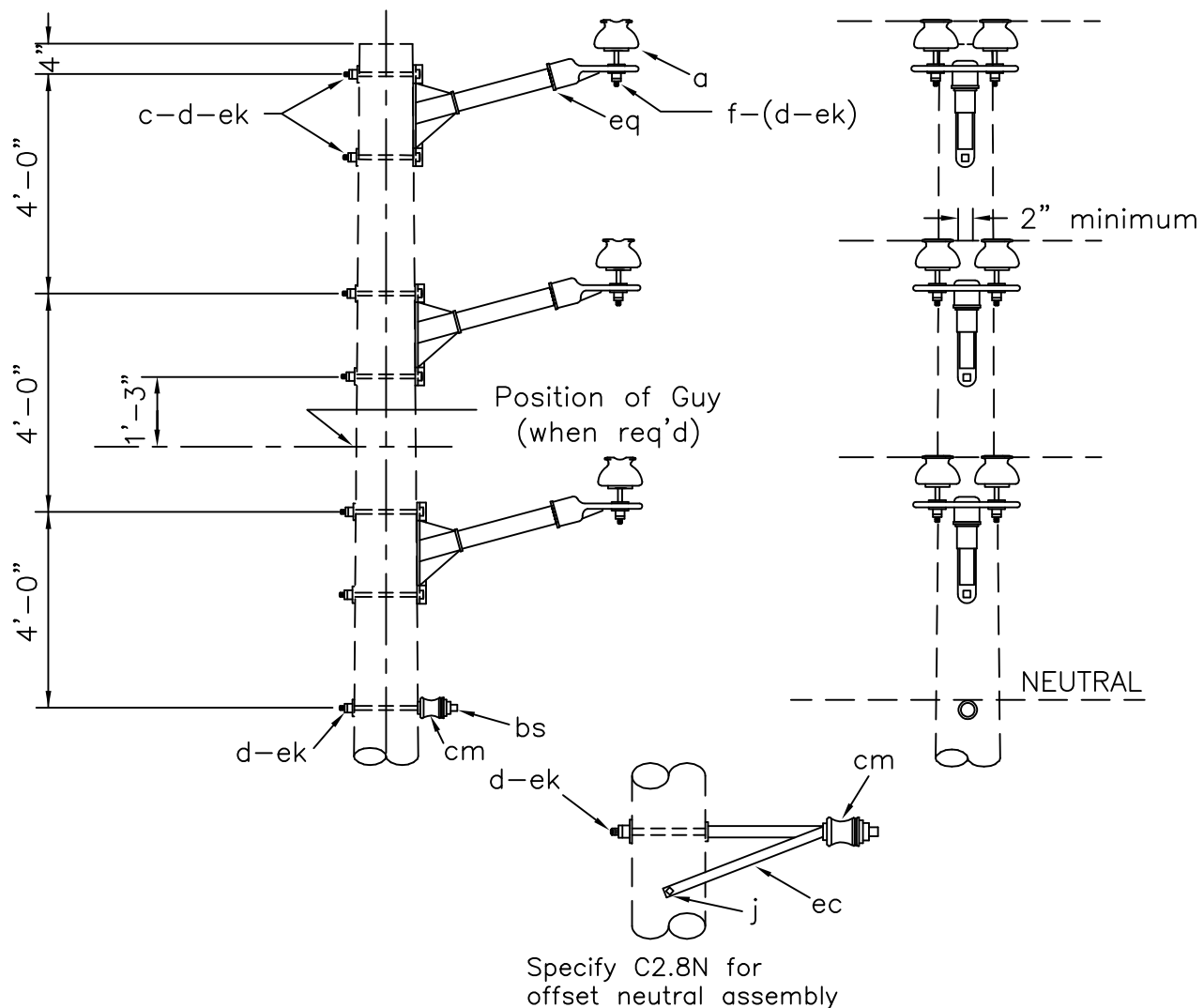

NOTE: These assemblies used for NESC Grade B construction.

		Assembly: C2.	
ITEM	MATERIAL	7N	8N
a	Insulator, pin type (12.47/7.2 kV)	6	6
c	Bolt, machine, 5/8" x req'd length	6	6
d	Washer, square 2 1/4"	7	7
f	Pin, crossarm, 5/8" x 6 1/2"	6	6
j	Screw, lag, 1/2" x 4"		2
bs	Bolt, single, upset	1	
cm	Insulator, spool, 3"	1	1
ec	Bracket, offset neutral		1
ek	Locknuts	7	7
eq	Bracket, insulator/equipment	3	3

Design Parameters:
 Maximum Line Angles
 5° - Small Conductors
 2° - Larger than #1/0

DOUBLE SUPPORT-NARROW PROFILE
 (TANGENT)

APRIL 2005

3 - PHASE PRIMARY
 12.47/7.2 kV

C2.7N
 C2.8N

RUS

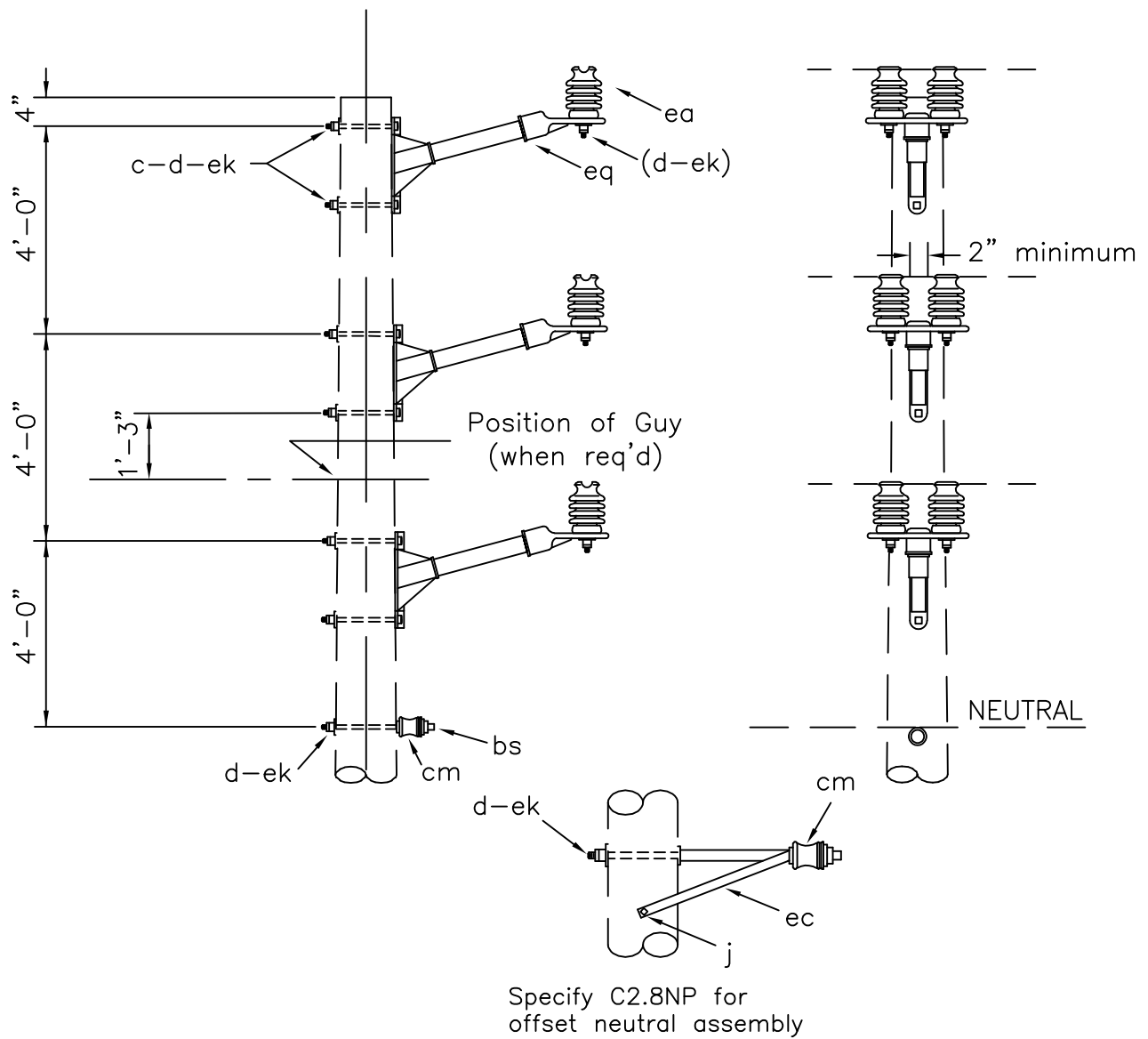

Specify C2.8NP for offset neutral assembly

NOTE: These assemblies used for NESC Grade B construction.

		Assembly: C2.	
ITEM	MATERIAL	7NP QTY	8NP QTY
c	Bolt, machine, 5/8" x req'd length	6	6
d	Washer, square 2 1/4"	7	7
j	Screw, lag, 1/2" x 4"		2
bs	Bolt, single, upset	1	
cm	Insulator, spool, 3"	1	1
ea	Insulator, post type (12.47/7.5 kV)	6	6
ec	Bracket, offset neutral		1
ek	Locknuts	7	7
eq	Bracket, insulator/equipment	3	3

Design Parameters:
 Maximum Line Angles
 5° - Small conductors
 2° - Larger than #1/0

DOUBLE SUPPORT-NARROW PROFILE
 (TANGENT) (POST INSULATORS)

APRIL 2005

3 - PHASE PRIMARY
 12.47/7.2 kV

C2.7NP
 C2.8NP

RUS

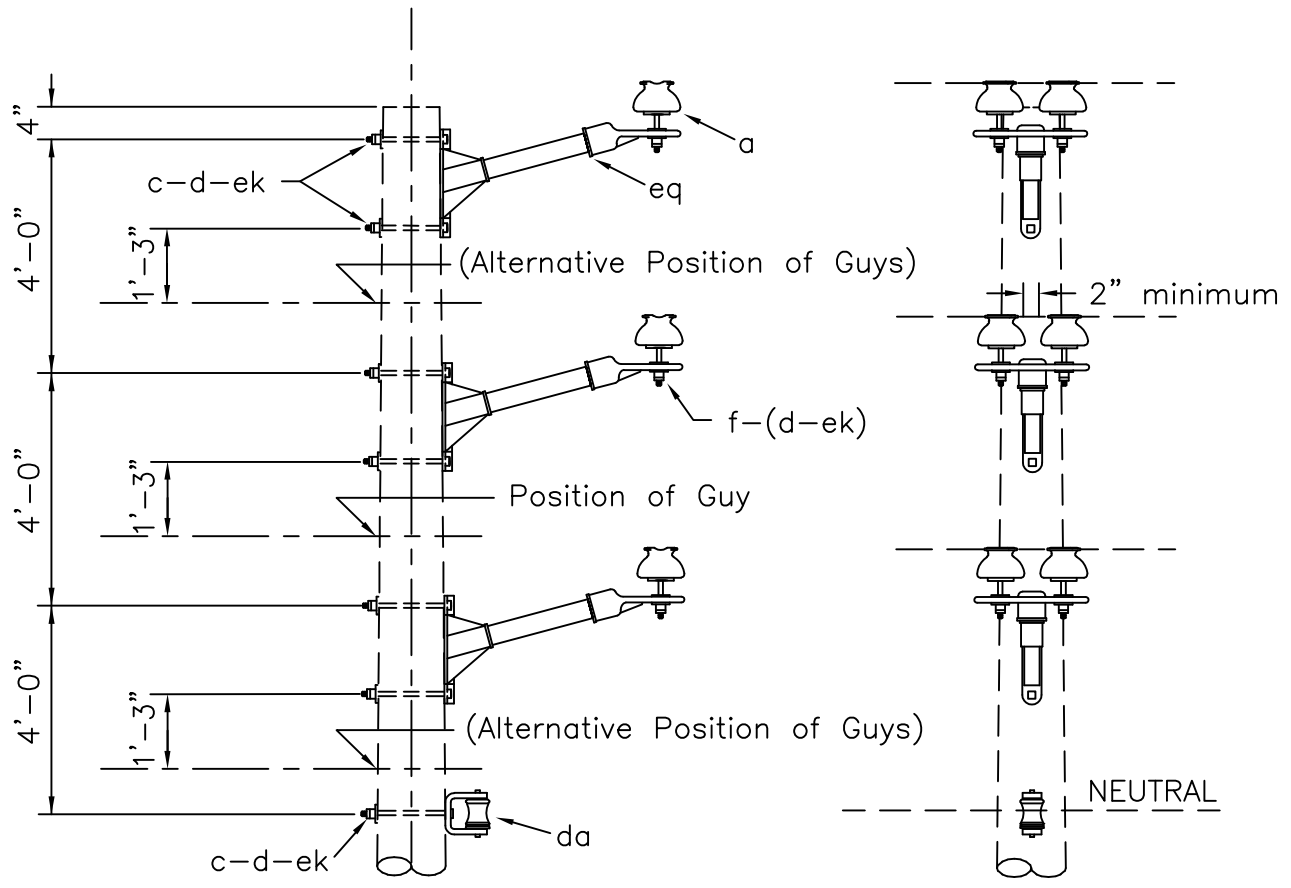

Assembly: C2.9N		QTY
ITEM	MATERIAL	
a	Insulator, pin type (12.47/7.2 kV)	6
c	Bolt, machine, 5/8" x req'd length	7
d	Washer, square 2 1/4"	7
f	Pin, crossarm, 5/8" x 6 1/2"	6
da	Bracket, insulated	1
ek	Locknuts	7
eq	Bracket, insulator/equipment	3

Design Parameters: Maximum Line Angles See TABLE IV	DOUBLE SUPPORT-NARROW PROFILE		
	APRIL 2005	3 - PHASE PRIMARY	C2.9N
	RUS	12.47/7.2 kV	

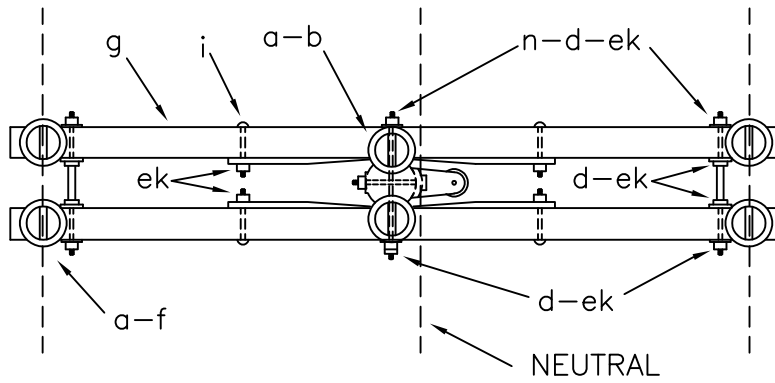

PLAN

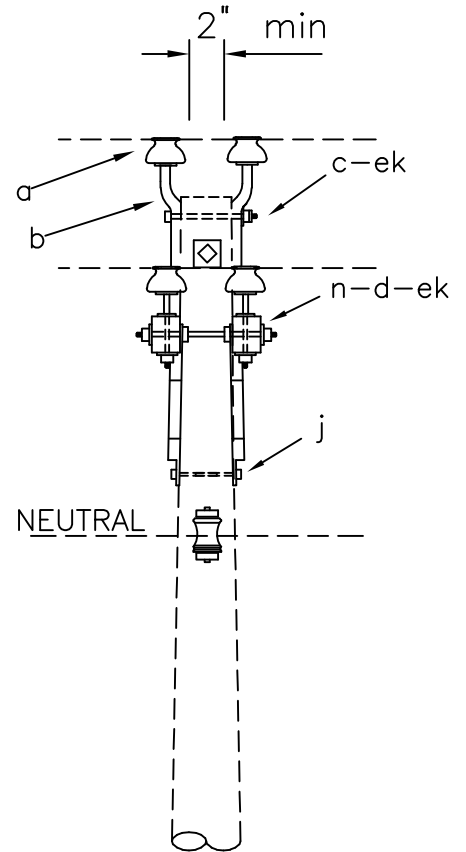
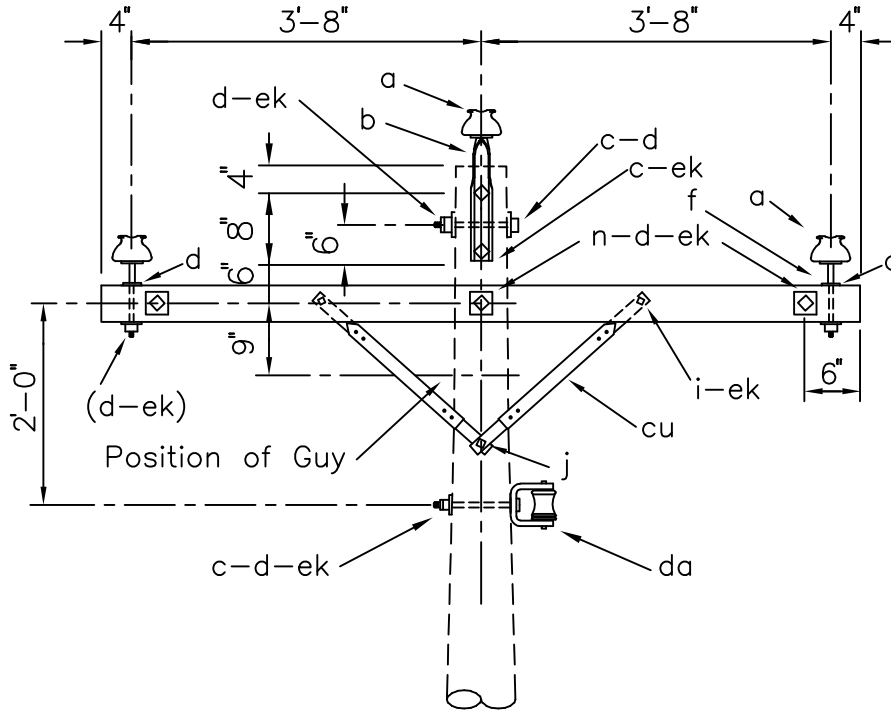

NEUTRAL

ITEM	QTY	MATERIAL
a	6	Insulator, pin type (12.47/7.2 kV)
b	2	Pin, pole top, 20", straight or offset
c	4	Bolt, machine, 5/8" x req'd length
d	17	Washer, square, 2 1/4"
f	4	Pin, crossarm, steel, 5/8" x 10 3/4"
g	2	Crossarm, 3 5/8" x 4 5/8" x 8' 0"
i	4	Bolt, carriage, 3/8" x 4 1/2"
j	2	Screw, lag, 1/2" x 4"
n	3	Bolt, double arming, 5/8" x req'd length
cu	4	Brace, 28"
da	1	Bracket, insulated
ek	18	Locknuts

DESIGN PARAMETERS:

See TABLE III

DOUBLE SUPPORT ON CROSSARMS

APRIL 2005

RUS

3 - PHASE PRIMARY
12.47/7.2 kV

C2.21
(C2)

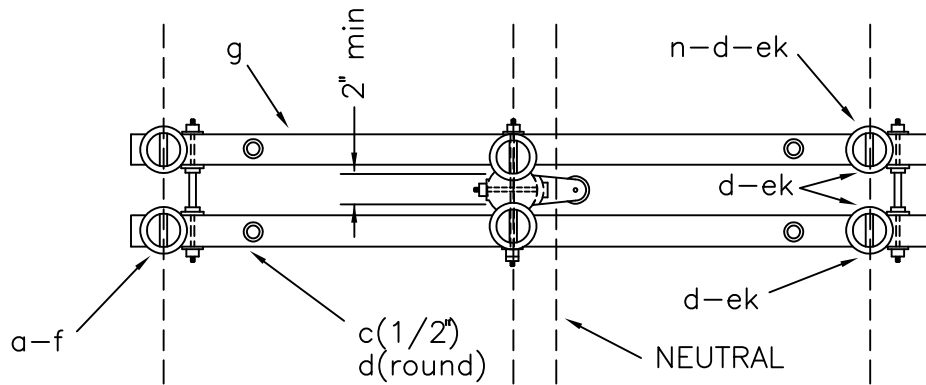

PLAN

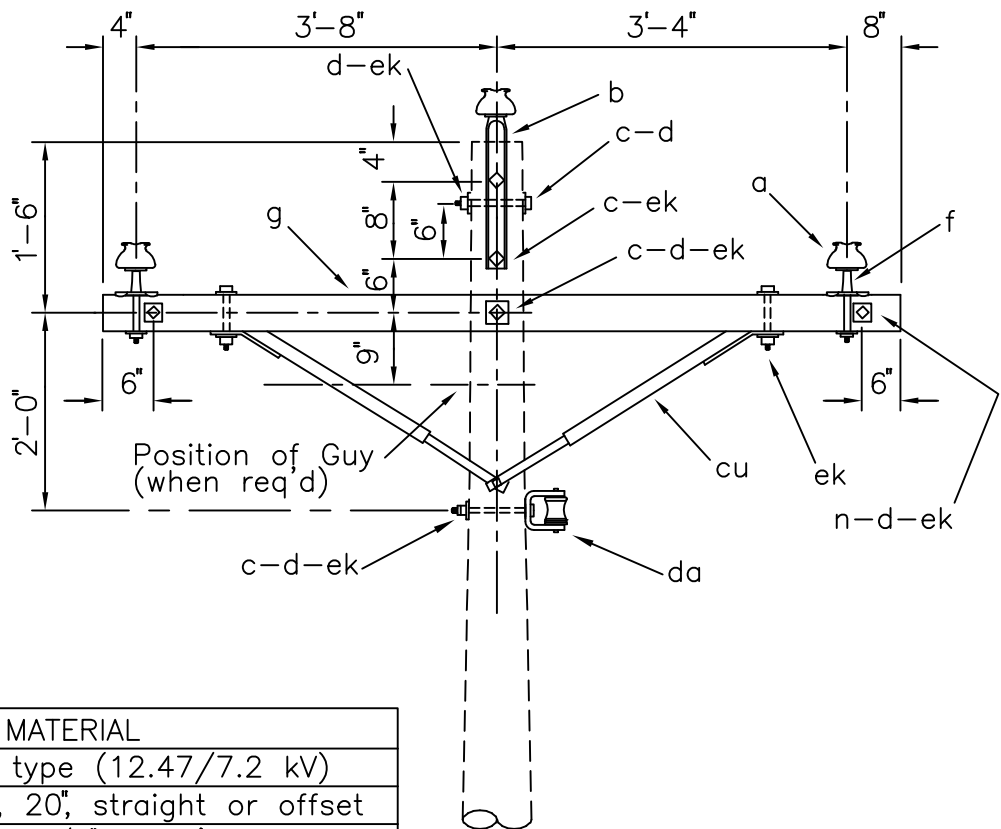

ITEM	QTY	MATERIAL
a	6	Insulator, pin type (12.47/7.2 kV)
b	2	Pin, pole top, 20", straight or offset
c	4	Bolt, machine, 1/2" x req'd length
c	5	Bolt, machine, 5/8" x req'd length
d	4	Washer, round, 1 3/8"
d	14	Washer, square, 2 1/4"
f	4	Pin, crossarm, steel, clamp type
g	2	Crossarm, 3 5/8" x 4 5/8" x 8' 0"
n	3	Bolt, double arming, 5/8" x req'd length
cu	2	Brace, wood, 60" span
da	1	Bracket, insulated
ek	19	Locknuts

DESIGN PARAMETERS:

See TABLE III

DOUBLE SUPPORT ON CROSSARMS
(LARGE CONDUCTORS)

APRIL 2005

RUS

3 - PHASE PRIMARY
12.47/7.2 kV

C2.21L
(C1-3)

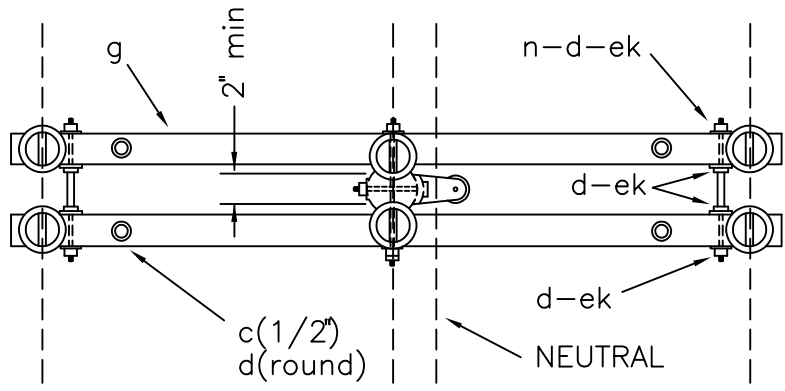

PLAN

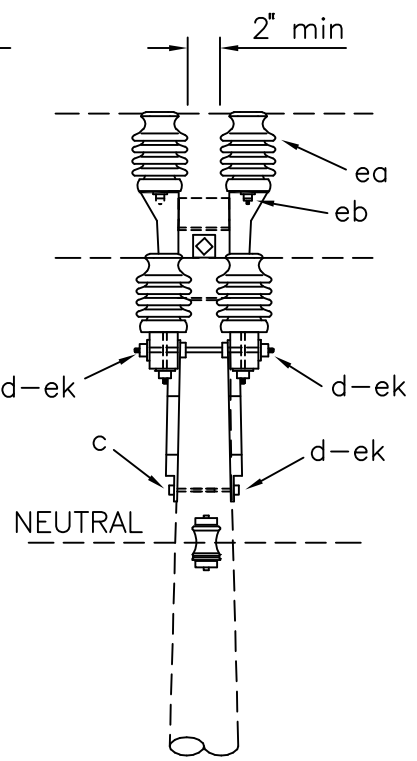
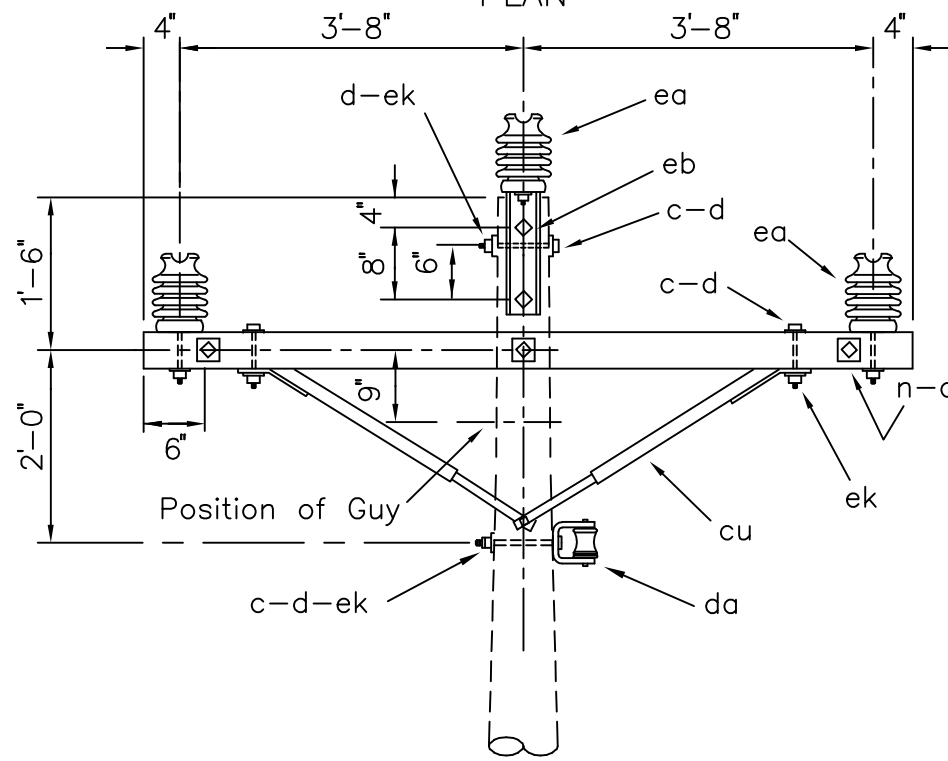

ITEM	QTY	MATERIAL
c	5	Bolt, machine, 5/8" x req'd length
c	4	Bolt, machine, 1/2" x req'd length
d	14	Washer, square, 2 1/4"
d	4	Washer, round, 1 3/8"
g	2	Crossarm, 3 5/8" x 4 5/8" x 8' 0"
n	3	Bolt, double arming, 5/8" x req'd length
cu	2	Brace, wood, 60" span
da	1	Bracket, insulated
ea	6	Insulator, post type (12.47/7.2 kV)
eb	2	Bracket, pole top
ek	19	Locknuts

DESIGN PARAMETERS:
See TABLE IV

DOUBLE SUPPORT ON CROSSARMS
(POST INSULATORS)

APRIL 2005	3 - PHASE PRIMARY 12.47/7.2 kV	C2.21P (C1-3P)
RUS		

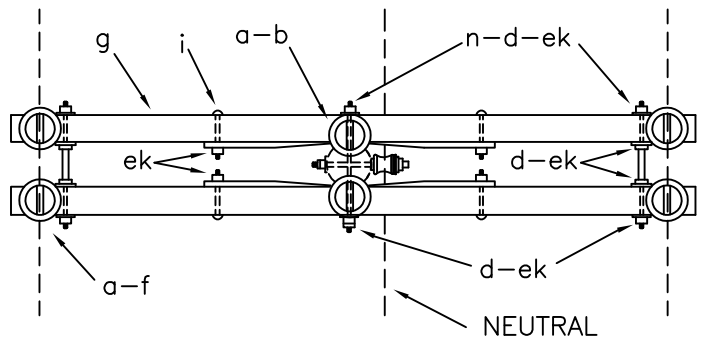

PLAN

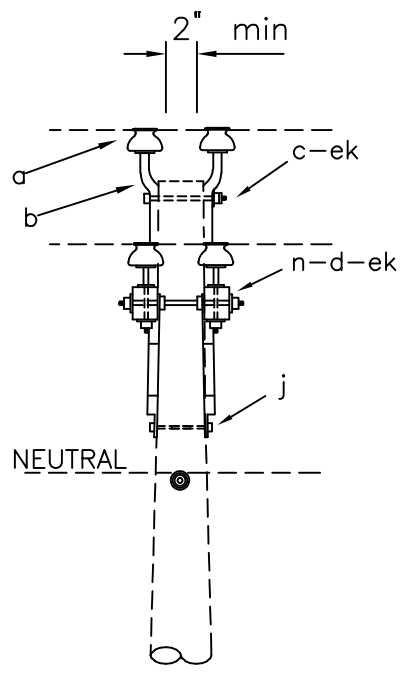
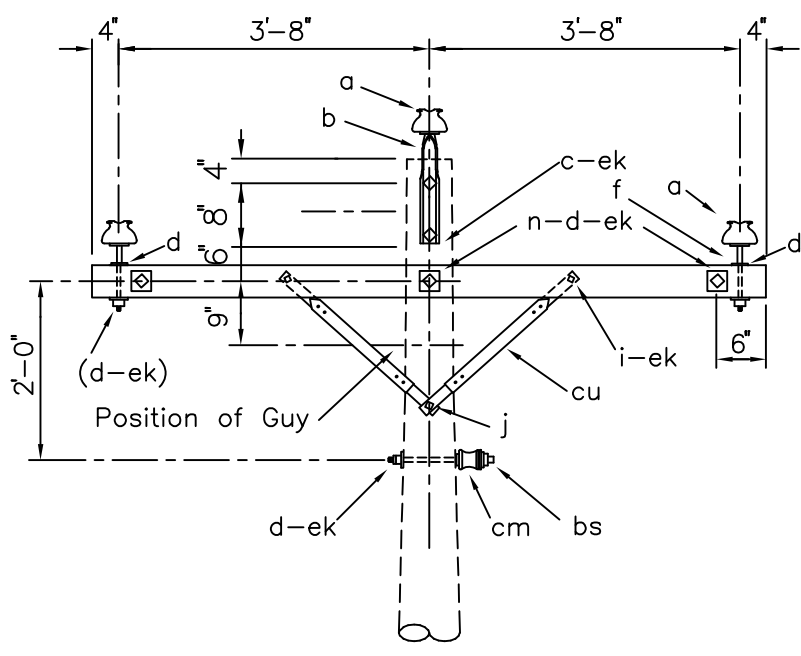

NOTE: These assemblies used for NESC Grade B construction.

ASSEMBLY: C2.		24	25
ITEM	MATERIAL	QTY	QTY
a	Insulator, pin type (12.47/7.2kV)	6	6
b	Pin, pole top, 20", straight or offset	2	2
c	Bolt, machine, 5/8" x req'd length	2	2
d	Washer, square 2 1/4"	15	15
f	Pin, crossarm, steel, 5/8" x 10 3/4"	4	4
g	Crossarm, 3 5/8" x 4 5/8" x 8'-0"	2	2
i	Bolt, carriage, 3/8" x 4 1/2"	4	4
j	Screw, lag, 1/2" x 4"	2	4
n	Bolt, double arm, 5/8" x req'd length	3	3
bs	Bolt, single, upset	1	
cm	Insulator, spool, 3"	1	1
cu	Brace, 28"	4	4
ec	Bracket, offset neutral		1
ek	Locknuts	17	17

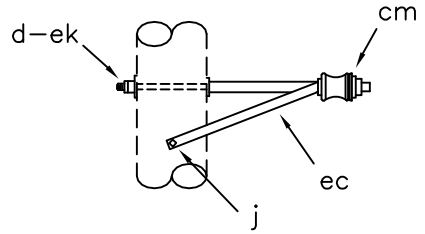

Specify C2.25 for offset neutral assembly

DESIGN PARAMETERS:

MAXIMUM LINE ANGLES:
5°-Small Conductors
2°-Larger than #1/0

DOUBLE SUPPORT ON CROSSARMS-TANGENT

APRIL 2005
RUS

3 - PHASE PRIMARY
12.47/7.2 kV

C2.24,C2.25
(C1-1,C1-1A)

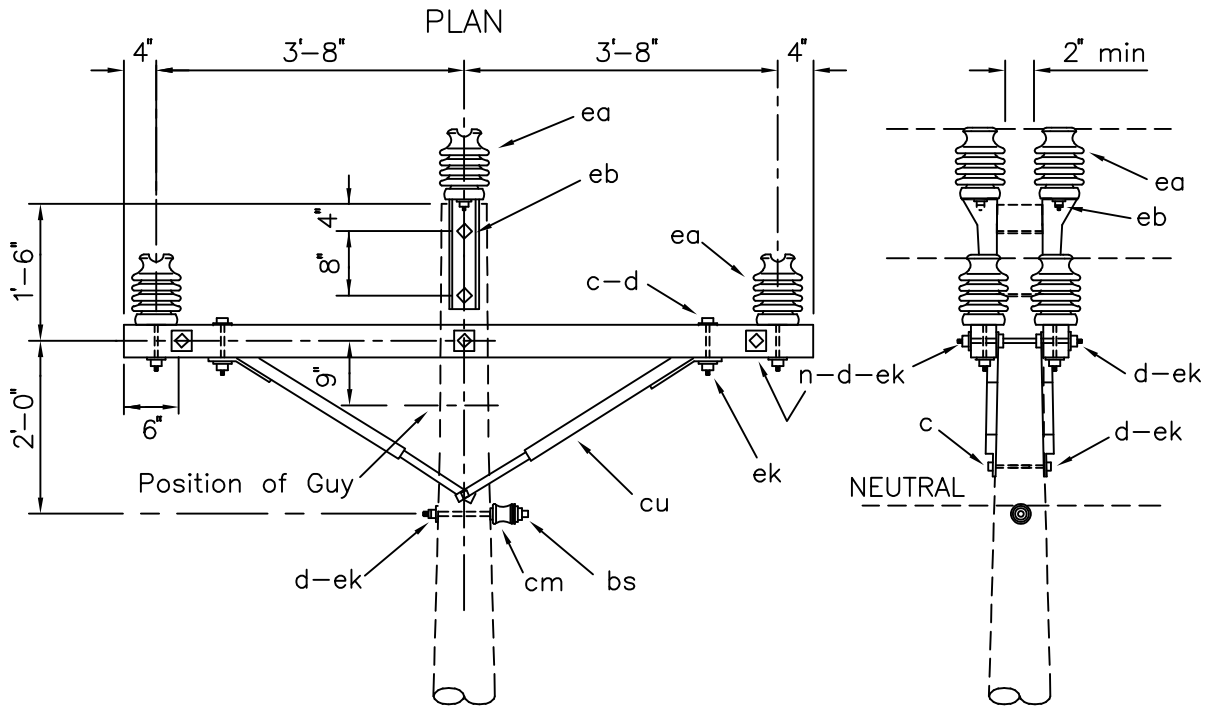
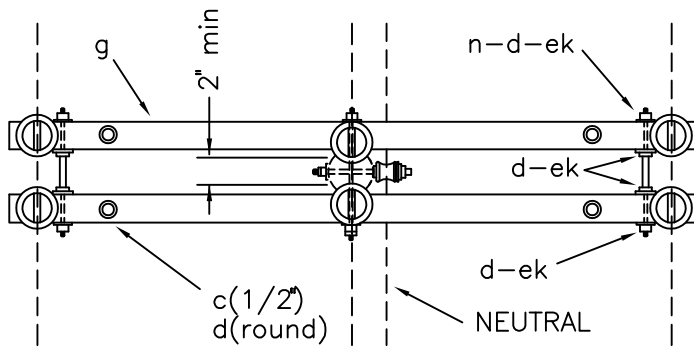

NOTE: These assemblies used for NESC Grade B construction.

ASSEMBLY: C2.		24P	25P
ITEM	MATERIAL	QTY	QTY
c	Bolt, machine, 5/8" x req'd length	3	3
c	Bolt, machine, 1/2" x req'd length	4	4
d	Washer, square, 2 1/4"	12	12
d	Washer, round, 1 3/8"	4	4
g	Crossarm, 3 5/8" x 4 5/8" x 8'-0"	2	2
n	Bolt, double arming, 5/8" x req'd length	3	3
bs	Bolt, single, upset	1	
cm	Insulator, spool, 3"	1	1
cu	Brace, wood, 60" span	2	2
ea	Insulator, post type (12.47/7.2kV)	6	6
eb	Bracket, pole top	2	2
ec	Bracket, offset neutral		1
ek	Locknuts	18	18

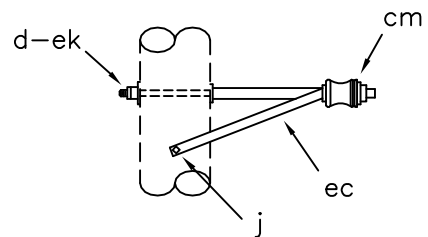

Specify C2.25P for offset neutral assembly

DESIGN PARAMETERS:

MAXIMUM LINE ANGLES:
5°-Small Conductors
2°-Larger than #1/0

DOUBLE SUPPORT ON CROSSARMS-TANGENT
(POST INSULATORS)

APRIL 2005

RUS

3 - PHASE PRIMARY
12.47/7.2 kV

C2.24P,C2.25P
(C1-1P,C1-1AP)

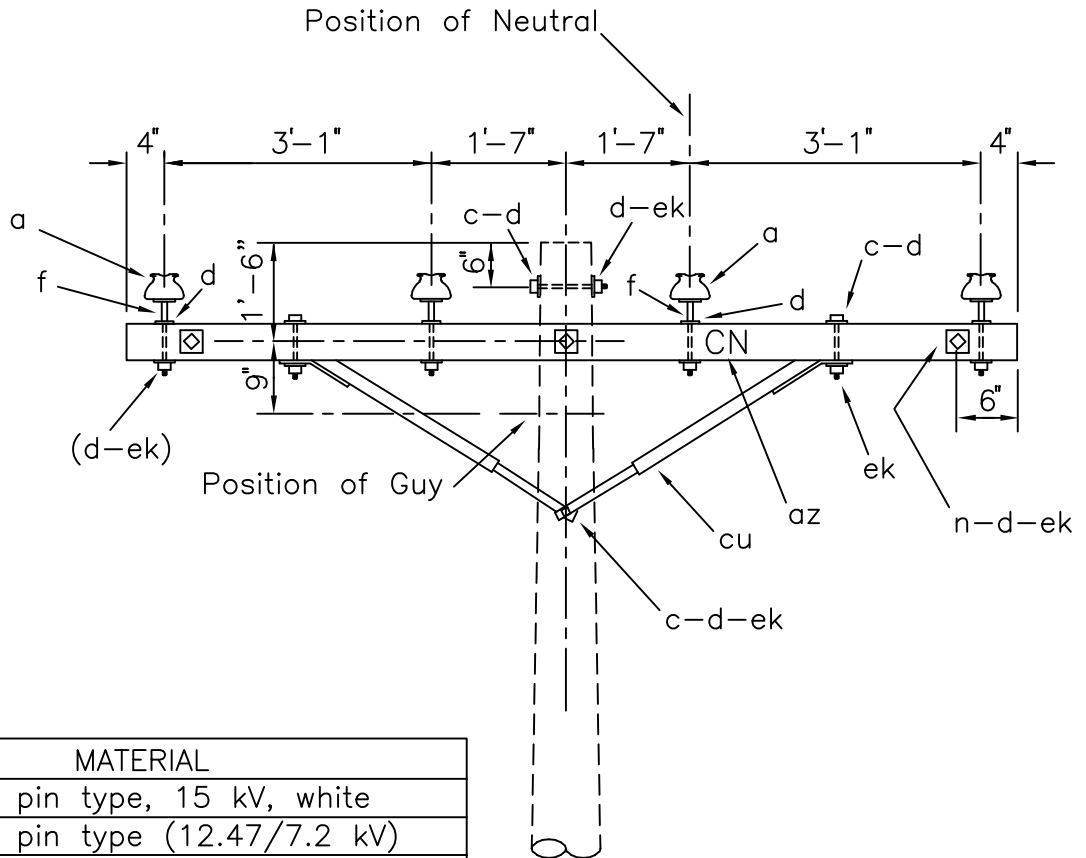
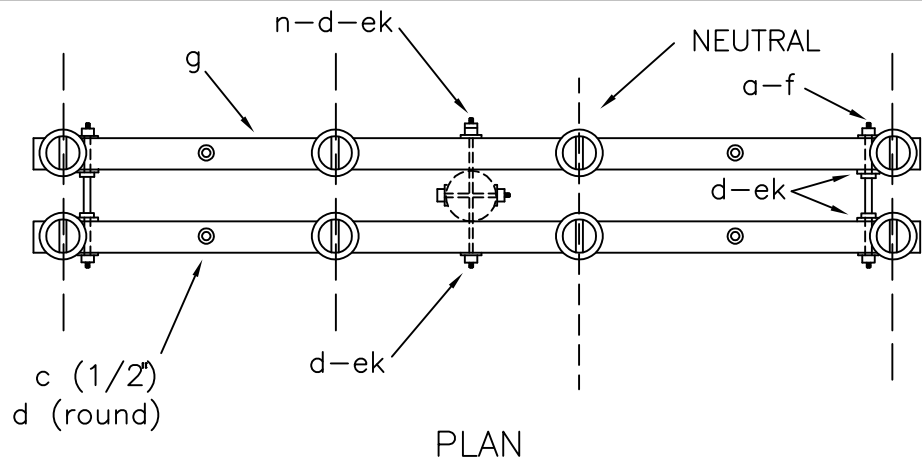

ITEM	QTY	MATERIAL
a	2	Insulator, pin type, 15 kV, white
a	6	Insulator, pin type (12.47/7.2 kV)
c	4	Bolt, machine, 1/2" x req'd length
c	2	Bolt, machine, 5/8" x req'd length
d	4	Washer, round, 1 3/8"
d	21	Washer, square, 2 1/4"
f	8	Pin, crossarm, steel, 5/8" x 10 3/4"
g	2	Crossarm, 3 5/8" x 4 5/8" x 10'-0"
n	3	Bolt double arming, 5/8" x req'd length
az	4	Letters, 2" C, 2" N, with 1" nails
cu	2	Brace, wood, 60" span
ek	16	Locknuts

NOTE: Install either identification letters or white insulators in neutral position.

DESIGN PARAMETERS:

See TABLE IV

DOUBLE SUPPORT, NEUTRAL ON CROSSARMS

APRIL 2005

RUS

3 - PHASE PRIMARY
12.47/7.2 kV

C2.51
(C9)

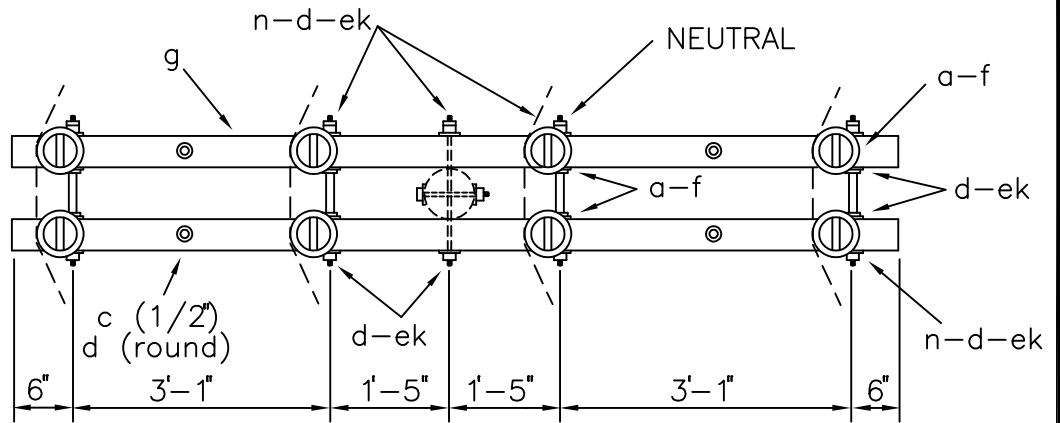

PLAN

Position of Neutral

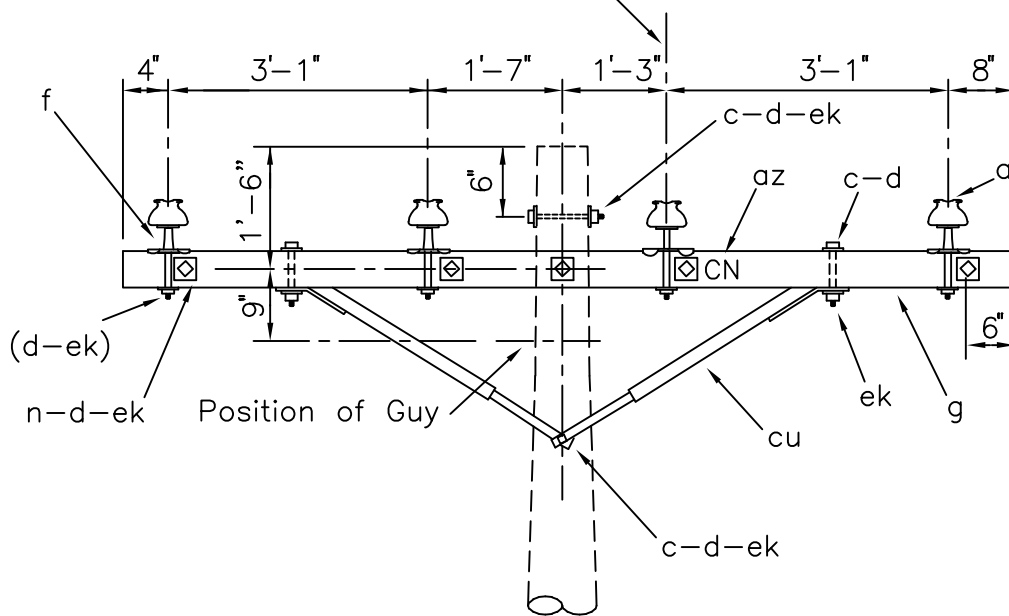

Position of Guy

ITEM	QTY	MATERIAL
a	2	Insulator, pin type, 15 kV, white
a	6	Insulator, pin type (12.47/7.2 kV)
c	4	Bolt, machine, 1/2" x req'd length
c	2	Bolt, machine, 5/8" x req'd length
d	4	Washer, round, 1 3/8"
d	21	Washer, square, 2 1/4"
f	8	Pin, crossarm, steel clamp type
g	2	Crossarm, 3 5/8" x 4 5/8" x 10'-0"
n	5	Bolt, double arming, 5/8" x req'd length
az	4	Letters, 2" C, 2" N, with 1" nails
cu	2	Brace, wood, 60" span
ek	24	Locknuts

NOTE: Install either identification letters (az) or white insulators in neutral position.

DESIGN PARAMETERS:

See TABLE V

DOUBLE SUPPORT, NEUTRAL ON CROSSARMS
(LARGE CONDUCTORS)

APRIL 2005

RUS

3 - PHASE PRIMARY
12.47/7.2 kV

C2.51L
(C9-2)

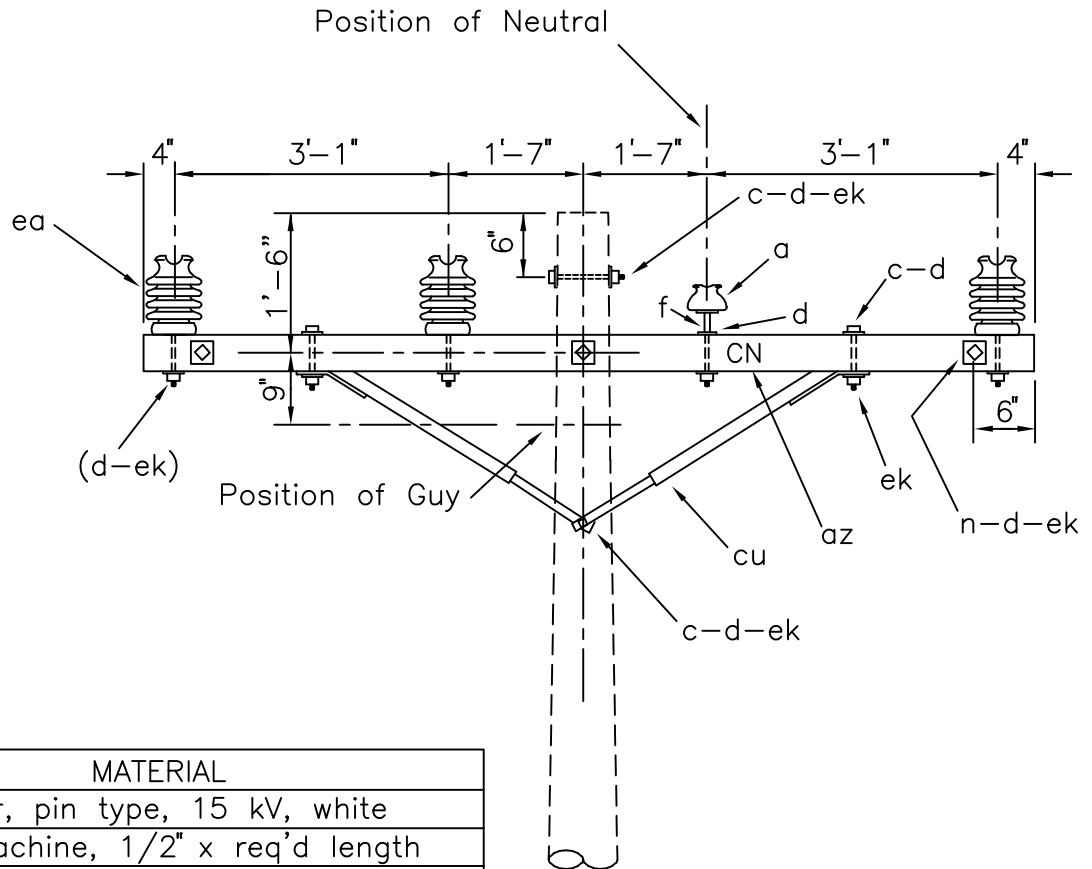
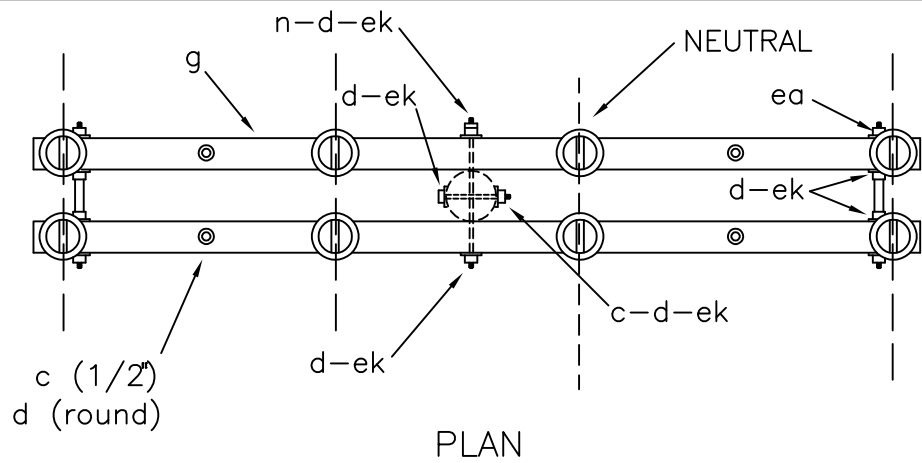

ITEM	QTY	MATERIAL
a	2	Insulator, pin type, 15 kV, white
c	4	Bolt, machine, 1/2" x req'd length
c	2	Bolt, machine, 5/8" x req'd length
d	4	Washer, round, 1 3/8"
d	15	Washer, square, 2 1/4"
f	2	Pin, crossarm, steel, 5/8" x 10 3/4"
g	2	Crossarm, 3 5/8" x 4 5/8" x 10'-0"
n	3	Bolt double arming, 5/8" x req'd length
az	4	Letters, 2" C, 2" N, with 1" nails
cu	2	Brace, wood, 60" span
ea	6	Insulator, post type (12.47/7.2 kV)
ek	16	Locknuts

NOTE: Install identification letters (az) (optional) in neutral position.

DESIGN PARAMETERS:

See TABLE IV

DOUBLE SUPPORT, NEUTRAL ON CROSSARMS
(POST INSULATORS)

APRIL 2005

RUS

3 - PHASE PRIMARY
12.47/7.2 kV

C2.51P
(C9-2PL)

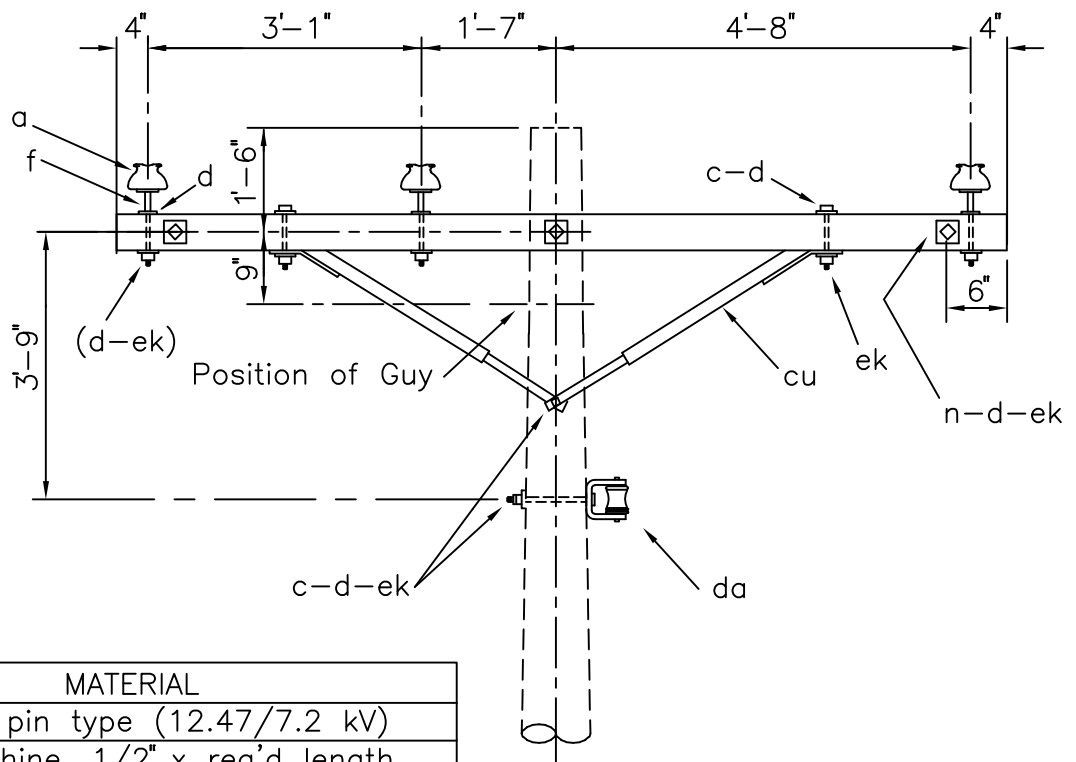
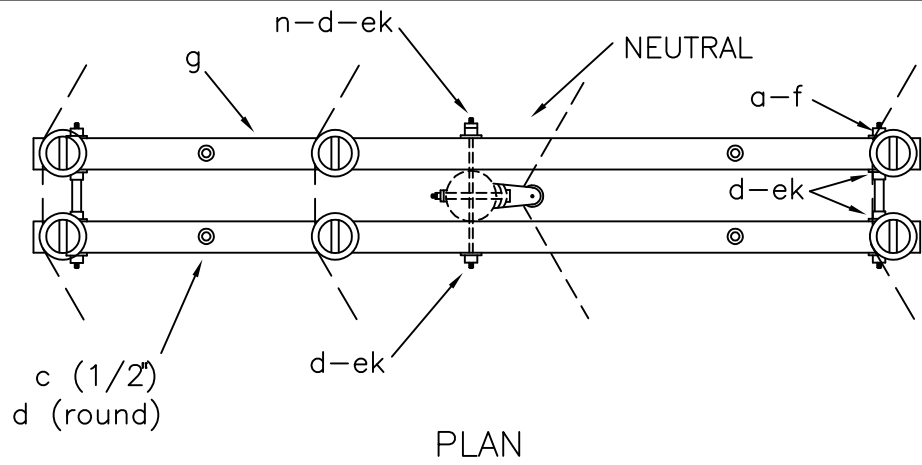

ITEM	QTY	MATERIAL
a	6	Insulator, pin type (12.47/7.2 kV)
c	4	Bolt, machine, 1/2" x req'd length
c	2	Bolt, machine, 5/8" x req'd length
d	4	Washer, round, 1 3/8"
d	18	Washer, square, 2 1/4"
f	6	Pin, crossarm, steel, 5/8" X 10 3/4"
g	2	Crossarm, 3 5/8" x 4 5/8" x 10'-0"
n	3	Bolt, double arm, 5/8" x req'd length
cu	2	Brace, wood, 60" span
da	1	Bracket, insulated
ek	16	Locknuts

NOTE:
Neutral assembly may be installed on opposite side of pole when necessary to increase midspan conductor clearance.

DESIGN PARAMETERS:

See TABLE IV

DOUBLE SUPPORT ON 10 FOOT CROSSARMS

APRIL 2005

RUS

3 - PHASE PRIMARY
12.47/7.2 kV

C2.52
(C2-1)

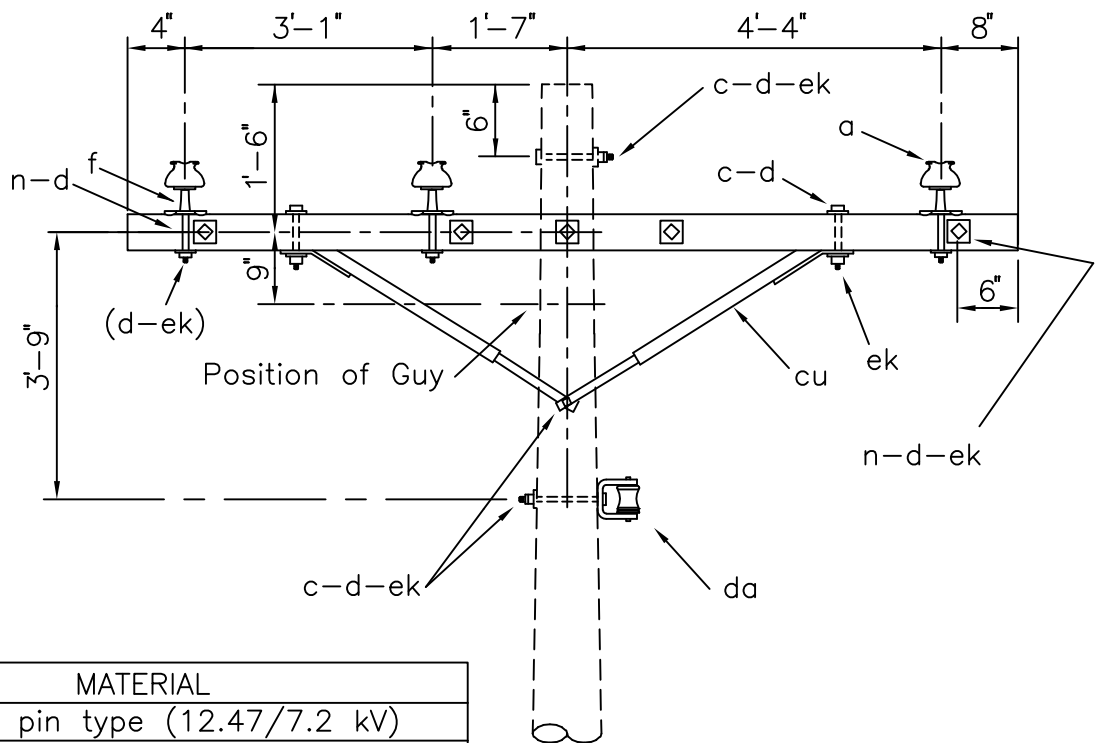
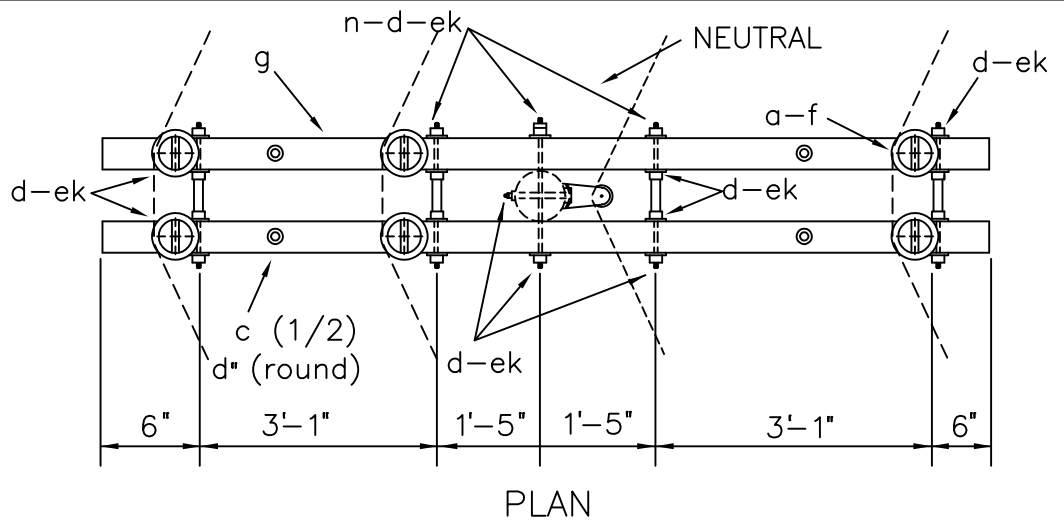

ITEM	QTY	MATERIAL
a	6	Insulator, pin type (12.47/7.2 kV)
c	4	Bolt, machine, 1/2" x req'd length
c	3	Bolt, machine, 5/8" x req'd length
d	4	Washer, round, 1 3/8"
d	22	Washer, square, 2 1/4"
f	6	Pin, crossarm, steel, clamp type
g	2	Crossarm, 3 5/8" x 4 5/8" x 10'-0"
n	5	Bolt, double arm, 5/8" x req'd length
cu	2	Brace, wood, 60" span
da	1	Bracket, w/ 3" x 3" spool insulator
ek	25	Locknuts

NOTE:
Neutral assembly may be installed on opposite side of pole when necessary to increase midspan conductor clearance.

DESIGN PARAMETERS:

See TABLE V

DOUBLE SUPPORT ON 10 FOOT CROSSARMS
(LARGE CONDUCTORS)

APRIL 2005

RUS

3 - PHASE PRIMARY
12.47/7.2 kV

C2.52L
(C2-2)

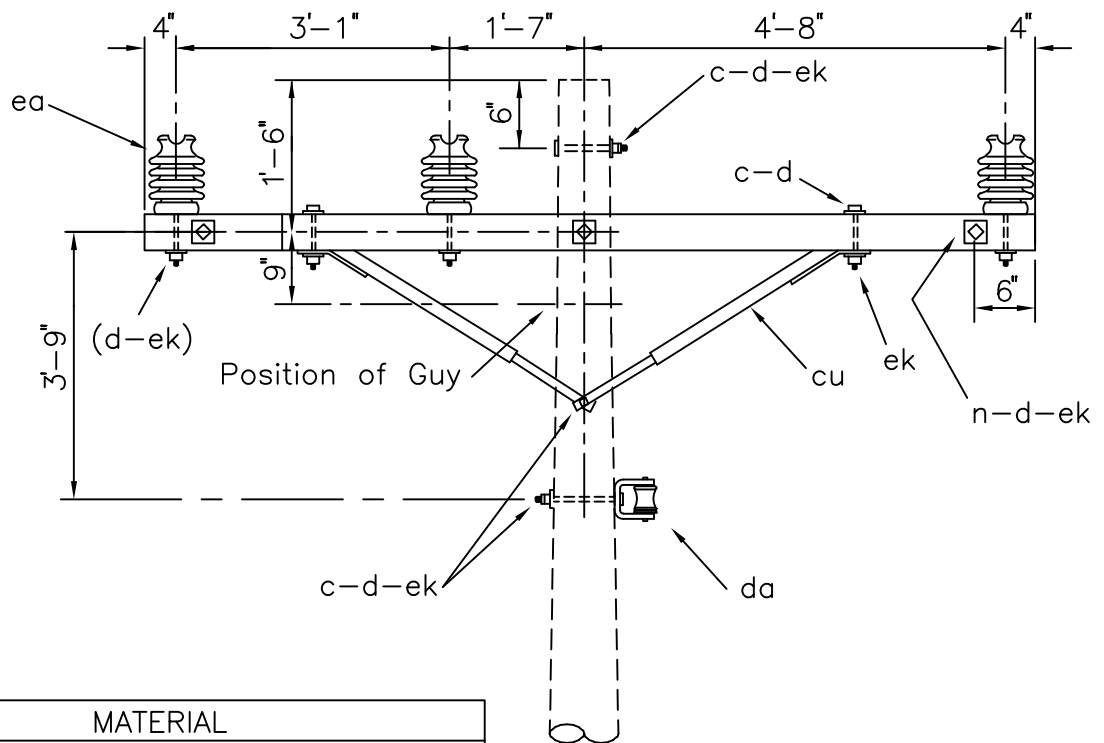
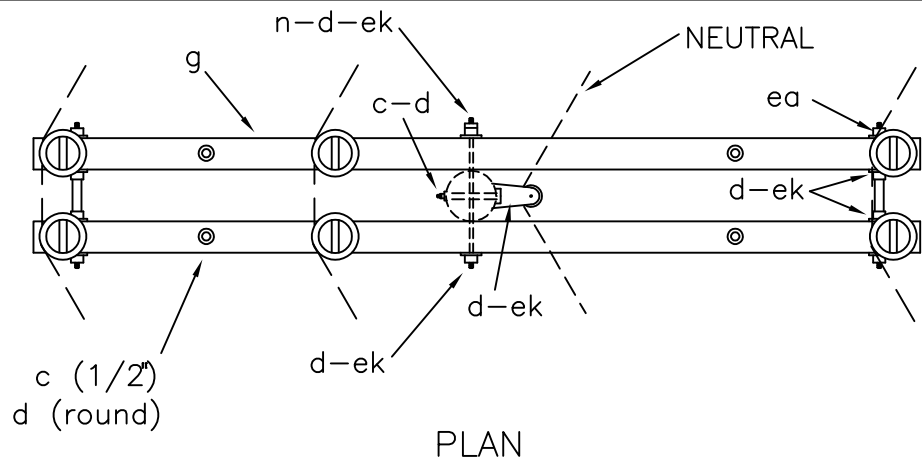

ITEM	QTY	MATERIAL
c	4	Bolt, machine, 1/2" x req'd length
c	3	Bolt, machine, 5/8" x req'd length
d	4	Washer, round, 1 3/8"
d	14	Washer, square, 2 1/4"
g	2	Crossarm, 3 5/8" x 4 5/8" x 10'-0"
n	3	Bolt, double arm, 5/8" x req'd length
cu	2	Brace, wood, 60" span
da	1	Bracket, Insulated
ea	6	Insulator, post type (12.47/7.2 kV)
ek	17	Locknuts

NOTE:
Neutral assembly may be installed on opposite side of pole when necessary to increase midspan conductor clearance.

DESIGN PARAMETERS:
See TABLE IV

DOUBLE SUPPORT ON 10 FOOT CROSSARMS
(POST INSULATORS)

APRIL 2005

RUS

3 - PHASE PRIMARY
12.47/7.2 kV

C2.52P
(C2-2PL)

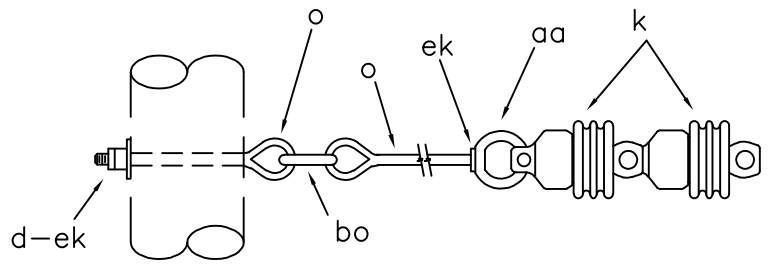
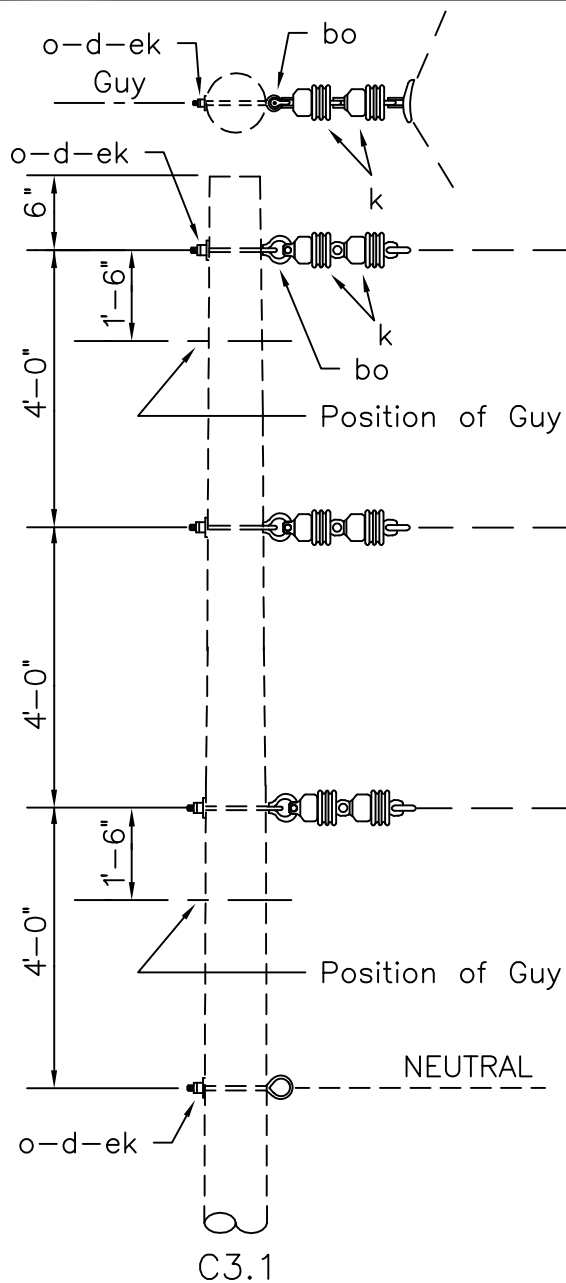

C3.2

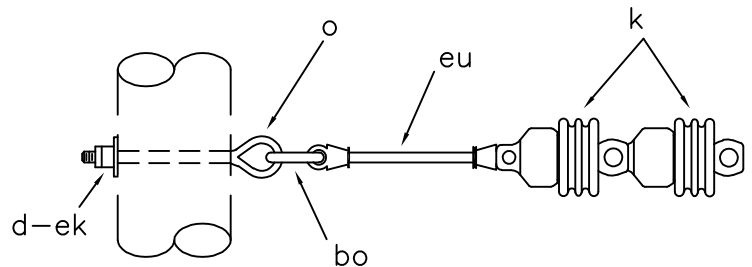

C3.3

NOTE: Extension link (item "eu" or "du") or eyebolt (item "o"), eyenut (item "aa") and locknut (item "ek") may be installed in 2 lower primary positions. Adjust material as required.

ASSEMBLY: C3

ITEM	MATERIAL	.1	.2	.3
d	Washer, square, 3", curved	4	4	4
k	Insulator, suspension, 4 1/4"	6	6	6
o	Bolt, eye, 5/8"x req'd length	4	7	4
aa	Nut, eye		3	
bo	Shackle, anchor	4	4	4
ek	Locknuts	4	7	4
eu	Link, extension, insulated			3
(du)	(Link, extension) - (optional)			(3)

DESIGN PARAMETERS:

PERMITTED TRANSVERSE
LOAD= 5000 lbs./Conductor
20° - 60°: #1/0 ACSR & Larger
30° - 60°: Smaller Conductors

SUSPENSION ANGLE

APRIL 2005

RUS

3 - PHASE PRIMARY
12.47/7.2 kV

C3.1,C3.2,C3.3
(C3)

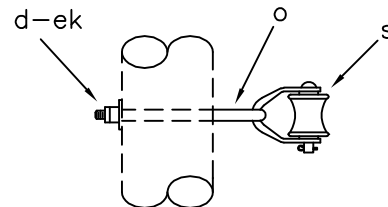
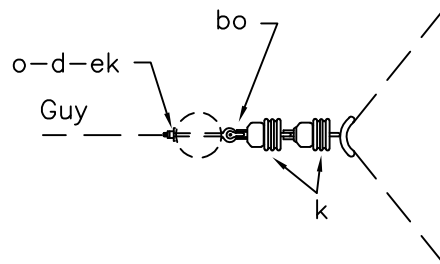
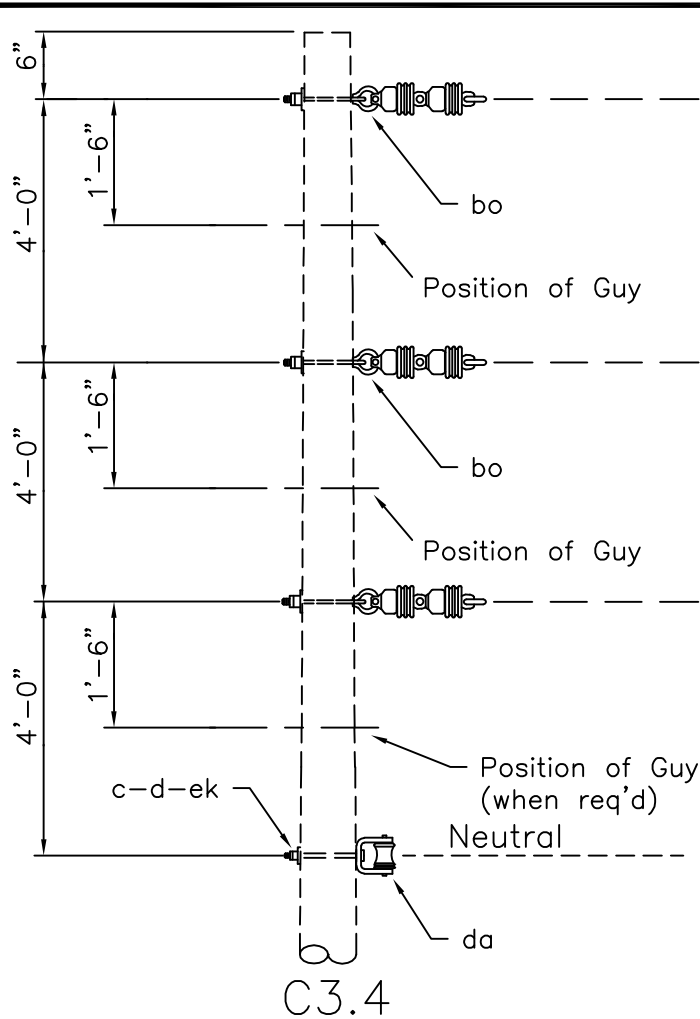

C3.7

- C3.5 = C3.4 neutral assembly + C3.2 primary subassembly
- C3.6 = C3.4 neutral assembly + C3.3 primary subassembly
- C3.8 = C3.7 neutral assembly + C3.2 primary subassembly
- C3.9 = C3.7 neutral assembly + C3.3 primary subassembly

NOTE: Extension link (item "eu" or "du") or eyebolt (item "o"), eyenut (item "aa") and locknut (item "ek") may be installed in lower primary positions. Adjust material as required.

ASSEMBLY: C3		.4	.5	.6	.7	.8	.9
ITEM	MATERIAL	QTY	QTY	QTY	QTY	QTY	QTY
c	Bolt, machine, 5/8" x req'd length	1	1	1			
d	Washer, square, 3", curved	4	4	4	4	4	4
k	Insulator, suspension, 4 1/4"	6	6	6	6	6	6
o	Bolt, eye, 5/8"x req'd length	3	6	3	4	7	4
s	Clevis, secondary, swinging, insulated				1	1	1
aa	Nut, eye		3			3	
bo	Shackle, anchor	3	3	3	3	3	3
da	Bracket, insulated	1	1	1			
ek	Locknuts	4	7	4	4	7	4
eu	Link, extension, insulated			3			3
(du)	(Link, extension) - (optional)			(3)			(3)

DESIGN PARAMETERS:

For ANSI Class 53-2 Spool Insulator (1 3/4") See Table VI

For ANSI Class 53-4 Spool Insulator (3") See Table VII

SUSPENSION ANGLE

APRIL 2005

RUS

3 - PHASE PRIMARY
12.47/7.2 kV

C3.4 - C3.9

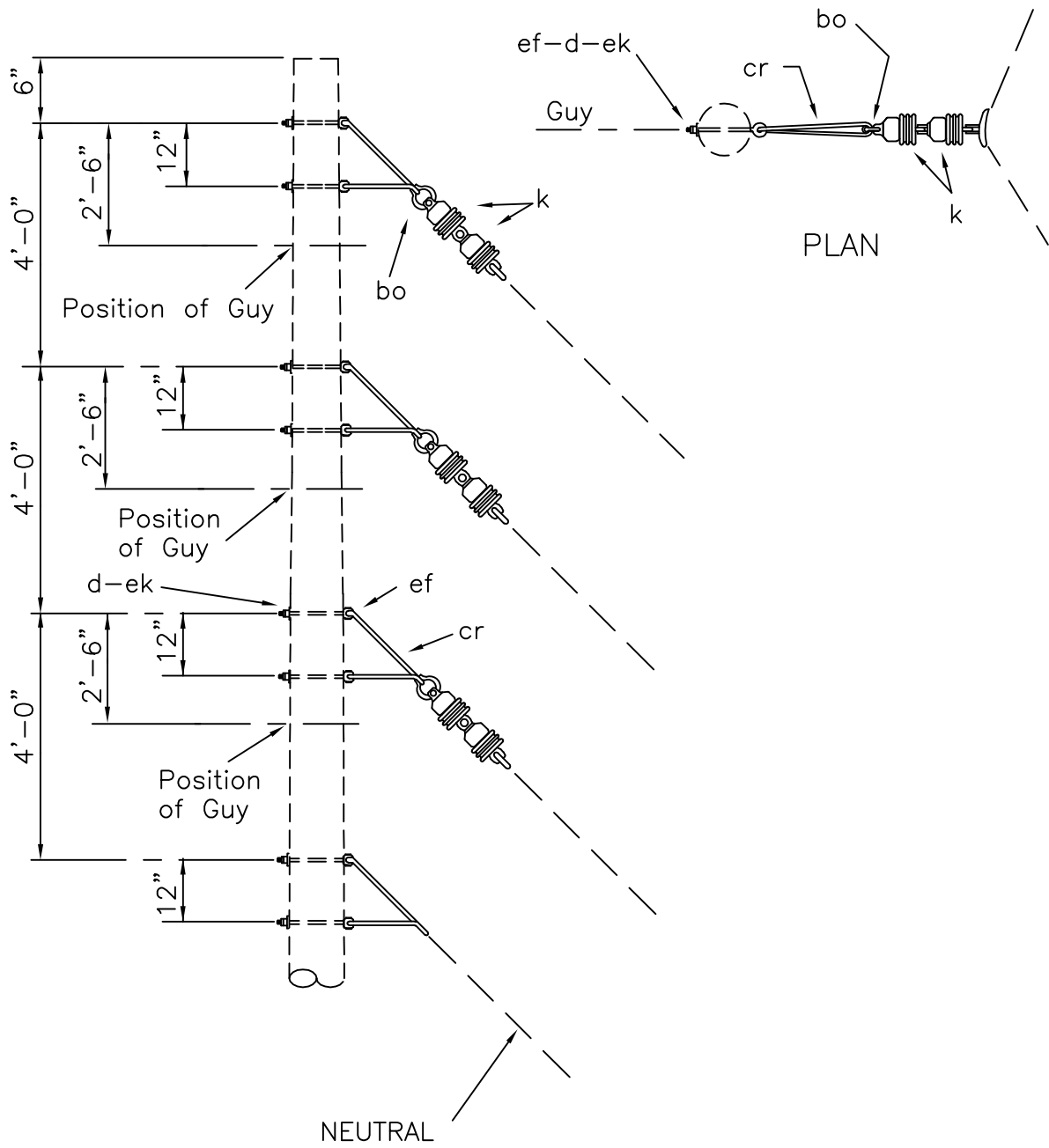

ITEM	QTY	MATERIAL
d	8	Washer, square, 3", curved
k	6	Insulator, suspension, 4 1/4"
bo	3	Shackle, anchor
cr	4	Bracket, angle, 5/8"
ef	8	Bolt, clevis, 5/8" x req'd length
ek	8	Locknuts

DESIGN PARAMETERS:
 PERMITTED TRANSVERSE
 LOAD= 5000 lbs./Conductor
 10° -30° Angles

SUSPENSION ANGLE
 (LARGE CONDUCTORS)

APRIL 2005	3 - PHASE PRIMARY 12.47/7.2 kV	C3.1L (C3-1)
RUS		

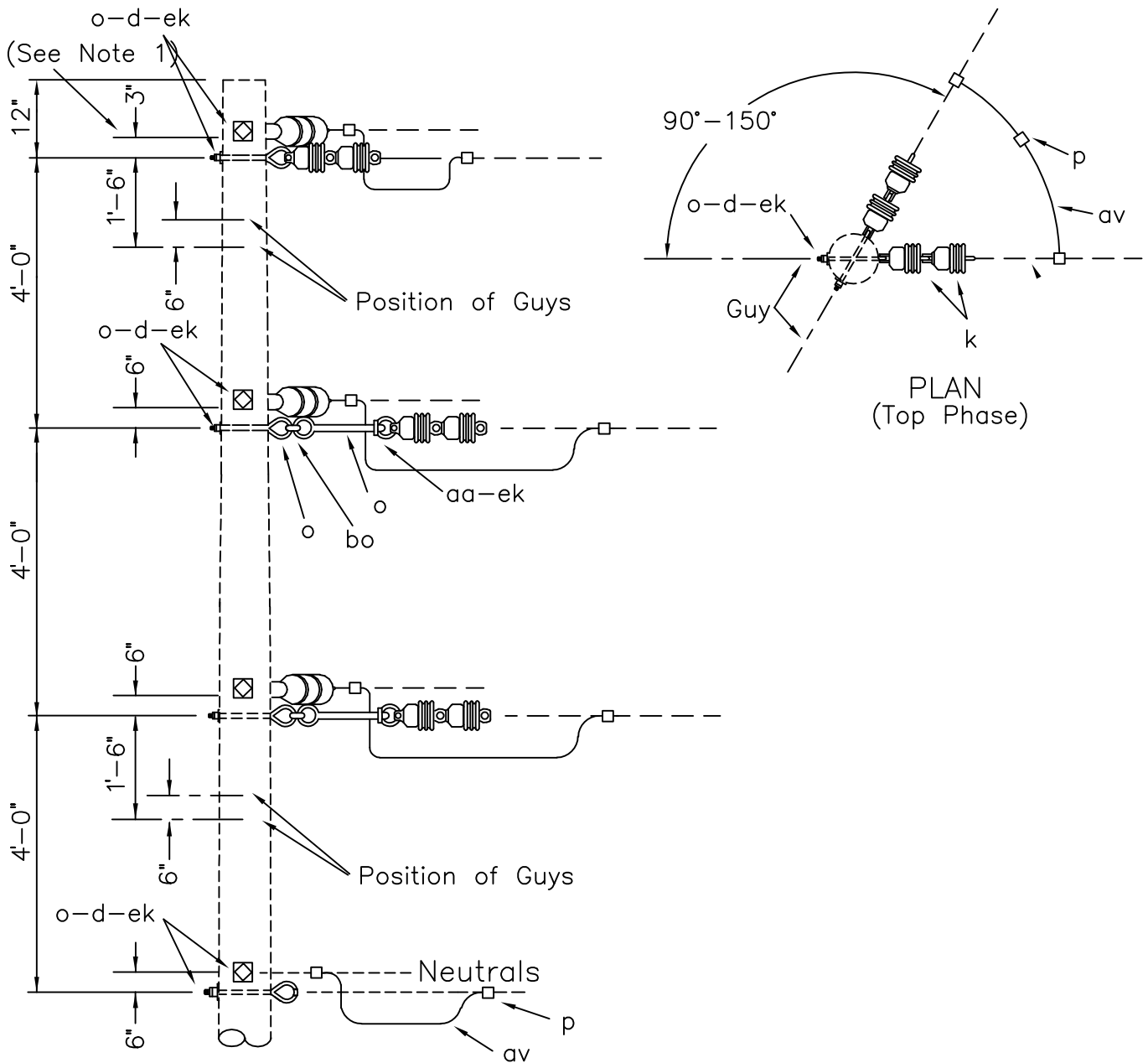

NOTES:

1. Separate 6" (top position only) when angle equals 90°.
2. This drawing shows two B5.1 plus two A5.02 assemblies and their material as an example. Any combination of B5.1 – B5.9, A4.1 – A5.9 and A5.01 – A5.03 assemblies may be installed. Record assemblies separately on staking sheets.
CAUTION: Use the appropriate permitted longitudinal loads.

ITEM	QTY	MATERIAL
		Primary Assemblies, as req'd (See Note 2)
p		Connectors, as req'd
av		Jumpers, as req'd

DESIGN PARAMETERS:

PERMITTED LONGITUDINAL
LOAD = 5000 lbs./Conductor

DEADEND ANGLE GUIDE (90°–150°)

APRIL 2005

RUS

3 – PHASE PRIMARY
12.47/7.2 kV

C4.1G
(C4-1)

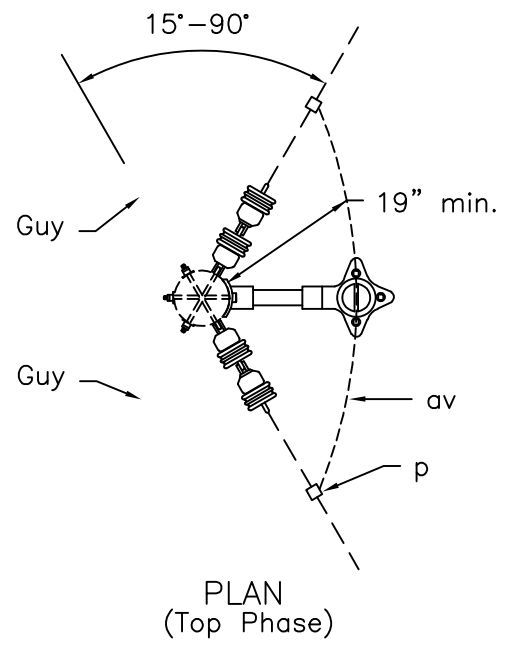
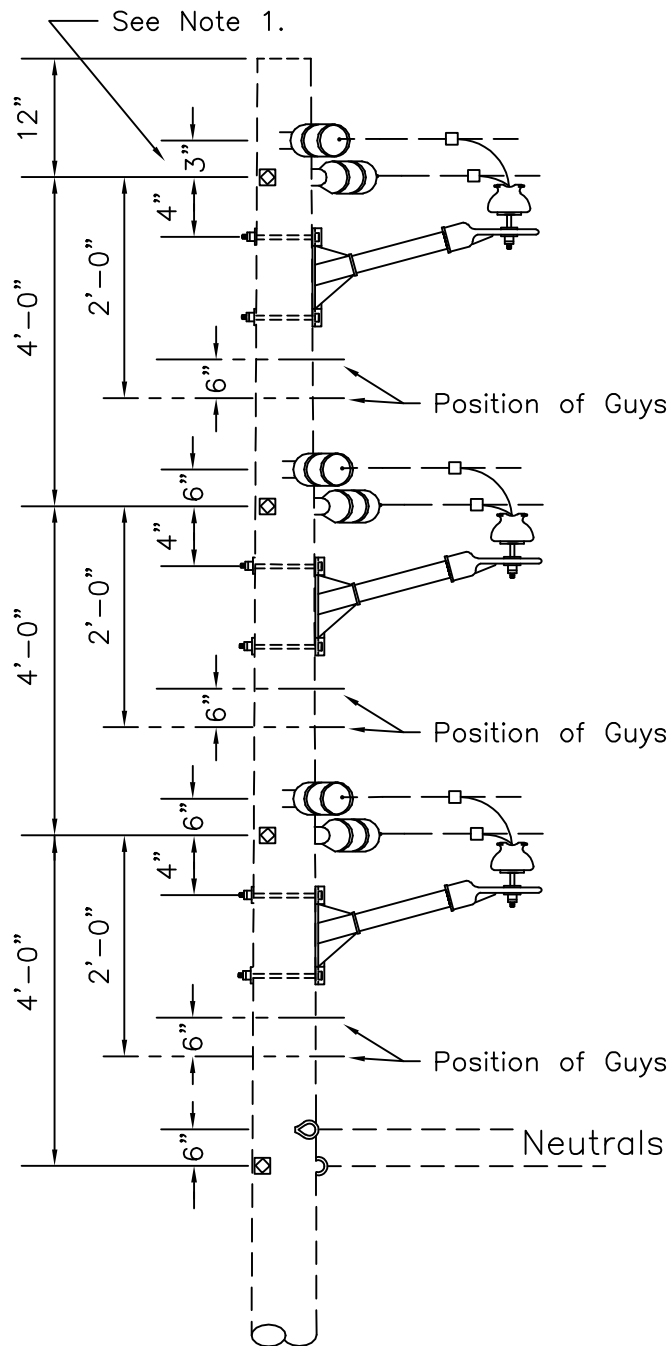

NOTES:

1. Separate 6" (top position only) when angle equals 90°.
2. This drawing shows three C5.1 and three A1.04N assemblies as an example. Any combination of three A1.04N plus C5.1 – C5.9, or A5.1 – A5.9 and A5.01 – A5.03 assemblies may be installed. Record assemblies separately on staking sheets.
CAUTION: Use the appropriate permitted longitudinal loads.

ITEM	QTY	MATERIAL
		Primary Assemblies, as req'd (See Note 2)
	3	A1.04N primary assemblies
p		Connectors, as req'd
av		Jumpers, as req'd

DESIGN PARAMETERS:
PERMITTED LONGITUDINAL
LOAD = 5000 lbs./Conductor

DEADEND ANGLE GUIDE (15°–90°)

APRIL 2005

3 – PHASE PRIMARY
12.47/7.2 kV

C4.2G

RUS

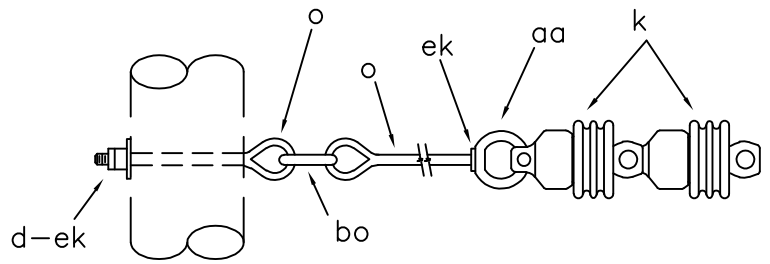
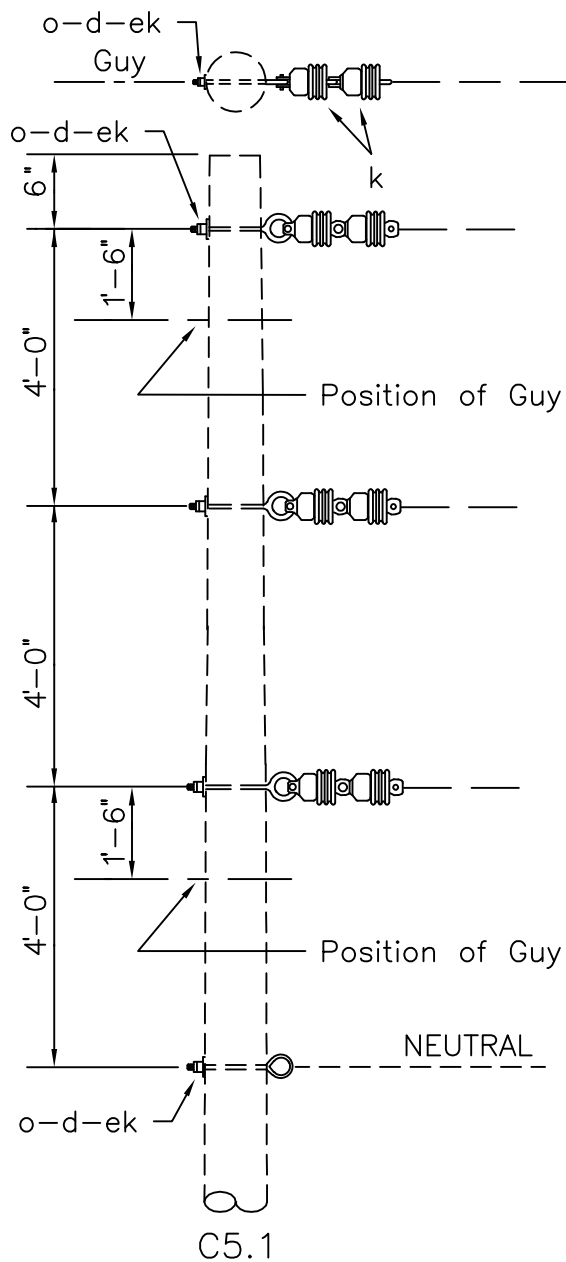

C5.2

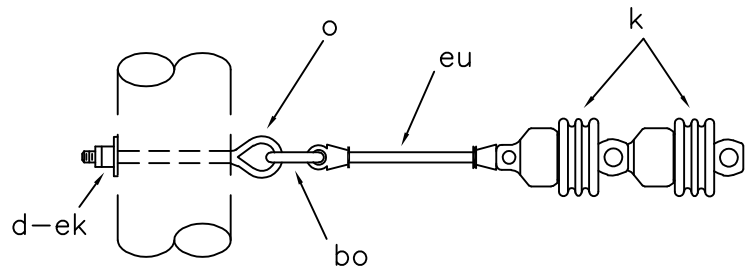

C5.3

NOTE: Extension link (item "eu" or "du") or eyebolt (item "o"), eyenut (item "aa") and locknut (item "ek") may be installed in 2 lower primary positions on assembly C5.1. Adjust material as required.

ASSEMBLY: C5

ITEM	MATERIAL	.1	.2	.3
d	Washer, square, 3", curved	4	4	4
k	Insulator, suspension, 4 1/4"	6	6	6
o	Bolt, eye, 5/8"x req'd length	4	7	4
aa	Nut, eye		3	
bo	Shackle, anchor		3	3
ek	Locknuts	4	7	4
eu	Link, extension, insulated			3
(du)	(Link, extension) - (optional)			(3)

DESIGN PARAMETERS:
 PERMITTED LONGITUDINAL
 LOAD = 5000 lbs./Conductor

SINGLE DEADENDS

APRIL 2005

RUS

3 - PHASE PRIMARY
 12.47/7.2 kV

C5.1,C5.2,C5.3
 (C5.1)

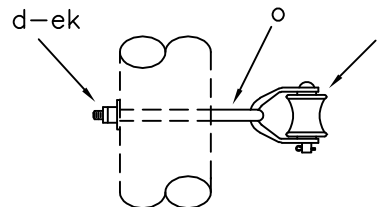
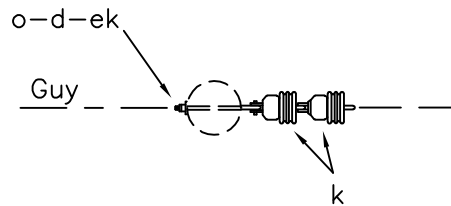
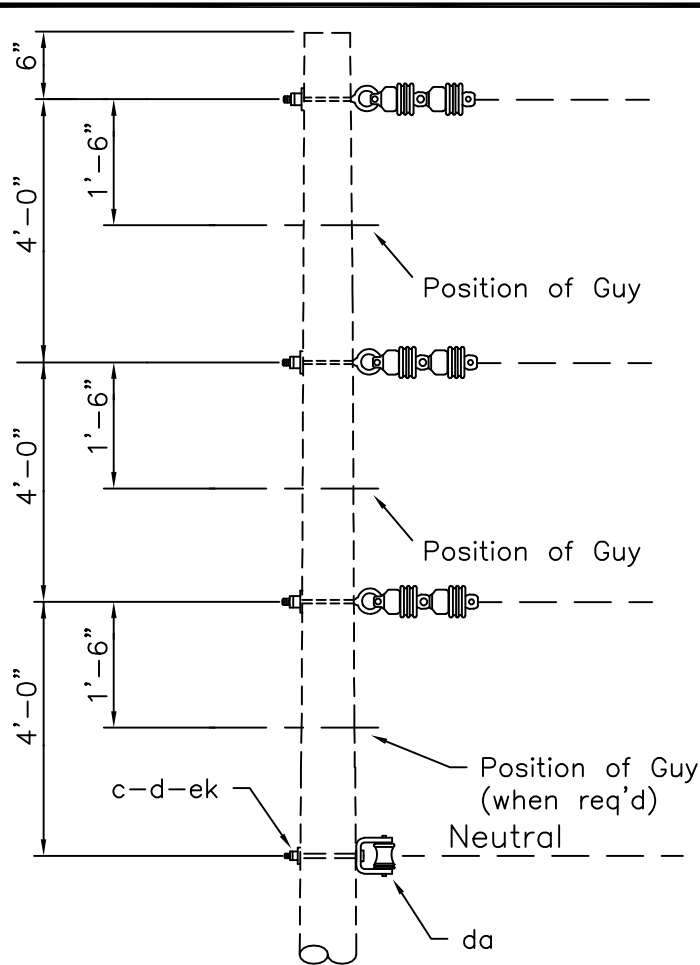

C5.7

C5.4

- C5.5 = C5.4 neutral assembly + C5.2 primary subassembly
- C5.6 = C5.4 neutral assembly + C5.3 primary subassembly
- C5.8 = C5.7 neutral assembly + C5.2 primary subassembly
- C5.9 = C5.7 neutral assembly + C5.3 primary subassembly

NOTE: Extension link (item "eu" or "du") or eyebolt (item "o"), eyenut (item "aa") and locknut (item "ek") may be installed in 2 lower primary positions in assembly C5.4. Adjust material as required.

ASSEMBLY: C5		.4	.5	.6	.7	.8	.9
ITEM	MATERIAL	QTY	QTY	QTY	QTY	QTY	QTY
c	Bolt, machine, 5/8" x req'd length	1	1	1			
d	Washer, square, 3", curved	4	4	4	4	4	4
k	Insulator, suspension, 4 1/4"	6	6	6	6	6	6
o	Bolt, eye, 5/8"x req'd length	3	6	3	4	7	4
s	Clevis, secondary, swinging, insulated				1	1	1
aa	Nut, eye		3			3	
bo	Shackle, anchor		3	3		3	3
da	Bracket, insulated	1	1	1			
ek	Locknuts	4	7	4	4	7	4
eu	Link, extension, insulated			3			3
(du)	(Link, extension) - (optional)			(3)			(3)

DESIGN PARAMETERS:

For ANSI Class 53-2 Spool Insulator (1 3/4") See Table VI

For ANSI Class 53-4 Spool Insulator (3") See Table VII

SINGLE DEADENDS

APRIL 2005

RUS

3 - PHASE PRIMARY
12.47/7.2 kV

C5.4 - C5.9

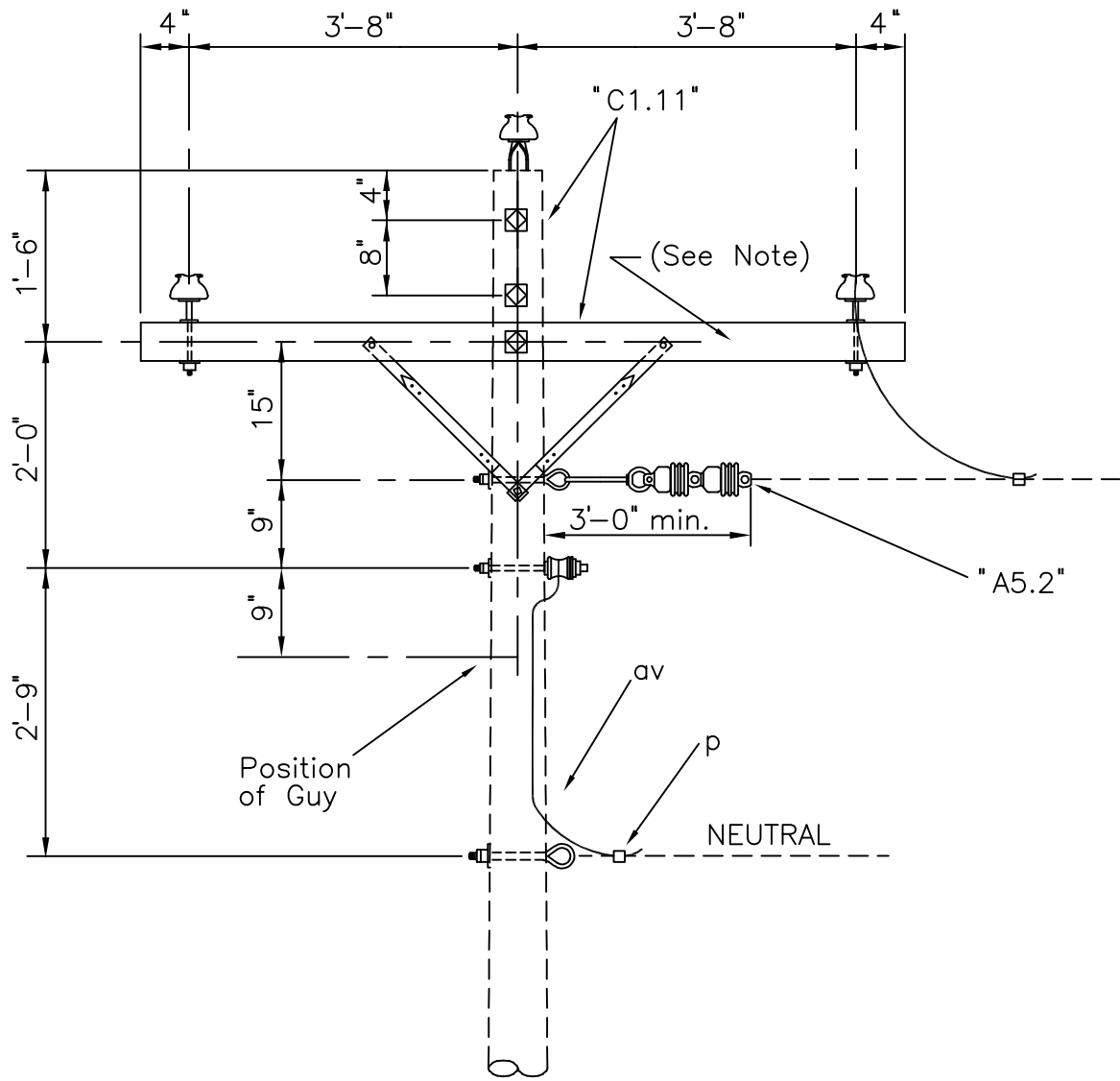

NOTE:

When tapping center phase, install post type insulator, "A1.011P", horizontally on crossarm, 19 inches (minimum) from surface of pole and fasten jumper to insulator.

ITEM	QTY	MATERIAL
	1	"C1.11" Primary Assembly
	1	"A5.2" Primary Assembly
P		Connectors, as req'd
av		Jumpers, as req'd

DESIGN PARAMETERS:

PERMITTED LONGITUDINAL
LOAD = 5,000 lbs./Conductor

SINGLE PHASE TAP GUIDE

APRIL 2005

RUS

3 - PHASE PRIMARY
12.47/7.2 kV

C5.11G

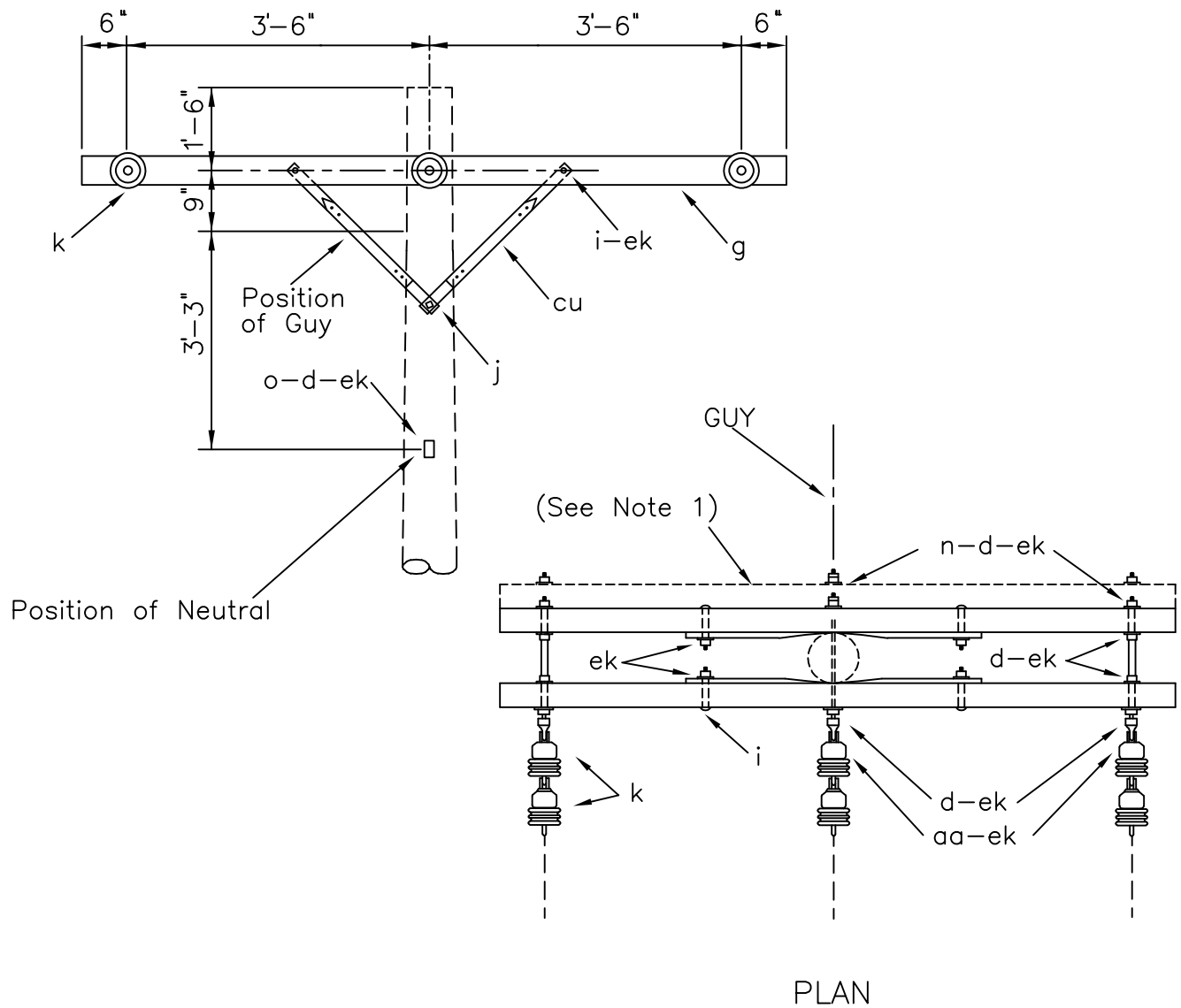

ITEM	QTY	MATERIAL
d	1	Washer, square, 3", curved
d	10	Washer, square, 2 1/4"
g	2	Crossarm, 3 5/8" x 4 5/8" x 8'-0"
i	4	Bolt, carriage, 3/8" x 4 1/2"
j	2	Screw, lag, 1/2" x 4"
k	6	Insulator, suspension, 4 1/4"
n	3	Bolt, double arming, 5/8" x req'd length
o	1	Bolt, eye, 5/8" x req'd length
aa	3	Nut, eye, 5/8"
cu	4	Brace, 28"
ek	18	Locknuts

NOTES:

1. Designate as "C5.31" for assembly with three crossarms.
2. Double arming eye bolt, item "dy," may be used instead of double arming bolt, item "n," and eye nut, item "aa."
3. Other neutral assemblies may be used. See Section N. Adjust material as needed.

DESIGN PARAMETERS:

PERMITTED UNBALANCED
CONDUCTOR TENSION:

See Table A (Exhibit 2)

SINGLE DEADEND ON CROSSARMS

APRIL 2005

RUS

3 - PHASE PRIMARY
12.47/7.2 kV

C5.21, C5.31
(C7), (C7-1)

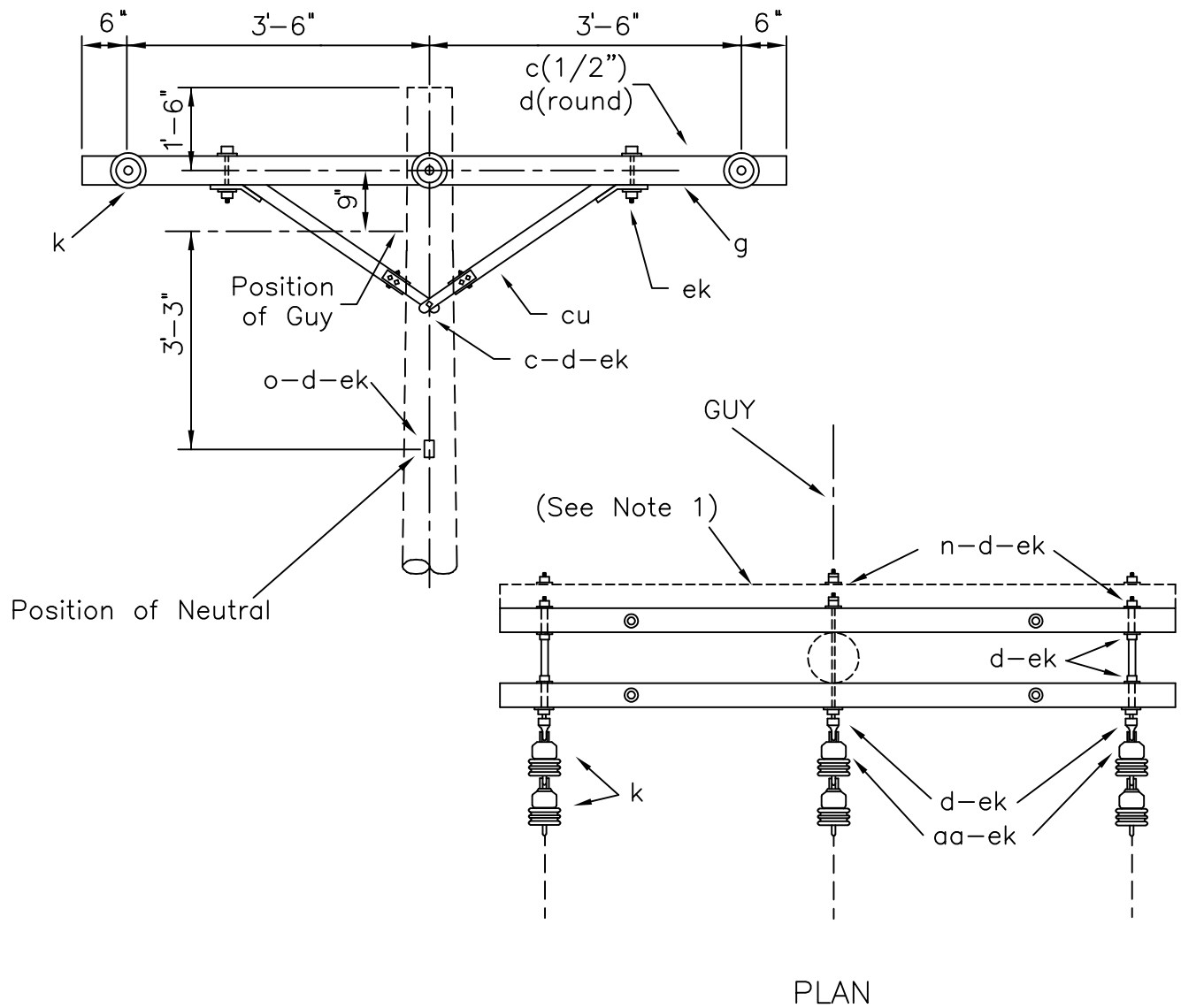

ITEM	QTY	MATERIAL
c	4	Bolt, machine, 1/2" x req'd length
d	4	Washer, round, 1 3/8"
d	1	Washer, square, 3", curved
d	11	Washer, square, 2 1/4"
g	2	Crossarm, 3 5/8" x 4 5/8" x 8'-0"
k	6	Insulator, suspension, 4 1/4"
n	3	Bolt, double arming, 5/8" x req'd length
o	1	Bolt, eye, 5/8" x req'd length
aa	3	Nut, eye, 5/8"
cu	2	Brace, wood, 60" span
ek	18	Locknuts

NOTES:

1. Designate as "C5.31L" for assembly with three crossarms.
2. Double arming eye bolt, item "dy," may be used instead of double arming bolt, item "n," and eye nut, item "aa."

DESIGN PARAMETERS:

PERMITTED UNBALANCED
CONDUCTOR TENSION:

See Table A (Exhibit 2)

SINGLE DEADEND ON CROSSARMS
(LARGE CONDUCTORS)

APRIL 2005

RUS

3 - PHASE PRIMARY
12.47/7.2 kV

C5.21L, C5.31L

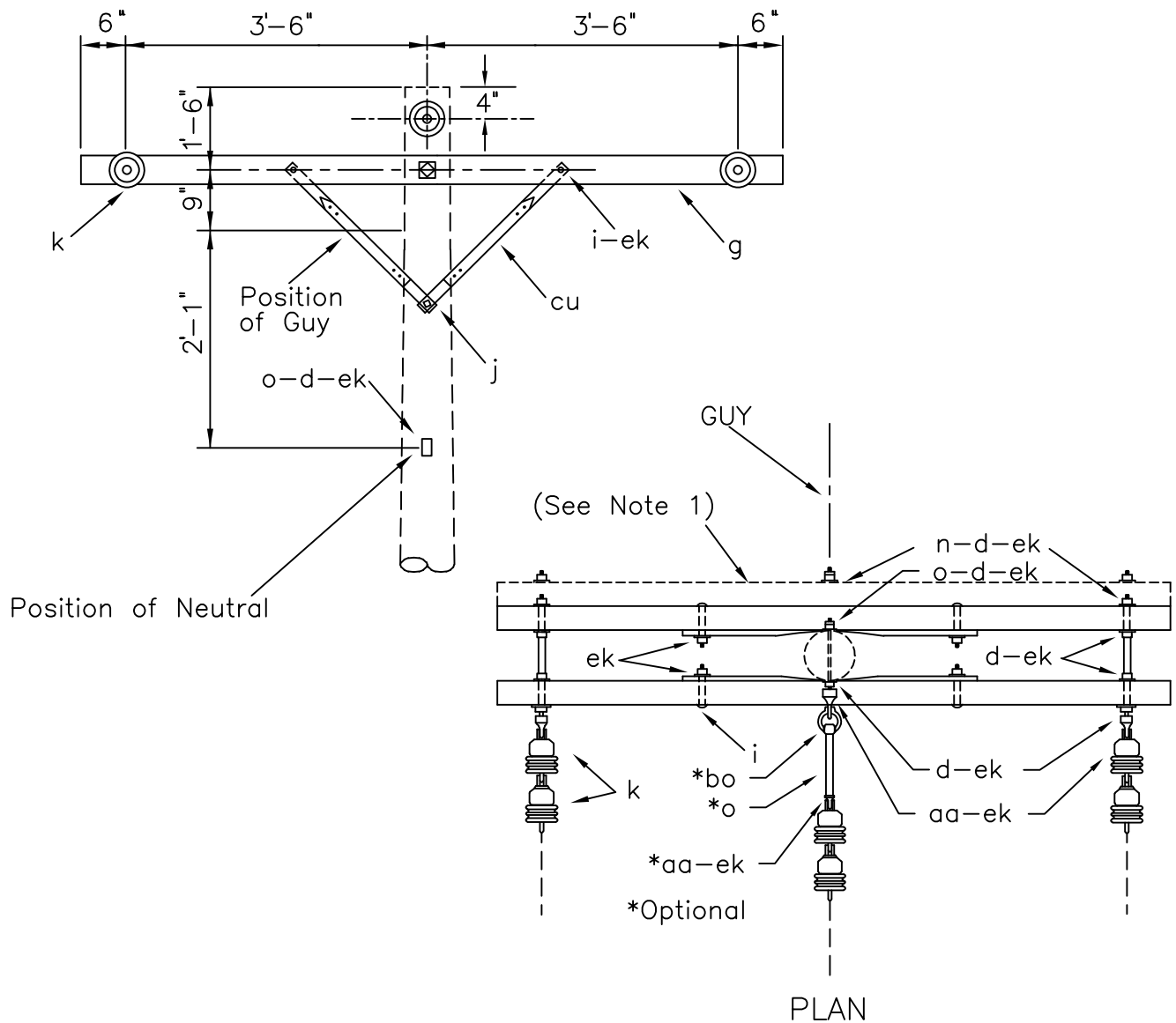

ITEM	QTY	MATERIAL
d	2	Washer, square, 3", curved
d	10	Washer, square, 2 1/4"
g	2	Crossarm, 3 5/8" x 4 5/8" x 8'-0"
i	4	Bolt, carriage, 3/8" x 4 1/2"
j	2	Screw, lag, 1/2" x 4"
k	6	Insulator, suspension, 4 1/4"
n	3	Bolt, double arming, 5/8" x req'd length
o	3	Bolt, eye, 5/8" x req'd length
aa	3	Nut, eye, 5/8"
bo	1	Shackle, anchor
cu	4	Brace, 28"
ek	19	Locknuts

NOTES:

1. Designate as "C5.32" for assembly with three crossarms.
2. Double arming eye bolt, item "dy," may be used instead of double arming bolt, item "n," and eye nut, item "aa."
3. Other neutral assemblies may be used. See Section N. Adjust material as needed.

DESIGN PARAMETERS:

PERMITTED UNBALANCED CONDUCTOR TENSION:

See Table A (Exhibit 2)

SINGLE DEADEND ON CROSSARMS—ALTERNATIVE

APRIL 2005

RUS

3 - PHASE PRIMARY
12.47/7.2 kV

C5.22, C5.32
(C7-2)

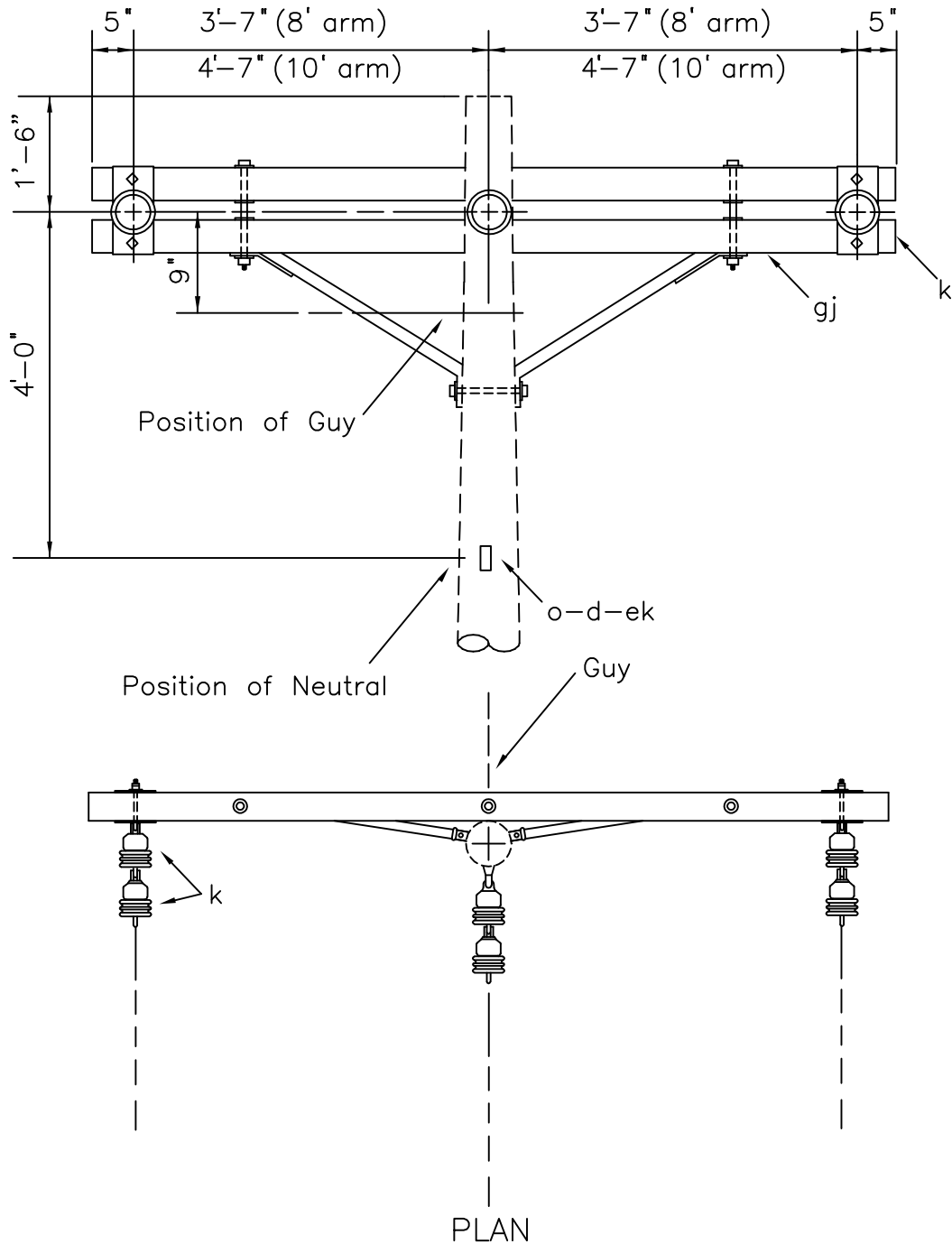

ITEM	QTY	MATERIAL
d	1	Washer, square, 3", curved
k	6	Insulator, suspension, 4 1/4"
o	1	Bolt, eye, 5/8" x req'd length
ek	1	Locknuts
gj	1	Crossarm Assembly

DESIGN PARAMETERS:

PERMITTED LONGITUDINAL LOAD
 EQUALS LESSER OF:
 5,000 lbs/Conductor, or
 Manufacturer's specifications
 times NESC strength factor.

SINGLE DEADEND ON CROSSARM ASSEMBLY

APRIL 2005

RUS

3 - PHASE PRIMARY
 12.47/7.2 kV

C5.71L
 (C7A)

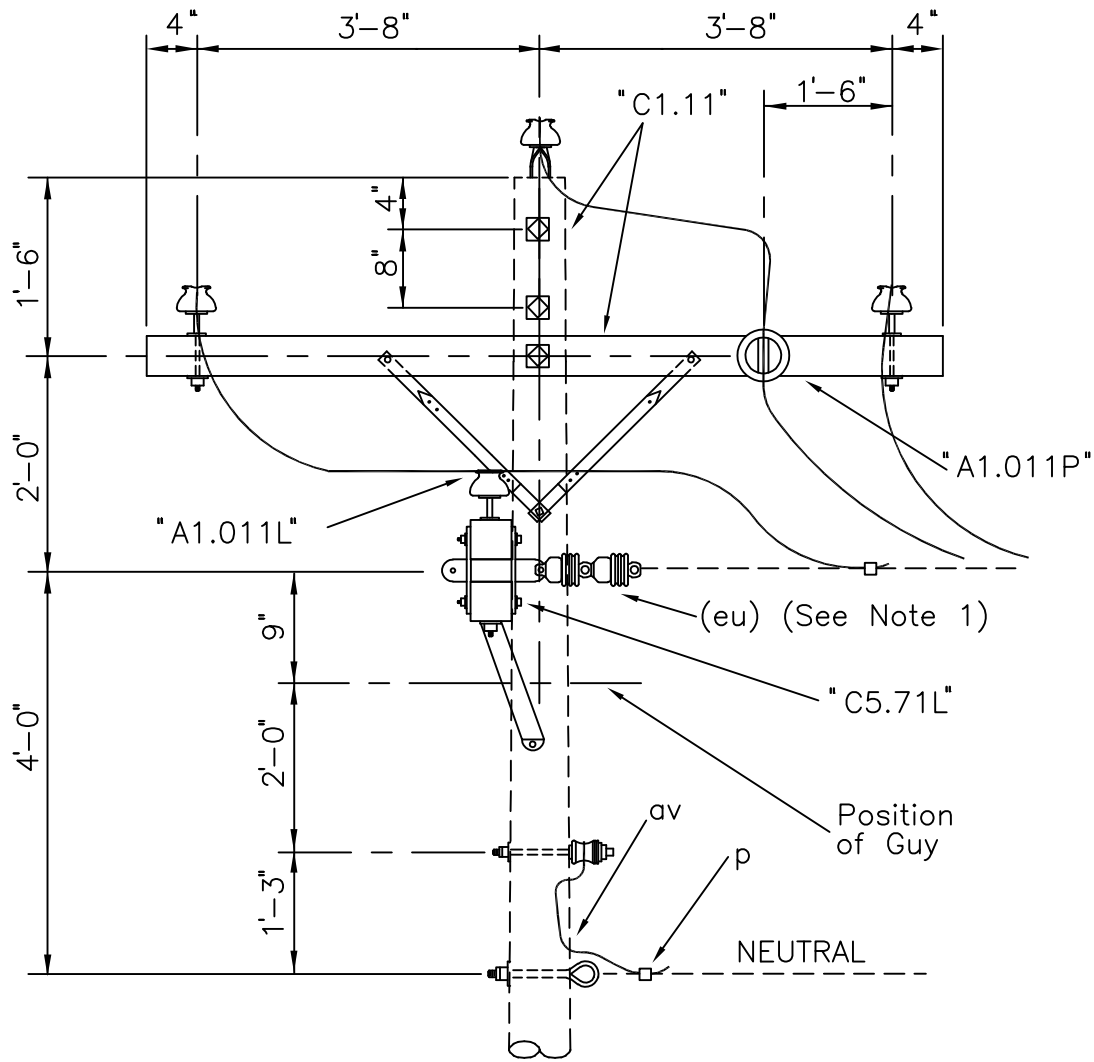

NOTES:

1. Install insulated extension link, item "eu", in center phase of tap.
2. Jumper wires to be a minium of 19 inches to surface of pole.

ITEM	QTY	MATERIAL
	1	C1.11 Primary Assembly
	1	C5.71L Primary Assembly
	(1)	(C5.21 or C5.31 Primary Assembly) (Use Table A – Exhibit 2)
	1	A1.011L Misc. Single Support
	1	A1.011P Misc. Single Support
P		Connectors, as req'd
av		Jumpers, as req'd
bo	1	Shackle, anchor
eu	1	Link, extension, insulated (18" min.)

DESIGN PARAMETERS:

PERMITTED LONGITUDINAL LOAD
EQUALS LESSER OF:
5,000 lbs./Conductor, or
Manufacturer's specifications
times NESC strength factor.

THREE PHASE HORIZONTAL TAP GUIDE

APRIL 2005

3 – PHASE PRIMARY
12.47/7.2 kV

C5.82G

RUS

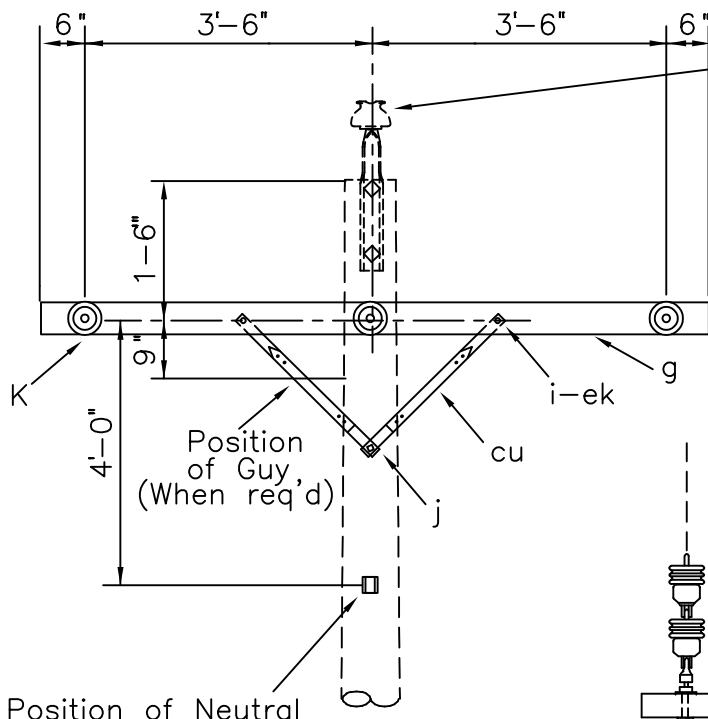

Position of Neutral
(See drawing "N6.1" for materials
and construction details)

(NOTE: Install "A1.01"
when extending conductor
across assembly.)

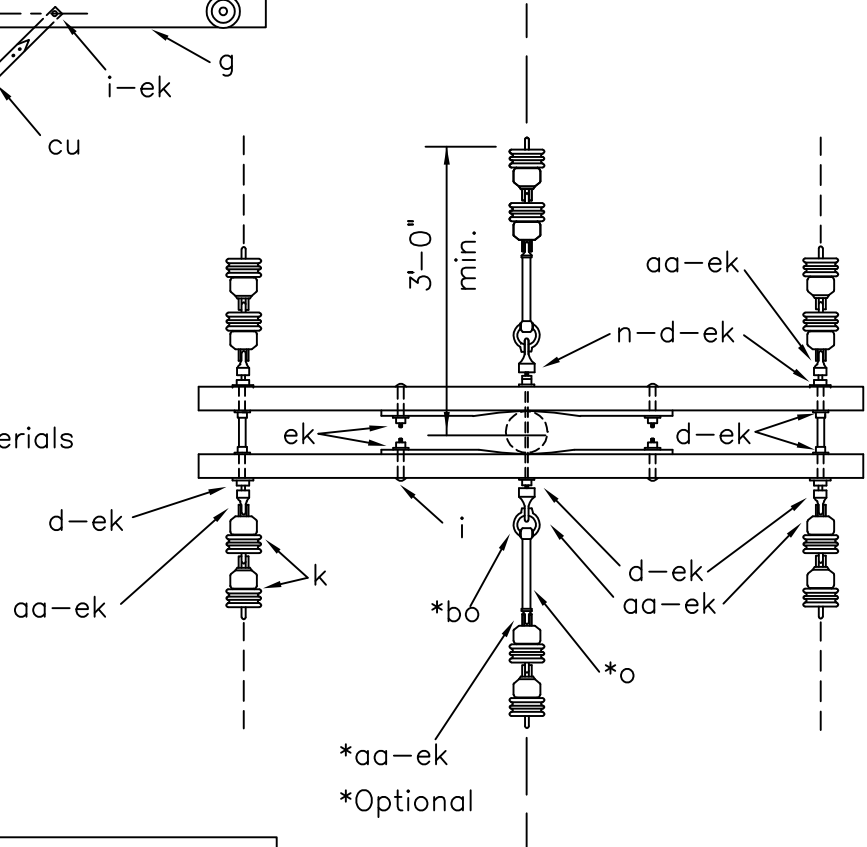

*aa-ek
*Optional

ITEM	QTY	MATERIAL
d	2	Washer, square, 3", curved
d	10	Washer, square, 2 1/4"
g	2	Crossarm, 3 5/8" x 4 5/8" x 8'-0"
i	4	Bolt, carriage, 3/8" x 4 1/2"
j	2	Screw, lag, 1/2" x 4"
k	12	Insulator, suspension, 4 1/4"
n	4	Bolt, double arming, 5/8" x req'd length
o	2	Bolt, eye, 5/8" x req'd length
p		Connectors, as req'd
aa	8	Nut, eye, 5/8"
av		Jumpers, as req'd
bo	2	Shackle, anchor
cu	4	Brace, 28"
ek	26	Locknuts

NOTES:

1. Double arming bolt, item "n," and eye nut, item "aa," may be replaced with double arming eye bolt, item "dy."
2. Maximum line angle may be increased to 15° by installing anchor shackles, item "bo," to (horizontal) eye nuts and installing side guys as req'd.
3. Designate as C6.31 for assembly with three crossarms.

DESIGN PARAMETERS:

PERMITTED UNBALANCED
CONDUCTOR TENSION:

See Table A (Exhibit 2)

MAXIMUM LINE ANGLE = 5°
(See Note 2)

DOUBLE DEADEND ON CROSSARMS

APRIL 2005

RUS

3 - PHASE PRIMARY
12.47/7.2 kV

C6.21 (C8)
C6.31

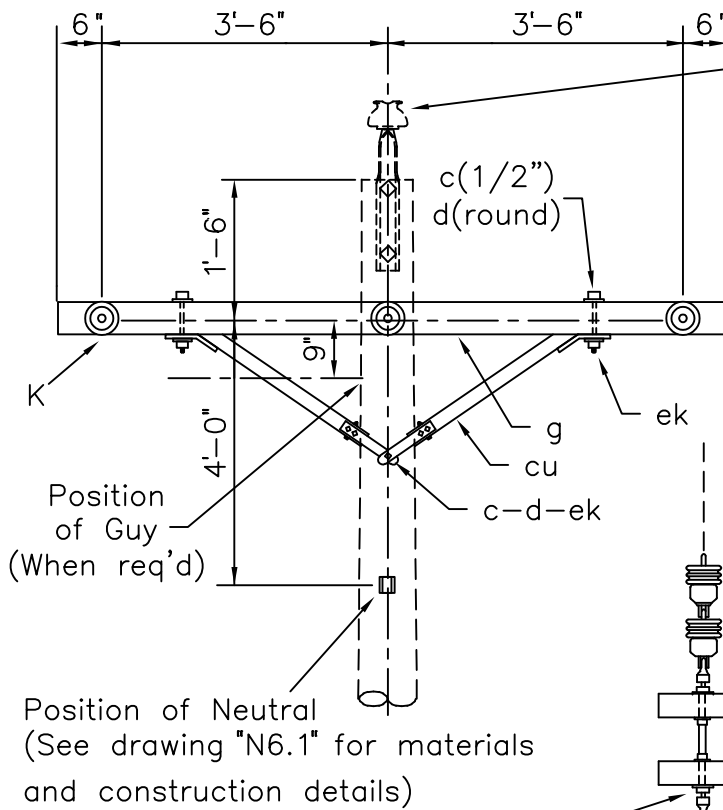

(NOTE: Install "A1.01" when extending conductor across assembly.)

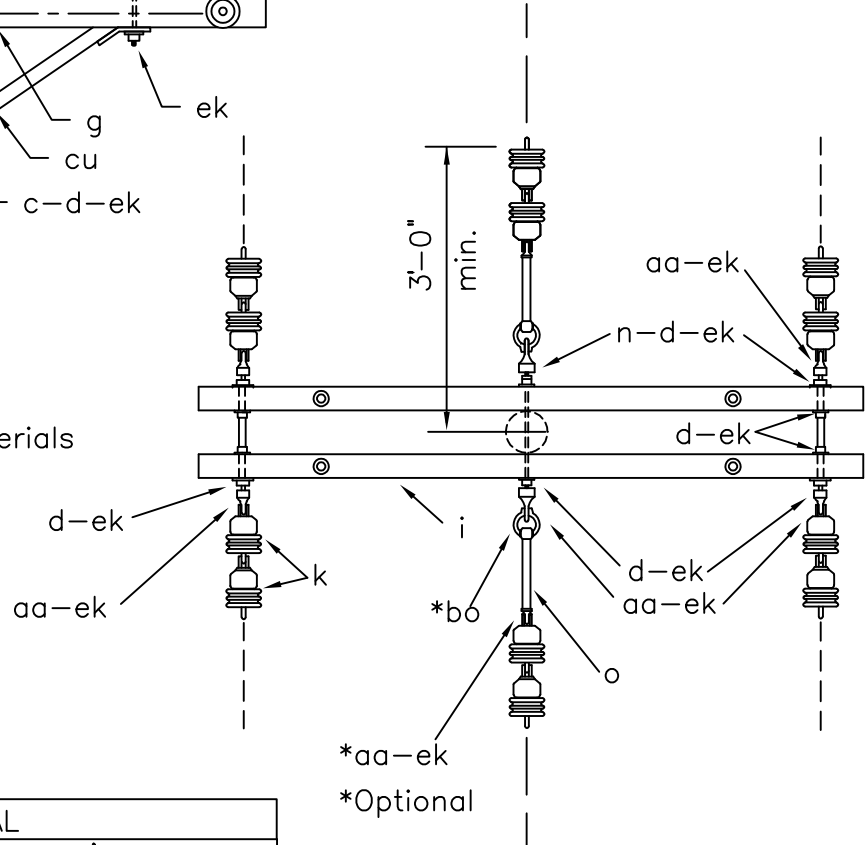

ITEM	QTY	MATERIAL
c	1	Bolt, machine, 5/8" x req'd length
c	4	Bolt, machine, 1/2" x req'd length
d	4	Washer, round, 1 3/8"
d	2	Washer, square, 3", curved
d	11	Washer, square, 2 1/4"
g	2	Crossarm, 3 5/8" x 4 5/8" x 8'-0"
k	12	Insulator, suspension, 4 1/4" "
n	4	Bolt, double arming, 5/8" x req'd length
o	2	Bolt, eye, 5/8" x req'd length
p		Connectors, as req'd
aa	8	Nut, eye, 5/8"
av		Jumpers, as req'd
bo	2	Shackle, anchor
cu	2	Brace, wood, 60" span
ek	27	Locknuts

NOTES:

1. Double arming bolt, item "n," and eye nut, item "aa," may be replaced with double arming eye bolt, item "dy."
2. Maximum line angle may be increased to 15° by installing anchor shackles, item "bo," to (horizontal) eye nuts and installing side guys as req'd.
3. Designate as C6.31L for assembly with three crossarms.

DESIGN PARAMETERS:
 PERMITTED UNBALANCED CONDUCTOR TENSION:
 See Table A (Exhibit 2)

DOUBLE DEADEND ON CROSSARMS
 (LARGE CONDUCTORS)

MAXIMUM LINE ANGLE = 5°
 (See Note 2)

APRIL 2005	3 - PHASE PRIMARY	C6.21L
RUS	12.47/7.2 kV	C6.31L (C8-3)

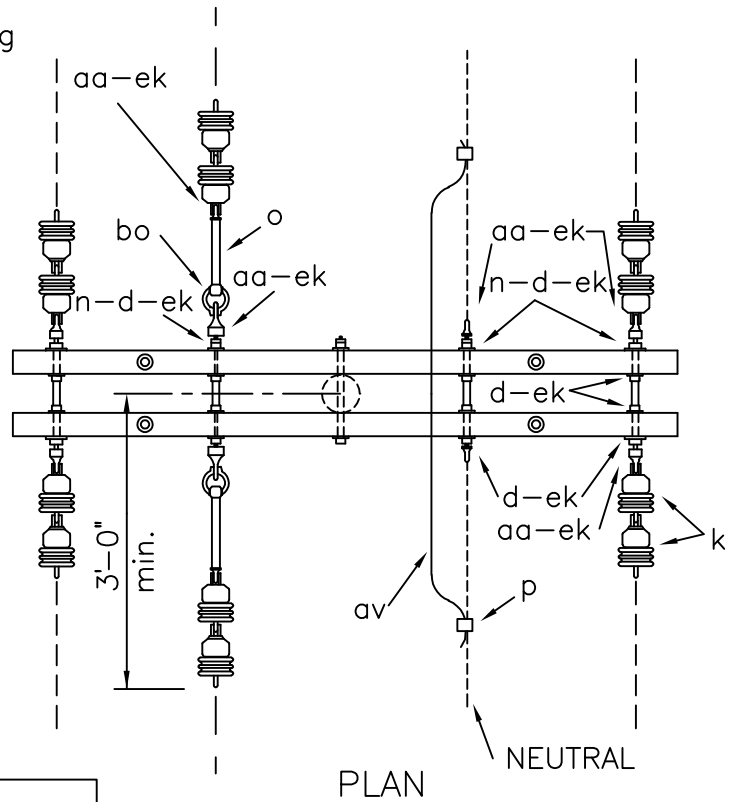
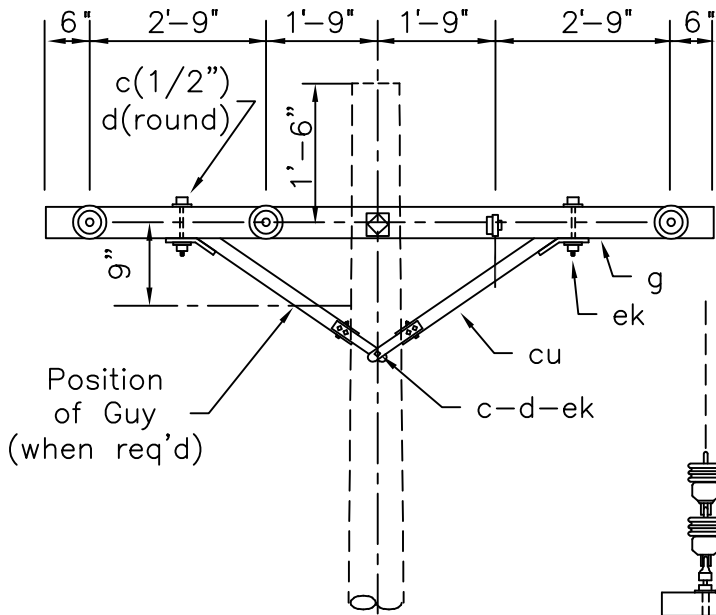

ITEM	QTY	MATERIAL
c	4	Bolt, machine, 1/2" x req'd length
c	2	Bolt, machine, 5/8" x req'd length
d	4	washer, round, 1 3/8"
d	19	Washer, square, 2 1/4"
g	2	Crossarm, 3 5/8" x 4 5/8" x 10'-0"
k	12	Insulator, suspension, 4 1/4"
n	4	Bolt, double arm, 5/8" x req'd length
o	2	Bolt, eye, 5/8" x req'd length
p		Connectors, as req'd
aa	10	Nut, eye, 5/8"
av		Jumpers, as req'd
bo	2	Shackle, anchor
cu	2	Brace, wood, 60" span
ek	29	Locknuts

NOTES:

1. Double arming bolt, item "n" and eye nut, item "aa", may be replaced with double arming eye bolt, item "dy."
2. Maximum line angle may be increased to 15° by installing anchor shackles, item "bo," to (horizontal) eye nuts and installing side guys as req'd.
3. See drawing "N6.21" for additional details.
4. Designate as "C6.53" for assembly with 3 crossarms.

DESIGN PARAMETERS:

PERMITTED UNBALANCED CONDUCTOR TENSION:

See Table B (Exhibit 2)

MAXIMUM LINE ANGLE = 5°
(See Note 2)

DOUBLE DEADEND ON 10 FOOT CROSSARMS

APRIL 2005

RUS

3 - PHASE PRIMARY
12.47/7.2 kV

C6.52, C6.53

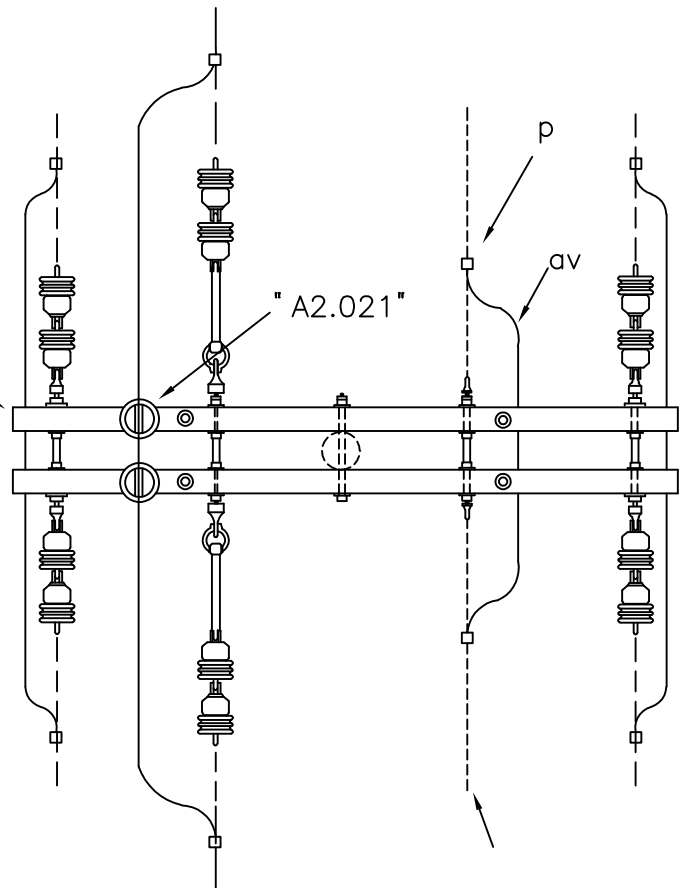
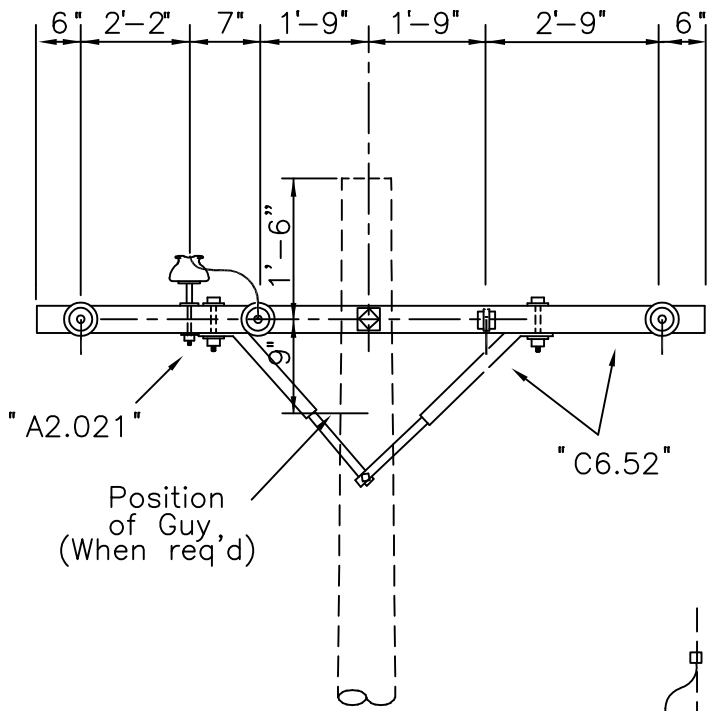

PLAN

NOTES:

1. See drawing "A6.22G" for alternate feed through of outside phases.
2. Crossarm may be installed 12" from top of pole.

ITEM	QTY	MATERIAL
	1	C6.51 Primary Assembly
	1	A2.021 Primary Assembly
P		Connectors, as req'd
av		Jumpers, as req'd

DESIGN PARAMETERS:
See: Table B (Exhibit 2)

DOUBLE DEADEND ON 10 FOOT CROSSARMS
(FEEDTHROUGH GUIDE)

APRIL 2005

RUS

3 - PHASE PRIMARY
12.47/7.2 kV

C6.52G

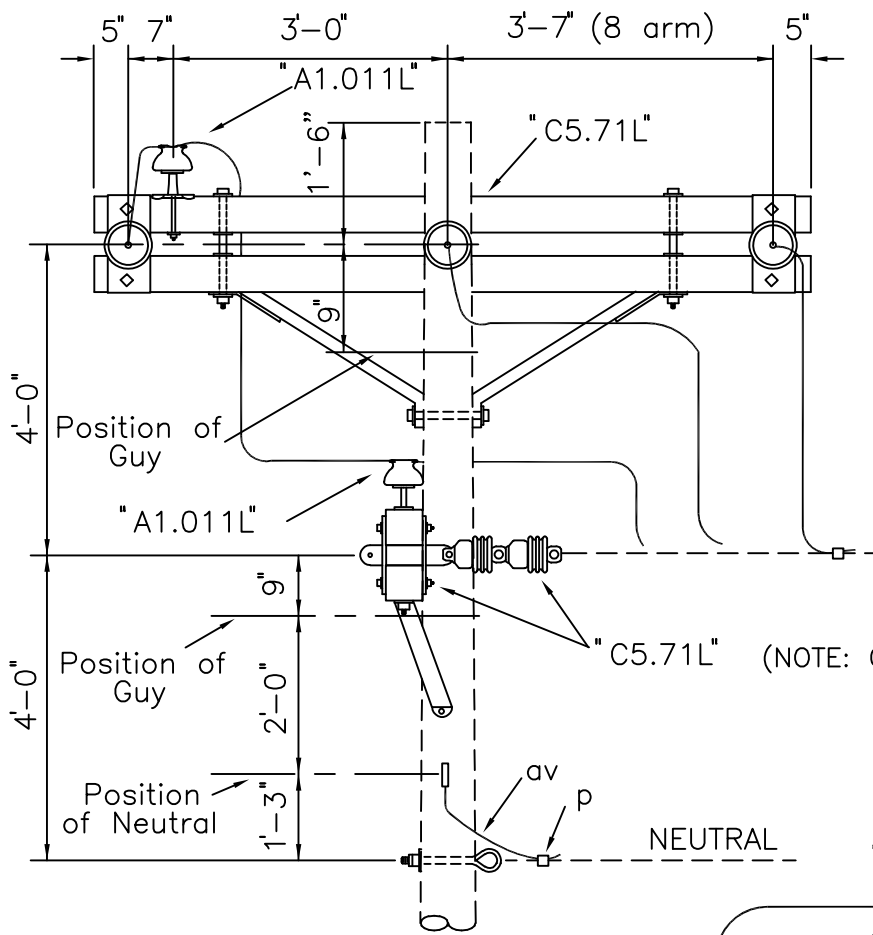

(NOTE: Other double or triple crossarm assemblies may be used.)

PLAN

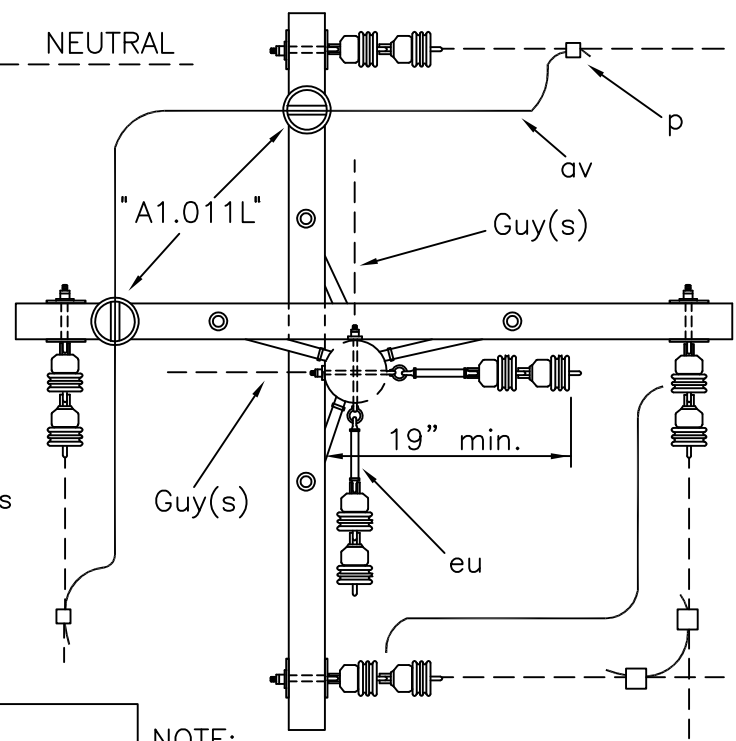

NOTE: Guy angle of top down guy needs to be less than 39° (4:5 guy lead to height ratio). A 1:1 guy ratio is permitted if 10 foot crossarm assembly is used in bottom position. Install guy strain insulator, "w" 60" minimum, in top down guy. (See "E1.5")

NOTE: Vertical deadends, Dwg. "C4.1," is preferred construction.

ITEM	QTY	MATERIAL
	2	C5.71L Primary (Crossarm) Assembly
	2	A1.011L Misc. Single Support
p		Connectors, as req'd
av		Jumpers, as req'd
eu	2	Link, extension, insulated, 12" min.

DESIGN PARAMETERS:

 PERMITTED LONGITUDINAL LOAD EQUALS LESSER OF:
 5,000 lbs./Conductor, or
 Manufacturer's specifications
 times NESC strength factor.

DOUBLE DEADENDS (BUCKARMS) GUIDE		
APRIL 2005	3 - PHASE PRIMARY	C6.91G
RUS	12.47/7.2 kV	

INDEX D

DOUBLE CIRCUIT PRIMARY POLE TOP ASSEMBLY UNITS

<u>DRAWING NUMBERS</u>		<u>DRAWING TITLE (DESCRIPTION)</u>
1728F-804 (New)	Bulletin 50-3 (Old)	
D1.4N D1.4NP D1.5N D1.5NP		SINGLE SUPPORT - NARROW PROFILE (TANGENT) (and POST INSULATORS)
D1.81 D1.82	(DC-C1)	SINGLE SUPPORT ON CROSSARMS (TANGENT)
D1.81L D1.82L		SINGLE SUPPORT ON CROSSARMS (TANGENT) (LARGE CONDUCTORS)
D1.81P D1.82P		SINGLE SUPPORT ON CROSSARMS (TANGENT) (POST INSULATORS)
D1.83		SINGLE SUPPORT ON CROSSARMS
D1.83L		SINGLE SUPPORT ON CROSSARMS (LARGE CONDUCTORS)
D1.83P		SINGLE SUPPORT ON CROSSARMS (POST INSULATORS)
D2.9N D2.9NP		DOUBLE SUPPORT - NARROW PROFILE (and POST INSULATORS)
D2.91 D2.91L	(DC-C2-1)	DOUBLE SUPPORT ON CROSSARMS DOUBLE SUPPORT ON CROSSARMS (LARGE CONDUCTORS)
D2.91P		DOUBLE SUPPORT ON CROSSARMS (POST INSULATORS)
D3.1G		SUSPENSION ANGLE GUIDE
D4.1G		DEADEND ANGLE GUIDE
D5.91G		THREE PHASE TAP GUIDE
D6.91	(DC-C8)	DOUBLE DEADENDS ON CROSSARMS (FEEDTHROUGH)

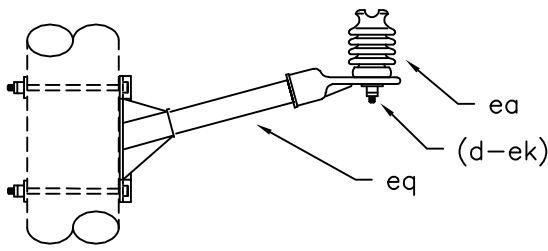

Specify D1.4NP or D1.5NP for post type insulators.

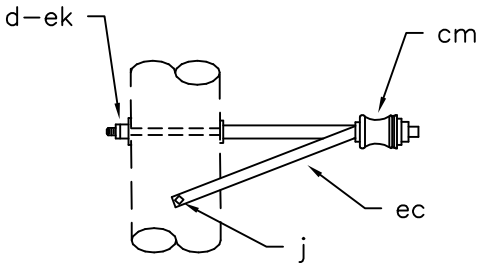

Specify D1.5N or D1.5NP for offset neutral assembly.

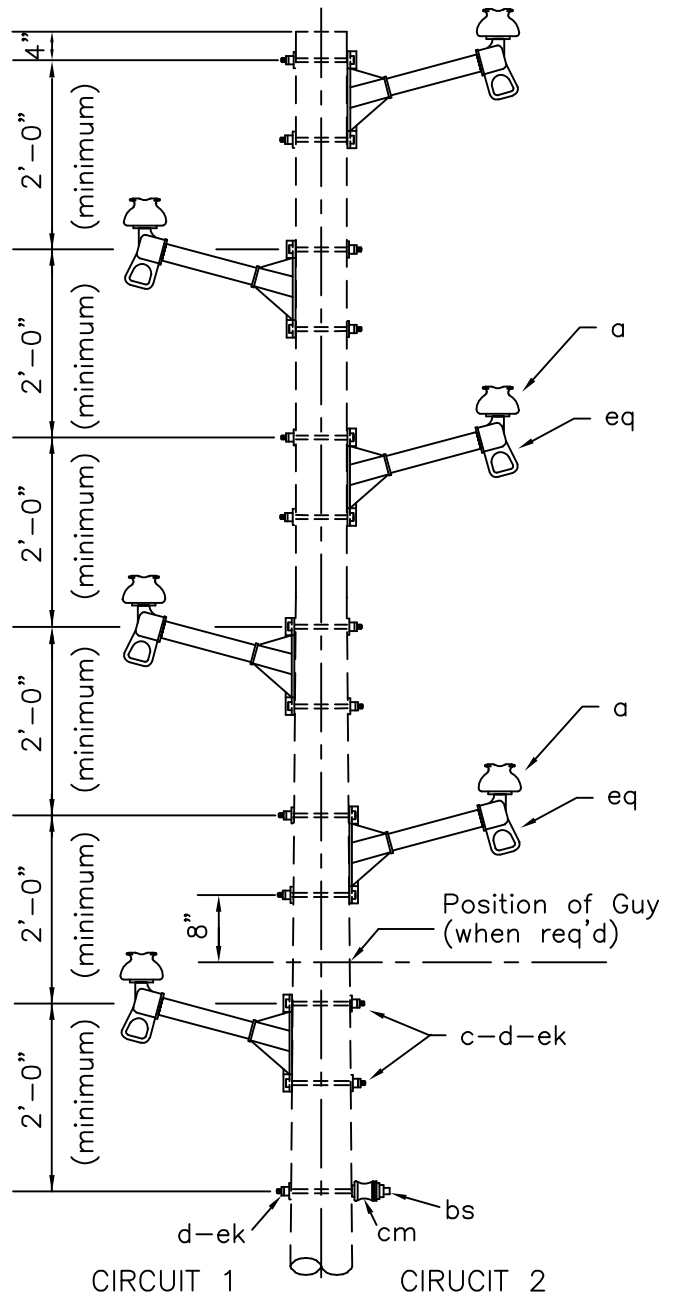

NOTE: If additional guying is required, use assembly D2.9N or D2.9NP.

ASSEMBLY: D1.		4N	4NP	5N	5NP
ITEM	MATERIAL	QTY	QTY	QTY	QTY
a	Insulator, pin type (12.47/7.2 kV)	6		6	
c	Bolt, machine, 5/8" x req'd length	12	12	12	12
d	Washer, square 2 1/4"	13	13	13	13
(f)	(Pin, crossarm, 5/8" x 6 1/2")	(6)		(6)	
j	Screw, lag, 1/2" x 4"			2	2
bs	Bolt, single, upset	1	1		
cm	Insulator, spool, 3"	1	1	1	1
ea	Insulator, post type (12.47/7.2kV)		6		6
ec	Bracket, offset, neutral			1	1
ek	Locknuts	13	13	13	13
eq	Bracket, insulator/equipment	6	6	6	6

(if req'd)

Design Parameters:

MAXIMUM LINE ANGLES:
5'-Small Conductors
2'-Larger than #1/0

SINGLE SUPPORT-NARROW PROFILE
(TANGENT)

APRIL 2005

RUS

DOUBLE CIRCUIT PRIMARY
12.47/7.2 kV

D1.4N,D1.4NP
D1.5N,D1.5NP

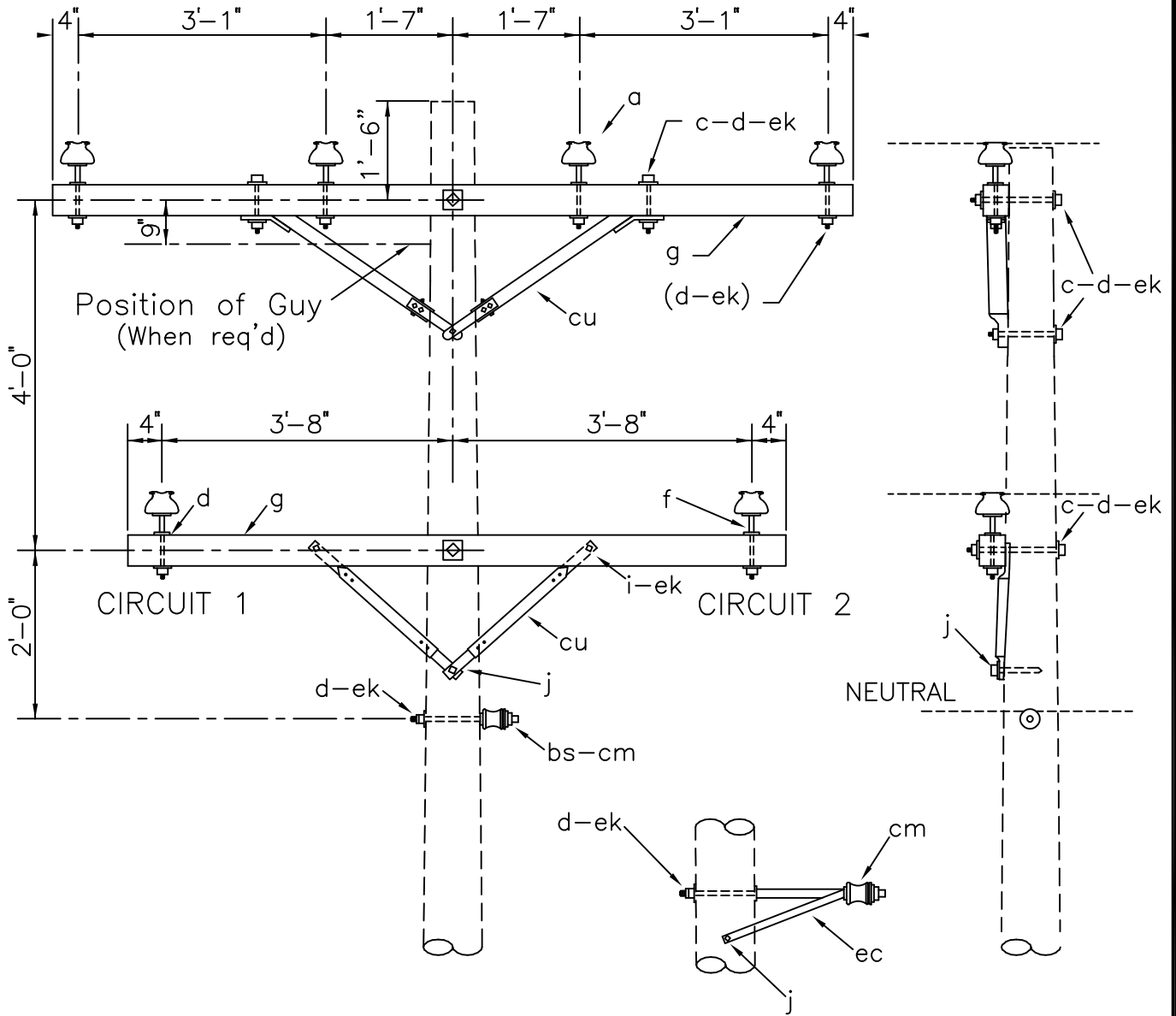

Specify D1.82 for
offset neutral assembly

ASSEMBLY: D1.

81 82

ITEM	MATERIAL	QTY	QTY
a	Insulator, pin type, (12.47/7.2 kV)	6	6
c	Bolt, machine, 1/2" x req'd length	2	2
c	Bolt, machine, 5/8 x req'd length	3	3
d	Washer, round, 1 3/8"	2	2
d	Washer, square, 2 1/4"	12	12
f	Pin, crossarm, steel, 5/8" x 10 3/4"	6	6
g	Crossarm, 3 5/8" x 4 5/8" x 8' - 0"	1	1
g	Crossarm, 3 5/8" x 4 5/8" x 10' - 0"	1	1

ASSEMBLY: D1.

81 82

ITEM	MATERIAL	QTY	QTY
i	Bolt, carriage, 3/8" x 4 1/2"	2	2
j	Screw, lag, 1/2" x 4"	1	3
bs	Bolt, single, upset	1	
cm	Insulator, spool, 3"	1	1
cu	Brace, 28"	2	2
cu	Brace, wood, 60" span	1	1
ec	Bracket, offset, neutral		1
ek	Locknuts	8	8

DESIGN PARAMETERS:

MAXIMUM LINE ANGLES:
5° - Small Conductors
2° - Larger than #1/0

SINGLE SUPPORT ON CROSSARMS
(TANGENT)

APRIL 2005

RUS

DOUBLE CIRCUIT PRIMARY
12.47/7.2 kV

D1.81 (DC-C1)
D1.82

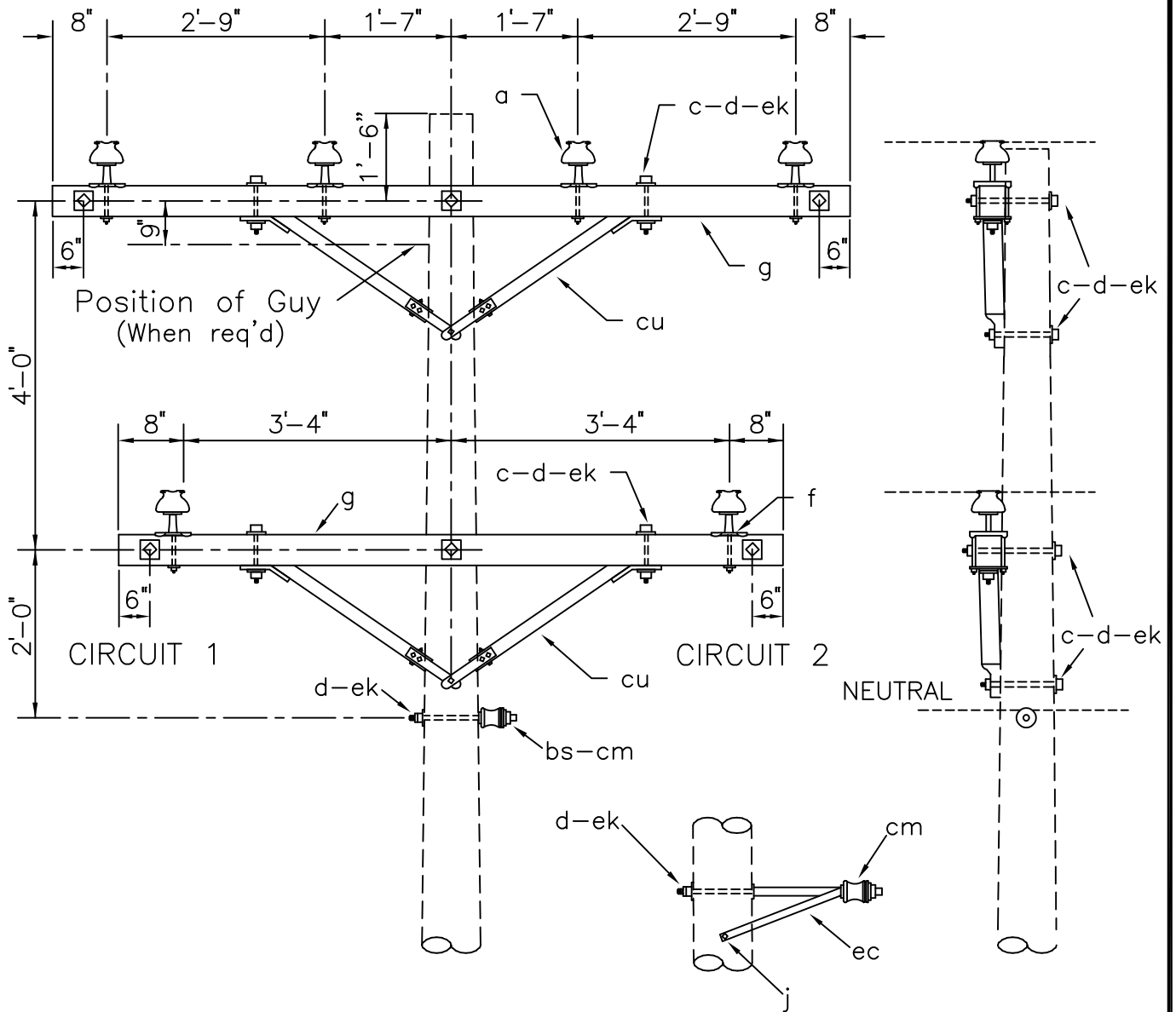

Specify D1.82L for
offset neutral assembly

ASSEMBLY: D1.		81L	82L
ITEM	MATERIAL	QTY	QTY
a	Insulator, pin type, (12.47/7.2 kV)	6	6
c	Bolt, machine, 1/2" x req'd length	4	4
c	Bolt, machine, 5/8" x req'd length	8	8
d	Washer, round, 1 3/8"	4	4
d	Washer, square, 2 1/4"	15	15
f	Pin, crossarm, steel, clamp type	6	6
g	Crossarm, 3 5/8" x 4 5/8" x 8' - 0"	1	1
g	Crossarm, 3 5/8" x 4 5/8" x 10' - 0"	1	1

ASSEMBLY: D1.		81L	82L
ITEM	MATERIAL	QTY	QTY
j	Screw, lag, 1/2" x 4"	0	3
bs	Bolt, single, upset	1	
cm	Insulator, spool, 3"	1	1
cu	brace, wood, 60" span	2	2
ec	Bracket, offset, neutral		1
ek	Locknuts	13	13

DESIGN PARAMETERS:

MAXIMUM LINE ANGLE = 2°

SINGLE SUPPORT ON CROSSARMS
(TANGENT) (LARGE CONDUCTORS)

APRIL 2005

RUS

DOUBLE CIRCUIT PRIMARY
12.47/7.2 kV

D1.81L
D1.82L

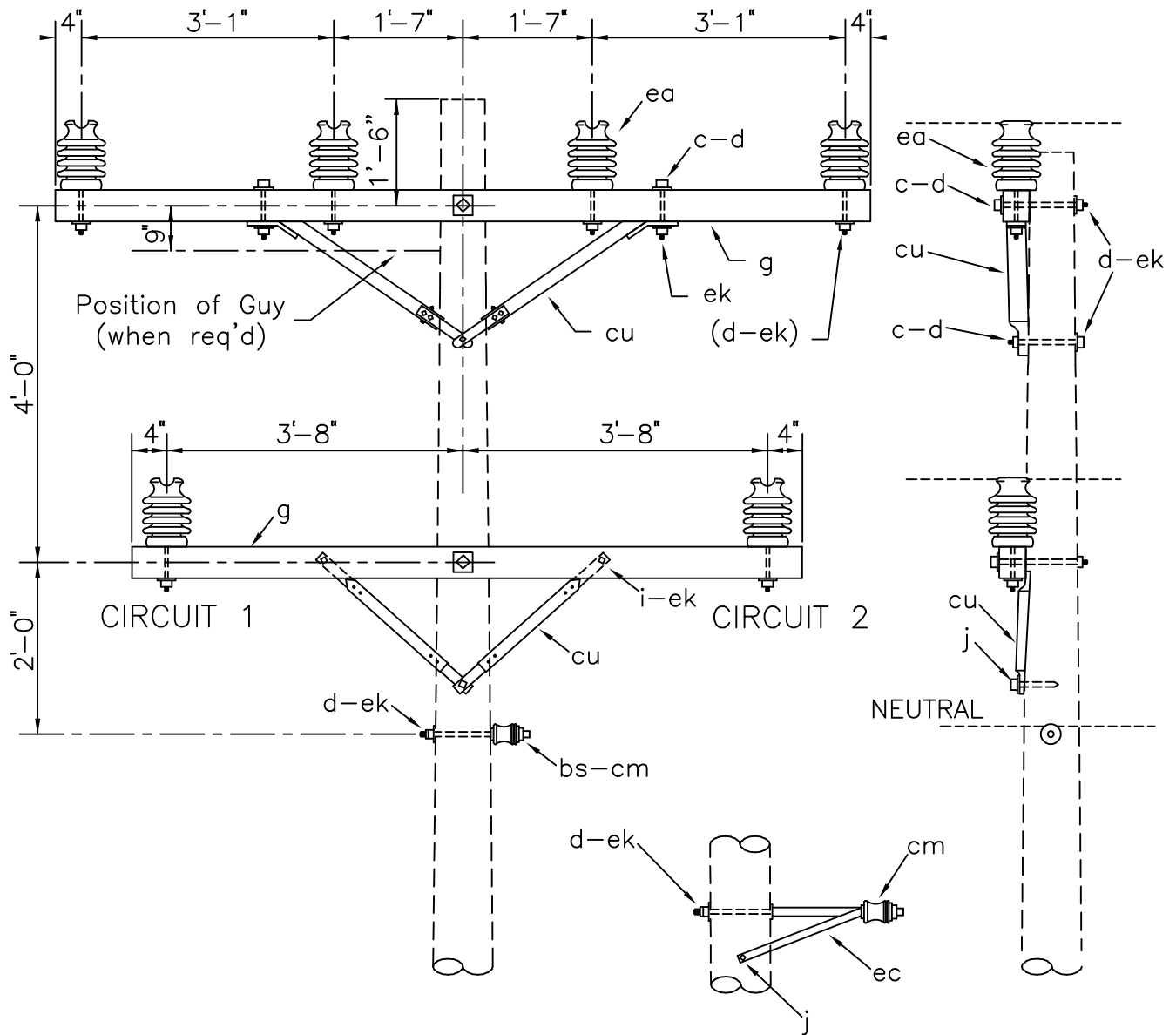

Specify D1.82P for offset neutral assembly

ASSEMBLY: D1. 81P 82P

ASSEMBLY: D1. 81P 82P

ITEM	MATERIAL	QTY	QTY
c	Bolt, machine, 1/2" x req'd length	2	2
c	Bolt, machine, 5/8 x req'd length	3	3
d	Washer, round, 1 3/8"	2	2
d	Washer, square, 2 1/4"	6	6
g	Crossarm, 3 5/8" x 4 5/8" x 8' - 0"	1	1
g	Crossarm, 3 5/8" x 4 5/8" x 10' - 0"	1	1
i	Bolt, carriage, 3/8" x 4 1/2"	2	2
j	Screw, lag, 1/2" x 4	1	3

ITEM	MATERIAL	QTY	QTY
bs	Bolt, single, upset	1	
cm	Insulator, spool, 3"	1	1
cu	Brace, 28"	2	2
cu	Brace, wood, 60" span	1	1
ea	Insulator, post type, (12.47/7.2 kV)	6	6
ec	Bracket, offset, neutral		1
ek	Locknuts	8	8

DESIGN PARAMETERS:

MAXIMUM LINE ANGLES:
 5° - Small Conductors
 2° - Larger than #1/0

SINGLE SUPPORT ON CROSSARMS
 (TANGENT) (POST INSULATORS)

APRIL 2005

RUS

DOUBLE CIRCUIT PRIMARY
 12.47/7.2 kV

D1.81P
 D1.82P

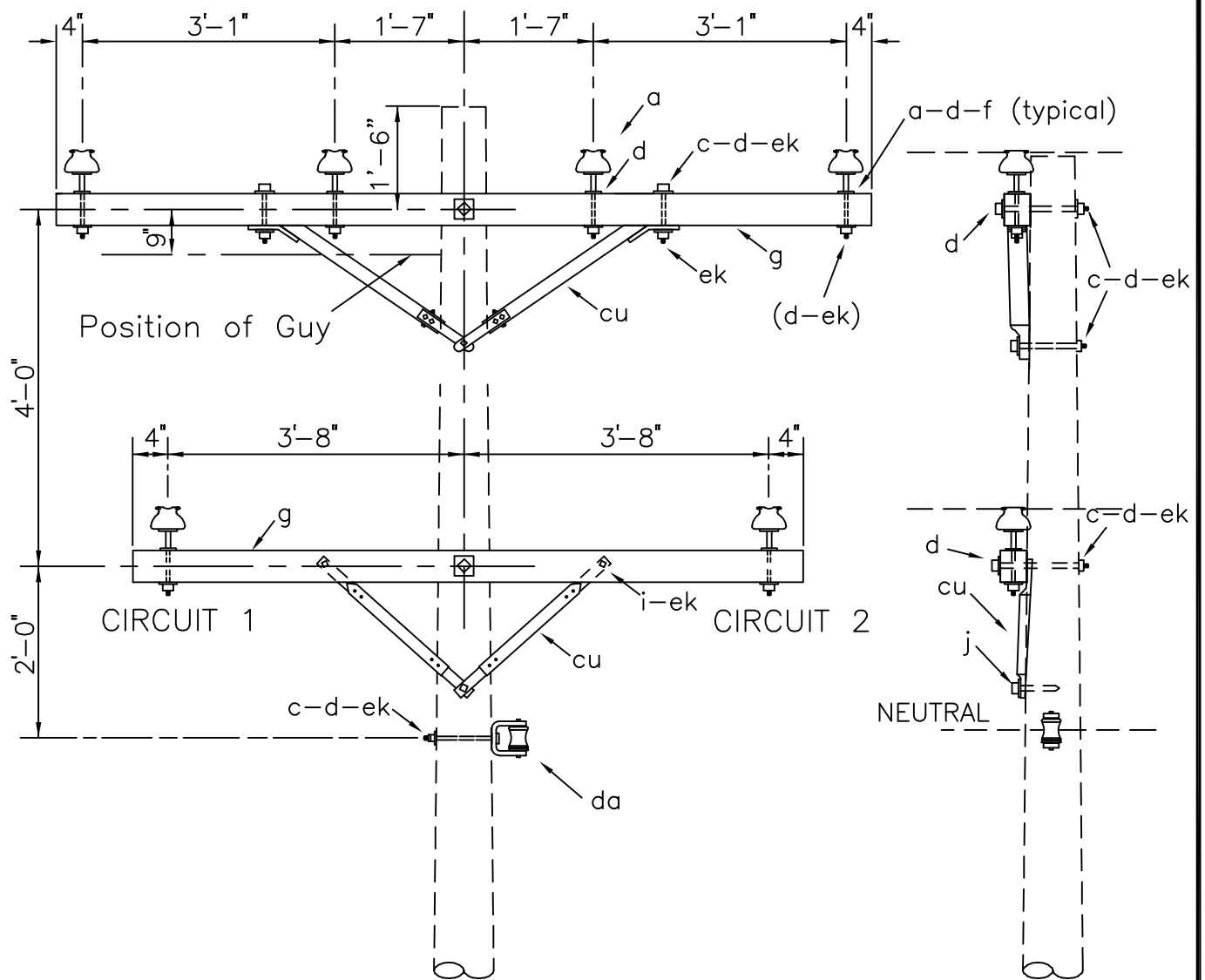

ITEM	QTY	MATERIAL
a	6	Insulator, pin type, (12.47/7.2 kV)
c	2	Bolt, machine, 1/2" x req'd length
c	4	Bolt, machine, 5/8" x length
d	2	Washer, round, 1 3/8"
d	12	Washer, square, 2 1/4"
f	6	Pin, crossarm, steel, 5/8" x 10 3/4"
g	1	Crossarm, 3 5/8" x 4 5/8" x 8'-0"

ITEM	QTY	MATERIAL
g	1	Crossarm, 3 5/8" x 4 5/8" x 10'-0"
i	2	Bolt, carriage, 3/8" x 4 1/2"
j	1	Screw, lag, 1/2" x 4"
cu	2	Brace, 28"
cu	1	Brace, wood, 60" span
da	1	Bracket, insulated
ek	8	Locknuts

DESIGN PARAMETERS:
See Table II

SINGLE SUPPORT ON CROSSARMS

APRIL 2005

DOUBLE CIRCUIT PRIMARY

RUS

12.47/7.2 kV

D1.83

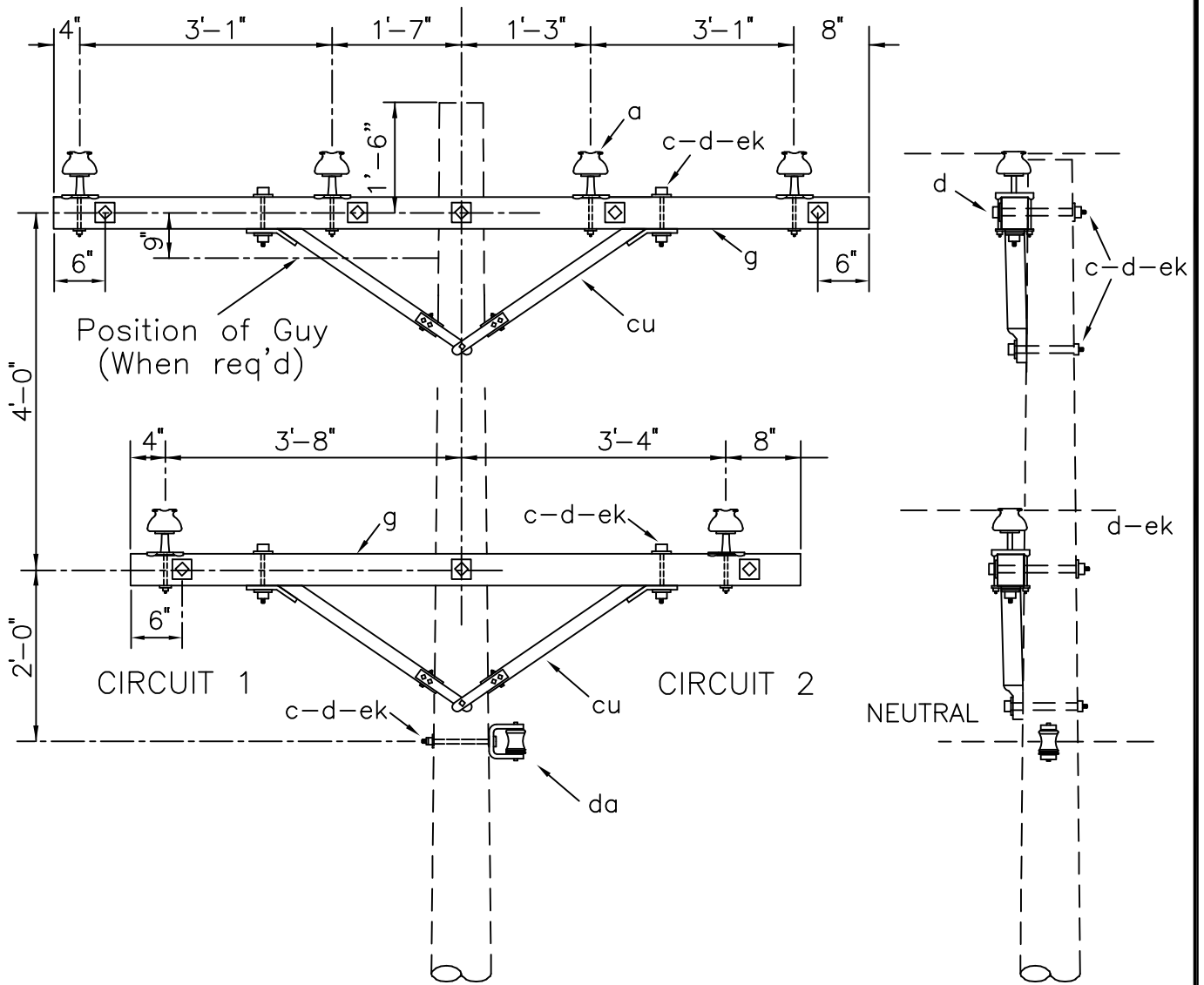

ITEM	QTY	MATERIAL
a	6	Insulator, pin type, (12.47/7.2 kV)
c	4	Bolt, machine, 1/2" x req'd length
c	11	Bolt, machine, 5/8" x length
d	4	Washer, round, 1 3/8"
d	19	Washer, square, 2 1/4"
f	6	Pin, crossarm, steel, clamp type
g	1	Crossarm, 3 5/8" x 4 5/8" x 8'-0"

ITEM	QTY	MATERIAL
g	1	Crossarm, 3 5/8" x 4 5/8" x 10'-0"
cu	2	Brace, wood, 60" span
da	1	Bracket, insulator
ek	15	Locknuts

DESIGN PARAMETERS:
See Table III

SINGLE SUPPORT ON CROSSARMS
(LARGE CONDUCTORS)

APRIL 2005

DOUBLE CIRCUIT PRIMARY
12.47/7.2 kV

RUS

D1.83L

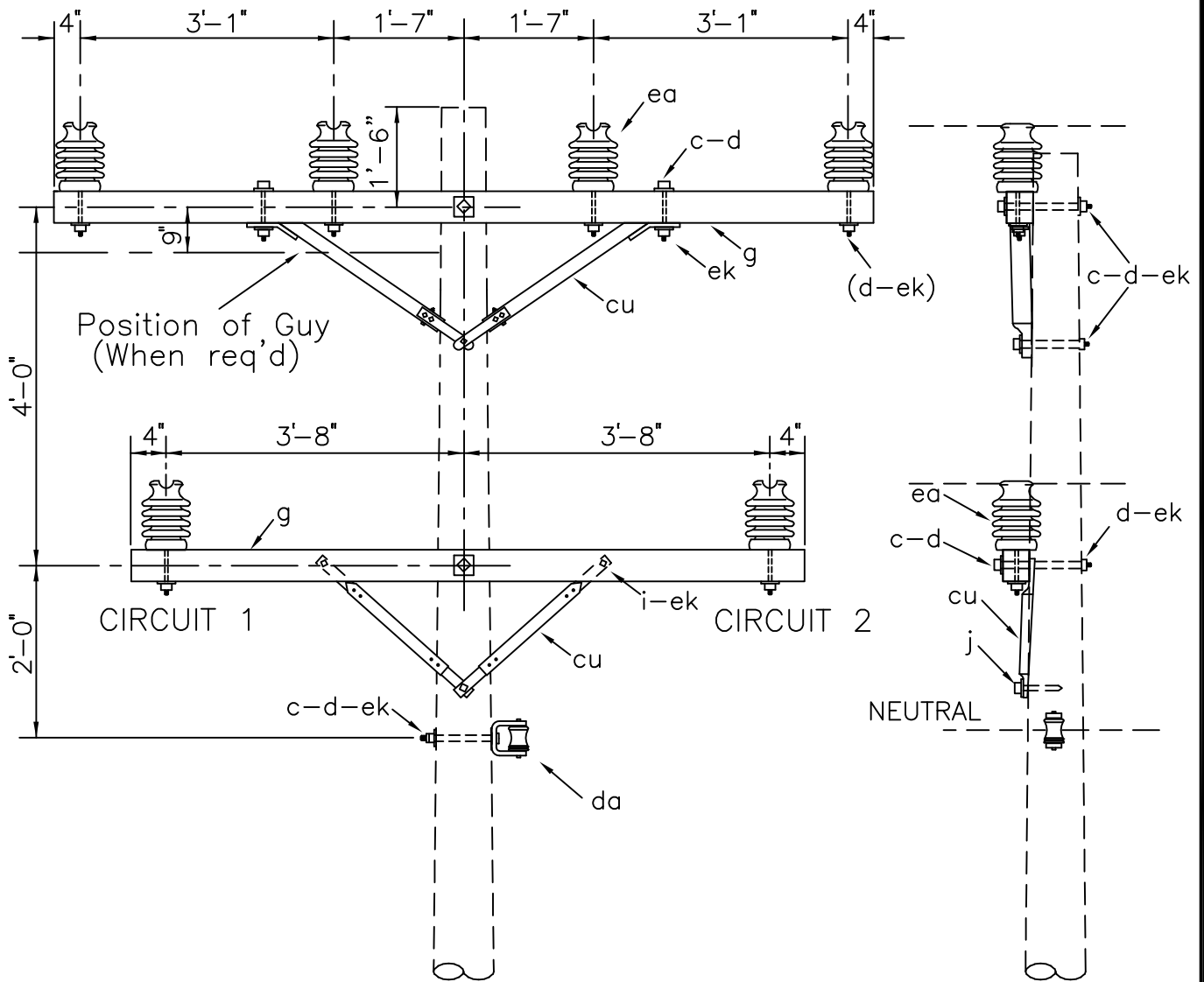

ITEM	QTY	MATERIAL
c	2	Bolt, machine, 1/2" x req'd length
c	4	Bolt, machine, 5/8" x req'd length
d	2	Washer, round, 1 3/8"
d	6	Washer, square, 2 1/4"
g	1	Crossarm, 3 5/8" x 4 5/8" x 8'-0"
g	1	Crossarm, 3 5/8" x 4 5/8" x 10'-0"
i	2	Bolt, carriage, 3/8" x 4 1/2"

ITEM	QTY	MATERIAL
j	1	Screw, lag, 1/2" x 4"
cu	2	Brace, 28"
cu	1	Brace, wood, 60" span
da	1	Bracket, insulated
ea	6	Insulator, post type, (12.47/7.2 kV)
ek	8	Locknuts

DESIGN PARAMETERS:
See Table II

SINGLE SUPPORT ON CROSSARMS
(POST INSULATORS)

APRIL 2005

DOUBLE CIRCUIT PRIMARY

RUS

12.47/7.2 kV

D1.83P

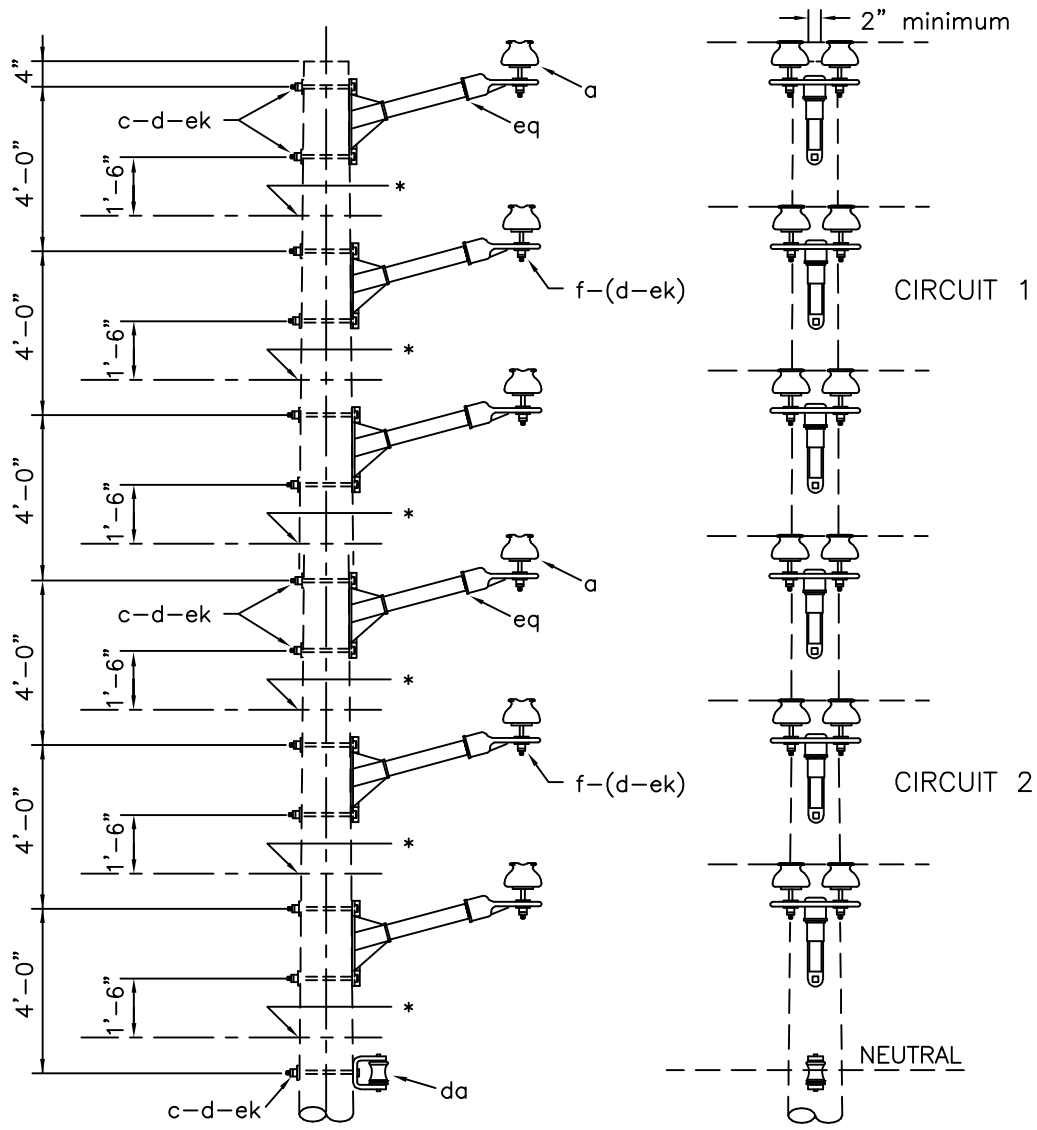

* Position of guys as required.

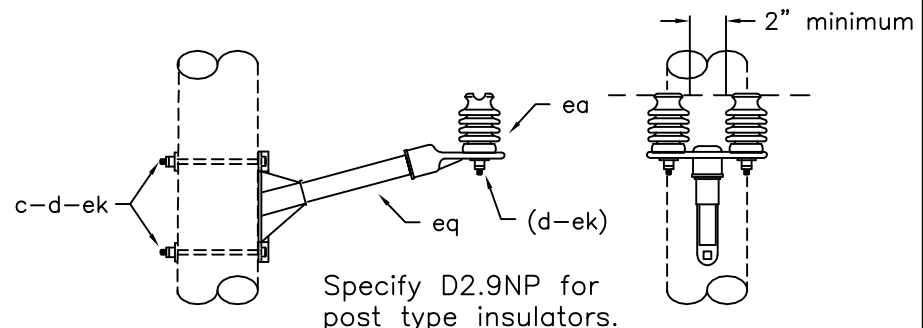

NOTE: See D3.1G or D4.1G for alternative construction.

ITEM	MATERIAL	Assembly: D2.	
		9N	9NP
		QTY	QTY
a	Insulator, pin type (12.47/7.2 kV)	12	
c	Bolt, machine, 5/8" x req'd length	13	13
d	Washer, square 2 1/4"	13	13
f	Pin, crossarm, 5/8" x 6 1/2"	12	
da	Bracket, insulated	1	1
ea	Insulator, post type (12.47/7.2kV)		12
ek	Locknuts	13	13
eq	Bracket, insulator/equipment	6	6

Design Parameters:
Maximum Line Angles
See TABLE IV

DOUBLE SUPPORT-NARROW PROFILE

APRIL 2005	DOUBLE CIRCUIT PRIMARY	D2.9N
RUS	12.47/7.2 kV	D2.9NP

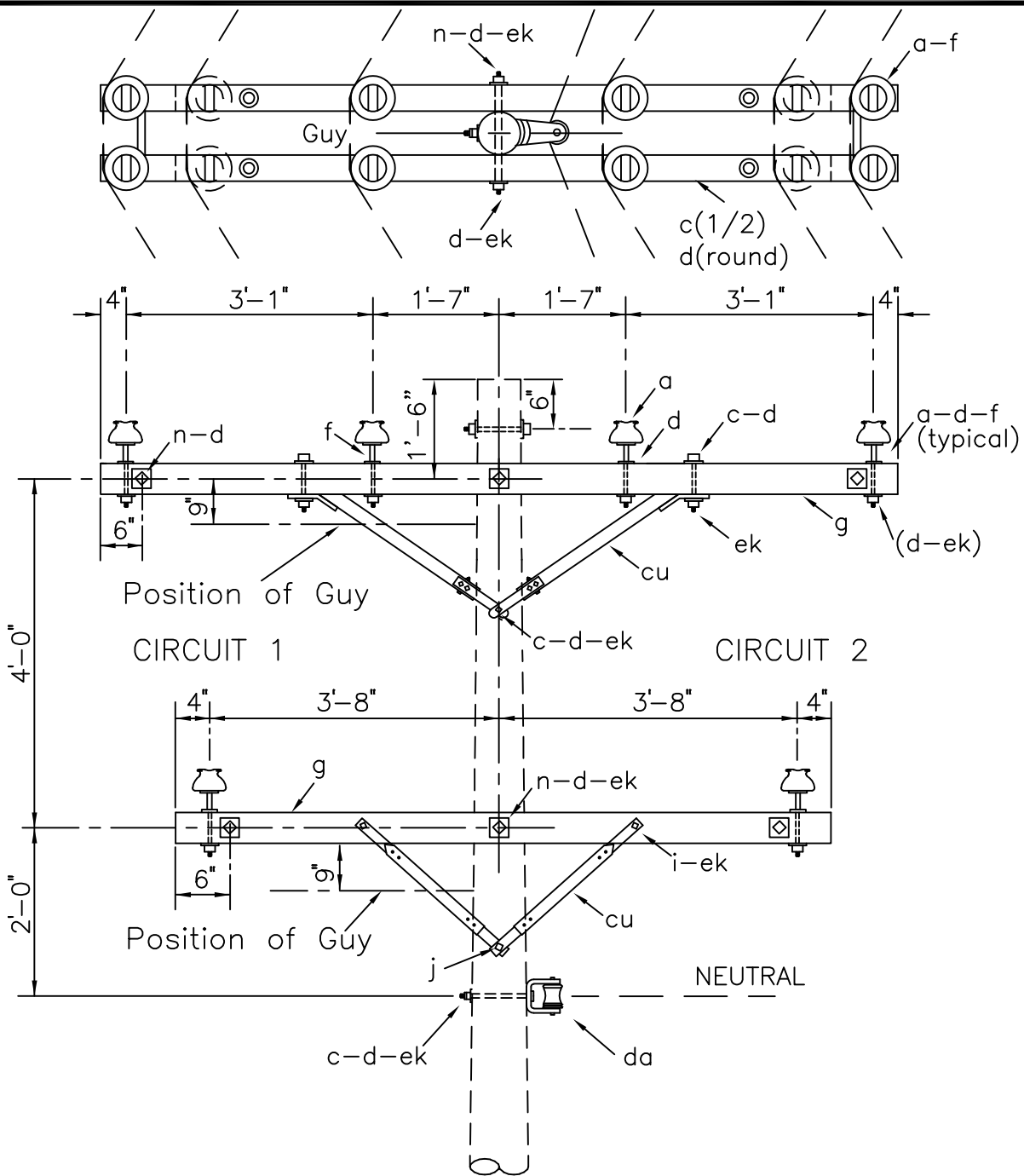

ITEM	QTY	MATERIAL
a	12	Insulator, pin type (12.47/7.2 kV)
c	4	Bolt, machine, 1/2" x req'd length
c	3	Bolt, machine, 5/8" x length
d	4	Washer, round, 1 3/8"
d	36	Washer, square, 2 1/4"
f	12	Pin, crossarm, steel, 5/8" x 10 3/4"
g	2	Crossarm, 3 5/8" x 4 5/8" x 10'-0"
g	2	Crossarm, 3 5/8" x 4 5/8" x 8'-0"

ITEM	QTY	MATERIAL
i	4	Bolt, carriage, 3/8" x 4 1/2"
j	2	Screw, lag, 1/2" x 4"
n	6	Bolt, double arming, 5/8" x req'd length
cu	4	Brace, 28"
cu	2	Brace, wood, 60" span
da	1	Bracket, insulated
ek	27	Locknuts

DESIGN PARAMETERS:
See Table IV

DOUBLE SUPPORT ON CROSSARMS

APRIL 2005

RUS

DOUBLE CIRCUIT PRIMARY
12.47/7.2 kV

D2.91
(DC-C2-1)

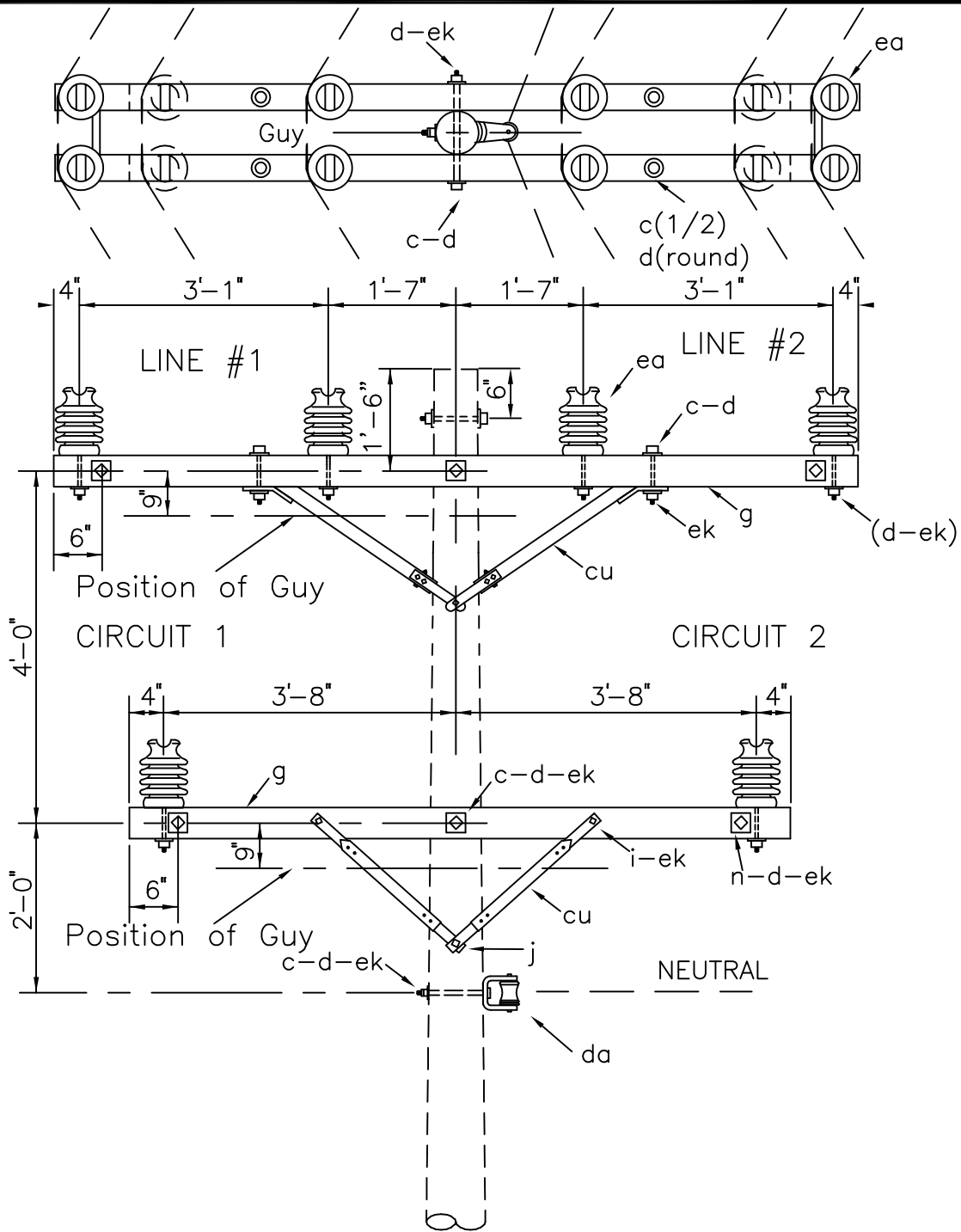

ITEM	QTY	MATERIAL
c	4	Bolt, machine, 1/2" x req'd length
c	5	Bolt, machine, 5/8" x req'd length
d	4	Washer, round, 1 3/8"
d	24	Washer, square, 2 1/4"
g	2	Crossarm, 3 5/8" x 4 5/8" x 10'-0"
g	2	Crossarm, 3 5/8" x 4 5/8" x 8'-0"
i	4	Bolt, carriage, 3/8" x 4 1/2"

ITEM	QTY	MATERIAL
j	2	Screw, lag, 1/2" x 4"
n	4	Bolt, double arming, 5/8" x req'd length
cu	4	Brace, 28"
cu	2	Brace, wood, 60" span
da	1	Bracket, insulated
ea	12	Insulator, post type, (12.47/7.2 kV)
ek	25	Locknuts

DESIGN PARAMETERS:
See Table IV

DOUBLE SUPPORT ON CROSSARMS
(POST INSULATORS)

APRIL 2005

DOUBLE CIRCUIT PRIMARY
12.47/7.2 kV

RUS

D2.91P

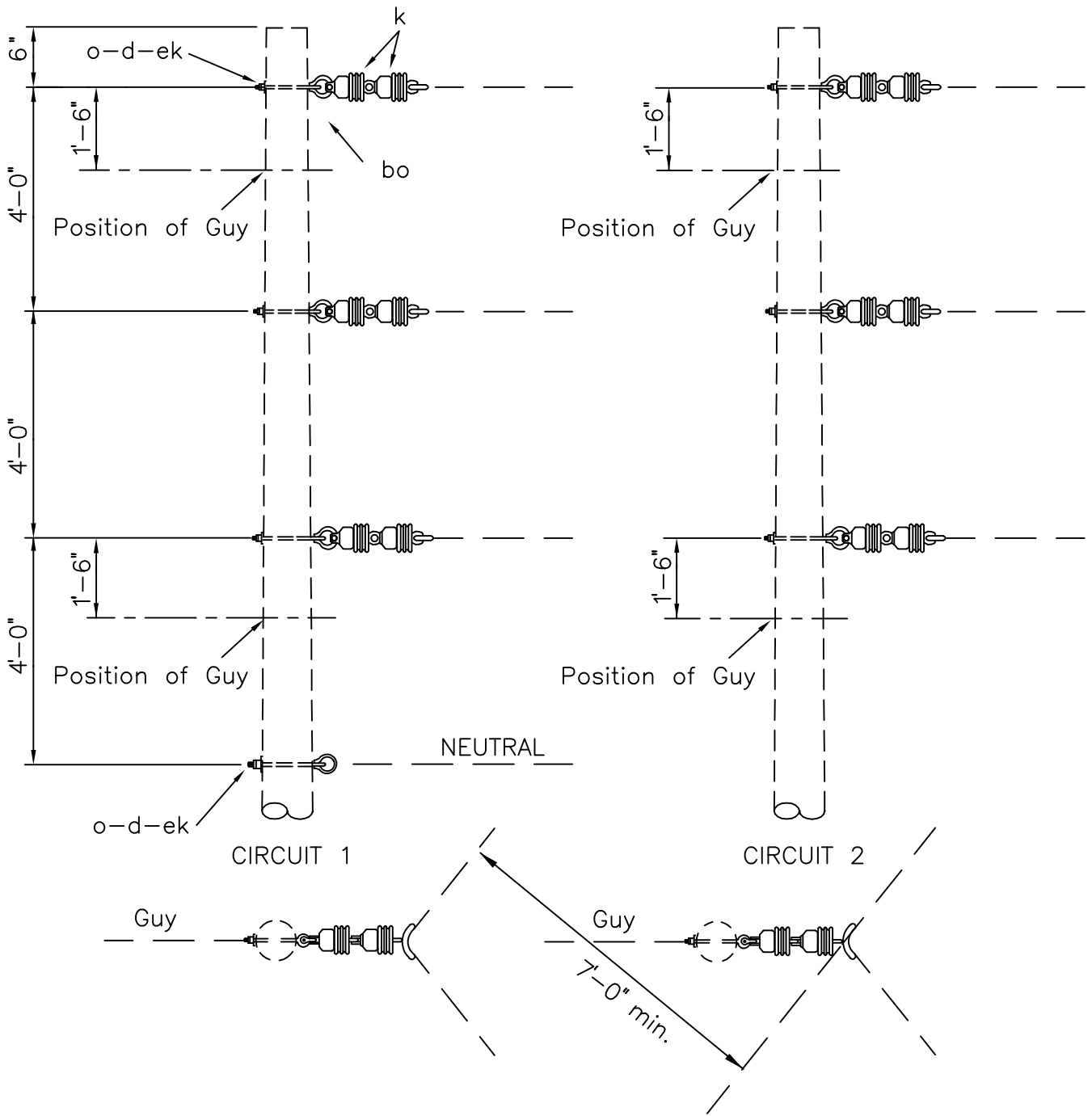

- NOTE: 1. The NESC requires a minimum separation of 5 feet between any energized conductor and any guy wire.
 2. See guy assembly "E2.1G", "E3.1LG", "E4.3LG".

ITEM	QTY	MATERIAL
	2	"C3.1" through "C3.9" Primary Assemblies (Delete material for one neutral subassembly: "o-d-ek")
	(2)	(Use "C3.1L" Primary Assembly for large conductors.) (Delete material for one neutral subassembly)

DESIGN PARAMETERS:

See "C3.1 through "C3.9"

SUSPENSION ANGLE GUIDE

APRIL 2005

DOUBLE CIRCUIT PRIMARY

RUS

12.47/7.2 kV

D3.1G

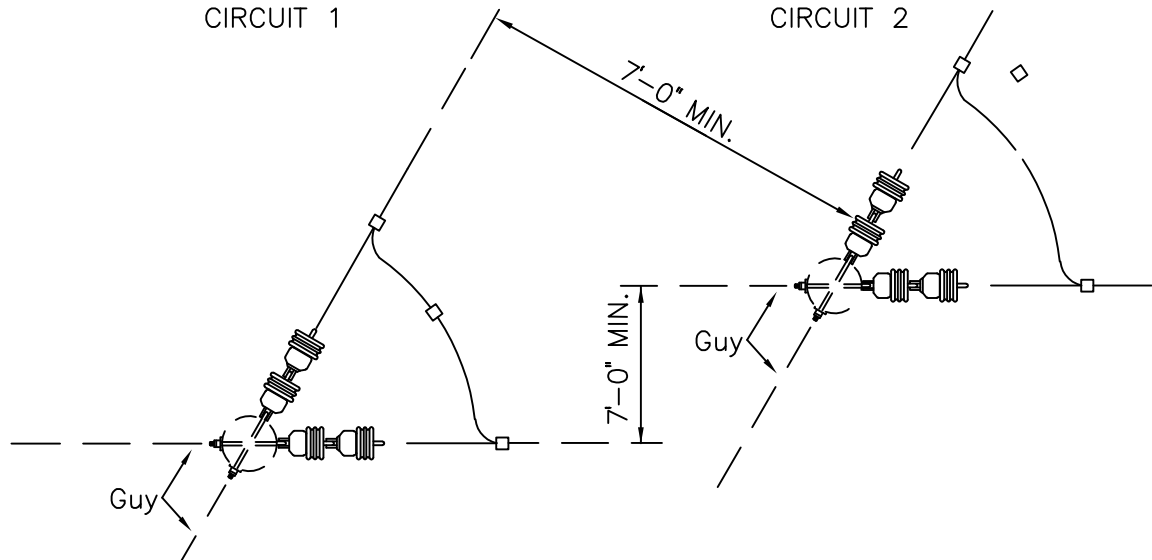
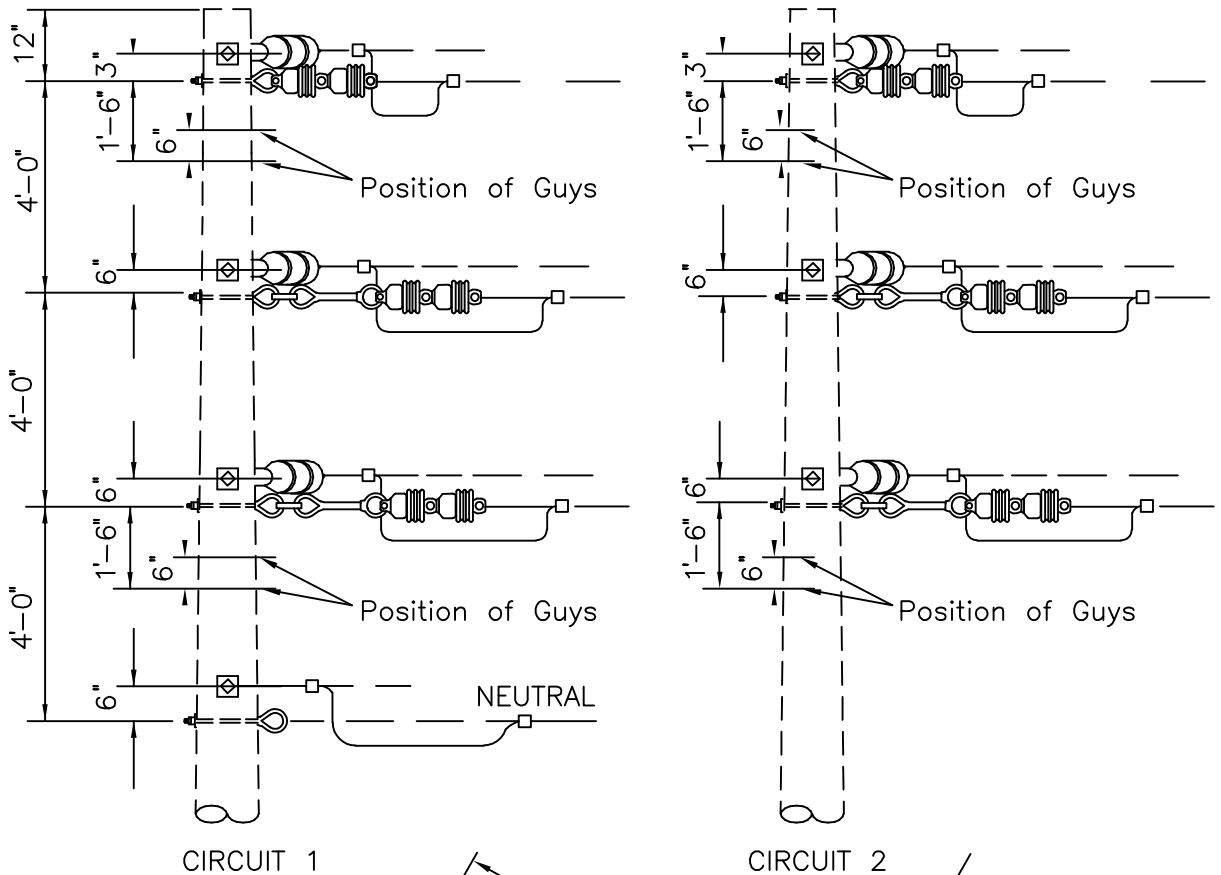

NOTES: 1. The NESC requires a minimum separation of 5 feet between any energized conductor and any guy wire.
 2. See guy assembly "E2.G", "E3.1LG" or "E4.3LG".

ITEM	QTY	MATERIAL
	4	"C3.1" through "C3.9" Primary Assemblies (Delete material for two neutral subassemblies: "o-d-ek")
p		Connectors, as req'd
av		Jumpers, as req'd

DESIGN PARAMETERS:

 See: "C4.1G"
 "C4.2G"

DEADEND ANGLE GUIDE		
APRIL 2005	DOUBLE CIRCUIT PRIMARY	
RUS	12.47/7.2 kV	D4.1G

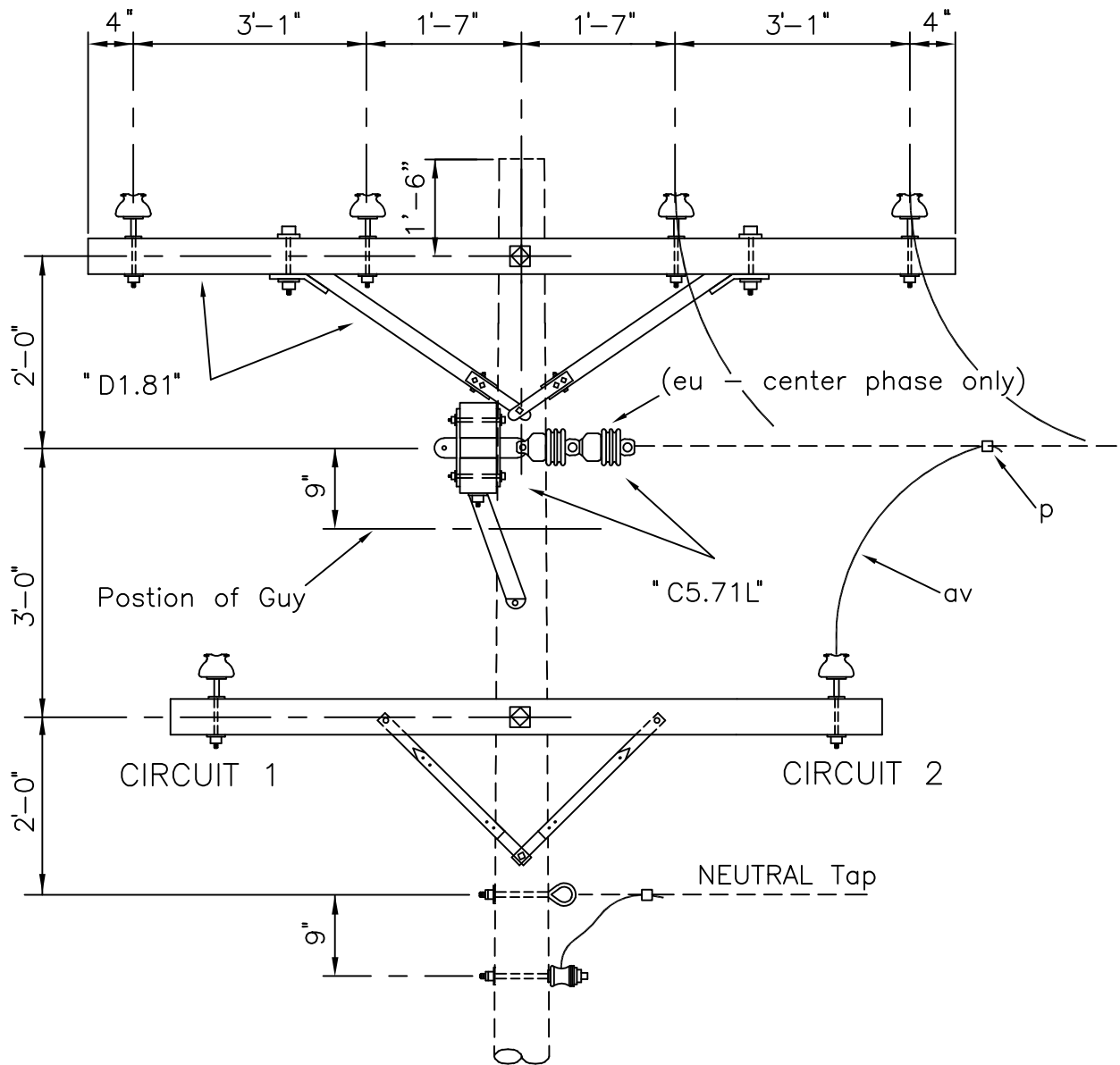

ITEM	QTY	MATERIAL
	1	C5.71L Primary Assembly
	1	D1.81 Primary Assembly
p		Connectors, as required
av		Jumpers, as required
eu		Link, extension, insulated, 12" min.

DESIGN PARAMETERS:

SEE: "C5.71L"
"D1.81"

THREE PHASE TAP GUIDE

APRIL 2005	DOUBLE CIRCUIT PRIMARY	D5.91G
RUS	12.47/7.2 kV	

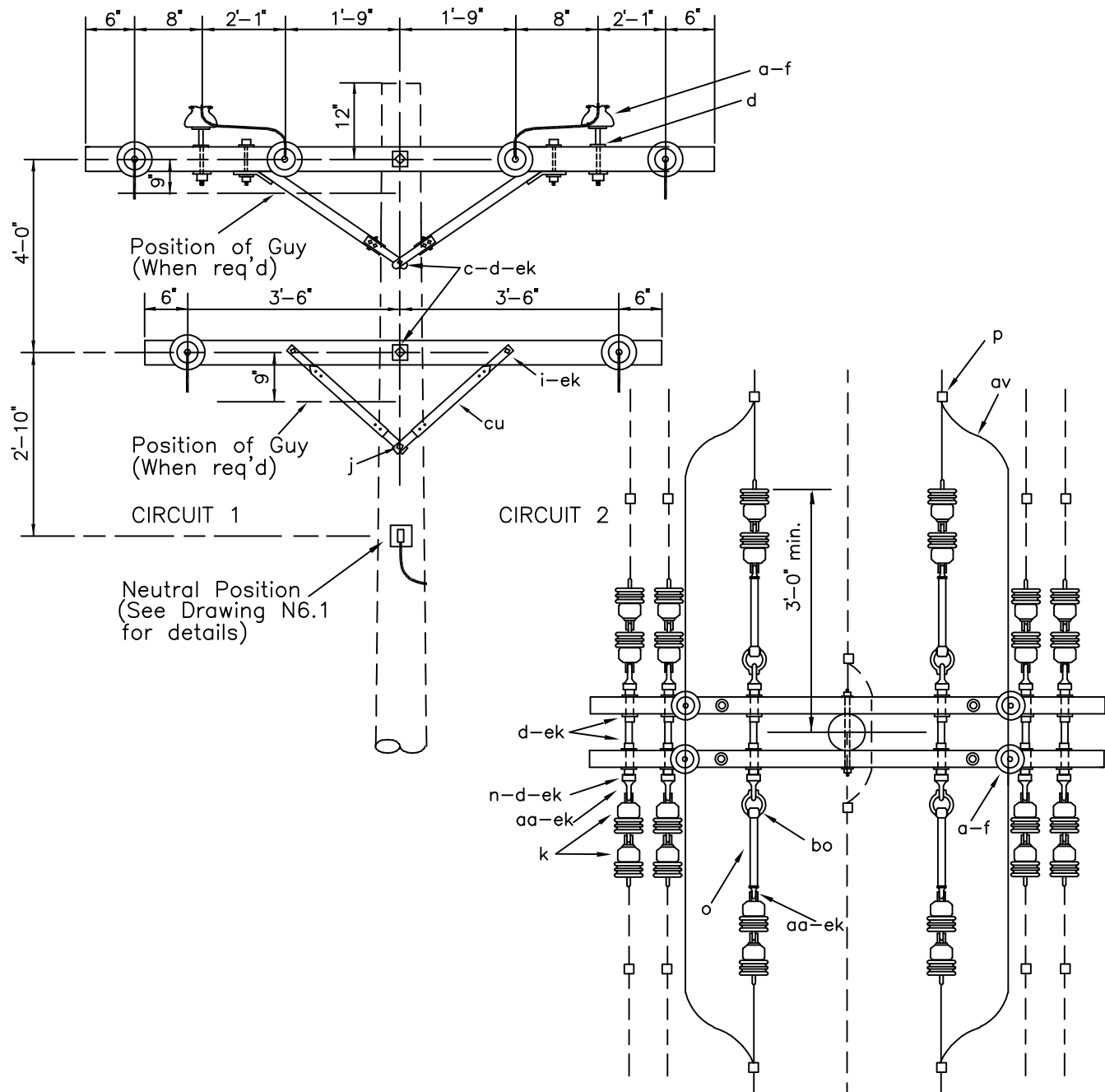

ITEM	QTY	MATERIAL
a	4	Insulator, pin type (12.47/7.2 kV)
c	4	Bolt, machine, 1/2 x req'd length
c	3	Bolt, machine, 5/8" x length
d	4	Washer, round, 1 3/8
d	33	Washer, square, 2 1/4
d	2	Washer, square, 3", curved
f	4	Pin, crossarm, steel, 5/8" x 10 3/4"
g	2	Crossarm, 3 5/8" x 4 5/8" x 10'-0"
g	2	Crossarm, 3 5/8" x 4 5/8" x 8'-0"
i	4	Bolt, carriage, 3/8" x 4 1/2"
j	2	Screw, lag, 1/2" x 4"

ITEM	QTY	MATERIAL
k	24	Insulator, suspension, 4 1/2"
n	7	Bolt, double arm, 5/8 x req'd length
o	4	Bolt, eye, 5/8" x req'd length
p		Connectors, as req'd
aa	18	Nut, eye
av		Jumpers, as req'd
bo	4	Shackle, anchor
cu	2	Brace, wood, 60" span
cu	4	Brace, 28"
ek	47	Locknuts

DESIGN PARAMETERS:

PERMITTED UNBALANCED
CONDUCTOR TENSION:

See Table B (Exhibit 2)

(See Notes on Drawing "C6.52")

DOUBLE DEADENDS ON CROSSARMS
(FEEDTHROUGH)

APRIL 2005

RUS

DOUBLE CIRCUIT PRIMARY
12.47/7.2 kV

D6.91
(DC-C8)

GUYING ASSEMBLY UNITS

<u>DRAWING NUMBERS</u>		<u>DRAWING TITLE (DESCRIPTION)</u>
1728F-804 (New)	Bulletin 50-3 (Old)	
E1.1	(E1-2)	SINGLE DOWN GUY (THROUGH BOLT TYPE)
E1.1L	(E1-3)	SINGLE DOWN GUY - HEAVY DUTY (THROUGH BOLT TYPE)
E1.2	(E3-3)	SINGLE DOWN GUY (WRAPPED TYPE)
E1.3L		SINGLE DOWN GUY - LARGE CONDUCTORS (POLE BAND TYPE)
E1.4	(E2-2)	SINGLE OVERHEAD GUY - (THROUGH BOLT TYPE)
E1.4L	(E2-3)	SINGLE OVERHEAD GUY - HEAVY DUTY (THROUGH BOLT TYPE)
E1.5		GUY STRAIN INSULATOR
E2.1G		DOUBLE DOWN GUY GUIDE - (THROUGH BOLT TYPE)
E3.1LG		THREE DOWN GUY GUIDE - HEAVY DUTY (THROUGH BOLT TYPE)
E4.3LG		FOUR DOWN GUY GUIDE - LARGE CONDUCTORS (POLE BAND TYPES)

CONSTRUCTION SPECIFICATIONS FOR GUYS

The design engineer shall determine the number and type of guys needed to be installed.

Guys shall be attached to the pole as shown in the construction drawings and shall be installed before conductors are strung. Deadend structure guys shall be installed, as nearly as practicable, in line with the pull of conductors. Guys that bisect line angles (bisector guys) at line angle structures shall be installed as nearly as practicable to the true bisector of the line angle.

The distance from the pole to the anchor rod (the guy lead) is recommended to be the same distance as from the ground to the guy attachment on the pole. This 1:1 guy slope is especially recommended on deadend structures.

Written permission from RUS is required prior to the installation of sidewalk guys and push poles. RUS will consider the use of sidewalk guys and push poles on a case-by-case basis.

The NESC requires that the grade of construction of guys be the same or higher as the grade of construction of: (1) the pole or structure to which they are attached, or (2) the highest grade required for any conductors supported by the pole or structure.

The permitted loads shown in the design parameters for guying assemblies have already been calculated by RUS by multiplying a strength factor of 0.85 to the RUS designated loading (or strength) of the guying assemblies. The strength factor of 0.85 was used by RUS as an additional safety factor and is based on the spirit of the rules of NESC Section 261 and NESC Table 261-1A.

The permitted loads shown on the guy assembly drawings shall be reduced by 25 percent for NESC Grade B construction.

The permitted loads on guy wires shall be determined by multiplying the rated breaking strength of the guy wire by the strength factor of 0.90 given in NESC Table 261-1A.

Guy strength that must be provided is determined by totaling all loads expected to be exerting tension on the guy assembly and guy wire(s) and multiplying this total load by the appropriate overload factors according to NESC Rule 253 and as shown in NESC Table 253-1.

CONSTRUCTION SPECIFICATIONS FOR GUYS (cont.)

If the separation on the pole between any guy attachment bolt or hardware and any phase conductor attachment bolt is less than 15 inches, then a guy strain insulator assembly (E5.1) shall be installed at the top of the guy and the guy wire shall be effectively grounded below the insulator by bonding the guy wire to the system neutral and the pole ground if present. Alternatively, an insulated extension link (item "eu") shall be installed in the primary conductor tap, deadend, or suspension angle subassembly where it attaches to the pole.

The purpose of this specification is to maintain minimum basic insulation impulse levels (BIL) and to increase clearances for line workers.

Down guy and overhead guy wires shall be effectively grounded in accordance with Rule 215C2 of the NESC and in accordance with the RUS assembly drawings. Effectively grounded guy wires provide a direct path to ground and thus decrease the chances of electric shock, serious injury and even death to a person standing on the ground and making contact with a guy wire that has accidentally become energized by means of contact with a primary, secondary, service or neutral conductor. Furthermore, effectively grounded guy wires bonded to anchor rods decrease the overall system impedance to ground and improve the chances of primary overcurrent protection devices to operate as designed.

Down guy and overhead guy wires may be insulated in portions of a borrower's service area if all 5 of the following conditions are met:

- (1) The borrower: (1) has records documenting that anchors or anchor rods have failed due to corrosion after less than 20 years of service, or (2) has performed and documented a study that has determined that insulating down guy wires is an adequate and economical method to mitigate predicted premature corrosion of anchors and anchor rods in the service area covered by the study. Such studies or records shall be made available for RUS review upon request;
- (2) Insulated down guys and their component parts shall be in compliance with all of the applicable rules of the NESC;
- (3) Only fiberglass guy strain insulators (item "w") shall be used to insulate guy wires and the insulators shall be installed at the top of the guy wire as depicted in assembly drawing E1.5;
- (4) RUS required bonding clamps are securely installed between the anchor rod and the guy wire attached to the anchor rod; and
- (5) The borrower has a special regimented maintenance program in place that periodically (as experience indicates) checks the insulation integrity of installed guy insulators.

CONSTRUCTION SPECIFICATIONS FOR GUYS *(cont.)*

Down guys installed on tangent, double deadend assemblies (e.g., A6.1) shall have a minimum clearance to the neutral conductor of 6 inches and shall have a guy strain insulator(s) installed at the top of the guy that extends from the pole attachment to at least 12 inches past the neutral conductor.¹ Alternatively, two down guys without guy strain insulators may be installed, one on each side of the neutral, such that clearance between each down guy wire and the neutral conductor is a minimum of 12 inches. For either of the above designs, the down guy wire shall be effectively bonded to ground in accordance with RUS specifications and the rules of the NESC.

¹ For example, the 6-inch clearance can be met for a down guy with a 30-foot guy lead that is attached to the pole 30 feet above the ground and 2.5 feet above the neutral by installing (offsetting) the guy anchor 6 feet perpendicular to the line of the neutral conductor.

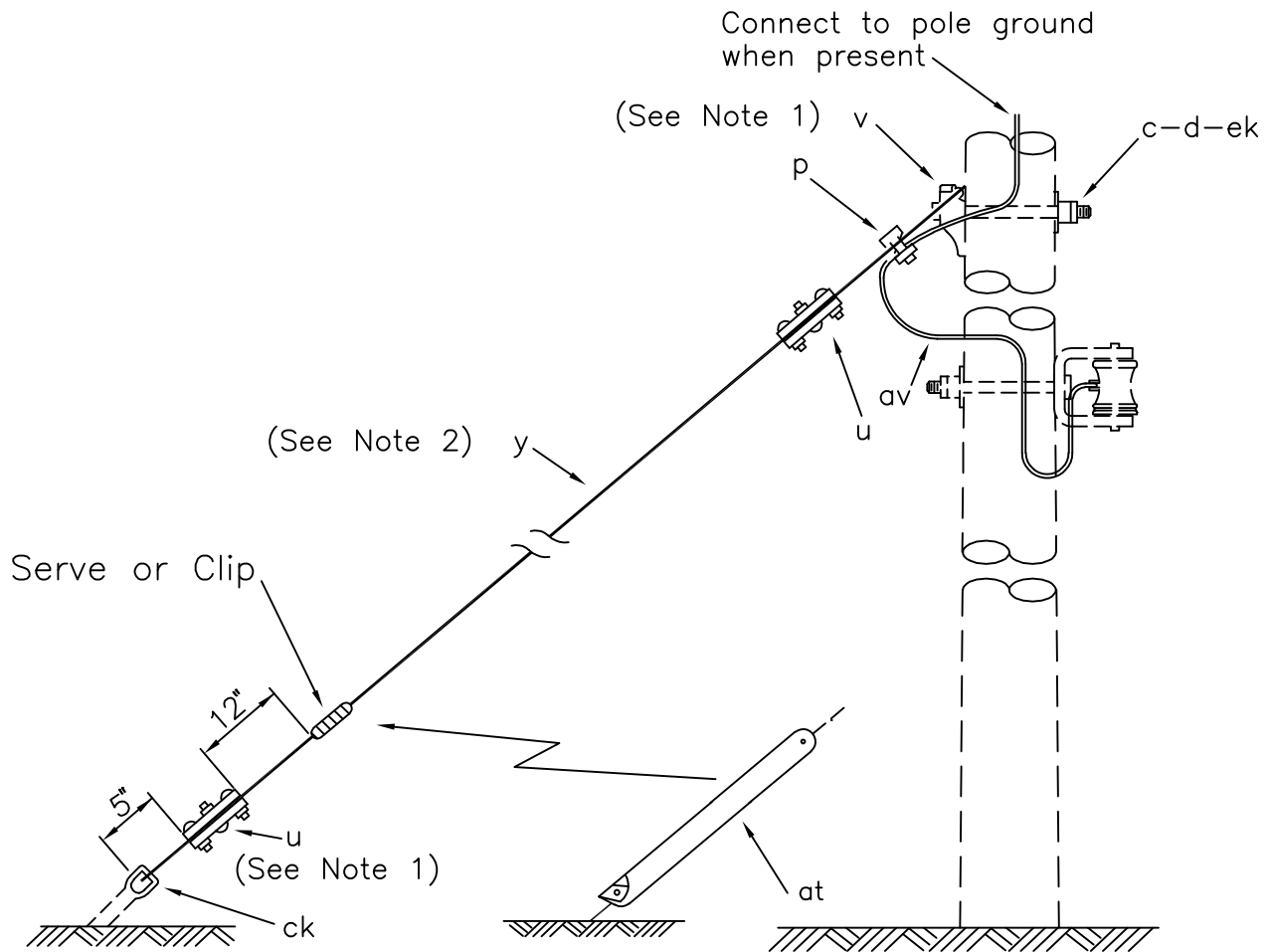

NOTES:

1. Other accepted and equivalent guy deadend (item "u") and attachment (item "v") material may be substituted for the ones shown.
2. Some types of guy attachments use 2 bolts and washer or lag screw (item "j"), change materials accordingly.
3. Specify guy wire size, type and required length.

ITEM	QTY	MATERIAL
c	1	Bolt, machine, 5/8" x req'd length
d	1	Washer, 3" square, curved
p		Connectors, guy bond and as req'd
u	2	Deadend for guy strand (See Note 1)
v	1	Guy attachment (See Note 1)
y		Guy wire, as req'd (See Note 3)
at	1	Guy marker
av		Jumpers, as req'd
ck	1	Clamp, anchor bonding
ek	1	Locknuts

DESIGN PARAMETERS:

PERMITTED LOAD IS LESSER OF:
 6,600 lbs (in any direction)
 or 90% of RATED BREAKING
 STRENGTH OF GUY WIRE

SINGLE DOWN GUY
 (THROUGH BOLT TYPE)

APRIL 2005

RUS

E1.1
 (E1-2)

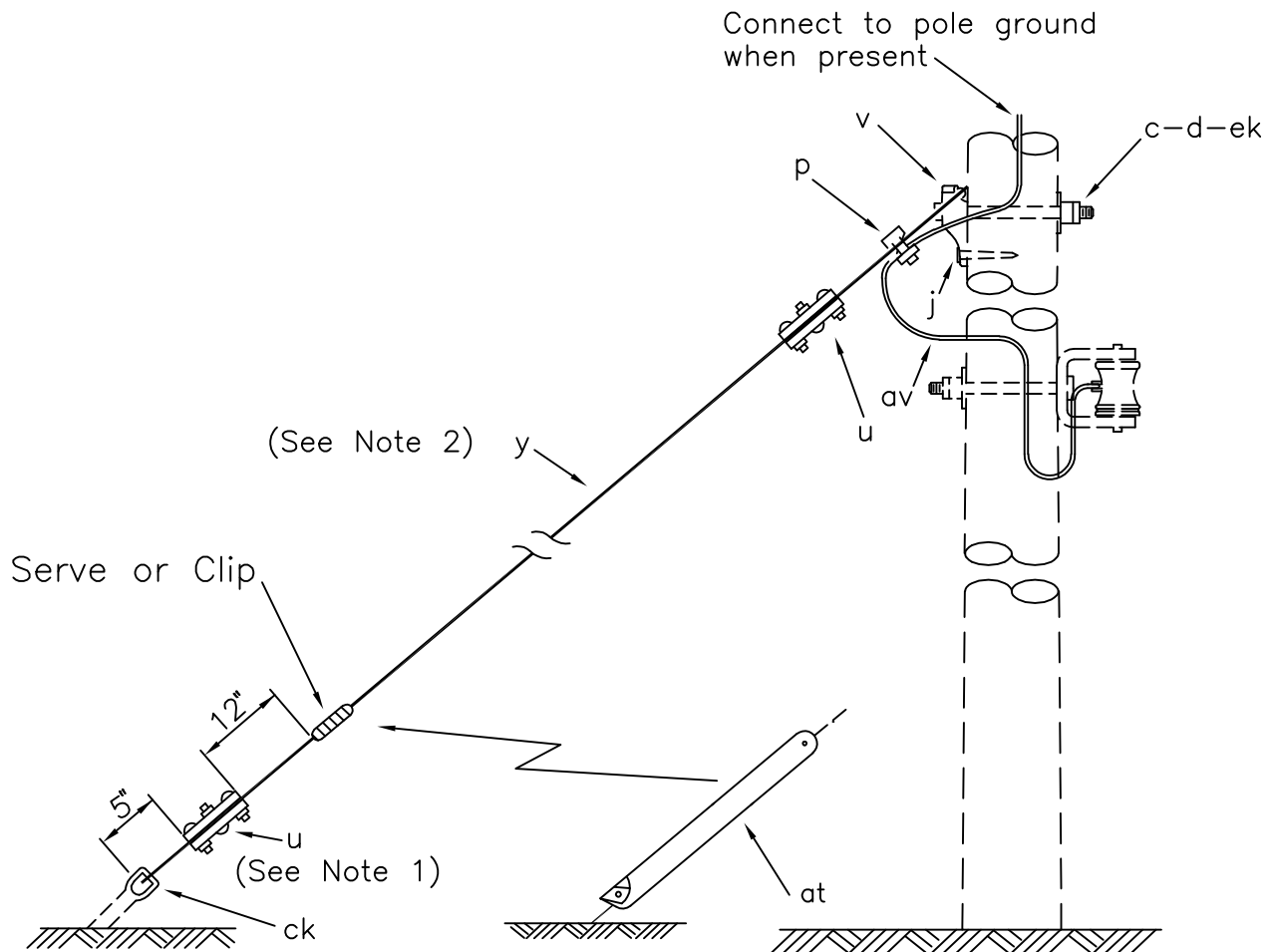

NOTES:

1. Other accepted and equivalent, heavy duty, guy deadend material (item "u") may be substituted for the ones shown.
2. Pole eye plate guy attachment and anchor shackle (item "bo") may be used.

ITEM	QTY	MATERIAL
c	1	Bolt, machine, 3/4" x req'd length
d	1	Washer, square, 4", curved
p		Connectors, guy bond and as req'd
j	1	Screw, lag, 1/2" x 4"
u	2	Deadend for guy strand, heavy duty
v	1	Guy attachment, guy hook type
y		Guy wire, as req'd (See Note 4)
at	1	Guy marker
av		Jumpers, as req'd
ck	1	Clamp, anchor bonding
ek	1	Locknuts

3. 2-5/8 machine bolts and 2-3 square curved washers may be used to install guy attachment.

4. Specify guy wire size, type and required length.

DESIGN PARAMETERS:

PERMITTED LOAD IS LEAST OF:
 8,500 lbs (in any direction)
 or 90% of RATED BREAKING
 STRENGTH OF GUY WIRE

SINGLE DOWN GUY – HEAVY DUTY
 (THROUGH BOLT TYPE)

APRIL 2005

RUS

E1.1L
 (E1-3)

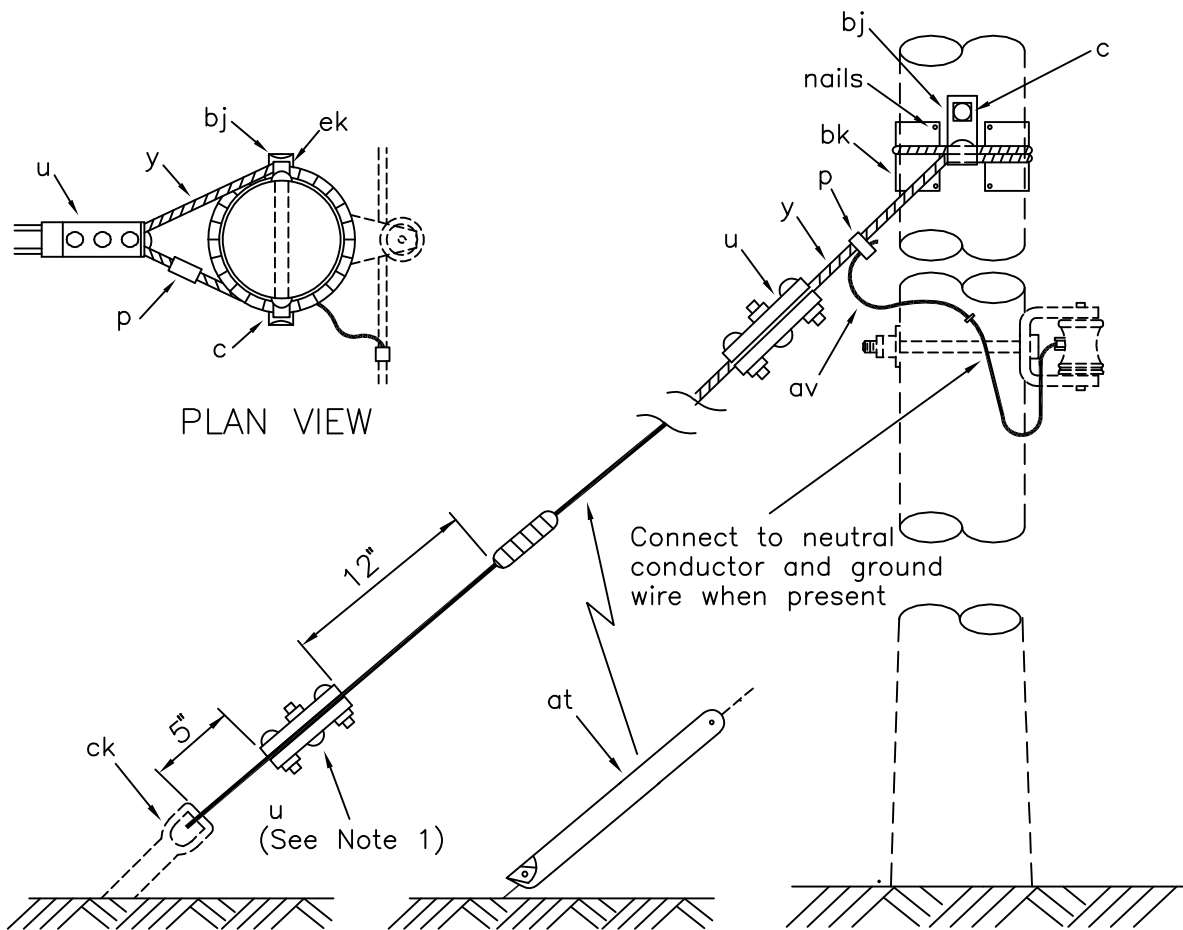

NOTES:

1. Other accepted and equivalent, heavy duty, guy clamps, (item "u"), may be substituted for the 3-bolt clamps shown
2. Specify guy wire size, type and required length.

ITEM	QTY	MATERIAL
c	1	Bolt, machine, 5/8" x req'd length
p		Connectors, guy bond and as req'd
u	2	Deadend for guy strand, heavy duty
y		Guy wire, as req'd (See Note 2)
at	1	Guy marker
av		Jumpers, as req'd
bj	2	Guy hook
bk	2	Guy Plate, 4" x 8", 14 gauge
ck	1	Clamp, anchor rod bonding
ek	1	Locknuts
	8	Nails, 8 penny galv.

DESIGN PARAMETERS:

PERMITTED LOAD =
90% of RATED BREAKING
STRENGTH OF GUY WIRE

SINGLE DOWN GUY
(WRAPPED TYPE)

APRIL 2005

RUS

E1.2
(E3-3)

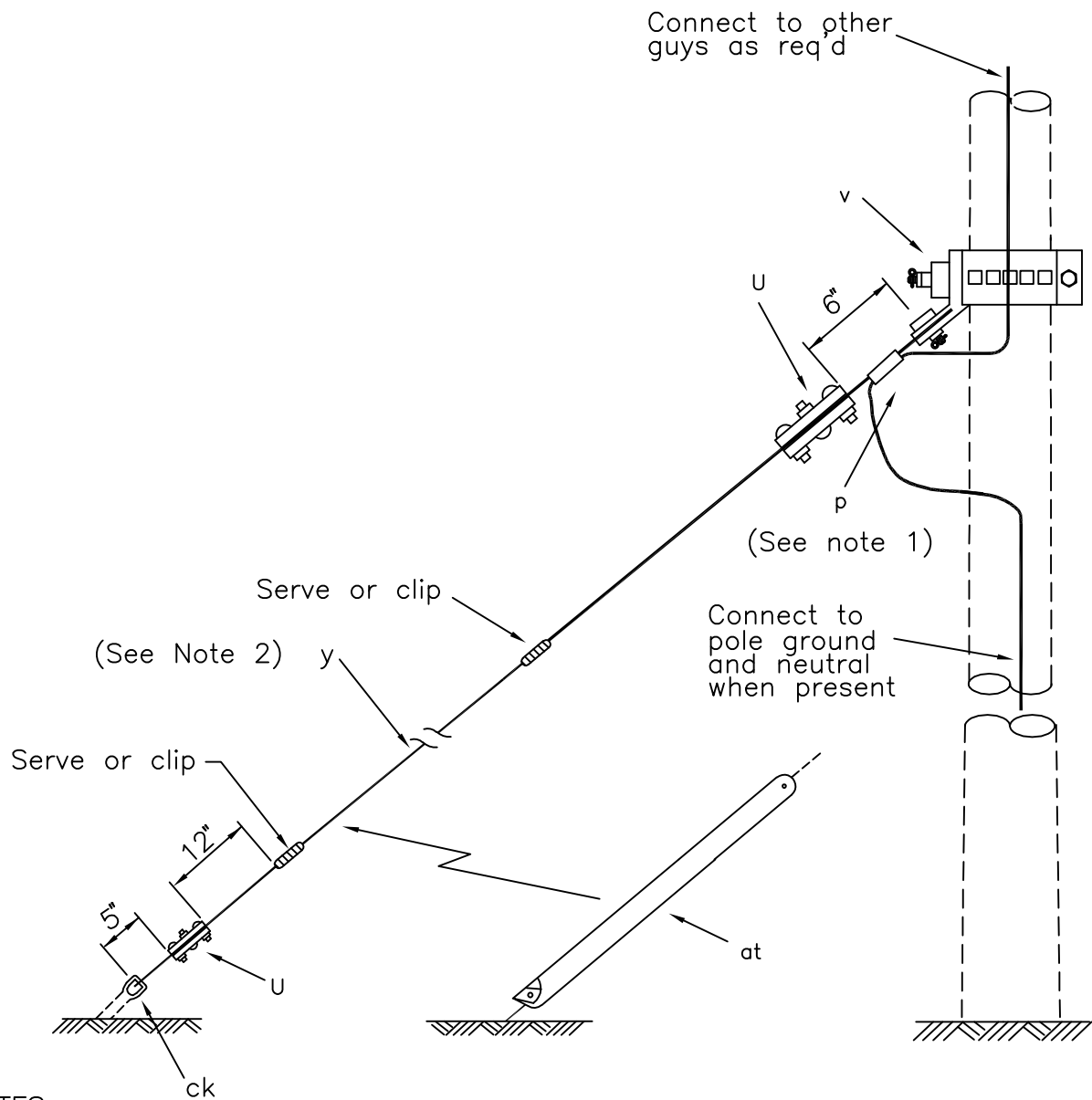

NOTES:

1. Other accepted and equivalent, heavy duty, guy deadend material (item "u") may be substituted for the ones shown..
2. Specify guy wire size, type and required length.

ITEM	QTY	MATERIAL
P		Connectors, guy bond as req'd
u	2	Deadend for guy strand, heavy duty
v	1	Guy attachment, pole band type
y		Guy wire, as req'd (See Note 2)
at	1	Guy marker
av		Jumpers, as req'd
ck	1	Clamp, anchor bonding

DESIGN PARAMETERS:

PERMITTED LOAD IS LESSER OF:
 8,500 lbs. (in any direction)
 or 90% of RATED BREAKING
 STRENGTH OF GUY WIRE

SINGLE DOWN GUY – LARGE CONDUCTORS
 (POLE BAND TYPE)

APRIL 2005

RUS

E1.3L

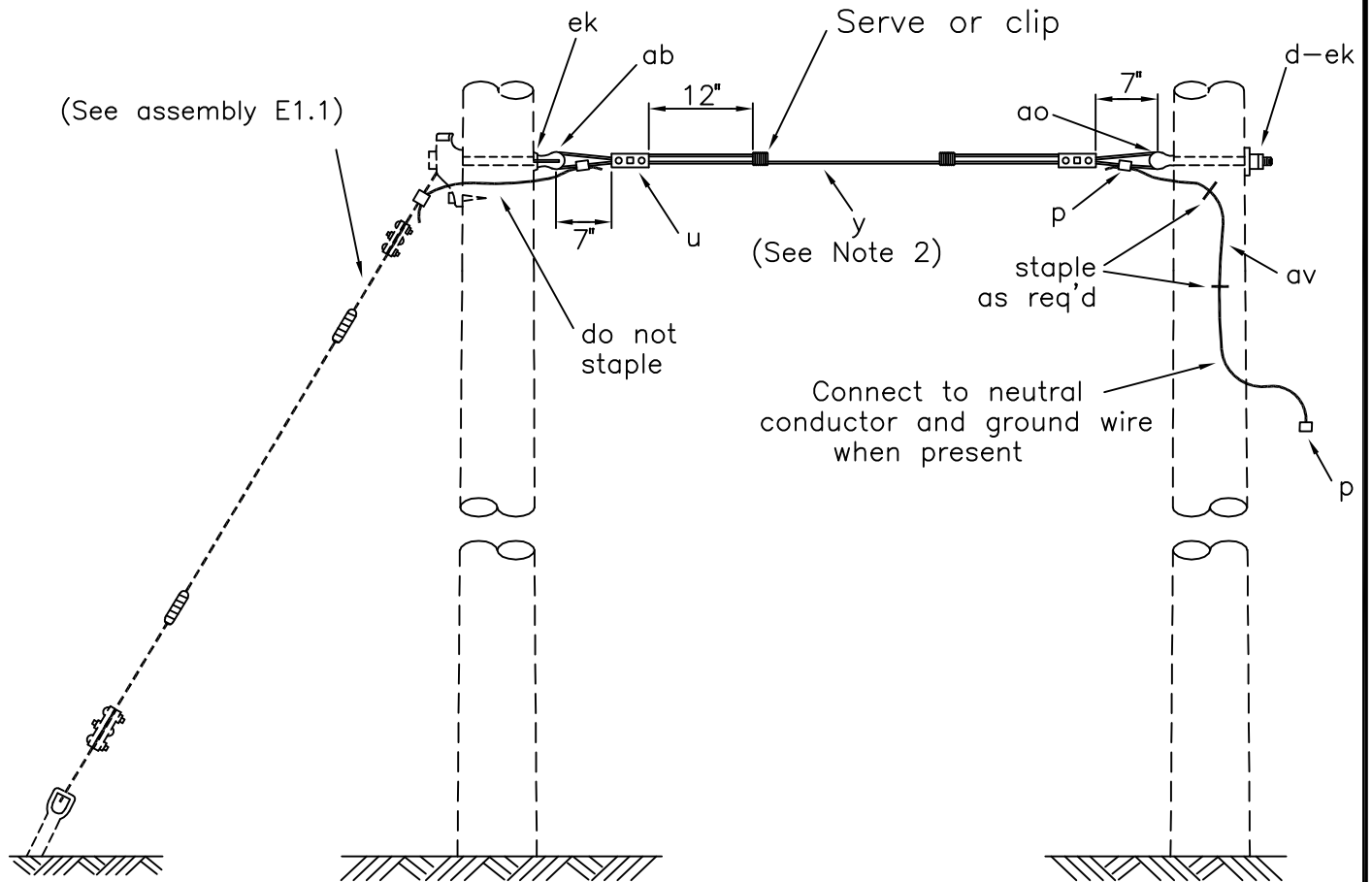

NOTES:

1. Other accepted and equivalent, guy deadends (item "u"), may be substituted for the 3-bolt clamps shown.
2. Specify guy wire size, type and required length.
3. Wrapped type overhead guys may be used. (See drawing E1.2 as guide)

ITEM	QTY	MATERIAL
d	1	Washer, 3" square, curved
p		Connectors, guy bond and as req'd
u	2	Deadend for guy strand, heavy duty
y		Guy wire, as req'd (See Note 2)
ab	1	Nut, thimble eye type, 5/8"
ao	1	Bolt, thimble eye, 5/8"x req'd length
av		Jumpers, as req'd
ek	2	Locknuts

DESIGN PARAMETERS:

PERMITTED LOAD IS LESSER OF:
 6,600 lbs. (HORIZONTAL)
 or 90 % of RATED BREAKING
 STRENGTH OF GUY WIRE

SINGLE OVERHEAD GUY
 (THROUGH BOLT TYPE)

APRIL 2005

RUS

E1.4
 (E2-2)

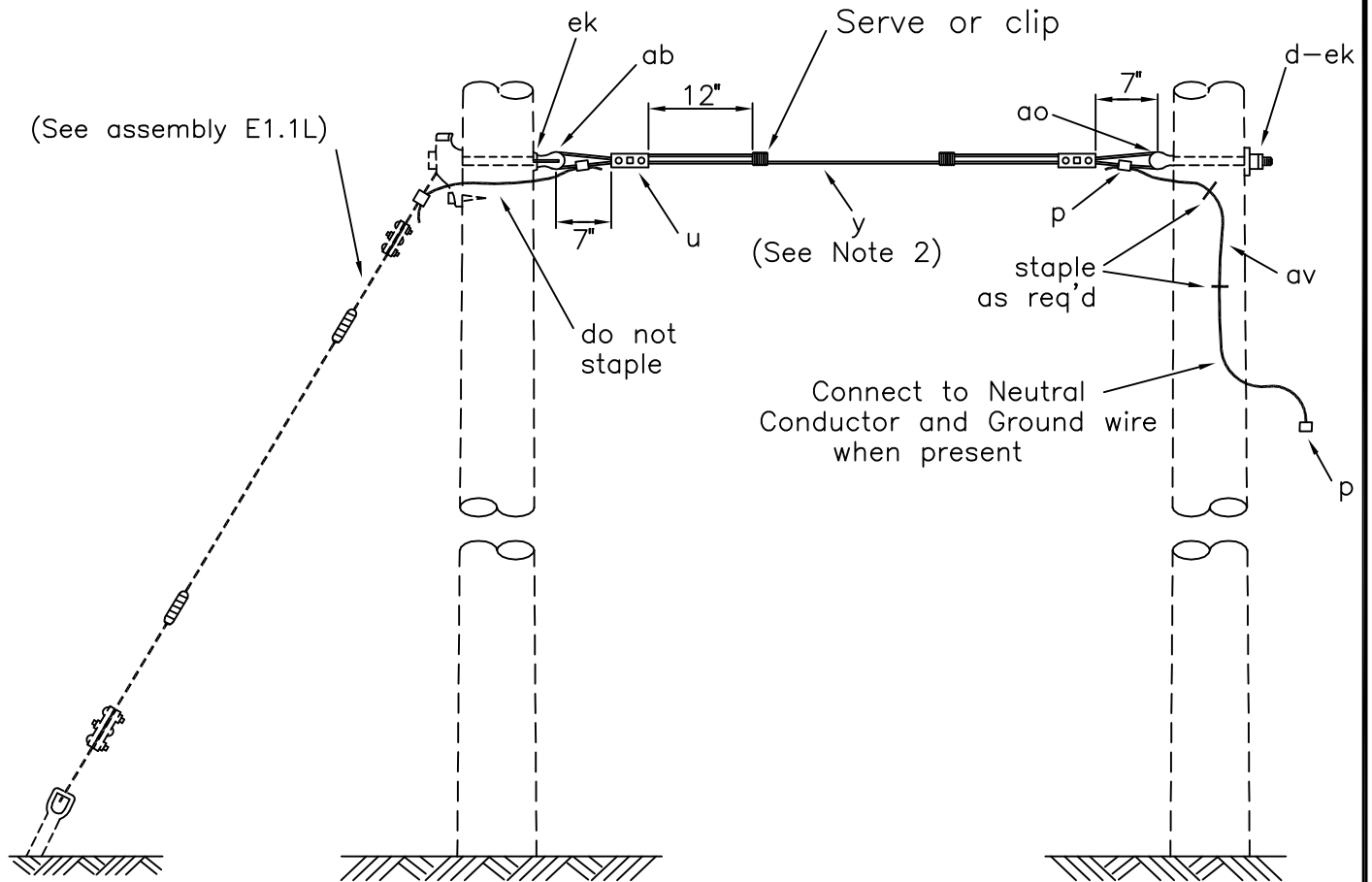

NOTES:

1. Other accepted and equivalent, guy deadends (item "u"), may be substituted for the 3-bolt clamps shown.
2. Specify guy wire size, type and required length.
3. Wrapped type overhead guys may be used. (See drawing E1.2 as guide)
4. Assembly requires 3/4" bolt on down guy assembly attachment.

ITEM	QTY	MATERIAL
d	1	Washer, 4" square, curved
p		Connectors, guy bond and as req'd
u	2	Deadend for guy strand, heavy duty
y		Guy wire, as req'd (See Note 2)
ab	1	Nut, thimble eye type, 3/4"
ao	1	Bolt, thimble eye, 3/4" x req'd length
av		Jumpers, as req'd
ek	2	Locknuts

DESIGN PARAMETERS:

PERMITTED LOAD IS LESSER OF:
 8,500 lbs. (HORIZONTAL)
 or 90 % of RATED BREAKING
 STRENGTH OF GUY WIRE

SINGLE OVERHEAD GUY – HEAVY DUTY
 (THROUGH BOLT TYPE)

APRIL 2005

RUS

E1.4L
 (E2-3)

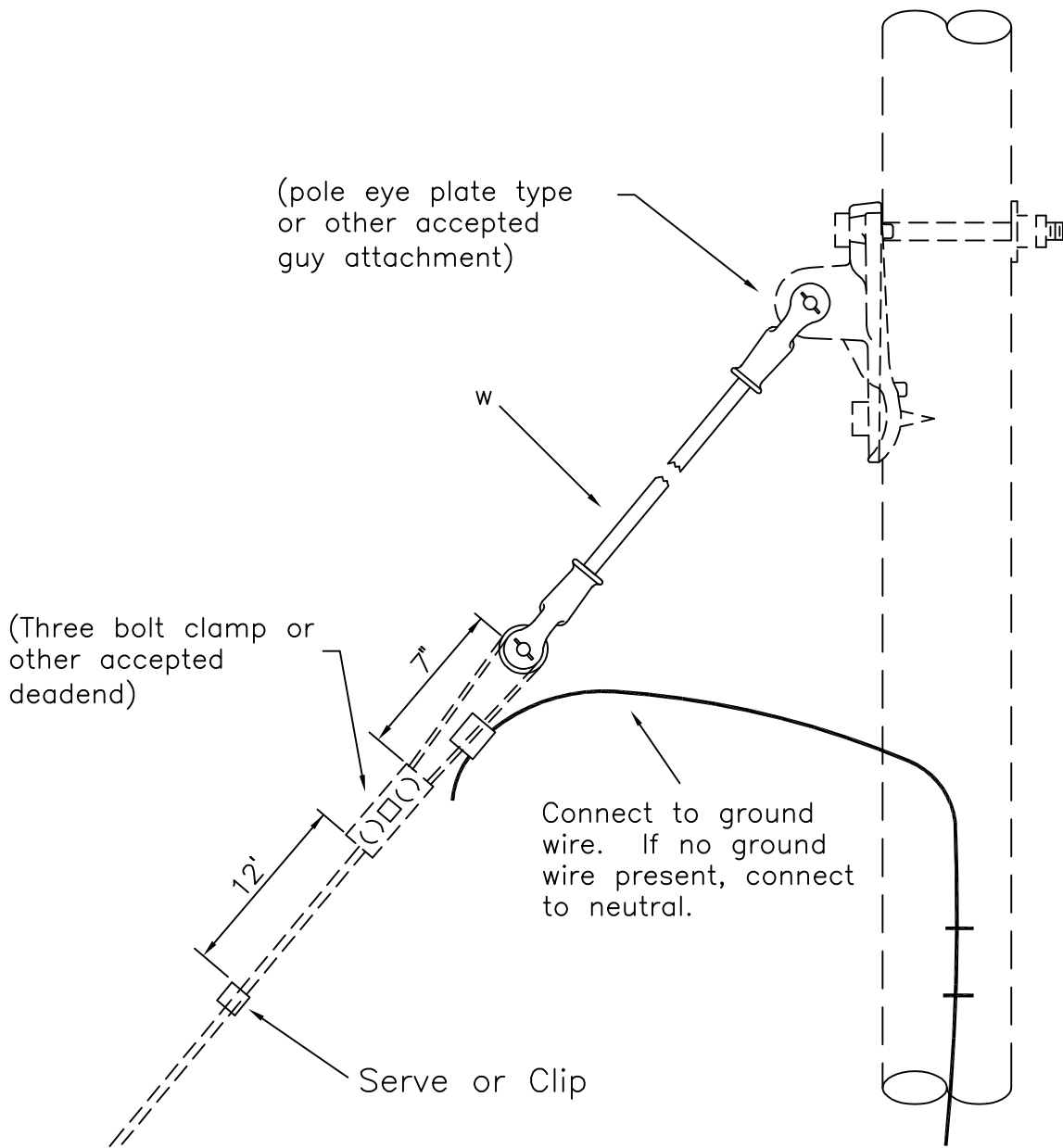

NOTE: Ground wire jumper may be attached to down guy wire below guy deadend connector.

ITEM	MATERIAL
w	Insulator, guy strain

DESIGN PARAMETERS:

PERMITTED LOAD = 8,500 lbs.

GUY STRAIN INSULATOR

APRIL 2005

RUS

E1.5

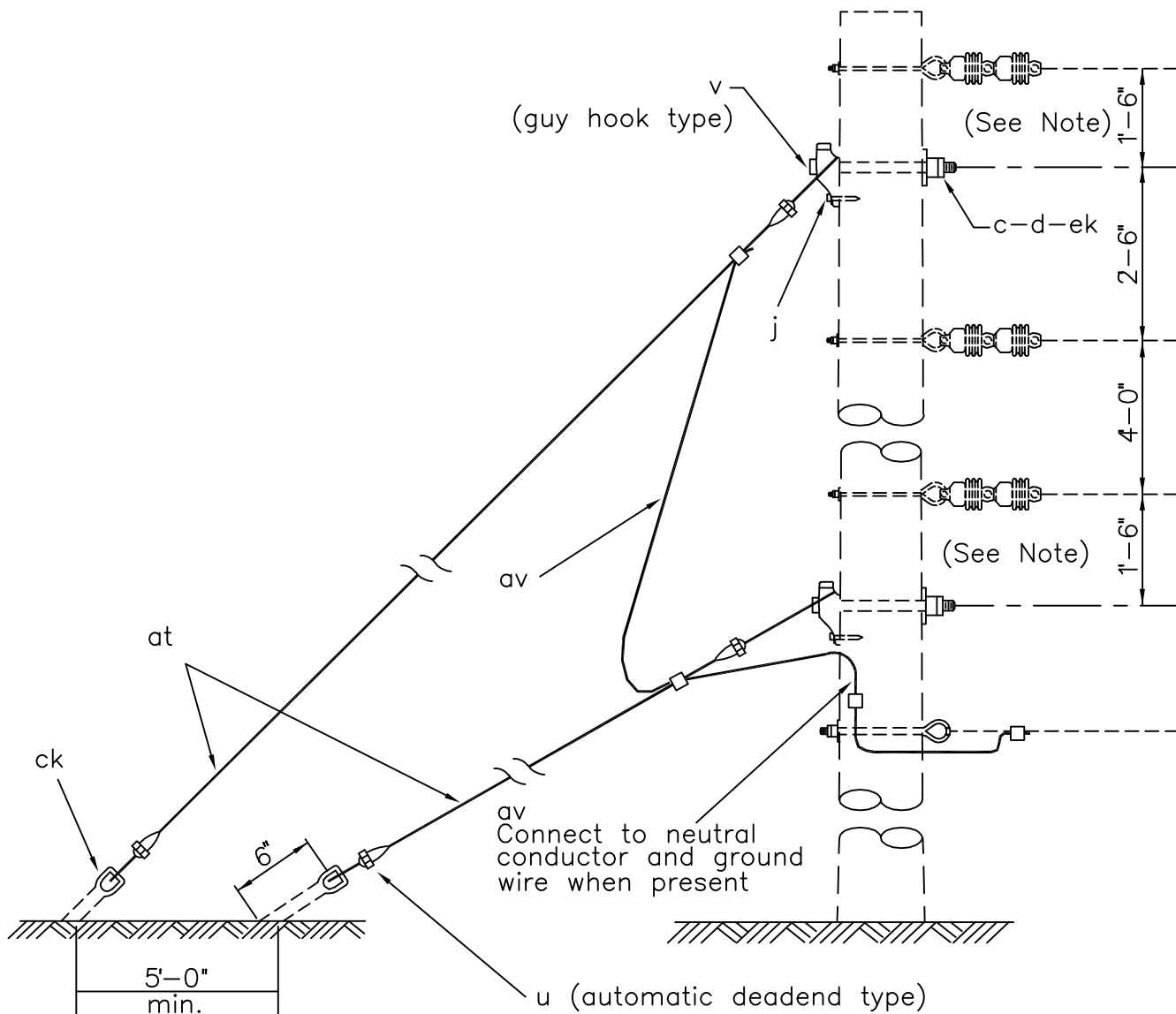

NOTES:

Position guys as shown on applicable pole top assembly unit if different than shown here. If distance between primary assembly and down guy is less than 12", install (minimum 12") guy strain insulator, (item "w"), or insulated extension link, (item "eu"), (minimum 12"), in primary assembly.

The following single down guy assemblies may be used, (multiply material quantities by 2):

- E1.1: Through Bolt Type (shown above)
- E1.1L: Through Bolt Type, Heavy Duty
- E1.2: Wrapped Type
- E1.3L: Pole Band Type

DESIGN PARAMETERS:

(See Single Down Guy drawings)

**DOUBLE DOWN GUY GUIDE
(THROUGH BOLT TYPE)**

APRIL 2005

RUS

E2.1G

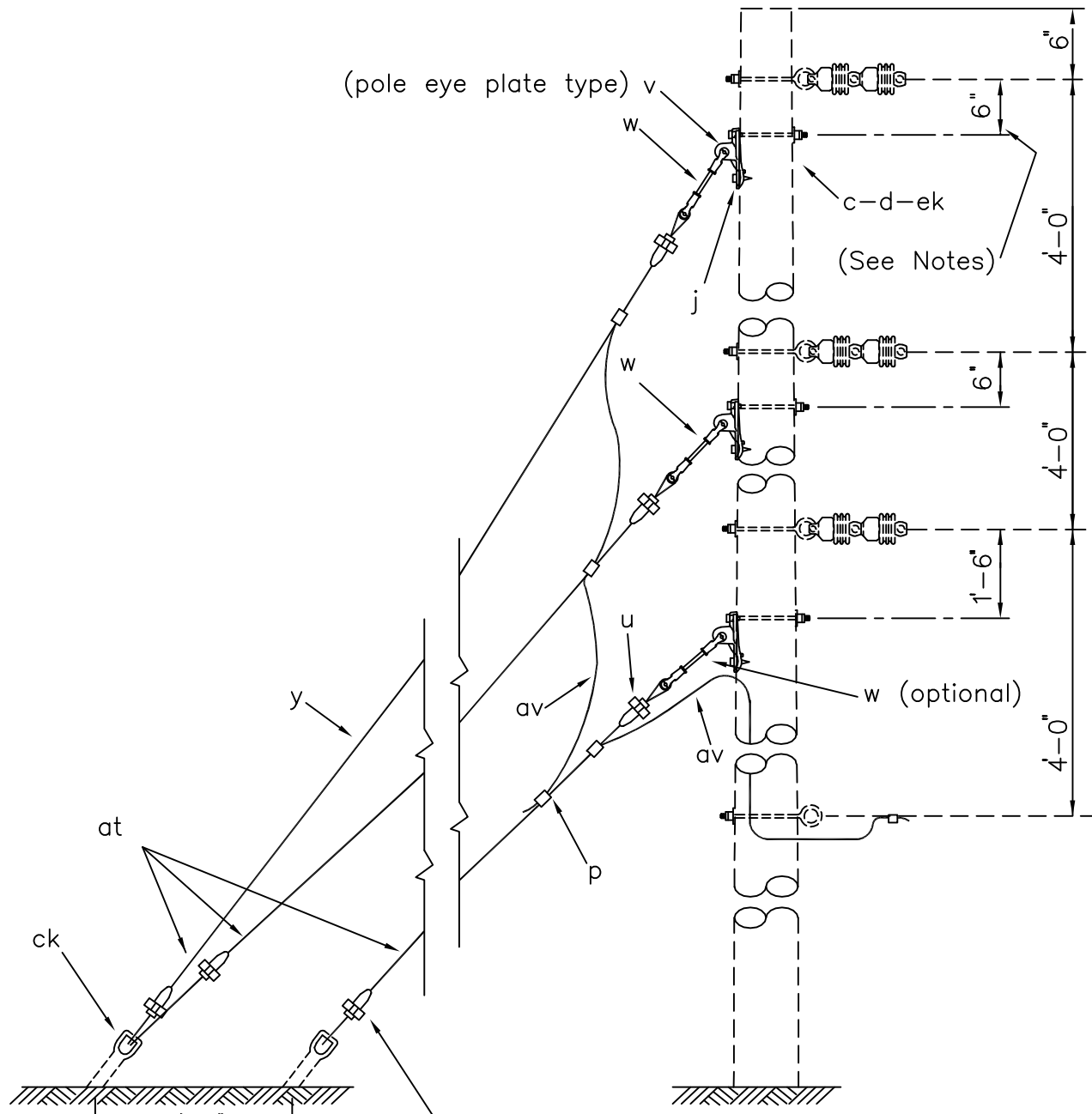

NOTES: $5'-0''$
min

Position guys as shown on applicable pole top assembly unit if different than shown here. If distance between primary assembly and down guy is less than 12", install (minimum 12") guy strain insulator, (item "w"), or insulated extension link, (item "eu"), (minimum 12"), in primary assembly. The following single down guy assemblies may be used,

(multiply material quantities by 3):

- E1.1: Through Bolt Type
- E1.1L: Through Bolt Type, Heavy Duty (shown above)
- E1.2: Wrapped Type
- E1.3L: Pole Band Type

DESIGN PARAMETERS:
(See Single Down Guy drawings)

THREE DOWN GUY GUIDE –
HEAVY DUTY (THROUGH BOLT TYPE)

APRIL 2005
RUS

E3.1LG

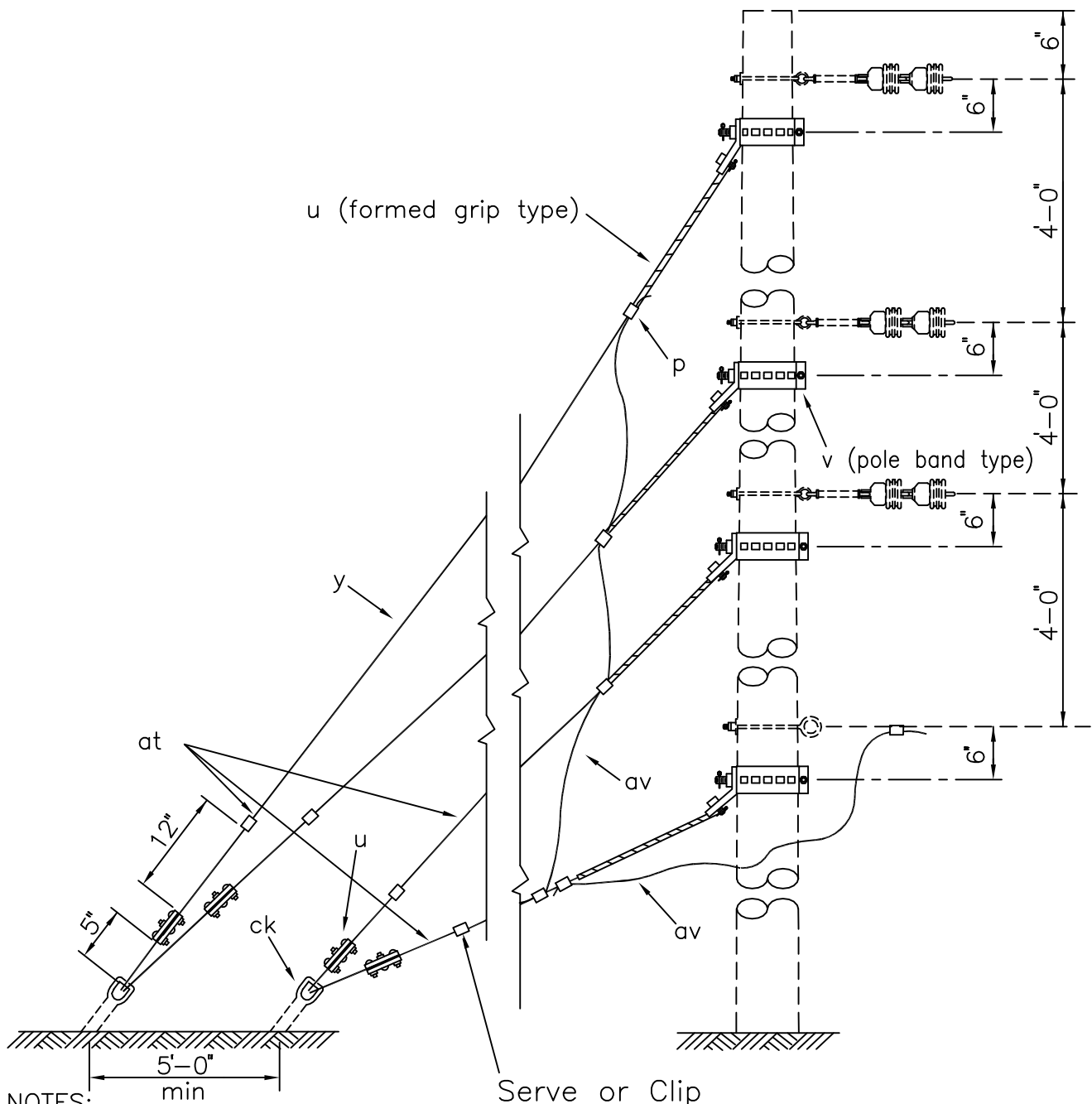

NOTES:

Position guys as shown on applicable pole top assembly unit if different than shown here. If distance between primary assembly and down guy is less than 12", install (minimum 12") guy strain insulator, (item "w"), or insulated extension link, (item "eu"), (minimum 12"), in primary assembly.

The following single down guy assemblies may be used, (multiply material quantities by 4):

- E1.1 : Through Bolt Type
- E1.1L: Through Bolt Type, Heavy Duty
- E1.2 : Wrapped Type
- E1.3L: Pole Band Type (Shown Above)

DESIGN PARAMETERS:

(See Single Down Guy drawings)

FOUR DOWN GUY GUIDE – LARGE CONDUCTORS (POLE BAND TYPE)

APRIL 2005

RUS

E4.3LG

INDEX F

ANCHOR ASSEMBLY UNITS

<u>DRAWING NUMBERS</u>		<u>DRAWING TITLE (DESCRIPTION)</u>
1728F-804 (New)	Bulletin 50-3 (Old)	
F1.6	(F1-1)	EXPANDING TYPE ANCHORS
F1.8	(F1-2)	
F1.10	(F1-3)	
F1.12	(F1-4)	
F2.6	(F1-1S)	SCREW ANCHORS (POWER INSTALLED)
F2.8	(F1-2S)	
F2.10	(F1-3S)	
F2.12	(F1-4S)	
F3.6	(F1-1P)	PLATE TYPE ANCHORS
F3.8	(F1-2P)	
F3.10	(F1-3P)	
F3.12	(F1-4P)	
F4.1	(F4-1E)	SERVICE ANCHORS
F4.2	(F4.1S)	
F5.1	(F5-1)	ROCK ANCHORS
F5.2	(F5-2)	
F5.3	(F5-3)	
F6.6	(F6-1)	SWAMP ANCHORS (POWER INSTALLED)
F6.8	(F6-2)	
F6.10	(F6-3)	

CONSTRUCTION SPECIFICATIONS FOR ANCHORING

As much as practicable, anchors and rods shall be installed in line with, and in the opposite direction of, the resultant strain of the conductors. Anchor assemblies shall be installed so that approximately 6 inches of the rod remains out of the ground. In cultivated fields or other locations as deemed necessary, the projection of the anchor rod above earth may be increased to a maximum of 12 inches to prevent burial of the rod eye.

The backfill of all anchor holes must be thoroughly tamped the full depth. After a cone anchor has been set in place, the hole shall be backfilled with coarse crushed rock for 2 feet above the anchor and tamped during the filling. The remainder of the hole shall be backfilled and tamped with dirt.

The designated holding powers shown on the anchor assembly drawings are based on the maximum holding power of average, Class 5 soil. When the anchor is installed in poorer soils, the holding power of the anchor shall be derated. A suggested guide is to derate by 25 percent in Class 6 soil and by 50 percent in Class 7 soil. For Class 8 soil it is usually necessary to use swamp anchors or power driven screw anchors which can penetrate the poor soil into firmer soil. See the "Soil Classifications" table on the following page for soil classes.

Log type anchors are acceptable for use on distribution systems. Refer to the appropriate drawings in RUS Bulletin 1728F-811, "Electric Transmission Specifications and Drawings, 115 kV through 230 kV" for assembly units and construction details.

SOIL CLASSIFICATIONS

<u>Class</u>	<u>Engineering Description</u>
0	Sound hard rock, unweathered
1	Very dense and/or cemented sands; coarse gravel and cobbles
2	Dense fine sand; very hard silts and clays (may be preloaded)
3	Dense clayed sand and gravel; very stiff to hard silts and clays
4	Medium dense sandy gravel; very stiff to hard silts and clays
5	Medium dense coarse sand and sandy gravels; stiff to very stiff silts and clays
6	Loose to medium dense fine to coarse sand; firm to stiff clays and silts
7	Loose fine sand; alluvium; loess; soft-firm clays; varved clays; fill
8	Peat; organic silts; inundated silts; fly ash

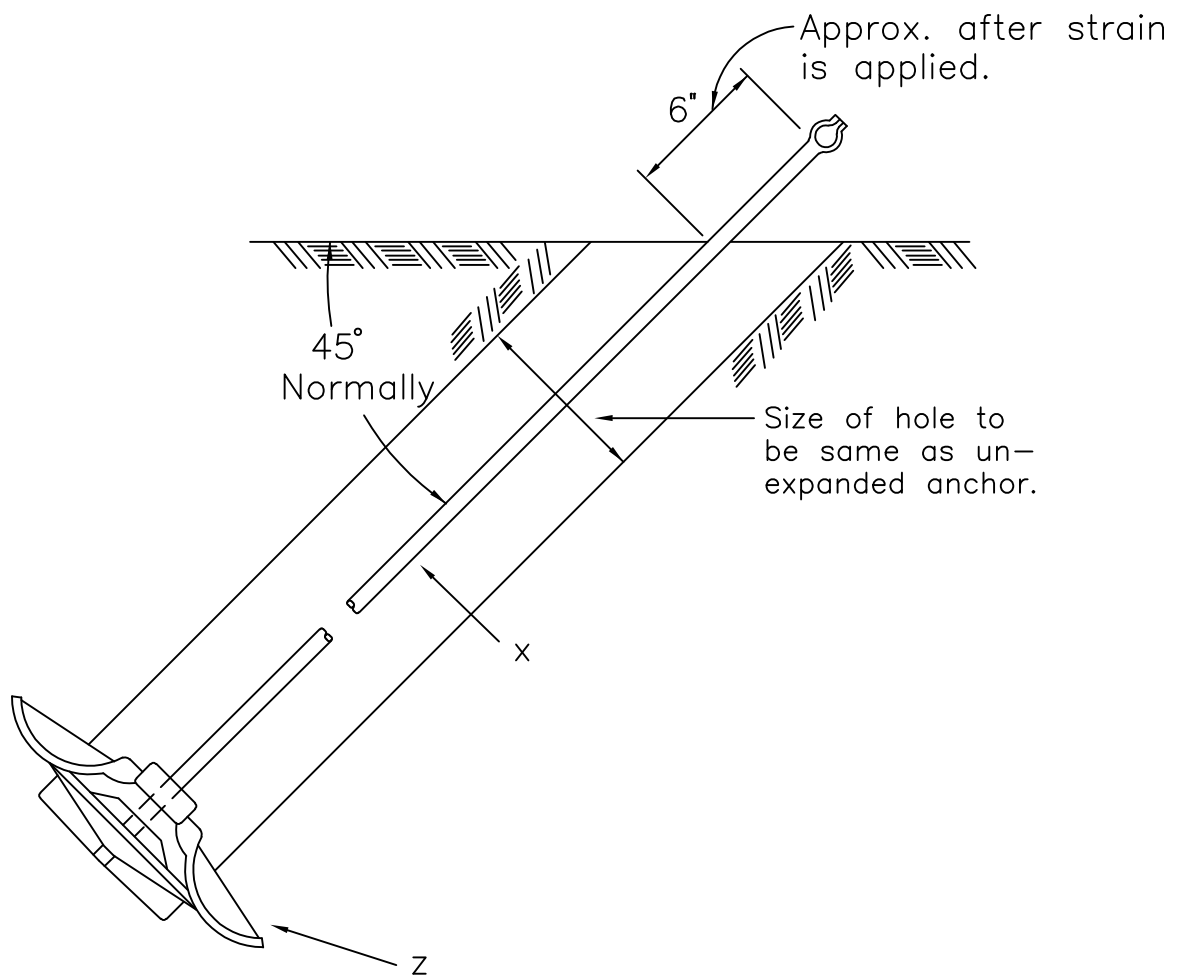

NOTE: Designated maximum holding power rating assumes proper installation in class 5 soil.

		ASSEMBLY: F1				ASSEMBLY NUMBERS	
		.6	.8	.10	.12	NEW	(OLD)
	Minimum Area (sq. in.)	90	100	120	135	F1.6	(F1-1)
ITEM	MATERIAL	QTY	QTY	QTY	QTY	F1.8	(F1-2)
x	Rod, anchor, thimble eye, 5/8" x 7'0"	1	1			F1.10	(F1-3)
x	Rod, anchor, twin eye, 3/4" X 8'0"			1	1	F1.12	(F1-4)
z	Anchor, expanding type	1	1	1	1		

DESIGN PARAMETERS:
DESIGNATED MAXIMUM
HOLDING POWER (lbs.)

F1.6: 6,000
F1.8: 8,000
F1.10: 10,000
F1.12: 12,000

EXPANDING TYPE ANCHORS

APRIL 2005

RUS

F1.6, F1.8, F1.10, F1.12

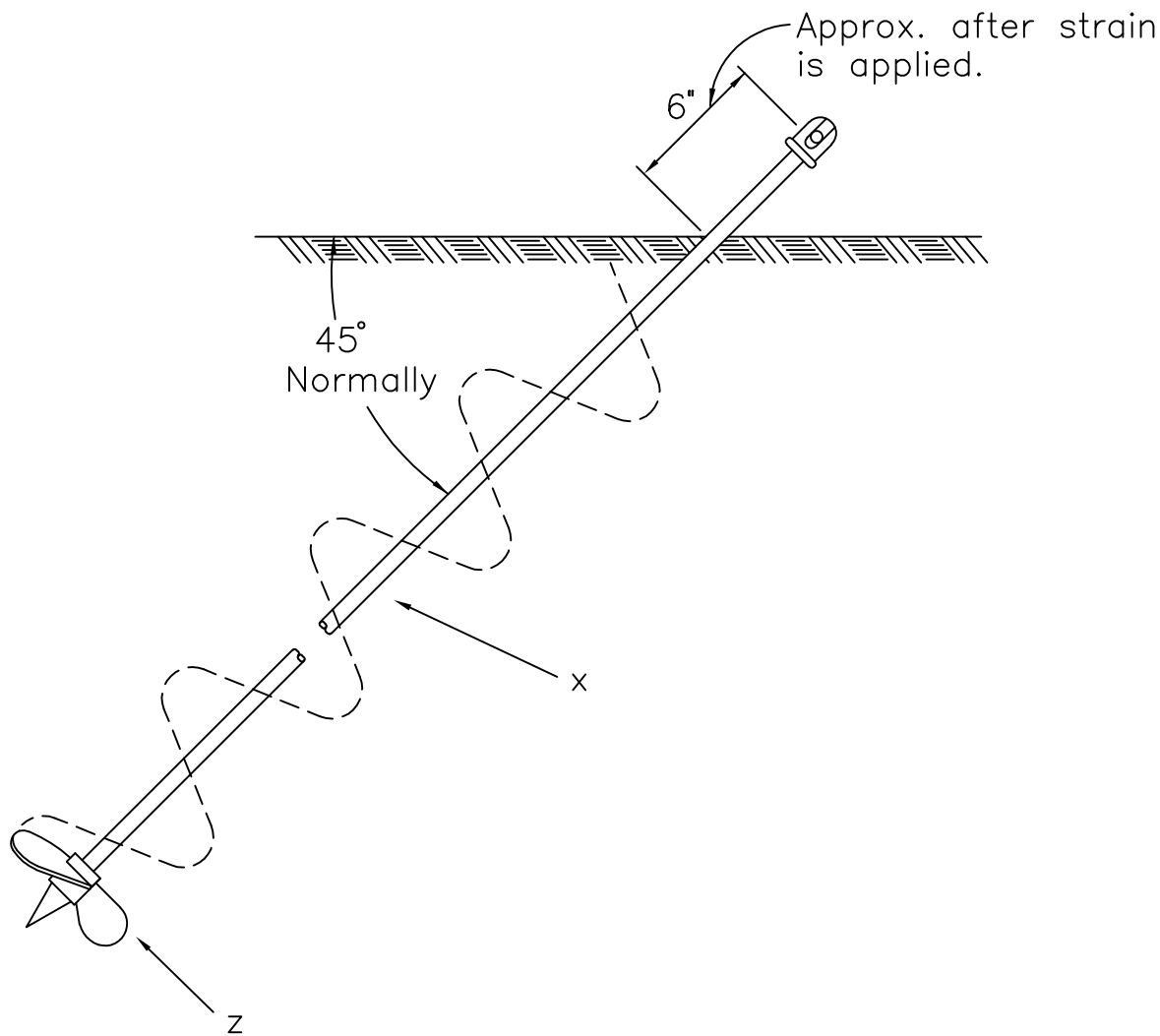

NOTE: Designated maximum holding power rating assumes proper installation in class 5 soil.

		ASSEMBLY: F2				ASSEMBLY NUMBERS	
		.6	.8	.10	.12	NEW	(OLD)
	Minimum Area (sq. in.)	90	100	120	135		
ITEM	MATERIAL	QTY	QTY	QTY	QTY	F2.6	(F1-1S)
x	Rod, anchor, thimble eye, 5/8" x 7'0"	1	1			F2.8	(F1-2S)
x	Rod, anchor, twin eye, 3/4 X 8'0"			1	1	F2.10	(F1-3S)
z	Anchor, screw type, power installed	1	1	1	1	F2.12	(F1-4S)

DESIGN PARAMETERS:
DESIGNATED MAXIMUM
HOLDING POWER (lbs.)

F2.6: 6,000
F2.8: 8,000
F2.10: 10,000
F2.12: 12,000

SCREW ANCHORS, (POWER INSTALLED)

APRIL 2005

RUS

F2.6, F2.8, F2.10, F2.12

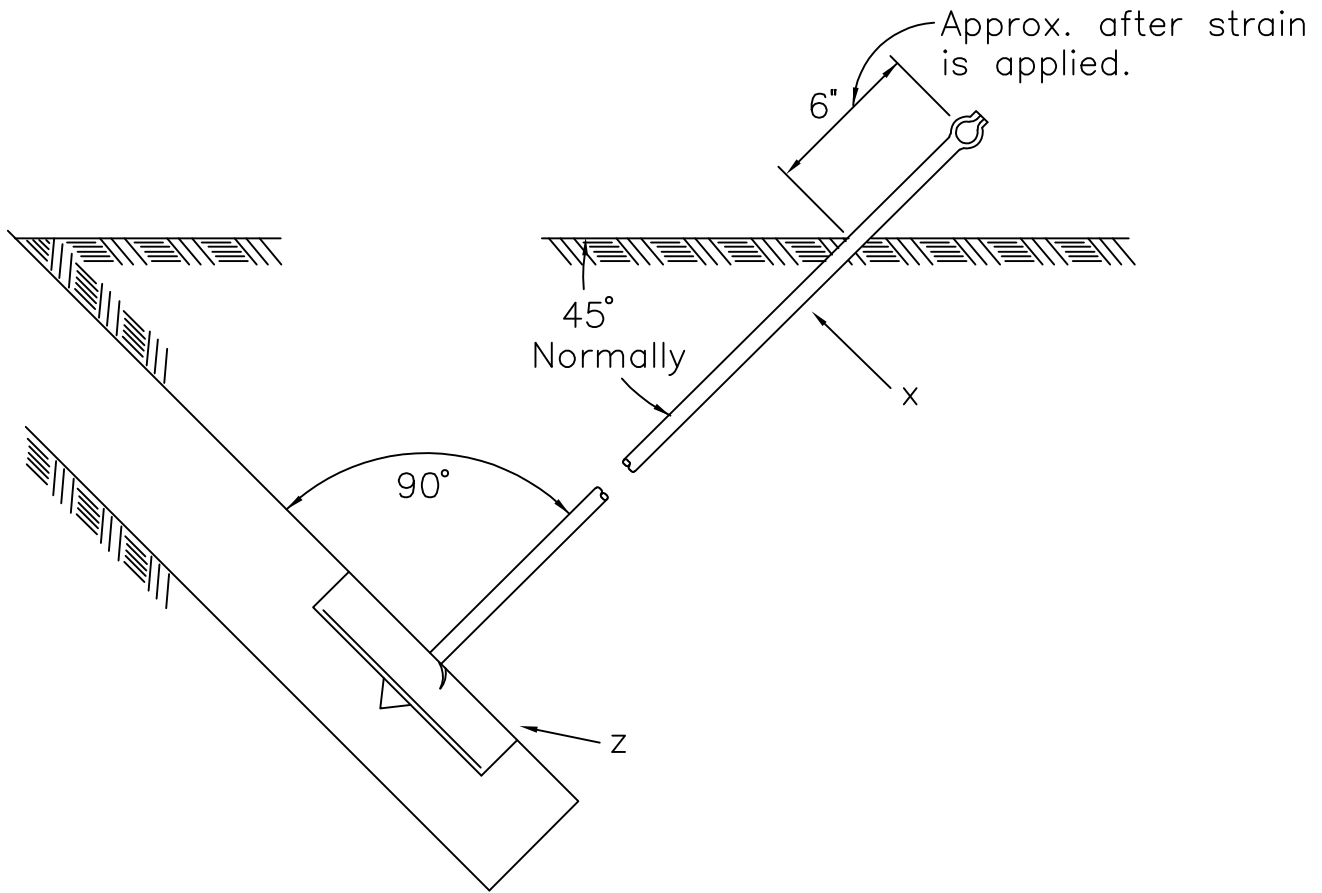

NOTE: Designated maximum holding power rating assumes proper installation in class 5 soil.

		ASSEMBLY: F3				ASSEMBLY NUMBERS	
		.6	.8	.10	.12	NEW	(OLD)
	Minimum Area (sq. in.)	90	100	120	135	F3.6	(F1-1P)
ITEM	MATERIAL	QTY	QTY	QTY	QTY	F3.8	(F1-2P)
x	Rod, anchor, thimble eye, 5/8" x 7'0"	1	1			F3.10	(F1-3P)
x	Rod, anchor, twin eye, 3/4" X 8'0"			1	1	F3.12	(F1-4P)
z	Anchor, plate type	1	1	1	1		

DESIGN PARAMETERS:
DESIGNATED MAXIMUM
HOLDING POWER (lbs.)

F3.6: 6,000
F3.8: 8,000
F3.10: 10,000
F3.12: 12,000

PLATE TYPE ANCHORS

APRIL 2005

RUS

F3.6, F3.8, F3.10, F3.12

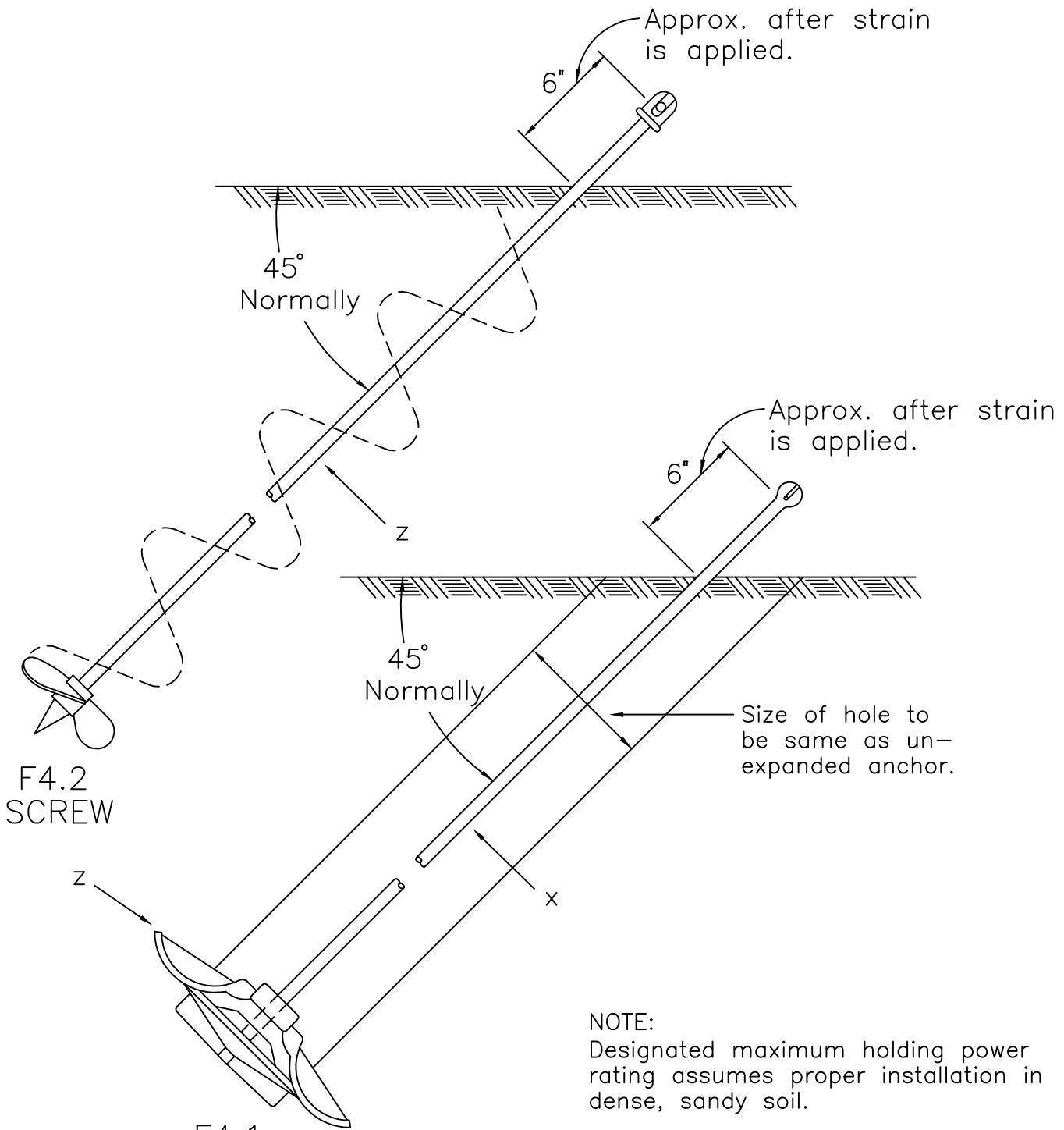

NOTE:
 Designated maximum holding power rating assumes proper installation in dense, sandy soil.

F4.1
 EXPANDING

ASSEMBLY:		F4.1	F4.2
ITEM	MATERIAL	QTY	QTY
x	Rod, anchor, thimble eye type	1	
z	Anchor, service, expanding type	1	
z	Anchor, service, screw type		1

ASSEMBLY NUMBERS	
NEW	(OLD)
F4.1	(F4-1E)
F4.2	(F4-1S)

DESIGN PARAMETERS: DESIGNATED MAXIMUM HOLDING POWER (lbs.) F4.1: 2,500 F4.2: 2,500	SERVICE ANCHORS	
	APRIL 2005	
	RUS	F4.1, F4.2

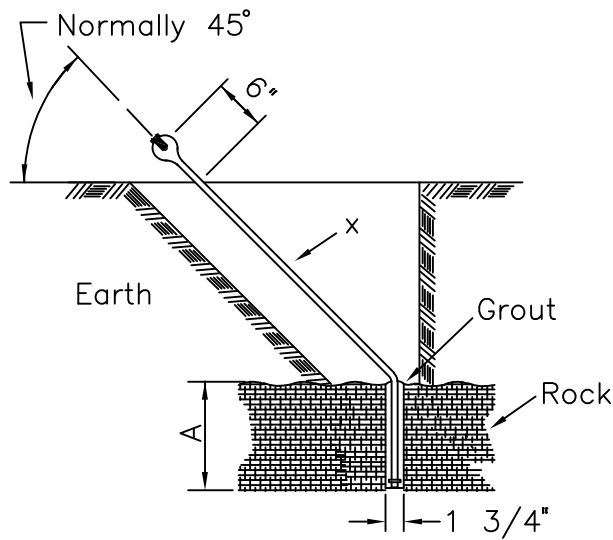

A = 18" min. for solid rock
 = 30" min. for stratified rock

F5.1

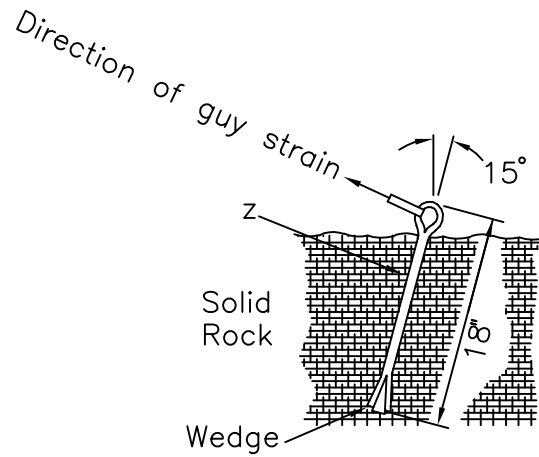

NOTE: 15" expanding type rock anchor may be used

F5.2

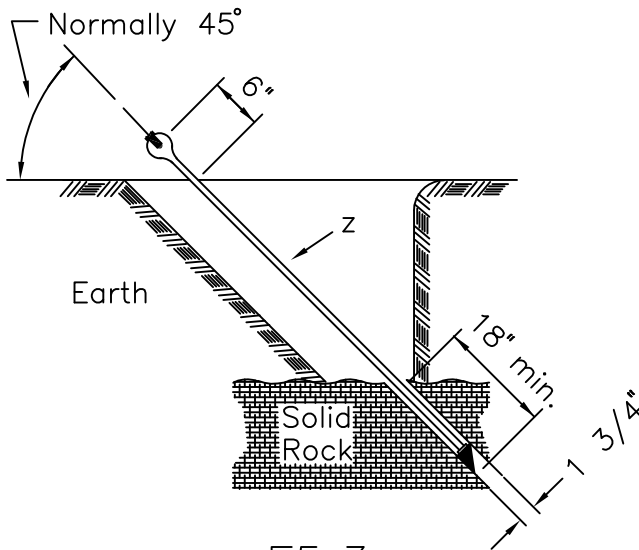

F5.3

NOTES:

1. Only one guy shall be attached to a rock anchor. Where more than one guy is required, space anchors 2 feet minimum apart and, where practical, install in direct line with pole.
2. Do not anchor to any boulder measuring less than 4 feet in diameter.

(* See Note)

		ASSEMBLY:			ASSEMBLY NUMBERS	
		F5.1	F5.2	F5.3	NEW	(OLD)
ITEM	MATERIAL	QTY	QTY	QTY		
x	Rod, anchor or thimble eye type	1			F5.1	(F5-1)
z	Anchor, expanding rock type		*	1	F5.2	(F5-2)
z	Anchor, rock, guy bolt type		1		F5.3	(F5-3)

DESIGN PARAMETERS:

ROCK ANCHORS

APRIL 2005

RUS

F5.1, F5.2, F5.3

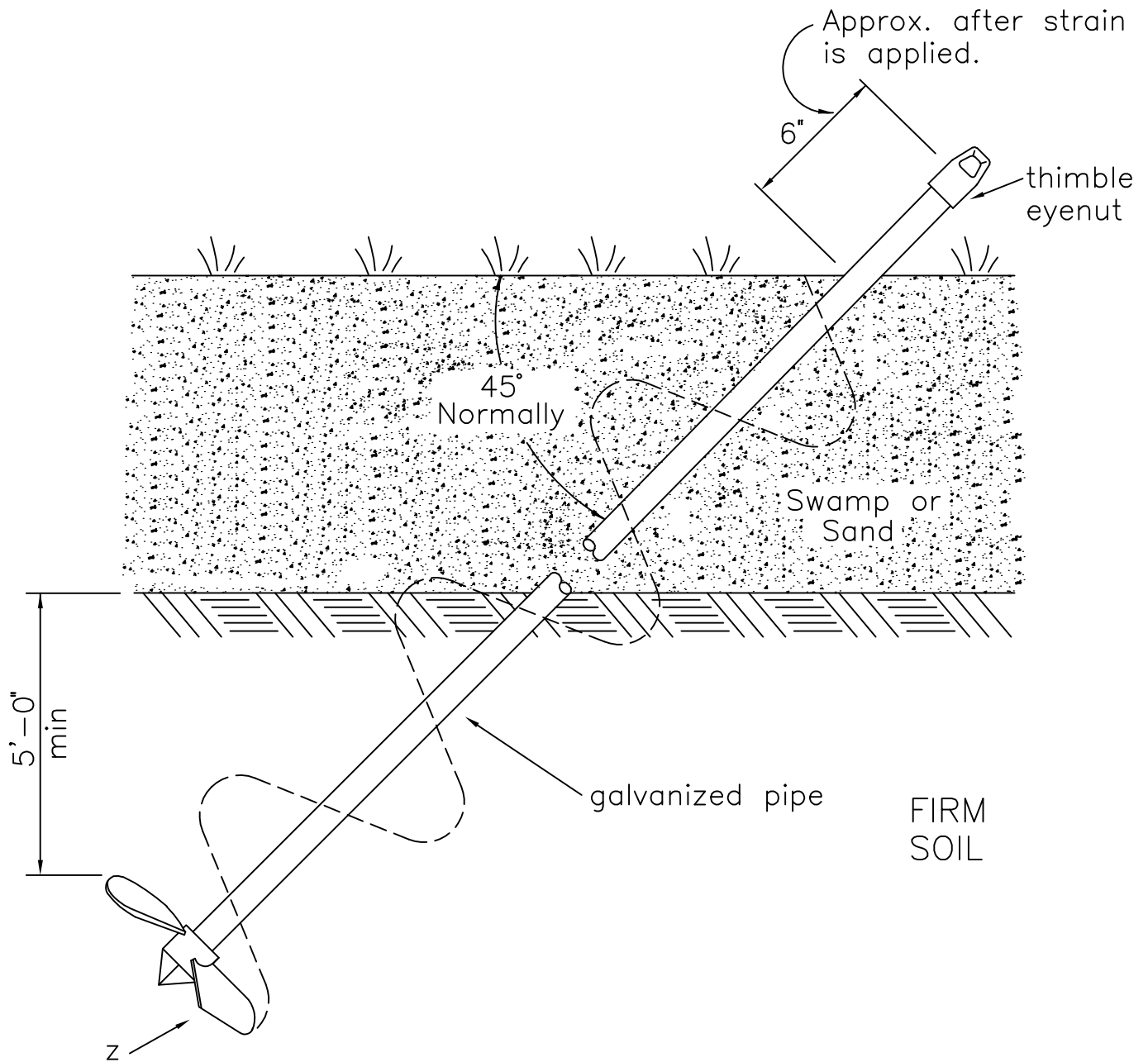

NOTE: Designated maximum holding power rating assumes proper installation. See anchor specifications for additional information.

ITEM	MATERIAL	F6.6	F6.8	F6.10	ASSEMBLY NUMBERS	
		QTY	QTY	QTY	NEW	(OLD)
z	Anchor, swamp type (diameter)	1-10"	1-12"	1-15"	F6.6	(F6-1)
	Nut, thimble eye type	1	1	1	F6.8	(F6-2)
	Pipe, galvanized, as req'd				F6.10	(F6-3)

DESIGN PARAMETERS:
DESIGNATED MAXIMUM
HOLDING POWER (lbs.)

F6.6: 6,000
F6.8: 8,000
F6.10: 10,000

SWAMP ANCHORS (POWER INSTALLED)

APRIL 2005

RUS

F6.6, F6.8, F6.10

TRANSFORMER ASSEMBLY UNITS

<u>DRAWING NUMBERS</u>		<u>DRAWING TITLE (DESCRIPTION)</u>
1728F-804 (New)	Bulletin 50-3 (Old)	
G1.1G	(M27-1A)	TRANSFORMER INSTALLATION GUIDE SINGLE -PHASE, POLE-TYPE TRANSFORMER
G1.2G		POLE TYPE TRANSFORMER LOCATION GUIDE
G1.2	(G105-) (G136-)	SINGLE-PHASE, CSP TRANSFORMER (TANGENT POLE)
G1.3	(G106-)	SINGLE-PHASE, CSP TRANSFORMER (DEADEND POLE)
G1.4 G1.5		SINGLE-PHASE, CONVENTIONAL TRANSFORMER (TANGENT POLE)
G1.6		SINGLE-PHASE, CONVENTIONAL TRANSFORMER (DEADEND POLE)
G1.7	(G9-) (G39-)	SINGLE-PHASE, CONVENTIONAL TRANSFORMER (TANGENT POLE)
G1.8	(G10-)	SINGLE-PHASE, CONVENTIONAL TRANSFORMER (DEADEND POLE)
G2.1	(G210-)	TWO-PHASE TRANSFORMER BANK OPEN-WYE PRIMARY OPEN-DELTA, 4 WIRE SECONDARY
G2.1G		TRANSFORMER / METER CONNECTION GUIDE THREE-PHASE, OPEN-WYE - OPEN DELTA FOR 120/240 VOLT POWER LOADS
G3.1	(G310-)	THREE-PHASE TRANSFORMER BANK UNGROUND-ED-WYE PRIMARY CENTER-TAP GROUNDED DELTA, 4 WIRE SECONDARY
G3.1G		TRANSFORMER / METER CONNECTION GUIDE UNGROUND-ED WYE - CENTER TAP GROUNDED DELTA FOR 120/240 VOLT POWER LOADS

TRANSFORMER ASSEMBLY UNITS

<u>DRAWING NUMBERS</u>		<u>DRAWING TITLE (DESCRIPTION)</u>
1728F-804 (New)	Bulletin 50-3 (Old)	
G3.2	(G311-)	THREE-PHASE TRANSFORMER BANK UNGROUND WYE - PRIMARY CORNER GROUNDED DELTA, 3 WIRE SECONDARY
G3.2G		TRANSFORMER / METER CONNECTION GUIDE UNGROUND WYE - CORNER GROUNDED DELTA FOR 240 OR 480 VOLT POWER LOADS
G3.3	(G312-)	THREE-PHASE TRANSFORMER BANK GROUNDED-WYE PRIMARY GROUNDED WYE, 4 WIRE SECONDARY
G3.3G		TRANSFORMER / METER CONNECTION GUIDE GROUNDED WYE - GROUNDED WYE FOR 120/208 VOLT POWER LOADS

CONSTRUCTION SPECIFICATIONS FOR TRANSFORMERS

It may be necessary, and it is permissible, to lower the neutral attachment on standard single-phase conventional type transformer assemblies an additional distance not exceeding 2 feet to provide adequate clearances for cutouts.

Where applicable, the external gap on surge arresters shall be set according to the manufacturer's recommended spacing.

The construction drawings for three-phase transformer banks (e.g., "G3.1") show cutouts (items "af") and arresters (items "ae) mounted adjacent to one another on the crossarm. However, a cutout and arrester, as shown, may be replaced with a combination cutout/arrester (item "ax"). This change will require a change in the assembly's material shown on the construction drawings. Moreover, the arresters may be mounted directly on the transformer tank. (The cutouts remain on the arm.) Any of the above mounting arrangements for three-phase transformer banks are acceptable; the choice is left to the design engineer.

The construction drawings for single-phase conventional transformer assemblies show surge arresters mounted directly on the transformer tank which maximizes transformer surge protection. Except for single-phase conventional transformers with open link fused cutouts (assemblies "G1.7" and "G1.8"), the arrester may be mounted on a crossarm, on a bracket (item "fn") adjacent to the cutout, or a combination cutout/arrester (item "ax") may be used. The choice of using any of these acceptable mounting arrangements is left to the design engineer.

Tank-mounted arresters provide maximum surge protection to transformers because of the arresters' minimum lead lengths. However, when arresters are mounted directly on transformer tanks, the fused cutouts have less surge protection and are subject to more frequent operations. Nuisance operations on fused cutouts with minimal surge protection can be lessened with the use of dual-element fuses.

The wiring schematics on the three-phase transformer/meter connection guide drawings (e.g., "G3.1G") are based on single-phase transformers with additive polarity. ANSI Standard C57-12.20 specifies that all single-phase transformers larger than 200 kVA have subtractive polarity. If the transformer/meter connection guides are used for single-phase transformers larger than 200 kVA, the schematic diagrams will need to be modified accordingly.

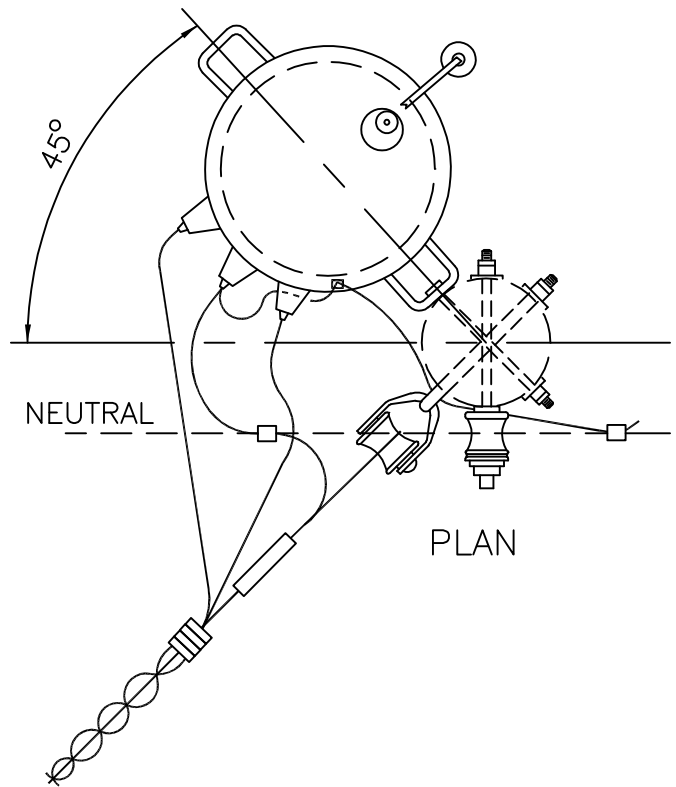

NOTES:

1. Install transformer on tangent poles on a quadrant on the opposite side of pole from primary neutral.
2. When it is necessary to install transformer in the same quadrant as a service drop, attach the service drops 4 inches below the transformer.
3. Install transformer so that primary neutral is at same height as bottom of transformer lid on tangent poles, or 3 inches above transformer lid on deadend poles.
4. Use compression type connectors (item "p").
5. Standard aluminum alloy or standard soft-drawn copper is recommended for the grounding loop conductor.
6. Transformer secondary bushings are not to be used for bi-metal connections.
7. Cover secondary terminals with moisture seal and/or dress conductor ends downward to prevent entry of moisture. (Minimum bending radius is six times the overall cable diameter).

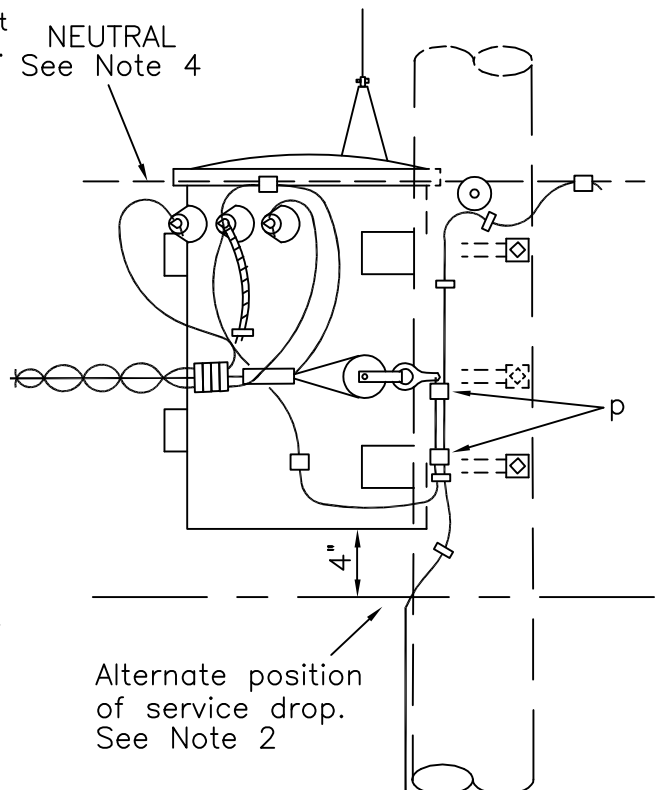

TRANSFORMER INSTALLATION GUIDE
SINGLE-PHASE, POLE-TYPE TRANSFORMER

APRIL 2005

RUS

G1.1G
(M27-1A)

TANGENT POLES

(Service(s) same as neutral)

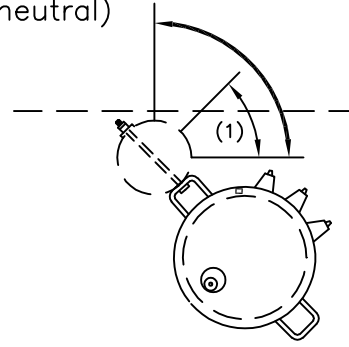
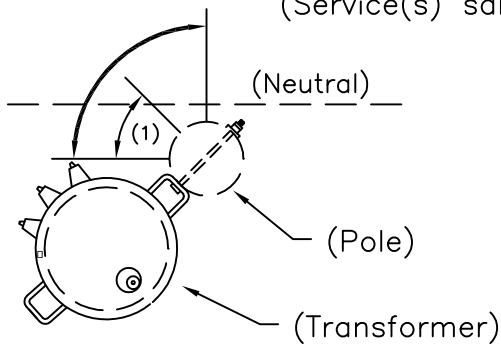

(Service(s) opposite side of neutral)

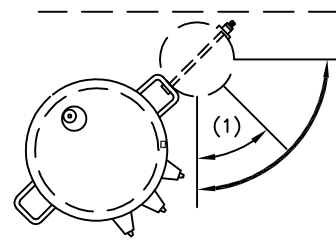
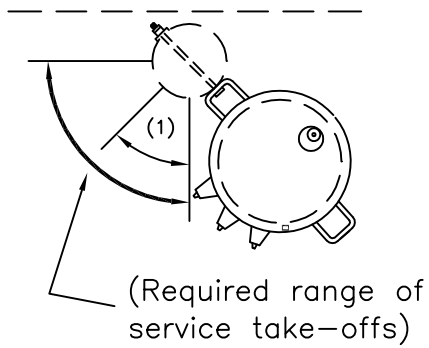

DEADEND POLES

(See Note 2)

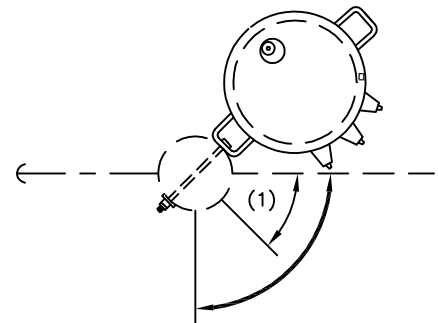
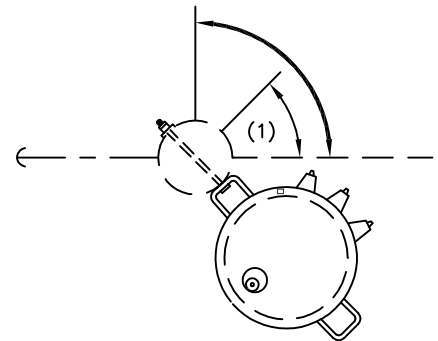
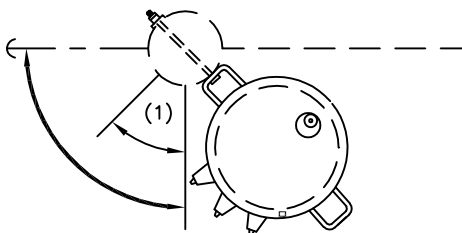
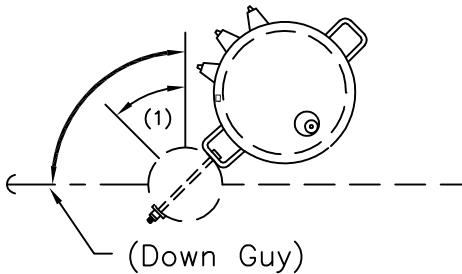

NOTES:

1. Lower service(s) to 4 inches below transformer if necessary for adequate clearances.
2. Lower transformer so that neutral is 3 inches above transformer lid.

POLE TYPE TRANSFORMER LOCATION GUIDE

APRIL 2005

RUS

G1.2G

Position of support when required

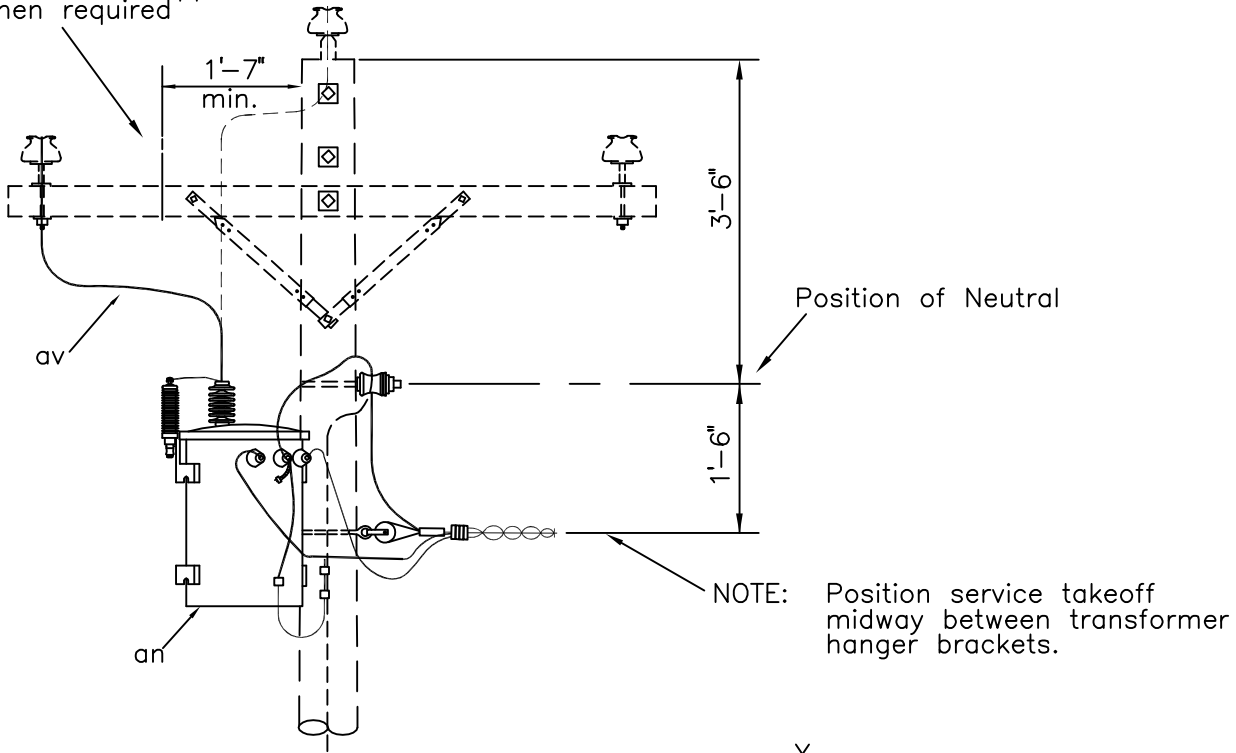

NOTE: Position service takeoff midway between transformer hanger brackets.

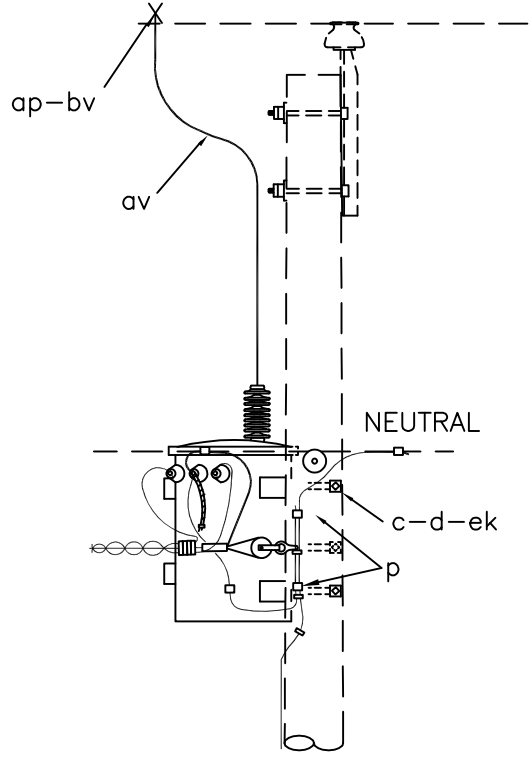
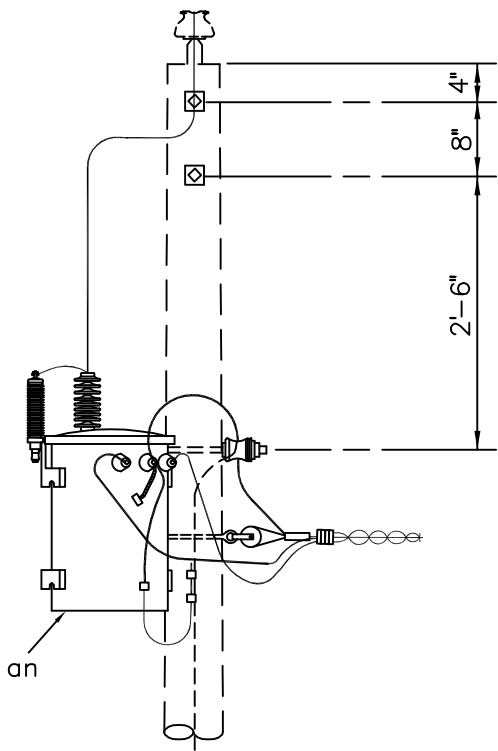

ITEM	QTY	MATERIAL
c	2	Bolt, machine, 5/8" x req'd length
d	2	Washer, square, 2 1/4"
P		Connectors, compression type, as req'd
an	1	Transformer, 12.47 kV, self-protected

ITEM	QTY	MATERIAL
ap	1	Clamp, hot line
av		Jumpers, stranded, as req'd
bv	1	Rod, armor (as req'd)
ek	2	Locknuts

DESIGN PARAMETERS:

See Guide Drawing "G1.1G"

SINGLE-PHASE, CSP TRANSFORMER (TANGENT POLE)

APRIL 2005

RUS

12.47/7.2 kV

G1.2

(G105-),(G136-)

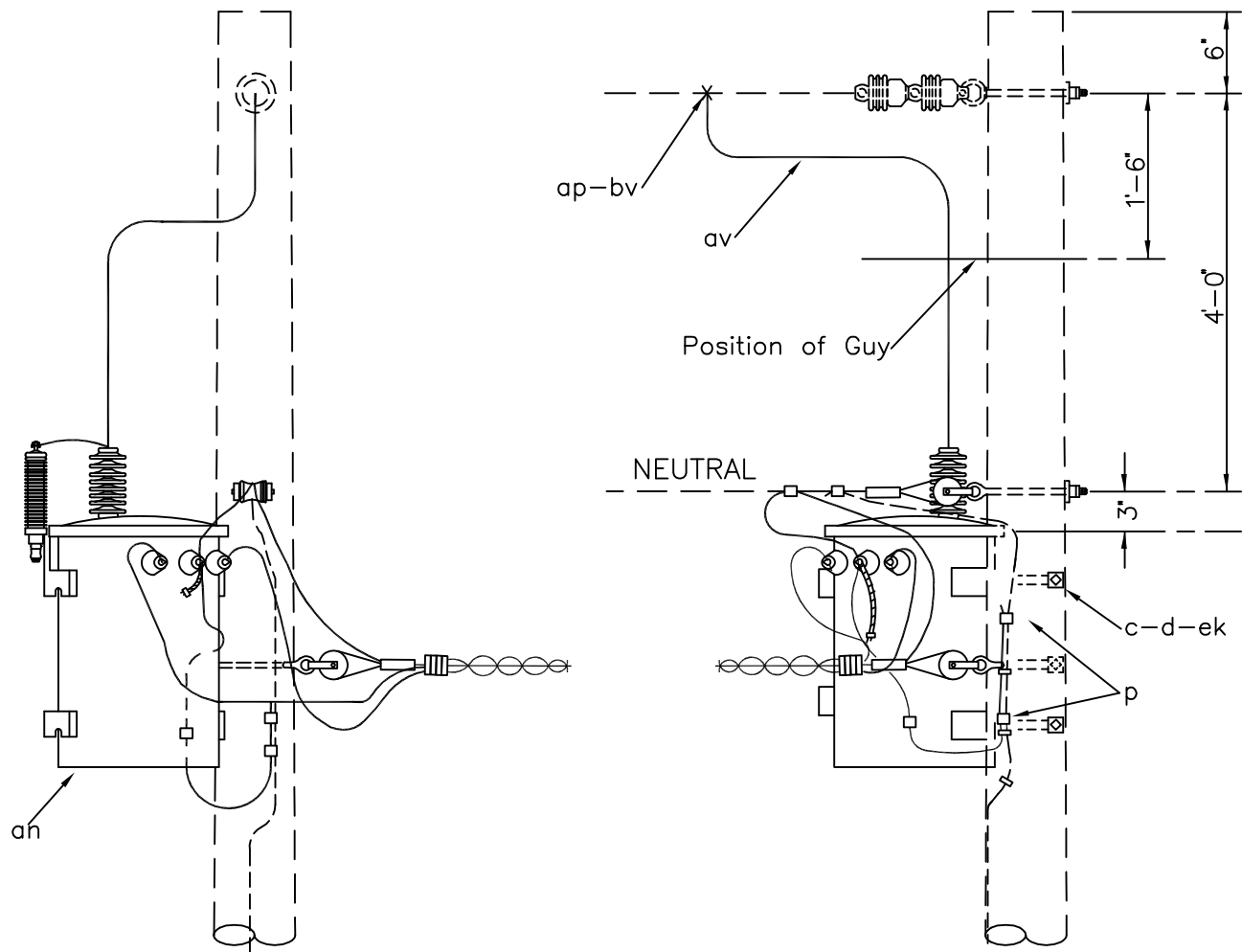

NOTE: Install transformer so that primary neutral is 3 inches above bottom of transformer lid on both single-phase and three-phase primary assemblies. See drawing "C5.21" for three-phase deadend.

ITEM	QTY	MATERIAL
c	2	Bolt, machine, 5/8" x req'd length
d	2	Washer, square, 2 1/4"
P		Connectors, compression type as req'd
an	1	Transformer, 12.47 kV, self protected

ITEM	QTY	MATERIAL
ap	1	Clamp, hot line
av		Jumpers, stranded, as req'd
bv	1	Rod, armor (as req'd)
ek	2	Locknuts

DESIGN PARAMETERS:

See Guide Drawing "G1.1G"

SINGLE-PHASE, CSP TRANSFORMER
(DEADEND POLE)

APRIL 2005

RUS

12.47/7.2 kV

G1.3

(G106-)

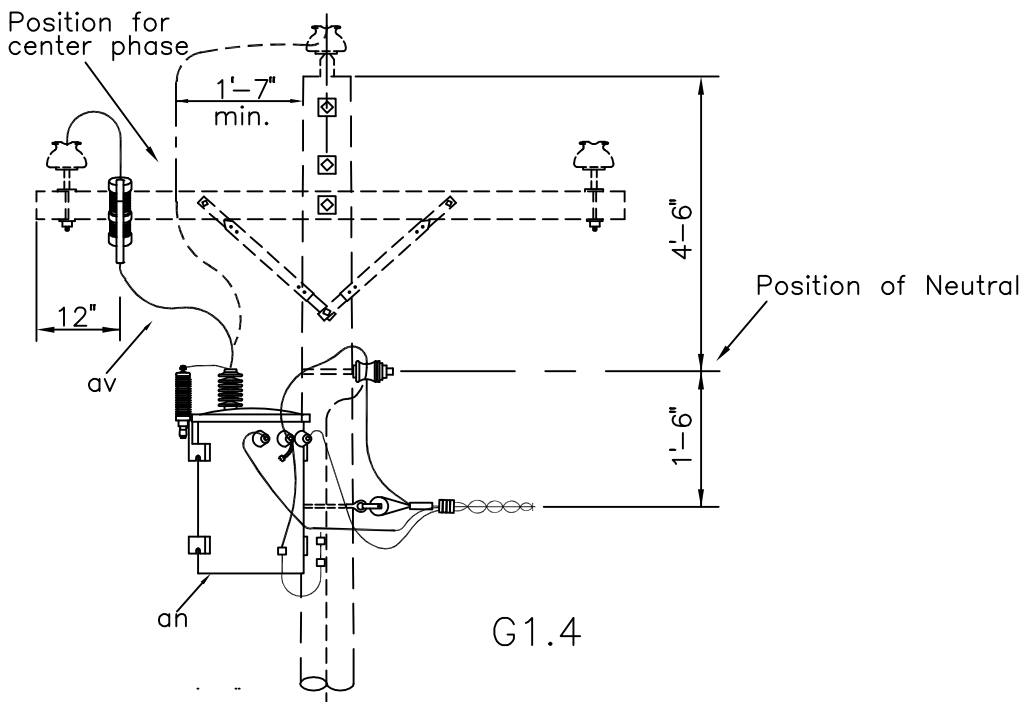

G1.4

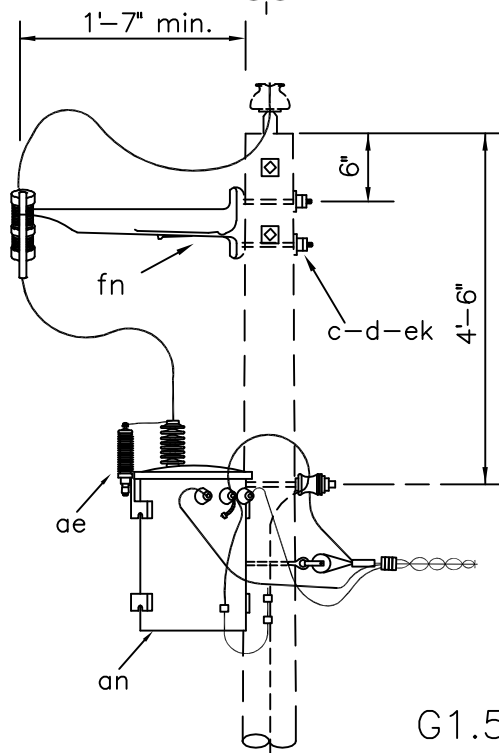

G1.5

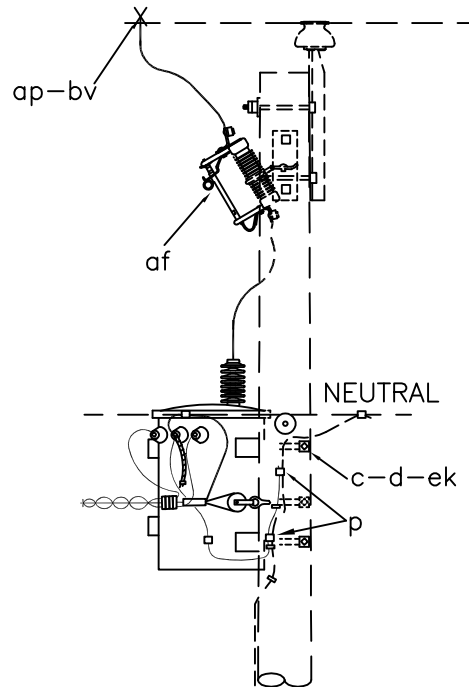

NOTE: Rotate cutout so the blade faces climbing face of pole.

ASSEMBLY: G1		.4	.5
ITEM	MATERIAL	QTY	QTY
c	Bolt, machine, 5/8" x req'd length	2	4
d	Washer, square, 2 1/4"	2	4
p	Connectors, as req'd		
ae	Arrester, surge (9 kV)	1	1
af	Cutout, dist., open (15 kV)	1	1
an	Transformer, 12.47 kV, conventional	1	1

ASSEMBLY: G1		.4	.5
ITEM	MATERIAL	QTY	QTY
ap	Clamp, hot line	1	1
av	Jumpers, stranded, as req'd		
bv	Rod, armor, as req'd		
ek	Locknuts,	2	4
fn	Bracket, extension		1

DESIGN PARAMETERS:

See Guide Drawing "G1.1G"

SINGLE-PHASE, CONVENTIONAL TRANSFORMER
(TANGENT POLE)

APRIL 2005

RUS

12.47/7.2 kV

G1.4

G1.5

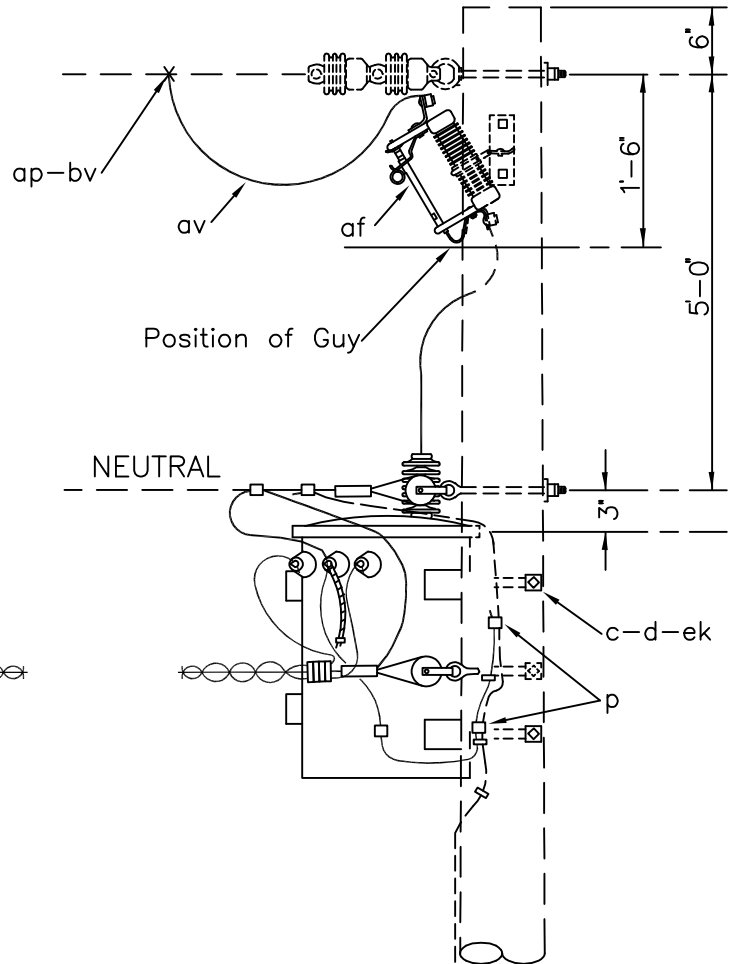
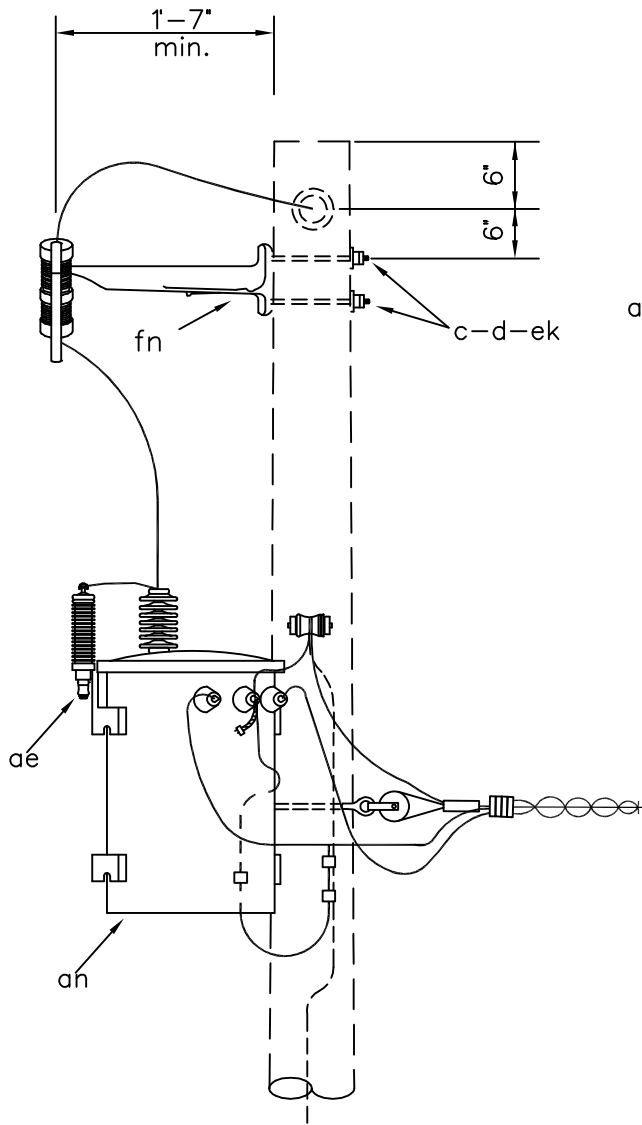

NOTE: Rotate cutout so that the blade faces climbing face of pole.

ITEM	QTY	MATERIAL
c	4	Bolt, machine, 5/8" x req'd length
d	4	Washer, square, 2 1/4"
P		Connectors, as req'd
ae	1	Arrester, surge (9 kV)
af	1	Cutout, dist. open (15 kV)
an	1	Transformer, 12.47 kV, conventional

ITEM	QTY	MATERIAL
ap	1	Clamp, hot line
av		Jumpers, stranded, as req'd
bv	1	Rod, armor as req'd
ek	4	Locknuts
fn	1	Bracket, extension

DESIGN PARAMETERS:

See Guide Drawing "G1.1G"

SINGLE-PHASE, CONVENTIONAL TRANSFORMER
(DEADEND POLE)

APRIL 2005

RUS

12.47/7.2 kV

G1.6

Position of support when required

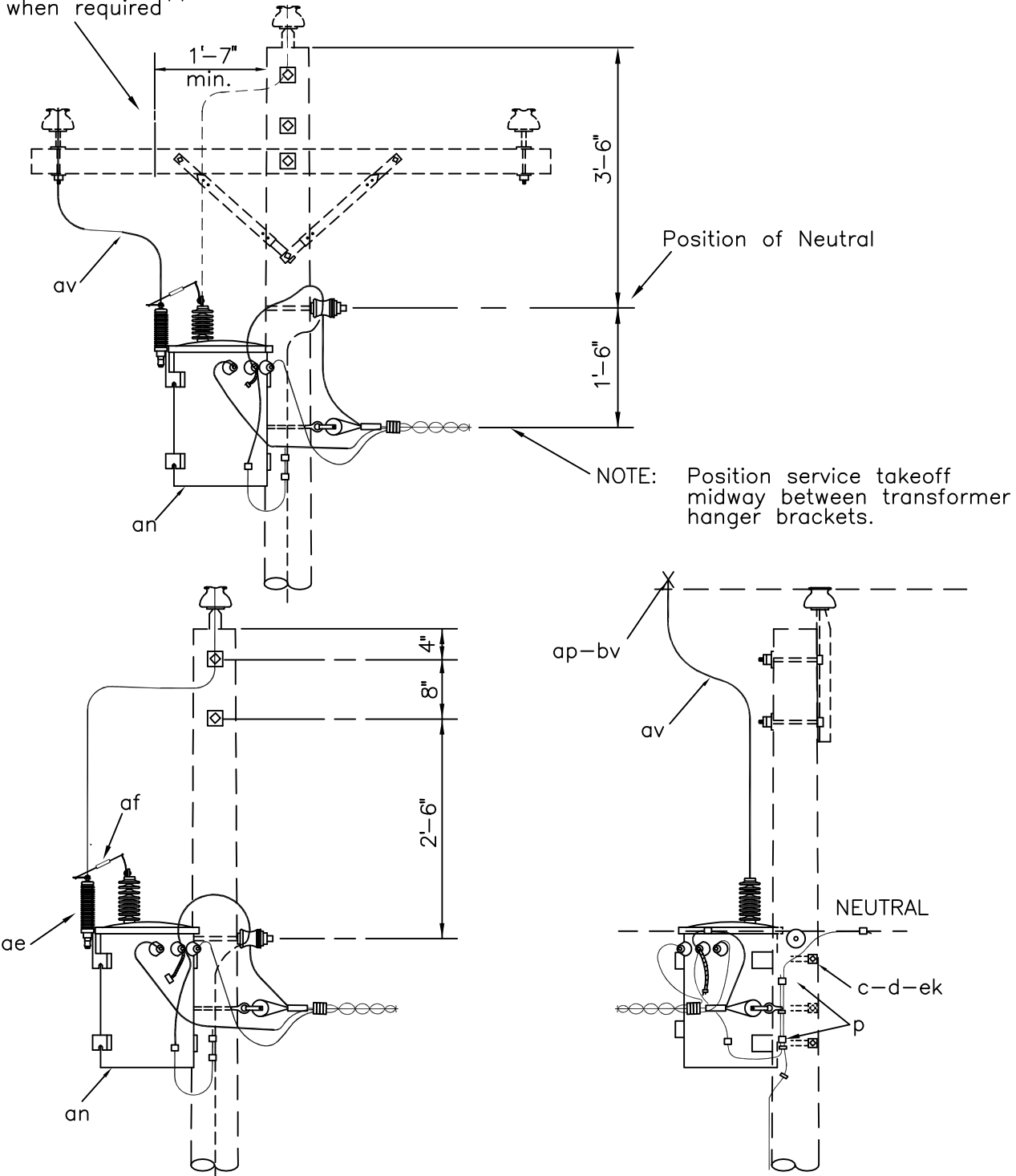

ITEM	QTY	MATERIAL
c	2	Bolt, machine, 5/8" x req'd length
d	2	Washer, square, 2 1/4"
P		Connectors, compression type, as req'd
an	1	Transformer, 12.47 kV, conventional
ae	1	Arrester, surge (9 kV)

ITEM	QTY	MATERIAL
af	1	Cutout, fuse, open link
ap	1	Clamp, hot line
av		Jumpers, stranded, as req'd
bv	1	Rod, armor (as req'd)
ek	2	Locknuts

DESIGN PARAMETERS:

See Guide Drawing "G1.1G"

SINGLE-PHASE,
CONVENTIONAL TRANSFORMER
(TANGENT POLE)

APRIL 2005

RUS

12.47/7.2 kV

G1.7
(G9-),(G39-)

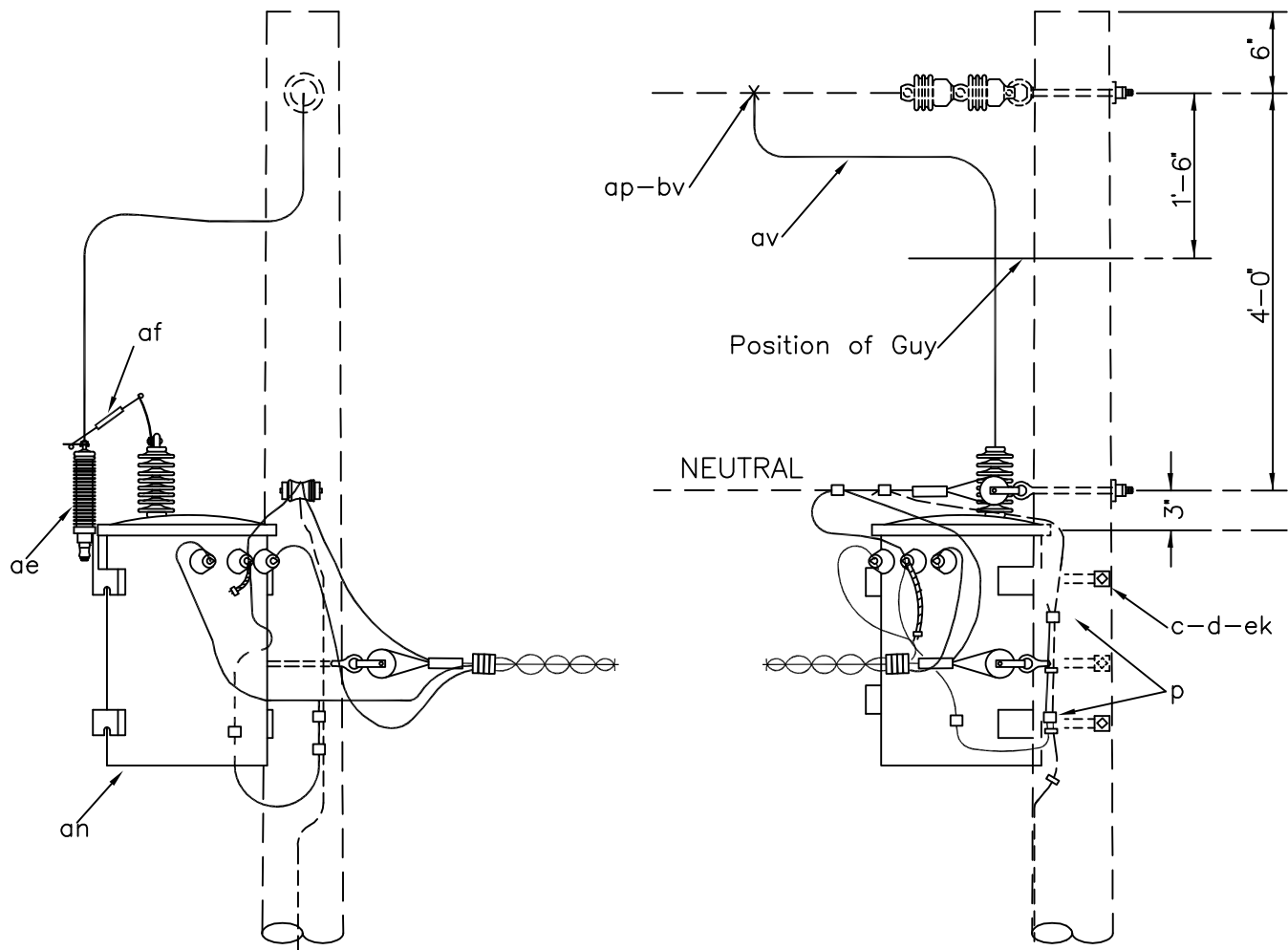

NOTE: Install transformer so that primary neutral is 3 inches above bottom of transformer lid on both single-phase and three-phase primary assemblies. See drawing "C5.21" for three-phase deadend.

ITEM	QTY	MATERIAL
c	2	Bolt, machine, 5/8" x req'd length
d	2	Washer, square, 2 1/4"
P		Connectors, compression type as req'd
an	1	Transformer, 12.47 kV, conventional
ae	1	Arrester, surge (9 kV)

ITEM	QTY	MATERIAL
af	1	Cutout, fuse, open link
ap	1	Clamp, hot line
av		Jumpers, stranded, as req'd
bv	1	Rod, armor (as req'd)
ek	2	Locknuts

DESIGN PARAMETERS:

See Guide Drawing "G1.1G"

SINGLE-PHASE,
CONVENTIONAL TRANSFORMER
(DEADEND POLE)

APRIL 2005

RUS

12.47/7.2 kV

G1.8
(G10-)

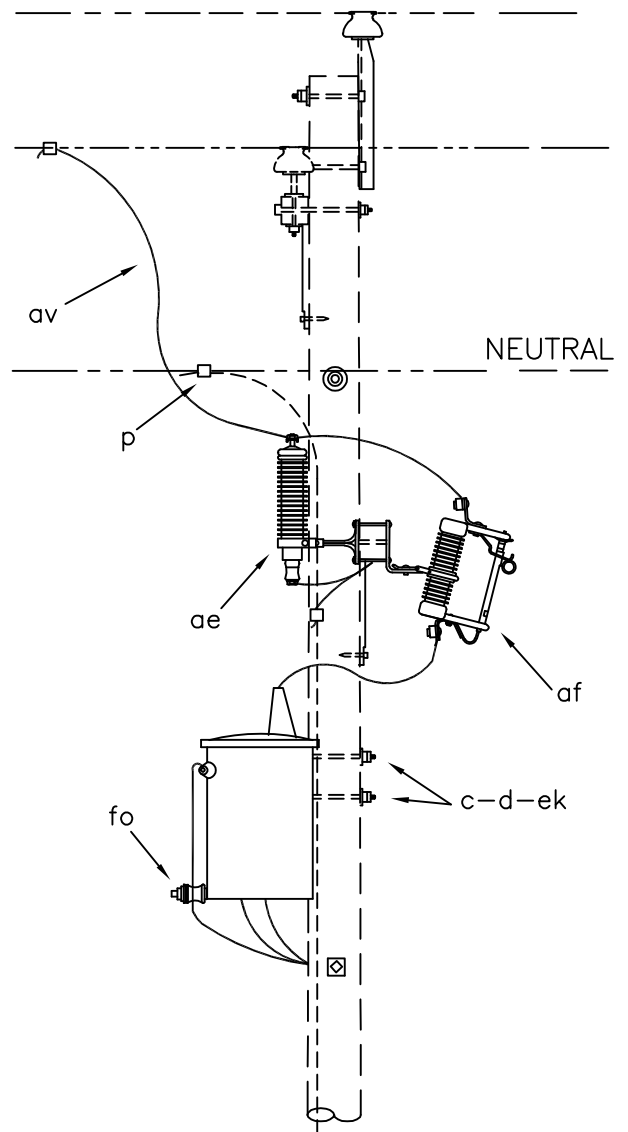
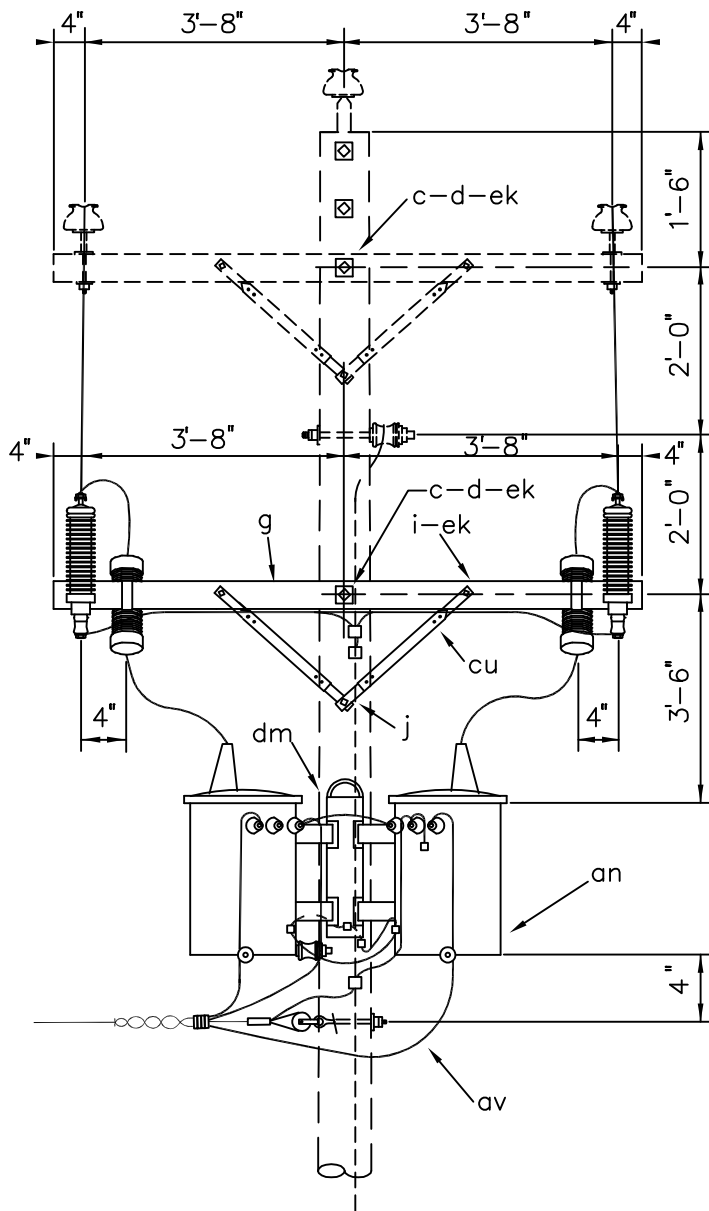

ITEM	QTY	MATERIAL
c	3	Bolt, machine, 5/8" x req'd length
d	4	Washer, square, 2 1/4"
g	1	Crossarm, 3 5/8" x 4 5/8" x 8'-0"
i	2	Bolt, carriage, 3/8" x 4 1/2"
j	1	Screw, lag, 1/2" x 4"
p		Connectors, as req'd
p		Connectors, compression, as req'd
ae	2	Arrester, surge, (9 kV)

ITEM	QTY	MATERIAL
af	2	Cutout, dist. open (15 kV)
an	2	Transformer, 12.47 kV, conv.
av		Jumpers, bare, stranded, as req'd
av		Jumpers, service, as req'd
cu	2	Brace, 28"
dm	1	Bracket, transformer
ek	5	Locknuts
fo	2	Bracket, transformer, insul.

DESIGN PARAMETERS:

See Guide Drawing "G2.1G"

TWO-PHASE TRANSFORMER BANK
OPEN-WYE PRIMARY
OPEN-DELTA, 4 WIRE SECONDARY

APRIL 2005

RUS

12.47/7.2 kV

G2.1
(G210-)

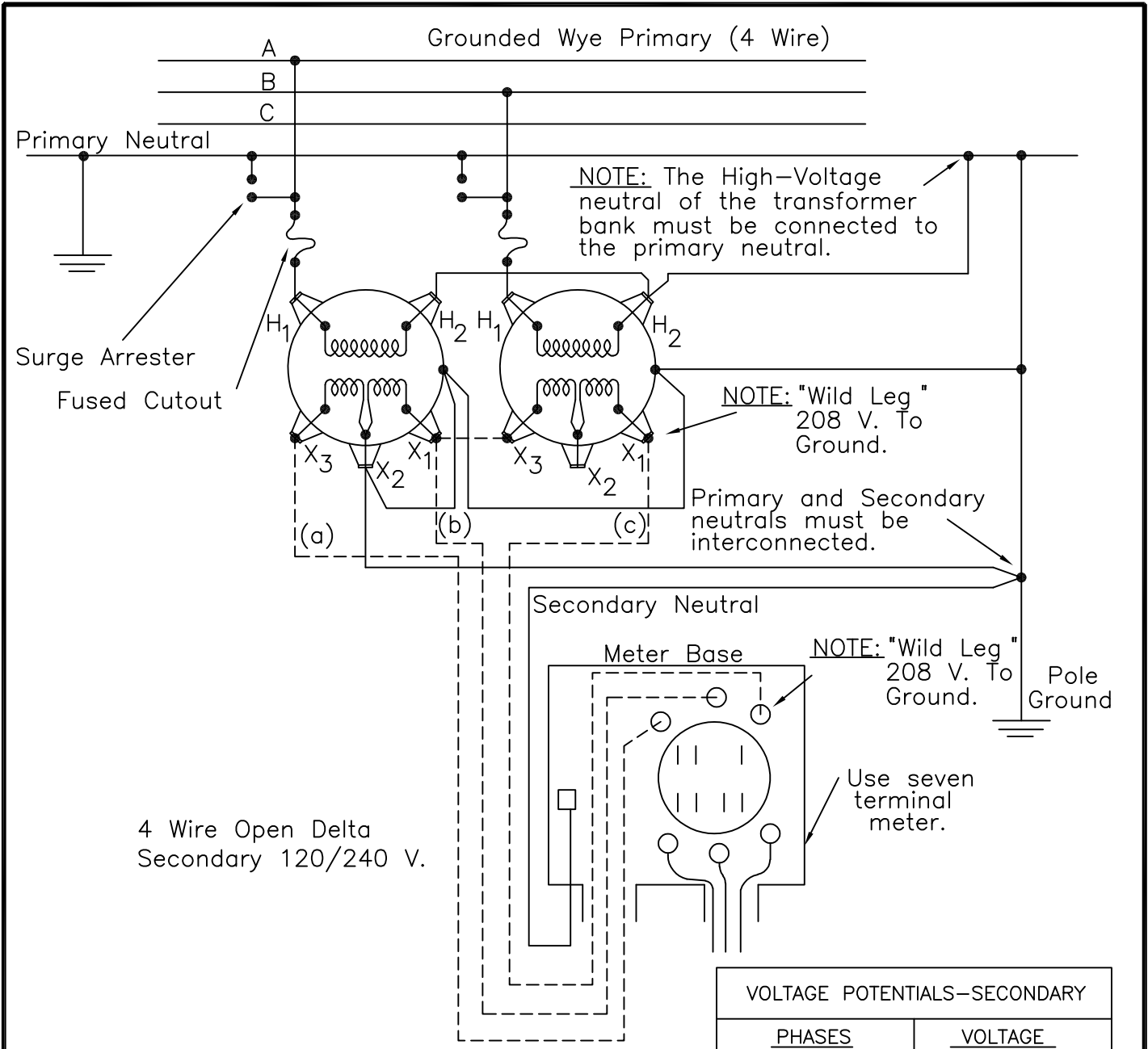

4 Wire Open Delta
Secondary 120/240 V.

VOLTAGE POTENTIALS—SECONDARY	
PHASES	VOLTAGE
a-b	240 VOLTS
b-c	240 VOLTS
a-c	240 VOLTS
a-N	120 VOLTS
b-N	120 VOLTS
c-N	208 VOLTS

APPLICATION: Used to supply large single-phase, 120/240 volt loads with small amount of three phase loads. Also used when only two phases of primary are available or during emergencies when one unit of a four-wire, wye-delta bank is disabled.

See drawing "G2.1" or "VG2.1" for construction details. One-bushing or two-bushing transformers may be used. Usually transformers of different KVA sizes are used.

BANK RATING: This bank has only 86.6% of the rating of the two units making up the three-phase bank and only 57.7% of the three-phase rating of a closed delta-delta bank of three transformers. Thus, it is relatively inefficient where three-phase loads predominate.

210° ANGULAR DISPLACEMENT

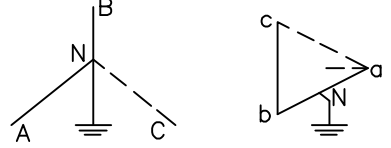

(Additive Polarity—See TRANSFORMER SPECIFICATIONS)

TRANSFORMER/METER CONNECTION GUIDE
THREE-PHASE, OPEN-WYE - OPEN DELTA
FOR 120/240 VOLT POWER LOADS

APRIL 2005

RUS

G2.1G

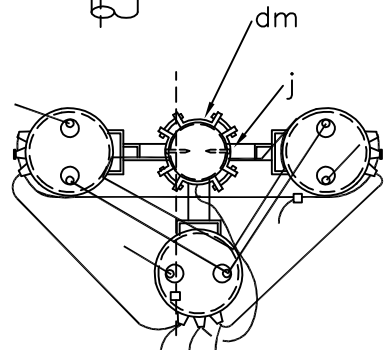
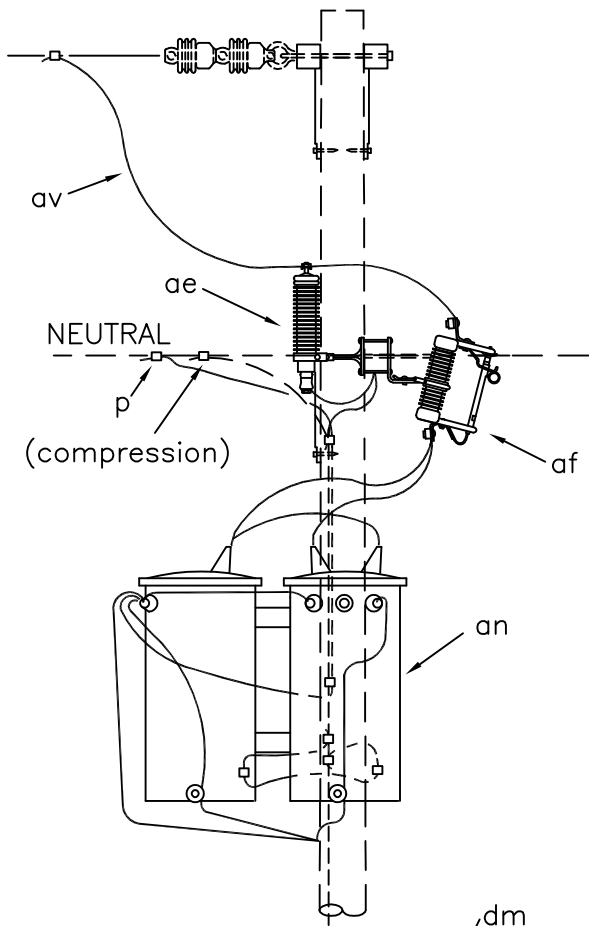
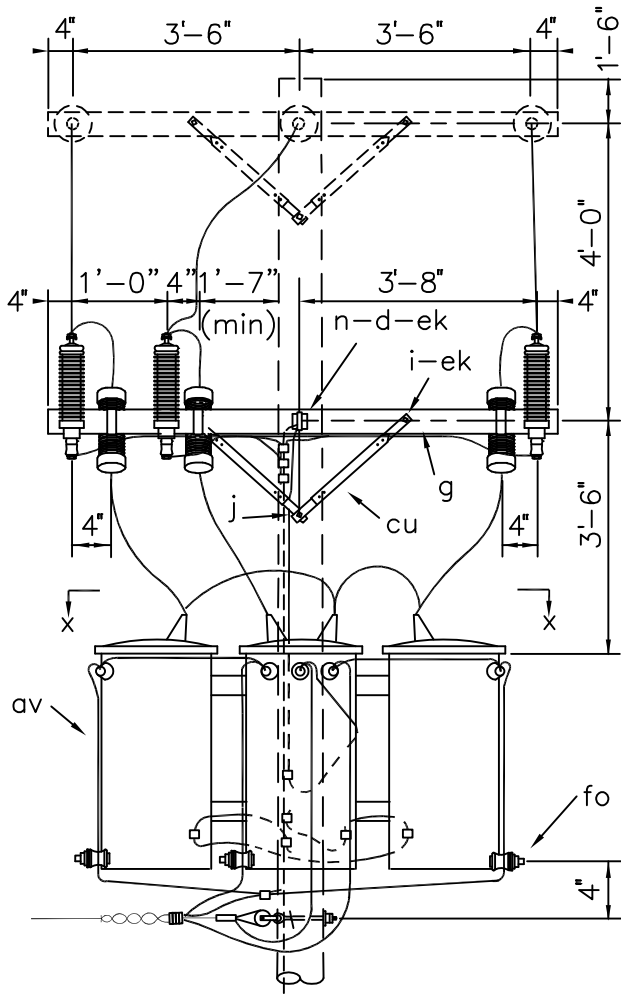

NOTES:

1. See Drawing "Q3.1" for additional connection and metering details.
2. All transformer tanks must be grounded.

ITEM	QTY	MATERIAL
d	2	Washer, square, 2 1/4"
g	1	Crossarm, 3 5/8" x 4 5/8" x 8'-0"
i	2	Bolt, carriage, 3/8" x 4 1/2"
j		Screw, lag, 1/2" x 4" as req'd
n	1	Bolt, dble arm, 5/8 x req'd length
p		Connectors, as req'd
p		Connectors, compression, as req'd
ae	3	Arrester, surge, (9 kV)

ITEM	QTY	MATERIAL
af	3	Cutout, dist. open (15 kV)
an	3	Transformer, 12.47 kV, conventional
av		Jumpers, bare, stranded
av		Jumpers, service, as req'd
cu	2	Brace, 28"
dm	1	Bracket, transformer, cluster with adapter plates as req'd
ek	5	Locknuts
fo	3	Bracket, transformer, insulated

DESIGN PARAMETERS:

See Guide Drawing "G3.1G"

THREE-PHASE TRANSFORMER BANK
 UNGROUNDED-WYE PRIMARY
 CENTER-TAP GROUNDED DELTA, 4 WIRE SECONDARY

APRIL 2005

3 - PHASE PRIMARY

G3.1

RUS

12.47/7.2 kV

(G310-)

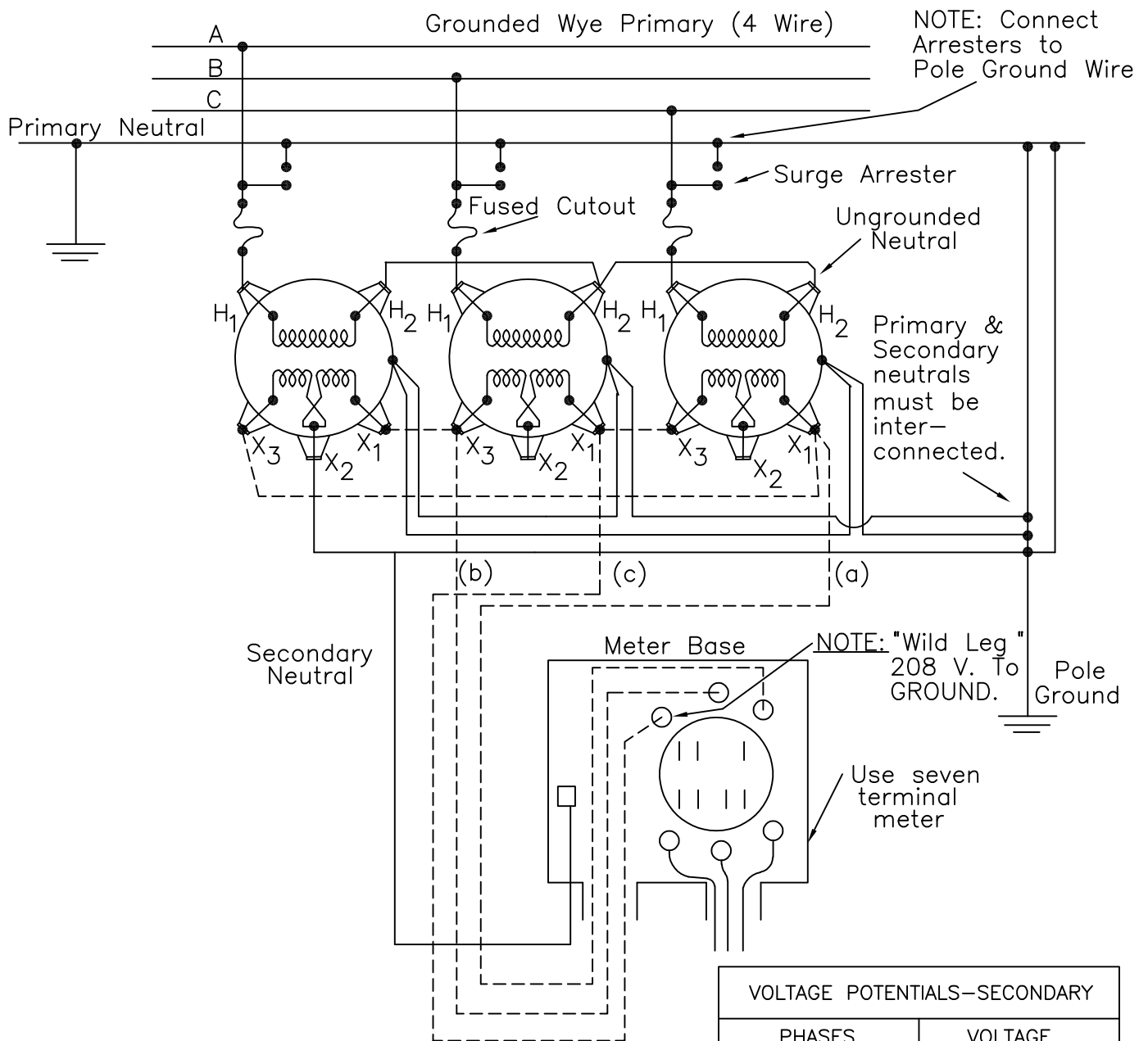

APPLICATION: Used to supply three-phase, 240 volt loads with small amounts of 120/240 volt single-phase loads.

See drawing "G3.1" or "VG3.1" for construction details.

CAUTION: Only ground one secondary neutral bushing of the three transformers. Connecting the high-voltage neutral to the system neutral may cause the transformer bank to burn out. Largest transformer capacity should not be more than 2 times the smallest transformer kVA.

BANK RATING: The center tapped transformer carries 2/3 of the 120/240 volt single-phase load; each of the three units carry 1/3 of the 240 volt three-phase load.

VOLTAGE POTENTIALS—SECONDARY	
PHASES	VOLTAGE
a-b	240 VOLTS
b-c	240 VOLTS
a-c	240 VOLTS
a-N	120 VOLTS
b-N	120 VOLTS
c-N	208 VOLTS

210° ANGULAR DISPLACEMENT

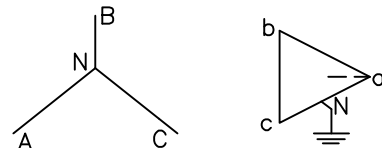

(Additive Polarity—See TRANSFORMER SPECIFICATIONS)

TRANSFORMER/METER CONNECTION GUIDE
 UNGROUNDED WYE – CENTER TAP GROUNDED DELTA
 FOR 120/240 VOLT POWER LOADS

APRIL 2005

3 - PHASE PRIMARY

RUS

G3.1G

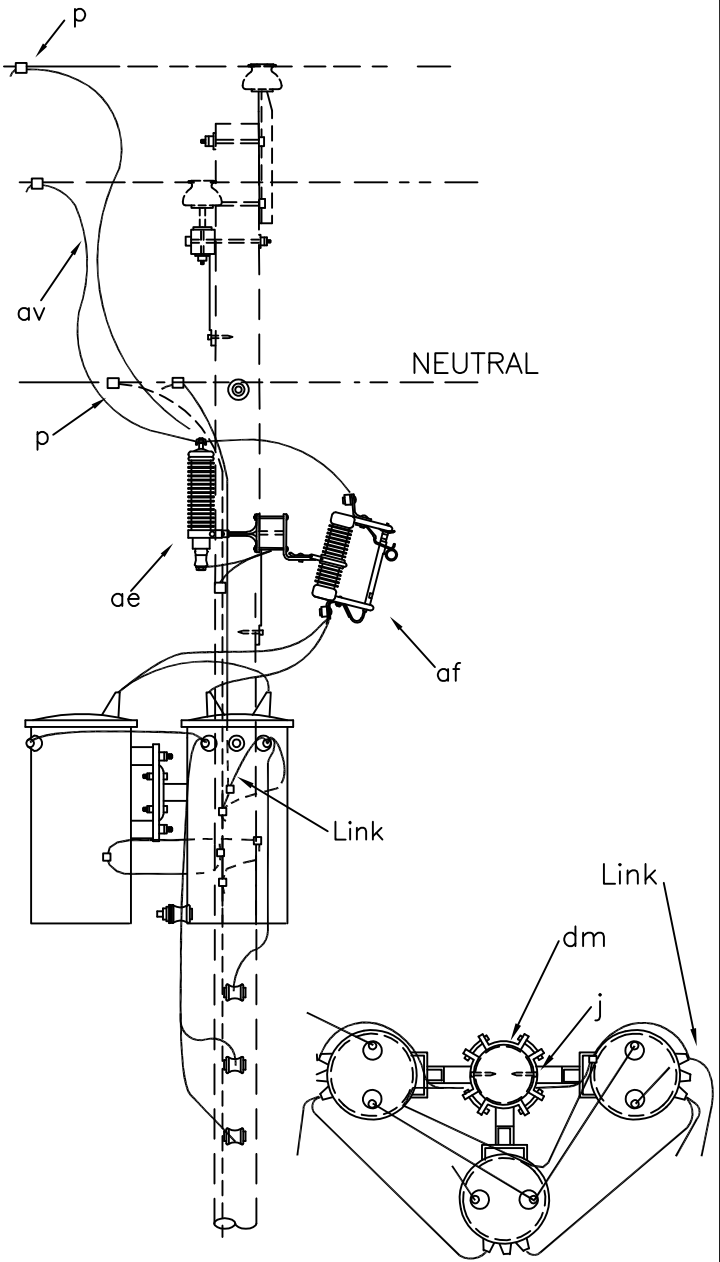
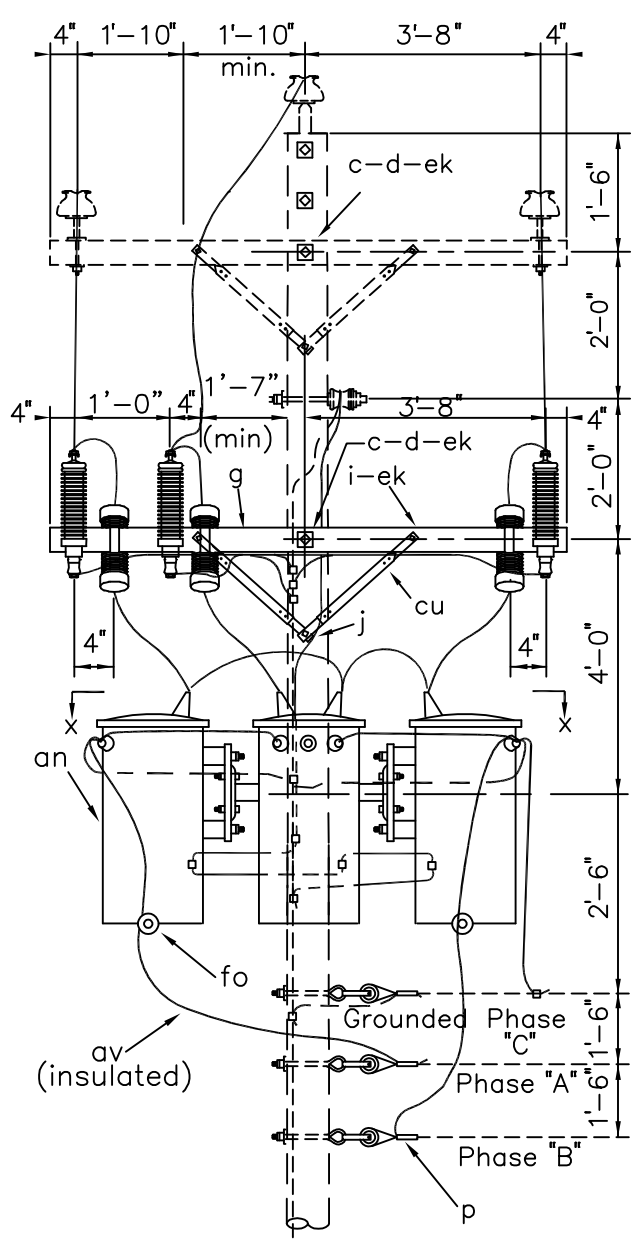

SECTION X-X

NOTES:

1. See Drawing "Q3.2" for additional connection and metering details.
2. This transformer connection not recommended for new services.

ITEM	QTY	MATERIAL
d	2	Washer, square, 2 1/4"
g	1	Crossarm, 3 5/8" x 4 5/8" x 8'-0"
i	2	Bolt, carriage, 3/8" x 4 1/2"
j		Screw, lag, 1/2" x 4", as req'd
n	1	Bolt, dble arm, 5/8" x req'd length
p		Connectors, as req'd
p		Connectors, compression, as req'd
ae	3	Arrester, surge, (9 kV)

ITEM	QTY	MATERIAL
af	3	Cutout, dist. open (15 kV)
an	3	Transformer, 12.47 kV, conventional
av		Jumpers, bare, stranded
av		Jumpers, service, as req'd
cu	2	Brace, 28"
dm	1	Bracket, transformer, cluster with adapter plates as req'd
ek	5	Locknuts
fo	3	Bracket, transformer, insulated

DESIGN PARAMETERS:

See Guide Drawing "G3.2G"

THREE-PHASE TRANSFORMER BANK
 UNGROUNDED-WYE PRIMARY
 CORNER GROUNDED DELTA, 3 WIRE SECONDARY

APRIL 2005

RUS

3 - PHASE PRIMARY

12.47/7.2 kV

G3.2

(G311-)

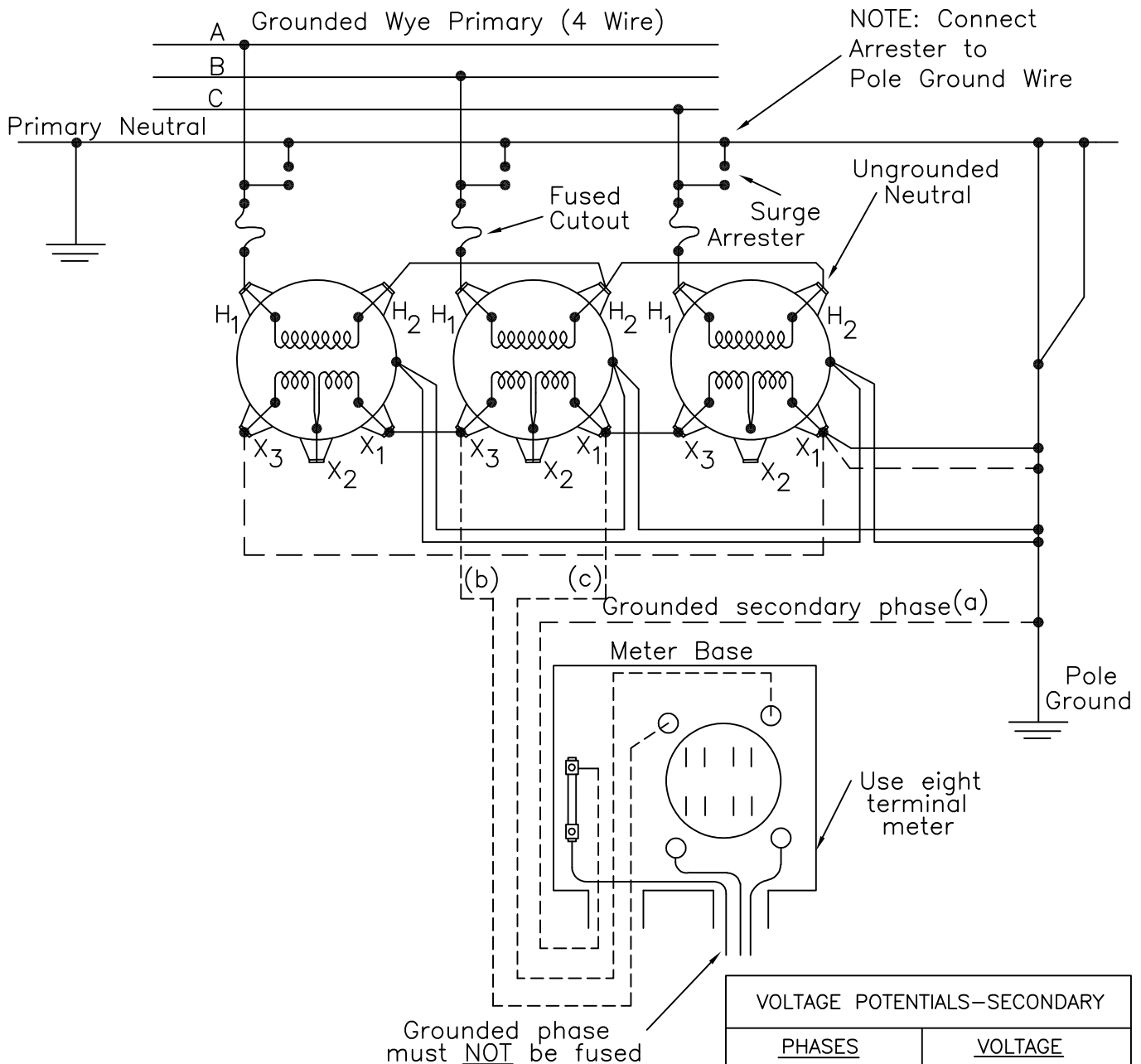

NOTE: Connect Arrester to Pole Ground Wire

Primary Neutral

Fused Cutout

Surge Arrester

Ungrounded Neutral

Pole Ground

Grounded secondary phase (a)

Use eight terminal meter

Grounded phase must NOT be fused

VOLTAGE POTENTIALS—SECONDARY	
PHASES	VOLTAGE
a-b	480 VOLTS
b-c	480 VOLTS
a-c	480 VOLTS
a-GRD	0 VOLTS
b-GRD	480 VOLTS
c-GRD	480 VOLTS

210° ANGULAR DISPLACEMENT

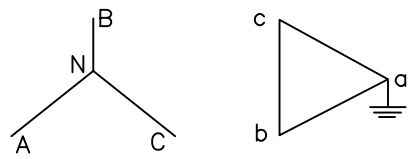

(Additive Polarity— See TRANSFORMER SPECIFICATIONS)

APPLICATION: Used to supply three-phase (only), 240 or 480 volt power loads.

See drawing "G3.2" or "VG3.2" for construction details.

BANK RATING: The maximum safe kVA rating of the bank is three times the kVA rating of the smallest transformer.

NOTES:

One-half of the above voltages apply when a 240 volt bank is used.

All tanks to be grounded.

Disconnect all secondary neutrals from tank and do not ground.

Do not ground bank on primary side. (If grounded, the bank would be a grounding bank for the entire circuit.)

The grounding secondary wire is a current carrying phase wire operating at ground potential and must be identified throughout the circuit run. It is not a neutral.

TRANSFORMER/METER CONNECTION GUIDE
 UNGROUNDED WYE – CORNER GROUNDED DELTA
 FOR 240 or 480 VOLT POWER LOADS

APRIL 2005

3 - PHASE PRIMARY

RUS

G3.2G

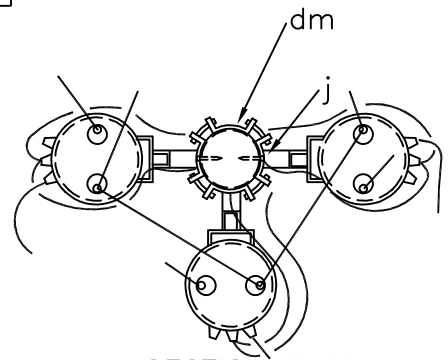
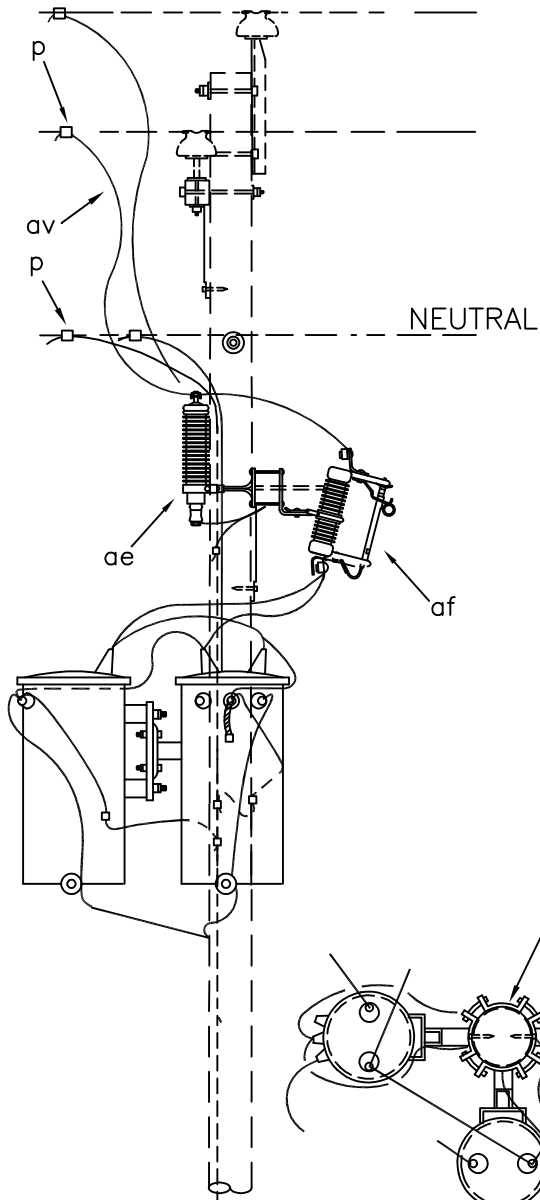
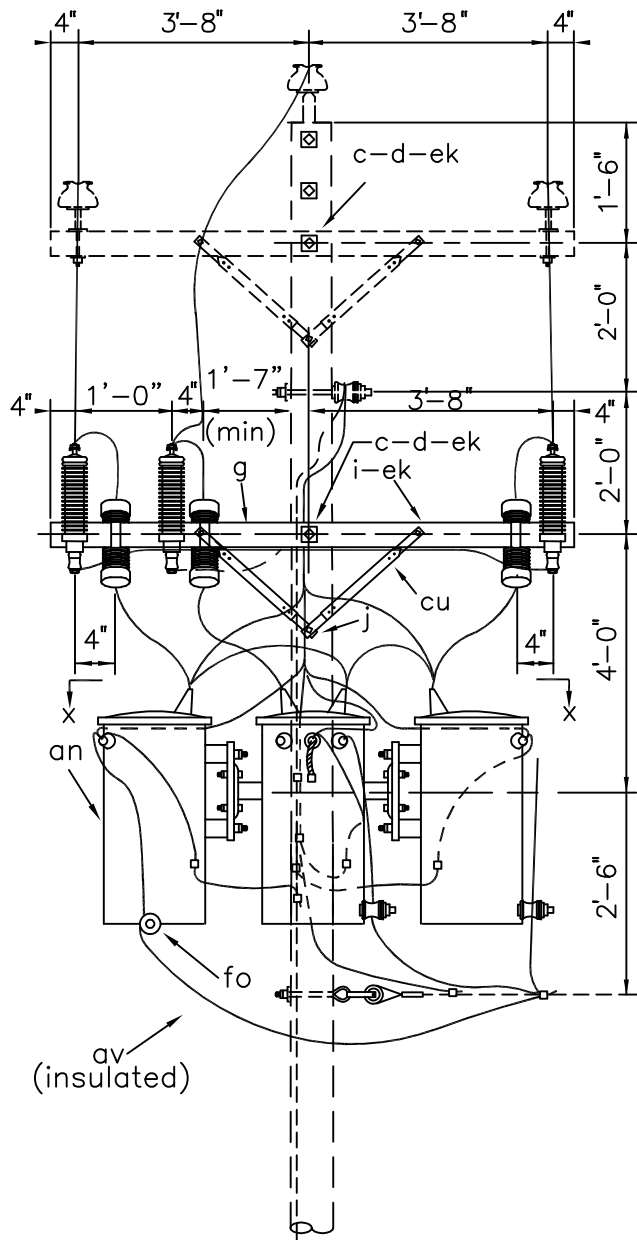

NOTES:

1. See Drawing "Q3.3" for additional connection and metering details.

ITEM	QTY	MATERIAL
d	2	Washer, square, 2 1/4"
g	1	Crossarm, 3 5/8" x 4 5/8" x 8'-0"
i	2	Bolt, carriage, 3/8" x 4 1/2"
j		Screw, lag, 1/2" x 4", as req'd
n	1	Bolt, dble arm, 5/8" x req'd length
p		Connectors, as req'd
p		Connectors, compression, as req'd
ae	3	Arrester, surge, (9 kV)

ITEM	QTY	MATERIAL
af	3	Cutout, dist. open (15 kV)
an	3	Transformer, 12.47 kV, conventional
av		Jumpers, bare, stranded
av		Jumpers, service, as req'd
cu	2	Brace, 28"
dm	1	Bracket, transformer, cluster with adapter plates as req'd
ek	5	Locknuts
fo	3	Bracket, transformer, insulated

DESIGN PARAMETERS:

See Guide Drawing "G3.3G"

THREE-PHASE TRANSFORMER BANK
 GROUNDED-WYE PRIMARY
 GROUNDED WYE, 4 WIRE SECONDARY

APRIL 2005

RUS

3 - PHASE PRIMARY

12.47/7.2 kV

G3.3

(G312-)

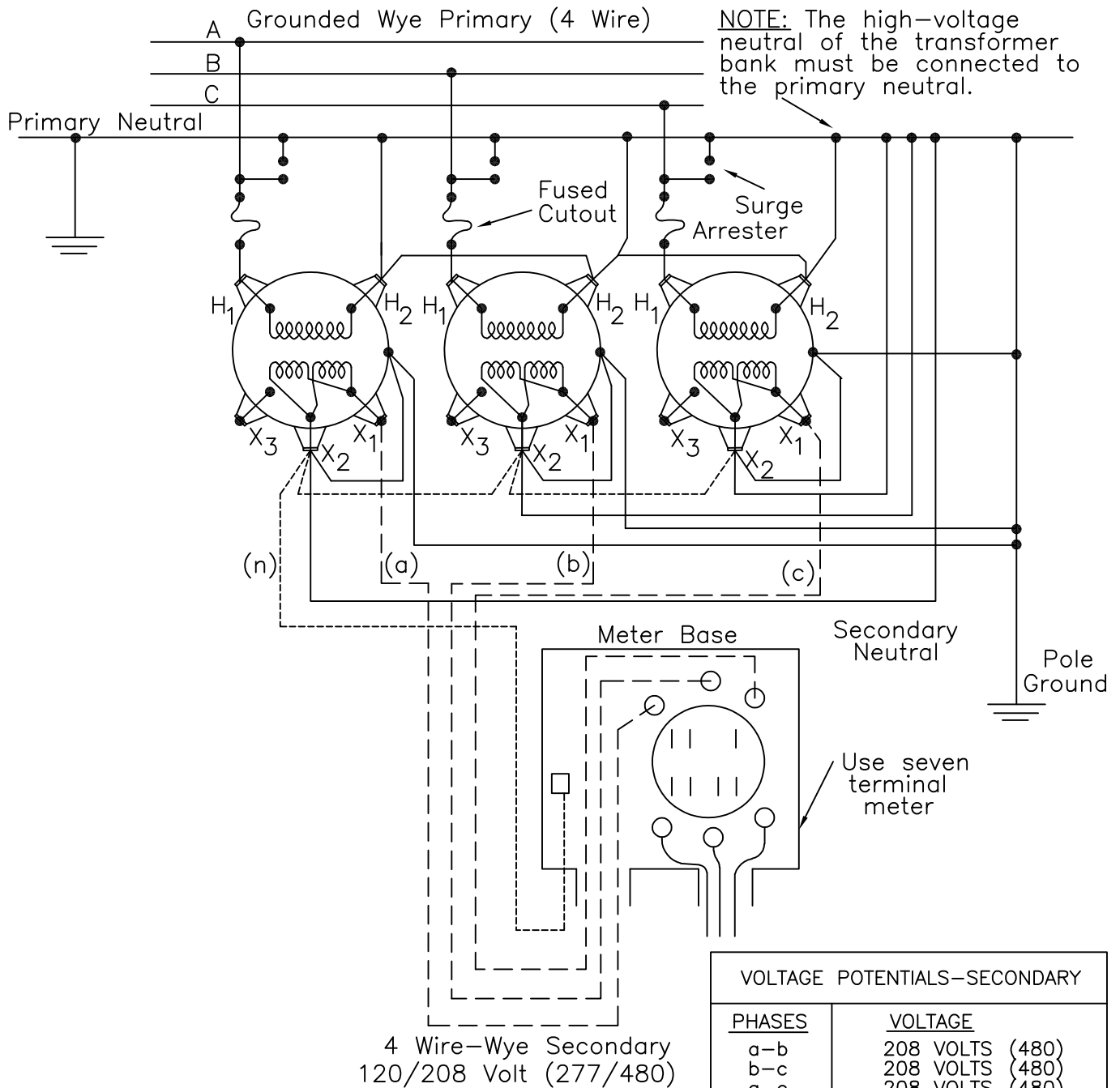

VOLTAGE POTENTIALS-SECONDARY	
PHASES	VOLTAGE
a-b	208 VOLTS (480)
b-c	208 VOLTS (480)
a-c	208 VOLTS (480)
a-N	120 VOLTS (277)
b-N	120 VOLTS (277)
c-N	120 VOLTS (277)

0° ANGULAR DISPLACEMENT

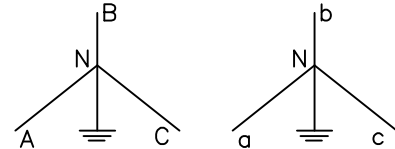

(Additive Polarity-
See TRANSFORMER SPECIFICATIONS)

APPLICATION: Used to supply 120/208 volt single-phase and 208 volt, three-phase power loads.

See drawing "G3.3" or "VG3.3" for construction details. Reconnect secondary windings of transformers as shown. Matched (impedance and kVA) transformers are usually used.

BANK RATING: Each unit will supply 1/3 of the three-phase load and all of the single-phase load connected to it.

CAUTION: The primary and secondary neutrals must be firmly tied together and grounded or else excessive secondary voltages may develop.

TRANSFORMER/METER CONNECTION GUIDE

GROUNDED WYE - GROUNDED WYE FOR 120/208 VOLT POWER LOADS

APRIL 2005

3 - PHASE PRIMARY

RUS

G3.3G

GROUNDING ASSEMBLY UNITS

<u>DRAWING NUMBERS</u>		<u>DRAWING TITLE (DESCRIPTION)</u>
1728F-804 (New)	Bulletin 50-3 (Old)	
H1.1	(M2-11)	GROUNDING ASSEMBLY - GROUND ROD TYPE
H2.1	(M2-13)	GROUNDING ASSEMBLY - TRENCH TYPE
H3.1	(M2-15)	GROUNDING ASSEMBLY - GROUND ROD TYPE (FOR SECTIONALIZING AIRBREAK SWITCH)
H4.1	(M2-15A)	GROUNDING ASSEMBLY - PLATFORM TYPE (FOR SECTIONALIZING AIRBREAK SWITCH)
H5.1	(M2-12)	GROUNDING IMPROVEMENT ASSEMBLY – PLATE TYPE
H5.2 H5.3	(M2-12A)	GROUNDING IMPROVEMENT ASSEMBLY – WRAP-AROUND TYPE

CONSTRUCTION SPECIFICATIONS FOR GROUNDING

Ground rods (item “ai”) shall be driven to their full length in undisturbed earth, a minimum of 2 feet from the face of the pole. The tops of the ground rods shall be at least 12 inches below the surface of the earth. The ground wire (item “av”) shall be attached to the rod with a ground rod clamp (item “aj”) and shall be secured to the pole with staples. The staples on the ground wire shall be spaced 2 feet part, except for the first 8 feet above the ground and the top 8 feet of the ground wire where they shall be spaced 6 inches apart.

The connection between the ground rod and the system neutral should be made by one continuous piece of conductor (the pole ground wire), and shall be installed in the shortest and most direct path according to the construction drawings. Splices, if required, shall be made using a compression type connector and shall be installed a minimum of 6 inches above the ground line. The pole ground wire shall be connected to the system neutral using a compression type connector.

All equipment shall have at least 2 connections from the frame, case, or tank to the multi-grounded system neutral conductor as shown on the construction drawings. The pole ground wire may be used for one or both of these connections.

All neutral conductors on the pole shall be bonded directly to each other, and connected to the pole ground wire if present. All equipment ground wires, neutral conductors, downguys, messenger wires, and surge-protection ground wires shall be interconnected and attached to a common (pole) ground wire in accordance with the requirements of the National Electrical Safety Code (NESC).

Borrowers shall install effectively grounded driven ground rods (assembly H1.1) or trench type grounding assemblies (assembly H2.1) a maximum of 1,320 feet (433 meters) apart along overhead distribution lines. Customer-owned or other installed electric service grounds shall not be counted in the above minimum grounding assembly requirement.

Whereas under certain circumstances, plate type and wrap-around type grounding improvement assemblies (assemblies H5.1 and H5.2, respectively) may meet the grounding electrode requirements of Rule 094B4 of the NESC, RUS does not allow these types of grounding assemblies to be used to meet the NESC requirement of 4 grounds per mile because the effectiveness of these types of grounds in “disturbed” earth is often questionable. However, RUS encourages the installation of these grounding improvement assemblies to augment and improve the overall grounding of the distribution system that in turn generally improves the performance of line protection devices and improves safety.

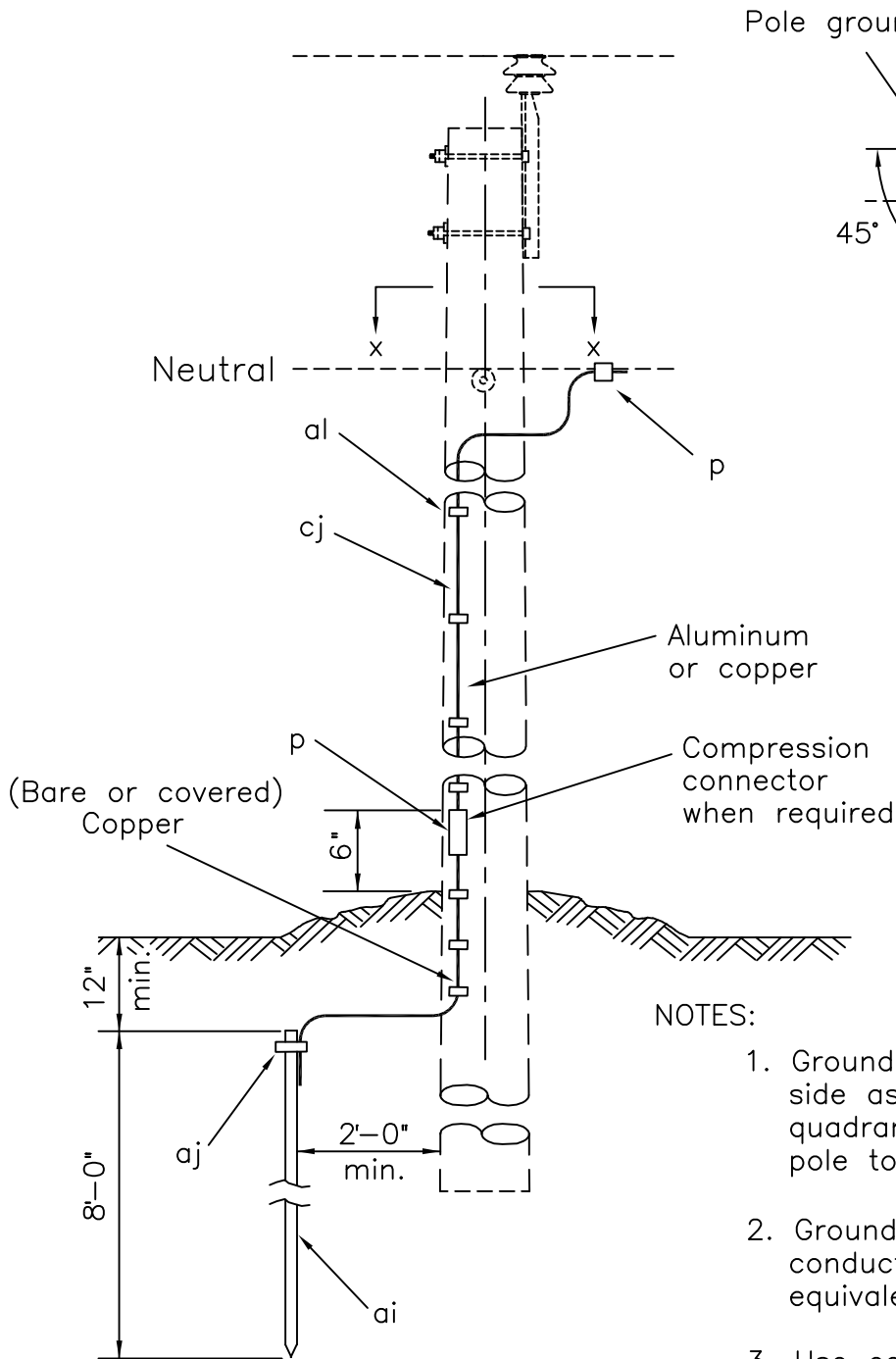

NOTES:

1. Ground wire to be located on same side as neutral conductor and in quadrant opposite climbing space or pole top pin.
2. Ground wire ("cj") to have minimum conductivity of No. 6 Copper or equivalent.
3. Use copper plated ground rod and copper ground wire and staples, or use galvanized steel ground rod, staples and soft annealed iron, 3-strand, 5/16" ground wire with class C galvanizing.

ITEM	QTY	MATERIAL
P		Connector, compression, as req'd
ai	1	Rod, ground, 5/8" min. diameter
aj	1	Clamp, ground rod
al		Staple, ground wire, as req'd
cj		Wire, pole ground, as req'd

GROUNDING ASSEMBLY – GROUND ROD TYPE

APRIL 2005

RUS

H1.1
(M2-11)

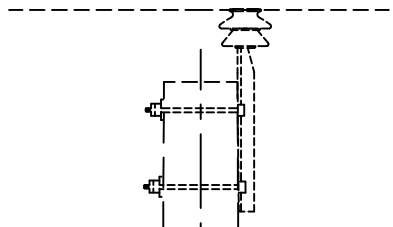

NOTES:

1. Ground wire to be located on same side as neutral conductor and in quadrant opposite climbing space or pole top pin.
2. Pole ground wire and other ground conductors shall be a minimum of No. 6 copper or equivalent.

Neutral

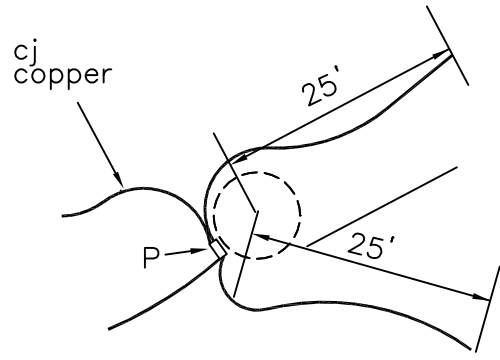
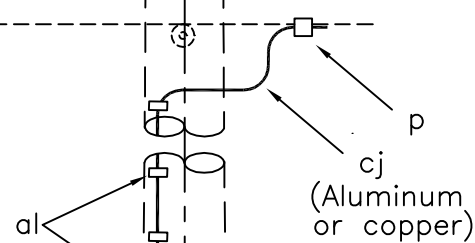

ALTERNATE B

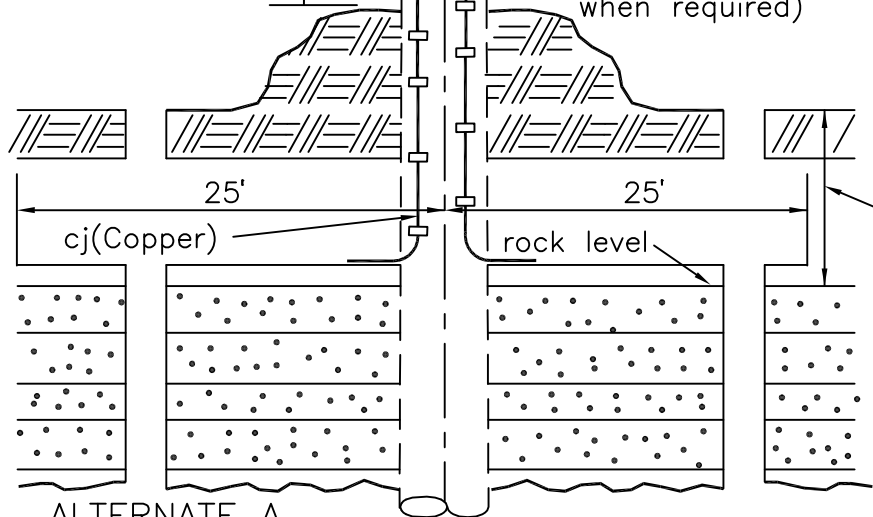
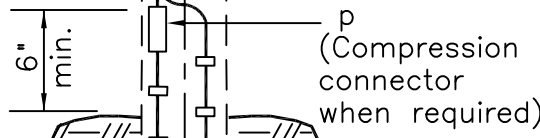

ALTERNATE A

ITEM	QTY	MATERIAL
P		Connector, compression, as req'd
al		Staple, ground wire, as req'd
cj		Wire pole ground as req'd See Note 3 on Drawing H1.1

GROUNDING ASSEMBLY — TRENCH TYPE

APRIL 2005

RUS

H2.1
(M2-13)

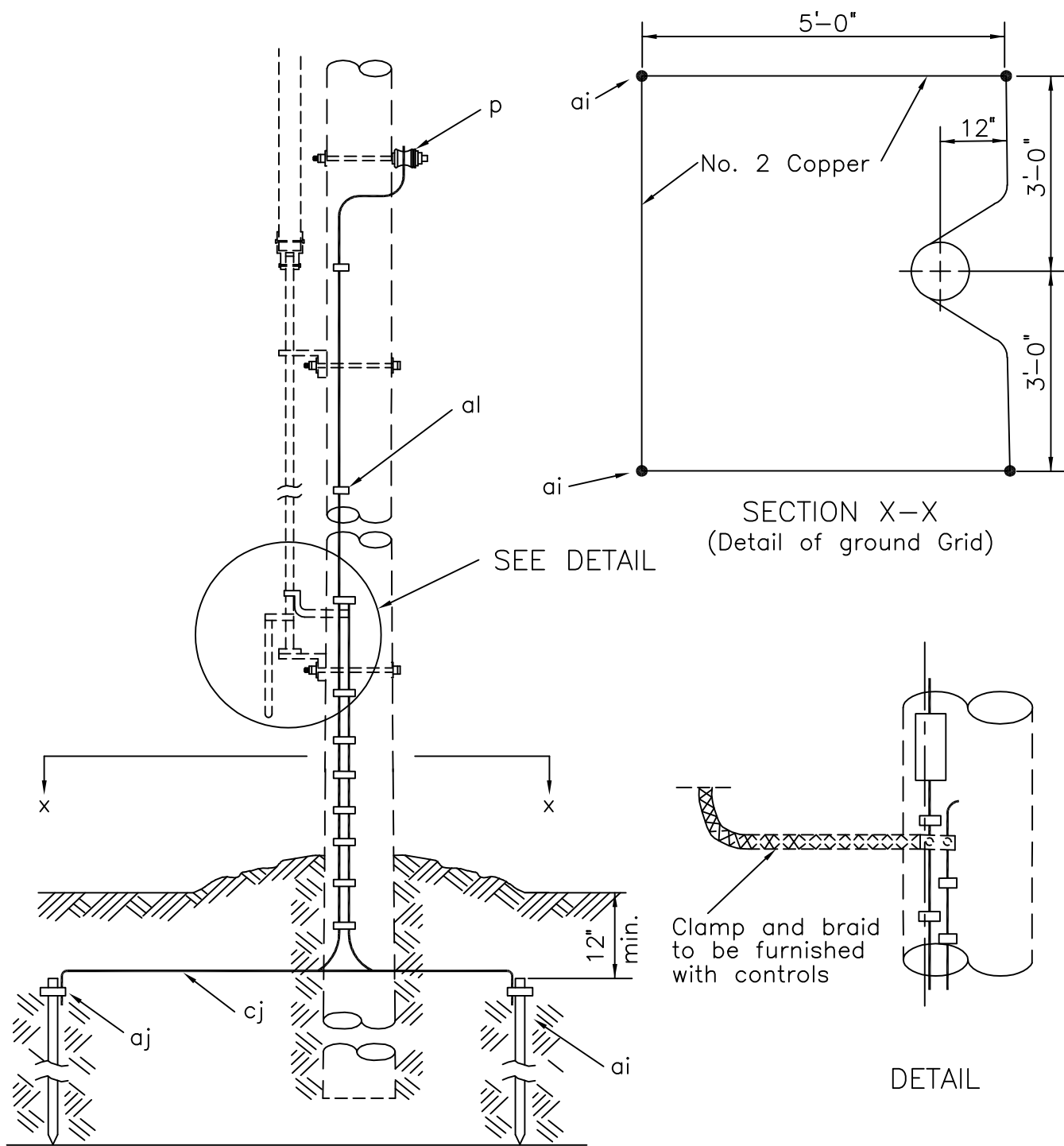

ITEM	QTY	MATERIAL
P		Connector, compression, as req'd
ai	4	Rod, ground, 5/8" min. dia., copper covered
aj	4	Clamp, ground rod
al		Staple, ground wire, (copper), as req'd
cj		Wire, pole ground, #2 S.D. Copper, as req'd

CAUTION: Rubber gloves should be worn when operating switch.

GROUNDING ASSEMBLY – GROUND ROD TYPE
(FOR SECTIONALIZING AIRBREAK SWITCH)

APRIL 2005

RUS

H3.1
(M2-15)

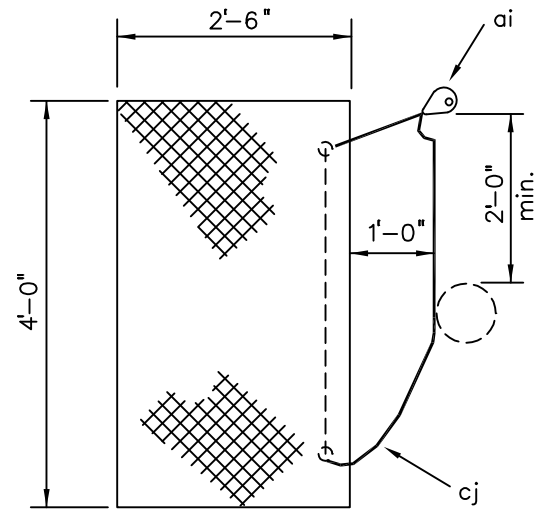
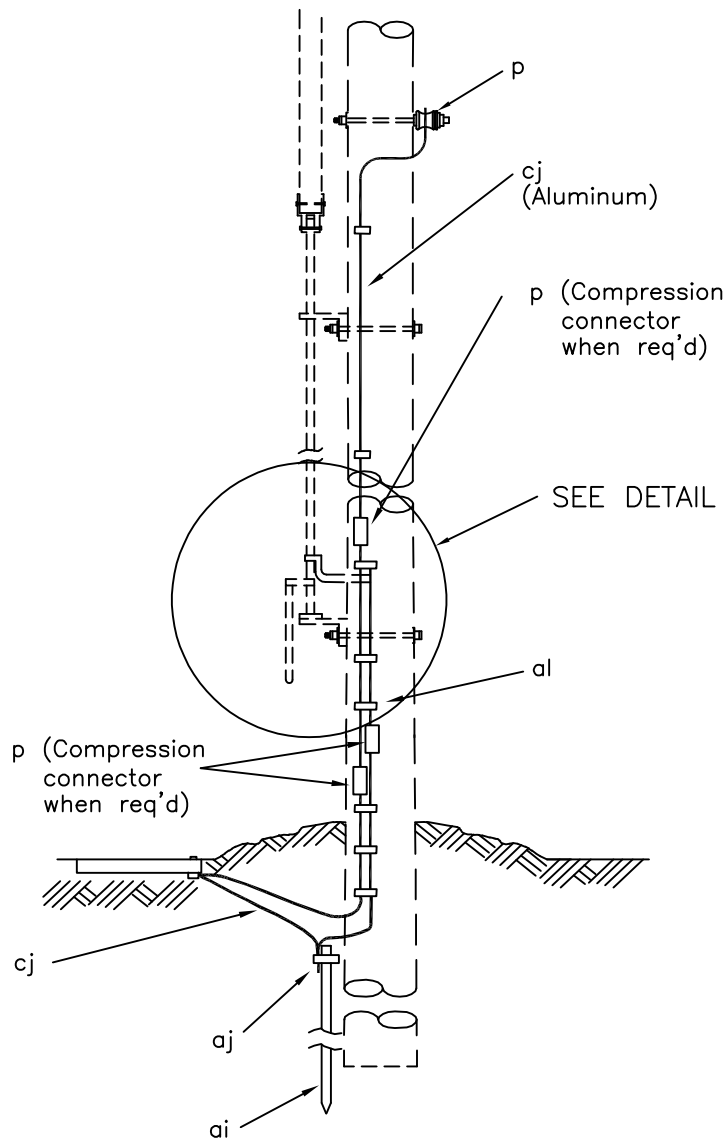

DETAIL OF PLATFORM

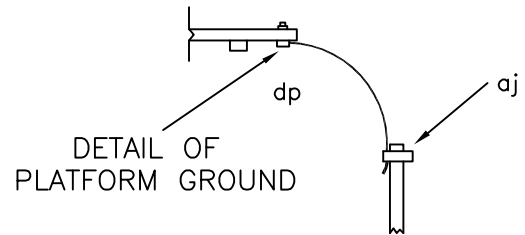

DETAIL OF PLATFORM GROUND

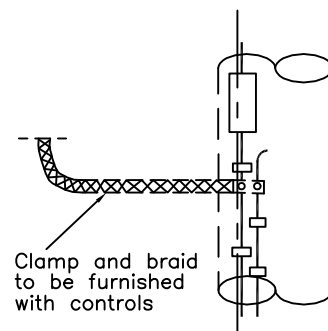

DETAIL

NOTE: Wear rubber gloves when operating switch.

ITEM	QTY	MATERIAL
P		Connector, compression, as req'd
ai	1	Rod, ground, 5/8 min. dia., (galv.)
aj	1	Clamp, ground rod, (galvanized steel)
al		Staple, ground wire, (galv.), as req'd
cj		Wire pole ground, as req'd Soft annealed iron, 5/16" with class C galvanizing
dp	2	Clamp, ground wire, with lock washer
	1	Platform, grounding plate, galv. iron

GROUNDING ASSEMBLY – PLATFORM TYPE
(FOR SECTIONALIZING AIRBREAK SWITCH)

APRIL 2005

RUS

H4.1
(M2-15A)

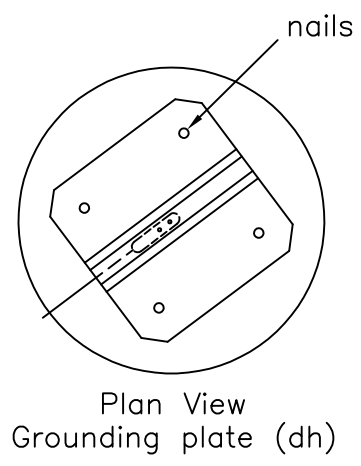
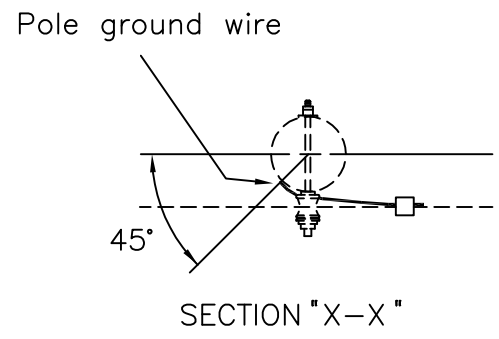
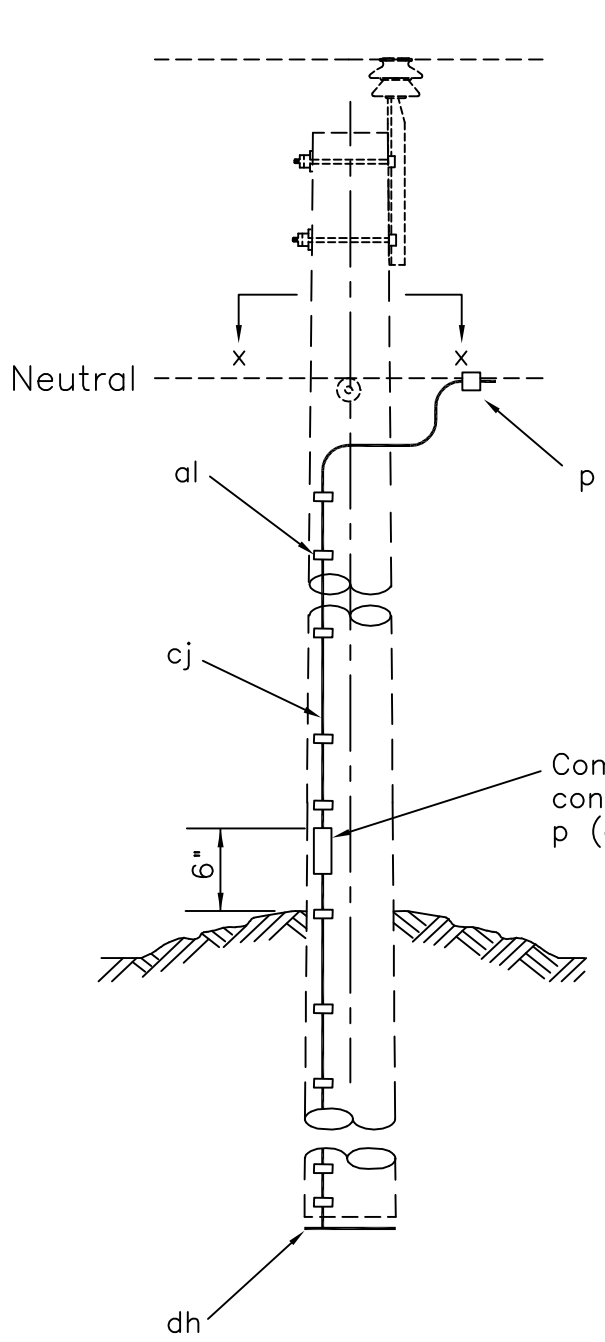

NOTES:

1. Ground wire to be located on same side as neutral conductor and in quadrant opposite climbing space or pole top pin.
2. Staples on ground wire shall be 2'-0" apart except for a distance of 8' above ground and 8' from top of pole where they shall be 6" apart.
3. Copper ground wire ("cj") to have a minimum conductivity of No. 6 Copper or equivalent.

ITEM	QTY	MATERIAL
P		Connector, compression, as req'd
al		Staple, ground wire, as req'd
cj		Wire, pole ground, as req'd
dh	1	Plate, grounding, butt type
	4	Nails, 1", galvanized, roofing

DESIGN PARAMETERS:

RUS SPECIFIES THAT THIS ASSEMBLY CAN NOT BE COUNTED AS A SYSTEM GROUNDING ELECTRODE REQUIRED BY THE NESC BUT RECOMMENDS ITS USE FOR OVERALL SYSTEM GROUNDING IMPROVEMENT.

GROUNDING IMPROVEMENT ASSEMBLY – PLATE TYPE

APRIL 2005
RUS

H5.1
(M2-12)

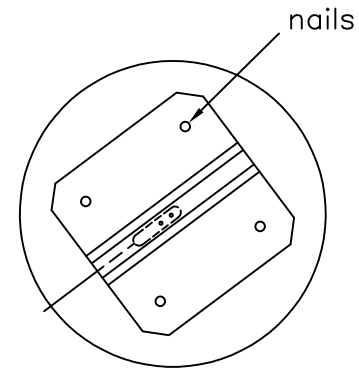
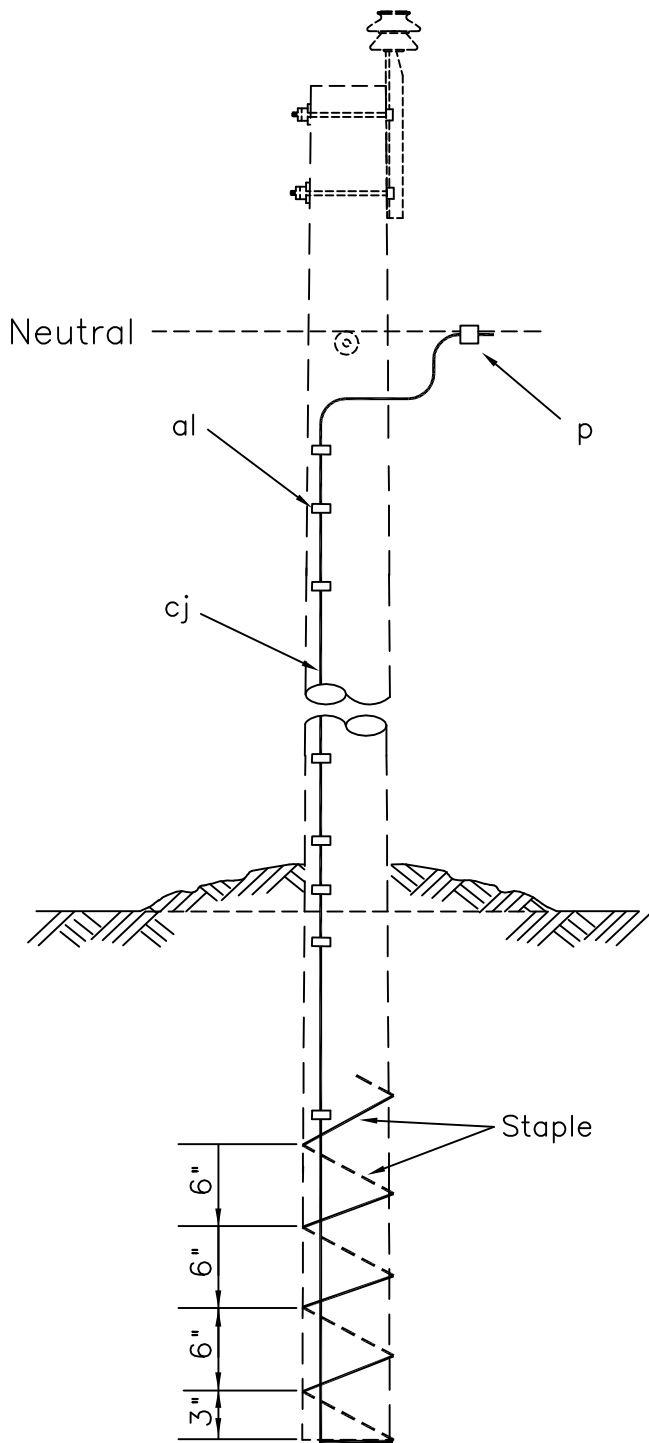

Plan View
Grounding plate (dh)

Designate assembly with
grounding plate as "H2.3"

NOTES:

1. Ground wire to be located on same side as neutral conductor and in quadrant opposite climbing space or pole top pin.
2. Staples on ground wire shall be 2'-0" apart except for a distance of 8' above ground and 8' from top of pole where they shall be 6" apart.
3. Copper ground wire ("cj") to have a minimum conductivity of No. 6 Copper or equivalent.

ASSEMBLY: H2.2 H2.3

ITEM	MATERIAL	QTY	QTY
P	Connector, compression, as req'd		
al	Staples, ground wire, as req'd		
cj	Wire, pole ground, as req'd		
dh	Plate, grounding, butt type		1
	Nails, 1", galvanized, roofing		4

DESIGN PARAMETERS:

RUS SPECIFIES THAT THIS ASSEMBLY CAN NOT BE COUNTED AS A SYSTEM GROUNDING ELECTRODE REQUIRED BY THE NESC BUT RECOMMENDS ITS USE FOR OVERALL SYSTEM GROUNDING IMPROVEMENT.

GROUNDING IMPROVEMENT ASSEMBLY –
WRAP-AROUND TYPE

APRIL 2005

RUS

H5.2,H5.3
(M2-12A)

INDEX J

SECONDARY ASSEMBLY UNITS

<u>DRAWING NUMBERS</u>		<u>DRAWING TITLE (DESCRIPTION)</u>
1728F-804 (New)	Bulletin 50-3 (Old)	
J1.1	(J8)	SECONDARY ASSEMBLIES - (SMALL ANGLE)
J1.2	(J5)	
J2.1	(J10)	SECONDARY ASSEMBLIES - (LARGE ANGLE)
J2.2	(J7), (J7C)	
J3.1	(J6), (J11)	SECONDARY ASSEMBLIES - (DEADEND, MISC.)
J4.1	(J12)	

**CONSTRUCTION SPECIFICATIONS FOR SECONDARY CONDUCTORS
AND SERVICE DROPS**

Secondary conductors may be bare or covered wires or multi-conductor service cable. The conductors shall be sagged in accordance with the manufacturer's recommendations.

Conductors for secondary underbuild on primary lines may be bare wires, except in those circumstances where conditions may necessitate that covered wires or service cable be used. Service drop conductors shall be covered wires or service cable in accordance with NESC Rule 234C3.

Secondary and service drop conductors shall be installed such that the climbing space on poles is not obstructed. For new construction there shall not be more than one splice per conductor in any span, and splices shall be located at least 10 feet from the conductor support. Covered conductors or service cables used for both the secondary and service drop may be installed in one continuous run.

The "permitted longitudinal loadings" shown on the assembly drawings are based on 50 percent of the mechanical-electrical ratings of the insulators. *All applied loads must be multiplied by the appropriate NESC overload factors when applicable.*

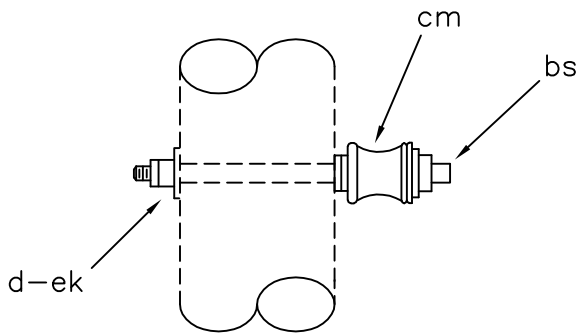

J1.1

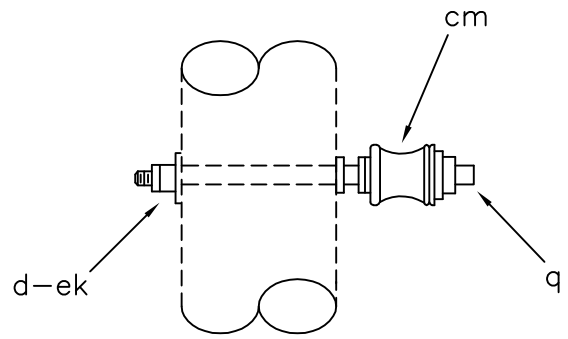

J1.2

ITEM	MATERIAL	J1.1	J1.2
		QTY	QTY
d	Washer, 2 1/4" square	1	1
q	Bolt, double upset		1
bs	Bolt, single upset	1	
cm	Insulator, spool	1	1
ek	Locknuts	1	1

DESIGN PARAMETERS:
MAXIMUM LINE ANGLES

5° - Small Conductors
2° - Larger than #1/0

SECONDARY ASSEMBLIES
(SMALL ANGLE)

APRIL 2005

RUS

J1.1,J1.2
(J8),(J5)

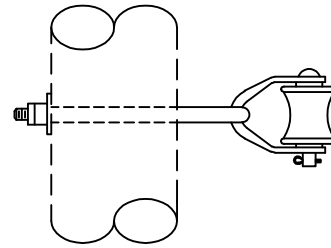
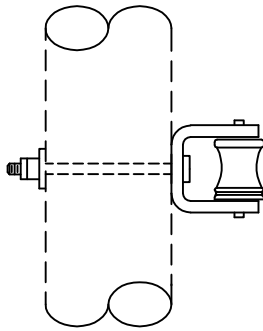
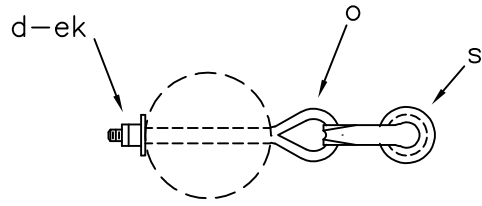
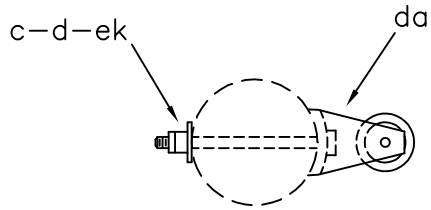

J2.1

J2.2

ITEM	MATERIAL	J2.1	J2.2
		QTY	QTY
c	Bolt, machine, 5/8" X req'd length	1	
d	Washer, 2 1/4" square	1	1
o	Bolt, eye, 5/8" X req'd length		1
s	Clevis, secondary, swinging, insulated		1
da	Bracket, insulated	1	
ek	Locknuts	1	1

DESIGN PARAMETERS:
MAXIMUM LINE ANGLES

J2.1: 60°
J2.2: 60°

SECONDARY ASSEMBLIES
(LARGE ANGLE)

APRIL 2005

RUS

J2.1,J2.2
(J10),(J7,J7C)

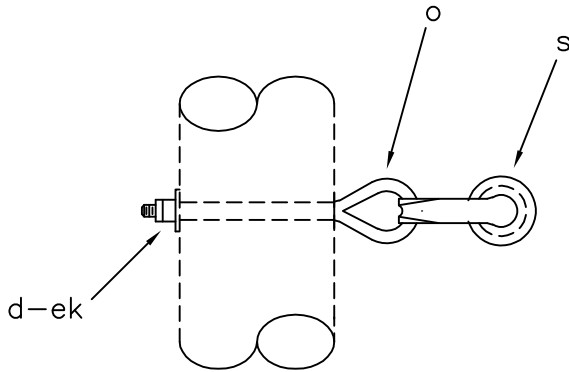
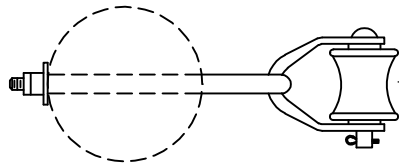

J3.1

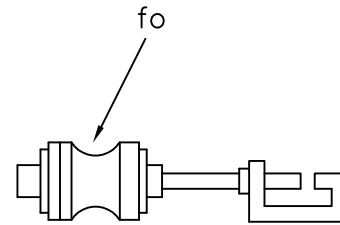

J4.1

ITEM	MATERIAL	J3.1	J4.1
		QTY	QTY
d	Washer, 2 1/4" square	1	
o	Bolt, eye, 5/8" x req'd length	1	
s	Clevis, secondary, swinging, insulated	1	
fo	Bracket, transformer secondary		1
ek	Locknuts	1	1

DESIGN PARAMETERS: (J3.1)

PERMITTED LONGITUDINAL LOADING:
 1,500 lbs. (ANSI Class 53-2 Insulator)
 2,250 lbs. (ANSI Class 53-4 Insulator)

SECONDARY ASSEMBLIES
 (DEADEND, MISC.)

APRIL 2005

RUS

J3.1,J4.1
 (J6,J11),(J12)

SERVICE ASSEMBLY UNITS

<u>DRAWING NUMBERS</u>		<u>DRAWING TITLE (DESCRIPTION)</u>
1728F-804 (New)	Bulletin 50-3 (Old)	
K1.1	(K14C)	SECERVICE ASSEMBLIES - (POLE MOUNTED)
K1.2	(K11C)	
K1.3	(K14), (K14L)	
K1.4	(K11), (K11L)	SECERVICE ASSEMBLIES - (POLE MOUNTED)
K1.5	(K15C)	
K2.1	(K10), (K10L)	SERVICE ASSEMBLIES
K2.2	(K10C)	
K2.3	(K10C)	
K3.1	(K17), (K17L)	SERVICE ASSEMBLIES - (MAST TYPE)
K3.2	(K16C)	
K4.1G	(M24)	CABLE SERVICE ASSEMBLY GUIDE
K4.2G	(M24-10)	MAST TYPE SERVICE ASSEMBLY GUIDE

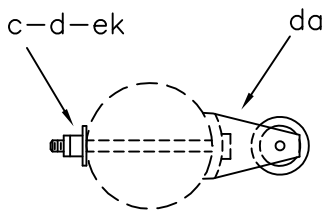

K1.1

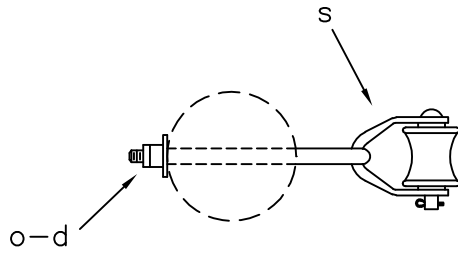

K1.2

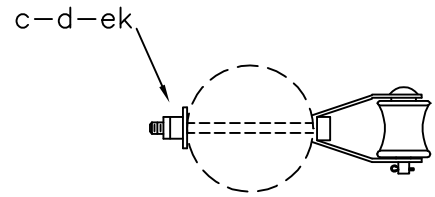

K1.3

		ASSEMBLY: K1		
ITEM	MATERIAL	.1	.2	.3
c	Bolt, machine, 5/8" X req'd length	1		1
d	Washer, 2 1/4" square	1	1	1
o	Bolt, eye, 5/8" X req'd length		1	
s	Clevis, secondary, swinging, insulated		1	
bh	Clevis, service, deadend, insulated			1
ek	Locknuts	1	1	1
da	Bracket, insulated	1		

ASSEMBLY NUMBERS	
NEW	(OLD)
K1.1	(K14C)
K1.2	(K11C)
K1.3	(K14)
	(K14L)

DESIGN PARAMETERS: PERMITTED LONGITUDINAL LOADING: 1,500 lbs. (ANSI Class 53-2 Insulator) 2,250 lbs. (ANSI Class 53-4 Insulator)	SERVICE ASSEMBLIES (POLE MOUNTED)	
	APRIL 2005	
	RUS	K1.1,K1.2,K1.3

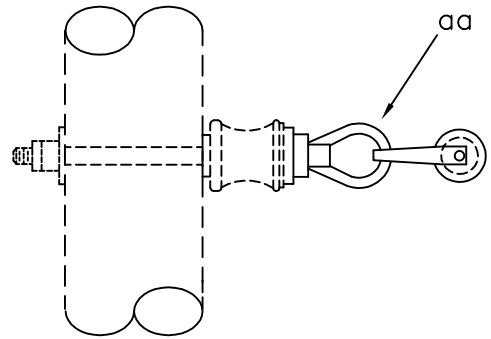
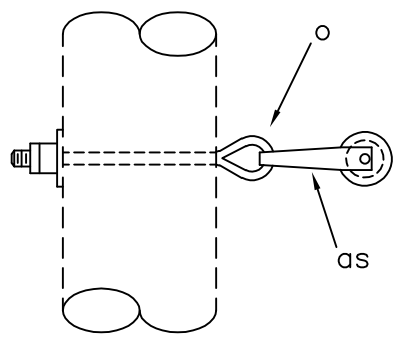
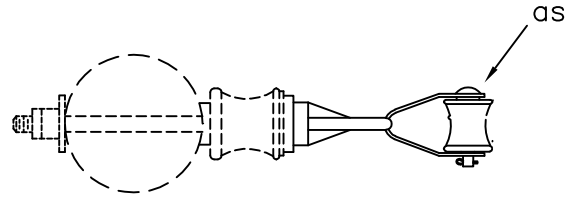
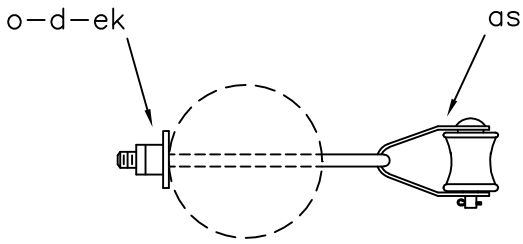

K1.4

K1.5

ASSEMBLY: K1

ITEM	MATERIAL	.4 QTY	.5 QTY
d	Washer, 2 1/4" square	1	
o	Bolt, eye, 5/8" X req'd length	1	
aa	Nut, eye		1
as	Clevis, service, swinging, insulated	1	1
ek	Locknuts	1	

DESIGN PARAMETERS:

PERMITTED LONGITUDINAL LOAD:
 1,500 lbs. (ANSI Class 53-2 Insulator)
 2,250 lbs. (ANSI Class 53-4 Insulator)

SERVICE ASSEMBLIES
 (POLE MOUNTED)

APRIL 2005

RUS

K1.4,K1.5
 (K11,K11L),(K15C)

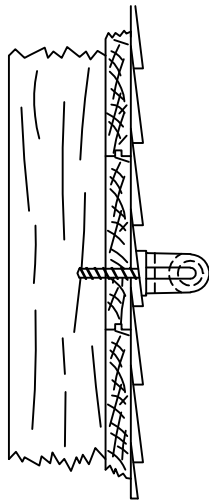
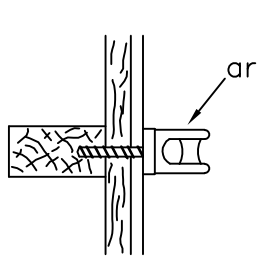

K2.1

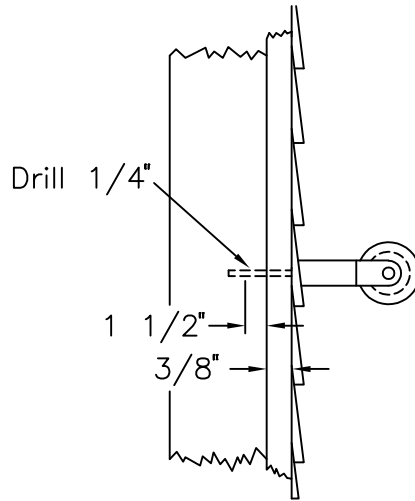
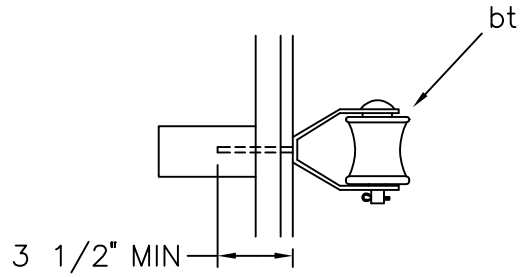

K2.2

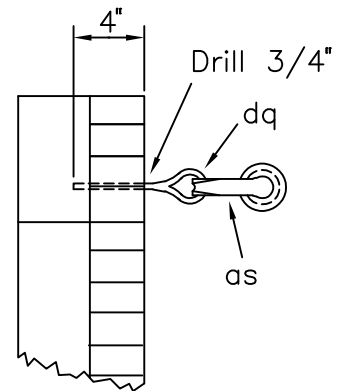

BRICK OR MASONRY

K2.3

NOTE: Assembly K2.1 not suitable for large conductors or cable services.

ASSEMBLY: K2		.1	.2	.3
ITEM	MATERIAL	QTY	QTY	QTY
ar	Wireholder	1		
as	Clevis, secondary, swinging, insulated			1
bt	Wireholder, clevis type insulated, #24 Woodscrew		1	
dq	Eye, screw, elliptical, 1/2" X 6"			1
	3/4" x 3 1/2" expansion shield			1

SERVICE ASSEMBLIES

APRIL 2005

RUS

K2.1,K2.2,K2.3
(K10,K10L),(K10C)

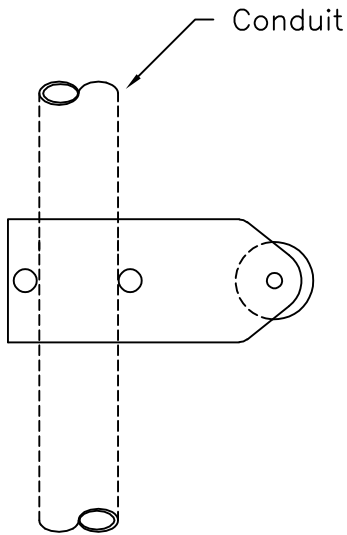
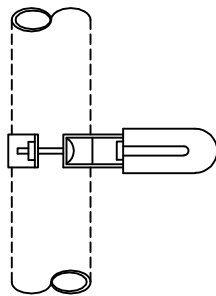
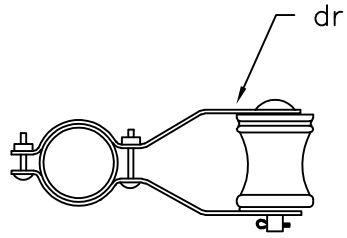
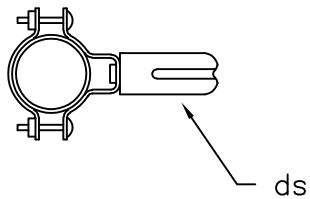

K3.1

K3.2

NOTE: Assembly K3.1 not suitable for loarge conductors or cable services.

ASSEMBLY: K3

ITEM	MATERIAL	.1	.2
dr	Clevis, conduit, insulated		1
ds	Wireholder, conduit	1	

DESIGN PARAMETERS:

PERMITTED LOADING (lbs)

	Deadend	Cantilever
K3.1	1500	800
K3.2	1500	400

SERVICE ASSEMBLIES
(MAST TYPE)

APRIL 2005

RUS

K3.1,K3.2
(K17,K17L),(K16C)

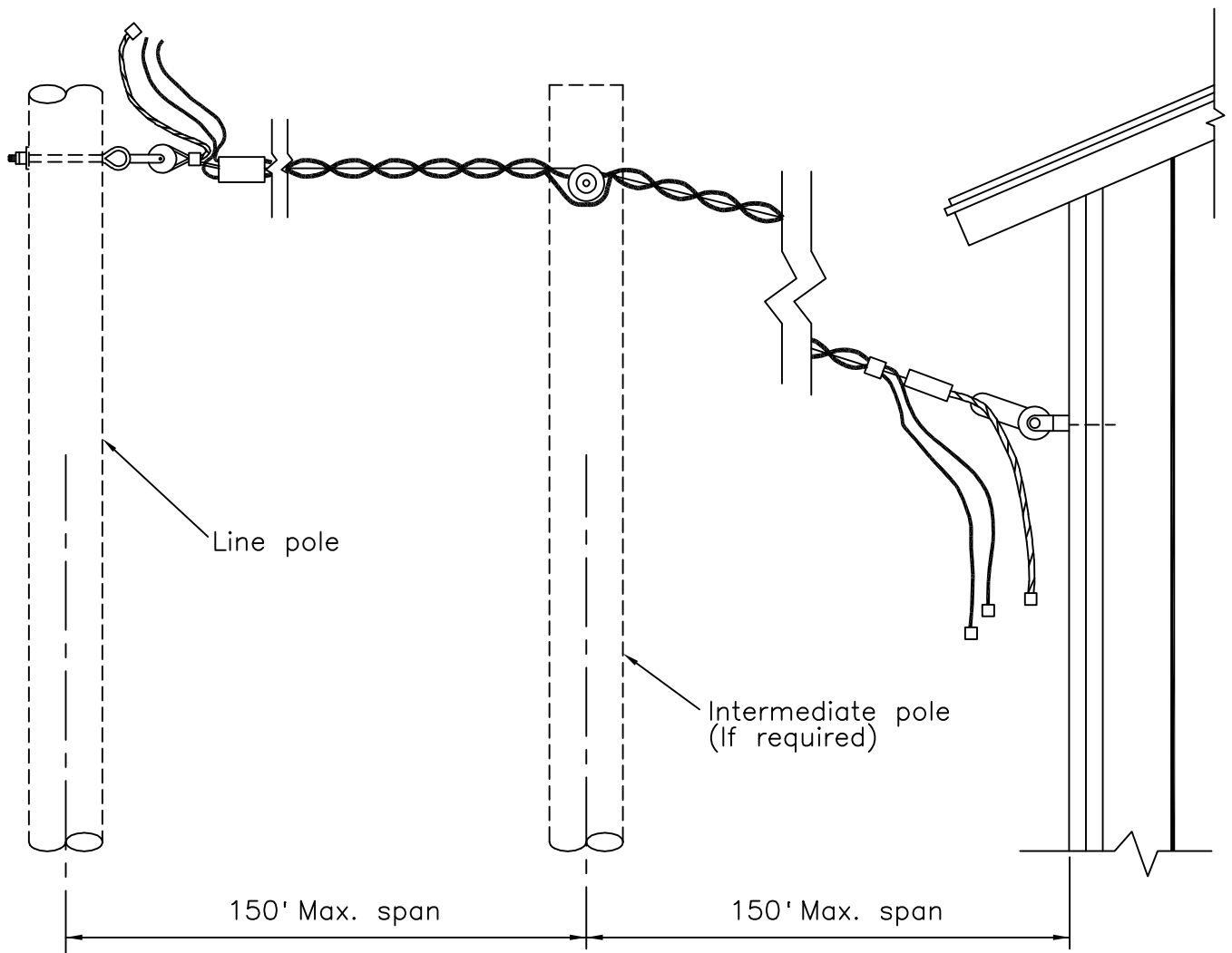
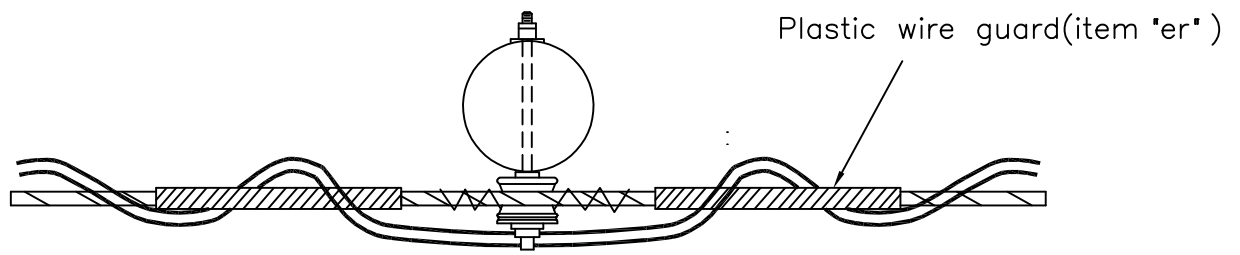

NOTES:

1. Services as short as possible are preferred.
2. See NESC Table 232-1 for minimum ground clearances.
3. Refer to secondary and service assemblies for construction details.
4. Service connectors to be insulated compression type.

CABLE SERVICE ASSEMBLY GUIDE

APRIL 2005

RUS

K4.1G
(M24)

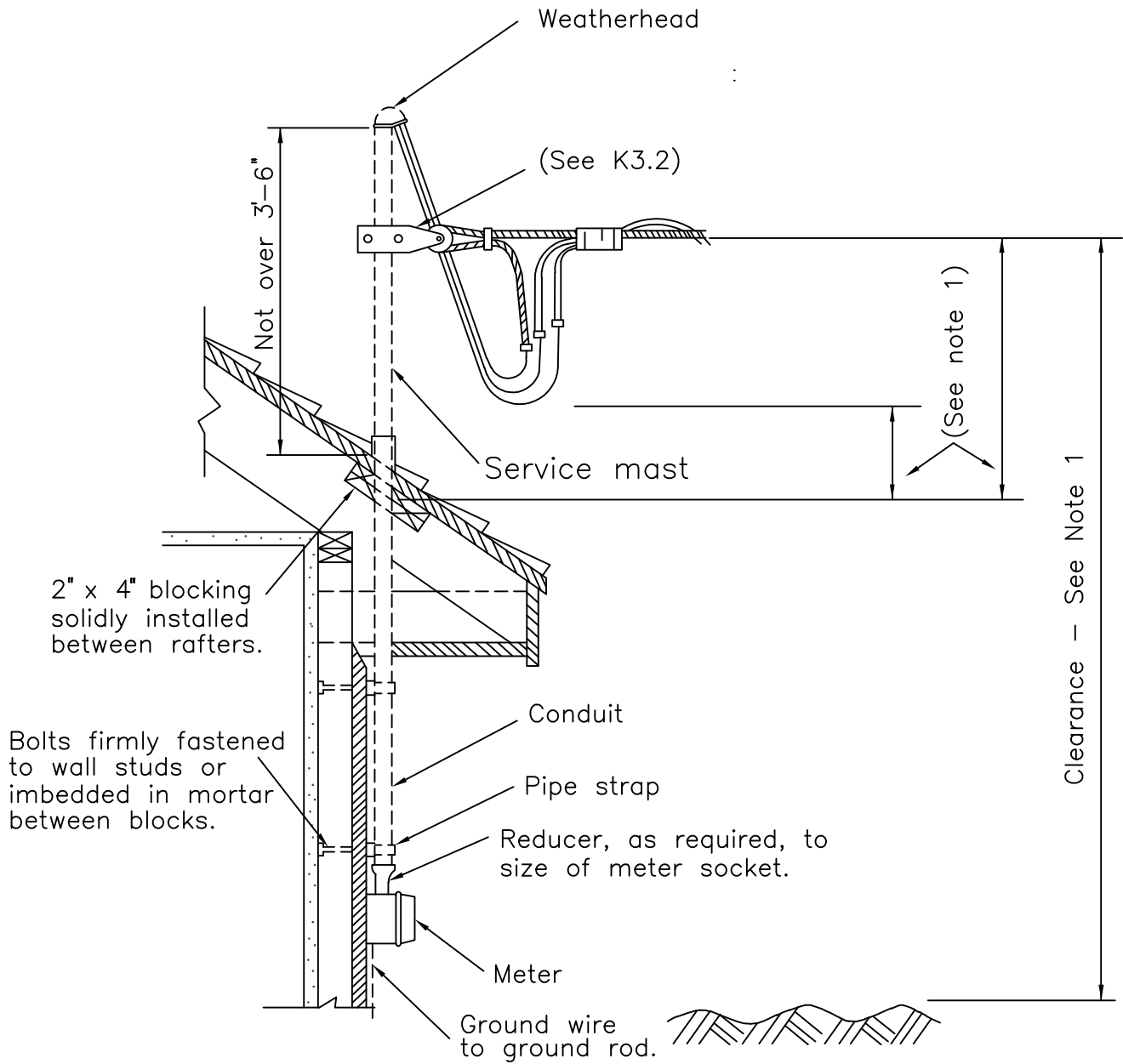

NOTES:

1. All clearances to be in conformance to the most stringent requirements of the NESC, NEC or other codes of governmental or regulating authorities as applicable.
2. If length of conduit exceeds 10 feet, coupling is permitted on end adjacent to meter.

MAST TYPE SERVICE ASSEMBLY GUIDE

APRIL 2005

RUS

K4.2G
(M24-10)

TYING ASSEMBLIES

<u>DRAWING NUMBERS</u>		<u>DRAWING TITLE (DESCRIPTION)</u>
1728F-804 (New)	Bulletin 50-3 (Old)	
L1.1	(M41-1)	PRIMARY ANGLE TYING ASSEMBLIES
L1.2	(M41-10)	
L1.3	(M42-3)	PRIMARY DEADEND TYING ASSEMBLIES
L1.4	(M42-21)	
L1.5	(M42-11)	
L2.1		NEUTRAL ANGLE TYING ASSEMBLIES
L2.2		
L2.3		NEUTRAL DEADEND TYING ASSEMBLIES
L2.4		
L2.5	(M42-13)	
L3.1	(M41-1)	NEUTRAL & SECONDARY ANGLE TYING ASSEMBLIES
L3.2	(M41-10)	
L3.3	(M42-21)	NEUTRAL & SECONDARY DEADEND TYING ASSEMBLIES - (COPPER)
L3.4	(M42-3)	
L3.5	(M42-11)	NEUTRAL & SECONDARY DEADEND TYING ASSEMBLIES - (ACSR)
L3.6		
L4.1		TYING ASSEMBLIES, SERVICES
L4.2		TYING ASSEMBLIES, CABLE SERVICES
L4.3		
L4.4		

**CONSTRUCTION SPECIFICATIONS FOR CONNECTORS, STIRRUPS,
CLAMPS, TAPS, AND JUMPERS**

Jumpers and other leads connected to line conductors shall have sufficient slack to allow free movement of the conductors without causing the jumpers to be pulled from their connectors. Even if not shown on the drawings, jumpers shall have at least two bends in a vertical plane, or one in a horizontal plane, or the equivalent.

All leads on equipment, such as transformers and reclosers, shall be a minimum of #6 copper conductivity. Where aluminum jumpers are used, a connection to unplated bronze terminals shall be made by splicing a short stub of copper to the aluminum jumpers using a compression connector suitable for the bimetallic connection.

Connectors and hot-line clamps suitable for the purpose shall be installed as shown on the drawings and also in accordance with the manufacturer's specifications and recommendations. On all hot-line clamp installations, the clamp and jumper shall be installed so that they are permanently bonded to the load side of the line, allowing the jumper to be de-energized when the clamp is disconnected.

Stirrups may be used to connect tap conductors (jumper wires) to primary conductors if the following criteria are met:

- The stirrup and hot line clamp are sized to meet or exceed the current carrying capacity of the tap conductor or equipment jumper;
- All stirrup conductors are made of copper or bronze;
- All stirrup conductors are made of #2 copper equivalent conductivity or larger;
- All-purpose or aluminum hot line clamps are not used with stirrups;
- All stirrups, connectors, and clamps are installed in accordance with the manufacturer's specifications;
- Stirrups with two compression connectors are not used in areas prone to aeolian vibration;
- Stirrups are not used to connect main lines together or to connect heavily loaded tap lines to main lines.

Stirrups are not recommended to be used to connect reclosers, autotransformers, or line regulators to primary conductors. Stirrups and hot line clamps shall not be used for sectionalizing taps nor taps for main lines for operational or maintenance purposes. Permanent compression or bolted type connectors shall be used because of their better current carrying capabilities and reliability. Line switches, fused cutouts, or solid blade cutouts should be used at line locations where occasional line sectionalizing may be required.

At locations where permanent connections using compression or bolted type connectors are not desired, and where the installation of sectionalizing equipment is also not desired, hot line clamps (over armor rod on aluminum conductors) shall be installed.

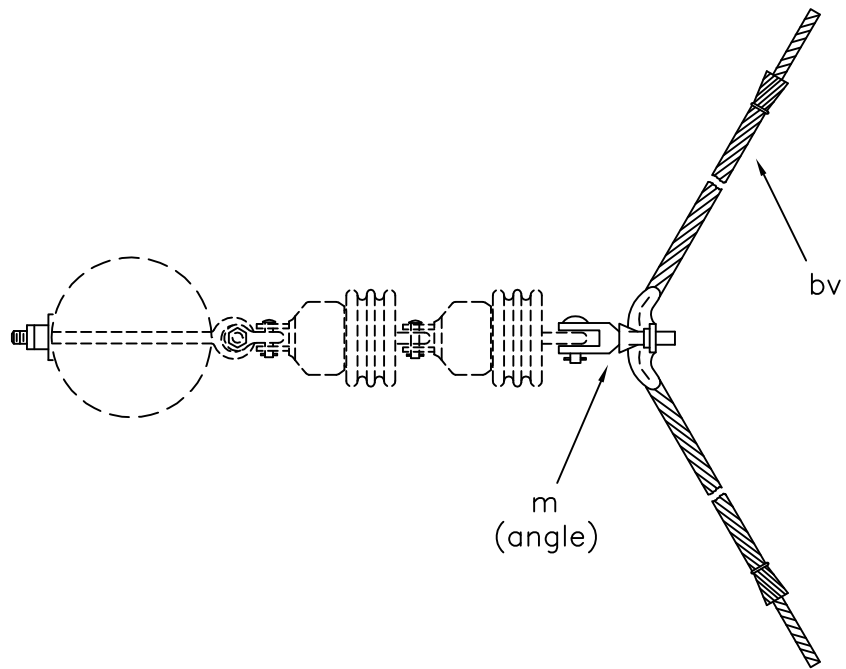
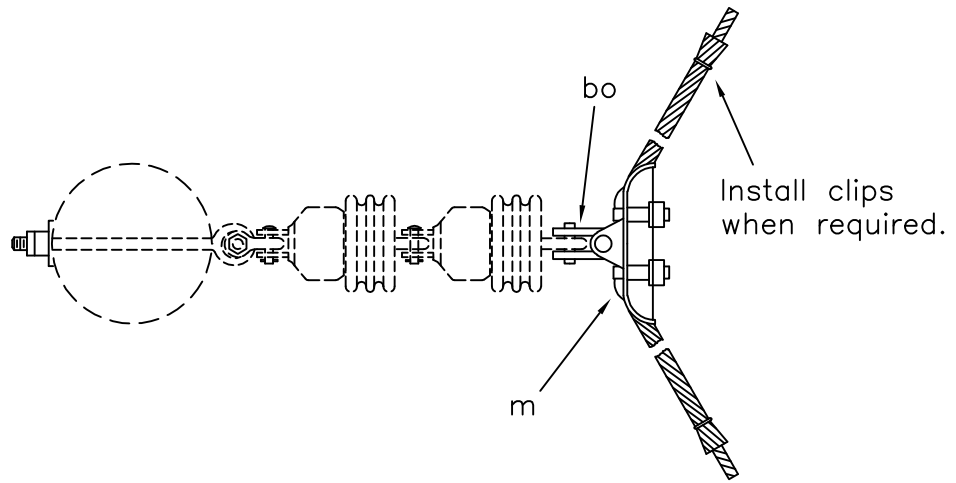

NOTES:

1. ACSR conductors require armor rods and clips (as shown).
2. Use angle suspension clamp with #2 or #4 ACSR only.

ASSEMBLY: L1		.1	.2
ITEM	MATERIAL	QTY	QTY
m	Clamp, 2 bolt, suspension (distribution)	1	
m	Clamp, angle, suspension (distribution)		1
bo	Shackle, anchor	1	1
bv	Rods, armor (as req'd)		

DESIGN PARAMETERS:

30° to 60° Line Angles

PRIMARY ANGLE TYING ASSEMBLIES

APRIL 2005

RUS

12.47/7.2 kV

L1.1,L1.2
(M41-1),(M41-10)

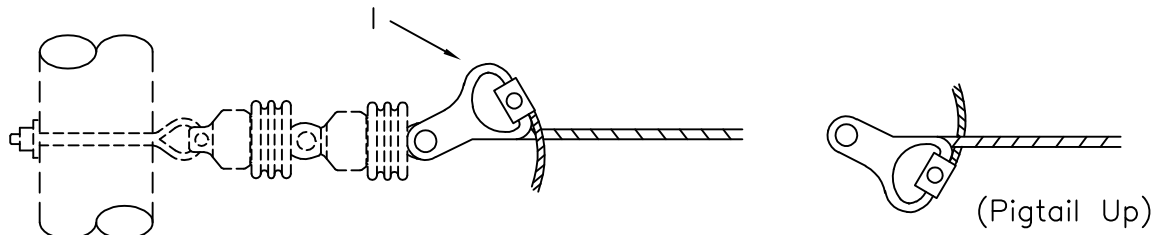

NOTE: For use with copper or copperweld-copper conductors only.

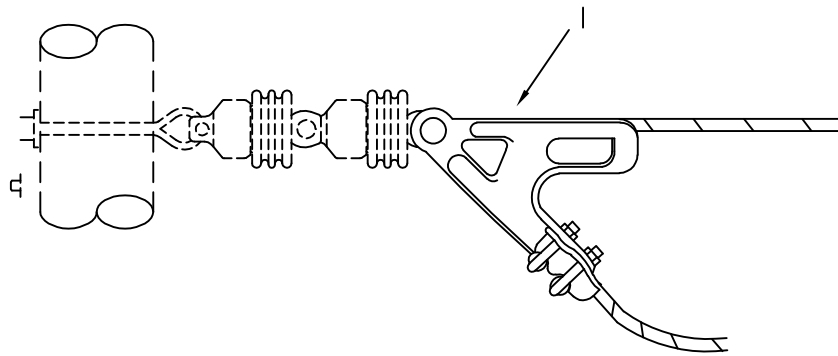
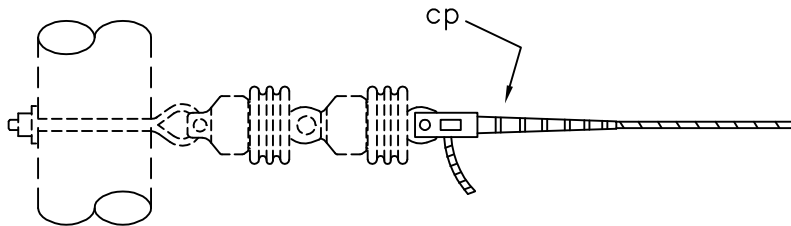

NOTES:

1. Item "by" may be substituted for item "cp" shown.
2. Specify "ej" clamp instead of "I" clamp for conductors larger than #4/0 ACSR.
3. Armor tape required for conductors in galvanized fittings not having aluminum liners.
4. Bend pigtails away from line conductors to avoid chafing.

ASSEMBLY NUMBERS	
NEW	(OLD)
L1.3	(M42-3)
L1.4	(M42-21)
L1.5	(M42-11)

ASSEMBLY: L1		.3	.4	.5
ITEM	MATERIAL	QTY	QTY	QTY
I	Clamp, deadend (distribution)	1		1
by	Deadend, automatic or formed type			(Not Shown)
cp	Deadend, compression type		1	

PRIMARY DEADEND TYING ASSEMBLIES

APRIL 2005

RUS

12.47/7.2 kV

L1.3,L1.4,L1.5

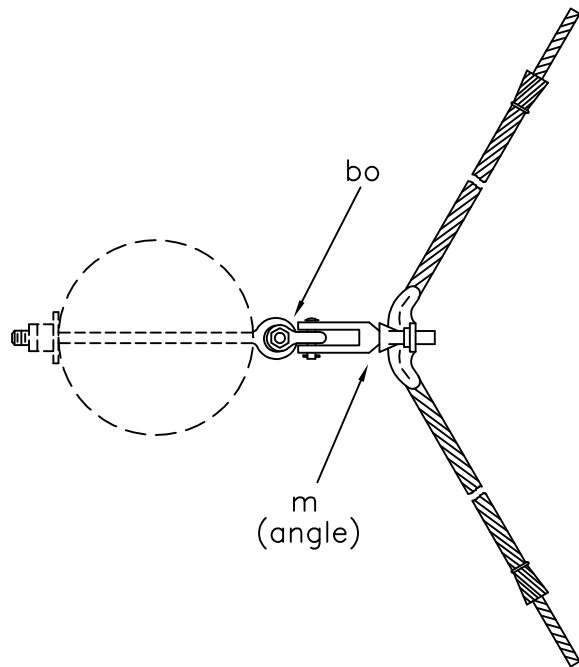
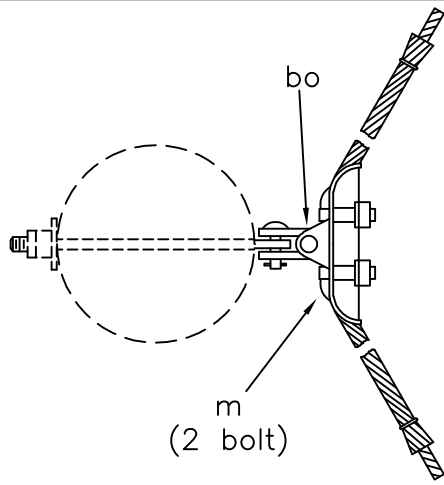

NOTES:

1. ACSR conductors require armor rods and clips (as shown).
2. Use angle suspension clamp with #2 or #4 ACSR only.

		ASSEMBLY: L2	
ITEM	MATERIAL	.1 QTY	.2 QTY
m	Clamp, 2 bolt, suspension (distribution)	1	
m	Clamp, angle, suspension (distribution)		1
bo	Shackle, anchor	1	1
bv	Rods, armor (as req'd)		

DESIGN PARAMETERS: 30° to 60° Line Angles	NEUTRAL ANGLE TYING ASSEMBLIES	
	APRIL 2005	
	RUS	L2.1,L2.2

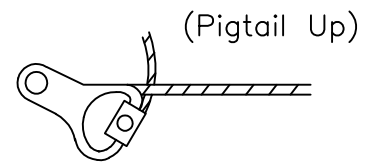
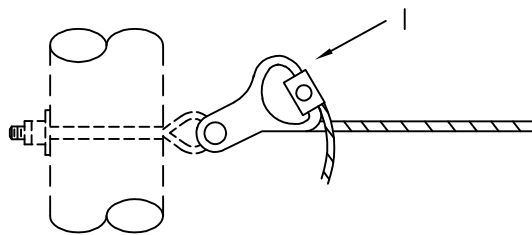

NOTE: For use with copper or copperweld-copper conductors only.

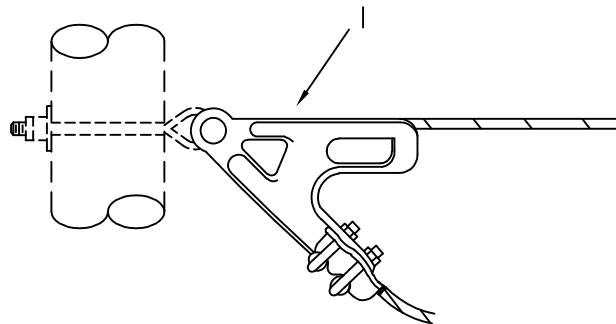
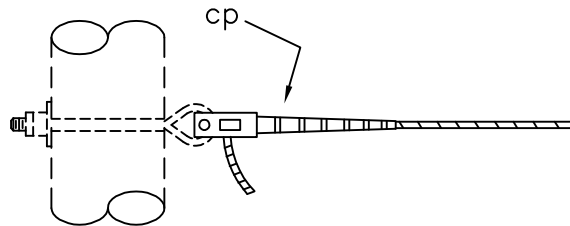

NOTES:

1. Item "by" may be substituted for item "cp" shown.
2. Specify "ej" clamp instead of "I" clamp for conductors larger than #4/0 ACSR.
3. Armor tape required for conductors in galvanized fittings not having aluminum liners.
4. Bend pigtails away from line conductors to avoid chafing.

		ASSEMBLY: L2		
ITEM	MATERIAL	.3 QTY	.4 QTY	.5 QTY
I	Clamp, deadend (distribution)	1		1
by	Deadend, automatic or formed type			(Not Shown)
cp	Deadend, compression type		1	

NEUTRAL DEADEND TYING ASSEMBLIES

APRIL 2005

RUS

L2.3,L2.4,L2.5

(M42-13)

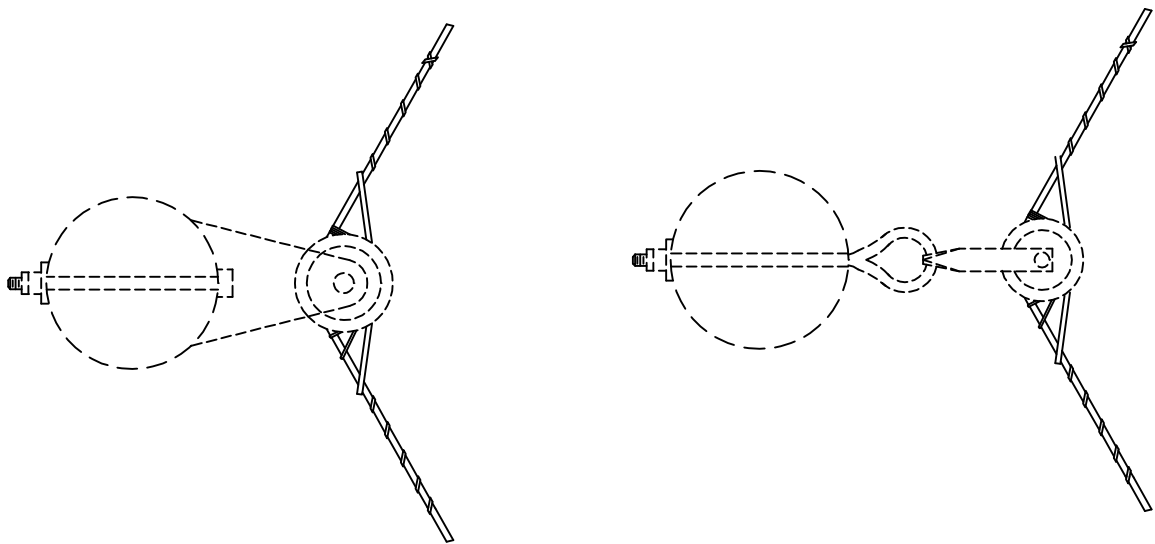

For use with copper or copperweld-copper conductors.

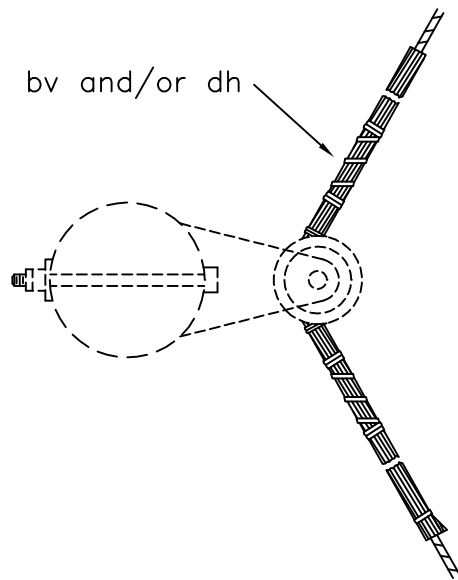

ACSR Conductors

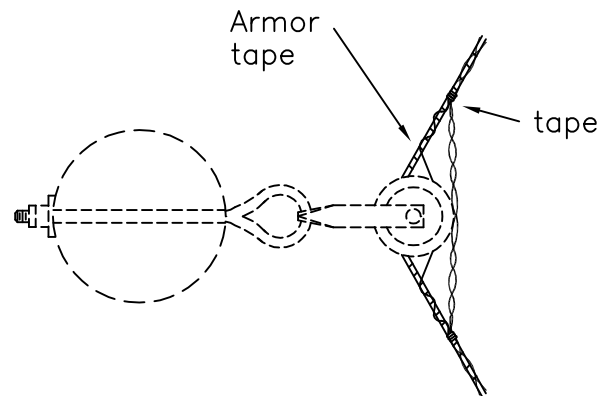

Self Supporting
Cable Conductors

ITEM	MATERIAL
bv	Rod, armor (formed type)
dh	Tie, insulator (formed type)

NEUTRAL & SECONDARY
ANGLE TYING ASSEMBLIES

APRIL 2005

RUS

L3.1,L3.2
(M41-1),(M41-10)

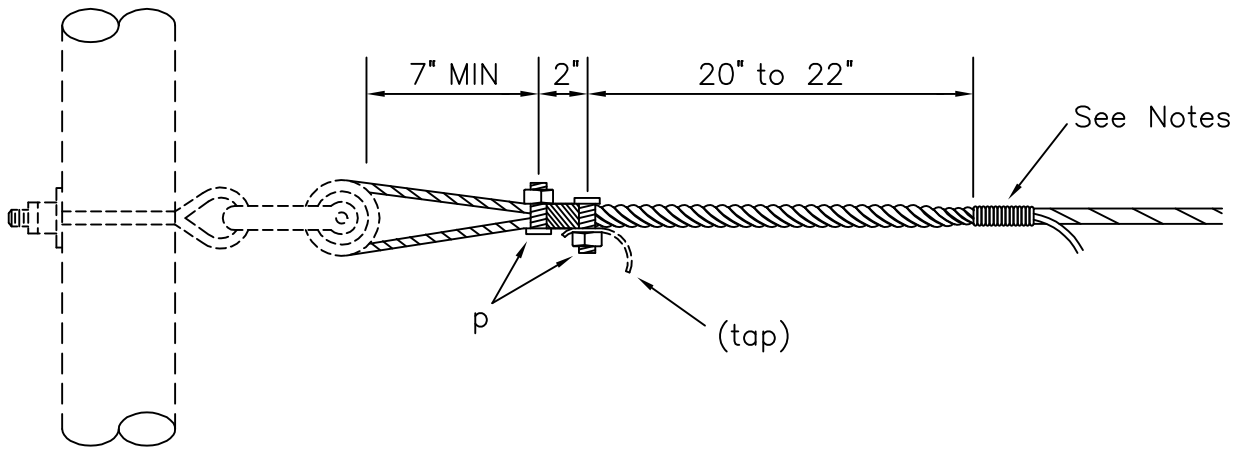
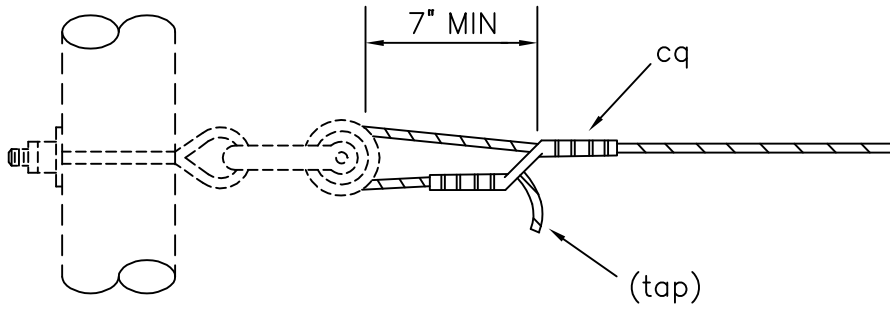

NOTES:

1. Bend all pigtails away from line conductor to avoid chafing.
2. Extend one strand of free end (the copperweld strand of copperweld-copper conductor) against line conductor. Wrap free ends of conductor along line conductor using same lay. Serve copper strands six turns each and then cut off.
3. For solid conductors, use same dimensions and install third connector "p" in lieu of serving.

ASSEMBLY: L3		.3	.4
ITEM	MATERIAL	QTY	QTY
p	Connectors, as req'd		
cq	Deadend, secondary	1	

NEUTRAL & SECONDARY
DEADEND TYING ASSEMBLIES (COPPER)

APRIL 2005

RUS

L3.3,L3.4
(M42-21),(M42-3)

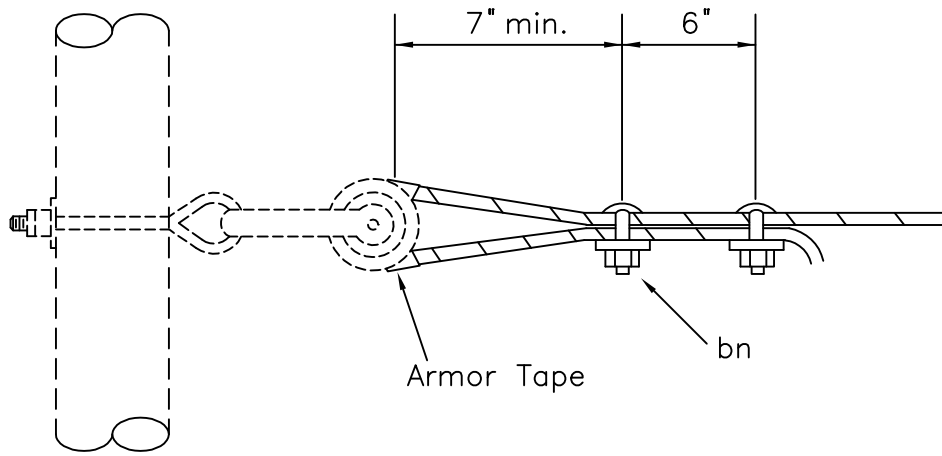
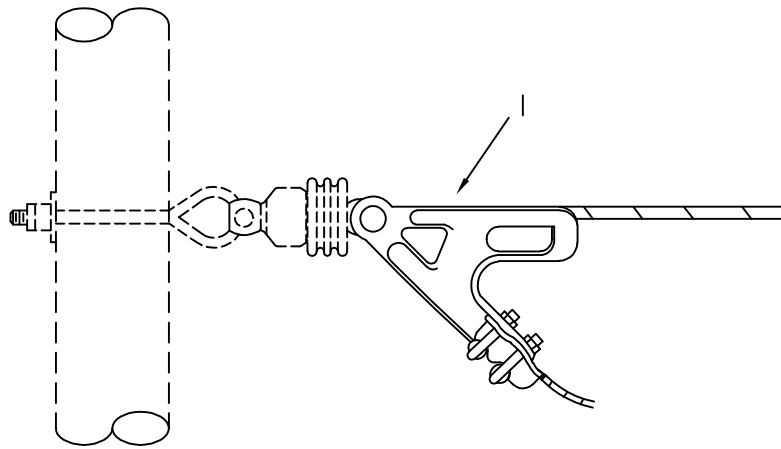

NOTES:

1. Armor tape wrapping to extend not more than two wraps beyond the mouth of deadend clamp or spool insulator.
2. For #1/0 and larger, use spool with 3" minimum groove diameter.

ASSEMBLY: L3 .5 .6

ITEM	MATERIAL	QTY	QTY
i	Clamp, deadend	1	
bn	Clamp, loop deadend		2

NEUTRAL & SECONDARY
DEADEND TYING ASSEMBLIES (ACSR)

APRIL 2005

RUS

L3.5,L3.6
(M42-11,13)

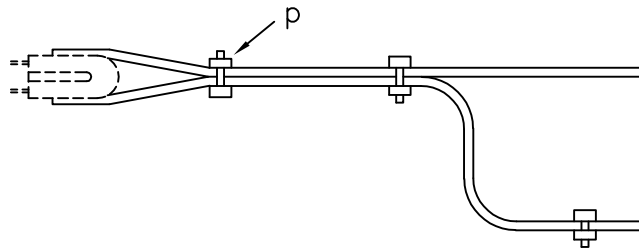
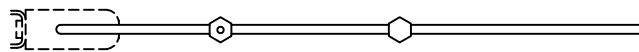
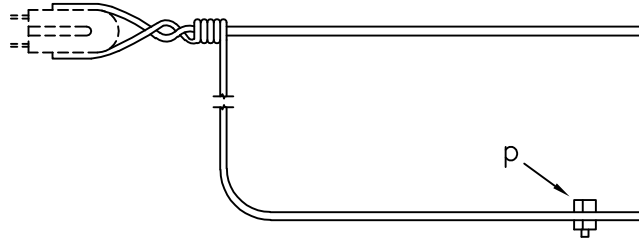
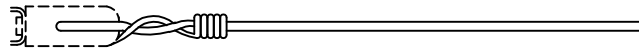

This type of construction should be used for small, aluminum covered conductors.

NOTE: Service connectors (p) to be applied over bare wire and then taped as required.

ITEM	MATERIAL
P	Connectors, as req'd

	TYING ASSEMBLY, SERVICES	
	APRIL 2005	
	RUS	L4.1

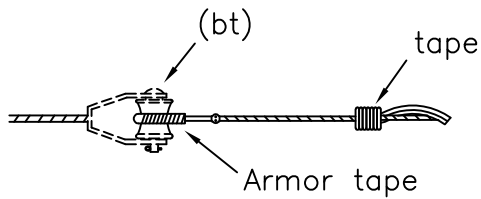

NOTE:
Groove diameter of insulator 1 3/4" min.

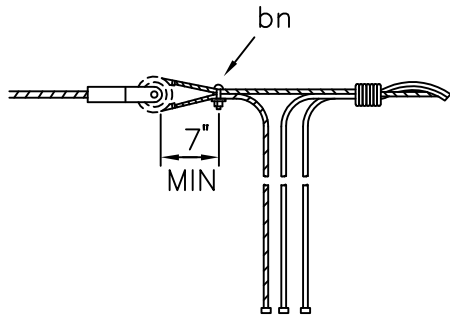

LOOP TYPE

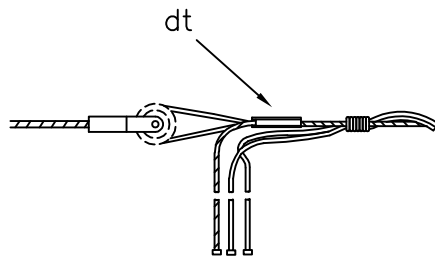
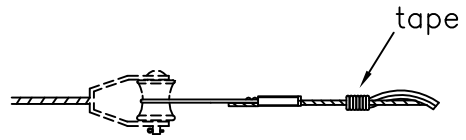

WEDGE TYPE

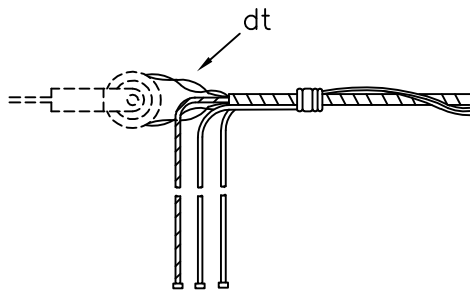
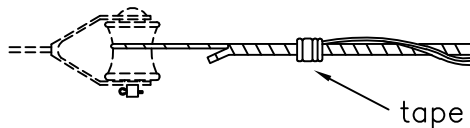

PREFORMED TYPE

NOTES:

1. This type of construction should be for 3 or 4 conductor service cables with bare ACSR neutral.
CAUTION: Not suitable for K2.1 or K3.1 Service Assemblies.
2. Service connectors (p) to be insulated, compression type.

ASSEMBLY: L4

ITEM	MATERIAL	.2	.3	.4
		QTY	QTY	QTY
dt	Service deadend, wedge type			1
dt	Service deadend, preformed type		1	
bn	Clamp, loop deadend	1		

TYING ASSEMBLIES, CABLE SERVICES

APRIL 2005

RUS

L4.2,L4.3,L4.4

MISCELLANEOUS ASSEMBLY UNITS AND GUIDES

<u>DRAWING NUMBERS</u>	<u>DRAWING TITLE (DESCRIPTION)</u>
1728F-804 (New)	Bulletin 50-3 (Old)
M1.30G	(R1) RIGHT-OF-WAY CLEARING GUIDE

SPECIFICATIONS FOR RIGHT-OF-WAY CLEARING

The right-of-way shall be prepared by removing trees, clearing underbrush, and trimming trees so that the right-of-way is cleared close to the ground and to the width specified. However, low growing shrubs, which will not interfere with the operation or maintenance of the line, can be left undisturbed if so directed by the property owner. Slash may be chipped and blown on the right-of-way if so allowed. Trim, but do not remove shade, fruit, or ornamental trees unless otherwise authorized.

All trimming shall be done using good arboricultural practices.

The landowner's written permission is usually required prior to cutting trees outside of the right-of-way. Trim trees fronting each side of the right-of-way symmetrically unless otherwise specified. Remove dead trees beyond the right-of-way which would strike the line in falling. Also, either remove or top leaning trees beyond the right-of-way that would strike the line in falling.

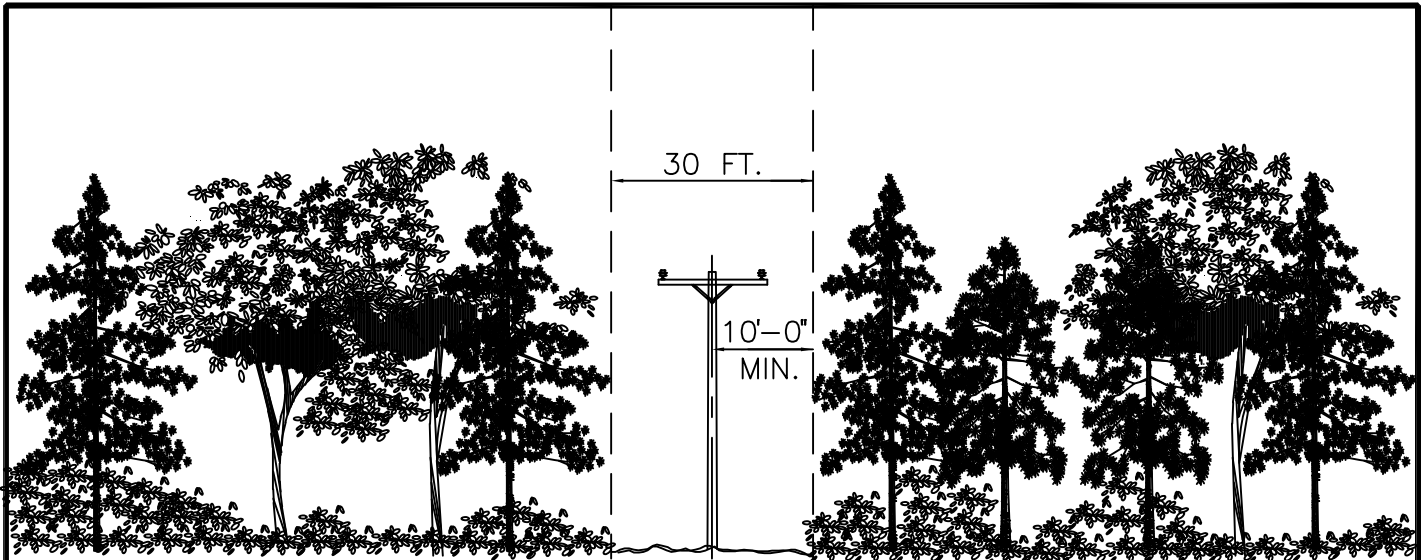

ELEVATION

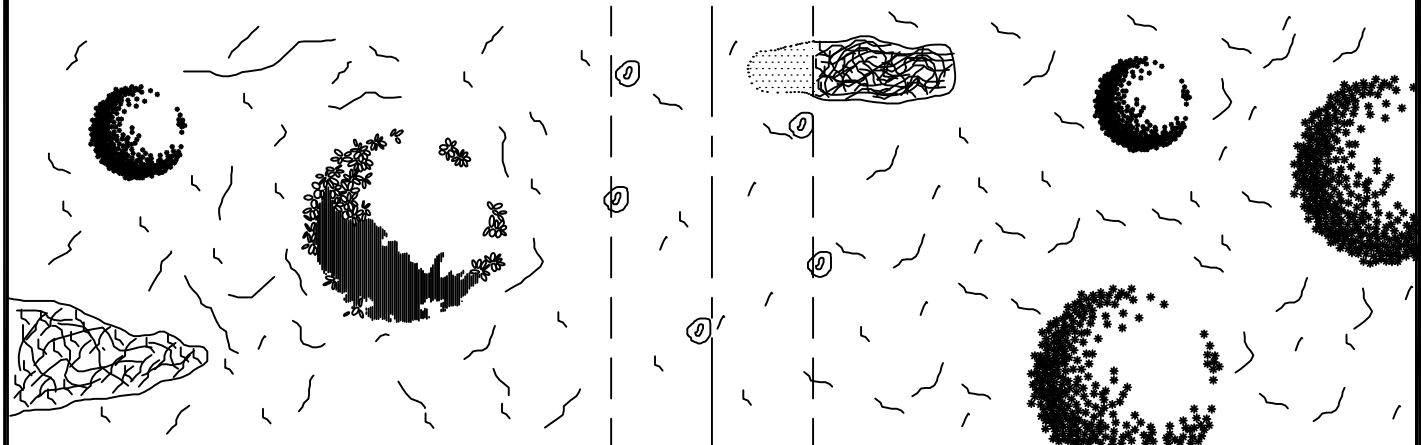

AFTER CLEARING

Underbrush

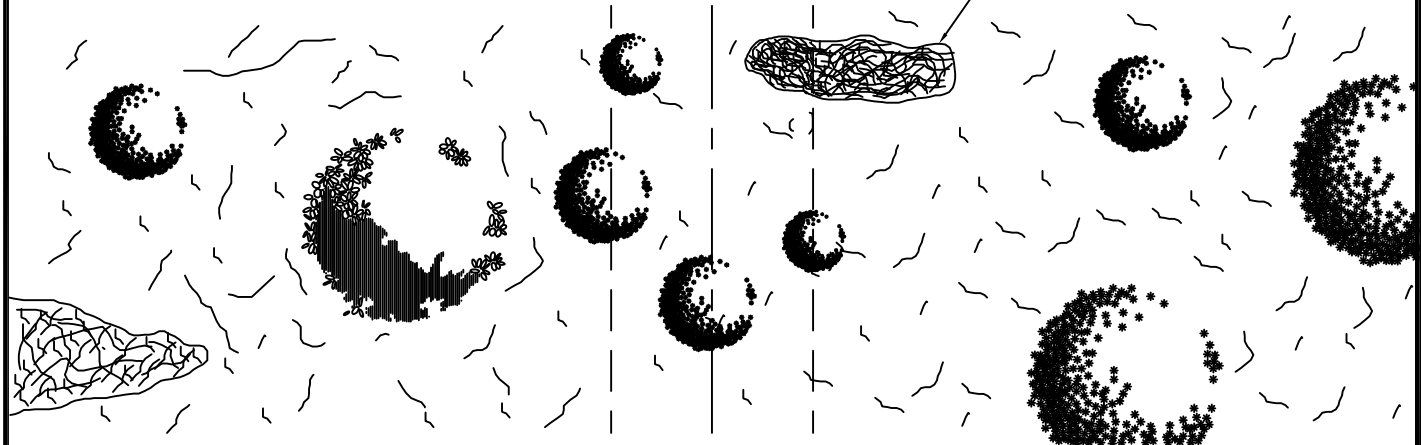

BEFORE CLEARING

NOTE:
Change suffix of drawing number to designate clearing width. (e.g. M1.30G specifies 30 foot wide clearing).

RIGHT-OF-WAY CLEARING GUIDE

APRIL 2005

RUS

M1.30G
(R1)

NEUTRAL ASSEMBLY UNITS

<u>DRAWING NUMBERS</u>		<u>DRAWING TITLE (DESCRIPTION)</u>
1728F-804 (New)	Bulletin 50-3 (Old)	
N1.1		NEUTRAL ASSEMBLIES - TANGENT
N1.2	(M5-19)	
N1.11		NEUTRAL SUPPORTS ON CROSSARMS
N2.21		
N2.1		NEUTRAL ASSEMBLIES - LARGE ANGLE
N2.1L		
N5.1	(M5-25)	NEUTRAL ASSEMBLIES - (SINGLE DEADENDS)
N5.2		
N5.3	(M5-26)	
N6.1		NEUTRAL ASSEMBLY - DOUBLE DEADEND
N6.21		NEUTRAL ASSEMBLY - DOUBLE DEADEND ON CROSSARMS

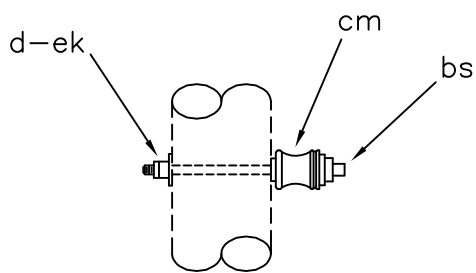

N1.1

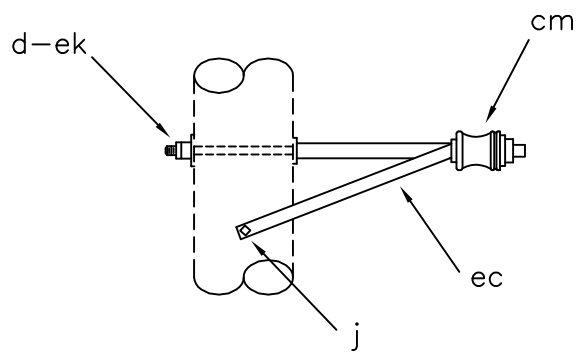

N1.2

ASSEMBLY:

ITEM	MATERIAL	N1.1	N1.2
		QTY	QTY
d	Washer, 2 1/4" square	1	1
j	Screw, lag, 1/2" x 4"		2
bs	Bolt, single, upset	1	
cm	Insulator, spool, 3"	1	1
ec	Bracket, offset neutral		1
ek	Locknuts	1	1

DESIGN PARAMETERS:

MAXIMUM LINE ANGLES:
 5° - Small Conductors
 2° - Larger than #1/0

NEUTRAL ASSEMBLIES – TANGENT

APRIL 2005

RUS

N1.1,
 N1.2 (M5-19)

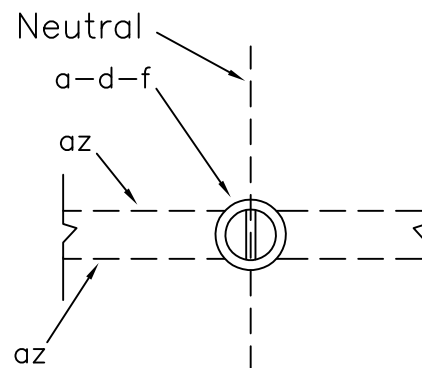
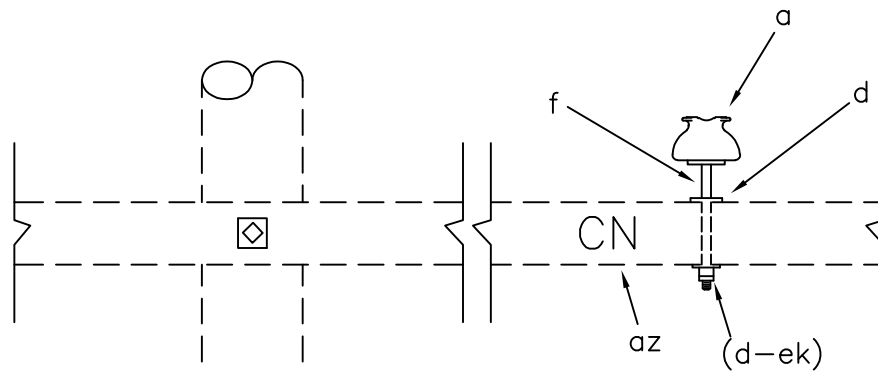

N1.11

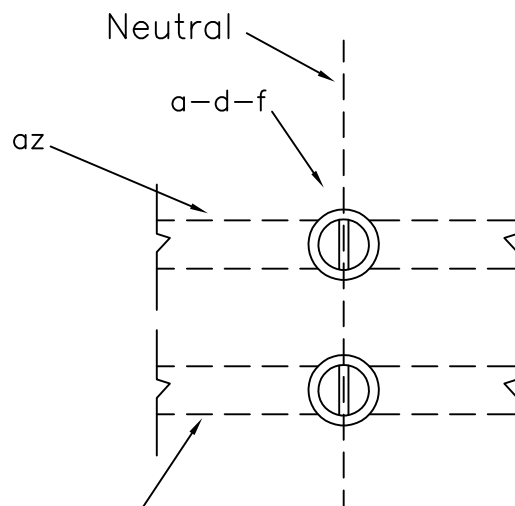

N2.21

NOTE: Install either identification letters (az) or white insulator(s).

ASSEMBLY:

ITEM	MATERIAL	ASSEMBLY:	
		N1.11	N2.21
		QTY	QTY
a	Insulator, pin type, 15 kV, white	1	2
d	Washer, 2 1/4" square	1	2
f	Pin, crossarm, steel, 5/8" x 10 3/4"	1	2
az	Letters, 2" C, 2" N, with 1" nails	4	4

DESIGN PARAMETERS:

N1.11: See TABLE II
N2.21: See TABLE IV

NEUTRAL SUPPORTS ON CROSSARMS

APRIL 2005

RUS

N1.11,
N2.21

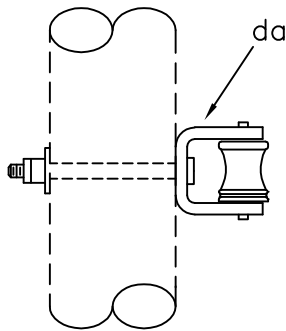
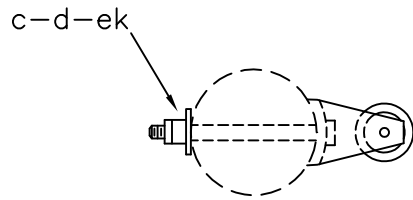

N2.1
(ANSI Class 53-2 Insulator)
N2.1L
(ANSI Class 53-4 Insulator)

		ASSEMBLY: N2	
ITEM	MATERIAL	.1 QTY	.1L QTY
c	Bolt, machine, 5/8" X req'd length	1	1
d	Washer, 2 1/4" square	1	1
o	Bolt, eye, 5/8" X req'd length		
s	Clevis, secondary, swinging, insulated		
da	Bracket, with 3" x 1 3/4" spool insulator	1	
da	Bracket, with 3" x 3" spool insulator		1
ek	Locknuts	1	1

DESIGN PARAMETERS:

N2.1: See TABLE VI
N2.1L: See TABLE VII

NEUTRAL ASSEMBLIES – LARGE ANGLE

APRIL 2005

RUS

N2.1, N2.1L

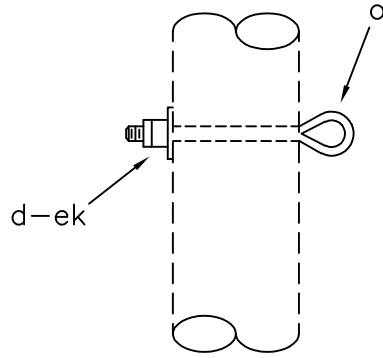

N5.1

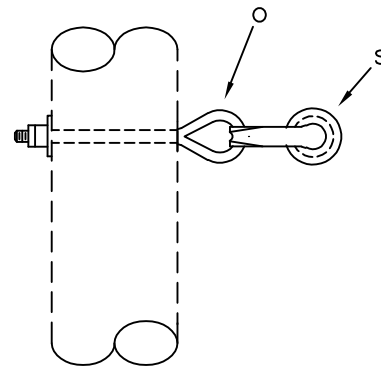
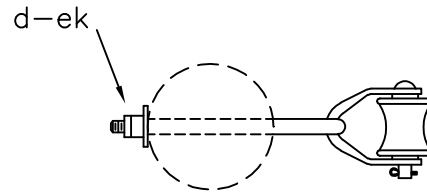

N5.2

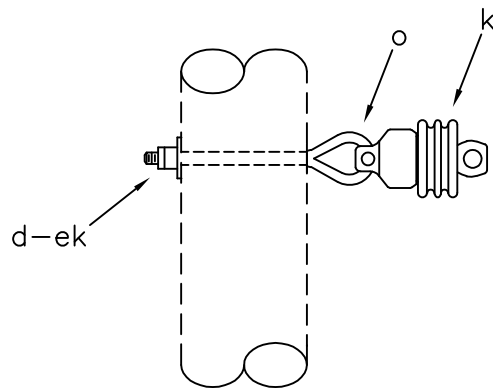

N5.3

ASSEMBLY: N5

ITEM	MATERIAL	.1	.2	.3
d	Washer, square 3" curved	1	1	1
k	Insulator, suspension, 4 1/4"			1
o	Bolt, eye, 5/8" X req'd length	1	1	1
s	Clevis, secondary, swinging, insulated		1	
ek	Locknuts	1	1	1

ASSEMBLY NUMBERS

NEW	(OLD)
N5.1	(M5-25)
N5.2	
N5.3	(M5-26)

DESIGN PARAMETERS:

PERMITTED LONGITUDINAL LOADING:

- N5.1, N5.3 = 5,000 lbs.
- N5.2 = 1,500 lbs.
- (ANSI Class 53-2 Insulator)
- N5.2 = 2,250 lbs.
- (ANSI Class 53-4 Insulator)

NEUTRAL ASSEMBLIES
(SINGLE DEADENDS)

APRIL 2005

RUS

N5.1, N5.2, N5.3

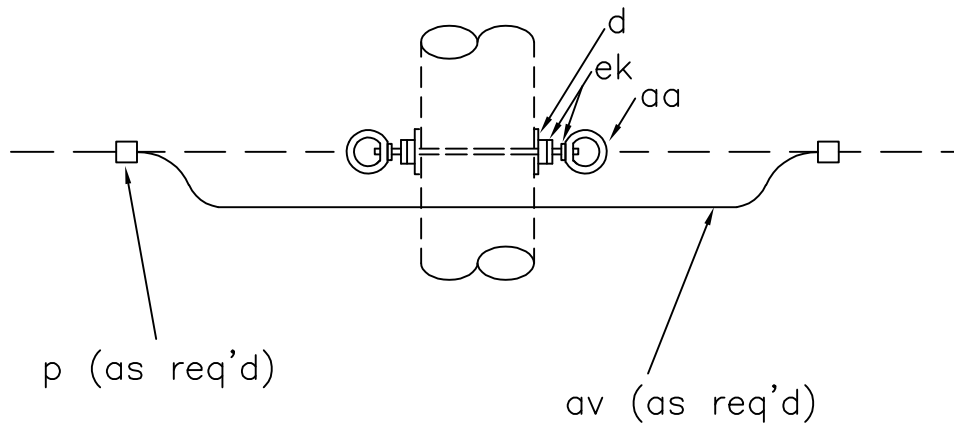

ITEM	QTY	MATERIAL
d	2	Washer, square 3" curve
n	1	Bolt, double arming, 5/8" x req'd length
p		Connectors, as req'd
aa	2	Nut, eye, 5/8"
av		Jumpers, as req'd
ek	4	Locknuts

DESIGN PARAMETERS:

PERMITTED LONGITUDINAL
LOADING: 5,000 lbs.

NEUTRAL ASSEMBLY – DOUBLE DEADEND

APRIL 2005

RUS

N6.1

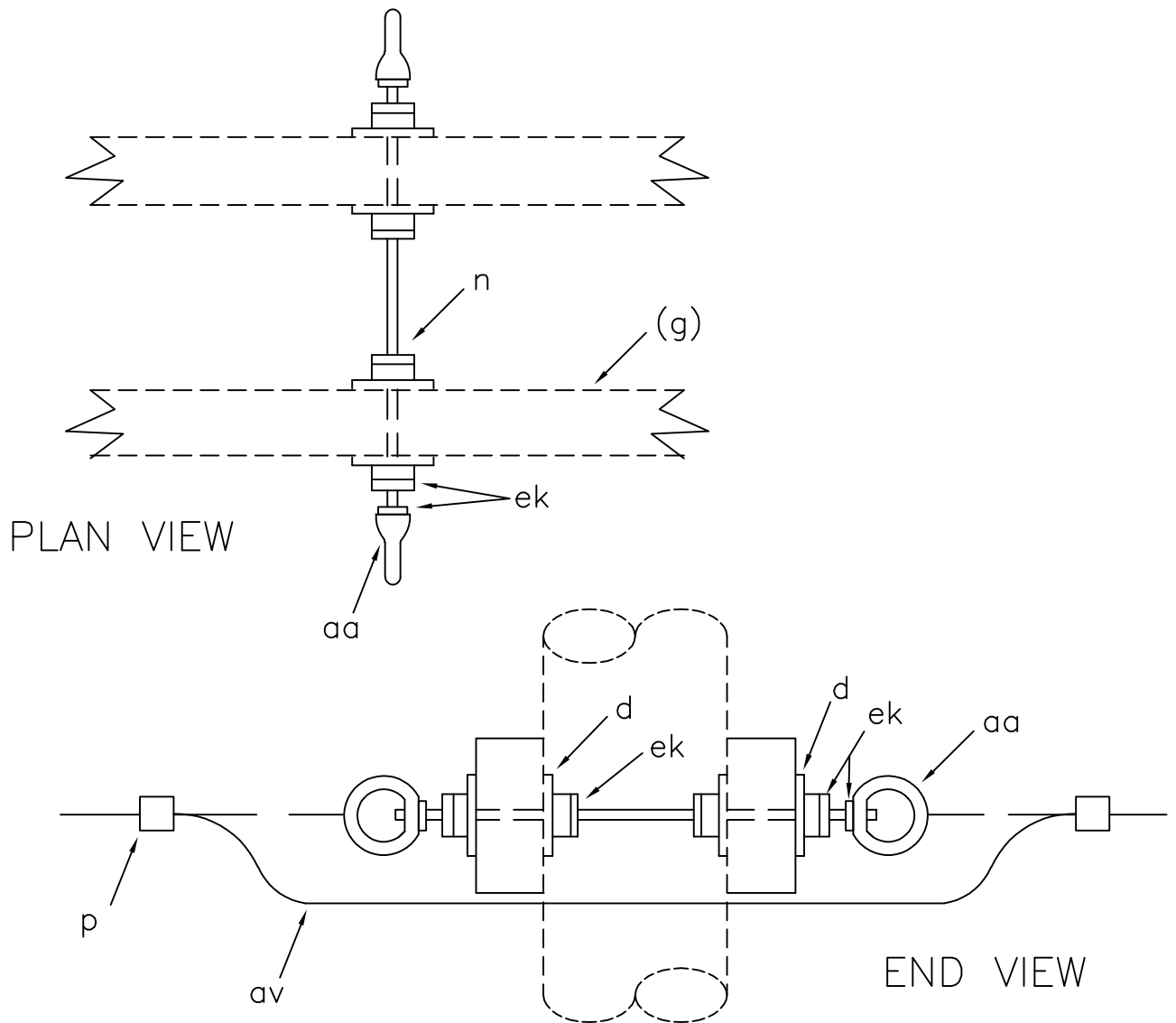

NOTES:

1. Doubling arming bolt, item "n" and eye nut, item "aa"; may be replaced with doubling arming eye bolt, item "dy."
2. Maximum line angle may be increased to 15° by installing anchor shackles, item "bo" to (horizontally mounted) eye nuts and installing side guys.

ITEM	QTY	MATERIAL
d	4	Washer, square, 2 1/4"
n	1	Bolt, double arming, 5/8" x req'd length
p		Connectors, as req'd
aa	2	Nut, eye, 5/8"
av		Jumpers, as req'd
ek	6	Locknuts

DESIGN PARAMETERS:

PERMITTED UNBALANCED TENSION:
(See drawings where assembly used)

ALLOWABLE LINE ANGLE = 5°
(See Note 2)

NEUTRAL ASSEMBLY –
DOUBLE DEADEND ON CROSSARMS

APRIL 2005

RUS

N6.21

PROTECTION ASSEMBLY UNITS

<u>DRAWING NUMBERS</u>		<u>DRAWING TITLE (DESCRIPTION)</u>
1728F-804 (New)	Bulletin 50-3 (Old)	
P1.01 P1.1	(M5-6)	SURGE ARRESTERS - SINGLE PHASE
P1.1NG		SURGE ARRESTER GUIDE - NARROW PROFILE
P1.3		SURGE ARRESTERS - 3 SINGLE PHASE
P3.1G		RAPTOR PROTECTION ASSEMBLY GUIDE SUPPORT ON 8-FOOT CROSSARMS (TANGENT)
P3.2G		RAPTOR PROTECTION ASSEMBLY GUIDE SUPPORT ON 10-FOOT CROSSARMS (TANGENT)
P3.3G		RAPTOR PROTECTION, PERCH GUARDS - GUIDE
P3.4G		RAPTOR PROTECTION, SINGLE-PHASE, CSP TRANSFORMER (TANGENT POLE)
P3.5G		RAPTOR PROTECTION ASSEMBLY GUIDE THREE-PHASE TRANSFORMER BANK

CONSTRUCTION SPECIFICATIONS FOR RAPTOR PROTECTION

Raptor injury and electrocution around power lines are major wildlife concerns of the U.S. Fish and Wildlife Service. Raptors are protected by the Endangered Species Act, the Eagle Protection Act, and the Migratory Bird Treaty Act. The electrocution issue may be a problem especially on lines with voltages of 69 kV or less. Reports indicate that raptor concerns exist primarily on distribution lines in western and southwestern states; however, hazards can exist anywhere in the United States where large birds are present.

The provisions included on the "P3" series of construction drawings will help to minimize or eliminate bird electrocutions. This construction should be used in areas where raptors or other large birds are present. It may be prudent to adopt these designs for all new construction.

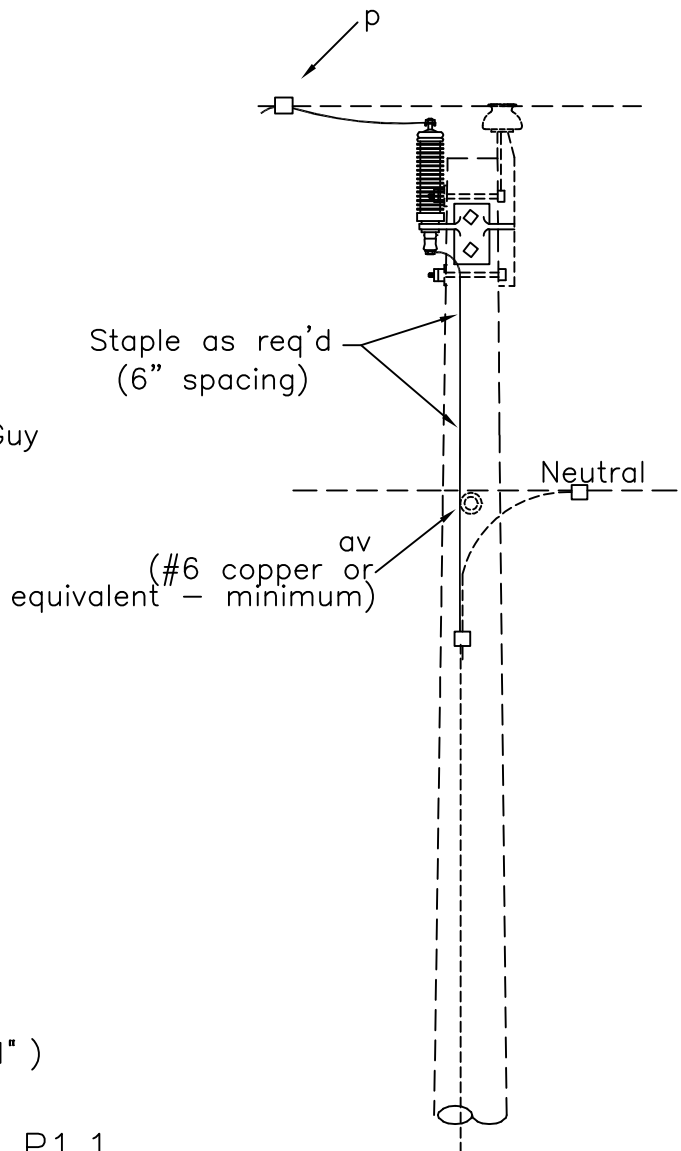
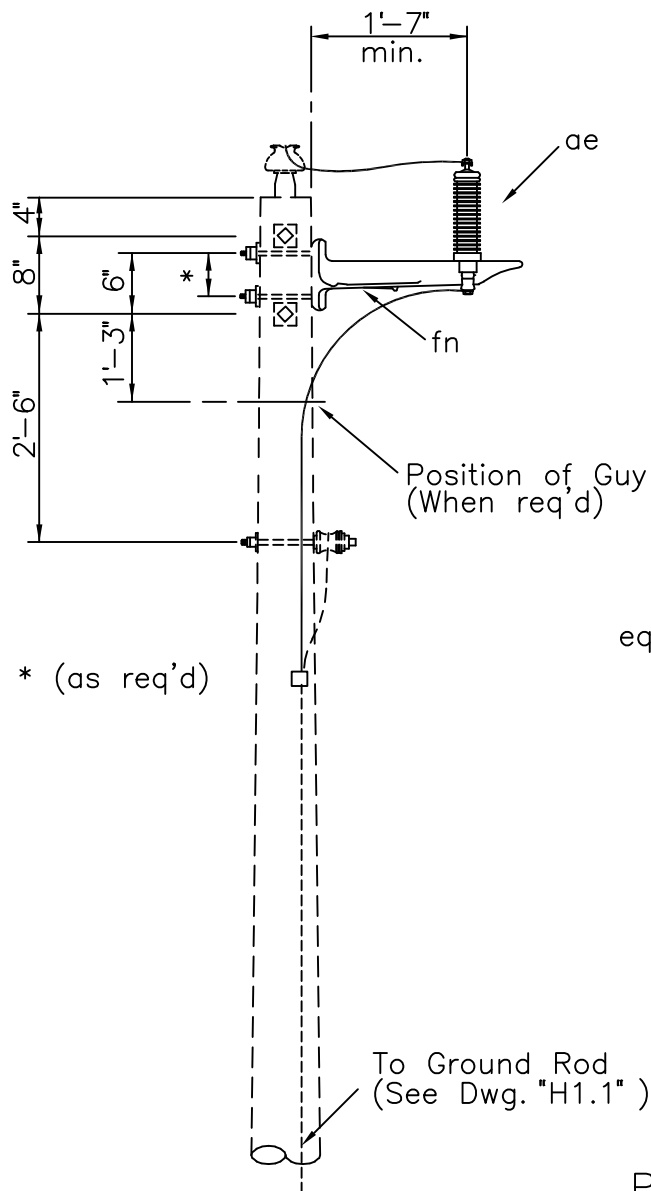

P1.1

NOTE: Use "P1.01" on existing arm, a minimum of 19" from face of pole.

ASSEMBLY: P1		.01	.1
ITEM	MATERIAL	QTY	QTY
c	Bolt, machine, 5/8 x req'd length		2
d	Washer, square, 2 1/4		2
p	Connectors, as req'd		
ae	Arrester, surge, (9 kV)	1	1
av	Jumpers, as req'd		
fn	Bracket, cutout extension		1
ek	Locknuts		2

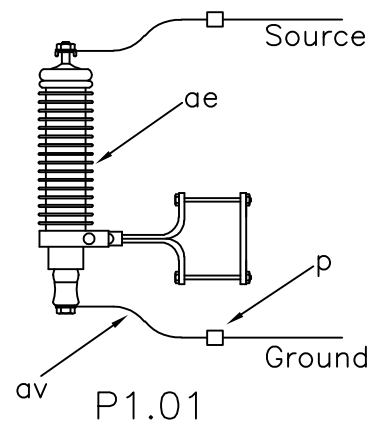

P1.01

SURGE ARRESTERS - SINGLE PHASE

APRIL 2005

RUS

1 - PHASE PRIMARY
12.47/7.2 kV

P1.01, (M5-6)
P1.1

A1.04N
(or A1.04NP)

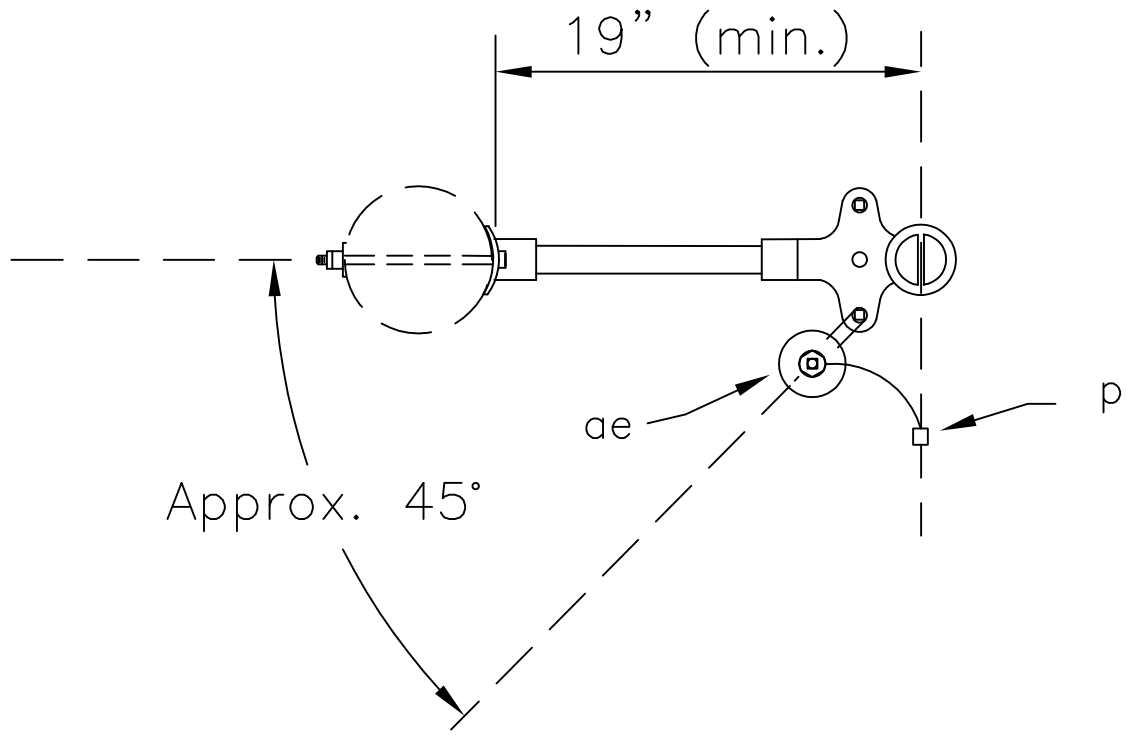
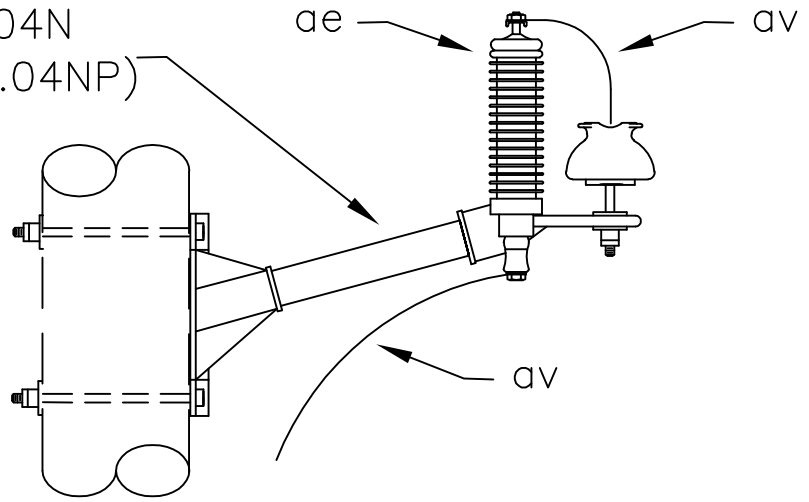

NOTE: May be used on an apparatus mounting bracket (item "fm") of any 1, 2 or 3-phase narrow profile assembly. Specify quantity of surge arresters (item "ae").

ITEM	MATERIAL
	Assembly A1.04N or A1.04NP
ae	Arrester, surge (9kV)
av	Jumpers, as req'd
p	Connectors, as req'd

Design Parameters:

SURGE ARRESTER GUIDE-NARROW PROFILE		
APRIL 2005	1 - PHASE PRIMARY	P1.1NG
RUS	12.47/7.2 kV	

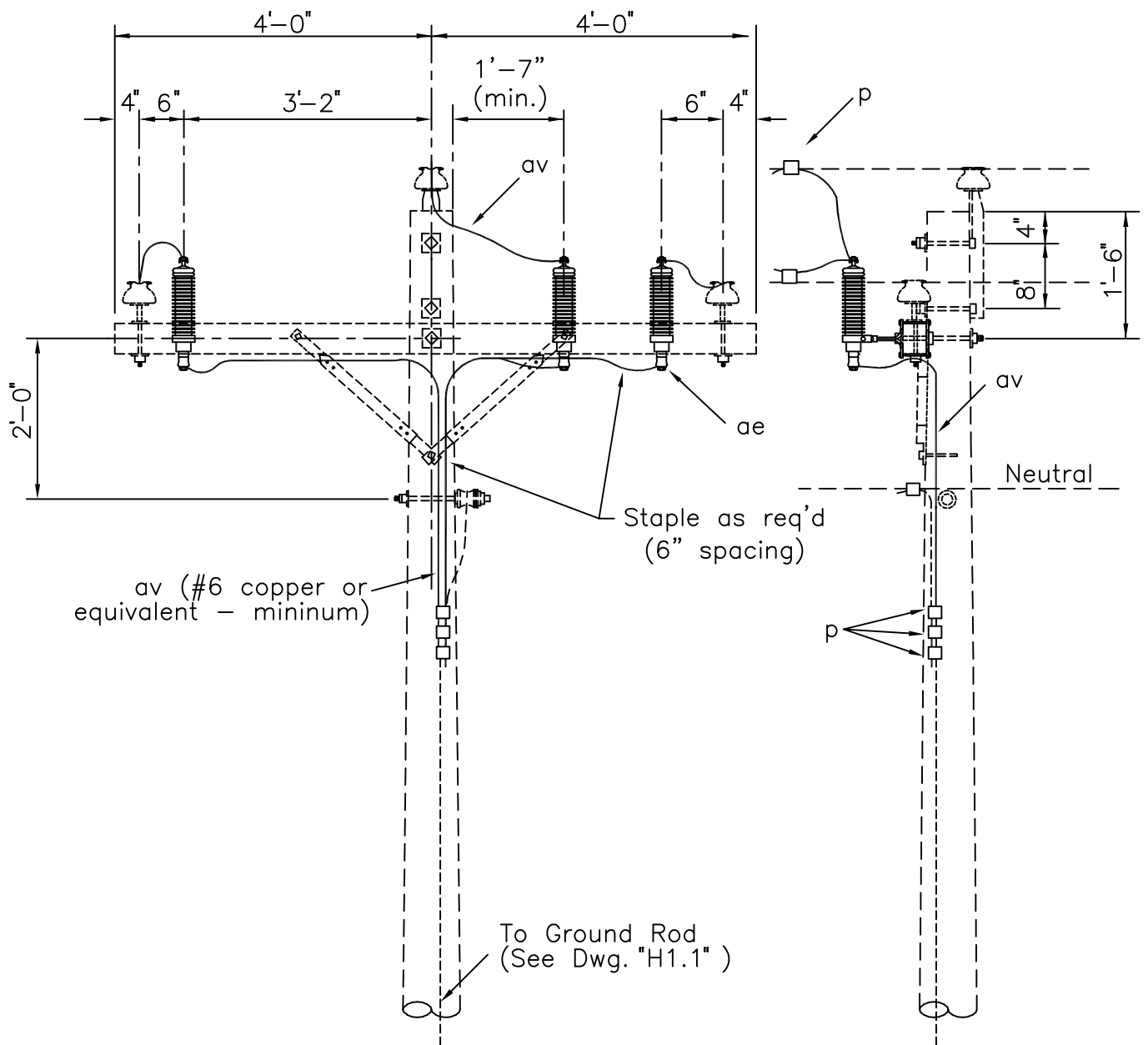

ITEM	QTY	MATERIAL
P		Connectors, as req'd
ae	3	Arrester, surge, (9 kV)
av		Jumpers, as req'd

SURGE ARRESTERS - 3 SINGLE PHASE

APRIL 2005

3 - PHASE PRIMARY
12.47/7.2 kV

RUS

P1.3

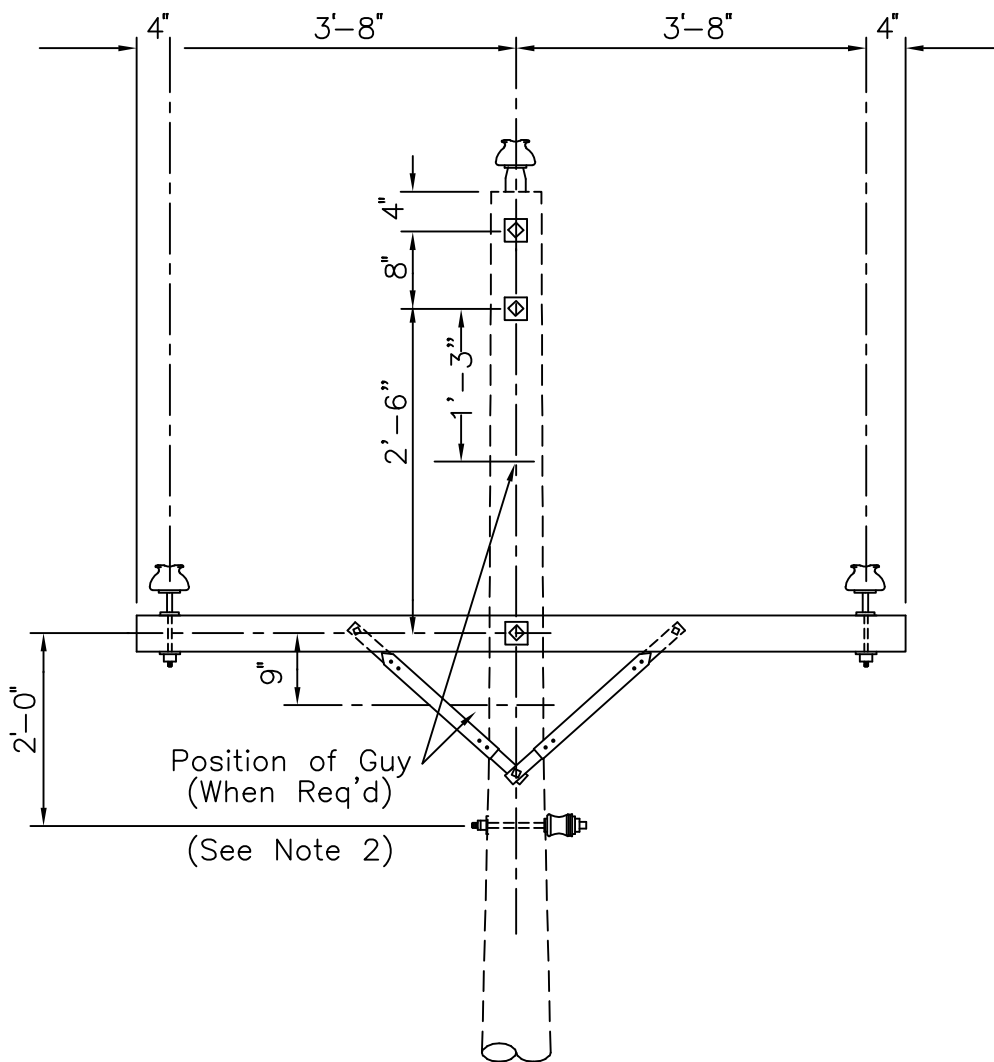

NOTES:

1. See "C1.11" and "C2.21" drawings for additional construction details and materials.
2. All down guys must be insulated at top of pole.

DESIGN PARAMETERS:

RAPTOR PROTECTION ASSEMBLY GUIDE
SUPPORT ON
8 FOOT CROSSARMS (TANGENT)

APRIL 2005

3 - PHASE PRIMARY
12.47/7.2 kV

P3.1G

RUS

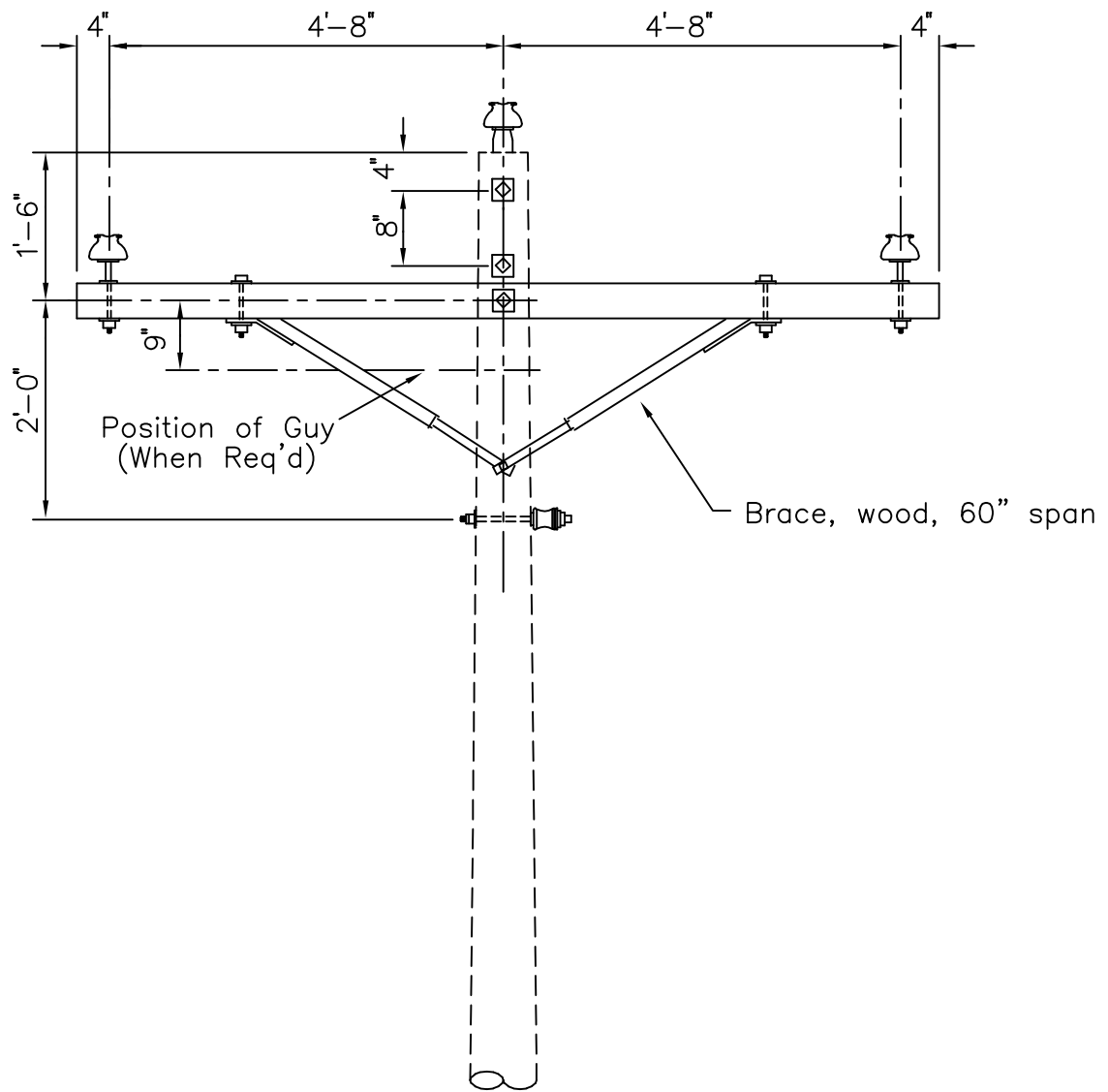

NOTE:

1. See "C1.11" and "C2.21" drawings for additional construction details and materials.

DESIGN PARAMETERS:

RAPTOR PROTECTION ASSEMBLY GUIDE
SUPPORT ON
10 FOOT CROSSARMS (TANGENT)

APRIL 2005

3 - PHASE PRIMARY
12.47/7.2 kV

RUS

P3.2G

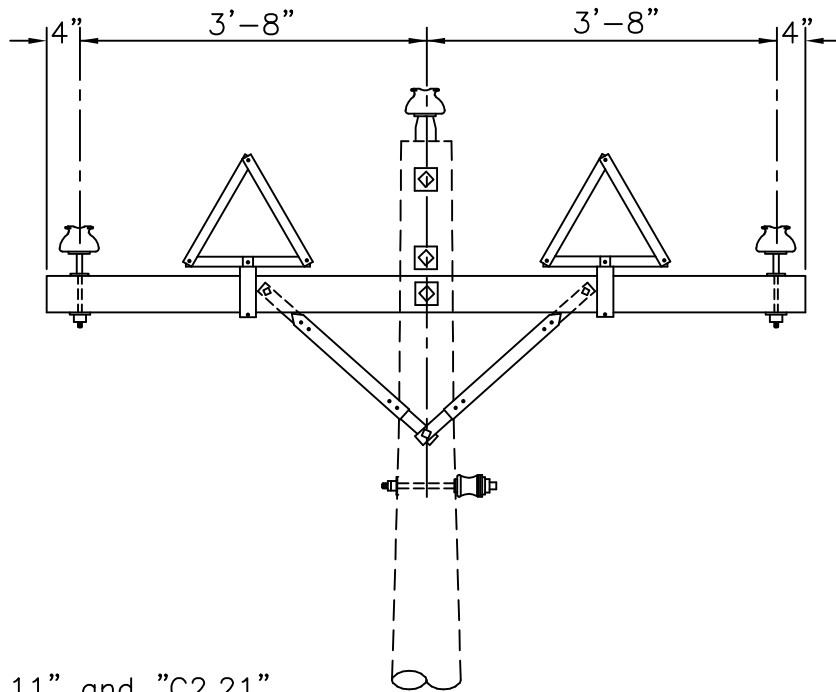
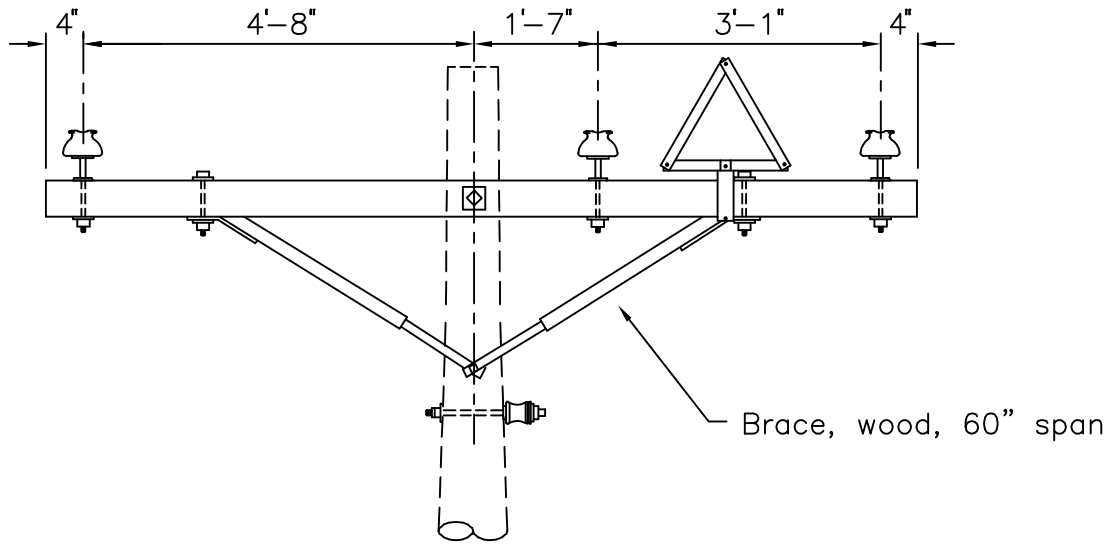

NOTE: See "C1.11" and "C2.21" drawings for additional construction details and materials.

DESIGN PARAMETERS:

RAPTOR PROTECTION
PERCH GUARDS—GUIDE

APRIL 2005

RUS

3-PHASE PRIMARY
12.47/7.2 kV

P3.3G

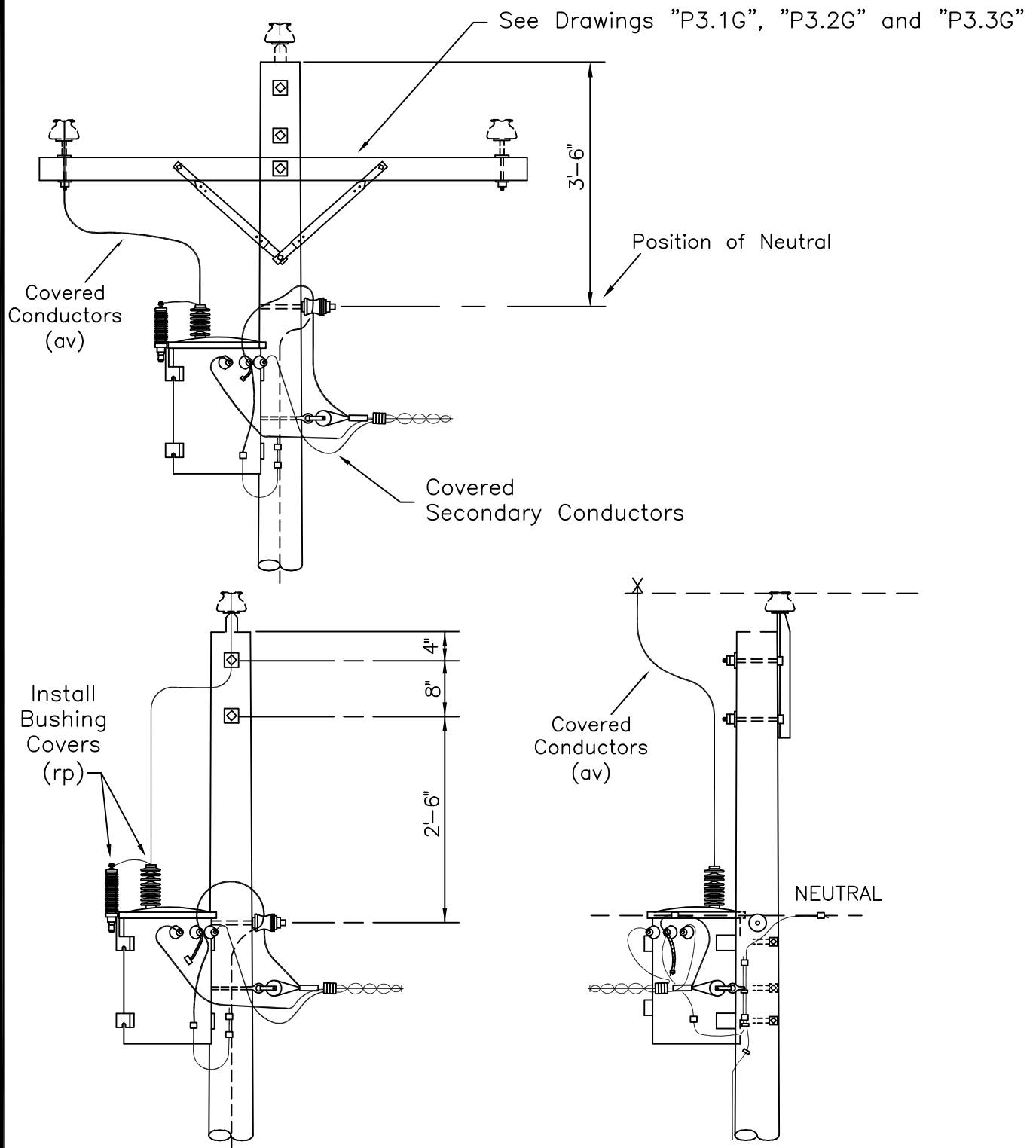

DESIGN PARAMETERS:

See Assembly "G1.2"

RAPTOR PROTECTION
SINGLE-PHASE, CSP TRANSFORMER
(TANGENT POLE)

APRIL 2005

RUS

12.47/7.2 kV

P3.4G

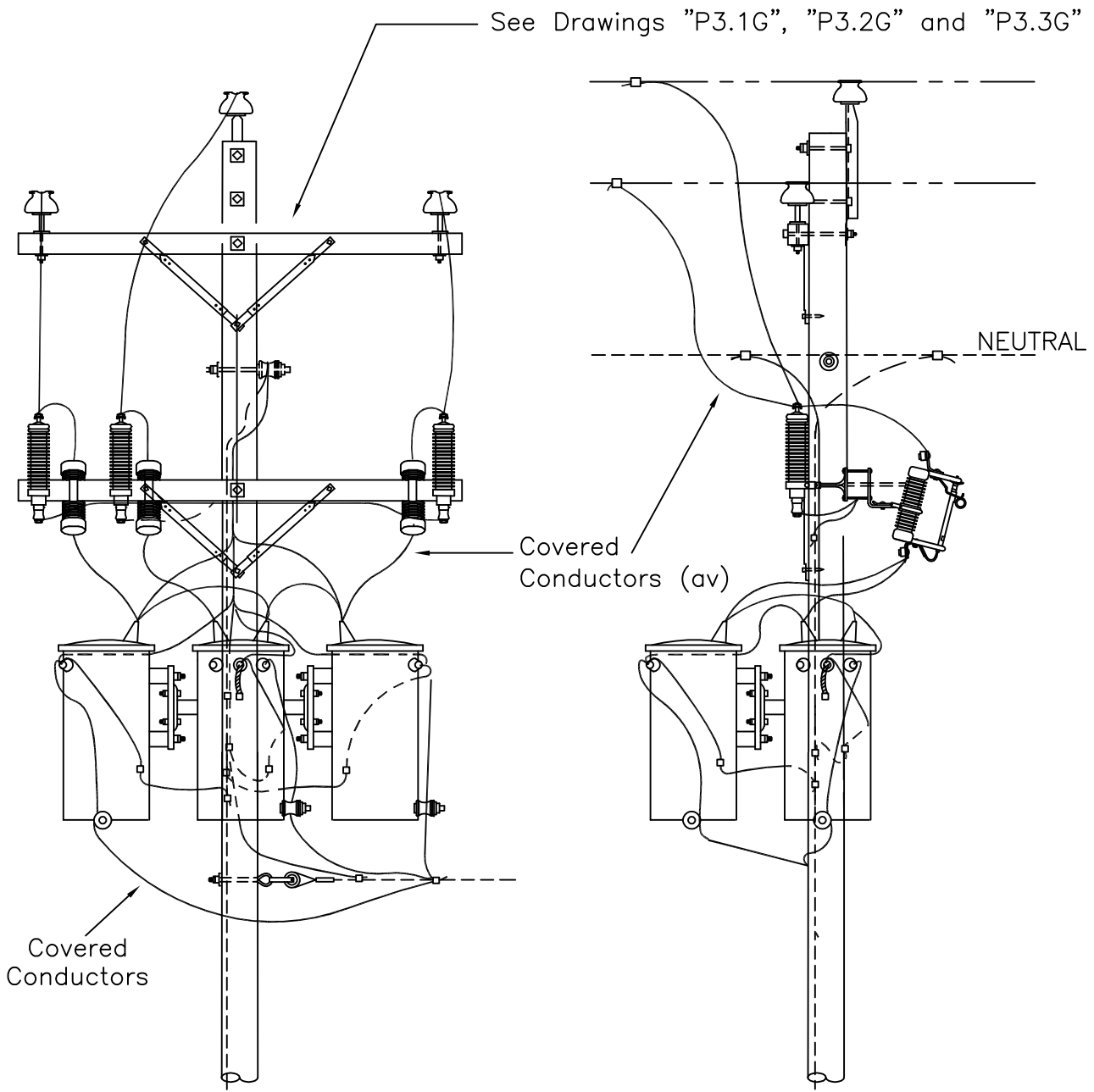

- Notes: 1. Specify Insulated Transformer covers (lids);
 Minimum Dielectric Strength 15kV
 2. Install bushing covers (rp) on all surge arresters
 and transformer bushings.

DESIGN PARAMETERS:

 See Assembly "G3.3"

RAPTOR PROTECTION ASSEMBLY GUIDE
 THREE-PHASE TRANSFORMER BANK

APRIL 2005	3 - PHASE PRIMARY	
RUS	12.47/7.2 kV	P3.5G

METERING ASSEMBLY UNITS

<u>DRAWING NUMBERS</u>		<u>DRAWING TITLE (DESCRIPTION)</u>
1728F-804 (New)	Bulletin 50-3 (Old)	
Q1.1	(M8)	SECONDARY METERING - SINGLE-PHASE, 120/240 VOLTS
Q2.1G	(M8-10)	POLE TYPE SERVICE ASSEMBLY GUIDE
Q2.2G	(M8-9)	YARD POLE METER INSTALLATION GUIDE
Q3.1	(M8-6)	SECONDARY METERING - THREE-PHASE, 120/240 VOLTS (4 WIRE DELTA)
Q3.2	(M8-12)	SECONDARY METERING - THREE-PHASE, 240 OR 480 VOLTS (3 WIRE CORNER GROUNDED DELTA)
Q3.3	(M8-11)	SECONDARY METERING - THREE-PHASE, 120/208 VOLTS (4 WIRE GROUNDED WYE)
Q4.1	(M8-15)	PRIMARY METERING, THREE-PHASE (4 WIRE GROUNDED WYE)

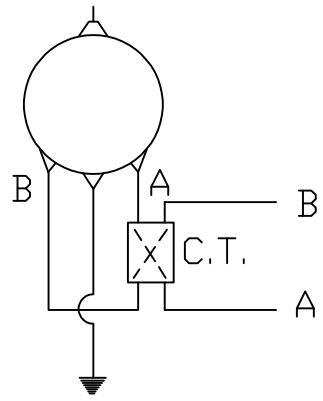
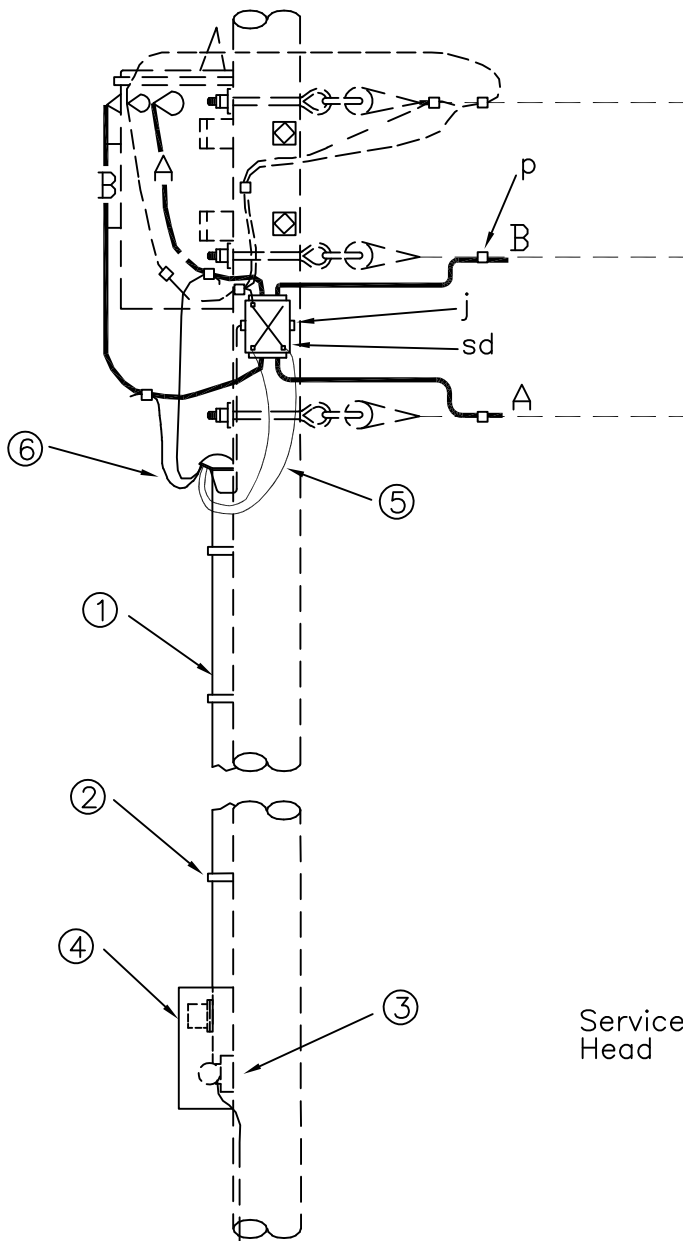

WIRING DIAGRAM

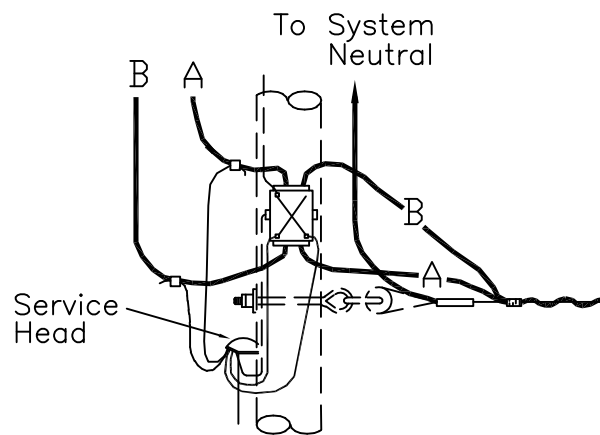

TRIPLEX SERVICE

NOTE: Customer owned, installed and maintained equipment, including "point of attachment" shall be located a minum of 5 feet away from this assembly.

ITEM	QTY	MATERIAL
j	2	Screw, lag, 1/2" x 4"
P		Connectors, as required
sd	1	Transformer, Current
①		Conduit, 1 1/4" as required
②		Straps, conduit, as required

ITEM	QTY	MATERIAL
③	1	Condulet, type LB
④	1	Meter box, meter and test block
⑤		Wire, No. 12, insulation for current
⑥		Wire, No. 14, insulation for potential

SECONDARY METERING
SINGLE PHASE, 120/240 VOLTS

APRIL 2005

RUS

Q1.1
(M8)

NOTES:

1. All Clearances and protective devices to be in conformance to the most stringent requirements of either the NESC, NEC or other codes of governmental or regulating authorities as applicable.
2. If length of conduit exceeds 10 feet, coupling is permitted on end adjacent to meter.
3. Guy pole as required.

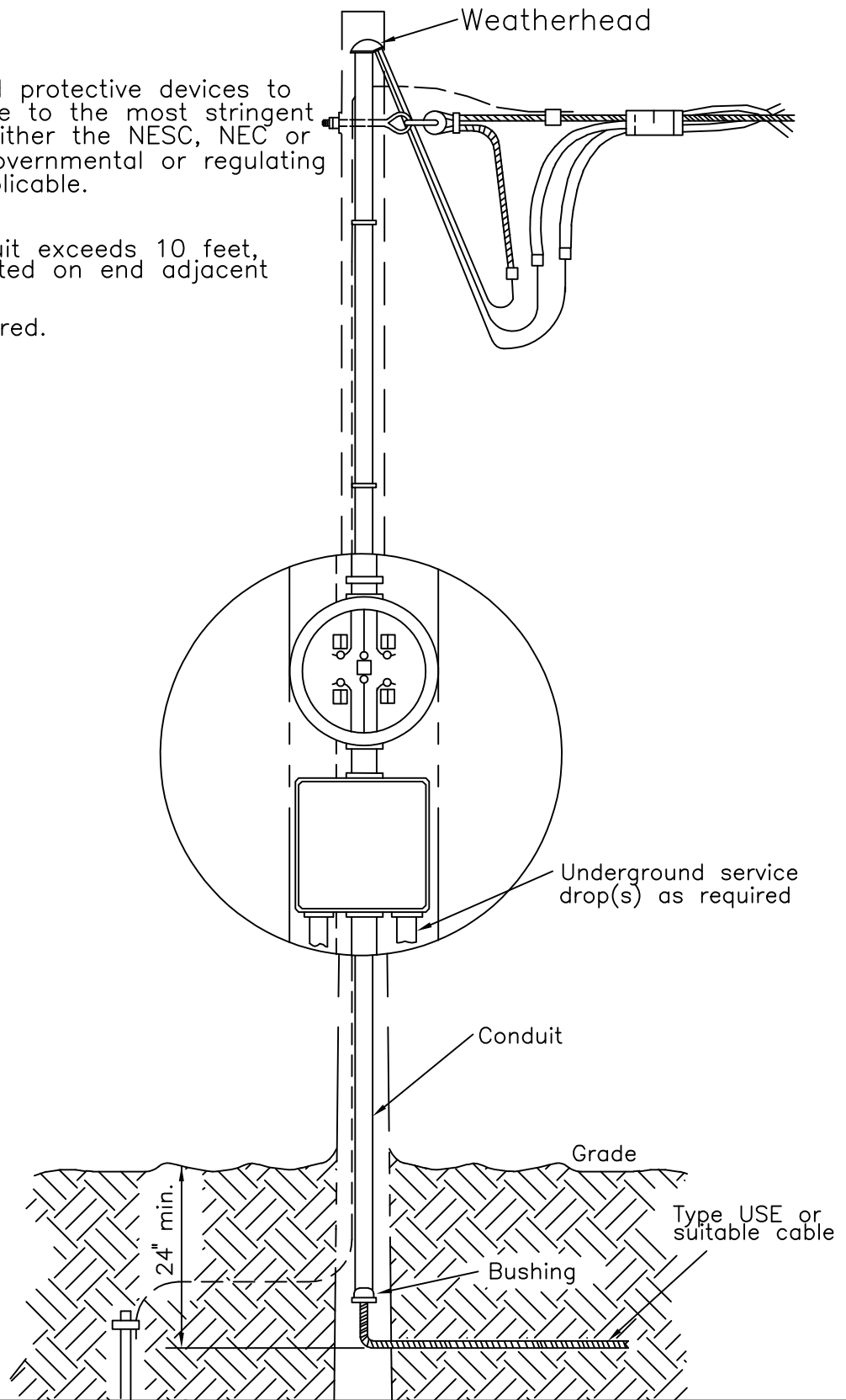

DESIGN PARAMETERS:
(See NOTE 1)

POLE TYPE SERVICE ASSEMBLY GUIDE

APRIL 2005

RUS

Q2.1G
(M8-10)

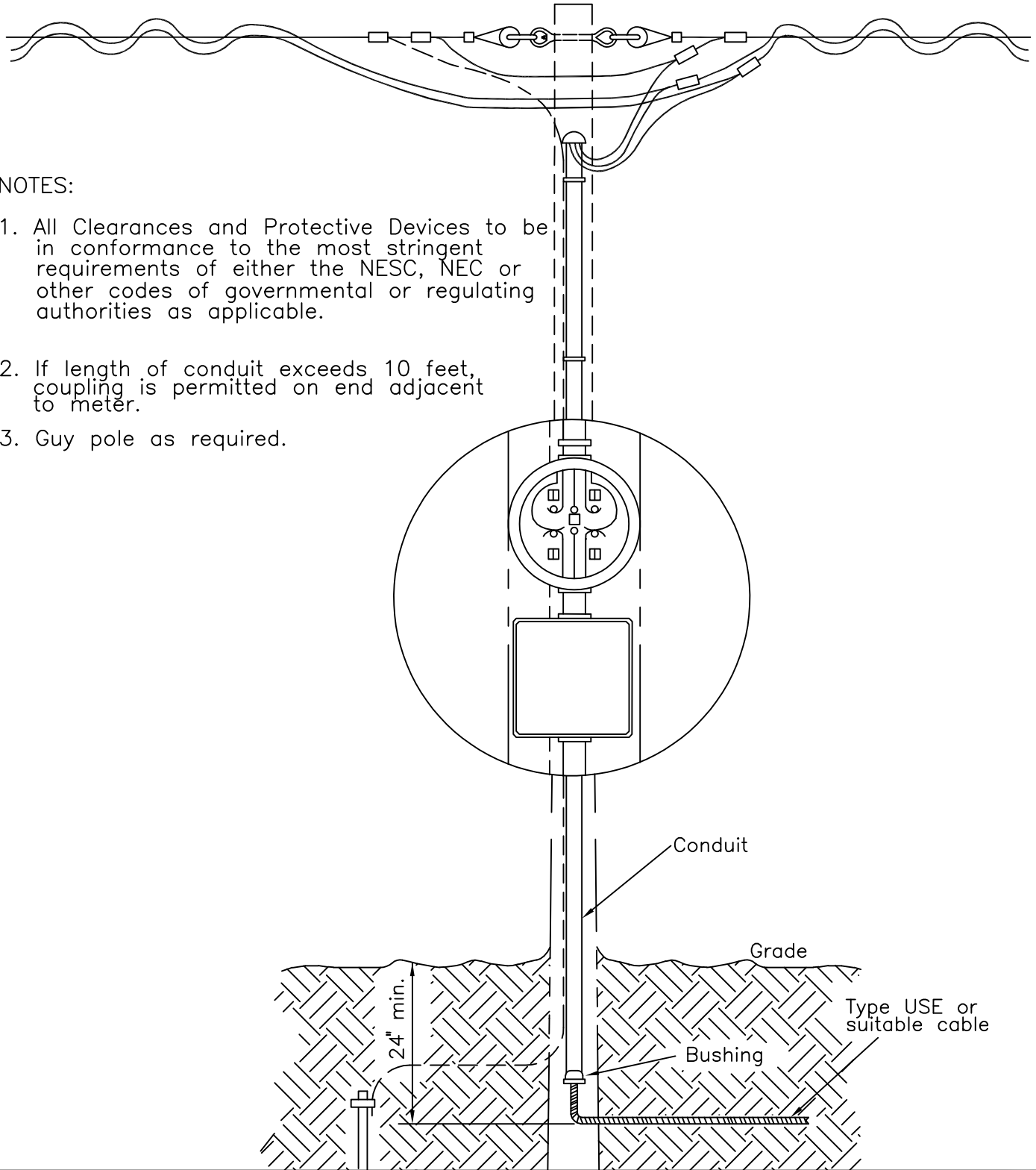

NOTES:

1. All Clearances and Protective Devices to be in conformance to the most stringent requirements of either the NESC, NEC or other codes of governmental or regulating authorities as applicable.
2. If length of conduit exceeds 10 feet, coupling is permitted on end adjacent to meter.
3. Guy pole as required.

DESIGN PARAMETERS:
(See NOTE 1)

YARD POLE METER INSTALLATION GUIDE

APRIL 2005

RUS

Q2.2G
(M8-9)

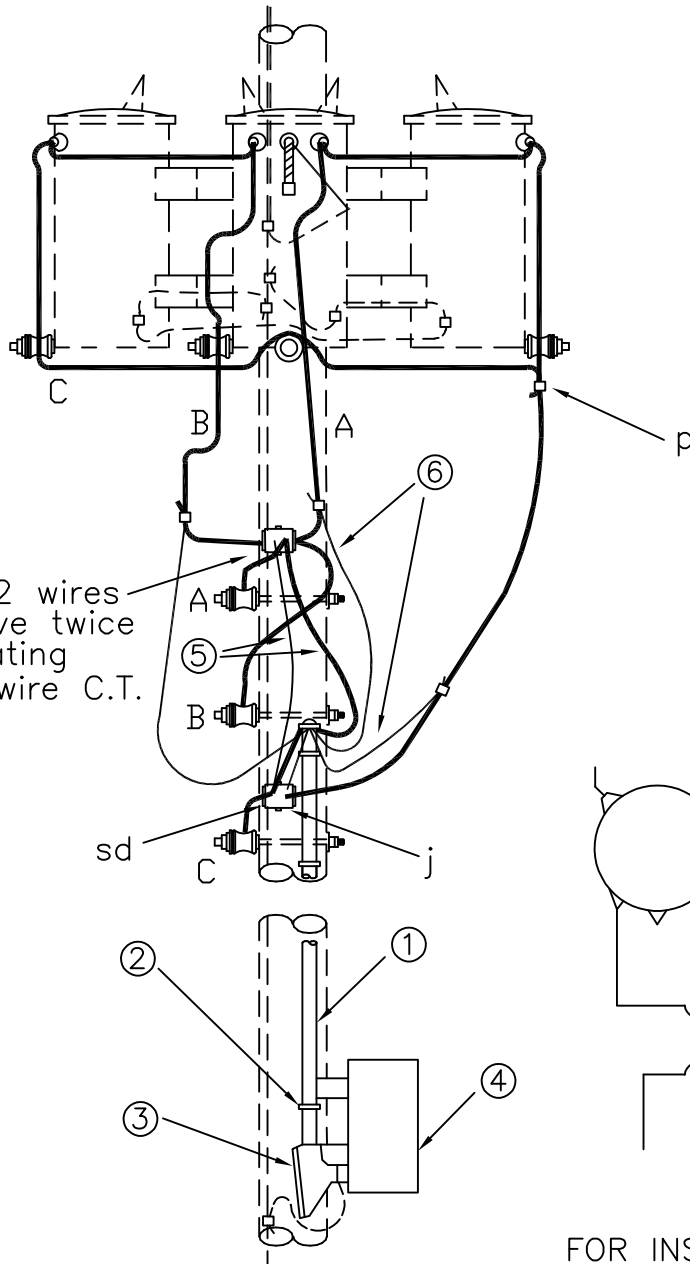

Note:

C.T. with 2 wires should have twice primary rating of single wire C.T.

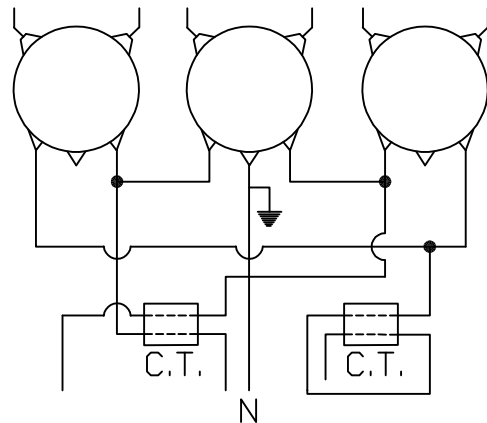

WIRING DIAGRAM FOR INSTRUMENT TRANSFORMERS

NOTE: Customer owned, installed and maintained equipment, including "point of attachment" shall be located a minum of 5 feet away from this assembly.

ITEM	QTY	MATERIAL
j	4	Screw, lag, 1/2" x 4"
P		Connectors, as required
sd	2	Transformer, Current
①		Conduit, 1 1/4" as required
②		Straps, conduit, as required

ITEM	QTY	MATERIAL
③	1	Condulet, type "LB"
④	1	Meter box, meter and test block
⑤		Wire, No. 12, insulation for current
⑥		Wire, No. 14, insulation for potential

SECONDARY METERING
THREE PHASE, 120/240 VOLTS
(4 WIRE DELTA)

APRIL 2005

RUS

Q3.1
(M8-6)

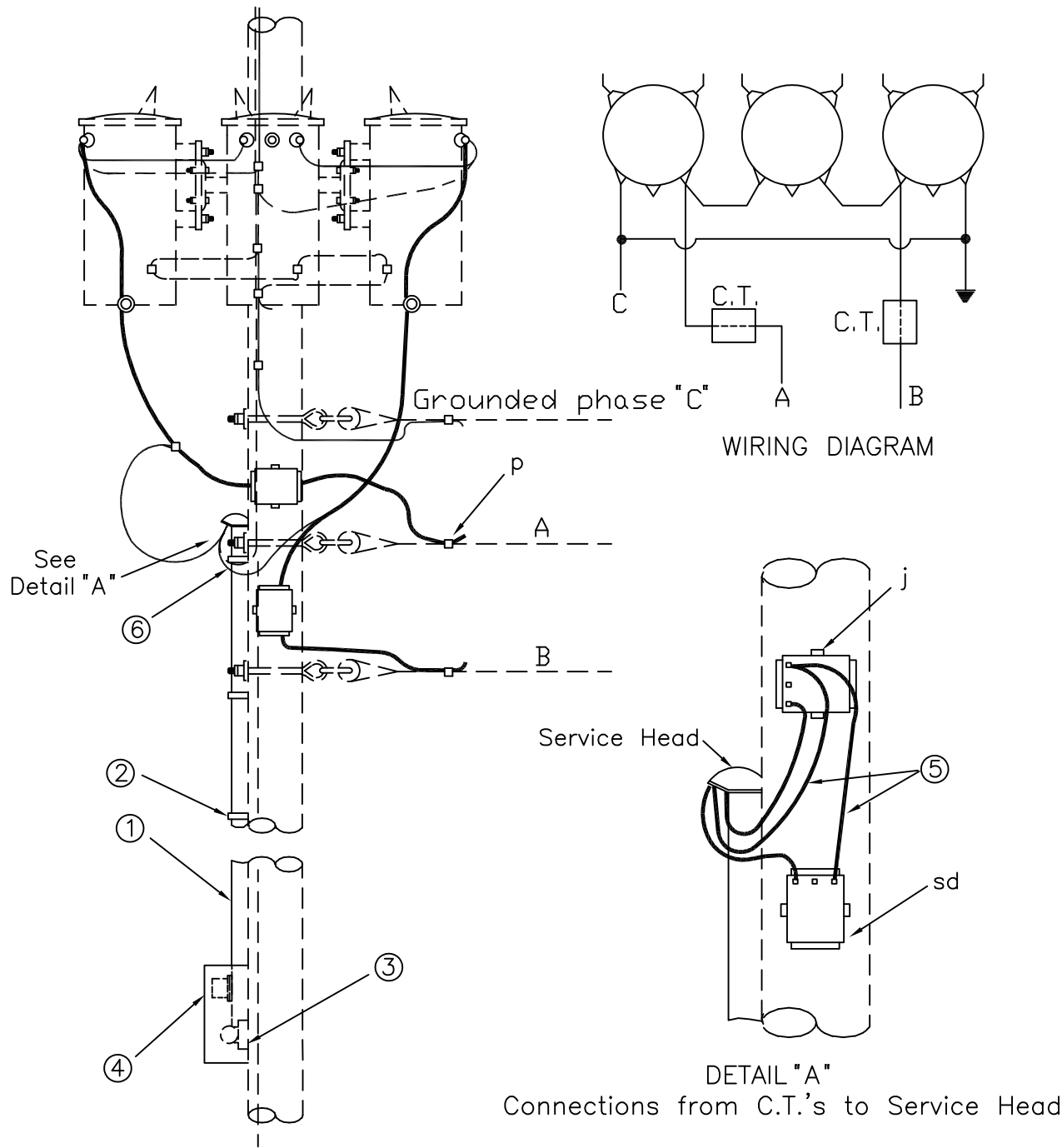

NOTES: PT metering is recommended for 480 volt service.
 Customer owned, installed and maintained equipment, including "point of attachment" shall be located a minimum of 5 feet away from this assembly.

ITEM	QTY	MATERIAL
j	4	Screw, lag, 1/2" x 4"
p		Connectors, as required
sd	2	Transformer, Current
①		Conduit, 1 1/4" as required
②		Straps, conduit, as required

ITEM	QTY	MATERIAL
③	1	Condulet, type "LB"
④	1	Meter box, meter and test block
⑤		Wire, No. 12, insulation for current
⑥		Wire, No. 14, insulation for potential

SECONDARY METERING
 THREE PHASE, 240 or 480 VOLTS
 (3 WIRE CORNER GROUNDED DELTA)

APRIL 2005

RUS

Q3.2
 (M8-12)

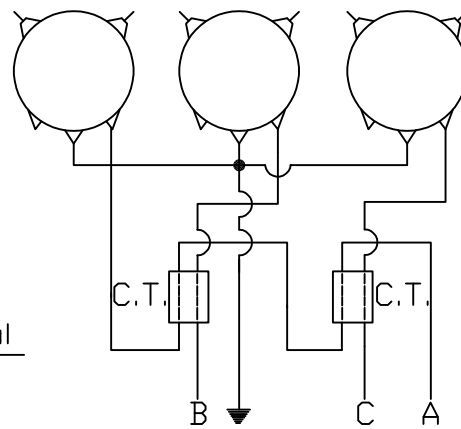
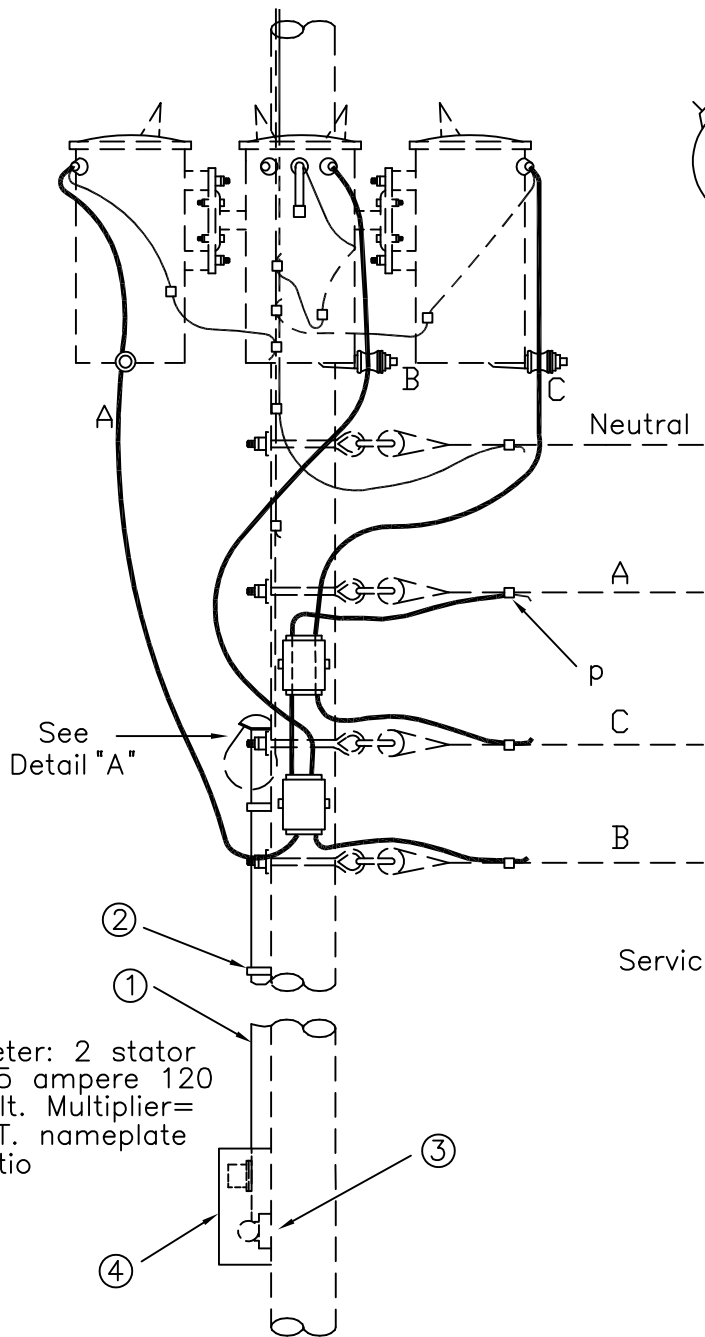

WIRING DIAGRAM

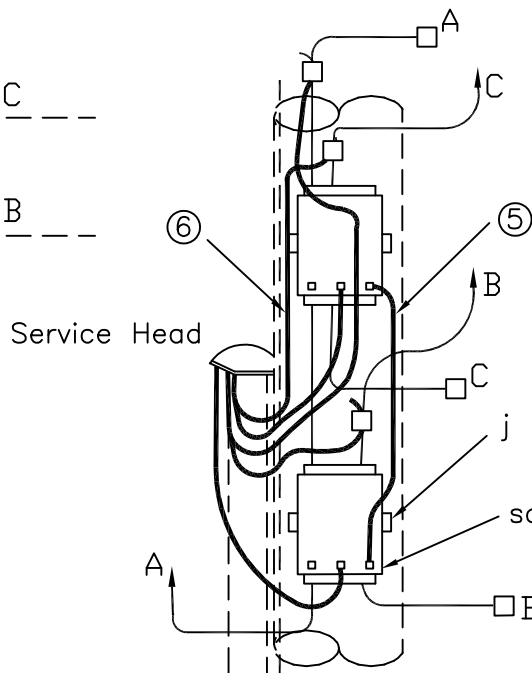

DETAIL "A"

Connections from C.T.'s to Service Head

NOTES: Ground current transformers as required (not shown)
 Customer owned, installed and maintained equipment, including "point of attachment" shall be located a minimum of 5 feet away from this assembly.

ITEM	QTY	MATERIAL
j	4	Screw, lag, 1/2" x 4"
P		Connectors, as required
sd	2	Transformer, Current
①		Conduit, 1 1/4" as required
②		Straps, conduit, as required

ITEM	QTY	MATERIAL
③	1	Condulet, type "LB"
④	1	Meter box, meter and test block
⑤		Wire, No. 12, insulation for current
⑥		Wire, No. 14, insulation for potential

SECONDARY METERING
 THREE PHASE, 120/208 VOLTS
 (4 WIRE GROUNDED WYE)

APRIL 2005

RUS

Q3.3
 (M8-11)

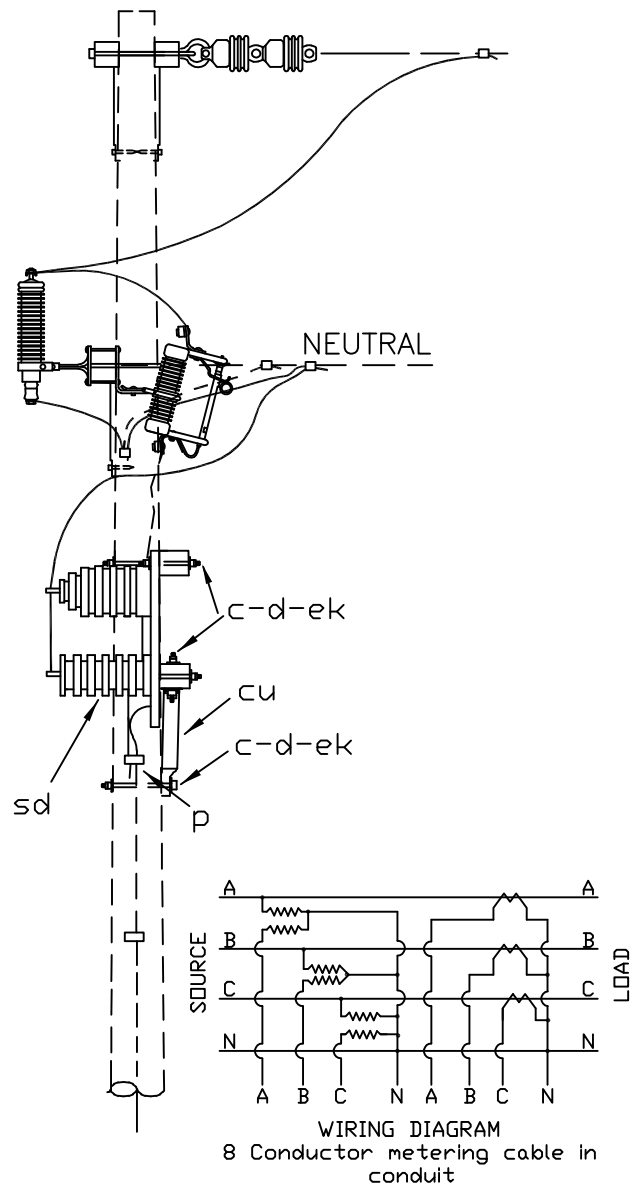
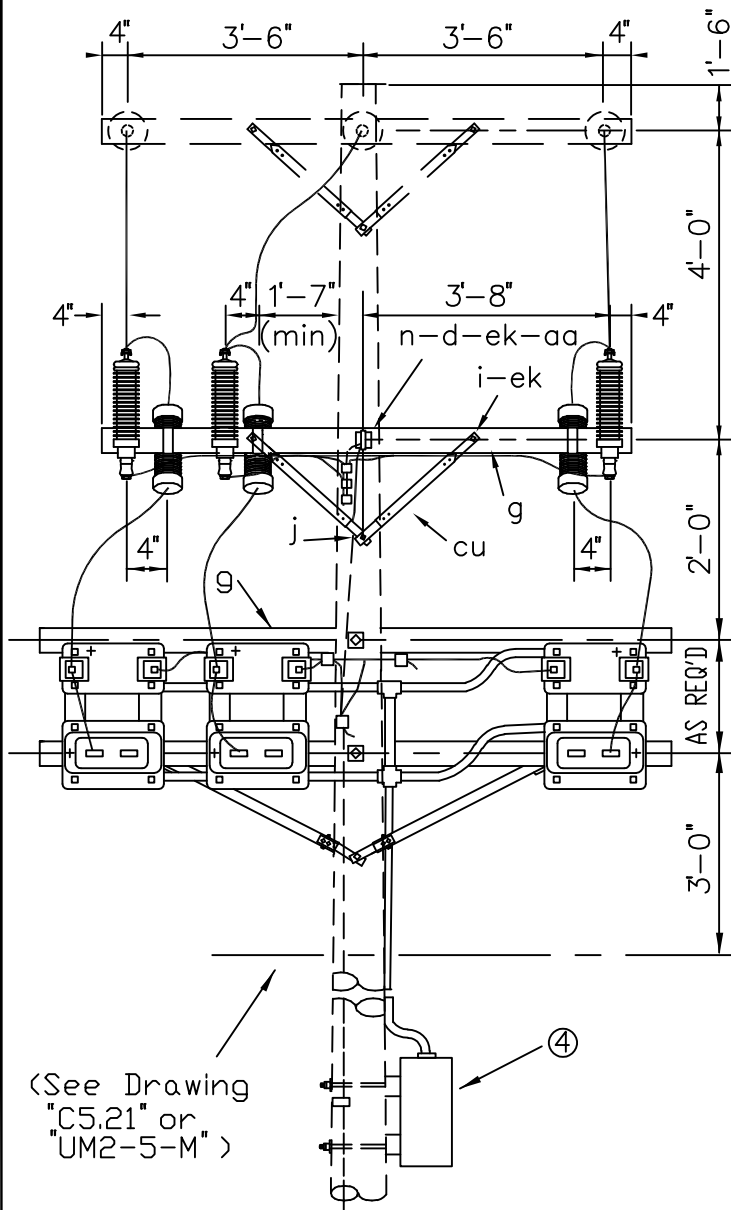

ITEM	QTY	MATERIAL
c	5	Bolt, machine, 5/8" x req'd length
c	26	Bolt, machine, 1/2" x req'd length
d	33	Washer, 2 1/4" square
d	2	Washer, round, 1 3/8" dia.
g	1	Crossarm, 3 5/8" x 4 5/8" x 8'-0"
g	2	Crossarm, 3 5/8" x 4 5/8" x 10'-0"
i	2	Bolt, carriage, 3/8" x 4 1/2"
j	1	Screw, lag, 1/2" x 4"
n	1	Bolt, double arming, 5/8" x req'd length
p		Connectors, as required
aa	1	Nut, eye, 5/8"
av		Jumper, primary, bare, as required

ITEM	QTY	MATERIAL
ae	3	Arrester, surge (9 kV)
af	3	Cutout, dist. open (15 kV)
cu	2	Brace, 28"
cu	1	Brace, wood, 60" span
④		Meter box, meter on test block
		Condulets, as required
sd	3	Transformer, current
se	3	Transformer, potential
ek	34	Locknuts
*	6	Mounting brackets
		Metering cable, as req'd

*Specify this item to be furnished by the transformer manufacturer.

PRIMARY METERING THREE PHASE
(4 WIRE GROUNDED WYE)

APRIL 2005		Q4.1
RUS	12.47/7.2 kV	(M8-15)

OIL CIRCUIT RECLOSER ASSEMBLY UNITS

<u>DRAWING NUMBERS</u>		<u>DRAWING TITLE (DESCRIPTION)</u>
1728F-804 (New)	Bulletin 50-3 (Old)	
R1.1	(M3-10)	OIL CIRCUIT RECLOSER
R1.2	(M3-23A)	OIL CIRCUIT RECLOSER - (WITH BYPASS CUTOUT)
R2.1	(M3-11A)	(THREE) OIL CIRCUIT RECLOSERS
R3.1	(M3-12A)	
R2.2	(M3-24A)	(THREE) OIL CIRCUIT RECLOSERS
R3.2	(M3-25A)	(WITH BYPASS SWITCHES)
R3.3	(M3-30)	THREE-PHASE OIL CIRCUIT RECLOSER WITH BY-PASS SWITCHES

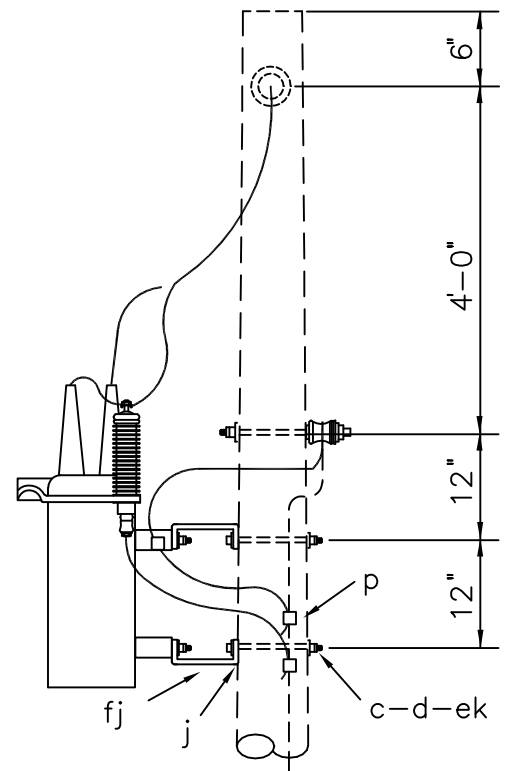
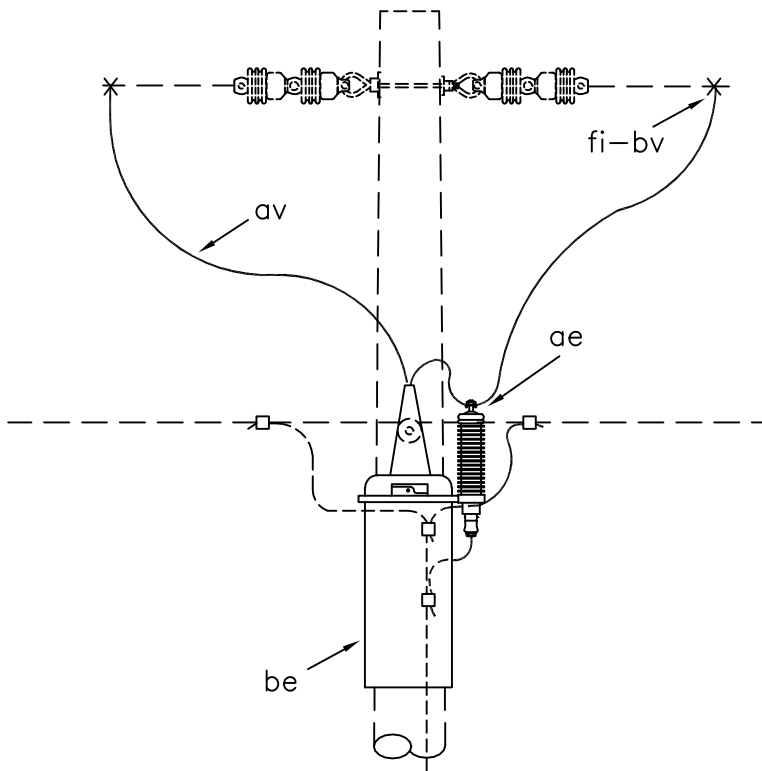
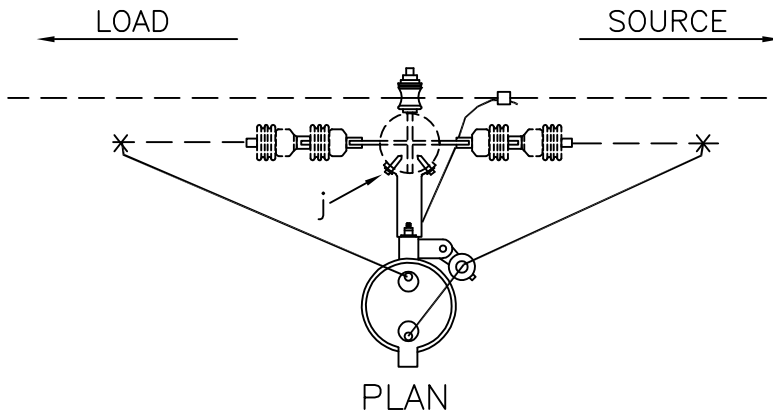

NOTE: The recloser terminal bushing connected to the coil should be connected to the source.

ITEM	QTY	MATERIAL
c	2	Bolt, machine, 5/8" x req'd length
d	2	Washer, square, 2 1/4"
j	4	Screw, lag, 1/2" x 4"
P		Connector, as required
ae	1	Arrester, surge (9 kV)
av		Jumpers, stranded, as required

ITEM	QTY	MATERIAL
be	1	Recloser, oil circuit (12.47 kV)
bv		Rod, armor, as req'd
ek	2	Locknuts
fi	2	Connector, hot line
fj	2	Brackets, extension, 9" long

OIL CIRCUIT RECLOSER

APRIL 2005

RUS

1 - PHASE PRIMARY
12.47/7.2 kV

R1.1
(M3-10)

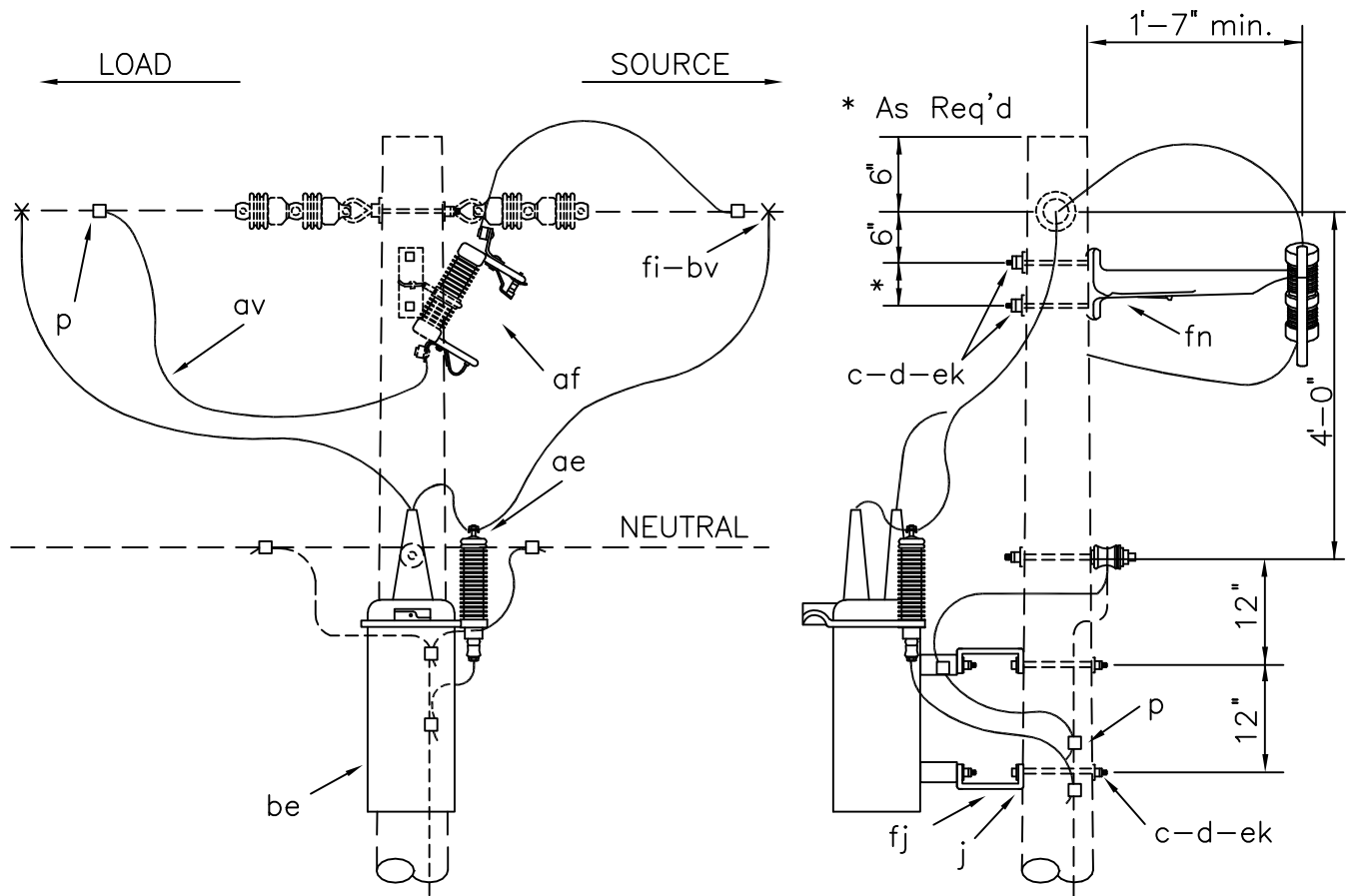

NOTE: The recloser terminal bushing connected to the coil should be connected to the source.

ITEM	QTY	MATERIAL
c	4	Bolt, machine, 5/8" x req'd length
d	4	Washer, square, 2 1/4"
j	4	Screw, lag, 1/2" x 4"
p		Connector, as required
ae	1	Arrestor, surge (9 kV)
af	1	Cutout, distribution, open (15 kV)
av		Jumpers, stranded, as required

ITEM	QTY	MATERIAL
be	1	Recloser, oil circuit (12.47 kV)
bv		Rod, armor, as req'd
ek	4	Locknuts
fi	2	Connector, hot line
fj	2	Brackets, extension, 9" long
fn	1	Bracket, extension

OIL CIRCUIT RECLOSER
(WITH BYPASS CUTOUT)

APRIL 2005

RUS

1 - PHASE PRIMARY
12.47/7.2 kV

R1.2
(M3-23A)

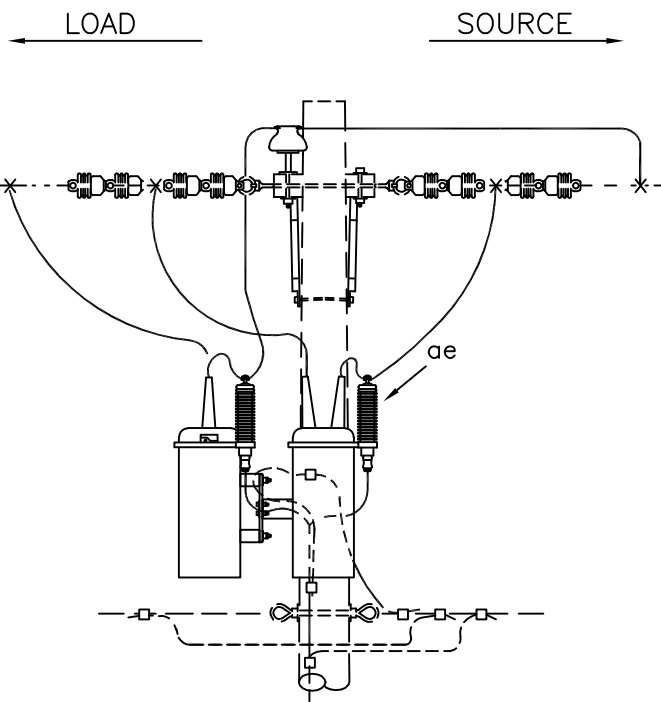
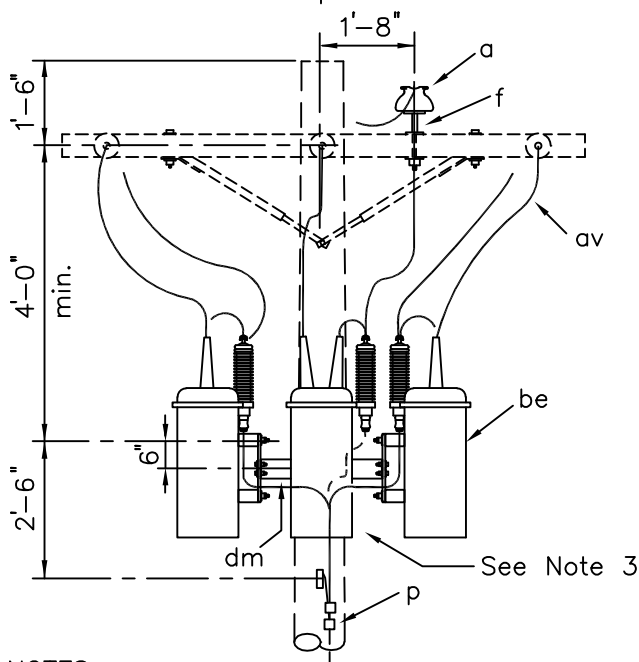
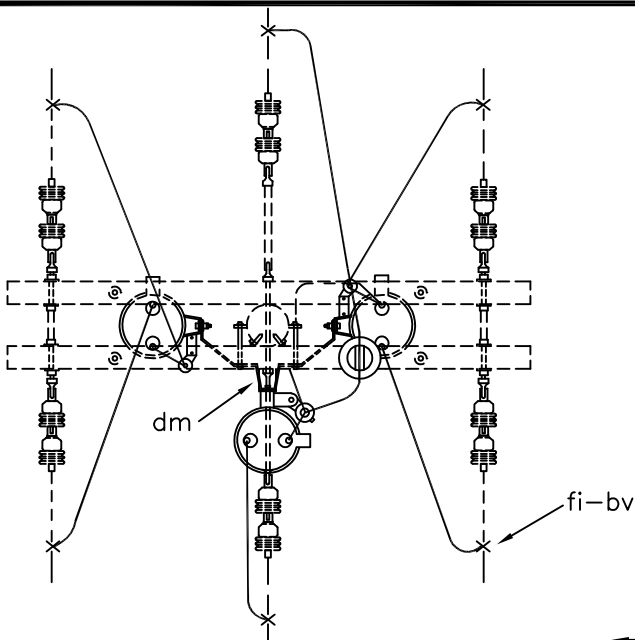

NOTES:

1. The recloser terminal bushing connected directly to the coil should be connected to the source.
2. For 2-phase installations, omit recloser and related items on center phase and designate as R2.1.
3. Each recloser tank shall have two connections to ground.

ITEM	QTY	MATERIAL
c	2	Bolt, machine, 5/8" x req'd length
d	3	Washer, square, 2 1/4"
a	1	Insulator, pin type, (12.47/7.2 kV)
f	1	Pin, crossarm, steel, 5/8" x 10 3/4"
p		Connector, as required
ae	3	Arrester, surge (9 kV)
av		Jumpers, stranded, as required

ITEM	QTY	MATERIAL
be	3	Recloser, oil circuit (12.47 kV)
bv	6	Rod, armor, as req'd
ek	2	Locknuts
fi	6	Connector, hot line
dm	1	Bracket, cluster type, with 14" adapter plate

(THREE) OIL CIRCUIT RECLOSERS

APRIL 2005

3 - PHASE PRIMARY
12.47/7.2 kV

R2.1,R3.1
(M3-11A),(M3-12A)

RUS

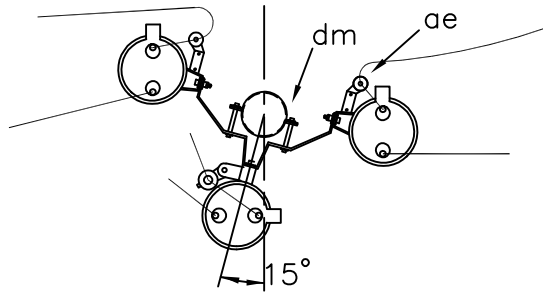

SECTION X-X

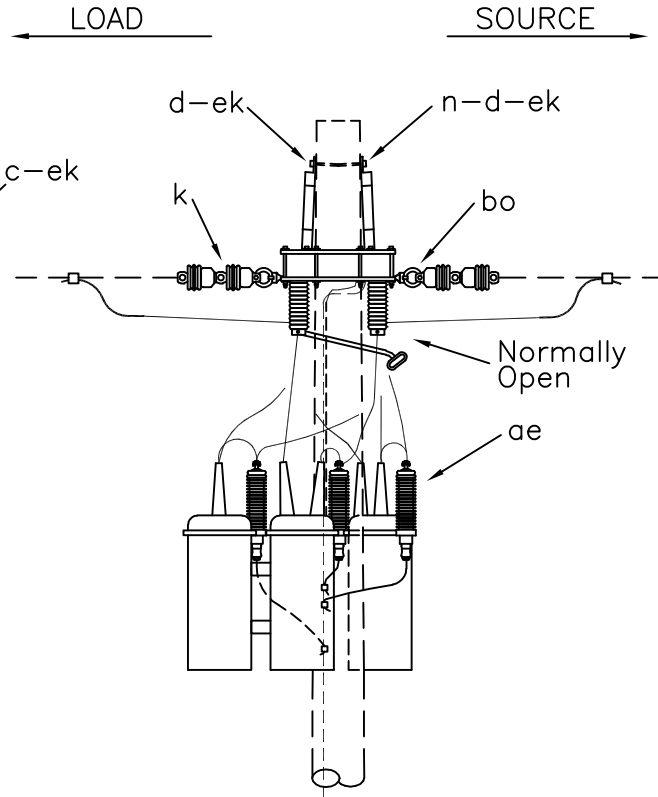
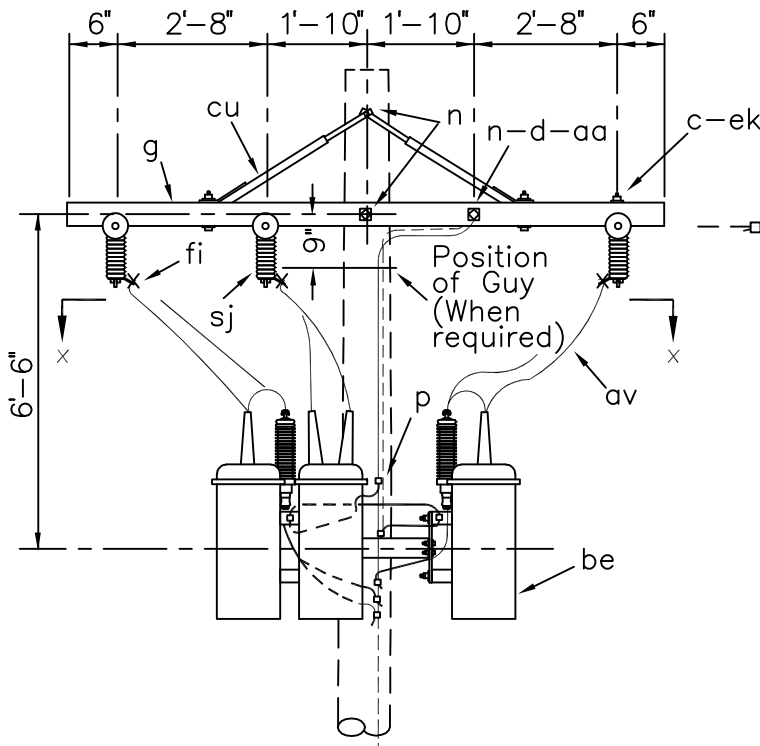

NOTES:

1. The recloser terminal bushing connected directly to the coil should be connected to the source.
2. For 2-phase installations, omit recloser and related items on center phase and designate as "R2.2".
3. Each recloser tank shall have two connections to ground.

ITEM	QTY	MATERIAL
c	4	Bolt, machine, 1/2" x req'd length
c	14	Bolt, machine, 5/8" x req'd length
d	4	Washer, round, 1 3/8"
d	10	Washer, square, 2 1/4"
g	2	Crossarm, 3 5/8" x 4 5/8" x 10'-0"
k	12	Insulator, suspension, 4 1/4"
n	3	Bolt, double arm, 5/8" x req'd length
p		Connectors, as required
aa	2	Nut, eye, 5/8"
ae	3	Arresters, surge, (9 kV)

ITEM	QTY	MATERIAL
av		Jumpers, stranded, as req'd
be	3	Recloser, oil circuit (12.47 kV)
bo	6	Shackle, anchor
cu	2	Brace, wood, 60" span
dm	1	Bracket, cluster type with 14" adapter plate
ek	28	Locknuts
fi	6	Connector, hot line
sj	3	Switch, OCR, by-pass, (15 kV)

(THREE) OIL CIRCUIT RECLOSERS
(WITH BYPASS SWITCHES)

APRIL 2005

RUS

3 - PHASE PRIMARY
12.47/7.2 kV

R2.2,R3.2
(M3-24A),(M3-25A)

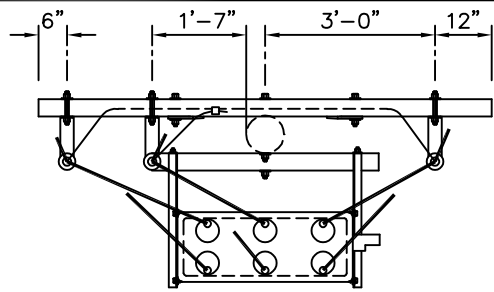

SECTION X-X

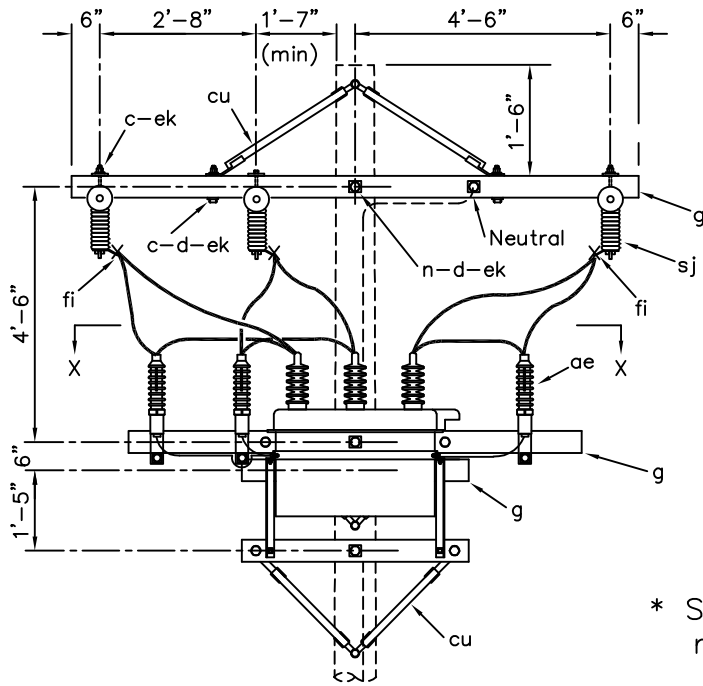
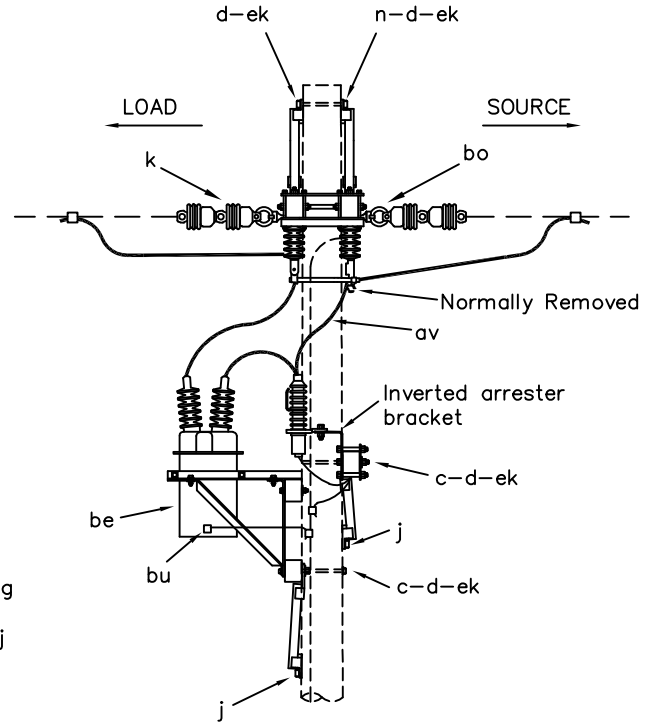

* Specify this item to be furnished by recloser manufacturer.

ITEM	NO.	MATERIAL	ITEM	NO.	MATERIAL
c	3	Bolt, machine, 5/8"x req'd length	aa	2	Nut, eye, 5/8"
c	4	Bolt, machine, 1/2"x req'd length	ae	3	Surge arrester
d	12	Washer, sq. 2-1/4"x 3/16", 13/16"hole	av	-	Jumpers, stranded, as req'd
d	4	Washer, rd. 1-3/8" dia., 9/16" hole	be	1	Recloser, oil circuit - 3 phase
g	2	Crossarm, 3-5/8"x 4-5/8"x 10'-0"	*	1	Mounting bracket for 3 phase recloser
g	1	Crossarm, 3-5/8"x 4-5/8"x 8'-0"	bo	6	Shackle, anchor
g	2	Crossarm, 3-5/8"x 4-5/8"x 4'-0"	bu	1	Connector, solderless
j	2	Screw, lag, 5/8"x req'd length	cu	2	Brace, crossarm, wood, 60" span
k	12	Insulator, suspension	cu	4	Brace, crossarm, wood, 28"
l	6	Clamp, deadend	ek	-	Locknuts, as req'd
n	3	Bolt, double arming, 5/8"x req'd length	fi	6	Connector, hot line
p	-	Connectors, as req'd	sj	3	Switch, recloser by-pass

THREE-PHASE OIL CIRCUIT RECLOSER WITH BY-PASS SWITCHES

APRIL 2005
RUS

3 - PHASE PRIMARY
12.47/7.2 kV

R3.3
(M3-30)

SECTIONALIZING ASSEMBLY UNITS

<u>DRAWING NUMBERS</u>		<u>DRAWING TITLE (DESCRIPTION)</u>
1728F-804 (New)	Bulletin 50-3 (Old)	
S1.01	(M5-9)	MISCELLANEOUS CUTOUTS AND DISCONNECT SWITCH
S1.02	(M5-10)	
S2.01		
S1.1	(M3-4)	CUTOUT - SINGLE PHASE
S1.1N		CUTOUT GUIDE - NARROW PROFILE
S1.3		COUTOUTS - (THREE SINGLE-PHASE)
S2.3	(M3-3B)	LINE TENSION SWITCHES – (THREE SINGLE-PHASE)
S2.21	(M3-2A)	DISCONNECT SWITCHES - (TWO OR THREE SINGLE-PHASE)
S2.31	(M3-3A)	
S2.32	(M3-15)	GROUP-OPERATED AIRBREAK SWITCH - (THREE-PHASE)
S3.1	(M3-41)	SECTIONALIZER
S3.2		SECTIONALIZER (WITH BYPASS CUTOUT)

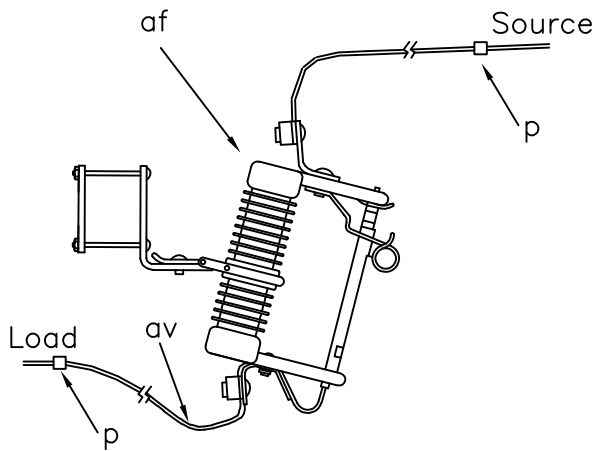

S1.01

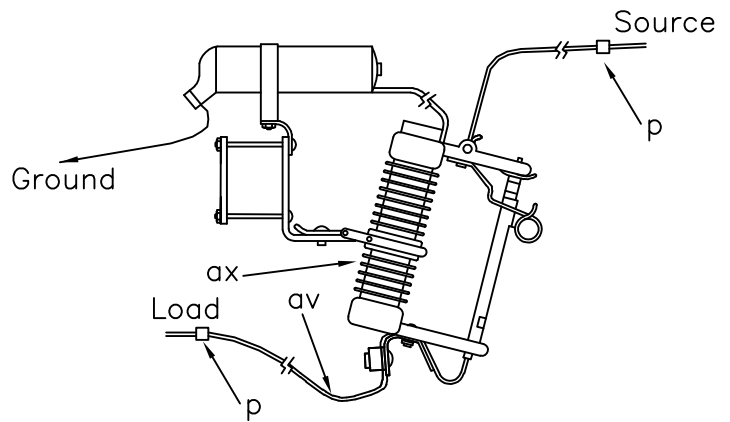

S1.02

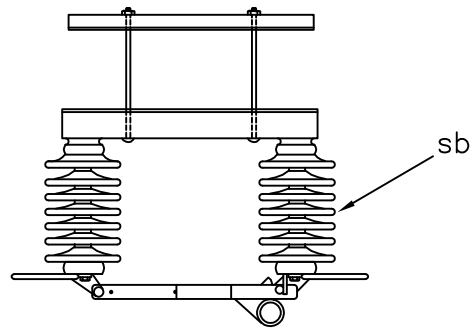

S2.01

NOTES: Specify cutouts to be furnished with fuse tube or switch blade.

"S2.01" may be used with assembly "C6.21" (mount braces above crossarm). See "S2.32".

		ASSEMBLY: S		
ITEM	MATERIAL	1.01	1.02	2.01
		QTY	QTY	QTY
P	Connector, as req'd			
af	Cutout, dist., open (15 kV)	1		
ax	Cutout, & Arrester Comb. (9 kV)		1	
av	Jumpers, as req'd			
sb	Switch, disconnect (15 kV)			1

MISCELLANEOUS CUTOUTS
AND DISCONNECT SWITCH

APRIL 2005

RUS

12.47/7.2 kV

S1.01,S1.02,S2.01
(M5-9),(M5-10)

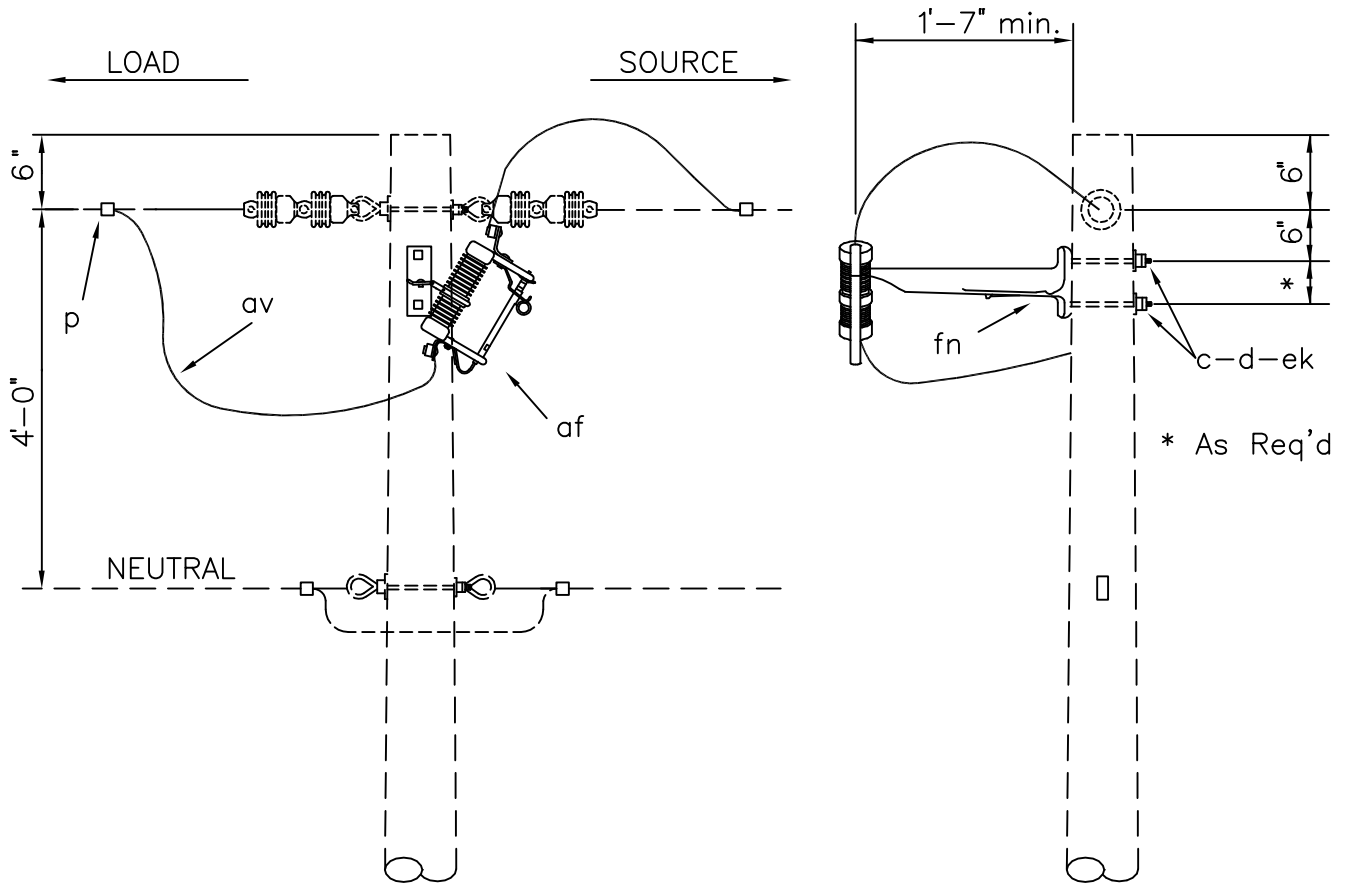

NOTE: Specify fuse size or solid blade

ITEM	QTY	MATERIAL
c	2	Bolt, machine, 5/8" x req'd length
d	2	Washer, square, 2 1/4"
p	2	Connector, compression type
af	1	Cutout, distribution, open (15 kV)
av		Jumpers, as required
ek	2	Locknuts
fn	1	Bracket, extension

CUTOUT – SINGLE PHASE

APRIL 2005

RUS

12.47/7.2 kV

S1.1
(M3-4)

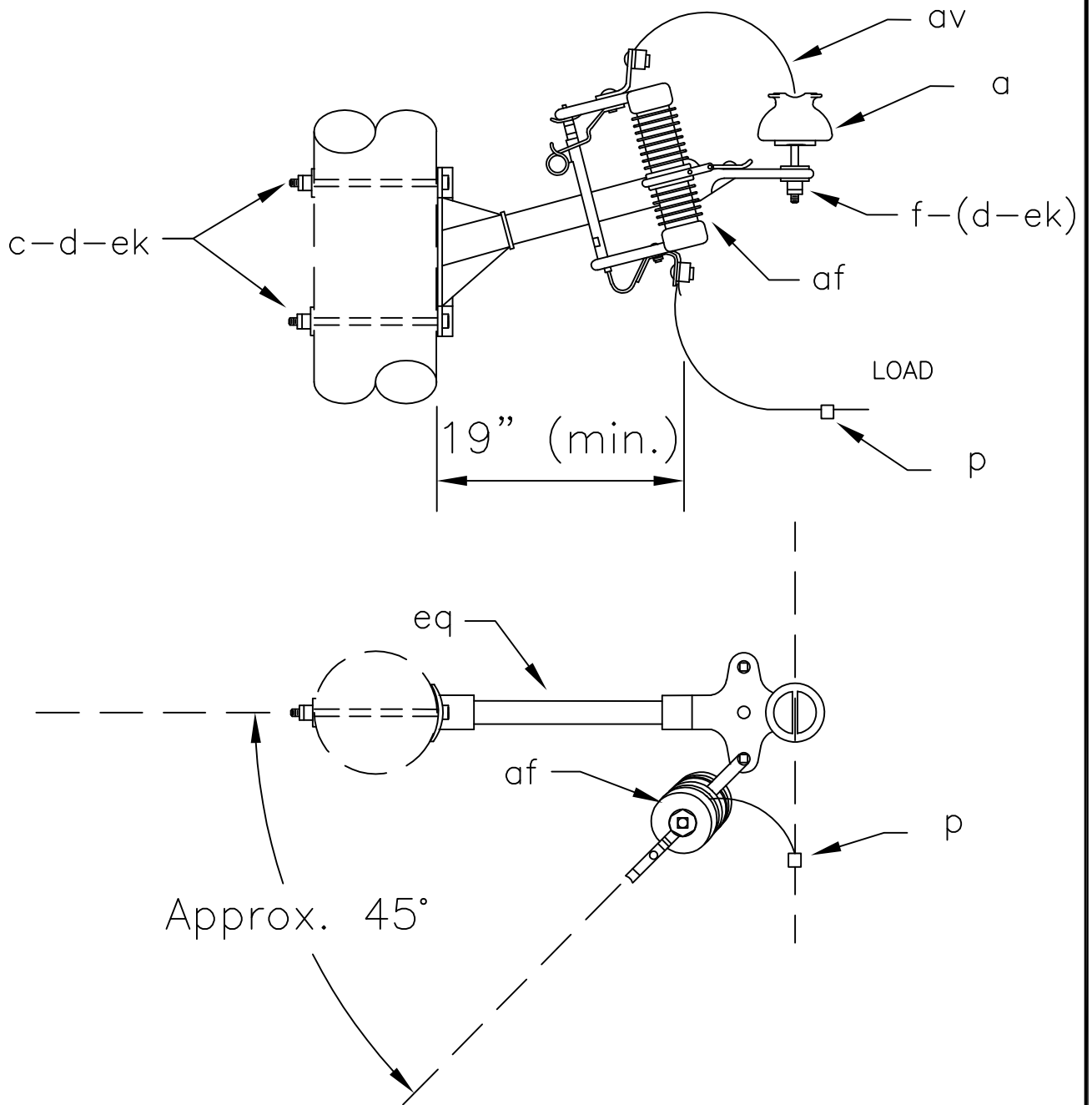

NOTE: Also see "A5.4NG".

ITEM	MATERIAL	QTY
a	Insulator, pin type (12.47/7.2 kV)	1
c	Bolt, machine, 5/8" x req'd length	2
d	Washer, square 2 1/4"	2
f	Pin, crossarm, 5/8" x 6 1/2"	1
af	Cutout, distribution, open (15kV)	1
av	Jumpers, as required	
ek	Locknuts	2
eq	Bracket, insulator/equipment	1

Design Parameters:

Maximum Line Angles:
See Table II

CUTOUT-NARROW PROFILE

APRIL 2005

RUS

1 - PHASE PRIMARY
12.47/7.2 kV

S1.1N

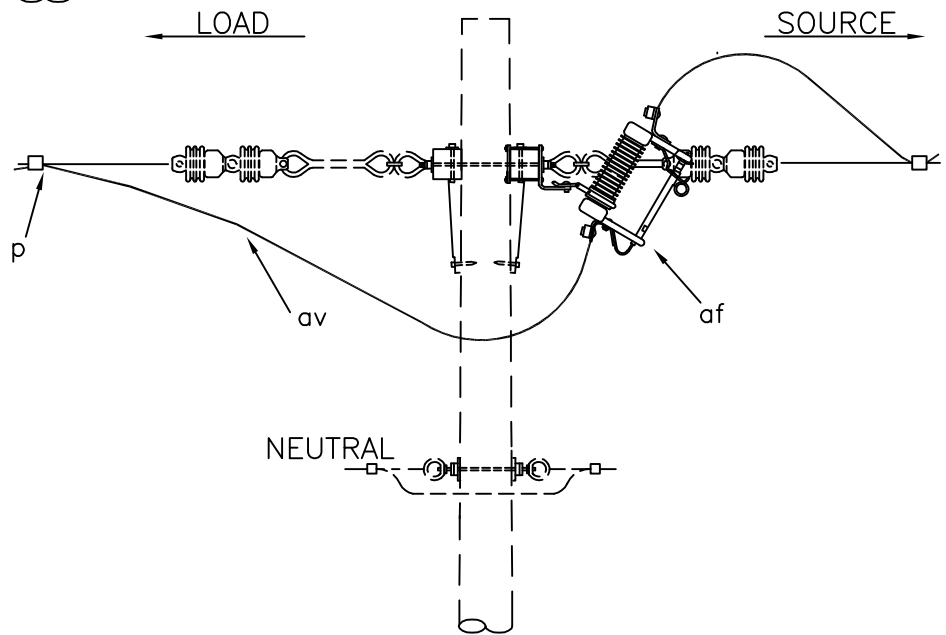
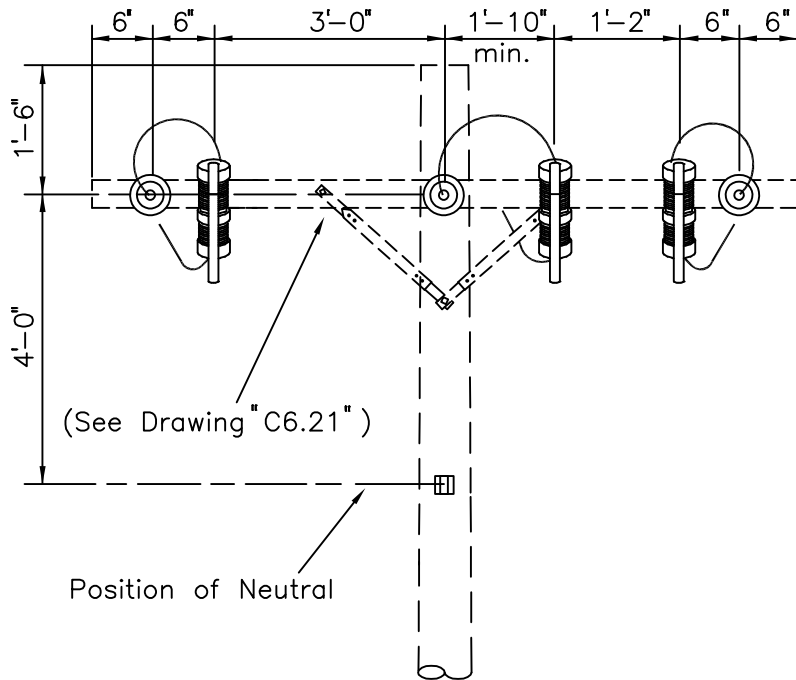

NOTES:

1. Specify fuse size or solid blade.
2. Mount cutouts so that blades face climbing face of pole.

ITEM	QTY	MATERIAL
P	6	Connector, compression type
af	3	Cutout, distribution open (15 kV)
av		Jumpers, as req'd

CUTOUTS
(THREE SINGLE-PHASE)

APRIL 2005

RUS

12.47/7.2 kV

S1.3

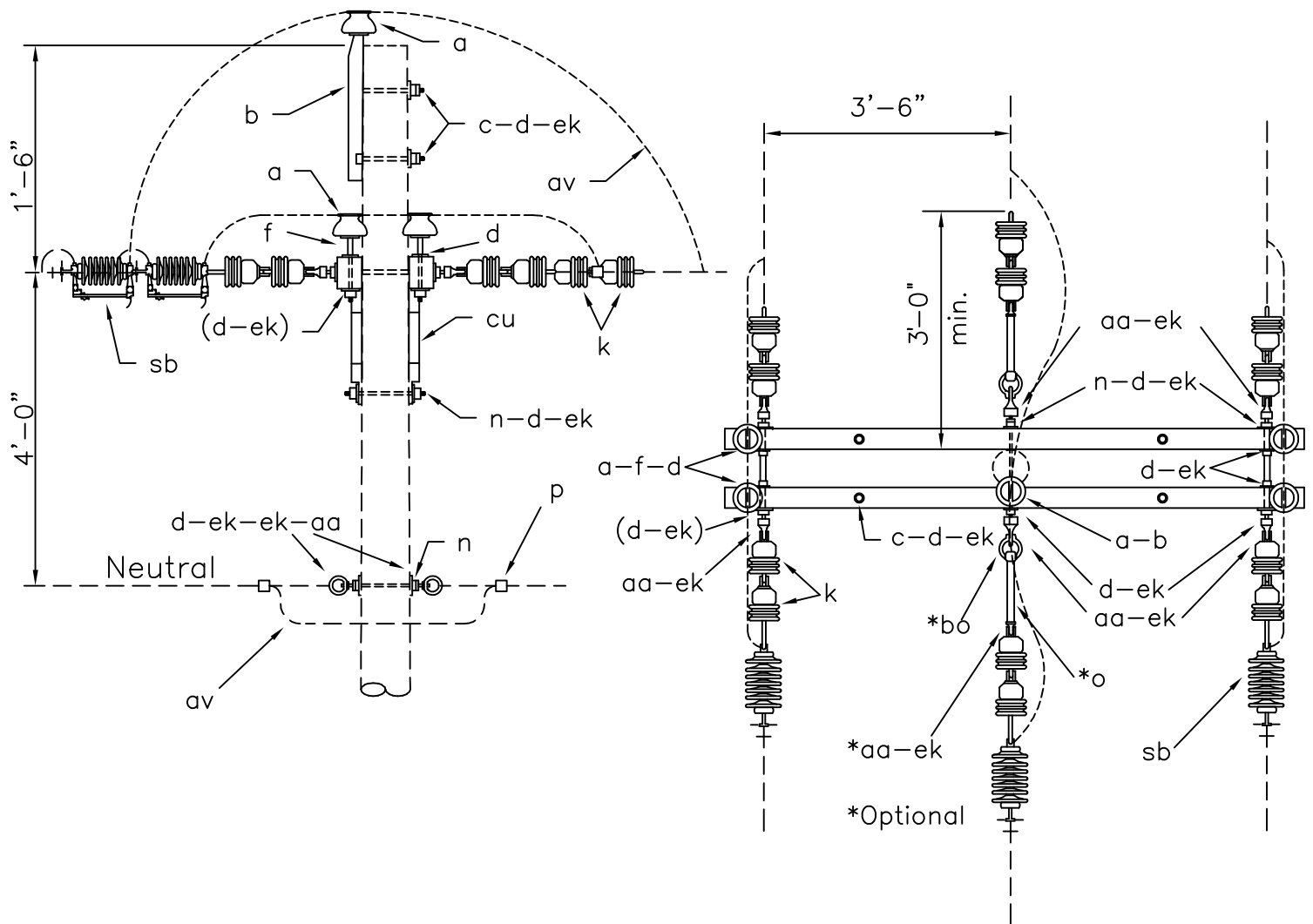

NOTE:
See Assembly C6.21 for additional details.

ITEM	QTY	MATERIAL	ITEM	QTY	MATERIAL
a	5	Insulator, pin type	o	2	Bolt, eye, 5/8" x req'd length
b	1	Pin, pole top, 20"	p		Connectors, as required
c	4	Bolt, machine, 1/2" x req'd length	aa	10	Nut, eye, 5/8"
c	2	Bolt, machine, 5/8" x req'd length	av		Jumpers and leads as req'd
d	20	Washer, square, 2 1/4"	bo	2	Shackle, anchor
d	4	Washer, round, 1 3/8"	cu	2	Brace, wood, 60" span
f	4	Pin, crossarm, steel, 5/8" x 10 3/4"	ek	30	Locknuts
g	2	Crossarm, 3 5/8" x 4 5/8" x 8'-0"	sb	3	Switch, line tension
k	12	Insulators, suspension			
n	5	Bolt, double arming, 5/8" x req'd length			

DESIGN PARAMETERS:

PERMITTED UNBALANCED
CONDUCTOR TENSION:

See Table A (Exhibit 2)

LINE TENSION SWITCHES
(THREE SINGLE-PHASE)

APRIL 2005

RUS

3 - PHASE PRIMARY
12.47/7.2 kV

S2.3 (M3-3B)

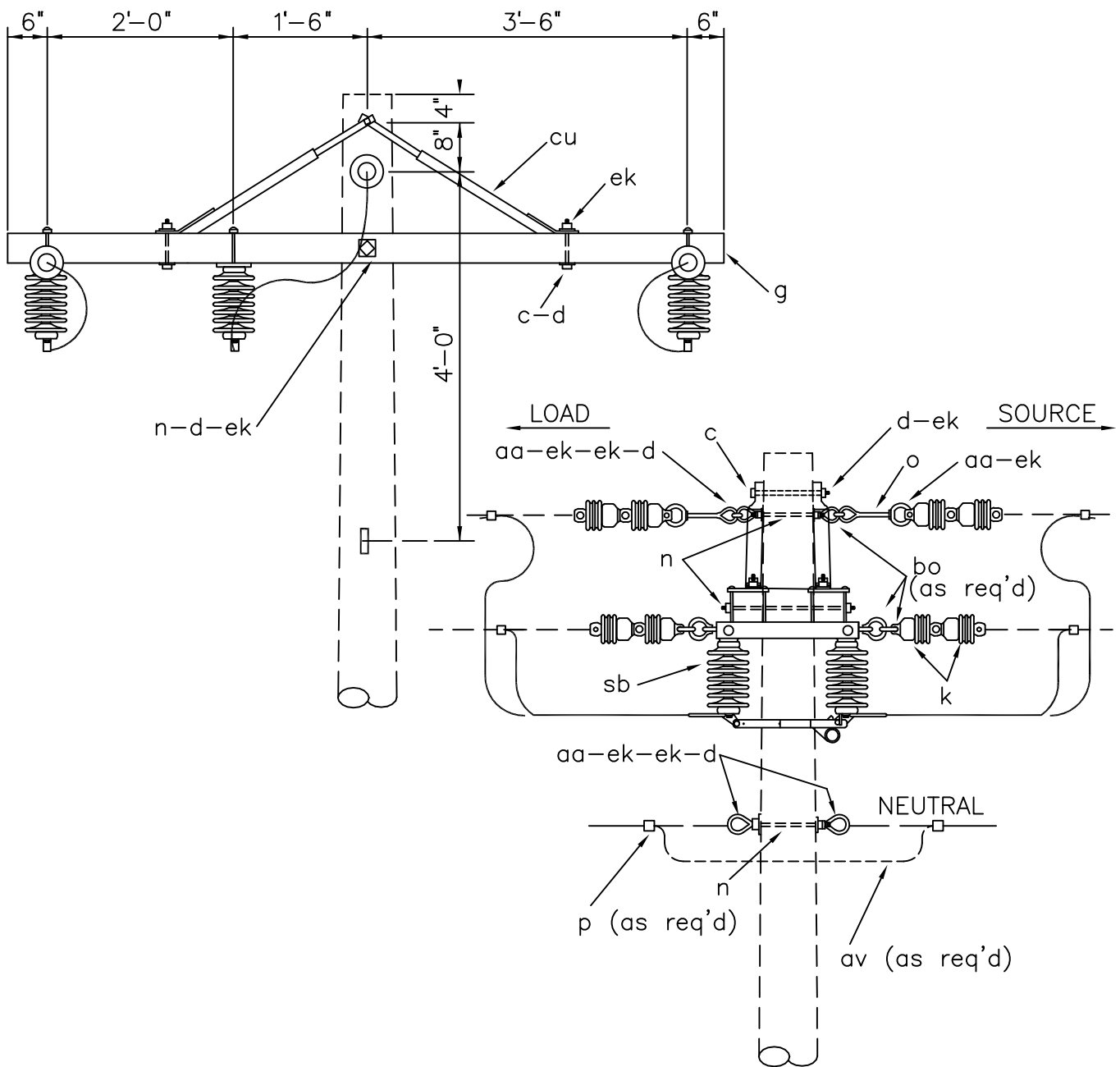

NOTE: For 2-phase installations, omit switch and related items on center phase and designate as "S2.21."

ITEM	QTY	MATERIAL
c	4	Bolt, machine, 1/2" x req'd length
c	1	Bolt, machine, 5/8" x req'd length
d	4	Washer, round, 1 3/8"
d	11	Washer, square, 2 1/4"
d	4	Washer, square, 3", curved
g	2	Crossarm, 3 5/8" x 4 5/8" x 8'-0"
k	12	Insulator, suspension, 4 1/4"
n	5	Bolt, double arm, 5/8" x req'd length

ITEM	QTY	MATERIAL
o	2	Bolt, eye, 5/8" x req'd length
p		Connectors, compression as required
aa	6	Nut, eye, 5/8"
av		Jumpers, as required
bo	6	Shackle, anchor
cu	2	Brace, wood, 60" span
sb	3	Switch, disconnect, 15 kV, with mounting hardware

DISCONNECT SWITCHES (TWO or THREE SINGLE-PHASE)

APRIL 2005

RUS

12.47/7.2 kV

S2.21,S2.31
(M3-2A),(M3-3A)

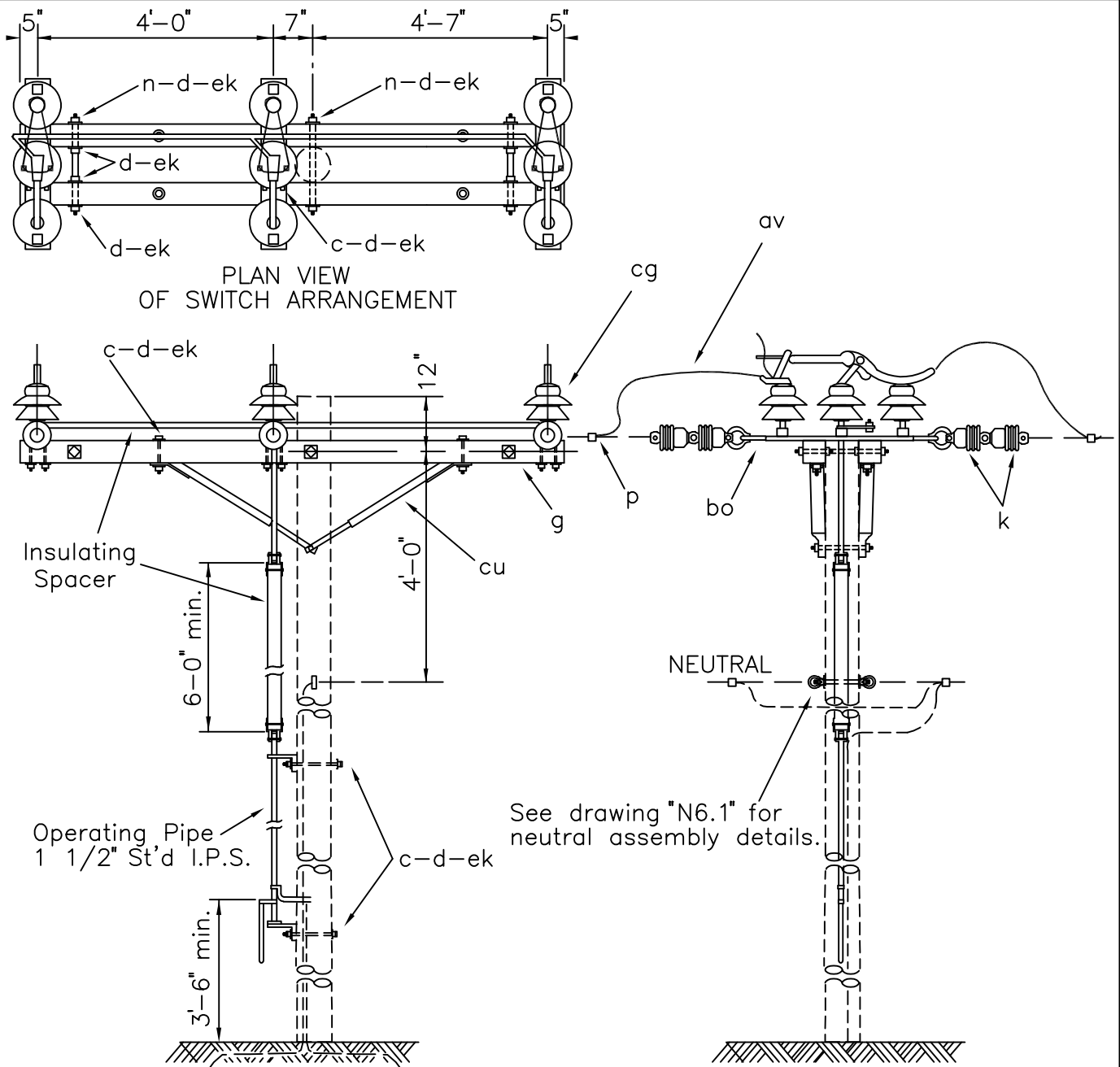

NOTES: See Dwg. "H4.1" (Preferred) or "H3.1" for required grounding assembly. RUS accepted pre-assembled, group operated, airbreak switches may be used. Install according to manufacturer's instructions.

ITEM	QTY	MATERIAL
c	4	Bolt, machine, 1/2" x req'd length
c	15	Bolt, machine, 5/8" x req'd length
d	4	Washer, round, 1 3/8"
d	25	Washer, square, 2 1/4"
d	2	Washer, square, 3"
g	2	Crossarm, 3 5/8" x 4 5/8" x 10'-0"
k	12	Insulator, suspension, 4 1/4"
n	4	Bolt, double arm, 5/8" x req'd length
p		Connectors, as required

ITEM	QTY	MATERIAL
aa	2	Nut, eye, 5/8"
av		Jumpers, as required
bo	6	Shackle, anchor
cg	1	Switch, airbreak, group operated 15 kV, w/ operating mechanism
cu	2	Brace, wood, 60" span
ek	33	Locknuts

GROUP-OPERATED AIRBREAK SWITCH
(THREE-PHASE)

APRIL 2005	3 - PHASE PRIMARY 12.47/7.2 kV	S2.32 (M3-15)
RUS		

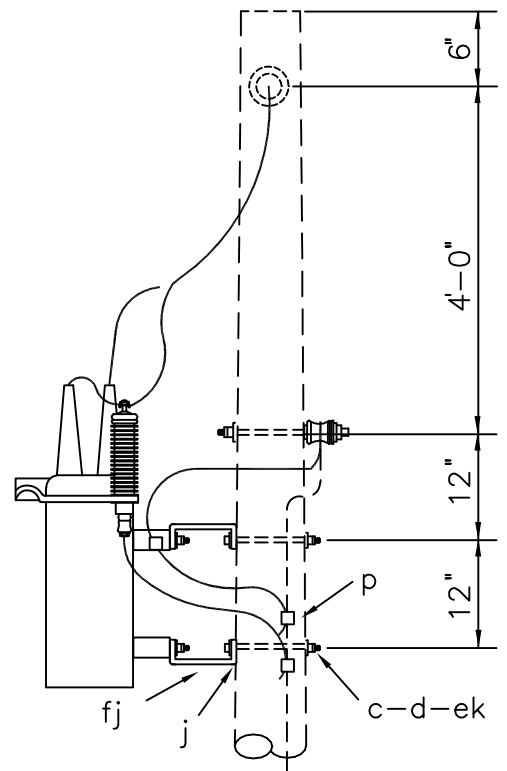
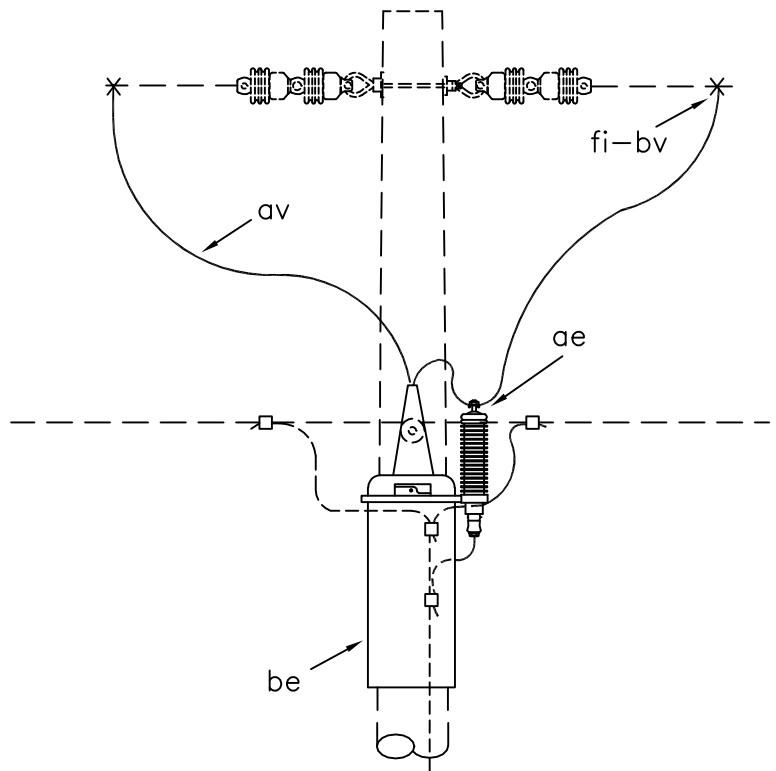
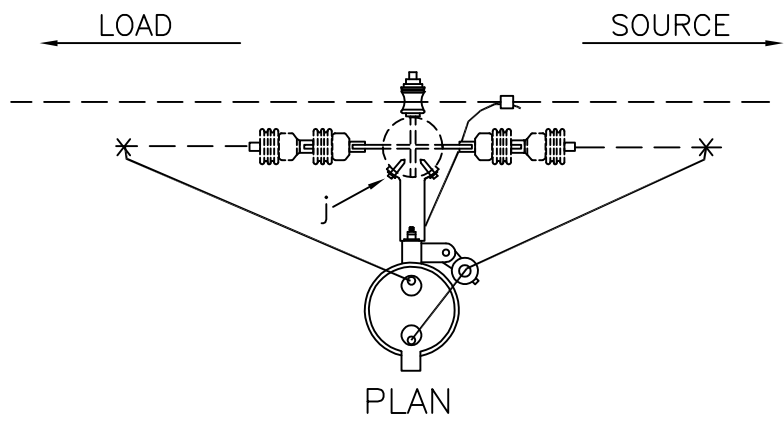

NOTE: The sectionalizer terminal bushing connected to the coil should be connected to the source.

ITEM	QTY	MATERIAL
c	2	Bolt, machine, 5/8" x req'd length
d	2	Washer, square, 2 1/4"
j	4	Screw, lag, 1/2" x 4"
P		Connector, as required
ae	1	Arrester, surge (9 kV)
av		Jumpers, stranded, as required

ITEM	QTY	MATERIAL
el	1	Sectionalizer (12.47 kV)
bv		Rod, armor, as req'd
ek	2	Locknuts
fi	2	Connector, hot line
fj	2	Brackets, extension, 9" long

SECTIONALIZER

APRIL 2005	1 - PHASE PRIMARY	S3.1 (M3-41)
RUS		

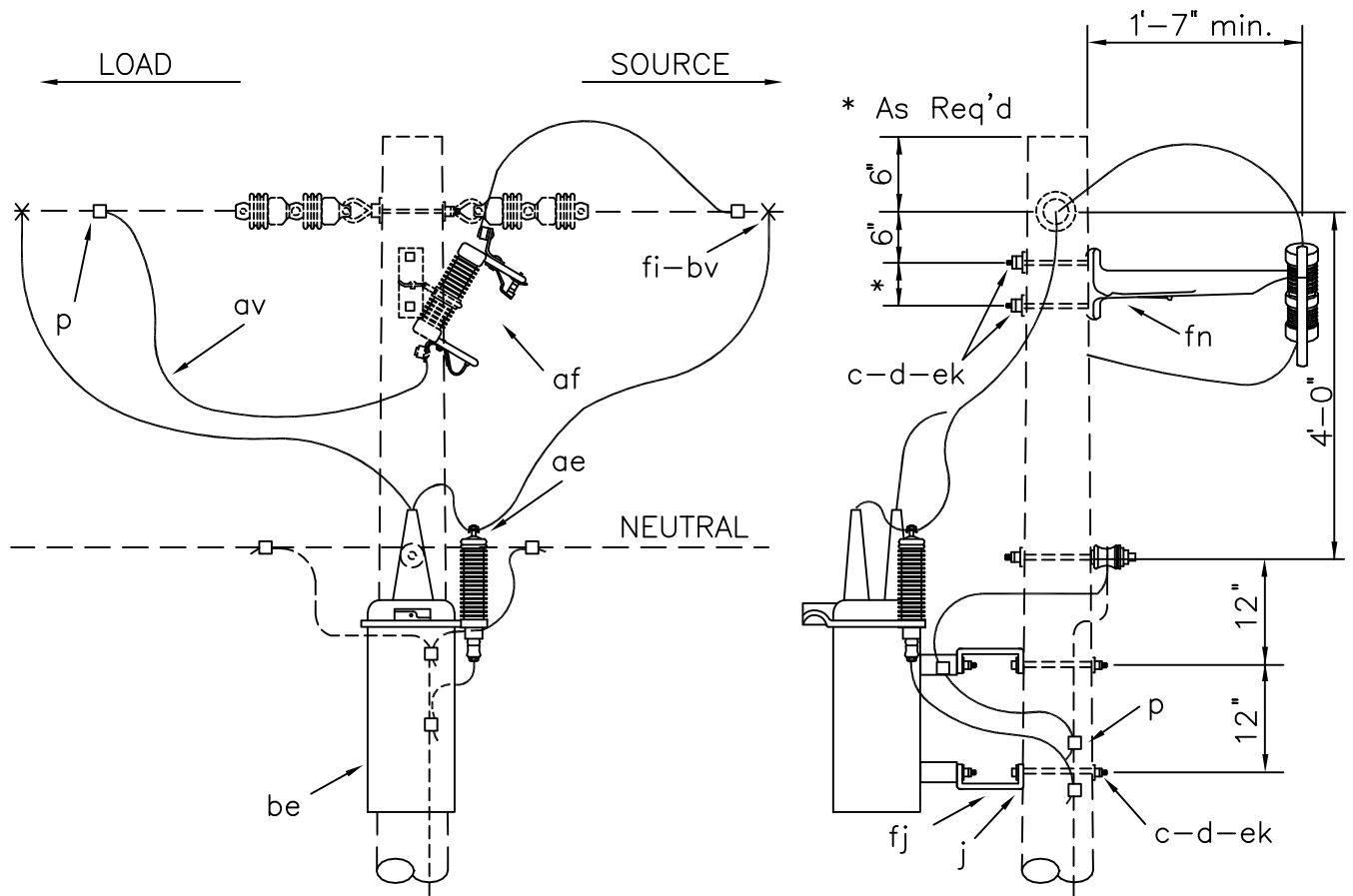

NOTE: The sectionalizer terminal bushing connected to the coil should be connected to the source.

ITEM	QTY	MATERIAL
c	4	Bolt, machine, 5/8" x req'd length
d	4	Washer, square, 2 1/4"
j	4	Screw, lag, 1/2" x 4"
p		Connector, as required
ae	1	Arrester, surge (9 kV)
af	1	Cutout, distribution, open (15 kV)
av		Jumpers, stranded, as required

ITEM	QTY	MATERIAL
el	1	Sectionalizer (12.47kV)
bv		Rod, armor, as req'd
ek	4	Locknuts
fi	2	Connector, hot line
fj	2	Brackets, extension, 9" long
fn	1	Bracket, extension

SECTIONALIZER

APRIL 2005

1 - PHASE PRIMARY

S3.2

RUS

12.47/7.2 kV

WOOD POLES, CROSSARMS AND BRACES

<u>DRAWING NUMBERS</u>		<u>DRAWING TITLE (DESCRIPTION)</u>
1728F-804 (New)	Bulletin 50-3 (Old)	
W1.1G	(M20)	POLE FRAMING GUIDE
W2.1G	(M19)	DISTRIBUTION CROSSARM DRILLING GUIDE
W3.1	(M5-17)	CROSSARM BRACES
W3.2	(M5-13)	

CONSTRUCTION SPECIFICATIONS FOR POLES AND CROSSARMS

Large, dense poles that have no serious defects shall be used at transformer, deadend, angle, and corner locations.

Poles shall be set so that the crossarm gains face in opposite directions on every other pole. However at line deadends, the last two poles shall be set so that the pole gains face the deadend. On unusually long spans, the poles shall be set so that the crossarm is located on the side of the pole away from the long span. On lines that curve, the crossarms shall be installed on the side of the pole that faces the midpoint of the curve. On sloping terrain, the crossarms shall be installed on the uphill side of the pole. Pole top insulator brackets and pole top pins shall be installed on the opposite side of the pole from the gain.

At line angles and deadends, poles shall be set such that they lean away from the strain of the primary conductors. They shall be set such that the final rake is not less than 1 inch for each 10 feet of pole height above ground after the conductors are installed at the required tension.

Newly set poles shall be backfilled and tamped to the full depth. Excess dirt shall be banked around the base of the pole.

POLE SETTING DEPTHS

The minimum depth for setting poles is:

Length of Pole (Feet)	Setting in Soil (Feet)	Setting in All Solid Rock (Feet)
20	4.0	3.0
25	5.0	3.5
30	5.5	3.5
35	6.0	4.0
40	6.0	4.0
45	6.5	4.5
50	7.0	4.5
55	7.5	5.0
60	8.0	5.0

“Setting in Soil” depths apply where:

- Poles are set in soil;
- There is a layer of soil of more than two (2) feet in depth over solid rock; or
- The hole in solid rock is not substantially vertical or the diameter of the hole at the surface of the rock exceeds approximately twice the diameter of the pole at the same level.

“Setting in All Solid Rock” depths shall apply where poles are set in solid rock and where the hole is substantially vertical, approximately uniform in diameter and large enough to permit the use of tamping bars the full depth of the hole.

Where there is a layer of soil two (2) feet or less in depth over solid rock, the depth of the hole shall be the depth of the soil in addition to the depth specified under “Setting in All Solid Rock” provided. However, this depth shall not exceed the depth specified under “Setting in Soil.”

On sloping ground, the depth of the hole shall be measured from the low side of the hole.

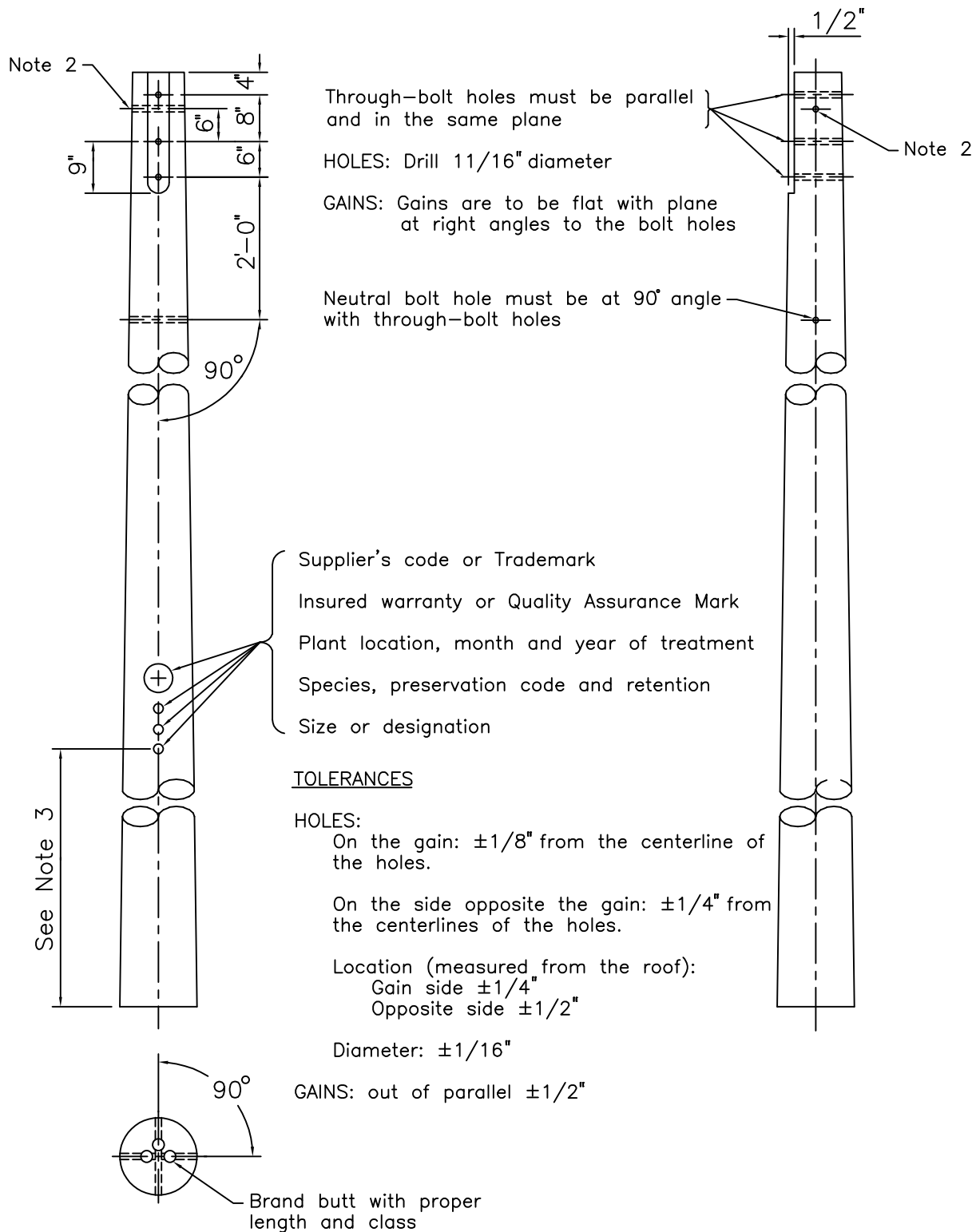

NOTES:

1. All poles shorter than 50 feet must be bored, roofed and gained before treatment, except that Class 7 and smaller poles need not be gained unless requested by purchaser. Roofs may be flat or at a 15° angle at the producer's option.
2. Anti-split bolt hole is optional and is to be drilled only when so specified by the purchaser.
3. Bottom of brand or center of metal disk shall be 10' $\pm 2"$ from the pole butt for poles less than 55' in length; 14' $\pm 2"$ for poles 55' and longer.

POLE FRAMING GUIDE

APRIL 2005

RUS

W1.1G
(M20)

TOLERANCES AND SIZES OF HOLES

	NOMINAL	GO	NO GO
Ⓐ	11/16"	5/8"	3/4"
Ⓑ	7/16"	3/8"	1/2"
Ⓒ	9/16"	1/2"	5/8"

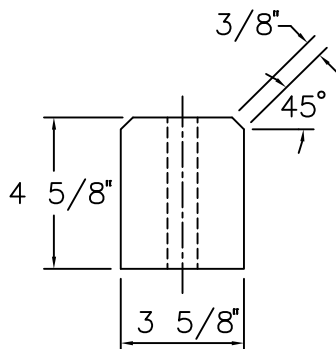
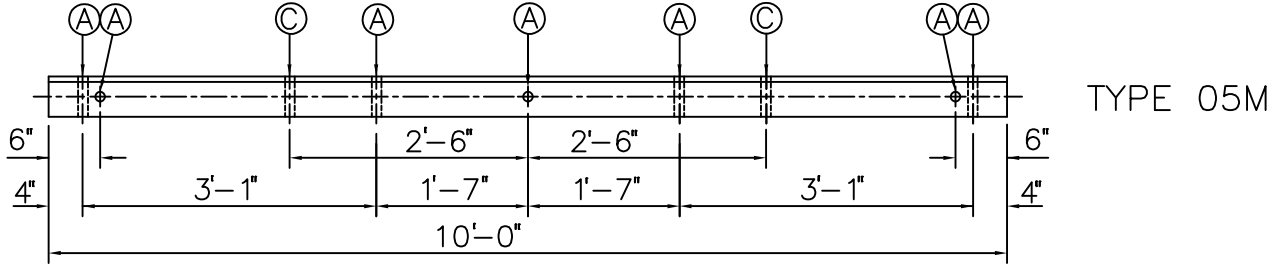
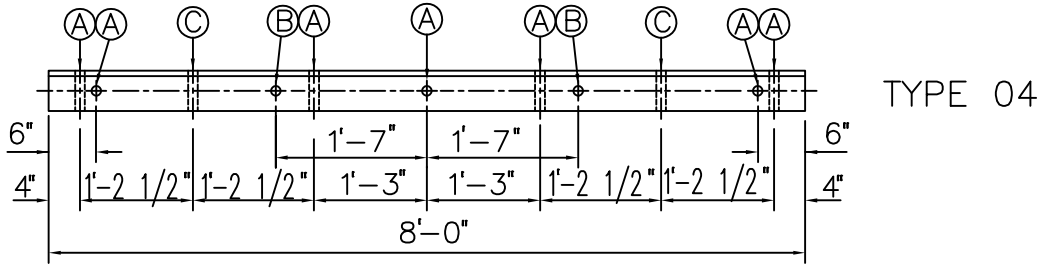

TYPICAL END SECTION

NOTES:

- Holes are to be located within $\pm 1/8"$
- Length of the crossarm is to be within $\pm 1/4"$
- The tolerance of the cross section is $+1/8"$ and $-0"$ at time of manufacture.
- All holes are to be drilled on centerlines of crossarm faces.

DISTRIBUTION CROSSARM DRILLING GUIDE

APRIL 2005

RUS

W2.1G
(M19)

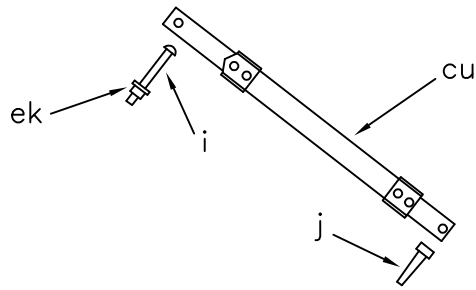

W3.1

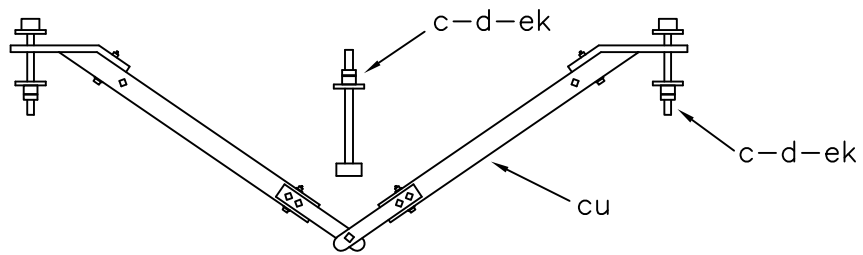

W3.2

ITEM	MATERIAL	W3.1	W3.2
		QTY	QTY
c	Bolt, machine, 1/2" x req'd length		2
c	Bolt, machine, 5/8" x req'd length		1
d	Washer, round, 1 3/8"		2
d	Washer, square, 2 1/4"		1
i	Bolt, carriage, 3/8" x 4 1/2"	1	
j	Screw, lag, 1/2" x 4"	1	
cu	Brace, 28", wood (or fiberglass)	1	
cu	Brace, wood, 60"		1
ek	Locknuts	1	3

CROSSARM BRACES

APRIL 2005

RUS

W3.1,W3.2
(M5-17),(M5-13)

INDEX Y

VOLTAGE ALTERATION EQUIPMENT ASSEMBLY UNITS

<u>DRAWING NUMBERS</u>		<u>DRAWING TITLE (DESCRIPTION)</u>
1728F-804 (New)	Bulletin 50-3 (Old)	
Y1.1	(M7-11)	VOLTAGE REGULATOR, POLE MOUNTED (ONE SINGLE-PHASE)
Y1.3	(M7-13)	VOLTAGE REGULATOR, PLATFORM MOUNTED (THREE SINGLE-PHASE)
Y2.1 Y2.2		AUTOTRANSFORMER, POLE MOUNTED (ONE SINGLE-PHASE, STEP-DOWN)
Y3.1	(M9-11)	SINGLE-PHASE CAPACITOR BANK
Y3.2 Y3.3	(M9-12) (M9-13)	THREE-PHASE CAPACITOR BANK
Y3.4		SWITCHED CAPACITOR BANK - THREE-PHASE

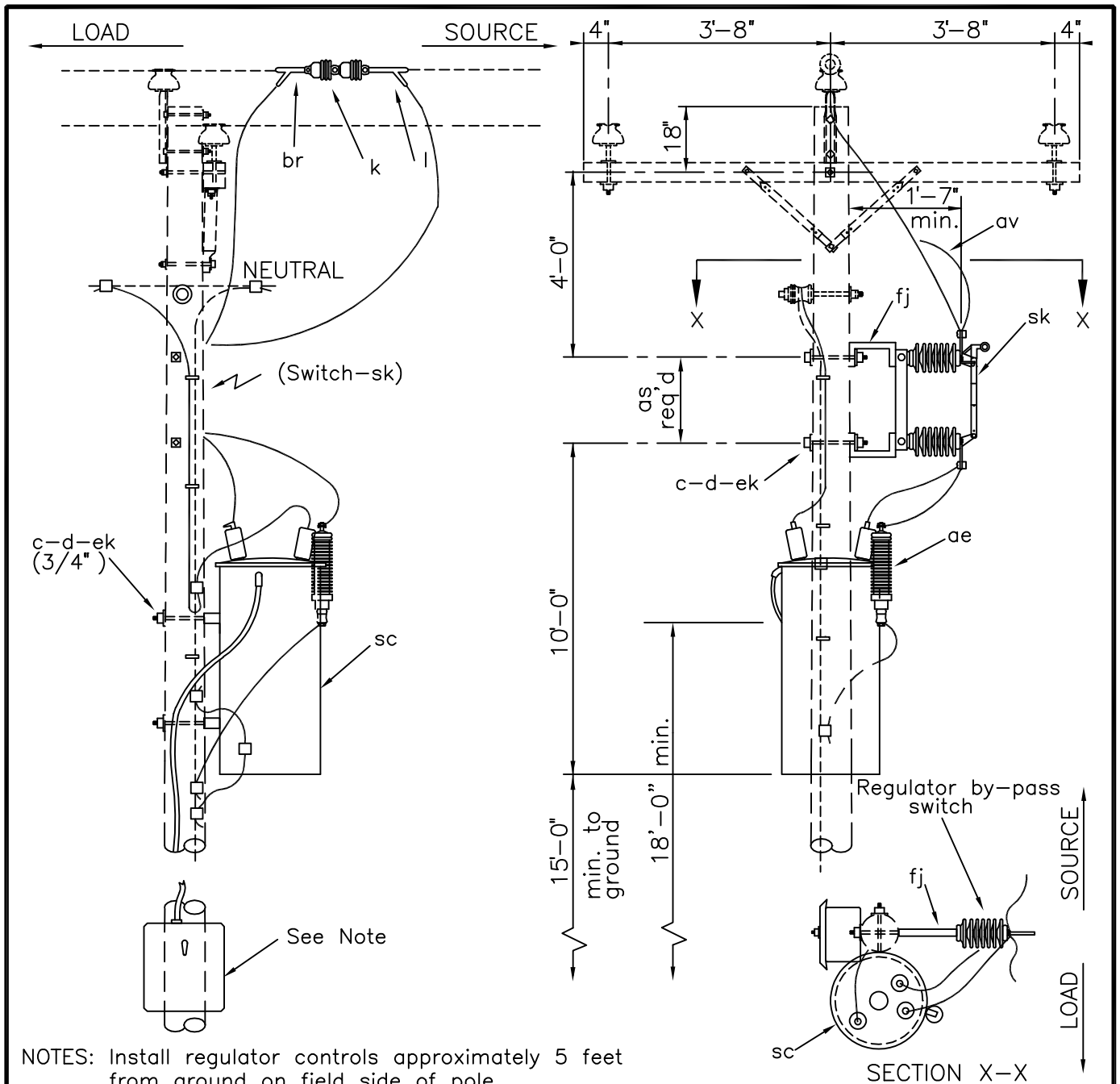

NOTES: Install regulator controls approximately 5 feet from ground on field side of pole. Control cable shall be properly shielded or installed in suitable conduit.

ITEM	QTY	MATERIAL
c	2	Bolt, machine, 5/8" x req'd length
c	2	Bolt, machine, 3/4" x req'd length
d	2	Washer, square, 2 1/4"
d	2	Washer, square, 3", curved
k	2	Insulator, suspension, 4 1/4
l	2	Clamp, deadend "
p		Connectors, compression, as req'd
ae	1	Arrester, surge (9 kV)

ITEM	QTY	MATERIAL
av		Jumpers, bare, stranded, as req'd
br	1	Chain link
bu		Connector, grounding
fj	2	Bracket, extension, 9"
sc	1	Regulator, voltage, step-type 12.47/7.2 kV
sk	1	Switch, regulator by-pass
ek	4	Locknuts

VOLTAGE REGULATOR, POLE MOUNTED
(ONE SINGLE-PHASE)

APRIL 2005

RUS

12.47/7.2 kV

Y1.1
(M7-11)

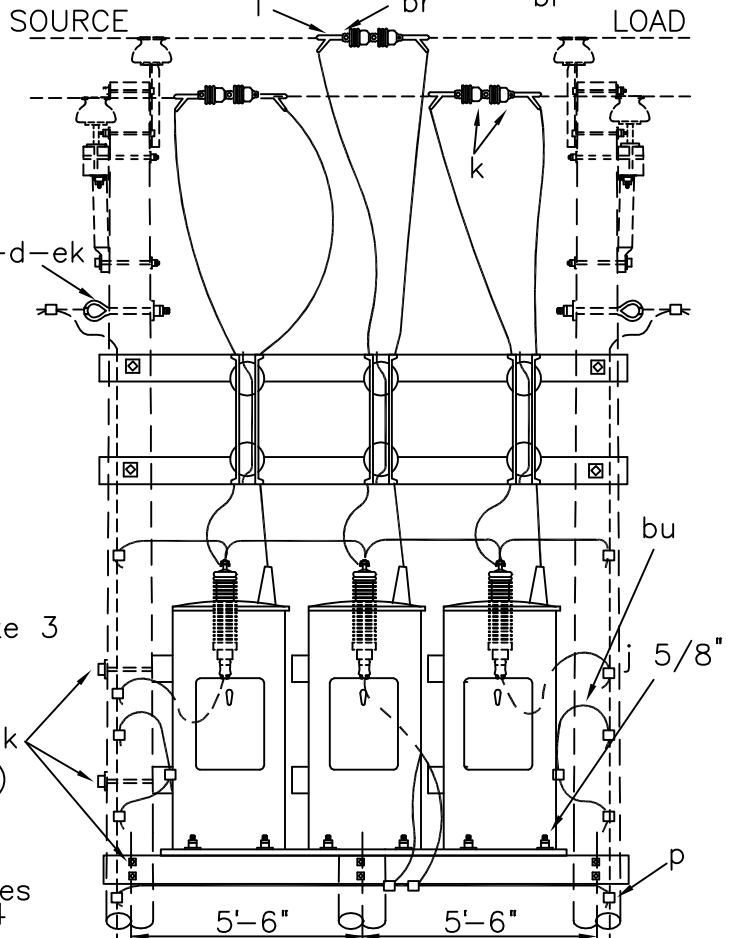
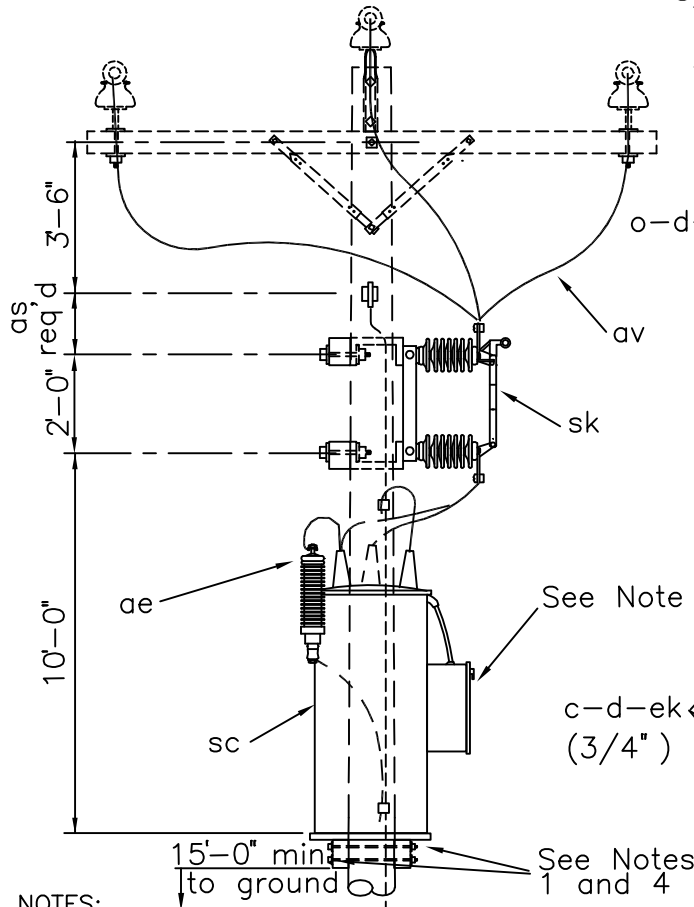
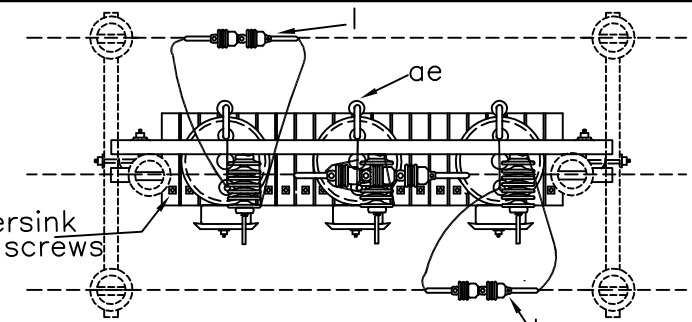
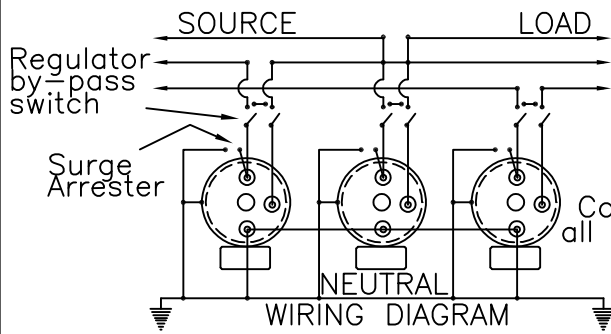

NOTES:

1. All structural timbers and planks to be treated as per RUS specifications.
2. Each regulator must be bolted to platform or pole.
3. Control boxes may be installed on poles below regulators, (Specify additional control cable).
4. 4 x 6.25 /ft. channel steel or 6 x 2.91#/ft. channel aluminum may be substituted for structural timbers.

ITEM	QTY	MATERIAL
c	12	Bolt, machine, 1/2" x req'd length
c	6	Bolt, machine, 5/8" x req'd length
c	6	Bolt, machine, 3/4" x req'd length
d	12	Washer, round, 1 3/8" diam.
d	24	Washer, square, 2 1/4"
j		Screw, lag, 1/2" x 5', as req'd
j	8	Screw, lag, 5/8" x 6"
k	6	Insulator, suspension, 4 1/4"
l	6	Clamp, deadend
o	2	Bolt, eye, 5/8" x req'd length
p		Connectors, compression, as req'd
ae	3	Arrester, surge (9 kV)

ITEM	QTY	MATERIAL
ae	3	Arrester, by-pass (furnished by manufacturer)
av		Jumpers, bare, stranded, as req'd
br	3	Chain link
bu	3	Connector, grounding
ek	26	Locknuts
sc	3	Regulator, voltage, step-type 12.47/7.2 kV
sk	3	Switch, regulator by-pass
	2	Structural timber, 4" x 12" x 12'
		Planks, 2" or 3" thick - length and number as req'd

VOLTAGE REGULATORS, PLATFORM MOUNTED
(THREE SINGLE-PHASE)

APRIL 2005

RUS

3 - PHASE PRIMARY
12.47/7.2 kV

Y1.3
(M7-13)

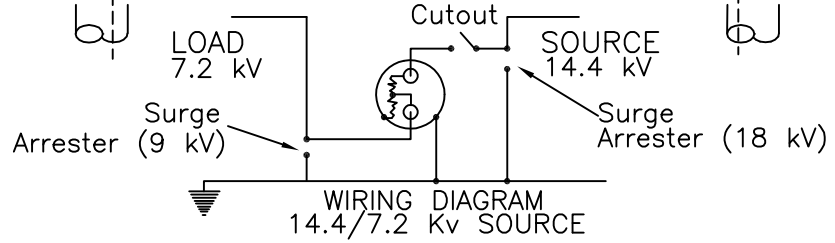
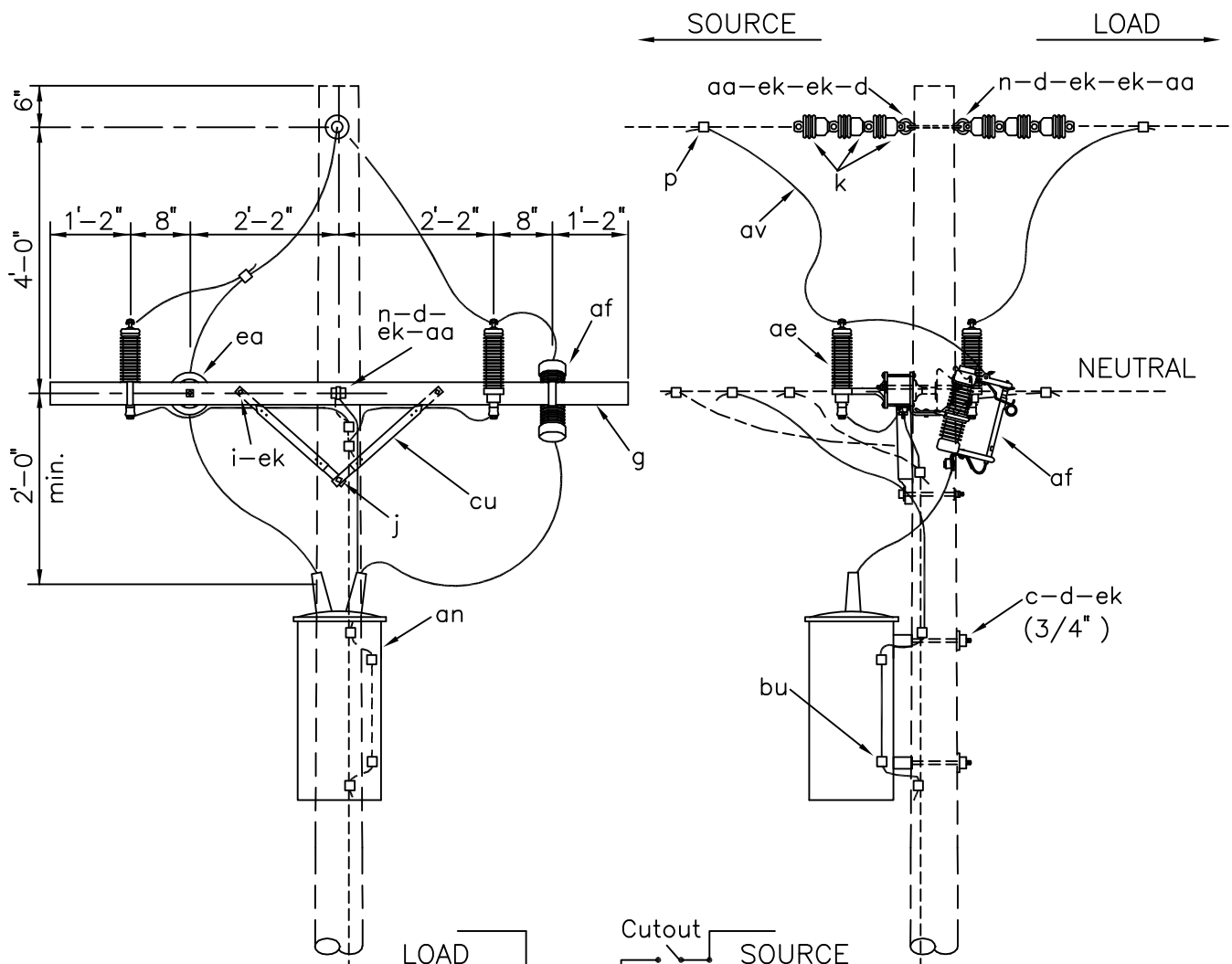

NOTE: For step-up operation, (7.2 kV source; 14.4 kV load), interchange the surge arrester locations, make autotransformer connections as required, and designate assembly as "Y2.2".

ITEM	QTY	MATERIAL
c	2	Bolt, machine, 3/4" x req'd length
d	1	Washer, square, 2 1/4"
d	5	Washer, square, 3", curved
g	1	Crossarm, 3 5/8" x 4 5/8" x 8'-0"
i	2	Bolt, carriage, 3/8" x 4 1/2"
j	1	Screw, lag, 1/2" x 4"
k	6	Insulator, suspension, 4 1/4"
n	2	Bolt, dbl arm, 5/8" x req'd length
p		Connectors, compression, as req'd

ITEM	QTY	MATERIAL
aa	4	Nut, eye, 5/8"
ae	1	Arrester, surge (9 kV)
ae	1	Arrester, surge (18 kV)
af	1	Cutout, dist. open (27 kV)
an	1	Transformer, auto, 14.4 kV 7.2 kV
av		Jumpers, bare, stranded, as req'd
bu	2	Connector, grounding
cu	2	Brace, 28"
ea	1	Insulator, post type, (25 kV)
ek	12	Locknuts

AUTOTRANSFORMER, POLE MOUNTED
(ONE SINGLE-PHASE, STEP-DOWN)

APRIL 2005	1 - PHASE PRIMARY (14.4 kV to 7.2 kV)	Y2.1, Y2.2
RUS		

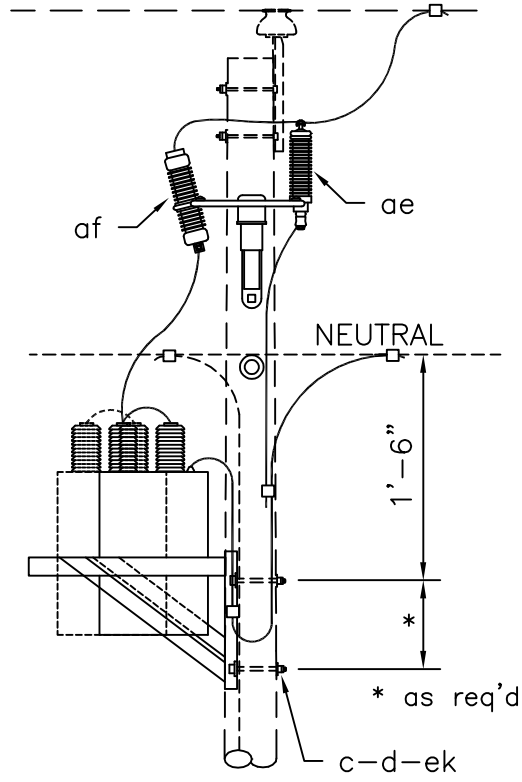
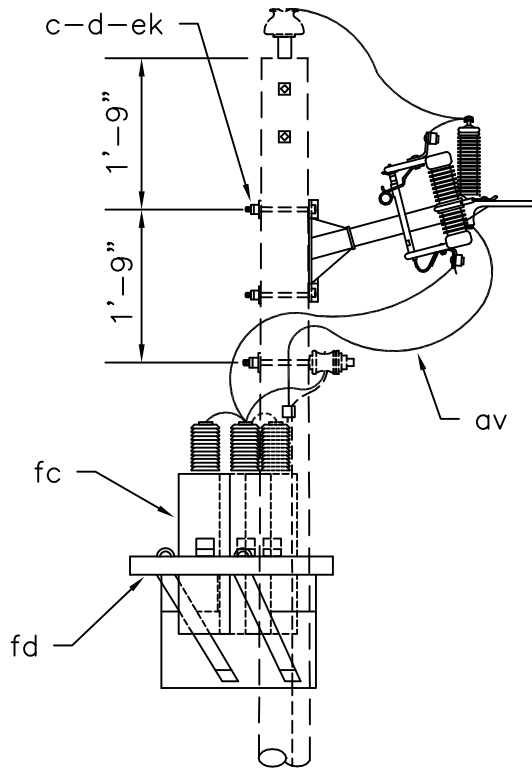
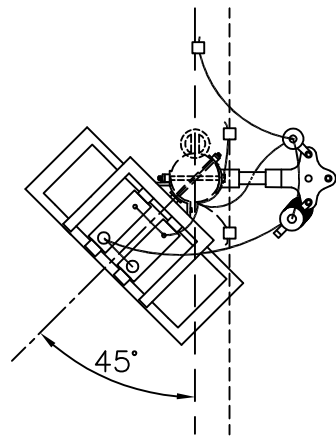

NOTES:

1. Specify number and kVAR required.
2. Load break cutouts for installations over 75 kVAR.
3. Specify insulating caps for primary terminal bushings.

ITEM	QTY	MATERIAL
c	4	Bolt, machine, 5/8" x req'd length
d	4	Washer, square, 2 1/4"
p		Connectors, as req'd
ae	1	Arrester, surge (9 kV)
af	1	Cutout, dist., loadbreak, (15 kV)
av		Jumpers, bare, stranded, as req'd
av		Jumpers, insulated, as req'd

ITEM	QTY	MATERIAL
dp	1	Clamp, ground wire
ek	4	Locknuts
eq	1	Bracket, insulator/equipment
fc		Capacitor, shunt, 12.47/7.2 kV (specify number and kVAR)
fd	1	Hanger, capacitor

SINGLE PHASE CAPACITOR ASSEMBLY

APRIL 2005

RUS

1 - PHASE PRIMARY
12.47/7.2 kV

Y3.1 (M9-11)

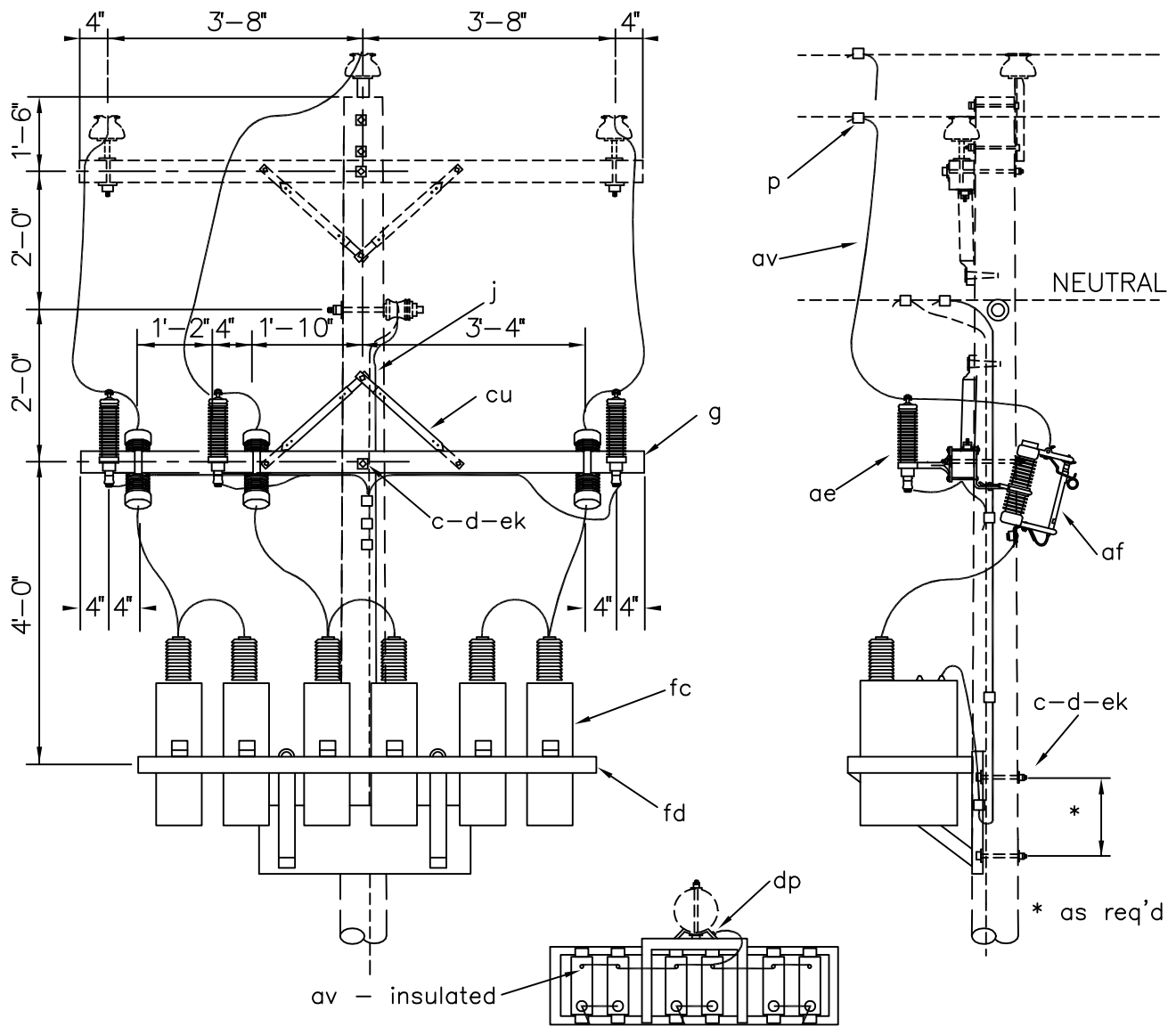

WIRING DIAGRAM

NOTE:

1. Specify insulating caps for primary terminal bushings.
2. For two-phase assemblies, omit capacitors and other material on center phase; designate assembly as "Y3.2."

ITEM	QTY	MATERIAL
c	3	Bolt, machine, 5/8" x req'd length
d	4	Washer, square, 2 1/4"
g	1	Crossarm, 3 5/8" X 4 5/8" X 8-0"
i	2	Bolt, carriage, 3/8" x 4 1/2"
j	1	Screw, lag, 1/2" x 4"
p		Connectors, as req'd
p		Connectors, compression, as req'd
ae	3	Arrester, surge (9 kV)
af	3	Cutout, dist., loadbreak, (15 kV)

ITEM	QTY	MATERIAL
av		Jumpers, bare, stranded, as req'd
av		Jumpers, insulated, as req'd
cu	2	Brace, 28"
dp	1	Clamp, ground wire
ek	5	Locknuts
fc		Capacitor, shunt, 12.47/7.2 kV (specify number and kVAR)
fd	1	Hanger, capacitor

THREE PHASE CAPACITOR BANK

APRIL 2005

RUS

3 - PHASE PRIMARY
12.47/7.2 kV

Y3.2,Y3.3
(M9-12),(M9-13)

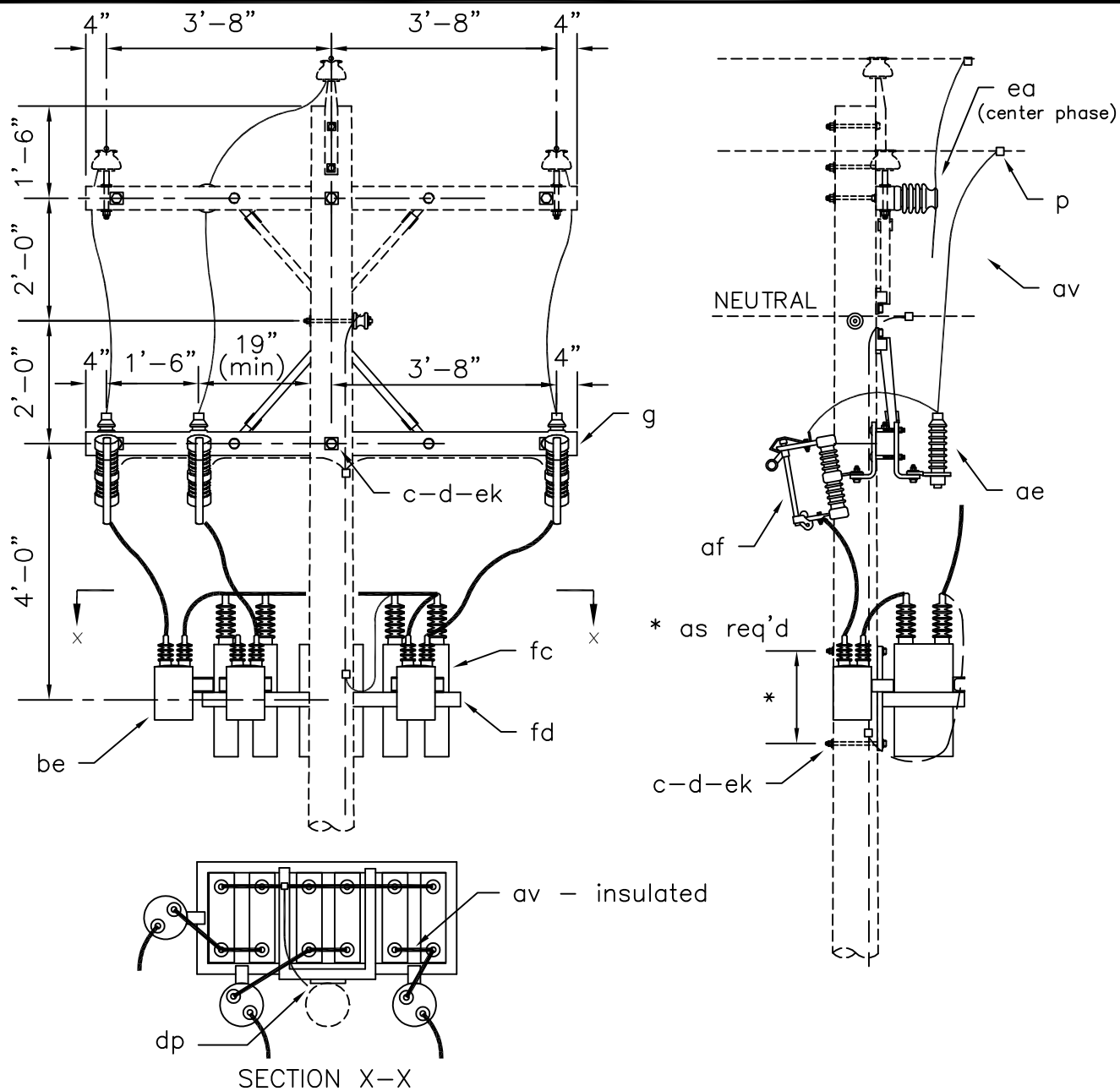

NOTE:

1. Specify insulating caps for primary terminal bushings.

ITEM	QTY	MATERIAL
c	3	Bolt, machine, 5/8" x req'd length
d	3	Washer, square, 2 1/4"
g	1	Crossarm, 3 5/8" X 4 5/8" X 8-0"
i	2	Bolt, carriage, 3/8" x 4 1/2"
j	1	Screw, lag, 1/2" x 4"
p		Connectors, as req'd
ae	3	Arrester, surge (9 kV)
af	3	Cutout, dist., loadbreak, (15 kV)
av		Jumpers, bare, stranded, as req'd

ITEM	QTY	MATERIAL
av		Jumpers, insulated, as req'd
be	3	Switch, oil, with controls
cu	2	Brace, 28
dp	1	Clamp, grbund wire
ea	1	Insulator, post type (15kv)
ek	5	Locknuts
fc		Capacitor, shunt, 12.47/7.2 kV (specify number and kVAR)
fd	1	Hanger, capacitor

THREE-PHASE SWITCHED CAPACITOR BANK

APRIL 2005

RUS

3 - PHASE PRIMARY
12.47/7.2 kV

Y3.4

Calculation of Maximum Line Angles

The following formula and the data tabulated below were used to calculate the maximum line angles on pin and spool insulator assemblies:

$$\sin(\theta/2) = \frac{P - (F_w \times S_w \times W_w)}{2 \times F_t \times T} \quad \theta = 2 \times \text{Arc sin} \left[\frac{P - (F_w \times S_w \times W_w)}{2 \times F_t \times T} \right]$$

Where:

- θ = Maximum Line Angle (calculated): [Degrees]
- P = Designated Maximum Transverse Load (allowed on pin or insulator): [lbs]
- F_w = Wind Overload Factor for Transverse Loads
- F_t = Wire Tension Overload Factor for Transverse Loads
- S_w = Wind Span (equals 1/2 sum of adjacent spans): [ft]
- W_w = Wind Load on Conductor: [lbs/ft] (See Table Below)
- T = Design Tension of Conductor: [lbs] (See Table Below)

From NESC Table 253-1 for Grade C Construction:

- F_w = 1.75 for non-crossing spans (Footnote 4 to Table 253-1)
- = 2.20 for crossing spans
- F_t = 1.30

CONDUCTOR SIZE & TYPE	Strength	Maximum Tension	Design Tension (T)(lbs)
4 ACSR (7/1)	2360	60%	1416
2 ACSR (6/1)	2850	60%	1710
2 ACSR (7/1)	3640	60%	2184
1/0 ACSR (6/1)	4380	60%	2628
123.3 AAC (7)	4460	60%	2676
2/0 ACSR (6/1)	5310	50%	2655
3/0 ACSR (6/1)	6620	50%	3310
4/0 ACSR (6/1)	8350	40%	3340
246.9 AAC (7)	8560	40%	3424
336.4 ACSR (18/1)	8680	40%	3472
336.4 ACSR (26/7)	14100	35%	4935

WIND LOAD (W_w) (lbs/ft) by NESC Loading District

	LIGHT	MEDIUM	HEAVY
4 ACSR (7/1)	0.1928	0.2523	0.4190
2 ACSR (6/1)	0.2370	0.2720	0.4387
2 ACSR (7/1)	0.2438	0.2750	0.4417
1/0 ACSR (6/1)	0.2985	0.2993	0.4660
123.3 AAC (7)	0.2985	0.2993	0.4660
2/0 ACSR (6/1)	0.3353	0.3157	0.4823
3/0 ACSR (6/1)	0.3765	0.3340	0.5007
4/0 ACSR (6/1)	0.4223	0.3543	0.5210
246.9 AAC (7)	0.4223	0.3543	0.5210
336.4 ACSR (18/1)	0.5130	0.3947	0.5613
336.4 ACSR (26/7)	0.5408	0.4070	0.5737

TABLE I
MAXIMUM LINE ANGLES (Degrees)
PIN and POST TYPE INSULATOR ASSEMBLIES

NESC Grade C Construction *(Re-calculate for NESC Grade B)*

Designated Maximum Transverse Load = **500** Lbs./Conductor

Note: Decrease line angle by 1 degree for poles adjacent to a crossing span.

<u>WIND SPAN (feet)</u>	<u>150</u>	<u>200</u>	<u>250</u>	<u>300</u>	<u>350</u>	<u>400</u>
<u>CONDUCTOR SIZE</u>	LIGHT LOADING DISTRICT					
4 ACSR (7/1)	14	13	13	12	12	11
2 ACSR (6/1)	11	11	10	10	9	9
2 ACSR (7/1)	9	8	8	8	7	7
1/0 ACSR (6/1)	7	7	6	6	5	5
123.3 AAAC (7)	7	7	6	6	5	5
2/0 ACSR (6/1)	7	6	6	5	5	4
3/0 ACSR (6/1)	5	5	4	4	4	3
4/0 ACSR (6/1)	5	5	4	4	3	3
246.9 AAAC (7)	5	5	4	4	3	3
336.4 ACSR (18/1)	5	4	3	3	2	2
336.4 ACSR (26/7)	3	3	2	2	2	1
	MEDIUM LOADING DISTRICT					
4 ACSR (7/1)	14	13	12	11	11	10
2 ACSR (6/1)	11	10	10	9	9	8
2 ACSR (7/1)	9	8	8	7	7	6
1/0 ACSR (6/1)	7	7	6	6	5	5
123.3 AAAC (7)	7	7	6	6	5	5
2/0 ACSR (6/1)	7	6	6	6	5	5
3/0 ACSR (6/1)	5	5	5	4	4	4
4/0 ACSR (6/1)	5	5	5	4	4	3
246.9 AAAC (7)	5	5	4	4	4	3
336.4 ACSR (18/1)	5	5	4	4	3	3
336.4 ACSR (26/7)	4	3	3	3	2	2
	HEAVY LOADING DISTRICT					
4 ACSR (7/1)	12	11	10	9	8	6
2 ACSR (6/1)	10	9	8	7	6	5
2 ACSR (7/1)	8	7	6	5	5	4
1/0 ACSR (6/1)	6	6	5	4	4	3
123.3 AAAC (7)	6	6	5	4	4	3
2/0 ACSR (6/1)	6	6	5	4	3	3
3/0 ACSR (6/1)	5	4	4	3	3	2
4/0 ACSR (6/1)	5	4	4	3	2	2
246.9 AAAC (7)	5	4	4	3	2	2
336.4 ACSR (18/1)	4	4	3	3	2	1
336.4 ACSR (26/7)	3	3	2	2	1	1

TABLE II
MAXIMUM LINE ANGLES (Degrees)
PIN and POST TYPE INSULATOR ASSEMBLIES
NESC Grade C Construction (Re-calculate for NESC Grade B)

Designated Maximum Transverse Load = **750** Lbs./Conductor

Note: Decrease line angle by 1 degree for poles adjacent to a crossing span.

<u>WIND SPAN (feet)</u>	<u>150</u>	<u>200</u>	<u>250</u>	<u>300</u>	<u>350</u>	<u>400</u>
<u>CONDUCTOR SIZE</u>	LIGHT LOADING DISTRICT					
4 ACSR (7/1)	22	21	21	20	20	19
2 ACSR (6/1)	18	17	17	16	16	15
2 ACSR (7/1)	14	13	13	13	12	12
1/0 ACSR (6/1)	11	11	10	10	10	9
123.3 AAAC (7)	11	11	10	10	9	9
2/0 ACSR (6/1)	11	11	10	10	9	9
3/0 ACSR (6/1)	9	8	8	7	7	6
4/0 ACSR (6/1)	8	8	7	7	6	6
246.9 AAAC (7)	8	8	7	7	6	6
336.4 ACSR (18/1)	8	7	7	6	6	5
336.4 ACSR (26/7)	5	5	5	4	4	3
	MEDIUM LOADING DISTRICT					
4 ACSR (7/1)	21	21	20	19	19	18
2 ACSR (6/1)	18	17	16	16	15	14
2 ACSR (7/1)	14	13	13	12	12	11
1/0 ACSR (6/1)	11	11	10	10	10	9
123.3 AAAC (7)	11	11	10	10	9	9
2/0 ACSR (6/1)	11	11	10	10	9	9
3/0 ACSR (6/1)	9	8	8	8	7	7
4/0 ACSR (6/1)	9	8	8	7	7	7
246.9 AAAC (7)	8	8	8	7	7	6
336.4 ACSR (18/1)	8	8	7	7	6	6
336.4 ACSR (26/7)	6	5	5	5	4	4
	HEAVY LOADING DISTRICT					
4 ACSR (7/1)	20	19	18	17	15	14
2 ACSR (6/1)	16	15	14	13	12	11
2 ACSR (7/1)	13	12	11	10	10	9
1/0 ACSR (6/1)	11	10	9	8	8	7
123.3 AAAC (7)	10	10	9	8	8	7
2/0 ACSR (6/1)	10	10	9	8	8	7
3/0 ACSR (6/1)	8	8	7	6	6	5
4/0 ACSR (6/1)	8	7	7	6	6	5
246.9 AAAC (7)	8	7	7	6	6	5
336.4 ACSR (18/1)	8	7	6	6	5	5
336.4 ACSR (26/7)	5	5	4	4	4	3

TABLE III
MAXIMUM LINE ANGLES (Degrees)
PIN and POST TYPE INSULATOR ASSEMBLIES
NESC Grade C Construction (Re-calculate for NESC Grade B)

Designated Maximum Transverse Load = **1,000** Lbs./Conductor

Note: Decrease line angle by 1 degree for poles adjacent to a crossing span.

<u>WIND SPAN (feet)</u>	<u>150</u>	<u>200</u>	<u>250</u>	<u>300</u>	<u>350</u>	<u>400</u>
<u>CONDUCTOR SIZE</u>	LIGHT LOADING DISTRICT					
4 ACSR (7/1)	30	29	29	28	28	27
2 ACSR (6/1)	24	24	23	23	22	22
2 ACSR (7/1)	19	19	18	18	17	17
1/0 ACSR (6/1)	16	15	15	14	14	13
123.3 AAAC (7)	15	15	14	14	13	13
2/0 ACSR (6/1)	15	15	14	14	13	13
3/0 ACSR (6/1)	12	12	11	11	10	10
4/0 ACSR (6/1)	12	11	11	10	10	9
246.9 AAAC (7)	11	11	11	10	10	9
336.4 ACSR (18/1)	11	10	10	9	9	8
336.4 ACSR (26/7)	8	7	7	6	6	6
	MEDIUM LOADING DISTRICT					
4 ACSR (7/1)	29	29	28	27	27	26
2 ACSR (6/1)	24	23	23	22	22	21
2 ACSR (7/1)	19	18	18	17	17	16
1/0 ACSR (6/1)	16	15	15	14	14	13
123.3 AAAC (7)	15	15	14	14	13	13
2/0 ACSR (6/1)	15	15	14	14	13	13
3/0 ACSR (6/1)	12	12	11	11	11	10
4/0 ACSR (6/1)	12	12	11	11	10	10
246.9 AAAC (7)	12	11	11	10	10	10
336.4 ACSR (18/1)	11	11	11	10	10	9
336.4 ACSR (26/7)	8	8	7	7	7	6
	HEAVY LOADING DISTRICT					
4 ACSR (7/1)	28	27	26	24	23	22
2 ACSR (6/1)	23	22	21	20	19	18
2 ACSR (7/1)	18	17	16	16	15	14
1/0 ACSR (6/1)	15	14	13	13	12	11
123.3 AAAC (7)	14	14	13	12	12	11
2/0 ACSR (6/1)	15	14	13	12	12	11
3/0 ACSR (6/1)	12	11	10	10	9	9
4/0 ACSR (6/1)	11	11	10	10	9	8
246.9 AAAC (7)	11	11	10	9	9	8
336.4 ACSR (18/1)	11	10	10	9	8	8
336.4 ACSR (26/7)	8	7	7	6	6	5

TABLE IV
MAXIMUM LINE ANGLES (Degrees)
PIN and POST TYPE INSULATOR ASSEMBLIES
NESC Grade C Construction (Re-calculate for NESC Grade B)

Designated Maximum Transverse Load = **1,500** Lbs./Conductor

Note: Decrease line angle by 1 degree for poles adjacent to a crossing span.

<u>WIND SPAN (feet)</u>	<u>150</u>	<u>200</u>	<u>250</u>	<u>300</u>	<u>350</u>	<u>400</u>
<u>CONDUCTOR SIZE</u>	LIGHT LOADING DISTRICT					
4 ACSR (7/1)	46	46	45	45	44	44
2 ACSR (6/1)	38	37	37	36	35	35
2 ACSR (7/1)	29	29	28	28	28	27
1/0 ACSR (6/1)	24	24	23	23	22	22
123.3 AAAC (7)	24	23	23	22	22	21
2/0 ACSR (6/1)	24	23	23	22	22	21
3/0 ACSR (6/1)	19	18	18	17	17	17
4/0 ACSR (6/1)	18	18	17	17	16	16
246.9 AAAC (7)	18	17	17	17	16	16
336.4 ACSR (18/1)	17	17	16	16	15	15
336.4 ACSR (26/7)	12	12	11	11	10	10
	MEDIUM LOADING DISTRICT					
4 ACSR (7/1)	46	45	44	44	43	42
2 ACSR (6/1)	37	37	36	36	35	34
2 ACSR (7/1)	29	29	28	28	27	27
1/0 ACSR (6/1)	24	24	23	23	22	22
123.3 AAAC (7)	24	23	23	22	22	21
2/0 ACSR (6/1)	24	23	23	22	22	21
3/0 ACSR (6/1)	19	18	18	18	17	17
4/0 ACSR (6/1)	19	18	18	17	17	17
246.9 AAAC (7)	18	18	17	17	17	16
336.4 ACSR (18/1)	18	17	17	16	16	16
336.4 ACSR (26/7)	12	12	12	12	11	11
	HEAVY LOADING DISTRICT					
4 ACSR (7/1)	44	43	42	41	39	38
2 ACSR (6/1)	36	35	34	33	32	31
2 ACSR (7/1)	28	27	27	26	25	24
1/0 ACSR (6/1)	23	23	22	21	20	20
123.3 AAAC (7)	23	22	21	21	20	19
2/0 ACSR (6/1)	23	22	22	21	20	19
3/0 ACSR (6/1)	18	18	17	17	16	15
4/0 ACSR (6/1)	18	17	17	16	16	15
246.9 AAAC (7)	18	17	16	16	15	15
336.4 ACSR (18/1)	17	17	16	15	15	14
336.4 ACSR (26/7)	12	12	11	11	10	10

TABLE V
MAXIMUM LINE ANGLES (Degrees)
PIN and POST TYPE INSULATOR ASSEMBLIES
NESC Grade C Construction (Re-calculate for NESC Grade B)

Designated Maximum Transverse Load = **2,000** Lbs./Conductor

Note: Decrease line angle by 1 degree for poles adjacent to a crossing span.

<u>WIND SPAN (feet)</u>	<u>150</u>	<u>200</u>	<u>250</u>	<u>300</u>	<u>350</u>	<u>400</u>
<u>CONDUCTOR SIZE</u>	LIGHT LOADING DISTRICT					
4 ACSR (7/1)	60	60	60	60	60	60
2 ACSR (6/1)	52	51	50	50	49	49
2 ACSR (7/1)	40	39	39	38	38	38
1/0 ACSR (6/1)	33	32	32	31	31	30
123.3 AAAC (7)	32	32	31	31	30	30
2/0 ACSR (6/1)	32	32	31	31	30	30
3/0 ACSR (6/1)	26	25	25	24	24	23
4/0 ACSR (6/1)	25	25	24	24	23	23
246.9 AAAC (7)	25	24	24	23	23	22
336.4 ACSR (18/1)	24	23	23	22	22	21
336.4 ACSR (26/7)	17	16	16	15	15	15
	MEDIUM LOADING DISTRICT					
4 ACSR (7/1)	60	60	60	60	60	59
2 ACSR (6/1)	51	51	50	49	49	48
2 ACSR (7/1)	40	39	39	38	38	37
1/0 ACSR (6/1)	33	32	32	31	31	30
123.3 AAAC (7)	32	32	31	31	30	30
2/0 ACSR (6/1)	32	32	31	31	30	30
3/0 ACSR (6/1)	26	25	25	24	24	24
4/0 ACSR (6/1)	25	25	25	24	24	23
246.9 AAAC (7)	25	24	24	24	23	23
336.4 ACSR (18/1)	24	24	23	23	22	22
336.4 ACSR (26/7)	17	17	16	16	16	15
	HEAVY LOADING DISTRICT					
4 ACSR (7/1)	60	60	59	58	57	55
2 ACSR (6/1)	50	49	48	47	46	45
2 ACSR (7/1)	39	38	37	36	35	35
1/0 ACSR (6/1)	32	31	30	30	29	28
123.3 AAAC (7)	31	31	30	29	29	28
2/0 ACSR (6/1)	31	31	30	29	29	28
3/0 ACSR (6/1)	25	24	24	23	23	22
4/0 ACSR (6/1)	25	24	24	23	22	22
246.9 AAAC (7)	24	24	23	22	22	21
336.4 ACSR (18/1)	24	23	22	22	21	21
336.4 ACSR (26/7)	17	16	16	15	15	14

TABLE VI
MAXIMUM LINE ANGLES (Degrees) ON SPOOL INSULATOR ASSEMBLIES
 NESC Grade C Construction (Re-calculate for NESC Grade B)
 (ANSI Class 53-2 Spool Insulator)

Designated Maximum Transverse Load = **1,500** Lbs./Conductor

Note: Decrease line angle by 1 degree for poles adjacent to a crossing span.

<u>WIND SPAN (feet)</u>	<u>150</u>	<u>200</u>	<u>250</u>	<u>300</u>	<u>350</u>	<u>400</u>
<u>CONDUCTOR SIZE</u>	LIGHT LOADING DISTRICT					
4 ACSR (7/1)	46	46	45	45	44	44
2 ACSR (6/1)	38	37	37	36	35	35
2 ACSR (7/1)	29	29	28	28	28	27
1/0 ACSR (6/1)	24	24	23	23	22	22
123.3 AAAC (7)	24	23	23	22	22	21
2/0 ACSR (6/1)	24	23	23	22	22	21
3/0 ACSR (6/1)	19	18	18	17	17	17
4/0 ACSR (6/1)	18	18	17	17	16	16
246.9 AAAC (7)	18	17	17	17	16	16
336.4 ACSR (18/1)	17	17	16	16	15	15
336.4 ACSR (26/7)	12	12	11	11	10	10
	MEDIUM LOADING DISTRICT					
4 ACSR (7/1)	46	45	44	44	43	42
2 ACSR (6/1)	37	37	36	36	35	34
2 ACSR (7/1)	29	29	28	28	27	27
1/0 ACSR (6/1)	24	24	23	23	22	22
123.3 AAAC (7)	24	23	23	22	22	21
2/0 ACSR (6/1)	24	23	23	22	22	21
3/0 ACSR (6/1)	19	18	18	18	17	17
4/0 ACSR (6/1)	19	18	18	17	17	17
246.9 AAAC (7)	18	18	17	17	17	16
336.4 ACSR (18/1)	18	17	17	16	16	16
336.4 ACSR (26/7)	12	12	12	12	11	11
	HEAVY LOADING DISTRICT					
4 ACSR (7/1)	44	43	42	41	39	38
2 ACSR (6/1)	36	35	34	33	32	31
2 ACSR (7/1)	28	27	27	26	25	24
1/0 ACSR (6/1)	23	23	22	21	20	20
123.3 AAAC (7)	23	22	21	21	20	19
2/0 ACSR (6/1)	23	22	22	21	20	19
3/0 ACSR (6/1)	18	18	17	17	16	15
4/0 ACSR (6/1)	18	17	17	16	16	15
246.9 AAAC (7)	18	17	16	16	15	15
336.4 ACSR (18/1)	17	17	16	15	15	14
336.4 ACSR (26/7)	12	12	11	11	10	10

TABLE VII
MAXIMUM LINE ANGLES (Degrees) ON SPOOL INSULATOR ASSEMBLIES
 NESC Grade C Construction (Re-calculate for NESC Grade B)
 (ANSI Class 53-4 Spool Insulator)

Designated Maximum Transverse Load = **2,250** Lbs./Conductor

Note: Decrease line angle by 1 degree for poles adjacent to a crossing span.

<u>WIND SPAN (feet)</u>	<u>150</u>	<u>200</u>	<u>250</u>	<u>300</u>	<u>350</u>	<u>400</u>
CONDUCTOR SIZE	LIGHT LOADING DISTRICT					
4 ACSR (7/1)	60	60	60	60	60	60
2 ACSR (6/1)	59	58	58	57	57	56
2 ACSR (7/1)	45	45	44	44	43	43
1/0 ACSR (6/1)	37	37	36	36	35	35
123.3 AAAC (7)	36	36	35	35	35	34
2/0 ACSR (6/1)	37	36	35	35	34	34
3/0 ACSR (6/1)	29	28	28	28	27	27
4/0 ACSR (6/1)	29	28	28	27	27	26
246.9 AAAC (7)	28	27	27	26	26	25
336.4 ACSR (18/1)	27	27	26	25	25	24
336.4 ACSR (26/7)	19	18	18	18	17	17
	MEDIUM LOADING DISTRICT					
4 ACSR (7/1)	60	60	60	60	60	60
2 ACSR (6/1)	59	58	57	57	56	55
2 ACSR (7/1)	45	45	44	44	43	42
1/0 ACSR (6/1)	37	37	36	36	35	35
123.3 AAAC (7)	36	36	35	35	35	34
2/0 ACSR (6/1)	37	36	36	35	35	34
3/0 ACSR (6/1)	29	29	28	28	27	27
4/0 ACSR (6/1)	29	28	28	27	27	27
246.9 AAAC (7)	28	28	27	27	26	26
336.4 ACSR (18/1)	28	27	27	26	26	25
336.4 ACSR (26/7)	19	19	19	18	18	18
	HEAVY LOADING DISTRICT					
4 ACSR (7/1)	60	60	60	60	60	60
2 ACSR (6/1)	57	56	55	54	53	52
2 ACSR (7/1)	44	43	42	42	41	40
1/0 ACSR (6/1)	36	36	35	34	33	33
123.3 AAAC (7)	36	35	34	34	33	32
2/0 ACSR (6/1)	36	35	34	34	33	32
3/0 ACSR (6/1)	29	28	27	27	26	26
4/0 ACSR (6/1)	28	28	27	26	26	25
246.9 AAAC (7)	27	27	26	26	25	24
336.4 ACSR (18/1)	27	26	26	25	24	24
336.4 ACSR (26/7)	19	18	18	17	17	17

LONGITUDINAL LOADING ON CROSSARM ASSEMBLIES

Applied vertical loads need to be considered when determining the permitted longitudinal loading of crossarm deadend assemblies. The following mathematical relationship, which relate vertical and longitudinal loading, has to be satisfied to avoid overstressing the wood fibers of crossarms:

$$\frac{\sum \text{Applied Vertical Moments}}{\text{Permitted Vertical Moment (Capacity)}} + \frac{\sum \text{Applied Longitudinal Moments}}{\text{Permitted Longitudinal Moment (Capacity)}} \leq 1$$

The following applies to RUS standard distribution, deadend, crossarm assemblies:

- *Permitted Vertical Moment (Capacity) of Assembly* = $N \times M_v \times F_s$
- *Permitted Longitudinal Moment (Capacity) of Assembly* = $N \times M_h \times F_s$
- $\sum \text{Applied Vertical Moments} =$
 $D_1 \times [(S_{in} \times W_1) + (S_{out} \times W_2)] \times F_{OLV} + D_2 \times [(S_{in} \times W_3) + (S_{out} \times W_4)] \times F_{OLV} + M_{LW}$
- $\sum \text{Applied Longitudinal Moments} =$
 $[D_1 \times (L_{1-in} - L_{1-out}) + D_2 \times (L_{2-in} - L_{2-out})] \times F_{OLL}$

The units of measure of the above four groups of terms are “ft-lbs.” Note that all of the calculations apply to one-half of the crossarm assembly (on either the right or left side of the pole looking parallel to the line). Each conductor attachment location, at a distance D_1 or D_2 from the center of the assembly, has either one conductor attached (“into” the assembly) or has two back-to-back conductors attached (one “into” and one “out from” the assembly).

Following are the definitions and values of the variables in the above equations:

M_v	= 7,650	Vertical crossarm moment (capacity) (ft-lbs)
M_h	= 5,060	Longitudinal crossarm moment (capacity) (ft-lbs)
M_{LW}	= 1,000	Load moment attributed to weight of lineworker (ft-lbs)
F_s	= 0.85	Strength Factor (2002 NESC Table 261-1A) - Grade C
	= 0.65	" " " " " " " - Grade B
F_{OLV}	= 1.90	Overload factor - Vertical (2002 NESC Table 253-1) - Grade C
	= 1.50	" " " " " " " - Grade B
F_{OLL}	= 1.30	Overload factor - Longitudinal (2002 NESC Table 253-1) - Grade C
	= 1.65	" " " " " " " - Grade B
D_1	= 1.75	Distance to nearest conductors on 10-foot crossarm assemblies (ft)
D_2	= 4.50	Distance to farthest conductors on 10-foot crossarm assemblies (ft)
D_1	= 3.50	Distance to conductor(s) on 8-foot crossarm assemblies (ft)
W_i	=	Vertical unit weight of conductor plus NESC ice and wind loads (lbs/ft)
S_{in}	=	One-half of the total span length "into" the assembly (ft)

S_{out}	=	One-half of the total span length "out from" the assembly (ft)
N	=	Number of crossarms
L_{in}	=	Tension of each conductor "into" the assembly (lbs)
L_{out}	=	Tension of each conductor "out from" the assembly (lbs)

For purposes of simplifying mechanical loading calculations, the following assumptions and approximations are made:

- All of the conductor spans "into" a crossarm assembly have the same length; all of the conductor spans "out from" a crossarm assembly have the same length. The length "S," where $S = S_{in} + S_{out}$, is called a "weight span."
- The tensions of all of the conductors into the crossarm assembly (L_{in}) are the same; the tensions of all of the conductors out from the crossarm assembly (L_{out}) are the same. "L" is the difference of the conductor tensions ($L = L_{in} - L_{out}$) at each (phase) conductor attachment location on the assembly.
- All of the conductors attached to the crossarm assembly are the same type and size as the largest conductor. Thus in the above equation: $W_1 = W_2 = W_3 = W_4 = W$.
- A load moment (M_{LW}) of 250 pounds (which might be attributed to a lineworker, materials or equipment) times 2 feet and times a constant overload factor of 2.0 (the product equals 1,000 ft-lbs) is added to the applied vertical load moments to satisfy NESC Rule 261D4b requirements. (**Note: Standard construction practices and RUS discourage lineworkers from standing on crossarms.**)

After applying the above assumptions and substitutions, the equation can be simplified and re-written as:

$$\frac{(D_1 + D_2) \times (W \times S) \times F_{OLV} + 1,000}{N \times M_v \times F_s} + \frac{(D_1 + D_2) \times L \times F_{OLL}}{N \times M_h \times F_s} \leq 1 \quad (\text{ft-lbs})$$

This equation can be solved for "L" as a function of all of the other variables in the equation. Tables A and B show the calculated *permitted unbalanced conductor tensions* ("L") for several commonly used distribution conductors versus three different weight spans ("S"), for standard RUS crossarm deadend assemblies and NESC Grade C construction.

TABLE A

PERMITTED UNBALANCED CONDUCTOR TENSION (Lbs / Phase)*
SINGLE and DOUBLE DEADEND ASSEMBLIES; 1 PHASE EACH SIDE OF POLE- NESC Grade C

CONDUCTOR SIZE	Vertical Loading (lbs/ft)	2 CROSSARMS			3 CROSSARMS		
		WEIGHT SPANS** (feet)			WEIGHT SPANS** (feet)		
		200	300	400	200	300	400
NESC LIGHT LOADING DISTRICT (0.00" Ice; 9 lb Wind)							
4 ACSR (7/1)	0.0670	1,730	1,720	1,710	2,670	2,670	2,660
2 ACSR (6/1)	0.0913	1,720	1,710	1,700	2,670	2,660	2,650
123.3 AAAC (7)	0.1157	1,720	1,710	1,700	2,660	2,650	2,640
1/0 ACSR (6/1)	0.1452	1,710	1,700	1,680	2,660	2,640	2,630
2/0 ACSR (6/1)	0.1831	1,700	1,690	1,670	2,650	2,630	2,610
3/0 ACSR (6/1)	0.2309	1,700	1,670	1,650	2,640	2,620	2,600
246.9 AAAC (7)	0.2318	1,700	1,670	1,650	2,640	2,620	2,600
4/0 ACSR (6/1)	0.2911	1,680	1,660	1,630	2,630	2,600	2,570
312.8 AAAC (19)	0.2936	1,680	1,650	1,630	2,630	2,600	2,570
336.4 ACSR (18/1)	0.3653	1,670	1,630	1,600	2,610	2,580	2,540
NESC MEDIUM LOADING DISTRICT (0.25" Ice; 4 lb Wind)							
4 ACSR (7/1)	0.2247	1,700	1,670	1,650	2,640	2,620	2,600
2 ACSR (6/1)	0.2673	1,690	1,660	1,640	2,630	2,610	2,580
123.3 AAAC (7)	0.3172	1,680	1,650	1,620	2,620	2,590	2,560
1/0 ACSR (6/1)	0.3467	1,670	1,640	1,610	2,620	2,580	2,550
2/0 ACSR (6/1)	0.3998	1,660	1,620	1,590	2,610	2,570	2,530
3/0 ACSR (6/1)	0.4647	1,650	1,610	1,560	2,600	2,550	2,510
246.9 AAAC (7)	0.4846	1,650	1,600	1,550	2,590	2,540	2,500
4/0 ACSR (6/1)	0.5439	1,630	1,580	1,530	2,580	2,530	2,470
312.8 AAAC (19)	0.5709	1,630	1,570	1,520	2,570	2,520	2,460
336.4 ACSR (18/1)	0.6557	1,610	1,550	1,490	2,560	2,490	2,430
NESC HEAVY LOADING DISTRICT (0.50" Ice; 4 lb Wind)							
4 ACSR (7/1)	0.5379	1,640	1,580	1,530	2,580	2,530	2,480
2 ACSR (6/1)	0.5989	1,620	1,570	1,510	2,570	2,510	2,450
123.3 AAAC (7)	0.6741	1,610	1,540	1,480	2,550	2,490	2,420
1/0 ACSR (6/1)	0.7036	1,600	1,540	1,470	2,550	2,480	2,410
2/0 ACSR (6/1)	0.7719	1,590	1,520	1,440	2,540	2,460	2,390
3/0 ACSR (6/1)	0.8539	1,570	1,490	1,410	2,520	2,440	2,350
246.9 AAAC (7)	0.8927	1,570	1,480	1,390	2,510	2,430	2,340
4/0 ACSR (6/1)	0.9520	1,560	1,460	1,370	2,500	2,410	2,320
312.8 AAAC (19)	1.0037	1,550	1,450	1,350	2,490	2,390	2,300
336.4 ACSR (18/1)	1.1015	1,530	1,420	1,310	2,470	2,370	2,260

NOTES: *Reduce tabulated tensions by 40% for NESC Grade B construction.*

**(Lbs/Phase) means tension difference at each point on crossarms where conductors are attached.*

*** Weight span equals 1/2 span length into assembly plus 1/2 span length out from assembly.*

Weight Span for single deadend assemblies only equals 1/2 span length into assembly.

Last 3 notes at end of TABLE B also apply to TABLE A.

TABLE B
PERMITTED UNBALANCED CONDUCTOR TENSION (Lbs / Phase)*
DOUBLE DEADEND ASSEMBLIES - 2 PHASES EACH SIDE OF POLE - NESC Grade C

CONDUCTOR SIZE	Vertical Loading (lbs/ft)	2 CROSSARMS			3 CROSSARMS		
		WEIGHT SPANS** (feet)			WEIGHT SPANS** (feet)		
		200	300	400	200	300	400
NESC LIGHT LOADING DISTRICT (0.00" Ice; 9 lb Wind)							
4 ACSR (7/1)	0.0670	960	950	950	1,490	1,480	1,480
2 ACSR (6/1)	0.0913	950	950	940	1,480	1,480	1,470
123.3 AAAC (7)	0.1157	950	940	930	1,480	1,470	1,460
1/0 ACSR (6/1)	0.1452	940	930	920	1,470	1,460	1,450
2/0 ACSR (6/1)	0.1831	940	920	900	1,470	1,450	1,430
3/0 ACSR (6/1)	0.2309	930	910	880	1,460	1,440	1,410
246.9 AAAC (7)	0.2318	930	900	880	1,460	1,430	1,410
4/0 ACSR (6/1)	0.2911	920	890	860	1,450	1,420	1,390
312.8 AAAC (19)	0.2936	920	890	860	1,450	1,420	1,390
336.4 ACSR (18/1)	0.3653	900	870	830	1,430	1,400	1,360
NESC MEDIUM LOADING DISTRICT (0.25" Ice; 4 lb Wind)							
4 ACSR (7/1)	0.2247	930	910	890	1,460	1,440	1,420
2 ACSR (6/1)	0.2673	920	890	870	1,450	1,420	1,400
123.3 AAAC (7)	0.3172	910	880	850	1,440	1,410	1,380
1/0 ACSR (6/1)	0.3467	900	870	840	1,430	1,400	1,370
2/0 ACSR (6/1)	0.3998	890	860	820	1,420	1,390	1,350
3/0 ACSR (6/1)	0.4647	880	840	790	1,410	1,370	1,320
246.9 AAAC (7)	0.4846	880	830	780	1,410	1,360	1,310
4/0 ACSR (6/1)	0.5439	870	810	760	1,400	1,340	1,290
312.8 AAAC (19)	0.5709	860	810	750	1,390	1,340	1,280
336.4 ACSR (18/1)	0.6557	850	780	720	1,380	1,310	1,250
NESC HEAVY LOADING DISTRICT (0.50" Ice; 4 lb Wind)							
4 ACSR (7/1)	0.5379	870	820	760	1,400	1,350	1,290
2 ACSR (6/1)	0.5989	860	800	740	1,390	1,330	1,270
123.3 AAAC (7)	0.6741	840	780	710	1,370	1,310	1,240
1/0 ACSR (6/1)	0.7036	840	770	700	1,370	1,300	1,230
2/0 ACSR (6/1)	0.7719	820	750	670	1,350	1,280	1,200
3/0 ACSR (6/1)	0.8539	810	720	640	1,340	1,250	1,170
246.9 AAAC (7)	0.8927	800	710	630	1,330	1,240	1,160
4/0 ACSR (6/1)	0.9520	790	700	600	1,320	1,230	1,130
312.8 AAAC (19)	1.0037	780	680	580	1,310	1,210	1,110
336.4 ACSR (18/1)	1.1015	760	650	550	1,290	1,180	1,080

NOTES: *Reduce tabulated tensions by 40% for NESC Grade B construction.*

**(Lbs/Phase) means tension difference at each point on crossarms where conductors are attached.*

***Weight span equals 1/2 span length into assembly plus 1/2 span length out from assembly.*

Calculations assume all conductors same size and type as largest conductor and level spans.

Assemblies have been multiplied by strength factor of 0.85 (2002 NESC Table 261-1A).

Applied loads have been multiplied by overload factors (2002 NESC Table 253-1).

Disposition of Assemblies in Bulletin 50-3 (D 804)

Old Assembly Number (Bulletin 50-3)	New Assembly Number (1728F-804)	Material Changes and Comments
A1	A1.1	No material changes
A1A	A1.2	No material changes
A1-1	A2.1	No material changes
A1-1A	A2.2	No material changes
A1P	A1.1P	No material changes
A1AP	A1.2P	No material changes
A1-1AP	A2.2P	No material changes
A1-1P	A2.1P	No material changes
A2	A2.3	No material changes
A2P	A2.3P	No material changes
A3	A3.1	Replace 2 washers abutting pole
A4	A4.1	Replace 4 washers abutting pole
A5	A5.1	Replace 2 washers abutting pole
A5-1		Discontinued (<i>Material same as A5.1; Replaced with A5.2G</i>)
A5-2	A5.2	Replace 2 washers abutting pole
A5-2A		Discontinued (<i>Same as A5.2 and note</i>)
A5-3		Discontinued (<i>Same as A5.1 and note</i>)
A5-4		Discontinued (<i>Combination of A5.1, A1.1 and A5.2G</i>)
A6	A6.1	Replace 4 washers abutting pole
A7	A5.21	No material changes
A7-1	A5.31	No material changes
A8	A6.21	No material changes
A9	A2.21	Add 4 washers under crossarm pins
A9P	A2.21P	Add 2 washers under crossarm pins
A9-1	A1.11	Add 2 washers under crossarm pins
A9-1P	A1.11P	Add 1 washer under crossarm pin
A22		Discontinued (<i>Combination of A1.11, A1.11 and A1.12G</i>)
A22P		Discontinued (<i>Combination of A1.11P, A1.1 and A1.12G</i>)
B1	B1.11	Add 2 washers under crossarm pins
B1A	B1.12	Add 2 washers under crossarm pins
B1P	B1.11P	No material changes
B1AP	B1.12P	No material changes
B1-1	B2.24	Add 4 washers under crossarm pins
B1-1A	B2.25	Add 4 washers under crossarm pins
B1-1P	B2.24P	No material changes
B1-1AP	B2.25P	No material changes
B2	B2.21	Add 4 washers under crossarm pins
B2P	B2.21P	No material changes
B3	B3.1	Replace 2 washers abutting pole and slight material changes

Disposition of Assemblies in Bulletin 50-3 (D 804)

Old Assembly Number (Bulletin 50-3)	New Assembly Number (1728F-804)	Material Changes and Comments
B3A		Discontinued (<i>Similar to B3.1</i>)
B4-1		Discontinued (<i>Replaced with guide B4.1G</i>)
B4-1A		Discontinued (<i>Replaced with guide B4.1G</i>)
B5-1	B5.1	Replace 3 washers abutting pole and slight material changes
B5-1A		Discontinued (<i>Similar to B5.1</i>)
B7	B5.21	Neutral position and material slightly different
B7-1	B5.31	Neutral position and material slightly different
B8	B6.21	Neutral and material slightly different
B9	B2.22	Add 6 washers under crossarm pins
B9-1	B1.14	Add 3 washers under crossarm pins
B9-2		Discontinued (<i>Same as B2.22 except for 10-foot crossarms</i>)
B9-3		Discontinued (<i>Same as B1.14 except for 10-foot crossarms</i>)
B9P	B2.22P	Add 2 washers under crossarm pins
B9-1P	B1.14P	Add 1 washer under crossarm pin
B9-2P		Discontinued (<i>Same as B2.22P except for 10-foot crossarms</i>)
B9-3P		Discontinued (<i>Same as B1.14P except for 10 foot crossarms</i>)
B22		Discontinued (<i>Same as two B1.11s</i>)
B22P		Discontinued (<i>Same as two B1.11Ps</i>)
C1	C1.11	Add 2 washers under crossarm pins
C1A	C1.12	Add 2 washers under crossarm pins
C1P	C1.11P	No material changes
C1AP	C1.12P	No material changes
C1PL		Discontinued (<i>Same as C1.11P except crossarm braces</i>)
C1-1	C2.24	Add 4 washers under crossarm pins
C1-1A	C2.25	Add 4 washers under crossarm pins
C1-1AP	C2.24P	No material changes
C1-1P	C2.25P	No material changes
C1-3P	C2.21P	No material changes
C1-4PL		Discontinued (<i>Second center insulator not needed</i>)
C1-2	C1.11L	No material changes
C1-3	C2.21L	No material changes
C1-4	C1.13L	No material changes
C2	C2.21	Add 4 washers under crossarm pins
C2-1	C2.52	Add 6 washers under crossarm pins
C2-2	C2.52L	No material changes
C2-2PL	C2.52P	2 fewer double arming bolts – optional
C3	C3.1	Replace 4 washers abutting pole; add neutral eyebolt
C3-1	C3.1L	Replace 8 washers abutting pole
C4-1		Discontinued (<i>Replaced with guide C4.1G</i>)

Disposition of Assemblies in Bulletin 50-3 (D 804)

Old Assembly Number (Bulletin 50-3)	New Assembly Number (1728F-804)	Material Changes and Comments
C5-1	C5.2	Replace 4 washers abutting pole
C7	C5.21	Replace 1 washer abutting pole
C7-1	C5.31	Replace 1 washer abutting pole
C7A	C5.71L	Replace 1 washer abutting pole
C7-2	C5.22	Slight material changes
C8	C6.21	Different neutral and crossarm brace materials
C8-1		Discontinued (<i>Replaced with C6.51</i>)
C8-2		Discontinued (<i>Similar to C5.21</i>)
C8-3	C6.31L	Different neutral position and materials
C9	C2.51	Add 8 washers under crossarm pins and anti-split bolt
C9-1	C1.41	Add 4 washers under crossarm pins
C9-2	C2.51L	Replace 2 crossarm pins with clamp-type
C9-3	C1.41L	Replace 1 crossarm pin with clamp-type
C9-1P	C1.41P	Add 1 washer under crossarm pin
C9-2PL	C2.51P	Add 2 washers under crossarm pins; 2 fewer double arming bolts – optional
C9-3PL		Discontinued (<i>Nearly same as C9-1P</i>)
C22		Discontinued (<i>Combination of C1.11, A1.11 and C6.91G</i>)
C24		Discontinued (<i>Replaced with C6.91G</i>)
DC-C1	D1.81	Add 6 washers under crossarm pins
DC-C1A		Discontinued
DC-C1-1A		Discontinued
DC-C1PL		Discontinued (<i>Replaced with D1.81P</i>)
DC-C1-3PL		Discontinued (<i>Replaced with D2.91P</i>)
DC-C2		Discontinued (<i>Wrong neutral for line angle</i>)
DC-C2-1	D2.91	Add 12 washers under crossarm pins
DC-C3		Discontinued (<i>Replaced by two C3's and D3.1G</i>)
DC-C4-1		Discontinued (<i>Replaced by four C3's and D4.1G</i>)
DC-C8	D6.91	Slightly different neutral and other material.
DC-C25		Discontinued (<i>Replace with guide drawing D5.91G</i>)
E1-1		Discontinued (<i>See E1.1</i>)
E1-2	E1.1	Add Guy Marker
E1-3	E1.1L	Add Guy Marker
E2-1		Discontinued
E2-2	E1.4	Different guy strand wire (<i>Different permitted loads</i>)
E2-3	E1.4L	Replace 5/8" thimble eye bolt and nut with 3/4"
E3-2		Discontinued
E3-3	E1.2	Add Guy Marker (<i>Different permitted loads</i>)
E3-10		Discontinued

Disposition of Assemblies in Bulletin 50-3 (D 804)

Old Assembly Number (Bulletin 50-3)	New Assembly Number (1728F-804)	Material Changes and Comments
E4-2		Discontinued <i>(See note 3 on E1.4)</i>
E4-3		Discontinued <i>(See note 3 on E1.4)</i>
E5-1		Discontinued
E5-2		Discontinued
E6-2		Discontinued <i>(See E2.1G)</i>
E6-3		Discontinued <i>(See E2.1G)</i>
E7-2		Discontinued <i>(See E3.1LG)</i>
E7-3		Discontinued <i>(See E3.1LG)</i>
E8-2		Discontinued <i>(See E4.3LG)</i>
E8-3		Discontinued <i>(See E4.3LG)</i>
E11		Discontinued <i>(See E1.2)</i>
E12		Discontinued <i>(See E1.2)</i>
F1-1	F1.6	No material changes
F1-2	F1.8	No material changes
F1-3	F1.10	No material changes
F1-4	F1.12	No material changes
F1-1C		Discontinued <i>(Not in List of Materials)</i>
F1-2C		Discontinued <i>(Not in List of Materials)</i>
F1-3C		Discontinued <i>(Not in List of Materials)</i>
F1-1P	F3.6	No material changes
F1-2P	F3.8	No material changes
F1-3P	F3.10	No material changes
F1-4P	F3.12	No material changes
F1-1S	F2.6	No material changes
F1-2S	F2.8	No material changes
F1-3S	F2.10	No material changes
F1-4S	F2.12	No material changes
F2-1		Discontinued
F2-2		Discontinued
F2-3		Discontinued
F2-4		Discontinued
F4-1E	F4.1	No material changes
F4-1S	F4.2	No material changes
F5-1	F5.1	No material changes
F5-2	F5.2	No material changes
F5-3	F5.3	No material changes
F6-1	F6.6	No material changes
F6-2	F6.8	No material changes
F6-3	F6.10	No material changes

Disposition of Assemblies in Bulletin 50-3 (D 804)

Old Assembly Number (Bulletin 50-3)	New Assembly Number (1728F-804)	Material Changes and Comments
G9-	G1.7	No material changes
G65-		Discontinued
G105-	G1.2	No material changes
G10-	G1.8	No material changes
G66-		Discontinued
G106-	G1.3	No material changes
G39-		Discontinued - <i>Same as G9-</i>
G67-		Discontinued
G136-		Discontinued - <i>Same as G105-</i>
G210-	G2.1	No material changes (<i>Drawing modified</i>)
G310-	G3.1	No material changes (<i>Drawing modified</i>)
G311-	G3.2	No material changes (<i>Drawing modified</i>)
G312-	G3.3	No material changes (<i>Drawing modified</i>)
J5	J1.2	No material changes
J6	J3.1	No material changes
J7	J2.2	No material changes
J7C		Discontinued - <i>Same as J7</i>
J8	J1.1	No material changes
J10	J2.1	No material changes
J11		Discontinued - <i>Same as J6</i>
J12	J4.1	No material changes
K10	K2.1	No material changes
K11	K1.4	No material changes
K14	K1.3	No material changes
K10C	K2.2	No material changes
(K10C)	K2.3	No material changes
K10L		Discontinued - <i>Same as K10</i>
K11L		Discontinued - <i>Same as K11</i>
K14L		Discontinued - <i>Same as K14</i>
K11C	K1.2	No material changes
K14C	K1.1	No material changes
K15C	K1.5	No material changes
K16C	K3.2	No material changes
K17	K3.1	No material changes
K17L		Discontinued - <i>Same as K17</i>
M2-1		Discontinued
M2-11	H1.1	No material changes
M2-2		Discontinued
M2-12	H5.1	No material changes

Disposition of Assemblies in Bulletin 50-3 (D 804)

Old Assembly Number (Bulletin 50-3)	New Assembly Number (1728F-804)	Material Changes and Comments
M2-2A		Discontinued
M2-12A	H5.2	No material changes
M2-2A2		Discontinued
M2-12A2		Discontinued
M2-3		Discontinued
M2-13	H2.1	No material changes
M2-7		Discontinued
M2-17		Discontinued
M2-9		Discontinued
M2-15	H3.1	No material changes
M2-15A	H4.1	No material changes
M3-1A		Discontinued
M3-4	S1.1	Replace lag screw with machine bolt and washer
M3-2A	S2.21	Slight material changes
M3-3A	S2.31	Slight material changes
M3-3B	S2.3	No material changes
M3-10	R1.1	Slight material changes (<i>Add bracket</i>)
M3-41	S3.1	Slight material changes (<i>Add bracket</i>)
M3-11		Discontinued (<i>See R3.1</i>)
M3-12		Discontinued (<i>Replaced with R3.1</i>)
M3-11A	R2.1	No material changes
M3-12A	R3.1	No material changes
M3-15	S2.32	Slight material changes
M3-23		Discontinued
M3-24		Discontinued
M3-25		Discontinued
M3-23A	R1.2	Slight material changes (<i>Add bracket</i>)
M3-24A	R2.2	Slight material changes
M3-25A	R3.2	Slight material changes
M3-30	R3.3	Slight material changes
M5-1		Discontinued
M5-2	A1.01	No material changes
M5-5	A1.011	Add 1 washer under crossarm pin
M5-6	P1.01	No material changes
M5-7	A1.011P	No material changes
M5-8	A5.02	No material changes
M5-9	S1.01	No material changes
M5-10	S1.02	No material changes
M5-11		Discontinued

Disposition of Assemblies in Bulletin 50-3 (D 804)

Old Assembly Number (Bulletin 50-3)	New Assembly Number (1728F-804)	Material Changes and Comments
M5-12		Discontinued
M5-13	W3.2	No material changes
M5-14		Discontinued
M5-16		Discontinued
M5-17	W3.1	No material changes
M5-18	A1.01P	No material changes
M5-19	N1.2	No material changes
M5-20		Discontinued (<i>See A5.3</i>)
M5-21		Discontinued
M5-22		Discontinued
M5-23		Discontinued
M5-24	A5.01	No material changes
M5-25	N5.1	Replace 1 washer abutting pole
M5-26	N5.3	Replace 1 washer abutting pole
M7-11	Y1.1	Minor material changes – <i>replace crossarms with bracket</i>
M7-13	Y1.3	Minor material changes
M8	Q1.1	Minor material changes
M8-6	Q3.1	No material changes
M8-9	Q2.2G	Modified guide drawing; no material
M8-10	Q2.1G	Modified guide drawing; no material
M8-11	Q3.3	Minor material changes
M8-12	Q3.2	Minor material changes
M8-15	Q4.1	Minor material changes
M9-11	Y3.1	No material changes
M9-12	Y3.2	Minor material changes
M9-13	Y3.3	Minor material changes
M19	W2.1G	Modified guide drawing; no material
M20	W1.1G	Modified guide drawing; no material
M21		Discontinued (<i>Guide drawing</i>)
M22-1		Discontinued (<i>Guide drawing</i>)
M22-2		Discontinued (<i>Guide drawing</i>)
M24	K4.1G	Modified guide drawing; no material
M24-1		Discontinued (<i>Guide drawing</i>)
M24-10	K4.2G	Modified guide drawing; no material
M26-5		Discontinued (<i>Guide drawing</i>)
M27		Discontinued (<i>Guide drawing</i>)
M27-1		Discontinued (<i>Guide drawing</i>)
M27-1A	G1.1G	Modified guide drawing; no material
M27-2		Discontinued (<i>Guide drawing</i>)

Disposition of Assemblies in Bulletin 50-3 (D 804)

Old Assembly Number (Bulletin 50-3)	New Assembly Number (1728F-804)	Material Changes and Comments
M28		Discontinued (<i>See G1.1G</i>)
M29-1		Discontinued (<i>See guide drawings in Sections A and C</i>)
M29-2		Discontinued (<i>See guide drawings in Sections A and C</i>)
M30-1		Discontinued (<i>Guide drawing</i>)
M30-2		Discontinued (<i>Guide drawing</i>)
M40-11		Discontinued (<i>Guide drawing</i>)
M41-1		Discontinued (<i>Replaced assemblies L1.1 and L3.1</i>)
M41-10		Discontinued (<i>Replaced assemblies L1.2 and L3.2</i>)
M42-3		Discontinued (<i>Replaced assemblies L1.3 and L3.4</i>)
M42-11		Discontinued (<i>Replaced assemblies L1.5 and L3.5</i>)
M42-13		Discontinued (<i>Replaced assembly L2.5</i>)
M42-21		Discontinued (<i>Replaced assemblies L1.4 and L3.3</i>)
M43-4		Discontinued (<i>Guide drawing</i>)
M43-10		Discontinued (<i>Guide drawing</i>)
M52-3		Discontinued (<i>Guide drawing</i>)
M52-4		Discontinued (<i>Guide drawing</i>)
R1	M1.30G	Modified guide drawing; no material
		<p>249 <u>Total Assemblies</u> (257 – 8 discontinued duplicates)</p> <p>82 Discontinued</p> <p>94 Re-used: No material changes</p> <p>37 Re-used: Washer changes only</p> <p><u>36 Re-used: Other slight material changes</u></p> <p>167 Total assemblies re-used</p> <p><u>32 Total Guide Drawings</u></p> <p>24 Discontinued</p> <p>8 Re-used</p> <p>180 Total pages</p>

Bulletin 1728F-804: New Assemblies and Guide Drawings	
NUMBER	ASSEMBLY / GUIDE DRAWING DESCRIPTION
NEW SINGLE-PHASE PRIMARY POLE TOP ASSEMBLIES	
A1.011L	SINGLE SUPPORT - PRIMARY
A1.04N A1.04NP	SINGLE SUPPORT – NARROW PROFILE
A1.3	SINGLE SUPPORT
A1.3P	SINGLE SUPPORT (POST INSULATORS)
A1.4N A1.5N	SINGLE SUPPORT – NARROW PROFILE (TANGENT)
A1.4NP A1.5NP	SINGLE SUPPORT – NARROW PROFILE (TANGENT) (POST INSULATORS)
A1.6N	SINGLE SUPPORT - NARROW PROFILE
A1.6NP	SINGLE SUPPORT – NARROW PROFILE (POST INSULATORS)
A1.12G	SINGLE PHASE JUNCTION GUIDE
A2.01 A2.01P A2.021 A2.021P	DOUBLE SUPPORT - PRIMARY
A2.04N A2.04NP	DOUBLE SUPPORT – NARROW PROFILE
A2.4N A2.5N	DOUBLE SUPPORT – NARROW PROFILE (TANGENT)
A2.4NP A2.5NP	DOUBLE SUPPORT – NARROW PROFILE (TANGENT) (POST INSULATORS)
A2.6N	DOUBLE SUPPORT - NARROW PROFILE
A2.6NP	DOUBLE SUPPORT – NARROW PROFILE (POST INSULATORS)
A3.2 A3.3	SUSPENSION ANGLE
A3.4 A3.5 A3.6 A3.7 A3.8 A3.9	SUSPENSION ANGLE
A4.2	DEADEND ANGLE (15° - 90°)
A5.03	SINGLE DEADENDS
A5.3	SINGLE DEADENDS

A5.4 A5.5 A5.6 A5.7 A5.8 A5.9	SINGLE DEADENDS
A5.2G	SINGLE PHASE TAP GUIDE
A5.3NG	SINGLE PHASE TAP GUIDE - NARROW PROFILE
A5.4NG	SINGLE PHASE TAP GUIDE - NARROW PROFILE (WITH CUTOUT AND ARRESTER)
A6.2	DOUBLE DEADEND (FEED THROUGH)
A6.22G	DOUBLE DEADEND GUIDE (FEED THROUGH ON CROSSARMS)
NEW TWO-PHASE PRIMARY POLE TOP ASSEMBLIES	
B1.1N B1.2N	SINGLE SUPPORT - NARROW PROFILE (TANGENT)
B1.1NP B1.2NP	SINGLE SUPPORT - NARROW PROFILE (TANGENT) (POST INSULATORS)
B1.3N	SINGLE SUPPORT - NARROW PROFILE
B1.3NP	SINGLE SUPPORT - NARROW PROFILE (POST INSULATORS)
B1.4N B1.5N	SINGLE SUPPORT - NARROW PROFILE (TANGENT)
B1.4NP B1.5NP	SINGLE SUPPORT - NARROW PROFILE (TANGENT) (POST INSULATORS)
B1.6N	SINGLE SUPPORT - NARROW PROFILE
B1.6NP	SINGLE SUPPORT - NARROW PROFILE (POST INSULATORS)
B1.7N B1.8N	SINGLE SUPPORT - NARROW PROFILE (TANGENT)
B1.7NP B1.8NP	SINGLE SUPPORT - NARROW PROFILE (TANGENT) (POST INSULATORS)
B1.9N	SINGLE SUPPORT - NARROW PROFILE
B1.9NP	SINGLE SUPPORT - NARROW PROFILE (POST INSULATORS)
B1.13	SINGLE SUPPORT ON CROSSARM
B1.13P	SINGLE SUPPORT ON CROSSARM (POST INSULATORS)
B2.1N B2.2N	DOUBLE SUPPORT - NARROW PROFILE (TANGENT)
B2.1NP B2.2NP	DOUBLE SUPPORT - NARROW PROFILE (TANGENT) (POST INSULATORS)
B2.3N	DOUBLE SUPPORT - NARROW PROFILE
B2.3NP	DOUBLE SUPPORT - NARROW PROFILE (POST INSULATORS)
B2.4N B2.5N	DOUBLE SUPPORT - NARROW PROFILE (TANGENT)
B2.4NP	DOUBLE SUPPORT - NARROW PROFILE (TANGENT)

B2.5NP	(POST INSULATORS)
B2.6N	DOUBLE SUPPORT - NARROW PROFILE
B2.6NP	DOUBLE SUPPORT - NARROW PROFILE (POST INSULATORS)
B2.7N B2.8N	DOUBLE SUPPORT – NARROW PROFILE (TANGENT)
B2.7NP B2.8NP	DOUBLE SUPPORT – NARROW PROFILE (TANGENT) (POST INSULATORS)
B2.9N	DOUBLE SUPPORT - NARROW PROFILE
B2.9NP	DOUBLE SUPPORT - NARROW PROFILE (POST INSULATORS)
B3.2 B3.3	SUSPENSION ANGLE
B3.4 B3.5 B3.6 B3.7 B3.8 B3.9	SUSPENSION ANGLE
B4.1G	DEADEND ANGLE GUIDE ($90^0 - 150^0$)
B4.2G	DEADEND ANGLE GUIDE ($15^0 - 90^0$)
B5.2 B5.3	SINGLE DEADENDS
B5.4 B5.5 B5.6 B5.7 B5.8 B5.9	SINGLE DEADENDS
NEW THREE-PHASE PRIMARY POLE TOP ASSEMBLIES	
C1.1N C1.2N	SINGLE SUPPORT – NARROW PROFILE (TANGENT)
C1.1NP C1.2NP	SINGLE SUPPORT – NARROW PROFILE (TANGENT) (POST INSULATORS)
C1.3N	SINGLE SUPPORT - NARROW PROFILE
C1.3NP	SINGLE SUPPORT - NARROW PROFILE (POST INSULATORS)
C1.4N C1.5N	SINGLE SUPPORT - NARROW PROFILE (TANGENT)
C1.4NP C1.5NP	SINGLE SUPPORT - NARROW PROFILE (TANGENT) (POST INSULATORS)
C1.6N	SINGLE SUPPORT - NARROW PROFILE
C1.6NP	SINGLE SUPPORT - NARROW PROFILE (POST INSULATORS)
C1.7N C1.8N	SINGLE SUPPORT - NARROW PROFILE (TANGENT)
C1.7NP C1.8NP	SINGLE SUPPORT - NARROW PROFILE) (TANGENT) (POST INSULATORS)

C1.9N	SINGLE SUPPORT - NARROW PROFILE
C1.9NP	SINGLE SUPPORT - NARROW PROFILE (POST INSULATORS)
C1.12L	SINGLE SUPPORT ON CROSSARM – (TANGENT) (LARGE CONDUCTORS)
C1.13	SINGLE SUPPORT ON CROSSARM
C1.13P	SINGLE SUPPORT ON CROSSARM (POST INSULATORS)
C1.81G	THREE-PHASE JUNCTION GUIDE
C2.1N C2.2N	DOUBLE SUPPORT – NARROW PROFILE (TANGENT)
C2.1NP C2.2NP	DOUBLE SUPPORT – TANGENT (POST INSULATORS) (NARROW PROFILE)
C2.3N	DOUBLE SUPPORT - NARROW PROFILE
C2.3NG	DOUBLE SUPPORT – NARROW PROFILE (ALTERNATIVE GUYING GUIDE)
C2.3NP	DOUBLE SUPPORT - NARROW PROFILE (POST INSULATORS)
C2.4N C2.5N	DOUBLE SUPPORT – NARROW PROFILE (TANGENT)
C2.4NP C2.5NP	DOUBLE SUPPORT – NARROW PROFILE TANGENT (POST INSULATORS)
C2.6N	DOUBLE SUPPORT - NARROW PROFILE
C2.6NP	DOUBLE SUPPORT - NARROW PROFILE (POST INSULATORS)
C2.7N C2.8N	DOUBLE SUPPORT – NARROW PROFILE (TANGENT)
C2.7NP C2.8NP	DOUBLE SUPPORT – NARROW PROFILE (TANGENT) (POST INSULATORS)
C2.9N	DOUBLE SUPPORT - NARROW PROFILE
C2.9NP	DOUBLE SUPPORT - NARROW PROFILE (POST INSULATORS)
C3.2 C3.3	SUSPENSION ANGLE
C3.4 C3.5 C3.6 C3.7 C3.8 C3.9	SUSPENSION ANGLE
C4.1G	DEADEND GUIDE ($90^{\circ} - 150^{\circ}$)
C4.2G	DEADEND GUIDE ($15^{\circ} - 90^{\circ}$)
C5.1 C5.3	SINGLE DEADENDS - VERTICAL
C5.4 C5.5 C5.6 C5.7 C5.8	SINGLE DEADENDS - VERTICAL

C5.9	
C5.11G	SINGLE PHASE TAP GUIDE
C5.21L C5.31L	SINGLE DEADEND ON CROSSARMS (LARGE CONDUCTORS)
C5.32	SINGLE DEADEND ON CROSSARMS - ALTERNATIVE
C5.82G	THREE PHASE HORIZONTAL TAP GUIDE
C6.31	DOUBLE DEADEND ON CROSSARMS
C6.21L	DOUBLE DEADEND ON CROSSARMS (LARGE CONDUCTORS)
C6.52 C6.53	DOUBLE DEADEND ON 10-FOOT CROSSARMS
C6.52G	DOUBLE DEADEND ON 10-FOOT CROSSARMS (FEEDTHROUGH GUIDE)
C6.91G	DOUBLE DEADENDS (BUCKARMS) GUIDE
NEW DOUBLE CIRCUIT PRIMARY POLE TOP ASSEMBLIES	
D1.4N D1.4NP D1.5N D1.5NP	SINGLE SUPPORT - NARROW PROFILE - (TANGENT) (and POST INSULATORS)
D1.82	SINGLE SUPPORT ON CROSSARMS - (TANGENT)
D1.81L D1.82L	SINGLE SUPPORT ON CROSSARMS - (TANGENT) (LARGE CONDUCTORS)
D1.81P D1.82P	SINGLE SUPPORT ON CROSSARMS - (TANGENT) (POST INSULATORS)
D1.83	SINGLE SUPPORT ON CROSSARMS
D1.83L	SINGLE SUPPORT ON CROSSARMS (LARGE CONDUCTORS)
D1.83P	SINGLE SUPPORT ON CROSSARMS (POST INSULATORS)
D2.9N D2.9NP	DOUBLE SUPPORT - NARROW PROFILE (and POST INSULATORS)
D2.91L	DOUBLE SUPPORT ON CROSSARMS (LARGE CONDUCTORS)
D2.91P	DOUBLE SUPPORT ON CROSSARMS (POST INSULATORS)
D3.1G	SUSPENSION ANGLE GUIDE
D4.1G	DEADEND ANGLE GUIDE
D5.91G	THREE PHASE TAP GUIDE
NEW GUYING ASSEMBLIES	
E1.3L	SINGLE DOWN GUY - LARGE CONDUCTORS (POLE BAND TYPE)
E1.5	GUY STRAIN INSULATOR
E2.1G	DOUBLE DOWN GUY GUIDE - (THROUGH BOLT TYPE)
E3.1LG	THREE DOWN GUY GUIDE - HEAVY DUTY (THROUGH BOLT TYPE)
E4.3LG	FOUR DOWN GUY GUIDE - LARGE CONDUCTORS (POLE BAND TYPES)

NEW TRANSFORMER ASSEMBLIES	
G1.2G	POLE TYPE TRANSFORMER LOCATION GUIDE
G1.4 G1.5	SINGLE-PHASE, CONVENTIONAL TRANSFORMER (TANGENT POLE)
G1.6	SINGLE-PHASE, CONVENTIONAL TRANSFORMER (DEADEND POLE)
G2.1G	TRANSFORMER / METER CONNECTION GUIDE THREE-PHASE, OPEN-WYE - OPEN DELTA FOR 120/240 VOLT POWER LOADS
G3.1G	TRANSFORMER / METER CONNECTION GUIDE UNGROUND WYE - CENTER TAP GROUNDED DELTA FOR 120/240 VOLT POWER LOADS
G3.2G	TRANSFORMER / METER CONNECTION GUIDE UNGROUND WYE - CORNER GROUNDED DELTA FOR 240 OR 480 VOLT POWER LOADS
G3.3G	TRANSFORMER / METER CONNECTION GUIDE GROUND WYE - GROUNDED WYE FOR 120/208 VOLT POWER LOADS
NEW GROUNDING ASSEMBLIES	
H5.3	GROUNDING IMPROVEMENT ASSEMBLIES - WRAP-AROUND TYPE
NEW TYING ASSEMBLIES	
L1.1 L1.2	PRIMARY ANGLE TYING ASSEMBLIES
L1.3 L1.4 L1.5	PRIMARY DEADEND TYING ASSEMBLIES
L2.1 L2.2	NEUTRAL ANGLE TYING ASSEMBLIES
L2.3 L2.4 L2.5	NEUTRAL DEADEND TYING ASSEMBLIES
L3.1 L3.2	NEUTRAL & SECONDARY ANGLE TYING ASSEMBLIES
L3.3 L3.4	NEUTRAL & SECONDARY DEADEND TYING ASSEMBLIES - (COPPER)
L3.5 L3.6	NEUTRAL & SECONDARY DEADEND TYING ASSEMBLIES - (ACSR)
L4.1	TYING ASSEMBLIES, SERVICES
L4.2 L4.3 L4.4	TYING ASSEMBLIES, SERVICES

NEW NEUTRAL ASSEMBLIES	
N1.1	NEUTRAL ASSEMBLIES - TANGENT
N1.11 N2.21	NEUTRAL SUPPORTS ON CROSSARMS
N2.1 N2.1L	NEUTRAL ASSEMBLIES - LARGE ANGLE
N5.2	NEUTRAL ASSEMBLIES - (SINGLE DEADENDS)
N6.1	NEUTRAL ASSEMBLY - DOUBLE DEADEND
N6.21	NEUTRAL ASSEMBLY - DOUBLE DEADEND ON CROSSARMS
NEW PROTECTION ASSEMBLIES	
P1.1	SURGE ARRESTERS - SINGLE PHASE
P1.1NG	SURGE ARRESTER GUIDE - NARROW PROFILE
P1.3	SURGE ARRESTERS - 3 SINGLE PHASE
P3.1G	RAPTOR PROTECTION ASSEMBLY GUIDE SUPPORT ON 8-FOOT CROSSARMS (TANGENT)
P3.2G	RAPTOR PROTECTION ASSEMBLY GUIDE SUPPORT ON 10-FOOT CROSSARMS (TANGENT)
P3.3G	RAPTOR PROTECTION, PERCH GUARDS - GUIDE
P3.4G	RAPTOR PROTECTION, SINGLE-PHASE, CSP TRANSFORMER (TANGENT POLE)
P3.5G	RAPTOR PROTECTION ASSEMBLY GUIDE THREE-PHASE TRANSFORMER BANK
NEW SECTIONALIZING ASSEMBLIES	
S2.01	MISCELLANEOUS CUTOUPS AND DISCONNECT SWITCH
S1.1N	CUTOUP GUIDE - NARROW PROFILE
S1.3	COUTOUTS - (THREE SINGLE-PHASE)
S3.2	SECTIONALIZER (WITH BYPASS CUTOUP)
NEW VOLTAGE ALTERATION EQUIPMENT ASSEMBLIES	
Y2.1 Y2.2	AUTOTRANSFORMER, POLE MOUNTED (ONE SINGLE-PHASE, STEP-DOWN)
Y3.4	SWITCHED CAPACITOR BANK - THREE PHASE
	<p>215 Total new assemblies (95 narrow profile) 32 Total new guide drawings (4 narrow profile)</p>

RUS Standard Format and Meaning of Overhead Distribution Assembly Numbers

The RUS standard numbering format for overhead distribution assemblies is: **L₁N₁.N₂**

L₁ is an alphabetic character that represents the category or group of similar assemblies that fulfill a similar and specific function in the construction or operation of an overhead distribution line. For example, the assemblies in category “C” are pole top assemblies that support three primary conductors (3-phase) and a neutral conductor.

The following table shows the 19 distribution assembly categories and the letter (L₁) RUS has assigned to represent them.

DESIGNATED MEANINGS of ASSEMBLY CATEGORY NUMBERS (L₁)		
A 1-Phase, pole-top	H Grounds	Q Metering
B 2-Phase, pole-top	J Secondaries	R Reclosers
C 3-Phase, pole-top	K Services	S Sectionalizing
D Double Circuit, pole-top	L Conductor Tying	W Poles, Crossarms
E Guys	M Miscellaneous	Y Volt. Alteration Equip.
F Anchors	N Neutrals	
G Transformers	P Protection	

N₁ is a numeric character that represents a subcategory or group of similar assemblies within a category. The different assemblies in a subcategory all fulfill the same specific functional purpose, but their function is somewhat different than the other assemblies within their associated assembly category (L₁). For example, within categories “A” through “D” the subcategory “1” assemblies are all *tangent or small angle* pole top assemblies that (only) support the primary and neutral conductors.

The following table shows the RUS designated meaning of the numbers (N₁) that represent the 6 subcategories within pole-top assembly categories “A” through “D”.

DESIGNATED MEANINGS of SUBCATEGORY NUMBERS (N₁) for POLE TOP ASSEMBLIES	
1	Tangent or Small Angles (single pin or post type insulators)
2	Small Angles (double pin or post type insulators)
3	Large Angles (suspension type insulators)
4	Large Angles (double deadends)
5	Single Deadends or Taps
6	Double Deadends

RUS has assigned meanings to the subcategory numbers (N₁) for the remaining 15 (L₁) categories of overhead distribution assemblies, however, the list and meanings of these numbers is long and varied and beyond the scope of this summary exhibit. The remaining subcategory numbers and their assigned meanings are tabulated in RUS

Bulletin 1728F-800, "Construction Assembly Unit Numbers and Format." This bulletin is posted on the RUS website at: <http://www.usda.gov/rus/electric/bulletins.htm>.

N₂, which is always either a one or two digit number, is defined as the *assembly identification number*. This number is used to differentiate the similar assemblies in a subcategory (N₁) of assemblies

RUS has assigned assembly identifications numbers from 11 through 99 to pole top assemblies that are constructed with crossarms. Furthermore, the two-digit crossarm assembly identification numbers have been assigned the designated meaning shown in the following table.

DESIGNATED MEANINGS of ASSEMBLY IDENTIFICATION NUMBERS (N₂) for CROSSARM ASSEMBLIES	
11-19	Single 8-foot crossarms
21-29	(1 set of) Double 8-foot crossarms
31-39	(1 set of) Triple 8-foot crossarms
41-49	Single 10-foot crossarms
51-59	(1 set of) Double 10-foot crossarms
61-69	<i>Not used – Reserved for future</i>
71-79	(1) Pre-assembled (manufactured) single crossarm assembly (item "gj")
81-89	Multiple crossarm assemblies
91-99	Multiple crossarm assemblies

The *prefix* "V" in front of a standard assembly number indicates that the assembly is used for 24.9/14.4 kV line construction. A standard assembly number with no prefix indicates that the assembly is used for 12.47/7.2 kV line construction.

A *suffix* is an alphabetic character placed at the end of a standard assembly number. A suffix describes the type of the assembly. Presently, RUS only uses the following 4 suffixes whose designated meanings are shown in parentheses:

G (Guide drawing, not an assembly) **N** (Narrow profile construction assembly)

L (Large conductor construction) **P** (Assembly with post type insulators)

Not all assembly numbers have suffixes and some may have more than one suffix letter.

TABLE OF SELECTED SI TO METRIC CONVERSIONS

LENGTH

<i>To Convert From</i>	<i>To</i>	<i>Multiply By</i>	
foot (ft.)	meter (m)	3.048	E-01
inch (in.)	meter (m)	2.540	E-02
kilometer (km)	meter (m)	1.000	E+03
mile (mi.)	meter (m)	1.609344	E+03

AREA

<i>To Convert From</i>	<i>To</i>	<i>Multiply By</i>	
circular mil (cmil)	square meter	5.067075	E-10
square centimeter	square meter	1.000	E-04
square foot	square meter	9.290304	E-02
square kilometer	square meter	1.000	E+06
square mile	square meter	2.589988	E+06

FORCE

<i>To Convert From</i>	<i>To</i>	<i>Multiply By</i>	
kilogram force (kgf)	newton (N)	9.806650	
kip	newton (N)	4.448222	E+03
pound force (lbf)	newton (N)	4.448222	

MASS

<i>To Convert From</i>	<i>To</i>	<i>Multiply By</i>	
pound (avoirdupois) (lb)	kilogram (kg)	4.535924	E-01