

UNITED STATES DEPARTMENT OF AGRICULTURE  
Rural Utilities Service

BULLETIN 1724E-214

**SUBJECT:** Guide Specification for Standard Class Steel Transmission Poles

**TO:** All Electric Borrowers

**EFFECTIVE DATE:** Date of Approval

**OFFICE OF PRIMARY INTEREST:** Transmission Branch, Electric Staff Division

**INSTRUCTIONS:** This is a new bulletin.

**AVAILABILITY:** This bulletin is available on the Rural Utilities Service website at <http://www.usda.gov/rus/electric>.

**PURPOSE:** This bulletin provides guidance for procuring standard class steel poles for transmission applications.



---

Blaine D. Stockton  
Assistant Administrator, Electric Program

7/2/01

---

Date

## TABLE OF CONTENTS

### Instructions

A. Purpose .....	4a
B. Scope .....	4a
C. Initial Design Considerations .....	4a
D. Information to be Completed by the Owner .....	4a
• Documents and General Information to be Added .....	5a
• Specifications and Technical Information to be Completed by Owner .....	5a
• Strength Requirements .....	5a
• Application Requirements .....	6a
E. Information to be completed by the Manufacturer .....	6a
• By all bidders .....	6a
• By successful bidder prior to fabrication .....	7a
• Test reports as requested by owner .....	8a

### Specification for Standard Class Steel Poles

1. Scope .....	1
2. Definitions .....	2
3. Codes and Standards .....	3
4. Conflicts Between Specifications, Drawings, and Reference Documents .....	3
5. General Requirements .....	3
5.1 Design Requirements .....	4
Figure 1 (Minimum Ultimate. Moment Capacity Diagram) .....	4
Table 1 (Strength Requirements) .....	5
5.2 Materials .....	7
5.3 Fabrication .....	7
5.4 Tolerances .....	9
5.5 Grounding .....	10
5.6 Climbing Devices .....	10
5.7 Splices .....	10
5.8 Appurtenances .....	11
5.9 Finishes .....	11
5.10 Markings .....	12
5.11 Inspection and Testing .....	13
5.12 Full Scale Structure Testing .....	13
6. Shipping and Delivery .....	14
6.1 Shipping .....	14
6.2 Delivery .....	15
7. Drawings and Information Supplied By The Manufacturer .....	15
7.1 Information to be Supplied with the proposal .....	15
7.2 Information to be Supplied prior to fabrication (As requested by the owner) .....	15
7.3 Test Reports (As requested) .....	16

8. Approval, Acceptance and Ownership .....	16
9. List of Attachments .....	16
Attachment A – Structure Dimensions and Pole Framing Drawings .....	17
Attachment B - Application Requirements .....	19
Attachment C - Bid Summary.....	21

### Appendices

APPENDIX A – COMMENTARY.....	A-1
APPENDIX B – EXAMPLES OF DRAWINGS.....	B-1
APPENDIX C – DESIGN EXAMPLE .....	C-1
APPENDIX D – SELECTED METRIC CONVERSIONS .....	D-1
APPENDIX E – CONTRIBUTORS .....	E-1

### INDEX:

#### MATERIALS AND EQUIPMENT:

POLES: Steel

    Guide Specifications for Standard Class Steel Poles

#### SPECIFICATIONS AND STANDARDS:

    Guide Specifications for Standard Class Steel Poles.

### ABBREVIATIONS

ACA	Ammoniacal Copper Arsenate	mph	miles per hour
ACSR	Aluminum conductor steel reinforced	NESC	National Electrical Safety Code
ACZA	Ammoniacal Copper Zinc Arsenate	NEMA	National Electrical Manufacturers Association
ANCO	American Nut Company	OLF	Overload factor
AISC	American Institute of Steel Construction	OHGW	Overhead ground wire
ANSI	American National Standards Institute	OSHA	Occupational Safety and Health Administration
ASCE	American Society of Civil Engineers	REA	Rural Electrification Administration
ASTM	American Society for Testing and Materials	RUS	Rural Utilities Service
AWS	American Welding Society	SSPC	Steel Structure Painting Council
CCA	Chromated Copper Arsenate	psf	pounds per square foot
DFT	Dry Film Thickness	psi	pounds per square inch
Eq. F	Equivalency Factor	UNC	unified standard series
IFI	Industrial Fastener Institute		
ksi	kips (1000 lb.) per square inch		
kV	kilovolt		

### REFERENCED ASTM SPECIFICATIONS

A6/ A6M	Specification for General Requirements for Rolled Structural Steel Bars, Plates, Shapes, and Sheet Piling
A36/A36M	Specification for Carbon Structural Steel
A123/A123M	Specification for Zinc (Hot-Dip Galvanized) Coatings on Iron and Steel Products
A143	Practice for Safeguarding Against Embrittlement of Hot-Dip Galvanized Structural Steel Products and Procedure for Detecting Embrittlement
A153/153M	Specification for Zinc Coating (Hot-Dip) on Iron and Steel Hardware
A325	Specification for High-Strength Bolts for Structural Steel Joints
A354	Specification for Quenched and Tempered Alloy Steel Bolts, Studs, and Other Externally Threaded Fasteners
A370	Test Methods and Definitions for Mechanical Testing of Steel Products
A384	Practice for Safeguarding Against Warpage and Distortion During Hot-Dip Galvanizing of Steel Assemblies
A570/A570M	Specification for Steel, Sheet and Strip, Carbon, Hot-Rolled, Structural Quality
A572/A572M	Specification for High-Strength Low-Alloy Columbium-Vanadium Structural Steel
A588/588M	Specification for High Strength Low-Alloy Structural Steel with 50 ksi Minimum Yield Point to 4 in. Thick
A595	Specification for Steel Tubes, Low-Carbon, Tapered for Structural Use
A607	Specification for Steel, Sheet and Strip, High-Strength, Low-Alloy, columbium or Vanadium, or Both, Hot-Rolled and Cold-Rolled
A673/A673M	Specification for Sampling Procedure for Impact Testing of Structural Steel
A687	Specification for High-Strength Nonheaded Steel Bolts and Studs
A871/A871M	Specification for High Strength Low-Alloy Structural Steel Plate with Atmospheric Corrosion Resistance
B695	Specification for Coatings of Zinc Mechanically Deposited on Iron and Steel
B696	Specification for Coatings of Cadmium Mechanically Deposited

**INSTRUCTIONS WHEN USING RUS GUIDE SPECIFICATIONS  
FOR STANDARD CLASS STEEL POLES**

**A. Purpose:** *This guide specification provides a basis for procuring direct embedded standard class steel poles for transmission applications. If poles are competitively bid, use of this specification will help to eliminate ambiguities that might arise in the evaluation process.*

*For simplification in these instructions and in the specification, owner also means owner's representative or engineer.*

*The owner is responsible for completing this specification and adding information, drawings and supplemental requirements as appropriate. It may be necessary for the owner to modify this specification in order to consider special applications or preferences.*

**B. Scope:** *This purchase specification covers the technical aspects of design, materials, manufacturing, inspection, testing, and delivery of direct embedded standard class steel poles. It is recommended that this specification be limited to single poles that are not guyed, not subjected to unbalanced lateral loads, or do not have unusual deflection or other special limitations. For applications that consider these items, it is recommended that the owner use "Guide Specifications for Steel Single Pole and H-Frame Structure," RUS Bulletin 1724E-204. This specification does not include front-end documents or specifications for construction. The owner has to add front-end documents including instructions to the bidders and general conditions. This specification may be expanded to include H-frame structures.*

**C. Initial Design Considerations:** *There are several engineering decisions required of the user of this specification to determine which standard class steel poles to specify. Some examples include, but are not limited to:*

- *Amount of foundation rotation in contributing to P-delta moments;*
- *Location of point of fixity;*
- *Embedment depths;*
- *Load cases to be considered in addition to those required by the National Electrical Safety Code (NESC); and*
- *Deflection limitations.*

*Prior to the selection of a standard class pole, the user should perform the engineering required for these types of issues or employ an engineering consultant to do so. See Appendix A for a discussion of some of these items.*

**D. Information to be completed by the owner** – *When using these specifications from this bulletin, the owner should detach the instructions (pages 1a through 8a) and the Commentary and the Appendices, and add or complete the following:*

***D.1 Documents and general information to be added to the technical specification:*** *Front-end documents and general information need to be added to this technical specification.*

- a. RUS Form 198, "Equipment Contract" (Recommended for competitive bidding)*
- b. Supplemental Instructions to Bidders*
- c. General Conditions*

*It is recommended that RUS Form 198 be used for competitive bidding. This form covers Notice and Instructions to Bidders, Proposal, and Equipment Contract. Other supplemental information, which the owner may want to add, includes Bid Submission, Bid Price and Schedule, Bid Acceptance Period, Bid Requirements, Bid Data, and Bidder's Qualifications. A section on General Conditions could include such items as Definitions of Terms, Inspection and Acceptance, Interpretation of Bid Documents, Addenda to the Bid Documents, Insurance Method of Payment (if Form 198 is not used), Quantities, and Tabulation of Unit Prices.*

***D.2 Specifications and technical information to be completed by the owner:***

***a. Configuration requirements and other information (Attachment A of the specification or equivalent):***

- (1) Pole Length;*
- (2) Pole Class;*
- (3) Pole Framing (Pole attachment requirements);*
- (4) Embedment depths (Groundline location);*

***b. Strength requirements***

***Standard class designations for steel poles***

*This specification establishes standard steel poles sizes. The engineer in the design process needs to select the appropriate standard class pole from Table 1 based on loading requirements and a calculated load 2 feet from the top.*

*Minimum design loads have to meet NESC requirements which are appropriate for the loading district, any local codes, the NESC extreme wind load provisions, and any necessary extreme ice and wind conditions with the appropriate overload factors. The design loads account for all loading cases, including wind on pole and secondary stresses from foundation deflection and rotation, and from vertical loads acting on lateral pole deflection (P-delta effect).*

*The ASCE Guidelines for Electrical Transmission Line Structural Loading can be used for developing loads produced by climate, accidents, construction and maintenance. Calculations need to include the vertical, transverse, and longitudinal loads with wind on the structure and the dead weight of the structure for any given loading condition applied simultaneously. All loads require appropriate overload factors.*

***c. Application Requirements (Attachment B to be completed by the owner.)***

- (1) Type of pole finish.*
- (2) Special Charpy requirements.*
- (3) Desired method of surface protection.*
- (4) Preference of climbing ladders, steps or stepbolts. Also, quantity of removable ladders, steps or step bolts to be supplied with the total order of poles should be specified.*
- (5) Location of climbing and /or working ladders or step bolts.*
- (6) Ground collar*
- (7) Pole grounding method.*
- (8) Delivery schedule, and free on board destination, and owner's contact.*
- (9) Miscellaneous additional items such as special attachments requirements, climbing devices, hot line maintenance requirements switch operating mechanisms, location of bolt holes for other equipment requirements.*
- (10) Pole tests (if required).*

***E. Information to be completed by the Manufacturer***

***E.1 The owner or owner's representative should have the following information completed and submitted by each bidder (attachment C or equivalent).***

- a. Design information (Pole Framing Drawing and length). This will demonstrate conformance with the design needs.*
- b. For each standard class steel pole, provide the diameter at the top, at the ground line, and at the bottom, plus the pole taper. This will demonstrate conformance with the requirements of paragraph 5.1.2c.*
- c. For each standard class steel pole, provide the following general information: the weight of each pole; the tip load of each pole class; the location of the point of fixity; the type of steel (ASTM number and yield); the pole cross sectional shape; and the connection details for multiple piece poles (slip/flange joints). This will demonstrate conformance with the requirements of paragraphs 5.1.1, 5.1.2, 5.1.3 and 5.1.6.*
- d. For each standard class steel pole provide the following calculations at the ground line: Moment, Shear, Axial load, and Cross sectional area. This will demonstrate conformance with the requirements of section 5.1.*
- e. For each standard class steel pole provide the following calculations at the point of fixity: Moment, Shear, Axial load, and Cross sectional area. This will demonstrate conformance with the requirements of section 5.1.*
- f. For each standard class steel pole, provide the wall thickness at the pole top, ground line, and bottom. This may be provided in catalog form.*

*g. For each standard class steel pole provide the pole top deflection due to design load.*

***E.2 The owner or owner's representative should have the following information completed by the successful bidder prior to the pole manufacture:***

*a. Description of pole including geometry, thickness, length, diameter, taper, and hole locations.*

*b. Complete design/erection reproducible drawings for each pole class.*

*c. Anticipated deflection of pole at specified tip load.*

*d. Connection and Assembly Details on multiple piece poles.*

***E.3 Test reports as requested by owner.***



## SPECIFICATIONS FOR STANDARD CLASS STEEL POLES

**1. SCOPE:** This specification covers the design, materials, welding, inspection, protective coatings, drawings and delivery of unguyed standard class, direct embedded, steel transmission poles. The poles are to be used in single pole, unguyed situations.

### 2. DEFINITIONS:

**Appurtenance** – Any hardware or structural members that are attached to the pole to make a complete structure.

**Bearing Plate** - A plate at the base of the pole that is intended to transfer the vertical loads of the pole.

**Cambering** – The fabrication of a slight convex curve in a pole.

**Charpy Impact** - The impact properties of the material which are used to evaluate the susceptibility of structural steel to brittle fracture. See ASTM A370 and ASCE Manual No. 72 for details.

**Crook** – A localized deviation from straightness that causes the centerline of one section of the pole not to align with the centerline of another section of the pole.

**Circumferential Weld /C-weld** - A weld perpendicular to the long axis of a structural member.

**D/t** - The ratio of the diameter of a tubular pole to the plate thickness.

**Engineer** – A registered or licensed person, who may be a staff employee or an outside consultant, who provides engineering services. Engineer also includes duly authorized assistants and representatives of the licensed person.

**Ground Collar** – An additional steel plate jacket that encapsulates the portion of the buried pole immediately above and below the *groundline*

**Group of Bolt Holes** - All of the holes in which an appurtenance will be attached.

**Guyed Structure** - A structure in which cable supports are used to increase its lateral load resistance.

**Groundline** – A designated location on the pole where the surface of the ground will be after installation of a direct embedded pole. The groundline location will be used to locate the *ground collar* and other attachments to the pole.

**Flanged Connection/splice** – A bolted type connection.

**Factored Load** - The design load that includes the appropriate *overload factor*.

**In-Line Face** – The face of the pole which “faces” an adjacent structure in the line.

**Longitudinal Weld** - A weld parallel to the long axis of a structural member.

**Manufacturer** – The company responsible for the fabrication of the poles. The manufacturer fabricates the poles based on the design drawings developed by the structural designer, which is the manufacturer’s engineer responsible for the structural design of the poles.

**Overload Factors (OLF)** – A multiplier, which is applied to each of the vertical, transverse and longitudinal structure loads to obtain an *ultimate load*.

**Owner** – The Rural Utilities Service borrower or owner's representative.

**P-delta Moment** – A measure of the increase in bending moment resulting from a structure’s displacement under load.

**Pole Height** - For this bulletin, this term is used interchangeably with *pole length*.

**Pole Length** - The length from the pole top to the bearing plate on the pole bottom.

**Pole Sweep** - The measure of deviation from straightness along the length of the pole.

**Point of Fixity** – The point where the maximum moment occurs. The actual location of this point is dependent on the characteristics of soils around the embedded portion of the pole. For this specification it will be assumed to be equal to 7 percent of the pole length.

**Slip Connection/splice** - A telescoping type connection of two tapered tubular pole sections.

**Standard Class Pole** – A direct embedded steel pole that is designed according to a standardized strength and loading criteria established by the owner.

**Taper** - The change in diameter of a tubular section from its base to its top.

**Tip Load** – The horizontal load that is applied to the standard class pole at a distance of 2 feet from the pole top.

**Ultimate Load** – The maximum design load that includes the appropriate *overload factor* specified.

**Yield Strength** – The minimum stress at which a material will start to physically deform without further increase in the load or which produces a permanent 0.2 percent deformation. This is also known as the elastic limit of the material.

**Ultimate Moment Capacity** - The moment that is developed in the pole at the time the yield strength of the pole is realized.

**w/t** – Ratio of a flat width of a multisided pole to the thickness of the steel plate.

**Weathering Steel** - Steel that conforms to ASTM A588 or A871. This steel forms a natural protective oxide layer on the surface.

### **3. CODES AND STANDARDS**

Codes, standards, or other documents referred to in this specification shall be considered as part of this specification. The following codes and standards are referenced:

- a. American Institute of Steel Construction (AISC), “Specification for the Design, Fabrication and Erection of Structural Steel for Buildings”, latest edition.
- b. American Society of Civil Engineers (ASCE) Standard, “Design of Steel Transmission Pole Structures”, Manual 72, latest edition.
- c. American Society of Testing and Materials (ASTM), various standards, latest revision.
- d. American Welding society (AWS), Structural Welding Code, AWS D1.1, latest edition.
- e. American National Standards Institute (ANSI), National Electrical Safety Code, ANSI C2, latest edition.
- f. Steel Structure Painting Council (SSPC); “Surface preparation Specification”, SPCC-SP6, latest edition.
- g. Occupational Safety and Health Standards, Occupational Safety and Health Administration (OSHA).

### **4. CONFLICT BETWEEN THIS SPECIFICATION, DRAWINGS, AND REFERENCES DOCUMENTS**

In the event of conflict between this specification and the above referenced documents, the requirements of this specification shall take precedence. In the case of conflict between several referenced documents, the most stringent requirement shall be followed. If a conflict exists between this specification or the referenced documents and the attached drawings, the attached drawings shall be followed. If clarification is necessary, contact the owner.

### **5. GENERAL REQUIREMENTS**

The design, fabrication, allowable stresses, processes, tolerances, and inspection shall conform to ASCE Standard, “Design of Steel Transmission Pole Structures” (Manual 72), latest edition, with the following additions and/or exceptions:

### 5.1 Design Requirements

**5.1.1** Pole designs shall be prepared for the attached Standard Class design loads. The poles shall be designed to meet ASCE Manual No. 72, “Design of Steel Transmission Pole Structures”, design methods. The point-of-fixity shall be considered to be located at a distance from the pole bottom that is equal to 7 percent of the pole length. ***The pole shall be symmetrically designed such that the strength required in any one direction shall be required in all directions about the longitudinal axis.***

**5.1.2** Using the corresponding values in Table 1, the poles shall be designed for the following requirements as illustrated by Figure 1.

- a. The pole shall develop the minimum ultimate moment capacity required in Table 1 at a distance of five feet from the pole top.
- b. The pole shall develop the minimum ultimate moment capacity above the point-of-fixity that is calculated by multiplying the tip load in Table 1 by the distance to the tip load.
- c. The geometry and taper of the pole shall be uniform throughout their entire length (top to butt).

**FIGURE 1**  
**Minimum Ultimate Moment Capacity Diagram along the Pole**

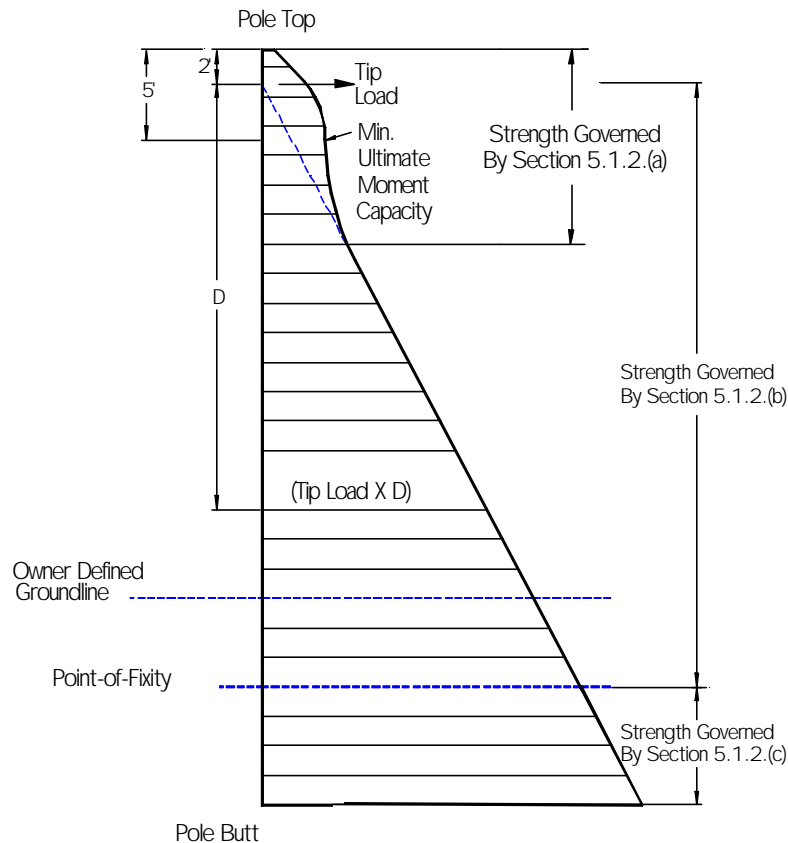

**5.1.3** The poles shall be designed to withstand the specified tip loading in Table 1 without exceeding a pole deflection of 15 percent of the pole length above the point of fixity when tested in accordance with ASCE Manual No. 72.

**5.1.4** Overall length of poles shall be designed and manufactured in incremental lengths of 5 feet.

**TABLE 1**  
**Strength Requirements**

Standard Class Designations for Steel Poles	Minimum Ultimate Moment Capacity At Five Feet From Pole Top (Ft.-Kip)	Horizontal Tip Load Applied 2 Ft from Pole Top (Lbs.)
S-12.0	96	12,000
S-11.0	88	11,000
S-10.0	80	10,000
S-09.0	72	9,000
S-08.0	64	8,000
S-07.0	57	7,125
S-06.2	50	6,250
S-05.4	44	5,450
S-04.7	38	4,700
S-04.0	32	4,000
S-03.4	27	3,375
S-02.8	23	2,825
S-02.3	19	2,325
S-01.9	15	1,875

**5.1.5** Poles shall be designed for the loads generated from handling and erecting without causing permanent deformation or damage to the pole when handled according to the manufacturer's instructions. Handling and erecting loads shall include but not be limited to, a one-point (tilting) pickup and a two point (horizontal) pickup.

**5.1.6** The maximum design unit stress shall be the minimum yield strength as stated in applicable ASTM specifications for the particular application and types of loads, including overload factors.

**5.1.7** Minimum plate thickness for all pole components shall be 3/16 inch.

**5.1.8** The owner shall provide the pole manufacturer with the load capabilities, attachment method, and attachment location of the appurtenances. The pole manufacture shall verify that the pole will not have a localized strength problem at the attachment point.

**5.1.9** All poles shall have bearing plates. Bearing plates shall have diameter not more than 2 inches greater than the maximum diameter at the pole butt.

**5.1.10** Galvanized poles shall have a drain hole at the bottom. This hole shall not be greater than 30 percent of the bearing plate area.

**5.1.11** Grade and type of steel shall be uniform for the poles.

**5.1.12** Ground collars to protect the pole groundline area from corrosive environments are required per Attachment B. Length of the ground collar shall be as specified in Attachment B.

**5.1.13** Ground collars shall have a minimum thickness of 3/16 inch; shall be centered at the groundline; and shall not be considered in strength calculations. A seal weld shall be provided around the ground collar at the top and bottom of the ground collar.

**5.1.14** The top of the pole shall be permanently covered with a structural steel plate that is bolted or otherwise permanently attached to the pole. The pole shall be delivered with the pole cover attached in place.

**5.1.15** Lifting lugs are optional. The manufacturer shall supply all guidelines for handling and erection of poles and arms.

**5.1.16** In the design of connections for vangs, brackets, or stiffeners attached to the pole shaft, care shall be taken to distribute the loads sufficiently to protect the wall of the pole from local buckling.

**5.1.17** Weathering steel structures shall be designed to eliminate water and refuse traps. The tubular sections shall be sealed from moisture entering the inside of the pole. Factory drilled holes shall be plugged to prevent moisture intrusion during shipping. Connections shall be designed to reduce the effect of pack-out by preventing moisture from entering the joint or by designing the connection to allow moisture to easily drain off.

**5.1.18** Plastic plugs shall be installed in all nuts welded to the structure and all tapped holes.

**5.1.19** Pole design and design calculations shall be the responsibility of the manufacturer.

**5.1.20** Poles shall be designed with the minimum number of joints.

**5.1.21** Field welding is not normally permitted. In rare instances, it will be permitted to make minor repairs. All welds must be approved by the owner and must follow the manufacturer's direction.

**5.1.22** Flange connections for weathering steel poles shall be designed to avoid packout.

**5.1.22** Application requirements: (See Attachment B)

## **5.2 Materials**

**5.2.1** All materials shall comply with the applicable requirements of ASTM specifications. Any modifications from ASTM specifications must be approved by the owner or the owner's representative.

**5.2.2** Steel utilized for the purposes of making poles shall conform with the following ASTM Specifications: ASTM A36, ASTM A570, ASTM A572, ASTM 588, ASTM A607, ASTM A871 or ASTM A595, and must be qualified to the requirements contained in ASTM A6/A6M-96b.

**5.2.3** Structural plate, and weld material, shall conform to ASTM A370 and ASCE Manual 72. Plates shall be heat-lot tested in conformance with ASTM A 673 Charpy V-Notch Impact test for properties of 15ft.lbs. at -20°F.

**5.2.4** For galvanized structures, steel used for the pole shaft and arms shall have a silicon content less than .06 percent.

**5.2.5** Bolts and nuts shall conform, as applicable to ASTM A307, ASTM A325, ASTM A354, ASTM A687. Locknuts or ANCO type self-locking nut shall be provided for each bolt. Locknuts shall be the galvanized MF or ANCO type. Other types of nut locking devices must be approved by the owner.

## **5.3 Fabrication**

**5.3.1** All welding shall be in accordance with the American Welding Society Code AWS D1.1, latest edition. Welders shall be qualified in accordance with AWS D1.1 welding procedures.

**5.3.2** One hundred percent penetration welds shall be required in, but not limited to, the following areas:

- Circumferential welds (C-welds) joining structural members;
- Longitudinal welds in the female portion of the joint within the slip joint area plus 6 inches;
- Welds at butt joints with back-up strips; and
- Longitudinal welds for a minimum length of 3 inches adjacent to C-welds, flange welds, base welds and ends of tubes.

**5.3.3** Full penetration, or equivalent 90 percent partial penetration with fillet overlay to develop the shaft capacity, shall be used for arm-to-arm brackets, vang-to-plate reinforcement, and arm box joints.

**5.3.4** Quality and acceptability along the entire length of full penetration welds shall be determined by visual and ultrasonic inspection.

**5.3.5** All other penetration welds shall have 60 percent minimum penetration. Quality and acceptability of all welds other than full penetration welds shall be determined by visual inspection, supplemented by magnetic particle, ultrasonic, or dye penetrant inspection.

**5.3.6** All weld back-up strips shall be welded continuous for the length of the welds. Care shall be exercised in the design of welded connections to avoid areas of high stress concentration that could be subject to fatigue or brittle fractures.

**5.3.7** Field welding shall not be permitted except with owner's, or owner's representative's approval and the manufacturer's direction in repairing the pole.

**5.3.8** All parts of the pole shall be neatly finished and free from kinks or twists. All holes, blocks, and clips shall be made with sharp tools and shall be clean-cut without torn or ragged edges.

**5.3.9** Before being laid out or worked in any manner, structural material shall be straight and clean. If straightening is necessary, it shall be done by methods that will not compromise the steel.

**5.3.10** Shearing and cutting shall be performed carefully and all portions of the work shall be finished neatly. Copes and re-entrant cuts shall be finished neatly.

**5.3.11** All forming or bending during fabrication shall be done by methods that will prevent embrittlement or loss of strength in the material being worked.

**5.3.12** Holes for connection bolts shall be 1/8 inch larger than the nominal diameter of the bolts. Holes in the flange plates for bolted splices shall be 1/8 inch larger than the bolt diameter. The details of all connections and splices shall be subject to the approval of the owner or the owner's representative.

**5.3.13** Holes in steel plates which are punched must be smooth and cylindrical without excessive tear out or depressions. Any burrs that remain after punching shall be removed by grinding, reaming, etc.

**5.3.14** Holes of any diameter may be drilled in plate of any thickness. Care shall be taken to maintain accuracy when drilling stacks of plates.

**5.3.15** Holes may be made by use of a machine guided oxygen torch. Flame cut edges shall reasonably smooth to minimize stress concentrations.

**5.3.16** Field drilled holes must be approved by the owner. If the manufacturer is aware of the owner's intent to field drill holes, the manufacture must supply a galvanizing touch-up kit for galvanized poles or a silicon sealant for weathering steel poles.



## 5.4 Tolerances

Manufacturing tolerances shall be limited to the following:

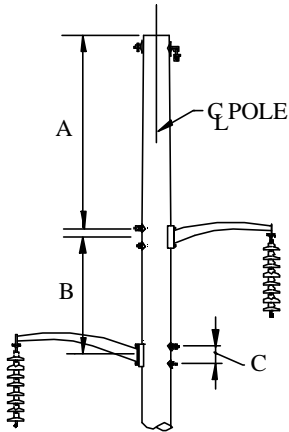
Pole Length	<u>One piece</u> : $\pm 2$ inches, or $\pm 1$ inch $\pm 1/8$ inch per 10 feet of length, whichever is greater (i.e. - 120 foot pole shall have a length of 120 feet $\pm 2\frac{1}{2}$ inches)	
	<u>Assembled pole with flange connections</u> : same as for one piece <u>Assembled pole with slip joint connections</u> : The accumulation of the slip joint tolerances not to exceed $-6''$ , $+12''$	
Pole Diameter	$-0$ inch, $+1/4$ inch	
Pole End Squareness	$\pm 1/2$ inch per foot of pole diameter	
Pole Sweep	$1/8$ inch per 10 feet of pole length	
Pole Twist	None Acceptable	
Slip Joint tolerances	Tolerances per manufacturers recommendations and total pole length requirements above. See Paragraph 5.7	
Pole Taper	See paragraph 5.1.2c .	
Location of Groups of Bolt Holes from Top of Pole	$\pm 1.0$ inches (tolerance to dimension 'A', Figure 2)	 <p>FIGURE 2</p>
Location of Centerline Between Groups of Bolt Holes	$\pm 1.0$ inch (tolerance to dimension 'B', Figure 2)	
Location of Holes Within a Group of Bolt Holes	$\pm 1/8$ inch (tolerance to dimension 'C', Figure 2)	
Bolt Hole Diameter	See Paragraph 5.3.12 for hole diameters	
Bolt Hole Alignment	Not to vary from the longitudinal pole centerline of that group of holes by more than $1/16$ inch	
Location of Identification Plate	$\pm 2.0$ inch	

## **5.5 Grounding**

**5.5.1** A grounding connection shall be welded to the pole shaft, 18 inches above the groundline or 6 inches above the ground collar. The grounding connection will be either the two-hole National Electrical Manufacturers (NEMA) pad, or a nut, or a threaded insert installed in the pole, or an approved alternative.

**5.5.2** Grounding pad face shall not be painted or covered with other coatings. The grounding nut thread and grounding pad threads shall be protected from coatings.

**5.5.3** Threaded inserts installed for grounding shall be made of Type 316 stainless steel and provided with standard ½ inch, 13 UNC threads. Threads shall be protected from unapproved coatings.

## **5.6 Climbing Devices**

### **5.6.1 Design Loads:**

**a. Step Bolts and removable steps:** The attachment to the pole for step bolts shall be designed to support a minimum of a 500 pound worker and equipment plus overload factor as defined in paragraph 5.6.2. The load shall be at the outer edge of the step or bolt.

**b. Removable Ladders:** The attachment to the pole for removable ladders shall be designed to support a minimum of a 500 pound worker and equipment plus overload factor as defined in paragraph 5.6.2. The load shall be at the outer edge of the step or bolt.

**5.6.2 OverLoad Factor:** An overload factor of 2.5 shall be applied to the design loads in 5.6.1 as required by OSHA. These loads shall be supported without failure.

**5.6.3 Location:** Climbing devices shall start 8 feet above groundline and extend to the pole top unless specified by the owner. The climbing device shall be spaced such that each step is 1 foot 6 inches apart and orientated to provide maximum ease of climbing. They shall be located to avoid interference with other attachments.

**5.6.4 Finish:** Step bolts, removable steps, and removable ladders shall be hot dipped galvanized.

**5.6.5 Intent of steps/ladder:** This system is intended for climbing the pole and working on the structure. It is not intended to replace the worker's fall arrest system.

## **5.7 Splices**

**5.7.1** Poles shall be designed with a minimum number of joints. Field welding shall not be allowed as part of the design of a new pole. The shaft joints to be made in the field shall be slip joints or bolted flange joints. Slip joints shall be designed for a nominal lap that will develop the full required design strength of the pole at that point. The minimum lap shall meet the requirements of

ASCE Manual No. 72. All welds on both sections of the pole, in the area of the splice, shall be complete penetration welds for at least a length equal to the maximum lap dimension.

**5.7.2** Manufacturer shall verify slip joint fit, through dimensional measurement or actual fit-up, before shipment. Joints should not interfere with threaded inserts, step nuts, ladder clips, or jacking nuts.

**5.7.3** Sufficient jacking lugs and permanent orientation marks shall be provided at all slips joints to ensure proper alignment and complete overlap of the joint.

**5.7.4** The axis of the pole shall not be distorted after the pole is mated. Shims shall not be allowed to straighten the pole unless approved by the owner. The owner reserves the right to reject a pole based on the improper mating of a pole splice.

## **5.8 Appurtenances**

**5.8.1** Appurtenance material shall be supplied by the owner. The owner shall provide the pole manufacturer connector and/or member locations, orientations, size, types, and strength capacities.

**5.8.2** The steel pole manufacturer and the owner shall work together to assure design coordination and fit up of all appurtenance connections and members to poles. Also refer to paragraph 5.1.8.

## **5.9 Finishes**

**5.9.1** The following finishes are acceptable: Galvanizing, zinc primer combined with paint, weathering steel, and a below grade coating.

- a. **Galvanizing** – All poles and structural components which are hot-dip galvanized shall meet all the requirements of ASTM A123 or ASTM A153. Measures shall be taken to prevent warping and distortion according to ASTM A384 and to prevent embrittlement according to ASTM A143. Poles made of ASTM A588 steel shall not be galvanized due to the high silicon content of the steel.

One gallon of zinc enriched paint shall be provided with each five poles.

- b. **Zinc Primer combined with Paint** – The paint shall be applied in accordance with the SPCC “Surface Preparations Specification”, SSPC-SP6, and the paint supplier’s recommendations.

**At a minimum, preparation of pole surface shall include:**

- shot or sand blasting and cleaning the pole prior to applying zinc primer and paint.

**The absolute minimum thickness of the zinc primer or paint is:**

- Zinc primer - 3 mils Dry Film Thickness (DFT).
- Paint - Two coats of finish paint, each 3 mils DFT, for a total thickness of 6 mils.
- One gallon each of primer and finish paint shall be supplied with each 5 poles.

- The pole manufacturer shall guarantee the pole against fading for a minimum of 5 years and against flaking for a minimum of 5 years

Hot dip galvanizing in accordance with ASTM A123 may be substituted for zinc primer with the approval of the owner.

c. **Weathering Steel** – Steel shall conform to ASTM A588 or A871. After fabrication, poles made of weathering steel shall be cleaned of oil, scale, etc., in accordance with the Steel Structure Painting Council’s “Surface Preparation Specification”, SSPC-SP6, to ensure uniform and rapid formation of the protective oxide layer.

d. **Coatings for the Embedded Portion of the Pole** A minimum 16 mil Dry Film Thickness of two component hydrocarbon extended polyurethane coating that is resistant to ultraviolet light shall be applied on the exposed surface of the embedded portion of the pole. The coating shall extend from the butt to 2 inches below the top of the ground collar, or 16 inches above groundline. Other coatings shall be approved by the owner prior to their use.

- One-quart container of touch up shall be provided with each five poles.

**5.9.2** Bolts and nuts with yield strengths under 100,000 psi shall be hot-dip galvanized per ASTM A153 and ASTM A143, or mechanically coated with zinc in accordance with ASTM B695, Class 50. Bolting materials with yield strengths in excess of 100,000 psi shall not be hot-dip galvanized. Instead, they shall be painted with zinc enriched paint or mechanically coated with zinc per ASTM B695, Class 50. Bolts and nuts made from weathering steel do not require a galvanizing coating.

**5.9.3** Compliance with coating thickness requirements shall be checked with a magnetic thickness gauge.

## **5.10 Markings**

**5.10.1** Each Pole shall be permanently marked on the pole shaft 60 inches above groundline and on the bottom side of the bearing plate with the following identifying information, unless specified otherwise by the owner:

- Manufacturer’s name
- Month and year of manufacture
- Length and class of pole
- Ultimate moment capacity of the pole
- Owner’s name
- Pole weight

**5.10.2** The identification information listed above shall be permanently marked on the transverse side of the pole. The method of identification shall be approved by the owner. The lettering shall be at least 3/4 inch in height.

**5.10.3** Information on the butt of the pole may be with permanent paint applied with a 1/2 inch wide brush. Paint identification markings may not be used in any other location.

**5.10.4** Each section of a spliced pole shall be marked such that the intended mate section can be easily identified. The markings shall be permanent and legible and contain at least the following information:

- Pole Length and Class (each section and total pole);
- Structure number (if known);

### **5.11 Inspection And Testing**

**5.11.1** The owner and the owner's representative shall have free entry at all times during fabrication, to all parts of the manufacturer's plant to inspect any part of the production of the poles covered by this specification.

**5.11.2** Steel members that are bent or warped or otherwise improperly fabricated shall be properly repaired or replaced at the sole discretion of the owner.

**5.11.3** The cost of tests made by the manufacturer (except full scale load tests on poles), including cost of the certified test reports shall be considered included in the bid price.

**5.11.4** The manufacturer shall make tests in accordance with ASTM A370 and A673 to verify that the material used in the structures meets the impact properties.

**5.11.5** Mill test reports showing chemical and physical properties of all material furnished under this specification shall be maintained by the manufacturer for a period of 5 years and shall be traceable to the pole.

**5.11.6** All plates over 1-1/2 inches thick shall be ultrasonically tested to assure against defects that could lead to lamellar tearing.

**5.11.7** Qualification of welders or welding operators will be verified as to conformance with the provisions of AWS D1.1.

**5.11.8** The manufacturer shall make certified welding reports for each pole. The reports covering welding shall include all welds of a pole. Each weld shall be clearly identified; and the report shall consist of the method of testing, whether the weld is acceptable, the identification of the pole, the date, and the name and signature of the inspector.

### **5.12 Full Scale Structure Testing**

**5.12.1** The poles that are to have full-scale load tests performed on them are listed in Attachment B. Cost for such test shall be the responsibility of the owner, shall be separated from the manufacturer's bid, and shall be negotiated in advance of any test preparation.

**5.12.2** Details of the test procedures and methods of measuring and recording test loads and deflections shall be specified by the manufacturer prior to testing and shall be subject to the review and approval of the owner or the owner's representative.

**5.12.3** Deflections shall be recorded in the transverse and longitudinal directions when applicable. Deflection measurements shall be taken under the no load condition both before and after testing.

**5.12.4** Material procurement for test poles shall be identical to material procurement procedures for regular production run poles.

**5.12.5** A full report listing results shall be submitted after completion of all testing. Copies of mill test reports shall be included in the load test report. The report shall also include a complete description of the load tests with diagrams and photographs.

**5.12.6** The owner or the owner's representative reserves the right to be present during testing and shall be notified 2 weeks prior to the start of pole test.

## **6. SHIPPING AND DELIVERY**

### **6.1 Shipping**

**6.1.1** Each shipment shall be accompanied by a bill of materials, identifiable by pole type and number. Bolts and miscellaneous hardware will be identified by the list for match up with the respective pole shaft. All parts that are required for any one pole shall be in one shipment, if possible.

**6.1.2** The owner and owner's representative shall be notified prior to shipment that such shipment is to take place, and they reserve the right to inspect the components prior to shipment. The notification shall give quantities, weight, name of common carrier used, and expected time of arrival.

**6.1.3** Salt-treated wood blocking and urethane foams shall not be used when shipping or storing weathering steel poles.

**6.1.4** Transportation and site handling shall be performed with acceptable equipment and methods by qualified personnel. The manufacturer shall exercise precaution to protect poles against damage in transit.

**6.1.5** Handling instructions shall be included with the pole shipment (If special handling is required).

## **6.2 Delivery**

**6.2.1** The owner may take delivery at a designated location with the delivering carrier's equipment. The manufacturer shall coordinate with the owner to ensure smooth and efficient delivery of poles.

**6.2.2** The owner will provide all labor, equipment, and materials for the unloading of poles at the project site. A pole is considered delivered when the pole is lifted from the trailer or semitrailer of the delivery carrier.

## **7. DRAWINGS AND INFORMATION TO BE SUPPLIED BY THE MANUFACTURER**

### **7.1 Information to be Supplied with the Proposal (See Attachment C)**

- a. Pole diameter at the top, groundline, and bottom.
- b. The pole taper of each pole in inches/foot.
- c. The calculated weight of each class and length of pole.
- d. General information about each pole length and class including tip load, location of point of fixity, type of steel used for the pole (ASTM number and yield), cross sectional shape, and connection details of multiple piece poles (slip joints/flange joints/welded to be one piece).
- e. Calculated groundline and point-of-fixity reactions due to the tip loadings (including shear, moment and axial reactions) in order to demonstrate conformance with the requirements of 5.1.1 and 5.1.2.
- f. Description of pole shaft cross section including thickness of the plate at the bottom, groundline and at the top.
- g. For each standard class pole, provide pole top deflection using the specified tip loading in order to demonstrate conformance with the requirements of and 5.1.3.
- h. The cost of each pole by size and length. Also the total order cost for each class and length of pole.

**7.2 Documentation to be Supplied for the Owner's Approval Prior to Fabrication (as requested by the owner)**: Documentation includes final design calculations for the pole shaft at 5-foot intervals and will be based upon the pole loading shown in Table 1. The following information shall be supplied:

- Total shear forces
- Moment
- Design Stress, Allowable stress, and Stress ratio
- Section moduli
- Cross-sectional area

- Deflection at the pole top due to tip load
- Detail drawings for each structure type giving weights of structure
- Bill of materials list (if any)
- Assembly instructions and erection drawings  
(Slip joint lengths and allowable tolerances)
- Special handling instructions (if required)

### **7.3 Test Reports (as requested).**

- a. Certified mill test reports for all structural material.
- b. Certified welding reports for each pole.
- c. Impact property test reports showing that the material used in the poles meets the impact properties.
- d. Test reports on coating thickness.
- e. Report of pole testing, when required, including photographs, and diagrams.

## **8. APPROVAL, ACCEPTANCE AND OWNERSHIP**

**8.1** Final designs must be approved by the owner or owner's representative before material ordering and fabrication. Material ordering and fabrication prior to approval will be at supplier's risk. It is understood that award of this contract does not constitute acceptance of design calculations submitted with the bid, if corrections are required in the final structure designs due to manufacturer's errors, omissions, or misinterpretations of the specifications, the quoted price shall not change. Approval of the drawings and calculations by the owner or the owner's Representative does not relieve the supplier of responsibility for the adequacy of the design, correctness of dimensions, details on the drawings, and the proper fit of parts.

**8.2** After delivery, the poles will be inspected and shall be free of dirt, oil blisters, flux, black spots, dross, teardrop edges, flaking paint or zinc; and in general shall be smooth, attractive, and unscarred. Poles not meeting this requirement shall be repaired or replaced by the manufacturer at no additional cost to the owner. Final decision to repair rather than replace a pole shall be at the owner's sole discretion.

**8.3** All final drawings shall become the property of the owner, who shall have full rights to reproduce drawings and use them as the owner sees fit.

**9. LIST OF ATTACHMENTS:** (Attachment A, and B to be completed by the engineer. Attachment C to be completed by the manufacturer)

- Attachment A, Pole Framing Drawings
- Attachment B, Application Requirements
- Attachment C, Bid Summary



**ATTACHMENT A**  
Structure dimensions  
and pole framing drawings

Blank Page

**ATTACHMENT B  
APPLICATION REQUIREMENTS**

1. Type of finish of the pole (indicate by checking one)  
Weathering \_\_\_\_\_  
Galvanized \_\_\_\_\_  
Zinc primer and paint \_\_\_\_\_
  
2. Special Charpy requirements \_\_\_\_\_
  
3. Surface protection desired for embedded portion of the pole (indicate by checking one or both)  
Polyurethane Coating \_\_\_\_\_  
Anodes \_\_\_\_\_
  
4. Climbing device type (indicate by checking one)  
Step Bolts \_\_\_\_\_  
Ladder \_\_\_\_\_  
Removable Steps \_\_\_\_\_
  
5. Location of climbing device \_\_\_\_\_
  
6. Length of ground collar \_\_\_\_\_
  
7. Grounding plate or nut \_\_\_\_\_
  
8. Delivery schedule \_\_\_\_\_
  
9. Free on board destination \_\_\_\_\_
  
10. Pole test (if required) \_\_\_\_\_
  
11. Additional Requirements (below) \_\_\_\_\_

Blank Page

**ATTACHMENT C**

**Standard Class Steel Pole Bid Summary**  
(Information to be supplied with the bid)

DESIGN INFORMATION					
Pole framing drawing					
Pole Class					
Pole Length					
POLE DESCRIPTION					
Top Diameter					
Groundline Diameter					
Bottom Diameter					
Taper (in/ft)					
GENERAL					
Pole Wt/ each					
Tip Load					
Point of Fixity Loc					
Steel (ASTM/yield )					
Cross section shape					
Splice joint type					
CALCULATIONS AT THE GROUNDLINE					
Moment					
Shear					
Axial					
Cross Sectional Area					
CALCULATIONS AT THE POINT OF FIXITY					
Moment					
Shear					
Axial					
Cross Sectional Area					
WALL THICKNESS					
Top					
Groundline					
Bottom					
DEFLECTION (Top)					
COST SUMMARY					
COST/POLE					
NUMBER OF POLES					
TOTAL COSTS					
COMMENTS :	TRANSMISSION LINE POLES				
	ATTACHMENT C BID SUMMARY - DESIGN INFORMATION, WEIGHTS, AND PRICE INFORMATION				
	(INFORMATION TO BE SUPPLIED WITH THE PROPOSAL)				

Blank Page

## **APPENDIX A COMMENTARY**

### **A. General**

The necessity of a clear bid specification for the purchase of standard class steel poles is very important to the bid evaluation process and the acquisition of structurally adequate poles. The specification should contain sufficient requirements and information so that all bids can be evaluated equally and so that the manufacturer clearly understands what is expected of the manufacturer.

#### **Scope**

While use of this standard class steel pole specification is not prohibited to poles which are guyed, which are subjected to unbalanced lateral loads or which have deflection or other special limitations, the owner must be prudent when using this specification in these types of applications.

It is recognized that, with the proper understanding and usage of some computerized structural analysis and transmission line design programs, it is possible to select a standard class steel pole which might otherwise be beyond the scope of this specification. The owner must be sure that combined bending and buckling analysis is performed, and that deflections are properly modeled.

The owner should recognize when the design of a steel pole may be more prudently accomplished using the "Guide Specification for Steel Single Pole and H-Frame Structures," RUS Bulletin 1724E-204, which requires the actual loading conditions to be specified. In using Bulletin 1724E-204, the manufacturer assumes full responsibility in designing and manufacturing a structurally adequate pole.

#### **Standard Class Pole**

In some cases, utilities prefer to specify certain steel poles to be designed according to a standardized loading criteria, much like the standard classifications for wood poles.

In utilizing standard class steel poles, a complete structural analysis is still required for all structures. All appropriate loading criteria are considered in the analysis. Once the required steel pole strength is determined, a standard class steel pole that meets the actual loading conditions can be selected. A complete design example is shown in Appendix C.

Without considering all the potential reasons for specifying standard class poles, this specification is developed in order to establish a standard classification system and to assist the owner in procuring a standard class steel pole which is properly designed for the intended loading criteria. This guide specification attempts to eliminate ambiguity in specifying and purchasing standard class steel poles. Since it has become a widespread practice in the industry to design and

manufacture poles which are based on the wood pole classification system of the American National Standards Institute (ANSI 05.1), the steel pole classifications developed in this specification generally follow the wood pole classification system. However, to avoid confusion with the wood pole classifications, the steel pole classifications have a unique naming system.

### **Wood Pole Equivalency**

In some cases, the owner may design a transmission line based on wood pole classifications as described in ANSI 05.1 and then wish to order steel poles which meet the wood pole equivalent loadings. Because of the differences in overload factors applied to wood poles in comparison to steel poles, the owner must be sure that the overload factors are properly accounted for in the design of the steel poles.

“Wood pole equivalent” is a term that may be defined in a number of ways. For purposes of this commentary, the term “wood pole equivalent” is defined as a standard class steel pole which is equated by required ultimate loading to an ANSI 05.1 standard class wood pole. The equation is made by a ratio of the overload factors applicable for each pole type and loading criteria.

The design and purchase of steel poles as an equivalent to wood poles can be vague even with clear instructions. As such, the owner should be sure that the equivalency is properly determined. Once the equivalency is determined, the owner should specify the standard class steel pole based on the classifications detailed in paragraph 5.1.2. In doing this, the manufacturer will not be involved in the equivalency process and the ambiguity should be eliminated.

The wood pole equivalency is based on the required ultimate moment capacity of the pole at the groundline based on embedment depths shown in ANSI 05.1. In obtaining a suitable equivalency, the owner must consider factors other than the equivalent groundline moment. For example, the differences in material and section properties of the wood pole versus the steel pole will result in differences in buckling analysis, pole deflections, secondary moments, applied wind forces, etc.

It is impossible to completely equate the steel pole and wood pole at all points along the pole. The owner must be certain that the steel pole selected by equivalency methods will have strength sufficient for the actual application.

### **Equivalency Factor (Eq.F)**

The equivalency factor (Eq.F) is defined as the ratio of the steel pole overload factor to the wood pole overload factor for a given loading condition.

For example, for NESC Grade B district wind loading, the steel pole overload factor is 2.5 and the wood pole overload factor is 4.0. Thus, the equivalency factor will be  $2.5/4.0 = 0.625$ .



The equivalency factor is a useful concept to understand as the owner requires a wood pole equivalent under various loading conditions and overload factors. Several examples of equivalencies are listed in the following sections.

#### **Wood Pole Equivalency - 2.5:4 Ratio (0.625 Eq.F)**

For the NESC Grade B district loadings, the NESC allows for an overload factor of 2.5 to be applied to a transverse wind load on a steel pole while it requires an overload factor of 4.0 to be applied to a transverse wind load on a wood pole. As such, the ultimate strength requirement for the steel pole will be less than the ultimate strength of the wood pole for the district wind loading conditions.

For example, the owner designs a transmission line for wood poles based on NESC district wind loading conditions. The owner wishes to purchase a steel pole that is equivalent to a Class 1 wood pole. Based on ANSI 05.1, the Class 1 wood pole groundline strength is derived by applying a horizontal ultimate load of 4,500 pounds at 2 feet from the pole top based on a simple cantilever. Since the owner had classed the wood pole based on an NESC overload factor of 4.0, the owner wishes to select a steel pole meeting the same NESC district wind loading conditions. To do this, the owner will multiply the required tip loading of 4,500 pounds by 2.5/4.0, which equals 2,812 pounds. The 2.5/4.0 ratio (or 0.625 Eq.F) adjusts for the difference between wood and steel district overload factors. The owner will then select a standard class steel pole which has an ultimate moment capacity based on the horizontal tip loading of at least 2,812 pounds. From paragraph 5.1.2, the owner selects a class S-02.8 pole, which has a tip loading of 2,825 pounds.

Based on the method shown in this example, Table A-1 of this Appendix at the end of this section is a tabulation of wood pole equivalencies based on the NESC Grade B district wind loading.

#### **Wood Pole Equivalency - 1.1:1.5 Ratio (0.733 Eq.F)**

For the NESC Grade B extreme wind loadings, this specification requires an overload factor of 1.1 to be applied to a transverse extreme wind load on a steel pole while the NESC requires an overload factor of 1.5 to be applied to a transverse extreme wind load on a wood pole. As such, the ultimate strength requirement for the steel pole will be less than the ultimate strength of the wood pole for the NESC extreme wind loading conditions.

For example, the owner designs a transmission line for wood poles based on NESC extreme wind loading conditions. The owner wishes to purchase a steel pole that is equivalent to a Class 1 wood pole. Based on ANSI 05.1, the Class 1 wood pole groundline strength is derived by applying a horizontal ultimate load of 4,500 pounds at 2 feet from the pole top based on a simple cantilever. Since the owner had classed the wood pole based on an NESC extreme wind overload factor of 1.5, the owner wishes to select a steel pole meeting the same extreme wind loading conditions. To do this, the owner will multiply the required tip loading of 4,500 pounds by 1.1/1.5, which

equals 3,300 pounds. The 1.1/1.5 ratio (or 0.733 Eq.F) adjusts for the difference between wood and steel extreme wind overload factors. The owner will then select a standard class steel pole which has an ultimate moment capacity based on the horizontal tip loading of at least 3,300 pounds. From paragraph 5.1.2, the owner selects a class S-03.4 pole, which has a tip loading of 3,375 pounds.

Based on the method shown in this example, Table A-2 at the end of this section is a tabulation of wood pole equivalencies based on the NESC Grade B extreme wind loading.

### **Wood Pole Equivalency - 1:1 Ratio (1.0 Eq.F)**

The owner may wish to order a steel pole that has the same ultimate strength as a specified wood pole class. One common application of this is when the owner designs a transmission line using wood pole properties, but utilizing steel pole overload factors. In this case, the owner has accounted for the difference in wood versus steel overload factors during the design of the project.

For example, the owner designs a transmission line for wood poles based on NESC district wind loading conditions. However for steel poles, the owner uses the NESC district wind load overload factor of 2.5 (applicable to steel poles) in the calculations. The owner selects a wood pole Class 1 at a specific location. Thus, the owner wishes to purchase a steel pole which is equivalent in ultimate strength to a Class 1 wood pole. Based on ANSI 05.1, the Class 1 wood pole groundline strength is derived by applying a horizontal ultimate load of 4,500 pounds at 2 feet from the pole top based on a simple cantilever. Therefore, the owner will require a steel pole with an ultimate moment capacity based on the same 4,500 pound tip loading. From paragraph 5.1.2, the owner selects a Class S-04.7 steel pole, which has a tip loading of 4,700 pounds.

Based on the method shown in this example, Table A-3 is a tabulation of wood pole equivalencies based on the ultimate-to-ultimate strength comparison, or 1.0 equivalency factor.

### **Other Wood Pole Equivalencies**

Using the wood pole equivalency methods described, the owner can develop equivalency tables for other ratios of wood versus steel overload factors.

For example, a heavy angle or deadend transmission line structure may be predominantly controlled by the conductor tension rather than wind on the wire. The NESC specifies an overload factor of 1.65 to be applied to steel pole wire tensions and an overload factor of 2.0 to be applied to wood pole wire tensions. The resulting equivalency ratio would be 1.65/2.0, or an equivalency factor of 0.825. From a review of the tables at the end of this section, Table A-2 of this Appendix has an equivalency factor of 0.733 while Table A-3 of this Appendix has an equivalency factor of 1.0. Rather than developing a new equivalency table for this special application, the owner might prefer to select a steel pole equivalency based on the Table A-3 which has an equivalency factor greater than the required factor of 0.825.

**TABLE A-1 - WOOD POLE EQUIVALENCY  
BASED ON 2.5:4 RATIO**

(0.625 Equivalency Factor)

(NESC Grade B District Wind Loading)

*(Equivalencies based on approximate groundline strength)*

<b>Design</b> Wood Pole Class Based on 4.0 OCF		<b>Select</b> Steel Pole Class Based on 2.5 OCF
H6		S-07.1
H5		S-06.2
H4		S-05.4
H3		S-04.7
H2		S-04.0
H1		S-03.4
1		S-02.8
2		S-02.3
3		S-01.9

**TABLE A-2 - WOOD POLE EQUIVALENCY  
BASED ON 1.1:1.5 RATIO**

(0.733 Equivalency Factor)

(NESC Grade B Extreme Wind Loading)

*(Equivalencies based on approximate groundline strength)*

<b>Design</b> Wood Pole Class Based on 1.5 OCF		<b>Select</b> Steel Pole Class Based on 1.1 OCF
H6		S-09.0
H5		S-08.0
H4		S-07.1
H3		S-05.4
H2		S-04.7
H1		S-04.0
1		S-03.4
2		S-02.8
3		S-02.3

**TABLE A-3 - WOOD POLE EQUIVALENCY  
BASED ON 1:1 RATIO**

(1.0 Equivalency Factor)

(Ultimate-to-Ultimate Comparison)

*(Equivalencies based on approximate groundline strength)*

<b>Design</b> Wood Pole Class		<b>Select</b> Steel Pole Class
H6		S-12.0
H5		S-10.0
H4		S-09.0
H3		S-08.0
H2		S-07.1
H1		S-05.4
1		S-04.7
2		S-04.0
3		S-03.4

**B. Design** (Section 5)

**Loads** (Paragraph 5.1)

The primary loads for steel poles are weather loads. Weather, construction and maintenance loads need to be determined by the owner in order to select the proper standard class pole.

Overload factors for NESC light, medium, and heavy loading districts should be at least equal to those given in the applicable edition of NESC for Grade B construction. The overload factor for extreme ice and extreme wind is recommended to be at least 1.1.

In addition to using the NESC district loading requirements, the ASCE publication No. 74, "Guidelines for Transmission Line Structure Loading" can be used to provide owners with procedures for the selection of design loads and load factors related to climate, accidents, construction and maintenance.

Once the design loadings have been determined, a design of the structure should be performed by the owner's engineer or structural designer. It is recommended that a nonlinear structural analysis computer program be utilized in order to consider the loadings, secondary moments (p-delta effect), and effects of foundation rotations and deflections. As a minimum, an approximate method

for determining the ultimate moment capacity should be utilized, such as the methods given in the "Design Manual for High Voltage Transmission Lines," RUS Bulletin 1724E-200.

Once the structural analysis has been completed, the owner's engineer or structural designer may select a standard class steel pole which has the ultimate moment capacity greater than the design loading requirements. Consideration should be given for strength requirements at all points along the pole, not just at the groundline.

### **P-Delta Moment**

Prior to selecting a standard class steel pole, the owner should determine the effect of the secondary moments due to the vertical loadings, including the effect of the pole weight, during the transmission line design process.

Whenever there is a transverse or longitudinal load, the pole will deflect in the direction of the load. As a result, the vertical load is no longer in its original position. The vertical load moves over as the pole deflects, causing additional moments in the pole. Also, the pole weight can place secondary moment loads in the pole. The additional stress caused by this secondary moment is dependent on the magnitude of the vertical load and deflected shape of the pole. Many pole designs, particularly tall poles, have to be calculated for the position of equilibrium of forces in the fully displaced position. The solution typically takes many iterations. A full nonlinear analysis will consider the change in orientation of the loads relative to the displaced positions of the structural members.

As a minimum, an approximate method for determining the effect of the secondary moments should be utilized, such as the method given in the RUS Bulletin 1724E-200.

### **Foundation Rotation and Deflection**

Although significant foundation rotation and deflection criteria are considered to be beyond the scope of this standard class steel pole specification, some allowances can be made for these effects. They should be considered during the owner's analysis of the actual loading conditions to apply to the steel pole. Typically, this type of analysis is accomplished by nonlinear structural analysis techniques.

Once the structural analysis has been completed (including foundation rotations and deflections, p-delta effect, etc.), the owner may select a standard class steel pole that has the ultimate moment capacity greater than the design loading requirements.

### **Longitudinal Loads**

It is recommended that RUS Bulletin 1724E-204 be utilized whenever the longitudinal loads may result in a significant unbalanced lateral loading condition.

Because steel poles are flexible structures, there may be a reduction in induced moments in a pole under some types of longitudinal loads due to the restraining effect of the overhead ground wires. Traditionally, static longitudinal loads are specified due to the complexity of calculating the influence of structure flexibility.

### **Guyed Poles and Guy Wires**

It is generally beyond the scope of this standard class steel pole specification to consider guyed poles and guy wires in the design of the structure. It is recommended that RUS Bulletin 1724E-204 be utilized instead.

It is generally agreed that a steel pole has less buckling strength than an equivalently classed wood pole. Wood poles are solid wood and the material in the heart of the pole can resist buckling. Standard class steel poles however, are thin walled, hollow structures with limited buckling strength. The forces resulting from the attachment of the guy wires to the standard class steel pole needs to be carefully analysis by a structural engineer. The steel pole and guy wire(s) must be designed as a system.

Any time a steel pole structure is guyed, the guy type, size, modulus of elasticity and guy slope or angle has to be determined by the owner and properly modeled in the analysis of the steel structure. The load in the guy wire should be limited to 65 percent of its ASTM rated breaking strength under actual ultimate loading conditions, as is required by RUS Bulletin 1724E-204. The steel pole and guy wire(s) must be designed as a system. The guy modulus of elasticity can increase from a minimum value at the time of manufacture, to a maximum value that results from periodic stretching and relaxing during the load cycles. Ranges from 19,000 ksi to 28,000 ksi have been stated. The ASCE steel pole specification (ASCE Manual No. 72) has suggested the engineer use a guy wire modulus of elasticity of 23,000 ksi whenever it is not specified.

The owner should use caution in using this equivalency method of sizing standard class steel poles and its usage should be prudently influenced by the owner's experience in similar applications where actual design loadings were utilized under similar guying conditions. However, a typical situation where the owner may wish to use this specification for guyed poles is when the owner uses a transmission line design computer program, or other structural analysis program, in which minimum strength values are input for each pole type and the program is capable of combined bending and buckling analysis of guyed steel poles.

#### **Point of Fixity (Paragraph 5.1.1)**

Point of fixity for this specification is defined as the location on the pole where maximum moment occurs. Maximum moment is calculated by the pole designer using the loadings provided by the owner and multiplying those loadings by the appropriate moment arms. The existing soil and backfill has to be able to support the pole with these bending moments applied. The location of

this point of fixity could be at or below the groundline. The exact location is theoretical and depends on the soil condition and backfill used to support the pole.

For the standard class pole, the point of fixity should remain at the same location on the pole, regardless of the embedment depth the owner may specify for a given application. Otherwise, the required pole strength could vary as the location of the point of fixity varies. Within the scope of this standard class pole specification, the point of fixity is arbitrarily considered to be located at a distance from the pole butt that is equal to 7 percent of the pole length. This value seems to work quite well over a range of pole lengths and is approximately the same value as a point of fixity located at 1/3 of the distance below the groundline based on an embedment depth of 10 percent of the pole length + 2 feet.

### **Pole Top Strength** (Paragraph 5.1.2.a)

This specification sets minimum ultimate moment capacity requirements near the pole top for each standard pole classification. The similar ANSI 05.1 requirement is generally overlooked, misunderstood or not considered by manufacturers and others who seek to standardize pole sizes based on the wood pole classifications.

Upon a careful study of the ANSI 05.1 wood pole specification, one should understand that the horizontal loading applied at 2 feet from the pole top is for the purpose of determining a required groundline ultimate moment capacity for any length pole of the given class. However, the minimum required wood pole top size is specified apart from the horizontal loading requirement

For example, according to ANSI 05.1, a Class 1 wood pole must have a circumference of 27 inches at the top. When applied to the Douglas Fir or Southern Yellow Pine poles with a fiber stress of 8,000 psi, the resulting top strength is calculated as 41.5 ft-kips for the Class 1 wood pole.

Because the conductors and shield wire supports are typically located on crossarms away from the pole axis, significant moments can be generated in the pole near the top. The moments are greatly increased whenever a braced pole top assembly is utilized. These moments are not accounted for by applying the horizontal ultimate loading alone. Therefore, in the design of transmission poles, it is critical that a minimum ultimate moment capacity be specified near the pole top. In the absence of a minimum top strength requirement, a steel pole top strength can theoretically be negligible.

The minimum pole top strength required by this specification should be suitable for most transmission line applications. However, the owner must be sure that the top strength is properly evaluated, especially when working with wood pole equivalencies and braced structures.

**Tip Loading** (Paragraph 5.1.2.b)

The tip loading is used to develop a required ultimate moment capacity diagram at any point along the pole from 2 feet below the pole top down to the point-of-fixity. This ultimate moment capacity is determined by multiplying the tip load by the moment arm based on a simple cantilever. As a result, the required ultimate moment diagram is linear in shape. This same method may be utilized in structural analysis and automated transmission line design computer programs to develop an array of ultimate moment requirements for standard steel pole sizes.

**Pole Deflection** (Paragraph 5.1.3)

Although significant horizontal pole deflection limitations are considered to be beyond the scope of this standard class steel pole specification, some allowances can be made for these effects. They should be considered during the analysis of the actual loading conditions applied to the steel pole. Typically, this type of analysis should be accomplished by nonlinear structural analysis techniques. Since the electrical clearances must be assured in the operation of transmission lines, deflections must remain within an acceptable range.

This specification limits the allowable pole deflection to 15 percent of the pole height above the point of fixity when the tip load specified in paragraph 5.1.2 is applied under a horizontal testing procedure.

The owner should recognize that the actual pole deflection for the application will be less than the specified deflection limit of 15 percent of the pole height. With the standard class pole, all of the loading is applied near the pole top. In a typical transmission line application, the actual horizontal loading will be some distance from the pole top. As such, the actual deflection at the conductor under short term ultimate loading conditions can be expected to be less than 10 percent of the height above ground.

The NESC requires that electrical clearances be maintained under a wind loading of 6 psf. It is expected that the deflection of a standard class pole under this 6 psf loading condition will be less than 3 percent of the height above ground.

For situations where the owner wishes to know the deflection for a standard class pole, the owner should use a suitable structural analysis computer program in which the actual design loading conditions and steel pole properties are input into the program, or the owner should ask the pole manufacturer to provide the analysis.

If the owner has special deflection limitations, it is recommended that RUS Bulletin 1724E-204 be utilized instead of this specification. In doing so, there will be little doubt as to what the actual pole deflections will be under all loading conditions.



**Minimum plate thickness** (Paragraph 5.1.7)

The intent of this guide is not to limit new technology. Use of plate thickness less than 3/16 inch may be possible. However, consensus from the committee members and based on current designs by the manufacturers, transmission size poles will normally require at least a plate thickness of 3/16 inch. If mild corrosion occurs, the percentage of reduced strength will be less the greater the wall thickness of the steel plate. Having the minimum plate thickness of 3/16 inch will also improve strength for mounting of davit arms and guy attachments. If an owner does decide to purchase poles with a wall thickness less than 3/16 inch, extra care should be taken in the field to avoid damage to the pole during storage, handling and installation. Small nicks in the galvanizing or other protective coating could exaggerate future problems. Also minor misalignments or poor fit of hardware during construction could cause a major problem. Ground collars on thin wall poles should be considered a necessity. Other sections of this commentary explain why poles purchased with this guide should not be used in guying situations, unless an engineer experienced with guyed steel structures oversees the design. This is especially true for poles of wall thickness less than 3/16 inch.

**Ground Collars** (Paragraphs 5.1.12 and 5.1.13)

Attachment B of the specification is set up to allow the owner to alter the requirement for a ground collar by putting “not required” on line 6. Ground collars are recommended for direct embedded weathering steel poles, but they are sometimes optional with galvanized steel poles. If ground collars are used, a length of 3 feet or greater is recommended.

The intent of ground collars on standard class steel poles is similar to the preservative of wood poles. The preservative protects the wood against rot and fungus attack. Similarly, the ground collar protects the steel pole from corrosion and mechanical damage.

The ground collar does not prevent nicks. The ground collar does provide nonstructural steel that can be sacrificed to corrosion. Corrosion can be due to many outside causes over which the owner has no control. A short list of potential causes includes road salt, fertilizer, poor/corrosive soil, and galvanic corrosion from pipeline crossings or underground electric lines. The ground collar also protects the pole from mechanical damage that may occur during construction or later by right-of-way crew or by property owners.

Whereas some utilities feel that galvanized poles with polyurethane coating do not need additional corrosion and mechanical protection, they do feel that weathering steel poles need additional protection to the patina and polyurethane coating. Some manufacturers claim that poles that are galvanized and the embedded portion coated with polyurethane coating (paragraph 5.9.1), do not require a ground collar. If nicks do occur to a galvanized pole, the galvanizing will act like a sacrificial anode and protect the nicked steel.

ASCE Manual No.72 states that bare weathering steel should not be used below grade due to the potential problems from corrosion. Some utilities add a round collar to all weathering steel poles. Still other utilities in dry climates with non-corrosive soils may not use ground collars. However, since the polyurethane coating can be nicked during construction, it is recommended that round collars be used on all weathering steel poles.

### **Charpy Requirements (Paragraph 5.2.3)**

Charpy test is a notch-bar impact test used to compare notch sensitivities of materials. The impact values cannot be converted into energy figures for use directly in engineering design. The impact value from the notch-bar impact test is used only as a comparison test. For example, if a type of steel has been found to have good notch toughness in service and its impact value is known, it is assumed that other types of steel having the same impact value will also have the same notch toughness. The ASCE design standard for steel poles has established impact values for the Charpy notch-bar impact test. These values are a function of yield stress, plate or bar thickness, and temperature.

Notch-bar impact tests are used to help determine if a normally ductile material might behave in a brittle manner. Three main factors that influence if a material will behave in a brittle or ductile manner are triaxiality, strain rate, and temperature. Ductile materials tend to become more brittle as triaxiality increases, strain rate increases, or temperature decreases. Since brittle materials require far less energy for fracture than ductile materials of the same strength, one can realize the importance of the Charpy test for steel poles used on transmission lines.

The tendency is to reduce temperature requirements of the Charpy test for structures to be in service in warm climates such as Louisiana or Florida. This is not recommended. However, for locations in which temperatures may be extremely low, lower temperature values may need to be specified.

The ASCE design standard specification contains Charpy requirements for structural plate, anchor bolts, and weld materials. The material used for making welds is required to meet the impact requirements for the lowest toughness requirements of the plates being joined.

### **Field Drilled Holes (Paragraph 5.3.16)**

Drilling holes in a pole during construction allows the maximum flexibility in the use of poles in unexpected situations. However, the cutting of the pole does effect the corrosion protection of the pole. For **galvanized poles and painted galvanized poles**, a drilled hole exposes bare steel to the weather. These holes need to be painted with a zinc rich touch up paint similar to described in paragraph 5.9.1.a. For poles made from **weathering steel** the hole can allow rain or ground water into the pole depending on the hole location. Weathering steel poles protect them selves from corrosion by constantly cycling from wet to dry. This cycling creates a water tight oxide layer. Inside the pole or under water the cycling cannot happen. Therefore, there is no corrosion

protection inside the pole. When water enters the pole through the field drilled holes corrosion starts. When field drilled holes are anticipated, the inside of weathering steel pole should be coated similar to the coating described in paragraph 5.9.1.d. If coating the inside is not practical then a thick coating of a silicon sealant shall be applied to the bolt and hole. **Field drilling of painted poles should be avoided** if possible. Drilling holes in painted poles destroys the water tightness and allows corrosion to start on the unprotected carbon steel. If holes cannot be avoided then a thick coating of a silicon sealant shall be applied to the bolt and hole.

### **Field Drilled Holes (wrong location/drilled in error)**

Occasionally a field-drilled hole will end up in the wrong location. A rule of thumb from The American Welding Society (AWS) says a defect or hole location is critical if another hole is spaced within 2.5 times the diameter of the hole in question. (i.e. two 1 inch holes should not be closer than 2 ½ inch edge to edge). A structural analysis of the actual conditions will possibly give a different answer. If the location is critical then a field weld repair is needed by a certified welder.

If the location is not critical then it can be filled with an automotive type freeze plug and painted with touch up paint. The hole should be plugged to keep birds and insects out of the pole and to slow or prevent corrosion to the inside of the pole. The above rule of thumb does not apply to holes that are drilled at the correct elevation but on the wrong face. These poles need to be reviewed by the manufacturer and repaired by a certified welder or these poles need to be replaced.

### **Pole Materials (Galvanized Steel vs Weathering Steel)**

Structural grade steel is a great product for many reasons. However it has one definite problem. Mother Nature wants to return it to its natural state of iron ore. Industry has used many ways to slow the corrosion process. In 1836 a chemist patented a means for coating iron with zinc. That process of hot dip galvanizing remains substantially unchanged today. In the 1900's another method was found. By having a relatively high copper content in the raw steel a dense patina oxide coating would form on the steel and act as a tight adhered barrier preventing future atmospheric corrosion. This steel was largely forgotten until the 1960's when US Steel started marketing their version of this steel as "COR-TEN". Today it is commonly called weathering steel.

The formation of dense patina oxide on weathering steel requires a cycling from wet to dry environment - optimally 50 percent wet and 50 percent dry. Departure from the 50/50 ratio will slow the oxide formation. Unfortunately, this limitation was not well understood in the 1960's and weathering steel was used in locations where water and dirt were trapped. The result was the oxide did not form and the corrosion continued as if the steel was normal bare steel. In some cases such as highway bridges and lattice towers the corrosion caused a problem that was given the name "pack-out". In this case the corrosion takes place between two pieces of steel that are bolted together in such a configuration that water is trapped and held. The corrosion products swell.

Ultimately the forces from the swelling can exceed the strength of the bolts. This can cause structural failure. As a result of this problem weathering steel developed a bad reputation. However, with prudent attention to details, weathering steel is being used by many utilities today.

Both galvanized steel and weathering steel have their advantages. Which is better is a question that has not been answered. Weathering steel normally has a cost advantage and can be factory welded to make a one-piece pole of any length. The one-piece length of galvanized poles is limited to the length of the galvanizing tank. Weathering steel becomes a dark brown wood color. A galvanized pole starts out shiny and ends up a dull gray. Some people say that weathering steel should not be used in areas of heavy road salt or in heavily fertilized farm fields. The weathering steel manufacturers found a number of poles in undesirable conditions, tested them and found that the oxide had formed and that corrosion was not a problem. This guide makes no judgment as to which material is better or gives any guidance in the use of one versus the other. If correctly used both will perform very well. If not used as intended, neither will perform as desired. It is recommended that the owner contact the pole supplier to select the best material for the pole's intended application.

### **Painted poles**

Painted bare steel poles are not recommended. These poles have more construction and maintenance expenses than poles with paint over zinc primer or paint over hot dip galvanizing. The inside surface of bare steel poles is not protected and the poles can corrode from the inside out. Also the outside paint is easily chipped leaving bare steel which may quickly corrode.

### **Weathering steel poles** (Paragraphs 5.9.1.c and 5.9.1.d)

There are environments where weathering steel is not recommended in a bare, uncoated condition because the protective, tight oxide will not form properly. These environments include: (1) atmospheres containing concentrated corrosive industrial fumes, (2) marine locations subject to salt-water spray or salt-laden fogs, or (3) applications where the steel may be continuously submerged in water (salt or fresh) or buried (bare) in soil. Use of weathering steel poles near roads that are salted during the winter should be avoided.

In general, weathering steel is intended for and is most often used in a bare, uncoated condition. However, those surfaces that will not be exposed to the weather or subjected to a wet-dry cycle should be protected from corrosion. Flat, horizontal surfaces are particularly vulnerable. Also, in areas where ground cover will grow to a height where it will contact the pole and rub the protective weathering steel coat off or in areas where the vegetation will keep the pole moist, the steel surface should be protected from corrosion by application of a coating. For direct embedded steel poles, the polyurethane coating may have to be extended above the top of the ground sleeve to protect the weathering steel pole from moisture entrapped by vegetation or rubbing by groundcover.

**Direct Embedded Poles** (Coating General)(Paragraph 5.9.1.d)

When poles are direct embedded, this specification requires a polyurethane coating to be applied to the exterior surface of the embedded portion of the pole. The top edge of the coating is not a smooth transition. Water and dirt can get trapped in this area. Therefore, we suggest that the transition be located about 2inch below the top of the ground collar where there is extra metal. Some poles get set in areas of high vegetation. These poles may require the coating to extend higher on the pole. A full discussion of this is given below.

**Bearing Plate, Coatings, Construction in Wet Areas** (Paragraph 5.9.1.d)

There are many problems associated with setting poles in wet areas and or bad soils. Two of these problems are floating poles and bog or swamp shoes. The floating poles can be due to the fact that some poles are designed without drain holes in the bearing plate. When soil conditions require the use of driller's mud during the augering process, the pole may float and it is impossible to set it in the foundation unless the water is removed from the hole, which may cause the sides of the hole to collapse. The pole could be set if there was a hole in the bearing plate to allow the fluid into the pole. Galvanized poles are allowed to have a drain hole in the bearing plate to facilitate the galvanizing process (paragraph 5.1.10). Weathering steel pole are not normally allowed to have this same hole due to absence of corrosion protection inside the pole. If weathering steel poles are used and a hole is placed in the bearing plate, then the inside of the pole should be coated similar to the embedded outside portion of the pole with a product similar to that described in paragraph 5.9.1.d above. The owner may want to coat the inside of galvanized poles with a coating similar that on the outside of the pole and described in paragraph 5.9.1.d.

The problem of swamp or bog shoe is the method of attaching the device to the pole. Normally this is done by drilling a hole through the pole and using a through bolt. The problem is these bolts may be at or below water line. Therefore they let water into the pole. This does not cause a major problem for galvanized poles. For weathering steel the steel needs to cycle from wet to dry to create the corrosion protection. This cannot happen under the above conditions. There are two solutions. One is to have the inside of the pole coated as described above, the other is to have the manufacture install water tight sleeved hole at the location of the attachment bolts.

**Structure Testing** (Paragraph 5.12)

An option is available in the specification for full scale testing of poles. For a manufacturer that has been designing and fabricating steel poles with the same processes for a good number of years, the need for testing of a steel pole is questionable. Pole testing may be appropriate in cases where there are unusual requirements, new fabrication techniques or when new suppliers are used to validate their design.

### **C. MISCELLANEOUS DESIGN INFORMATION**

#### **Direct Embedded Poles Near Electric Generating Plants and Substations**

Use of direct embedded steel poles should be evaluated for the first two spans outside of a substation or generating plant. The large amount of copper used in a substation grounding grid may create a galvanic corrosion cell, with the steel of the pole sacrificing itself. Anodes or extra subsurface protection may be needed.

#### **Additional Protection**

The owner or owner's representative should determine if anodes should protect the embedded poles. If it is necessary, requirements for sacrificial anodes and their installation should be incorporated in the construction specification.

#### **Electrical Grounding and Polyurethane Coating**

When poles are direct embedded, this specification requires a polyurethane coating to be applied to the exterior surface of the embedded portion of the pole. This coating will tend to insulate the pole from the ground and as such, supplemental grounding may be necessary.

#### **Ground Rods**

Use of copper or copperclad groundwire and rods should be avoided with direct embedded poles. Galvanized rods and couplings are suggested.

### **D. SHIPPING** (Paragraph 6.1.3)

Lumber treated with salts (ACA, ACZA, CCA) to retard "decay or fire" will chemically attack the steel. Urethane foam or some foam containing fire retardents should also not be used in packaging and shipping. When these materials become wet, they become very corrosive.

### **E. DRAWINGS AND INFORMATION TO BE SUPPLIED BY THE MANUFACTURER**

(Section 7)

In order to properly evaluate bids, the specification requires certain information to be supplied with the bid. This information may be supplied on the preliminary drawings from the Bidder. If the forms in Attachment C are used, one will be able to quickly review the information on the sample forms and simultaneously compare the information from the different manufacturers.

**EXAMPLES OF DRAWINGS  
(ATTACHMENT A OF THE SPECIFICATION)**

Structure dimensions,  
pole framing drawings, and details

Detail "A"  
Detail "J"

See Note 4

X

A

B

Step Bolt Spacing

See Dwg. TM-S2 for details

Pole Identification

Note 4

Designated groundline

Ground collar

1'-6"

1'-6"

1'-6"

8'-0"

1'-0"

**LIST OF MATERIALS**

DWG. REF.	QTY.	DESCRIPTION	ITEM	DET.	CODE No.
1	6	7/8" Bolt, Machine, by req'd length	c		
2	6	Washer, 4"sq x 1/4", 15/16 hole(note 1)	d		
3	1	7/8" Clamp, Groundwire + 1 nut	dp		
4	6	7/8" Locknut, MF type	ek		
5	3	Insulator, Line Post, Polymer w/clamp		TM-3P	
6	1	OHGW SUPPORT ASSEMBLY	-	TM-6B	
7	1	OHGW ASSEMBLY, TANGENT	-	TM-4	

**NOTES**

- For flat sides of a multisided pole, use a flat washer for item 2 of the List of Materials. For round poles, use a curved washer.
- Orientation of step bolts is indicated on drawing TM-S2.
- Groundline location and embedment depths are specified on the POLE FRAMING drawing.
- Location of grounding nut and grounding plate is shown on the POLE FRAMING drawing.
- The following materials are to be specified on the plan and profile drawings and staking sheets: POLES, POLE GROUNDING ASSEMBLY, AND ANY ADDITIONAL FOUNDATION UNITS

**DETAIL "A"**  
O.H.G.W. SUPPORT  
TM-6B

**DETAIL "J"**  
POST INSULATOR

**INFORMATION FOR POLE MANUFACTURERS**

DIMENSION A & B		EXAMPLE	
VOLTAGE	A	B	TRANSMISSION LINE STRUCTURE
115 kv	8'-0"	8'-0"	TANGENT HORIZONTAL LINE POST (Steel Pole - 115kv)
NO.	REVISION	DATE	
	Mar., 2001		TFS-115



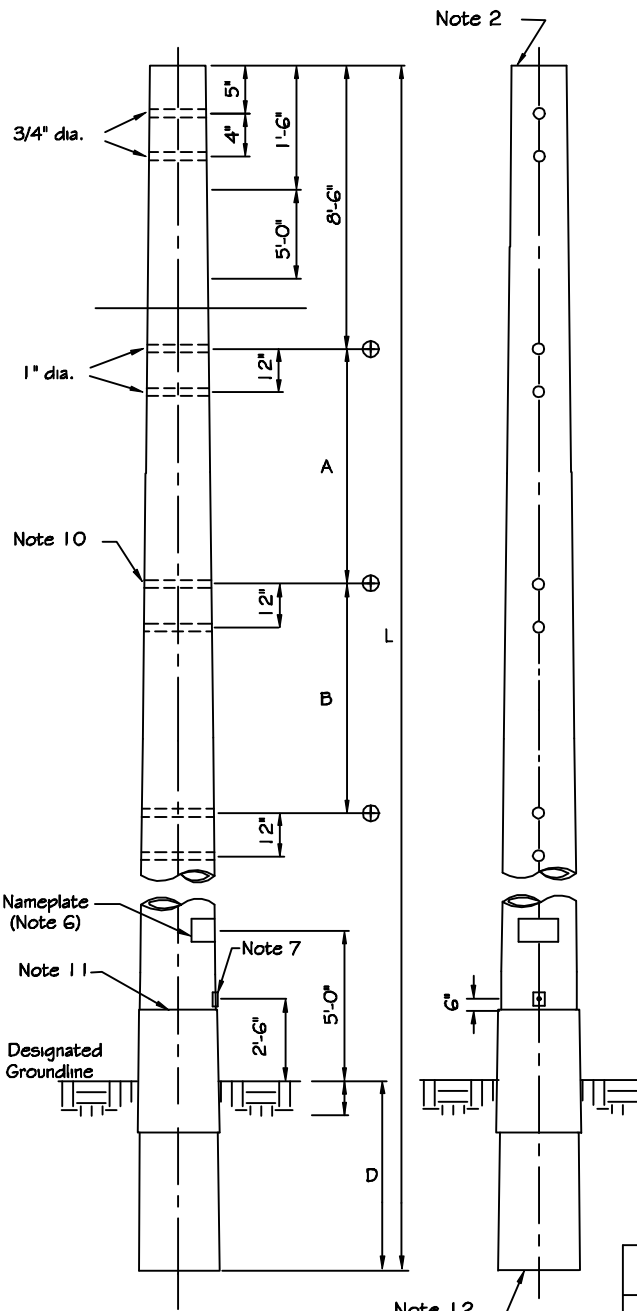
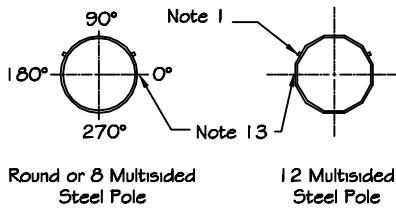

**NOTES:**

1. Provide 3/4"x7 1/2" galvanized stepbolts with locknuts at 1'-6" staggered spacing from 8' above designated groundline to 2' below poletop. Step bolts orientation is indicated on Drawing TM-S2.
2. The top of the pole shall be permanently covered structural steel plate that is bolted or otherwise permanently attached to the pole. The pole shall be delivered with the pole cover attached in place.
3. Plastic plugs shall be installed in all nuts welded to the structure and all tapped holes.
4. For splice details, see drawing TM-S1.
5. Tolerances: Section 5.4 of the specifications
6. Nameplate shall be located as shown with the following minimum information:  
 Manufacturer's name  
 Month and Year of manufacture  
 Length and class of pole  
 Ultimate moment capacity of the pole  
 Owner's name  
 Pole weight
7. Engineer to specify type of grounding connection. For grounding plate/nut details, see drawing TM-S1.
8. Dimensions "D" from pole butt to designated groundline is given below:

L	70'	75'	80'	85'	90'	95'	100'
D	(Engineer to specify)						

9. Dimension "A" and "B" are as follows:  
 A = 8'-0"  
 B = 8'-0"
10. Mounting holes for insulator located on 0-180°
11. Ground collars shall have a minimum thickness of 3/16", have a length of 4 feet, and be located on the centerline of the designated groundline.
12. For galvanized poles, the drain hole in the bottom bearing plate shall not be greater than 30% of the bearing plate area.
13. For all multisided sections, a flat side should be on the 0-180° axis.

**EXAMPLE**  
**TRANSMISSION POLES**  
**TPS-115 POLE FRAMING DRAWING**  
**(Steel)**

NO.	REVISION	DATE	Mar., 2001				TPFS-115



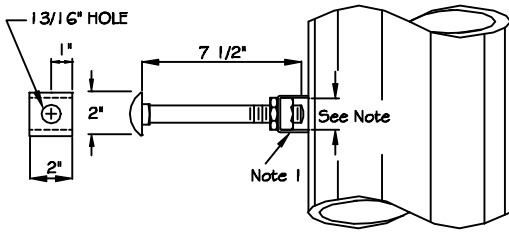

FOR GALVANIZED, WEATHERING & PAINTED STEEL

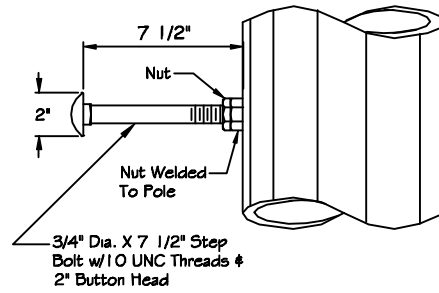

FOR SELF WEATHERING STEEL

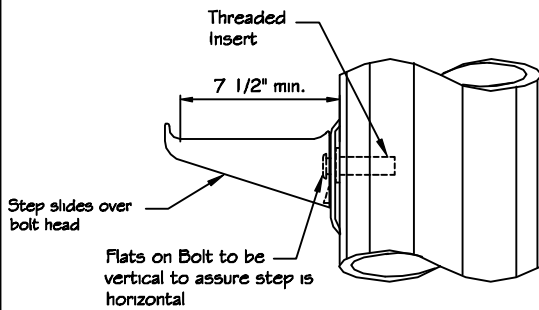

FOR GALVANIZED AND PAINTED STEEL

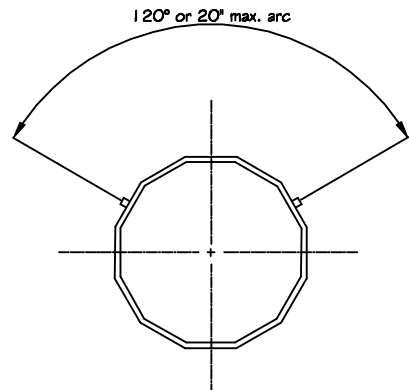
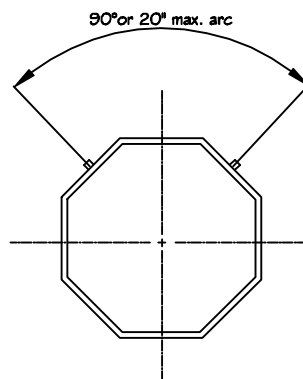
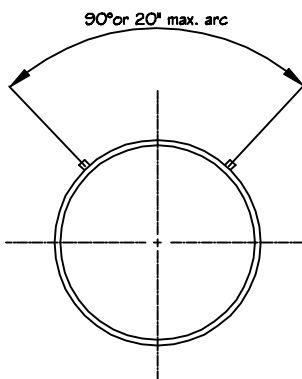

TYPICAL ORIENTATION FOR STEPBOLT CLIPS OR NUTS

NOTES:

1. Step bolt clip shall be designed and fabricated to prevent square nut rotation while step bolt is installed.
2. Step bolts are located per owner's drawings.

EXAMPLE			
TRANSMISSION LINE STRUCTURE			
STEEL POLE STRUCTURE			
CLIMBING DETAILS			
		Mar., 2001	
NO.	REVISION	DATE	TM-S2

Blank Page

**APPENDIX C  
DESIGN EXAMPLE**

**Example 1:** For the TUS-1 pole structure and loading conditions given below, determine the “standard class steel pole”:

**General information:**

Line voltage: 161 kV  
Design by: ACME Engineers  
Structure type: TUS-1 Steel Pole Structures

**Geometry of the structure and location of loads:**

	<u>Distance from Pole Top, Ft.</u>
OHW	0.25
COND-1	9.00
COND-2	15.00
COND-3	21.00
At Gd. Line-assumed	70.00
Pole-End	80.00

Overall pole length is 80 feet. The above dimensions assume a 10.0 foot embedment depth for the steel pole (using standard rule for wood poles of 10 percent pole length plus 2 feet). Assume top of the pole has a 10 inch diameter, and the groundline diameter is 20 inches.

**Overload Factors (OLFs) used in this example:**

For NESC Light, Medium, or Heavy Loading District Loads

Vertical	1.50	Wind on Pole	2.50
Transv. Wind	2.50	Transv. Line Angle	1.65
Longitudinal Loads	1.10		
For Extreme Wind Loads	1.10		

**Conductor and OHGW Data:**

OHW:	3/8”HSS R.B.S = 10,800 lbs.
161 kV Conductor:	Drake (795 26/7 ACSR) R.B.S = 31,500 lbs.
Vertical Span	900 ft.
Horizontal Span	750 ft.
Line Angle	0 degrees

**Load Cases:**

**Load Case A:** NESC Medium District Loads

**Load Case B:** 80 Mph Extreme Wind Load  
(1.1 OCF applied)

**Loading Information (summary):**

NESC Medium Loading Data

	<u>Cond. Tension (kips)</u>	<u>Transverse lb./ft.</u>	<u>Vertical lb./ft.</u>
Drake -161kV	7.91	.536	1.516
OHGW - 3/8 HSS	2.56	.287	.463

Extreme Wind Loading Data (16 psf)

	<u>Cond. Tension (kips)</u>	<u>Transverse lb./ft.</u>	<u>Vertical lb./ft.</u>
Drake -161kV	6.54	1.4773	1.0940
OHGW - 3/8 HSS	1.23	.4800	.2730

**Calculate forces and moments at the groundline:**

(assumes no pole rotation)

• **NESC Medium District Loading**

	<u>Load Due to Wind on Wire</u>	<u>Load Due to Line Angle (kips)</u>	<u>Total Transv. Load W/OCF (kips)</u>	<u>Moment Arm Feet</u>	<u>Ultimate Moments Ft. kips @Groundline</u>
OHGW	.22	0	0.54	69.75	37.5
COND-1	.40	0	1.01	61.00	61.3
COND-2	.40	0	1.01	55.00	55.3
COND-3	.40	0	1.01	49.00	49.2
Groundline				0.0	
Totals for Wire Loads			3.57		203.4
Wind on the Pole			0.88		27.2
Moments due to unbalanced vertical Wire Load					16.4
Moment due to deflection for weight of pole and for wires (p-delta moment)(Approximated)					28.8
Total Transverse Shear @grdline			4.45		--
Total Moments at Groundline			--		275.8

TOTAL RESULTANT GROUNDLINE MOMENT = 275.8 ft. kips

- **Extreme Wind Load**

Similar calculations are performed for the extreme wind load.

TOTAL GROUND LINE MOMENT FOR THE EXTREME WIND LOAD = 316 ft. kips

- **Conclusions: The Extreme Wind Loading load controls design.**

**Determine which “standardized” steel pole design to use:**

Distance 2' from top to groundline =  $70' - 2.0' = 68'$

Load 2' from the top to cause a 316 ft.-kip moment  
at groundline:  $= 316 \text{ ft-kips}/68' = 4646 \text{ lbs.}$

Based on the above calculated tip load, use a **S-04.7 pole**

Perform a quick check to verify the assumed embedment depth using Bulletin 1724E-205, “Design Guide: Embedment Depths for Concrete and Steel Poles”.

**Example 2: An existing 161 kV single pole line is composed of Douglas Fir wood poles. In several locations, steel poles are to replace wood pecker damaged wood poles. The existing damaged poles are 80 ft class 1 wood poles with the TUS pole top assembly. Determine which standard size pole should be used to replace the wood pole. Extreme wind design load is 16 psf (80 mph). The line is located in the heavy loading district. The conductor is 795 Drake and the overhead groundwire is 3/8" HSS.**

NESC heavy district loads with an overload factor of 4 controlled the design of the original wood pole line. A quick comparison of the unit loads for the extreme wind and the NESC heavy district load with overload factors for steel, indicates that the NESC heavy district and not the extreme wind load will control the design of the steel pole. Because extreme wind does not control the design, the engineer may use Table A-1.

Table A-1 indicates that a **S02.8** may be used. However, in order to account for the additional moment due to deflection from the dead weight of the steel pole and the loaded weight of the conductors, the engineer should select a pole, one class greater in strength from this table. **A standard class S-03.4 should be used.**

**Example 3: Same as example 2, except the line must sustain 100 mph extreme wind loads.**

NESC heavy district loads with an overload factor of 4 controlled the design of the original wood pole line. A quick comparison of the unit loads for the extreme wind and the NESC heavy

district load with overload factors for steel, indicates that the 100 mph extreme wind load will control the design of the steel pole (an overload factor of 1.1 is used for extreme wind loads). Because the extreme wind load with an overload factor of 1.1 is greater than the NESC district load with an overload factor of 4.0, extreme wind will control the design. Table A-2 should be used to select the appropriate pole.

In order to account for the additional moment due to deflection from the dead weight of the steel pole and the loaded weight of the conductors, the engineer should select one pole class up from the table. **A standard class S-04.0 should be selected.**

In example 2, calculations for the actual line conditions may actually show that a S-02.8 may be used to replace the 80 class 1 wood pole. Likewise, the engineer might find that a C-03.4 may be adequate for example 3 if calculations are performed using actual line conditions.



**APPENDIX D**  
**SELECTED METRIC CONVERSIONS**

## APPENDIX D

## SELECTED METRIC CONVERSIONS

AREA

To Convert From	To	Multiply by	
circular mil (cmil)	square meter (m <sup>2</sup> )	5.067075	E-10
square centimeter (cm <sup>2</sup> )	square meter (m <sup>2</sup> )	*1.000	E-04
square foot (ft <sup>2</sup> )	square meter (m <sup>2</sup> )	*9.290304	E-02
square inch (in <sup>2</sup> )	square meter (m <sup>2</sup> )	*6.451600	E-04
square kilometer (km <sup>2</sup> )	square meter (m <sup>2</sup> )	*1.000	E+06
square mile (mi <sup>2</sup> )	square meter (m <sup>2</sup> )	2.589988	E+06

FORCE

To Convert From	To	Multiply by	
kilogram force (kgf)	Newton (N)	*9.806650	
kip	Newton (N)	4.448222	E+03
pound force (lbf)	Newton (N)	4.44822	

FORCE PER LENGTH

To Convert From	To	Multiply By	
kilogram force per meter (kgf/m)	Newton per meter (N/m)	*9.806650	
pound per foot (lb/ft)	Newton per meter (N/m)	1.459390	E+01

DENSITY

To Convert From	To	Multiply By	
pound per cubic inch (lb/in <sup>3</sup> )	kilogram per cubic meter (kg/m <sup>3</sup> )	2.767990	E+04
pound per cubic foot (lb/ft <sup>3</sup> )	kilogram per cubic meter (kg/m <sup>3</sup> )	1.601846	E+01

LENGTH

To Convert From	To	Multiply By	
foot (ft)	meter (m)	3.048	E-01
inch (in)	meter (m)	*2.540	E-02
kilometer (km)	meter (m)	*1.000	E+03
mile (mi)	meter (m)	*1.609344	E+03

\*Exact Conversion.

Selected SI-Metric Conversions, Cont.

LOAD CONCENTRATION

<u>To Convert From</u>	<u>To</u>	<u>Multiply By</u>	
pound per square inch (lb/in <sup>2</sup> )	kilograms per square meter (kg/m <sup>2</sup> )	7.030696	E+02
pound per square foot (lb/ft <sup>2</sup> )	kilograms per square meter (kg/m <sup>2</sup> )	4.788026	
ton per square foot (ton/ft <sup>2</sup> )	kilograms per square meter (kg/m <sup>2</sup> )	9.071847	E+02

PRESSURE

<u>To Convert From</u>	<u>To</u>	<u>Multiply By</u>	
kip per square inch (kip/in <sup>2</sup> )	Pascal (Pa)	6.894757	E+06
kip per square foot (kip/ft <sup>2</sup> )	Pascal (Pa)	4.788026	E+04
Newton per square meter (N/m <sup>2</sup> )	Pascal (Pa)	*1.000	
pound per square foot (lb/ft <sup>2</sup> )	Pascal (Pa)	4.788026	E+01
pound per square inch (lb/in <sup>2</sup> )	Pascal (Pa)	6.894757	E+03

BENDING MOMENT

<u>To Convert From</u>	<u>To</u>	<u>Multiply By</u>	
kilogram force meter (kgf-m)	Newton meter (N-m)	*9.806650	
kip-foot (kip-ft)	Newton meter (N-m)	1.355818	E+02
pound-foot (lb-ft)	Newton meter (N-m)	1.355818	

VELOCITY

<u>To Convert From</u>	<u>To</u>	<u>Multiply By</u>	
foot per second (ft/s)	meter per second (m/s)	*3.048	E-01
kilometer per hour (km/h)	meter per second (m/s)	2.777778	E-01
mile per hour (mi/h)	meter per second (m/s)	4.370300	E-01
meter per hour (m/h)	meter per second (m/s)	2.777778	E-04

\*Exact Conversion.

**Blank Page**

## APPENDIX E

### CONTRIBUTORS

The following members of the Transmission Line Subcommittee of the National Rural Electric Cooperative Association, Transmission and Distribution Engineering Committee provided invaluable assistance in preparing this document.

Ballard, Dominic, **East Kentucky Power Coop.**, Winchester, KY  
Burch, John, **Florida Keys Electric Coop.**, Tavernier, FL  
Emmons, Doug, **Hoosier Energy REC**, Bloomington, IN  
Heald, Donald, USDA, **Rural Utilities Service**, Washington, D.C.  
Hetherington, Bill, **Lee County Electric Coop.**, North Fort Myers, FL  
Johnson, Robert, **Arkansas Electric Coop.**, Little Rock, AR  
Lukkarila, Charles, **Great River Energy**, Elk River, MN  
McCall, Charles, **Georgia Transmission Company**, Tucker, GA  
Nicholson, Norris, USDA, **Rural Utilities Service**, Washington, D.C.  
Oldham, Robert, **Southern Maryland Electric Coop.**, Hughesville, MD  
Smith, Art, **Patterson & Dewar Engineers**, Decatur, GA  
Turner, David, **Lower Colorado River Authority**, Austin, TX  
Twitty, John, **Alabama Electric Coop.**, Andalusia, AL