

**Applying Infrared Thermography for the Purpose of  
Identifying Concealed Wood Framing Member Type and  
Subsurface Anomalies with Intended Application Towards  
Historic Structures**

**Principal Investigator:**

**Michael Spencer, Assistant Professor,**

**University of Kentucky, College of Design,  
Department of Historic Preservation**

**with collaboration from**

**Dr. Lynn Penn, Dr. John Nychka, Liz Boyer, John Liebertz and Laura Everdale**

**Grant #: MT-2210-06-NC-10**

**Applying Infrared Thermography for the Purpose of  
Identifying Concealed Wood Framing Member Type and  
Subsurface Anomalies with Intended Application Towards  
Historic Structures**

**Grant #: MT-2210-06-NC-10**

**Principal Investigator:**

**Michael Spencer, Assistant Professor,**

**University of Kentucky, College of Design,  
Department of Historic Preservation  
117 Pence Hall  
Lexington, Kentucky 40506-0041  
www.uky.edu**

**with collaboration from**

**Dr. John Nychka, Dr. Lynn Penn, Liz Boyer, Laura Everdale and John Liebertz**

Funding for this research was partially provided by the National Park Service's National Center for Preservation Technology and Training, Natchitoches, Louisiana. NCPTT promotes and enhances the preservation of prehistoric and historic resources in the United States for present and future generations through the advancement and dissemination of preservation technology and training. NCPTT's preservation technology and training grants program develops partners in non-profit organizations, universities and government agencies throughout the United States to complete critical preservation work and lend significant support to cutting-edge developments in the conservation and preservation community.

Final Report was Submitted August 24, 2008

Cover Image: IRT image of a wood sample showing three distinct areas of simulated subsurface deterioration. These areas are indicated by circular patterns in the center of the image. (Image by author, 2008)

**Applying Infrared Thermography for the Purpose of Identifying Concealed Wood Framing Member Type and Subsurface Anomalies with Intended Application Towards Historic Structures**

**Table of Contents:**

Image Listing.....IV  
Charts Listing.....VII  
Executive Summary.....VIII

**I Background:**

Introduction.....1  
Project Mission, Objectives and Overview.....4  
History of Infrared Thermography.....6  
Infrared Thermography Terminology and Basic Concepts.....8  
Types of IRT Testing Methods.....11  
Basic Heat Transfer Concepts.....16  
Thermal Characteristics of Wood.....19

**II Equipment:**

Equipment.....28

**III Methodology:**

IR camera Calibration, Emissivity and Reflected Temperature.....34  
Wall Section Construction.....35  
Testing Methodology and Protocols for Wood Species Identification.....38

Wood Deterioration Sample Fabrication.....	47
Subsurface Anomaly Testing Methodology.....	48
Field Testing.....	50
Obtaining Results and Measurements.....	53
<b>IV Results, Discussion and Conclusion:</b>	
Testing Results and Discussion for Wood Species Identification.....	56
Subsurface Anomaly Recognition Results and Discussion.....	63
Objectives I, II and V Results and Discussion.....	65
Conclusions.....	77
Acknowledgments.....	81
<b>V References:</b>	
References.....	82

**List of Images:**

Fig.1: Image of 19th century frame structure, Lexington, Kentucky.....1

Fig.2: IR image of portion of same 19th century frame structure showing framing members... 1

Fig.3: Electromagnetic spectrum.....6

Fig.4: Diagram of IRT testing process.....11

Fig.5: IR image of moisture related anomaly at Ashland Estate, Lexington, Kentucky.....12

Fig.6: IR image of concealed studs on a frame addition, Lexington, Kentucky.....12

Fig.7: Schematic showing the reflection mode of IRT.....14

Fig.8: Schematic showing the transmission mode of IRT.....15

Fig.9: Image of thermal bridging occurring on a rooftop during winter.....16

Fig.10: Illustration of thermal transfer and decline.....17

Fig.11: x7 magnification of wood illustrating grain direction.....19

Fig.12: Illustration showing the three wood planes.....20

Fig.13: Illustration of coniferous wood section at x25 magnification.....21

Fig.14: x90 magnification of Red Oak.....22

Fig.15: x40 magnification of all wood species used in testing.....23

Fig.16: IR camera used for testing.....28

Fig.17: Results of ThermaCAM® Researcher Pro 2.8 SR-2 software.....29

Fig.18: Placement of thermocouples on small wall section.....31

Fig.19: Image of data acquisition unit used to obtain data from thermocouples.....31

Fig.20: Moisture meter.....32

Fig.21: 1100 watt IR lamp.....33

Fig.22: 300 watt halogen lamp.....33

Fig.23: Image of small mock wall section.....	36
Fig.24: Drawing showing dimensions of small wall section.....	36
Fig.25: Large wall section modules fit together.....	37
Fig.26: Large wall section modules apart.....	37
Fig.27: Large wall section casters.....	37
Fig.28: Large wall section vice clamps used to hold samples.....	37
Fig.29: Placement of 300 watt halogen lamp in relation to small wall section.....	38
Fig.30: ESSC, Cincinnati, Ohio exterior view of environmental chamber.....	43
Fig.31: ESSC, Cincinnati, Ohio interior view of environmental chamber.....	43
Fig.32: Profile analysis of two IR images obtained from two separate methodologies.....	45
Fig.33: Illustration of sample fabricated for deterioration testing.....	47
Fig.34: Placement of spot analysis on wall section surface to obtain data.....	54
Fig.35: IR image of deterioration sample after 20 seconds using the reflective mode.....	63
Fig.36: IR image of deterioration sample after 30 seconds using the reflective mode.....	63
Fig.37: Plot analysis showing results of modified deterioration sample.....	64
Fig.38: IR image of modified deterioration sample.....	64
Fig.39: Image of a typical brace frame structure with different wood species noted.....	67
Fig.40: Annotated database page.....	68
Fig.41: Database homepage.....	69
Fig.42: Database active thermography page.....	70
Fig.43: Database step heating (long pulse), reflective and transmission mode page.....	71
Fig.44: Database small wall section, long pulse, transmission mode, semi-controlled environment protocol/procedure page.....	72
Fig.45: Continued.....	73

Fig.46: Database listing of small wall section, semi-controlled environment, transmission mode, 300 watt halogen bulb tests.....	74
Fig.47: Continued.....	75
Fig.48: Database individual test page with downloadable data from each test.....	76
Fig.49: Example of resistance drilling results.....	77
Fig.50: Time of flight (TOF) testing.....	77
Fig.51: Field use of IR camera.....	78
Fig.52: IR image showing concealed down bracing and studs.....	79
Fig.53: IR image showing rafters and collar ties behind plaster and lathe.....	79
Fig.54: Composite image of Ashland Estate, Lexington, Kentucky.....	79
Fig.55: Close-up of Ashland image showing moisture infiltration.....	79

**List of Charts:**

Chart 1: Correlation between specific gravity and thermal conductivity.....25

Chart 2: Ambient temperatures affect on % temperature change of heating apparatus.....57

Chart 3: Ambient temperatures affect on % temperature change of analysis spot 1.....57

Chart 4: % change of analysis spot 1 vs. % change of analysis spot 2.....58

Chart 5: Change in temperature per minute of interior and exterior wall section surfaces.....59

Chart 6: Temperature increase of exterior surface, over sample stud, for 240 minutes.....59

**List of Tables:**

Table 1: Emissivity values for selected materials.....10

Table 2: Thermal conductivity values (k values) for selected materials.....18

Table 3: Specific gravities of some common woods.....24

Table 4: Thermal conductivity values (k values) for selected woods.....27

Table 5: Influence of wood physical characteristics on thermal conductivity.....27

Table 6: Ideal testing protocol for small wall sections.....41

Table 7: Ideal testing protocol for large wall sections.....46

Table 8: Ideal testing protocol for field tests.....52

Table 9: Linear slopes for all tested wood species in increments of 30 minutes.....60

Table 10: Wood test samples relationship between linear slope and thermal conductivity,  
small wall sections.....61

Table 11: Wood test samples relationship between linear slope and thermal conductivity,  
large wall sections.....62



## **Executive Summary:**

Infrared thermography (IRT) has been in use for decades as a means of nondestructive testing. However limited research has been conducted on applying this technology towards historic preservation, particularly wood framed structures. Furthermore, hardware and information relating to this technology and its preservation applications can be difficult to obtain and interpret resulting in limited use by preservationists. Research conducted at the University of Kentucky through a grant from the National Center for Preservation Technology and Training (NCPTT) begins to address some of these issues.

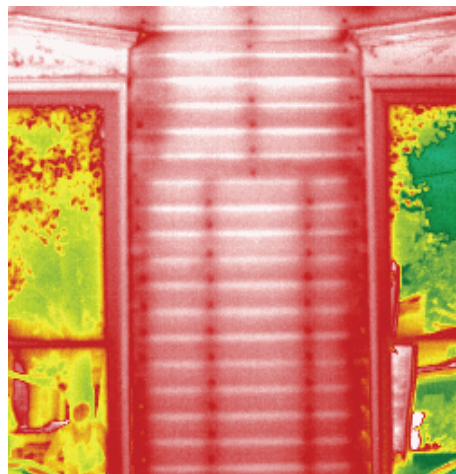
Research primarily focused on wood and to what extent infrared thermography could assist in interpreting this material within historic structures for conservation, restoration and rehabilitation purposes. Because of woods anisotropic characteristics this proved to be a difficult task. Therefore, primary research was conducted to determine whether woods thermal characteristics varied enough among species that type could be distinguished within a wall system. Coinciding with this was a brief look at subsurface deterioration within wood samples and potential for identification within wall systems. This information is useful during work on historic structures as load capacities vary among wood type and deterioration levels. Determination of such characteristics can also prevent unnecessary destructive investigations resulting in more accurate and preservation friendly cost estimates.

Due to the nature of such testing, mainly the need to obtain results in the field from in-situ samples, traditional ASTM standards for laboratory testing of clear wood samples were not applicable. ASTM standards for IRT testing using passive methods were likewise not applicable as active thermography was employed. Therefore, new procedures and protocols were developed relying primarily on previous studies as well as successes achieved throughout the research process. The resulting protocols as well as results are therefore in need of further refinement, however they have provided the proof of concept necessary to continue and expand research into field testing and various wall configurations. Aiding in the interpretation of results and methods used during research are sections outlining basic concepts associated with infrared thermography, heat transfer and the thermal characteristics of wood.

## **Introduction:**

Advances in technology since the National Historic Preservation Act of 1966 have provided new tools and techniques necessitating re-evaluation of how preservationists analyze and interpret the historic built environment. These advances include the creation of hardware and software enabling the preservationist to perform traditional tasks more accurately and efficiently while also providing structural access unimaginable fifty-two years ago. State of the art nondestructive evaluation (NDE) techniques are responsible for much of this unprecedented improvement in structural assessments and in making previously concealed areas, such as walls, accessible. The use of NDE techniques in conjunction with powerful analytical software has made historical structural assessments more accurate, legible and efficient. Benefits of NDE techniques are without question aligned with the tenets of the preservation field since they promote much of the ideals set forth in the Secretary of Interiors Guidelines for restoration, rehabilitation and preservation, most notably retention of historic material.<sup>1</sup> Therefore, it's logical that preservationists now look more favorably upon new nondestructive techniques and technologies as well as the new perspectives they provide.

However, despite this acceptance, preservation as a discipline still lags behind in technological application due in large part to financial concerns, mainly equipment cost. Financial issues corresponding to the obtainment and implementation of new technologies is a perennial issue within the field. This translates into untapped potential as certain technologies, while common in fields like engineering, are as yet unutilized within the discipline. Infrared thermography (IRT) is one technology that until recently had seen little use in the preservation field due to the large cost of equipment. However, advancement and refinement of IRT technology has reduced this cost, spurring research into heritage applications. Although current research is being conducted in the field much is preliminary or has dealt primarily with the issues of moisture and structural identification (**fig. 1 & 2**). This leaves research into potential materials identification and deterioration, most notably wood, underdeveloped. Research presented here looks primarily at this particular area while noting other technologies useful in the quantitative and qualitative assessment of concealed deterioration or materials identification.



**Fig. 1 & 2:** Digital picture of an early 19<sup>th</sup> century frame structure in Lexington, Ky. (top). The red box indicates where the infrared picture (bottom) was taken. Note the identification of an otherwise unsuspected framing system. (Photos by John Liebertz, 2007)

<sup>1</sup>W.Brown Morton, Gary L. Hume and Kay D. Weeks, *The Secretary of Interiors Standards for Rehabilitation*, 1990 edition, (Washington: U.S Government Printing Office, 1990), pg 6.

Infrared thermography (IRT), although understood since the discovery of infrared waves by Sir William Herschel in 1800, has only been utilized on a large scale in the public sector since the 1960's. Only as recently as 2004 has an IRT camera been developed specifically for structural applications (FLIR's, B1, B2 and B20 models).<sup>2</sup> However, application of IRT to structures is not new as studies have been undertaken extensively in the areas of energy loss (heat loss) and moisture. Notably these studies made little mention of the structural age or specific material composition (wood species) under investigation, unless already known, and instead took a much broader approach in formulating their predictive thermal models. This may be appropriate for modern construction adhering to standards set forth by the ASTM and national building codes; however historic structures present a spectacular variation from consistency, not only structure to structure but also brick to brick. This inconsistency increases the unknown parameters making predictive modeling difficult at best although not entirely useless. While individual accuracy may be difficult to obtain, averages from multiple samples at various locations within a structure provide a more reliable base from which to compare. However, thermal modeling, although mentioned, is not a primary objective of this research. Rather this research seeks to expand upon thermal wood species identification, deterioration and defects establishing proof of concept and noting variations within wall systems with further research into aged materials and finally intact historic structures.

In addition to the lack of IRT research conducted on wood and historic wood structures, there is also limited information on proper protocol and condition parameters when dealing with historic structures in general. Some general information is available as well as case study examples but there is of yet no systematic process or set of guidelines in place to ensure eventual compatibility, comparison and verification of IRT field test results between members of the preservation community. Creation of such guidelines will allow for the compilation of comparable data and formation of an IRT database. This database will potentially allow investigators the opportunity to evaluate similar construction techniques, abnormalities and materials without having to perform the multitude of tests needed upon initial investigation. Such a tool also has the benefit of disseminating information to those new to the technique and ensuring a high standard of analysis and evaluation.

Creation of such a database is by no means a quick process or without problems. Numerous materials, material combinations, environmental conditions and abnormalities exist as would need to be thermally modeled and verified both in the lab and through field tests. Such a database would also need to recognize the various IR cameras used in testing, algorithms used in modeling and software programs used for interpretation. Eventual expansion of the database to include additional nondestructive and minimally invasive tools would also be advisable as these tools, when used in conjunction with IRT, can provide additional accuracy and confirmation of results.

Practical implications of research into this area are numerous not only for preservationists but also for those in the construction industry. While the obvious advantage of material retention and concealed feature identification exist there is also the added benefit of cost reduction

---

<sup>2</sup>FLIR, *FLIR Systems User's Manual, ThermaCAM Researcher*, Professional edition, (2006), pg 7.

associated with preservation, restoration and rehabilitation projects. This is accomplished through accurate preliminary analysis of a structure that can generate data applicable to existing load capacities, current deterioration/defect conditions and general structural assessments, replacing the antiquated and often costly approach of “see as you go”. With the excuse of the “unknown cost” dispelled, the hope is that more historic structures will be retained rather than the current trend of demolition and rebuild, preserving both our cultural heritage as well as environment.

## **Project Mission, Objectives and Overview:**

Research at the University of Kentucky's College of Design Department of Historic Preservation, funded by the National Center for Preservation Technology and Training (NCPTT) is looking at ways to maximize the benefits of nondestructive evaluation (NDE) within the field of historic preservation. This includes the dissemination of data and knowledge through new and traditional means as well as promoting the use of NDE technology through easy to follow guidelines and interactive analysis databases. Initial research, as funded by the NCPTT, has primarily focused on infrared thermography (IRT) with the following objectives;

- I. Establishing preliminary IRT calibrations, parameters and protocol tailored primarily to wood frame structural systems.
- II. Providing background into woods physical and chemical characteristics that can affect thermal conductivity.
- III. Identification of surface and subsurface abnormalities within wood and wall systems.
- IV. Proof of concept for practical and field applicable use of IRT to distinguish variations of wood species within wall systems.
- V. Establishment of a preliminary IRT and other NDE techniques database template for eventual dissemination of knowledge.

### *Objective I:*

The objective of establishing preliminary IRT protocol and parameters tailored to wood and historic wood framed structures looks to build on previous research to adopt a more systematic and straightforward approach. This includes providing information on investigation setups, favorable environmental testing conditions and methods for analysis through IRT testing in the lab and field.

### *Objective II:*

Background into woods' physical and chemical properties is essential to understanding how heat propagates through the various species and therefore, directly correlates with IRT assessment. These characteristics will be examined individually and as an entirety to determine their potential impact on IRT investigations.

### *Objective III:*

Understanding how certain physical characteristics affect the thermal conductivity of wood enables better interpretation of abnormalities when testing individual samples, mock wall sections and historic structures. This objective also seeks to examine the benefits of various IRT approaches and their potential for abnormality detection both in terms of depth and size.

### *Objective IV:*

Perhaps the largest and most unpredictable objective of this research is the examination of individual wood species within a wall system to determine the presence of any individual identifying thermal characteristics. This is based on previous thermal conductivity studies that have shown various rates within wood species, albeit not within a wall system. Proof of such thermal variations would enable the identification of wood type assisting in the structural

assessment of historic structures as well as assisting in building technology and methodology studies. Construction of mobile large and small wall sections with interchangeable wood studs allowed for multiple species to be tested under the same conditions. Transportability also meant that environmental conditions could be relegated for testing purposes, something difficult to achieve in a real world application.

*Objective V:*

The last objective aims to provide information from this and previous research relating to IRT and other NDE techniques within a user friendly web based format. Ideally, this will provide the opportunity for dissemination of knowledge relating to NDE technologies as well as raw and interpreted data that can be used for comparison and analysis purposes.

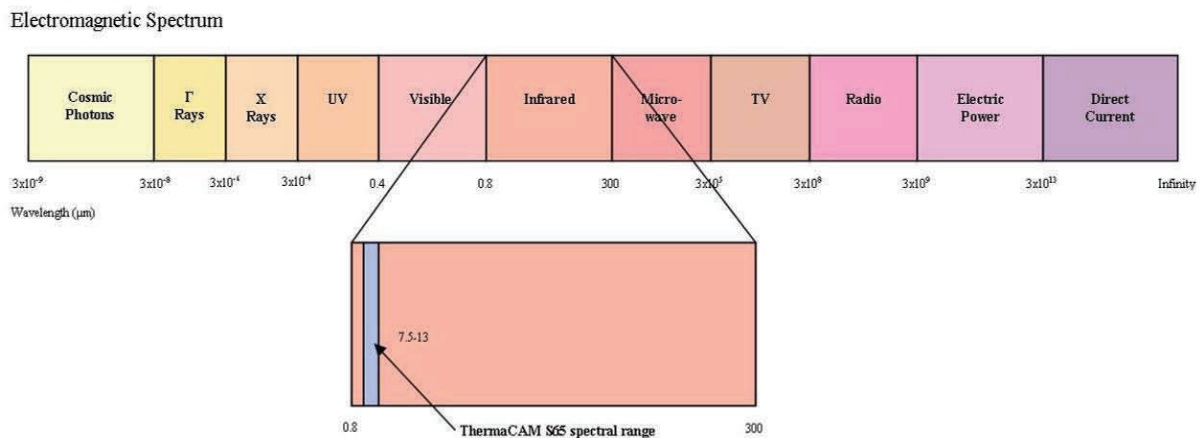
In an effort to realize these objectives over seventy hours of IRT tests were performed with additional hours devoted to field testing and traditional research. Specifics relating to data gathered are as follows;

- 4,200 + infrared images generated
- 76,800 data points generated from each image
- 4,608,000 data points generated from each 60 minute test
- 322,560,000 + total data points generated

Information gained from testing and research proved to be helpful in verifying and accomplishing many of the objectives listed. While results from these tests will be discussed and analyzed in subsequent chapters it is important to note that there is still much to accomplish in the field or IRT as applied to historic structures.

## History of Infrared Thermography:

Infrared thermography (IRT) is the measurement of surface temperature distribution through non-contact methods.<sup>3</sup> This is possible due to the ability of IR wavelengths to travel through the atmosphere as well as their correlation with temperature. Through an infrared camera these IR wavelengths can be measured producing pseudo images of materials and their surface, and in some cases subsurface, thermal characteristics. Infrared thermography's relationship to the study of heat measurement is undeniable and therefore its history is linked directly with that of heat measurement and thermal dynamics.



**Fig. 3:** An illustration of the electromagnetic spectrum showing infrareds relationship to other spectral ranges. The infrared camera used to conduct this research has a spectral range between 7.5-13  $\mu\text{m}$ 's as noted by the light blue band and black arrow. (Illustration by author, 2007)

The field of thermal dynamics has existed for millennium but for our purposes the creation of the first glass thermometer by Galileo in 1593 marks the beginning of its scientific understanding. Over two centuries would pass after Galileo's invention before Sir William Herschel of England, in 1800, mistakenly discovered the infrared spectra. The discovery occurred when Herschel used a prism to observe the sun, separating the visible spectra from blue to red, and noted that temperatures were still elevated beyond the red band where no radiation was visible. Sir Isaac Newton had also performed a similar experiment however, Herschel was the first to notice that the distance where the heating is greatest has a specific location beyond visual light establishing the basis for the electromagnetic spectrum.<sup>4</sup>

This realization led to the understanding that only a small portion of electromagnetic radiation falls within the visible spectrum. Infrared radiation has longer wavelengths than visible light and therefore falls outside the limits of detection of the human eye (**fig. 3**). Herschel also derived a number of other findings from this research most notably that infrared radiation varies

<sup>3</sup>Xavier P. V. Maldague, *Theory and Practice of Infrared Technology for Nondestructive Testing*, (New York: John Wiley & Sons, Inc., 2001), pg 1.

<sup>4</sup>FLIR, pg 111.

with material.<sup>5</sup> Further research into the area of infrared and temperature measurement resulted in a number of discoveries between the early 19<sup>th</sup> century and today.

- 1829: Nobili invents the first thermocouple
- 1833: Melloni makes the first thermopile
- 1840: John Herschel produces first infrared image through differential evaporation.
- 1880: A. Longley invents the bolometer
- 1900: Max Planck clarifies Herschel's experiment
- 1917: Photoconductive detector invented, more sensitive
- 1960's and 70's: First commercial infrared cameras available
- 1980's: Development of the focal plane array (FPA)<sup>6</sup>

Modern infrared cameras are vastly improved from the 60's and 70's combining portability and durability with accuracy, improved resolution and efficiency. While the majority of IR applications, about 80%, are still associated with the military, private sector applications have continued to expand from the early 60's.<sup>7</sup> Through the years various research, mostly concentrated in the areas of defense, electrical engineering, aerospace and industrial manufacturing has provided the guidelines to IRT's capabilities; however the field still holds potential for further developments and applications.

---

<sup>5</sup>Omega, "A Historical Perspective," *Transactions in Measurement and Control*, vol. 1 3<sup>rd</sup> edition, (2004), pg 10-14.

<sup>6</sup>Maldague, pg 8-9.

<sup>7</sup>Maldague, pg 10-11.



## **Infrared Thermography Terminology and Basic Concepts:**

Over 200 years of research in the field of thermal dynamics and infrared thermography has produced a multitude of literature. While the theories and equations presented are important aspects of this discipline, and indeed necessary, from a preservation perspective attention need only be given to a very small portion of the larger body of research. Reasoning behind this approach deals primarily with preservation's application of the technology. Preservationists will not be responsible for new developments concerning equations, hardware or software but instead will seek to apply what has been developed in through alternative applications. Eventually, if the market warrants, these applications will promote the development of hardware and software specific for the disciplines needs. That said, some general understanding of infrared, infrared thermography and thermal dynamics is necessary if sound investigations and analysis are to be conducted.

### *Blackbody:*

The observed definition of a blackbody is "an object which absorbs all radiation that impinges on it at any wavelength". This is further explained in Kirchoff's law which states that "a body capable of absorbing all radiation at any wavelength is equally capable in the emission of radiation".<sup>8</sup> However, a more simplistic definition states that,

"a blackbody is a theoretical surface that absorbs all radiant energy that falls on it, and radiates electromagnetic energy at all frequencies, from radio waves to gamma rays, with an intensity distribution dependent on its temperature.

Because all visible light falling on such a surface is absorbed without reflection, the surface will appear black as long as its temperature is such that its emission peak is not in the visible portion of the spectrum."<sup>9</sup>

Building on this principal is a piece of equipment known as a cavity radiator. This piece of equipment in its basic form is a heater placed within an enclosure containing a small opening that allows small amounts of radiation to enter and exit. The exiting radiation approximates that of a blackbody. This equipment is particularly useful when calibrating infrared cameras as it radiates uncompromised electromagnetic energy that can be converted to provide accurate thermal imaging. However, materials under investigation are rarely perfect blackbodies and therefore variables such as reflection, absorption and transmission will affect readings.

### *Reflection, Absorption and Transmission:*

The three variables of reflection, absorption and transmission will always account individually for a percentage of the total sum of radiation being transferred to an object or material under investigation. Further explained, this means that the radiation the object is subjected to will either be absorbed ( $\alpha$ ), reflected ( $\rho$ ) or transmitted ( $\tau$ ). As each of these variables accounts for a percentage of the total radiation the sum of the three will always equal one, providing the equation:<sup>10</sup>

---

<sup>8</sup>FLIR, pg 116.

<sup>9</sup>Britannica Concise Encyclopedia, "Definition of a Blackbody," <http://www.britannica.com/>, 18 March 2008.

<sup>10</sup>FLIR, pg 121.

$$\alpha_{\lambda} + \rho_{\lambda} + \tau_{\lambda} = 1$$

The subscript  $\lambda$  is used to symbolize the relationship between the radiation and wavelength. This equation can also be re-written as the flux incident ( $\Phi_i$ ) equals the sum of flux reflected ( $\Phi_r$ ), flux absorbed ( $\Phi_a$ ) and flux transmitted ( $\Phi_t$ );<sup>11</sup>

$$\Phi_r + \Phi_a + \Phi_t = \Phi_i$$

While the above equation is applicable to most materials some opaque materials have a flux transmitted value of zero ( $\Phi_t = 0$ ). Perfect mirrors also have a value of zero for both  $\Phi_a$  and  $\Phi_t$ . Within a perfect blackbody all the incident flux is absorbed:  $\Phi_i = \Phi_a$ .<sup>12</sup> While perfect mirrors and blackbodies both have known variable percentages (mirrors reflect 100%, blackbodies absorb 100%), most materials do not. One method of accounting for these varying radiation emissions, and therefore accurately recording IRT temperature distributions, is through the calculation of an objects emissivity.

#### *Emissivity:*

Emissivity is expressed as a ratio of the radiation emitted by the surface of a material to the radiation emitted by a blackbody, both under the same parameters of temperature, direction and spectral band.<sup>13</sup> Essentially what emissivity calculations accomplish are corrections in variable radiation emissions from different materials allowing for accurate temperature measurement. As might be expected almost every material has a different emissivity which is expressed on a unit less scale of 0 to 1, 0 being perfectly reflective (perfect mirror) and 1 being perfectly absorbent (perfect blackbody). Unfortunately, emissivity values are not constant even for individual materials and change based on factors such as temperature. This is especially true for materials like metal whose emissivity increases considerably with temperature. Oxidized iron and steel is a good example of this as the emissivity at 100°C is 0.74 while at 1227°C the emissivity climbs to 0.89.<sup>14</sup> Tabular emissivity values do exist for various materials under certain conditions (**table 1**); however these are general and determination of objects emissivity should be undertaken before beginning any investigation if accurate temperature measurements are required.

#### *Additional Variables:*

While absorption, reflection and transmission may be the three largest variables when trying to accurately measure radiation emission from an object, environmental variables also need to be assessed. This includes accounting for background radiation which can be reflected from other objects or inherently present in the atmosphere. Other variables that can have an affect on accurate thermal measurements include atmospheric temperature, object distance and relative humidity. The infrared camera employed during this research accounted for and calibrated the camera based on values specified for these variables enabling accurate measurements.

---

<sup>11</sup>Maldague, pg 31.

<sup>12</sup>Maldague, pg 31.

<sup>13</sup>Omega, pg 78.

<sup>14</sup>FLIR, pg 137.

*Selected Emissivity Values:*

(Materials used for this research are noted with an \*)

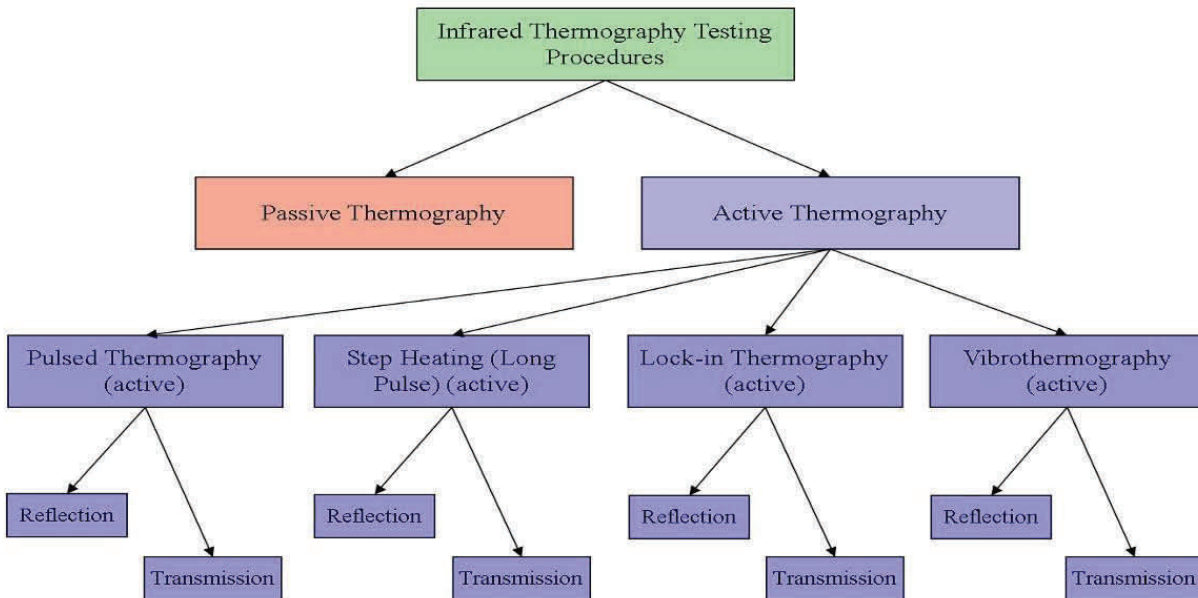
<b>Material</b>	<b>Description</b>	<b>Temperature (C°)</b>	<b>Spectrum (SW: 2-5µm, LW: 8-14µm, LLW 6.5-20µm)</b>	<b>Value</b>
Aluminum	Foil	27	LW	0.04
Aluminum	Anodized black dull	70	LW	0.95
Asphalt paving		4	LLW	0.967
Brick	Common	17	SW	0.86-0.81
Gypsum		20	all	0.8-0.9
Pine	planed	70	LW	0.81-0.89
Oak	planed	70	LW	0.88
Cedar*	planed	21	LW	0.665

**Table 1**<sup>15</sup>

---

<sup>15</sup>FLIR, pg 131-146.

## Types of IRT Testing Methods:



**Fig. 4:** Various infrared thermography testing procedures exist, each with advantages and disadvantages. The illustration above shows these procedures beginning with the two main methods, passive and active thermography and ending with the two types of heating methods, reflection and transmission. (Illustration by author, 2008)

### *Passive Thermography:*

Passive thermography is the most frequent type of thermographic technique employed during IRT building investigations as it requires little to no preparation. This procedure relies on the ambient air temperature and environmental conditions to expose potential anomalies. These anomalies, when viewed through an IRT image, can register as distinct thermal contrasts, or differences, within similar materials (**fig. 5**). Temperature differences are typically noted as *delta-T* ( $\Delta T$ ) values. Typically, areas with a  $\Delta T$  value  $>5^{\circ}\text{C}$  warrant further investigation as there is a strong possibility of the presence of deterioration.<sup>16</sup>

However, it should be cautioned that there are many reasons why a  $\Delta T$  value could be  $>5^{\circ}\text{C}$  when dealing with historic structures besides the presence of deterioration. One reason relates to the thermal affect that subsurface materials can have on surface materials temperature. Probably the best example deals with framed structures clad in wood or synthetic siding (**fig. 6**). These structures can exhibit thermal contrasts  $>5^{\circ}\text{C}$ ; however, this relates to the presence of underlying framing members and not to deterioration. Other reasons why  $\Delta T$  can be  $>5^{\circ}\text{C}$  during a passive test involve false readings which can occur due to environmental conditions and human error. With the possibility of false readings and with the introduction of potential human error, it is important that common sense is exercised and that the structure under investigation is surveyed visually as well as through the lens of an IRT camera.

<sup>16</sup>Maldague, pg 1-2

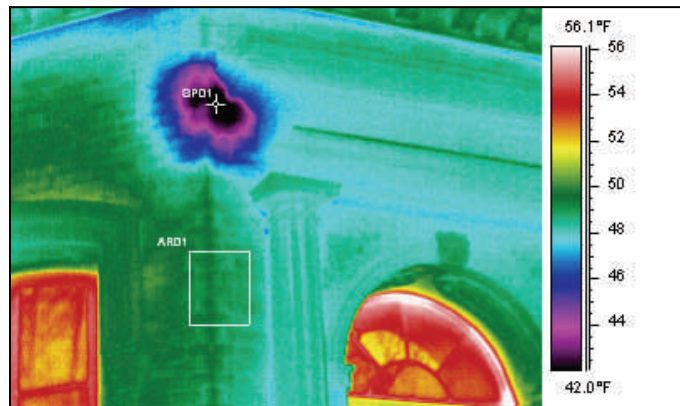
Although passive thermography typically produces qualitative data the process has proven extremely effective in detection of moisture and the identification of concealed structural elements within historic buildings (fig. 5 & 6).

Furthermore, unlike active thermography, large areas can be surveyed quickly with no need for electricity to power the heating apparatus, sometimes difficult to find in vacated historic structures. This particular type of thermography was used throughout this research as a means to identify areas of potential interest in structures under investigation.

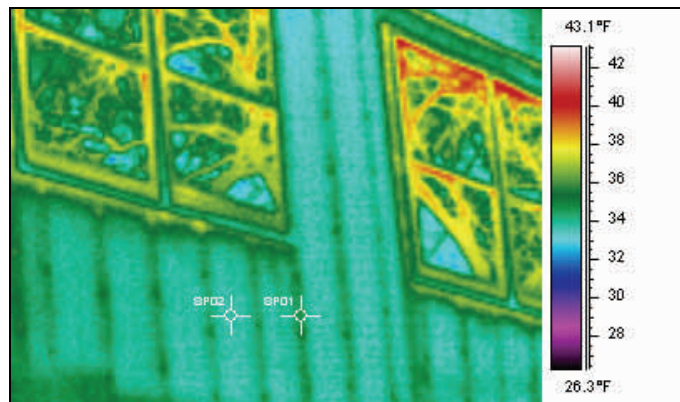
#### *Active Thermography:*

Unlike passive thermography, active thermography uses the application of heat to assist in the location of anomalies and to provide quantitative data. This quantitative data can be of great use when utilizing thermal modeling for comparative purposes as well as indicating potential variations in concealed wall materials. Another advantage of active thermography is its ability to enhance thermal contrasts present in surface and subsurface anomalies. These contrasts may not be recognizable when utilizing passive thermography as the thermal gradient may not rise above noise levels. However, active thermography increases thermal contrast as well as promote increased depth and size detection of anomalies within surrounding sound material.

While benefits of active thermography are numerous there are disadvantages as well. Heating is a primary concern as it is often difficult to heat a portion of an historic structure uniformly, necessary when trying to obtain quantitative data. Furthermore, the heating mechanisms are often small in size and therefore regulated to observations within a small confined area. When using any heating device around



**Fig. 5:** IRT image of Ashland Estate, Lexington, Kentucky (ca. 1854) indicating a thermal anomaly (dark area) on the brick facade. The thermal gradient between the temperature of the center of the anomaly and the average temperature of sound brick directly below registered a  $\Delta T$  value of 9°F. The area when checked with a moisture meter was well above comparative levels. Passive thermography was used to detect this anomaly. (Photo by author, 2007)



**Fig. 6:** This IRT image, taken on a cold night (28°F), shows the wood frame structural system below 1/4" masonry siding on a ca 1958 rancher. Although no active measures were taken to heat this facade the interior of the structure was heated to 68°F creating a thermal gradient of 40°F, thereby enhancing the contrast between the thermal bridges, the studs, and the insulated wall cavities. The  $\Delta T$  value between the stud (34.8°F) and the wall cavity area (33.8°F) was 1°F. (Photo by author, 2007)

historic materials there is also the risk of thermal degradation. Despite these drawbacks active thermography is a useful method and is routinely employed in IRT research, including tests conducted in obtaining this data.

As indicated by **figure 4** there are four main types of active thermography, pulsed thermography, step thermography, lock-in thermography and vibrothermography. Each method has its uses with distinct advantages and disadvantages. However, because of their low learning curve and applicable use with historic structural systems only pulse and step thermography will be discussed in any detail.

*Pulsed Thermography (active):*

One of the most utilized methods of IRT investigation is pulsed thermography. This method involves using short bursts of heat to send a thermal “pulse” propagating through an object. The object is then analyzed by observing the thermal decay with anomalies exhibiting abnormal characteristics due to thermal propagation interference. Depending upon the type of anomaly the abnormal characteristics could be hotter or colder than surrounding material providing a clear  $\Delta T$  value. It is important to note at this time that  $T_d$ , the temperature associated with the abnormality, should always be measured from the abnormalities center.<sup>17</sup> As might be expected shallow subsurface defects take less time to manifest than deeper abnormalities due to the time required for the thermal pulse to propagate entirely through the material. The size of the defect can also be gleaned by evaluating the thermal contrast with larger contrasts typically denoting larger defects however, this contrast decreases with depth.<sup>18</sup>

Research has effectively utilized pulsed thermography to identify subsurface defects in real world applications. One study, “Using Infrared Thermography to Analyze Substrate and Adhesive Effects in Bonded Structures”, conducted in 2004, was able to identify cracks, delaminations, impact damage and disbonding occurring in a variety of materials and composites relating to the aeronautical industry. Defects were identified at depths of 2mm, deeper than that the contrast was reduced to noise levels. Size of the defects ranged from 2 mm – 8 mm.<sup>19</sup> Although not ideal for comparison with historic structures, this research does illustrate the potential of pulse thermography for defect identification.

Another advantage of pulse thermography includes the relatively short exposure time of the material to the heating mechanism, reducing the risk of thermal degradation, particularly worrisome when investigating heat sensitive materials such as wood. However, to create an effective “pulse” capable of deep propagation, the initial burst of heat needs to be intense. As of yet effective depth penetration for this method has been relatively limited often only reaching 3 cm.<sup>20</sup>

*Step or Long Pulse Thermography (active):*

During this heating procedure the surface temperature of an object is monitored for any

---

<sup>17</sup>Carosena Meola, Giovanni Maria Carlomagno and Giuseppe Giorleo, “Using Infrared Thermography to Analyze Substrate and Adhesive Effects in Bonded Structures,” *J. Adhesion Sci. Technol.*, vol. 18 no. 6, (2004), pg 619.

<sup>18</sup>Meola, pg 619.

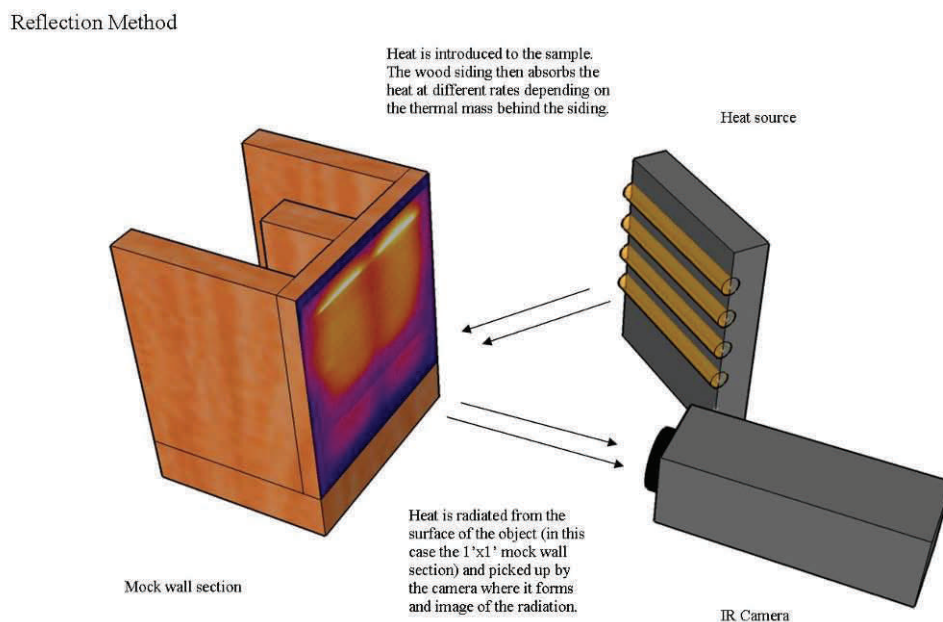
<sup>19</sup>Meola, pg 626.

<sup>20</sup>Elisabetta Rosina and Nicola Ludwig, *Optimal Thermographic Procedures for Moisture Analysis in Building Materials*, pg 1. The test performed indicated that it made use of the pulsed reflection method.

anomalies much the same as with the pulsed method. However, the difference between the two is that the step method observes the object as it is continually heated. This method is particularly effective when looking at structural systems as it provides a clear and complete view of concealed materials whereas the pulsed method may not always affect deeper structural elements therefore preventing their identification. This method, like the pulsed method, is also limited by the heating mechanism as to the size of the space that can be investigated removing one of IRT's key advantages of coverage and efficiency.

*Reflection and Transmission Modes (heating apparatus placement):*

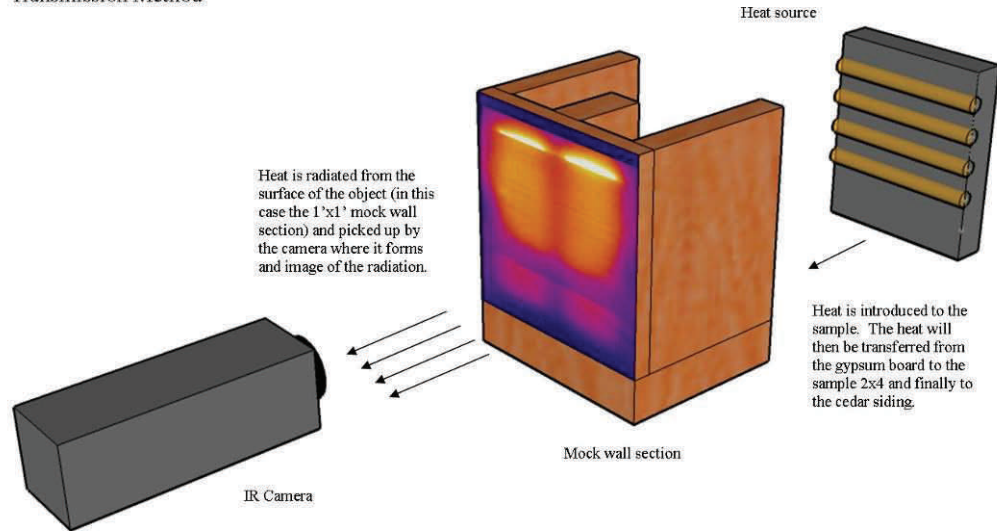
Reflection and transmission modes refer not to the type of thermography employed but to the placement of the heating apparatus and IR recording equipment. The reflection mode (**fig. 7**) has both the heating apparatus and IR detector on the same side of the sample whereas the transmission mode (**fig. 8**) places the heating apparatus on the opposite side of the object under investigation.<sup>21</sup> Most field research has utilized the reflective method as access to both sides of a structure can sometimes be impossible. However, for the objectives of this research the transmission mode worked well as it enabled the camera to be placed directly in front and the heating source directly behind the mock wall section providing the most uniform heat as well as minimal image distortion. During investigation of subsurface wood defects both methods were utilized in an effort to see which performed better.



**Fig. 7:** A schematic showing the arrangement of the heating apparatus, the IR camera and the mock wall section during an active thermographic test that is using the reflection mode. Note the off centered position of the heating apparatus, ideally another unit would be placed on the opposite side of the IR camera to promote even heating. (Illustration by author, 2008)

<sup>21</sup>Maldague, pg 351

## Transmission Method



**Fig. 8:** This schematic depicts the transmission mode also in conjunction with active thermography. Note the placement of the heating apparatus on the opposite side from the IR camera. While this method can take longer to produce results it provides the most consistent and even heating of the object. (Illustration by author, 2008)



## **Basic Heat Transfer Concepts:**

Heat transfer studies the flow of heat from a relatively warm material to a comparatively cooler one. How well the material accomplishes this transfer is referred to as its conductivity. The method of heat transfer can be one of two types; radiation or diffusion, with diffusion often subdivided into conduction and convection.<sup>22</sup> Day to day processes often combine these transfer types creating various heat exchanges between solids, gases and liquids. Active thermographic testing methods for IRT employ a combination of heat transfer types as well. The attributes of these various types of heat transfer methods and the thermal conductivity rates of individual materials are necessary to understand when analyzing IRT images or creating any predictive thermal model.



**Fig. 9:** A thermal bridge, such as the rafters in this photograph, act as a better thermal conductor than the surrounding materials, in this case fiber glass wool insulation. IRT can help make this differences visible without the need for a cold frosty morning. (Photo by author, 2007)

### *Conductivity:*

Thermal conductivity is often represented by the symbol  $k$  and is expressed in units  $\text{Wm}^\circ\text{C}^{-1}$  ( $\text{W}/\text{m}^2\text{-}^\circ\text{C}$ ). The  $k$  of any material plays an integral part in how heat is transferred during the processes of conduction, radiation or convection. Typically  $k$  values  $> 40 \text{ Wm}^\circ\text{C}^{-1}$  promote heat exchange while values  $< 10 \text{ Wm}^\circ\text{C}^{-1}$  act as insulators.<sup>23</sup> Values associated with  $k$  are often unique even varying between wood species. Previous research has established  $k$  values for a wide breadth of materials, including numerous wood species (**table 2**). With this information it is possible to surmise that even within a wall system, given similar parameters, various wood species, materials and deterioration would conduct heat differently providing different  $k$  values. This concept is seen in the wide  $k$  value ranges of various wall and roof configurations due in part to their various composition and configurations. These configurations include

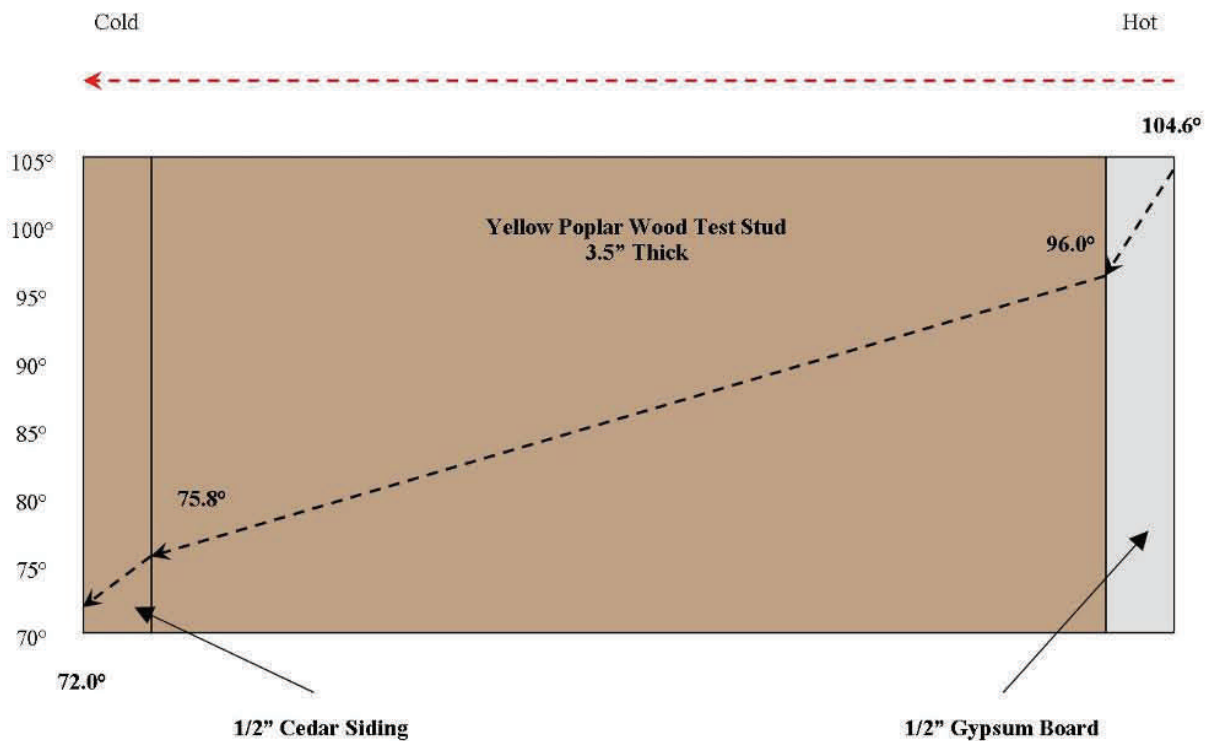
frame walls ( $0.8\text{-}5.0 \text{ Wm}^\circ\text{C}^{-1}$ ), finished masonry walls ( $0.5\text{-}6.0 \text{ Wm}^\circ\text{C}^{-1}$ ), un-insulated roofs ( $1.2\text{-}4.0 \text{ Wm}^\circ\text{C}^{-1}$ ) and insulated roofs ( $0.3\text{-}2.0 \text{ Wm}^\circ\text{C}^{-1}$ ).<sup>24</sup> While  $k$  values differ with various material types and compositions they can also vary within the same material as the value is often temperature and moisture dependent. Furthermore, the same material, under the same conditions, can also express different  $k$  values. Wood is perhaps the best example of this as it is considered to be an anisotropic material meaning that it conducts heat differently in different directions. This is due to the fact that wood is comprised of cellular and fibrous structures that configure to form the grain direction. This allows wood to conduct heat differently along the grain than perpendicular to the grains axis. Materials that are more homogenous in nature, such

<sup>22</sup>Vedat S. Arpaci, *Conduction Heat Transfer*, (Reading, Mass.: Addison-Wesley Publishing Company, 1966), pg 9.

<sup>23</sup>John H. Lienhard, *A Heat Transfer Textbook*, (Englewood Cliffs, New Jersey: Prentice-Hall Inc., 1981), pg 63.

<sup>24</sup>Lienhard, pg 62.

as brick and metals, are considered to be isotropic, meaning that they conduct heat identically in all directions.<sup>25</sup>



**Fig. 10:** Illustration showing the thermal transfer and decline as the heat pulse propagates through various materials. Easily discernable is the difference in thermal conductivity ( $k$  values) between the gypsum board and the wood materials. (Illustration by author, 2008)

*Diffusion (Conduction and Convection):*

Conduction and convection are in the truest sense methods of diffusion. Diffusion is defined as the transfer of heat through a medium or from one object to another if a non-uniform temperature distribution exists. On a molecular scale the method of diffusion relates to the exchange of kinetic energy from warmer to cooler molecules.<sup>26</sup> The method of convection is distinguished from conduction because of the medium that it uses for the diffusion of heat. Convection accomplishes diffusion through moving, deformable bodies, liquids and gases, whereas conduction uses moving or stationary rigid bodies, solids.<sup>27</sup>

*Radiation:*

Radiation makes use of electromagnetic energy transfer to convey heat. This happens when moving particles, in a substance above zero degrees Kelvin, create energy in a similar manner to diffusion. However, with radiation a portion of the internal energy is continuously converted

<sup>25</sup> Adrian Bejan and Allan D. Kraus, *Heat Transfer Handbook*. (John Wiley & Sons, 2003), pg 164.

<sup>26</sup> Arpaci, pg 9

<sup>27</sup> Arpaci, pg 9.

to electromagnetic waves. These waves travel through space at the speed of light until they hit and are absorbed by another body and converted back into internal energy.<sup>28</sup>

*Thermal Conductivity Values for Selected Materials:*  
 (Materials used for this research are noted with an \*)

<b>Material</b>	<b>Temperature Tested (C°)</b>	<b><i>k</i> (W m<sup>-1</sup> °C<sup>-1</sup>)</b>
Asphalt	20-55	0.74-0.076
Brick (common)	20	0.69
Stone (limestone)	100-300	1.26-1.33
Cement (mortar)	23	1.16
Gypsum*	20	0.48
Wood (Spruce-Pine-Fir)*	23	0.11
Wood (Southern Yellow Pine)*	23	0.147
Glass Wool (1.5lb/ft <sup>3</sup> )	23	0.038
Aluminum (pure)	20	204
Iron (wrought)	20	59

**Table 2<sup>29</sup>**

---

<sup>28</sup>Arpaci, pg 9.

<sup>29</sup>Maldague, pg 632-638

## Thermal Characteristics of Wood:

Wood is and has been the most prevalent construction material in the United States. Historically, everything from industrial structures to high style mansions like the Breakers in Newport, RI has utilized this versatile building material. Due to this widespread use, its physical characteristics and its use in frame construction, which as a heterogeneous wall system provides excellent thermal contrasts, the material was ideal for IRT research. However, unlike brick, wood exhibits numerous characteristics that have potential to affect thermal conductivity. The effect of these characteristics is clear when tabulated  $k$  values (**table 4**) are compared among species. Characteristics include grain direction, pore size and dispersion, tracheid size and dispersion, fiber size, resin canal size and quantity, cellular structure, density (specific gravity), moisture content and irregularities (knots). Understanding these physical characteristics and their impact on thermal dispersion is essential to making IRT an effective and accurate tool when investigating and analyzing wood materials.



**Fig. 11:** 7x magnification of wood indicating the distinct grain direction (red arrow). (Photo by Liz Boyer, 2008)

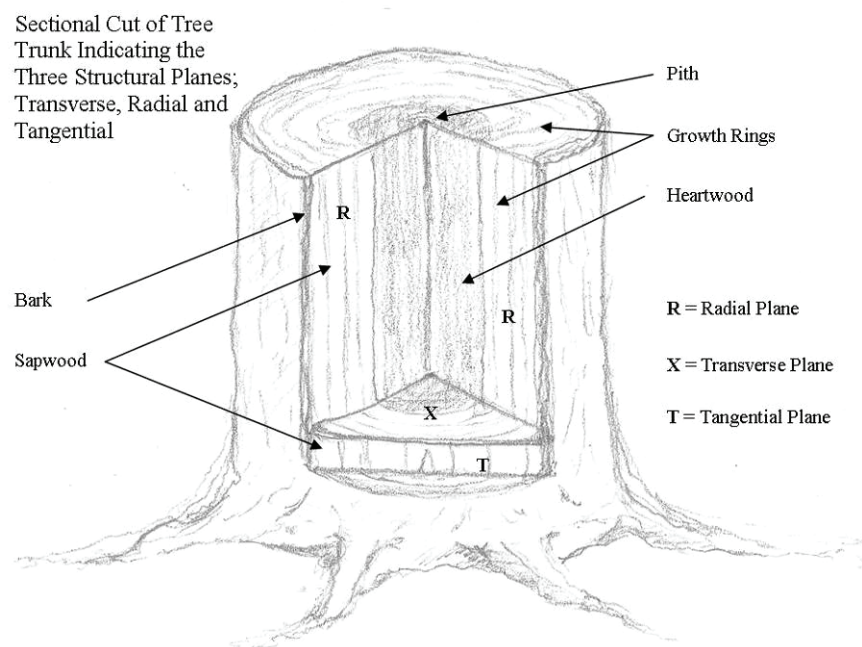
### *Grain Orientation:*

The most pertinent characteristic of wood in regards to thermal conductivity is the grain or cellular orientation. Wood grain is comprised of longitudinal cells which run perpendicular to the ground or parallel to the trees stem (trunk). These cells form outward from the trees pith, or core, in concentric circles alternating between earlywood (light) and latewood (dark) and are often referred to as the trees “growth rings”.

Because the orientation of the grain has such a profound affect on woods  $k$  values, on average 1.8 times greater with the grain, the identification of the wood plane under investigation is particularly important.<sup>30</sup> The types of wood structural planes are radial (R), transverse (X), and

<sup>30</sup>William Simpson and Anton TenWolde, *Physical Properties and Moisture Relations of Wood*, Chapter 3, pg 17.

tangential (T) (**fig. 12**) each with different  $k$  values.<sup>31</sup> These planes are also associated with different types and quality of lumber cuts, sometimes mentioned in archival research or historic building specifications. Such documents can be of great assistance to an IRT investigator as evidence of the lumber cut is often concealed behind a layer of plaster. Quarter sawn lumber, which possesses a low rate of expansion and warping, is created from the radial plane. The transverse plane is the wood plane seen when counting growth rings or the butt end of a typical piece of modern lumber. This modern lumber is created from the tangential plane and is often referred to as “slab sawn” lumber. Transverse wood possesses the lowest and most equal rate of expansion whereas slab sawn or tangentially cut wood has a very high rate of expansion and warping. Today’s market is comprised of roughly 90% slab sawn lumber due to the efficient cutting process which also maximizes board feet produced from a single tree.



**Fig. 12:** Illustration showing the various wood planes within the context of a tree trunk. Note how the growth rings create different visual patterns on the wood depending on the cut. (Illustration by author, 2008)

Each type of wood plane also has a distinct visual appearance created from the visual contrast between the light earlywood and darker latewood. This visual contrast is created by different cell characteristics influenced by environmental conditions. This aesthetic effect is also described as a wood’s “grain”, although this and the previous use should not be confused. Distinct differences between earlywood and latewood are referred to as an uneven grain while a more homogenous appearance denotes an even grain. Southern yellow pine or Longleaf pine (*Pinus palustris*) is one example of a wood with an uneven grain whereas American Basswood (*Tilia americana*) exhibits an even grain. Temperate climates, such as those found in the United States and Europe, are ideal for ring formation due to the seasonal affects on a trees

<sup>31</sup> Bruce Hoadley, *Identifying Wood: Accurate Results with Simple Tools*, (Newtown, Conn.: The Taunton Press, 1990), pg 12-13.

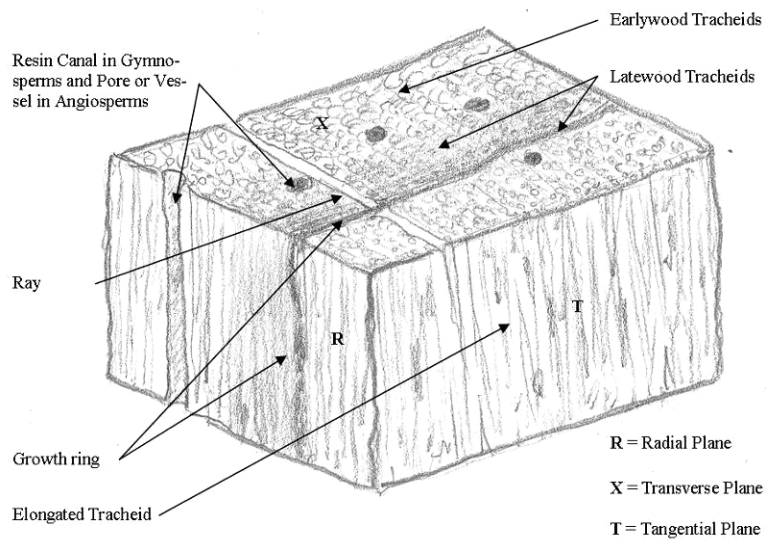
cellular growth rate. However, where clear growing seasons do not exist, such as tropical climates, woods often lack clear growth ring distinctions. This is not to say that clear ring distinctions always exist in temperate climate wood, this is far from the truth. Ring distinction is not a constant and varies based on environmental factors which can change year to year, season to season and species to species.

Although the term “cell” has been used loosely to describe a trees grain and growth rings there are in fact many types of cells and fibers that comprise latewood and earlywood. These types can vary from species to species with distinct differences noted between angiosperms (hardwoods) and gymnosperms (conifers or softwoods). Generally variations within a specie’s cells include cell size, cellular wall thickness and distribution of cell types.<sup>32</sup>

*Conifer Cell Types (Softwoods):*

One of the primary cells in coniferous tissue is the tracheid. Parenchyma cells and epithelial cells also can be found but are too few in number to greatly influence a woods thermal conductivity. Tracheids come in two forms, with the denser, and therefore higher  $k$  value, of the two found in latewood. Latewood tracheids are characterized by small cellular diameters, a somewhat flattened shape and slightly thicker cellular walls whereas earlywood tracheids have larger cellular diameters, a rounder shape and thinner cellular walls.<sup>33</sup> Observing trachied diameters can also be useful in species identification as certain species have specific diameter sizes. This diameter size can also be used as an indication of the woods potential  $k$  value, as there is a correlation with density. However, it is important that only the diameters of the transverse plane (**fig. 12 & 13**) be examined when making comparisons.<sup>34</sup>

Magnified View (x25) of a Piece of Conifer Wood.



**Fig. 13:** Illustration showing the magnified composition of a coniferous wood. Visible under x25 magnification are tracheids, resin canals and rays. Also note how the wood planes correspond to the cellular orientations. (Illustration by author, 2008)

Resin canals, like tracheids, also have an influence on the thermal conductivity of wood in certain species. These canals are not classified as cells, but are instead spaces between cells, running parallel to the trees stem, that help to transport “pitch” or “resin” to seal wounds.

<sup>32</sup>Hoadley, pg 10.

<sup>33</sup>Hoadley, pg 14-15.

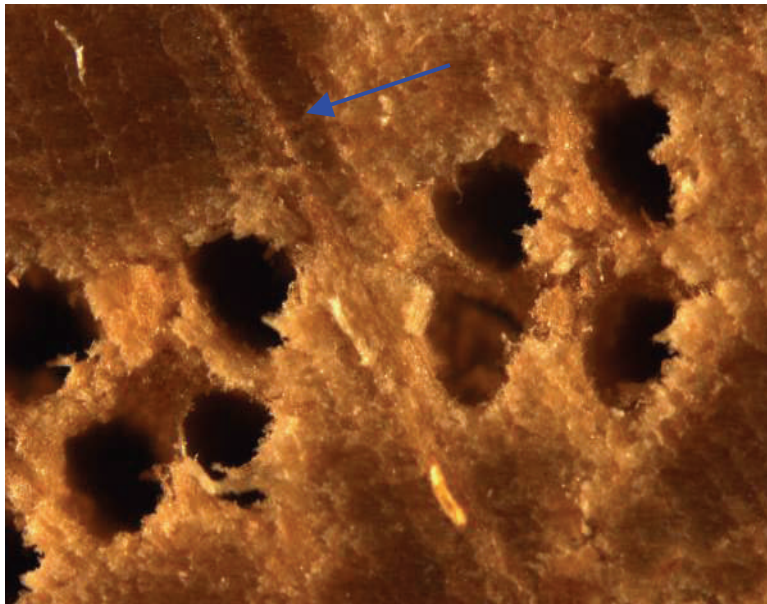
<sup>34</sup>Hoadley, pg 16-17

These resin canals are only found in softwood species.<sup>35</sup> Resin canals are mentioned due to their rather large diameters compared to tracheids.

#### *Hardwood Cell Types:*

Angiosperm or hardwood cells tend to appear in greater variety and size than their gymnosperm counterpart. Four basic cell types exist within hardwoods; they are vessels (or pores), fibers, ray cells and longitudinal parenchyma (tracheids). Pores are the largest and therefore most apparent features when looking at the transverse plane (**fig. 12 and 14**). While pores may be large they only constitute a fraction of the total transverse plane and there is little correlation between the overall density of a species and pore sizes. This is important as high density woods typically have higher  $k$  values. Most pores are visible with the naked eye but with x10 magnification almost all can be clearly seen. Diameter sizes can range from a minimum of 50-60 $\mu\text{m}$  to over 300 $\mu\text{m}$  in some Oak species. Another characteristic of pores are their arrangement and distribution on the transverse plane. When the pores are uniformly distributed and similar in size they are classified as diffuse-porous. Ring-porous is another type of distribution occurring when the pores are concentrated in earlywood and larger in diameter than pores seen in latewood. Lastly, semi-ring porous or semi-diffuse porous occurs when there is no clear delineation between pore size or apparent pore clustering in either the latewood or earlywood.<sup>36</sup>

Ray cells, like pores, can also be apparent to the naked eye on a transverse plane and vary in thickness from one cell to many cells (**fig. 14**). Some rays can be as small as 10-15 $\mu\text{m}$  or as wide as 300 $\mu\text{m}$ 's. Less recognizable than pores and ray cells are fibers. Fibers tend to run parallel to the grain appearing denser than surrounding pores and ray cells due to their smaller size and thicker cell walls. Longitudinal parenchyma and tracheids are the last two types of cells found in hardwoods. Both of these cell types vary greatly depending on the species of



hardwood. Some species such as black cherry have no parenchyma while others have a few identified by sections or areas of lighter-colored lines. Tracheids are much less apparent in hardwoods and often undistinguishable from parenchyma without significant magnification.<sup>37</sup>

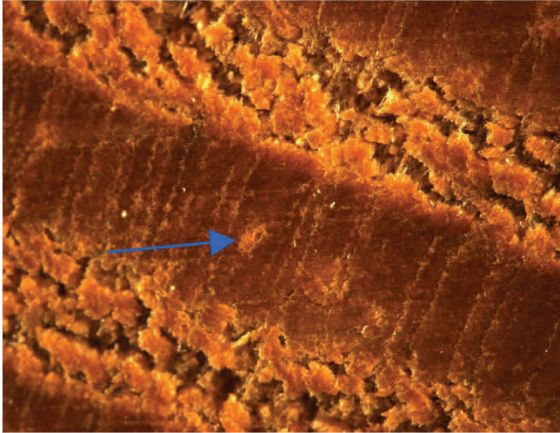
**Fig. 14:** x90 magnification of the Red Oak species used in testing. The pores are clearly visible in this picture as are rays indicated by the arrow. (Photo by Liz Boyer, 2008)

<sup>35</sup>Herbert L. Edlin, *What Wood Is That?*, (New York: Viking Penguin Inc., 1969), pg 37.

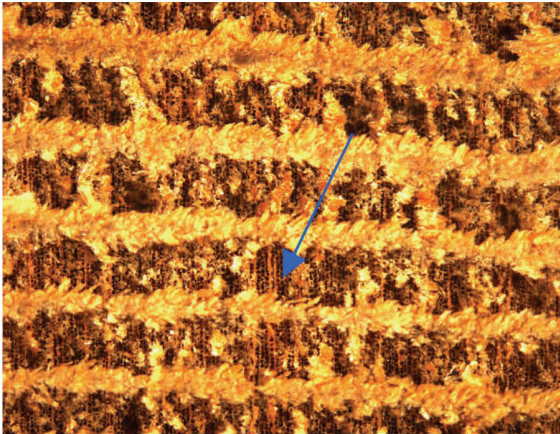
<sup>36</sup>Edlin, pg 38-39.

<sup>37</sup>Hoadley, pg 28-29.

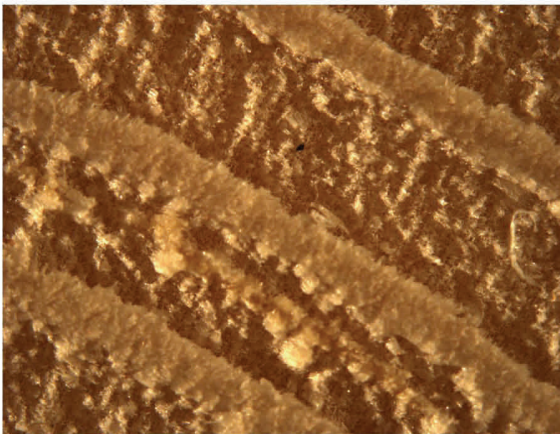
## Softwoods



**Longleaf Pine (SYP):** x40 magnification showing the resin canals (arrow) as well as the clear latewood and early wood distinction.

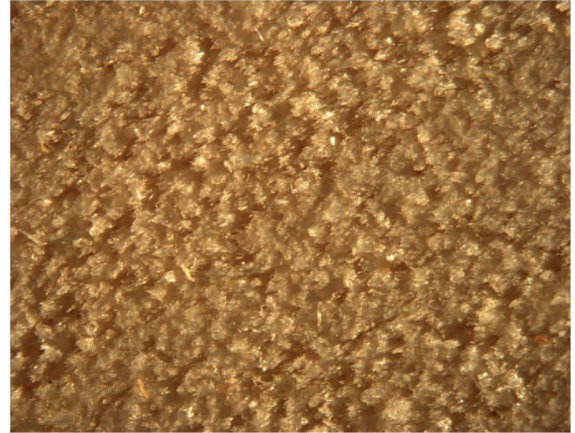


**Western Red Cedar:** Cedar sample under x40 magnification showing clear earlywood and latewood distinctions as well as tracheids (arrow).

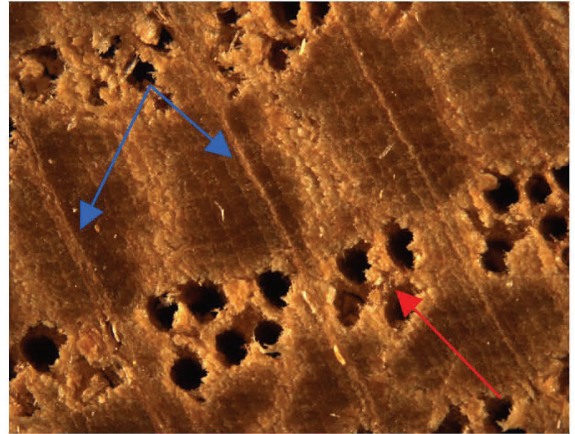


**Spruce-Pine-Fir:** Although noticeable earlywood and latewood this particular sample exhibits little color distinction. Tracheids are visible but small.

## Hardwoods



**Yellow Poplar:** x40 magnification, notice the “even” grain of the sample. Pores are too small to be clearly visible under this magnification.



**Red Oak:** x40 magnification with pores (red arrow) and rays (blue arrow) clearly visible. Oak is known for its large pores.

The samples magnified are those used during IRT experimentation. All pictures taken by Liz Boyer, a research assistant in the Department of Historic Preservation at the University of Kentucky. (2008)



*Density:*

Density is another factor affecting woods thermal conductivity. The term, as it applies to wood, is defined as the weight per unit of volume, expressed as pounds per cubic foot or grams per cubic centimeter. Water is typically the substance that is used for density comparisons due in large part because it can be expressed simply as 1 g. /cm<sup>3</sup> (62.4 lb. / ft.<sup>3</sup>). This comparison or relative density is termed specific gravity. When determining the specific gravity of wood it is necessary to avoid the weight effects that water within the wood might have, therefore the wood is dried to a moisture content of 12%. Woods with specific gravities >1 are denser than water whereas woods with a number <1 are not.<sup>38</sup> This also means that woods with higher specific gravities are harder as well as retain less moisture than those with lower values. Perhaps most importantly is the correlation between high specific gravities and high *k* values.

*Specific Gravities of Some Common Woods:*

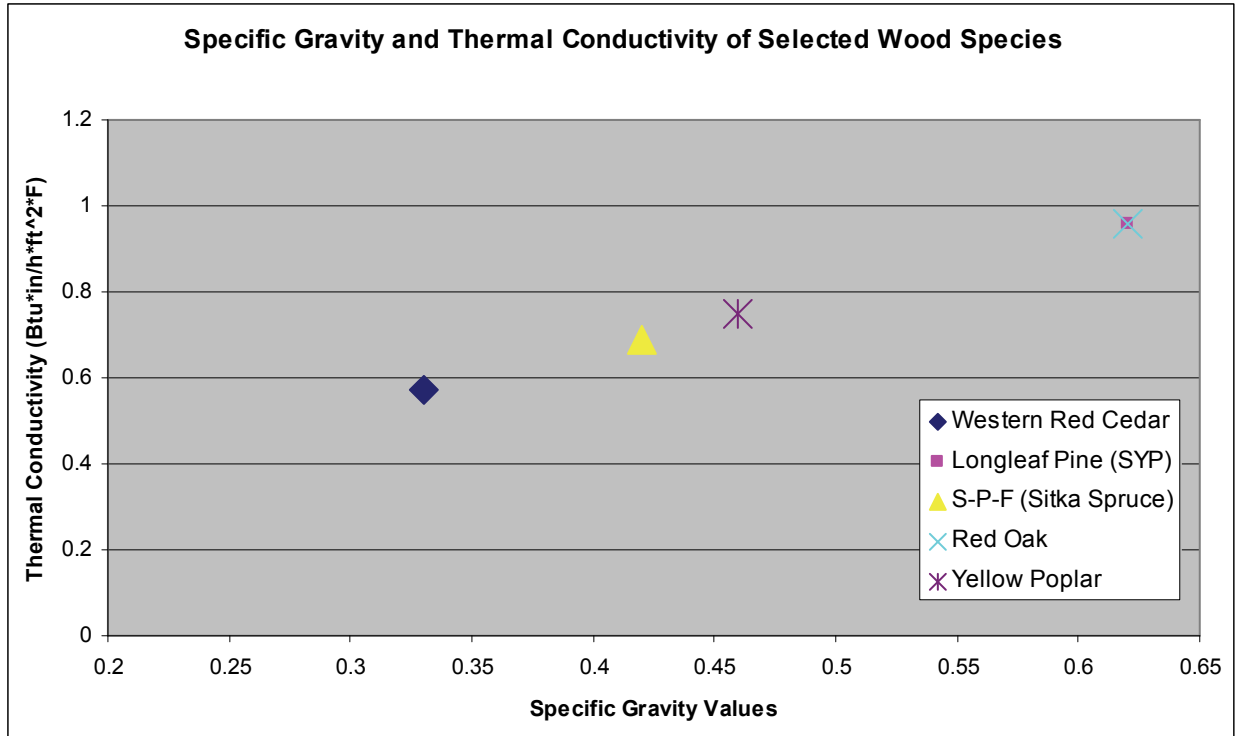
(Woods used for this research are noted with an \*)

Scientific Name	Common Name	Average Specific Gravity*see below
<i>Softwoods</i>		
Thuja plicata*	Western redcedar	.33
Pinus palustris*	Longleaf pine (SYP)	.62
Standard Lumber (SPF)*	Spruce-Pine-Fir	
Abies balsamea	Balsam Fir	.37
Pinus banksiana	Jack Pine	.45
Pinus resinosa	Red Pine	.46
Pseudotsuga menziesii	Dougllass-fir	.52
Picea sitchensis	Sitka spruce	.42
Pinus taeda	Loblolly	.54
<i>Hardwoods</i>		
Liriodendron tulipifera*	Yellow-poplar	.46
Quercus falcate*	Southern red oak	.62
Castanea dentata	American chestnut	.45
Acer rubrum	Red maple	.56
Acer saccharum	Sugar maple	.66
Tilia americana	American basswood	.38

**Table 3**<sup>39</sup> \*Specific gravity is based on 12% moisture content of the wood.

<sup>38</sup>Hoadley, pg 47.

<sup>39</sup>Simpson, pg 19-20.



**Chart 1:** A chart showing the correlation between density (specific gravity) and thermal conductivity of wood species used during testing. (Chart by author, 2007)<sup>40</sup>

*Moisture:*

Moisture like grain direction and density can have a substantial effect on the thermal conductivity of wood. The moisture content within wood is expressed in fraction or percentage form and is the comparison of the weight of water within the wood to the weight of oven dried (12% MC) wood. Standing trees can have moisture rates that range from 30% to over 200%. Most often sapwood in softwoods has greater moisture content than heartwood whereas in hardwoods the difference between the two varies depending on species.<sup>41</sup> Moisture levels for species used in this research were relatively low, measuring in the vicinity of 6-6.4% making this less of an issue than might be found in a field study. However, thermal conductivity tends to increase as moisture content increases in wood.

*Irregularities:*

Irregularities are common within all wood species and are characteristics that have the potential to alter thermal conductivity. Some typical irregularities that might be present in cut lumber include reaction wood (called compression wood in softwoods and tension wood in hardwoods), juvenile wood, pith wood, limbs (knots), pitch, pitch pockets and decay including insect damage and rot.

Reaction or compression wood is found in stems or braches that are not parallel to the pull of gravity, typically on the underside of softwoods. As the name implies this part of the trees stem

<sup>40</sup>Simpson, pg 19-20

<sup>41</sup>Simpson, pg 1

is placed under compression. This is often seen in curved tree stems that for some reason are no longer perpendicular to the ground. The reason that this condition becomes an issue when talking about thermal conductivity of wood is that both the macroscopic and microscopic features are different from normal growth characteristics. Wide growth rings, wide latewood tracheids with thick cell walls and off-centered piths are three abnormalities associated with reaction wood in softwoods. Reaction wood is also denser than normal wood and tends to cleave relatively easily instead of splintering.<sup>42</sup>

Hardwoods are less likely to have some of the abnormalities associated with reaction wood that softwoods can possess, including off-centered piths. Instead, abnormalities associated with this irregularity are often more difficult to identify and can include variations in color and luster. Fuzzy or wooly surfaces associated with uneven breaks within the wood's fiber structure are some indications that tension wood may be present. However, the biggest variances may be microscopically within the wood fibers themselves. Tension fibers typically develop an inner gelatinous layer, abundant in earlywood. Reaction wood in hardwoods often occurs on the upper side of a leaning stem as opposed to the underside in softwoods. As this portion of the stem is often in tension the term "tension wood" also applies.<sup>43</sup>

Reaction wood, either tension or compression, is important to understand when using any thermal diagnosis on historic structures especially those found in Europe. While not as prevalent here in the United States due to its use predating 1607, cruck construction was a common method of timber framing in medieval Europe dating from the 13<sup>th</sup> century, Harlowbury, Essex, UK, 1221-1225, until the end of the medieval age, 1550.<sup>44</sup> Cruck construction consisted of finding trees with natural bends, hewing or sawing them in half and then placing the two pieces opposite each other forming a rudimentary rafter system complete with structural posts.

Juvenile wood is another abnormality that is especially relevant to IRT investigations. This type of irregularity dates from the time of the first tree plantations, mid 19<sup>th</sup> century in the United States, and continues in modern day construction. Before this time the wood was classified as "old growth", a somewhat misleading term, but nonetheless one that for our purposes denotes denser wood. Located close to the pith, juvenile wood usually forms in the first years of a tree's life, however in areas with less competition for resources the formation of juvenile wood can continue for over fifteen years. In some cases this type of wood can form a core seven inches in diameter around the tree's pith. Environments ideal for extended growth of juvenile wood are tree plantations, especially those cultivating softwoods species. Trees grown naturally have little or no juvenile wood, however this is somewhat dependent on the species. Also dependent on the species is wood's physical transition from juvenile wood to mature wood. Some species see a very distinct change while in others change can be gradual. Characteristics of juvenile wood that differ from normal mature woods include lower densities, larger cell size, relative number or arrangements of cells and microscopic appearance.<sup>45</sup>

---

<sup>42</sup>Hoadley, pg 54-56.

<sup>43</sup>Hoadley, pg 56-57.

<sup>44</sup> John Walker, "Essex Medieval House: Type and Method of Construction," *Regional Variation in Timber Framing, In England and Wales Down to 1550*, (Chelmsford, Essex: Essex County Council, 1998), pg 5.

<sup>45</sup>Hoadley, pg 58.

Historically the pith, or center component of wood was not used for lumber as readily as it is today. However, round, half round and some hand hewn members incorporate pith wood making it necessary to understand. Like many of the other abnormalities or irregularities associated with wood, pith wood can have distinctive physical characteristics that could have an impact on thermal conductivity. Most relevant to thermal conductivity is the increased density of pith wood compared to outer wood.<sup>46</sup>

*Thermal Conductivity Values for Selected Woods:*  
(Woods used for this research are noted with an \*)

Material (wood)	Temperature Tested (C°)	$k$ (W m <sup>-1</sup> °C <sup>-1</sup> (Btu·in/h·ft <sup>2</sup> ·°F))
Oak, Southern Red*	20	0.14 (0.96)
Oak, White	20	0.16 (1.10)
Poplar, Yellow*	20	0.11 (0.75)
Cedar, Western Red*	20	0.083 (0.57)
Fir, Douglass	20	0.12 (0.82)
Pine, Longleaf (SYP)*	20	0.14 (0.96)
Spruce, Sitka*	20	0.10 (0.69)
Basswood, American	20	0.092 (0.64)
Sycamore, American	20	0.12 (0.86)

**Table 4** \*\* All samples conductivity based on a Owendry MC<sup>47</sup>

*Influence of Wood Characteristics on Thermal Conductivity:*

Characteristic	Degree of Influence on Thermal Conductivity	Description
Grain Direction	High (avg. 1.8x higher w/grain)	Longitudinal direction of the wood cells
Density	High	
Moisture	High	Varies considerably
Irregularities: Reaction wood Knots Juvenile wood	Low-Medium Low Medium (not widespread) Low	Varies considerably, can affect a small % or a large %.

**Table 5**

<sup>46</sup>Hoadley, pg 59

<sup>47</sup>Simpson, pg 19-20

## **Equipment:**

IRT equipment has a wide range of vendors, manufacturers and model types. One infrared camera website listed a total of 21 manufacturers, mostly European and American. Although based on the same principles of infrared detection every manufacturer has various models and lines that are constructed or calibrated for specific tasks. These uses include but are not limited to military, law enforcement, fire and safety, electrical inspection, preventive maintenance, building inspections, security, research and electronics research. Due to this wide selection it is important that the camera selected fulfills the specific requirements set forth in the research mission and objectives. Other items that should also be considered carefully include temperature measurement devices, moisture meters, heating devices and other temperature control apparatus. When selecting all items it is important to not only consider cost but also application. The question should always be asked, especially in preservation, whether the device is practical, user-friendly and accessible enough for widespread deployment.

### *Infrared Camera:*

The camera used for research and field observations was manufactured by FLIR systems. FLIR is one of the largest providers of infrared cameras in the world with a large selection of models and price ranges. While cost factored greatly in the decision on which model to choose it was not the sole factor. Accuracy, portability and durability were also necessary to consider. Accuracy was essential in that  $\Delta T$  values were likely to be  $< 1^{\circ}\text{F}$  and in some cases  $< 0.1^{\circ}\text{F}$ . Portability was necessary as field investigations often involve tight spaces and structures far removed from the grid. Lastly, durability was required as a camera not capable of handling bumps or shocks would be a costly blunder in the field of historic preservation.

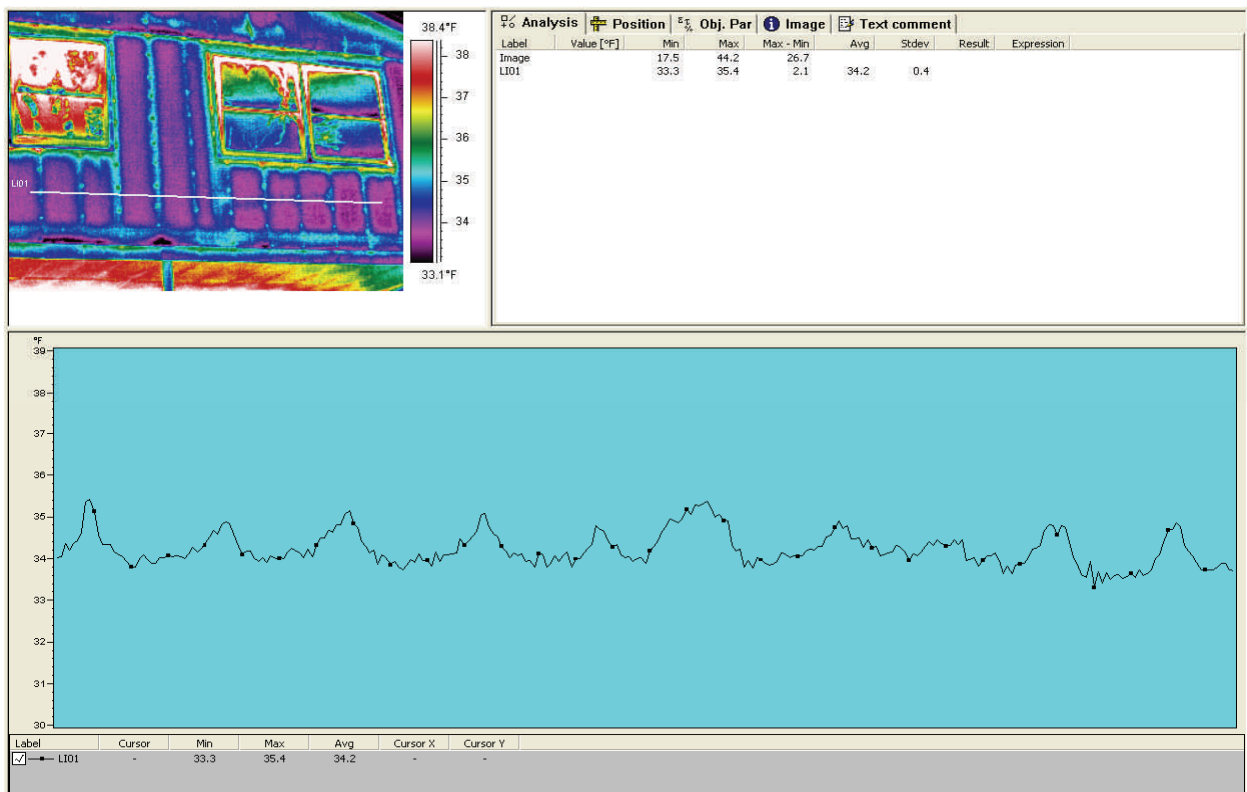
These requirements in addition to affordability all informed the decision to use the FLIR ThermaCAM® S65 HS. This particular model was designed for field work comparable to what a preservationist might encounter and although it lacks various spectral range capabilities, its



**Fig. 16:** Photo showing the ThermaCAM S65 HS mounted on a tripod for stationary viewing. Note the LCD screen for easy viewing and the straps for portability in the field. (Photo by author, 2007)

widespread use, small learning curve and track record in the field of building inspections made it a desirable choice.<sup>48</sup> The ThermoCAM® S65 HS can be rented on a monthly basis for approximately \$5,200, a small fraction of the purchase price of around \$42,000 in 2007. Less expensive cameras also share many of the same features of this particular model making accurate data comparison possible.<sup>49</sup>

Specific features as they concern the ThermoCAM® S65 HS include dust and water resistance as well as user friendly LCD screen and joystick navigated menus. Rechargeable batteries with two hour continuous operating capabilities are another important feature as is the ability of the camera to operate effectively in temperature conditions ranging from 5-122°F. Regarding temperature measurement the camera uses a focal plane array (FPA) 320 x 240 uncooled microbolometer detector that detects radiation between 7.5-13 μm's (fig. 3). This means that in any given picture the camera generates 76,800 data points, pixels, increasing image accuracy



**Fig. 17:** Screen image of FLIR's ThermoCAM Researcher Pro 2.8 SR-2 showing a profile analysis using a line across the IR image. The profile clearly shows the location of the studs and resulting temperature differences. (Photo by author, 2007)

<sup>48</sup>FLIR cameras such as the ThermoCAM® Merlin and the ThermoCAM® Phoenix, offer various spectral range capabilities including near infrared (NIR), mid wave infrared (MWIR), and long wave infrared (LWIR).

<sup>49</sup>Other FLIR models that share similar spectral capabilities and other characteristics are listed in the ThermoVision™ A series. These are the most cost effective cameras offered by FLIR and start around \$12,000.

over past IR cameras. Range of measurement spans from -40°F (-40°C) to 3632°F (2000°C) with individual pixel accuracy up to 0.14°F (0.08°C).<sup>50</sup>

Researcher Pro 2.8 SR-2. This particular software allows the user to vary IR image capture from a single image, to time lapse, to a streaming image feed. Time lapse image capture was of particular interest for this research as images for every test were taken every minute over a four hour period. This information could then be interpreted through the FLIR software by designating areas, lines or even spots of interest that could then be interpreted through histograms, plots and profiles over a four hour period. Specific temperature information obtained from these interpretations included the standard deviation, mean, median, low and high values. Additionally the software was able to assist in lowering the temperature range increasing visual contrast as well as changing the color palette used to represent various temperatures. Compatibility was also facilitated by this software as data was easily integrated into programs such as Matlab® and Microsoft Excel®. Perhaps most importantly is the software's ability to interact with the IR camera to provide settings and parameters that account for emissivity, ambient temperature, reflective temperature, distance and relative humidity.

#### *Data Acquisition Unit and Thermocouples:*

The IR camera was able to map the surface of the mock wall section well; however, it was not able to measure the temperature of the wall section facing the heat source. This particular measurement (A) (**fig. 18**) is important to know in that it helps the investigator understand about how much thermal energy is actually reaching the specimen and not lost through radiation. Temperature measurements were also taken on the back side of the gypsum board (B), the interior of the weatherboard siding (C), and the front of the wall section (D) to help verify IR measurements and provide an accurate picture of the thermal propagation as it moved through each wall section and sample. Thermocouples were used for measuring these temperature variations.

Due to the relative small size of the samples and the need for accuracy SA1XL's type E (-100 to 500°C) self adhesive thermocouples were used. Other types and designs of thermocouples exist but this particular type enabled the thermocouples to be directly applied to the surface of the material rather than inserted through a pre-drilled hole, simplifying the experimental design and also preventing a potential affect on thermal propagation. Type E thermocouples also provided the accuracy and the temperature range needed during testing. This differs from a number of thermocouple types, J, K, R, S, B, and N which are designed for high temperature measurements up to 1400°C.<sup>51</sup>

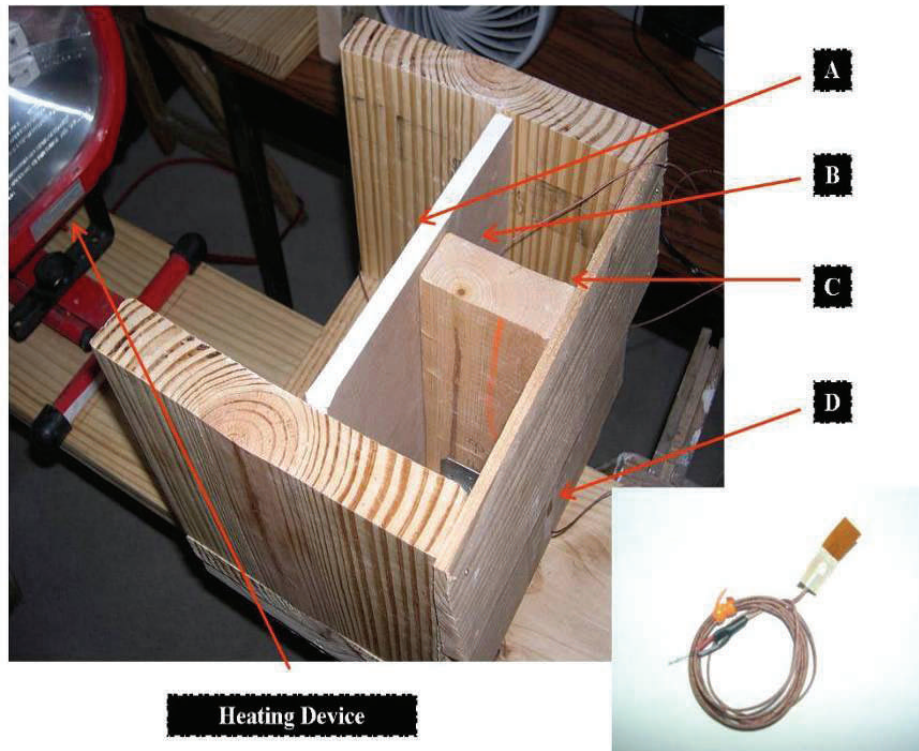
While thermocouples were used to obtain temperature data the OMB-DAQ-54 (**fig. 19**) was used to translate and store temperature values. This data acquisition unit manufactured by Omega instruments provides terminals for up to five thermocouples to be employed at the same time as well as a USB connection to a computer. Corresponding software logs the information from the thermocouples, displaying the information in real time as a temperature or stores it in a

---

<sup>50</sup> FLIR promotional material and users manual, 2007.

<sup>51</sup>Omega, *Omega Temperature Measurement Handbook*, (Omega Engineering, Stamford: CT, 2007) pg A-10.

designated file type. The type of file formatting includes Matlab®, ASCII, DIAdem, Wav, Postview and a number of others including a direct link to Microsoft Excel®. Software associated with the unit also offers the ability to set temperature measurements over a period of time. This research used this feature to facilitate temperature measurements that were taken every 7.5 seconds and then averaged every 8 measurements. This meant that an averaged value was presented every minute helping to mitigate any thermal anomalies. Accuracy of the thermocouples and the data acquisition unit was 0.015% of the reading.<sup>52</sup>



**Fig. 18:** Photograph showing the small mock wall section in relation to the heating device. Each notation, A, B, C and D all used type E thermocouples as represented in the inset picture. The adhesive end (red circle) was attached in all these locations and measured the temperature as heat propagated through the wall section. (Photo and annotations by author, 2008)

**Fig. 19:** Omega data acquisition unit (OMB-DAQ-54) used to acquire temperature readings throughout the mock wall section. Type E thermal couples were used in conjunction with this unit with measurements taken every 7.5 seconds. The thermal couple terminals are located at the bottom right of the unit. (Photo by author, 2007)



<sup>52</sup>Omega, *Omega OMB-DAQ-54 User's Guide*, (Omega Engineering, Stamford: CT, 2007) pg 2-10.



### *Moisture Meter:*

Thermal conductivity rates in wood and other materials vary considerably depending on moisture content. This makes the testing of samples for moisture of special importance. One of the most accurate methods of determining moisture content is through the measurement of electrical resistance between two electrodes or “pins” inserted into the wood at varying depths. The type of moisture meter used for this is known as a conductance or resistance type meter. Dielectric meters are also available and use surface electrodes to measure moisture of relatively dry wood. However, these types of meters generally fail to give accurate readings of moisture content below the surface of the wood or material under investigation. Their main advantage is that they do not need to penetrate the wood to obtain measurements.<sup>53</sup> The model selected for this research was the Delmhorst BD-2100 (**fig. 20**) with various size electrodes for different penetration depths. This particular model comes with settings for both wood and gypsum board that have been calibrated. Accuracy of the device is around 0.2% and its given range is 6-40% for wood and 0.2-50% for gypsum board. The meter also has a relative scale of 1-100 which can be used for qualitative assessments.<sup>54</sup>



**Fig. 20:** Picture of the Delmhorst BD-2100 unit (orange) and accompanying pin set. The pin in the middle is used for deep wood penetration and is insulated on all sides so that the reading obtained is only from the tips of the pins. (Photo by author, 2007)

### *Lamps/Heating Apparatus:*

Although some passive IRT was used for structural observations most of the research utilized pulsed or step thermography with both reflection and transmission heating methods. However, depending on the type of IRT investigation performed two types of heat lamps were used. The first was a typical 300 watt type T, halogen bulb (**fig. 22**), used during transmission step thermography. This heat source was chosen because of its availability, widespread use and cost. Due to its relatively low thermal output it was also safe to use near wood and other historic materials without the risk of fire or thermal degradation. The average temperature generated was 109.1°F, 36.9°F above ambient room temperature. This provided enough heat to

<sup>52</sup>Omega, *Omega OMB-DAQ-54 User's Guide*, (Omega Engineering, Stamford: CT, 2007) pg 2-10.

<sup>53</sup>James, William L. *Electric Moisture Meters for Wood*. Gen. Tech., Rep. FPL-GTR-6. Madison, WI: U.S. Department of Agriculture, Forest Service, Forest Products Laboratory; 1988, pg. 1-14.

<sup>54</sup>Delmhorst Instrument Company, *BD-2100 Owners Manual*, Towaco, NJ, 1999.

create a distinct, on average 2.3°F, difference between the area where the concealed stud was located and the adjacent siding.

The second heat source was an IR lamp, model # GPR1100MW (**fig. 21**). This particular heating device utilized medium wave IR lamps that on high produced 1100watts and enabled high temperatures to be achieved quickly. Due to the extreme heat produced and the chance of thermo-degradation this method was only utilized for reflective pulse thermographic experiments where there was no danger of long term exposure.

While the lamps worked for heating the smaller samples and wall sections the larger wall section required a different heating apparatus. The heat source used for these tests was a 1500 watt (5,120 BTU) Delonghi TRD0715T oil-filled radiator. The benefit to this heating apparatus was its rather even heating ability over a large area compared to the lamps used for the other tests. However, the radiator was slow to warm and to create the thermal gradient necessary for observations.



**Fig. 21-22:** Photographs showing the IR heat lamp on the left and the 300 watt type J lamp on the right. While the IR lamp posed a fire hazard the 300 watt lamp was able to be left unattended as temperatures never approached the threshold for thermal degradation. (Photo by author, 2007)

## **Methodology:**

Infrared Thermography experiments were conducted to address three of the five research objectives listed in the introduction. These three objectives included:

- I. Establishing preliminary IRT calibrations, parameters and protocol tailored primarily to wood framed structural systems for the purpose of wood species and deterioration identification.
- III. Identification of surface and subsurface abnormalities within wood and wall systems.
- IV. Proof of concept for use of IRT to distinguish variations of wood species within wall systems.

Three IRT protocols were developed from the various methodologies used during testing and include protocols for testing wall sections within a controlled environment, semi-controlled environment and during field testing. The various methodologies employed revolved around construction and testing of 1'-0" x 1'-0" wall sections, 6'-0" x 4'-0" wall sections and fabricated wood deterioration samples. Initial testing methodologies and IR camera calibrations were based on previous IRT studies, industry standards, manufacture guidelines and ASTM standards where applicable. The ASTM standards utilized included C1046-95, C1060-90, D4788-88, E1213-97, E1311-89 and E1316-04. Currently no ASTM standard or published methodology exists for the testing of wood frame structures for the purposes of species and deterioration identification. The methodologies used in testing reflected this and evolved based on testing successes and failures.

### ***Determination of an Object's Reflected Temperature and Emissivity:***

While IRT methods and protocols may vary with the material, deterioration or environment under investigation the protocol for obtaining an objects emissivity remains constant. This is an important parameter to set correctly so that quantifiable temperature measurements can be obtained. Since the project used a FLIR camera and corresponding software their method of obtaining emissivity values was employed.

First, before calculating the object's emissivity, it is necessary to determine the reflected apparent temperature or background temperature. This is different from the atmospheric temperature and is obtained through a relatively simple process:

1. Set the parameters/settings on the camera that you already know (relative humidity, distance to object and atmospheric temperature).
2. Crumple a large piece of aluminum foil (emissivity value of 1.0).
3. Un-crumple piece of foil and attach it to a firm backing of the same size (cardboard, foam board, or any other stiff material).
4. Place the foil in front of the object under investigation with the foil side facing the camera.
5. Set the emissivity value to 1.0.
6. Take a thermal reading of the foil using the box analysis tool on the FLIR software

or camera. This feature provides an average temperature rather than a single spot reading, helpful if there is any temperature variation on the surface of the foil.

7. Record the temperature measured. **This is your reflected temperature.**<sup>55</sup>

Upon obtaining the reflected temperature the emissivity can be calculated as follows:

1. Set the reflected temperature obtained from the last procedure on either the FLIR camera, or if you are analyzing an IR image, on the software settings.
2. Place a piece of standard black electrical tape with an emissivity of 0.97 on the object under investigation.
3. Heat the object evenly at least 36°F (20K) above ambient room temperature.
4. Take a still IR image of the object, including the electrical tape in the picture (make sure the image is clear and in-focus).
5. Adjust the level and span of the image to provide the best contrast in order to locate the electrical tape.
6. Set the emissivity to 0.97, that of the electrical tape.
7. Measure the temperature of the tape using the box analysis tool remembering to record it.
8. Move the same box analysis tool to the adjacent objects surface, making sure the surface is the surface of the material under investigation and is as consistent as possible (void of paint, major surface anomalies or any other marks).
9. Change the emissivity setting on the camera or the software so that the temperature being measured on the objects surface matches the temperature of the electrical tape. **The final value is the objects emissivity** at that atmospheric temperature.<sup>56</sup>

Since reflected temperature varies substantially with atmospheric temperature it is a good idea to re-determine its value before each series of tests so that data remains accurate. Emissivity is less apt to change based on normal atmospheric temperature changes especially when dealing with wood.

#### ***Wall Section Construction, 1'-0" x 1'-0" and 6'-0" x 4'-0":***

The majority of IRT tests were performed using a 1'-0" x 1'-0", mock wall section (**fig.23**). Other tests were also performed using a larger 6'-0" x 4'-0" wall section. Five wood species were examined within the 1'-0" x 1'-0" wall section in the form of 2"x 4"x 8" studs.

- Northern Red Oak (sample A)
- Western Red Cedar (sample A)
- Yellow Poplar (sample A)
- Douglass Fir (sample A & B)
- Longleaf Pine or *Southern Yellow Pine* (sample A)

---

<sup>55</sup>FLIR, pg. 99-101

<sup>56</sup>FLIR, pg. 102-103

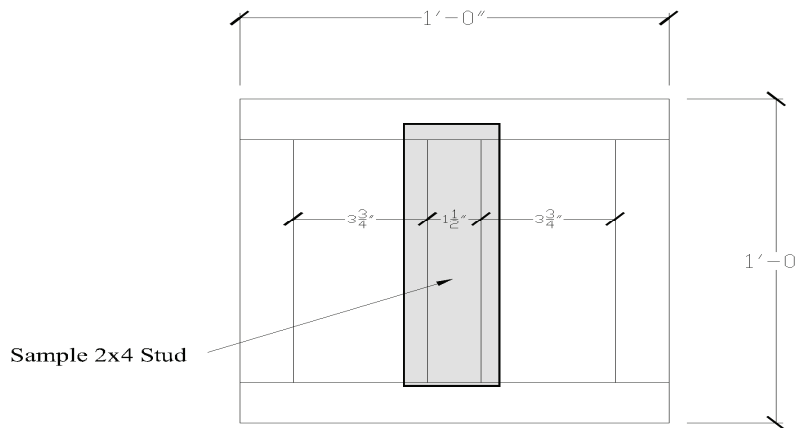
Ideally each of the five wood species tested would have at least two different samples to investigate in order to account for any irregularities. However, due to time constraints only Douglass Fir had multiple samples.

The sample studs were inserted into the mock wall section and held by two thin gauge metal fasteners. The use of the same wall section provided consistency helping to reduce any problems in material

variation, especially the cedar weatherboard siding. This siding measured  $\frac{4}{8}$ " thick at its base and tapered to  $\frac{1}{8}$ ". The siding was overlapped  $1\frac{1}{2}$ ". Gypsum board,  $\frac{1}{2}$ " thick, was placed opposite the siding, concealing the sample stud. When complete the wall measured  $4\frac{1}{2}$ " thick. No insulation or moisture vapor wrap was used for construction of these wall sections.



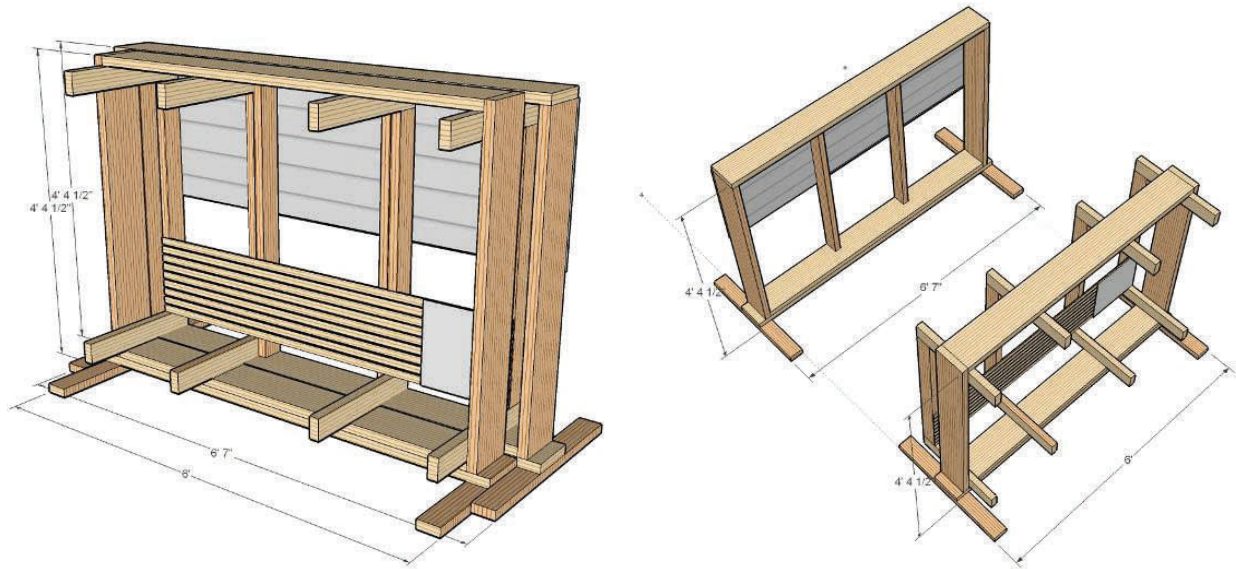
**Fig. 23:** Photograph showing one of the small 1'x1' wall sections. Clearly visible is the gypsum board (right), stud (arrow) and cedar siding (left). (Photo by author, 2008)



**Fig. 24:** Illustration showing the dimensions of the small 1'-0" x 1'-0" wall section from the front minus the cedar weatherboard siding. The grey box highlights where the sample stud is relative to the wall cavities (either side measuring 3.75") and the sides of the wall section. (Illustration by author, 2007)

Similar tests were also carried out on larger mock wall sections built using the same materials and same parameters. These wall sections measured four feet high and six feet wide. Each component of the wall, including the drywall and weatherboard siding with the sample 2x4's was built individually (**fig. 25-26**). This allowed for the wall sections to be placed together once the samples had been inserted creating a concealed wall system  $4\frac{1}{2}$ " thick, complete with siding, studs and gypsum board. Three adjustable vice grips allowed for up to three samples to be tested simultaneously and then changed. The sample studs were spaced at intervals of 1'-11" on center in order to provide for enough air flow to simulate a un-insulated wall cavity as well as to insure that no thermal bridging would occur between elements thereby blurring results. The addition of insulation to the wall sections under investigation will in all likelihood have an effect on results.<sup>57</sup> Holding the studs at the base were adjustable vice clamps (**fig. 28**). Due to the size of these modules, each had a set of casters enabling it to be rolled into position (**fig. 27**).

<sup>57</sup>ASTM International, C 1060-90 (2003), *Standard Practice for Thermographic Inspection of Insulation Installations in Envelope Cavities of Frame Buildings*, Vol. 04.06, pp 538.



**Fig. 25 & 26:** Illustration showing how the large mock wall sections various “modules” came together (left image). The illustration on the right shows the unit housing the samples and siding (upper left) as well as the unit with the drywall (lower right). Placed together the sections formed a closed wall section with the sample studs in the middle. During construction the design was adjusted so that the studs from the drywall module did not come into contact with the sample studs. Instead of the 1’-11” on center spacing of the studs originally planned, spacing was changed to 10 ½” on center. The units were placed on casters so that they could simply be rolled apart when interchanging sample studs. (Illustrations by author, 2007)



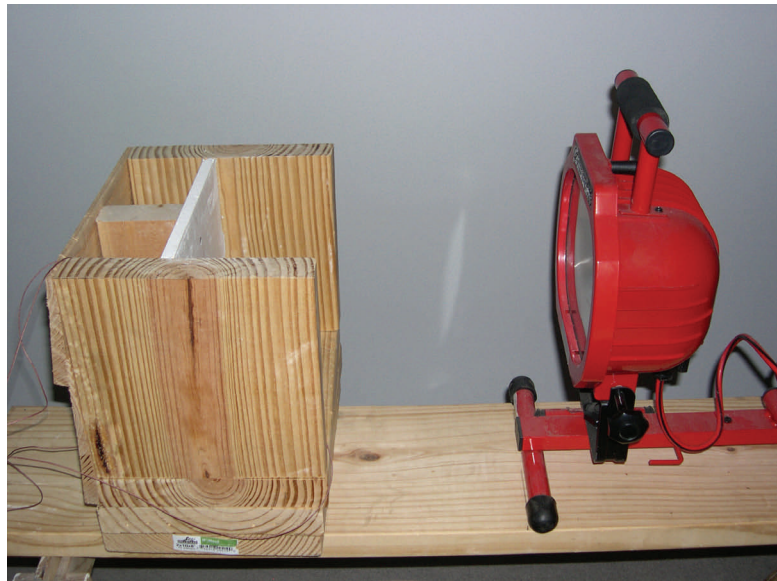
**Fig. 27:** Photo showing the casters used to wheel the larger wall sections into testing positions. The casters could also be locked to prevent sliding in transition or movement during testing. (Photograph by author, 2007)



**Fig. 28:** Photo showing the clamps used to secure sample studs in the large mock wall section. Due to adjustability various sized wood members could be used. (Photograph by author, 2007)

### ***1'-0" x 1'-0" Wall Section Testing Methodology for Species Identification Within A Semi-Controlled Environment:***

The transmission long pulse IRT method was applied during the semi-controlled environment testing of the small wall sections for determination of species identification (**fig. 8**). However, the methodology used to obtain data differs from the ideal testing protocol created in **table 6**. The initial methodology used for testing was based primarily on previous IRT research as well as applicable ASTM standards. The ideal testing protocol stems from corrections and observations made throughout testing in an effort to promote accuracy and efficiency. Changes incorporated into the ideal protocol are both procedural and equipment related.



**Fig. 29:** Photo showing the placement of the 300 watt halogen lamp heat source fifteen inches from the gypsum board of the 1' x 1' mock wall section. The IR camera would be five feet to the left facing the sample and the lamp. (Photograph by author, 2007)

The type of IRT procedure establishes much of the protocol used during the testing methodology. Transmission long pulse IRT, as previously noted, was the type of active thermography employed to determine variations among wood species. The use of this method of IRT stems from passive IRT testing of building envelopes mentioned in ASTM C 1060-90 (2003), *Standard Practice for Thermographic Inspection of Insulation Installations in Envelope Cavities of Frame Buildings* as well as other IRT literature. While this standard only outlines the passive method for identifying areas with or without insulation, the general passive IRT concept of utilizing thermal differences between two sides of a wall can be enhanced through artificial heating on one side resulting in a more distinct material heat flux on the other, observed side.<sup>58</sup> While this IRT method has advantages and disadvantages that will be discussed later, it is important to note that other active IRT techniques can also be used for frame structure investigations and may be preferable when trying to observe larger areas or attain more quantitative results. For obtaining these type of results Rosina and Robinson have utilized Lockin and Pulsed thermography.<sup>59</sup>

Using the transmission mode dictates that both the FLIR ThermoCAM® S65 HS IR camera as well as the 300 watt halogen lamp be placed perpendicular to the wall section under investigation. The IR camera faces towards the wall sections unheated side whereas the heating

<sup>58</sup>ASTM International, C 1060-90 (2003), *Standard Practice for Thermographic Inspection of Insulation Installations in Envelope Cavities of Frame Buildings*, Vol. 04.06, pp 538.

<sup>59</sup>Elisabetta Rosina and Elwin C. Robinson, *Applying Infrared Thermography to Historic Wood-Framed Buildings in North America*, APT Bulletin, Vol. 33, No. 4 (2002), pp. 38.

apparatus, in this case the 300 watt bulb, is placed on the opposite side of the wall section facing the IR camera. Both the camera and the heating apparatus were placed at the same height, level with the wall section. The IR camera was placed 5 feet from the sample based on the field of view (FOV) while the heat source was located 15 inches (38.1 cm) from the wall sections gypsum board (**fig. 29**). While the distance of the heating apparatus is not the same as that which is noted by Rosina and Ludwig, they specify a greater distance of 23.64 inches (60 cm), only one 300 watt halogen bulb was used instead of their two 500 watt halogen bulbs.<sup>60</sup> Having the 300 watt halogen bulb in closer proximity allowed for a more intense heat flux on the sample as less was lost due to radiation. This placement also allowed enough space so that the heat energy or flux generated was able to disperse enough before reaching the sample so that a more even heating of the sample was obtained. The main goal of the heating apparatus is to create a  $\Delta T$  between the two sides of the wall section that is  $\geq 18^{\circ}\text{F}$  ( $10^{\circ}\text{C}$ ). While ASTM standard C 1060-90 states that this  $\Delta T$  should be kept for a period of 4 hours prior to testing to allow sufficient thermal propagation the heat sources used in testing were efficient enough to create larger  $\Delta T$  values and therefore expedite thermal propagation so only a fraction of the time was required before thermal variations on the wall sections surface were noticeable.<sup>61</sup> However, the testing was still run for 4 hours so that the thermal propagation through the wood sample and wall section could be measured.

The heating apparatus used in active thermography testing is an important component. The correct amount of heat, evenly dispersed, is needed to provide a distinguishable and interpretable heat flux among concealed materials. However, high temperatures,  $131\text{-}149^{\circ}\text{F}$  ( $55\text{-}65^{\circ}\text{C}$ ) can begin to cause thermal degradation within the wood being tested canceling any positive affects the NDT might have contributed.<sup>62</sup> Numerous environmental factors, such as air flow, can also adversely affect the heat transfer required for IRT investigations.<sup>63</sup> While the use of halogen, IR and quartz lamps provide the necessary quantities they often fail to evenly and effectively disperse heat flux to the area of study. The use of the transmission method of active thermography does offer the opportunity to address the heating issue in a different manner than the reflective method. Instead of setting the heating mechanism away from the area under investigation silicone rubber heaters can be directly applied to the areas surface. This offers the advantage of a more controlled and directed heating to a particular area or with the use of multiple heaters multiple areas can be investigated simultaneously providing accurate qualitative and quantitative results without the issue of uneven heating or environmental variables such as wind. The reflective method, due to its reliance on a single wall surface does not allow for this type of heating as the apparatus would obscure the IR image and area under investigation.

Once equipment was in place, the sample's emissivity was calculated for inclusion in the cameras calibration. Due to the rather small fluctuation of ambient temperatures throughout

---

<sup>60</sup>Elisabetta Rosina and Nicola Ludwig, *Optimal Thermographic Procedures for Moisture Analysis in Building Materials: Study Cases from Northern Italy*, (paper presented at Thermosense XX, Orlando, Fla., April 1998), pp. 3.

<sup>61</sup>ASTM International, C 1060-90 (2003), pp 541.

<sup>62</sup>Weaver, Martin, *Conserving Buildings*, (Preservation Press, John Wiley & Sons, Inc. New York: 1997)pp. 20-21.

<sup>63</sup>ASTM International, C 1060-90 (2003), pp. 541.



testing the emissivity only needed to be determined once, the reflective temperature was computed before each test was performed.

Because environmental conditions can influence the results of an IRT investigation, especially when utilizing ambient air temperatures, “Ambient air temperature measurements cannot account for the strong radiative effects of the sun or for convective effects from wind...”<sup>64</sup> Therefore, the methodology used to examine the small wall sections incorporated protocols designed to limit these affects. Air flow as noted, when exceeding 15 mph (6.7 m/s) can affect IRT readings as can solar radiation and additional thermal bodies.<sup>65</sup> Reducing air flow to acceptable levels within the semi-controlled environment meant that all windows, doors and HVAC units were turned off thereby preventing any undue effects caused by convection. Prevention of solar radiation required that the testing be setup away from areas that experienced direct sunlight and that all blinds were closed. Optimally, sunlight could be kept to 0 lux, air flow at 0.1 m/s, relative humidity constant at 50% and ambient temperature regulated to around 77°F (25°C).<sup>66</sup> ASTM standard C 1060-90 (2003) also mentions keeping ambient temperatures where testing is to occur at  $77 \pm 9^\circ\text{F}$  ( $25 \pm 5^\circ\text{C}$ ) albeit during passive thermography testing.<sup>67</sup> While not all these parameters could be met within the semi-controlled environment they were kept to a minimum. Ambient temperature as recommended was kept at  $77 \pm 9^\circ\text{F}$ , relative humidity was kept constant at  $20 \pm 10\%$  RH, sunlight around 50-80 lux and wind speed near 0.1 m/s. Other parameters such as test participants or observers were kept constant so there was no loss or gain of additional thermal bodies. Type E thermocouples placed at strategic locations on and around the sample provided the means from which to monitor temperatures and thermal gradients. Insuring consistent readings meant placing them in the same locations, over and around the sample 2x4, during each test and on the same x and y planes in relation to each other (**fig. 18**). Once procedures to insure environmental conditions were in place, the room was allowed to reach a steady state and the materials allowed to reach equilibrium with the surrounding temperature, this typically meant leaving the room untouched for up to 12 hours before testing was begun.<sup>68</sup> Typically tests were started at 6 am and finished at 10 am so that environmental parameters like solar radiation were consistent throughout testing.

Before testing started, moisture levels of all materials within the mock wall section were determined. The moisture content of wood has a very noticeable affect on the thermal conductivity of the material and therefore is an important variable to know.<sup>69</sup> As test values were to be compared to thermal conductivity values of previously tested wood with a moisture content of <6% the samples were checked to meet this requirement. If samples were determined to have moisture levels exceeding 6% they were placed in a drying oven for an appropriate amount of time.

Once testing began IR images were taken at minute intervals and thermocouple readings every 7.5 seconds and then averaged in blocks of 8 readings providing one measurement every minute

---

<sup>64</sup>Ibid.

<sup>65</sup>Ibid.

<sup>66</sup>Elisabetta Rosina and Nicola Ludwig, *Optimal Thermographic Procedures*, pp. 5.

<sup>67</sup>ASTM International, C 1060-90 (2003), pp 540.

<sup>68</sup>Elisabetta Rosina and Jonathan Spodek, *Using Infrared Thermography to Detect Moisture in Historic Masonry: A Case Study in Indiana*, APT Bulletin, Vol. 34, No. 1 (2003), pp. 12.

<sup>69</sup>Simpson and TenWolde, *Physical Properties and Moisture Relations of Wood*, pp. 19-20.

for 240 minutes. Images were all taken in the 7-15 $\mu$ m's spectral range. Tests were performed a minimum of five times for each small wall section sample.

*Ideal 1'-0" x 1'-0" Mock Wall Section Testing Protocol for Species Identification Within a Semi-Controlled Environment Using Transmission Long Pulse IRT:*

#	Procedure	Description
1	Place IR camera (type specified in equipment list) 5'-0" from wall section measuring 1'-0" x 1'-0" based on the camera lens FOV (24° x 18°). The camera should be on a tripod raised to a level that places it on the same plane and directly centered on the wall section.	IR camera should line up perpendicular to the mock wall section facing the "exterior" (weatherboard). Placing the camera perpendicular to the center of the wall section helps with image distortion providing a flatter image for analysis. <sup>70</sup>
2	Calculate emissivity and reflected temperature by following procedures outlined previously. <sup>71</sup>	As these test are performed in a semi-controlled environment with changing environmental variables the reflected temperature should be checked at the start of each test. The emissivity value of the wood siding need only be checked once.
3	Test moisture content of wood.	<6% for this series of tests.
4	Place 1 wood sample in wall section. Samples as well as the wall section should conform to specifications listed in the previous construction section of the 1'-0" x 1'-0" wall section. Surface inconsistencies such as paint/knots should be avoided	Place sample between adjustable metal clips. Samples should be standard 2x4's with wood grain direction consistent. There should be no air gap between the stud and the gypsum board/plaster and siding.
5	Attach type E thermocouples to the sample. Make sure the thermocouples are located at key areas in line with the heating apparatus, along the same X and Y planes and in a location to measure ambient temperature. The thermocouples should not be placed where they can obstruct the IR image	Type E thermocouples provide the range and accuracy needed for these types of tests. There are self adhesive versions so physically affixing the thermocouples to the studs, a procedure that could disrupt the thermal propagation, is not necessary.
6	Use 4"x12" (2.5W/in <sup>2</sup> ) silicone rubber fiberglass insulated heater with adhesive. The heater should be placed parallel and centered to the area of siding to be analyzed but on the opposite side (interior side). The heater should span the entire 12" width of the wall section including both the wall cavity as well as the sample..	Special care should be taken to make sure temperature <b>can be controlled and observed</b> to prevent thermal degradation of the wood.
7	Setup all necessary parameters for the IR camera, silicone rubber heaters, data acquisition units and thermocouples for remote starting and ending. Also insure that the environmental chamber has appropriate wind speeds (<0.1 m/s) and light (50-80 lx) through shutting doors, windows, drawing blinds and turning off HVAC units. (see step 11 for further details)	Setting the equipment to obtain temperatures remotely will avoid any time related errors as well as provide minimum interaction with materials. Preparing the room for environmental conditions will ensure consistent results. Once environmental conditions are controlled the material should be left for at least 3 hours to reach equilibrium. <sup>72</sup>

<sup>70</sup>ASTM International, C 1060-90 (2003), pp 538.

<sup>71</sup>ASTM International, C 1060-90 (2003), pp 541.

<sup>72</sup>FLIR, pp. 99-105

8	Monitor thermocouple readings and IR camera temperatures to insure materials have reached equilibrium. Room temperature should be $77 \pm 9^{\circ}\text{F}$ ( $25 \pm 5^{\circ}\text{C}$ ) and RH $20 \pm 10\%$ . <sup>73</sup>	Any $\Delta\text{T}$ present within the wall section should also be avoided. Thermocouples should measure $\leq 0.5^{\circ}\text{F}$ of each other.
9	Once temperatures have reach equilibrium with the ambient temperature, input remaining parameters including temperature and relative humidity. Also calculate and input reflected temperature.	Although the reflected temperature was calculated at the same time as the emissivity it should be done before each tests as small temperature changes can affect its value unlike the emissivity.
10	Set IR camera's image capture to 1 per minute for 240 minutes (4 hours), with a one minute delay to allow for the thermocouples to get in sync. Thermocouples should be set to capture temperature readings every 7.5 seconds with block averages every 8 readings, resulting in one value per minute. The silicone rubber heaters should also be set for remote start and temperature settings of $\leq 131^{\circ}\text{F}$ .	<b>Step 10</b> should be done previously during <b>step 7</b> . However, these devices should be activated simultaneously at this time. A minimum $\Delta\text{T}$ of $18^{\circ}\text{F}$ ( $10^{\circ}\text{C}$ ) is required between the interior (heating) and exterior (unheated) surfaces, this can be verified with the thermocouples. <sup>74</sup>
11	Turn off test at the end of 60 minutes (1 hour).	
12	Repeat steps 3-11 for additional tests.	
13	Test each sample a minimum of 5 times.	

**Table 6:** This is a preliminary “ideal” protocol for obtaining IRT measurements within a semi-controlled environment when investigating a mock wall section measuring 1’-0” x 1’-0”. This protocol can be applied to other wall section sizes under the same environmental conditions as well as wood samples with different grain orientations as well as moisture content.

### ***6’-0” x 4’-0” Mock Wall Section Testing Methodology for Species Identification Within A Controlled Environment:***

Whereas the small wall sections previously tested within a semi-controlled environment provided the opportunity for relatively quick assessments and observations the construction and testing of a larger wall section within an environmental chamber allowed for more accurate assessments and analysis. Perhaps the most important factor is the ability of a large wall section to portray internal cavity air convection more realistically, therefore contributing to a more accurate analysis. This is an especially important factor when dealing with un-insulated walls.<sup>75</sup>

The methodology used to evaluate wood species samples using a large mock wall section placed within an environmentally controlled chamber was similar to the smaller wall section tests previously described. Transmission long pulse thermography was used for many of the same reasons that will be described during the results and discussion section of this research. However, because of the size of the wall section, the size of the chamber and the ability to control environmental conditions notable differences in methodology and protocol existed.

<sup>73</sup>ASTM International, C 1060-90 (2003), pp 540.

<sup>74</sup>ASTM International, C 1060-90 (2003), pp 541.

<sup>75</sup>ASTM International, C 1046-95 (2001), *Standard Practice for In-Situ Measurement of Heat Flux and Temperature on Building Envelope Components*, Vol. 04.06, pp 516.

Previous research coupled with observations and ASTM standards still influenced much of the testing methodology and protocol. Rosina and Ludwig's paper entitled *Optimal Thermographic Procedures for Moisture Analysis in Building Materials*, as it described IR procedures coinciding with climate controlled testing proved a helpful resource. What was learned through these tests was then applied to the ideal testing protocol so that future testing can avoid some of the problems encountered (**table 7**).

Placement of the FLIR ThermaCAM® S65 HS IR camera, heating apparatus and the wall sections correctly within the environmental chamber was the first task. Due to the IR cameras relatively small field of view (FOV) of  $24^\circ \times 18^\circ$  a distance of  $14'-1\frac{3}{8}"$  was needed between the camera lens and the cedar siding to include the entire wall section. Additional space of  $5'-0"$  was needed to add the heating apparatus module, gypsum board module and camera tripod requiring a total space of  $19'-1\frac{3}{8}"$ . The advantage of having the entire wall section within one IR image was the ability to qualitatively compare up to three different wood samples.<sup>76</sup> However the largest chamber found within a reasonable distance was located at ESSC contract testing laboratories in Cincinnati, Ohio. This chamber failed to meet the minimum requirement of roughly  $20'-0"$  so it was decided that only one sample with two "control" S-P-F studs would be analyzed at a time. This meant that the camera was placed at a distance of  $6'-5"$ . Future tests will use a  $45^\circ \times 34^\circ$  wide angle IR lens allowing for a shorter chamber distance and a more inclusive image.<sup>77</sup>



**Fig. 30 & 31:** Two images showing the environmental chamber at ESSC, Cincinnati, Ohio, used for testing the large wall sections. The two doors and ramp (left image) allowed the wall sections be we easily placed within the chamber. The interior of the chamber (right) shows the camera and the wall section (extreme left of the image). Note the wires passing out through the two holes (center), these connect the heating apparatus, thermocouples and IR camera to the computer outside the chamber. (Photo by author, 2007)

Despite space issues the camera and the heating apparatus were placed in similar arrangements to the smaller wall sections with the heating apparatus on the interior (gypsum board) side and

<sup>76</sup>Rosina and Robinson, *Applying Infrared Thermography to Historic Wood-Framed Buildings in North America*, pp. 38.

<sup>77</sup>The wall section could have been altered to fit the space requirements dictated by the size of the chamber and the FOV of the camera, however it was important that the wall section have reasonable wall cavities and stud spacing so that internal convection and thermal stud conduction could more appropriately mimic a field situation.

the IR camera facing the weatherboard cedar siding. Both pieces of equipment were placed perpendicular to the wall section. The heating apparatus used in this series of tests was a 1500 watt (5120 BTU) Delonghi TRD0715T oil-filled radiator, different from the 300 watt halogen bulb used for the smaller sections due to the size of the wall section, necessity of an even heating over a larger space and the need to create a  $\Delta T$  value between the interior and exterior of 18°F (10°C).<sup>78</sup> Construction of an insulated heating module, that when connected with the other modules, formed an enclosed area allowing for a more rapid heating of the samples. Placed within the insulated module was a small fan to help increase circulation of hot air for a more even and uniform heating. Because this area was not under thermal investigation the air speed created by the fan resulted in no adverse affects. The heating device was placed 1.5 ft from the gypsum board when the modules were connected.

After the initial setup of the materials and equipment, the reflected temperature as well as the emissivity of the material was calculated using the previously mentioned procedures. The camera, thermocouples and the heating device were also wired to a control table setup outside of the environmental chamber so that start and end times could be controlled remotely without having to disturb air temperatures (**fig. 31**). Thermocouples were placed using the same parameters as with the small wall sections. The camera was set to take IR images every minute for 30 minutes as were the thermocouples. The radiator heating mechanism was controlled by a simple on/off toggle switch and set at its highest setting (1500 watts).

Once all settings and IR camera calibrations were in place the chamber was closed and the temperature ramped down to 55°F. The temperature in the chamber was set at 55°F to enhance the thermal propagation from the interior (heated side) of the wall section once testing began, decreasing the time required for the necessary  $\Delta T$ .<sup>79</sup> Loss of accuracy of IR cameras, as mentioned by Rosina, operating below 40°F (5°C) was noted.<sup>80</sup> Chamber light was kept at <10 lx and air flow below 0.1 m/s. Relative humidity, as it has almost no affect in such close proximity to the material under investigation, was not a big concern, however it was maintained consistently at 30% RH. The temperature was maintained long enough to allow the materials to reach equilibrium with the ambient temperature whereby the chamber was turned off and the test started. Turning the chamber off, and therefore not maintaining a constant ambient temperature throughout testing was a necessary procedure. Earlier tests, not included in the results, maintained 55°F for the entire test; however the chamber was sufficiently powerful enough to override any thermal gradients created by the heating apparatus on the exterior surface of the wall section. Since no thermal gradient was created there could be nothing to compare (**fig. 32**). Allowing the room's ambient temperature to rise minimally during testing provided for a more realistic approach as room temperatures as well as exterior material and atmospheric temperatures all respond to added thermal energy. After 30 minutes the testing was stopped and the chamber doors were opened. The wall sections were separated and the heating apparatus allowed to cool. This process took a relatively long time, 3+ hours, due to the ability of the radiator to retain heat, only allowing 2 tests per day. The primary concern was to avoid providing the heating apparatus with a "head start" or the existence of any excessive

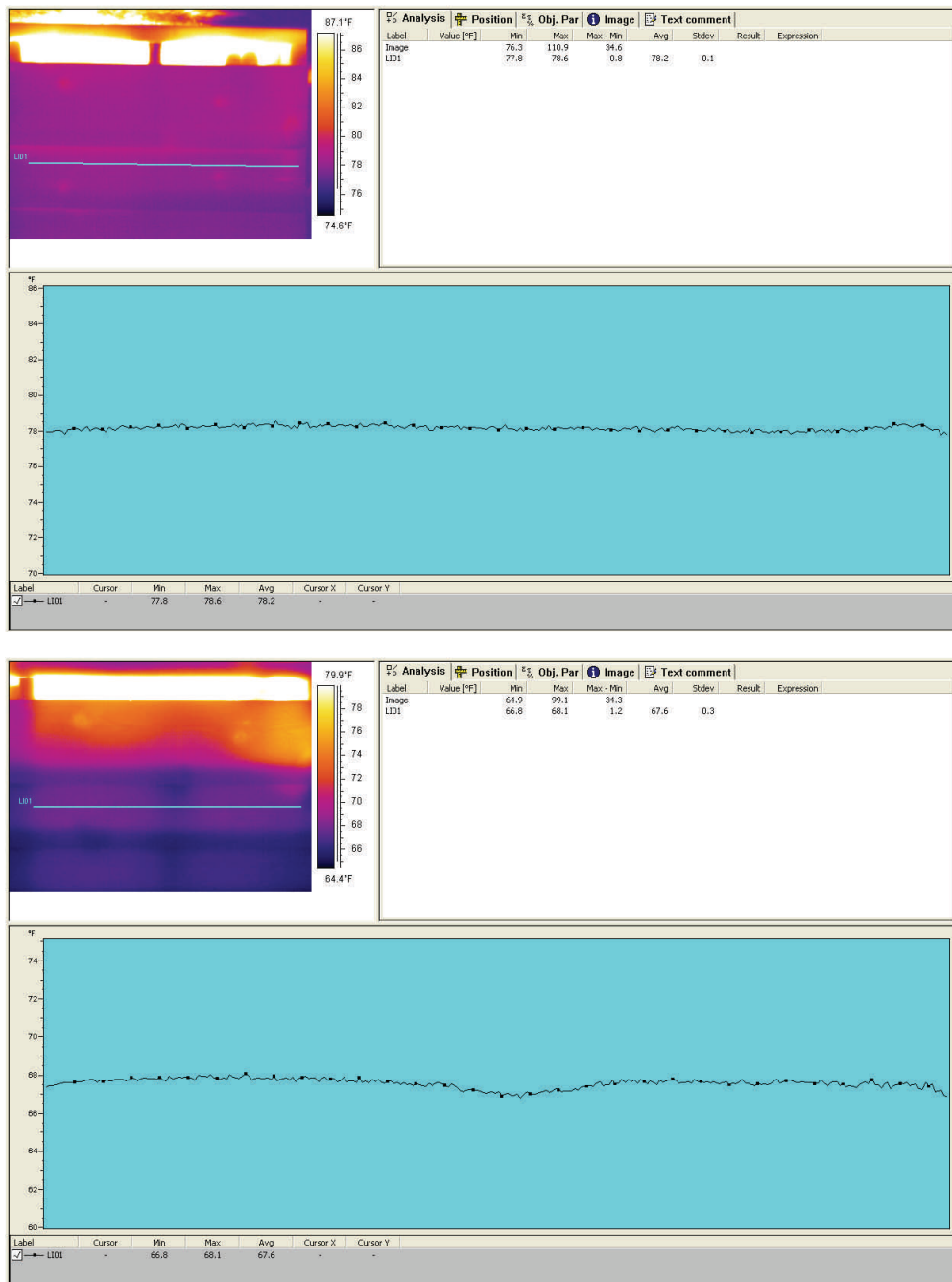
---

<sup>78</sup>ASTM International, C 1060-90 (2003), pp 541.

<sup>79</sup>Ibid

<sup>80</sup>Rosina and Robinson, *Applying Infrared Thermography to Historic Wood-Framed Buildings in North America*, pp 43.

thermal gradients that would not be taken care of during the ramping down of the chamber to 55°F. Once it was determined that no thermal gradients existed the testing was started again.



**Fig. 32:** Both images are of the large wall sections tested in the ESSC environmentally controlled chamber. However the top image shows the thermal profile of the siding's surface after 30 minutes of heating where the temperature of the chamber has been maintained at 55°F. Note the consistent coloration of the woods surface indicative of an even temperature. The profile created by the line analysis also shows little change. This can be compared to the lower image that ceased environmental control after materials had reached 55°F. Note the obvious thermal differences in the image as well as the profile, the dip noting where the stud is located. (Images by author, 2007)

*Ideal 6'-0" x 4'-0" Mock Wall Section Testing Protocol for Species Identification Within a Controlled Environment Using Transmission Long Pulse IRT:*

#	Procedure	Description
1	Place IR camera (type specified in equipment list) a minimum of 14' 1 <sup>3</sup> / <sub>8</sub> " from wall section measuring 6' x 4' (based on 24° x 18° lens). The camera should be on a tripod raised to 2' to allow the field of view of the camera to capture the entire wall section	IR camera should line up perpendicular to mock wall section facing the side with weatherboard (exterior). Placing the camera facing the center of the wall section helps with image distortion providing a flatter image for analysis. <sup>81</sup>
2	Calculate emissivity and reflected temperature by following procedures previously outlined. <sup>82</sup>	Obtaining the sidings emissivity should be done prior to testing. The reflective temperature can be done in conjunction with testing by leaving a reflective aluminum surface inside the chamber, within the camera's FOV. However, the reflective temperature should be inserted into the camera's parameters before IR readings are taken.
3	Test moisture content of wood.	<6% for this series of tests.
4	Place 3 wood samples in wall section. These samples as well as the wall section should conform to specifications listed in the previous construction section. At this time make sure that the wood siding surface is relatively consistent and free from knots and paint in areas to be analyzed. <sup>83</sup>	Place samples between adjustable metal vices. Samples should be standard 2x4's with wood grain direction and cut noted and consistent. There should be no gap between the gypsum board/plaster, the stud and the siding. Monochromatic surfaces provide the best surfaces for analysis.
5	Attach type E thermocouples to the sample. Make sure that thermocouples are located at key areas along the same X and Y planes as the heating apparatus. At a minimum thermocouples should be placed in locations to measure interior surface temperature, wall cavity temperature and exterior surface temperature for each of the heating devices employed. Ambient temperature should also be measured. <sup>84</sup>	Type E thermocouples provide the range and accuracy needed for these types of tests. There are self adhesive versions so physically affixing the thermocouples to the studs/plaster/drywall is not required. Thermocouples should be placed as closely as possible to the areas under analysis, however care should be taken not to obstruct the IR image with thermocouples.
6	Use 2, 4"x36" (2.5W/in <sup>2</sup> ) silicone rubber heaters, placed end to end across the entire 6'-0" of the interior (drywall) portion of the wall section. The 4" width of the heaters should center on the area of siding to be analyzed by the IR camera, taking care to avoid the overlap in the siding when placing.	Special care should be taken to make sure temperature <b>can be controlled and observed</b> to prevent thermal degradation. Temperatures should be kept <131-149°F. <sup>85</sup>
7	Setup control functions for IR camera, data acquisition units, thermocouples and heating apparatus for remote operation. Input all necessary...	Set IR camera's image capture to 1 per minute for 60 minutes (1 hour), with a one minute delay to allow for the thermocouples to...

<sup>81</sup>ASTM International, C 1060-90 (2003), pp 538.

<sup>82</sup>FLIR, pp. 99-105

<sup>83</sup>Rosina and Spodek, *Using Infrared Thermography to Detect Moisture in Historic Masonry*, pp. 13.

<sup>84</sup>ASTM International, C 1046-95 (2001), pp 516.

<sup>85</sup>Weaver, *Conserving Buildings*, pp. 20-21.

7 cont...	...environmental parameters possible at this time.	...get in sync. Thermocouples should be set to capture temperature readings every 7.5 seconds with block averages every 8 readings, resulting in one value per minute.
8	Set chamber to 75°F (25°C), 50% RH, 0 lux, 0.1 m/s air speed. <sup>86</sup>	Time should be given to allow all materials to reach equilibrium with ambient temperature. A minimum $\Delta T$ of 0.5°F between thermocouples should be achieved.
9	Once the materials reach 75°F calculate reflective temperature and insert remaining environmental parameters into IRT software.	Use the aluminum foil placed within the chamber and the FOV.
10	Turn chamber off simultaneously beginning IR camera, thermocouples and heating apparatus.	The heating apparatus should generate a minimum $\Delta T$ between the exterior and interior $\geq 18^\circ\text{F}$ ( $10^\circ\text{C}$ ). <sup>87</sup>
11	Turn equipment off after 4 hours.	
12	Allow for heating apparatus and materials to cool to ambient temperature (open doors on environmental chamber).	This should be done for a minimum of 3 hours. <sup>88</sup>
13	Repeat steps 3-11 for additional tests.	
14	Test each sample a minimum of 5 times.	

**Table 7:** This is a preliminary “ideal” protocol for obtaining IRT measurements within a semi-controlled environment when investigating a mock wall section measuring 6’-0” x 4’-0”. This protocol can be applied to other wall section sizes under the same environmental conditions as well as wood samples with different grain orientations and moisture content..

***Deterioration Sample Fabrication, 8½” x 3½” x 1½”***:

The fabrication of samples and methodologies involved in the identification of subsurface wood defects and deterioration differed considerably from the identification of wood species variations. While wood possesses some additional problems of subsurface anomaly detection compared to more conductive and homogenous materials such as brick, metals and metal laminates tests have been conducted demonstrating that it is possible. However, many of these tests only investigate anomalies 0.5-2.5 mm below the surface. Likewise much of the testing uses small holes, 2-10 mm in diameter, rather than simulating actual wood



**Fig. 33:** Illustration showing the size of the wood sample used for deterioration analysis. Note the drilled holes. From top to bottom in terms of below surface depth/depth of simulated deterioration; 0.50”/0.25”, 0.63”/0.13”, 0.69”/0.06”. (Illustration by author, 2007)

<sup>86</sup>Rosina and Ludwig, *Optimal Thermographic Procedures*, pp. 5.

<sup>87</sup>ASTM International, C 1060-90 (2003), pp 541.

<sup>88</sup>ASTM International, C 1060-90 (2003), pp 541.



decay which would be larger in size as well as contain thermally conductive material.<sup>89</sup> The samples used during this research sought to mimic some of the more basic concepts of non-moist subsurface deterioration as outlined in some previous nondestructive IRT assessments conducted on utility poles for the purpose of determining whether further research was warranted for using IRT in this capacity for historic structure evaluations. Some field testing has indicated that IRT can convey accurate information regarding interior deterioration, both old and new, caused by termites indicating some further possibilities in this area.<sup>90</sup> However, it should be noted that research conducted by Wyckhuysse and Maldague has indicated that detection depths of wood defects is at most 6 cm using the transmission mode and that dry defects with filler material are typically undetectable. Moist defects and holes are however noted as being detectable showing some promise for this use of IRT.<sup>91</sup>

Fabrication of the samples was based on standard 2x4 dimensions for depth, 1 ½”, and for width, 3 ½”, but the samples only measured 5 ½” long. Inserted within this sample were three ½” diameter areas of simulated decay each located at 11/16”, 10/16” and 8/16” below the surface (**fig. 33**). Corresponding to the increased depths of simulated deterioration was the size of the deterioration, as the depth grew the holes depth got smaller. Further explained this means that the area of deterioration 11/16” below the surface was itself 1/16” deep that’s compared to the area 8/16” below the surface which measured 4/16” deep. This also meant that the hole closest to the surface was also the largest in terms of depth and so carried with it the greatest possibility of IRT detection. Subsequently the ability to detect the smaller deeper holes was increasingly less likely but provided two parameters which could be investigated separately, should the method show promise. Filling each area of simulated decay was a composite of sawdust and epoxy. Careful attention was paid to mark the drill depths on the top of each sample before the composite was put in place. This sample fabrication is similar to the methods described by Wyckhuysse and Maldague in their paper “A Study of Wood Inspection by Infrared Thermography, Part II: Thermography for Wood Defects Detection.”<sup>92</sup>

### ***Deterioration Sample, 5½” x 3½” x 1½” Testing Methodology Within A Semi-Controlled Environment:***

The methodology involved to test subsurface deterioration within the fabricated sample is based on methods put forth by Maldague, Meola, Carlomagno and Giorleo. The Maldague technique is, however, the only method that involves wood specimens, the others refer to bonded aluminum joints, glass-reinforced epoxy composites and carbon-reinforced epoxy composites. Despite the material differences both methodologies mention many of the same IRT techniques. The method of IRT applied to the fabricated sample tested was the reflection pulse method or pulse phase thermography. This method analyzes the cooling stage, or thermal decay after the sample has been heated and is based on thermal propagation through a material.

---

<sup>89</sup>Maldague, *Theory and Practice of Infrared Technology For Nondestructive Testing*, pp. 495-497.

<sup>90</sup>Gilberg, Riegel, Melia and Leonard, Detecting Subterranean Termite Activity with Infrared Thermography: A Case Study, *APT Bulletin*, Vol. 34, No. 2/3. (2003), pp. 51.

<sup>91</sup>Maldague and Wyckhuysse, A Study of Wood Inspection by Infrared Thermography, Part II: Thermography for Wood Defects Detection, *Research in Nondestructive Evaluation* (2001): 13-21.

<sup>92</sup>Maldague and Wyckhuysse, A Study of Wood Inspection by Infrared Thermography, 13-21.

“The presence of a defect, at a certain depth, interferes with the heat propagation and such interference produces a local surface temperature variation...Generally, a surface defect becomes immediately visible, while a deep defect becomes visible with a certain delay. A large surface defect is associated with a large contrast and the contrast weakens as the size of the defect decreases or depth increases. Of course, the thermal contrast depends on the difference between the thermal conductivity of the sound material and that of the inhomogeneity.”<sup>93</sup>

The reflection mode of active thermography was chosen over the transmission mode for this particular testing series as the 1100 watt IR lamp heat source could create a more intense heat pulse faster in a position facing the side to be analyzed. This was particularly important as the heat pulse only lasted 20-30 seconds in duration compared to the much longer times used in species identification testing. The reflection mode also allows for the determination of defect depth as opposed to the transmission mode where thermal signals arrive at the samples surface at the same time despite the defect depth.<sup>94</sup>

The use of the reflective mode meant that the FLIR ThermoCAM® S65 HS IR camera, the heating apparatus and the sample all had to be rearranged from the species transmission mode testing. Due to the need for quick thermal propagation the heating apparatus was located relatively close to the sample, 18 inches and at a 45° angle. The camera was located only 2 feet from the sample providing the closest focused images possible. Holding the sample in place was a drill vice that enabled the sample to have minimum contact with other materials.

Environmental concerns were also taken into account much the same as with the small wall section used for species identification testing. This meant reducing the effects of air flow, solar radiation, additional thermal bodies and fluctuating temperatures. Therefore, before any testing was conducted all HVAC systems were turned off, windows, blinds and doors closed and the rooms left to stabilize for at least 12 hours.<sup>95</sup> Temperature within the room was also kept at the ASTM C 1060-90 (2003) recommended  $77 \pm 9^{\circ}\text{F}$  ( $25 \pm 5^{\circ}\text{C}$ ).<sup>96</sup> Relative humidity was kept as stable as possible at  $50 \pm 10\%$ . Both airspeed and solar radiation were also kept as consistent as possible with values of 50-80 lux and 0.1 m/s respectively. Monitoring the temperature of the environment were two type E thermocouples placed on either side of the sample with care taken not to obscure the areas under IR investigation and analysis.

Additionally the physical properties of the wood sample was noted including the moisture content which was kept at <6%. The grain direction as well as any observable surface defects or growth ring patterns were also noted. Lastly any saw or plane marks apparent on the surface were noted.

The heating apparatus, IR camera and the thermocouples were all setup for a remote and simultaneous start. Both the IR camera and the thermocouples were set to take images/readings

---

<sup>93</sup>Meola, Carlomagno and Giorleo, *Using Infrared Thermography to Analyze Substrate and Adhesive Effects in Bonded Structures*, J. Adhesion Sci. Technol., Vol. 18, No. 6, pp. 619-620.

<sup>94</sup>Maldague and Wyckhuysse, *A Study of Wood Inspection by Infrared Thermography*, 16.

<sup>95</sup>Rosina and Spodek, *Using Infrared Thermography to Detect Moisture in Historic Masonry*, pp. 12.

<sup>96</sup>ASTM International, C 1060-90 (2003), pp 540.

every second whereas the heating apparatus was set for exposures of 20 seconds during one series of tests and 30 seconds for another.<sup>97</sup> The duration of the tests extended to 3 minutes to include the thermal decay of the sample. All images were taken in the 7-15 $\mu$ m's spectral range.

Currently, not enough testing has been conducted on subsurface defects of wood or their detectability within a wall system to warrant an ideal protocol. Further discussion of where IRT investigations can continue regarding subsurface wood anomalies and their detectability within concealed historic structural systems can be found in later chapters.

### ***Field Testing Using Transmission Long Pulse IRT for Species Identification:***

Testing IRT in the field or on actual historic structures brings a number of additional environmental concerns into the equation. While the focus here will be on active IRT rather than passive investigations in historic structures the two do share some overlaps when specifying ideal procedures and environmental conditions. The various environmental conditions that affect IRT investigations in the field include atmospheric temperature, addition of thermal bodies, solar radiation, air speed and, of course, the physical and chemical properties of the material under investigation.

Atmospheric temperature is one of the biggest environmental factors when performing an IRT investigation in the field. Due to IR camera detection capabilities, material temperatures above 40°F (5°C) result in more accurate IRT readings.<sup>98</sup> When using IRT below 32°F (0°C) there is also a greater chance for false readings particularly where ice can form on or within structure.<sup>99</sup> ASTM standards are however more particular suggesting that the interior temperature of the structure be 77  $\pm$  9°F (25  $\pm$  5°C).<sup>100</sup> Following these guidelines is particularly important when comparing IRT data that is expressed as a function of time as ambient temperature affects the rate of temperature increase from the heating apparatus as well as the maximum temperature achievable.

Factors affecting the atmospheric or ambient temperatures during an IRT investigation include the presence of additional thermal bodies (people) and solar radiation. While not a large issue of concern in vast rooms or outside, the presence of people and the unavoidable comings and goings associated with testing can both add and subtract thermal generators affecting the ambient temperature, noticeably so in smaller, interior rooms. Therefore, it is important to make sure that equipment is setup for remote access and all unnecessary movement is controlled.

---

<sup>97</sup>Maldague, *Theory and Practice of Infrared Technology For Nondestructive Testing*, pp. 496.; Meola, Carlo-magno and Giorleo, *Using Infrared Thermography to Analyze Substrate and Adhesive Effects in Bonded Structures*, pp. 622.

<sup>98</sup>Rosina and Robinson, *Applying Infrared Thermography to Historic Wood-Framed Buildings in North America*, pp 43.

<sup>99</sup>ASTM International, D 4789-03, *Standard Test Method For Detecting Delaminations in Bridge Decking Using IRT*, Vol. 04.03, pp 507.

<sup>100</sup>ASTM International, C 1060-90 (2003), pp 541.

Solar radiation is a much larger concern for both active and passive IRT investigations. Numerous factors can potentially affect how much solar radiation will reach a structure and more particularly a single component of that structure. Some of these factors include the structures location geographically (latitude), orientation of the structure, the season, time of day, weather and the surroundings (is it in a city with tall buildings or an open field). These factors should all be noted when conducting IRT field investigations. Ideally when conducting an active IRT test on a frame structure solar radiation should be avoided for a minimum of 3 hours, however some source increase this time to 12 hours.<sup>101</sup> The important thing to keep in mind is that, when trying to determine the wood species of a concealed wood element, both wall surfaces involved in the IRT transmission investigation are as close to the ambient temperature as possible. Accomplishing this means that the factors mentioned before that affect solar radiation need to be investigated. Other steps such as planning tests during early morning hours, preferably before dawn and opening the structure to the exterior will help obtain the appropriate temperatures.

Air speed is another environmental factor that can affect results to some extent as evaporation and therefore cooling is affected. When dealing with frame structures the recommended air speed is < 15 mph (6.7 m/s).<sup>102</sup> It should be noted that in some instances where evaporation is desired, for example when measuring moisture damage or content, wind and convective currents may be desirable. Air currents or convection within un-insulated wall cavities is also something that should be noted. Therefore, before conducting an active IRT test an observation should be done to insure that no fire blocks or other obstructions might create different conditions thereby hindering comparisons between wall cavities. If resources allow three separate heating devices, (2 laid end to end) 4” x 36” silicone rubber heaters, should be placed along a single y-axis, one at the bottom and top of the stud space (room height) and one in the middle.<sup>103</sup> These heaters should be placed so that they align as best as possible with the middle of the un-overlapping sections of siding that will be viewed and analyzed by the IR camera.

The moisture content of the wood and plaster should also be determined before testing begins. There is a distinct relationship between the thermal conductivity of wood and its moisture content therefore in order to compare structural members and identify any variations in wood species the moisture content needs to be determined. This can be accomplished through pin or pin less moisture meters. The use of the pins allows for direct determination of the woods moisture content whereas the pin less meter merely takes readings from the surface. Of course, when conducting nondestructive assessments the advantage of the pin less meter might prove the better. Quick thermal observations using passive thermography can also convey information regarding any potential moisture differences or areas where deterioration might affect readings. Coinciding with the physical characteristics of the wood under investigation is the cut or grain direction. This should be determined if possible through archival research looking at typical building types and technologies available during the period of construction. Comparing IRT results might also help determine this characteristic. Delamination of drywall

---

<sup>101</sup>ASTM International, C 1060-90 (2003), pp 541 ; Rosina and Spodek, *Using Infrared Thermography to Detect Moisture in Historic Masonry*, pp. 13.

<sup>102</sup>ASTM International, C 1060-90 (2003), pp 541.

<sup>103</sup>ASTM International, C 1046-95 (2001), pp 516.

and plaster can also affect results by interfering with thermal propagation and should be identified. Lastly, the surfaces under investigation should be as homogenous and as monochromatic as possible as different paints and colors can affect emissivity and therefore results.<sup>104</sup>

*Ideal Wood Species Identification Field Testing Procedure Using Transmission Long Pulse IRT (Preliminary):*

#	Procedure	Description
1	Conduct a conditions assessment using passive IRT to identify areas where thermal conductivity might be altered due to deterioration framing placement, fire blocks or delaminating wall surfaces. Passive IRT should rely on solar radiation for thermal gradients.	Moisture readings of wood and plaster should be taken if possible at this point. Archival research should also be conducted in an attempt to determine probable wood grain directions based on wood cut.
2	Depending on the cameras FOV select at least two studs spaced a consistent distance apart. Set the camera on a tripod far enough away from the exterior wall surface so that both studs and wall cavity are included in the image. The camera should be on a tripod and raised to a height that places it about midway between the ceiling and the floor if possible.	The IR camera should be placed perpendicular to the wall. This will minimize image distortion as well as provide an easier image to compare and analyze.
3	Calculate emissivity of the exterior surface material. Make sure that the material is monochromatic	Follow previous outlined procedures.
4	Use 2, 4"x36" (2.5W/in <sup>2</sup> ) silicone rubber heaters, placed end to end across the entire 6'-0" of the interior wall, covering all studs and wall cavities being analyzed. The 4" width of the heaters should center on the area of exterior siding/wall to be analyzed by the IR camera, taking care to avoid any overlap siding on the opposite interior wall during placement. This process should be repeated until there are three 6' x 4" heating strips placed along the top, middle and bottom of the wall.	Special care should be taken to make sure temperature <b>can be controlled and observed</b> to prevent thermal degradation. Temperatures should be kept <131-149°F.
5	Place type E, self adhesive thermocouples on the exterior wall aligning as best as possible with the heating apparatus. There should be a thermocouple placed at each stud and each wall cavity mirroring the three heating apparatus on the opposite side of the wall. Thermocouples should also be placed to measure interior and exterior ambient temperatures.	Type E thermocouples provide the range and accuracy needed for these types of tests. Thermocouples should be placed as closely as possible to the areas under analysis, however care should be taken not to obstruct the IR image with thermocouples.

<sup>104</sup>Rosina and Spodek, *Using Infrared Thermography to Detect Moisture in Historic Masonry*, pp. 13.

#	Procedure	Description
6	Setup control functions for IR camera, data acquisition units, thermocouples and heating apparatus for remote operation. Input all necessary environmental parameters possible at this time.	Set IR camera's image capture to 1 per minute for 60 minutes (1 hour), with a one minute delay to allow for the thermocouples to get in sync. Thermocouples should be set to capture temperature readings every 7.5 seconds with block averages every 8 readings, resulting in one value per minute.
7	Prepare the house environmentally. All doors and windows should be opened. HVAC units should be turned off. The ideal ambient temperature of $77 \pm 9^{\circ}\text{F}$ ( $25 \pm 5^{\circ}\text{C}$ ) should be ascertained if possible (dependent on time of year) but more importantly temperatures on the exterior and interior of the wall should be relatively close and at a steady state. Tests should not be conducted when temperatures are $<32^{\circ}\text{F}$ ( $0^{\circ}\text{C}$ ). Wind speed should be $<15$ mph (6.7 m/s) at the time of the test. Solar radiation should be at a minimum.	Reaching the same steady state temperature for each frame wall surface can take a minimum of 3 hours and sometimes up to 12. The best time to conduct field tests is early morning before sunrise when wind and solar radiation is at a minimum. However, all environmental issues such as opening the house and turning off the HVAC should be done a minimum of 3 hours beforehand.
8	Verify environmental parameters, temperature and relative humidity making sure temperatures are reasonably uniform and steady to determine of testing is ready to proceed. Calculate reflected temperature.	Place these parameters in the IR cameras calibration parameters.
9	Start testing. All equipment should be started simultaneously.	The heating apparatus should generate a minimum $\Delta T$ between the exterior and interior $\geq 18^{\circ}\text{F}$ ( $10^{\circ}\text{C}$ ). Greater thermal gradients between the exterior and interior temperatures results in a faster thermal gradient on the exterior surface between the studs and the wall cavity.
10	Turn off test at the end of 240 minutes (4 hours).	
11	Repeat steps 6-9 for additional tests in the same location, steps 1-9 for a new location.	
12	Test each wall area a minimum of 5 times.	

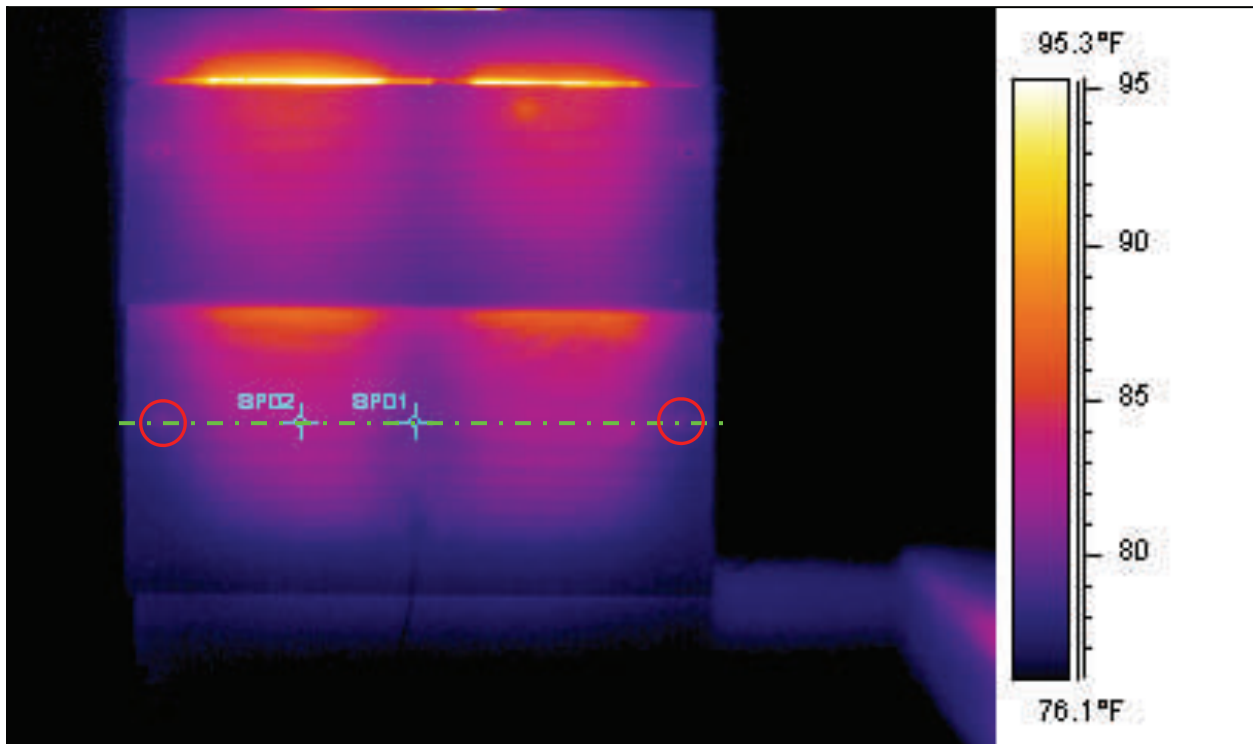
**Table 8:** This is a preliminary protocol for conducting field IRT tests using the long pulse transmission method for the purpose of identifying species of concealed wood structural members. Additional field testing will be required to verify this protocol and additions and alterations may be made at a later date.

### Methods for Obtaining Measurements and Results From Species and Deterioration Testing:

Results from the various tests were transmitted directly through a firewire connection from the IR camera to a computer equipped with Researcher Pro 2.8 SR-2 software. This connection

allowed for real time video feed from the infrared camera directly to the computer desktop where the IR images could be viewed as a continuous stream during testing as well as analyzed later. The color palette of the IR images could also be altered as well as the temperature scale for increased image clarity. The software enabled data to be analyzed in a number of ways from histograms to profiles to plots using a number of different tools such as spots, rectangles, and lines. Data could also be converted into ACSII files and then placed in Microsoft Excel to assist in organization of the 76,800 data points generated from each image. The sheer amount of data necessitated the need for a standard method or protocol for analysis.

Placement of the analysis tools on the IR images used in analysis was the first task. The spots that were being used for obtaining data needed to be located on the same x-axis as each other in each image. This was especially important as the thickness of the cedar weatherboard siding changed along the y-axis of the wall sections from  $\frac{1}{8}$ " to  $\frac{5}{8}$ ". Along this same x-axis each spot was moved until the highest and lowest temperatures were located, correlating with the location of the concealed stud (cool) and the middle of the wall cavity (hot). This rarely resulted in any movement of the spots but allowed for adjustments should anything have been inadvertently moved. The image used for placement was the last image taken for each of the species tests as this image typically had the greatest thermal gradient. However, if the camera was moved more than a few centimeters this meant that the analysis spots had to be readjusted. Two nails were placed along the same x-axis at the ends of each wall section for this explicit purpose. These



**Fig. 34:** IR image of the 1' x 1' mock wall section. Note the placement of the two spot analysis tools on the same x-axis (dashed green line). If you look closely you can discern two small thermal anomalies (red circles), these are the nail holes used to align the spots on the IR image. The spots are then moved along this x-axis (dashed green line) until the highest and lowest temperatures are located. (Image by author, 2007)

nails could be seen on the IR images and created a straight imaginary line along the x-axis of the siding at a constant thickness of  $\frac{3}{8}$ " (**fig. 34**). Repositioning the spots simply required that they be moved until they once again sat along this imaginary line.

Once the spot analysis tools were correctly positioned on the IR image a plot analysis was conducted. This involved plotting the temperature of the two spots, one on the stud one on the wall cavity, as they were heated over the test period. This information, like the thermocouple measurements, was saved in ASCII file format where it was later copied into Microsoft excel and compared. Once in Microsoft excel the readings for the two spots were converted from temperature readings to a percentage change from starting temperatures. The percentages for both spots were then plotted as functions as each other since the wall cavity was a constant in each test. Using percentage change also allowed for comparison of different tests with different ambient temperatures as the linear equation, or slope, formed was not dependent on time or direct temperature.



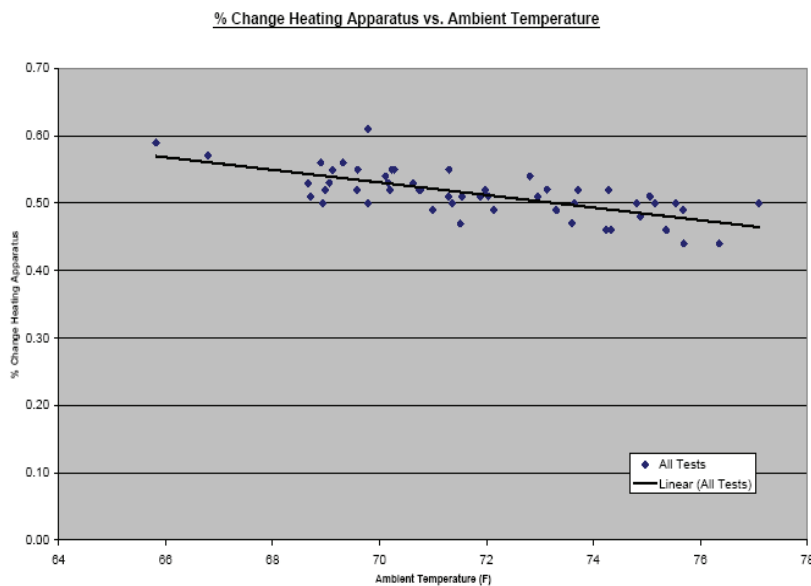
## **Results:**

Results of IRT testing can be broken down by the five original objectives outlined in the introduction. However, these objectives fall into two distinct categories, those that involved actual testing, objectives III and IV, and those which were based around observations, research and dissemination, objectives I, II and V. Generally the objectives were completed as originally intended, although some were not able to be completely finalized as testing raised a number of new questions requiring further investigation. This particularly affected objective V which presented the idea of establishing a preliminary IRT and other NDE techniques database template for eventual dissemination of knowledge. Because a number of the protocols developed and results obtained will require further verification this template will need to be altered; therefore what is presented is more preliminary than previously anticipated. This also touches on the needed refinement of testing protocols, objective I as well as further discussion into standardization of IRT testing. While ideal protocols are described during the methodology, the introduction of new equipment, namely the silicone rubber heating apparatus, will require further testing to verify its capabilities. However, aside from these shortcomings, much was learned regarding IRT's ability to investigate and distinguish wood characteristics within frame systems. Further research into this field can continue to refine IRT's contribution structural investigations, particularly as they relate to historic wood framed structures.

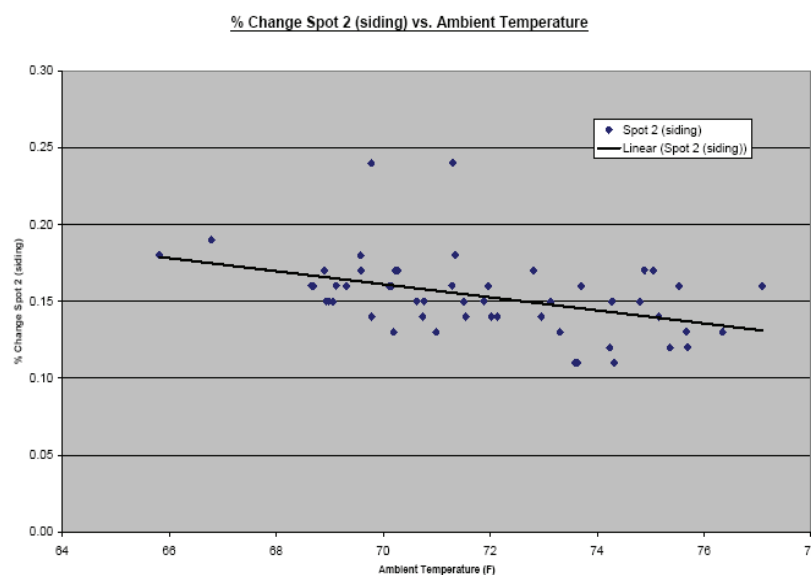
## **Testing Results and Discussion:**

Testing results presented correspond primarily to objectives III and IV which address the issues of surface and subsurface wood anomalies and wood species identification within enclosed wall systems. All results are from tests involving the use of transmission long pulse IRT or reflective short pulse IRT in the case of surface and subsurface anomaly recognition. Transmission long pulse was chosen for a variety of reasons. One reason concerned the lack of testing and experimentation conducted using this method as it concerns structural investigations. Secondly, while the transmission mode may not always be ideal, as it requires both sides of a wall for investigation (one heated and one observed), it has the potential to use more efficient and effective heating apparatus as the IR camera on the observed side of the wall can remain perpendicular to the surface without having to worry about the heating apparatus obstructing the FOV. The issue concerning wall accesses is typically not as large a problem as it may seem, with interior and ground floor walls easily accessible. Access to higher floors presents somewhat of an issue but can be resolved the majority of times by utilizing a lift. Basement walls typically are not of frame construction and therefore do not fall under the protocols and analysis outlined in this research. Lastly, the transmission method can potentially provide a more complete picture of the thermal conductivity of a wall and what lies within. This is in part due to the fact that the thermal radiation has to propagate through the entire series of materials, unlike the reflective method which relies on the interpretation of the surface reflection of the thermal radiation allowing for only small subsurface penetration. The results described are further categorized by the parameters of the test performed; semi-controlled environment v. controlled environment; as well as the size of the wall section under investigation. Relevant to these results and presented alongside are general observations regarding environmental parameters affecting IRT testing.

One such environmental parameter is the ambient temperature during IRT testing. This is important to this research as many of the tests were performed utilizing ambient temperature and all field testing is based around this variable. The affects of ambient temperature on testing can be clearly seen when plotting it as a function of the percentage increase in both the heating apparatus as well as IR image spot analysis (**charts 2 & 3**). Graph A indicates that the final percentage change in the temperature increase of the heating apparatus is directly related to the ambient temperature, with cooler temperatures providing a greater percentage change. This increase in the percentage change directly correlates to the percentage change in both IR analysis spots used for obtaining results. Simply put, the IR images showed a greater thermal percent change on the wall sections exterior surface when ambient temperatures were cooler.

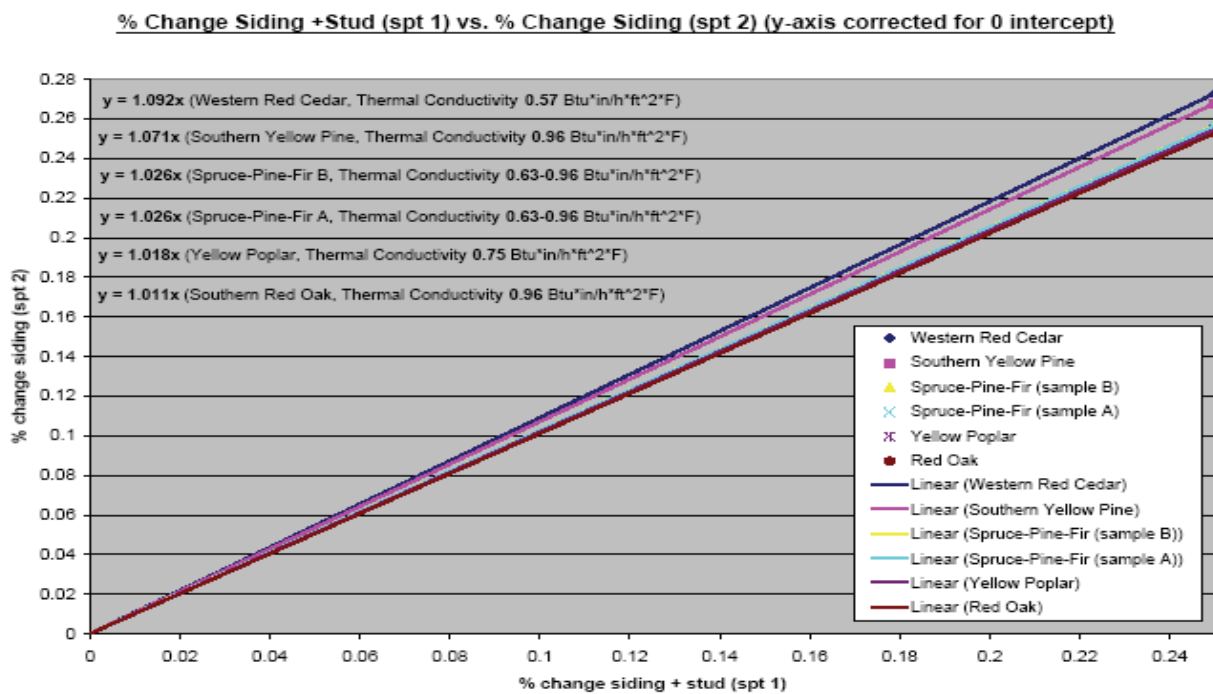


**Chart 2:** Chart 2 shows the affect that ambient air temperature has on the percentage increase of the heating apparatus used. As you can see the cooler the ambient temperature the higher percentage change in temperature increase. (Chart by author, 2008)



**Chart 3:** Chart 3 shows the ramifications of this by comparing the ambient temperature to the percentage change in one of the spots used for analysis. Again the cooler the temperature the greater percentage change. This makes IRT comparisons difficult when looking at temperature as a function of time therefore the percent changes of both spots were analyzed as functions of each other. Because spot 2 was always measuring the same variable any variations in linear slope were caused by spot 1 which analyzed the sample stud + the siding. (Chart by author, 2008)

This is of particular interest as wood species linear variations are more pronounced the greater the percentage surface temperature change on the exterior of the wall sections surface (**chart 4**). While this investigation examined the IR analysis spot data for each test as a function of the percentage increase of spot 1 (stud + siding + gypsum board) v. spot 2 (siding + gypsum board) effectively negating any issues with starting ambient temperature, problems can occur when temperature is plotted as a function of time. During these circumstances it is of particular importance to ensure that tests are conducted at the same ambient temperature for effective quantitative comparisons of results or that accurate thermal modeling is conducted to compensate and correct for the variations in percentage temperature change over a set time. However, it should be noted that the discrepancies in percent change of temperature as a function of time caused by starting ambient temperature variations is a final value and that there is good correlation between tests with different starting ambient temperature values and percentage change as a function of time within the first 15 minutes of heating. However, this amount of time fails to produce the thermal percentage changes necessary for accurate data interpretation.

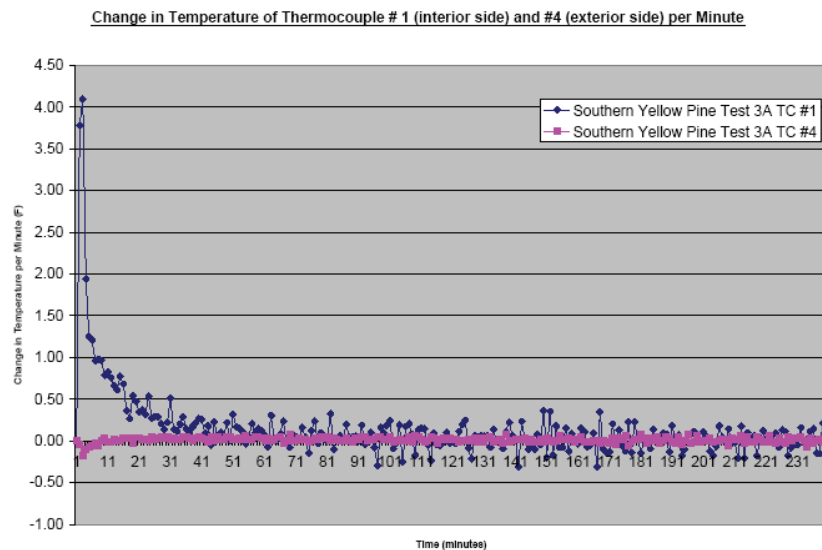


**Chart 4:** This graph plots the percentage changes of spots 1 & 2 of the small wall sections in a semi-controlled environment as they relate to each other over 240 minutes. Trendlines are used to help distinguish species as there is initial overlap when looking at scatter plots. However, linear variations become more pronounced the larger the percentage values. (Chart by author, 2008)

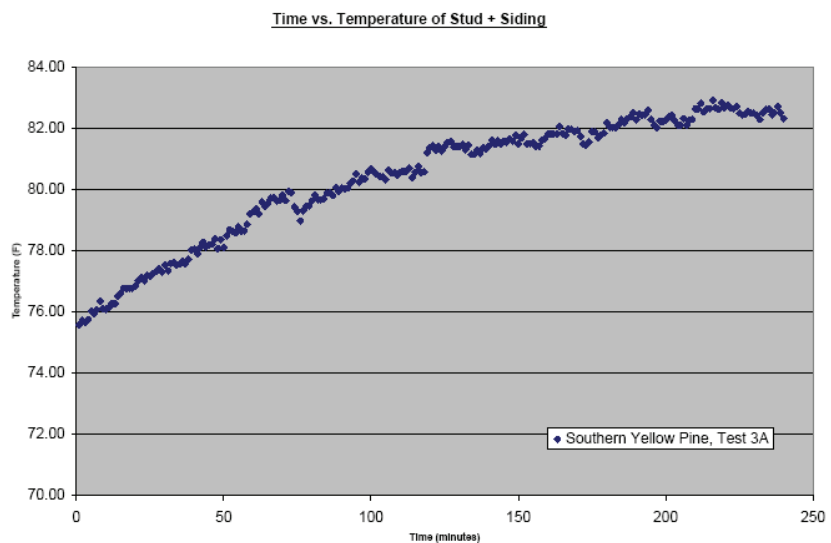
The issue of time is an important one when dealing with IRT investigations, particularly as it relates to the necessary time needed to run a single test. Results from the testing of the small wall sections within the semi-controlled environment indicate that the temperature increase, per minute, on the heated side of the wall section levels out after about 60 minutes (**chart 5**). When the percentage temperature change of the same side is viewed in entirety or a compilation of minutes, a similar leveling in temperature change can be distinguished. However, due to the use of the transmission method of IRT, the relevant thermal changes necessary on the observed

side of the wall section are delayed and more consistent. Where 60 minutes seems to be the period with the most drastic percent changes on the heated side of the wall section the observed side (exterior) stays consistent for almost the entire 240 minutes with the exception of a brief spike during the first 10 minutes. (chart 5). However, chart 6 and table 9 clearly show that the linear slope of the scatter plots begins to level on the observed side after about 75 minutes. While the first 75 minutes may determine the general slope of the line used to distinguish wood species the remaining 165 minutes refine the slope helping sort the slight variations among similar wood types. The need for the entire 240 minutes can be seen clearly when looking at table 9 which shows the compiled linear slope equations of each wood type after 30 minute intervals. What stands out after the first 30 minutes is the relatively low thermal conductivity of Western Red Cedar, a correct observation, and the general close proximity of every other species type in slope, mostly indistinguishable or incorrect in terms of relationship to thermal conductivity. Not until 180 minutes do values seem to correlate to published thermal

**Chart 5:** Chart 5 shows the change in temperature per minute of both sides of the small wall section during testing. The blue line denotes the side facing the heater whereas the magenta color is the temperature change of the observed side. Note the extreme initial spike in temperature change on the heated side and the rather gradual increase on the observed side. The unsettled nature of the temperature change on the heated side of the wall section is also due to the heat pulses emitted from the 300 watt halogen bulb. (Chart by author 2008)



**Chart 6:** While temperature change per minute is consistent on the observed side of the wall section (chart 5) when the temperature increase is viewed in entirety its easy to observe that the first 75 minutes produce the steepest linear slope in terms of temperature gain, resulting in a temperature change of almost 4.5°F. The remaining 165 minutes only manages a temperature gain of 3.5°F. (Chart by author, 2008)



conductivity rates with the next 60 minutes (240 total) further distinguishing variations. This length of time is due in large part to the time required for the heat generated to fully propagate through the wall section and might be diminished with more efficient heating apparatus. Starting ambient temperature also plays a part in the initial linear slope and the rate of change. When looking at percentage temperature changes, differentiation among species typically occurs when spot 1 reaches a temperature increase of roughly 10% and spot 2 an increase of about 12%. The use of more efficient and effective heaters as specified in the “ideal” protocol should be able to reduce the time needed for accurate results to well under 240 minutes, however further testing will need to be conducted. Thermal modeling can also provide more accurate testing times based on the heating apparatus used, published thermal conductivity rates and ambient temperature.<sup>106</sup>

Small Wall Sections (1’x1’)	Red Oak (linear slope)	S-P-F A (linear slope)	S-P-F B (linear slope)	Southern Yellow Pine (linear slope)	Poplar (linear slope)	Western Red Cedar (linear slope)
<b>30 minutes</b>	y = 1.4542x	y = 1.3997x	y = 1.5214x	y = 1.5363x	y = 1.4561x	y = 1.6253x
<b>60 minutes</b>	y = 1.3294x	y = 1.2722x	y = 1.3012x	y = 1.3426x	y = 1.2715x	y = 1.3753x
<b>90 minutes</b>	y = 1.2039x	y = 1.1563x	y = 1.1829x	y = 1.2374x	y = 1.1647x	y = 1.2456x
<b>120 minutes</b>	y = 1.1329x	y = 1.1037x	y = 1.1232x	y = 1.1707x	y = 1.1078x	y = 1.1801x
<b>150 minutes</b>	y = 1.0808x	y = 1.0694x	y = 1.0819x	y = 1.1271x	y = 1.0732x	y = 1.1445x
<b>180 minutes</b>	y = 1.0462x	y = 1.0474x	y = 1.0566x	y = 1.1009x	y = 1.0466x	y = 1.1180x
<b>210 minutes</b>	y = 1.0262x	y = 1.0338x	y = 1.0389x	y = 1.0806x	y = 1.0292x	y = 1.1036x
<b>240 minutes</b>	y = 1.0112x	y = 1.0256x	y = 1.0259x	y = 1.0712x	y = 1.0183x	y = 1.0916x

**Table 9:** Chart x provides the linear slopes of each series of tests conducted for each wood species type over incremental periods. This shows the changing rate of percentage temperature changes for spot 1 and spot 2 over the entire 240 minutes. The lower the linear slope, typically the more dense and therefore more conductive. However it takes roughly 180 minutes before linear equation values coincide with published thermal conductivity rates. (Table by author, 2008)

Since the affects of wind and solar radiation were minimized during pre-test procedures their affect was minimal and null when dealing with the environmental chamber tests. Relative humidity remained reasonably consistent and was seen as having no affect on the data or results obtained.

*Objective IV Results, Proof of Concept for use of IRT to Distinguish Variations of Wood Species Within Wall Systems:*

Results concerning objective IV were obtained from two different sets of tests. The first set of tests employed a small wall section within a semi-controlled environment whereas the following set of tests utilized a larger wall section within an environmentally controlled chamber. The methodology discussed previously outlines the specifics in terms of type of IRT used as well as the testing procedure and data obtainment protocol. Therefore, it is understood that each species type was tested individually on at least five separate occasions when

<sup>106</sup>Published thermal conductivity rates for wood typically vary by up to 20%. This is due to the anisotropic nature of wood and the large number of physical and chemical attributes that can affect thermal conductivity.

investigating the small wall sections and that only three material types were tested a limited number of times using the larger wall sections.

Results from the small wall sections were all encouraging. Individual species tests plotted as percentage temperature changes of spot 1 v spot 2 over 240 minutes, correlated well with other tests of the same sample. Linear correlation values or R<sup>2</sup> values for these small wall section tests, ranged from 0.9858 up to 0.9941 after 240 minutes, indicating that testing and results were consistent. When these linear scatter plots were set against other species distinct groupings based on wood species began to emerge (**chart 4**). However, standard deviation within each species test set does create some overlap in values, especially when spot 1's percentage change is <10% and spot 2's percentage change is <12%. There is also more overlap among wood species with similar thermal conductivity values such as the Spruce-Pine-Fir and Poplar. Therefore, the need for multiple tests as well as extended testing times that create percentage changes >12% for spot 1 and >10% for spot 2 is apparent so that linear trendline distinctions can be enhanced.

The linear trendlines, or lines of best fit, for each species created from the various tests conducted are important to distinguishing species type. Each linear equation, takes into account the various percentage change of each spot, both on and off the concealed stud, and presents them as functions of each other. This allows species type to be tested without previous knowledge as the results can be matched using **chart 4** and corresponding values (exp: if spot 1 =12% and spot 2 =12% then the species is Red Oak). The linear slope is another good indication of species type. This is presented as a y = x equation, with x being a known value (**tables 9 & 10**). Linear slopes as they relate to the comparison of percentage changes for spot 1 and 2 seems to be distinct for each species type however, it has yet to be seen if these distinctions are transferable or whether they only relate to the single wall section tested. Due to the use of different heating apparatus in the small wall section tests and the large wall section tests these results should not be directly compared. The heating apparatus should be consistent for comparison purposes.

Species	Sample	IR Linear Slope	Thermal Conductivity Rates (Btu*in/h*ft <sup>2</sup> *F°)
Western Red Cedar	A	y = 1.092x	0.57
Southern Yellow Pine	A	y = 1.071x	0.96
Spruce-Pine-Fir	B	y = 1.026x	0.63-0.96
Spruce-Pine-Fir	A	y = 1.026x	0.63-0.96
Yellow Poplar	A	y = 1.018x	0.75
Southern Red Oak	A	y = 1.011x	0.96

**Table 10:** This chart indicates the linear relationship of the samples tested with their published thermal conductivity rates, keep in mind that thermal conductivities can vary by as much as 20%. (Table by author, 2008)

Specific x values from testing of all five species also demonstrate good correlation with published thermal conductivity rates and in turn density values (**table 10**). Western Red Cedar,

a less dense wood with a thermal conductivity value of 0.57 (Btu\*in/h\*ft<sup>2</sup>\*F°) has a relatively steep slope,  $y = 1.092x$ , when compared to other denser species of wood, like Red Oak, with a more shallow slope of  $y = 1.011x$  and a thermal conductivity value of 0.96 (Btu\*in/h\*ft<sup>2</sup>\*F°). This means that according to the IR data and the resulting linear trendline that Western Red Cedar will show a lower percent change where the concealed stud is located compared to Red Oak given that the percent change of the siding, the constant, is the same value. This is an observation that we would expect to see as denser wood is typically a better thermal conductor. The only aberration in test results concerned the linear slope of the Southern Yellow Pine. Typically a dense thermally conductive wood, Southern Yellow Pine's slope characterizes it as somewhat less conductive than both Spruce-Pine-Fir and Poplar. Tests also confirmed that wood of the same species, but from two different sources, as seen with Spruce-Pine-Fir samples A and B, have virtually indistinguishable linear equations of  $y = 1.0256x$  and  $y = 1.0259x$  respectively.

Climate controlled testing performed at ESSC laboratories in a walk-in climate controlled chamber also indicated variations between wood species. Due to time constraints only two tests each were conducted on SYP and S-P-F samples. One test was also conducted on a stainless steel stud used in modern construction. However, because of the success of the tests conducted on the smaller wall sections and the positive initial results from the larger wall section more testing is warranted. What this further testing would hope to provide is confirmation within a climate controlled chamber of the ability of IRT to distinguish wood species type concealed within a frame type wall as well as determine if linear values calculated with the small wall sections in any way relate to those of the larger wall sections and are therefore independent of testing parameters unique to each mock wall section. This would require that the testing within the chambers be extended to a full four hours rather than the 30 minutes previously used. Silicone rubber heaters, as mentioned previously, would also be used to assist in consistency and thermal conductivity. However, this would still leave the need for further testing of different wood species within different frame construction types and with different physical and chemical characteristics.

Species	Sample	IR Linear Slope	Thermal Conductivity Rates (Btu*in/h*ft <sup>2</sup> *F°)
Stainless Steel	A	$y = 0.986x$	95.68
Southern Yellow Pine	A	$y = 1.011x$	0.63-0.96
Spruce-Pine-Fir	A	$y = 1.038x$	0.63-0.96

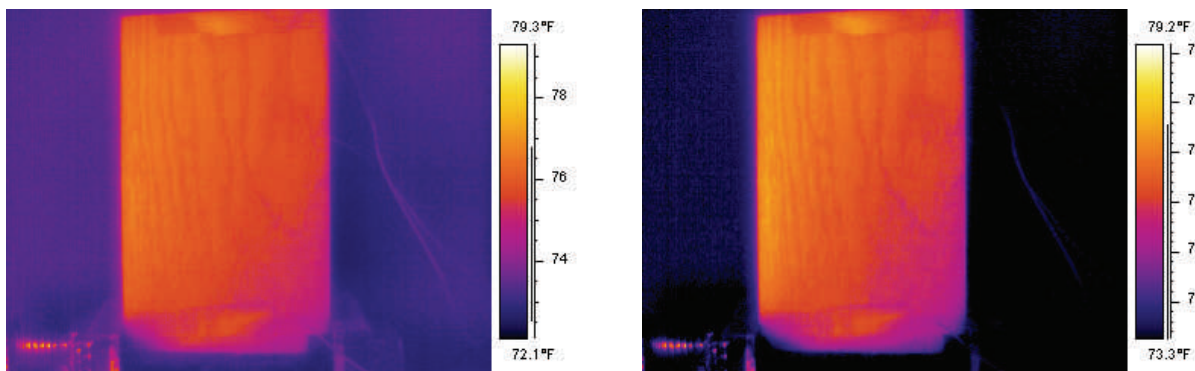
**Table 11:** This chart indicates the linear relationship of the large wall section samples tested in the environmentally controlled room adjacent to their published thermal conductivity rates, keep in mind that thermal conductivities can vary by as much as 20%. (Table by author, 2008)

Specific results from the climate controlled testing of the large mock wall sections, like the smaller wall section tests, related well to published thermal conductivity rates (**table 11**). Stainless steel as expected presented the lowest sloped linear equation of  $y = 0.986x$ ; this is partially due to the studs material but also due to its low mass and therefore quick thermal propagation. Southern Yellow Pine, unlike in the small wall section tests, provided a relatively low slope of  $y = 1.011x$  compared to the Spruce-Pine-Fir sample which this time had a steeper

pitch of  $y = 1.038x$ . This relationship again is what we would expect to see; however it disagrees to the previous testing values presented from the smaller wall section tests (**table 10**). These discrepancies can be explained in a number of ways including the different testing parameters and heating apparatus used for each series of tests. Wood's physical characteristics can also be partially responsible as even published thermal conductivity rates of wood vary by as much as 20%. What is important is that there is a clear delineation between linear equations and trendlines indicating wood species variation. Another factor to consider is the age of the wood under investigation and whether historic samples, apart from old growth vs. plantation growth, exhibit any distinct thermal differences among the same species.

*Objective III, Identification of Surface and Subsurface Abnormalities Within Wood Samples:*

Results from the IRT investigations involving the detection of surface and subsurface anomalies were mixed. The detection of surface anomalies such as earlywood, latewood, knots and scratches were clearly visible as one might expect due to the obvious variations in color and density (**fig. 35 & 36**). However, subsurface anomalies were not visible using the original methodology based on the reflective mode of IRT testing and dry filled decay simulation. This was due in part to the simulated decays similar thermal conductivity values. Due to the failure



**Fig. 35 & 36:** The image on the left is the Red Oak sample after 20 seconds exposure to the 1100 watt IR lamp. The image on the right is the same sample in another test after 30 seconds exposure time. Note that the wood grain is clearly visible in each image however there are no indications of the three areas of simulated deterioration present below the woods surface. (Images by author, 2008)

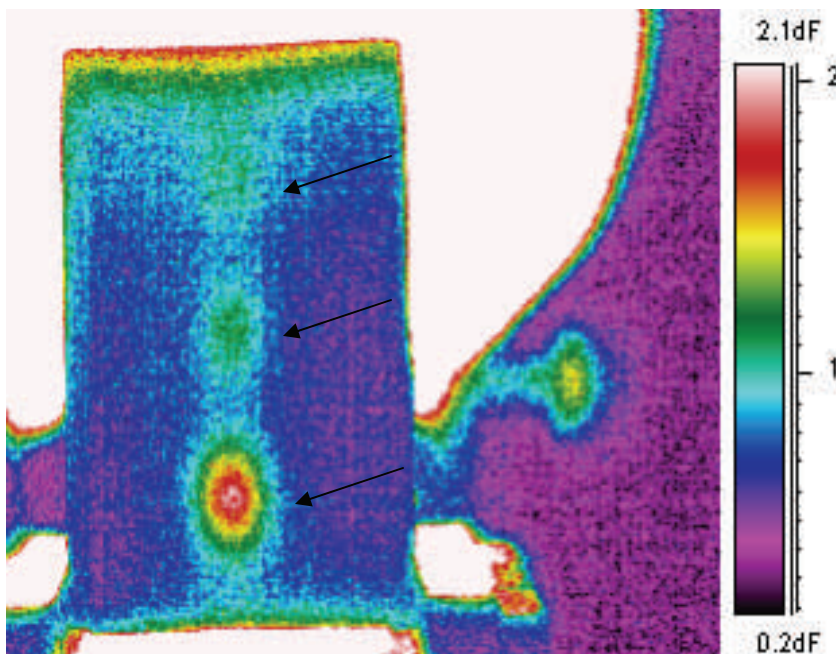
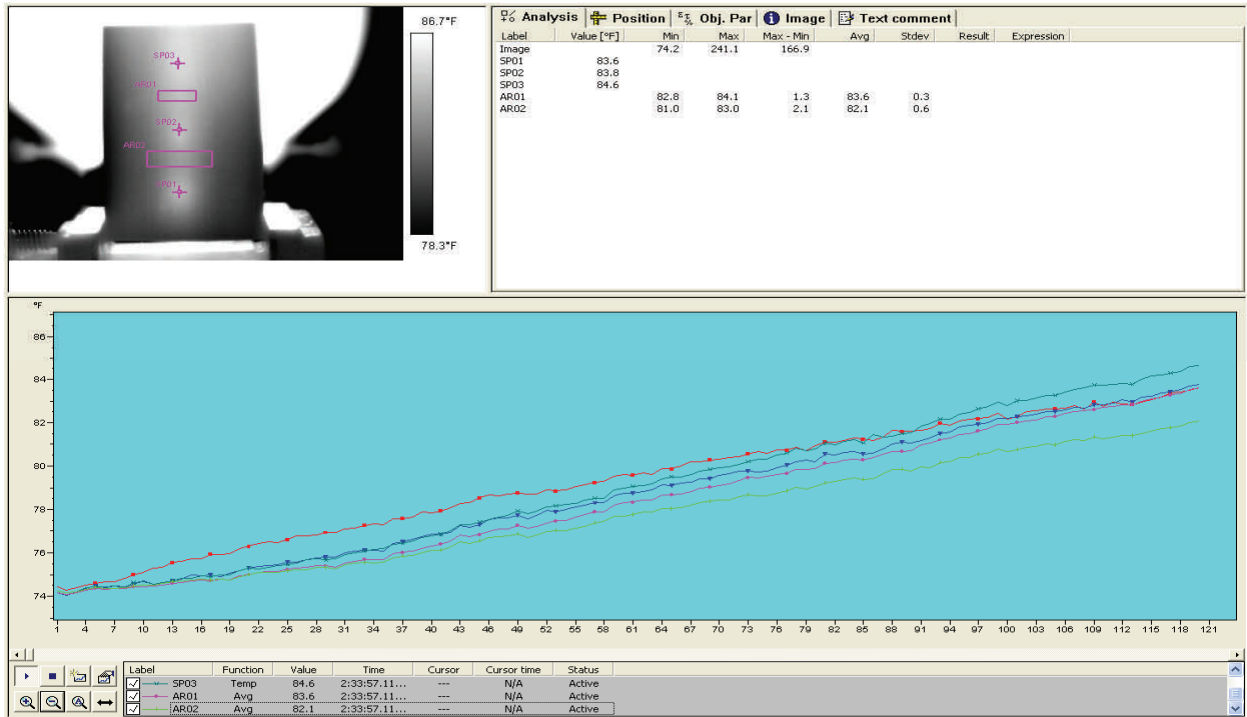
of this test methodology testing procedure was altered as was the test sample.

Alterations to the test sample included halving the thickness from 1½” to ¾” as well as drilling out the simulated decay leaving holes ⅜”, ¼” and ⅛” below the surface of the wood. The transmission method was also employed as was the use of the 300 watt halogen bulb placed 8 inches from the sample on the opposite side. These changes, although a drastic departure from the original methodology, did produce favorable results similar to what Maldague and Wyckhuysse encountered.<sup>107</sup> During one IRT test lasting 10 minutes and using these parameters all three holes were clearly visible and distinguishable after only 5 minutes with the largest of the holes visible after only 20 seconds. Through observations it appears that the ideal heating time is between 5-6 minutes after which the effects of conductivity fade as the observed surface begins to reach a thermal equilibrium (**fig. 37**). The successes of this study warrants further

<sup>107</sup>Maldague and Wyckhuysse, A Study of Wood Inspection by Infrared Thermography, 20.



investigation into the use of the transmission mode and the development of a protocol for subsurface detection of wood anomalies within building wall systems. However, as previously noted there are drawbacks to the use of the transmission mode, namely the inability to determine defect depth as well as recognition of dry defects.<sup>108</sup> These problems as well as others can be handled by combining other nondestructive as well as minimally invasive technologies to provide more quantitative information. The use of thermal modeling can also be a useful tool and should help provide improved deterioration recognition.



**Fig. 37 & 38:** The top image shows the plot results after a 10 minute test. Note the placement of the spots over the areas of simulated deterioration with spot 1 being situated over the shallowest area of deterioration at only 1/8". Note also how all three spots in the plot graph separate from the boxed areas (average temperature of sound wood) increasing in temperature considerably faster. The x-axis values should be multiplied x5 to determine actual time in seconds. The image on the left is the result of determining the temperature difference between the first and last IRT images, note the three distinct areas of deterioration. (Images by author, 2008)

<sup>108</sup>Maldague and Wyckhuys, A Study of Wood Inspection by Infrared Thermography, 16, 20.

## **Other Results and Discussion:**

### *Objective I, Establishing Preliminary IRT Calibrations, Parameters and Protocol Tailored to Wood Framed Structural Systems:*

Objective I centered around the development of IRT calibrations, protocols and procedures that could be used for determining wood type within concealed frame structures. The methodology section outlines the ideal protocols developed for specific conditions and materials as well as field investigations relying on published information and information gleaned from research. Specifically, the ideal protocols developed include testing of small 1'x1' wall sections within a semi-controlled environment, larger 6'x4' wall sections within a controlled environment and field testing protocol all utilizing the long pulse transmission method of IRT.

Calibration of the IR camera used in testing is the first process that is discussed when examining the protocols developed for this particular type of IRT testing. Properly calibrating the IR camera includes determining the reflective temperature as well as the emissivity value of the materials surface under examination. Following the steps necessary to achieve proper calibration will help the investigator obtain accurate thermal temperature readings rather than purely qualitative data. Due to the long use of IRT in other fields, procedures for proper camera calibration have been readily available from manufacturers of IR cameras, such as FLIR Systems Inc. and are listed in a step by step fashion at the beginning of the methodology section.

Development of the various "ideal" protocols and procedures came from published literature as well as observations made during testing. This trial and error approach was necessary as only a few articles have been published regarding wood frame structures and few details exist about specific testing protocols. Wood as a material also presents thermal issues not encountered when examining more homogenous materials such as brick or metals. ASTM standards for passive thermographic investigations of frame structures as well as articles published by Rosina and Maldague provided a good starting point, however these articles mostly revolve around the use of reflective IRT testing. Due to time limitations reflective thermography was not explored as an alternative, although other research indicates that it can be a very affective tool and, therefore, warrants testing in regards to wood type identification. Other types of IRT testing that hold potential for this type of investigation include short pulse as well as Lock-in thermography.

The lack of previous research into the field of wood IRT investigations and frame structures provided the basis for the two wall sections constructed as well as the two types of testing locations. Small wall sections were tested first within a semi-controlled environment to discern the affects of ambient temperature and other environmental factors on results. Information gathered during this testing process also helped to shed some light on possible field testing protocol. Environmentally controlled testing of the large wall sections helped confirm wood type variations but also allowed for a more realistic glimpse of what a field test might observe in terms of convection within an un-insulated wall cavity. These observations formed the basis for the initial environmental parameters, location of thermocouples and heating apparatus, the

testing time frame and, of course, the type of heating apparatus used and corresponding temperature settings.

However, despite significant strides in developing an ideal protocol for wood type identification within wall systems, there is still work to be done. The introduction of the silicone rubber heaters into the protocol means that these will need to be tested. Investigations using two IR cameras, each measuring different wavelengths might also be useful as fused images could provide enhanced interpretation. Additional variables including the composition of wall sections, environmental factors, introduction of additional wood types, various physical and chemical compositions of wood and more field testing will all need to be investigated to help refine and develop the proper protocol.

*Objective II, Providing Background into Woods Physical and Chemical Characteristics That Can Affect Thermal Conductivity:*

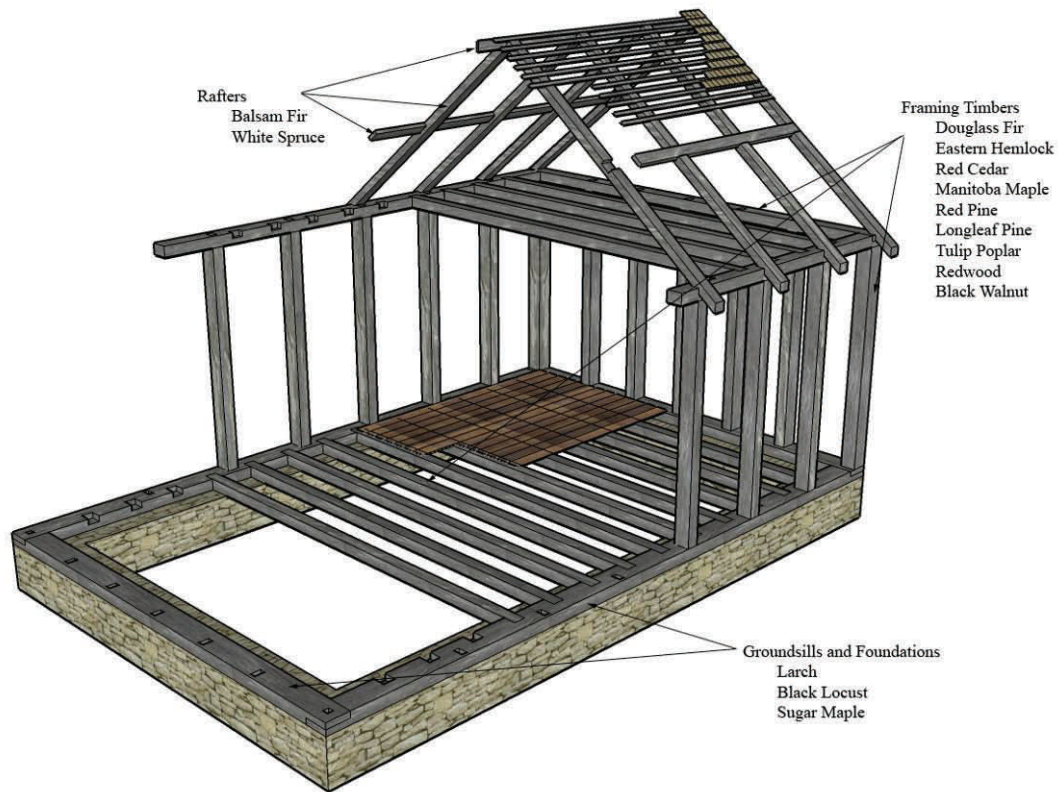
Objective II examined wood's physical and chemical characteristics and how these attributes affect thermal conductivity, providing a basis for understanding what IRT might be able to convey about wood. From the research conducted it is apparent that a variety of factors can influence the thermal conductivity of wood and that this is compounded by the fact that wood is an anisotropic material. However, these characteristics do help to provide wood species type with distinct thermal conductivity values that can be measured using IRT.

The problem to an effective investigation is insuring that variables, such as grain direction and moisture content, are consistent between species during testing or consistent with previous tests conducted, so information can be directly compared. When dealing with concealed wood structural members within an historic structure, this information can often be difficult to obtain. Preliminary IRT investigations using passive measures should at the very least be undertaken to determine the size of the wood members, any current moisture penetration and the location of members.

Moisture content can be measured in one of two ways. The most accurate manner involves the use of a resistance type meter that measures using two electrodes or pins. However, this type damages any surface material. The other non-invasive type is the dielectric meter which is pin less; however this only measures the wall surface moisture content not providing an adequate reading of the wood. Since moisture content of wood greatly affects its thermal conductivity this is an important variable to get correct. One way to obtain an accurate reading is to look for any exposed wood members on the same floor or in reasonably close proximity. This might require removing a baseboard or even a HVAC vent where the use of the resistance meter can be used without damaging finish materials. Caution should be taken to take a reading from an area that is not affected by decay or moisture and is located in a similar micro-environment as the wood members under investigation.

Determination of wood grain is another important aspect and perhaps the most difficult to obtain. Archival research as well as a conditions assessment that looks at grain orientation and cut of exposed wood members are two ways to potentially shed light on this issue. Historic structures typically contain a variety of different wood cuts within their structural framing,

some relating to member placement such as corner posts and others as a result of various construction phases (**fig. 39**). The use of active IRT might also be able to help determine grain direction by qualitatively comparing two or more concealed wood members at a time. Since thermal conductivity is roughly 1.8x greater with the grain any large variations falling outside of wood type variations (usually rather small) should be easily distinguishable and at the very least raise questions.




**Fig. 39:** This illustration is of a typical brace frame structure common during the period between the late 18<sup>th</sup> century and mid 19<sup>th</sup> century. Structural members varied in size, corner posts often much larger than studs and joists. Different species were often used in different structural capacities based on certain characteristics; these are noted on the drawing. (Illustration by author, 2008)

*Objective V, Establishment of a Preliminary IRT and Other NDE Techniques Database Template for the Eventual Dissemination of Knowledge:*

Objective V dealt with the establishment of a preliminary web based IRT and other NDE techniques database template to assist in the dissemination of IRT information relevant to historic structures. The goal of establishing such a template was twofold. First, it sought to begin standardization of IRT testing for a variety of issues concerning historic structures as well as data presented so that information could be easily compared. Secondly, this template sought to provide information that could be easily accessible and interpreted by those interested in the preservation or conservation of historic structures without knowledge of advanced thermal modeling or associated software and algorithms. While originally the database template sought to include other NDE techniques only an IRT template was developed.

Inclusion within any database first requires that testing be consistent and therefore proper procedure for inclusion should follow ideal protocols outlined in the methodology section. Proper labeling is also required so that relevant files can be viewed and easily retrieved as the database grows. The information required on each sheet relates to parameters and results used during this research and so more specifically applies to determining wood type rather than deterioration or other characteristics. However, the general model can be adapted to apply to other IRT techniques and investigations. Proper formatting of data is noted on the template page and mainly involves conversion to Excel. Specific information regarding the database template is noted below as annotations on an image of the template. The subsequent pages show one link chain from the databases homepage to actual testing results. Green objects are typically the objects linking the pages together.

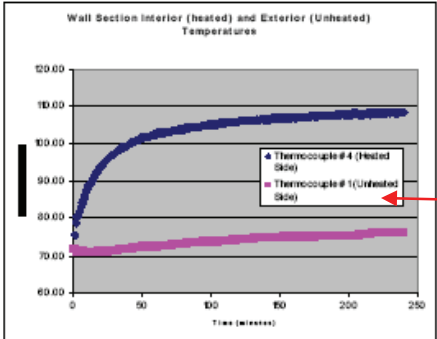
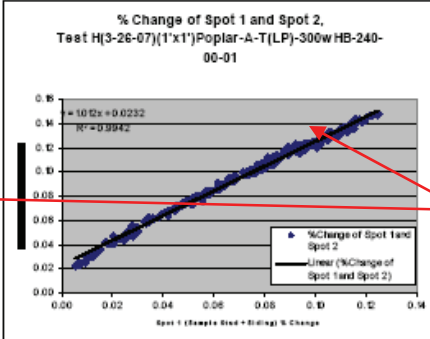
**Database**  
**Active Infrared Thermography**  
**Step Heating (Long Pulse) Thermography Testing**  
**Wood Species Identification**  
**Small 1'x1' Wall Sections**  
**Semi-Controlled Climate**  
**Test Results**  
**H(3-26-08(1'x1')Poplar-A-T(LP)-300wHB-240-00-01**



Test #/Sample	1A
Date	3/26/2007
Wood Moisture (%)	<6%
Emissivity	0.655
Camera Distance	5ft
Atmospheric Temperature (°F)	71.88
Reflected Temperature (°F)	71.98
Relative Humidity (%)	22%
TC #1 -TC #4 (heated—non heated side)	0.04
ΔT TC#1heated side (final)	36.47
ΔT Spot 1(final)	9.01
ΔT Spot 2(final)	10.76
spt 2 - spt 1(final)	1.77
% change spt 1 (final)	0.12
% change spt 2(final)	0.15
% change TC#1 heated side (final)	0.51
Final Temperature TC#1 (heated side)	108.35

**Downloads**

- [Image Download \(ThermaCAM Research Sequence File 35.6mb\)](#)
- [Spot 1 Values \(Download 14kb\)](#)
- [Spot 2 Values \(Download 14kb\)](#)
- [Thermocouple Temperatures \(Download 15.5kb\)](#)
- [Poplar Test Excel Sheet Results and Analysis \(Download 1.32mb\)](#)

Test information including the type of IRT used, the type of test, the sample, climate information and the actual test filing notation/labeling.

IRT test image of small wall section with analysis spots 1 and 2 noted on image. Each image can be downloaded providing the researcher with actual values over the 240 minute test.

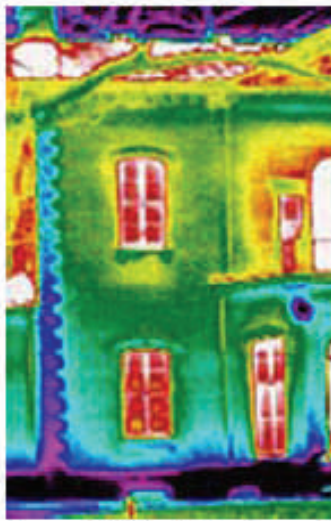
Downloads include the IR image, the two spot values over 240 min, the thermocouple measurements and the excel sheet with various results,

Chart showing the key parameters and values of each test. This information can also be found in the downloaded Excel sheet.

Graphs showing the temperature over 240 minutes and the spot analysis relationship.

**Fig. 40**

# Nondestructive Evaluations (NDE's) of Historic Structures Database



**U.K. UNIVERSITY OF KENTUCKY**  
College of Design  
Center for Historic Architecture and Preservation

## Mission and Objective:

This website is designed to archive various tests and field investigations that have utilized nondestructive techniques that can be applied to better understand the design, materials, building pathology, condition and integrity of historic structures. Additionally it is hoped that this information can be presented in formats accessible and legible to all preservationists thereby encouraging the use of NDE when investigating the tangible past as well as providing a repository to assist in various academic pursuits.

## Submitting Tests and Field Investigations:

Calibrations

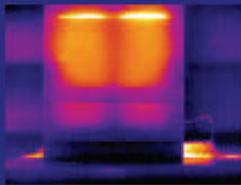
Protocols/Procedures

Labeling

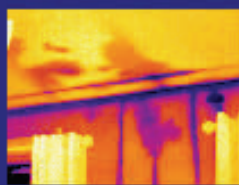
## Database:

### Infrared Thermography

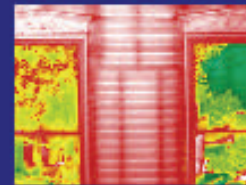
#### Active IRT Testing



#### Passive IRT Testing



#### IRT Images



### Other NDE Techniques

#### Resistance Drilling



#### Time of Flight Testing (TOF)



This website was created through a grant from the National Center for Preservation Technology and Training (NCPTT) and through the University of Kentucky, Department of Historic Preservation

**Fig. 41:** This is the databases homepage offering a variety of options, the “active” IRT testing link is the one being followed.

## Database Active Infrared Thermography Testing

### What is Active Thermography?

#### *Active Thermography:*

Unlike passive thermography, active thermography uses the application of heat to assist in the location of anomalies and to provide quantitative data. This quantitative data can be of great use when utilizing thermal modeling for comparative purposes as well as indicating potential variations in concealed wall materials. Another advantage of active thermography is its ability to enhance thermal contrasts present in surface and subsurface anomalies. These contrasts may not be recognizable when utilizing passive thermography as the thermal gradient may not rise above noise levels. However, active thermography increases thermal contrast as well as promote increased depth and size detection of anomalies within surrounding sound material.

### What are the Various Modes of Active IRT Investigations?

#### *Transmission Mode vs. Reflection Mode:*

Reflection and transmission schemes refer not to the type of thermography employed but to the placement of the heating apparatus and IR recording equipment. The reflection scheme (**fig. 1**) has both the heating apparatus and IR detector on the same side of the sample whereas the transmission scheme (**fig. 2**) places the heating apparatus on the opposite side of the object under investigation. Most field research has utilized the reflective method as access to both sides of a structure can sometimes be impossible. However, for the objectives of this research the transmission scheme worked well as it enabled the camera to be placed directly in front and the heating source directly behind the mock wall section providing the most uniform heat as well as minimal image distortion. During investigation of subsurface wood defects both methods were utilized in an effort to see which performed better.

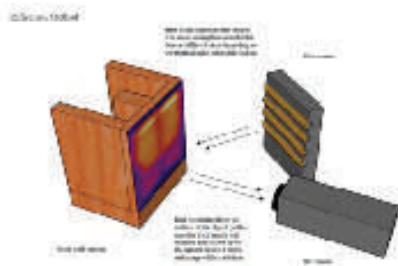


Fig. 1

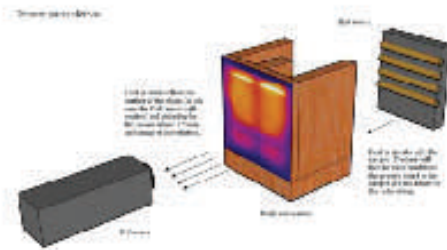


Fig. 2

### Types of Active Thermography Tests:

Step Heating (Long Pulse) Thermography

Tests

Pulsed Thermography

Tests

Lock-in Thermography

Tests

Vibrothermography

Tests

**Fig. 42:** The following page informs the user about active thermography and presents various options as to the type used. The link followed is the “step heating” link.

**Database**  
**Active Infrared Thermography**  
**Step Heating (Long Pulse) Thermography Testing**

**What is Step Heating (Long Pulse) Thermography?**

*Step Heating:*

During this heating procedure the surface temperature of an object is monitored for any anomalies much the same as with the pulsed method. However, the difference between the two is that the step method observes the object as it is continually heated. This method is particularly effective when looking at structural systems as it provides a clear and complete view of concealed materials whereas the pulsed method may not always affect deeper structural elements therefore preventing their identification. This method, like the pulsed method, is also limited by the heating mechanism as to the size of the space that can be investigated removing one of IRT's key advantages of coverage and efficiency.

**Transmission Mode Tests:**

Testing Index:

A B C D E F G H I J K L M N O P Q R S T U V W X Y Z

**I. Wood Species Identification**

<i>1'-0" x 1'-0" Small Wall Sections</i>	<i>6'-0" x 4'-0" Large Wall Sections</i>	<i>Field Testing</i>	<i>Comparison Studies</i>
Climate Controlled	Climate Controlled		Climate Controlled
<u>Semi-Controlled</u>	Semi-Controlled	Semi-Controlled	Semi-Controlled

**Reflection Mode:**

Testing Index:

A B C D E F G H I J K L M N O P Q R S T U V W X Y Z

*None Currently Listed*

**Fig. 43:** The active thermography, step heating page offers the choice of the two modes of IRT used, reflection or transmission. The wood species test chosen is located in the transmission index under wood species identification within a semi-controlled environment.



**Database**  
**Active Infrared Thermography**  
**Step Heating (Long Pulse) Thermography Testing**  
**Wood Species Identification**  
**Small 1'x1' Wall Sections**  
**Semi-Controlled Climate**

**Protocol/Procedure**

*Ideal 1'-0" x 1'-0" Mock Wall Section Testing Protocol for Species Identification Within a Semi-Controlled Environment Using Transmission Long Pulse IRT:*

#	Procedure	Description
1	Place IR camera (FLIR ThermoCAM S65 HSV or equivalent) 5'-0" from wall section measuring 1'-0" x 1'-0" based on the camera lens FOV (24° x 18°). The camera should be on a tripod raised to a level that places it on the same plane and directly centered on the wall section.	IR camera should line up perpendicular to the mock wall section facing the "exterior" (weatherboard). Placing the camera perpendicular to the center of the wall section helps with image distortion providing a flatter image for analysis. <sup>16</sup>
2	Calculate emissivity and reflected temperature by following procedures outlined previously. <sup>18</sup>	As these test are performed in a semi-controlled environment with changing environmental variables the reflected temperature should be checked at the start of each test. The emissivity value of the wood siding need only be checked once.
3	Test moisture content of wood.	<6% for this series of tests.
4	Place 1 wood sample in wall section. Samples as well as the wall section should conform to specifications listed in the previous construction section of the 1'-0" x 1'-0" wall section. Surface inconsistencies such as paint/knots should be avoided	Place sample between adjustable metal clips. Samples should be standard 2x4's with wood grain direction consistent. There should be no air gap between the stud and the gypsum board/plaster and siding.
5	Attach type E thermocouples to the sample. Make sure the thermocouples are located at key areas in line with the heating apparatus, along the same X and Y planes and in a location to measure ambient temperature. The thermocouples should not be placed where they can obstruct the IR image	Type E thermocouples provide the range and accuracy needed for these types of tests. There are self adhesive versions so physically affixing the thermocouples to the studs, a procedure that could disrupt the thermal propagation, is not necessary.
6	Use 4"x12" (2.5W/in <sup>2</sup> ) silicone rubber fiberglass insulated heater with adhesive. The heater should be placed parallel and centered to the area of siding to be analyzed but on the opposite side (interior side). The heater should span the entire 12" width of the wall section including both the wall cavity as well as the sample..	Special care should be taken to make sure temperature <u>can be controlled and observed</u> to prevent thermal degradation of the wood.
7	Setup all necessary parameters for the IR camera, silicone rubber heaters, data acquisition units and thermocouples for remote starting and ending. Also insure that the environmental chamber has appropriate wind speeds (<0.1 m/s) and light (50-80 lx) through shutting doors, windows, drawing blinds and turning off HVAC units. (see step 11 for further details)	Setting the equipment to obtain temperatures remotely will avoid any time related errors as well as provide minimum interaction with materials. Preparing the room for environmental conditions will ensure consistent results. Once environmental conditions are controlled the material should be left for at least 3 hours to reach equilibrium. <sup>17</sup>



Fig. 44: This page describes the proper protocol, the arrow links to the remainder as well as test results.

**Database**  
**Active Infrared Thermography**  
**Step Heating (Long Pulse) Thermography Testing**  
**Wood Species Identification**  
**Small 1'x1' Wall Sections**  
**Semi-Controlled Climate**

**Protocol/Procedure (continued)**

*Ideal 1'-0" x 1'-0" Mock Wall Section Testing Protocol for Species Identification Within a Semi-Controlled Environment Using Transmission Long Pulse IRT:*

8	Monitor thermocouple readings and IR camera temperatures to insure materials have reached equilibrium. Room temperature should be $77 \pm 9^\circ\text{F}$ ( $25 \pm 5^\circ\text{C}$ ) and RH $20 \pm 10\%$ . <sup>19</sup>	Any $\Delta T$ present within the wall section should also be avoided. Thermocouples should measure $\leq 0.5^\circ\text{F}$ of each other.
9	Once temperatures have reach equilibrium with the ambient temperature, input remaining parameters including temperature and relative humidity. Also calculate and input reflected temperature.	Although the reflected temperature was calculated at the same time as the emissivity it should be done before each tests as small temperature changes can affect its value unlike the emissivity.
10	Set IR camera's image capture to 1 per minute for 240 minutes (4 hours), with a one minute delay to allow for the thermocouples to get in sync. Thermocouples should be set to capture temperature readings every 7.5 seconds with block averages every 8 readings, resulting in one value per minute. The silicone rubber heaters should also be set for remote start and temperature settings of $\leq 131^\circ\text{F}$ .	Step 10 should be done previously during step 7. However, these devices should be activated simultaneously at this time. A minimum $\Delta T$ of $18^\circ\text{F}$ ( $10^\circ\text{C}$ ) is required between the interior (heating) and exterior (unheated) surfaces, this can be verified with the thermocouples. <sup>20</sup>
11	Turn off test at the end of 60 minutes (1 hour).	
12	Repeat steps 3-11 for additional tests.	
13	Test each sample a minimum of 5 times.	

<sup>16</sup>ASTM International, C 1060-90 (2003), pp 538.

<sup>17</sup>ASTM International, C 1060-90 (2003), pp 541.

<sup>18</sup>FLIR, pp. 99-105

<sup>19</sup>ASTM International, C 1060-90 (2003), pp 540.

<sup>20</sup>ASTM International, C 1060-90 (2003), pp 541.

[Continue to Test Results](#)

**Fig. 45:** The end of the protocol page for small wall sections within semi-controlled environments for the determination of wood species provides a link to test results.

**Database  
Active Infrared Thermography  
Step Heating (Long Pulse) Thermography Testing  
Wood Species Identification  
Small 1'x1' Wall Sections  
Semi-Controlled Climate  
Test List**

**Heating Apparatus: 300 watt Halogen Bulb**

***Liriodendron tulipifera*, Poplar**

H(3-26-07)(1'x1')Poplar-A-T(LP)-300wHB-240-00-01	H(5-14-07)(1'x1')Poplar-A-T(LP)-300wHB-240-00-06
H(3-27-07)(1'x1')Poplar-A-T(LP)-300wHB-240-00-02	H(5-16-07)(1'x1')Poplar-A-T(LP)-300wHB-240-00-07
H(3-27-07)(1'x1')Poplar-A-T(LP)-300wHB-240-00-03	H(5-17-07)(1'x1')Poplar-A-T(LP)-300wHB-240-00-08
H(3-29-07)(1'x1')Poplar-A-T(LP)-300wHB-240-00-04	
H(3-30-07)(1'x1')Poplar-A-T(LP)-300wHB-240-00-05	

***Pinus palustris*, Longleaf Pine or Southern Yellow Pine**

H(3-11-07)(1'x1')LP-A-T(LP)-300wHB-240-00-03	H(4-29-07)(1'x1')LP-A-T(LP)-300wHB-240-00-08
H(3-11-07)(1'x1')LP-A-T(LP)-300wHB-240-00-04	H(5-7-07)(1'x1')LP-A-T(LP)-300wHB-240-00-09
H(3-15-07)(1'x1')LP-A-T(LP)-300wHB-240-00-05	H(5-8-07)(1'x1')LP-A-T(LP)-300wHB-240-00-10
H(4-25-07)(1'x1')LP-A-T(LP)-300wHB-240-00-06	H(5-12-07)(1'x1')LP-A-T(LP)-300wHB-240-00-12
H(4-28-07)(1'x1')LP-A-T(LP)-300wHB-240-00-07	H(5-13-07)(1'x1')LP-A-T(LP)-300wHB-240-00-13

***Quercus falcate*, Southern Red Oak**

H(3-16-07)(1'x1')RedOak-A-T(LP)-300wHB-240-00-01	H(3-19-07)(1'x1')RedOak-A-T(LP)-300wHB-240-00-06
H(3-17-07)(1'x1')RedOak-A-T(LP)-300wHB-240-00-02	H(5-20-07)(1'x1')RedOak-A-T(LP)-300wHB-240-00-07
H(3-17-07)(1'x1')RedOak-A-T(LP)-300wHB-240-00-03	H(5-21-07)(1'x1')RedOak-A-T(LP)-300wHB-240-00-08
H(3-18-07)(1'x1')RedOak-A-T(LP)-300wHB-240-00-04	H(5-22-07)(1'x1')RedOak-A-T(LP)-300wHB-240-00-09
H(3-18-07)(1'x1')RedOak-A-T(LP)-300wHB-240-00-05	

More Results



**Fig. 46:** This page lists the various tests stating what heating apparatus was used, the type of sample and the actual test.

**Database  
Active Infrared Thermography  
Step Heating (Long Pulse) Thermography Testing  
Wood Species Identification  
Small 1'x1' Wall Sections  
Semi-Controlled Climate  
Test List**

**Heating Apparatus: 300 watt Halogen Bulb (continued)**

**Spruce-Pine-Fir (S-P-F)**

H(3-6-07)(1'x1')LP-A-T(LP)-300wHB-240-00-02	H(4-8-07)(1'x1')LP-B-T(LP)-300wHB-240-00-14
H(3-7-07)(1'x1')LP-A-T(LP)-300wHB-240-00-04	H(4-11-07)(1'x1')LP-B-T(LP)-300wHB-240-00-15
H(3-9-07)(1'x1')LP-A-T(LP)-300wHB-240-00-05	H(4-14-07)(1'x1')LP-B-T(LP)-300wHB-240-00-16
H(3-31-07)(1'x1')LP-A-T(LP)-300wHB-240-00-07	H(4-15-07)(1'x1')LP-B-T(LP)-300wHB-240-00-17
H(3-31-07)(1'x1')LP-A-T(LP)-300wHB-240-00-08	H(4-18-07)(1'x1')LP-B-T(LP)-300wHB-240-00-18
H(4-1-07)(1'x1')LP-A-T(LP)-300wHB-240-00-09	H(4-21-07)(1'x1')LP-B-T(LP)-300wHB-240-00-19
H(4-2-07)(1'x1')LP-A-T(LP)-300wHB-240-00-10	H(4-22-07)(1'x1')LP-B-T(LP)-300wHB-240-00-20
H(4-3-07)(1'x1')LP-A-T(LP)-300wHB-240-00-11	H(4-23-07)(1'x1')LP-B-T(LP)-300wHB-240-00-21
H(4-4-07)(1'x1')LP-A-T(LP)-300wHB-240-00-12	H(4-24-07)(1'x1')LP-B-T(LP)-300wHB-240-00-22
H(4-7-07)(1'x1')LP-B-T(LP)-300wHB-240-00-13	

***Thuja plicata*, Western Red Cedar**

H(3-20-07)(1'x1')LP-A-T(LP)-300wHB-240-00-01	H(5-19-07)(1'x1')LP-A-T(LP)-300wHB-240-00-06
H(3-21-07)(1'x1')LP-A-T(LP)-300wHB-240-00-02	
H(3-22-07)(1'x1')LP-A-T(LP)-300wHB-240-00-03	
H(3-24-07)(1'x1')LP-A-T(LP)-300wHB-240-00-04	
H(3-25-07)(1'x1')LP-A-T(LP)-300wHB-240-00-05	

**Fig. 47:** This is the remainder of tests conducted on the small wall sections. Clicking on any of these boxes will take the user to the actual results page with downloads for each test so that actual results and figures can be viewed.

**Database**  
**Active Infrared Thermography**  
**Step Heating (Long Pulse) Thermography Testing**  
**Wood Species Identification**  
**Small 1'x1' Wall Sections**  
**Semi-Controlled Climate**  
**Test Results**  
**H(3-26-08)(1'x1')Poplar-A-T(LP)-300wHB-240-00-01**



Test #/Sample	1A
Date	3/26/2007
Wood Moisture (%)	<6%
Emissivity	0.655
Camera Distance	5ft
Atmospheric Temperature (°F)	71.88
Reflected Temperature (°F)	71.98
Relative Humidity (%)	22%
TC #1 -TC #4 (heated—non heated side)	0.04
ΔT TC#1heated side (final)	36.47
ΔT Spt 1(final)	9.01
ΔT Spt 2(final)	10.76
spt 2 - spt 1(final)	1.77
% change spt 1 (final)	0.12
% change spt 2(final)	0.15
% change TC#1 heated side (final)	0.51
Final Temperature TC#1 (heated side)	108.35

**Downloads**

- [Image Download \(ThermaCAM Research Sequence File 35.6mb\)](#)
- [Spot 1 Values \(Download 14kb\)](#)
- [Spot 2 Values \(Download 14kb\)](#)
- [Thermocouple Temperatures \(Download 15.5kb\)](#)
- [Poplar Test Excel Sheet Results and Analysis \(Download 1.32mb\)](#)

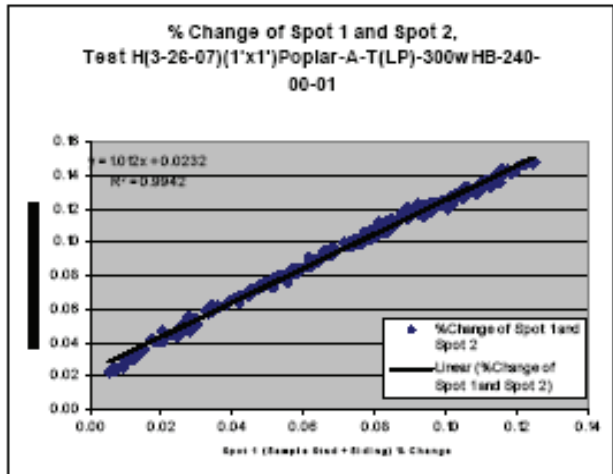
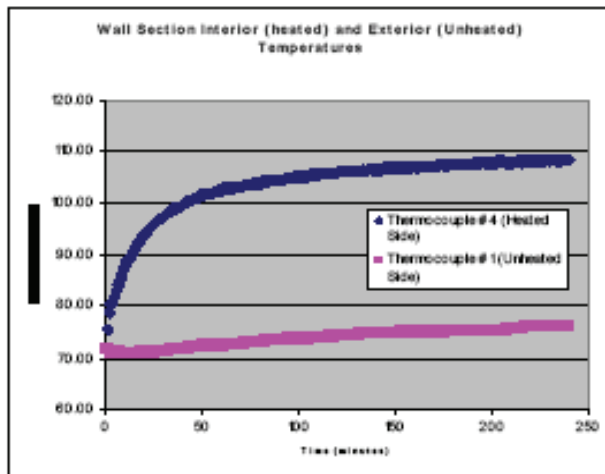


Fig. 48: This is the results page annotated previously. More specific information can be gathered from the downloads.

## Conclusions:

The use of IRT for building envelope inspection has been around for nearly half a century. During that time giant leaps have occurred making the technology more affordable, portable and user friendly. Over the past few years increasing interest in historic structures has helped to promote the use of nondestructive testing or evaluation (NDE) rather than the more conventional invasive methods of assessment. These methods include but are not limited to, radiography, ultrasonic's, magnetometry, resistance drilling and infrared thermography (**fig. 49 & 50**). The benefits to developing such techniques for the conservation of historic structures are both cultural and financial. These benefits are particularly apparent during maintenance, rehabilitation, restoration or preservation efforts.



**Fig. 49 & 50:** Image B (left) shows the results of a resistance drilling test chart where a 3mm drill bit measures for wood density variations, note the paper as it measures density in a 1:1 ratio with the center or “rotten” portion of the stump showing as the dip in the readings. This device is not a truly a NDE tool it is minimally invasive to the point that it has little or no visual affect. Image 50 (right) shows the author using an impulse velocity tool which qualitatively determine areas of decay based on the transmission of waves through a wood. (Photo 49 by author and photo 50 by Danae Peckler, 2007)

One of the largest excuses as to why rehabilitation, preservation or restoration of an historic structure is not economically feasible often has to do with the buildings structural systems and the lack of knowledge concerning its design and condition. This is particularly true with frame structures as they are more susceptible to deterioration caused by insect infestation or moisture related decay. Frame structures also present the problem that the majority of their structural system is concealed behind plaster and lathe. This provides little information for designers, preservationists and engineers to base decisions such as cost estimation (too many unknowns for an accurate cost assessment), restoration potential (what material remains hidden from view) and load capacity (type, placement, size and condition of wood members) on (**fig. 51**).

Typically invasive measures such as removing plaster have been used to determine a portion of the structures condition and to base potential and cost estimation on, however this rarely gives a comprehensive image. Therefore, it has been common practice amongst practitioners outside of the preservation and conservation related fields to take a more pragmatic approach and simply “gut” the structure, taking it down to the studs. This approach allows for quick inspection and replacement of any decayed or compromised structural elements as well as uncovering any hidden features. Accurate cost estimations can also be developed after demolition; however the downside is the loss of the majority of the structures material integrity compromising its historic value and significance.

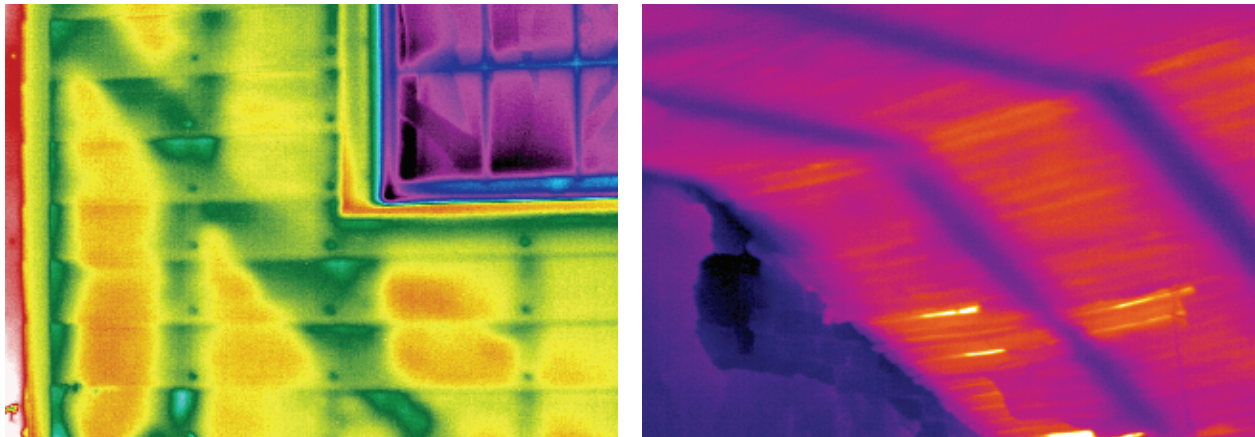


**Fig. 51:** Figure 51 shows University of Kentucky research assistant Laura Everdale using the IR camera to investigate a frame structure in Manchester, Kentucky. The IR camera helped provide information about the frame structure of the building as well as areas of moisture infiltration. (Photo by author, 2007)

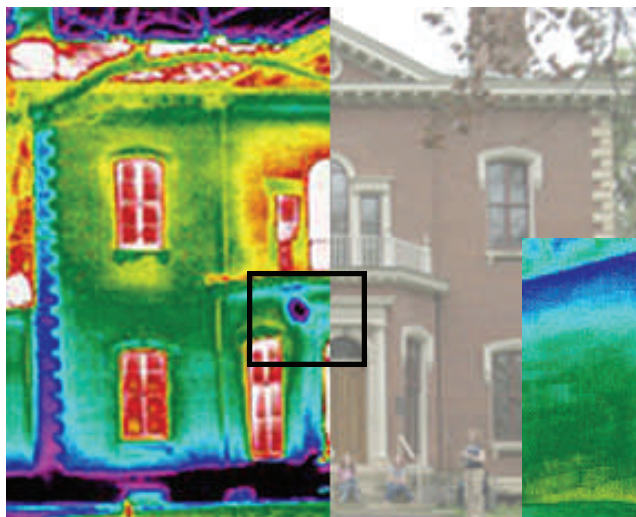
Nondestructive evaluation helps determine issues concerning load capacity, cost estimation and restoration potential while retaining the structures historic fabric. Infrared thermography has for years been used to locate concealed structural members providing accurate information as to size and configuration (**fig. 52& 53**). The ability of IRT to locate structural elements has also led to its use in finding concealed features such as doors and windows which tell a story of the structures development over time. Coinciding with the identification of structural and aesthetic features hidden from view, IRT has also shown the ability to detect areas of moisture infiltration (**fig. 54 & 55**), often associated with decay, termite damage and infestations and gaps in the building envelope, all important to structural maintenance.

The research presented here builds on the previous uses of IRT in an attempt to better understand concealed wood members as well as deterioration within those members. This is accomplished through the understanding of wood’s physical and chemical attributes, development of proper IRT protocols for frame structure investigations and ultimately dissemination of this knowledge to others within preservation related fields. Identification of wood type has a number of applications the first of which assists the engineer in load calculations as different wood species have different load bearing capabilities. This coupled with other IRT applications can provide an accurate structural assessment of a wood framed structure reducing cost estimation errors, insuring a sound structural system and retaining

historic fabric. Secondly, identification of wood type provides information pertinent to architectural historians regarding past construction practices. Identification can assist in mapping these variations in frame construction locally, regionally and nationally painting a picture of regionalism and heritage throughout the United States as well as denoting the more unique configurations from the vernacular. Lastly, research associated with IRT detection of wood type has potential to contribute to IRT research revolving around other wood attributes affected by thermal conductivity, namely deterioration.

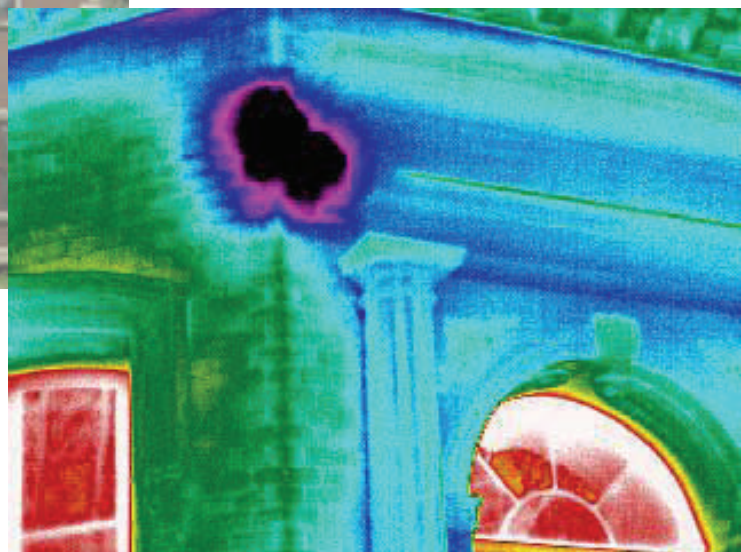


**Fig. 52 & 53:** Figure 52 (left) shows the down bracing of an early 19th century structure in downtown Lexington, Kentucky. Notice the difference in size between the studs (vertical members) and the down brace itself. Figure 53 (right) shows collar ties and rafters located in the attic of the early 19th century Green River Inn located in Greensburg, Kentucky. These structural elements are located behind a layer a 1/4" of plaster and a layer of wood lathe, however the wood members are still clearly discernable. (Left photo by John Liebertz, right photo by author, 2007)



**Fig. 54:** Figure 54 shows the historic Henry Clay estate located in Lexington, Kentucky as 1/2 IR image and 1/2 regular photograph to indicate what variations appear when using IRT. Note the dark spot (box). (Photo by author, 2007)

**Fig. 55:** Figure 55 is a close up of the boxed area showing the IR anomaly. While not visible to the naked eye the IR camera was able to distinguish this spot which turned out to be moisture infiltration. Spotting this early saved the foundation money in future repairs. (Photo by author, 2007)





Future IRT investigations will continue to examine wood's thermal characteristics as applied to concealed framed structures with the hopes of providing more and accurate data sets that can assist in IRT interpretations. This will include the investigation of more wood species, different wall configurations, inclusion of various environmental and sample variables and computer modeling to assist in providing more quantitative results. The additional types of wall sections will be modeled accurately on historic field examples so that lab and field tests can be compared. Incorporation of other nondestructive techniques with IRT will also be pursued providing information where IRT may not be as affective. Such tool suites, when used in conjunction with each other, have potential to utilize the advantages of a number of different NDE techniques maximizing effectiveness and efficiency. The eventual goal of this research is to assist owners, designers and contractors in making the most informed decisions possible concerning historic structures so that the processes of rehabilitation and restoration are cost affective and better suited to the conservation of historic fabric.

## **Acknowledgements:**

First and foremost this research would not have been possible except for the grant provided by the National Center for Preservation Technology and Training (NCPTT) of the United States Department of the Interior, National Park Service (NPS). In particular we would like to thank Dr. Mary Striegel, Chief of the Materials Research Program, for her patience and assistance in completing this research.

Special thanks is also in order for Dr. Lynn Penn, formerly of the University of Kentucky and now Head of the Department of Chemistry at Drexel University. Without her assistance this research would never have begun nor would this grant have ever been written. Dr. John Nychka, also formerly of the University of Kentucky's, Department of Chemical Engineering and now at the University of Alberta's Department of Chemical and Materials Engineering is also to thank for his assistance in methodology and testing procedures as well as possible data interpretation. Dr. Rich Eitel of the University of Kentucky's, Department of Chemical Engineering likewise offered assistance and advice in interpretation of results and possible improvements to protocols and procedures.

Thanks is also in order to the University of Kentucky's Research Foundation for grant funding to purchase an infrared thermography camera to continue research into this area of nondestructive testing. Procuring this piece of equipment enables research to continue long after the submittal of this report, continuing the research begun by the grant from the NCPTT.

Within the University of Kentucky's, College of Design where the Department of Historic Preservation is located, thanks is due to two former deans, Dean David Mohney and interim Dean David Biagi. Both helped secure the space necessary to conduct research far from typical school related distractions as well as offer encouragement throughout the process. Ginny Miller and Angela Back, in the deans office, provided assistance with budgeting as well as paperwork and for that I am eternally grateful. Clyde Carpenter, the Director of the Preservation program, has also been helpful throughout the process assisting in revisions as well as offering help throughout the entire process in the form of encouragement.

Three student research assistants, Liz Boyer, Laura Everdale and John Liebertz, within the Department of Historic Preservation also provided invaluable assistance collecting references and running wood samples between IRT testing and the forestry department for identification. They also provided numerous images to this study as well as assisting with the construction of wall sections and fabrication of deterioration samples. Lastly, I would like to thank my family and particularly my wife and colleague, Danae Peckler, whose insightful comments helped me to bring my ideas to reality.

## **References:**

Andrews, D.D. and D.F. Stenning, ed. *Regional Variation in Timber-Framed Building In England and Wales Down to 1550*. Chelmsford, Essex (UK): Essex County Council, 1998.

Arpaci, Vedat S. *Conduction Heat Transfer*. Reading, MA: Addison-Wesley Publishing Company, 1966

Bradshaw, Brian K., Robert J. Ross, Roy F. Pellerin, Xiping Wang and Robert H. White. *Wood and Timber Condition Assessment Manual*. Madison, Wisconsin: Forest Products Society, 2004.

Brady, George S. and Henry R. Clauser. *Materials Handbook; An Encyclopedia of Managers, Technical Professionals, Purchasing and Production Managers, Technicians, Supervisors, and Foremen, 11th Edition*. New York: McGraw-Hill Book Company, 1977.

Carlomagno, Giovanni M., Giuseppe Giorleo and Carosena Meola. "Using Infrared Thermography to Analyze Substrate and Adhesive Effects in Bonded Structures," *J. Adhesion Sci. Technol.*, Vol. 18, No. 6 (2004): 617-634.

Carslaw, H.S. and J.C. Jaeger. *Conduction of Heat in Solids*. Oxford: Clarendon Press, 1948

Cess, R.D. and E.M. Sparrow. *Radiation Heat Transfer*. Belmont, California: Brooks/Cole Publishing Co., 1970.

Edlin, Herbert L. *What Wood is That? A Manual of Wood Identification*. New York: Viking, 1969.

FLIR Systems, *User's Manual ThermaCAM Researcher Professional Edition. Version 2.8 SR-3*. 2006.

Fujui, Y., S. Naito, S. Okumura and Y. Sawada. "Thermographic Measurement of Slope of Grain Using the Thermal Anisotropy of Wood," *Mokuzai Gakkaishi* (2000)

Giberg, Mark, Jack Leonard, Bob Melia and Claudia Riegel. "Detecting Subterranean Activity with Infrared Thermography: A Case Study," *APT Bulletin*, Vol. 34, No. 2/3 (2003): 47-53.

Hoadley, Bruce R. *Identifying Wood; Accurate Results with Simple Tools*. Newtown, CT: Taunton Press, Inc., 1990.

Howell, John R. and Robert Siegel. *Thermal Radiation Heat Transfer*. New York: McGraw-Hill Book Company, 1972.

Hum-Hartley, Susan. "Nondestructive Testing for Heritage Structures," *Bulletin of the Association for Preservation Technology*, Vol. 10, No. 3 (1978): 4-20.

James, William L. "Electric Moisture Meters for Wood." *Gen. Tech., Rep. FPL-GTR-6*. Madison, WI: U.S. Department of Agriculture, Forest Service, Forest Products Laboratory (1988): 1-14.

Ketkar, Satish P. *Numerical Thermal Analysis*. New York: The MacNeal-Schwendler Corporation, 1999.

Lienhard, John H. *A Heat Transfer Textbook*. Englewood Cliffs, New Jersey: Prentice-Hall, Inc., 1981.

Ludwig, Nicola and Elisabetta Rosina. "Optimal Thermographic Procedures for Moisture Analysis in Buildings Materials," paper presented at the Thermosense XX—An International Conference in Thermal Sensing, Imaging and Diagnostic Applications, Orlando (USA), April 1998.

Maldague, X. P. and A. Wyckhuys. "A Study of Wood Inspection by Infrared Thermography Part I: Wood Pole Inspection by Infrared Thermography," *Research in Nondestructive Evaluation* (2001)

Maldague, X. P. and A. Wyckhuys. "A Study of Wood Inspection by Infrared Thermography Part II: Wood Pole Inspection by Infrared Thermography," *Research in Nondestructive Evaluation* (2001)

Maldague, Xavier P. V. *Theory and Practice of Infrared Technology for Nondestructive Testing*. New York: John Wiley & Sons, Inc., 2001.

Murata, K. and T. Sadoh, "Heat Absorption and Transfer in Softwoods and Their Knot Surfaces," *Mokuzai Gakkaishi* (1994)

Omega Engineering, *Omega Temperature Measurement Handbook, 6th Edition*. 2007

Pellerin, Roy F. and Robert J. Ross, ed. *Nondestructive Evaluation of Wood*. Madison, Wisconsin: Forest Products Society, 2002.

Robinson, Elwin C. and Elisabetta Rosina. "Applying Infrared Thermography to Historic Wood-Framed Buildings in North America." *APT Bulletin*, Vol. 33, No. 4 (2002): 27-44.

Rosina, Elisabetta and Jonathan Spodek. "Using Infrared Thermography to Detect Moisture in Historic Masonry: A Case Study in Indiana," *APT Bulletin*, Vol. 34, No. 1 (2003): 11-16.

Shmulsky, R., P.H. Steele and F.Quin. "Locating Knots in Wood with an Infrared Detector System," *Forest Products Journal* (1998)

Silman, Robert. "Applications of Non-Destructive Evaluation Techniques in Historic Buildings," *APT Bulletin*, Vol. 27, No. 1/2 (1996): 69-73.

Simpson, William and Anton TenWolde. "Physical Properties and Moisture Relations of Wood." In *Wood Handbook-Wood as an Engineering Material*, chapter 3 pp. 1-24. Madison, Wisconsin: Forest Service, 1999.

Spiro, Irving J. ed. "Modern Utilization of Infrared Technology V." *Proceedings of the Society of Photo-Optical Instrumentation Engineers*, vol. 197 (1979)

Swanke Hayden Connel Architects. *Historic Preservation Project Planning & Estimating*. Kingston, MA: RSMeans, 2000.

Weaver, Martin E. *Conserving Buildings, A Manual of Techniques and Materials*. New York: John Wiley & Sons, Inc., 1997.

Williams, T.L. ed. "Application of Infrared Technology." *Proceedings of the Society of Photo-Optical Instrumentation Engineers*, vol. 918 (1988)

"ASTM E 1316-04 Section J: Infrared Examination," ASTM Standards (2004) vol. 03.03: 700-701

"ASTM E 1213-97 Standard Test Method for Minimum Resolvable Temperature Difference for Thermal Imaging Systems," ASTM Standards (2004) vol. 03.03: 630-632

"ASTM C 1046-95 Standard Practice for In-Situ Measurement of Heat Flux and Temperature on Building Envelope Components," ASTM Standards (2004) vol. 04.06: 509-517

"ASTM C 1060-90 Standard Practice for Thermographic Inspection of Insulation Installations in Envelope Cavities of Frame Buildings," ASTM Standards (2004) vol. 04.06: 536-541

"ASTM D 4788-03 Standard Test Method for Detecting Delaminations in Bridge Decking Using IRT," ASTM Standards (2004) vol. 04.03: 507